

**ELECTROMAGNETIC EMISSIONS COMPLIANCE REPORT  
INTENTIONAL RADIATOR CERTIFICATION TO  
FCC PART 15 SUBPART C REQUIREMENT**

*OF*

**3.5 Inch Diamond 1(with WIFI)**

**MODEL No.: DF03510-08-XXXX(X=A-Z, 0-9, a-z), J-Touch**

**BRAND NAME: N/A**

**FCC ID: V37-35WIFI6229**

**REPORT NO: KA09106029E**

**ISSUE DATE: November 15, 2009**

*Prepared for*

**WIN ACCORD LTD.**

**12F, 225, Sec 5, 105 Song Shan Dist., Nan Jing East Road, Taipei, Taiwan**

*Prepared by*

**DONGGUAN EMTEK CO., LTD**

**No.281, Guantai Road, Nancheng District,  
Dongguan, Guangdong, China**

**TEL: 86-769-22807078**

**FAX: 86-769-22807079**

**VERIFICATION OF COMPLIANCE**

Applicant:	WIN ACCORD LTD. 12F, 225, Sec 5, 105 Song Shan Dist., Nan Jing East Road, Taipei, Taiwan
Manufacturer:	WIN ACCORD LTD. 12F, 225, Sec 5, 105 Song Shan Dist., Nan Jing East Road, Taipei, Taiwan
Product Description:	3.5 Inch Diamond 1(with WIFI)
Brand Name:	N/A
Model Number:	Basic Model: DF03510-08-XXX(X=A-Z, 0-9, a-z) Additional Model: J-Touch (Note: Those models are the same except appearance and model names, all models use the same FCC ID Number.)
Serial Number:	N/A
File Number:	KA09106029E
Date of Test:	October 29, 2009 to November 15, 2009

**We hereby certify that:**

The above equipment was tested by DONGGUAN EMTEK CO., LTD. The test data, data evaluation, test procedures, and equipment configurations shown in this report were made in accordance with the procedures given in ANSI C63.4 (2003) and the energy emitted by the sample EUT tested as described in this report is in compliance with conducted and radiated emission limits of FCC Rules Part 15.247. also, the model complies with Canadian RSS-210 Issue 6 standard.

The test results of this report relate only to the tested sample identified in this report.

*Approved By*



---

*Nicol Lee / Q.A. Manager*  
**DONGGUAN EMTEK CO., LTD.**

## Table of Contents

<b>1. GENERAL INFORMATION .....</b>	<b>5</b>
1.1 PRODUCT DESCRIPTION.....	5
1.2 RELATED SUBMITTAL(S) / GRANT (S) .....	6
1.3 TEST METHODOLOGY .....	6
1.4 SPECIAL ACCESSORIES .....	6
1.5 EQUIPMENT MODIFICATIONS .....	6
1.6 TEST FACILITY .....	6
<b>2. SYSTEM TEST CONFIGURATION .....</b>	<b>7</b>
2.1 EUT CONFIGURATION.....	7
2.2 EUT EXERCISE .....	7
2.3 TEST PROCEDURE .....	7
2.4 CONFIGURATION OF TESTED SYSTEM.....	7
<b>3. DESCRIPTION OF TEST MODES.....</b>	<b>9</b>
<b>4. CONDUCTED EMISSIONS TEST .....</b>	<b>10</b>
4.1 MEASUREMENT PROCEDURE:.....	10
4.2 TEST SET-UP (BLOCK DIAGRAM OF CONFIGURATION) .....	10
4.3 MEASUREMENT EQUIPMENT USED: .....	10
4.4 CONDUCTED EMISSION LIMIT .....	11
4.5 MEASUREMENT RESULT:.....	11
4.6 CONDUCTED MEASUREMENT PHOTOS: .....	12
<b>5. RADIATED EMISSION TEST .....</b>	<b>13</b>
5.1 MEASUREMENT PROCEDURE.....	13
5.2 TEST SET-UP (BLOCK DIAGRAM OF CONFIGURATION) .....	14
5.3 MEASUREMENT EQUIPMENT USED: .....	15
5.4 RADIATED EMISSION LIMIT.....	15
5.5 MEASUREMENT RESULT .....	16
5.6 RADIATED MEASUREMENT PHOTOS: .....	31
<b>6. OCCUPIED BANDWIDTH TEST.....</b>	<b>32</b>
6.1 MEASUREMENT PROCEDURE.....	32
6.2 TEST SET-UP (BLOCK DIAGRAM OF CONFIGURATION) .....	32
6.3 MEASUREMENT EQUIPMENT USED: .....	32
6.4 LIMIT .....	32
6.5 MEASUREMENT RESULTS:.....	32
<b>7. MAXIMUM PEAK OUTPUT POWER TEST .....</b>	<b>41</b>
7.1 MEASUREMENT PROCEDURE.....	41
7.2 TEST SET-UP (BLOCK DIAGRAM OF CONFIGURATION) .....	41
7.3 MEASUREMENT EQUIPMENT USED: .....	41

7.4 PEAK POWER OUTPUT LIMIT..... 41

7.5 MEASUREMENT RESULTS: ..... 42

**8.BAND EDGE TEST..... 43**

8.1 MEASUREMENT PROCEDURE..... 43

8.2 TEST SET-UP (BLOCK DIAGRAM OF CONFIGURATION) ..... 43

8.3 MEASUREMENT EQUIPMENT USED: ..... 43

8.4 MEASUREMENT RESULTS:..... 44

**9. POWER DENSITY..... 52**

9.1 TEST EQUIPMENT..... 52

9.2 MEASURING INSTRUMENTS AND SETTING..... 52

9.3 TEST PROCEDURES ..... 52

9.4 BLOCK DIAGRAM OF TEST SETUP..... 52

9.5 LIMIT ..... 52

9.6. TEST RESULT ..... 53

**10 ANTENNA APPLICATION..... 61**

10.1 ANTENNA REQUIREMENT ..... 61

10.2 RESULT ..... 61

**11.ANTENNA PORT EMISSION..... 62**

11.1 TEST EQUIPMENT..... 62

11.2 MEASURING INSTRUMENTS AND SETTING..... 62

11.3 TEST PROCEDURES ..... 62

11.4 BLOCK DIAGRAM OF TEST SETUP..... 62

11.5. TEST RESULT ..... 62

**12. RF EXPOSURE EVALUATION..... 69**

12.1 FRIIS TRANSMISSION FORMULA:  $P_D=(P_{OUT}*G)/(4*\pi*R^2)$  ..... 69

12.2 MEASUREMENT RESULT ..... 69

# 1. GENERAL INFORMATION

## 1.1 Product Description

A major technical descriptions of EUT is described as following:

- A). Standards: IEEE 802.11b/g/n
- B). Operation Frequency: 2400-2483.5MHz
- C). Modulation: OFDM (11g, 11n), BPSK, QPSK, CCK (11b)
- D). Number of Channel: IEEE 802.11b/g, 802.11n HT20:11 Channels  
 IEEE 802.11n HT40 :7 Channels
- E). Data Rate: IEEE802.11b : 11 , 5.5 , 2 , 1 Mbps  
 IEEE802.11g : 54 , 48 , 36 , 24 , 18 , 12 , 9 , 6 Mbps  
 IEEE802.11n HT20 : 130 , 117 , 104 , 78 , 52 , 39 , 26 , 13 Mbps  
 IEEE802.11n HT40 : 270 , 243 , 216 , 162 , 108 , 81 , 54 , 27 Mbps
- F). Transmit Power: 13dBm
- G). Antenna GAIN: 2dBi
- H). Antenna Type: WLAN 802.11b/g/n Mini-Card
- I). Power Supply: AC 100-240V 50/60Hz by AC adaptor

IEEE 802.11b/g, 802.11n HT20

Channel	Frequency (MHz)	Channel	Frequency (MHz)	Channel	Frequency (MHz)
1	2412	5	2432	9	2452
2	2417	6	2437	10	2457
3	2422	7	2442	11	2462
4	2427	8	2447		

IEEE802.11n HT40

Channel	Frequency (MHz)	Channel	Frequency (MHz)	Channel	Frequency (MHz)
1	2422	5	2442		
2	2427	6	2447		
3	2432	7	2452		
4	2437				

Note:

1. This device is a 2.4GHz 3.5 Inch Diamond 1(with WIFI) included 802.11b, 802.11g and 802.11n 2.4GHz transceiver function.
2. Test of channel was included the lowest middle and highest frequency in highest data rate and to perform the test, then record on this report.

## 1.2 Related Submittal(s) / Grant (s)

This submittal(s) (test report) is intended for FCC ID: V37-35WIFI6229 filing to comply with Section 15.247 of the FCC Part 15, Subpart C Rules. The composite system (receiver) is compliance with Subpart B is authorized under a DoC procedure.

## 1.3 Test Methodology

Both conducted and radiated testing were performed according to the procedures in ANSI C63.4 (2003). Radiated testing was performed at an antenna to EUT distance 3 meters.

## 1.4 Special Accessories

Not available for this EUT intended for grant.

## 1.5 Equipment Modifications

Not available for this EUT intended for grant.

## 1.6 Test Facility

### Site Description

EMC Lab.

: Accredited by CNAS, 2005.11.02

The certificate is valid until 2010.11

The Laboratory has been assessed and proved to be in compliance with CNAS/CL01:2006(identical to ISO/IEC17025:2005)

The Certificate Registration Number is L2291

Accredited by TUV Rheinland Shenzhen, 2008.5

The certificate is valid until 2009.12

The Laboratory has been assessed according to the requirements ISO/IEC 17025

Accredited by FCC, Nov. 05, 2008

The Certificate Registration Number is 247565.

Accredited by Industry Canada, May 24, 2008

The Certificate Registration Number is 46405-4480

Name of Firm

: DONGGUAN EMTEK CO., LTD

Site Location

: No.281, Guantai Road, Nancheng District,  
Dongguan, Guangdong, China

## 2. System Test Configuration

### 2.1 EUT Configuration

The EUT configuration for testing is installed on RF field strength measurement to meet the Commissions requirement and operating in a manner which intends to maximize its emission characteristics in a continuous normal application.

### 2.2 EUT Exercise

The Transmitter was operated in the normal operating mode. the Tx frequency was fixed which was for the purpose of the measurements.

### 2.3 Test Procedure

#### 2.3.1 Conducted Emissions

The EUT is a placed on as turn table which is 0.8 m above ground plane. According to the requirements in Section 13.1.4.1 of ANSI C63.4-2003. Conducted emissions from the EUT measured in the frequency range between 0.15 MHz and 30MHz using CISPR Quasi-Peak and average detector mode.

#### 2.3.2 Radiated Emissions

The EUT is a placed on as turn table which is 0.8 m above ground plane. The turn table shall rotate 360 degrees to determine the position of maximum emission level. EUT is set 3m away from the receiving antenna which varied from 1m to 4m to find out the highest emission. And also, each emission was to be maximized by changing the polarization of receiving antenna both horizontal and vertical. In order to find out the max. emission, the relative positions of this hand-held transmitter(EUT) was rotated through three orthogonal axes according to the requirements in Section 13.1.4.1 of ANSI C63.4-2003.

### 2.4 Configuration of Tested System

**Fig. 2-1 Configuration of Tested System**

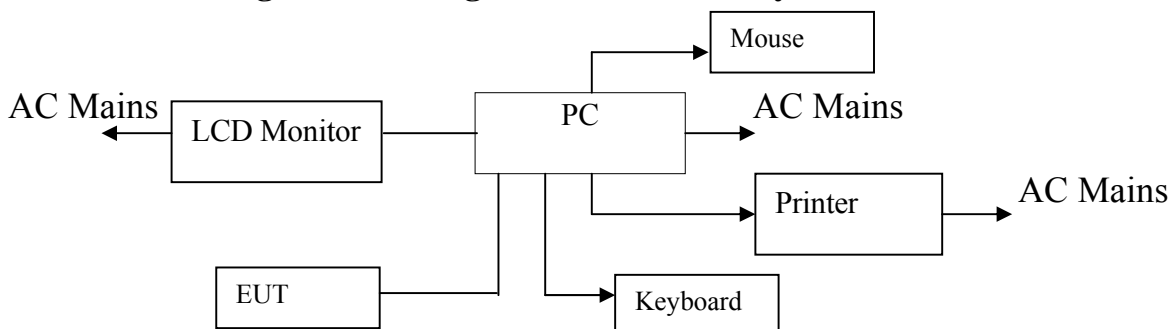

Table 2-1 Equipment Used in Tested System

Item	Equipment	Mfr/Brand	Model/Type No.	FCC ID	Series No.	Note
1.	3.5 Inch Diamond 1(with WIFI)	J-Touch	FDF03510-08-XX(X=A-Z, 0-9, a-z)	V37-35WIFI6229	N/A	<b>EUT</b>
2.	LCD Monitor	DELL	E1909WF	N/A	N/A	
3.	Printer	HP	Q5911A	N/A	CNCK512065	
4.	Keyboard	DELL	L30U	N/A	ON277F	
5.	Mouse	DELL	M-UAR DEL7	N/A	XN966	
6.	PC	DELL	DCSM	N/A	CXBMMZX	

**Note:**

- (1) Unless otherwise denoted as EUT in 『Remark』 column , device(s) used in tested system is a support equipment.



### 3. Description of test modes

The Transmitter of EUT is a 3.5 Inch Diamond 1(with WIFI) and powered by host equipment. This is Digital Transmission system(DTS) and have four type of modulation DBPSK DQPSK CCK&OFDM. The data rates are 54Mbps.

The equipment enables high-speed access without wires to network assets. This adapter uses the WLAN802.11b/g/n protocol to enable wireless communications between the host computer and computers, in the same way that the computer would use an Ethernet adapter.

IEEE 802.11 b, 802.11g, 802.11n HT20 mode

1. For lowest channel : 2412MHz(Channel 1)
2. For middle channel : 2437MHz(Channel 6)
3. For highest channel: 2462MHz(Channel 11)

IEEE 802.11b mode: 11Mbps data rates (worst case) were chosen for full testing.

IEEE 802.11g mode: 6Mbps data rates (worst case) were chosen for full testing.

IEEE 802.11n HT20 mode: 13Mbps data rates (worst case) were chosen for full testing.

IEEE 802.11 b, 802.11g, 802.11n HT20 mode

1. For lowest channel : 2422MHz(Channel 1)
2. For middle channel : 2437MHz(Channel 4)
3. For highest channel: 2452MHz(Channel 7)

IEEE 802.11n HT40 mode: 27Mbps data rates (worst case) were chosen for full testing.

#### **EUT operating conditions:**

The EUT exercise program used during conducted testing was designed to exercise the EUT in a manner similar to typical use, The exercise sequence is listed as below:

1. Setup the EUT and simulators as shown on 2.4.
2. Turn on the power of all equipments.
3. The EUT Ping with the wireless router.
4. Repeat the above steps.

#### 4. Conducted Emissions Test

##### 4.1 Measurement Procedure:

1. The EUT was placed on a table, which is 0.8m above ground plane.
2. Maximum procedure was performed on the six highest emissions to ensure EUT compliance.
3. Repeat above procedures until all frequency measured was complete.

##### 4.2 Test SET-UP (Block Diagram of Configuration)

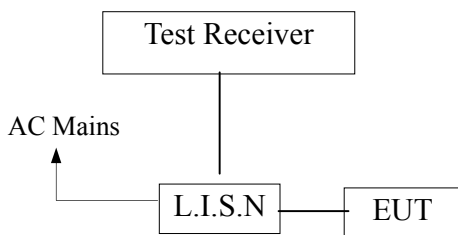

##### 4.3 Measurement Equipment Used:

Conducted Emission Test Site # 4					
EQUIPMENT TYPE	MFR	MODEL NUMBER	SERIAL NUMBER	LAST CAL.	CAL DUE.
Test Receiver	Rohde & Schwarz	ESCS30	828985/018	05/29/2009	05/29/2010
L.I.S.N	Rohde & Schwarz	ESH2-Z5	834549/005	05/29/2009	05/29/2010
L.I.S.N	Rohde & Schwarz	ESH2-Z5	834549/005	05/29/2009	05/29/2010
50ΩCoaxial Switch	Anritsu	MP59B	M20531	05/29/2009	05/29/2010

**4.4 Conducted Emission Limit**  
**(7) Conducted Emission**

Frequency(MHz)	Quasi-peak	Average
0.15-0.5	66-56	56-46
0.5-5.0	56	46
5.0-30.0	60	50

**Note:**

1. The lower limit shall apply at the transition frequencies
2. The limit decreases in line with the logarithm of the frequency in the range of 0.15 to 0.50MHz.

**4.5 Measurement Result:**

Date of Test:	<u>November 02, 2009</u>	Temperature:	<u>22°C</u>
Frequency Detector:	<u>0.15~30MHz</u>	Humidity:	<u>50%</u>
Test Result:	<u>PASS</u>	Test Mode:	<u>ON</u>

Test Line	Frequency MHz	Emission Level QP dB(μV)	Emission Level AV dB(μV)	Limits QP dB(μV)	Limits AV dB(μV)	Margin QP dB(μV)	Margin AV dB(μV)
Neutral	0.190	53.51	45.94	64.04	54.04	-10.53	-8.10
	0.245	44.58	37.33	61.92	51.92	-17.34	-14.59
	0.315	47.61	41.25	59.84	49.84	-12.23	-8.59
	0.375	43.53	36.34	58.39	48.39	-14.86	-12.05
	0.435	39.53	32.35	57.16	47.16	-17.63	-14.81
	21.251	35.18	32.51	60.00	50.00	-24.82	-17.49
Line	0.190	52.36	44.97	64.04	54.04	-11.68	-9.07
	0.245	43.94	38.61	61.92	51.92	-17.98	-13.31
	0.305	40.61	36.94	60.11	50.11	-19.50	-13.17
	0.375	43.91	37.91	58.39	48.39	-14.48	-10.48
	0.440	42.61	38.36	57.06	47.06	-14.45	-8.70
	22.152	36.51	33.10	60.00	50.00	-23.49	-16.90

**4.6 Conducted Measurement Photos:**



## **5. Radiated Emission Test**

### **5.1 Measurement Procedure**

- 1 The EUT was placed on a turn table which is 0.8m above ground plane.
2. Maximum procedure was performed on the six highest emissions to ensure EUT compliance.
3. And also, each emission was to be maximized by changing the polarization of receiving antenna both horizontal and vertical.
4. Repeat above procedures until all frequency measured were complete.

### 5.2 Test SET-UP (Block Diagram of Configuration)

(A) Radiated Emission Test Set-Up, Frequency Below 30MHz

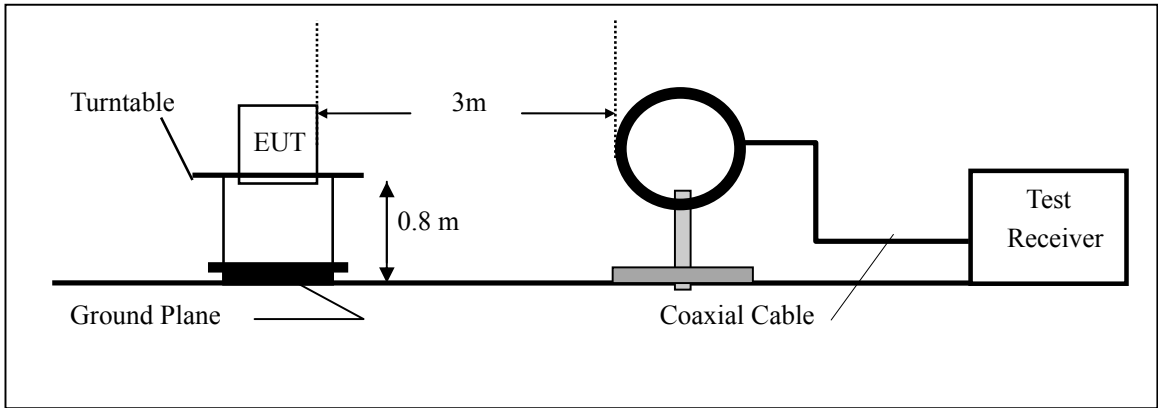

(B) Radiated Emission Test Set-Up, Frequency Below 1000MHz

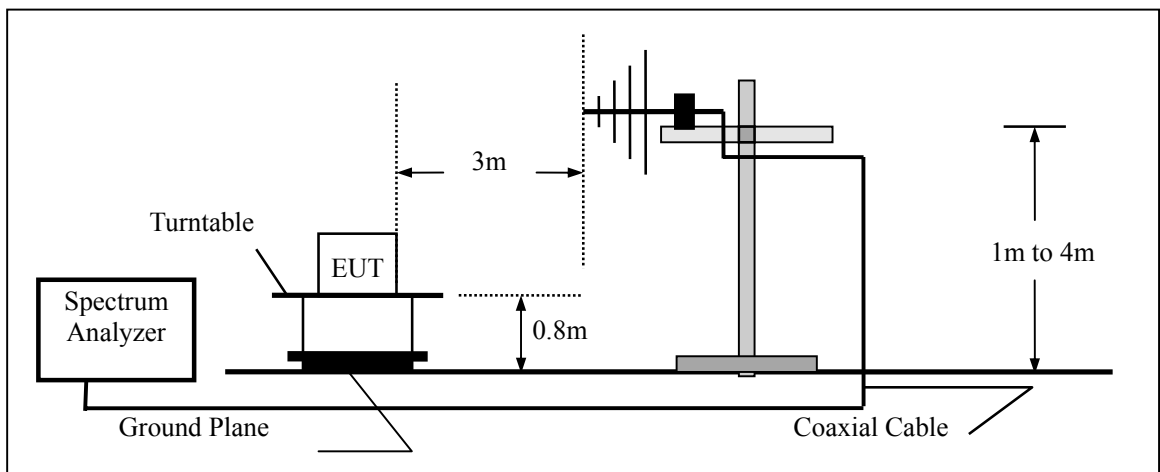

(C) Radiated Emission Test Set-Up, Frequency above 1000MHz

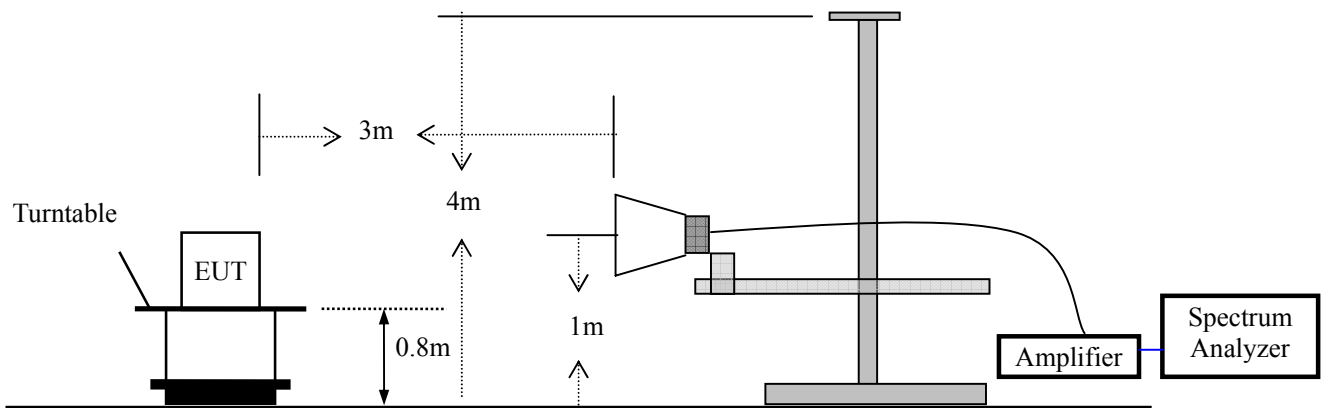

**5.3 Measurement Equipment Used:**

EQUIPMENT TYPE	MFR	MODEL NUMBER	SERIAL NUMBER	LAST CAL.	CAL DUE.
Spectrum Analyzer	Rohde & Schwarz	FSP7	839511/010	05/29/2009	05/29/2010
Spectrum Analyzer	Agilent	E4446A	MY43360126	05/29/2009	05/29/2010
EMI Test Receiver	Rohde & Schwarz	ESU	1302.6005.26	05/29/2009	05/29/2010
Pre-Amplifier	HP	8447D	2944A07999	05/29/2009	05/29/2010
Bilog Antenna	Schwarzbeck	VULB9163	142	05/29/2009	05/29/2010
Loop Antenna	ARA	PLA-1030/B	1029	05/29/2009	05/29/2010
Horn Antenna	Schwarzbeck	BBHA9170	BBHA9170399	05/29/2009	05/29/2010
Horn Antenna	Schwarzbeck	BBHA 9120	D143	05/29/2009	05/29/2010

**5.4 Radiated emission limit**

**FCC Class B Limit at 3m**

Frequency MHz	Distance Meter	Field Strength uV/m	Field Strength dBuV/m
30~88	3	100	40.0
88~216	3	150	43.5
216~960	3	200	46.0
Above 960	3	500	54.0

Note: The frequencies above 1000MHz, as measured using instrumentation with a peak detector function was corresponding to 20dB above maximum permitted average limit.

### 5.5 Measurement Result

Operation Mode: Channel 1                      Test Date : 11/02/2009  
Frequency Range: 30~1000MHz              Temperature : 28 °C  
Test Result: PASS                              Humidity : 65 %  
Measured Distance: 3m                        Test By: Jeese

Freq. (MHz)	Ant.Pol. H/V	Emission Level (dBuV)	Limit 3m (dBuV/m)	Margin (dB)	Note
37.760	V	28.25	40	-11.75	PK
99.840	V	29.68	43.5	-13.82	PK
214.300	V	34.51	43.5	-8.99	PK
470.380	V	34.70	46	-11.30	PK
651.510	V	38.61	46	-7.39	PK
848.680	V	43.40	46	-2.60	PK
99.840	H	30.36	40	-9.64	PK
138.640	H	32.98	43.5	-10.52	PK
202.660	H	34.84	43.5	-8.66	PK
361.740	H	28.54	46	-17.46	PK
476.200	H	31.79	46	-14.21	PK
831.220	H	39.92	46	-6.08	PK

- Note:**
- (1) All Readings are Peak Value.
  - (2) Emission Level= Reading Level+Probe Factor +Cable Loss
  - (3) The average measurement was not performed when the peak measured data under the limit of average detection.



Operation Mode:	Channel 6	Test Date :	11/02/2009
Frequency Range:	30~1000MHz	Temperature :	28 °C
Test Result:	PASS	Humidity :	65 %
Measured Distance:	3m	Test By:	Jees

Freq. (MHz)	Ant.Pol. H/V	Emission Level (dBuV)	Limit 3m (dBuV/m)	Margin (dB)	Note
36.450	V	29.65	40	-10.35	PK
98.650	V	32.14	43.5	-11.36	PK
218.870	V	36.89	46	-9.11	PK
485.560	V	38.56	46	-7.44	PK
687.120	V	38.41	46	-7.59	PK
856.680	V	40.15	46	-5.85	PK
95.150	H	30.25	40	-9.75	PK
167.340	H	33.45	43.5	-10.05	PK
210.560	H	35.86	43.5	-7.64	PK
398.560	H	36.47	46	-9.53	PK
490.170	H	38.51	46	-7.49	PK
843.760	H	41.54	46	-4.46	PK

- Note:**
- (1) All Readings are Peak Value and AV.
  - (2) Emission Level= Reading Level+Probe Factor +Cable Loss
  - (3) The average measurement was not performed when the peak measured data under the limit of average detection.

Operation Mode: Channel 11                      Test Date : 11/02/2009  
 Frequency Range: 30~1000MHz                  Temperature : 28 °C  
 Test Result: PASS                                      Humidity : 65 %  
 Measured Distance: 3m                                Test By: Jeos

Freq. (MHz)	Ant.Pol. H/V	Emission Level (dBUV)	Limit 3m (dBUV/m)	Margin (dB)	Note
45.350	V	30.25	40	-9.75	PK
95.780	V	33.45	43.5	-10.05	PK
219.420	V	35.86	46	-10.14	PK
487.560	V	35.36	46	-10.64	PK
654.850	V	38.51	46	-7.49	PK
859.450	V	39.86	46	-6.14	PK
96.220	H	35.32	40	-4.68	PK
162.860	H	38.43	43.5	-5.07	PK
211.210	H	37.98	43.5	-5.52	PK
657.560	H	38.54	46	-7.46	PK
852.980	H	40.21	46	-5.79	PK

**Note:** (1) All Readings are Peak Value and AV.  
 (2) Emission Level= Reading Level+Probe Factor +Cable Loss  
 (3) The average measurement was not performed when the peak measured data under the limit of average detection.

Operation Mode: 802.11b(Channel 1) Test Date : 11/02/2009  
 Frequency Range: Above 1GHz Temperature : 28 °C  
 Test Result: PASS Humidity : 65 %  
 Measured Distance: 3m Test By: Jeos

Freq. (MHz)	Ant.Pol. H/V	Emission Level(dBuV)		Limit 3m(dBuV/m)		Margin(dB)	
		PK	AV	PK	AV	PK	AV
4824.12	V	49.34	38.60	74.00	54.00	-24.66	-15.4
7236.20	V	52.47	37.32	74.00	54.00	-21.53	-16.68
9648.33	V	49.47	34.36	74.00	54.00	-24.53	-19.64
12060.51	V	52.64	37.25	74.00	54.00	-21.36	-16.75
14472.30	V	45.93	32.47	74.00	54.00	-28.07	-21.53
16884.52	V	43.54	31.96	74.00	54.00	-30.46	-22.04
4824.20	H	49.64	36.35	74.00	54.00	-24.36	-17.65
7236.26	H	51.93	40.69	74.00	54.00	-22.07	-13.31
9647.61	H	48.54	38.34	74.00	54.00	-25.46	-15.66
12060.32	H	43.37	37.21	74.00	54.00	-30.63	-16.79
14472.76	H	44.68	34.31	74.00	54.00	-29.32	-19.69
16884.35	H	42.69	31.57	74.00	54.00	-31.31	-22.43

**No others harmonics emissions are higher than 20dB below the limits of 47 CFR Part 15.247.**

**Note:** (1) All Readings are Peak Value and AV.  
 (2) Emission Level= Reading Level+Probe Factor +Cable Loss  
 (3) The average measurement was not performed when the peak measured data under the limit of average detection.

Operation Mode: 802.11b(Channel 6) Test Date : 11/02/2009  
 Frequency Range: Above 1GHz Temperature : 28 °C  
 Test Result: PASS Humidity : 65 %  
 Measured Distance: 3m Test By: Jeese

Freq. (MHz)	Ant.Pol. H/V	Emission Level(dBuV)		Limit 3m(dBuV/m)		Margin(dB)	
		PK	AV	PK	AV	PK	AV
4874.21	V	50.68	37.40	74.00	54.00	-23.32	-16.60
7310.15	V	53.26	34.42	74.00	54.00	-20.74	-19.58
9748.65	V	52.21	32.64	74.00	54.00	-21.79	-21.36
12185.15	V	55.72	39.26	74.00	54.00	-18.28	-14.74
14622.22	V	52.42	40.26	74.00	54.00	-21.58	-13.74
17059.43	V	50.24	41.74	74.00	54.00	-23.76	-12.26
4873.20	H	48.25	38.50	74.00	54.00	-25.75	-15.50
7311.42	H	40.63	36.42	74.00	54.00	-33.37	-17.58
9747.58	H	44.58	35.51	74.00	54.00	-29.42	-18.49
12184.43	H	52.35	38.21	74.00	54.00	-21.65	-15.79
14624.21	H	54.24	42.39	74.00	54.00	-19.76	-11.61
17058.45	H	56.85	43.76	74.00	54.00	-17.15	-10.24

**No others harmonics emissions are higher than 20dB below the limits of 47 CFR Part 15.247.**

- Note:**
- (1) All Readings are Peak Value and AV.
  - (2) Emission Level= Reading Level+Probe Factor +Cable Loss
  - (3) The average measurement was not performed when the peak measured data under the limit of average detection.

Operation Mode: 802.11b (Channel 11) Test Date : 11/02/2009  
 Frequency Range: Above 1GHz Temperature : 28 °C  
 Test Result: PASS Humidity : 65 %  
 Measured Distance: 3m Test By: Jeos

Freq. (MHz)	Ant.Pol. H/V	Emission Level(dBuV)		Limit 3m(dBuV/m)		Margin(dB)	
		PK	AV	PK	AV	PK	AV
4923.83	V	52.23	40.78	74.00	54.00	-21.77	-13.22
7386.45	V	44.24	32.55	74.00	54.00	-29.76	-21.45
9848.32	V	50.41	37.24	74.00	54.00	-23.59	-16.76
12310.26	V	52.48	35.25	74.00	54.00	-21.52	-18.75
14772.60	V	55.24	42.13	74.00	54.00	-18.76	-11.87
17234.29	V	56.87	43.25	74.00	54.00	-17.13	-10.75
4923.22	H	50.34	39.35	74.00	54.00	-23.66	-14.65
7386.42	H	43.34	33.69	74.00	54.00	-30.66	-20.31
9848.65	H	52.13	40.20	74.00	54.00	-21.87	-13.80
12310.23	H	45.69	33.68	74.00	54.00	-28.31	-20.32
14772.60	H	53.67	41.14	74.00	54.00	-20.33	-13.86
17234.54	H	55.75	40.28	74.00	54.00	-18.25	-13.72

**No others harmonics emissions are higher than 20dB below the limits of 47 CFR Part 15.247.**

- Note:**
- (1) All Readings are Peak Value and AV.
  - (2) Emission Level= Reading Level+Probe Factor +Cable Loss
  - (3) The average measurement was not performed when the peak measured data under the limit of average detection.

Operation Mode: 802.11g(Channel 1) Test Date : 11/02/2009  
 Frequency Range: Above 1GHz Temperature : 28 °C  
 Test Result: PASS Humidity : 65 %  
 Measured Distance: 3m Test By: Jeos

Freq. (MHz)	Ant.Pol. H/V	Emission Level(dBuV)		Limit 3m(dBuV/m)		Margin(dB)	
		PK	AV	PK	AV	PK	AV
4824.15	V	50.34	32.65	74.00	54.00	-23.66	-21.35
7236.25	V	53.65	34.26	74.00	54.00	-20.35	-19.74
9648.42	V	55.46	40.10	74.00	54.00	-18.54	-13.90
12060.44	V	52.15	37.28	74.00	54.00	-21.85	-16.72
1447236	V	53.45	42.15	74.00	54.00	-20.55	-11.85
16884.35	V	45.72	34.26	74.00	54.00	-28.28	-19.74
4824.34	H	50.36	40.21	74.00	54.00	-23.64	-13.79
7236.37	H	44.35	34.62	74.00	54.00	-29.65	-19.38
9647.67	H	52.20	39.26	74.00	54.00	-21.80	-14.74
12060.24	H	56.57	42.36	74.00	54.00	-17.43	-11.64
14472.60	H	53.42	40.10	74.00	54.00	-20.58	-13.90
16884.46	H	55.48	42.28	74.00	54.00	-18.52	-11.72

**No others harmonics emissions are higher than 20dB below the limits of 47 CFR Part 15.247.**

- Note:**
- (1) All Readings are Peak Value and AV.
  - (2) Emission Level= Reading Level+Probe Factor +Cable Loss
  - (3) The average measurement was not performed when the peak measured data under the limit of average detection.

Operation Mode: 802.11g(Channel 6) Test Date : 11/02/2009  
 Frequency Range: Above 1GHz Temperature : 28 °C  
 Test Result: PASS Humidity : 65 %  
 Measured Distance: 3m Test By: Jeese

Freq. (MHz)	Ant.Pol. H/V	Emission Level(dBuV)		Limit 3m(dBuV/m)		Margin(dB)	
		PK	AV	PK	AV	PK	AV
4874.11	V	51.24	40.75	74.00	54.00	-22.76	-13.25
7310.23	V	54.52	43.84	74.00	54.00	-19.48	-10.16
9748.17	V	58.74	40.21	74.00	54.00	-15.26	-13.79
12185.11	V	54.52	43.28	74.00	54.00	-19.48	-10.72
14622.23	V	53.48	42.45	74.00	54.00	-20.52	-11.55
17059.31	V	54.22	40.33	74.00	54.00	-19.78	-13.67
4874.23	H	52.58	43.11	74.00	54.00	-21.42	-10.89
7310.56	H	54.65	35.34	74.00	54.00	-19.35	-18.66
9748.54	H	56.82	40.17	74.00	54.00	-17.18	-13.83
12185.21	H	54.17	42.56	74.00	54.00	-19.83	-11.46
14622.30	H	51.48	46.85	74.00	54.00	-22.52	-7.15
17059.31	H	50.87	42.20	74.00	54.00	-23.13	-11.80

**No others harmonics emissions are higher than 20dB below the limits of 47 CFR Part 15.247.**

- Note:**
- (1) All Readings are Peak Value and AV.
  - (2) Emission Level= Reading Level+Probe Factor +Cable Loss
  - (3) The average measurement was not performed when the peak measured data under the limit of average detection.

Operation Mode: 802.11g(Channel 11) Test Date : 11/02/2009  
 Frequency Range: Above 1GHz Temperature : 28 °C  
 Test Result: PASS Humidity : 65 %  
 Measured Distance: 3m Test By: Jeos

Freq. (MHz)	Ant.Pol. H/V	Emission Level(dBuV)		Limit 3m(dBuV/m)		Margin(dB)	
		PK	AV	PK	AV	PK	AV
4924.23	V	52.23	40.78	74.00	54.00	-21.77	-13.22
7386.34	V	54.24	42.55	74.00	54.00	-19.76	-11.45
9848.32	V	50.41	40.24	74.00	54.00	-23.59	-13.76
12310.13	V	52.48	40.25	74.00	54.00	-21.52	-13.75
14772.54	V	55.24	42.13	74.00	54.00	-18.76	-11.87
17234.22	V	56.87	43.25	74.00	54.00	-17.13	-10.75
4923.21	H	52.13	40.20	74.00	54.00	-21.87	-13.80
7386.41	H	45.69	33.68	74.00	54.00	-28.31	-20.32
9848.32	H	53.67	41.14	74.00	54.00	-20.33	-13.86
12310.12	H	55.75	40.28	74.00	54.00	-18.25	-13.72
14772.56	H	50.33	37.26	74.00	54.00	-23.67	-16.74
17234.32	H	49.61	35.93	74.00	54.00	-24.39	-18.07

**No others harmonics emissions are higher than 20dB below the limits of 47 CFR Part 15.247.**

**Note:** (1) All Readings are Peak Value and AV.  
 (2) Emission Level= Reading Level+Probe Factor +Cable Loss  
 (3) The average measurement was not performed when the peak measured data under the limit of average detection.



Operation Mode: 802.11n H20(Channel 1) Test Date : 11/02/2009  
 Frequency Range: Above 1GHz Temperature : 28 °C  
 Test Result: PASS Humidity : 65 %  
 Measured Distance: 3m Test By: Jeos

Freq. (MHz)	Ant.Pol. H/V	Emission Level(dBuV)		Limit 3m(dBuV/m)		Margin(dB)	
		PK	AV	PK	AV	PK	AV
4824.15	V	50.43	42.32	74.00	54.00	-23.57	-11.68
7236.32	V	51.24	40.75	74.00	54.00	-22.76	-13.25
9648.35	V	54.52	43.84	74.00	54.00	-19.48	-10.16
12060.56	V	48.74	40.21	74.00	54.00	-25.26	-13.79
14472.34	V	54.52	43.28	74.00	54.00	-19.48	-10.72
16884.32	V	53.48	42.45	74.00	54.00	-20.52	-11.55
4824.12	H	52.56	45.21	74.00	54.00	-21.44	-8.79
7236.15	H	50.58	43.52	74.00	54.00	-23.42	-10.48
9647.12	H	52.58	43.11	74.00	54.00	-21.42	-10.89
12060.34	H	54.65	35.34	74.00	54.00	-19.35	-18.66
14472.76	H	56.82	40.17	74.00	54.00	-17.18	-13.83
16884.42	H	54.17	42.56	74.00	54.00	-19.83	-11.46

**No others harmonics emissions are higher than 20dB below the limits of 47 CFR Part 15.247.**

- Note:**
- (1) All Readings are Peak Value and AV.
  - (2) Emission Level= Reading Level+Probe Factor +Cable Loss
  - (3) The average measurement was not performed when the peak measured data under the limit of average detection.

Operation Mode: 802.11n H20 (Channel 6) Test Date : 11/02/2009  
 Frequency Range: Above 1GHz Temperature : 28 °C  
 Test Result: PASS Humidity : 65 %  
 Measured Distance: 3m Test By: Jeese

Freq. (MHz)	Ant.Pol. H/V	Emission Level(dBuV)		Limit 3m(dBuV/m)		Margin(dB)	
		PK	AV	PK	AV	PK	AV
4874.16	V	54.24	42.39	74.00	54.00	-19.76	-11.61
7310.21	V	56.85	43.76	74.00	54.00	-17.15	-10.24
9748.61	V	51.24	40.75	74.00	54.00	-22.76	-13.25
12185.23	V	54.52	43.84	74.00	54.00	-19.48	-10.16
14622.21	V	52.58	43.11	74.00	54.00	-21.42	-10.89
17059.40	V	54.65	35.34	74.00	54.00	-19.35	-18.66
4873.23	H	55.75	40.28	74.00	54.00	-18.25	-13.72
7311.24	H	50.33	37.26	74.00	54.00	-23.67	-16.74
9747.34	H	44.58	40.51	74.00	54.00	-29.42	-13.49
12184.47	H	52.35	40.21	74.00	54.00	-21.65	-13.79
14624.35	H	55.24	42.13	74.00	54.00	-18.76	-11.87
17058.46	H	56.87	43.25	74.00	54.00	-17.13	-10.75

**No others harmonics emissions are higher than 20dB below the limits of 47 CFR Part 15.247.**

- Note:**
- (1) All Readings are Peak Value and AV.
  - (2) Emission Level= Reading Level+Probe Factor +Cable Loss
  - (3) The average measurement was not performed when the peak measured data under the limit of average detection.

Operation Mode: 802.11n H20 (Channel 11) Test Date : 11/02/2009  
 Frequency Range: Above 1GHz Temperature : 28 °C  
 Test Result: PASS Humidity : 65 %  
 Measured Distance: 3m Test By: Jees

Freq. (MHz)	Ant.Pol. H/V	Emission Level(dBuV)		Limit 3m(dBuV/m)		Margin(dB)	
		PK	AV	PK	AV	PK	AV
4923.65	V	52.63	43.28	74.00	54.00	-21.37	-10.72
7386.43	V	54.85	42.45	74.00	54.00	-19.15	-11.55
9848.33	V	54.71	40.33	74.00	54.00	-19.29	-13.67
12310.20	V	50.25	39.26	74.00	54.00	-23.75	-14.74
14772.67	V	51.26	42.36	74.00	54.00	-22.74	-11.64
17234.45	V	50.69	40.10	74.00	54.00	-23.31	-13.90
4923.21	H	51.56	40.75	74.00	54.00	-22.44	-13.25
7386.48	H	50.39	43.84	74.00	54.00	-23.61	-10.16
9848.62	H	49.86	41.34	74.00	54.00	-24.14	-12.66
12310.21	H	52.34	40.89	74.00	54.00	-21.66	-13.11
14772.65	H	53.21	39.58	74.00	54.00	-20.79	-14.42
17234.52	H	52.17	40.15	74.00	54.00	-21.83	-13.85

**No others harmonics emissions are higher than 20dB below the limits of 47 CFR Part 15.247.**

**Note:** (1) All Readings are Peak Value and AV.  
 (2) Emission Level= Reading Level+Probe Factor +Cable Loss  
 (3) The average measurement was not performed when the peak measured data under the limit of average detection.

Operation Mode: 802.11n H40 (Channel 1) Test Date : 11/02/2009  
 Frequency Range: Above 1GHz Temperature : 28 °C  
 Test Result: PASS Humidity : 65 %  
 Measured Distance: 3m Test By: Jeos

Freq. (MHz)	Ant.Pol. H/V	Emission Level(dBuV)		Limit 3m(dBuV/m)		Margin(dB)	
		PK	AV	PK	AV	PK	AV
4844.11	V	54.65	39.65	74.00	54.00	-19.35	-14.35
7266.25	V	56.82	41.25	74.00	54.00	-17.18	-12.75
9688.46	V	52.20	40.58	74.00	54.00	-21.80	-13.42
12110.44	V	56.57	41.07	74.00	54.00	-17.43	-12.93
14532.36	V	52.87	39.62	74.00	54.00	-21.13	-14.38
16954.35	V	49.89	38.96	74.00	54.00	-24.11	-15.04
4844.21	H	51.45	38.54	74.00	54.00	-22.55	-15.46
7266.28	H	54.23	40.16	74.00	54.00	-19.77	-13.84
9688.32	H	51.20	41.59	74.00	54.00	-22.8	-12.41
12110.48	H	52.35	41.26	74.00	54.00	-21.65	-12.74
14532.54	H	51.64	42.10	74.00	54.00	-22.36	-11.90
16954.87	H	52.12	40.68	74.00	54.00	-21.88	-13.32

**No others harmonics emissions are higher than 20dB below the limits of 47 CFR Part 15.247.**

**Note:** (1) All Readings are Peak Value and AV.  
 (2) Emission Level= Reading Level+Probe Factor +Cable Loss  
 (3) The average measurement was not performed when the peak measured data under the limit of average detection.

Operation Mode: 802.11n H40 (Channel 4) Test Date : 11/02/2009  
 Frequency Range: Above 1GHz Temperature : 28 °C  
 Test Result: PASS Humidity : 65 %  
 Measured Distance: 3m Test By: Jeos

Freq. (MHz)	Ant.Pol. H/V	Emission Level(dBuV)		Limit 3m(dBuV/m)		Margin(dB)	
		PK	AV	PK	AV	PK	AV
4874.04	V	52.63	40.41	74.00	54.00	-21.37	-13.59
7310.87	V	53.48	42.36	74.00	54.00	-20.52	-11.64
9748.23	V	55.27	41.63	74.00	54.00	-18.73	-12.37
12185.32	V	54.64	42.85	74.00	54.00	-19.36	-11.15
14622.34	V	53.12	41.69	74.00	54.00	-20.88	-12.31
17059.39	V	54.25	41.52	74.00	54.00	-19.75	-12.48
4874.13	H	50.96	39.85	74.00	54.00	-23.04	-14.15
7310.45	H	51.46	40.34	74.00	54.00	-22.54	-13.66
9748.21	H	52.78	41.56	74.00	54.00	-21.22	-12.44
12185.32	H	51.69	42.96	74.00	54.00	-22.31	-11.04
14622.24	H	52.75	41.74	74.00	54.00	-21.25	-12.26
17059.12	H	51.47	40.36	74.00	54.00	-22.53	-13.64

**No others harmonics emissions are higher than 20dB below the limits of 47 CFR Part 15.247.**

**Note:** (1) All Readings are Peak Value and AV.  
 (2) Emission Level= Reading Level+Probe Factor +Cable Loss  
 (3) The average measurement was not performed when the peak measured data under the limit of average detection.

Operation Mode: 802.11n H40 (Channel 7) Test Date : 11/02/2009  
 Frequency Range: Above 1GHz Temperature : 28 °C  
 Test Result: PASS Humidity : 65 %  
 Measured Distance: 3m Test By: Jeos

Freq. (MHz)	Ant.Pol. H/V	Emission Level(dBuV)		Limit 3m(dBuV/m)		Margin(dB)	
		PK	AV	PK	AV	PK	AV
4904.21	V	54.68	40.78	74.00	54.00	-19.32	-13.22
7356.12	V	51.69	41.20	74.00	54.00	-22.31	-12.8
9808.24	V	52.84	41.53	74.00	54.00	-21.16	-12.47
12260.25	V	51.47	41.63	74.00	54.00	-22.53	-12.37
14712.47	V	52.36	40.85	74.00	54.00	-21.64	-13.15
17164.28	V	51.49	41.42	74.00	54.00	-22.51	-12.58
4904.14	H	51.69	41.63	74.00	54.00	-22.31	-12.37
7356.32	H	50.68	42.96	74.00	54.00	-23.32	-11.04
9808.24	H	51.58	40.23	74.00	54.00	-22.42	-13.77
12260.26	H	51.75	39.94	74.00	54.00	-22.25	-14.06
14712.32	H	50.33	41.25	74.00	54.00	-23.67	-12.75
17164.51	H	50.26	40.63	74.00	54.00	-23.74	-13.37

**No others harmonics emissions are higher than 20dB below the limits of 47 CFR Part 15.247.**

- Note:**
- (1) All Readings are Peak Value and AV.
  - (2) Emission Level= Reading Level+Probe Factor +Cable Loss
  - (3) The average measurement was not performed when the peak measured data under the limit of average detection.

**5.6 Radiated Measurement Photos:**



## 6. Occupied Bandwidth test

### 6.1 Measurement Procedure

The EUT was operating in IEEE 802.11b/g/n mode or could be controlled its channel. Printed out the test result from the spectrum by hard copy function.

### 6.2 Test SET-UP (Block Diagram of Configuration)

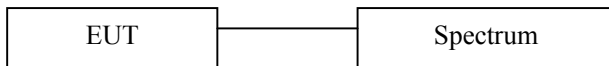

### 6.3 Measurement Equipment Used:

Same as 5.3 Radiated Emission Measurement.

### 6.4 Limit

The minimum 6dB bandwidth shall be at least 500kHz.

### 6.5 Measurement Results:

Refer to attached data chart.

Spectrum Detector:	PK	Test Date :	11/02/2009
Test By:	Andy	Temperature :	28 °C
Test Result:	PASS	Humidity :	65 %

802.11b:

Channel number	Channel frequency (MHz)	Measurement level (MHz)	Required Limit (KHz)
1	2412	10.22	>500
6	2437	10.26	>500
11	2462	10.21	>500



### 802.11b Channel 1

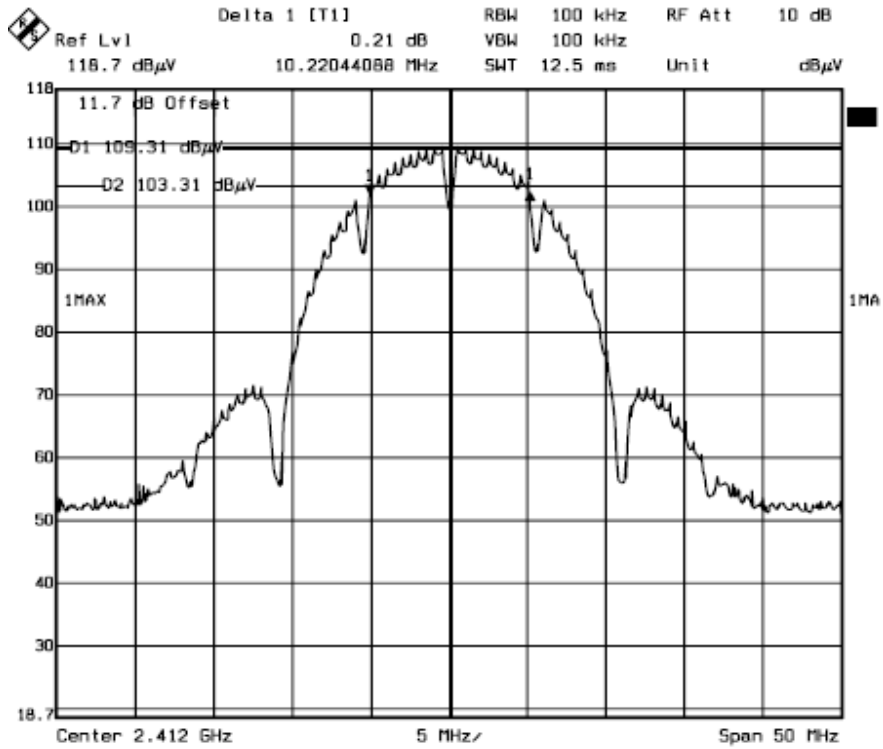

### Channel 6

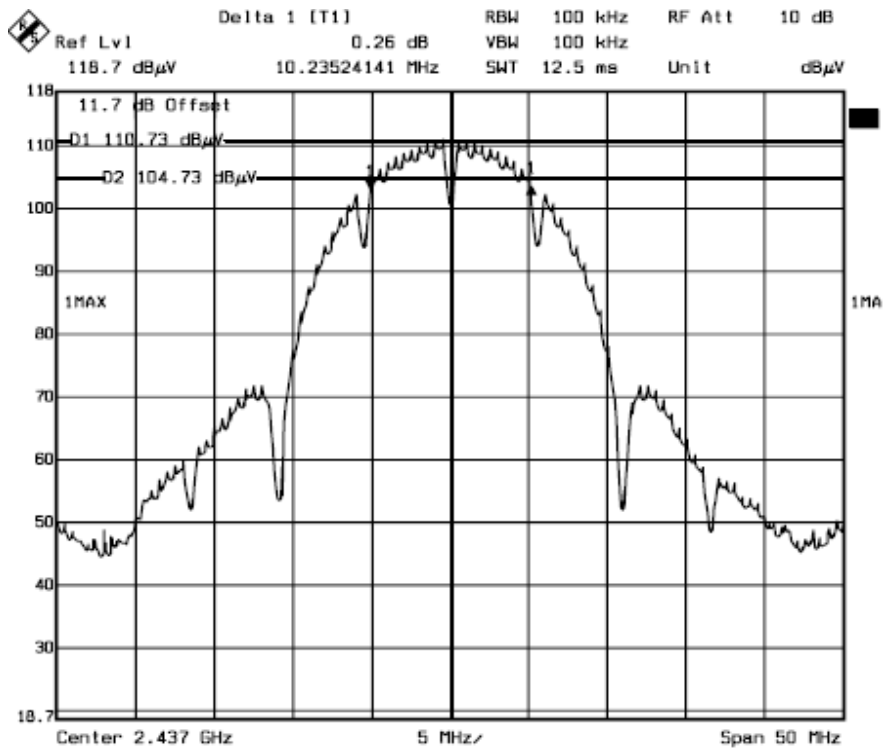

Channel 11

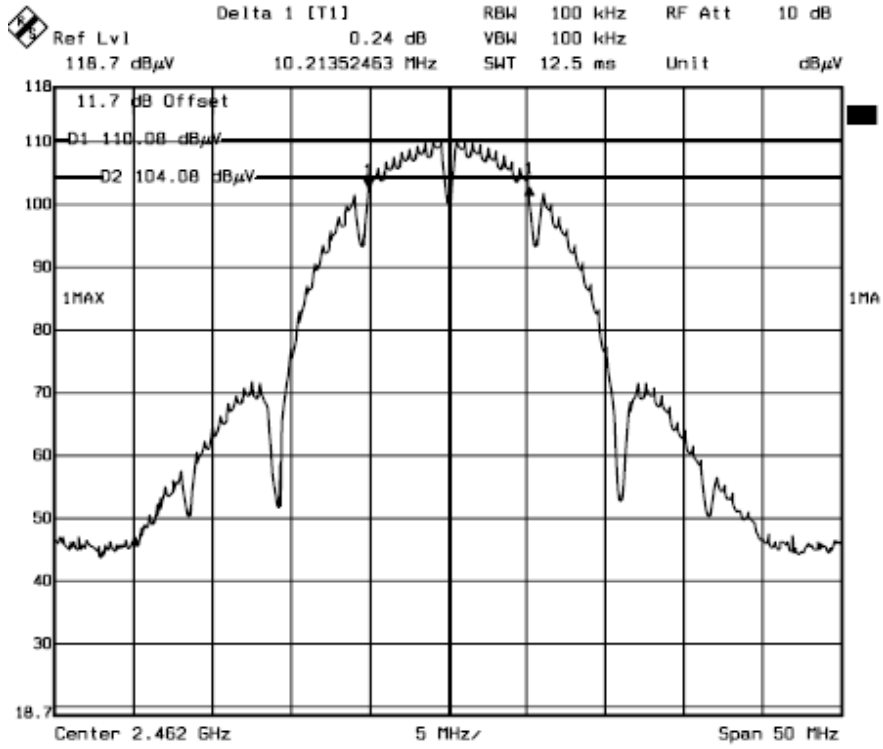

802.11g:

Channel number	Channel frequency (MHz)	Measurement level (MHz)	Required Limit (KHz)
1	2412	16.63	>500
6	2437	16.63	>500
11	2462	16.63	>500

802.11g Channel 1

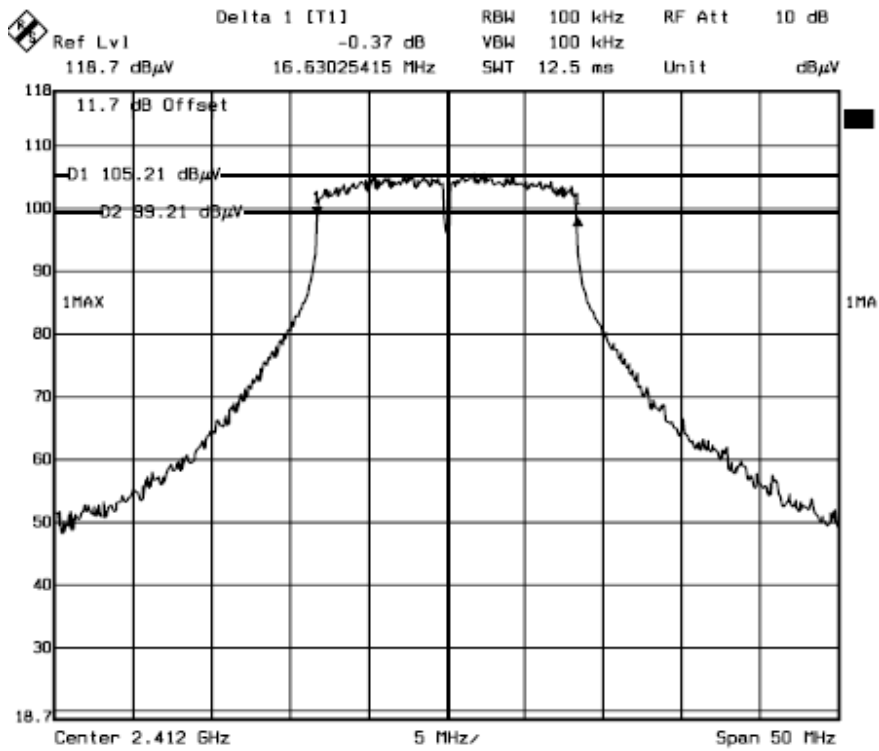

Channel 6

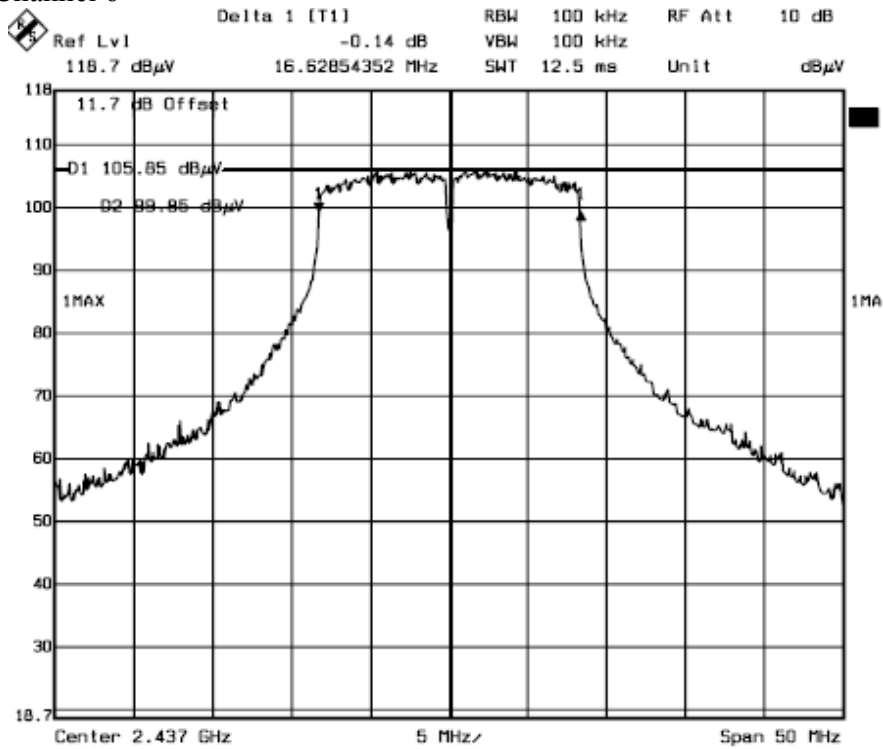

Channel 11

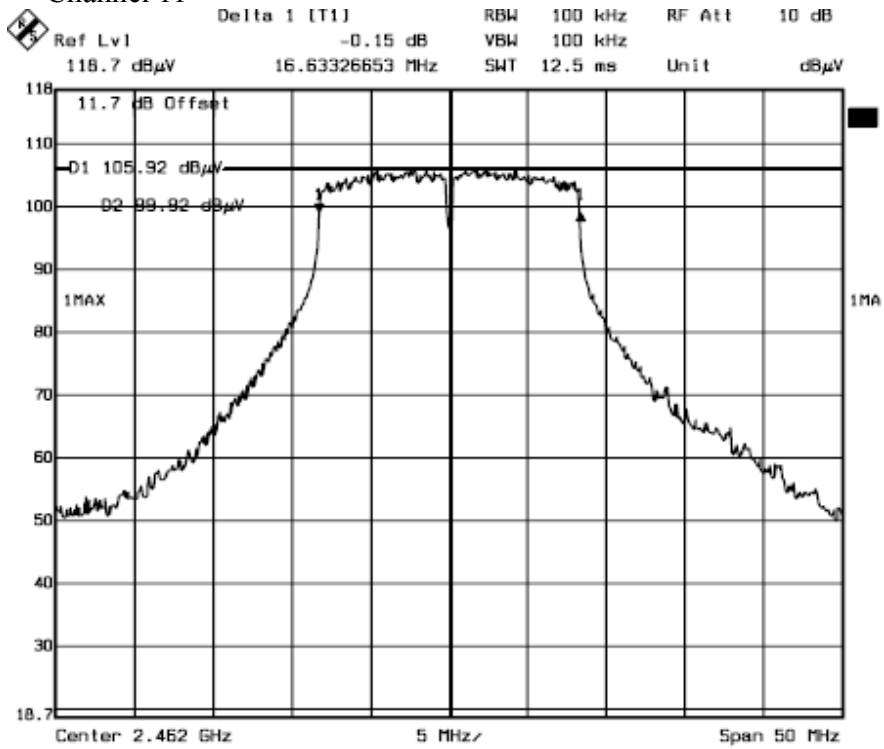

802.11n H20:

Channel number	Channel frequency (MHz)	Measurement level (MHz)	Required Limit (KHz)
1	2412	17.83	>500
6	2437	17.83	>500
11	2462	17.83	>500

Channel 1

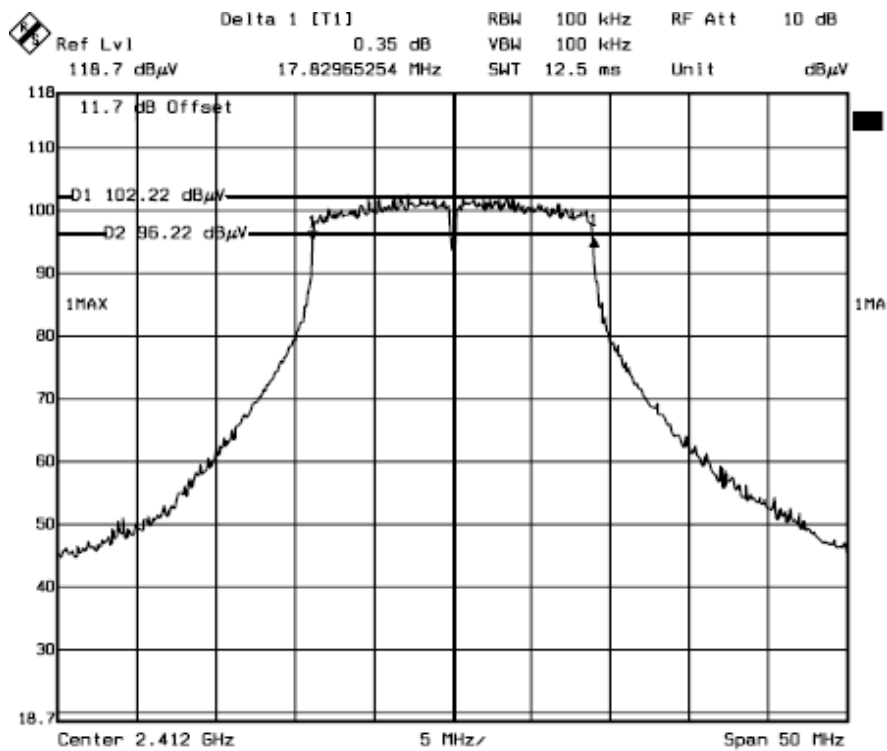

Channel 6

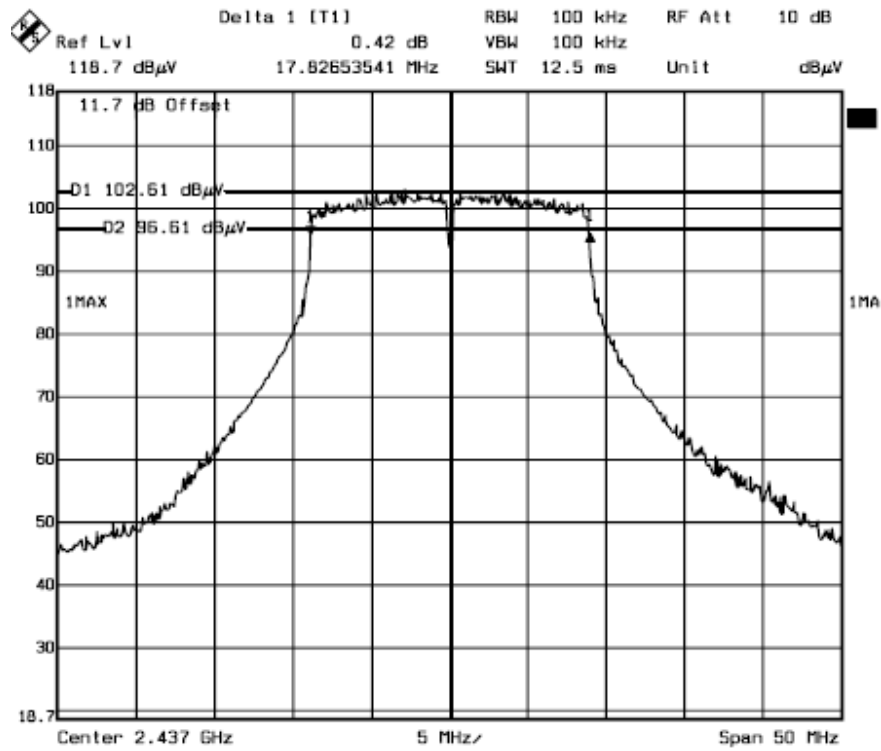

Channel 11

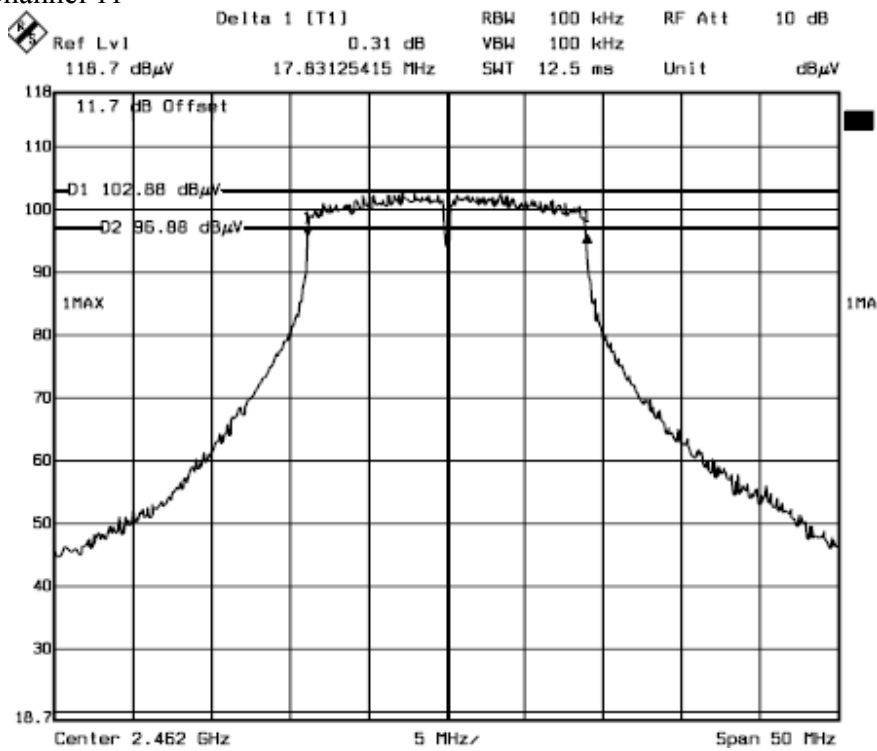

802.11n H40:

Channel number	Channel frequency (MHz)	Measurement level (MHz)	Required Limit (KHz)
1	2422	37.04	>500
4	2437	37.05	>500
7	2452	37.07	>500

Channel 1

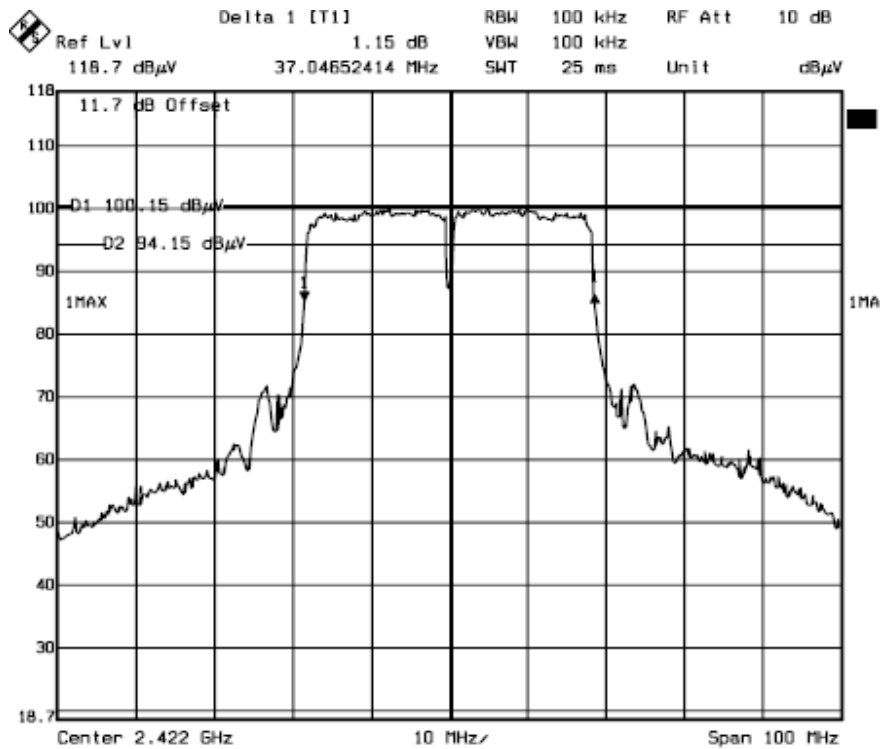

Channel 4

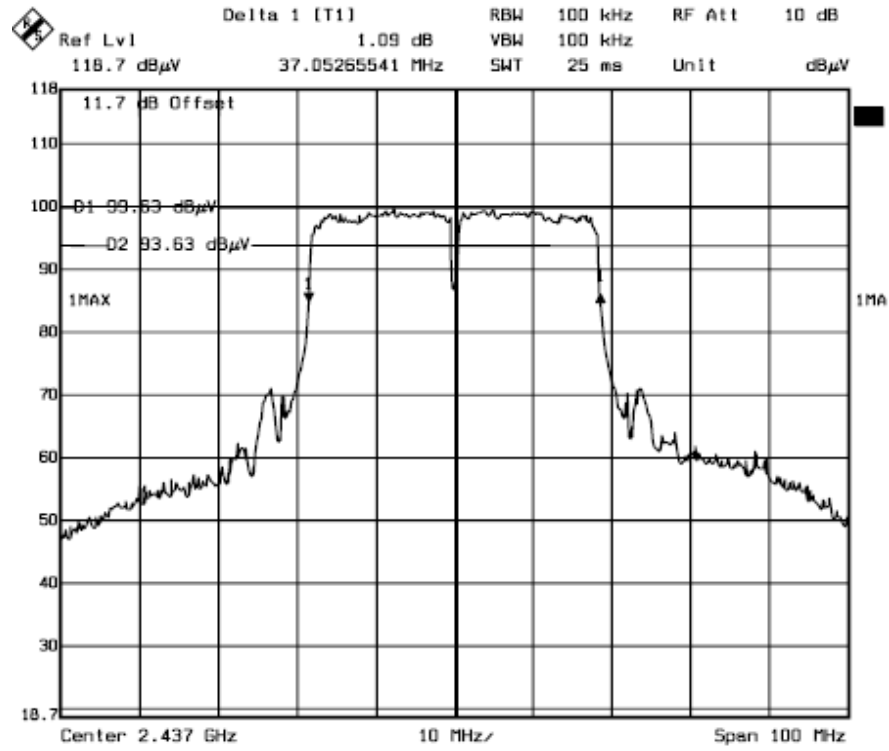

Channel 7

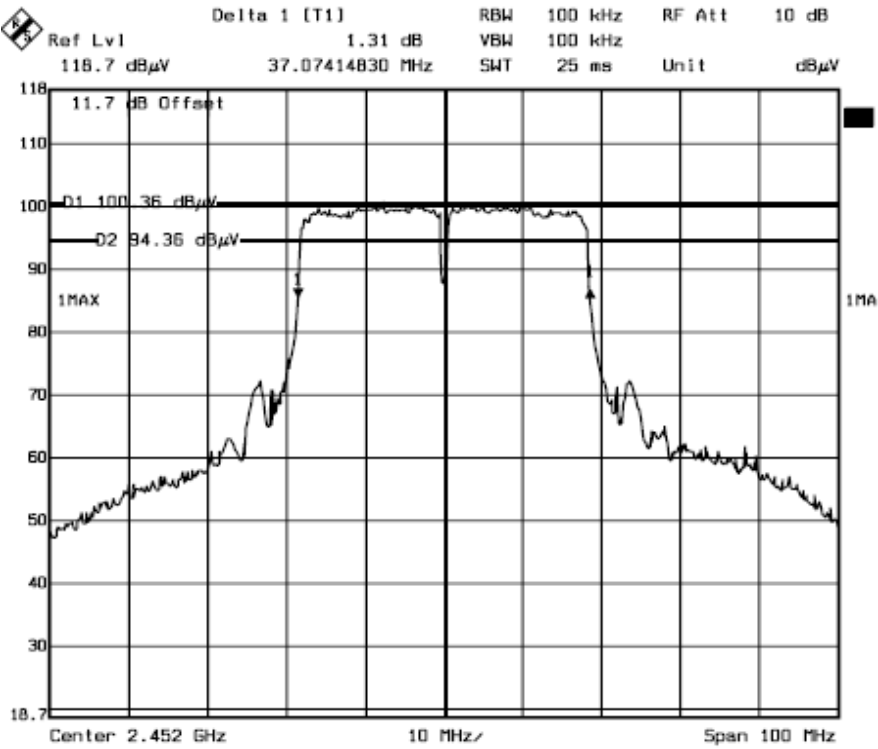



## 7. MAXIMUM PEAK OUTPUT POWER TEST

### 7.1 Measurement Procedure

- The Transmitter output (antenna port) was connected to the power meter.
- Turn on the EUT and power meter and then record the peak power value.
- Repeat above procedures on all channels needed to be tested.

### 7.2 Test SET-UP (Block Diagram of Configuration)

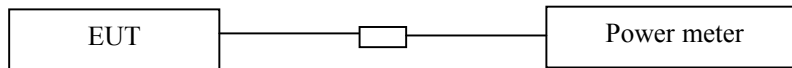

### 7.3 Measurement Equipment Used:

EQUIPMENT TYPE	MFR	MODEL NUMBER	SERIAL NUMBER	LAST CAL.	CAL DUE.
Power meter	Boonton	4232A	29001	05/29/2009	05/29/2010
Power sensor	Boonton	51011-EMC	31184	05/29/2009	05/29/2010

### 7.4 Peak Power output limit

The maximum peak power shall be less 1Watt.

**7.5 Measurement Results:**

Refer to attached data chart.

Spectrum Detector: PK Test Date : 11/02/2009  
 Test By: Andy Temperature : 28 °C  
 Test Result: PASS Humidity : 65 %  
 802.11b

Channel number	Channel Frequency (MHz)	Peak Power output(dBm)	Peak Power Limit(W)	Pass/Fail
1	2412.00	10.35	1W(30dBm)	PASS
6	2437.00	11.76	1W(30dBm)	PASS
11	2462.00	10.23	1W(30dBm)	PASS

802.11g

Channel number	Channel Frequency (MHz)	Peak Power output(dBm)	Peak Power Limit(W)	Pass/Fail
1	2412.00	11.52	1W(30dBm)	PASS
6	2437.00	11.89	1W(30dBm)	PASS
11	2462.00	11.06	1W(30dBm)	PASS

802.11n H20

Channel number	Channel Frequency (MHz)	Peak Power output(dBm)	Peak Power Limit(W)	Pass/Fail
1	2412.00	10.45	1W(30dBm)	PASS
6	2437.00	10.23	1W(30dBm)	PASS
11	2462.00	10.42	1W(30dBm)	PASS

802.11n H40

Channel number	Channel Frequency (MHz)	Peak Power output(dBm)	Peak Power Limit(W)	Pass/Fail
1	2422.00	10.18	1W(30dBm)	PASS
4	2437.00	10.85	1W(30dBm)	PASS
7	2452.00	10.93	1W(30dBm)	PASS

## 8. Band EDGE test

### 8.1 Measurement Procedure

1. The EUT was Operating in hopping mode or could be controlled its channel. Printed out test result from the spectrum by hard copy function.
2. The EUT was placed on a turn table which is 0.8m above ground plane.
3. Maximum procedure was performed on the six highest emissions to ensure EUT compliance.
4. And also, each emission was to be maximized by changing the polarization of receiving antenna both horizontal and vertical.
5. Repeat above procedures until all frequency measured were complete.

### 8.2 Test SET-UP (Block Diagram of Configuration)

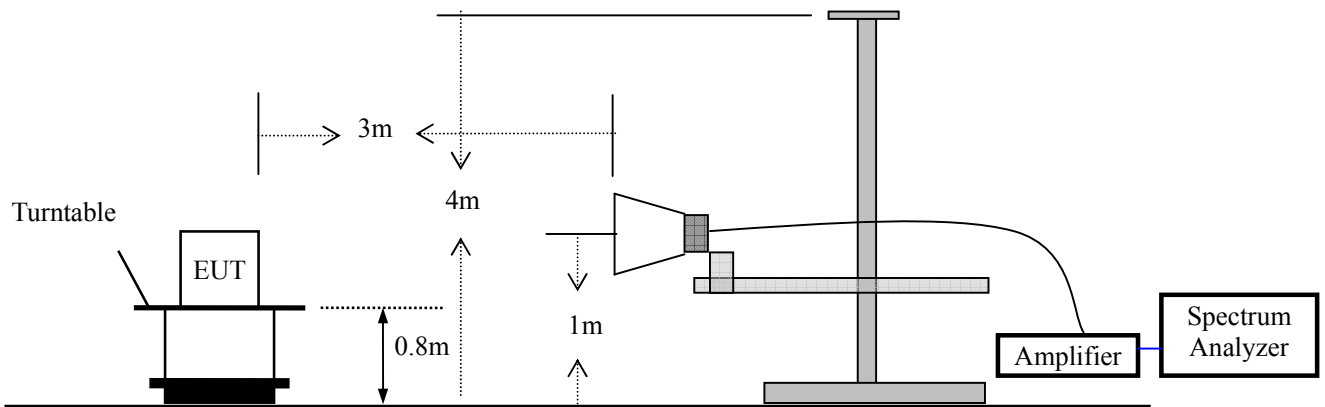

### 8.3 Measurement Equipment Used:

Same as 5.3 Radiated Emission Measurement.

**8.4 Measurement Results:**

Refer to attached data chart.

Spectrum Detector: PK                      Test Date : November 03, 2009  
 Test By: Andy                                Temperature : 28 °C  
 Test Result: PASS                          Humidity : 65 %

**802.11b:**

1. Conducted Test

Frequency (MHz)	Peak Power Output(dBm)	Emission read Value(dBm)	Result of Band edge(dBc)	Band edge Limit(dBc)
<2400	6.58	-55.17	61.75	>20dBc
>2483.5	7.46	-52.15	59.61	>20dBc

2. Radiated emission test

Frequency (MHz)	Antenna polarization (H/V)	Emission (dBuV/m)		Band edge Limit (dBuV/m)	
		PK	AV	PK	AV
<2400	V	59.67	41.52	74.00	54.00
>2483.5	V	58.42	40.69	74.00	54.00

802.11b CH1

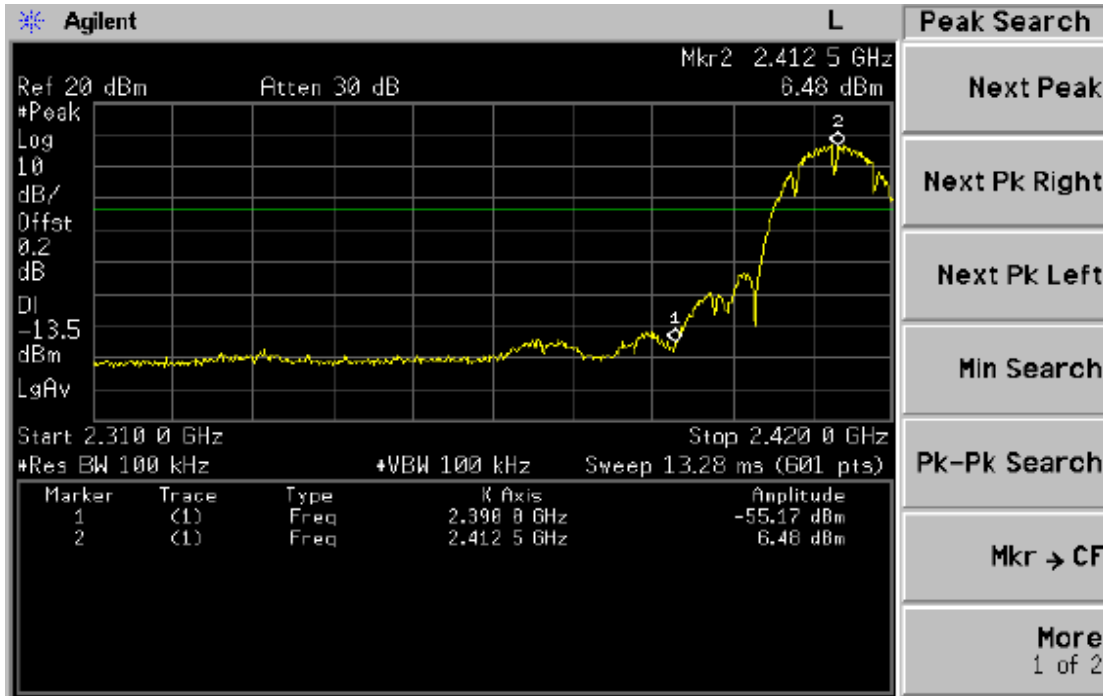

CH11

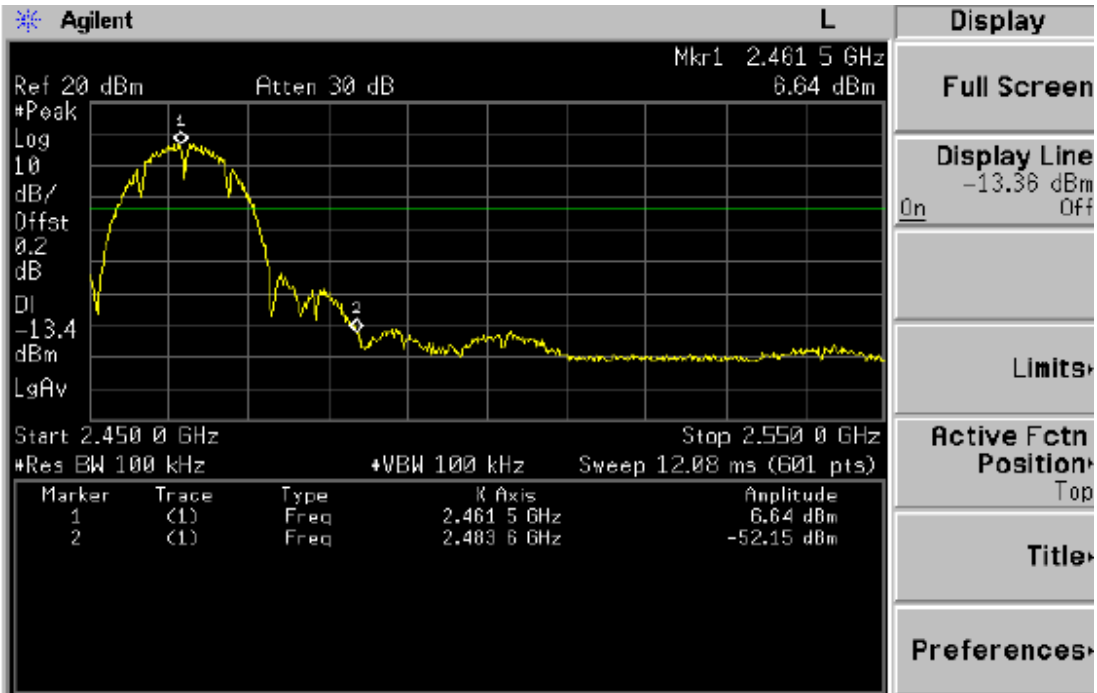

**802.11g:**

## 1. Conducted Test

Frequency (MHz)	Peak Power Output(dBm)	Emission read Value(dBm)	Result of Band edge(dBc)	Band edge Limit(dBc)
<2400	6.35	-48.48	54.83	>20dBc
>2483.5	7.41	-47.12	54.53	>20dBc

## 2. Radiated emission test

Frequency (MHz)	Antenna polarization (H/V)	Emission (dBuV/m)		Band edge Limit (dBuV/m)	
		PK	AV	PK	AV
<2400	V	57.86	42.07	74.00	54.00
>2483.5	V	57.92	40.12	74.00	54.00

802.11g CH1

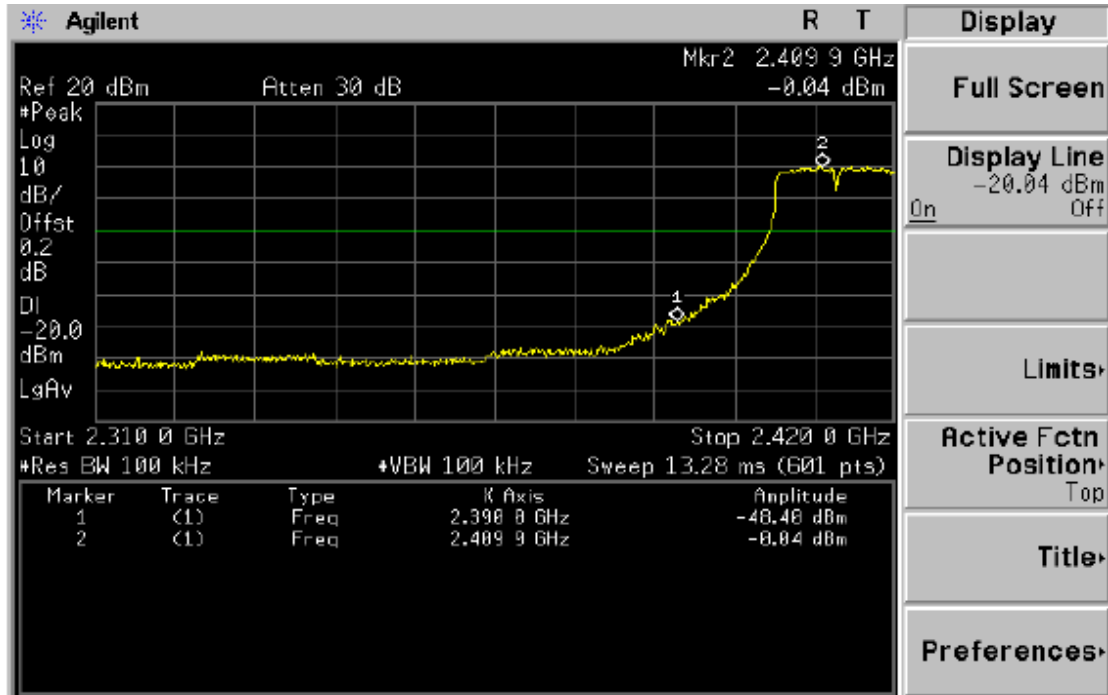

CH11

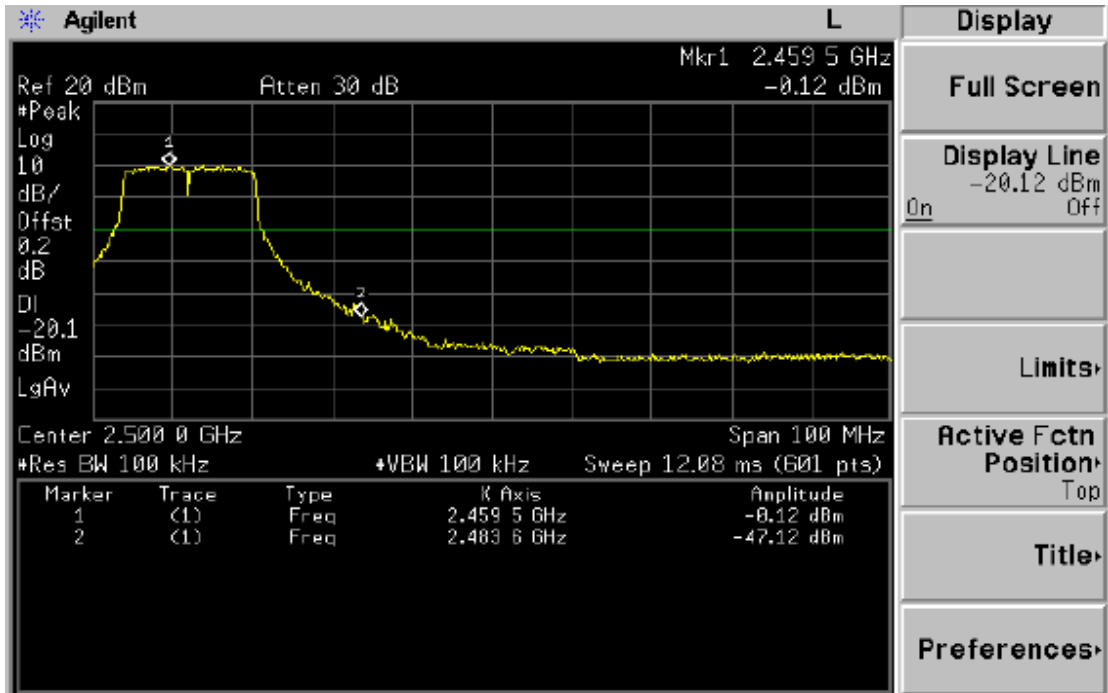

**802.11n H20:**

## 1. Conducted Test

Frequency (MHz)	Peak Power Output(dBm)	Emission read Value(dBm)	Result of Band edge(dBc)	Band edge Limit(dBc)
<2400	8.42	-52.74	61.16	>20dBc
>2483.5	8.69	-48.51	57.20	>20dBc

## 2. Radiated emission test

Frequency (MHz)	Antenna polarization (H/V)	Emission (dBuV/m)		Band edge Limit (dBuV/m)	
		PK	AV	PK	AV
<2400	V	58.61	43.17	74.00	54.00
>2483.5	V	57.69	41.85	74.00	54.00



CH1

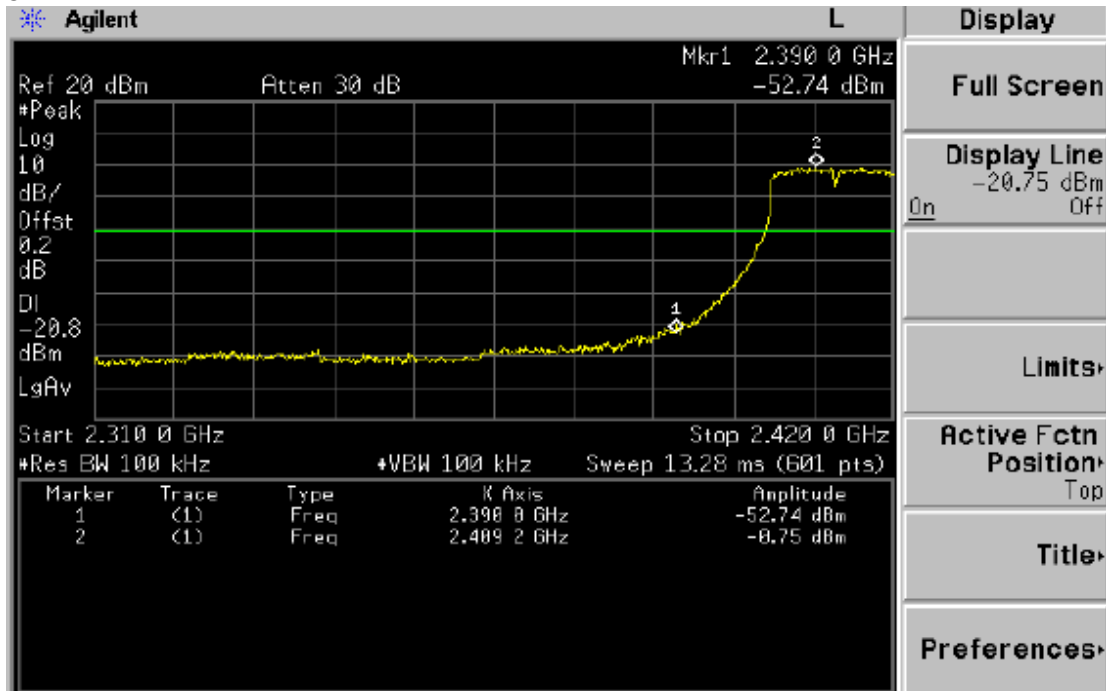

CH11

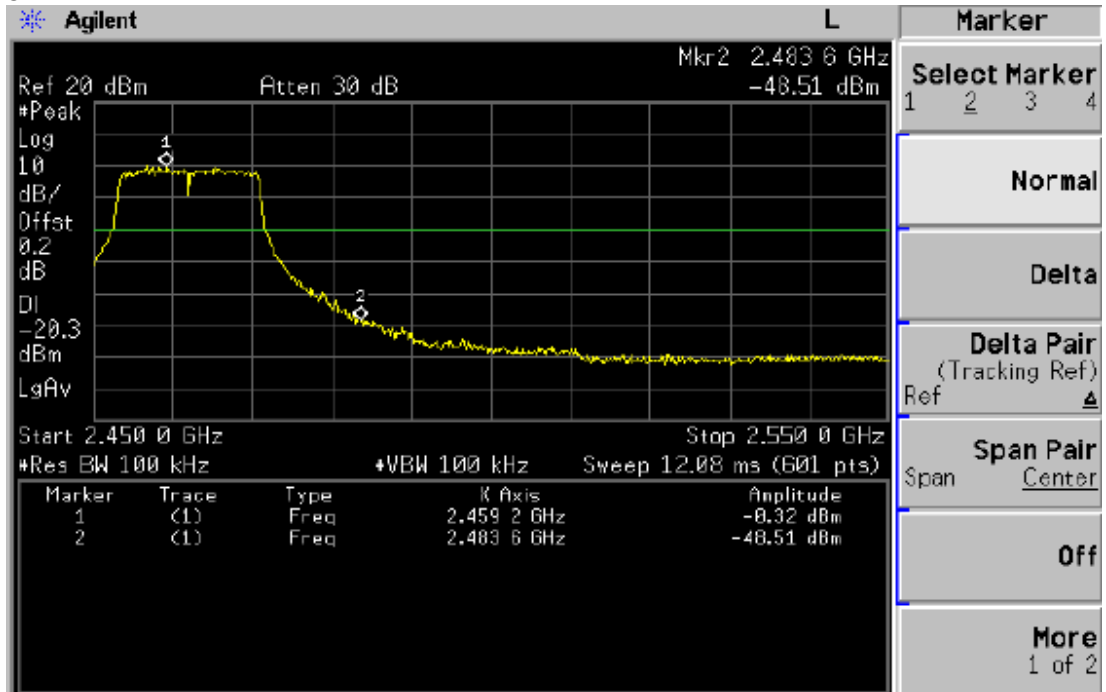

**802.11n H40:**

## 1. Conducted Test

Frequency (MHz)	Peak Power Output(dBm)	Emission read Value(dBm)	Result of Band edge(dBc)	Band edge Limit(dBc)
<2400	8.54	-58.15	66.69	>20dBc
>2483.5	9.01	-48.17	57.18	>20dBc

## 2. Radiated emission test

Frequency (MHz)	Antenna polarization (H/V)	Emission (dBuV/m)		Band edge Limit (dBuV/m)	
		PK	AV	PK	AV
<2400	V	58.42	42.47	74.00	54.00
>2483.5	V	56.81	41.64	74.00	54.00

CH1



CH11



## 9. Power density

### 9.1 Test Equipment

EQUIPMENT TYPE	MFR	MODEL NUMBER	SERIAL NUMBER	LAST CAL.	CAL DUE.
Spectrum Analyzer	Rohde & Schwarz	FSP7	839511/010	05/29/2009	05/29/2010

### 9.2 Measuring Instruments and setting

The following table is the setting of spectrum analyzer.

Spectrum analyzer	Setting
Attenuation	Auto
Span Frequency	1.5MHz
RB	3kHz
VB	30kHz
Detector	Peak
Trace	Max hold
Sweep Time	500s

### 9.3 Test Procedures

- The transmitter output (antenna port) was connected to the spectrum analyzer.
- Set RBW of spectrum analyzer to 3kHz and VBW to 30kHz, Set Detector to Peak, Trace to Max Hold.
- Mark the frequency with maximum peak power as the center of the display of the spectrum.
- Set the span to 1.5MHz and the sweep time to 500s and record the maximum peak value.

### 9.4 Block Diagram of Test setup

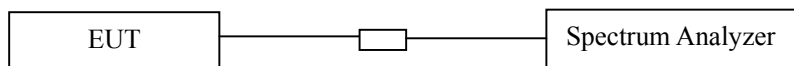

### 9.5 Limit

The transmitted power density averaged over any 1 second interval shall not be greater +8dBm in any 3KHz bandwidth.

### 9.6. Test Result

Spectrum Detector: PK                      Test Date : 11/03/2009  
 Test By: Andy                                Temperature : 28 °C  
 Test Result: PASS                          Humidity : 65 %

802.11b

Frequency (MHz)	Measurement Level (dBm)	Required limit (dBm)	Result
2412.00	-16.29	<8dBm	PASS
2437.00	-15.14	<8dBm	PASS
2462.00	-15.75	<8dBm	PASS

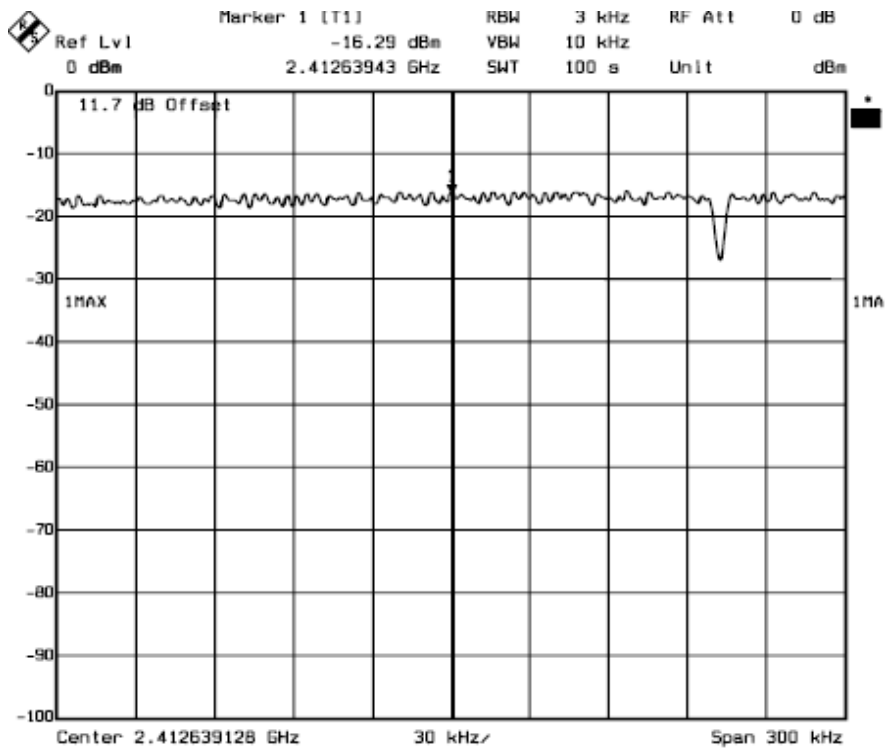

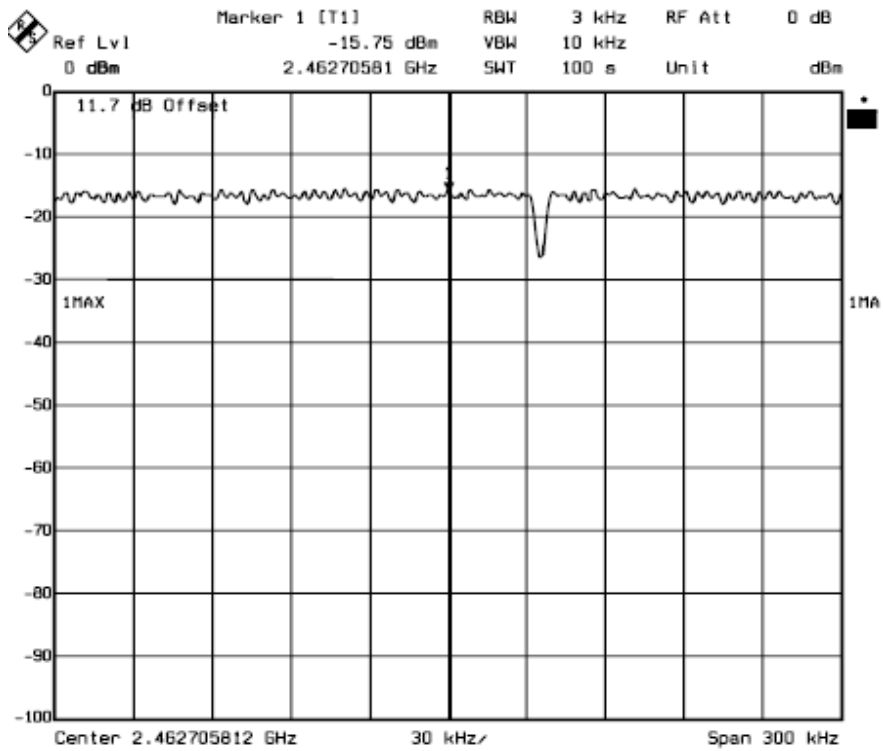
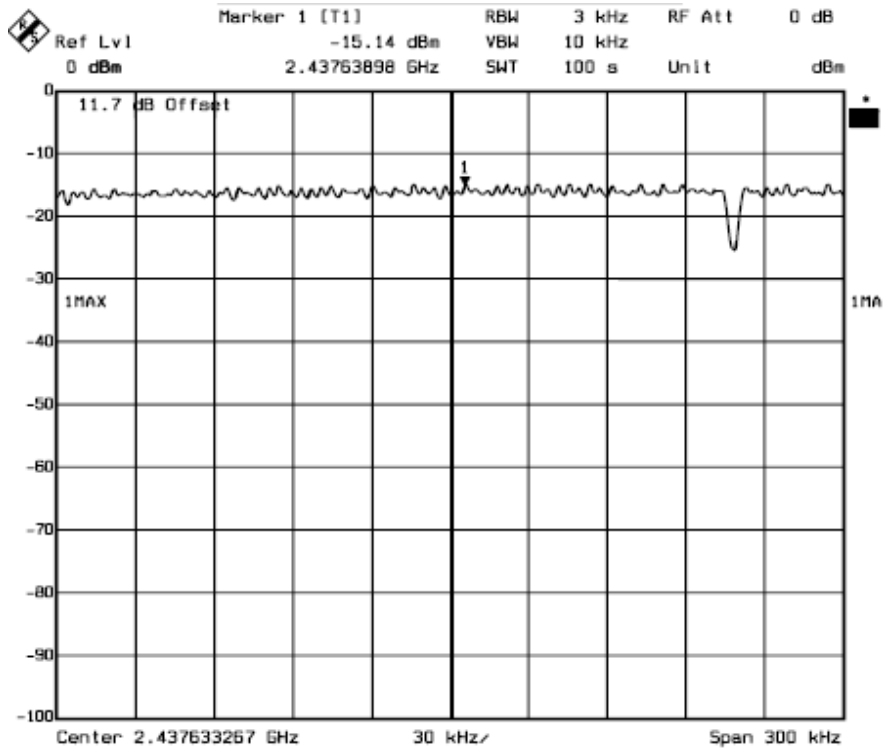

802.11g

Frequency (MHz)	Measurement Level (dBm)	Required limit (dBm)	Result
2412.00	-17.61	<8dBm	PASS
2437.00	-16.28	<8dBm	PASS
2462.00	-10.10	<8dBm	PASS

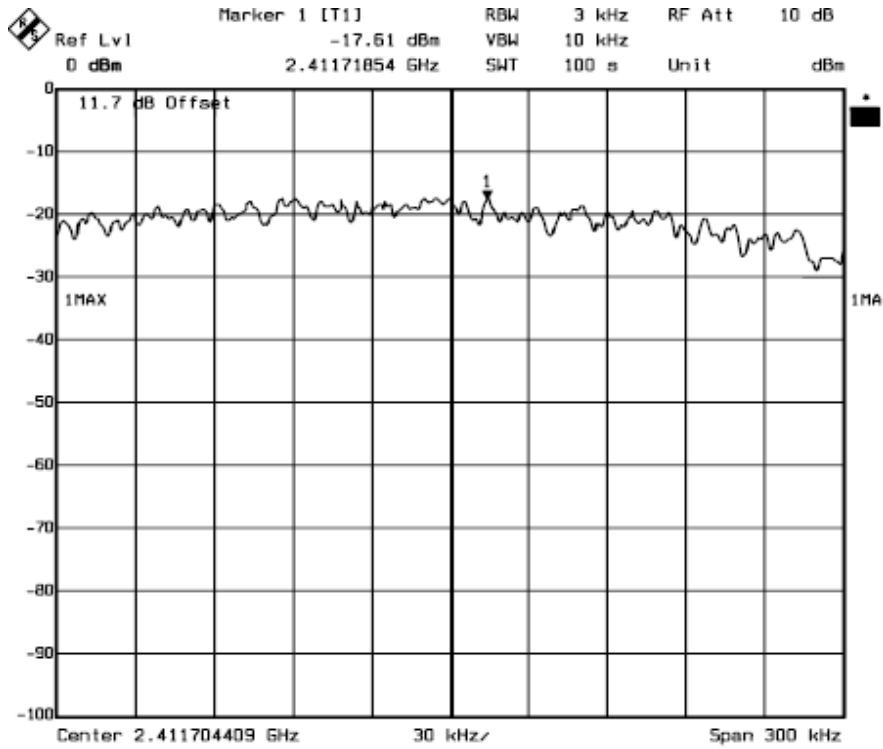

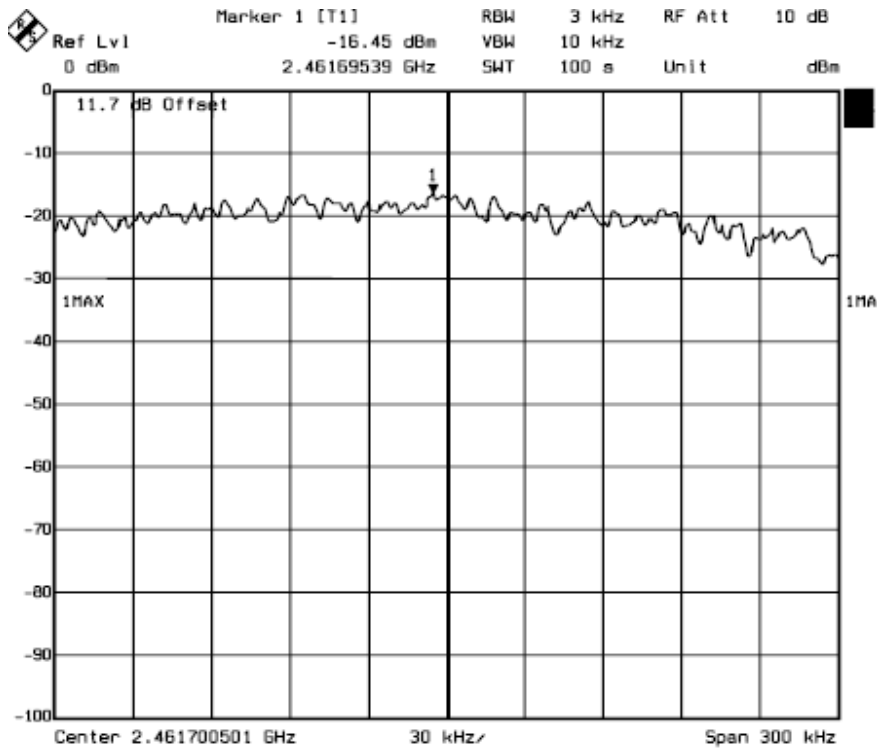
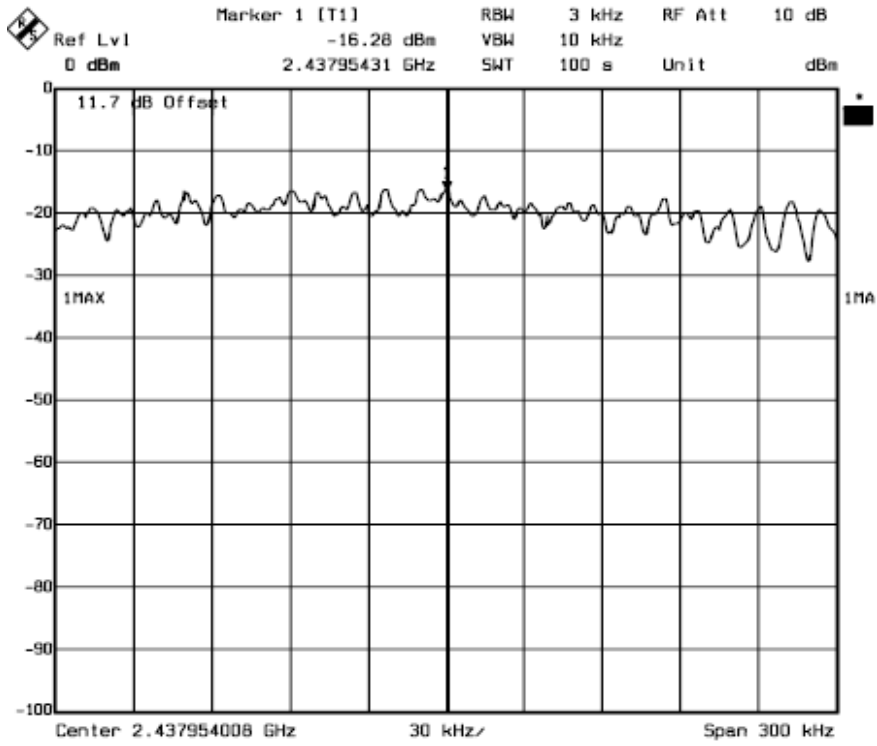



802.11n H20

Frequency (MHz)	Measurement Level (dBm)	Required limit (dBm)	Result
2412.00	-19.71	<8dBm	PASS
2437.00	-19.77	<8dBm	PASS
2462.00	-18.90	<8dBm	PASS

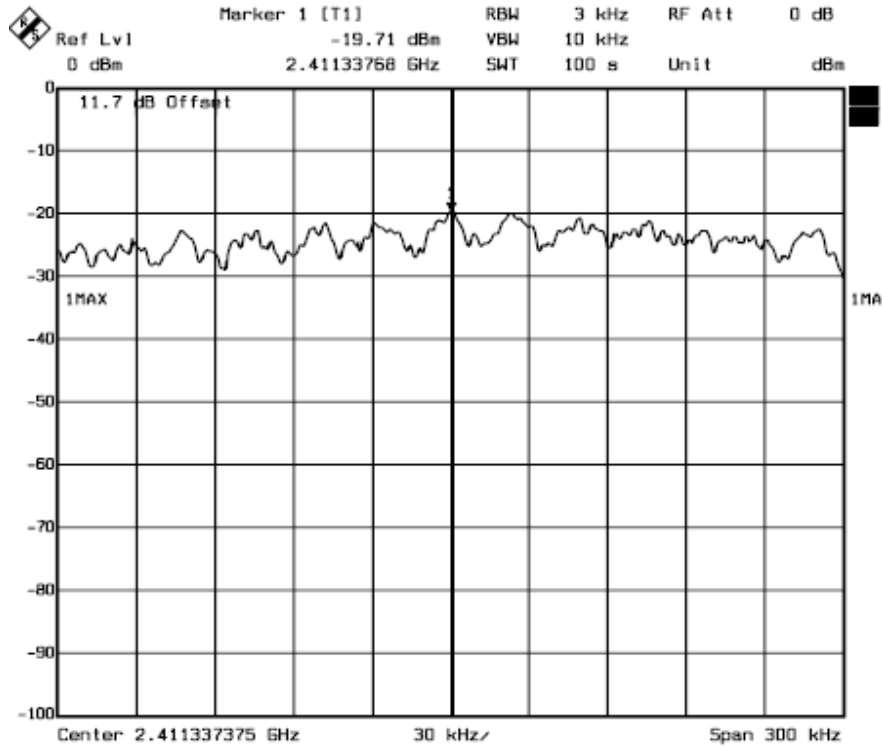

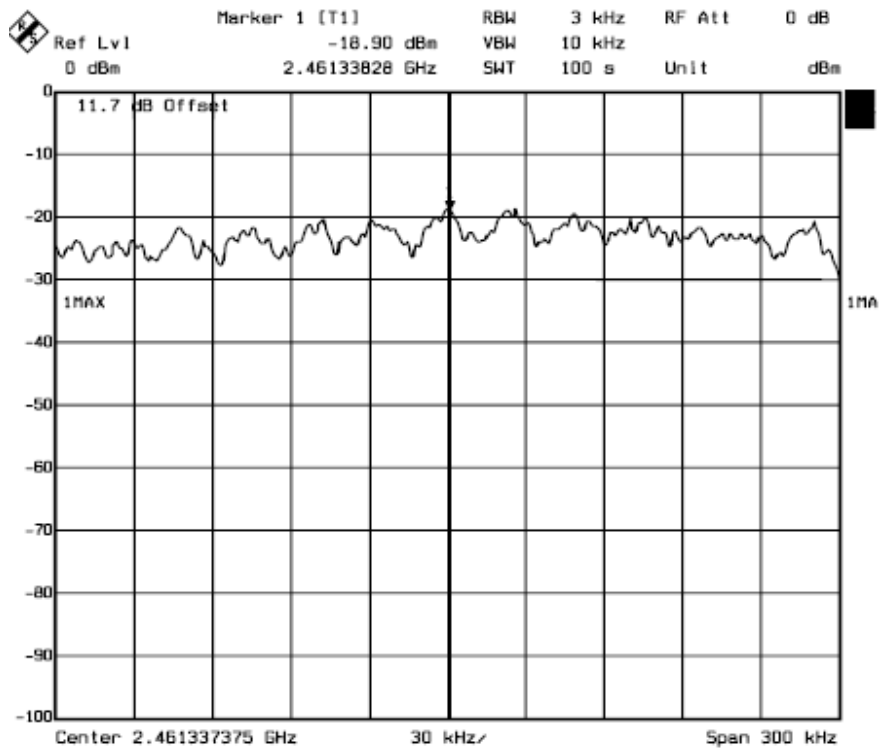
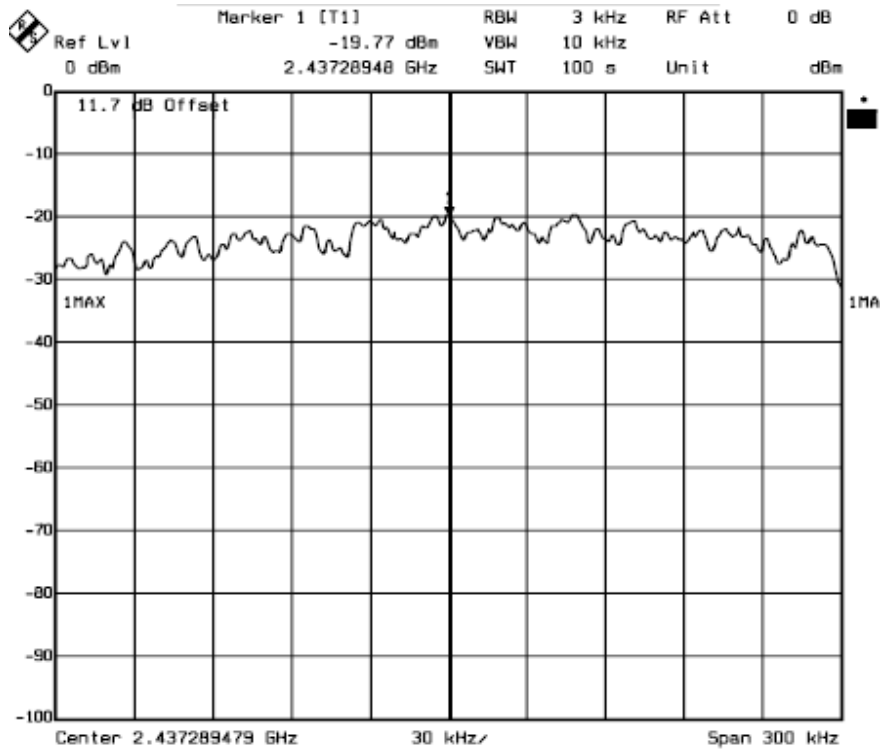

802.11n H40

Frequency (MHz)	Measurement Level (dBm)	Required limit (dBm)	Result
2422.00	-18.26	<8dBm	PASS
2437.00	-18.59	<8dBm	PASS
2452.00	-18.52	<8dBm	PASS

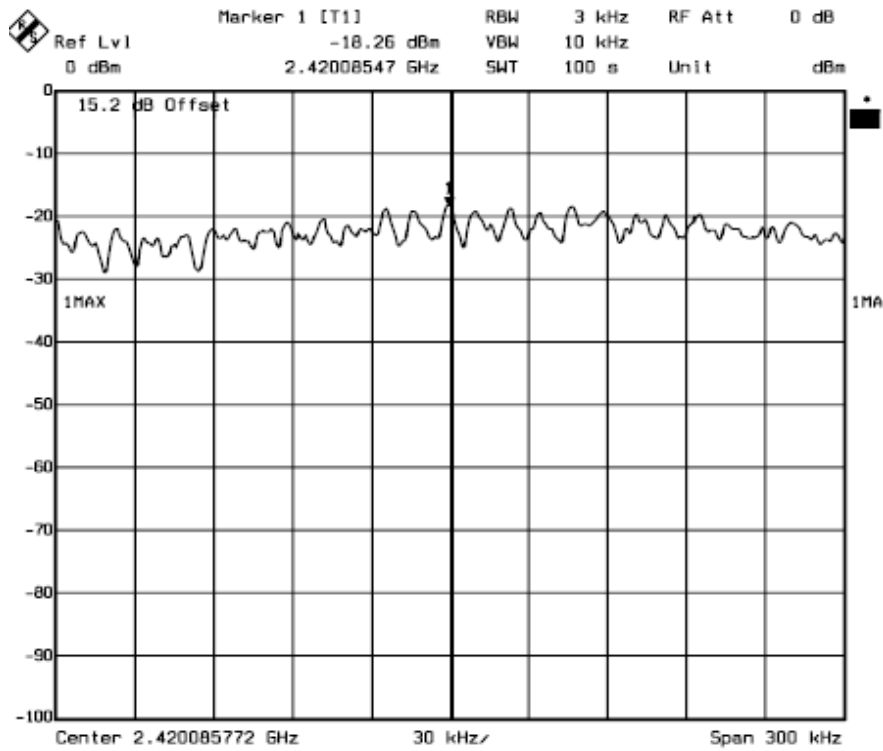

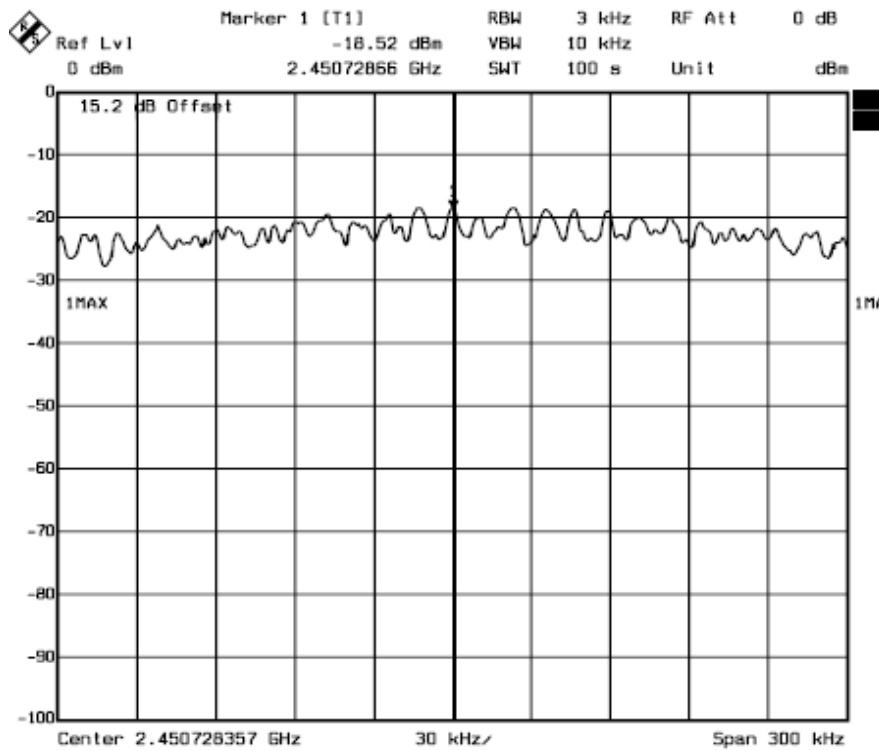
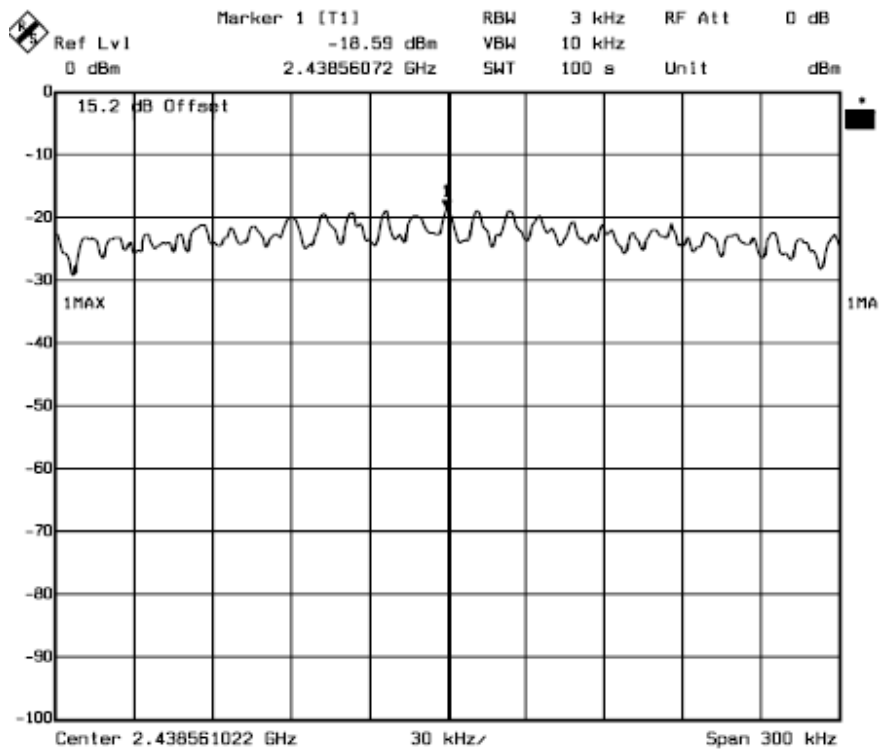

## **10 Antenna Application**

### **10.1 Antenna requirement**

The EUT'S antenna is met the requirement of FCC part 15C section 15.203.

### **10.2 Result**

The EUT's antenna used a chip antenna and integrated on PCB, The antenna's gain is 2dBi and meets the requirement.

## 11. Antenna Port Emission

### 11.1 Test Equipment

EQUIPMENT TYPE	MFR	MODEL NUMBER	SERIAL NUMBER	LAST CAL.	CAL DUE.
Spectrum Analyzer	Rohde & Schwarz	FSP7	839511/010	05/29/2009	05/29/2010

### 11.2 Measuring Instruments and setting

The following table is the setting of spectrum analyzer.

Spectrum analyzer	Setting
Attenuation	Auto
RB	100kHz
VB	100kHz
Detector	Peak
Trace	Max hold

### 11.3 Test Procedures

The conducted spurious emissions were measured conducted using a spectrum analyzer at low, mid, and hi channels, The limit was determined by attenuation 20dB of the RF peak power output.

### 11.4 Block Diagram of Test setup

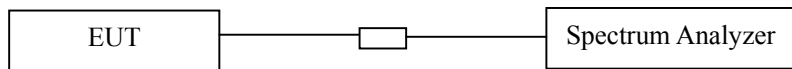

### 11.5. Test Result

PASS.

802.11b CH1

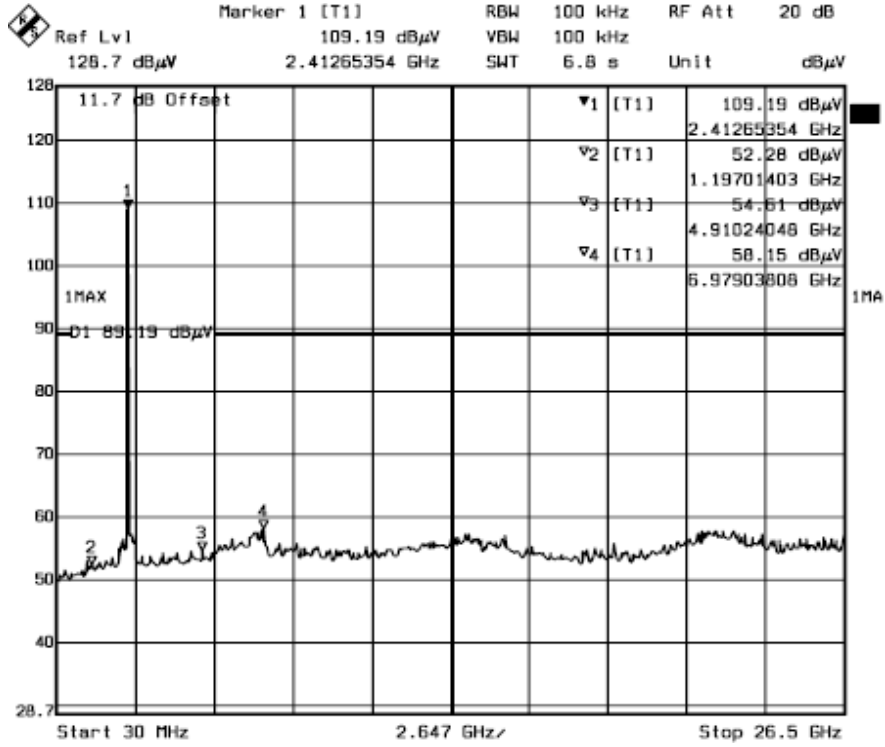

802.11b CH6

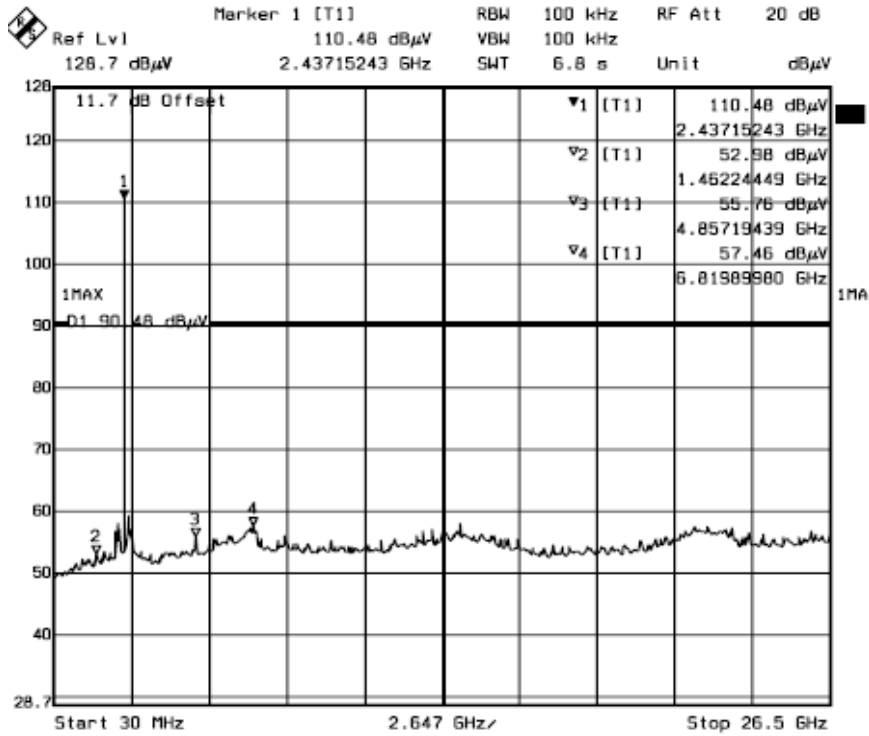

802.11b CH11

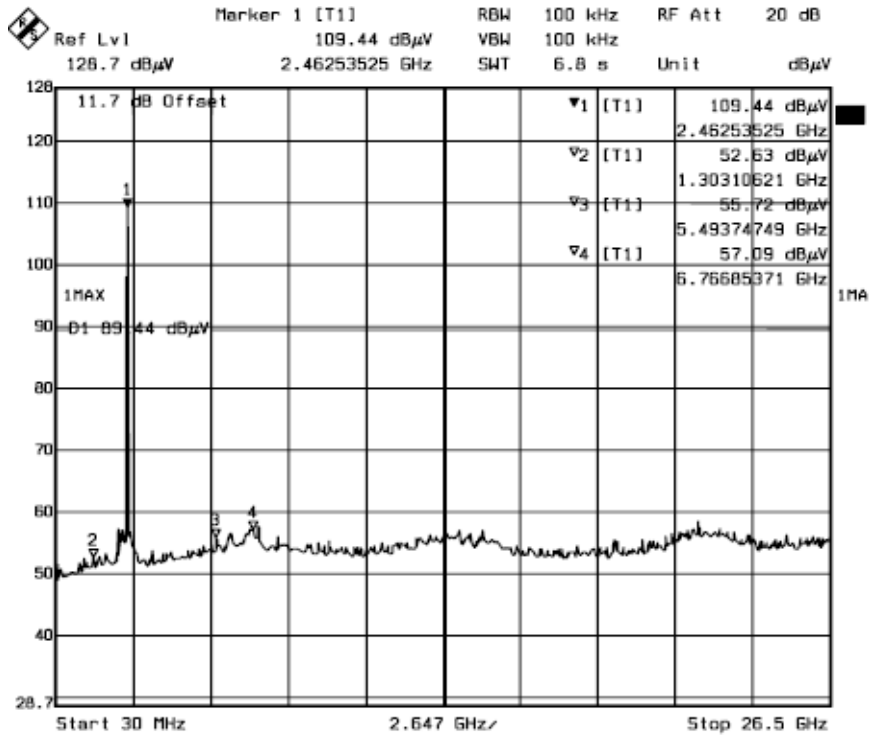

802.11g CH1

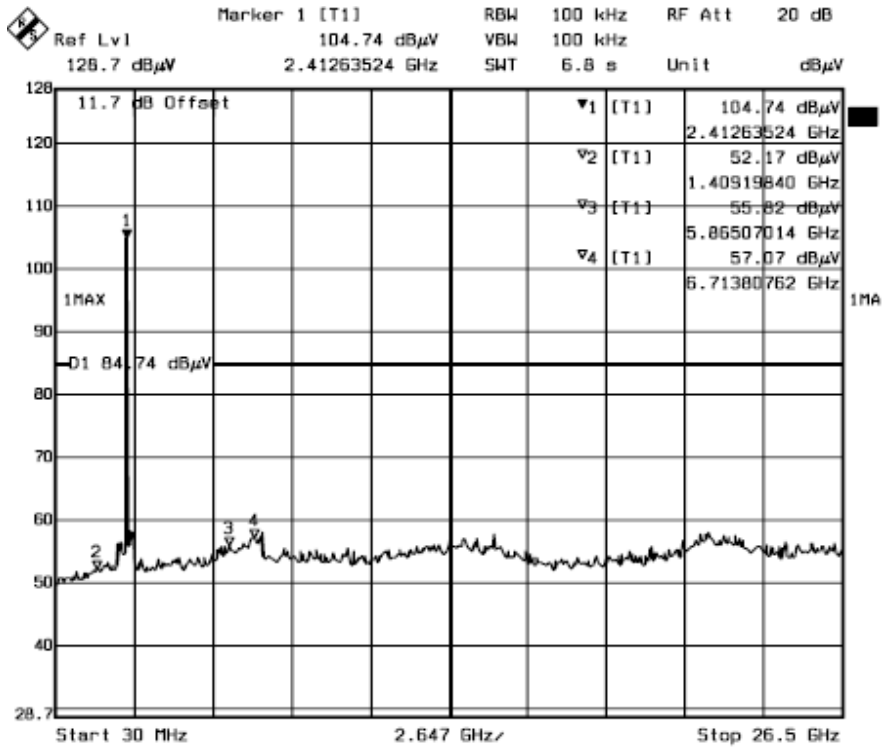



802.11g CH6

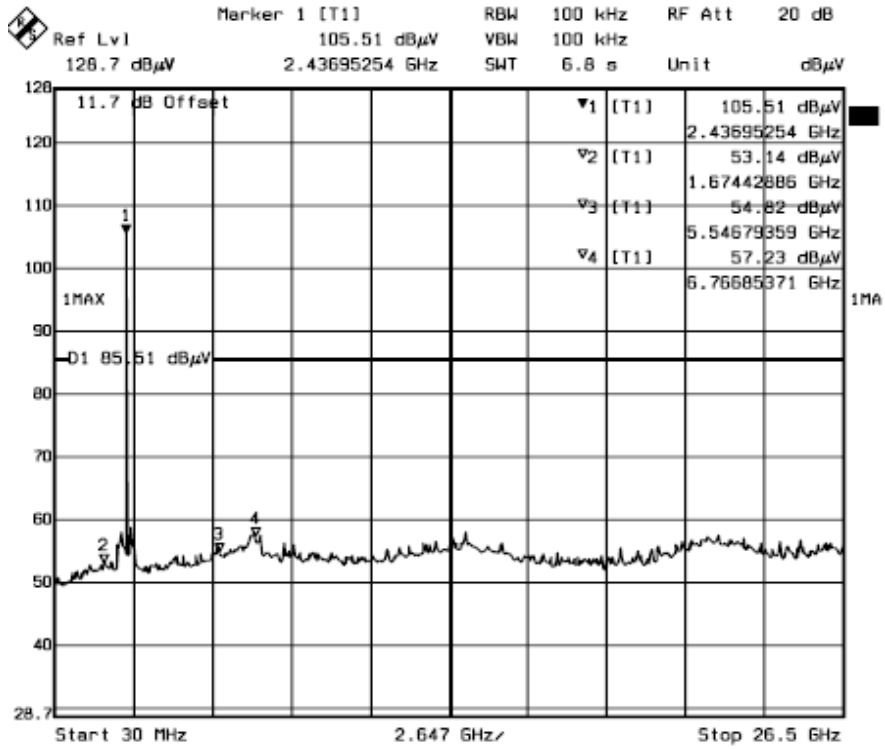

802.11g CH11

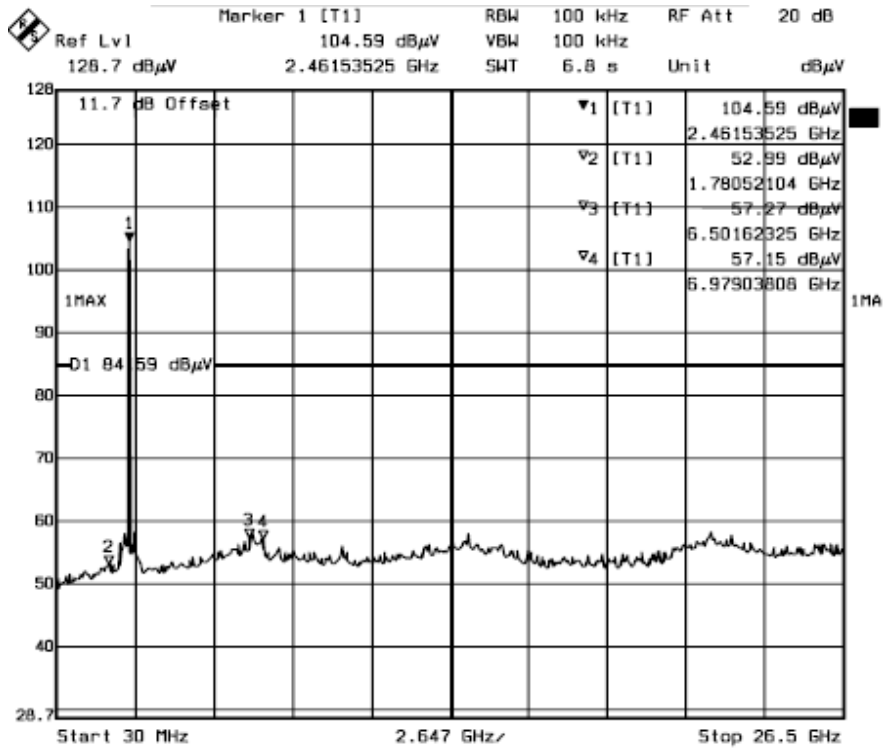

801.11n H20 CH1

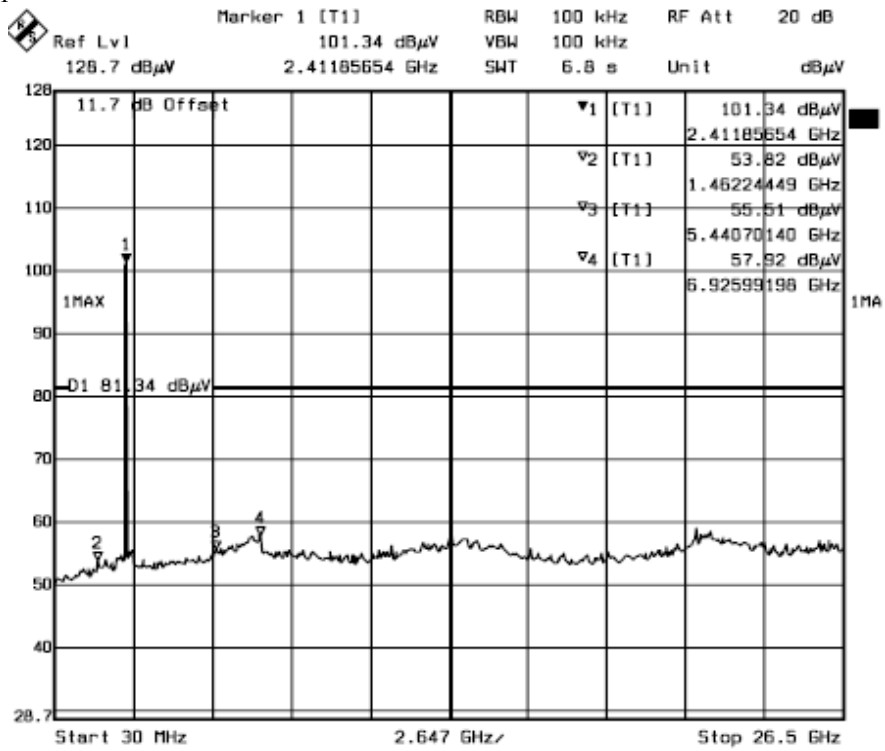

801.11n H20 CH6

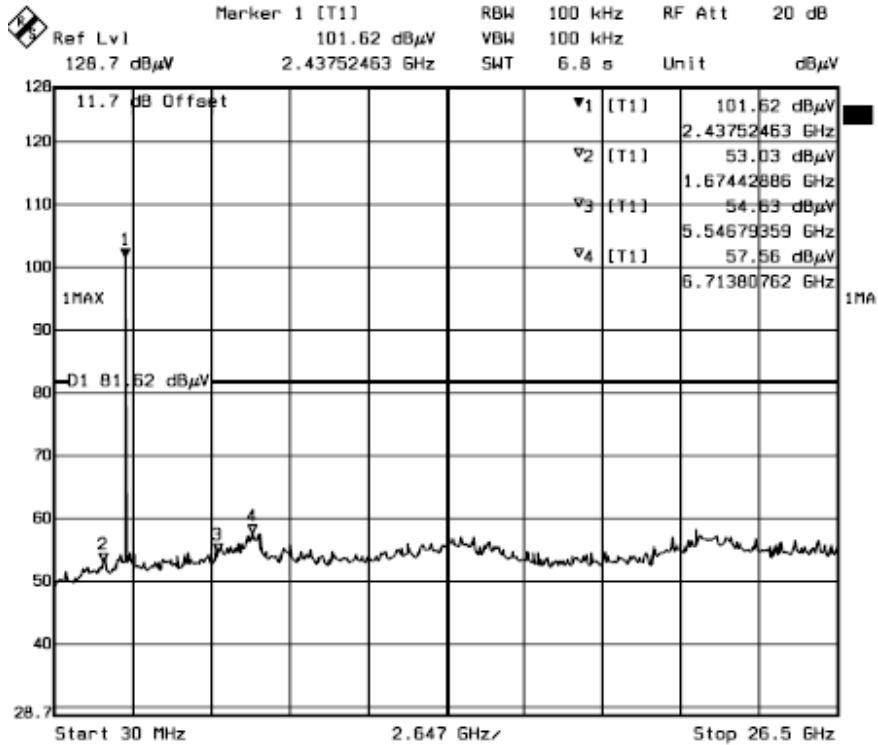

801.11n H20 CH11

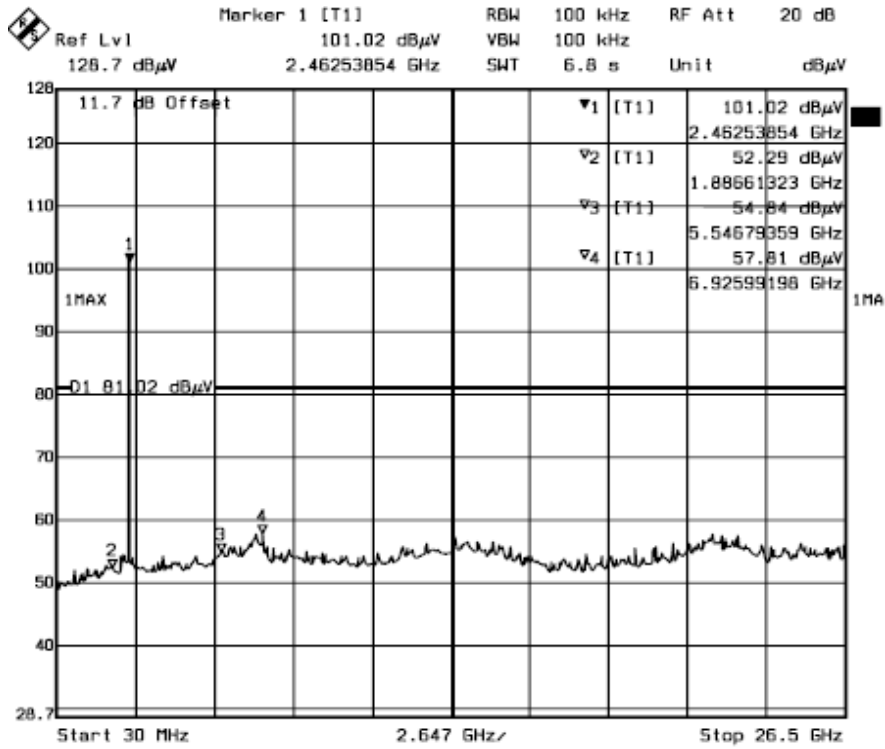

801.11n H40 CH1

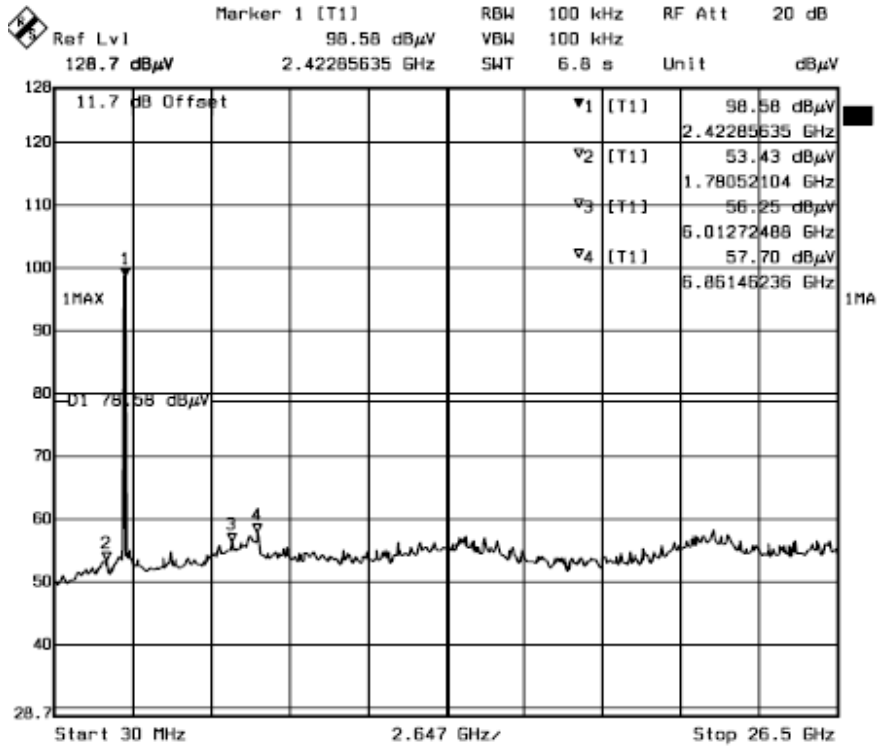

801.11n H40 CH6

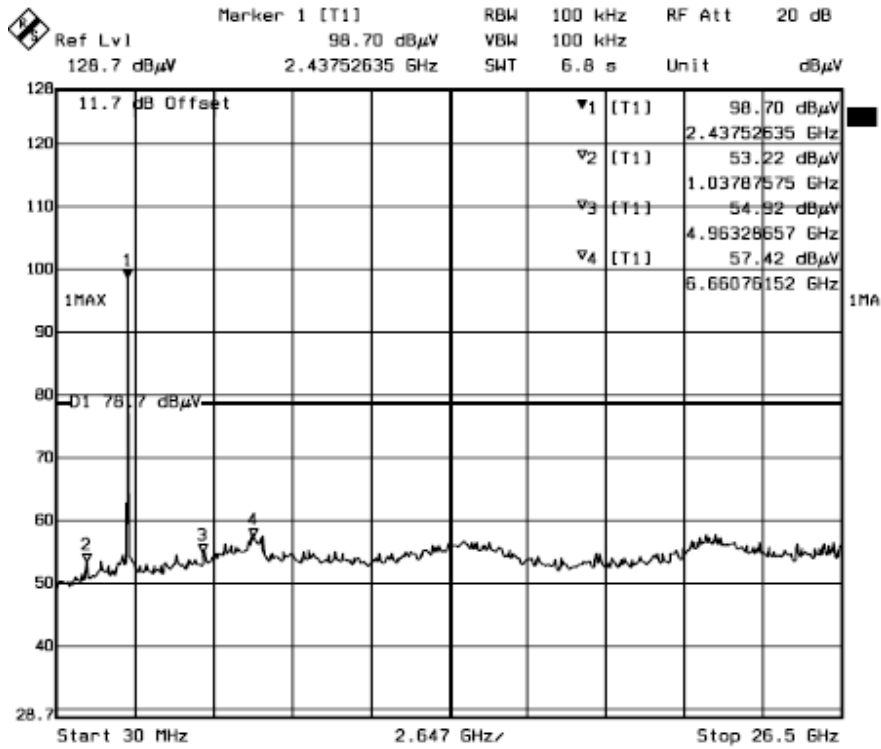

801.11n H40 CH11

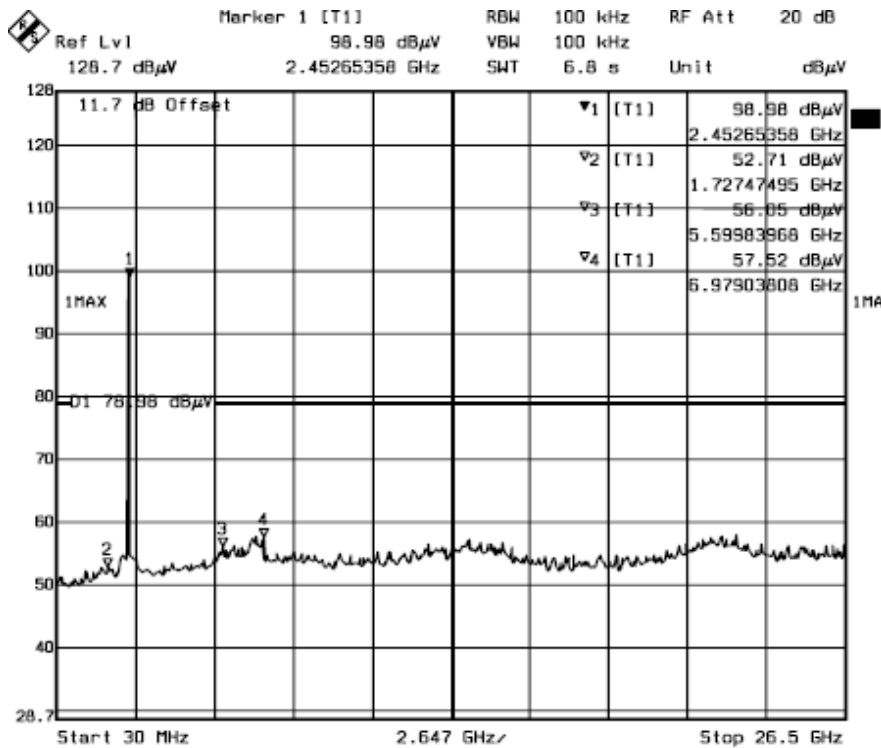

**12.RF EXPOSURE EVALUATION**

According to FCC 1.1310: The criteria listed in the following table shall be used to evaluate the environment impact of human exposure to radio frequency(RF) Radiation as specified in § 1.1307(b)

Limits for Maximum Permissible Exposure(MPE)

Frequency Range(MHz)	Electric Field Strength(V/m)	Magnetic Field Strength(A/m)	Power Density(mW/cm <sup>2</sup> )	Average Time
<b>(A) Limits for Occupational/Control Exposures</b>				
<b>300-1500</b>	--	--	<b>F/300</b>	<b>6</b>
<b>1500-100000</b>	--	--	<b>5</b>	<b>6</b>
<b>(B) Limits for General Population/Uncontrol Exposures</b>				
<b>300-1500</b>	--	--	<b>F/1500</b>	<b>6</b>
<b>1500-100000</b>	--	--	<b>1</b>	<b>30</b>

**12.1 Friis transmission formula:  $P_d = (P_{out} * G) / (4 * \pi * R^2)$**

Where

$P_d$ = Power density in mW/cm<sup>2</sup>

$P_{out}$ =output power to antenna in Mw

G= gain of antenna in linear scale

$\pi$ =3.1416

R= distance between observation point and center of the radiator in cm

$P_d$  the limit of MPE, 1mW/cm<sup>2</sup>. If we know the maximum gain of the antenna and total power input to the antenna, through the calculation, we will know the distance where the MPE limit is reached.

**12.2 Measurement Result**

Antenna gain: 4 dBi

Mode	Output Peak power (dBm)	Output Peak power (mW)	Antenna Gain (dBi)	Power density at 20cm (mW/ cm <sup>2</sup> )	Power density Limits (mW/cm <sup>2</sup> )
802.11b	11.76	14.99	2	0.00596	1
802.11g	11.89	15.45	2	0.00615	1
802.11n H20	10.45	11.09	2	0.00441	1
802.11n H40	10.93	12.39	2	0.00493	1

### General Appearance of the EUT





