

Title		2.4GHz Mini PCI MIMO - RT3062	
Size	Document Number	PEN-RT3062-V12ST-2X2.SCH	
B		Date:	Friday, January 16, 2009
		Sheet	1 of 8
		Rev	1.2

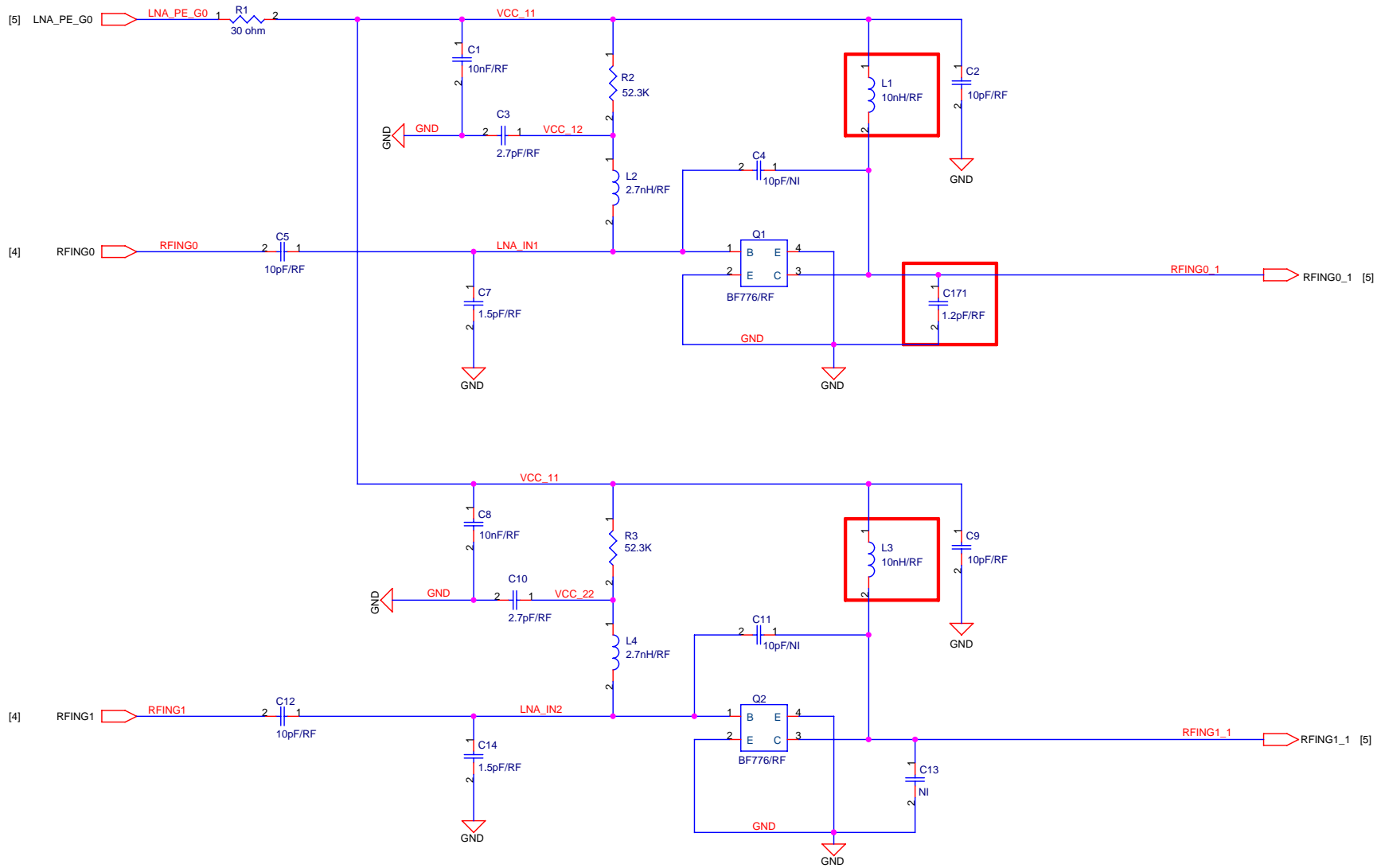

Title		2.4GHz LNA	
Size	Document Number	Rev	
B	2-LNA.SCH	1.2	
Date:	Tuesday, January 13, 2009	Sheet	2 of 8

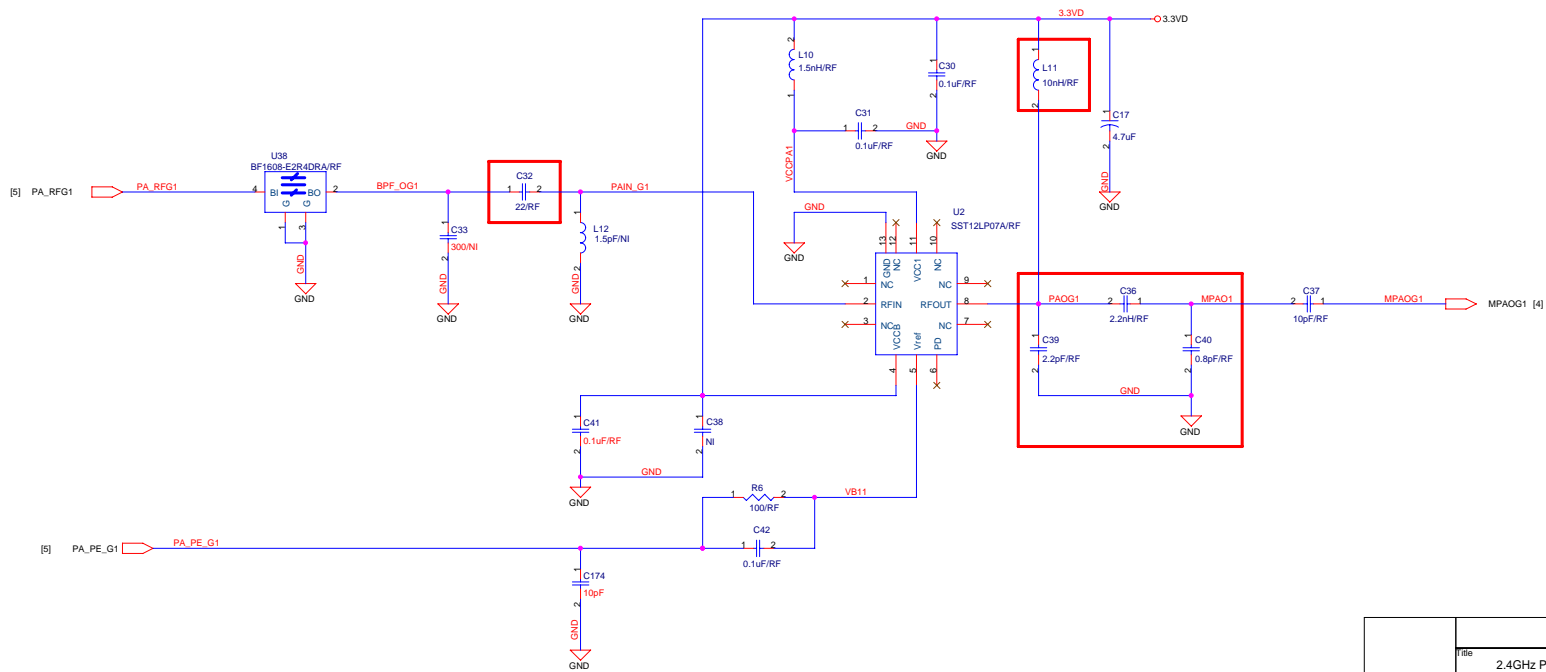
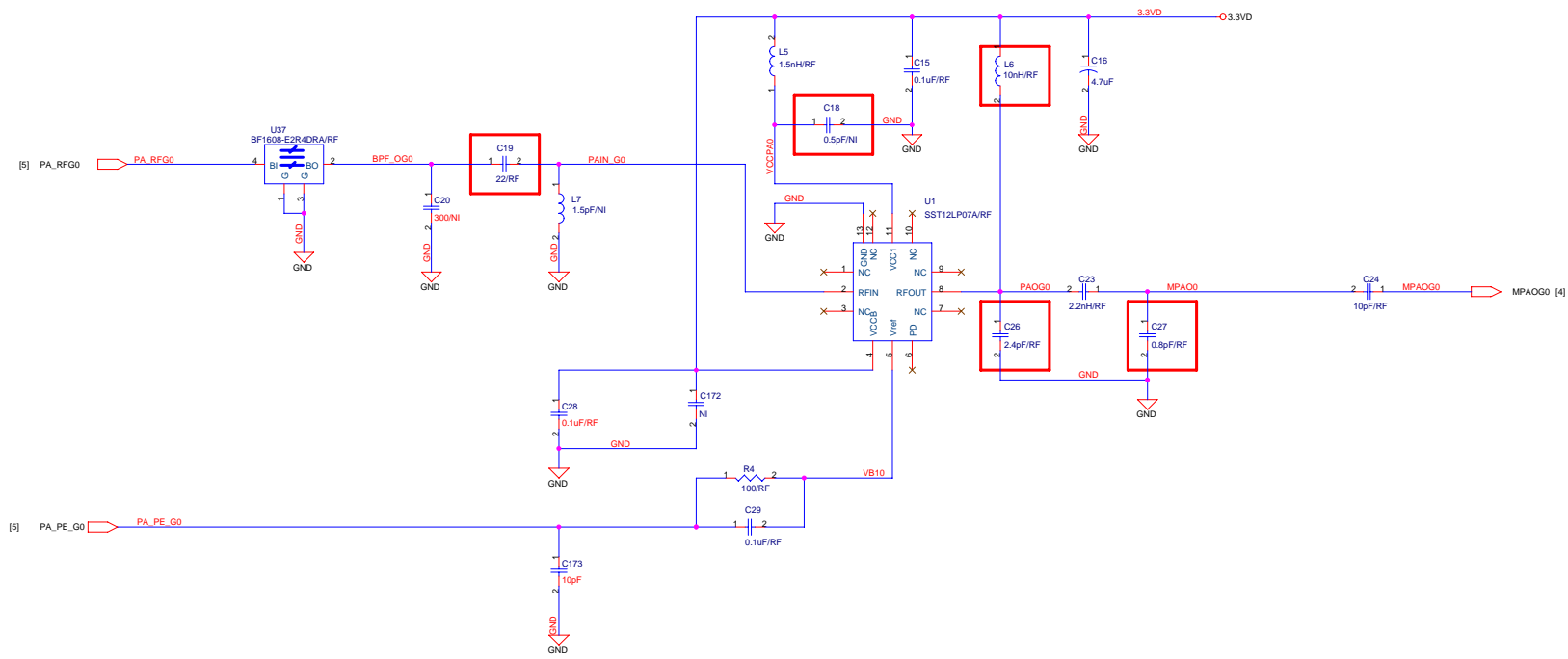

File		
2.4GHz PA		
Size	Document Number	Rev
C	2-PA.SCH	1.2
Date	Friday, January 16, 2009	Sheet 3 of 8

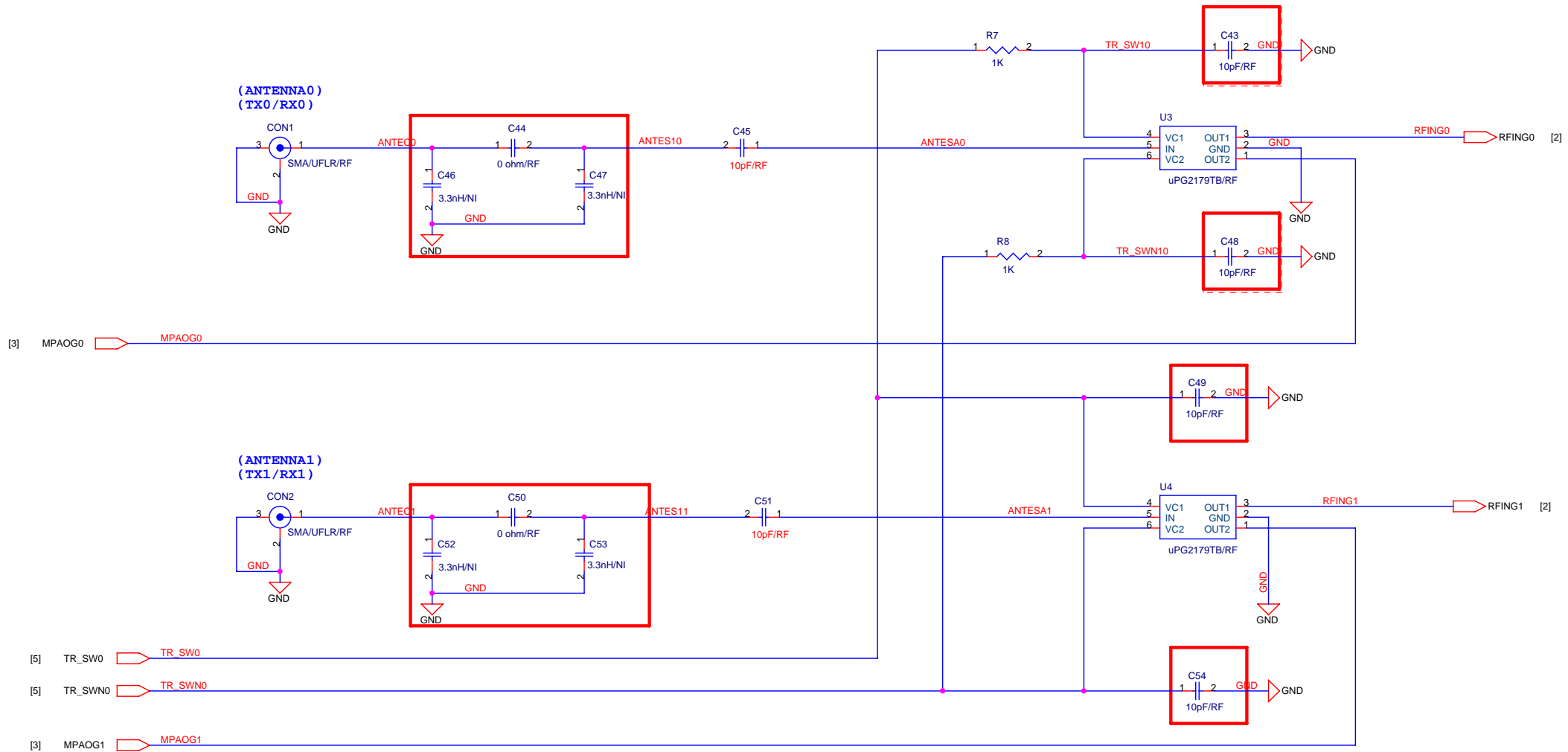

Title		Front-End
Size	Document Number	Rev
B	3-FrontEnd.SCH	1.2
Date:	Tuesday, January 13, 2009	Sheet 4 of 8

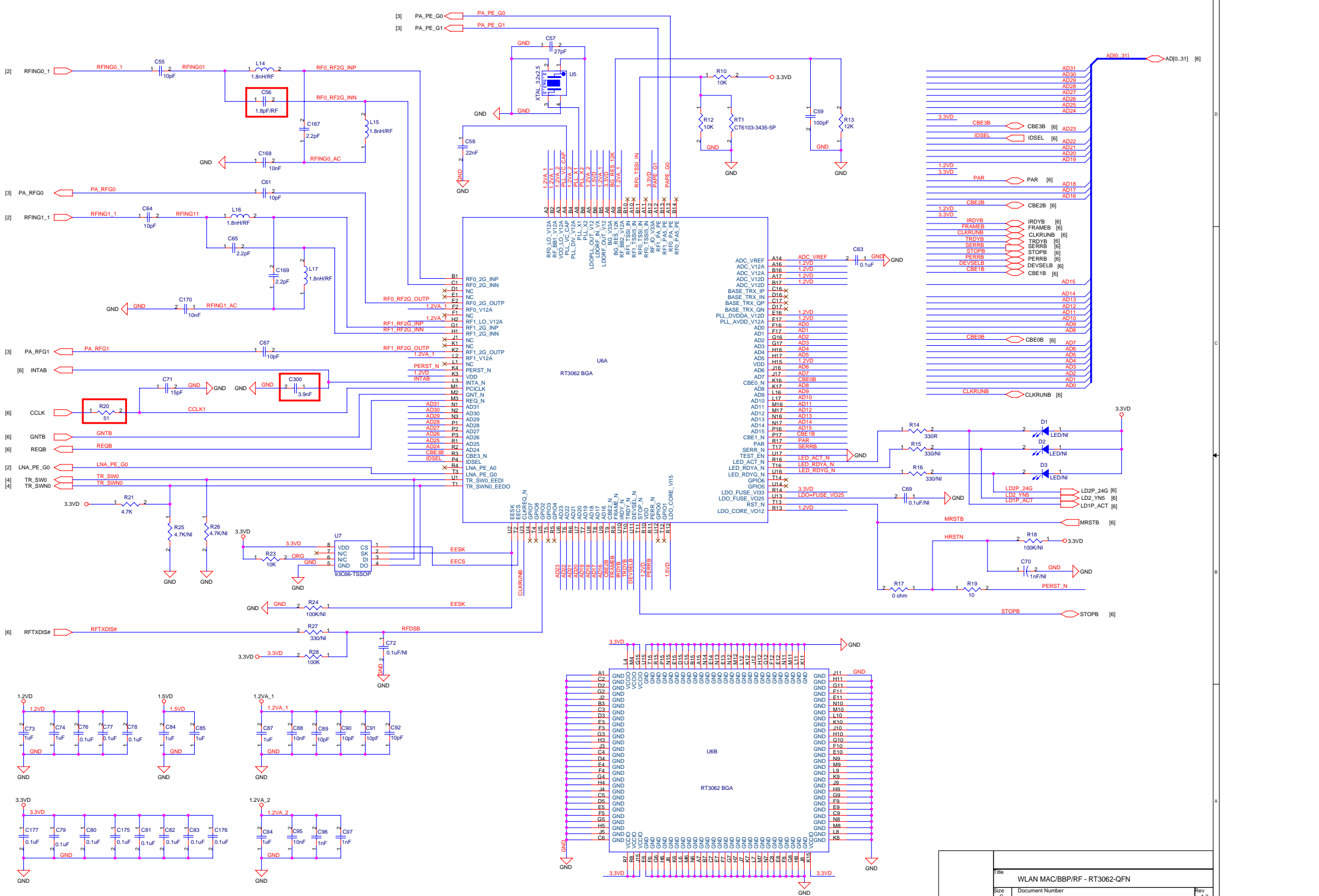

File		
WLAN MAC/BBP/RF - RT3062-QFN		
Size	Document Number	Rev
C	4-RT3062-WLAN.SCH	1.2
Date	Friday, January 16, 2009	Sheet 5 of 8

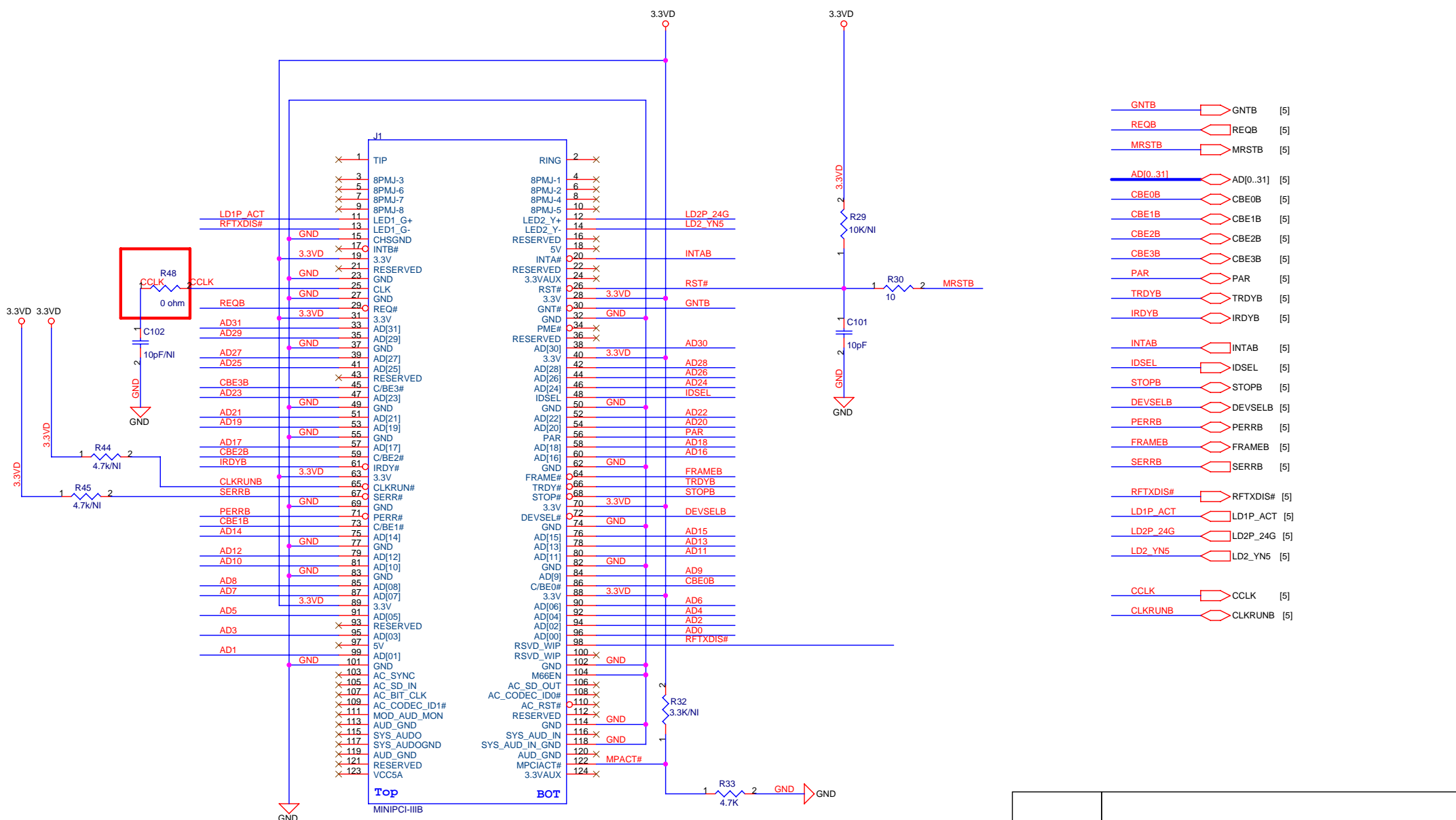

- GNTB [5]
- REQB [5]
- MRSTB [5]
- AD[0..31] [5]
- CBE0B [5]
- CBE1B [5]
- CBE2B [5]
- CBE3B [5]
- PAR [5]
- TRDYB [5]
- IRDYB [5]
- INTAB [5]
- IDSEL [5]
- STOPB [5]
- DEVSELB [5]
- PERRB [5]
- FRAMEB [5]
- SERRB [5]
- RFTXDIS# [5]
- LD1P_ACT [5]
- LD2P_24G [5]
- LD2_YN5 [5]
- CCLK [5]
- CLKRUNB [5]

Type IIIB

Title		
Mini PCI Interface and Power		
Size	Document Number	Rev
B	5-MINIPCI-3B.SCH	1.2
Date:	Friday, January 16, 2009	Sheet 6 of 8

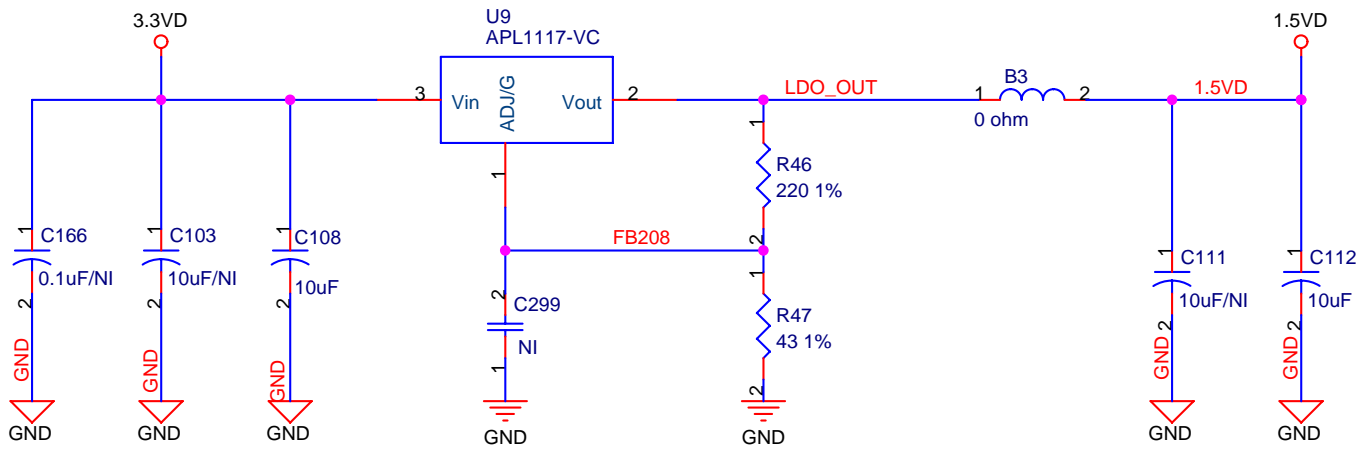

Title		
Power Supply		
Size	Document Number	Rev
A	6-POWER.SCH	1.2
Date:	Friday, January 16, 2009	Sheet 7 of 8