

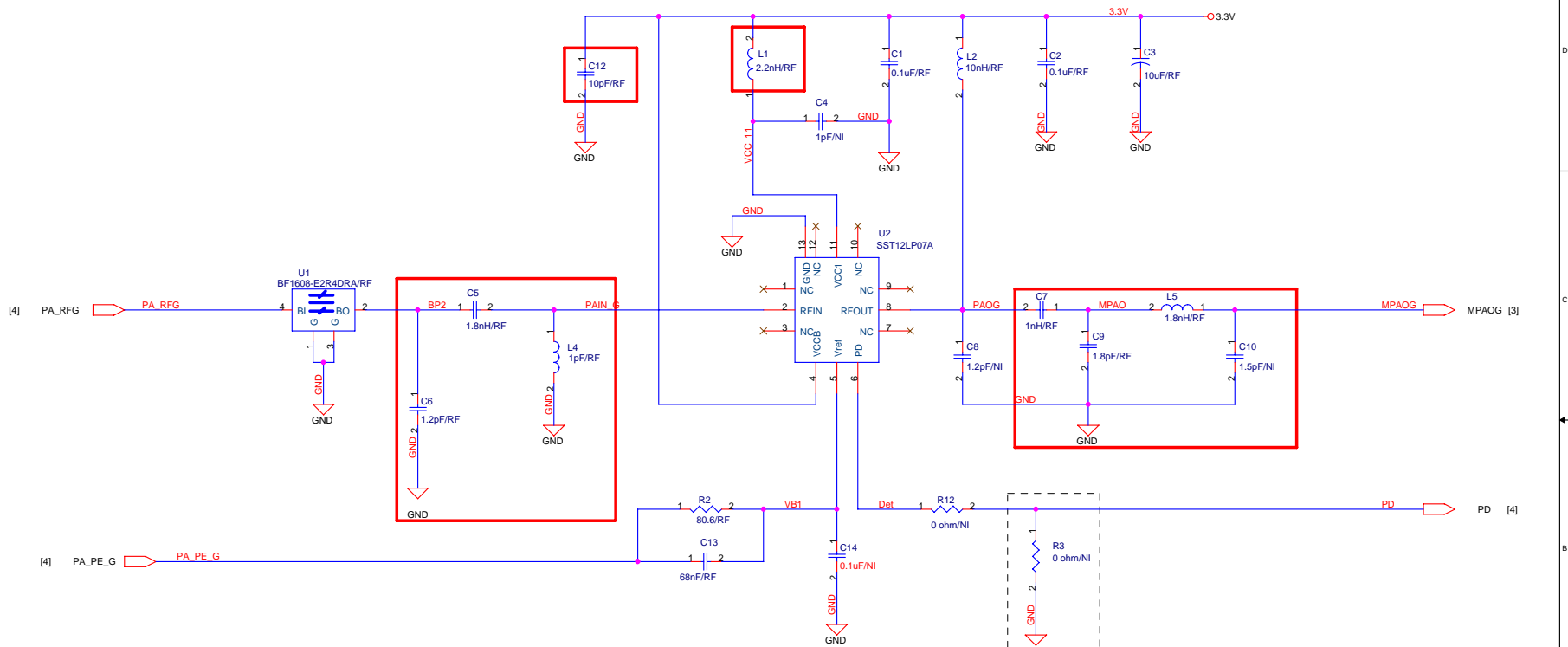

Filename:
HMC-RT3090-QFN-V14ST-BPF-CON1-081104.DSN

		RALINK TECHNOLOGY, CORP.	
		Title: 2.4GHz PCIe Half-Mini Card - RT3090	
Size B	Document Number HMC-RT3090-QFN-V14ST.SCH		Rev 1.4
	Date: Tuesday, November 04, 2008	Sheet 1 of 7	



Close to PA

		RALINK TECHNOLOGY, CORP.	
		Title: 2.4GHz PA	
Size: B	Document Number: 1-PA-SST12LP07A.SCH		Rev: 1.4
Date: Tuesday, November 04, 2008	Sheet: 2	of: 7	

CON1(1T OR 1R) ==> Put C17,U5,C27.C39
 ==> Remove C18,C80.CON2,C24,C22,C25,C11

CON1(1T), CON2(1R) ==> Put C18,C80,CON2,C24,C22,C25,C11
 ==> Remove C17,U5,C27,C39

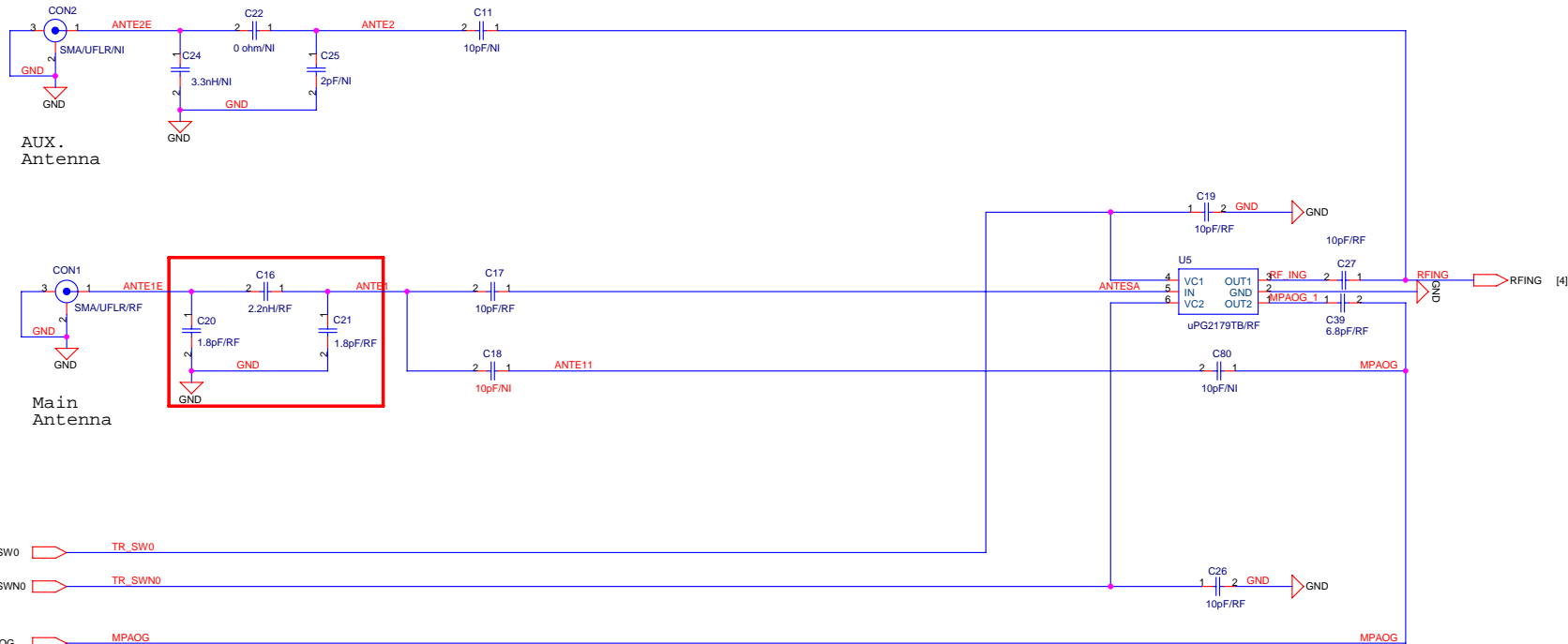

- [4] TR_SW0 TR_SW0
- [4] TR_SWN0 TR_SWN0
- [2] MPAOG MPAOG

		RALINK TECHNOLOGY, CORP.	
		Title: Front_End	
Size: B	Document Number: 2-Front_End.SCH	Rev: 1.4	
Date: Tuesday, November 04, 2008	Sheet: 3	of 7	

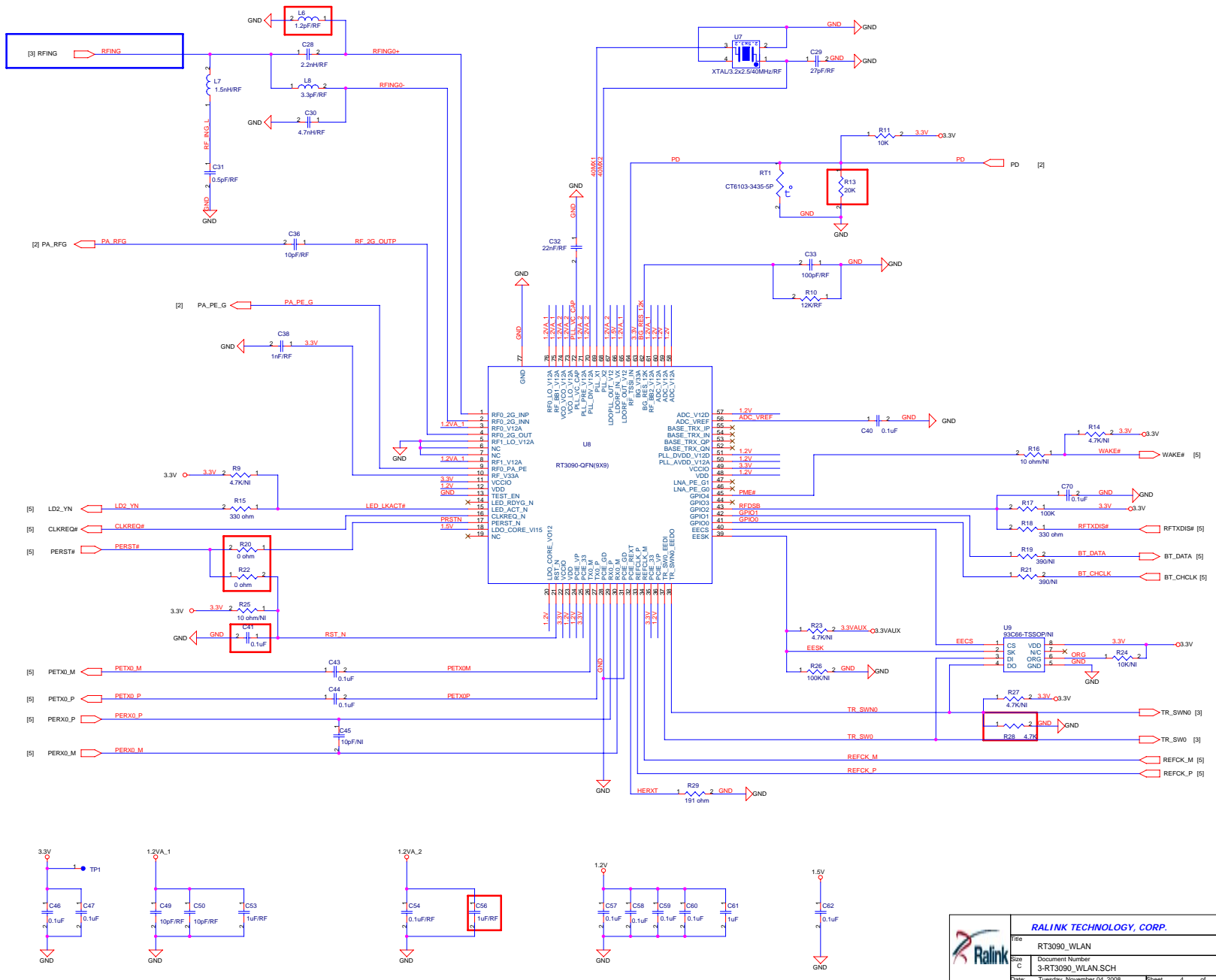

 RALINK TECHNOLOGY, CORP.		Title	
		RT3090_WLAN	
Size		Document Number	
C		3-RT3090_WLAN.SCH	
Date		Tuesday, November 04, 2008	
Sheet		4 of 7	
Rev		1.4	

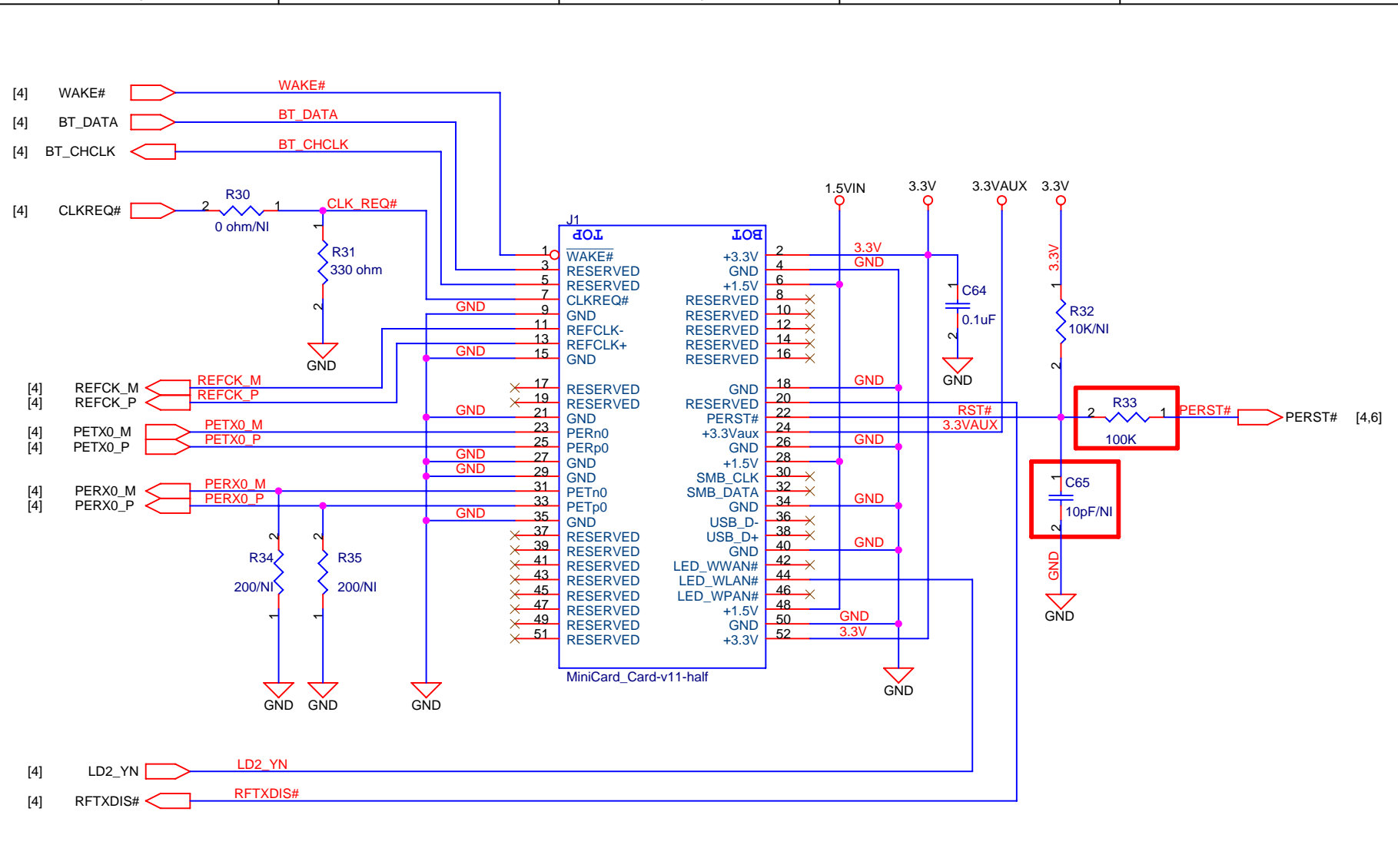

RALINK TECHNOLOGY, CORP.

Title		
PCI Express Mini Card Interface		
Size	Document Number	Rev
A	4-MiniCard_Half.SCH	1.4
Date:	Tuesday, November 04, 2008	Sheet 5 of 7

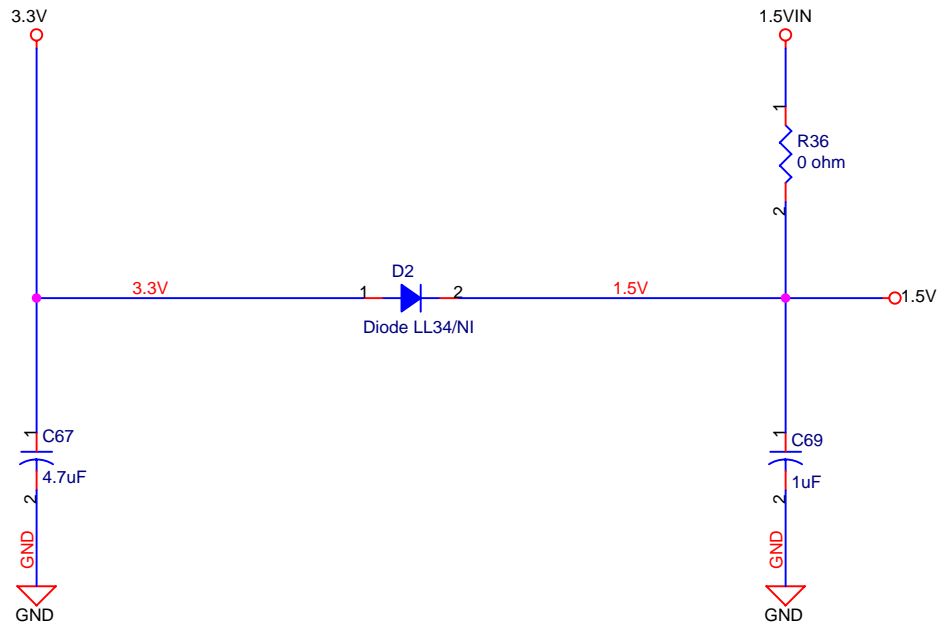

RALINK TECHNOLOGY, CORP.

Title		
Power Supply		
Size	Document Number	Rev
A	5-POWER.SCH	1.4
Date:	Monday, November 03, 2008	Sheet 6 of 7