

**SAMPLE & SPECIFICATION FOR APPROVAL**

Customer: T2 Mobile (Shanghai) Limited

Model NO: PM86W

Customer P/N: PM86W\_TOP\_ANT\_HM0169-DA (BQA39FOA16C0)

Version: V0.1

Specification Describe: PM86W TOP Antenna (Carrier + LDS)



Vendor P/N: HM0169-DA

Date: 2023/03/27

Sample and datasheet must be approved for 5 PCS .

No Customer appointed Material				Assign Part
	R&D		QE	Sales
Department	MD	HW	Quality and Eng. Dep.	Sale& Marketing
Checked By	LIXU	Li ShengHua	LiWeiWei	LiMin
Approved By	LIXueQin	WangJinhui	YeLing	YiQin
Final Judgment	LiLinHua	LiLinHua	LiLinHua	LiLinHua
Remark				

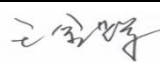
**Antenna Approval Sheet**

Customer	T2 Mobile (Shanghai) Limited		
Customer P/N	PM86W_TOP_ANT_HM0169-DA ( BQA39F0A16C0)		
Model	PM86W		
P/N	HM0169-DA		
Description	PM86W-TOP ANTENNA (Carrier+LDS)		
Frequency	2G:GSM850/GSM900/GSM1800/GSM1900 3G:WB1/B2/B4/B5/B6/B8/B19; 4G:LTEB1/B2/B3/B4/B5/B7/B8/B12/B13/B17/B19/B20/B25/B26/B28/B38/B39/B40/B41/ B66		
Initial Date	2023/03/27		
Revision	A		
Author	RF Engineer	ME	Confirm
	WangJinhui 	SunQua 	YIQIN 
Tel.	18015467688	13405120400	
Approval	R&D	PM	QE

**Customer Signature**

## Catalog

1. Summary.....		5
2. Antenna Structure.....		5
3. Device Conditions.....		5
4. Test Environment.....		6
5. Antenna Test Results.....		6
5.1 Antenna Photos .....		6
5.2 Matching Network .....		7
5.2.1 matching network for DIV antenna.....		7
5.2.2 matching network for 3IN1 antenna .....		7
5.2.3 matching network for BLE antenna .....		8
5.3 VSWR (S11).....		9
5.3.1 VSWR for DIV antenna .....		9
5.3.2 VSWR for 3IN1 antenna .....		10
5.3.3 VSWR for BLE antenna .....		11
5.4 Efficiency &Peak Gain.....		12
5.4.1 Efficiency &Peak Gain for DIV antenna.....		12
5.4.2 Efficiency &Peak Gain for 3in1 antenna .....		12
5.4.3 Efficiency &Peak Gain for BLE antenna .....		13
5.5 Radiation Pattern .....		14
5.5.1 Radiation Pattern for DIV antenna .....		14

5.5.2 Radiation Pattern for 3IN1 antenna .....	15
5.5.3 Radiation Pattern for BLE antenna .....	16
5.6 NFC Antenna Test Result .....	16
5.6.1 NFC Antenna matching.....	16
5.6.2 NFC Antenna Return Loss(S11,Smith).....	16
5.6.3 NFC Antenna Read card distance .....	18
6. Mechanical Drawings .....	19
7. Dimension Report.....	20

## 1. Summary

This is the TOP antenna approval sheet.

Working band :

DIV Antenna:

2G:GSM850/GSM900/GSM1800/GSM1900

3G:WB1/B2/B4/B5/B6/B8/B19;

4G:LTEB1/B2/B3/B4/B5/B7/B8/B12/B13//B17/B19/B20/B25/B26/B28/B38/B39/B40/B  
41/B66

3IN1 Antenna: 1575.42/2400-2500/5150-5850MHz

BLE Antenna: 2400-2482MHz

NFC Antenna : 13.56MHz

## 2. Antenna Structure

Carrier + LDS

## 3. Device Conditions

BLANK

Picture1 PM86W Mobile phone photo

Project NameT2 Mobile_TOP antenna		Document:	5
Date :2023-03-27	Version: A	Pointmobile_PM86W_TOP antenna Approval Sheet_A	

#### 4. Test Environment

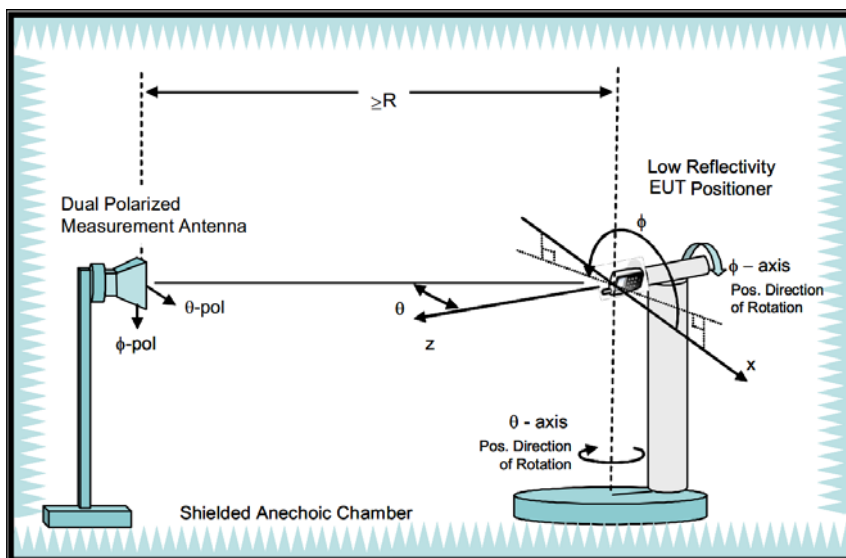

Picture 2 Test Environment photo

#### 5. Antenna Test Results

##### 5.1 Antenna Photos

BLANK

Picture 3 PM86W TOP antenna photo

## 5.2 Matching Network

### 5.2.1 matching network for DIV antenna

RF1	0Ω
RF2	12nH
RF3	33nH
RF4	33nH

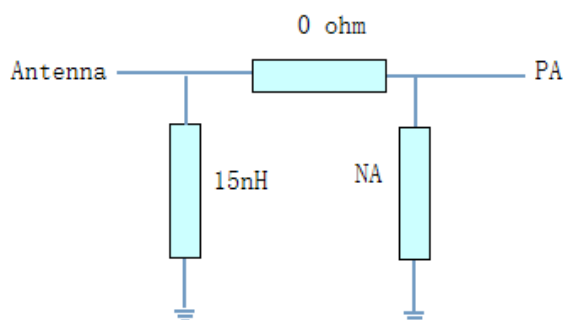

Picture 4 Matching network for DIV antenna

### 5.2.2 matching network for 3IN1 antenna

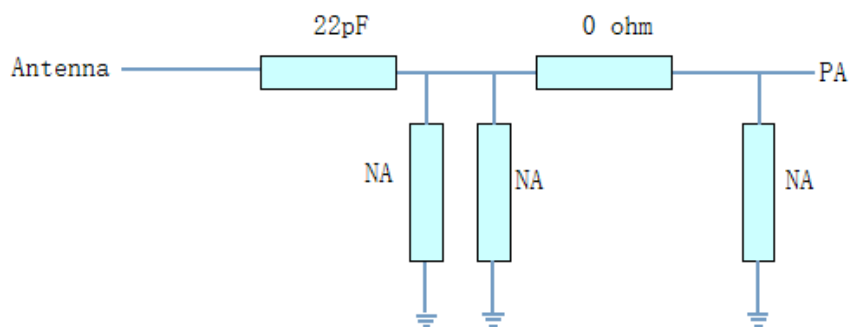

Picture 5 Matching network for 3IN1 antenna

5.2.3 matching network for BLE antenna

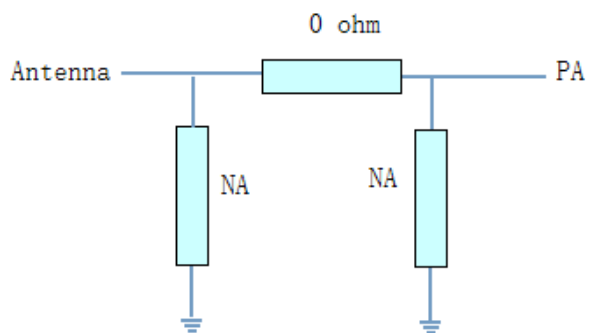

Picture 6 Matching network for BLE antenna



### 5.3 VSWR (S11)

#### 5.3.1 VSWR for DIV antenna

Frequency(MHz)	VSWR
748	2.48
960	2.91
1805	4.54
2300	3.16
2690	1.31

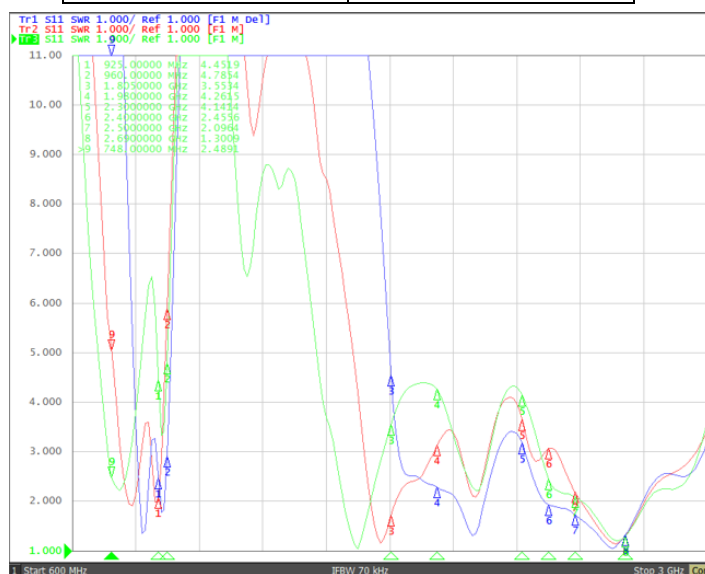

Picture 7 VSWR for DIV antenna

### 5.3.2 VSWR for 3IN1 antenna

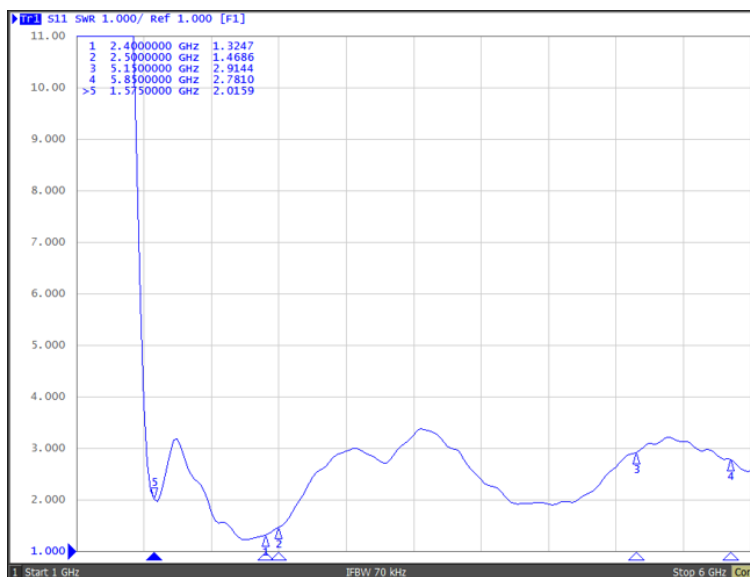

Picture 8 VSWR for 3IN1 antenna

### 5.3.3 VSWR for BLE antenna

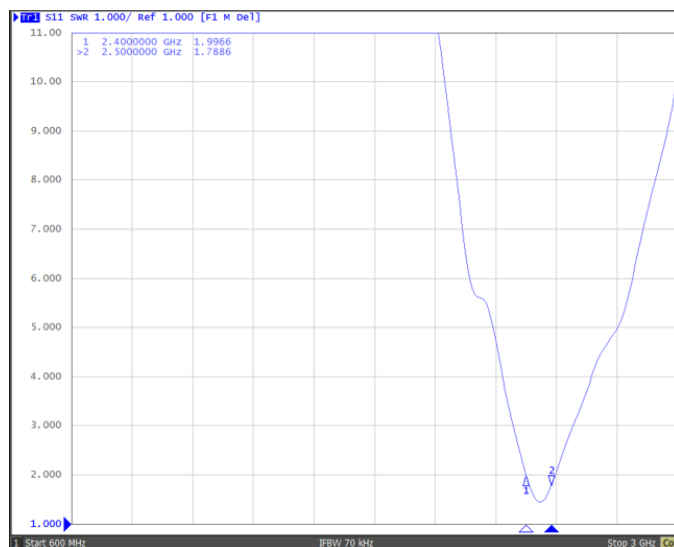

Picture 9 VSWR for BLE antenna

## 5.4 Efficiency & Peak Gain

### 5.4.1 Efficiency & Peak Gain for DIV antenna

RF1									RF2			RF3/RF4		
Freq (MHz)	Effi (%)	Gain (dBi)	Freq (MHz)	Effi (%)	Gain (dBi)	Freq (MHz)	Effi (%)	Gain (dBi)	Freq (MHz)	Effi (%)	Gain (dBi)	Freq (MHz)	Effi (%)	Gain (dBi)
910	22.35	-1.53	2070	33.14	2.38	2390	29.47	1.98	790	14.36	-6.38	720	17.88	-0.85
920	23.56	-0.82	2080	33.02	2.41	2400	28.66	1.81	800	13.56	-7.07	730	16.77	-0.9
930	21.32	-0.51	2090	34.73	2.67	2410	29.82	1.9	810	14.25	-6.21	740	18.25	-1.56
940	20.25	-0.65	2100	34.08	2.58	2420	29.79	1.79	820	12.81	-5.85	750	15.36	-1.56
950	19.5	-0.38	2110	34.73	2.61	2430	30.16	1.77	830	17.9	-4.67	760	17.51	-1.63
960	20.35	-0.83	2120	37.48	2.84	2440	30.3	1.74	840	18.31	-4.6	770	16.66	-1.8
1800	42.03	-0.05	2130	35.1	2.44	2450	32.28	2.03	850	19.38	-4.11	780	18.98	-3.22
1810	44.61	0.1	2140	30.31	1.73	2460	31.54	2.01	860	22.87	-3.27	790	13.26	-5.02
1820	50.61	0.59	2150	29.48	1.49	2470	33.62	2.37	870	21.56	-2.62	800	12.65	-6.11
1830	54.27	0.78	2160	28.74	1.28	2480	34.02	2.51	880	22.89	-2.62			
1840	56.52	0.83	2170	27.14	0.99	2490	31.61	2.27	890	19.66	-1.78			
1850	61.23	1.29	2180	23.81	0.35	2500	30.46	2.14	900	20.36	-1.67			
1860	47.63	0.38	2190	20.99	-0.19	2510	35.87	2.82						
1870	53.76	1	2200	20.17	-0.4	2520	38.15	3.1						
1880	57.39	1.52	2210	20.73	-0.25	2530	39.32	3.21						
1890	50.38	1.26	2220	20.6	-0.28	2540	37.51	3.05						
1900	48.8	1.4	2230	21.88	0.01	2550	34.44	2.67						
1910	50.22	1.78	2240	24.22	0.51	2560	33.57	2.54						
1920	56.04	2.49	2250	25.71	0.79	2570	34	2.59						
1930	53.17	2.48	2260	27.1	1.03	2580	33.52	2.47						
1940	50.75	2.56	2270	28.74	1.4	2590	38.98	3.08						
1950	49.04	2.73	2280	28.88	1.52	2600	41.88	3.33						
1960	52.39	3.31	2290	30.38	1.82	2610	42.23	3.23						
1970	48.32	3.25	2300	33.74	2.3	2620	44.67	3.34						
1980	42.45	2.94	2310	32.93	2.23	2630	47.93	3.58						
2000	42.26	3.21	2320	33.52	2.32	2640	44.81	3.22						
2010	39.53	2.98	2330	34.57	2.49	2650	49.32	3.62						
2020	33	2.24	2340	33.43	2.39	2660	50.6	3.69						
2030	32.61	2.21	2350	36.78	2.82	2670	53.48	3.9						
2040	31.83	2.13	2360	35.34	2.68	2680	57.79	4.16						
2050	30.82	2.01	2370	30.27	2.04	2690	58.11	4.07						
2060	32.49	2.28	2380	28.76	1.86	2700	56.86	3.9						

### 5.4.2 Efficiency & Peak Gain for 3in1 antenna

Freq (MHz)	Effi (%)	Gain (dBi)	Freq (MHz)	Effi (%)	Gain (dBi)	Freq (MHz)	Effi (%)	Gain (dBi)
1540	26.75	0.05	2400	36.88	2.7	5100	40.2	1.04
1550	30.11	0.56	2410	39.7	3.1	5150	35.96	0.75
1560	33.14	1.09	2420	38.81	3.08	5200	30.9	-0.26
1570	36.15	1.6	2430	37.92	3.04	5250	25.88	-1.15
1580	40.03	2.04	2440	38.37	3.11	5300	28.86	-0.96
1590	39.95	2.03	2450	35.7	2.82	5350	34.54	-0.15
1600	37.74	1.64	2460	35.54	2.85	5400	35.82	0.19
1610	37.59	1.41	2470	37.93	3.13	5450	34.85	0.41
			2480	40.15	3.27	5500	34.1	0.48
			2490	43.71	3.56	5550	34.38	0.55
			2500	43.73	3.43	5600	35.57	0.58
						5650	40.18	1.09
						5700	40.35	0.64
						5750	36.42	0.15
						5800	34.82	-0.47
						5850	39.32	0.01

### 5.4.3 Efficiency & Peak Gain for BLE antenna

Freq (MHz)	Effi (%)	Gain (dBi)
2400	27.46	-2.58
2410	28.07	-1.93
2420	29.47	-1.56
2430	30.09	-1.39
2440	29.97	-0.89
2450	31.95	-0.85
2460	31.43	-0.87
2470	30.76	-0.62
2480	31.26	-0.84
2490	29.59	-0.99
2500	28.66	-0.92

## 5.5 Radiation Pattern

### 5.5.1 Radiation Pattern for DIV antenna

#### PATH-RF1 (925-960MHz,1805-2040MHz)

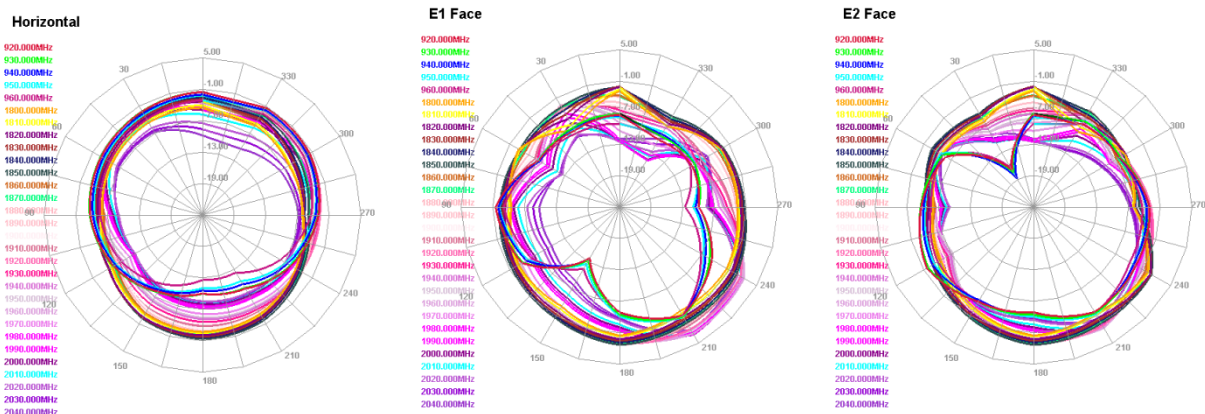

#### PATH-RF1 (2050-2170MHz,2300-2400MHz)

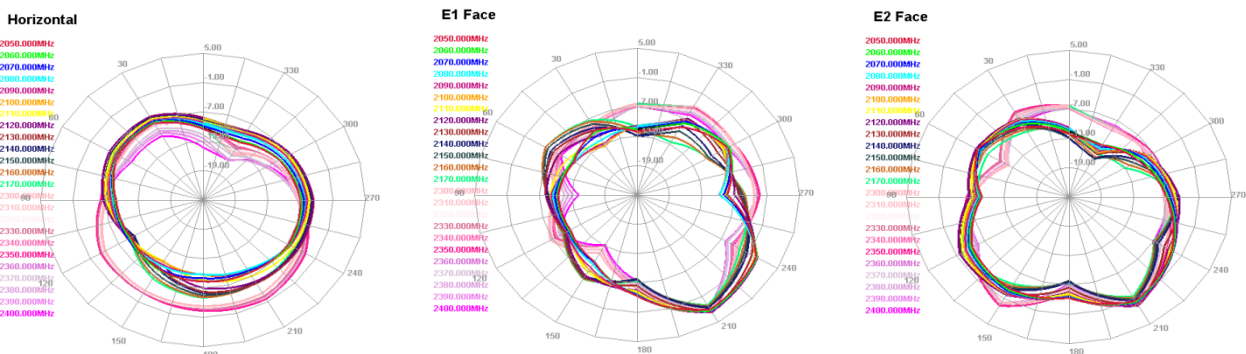

#### PATH-RF1 (2410-2690MHz)

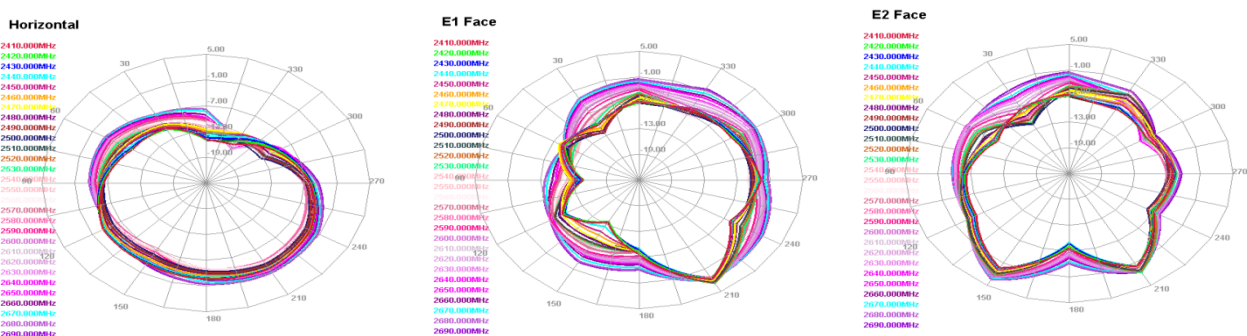

**PATH-RF2**

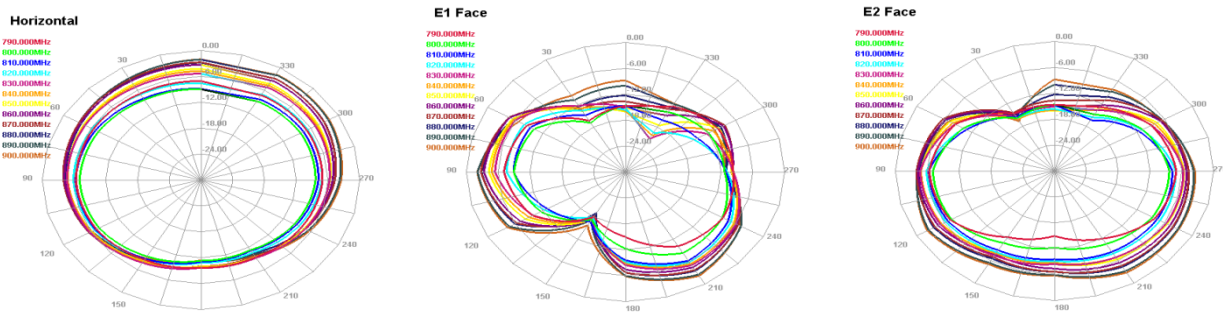

**PATH-RF3/RF4**

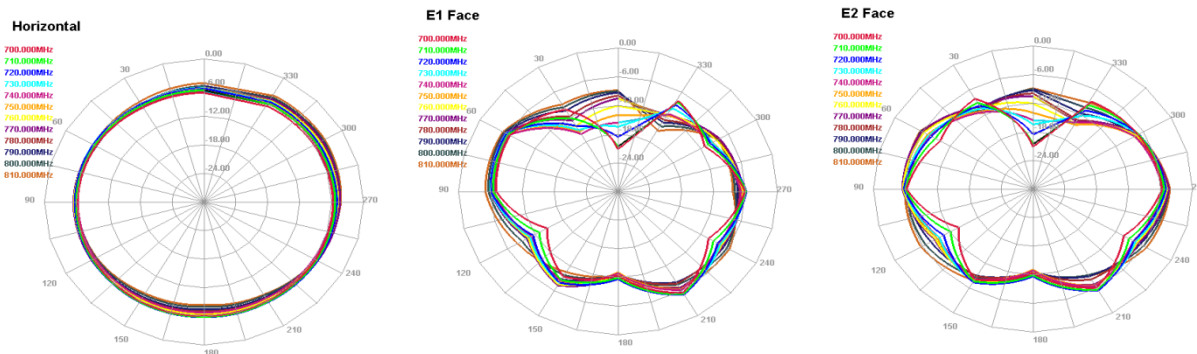

**5.5.2 Radiation Pattern for 3IN1 antenna**

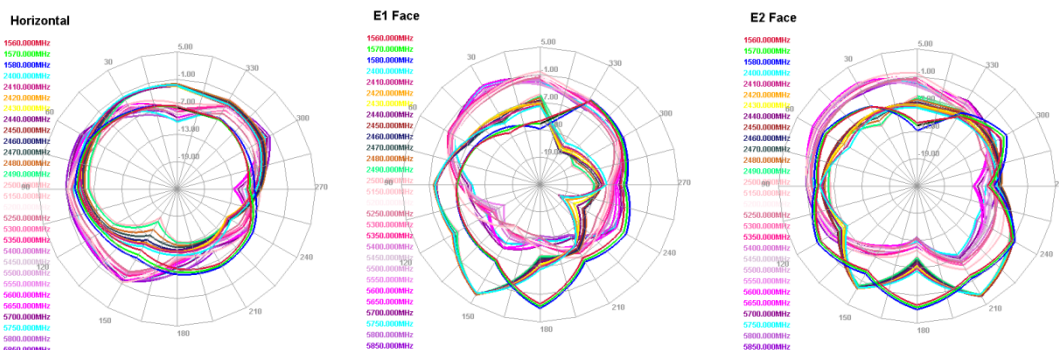

### 5.5.3 Radiation Pattern for BLE antenna

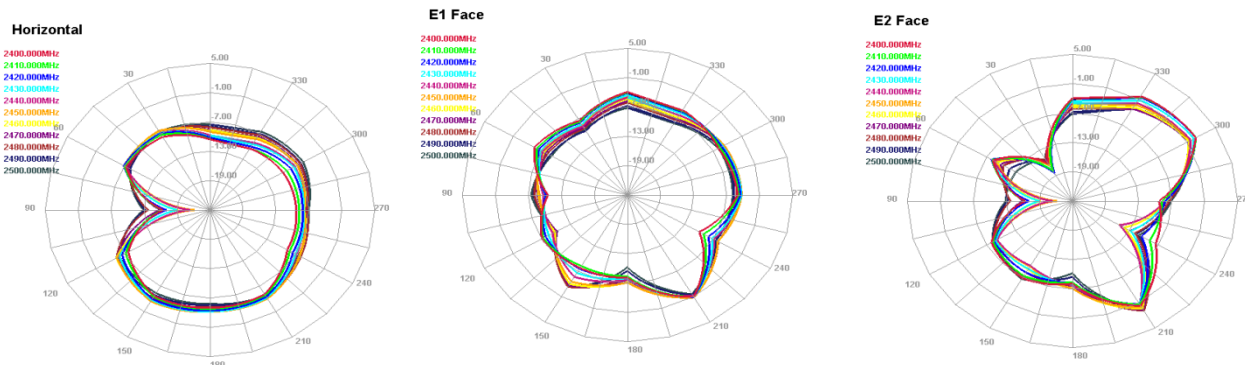

### 5.6 NFC Antenna Test Result

#### 5.6.1 NFC Antenna matching

Description	
L1501 & L1502	77nH
C1506 & C1507	560pF
C1510 & C1513	120pF
C1511 & C1512	NC
C1514 & C1509	27pF
C1515 & C1508	180pF
C1528 & C1529	33pF

#### 5.6.2 NFC Antenna Return Loss(S11,Smith)

Frequency(MHz)	S11(dB)
13.56	-3.54



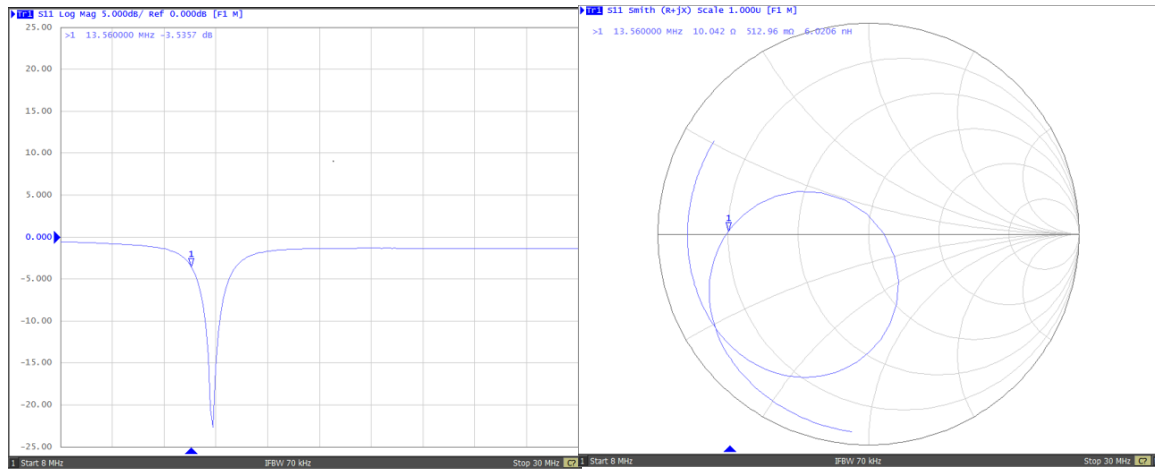

Picture 9 S11/Smith of NFC Antenna

**5.6.3 NFC Antenna Read card distance**

Card type	Description	Spec	Distance(mm)
NFC 01	type A read only (ISO14443-3A/Type A)	> 50	67
NFC 02	type A R/W free (ISO14443-3A/Type A)	> 50	67
NFC 03	type 2 locked (ISO14443-3A/Mifare Ultra light+)	> 30	72
NFC 04	type 2 R/W free (ISO14443-3A/Mifare Ultra light+)	> 30	65
NFC 05	type 3 R/W free (JIS X 6319-4/Type F)	> 30	65
NFC 06	type 4 R/W free A (ISO14443-3A/Mifare Classic)	> 30	42
NFC 07	type 4 R/W free B (ISO14443-3B/Type B)	> 30	39
NFC 08	type 4 32k bytes R/W free (ISO14443-3A/Type A)	> 30	55
NFC 09	Mifare tag R/W free (ISO14443-3A/Mifare Classic1K)	> 50	50
NFC 10	type 5 R/W free (ISO15693/Type V)	> 90	80

### 6. Mechanical Drawings

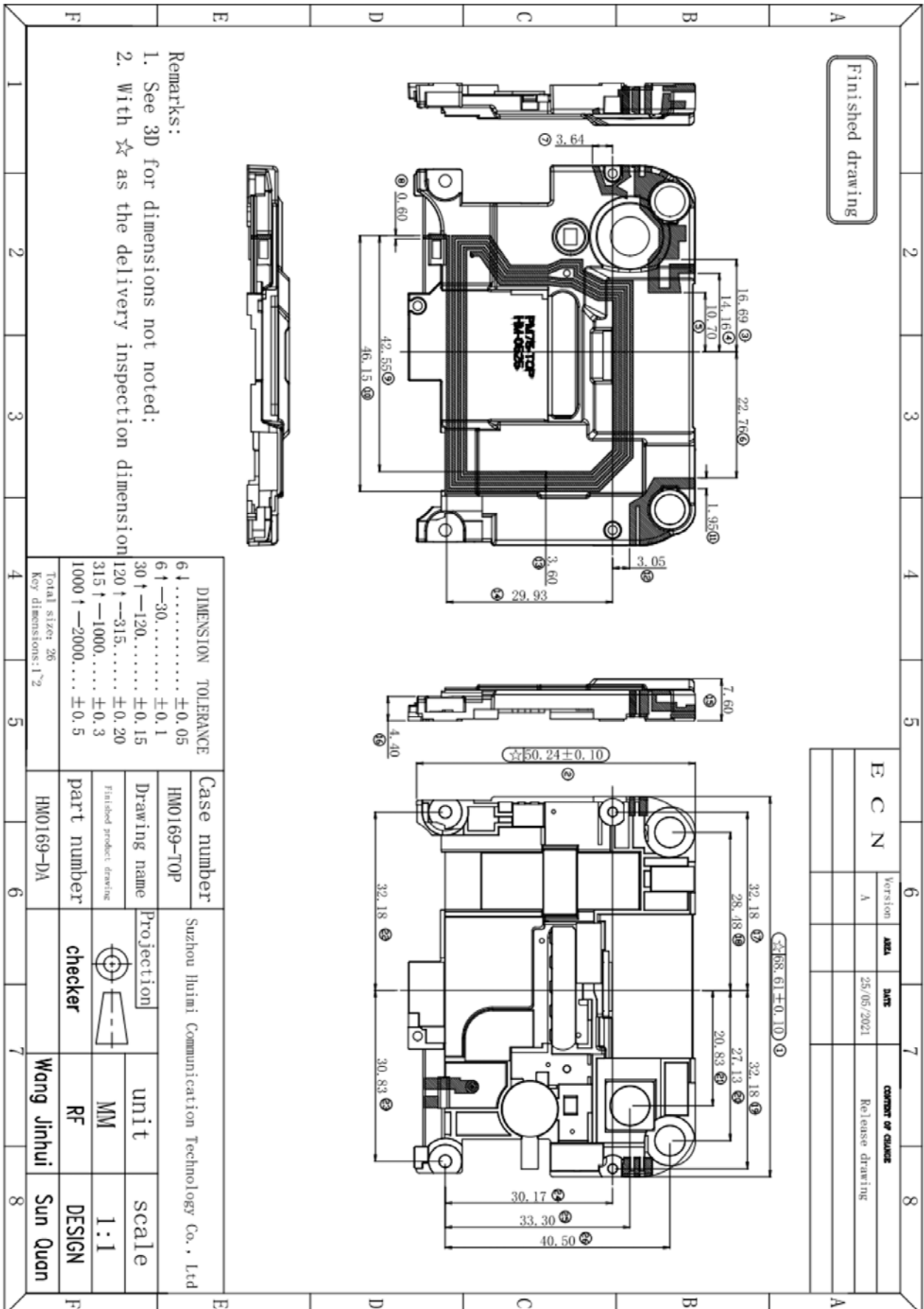

## 7. Dimension Report

Suzhou Huimi Communication Technology Co., Ltd													
Dimensional inspection report													
customer			Point Mobile			project name		PM75		Drawing version		A	
Name of our project			HM0169			Antenna name		TOP-LDS		Date of measurement		2021/5/28	
序号	尺寸性质	尺寸	公差		测量工具						OK/NG	备注	
			上限	下限		1	2	3	4	5			
1	*	68.61	0.10	0.10		68.65	68.60	68.63	68.63	68.66		OK	
2	*	50.24	0.10	0.10		50.25	50.28	50.23	50.22	50.26		OK	
3		16.69	0.10	0.10		16.73	16.70	16.68	16.66	16.70		OK	
4		14.16	0.10	0.10		14.18	14.15	14.16	14.11	14.17		OK	
5		10.70	0.10	0.10		10.72	10.70	10.73	10.72	10.75		OK	
6		22.76	0.10	0.10		22.77	22.75	22.73	22.79	22.77		OK	
7		3.64	0.05	0.05		3.66	3.65	3.68	3.64	3.66		OK	
8		0.60	0.05	0.05		0.62	0.61	0.60	0.62	0.61		OK	
9		42.55	0.15	0.15		42.58	42.62	42.61	42.56	42.58		OK	
10		46.15	0.15	0.15		46.18	46.21	46.20	46.15	46.17		OK	
11		1.95	0.05	0.05		1.98	1.95	1.96	1.97	1.96		OK	
12		3.05	0.05	0.05		3.03	3.02	3.05	3.04	3.06		OK	
13		3.60	0.05	0.05		3.62	3.63	3.60	3.60	3.61		OK	
14		29.93	0.10	0.10		29.95	29.98	29.96	29.99	29.97		OK	
15		7.60	0.10	0.10		7.62	7.63	7.63	7.61	7.60		OK	
16		4.40	0.05	0.05		4.41	4.40	4.42	4.40	4.41		OK	
17		32.18	0.15	0.15		32.21	32.19	32.23	32.17	32.20		OK	
18		28.48	0.10	0.10		28.51	28.46	28.49	28.50	28.44		OK	
19		32.18	0.15	0.15		32.19	32.20	32.17	32.23	32.16		OK	
20		27.13	0.10	0.10		27.16	27.13	27.15	27.14	27.16		OK	
21		20.83	0.10	0.10		20.85	20.88	20.86	20.85	20.84		OK	
22		32.18	0.15	0.15		32.19	32.23	32.22	32.21	32.19		OK	
23		30.83	0.15	0.15		30.85	30.88	30.85	30.86	30.84		OK	
24		30.17	0.15	0.15		30.21	30.18	30.19	30.18	30.17		OK	
25		33.30	0.15	0.15		33.32	33.30	33.28	33.31	33.30		OK	
26		40.50	0.15	0.15		40.52	40.55	40.51	40.53	40.49		OK	