

TEST REPORT



DT&C Co., Ltd.

42, Yurim-ro, 154Beon-gil, Cheoin-gu, Yongin-si, Gyeonggi-do, Korea, 17042
Tel : 031-321-2664, Fax : 031-321-1664

1. Report No : DRTFCC1902-0054

2. Customer

- Name (FCC) : POINTMOBILE CO., LTD. / Name (IC) : POINTMOBILE CO.,LTD
- Address (FCC) : B-9F, Kabul Great Valley 32 Digital-ro 9-gil, Geumcheon-gu Seoul South Korea 153-709
- Address (IC) : B-9F Kabul Great Valley, 32, Digital-ro 9-gil, Geumcheon-gu Seoul Korea (Republic Of)

3. Use of Report : FCC & IC Original Grant

4. Product Name / Model Name : Mobile Computer / PM85G

FCC ID : V2X-PM85G / IC : 10664A-PM85G

5. Test Method Used : KDB971168 D01v03, ANSI/TIA-603-E-2016, ANSI C63.26-2015

Test Specification : §2, §22, §24, §27, §90

RSS-130 Issue 2, 132 Issue 3, 133 Issue 6, 139 Issue 3, 140 Issue 1, 199 Issue 3

6. Date of Test : 2018.11.30 ~ 2019.02.24

7. Testing Environment : Refer to appended test report.

8. Test Result : Refer to the attached test result.

Affirmation	Tested by	Reviewed by
	Name : SunGeun Lee  (Signature)	Name : Geunki Son  (Signature)

The test results presented in this test report are limited only to the sample supplied by applicant and the use of this test report is inhibited other than its purpose. This test report shall not be reproduced except in full, without the written approval of DT&C Co., Ltd.

2019 . 02 . 26 .

DT&C Co., Ltd.

If this report is required to confirmation of authenticity, please contact to report@dtnc.net

Test Report Version

Test Report No.	Date	Description
DRTFCC1902-0054	Feb. 26, 2019	Initial issue

Table of Contents

1. GENERAL INFORMATION	5
2. INTRODUCTION	7
2.1 EUT DESCRIPTION	7
2.2. EUT CAPABILITIES	7
2.3. TESTING ENVIRONMENT	7
2.4 MEASURING INSTRUMENT CALIBRATION.....	7
2.5. MEASUREMENT UNCERTAINTY	7
2.6. TEST FACILITY.....	7
3. DESCRIPTION OF TESTS.....	8
3.1 ERP & EIRP (Effective Radiated Power & Equivalent Isotropic Radiated Power)	8
3.2 PEAK TO AVERAGE RATIO	10
3.3 OCCUPIED BANDWIDTH.....	11
3.4 BAND EDGE EMISSIONS AT ANTENNA TERMINAL	12
3.5 SPURIOUS AND HARMONIC EMISSIONS AT ANTENNA TERMINAL	14
3.6 UNDESIRABLE EMISSIONS	15
3.7 FREQUENCY STABILITY	16
4. LIST OF TEST EQUIPMENT	17
5. SUMMARY OF TEST RESULTS	18
6. SAMPLE CALCULATION	19
7. TEST DATA.....	21
7.1 OCCUPIED BANDWIDTH.....	21
7.2 PEAK TO AVERAGE RATIO	21
7.3 BAND EDEG EMISSIONS (Conducted).....	21
7.4 SPURIOUS AND HARMONICS EMISSIONS (Conducted)	21
7.5 ERP & EIRP	22
7.5.1 LTE Band 12, 17.....	22
7.5.2 LTE Band 12.....	22
7.5.3 LTE Band 13.....	23
7.5.4 LTE Band 14.....	23
7.5.5 LTE Band 5.....	24
7.5.6 LTE Band 4.....	25
7.5.7 LTE Band 2.....	26
7.5.8 LTE Band 41.....	27
7.5.9 LTE Band 7.....	28
7.6 UNDESIRABLE EMISSIONS (Radiated).....	29
7.6.1 LTE Band 12, 17.....	29
7.6.2 LTE Band 12.....	30
7.6.3 LTE Band 13.....	31
7.6.4 LTE Band 14.....	32
7.6.5 LTE Band 5.....	33
7.6.6 LTE Band 4.....	35
7.6.7 LTE Band 2.....	36
7.6.8 LTE Band 41.....	37
7.6.9 LTE Band 7.....	38
7.7 FREQUENCY STABILITY	39
7.7.1 LTE Band 12, 17.....	39
7.7.2 LTE Band 13.....	40
7.7.3 LTE Band 14.....	41
7.7.4 LTE Band 5.....	42
7.7.5 LTE Band 4.....	43
7.7.6 LTE Band 2.....	44
7.7.7 LTE Band 41.....	45

7.7.8 LTE Band 7.....	46
8. TEST PLOTS	47
8.1 OCCUPIED BANDWIDTH.....	47
8.1.1 LTE Band 12, 17.....	47
8.1.2 LTE Band 12.....	49
8.1.3 LTE Band 13.....	51
8.1.4 LTE Band 14.....	53
8.1.5 LTE Band 5.....	55
8.1.6 LTE Band 4.....	59
8.1.7 LTE Band 2.....	65
8.1.8 LTE Band 41.....	71
8.1.9 LTE Band 7.....	75
8.2 PEAK TO AVERAGE RATIO.....	79
8.2.1 LTE Band 12, 17.....	79
8.2.2 LTE Band 12.....	81
8.2.3 LTE Band 13.....	83
8.2.4 LTE Band 14.....	85
8.2.5 LTE Band 5.....	87
8.2.6 LTE Band 4.....	91
8.2.7 LTE Band 2.....	97
8.2.8 LTE Band 41.....	103
8.2.9 LTE Band 7.....	107
8.3 BAND EDGE EMISSIONS(Conducted).....	111
8.3.1 LTE Band 12, 17.....	111
8.3.2 LTE Band 12.....	115
8.3.3 LTE Band 13.....	119
8.3.4 LTE Band 14.....	127
8.3.5 LTE Band 5.....	129
8.3.6 LTE Band 4.....	137
8.3.7 LTE Band 2.....	149
8.3.8 LTE Band 41.....	161
8.3.9 LTE Band 7.....	167
8.4 SPURIOUS AND HARMONICS EMISSIONS(Conducted)	173
8.4.1 LTE Band 12, 17.....	173
8.4.2 LTE Band 12.....	176
8.4.3 LTE Band 13.....	180
8.4.4 LTE Band 14.....	182
8.4.5 LTE Band 5.....	184
8.4.6 LTE Band 4.....	190
8.4.7 LTE Band 2.....	208
8.4.8 LTE Band 41.....	226
8.4.9 LTE Band 7.....	238

1. GENERAL INFORMATION

Applicant Name(FCC)	:	POINTMOBILE CO., LTD.
Applicant Name(IC)	:	POINTMOBILE CO.,LTD
Address(FCC)	:	B-9F, Kabul Great Valley 32 Digital-ro 9-gil, Geumcheon-gu Seoul South Korea 153-709
Address(IC)	:	B-9F Kabul Great Valley, 32, Digital-ro 9-gil, Geumcheon-gu Seoul Korea (Republic Of)
FCC ID	:	V2X-PM85G
IC	:	10664A-PM85G
FCC Classification	:	PCS Licensed Transmitter held to ear (PCE)
EUT Type	:	Mobile Computer
Model Name(FCC, IC)	:	PM85G
Add Model Name(FCC)	:	XT200WA
Add Model Name(IC)	:	-
Supplying power	:	DC 3.85 V
Antenna Information	:	PIFA Antenna

Mode	TX Frequency (MHz)	Emission Designator	Modulation	ERP(FCC&IC)		EIRP	
				Max power (dBm)	Max power (W)	Max power (dBm)	Max power (W)
LTE Band 12, 17	704 ~ 711	8M96G7D	QPSK	23.28	0.213	-	-
LTE Band 12, 17	704 ~ 711	8M94W7D	16QAM	21.77	0.150	-	-
LTE Band 12, 17	701.5 ~ 713.5	4M48G7D	QPSK	21.98	0.158	-	-
LTE Band 12, 17	701.5 ~ 713.5	4M49W7D	16QAM	21.23	0.133	-	-
LTE Band 12	700.5 ~ 714.5	2M69G7D	QPSK	21.89	0.155	-	-
LTE Band 12	700.5 ~ 714.5	2M69W7D	16QAM	21.48	0.141	-	-
LTE Band 12	699.7 ~ 715.3	1M09G7D	QPSK	21.99	0.158	-	-
LTE Band 12	699.7 ~ 715.3	1M09W7D	16QAM	20.99	0.126	-	-
LTE Band 13	782 ~ 782	8M90G7D	QPSK	19.99	0.100	-	-
LTE Band 13	782 ~ 782	8M92W7D	16QAM	19.41	0.087	-	-
LTE Band 13	779.5 ~ 784.5	4M49G7D	QPSK	20.24	0.106	-	-
LTE Band 13	779.5 ~ 784.5	4M48W7D	16QAM	19.18	0.083	-	-
LTE Band 14	793 ~ 793	8M91G7D	QPSK	21.24	0.133	-	-
LTE Band 14	793 ~ 793	8M94W7D	16QAM	20.84	0.121	-	-
LTE Band 14	790.5 ~ 795.5	4M47G7D	QPSK	22.47	0.177	-	-
LTE Band 14	790.5 ~ 795.5	4M47W7D	16QAM	21.92	0.156	-	-

Mode	TX Frequency (MHz)	Emission Designator	Modulation	ERP(For the FCC)		EIRP(For the IC)	
				Max power (dBm)	Max power (W)	Max power (dBm)	Max power (W)
LTE Band 5	829 ~ 844	8M98G7D	QPSK	22.53	0.179	24.68	0.294
LTE Band 5	829 ~ 844	8M93W7D	16QAM	21.82	0.152	23.97	0.249
LTE Band 5	826.5 ~ 846.5	4M48G7D	QPSK	22.29	0.169	24.44	0.278
LTE Band 5	826.5 ~ 846.5	4M49W7D	16QAM	21.34	0.136	23.49	0.223
LTE Band 5	825.5 ~ 847.5	2M69G7D	QPSK	22.10	0.162	24.25	0.266
LTE Band 5	825.5 ~ 847.5	2M69W7D	16QAM	21.42	0.139	23.57	0.228
LTE Band 5	824.7 ~ 848.3	1M09G7D	QPSK	22.57	0.181	24.72	0.296
LTE Band 5	824.7 ~ 848.3	1M09W7D	16QAM	21.70	0.148	23.85	0.243

Mode	TX Frequency (MHz)	Emission Designator	Modulation	EIRP(FCC & IC)	
				Max power(dBm)	Max power(W)
LTE Band 4	1720 ~ 1745	17M9G7D	QPSK	23.07	0.203
LTE Band 4	1720 ~ 1745	18M0W7D	16QAM	22.56	0.180
LTE Band 4	1717.5 ~ 1747.5	13M5G7D	QPSK	23.34	0.216
LTE Band 4	1717.5 ~ 1747.5	13M4W7D	16QAM	22.72	0.187
LTE Band 4	1715 ~ 1750	8M97G7D	QPSK	23.05	0.202
LTE Band 4	1715 ~ 1750	8M96W7D	16QAM	22.43	0.175
LTE Band 4	1712.5 ~ 1752.5	4M49G7D	QPSK	22.45	0.176
LTE Band 4	1712.5 ~ 1752.5	4M48W7D	16QAM	21.78	0.151
LTE Band 4	1711.5 ~ 1753.5	2M70G7D	QPSK	23.02	0.200
LTE Band 4	1711.5 ~ 1753.5	2M69W7D	16QAM	22.33	0.171
LTE Band 4	1710.7 ~ 1754.3	1M08G7D	QPSK	22.34	0.171
LTE Band 4	1710.7 ~ 1754.3	1M09W7D	16QAM	21.66	0.147
LTE Band 2	1860 ~ 1900	17M9G7D	QPSK	23.47	0.222
LTE Band 2	1860 ~ 1900	17M9W7D	16QAM	22.63	0.183
LTE Band 2	1857.5 ~ 1902.5	13M4G7D	QPSK	24.53	0.284
LTE Band 2	1857.5 ~ 1902.5	13M4W7D	16QAM	23.97	0.249
LTE Band 2	1855 ~ 1905	8M95G7D	QPSK	24.36	0.273
LTE Band 2	1855 ~ 1905	8M93W7D	16QAM	23.72	0.236
LTE Band 2	1852.5 ~ 1907.5	4M49G7D	QPSK	23.91	0.246
LTE Band 2	1852.5 ~ 1907.5	4M48W7D	16QAM	23.18	0.208
LTE Band 2	1851.5 ~ 1908.5	2M70G7D	QPSK	23.29	0.213
LTE Band 2	1851.5 ~ 1908.5	2M69W7D	16QAM	22.02	0.159
LTE Band 2	1850.7 ~ 1909.3	1M08G7D	QPSK	22.81	0.191
LTE Band 2	1850.7 ~ 1909.3	1M09W7D	16QAM	22.40	0.174
LTE Band 41	2506 ~ 2680	17M8G7D	QPSK	24.54	0.284
LTE Band 41	2506 ~ 2680	17M8W7D	16QAM	23.69	0.234
LTE Band 41	2503.5 ~ 2682.5	13M3G7D	QPSK	23.83	0.242
LTE Band 41	2503.5 ~ 2682.5	13M2W7D	16QAM	22.93	0.196
LTE Band 41	2501 ~ 2685	8M85G7D	QPSK	23.54	0.226
LTE Band 41	2501 ~ 2685	8M88W7D	16QAM	22.63	0.183
LTE Band 41	2498.5 ~ 2687.5	4M47G7D	QPSK	23.85	0.243
LTE Band 41	2498.5 ~ 2687.5	4M46W7D	16QAM	22.97	0.198
LTE Band 7	2510 ~ 2560	17M9G7D	QPSK	22.54	0.179
LTE Band 7	2510 ~ 2560	17M9W7D	16QAM	21.98	0.158
LTE Band 7	2507.5 ~ 2562.5	13M4G7D	QPSK	22.52	0.179
LTE Band 7	2507.5 ~ 2562.5	13M4W7D	16QAM	21.80	0.151
LTE Band 7	2505 ~ 2565	8M98G7D	QPSK	22.36	0.172
LTE Band 7	2505 ~ 2565	8M97W7D	16QAM	21.99	0.158
LTE Band 7	2502.5 ~ 2567.5	4M49G7D	QPSK	22.14	0.164
LTE Band 7	2502.5 ~ 2567.5	4M48W7D	16QAM	21.68	0.147

2. INTRODUCTION

2.1 EUT DESCRIPTION

The Equipment Under Test (EUT) supports GSM/WCDMA/LTE Phone with Bluetooth, WLAN, NFC.

2.2. EUT CAPABILITIES

This EUT contains the following capabilities:

850/1900 GSM/EDGE, 850/1700/1900 WCDMA/HSUPA, Multi-band LTE, 802.11b/g/n/ac WLAN(2.4GHz)
802.11a/n/ac WLAN(5GHz), Bluetooth(BDR, EDR, LE), NFC.

2.3. TESTING ENVIRONMENT

Ambient Condition	
▪ Temperature	+21 °C ~ +27 °C
▪ Relative Humidity	40 % ~ 47 %

2.4 MEASURING INSTRUMENT CALIBRATION

The measuring equipment, which was utilized in performing the tests documented herein, has been calibrated in accordance with the manufacturer's recommendations for utilizing calibration equipment, which is traceable to recognized national standards.

2.5. MEASUREMENT UNCERTAINTY

The measurement uncertainties shown below were calculated in accordance with requirements of ANSI C 63.4-2014. All measurement uncertainty values are shown with a coverage factor of $k = 2$ to indicate a 95 % level of confidence.

Parameter	Measurement uncertainty
Radiated Disturbance (Below 1 GHz)	5.1 dB (The confidence level is about 95 %, $k = 2$)
Radiated Disturbance (1 GHz ~ 18 GHz)	5.4 dB (The confidence level is about 95 %, $k = 2$)
Radiated Disturbance (Above 18 GHz)	5.3 dB (The confidence level is about 95 %, $k = 2$)

2.6. TEST FACILITY

DT&C Co., Ltd.	
The 3 m test site and conducted measurement facility used to collect the radiated data are located at the 42, Yurim-ro, 154beon-gil, Cheoin-gu, Yongin-si, Gyeonggi-do, Korea 17042.	
The test site complies with the requirements of § 2.948 according to ANSI 63.4-2014.	
- FCC MRA Accredited Test Firm No. : KR0034	
- IC Test site No. : 5740A-4	
www.dtnet.net	
Telephone	: + 82-31-321-2664
FAX	: + 82-31-321-1664

3. DESCRIPTION OF TESTS

3.1 ERP & EIRP (Effective Radiated Power & Equivalent Isotropic Radiated Power)

Test Set-up

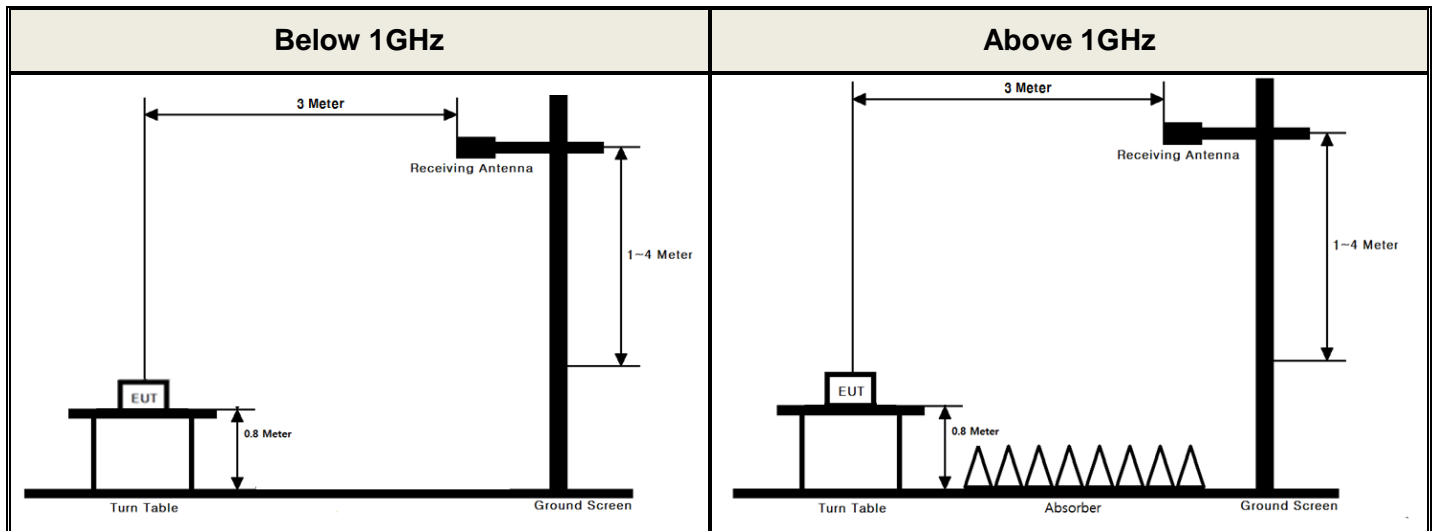

These measurements were performed at 3 m test site. The equipment under test is placed on a non-conductive table 0.8-meters above a turntable which is flush with the ground plane and 3 meters from the receive antenna. For measurements above 1GHz absorbers are placed on the floor between the turn table and the antenna mast in such a way so as to maximize the reduction of reflections. For measurements below 1 GHz, the absorbers are removed.

Test Procedure

- ANSI/TIA-603-E-2016 - Section 2.2.17
- KDB971168 D01v03 - Section 5.2.2
- ANSI C63.26-2015 – Section 5.2.4.4.1

Test setting

1. Set span to 2 x to 3 x the OBW.
2. Set RBW = 1% to 5% of the OBW.
3. Set VBW \geq 3 x RBW.
4. Set number of points in sweep \geq 2 x span / RBW.
5. Sweep time:
 - 1) Set = auto-couple, or
 - 2) Set \geq [10 x (number of points in sweep) x (transmission period)] for single sweep (automation-compatible) measurement. Transmission period is the on and off time of the transmitter.
6. Detector = power averaging (rms).
7. If the EUT can be configured to transmit continuously, then set the trigger to free run.
8. If the EUT cannot be configured to transmit continuously, then use a sweep trigger with the level set to enable triggering only on full power bursts and configure the EUT to transmit at full power for the entire duration of each sweep. Verify that the sweep time is less than or equal to the transmission burst duration. Time gating can also be used under similar constraints (i.e., configured such that measurement data is collected only during active full-power transmissions).
9. Trace average at least 100 traces in power averaging (rms) mode if sweep is set to auto-couple. To accurately determine the average power over multiple symbols, it can be necessary to increase the number of traces to be averaged above 100 or, if using a manually configured sweep time, increase the sweep time.

10. Compute the power by integrating the spectrum across the OBW of the signal using the instrument's band or channel power measurement function, with the band/channel limits set equal to the OBW band edges. If the instrument does not have a band or channel power function, then sum the spectrum levels (in linear power units) at intervals equal to the RBW extending across the entire OBW of the spectrum.

The receiver antenna height and turntable rotations were adjusted for the highest reading on the receive spectrum analyzer.

A half-wave dipole was substituted in place of the EUT. This dipole antenna was driven by a signal generator and the level of the signal generator was adjusted to obtain the same receive spectrum analyzer reading. The conducted power at the terminal of the substitute antenna is measured.

The ERP/EIRP is calculated using the following formula:

ERP/EIRP = The conducted power at the substitute antenna's terminal [dBm] + Substitute Antenna gain [dBd for ERP , dBi for EIRP]

For readings above 1 GHz, the above procedure is repeated using horn antennas and the difference between the gain of the horn antenna and an isotropic antenna are taken into consideration.

3.2 PEAK TO AVERAGE RATIO

Test set-up

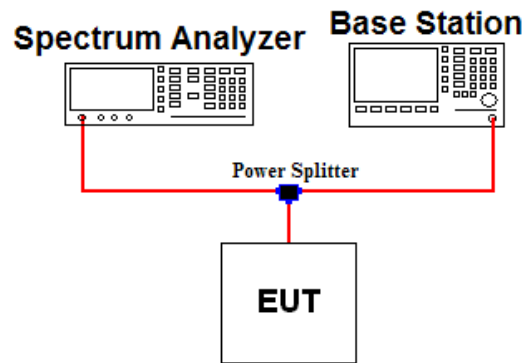

Test Procedure

- KDB971168 D01v03 - Section 5.7.2
- ANSI C63.26-2015 – Section 5.2.3.4

A peak to average ratio measurement is performed at the conducted port of the EUT.

The spectrum analyzers Complementary Cumulative Distribution Function (CCDF) measurement profile is used to determine the largest deviation between the average and the peak power of the EUT in a given bandwidth. The CCDF curve shows how much time the peak waveform spends at or above a given average power level. The present of time the signal spends at or above the level defines the probability for that particular power level.

Test setting

The spectrum Analyzer's CCDF measurement function is enabled.

1. Set resolution/measurement bandwidth \geq OBW or specified reference bandwidth.
2. Set the number of counts to a value that stabilizes the measured CCDF curve.
3. Set the measurement interval as follows:
 - 1) For continuous transmissions, set to the greater of $[10 \times (\text{number of points in sweep}) \times (\text{transmission symbol period})]$ or 1 ms.
 - 2) For burst transmissions, employ an external trigger that is synchronized with the EUT burst timing sequence, or use the internal burst trigger with a trigger level that allows the burst to stabilize. Set the measurement interval to a time that is less than or equal to the burst duration.
 - 3) If there are several carriers in a single antenna port, the peak power shall be determined for each individual carrier (by disabling the other carriers while measuring the required carrier) and the total peak power calculated from the sum of the individual carrier peak powers.
4. Record the maximum PAPR level associated with a probability of 0.1%.
5. The peak power level is calculated from the sum of the PAPR value from step d) to the measured average power.

3.3 OCCUPIED BANDWIDTH.

Test set-up

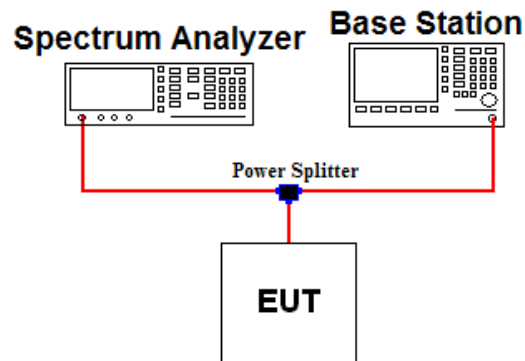

Test Procedure

- KDB971168 D01v03 - Section 4.3
- ANSI C63.26-2015 – Section 5.4.4

The occupied bandwidth, that is the frequency bandwidth such that, below its lower and above its upper frequency limits, the mean powers radiated are each equal to 0.5 percent of the total mean power of a given emission.

Test setting

1. The signal analyzer's automatic bandwidth measurement capability was used to perform the 99 % occupied bandwidth and the 26 dB bandwidth. The bandwidth measurement was not influenced by any intermediate power nulls in the fundamental emission.
2. $RBW = 1 \sim 5 \%$ of the expected OBW & $VBW \geq 3 \times RBW$
3. Detector = Peak
4. Trance mode = Max hold
5. Sweep = Auto couple
6. The trace was allowed to stabilize
7. If necessary, step 2 ~ 6 were repeated after changing the RBW such that it would be within 1 ~ 5 % of the 99 % occupied bandwidth observed in step 6.

3.4 BAND EDGE EMISSIONS AT ANTENNA TERMINAL

Test set-up

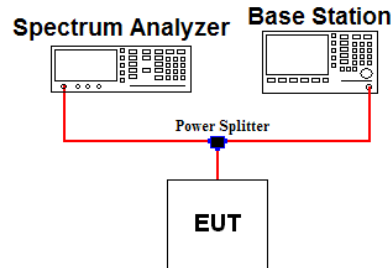

Test Procedure

- KDB971168 D01v03 - Section 6
- ANSI C63.26-2015 – Section 5.7

All out of band emissions are measured by means of a calibrated spectrum analyzer. The EUT was setup to maximum output power at its lowest and highest channel with all bandwidths, modulations and RB configurations.

The power of any spurious emission shall be attenuated below the transmitter power (P) by at least $43 + 10 \log(P)$ dB.

Test setting

1. Start and stop frequency were set such that the band edge would be placed in the center of the plot
2. Span was set large enough so as to capture all out of band emissions near the band edge
3. RBW $\geq 1\%$ of the emission bandwidth
4. VBW $\geq 3 \times$ RBW
5. Detector = RMS & Trace mode = Max hold
6. Sweep time = Auto couple or 1 s for band edge
7. Number of sweep point $\geq 2 \times$ span / RBW
8. The trace was allowed to stabilize

Note 1: Per Part 22.917(b)(1) / 24.238(b) / 27.53(h) in the 1 MHz bands immediately outside and adjacent to the frequency block a resolution bandwidth of at least one percent of the emission bandwidth of the fundamental emission of the transmitter may be employed to demonstrate compliance with the out-of-band emissions limit.

The emission bandwidth is defined as the width of the signal between two points, one below the carrier center frequency and one above the carrier center frequency, outside of which all emission are attenuated at least 26 dB below the transmitter power.

Note 2: Per Part 27(g) for operations in the 600 MHz band and the 698-746 MHz band, compliance with this provision is based on the use of measurement instrumentation employing a resolution bandwidth of 100 kilohertz or greater. However, in the 100 kilohertz bands immediately outside and adjacent to a licensee's frequency block, a resolution bandwidth of at least 30 kHz may be employed.

Note 3: Per Part 27.53(c.4) for all frequencies between 763-775 MHz and 793-805 MHz, the FCC limit is $65 + 10 \log_{10}(P[\text{Watts}]) = -35 \text{ dBm}$ in a 6.25 kHz bandwidth.

Note 4: For part 27.53(m)(4) the attenuation factor shall be not less than $40 + 10 \log(P)$ dB on all frequencies between the channel edge and 5 megahertz from the channel edge, $43 + 10 \log(P)$ dB on all frequencies between 5 megahertz and X megahertz from the channel edge, and $55 + 10 \log(P)$ dB on all frequencies more than X megahertz from the channel edge, where X is the greater of 6 megahertz or the actual emission bandwidth as defined in paragraph (m)(6) of this section. In addition, the attenuation factor shall not be less than $43 + 10 \log(P)$ dB on all frequencies between 2490.5 MHz and 2496 MHz and $55 + 10 \log(P)$ dB at or below 2490.5 MHz.

Note 5: Per part 27.53(m)(6) in the 1 MHz bands immediately outside and adjacent to the frequency block a resolution bandwidth of at least two percent may be employed, except when the 1 MHz band is 2495-2496 MHz, in which case a resolution bandwidth of at least one percent may be employed.

Note 6: Per Part 90.543(e) for operations in the 758-768 MHz and the 788-798 MHz bands, the power of any emission outside the licensee's frequency band(s) of operation shall be attenuated below the transmitter power (P) within the licensed band(s) of operation, measured in watts, in accordance with the following:

- (1) On all frequencies between 769-775 MHz and 799-805 MHz, by a factor not less than $76 + 10 \log (P)$ dB in a 6.25 kHz band segment, for base and fixed stations.
- (2) On all frequencies between 769-775 MHz and 799-805 MHz, by a factor not less than $65 + 10 \log (P)$ dB in a 6.25 kHz band segment, for mobile and portable stations.
- (3) On any frequency between 775-788 MHz, above 805 MHz, and below 758 MHz, by at least $43 + 10 \log (P)$ dB.
- (4) Compliance with the provisions of paragraphs (e)(1) and (2) of this section is based on the use of measurement instrumentation such that the reading taken with any resolution bandwidth setting should be adjusted to indicate spectral energy in a 6.25 kHz segment.
- (5) Compliance with the provisions of paragraph (e)(3) of this section is based on the use of measurement instrumentation employing a resolution bandwidth of 100 kHz or greater. However, in the 100 kHz bands immediately outside and adjacent to the frequency block, a resolution bandwidth of 30 kHz may be employed.

3.5 SPURIOUS AND HARMONIC EMISSIONS AT ANTENNA TERMINAL

Test set-up

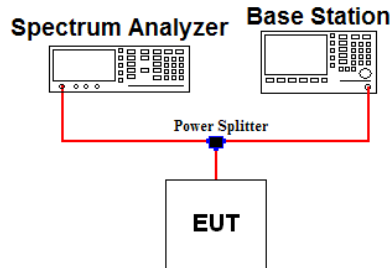

Test Procedure

- KDB971168 D01v03 - Section 6
- ANSI C63.26-2015 – Section 5.7

The level of the carrier and the various conducted spurious and harmonic frequencies is measured by means of a calibrated spectrum analyzer. The EUT was setup to maximum output power at its low, middle, high channel with all bandwidths, modulations and RB configurations. The spectrum is scanned from 9 kHz up to a frequency including its 10th harmonic.

The power of any spurious emission shall be attenuated below the transmitter power (P) by at least $43 + 10 \log(P)$ dB.

Test setting

1. RBW = 100 kHz (Below 1 GHz) or 1 MHz (Above 1 GHz) & VBW $\geq 3 \times$ RBW (Refer to Note 1)
2. Detector = RMS & Trace mode = Max hold
3. Sweep time = Auto couple
4. Number of sweep point $\geq 2 \times$ span / RBW
5. The trace was allowed to stabilize

Note 1: Compliance with these provisions is based on the use of measurement instrumentation employing a resolution bandwidth of 100 kHz or greater for frequencies less than 1GHz and 1MHz or greater for frequencies greater than 1GHz.

3.6 UNDESIRABLE EMISSIONS

Test Set-up

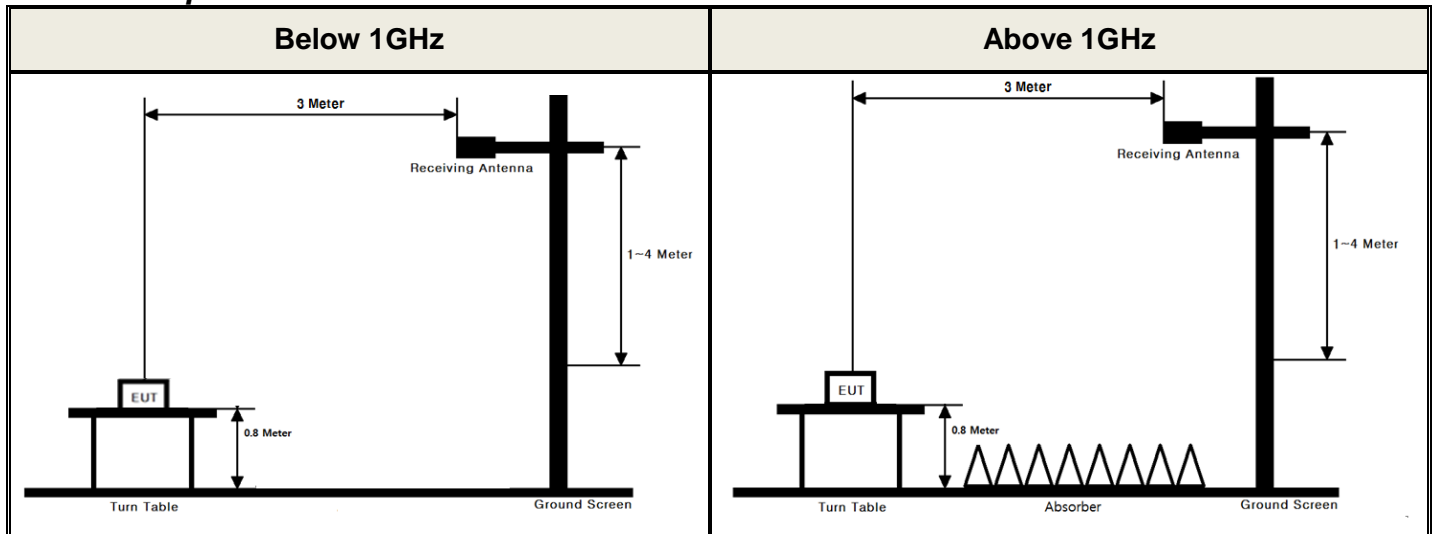

These measurements were performed at 3 test site. The equipment under test is placed on a non-conductive table 0.8-meters above a turntable which is flush with the ground plane and 3 meters from the receive antenna. For measurements above 1 GHz absorbers are placed on the floor between the turn table and the antenna mast in such a way so as to maximize the reduction of reflections. For measurements below 1 GHz, the absorbers are removed.

Test Procedure

- ANSI/TIA-603-E-2016 - Section 2.2.12
- KDB971168 D01v03 - Section 5.8
- ANSI C63.26-2015 – Section 5.5

Test setting

1. RBW = 100 kHz for below 1 GHz and 1 MHz for above 1 GHz / VBW \geq 3 X RBW
2. Detector = RMS & Trace mode = Max hold
3. Sweep time = Auto couple
4. Number of sweep point \geq 2 X span / RBW
5. The trace was allowed to stabilize

The receive antenna height and turntable rotations were adjusted for the highest reading on the receive spectrum analyzer.

For radiated power measurements below 1 GHz, a half-wave dipole was substituted in place of the EUT. This dipole antenna was driven by a signal generator and the level of the signal generator was adjusted to obtain the same spectrum analyzer reading.

For radiated power measurements above 1 GHz, a Horn antenna was substituted in place of the EUT. This Horn antenna was driven by a signal generator and the level of the signal generator was adjusted to obtain the same spectrum analyzer reading. The difference between the gain of the horn and an isotropic antenna are taken into consideration.

This measurement was performed with the EUT oriented in 3 orthogonal axis.

3.7 FREQUENCY STABILITY

Test Set-up

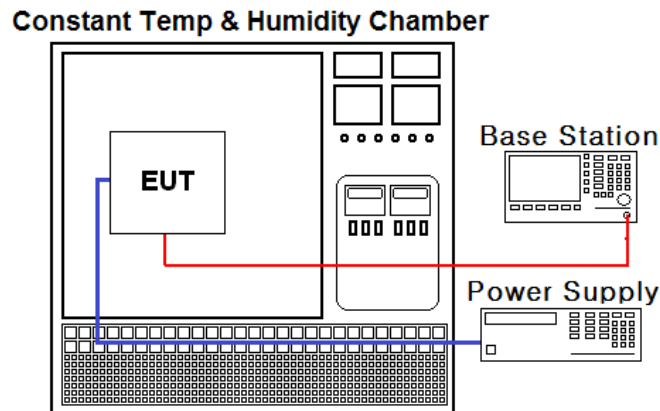

Test Procedure

- ANSI/TIA-603-E-2016
- KDB971168 D01v03 - Section 9

The frequency stability of the transmitter is measured by:

a.) **Temperature:**

The temperature is varied from - 30 °C to + 50 °C using an environmental chamber.

b.) **Primary Supply Voltage:**

The primary supply voltage is varied from 85 % to 115 % of the nominal value for non hand-carried battery and AC powered equipment. For hand-carried, battery-powered equipment, primary supply voltage is reduced to the battery operating end point which shall be specified by the manufacturer.

Specification:

The frequency stability shall be sufficient to ensure that the fundamental emission stays within the authorized frequency block for Part 24, 27. The frequency stability of the transmitter shall be maintained within $\pm 0.00025\%$ (± 2.5 ppm) of the center frequency for Part 22.

Time Period and Procedure:

1. The carrier frequency of the transmitter is measured at room temperature.
(20 °C to provide a reference)
2. The equipment is turned on in a "standby" condition for one minute before applying power to the transmitter. Measurement of the carrier frequency of the transmitter is made within one minute after applying power to the transmitter.
3. Frequency measurements are made at 10 °C intervals ranging from -30 °C to +50 °C.
A period of at least one half-hour is provided to allow stabilization of the equipment at each temperature level.

4. LIST OF TEST EQUIPMENT

Type	Manufacturer	Model	Cal.Date (yy/mm/dd)	Next.Cal. Date (yy/mm/dd)	S/N
Spectrum Analyzer	Agilent Technologies	N9020A	18/07/09	19/07/09	MY46471251
Spectrum Analyzer	Agilent Technologies	N9020A	18/07/09	19/07/09	MY50410163
Spectrum Analyzer	Agilent Technologies	N9020A	17/12/28 18/12/19	18/12/28 19/12/19	MY49060056
Spectrum Analyzer	Agilent Technologies	N9030A	18/07/09	19/07/09	MY53310140
DC power supply	Agilent Technologies	66332A	18/07/02	19/07/02	MY43001172
Multimeter	FLUKE	17B	17/12/26 18/12/18	18/12/26 19/12/18	26030065WS
Power Splitter	Anritsu	K241B	17/12/27 18/12/19	18/12/27 19/12/19	016681
Temp & Humi	SJ Science	SJ-TH-S50	18/07/06	19/07/06	U5542113
Radio Communication Analyzer	Anritsu	MT8820C	18/07/03	19/07/03	6200978101
Thermohygrometer	BODYCOM	BJ5478	18/01/03 18/12/27	19/01/03 19/12/27	120612-2
Thermohygrometer	BODYCOM	BJ5478	18/01/03 18/12/27	19/01/03 19/12/27	120612-1
Signal Generator	Rohde Schwarz	SMBV100A	17/12/27 18/12/19	18/12/27 19/12/19	255571
Signal Generator	Rohde Schwarz	SMF100A	18/06/07	19/06/07	102341
Loop Antenna	Schwarzbeck	FMZB1513	18/01/30	20/01/30	1513-128
Bilog Antenna	Schwarzbeck	VULB 9160	18/07/13	20/07/13	3359
Dipole Antenna	Schwarzbeck	VHA9103	17/03/14	19/03/14	2116
Dipole Antenna	Schwarzbeck	VHA9103	18/04/13	20/04/13	2117
Dipole Antenna	Schwarzbeck	UHA9105	17/03/14	19/03/14	2261
Dipole Antenna	Schwarzbeck	UHA9105	18/04/13	20/04/13	2262
HORN ANT	ETS	3117	18/05/10	20/05/10	00140394
HORN ANT	ETS	3117	18/03/26	20/03/26	00152145
HORN ANT	A.H.Systems	SAS-574	17/04/25	19/04/25	154
HORN ANT	A.H.Systems	SAS-574	17/07/31	19/07/31	155
Amplifier	RF Bay Inc	MPA-40-40	17/12/28 18/12/20	18/12/28 19/12/20	21151801
Amplifier	EMPOWER	BBS3Q7ELU	18/07/10	19/07/10	1020
PreAmplifier	H.P	8447D	17/12/26 18/12/18	18/12/26 19/12/18	2944A07774
PreAmplifier	Agilent	8449B	18/07/05	19/07/05	3008A02108
PreAmplifier	A.H.Systems Inc.	PAM-1840VH	18/07/06	19/07/17	163
High-pass filter	Wainwright	WHKX12-935-1000-15000-40SS	18/07/05	19/07/05	7
High-pass filter	Wainwright	WHKX12-2580-3000-18000-80SS	18/07/05	19/07/05	3
High-pass filter	Wainwright	WHNX8.5/26.5G-6SS	18/07/03	19/07/03	1
Cable	DTNC	Cable	18/07/06	19/07/06	M-01
Cable	DTNC	Cable	18/07/06	19/07/06	M-02
Cable	Junkosha	MWX315	18/11/19	19/11/19	M-05
Cable	Junkosha	MWX221	18/11/19	19/11/19	M-06
Cable	Junkosha	MWX241	18/06/25	19/06/25	G-04
Cable	Junkosha	MWX241	18/06/25	19/06/25	G-07
Cable	Radiall	Cable	18/07/05	19/07/05	RF-84

Note1: The measurement antennas were calibrated in accordance to the requirements of ANSI C63.5-2017.

Note2: The cable is not a regular calibration item, so it has been calibrated by DT & C itself.

5. SUMMARY OF TEST RESULTS

FCC Part Section(s)	RSS Section(s)	Test Description	Test Limit	Test Condition	Status Note 1
2.1046	-	Conducted Output Power	N/A	Conducted	C Note2
2.1049	RSS-GEN[6.7]	Occupied Bandwidth	N/A		C
24.232(d) 27.50(d.5)	RSS-130 [4.6] RSS-132 [5.4] RSS-133 [6.4] RSS-139 [6.5] RSS-140 [4.3] RSS-199 [4.4]	Peak to Average Ratio	< 13 dB		C
2.1051 22.917(a) 24.238(a) 27.53(c) 27.53(g) 27.53(h)	RSS-130 [4.7] RSS-132 [5.5] RSS-133 [6.5] RSS-139 [6.6]	Band Edge / Conducted Spurious Emissions	> 43 + 10log ₁₀ (P) dB at Band edge and for all out-of-band emissions		C
27.53(c.4)	RSS-130 [4.7.2]	Undesirable Emissions in 763 ~ 775MHz & 793 ~ 805MHz	< 65 + 10 log ₁₀ (P) dB		
27.53(m)	RSS-199 [4.5]	Band Edge / Conducted Spurious Emissions	> 40 + 10log ₁₀ (P) dB at channel edge and 5 MHz from the channel edge > 43 + 10log ₁₀ (P) dB at 5 MHz and X MHz from the channel edge > 55 + 10log ₁₀ (P) dB at all frequencies more than X MHz from the channel edge		C
90.543(e)	RSS-140 [4.4]	Band Edge / Conducted Spurious Emissions	On all frequencies between 769-775 MHz and 799-805 MHz, by a factor not less than > 65 + 10 log (P) dB in a 6.25 kHz On any frequency between 775-788 MHz, above 805 MHz, and below 758 MHz, by at least > 43 + 10 log (P) dB.		
2.1055 22.355 24.235 27.54 90.213	RSS-130 [4.5] RSS-132 [5.3] RSS-133 [6.3] RSS-139 [6.4] RSS-140 [4.2] RSS-199 [4.3]	Frequency Stability	< 2.5 ppm (Part 22) or Fundamental emissions must stay within Authorized frequency block (Part 24, 27, 90)		C
27.50(b.10) 27.50(c.10) 90.524(a.7)	RSS-130 [4.6] RSS-140 [4.3]	Radiated Output Power (B12, 13, 14, 17)	< 3 Watts max. ERP (FCC & IC)	Radiated	C
22.913(a.5)	RSS-132 [5.4]	Radiated Output Power (B5)	< 7 Watts max. ERP (FCC) < 11.5 Watts max. EIRP (IC)		C
27.50(d.4)	RSS-139 [6.5]	Radiated Output Power (B4)	< 1 Watts max. EIRP (FCC & IC)		C
24.232(c) 27.50(h.2)	RSS-133 [6.4] RSS-199 [4.4]	Radiated Output Power (B2, 7, 41)	< 2 Watts max. EIRP (FCC & IC)		C
2.1053 22.917(a) 24.238(a) 27.53(c) 27.53(g) 27.53(h) 90.543(e)	RSS-130 [4.7] RSS-132 [5.5] RSS-133 [6.5] RSS-139 [6.6] RSS-140 [4.4]	Undesirable Emissions	> 43 + 10log ₁₀ (P) dB for all out-of-band emissions		C
27.53(m)	RSS-199 [4.5]	Undesirable Emissions (B7, 41)	> 55 + 10log ₁₀ (P) dB for all out-of-band emissions		C
27.53(f) 90.543(f)	RSS-130 [4.7.2] RSS-140 [4.4]	Undesirable Emissions in 1559 ~ 1610MHz	< -70 dBW/MHz (for wideband signals) < -80 dBW (for discrete emissions of less than 700 Hz bandwidth)		C

Note 1: **C**=Comply **NC**=Not Comply **NT**=Not Tested **NA**=Not Applicable
 Note 2: Refer to RF Exposure Report (Test Report SAR)

6. SAMPLE CALCULATION

A. Emission Designator

LTE Band 12, 17(QPSK)

Emission Designator = **8M96G7D**
LTE OBW = 8.962 MHz
G = Phase Modulation
7 = Quantized/Digital Info
D = Data Transmission

LTE Band 13(QPSK)

Emission Designator = **8M90G7D**
LTE OBW = 8.904 MHz
G = Phase Modulation
7 = Quantized/Digital Info
D = Data Transmission

LTE Band 14(QPSK)

Emission Designator = **8M91G7D**
LTE OBW = 8.909 MHz
G = Phase Modulation
7 = Quantized/Digital Info
D = Data Transmission

LTE Band 5(QPSK)

Emission Designator = **8M98G7D**
LTE OBW = 8.976 MHz
G = Phase Modulation
7 = Quantized/Digital Info
D = Data Transmission

LTE Band 4(QPSK)

Emission Designator = **17M9G7D**
LTE OBW = 17.931 MHz
G = Phase Modulation
7 = Quantized/Digital Info
D = Data Transmission

LTE Band 2(QPSK)

Emission Designator = **17M9G7D**
LTE OBW = 17.895 MHz
G = Phase Modulation
7 = Quantized/Digital Info
D = Data Transmission

LTE Band 12, 17(16QAM)

Emission Designator = **8M94W7D**
LTE OBW = 8.937 MHz
W = Amplitude/Angle Modulated
7 = Quantized/Digital Info
D = Data Transmission

LTE Band 13(16QAM)

Emission Designator = **8M92W7D**
LTE OBW = 8.922 MHz
W = Amplitude/Angle Modulated
7 = Quantized/Digital Info
D = Data Transmission

LTE Band 14(16QAM)

Emission Designator = **8M94W7D**
LTE OBW = 8.935 MHz
W = Amplitude/Angle Modulated
7 = Quantized/Digital Info
D = Data Transmission

LTE Band 5(16QAM)

Emission Designator = **8M94W7D**
LTE OBW = 8.935 MHz
W = Amplitude/Angle Modulated
7 = Quantized/Digital Info
D = Data Transmission

LTE Band 4(16QAM)

Emission Designator = **18M0W7D**
LTE OBW = 17.963 MHz
W = Amplitude/Angle Modulated
7 = Quantized/Digital Info
D = Data Transmission

LTE Band 2(16QAM)

Emission Designator = **17M9W7D**
LTE OBW = 17.878 MHz
W = Amplitude/Angle Modulated
7 = Quantized/Digital Info
D = Data Transmission

LTE Band 41(QPSK)

Emission Designator = **17M8G7D**
 LTE OBW = 17.814 MHz
 G = Phase Modulation
 7 = Quantized/Digital Info
 D = Data Transmission

LTE Band 7(QPSK)

Emission Designator = **17M9G7D**
 LTE OBW = 17.895 MHz
 G = Phase Modulation
 7 = Quantized/Digital Info
 D = Data Transmission

LTE Band 41(16QAM)

Emission Designator = **17M8W7D**
 LTE OBW = 17.784 MHz
 W = Amplitude/Angle Modulated
 7 = Quantized/Digital Info
 D = Data Transmission

LTE Band 7(16QAM)

Emission Designator = **17M9W7D**
 LTE OBW = 17.888 MHz
 W = Amplitude/Angle Modulated
 7 = Quantized/Digital Info
 D = Data Transmission

B. For substitution method

EIRP for Band 41

Channel Bandwidth (MHz)	Test Frequency (MHz)	Test Mode	RB Size/ Offset	Spectrum Reading Value(dBm)	EUT Axis	Ant Pol (H/V)	Level(dBm) @ Ant Terminal	TX Ant Gain (dBi)	EIRP (dBm)	EIRP (W)
20	2593	QPSK	1/50	-24.10	X	H	18.63	5.91	24.54	0.284

ERP or EIRP = Level @ Ant Terminal LEVEL(dBm) + Tx Ant. Gain

- 1) The EUT mounted on a non-conductive turntable is 0.8 meter above test site ground level.
- 2) During the test, the turn table is rotated until the maximum signal is found.
- 3) Record the field strength meter's level.
- 4) Replace the EUT with dipole/Horn antenna that is connected to a calibrated signal generator.
- 5) Increase the signal generator output till the field strength meter's level is equal to the item (3).
- 6) The signal generator output level with substituted antenna gain is the rating of ERP, EIRP or Radiated spurious emission.

7. TEST DATA

7.1 OCCUPIED BANDWIDTH

- Plots of the EUT's Occupied Bandwidth are shown in Clause 8.1

7.2 PEAK TO AVERAGE RATIO

- Plots of the EUT's Peak- to- Average Ratio are shown in Clause 8.2

7.3 BAND EDGE EMISSIONS (Conducted)

- Plots of the EUT's Band Edge Emissions are shown in Clause 8.3

7.4 SPURIOUS AND HARMONICS EMISSIONS (Conducted)

- Plots of the EUT's Spurious Emissions are shown in Clause 8.4

7.5 ERP & EIRP

7.5.1 LTE Band 12, 17

Channel Bandwidth (MHz)	Test Frequency (MHz)	Test Mode	RB Size/ Offset	Ant Pol (H/V)	Level(dBm) @ Ant Terminal	TX Ant Gain (dBd)	ERP (dBm)	ERP (W)
10	704	QPSK	1/0	H	22.00	1.28	23.28	0.213
		16QAM	1/0	H	20.27	1.28	21.55	0.143
	711	QPSK	1/0	H	21.66	1.28	22.94	0.197
		16QAM	1/0	H	20.49	1.28	21.77	0.150
5	701.5	QPSK	1/12	H	20.68	1.28	21.96	0.157
		16QAM	1/12	H	19.42	1.28	20.70	0.117
	707.5	QPSK	1/12	H	20.70	1.28	21.98	0.158
		16QAM	1/12	H	19.95	1.28	21.23	0.133
	713.5	QPSK	1/12	H	19.87	1.28	21.15	0.130
		16QAM	1/12	H	19.16	1.28	20.44	0.111

Note: This device was tested under all bandwidths, modulations and RB configurations and the worst case data are reported in the table above.

7.5.2 LTE Band 12

Channel Bandwidth (MHz)	Test Frequency (MHz)	Test Mode	RB Size/ Offset	Ant Pol (H/V)	Level(dBm) @ Ant Terminal	TX Ant Gain (dBd)	ERP (dBm)	ERP (W)
3	700.5	QPSK	1/0	H	19.93	1.28	21.21	0.132
		16QAM	1/0	H	19.68	1.28	20.96	0.125
	707.5	QPSK	1/0	H	20.61	1.28	21.89	0.155
		16QAM	1/0	H	20.20	1.28	21.48	0.141
	714.5	QPSK	1/0	H	19.84	1.28	21.12	0.129
		16QAM	1/0	H	19.31	1.28	20.59	0.115
1.4	699.7	QPSK	1/2	H	19.85	1.28	21.13	0.130
		16QAM	1/2	H	19.33	1.28	20.61	0.115
	707.5	QPSK	1/2	H	20.71	1.28	21.99	0.158
		16QAM	1/2	H	19.71	1.28	20.99	0.126
	715.3	QPSK	1/2	H	19.32	1.28	20.60	0.115
		16QAM	1/2	H	18.96	1.28	20.24	0.106

Note: This device was tested under all bandwidths, modulations and RB configurations and the worst case data are reported in the table above.

7.5.3 LTE Band 13

Channel Bandwidth (MHz)	Test Frequency (MHz)	Test Mode	RB Size/ Offset	Ant Pol (H/V)	Level(dBm) @ Ant Terminal	TX Ant Gain (dBd)	ERP (dBm)	ERP (W)
10	782	QPSK	1/49	H	18.73	1.26	19.99	0.100
		16QAM	1/49	H	18.15	1.26	19.41	0.087
5	779.5	QPSK	1/12	H	18.01	1.26	19.27	0.085
		16QAM	1/12	H	17.16	1.26	18.42	0.070
	784.5	QPSK	1/12	H	18.99	1.25	20.24	0.106
		16QAM	1/12	H	17.93	1.25	19.18	0.083

Note: This device was tested under all bandwidths, modulations and RB configurations and the worst case data are reported in the table above.

7.5.4 LTE Band 14

Channel Bandwidth (MHz)	Test Frequency (MHz)	Test Mode	RB Size/ Offset	Ant Pol (H/V)	Level(dBm) @ Ant Terminal	TX Ant Gain (dBd)	ERP (dBm)	ERP (W)
10	793	QPSK	1/25	H	19.99	1.25	21.24	0.133
		16QAM	1/25	H	19.59	1.25	20.84	0.121
5	790.5	QPSK	1/24	H	20.17	1.25	21.42	0.139
		16QAM	1/24	H	19.50	1.25	20.75	0.119
	795.5	QPSK	1/24	H	21.22	1.25	22.47	0.177
		16QAM	1/24	H	20.67	1.25	21.92	0.156

Note: This device was tested under all bandwidths, modulations and RB configurations and the worst case data are reported in the table above.

7.5.5 LTE Band 5

Channel Bandwidth (MHz)	Test Frequency (MHz)	Test Mode	RB Size/ Offset	Ant Pol (H/V)	Level(dBm) @ Ant Terminal	TX Ant Gain (dBd)	ERP (dBm)	ERP (W)
10	829	QPSK	1/0	H	19.64	1.23	20.87	0.122
		16QAM	1/0	H	19.02	1.23	20.25	0.106
	836.5	QPSK	1/0	H	20.18	1.22	21.40	0.138
		16QAM	1/0	H	19.51	1.22	20.73	0.118
	844	QPSK	1/0	H	21.32	1.21	22.53	0.179
		16QAM	1/0	H	20.61	1.21	21.82	0.152
5	826.5	QPSK	1/24	H	19.87	1.23	21.10	0.129
		16QAM	1/24	H	19.24	1.23	20.47	0.111
	836.5	QPSK	1/24	H	20.89	1.22	22.11	0.163
		16QAM	1/24	H	20.11	1.22	21.33	0.136
	846.5	QPSK	1/24	H	21.08	1.21	22.29	0.169
		16QAM	1/24	H	20.13	1.21	21.34	0.136
3	825.5	QPSK	1/14	H	19.59	1.23	20.82	0.121
		16QAM	1/14	H	18.83	1.23	20.06	0.101
	836.5	QPSK	1/14	H	20.31	1.22	21.53	0.142
		16QAM	1/14	H	19.71	1.22	20.93	0.124
	847.5	QPSK	1/14	H	20.89	1.21	22.10	0.162
		16QAM	1/14	H	20.21	1.21	21.42	0.139
1.4	824.7	QPSK	1/0	H	19.85	1.23	21.08	0.128
		16QAM	1/0	H	19.36	1.23	20.59	0.115
	836.5	QPSK	1/0	H	20.22	1.22	21.44	0.139
		16QAM	1/0	H	19.72	1.22	20.94	0.124
	848.3	QPSK	1/0	H	21.36	1.21	22.57	0.181
		16QAM	1/0	H	20.49	1.21	21.70	0.148

Note: This device was tested under all bandwidths, modulations and RB configurations and the worst case data are reported in the table above.

7.5.6 LTE Band 4

Channel Bandwidth (MHz)	Test Frequency (MHz)	Test Mode	RB Size/ Offset	Ant Pol (H/V)	Level(dBm) @ Ant Terminal	TX Ant Gain (dBi)	EIRP (dBm)	EIRP (W)
20	1720	QPSK	1/50	H	15.94	5.95	21.89	0.155
		16QAM	1/50	H	15.29	5.95	21.24	0.133
	1732.5	QPSK	1/50	H	17.23	5.84	23.07	0.203
		16QAM	1/50	H	16.40	5.84	22.24	0.167
	1745	QPSK	1/50	H	17.22	5.73	22.95	0.197
		16QAM	1/50	H	16.83	5.73	22.56	0.180
15	1717.5	QPSK	1/74	H	15.81	5.97	21.78	0.151
		16QAM	1/74	H	14.88	5.97	20.85	0.122
	1732.5	QPSK	1/74	H	17.50	5.84	23.34	0.216
		16QAM	1/74	H	16.88	5.84	22.72	0.187
	1747.5	QPSK	1/74	H	16.73	5.70	22.43	0.175
		16QAM	1/74	H	16.28	5.70	21.98	0.158
10	1715	QPSK	1/0	H	17.05	6.00	23.05	0.202
		16QAM	1/0	H	16.43	6.00	22.43	0.175
	1732.5	QPSK	1/0	H	16.78	5.84	22.62	0.183
		16QAM	1/0	H	15.88	5.84	21.72	0.149
	1750	QPSK	1/0	H	17.27	5.68	22.95	0.197
		16QAM	1/0	H	16.73	5.68	22.41	0.174
5	1712.5	QPSK	1/12	H	16.27	6.02	22.29	0.169
		16QAM	1/12	H	15.51	6.02	21.53	0.142
	1732.5	QPSK	1/12	H	16.41	5.84	22.25	0.168
		16QAM	1/12	H	15.94	5.84	21.78	0.151
	1752.5	QPSK	1/12	H	16.80	5.65	22.45	0.176
		16QAM	1/12	H	16.02	5.65	21.67	0.147
3	1711.5	QPSK	1/0	H	15.26	6.03	21.29	0.135
		16QAM	1/0	H	14.39	6.03	20.42	0.110
	1732.5	QPSK	1/0	H	16.65	5.84	22.49	0.177
		16QAM	1/0	H	15.52	5.84	21.36	0.137
	1753.5	QPSK	1/0	H	17.39	5.63	23.02	0.200
		16QAM	1/0	H	16.70	5.63	22.33	0.171
1.4	1710.7	QPSK	1/5	H	15.25	6.03	21.28	0.134
		16QAM	1/5	H	14.39	6.03	20.42	0.110
	1732.5	QPSK	1/5	H	16.32	5.84	22.16	0.164
		16QAM	1/5	H	15.78	5.84	21.62	0.145
	1754.3	QPSK	1/5	H	16.72	5.62	22.34	0.171
		16QAM	1/5	H	16.04	5.62	21.66	0.147

Note: This device was tested under all bandwidths, modulations and RB configurations and the worst case data are reported in the table above.

7.5.7 LTE Band 2

Channel Bandwidth (MHz)	Test Frequency (MHz)	Test Mode	RB Size/ Offset	Ant Pol (H/V)	Level(dBm) @ Ant Terminal	TX Ant Gain (dBi)	EIRP (dBm)	EIRP (W)
20	1860	QPSK	1/99	H	18.50	4.91	23.41	0.219
		16QAM	1/99	H	17.72	4.91	22.63	0.183
	1880	QPSK	1/99	H	17.91	4.80	22.71	0.187
		16QAM	1/99	H	17.26	4.80	22.06	0.161
	1900	QPSK	1/99	H	18.78	4.69	23.47	0.222
		16QAM	1/99	H	17.45	4.69	22.14	0.164
15	1857.5	QPSK	1/74	H	19.61	4.92	24.53	0.284
		16QAM	1/74	H	19.05	4.92	23.97	0.249
	1880	QPSK	1/74	H	19.45	4.80	24.25	0.266
		16QAM	1/74	H	18.90	4.80	23.70	0.234
	1902.5	QPSK	1/74	H	19.10	4.68	23.78	0.239
		16QAM	1/74	H	18.03	4.68	22.71	0.187
10	1855	QPSK	1/0	H	19.07	4.94	24.01	0.252
		16QAM	1/0	H	18.26	4.94	23.20	0.209
	1880	QPSK	1/0	H	19.43	4.80	24.23	0.265
		16QAM	1/0	H	18.92	4.80	23.72	0.236
	1905	QPSK	1/0	H	19.69	4.67	24.36	0.273
		16QAM	1/0	H	18.66	4.67	23.33	0.215
5	1852.5	QPSK	1/12	H	18.92	4.95	23.87	0.244
		16QAM	1/12	H	18.17	4.95	23.12	0.205
	1880	QPSK	1/12	H	19.11	4.80	23.91	0.246
		16QAM	1/12	H	18.38	4.80	23.18	0.208
	1907.5	QPSK	1/12	H	18.78	4.65	23.43	0.220
		16QAM	1/12	H	17.82	4.65	22.47	0.177
3	1851.5	QPSK	1/7	H	17.43	4.95	22.38	0.173
		16QAM	1/7	H	16.76	4.95	21.71	0.148
	1880	QPSK	1/7	H	17.40	4.80	22.20	0.166
		16QAM	1/7	H	16.45	4.80	21.25	0.133
	1908.5	QPSK	1/7	H	18.64	4.65	23.29	0.213
		16QAM	1/7	H	17.37	4.65	22.02	0.159
1.4	1850.7	QPSK	1/2	H	17.17	4.96	22.13	0.163
		16QAM	1/2	H	16.63	4.96	21.59	0.144
	1880	QPSK	1/2	H	18.01	4.80	22.81	0.191
		16QAM	1/2	H	17.60	4.80	22.40	0.174
	1909.3	QPSK	1/2	H	17.68	4.64	22.32	0.171
		16QAM	1/2	H	16.93	4.64	21.57	0.144

Note: This device was tested under all bandwidths, modulations and RB configurations and the worst case data are reported in the table above.

7.5.8 LTE Band 41

Channel Bandwidth (MHz)	Test Frequency (MHz)	Test Mode	RB Size/Offset	Ant Pol (H/V)	Level(dBm) @ Ant Terminal	TX Ant Gain (dBi)	EIRP (dBm)	EIRP (W)
20	2506	QPSK	1/50	H	17.25	5.96	23.21	0.209
		16QAM	1/50	H	16.41	5.96	22.37	0.173
	2593	QPSK	1/50	H	18.63	5.91	24.54	0.284
		16QAM	1/50	H	17.78	5.91	23.69	0.234
	2680	QPSK	1/50	H	17.01	6.18	23.19	0.208
		16QAM	1/50	H	16.14	6.18	22.32	0.171
15	2503.5	QPSK	1/0	H	16.50	5.97	22.47	0.177
		16QAM	1/0	H	15.72	5.97	21.69	0.148
	2593	QPSK	1/0	H	17.92	5.91	23.83	0.242
		16QAM	1/0	H	17.02	5.91	22.93	0.196
	2682.5	QPSK	1/0	H	16.92	6.19	23.11	0.205
		16QAM	1/0	H	16.00	6.19	22.19	0.166
10	2501	QPSK	1/0	H	16.78	5.98	22.76	0.189
		16QAM	1/0	H	15.84	5.98	21.82	0.152
	2593	QPSK	1/0	H	17.62	5.91	23.53	0.225
		16QAM	1/0	H	16.72	5.91	22.63	0.183
	2685	QPSK	1/0	H	17.34	6.20	23.54	0.226
		16QAM	1/0	H	16.17	6.20	22.37	0.173
5	2498.5	QPSK	1/12	H	16.86	5.98	22.84	0.192
		16QAM	1/12	H	16.21	5.98	22.19	0.166
	2593	QPSK	1/12	H	17.94	5.91	23.85	0.243
		16QAM	1/12	H	17.06	5.91	22.97	0.198
	2687.5	QPSK	1/12	H	17.16	6.21	23.37	0.217
		16QAM	1/12	H	16.37	6.21	22.58	0.181

Note: This device was tested under all bandwidths, modulations and RB configurations and the worst case data are reported in the table above.

7.5.9 LTE Band 7

Channel Bandwidth (MHz)	Test Frequency (MHz)	Test Mode	RB Size/Offset	Ant Pol (H/V)	Level(dBm) @ Ant Terminal	TX Ant Gain (dBi)	EIRP (dBm)	EIRP (W)
20	2510	QPSK	1/50	H	15.72	5.95	21.67	0.147
		16QAM	1/50	H	15.11	5.95	21.06	0.128
	2535	QPSK	1/50	H	16.52	5.89	22.41	0.174
		16QAM	1/50	H	15.89	5.89	21.78	0.151
	2560	QPSK	1/50	H	16.68	5.86	22.54	0.179
		16QAM	1/50	H	16.12	5.86	21.98	0.158
15	2507.5	QPSK	1/74	H	15.57	5.96	21.53	0.142
		16QAM	1/74	H	14.99	5.96	20.95	0.124
	2535	QPSK	1/74	H	16.63	5.89	22.52	0.179
		16QAM	1/74	H	15.91	5.89	21.80	0.151
	2562.5	QPSK	1/74	H	16.30	5.87	22.17	0.165
		16QAM	1/74	H	15.04	5.87	20.91	0.123
10	2505	QPSK	1/0	H	13.76	5.97	19.73	0.094
		16QAM	1/0	H	13.40	5.97	19.37	0.086
	2535	QPSK	1/0	H	16.44	5.89	22.33	0.171
		16QAM	1/0	H	16.10	5.89	21.99	0.158
	2565	QPSK	1/0	H	16.49	5.87	22.36	0.172
		16QAM	1/0	H	15.90	5.87	21.77	0.150
5	2502.5	QPSK	1/12	H	14.40	5.97	20.37	0.109
		16QAM	1/12	H	13.97	5.97	19.94	0.099
	2535	QPSK	1/12	H	16.22	5.89	22.11	0.163
		16QAM	1/12	H	15.68	5.89	21.57	0.144
	2567.5	QPSK	1/12	H	16.26	5.88	22.14	0.164
		16QAM	1/12	H	15.80	5.88	21.68	0.147

Note: This device was tested under all bandwidths, modulations and RB configurations and the worst case data are reported in the table above.

7.6 UNDESIRABLE EMISSIONS (Radiated)

7.6.1 LTE Band 12, 17

B.W (MHz)	Test Freq. (MHz)	RB Size/ Offset	Test Mode	Freq.(MHz)	Ant Pol (H/V)	Level(dBm) @ Ant Terminal	TX Ant Gain(dBd)	Result		Limit (dBc)
								(dBm)	(dBc)	
10	704	1/0	QPSK	1399.16	H	-53.61	2.69	-50.92	74.20	36.28
				2098.81	H	-42.49	3.01	-39.48	62.76	
			16QAM	1399.05	H	-53.25	2.69	-50.56	72.11	34.55
				2098.75	H	-42.40	3.00	-39.40	60.95	
	711	1/0	QPSK	1413.20	H	-53.01	2.82	-50.19	73.13	35.94
				2119.66	H	-42.09	3.09	-39.00	61.94	
16QAM			1413.07	H	-52.88	2.82	-50.06	71.83	34.77	
			2119.81	H	-42.25	3.09	-39.16	60.93		
5	701.5	1/12	QPSK	1402.87	H	-54.27	2.72	-51.55	73.51	34.96
				2104.62	H	-45.47	3.03	-42.44	64.40	
			16QAM	1403.17	H	-54.19	2.72	-51.47	72.17	33.70
				2104.66	H	-45.48	3.03	-42.45	63.15	
	707.5	1/12	QPSK	1415.23	H	-53.72	2.85	-50.87	72.85	34.98
				2122.49	H	-42.75	3.10	-39.65	61.63	
			16QAM	1514.09	H	-54.44	3.57	-50.87	72.10	34.23
				2122.36	H	-42.56	3.10	-39.46	60.69	
	713.5	1/12	QPSK	1426.98	H	-51.95	2.97	-48.98	70.13	34.15
				2140.50	H	-44.67	3.18	-41.49	62.64	
			16QAM	1426.88	H	-51.63	2.96	-48.67	69.11	33.44
				2140.52	H	-44.37	3.18	-41.19	61.63	

Note 1: Limit Calculation = $43 + 10\log_{10}(P[\text{Watts}])$

Note 2: This device was tested under all bandwidths, modulations and RB configurations and the worst case data are reported in the table above.

Note 3: The frequency spectrum is examined from 9 kHz to the 10th harmonic of the fundamental frequency of the transmitter. No other spurious and harmonic emissions were reported greater than listed emissions above table.

7.6.2 LTE Band 12

B.W (MHz)	Test Freq. (MHz)	RB Size/Offset	Test Mode	Freq.(MHz)	Ant Pol (H/V)	Level(dBm) @ Ant Terminal	TX Ant Gain(dBd)	Result		Limit (dBc)
								(dBm)	(dBc)	
3	700.5	1/0	QPSK	1400.33	H	-53.57	2.69	-50.88	72.09	34.21
				2097.80	H	-46.84	3.00	-43.84	65.05	
			16QAM	1400.74	H	-53.81	2.70	-51.11	72.07	33.96
				2097.86	H	-46.18	3.00	-43.18	64.14	
	707.5	1/0	QPSK	1412.39	H	-52.87	2.82	-50.05	71.94	34.89
				2118.81	H	-44.87	3.09	-41.78	63.67	
			16QAM	1412.43	H	-52.70	2.82	-49.88	71.36	34.48
				2118.72	H	-43.73	3.09	-40.64	62.12	
	714.5	1/0	QPSK	1426.42	H	-51.52	2.96	-48.56	69.68	34.12
				2139.75	H	-43.25	3.18	-40.07	61.19	
			16QAM	1426.47	H	-51.35	2.96	-48.39	68.98	33.59
				2139.81	H	-43.18	3.18	-40.00	60.59	
1.4	699.7	1/2	QPSK	1399.41	H	-54.41	2.69	-51.72	72.85	34.13
				2098.90	H	-43.77	3.01	-40.76	61.89	
			16QAM	1399.35	H	-53.97	2.69	-51.28	71.89	33.61
				2098.78	H	-42.94	3.00	-39.94	60.55	
	707.5	1/2	QPSK	1414.78	H	-53.03	2.84	-50.19	72.18	34.99
				2122.32	H	-41.61	3.10	-38.51	60.50	
			16QAM	1414.87	H	-52.42	2.84	-49.58	70.57	33.99
				2122.28	H	-42.13	3.10	-39.03	60.02	
	715.3	1/2	QPSK	1430.26	H	-51.06	3.00	-48.06	68.66	33.60
				2145.76	H	-42.09	3.20	-38.89	59.49	
			16QAM	1430.58	H	-51.54	3.00	-48.54	68.78	33.24
				2145.56	H	-42.04	3.20	-38.84	59.08	

Note 1: Limit Calculation = $43 + 10\log_{10}(P[\text{Watts}])$

Note 2: This device was tested under all bandwidths, modulations and RB configurations and the worst case data are reported in the table above.

Note 3: The frequency spectrum is examined from 9 kHz to the 10th harmonic of the fundamental frequency of the transmitter. No other spurious and harmonic emissions were reported greater than listed emissions above table.

7.6.3 LTE Band 13

B.W (MHz)	Test Freq. (MHz)	RB Size/ Offset	Test Mode	Freq.(MHz)	Ant Pol (H/V)	Level(dBm) @ Ant Terminal	TX Ant Gain(dBd)	Result		Limit (dBc)
								(dBm)	(dBc)	
10	782	1/49	QPSK	2359.34	H	-40.71	3.79	-36.92	56.91	32.99
			16QAM	2359.17	H	-40.18	3.79	-36.39	55.80	32.41
5	779.5	1/12	QPSK	2338.55	H	-39.16	3.77	-35.39	54.66	32.27
			16QAM	2338.41	H	-39.38	3.77	-35.61	54.03	31.42
	784.5	1/12	QPSK	2353.48	H	-39.36	3.79	-35.57	55.81	33.24
			16QAM	2353.54	H	-39.27	3.79	-35.48	54.66	32.18

Note 1: Limit Calculation = $43 + 10\log_{10}(P[\text{Watts}])$

Note 2: This device was tested under all bandwidths, modulations and RB configurations and the worst case data are reported in the table above.

Note 3: The frequency spectrum is examined from 9 kHz to the 10th harmonic of the fundamental frequency of the transmitter. No other spurious and harmonic emissions were reported greater than listed emissions above table.

UNDESIRABLE EMISSIONS IN 1559~1610MHz (LTE Band 13)

B.W (MHz)	Test Freq. (MHz)	RB Size/ Offset	Test Mode	Freq.(MHz)	Ant Pol (H/V)	Level(dBm) @ Ant Terminal	TX Ant Gain(dBi)	Result	Margin	Limit (dBm/MHz)
								(dBm)	(dB)	
10	782	1/49	QPSK	1573.08	H	-55.74	5.96	-49.78	9.78	-40.00
		1/49	16QAM	1572.90	H	-54.60	5.96	-48.64	8.64	
5	779.5	1/12	QPSK	1559.24	H	-57.04	5.94	-51.10	11.10	
		1/12	16QAM	1559.18	H	-56.65	5.94	-50.71	10.71	
	784.5	1/12	QPSK	1568.73	H	-56.29	5.96	-50.33	10.33	
		1/12	16QAM	1569.00	H	-55.33	5.96	-49.37	9.37	

7.6.4 LTE Band 14

B.W (MHz)	Test Freq. (MHz)	Test Mode	RB Size/ Offset	Freq.(MHz)	Ant Pol (H/V)	Level(dBm) @ Ant Terminal	TX Ant Gain(dBd)	Result		Limit (dBc)
								(dBm)	(dBc)	
10	793	QPSK	1/25	2379.17	H	-35.65	3.78	-31.87	53.11	34.24
		16QAM	1/25	2379.34	H	-35.35	3.78	-31.57	52.41	33.84
5	790.5	QPSK	1/24	2378.08	H	-34.39	3.78	-30.61	52.03	34.42
		16QAM	1/24	2377.96	H	-34.12	3.78	-30.34	51.09	33.75
	795.5	QPSK	1/24	2393.00	H	-35.15	3.77	-31.38	53.85	35.47
		16QAM	1/24	2392.98	H	-34.93	3.77	-31.16	53.08	34.92

Note 1: Limit Calculation = $43 + 10\log_{10}(P[\text{Watts}])$

Note 2: This device was tested under all bandwidths, modulations and RB configurations and the worst case data are reported in the table above.

Note 3: The frequency spectrum is examined from 9 kHz to the 10th harmonic of the fundamental frequency of the transmitter. No other spurious and harmonic emissions were reported greater than listed emissions above table.

UNDESIRABLE EMISSIONS IN 1559~1610MHz (LTE Band 14)

B.W (MHz)	Test Freq. (MHz)	Test Mode	RB Size/ Offset	Freq.(MHz)	Ant Pol (H/V)	Level(dBm) @ Ant Terminal	TX Ant Gain(dBi)	Result	Margin	Limit (dBm/MHz)
								(dBm)	(dB)	
10	793	QPSK	1/25	1586.40	V	-52.89	5.98	-46.91	6.91	-40.00
		16QAM	1/25	1586.22	V	-53.76	5.98	-47.78	7.78	
5	790.5	QPSK	1/24	1585.51	H	-54.18	5.98	-48.20	8.20	
		16QAM	1/24	1585.37	H	-53.88	5.98	-47.90	7.90	
	795.5	QPSK	1/24	1595.10	H	-53.39	5.99	-47.40	7.40	
		16QAM	1/24	1595.23	H	-53.27	5.99	-47.28	7.28	

7.6.5 LTE Band 5

B.W (MHz)	Test Freq. (MHz)	RB Size/ Offset	Test Mode	Freq.(MHz)	Ant Pol (H/V)	Level(dBm) @ Ant Terminal	TX Ant Gain(dBd)	Result		Limit (dBc)
								(dBm)	(dBc)	
10	829	1/0	QPSK	1649.07	H	-55.44	3.82	-51.62	72.49	33.87
				2473.80	H	-38.51	3.79	-34.72	55.59	
			16QAM	1649.41	H	-54.92	3.82	-51.10	71.35	33.25
				2473.75	H	-38.67	3.79	-34.88	55.13	
	836.5	1/0	QPSK	1664.11	H	-54.08	3.87	-50.21	71.61	34.40
				2496.35	H	-36.81	3.82	-32.99	54.39	
			16QAM	1664.42	H	-53.71	3.87	-49.84	70.57	33.73
				2496.30	H	-36.64	3.82	-32.82	53.55	
	844	1/0	QPSK	1679.19	H	-54.85	3.91	-50.94	73.47	35.53
				2518.76	H	-38.37	3.78	-34.59	57.12	
			16QAM	1679.21	H	-55.33	3.91	-51.42	73.24	34.82
				2518.75	H	-38.56	3.78	-34.78	56.60	
5	826.5	1/24	QPSK	1657.50	H	-54.73	3.84	-50.89	71.99	34.10
				2486.10	H	-37.22	3.81	-33.41	54.51	
			16QAM	1657.00	H	-55.21	3.84	-51.37	71.84	33.47
				2485.99	H	-37.20	3.81	-33.39	53.86	
	836.5	1/24	QPSK	1677.63	H	-54.51	3.91	-50.60	72.71	35.11
				2516.04	H	-38.04	3.79	-34.25	56.36	
			16QAM	1677.46	H	-55.18	3.91	-51.27	72.60	34.33
				2516.03	H	-37.84	3.79	-34.05	55.38	
	846.5	1/24	QPSK	1697.16	H	-56.21	3.97	-52.24	74.53	35.29
				2546.11	H	-37.31	3.71	-33.60	55.89	
			16QAM	1697.29	H	-56.21	3.97	-52.24	73.58	34.34
				2545.90	H	-37.13	3.71	-33.42	54.76	
3	825.5	1/14	QPSK	1653.60	H	-56.19	3.83	-52.36	73.18	33.82
				2480.18	H	-37.70	3.80	-33.90	54.72	
			16QAM	1653.45	H	-56.30	3.83	-52.47	72.53	33.06
				2480.26	H	-37.75	3.80	-33.95	54.01	
	836.5	1/14	QPSK	1675.40	H	-54.96	3.90	-51.06	72.59	34.53
				2513.34	H	-38.55	3.80	-34.75	56.28	
			16QAM	1675.42	H	-55.68	3.90	-51.78	72.71	33.93
				2513.23	H	-38.11	3.80	-34.31	55.24	
	847.5	1/14	QPSK	1697.34	H	-56.13	3.97	-52.16	74.26	35.10
				2546.21	H	-37.28	3.71	-33.57	55.67	
			16QAM	1697.43	H	-55.80	3.97	-51.83	73.25	34.42
				2546.24	H	-36.95	3.71	-33.24	54.66	

B.W (MHz)	Test Freq. (MHz)	RB Size/ Offset	Test Mode	Freq.(MHz)	Ant Pol (H/V)	Level(dBm) @ Ant Terminal	TX Ant Gain(dBd)	Result		Limit (dBc)
								(dBm)	(dBc)	
1.4	824.7	1/0	QPSK	1648.84	H	-55.48	3.82	-51.66	72.74	34.08
				2472.86	H	-38.17	3.79	-34.38	55.46	
			16QAM	1648.33	H	-54.46	3.82	-50.64	71.23	33.59
				2472.60	H	-38.09	3.79	-34.30	54.89	
	836.5	1/0	QPSK	1672.23	H	-55.09	3.89	-51.20	72.64	34.44
				2508.11	H	-38.13	3.81	-34.32	55.76	
			16QAM	1671.70	H	-55.24	3.89	-51.35	72.29	33.94
				2508.05	H	-37.93	3.81	-34.12	55.06	
	848.3	1/0	QPSK	1695.67	H	-55.37	3.97	-51.40	73.97	35.57
				2543.56	H	-37.08	3.72	-33.36	55.93	
			16QAM	1695.81	H	-55.25	3.97	-51.28	72.98	34.70
				2543.56	H	-37.11	3.72	-33.39	55.09	

Note 1: Limit Calculation = $43 + 10\log_{10}(P[\text{Watts}])$

Note 2: This device was tested under all bandwidths, modulations and RB configurations and the worst case data are reported in the table above.

Note 3: The frequency spectrum is examined from 9 kHz to the 10th harmonic of the fundamental frequency of the transmitter. No other spurious and harmonic emissions were reported greater than listed emissions above table.

7.6.6 LTE Band 4

B.W (MHz)	Test Freq. (MHz)	RB Size/Offset	Test Mode	Freq.(MHz)	Ant Pol (H/V)	Level(dBm) @ Ant Terminal	TX Ant Gain(dBi)	Result		Limit (dBc)
								(dBm)	(dBc)	
20	1720	1/50	QPSK	5159.00	H	-53.41	10.27	-43.14	65.03	34.89
			16QAM	5159.05	H	-53.38	10.27	-43.11	64.35	34.24
	1732.5	1/50	QPSK	5197.98	H	-52.55	10.34	-42.21	65.28	36.07
			16QAM	5197.54	H	-52.74	10.34	-42.40	64.64	35.24
	1745	1/50	QPSK	5234.15	H	-54.06	10.33	-43.73	66.68	35.95
			16QAM	5234.23	H	-53.80	10.33	-43.47	66.03	35.56
15	1717.5	1/74	QPSK	5176.81	H	-53.86	10.30	-43.56	65.34	34.78
			16QAM	5176.70	H	-53.74	10.30	-43.44	64.29	33.85
	1732.5	1/74	QPSK	5219.51	H	-53.76	10.33	-43.43	66.77	36.34
			16QAM	5219.63	H	-53.72	10.33	-43.39	66.11	35.72
	1747.5	1/74	QPSK	5267.37	H	-53.38	10.32	-43.06	65.49	35.43
			16QAM	5267.15	H	-53.22	10.32	-42.90	64.88	34.98
10	1715	1/0	QPSK	5128.60	H	-53.78	10.26	-43.52	66.57	36.05
			16QAM	5128.94	H	-53.76	10.26	-43.50	65.93	35.43
	1732.5	1/0	QPSK	5182.18	H	-53.69	10.31	-43.38	66.00	35.62
			16QAM	5182.34	H	-53.63	10.31	-43.32	65.04	34.72
	1750	1/0	QPSK	5235.84	H	-53.41	10.33	-43.08	66.03	35.95
			16QAM	5235.90	H	-53.29	10.33	-42.96	65.37	35.41
5	1712.5	1/12	QPSK	5137.68	H	-53.27	10.26	-43.01	65.30	35.29
			16QAM	5137.05	H	-53.13	10.26	-42.87	64.40	34.53
	1732.5	1/12	QPSK	5199.11	H	-52.71	10.34	-42.37	64.62	35.25
			16QAM	5199.37	H	-52.65	10.34	-42.31	64.09	34.78
	1752.5	1/12	QPSK	5257.50	H	-53.45	10.32	-43.13	65.58	35.45
			16QAM	5257.93	H	-53.33	10.32	-43.01	64.68	34.67
3	1711.5	1/0	QPSK	5131.20	H	-54.04	10.26	-43.78	65.07	34.29
			16QAM	5131.67	H	-53.79	10.26	-43.53	63.95	33.42
	1732.5	1/0	QPSK	5194.17	H	-53.24	10.33	-42.91	65.40	35.49
			16QAM	5194.69	H	-52.99	10.33	-42.66	64.02	34.36
	1753.5	1/0	QPSK	5255.98	H	-53.41	10.32	-43.09	66.11	36.02
			16QAM	5255.73	H	-53.23	10.32	-42.91	65.24	35.33
1.4	1710.7	1/5	QPSK	5134.35	H	-53.33	10.26	-43.07	64.35	34.28
			16QAM	5134.91	H	-53.14	10.26	-42.88	63.30	33.42
	1732.5	1/5	QPSK	5201.68	H	-53.20	10.34	-42.86	65.02	35.16
			16QAM	5201.01	H	-53.01	10.34	-42.67	64.29	34.62
	1754.3	1/5	QPSK	5265.83	H	-52.84	10.32	-42.52	64.86	35.34
			16QAM	5265.31	H	-52.66	10.32	-42.34	64.00	34.66

Note 1: Limit Calculation = $43 + 10\log_{10}(P[\text{Watts}])$

Note 2: This device was tested under all bandwidths, modulations and RB configurations and the worst case data are reported in the table above.

Note 3: The frequency spectrum is examined from 9 kHz to the 10th harmonic of the fundamental frequency of the transmitter. No other spurious and harmonic emissions were reported greater than listed emissions above table.

7.6.7 LTE Band 2

B.W (MHz)	Test Freq. (MHz)	RB Size/ Offset	Test Mode	Freq.(MHz)	Ant Pol (H/V)	Level(dBm) @ Ant Terminal	TX Ant Gain(dBi)	Result		Limit (dBc)
								(dBm)	(dBc)	
20	1860	1/99	QPSK	5606.90	H	-53.29	10.59	-42.70	66.11	36.41
			16QAM	5607.76	H	-53.38	10.59	-42.79	65.42	35.63
	1880	1/99	QPSK	5666.66	H	-51.65	10.69	-40.96	63.67	35.71
			16QAM	5667.08	H	-52.07	10.69	-41.38	63.44	35.06
	1900	1/99	QPSK	5726.83	H	-49.61	10.72	-38.89	62.36	36.47
			16QAM	5727.08	H	-49.80	10.72	-39.08	61.22	35.14
15	1857.5	1/74	QPSK	5592.77	H	-53.73	10.56	-43.17	67.70	37.53
			16QAM	5593.01	H	-53.81	10.56	-43.25	67.22	36.97
	1880	1/74	QPSK	5659.71	H	-51.75	10.68	-41.07	65.32	37.25
			16QAM	5660.17	H	-50.43	10.68	-39.75	63.45	36.70
	1902.5	1/74	QPSK	5727.61	H	-47.63	10.72	-36.91	60.69	36.78
			16QAM	5727.79	H	-49.06	10.72	-38.34	61.05	35.71
10	1855	1/0	QPSK	5552.06	H	-51.23	10.42	-40.81	64.82	37.01
			16QAM	5551.89	H	-52.59	10.42	-42.17	65.37	36.20
	1880	1/0	QPSK	5626.55	H	-51.18	10.62	-40.56	64.79	37.23
			16QAM	5626.73	H	-51.50	10.62	-40.88	64.60	36.72
	1905	1/0	QPSK	5701.76	H	-50.42	10.74	-39.68	64.04	37.36
			16QAM	5701.88	H	-50.90	10.74	-40.16	63.49	36.33
5	1852.5	1/12	QPSK	5557.43	H	-52.86	10.44	-42.42	66.29	36.87
			16QAM	5557.86	H	-52.95	10.44	-42.51	65.63	36.12
	1880	1/12	QPSK	5640.02	H	-52.19	10.64	-41.55	65.46	36.91
			16QAM	5640.23	H	-52.03	10.64	-41.39	64.57	36.18
	1907.5	1/12	QPSK	5722.37	H	-50.35	10.73	-39.62	63.05	36.43
			16QAM	5722.56	H	-51.20	10.73	-40.47	62.94	35.47
3	1851.5	1/7	QPSK	5554.30	H	-51.95	10.42	-41.53	63.91	35.38
			16QAM	5554.67	H	-51.66	10.43	-41.23	62.94	34.71
	1880	1/7	QPSK	5640.08	H	-50.31	10.64	-39.67	61.87	35.20
			16QAM	5640.16	H	-50.26	10.64	-39.62	60.87	34.25
	1908.5	1/7	QPSK	5725.07	H	-51.56	10.72	-40.84	64.13	36.29
			16QAM	5725.68	H	-51.54	10.72	-40.82	62.84	35.02
1.4	1850.7	1/2	QPSK	5551.69	H	-49.69	10.42	-39.27	61.40	35.13
			16QAM	5551.95	H	-50.16	10.42	-39.74	61.33	34.59
	1880	1/2	QPSK	5639.68	H	-51.44	10.64	-40.80	63.61	35.81
			16QAM	5639.51	H	-49.79	10.64	-39.15	61.55	35.40
	1909.3	1/2	QPSK	5727.66	H	-51.06	10.72	-40.34	62.66	35.32
			16QAM	5727.20	H	-51.28	10.72	-40.56	62.13	34.57

Note 1: Limit Calculation = $43 + 10\log_{10}(P[\text{Watts}])$

Note 2: This device was tested under all bandwidths, modulations and RB configurations and the worst case data are reported in the table above.

Note 3: The frequency spectrum is examined from 9 kHz to the 10th harmonic of the fundamental frequency of the transmitter. No other spurious and harmonic emissions were reported greater than listed emissions above table.

7.6.8 LTE Band 41

B.W (MHz)	Test Freq. (MHz)	RB Size/ Offset	Test Mode	Freq.(MHz)	Ant Pol (H/V)	Level(dBm) @ Ant Terminal	TX Ant Gain(dBi)	Result		Limit (dBc)
								(dBm)	(dBc)	
20	2506	1/50	QPSK	7519.75	H	-51.76	11.94	-39.82	63.03	48.21
			16QAM	7518.34	H	-51.14	11.94	-39.20	61.57	47.37
	2593	1/50	QPSK	7779.25	H	-51.42	12.28	-39.14	63.68	49.54
			16QAM	7779.51	H	-51.37	12.28	-39.09	62.78	48.69
	2680	1/50	QPSK	8040.04	H	-51.15	12.53	-38.62	61.81	48.19
			16QAM	8040.38	H	-51.21	12.53	-38.68	61.00	47.32
15	2503.5	1/0	QPSK	7486.33	H	-51.20	11.88	-39.32	61.79	47.47
			16QAM	7486.76	H	-50.94	11.88	-39.06	60.75	46.69
	2593	1/0	QPSK	7756.61	H	-51.89	12.30	-39.59	63.42	48.83
			16QAM	7758.04	H	-51.34	12.30	-39.04	61.97	47.93
	2682.5	1/0	QPSK	8023.53	H	-51.20	12.51	-38.69	61.80	48.11
			16QAM	8024.32	H	-51.49	12.51	-38.98	61.17	47.19
10	2501	1/0	QPSK	7486.40	H	-50.58	11.88	-38.70	61.46	47.76
			16QAM	7486.82	H	-50.94	11.88	-39.06	60.88	46.82
	2593	1/0	QPSK	7765.57	H	-51.74	12.29	-39.45	62.98	48.53
			16QAM	7764.95	H	-51.17	12.30	-38.87	61.50	47.63
	2685	1/0	QPSK	8041.34	H	-51.45	12.53	-38.92	62.46	48.54
			16QAM	8040.69	H	-51.75	12.53	-39.22	61.59	47.37
5	2498.5	1/12	QPSK	7495.29	H	-50.27	11.90	-38.37	61.21	47.84
			16QAM	7495.50	H	-50.06	11.91	-38.15	60.34	47.19
	2593	1/12	QPSK	7779.17	H	-51.35	12.28	-39.07	62.92	48.85
			16QAM	7778.60	H	-51.00	12.28	-38.72	61.69	47.97
	2687.5	1/12	QPSK	8063.35	H	-50.27	12.55	-37.72	61.09	48.37
			16QAM	8062.48	H	-50.32	12.55	-37.77	60.35	47.58

Note 1: Limit Calculation = $55 + 10\log_{10}(P[\text{Watts}])$

Note 2: This device was tested under all bandwidths, modulations and RB configurations and the worst case data are reported in the table above.

Note 3: The frequency spectrum is examined from 9 kHz to the 10th harmonic of the fundamental frequency of the transmitter. No other spurious and harmonic emissions were reported greater than listed emissions above table

7.6.9 LTE Band 7

B.W (MHz)	Test Freq. (MHz)	RB Size/ Offset	Test Mode	Freq.(MHz)	Ant Pol (H/V)	Level(dBm) @ Ant Terminal	TX Ant Gain(dBi)	Result		Limit (dBc)
								(dBm)	(dBc)	
20	2510	1/50	QPSK	5020.95	H	-53.24	10.04	-43.20	64.87	46.67
			16QAM	5020.02	H	-52.69	10.04	-42.65	63.71	46.06
	2535	1/50	QPSK	5070.39	H	-52.57	10.16	-42.41	64.82	47.41
			16QAM	5070.41	H	-52.42	10.16	-42.26	64.04	46.78
	2560	1/50	QPSK	5121.14	H	-53.13	10.27	-42.86	65.40	47.54
			16QAM	5119.99	H	-53.78	10.27	-43.51	65.49	46.98
15	2507.5	1/74	QPSK	5015.19	H	-53.67	10.03	-43.64	65.17	46.53
			16QAM	5015.23	H	-53.48	10.03	-43.45	64.40	45.95
	2535	1/74	QPSK	5069.00	H	-53.51	10.16	-43.35	65.87	47.52
			16QAM	5069.42	H	-53.64	10.16	-43.48	65.28	46.80
	2562.5	1/74	QPSK	5125.44	H	-53.41	10.26	-43.15	65.32	47.17
			16QAM	5125.27	H	-53.31	10.26	-43.05	63.96	45.91
10	2505	1/0	QPSK	5009.50	H	-53.46	10.02	-43.44	63.17	44.73
			16QAM	5009.88	H	-53.26	10.02	-43.24	62.61	44.37
	2535	1/0	QPSK	5069.41	H	-52.20	10.16	-42.04	64.37	47.33
			16QAM	5069.59	H	-52.37	10.16	-42.21	64.20	46.99
	2565	1/0	QPSK	5130.97	H	-54.79	10.26	-44.53	66.89	47.36
			16QAM	5130.71	H	-54.22	10.26	-43.96	65.73	46.77
5	2502.5	1/12	QPSK	5004.20	H	-53.16	10.01	-43.15	63.52	45.37
			16QAM	5004.39	H	-53.00	10.01	-42.99	62.93	44.94
	2535	1/12	QPSK	5070.21	H	-53.65	10.16	-43.49	65.60	47.11
			16QAM	5070.10	H	-53.72	10.16	-43.56	65.13	46.57
	2567.5	1/12	QPSK	5134.68	H	-53.27	10.26	-43.01	65.15	47.14
			16QAM	5135.78	H	-53.72	10.26	-43.46	65.14	46.68

Note 1: Limit Calculation = $55 + 10\log_{10}(P[\text{Watts}])$

Note 2: This device was tested under all bandwidths, modulations and RB configurations and the worst case data are reported in the table above.

Note 3: The frequency spectrum is examined from 9 kHz to the 10th harmonic of the fundamental frequency of the transmitter. No other spurious and harmonic emissions were reported greater than listed

7.7 FREQUENCY STABILITY

7.7.1 LTE Band 12, 17

OPERATING FREQUENCY : 707.5 MHz
 REFERENCE VOLTAGE : 3.85 VDC
 LIMIT(FCC&IC) : The frequency stability shall be sufficient to ensure that the fundamental emission stays within the authorized frequency block.

VOLTAGE (%)	POWER (V DC)	TEMP (°C)	FREQUENCY (Hz)	FREQ.Dev (Hz)	Deviation	
					(ppm)	(%)
100%	3.85	+20(Ref)	707,499,995	-5	-0.0071	-0.000000707
100%		-30	707,500,003	3	0.0042	0.000000424
100%		-20	707,499,998	-2	-0.0028	-0.000000283
100%		-10	707,500,006	6	0.0085	0.000000848
100%		0	707,500,009	9	0.0127	0.000001272
100%		+10	707,500,004	4	0.0057	0.000000565
100%		+20	707,499,995	-5	-0.0071	-0.000000707
100%		+30	707,500,001	1	0.0014	0.000000141
100%		+40	707,500,002	2	0.0028	0.000000283
100%		+50	707,499,998	-2	-0.0028	-0.000000283
115%	4.43	+20	707,500,004	4	0.0057	0.000000565
BATT.ENDPOINT	3.50	+20	707,499,992	-8	-0.0113	-0.000001131

Note. Based on the results of the frequency stability test at the center channel the frequency deviation results measured are very small. As such it is determined that the channels at the band edge would remain inband when the maximum measured frequency deviation noted during the frequency stability tests is applied. Therefore the device is determined to remain operating in band over the temperature and voltage range as tested.

7.7.2 LTE Band 13

OPERATING FREQUENCY : 782 MHz
 REFERENCE VOLTAGE : 3.85 VDC
 LIMIT(FCC&IC) : The frequency stability shall be sufficient to ensure that the fundamental emission stays within the authorized frequency block.

VOLTAGE (%)	POWER (V DC)	TEMP (°C)	FREQUENCY (Hz)	FREQ.Dev (Hz)	Deviation	
					(ppm)	(%)
100%	3.85	+20(Ref)	782,000,003	3	0.0038	0.000000384
100%		-30	782,000,009	9	0.0115	0.000001151
100%		-20	781,999,999	-1	-0.0013	-0.000000128
100%		-10	781,999,993	-7	-0.0090	-0.000000895
100%		0	782,000,011	11	0.0141	0.000001407
100%		+10	782,000,005	5	0.0064	0.000000639
100%		+20	782,000,003	3	0.0038	0.000000384
100%		+30	782,000,008	8	0.0102	0.000001023
100%		+40	781,999,997	-3	-0.0038	-0.000000384
100%		+50	782,000,006	6	0.0077	0.000000767
115%	4.43	+20	782,000,002	2	0.0026	0.000000256
BATT.ENDPOINT	3.50	+20	782,000,004	4	0.0051	0.000000512

Note. Based on the results of the frequency stability test at the center channel the frequency deviation results measured are very small. as such it is determined that the channels at the band edge would remain inband when the maximum measured frequency deviation noted during the frequency stability tests is applied. therefore the device is determined to remain operating in band over the temperature and voltage range as tested.

7.7.3 LTE Band 14

OPERATING FREQUENCY : 793 MHz
 REFERENCE VOLTAGE : 3.85 VDC
 DEVIATION LIMIT(FCC&IC) : The frequency stability shall be sufficient to ensure that the fundamental emission stays within the authorized frequency block.

VOLTAGE (%)	POWER (V DC)	TEMP (°C)	FREQUENCY (Hz)	FREQ.Dev (Hz)	Deviation	
					(ppm)	(%)
100%	3.85	+20(Ref)	792,999,991	-9	-0.0113	-0.000001135
100%		-30	792,999,998	-2	-0.0025	-0.000000252
100%		-20	793,000,005	5	0.0063	0.000000631
100%		-10	793,000,003	3	0.0038	0.000000378
100%		0	792,999,993	-7	-0.0088	-0.000000883
100%		+10	793,000,013	13	0.0164	0.000001639
100%		+20	792,999,991	-9	-0.0113	-0.000001135
100%		+30	792,999,993	-7	-0.0088	-0.000000883
100%		+40	792,999,998	-2	-0.0025	-0.000000252
100%		+50	793,000,008	8	0.0101	0.000001009
115%		4.43	+20	793,000,004	4	0.0050
BATT.ENDPOINT	3.50	+20	792,999,997	-3	-0.0038	-0.000000378

Note. Based on the results of the frequency stability test at the center channel the frequency deviation results measured are very small. as such it is determined that the channels at the band edge would remain inband when the maximum measured frequency deviation noted during the frequency stability tests is applied. therefore the device is determined to remain operating in band over the temperature and voltage range as tested.

7.7.4 LTE Band 5

OPERATING FREQUENCY : 836.5 MHz
 REFERENCE VOLTAGE : 3.85 VDC
 DEVIATION LIMIT(FCC&IC) : ± 0.00025 % or 2.5 ppm

VOLTAGE (%)	POWER (V DC)	TEMP (°C)	FREQUENCY (Hz)	FREQ.Dev (Hz)	Deviation	
					(ppm)	(%)
100%	3.85	+20(Ref)	836,499,996	-4	-0.0048	-0.000000478
100%		-30	836,500,002	2	0.0024	0.000000239
100%		-20	836,500,003	3	0.0036	0.000000359
100%		-10	836,500,004	4	0.0048	0.000000478
100%		0	836,499,998	-2	-0.0024	-0.000000239
100%		+10	836,500,006	6	0.0072	0.000000717
100%		+20	836,499,996	-4	-0.0048	-0.000000478
100%		+30	836,499,999	-1	-0.0012	-0.000000120
100%		+40	836,499,996	-4	-0.0048	-0.000000478
100%		+50	836,499,996	-4	-0.0048	-0.000000478
115%		4.43	+20	836,500,001	1	0.0012
BATT.ENDPOINT	3.50	+20	836,500,005	5	0.0060	0.000000598

7.7.5 LTE Band 4

OPERATING FREQUENCY : 1732.5 MHz
 REFERENCE VOLTAGE : 3.85 VDC
 LIMIT(FCC&IC) : The frequency stability shall be sufficient to ensure that the fundamental emission stays within the authorized frequency block.

VOLTAGE (%)	POWER (V DC)	TEMP (°C)	FREQUENCY (Hz)	FREQ.Dev (Hz)	Deviation	
					(ppm)	(%)
100%	3.85	+20(Ref)	1,732,500,003	3	0.0017	0.000000173
100%		-30	1,732,499,999	-1	-0.0006	-0.000000058
100%		-20	1,732,500,004	4	0.0023	0.000000231
100%		-10	1,732,500,008	8	0.0046	0.000000462
100%		0	1,732,500,002	2	0.0012	0.000000115
100%		+10	1,732,500,002	2	0.0012	0.000000115
100%		+20	1,732,500,003	3	0.0017	0.000000173
100%		+30	1,732,499,999	-1	-0.0006	-0.000000058
100%		+40	1,732,499,993	-7	-0.0040	-0.000000404
100%		+50	1,732,500,003	3	0.0017	0.000000173
115%		4.43	+20	1,732,500,004	4	0.0023
BATT.ENDPOINT	3.50	+20	1,732,500,001	1	0.0006	0.000000058

Note. Based on the results of the frequency stability test at the center channel the frequency deviation results measured are very small. As such it is determined that the channels at the band edge would remain inband when the maximum measured frequency deviation noted during the frequency stability tests is applied. Therefore the device is determined to remain operating in band over the temperature and voltage range as tested.

7.7.6 LTE Band 2

OPERATING FREQUENCY : 1880 MHz
 REFERENCE VOLTAGE : 3.85 VDC
 LIMIT(FCC) : The frequency stability shall be sufficient to ensure that the fundamental emission stays within the authorized frequency block.
 LIMIT(IC) : ± 0.00025 % or 2.5 ppm

VOLTAGE (%)	POWER (V DC)	TEMP (°C)	FREQUENCY (Hz)	FREQ.Dev (Hz)	Deviation	
					(ppm)	(%)
100%	3.85	+20(Ref)	1,880,000,002	2	0.0011	0.000000106
100%		-30	1,879,999,999	-1	-0.0005	-0.000000053
100%		-20	1,880,000,000	0	0.0000	0.000000000
100%		-10	1,879,999,997	-3	-0.0016	-0.000000160
100%		0	1,880,000,002	2	0.0011	0.000000106
100%		+10	1,879,999,996	-4	-0.0021	-0.000000213
100%		+20	1,880,000,002	2	0.0011	0.000000106
100%		+30	1,880,000,005	5	0.0027	0.000000266
100%		+40	1,880,000,001	1	0.0005	0.000000053
100%		+50	1,880,000,002	2	0.0011	0.000000106
115%		4.43	+20	1,880,000,004	4	0.0021
BATT.ENDPOINT	3.50	+20	1,880,000,002	2	0.0011	0.000000106

Note. Based on the results of the frequency stability test at the center channel the frequency deviation results measured are very small. As such it is determined that the channels at the band edge would remain inband when the maximum measured frequency deviation noted during the frequency stability tests is applied. Therefore the device is determined to remain operating in band over the temperature and voltage range as tested.

7.7.7 LTE Band 41

OPERATING FREQUENCY : 2593 MHz
 REFERENCE VOLTAGE : 3.85 VDC
 LIMIT(FCC&IC) : The frequency stability shall be sufficient to ensure that the fundamental emission stays within the authorized frequency block.

VOLTAGE (%)	POWER (V DC)	TEMP (°C)	FREQUENCY (Hz)	FREQ.Dev (Hz)	Deviation	
					(ppm)	(%)
100%	3.85	+20(Ref)	2,592,999,995	-5	-0.0019	-0.000000193
100%		-30	2,593,000,004	4	0.0015	0.000000154
100%		-20	2,592,999,999	-1	-0.0004	-0.000000039
100%		-10	2,592,999,997	-3	-0.0012	-0.000000116
100%		0	2,593,000,004	4	0.0015	0.000000154
100%		+10	2,593,000,001	1	0.0004	0.000000039
100%		+20	2,592,999,995	-5	-0.0019	-0.000000193
100%		+30	2,592,999,996	-4	-0.0015	-0.000000154
100%		+40	2,593,000,001	1	0.0004	0.000000039
100%		+50	2,593,000,007	7	0.0027	0.000000270
115%	4.43	+20	2,592,999,997	-3	-0.0012	-0.000000116
BATT.ENDPOINT	3.50	+20	2,592,999,999	-1	-0.0004	-0.000000039

Note. Based on the results of the frequency stability test at the center channel the frequency deviation results measured are very small. As such it is determined that the channels at the band edge would remain inband when the maximum measured frequency deviation noted during the frequency stability tests is applied. Therefore the device is determined to remain operating in band over the temperature and voltage range as tested.

7.7.8 LTE Band 7

OPERATING FREQUENCY : 2535 MHz
 REFERENCE VOLTAGE : 3.85 VDC
 LIMIT(FCC&IC) : The frequency stability shall be sufficient to ensure that the fundamental emission stays within the authorized frequency block.

VOLTAGE (%)	POWER (V DC)	TEMP (°C)	FREQUENCY (Hz)	FREQ.Dev (Hz)	Deviation	
					(ppm)	(%)
100%	3.85	+20(Ref)	2,534,999,999	-1	-0.0004	-0.000000039
100%		-30	2,535,000,004	4	0.0016	0.000000158
100%		-20	2,535,000,002	2	0.0008	0.000000079
100%		-10	2,535,000,009	9	0.0036	0.000000355
100%		0	2,534,999,994	-6	-0.0024	-0.000000237
100%		+10	2,535,000,004	4	0.0016	0.000000158
100%		+20	2,534,999,999	-1	-0.0004	-0.000000039
100%		+30	2,535,000,003	3	0.0012	0.000000118
100%		+40	2,535,000,007	7	0.0028	0.000000276
100%		+50	2,534,999,994	-6	-0.0024	-0.000000237
115%		4.43	+20	2,535,000,001	1	0.0004
BATT.ENDPOINT	3.50	+20	2,535,000,005	5	0.0020	0.000000197

Note. Based on the results of the frequency stability test at the center channel the frequency deviation results measured are very small. As such it is determined that the channels at the band edge would remain inband when the maximum measured frequency deviation noted during the frequency stability tests is applied. Therefore the device is determined to remain operating in band over the temperature and voltage range as tested.

8. TEST PLOTS

Note: All bandwidths, RB configurations, and modulations were investigated.
The worst case test results are reported.

8.1 OCCUPIED BANDWIDTH

8.1.1 LTE Band 12, 17

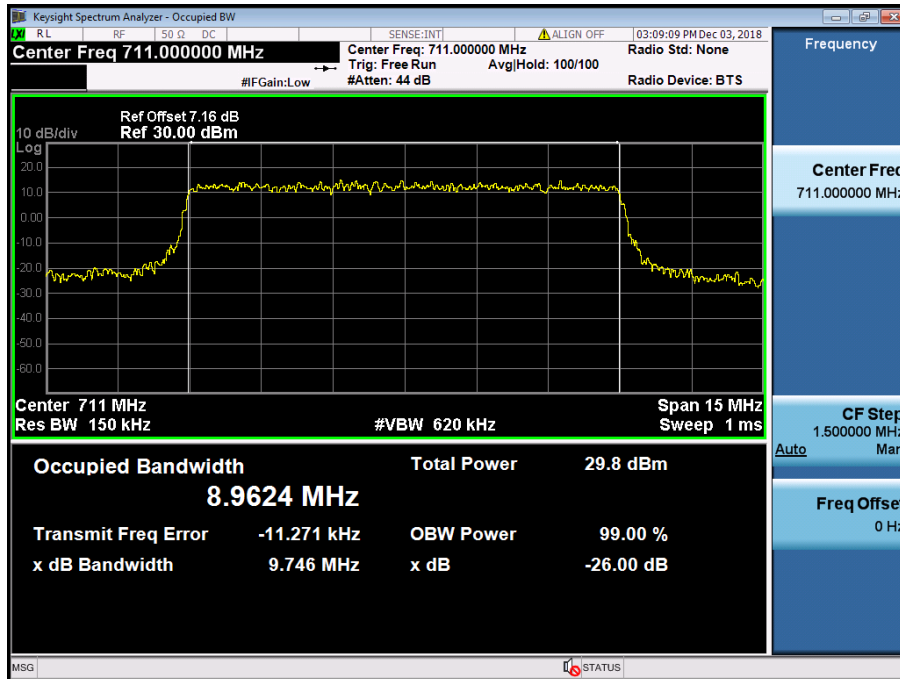

LTE Band 12, 17 / 10 MHz / QPSK - RB Size 50

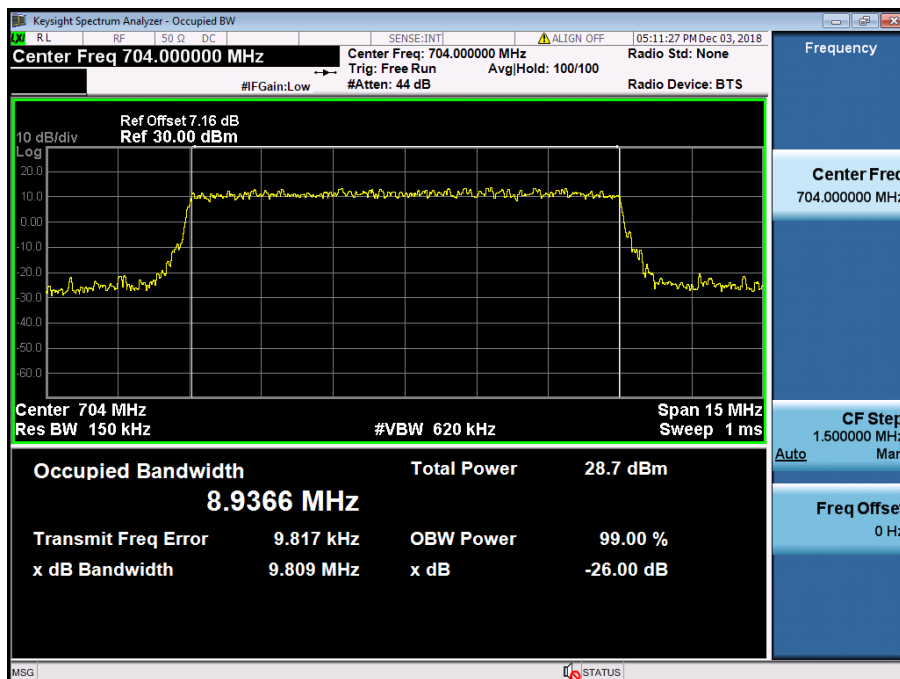

LTE Band 12, 17 / 10 MHz / 16QAM - RB Size 50

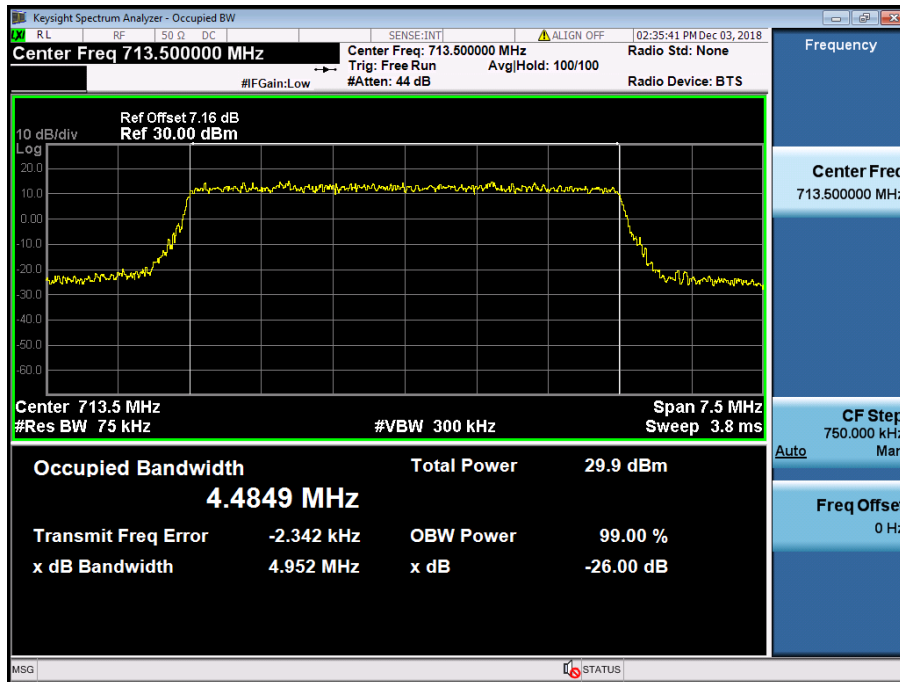

LTE Band 12, 17 / 5 MHz / QPSK - RB Size 25

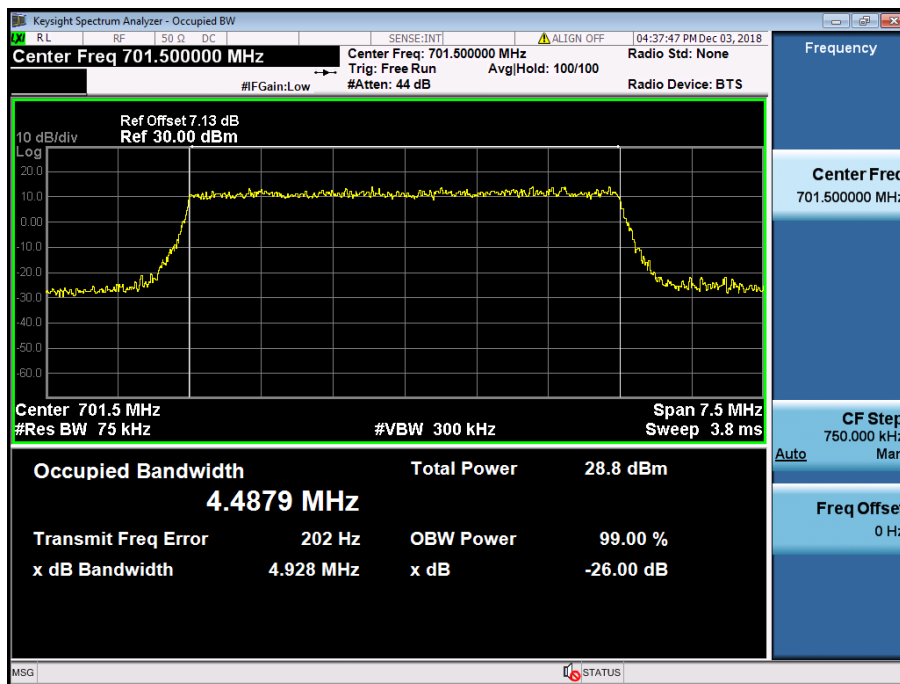

LTE Band 12, 17 / 5 MHz / 16QAM - RB Size 25

8.1.2 LTE Band 12

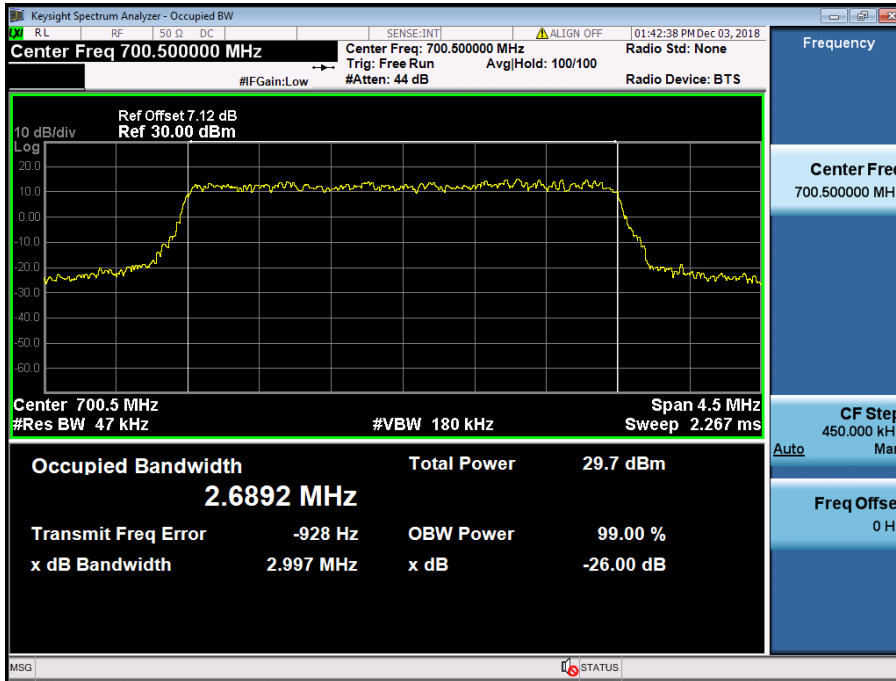

LTE Band 12 / 3 MHz / QPSK - RB Size 15

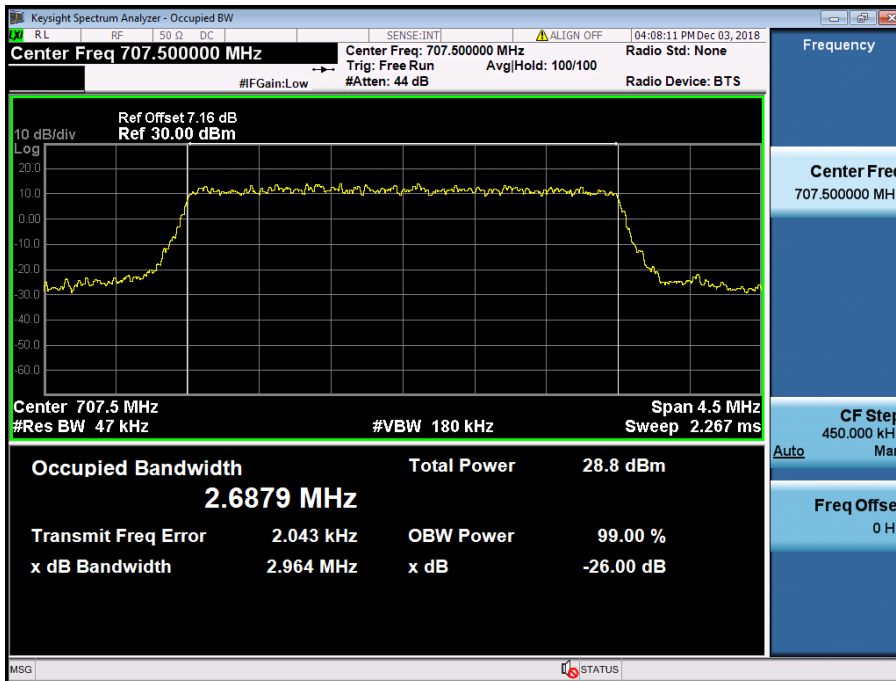

LTE Band 12 / 3 MHz / 16QAM - RB Size 15



LTE Band 12 / 1.4 MHz / QPSK - RB Size 6

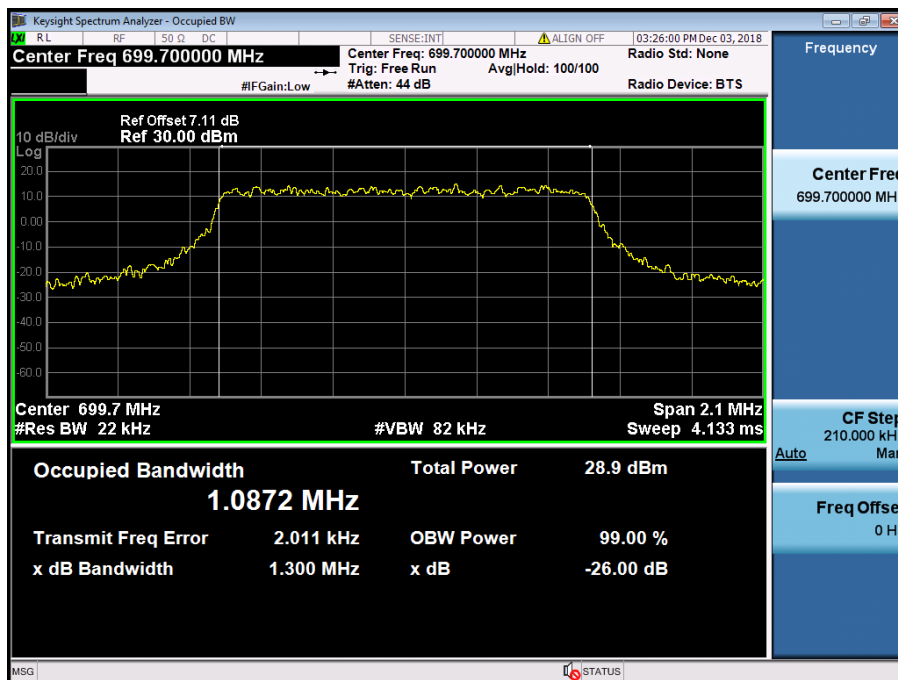

LTE Band 12 / 1.4 MHz / 16QAM - RB Size 6

8.1.3 LTE Band 13

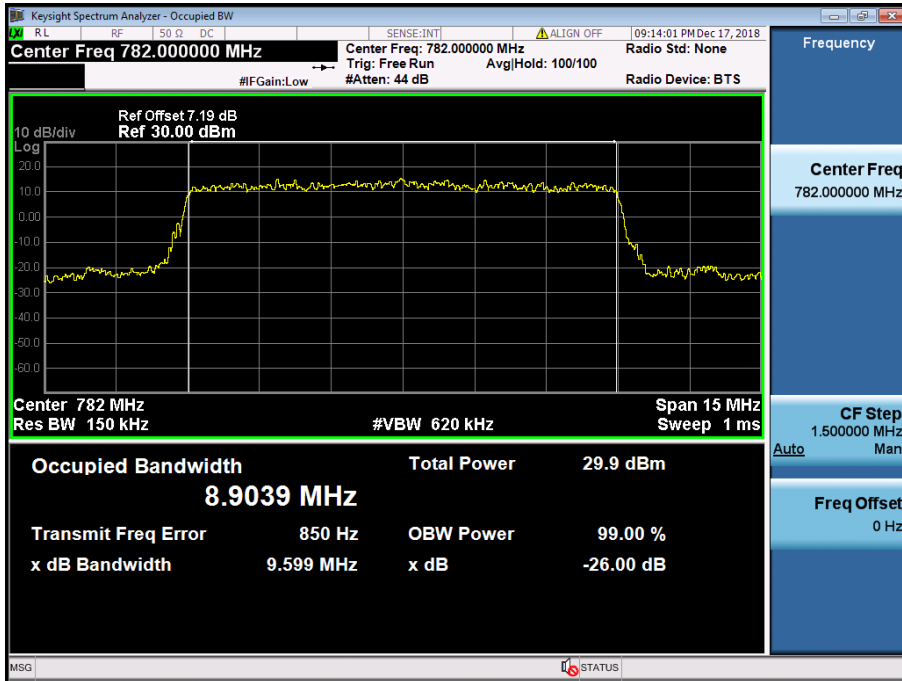

LTE Band 13 / 10 MHz / QPSK - RB Size 50

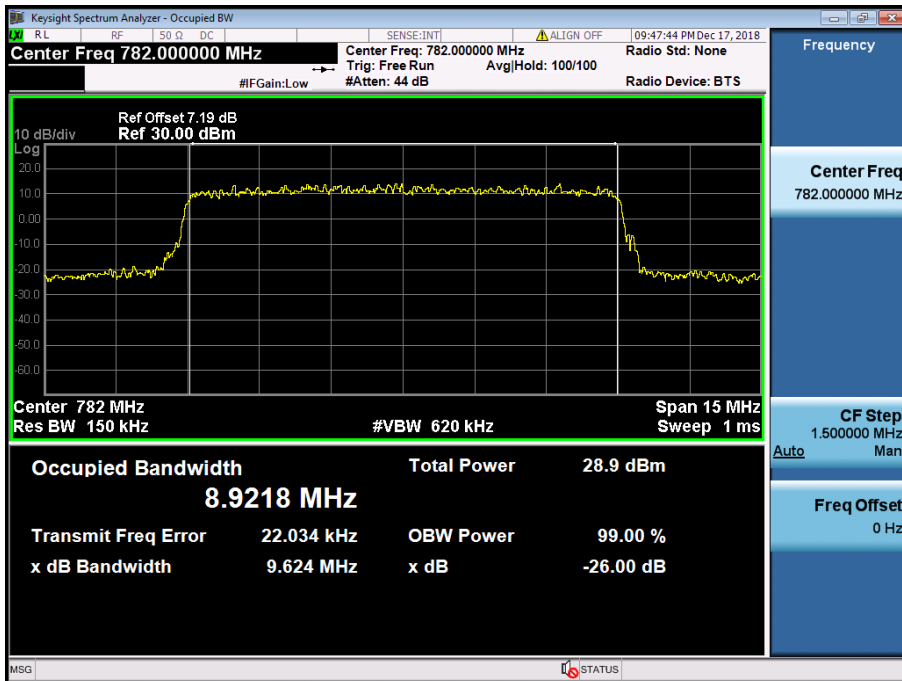

LTE Band 13 / 10 MHz / 16QAM - RB Size 50



LTE Band 13 / 5 MHz / QPSK - RB Size 25

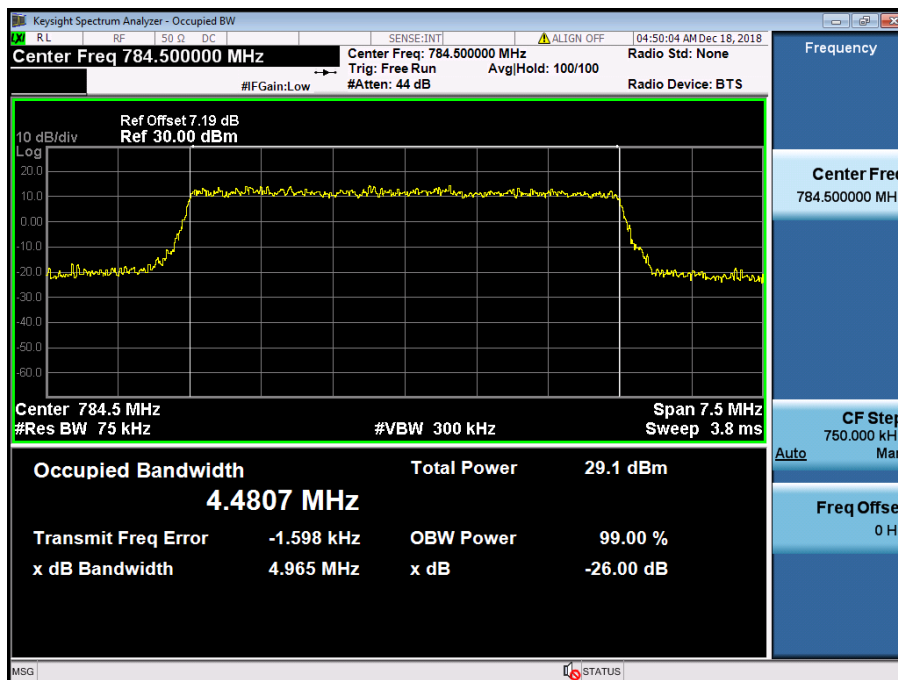

LTE Band 13 / 5 MHz / 16QAM - RB Size 25

8.1.4 LTE Band 14

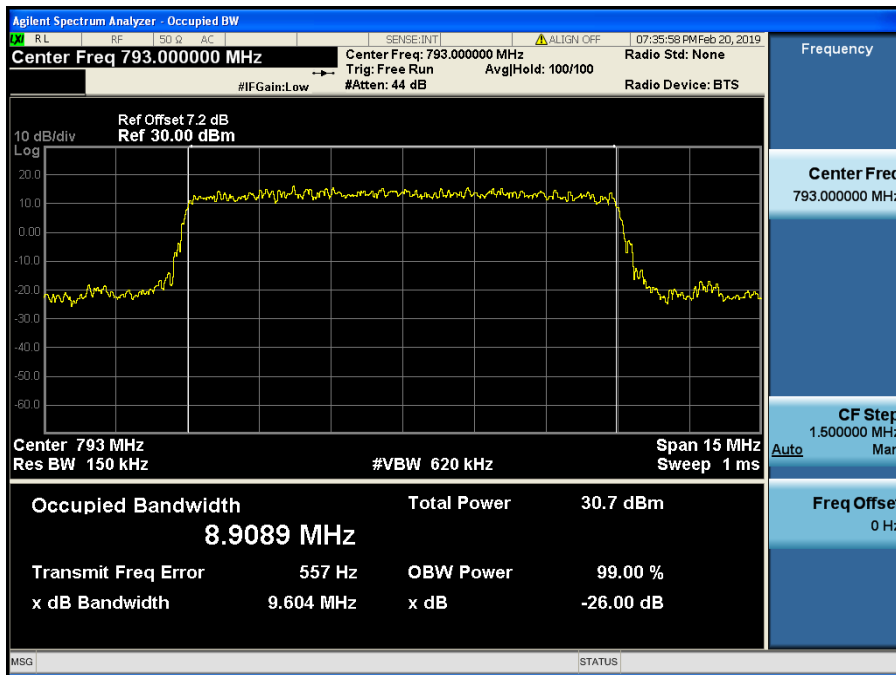

LTE Band 14 / 10 MHz / QPSK - RB Size 50

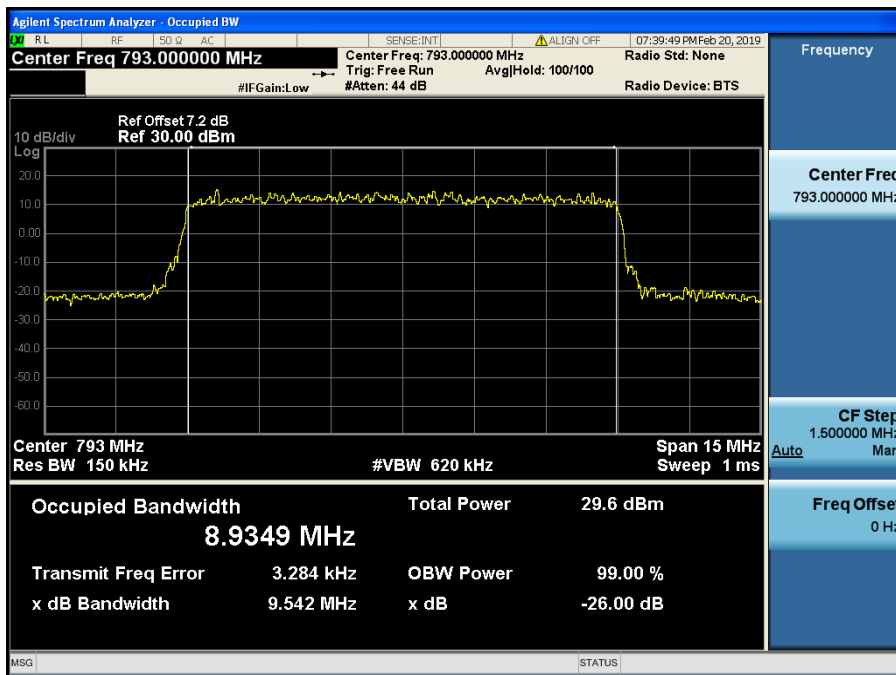

LTE Band 14 / 10 MHz / 16QAM - RB Size 50

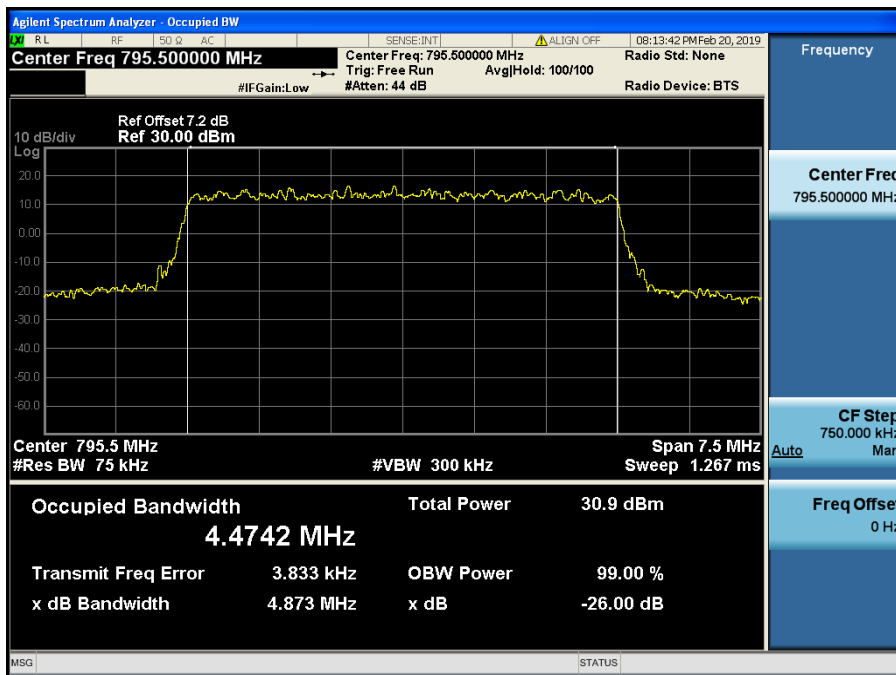

LTE Band 14 / 5 MHz / QPSK - RB Size 25

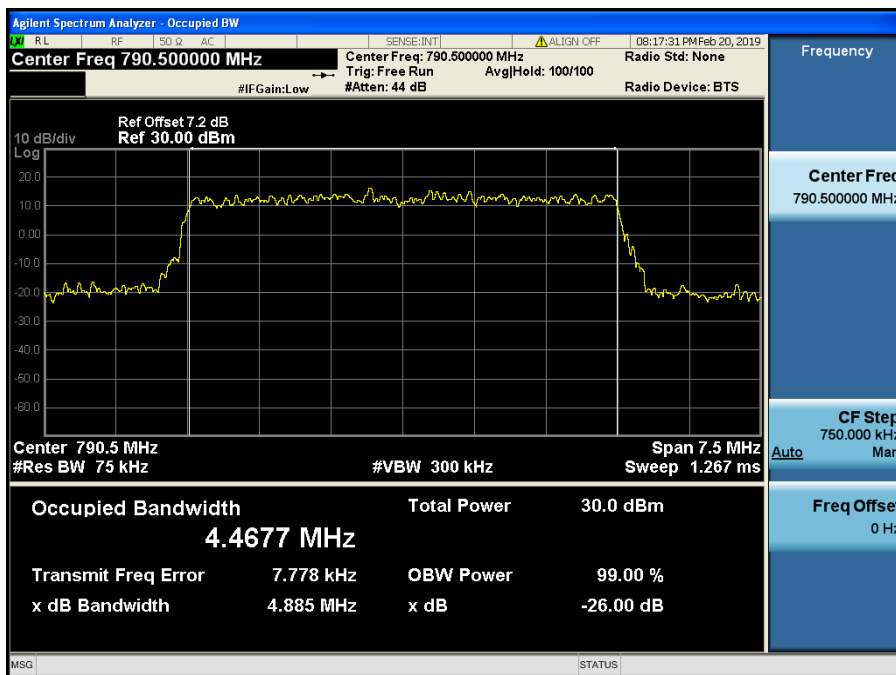

LTE Band 14 / 5 MHz / 16QAM - RB Size 25

8.1.5 LTE Band 5

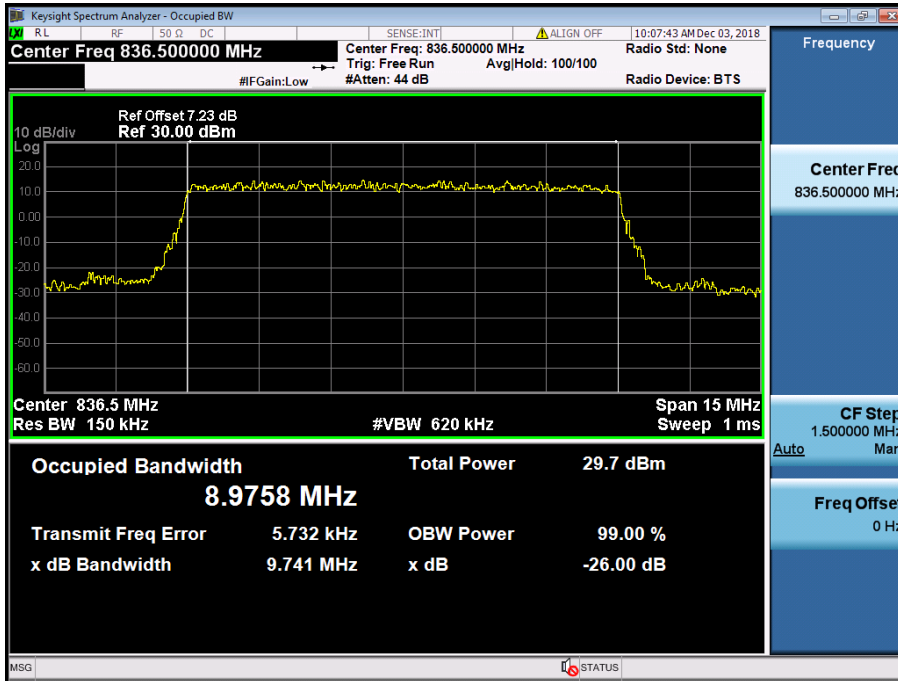

LTE Band 5 / 10 MHz / QPSK - RB Size 50

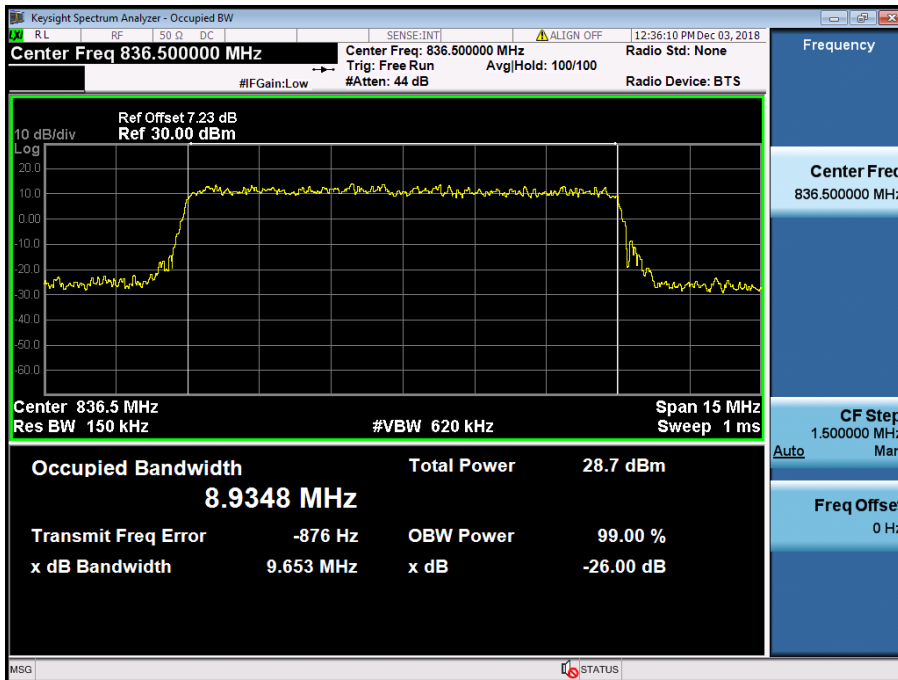

LTE Band 5 / 10 MHz / 16QAM - RB Size 50

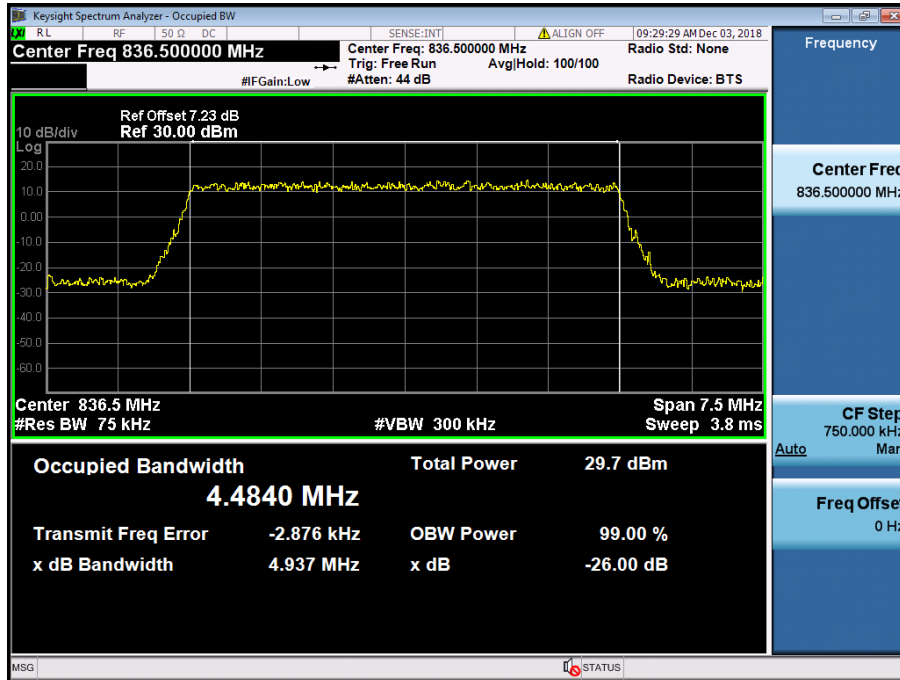

LTE Band 5 / 5 MHz / QPSK - RB Size 25

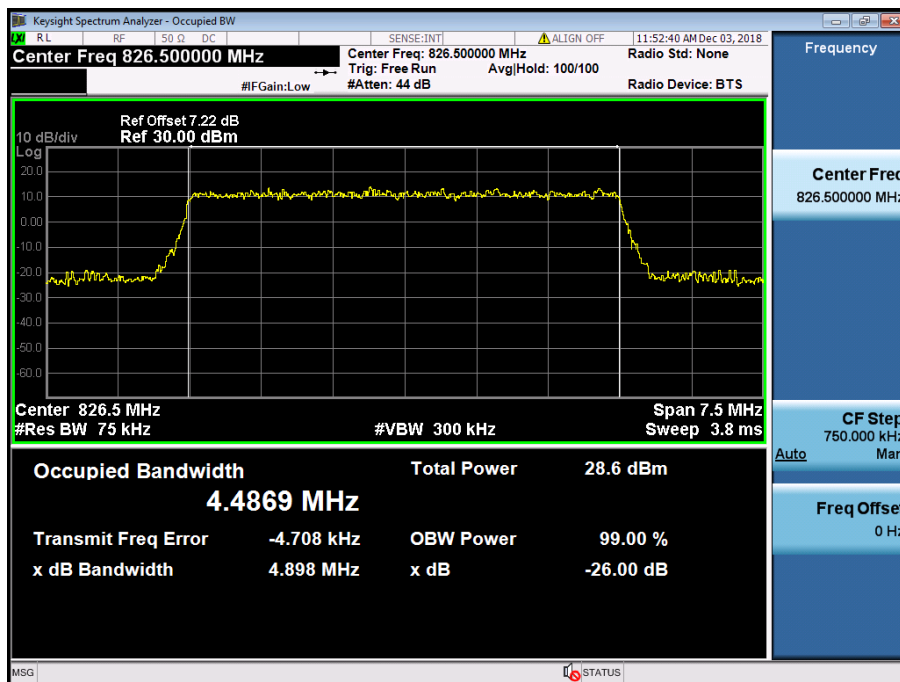

LTE Band 5 / 5 MHz / 16QAM - RB Size 25

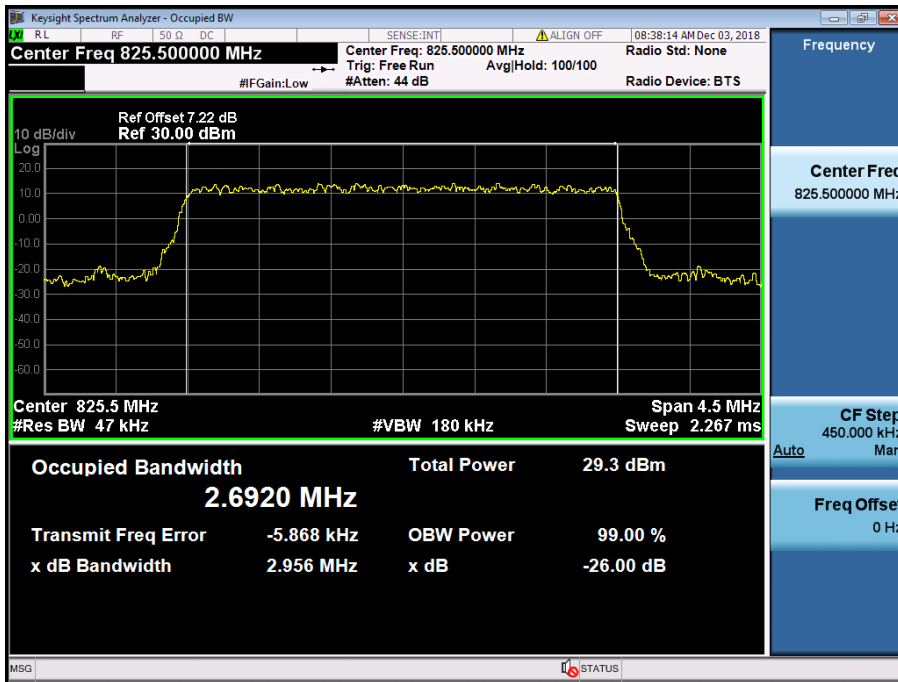

LTE Band 5 / 3 MHz / QPSK - RB Size 15

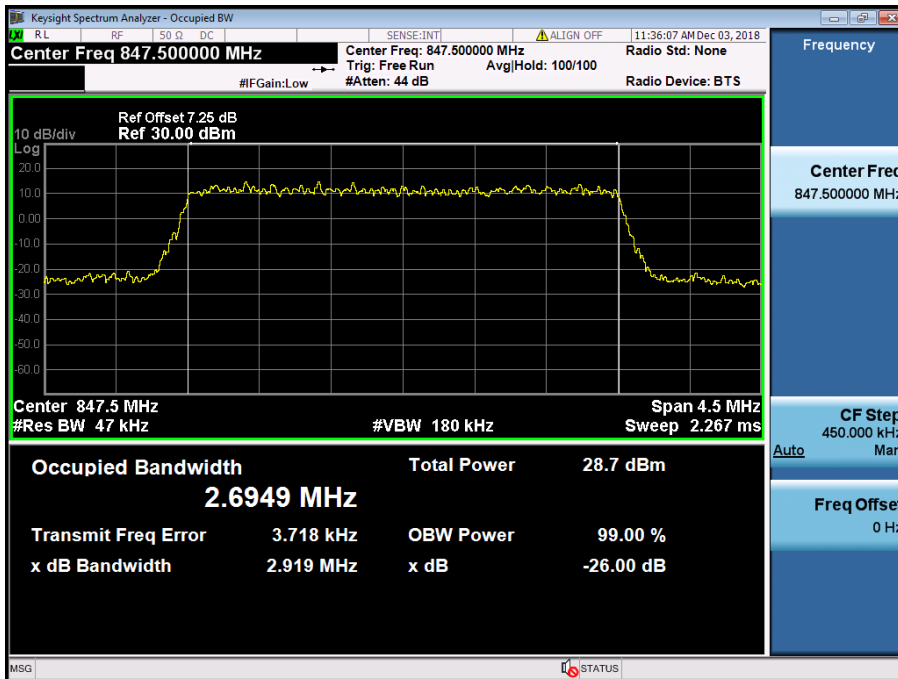

LTE Band 5 / 3 MHz / 16QAM - RB Size 15



LTE Band 5 / 1.4 MHz / QPSK - RB Size 6

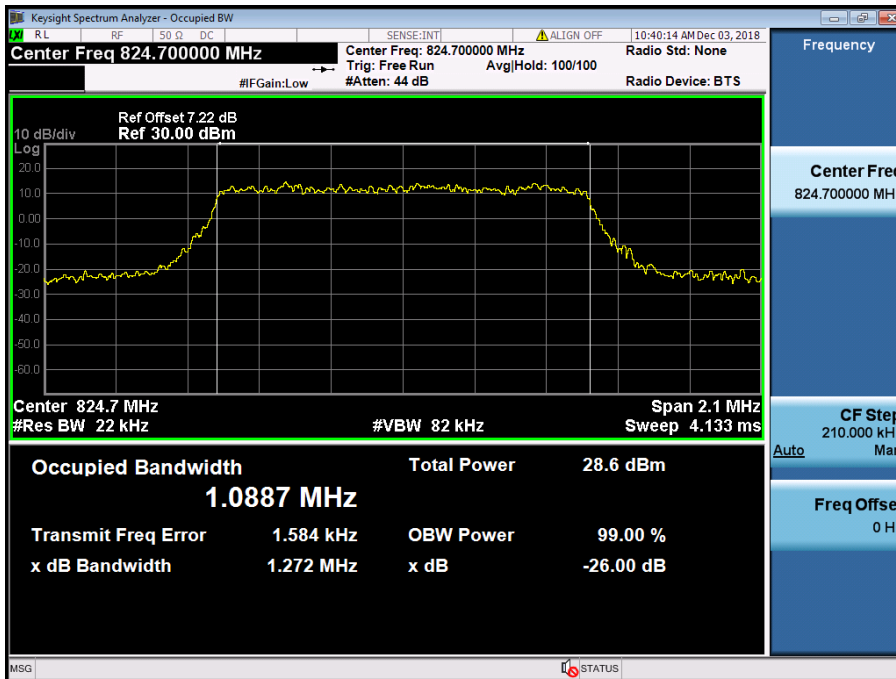

LTE Band 5 / 1.4 MHz / 16QAM - RB Size 6

8.1.6 LTE Band 4

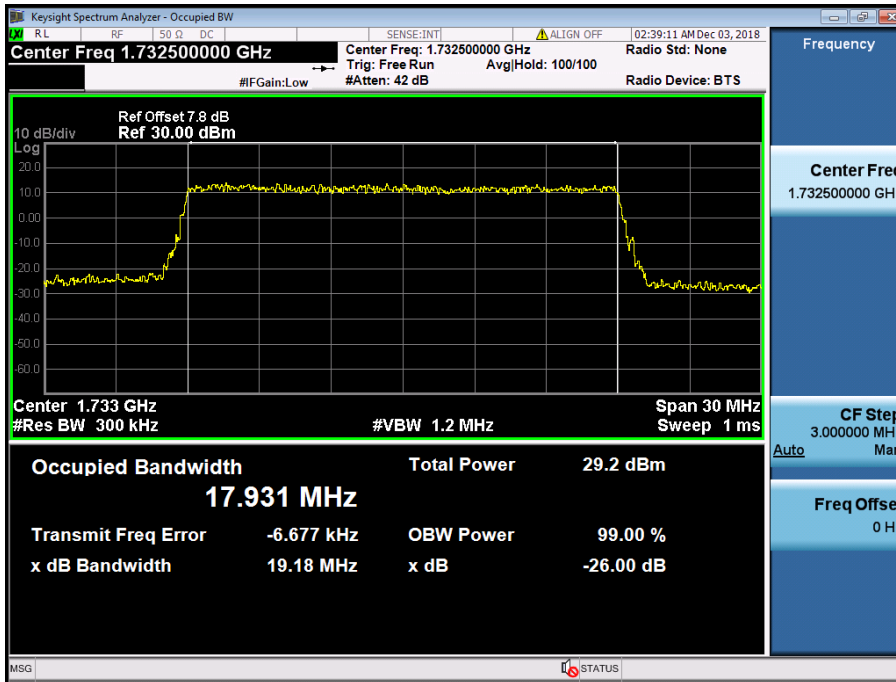

LTE Band 4 / 20 MHz / QPSK - RB Size 100

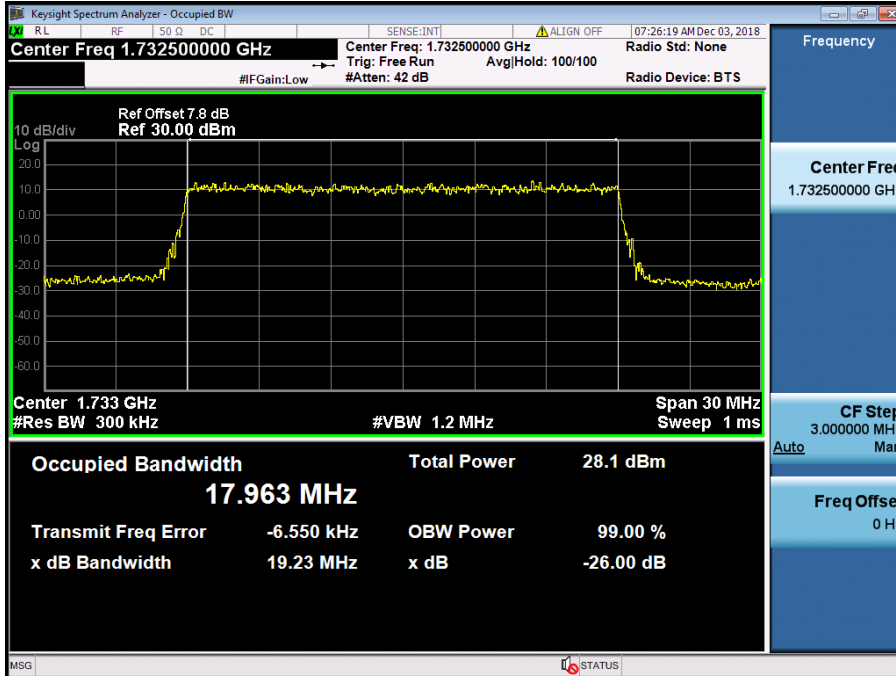

LTE Band 4 / 20 MHz / 16QAM - RB Size 100

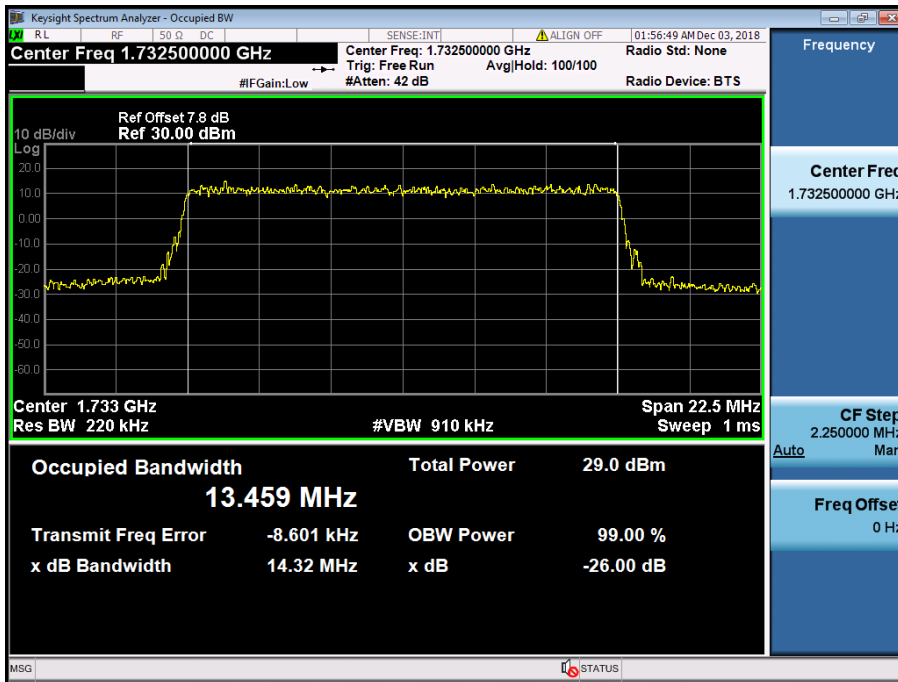

LTE Band 4 / 15 MHz / QPSK - RB Size 75

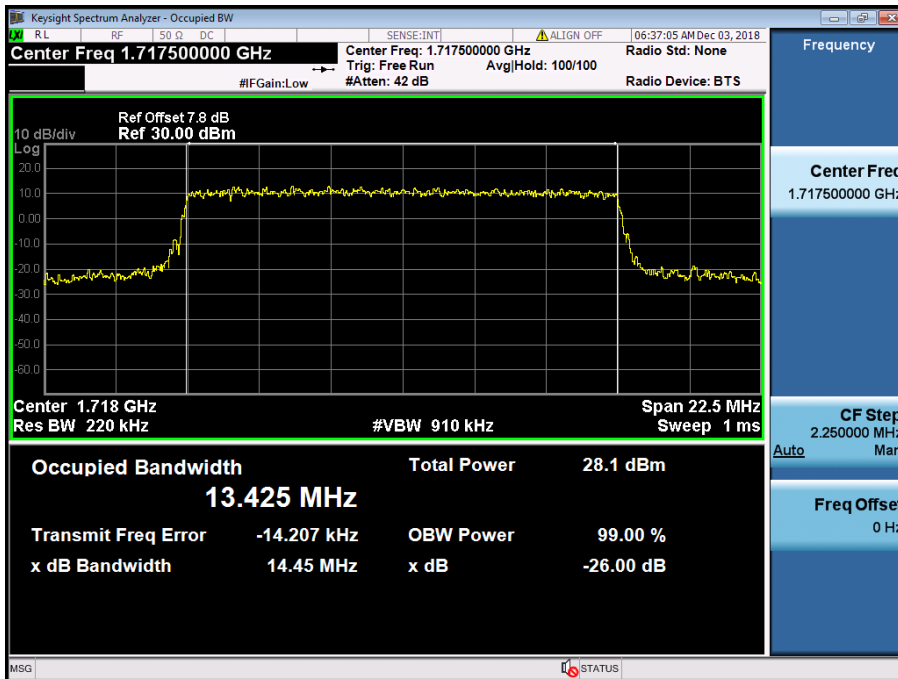

LTE Band 4 / 15 MHz / 16QAM - RB Size 75

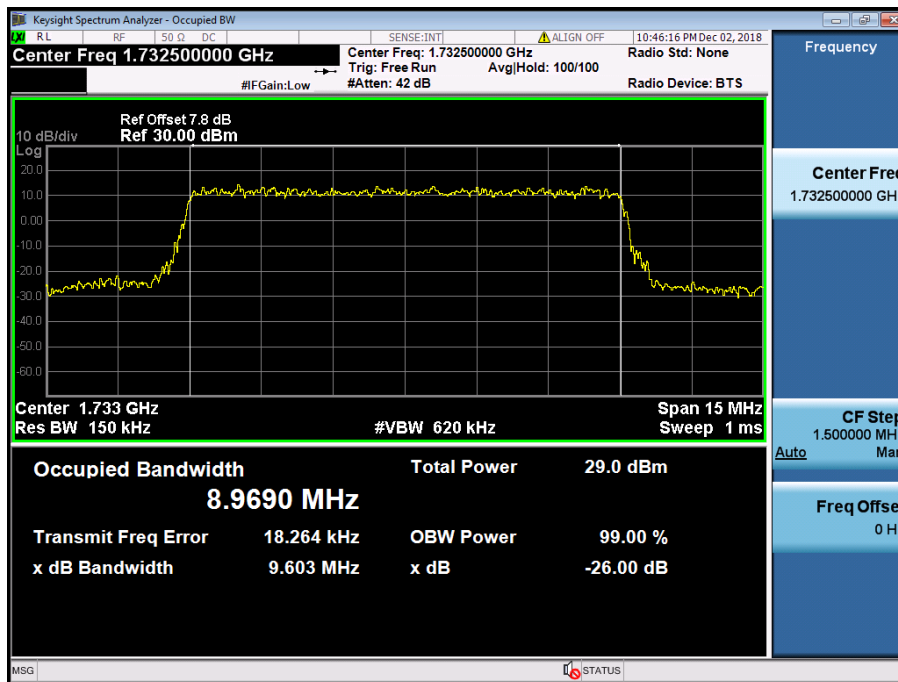

LTE Band 4 / 10 MHz / QPSK - RB Size 50

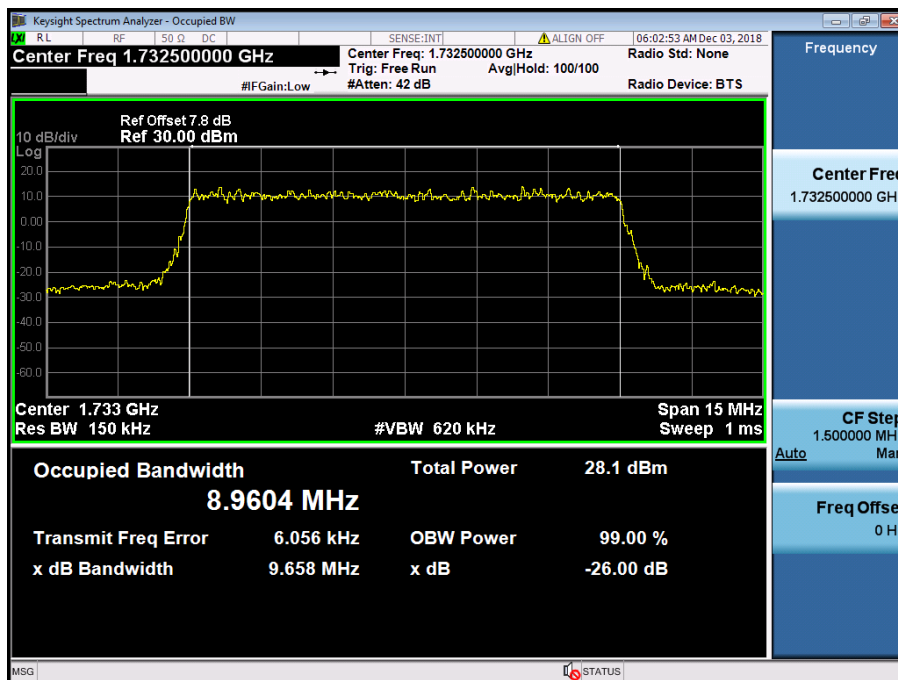

LTE Band 4 / 10 MHz / 16QAM - RB Size 50

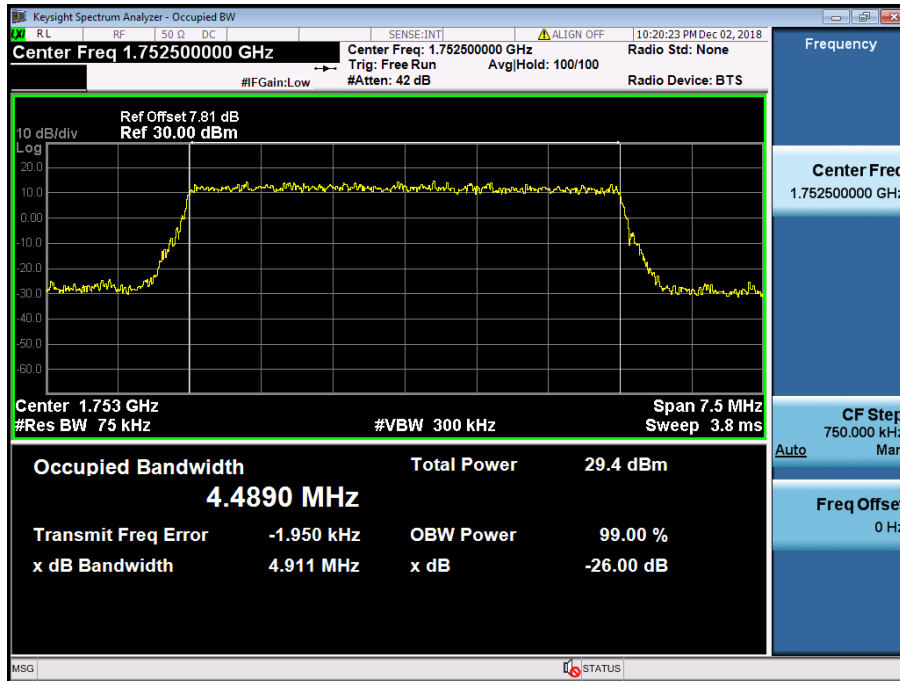

LTE Band 4 / 5 MHz / QPSK - RB Size 25

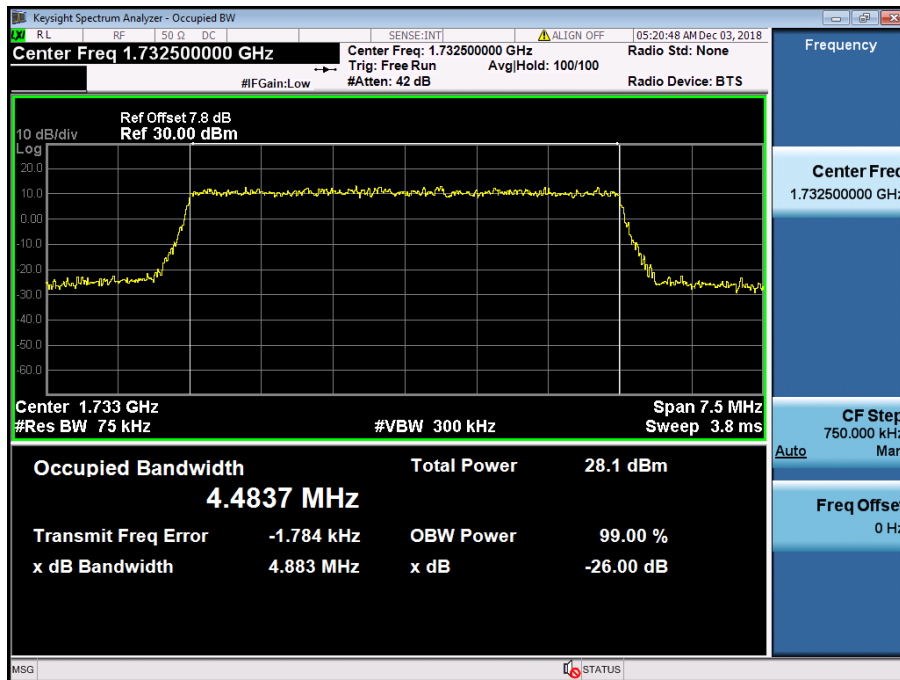

LTE Band 4 / 5 MHz / 16QAM - RB Size 25

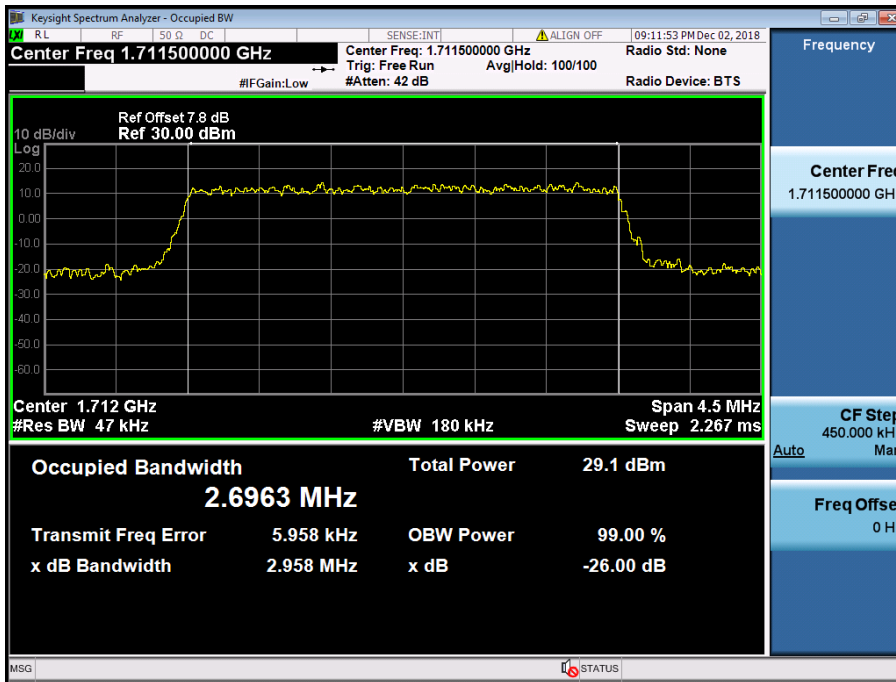

LTE Band 4 / 3 MHz / QPSK - RB Size 15

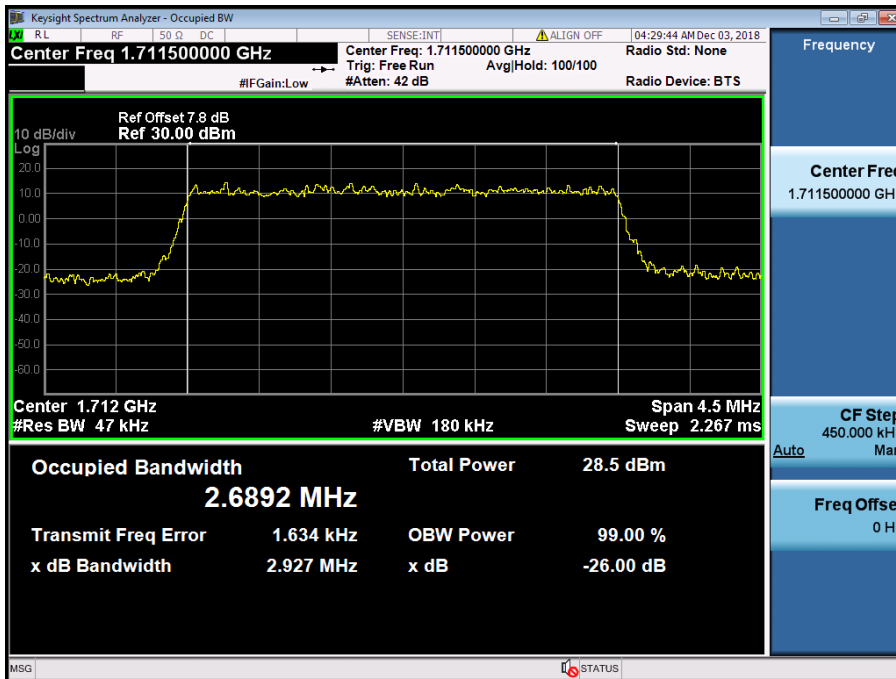

LTE Band 4 / 3 MHz / 16QAM - RB Size 15

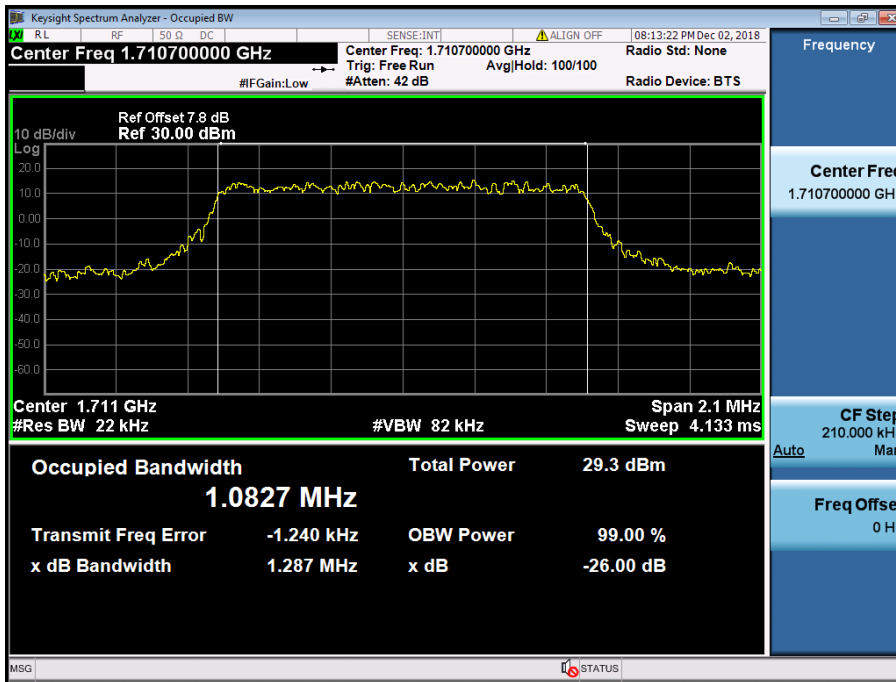

LTE Band 4 / 1.4 MHz / QPSK - RB Size 6

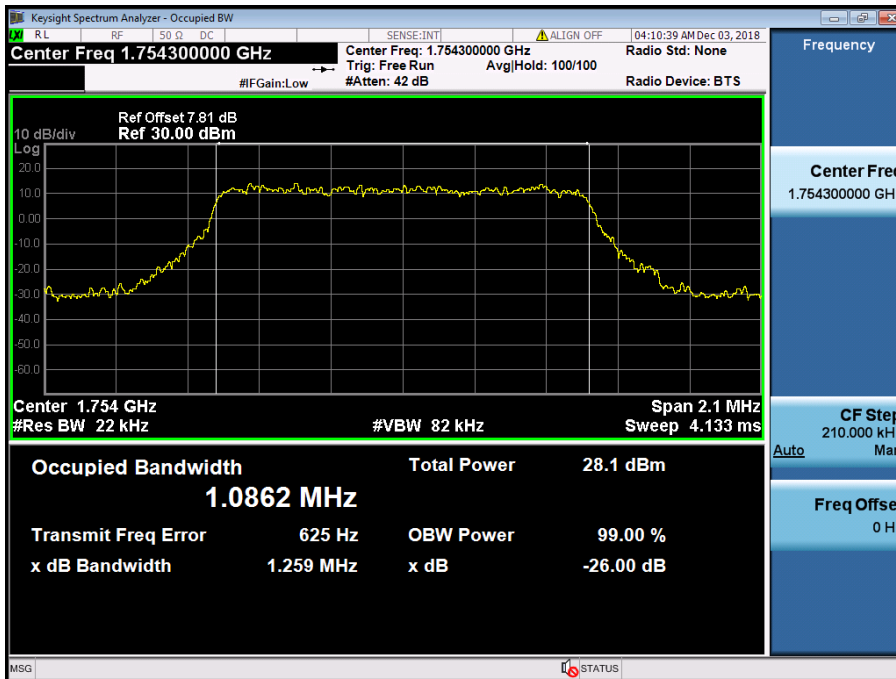

LTE Band 4 / 1.4 MHz / 16QAM - RB Size 6

8.1.7 LTE Band 2

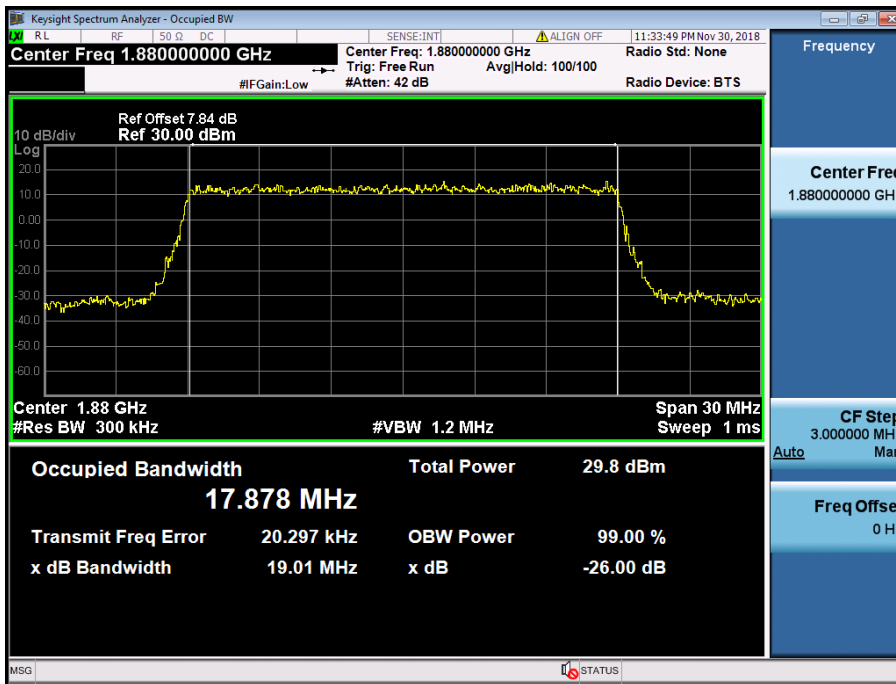

LTE Band 2 / 20 MHz / QPSK - RB Size 100

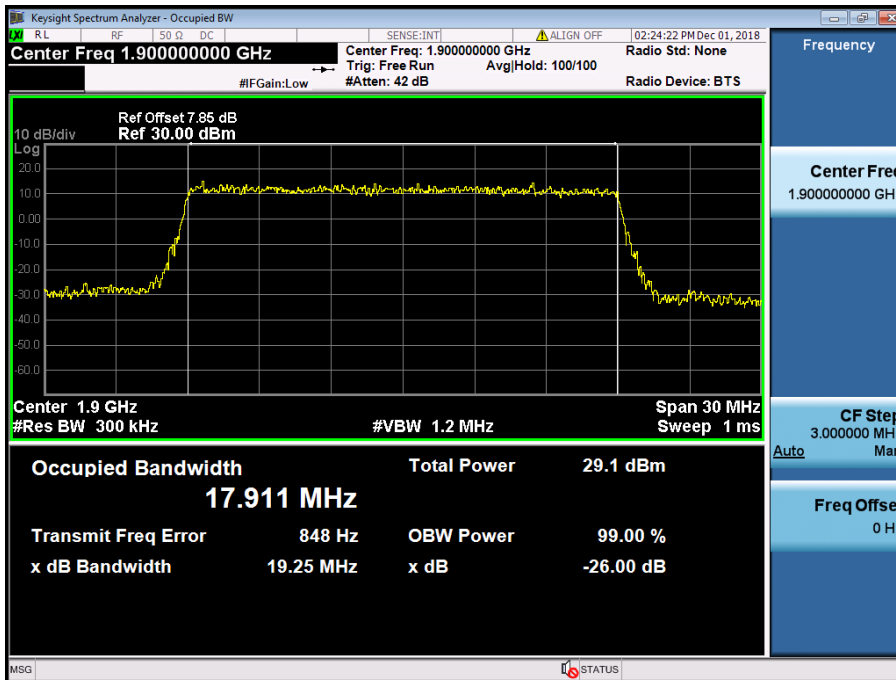

LTE Band 2 / 20 MHz / 16QAM - RB Size 100

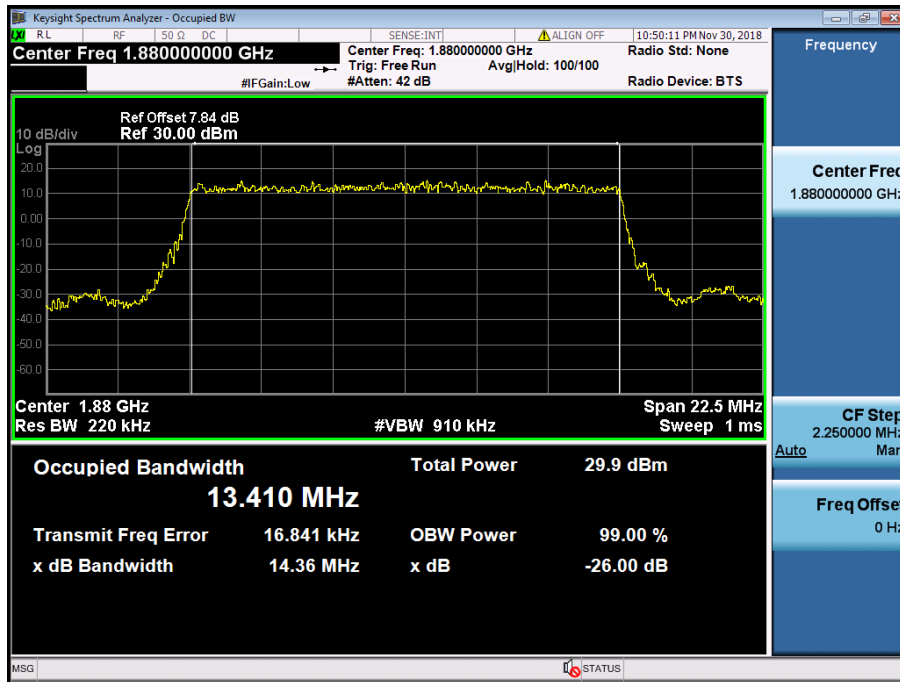

LTE Band 2 / 15 MHz / QPSK - RB Size 75

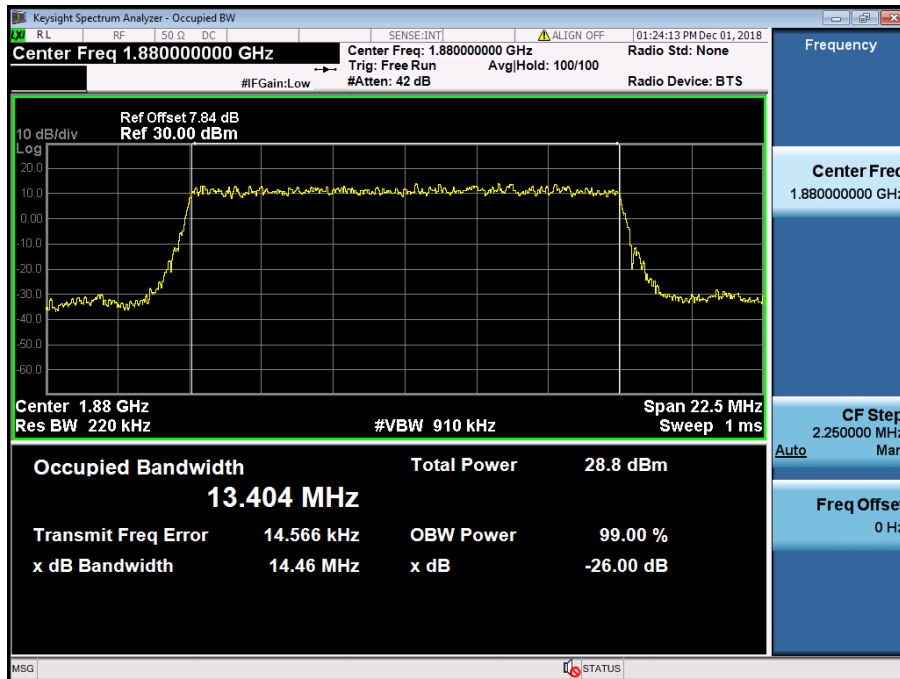

LTE Band 2 / 15 MHz / 16QAM - RB Size 75

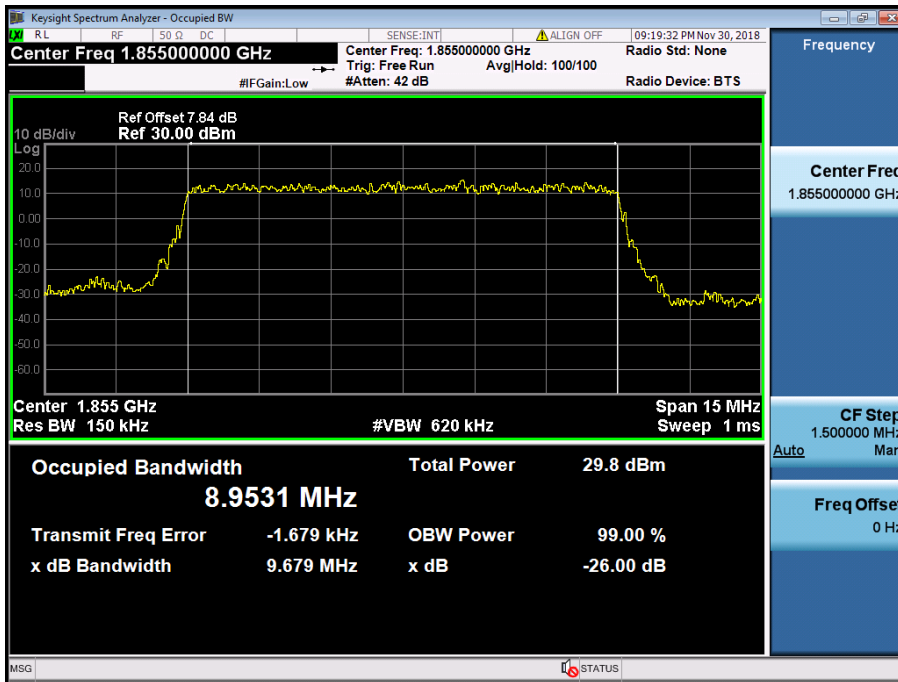

LTE Band 2 / 10 MHz / QPSK - RB Size 50

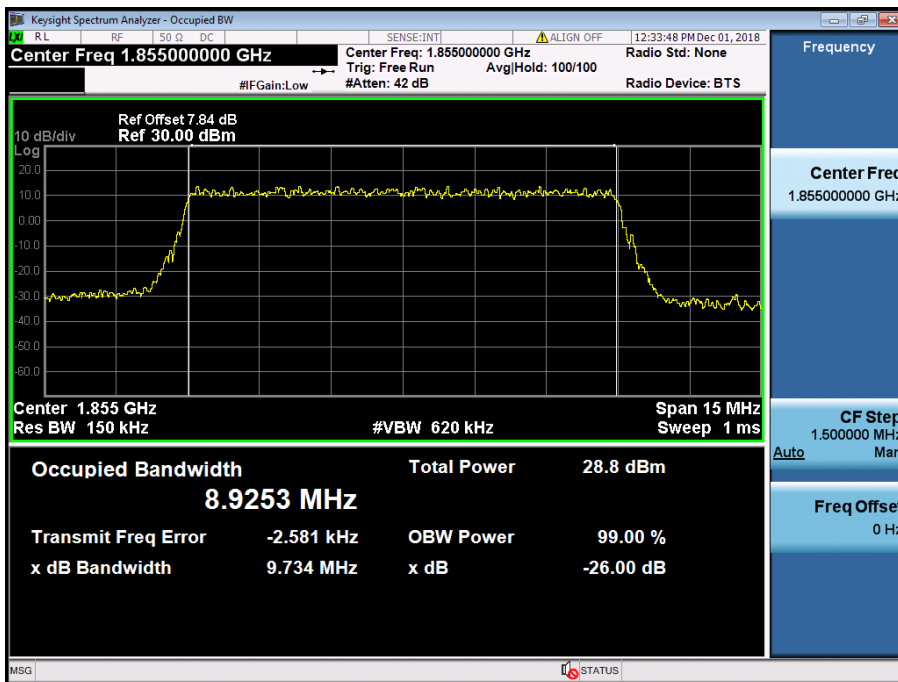

LTE Band 2 / 10 MHz / 16QAM - RB Size 50

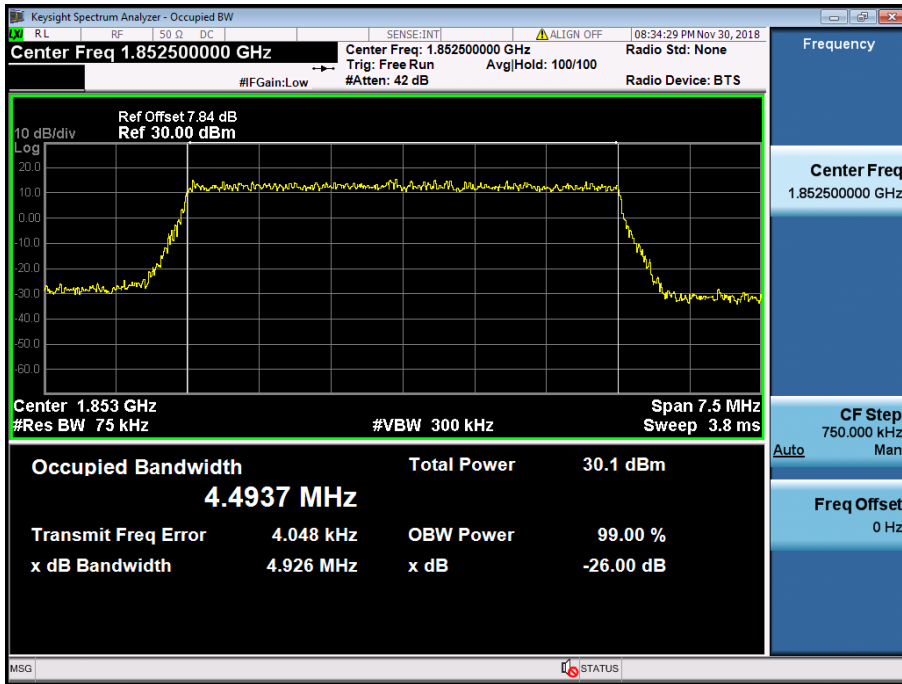

LTE Band 2 / 5 MHz / QPSK - RB Size 25

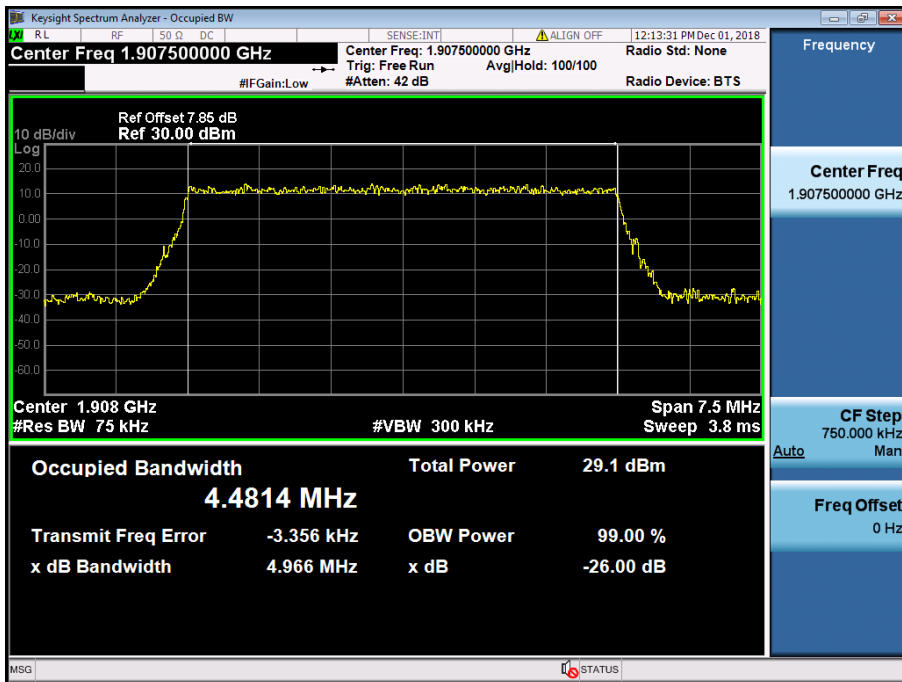

LTE Band 2 / 5 MHz / 16QAM - RB Size 25

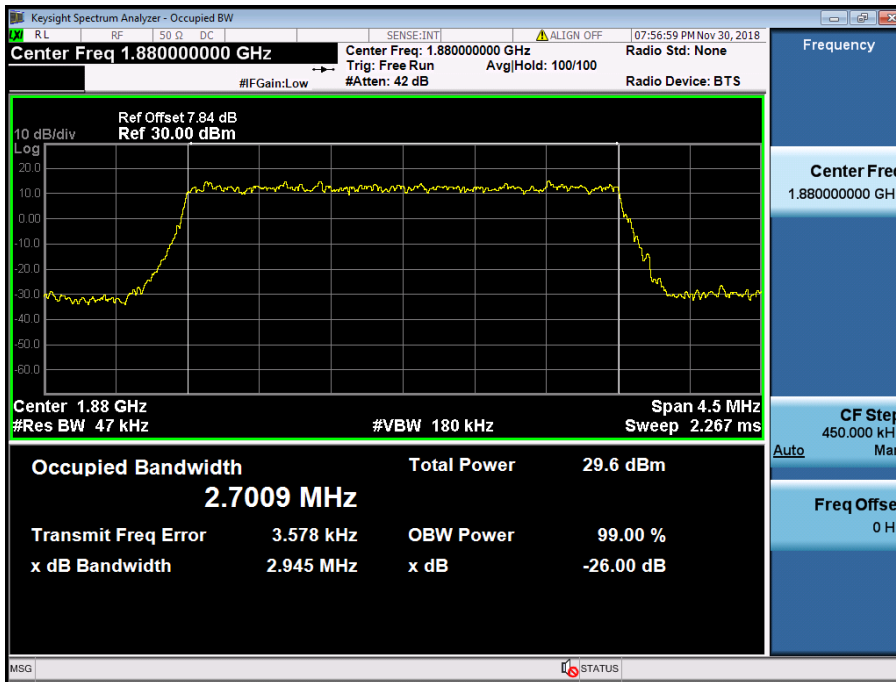

LTE Band 2 / 3 MHz / QPSK - RB Size 15

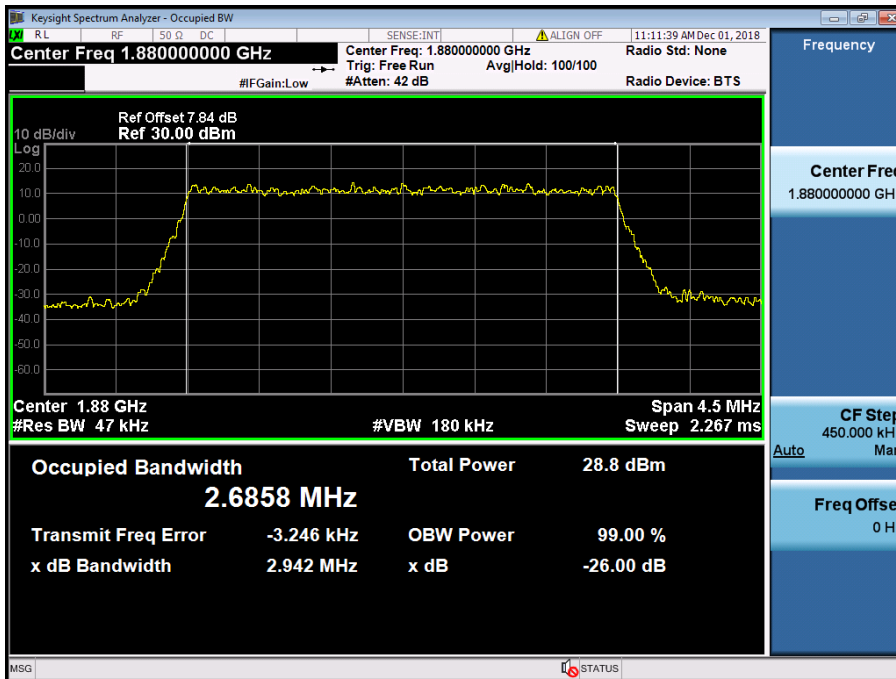

LTE Band 2 / 3 MHz / 16QAM - RB Size 15

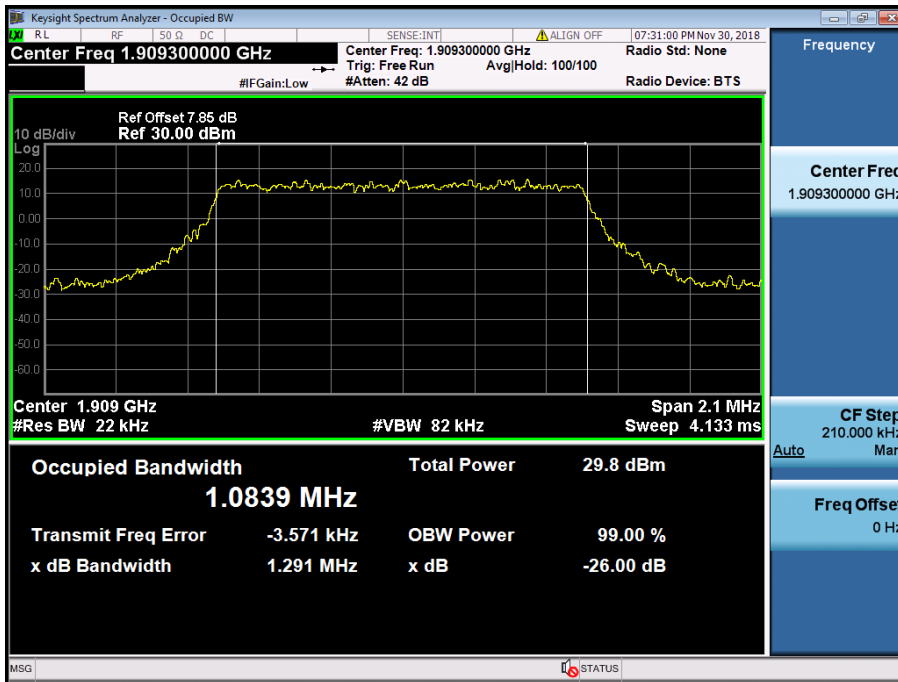

LTE Band 2 / 1.4 MHz / QPSK - RB Size 6

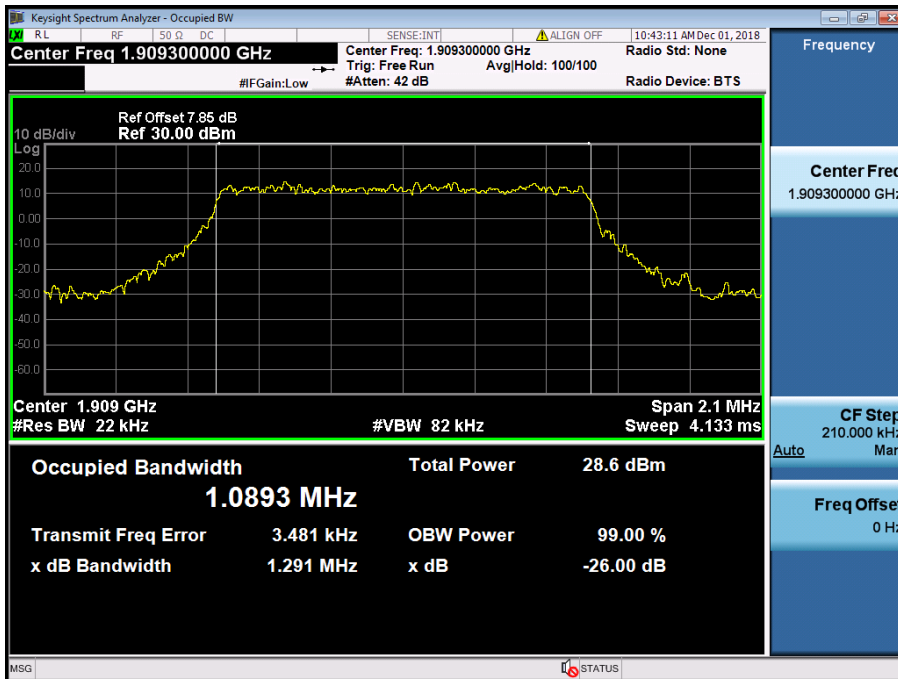

LTE Band 2 / 1.4 MHz / 16QAM - RB Size 6

8.1.8 LTE Band 41

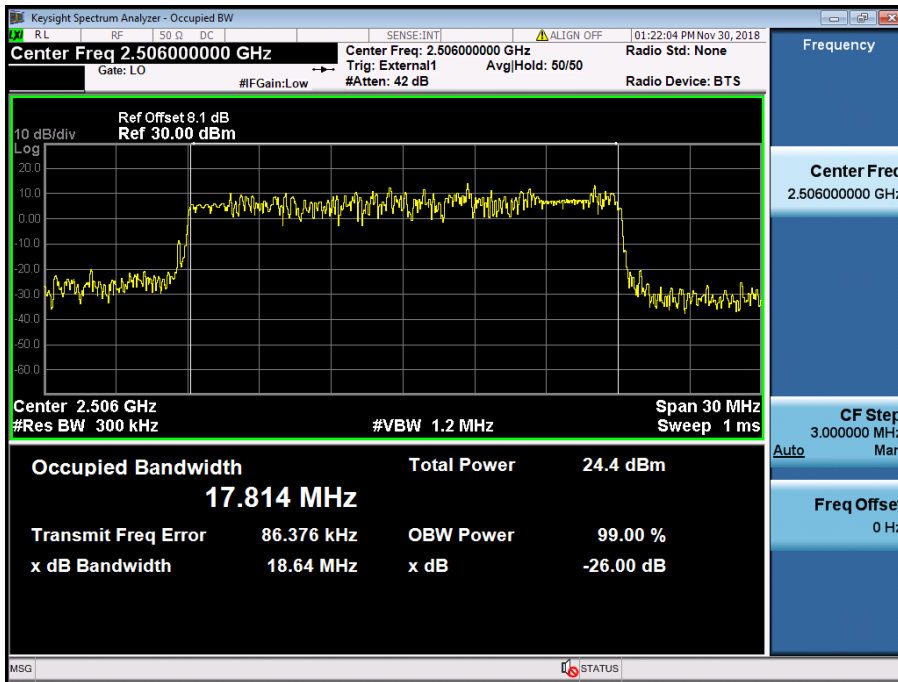

LTE Band 41 / 20 MHz / QPSK - RB Size 100

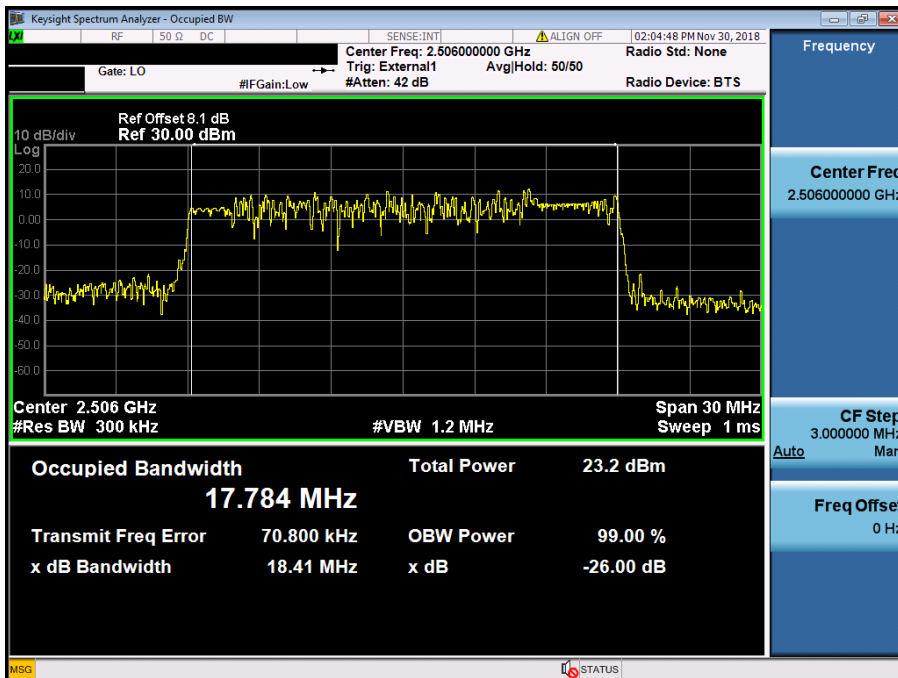

LTE Band 41 / 20 MHz / 16QAM - RB Size 100

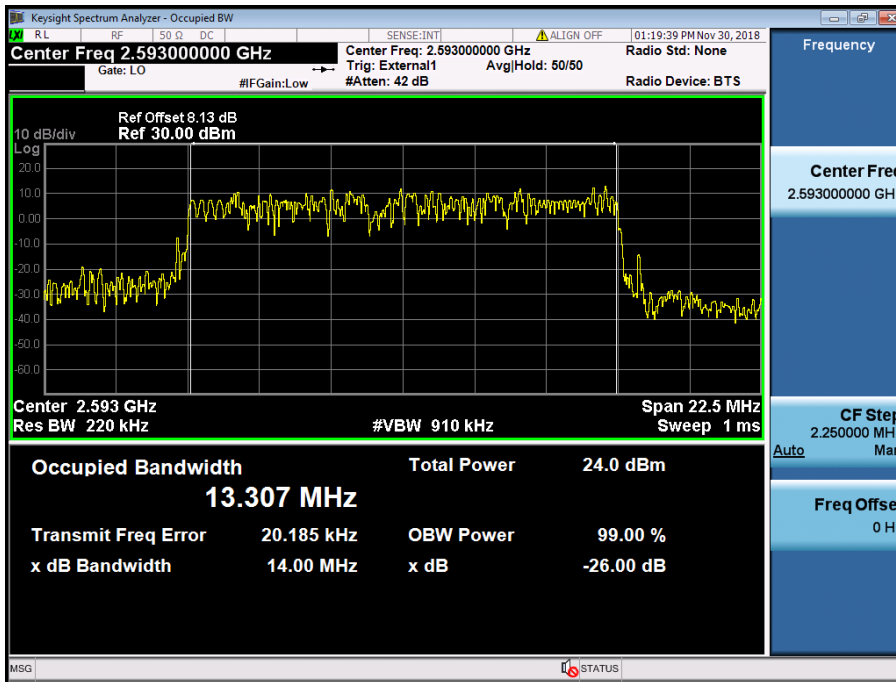

LTE Band 41 / 15 MHz / QPSK - RB Size 75

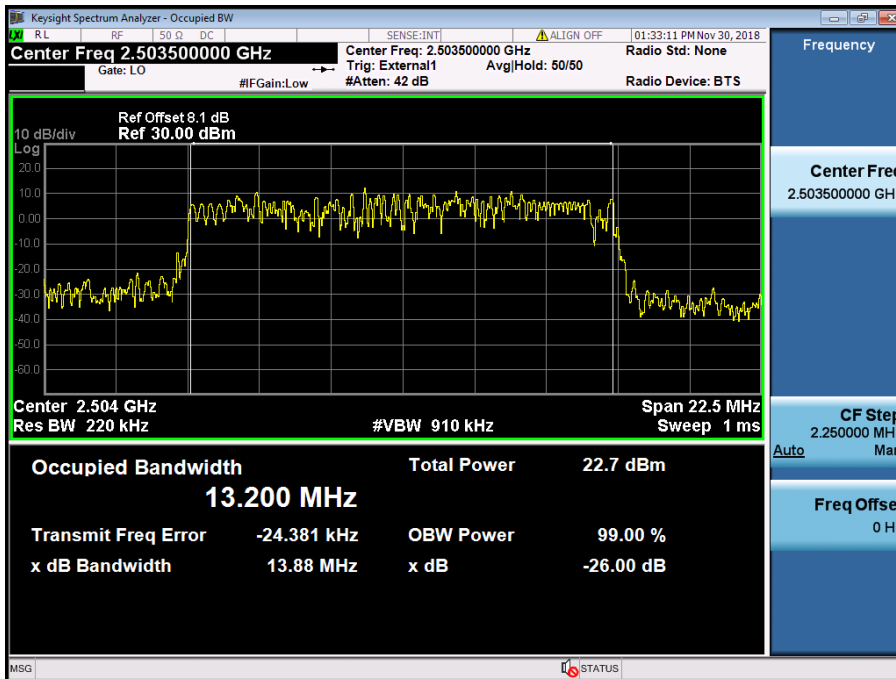

LTE Band 41 / 15 MHz / 16QAM - RB Size 75

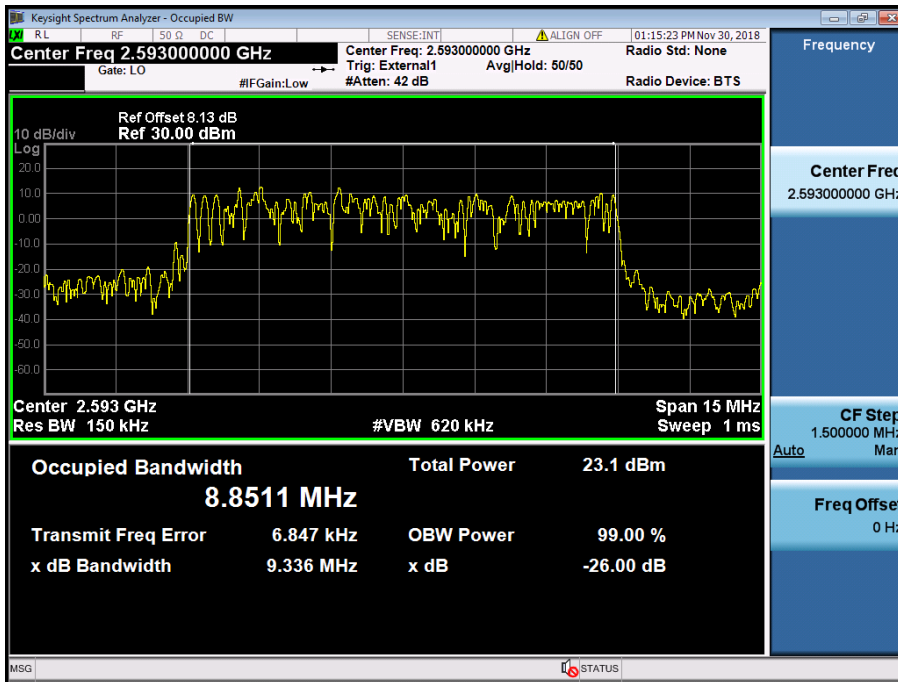

LTE Band 41 / 10 MHz / QPSK - RB Size 50

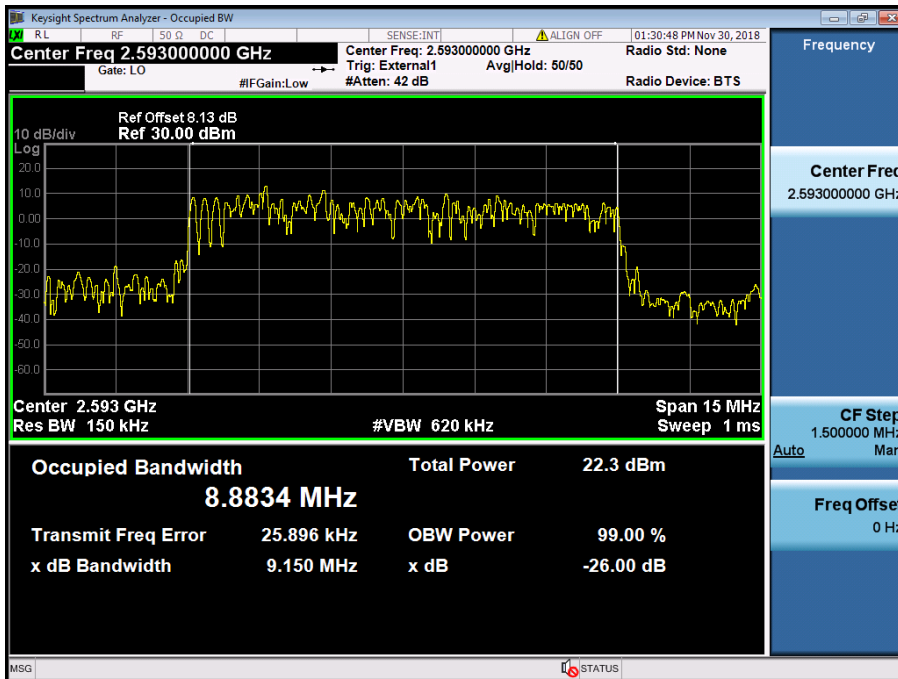

LTE Band 41 / 10 MHz / 16QAM - RB Size 50

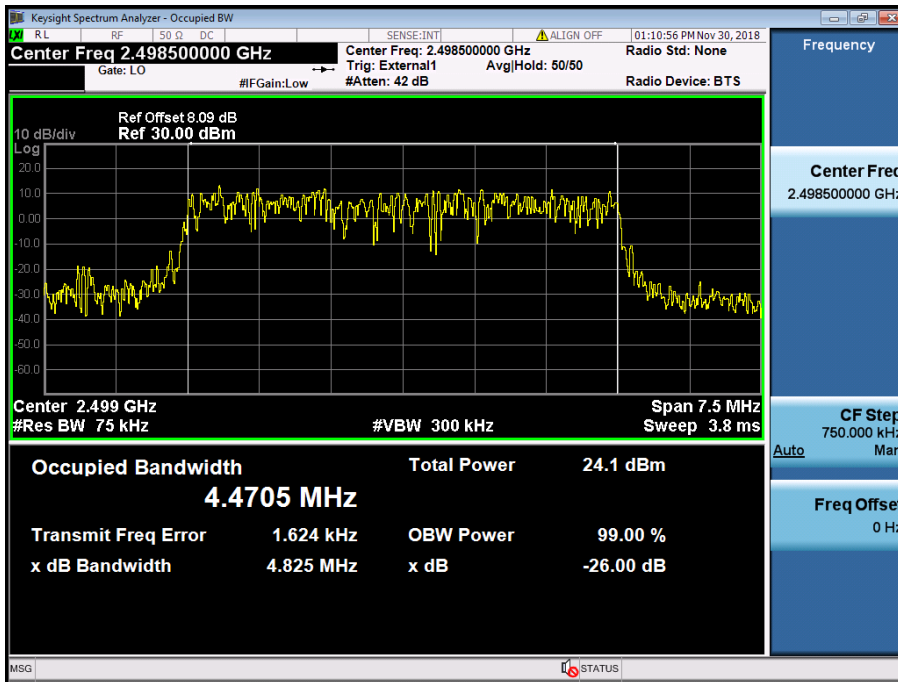

LTE Band 41 / 5 MHz / QPSK - RB Size 25

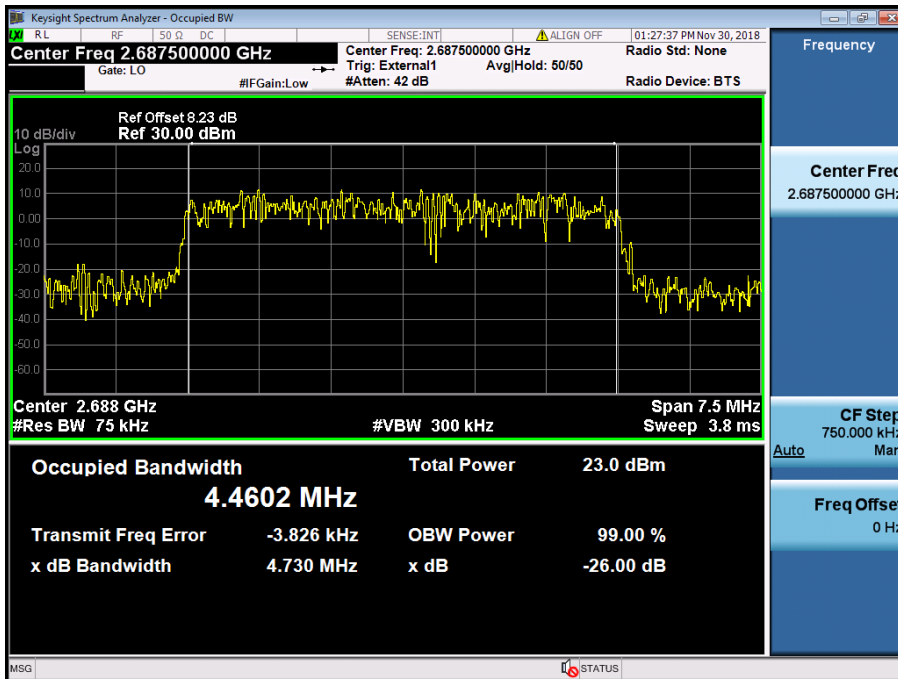

LTE Band 41 / 5 MHz / 16QAM - RB Size 25

8.1.9 LTE Band 7

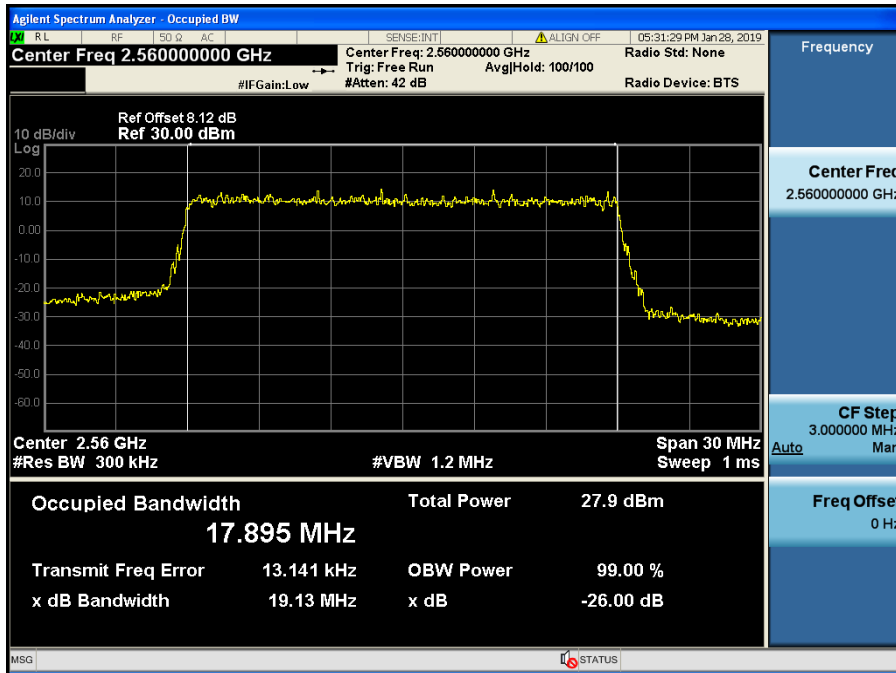

LTE Band 7 / 20 MHz / QPSK - RB Size 100

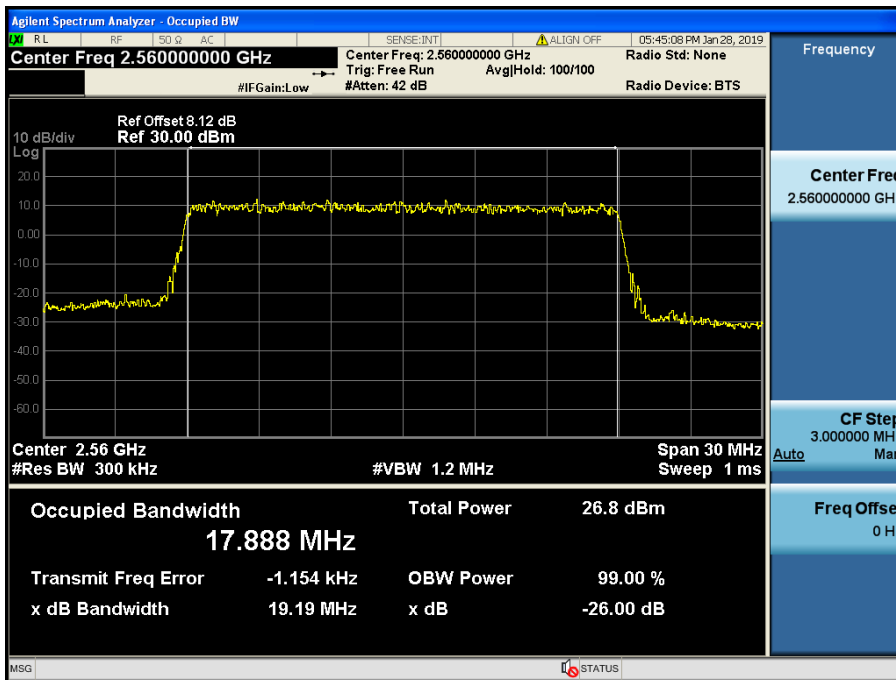

LTE Band 7 / 20 MHz / 16QAM - RB Size 100

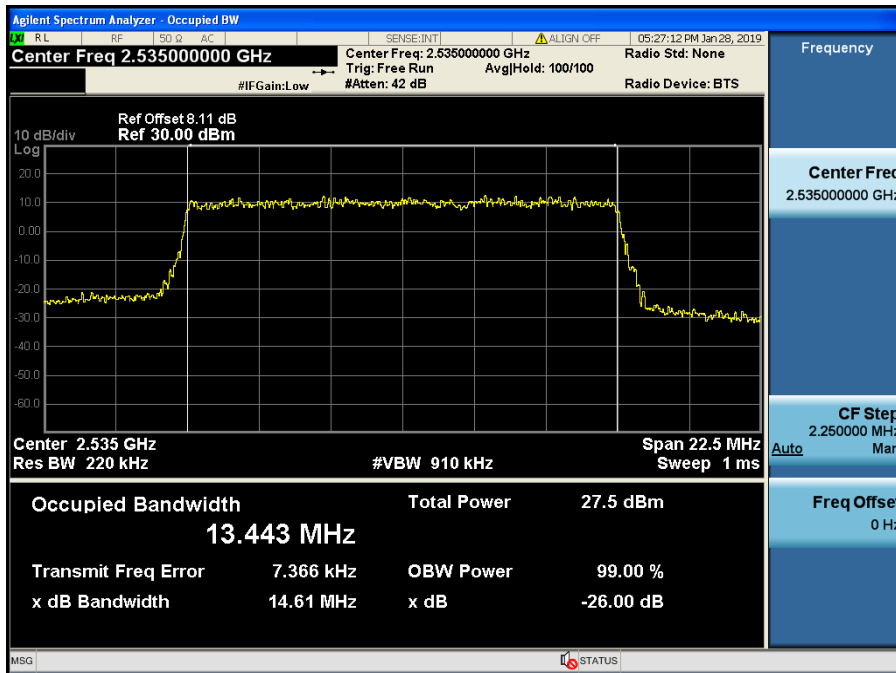

LTE Band 7 / 15 MHz / QPSK - RB Size 75

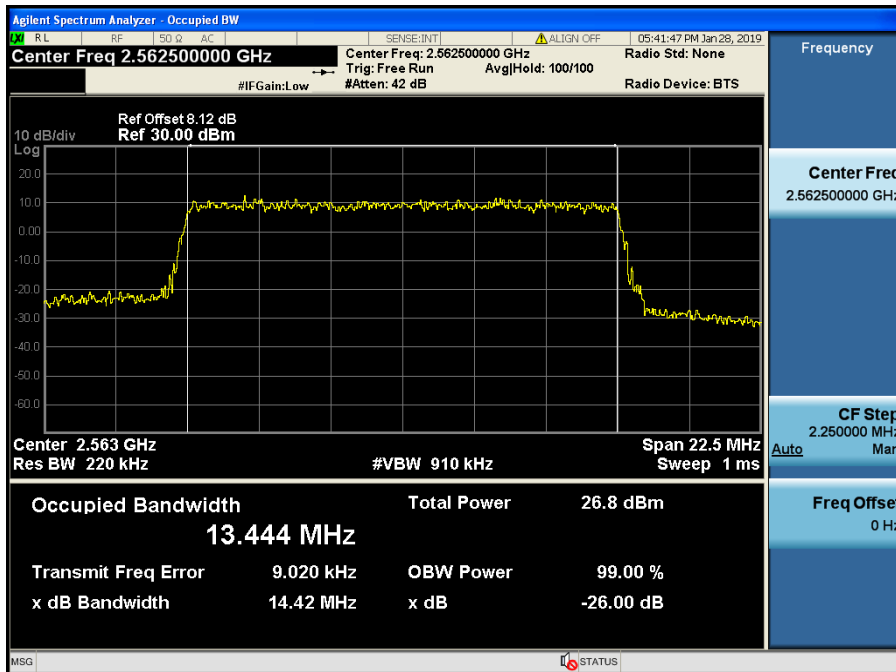

LTE Band 7 / 15 MHz / 16QAM - RB Size 75

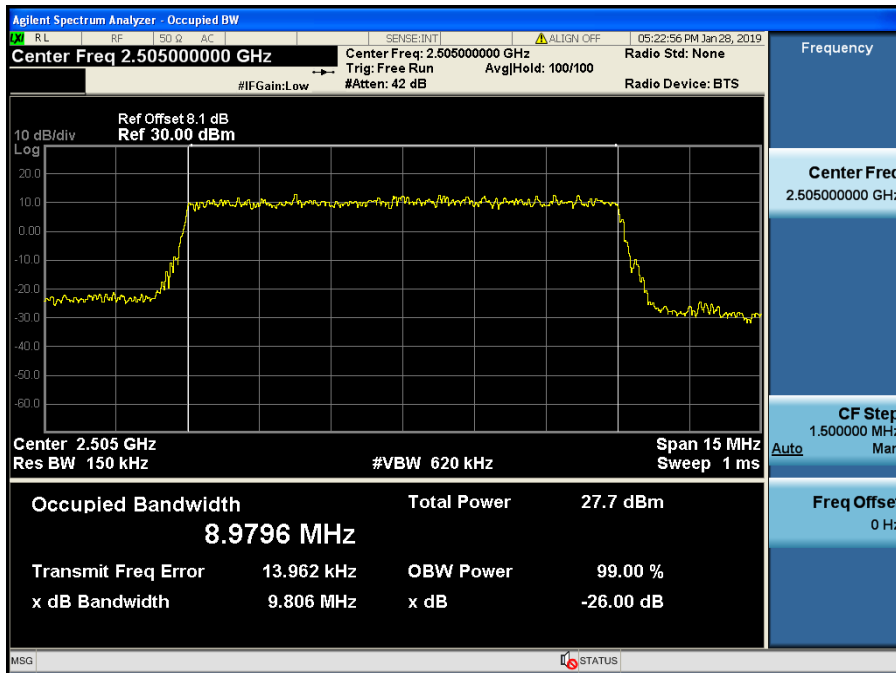

LTE Band 7 / 10 MHz / QPSK - RB Size 50

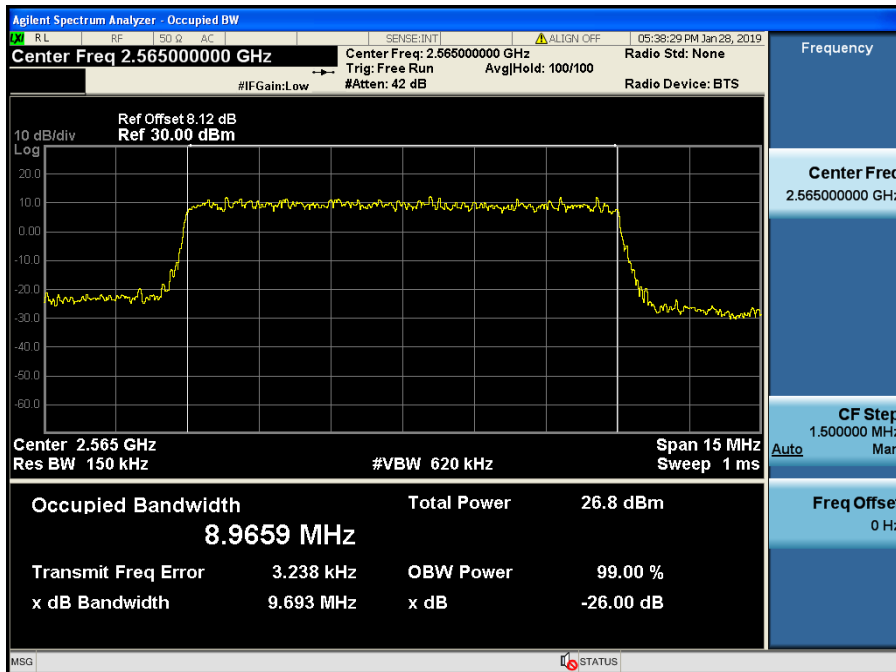

LTE Band 7 / 10 MHz / 16QAM - RB Size 50

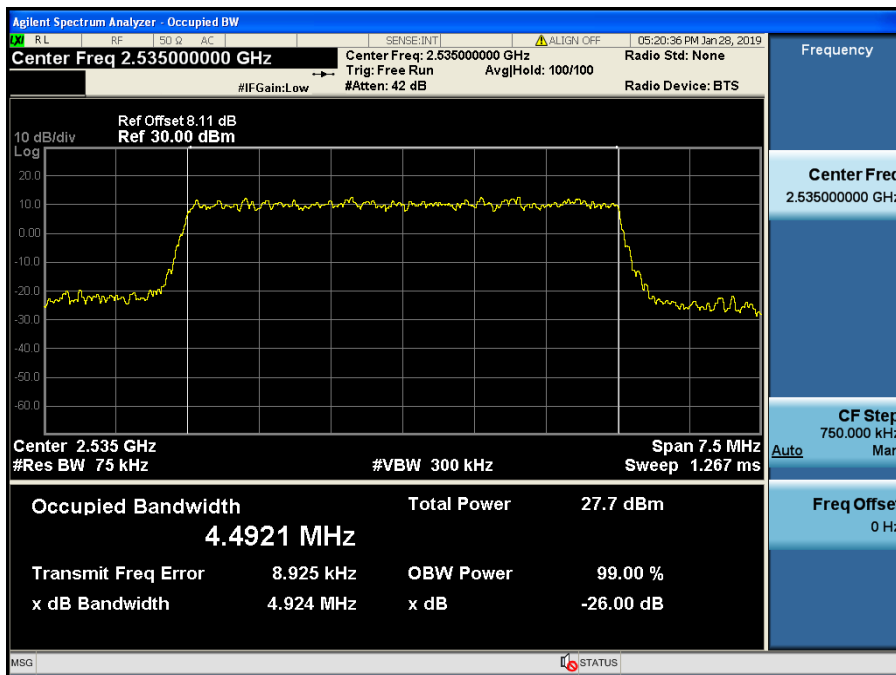

LTE Band 7 / 5 MHz / QPSK - RB Size 25

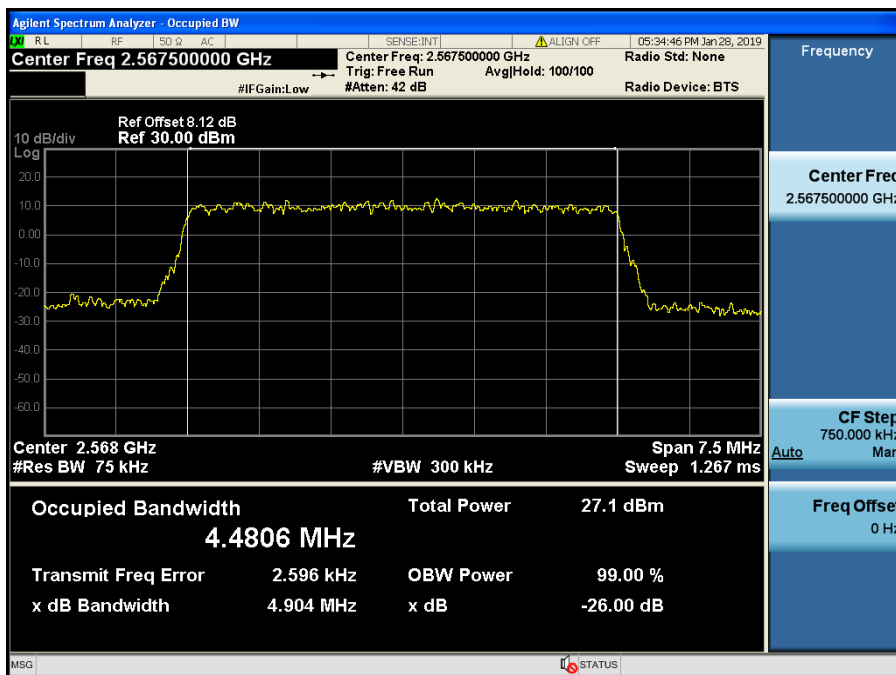

LTE Band 7 / 5 MHz / 16QAM - RB Size 25

8.2 PEAK TO AVERAGE RATIO

8.2.1 LTE Band 12, 17

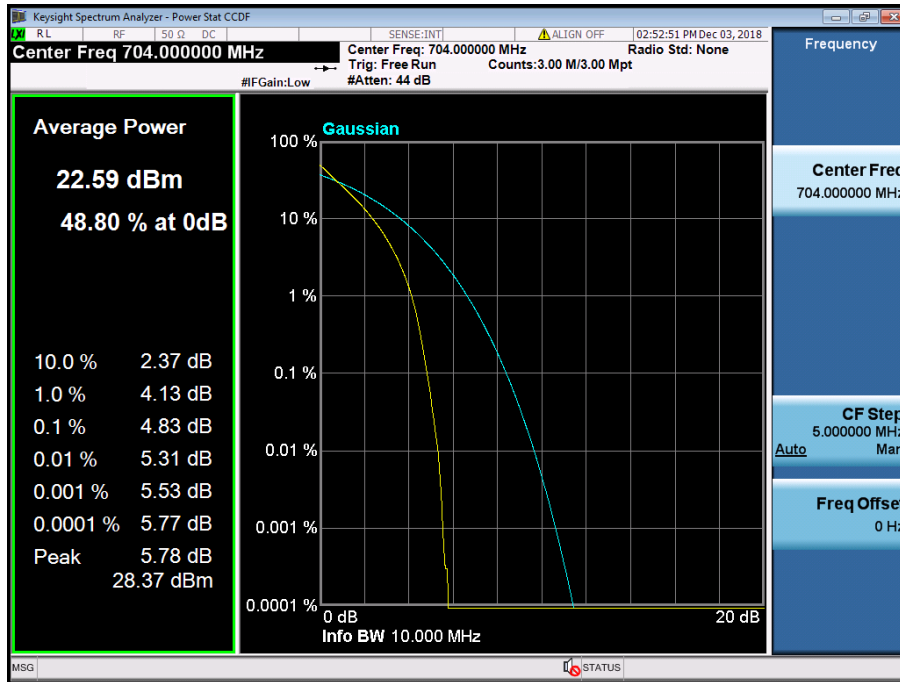

LTE Band 12, 17 / 10 MHz / QPSK - RB Size 50

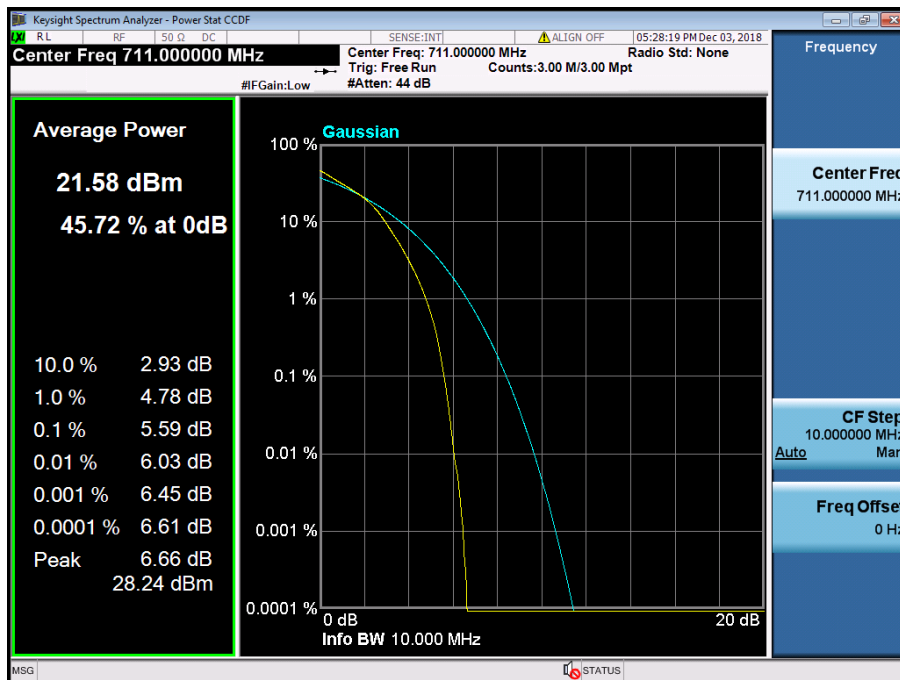

LTE Band 12, 17 / 10 MHz / 16QAM - RB Size 50

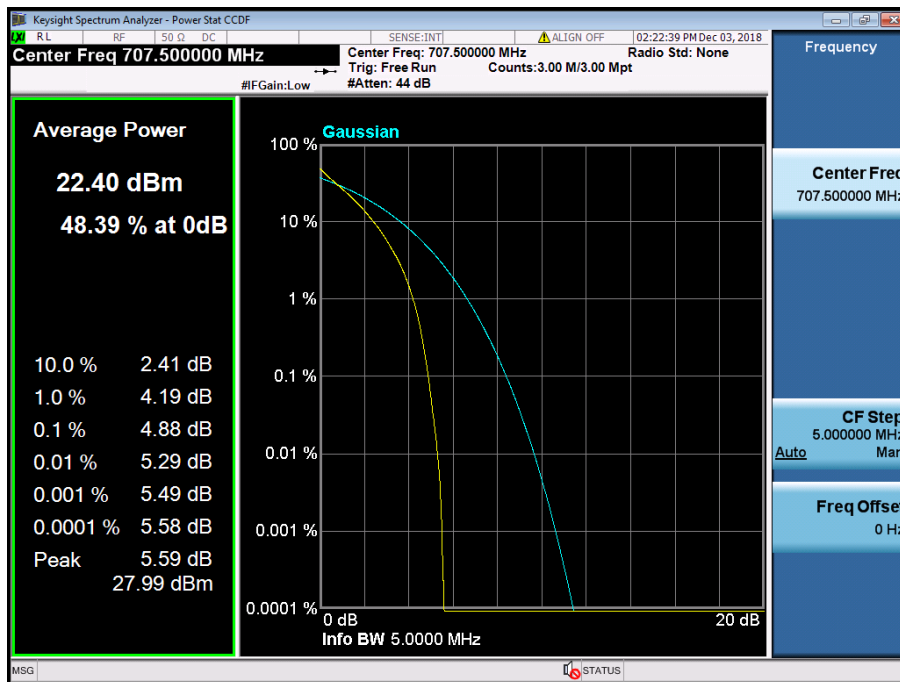

LTE Band 12, 17 / 5 MHz / QPSK - RB Size 25

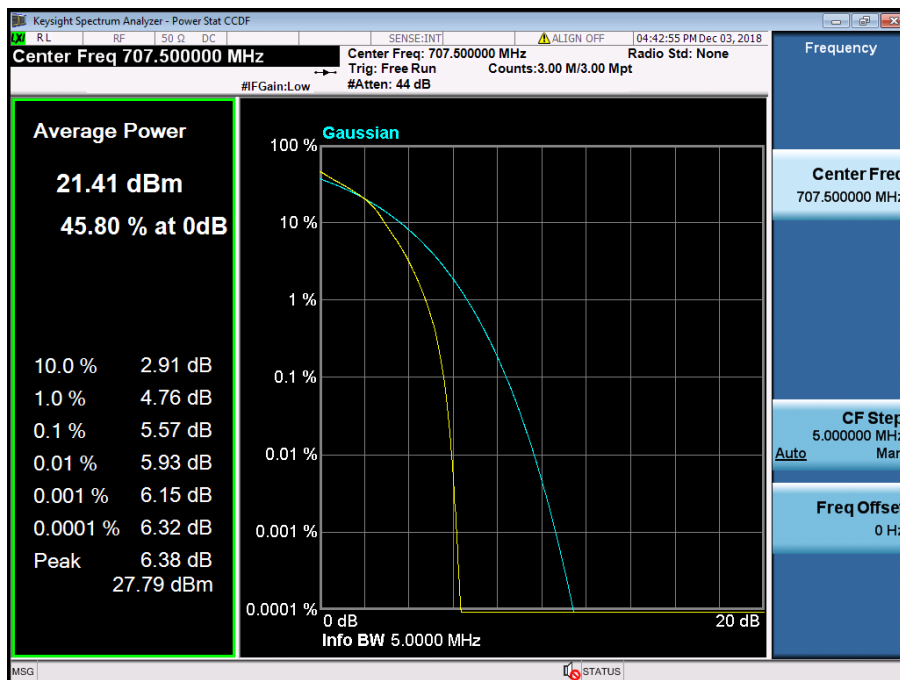

LTE Band 12, 17 / 5 MHz / 16QAM - RB Size 25

8.2.2 LTE Band 12

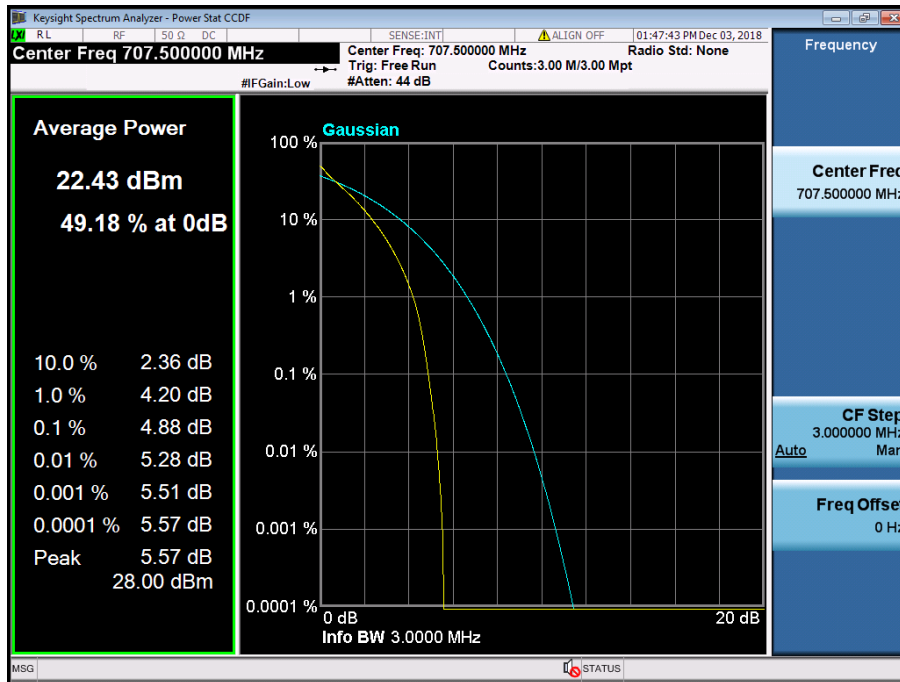

LTE Band 12 / 3 MHz / QPSK - RB Size 15

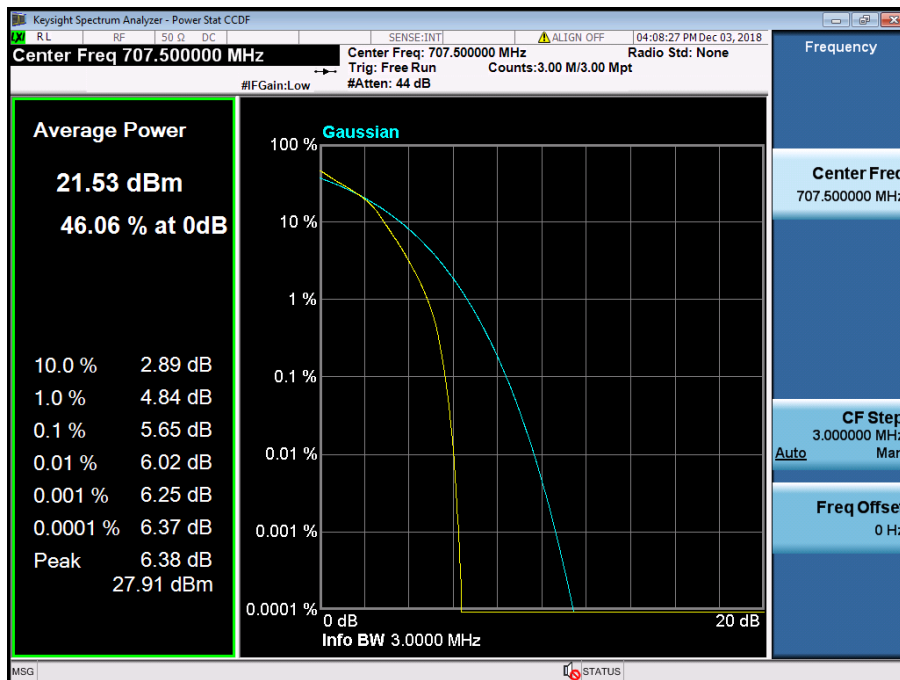

LTE Band 12 / 3 MHz / 16QAM - RB Size 15

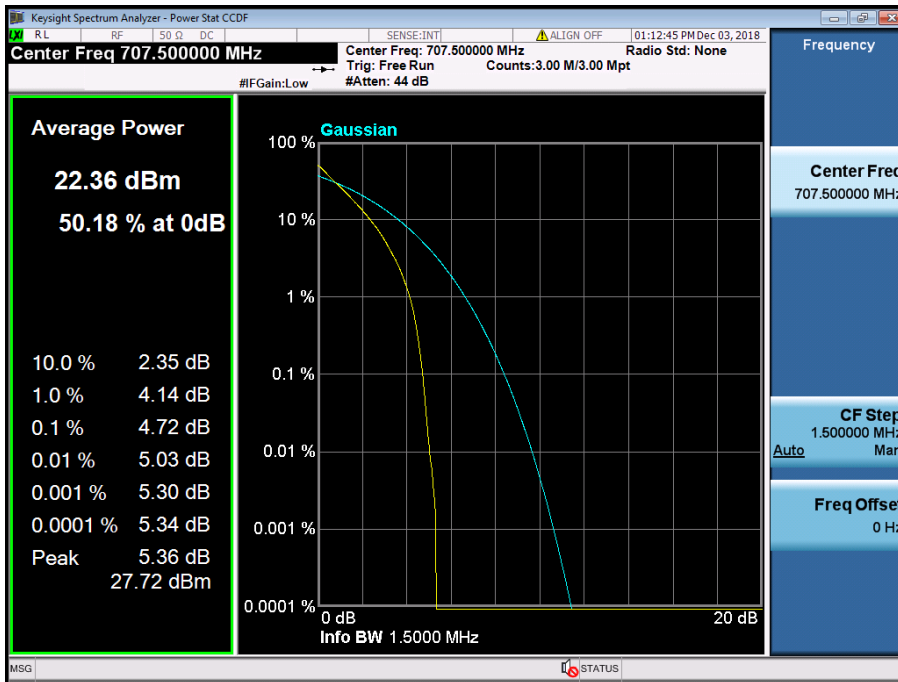

LTE Band 12 / 1.4 MHz / QPSK - RB Size 6

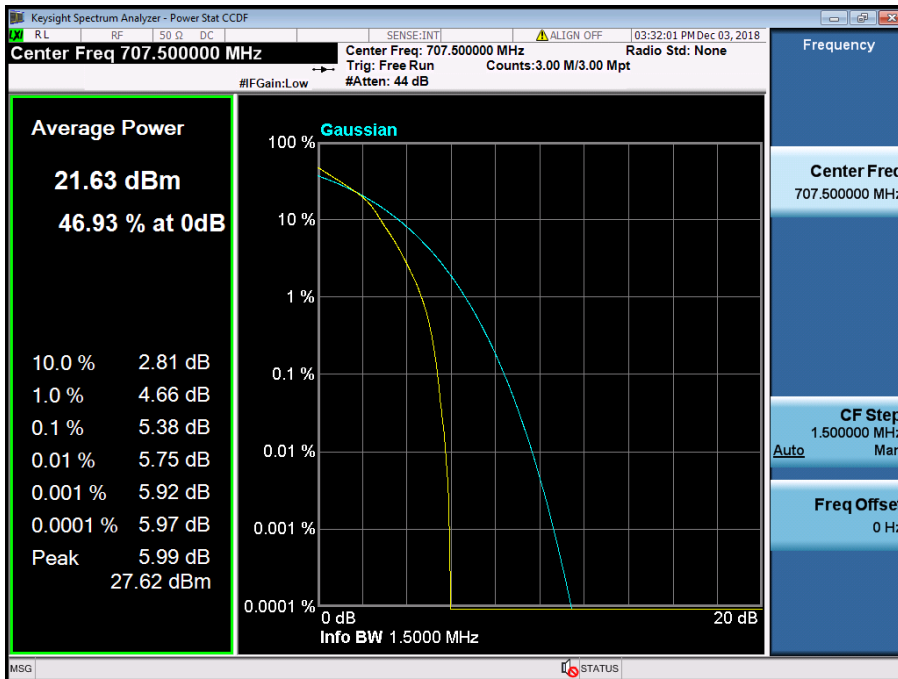

LTE Band 12 / 1.4 MHz / 16QAM - RB Size 6

8.2.3 LTE Band 13

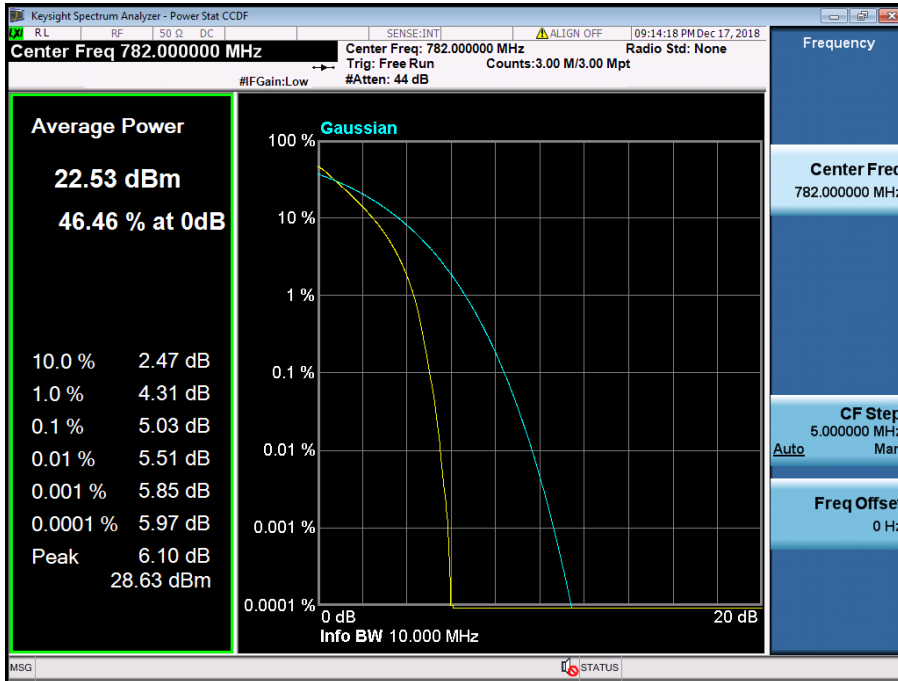

LTE Band 13 / 10 MHz / QPSK - RB Size 50

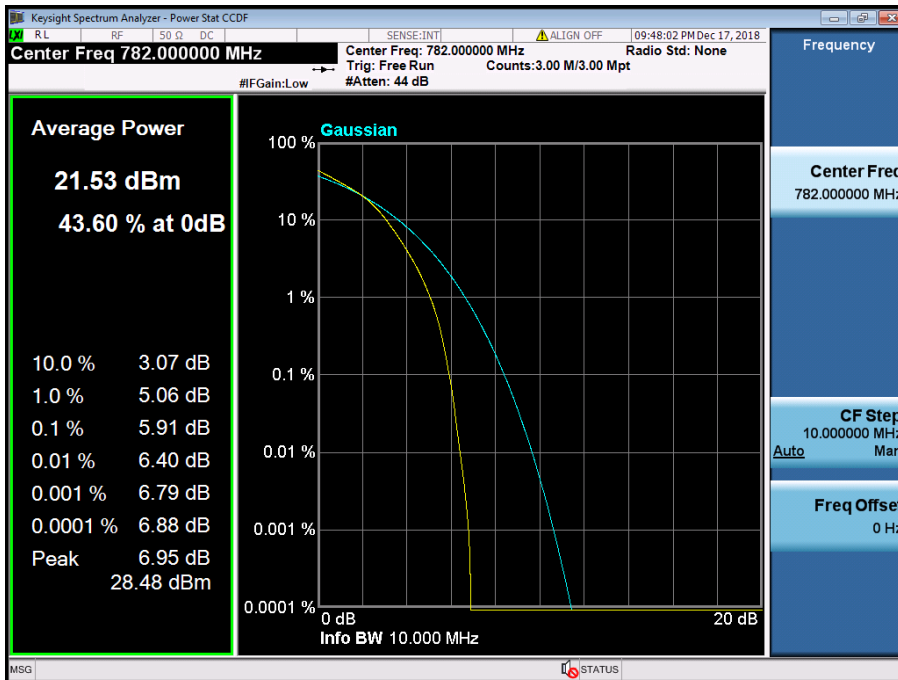

LTE Band 13 / 10 MHz / 16QAM - RB Size 50

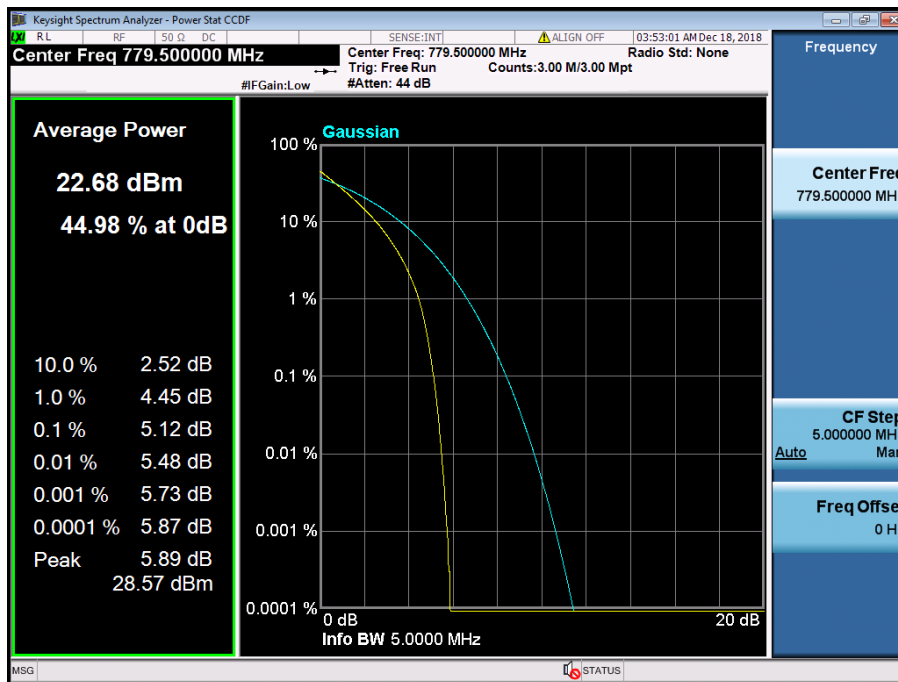

LTE Band 13 / 5 MHz / QPSK - RB Size 25

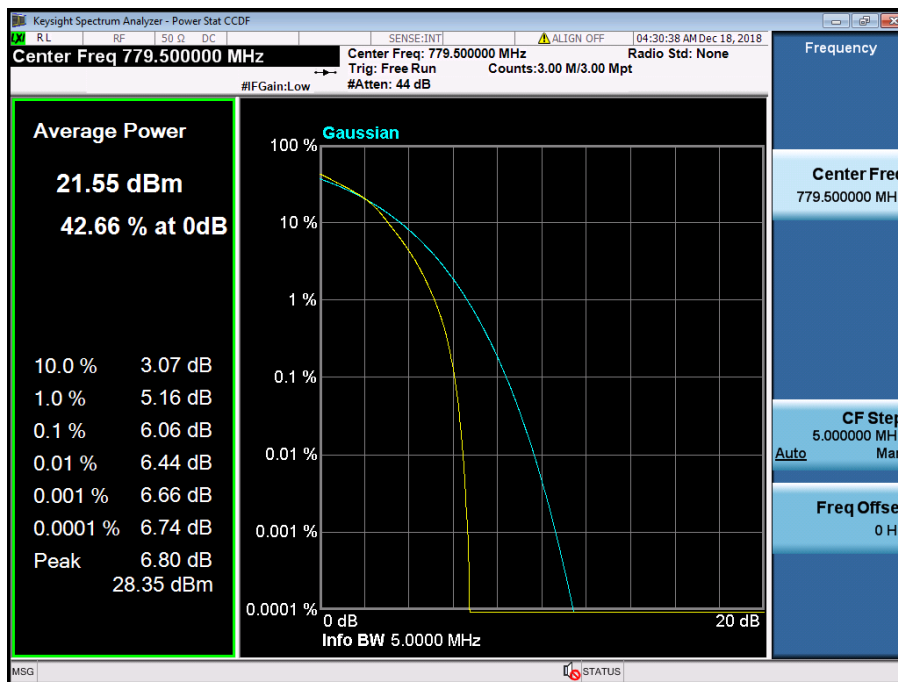

LTE Band 13 / 5 MHz / 16QAM - RB Size 25

8.2.4 LTE Band 14

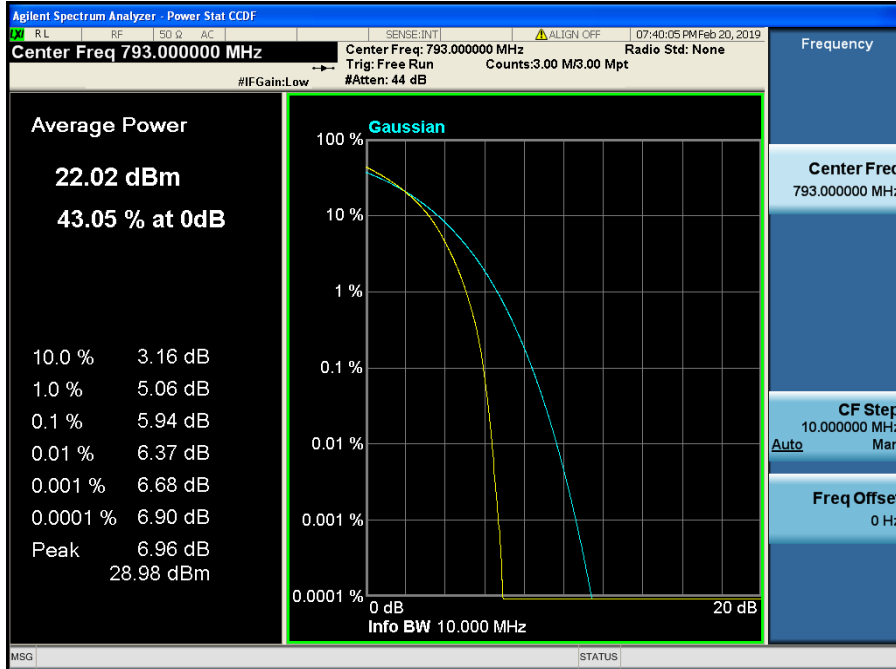
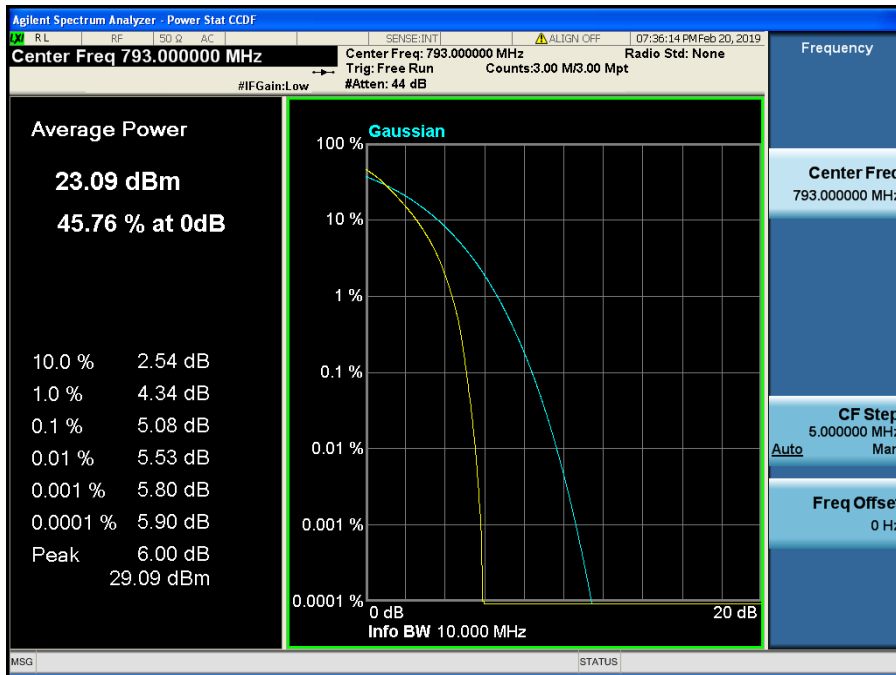

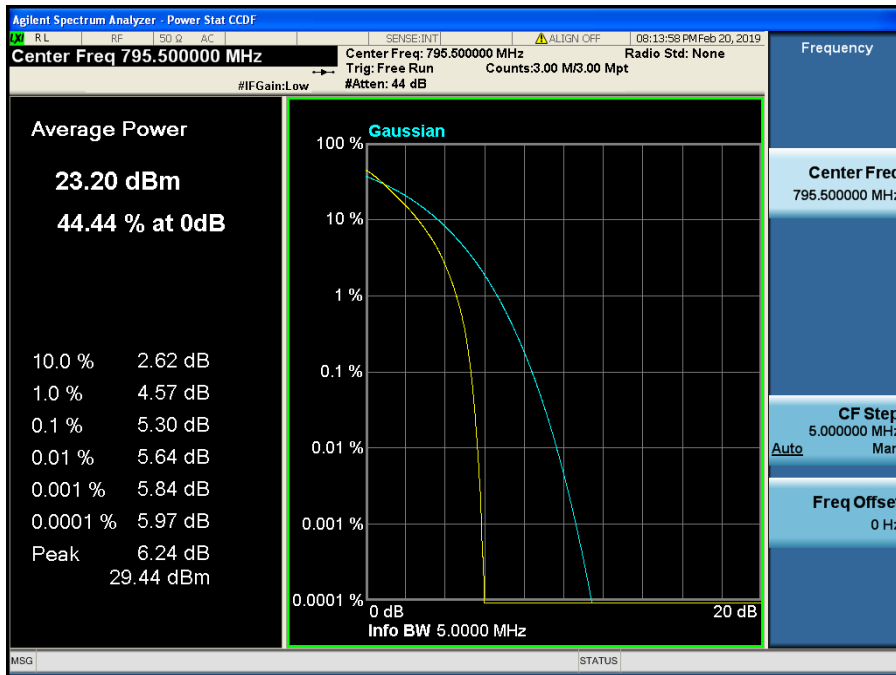

LTE Band 14 / 5 MHz / QPSK - RB Size 25

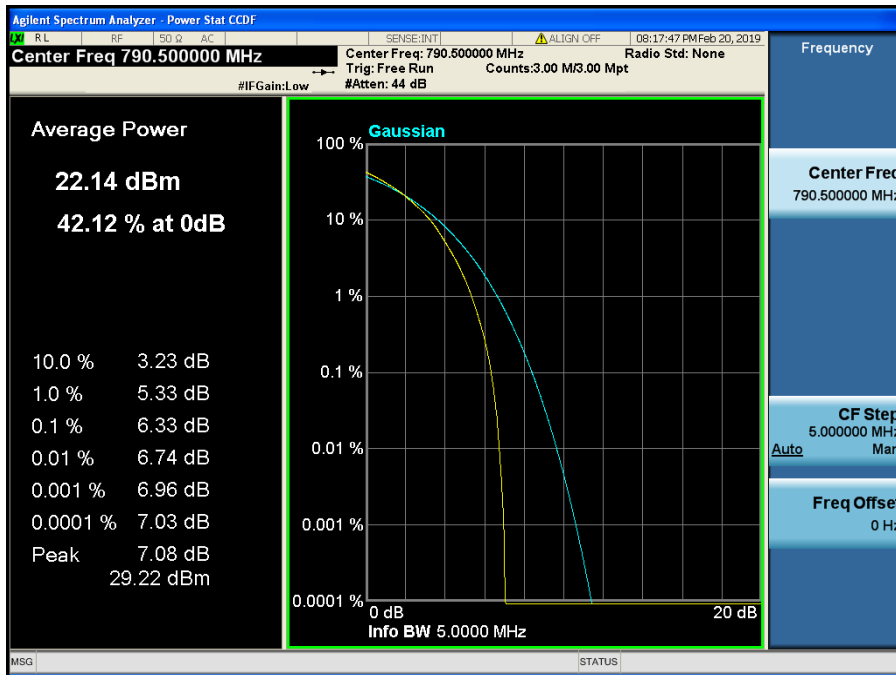

LTE Band 14 / 5 MHz / 16QAM - RB Size 25

8.2.5 LTE Band 5

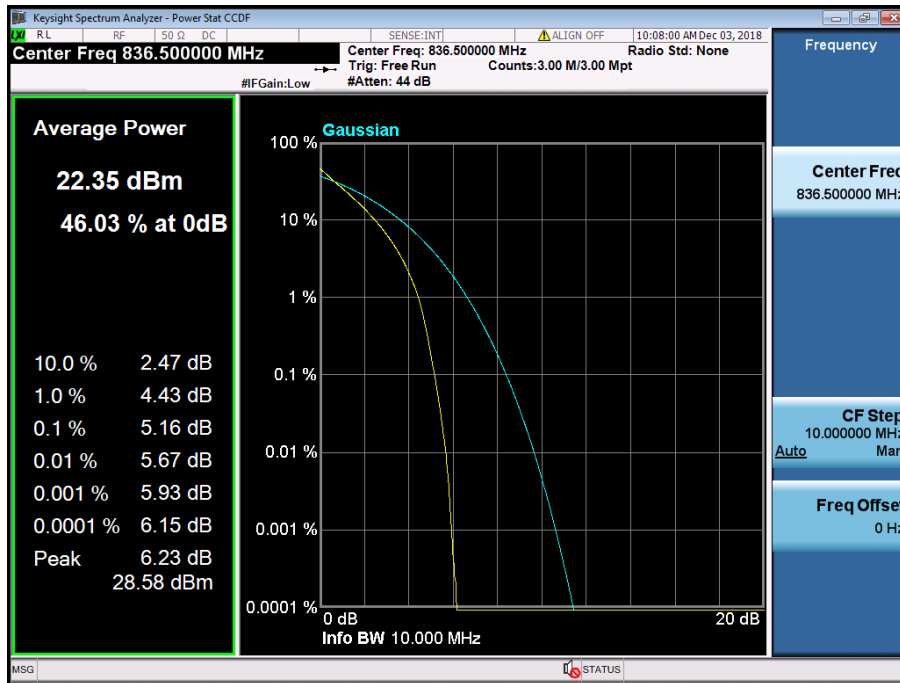

LTE Band 5 / 10 MHz / QPSK - RB Size 50

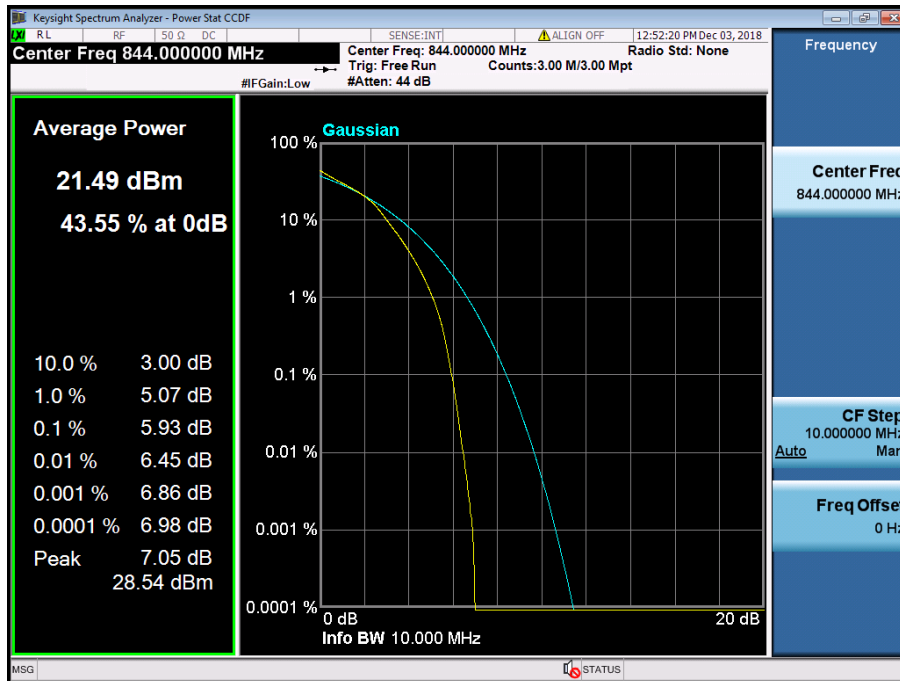

LTE Band 5 / 10 MHz / 16QAM - RB Size 50

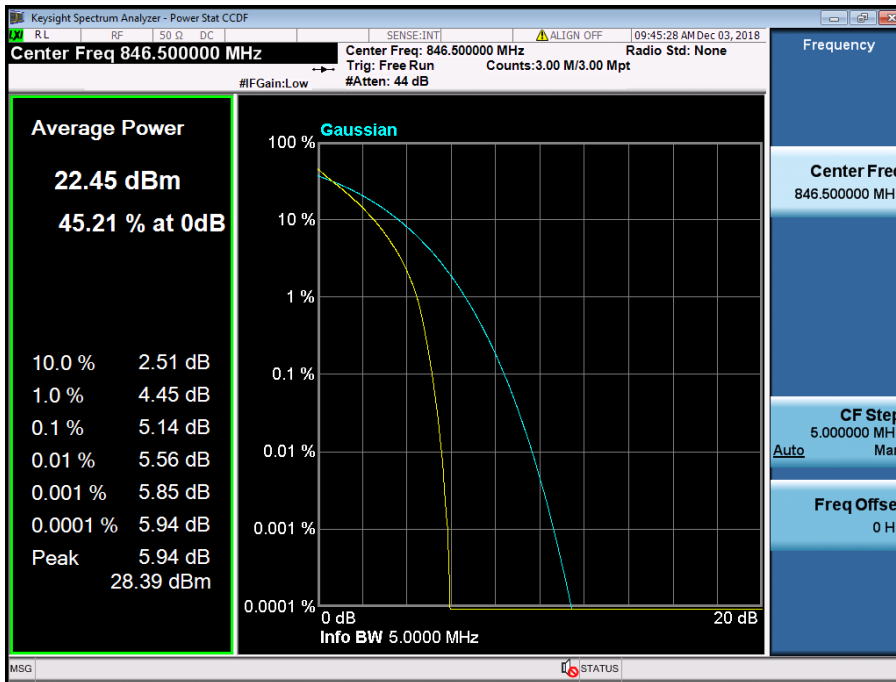

LTE Band 5 / 5 MHz / QPSK - RB Size 25

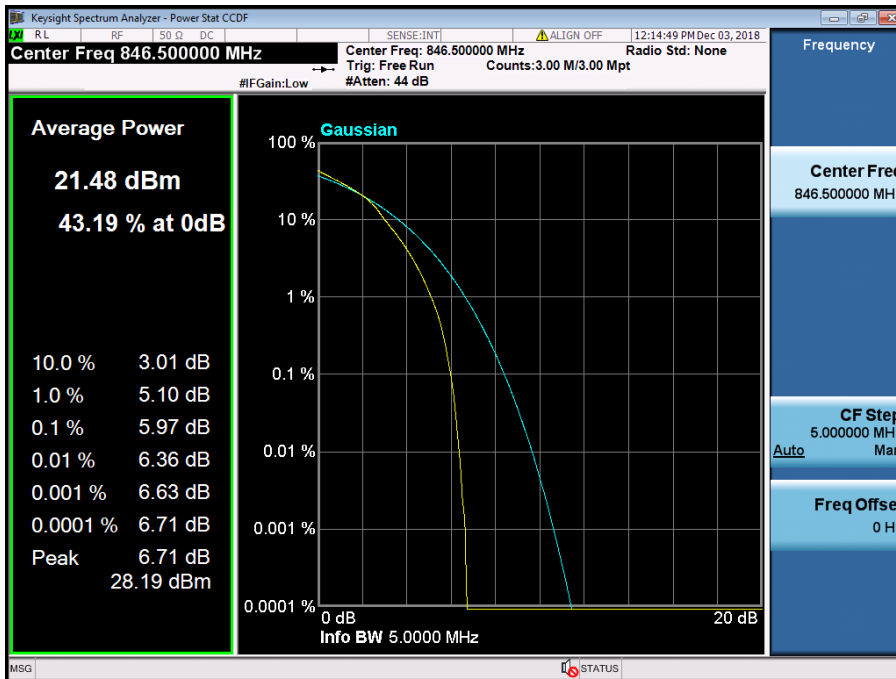

LTE Band 5 / 5 MHz / 16QAM - RB Size 25

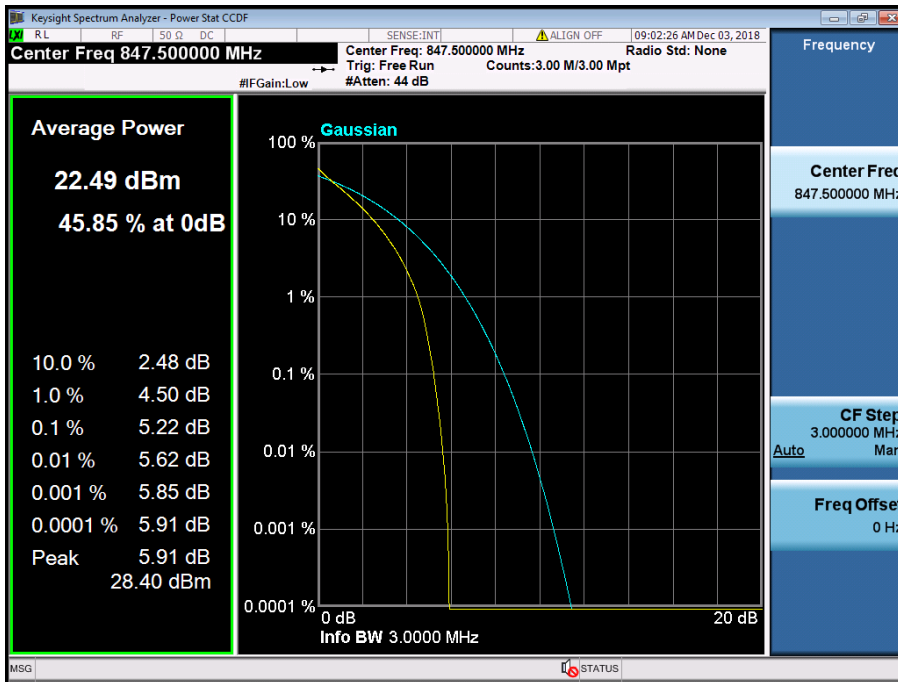

LTE Band 5 / 3 MHz / QPSK - RB Size 15

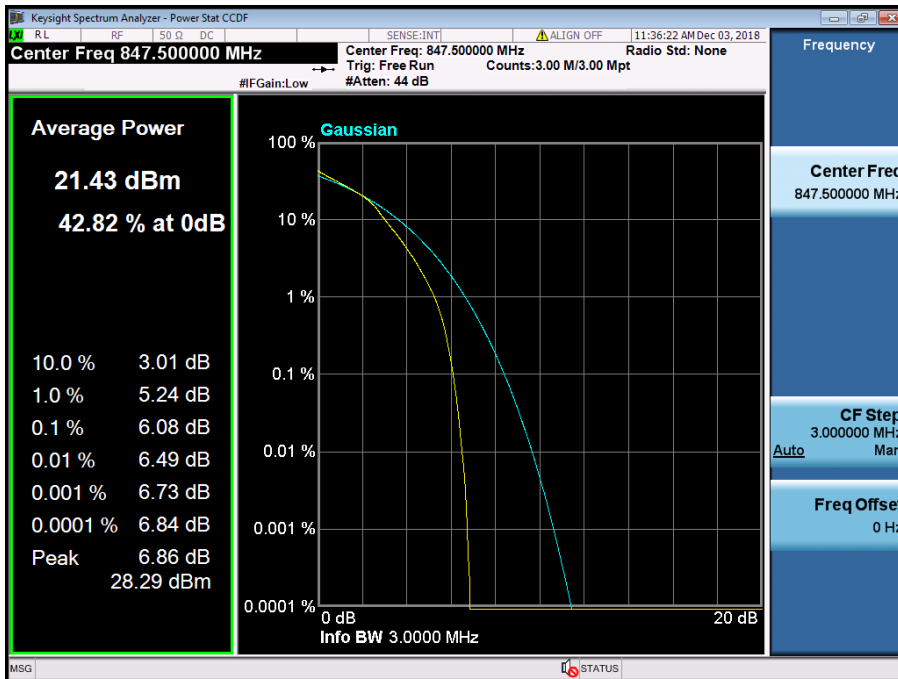

LTE Band 5 / 3 MHz / 16QAM - RB Size 15

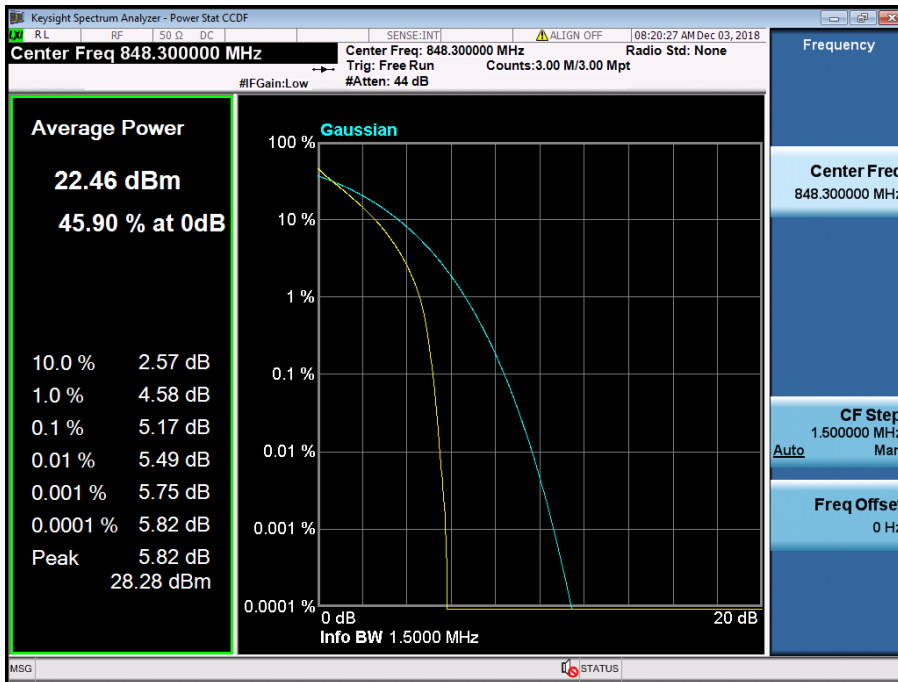

LTE Band 5 / 1.4 MHz / QPSK - RB Size 6

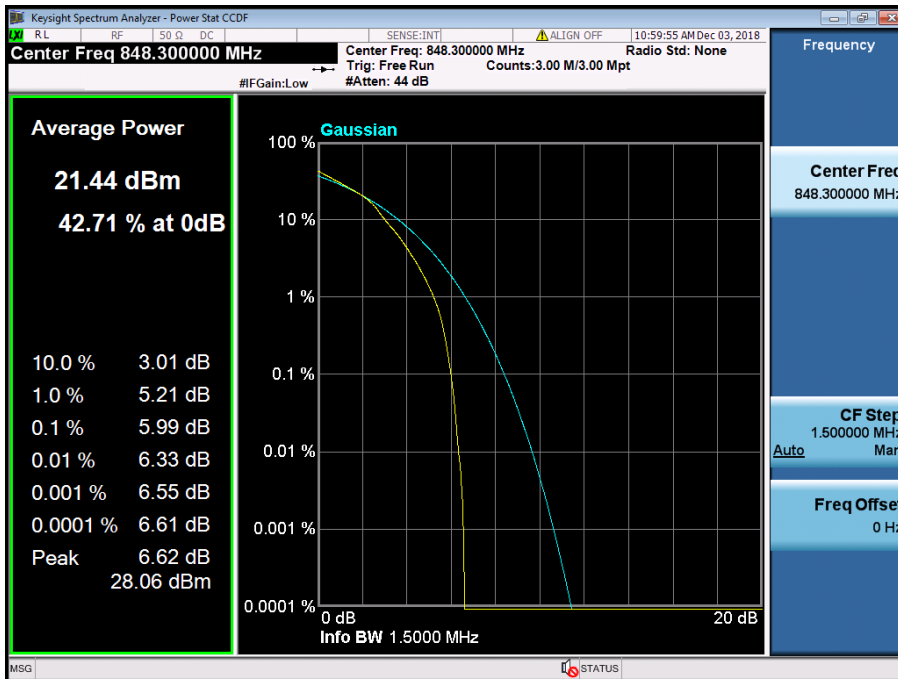

LTE Band 5 / 1.4 MHz / 16QAM - RB Size 6