



# TEST REPORT



**DT&C Co., Ltd.**

42, Yurim-ro, 154Beon-gil, Cheoin-gu, Yongin-si, Gyeonggi-do, Korea, 17042  
Tel : 031-321-2664, Fax : 031-321-1664

1. Report No : DRTFCC1706-0120
2. Customer
  - Name : POINT MOBILE CO.,LTD
  - Address : B-9F, Kabul Great Valley 32 Digital-ro 9-gil, Geumcheon-gu Seoul South Korea  
153-709
3. Use of Report : FCC & IC Original Grant
4. Product Name / Model Name : Mobile Computer / FCC: PM80, IC: PM80P  
FCC ID / IC : V2X-PM80G1 / 10664A-PM80G1
5. Test Method Used : KDB Procedure  
Test Specification : FCC Part 22, 24  
RSS-132 Issue 3, 133 Issue 6
6. Date of Test : 2017.04.13 ~ 2017.05.19
7. Testing Environment : See appended test report.
8. Test Result : Refer to the attached test result.

Affirmation	Tested by	Technical Manager
	Name : JaeHyeok Bang 	Name : GeunKi Son  (Signature)

The test results presented in this test report are limited only to the sample supplied by applicant and the use of this test report is inhibited other than its purpose. This test report shall not be reproduced except in full, without the written approval of DT&C Co., Ltd.

2017 . 06 . 29 .

**DT&C Co., Ltd.**

If this report is required to confirmation of authenticity, please contact to [report@dtnc.net](mailto:report@dtnc.net)

## Test Report Version

Test Report No.	Date	Description
DRTFCC1706-0120	Jun. 29, 2017	Initial issue

## Table of Contents

<b>1. GENERAL INFORMATION .....</b>	<b>4</b>
<b>2. INTRODUCTION .....</b>	<b>5</b>
2.1. EUT DESCRIPTION .....	5
2.2. SUPPORT EQUIPMENT .....	5
2.3. MEASURING INSTRUMENT CALIBRATION.....	5
2.4. MEASUREMENT UNCERTAINTY.....	5
2.5. TEST FACILITY .....	5
<b>3. DESCRIPTION OF TESTS .....</b>	<b>6</b>
3.1 ERP & EIRP .....	6
3.2 PEAK TO AVERAGE RATIO .....	8
3.3 OCCUPIED BANDWIDTH.....	10
3.4 BAND EDGE EMISSIONS AT ANTENNA TERMINAL.....	11
3.5 SPURIOUS AND HARMONIC EMISSIONS AT ANTENNA TERMINAL.....	12
3.6 RADIATED SPURIOUS EMISSIONS .....	13
3.7 FREQUENCY STABILITY / VARIATION OF AMBIENT TEMPERATURE .....	14
<b>4. LIST OF TEST EQUIPMENT.....</b>	<b>15</b>
<b>5. SUMMARY OF TEST RESULTS .....</b>	<b>16</b>
<b>6. SAMPLE CALCULATION .....</b>	<b>17</b>
<b>7. TEST DATA .....</b>	<b>18</b>
7.1 PEAK TO AVERAGE RATIO .....	18
7.2 OCCUPIED BANDWIDTH.....	18
7.3 SPURIOUS AND HARMONIC EMISSIONS AT ANTENNA TERMINAL.....	18
7.4 BAND EDGE .....	18
7.5 Effective Radiated Power .....	19
7.6 Equivalent Isotropic Radiated Power .....	20
7.7 RADIATED SPURIOUS EMISSIONS .....	21
7.7.1 RADIATED SPURIOUS EMISSIONS (WCDMA850).....	21
7.7.2 RADIATED SPURIOUS EMISSIONS (HSUPA850) .....	22
7.7.3 RADIATED SPURIOUS EMISSIONS (WCDMA1900).....	23
7.7.4 RADIATED SPURIOUS EMISSIONS (HSUPA1900) .....	24
7.8 FREQUENCY STABILITY .....	25
7.8.1 FREQUENCY STABILITY (WCDMA850).....	25
7.8.2 FREQUENCY STABILITY (WCDMA1900).....	26
<b>8. TEST PLOTS .....</b>	<b>27</b>
8.1 Peak to Average Ratio.....	27
8.2 Occupied Bandwidth (99 % Bandwidth).....	29
8.3 Spurious Emissions at Antenna Terminal .....	37
8.4 Band Edge .....	47

## 1. GENERAL INFORMATION

**Applicant Name:** POINT MOBILE CO.,LTD  
**Address:** B-9F, Kabul Great Valley 32 Digital-ro 9-gil, Geumcheon-gu Seoul South Korea 153-709  
**FCC ID** : V2X-PM80G1  
**IC** : 10664A-PM80G1  
**EUT** : Mobile Computer  
**Model Name(FCC)** : PM80  
**Add Model Name(FCC)** : CHD8, XT2  
**Model Name(IC)** : PM80P  
**Add Model Name(IC)** : XT2P  
**Supplying power** : DC 3.8 V  
**Antenna Information** : Internal Antenna  
**Antenna Gain** : 850 Band: -2.36 dBi  
 1900 Band: 0.95 dBi

Mode	Tx Frequency (MHz)	Emission Designator	ERP(Max.power)		EIRP(Max.power)	
			dBm	W	dBm	W
WCDMA850	826.4 ~ 846.6 MHz	4M18F9W	<b>19.18</b>	<b>0.083</b>	<b>21.33</b>	<b>0.136</b>
HSUPA850	826.4 ~ 846.6 MHz	4M18F9W	18.52	0.071	20.67	0.117
WCDMA1900	1852.4 ~ 1907.6 MHz	4M18F9W	-	-	<b>23.09</b>	<b>0.204</b>
HSUPA1900	1852.4 ~ 1907.6 MHz	4M18F9W	-	-	22.33	0.171

Note: FCC is 850 band based on ERP.

## 2. INTRODUCTION

### 2.1. EUT DESCRIPTION

The Equipment under Test (EUT) supports WCDMA, LTE, WLAN, Bluetooth and NFC.

### 2.2. SUPPORT EQUIPMENT

Equipment	Model No.	Serial No.	Manufacturer	Note
-	-	-	-	-
-	-	-	-	-

Note: The above equipment were supported by manufacturer.

### 2.3. MEASURING INSTRUMENT CALIBRATION

The measuring equipment, which was utilized in performing the tests documented herein, has been calibrated in accordance with the manufacturer's recommendations for utilizing calibration equipment, which is traceable to recognized national standards.

### 2.4. MEASUREMENT UNCERTAINTY

Where relevant, the following measurement uncertainty levels have been estimated for tests performed on the EUT as specified in CISPR 16-4-2.

Test items	Measurement uncertainty
Conducted spurious emission	0.92 dB (The confidence level is about 95 %, k = 2)
Radiated spurious emission (1 GHz Below)	5.1 dB (The confidence level is about 95 %, k = 2)
Radiated spurious emission (1 GHz ~ 18 GHz)	5.4 dB (The confidence level is about 95 %, k = 2)
Radiated spurious emission (18 GHz Above)	5.3 dB (The confidence level is about 95 %, k = 2)

### 2.5. TEST FACILITY

The 3m test site and conducted measurement facility used to collect the radiated data are located at the 42, Yurim-ro, 154beon-gil, Cheoin-gu, Yongin-si, Gyeonggi-do, Korea 449-935. The site is constructed in conformance with the requirements.

**- Semi anechoic chamber registration Number: 165783 (FCC) & 5740A-3 (IC)**

### 3. DESCRIPTION OF TESTS

#### 3.1 ERP & EIRP

(Effective Radiated Power & Equivalent Isotropic Radiated Power)

##### Test Set-up

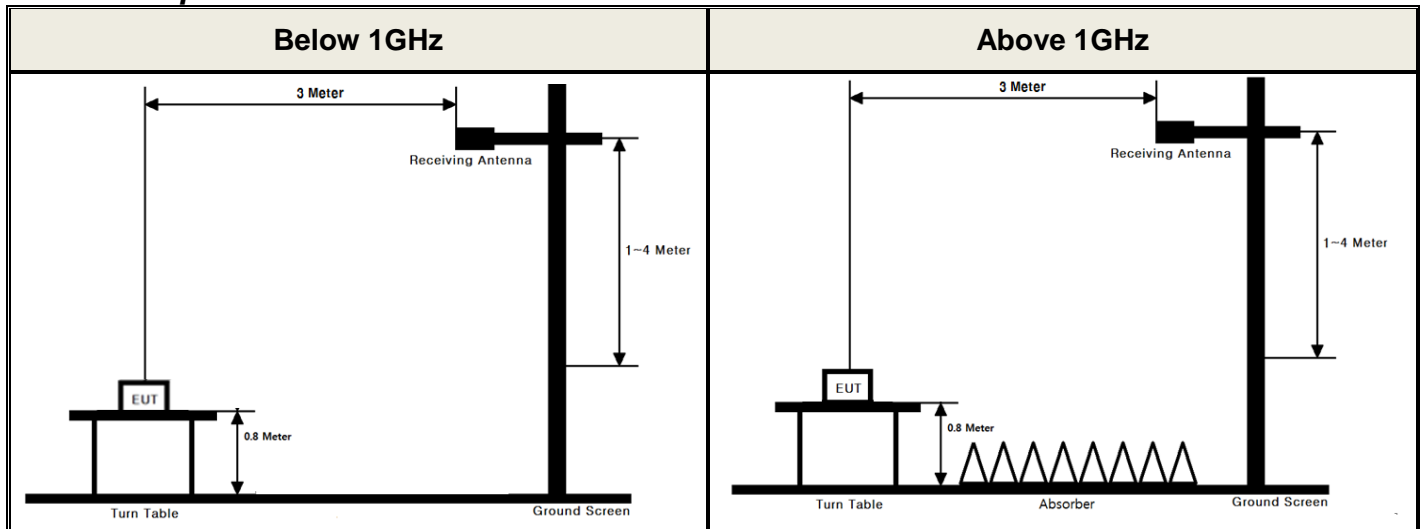

##### Test Procedure

- ANSI/TIA-603-E-2016 - Section 2.2.17
- KDB971168 v02r02 - Section 5.2.1

These measurements were performed at 3 m test site. The equipment under test is placed on a non-conductive table 0.8-meters above a turntable which is flush with the ground plane and 3 meters from the receive antenna. For measurements above 1GHz absorbers are placed on the floor between the turn table and the antenna mast in such a way so as to maximize the reduction of reflections. For measurements below 1 GHz, the absorbers are removed.

##### Test setting

1. Set span to at least 1.5 times the OBW.
2. Set RBW = 1-5 % of the OBW, not to exceed 1 MHz.
3. Set VBW  $\geq 3 \times$  RBW.
4. Set number of points in sweep  $\geq 2 \times$  span / RBW.
5. Sweep time = auto couple.
6. Detector = RMS (power averaging).
7. If the EUT can be configured to transmit continuously (i.e., burst duty cycle  $\geq 98$  %), then set the trigger to free run.
8. If the EUT cannot be configured to transmit continuously (i.e., burst duty cycle  $< 98$  %), then use a sweep trigger with the level set to enable triggering only on full power bursts and configure the EUT to transmit at full power for the entire duration of each sweep.  
Ensure that the sweep time is less than or equal to the transmission burst duration.
9. Trace average at least 100 traces in power averaging (i.e., RMS) mode.
10. Compute the power by integrating the spectrum across the OBW of the signal using the instrument's band power measurement function, with the band limits set equal to the OBW band edges. If the instrument does not have a band power function, then sum the spectrum levels (in linear power units) at intervals equal to the RBW extending across the entire OBW of the spectrum.

The receive antenna height and turntable rotations were adjusted for the highest reading on the receive spectrum analyzer.

A half-wave dipole was substituted in place of the EUT. This dipole antenna was driven by a signal generator and the level of the signal generator was adjusted to obtain the same receive spectrum analyzer reading. The conducted power at the terminal of the substitute antenna is measured.

The ERP/EIRP is calculated using the following formula:

**ERP/EIRP = The conducted power at the substitute antenna's terminal [dBm] + Substitute Antenna gain [dBd for ERP , dBi for EIRP]**

For readings above 1 GHz, the above procedure is repeated using horn antennas and the difference between the gain of the horn antenna and an isotropic antenna are taken into consideration.

## 3.2 PEAK TO AVERAGE RATIO

### Test set-up

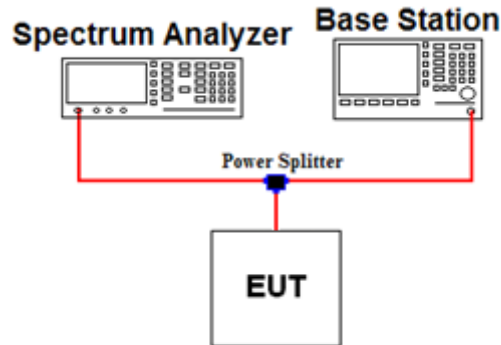

### Test Procedure

A peak to average ratio measurement is performed using the following procedure.

#### ■ CCDF Procedure

##### - KDB971168 v02r02-Section 5.7.1

1. Set resolution/measurement bandwidth  $\geq$  signal's occupied bandwidth
2. Set the number of counts to a value that stabilizes the measured CCDF curve
3. Set the measurement interval as follows:
  - 1) For continuous transmissions, set to 1 ms
  - 2) For burst transmissions, employ an external trigger that is synchronized with the EUT burst timing sequence, or use the internal burst trigger with a trigger level that allows the burst to stabilize and set the measurement interval to a time that is less than or equal to the burst duration.
4. Record the maximum PAPR level associated with a probability of 0.1%



## ■ Alternate Procedure

### - KDB971168 v02r02-Section 5.7.2

Use one of the measurement procedures of the peak power and record as  $P_{Pk}$ .

Use one of the measurement procedures of the average power and record as  $P_{Avg}$ .

Both the peak and average power levels must be expressed in the same logarithmic units (e.g., dBm). Determine the PAPR from:

$$\text{PAPR (dB)} = P_{Pk} \text{ (dBm)} - P_{Avg} \text{ (dBm)}.$$

### - Peak Power Measurement

1. Set the RBW  $\geq$  OBW
2. Set VBW  $\geq 3 \times$  RBW
3. Set span  $\geq 2 \times$  RBW
4. Sweep time = auto couple
5. Detector = peak
6. Ensure that the number of measurement points  $\geq$  span/RBW.
7. Trace mode = max hold
8. Allow trace to fully stabilize.
9. Use the peak marker function to determine the peak amplitude level.

### - Average Power Measurement

1. Set span to at least 1.5 times the OBW.
2. Set RBW = 1-5% of the OBW, not to exceed 1 MHz.
3. Set VBW  $\geq 3 \times$  RBW.
4. Set number of points in sweep  $\geq 2 \times$  span / RBW.
5. Sweep time = auto-couple.
6. Detector = RMS (power averaging).
7. If the EUT can be configured to transmit continuously (i.e., burst duty cycle  $\geq 98\%$ ), then set the trigger to free run.
8. If the EUT cannot be configured to transmit continuously (i.e., burst duty cycle  $< 98\%$ ), then use a sweep trigger with the level set to enable triggering only on full power bursts and configure the EUT to transmit at full power for the entire duration of each sweep.  
Ensure that the sweep time is less than or equal to the transmission burst duration.
9. Trace average at least 100 traces in power averaging (i.e., RMS) mode.
10. Compute the power by integrating the spectrum across the OBW of the signal using the instrument's band power measurement function, with the band limits set equal to the OBW band edges. If the instrument does not have a band power function, then sum the spectrum levels (in linear power units) at intervals equal to the RBW extending across the entire OBW of the spectrum.

### 3.3 OCCUPIED BANDWIDTH.

#### Test set-up

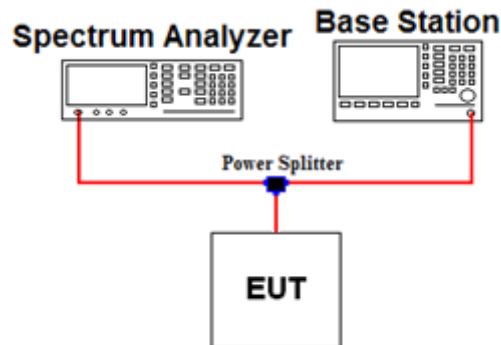

#### Offset value information

Frequency (MHz)	Offset Value (dB)	Frequency (MHz)	Offset Value (dB)
826.4	7.22	1852.4	8.20
836.6	7.23	1880.0	8.25
846.6	7.23	1907.6	8.28
-	-	-	-

Note. 1: The offset values from EUT to Spectrum analyzer were measured and used for test.  
 Offset value = Cable A + Splitter + Cable B

#### Test Procedure

- **KDB971168 v02r02-Section 4.2**

The occupied bandwidth, that is the frequency bandwidth such that, below its lower and above its upper frequency limits, the mean powers radiated are each equal to 0.5 percent of the total mean power of a given emission.

#### Test setting

1. The signal analyzer`s automatic bandwidth measurement capability was used to perform the 99 % occupied bandwidth and the 26 dB bandwidth. The bandwidth measurement was not influenced by any intermediate power nulls in the fundamental emission.
2.  $RBW = 1 \sim 5 \%$  of the expected OBW &  $VBW \geq 3 \times RBW$
3. Detector = Peak
4. Trance mode = Max hold
5. Sweep = Auto couple
6. The trace was allowed to stabilize
7. If necessary, step 2 ~ 6 were repeated after changing the RBW such that it would be within  $1 \sim 5 \%$  of the 99 % occupied bandwidth observed in step 6.

### 3.4 BAND EDGE EMISSIONS AT ANTENNA TERMINAL.

#### Test set-up

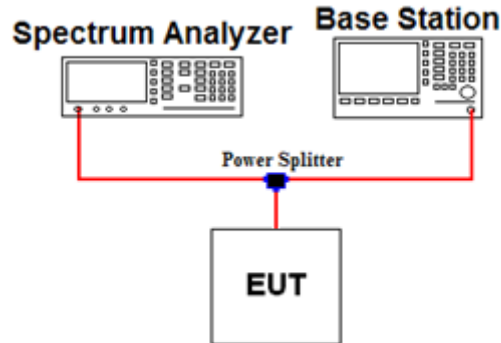

#### Offset value information

Frequency (MHz)	Offset Value (dB)	Frequency (MHz)	Offset Value (dB)
823.0	7.22	1849.0	8.19
824.0	7.22	1850.0	8.20
849.0	7.24	1910.0	8.28
850.0	7.24	1911.0	8.28
-	-	-	-

Note. 1: The offset value from EUT to Spectrum analyzer was measured and used for test.  
Offset value = Cable A + Splitter + Cable B

#### Test Procedure

##### - KDB971168 v02r02 - Section 6.0

All out of band emissions are measured by means of a calibrated spectrum analyzer. The EUT was setup to maximum output power at its lowest and highest channel with all modulations.

The power of any spurious emission shall be attenuated below the transmitter power (P) by at least  $43 + 10 \log(P)$  dB

#### Test setting

1. Start and stop frequency were set such that the band edge would be placed in the center of the plot
2. Span was set large enough so as to capture all out of band emissions near the band edge
3. RBW  $\geq 1\%$  of the emission
4. VBW  $\geq 3 \times$  RBW
5. Detector = RMS & Trace mode = Max hold
6. Sweep time = Auto couple or 1 s for band edge
7. Number of sweep point  $\geq 2 \times$  span / RBW
8. The trace was allowed to stabilize

Note 1: In the 1 MHz bands immediately outside and adjacent to the frequency block a resolution bandwidth of **at least one percent** of the emission bandwidth of the fundamental emission of the transmitter may be employed to demonstrate compliance with the out-of-band emissions limit. The emission bandwidth is defined as the width of the signal between two points, one below the carrier center frequency and one above the carrier center frequency, outside of which all emission are attenuated at least 26 dB below the transmitter power.

### 3.5 SPURIOUS AND HARMONIC EMISSIONS AT ANTENNA TERMINAL.

**Test set-up**

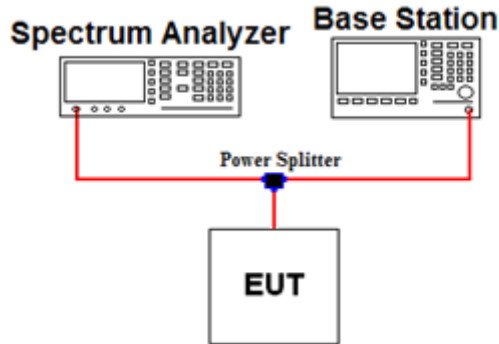

**Offset value information**

Frequency (MHz)	Offset Value (dB)	Frequency (MHz)	Offset Value (dB)
10000.0	11.98	20000.0	14.31
-	-	-	-
-	-	-	-

Note. 1: The offset value from EUT to Spectrum analyzer was measured and used for test.  
 Offset value = Cable A + Splitter + Cable B

**Test Procedure**

**- KDB971168 v02r02 - Section 6.0**

The level of the carrier and the various conducted spurious and harmonic frequencies is measured by means of a calibrated spectrum analyzer. The EUT was setup to maximum output power at its low, middle, high channel with all bandwidths. The spectrum is scanned from 30 MHz up to a frequency including its 10<sup>th</sup> harmonic.

The power of any spurious emission shall be attenuated below the transmitter power (P) by at least  $43 + 10 \log(P)$  dB

Test setting

1. RBW = 100 KHz or 1 MHz & VBW ≥ 3 X RBW ( Refer to Note 1)
2. Detector = RMS & Trace mode = Max hold
3. Sweep time = Auto couple
4. Number of sweep point ≥ 2 X span / RBW
5. The trace was allowed to stabilize

Note 1: Compliance with these provisions is based on the use of measurement instrumentation employing a resolution bandwidth of 100 kHz or greater for frequencies less than 1GHz and 1MHz or greater for frequencies greater than 1GHz.

### 3.6 RADIATED SPURIOUS EMISSIONS

#### Test Set-up

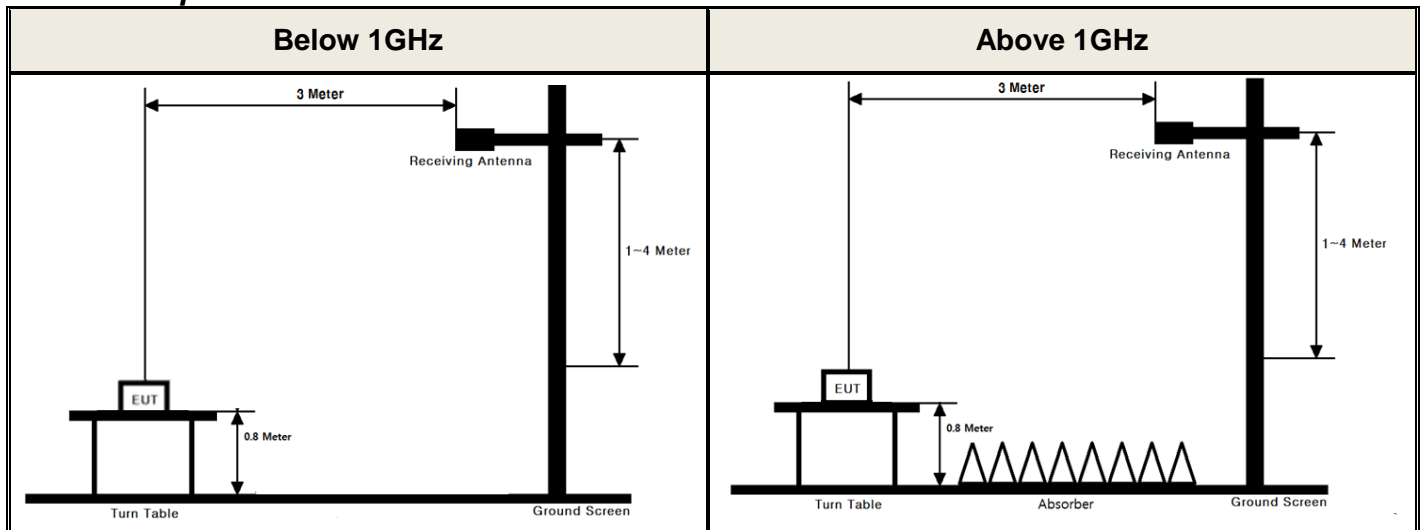

#### Test Procedure

- ANSI/TIA-603-E-2016 - Section 2.2.12
- KDB971168 v02r02 - Section 5.8

These measurements were performed at 3 m test site. The equipment under test is placed on a non-conductive table 0.8-meters above a turntable which is flush with the ground plane and 3 meters from the receive antenna. For measurements above 1GHz absorbers are placed on the floor between the turn table and the antenna mast in such a way so as to maximize the reduction of reflections. For measurements below 1 GHz, the absorbers are removed.

#### Test setting

1. RBW = 100 kHz for below 1 GHz and 1 MHz for above 1 GHz / VBW  $\geq$  3 X RBW
2. Detector = Peak & Trace mode = Max hold
3. Sweep time = Auto couple
4. Number of sweep point  $\geq$  2 X span / RBW
5. The trace was allowed to stabilize

The receive antenna height and turntable rotations were adjusted for the highest reading on the receive spectrum analyzer.

For radiated power measurements below 1 GHz, a half-wave dipole was substituted in place of the EUT. This dipole antenna was driven by a signal generator and the level of the signal generator was adjusted to obtain the same spectrum analyzer reading.

For radiated power measurements above 1 GHz, a Horn antenna was substituted in place of the EUT. This Horn antenna was driven by a signal generator and the level of the signal generator was adjusted to obtain the same spectrum analyzer reading. The difference between the gain of the horn and an isotropic antenna are taken into consideration.

This measurement was performed with the EUT oriented in 3 orthogonal axis.

### 3.7 FREQUENCY STABILITY / VARIATION OF AMBIENT TEMPERATURE

#### Test Set-up

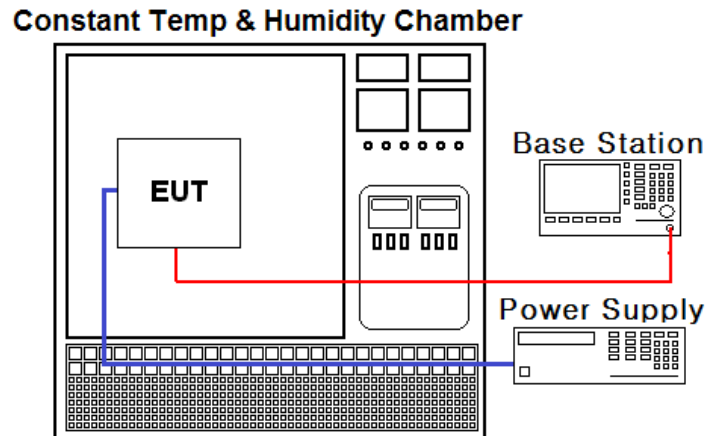

#### Test Procedure

- ANSI/TIA-603-E-2016
- KDB971168 v02r02 - Section 9.0

The frequency stability of the transmitter is measured by:

#### a.) Temperature:

The temperature is varied from - 30 °C to + 50 °C using an environmental chamber.

#### b.) Primary Supply Voltage:

The primary supply voltage is varied from 85 % to 115 % of the nominal value for non hand-carried battery and AC powered equipment. For hand-carried, battery-powered equipment, primary supply voltage is reduced to the battery operating end point which shall be specified by the manufacturer.

#### Specification:

The frequency stability shall be sufficient to ensure that the fundamental emission stays within the authorized frequency block for Part 24. The frequency stability of the transmitter shall be maintained within  $\pm 0.00025\%$  ( $\pm 2.5$  ppm) of the center frequency for Part 22.

#### Time Period and Procedure:

1. The carrier frequency of the transmitter is measured at room temperature.  
(20 °C to provide a reference)
2. The equipment is turned on in a "standby" condition for one minute before applying power to the transmitter. Measurement of the carrier frequency of the transmitter is made within one minute after applying power to the transmitter.
3. Frequency measurements are made at 10 °C intervals ranging from -30 °C to +50 °C.  
A period of at least one half-hour is provided to allow stabilization of the equipment at each temperature level.

#### 4. LIST OF TEST EQUIPMENT

Type	Manufacturer	Model	Cal.Date (yy/mm/dd)	Next.Cal. Date (yy/mm/dd)	S/N
Spectrum Analyzer	Agilent Technologies	N9020A	17/01/11	18/01/11	MY50200828
Spectrum Analyzer	Agilent Technologies	N9020A	16/10/11	17/10/11	MY46471251
DC Power Supply	Agilent Technologies	66332A	16/09/08	17/09/08	GB42110550
Thermohygrometer	HCT	HCT-1	16/09/09	17/09/09	NONE
Temp & Humi Test Chamber	SJ Science	SJ-TH-S50	17/01/25	18/01/25	SJ-TH-S50-120203
Signal Generator	Rohde Schwarz	SMF100A	16/06/23	17/06/23	102341
Signal Generator	Rohde Schwarz	SMBV100A	17/01/04	18/01/04	255571
Multimeter	FLUKE	17B	17/04/12	18/04/12	26030065WS
Loop Antenna	Schwarzbeck	FMZB1513	16/04/22	18/04/22	1513-128
BILOG ANTENNA	Schwarzbeck	VULB 9160	16/11/11	18/11/11	3151
Dipole Antenna	Schwarzbeck	VHA9103	17/03/14	19/03/14	2116
Dipole Antenna	Schwarzbeck	VHA9103	16/04/15	18/04/15	2117
Dipole Antenna	Schwarzbeck	UHA9105	17/03/14	19/03/14	2261
Dipole Antenna	Schwarzbeck	UHA9105	16/04/15	18/04/15	2262
HORN ANT	ETS	3117	16/05/13	18/05/13	00140394
HORN ANT	ETS	3117	16/02/26	18/02/26	00152145
HORN ANT	A.H.Systems	SAS-574	17/04/25	19/04/25	154
HORN ANT	A.H.Systems	SAS-574	15/09/03	17/09/03	155
PreAmplifier	TSJ	MLA-010K01-B01-27	17/03/06	18/03/06	1844539
Amplifier	EMPOWER	BBS3Q7ELU	16/09/08	17/09/08	1020
Amplifier	Agilent	8449B	16/10/19	17/10/19	3008A02108
High-pass filter	Wainwright	WHKX12-935-1000-15000-40SS	16/09/09	17/09/09	7
High-pass filter	Wainwright	WHKX12-2580-3000-18000-80SS	16/09/09	17/09/09	3
High-pass filter	Wainwright	WHNX5.0	16/09/08	17/09/08	8
Power Splitter	Anritsu	K241B	16/10/18	17/10/18	1701061
8960 Series 10 Wireless Comms Test Set	Agilent Technologies	E5515C	16/09/09	17/09/09	GB41321164

## 5. SUMMARY OF TEST RESULTS

FCC Part Section(s)	RSS Section(s)	Parameter	Status Note 1
2.1046	-	Conducted Output Power	<b>C</b> <sup>Note 2</sup>
22.913(a) 24.232(c)	RSS-132 [5.4] RSS-133 [6.4]	Effective Radiated Power Equivalent Isotropic Radiated Power	<b>C</b>
22.917(a) 24.238(a) 2.1049	RSS-Gen [6.6]	Occupied Bandwidth	<b>C</b>
22.917(a) 24.238(a) 2.1051	RSS-132 [5.5] RSS-133 [6.5]	Band Edge Spurious and Harmonic Emissions at Antenna Terminal	<b>C</b>
24.232(d)	RSS-132 [5.4] RSS-133 [6.4]	Peak to Average Ratio	<b>C</b>
22.917(a) 24.238(a) 2.1053	RSS-132 [5.5] RSS-133 [6.5]	Radiated Spurious and Harmonic Emissions	<b>C</b>
22.355 24.235 2.1055	RSS-132 [5.3] RSS-133 [6.3]	Frequency Stability	<b>C</b>
Note 1: <b>C</b> =Comply <b>NC</b> =Not Comply <b>NT</b> =Not Tested <b>NA</b> =Not Applicable Note 2: Refer to RF Exposure Report (SAR_Test_Report)			

The sample was tested according to the following specification:  
**ANSI/TIA/EIA-603-E-2016 and KDB 971168 D01 v02r02**



## 6. SAMPLE CALCULATION

### A. Emission Designator

#### WCDMA850 Emission Designator

Emission Designator = **4M18F9W**  
 WCDMA OBW = 4.17590 MHz  
 (Measured at the 99.75 % power bandwidth)  
 F = Frequency Modulation  
 9 = Composite Digital Information  
 W = Combination (Audio/Data)

#### WCDMA1900 Emission Designator

Emission Designator = **4M18F9W**  
 WCDMA OBW = 4.17990 MHz  
 (Measured at the 99.75 % power bandwidth)  
 F = Frequency Modulation  
 9 = Composite Digital Information  
 W = Combination (Audio/Data)

#### HSUPA850 Emission Designator

Emission Designator = **4M18F9W**  
 HSUPA OBW = 4.17660 MHz  
 (Measured at the 99.75 % power bandwidth)  
 F = Frequency Modulation  
 9 = Composite Digital Information  
 W = Combination (Audio/Data)

#### HSUPA1900 Emission Designator

Emission Designator = **4M18F9W**  
 HSUPA OBW = 4.17600 MHz  
 (Measured at the 99.75 % power bandwidth)  
 F = Frequency Modulation  
 9 = Composite Digital Information  
 W = Combination (Audio/Data)

### B. For substitution method

MODE	Channel	Freq.(MHz)	Spectrum Reading Value(dBm)	EUT Axis	Ant Pol (H/V)	Level(dBm) @ Ant Terminal	TX Ant Gain(dBi)	EIRP	
								(dBm)	(W)
WCDMA1900	9400	1880.0	-23.86	Y	H	18.17	4.92	23.09	0.204

#### ERP or EIRP = Level @ Ant Terminal LEVEL(dBm) + Tx Ant. Gain

- 1) The EUT mounted on a non-conductive turntable is 0.8 meter above test site ground level.
- 2) During the test, the turn table is rotated until the maximum signal is found.
- 3) Record the field strength meter's level.
- 4) Replace the EUT with dipole/Horn antenna that is connected to a calibrated signal generator.
- 5) Increase the signal generator output till the field strength meter's level is equal to the item (3).
- 6) The signal generator output level with substituted antenna gain is the rating of ERP, EIRP or Radiated spurious emission.

## 7. TEST DATA

### 7.1 PEAK TO AVERAGE RATIO

- Plots of the EUT's Peak- to- Average Ratio are shown in Clause 8.1

### 7.2 OCCUPIED BANDWIDTH

Band	Channel	Frequency	Test Result (kHz)
WCDMA850	4132	826.4	4175.90
	4183	836.6	4163.60
	4233	846.6	4147.40
HSUPA850	4132	826.4	4150.00
	<b>4183</b>	<b>836.6</b>	<b>4176.60</b>
	4233	846.6	4169.50
WCDMA1900	<b>9262</b>	<b>1852.4</b>	<b>4179.90</b>
	9400	1880.0	4174.60
	9538	1907.6	4167.10
HSUPA1900	9262	1852.4	4176.00
	9400	1880.0	4169.50
	9538	1907.6	4154.70

- Plots of the EUT's Occupied Bandwidth are shown in Clause 8.2

### 7.3 SPURIOUS AND HARMONIC EMISSIONS AT ANTENNA TERMINAL

- Plots of the EUT's Conducted Spurious Emissions are shown in Clause 8.3

### 7.4 BAND EDGE

- Plots of the EUT's Band Edge are shown in Clause 8.4

## 7.5 Effective Radiated Power

### - WCDMA850 data

Freq(MHz) CH	EUT Position (Axis)	Test mode 12.2 kbps RMC						
		Pol. (H/V)	LEVEL@ TX ANTENNA TERMINAL (dBm)	Antenna Gain (dBd)	ERP (dBm)	ERP (W)	Rated Voltage	Note.
826.4 4132	Z	H	17.95	1.23	19.18	0.083	DC 3.8V	-
836.6 4183	Z	H	16.34	1.22	17.56	0.057	DC 3.8V	-
846.6 4233	Z	H	15.02	1.21	16.23	0.042	DC 3.8V	-

### - HSUPA850 data

Freq(MHz) CH	EUT Position (Axis)	Test mode subtest 1						
		Pol. (H/V)	LEVEL@ TX ANTENNA TERMINAL (dBm)	Antenna Gain (dBd)	ERP (dBm)	ERP (W)	Rated Voltage	Note.
826.4 4132	Z	H	17.29	1.23	18.52	0.071	DC 3.8V	-
836.6 4183	Z	H	15.04	1.22	16.26	0.042	DC 3.8V	-
846.6 4233	Z	H	14.17	1.21	15.38	0.035	DC 3.8V	-

#### NOTES:

This EUT was tested under all configurations and the highest power is reported in WCDMA mode with HSDPA inactive at 12.2 kbps RMC and TPC bits set to "1" and HSUPA mode with 12.2 kbps + HSPA and subtest 1. Also, we have done x plane in EUT and horizontal and vertical polarization of detecting antenna.

The worst case data is reported.

## 7.6 Equivalent Isotropic Radiated Power

### - WCDMA1900 data

Freq(MHz) CH	EUT Position (Axis)	Test mode 12.2 kbps RMC						
		Pol. (H/V)	LEVEL@ TX ANTENNA TERMINAL (dBm)	Antenna Gain (dBi)	EIRP (dBm)	EIRP (W)	Rated Voltage	Note.
1852.4 9262	Y	H	17.34	5.06	22.40	0.174	DC 3.8V	-
1880.0 9400	Y	H	18.17	4.92	23.09	0.204	DC 3.8V	-
<b>1907.6 9538</b>	<b>Y</b>	<b>H</b>	<b>18.31</b>	<b>4.77</b>	<b>23.08</b>	<b>0.203</b>	<b>DC 3.8V</b>	<b>-</b>

### - HSUPA1900 data

Freq(MHz) CH	EUT Position (Axis)	Test mode subtest 1						
		Pol. (H/V)	LEVEL@ TX ANTENNA TERMINAL (dBm)	Antenna Gain (dBi)	EIRP (dBm)	EIRP (W)	Rated Voltage	Note.
1852.4 9262	Y	H	16.83	5.06	21.89	0.155	DC 3.8V	-
1880.0 9400	Y	H	17.17	4.92	22.09	0.162	DC 3.8V	-
<b>1907.6 9538</b>	<b>Y</b>	<b>H</b>	<b>17.56</b>	<b>4.77</b>	<b>22.33</b>	<b>0.171</b>	<b>DC 3.8V</b>	<b>-</b>

#### NOTES:

This EUT was tested under all configurations and the highest power is reported in WCDMA mode with HSDPA inactive at 12.2 kbps RMC and TPC bits set to "1" and HSUPA mode with 12.2 kbps + HSPA and subtest 1. Also, we have done x plane in EUT and horizontal and vertical polarization of detecting antenna.

The worst case data is reported.

## 7.7 RADIATED SPURIOUS EMISSIONS

### 7.7.1 RADIATED SPURIOUS EMISSIONS (WCDMA850)

Channel (ERP)	Freq. (MHz)	EUT Position (Axis)	POL (H/V)	LEVEL@ ANTENNA TERMINAL (dBm)	Substitute Antenna Gain (dBd)	Correct Generator Level (dBm)	Result (dBc)	Limit (dBc)
4132 (0.083 W)	1650.74	Y	H	-49.29	3.78	-45.51	64.69	32.18
	2482.50	X	H	-50.21	4.05	-46.16	65.34	
4183 (0.057 W)	1675.00	Y	H	-52.21	3.78	-48.43	65.99	30.56
	2512.14	X	H	-51.25	4.04	-47.21	64.77	
4233 (0.042 W)	1691.64	Y	H	-54.54	3.79	-50.75	66.98	29.23
	2542.50	X	H	-50.40	4.06	-46.34	62.57	

- Limit Calculation=  $43 + 10 \log_{10}(\text{ERP [W]})$  [dBc]

- No other spurious and harmonic emissions were reported greater than listed emissions above table.

#### NOTES:

This EUT was tested under all configurations and the highest power is reported in WCDMA mode with HSDPA inactive at 12.2 kbps RMC and TPC bits set to "1" and HSUPA mode with 12.2 kbps + HSPA and subtest 1. Also, we have done x plane in EUT and horizontal and vertical polarization of detecting antenna. The worst case data is reported.

### 7.7.2 RADIATED SPURIOUS EMISSIONS (HSUPA850)

Channel (ERP)	Freq. (MHz)	EUT Position (Axis)	POL (H/V)	LEVEL@ ANTENNA TERMINAL (dBm)	Substitute Antenna Gain (dBd)	Correct Generator Level (dBm)	Result (dBc)	Limit (dBc)
4132 (0.071 W)	1651.36	Y	H	-49.76	3.78	-45.98	64.50	31.52
	2482.69	X	H	-51.30	4.05	-47.25	65.77	
4183 (0.042 W)	1674.83	Y	H	-52.70	3.78	-48.92	65.18	29.26
	2511.98	X	H	-52.81	4.04	-48.77	65.03	
4233 (0.035 W)	1690.88	Y	H	-55.68	3.79	-51.89	67.27	28.38
	2541.42	X	V	-51.18	4.06	-47.12	62.50	

- Limit Calculation=  $43 + 10 \log_{10}(\text{ERP [W]})$  [dBc]

- No other spurious and harmonic emissions were reported greater than listed emissions above table.

#### NOTES:

This EUT was tested under all configurations and the highest power is reported in WCDMA mode with HSDPA inactive at 12.2 kbps RMC and TPC bits set to "1" and HSUPA mode with 12.2 kbps + HSPA and subtest 1. Also, we have done x plane in EUT and horizontal and vertical polarization of detecting antenna. The worst case data is reported.

### 7.7.3 RADIATED SPURIOUS EMISSIONS (WCDMA1900)

Channel (EIRP)	Freq. (MHz)	EUT Position (Axis)	POL (H/V)	LEVEL@ ANTENNA TERMINAL (dBm)	Substitute Antenna Gain (dBi)	Correct Generator Level (dBm)	Result (dBc)	Limit (dBc)
9262 (0.174 W)	3703.72	Z	H	-53.77	8.49	-45.28	67.68	35.40
	-	-	-	-	-	-	-	
	-	-	-	-	-	-	-	
9400 (0.204 W)	3758.74	Z	H	-55.09	8.51	-46.58	69.67	36.09
	-	-	-	-	-	-	-	
	-	-	-	-	-	-	-	
9538 (0.203 W)	3816.96	Z	H	-54.85	8.55	-46.30	69.38	36.08
	-	-	-	-	-	-	-	
	-	-	-	-	-	-	-	

- Limit Calculation =  $43 + 10 \log_{10}(\text{EIRP [W]})$  [dBc]

- No other spurious and harmonic emissions were reported greater than listed emissions above table.

#### NOTES:

This EUT was tested under all configurations and the highest power is reported in WCDMA mode with HSDPA inactive at 12.2 kbps RMC and TPC bits set to "1" and HSUPA mode with 12.2 kbps + HSPA and subtest 1. Also, we have done x plane in EUT and horizontal and vertical polarization of detecting antenna.

The worst case data is reported.

### 7.7.4 RADIATED SPURIOUS EMISSIONS (HSUPA1900)

Channel (EIRP)	Freq. (MHz)	EUT Position (Axis)	POL (H/V)	LEVEL@ ANTENNA TERMINAL (dBm)	Substitute Antenna Gain (dBi)	Correct Generator Level (dBm)	Result (dBc)	Limit (dBc)
9262 (0.155 W)	3702.98	Z	H	-52.81	8.49	-44.32	66.21	34.89
	-	-	-	-	-	-	-	
	-	-	-	-	-	-	-	
9400 (0.162 W)	3759.33	Z	H	-55.08	8.51	-46.57	68.66	35.09
	-	-	-	-	-	-	-	
	-	-	-	-	-	-	-	
9538 (0.171 W)	3815.99	Z	H	-54.07	8.55	-45.52	67.85	35.33
	-	-	-	-	-	-	-	
	-	-	-	-	-	-	-	

- Limit Calculation =  $43 + 10 \log_{10}(\text{EIRP [W]})$  [dBc]

- No other spurious and harmonic emissions were reported greater than listed emissions above table.

#### NOTES:

This EUT was tested under all configurations and the highest power is reported in WCDMA mode with HSDPA inactive at 12.2 kbps RMC and TPC bits set to "1" and HSUPA mode with 12.2 kbps + HSPA and subtest 1. Also, we have done x plane in EUT and horizontal and vertical polarization of detecting antenna.

The worst case data is reported.



## 7.8 FREQUENCY STABILITY

### 7.8.1 FREQUENCY STABILITY (WCDMA850)

OPERATING FREQUENCY : 836,600,000 Hz  
 CHANNEL : 4183(Mid)  
 REFERENCE VOLTAGE : 3.80 V DC  
 DEVIATION LIMIT(FCC & IC) :  $\pm 0.00025\%$  or  $\pm 2.5$  ppm

VOLTAGE (%)	POWER (V DC)	TEMP (°C)	FREQ (Hz)	Deviation	
				(ppm)	(%)
100%	3.80	+20(Ref)	836,600,007	0.008	0.00000084
100%		-30	836,600,004	0.005	0.00000048
100%		-20	836,599,998	-0.002	-0.00000024
100%		-10	836,599,997	-0.004	-0.00000036
100%		0	836,599,993	-0.008	-0.00000084
100%		+10	836,599,995	-0.006	-0.00000060
100%		+20	836,600,007	0.008	0.00000084
100%		+30	836,600,005	0.006	0.00000060
100%		+40	836,599,997	-0.004	-0.00000036
100%		+50	836,599,996	-0.005	-0.00000048
115%		4.37	+20	836,599,997	-0.004
BATT.ENDPOINT	3.50	+20	836,600,007	0.008	0.00000084

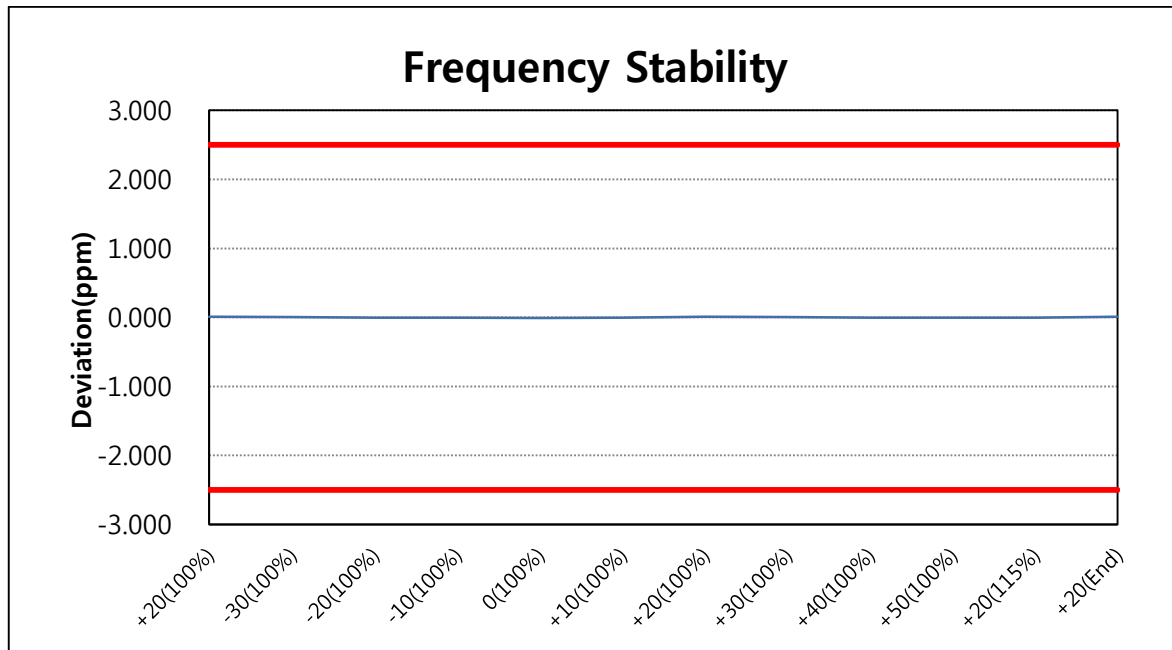

### 7.8.2 FREQUENCY STABILITY (WCDMA1900)

OPERATING FREQUENCY : 1,880,000,000 Hz  
 CHANNEL : 9400(Mid)  
 REFERENCE VOLTAGE : 3.80 V DC  
 LIMIT(FCC) : The frequency stability shall be sufficient to ensure that the fundamental emission stays within the authorized frequency block.  
 DEVIATION LIMIT(IC) :  $\pm 0.00025$  % or 2.5 ppm

VOLTAGE (%)	POWER (V DC)	TEMP (°C)	FREQ (Hz)	Deviation	
				(ppm)	(%)
100%	3.80	+20(Ref)	1,880,000,016	0.009	0.00000085
100%		-30	1,880,000,007	0.004	0.00000037
100%		-20	1,880,000,006	0.003	0.00000032
100%		-10	1,880,000,008	0.004	0.00000043
100%		0	1,880,000,002	0.001	0.00000011
100%		+10	1,880,000,005	0.003	0.00000027
100%		+20	1,880,000,016	0.009	0.00000085
100%		+30	1,880,000,003	0.002	0.00000016
100%		+40	1,880,000,005	0.003	0.00000027
100%		+50	1,880,000,014	0.007	0.00000074
115%	4.37	+20	1,880,000,008	0.004	0.00000043
BATT.ENDPOINT	3.50	+20	1,880,000,005	0.003	0.00000027

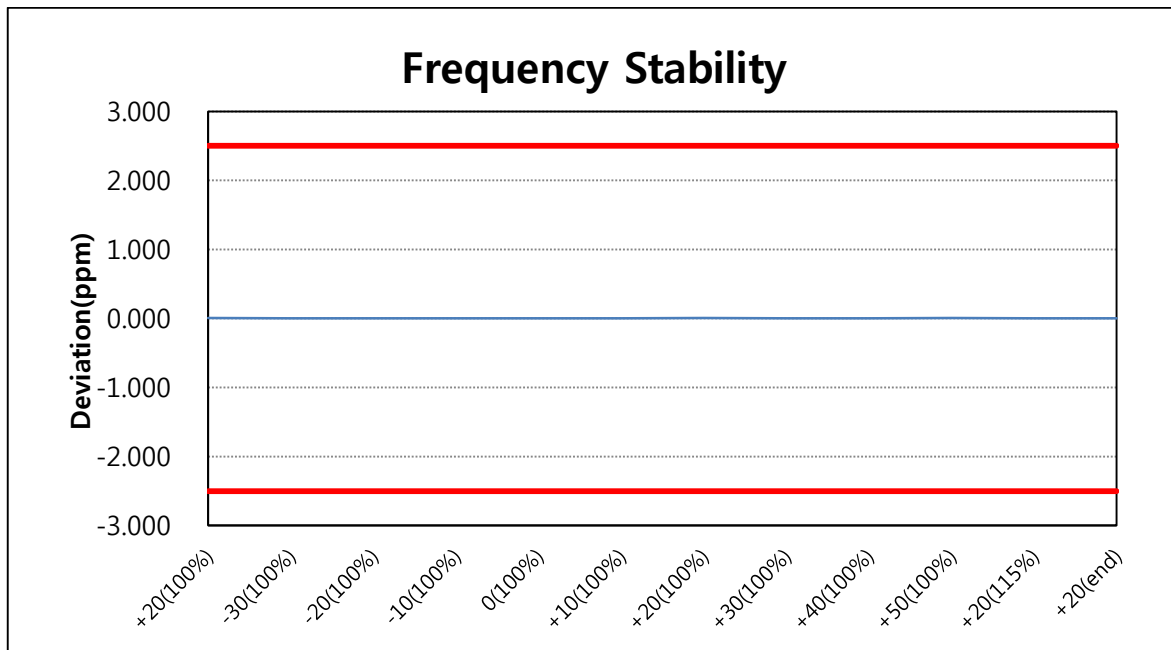

**Note.** Based on the results of the frequency stability test at the center channel the frequency deviation results measured are very small. as such it is determined that the channels at the band edge would remain inband when the maximum measured frequency deviation noted during the frequency stability tests is applied. therefore the device is determined to remain operating in band over the temperature and voltage range as tested.

## 8. TEST PLOTS

### 8.1 Peak to Average Ratio

#### WCDMA850 & Channel: 4183

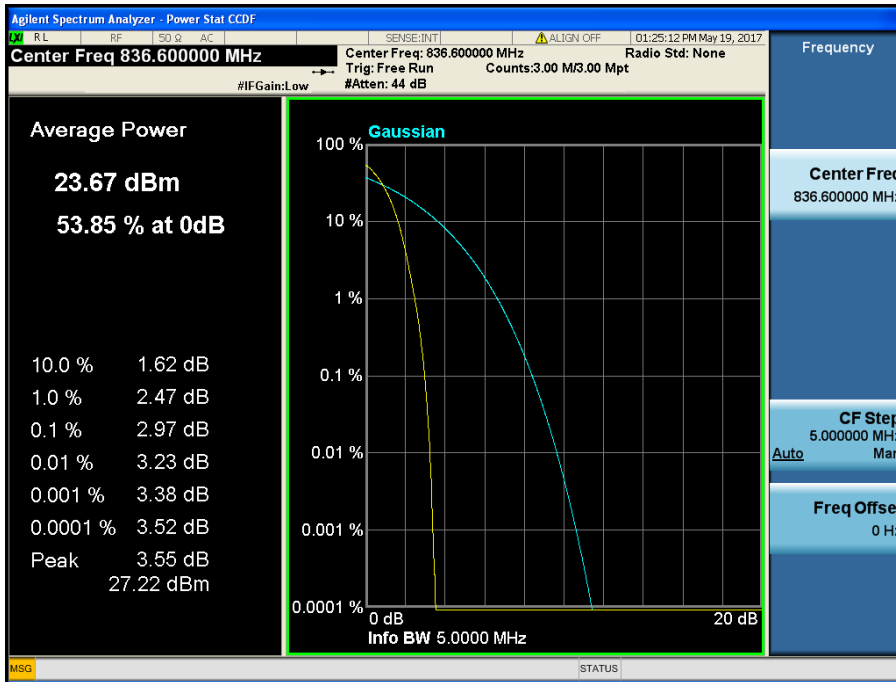

#### HSUPA850 & Channel: 4183

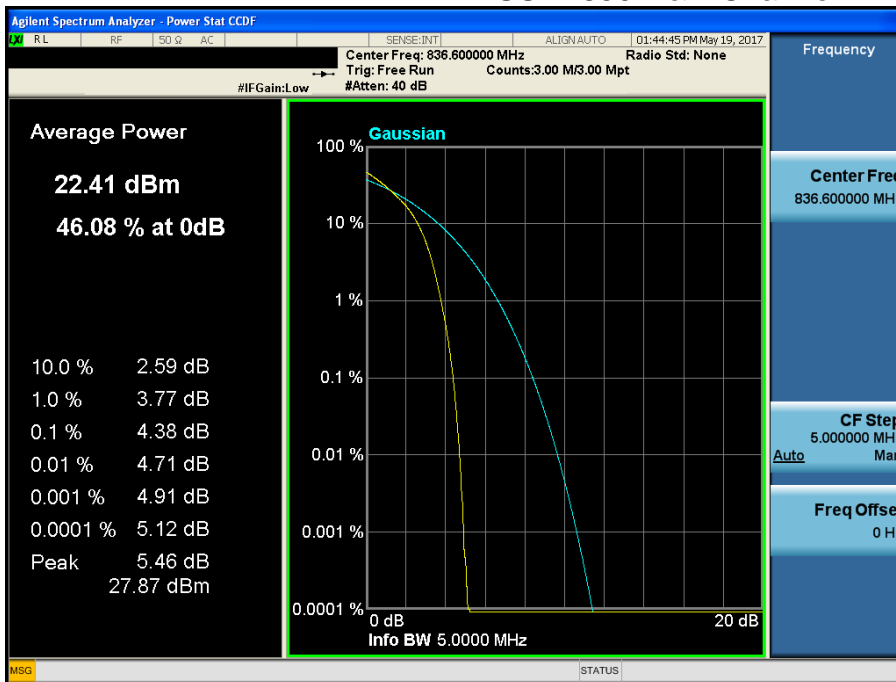

WCDMA1900 & Channel: 9400

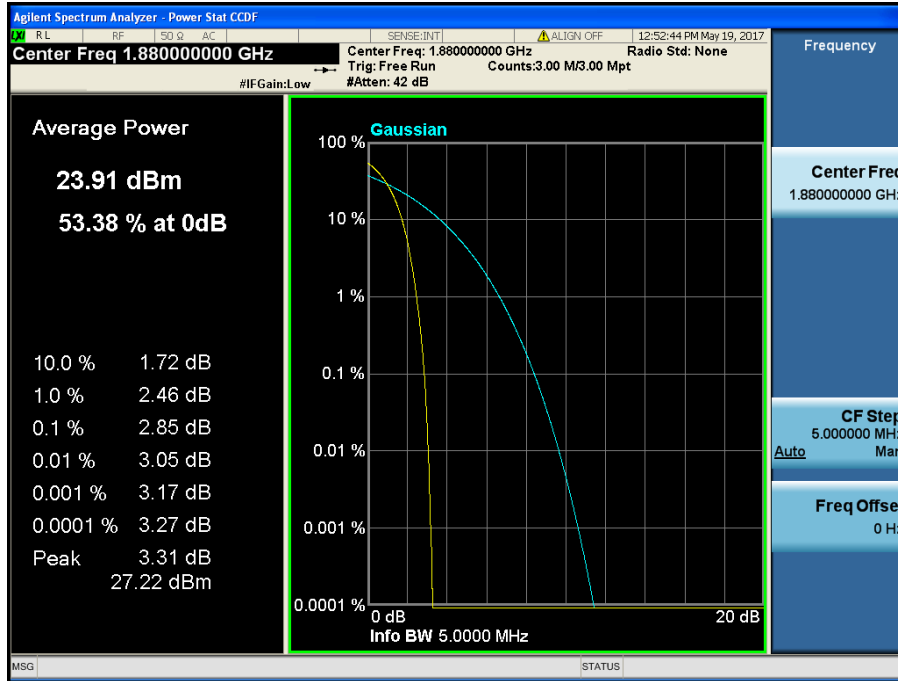

HSUPA1900 & Channel: 9400

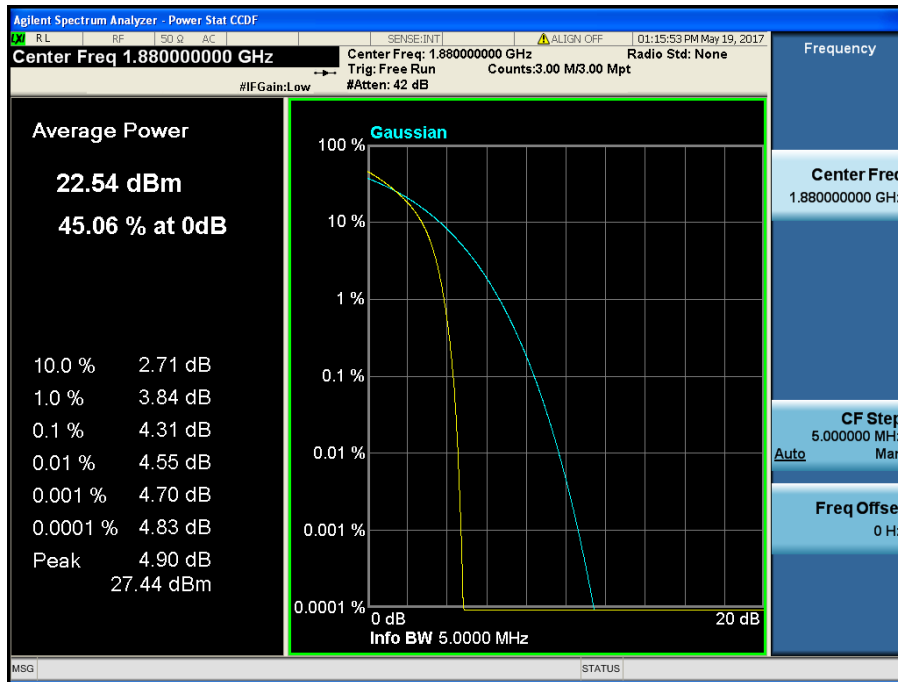

### 8.2 Occupied Bandwidth (99 % Bandwidth)

#### WCDMA850 & Channel: 4132

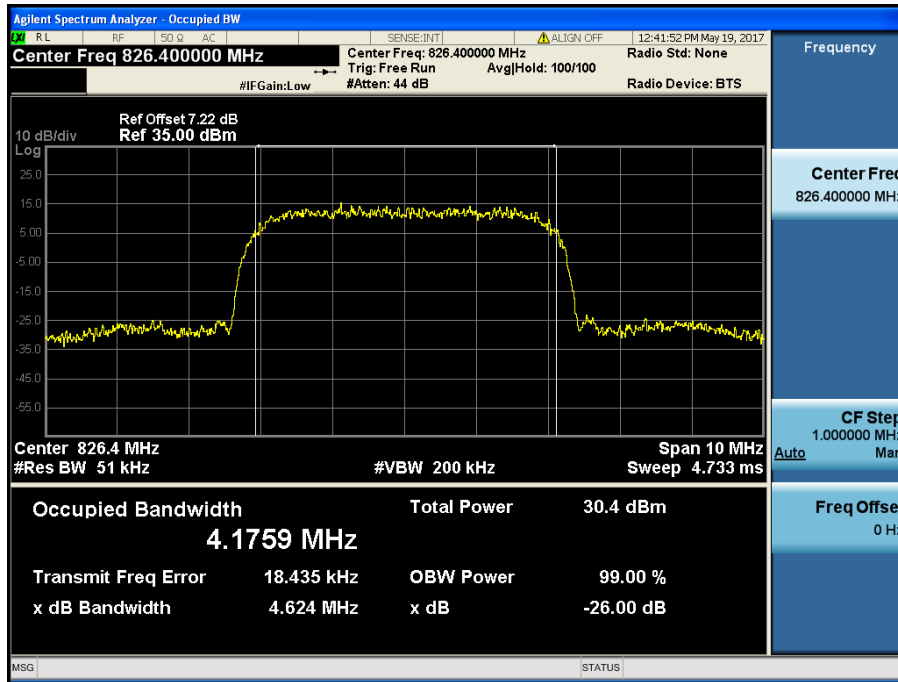

#### WCDMA850 & Channel: 4183

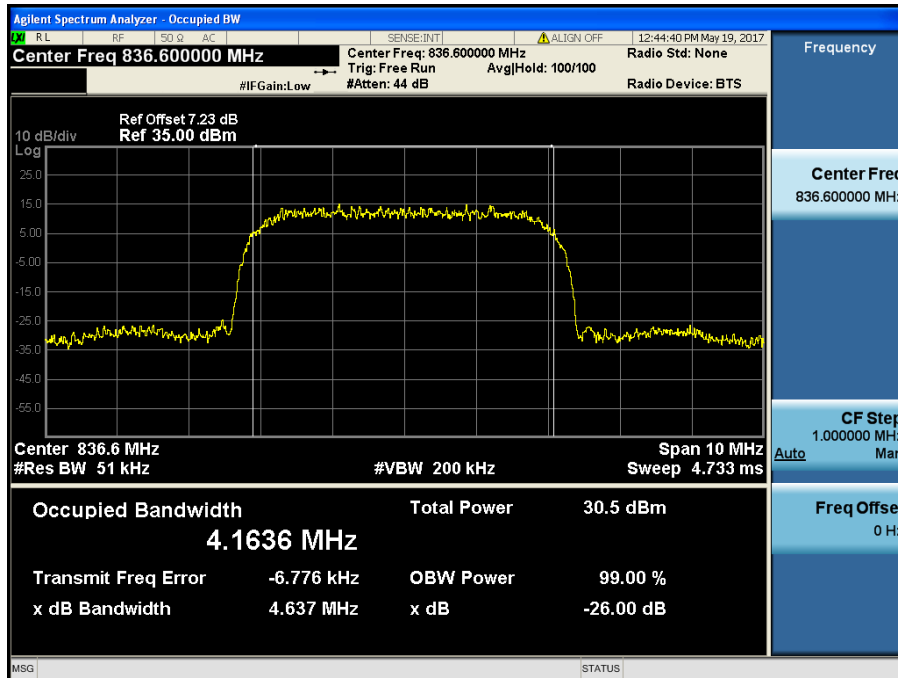

WCDMA850 & Channel: 4233

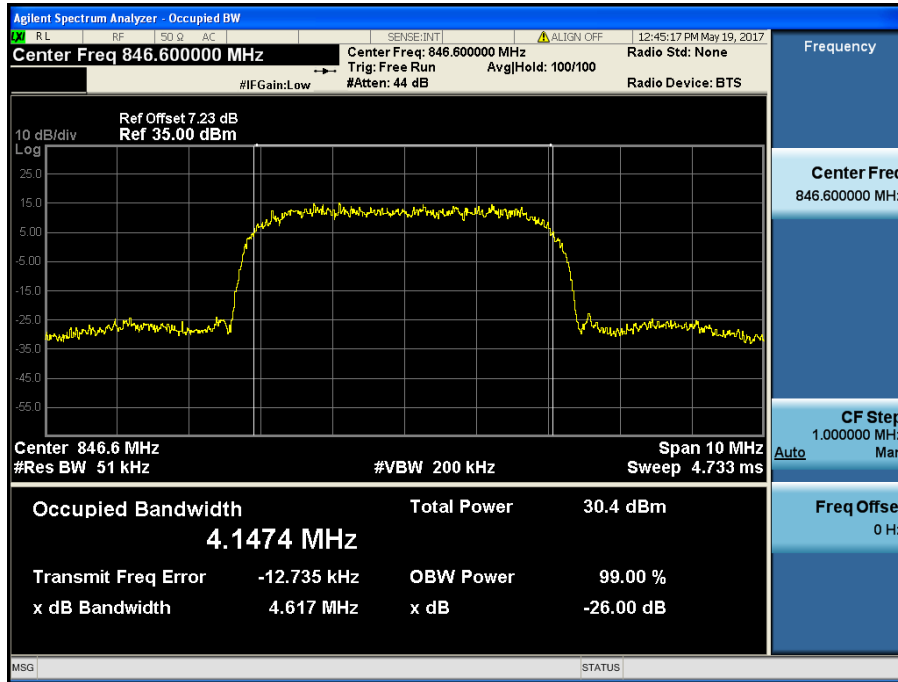

HSUPA850 & Channel: 4132

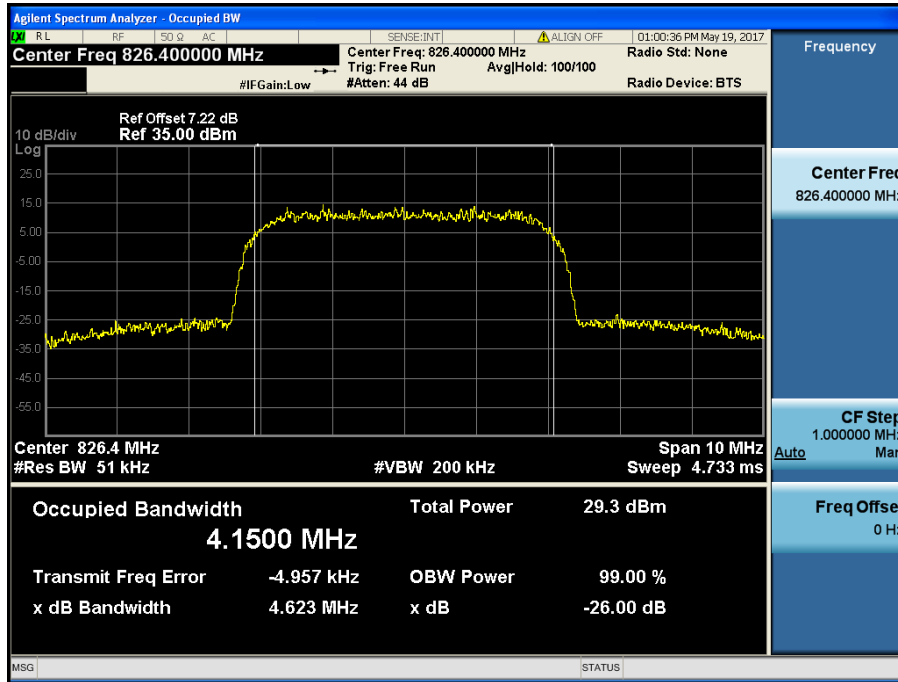

HSUPA850 & Channel: 4183

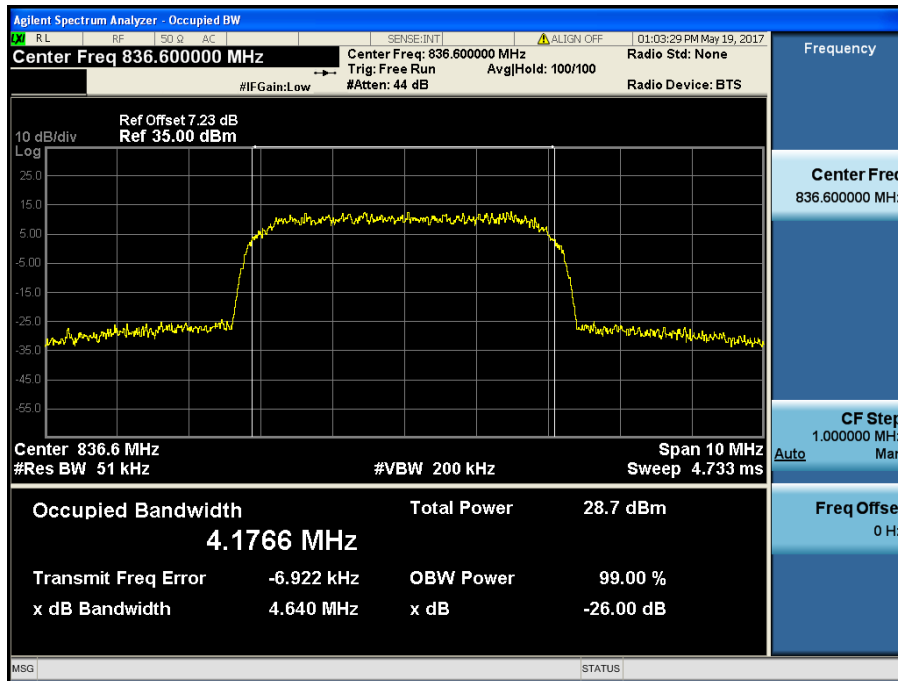





WCDMA1900 & Channel: 9262

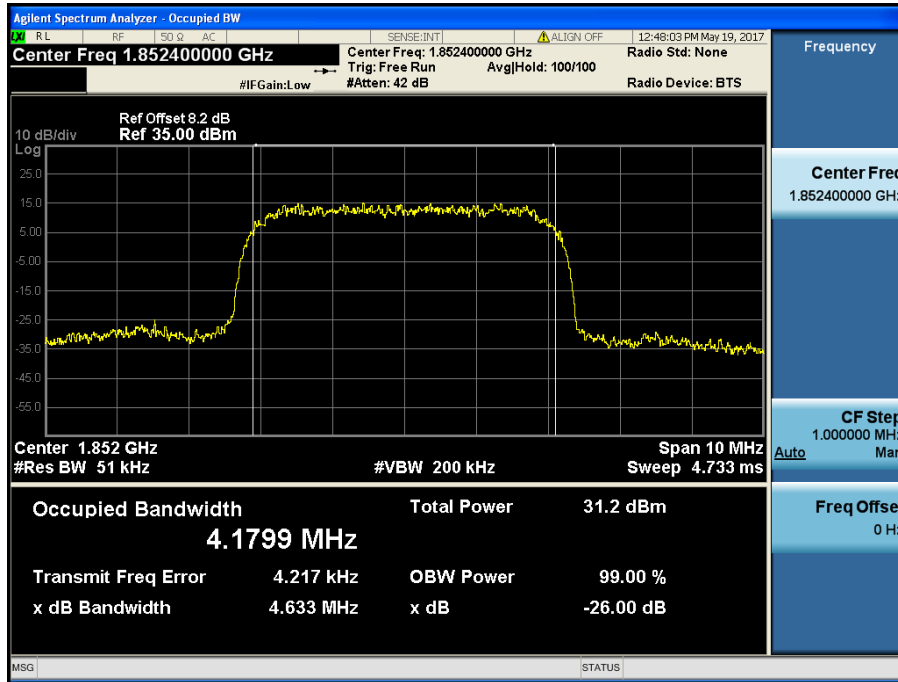

WCDMA1900 & Channel: 9400

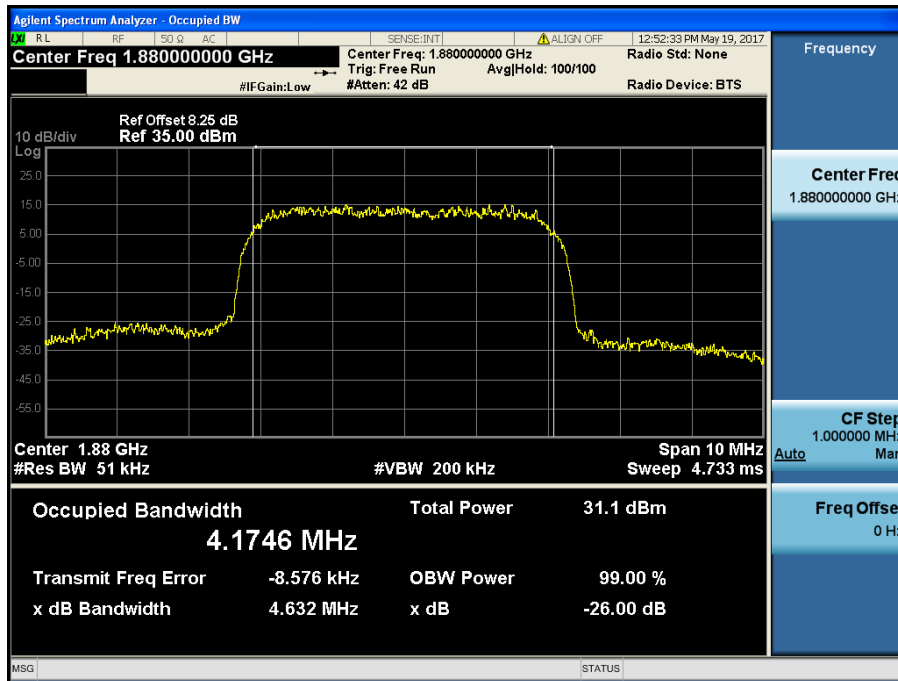

WCDMA1900 & Channel: 9538

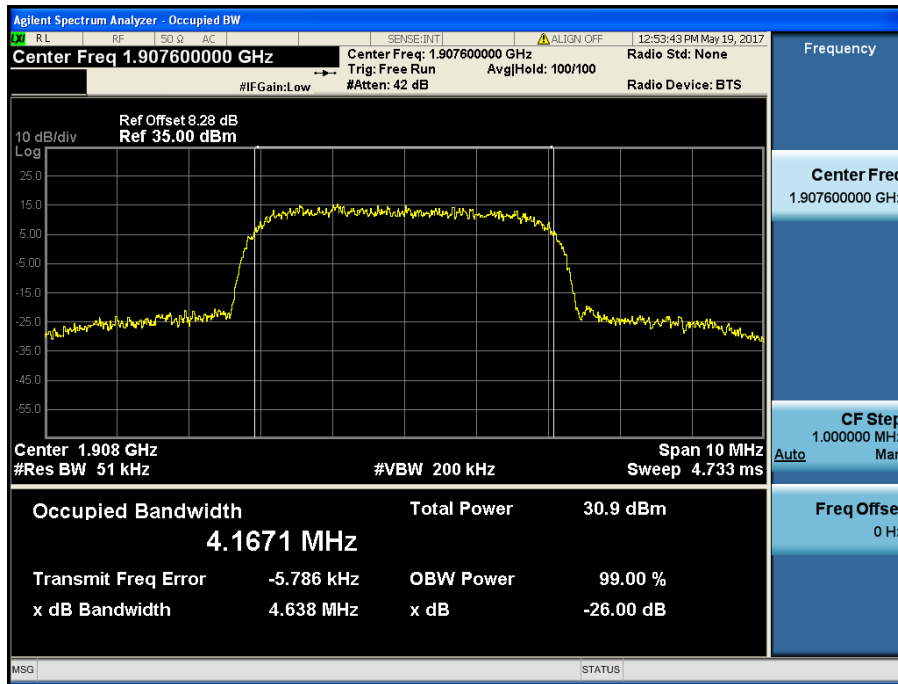

HSUPA1900 & Channel: 9262

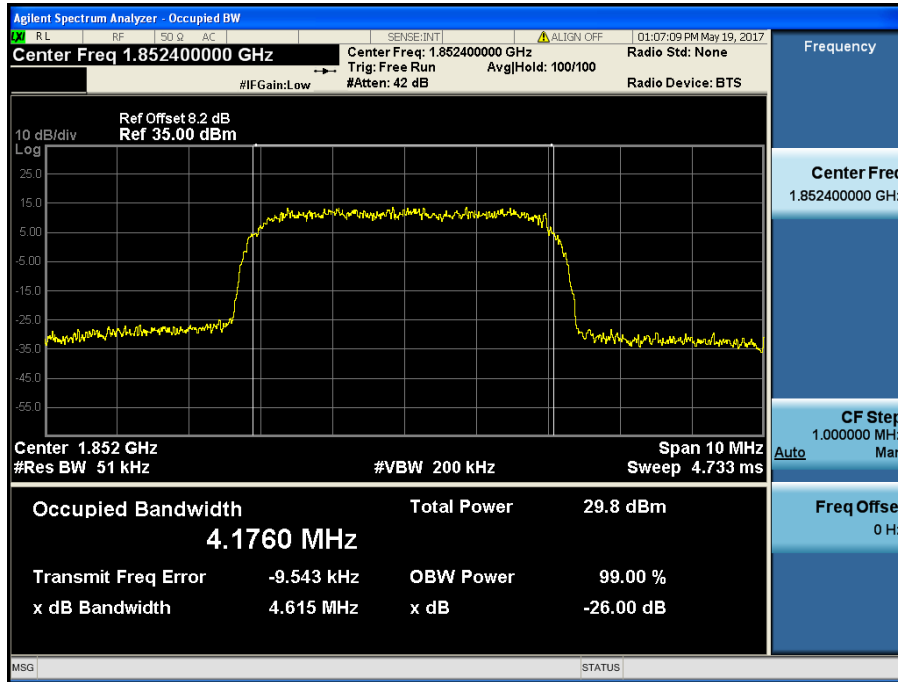

HSUPA1900 & Channel: 9400

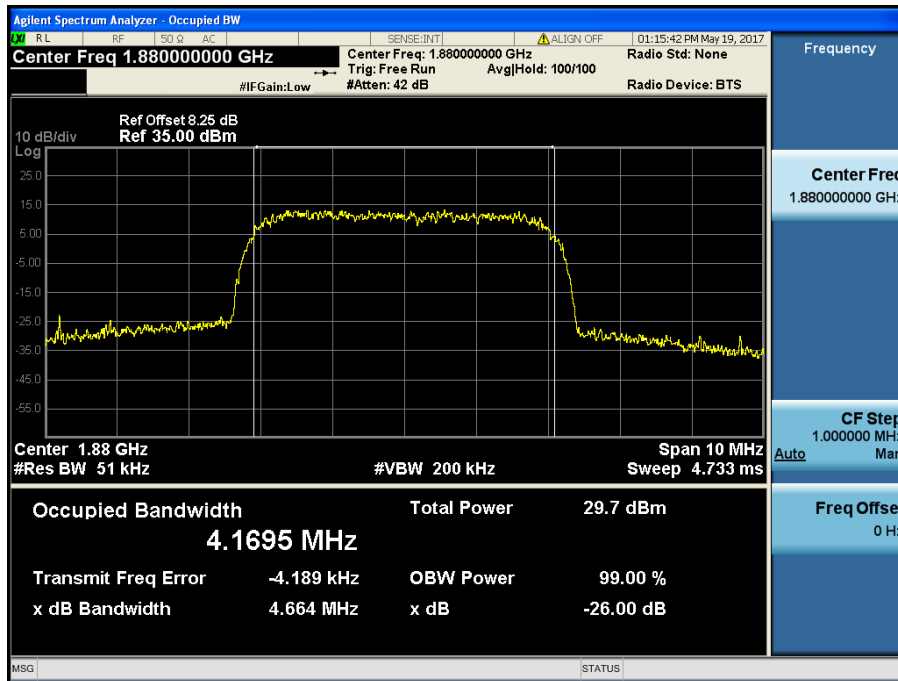

HSUPA1900 & Channel: 9538

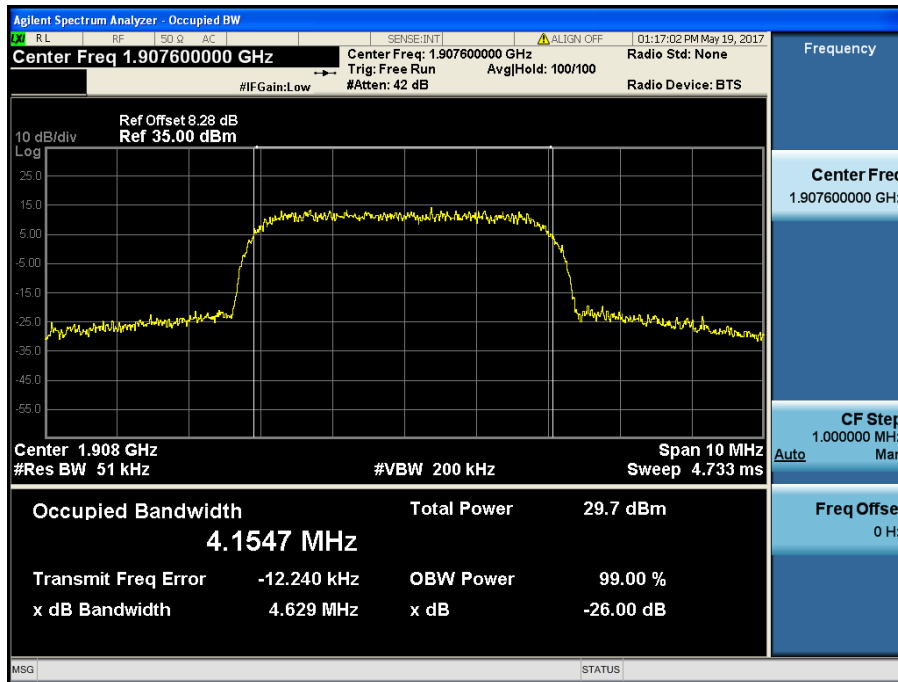

### 8.3 Spurious Emissions at Antenna Terminal

#### WCDMA850 & Channel: 4132

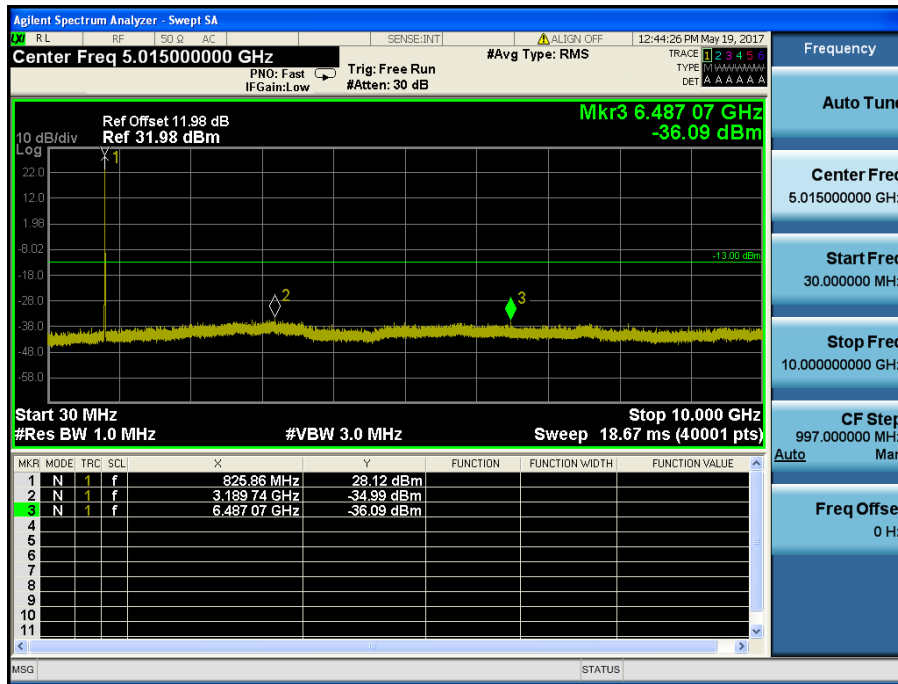

#### WCDMA850 & Channel: 4183

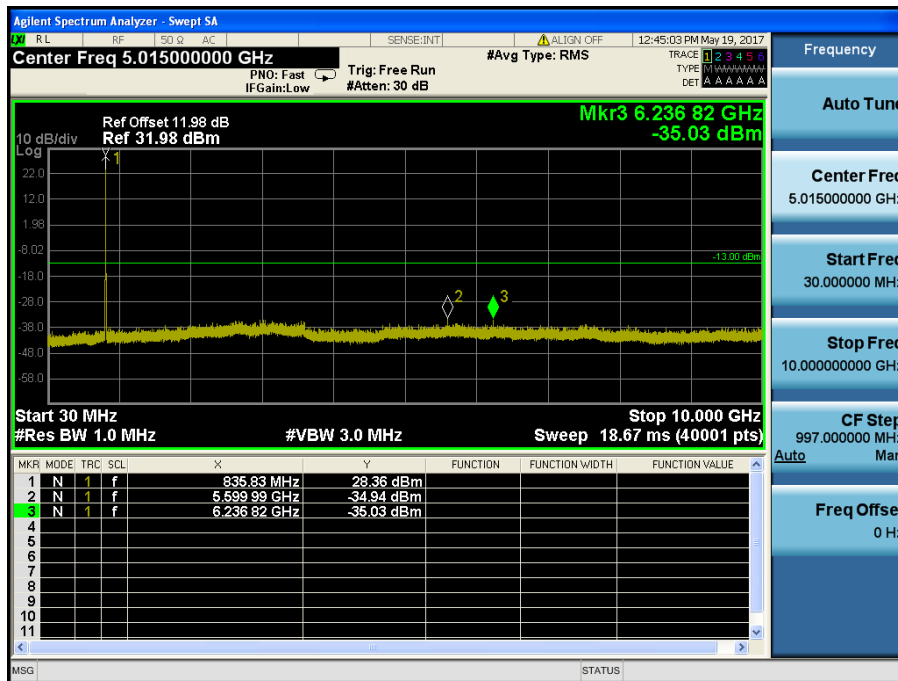

WCDMA850 & Channel: 4233

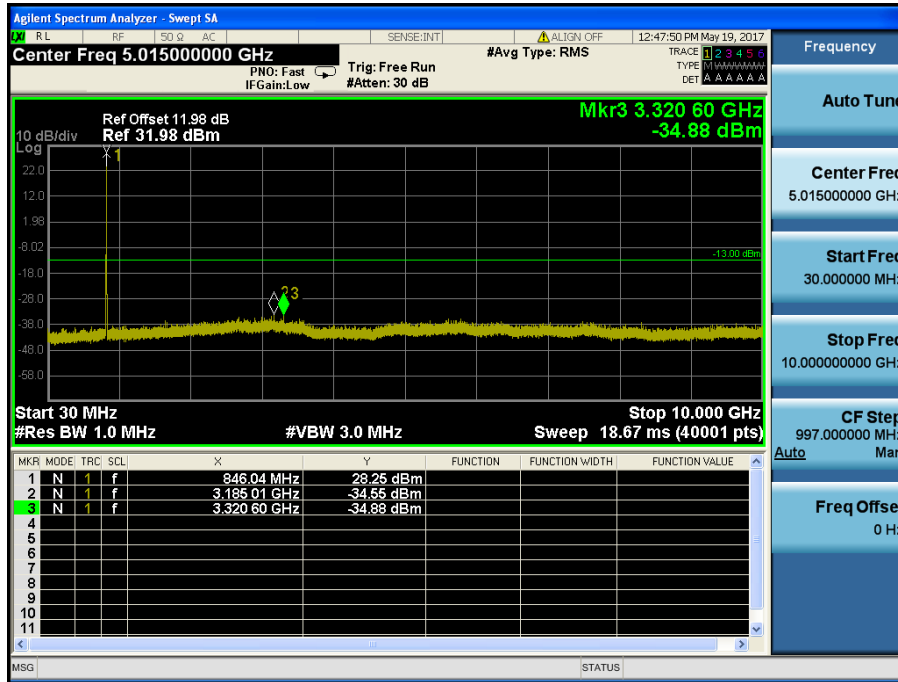

HSUPA850 & Channel: 4132

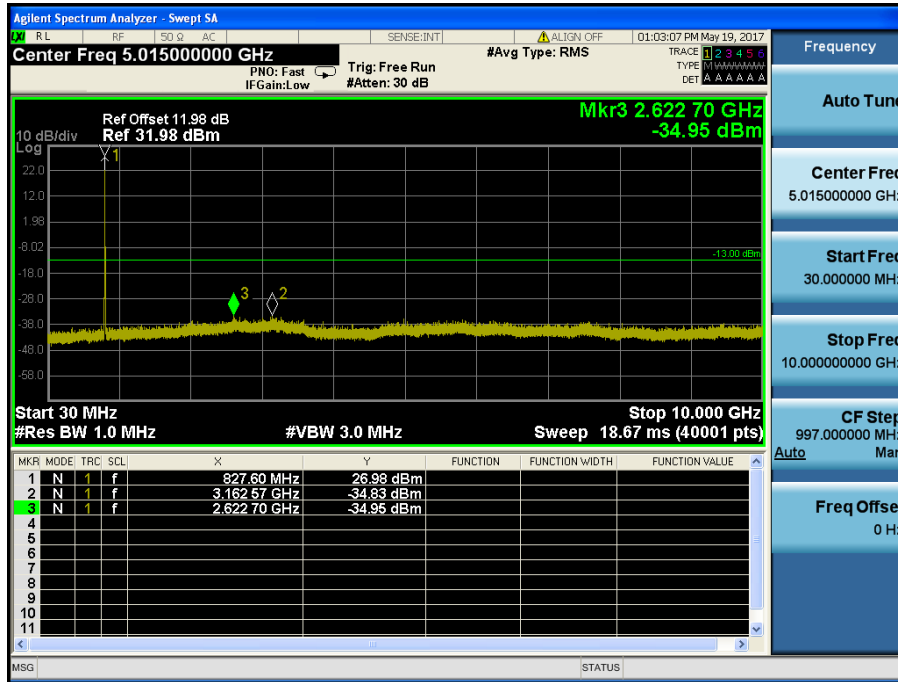

HSUPA850 & Channel: 4183

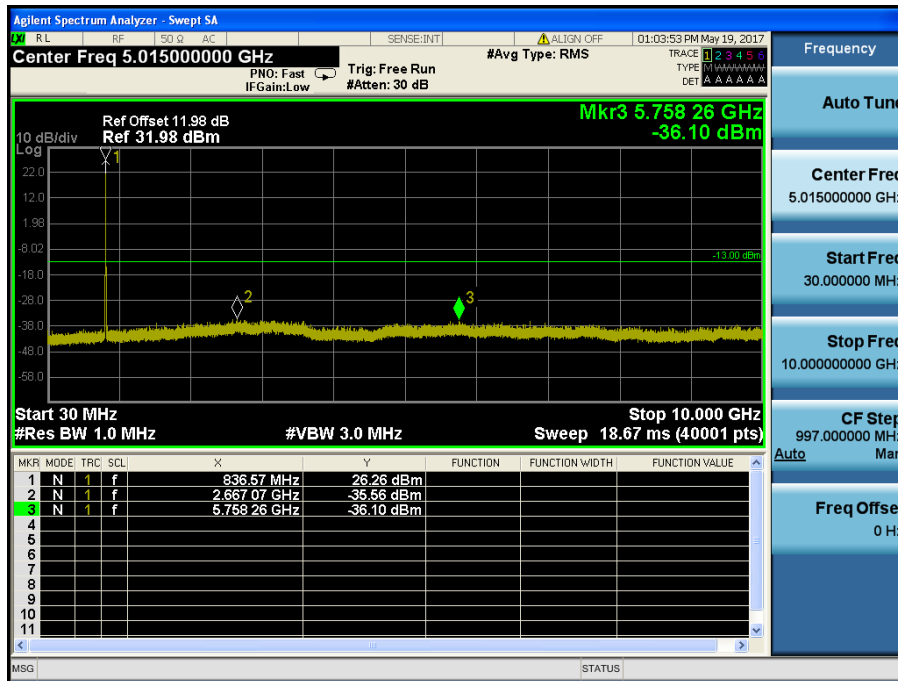

HSUPA850 & Channel: 4233

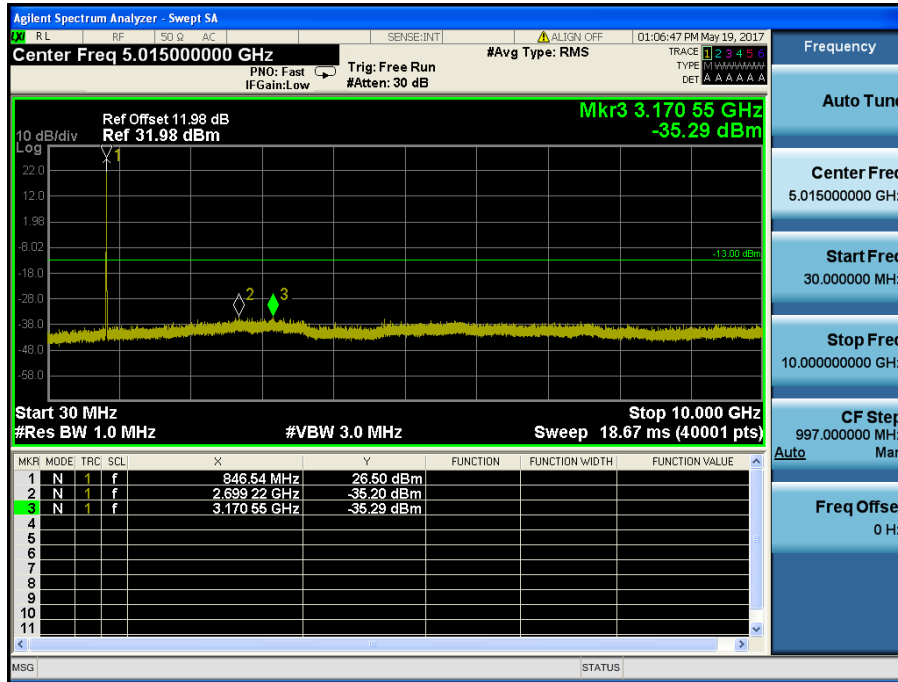



WCDMA1900 & Channel: 9262

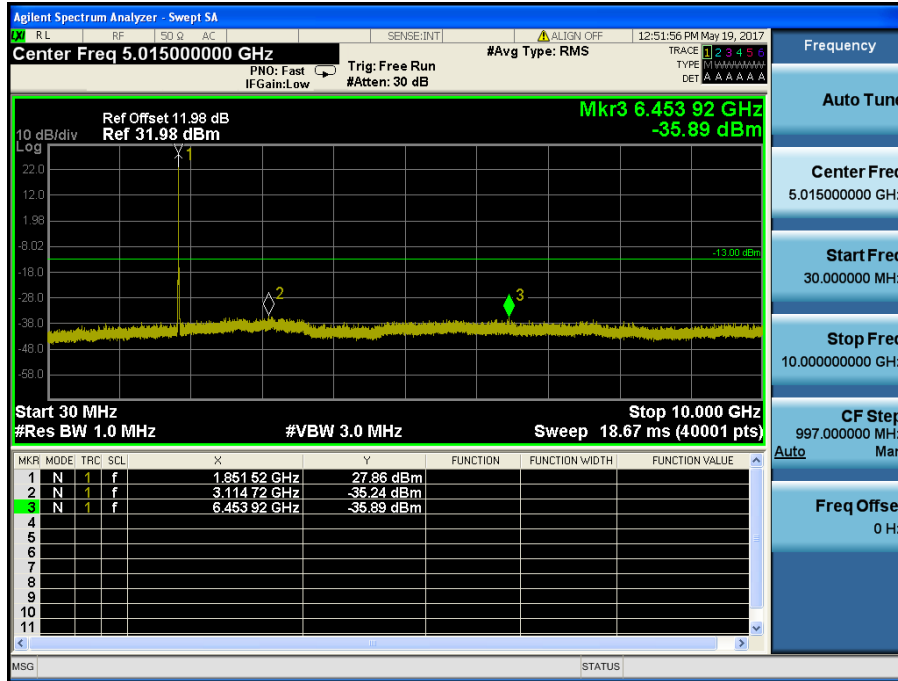

WCDMA1900 & Channel: 9262

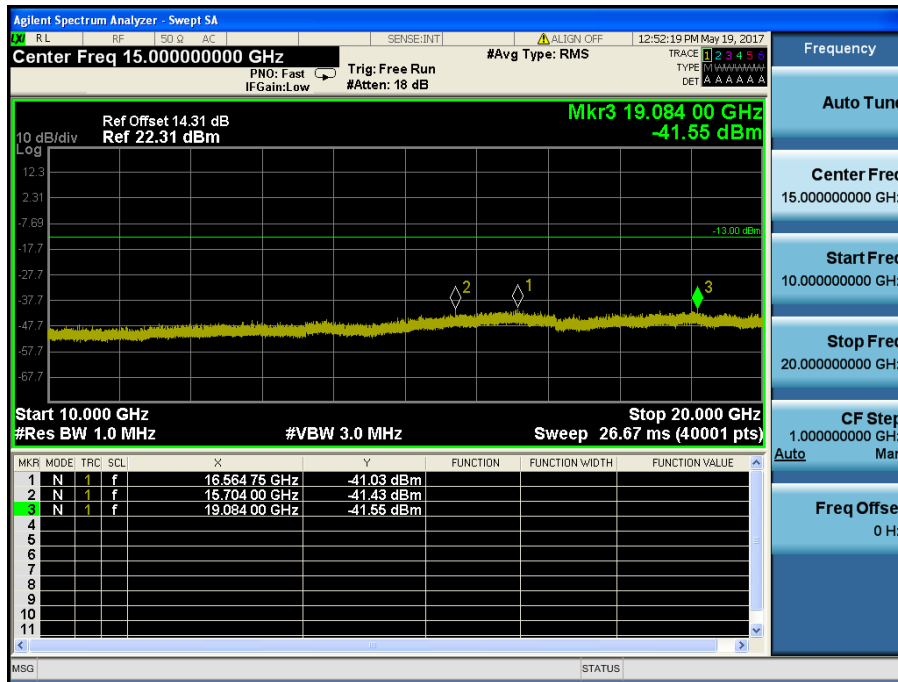

WCDMA1900 & Channel: 9400

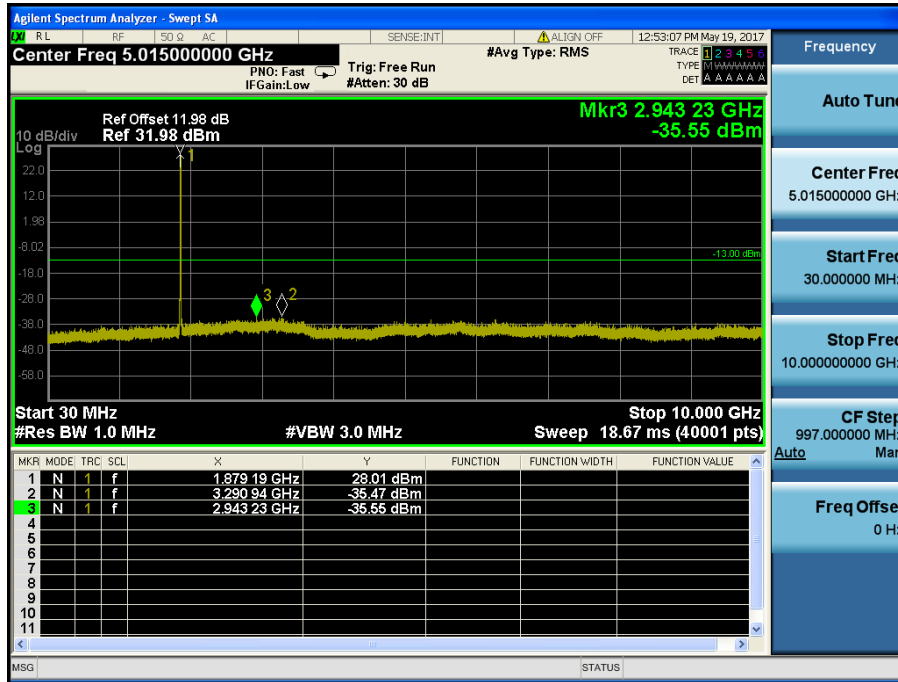

WCDMA1900 & Channel: 9400

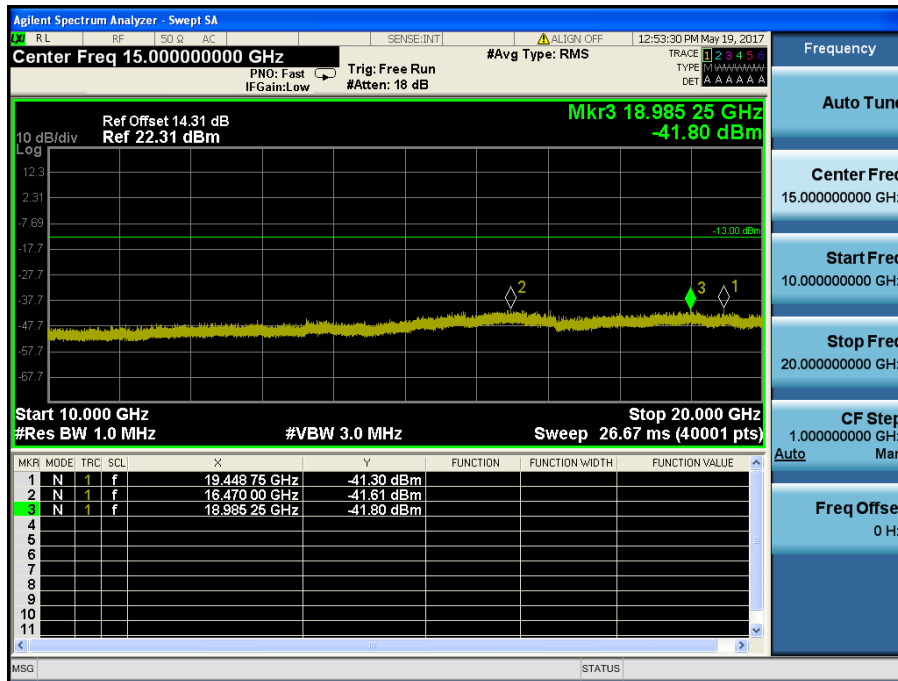

WCDMA1900 & Channel: 9538

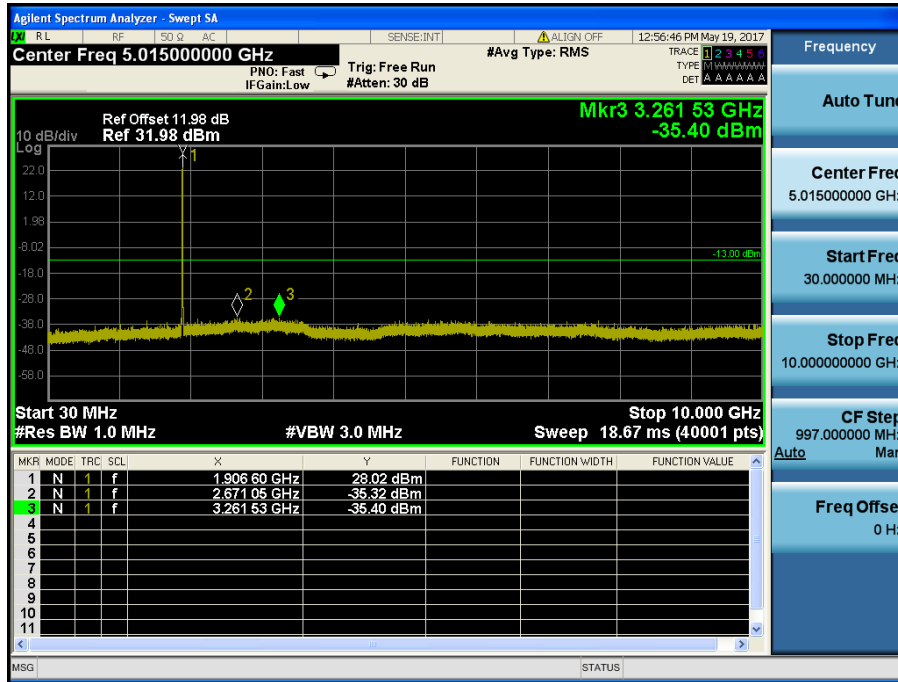

WCDMA1900 & Channel: 9538

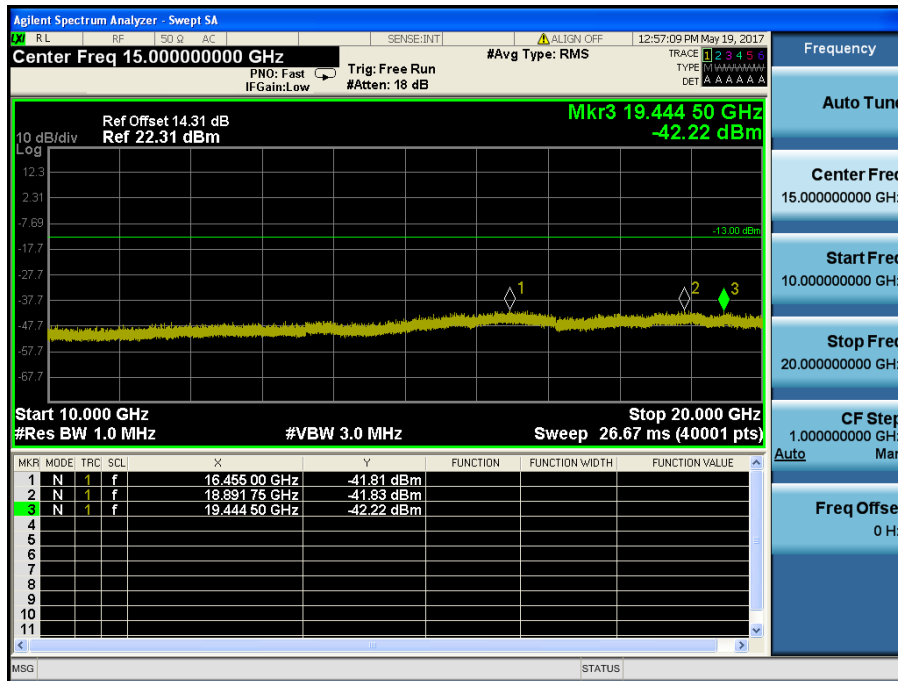

HSUPA1900 & Channel: 9262

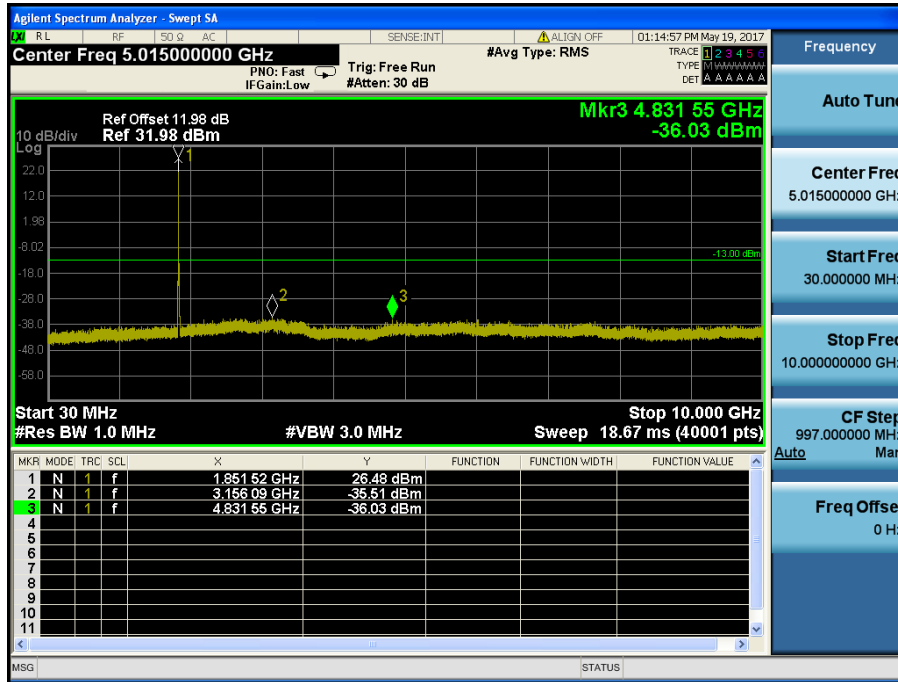

HSUPA 1900 & Channel: 9262

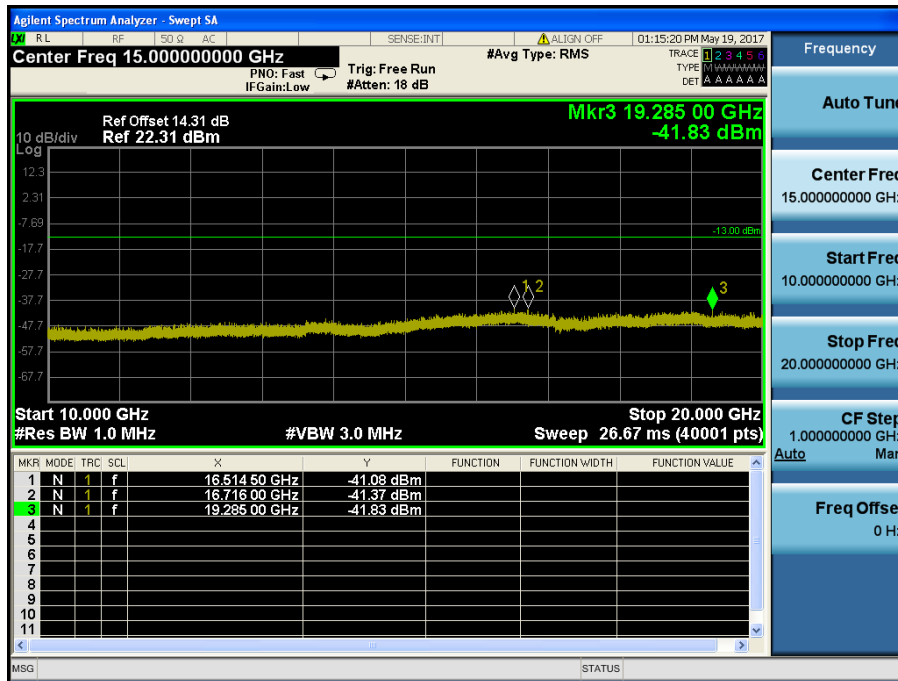

HSUPA1900 & Channel: 9400

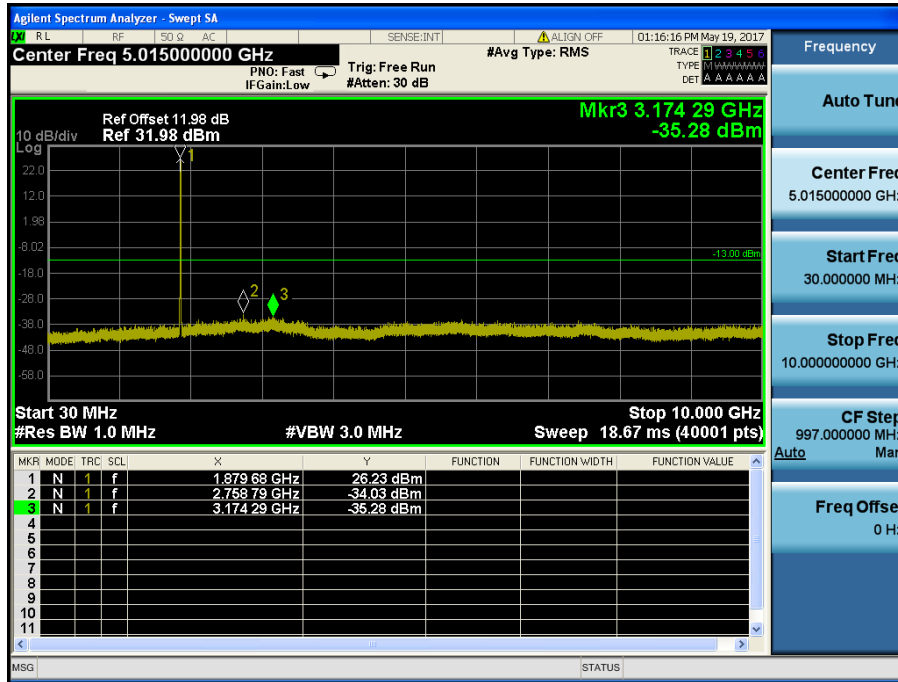

HSUPA1900 & Channel: 9400

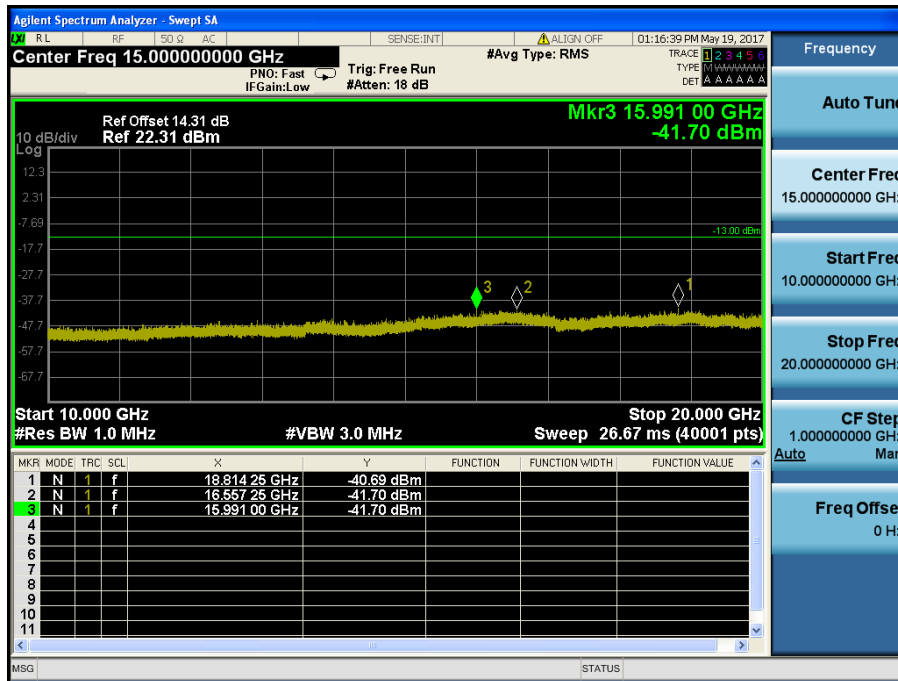

HSUPA1900 & Channel: 9538

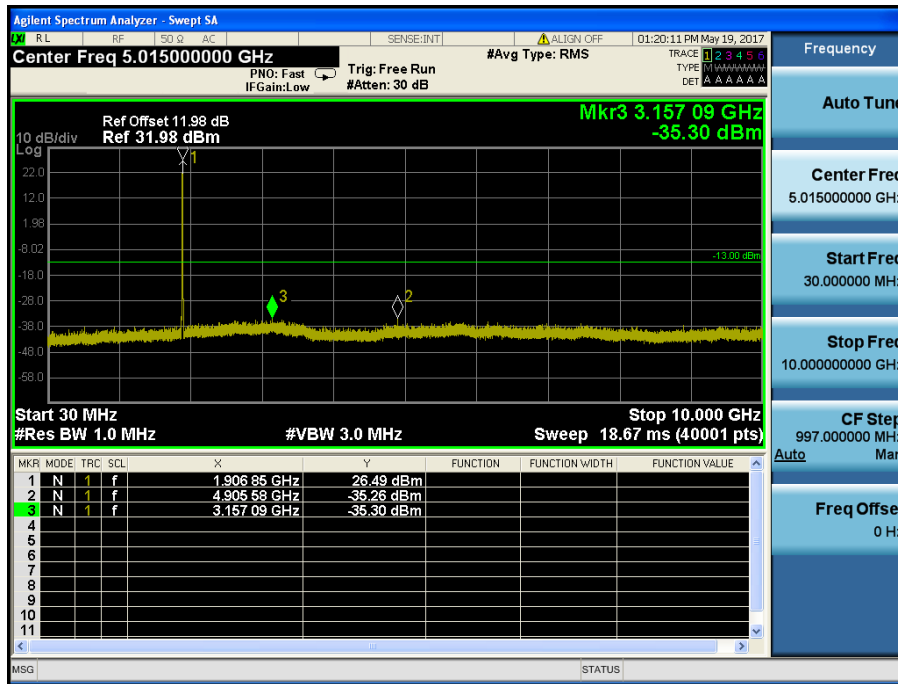

HSUPA1900 & Channel: 9538

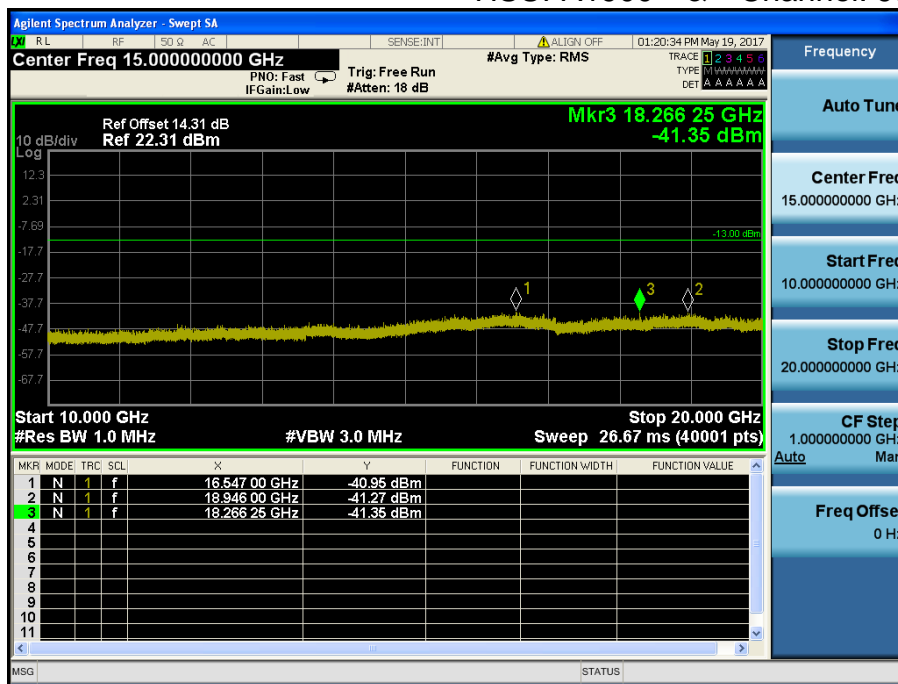

8.4 Band Edge

WCDMA850& Channel: 4132

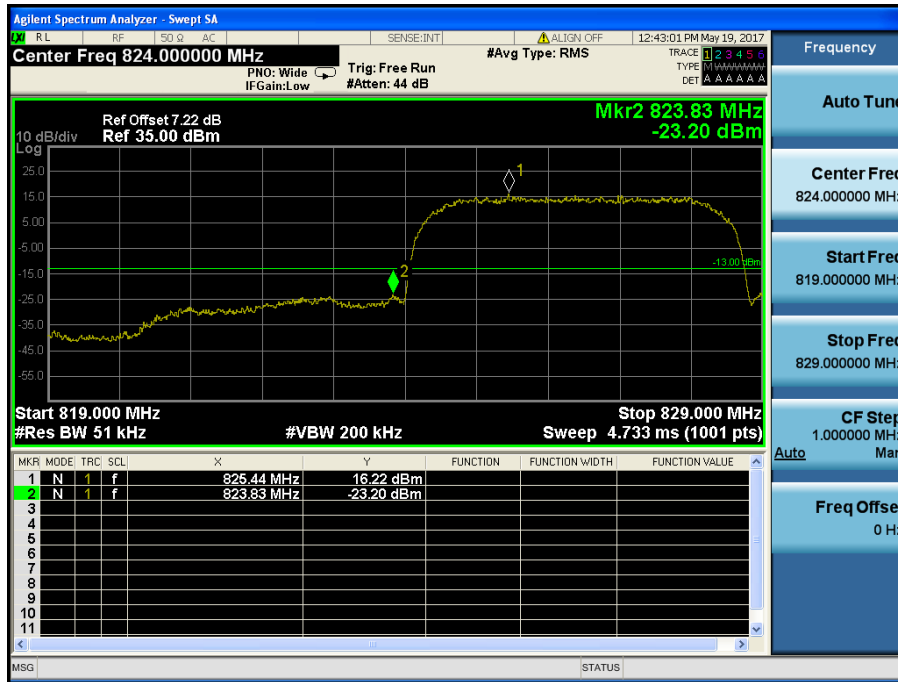

WCDMA850& Channel: 4132

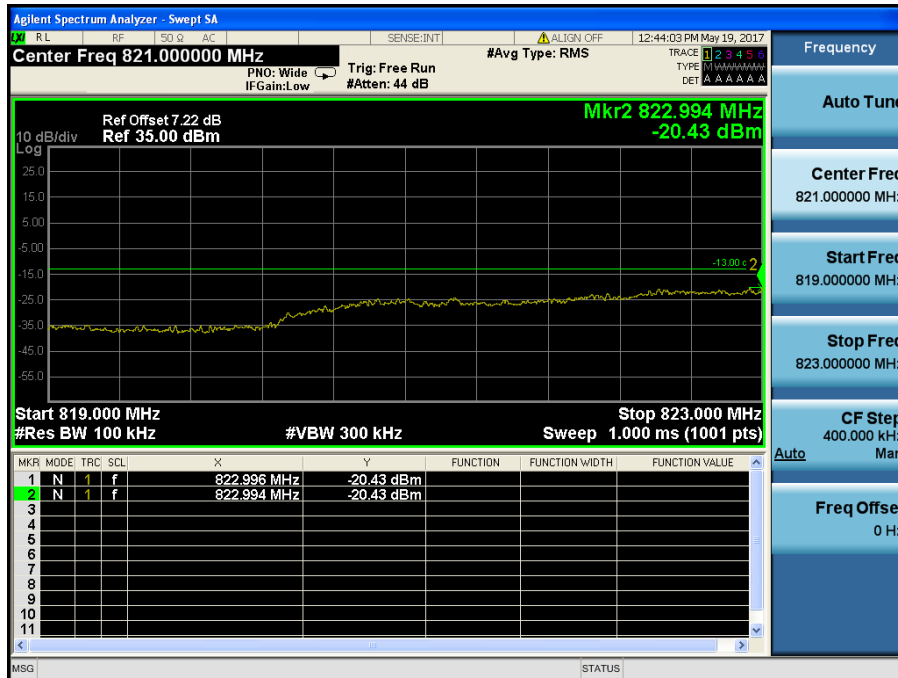

WCDMA850& Channel: 4233



WCDMA850& Channel: 4233

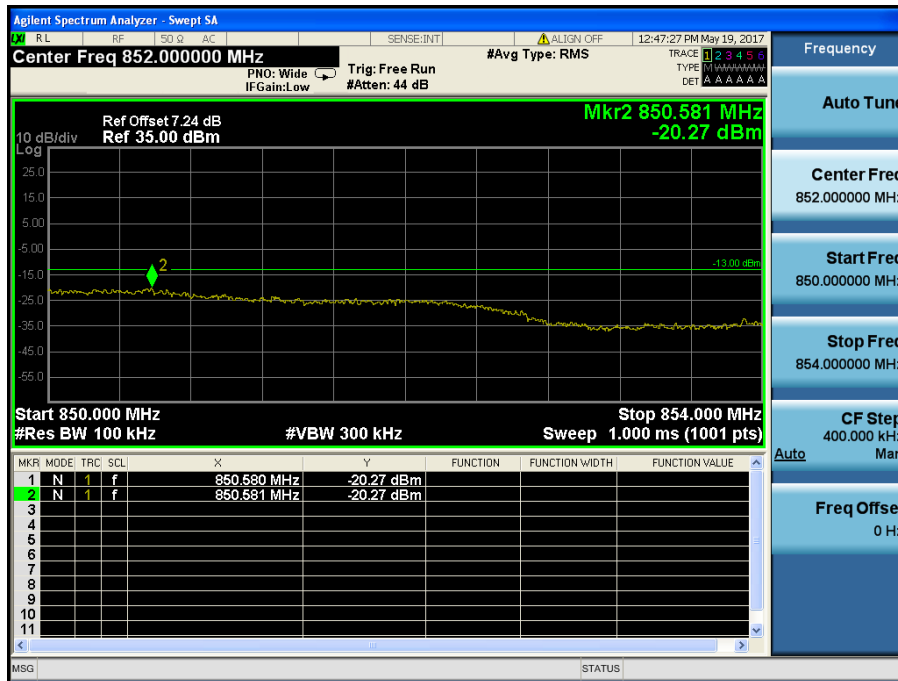



HSUPA850& Channel: 4132



HSUPA850 & Channel: 4132

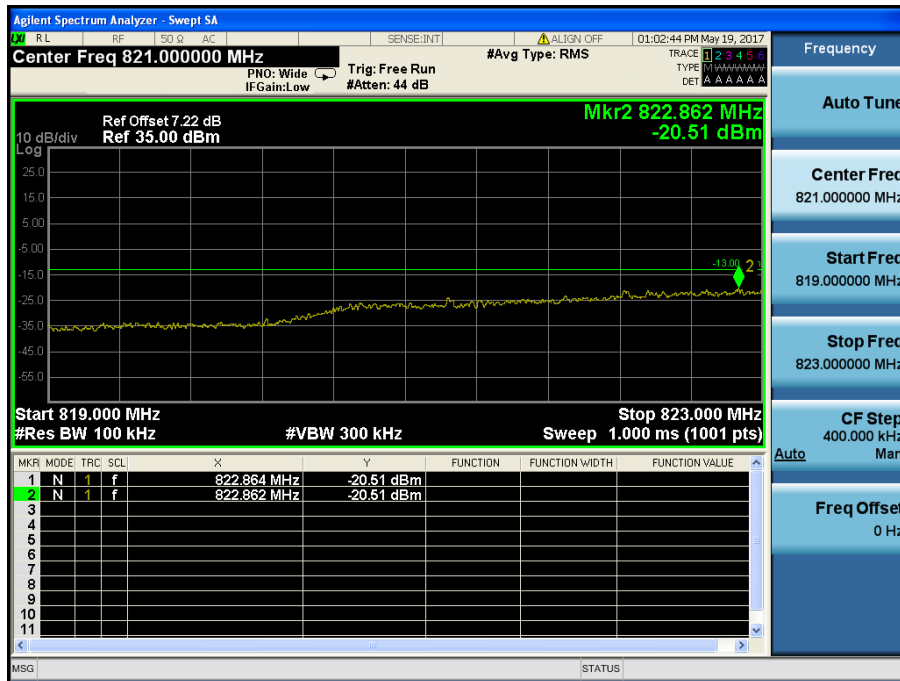

HSUPA850 & Channel: 4233



HSUPA850 & Channel: 4233

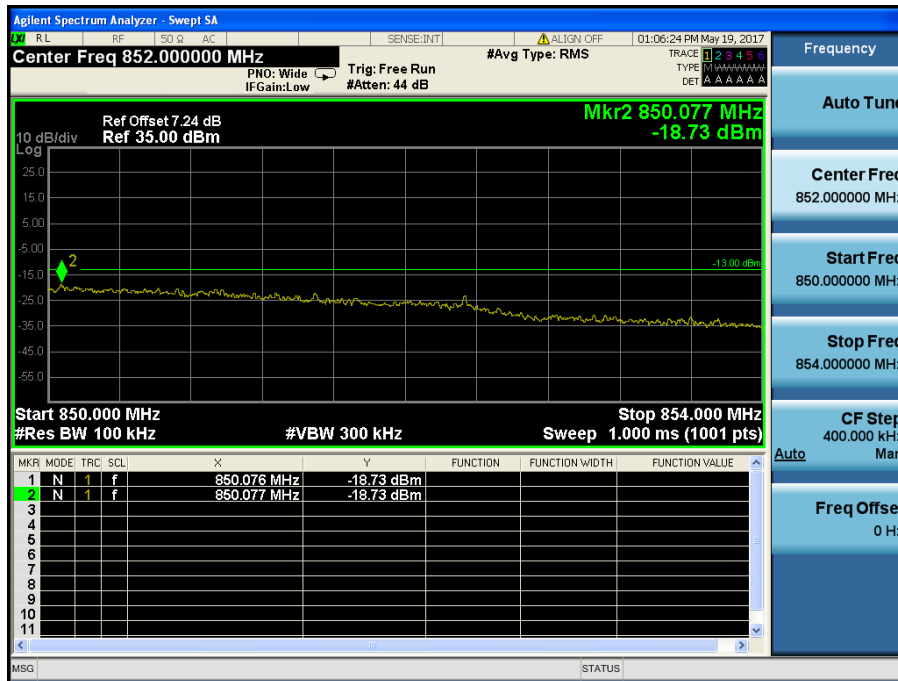

WCDMA1900 & Channel: 9262

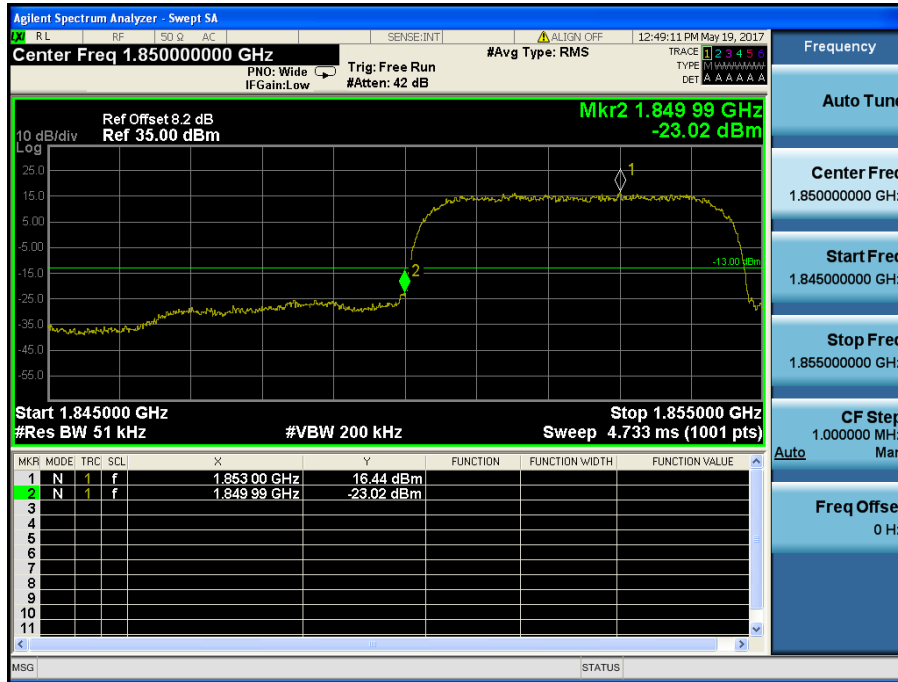

WCDMA1900 & Channel: 9262

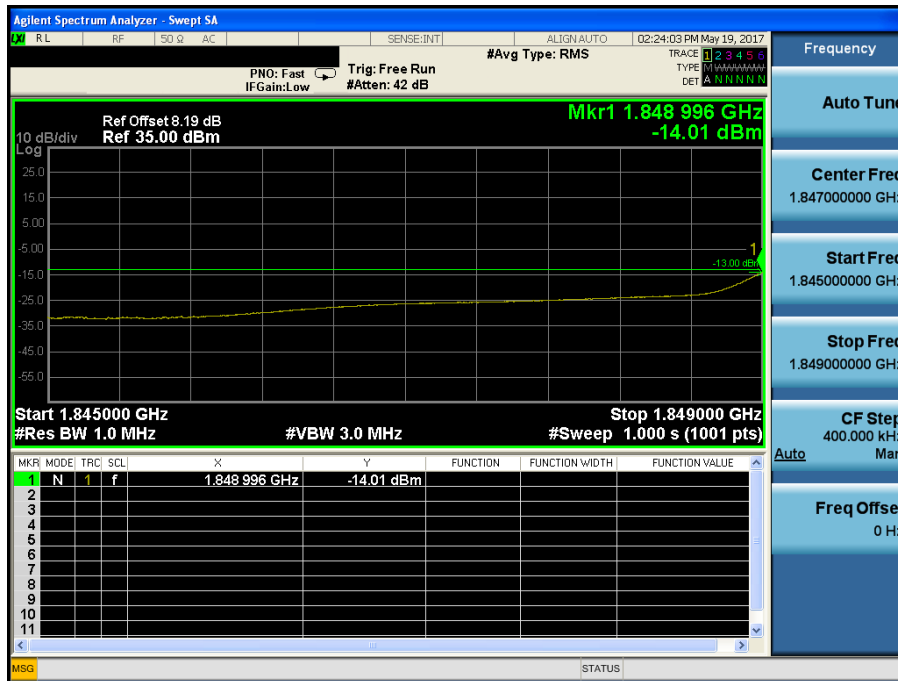

WCDMA1900 & Channel: 9538



WCDMA1900 & Channel: 9538

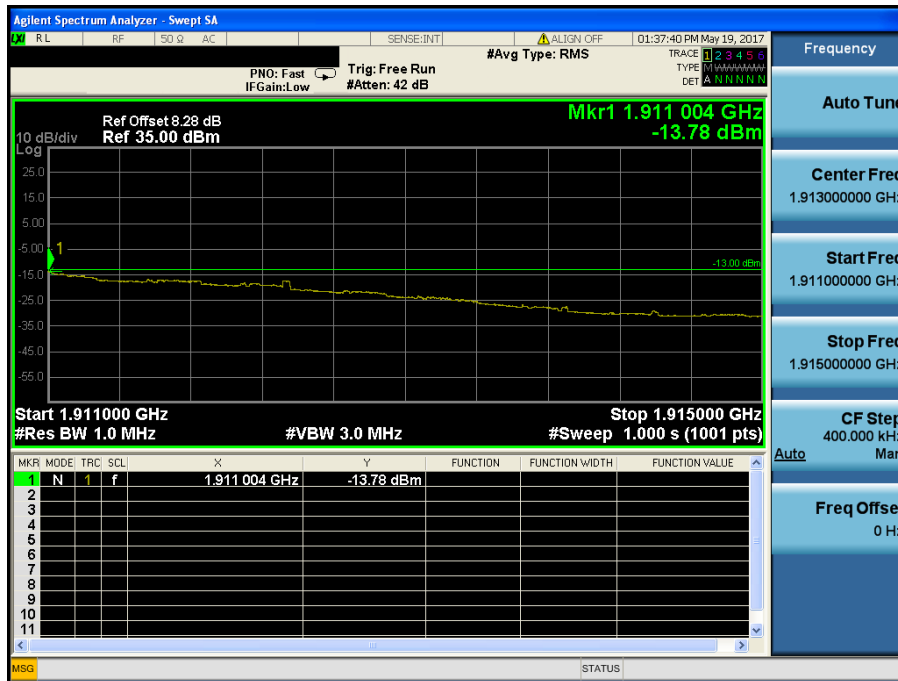

HSUPA1900 & Channel: 9262

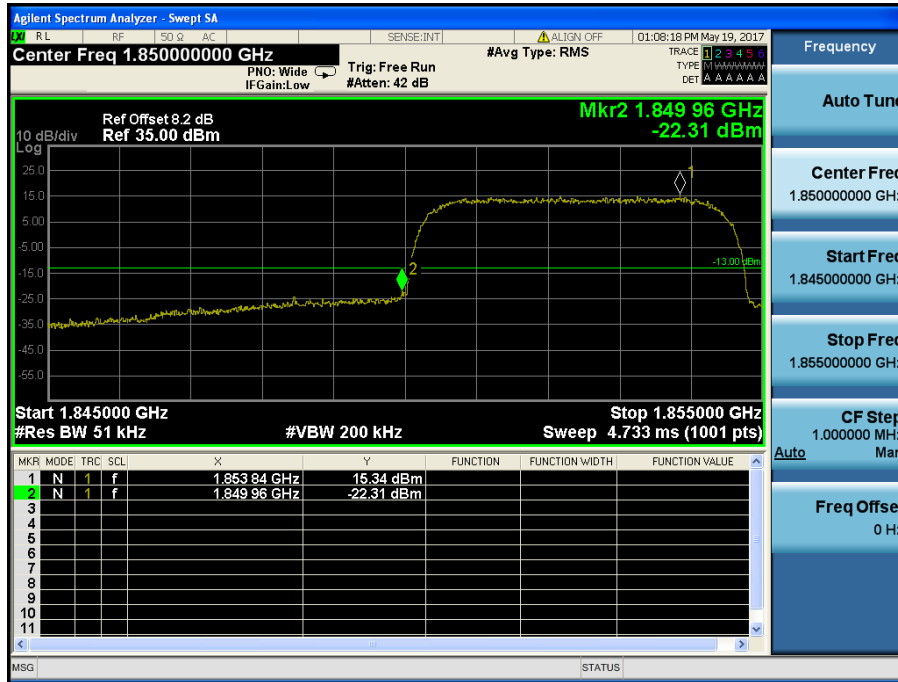

HSUPA1900 & Channel: 9262

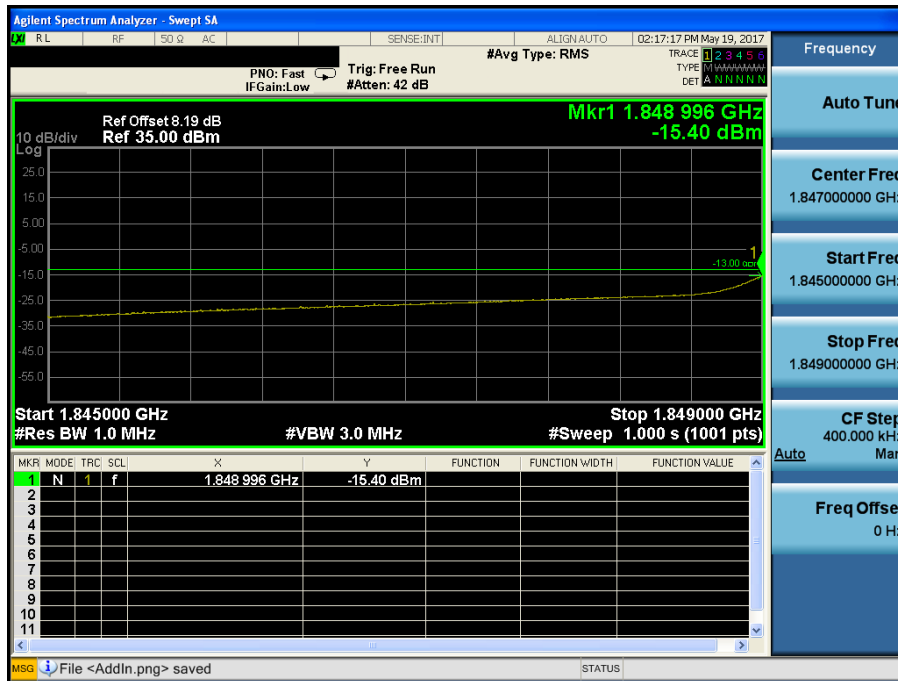

HSUPA1900 & Channel: 9538

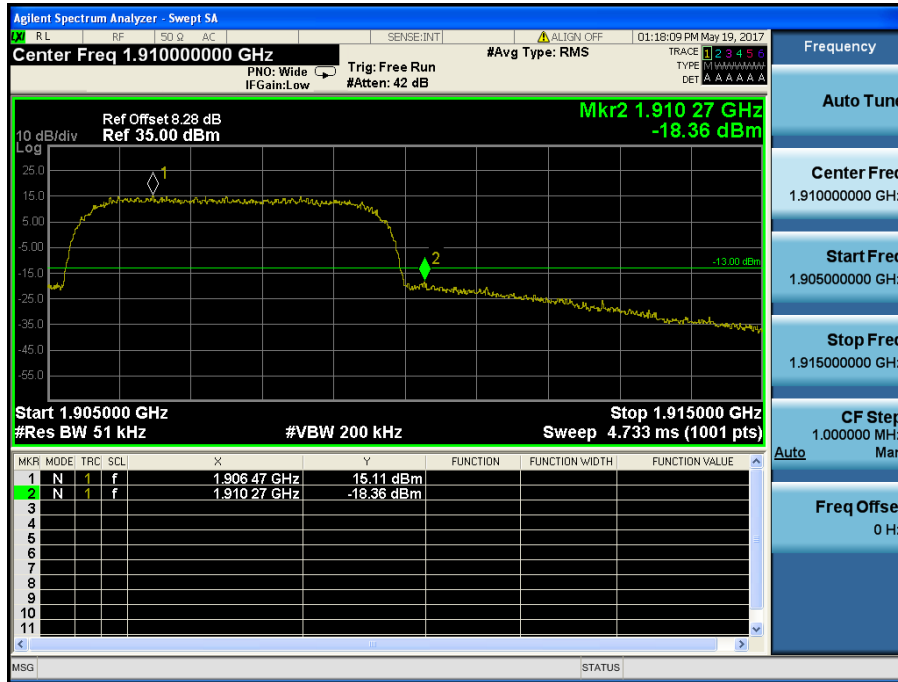

HSUPA1900 & Channel: 9538

