

TEST REPORT



DT&C Co., Ltd.

42, Yurim-ro, 154Beon-gil, Cheoin-gu, Yongin-si, Gyeonggi-do, Korea, 17042
Tel : 031-321-2664, Fax : 031-321-1664

1. Report No : DRTFCC2111-0135

2. Customer

- Name (FCC) : Point Mobile Co., LTD. / Name (IC) : POINTMOBILE CO.,LTD
- Address (FCC) : B-9F, Kabul Great Valley 32 Digital-ro 9-gil, Geumcheon-gu Seoul South Korea
153-709
- Address (IC) : B-9F Kabul Great Valley, 32, Digital-ro 9-gil, Geumcheon-gu Seoul Korea
(Republic Of)

3. Use of Report : FCC & IC Certification

4. Product Name / Model Name : Mobile Computer / PM75

FCC ID: V2X-PM75

IC: 10664A-PM75

5. FCC Regulation(s): Part 15.225

IC Standard(s): RSS-210 Issue 10, RSS-Gen Issue 5

Test Method used: ANSI C63.10-2013

6. Date of Test : 2021.09.17 ~ 2021.11.03

7. Location of Test : Permanent Testing Lab On Site Testing

8. Testing Environment : See appended test report.

9. Test Result : Refer to the attached Test Result

The results shown in this test report refer only to the sample(s) tested unless otherwise stated.

This test report is not related to KOLAS accreditation.

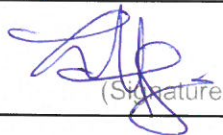
| | | |
|-------------|---|---|
| Affirmation | Tested by | Reviewed by |
| | Name : SeungMin Gil  (Signature) | Name : JaeJin Lee  (Signature) |

2021 . 11 . 17 .

DT&C Co., Ltd.

If this report is required to confirmation of authenticity, please contact to report@dtnc.net

Test Report Version

| Test Report No. | Date | Description | Revised by | Reviewed by |
|-----------------|---------------|---------------|--------------|-------------|
| DRTFCC2111-0135 | Nov. 17, 2021 | Initial issue | SeungMin Gil | JaeJin Lee |
| | | | | |
| | | | | |
| | | | | |
| | | | | |
| | | | | |
| | | | | |
| | | | | |
| | | | | |

CONTENTS

| | |
|--|-----------|
| 1. General Information..... | 4 |
| 1.1. Description of EUT | 4 |
| 1.2. Declaration by the applicant / manufacturer | 4 |
| 1.3. Testing Laboratory | 5 |
| 1.4. Testing Environment..... | 5 |
| 1.5. Measurement Uncertainty | 5 |
| 1.6. Test Equipment List..... | 6 |
| 2. Test Methodology | 7 |
| 2.1. EUT Configuration..... | 7 |
| 2.2. EUT Exercise | 7 |
| 2.3. General Test Procedures..... | 7 |
| 2.4. Description of Test Mode..... | 7 |
| 2.5. Tested frequency | 7 |
| 3. Antenna Requirements..... | 8 |
| 4. Summary of Test Result | 9 |
| 5. Test Result | 10 |
| 5.1. 20dB bandwidth & Occupied Bandwidth | 10 |
| 5.2. In-band emissions..... | 11 |
| 5.3. Out-of-band emissions | 13 |
| 5.4. Frequency Stability | 15 |
| 5.5. AC Power-Line Conducted Emissions..... | 16 |

1. General Information

1.1. Description of EUT

| | |
|---|---|
| Equipment Class | Low Power Communications Device Transmitter (DXX) |
| Product Name | Mobile computer |
| Model Name | PM75 |
| Add Model Name | - |
| Firmware Version Identification Number | 75.00 |
| EUT Serial Number | 21197A0022 |
| Power Supply | DC 3.85 V |
| Frequency Range | 13.560 MHz |
| Modulation Type | ASK |
| Antenna Type | Loop Antenna |

1.2. Declaration by the applicant / manufacturer

N/A

1.3. Testing Laboratory

| | |
|--|--------------------|
| DT&C Co., Ltd. | |
| The 3 m test site and conducted measurement facility used to collect the radiated data are located at the 42, Yurim-ro, 154beon-gil, Cheoin-gu, Yongin-si, Gyeonggi-do, Korea 17042. | |
| The test site complies with the requirements of § 2.948 according to ANSI C63.4-2014. | |
| - FCC & IC MRA Designation No. : KR0034 | |
| - ISED#: 5740A | |
| www.dtnc.net | |
| Telephone | : + 82-31-321-2664 |
| FAX | : + 82-31-321-1664 |

1.4. Testing Environment

| Ambient Condition | |
|---------------------|-----------------|
| ▪ Temperature | +22 °C ~ +24 °C |
| ▪ Relative Humidity | +42 % ~ +47 % |

1.5. Measurement Uncertainty

The measurement uncertainties shown below were calculated in accordance with requirements of ANSI C63.4-2014 and ANSI C63.10-2013. All measurement uncertainty values are shown with a coverage factor of $k = 2$ to indicate a 95 % level of confidence.

| Parameter | Measurement uncertainty |
|----------------------------------|---|
| AC power-line conducted emission | 3.4 dB (The confidence level is about 95 %, $k = 2$) |
| Radiated emission (Below 1 GHz) | 4.9 dB (The confidence level is about 95 %, $k = 2$) |

1.6. Test Equipment List

| Type | Manufacturer | Model | Cal.Date (yy/mm/dd) | Next.Cal.Date (yy/mm/dd) | S/N |
|--------------------------|----------------------|------------------------------------|------------------------|-----------------------------|-------------------|
| Spectrum Analyzer | Agilent Technologies | N9020A | 21/06/24 | 22/06/24 | MY50200834 |
| Spectrum Analyzer | Agilent Technologies | N9020A | 21/06/24 | 22/06/24 | US47360812 |
| DC Power Supply | Agilent Technologies | 66332A | 21/06/24 | 22/06/24 | US37473422 |
| Multimeter | FLUKE | 17B+ | 20/12/16 | 21/12/16 | 36390701WS |
| Signal Generator | Rohde Schwarz | SMBV100A | 20/12/16 | 21/12/16 | 255571 |
| Thermohygrometer | BODYCOM | BJ5478 | 20/12/16 | 21/12/16 | 120612-1 |
| Thermohygrometer | BODYCOM | BJ5478 | 20/12/16 | 21/12/16 | 120612-2 |
| Loop Antenna | ETS-Lindgren | 6502 | 21/01/28 | 23/01/28 | 00226186 |
| BILOG ANTENNA | Schwarzbeck | VULB 9160 | 20/12/16 | 21/12/16 | 3362 |
| PreAmplifier | H.P | 8447D | 20/12/16 | 21/12/16 | 2944A07774 |
| Temp & Humi Test Chamber | SJ Science | SJ-TH-S50 | 20/12/14 | 21/12/14 | SJ-TH-S50-140205 |
| Cable | HUBER+SUHNER | SUCOFLEX100 | 21/01/08 | 22/01/08 | M-01 |
| Cable | HUBER+SUHNER | SUCOFLEX100 | 21/01/08 | 22/01/08 | M-02 |
| Cable | JUNFLON | MWX241 | 21/01/08 | 22/01/08 | M-03 |
| Cable | JUNFLON | J12J101757-00 | 21/01/08 | 22/01/08 | M-07 |
| Cable | HUBER+SUHNER | SUCOFLEX106 | 21/01/08 | 22/01/08 | M-09 |
| EMI Receiver | ROHDE&SCHWARZ | ESU | 21/01/19 | 22/01/19 | 100538 |
| PULSE LIMITER | Rohde Schwarz | ESH3-Z2 | 21/08/23 | 22/08/23 | 101333 |
| LISN | SCHWARZBECK | NSLK 8128 RC | 20/10/23 21/10/22 | 21/10/23 22/10/22 | 8128 RC-387 |
| HYGROMETER | TESTO | 608-H1 | 21/01/19 | 22/01/19 | 34862883 |
| Cable | DT&C | Cable | 21/01/05 | 22/01/05 | RFC-69 |
| Test Software | tsj | Radiated Emission Measurement | N/A | N/A | Version 2.00.0177 |
| Test Software | tsj | Noise Terminal Voltage Measurement | N/A | N/A | Version 2.00.0170 |

Note1: The measurement antennas were calibrated in accordance to the requirements of ANSI C63.5-2017.

Note2: The cable is not a regular calibration item, so it has been calibrated by DT & C itself.

2. Test Methodology

The tests were performed according to the ANSI C63.10-2013.

2.1. EUT Configuration

The EUT configuration for testing is installed on RF field strength measurement to meet the Commissions requirement and operating in a manner that intends to maximize its emission characteristics in a continuous normal application.

2.2. EUT Exercise

The EUT was operated in the test mode to fix the TX frequency that was for the purpose of the measurements. According to its specifications, the EUT must comply with the requirements of the FCC and IC rules.

2.3. General Test Procedures

Conducted Emissions

According to the requirements in Section 6.2 of ANSI C63.10, the EUT is placed on the wooden table, which is 0.8 m above ground plane and the conducted emissions from the EUT are measured in the frequency range between 0.15 MHz and 30MHz using CISPR Quasi-peak and Average detector.

Radiated Emissions

The EUT is placed on a non-conductive table, which is 0.8 m above ground plane. The turntable shall rotate 360 degrees to determine the position of maximum emission level. EUT is set 3 m away from the receiving antenna, which varied from 1 m to 4 m to find out the highest emission. And also, each emission was to be maximized by changing the polarization of receiving antenna both horizontal and vertical. In order to find out the highest emission, the relative positions of this hand-held transmitter (EUT) was rotated through three orthogonal axes according to the requirements in Section 6.3 of ANSI C63.10

2.4. Description of Test Mode

| | |
|-------------------|------------------------------|
| Test mode1 | Continuous transmitting mode |
|-------------------|------------------------------|

The EUT has been tested with the operating condition for maximizing the emission characteristics. And the internal firmware was used for staying in continuous transmitting mode.

2.5. Tested frequency

| Channel | Tested Frequency(MHz) |
|----------------|-----------------------|
| Lowest | 13.560 |
| Middle | - |
| Highest | - |

3. Antenna Requirements

An intentional radiator antenna shall be designed to ensure that no antenna other than that furnished by the responsible party can be used with the device. The use of a permanently attached antenna or of an antenna that uses a unique coupling to the intentional radiator shall be considered sufficient to comply with the provisions of this section.

**The internal antenna is attached on the PCB using the special spring tension.
Therefore this E.U.T Complies with the requirement of §15.203**

4. Summary of Test Result

| FCC part section(s) | RSS section(s) | Test Description | Limit | Test condition | Status Note 1 |
|---|--------------------------------------|------------------------|---|---------------------------|---------------|
| 15.215(c) | - | 20 dB Bandwidth | - | Radiated | C |
| - | RSS-Gen [6.7] | Occupied Bandwidth | - | | C |
| 15.225(a) | RSS-210 [B6(a)] | In-Band Emissions | 15,848 $\mu\text{V}/\text{m}$ @ 30 m 13.553 MHz – 13.567 MHz | | C Note 3 |
| 15.225(b) | RSS-210 [B6(b)] | In-Band Emissions | 334 $\mu\text{V}/\text{m}$ @ 30 m 13.410 MHz – 13.553 MHz 13.567 MHz – 13.710 MHz | | C Note 3 |
| 15.225(c) | RSS-210 [B6(c)] | In-Band Emissions | 106 $\mu\text{V}/\text{m}$ @ 30 m 13.110 MHz – 13.410 MHz 13.710 MHz – 14.010 MHz | | C Note 3 |
| 15.225(d) 15.209 | RSS-210 [B6(d)] RSS-Gen [8.9] | Out-of Band Emissions | Emissions outside of the specified band (13.110 MHz - 14.010 MHz) must meet the radiated limits detailed in 15.209 (Refer to section 5.3) | | C Note 3 |
| 15.225(e) | RSS-210 [B6] | Frequency Stability | ± 0.01 % of operating frequency | Temp & Humid Test Chamber | C |
| 15.207 | RSS-Gen [8.8] | AC Conducted Emissions | Part 15.207 (Refer to section 5.5) | AC Line Conducted | C |
| 15.203 | - | Antenna Requirements | Part 15.203 (Refer to section 3) | - | C |
| Note 1: C = Comply NC = Not Comply NT = Not Tested NA = Not Applicable Note 2: For radiated emission tests below 30 MHz were performed on semi-anechoic chamber which is correlated with OATS. Note 3: This test item was performed in three orthogonal EUT positions and the worst case data was reported. | | | | | |

5. Test Result

5.1. 20dB bandwidth & Occupied Bandwidth

- Procedure: ANSI C63.10-2013 Section 6.9.2, RSS-Gen [6.7]

The 20 dB Bandwidth is measured with a spectrum analyzer connected via a receive antenna placed near the EUT while the EUT is operating in transmission mode.

1. Center frequency = EUT channel center frequency
2. Span = 2 ~ 5 times the OBW
3. RBW = 1 % ~ 5 % OBW
4. VBW ≥ 3 x RBW
5. Detector = Peak
6. Trace = Max hold
7. The trace was allowed to stabilize
8. Determine the reference value = Set the spectrum analyzer marker to the highest level of the displayed trace
9. Using the marker-delta function of the instrument, determine the “-xx dB down amplitude” using [(reference value) - xx].
10. Reset the marker-delta function and move the marker to the other side of the emission until the delta marker amplitude is at the same level as the reference marker amplitude. The marker-delta frequency reading at this point is the specified emission bandwidth.

- Measurement Data: Comply

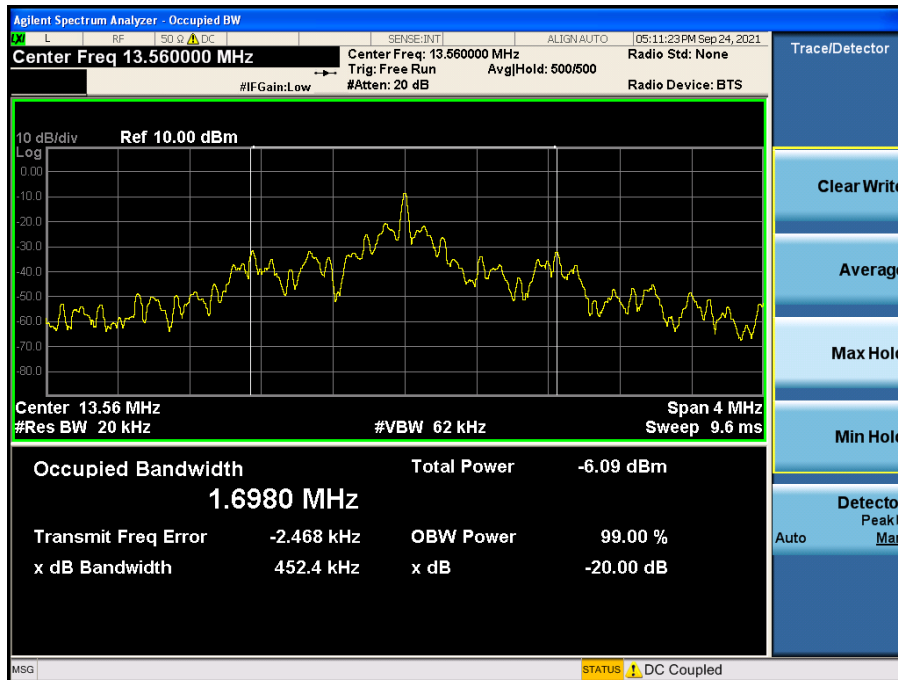

| Tested Frequency (MHz) | 20 dB BW (MHz) | Occupied BW (MHz) |
|------------------------|----------------|-------------------|
| 13.560 | 0.452 | 1.698 |

- Minimum Standard: NA

5.2. In-band emissions

- Test Configuration

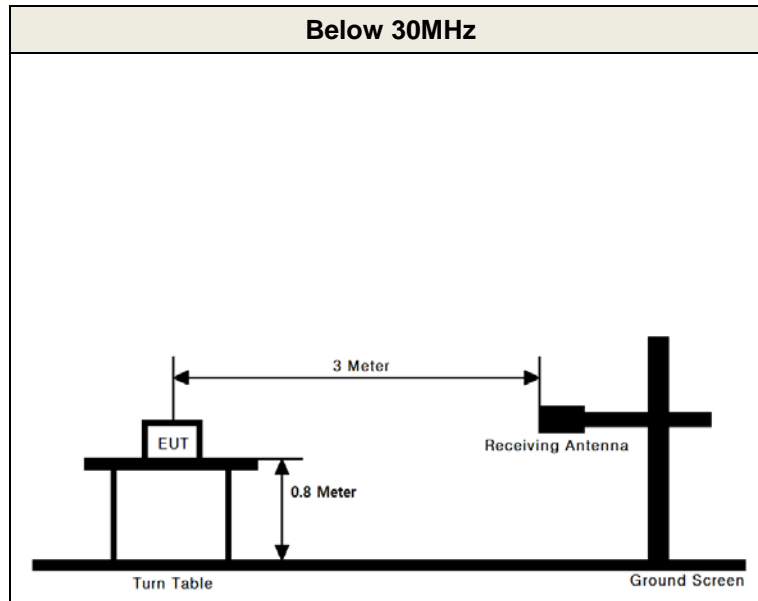

- **Procedure:** The radiated emission was tested according to the **section 6.4 of the ANSI C63.10-2013.**

The EUT was placed on a 0.8 m high non-conductive table and it was placed at 3m distance from the antenna. Measurements were performed for each of the three antenna orientations. (ie. parallel, perpendicular, and ground-parallel)

Also, measurements were performed with the EUT oriented in 3 orthogonal axis and rotated 360 degrees to determine worst-case orientation for maximum emissions.

RBW = As specified in below table, VBW ≥ 3 x RBW, Sweep = Auto, Detector = Peak
Trace mode = Max Hold until the trace stabilizes.

| Frequency | RBW |
|----------------|---------------|
| 9 - 150 kHz | 200 – 300 Hz |
| 0.15 - 30 MHz | 9 – 10 kHz |
| 30 – 1 000 MHz | 100 – 120 kHz |
| > 1000 MHz | 1 MHz |

- **Minimum Standard: Part 15.225(a), (b), (c) & RSS-210 [B6(a), (b), (c)]**

| Frequency Band [MHz] | Limit at 30 m measurement distance | |
|------------------------------------|------------------------------------|----------|
| | [uV/m] | [dBuV/m] |
| 13.553 - 13.567 | 15,848 | 84.0 |
| 13.410 - 13.553 13.567 - 13.710 | 334 | 50.5 |
| 13.110 - 13.410 13.710 - 14.010 | 106 | 40.5 |

- Measurement Data:

| Test Frequency Band [MHz] | Freq. [MHz] | EUT Axis. | ANT (Note 1) | Reading Level [dBuV] | TF [dB/m] | Field Strength @3 m [dBuV/m] | Field Strength @30 m [dBuV/m] | Limit [dBuV/m] | Margin [dB] |
|---------------------------|-------------|-----------|--------------|----------------------|-----------|------------------------------|-------------------------------|----------------|-------------|
| 13.110 ~ 13.410 | 13.348 | Y | P | 31.1 | 10.5 | 41.6 | 1.6 | 40.5 | 38.9 |
| 13.410 ~ 13.553 | 13.553 | Y | P | 44.2 | 10.5 | 54.7 | 14.7 | 50.5 | 35.8 |
| 13.553 ~ 13.567 | 13.560 | Y | P | 48.6 | 10.5 | 59.1 | 19.1 | 84.0 | 64.9 |
| 13.567 ~ 13.710 | 13.568 | Y | P | 42.3 | 10.5 | 52.8 | 12.8 | 50.5 | 37.7 |
| 13.710 ~ 14.010 | 13.771 | Y | P | 28.8 | 10.5 | 39.3 | -0.7 | 40.5 | 41.2 |

Note 1. Loop antenna orientation

“P”: Parallel, “V”: perpendicular, “G”: ground-parallel

Note 2. This test item was performed at 3 m and the data were extrapolated to the specified measurement distance of 30 m using the square of an inverse linear distance extrapolation factor (40 dB/decade) as specified in §15.31(f)2.

▪ Extrapolation Factor = $40 \log(3\text{m} / 30\text{m}) = -40$

Note 3. All data were recorded using a spectrum analyzer employing a peak detector.

If PK results were meet Quasi-peak limit, Quasi-peak measurements were omitted.

Note 4. Sample Calculation.

Margin = Limit – Field Strength @ 30 m / Field Strength @ 30 m = Field Strength @ 3 m – 40 dB

Field Strength @ 3 m = Reading + TF / TF = AF + CL

Where, TF = Total Factor, AF = Antenna Factor, CL = Cable Loss

5.3. Out-of-band emissions

- Test configuration

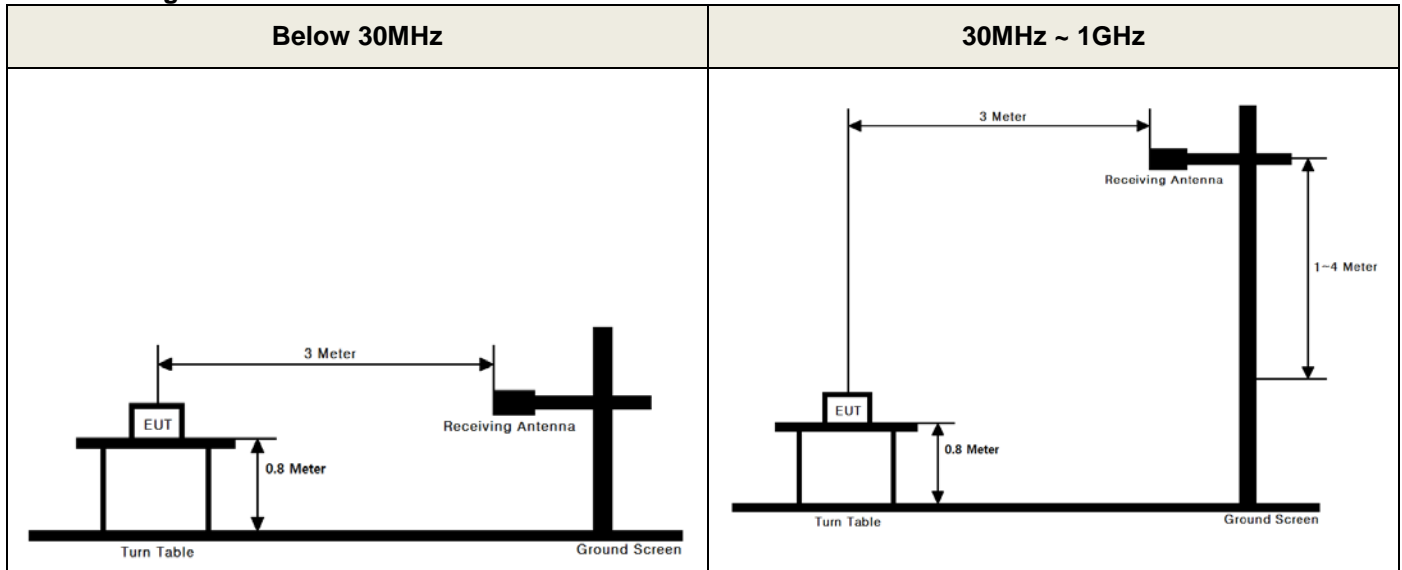

- **Procedure:** The radiated emission was tested according to the **section 6.4, 6.5 of the ANSI C63.10-2013.**

For below 30 MHz, measurements were performed as described in section 4.2.3.

For above 30 MHz;

The turntable shall rotate 360 degrees to determine the position of maximum emission level. EUT is set 3 m away from the receiving antenna, which varied from 1 m to 4 m to find out the highest emission. And also, each emission was to be maximized by changing the polarization of receiving antenna both horizontal and vertical. In order to find out the highest emission, the relative positions of the EUT were rotated through three orthogonal axes.

RBW = As specified in below table, VBW ≥ 3 x RBW, Sweep = Auto, Detector = Peak

Trace mode = Max Hold until the trace stabilizes.

| Frequency | RBW |
|----------------|---------------|
| 9 - 150 kHz | 200 – 300 Hz |
| 0.15 - 30 MHz | 9 – 10 kHz |
| 31 – 1 000 MHz | 101 – 120 kHz |
| > 1000 MHz | 1 MHz |

- **Minimum Standard: Part 15.209, 225(d) & RSS-210[B6(d)], RSS-Gen[8.9]**

The field strength of any emissions appearing outside of the 13.110 - 14.010 MHz band shall not exceed the general radiated emission limits as below.

| Frequency (MHz) | FCC Limit (uV/m) | IC Limit (uA/m) | Measurement Distance (m) |
|-----------------|------------------|-------------------|--------------------------|
| 0.009 – 0.490 | 2 400 / F (kHz) | 6.37/F (F in kHz) | 300 |
| 0.490 – 1.705 | 2 4000 / F (kHz) | 63.7/F (F in kHz) | 30 |
| 1.705 – 30.0 | 30 | 0.08 | 30 |

| Frequency (MHz) | FCC Limit (uV/m) | IC Limit (uV/m) | Measurement Distance (m) |
|-----------------|------------------|-----------------|--------------------------|
| 30 ~ 88 | 100 ** | 100 | 3 |
| 88 ~ 216 | 150 ** | 150 | 3 |
| 216 ~ 960 | 200 ** | 200 | 3 |
| Above 960 | 500 | 500 | 3 |

**Except as provided in paragraph (g), fundamental emissions from intentional radiators operating under this section shall not be located in the frequency bands 54-72 MHz, 76-88 MHz, 174-216 MHz or 470-806 MHz. However, operation within these frequency bands is permitted under other sections of this part, e.g., §§15.231 and 15.241.

- Measurement Data:

| Frequency [MHz] | EUT Axis. | ANT (Note 1) | Reading [dBuV] | TF [dB/m] | DCF [dB] | Electric Field Strength [dBuV/m] | Magnetic Field Strength [dBuA/m] | Limit [dBuV/m] | Limit [dBuA/m] | Margin [dB] |
|-----------------|-----------|--------------|----------------|-----------|----------|----------------------------------|----------------------------------|----------------|----------------|-------------|
| 0.519 | Y | P | 37.1 | 11.2 | -40 | 8.3 | -43.2 | 33.3 | -18.2 | 25.0 |
| 27.120 | Y | P | 14.4 | 9.2 | -40.0 | -16.4 | -67.9 | 29.5 | -21.9 | 45.9 |
| 40.670 | Y | V | 33.7 | -8.9 | N/A | 24.8 | - | 40.0 | - | 15.2 |
| 169.680 | Y | V | 32.8 | -7.1 | N/A | 25.7 | - | 43.5 | - | 17.8 |
| 248.250 | Y | V | 31.9 | -7.1 | N/A | 24.8 | - | 46.0 | - | 21.2 |
| 741.974 | Y | H | 26.9 | 4.6 | N/A | 31.5 | - | 46.0 | - | 14.5 |
| 950.517 | Y | V | 25.5 | 8.3 | N/A | 33.8 | - | 46.0 | - | 12.2 |
| - | - | - | - | - | - | - | - | - | - | - |
| - | - | - | - | - | - | - | - | - | - | - |

Note 1. No other spurious and harmonic emissions were reported greater than listed emissions above table.

Note 2. All data were recorded using a spectrum analyzer employing a peak detector.

If PK results were meet Quasi-peak limit, Quasi-peak measurements were omitted.

Note 3. Loop antenna orientation (30 MHz Below)

“P”= Parallel, “V”= perpendicular, “G”= ground-parallel

Bilog antenna polarization (30 MHz above)

“H”= Horizontal, “V”= Vertical

Note 4. Information of Distance Correction Factor

For finding emissions, measurements may be performed at a distance closer than that specified in the regulations.

In this case, the distance factor is applied to the result.

- Calculation of distance correction factor

At frequencies below 30 MHz = $40 \log(\text{tested distance} / \text{specified distance})$

At frequencies at or above 30 MHz = $20 \log(\text{tested distance} / \text{specified distance})$

When distance factor is “N/A”, the measurements were performed at the specified distance and distance factor is not applied.

Note 5. Sample calculation

Margin = Limit[dBuV/m] – Electric Field Strength

Electric Field Strength (dBuV/m) = Reading + TF – DCF

Magnetic Field Strength (dBuA/m) = Electric Field Strength – 51.5 dB

TF = AF + CL – AG

Where, TF = Total Factor, AF = Antenna Factor, CL = Cable Loss, AG = Amplifier Gain,

DCF = Distance Factor

5.4. Frequency Stability

- Procedure:

Part 15.225 requires that devices operating in the 13.553 – 13.567 MHz shall maintain the carrier frequency within 0.01 % of the operating frequency over the temperature variation of -20 degrees to + 50 degrees C at normal supply voltage.

- Measurement Data: Comply

Operating Frequency : 13,560,000 Hz

| VOLTAGE (%) | POWER (V _{DC}) | TEMP (°C) | Frequency (Hz) | Freq. Dev. (Hz) | Deviation (%) |
|----------------|--------------------------|-----------|----------------|-----------------|---------------|
| 100% | 3.850 | +20(ref) | 13,559,687 | -313 | 0.002 308 |
| 100% | | -20 | 13,559,766 | -234 | 0.001 726 |
| 100% | | -10 | 13,559,777 | -223 | 0.001 645 |
| 100% | | 0 | 13,559,766 | -234 | 0.001 726 |
| 100% | | +10 | 13,559,742 | -258 | 0.001 903 |
| 100% | | +20 | 13,559,687 | -313 | 0.002 308 |
| 100% | | +30 | 13,559,743 | -257 | 0.001 895 |
| 100% | | +40 | 13,559,669 | -331 | 0.002 441 |
| 100% | | +50 | 13,559,626 | -374 | 0.002 758 |
| 115% | | 4.43 | +20 | 13,559,713 | -287 |
| Batt.End point | 3.10 | +20 | 13,559,629 | -371 | -0.002 736 |

- Minimum Standard: Part 15. 225(e) & RSS-210 [B6]

The frequency tolerance of the carrier signal shall be maintained within ± 0.01 % of the operating frequency.

5.5. AC Power-Line Conducted Emissions

- Test Requirements and limit, Part 15.207 & RSS-Gen [8.8]

An intentional radiator that is designed to be connected to the public utility (AC) power line, the radio frequency voltage that is conducted back onto the AC power line on any frequency or frequencies, within the band 150 kHz to 30 MHz, shall not exceed the limits in the following table, as measured using a 50 uH/50 ohm line impedance stabilization network (LISN).

Compliance with the provision of this paragraph shall on the measurement of the radio frequency voltage between each power line and ground at the power terminal. The lower applies at the boundary between the frequency ranges.

| Frequency Range (MHz) | Conducted Limit (dBuV) | |
|-----------------------|------------------------|------------|
| | Quasi-Peak | Average |
| 0.15 ~ 0.5 | 66 to 56 * | 56 to 46 * |
| 0.5 ~ 5.0 | 56 | 46 |
| 5 ~ 30 | 60 | 50 |

* Decreases with the logarithm of the frequency

Compliance with this provision shall be based on the measurement of the radio frequency voltage between each power line (LINE and NEUTRAL) and ground at the power terminals.

- Test Configuration

See test photographs for the actual connections between EUT and support equipment.

- Test Procedure

Conducted emissions from the EUT were measured according to the ANSI C63.10-2013.

1. The test procedure is performed in a 6.5 m × 3.5 m × 3.5 m (L × W × H) shielded room. The EUT along with its peripherals were placed on a 1.0 m (W) × 1.5 m (L) and 0.8 m in height wooden table and the EUT was adjusted to maintain a 0.4 meter space from a vertical reference plane.
2. The EUT was connected to power mains through a line impedance stabilization network (LISN) which provides 50 ohm coupling impedance for measuring instrument and the chassis ground was bounded to the horizontal ground plane of shielded room.
3. All peripherals were connected to the second LISN and the chassis ground also bounded to the horizontal ground plane of shielded room.
4. The excess power cable between the EUT and the LISN was bundled. The power cables of peripherals were unbundled. All connecting cables of EUT and peripherals were moved to find the maximum emission.

- **Measurement Data: Comply** (refer to the next page)

Measurement Data (With antenna terminated)

Results of Conducted Emission

DTNC

Date 2021-11-03

Order No.
Model No. PM75
Serial No.
Test Condition NFC

Reference No.
Power Supply
Temp/Humi. 23 °C / 47 %
Operator S.M.Gil

Memo

LIMIT : FCC P15.207 QP
FCC P15.207 AV

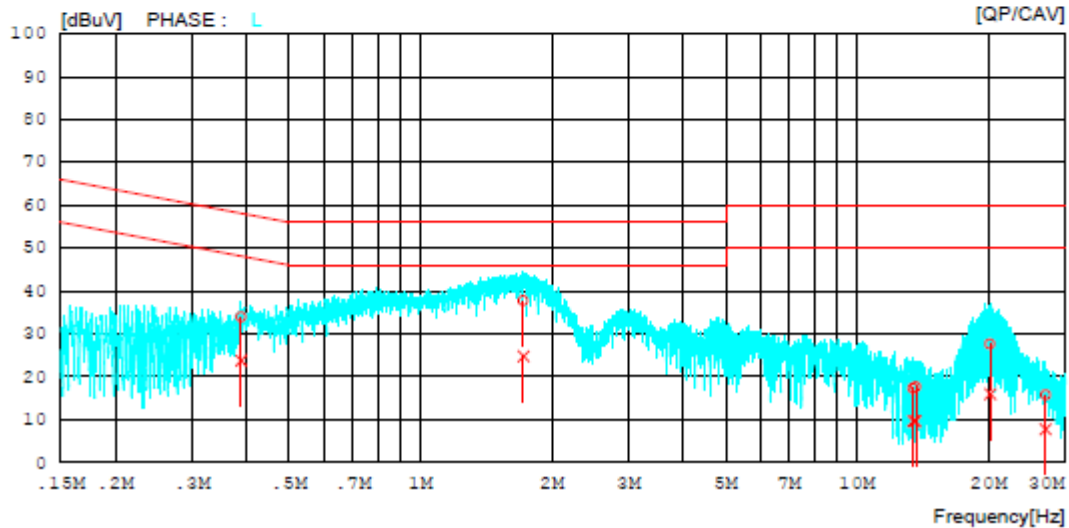
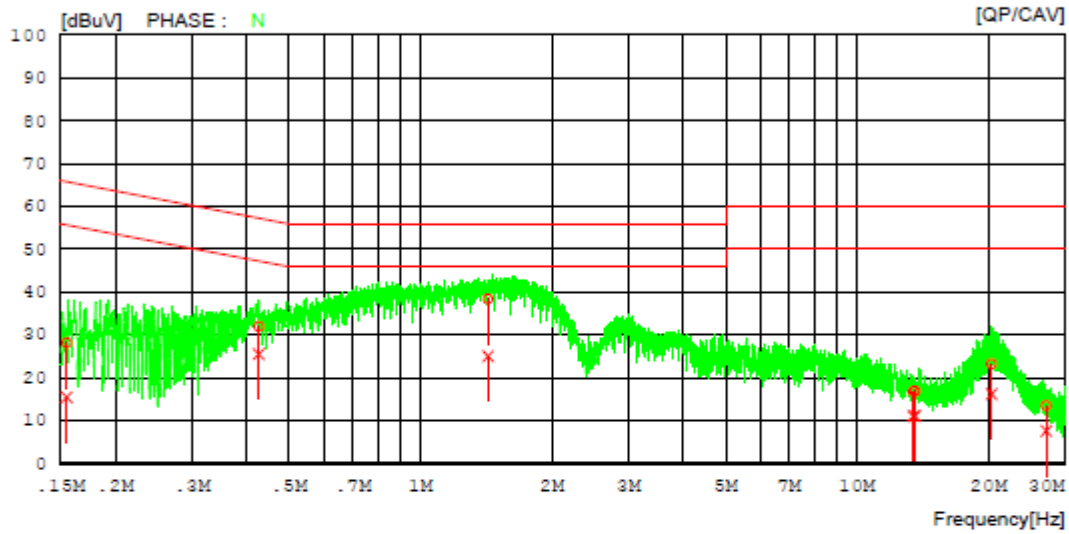

Measurement Data (With antenna terminated)

Results of Conducted Emission

DTNC Date 2021-11-03

| | | | |
|----------------|------|---------------|--------------|
| Order No. | | Reference No. | |
| Model No. | PM75 | Power Supply | |
| Serial No. | | Temp/Humi. | 23 °C / 47 % |
| Test Condition | NFC | Operator | S.M.Gil |

Memo

LIMIT : FCC P15.207 QP
FCC P15.207 AV

| NO | FREQ [MHz] | READING | | C. FACTOR [dB] | RESULT | | LIMIT | | MARGIN | | PHASE |
|----|---------------|--------------|---------------|-------------------|--------------|---------------|--------------|---------------|--------------|---------------|-------|
| | | QP [dBuV] | CAV [dBuV] | | QP [dBuV] | CAV [dBuV] | QP [dBuV] | CAV [dBuV] | QP [dBuV] | CAV [dBuV] | |
| 1 | 0.15468 | 18.26 | 5.53 | 9.90 | 28.16 | 15.43 | 65.74 | 55.74 | 37.58 | 40.31 | N |
| 2 | 0.42630 | 22.05 | 15.65 | 9.91 | 31.96 | 25.56 | 57.32 | 47.32 | 25.36 | 21.76 | N |
| 3 | 1.42827 | 28.50 | 15.10 | 9.95 | 38.45 | 25.05 | 56.00 | 46.00 | 17.55 | 20.95 | N |
| 4 | 13.47917 | 6.62 | 0.94 | 10.18 | 16.80 | 11.12 | 60.00 | 50.00 | 43.20 | 38.88 | N |
| 5 | 13.58885 | 6.68 | 0.96 | 10.18 | 16.86 | 11.14 | 60.00 | 50.00 | 43.14 | 38.86 | N |
| 6 | 20.33626 | 12.95 | 5.95 | 10.26 | 23.21 | 16.21 | 60.00 | 50.00 | 36.79 | 33.79 | N |
| 7 | 27.14768 | 3.18 | -2.74 | 10.35 | 13.53 | 7.61 | 60.00 | 50.00 | 46.47 | 42.39 | N |
| 8 | 0.38810 | 24.02 | 13.81 | 9.91 | 33.93 | 23.72 | 58.10 | 48.10 | 24.17 | 24.38 | L |
| 9 | 1.72149 | 27.62 | 14.64 | 10.06 | 37.68 | 24.70 | 56.00 | 46.00 | 18.32 | 21.30 | L |
| 10 | 13.44782 | 6.92 | -0.78 | 10.38 | 17.30 | 9.60 | 60.00 | 50.00 | 42.70 | 40.40 | L |
| 11 | 13.62122 | 7.19 | -0.74 | 10.38 | 17.57 | 9.64 | 60.00 | 50.00 | 42.43 | 40.36 | L |
| 12 | 20.20185 | 17.17 | 5.43 | 10.46 | 27.63 | 15.89 | 60.00 | 50.00 | 32.37 | 34.11 | L |
| 13 | 27.02973 | 5.27 | -2.79 | 10.48 | 15.75 | 7.69 | 60.00 | 50.00 | 44.25 | 42.31 | L |