



Estech Co., Ltd.

97-1, Hooeok-ri, Majang-myun, Ichion-city, Gyonggi-do, South Korea
TEL : +82 31 6318037 FAX : +82 31 6318039 www.estech.co.kr

Test Report for FCC

FCC ID : V2X-PM60-1

Report Number		ESTF151410-006		
Applicant	Company name	POINTMOBILE CO.,LTD		
	Address	GASAN-DONG B-9F KABUL GREAT VALLEY 32 DIGITAL-RO9-GIL GEUMCHEON-GU SEOUL 153-709 KOREA		
	Telephone	82-70-7090-2676		
Product	Product name	Mobile Computer		
	Model No.	PM60	Manufacturer	POINTMOBILE CO.,LTD
	Serial No.	NONE	Country of origin	CHINA
Test date	2014-07-10~ 2014-08-10		Date of issue	17-Aug-14
Testing location	ESTECH Co., Ltd. 97-1, Hooeok-ri, Majang-myeon, Icheon-si, Gyeonggi-do, Korea			
Standard	FCC PART 15 Subpart E (15.407):2010 , ANSI C 63.4(2009) , KDB 789033 D01(2014). FCC 06-96(2006)			
Measurement facility registration number		915135		
Tested by	Engineer K.H.Chung		(Signature)	
Reviewed by	Engineering Manager J.M.Yang		(Signature)	
Abbreviation	OK, Pass = Passed, Fail = Failed, N/A = not applicable			
<p>* Note</p> <ul style="list-style-type: none"> - This test report is not permitted to copy partly without our permission - This test result is dependent on only equipment to be used - This test result based on a single evaluation of one sample of the above mentioned - Additional SKU(s) : PM60G152356E0C, PM60G154356E0C, PM60G152357E0C, PM60G154357E0C, PM60G152356KKC, PM60G172356KKC, PM60G174356KKC, PM60G152357KKC, PM60G172357KKC, PM60G174357KKC, PM60G172356E0C, PM60G172357E0C, PM60G174357E0C 				



Estech Co., Ltd.

97-1, Hooeok-ri, Majang-myun, Ichion-city, Gyonggi-do, South Korea
TEL : +82 31 6318037 FAX : +82 31 6318039 www.estech.co.kr

Contents 1

1. Laboratory Information	4
2. Description of EUT	5
3. Test Standards	7
4. Measurement condition	8
4.1 Measurement equipment	8
4.2 EUT Operation	9
4.3 Configuration and Peripherals	9
4.4 EUT and Support equipment	10
4.5 Cable Connecting	10
5. Measurement of radiated emission.....	11
5.1 Measurement equipment	11
5.2 Environmental conditions	11
5.3 Measurement Instrument setting for Radiated Emission	12
5.4 Test data (Below 1 GHz).....	13
5.5 Test data (Above 1 GHz).....	19
6. Unwanted Emission	25
6.1 Measurement equipments	25
6.2 Environmental Condition	25
6.3 Test Result of Unwanted Emission.....	26
7. Measurement of conducted disturbance	42
7.1 Measurement equipments	42
7.2 Environmental Condition	42
7.3 Test data	43

Appendix I Special diagram

Appendix II Antenna Requirement



Estech Co., Ltd.

97-1, Hooeok-ri, Majang-myun, Ichion-city, Gyonggi-do, South Korea
TEL : +82 31 6318037 FAX : +82 31 6318039 www.estech.co.kr

8. On Time, Duty Cycle and Measurement Methods	49
8.1 Test procedure	49
8.2 Test instruments and measurement setup	49
8.3 Measurement results	49
8.4 Trace data	50
9. Emission bandwidth and 99% Occupied Bandwidth	51
9.1 Test procedure	51
9.2 Test instruments and measurement setup	51
9.3 Measurement results	54
9.4 Trace data	54
10. MAXIMUM CONDUCTED OUTPUT POWER	66
10.1 Test procedure	66
10.2 Test instruments and measurement setup	66
10.3 Measurement results	66
11. Peak power spectral density (PPSD)	69
11.1 Test procedure	69
11.2 Test instruments and measurement setup	69
11.3 Measurement results	70
11.4 Trace data	72
12. Peak excursion measurement	84
12.1 Test procedure	84
12.2 Test instruments and measurement setup	84
12.3 Measurement results of band-edge & out of emission	84
12.4 Trace data of PEAK EXCURSION	85
13. DYNAMIC FREQUENCY SELECTION	86
14. Photographs of test setup	97
14.1 Setup for Radiated Test : 30 ~ 1000 MHz	97
14.2 Setup for Radiated Test : Above 1000 MHz ~	98
14.3 Setup for Conducted Test : 0.15 ~ 30 MHz	99
14.4 Photographs of EUT	100



Estech Co., Ltd.

97-1, Hooeok-ri, Majang-myun, Ichion-city, Gyonggi-do, South Korea
TEL : +82 31 6318037 FAX : +82 31 6318039 www.estech.co.kr

1. Laboratory Information

1.1 General

This EUT (Equipment Under Test) has been shown to be capable of compliance with the applicable technical standards and is tested in accordance with the measurement procedures as indicated in this report.

ESTECH Lab attests to accuracy of test data. All measurement reported herein were performed by ESTECH Co., Ltd.

ESTECH Lab assume full responsibility for the completeness of these measurements and vouch for the qualifications of all persons taking them.

1.2 Test Lab.

Corporation Name : ESTECH Co., Ltd.

Head Office : Suite 1015 World Meridian II, 123 Gasan Digital 2-ro, Geumcheon-gu, Seoul 153-759, R. O. Korea

EMC Test Lab. : 347-69, Jungbu-daero 147beon-gil, Majang-myeon, Icheon-si, Gyeonggi-do 467-811, R. O. Korea

1.3 Official Qualification(s)

KCC : Granted Accreditation from Ministry of Information & Communication for EMC, Safety and Telecommunication

FCC : Conformity Assessment Body(CAB) with registration number 659627 under APEC TEL MRA between the RRA and the FCC

VCCI : Granted Accreditation from Voluntary Control Council for Interference from ITE



Estech Co., Ltd.

97-1, Hooeok-ri, Majang-myun, Ichion-city, Gyonggi-do, South Korea
TEL : +82 31 6318037 FAX : +82 31 6318039 www.estech.co.kr

2. Description of EUT

2.1 Summary of Equipment Under Test (WLAN)

Modulation Type : WLAN(OFDM)
 Transfer Rate : up to 65 Mbps
 MAXIMUM CONDUCTED OUTPUT POWER : 802.11a, 52 CH : 0.012 W , 802.11n(5.0 GHz), 60 CH : 0.012 W
 Rating : INPUT : (100 – 240)Va.c , (50 / 60)Hz , 21~34VA 0.4 A
 : OUTPUT : 5.0 Vd.c. , 2.0 A
 Receipt Date : 15-May-14
 X-tal list(s) or Frequencies generated : The highest operating frequency is 5700 MHz(WLAN)
 : XTAL : 32.768 kHz , OSC : 26 MHz , WLAN : 5700 MHz

2.2 General descriptions of EUT

Operating System	Microsoft Windows Embedded Handheld 6.5 Pro
Application Software	Tools and Demos
Processor	Cortex-A8 1GHz
Memory	512MB RAM X 1GB Flash
Storage Expansion	User accessible Micro SD memory card slot.
Display	3.5 in. transmissive active matrix 65K color LCD with backlight, VGA (480 x 640)
Scan Engine	1D engine: N4313 2D engine : N560x
Keypad	Numeric , Qwerty
Audio	Built-in microphone and speaker
I/O	High speed USB 2.0 from cradle (or I/O cable)
Battery	Li-Ion battery 3.7V / 4000 mAh / 14.8Wh
Expected Hours of Operation	8.5+ hours (with scan and continuously transmitting if using new standard Li-ion battery)
Charging	5V input through MicroUSB port.
Expected Charge Time	Capacity: 4000mAh—approx.5 hours
Charging Peripherals	MicroUSB Adaptor Single Slot cradle—single-bay terminal charge/communicate Single Ethernet cradle—single-bay terminal charge/communication base (Via Ethernet connection) Quad Battery Charger
WPAN	Bluetooth Class II (10 m) v2.1 Enhanced Data Rate (EDR) with internal antenna.
WLAN	Dual Mode 802.11 a/b/g/n (11 Mbps/54 Mbps) with internal antenna
WLAN Security	Wi-Fi Certified, 802.1X, WPA2, EAP, WEP, LEAP, TKIP, MSD, EAP-TLS, EAP-TTLS, WPAPSK, PEAP, CCXv4



Estech Co., Ltd.

97-1, Hooeok-ri, Majang-myun, Ichion-city, Gyonggi-do, South Korea
TEL : +82 31 6318037 FAX : +82 31 6318039 www.estech.co.kr

2.2 General descriptions of EUT

WWAN	GSM : Quad band, 850/900/1800/1900MHz UMTS/HSPA+: Five band, 800/850/900/1900/2100MHz
GPS	Standalone and Assisted GPS
Operating Temperature	-20° to 55°C
Charging Temperature	0~45 °C (±3 °C)
Storage Temperature	-25°C to 70°C
Humidity	95% humidity, non-condensing
Construction	High impact resistant PC/ABS housings Magnesium alloy internal chassis with component shock mounts
Drop	1.22m multiple drops to concrete, MIL-STD-810G, Method 516.6, Procedure
Tumble	3.3 ft (1.0m) tumbles (500 drops)
ESD	Air: ± 15kV Direct: ± 8kV
Environmental	Independently certified to meet IP65 standards for moisture and particle resistance
Dimensions	H; 157.4mm x W; 74.2mm x L; 25.8mm(top)
Scanner / Decode Capabilities	1D Laser model : N4313 Laser engine. Decodes all standard 1D codes. 2D engine model : N560X 2D Imager. Decodes all standard 1D, 2D Postal, and OCR codes.



Estech Co., Ltd.

97-1, Hooeok-ri, Majang-myun, Ichion-city, Gyonggi-do, South Korea

TEL : +82 31 6318037 FAX : +82 31 6318039 www.estech.co.kr

3. Test Standards

Test Standard : FCC PART 15 Subpart E (15.407) : 2010

This Standard sets out the regulations under which an intentional, unintentional, or incidental radiator may be operated without an individual license. It also contains the technical specifications, administrative requirements and other conditions relating to the marketing of Part 15 devices.

Test Method : ANSI C 63.4 (2009) & KDB 789033 D01 (2014)

This standard sets forth uniform methods of measurement of radio-frequency (RF) signals and noise emitted from both unintentional and intentional emitters of RF energy in the frequency range 9 kHz to 40 GHz. Methods for the measurement of radiated and AC power-line conducted radio noise are covered and may be applied to any such equipment unless otherwise specified by individual equipment requirements. These methods cover measurement of certain devices that deliberately radiate energy, such as intentional emitters, but does not cover licensed transmitters. This standard is not intended for certification/approval of avionic equipment or for industrial, scientific, and medical (ISM) equipment. These methods apply to the measurement of individual units or systems comprised of multiple units.

Summary of Test Results

Applied Standard : 47 CFR Part 15 Subpart E & RSS 210-Part I and II					remark
Standard	IC Standard	Test Type	Result	Remark	
15.207	RSS-Gen 7.2.2	AC Power Conducted Emission	Pass	Meet the requirement	
15.205 15.209 15.407(b)(1) 15.407(b)(2) 15.407(b)(3)	A8.5	Transmitter radiated spurious emissions and Conducted spurious emission	Pass	Meet the requirement	
N/A	A9.2(2)	26 dB Bandwidth	Pass	Meet the requirement	KDB 789033
	A9.2(1)	99 % Bandwidth	Pass	Meet the requirement	KDB 789033
15.407(a)(1) 15.407(a)(2)	A9.2(1)	Maximum output power	Pass	Meet the requirement	
15.407(a)(1) 15.407(a)(2)	A9.2(1)	Power Spectral Density	Pass	Meet the requirement	
15.407(a)(6)	A9.3	Band Edge Measurement	Pass	Meet the requirement	
15.407(h)	A9.4(b)	DFS - Channel closing transmission time - Channel move time - Non occupied period	Pass	Meet the requirement	



Estech Co., Ltd.

97-1, Hooeok-ri, Majang-myun, Ichion-city, Gyonggi-do, South Korea
TEL : +82 31 6318037 FAX : +82 31 6318039 www.estech.co.kr

4. Measurement Condition

4.1 EUT Operation(For 802.11a , 802.11n)

a. Channel

Ch.	Frequency	Ch.	Frequency
36	5180 MHz	100	5500 MHz
⋮	⋮	⋮	⋮
64	5320 MHz	140	5700 MHz
⋮	⋮	⋮	⋮

b. Measurement Channel(Indoor): WLAN: Low(5180 MHz), Middle(5200 MHz), High(5240 MHz)

Measurement Channel(Indoor/DFS/TPC) : WLAN: Low(5260 MHz) , Middle(5300 MHz) , High(5320 MHz)

Measurement Channel(DFS/TPC) : WLAN: Low(5500 MHz) , Middle(5580 MHz) , High(5700 MHz)

c. Test Mode : Continuous Output, OFDM

d. Test rate : the worst case of rate 802.11a(6 Mbps) , 802.11n(6.5 Mbps)



Estech Co., Ltd.

97-1, Hooeok-ri, Majang-myun, Ichion-city, Gyonggi-do, South Korea
TEL : +82 31 6318037 FAX : +82 31 6318039 www.estech.co.kr

4.2 EUT Operation.

- * Execute a RF test program to enable EUT under transmission/receiving condition continuously at specific channel frequency.
- * The worst data were recorded 1D scanner the results after testing each of the 1D scanner and 2D scanner.
- *. Transmit mode and receive mode was each test.
- *. Highest frequency of the EUT is above 1 GHz, the measurement shall be made up to 10 th the highest frequency or 40 GHz, But the EUT wasn't Detected from 3th any other spurious and harmonic emissions.

4.3 Configuration and Peripherals

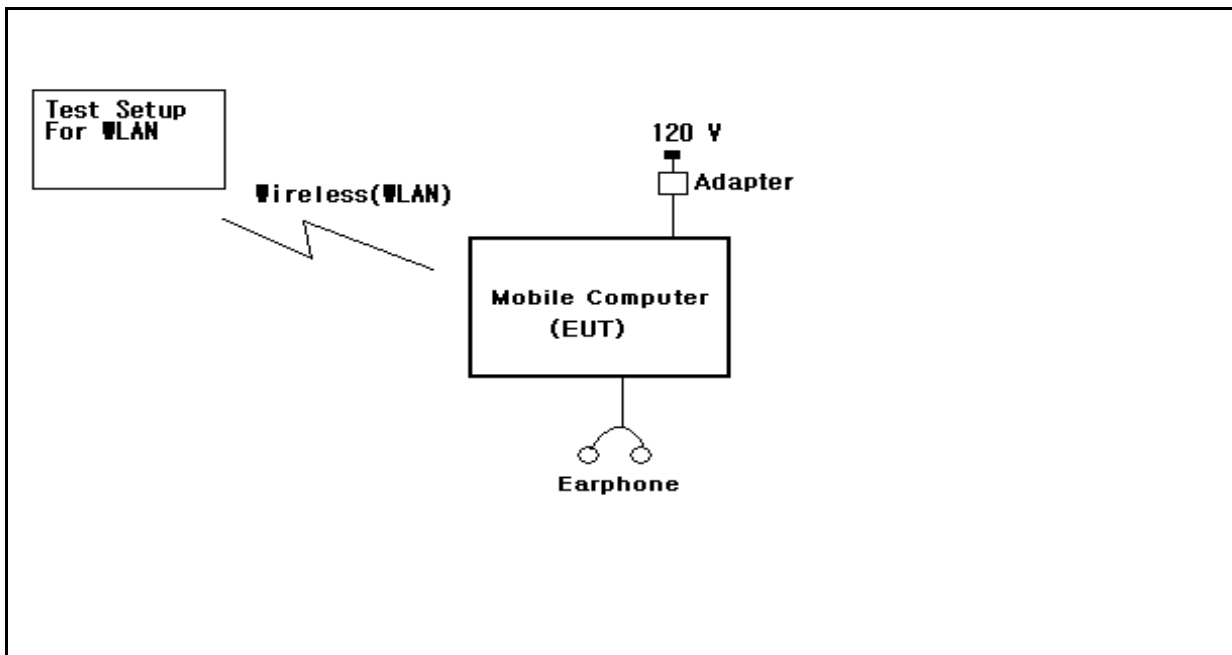



Estech Co., Ltd.

97-1, Hooeok-ri, Majang-myun, Ichion-city, Gyonggi-do, South Korea

TEL : +82 31 6318037 FAX : +82 31 6318039 www.estech.co.kr

4.4 EUT and Support equipment

Equipment Name	Model Name	S/N	Manufacturer	Remark (FCC ID)
Mobile Computer	PM60	NONE	POINTMOBILE CO.,LTD	EUT
Adapter	KSAS0100500200D5	NONE	Kuantech(BeiHai) Co., Ltd.	
Earphone	NONE	NONE	SAMSUNG	

4.5 Cable Connecting

Start Equipment		End Equipment		Cable Standard		Remark
Name	I/O port	Name	I/O port	Length	Shielded	
Mobile Computer	Power	Adapter	-	2.0	Unshielded	
Mobile Computer	Head Phone	Earphone	-	1.0	Unshielded	



Estech Co., Ltd.

97-1, Hooeok-ri, Majang-myun, Ichion-city, Gyonggi-do, South Korea

TEL : +82 31 6318037 FAX : +82 31 6318039 www.estech.co.kr

5. Measurement of radiated disturbance

Above 30 MHz Electric Field strength was measured in accordance with FCC PART 15.205, 15.209 & IC RSS-210 (A8.5). The test setup was made according to ANSI C 63.4 (2009) & KDB 789033 D01 Semi-anechoic chamber, which allows a 3 m distance measurement. The EUT was placed in the center of styrofoam turntable. The height of this table was 0.8 m. The measurement was conducted with both horizontal and vertical antenna polarization. The turntable has fully rotated. For further description of the configuration refer to the picture of the test setup.

5.1 Measurement equipments

Equipment Name	Type	Manufacturer	Serial No.	Next Calibration date
TEST Receiver	ESC17	ROHDE & SCHWARZ	100916	23-Jan-15
Logbicon Antenna	VULB 9168	SCHWARZBECK	237	13-Jan-15
Turn Table	DT3000-2t	Innco System GmbH	N/A	-
Antenna Mast	MA4000-EP	Innco System GmbH	N/A	-
PREAMPLIFIER	8449B	AGILENT	3008A00595	13-Jan-15
Horn Antenna	BBHA9120D	SCHWARZBECK	469	11-Nov-14
Test Receiver	ESPI7	ROHDE & SCHWARZ	100185	13-Jan-15
Spectrum Analyzer	R3273	ADVANTEST	110600592	13-Jan-15
Turn Table	DT1500-S	Innco System GmbH	N/A	-
Antenna Mast	MA4000-EP	Innco System GmbH	N/A	-
Pyramidal Horn Antenna	3160-09-01	EST-LINDGREN	00102642	14-Nov-14
Antenna Master & Turn table controller	C02000-P	Innco System GmbH	CO2000/642 /28051111/L	-
Spectrum Analyzer	FSV40	ROHDE & SCHWARZ	100939	23-Jan-15
Double Ridged Horn Antenna	SAS-574	A.H.SYSTEMS	154	17-Mar-15
PREAMPLIFIER	83051A	AGILENT	3950M00201	2-Jun-15

5.2 Environmental Condition

Below 1 GHz -Test Place : 10 m Semi-anechoic chamber

Wireless LAN 802.11a CH - 40

Temperature (°C) : 21.5 °C
Humidity (% R.H.) : 48.8 % R.H.

Wireless LAN 802.11n CH - 40

Temperature (°C) : 21.3 °C
Humidity (% R.H.) : 51.4 % R.H.

Wireless LAN 802.11a CH - 60

Temperature (°C) : 22.5 °C
Humidity (% R.H.) : 44.9 % R.H.

Wireless LAN 802.11n CH - 60

Temperature (°C) : 22.7 °C
Humidity (% R.H.) : 51.6 % R.H.

Wireless LAN 802.11a CH - 116

Temperature (°C) : 21.1 °C
Humidity (% R.H.) : 46.8 % R.H.

Wireless LAN 802.11n CH - 116

Temperature (°C) : 22.1 °C
Humidity (% R.H.) : 51.8 % R.H.

Above 1 GHz -Test Place : 3 m Semi-anechoic chamber

Wireless LAN 802.11a CH - 36.40.48

Temperature (°C) : 21.8 °C
Humidity (% R.H.) : 51.1 % R.H.

Wireless LAN 802.11n CH - 36.40.48

Temperature (°C) : 22.8 °C
Humidity (% R.H.) : 54.2 % R.H.

Wireless LAN 802.11a CH - 52.60.64

Temperature (°C) : 22.0 °C
Humidity (% R.H.) : 53.2 % R.H.

Wireless LAN 802.11n CH - 52.60.64

Temperature (°C) : 22.0 °C
Humidity (% R.H.) : 52.2 % R.H.

Wireless LAN 802.11a CH - 100.116.140

Temperature (°C) : 21.4 °C
Humidity (% R.H.) : 51.9 % R.H.

Wireless LAN 802.11n CH - 100.116.140

Temperature (°C) : 23.0 °C
Humidity (% R.H.) : 51.8 % R.H.



Estech Co., Ltd.

97-1, Hooeok-ri, Majang-myun, Ichion-city, Gyonggi-do, South Korea
TEL : +82 31 6318037 FAX : +82 31 6318039 www.estech.co.kr

5.3 Measurement Instrument setting for Radiated Emission

5.3.1 Frequency range below 1 GHz

RBW: 120 kHz , VBW: 3 x RBW , Detector: Quasi Peak

5.3.2 Frequency range above 1 GHz

Peak Power Measurement Procedure (KDB 789033 section H3) 5)

a.RBW: 1 MHz , VBW: 3 MHz

b.Trace mode = max hold

c.Detector: Peak

d.Sweep time = auto

Average Power Measurement Procedures (KDB 789033 section H3) 6)

a.Set analyzer center frequency to the frequency associated with the emission

b.RBW: 1 MHz , VBW: 3 MHz

c.Detector : RMS detector

d.Sweep time = auto

Note

Band	Duty cycle(%)	Ton (ms)	Ton + Toff (ms)	DCF=10*log(1/Duty) (dB)
802.11a	58.21	1.41	2.43	2.35
802.11n	57.99	1.33	2.29	2.37

***This was applied of duty cycle factor for average value because of measured with the EUT transmitting continuously less than 100% duty cycle at its maximum power control level.**



Estech Co., Ltd.

97-1, Hooeok-ri, Majang-myun, Ichion-city, Gyonggi-do, South Korea
TEL : +82 31 6318037 FAX : +82 31 6318039 www.estech.co.kr

5.4-1 Test Data for wireless LAN (802.11a) – CH 40

Test Date : 14-Jul-14

Measurement Distance : 3 m

Frequency (MHz)	Reading (dB μ V)	Position (V/H)	Height (m)	Correction Factor		Result Value		
				Ant Factor (dB)	Cable (dB)	Limit (dB μ V/m)	Result (dB μ V/m)	Margin (dB)
32.50	9.48	V	1.8	11.27	0.86	40.00	21.60	-18.40
88.60	11.41	H	2.2	7.88	1.43	43.50	20.72	-22.78
78.20	20.46	V	1.4	9.70	1.35	40.00	31.51	-8.49
91.70	13.94	V	2.2	7.75	1.46	43.50	23.15	-20.35
97.80	12.22	V	2.4	8.15	1.51	43.50	21.88	-21.62
148.10	6.25	H	2.1	12.46	1.86	43.50	20.57	-22.93
172.80	9.49	H	1.2	11.98	2.00	43.50	23.47	-20.03
193.80	18.53	H	3.2	10.11	2.12	43.50	30.76	-12.74
312.00	7.12	H	3.1	13.82	2.71	46.00	23.65	-22.35
433.80	5.43	H	2.6	16.58	3.21	46.00	25.22	-20.78
Remark	<p>H : Horizontal, V : Vertical TEST MODE : 802.11a-CH 40 (5200 MHz)</p> <p>*Checked in all 3 axis and the maximum measured data were reported.(Worst data is Z axis of position)</p> <p>*Result Value = Reading + Ant Factor + Cable loss</p> <p>*The resolution bandwidth and video bandwidth of test receiver/spectrum analyzer is 120 kHz for Quasi-peak detection at frequency below 1 GHz.</p>							



Estech Co., Ltd.

97-1, Hooeok-ri, Majang-myun, Ichion-city, Gyonggi-do, South Korea
TEL : +82 31 6318037 FAX : +82 31 6318039 www.estech.co.kr

5.4-2 Test Data for wireless LAN (802.11a) – CH 60

Test Date : 14-Jul-14

Measurement Distance : 3 m

Frequency (MHz)	Reading (dB μ V)	Position (V/H)	Height (m)	Correction Factor		Result Value		
				Ant Factor (dB)	Cable (dB)	Limit (dB μ V/m)	Result (dB μ V/m)	Margin (dB)
32.60	10.33	V	1.6	11.27	0.86	40.00	22.46	-17.54
48.10	9.43	V	2.4	12.91	1.05	40.00	23.39	-16.61
72.50	16.30	V	2.8	10.76	1.30	40.00	28.36	-11.64
149.00	7.34	V	1.9	12.49	1.86	43.50	21.69	-21.81
172.80	9.03	H	3.8	11.98	2.00	43.50	23.01	-20.49
193.80	17.56	H	3.4	10.11	2.12	43.50	29.79	-13.71
227.30	10.22	H	2.6	10.72	2.30	46.00	23.25	-22.75
290.30	6.79	V	3.2	13.20	2.61	46.00	22.61	-23.39
300.00	8.30	H	1.4	13.55	2.66	46.00	24.51	-21.49
420.00	4.89	H	1.7	16.27	3.16	46.00	24.31	-21.69
Remark	<p>H : Horizontal, V : Vertical TEST MODE : 802.11a-CH 60 (5300 MHz)</p> <p>*Checked in all 3 axis and the maximum measured data were reported.(Worst data is Z axis of position)</p> <p>*Result Value = Reading + Ant Factor + Cable loss</p> <p>*The resolution bandwidth and video bandwidth of test receiver/spectrum analyzer is 120 kHz for Quasi-peak detection at frequency below 1 GHz.</p>							



Estech Co., Ltd.

97-1, Hooeok-ri, Majang-myun, Ichion-city, Gyonggi-do, South Korea
TEL : +82 31 6318037 FAX : +82 31 6318039 www.estech.co.kr

5.4-3 Test Data for wireless LAN (802.11a) – CH 116

Test Date : 14-Jul-14

Measurement Distance : 3 m

Frequency (MHz)	Reading (dB μ V)	Position (V/H)	Height (m)	Correction Factor		Result Value		
				Ant Factor (dB)	Cable (dB)	Limit (dB μ V/m)	Result (dB μ V/m)	Margin (dB)
33.60	10.73	V	1.9	11.32	0.87	40.00	22.92	-17.08
48.00	4.98	V	2.2	12.91	1.05	40.00	18.94	-21.06
148.10	8.34	V	3.1	12.46	1.86	43.50	22.66	-20.84
172.80	8.60	H	3.7	11.98	2.00	43.50	22.58	-20.92
193.80	12.57	V	3.2	10.11	2.12	43.50	24.80	-18.70
197.50	12.47	H	3.2	9.73	2.15	43.50	24.35	-19.15
300.00	8.75	H	2.6	13.55	2.66	46.00	24.96	-21.04
Remark	<p>H : Horizontal, V : Vertical TEST MODE : 802.11a-CH 116 (5580 MHz)</p> <p>*Checked in all 3 axis and the maximum measured data were reported.(Worst data is Z axis of position)</p> <p>*Result Value = Reading + Ant Factor + Cable loss</p> <p>*The resolution bandwidth and video bandwidth of test receiver/spectrum analyzer is 120 kHz for Quasi-peak detection at frequency below 1 GHz.</p>							



Estech Co., Ltd.

97-1, Hooeok-ri, Majang-myun, Ichion-city, Gyonggi-do, South Korea
TEL : +82 31 6318037 FAX : +82 31 6318039 www.estech.co.kr

5.4-4 Test Data for wireless LAN (802.11n) – CH 40

Test Date : 15-Jul-14

Measurement Distance : 3 m

Frequency (MHz)	Reading (dB μ V)	Position (V/H)	Height (m)	Correction Factor		Result Value		
				Ant Factor (dB)	Cable (dB)	Limit (dB μ V/m)	Result (dB μ V/m)	Margin (dB)
33.20	10.55	V	1.9	11.30	0.87	40.00	22.72	-17.28
74.30	13.55	V	2.1	10.42	1.31	40.00	25.29	-14.71
144.00	5.95	V	1.7	12.34	1.83	43.50	20.12	-23.38
148.10	10.45	V	3.0	12.46	1.86	43.50	24.77	-18.73
193.70	13.90	H	3.7	10.12	2.12	43.50	26.14	-17.36
300.00	8.23	H	3.2	13.55	2.66	46.00	24.44	-21.56
Remark	<p>H : Horizontal, V : Vertical TEST MODE : 802.11n-CH 40 (5200 MHz)</p> <p>*Checked in all 3 axis and the maximum measured data were reported.(Worst data is Z axis of position)</p> <p>*Result Value = Reading + Ant Factor + Cable loss</p> <p>*The resolution bandwidth and video bandwidth of test receiver/spectrum analyzer is 120 kHz for Quasi-peak detection at frequency below 1 GHz.</p>							



Estech Co., Ltd.

97-1, Hooeok-ri, Majang-myun, Ichion-city, Gyonggi-do, South Korea
TEL : +82 31 6318037 FAX : +82 31 6318039 www.estech.co.kr

5.4-5 Test Data for wireless LAN (802.11n) – CH 60

Test Date : 15-Jul-14

Measurement Distance : 3 m

Frequency (MHz)	Reading (dB μ V)	Position (V/H)	Height (m)	Correction Factor		Result Value		
				Ant Factor (dB)	Cable (dB)	Limit (dB μ V/m)	Result (dB μ V/m)	Margin (dB)
34.30	11.08	V	1.1	11.36	0.88	40.00	23.32	-16.68
60.20	7.49	H	2.4	12.27	1.18	40.00	20.94	-19.06
69.30	10.96	V	2.4	11.29	1.27	40.00	23.53	-16.47
78.60	16.55	V	3.4	9.63	1.35	40.00	27.53	-12.47
148.10	8.86	H	3.2	12.46	1.86	43.50	23.18	-20.32
193.80	16.52	H	4.0	10.11	2.12	43.50	28.75	-14.75
300.00	9.60	H	1.9	13.55	2.66	46.00	25.81	-20.19
Remark	<p>H : Horizontal, V : Vertical TEST MODE : 802.11n-CH 60 (5300 MHz)</p> <p>*Checked in all 3 axis and the maximum measured data were reported.(Worst data is Z axis of position)</p> <p>*Result Value = Reading + Ant Factor + Cable loss</p> <p>*The resolution bandwidth and video bandwidth of test receiver/spectrum analyzer is 120 kHz for Quasi-peak detection at frequency below 1 GHz.</p>							



Estech Co., Ltd.

97-1, Hooeok-ri, Majang-myun, Ichion-city, Gyonggi-do, South Korea
TEL : +82 31 6318037 FAX : +82 31 6318039 www.estech.co.kr

5.4-6 Test Data for wireless LAN (802.11n) – CH 116

Test Date : 15-Aug-14

Measurement Distance : 3 m

Frequency (MHz)	Reading (dB μ V)	Position (V/H)	Height (m)	Correction Factor		Result Value		
				Ant Factor (dB)	Cable (dB)	Limit (dB μ V/m)	Result (dB μ V/m)	Margin (dB)
32.30	11.20	V	1.4	11.26	0.86	40.00	23.31	-16.69
48.00	5.10	V	3.0	12.91	1.05	40.00	19.06	-20.94
79.70	8.41	V	3.1	9.43	1.36	40.00	19.19	-20.81
144.00	4.92	H	3.6	12.34	1.83	43.50	19.09	-24.41
148.10	8.28	V	1.9	12.46	1.86	43.50	22.60	-20.90
172.80	11.07	H	4.0	11.98	2.00	43.50	25.05	-18.45
193.50	14.71	H	4.0	10.14	2.12	43.50	26.97	-16.53
197.50	13.11	H	2.9	9.73	2.15	43.50	24.99	-18.51
300.00	5.32	H	1.4	13.55	2.66	46.00	21.53	-24.47
Remark	<p>H : Horizontal, V : Vertical TEST MODE : 802.11n-CH 116 (5580 MHz)</p> <p>*Checked in all 3 axis and the maximum measured data were reported.(Worst data is Z axis of position)</p> <p>*Result Value = Reading + Ant Factor + Cable loss</p> <p>*The resolution bandwidth and video bandwidth of test receiver/spectrum analyzer is 120 kHz for Quasi-peak detection at frequency below 1 GHz.</p>							



Estech Co., Ltd.

97-1, Hooeok-ri, Majang-myun, Ichion-city, Gyonggi-do, South Korea
 TEL : +82 31 6318037 FAX : +82 31 6318039 www.estech.co.kr

5.5-1 Test Data for wireless LAN (802.11a) – CH 36, 40, 48

Test Date : 17-Jul-14

Measurement Distance : 3 m

Frequency (MHz)	Reading (dBμV)	Position (V/H)	Height (m)	Correction Factor		Duty Cycle Correction (dB)	Result Value		
				Ant Factor (dB)	Cable (dB)		Limit (dBμV/m)	Result (dBμV/m)	Margin (dB)
PEAK (RBW:1 MHz VBW:3 MHz)									
10360.00	34.98	H	1.2	39.52	-15.34	0.00	74.00	59.16	-14.84
10360.00	35.65	V	1.1	39.52	-15.34	0.00	74.00	59.83	-14.17
Average (RBW:1 MHz VBW:3 MHz)									
10360.00	22.24	H	1.2	39.52	-15.34	2.32	54.00	48.74	-5.26
10360.00	22.39	V	1.1	39.52	-15.34	2.32	54.00	48.89	-5.11
PEAK (RBW:1 MHz VBW:3 MHz)									
10400.00	34.77	H	1.2	39.60	-15.34	0.00	74.00	59.03	-14.97
10400.00	34.98	V	1.2	39.60	-15.30	0.00	74.00	59.28	-14.72
Average (RBW:1 MHz VBW:3 MHz)									
10400.00	20.66	H	1.2	39.60	-15.30	2.32	54.00	47.28	-6.72
10400.00	20.34	V	1.2	39.60	-15.30	2.32	54.00	46.96	-7.04
PEAK (RBW:1 MHz VBW:3 MHz)									
10480.00	36.21	H	1.1	39.76	-15.30	0.00	74.00	60.67	-13.33
10480.00	35.84	V	1.2	39.76	-15.30	0.00	74.00	60.30	-13.70
Average (RBW:1 MHz VBW:3 MHz)									
10480.00	22.21	H	1.1	39.76	-15.30	2.32	54.00	48.99	-5.01
10480.00	22.81	V	1.2	39.76	-15.34	2.32	54.00	49.55	-4.45
Remark	<p>H : Horizontal, V : Vertical TEST MODE : 802.11a-CH 36 (5180 MHz), CH 40 (5200 MHz), CH 48 (5240 MHz)</p> <p>*The TX signal wasn't detected from 3th harmonics. *Checked in all 3 axis and the maximum measured data were reported.(Worst data is Z axis of position) *Total = Reading Value + Antenna Factor + Cable Loss - Amp Gain + Duty Cycle Correction</p> <p>FYI a. Ton Time : 2.42 ms b. duty cycle : 58.59 % c. DCF : 2.32 dB</p>								



Estech Co., Ltd.

97-1, Hooeok-ri, Majang-myun, Ichion-city, Gyonggi-do, South Korea
TEL : +82 31 6318037 FAX : +82 31 6318039 www.estech.co.kr

5.5-2 Test Data for wireless LAN(802.11a) – CH 52, 60, 64

Test Date : 17-Jul-14

Measurement Distance : 3 m

Frequency (MHz)	Reading (dB μ V)	Position (V/H)	Height (m)	Correction Factor		Duty Cycle Correction (dB)	Result Value		
				Ant Factor (dB)	Cable (dB)		Limit (dB μ V/m)	Result (dB μ V/m)	Margin (dB)
PEAK (RBW:1 MHz VBW:3 MHz)									
10520.00	34.87	H	1.2	39.85	-15.34	0.00	74.00	59.38	-14.62
10520.00	35.79	V	1.3	39.85	-15.34	0.00	74.00	60.30	-13.70
Average (RBW:1 MHz VBW:3 MHz)									
10520.00	24.98	H	1.2	39.85	-15.34	2.32	54.00	51.81	-2.19
10520.00	24.81	V	1.3	39.85	-15.34	2.32	54.00	51.64	-2.36
PEAK (RBW:1 MHz VBW:3 MHz)									
10600.00	35.87	H	1.1	40.01	-15.34	0.00	74.00	60.54	-13.46
10600.00	35.80	V	1.2	40.01	-15.30	0.00	74.00	60.51	-13.49
Average (RBW:1 MHz VBW:3 MHz)									
10600.00	22.21	H	1.1	40.01	-15.30	2.32	54.00	49.24	-4.76
10600.00	22.51	V	1.2	40.01	-15.30	2.32	54.00	49.54	-4.46
PEAK (RBW:1 MHz VBW:3 MHz)									
10640.00	34.87	H	1.1	40.09	-15.30	0.00	74.00	59.66	-14.34
10640.00	34.91	V	1.1	40.09	-15.30	0.00	74.00	59.70	-14.30
Average (RBW:1 MHz VBW:3 MHz)									
10640.00	21.11	H	1.1	40.09	-15.30	2.32	54.00	48.22	-5.78
10640.00	21.71	V	1.1	40.09	-15.34	2.32	54.00	48.78	-5.22
Remark	<p>H : Horizontal, V : Vertical TEST MODE : 802.11a-CH 52 (5260 MHz), CH 60 (5300 MHz), CH 64 (5320 MHz)</p> <p>*The TX signal wasn't detected from 3th harmonics. *Checked in all 3 axis and the maximum measured data were reported.(Worst data is Z axis of position) *Total = Reading Value + Antenna Factor + Cable Loss - Amp Gain + Duty Cycle Correction</p> <p>FYI a. Ton Time : 2.42 ms b. duty cycle : 58.59 % c. DCF : 2.32 dB</p>								



Estech Co., Ltd.

97-1, Hooeok-ri, Majang-myun, Ichion-city, Gyonggi-do, South Korea
 TEL : +82 31 6318037 FAX : +82 31 6318039 www.estech.co.kr

5.5-3 Test Data for wireless LAN(802.11a) – CH 100, 116, 140

Test Date : 17-Jul-14

Measurement Distance : 3 m

Frequency (MHz)	Reading (dB μ V)	Position (V/H)	Height (m)	Correction Factor		Duty Cycle Correction (dB)	Result Value		
				Ant Factor (dB)	Cable (dB)		Limit (dB μ V/m)	Result (dB μ V/m)	Margin (dB)
PEAK (RBW:1 MHz VBW:3 MHz)									
11000.00	35.11	H	1.1	40.83	-15.34	0.00	74.00	60.60	-13.40
11000.00	35.12	V	1.2	40.83	-15.34	0.00	74.00	60.61	-13.39
Average (RBW:1 MHz VBW:3 MHz)									
11000.00	21.83	H	1.1	40.83	-15.34	2.32	54.00	49.64	-4.36
11000.00	20.91	V	1.2	40.83	-15.34	2.32	54.00	48.72	-5.28
PEAK (RBW:1 MHz VBW:3 MHz)									
11160.00	36.07	H	1.2	40.54	-15.34	0.00	74.00	61.27	-12.73
11160.00	36.22	V	1.2	40.54	-15.30	0.00	74.00	61.46	-12.54
Average (RBW:1 MHz VBW:3 MHz)									
11160.00	21.64	H	1.2	40.54	-15.30	2.32	54.00	49.20	-4.80
11160.00	20.72	V	1.2	40.54	-15.30	2.32	54.00	48.28	-5.72
PEAK (RBW:1 MHz VBW:3 MHz)									
11400.00	35.81	H	1.2	40.10	-15.30	0.00	74.00	60.61	-13.39
11400.00	34.91	V	1.4	40.10	-15.30	0.00	74.00	59.71	-14.29
Average (RBW:1 MHz VBW:3 MHz)									
11400.00	21.64	H	1.2	40.10	-15.30	2.32	54.00	48.76	-5.24
11400.00	22.11	V	1.4	40.10	-15.34	2.32	54.00	49.19	-4.81
Remark	<p>H : Horizontal, V : Vertical TEST MODE : 802.11a-CH 100 (5500 MHz), CH 116 (5580 MHz), CH 140 (5700 MHz)</p> <p>*The TX signal wasn't detected from 3th harmonics. *Checked in all 3 axis and the maximum measured data were reported.(Worst data is Z axis of position) *Total = Reading Value + Antenna Factor + Cable Loss - Amp Gain + Duty Cycle Correction</p> <p>FYI a. Ton Time : 2.42 ms b. duty cycle : 58.59 % c. DCF : 2.32 dB</p>								



Estech Co., Ltd.

97-1, Hooeok-ri, Majang-myun, Ichion-city, Gyonggi-do, South Korea
 TEL : +82 31 6318037 FAX : +82 31 6318039 www.estech.co.kr

5.5-4 Test Data for wireless LAN(802.11n) – CH 36, 40, 48

Test Date : 18-Jul-14

Measurement Distance : 3 m

Frequency (MHz)	Reading (dBμV)	Position (V/H)	Height (m)	Correction Factor		Duty Cycle Correction (dB)	Result Value		
				Ant Factor (dB)	Cable (dB)		Limit (dBμV/m)	Result (dBμV/m)	Margin (dB)
PEAK (RBW:1 MHz VBW:3 MHz)									
10360.00	32.61	H	1.2	39.52	-15.34	0.00	74.00	56.79	-17.21
10360.00	32.25	V	1.3	39.52	-15.34	0.00	74.00	56.43	-17.57
Average (RBW:1 MHz VBW:3 MHz)									
10360.00	22.21	H	1.2	39.52	-15.34	2.35	54.00	48.74	-5.26
10360.00	22.44	V	1.3	39.52	-15.34	2.35	54.00	48.97	-5.03
PEAK (RBW:1 MHz VBW:3 MHz)									
10400.00	33.68	H	1.4	39.60	-15.34	0.00	74.00	57.94	-16.06
10400.00	33.67	V	1.4	39.60	-15.30	0.00	74.00	57.97	-16.03
Average (RBW:1 MHz VBW:3 MHz)									
10400.00	22.61	H	1.4	39.60	-15.30	2.35	54.00	49.26	-4.74
10400.00	21.92	V	1.4	39.60	-15.30	2.35	54.00	48.57	-5.43
PEAK (RBW:1 MHz VBW:3 MHz)									
10480.00	34.12	H	1.3	39.76	-15.30	0.00	74.00	58.58	-15.42
10480.00	34.21	V	1.2	39.76	-15.30	0.00	74.00	58.67	-15.33
Average (RBW:1 MHz VBW:3 MHz)									
10480.00	22.24	H	1.3	39.76	-15.30	2.35	54.00	49.05	-4.95
10480.00	21.91	V	1.2	39.76	-15.34	2.35	54.00	48.68	-5.32
Remark	<p>H : Horizontal, V : Vertical TEST MODE : 802.11n-CH 36 (5180 MHz), CH 40 (5200 MHz), CH 48 (5240 MHz)</p> <p>*The TX signal wasn't detected from 3th harmonics. *Checked in all 3 axis and the maximum measured data were reported.(Worst data is Z axis of position) *Total = Reading Value + Antenna Factor + Cable Loss - Amp Gain + Duty Cycle Correction</p> <p>FYI a. Ton Time : 2.33 ms b. duty cycle : 58.26 % c. DCF : 2.35 dB</p>								



Estech Co., Ltd.

97-1, Hooeok-ri, Majang-myun, Ichion-city, Gyonggi-do, South Korea
 TEL : +82 31 6318037 FAX : +82 31 6318039 www.estech.co.kr

5.5-5 Test Data for wireless LAN(802.11n) – CH 52, 60, 64

Test Date : 18-Jul-14

Measurement Distance : 3 m

Frequency (MHz)	Reading (dBμV)	Position (V/H)	Height (m)	Correction Factor		Duty Cycle Correction (dB)	Result Value		
				Ant Factor (dB)	Cable (dB)		Limit (dBμV/m)	Result (dBμV/m)	Margin (dB)
PEAK (RBW:1 MHz VBW:3 MHz)									
10520.00	34.97	H	1.2	39.85	-22.60	0.00	74.00	52.22	-21.78
10520.00	34.65	V	1.3	39.85	-22.60	0.00	74.00	51.90	-22.10
Average (RBW:1 MHz VBW:3 MHz)									
10520.00	23.11	H	1.2	39.85	-22.60	2.35	54.00	42.71	-11.29
10520.00	23.01	V	1.3	39.85	-22.60	2.35	54.00	42.61	-11.39
PEAK (RBW:1 MHz VBW:3 MHz)									
10600.00	34.21	H	1.1	40.01	-15.34	0.00	74.00	58.88	-15.12
10600.00	33.67	V	1.4	40.01	-15.30	0.00	74.00	58.38	-15.62
Average (RBW:1 MHz VBW:3 MHz)									
10600.00	22.24	H	1.1	40.01	-15.30	2.35	54.00	49.30	-4.70
10600.00	21.44	V	1.4	40.01	-15.30	2.35	54.00	48.50	-5.50
PEAK (RBW:1 MHz VBW:3 MHz)									
10640.00	32.87	H	1.2	40.09	-15.30	0.00	74.00	57.66	-16.34
10640.00	32.94	V	1.3	40.09	-15.30	0.00	74.00	57.73	-16.27
Average (RBW:1 MHz VBW:3 MHz)									
10640.00	22.74	H	1.2	40.09	-15.30	2.35	54.00	49.88	-4.12
10640.00	22.49	V	1.3	40.09	-15.34	2.35	54.00	49.59	-4.41
Remark	<p>H : Horizontal, V : Vertical TEST MODE : 802.11n-CH 52 (5260 MHz), CH 60 (5300 MHz), CH 64 (5320 MHz)</p> <p>*The TX signal wasn't detected from 3th harmonics. *Checked in all 3 axis and the maximum measured data were reported.(Worst data is Z axis of position) *Total = Reading Value + Antenna Factor + Cable Loss - Amp Gain + Duty Cycle Correction</p> <p>FYI a. Ton Time : 2.33 ms b. duty cycle : 58.26 % c. DCF : 2.35 dB</p>								



Estech Co., Ltd.

97-1, Hooeok-ri, Majang-myun, Ichion-city, Gyonggi-do, South Korea
 TEL : +82 31 6318037 FAX : +82 31 6318039 www.estech.co.kr

5.5-6 Test Data for wireless LAN(802.11n) – CH 100, 116, 140

Test Date : 18-Jul-14

Measurement Distance : 3 m

Frequency (MHz)	Reading (dBμV)	Position (V/H)	Height (m)	Correction Factor		Duty Cycle Correction (dB)	Result Value		
				Ant Factor (dB)	Cable (dB)		Limit (dBμV/m)	Result (dBμV/m)	Margin (dB)
PEAK (RBW:1 MHz VBW:3 MHz)									
11000.00	34.61	H	1.2	40.83	-15.34	0.00	74.00	60.10	-13.90
11000.00	35.01	V	1.4	40.83	-15.34	0.00	74.00	60.50	-13.50
Average (RBW:1 MHz VBW:3 MHz)									
11000.00	21.11	H	1.2	40.83	-15.34	2.35	54.00	48.95	-5.05
11000.00	21.34	V	1.4	40.83	-15.34	2.35	54.00	49.18	-4.82
PEAK (RBW:1 MHz VBW:3 MHz)									
11160.00	33.22	H	1.4	40.54	-15.34	0.00	74.00	58.42	-15.58
11160.00	34.31	V	1.2	40.54	-15.30	0.00	74.00	59.55	-14.45
Average (RBW:1 MHz VBW:3 MHz)									
11160.00	21.61	H	1.4	40.54	-15.30	2.35	54.00	49.20	-4.80
11160.00	21.24	V	1.2	40.54	-15.30	2.35	54.00	48.83	-5.17
PEAK (RBW:1 MHz VBW:3 MHz)									
11400.00	34.33	H	1.2	40.10	-15.30	0.00	74.00	59.13	-14.87
11400.00	33.67	V	1.1	40.10	-15.30	0.00	74.00	58.47	-15.53
Average (RBW:1 MHz VBW:3 MHz)									
11400.00	21.17	H	1.2	40.10	-15.30	2.35	54.00	48.32	-5.68
11400.00	21.22	V	1.1	40.10	-15.34	2.35	54.00	48.33	-5.67
Remark	<p>H : Horizontal, V : Vertical TEST MODE : 802.11n-CH 100 (5500 MHz), CH 116 (5580 MHz), CH 140 (5700 MHz)</p> <p>*The TX signal wasn't detected from 3th harmonics. *Checked in all 3 axis and the maximum measured data were reported.(Worst data is Z axis of position) *Total = Reading Value + Antenna Factor + Cable Loss - Amp Gain + Duty Cycle Correction</p> <p>FYI a. Ton Time : 2.33 ms b. duty cycle : 58.26 % c. DCF : 2.35 dB</p>								



Estech Co., Ltd.

97-1, Hooeok-ri, Majang-myun, Ichion-city, Gyonggi-do, South Korea

TEL : +82 31 6318037 FAX : +82 31 6318039 www.estech.co.kr

6. Unwanted Emission

Above 30 MHz Electric Field strength was measured in accordance with FCC PART 15.205, 15.209 The test setup was made according to ANSI C 63.4 (2009) & KDB 789033 D01 Semi-anechoic chamber, which allows a 3 m distance measurement. The EUT was placed in the center of styrofoam turntable. The height of this table was 0.8 m. The measurement was conducted with both horizontal and vertical antenna polarization. The turntable has fully rotated. For further description of the configuration refer to the picture of the test setup.

6.1 Measurement equipments

Equipment Name	Type	Manufacturer	Serial No.	Next Calibration date
TEST Receiver	ESCI7	ROHDE & SCHWARZ	100916	23-Jan-15
Logbicon Antenna	VULB 9168	SCHWARZBECK	237	13-Jan-15
Turn Table	DT3000-2t	Innco System GmbH	N/A	-
Antenna Mast	MA4000-EP	Innco System GmbH	N/A	-
PREAMPLIFIER	8449B	AGILENT	3008A00595	13-Jan-15
Horn Antenna	BBHA9120D	SCHWARZBECK	469	11-Nov-14
Test Receiver	ESPI7	ROHDE & SCHWARZ	100185	13-Jan-15
Spectrum Analyzer	R3273	ADVANTEST	110600592	13-Jan-15
Turn Table	DT1500-S	Innco System GmbH	N/A	-
Antenna Mast	MA4000-EP	Innco System GmbH	N/A	-
Pyramidal Horn Antenna	3160-09-01	EST-LINDGREN	102642	14-Nov-14
Antenna Master & Turn table controller	C02000-P	Innco System GmbH	CO2000/642 /28051111/L	-
Spectrum Analyzer	FSV40	ROHDE & SCHWARZ	100939	23-Jan-15
Double Ridged Horn Antenna	SAS-574	A.H.SYSTEMS	154	17-Mar-15
PREAMPLIFIER	83051A	AGILENT	3950M00201	2-Jun-15

6.2 Environmental Condition

Above 1 GHz -Test Place : 3 m Semi-anechoic chamber

Wireless LAN 802.11a CH - 36 .64 . 100 . 140

Temperature (°C) : 22.5 °C
Humidity (% R.H.) : 48.6 % R.H.

Temperature (°C) : 22.7 °C
Humidity (% R.H.) : 49.3 % R.H.

Wireless LAN 802.11n CH - 36 .64 . 100 . 140

Temperature (°C) : 22.3 °C
Humidity (% R.H.) : 47.7 % R.H.



Estech Co., Ltd.

97-1, Hooeok-ri, Majang-myun, Ichion-city, Gyonggi-do, South Korea
TEL : +82 31 6318037 FAX : +82 31 6318039 www.estech.co.kr

6.3-1 Test Result of Unwanted Emission

RF Radiated Measurement (Horizontal) – Mode 1 : 802.11a

Channel No.	Frequency (MHz)	Reading (dBm)	Correction Factor		Measure Level (dBm/m)	Margin (dB)	Limit (dBm/m)	Result
			Ant Factor (dB)	Cable-Amp (dB)				
36 (Peak)	5148.40	-57.69	31.94	-23.2	-48.95	-21.95	-27.00	Pass
	5149.50	-59.05	31.94	-23.2	-50.31	-23.31	-27.00	Pass

Figure Channel 36 : Horizontal (Peak)

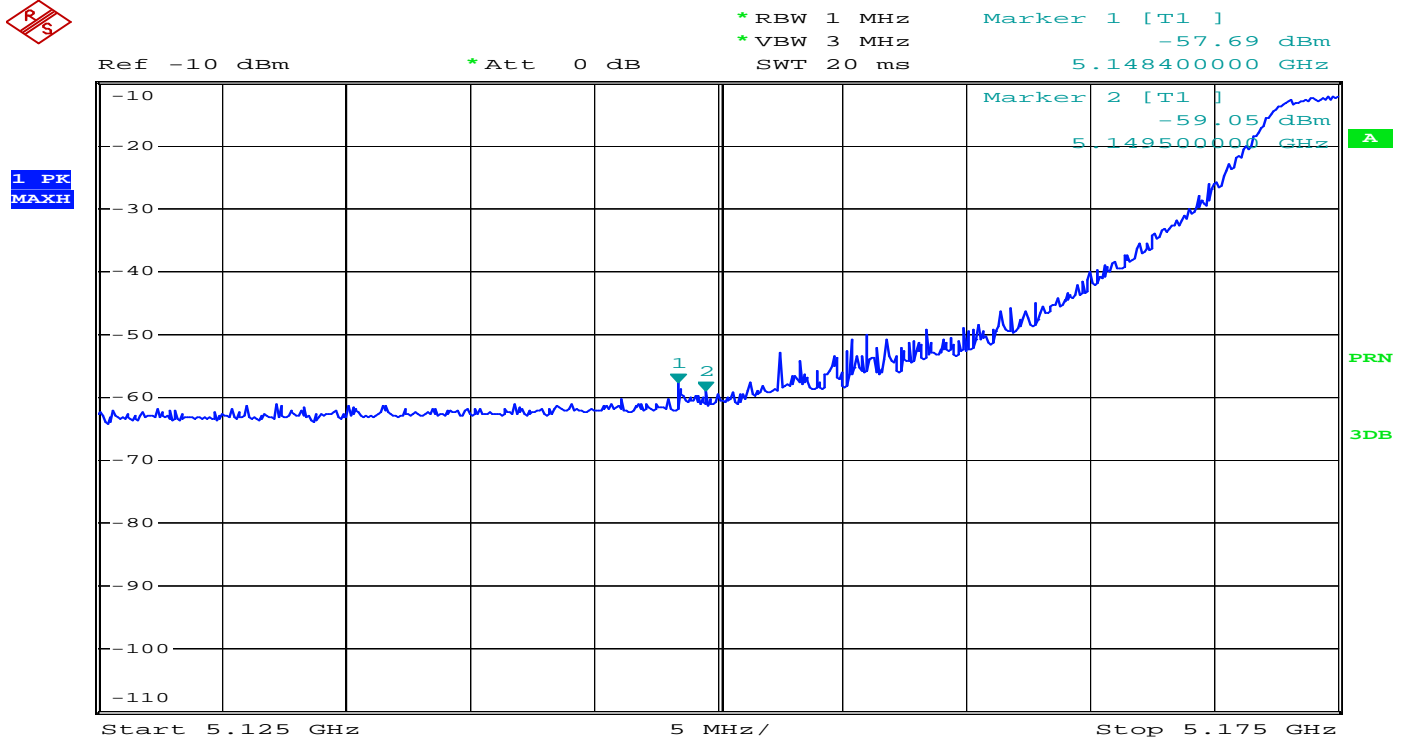

Comment : 14-00824_HOR(802.11a_CH36_5180MHz)_PK
Date : 27.SEP.2014 11:39:16



Estech Co., Ltd.

97-1, Hooeok-ri, Majang-myun, Ichion-city, Gyonggi-do, South Korea
 TEL : +82 31 6318037 FAX : +82 31 6318039 www.estech.co.kr

6.3-2 Test Result of Unwanted Emission

RF Radiated Measurement (Vertical) – Mode 1 : 802.11a

Channel No.	Frequency (MHz)	Reading (dBm)	Correction Factor		Mesure Level (dBm/m)	Margin (dB)	Limit (dBm/m)	Result
			Ant Factor (dB)	Cable-Amp (dB)				
36 (Peak)	5148.90	-58.26	31.94	-23.2	-49.52	-22.52	-27.00	Pass
	5149.90	-58.42	31.94	-23.2	-49.68	-22.68	-27.00	Pass

Figure Channel 36 : Vertical (Peak)

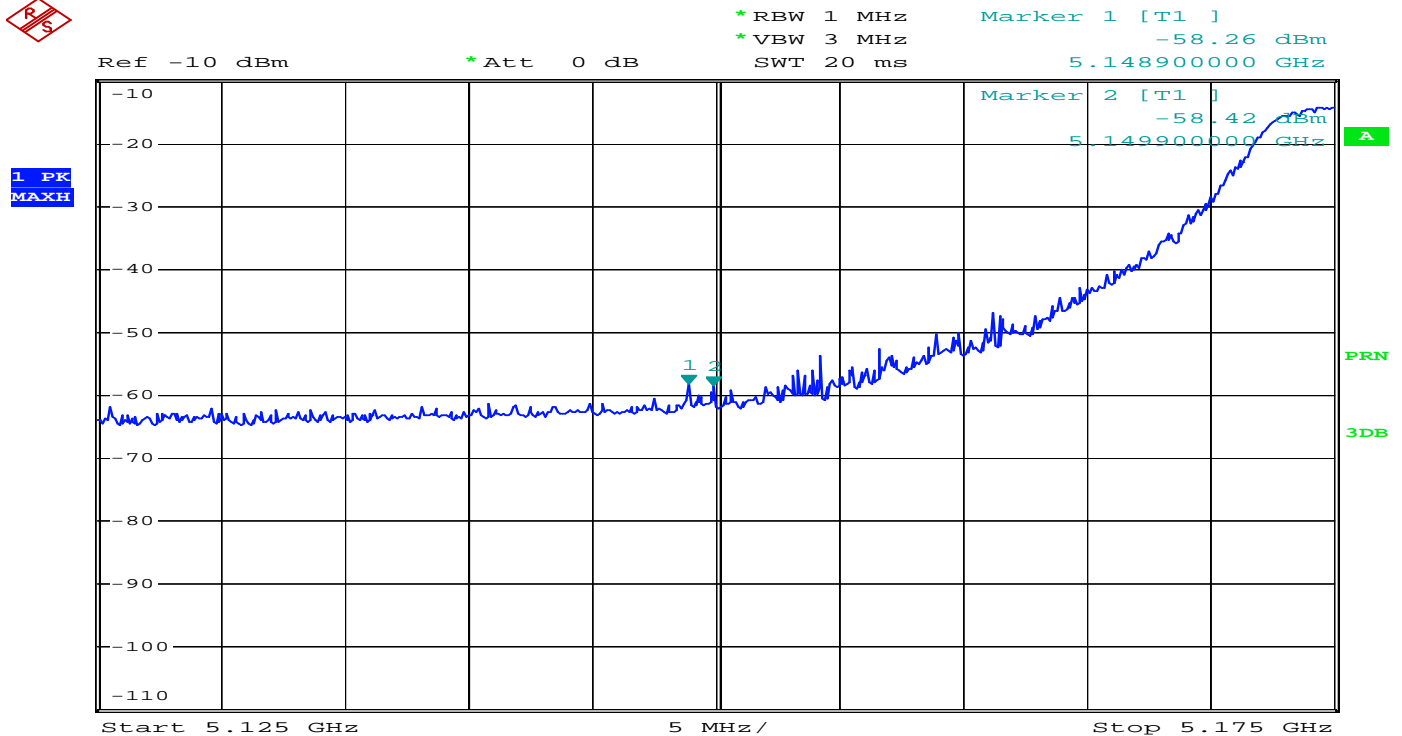

Comment : 14-00824_VER(802.11a_CH36_5180MHz)_PK
 Date : 27.SEP.2014 11:41:10



Estech Co., Ltd.

97-1, Hooeok-ri, Majang-myun, Ichion-city, Gyonggi-do, South Korea
TEL : +82 31 6318037 FAX : +82 31 6318039 www.estech.co.kr

6.3-3 Test Result of Unwanted Emission

RF Radiated Measurement (Horizontal) – Mode 1 : 802.11a

Channel No.	Frequency (MHz)	Reading (dBm)	Correction Factor		Mesure Level (dBm/m)	Margin (dB)	Limit (dBm/m)	Result
			Ant Factor (dB)	Cable-Amp (dB)				
64 (Peak)	5352.10	-55.66	32.04	-22.9	-46.52	-19.52	-27.00	Pass
	5350.10	-55.92	32.04	-22.9	-46.78	-19.78	-27.00	Pass

Figure Channel 64 : Horizontal (Peak)

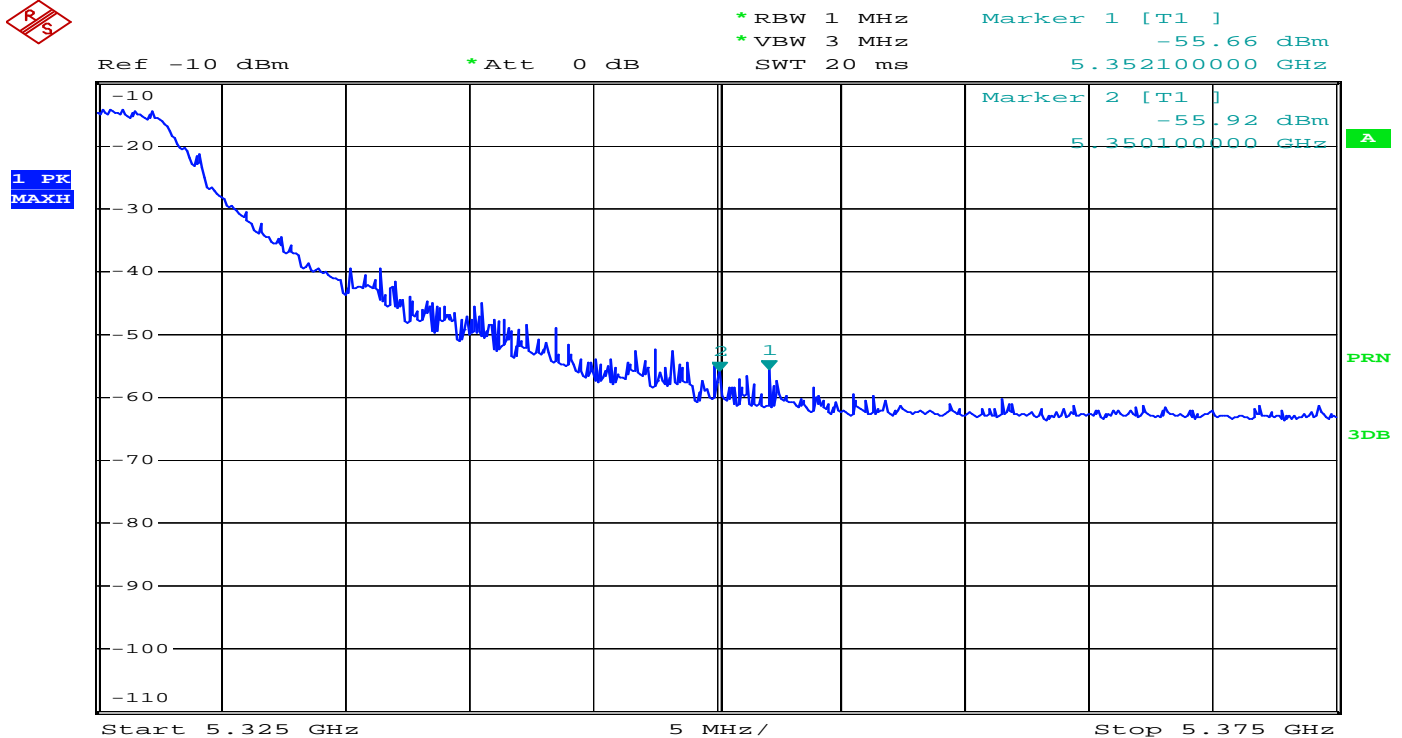

Comment : 14-00824_HOR(802.11a_CH64_5320MHz)_PK
Date : 27.SEP.2014 11:45:44



Estech Co., Ltd.

97-1, Hooeok-ri, Majang-myun, Ichion-city, Gyonggi-do, South Korea
 TEL : +82 31 6318037 FAX : +82 31 6318039 www.estech.co.kr

6.3-4 Test Result of Unwanted Emission

RF Radiated Measurement (Vertical) – Mode 1 : 802.11a

Channel No.	Frequency (MHz)	Reading (dBm)	Correction Factor		Mesure Level (dBm/m)	Margin (dB)	Limit (dBm/m)	Result
			Ant Factor (dB)	Cable-Amp (dB)				
64 (Peak)	5350.20	-56.46	32.04	-22.9	-47.32	-20.32	-27.00	Pass
	5351.50	-55.13	32.04	-22.9	-45.99	-18.99	-27.00	Pass

Figure Channel 64 : Vertical (Peak)

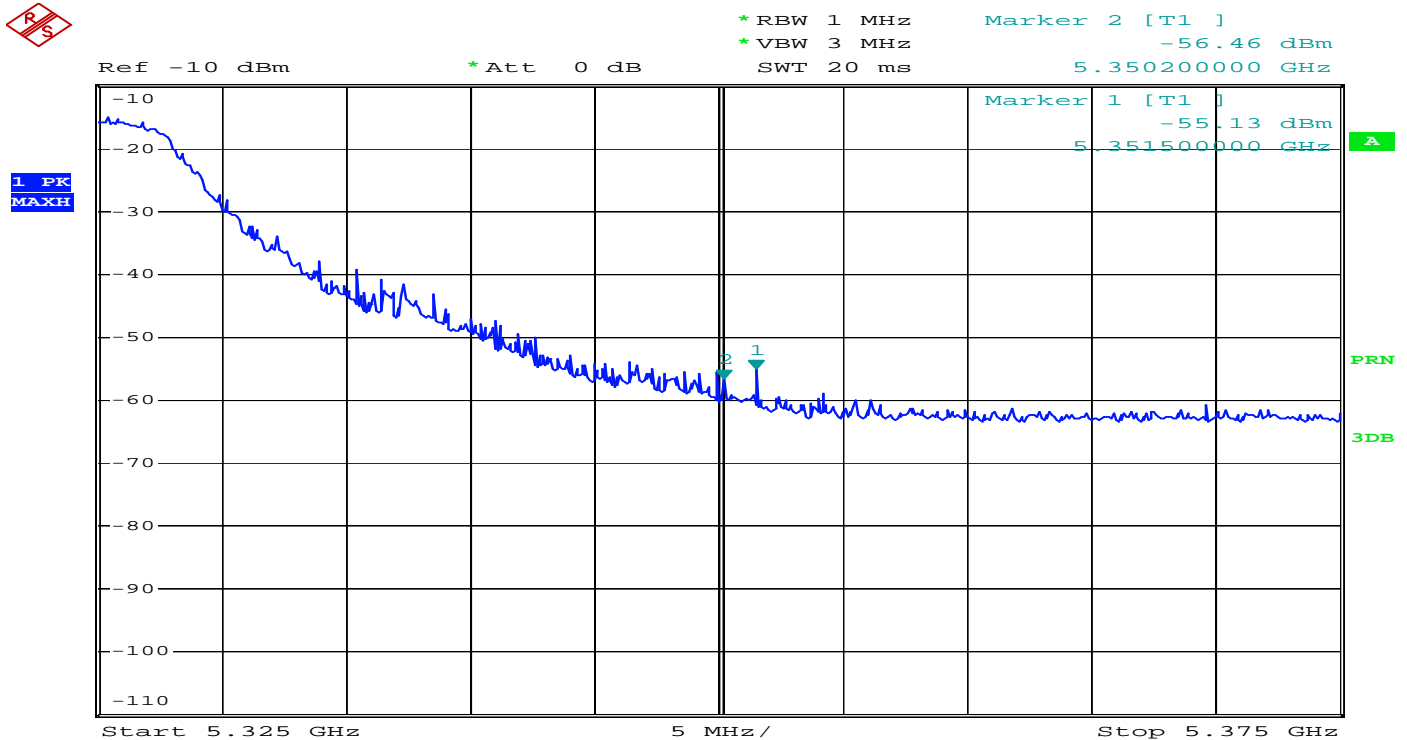

Comment : 14-00824_VER(802.11a_CH64_5320MHz)_PK
 Date : 27.SEP.2014 11:44:00



Estech Co., Ltd.

97-1, Hooeok-ri, Majang-myun, Ichion-city, Gyonggi-do, South Korea
 TEL : +82 31 6318037 FAX : +82 31 6318039 www.estech.co.kr

6.3-5 Test Result of Unwanted Emission

RF Radiated Measurement (Horizontal) – Mode 1 : 802.11a

Channel No.	Frequency (MHz)	Reading (dBm)	Correction Factor		Measure Level (dBm/m)	Margin (dB)	Limit (dBm/m)	Result
			Ant Factor (dB)	Cable-Amp (dB)				
100 (Peak)	5469.30	-54.84	32.10	-22.9	-45.64	-18.64	-27.00	Pass
	5470.20	-54.42	32.10	-22.9	-45.22	-18.22	-27.00	Pass

Figure Channel 100 : Horizontal (Peak)

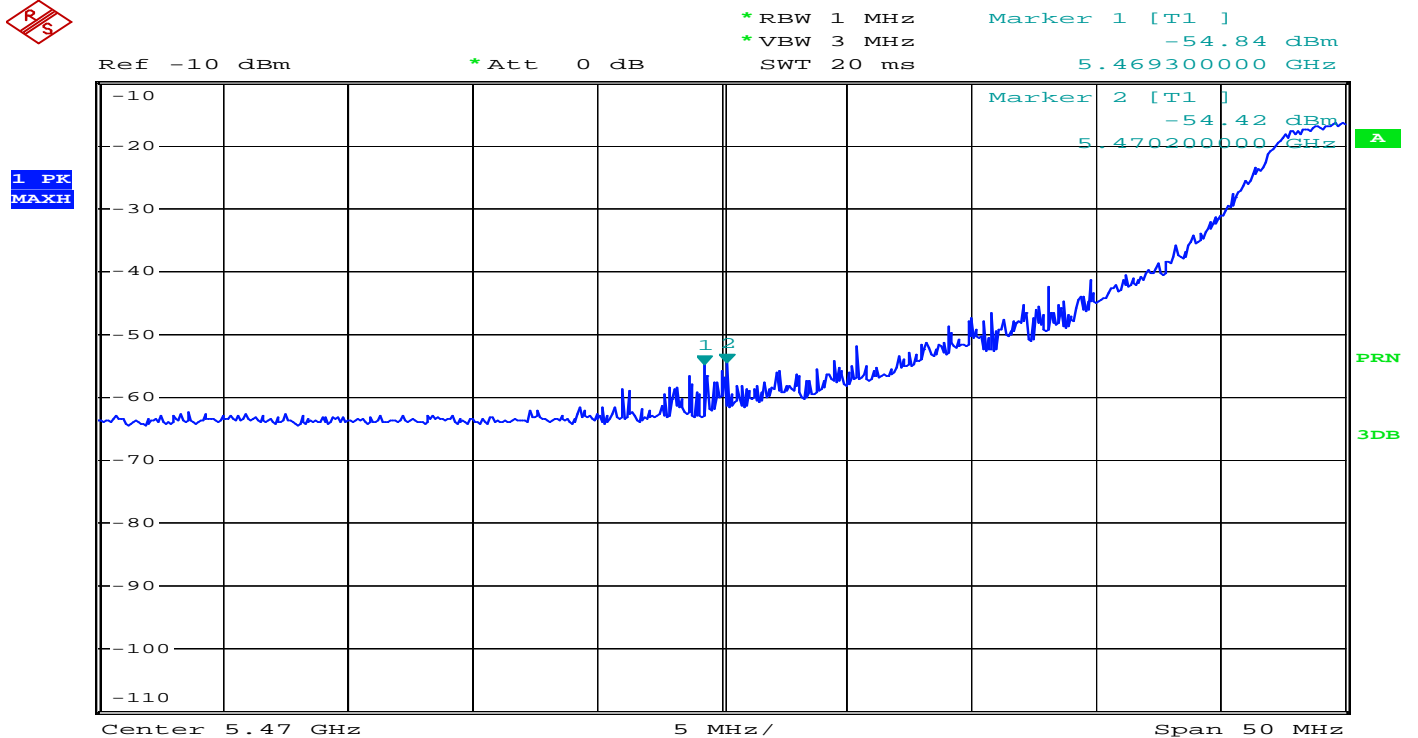

Comment : 14-00824_HOR(802.11a_CH100_5500MHz)_PK
 Date : 27.SEP.2014 11:53:03



Estech Co., Ltd.

97-1, Hooeok-ri, Majang-myun, Ichion-city, Gyonggi-do, South Korea
 TEL : +82 31 6318037 FAX : +82 31 6318039 www.estech.co.kr

6.3-6 Test Result of Unwanted Emission

RF Radiated Measurement (Vertical) – Mode 1 : 802.11a

Channel No.	Frequency (MHz)	Reading (dBm)	Correction Factor		Measure Level (dBm/m)	Margin (dB)	Limit (dBm/m)	Result
			Ant Factor (dB)	Cable-Amp (dB)				
100 (Peak)	5467.60	-56.08	32.10	-22.9	-46.88	-19.88	-27.00	Pass
	5469.30	-54.61	32.10	-22.9	-45.41	-18.41	-27.00	Pass

Figure Channel 100 :

Vertical (Peak)

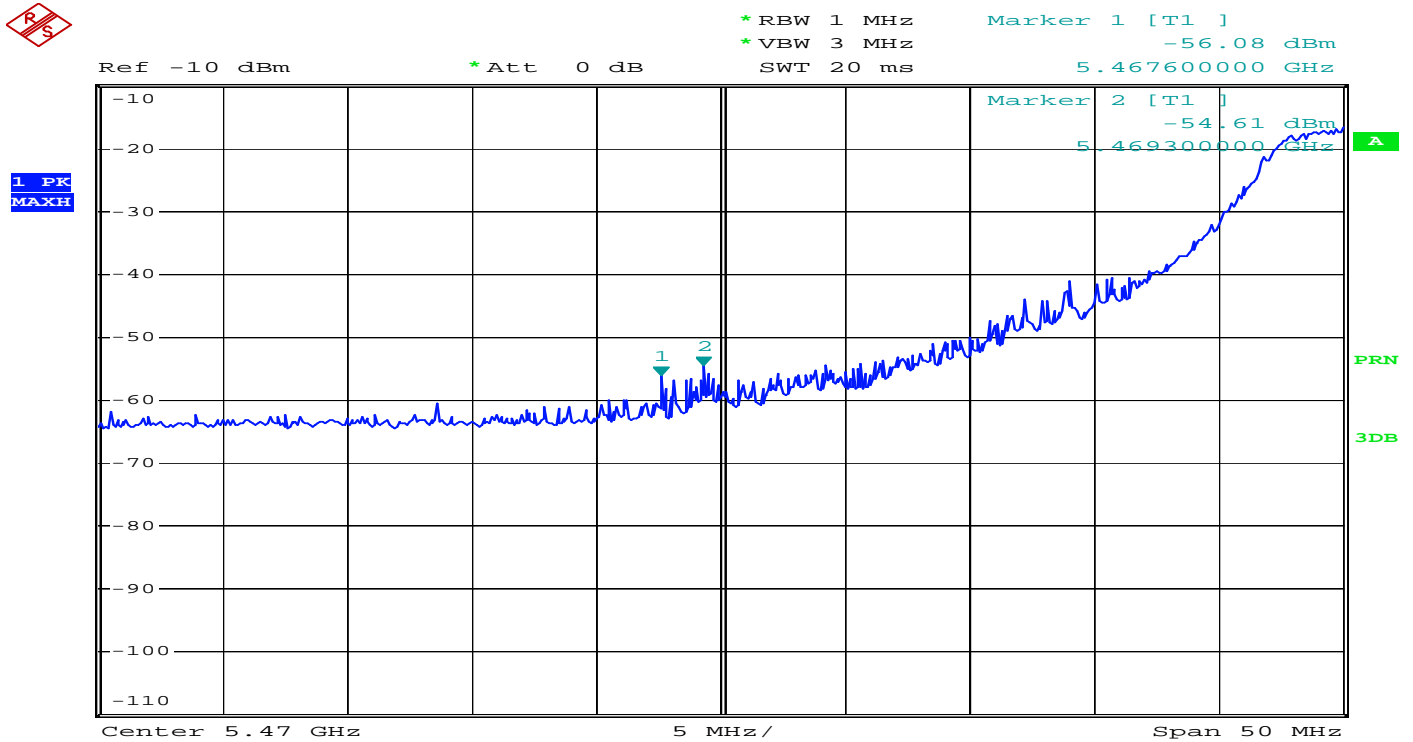

Comment : 14-00824_VER(802.11a_CH100_5500MHz)_PK
 Date : 27.SEP.2014 11:55:28



Estech Co., Ltd.

97-1, Hooeok-ri, Majang-myun, Ichion-city, Gyonggi-do, South Korea
TEL : +82 31 6318037 FAX : +82 31 6318039 www.estech.co.kr

6.3-7 Test Result of Unwanted Emission

RF Radiated Measurement (Horizontal) – Mode 1 : 802.11a

Channel No.	Frequency (MHz)	Reading (dBm)	Correction Factor		Mesure Level (dBm/m)	Margin (dB)	Limit (dBm/m)	Result
			Ant Factor (dB)	Cable-Amp (dB)				
140 (Peak)	5725.60	-58.56	32.24	-22.1	-48.42	-21.42	-27.00	Pass
	5727.40	-58.62	32.24	-22.1	-48.48	-21.48	-27.00	Pass

Figure Channel 140 : Horizontal (Peak)

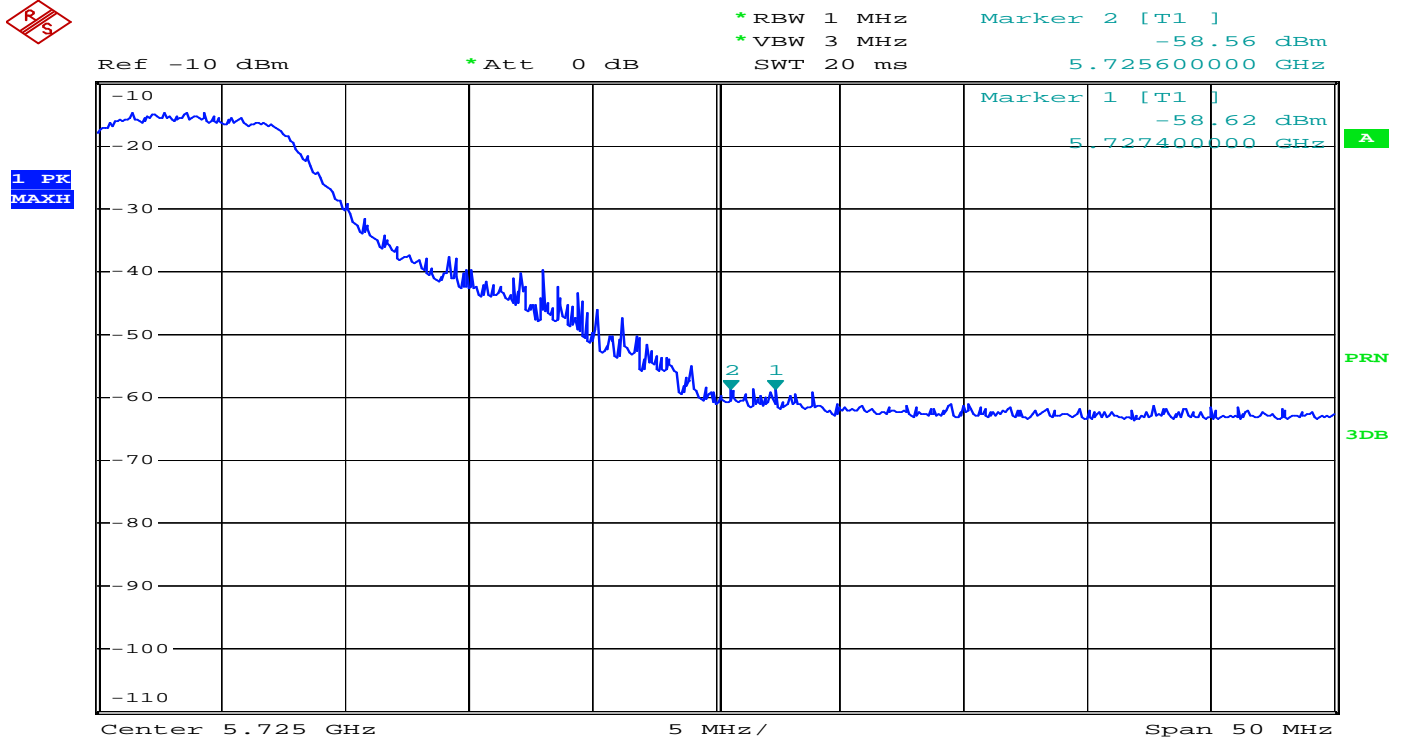

Comment : 14-00824_HOR(802.11a_CH140_5700MHz)_PK
Date : 27.SEP.2014 12:00:10



Estech Co., Ltd.

97-1, Hooeok-ri, Majang-myun, Ichion-city, Gyonggi-do, South Korea
TEL : +82 31 6318037 FAX : +82 31 6318039 www.estech.co.kr

6.3-8 Test Result of Unwanted Emission

RF Radiated Measurement (Vertical) – Mode 1 : 802.11a

Channel No.	Frequency (MHz)	Reading (dBm)	Correction Factor		Mesure Level (dBm/m)	Margin (dB)	Limit (dBm/m)	Result
			Ant Factor (dB)	Cable-Amp (dB)				
140 (Peak)	5726.90	-58.28	32.04	-22.9	-49.14	-22.14	-27.00	Pass
	5725.60	-58.63	32.04	-22.9	-49.49	-22.49	-27.00	Pass

Figure Channel 140 : Vertical (Peak)

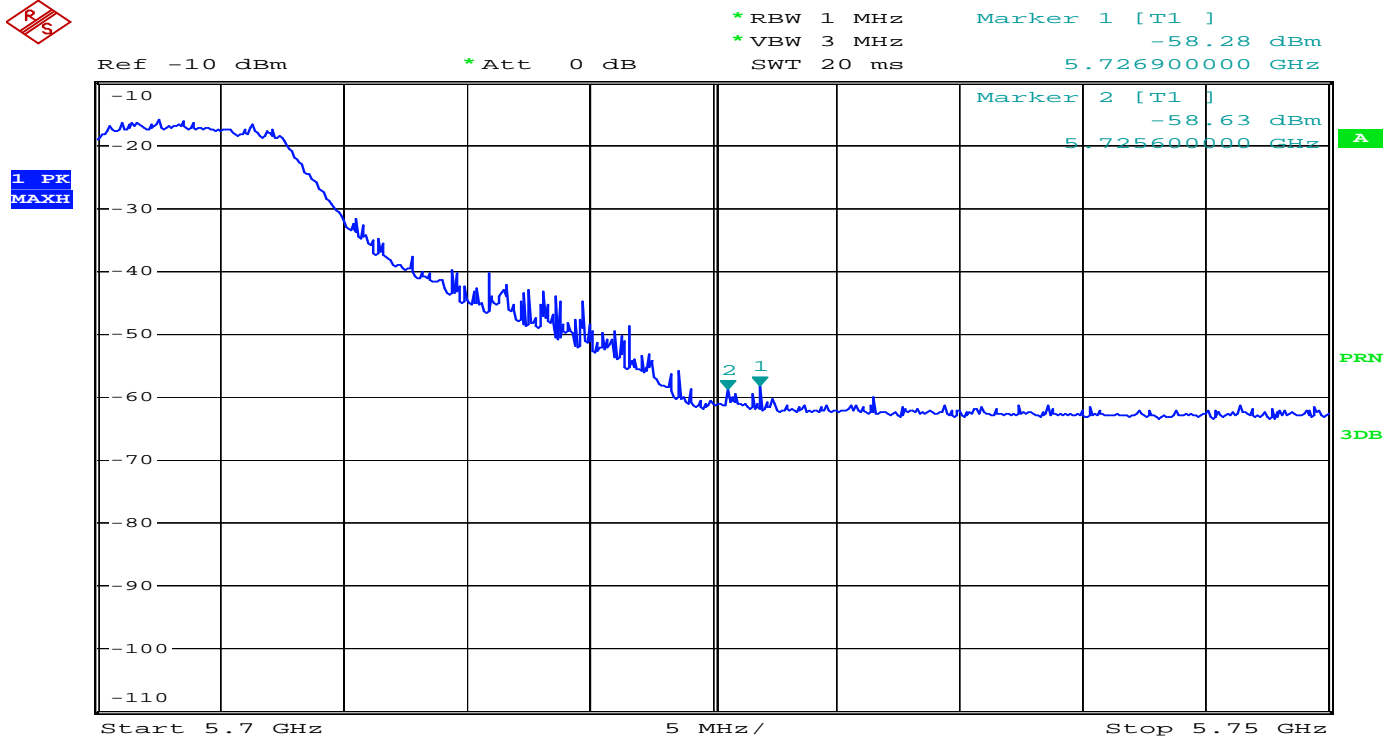

Comment : 14-00824_VER(802.11a_CH140_5700MHz)_PK
Date : 27.SEP.2014 11:58:44



Estech Co., Ltd.

97-1, Hooeok-ri, Majang-myun, Ichion-city, Gyonggi-do, South Korea
 TEL : +82 31 6318037 FAX : +82 31 6318039 www.estech.co.kr

6.3-9 Test Result of Unwanted Emission

RF Radiated Measurement (Horizontal) – Mode 1 : 802.11n

Channel No.	Frequency (MHz)	Reading (dBm)	Correction Factor		Measure Level (dBm/m)	Margin (dB)	Limit (dBm/m)	Result
			Ant Factor (dB)	Cable-Amp (dB)				
36 (Peak)	5150.20	-58.61	31.94	-23.2	-49.87	-22.87	-27.00	Pass
	5148.90	-57.41	31.94	-23.2	-48.67	-21.67	-27.00	Pass

Figure Channel 36 :

Horizontal (Peak)

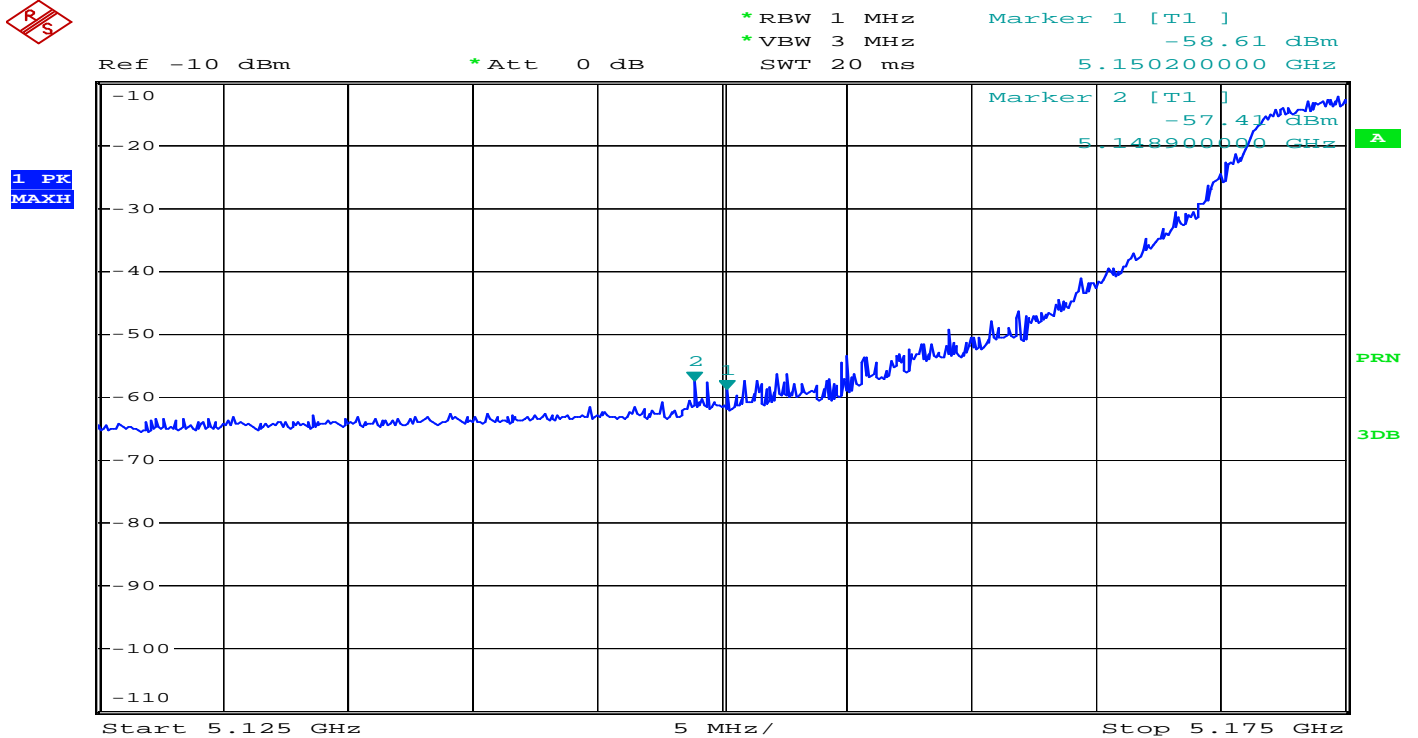

Comment : 14-00824_HOR(n,CH36-5180 MHz)
 Date : 27.SEP.2014 18:48:46



Estech Co., Ltd.

97-1, Hooeok-ri, Majang-myun, Ichion-city, Gyonggi-do, South Korea
 TEL : +82 31 6318037 FAX : +82 31 6318039 www.estech.co.kr

6.3-10 Test Result of Unwanted Emission

RF Radiated Measurement (Vertical) – Mode 1 : 802.11n

Channel No.	Frequency (MHz)	Reading (dBm)	Correction Factor		Measure Level (dBm/m)	Margin (dB)	Limit (dBm/m)	Result
			Ant Factor (dB)	Cable-Amp (dB)				
36 (Peak)	5148.70	-61.22	31.94	-23.2	-52.48	-25.48	-27.00	Pass
	5150.10	-61.00	31.94	-23.2	-52.26	-25.26	-27.00	Pass

Figure Channel 36 : Vertical (Peak)

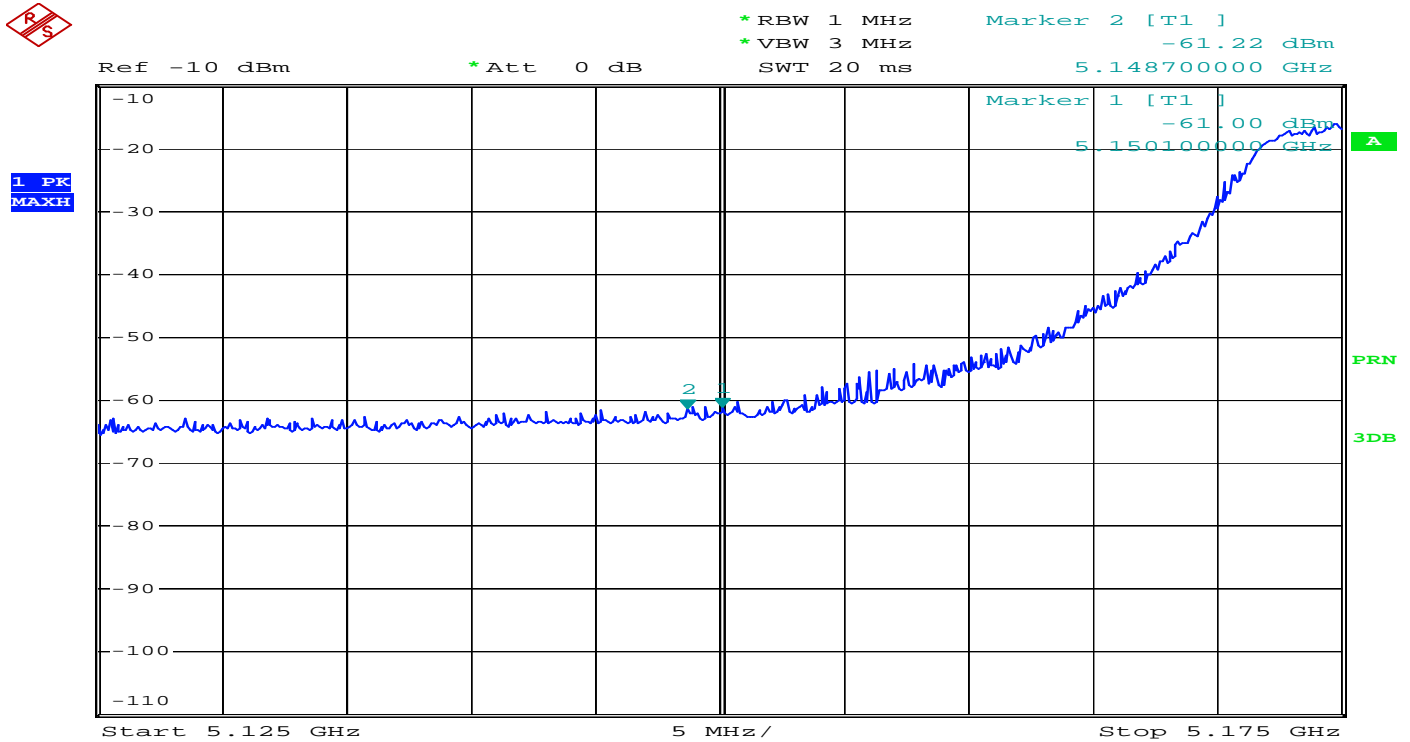

Comment : 14-00824_VER(n,CH36-5180 MHz)
 Date : 27.SEP.2014 18:45:58



Estech Co., Ltd.

97-1, Hooeok-ri, Majang-myun, Ichion-city, Gyonggi-do, South Korea
TEL : +82 31 6318037 FAX : +82 31 6318039 www.estech.co.kr

6.3-11 Test Result of Unwanted Emission

RF Radiated Measurement (Horizontal) – Mode 1 : 802.11n

Channel No.	Frequency (MHz)	Reading (dBm)	Correction Factor		Mesure Level (dBm/m)	Margin (dB)	Limit (dBm/m)	Result
			Ant Factor (dB)	Cable-Amp				
64 (Peak)	5354.70	-58.76	32.04	-22.9	-49.62	-22.62	-27.00	Pass
	5350.40	-57.97	32.04	-22.9	-48.83	-21.83	-27.00	Pass

Figure Channel 64 : Horizontal (Peak)

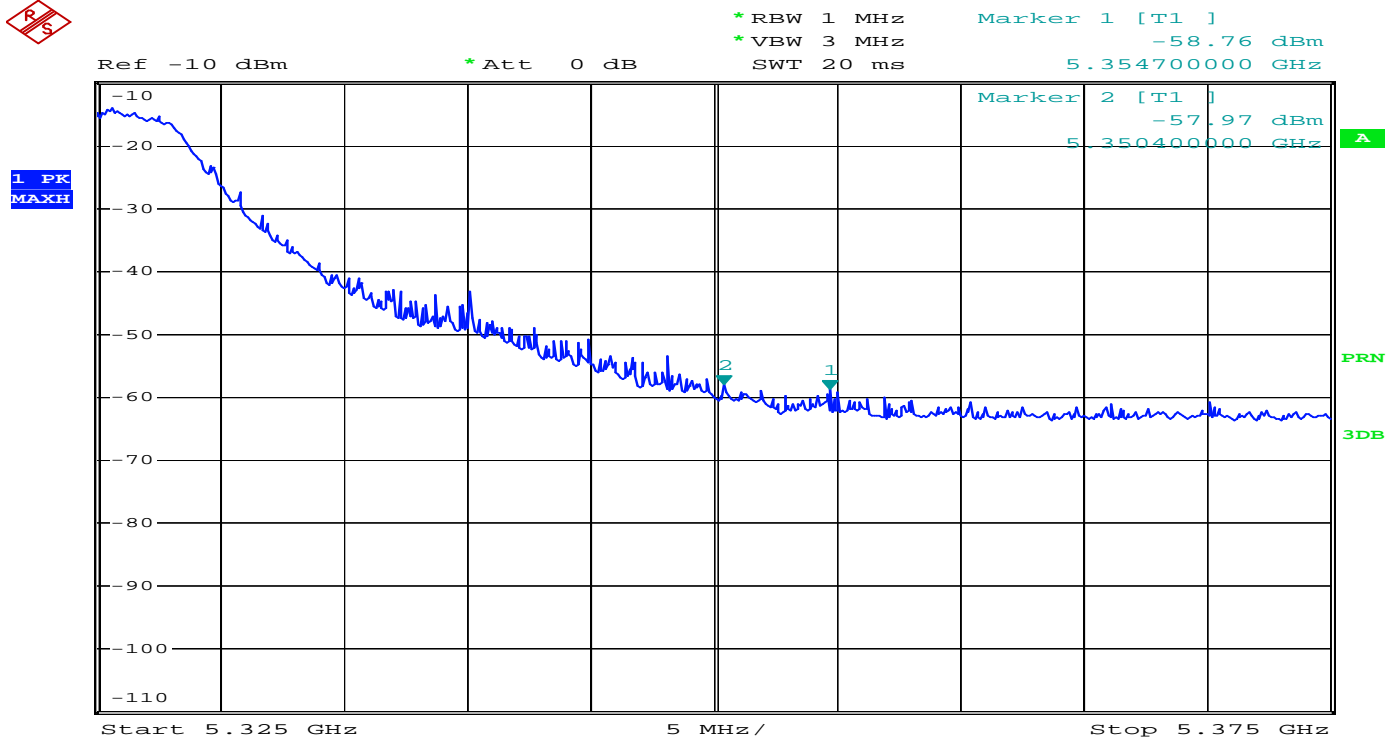

Comment : 14-00824_HOR(802.11n_CH64_5320MHz)_PK
Date : 27.SEP.2014 12:14:54



Estech Co., Ltd.

97-1, Hooeok-ri, Majang-myun, Ichion-city, Gyonggi-do, South Korea
 TEL : +82 31 6318037 FAX : +82 31 6318039 www.estech.co.kr

6.3-12 Test Result of Unwanted Emission

RF Radiated Measurement (Horizontal) – Mode 1 : 802.11n

Channel No.	Frequency (MHz)	Reading (dBm)	Correction Factor		Measure Level (dBm/m)	Margin (dB)	Limit (dBm/m)	Result
			Ant Factor (dB)	Cable-Amp (dB)				
64 (Peak)	5352.30	-58.25	32.04	-22.9	-62.26	-35.26	-27.00	Pass
	5350.10	-59.23	32.04	-22.9	-62.26	-35.26	-27.00	Pass

Figure Channel 64 :

Vertical (Peak)

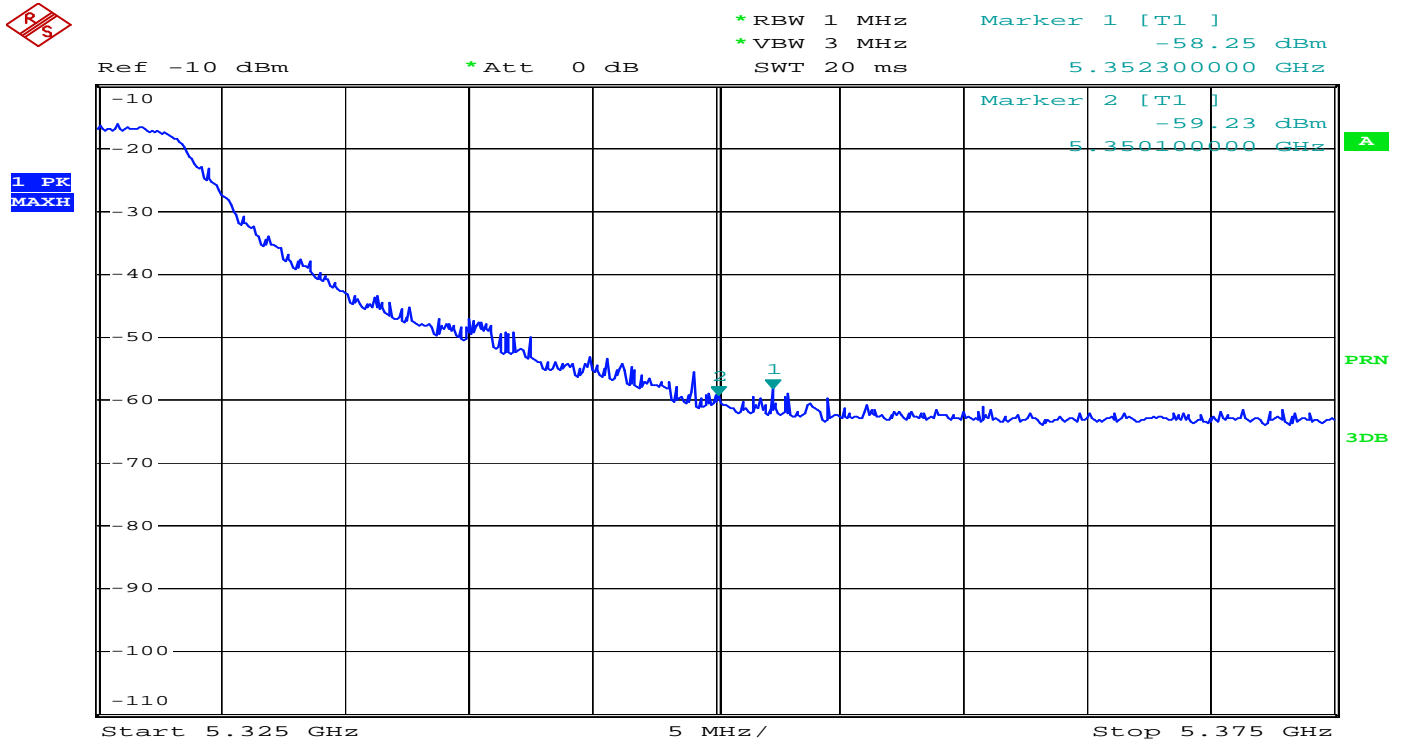

Comment : 14-00824_VER(802.11n_CH64_5320MHz)_PK
 Date : 27.SEP.2014 12:16:46



Estech Co., Ltd.

97-1, Hooeok-ri, Majang-myun, Ichion-city, Gyonggi-do, South Korea
TEL : +82 31 6318037 FAX : +82 31 6318039 www.estech.co.kr

6.3-13 Test Result of Unwanted Emission

RF Radiated Measurement (Horizontal) – Mode 1 : 802.11n

Channel No.	Frequency (MHz)	Reading (dBm)	Correction Factor		Measure Level (dBm/m)	Margin (dB)	Limit (dBm/m)	Result
			Ant Factor (dB)	Cable-Amp (dB)				
100 (Peak)	5469.50	-55.61	32.10	-22.9	-46.41	-19.41	-27.00	Pass
	5467.90	-58.86	32.10	-22.9	-49.66	-22.66	-27.00	Pass

Figure Channel 100 : Horizontal (Peak)

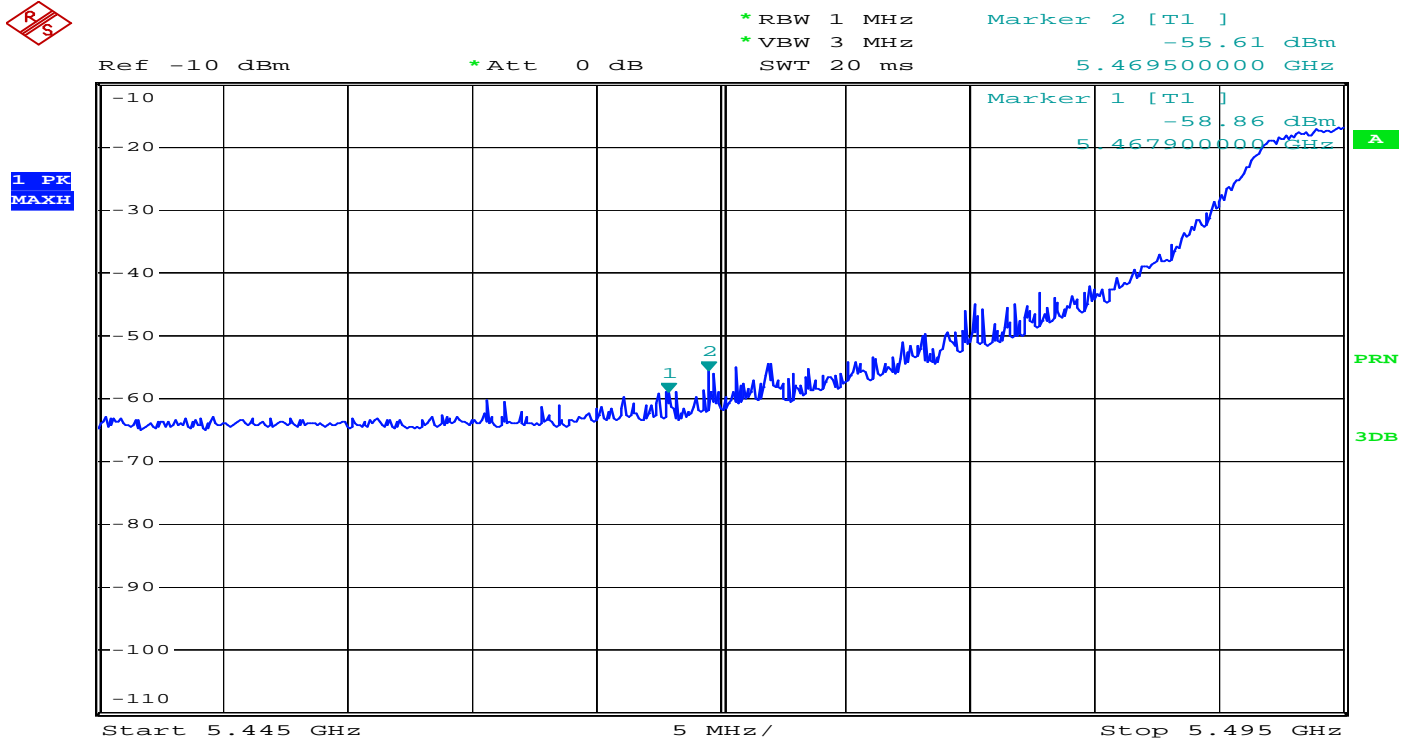

Comment: 14-00824_HOR(802.11n_CH100_5500MHz)_PK
Date: 27.SEP.2014 12:11:49



Estech Co., Ltd.

97-1, Hooeok-ri, Majang-myun, Ichion-city, Gyonggi-do, South Korea
TEL : +82 31 6318037 FAX : +82 31 6318039 www.estech.co.kr

6.3-14 Test Result of Unwanted Emission

RF Radiated Measurement (Vertical) – Mode 1 : 802.11n

Channel No.	Frequency (MHz)	Reading (dBm)	Correction Factor		Measure Level (dBm/m)	Margin (dB)	Limit (dBm/m)	Result
			Ant Factor (dB)	Cable-Amp (dB)				
100 (Peak)	5468.80	-57.59	32.10	-22.9	-48.39	-21.39	-27.00	Pass
	5469.90	-55.06	32.10	-22.9	-45.86	-18.86	-27.00	Pass

Figure Channel 100 :

Vertical (Peak)

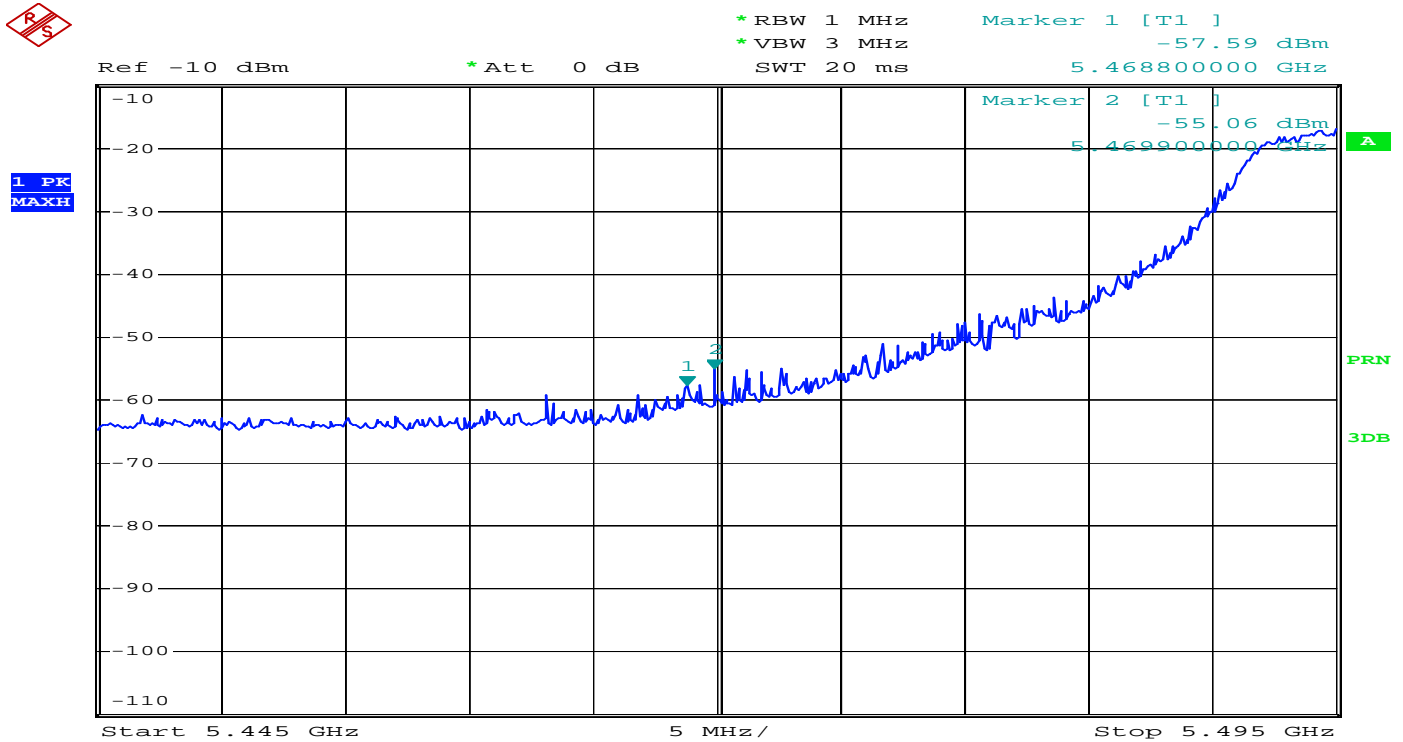

Comment : 14-00824_VER(802.11n_CH100_5500MHz)_PK
Date : 27.SEP.2014 12:10:18



Estech Co., Ltd.

97-1, Hooeok-ri, Majang-myun, Ichion-city, Gyonggi-do, South Korea
 TEL : +82 31 6318037 FAX : +82 31 6318039 www.estech.co.kr

6.3-15 Test Result of Unwanted Emission

RF Radiated Measurement (Horizontal) – Mode 1 : 802.11n

Channel No.	Frequency (MHz)	Reading (dBm)	Correction Factor		Mesure Level (dBm/m)	Margin (dB)	Limit (dBm/m)	Result
			Ant Factor (dB)	Cable-Amp (dB)				
140 (Peak)	5728.00	-57.97	32.24	-22.1	-47.83	-20.83	-27.00	Pass
	5725.50	-56.38	32.24	-22.1	-46.24	-19.24	-27.00	Pass

Figure Channel 140 : Horizontal (Peak)

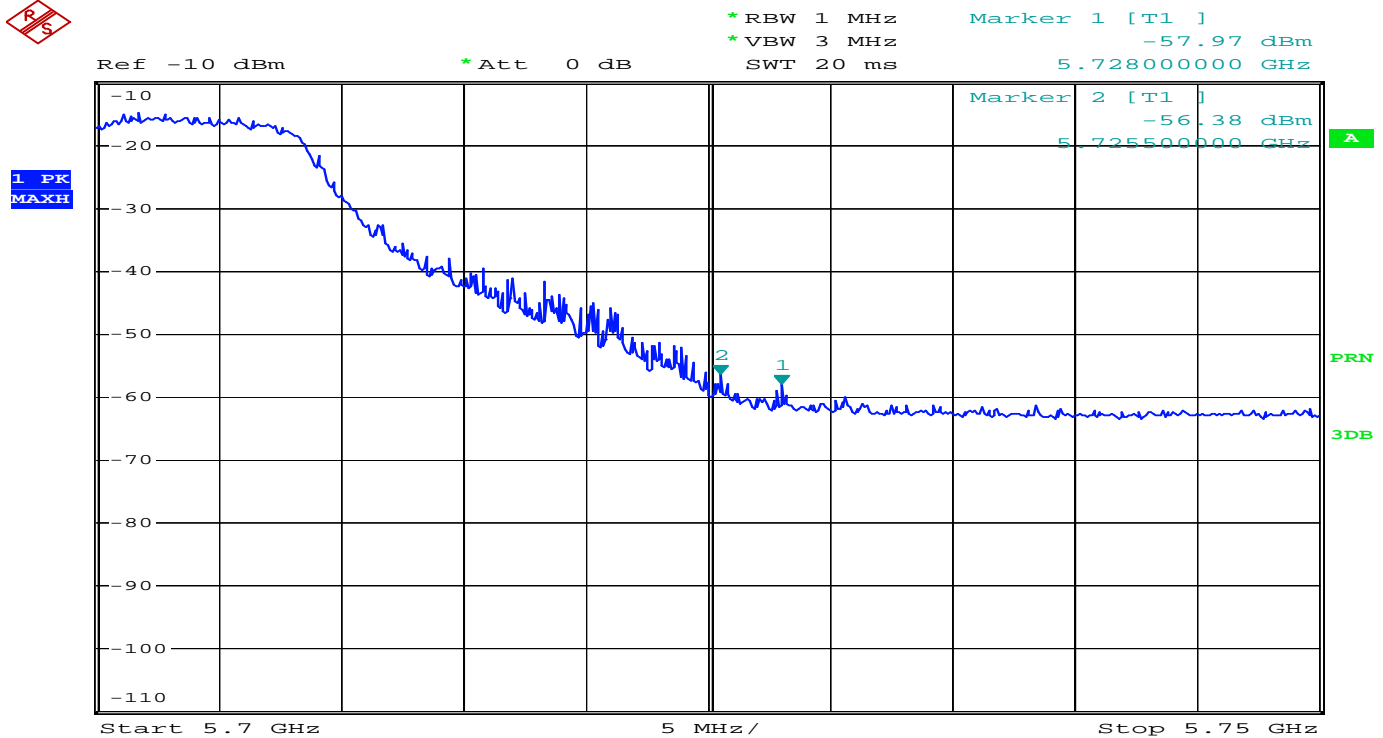

Comment : 14-00824_HOR(802.11n_CH140_5700MHz)_PK
 Date : 27.SEP.2014 12:04:26



Estech Co., Ltd.

97-1, Hooeok-ri, Majang-myun, Ichion-city, Gyonggi-do, South Korea
 TEL : +82 31 6318037 FAX : +82 31 6318039 www.estech.co.kr

6.3-16 Test Result of Unwanted Emission

RF Radiated Measurement (Vertical) – Mode 1 : 802.11n

Channel No.	Frequency (MHz)	Reading (dBm)	Correction Factor		Measure Level (dBm/m)	Margin (dB)	Limit (dBm/m)	Result
			Ant Factor (dB)	Cable-Amp (dB)				
140 (Peak)	5728.40	-59.46	32.04	-22.9	-50.32	-23.32	-27.00	Pass
	5724.90	-56.18	32.04	-22.9	-47.04	-20.04	-27.00	Pass

Figure Channel 140 :

Vertical(Peak)

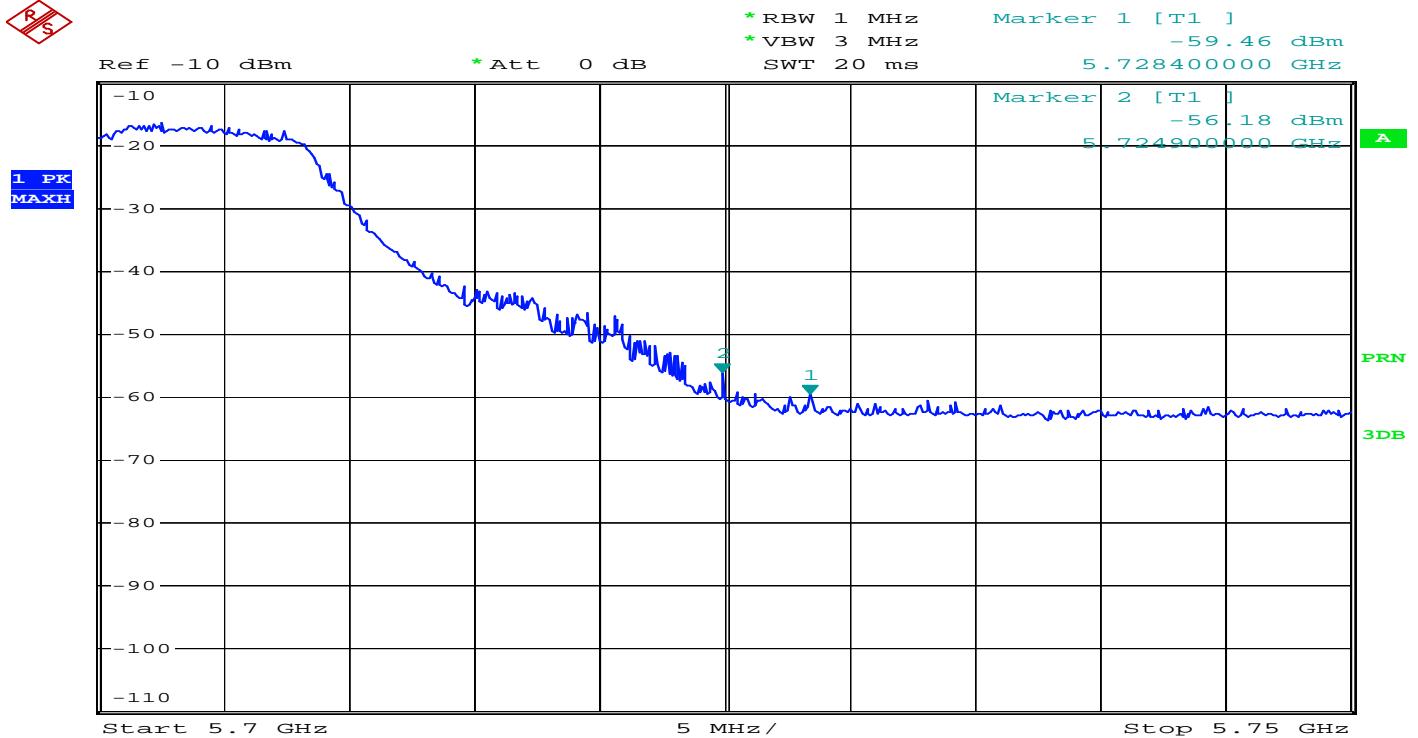

Comment : 14-00824_VER(802.11n_CH140_5700MHz)_PK
 Date : 27.SEP.2014 12:06:46



Estech Co., Ltd.

97-1, Hooeok-ri, Majang-myun, Ichion-city, Gyonggi-do, South Korea
TEL : +82 31 6318037 FAX : +82 31 6318039 www.estech.co.kr

7. Measurement of conducted disturbance

The continuous disturbance voltage of AC Mains in the frequency from 0.15 MHz to 30 MHz was measured in accordance to FCC PART 15.207 & IC RSS-Gen 7.2.2. The test setup was made according to ANSI C 63.4 (2009) in a shielded room. The EUT was placed on a non-conductive table at least 0.8 m above the ground plan. A grounded vertical reference plane was positioned in a distance of 0.4 m from the EUT. The distance from the EUT to other metal surfaces was at least 0.8 m. The EUT was only earthen by its power cord through the line impedance stabilizing network. The power cord has been bundled to a length of 1.0 m. The test receiver with Quasi Peak detector complies with CISPR 16.

7.1 Measurement equipments

Equipment Name	Type	Manufacturer	Serial No.	Next Calibration date
EMI TEST Receiver	ESPI	Rohde & Schwarz	100005	13-Jan-15
LISN	ENV216	Rohde & Schwarz	101231	24-Aug-14
LISN	ESH3-Z5	Rohde & Schwarz	836679/025	15-Jan-15
Pulse Limiter	ESH3Z2	Rohde & Schwarz	NONE	13-Jan-15

7.2 Environmental Condition

Test Place : Shielded Room

Wireless LAN 802.11a Mode (CH 40)

Temperature (°C) : 21.5 °C

Humidity (% R.H.) : 48.8 % R.H.

Wireless LAN 802.11a Mode (CH 60)

Temperature (°C) : 22.5 °C

Humidity (% R.H.) : 44.9 % R.H.

Wireless LAN 802.11a Mode (CH 116)

Temperature (°C) : 22.5 °C

Humidity (% R.H.) : 46.8 % R.H.

Wireless LAN 802.11n Mode (CH 40)

Temperature (°C) : 21.8 °C

Humidity (% R.H.) : 51.1 % R.H.

Wireless LAN 802.11n Mode (CH 60)

Temperature (°C) : 22.0 °C

Humidity (% R.H.) : 53.2 % R.H.

Wireless LAN 802.11n Mode (CH 116)

Temperature (°C) : 21.4 °C

Humidity (% R.H.) : 51.9 % R.H.



Estech Co., Ltd.

97-1, Hooeok-ri, Majang-myun, Ichion-city, Gyonggi-do, South Korea

TEL : +82 31 6318037 FAX : +82 31 6318039 www.estech.co.kr

7.3 Test Data for wireless LAN (802.11a) – ch 40

Test Date : 14-Jul-14

Frequency (MHz)	Correction Factor		Line (H/N)	Quasi-peak Value			Average Value		
	Lisn (dB)	Cable (dB)		Limit (dB μ V)	Reading (dB μ V)	Result (dB μ V)	Limit (dB μ V)	Reading (dB μ V)	Result (dB)
0.20	0.15	0.19	N	63.61	46.59	46.93	53.61		
0.29	0.15	0.20	N	60.52	41.31	41.66	50.52		
0.31	0.15	0.20	H	59.97	50.31	40.35	49.97		
0.39	0.16	0.20	H	58.06	49.98	37.13	48.06		
0.39	0.16	0.20	N	58.06	46.93	37.66	48.06		
0.52	0.16	0.21	H	56.00	46.65	38.16	46.00		
Remark	TEST MODE : 802.11a – CH 40(5200 MHz) H : Hot Line, N : Neutral Line *Correction Factor = Lisn + Cable *Result = Correction Factor + Reading								



Estech Co., Ltd.

97-1, Hooeok-ri, Majang-myun, Ichion-city, Gyonggi-do, South Korea

TEL : +82 31 6318037 FAX : +82 31 6318039 www.estech.co.kr

7.3 Test Data for wireless LAN (802.11a) – ch 60

Test Date : 14-Jul-14

Frequency (MHz)	Correction Factor		Line (H/N)	Quasi-peak Value			Average Value		
	Lisn (dB)	Cable (dB)		Limit (dB μ V)	Reading (dB μ V)	Result (dB μ V)	Limit (dB μ V)	Reading (dB μ V)	Result (dB)
0.19	0.15	0.19	N	64.04	46.09	46.43	54.04		
0.21	0.15	0.19	H	63.21	44.18	44.52	53.21		
0.29	0.15	0.20	H	60.52	40.14	40.49	50.52		
0.31	0.15	0.20	N	59.97	40.22	40.57	49.97		
0.40	0.16	0.20	N	57.85	46.11	36.64	47.85		
0.51	0.16	0.21	H	56.00	45.97	36.96	46.00		
Remark	TEST MODE : 802.11a – CH 60(5300 MHz) H : Hot Line, N : Neutral Line *Correction Factor = Lisn + Cable *Result = Correction Factor + Reading								



Estech Co., Ltd.

97-1, Hooeok-ri, Majang-myun, Ichion-city, Gyonggi-do, South Korea

TEL : +82 31 6318037 FAX : +82 31 6318039 www.estech.co.kr

7.3 Test Data for wireless LAN (802.11a) – ch 116

Test Date : 14-Jul-14

Frequency (MHz)	Correction Factor		Line (H/N)	Quasi-peak Value			Average Value		
	Lisn (dB)	Cable (dB)		Limit (dB μ V)	Reading (dB μ V)	Result (dB μ V)	Limit (dB μ V)	Reading (dB μ V)	Result (dB)
0.18	0.13	0.17	H	64.49	46.63	46.93	54.49		
0.19	0.15	0.19	N	64.04	47.76	48.10	54.04		
0.28	0.15	0.20	H	60.82	40.42	40.77	50.82		
0.28	0.15	0.20	N	60.82	42.13	42.48	50.82		
0.37	0.16	0.20	H	58.50	39.01	39.37	48.50		
0.55	0.16	0.21	H	56.00	36.87	37.24	46.00		
Remark	TEST MODE : 802.11a – CH 116(5580 MHz) H : Hot Line, N : Neutral Line *Correction Factor = Lisn + Cable *Result = Correction Factor + Reading								



Estech Co., Ltd.

97-1, Hooeok-ri, Majang-myun, Ichion-city, Gyonggi-do, South Korea
 TEL : +82 31 6318037 FAX : +82 31 6318039 www.estech.co.kr

7.3 Test Data for wireless LAN (802.11n) – ch 40

Test Date : 15-Jul-14

Frequency (MHz)	Correction Factor		Line (H/N)	Quasi-peak Value			Average Value		
	Lisn (dB)	Cable (dB)		Limit (dB μ V)	Reading (dB μ V)	Result (dB μ V)	Limit (dB μ V)	Reading (dB μ V)	Result (dB)
0.15	0.15	0.19	H	66.00	42.59	42.93	56.00		
0.18	0.15	0.19	N	64.49	39.41	39.75	54.49		
0.21	0.15	0.19	H	63.21	43.32	43.66	53.21		
0.28	0.15	0.20	H	60.82	39.04	39.39	50.82		
0.36	0.16	0.20	H	58.73	37.65	38.01	48.73		
0.54	0.16	0.21	N	56.00	37.46	37.83	46.00		
Remark	TEST MODE : 802.11n – CH 40(5200 MHz) H : Hot Line, N : Neutral Line *Correction Factor = Lisn + Cable *Result = Correction Factor + Reading								



Estech Co., Ltd.

97-1, Hooeok-ri, Majang-myun, Ichion-city, Gyonggi-do, South Korea
 TEL : +82 31 6318037 FAX : +82 31 6318039 www.estech.co.kr

7.3 Test Data for wireless LAN (802.11n) – ch 60

Test Date : 15-Jul-14

Frequency (MHz)	Correction Factor		Line (H/N)	Quasi-peak Value			Average Value		
	Lisn (dB)	Cable (dB)		Limit (dB μ V)	Reading (dB μ V)	Result (dB μ V)	Limit (dB μ V)	Reading (dB μ V)	Result (dB)
0.18	0.13	0.17	H	64.49	35.25	35.55	54.49		
0.18	0.15	0.19	N	64.49	52.07	52.41	54.49	37.32	37.66
0.28	0.15	0.20	N	60.82	39.97	40.32	50.82		
0.52	0.16	0.21	H	56.00	34.13	34.50	46.00		
0.65	0.17	0.21	N	56.00	36.70	37.08	46.00		
13.71	0.73	0.46	H	60.00	33.23	34.41	50.00		
Remark	TEST MODE : 802.11a – CH 60(5300 MHz) H : Hot Line, N : Neutral Line *Correction Factor = Lisn + Cable *Result = Correction Factor + Reading								



Estech Co., Ltd.

97-1, Hooeok-ri, Majang-myun, Ichion-city, Gyonggi-do, South Korea
 TEL : +82 31 6318037 FAX : +82 31 6318039 www.estech.co.kr

7.3 Test Data for wireless LAN (802.11n) – ch 116

Test Date : 15-Jul-14

Frequency (MHz)	Correction Factor		Line (H/N)	Quasi-peak Value			Average Value		
	Lisn (dB)	Cable (dB)		Limit (dB μ V)	Reading (dB μ V)	Result (dB μ V)	Limit (dB μ V)	Reading (dB μ V)	Result (dB)
0.16	0.15	0.19	H	65.46	53.11	53.45	55.46	39.17	39.51
0.16	0.15	0.19	N	65.46	56.16	56.50	55.46	38.87	39.21
0.23	0.15	0.19	N	62.45	41.57	41.91	52.45		
0.24	0.15	0.19	H	62.10	43.67	44.01	52.10		
0.31	0.15	0.20	N	59.97	43.96	44.31	49.97		
0.32	0.15	0.20	H	59.71	41.79	42.14	49.71		
Remark	TEST MODE : 802.11a – CH 116(5580 MHz) H : Hot Line, N : Neutral Line *Correction Factor = Lisn + Cable *Result = Correction Factor + Reading								



Estech Co., Ltd.

97-1, Hooeok-ri, Majang-myun, Ichion-city, Gyonggi-do, South Korea
TEL : +82 31 6318037 FAX : +82 31 6318039 www.estech.co.kr

8. On Time, Duty Cycle and Measurement Methods

8.1 Test procedure

KDB 789033 v01r04- Section B Duty Cycle (x), Transmission Duration (T), and Maximum Power Control Level

8.2 Test instruments and measurement setup

The spectrum analyzer is set to as following.

- . RBW= 8 MHz
- . VBW= 50 MHz
- . Span= Zero

6dB Bandwidth Test Instruments

Description	Model	Serial Number	Cal. Due Date
Spectrum Analyzer	E4440A	US42041281	2015-01-27

8.3 Measurement results

EUT	Mobile Computer	MODEL	PM60
MODE	OFDM	ENVIRONMENTAL CONDITION	24 °C, 44 % R.H.
INPUT POWER	120 Va.c., 60 Hz		

(802.11a)

Mode	On Time B (msec)	Period (msec)	Duty Cycle (linear)	Duty Cycle (%)	Duty Cycle Correction Factor (dBm)	Minimum VBW (KHz)
802.11a	2.43	1.41	0.58	58.22	2.35	0.41
802.11n	2.29	1.33	0.58	57.99	2.37	0.44



Estech Co., Ltd.

97-1, Hooeok-ri, Majang-myun, Ichion-city, Gyonggi-do, South Korea

TEL : +82 31 6318037 FAX : +82 31 6318039 www.estech.co.kr

8.4 Trace data

OFDM (802.11a-36ch)

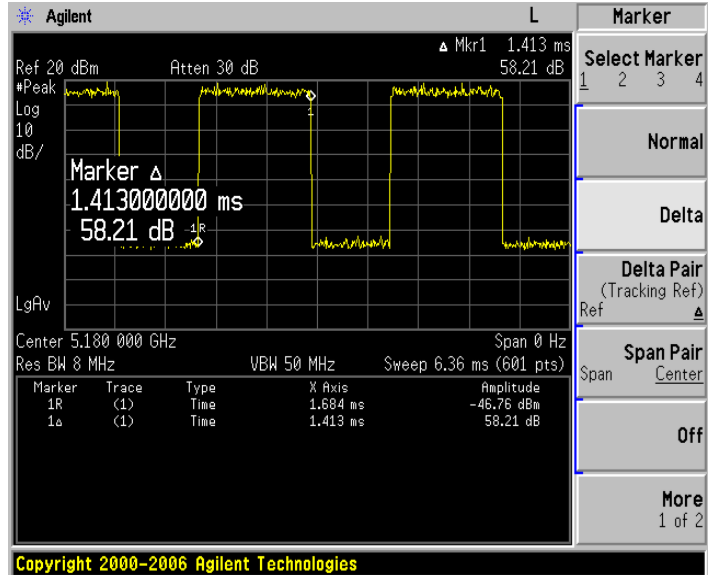
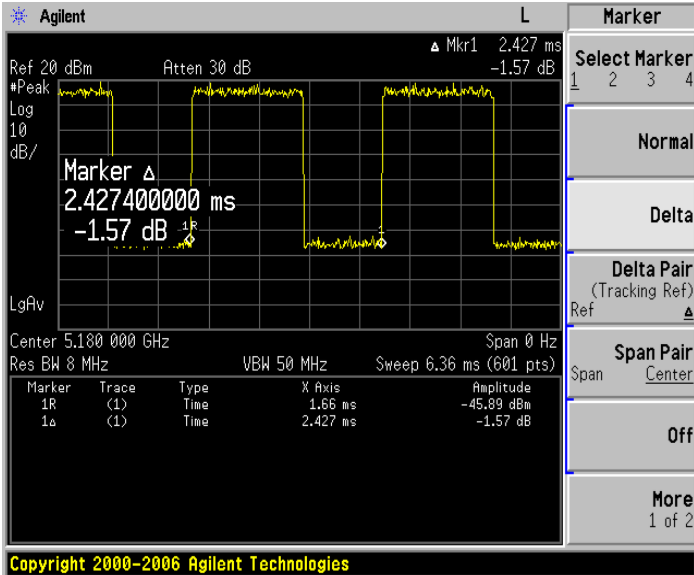

OFDM (802.11n-36ch)

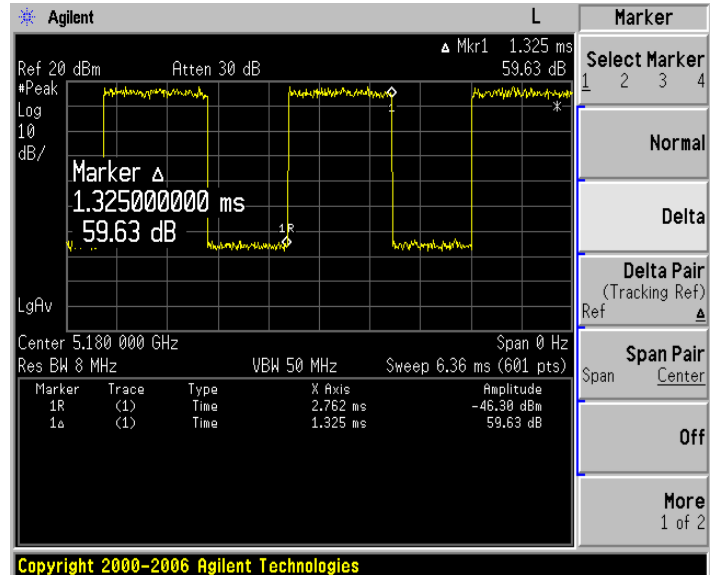
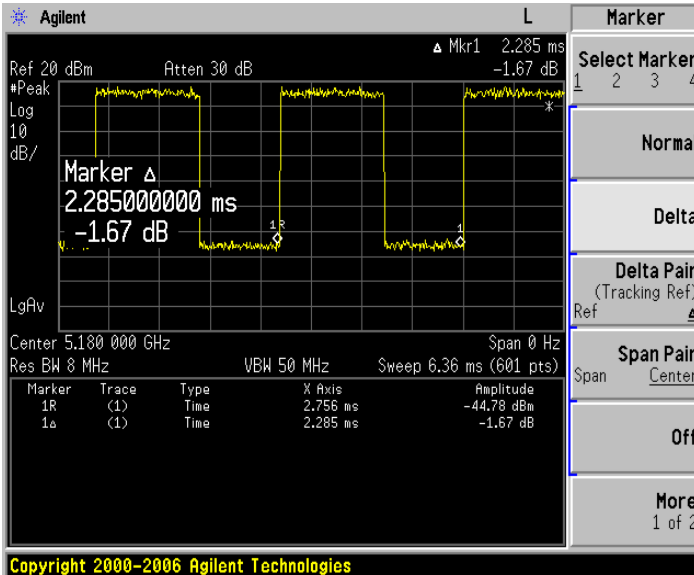



Estech Co., Ltd.

97-1, Hooeok-ri, Majang-myun, Ichion-city, Gyonggi-do, South Korea
TEL : +82 31 6318037 FAX : +82 31 6318039 www.estech.co.kr

9. Emission bandwidth and 99% Occupied Bandwidth

9.1 Test procedure

KDB 789033 v01r04- Section C and D Emission bandwidth and 99 Percent Occupied Bandwidth

9.2 Test instruments and measurement setup

The spectrum analyzer is set to as following.

- 1) Set RBW = approximately 1% of the emission bandwidth.
- 2) Set the VBW > RBW.
- 3) Detector = Peak
- 4) Trace mode = max hold.
- 5) Measure the maximum width of the emission that is 26 dB down from the peak of the emission. Compare this with the RBW setting of the analyzer. Readjust RBW and repeat measurement as needed until the RBW/EBW ratio is approximately 1%.

The following procedure shall be used for measuring (99 %) power bandwidth.

- 1) Set center frequency to the nominal EUT channel center frequency.
- 2) Set span = 1.5 times to 5.0 times the OBW.
- 3) Set RBW = 1 % to 5 % of the OBW
- 4) Set VBW $\geq 3 \cdot$ RBW
- 5) Video averaging is not permitted. Where practical, a sample detection and single sweep mode shall be used. Otherwise, peak detection and max hold mode (until the trace stabilizes) shall be used.
- 6) Use the 99 % power bandwidth function of the instrument (if available).
- 7) If the instrument does not have a 99 % power bandwidth function, the trace data points are recovered and directly summed in power units. The recovered amplitude data points, beginning at the lowest frequency, are placed in a running sum until 0.5 % of the total is reached; that frequency is recorded as the lower frequency. The process is repeated until 99.5 % of the total is reached; that frequency is recorded as the upper frequency. The 99% occupied bandwidth is the difference between these two frequencies.

. Sweep= suitable duration based on the EUT specification.

Description	Model	Serial Number	Cal. Due Date
Spectrum Analyzer	E4440A	US42041281	2015-01-27



Estech Co., Ltd.

97-1, Hooeok-ri, Majang-myun, Ichion-city, Gyonggi-do, South Korea
TEL : +82 31 6318037 FAX : +82 31 6318039 www.estech.co.kr

9.3 Measurement results

EUT	Mobile Computer	MODEL	PM60
MODE	OFDM	ENVIRONMENTAL CONDITION	24 °C, 44 % R.H.
INPUT POWER	120 Va.c., 60 Hz		

(802.11a)

Channel Frequency (MHz)	99% bandwidth	Bandwidth at 26dB below(MHz)
5180	16.50	20.95
5200	16.43	22.88
5240	16.49	21.43

(802.11a)

Channel Frequency (MHz)	99% bandwidth	Bandwidth at 26dB below(MHz)
5260	16.52	20.97
5300	16.47	21.61
5320	16.53	22.14

(802.11a)

Channel Frequency (MHz)	99% bandwidth	Bandwidth at 26dB below(MHz)
5500	16.53	22.07
5580	16.50	21.55
5700	16.51	21.51

(802.11n)

Channel Frequency (MHz)	99% bandwidth	Bandwidth at 26dB below(MHz)
5180	17.69	22.46
5200	17.59	22.00
5240	17.65	23.23



Estech Co., Ltd.

97-1, Hooeok-ri, Majang-myun, Ichion-city, Gyonggi-do, South Korea
TEL : +82 31 6318037 FAX : +82 31 6318039 www.estech.co.kr

EUT	Mobile Computer	MODEL	PM60
MODE	OFDM	ENVIRONMENTAL CONDITION	24 °C, 44 % R.H.
INPUT POWER	120 Va.c., 60 Hz		

(802.11n)

Channel Frequency (MHz)	99% bandwidth	Bandwidth at 26dB below(MHz)
5260	17.61	22.19
5300	17.66	22.58
5320	16.50	21.49

(802.11n)

Channel Frequency (MHz)	99% bandwidth	Bandwidth at 26dB below(MHz)
5500	17.69	23.03
5580	17.66	23.08
5700	17.71	22.00



Estech Co., Ltd.

97-1, Hooeok-ri, Majang-myun, Ichion-city, Gyonggi-do, South Korea

TEL : +82 31 6318037 FAX : +82 31 6318039 www.estech.co.kr

9.4 Trace data

OFDM (802.11a-36ch)

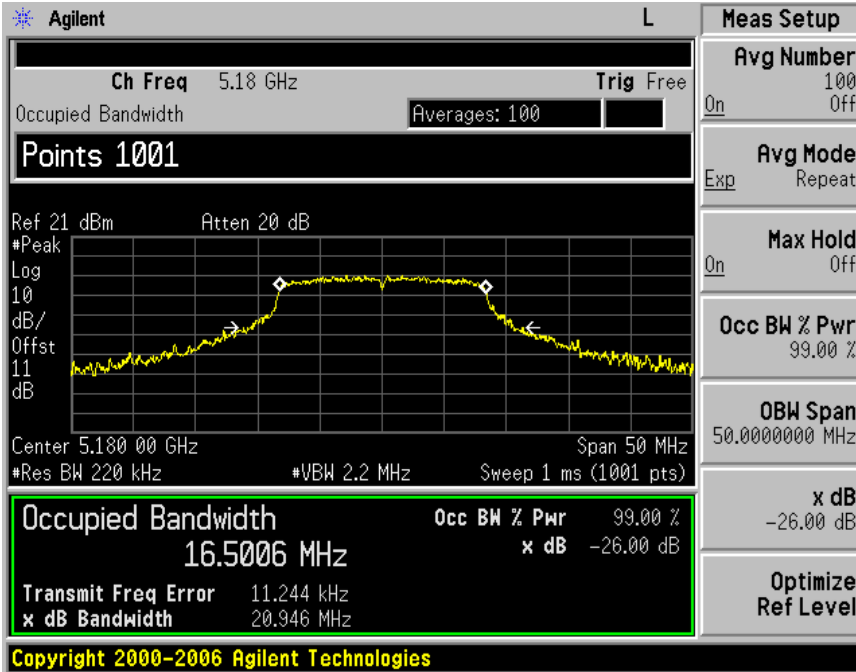

OFDM (802.11a-40ch)

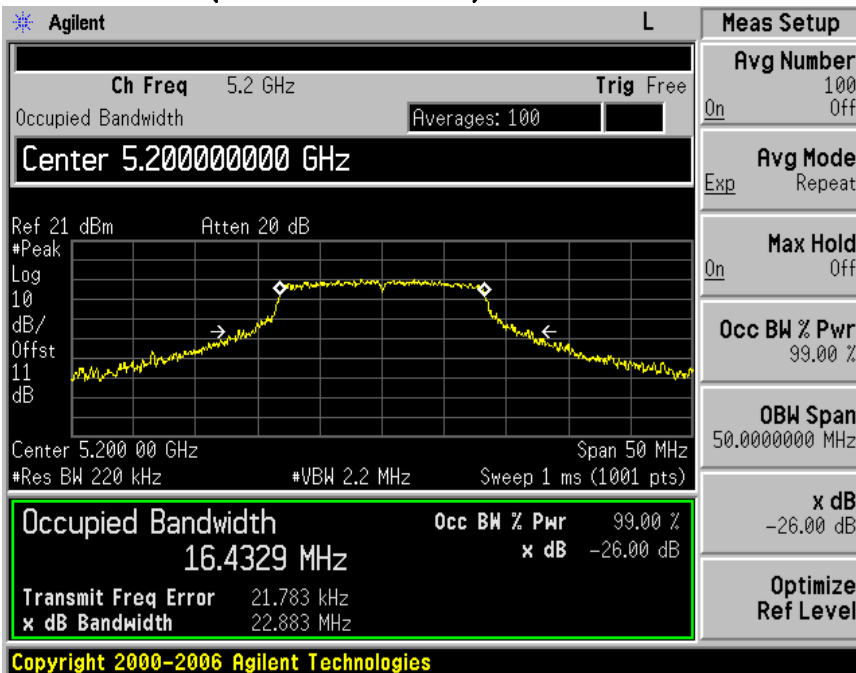



Estech Co., Ltd.

97-1, Hooeok-ri, Majang-myun, Ichion-city, Gyonggi-do, South Korea
TEL : +82 31 6318037 FAX : +82 31 6318039 www.estech.co.kr

OFDM (802.11a-48ch)





Estech Co., Ltd.

97-1, Hooeok-ri, Majang-myun, Ichion-city, Gyonggi-do, South Korea

TEL : +82 31 6318037 FAX : +82 31 6318039 www.estech.co.kr

OFDM (802.11a-52ch)

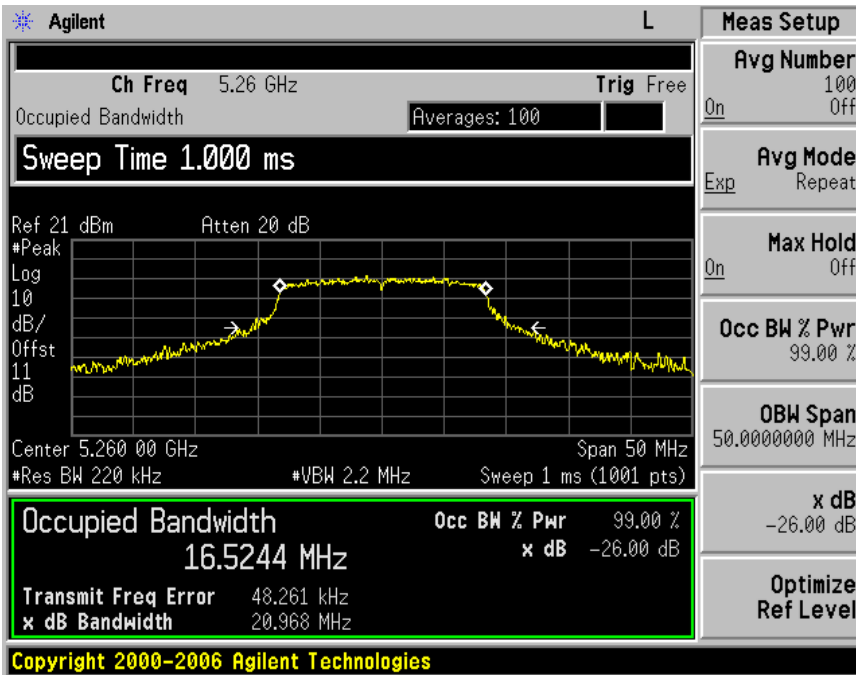

OFDM (802.11a-60ch)

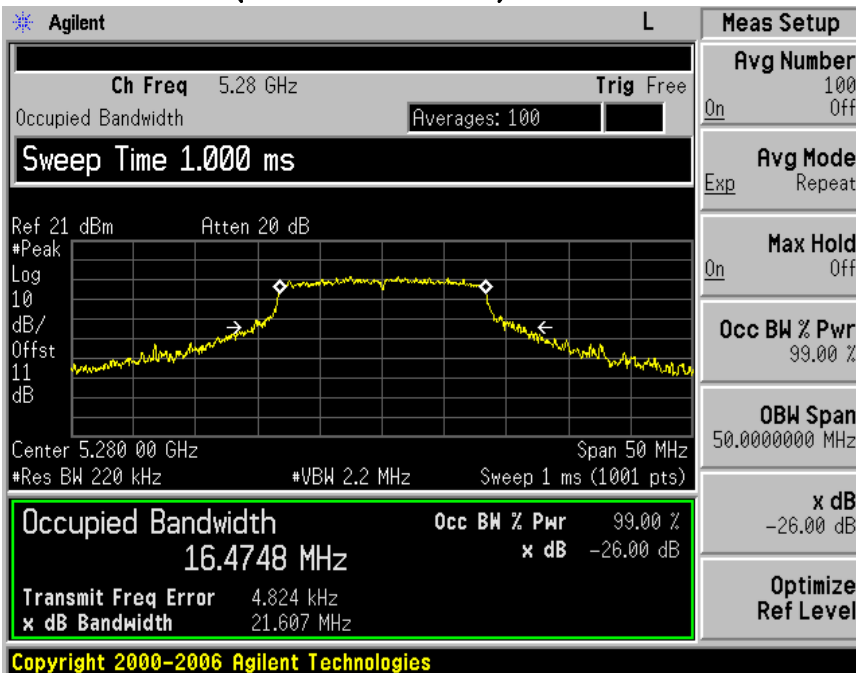



Estech Co., Ltd.

97-1, Hooeok-ri, Majang-myun, Ichion-city, Gyonggi-do, South Korea
TEL : +82 31 6318037 FAX : +82 31 6318039 www.estech.co.kr

OFDM (802.11a-64ch)

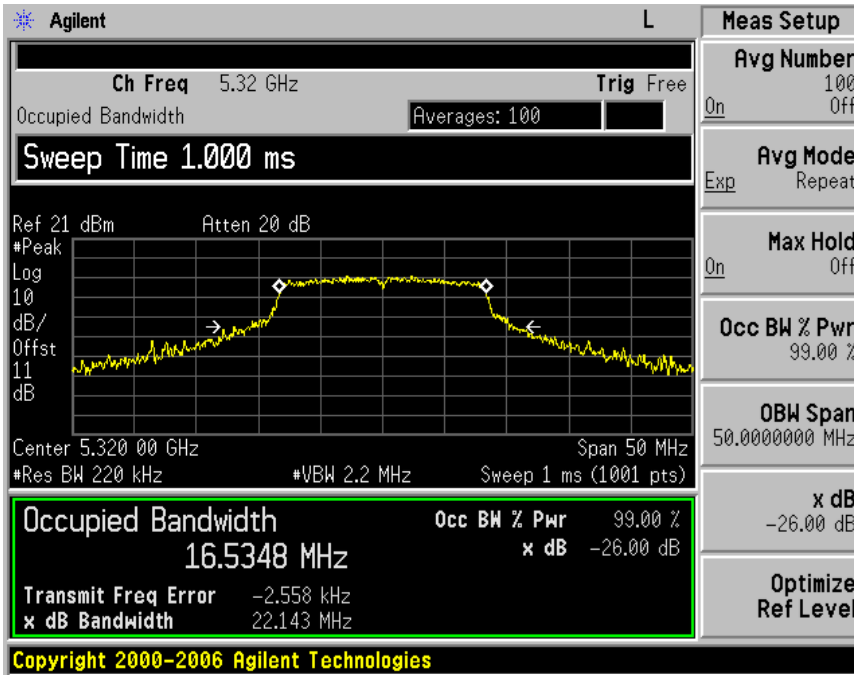



Estech Co., Ltd.

97-1, Hooeok-ri, Majang-myun, Ichion-city, Gyonggi-do, South Korea

TEL : +82 31 6318037 FAX : +82 31 6318039 www.estech.co.kr

OFDM (802.11a-100ch)

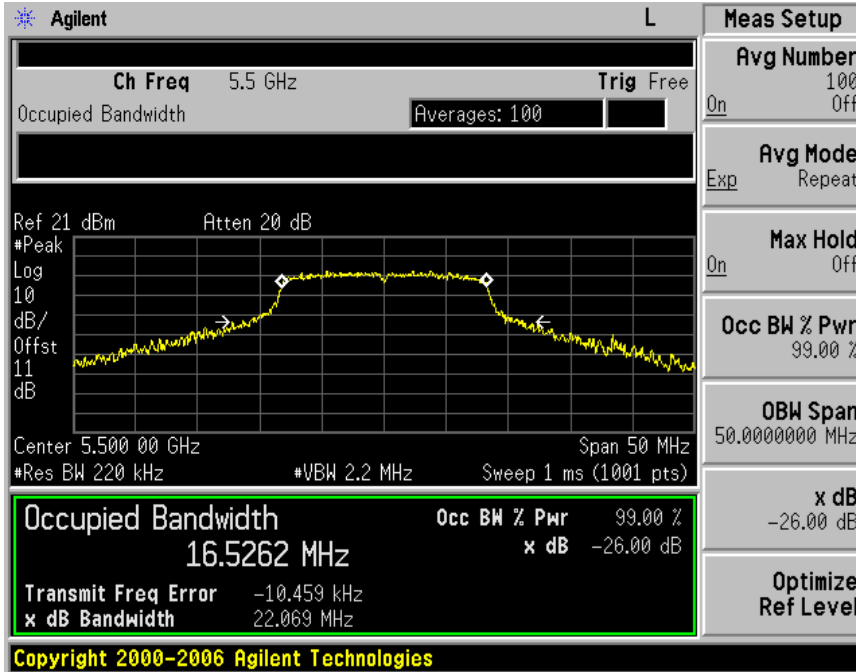

OFDM (802.11a-116ch)

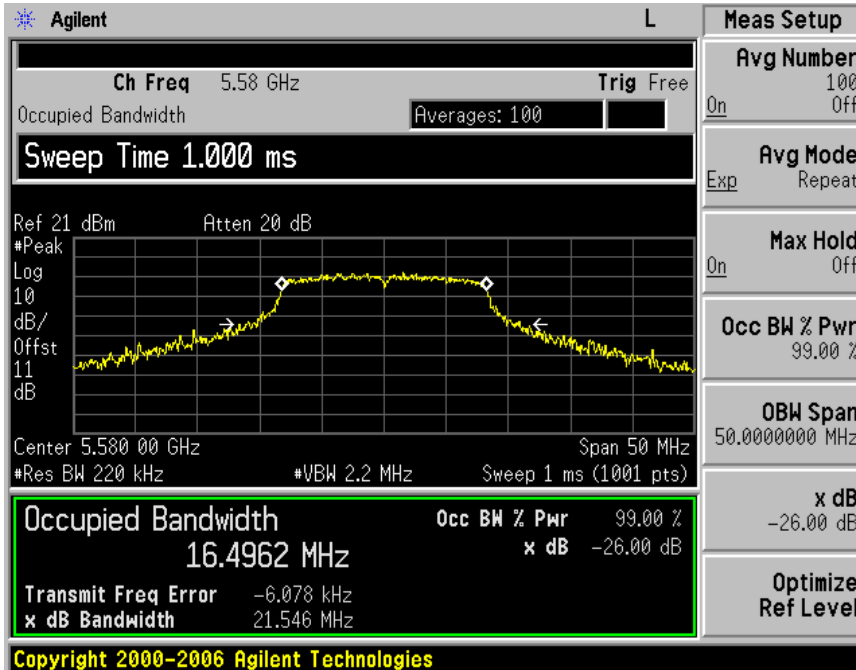



Estech Co., Ltd.

97-1, Hooeok-ri, Majang-myun, Ichion-city, Gyonggi-do, South Korea
TEL : +82 31 6318037 FAX : +82 31 6318039 www.estech.co.kr

OFDM (802.11a-140ch)

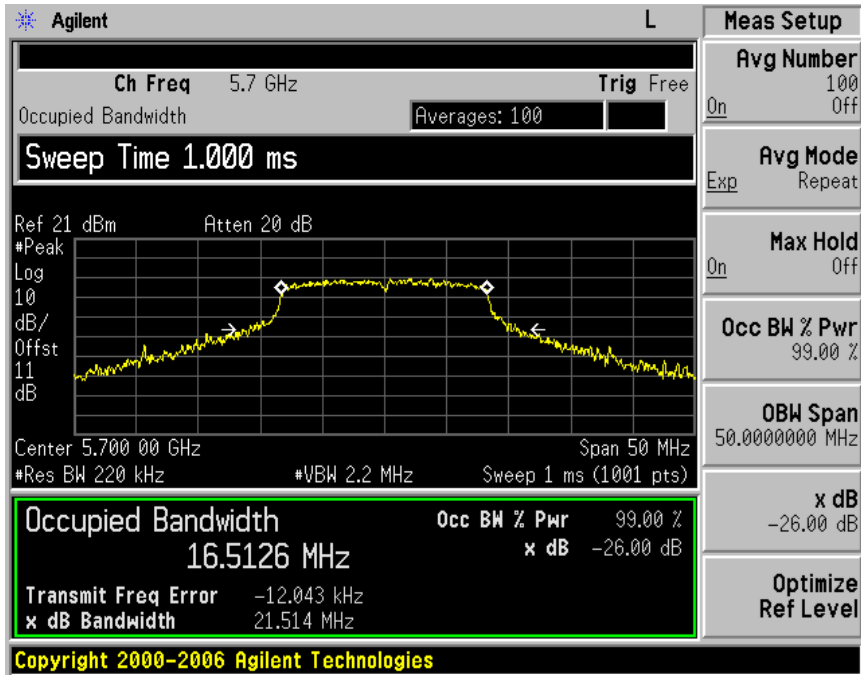



Estech Co., Ltd.

97-1, Hooeok-ri, Majang-myun, Ichion-city, Gyonggi-do, South Korea

TEL : +82 31 6318037 FAX : +82 31 6318039 www.estech.co.kr

OFDM (802.11n-36ch)

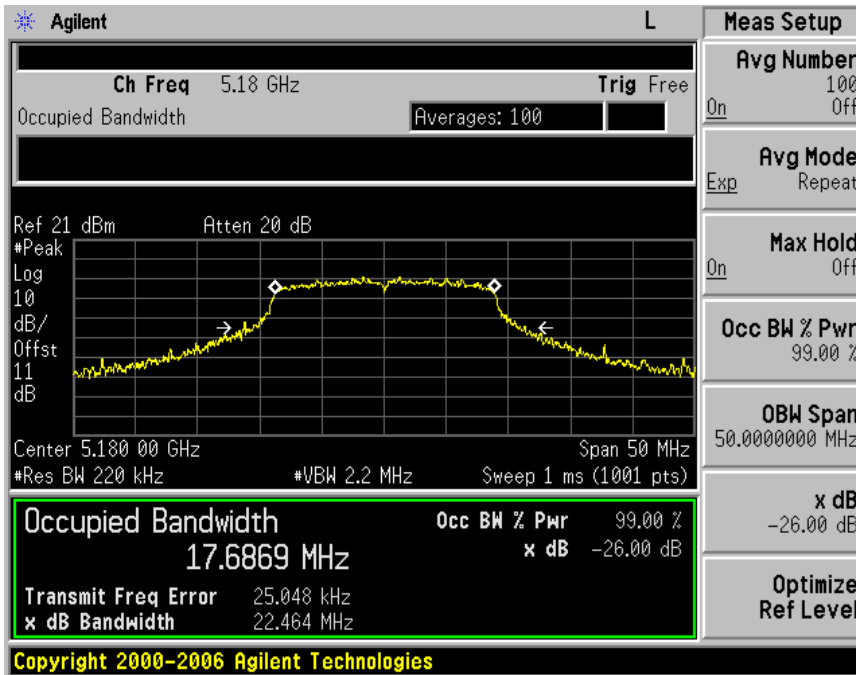

OFDM (802.11n-40ch)

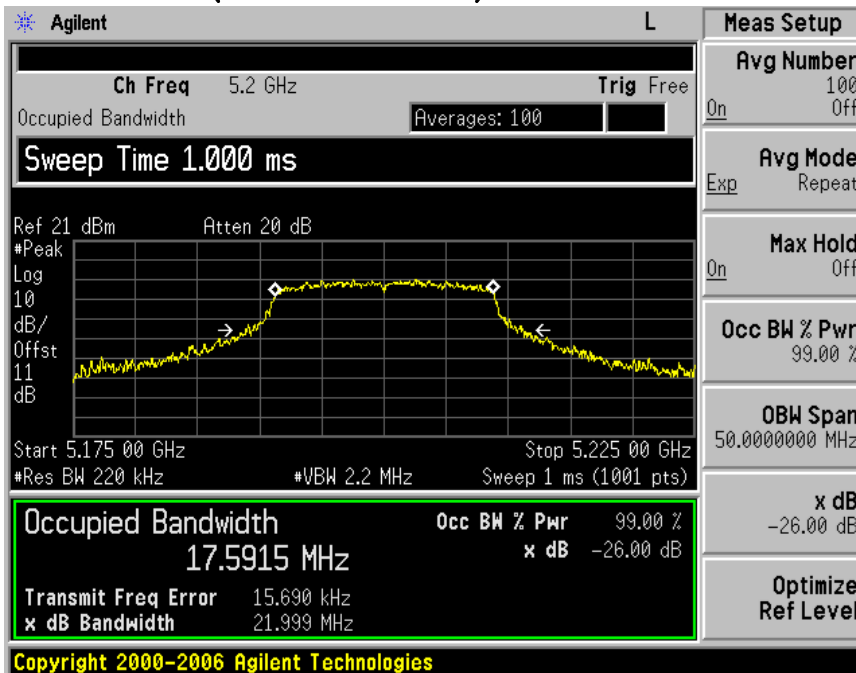



Estech Co., Ltd.

97-1, Hooeok-ri, Majang-myun, Ichion-city, Gyonggi-do, South Korea
TEL : +82 31 6318037 FAX : +82 31 6318039 www.estech.co.kr

OFDM (802.11n-48ch)

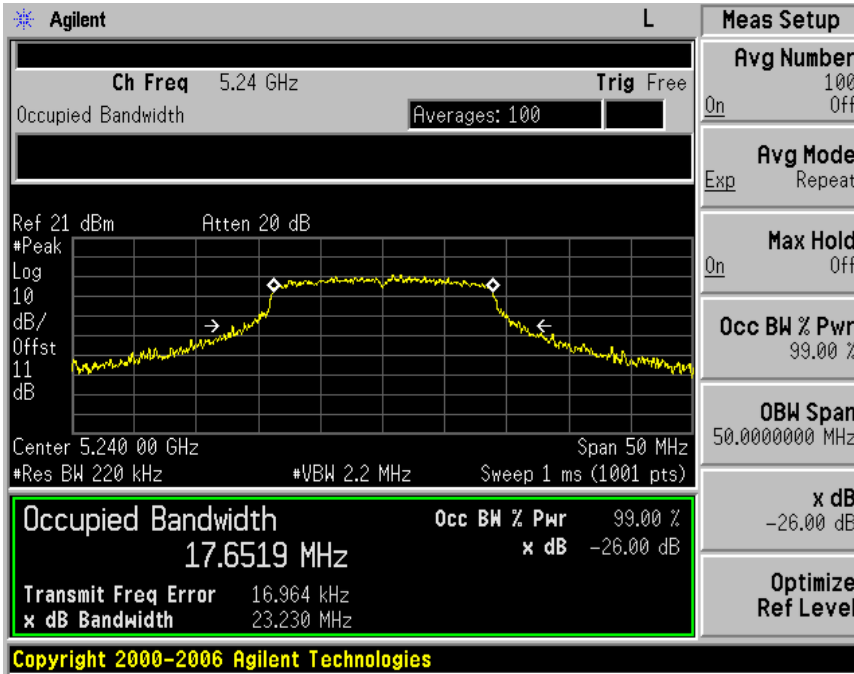



Estech Co., Ltd.

97-1, Hooeok-ri, Majang-myun, Ichion-city, Gyonggi-do, South Korea

TEL : +82 31 6318037 FAX : +82 31 6318039 www.estech.co.kr

OFDM (802.11n-52ch)

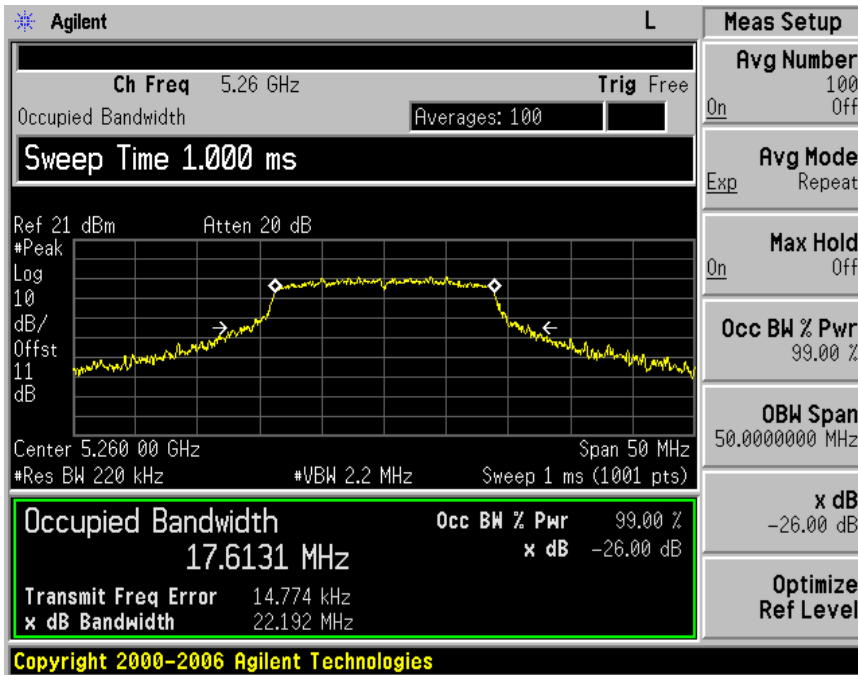

OFDM (802.11n-60ch)

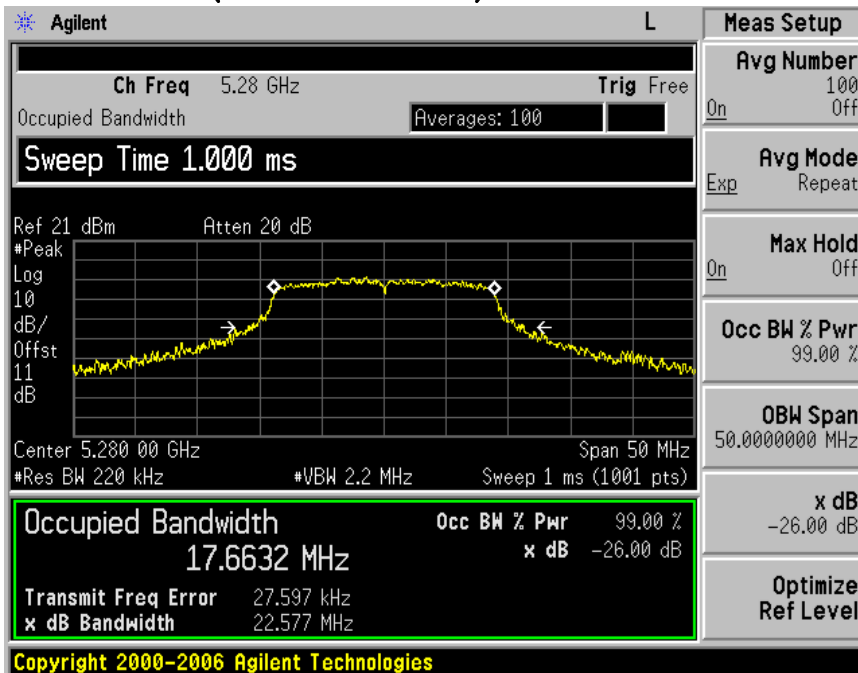



Estech Co., Ltd.

97-1, Hooeok-ri, Majang-myun, Ichion-city, Gyonggi-do, South Korea
TEL : +82 31 6318037 FAX : +82 31 6318039 www.estech.co.kr

OFDM (802.11n-64ch)

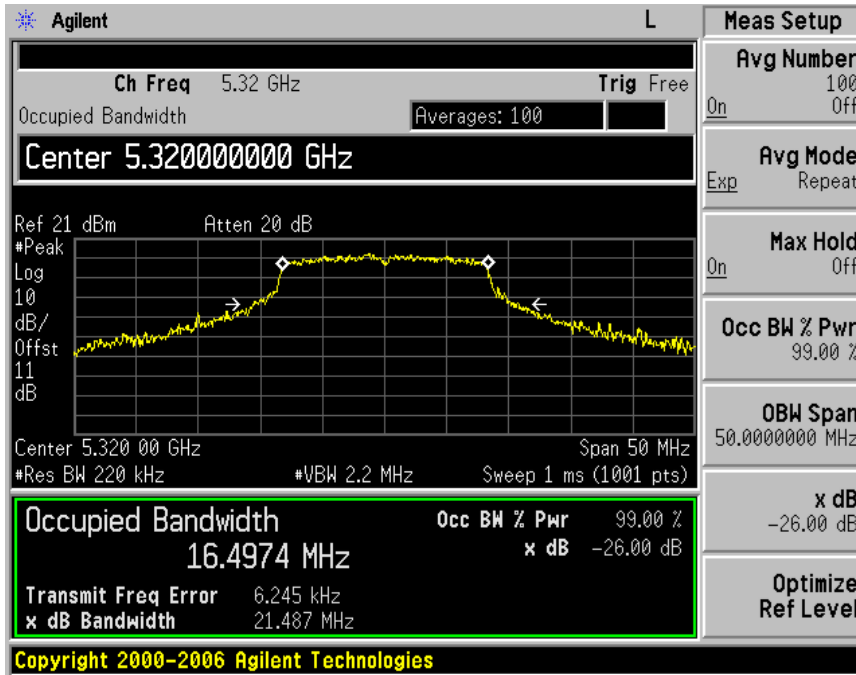



Estech Co., Ltd.

97-1, Hooeok-ri, Majang-myun, Ichion-city, Gyonggi-do, South Korea

TEL : +82 31 6318037 FAX : +82 31 6318039 www.estech.co.kr

OFDM (802.11n-100ch)

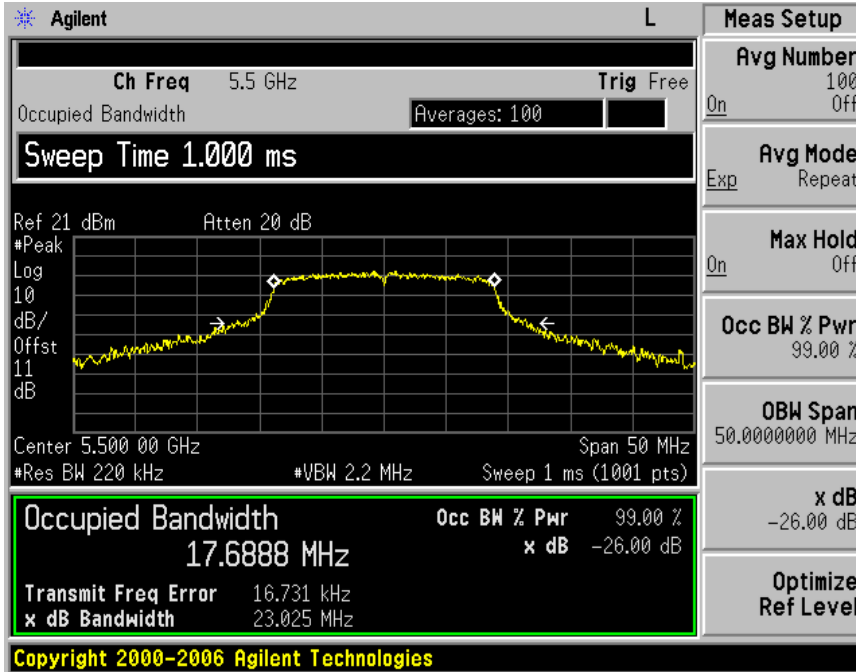

OFDM (802.11n-116ch)

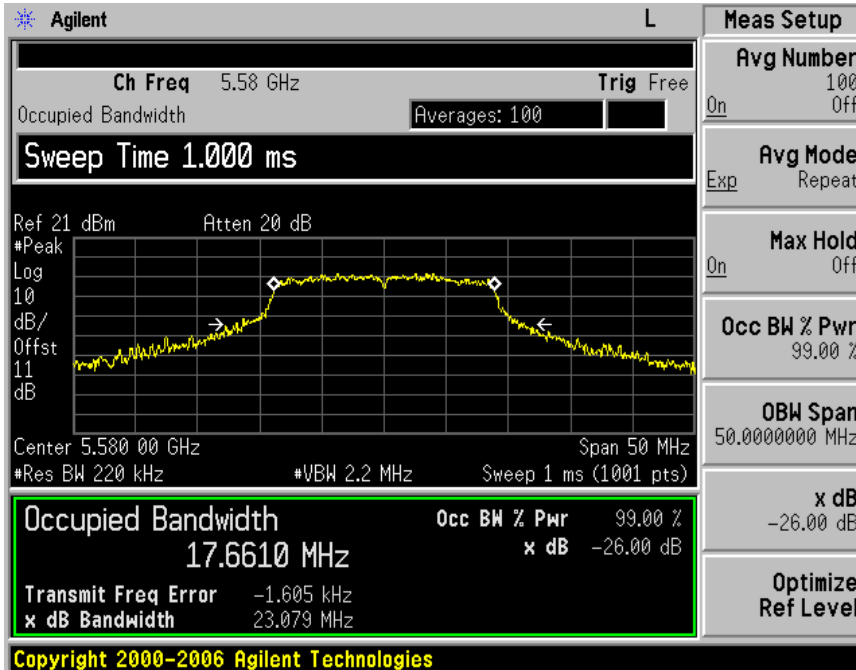



Estech Co., Ltd.

97-1, Hooeok-ri, Majang-myun, Ichion-city, Gyonggi-do, South Korea
TEL : +82 31 6318037 FAX : +82 31 6318039 www.estech.co.kr

OFDM (802.11n-140ch)

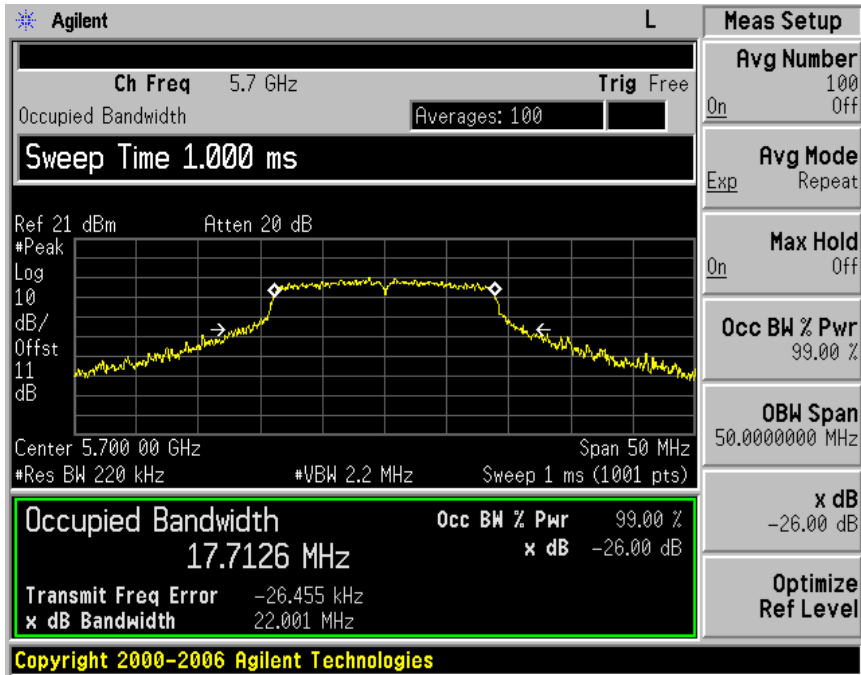



Estech Co., Ltd.

97-1, Hooeok-ri, Majang-myun, Ichion-city, Gyonggi-do, South Korea

TEL : +82 31 6318037 FAX : +82 31 6318039 www.estech.co.kr

10. MAXIMUM CONDUCTED OUTPUT POWER

10.1 Test procedure

KDB 789033 v01r04- Section E d) Maximum conducted output power

10.2 Test instruments and measurement setup

The spectrum analyzer is set to as following.

- (i) Measure the duty cycle, x , of the transmitter output signal as described in section B).
- (ii) Set span to encompass the 26 dB EBW (or, alternatively, the entire 99% occupied bandwidth) of the signal.
- (iii) Set RBW = 1 MHz.
- (iv) Set VBW \geq 3 MHz.
- (v) Number of points in sweep \geq 2 Span / RBW. (This ensures that bin-to-bin spacing is \leq RBW/2, so that narrowband signals are not lost between frequency bins.)
- (vi) Sweep time = auto.
- (vii) Detector = RMS (i.e., power averaging), if available. Otherwise, use sample detector mode.
- (viii) Do not use sweep triggering. Allow the sweep to "free run".
- (ix) Trace average at least 100 traces in power averaging (i.e., RMS) mode; however, the number of traces to be averaged shall be increased above 100 as needed to ensure that the average accurately represents the true average over the on and off periods of the transmitter.
- (x) Compute power by integrating the spectrum across the 26 dB EBW (or, alternatively, the entire 99% occupied bandwidth) of the signal using the instrument's band power measurement function with band limits set equal to the EBW (or occupied bandwidth) band edges. If the instrument does not have a band power function, sum the spectrum levels (in power units) at 1 MHz intervals extending across the 26 dB EBW (or, alternatively, the entire 99% occupied bandwidth) of the signal.
- (xi) Add $10 \log(1/x)$, where x is the duty cycle, to the measured power in order to compute the average power during the actual transmission times (because the measurement represents an average over both the on and off times of the transmission). For example, add $10 \log(1/0.25) = 6$ dB if the duty cycle is 25 percent.

Limits FCC § 15.407 (a)(1) , IC RSS-210 A9.2 (1)

Maximum Peak Output Power Test Instruments

Description	Model	Serial Number	Cal. Due Date
Spectrum Analyzer	E4440A	US42041281	2015-01-27

10.3 Measurement results

EUT	Mobile Computer	MODEL	PM60
MODE	OFDM	ENVIRONMENTAL CONDITION	24 °C, 43 % R.H.
INPUT POWER	120 Va.c., 60 Hz		



Estech Co., Ltd.

97-1, Hooeok-ri, Majang-myun, Ichion-city, Gyonggi-do, South Korea
TEL : +82 31 6318037 FAX : +82 31 6318039 www.estech.co.kr

(802.11a)

CHANNEL	Channel requency (MHz)	Conducted Power Output(dBm)			Measured + Factor(dBm)	Measured + Factor(mW)
		Detector	(dBm)	Factor		
36	5180	AVG	8.09	2.35	10.44	11.07
40	5200	AVG	8.14	2.35	10.49	11.19
48	5240	AVG	8.41	2.35	10.76	11.91

(802.11a)

EUT	Mobile Computer	MODEL	PM60
MODE	OFDM	ENVIRONMENTAL CONDITION	24 °C, 43 % R.H.
INPUT POWER	120 Va.c., 60 Hz		

CHANNEL	Channel requency (MHz)	Conducted Power Output(dBm)			Measured + Factor(dBm)	Measured + Factor(mW)
		Detector	(dBm)	Factor		
52	5260	AVG	8.29	2.35	10.64	11.59
60	5300	AVG	8.89	2.35	11.24	13.30
64	5320	AVG	8.88	2.35	11.23	13.27

(802.11a)

EUT	Mobile Computer	MODEL	PM60
MODE	OFDM	ENVIRONMENTAL CONDITION	24 °C, 43 % R.H.
INPUT POWER	120 Va.c., 60 Hz		

CHANNEL	Channel requency (MHz)	Conducted Power Output(dBm)			Measured + Factor(dBm)	Measured + Factor(mW)
		Detector	(dBm)	Factor		
100	5500	AVG	10.13	2.35	12.48	17.70
116	5580	AVG	9.67	2.35	12.02	15.92
140	5700	AVG	7.76	2.35	10.11	10.26



Estech Co., Ltd.

97-1, Hooeok-ri, Majang-myun, Ichion-city, Gyonggi-do, South Korea

TEL : +82 31 6318037 FAX : +82 31 6318039 www.estech.co.kr

(802.11n)

EUT	Mobile Computer	MODEL	PM60
MODE	OFDM	ENVIRONMENTAL CONDITION	24 °C, 43 % R.H.
INPUT POWER	120 Va.c., 60 Hz		

CHANNEL	Channel requency (MHz)	Conducted Power Output(dBm)			Measured + Factor(dBm)	Measured + Factor(mW)
		Detector	(dBm)	Factor		
36	5180	AVG	7.90	2.37	10.27	10.64
40	5200	AVG	7.61	2.37	9.98	9.95
48	5240	AVG	7.96	2.37	10.33	10.79

(802.11n)

EUT	Mobile Computer	MODEL	PM60
MODE	OFDM	ENVIRONMENTAL CONDITION	24 °C, 43 % R.H.
INPUT POWER	120 Va.c., 60 Hz		

CHANNEL	Channel requency (MHz)	Conducted Power Output(dBm)			Measured + Factor(dBm)	Measured + Factor(mW)
		Detector	(dBm)	Factor		
52	5260	AVG	8.27	2.37	10.64	11.59
60	5300	AVG	8.80	2.37	11.17	13.09
64	5320	AVG	8.46	2.37	10.83	12.11

(802.11n)

EUT	Mobile Computer	MODEL	PM60
MODE	OFDM	ENVIRONMENTAL CONDITION	24 °C, 43 % R.H.
INPUT POWER	120 Va.c., 60 Hz		

CHANNEL	Channel requency (MHz)	Conducted Power Output(dBm)			Measured + Factor(dBm)	Measured + Factor(mW)
		Detector	(dBm)	Factor		
100	5500	AVG	10.57	2.37	12.94	19.68
116	5580	AVG	9.52	2.37	11.89	15.45
140	5700	AVG	8.18	2.37	10.55	11.35



Estech Co., Ltd.

97-1, Hooeok-ri, Majang-myun, Ichion-city, Gyonggi-do, South Korea

TEL : +82 31 6318037 FAX : +82 31 6318039 www.estech.co.kr

11. Peak power spectral density (PPSD)

11.1 Test procedure

KDB 789033 v01r04- Section F) Peak power spectral density (PPSD)

11.2 Test instruments and measurement setup

The spectrum analyzer is set to as following.

- 1) Create an average power spectrum for the EUT operating mode being tested by following the instructions in section E)2) for measuring maximum conducted output power using a spectrum analyzer or EMI receiver: select the appropriate test method (SA-1, SA-2, SA-3, or alternatives to each) and apply it up to, but not including, the step labeled, "Compute power...". (This
- 2) Use the peak search function on the instrument to find the peak of the spectrum.
- 3) Make the following adjustments to the peak value of the spectrum, if applicable:
 - a) If Method SA-2 or SA-2 Alternative was used, add $10 \log(1/x)$, where x is the duty cycle, to the peak of the spectrum.
 - b) If Method SA-3 Alternative was used and the linear mode was used in step E)2)g)(viii), add 1 dB to the final result to compensate for the difference between linear averaging and power
- 4) The result is the PPSD.
- 5) The above procedures make use of 1 MHz resolution bandwidth to satisfy the 1 MHz measurement bandwidth specified in the 15.407(a)(5). That rule section also permits use of resolution bandwidths less than 1 MHz "provided that the measured power is integrated to show the total power over the measurement bandwidth" (i.e., 1 MHz). If measurements are performed using a reduced resolution bandwidth and integrated over 1 MHz bandwidth, the following
 - a) Set $RBW \geq 1/T$, where T is defined in section B)1)a).
 - b) Set $VBW \geq 3 RBW$
 - c) Care must be taken to ensure that the measurements are performed during a period of continuous transmission or are corrected upward for duty cycle.

Limits : FCC § 15.407 (a)(1) IC RSS-210 A9.2(1)

The peak power density Test Instruments

Description	Model	Serial Number	Cal. Due Date
Spectrum Analyzer	E4440A	US42041281	2015-01-27



Estech Co., Ltd.

97-1, Hooeok-ri, Majang-myun, Ichion-city, Gyonggi-do, South Korea
TEL : +82 31 6318037 FAX : +82 31 6318039 www.estech.co.kr

11.3 Measurement results

EUT	Mobile Computer	MODEL	PM60
MODE	OFDM	ENVIRONMENTAL CONDITION	23 °C, 43 % R.H.
INPUT POWER	120 Va.c., 60 Hz		

802.11a

CHANNEL	Channel Frequency (MHz)	Measured PPSD (dBm)	PPSD Limit	Margin
36	5180	1.17	4.0	2.83
40	5200	0.55	4.0	3.45
48	5240	1.19	4.0	2.81

802.11a

CHANNEL	Channel Frequency (MHz)	Measured PPSD (dBm)	PPSD Limit	Margin
52	5260	1.59	11.0	9.41
60	5300	1.95	11.0	9.05
64	5320	1.20	11.0	9.80

802.11a

CHANNEL	Channel Frequency (MHz)	Measured PPSD (dBm)	PPSD Limit	Margin
100	5500	2.79	11.0	8.21
116	5580	2.64	11.0	8.36
140	5700	0.42	11.0	10.58

802.11n

CHANNEL	Channel Frequency (MHz)	Measured PPSD (dBm)	PPSD Limit	Margin
36	5180	0.70	4.0	3.30
40	5200	0.01	4.0	3.99
48	5240	0.95	4.0	3.05



Estech Co., Ltd.

97-1, Hooeok-ri, Majang-myun, Ichion-city, Gyonggi-do, South Korea
TEL : +82 31 6318037 FAX : +82 31 6318039 www.estech.co.kr

11.3 Measurement results

EUT	Mobile Computer	MODEL	PM60
MODE	OFDM	ENVIRONMENTAL CONDITION	23 °C, 43 % R.H.
INPUT POWER	120 Va.c., 60 Hz		

802.11n

CHANNEL	Channel Frequency (MHz)	Measured PPSD (dBm)	PPSD Limit	Margin
52	5260	1.48	11.0	9.52
60	5300	1.50	11.0	9.50
64	5320	1.42	11.0	9.58

802.11n

CHANNEL	Channel Frequency (MHz)	Measured PPSD (dBm)	PPSD Limit	Margin
100	5500	3.07	11.0	7.93
116	5580	1.68	11.0	9.32
140	5700	0.29	11.0	10.71



Estech Co., Ltd.

97-1, Hooeok-ri, Majang-myun, Ichion-city, Gyonggi-do, South Korea
TEL : +82 31 6318037 FAX : +82 31 6318039 www.estech.co.kr

11.4 Trace data OFDM (802.11a-36ch) (Avg)

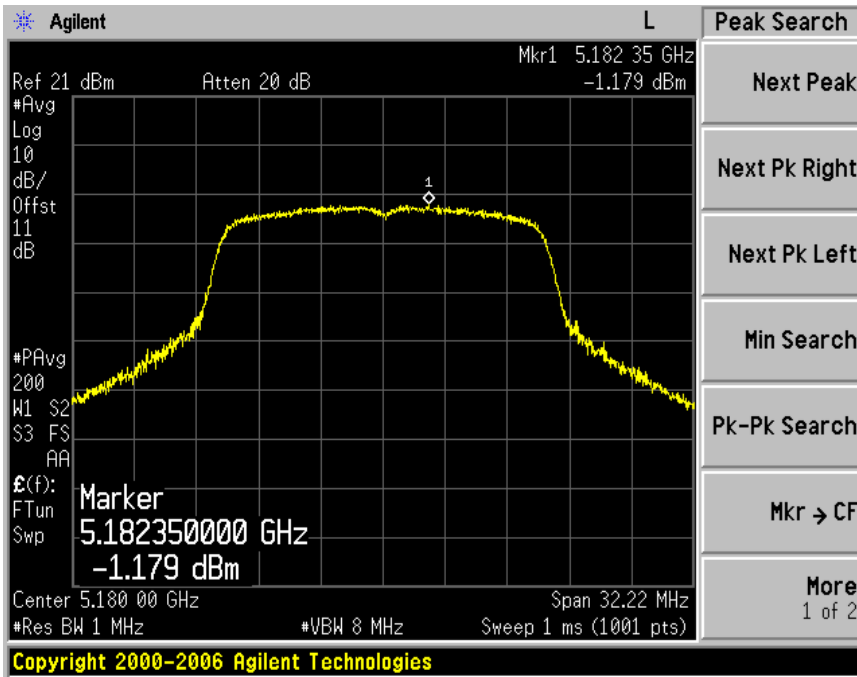

OFDM (802.11a-40ch) (Avg)

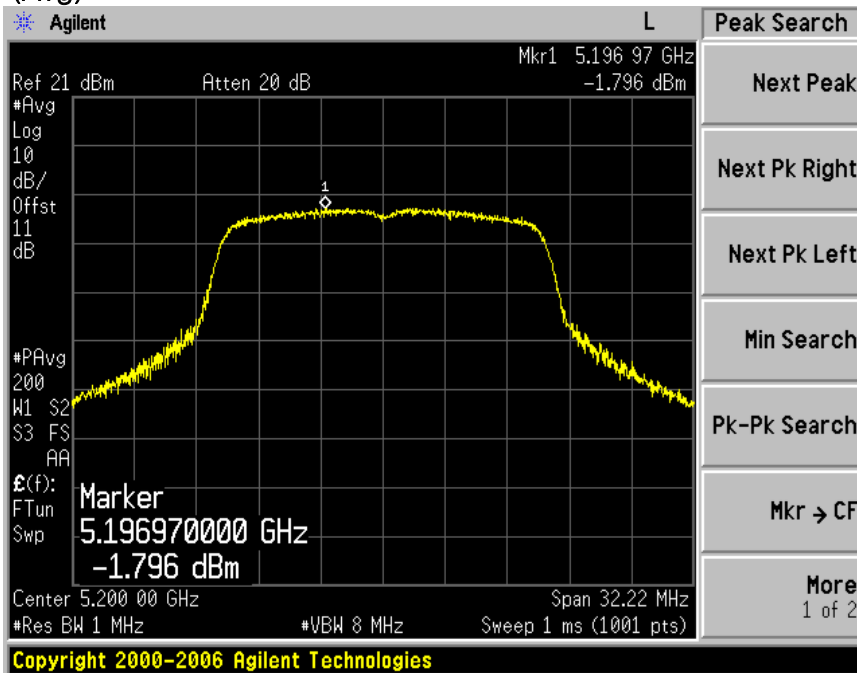



Estech Co., Ltd.

97-1, Hooeok-ri, Majang-myun, Ichion-city, Gyonggi-do, South Korea
TEL : +82 31 6318037 FAX : +82 31 6318039 www.estech.co.kr

OFDM (802.11a-48ch) (Avg)

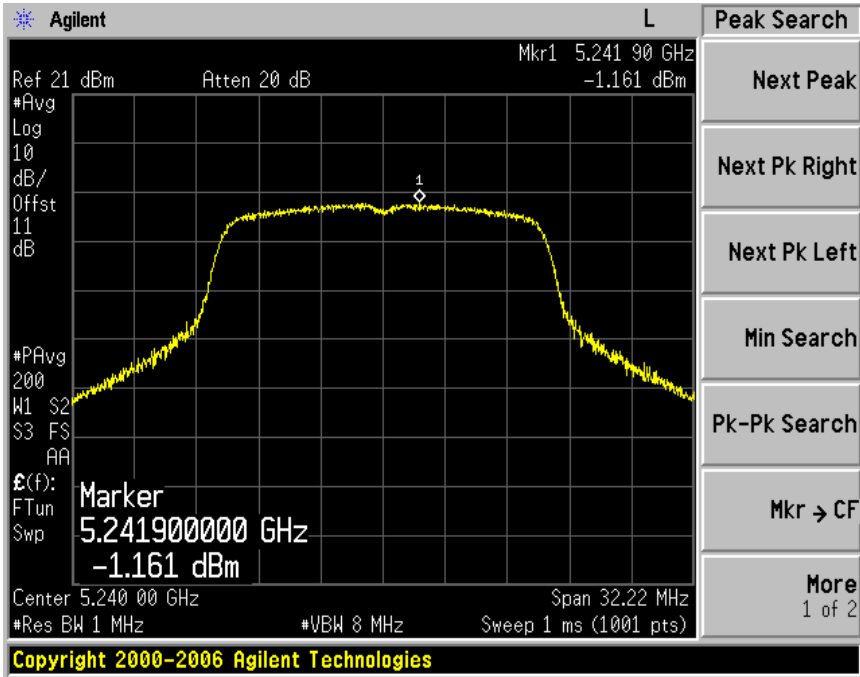



Estech Co., Ltd.

97-1, Hooeok-ri, Majang-myun, Ichion-city, Gyonggi-do, South Korea
TEL : +82 31 6318037 FAX : +82 31 6318039 www.estech.co.kr

OFDM (802.11a-52ch)

(Avg)

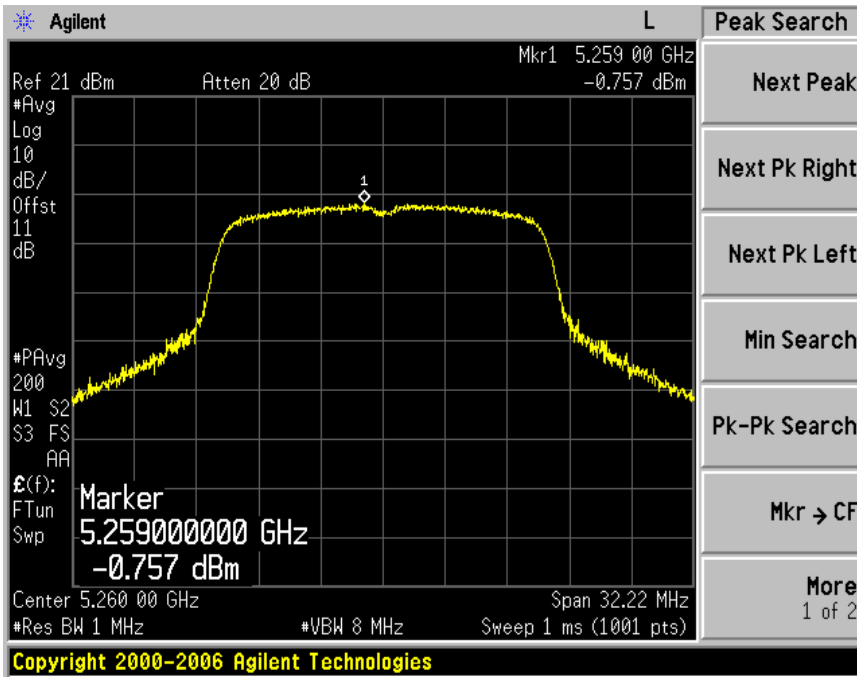

OFDM (802.11a-60ch)

(Avg)

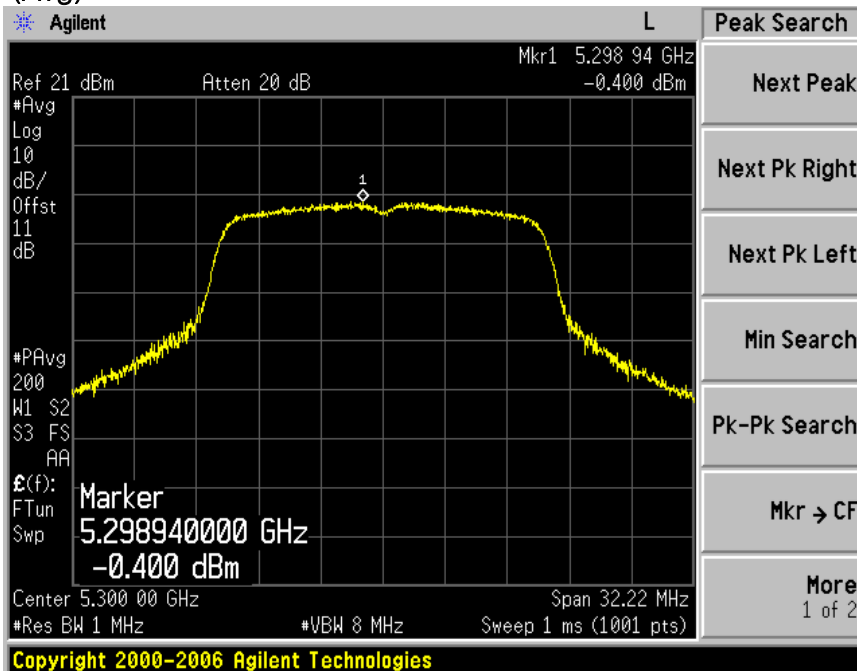



Estech Co., Ltd.

97-1, Hooeok-ri, Majang-myun, Ichion-city, Gyonggi-do, South Korea
TEL : +82 31 6318037 FAX : +82 31 6318039 www.estech.co.kr

OFDM (802.11a-64ch) (Avg)

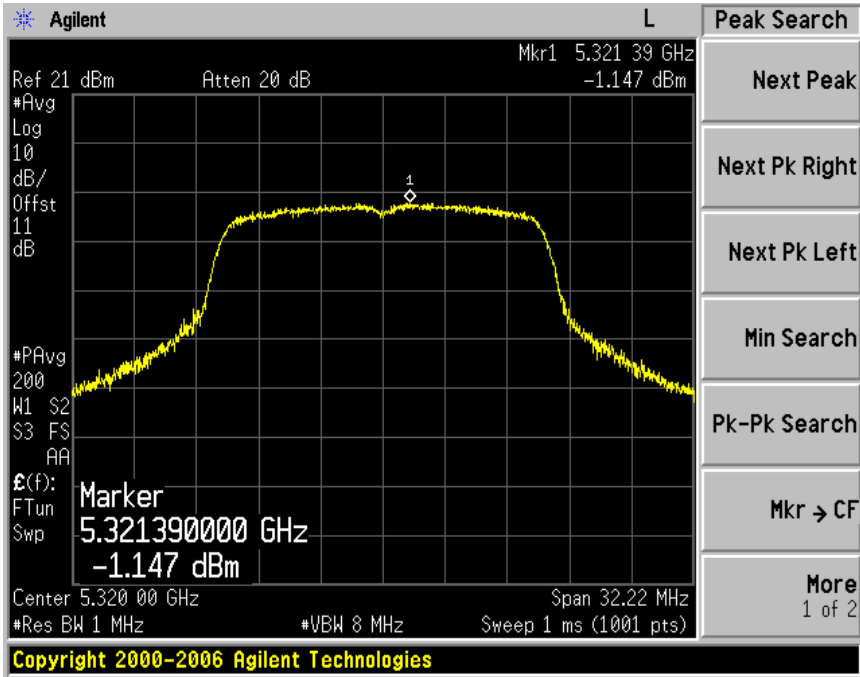



Estech Co., Ltd.

97-1, Hooeok-ri, Majang-myun, Ichion-city, Gyonggi-do, South Korea
TEL : +82 31 6318037 FAX : +82 31 6318039 www.estech.co.kr

OFDM (802.11a-100ch) (Avg)

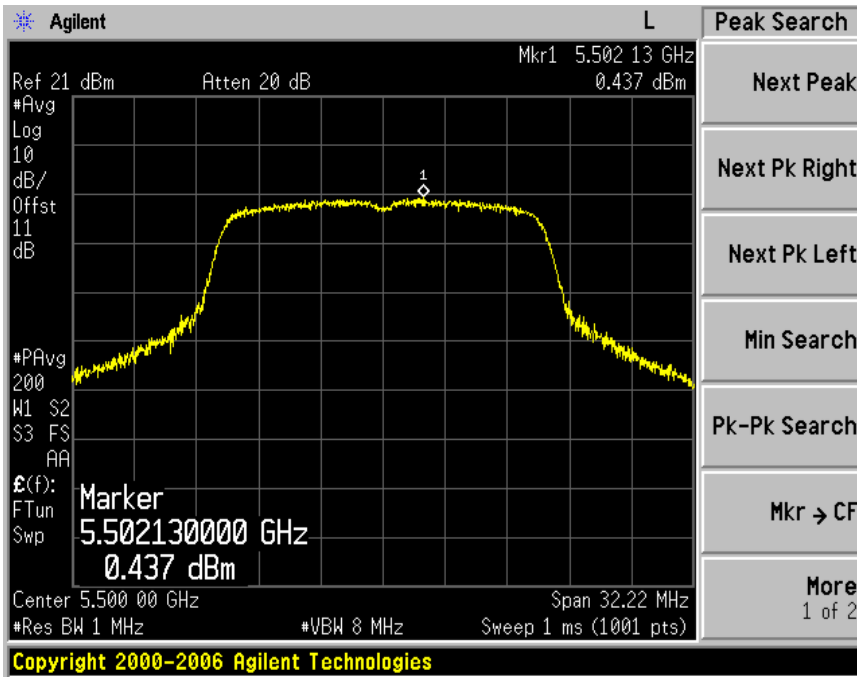

OFDM (802.11a-116ch) (Avg)

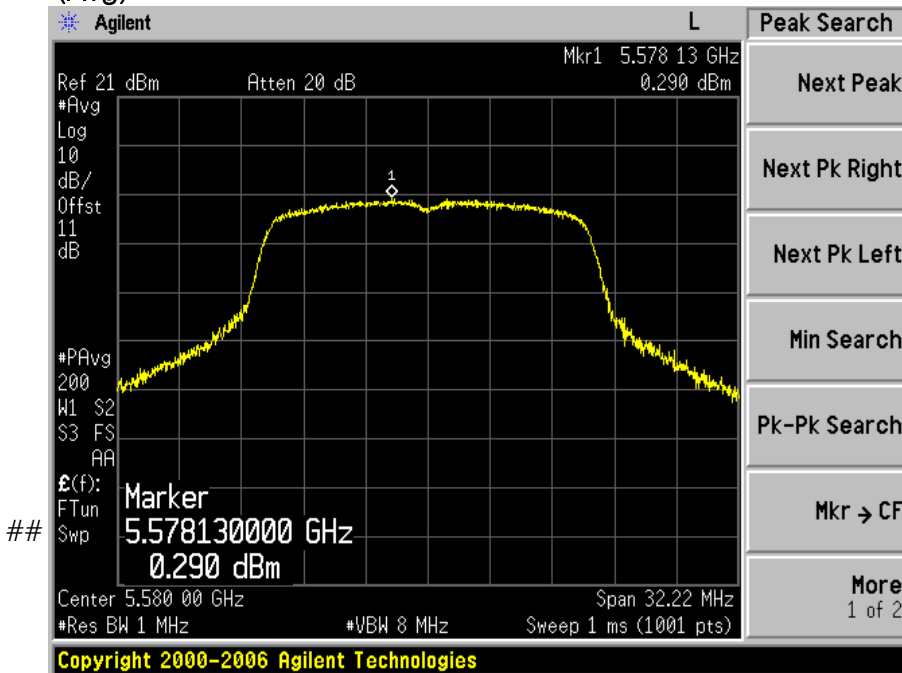



Estech Co., Ltd.

97-1, Hooeok-ri, Majang-myun, Ichion-city, Gyonggi-do, South Korea
TEL : +82 31 6318037 FAX : +82 31 6318039 www.estech.co.kr

OFDM (802.11a-140ch) (Avg)

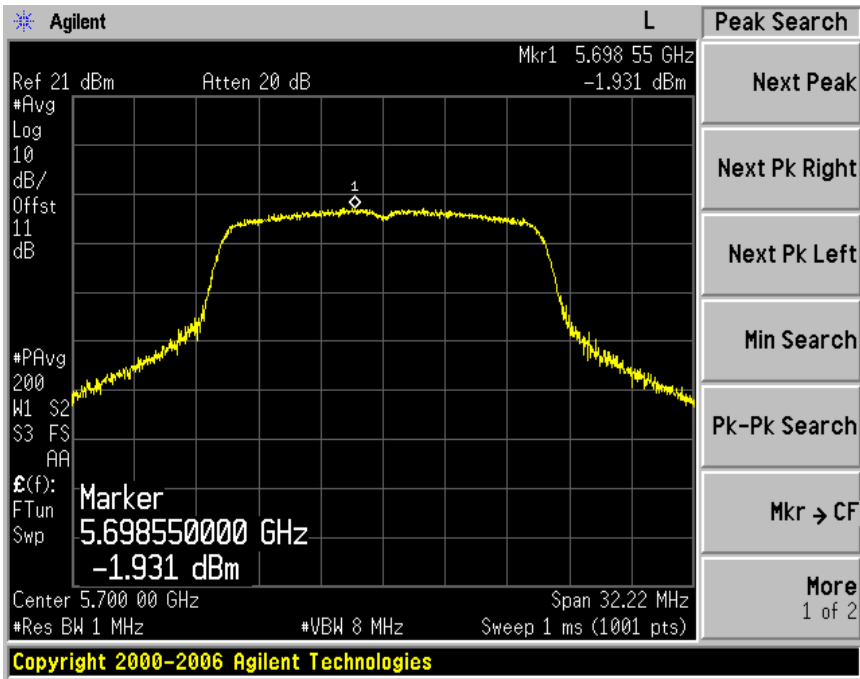

##



Estech Co., Ltd.

97-1, Hooeok-ri, Majang-myun, Ichion-city, Gyonggi-do, South Korea
TEL : +82 31 6318037 FAX : +82 31 6318039 www.estech.co.kr

11.4 Trace data OFDM (802.11n-36ch) (Avg)

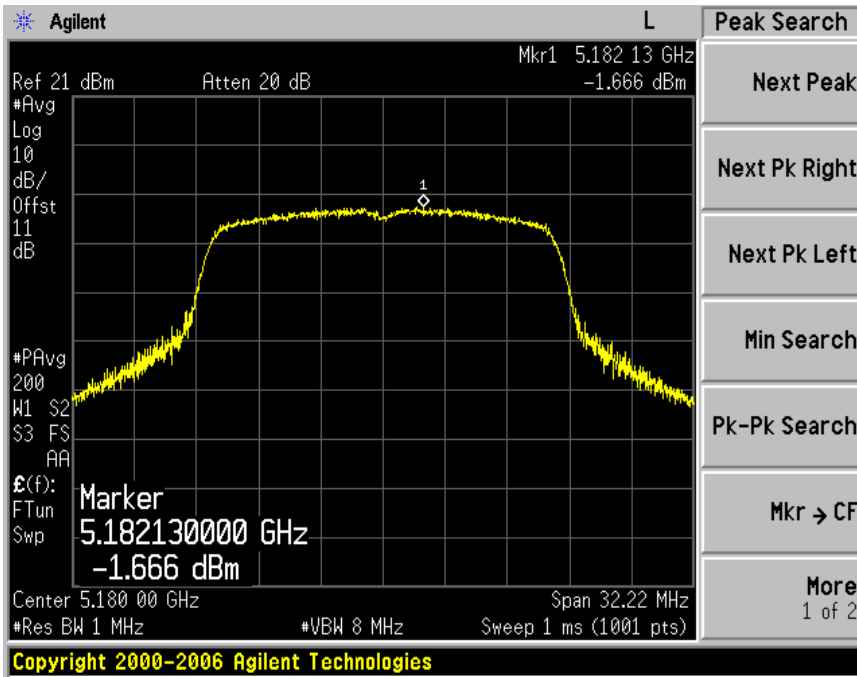

OFDM (802.11n-40ch) (Avg)

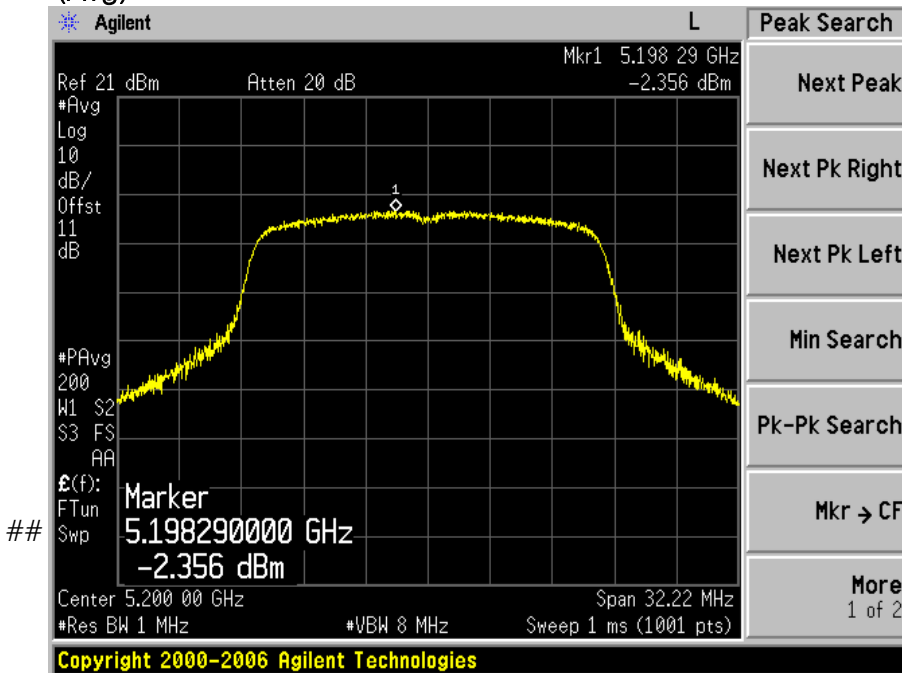



Estech Co., Ltd.

97-1, Hooeok-ri, Majang-myun, Ichion-city, Gyonggi-do, South Korea
TEL : +82 31 6318037 FAX : +82 31 6318039 www.estech.co.kr

OFDM (802.11n-48ch) (Avg)

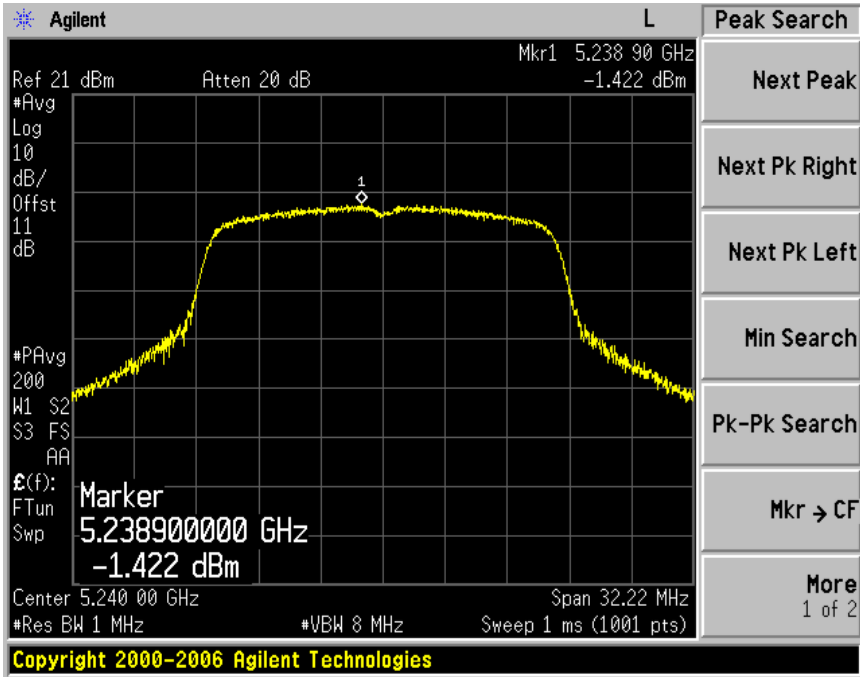



Estech Co., Ltd.

97-1, Hooeok-ri, Majang-myun, Ichion-city, Gyonggi-do, South Korea
TEL : +82 31 6318037 FAX : +82 31 6318039 www.estech.co.kr

OFDM (802.11n-52ch) (Avg)

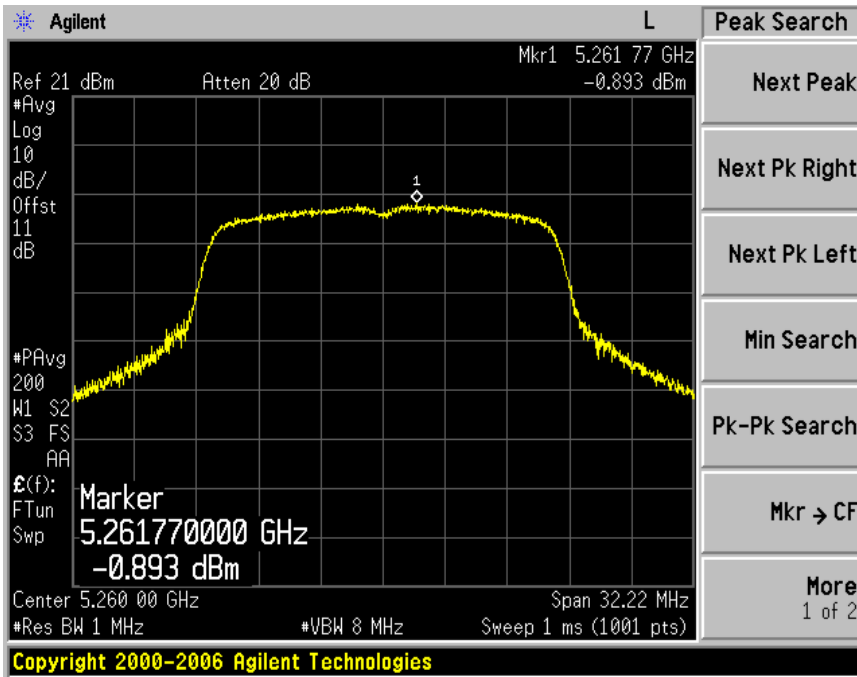

OFDM (802.11n-60ch) (Avg)

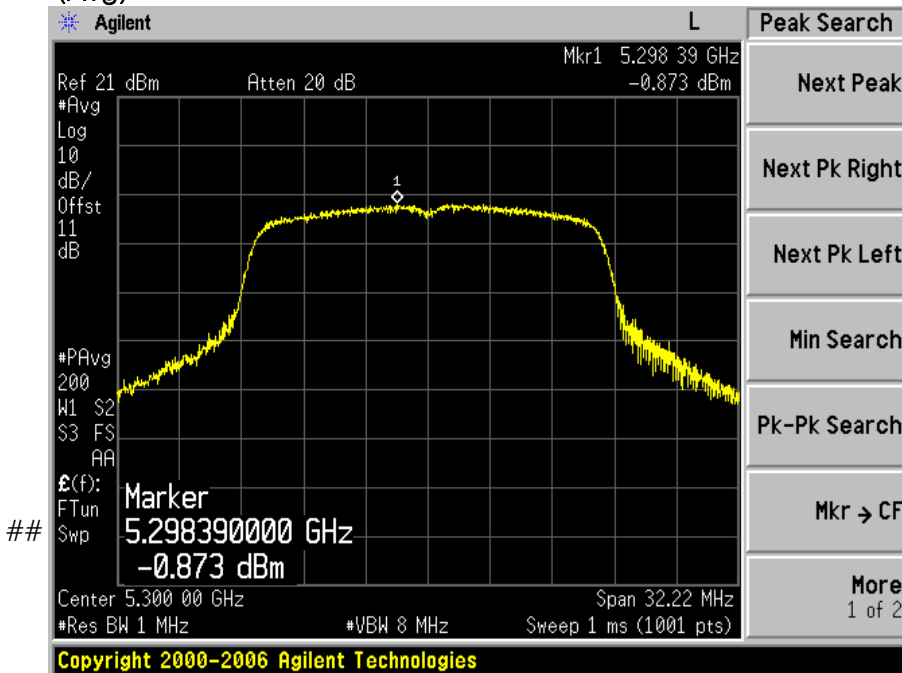



Estech Co., Ltd.

97-1, Hooeok-ri, Majang-myun, Ichion-city, Gyonggi-do, South Korea
TEL : +82 31 6318037 FAX : +82 31 6318039 www.estech.co.kr

OFDM (802.11n-64ch) (Avg)

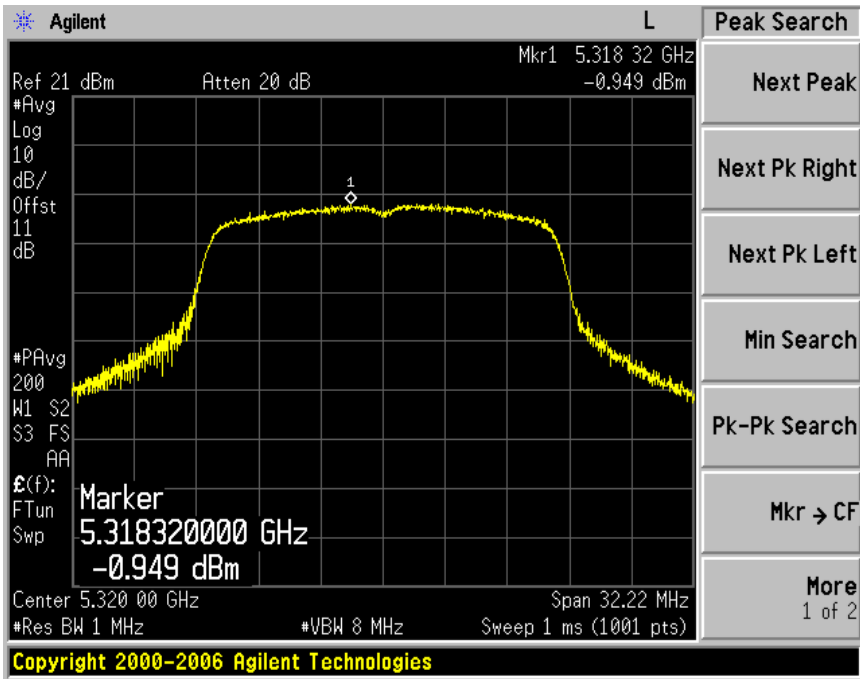



Estech Co., Ltd.

97-1, Hooeok-ri, Majang-myun, Ichion-city, Gyonggi-do, South Korea
TEL : +82 31 6318037 FAX : +82 31 6318039 www.estech.co.kr

OFDM (802.11n-100ch) (Avg)

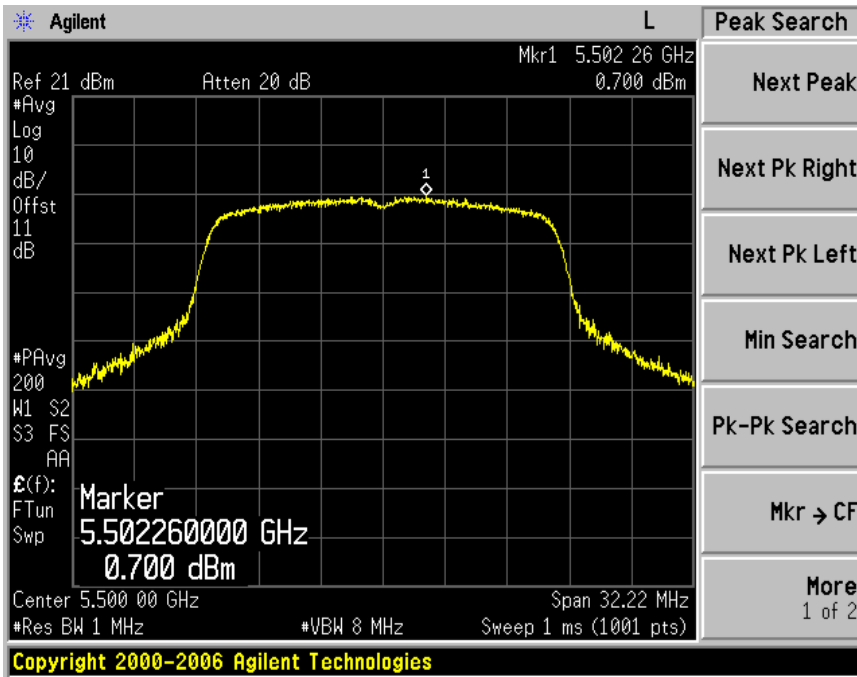

OFDM (802.11n-116ch) (Avg)

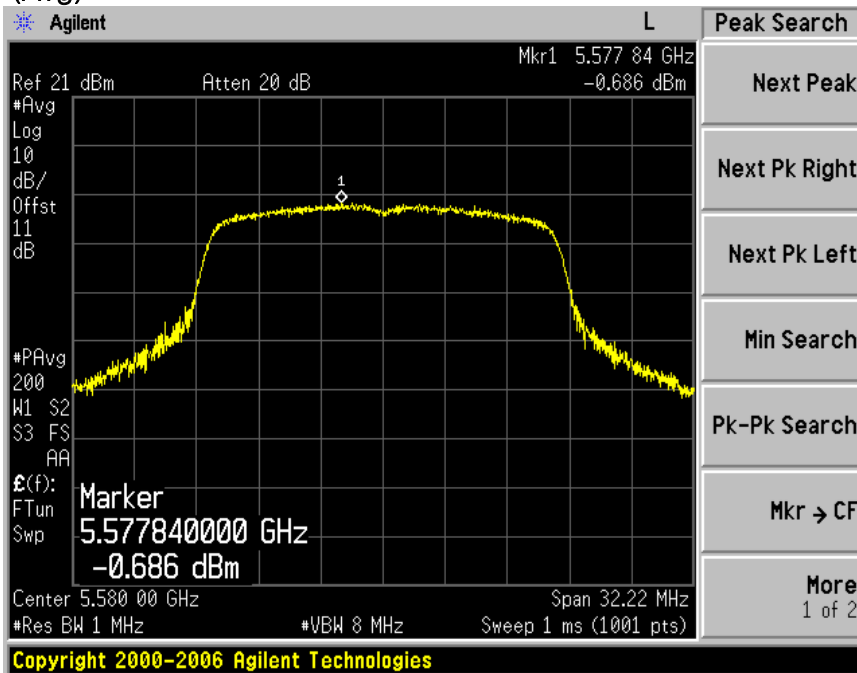



Estech Co., Ltd.

97-1, Hooeok-ri, Majang-myun, Ichion-city, Gyonggi-do, South Korea
TEL : +82 31 6318037 FAX : +82 31 6318039 www.estech.co.kr

OFDM (802.11n-140ch) (Avg)

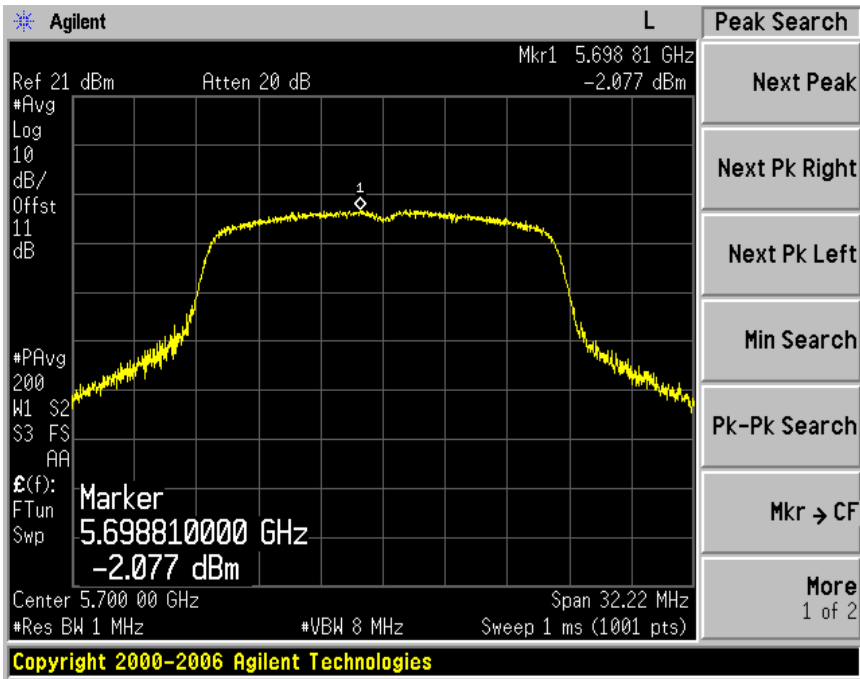



Estech Co., Ltd.

97-1, Hooeok-ri, Majang-myun, Ichion-city, Gyonggi-do, South Korea
TEL : +82 31 6318037 FAX : +82 31 6318039 www.estech.co.kr

12. Peak excursion measurement

12.1 Test procedure

KDB 789033 v01r04- Section G) Peak excursion measurement

12.2 Test instruments and measurement setup

The spectrum analyzer is set to as following.

- a) Set RBW = 1 MHz.
- b) VBW ≥ 3 MHz.
- c) Detector = peak.
- d) Trace mode = max-hold.
- e) Allow the sweeps to continue until the trace stabilizes.
- f) Use the peak search function to find the peak of the spectrum

Limit : FCC § 15.407 (a) (6)

Band Edge&Out of Emission Test Instruments

Description	Model	Serial Number	Cal. Due Date
Spectrum Analyzer	E4440A	US41421291	2015-01-27
Spectrum Analyzer	FSV40	100939	2015-01-23

12.3 Measurement results of band-edge & out of emission

802.11a

EUT	Mobile Computer	MODEL	PM60
MODE	OFDM	ENVIRONMENTAL CONDITION	23 °C, 43 % R.H.
INPUT POWER	120 Va.c., 60 Hz		

Frequency (channel)	Mode (Data Rate)	Measured Peak Excursion Ratio [dBm]	Max Permissible Peak Excursion Ratio [dBm]	Margin
5180(36)	802.11a(6Mbps)	9.75	13.00	3.25
5180(36)	802.11n(6.5Mbps)	9.52	13.00	3.48



Estech Co., Ltd.

97-1, Hooeok-ri, Majang-myun, Ichion-city, Gyonggi-do, South Korea
TEL : +82 31 6318037 FAX : +82 31 6318039 www.estech.co.kr

12.4 Trace data of PEAK EXCURSION OFDM (802.11a-36ch)

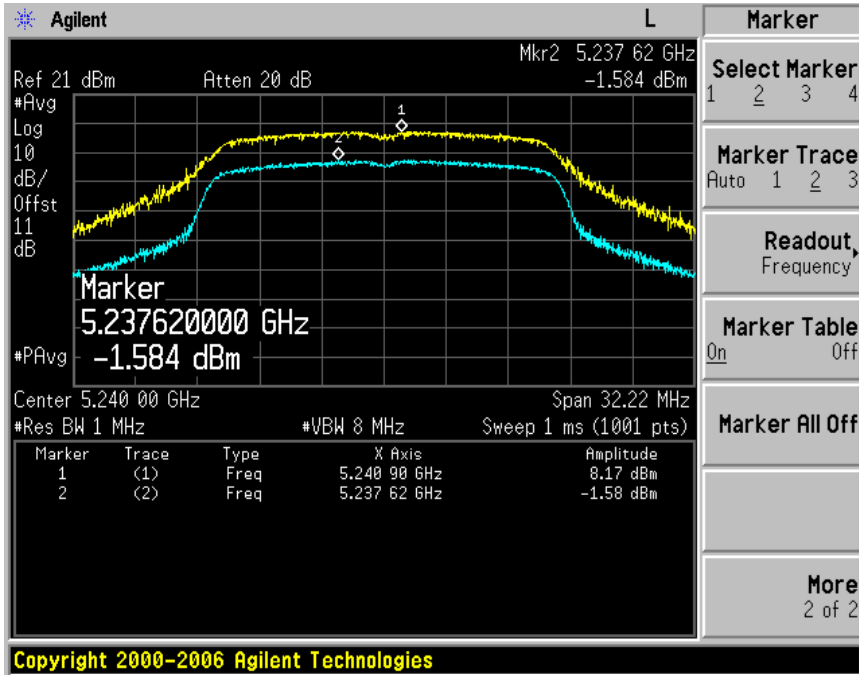

OFDM (802.11n-36ch)

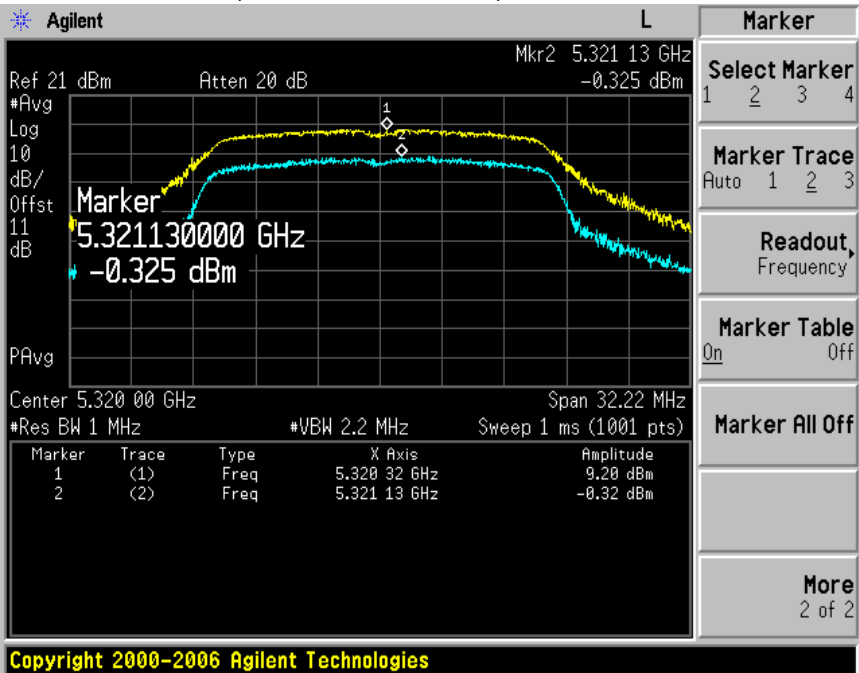



Estech Co., Ltd.

97-1, Hooeok-ri, Majang-myun, Ichion-city, Gyonggi-do, South Korea
TEL : +82 31 6318037 FAX : +82 31 6318039 www.estech.co.kr

13. DYNAMIC FREQUENCY SELECTION

13.1 Overview

Limits

INDUSTRY CANADA

IC RSS-210 is closely harmonized with FCC Part 15 DFS rules. The deviations are as follows :

RSS-210 Issue 7 A9.4 (b) (ii) Channel Availability Check Time

RSS-210 Issue 7 A9.4 (b) (iv) Channel closing time the maximum channel closing time is 260ms

FCC

§ 15.407(h) and FCC 06-96 APPENDIX"COMPLIANCE MEASUREMENT PROCEDURES FOR UNLICENSED-NATIONAL INFORMATION INFRASTRUCTURE DEVCIES OPERATING IN THE 5250-5350 MHz AND 5470-5725 MHz BANDS INCORPORATING DYNAMIC FREQUENCY SELETION"

Table 1 : Applicability of DFS requirements prio to use of a channel

Requirement	Operational mode		
	Master	Client(without radar detection)	Client(with radar detection)
Non-Occupancy Period	Yes	Not required	Yes
DFS Detection Threshold	Yes	Not required	Yes
Channel Availavility Check Time	Yes	Not required	Not required
Uniform Spreading	Yes	Not required	Not required

Table 2: Applicability of DFS requirements during normal operation

Requirement	Operational Mode		
	Master	Client (without radar detection)	Client(with radar detection)
DFS Detection Threshold	Yes	Not required	Yes
Channel Closing Transmission Time	Yes	Yes	Yes
Channel Move Time	Yes	Yes	Yes



Estech Co., Ltd.

97-1, Hooeok-ri, Majang-myun, Ichion-city, Gyonggi-do, South Korea
TEL : +82 31 6318037 FAX : +82 31 6318039 www.estech.co.kr

Table 3 : Interference Threshold values, Master or Client incorporating in-Service Monitoring

Maximum	Value (See Notes 1 and 2)
≥ 200 milliwatt	-64 dBm
< 200 milliwatt	-62 dBm

Note 1: This is the level at the input of the receiver assuming a 0 dBi receive antenna. Note 2: Throughout these test procedures an additional 1 dB has been added to the amplitude of the test transmission waveforms to account for variations in measurement equipment. This will ensure that the test signal is at or above the detection threshold level to trigger a DFS response.

Table 4 provides the response requirements for Master and Client Devices incorporating DFS.

Parameter	Value
Non-occupancy period	Minimum 30 minutes
Channel Availability Check Time	60 seconds
Channel Move Time	10 seconds See Note 1.
Channel Closing Transmission Time	200 milliseconds + an aggregate of 60 milliseconds over remaining 10 second period. See Notes 1 and 2.
U-NII Detection Bandwidth	Minimum 80% of the U-NII 99% transmission power bandwidth. See Note 3.

Note 1: The instant that the Channel Move Time and the Channel Closing Transmission Time begins is as follows: • For the Short Pulse Radar Test Signals this instant is the end of the Burst. • For the Frequency Hopping radar Test Signal, this instant is the end of the last radar Burst generated. • For the Long Pulse Radar Test Signal this instant is the end of the 12 second period defining the Radar Waveform. Note 2: The Channel Closing Transmission Time is comprised of 200 milliseconds starting at the beginning of the Channel Move Time plus any additional intermittent control signals required to facilitate a Channel move (an aggregate of 60 milliseconds) during the remainder of the 10 second period. The aggregate duration of control signals will not count quiet periods in between transmissions. Note 3: During the U-NII Detection Bandwidth detection test, radar type 1 is used and for each frequency step the minimum percentage of detection is 90 percent. Measurements are performed with no data traffic.



Estech Co., Ltd.

97-1, Hooeok-ri, Majang-myun, Ichion-city, Gyonggi-do, South Korea

TEL : +82 31 6318037 FAX : +82 31 6318039 www.estech.co.kr

Table 5 – Short Pulse Radar Test Waveforms

Radar Type	Pulse Width (μsec)	PRI (μsec)	Number of Pulses	Minimum Percentage of Successful Detection	Minimum Number of Trials
1	1	1428	18	60%	30
2	1-5	150-230	23-29	60%	30
3	6-10	200-500	16-18	60%	30
4	11-20	200-500	12-16	60%	30
Aggregate (Radar Types 1-4)				80%	120

Table 6 – Long Pulse Radar Test Waveform

Radar Type	Pulse Width (μsec)	Chirp Width (MHz)	PRI (μsec)	Number of Pulses per Burst	Number of Bursts	Minimum Percentage of Successful Detection	Minimum Number of Trials
5	50-100	5-20	1000-2000	1-3	8-2	80%	30

Table 7 – Frequency Hopping Radar Test Waveform

Radar Type	Pulse Width (μsec)	Chirp Width (MHz)	PRI (μsec)	Number of Pulses per Burst	Number of Bursts	Minimum Percentage of Successful Detection	Minimum Number of Trials
6	1	333	300	9	0.333	70%	30



Estech Co., Ltd.

97-1, Hooeok-ri, Majang-myun, Ichion-city, Gyonggi-do, South Korea

TEL : +82 31 6318037 FAX : +82 31 6318039 www.estech.co.kr

TEST AND MEASUREMENT SYSTEM AND Procedure

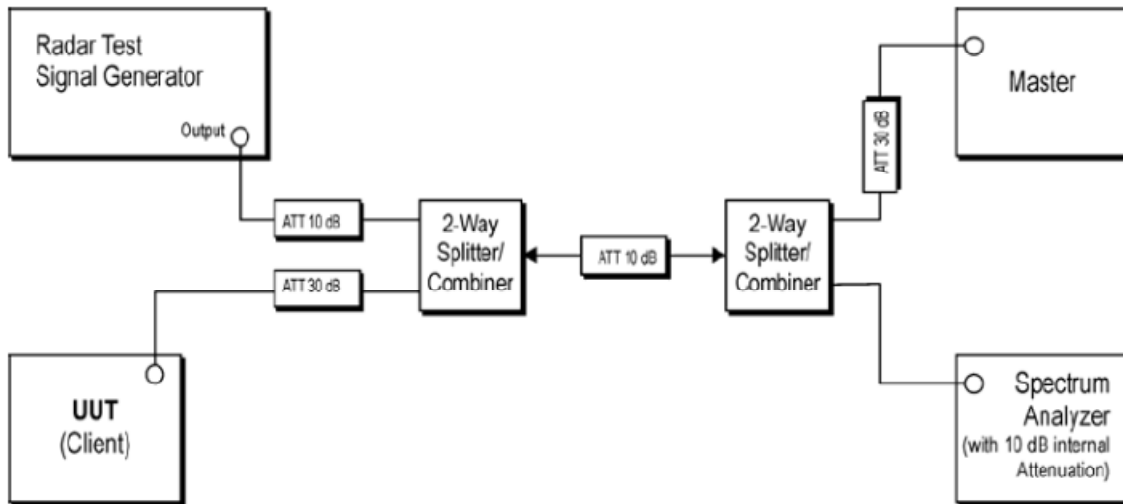

1. the radar pulse generator is setup to provide a pulse at the frequency that the Master and Client are operating.
2. The vector signal generator is adjusted to provide the radar burst at a level of approximately – 62kBm at the antenna of the Master device
3. A trigger is provided from the pulse generator to the DFS monitoring system in order to capture the traffic and the occurrence of the radar pulse
4. The Client Device (EUT) is set up per the diagram in Figure 3–1 and communications between the Master device and the Client is established
5. The MPEG file specified by the FCC (6 1/2 Magic Hours)is streamed from the "file computer" through the Master to the Slave Device and played in full motion video using media player Classic Ver.6.4.8.6 in order to properly load the network
6. The real time spectrum analyzer is set to record a 12 sec window to any transmissions occurring up to and after 10sec
7. The system is again setup and the monitoring time is shotened in order to capture the channel closing transmission time. This time is measured to insure that the client ceases transmissin within 200ms and the aggregate of emissions occurring after 200ms up to 10 sec do not exceed 60ms
8. After the initial radar burst the channel is monitored for 30 minututes to insure no transmission or beacons occur. A second monitoring setup is used to verify that the Master and Client have both moved to different channels



Estech Co., Ltd.

97-1, Hooeok-ri, Majang-myun, Ichion-city, Gyonggi-do, South Korea

TEL : +82 31 6318037 FAX : +82 31 6318039 www.estech.co.kr

13.2 Measurement results

Description	Model	Serial Number	Cal. Due Date
Spectrum Analyzer	E4440A	US42041281	2015-01-27
Vector Signal Generator	SMBV100A	256663	2015-01-23

Description	Manufactur	Model	S/N nember	FCC ID
Wireless AP	Ruckus	Zone Flex 7363	4609550002	U2M-zf73xx-1



Estech Co., Ltd.

97-1, Hooeok-ri, Majang-myun, Ichion-city, Gyonggi-do, South Korea

TEL : +82 31 6318037 FAX : +82 31 6318039 www.estech.co.kr

RADAR WAVEFORM AND TRAFFIC

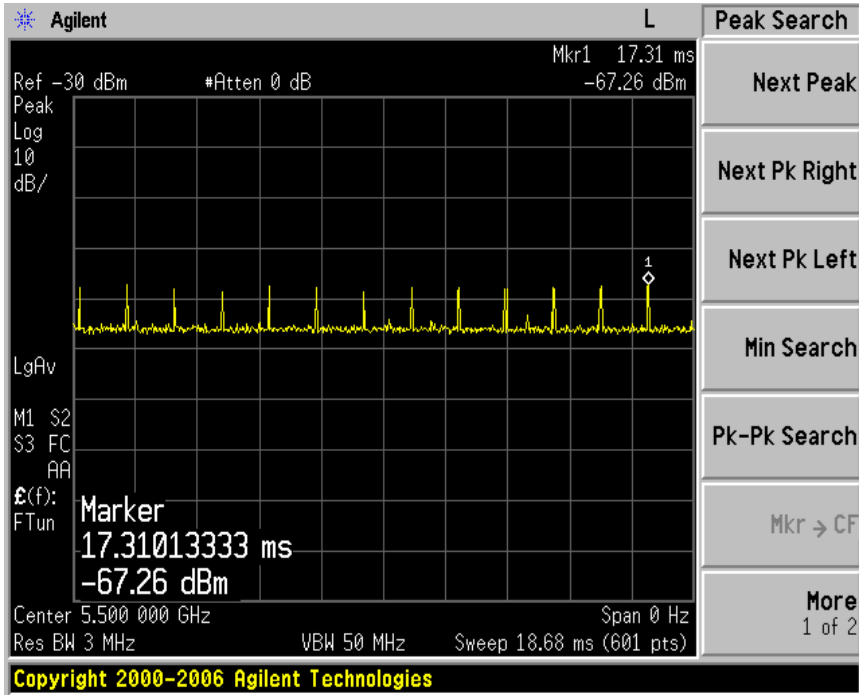



Estech Co., Ltd.

97-1, Hooeok-ri, Majang-myun, Ichion-city, Gyonggi-do, South Korea

TEL : +82 31 6318037 FAX : +82 31 6318039 www.estech.co.kr

RADAR WAVEFORM AND TRAFFIC

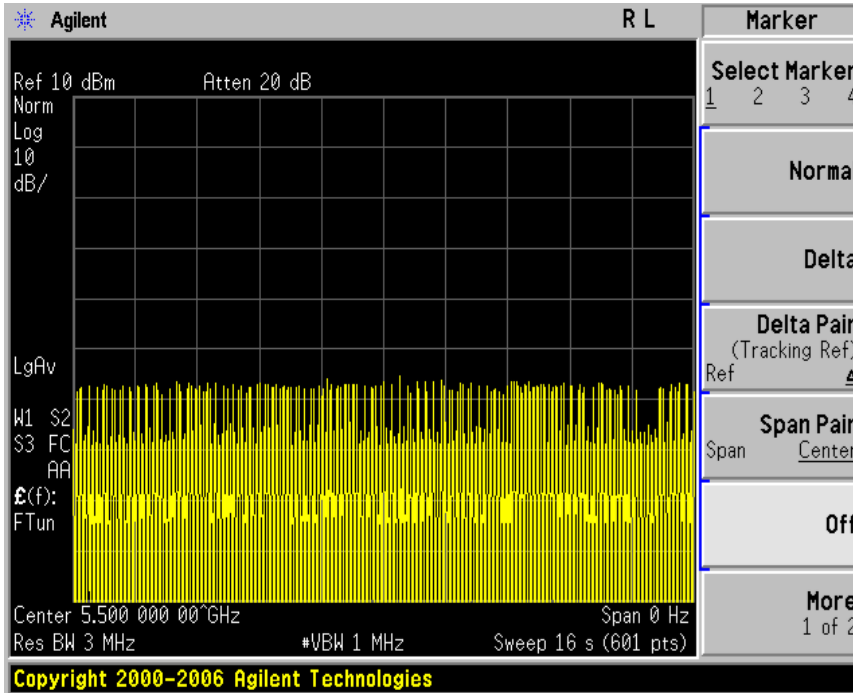



Estech Co., Ltd.

97-1, Hooeok-ri, Majang-myun, Ichion-city, Gyonggi-do, South Korea
TEL : +82 31 6318037 FAX : +82 31 6318039 www.estech.co.kr

MOVE AND CLOSING TIME

REPORTING NOTES

The reference marker is set at the end of last radar pulse.

the delta marker is set at the end of the last WKAN transmission following the radar pulse. This delta is the channel move time

the aggregate channel closing transmission time is calculated as follows :

Aggregate Transmission Time =

(Number of analyzer bins showing transmission)*(dwell time per bin)

The observation period over which the FCC aggregate time is calculated begins at (Reference Marker + 200msec) and ends no earlier than (Reference Marker + 10 sec).

the observation peiod over which the IC aggregate time is calculated begins at (Reference Marker) and ends no earlier than (Reference Marker +10 Sec)

RESULT

Agency	Channel Move Time (sec)	Limit (sec)
FCC/IC	5.546	10

Agency	Aggregate Channel Closing Transmission Time (msec)	Limit (msec)
FCC	32	60
IC	232	260



Estech Co., Ltd.

97-1, Hooeok-ri, Majang-myun, Ichion-city, Gyonggi-do, South Korea

TEL : +82 31 6318037 FAX : +82 31 6318039 www.estech.co.kr

MOVE TIME

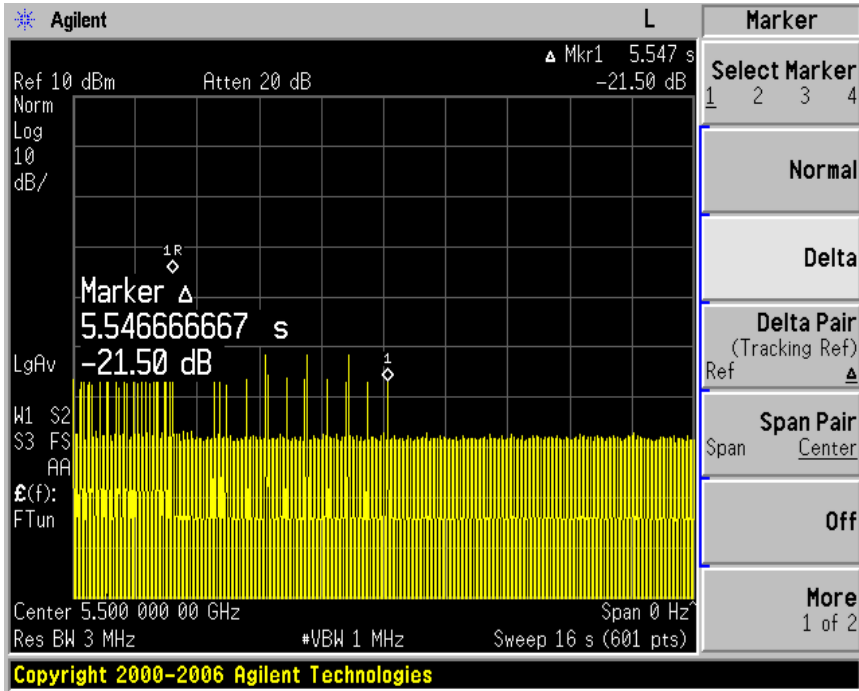



Estech Co., Ltd.

97-1, Hooeok-ri, Majang-myun, Ichion-city, Gyonggi-do, South Korea

TEL : +82 31 6318037 FAX : +82 31 6318039 www.estech.co.kr

CHANNEL CLOSING TIME

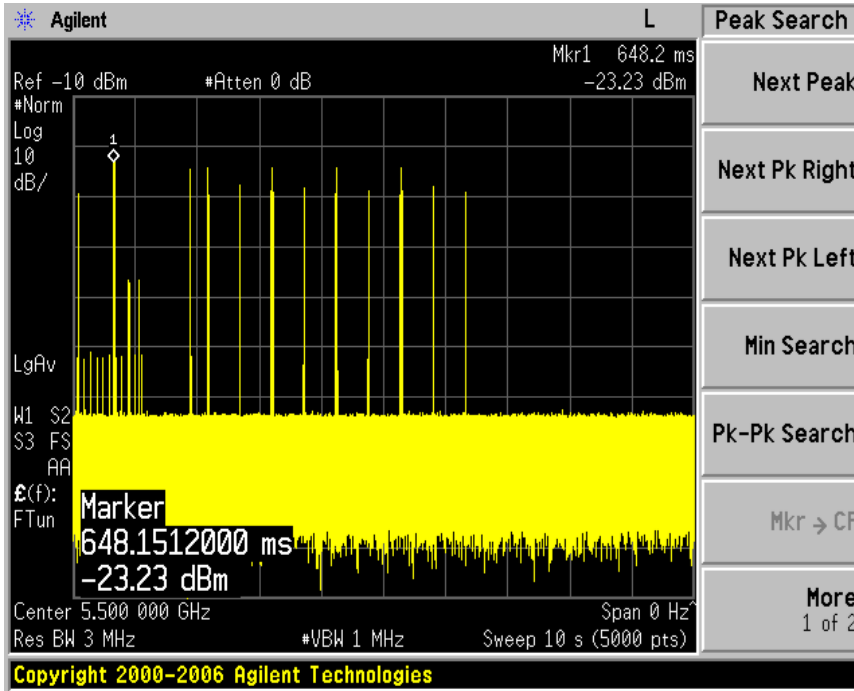



Estech Co., Ltd.

97-1, Hooeok-ri, Majang-myun, Ichion-city, Gyonggi-do, South Korea
TEL : +82 31 6318037 FAX : +82 31 6318039 www.estech.co.kr

Non-occupancy period

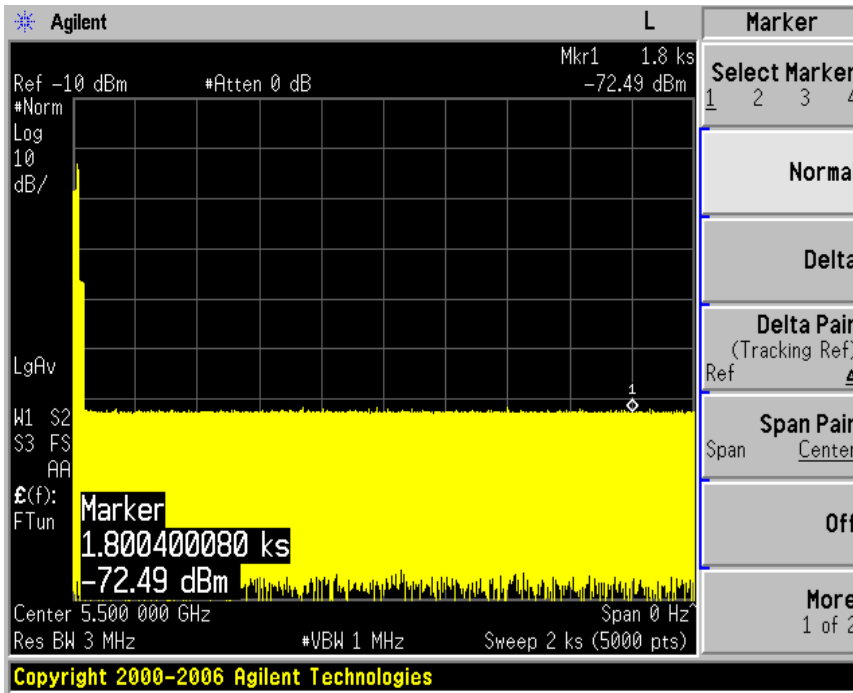



Estech Co., Ltd.

97-1, Hooeok-ri, Majang-myun, Ichion-city, Gyonggi-do, South Korea

TEL : +82 31 6318037 FAX : +82 31 6318039 www.estech.co.kr

14. Photographs of test setup

14.1. Setup for Radiated Test : 30 ~ 1 000 MHz

[Front]



[Rear]

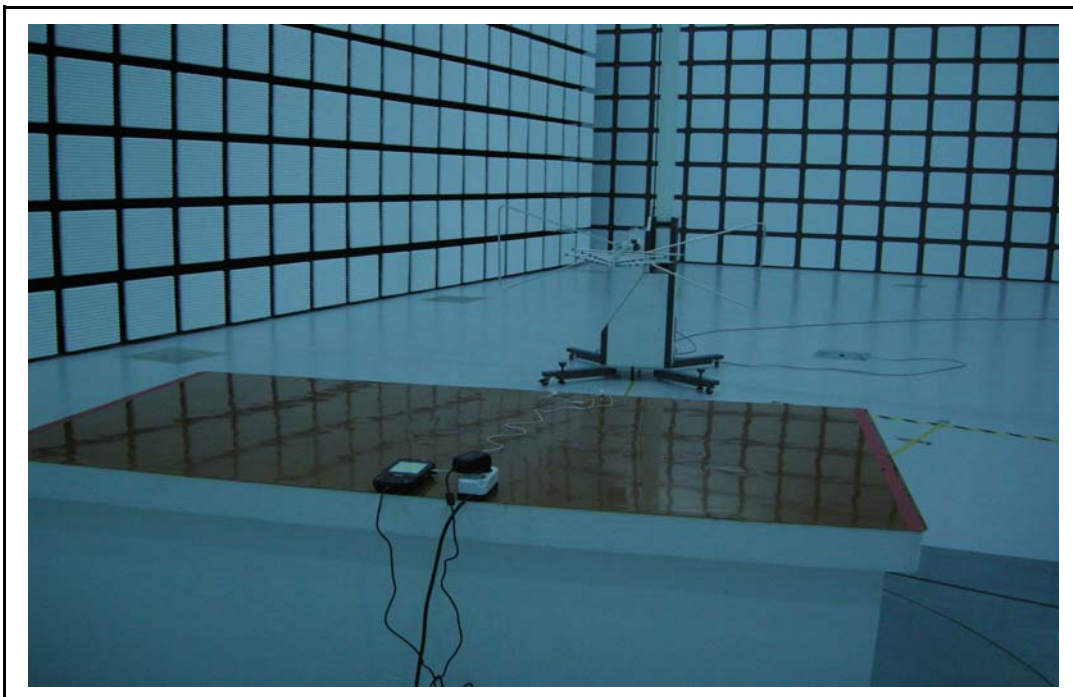



Estech Co., Ltd.

97-1, Hooeok-ri, Majang-myun, Ichion-city, Gyonggi-do, South Korea
TEL : +82 31 6318037 FAX : +82 31 6318039 www.estech.co.kr

14.2. Setup for Radiated Test :Above 1 000 MHz

[Front]



[Rear]

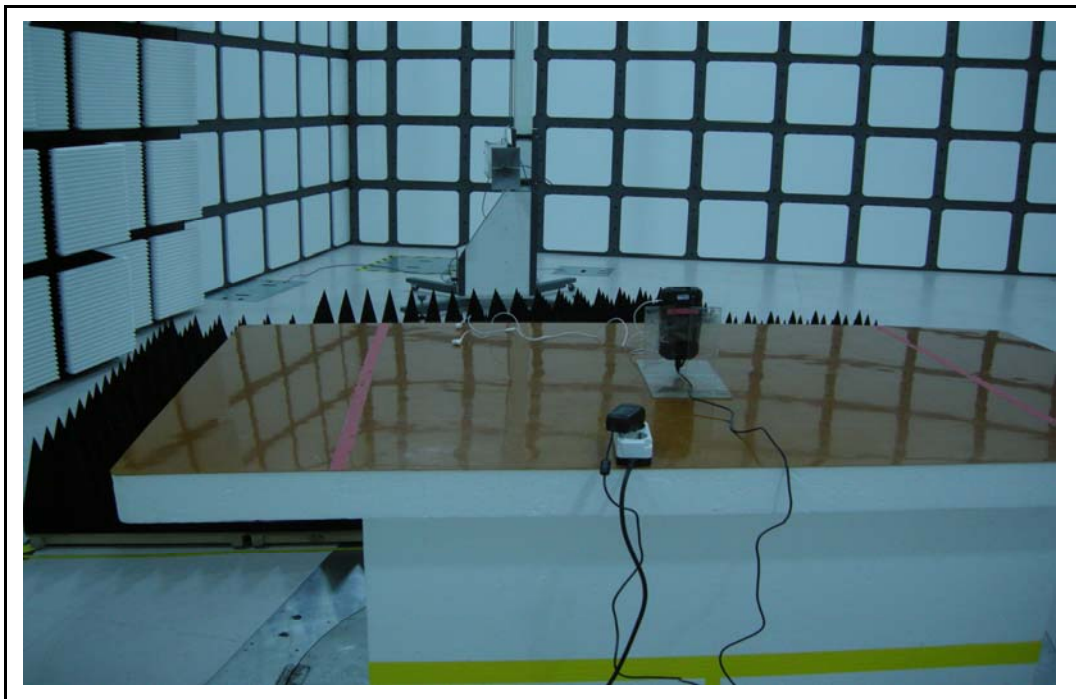



Estech Co., Ltd.

97-1, Hooeok-ri, Majang-myun, Ichion-city, Gyonggi-do, South Korea
TEL : +82 31 6318037 FAX : +82 31 6318039 www.estech.co.kr

14.3. Setup for Conducted Test : 0.15 ~ 30 MHz

[Front]



[Rear]





Estech Co., Ltd.

97-1, Hooeok-ri, Majang-myun, Ichion-city, Gyonggi-do, South Korea

TEL : +82 31 6318037 FAX : +82 31 6318039 www.estech.co.kr

14.4. Photographs of EUT

[Front]



[Rear]



Appendix 1. Special diagram for Wireless LAN

* 802.11a - CH 40(5220 MHz)

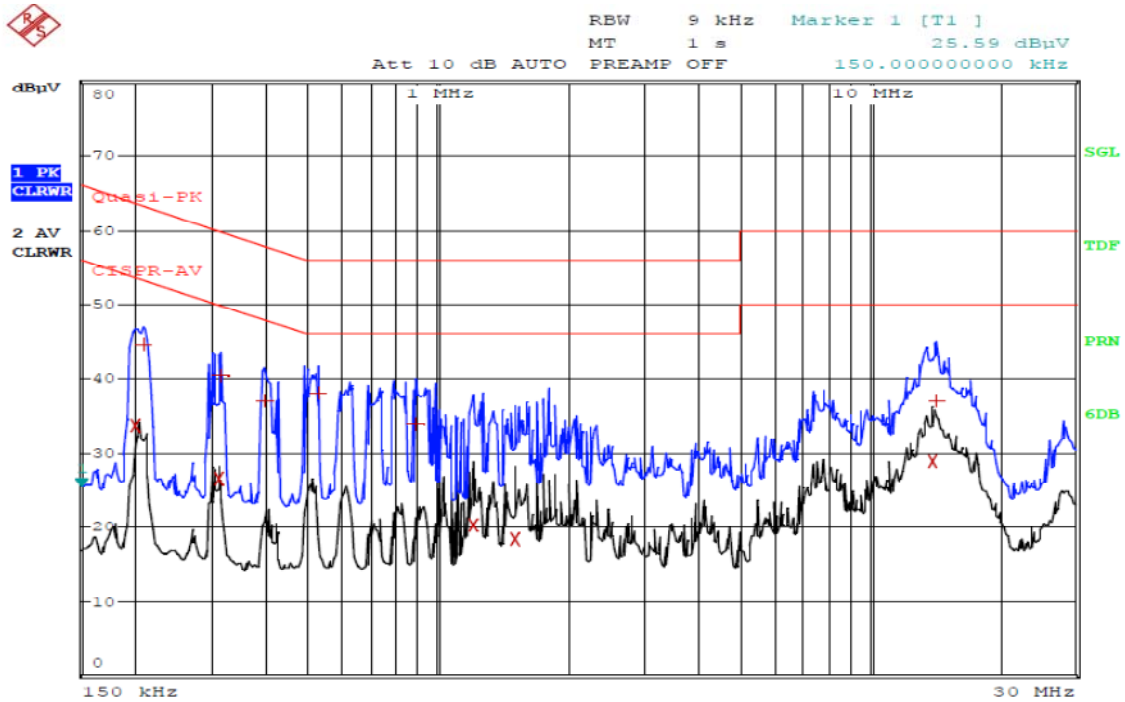

Comment: 14-00824_HOT(802.11a, CH 40-5220 MHz)
Date: 14.JUL.2014 13:50:52

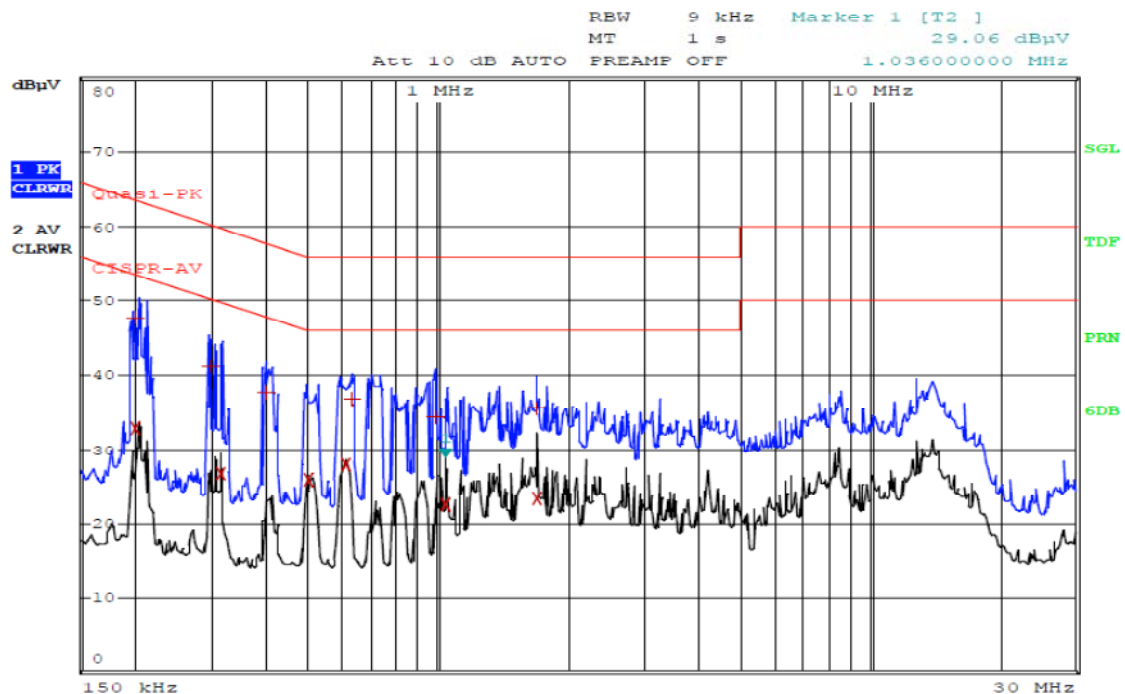

Comment: 14-00824_NEUTRAL(802.11a, CH 40-5220 MHz)
Date: 14.JUL.2014 13:43:30

Appendix 1. Special diagram for Wireless LAN

* 802.11a - CH 60(5300 MHz)

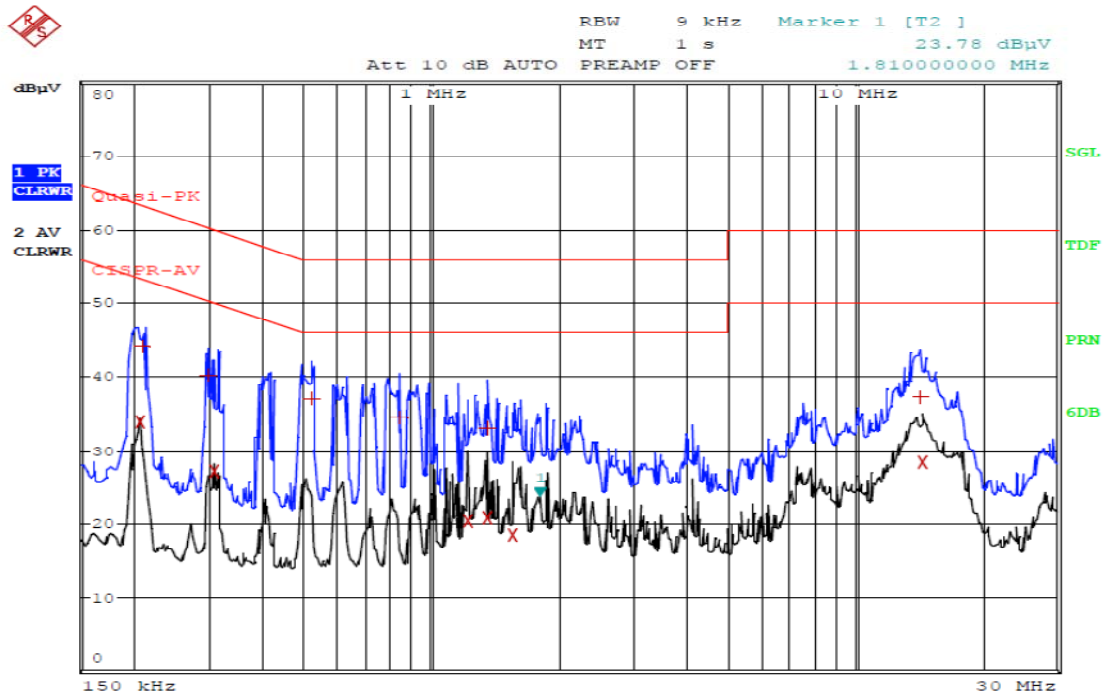

Comment: 14-00824_HOT(802.11a, CH 60-5300 MHz)
Date: 14.JUL.2014 13:56:23

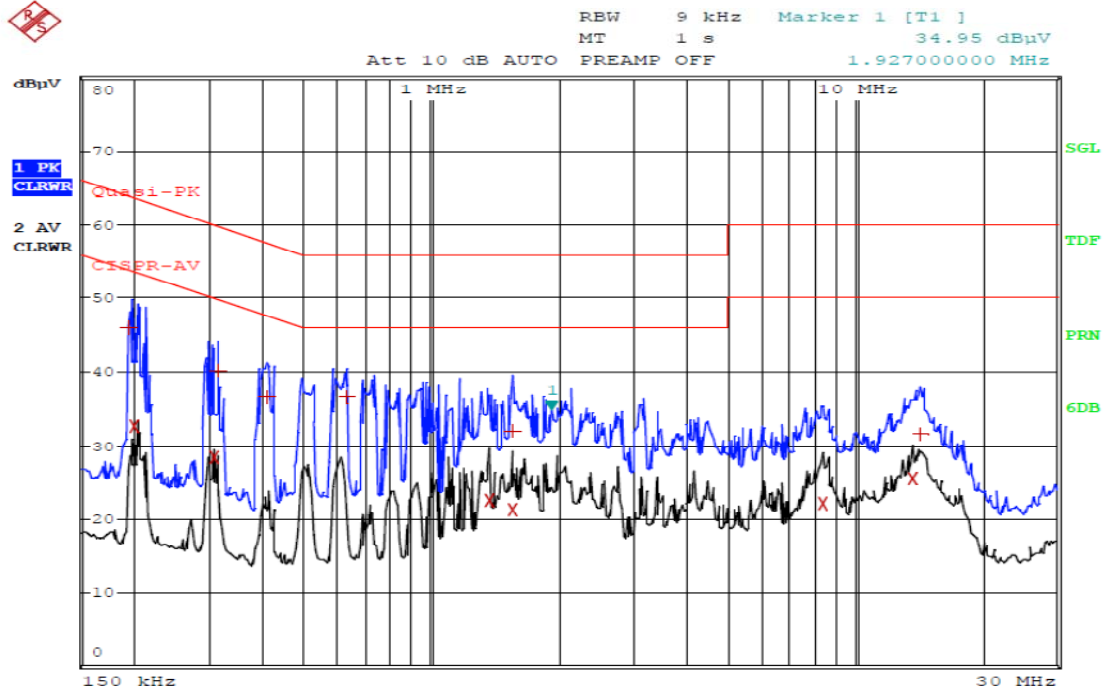

Comment: 14-00824_NEUTRAL(802.11a CH 60-5300 MHz)
Date: 14.JUL.2014 14:03:50

Appendix 1. Special diagram for Wireless LAN

*802.11a - CH 116(5580 MHz)

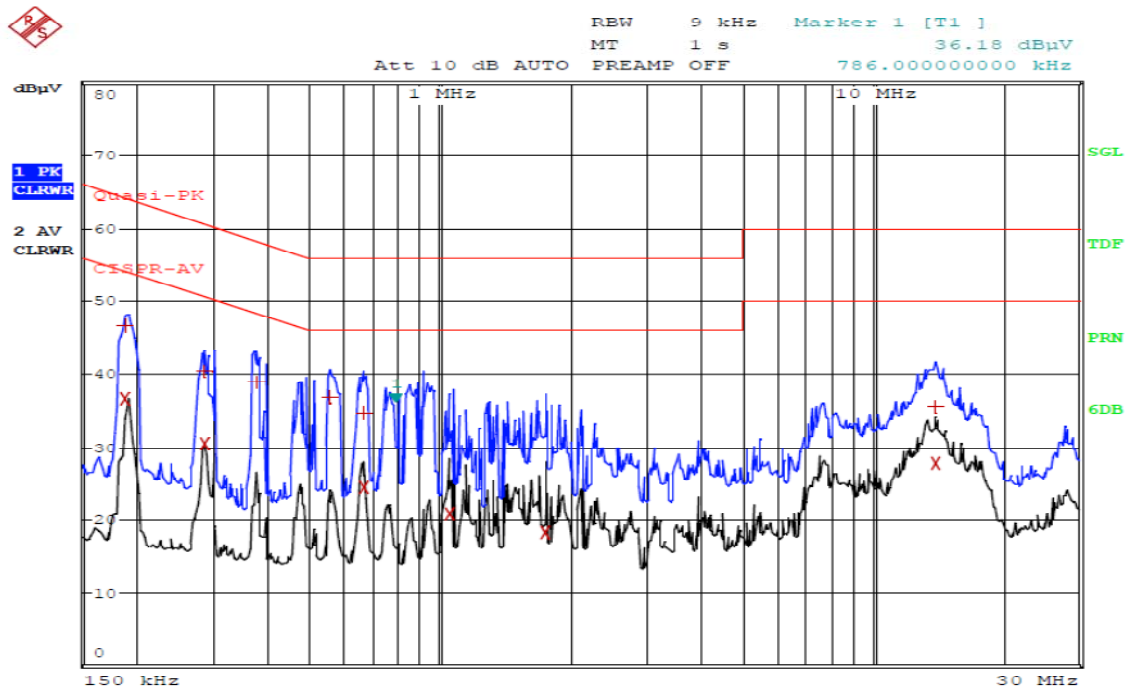

Comment: 14-00824_HOT(802.11a, CH 116-5580 MHz)
Date: 14.JUL.2014 14:28:35

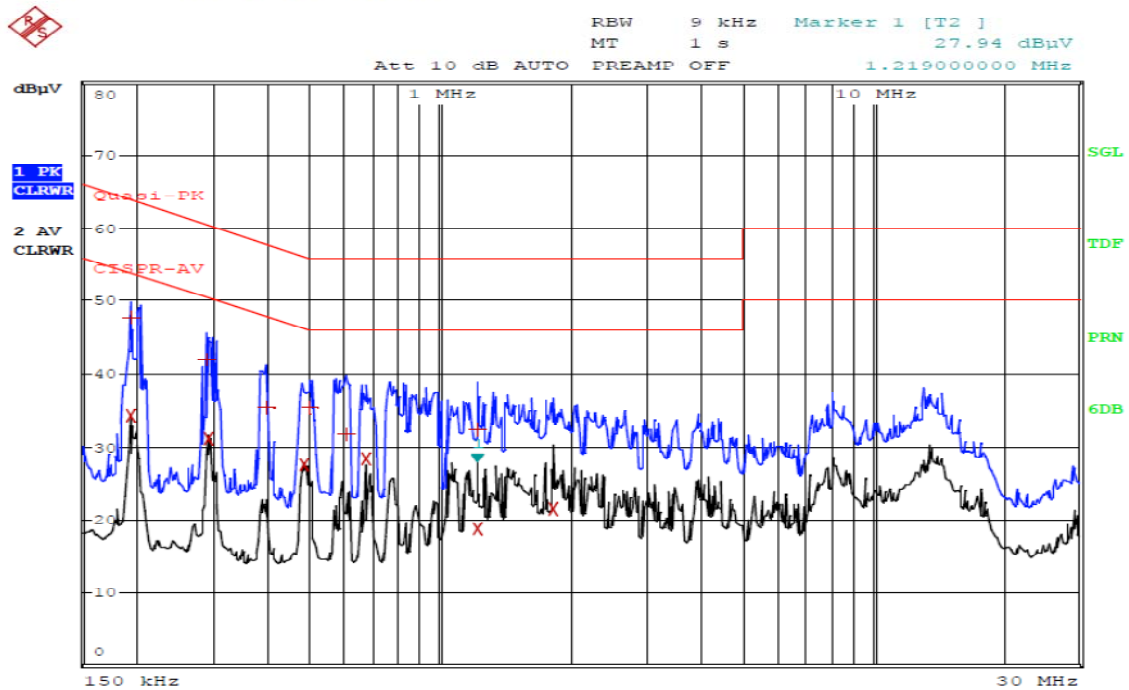

Comment: 14-00824_NEUTRAL(802.11a, CH 116-5580 MHz)
Date: 14.JUL.2014 14:22:19

Appendix 1. Special diagram for Wireless LAN

* 802.11n - CH 40(5220 MHz)

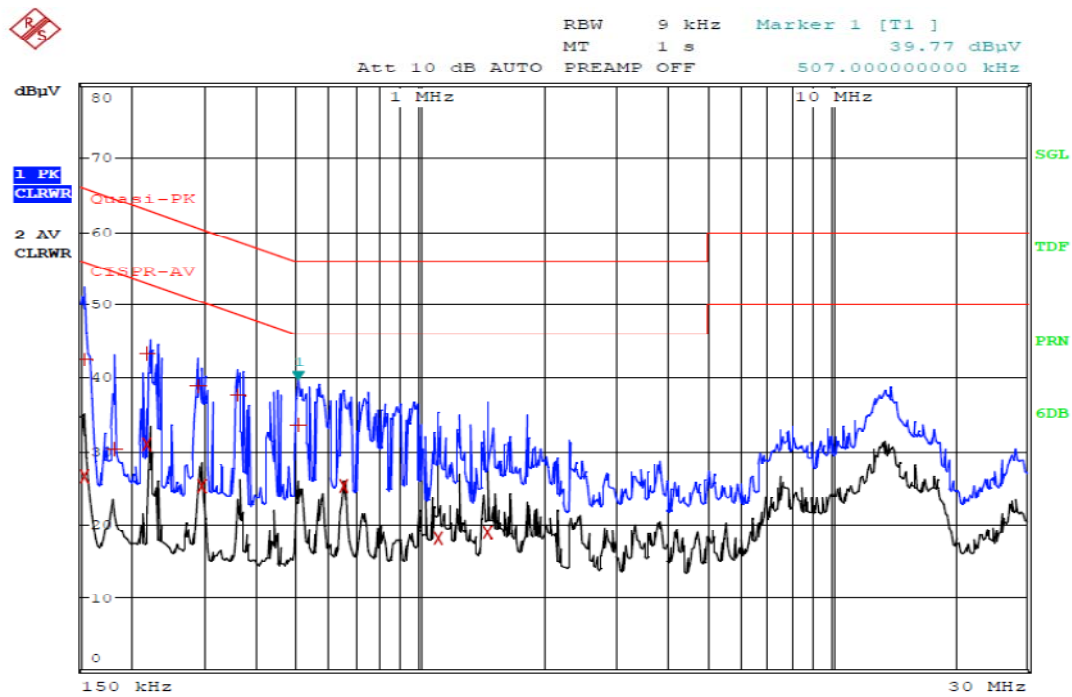

Comment: 14-00824_HOT(802.11n, CH 40-5220 MHz)
Date: 15.JUL.2014 14:50:14

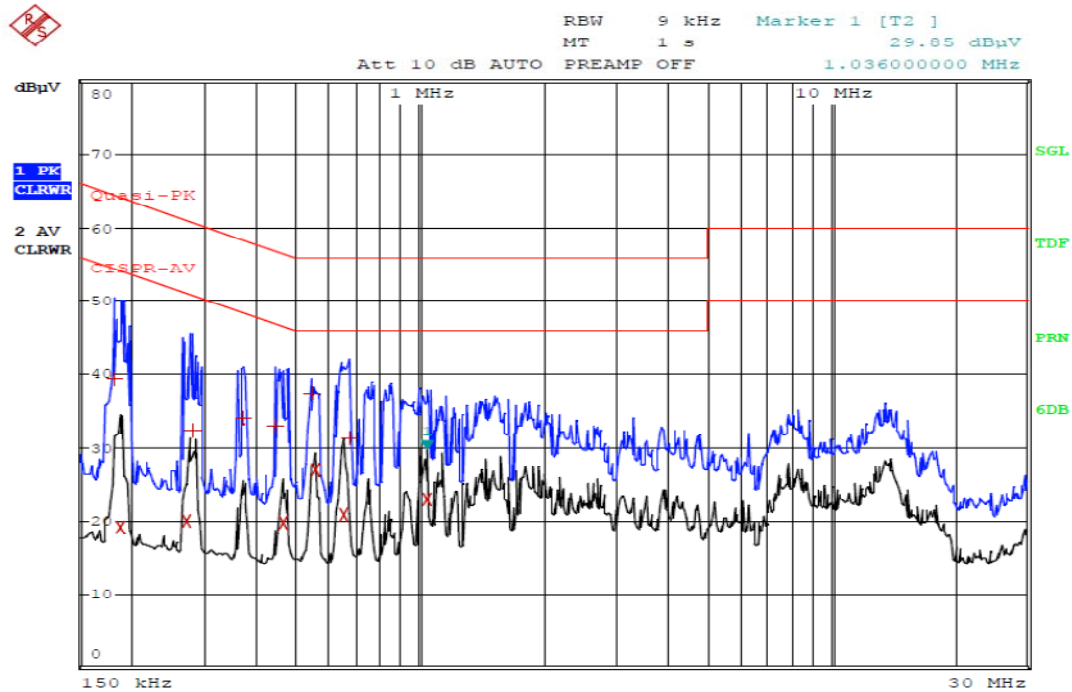

Comment: 14-00824_NEUTRAL(802.11n, CH 40-5220 MHz)
Date: 15.JUL.2014 14:46:55

Appendix 1. Special diagram for Wireless LAN

*802.11n – CH 60(5300 MHz)

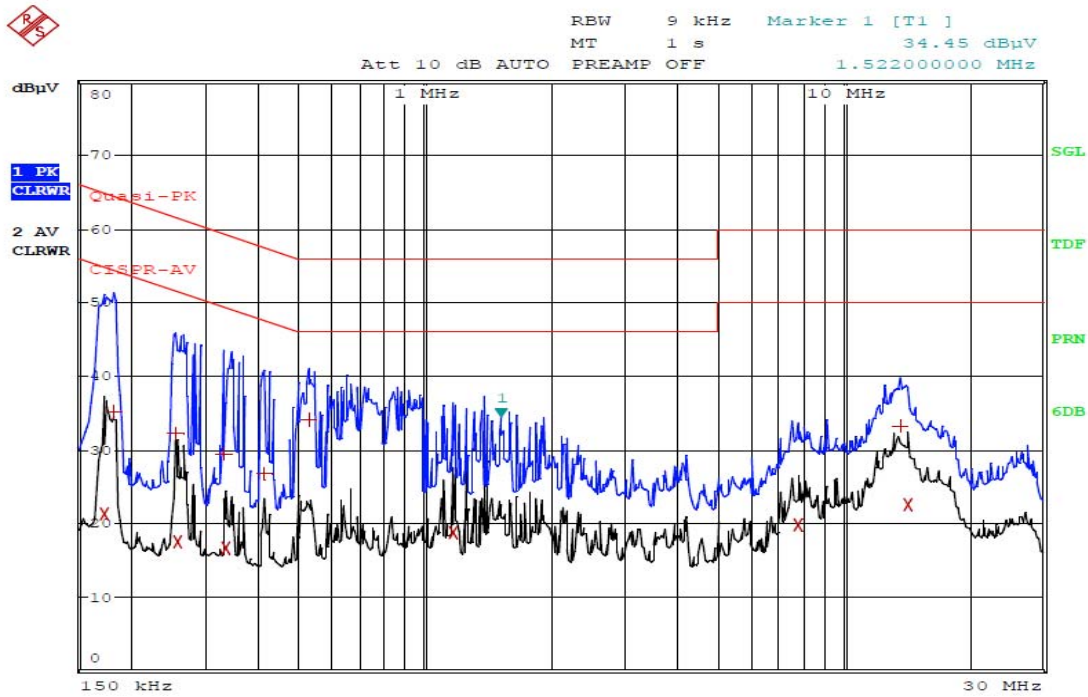

Comment: 14-00824_HOT(802.11n, CH 60-5300 MHz)
 Date: 15.JUL.2014 11:48:43

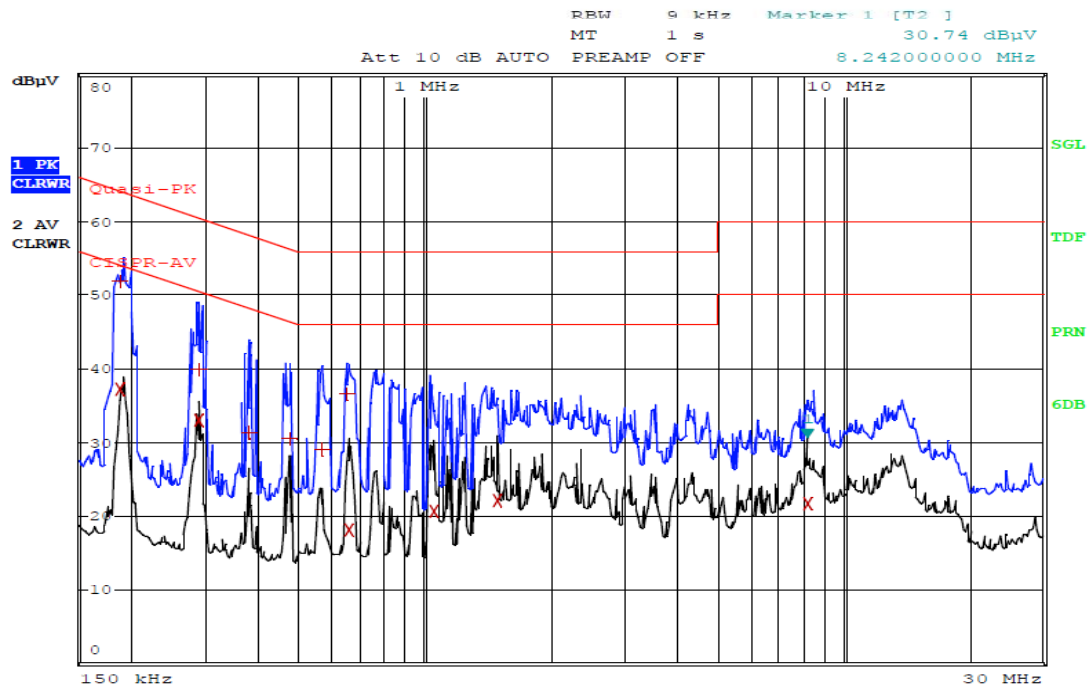

Comment: 14-00824_NEUTRAL(802.11n, CH 60-5300 MHz)
 Date: 15.JUL.2014 11:44:41

Appendix 1. Special diagram for Wireless LAN

*802.11n – CH 116(5580 MHz)

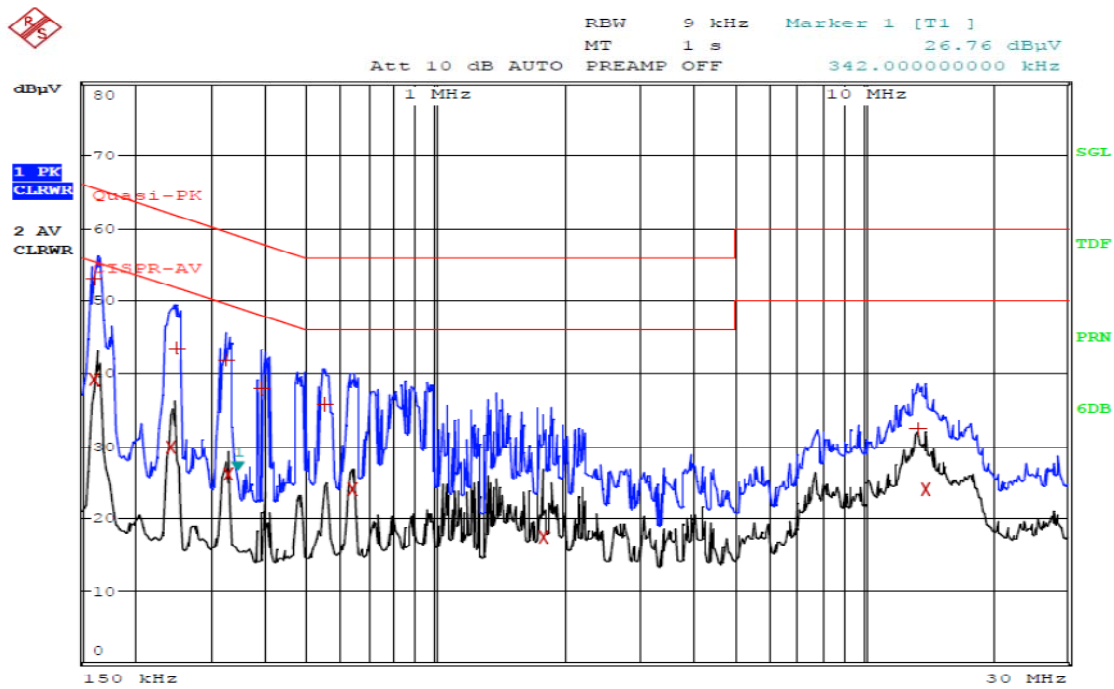

Comment: 14-00824_HOT(802.11n, CH 116-5580 MHz)
 Date: 14.JUL.2014 10:20:15

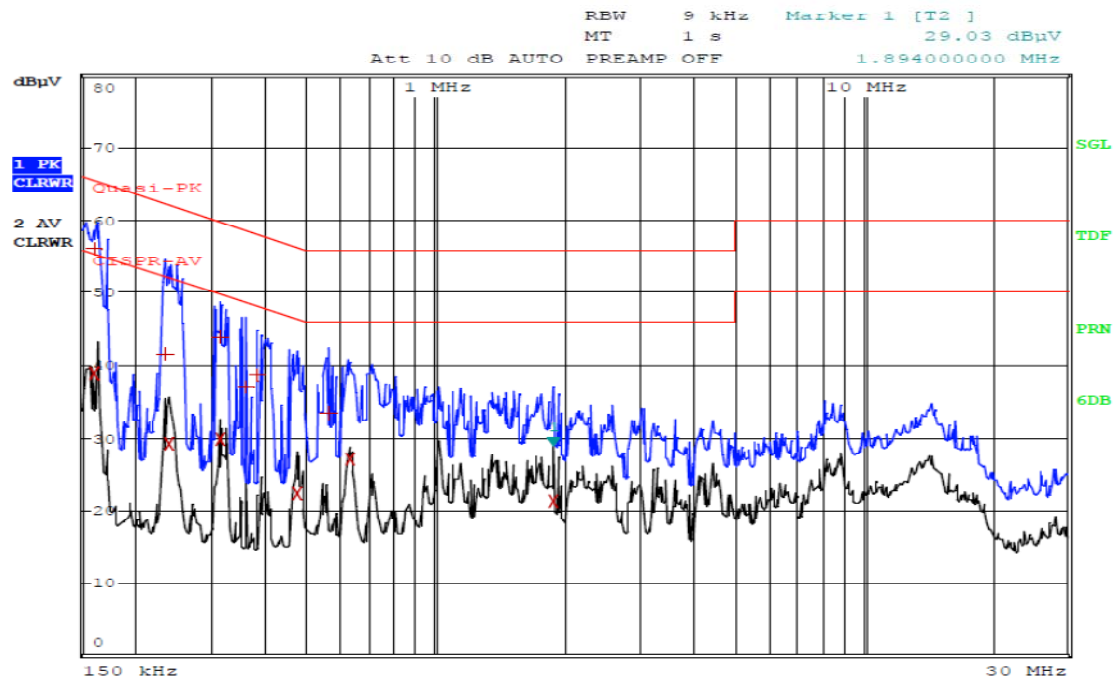

Comment: 14-00824_NEUTRAL(802.11n, CH 116-5580 MHz)
 Date: 14.JUL.2014 10:15:58