



Neutron Engineering Inc.

FCC Radio Test Report

FCC ID: UZZW3TRANSMITTER

This report concerns (check one): Original Grant Class II Change

Issued Date : Feb. 16, 2012
Project No. : 1201C005
Equipment : Wireless Audio Sender
Model Name : W3
Applicant : Beautiful Enterprise Co., Ltd.
Address : 26th Floor, Beautiful Group Tower, 77 Connaught Road Central, Hong Kong

Tested by:
Neutron Engineering Inc. EMC Laboratory
Date of Receipt: Jan. 04, 2012
Date of Test:
Jan. 04, 2012 ~ Feb. 15, 2012

Testing Engineer : David Mao
(David Mao)

Technical Manager : Leo Hung
(Leo Hung)

Authorized Signatory : Steven Lu
(Steven Lu)

Neutron Engineering Inc.

**No.3, Jinshagang 1st Road, ShiXia, Dalang
Town, Dong Guan, China.
TEL : (0769) 8318-3000 FAX : (0769) 8319-6000**



Declaration

Neutron represents to the client that testing is done in accordance with standard procedures as applicable and that test instruments used has been calibrated with the standards traceable to National Measurement Laboratory (**NML**) of **R.O.C.**, or National Institute of Standards and Technology (**NIST**) of **U.S.A.**

Neutron's reports apply only to the specific samples tested under conditions. It is manufacture's responsibility to ensure that additional production units of this model are manufactured with the identical electrical and mechanical components. **Neutron** shall have no liability for any declarations, inferences or generalizations drawn by the client or others from **Neutron** issued reports.

Neutron's reports must not be used by the client to claim product endorsement by the authorities or any agency of the Government.

This report is the confidential property of the client. As a mutual protection to the clients, the public and **Neutron-self**, extracts from the test report shall not be reproduced except in full with **Neutron's** authorized written approval.

Neutron's laboratory quality assurance procedures are in compliance with the **ISO Guide 17025** requirements, and accredited by the conformity assessment authorities listed in this test report.

Limitation

For the use of the authority's logo is limited unless the Test Standard(s)/Scope(s)/Item(s) mentioned in this test report is (are) included in the conformity assessment authorities acceptance respective.



Table of Contents	Page
1 . CERTIFICATION	5
2 . SUMMARY OF TEST RESULTS	6
2.1 TEST FACILITY	7
2.2 MEASUREMENT UNCERTAINTY	7
3 . GENERAL INFORMATION	8
3.1 GENERAL DESCRIPTION OF EUT	8
3.2 DESCRIPTION OF TEST MODES	10
3.3 TABLE OF PARAMETERS OF TEXT SOFTWARE SETTING	11
3.4 BLOCK DIGRAM SHOWING THE CONFIGURATION OF SYSTEM TESTED	12
3.5 DESCRIPTION OF SUPPORT UNITS	14
4 . EMC EMISSION TEST	15
4.1 CONDUCTED EMISSION MEASUREMENT	15
4.1.1 POWER LINE CONDUCTED EMISSION LIMITS	15
4.1.2 MEASUREMENT INSTRUMENTS LIST	15
4.1.3 TEST PROCEDURE	16
4.1.4 DEVIATION FROM TEST STANDARD	16
4.1.5 TEST SETUP	16
4.1.6 EUT OPERATING CONDITIONS	16
4.1.7 TEST RESULTS	17
4.2 RADIATED EMISSION MEASUREMENT	21
4.2.1 RADIATED EMISSION LIMITS	21
4.2.2 MEASUREMENT INSTRUMENTS LIST	22
4.2.3 TEST PROCEDURE	23
4.2.4 DEVIATION FROM TEST STANDARD	23
4.2.5 TEST SETUP	24
4.2.6 EUT OPERATING CONDITIONS	24
4.2.7 TEST RESULTS (BELOW 30MHz)	25
4.2.8 TEST RESULTS (BETWEEN 30 – 1000 MHz)	26
4.2.9 TEST RESULTS (ABOVE 1000 MHz)	28
5 . BANDWIDTH TEST	40
5.1 APPLIED PROCEDURES / LIMIT	40
5.1.1 MEASUREMENT INSTRUMENTS LIST	40
5.1.2 TEST PROCEDURE	40
5.1.3 DEVIATION FROM STANDARD	40
5.1.4 TEST SETUP	40
5.1.5 EUT OPERATION CONDITIONS	40



Table of Contents	Page
5.1.6 TEST RESULTS	41
6 . MAXIMUM OUTPUT POWER TEST	43
6.1 APPLIED PROCEDURES / LIMIT	43
6.1.1 MEASUREMENT INSTRUMENTS LIST	43
6.1.2 TEST PROCEDURE	43
6.1.3 DEVIATION FROM STANDARD	43
6.1.4 TEST SETUP	43
6.1.5 EUT OPERATION CONDITIONS	43
6.1.6 TEST RESULTS	44
7 . ANTENNA CONDUCTED SPURIOUS EMISSION	46
7.1 APPLIED PROCEDURES / LIMIT	46
7.1.1 MEASUREMENT INSTRUMENTS LIST	46
7.1.2 TEST PROCEDURE	46
7.1.3 DEVIATION FROM STANDARD	46
7.1.4 TEST SETUP	46
7.1.5 EUT OPERATION CONDITIONS	46
7.1.6 TEST RESULTS	47
8 . POWER SPECTRAL DENSITY TEST	52
8.1 APPLIED PROCEDURES / LIMIT	52
8.1.1 MEASUREMENT INSTRUMENTS LIST	52
8.1.2 TEST PROCEDURE	52
8.1.3 DEVIATION FROM STANDARD	52
8.1.4 TEST SETUP	52
8.1.5 EUT OPERATION CONDITIONS	52
8.1.6 TEST RESULTS	53
9 . EUT TEST PHOTO	55



1. CERTIFICATION

Equipment: Wireless Audio Sender

Brand Name :  **audioengine**

Model Name.: W3

Applicant: Beautiful Enterprise Co., Ltd.

Factory: Shenzhen Synchron Electronics Co., Ltd.

Address: No. 9 Mei Li Road, Xia Mei Lin, Fu Tian Area, Shenzhen, China

Date of Test: Jan. 04, 2013 ~ Feb. 12, 2012

Test Item: ENGINEERING SAMPLE

Standards: FCC Part15, Subpart C(15.247)/ ANSI C63.4 : 2003

The above equipment has been tested and found compliance with the requirement of the relative standards by Neutron Engineering Inc. EMC Laboratory.

The test data, data evaluation, and equipment configuration contained in our test report (Ref No. NEI-FCCP-1-1201C005) were obtained utilizing the test procedures, test instruments, test sites that has been accredited by the Authority of NVLAP and TAF according to the ISO-17025 quality assessment standard and technical standard(s).



2. SUMMARY OF TEST RESULTS

Test procedures according to the technical standards:

FCC Part15 (15.247) , Subpart C			
StandardSection	Test Item	Judgment	Remark
15.207	Conducted Emission	PASS	
15.247(d)	Antenna conducted Spurious Emission	PASS	
15.247(a)(2)	6dB Bandwidth	PASS	
15.247(b)(3)	Peak Output Power	PASS	
15.209/15.205	Radiated Spurious Emission	PASS	
15.247(e)	Power Spectral Density	PASS	
15.203	Antenna Requirement	PASS	

NOTE:

(1) " N/A " denotes test is not applicable in this Test Report



2.1 TEST FACILITY

The test facilities used to collect the test data in this report is **DG-C02/DG-CB03** at the location of No.3,Jinshagang 1st Road, ShiXia, Dalang Town,Dong Guan, China.523792

DG-C02 : (FCC RN: 247470)

DG-CB03 : (VCCI RN: G-95; FCC RN: 319330; IC Assigned Code: 4428B-1)

2.2 MEASUREMENT UNCERTAINTY

Where relevant, the following measurement uncertainty levels have been estimated for tests performed on the EUT as specified in CISPR 16-4-2:

The reported uncertainty of measurement $y \pm U$, where expanded uncertainty U is based on a standard uncertainty multiplied by a coverage factor of $k=2$, providing a level of confidence of approximately **95 %**.

A. Conducted Measurement :

Test Site	Method	Measurement Frequency Range	U , (dB)	NOTE
DG-C02	CISPR	150 KHz ~ 30MHz	1.94	

B. Radiated Measurement :

Test Site	Method	Measurement Frequency Range	Ant. H / V	U , (dB)	NOTE
DG-CB03	CISPR	30MHz ~ 200MHz	V	2.48	
		30MHz ~ 200MHz	H	2.16	
		200MHz ~ 1,000MHz	V	2.50	
		200MHz ~ 1,000MHz	H	2.66	



3. GENERAL INFORMATION

3.1 GENERAL DESCRIPTION OF EUT

Equipment	Wireless Audio Sender
Brand Name	audioengine
Model Name.	W3
OEM Brand/Model Name	N/A
Model Difference	N/A
Product Description	The EUT is a Wireless Audio Sender.
	Operation Frequency: 2405~2477 MHz
	Modulation Type: $\pi/4$ -DQPSK
	Date rate: 2Kbps
	Number of Channel 37CH .Please see Note 2.
	Antenna Designation: Please see Note 3.
	Antenna Gain(Peak) (please see page 9)
	Output Power: -2.83dBm
	Based on the application, features, or specification exhibited in User's Manual, the EUT is considered as an ITE/Computing Device. More details of EUT technical specification, please refer to the User's Manual.
Channel List	Please refer to the Note 2.
Power Source	#1 DC Voltage supplied from AC/DC adapter. Brand: audioengine Model:GPE060B-050100-Z
	#2 DC Voltage supplied from Host System
Power Rating	#1 I/P AC 100-240V~50/60Hz 0.2A O/P DC 5V 1000mA #2 I/P AC 120V/60Hz O/P DC 5V
Connecting I/O Port(s)	Please refer to the User's Manual

Note:

1. For a more detailed features description, please refer to the manufacturer's specifications or the User's Manual.



2.

Channel	Frequency (MHz)	Channel	Frequency (MHz)
01	2405MHz	20	2443MHz
02	2407MHz	21	2445MHz
03	2409MHz	22	2447MHz
04	2411MHz	23	2449MHz
05	2413MHz	24	2451MHz
06	2415MHz	25	2453MHz
07	2417MHz	26	2455MHz
08	2419MHz	27	2457MHz
09	2421MHz	28	2459MHz
10	2423MHz	29	2461MHz
11	2425MHz	30	2463MHz
12	2427MHz	31	2465MHz
13	2429MHz	32	2467MHz
14	2431MHz	33	2469MHz
15	2433MHz	34	2471MHz
16	2435MHz	35	2473MHz
17	2437MHz	36	2475MHz
18	2439MHz	37	2477MHz
19	2441MHz		

3. Table for Filed Antenna

Ant.	Brand	Model Name	Antenna Type	Connector	Gain (dBi)
E1	N/A	N/A	Chip Antenna	N/A	2
E2	N/A	N/A	Chip Antenna	N/A	2

Only “one” antenna is selected for use at any one time.



3.2 DESCRIPTION OF TEST MODES

To investigate the maximum EMI emission characteristics generated from EUT, the test system was pre-scanning tested based on the consideration of following EUT operation mode or test configuration mode which possible have effect on EMI emission level. Each of these EUT operation mode(s) or test configuration mode(s) mentioned above was evaluated respectively.

Pretest Mode	Description
Mode 1	CH Lower – 2405MHz
Mode 2	CH Middle – 2441MHz
Mode 3	CH Highest -2477MHz
Mode 4	Wireless - PC MODE
Mode 5	Wireless - Adapter Supply

The EUT system operated these modes were found to be the worst case during the pre-scanning test as Following:

For Conducted Test	
Final Test Mode	Description
Mode 4	Wireless - PC MODE
Mode 5	Wireless - Adapter Supply

For Radiated Test	
Final Test Mode	Description
Mode 1	CH Lower – 2405MHz
Mode 2	CH Middle – 2441MHz
Mode 3	CH Highest -2477MHz

Note:

(1) The measurements are performed at the highest, middle, lowest available channels.



3.3 TABLE OF PARAMETERS OF TEXT SOFTWARE SETTING

During testing channel & power controlling software provided by the customer was used to control the operating channel as well as the output power level. The RF output power selection is for the setting of RF output power expected by the customer and is going to be fixed on the firmware of the final end product power parameters:

Test software Version	Test Program: AMD2debug		
Frequency	2405 MHz	2441 MHz	2477 MHz
	N/A	N/A	N/A

3.4 BLOCK DIGRAM SHOWING THE CONFIGURATION OF SYSTEM TESTED

Conducted:

Wireless - PC MODE

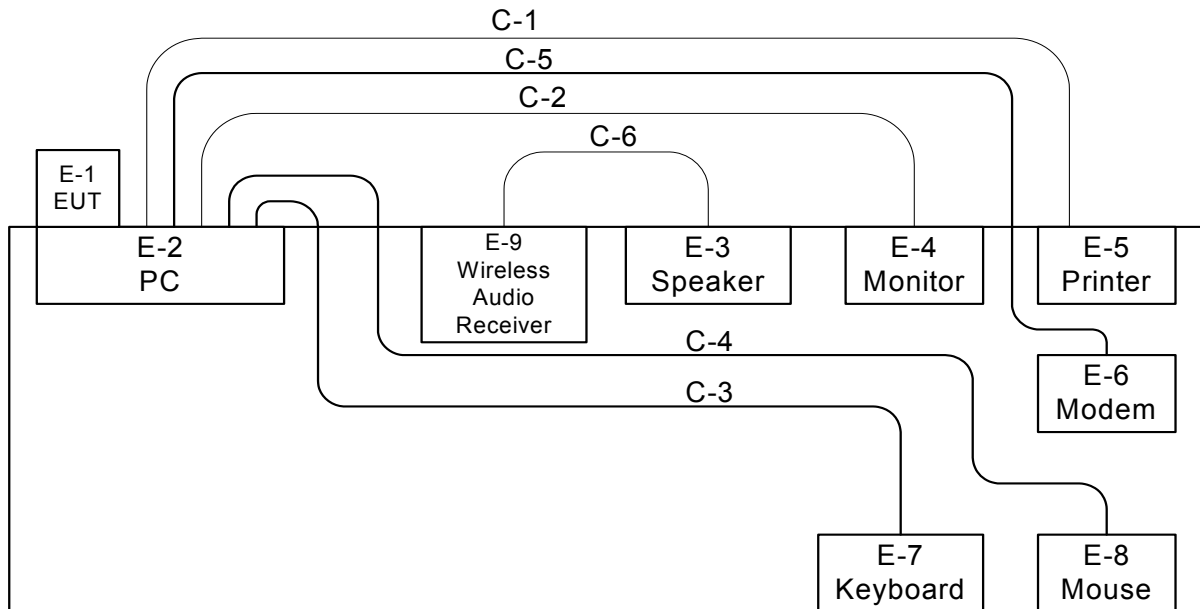

Wireless - Adapter Supply

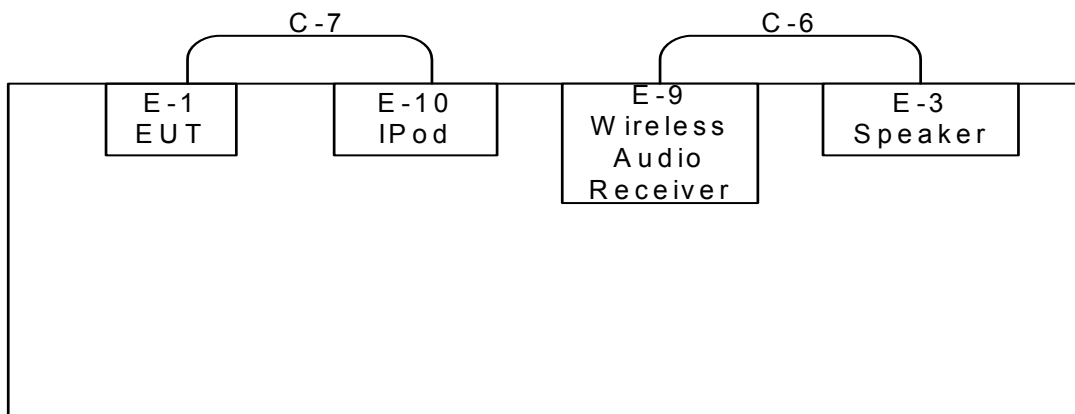

- C-1: Parallel Cable
- C-2: D-Sub Cable
- C-3: USB Cable
- C-4: USB Cable
- C-5: RS232 Cable
- C-6: Audio Cable
- C-7: Audio Cable



Radiated:

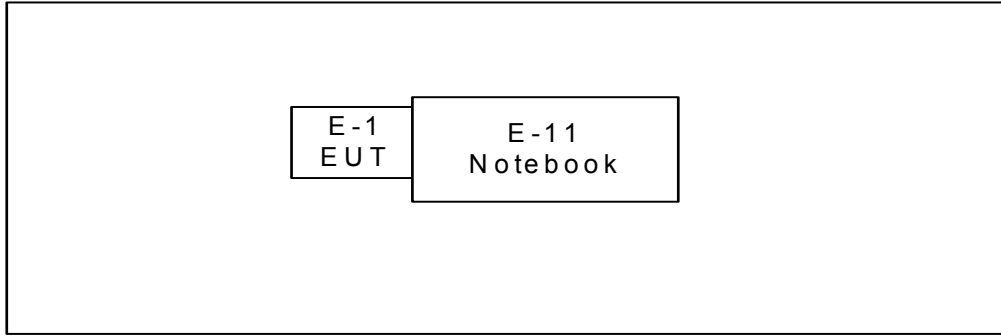



3.5 DESCRIPTION OF SUPPORT UNITS

The EUT has been tested as an independent unit together with other necessary accessories or support units. The following support units or accessories were used to form a representative test configuration during the tests.

Item	Equipment	Mfr/Brand	Model/Type No.	FCC ID	Series No.	Note
E-1	Wireless Audio Sender	audioengine	W3	UZZW3TRANSMITTER	N/A	EUT
E-2	PC	Dell 745	DCSM	DOC	G7K832X	
E-3	Speak	iHome	iDM15	N/A	N/A	
E-4	LCD monitor	Dell	E177FPc	DOC	CNOFJ179-64180-6A G-1WNS	
E-5	Printer	SII	DPU-414	DOC	3018507 B	
E-6	Modem	ACEEX	DM-1414V	IFAXDm1414	0603002131	
E-7	USB Keyboard	Dell	L100	DOC	CNORH6596589071T 08NE	
E-8	USB Mouse	Dell	MO56UOA	DOC	FQJ000BS	
E-9	Wireless Audio Receiver	audioengine	W3	UZZW3RECEIVER	N/A	
E-10	Ipod MP4	APPLE	A1136	DOC	8M637MYXV9M	
E-11	NETBOOK	DELL	1420	N/A	N/A	

Item	Shielded Type	Ferrite Core	Length	Note
C-1	YES	NO	1.8M	
C-2	YES	YES	1.8M	
C-3	YES	YES	1.5M	
C-4	YES	NO	1.5m	
C-5	NO	NO	1.8M	
C-6	NO	NO	0.5M	
C-7	NO	NO	0.5M	

Note:

- (1) The support equipment was authorized by Declaration of Confirmation.
- (2) For detachable type I/O cable should be specified the length in m in 『Length』 column.



4. EMC EMISSION TEST

4.1 CONDUCTED EMISSION MEASUREMENT

4.1.1 POWER LINE CONDUCTED EMISSION LIMITS (Frequency Range 150KHz-30MHz)

FREQUENCY (MHz)	Class A (dBuV)		Class B (dBuV)	
	Quasi-peak	Average	Quasi-peak	Average
0.15 -0.5	79.00	66.00	66 - 56 *	56 - 46 *
0.50 -5.0	73.00	60.00	56.00	46.00
5.0 -30.0	73.00	60.00	60.00	50.00

Note:

- (1) The tighter limit applies at the band edges.
- (2) The limit of " * " marked band means the limitation decreases linearly with the logarithm of the frequency in the range.

4.1.2 MEASUREMENT INSTRUMENTS LIST

Item	Kind of Equipment	Manufacturer	Type No.	Serial No.	Calibrated until
1	LISN	EMCO	3816/2	00052765	May.26.2012
2	LISN	R&S	ENV216	100087	May.26.2012
3	Test Cable	N/A	C_17	N/A	Mar.30.2012
4	EMI TEST RECEIVER	R&S	ESCS30	826547/022	May.26.2012
5	50Ω Terminator	SHX	TF2-3G-A	08122902	May.26.2012

Remark: " N/A" denotes No Model Name. , Serial No. or No Calibration specified.

The following table is the setting of the receiver

Wireless Audio Sender Parameters	Setting
Attenuation	10 dB
Start Frequency	0.15 MHz
Stop Frequency	30 MHz
IF Bandwidth	9 kHz

4.1.3 TEST PROCEDURE

- a. The EUT was placed 0.8 meters from the horizontal ground plane with EUT being connected to the power mains through a line impedance stabilization network (LISN). All other support equipments powered from additional LISN(s). The LISN provide 50 Ohm/ 50uH of coupling impedance for the measuring instrument.
- b. Interconnecting cables that hang closer than 40 cm to the ground plane shall be folded back and forth in the center forming a bundle 30 to 40 cm long.
- c. I/O cables that are not connected to a peripheral shall be bundled in the center. The end of the cable may be terminated, if required, using the correct terminating impedance. The overall length shall not exceed 1 m.
- d. LISN at least 80 cm from nearest part of EUT chassis.
- e. For the actual test configuration, please refer to the related Item –EUT Test Photos.

4.1.4 DEVIATION FROM TEST STANDARD

No deviation

4.1.5 TEST SETUP

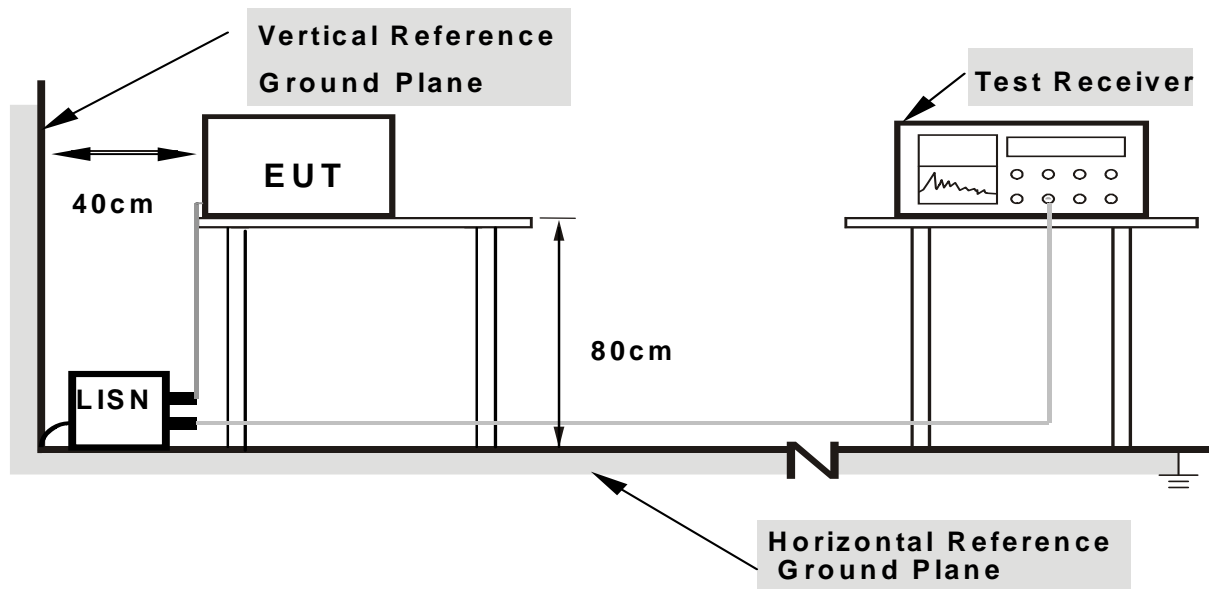

- Note: 1.Support units were connected to second LISN.**
2.Both of LISNs (AMN) are 80 cm from EUT and at least 80 from other units and other metal planes

4.1.6 EUT OPERATING CONDITIONS

The EUT was configured for testing in a typical fashion (as a customer would normally use it). The EUT has been programmed to continuously transmit during test. This operating condition was tested and used to collect the included data.

The EUT was programmed to be in continuously transmitting mode.



4.1.7 TEST RESULTS

EUT :	Wireless Audio Sender	Model Name. :	W3
Temperature :	25 °C	Relative Humidity :	58 %
Pressure :	1009 hPa	Test Power :	AC 120V/60Hz
Test Mode :	PC MODE		

Freq. (MHz)	Terminal L/N	Measured(dBuV)		Limits(dBuV)		Margin (dB)	Note
		QP-Mode	AV-Mode	QP-Mode	AV-Mode		
0.23	Line	36.71	*	62.38	52.38	-25.67	(QP)
0.53	Line	35.82	*	56.00	46.00	-20.18	(QP)
0.80	Line	37.87	*	56.00	46.00	-18.13	(QP)
1.34	Line	41.15	*	56.00	46.00	-14.85	(QP)
1.51	Line	43.92	*	56.00	46.00	-12.08	(QP)
2.14	Line	40.58	*	56.00	46.00	-15.42	(QP)

Remark

- (1) All readings are QP Mode value unless otherwise stated AVG in column of Note. If the QP Mode Measured value compliance with the QP Limits and lower than AVG Limits, the EUT shall be deemed to meet both QP & AVG Limits and then only QP Mode was measured, but AVG Mode didn't perform. In this case, a " * " marked in AVG Mode column of Interference Voltage Measured.
- (2) Measuring frequency range from 150KHz to 30MHz.
- (3) " N/A" denotes test is not applicable in this Test Report.

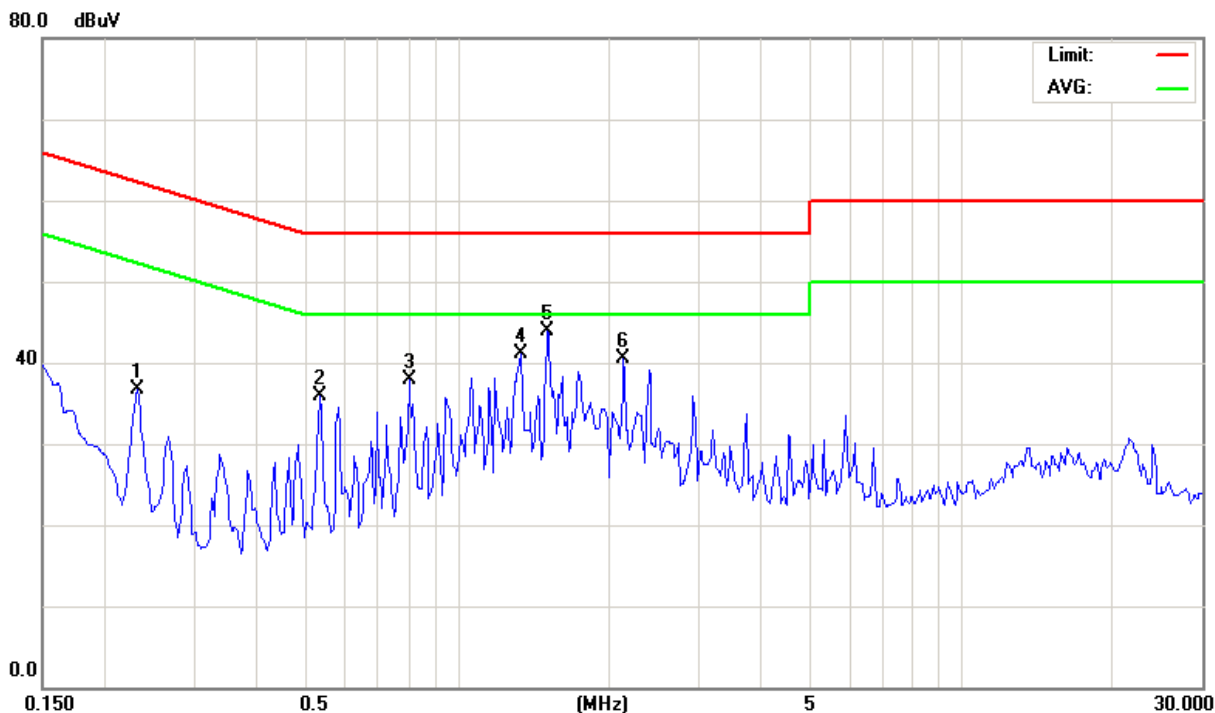



EUT :	Wireless Audio Sender	Model Name. :	W3
Temperature :	25 °C	Relative Humidity :	58 %
Pressure :	1009 hPa	Test Power :	AC 120V/60Hz
Test Mode :	PC MODE		

Freq. (MHz)	Terminal L/N	Measured(dBuV)		Limits(dBuV)		Margin (dB)	Note
		QP-Mode	AV-Mode	QP-Mode	AV-Mode		
0.15	Neutral	38.80	*	66.00	56.00	-27.20	(QP)
0.23	Neutral	38.73	*	62.38	52.38	-23.65	(QP)
0.58	Neutral	33.79	*	56.00	46.00	-22.21	(QP)
0.80	Neutral	35.42	*	56.00	46.00	-20.58	(QP)
1.61	Neutral	32.08	*	56.00	46.00	-23.92	(QP)
5.88	Neutral	31.50	*	60.00	50.00	-28.50	(QP)

Remark

- (1) All readings are QP Mode value unless otherwise stated AVG in column of Note. If the QP Mode Measured value compliance with the QP Limits and lower than AVG Limits, the EUT shall be deemed to meet both QP & AVG Limits and then only QP Mode was measured, but AVG Mode didn't perform. In this case, a "*" marked in AVG Mode column of Interference Voltage Measured.
- (2) Measuring frequency range from 150KHz to 30MHz.
- (3) "N/A" denotes test is not applicable in this Test Report.

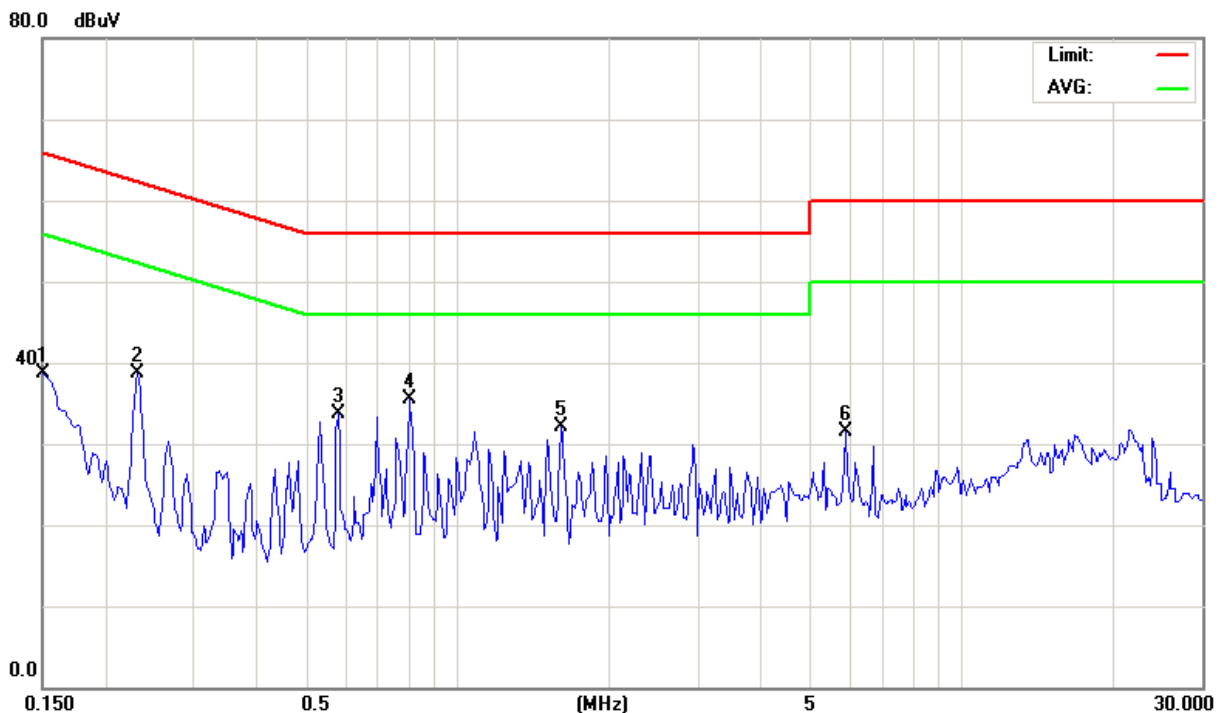



EUT :	Wireless Audio Sender	Model Name. :	W3
Temperature :	25 °C	Relative Humidity :	58 %
Pressure :	1009 hPa	Test Power :	AC 120V/60Hz
Test Mode :	Adapter Supply		

Freq. (MHz)	Terminal L/N	Measured(dBuV)		Limits(dBuV)		Margin (dB)	Note
		QP-Mode	AV-Mode	QP-Mode	AV-Mode		
0.25	Line	42.98	*	61.83	51.83	-18.85	(QP)
0.32	Line	48.73	34.38	59.76	49.76	-11.03	(QP)
0.56	Line	43.01	*	56.00	46.00	-12.99	(QP)
1.16	Line	40.38	*	56.00	46.00	-15.62	(QP)
1.78	Line	40.55	*	56.00	46.00	-15.45	(QP)
4.11	Line	37.86	*	56.00	46.00	-18.14	(QP)

Remark

- (1) All readings are QP Mode value unless otherwise stated AVG in column of Note. If the QP Mode Measured value compliance with the QP Limits and lower than AVG Limits, the EUT shall be deemed to meet both QP & AVG Limits and then only QP Mode was measured, but AVG Mode didn't perform. In this case, a "*" marked in AVG Mode column of Interference Voltage Measured.
- (2) Measuring frequency range from 150KHz to 30MHz.
- (3) "N/A" denotes test is not applicable in this Test Report.

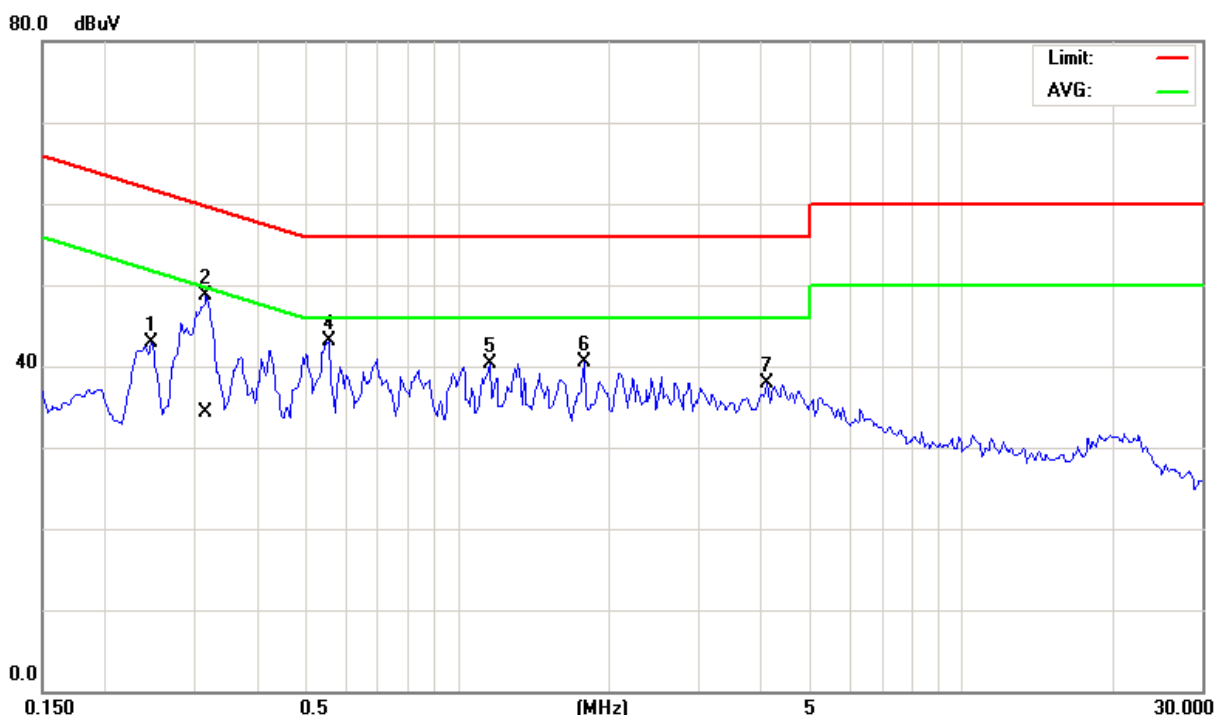



EUT :	Wireless Audio Sender	Model Name. :	W3
Temperature :	25 °C	Relative Humidity :	58 %
Pressure :	1009 hPa	Test Power :	AC 120V/60Hz
Test Mode :	Adapter Supply		

Freq. (MHz)	Terminal L/N	Measured(dBuV)		Limits(dBuV)		Margin (dB)	Note
		QP-Mode	AV-Mode	QP-Mode	AV-Mode		
0.32	Neutral	40.72	*	59.76	49.76	-19.04	(QP)
0.46	Neutral	35.87	*	56.65	46.65	-20.78	(QP)
0.63	Neutral	36.76	*	56.00	46.00	-19.24	(QP)
1.07	Neutral	34.20	*	56.00	46.00	-21.80	(QP)
4.63	Neutral	33.49	*	56.00	46.00	-22.51	(QP)
19.41	Neutral	31.82	*	60.00	50.00	-28.18	(QP)

Remark

- (1) All readings are QP Mode value unless otherwise stated AVG in column of Note. If the QP Mode Measured value compliance with the QP Limits and lower than AVG Limits, the EUT shall be deemed to meet both QP & AVG Limits and then only QP Mode was measured, but AVG Mode didn't perform. In this case, a "*" marked in AVG Mode column of Interference Voltage Measured.
- (2) Measuring frequency range from 150KHz to 30MHz.
- (3) "N/A" denotes test is not applicable in this Test Report.

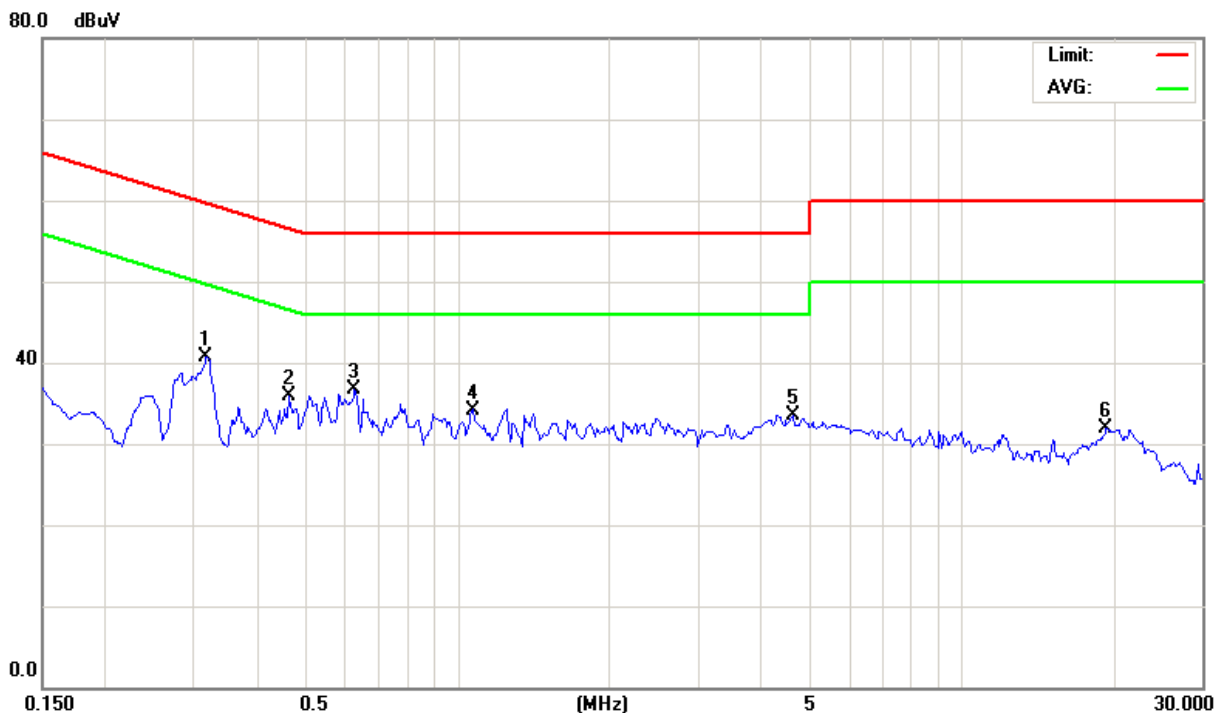



4.2 RADIATED EMISSION MEASUREMENT

4.2.1 RADIATED EMISSION LIMITS (Frequency Range 9KHz-1000MHz)

20dBc in any 100 kHz bandwidth outside the operating frequency band. In case the emission fall within the restricted band specified on 15.205(a), then the 15.209(a) limit in the table below has to be followed.

Frequencies (MHz)	Field Strength (micorvolts/meter)	Measurement Distance (meters)
0.009~0.490	2400/F(KHz)	300
0.490~1.705	24000/F(KHz)	30
1.705~30.0	30	30
30~88	100	3
88~216	150	3
216~960	200	3
Above 960	500	3

LIMITS OF RADIATED EMISSION MEASUREMENT (Above 1000MHz)

FREQUENCY (MHz)	(dBuV/m) (at 3m)	
	PEAK	AVERAGE
Above 1000	74	54

Notes:

- (1) The limit for radiated test was performed according to FCC PART 15C.
- (2) The tighter limit applies at the band edges.
- (3) Emission level (dBuV/m)=20log Emission level (uV/m).

FREQUENCY RANGE OF RADIATED MEASUREMENT (For unintentional radiators)

Highest frequency generated or Upper frequency of measurement used in the device or on which the device operates or tunes (MHz)	Range (MHz)
Below 1.705	30
1.705 – 108	1000
108 – 500	2000
500 – 1000	5000
Above 1000	5 th harmonic of the highest frequency or 40 GHz, whichever is lower



4.2.2 MEASUREMENT INSTRUMENTS LIST

Item	Kind of Equipment	Manufacturer	Type No.	Serial No.	Calibrated until
1	Antenna	Schwarbeck	VULB9160	9160-3232	Jun .04.2012
2	Amplifier	HP	8447D	2944A09673	May.26.2012
3	Test Wireless Audio Sender	R&S	ESCI	100382	May.26.2012
4	Test Cable	N/A	C-01_CB03	N/A	Jul.01.2012
5	Antenna	ETS	3115	00075789	May.26.2012
6	Amplifier	Agilent	8449B	3008A02274	May.26.2012
7	Spectrum	Agilent	E4408B	US39240143	Jan. 03, 2013
8	Test Cable	HUBER+SUHNER	C-45	N/A	May.04.2012
9	Controller	CT	SC100	N/A	N/A
10	Triple Loop Antenna	Schwarzbeck	HXYZ9170	9170-110	May.26.2012
11	Active Loop Antenna	R&S	HFH2-Z2	830749/020	May.26.2012

Note

1. The calibration interval of the above test instruments is 12 months and the calibrations are traceable to NML/ROC and NIST/USA.
2. The test was performed in DG-CB03 (Below 1GHz/Above 1GHz)
3. The Horn antenna and HP preamplifier (model: 8449B) /EMC preamplifier (model: EMC2654045) are used only for the measurement of emission frequency above 1GHz if tested.
4. The IC Site Registration No. is 4428B-1 (DG-CB03)
5. The FCC Site Registration No. is 319330 (DG-CB03)

Spectrum Parameter	Setting
Attenuation	Auto
Start Frequency	1000 MHz
Stop Frequency	10th carrier harmonic
RB / VB (emission in restricted band)	1 MHz / 1 MHz for Peak, Average=PK-duty cycle

Wireless Audio Sender Parameter	Setting
Attenuation	Auto
Start ~ Stop Frequency	9kHz~150kHz / RB 200Hz for QP
Start ~ Stop Frequency	150kHz~30MHz / RB 9kHz for QP
Start ~ Stop Frequency	30MHz~1000MHz / RB 120kHz for QP



4.2.3 TEST PROCEDURE

- a. The measuring distance of at 3 m shall be used for measurements at frequency up to 1GHz. For frequencies above 1GHz, any suitable measuring distance may be used.
- b. The EUT was placed on the top of a rotating table 0.8 meters above the ground at a 3m meter semi-anechoic chamber. The table was rotated 360 degrees to determine the position of the highest radiation.
- c. The height of the equipment or of the substitution antenna shall be 0.8 m; the height of the test antenna shall vary between 1 m to 4 m. Both horizontal and vertical polarizations of the antenna are set to make the measurement.
- d. The initial step in collecting conducted emission data is a spectrum analyzer peak detector mode pre-scanning the measurement frequency range. Significant peaks are then marked and then Quasi Peak detector mode re-measured.
- e. If the Peak Mode measured value compliance with and lower than Quasi Peak Mode Limit, the EUT shall be deemed to meet QP Limits and then no additional QP Mode measurement performed.
- f. For the actual test configuration, please refer to the related Item –EUT Test Photos.

4.2.4 DEVIATION FROM TEST STANDARD

No deviation

4.2.5 TEST SETUP

(A) Radiated Emission Test Set-Up Frequency Below 1 GHz

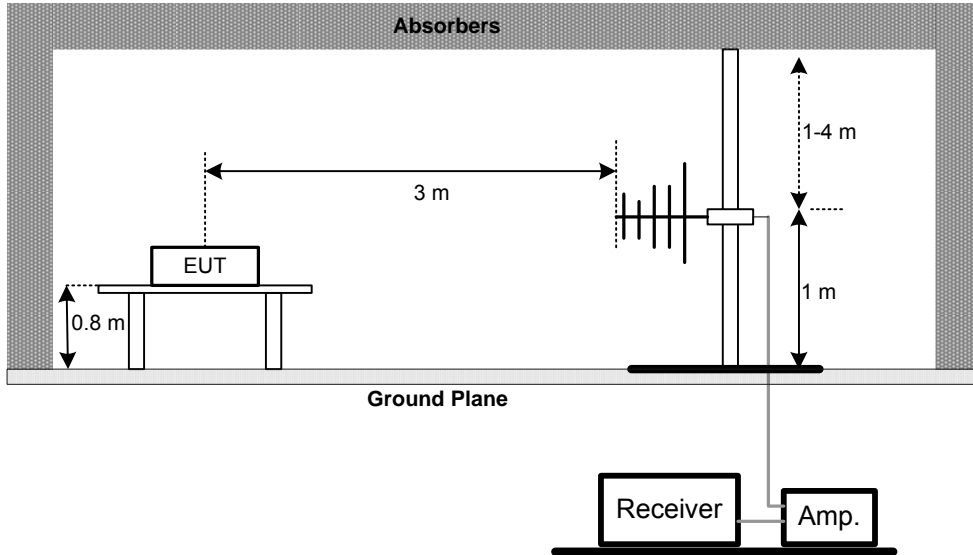

(B) Radiated Emission Test Set-Up Frequency Above 1 GHz

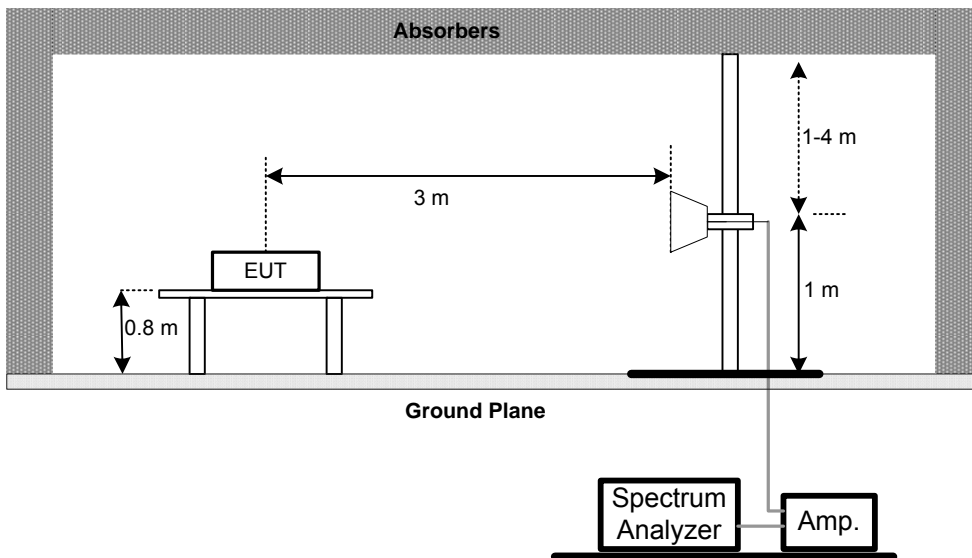

4.2.6 EUT OPERATING CONDITIONS

The EUT tested system was configured as the statements of 4.1.6 Unless otherwise a special operating condition is specified in the follows during the testing.



4.2.7 TEST RESULTS (BELOW 30MHz)

EUT :	Wireless Audio Sender	Model Name. :	W3
Temperature :	25°C	Relative Humidity :	58 %
Pressure :	1009 hPa	Test Power :	AC 120V/60Hz
Test Mode :	TX Mode		

Freq. (MHz)	Ant. 0°/90°	Reading(RA) (dBuV)	Corr.Factor(CF) (dB)	Measured(FS) (dBuV/m)	Limits(QP) (dBuV/m)	Margin (dB)	Note
0.05	0°	51.12	22.53	73.65	113.98	-40.33	PK
0.50	0°	28.09	19.81	47.90	73.69	-25.79	PK
1.57	0°	28.68	19.54	48.22	63.66	-15.44	PK
4.77	0°	21.77	18.38	40.15	69.54	-29.39	PK
10.54	0°	34.30	17.83	52.13	69.54	-17.41	PK
15.49	0°	39.06	18.03	57.09	69.54	-12.45	PK

Freq. (MHz)	Ant. 0°/90°	Reading(RA) (dBuV)	Corr.Factor(CF) (dB)	Measured(FS) (dBuV/m)	Limits(QP) (dBuV/m)	Margin (dB)	Note
0.32	90°	52.04	20.23	72.27	97.47	-25.20	PK
0.88	90°	37.17	20.08	57.25	68.71	-11.46	PK
1.54	90°	24.23	19.55	43.78	63.85	-20.07	PK
7.24	90°	27.28	18.02	45.30	69.54	-24.24	PK
12.12	90°	33.54	17.93	51.47	69.54	-18.07	PK
18.25	90°	39.57	17.65	57.22	69.54	-12.33	PK

Remark :

- (1) The amplitude of spurious emissions which are attenuated by more than 20 dB below the permissible value has no need to be reported ◦
- (2) Distance extrapolation factor = 40 log (specific distance / test distance) (dB); ◦
- (3) Limit line = specific limits (dBuV) + distance extrapolation factor. ◦



4.2.8 TEST RESULTS (BETWEEN 30 – 1000 MHz)

EUT :	Wireless Audio Sender	Model Name. :	W3
Temperature :	25°C	Relative Humidity :	58 %
Pressure :	1009 hPa	Test Power :	AC 120V/60Hz
Test Mode :	TX Mode 2405MHz		

Freq. (MHz)	Ant. H/V	Reading(RA) (dBuV)	Corr.Factor(CF) (dB)	Measured(FS) (dBuV/m)	Limits(QP) (dBuV/m)	Margin (dB)	Note
143.98	V	41.42	-17.66	23.76	43.50	- 19.74	
192.48	V	43.08	-16.69	26.39	43.50	- 17.11	
277.35	V	38.83	-12.81	26.02	46.00	- 19.98	
466.50	V	37.53	-7.87	29.66	46.00	- 16.34	
493.18	V	39.92	-7.46	32.46	46.00	- 13.54	
798.73	V	40.39	-1.90	38.49	46.00	- 7.51	

Remark :

- (1) Reading in which marked as QP or Peak means measurements by using are Quasi-Peak Mode or Peak Mode with Detector BW=120KHz ; SPA setting in RBW=120KHz, VBW =120KHz, Swp. Time = 0.3 sec./MHz ◦
- (2) Measuring frequency range from 30MHz to 1000MHz ◦
- (3) Measured level (dBuV/m)= Raw value (dBuV) + Correction Factor(dB/m).
Correction Factor (dB/m) = Antenna Factor (dB/m) + Cable Factor(dB).
Margin value = Emission level – Limit value.
- (4) All readings are Peak unless otherwise stated QP in column of 『 Note 』 . Peak denotes that the Peak reading compliance with the QP Limits and then QP Mode measurement didn't perform ◦
- (5) If the peak scan value lower limit more than 20dB, then this signal data does not show in table ◦

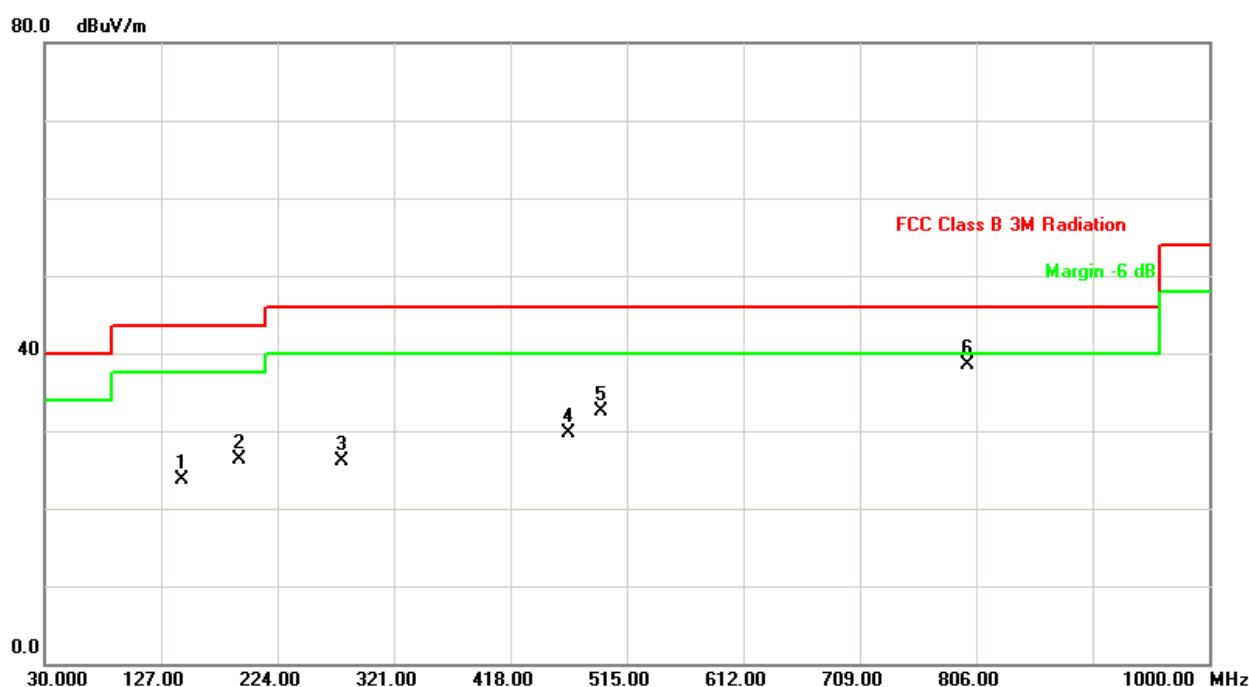



EUT :	Wireless Audio Sender	Model Name. :	W3
Temperature :	25°C	Relative Humidity :	58 %
Pressure :	1009 hPa	Test Power :	AC 120V/60Hz
Test Mode :	TX Mode 2405MHz		

Freq. (MHz)	Ant. H/V	Reading(RA) (dBUV)	Corr.Factor(CF) (dB)	Measured(FS) (dBUV/m)	Limits(QP) (dBUV/m)	Margin (dB)	Note
143.98	H	48.16	-17.66	30.50	43.50	- 13.00	
192.48	H	48.78	-16.69	32.09	43.50	- 11.41	
289.48	H	46.81	-12.08	34.73	46.00	- 11.27	
369.50	H	43.37	-10.13	33.24	46.00	- 12.76	
493.18	H	41.60	-7.46	34.14	46.00	- 11.86	
847.23	H	39.12	-0.93	38.19	46.00	- 7.81	

Remark :

- (1) Reading in which marked as QP or Peak means measurements by using are Quasi-Peak Mode or Peak Mode with Detector BW=120KHz ; SPA setting in RBW=120KHz, VBW =120KHz, Swp. Time = 0.3 sec./MHz ◦
- (2) Measuring frequency range from 30MHz to 1000MHz ◦
- (3) Measured level (dBUV/m)= Raw value (dBUV) + Correction Factor(dB/m).
Correction Factor (dB/m) = Antenna Factor (dB/m) + Cable Factor(dB).
Margin value = Emission level – Limit value.
- (4) All readings are Peak unless otherwise stated QP in column of 『 Note 』 . Peak denotes that the Peak reading compliance with the QP Limits and then QP Mode measurement didn't perform ◦
- (5) If the peak scan value lower limit more than 20dB, then this signal data does not show in table ◦

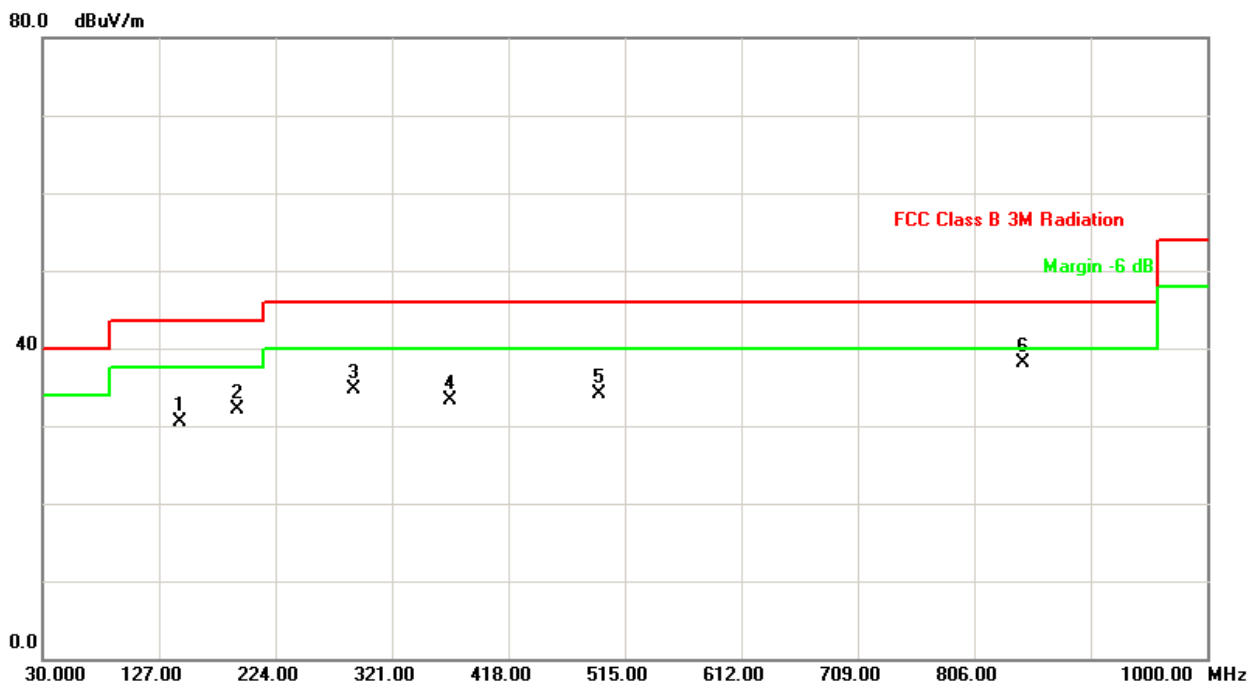



4.2.9 TEST RESULTS (ABOVE 1000 MHz)

EUT :	Wireless Audio Sender	Model Name. :	W3
Temperature :	25°C	Relative Humidity :	51%
Pressure :	1009 hPa	Test Power :	AC 120V/60Hz
Test Mode :	TX 2405MHz		

Freq. (MHz)	Ant.Pol. H/V	Reading		Ant./CF CF(dB)	Act.		Limit		Note
		Peak (dBuV)	AV (dBuV)		Peak (dBuV/m)	AV (dBuV/m)	Peak (dBuV/m)	AV (dBuV/m)	
2390.00	V	22.85	10.90	31.91	54.76	42.81	74.00	54.00	X/E
2405.13	V	59.28	56.43	31.90	91.18	88.33			X/F
4808.20	V	45.65	36.63	5.23	50.88	41.86	74.00	54.00	X/H

Remark :

- (1) All readings are Peak unless otherwise stated QP in column of 『Note』. Peak denotes that the Peak reading compliance with the QP Limits and then QP Mode measurement didn't perform.
- (2) Measuring frequency range from 30MHz to 1000MHz or the 10th harmonic of highest fundamental frequency. "F" denotes fundamental frequency; "H" denotes spurious frequency. "E" denotes band edge frequency. (This judgment method includes the Band Edge Requirement.)
- (3) Radiated emissions measured in frequency range above 1000MHz were made with an instrument using Peak detector mode and AV detector mode of the emission.
- (4) Data of measurement within this frequency range shown " * " in the table above means the reading of emissions are attenuated more than 20dB below the permissible limits or the field strength is too small to be measured.
- (5) A preamp and high pass filter were used for this test in order to provide sufficient measurement sensitivity.
- (6) EUT Orthogonal Axis :
"X" - denotes Laid on Table ; "Y" - denotes Vertical Stand ; "Z" - denotes Side Stand
- (7) During the measurements above 1 GHz it is taken care of that the EUT is always within the 3 dB cone of radiation BW of the used antenna
- (8) Reading in which marked as Peak or AVG means measurements by using are Peak Mode or AVG with Detector BW=1MHz ; SPA setting in RBW=1MHz, VBW =1MHz, Swp. Time = 0.3 sec./MHz, AVG Mode with detector BW=1MHz ; SPA setting in RBW=1MHz, VBW =10Hz, Swp. Time = 0.3 sec./MHz.
- (9) Measured level (dBuV/m)= Raw value (dBuV) + Correction Factor(dB/m).
Correction Factor (dB/m) = Antenna Factor (dB/m) + Cable Factor(dB).
Margin value = Emission level – Limit value.



TX 2405MHz (Above 1000 MHz, Vertical)

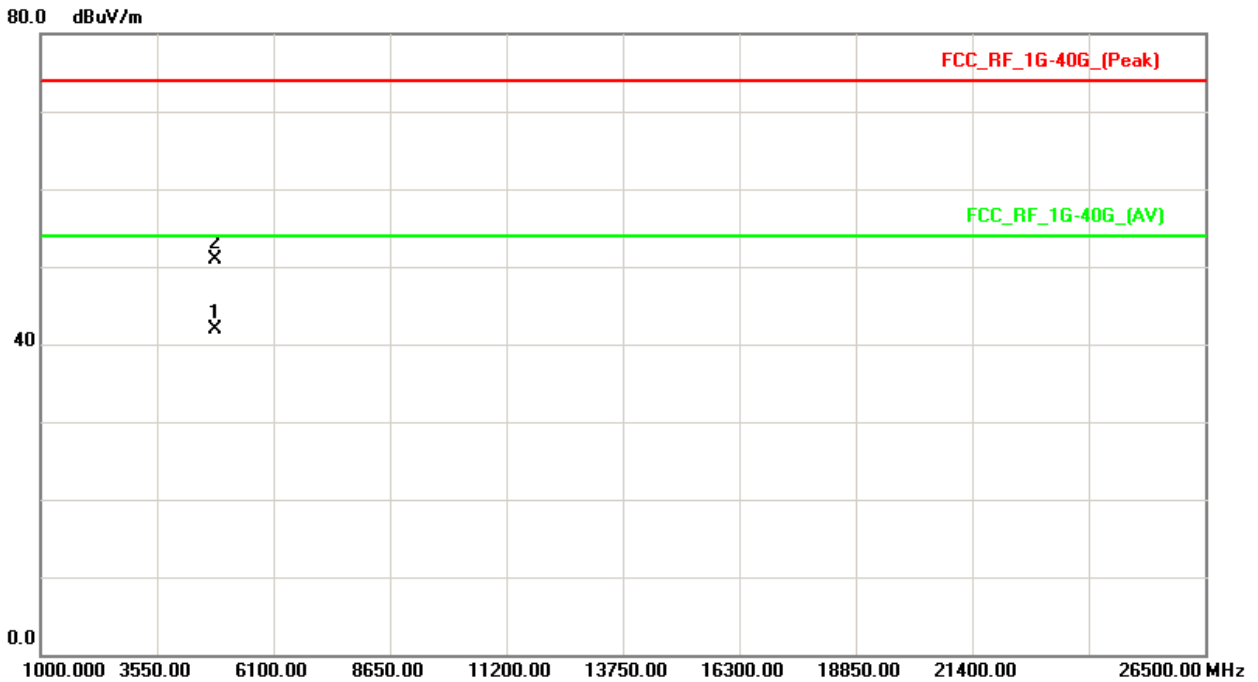
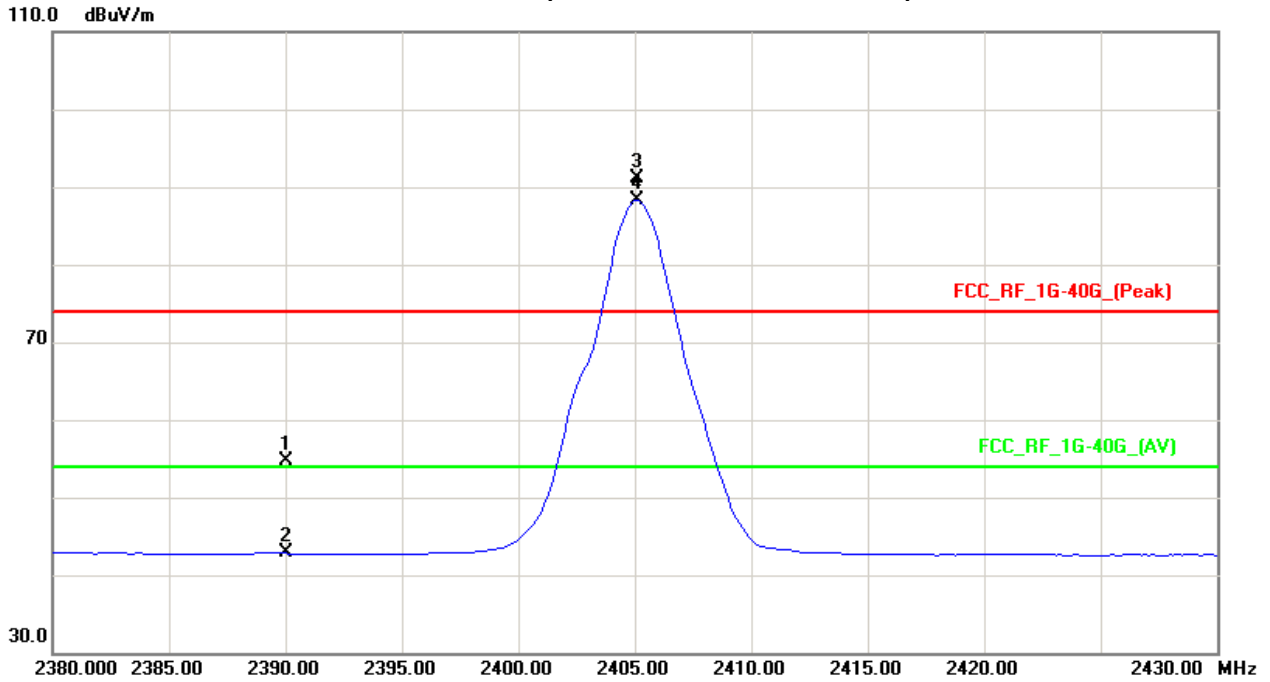



EUT :	Wireless Audio Sender	Model Name. :	W3
Temperature :	25°C	Relative Humidity :	51%
Pressure :	1009 hPa	Test Power :	AC 120V/60Hz
Test Mode :	TX 2405MHz		

Freq. (MHz)	Ant.Pol. H/V	Reading		Ant./CF CF(dB)	Act.		Limit		Note
		Peak (dBuV)	AV (dBuV)		Peak (dBuV/m)	AV (dBuV/m)	Peak (dBuV/m)	AV (dBuV/m)	
2390.00	H	22.60	11.09	31.91	54.51	43.00	74.00	54.00	X/E
2405.25	H	63.69	60.87	31.90	95.59	92.77			X/F
4808.80	H	43.62	31.17	5.23	48.85	36.40	74.00	54.00	X/H

Remark :

- (1) All readings are Peak unless otherwise stated QP in column of 『Note』 . Peak denotes that the Peak reading compliance with the QP Limits and then QP Mode measurement didn't perform ◦
- (2) Measuring frequency range from 30MHz to 1000MHz or the 10th harmonic of highest fundamental frequency ◦ "F" denotes fundamental frequency; "H" denotes spurious frequency. "E" denotes band edge frequency. (This judgment method includes the Band Edge Requirement.)
- (3) Radiated emissions measured in frequency range above 1000MHz were made with an instrument using Peak detector mode and AV detector mode of the emission ◦
- (4) Data of measurement within this frequency range shown " * " in the table above means the reading of emissions are attenuated more than 20dB below the permissible limits or the field strength is too small to be measured.
- (5) A preamp and high pass filter were used for this test in order to provide sufficient measurement sensitivity.
- (6) EUT Orthogonal Axis :
"X" - denotes Laid on Table ; "Y" - denotes Vertical Stand ; "Z" - denotes Side Stand
- (7) During the measurements above 1 GHz it is taken care of that the EUT is always within the 3 dB cone of radiation BW of the used antenna
- (8) Reading in which marked as Peak or AVG means measurements by using are Peak Mode or AVG with Detector BW=1MHz ; SPA setting in RBW=1MHz, VBW =1MHz, Swp. Time = 0.3 sec./MHz, AVG Mode with detector BW=1MHz ; SPA setting in RBW=1MHz, VBW =10Hz, Swp. Time = 0.3 sec./MHz ◦
- (9) Measured level (dBuV/m)= Raw value (dBuV) + Correction Factor(dB/m).
Correction Factor (dB/m) = Antenna Factor (dB/m) + Cable Factor(dB).
Margin value = Emission level – Limit value.



TX 2405MHz (Above 1000 MHz, Horizontal)

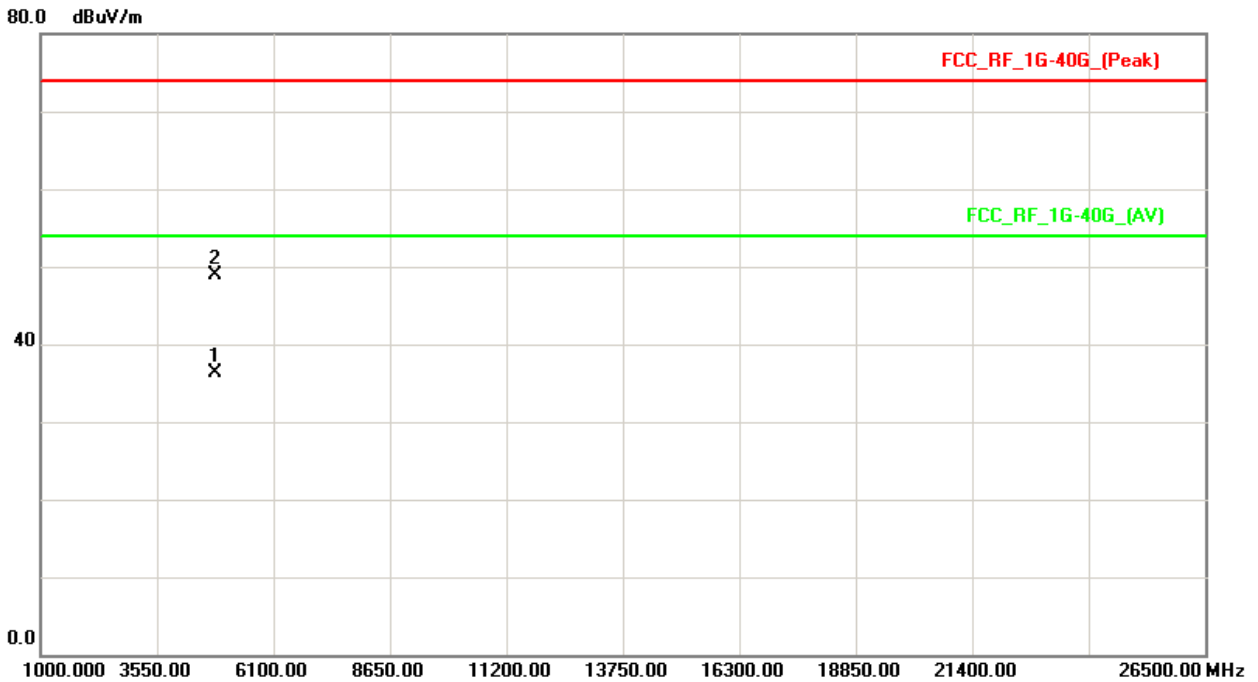
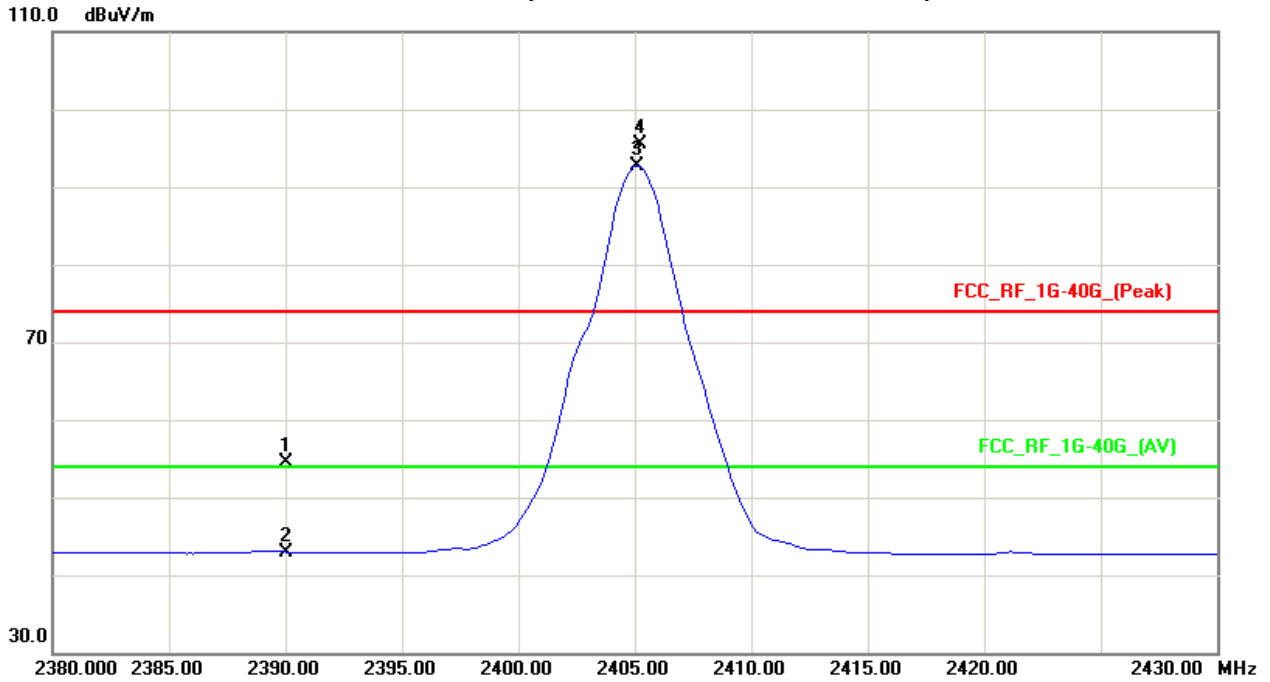



EUT :	Wireless Audio Sender	Model Name. :	W3
Temperature :	25°C	Relative Humidity :	58 %
Pressure :	1009 hPa	Test Power :	AC 120V/60Hz
Test Mode :	TX 2441MHz		

Freq. (MHz)	Ant.Pol. H/V	Reading		Ant./CF CF(dB)	Act.		Limit		Note
		Peak (dBuV)	AV (dBuV)		Peak (dBuV/m)	AV (dBuV/m)	Peak (dBuV/m)	AV (dBuV/m)	
2440.88	V	63.24	60.49	31.85	95.09	92.34			X/F
4879.95	V	45.64	37.17	5.49	51.13	42.66	74.00	54.00	X/H

Remark :

- (1) All readings are Peak unless otherwise stated QP in column of 『Note』 . Peak denotes that the Peak reading compliance with the QP Limits and then QP Mode measurement didn't perform .
- (2) Measuring frequency range from 30MHz to 1000MHz or the 10th harmonic of highest fundamental frequency .“F” denotes fundamental frequency; “H” denotes spurious frequency. “E” denotes band edge frequency. (This judgment method includes the Band Edge Requirement.)
- (3) Radiated emissions measured in frequency range above 1000MHz were made with an instrument using Peak detector mode and AV detector mode of the emission .
- (4) Data of measurement within this frequency range shown “ * ” in the table above means the reading of emissions are attenuated more than 20dB below the permissible limits or the field strength is too small to be measured.
- (5) A preamp and high pass filter were used for this test in order to provide sufficient measurement sensitivity.
- (6) EUT Orthogonal Axis :
“X” - denotes Laid on Table ; “Y” - denotes Vertical Stand ; “Z” - denotes Side Stand
- (7) During the measurements above 1 GHz it is taken care of that the EUT is always within the 3 dB cone of radiation BW of the used antenna
- (8) Reading in which marked as Peak or AVG means measurements by using are Peak Mode or AVG with Detector BW=1MHz ; SPA setting in RBW=1MHz, VBW =1MHz, Swp. Time = 0.3 sec./MHz, AVG Mode with detector BW=1MHz ; SPA setting in RBW=1MHz, VBW =10Hz, Swp. Time = 0.3 sec./MHz .
- (9) Measured level (dBuV/m)= Raw value (dBuV) + Correction Factor(dB/m).
Correction Factor (dB/m) = Antenna Factor (dB/m) + Cable Factor(dB).
Margin value = Emission level – Limit value.



TX 2441MHz (Above 1000 MHz, Vertical)

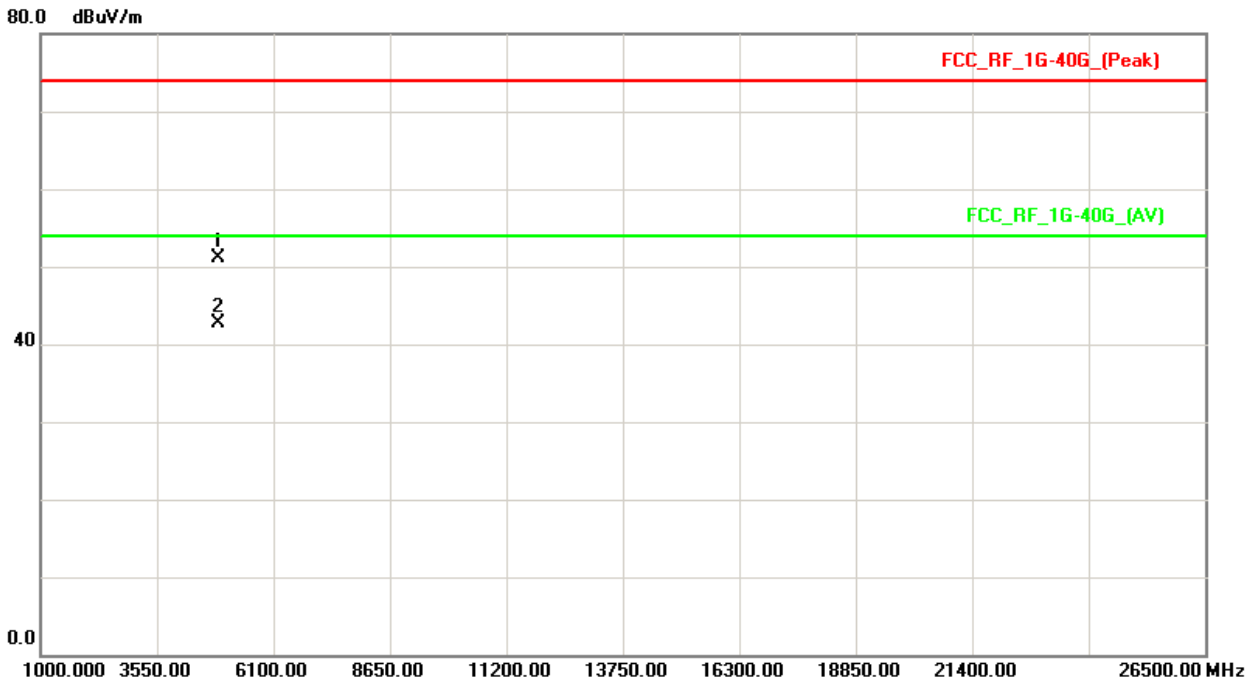
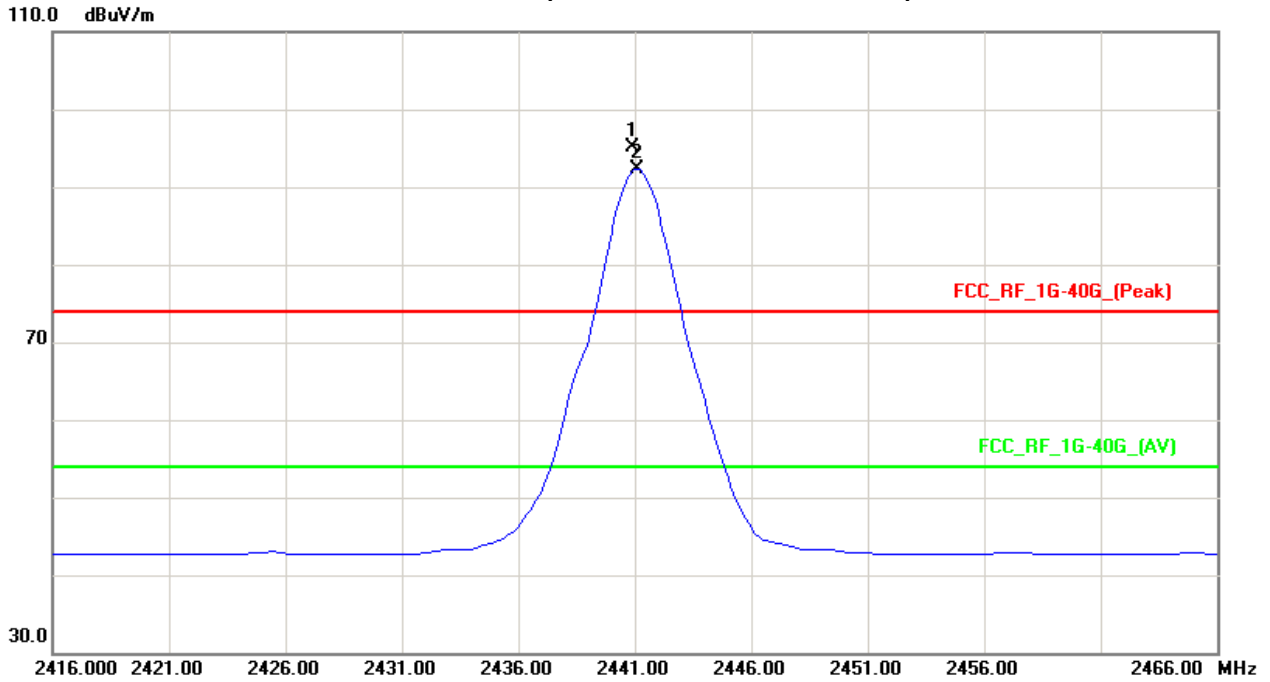



EUT :	Wireless Audio Sender	Model Name. :	W3
Temperature :	25°C	Relative Humidity :	58 %
Pressure :	1009 hPa	Test Power :	AC 120V/60Hz
Test Mode :	TX 2441MHz		

Freq. (MHz)	Ant.Pol. H/V	Reading		Ant./CF CF(dB)	Act.		Limit		Note
		Peak (dBuV)	AV (dBuV)		Peak (dBuV/m)	AV (dBuV/m)	Peak (dBuV/m)	AV (dBuV/m)	
2441.00	H	62.38	59.48	31.85	94.23	91.33			X/F
4880.25	H	44.63	34.11	5.49	50.12	39.60	74.00	54.00	X/H

Remark :

- (1) All readings are Peak unless otherwise stated QP in column of 『Note』 . Peak denotes that the Peak reading compliance with the QP Limits and then QP Mode measurement didn't perform .
- (2) Measuring frequency range from 30MHz to 1000MHz or the 10th harmonic of highest fundamental frequency .“F” denotes fundamental frequency; “H” denotes spurious frequency. “E” denotes band edge frequency. (This judgment method includes the Band Edge Requirement.)
- (3) Radiated emissions measured in frequency range above 1000MHz were made with an instrument using Peak detector mode and AV detector mode of the emission .
- (4) Data of measurement within this frequency range shown “ * ” in the table above means the reading of emissions are attenuated more than 20dB below the permissible limits or the field strength is too small to be measured.
- (5) A preamp and high pass filter were used for this test in order to provide sufficient measurement sensitivity.
- (6) EUT Orthogonal Axis :
“X” - denotes Laid on Table ; “Y” - denotes Vertical Stand ; “Z” - denotes Side Stand
- (7) During the measurements above 1 GHz it is taken care of that the EUT is always within the 3 dB cone of radiation BW of the used antenna
- (8) Reading in which marked as Peak or AVG means measurements by using are Peak Mode or AVG with Detector BW=1MHz ; SPA setting in RBW=1MHz, VBW =1MHz, Swp. Time = 0.3 sec./MHz, AVG Mode with detector BW=1MHz ; SPA setting in RBW=1MHz, VBW =10Hz, Swp. Time = 0.3 sec./MHz .
- (9) Measured level (dBuV/m)= Raw value (dBuV) + Correction Factor(dB/m).
Correction Factor (dB/m) = Antenna Factor (dB/m) + Cable Factor(dB).
Margin value = Emission level – Limit value.



TX 2441MHz (Above 1000 MHz, Horizontal)

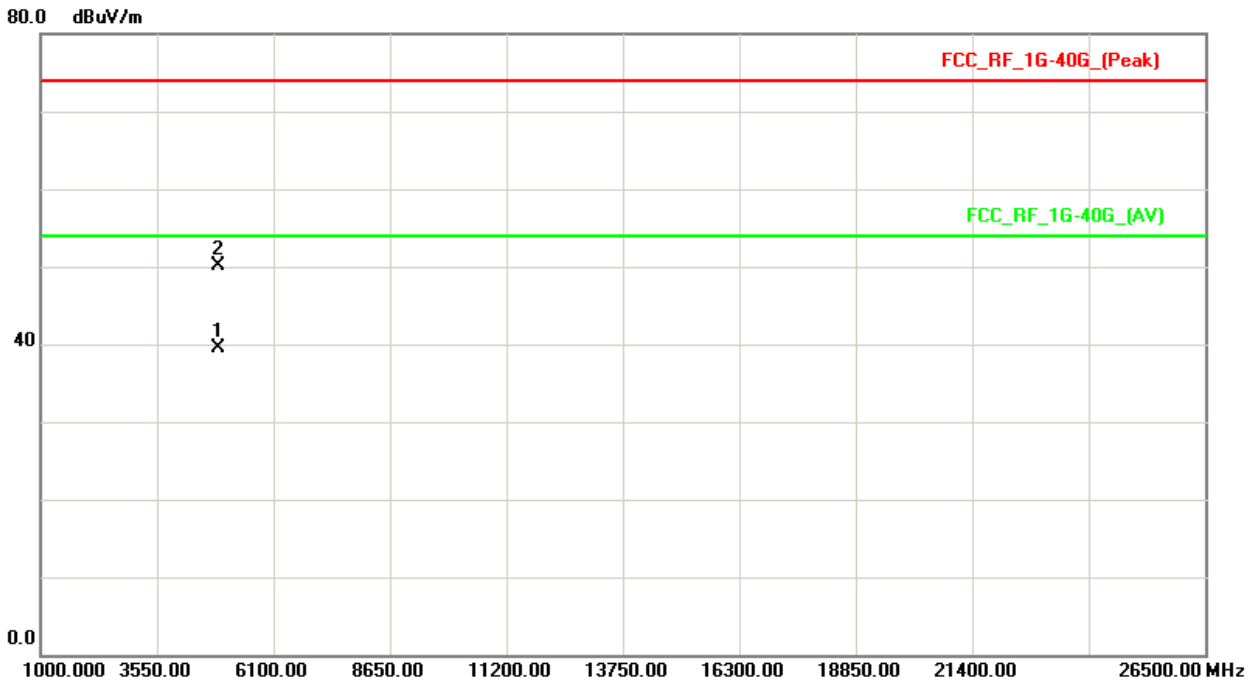
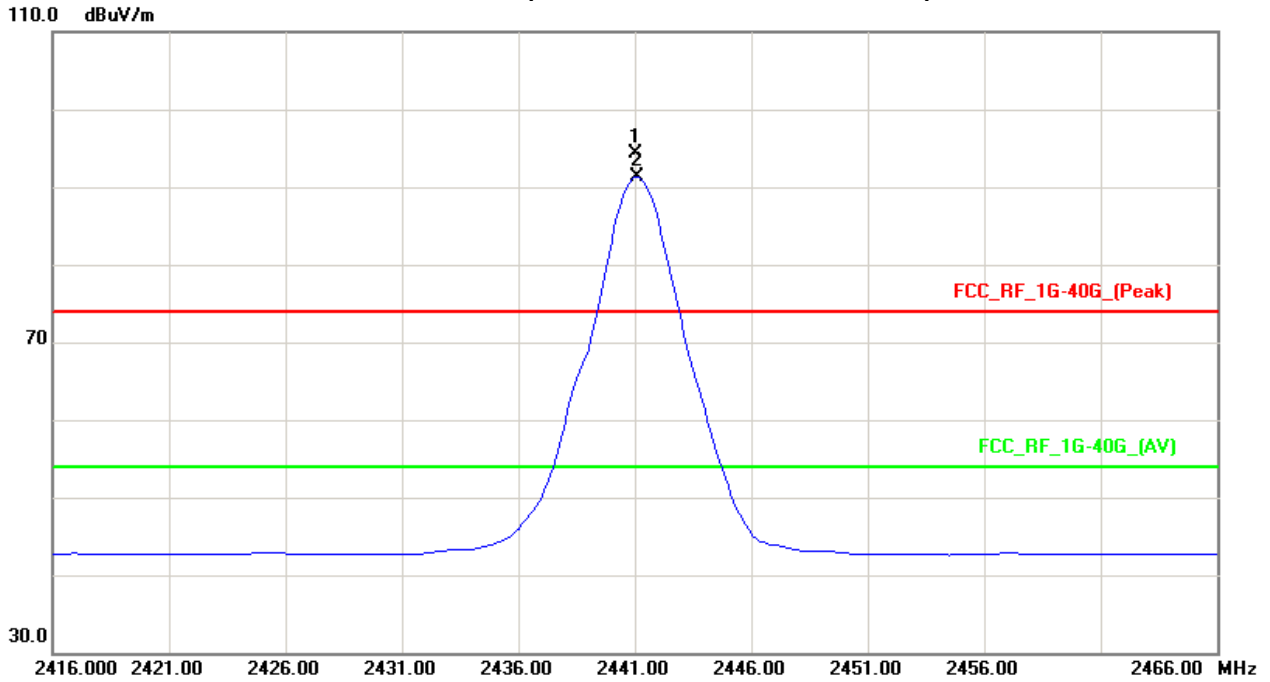



EUT :	Wireless Audio Sender	Model Name. :	W3
Temperature :	25°C	Relative Humidity :	58 %
Pressure :	1009 hPa	Test Power :	AC 120V/60Hz
Test Mode :	TX 2477MHz		

Freq. (MHz)	Ant.Pol. H/V	Reading		Ant./CF CF(dB)	Act.		Limit		Note
		Peak (dBuV)	AV (dBuV)		Peak (dBuV/m)	AV (dBuV/m)	Peak (dBuV/m)	AV (dBuV/m)	
2477.13	V	62.94	59.99	31.81	94.75	91.80			X/F
2483.50	V	24.49	12.13	31.80	56.29	43.93	74.00	54.00	X/E
4952.30	V	45.46	36.31	5.76	51.22	42.07	74.00	54.00	X/H

Remark :

- (1) All readings are Peak unless otherwise stated QP in column of 『Note』 . Peak denotes that the Peak reading compliance with the QP Limits and then QP Mode measurement didn't perform .
- (2) Measuring frequency range from 30MHz to 1000MHz or the 10th harmonic of highest fundamental frequency .“F” denotes fundamental frequency; “H” denotes spurious frequency. “E” denotes band edge frequency. (This judgment method includes the Band Edge Requirement.)
- (3) Radiated emissions measured in frequency range above 1000MHz were made with an instrument using Peak detector mode and AV detector mode of the emission .
- (4) Data of measurement within this frequency range shown “ * ” in the table above means the reading of emissions are attenuated more than 20dB below the permissible limits or the field strength is too small to be measured.
- (5) A preamp and high pass filter were used for this test in order to provide sufficient measurement sensitivity.
- (6) EUT Orthogonal Axis :
“X” - denotes Laid on Table ; “Y” - denotes Vertical Stand ; “Z” - denotes Side Stand
- (7) During the measurements above 1 GHz it is taken care of that the EUT is always within the 3 dB cone of radiation BW of the used antenna
- (8) Reading in which marked as Peak or AVG means measurements by using are Peak Mode or AVG with Detector BW=1MHz ; SPA setting in RBW=1MHz, VBW =1MHz, Swp. Time = 0.3 sec./MHz, AVG Mode with detector BW=1MHz ; SPA setting in RBW=1MHz, VBW =10Hz, Swp. Time = 0.3 sec./MHz .
- (9) Measured level (dBuV/m)= Raw value (dBuV) + Correction Factor(dB/m).
Correction Factor (dB/m) = Antenna Factor (dB/m) + Cable Factor(dB).
Margin value = Emission level – Limit value.



TX 2477MHz (Above 1000 MHz, Vertical)

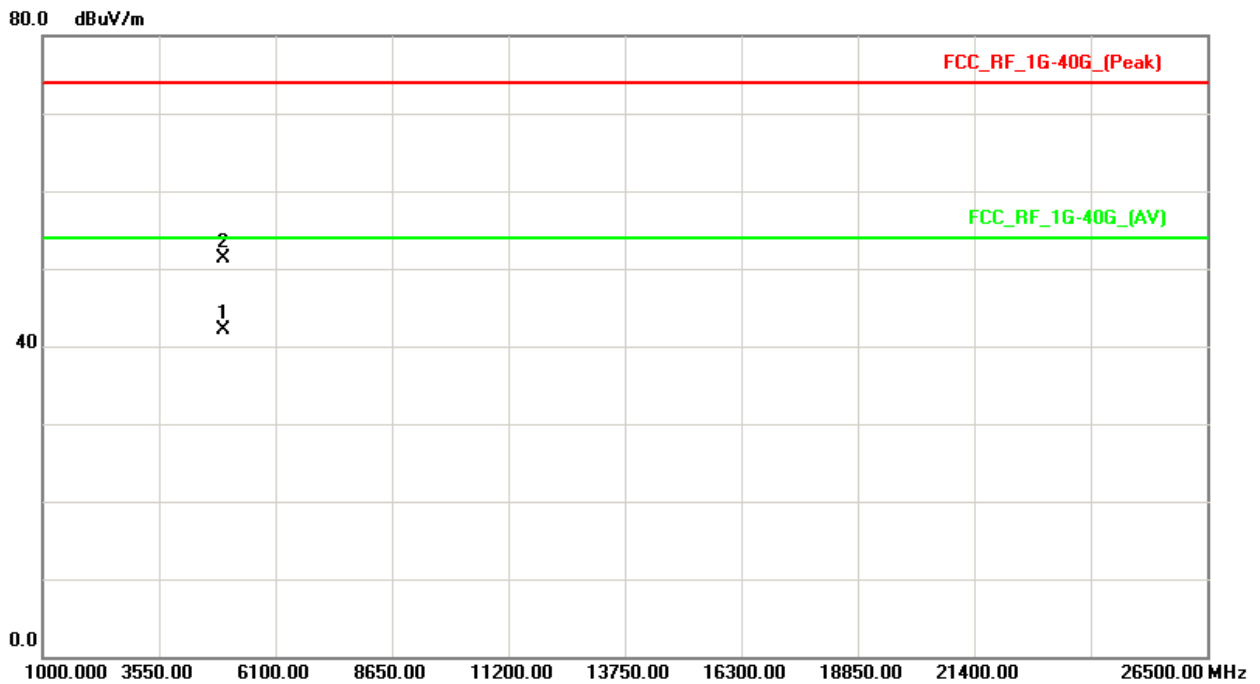
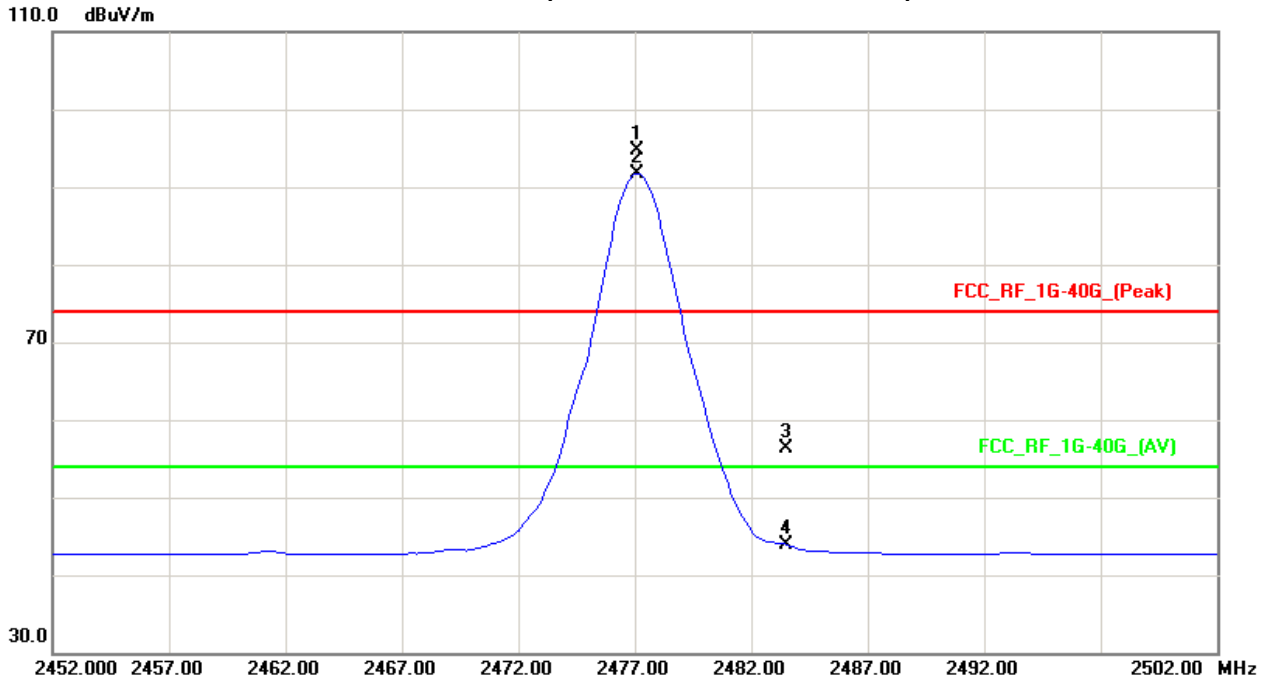



EUT :	Wireless Audio Sender	Model Name. :	W3
Temperature :	25°C	Relative Humidity :	58 %
Pressure :	1009 hPa	Test Power :	AC 120V/60Hz
Test Mode :	TX 2477MHz		

Freq. (MHz)	Ant.Pol. H/V	Reading		Ant./CF CF(dB)	Act.		Limit		Note
		Peak (dBuV)	AV (dBuV)		Peak (dBuV/m)	AV (dBuV/m)	Peak (dBuV/m)	AV (dBuV/m)	
2477.25	H	60.60	57.66	31.81	92.41	89.47			X/F
2483.50	H	23.60	11.53	31.80	55.40	43.33	74.00	54.00	X/E
4951.90	H	43.95	33.92	5.75	49.70	39.67	74.00	54.00	X/H

Remark :

- (1) All readings are Peak unless otherwise stated QP in column of 『Note』 . Peak denotes that the Peak reading compliance with the QP Limits and then QP Mode measurement didn't perform ◦
- (2) Measuring frequency range from 30MHz to 1000MHz or the 10th harmonic of highest fundamental frequency ◦ "F" denotes fundamental frequency; "H" denotes spurious frequency. "E" denotes band edge frequency. (This judgment method includes the Band Edge Requirement.)
- (3) Radiated emissions measured in frequency range above 1000MHz were made with an instrument using Peak detector mode and AV detector mode of the emission ◦
- (4) Data of measurement within this frequency range shown " * " in the table above means the reading of emissions are attenuated more than 20dB below the permissible limits or the field strength is too small to be measured.
- (5) A preamp and high pass filter were used for this test in order to provide sufficient measurement sensitivity.
- (6) EUT Orthogonal Axis :
"X" - denotes Laid on Table ; "Y" - denotes Vertical Stand ; "Z" - denotes Side Stand
- (7) During the measurements above 1 GHz it is taken care of that the EUT is always within the 3 dB cone of radiation BW of the used antenna
- (8) Reading in which marked as Peak or AVG means measurements by using are Peak Mode or AVG with Detector BW=1MHz ; SPA setting in RBW=1MHz, VBW =1MHz, Swp. Time = 0.3 sec./MHz, AVG Mode with detector BW=1MHz ; SPA setting in RBW=1MHz, VBW =10Hz, Swp. Time = 0.3 sec./MHz ◦
- (9) Measured level (dBuV/m)= Raw value (dBuV) + Correction Factor(dB/m).
Correction Factor (dB/m) = Antenna Factor (dB/m) + Cable Factor(dB).
Margin value = Emission level – Limit value.



TX 2477MHz (Above 1000 MHz, Horizontal)

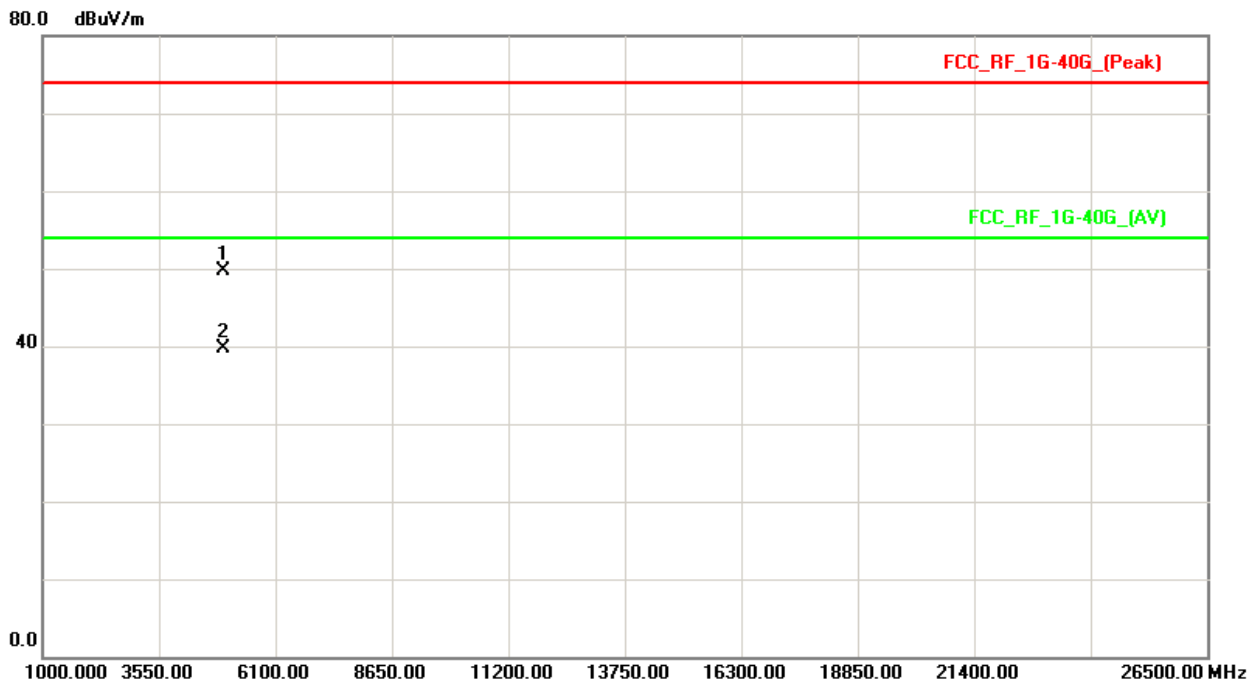
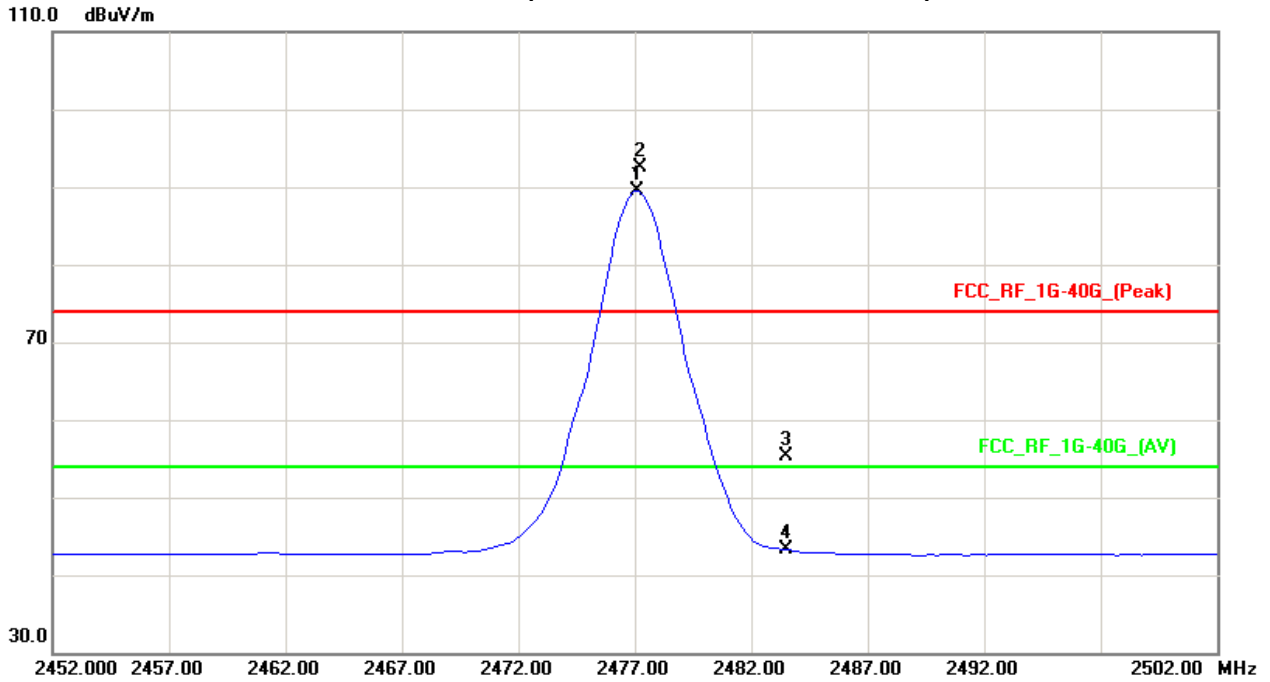



5. BANDWIDTH TEST

5.1 APPLIED PROCEDURES / LIMIT

FCC Part15 (15.247) , Subpart C				
Section	Test Item	Limit	Frequency Range (MHz)	Result
15.247(a)(2)	Bandwidth	$\geq 500\text{KHz}$ (6dB bandwidth)	2400-2483.5	PASS

5.1.1 MEASUREMENT INSTRUMENTS LIST

Item	Kind of Equipment	Manufacturer	Type No.	Serial No.	Calibrated until
1	Spectrum Analyzer	R&S	FSP_40	100129	Jan. 03, 2013

Remark: " N/A" denotes No Model Name , Serial No. or No Calibration specified.

- The calibration interval of the above test instruments is 12 months and the calibrations are traceable to NML/ROC and NIST/USA.

5.1.2 TEST PROCEDURE

- The EUT was directly connected to the spectrum analyzer and antenna output port as show in the block diagram below,
- Spectrum Setting : RBW= 100KHz, VBW=100KHz, Sweep time = 2.5 ms.

5.1.3 DEVIATION FROM STANDARD

No deviation.

5.1.4 TEST SETUP



5.1.5 EUT OPERATION CONDITIONS

The EUT tested system was configured as the statements of 4.1.6 Unless otherwise a special operating condition is specified in the follows during the testing.



5.1.6 TEST RESULTS

EUT :	Wireless Audio Sender	Model Name. :	W3
Temperature :	25 °C	Relative Humidity :	55 %
Pressure :	1009 hPa	Test Power :	AC 120V/60Hz
Test Mode :	TX MODE /CH01, CH19, CH37		

Test Channel	Frequency (MHz)	Bandwidth (MHz)	LIMIT (MHz)
CH01	2405	1.100	>=500KHz
CH19	2441	1.090	>=500KHz
CH37	2477	1.120	>=500KHz

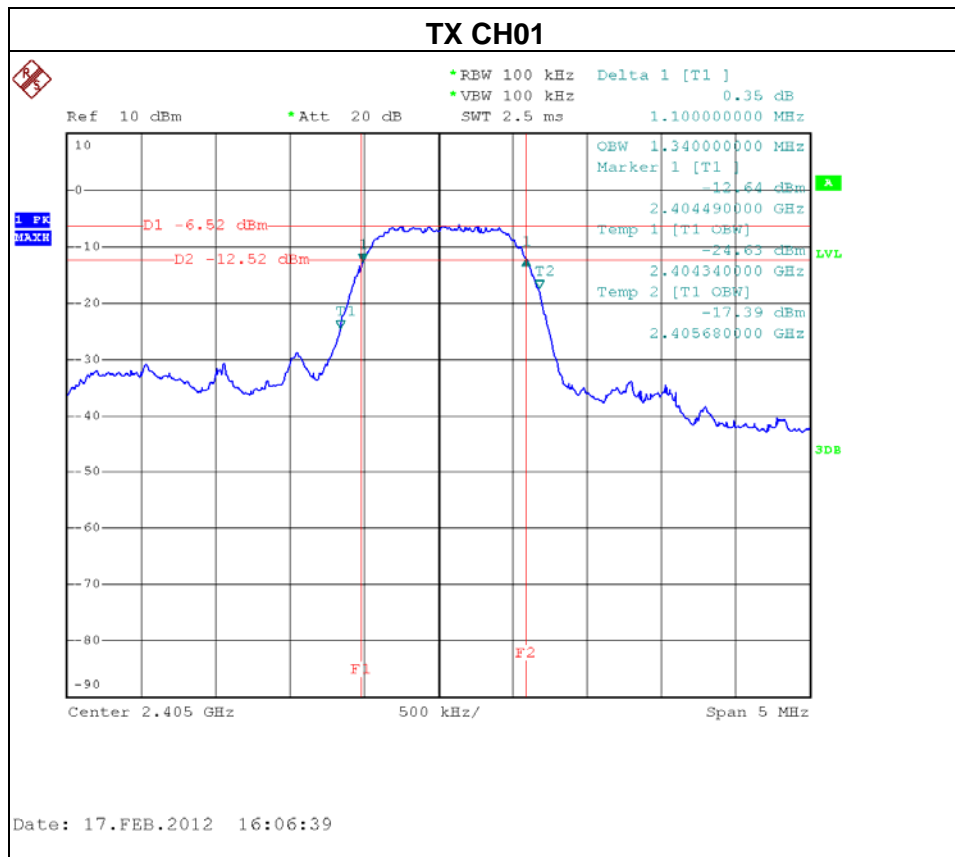

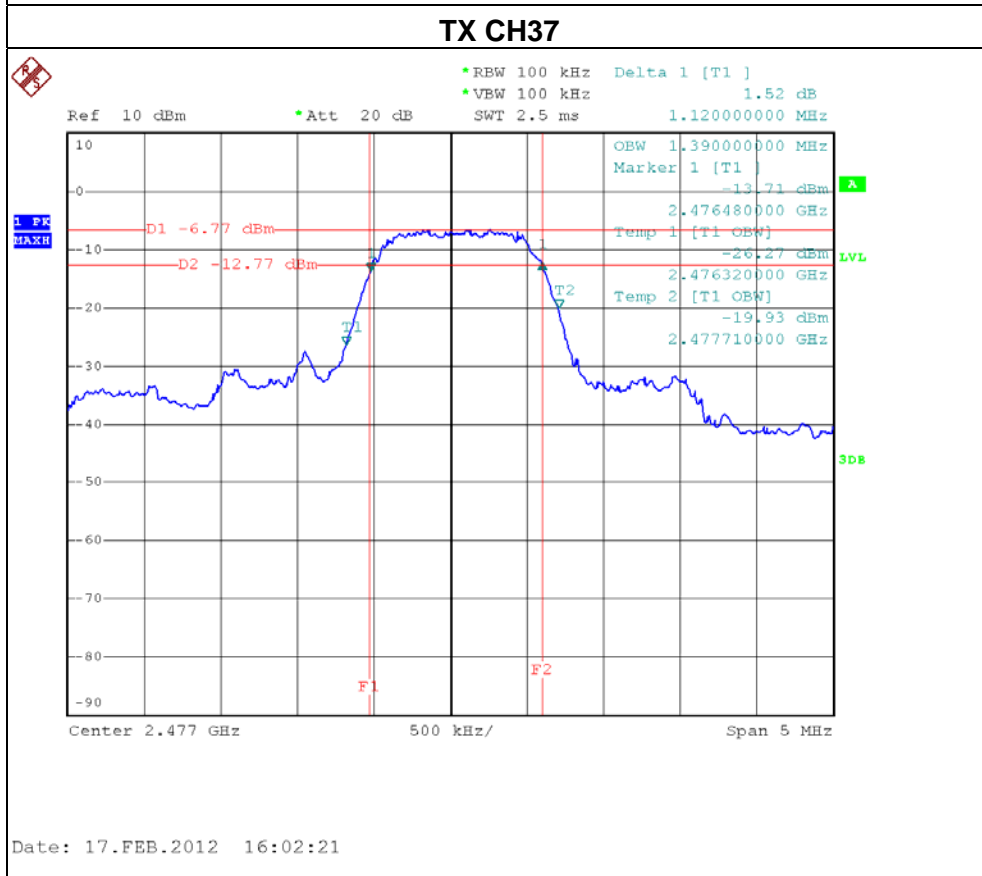
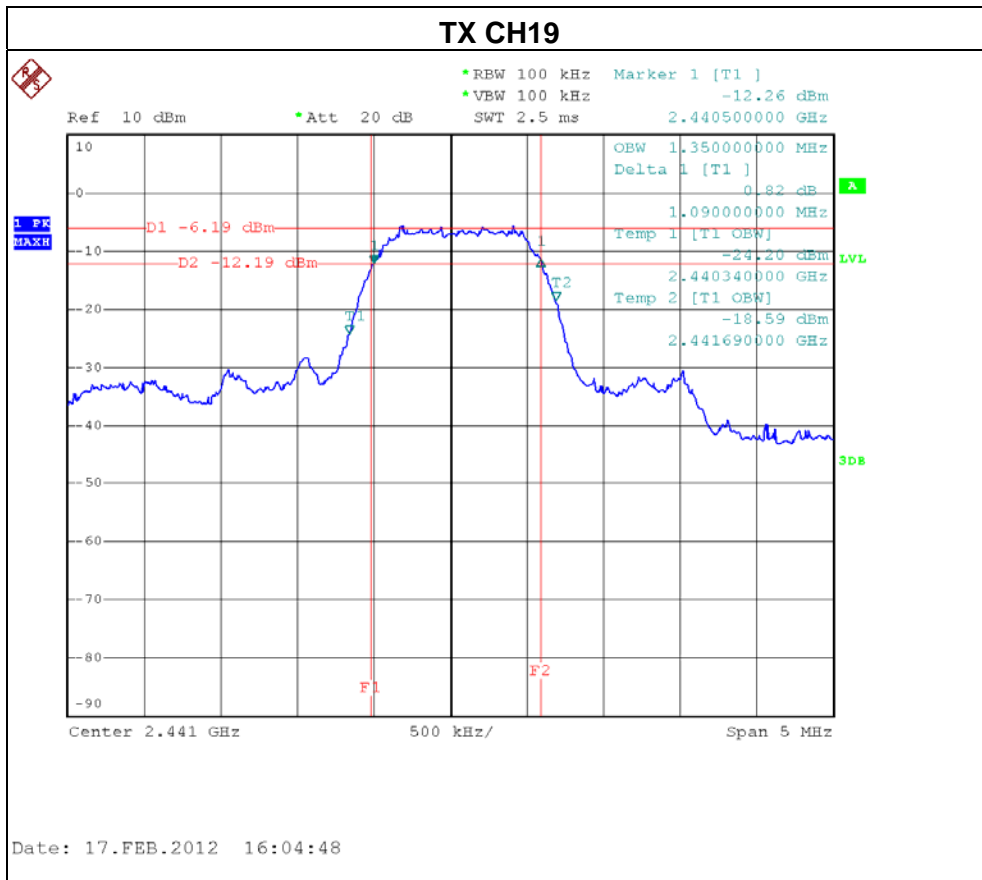



6. MAXIMUM OUTPUT POWER TEST

6.1 APPLIED PROCEDURES / LIMIT

FCC Part15 (15.247) , Subpart C				
Section	Test Item	Limit	Frequency Range (MHz)	Result
15.247(b)(3)	Maximum Output Power	1 watt or 30dBm	2400-2483.5	PASS

6.1.1 MEASUREMENT INSTRUMENTS LIST

Item	Kind of Equipment	Manufacturer	Type No.	Serial No.	Calibrated until
1	P-series Power meter	Agilent	N1911A	MY45100473	Apr.29.2012
2	Wireband Power sensor	Agilent	N1921A	MY51100041	Apr.29.2012

Remark: " N/A" denotes No Model Name , Serial No. or No Calibration specified.

1. The calibration interval of the above test instruments is 12 months and the calibrations are traceable to NML/ROC and NIST/USA.

6.1.2 TEST PROCEDURE

- a. The EUT was directly connected to the Power meter and antenna output port as show in the block diagram below,

6.1.3 DEVIATION FROM STANDARD

No deviation.

6.1.4 TEST SETUP



6.1.5 EUT OPERATION CONDITIONS

The EUT tested system was configured as the statements of 4.1.6 Unless otherwise a special operating condition is specified in the follows during the testing. Transmit output power was measured while the host equipment supply voltage was varied from 85 % to 115 % of the nominal rated supply voltage. No change in transmit output power was observed.



6.1.6 TEST RESULTS

EUT :	Wireless Audio Sender	Model Name. :	W3
Temperature :	25 °C	Relative Humidity :	55 %
Pressure :	1009 hPa	Test Power :	AC 120V/60Hz
Test Mode :	TX MODE / CH01, CH19, CH37		

Maximum Output Power

Test Channel	Frequency (MHz)	Output Power (dBm)	LIMIT (dBm)	LIMIT (W)
CH01	2405	-2.83	30	1
CH19	2441	-2.86	30	1
CH37	2477	-3.53	30	1

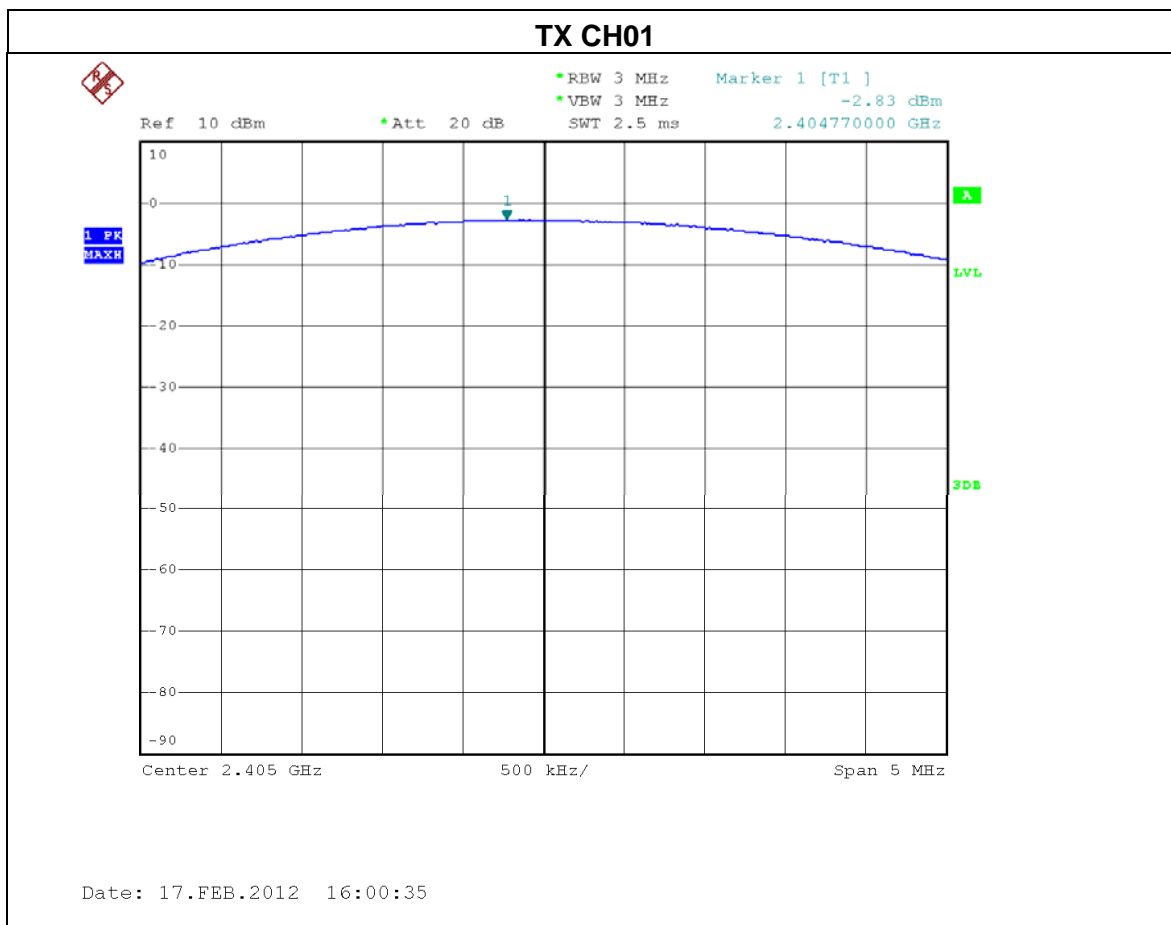

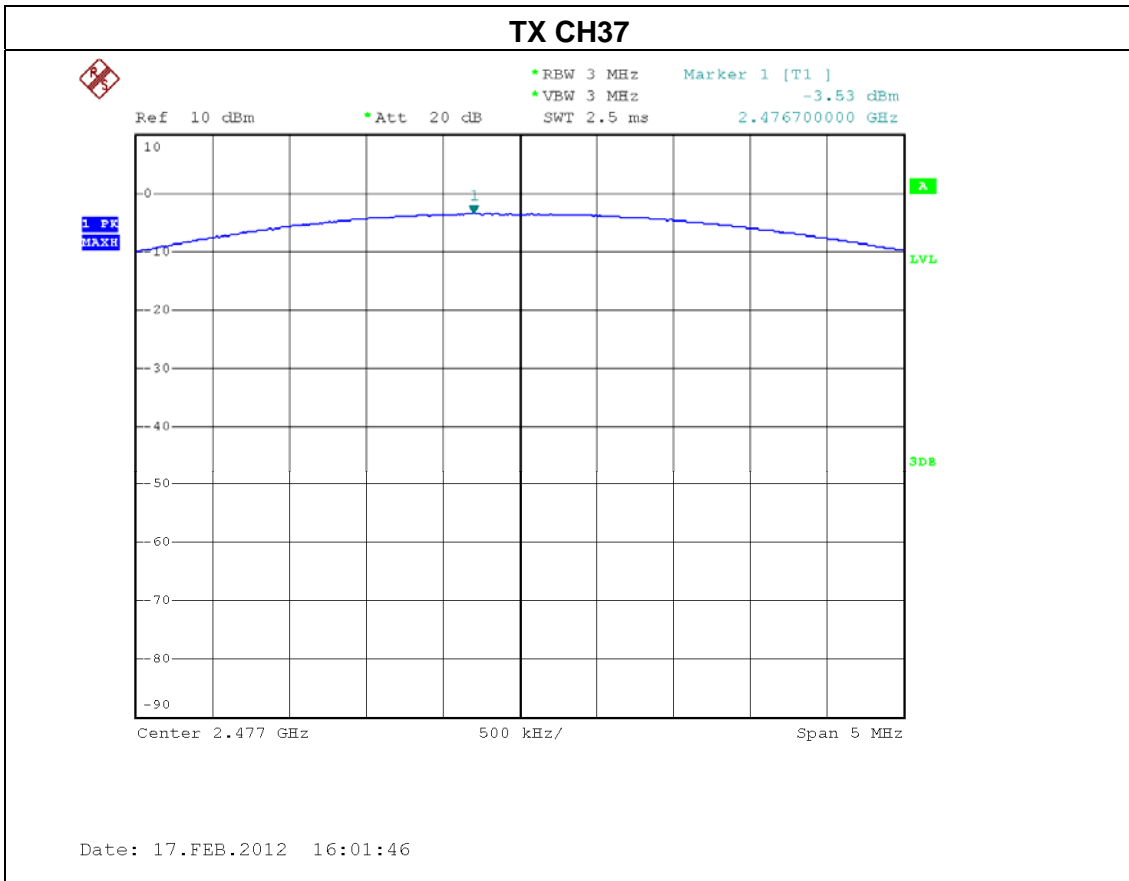
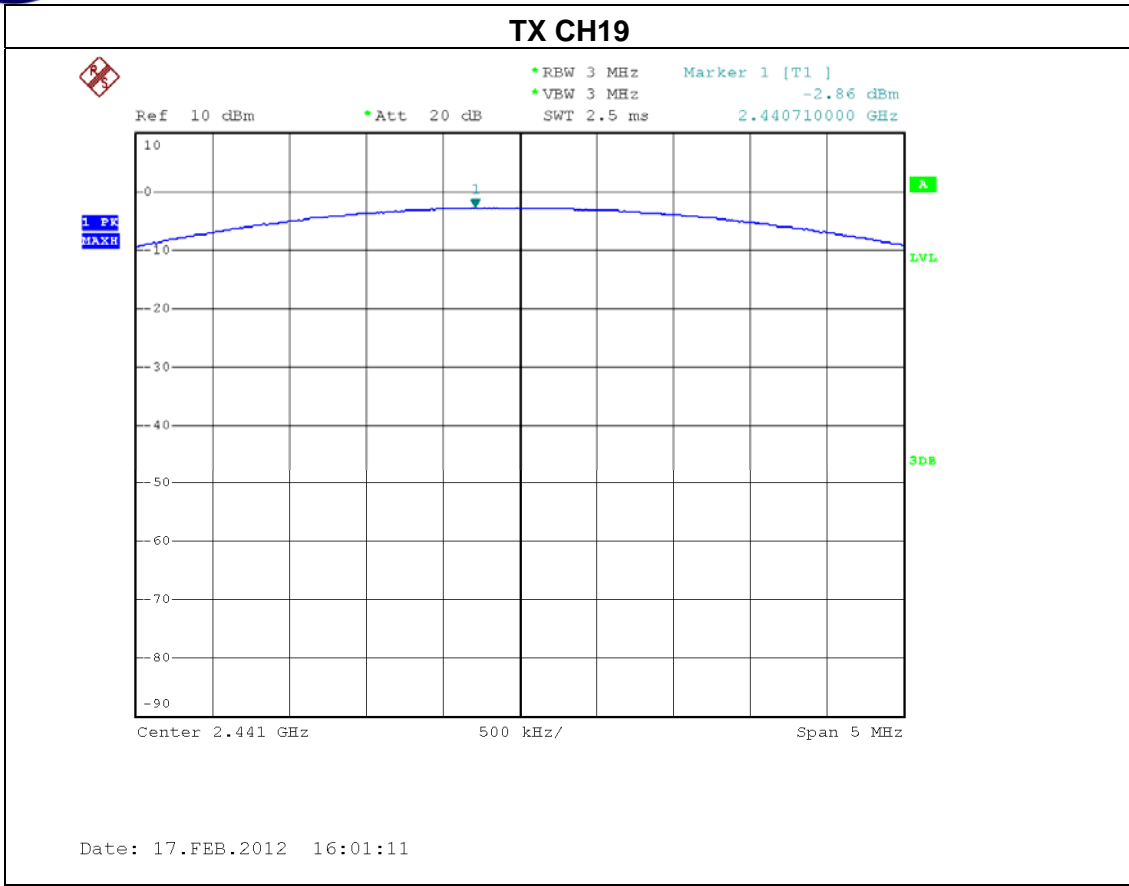



7. ANTENNA CONDUCTED SPURIOUS EMISSION

7.1 APPLIED PROCEDURES / LIMIT

50dBc in any 100 kHz bandwidth outside the operating frequency band. In case the emission fall within the restricted band specified on 15.205(a), then the 15.209(a) limit in the table below has to be followed.

Frequencies (MHz)	Field Strength (micorvolts/meter)	Measurement Distance (meters)
0.009~0.490	2400/F(KHz)	300
0.490~1.705	24000/F(KHz)	30
1.705~30.0	30	30
30~88	100	3
88~216	150	3
216~960	200	3
Above 960	500	3

7.1.1 MEASUREMENT INSTRUMENTS LIST

Item	Kind of Equipment	Manufacturer	Type No.	Serial No.	Calibrated until
1	Spectrum Analyzer	R&S	FSP 40	100185	Jan. 03, 2013

Remark: " N/A" denotes No Model Name. , Serial No. or No Calibration specified.

- The calibration interval of the above test instruments is 12 months and the calibrations are traceable to NML/ROC and NIST/USA.

7.1.2 TEST PROCEDURE

- The EUT was directly connected to the spectrum analyzer and antenna output port as show in the block diagram below,
- Spectrum Setting : RBW= 100KHz, VBW=100KHz, Sweep time = 10 ms.

7.1.3 DEVIATION FROM STANDARD

No deviation.

7.1.4 TEST SETUP

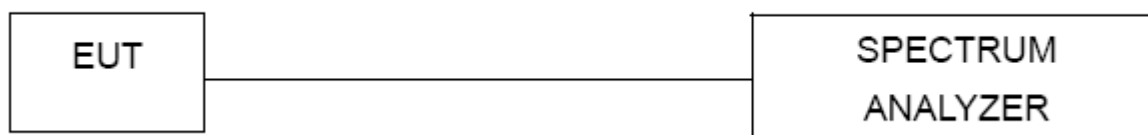

7.1.5 EUT OPERATION CONDITIONS

The EUT tested system was configured as the statements of 4.1.6 Unless otherwise a special operating condition is specified in the follows during the testing.



7.1.6 TEST RESULTS

EUT :	Wireless Audio Sender	Model Name. :	W3
Temperature :	25 °C	Relative Humidity :	55 %
Pressure :	1009 hPa	Test Power :	AC 120V/60Hz
Test Mode :	TX MODE /CH01, CH19, CH37		

Channel of Worst Data: CH01			
The max. radio frequency power in any 100kHz bandwidth within the frequency band		The max. radio frequency power in any 100 kHz bandwidth within the frequency band.	
FREQUENCY(MHz)	POWER(dBm)	FREQUENCY(MHz)	POWER(dBm)
2367.60	-60.37	2484.80	-56.94
Result			
In any 100kHz bandwidth outside the frequency band, the radio frequency power is at least 50dB below that in the 100kHz bandwidth within the band that contains the highest level of the desired power.			

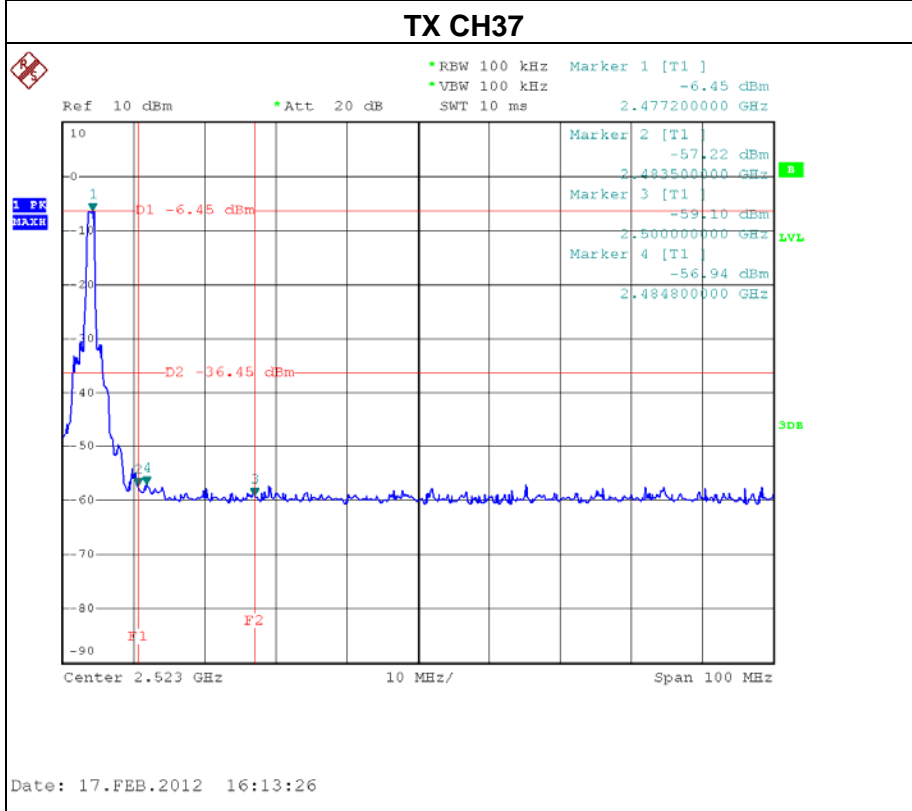
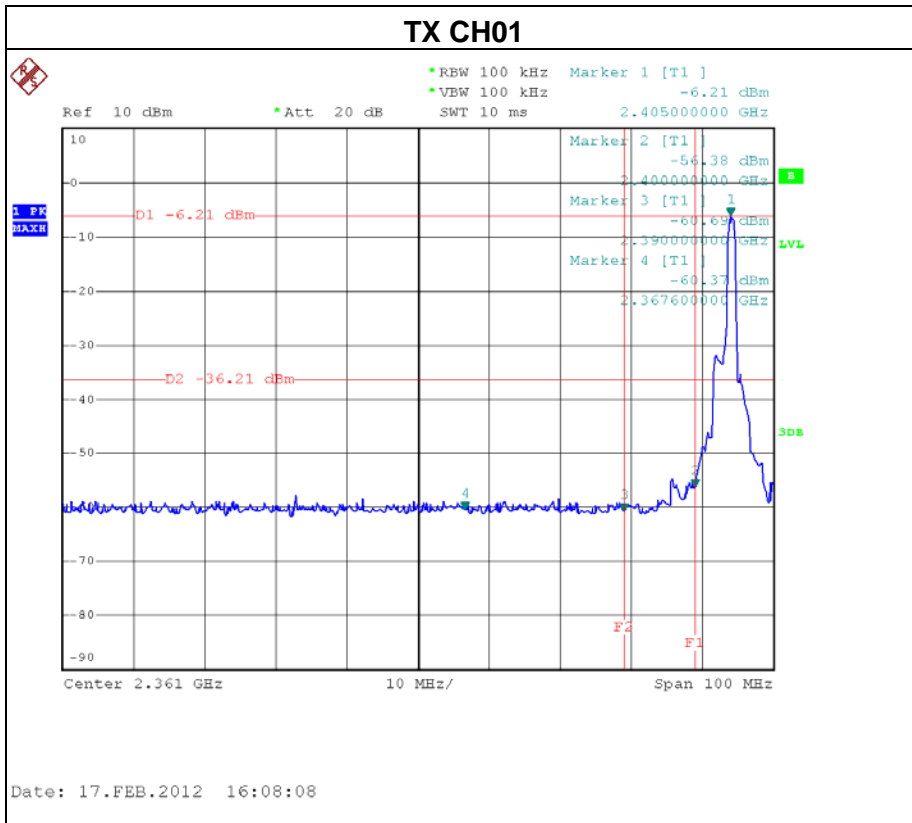

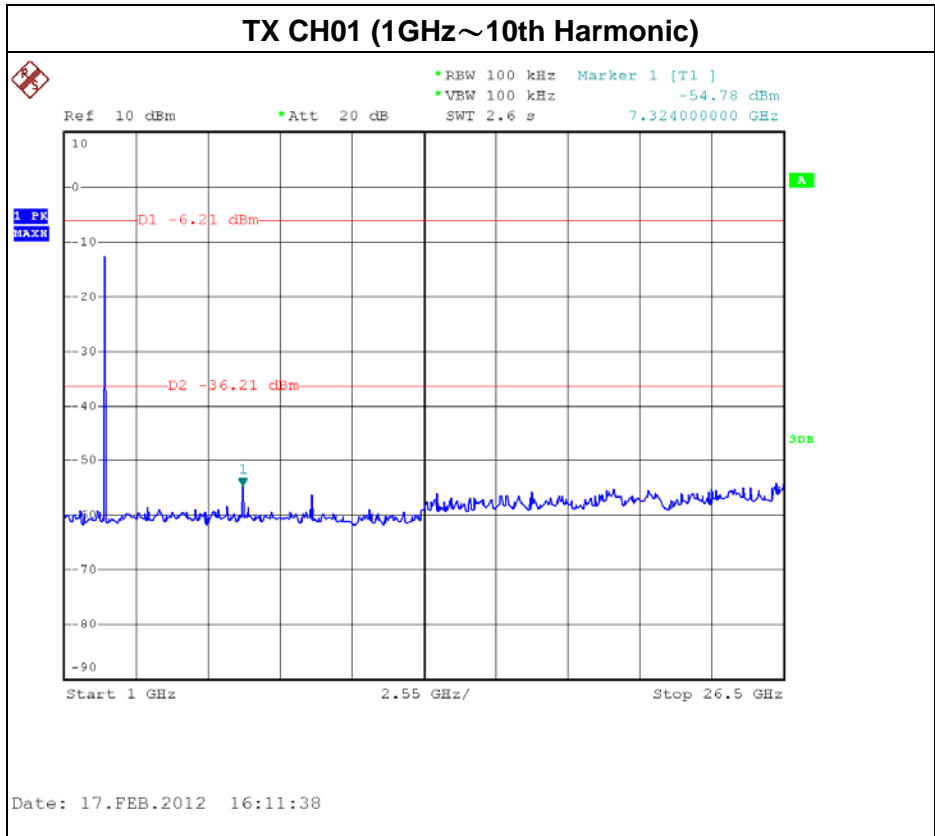
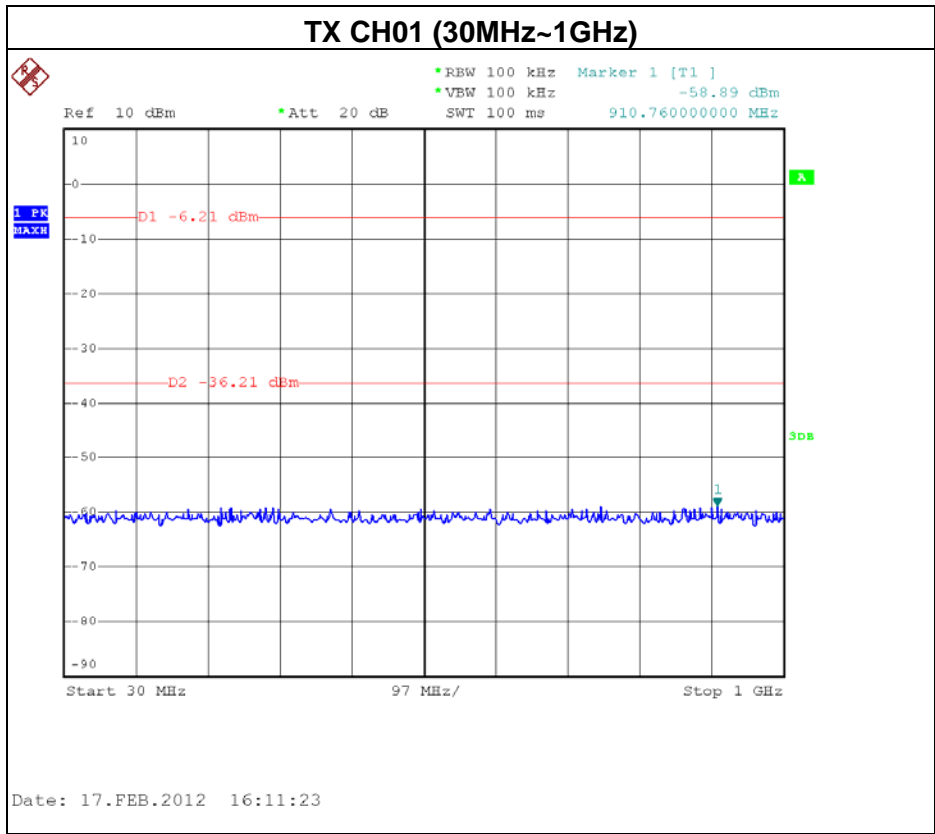

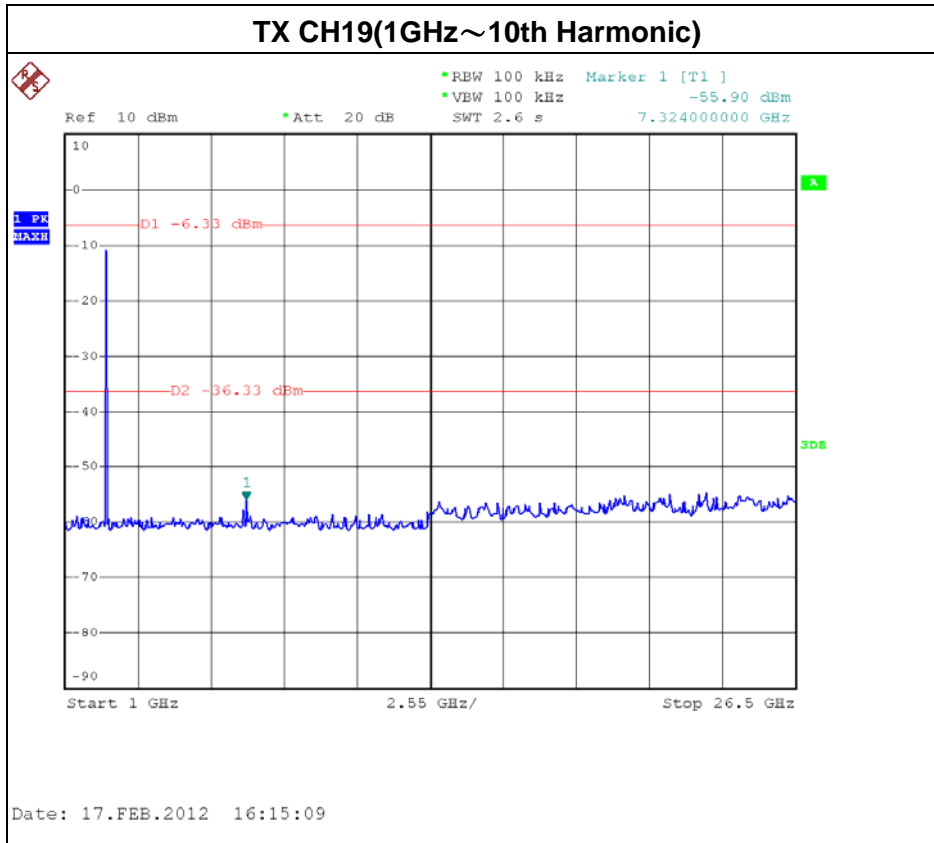
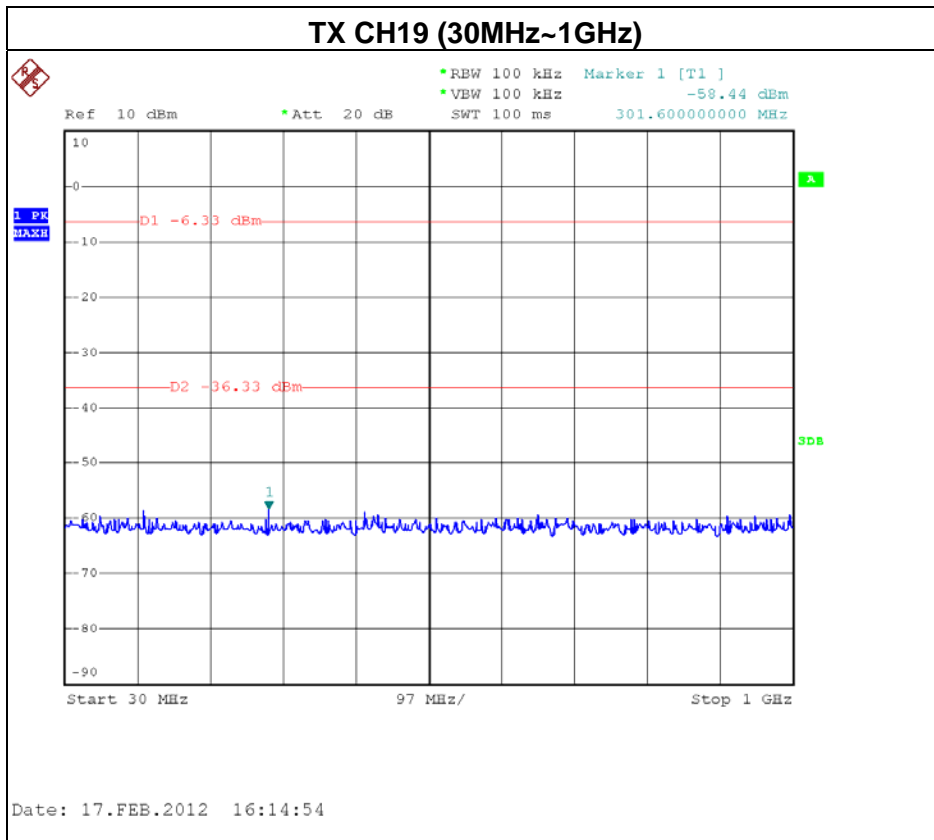

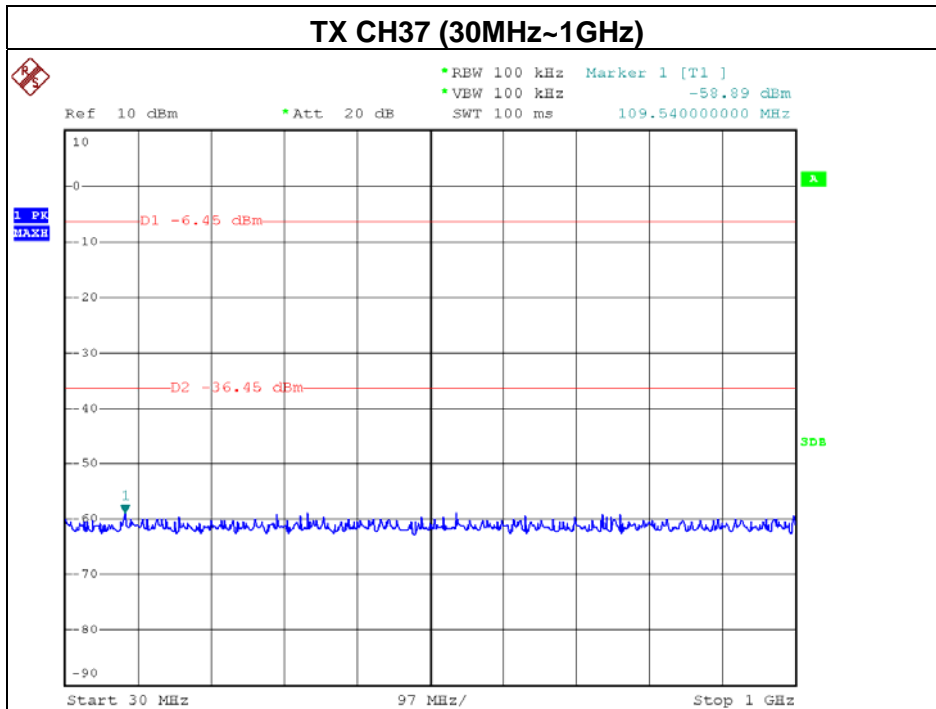

Date: 17.FEB.2012 16:14:21

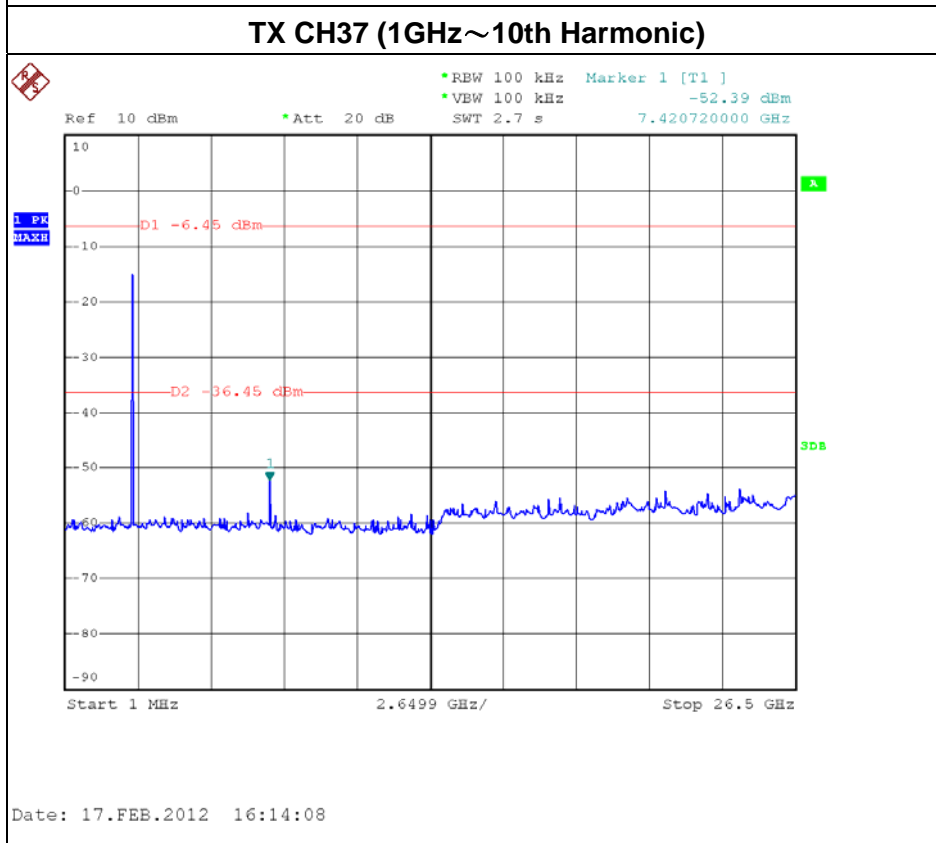

Date: 17.FEB.2012 16:14:08



8. POWER SPECTRAL DENSITY TEST

8.1 APPLIED PROCEDURES / LIMIT

FCC Part15 (15.247) , Subpart C				
Section	Test Item	Limit	Frequency Range (MHz)	Result
15.247(e)	Power Spectral Density	8 dBm (in any 3KHz)	2400-2483.5	PASS

8.1.1 MEASUREMENT INSTRUMENTS LIST

Item	Kind of Equipment	Manufacturer	Type No.	Serial No.	Calibrated until
1	Spectrum Analyzer	R&S	FSP_40	100129	Jan. 03, 2013

Remark: " N/A" denotes No Model Name , Serial No. or No Calibration specified.

1. The calibration interval of the above test instruments is 12 months and the calibrations are traceable to NML/ROC and NIST/USA.

8.1.2 TEST PROCEDURE

- a. The EUT was directly connected to the spectrum analyzer and antenna output port as show in the block diagram below,
- b. Spectrum Setting : RBW=3KHz, VBW=30 KHz, Sweep time = 500s.

8.1.3 DEVIATION FROM STANDARD

No deviation.

8.1.4 TEST SETUP



8.1.5 EUT OPERATION CONDITIONS

The EUT tested system was configured as the statements of 4.1.6 Unless otherwise a special operating condition is specified in the follows during the testing.



8.1.6 TEST RESULTS

EUT :	Wireless Audio Sender	Model Name. :	W3
Temperature :	25 °C	Relative Humidity :	55 %
Pressure :	1009 hPa	Test Power :	AC 120V/60Hz
Test Mode :	TX MODE /CH01, CH19, CH37		

Test Channel	Frequency (MHz)	Power Density (dBm)	LIMIT (dBm)
CH01	2405	-18.40	8
CH19	2441	-19.78	8
CH37	2477	-20.88	8

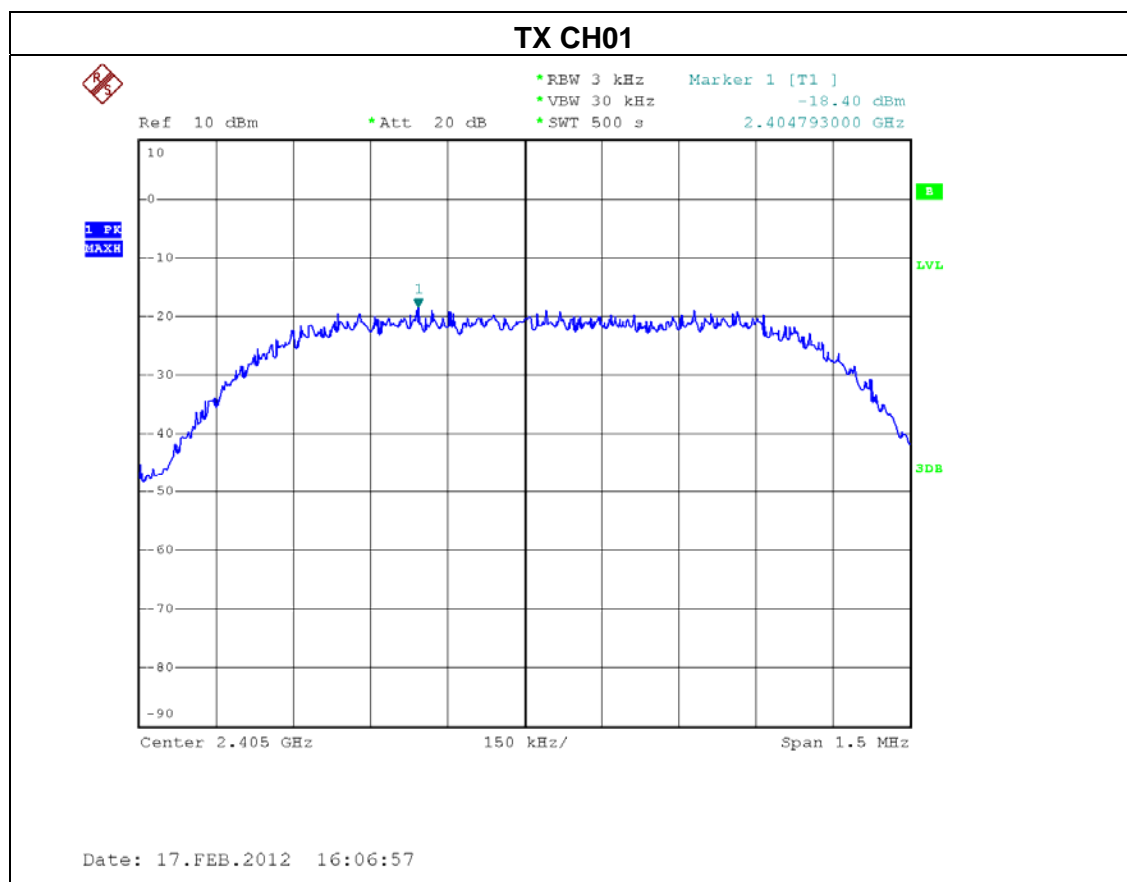

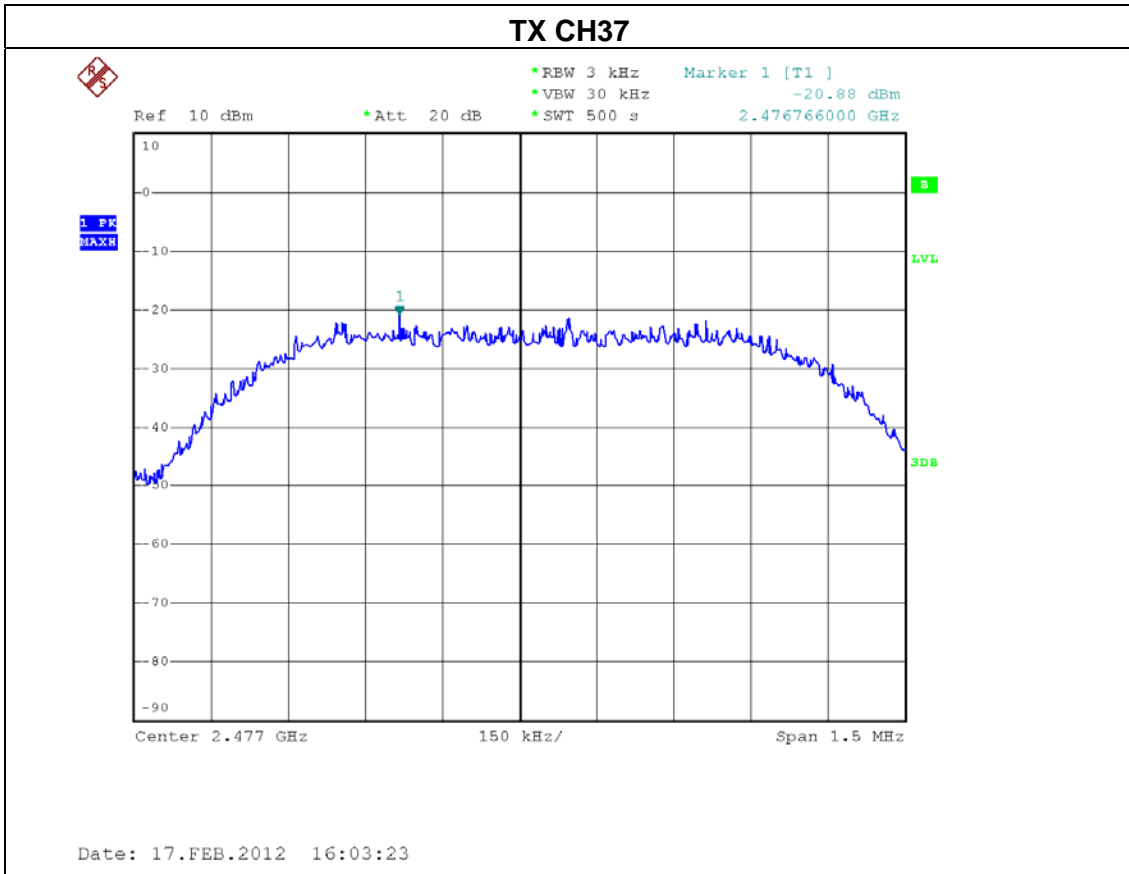
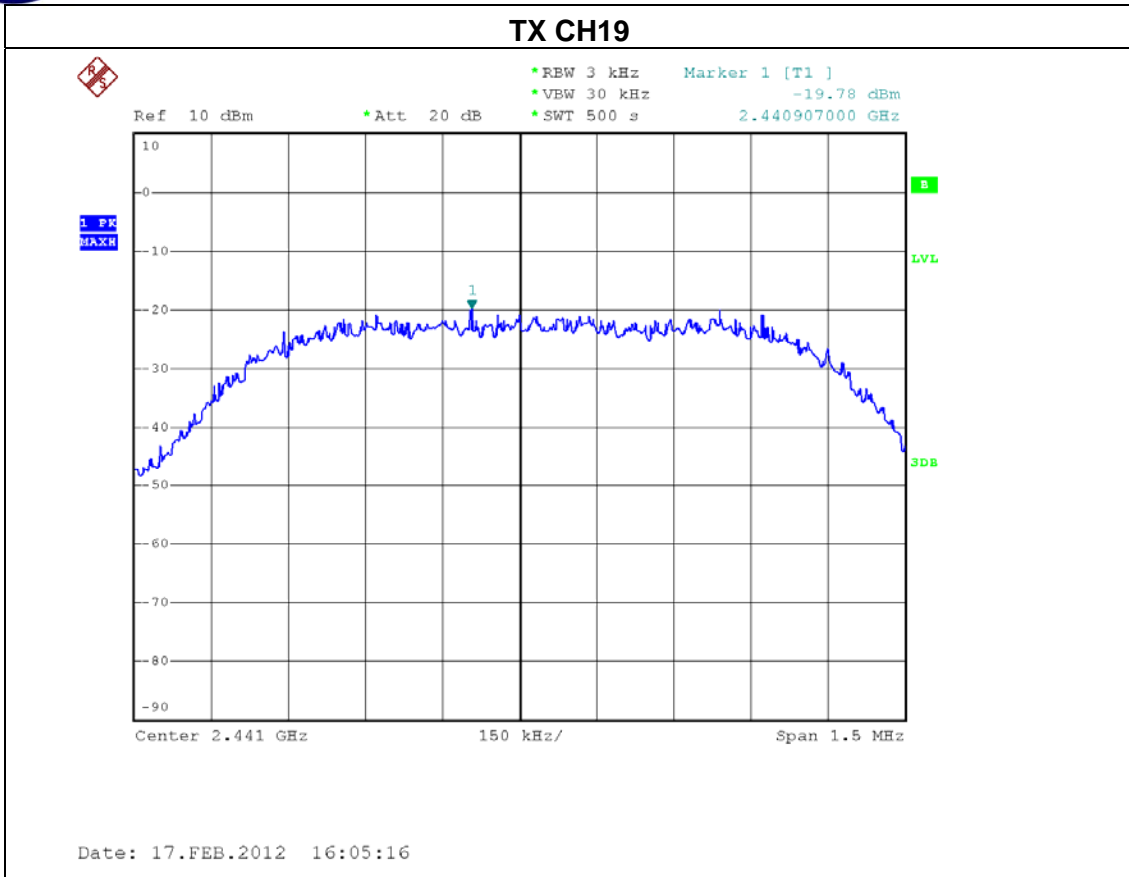



9. EUT TEST PHOTO

**Conducted Measurement Photos
Wireless - PC MODE**





**Conducted Measurement Photos
Wireless - Adapter Supply**

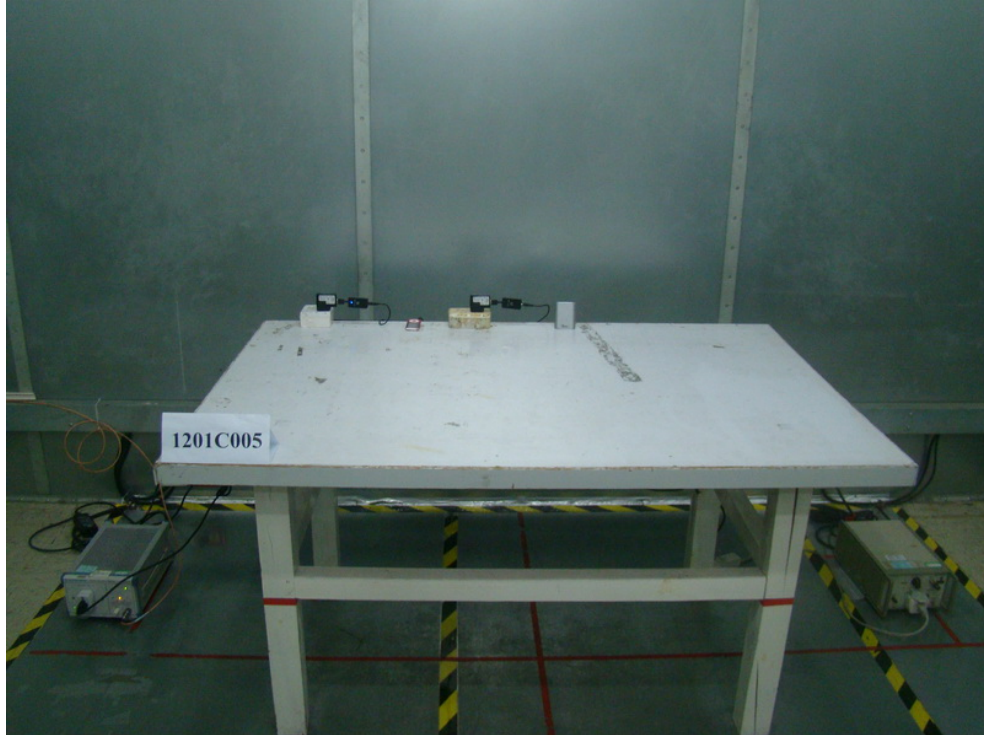

**Radiated Measurement Photos
9K~30MHz**

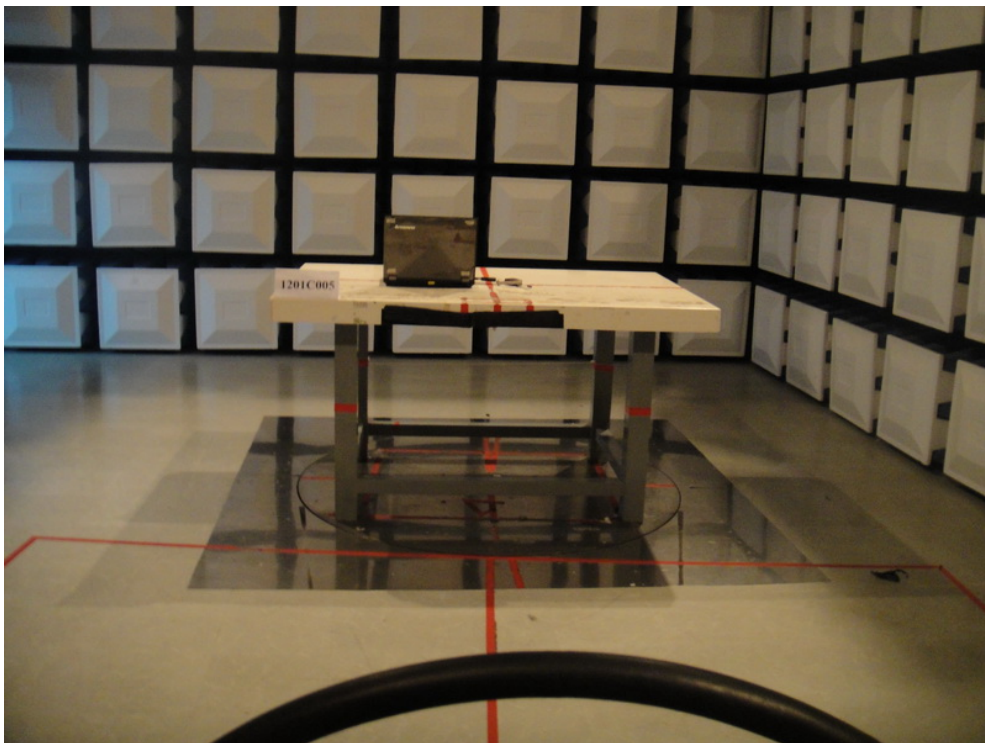
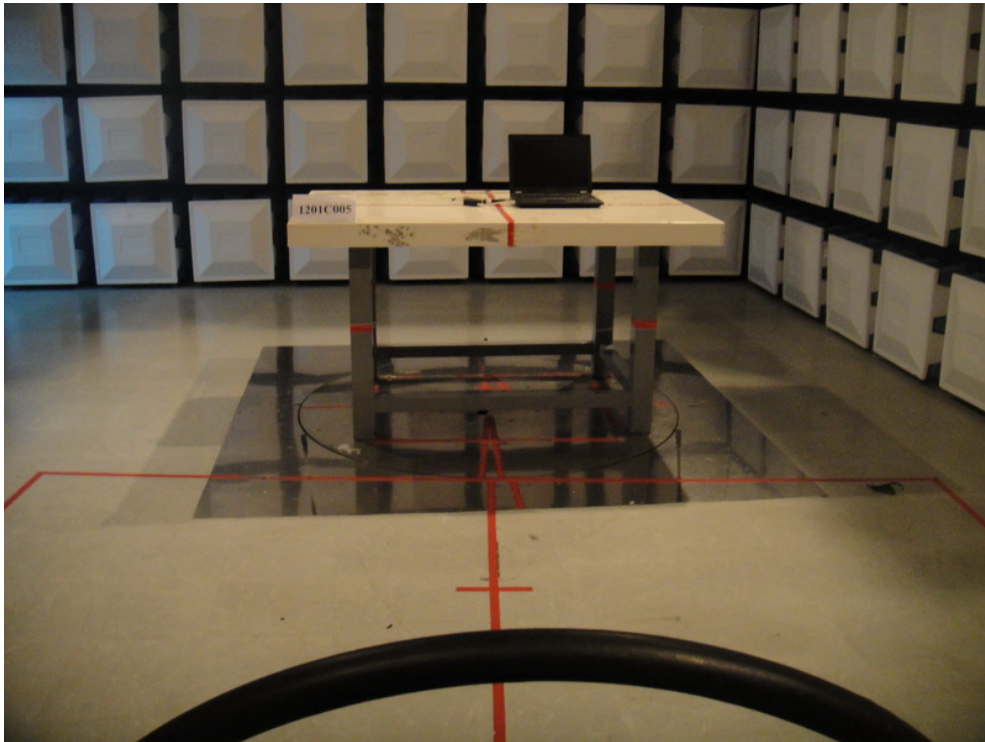

**Radiated Measurement Photos
30M~1000MHz**

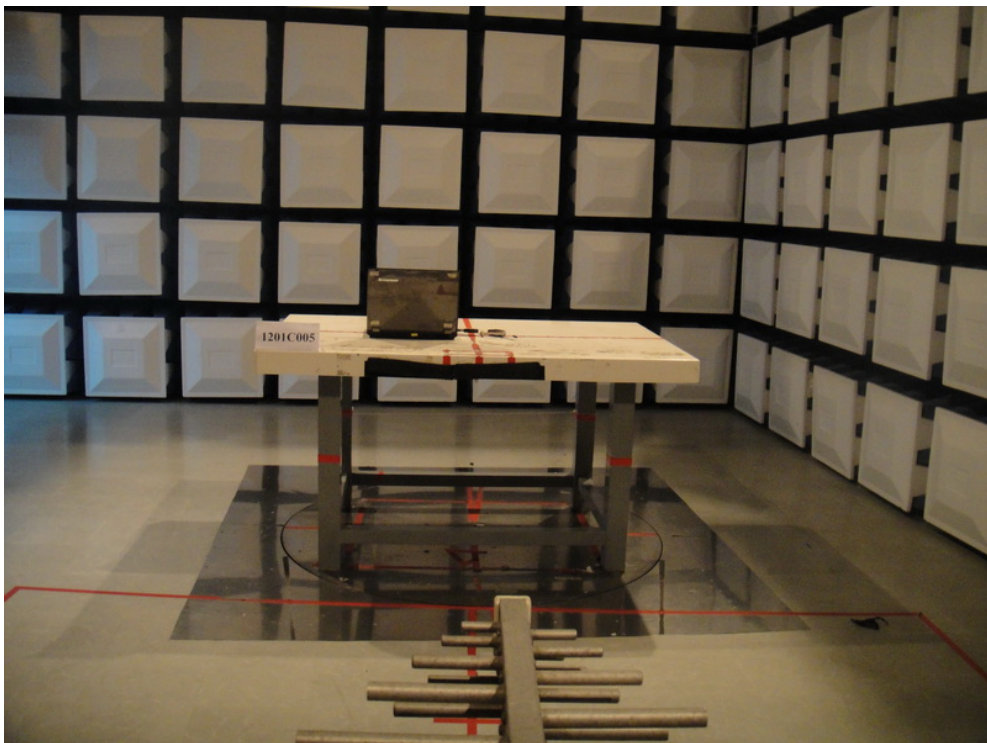
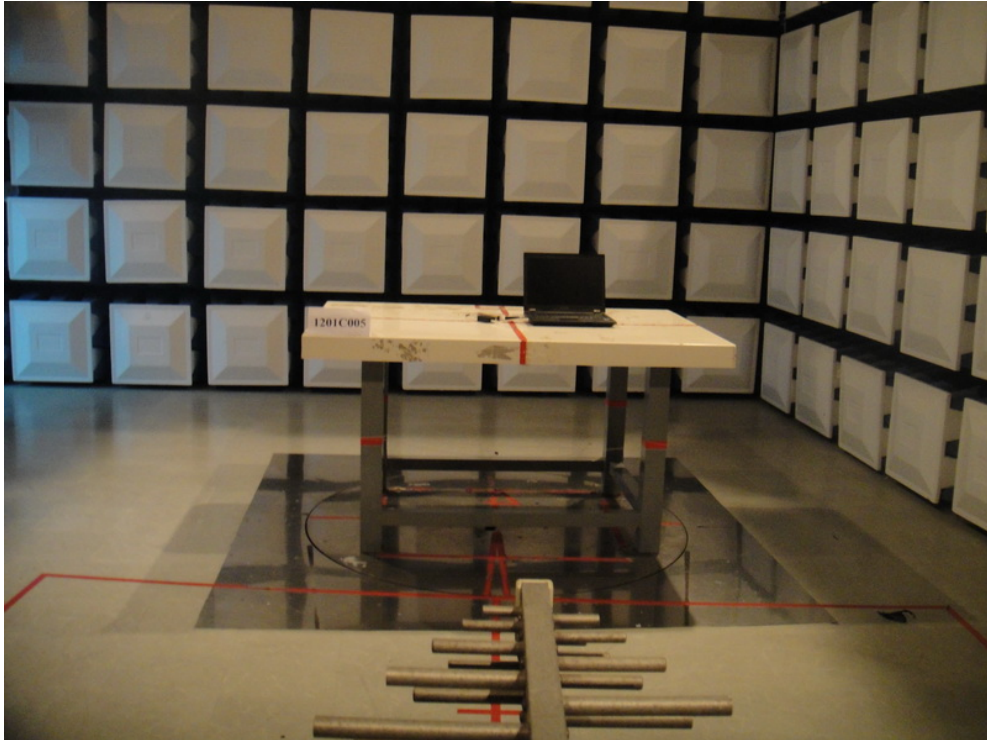



**Radiated Measurement Photos
Above 1000MHz**

