

FCC EMC Test Report

Project No. : 1907C167
Equipment : Desktop Audio System
Brand Name :  **YAMAHA**
Test Model : TSX-B237
Series Model : N/A
Applicant : Beautiful Enterprise Co., Ltd.
Address : 27th Floor, Beautiful Group Tower, 77 Connaught Road Central, Hong Kong
Manufacturer : Beautiful Enterprise Co., Ltd.
Address : 27th Floor, Beautiful Group Tower, 77 Connaught Road Central, Hong Kong
Factory : Shenzhen Synchron Electronics Co., Ltd.
Address : No.9 Mei Li Road, Xia Mei Lin, Fu Tian Area, Shenzhen, Guangdong, P.R. China.
Date of Receipt : Jul. 23, 2019
Date of Test : Jul. 21, 2019 ~ Sep. 24, 2019
Issued Date : Nov. 18, 2019
Report Version : R01
Test Sample : Engineering Sample No.: DG2019090910
Standard(s) : FCC Part 18

The above equipment has been tested and found compliance with the requirement of the relative standards by BTL Inc.

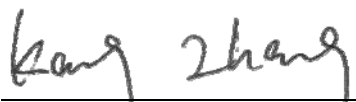

Prepared by : Kang Zhang

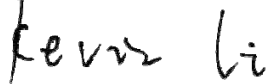

Approved by : Kevin Li



Certificate #5123.02

Add: No.3, Jinshagang 1st Road, Shixia, Dalang Town, Dongguan, Guangdong, China.

Tel: +86-769-8318-3000

Web: www.newbtl.com

Declaration

BTL represents to the client that testing is done in accordance with standard procedures as applicable and that test instruments used has been calibrated with standards traceable to international standard(s) and/or national standard(s).

BTL's reports apply only to the specific samples tested under conditions. It is manufacture's responsibility to ensure that additional production units of this model are manufactured with the identical electrical and mechanical components. **BTL** shall have no liability for any declarations, inferences or generalizations drawn by the client or others from **BTL** issued reports.

The report must not be used by the client to claim product certification, approval, or endorsement by NIST, A2LA, or any agency of the U.S. Government.

This report is the confidential property of the client. As a mutual protection to the clients, the public and ourselves, the test report shall not be reproduced, except in full, without our written approval.

BTL's laboratory quality assurance procedures are in compliance with the **ISO/IEC 17025** requirements, and accredited by the conformity assessment authorities listed in this test report.

BTL is not responsible for the sampling stage, so the results only apply to the sample as received.

The information, data and test plan are provided by manufacturer which may affect the validity of results, so it is manufacturer's responsibility to ensure that the apparatus meets the essential requirements of applied standards and in all the possible configurations as representative of its intended use.

Limitation

For the use of the authority's logo is limited unless the Test Standard(s)/Scope(s)/Item(s) mentioned in this test report is (are) included in the conformity assessment authorities acceptance respective.

Please note that the measurement uncertainty is provided for informational purpose only and are not use in determining the Pass/Fail results.

Table of Contents	Page
REPORT ISSUED HISTORY	4
1 . SUMMARY OF TEST RESULTS	5
1.1 TEST FACILITY	6
1.2 MEASUREMENT UNCERTAINTY	6
1.3 TEST ENVIRONMENT CONDITIONS	6
2 . GENERAL INFORMATION	7
2.1 GENERAL DESCRIPTION OF EUT	7
2.2 DESCRIPTION OF TEST MODES	8
2.3 EUT OPERATING CONDITIONS	9
2.4 BLOCK DIAGRAM SHOWING THE CONFIGURATION OF SYSTEM TESTED	9
2.5 DESCRIPTION OF SUPPORT UNITS	10
3 . EMC EMISSION TEST	11
3.1 AC POWER LINE CONDUCTED EMISSIONS TEST	11
3.1.1 LIMIT	11
3.1.2 MEASUREMENT INSTRUMENTS LIST	11
3.1.3 TEST PROCEDURE	12
3.1.4 DEVIATION FROM TEST STANDARD	12
3.1.5 TEST SETUP	12
3.1.6 TEST RESULTS	12
3.2 RADIATED EMISSIONS 9KHZ TO 30MHZ	15
3.2.1 LIMITS	15
3.2.2 MEASUREMENT INSTRUMENTS LIST	15
3.2.3 TEST PROCEDURE	16
3.2.4 DEVIATION FROM TEST STANDARD	16
3.2.5 TEST SETUP	16
3.2.6 TEST RESULTS	16
4 . EUT TEST PHOTO	19

REPORT ISSUED HISTORY

Report Version	Description	Issued Date
R00	Original Issue.	Nov. 14, 2019
R01	Updated the Antenna of the item radiated emission 9kHz to 30MHz.	Nov. 18, 2019

1. SUMMARY OF TEST RESULTS

Emission		
Ref Standard(s)	Test Item	Result
FCC/OST MP-5 (1986)	AC Power Line Conducted Emissions	PASS
	Radiated emission 9kHz to 30MHz	PASS
	Radiated emission between 30MHz and 1000MHz	N/A
	Radiated emission Above 1 GHz	N/A

NOTE:

(1) "N/A" denotes test is not applicable to this device.

1.1 TEST FACILITY

The test facilities used to collect the test data in this report at the location of No.3, Jinshagang 1st Road, Shixia, Dalang Town, Dongguan, Guangdong, China.

BTL's Test Firm Registration Number for FCC: 357015

BTL's Designation Number for FCC: CN1240

1.2 MEASUREMENT UNCERTAINTY

ISO/IEC 17025 requires that an estimate of the measurement uncertainties associated with the emissions test results be included in the report. The measurement uncertainties given below are based on a 95% confidence level (based on a coverage factor (k=2))

The BTL measurement uncertainty as below table:

A. AC power line conducted emissions test:

Test Site	Method	Measurement Frequency Range	U,(dB)
DG-C02	CISPR	150 kHz ~ 30MHz	2.32

B. Radiated emissions test:

Test Site	Method	Measurement Frequency Range	U,(dB)
DG-CB01	CISPR	9kHz ~ 150kHz	2.58
		150kHz ~ 30MHz	2.70

Note: Unless specifically mentioned, the uncertainty of measurement has not been taken into account to declare the compliance or non-compliance to the specification.

1.3 TEST ENVIRONMENT CONDITIONS

Test Item	Temperature	Humidity	Tested By
AC Power Line Conducted Emissions	25°C	53%	Lea Lu
Radiated emissions 9kHz to 30MHz	25°C	60%	Peppa Zhang

2. GENERAL INFORMATION

2.1 GENERAL DESCRIPTION OF EUT

Equipment	Desktop Audio System
Brand Name	 YAMAHA
Test Model	TSX-B237
Series Model	N/A
Model Difference(s)	N/A
S/N	Z003209UW, Z003289UW
Power Source	AC Mains.
Power Rating	120V~ 60Hz 42W
Connecting I/O Port(s)	1* USB port 1* AUX port 1* HEADPHONE port 1* FM ANT port 1* AC port
Highest Internal Frequency(Fx)	Highest frequency: 4Ghz Qi: 127.7 kHz

Note:

1. For a more detailed features description, please refer to the manufacturer's specifications or the user's manual.
2. EUT has two sample, tested the sample Z003209UW and recorded in the report.

2.2 DESCRIPTION OF TEST MODES

To investigate the maximum EMI emission characteristics generates from EUT, the test system was pre-scanning tested base on the consideration of following EUT operation mode or test configuration mode which possible have effect on EMI emission level. Each of these EUT operation mode(s) or test configuration mode(s) mentioned above was evaluated respectively.

Pretest Mode	Description
Mode 1	AUX IN +Qi10W+USB 5V1A(earphone)
Mode 2	AUX IN + Qi10W+USB 5V1A (speaker)
Mode 3	BT Play + Qi10W+USB 5V1A (earphone)
Mode 4	CD Play + Qi10W+USB 5V1A (earphone)
Mode 5	USB Play + Qi10W (earphone)
Mode 6	FM 88MHz + Qi10W+USB 5V1A (earphone)
Mode 7	FM 98MHz + Qi10W+USB 5V1A (earphone)
Mode 8	FM 108MHz + Qi10W+USB 5V1A (earphone)
Mode 9	DAB 5B + Qi10W+USB 5V1A (earphone)
Mode 10	DAB 9D + Qi10W+USB 5V1A (earphone)
Mode 11	DAB 13F + Qi10W+USB 5V1A (earphone)

AC Power Line Conducted Emissions test	
Final Test Mode	Description
Mode 1	AUX IN +Qi10W+USB 5V1A(earphone)

Radiated Emissions 9kHz to 30MHz test	
Final Test Mode	Description
Mode 1	AUX IN +Qi10W+USB 5V1A(earphone)

Note:

1. Pretest Mode 1-11, the worst case is Mode 1 and recorded in this report.

2.3 EUT OPERATING CONDITIONS

The EUT exercise program used during radiated and/or conducted emission measurement was designed to exercise the various system components in a manner similar to a typical use. The standard test signals and output signal as following:

1. EUT places the phone on a wireless charging device.
2. EUT connects to Earphone via Earphone cable.
3. EUT connects to iPod via Audio cable.
4. EUT connects to iPod via BT function.
5. EUT connects to FM STEREO FM-AM SIGNAL GENERATOR via FM&DAB function.
6. EUT connected to EUT (Remote) via BT function.

2.4 BLOCK DIAGRAM SHOWING THE CONFIGURATION OF SYSTEM TESTED

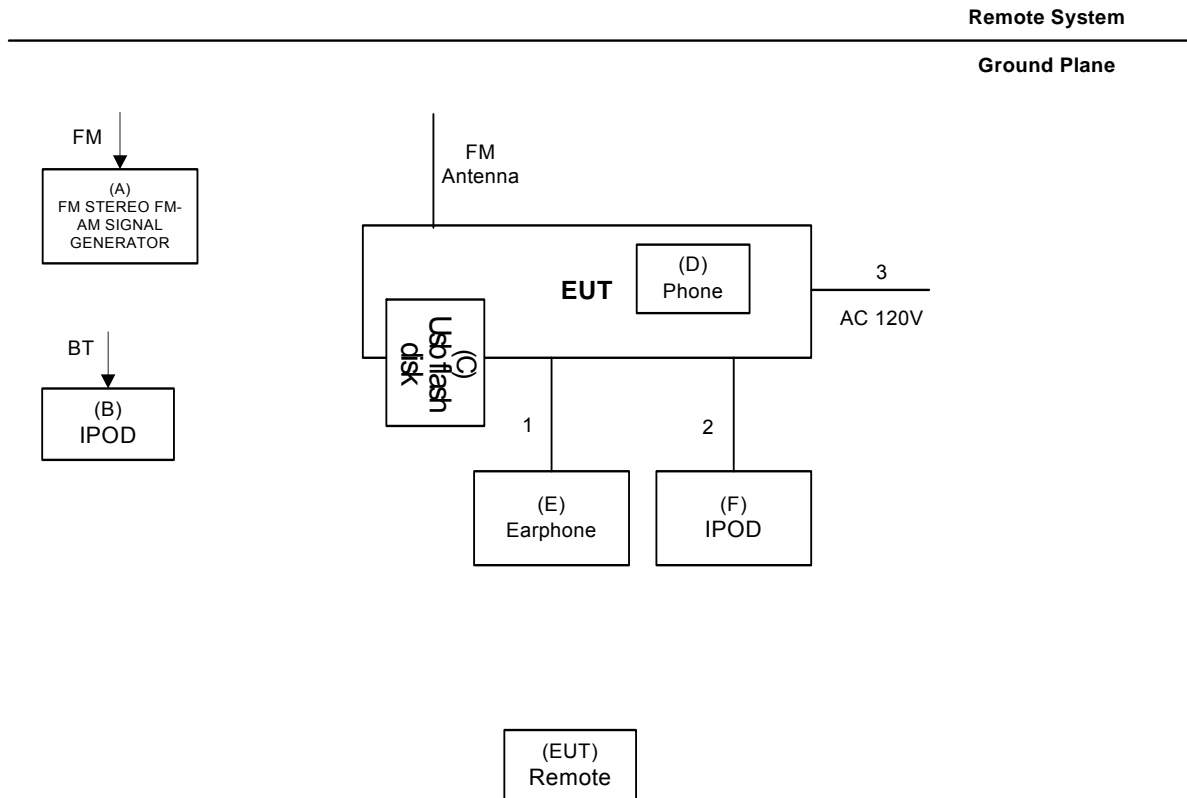

2.5 DESCRIPTION OF SUPPORT UNITS

The EUT has been tested as an independent unit together with other necessary accessories or support units. The following support units or accessories were used to form a representative test configuration during the tests.

Item	Equipment	Mfr/Brand	Model/Type No.	Series No.
A	FM STEREO FM-AM SIGNAL GENERATOR	KENWOOD	SG-5110	HR1010098
B	iPod	APPLE	A1574	CCQTJ1N3GGK8
C	USB Flash Disk	Kingston	N/A	N/A
D	Phone	APPLE	MQA82ZP/A	G6TWW7UDJCL6
E	Earphone	Apple	N/A	N/A
F	iPod	APPLE	A1574	CCQTM01GGGK8

Item	Cable Type	Shielded Type	Ferrite Core	Length
1	Earphone cable	NO	NO	1.2m
2	Audio cable	NO	NO	1.8m
3	AC cable	NO	NO	1.5m

3. EMC EMISSION TEST

3.1 AC POWER LINE CONDUCTED EMISSIONS TEST

3.1.1 LIMIT

Frequency of Emission (MHz)	Class B (dBuV)	
	Quasi-peak	Average
0.15 - 0.5	66 - 56 *	56 - 46 *
0.5 - 5.0	56.00	46.00
5.0 - 30.0	60.00	50.00

Note:

- (1) The tighter limit applies at the band edges.
- (2) The limit of " * " marked band means the limitation decreases linearly with the logarithm of the frequency in the range.
- (3) The test result calculated as following:
 Measurement Value = Reading Level + Correct Factor
 Correct Factor = Insertion Loss + Cable Loss + Attenuator Factor(if use)
 Margin Level = Measurement Value - Limit Value

3.1.2 MEASUREMENT INSTRUMENTS LIST

Item	Kind of Equipment	Manufacturer	Type No.	Serial No.	Calibrated until
1	EMI Test Receiver	R&S	ESCI	100382	Mar. 10, 2020
2	LISN	EMCO	3816/2	52765	Mar. 10, 2020
3	TWO-LINE V-NETWORK	R&S	ENV216	101447	May. 19, 2020
4	50Ω Terminator	SHX	TF5-3	15041305	Mar. 10, 2020
5	Measurement Software	Farad	EZ-EMC Ver.NB-03A1-01	N/A	N/A
6	Cable	N/A	RG223	12m	Mar. 12, 2020

Remark: "N/A" denotes no model name, serial no. or calibration specified.
 All calibration period of equipment list is one year.

3.1.3 TEST PROCEDURE

- a. The EUT was placed 0.8 meters from the horizontal ground plane with EUT being connected to the power mains through a line impedance stabilization network (LISN). All other support equipment powered from additional LISN(s). The LISN provide 50 Ohm/ 50uH of coupling impedance for the measuring instrument.
- b. Interconnecting cables that hang closer than 40 cm to the ground plane shall be folded back and forth in the center forming a bundle 30 to 40 cm long.
- c. I/O cables that are not connected to a peripheral shall be bundled in the center. The end of the cable may be terminated, if required, using the correct terminating impedance. The overall length shall not exceed 1 m.
- d. LISN at least 80 cm from nearest part of EUT chassis.
- e. For the actual test configuration, please refer to the related Item –EUT Test Photos.
- f. Measuring frequency range from 150KHz to 30MHz.

3.1.4 DEVIATION FROM TEST STANDARD

No deviation

3.1.5 TEST SETUP

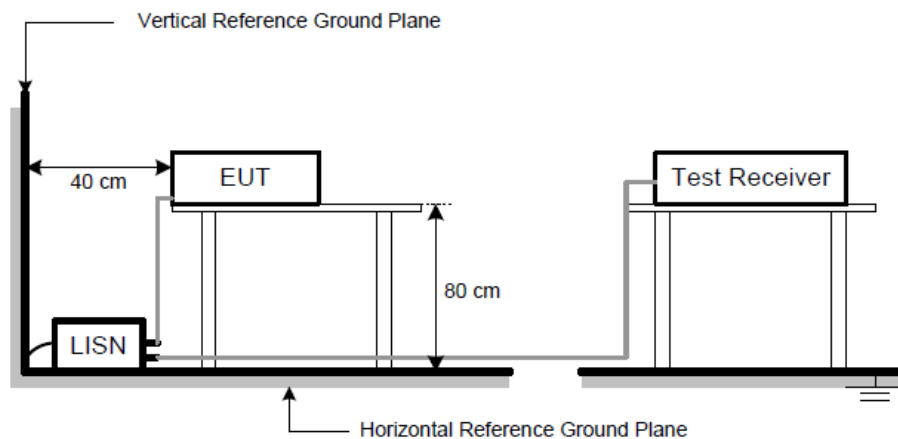

3.1.6 TEST RESULTS

Remark

- (1) Reading in which marked as QP means measurements by using are Quasi-Peak Mode with Detector BW=9 kHz; SPA setting in RBW=10 kHz, VBW =10 kHz, Swp. Time = 0.3 sec./MHz. Reading in which marked as AV means measurements by using are Average Mode with instrument setting in RBW=10 kHz, VBW=10 kHz, Swp. Time =0.3 sec./MHz.
- (2) All readings are QP Mode value unless otherwise stated AVG in column of 『Note』. If the QP Mode Measured value compliance with the QP Limits and lower than AVG Limits, the EUT shall be deemed to meet both QP & AVG Limits and then only QP Mode was measured, but AVG Mode didn't perform. In this case, a “*” marked in AVG Mode column of Interference Voltage Measured.

Test Voltage	AC 120V/60Hz	Phase	Line
Test Mode	Mode 1		

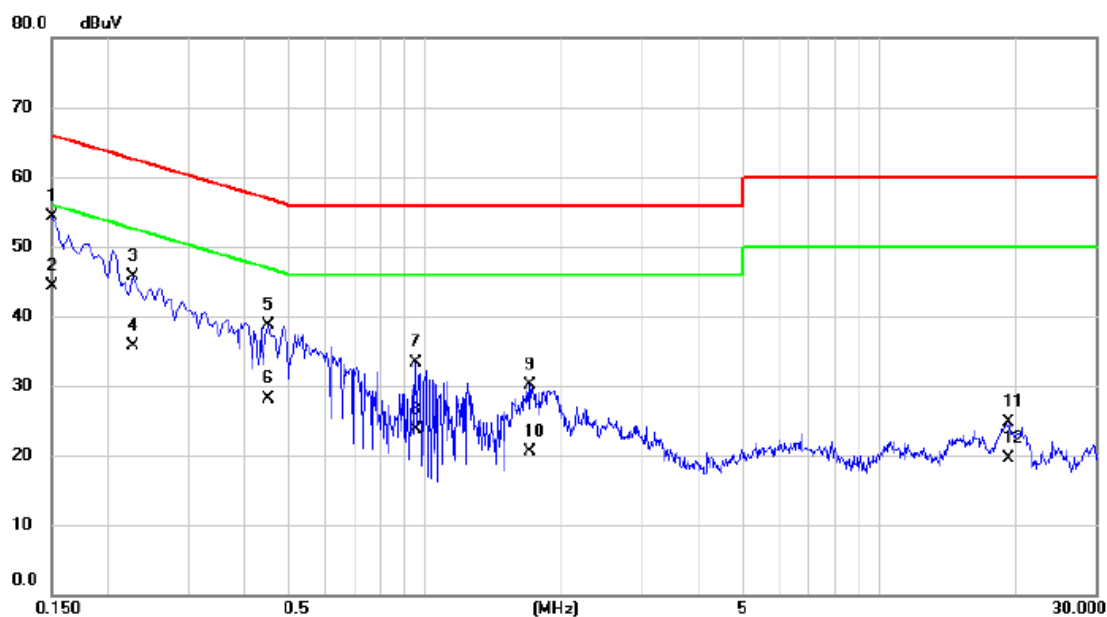

No.	Mk.	Freq. MHz	Reading Level dBuV	Correct Factor dB	Measure- ment dBuV	Limit dBuV	Margin dB	Detector	Comment
1		0.1500	44.45	9.82	54.27	66.00	-11.73	QP	
2	*	0.1500	34.50	9.82	44.32	56.00	-11.68	AVG	
3		0.2265	35.84	9.82	45.66	62.58	-16.92	QP	
4		0.2265	25.80	9.82	35.62	52.58	-16.96	AVG	
5		0.4515	28.89	9.87	38.76	56.85	-18.09	QP	
6		0.4515	18.30	9.87	28.17	46.85	-18.68	AVG	
7		0.9510	23.29	9.92	33.21	56.00	-22.79	QP	
8		0.9510	13.70	9.92	23.62	46.00	-22.38	AVG	
9		1.6980	20.23	9.97	30.20	56.00	-25.80	QP	
10		1.6980	10.50	9.97	20.47	46.00	-25.53	AVG	
11		19.3110	13.51	11.12	24.63	60.00	-35.37	QP	
12		19.3110	8.40	11.12	19.52	50.00	-30.48	AVG	

Test Voltage	AC 120V/60Hz	Phase	Neutral
Test Mode	Mode 1		

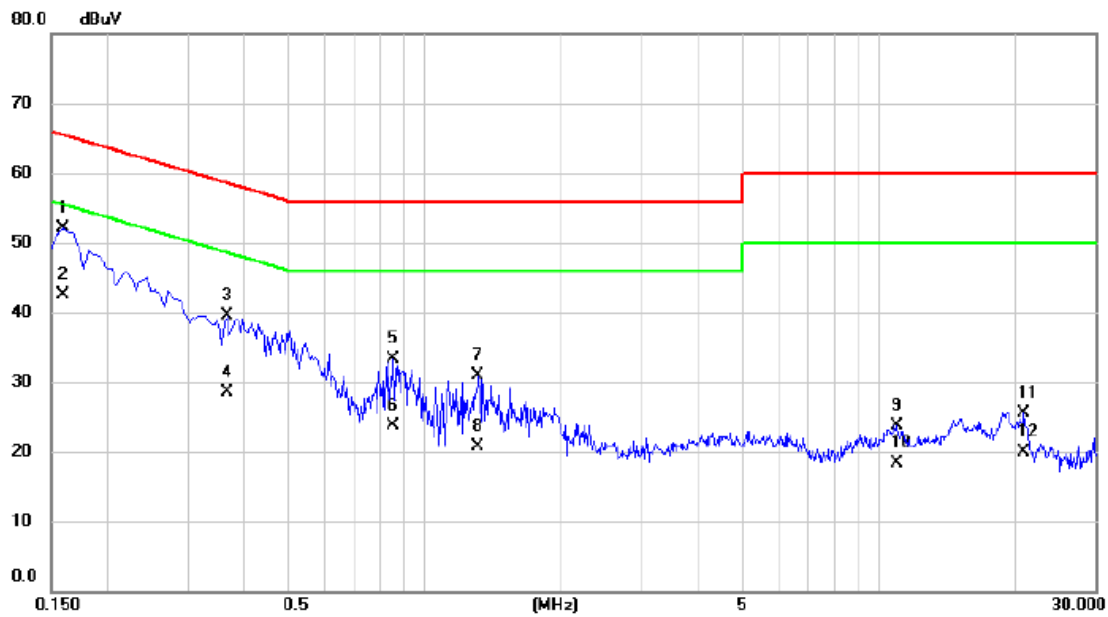

No.	Mk.	Freq. MHz	Reading Level dBuV	Correct Factor dB	Measure- ment dBuV	Limit dBuV	Margin dB	Detector	Comment
1		0.1590	42.11	9.91	52.02	65.52	-13.50	QP	
2	*	0.1590	32.60	9.91	42.51	55.52	-13.01	AVG	
3		0.3660	29.50	9.99	39.49	58.59	-19.10	QP	
4		0.3660	18.50	9.99	28.49	48.59	-20.10	AVG	
5		0.8520	23.25	10.09	33.34	56.00	-22.66	QP	
6		0.8520	13.70	10.09	23.79	46.00	-22.21	AVG	
7		1.3110	20.84	10.14	30.98	56.00	-25.02	QP	
8		1.3110	10.50	10.14	20.64	46.00	-25.36	AVG	
9		10.9410	12.90	10.80	23.70	60.00	-36.30	QP	
10		10.9410	7.50	10.80	18.30	50.00	-31.70	AVG	
11		20.8320	14.03	11.48	25.51	60.00	-34.49	QP	
12		20.8320	8.50	11.48	19.98	50.00	-30.02	AVG	

3.2 RADIATED EMISSIONS 9KHZ TO 30MHZ

3.2.1 LIMITS

Operating frequency	Field Strength (uV/m)	Measurement Distance (meters)	F.S Limitation at 3m Distance
			(dBuV/m)
Any non-ISM	15	300	103.50

NOTE:

- (1) The Equipment is for 18.305(b) Any type unless otherwise specified (miscellaneous) Operating frequency in any non-ISM frequency
- (2) Operation of ISM equipment within the following safety, search and rescue frequency bands is prohibited: 490–510 kHz, 2170–2194 kHz, 8354–8374 kHz, 121.4–121.6 MHz, 156.7–156.9 MHz, and 242.8–243.2 MHz.
- (3) Distance extrapolation factor = $40 \log(\text{specific distance} / \text{test distance})$ (dB);
Limit line = specific limits (dBuV) + distance extrapolation factor.
- (4) The test result calculated as following:
 Measurement Value = Reading Level + Correct Factor
 Correct Factor = Antenna Factor + Cable Loss
 Margin Level = Measurement Value - Limit Value

3.2.2 MEASUREMENT INSTRUMENTS LIST

Item	Kind of Equipment	Manufacturer	Type No.	Serial No.	Calibrated until
1	Antenna	EM	EM-6876-1	230	Jan. 15, 2020
2	EMI Test Receiver	R&S	ESCI	100895	Mar. 10, 2020
3	Cable	Mlcable Inc.	B10-01-01-15M(10MHz~26.5GHz)	18047122	Mar. 22, 2020
4	Controller	ETS-Lindgren	2090	N/A	N/A
5	Measurement Software	Farad	EZ-EMC Ver.NB-03A1-01	N/A	N/A

Remark: "N/A" denotes no model name, serial no. or calibration specified.
 All calibration period of equipment list is one year.

3.2.3 TEST PROCEDURE

- The EUT was placed on the top of a rotating table 0.8 meters above the ground at a 3 meter semi-anechoic chamber. The table was rotated 360 degrees to determine the position of the highest radiation.
- The height of the equipment or of the substitution antenna shall be 0.8 m; the antenna shall be supported in the vertical plane and be rotatable about a vertical axis. The lowest point of the loop shall be 1 m above ground level.
- The initial step in collecting radiated emission data is a spectrum analyzer peak detector mode pre-scanning the measurement frequency range. Significant peaks are then marked and then Quasi Peak detector mode re-measured.
- If the Peak Mode measured value compliance with and lower than Quasi Peak Mode Limit, the EUT shall be deemed to meet QP Limits and then no additional QP Mode measurement performed.
- For the actual test configuration, please refer to the related Item –EUT Test Photos.

3.2.4 DEVIATION FROM TEST STANDARD

No deviation

3.2.5 TEST SETUP

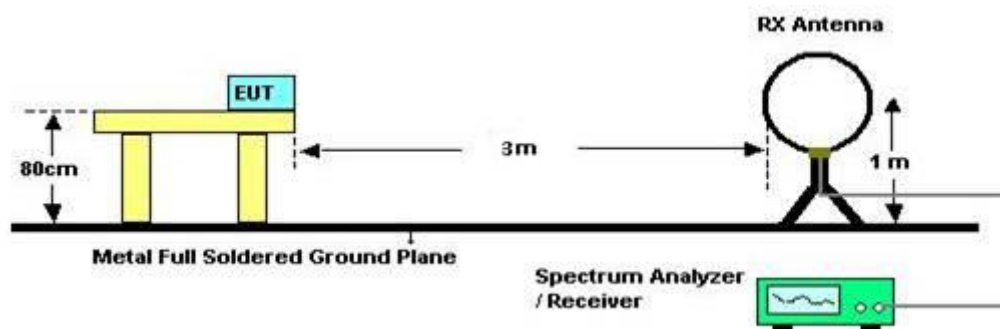

3.2.6 TEST RESULTS

Remark:

- All readings are Peak unless otherwise stated QP in column of 『 Note 』 . Peak denotes that the Peak reading compliance with the QP Limits and then QP Mode measurement didn't perform ◦
- Measuring frequency range from 9kHz to 30MHz.
- If the peak scan value lower limit more than 20dB, then this signal data does not show in table.

Test Voltage:	AC 120V/60Hz
Test Mode:	Mode 1

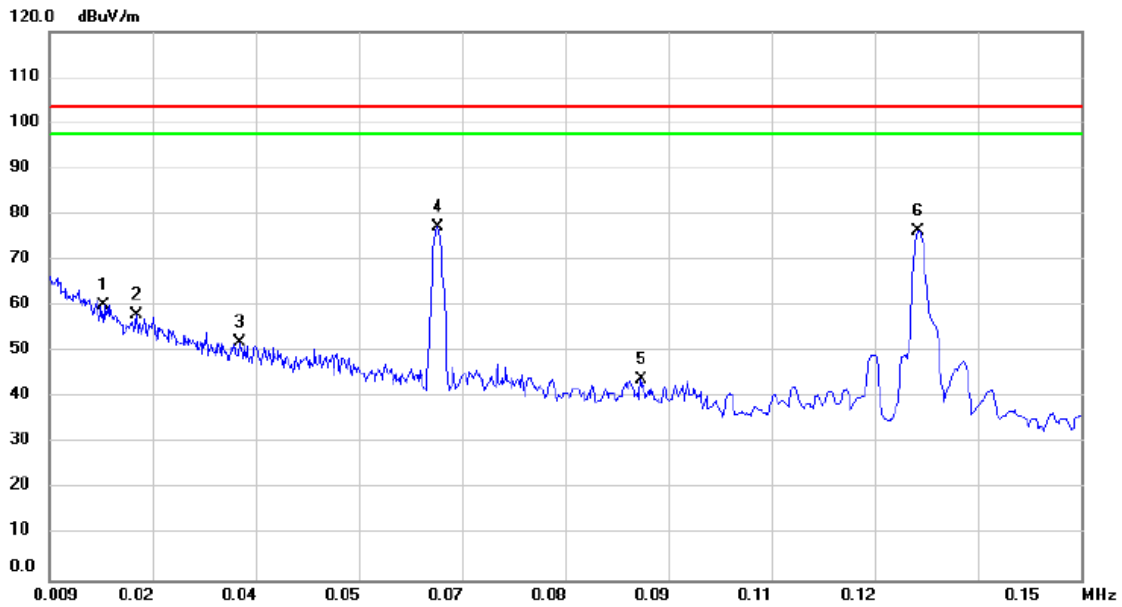

No. Mk.	Freq. MHz	Reading Level dBuV	Correct Factor dB	Measure- ment dBuV/m	Limit dBuV/m	Margin dB	Detector	Comment
1	0.0165	45.24	14.87	60.11	103.50	-43.39	QP	
2	0.0210	44.10	13.82	57.92	103.50	-45.58	QP	
3	0.0350	38.30	13.88	52.18	103.50	-51.32	QP	
4 *	0.0622	63.51	13.73	77.24	103.50	-26.26	QP	
5	0.0900	30.51	13.54	44.05	103.50	-59.45	QP	
6	0.1278	62.83	13.55	76.38	103.50	-27.12	QP	

Test Voltage:	AC 120V/60Hz
Test Mode:	Mode 1

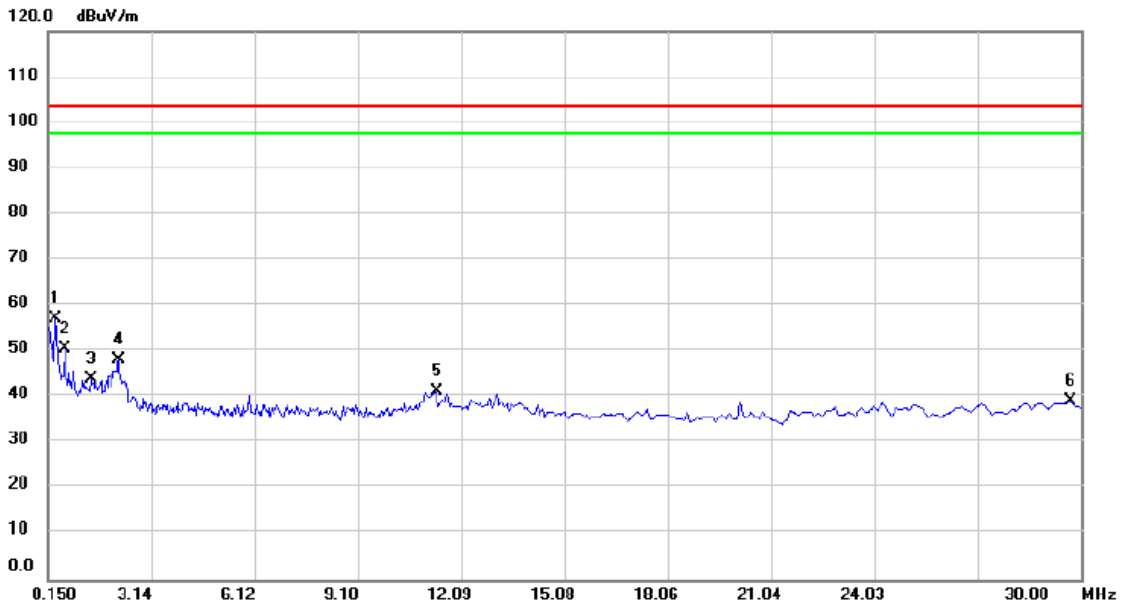

No.	Mk.	Freq. MHz	Reading Level dBuV	Correct Factor dB	Measure- ment dBuV/m	Limit dBuV/m	Margin dB	Detector	Comment
1	*	0.3810	43.70	13.35	57.05	103.50	-46.45	QP	
2		0.6370	37.62	12.80	50.42	103.50	-53.08	QP	
3		1.3956	31.81	12.23	44.04	103.50	-59.46	QP	
4		2.1897	36.46	11.71	48.17	103.50	-55.33	QP	
5		11.3771	29.52	11.61	41.13	103.50	-62.37	QP	
6		29.6837	22.15	16.93	39.08	103.50	-64.42	QP	

4. EUT TEST PHOTO

AC Power Line Conducted Emissions



Radiated Emissions 9 KHz to 30 MHz

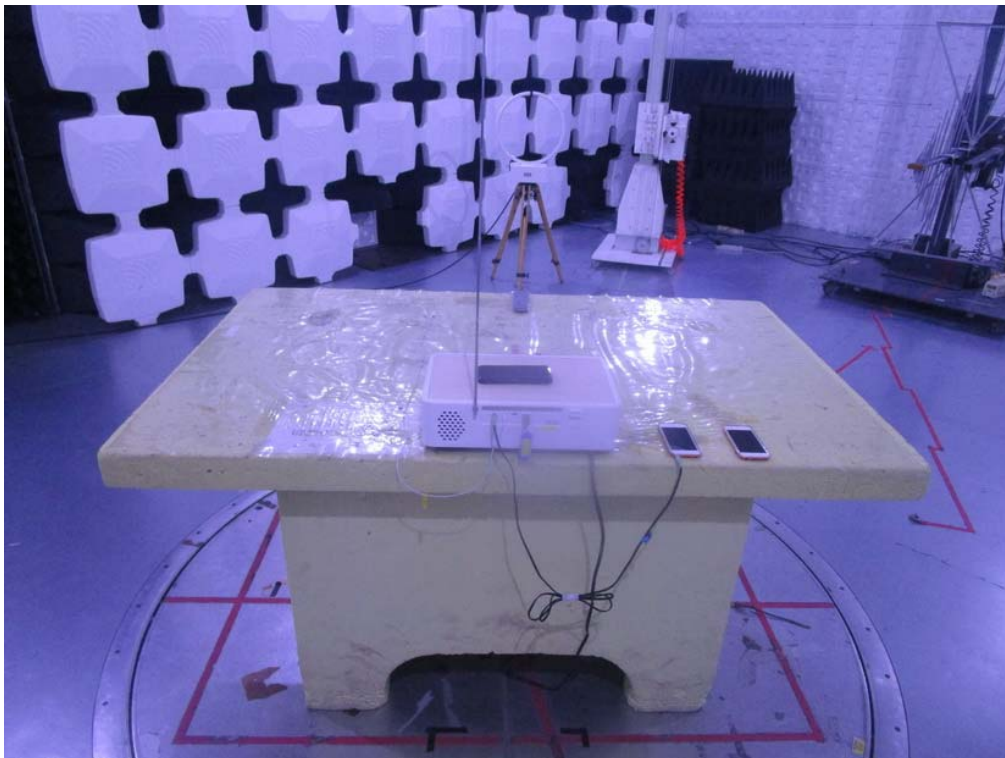
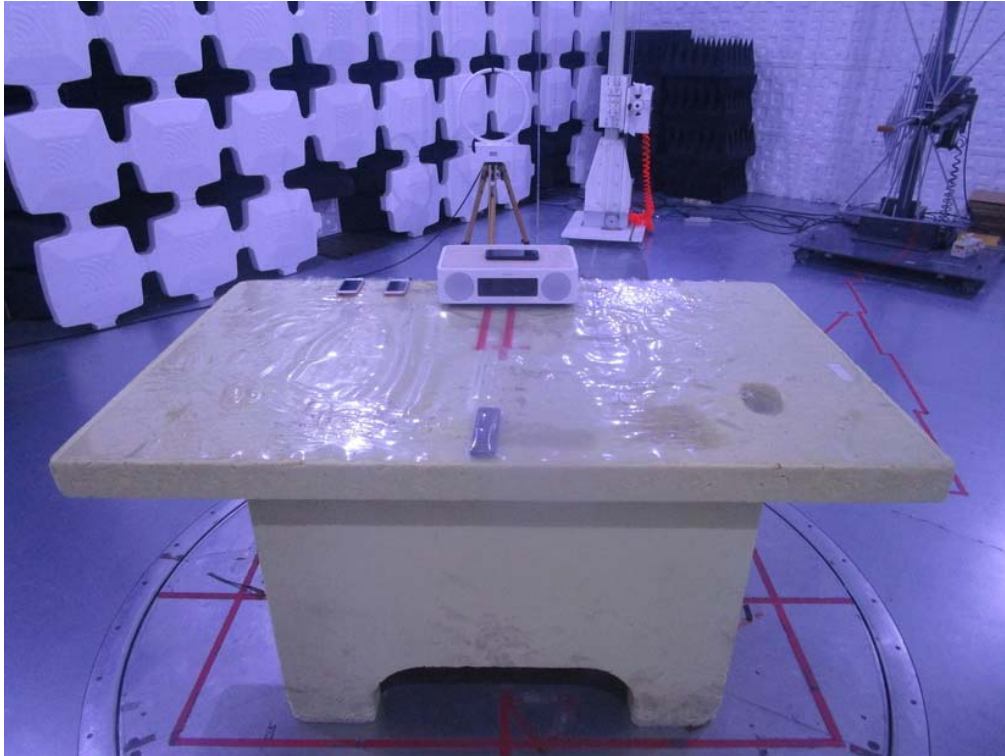

End of Test Report