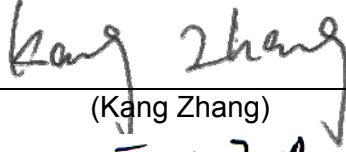
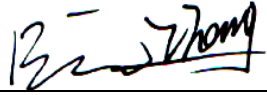

FCC EMC Test Report

Project No. : 1905C134
Equipment : Charge Rise
Model Name : SFQ-15
Applicant : N/A
Address : Beautiful Enterprise Co., Ltd.
27th Floor, Beautiful Group Tower, 77 Connaught Road
Central, Hong Kong

Date of Receipt : May 30, 2019
Date of Test : May 31, 2019 ~ Jun. 27, 2019
Issued Date : Jul. 17, 2019
Tested by : BTL Inc.

Testing Engineer : 
(Kang Zhang)

Technical Manager : 
(Bill Zhang)

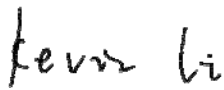
Authorized Signatory : 
(Kevin Li)

B T L I N C .

No.3, Jinshagang 1st Road, Shixia, Dalang Town, Dongguan,
Guangdong, China.

TEL: +86-769-8318-3000 FAX: +86-769-8319-6000



Certificate #5123.02

Declaration

BTL represents to the client that testing is done in accordance with standard procedures as applicable and that test instruments used has been calibrated with standards traceable to international standard(s) and/or national standard(s).

BTL's reports apply only to the specific samples tested under conditions. It is manufacture's responsibility to ensure that additional production units of this model are manufactured with the identical electrical and mechanical components. **BTL** shall have no liability for any declarations, inferences or generalizations drawn by the client or others from **BTL** issued reports.

The report must not be used by the client to claim product certification, approval, or endorsement by NVLAP, NIST, A2LA, or any agency of the U.S. Government.

This report is the confidential property of the client. As a mutual protection to the clients, the public and ourselves, the test report shall not be reproduced, except in full, without our written approval.

BTL's laboratory quality assurance procedures are in compliance with the **ISO/IEC 17025** requirements, and accredited by the conformity assessment authorities listed in this test report.

BTL is not responsible for the sampling stage, so the results only apply to the sample as received.

The information, data and test plan are provided by manufacturer which may affect the validity of results, so it is manufacturer's responsibility to ensure that the apparatus meets the essential requirements of applied standards and in all the possible configurations as representative of its intended use.

Limitation

For the use of the authority's logo is limited unless the Test Standard(s)/Scope(s)/Item(s) mentioned in this test report is (are) included in the conformity assessment authorities acceptance respective.

Please note that the measurement uncertainty is provided for informational purpose only and are not use in determining the Pass/Fail results.

Table of Contents	Page
REPORT ISSUED HISTORY	4
1 . GENERAL SUMMARY	5
2 . SUMMARY OF TEST RESULTS	6
2.1 TEST FACILITY	7
2.2 MEASUREMENT UNCERTAINTY	7
3 . GENERAL INFORMATION	8
3.1 GENERAL DESCRIPTION OF EUT	8
3.2 DESCRIPTION OF TEST MODES	8
3.3 EUT OPERATING CONDITIONS	9
3.4 BLOCK DIAGRAM SHOWING THE CONFIGURATION OF SYSTEM TESTED	9
3.5 DESCRIPTION OF SUPPORT UNITS	9
4 . EMC EMISSION TEST	10
4.1 CONDUCTED EMISSION MEASUREMENT	10
4.1.1 POWER LINE CONDUCTED EMISSION	10
4.1.2 TEST PROCEDURE	10
4.1.3 DEVIATION FROM TEST STANDARD	10
4.1.4 TEST SETUP	11
4.1.5 EUT OPERATING CONDITIONS	11
4.1.6 TEST RESULTS	11
4.2 RADIATED EMISSION MEASUREMENT	12
4.2.1 LIMITS OF RADIATED EMISSION MEASUREMENT	12
4.2.2 TEST PROCEDURE	12
4.2.3 DEVIATION FROM TEST STANDARD	12
4.2.4 TEST SETUP	13
4.2.5 TEST RESULTS - 9KHZ TO 30MHZ	13
5 . MEASUREMENT INSTRUMENTS LIST	14
6 . EUT TEST PHOTO	15
APPENDIX A - CONDUCTED EMISSION	17
APPENDIX B - RADIATED EMISSION (9KHZ TO 30MHZ)	20

REPORT ISSUED HISTORY

Report Version	Description	Issued Date
R00	Original Issue.	Jul. 11, 2019
R01	Revised telefication comments.	Jul. 17, 2019

1. GENERAL SUMMARY

Equipment : Charge Rise
Brand Name : **SOUNDFREQ**[®]
Test Model : SFQ-15
Series Model : N/A
Applicant : Beautiful Enterprise Co., Ltd.
Manufacturer : Beautiful Enterprise Co., Ltd.
Address : 27th Floor, Beautiful Group Tower, 77 Connaught Road Central, Hong Kong
Factory : Shenzhen Synchron Electronics Co., Ltd.
Address : No. 9 Mei Li Road, Xia Mei Lin, Fu Tian Area, Shenzhen, Guangdong, P.R.
China
Date of Test : May 31, 2019 ~ Jun. 27, 2019
Test Sample : Engineering Sample No.: DG19053051
Standard(s) : FCC Part 18
FCC/OET MP-5

The above equipment has been tested and found compliance with the requirement of the relative standards by BTL Inc.

The test data, data evaluation, and equipment configuration contained in our test report (Ref No. BTL-FCCE-2-1905C134) were obtained utilizing the test procedures, test instruments, test sites that has been accredited by the Authority of A2LA according to the ISO/IEC 17025 quality assessment standard and technical standard(s).

2. SUMMARY OF TEST RESULTS

Test procedures according to the technical standards:

EMC Emission			
Standard(s)	Test Item	Judgment	Remark
FCC Part 18 FCC/OET MP-5	Conducted Emission	PASS	
	Radiated emission between 9kHz and 30MHz	PASS	NOTE(2)
	Radiated emission between 30MHz and 1000MHz	N/A	NOTE(1)
	Radiated emission Above 1 GHz	N/A	NOTE(1)

NOTE:

(1) "N/A" denotes test is not applicable to this device.

(2) The main frequency of wireless charge is below 1.705MHz , so radiation test to 30MHz.

2.1 TEST FACILITY

The test facilities used to collect the test data in this report at the location of No.3, Jinshagang 1st Road, Shixia, Dalang Town, Dongguan, Guangdong, China.

BTL's Test Firm Registration Number for FCC: 357015

BTL's Designation Number for FCC: CN1240

2.2 MEASUREMENT UNCERTAINTY

Where relevant, the following measurement uncertainty levels have been estimated for tests performed on the EUT as specified in CISPR 16-4-2, The BTL measurement uncertainty is less than the CISPR 16-4-2 U_{CISPR} requirement.

The reported uncertainty of measurement $y \pm U$, where expanded uncertainty U is based on a standard uncertainty multiplied by a coverage factor of $k=2$, providing a level of confidence of approximately **95%**.

A. Conducted Measurement :

Test Site	Method	Measurement Frequency Range	U, (dB)
DG-C01	CISPR	150 kHz ~ 30MHz	3.16

B. Radiated Measurement :

Test Site	Method	Measurement Frequency Range	U,(dB)
DG-CB01	CISPR	9kHz ~ 30MHz	3.42

Note: Unless specifically mentioned, the uncertainty of measurement has not been taken into account to declare the compliance or non-compliance to the specification.

3. GENERAL INFORMATION

3.1 GENERAL DESCRIPTION OF EUT

Equipment	Charge Rise
Brand Name	SOUNDFREQ®
Test Model	SFQ-15
Series Model	N/A
Model Difference(s)	N/A
Hardware Version	V1.0
Software Version	V1.0
Power Source	DC voltage supplied from AC/DC adapter. Model: DYS836-120250W-K
Power Rating	I/P: 100-240V ~50/60Hz, 1.0A MAX O/P: 12.0V \equiv 2.5A
Connecting I/O Port(s)	1* DC port 2* USB port

Note:

1. For a more detailed features description, please refer to the manufacturer's specifications or the user's manual.

3.2 DESCRIPTION OF TEST MODES

To investigate the maximum EMI emission characteristics generated from EUT, the test system was pre-scanning tested based on the consideration of following EUT operation mode or test configuration mode which possible have effect on EMI emission level. Each of these EUT operation mode(s) or test configuration mode(s) mentioned above was evaluated respectively.

Pretest Mode	Description
Mode 1	Operating+USB(1A) Discharging+USB(2.1A) Discharging+ Wireless Discharging

For Conducted Test	
Final Test Mode	Description
Mode 1	Operating+USB(1A) Discharging+USB(2.1A) Discharging+ Wireless Discharging

For Radiated Test	
Final Test Mode	Description
Mode 1	Operating+USB(1A) Discharging+USB(2.1A) Discharging+ Wireless Discharging

3.3 EUT OPERATING CONDITIONS

The EUT exercise program used during radiated and/or conducted emission measurement was designed to exercise the various system components in a manner similar to a typical use. The standard test signals and output signal as following:

1. EUT connected to adapter via DC cable for power supply.
2. EUT connected to LOAD via USB cable.

3.4 BLOCK DIAGRAM SHOWING THE CONFIGURATION OF SYSTEM TESTED

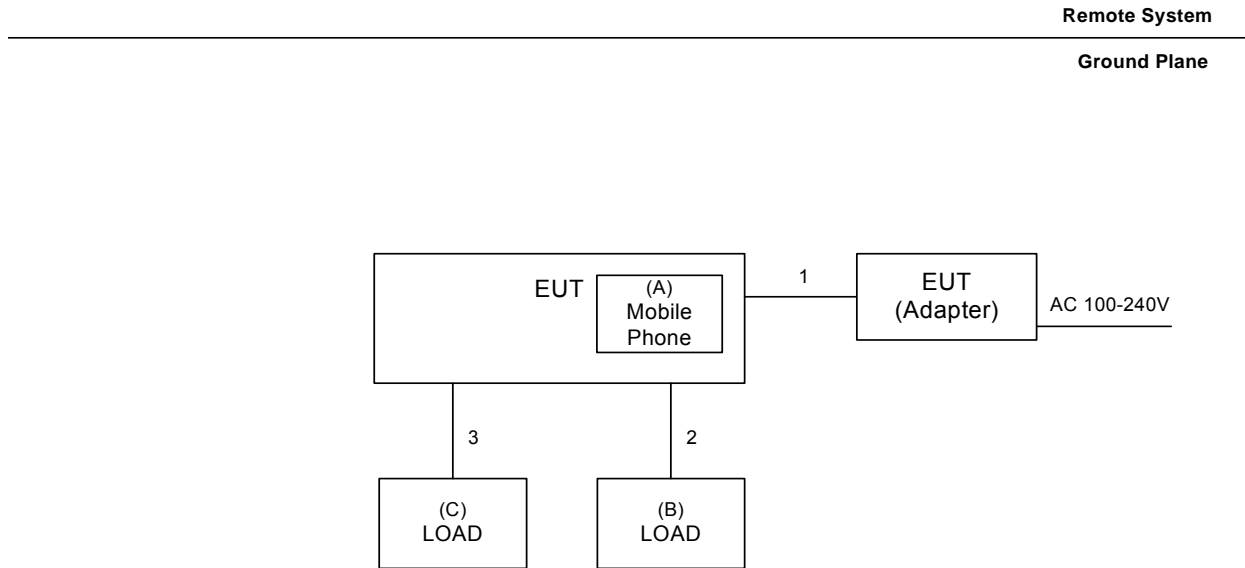

3.5 DESCRIPTION OF SUPPORT UNITS

The EUT has been tested as an independent unit together with other necessary accessories or support units. The following support units or accessories were used to form a representative test configuration during the tests.

Item	Equipment	Mfr/Brand	Model/Type No.	Series No.
A	Mobile Phone	Apple	iPhoneX	N/A
B	LOAD	N/A	N/A	N/A
C	LOAD	N/A	N/A	N/A

Item	Shielded Type	Ferrite Core	Length	Note
1	NO	NO	1.5m	DC Cable
2	NO	NO	1.0m	USB Cable
3	NO	NO	1.0m	USB Cable

4. EMC EMISSION TEST

4.1 CONDUCTED EMISSION MEASUREMENT

4.1.1 POWER LINE CONDUCTED EMISSION (Frequency Range 150KHz-30MHz)

FREQUENCY (MHz)	Conducted limit (dBuV)	
	Quasi-peak	Average
0.15- 0.5	66 - 56 *	56 - 46 *
0.5 -5.0	56.00	46.00
5.0 -30.0	60.00	50.00

Note:

- (1) The tighter limit applies at the band edges.
- (2) The limit of " * " marked band means the limitation decreases linearly with the logarithm of the frequency in the range.
- (3) The test result calculated as following:
 Measurement Value = Reading Level + Correct Factor
 Correct Factor = Insertion Loss + Cable Loss + Attenuator Factor(if use)
 Margin Level = Measurement Value - Limit Value

4.1.2 TEST PROCEDURE

- a. The EUT was placed 0.8 meters from the horizontal ground plane with EUT being connected to the power mains through a line impedance stabilization network (LISN). All other support equipment powered from additional LISN(s). The LISN provide 50 Ohm/ 50uH of coupling impedance for the measuring instrument.
- b. Interconnecting cables that hang closer than 40 cm to the ground plane shall be folded back and forth in the center forming a bundle 30 to 40 cm long.
- c. I/O cables that are not connected to a peripheral shall be bundled in the center. The end of the cable may be terminated, if required, using the correct terminating impedance. The overall length shall not exceed 1 m.
- d. LISN at least 80 cm from nearest part of EUT chassis.
- e. For the actual test configuration, please refer to the related Item –EUT Test Photos..

4.1.3 DEVIATION FROM TEST STANDARD

No deviation

4.1.4 TEST SETUP

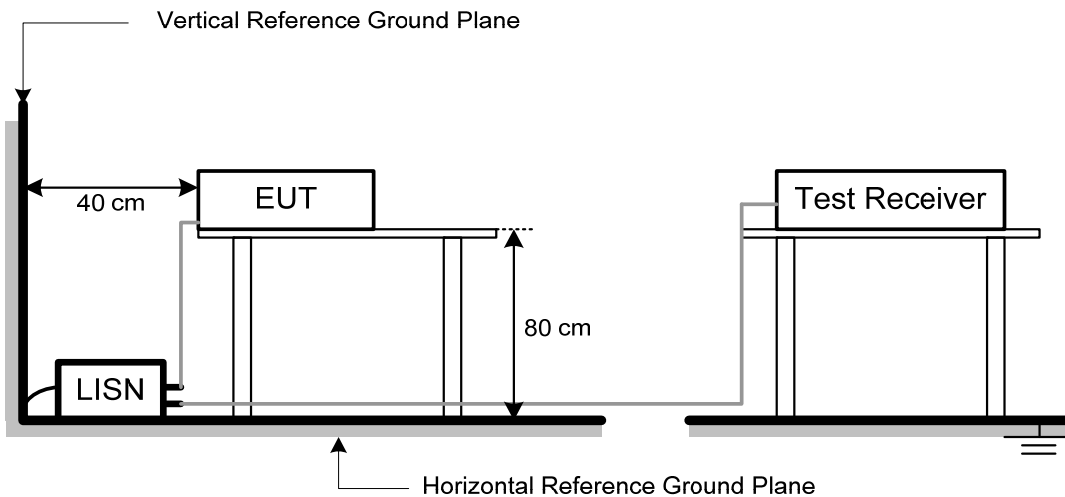

4.1.5 EUT OPERATING CONDITIONS

The EUT exercise program used during radiated and/or conducted emission measurement was designed to exercise the various system components in a manner similar to a typical use.

4.1.6 TEST RESULTS

Please refer to the Appendix A.

Temperature: 25°C Relative Humidity: 53%

Remark

- (1) Reading in which marked as QP means measurements by using are Quasi-Peak Mode with Detector BW=9KHz; SPA setting in RBW=10KHz, VBW =10KHz, Swp. Time = 0.3 sec./MHz ◦ Reading in which marked as AV means measurements by using are Average Mode with instrument setting in RBW=10KHz, VBW =10KHz, Swp. Time =0.3 sec./MHz ◦
- (2) All readings are QP Mode value unless otherwise stated AVG in column of『Note』. If the QP Mode Measured value compliance with the QP Limits and lower than AVG Limits, the EUT shall be deemed to meet both QP & AVG Limits and then only QP Mode was measured, but AVG Mode didn't perform ◦ In this case, a “ * ” marked in AVG Mode column of Interference Voltage Measured ◦
- (3) Measuring frequency range from 150KHz to 30MHz ◦

4.2 RADIATED EMISSION MEASUREMENT

4.2.1 LIMITS OF RADIATED EMISSION MEASUREMENT

Operating frequency	Field Strength (uV/m)	Measurement Distance (meters)	F.S Limitation at 3m Distance
			(dBuV/m)
Any ISM	25	300	107.96
Any non-ISM	15	300	103.52

Notes:

- (1) The Equipment is for 18.305(b) Any type unless otherwise specified (miscellaneous) Operating frequency in any non-ISM frequency
- (2) Operation of ISM equipment within the following safety, search and rescue frequency bands is prohibited: 490–510 kHz, 2170–2194 kHz, 8354–8374 kHz, 121.4–121.6 MHz, 156.7–156.9 MHz, and 242.8–243.2 MHz.
- (3) Distance extrapolation factor = $40 \log(\text{specific distance} / \text{test distance})$ (dB);
Limit line = specific limits (dBuV) + distance extrapolation factor.
- (4) The test result calculated as following:
Measurement Value = Reading Level + Correct Factor
Correct Factor = Antenna Factor + Cable Loss - Amplifier Gain(if use)
Margin Level = Measurement Value - Limit Value

4.2.2 TEST PROCEDURE

- a. The EUT was placed on the top of a rotating table 0.8 meters above the ground at a 1m or 3 meter semi-anechoic chamber. The table was rotated 360 degrees to determine the position of the highest radiation.
- b. The height of the equipment or of the substitution antenna shall be 0.8 m; the height of the test antenna shall vary between 1 m to 4 m. Both horizontal and vertical polarizations of the antenna are set to make the measurement.
- c. The initial step in collecting radiated emission data is a spectrum analyzer peak detector mode pre-scanning the measurement frequency range. Significant peaks are then marked and then Quasi Peak detector mode re-measured.
- d. If the Peak Mode measured value compliance with and lower than Quasi Peak Mode Limit, the EUT shall be deemed to meet QP Limits and then no additional QP Mode measurement performed.
- e. For the actual test configuration, please refer to the related Item –EUT Test Photos.

4.2.3 DEVIATION FROM TEST STANDARD

No deviation

4.2.4 TEST SETUP

For radiated emissions between 9kHz and 30MHz

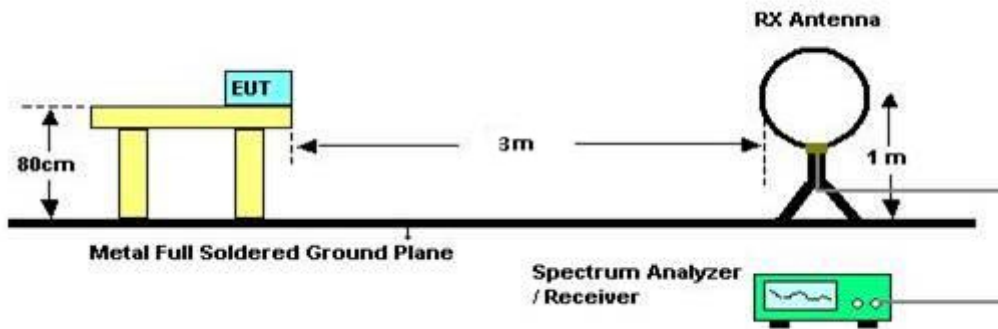

4.2.5 TEST RESULTS - 9KHZ TO 30MHZ

Please refer to the Appendix B.

Temperature: 25°C Relative Humidity: 60%

Remark:

- (1) All readings are Peak unless otherwise stated QP in column of 『Note』 . Peak denotes that the Peak reading compliance with the QP Limits and then QP Mode measurement didn't perform ◦
- (2) Measuring frequency range from 9kHz to 30MHz.
- (3) If the peak scan value lower limit more than 20dB, then this signal data does not show in table.

5. MEASUREMENT INSTRUMENTS LIST

Conducted Emission					
Item	Kind of Equipment	Manufacturer	Type No.	Serial No.	Calibrated until
1	50Ω Terminator	SHX	TF2-3G-A	8122901	Mar. 10, 2020
2	TWO-LINE V-NETWORK	R&S	ENV216	100526	Mar. 10, 2020
3	EMI Test Receiver	R&S	ESR3	101862	Aug. 11, 2019
4	Artificial-Mains Network	SCHWARZBEC K	NSLK 8127	8127685	Mar. 10, 2020
5	TRANSIENT LIMITER	EM	EM-7600	772	Mar. 10, 2020
6	Cable	N/A	N/A(6m)	N/A	Mar. 12, 2020
7	Measurement Software	Farad	EZ-EMC Ver.NB-03A1-01	N/A	N/A

Radiated Emission-9KHz to 30MHz					
Item	Kind of Equipment	Manufacturer	Type No.	Serial No.	Calibrated until
1	Loop Antenna	EM	EM-6876-1	230	Jan. 15, 2020
2	EMI Test Receiver	R&S	ESCI	100895	Mar. 10, 2020
3	Cable	N/A	RG400 (C-101(3m)+ C-70(6m))	N/A	May. 31, 2020
4	Measurement Software	Farad	EZ-EMC Ver.NB-03A1-01	N/A	N/A

Remark: "N/A" denotes no model name, serial no. or calibration specified.
All calibration period of equipment list is one year.

6. EUT TEST PHOTO

Conducted Emission



Radiated emission 9KHz to 30MHz

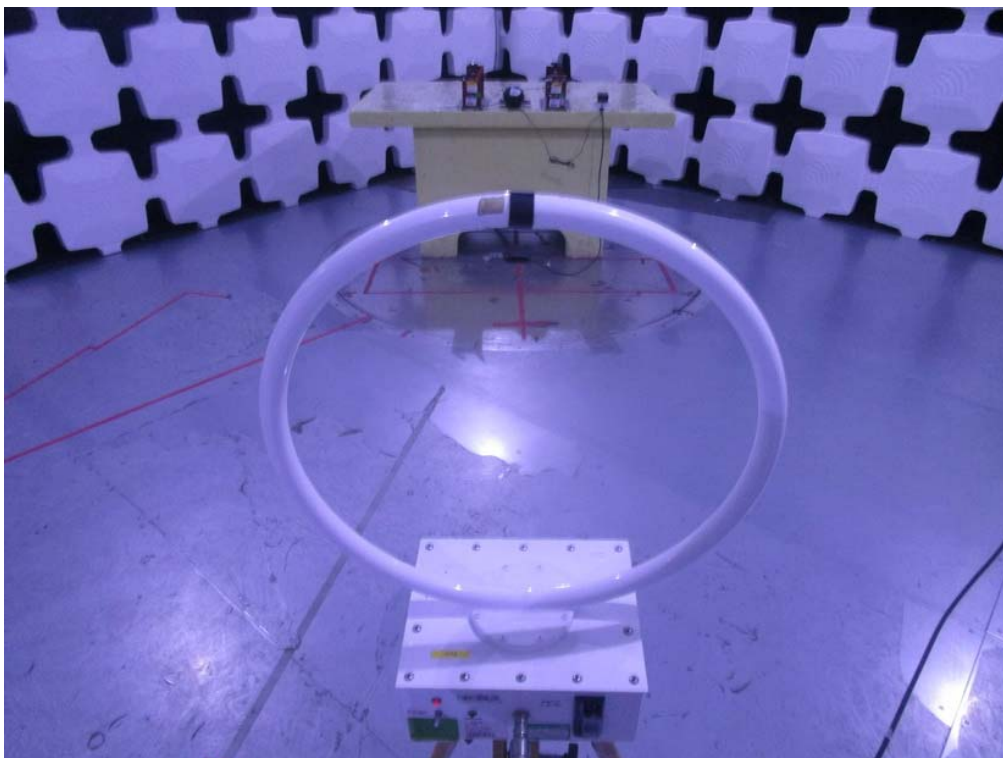
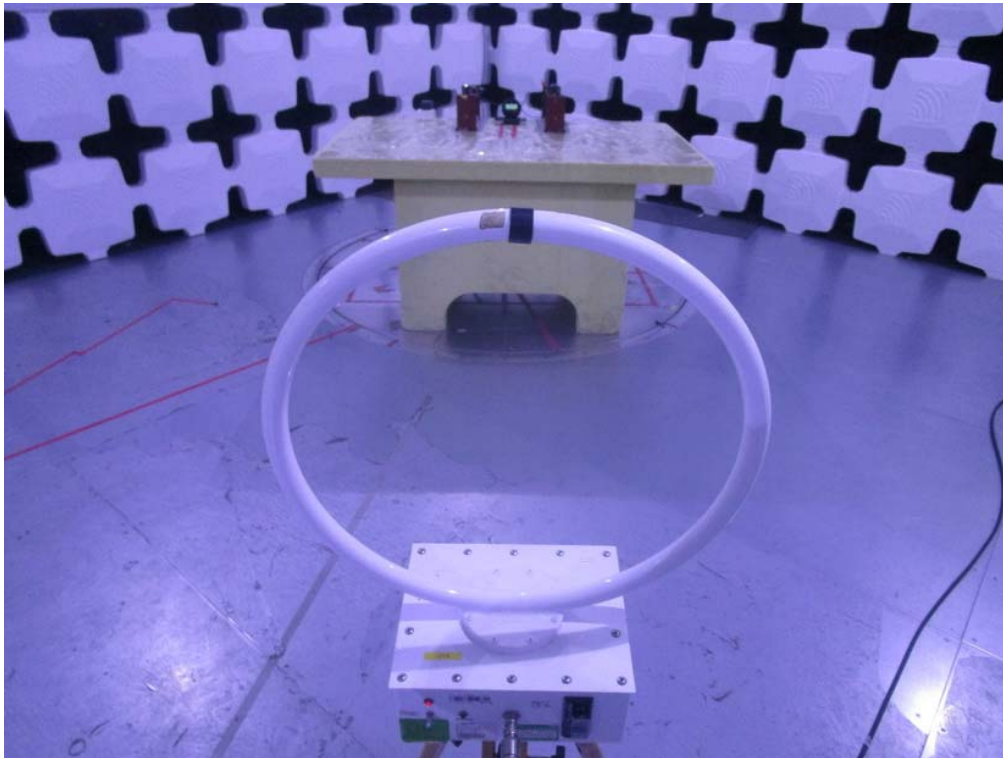

APPENDIX A - CONDUCTED EMISSION

Test Voltage:	AC 120V/60Hz
Test Mode:	Mode 1

Phase: Line

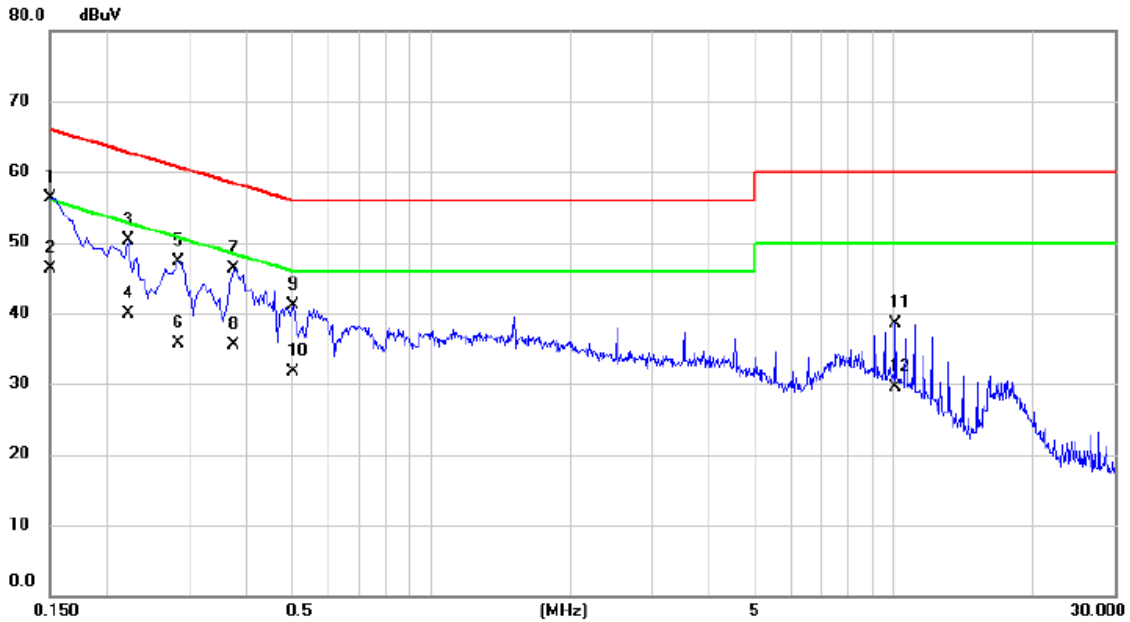

No.	Mk.	Freq. MHz	Reading Level dBuV	Correct Factor dB	Measure- ment dBuV	Limit dBuV	Margin dB	Detector	Comment
1	*	0.1500	46.55	9.82	56.37	66.00	-9.63	QP	
2		0.1500	36.52	9.82	46.34	56.00	-9.66	AVG	
3		0.2220	40.54	9.81	50.35	62.74	-12.39	QP	
4		0.2220	30.15	9.81	39.96	52.74	-12.78	AVG	
5		0.2850	37.43	9.84	47.27	60.67	-13.40	QP	
6		0.2850	25.85	9.84	35.69	50.67	-14.98	AVG	
7		0.3750	36.45	9.85	46.30	58.39	-12.09	QP	
8		0.3750	25.61	9.85	35.46	48.39	-12.93	AVG	
9		0.5055	31.30	9.88	41.18	56.00	-14.82	QP	
10		0.5055	21.85	9.88	31.73	46.00	-14.27	AVG	
11		10.0815	27.92	10.49	38.41	60.00	-21.59	QP	
12		10.0815	18.96	10.49	29.45	50.00	-20.55	AVG	

Test Voltage:	AC 120V/60Hz
Test Mode:	Mode 1

Phase: Neutral

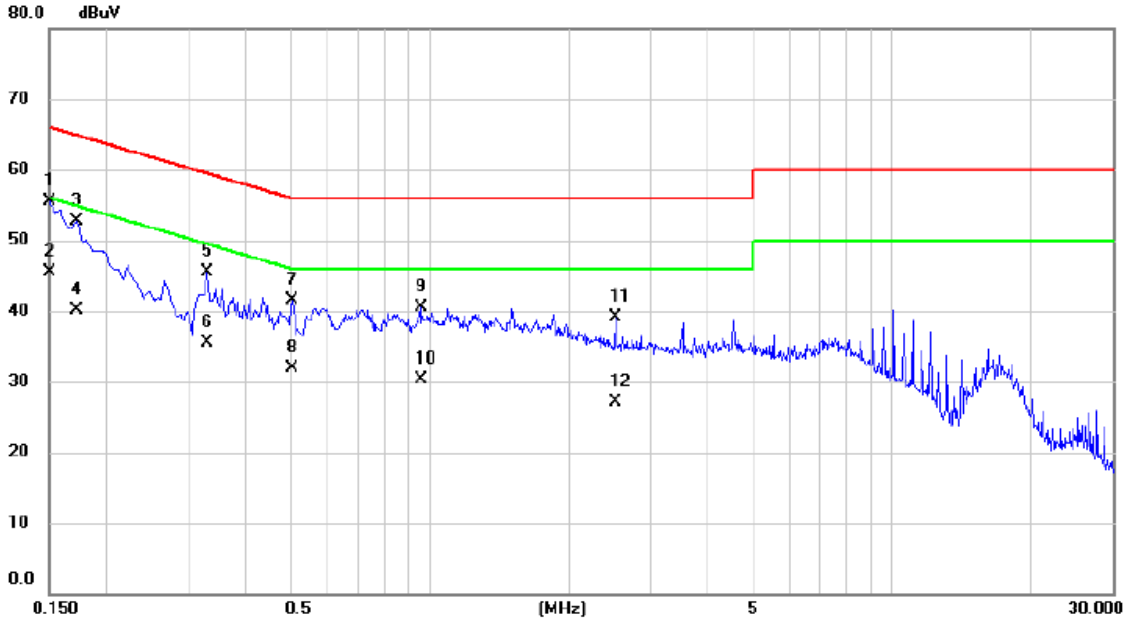

No.	Mk.	Freq. MHz	Reading Level dBuV	Correct Factor dB	Measure- ment dBuV	Limit dBuV	Margin dB	Detector	Comment
1		0.1500	45.53	9.91	55.44	66.00	-10.56	QP	
2	*	0.1500	35.56	9.91	45.47	56.00	-10.53	AVG	
3		0.1725	42.85	9.91	52.76	64.84	-12.08	QP	
4		0.1725	30.14	9.91	40.05	54.84	-14.79	AVG	
5		0.3300	35.54	9.98	45.52	59.45	-13.93	QP	
6		0.3300	25.62	9.98	35.60	49.45	-13.85	AVG	
7		0.5055	31.40	10.03	41.43	56.00	-14.57	QP	
8		0.5055	21.85	10.03	31.88	46.00	-14.12	AVG	
9		0.9555	30.41	10.11	40.52	56.00	-15.48	QP	
10		0.9555	20.18	10.11	30.29	46.00	-15.71	AVG	
11		2.5215	28.81	10.22	39.03	56.00	-16.97	QP	
12		2.5215	16.85	10.22	27.07	46.00	-18.93	AVG	

APPENDIX B - RADIATED EMISSION (9KHZ TO 30MHZ)

Test Voltage:	AC 120V/60Hz
Test Mode:	Mode 1

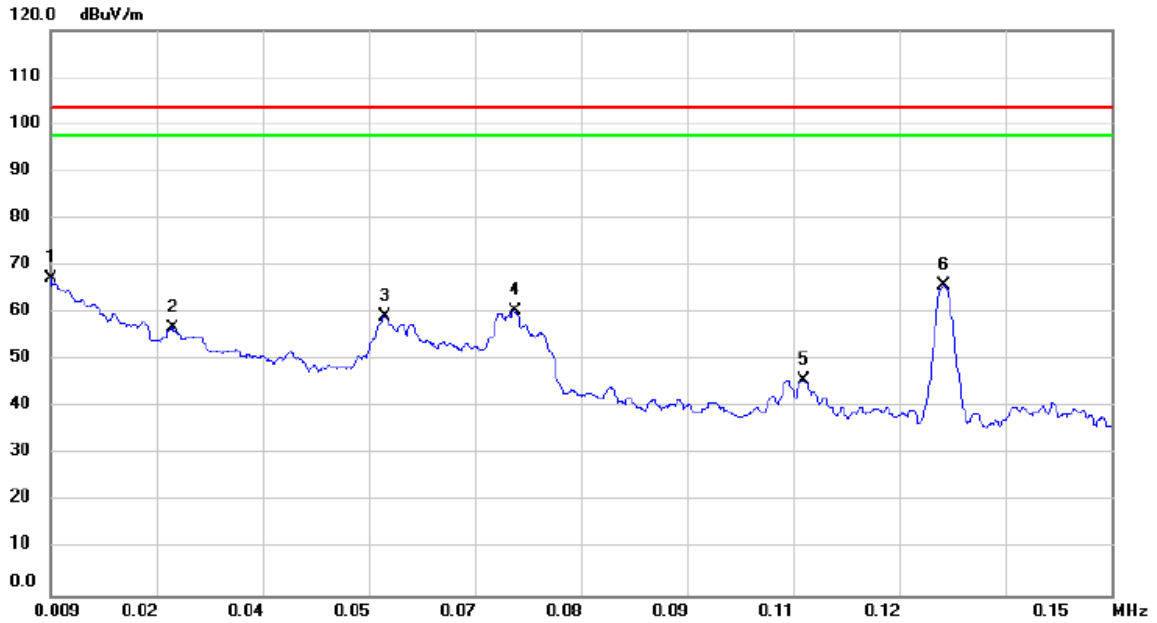

No.	Mk.	Freq. MHz	Reading Level dBuV	Correct Factor dB	Measure- ment dBuV/m	Limit dBuV/m	Margin dB	Detector	Comment
1	*	0.0090	50.01	17.32	67.33	103.50	-36.17	QP	
2		0.0252	42.91	13.84	56.75	103.50	-46.75	QP	
3		0.0534	45.39	13.88	59.27	103.50	-44.23	QP	
4		0.0707	46.71	13.60	60.31	103.50	-43.19	QP	
5		0.1091	32.34	13.54	45.88	103.50	-57.62	QP	
6		0.1278	52.34	13.55	65.89	103.50	-37.61	QP	

Test Voltage:	AC 120V/60Hz
Test Mode:	Mode 1

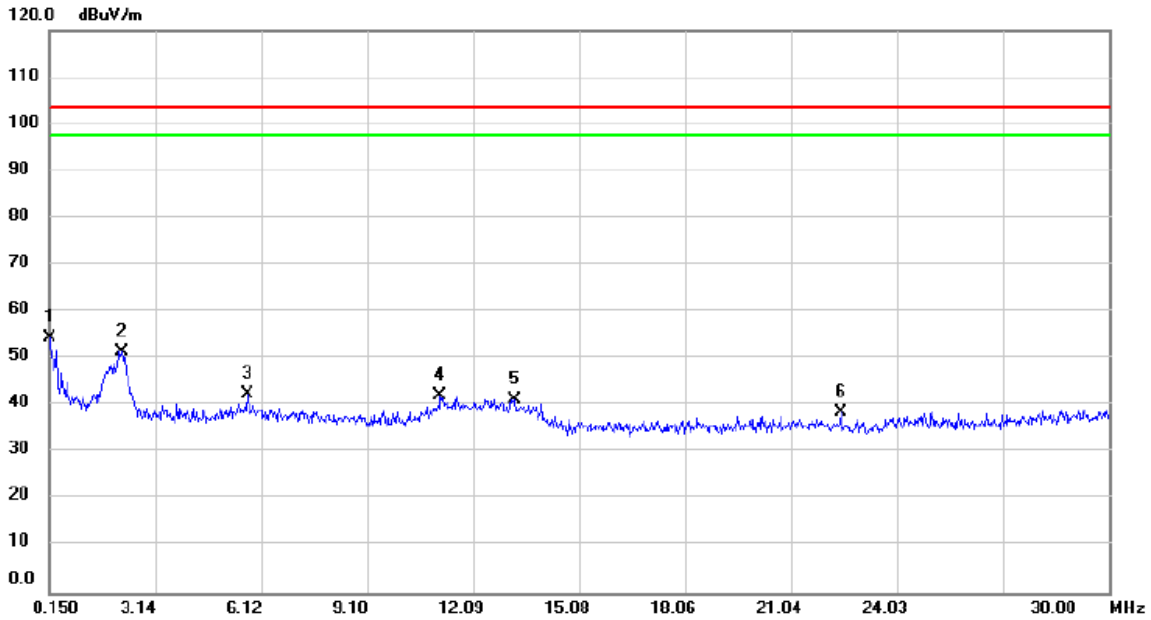

No.	Mk.	Freq. MHz	Reading Level dBuV	Correct Factor dB	Measure- ment dBuV/m	Limit dBuV/m	Margin dB	Detector	Comment
1	*	0.1500	41.04	13.56	54.60	103.50	-48.90	QP	
2		2.2096	39.86	11.69	51.55	103.50	-51.95	QP	
3		5.7320	31.55	10.97	42.52	103.50	-60.98	QP	
4		11.1647	30.49	11.62	42.11	103.50	-61.39	QP	
5		13.2541	29.62	11.59	41.21	103.50	-62.29	QP	
6		22.4480	25.63	12.90	38.53	103.50	-64.97	QP	

End of Test Report