



FCC/IC Radio Test Report

FCC ID: UZZSFQ04A

IC: 7633A-SFQ04A

This report concerns (check one): Original Grant Class II Change

Issued Date : Jun. 18, 2013
Project No. : 1201C016A
Equipment : Bluetooth Module
Model Name : BC05 ROM
Applicant : Beautiful Enterprise Co., Ltd.
Address : 26th Floor, Beautiful Group Tower, 77 Connaught Road Central, Hong Kong
Manufacturer : Beautiful Enterprise Co., Ltd.
Address : 26th Floor, Beautiful Group Tower, 77 Connaught Road Central, Hong Kong

Tested by:
Neutron Engineering Inc. EMC Laboratory
Date of Receipt: Jun. 13, 2013
Date of Test:
Jun. 13, 2013 ~ Jun. 17, 2013

Testing Engineer : David Mao
(David Mao)

Technical Manager : Leo Hung
(Leo Hung)

Authorized Signatory : Steven Lu
(Steven Lu)

Neutron Engineering Inc.

**No.3, Jinshagang 1st Road, ShiXia, Dalang
Town, Dong Guan, China.
TEL : (0769) 8318-3000 FAX : (0769) 8319-6000**



Declaration

Neutron represents to the client that testing is done in accordance with standard procedures as applicable and that test instruments used has been calibrated with the standards traceable to National Measurement Laboratory (**NML**) of **CHINA**, or National Institute of Standards and Technology (**NIST**) of **U.S.A.**

Neutron's reports apply only to the specific samples tested under conditions. It is manufacture's responsibility to ensure that additional production units of this model are manufactured with the identical electrical and mechanical components. **Neutron** shall have no liability for any declarations, inferences or generalizations drawn by the client or others from **Neutron** issued reports.

Neutron's reports must not be used by the client to claim product endorsement by the authorities or any agency of the Government.

This report is the confidential property of the client. As a mutual protection to the clients, the public and **Neutron-self**, extracts from the test report shall not be reproduced except in full with **Neutron's** authorized written approval.

Neutron's laboratory quality assurance procedures are in compliance with the **ISO Guide 17025** requirements, and accredited by the conformity assessment authorities listed in this test report.

Limitation

For the use of the authority's logo is limited unless the Test Standard(s)/Scope(s)/Item(s) mentioned in this test report is (are) included in the conformity assessment authorities acceptance respective.



Table of Contents	Page
1 . CERTIFICATION	5
2 . SUMMARY OF TEST RESULTS	6
2.1 TEST FACILITY	7
2.2 MEASUREMENT UNCERTAINTY	7
3 . GENERAL INFORMATION	8
3.1 GENERAL DESCRIPTION OF EUT	8
3.2 DESCRIPTION OF TEST MODES	10
3.3 TABLE OF PARAMETERS OF TEXT SOFTWARE SETTING	10
3.4 BLOCK DIGRAM SHOWING THE CONFIGURATION OF SYSTEM TESTED	11
3.5 DESCRIPTION OF SUPPORT UNITS	12
4 . EMC EMISSION TEST	13
4.1 CONDUCTED EMISSION MEASUREMENT	13
4.1.1 POWER LINE CONDUCTED EMISSION LIMITS	13
4.1.2 MEASUREMENT INSTRUMENTS LIST AND SETTING	13
4.1.3 TEST PROCEDURE	14
4.1.4 DEVIATION FROM TEST STANDARD	14
4.1.5 TEST SETUP	14
4.1.6 EUT OPERATING CONDITIONS	14
4.1.7 TEST RESULTS	15
4.2 RADIATED EMISSION MEASUREMENT	18
4.2.1 RADIATED EMISSION LIMITS	18
4.2.2 MEASUREMENT INSTRUMENTS LIST ANS SETTING	19
4.2.3 TEST PROCEDURE	20
4.2.4 DEVIATION FROM TEST STANDARD	20
4.2.5 TEST SETUP	21
4.2.6 EUT OPERATING CONDITIONS	22
4.2.7 TEST RESULTS (BELOW 30MHZ)	23
4.2.8 TEST RESULTS (BETWEEN30 – 1000 MHZ)	24
4.2.9 TEST RESULTS (ABOVE 1000 MHZ)	37
5 . NUMBER OF HOPPING CHANNEL	61
5.1 APPLIED PROCEDURES / LIMIT	61
5.1.1 MEASUREMENT INSTRUMENTS LIST AND SETTING	61
5.1.2 TEST PROCEDURE	61
5.1.3 DEVIATION FROM STANDARD	61
5.1.4 TEST SETUP	61
5.1.5 EUT OPERATION CONDITIONS	61
5.1.6 TEST RESULTS	62
6 . AVERAGE TIME OF OCCUPANCY	64



Table of Contents	Page
6.1 APPLIED PROCEDURES / LIMIT	64
6.1.1 MEASUREMENT INSTRUMENTS LIST	64
6.1.2 TEST PROCEDURE	64
6.1.3 DEVIATION FROM STANDARD	64
6.1.4 TEST SETUP	65
6.1.5 EUT OPERATION CONDITIONS	65
6.1.6 TEST RESULTS	66
7 . HOPPING CHANNEL SEPARATION MEASUREMENT	78
7.1 APPLIED PROCEDURES / LIMIT	78
7.1.1 MEASUREMENT INSTRUMENTS LIST AND SETTING	78
7.1.2 TEST PROCEDURE	78
7.1.3 DEVIATION FROM STANDARD	78
7.1.4 TEST SETUP	78
7.1.5 EUT OPERATION CONDITIONS	78
7.1.6 TEST RESULTS	79
8 . BANDWIDTH TEST	83
8.1 APPLIED PROCEDURES / LIMIT	83
8.1.1 MEASUREMENT INSTRUMENTS LIST AND SETTING	83
8.1.2 TEST PROCEDURE	83
8.1.3 DEVIATION FROM STANDARD	83
8.1.4 TEST SETUP	83
8.1.5 EUT OPERATION CONDITIONS	83
8.1.6 TEST RESULTS	84
9 . PEAK OUTPUT POWER TEST	88
9.1 APPLIED PROCEDURES / LIMIT	88
9.1.1 MEASUREMENT INSTRUMENTS LIST AND SETTING	88
9.1.2 TEST PROCEDURE	88
9.1.3 DEVIATION FROM STANDARD	88
9.1.4 TEST SETUP	88
9.1.5 EUT OPERATION CONDITIONS	88
9.1.6 TEST RESULTS	89
10 . ANTENNA CONDUCTED SPURIOUS EMISSION	93
10.1 APPLIED PROCEDURES / LIMIT	93
10.1.1 MEASUREMENT INSTRUMENTS LIST AND SETTING	93
10.1.2 TEST PROCEDURE	93
10.1.3 DEVIATION FROM STANDARD	93
10.1.4 TEST SETUP	93
10.1.5 EUT OPERATION CONDITIONS	93
10.1.6 TEST RESULTS	94
11 . EUT TEST PHOTO	106



1. CERTIFICATION

Equipment : Bluetooth Module
Brand Name : N/A
Model Name : BC05 ROM
Applicant : Beautiful Enterprise Co., Ltd.
Factory : Shenzhen Synchron Electronics Co., Ltd.
Address : No. 9 Mei Li Road, Xia Mei Lin, Fu Tian Area, Shenzhen, Guangdong, China
Date of Test : Jun. 13, 2013 ~ Jun. 17, 2013
Test Item : ENGINEERING SAMPLE
FCC Part15, Subpart C(15.247) / ANSI C63.4 : 2009
Standards : FCC Public Notice DA 00-705, March 30, 2000.
Canada RSS-210:2010
RSS-GEN Issue 3, Dec 2010

The above equipment has been tested and found compliance with the requirement of the relative standards by Neutron Engineering Inc. EMC Laboratory.

The test data, data evaluation, and equipment configuration contained in our test report (Ref No. NEI-FICP-1-1201C016A) were obtained utilizing the test procedures, test instruments, test sites that has been accredited by the Authority of TAF according to the ISO-17025 quality assessment standard and technical standard(s).



2. SUMMARY OF TEST RESULTS

Test procedures according to the technical standards:

APPLIED STANDARD: 47 CFR Part 15, Subpart C; Canada RSS-210:2010				
Standard Section		Test Item	Judgment	Remark
RSS-210 RSS-GEN Issue 3, Dec 2010	47 CFR Part 15			
RSS-GEN Issue 3, Dec 2010 7.2.4	15.207	Conducted Emission	PASS	
RSS-210, Issue 8, Annex 8, Section 8.5	15.247(d)	Antenna conducted Spurious Emission	PASS	
RSS-210, Issue 8, Annex 8, Section A8.1(b)	15.247 (a)(1)	Hopping Channel Separation	PASS	
RSS-210 Annex 8 (A8.1b)	15.247 (b)(1)	Peak Output Power	PASS	
RSS-210, Issue 8, Annex 8, Section 8.5	15.247(d) 15.209	Radiated Spurious Emission	PASS	
RSS-210, Issue 8, Annex 8, Section A8.1(d)	15.247 (a)(1)(iii)	Number of Hopping Frequency	PASS	
RSS-210, Issue 8, Annex 8, Section A8.1(d)	15.247 (a)(1)(iii)	Dwell Time	PASS	
RSS-GEN Issue 3, Dec 2010 7.2.2	15.205	Restricted Bands	PASS	
RSS-210, Issue 8, Annex 8, Section A8.4	15.203	Antenna Requirement	PASS	

NOTE:

- (1) "N/A" denotes test is not applicable in this test report.
- (2) According to FCC Public Notice DA 00-705, March 30, 2000.



2.1 TEST FACILITY

The test facilities used to collect the test data in this report is **DG-C02/DG-CB03** at the location of No.3,Jinshagang 1st Road, ShiXia, Dalang Town, Dong Guan, China.523792

Neutron's test firm number for FCC 319330

Neutron's test firm number for IC 4428B-1

2.2 MEASUREMENT UNCERTAINTY

Where relevant, the following measurement uncertainty levels have been estimated for tests performed on the EUT as specified in CISPR 16-4-2:

The reported uncertainty of measurement $y \pm U$, where expanded uncertainty U is based on a standard uncertainty multiplied by a coverage factor of $k=2$, providing a level of confidence of approximately **95 %**.

A. Conducted Measurement :

Test Site	Method	Measurement Frequency Range	U , (dB)	NOTE
DG-C02	CISPR	150 KHz ~ 30MHz	1.94	

B. Radiated Measurement :

Test Site	Method	Measurement Frequency Range	Ant. H / V	U,(dB)	NOTE
DG-CB03	CISPR	30MHz ~ 200MHz	V	3.82	
		30MHz ~ 200MHz	H	3.60	
		200MHz ~ 1,000MHz	V	3.86	
		200MHz ~ 1,000MHz	H	3.94	
		1GHz~18GHz	V	3.12	
		1GHz~18GHz	H	3.68	
		18GHz~40GHz	V	4.15	
		18GHz~40GHz	H	4.14	

3. GENERAL INFORMATION

3.1 GENERAL DESCRIPTION OF EUT

Equipment	Bluetooth Module	
Brand Name	N/A	
Model Name For FCC	BC05 ROM	
Model Difference	N/A	
Product Description	The EUT is a Bluetooth Module.	
	Operation Frequency	2402~2480 MHz
	Modulation Technology	GFSK(1Mbps)
	Bit Rate of Transmitter	π /4-DQPSK(2Mbps) 8-DPSK(3Mbps)
	Number of Channel	79 CH, Please see note 2.(Page 9)
	Antenna Designation	Please see note 3.(Page 9)
	Antenna Gain(Peak)	
	Output Power	1.24 dBm (1Mbps) 0.15 dBm (3Mbps)
	More details of EUT technical specification, please refer to the User's Manual.	
Power Source	#1: DC Voltage supplied from AC/DC adapter Brand name: KINGWALL ; Model name: AS190-090-AC200; #2: DC Voltage supplied from AC/DC adapter	
	 Brand name: Model name: S018KM0900200 #3: DC Voltage supplied from Lithium Battery. Model name: LC18650	
Power Rating	#1: I/P AC 100-240V~50/60Hz, 0.7A O/P DC 9.0V, 2.0A #2: I/P AC 100-240V~50/60Hz, 0.5A O/P DC 9.0V, 2.0A #3: DC 3.7V, 2200mA	
Connecting I/O Port(s)	Please refer to the User's Manual	

Note:

1. For a more detailed features description, please refer to the manufacturer's specifications or the User's Manual.



2.

Channel List					
Channel	Frequency (MHz)	Channel	Frequency (MHz)	Channel	Frequency (MHz)
00	2402	27	2429	54	2456
01	2403	28	2430	55	2457
02	2404	29	2431	56	2458
03	2405	30	2432	57	2459
04	2406	31	2433	58	2460
05	2407	32	2434	59	2461
06	2408	33	2435	60	2462
07	2409	34	2436	61	2463
08	2410	35	2437	62	2464
09	2411	36	2438	63	2465
10	2412	37	2439	64	2466
11	2413	38	2440	65	2467
12	2414	39	2441	66	2468
13	2415	40	2442	67	2469
14	2416	41	2443	68	2470
15	2417	42	2444	69	2471
16	2418	43	2445	70	2472
17	2419	44	2446	71	2473
18	2420	45	2447	72	2474
19	2421	46	2448	73	2475
20	2422	47	2449	74	2476
21	2423	48	2450	75	2477
22	2424	49	2451	76	2478
23	2425	50	2452	77	2479
24	2426	51	2453	78	2480
25	2427	52	2454		
26	2428	53	2455		

3.

Table for Filed Antenna

Ant.	Brand	Model Name	Antenna Type	Connector	Gain (dBi)
1	N/A	N/A	Printed Antenna	N/A	-1.72



3.2 DESCRIPTION OF TEST MODES

To investigate the maximum EMI emission characteristics generated from EUT, the test system was pre-scanning tested based on the consideration of following EUT operation mode or test configuration mode which possibly have effect on EMI emission level. Each of these EUT operation mode(s) or test configuration mode(s) mentioned above was evaluated respectively.

Pretest Mode	Description
Mode 1	TX Mode NOTE (1)
Mode 2	Bluetooth

The EUT system operated these modes were found to be the worst case during the pre-scanning test as following:

For Conducted Emission	
Final Test Mode	Description
Mode 2	Bluetooth

For Radiated Emission	
Final Test Mode	Description
Mode 1	TX Mode NOTE (1)

Note:

(1) The measurements are performed at the high, middle, low available channels.

3.3 TABLE OF PARAMETERS OF TEST SOFTWARE SETTING

During testing channel & power controlling software provided by the customer was used to control the operating channel as well as the output power level. The RF output power selection is for the setting of RF output power expected by the customer and is going to be fixed on the firmware of the final end product power parameters of FHSS

Test software version	Bluetest		
Frequency	2402 MHz	2441 MHz	2480 MHz
Parameters-1Mbps	63	63	63
Parameters-3Mbps	100	100	100



3.4 BLOCK DIGRAM SHOWING THE CONFIGURATION OF SYSTEM TESTED

Conducted:

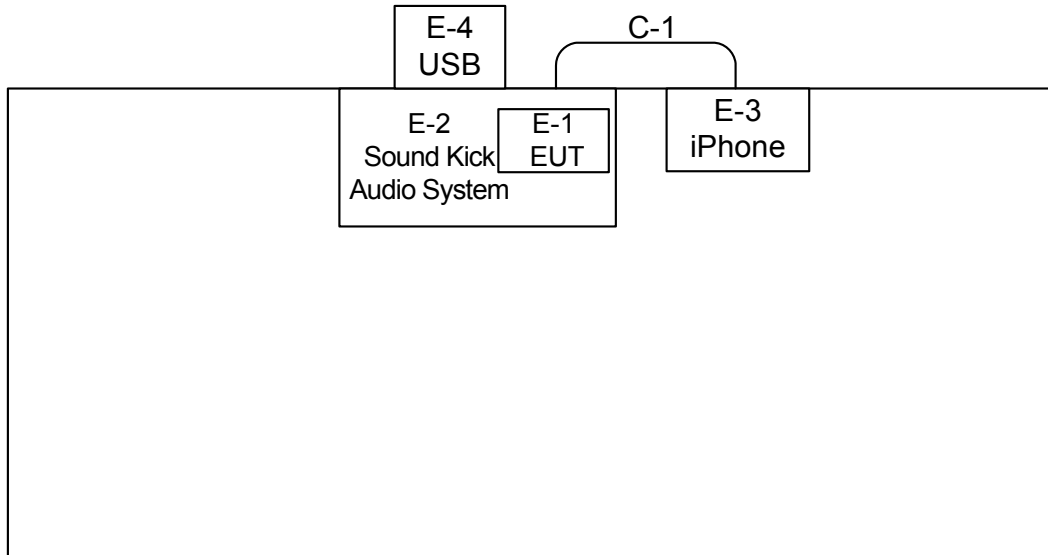

C-1: AUX IN Cable

Radiated:

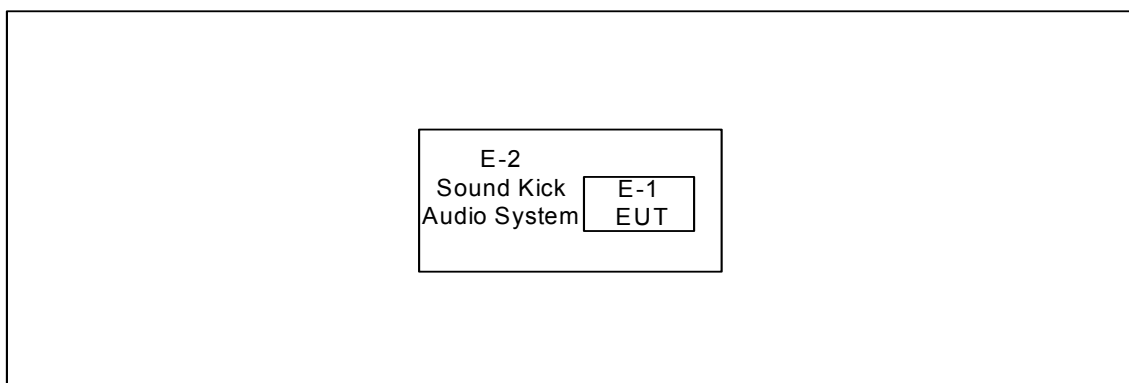



3.5 DESCRIPTION OF SUPPORT UNITS

The EUT has been tested as an independent unit together with other necessary accessories or support units. The following support units or accessories were used to form a representative test configuration during the tests.

Item	Equipment	Mfr/Brand	Model/Type No.	FCC ID	Series No.	Note
E-1	Bluetooth Module	N/A	BC05 ROM	UZZSFQ04A	N/A	EUT
E-2	Sound Kick Audio System	SOUNDFREQ®	SFQ-04	UZZSFQ04 7633A-SFQ04	N/A	
E-3	iPhone 3	APPLE	A1241	BCGA1241	N/A	
E-4	Flash Disk	Kingston	DTI/1GB	DOC	520B21E4-8199 57C	

Item	Shielded Type	Ferrite Core	Length	Note
C-1	NO	NO	1.52m	

Note:

- (1) For detachable type I/O cable should be specified the length in m in 『Length』 column.



4. EMC EMISSION TEST

4.1 CONDUCTED EMISSION MEASUREMENT

4.1.1 POWER LINE CONDUCTED EMISSION Limits (Frequency Range 150KHz-30MHz)

FREQUENCY (MHz)	Class A (dBuV)		Class B (dBuV)		Standard
	Quasi-peak	Average	Quasi-peak	Average	
0.15 -0.5	79.00	66.00	66 - 56 *	56 - 46 *	CISPR
0.50 -5.0	73.00	60.00	56.00	46.00	CISPR
5.0 -30.0	73.00	60.00	60.00	50.00	CISPR

0.15 -0.5	79.00	66.00	66 - 56 *	56 - 46 *	FCC
0.50 -5.0	73.00	60.00	56.00	46.00	FCC
5.0 -30.0	73.00	60.00	60.00	50.00	FCC

Note:

- (1) The tighter limit applies at the band edges.
- (2) The limit of " * " marked band means the limitation decreases linearly with the logarithm of the frequency in the range.

4.1.2 MEASUREMENT INSTRUMENTS LIST AND SETTING

Item	Kind of Equipment	Manufacturer	Type No.	Serial No.	Calibrated until
1	LISN	EMCO	3816/2	00052765	Apr. 25, 2014
2	LISN	R&S	ENV216	100087	Nov.16.2013
3	Test Cable	N/A	C_17	N/A	Mar.15.2014
4	EMI TEST RECEIVER	R&S	ESCS30	826547/022	Apr. 25, 2014
5	50Ω Terminator	SHX	TF2-3G-A	08122902	Apr. 25, 2014

Remark: "N/A" denotes no model name, serial no. or calibration specified.

All calibration period of Equipment List is One Year.

The following table is the setting of the receiver

Receiver Parameters	Setting
Attenuation	10 dB
Start Frequency	0.15 MHz
Stop Frequency	30 MHz
IF Bandwidth	9 kHz

4.1.3 TEST PROCEDURE

- a. The EUT was placed 0.8 meters from the horizontal ground plane with EUT being connected to the power mains through a line impedance stabilization network (LISN). All other support equipments powered from additional LISN(s). The LISN provide 50 Ohm/ 50uH of coupling impedance for the measuring instrument.
- b. Interconnecting cables that hang closer than 40 cm to the ground plane shall be folded back and forth in the center forming a bundle 30 to 40 cm long.
- c. I/O cables that are not connected to a peripheral shall be bundled in the center. The end of the cable may be terminated, if required, using the correct terminating impedance. The overall length shall not exceed 1 m.
- d. LISN at least 80 cm from nearest part of EUT chassis.
- e. For the actual test configuration, please refer to the related Item –EUT Test Photos.

4.1.4 DEVIATION FROM TEST STANDARD

No deviation

4.1.5 TEST SETUP

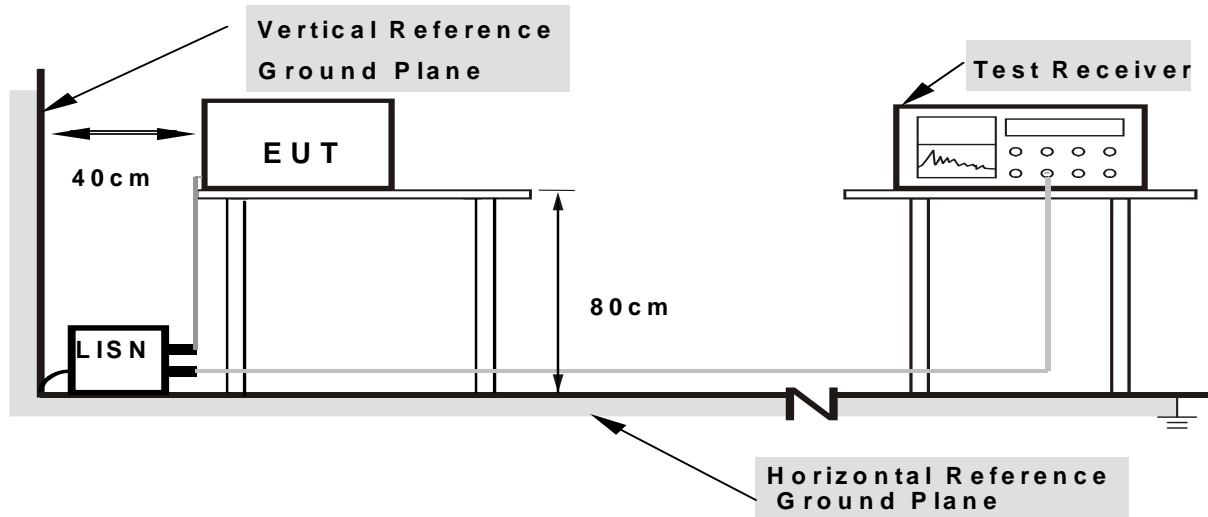

- Note:**
- 1. Support units were connected to second LISN.
 - 2. Both of LISNs (AMN) are 80 cm from EUT and at least 80 from other units and other metal planes

4.1.6 EUT OPERATING CONDITIONS

The EUT was configured for testing in a typical fashion (as a customer would normally use it). The EUT has been programmed to continuously transmit during test. This operating condition was tested and used to collect the included data.
 The EUT is continue Transmitter/Receive data or Hopping on mode.



4.1.7 TEST RESULTS

Remark

- (1) All readings are QP Mode value unless otherwise stated AVG in column of 'Note'. If the QP Mode Measured value compliance with the QP Limits and lower than AVG Limits, the EUT shall be deemed to meet both QP & AVG Limits and then only QP Mode was measured, but AVG Mode didn't perform. In this case, a " * " marked in AVG Mode column of Interference Voltage Measured.
- (2) Measuring frequency range from 150KHz to 30MHz.



EUT:	Bluetooth Module	Model Name :	BC05 ROM
Temperature:	23 °C	Relative Humidity:	50 %
Test Power:	AC 120V/60Hz	Phase:	Line
Test Mode:	Bluetooth		

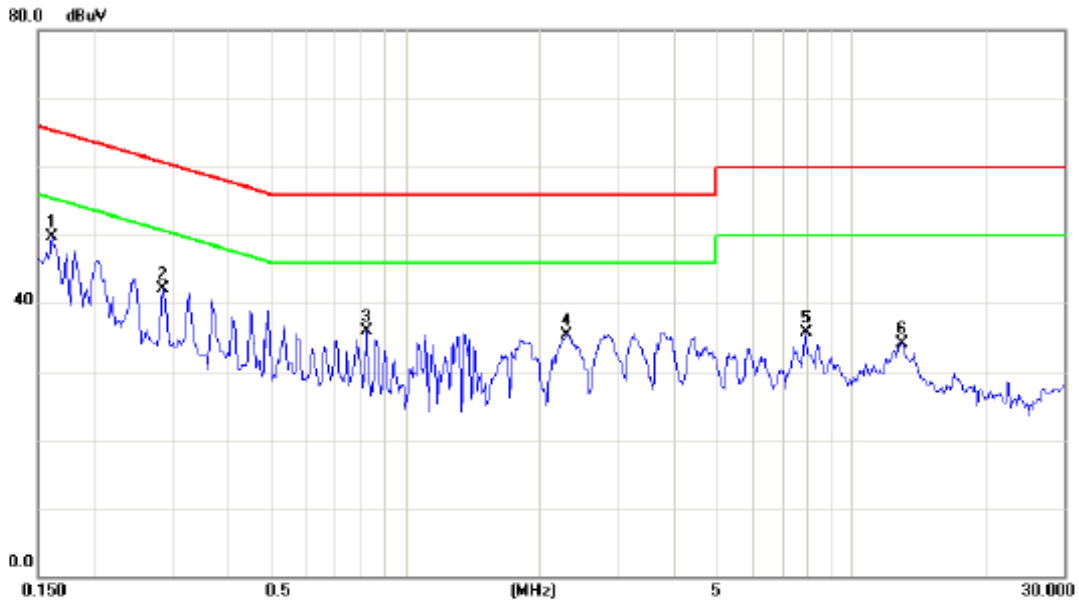

No.	Mk.	Freq. MHz	Reading Level dBuV	Correct Factor dB	Measure- ment dBuV	Limit dBuV	Over dB	Detector	Comment
1	*	0.1617	39.88	9.79	49.67	65.38	-15.71	peak	
2		0.2867	32.35	9.78	42.13	60.62	-18.49	peak	
3		0.8215	26.04	9.79	35.83	56.00	-20.17	peak	
4		2.3022	25.35	9.96	35.31	56.00	-20.69	peak	
5		7.8944	25.54	10.09	35.63	60.00	-24.37	peak	
6		12.9885	23.82	10.38	34.20	60.00	-25.80	peak	



EUT:	Bluetooth Module	Model Name :	BC05 ROM
Temperature:	23 °C	Relative Humidity:	50 %
Test Power:	AC 120V/60Hz	Phase:	Neutral
Test Mode:	Bluetooth		

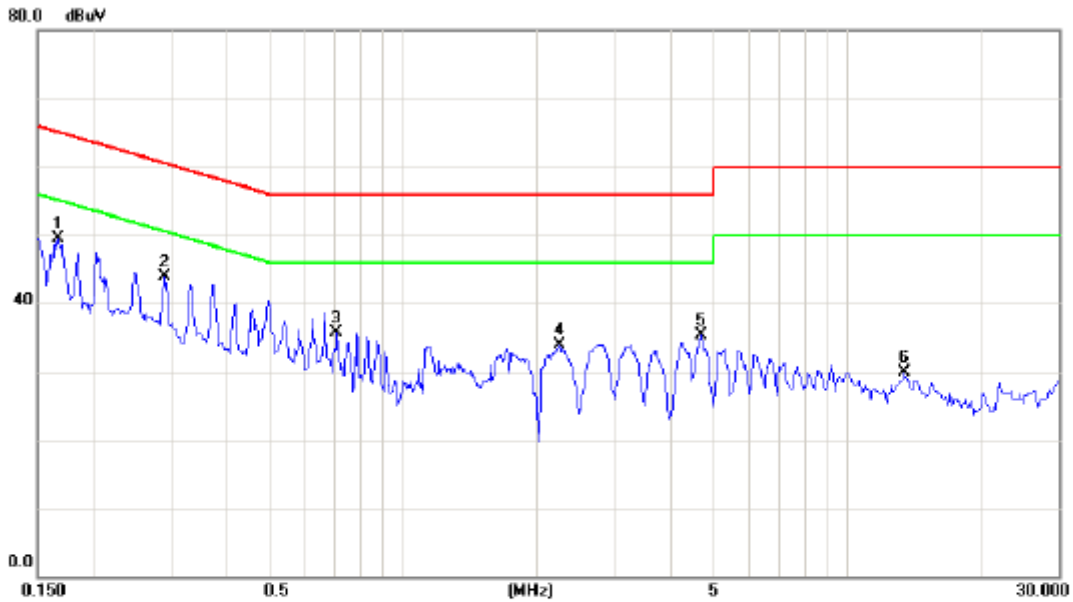

No. Mk.	Freq. MHz	Reading Level dBuV	Correct Factor dB	Measurement dBuV	Limit dBuV	Over dB	Detector	Comment
1 *	0.1668	39.68	9.79	49.47	65.12	-15.65	peak	
2	0.2908	34.03	9.78	43.81	60.50	-16.69	peak	
3	0.7085	26.13	9.60	35.73	56.00	-20.27	peak	
4	2.2515	24.01	9.81	33.82	56.00	-22.18	peak	
5	4.7031	25.39	9.85	35.24	56.00	-20.76	peak	
6	13.4100	18.84	11.06	29.90	60.00	-30.10	peak	



4.2 RADIATED EMISSION MEASUREMENT

4.2.1 RADIATED EMISSION LIMITS (Frequency Range 9kHz-1000MHz)

20dBc in any 100 kHz bandwidth outside the operating frequency band. In case the emission fall within the restricted band specified on 15.205(a), then the 15.209(a) limit in the table below has to be followed.

Frequencies (MHz)	Field Strength (microrvolts/meter)	Measurement Distance (meters)
0.009~0.490	2400/F(KHz)	300
0.490~1.705	24000/F(KHz)	30
1.705~30.0	30	30
30~88	100	3
88~216	150	3
216~960	200	3
Above 960	500	3

LIMITS OF RADIATED EMISSION MEASUREMENT (Above 1000MHz)

FREQUENCY (MHz)	(dBuV/m) (at 3M)	
	PEAK	AVERAGE
Above 1000	74	54

Notes:

- (1) The limit for radiated test was performed according to FCC PART 15C.
- (2) The tighter limit applies at the band edges.
- (3) Emission level (dBuV/m)=20log Emission level (uV/m).

FREQUENCY RANGE OF RADIATED MEASUREMENT (For unintentional radiators)

Highest frequency generated or Upper frequency of measurement used in the device or on which the device operates or tunes (MHz)	Range (MHz)
Below 1.705	30
1.705 – 108	1000
108 – 500	2000
500 – 1000	5000
Above 1000	5 th harmonic of the highest frequency or 40 GHz, whichever is lower



4.2.2 MEASUREMENT INSTRUMENTS LIST AND SETTING

Item	Kind of Equipment	Manufacturer	Type No.	Serial No.	Calibrated until
1	Antenna	Schwarzbeck	VULB9160	9160-3232	Apr. 25, 2014
2	Amplifier	HP	8447D	2944A09673	Apr. 25, 2014
3	Test Receiver	R&S	ESCI	100382	Apr. 25, 2014
4	Test Cable	N/A	C-01_CB03	N/A	Jun.30.2013
5	Antenna	ETS	3115	00075789	Apr. 25, 2014
6	Amplifier	Agilent	8449B	3008A02274	Apr. 25, 2014
7	Spectrum	Agilent	E4408B	US39240143	Nov. 16.2013
8	Test Cable	HUBER+SUHNER	C-45	N/A	May.01.2014
9	Controller	CT	SC100	N/A	N/A
10	Horn Antenna	EMCO	3115	9605-4803	Apr. 25, 2014
11	Active Loop Antenna	R&S	HFH2-Z2	830749/020	Apr. 25, 2014
12	Broad-Band Horn Antenna	Schwarzbeck	BBHA 9170	9170319	Oct.12.2013

Remark: "N/A" denotes no model name, serial no. or calibration specified.
All calibration period of Equipment List is One Year.

Spectrum Parameter	Setting
Attenuation	Auto
Start Frequency	1000 MHz
Stop Frequency	10th carrier harmonic
RB / VB (emission in restricted band)	1 MHz / 1 MHz for Peak, 1 MHz / 10Hz for Average

Receiver Parameter	Setting
Attenuation	Auto
Start ~ Stop Frequency	9kHz~90kHz for PK/AVG detector
Start ~ Stop Frequency	90kHz~110kHz for QP detector
Start ~ Stop Frequency	110kHz~490kHz for PK/AVG detector
Start ~ Stop Frequency	490kHz~30MHz for QP detector
Start ~ Stop Frequency	30MHz~1000MHz for QP detector



4.2.3 TEST PROCEDURE

- a. The EUT was placed on the top of a rotating table 0.8 meters above the ground at a 3 meter semi-anechoic chamber. The table was rotated 360 degrees to determine the position of the highest radiation.(below 1GHz)
- b. The EUT was placed on the top of a rotating table 0.8 meters above the ground at a 3 meter semi-anechoic chamber. The table was rotated 360 degrees to determine the position of the highest radiation.(above 1GHz)
- c. The height of the equipment or of the substitution antenna shall be 0.8 m; the height of the test antenna shall vary between 1 m to 4 m. Both horizontal and vertical polarizations of the antenna are set to make the measurement.
- d. The initial step in collecting conducted emission data is a spectrum analyzer peak detector mode pre-scanning the measurement frequency range. Significant peaks are then marked and then Quasi Peak detector mode re-measured.
- e. If the Peak Mode measured value compliance with and lower than Quasi Peak Mode Limit, the EUT shall be deemed to meet QP Limits and then no additional QP Mode measurement performed.
- f. For the actual test configuration, please refer to the related Item –EUT Test Photos.

4.2.4 DEVIATION FROM TEST STANDARD

No deviation

4.2.5 TEST SETUP

(A) Radiated Emission Test Set-Up Frequency Below 1 GHz

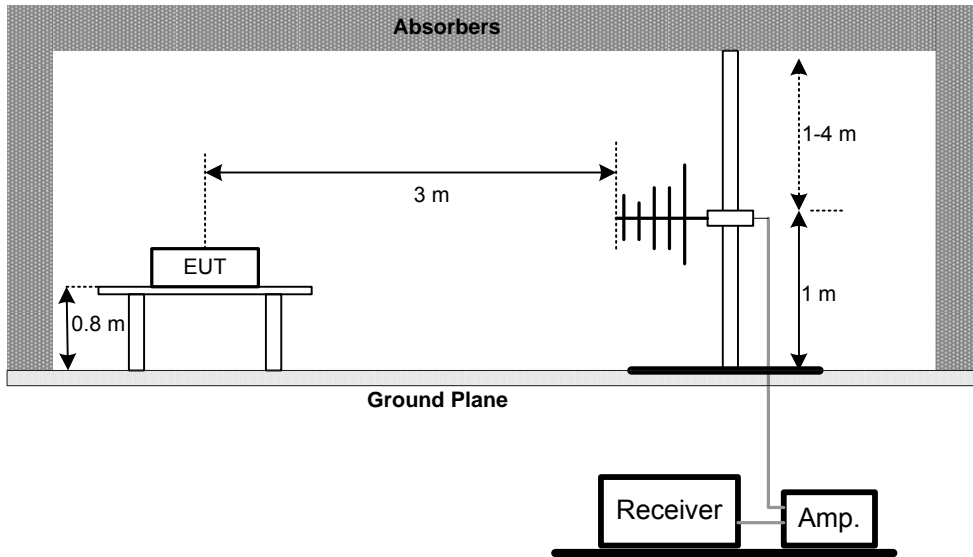

(B) Radiated Emission Test Set-Up Frequency Above 1 GHz

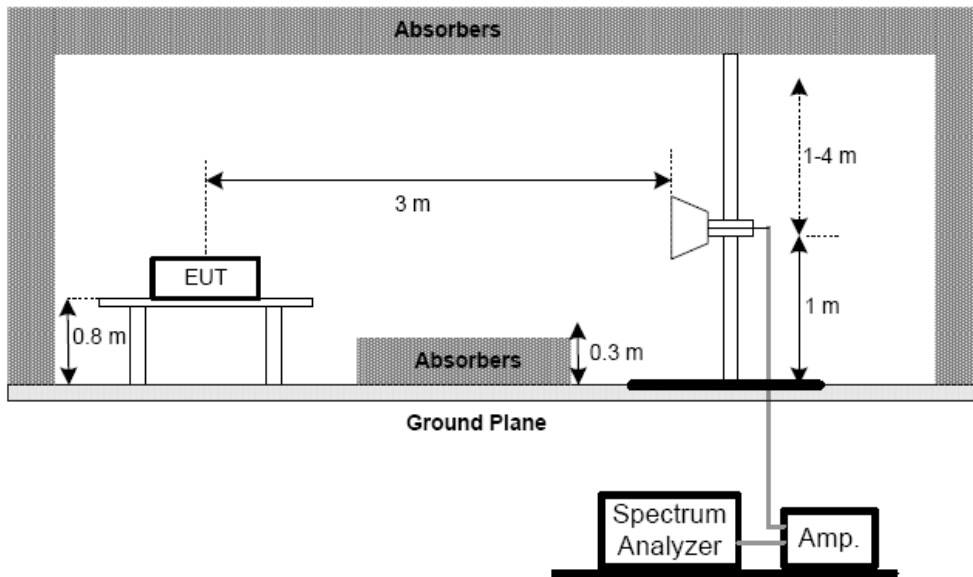

(C) For radiated emissions below 30MHz

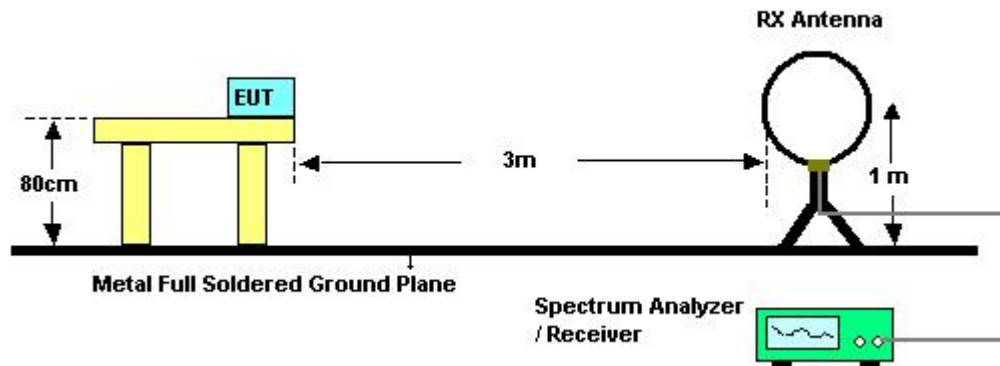

4.2.6 EUT OPERATING CONDITIONS

The EUT tested system was configured as the statements of 4.1.6 Unless otherwise a special operating condition is specified in the follows during the testing.



4.2.7 TEST RESULTS (BELOW 30MHZ)

EUT:	Bluetooth Module	Model Name:	BC05 ROM
Temperature:	24 °C	Relative Humidity:	46 %
Test Voltage:	AC120V/60Hz		
Test Mode:	TX 2402MHz –CH00-1Mbps		

Freq. (MHz)	Ant. 0°/90°	Reading(RA) (dBuV)	Corr.Factor(CF) (dB)	Measured(FS) (dBuV/m)	Limits(QP) (dBuV/m)	Margin (dB)	Note
0.0411	0°	21.21	22.96	44.17	115.33	-71.15	AVG
0.0411	0°	34.98	23.76	58.74	135.33	-76.59	PEAK
0.3512	0°	19.14	20.16	39.30	96.69	-57.40	AVG
0.3512	0°	35.01	21.90	56.91	116.69	-59.79	PEAK
0.4668	0°	20.18	19.88	40.06	94.22	-54.16	AVG
0.4668	0°	33.65	20.14	53.79	114.22	-60.43	PEAK
2.8123	0°	28.71	19.01	47.72	69.54	-21.82	QP
4.2050	0°	27.58	18.84	46.42	69.54	-23.12	QP
5.1240	0°	29.65	18.19	47.84	69.54	-21.70	QP

Freq. (MHz)	Ant. 0°/90°	Reading(RA) (dBuV)	Corr.Factor(CF) (dB)	Measured(FS) (dBuV/m)	Limits(QP) (dBuV/m)	Margin (dB)	Note
0.0800	90°	18.56	21.80	40.36	109.54	-69.18	AVG
0.0800	90°	28.68	22.25	50.93	129.54	-78.61	PEAK
0.4102	90°	20.58	20.02	40.60	95.34	-54.75	AVG
0.4102	90°	33.96	21.19	55.15	115.34	-60.20	PEAK
2.7351	90°	27.88	19.06	46.94	69.54	-22.60	QP
3.5214	90°	29.46	18.95	48.41	69.54	-21.13	QP
5.1254	90°	26.58	18.19	44.77	69.54	-24.77	QP
5.2231	90°	25.61	18.18	43.79	69.54	-25.75	QP

Remark :

- (1) The amplitude of spurious emissions which are attenuated by more than 20 dB below the permissible value has no need to be reported.
- (2) Distance extrapolation factor = $40 \log(\text{specific distance} / \text{test distance})$ (dB);
- (3) Limit line = specific limits (dBuV) + distance extrapolation factor..



4.2.8 TEST RESULTS (BETWEEN 30 – 1000 MHZ)

Remark :

- (1) Reading in which marked as QP or Peak means measurements by using are Quasi-Peak Mode or Peak Mode with Detector BW=120KHz ; SPA setting in RBW=120KHz, VBW =120KHz, Swp. Time = 0.3 sec./MHz.
- (2) All readings are Peak unless otherwise stated QP in column of 『Note』 . Peak denotes that the Peak reading compliance with the QP Limits and then QP Mode measurement didn't perform.
- (3) Measuring frequency range from 30MHz to 1000MHz.
- (4) If the peak scan value lower limit more than 20dB, then this signal data does not show in table.



EUT:	Bluetooth Module	Model Name:	BC05 ROM
Temperature:	24 °C	Relative Humidity:	56 %
Test Power:	AC120V/60Hz	Phase:	Vertical
Test Mode:	TX 2402MHz –CH00-1Mbps		

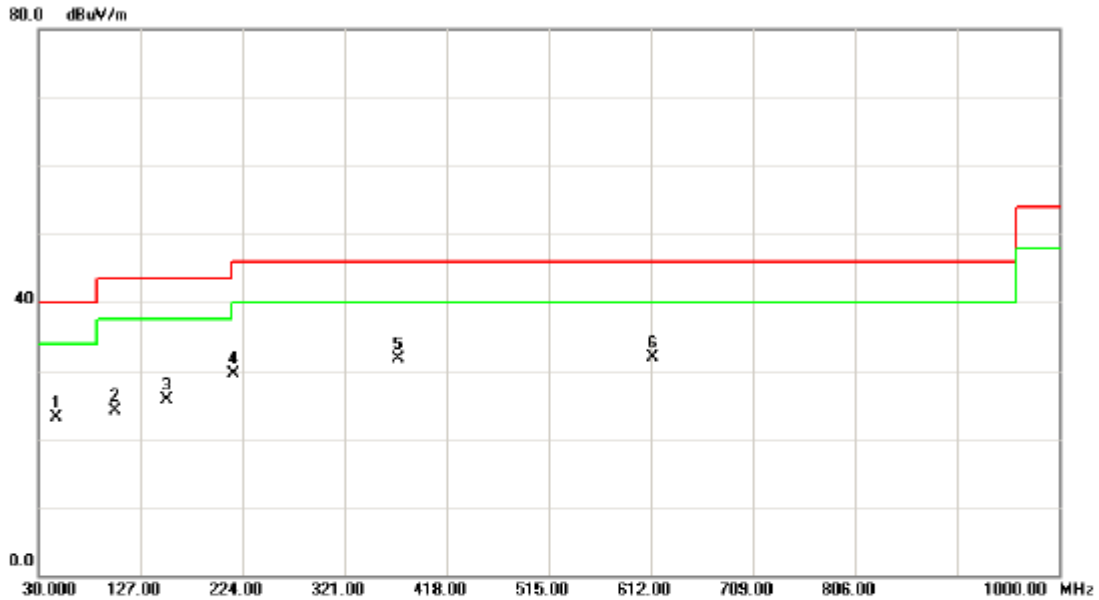

No.	Mk.	Freq. MHz	Reading Level dBuV	Correct Factor dB	Measure- ment dBuV/m	Limit dBuV/m	Over dB	Detector	Comment
1		47.2600	40.19	-17.09	23.10	40.00	-16.90	peak	
2		102.4500	42.49	-18.40	24.09	43.50	-19.41	peak	
3		152.1300	43.25	-17.58	25.67	43.50	-17.83	peak	
4		216.1300	45.55	-16.03	29.52	46.00	-16.48	peak	
5		372.7300	41.64	-10.01	31.63	46.00	-14.37	peak	
6	*	614.5200	35.86	-4.00	31.86	46.00	-14.14	peak	



EUT:	Bluetooth Module	Model Name:	BC05 ROM
Temperature:	24 °C	Relative Humidity:	56 %
Test Power:	AC120V/60Hz	Phase:	Horizontal
Test Mode:	TX 2402MHz –CH00-1Mbps		

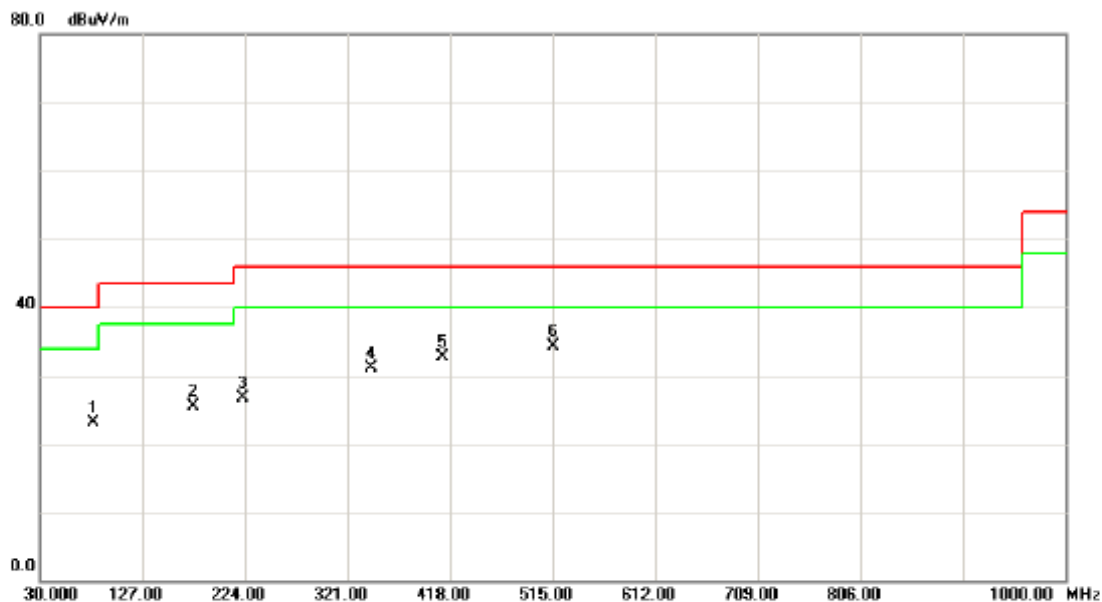

No.	Mk.	Freq. MHz	Reading Level dBuV	Correct Factor dB	Measure- ment dBuV/m	Limit dBuV/m	Over dB	Detector	Comment
1		81.4100	42.25	-19.08	23.17	40.00	-16.83	peak	
2		175.4200	42.62	-17.08	25.54	43.50	-17.96	peak	
3		222.2700	42.52	-15.80	26.72	46.00	-19.28	peak	
4		343.7100	42.04	-11.00	31.04	46.00	-14.96	peak	
5		411.1300	41.60	-8.82	32.78	46.00	-13.22	peak	
6	*	515.3500	41.16	-6.79	34.37	46.00	-11.63	peak	



EUT:	Bluetooth Module	Model Name:	BC05 ROM
Temperature:	24 °C	Relative Humidity:	56 %
Test Power:	AC120V/60Hz	Phase:	Vertical
Test Mode:	TX 2441MHz –CH39-1Mbps		

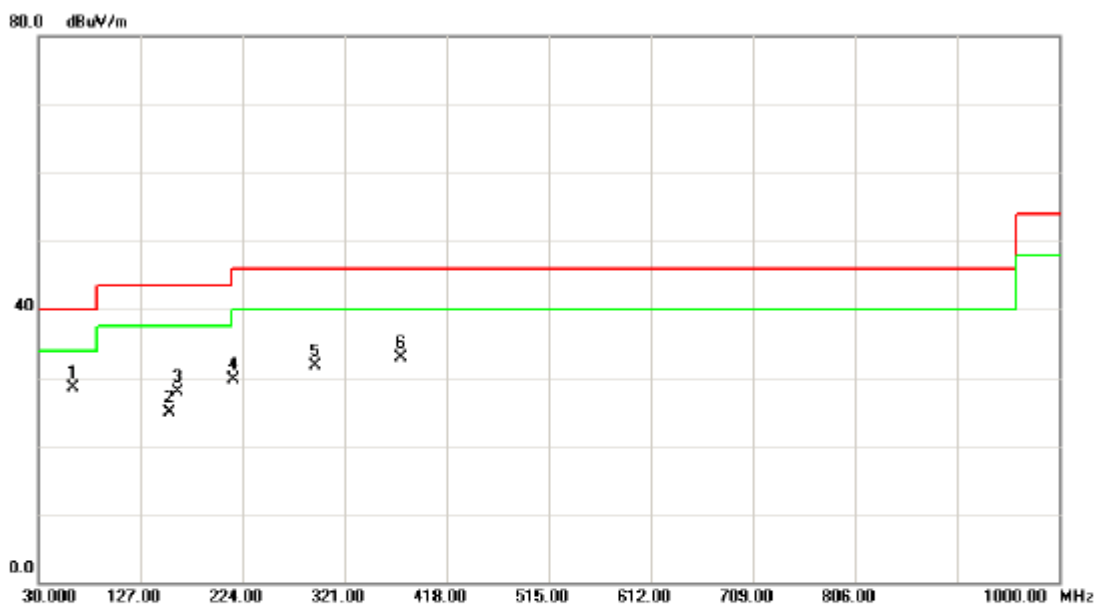

No.	Mk.	Freq. MHz	Reading Level dBuV	Correct Factor dB	Measure- ment dBuV/m	Limit dBuV/m	Over dB	Detector	Comment
1	*	63.5100	46.06	-17.56	28.50	40.00	-11.50	peak	
2		154.5100	42.42	-17.60	24.82	43.50	-18.68	peak	
3		162.4300	45.51	-17.57	27.94	43.50	-15.56	peak	
4		215.5000	45.67	-16.06	29.61	43.50	-13.89	peak	
5		293.2200	43.80	-12.05	31.75	46.00	-14.25	peak	
6		375.1100	42.75	-9.93	32.82	46.00	-13.18	peak	



Neutron Engineering Inc.

EUT:	Bluetooth Module	Model Name:	BC05 ROM
Temperature:	24 °C	Relative Humidity:	56 %
Test Power:	AC120V/60Hz	Phase:	Horizontal
Test Mode:	TX 2441MHz –CH39-1Mbps		

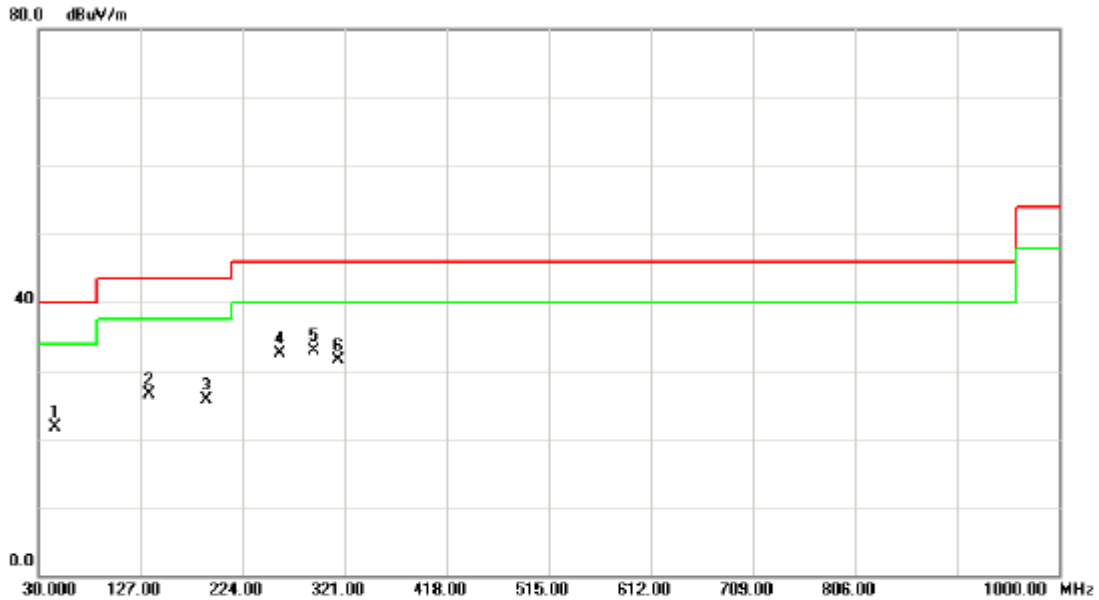

No. Mk.	Freq. MHz	Reading Level dBuV	Correct Factor dB	Measurement dBuV/m	Limit dBuV/m	Over dB	Detector	Comment
1	46.7200	38.85	-17.09	21.76	40.00	-18.24	peak	
2	135.4900	44.51	-17.91	26.60	43.50	-16.90	peak	
3	189.2600	42.50	-16.75	25.75	43.50	-17.75	peak	
4	259.2400	46.33	-13.91	32.42	46.00	-13.58	peak	
5 *	292.4400	45.03	-12.05	32.98	46.00	-13.02	peak	
6	315.3300	43.16	-11.69	31.47	46.00	-14.53	peak	



EUT:	Bluetooth Module	Model Name:	BC05 ROM
Temperature:	24 °C	Relative Humidity:	56 %
Test Power:	AC120V/60Hz	Phase:	Vertical
Test Mode:	TX 2480MHz –CH78-1Mbps		

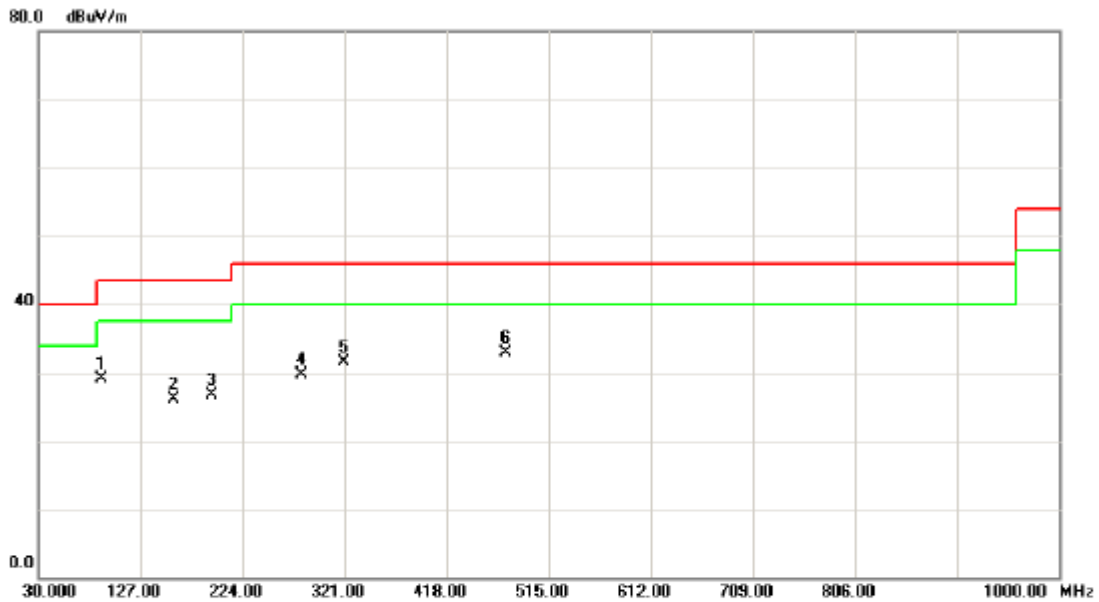

No.	Mk.	Freq. MHz	Reading Level dBuV	Correct Factor dB	Measure- ment dBuV/m	Limit dBuV/m	Over dB	Detector	Comment
1		90.2700	48.09	-19.04	29.05	43.50	-14.45	peak	
2		158.8100	43.69	-17.65	26.04	43.50	-17.46	peak	
3		195.5200	43.25	-16.63	26.62	43.50	-16.88	peak	
4		280.8200	42.28	-12.60	29.68	46.00	-16.32	peak	
5		320.5400	43.09	-11.57	31.52	46.00	-14.48	peak	
6	*	474.5600	40.60	-7.74	32.86	46.00	-13.14	peak	



EUT:	Bluetooth Module	Model Name:	BC05 ROM
Temperature:	24 °C	Relative Humidity:	56 %
Test Power:	AC120V/60Hz	Phase:	Horizontal
Test Mode:	TX 2480MHz –CH78-1Mbps		

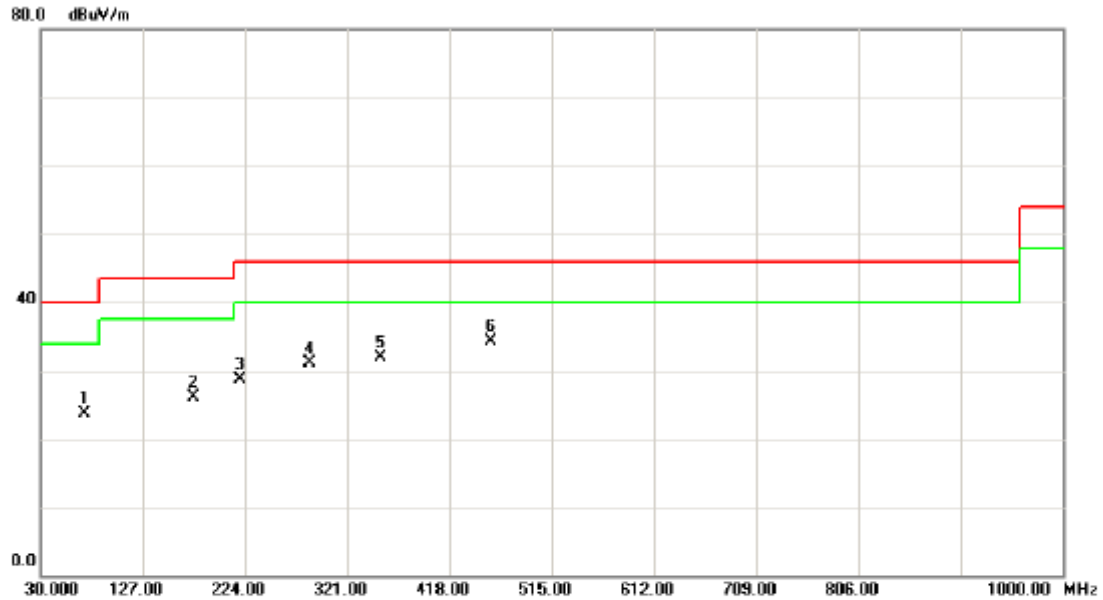

No.	Mk.	Freq. MHz	Reading Level dBuV	Correct Factor dB	Measure- ment dBuV/m	Limit dBuV/m	Over dB	Detector	Comment
1		72.5100	42.25	-18.57	23.68	40.00	-16.32	peak	
2		175.2600	43.26	-17.08	26.18	43.50	-17.32	peak	
3		219.2100	44.63	-15.89	28.74	46.00	-17.26	peak	
4		285.2900	43.42	-12.34	31.08	46.00	-14.92	peak	
5		352.1200	42.61	-10.76	31.85	46.00	-14.15	peak	
6	*	457.3800	42.37	-8.00	34.37	46.00	-11.63	peak	



EUT:	Bluetooth Module	Model Name:	BC05 ROM
Temperature:	24 °C	Relative Humidity:	56 %
Test Power:	AC120V/60Hz	Phase:	Vertical
Test Mode:	TX 2402MHz –CH00-3Mbps		

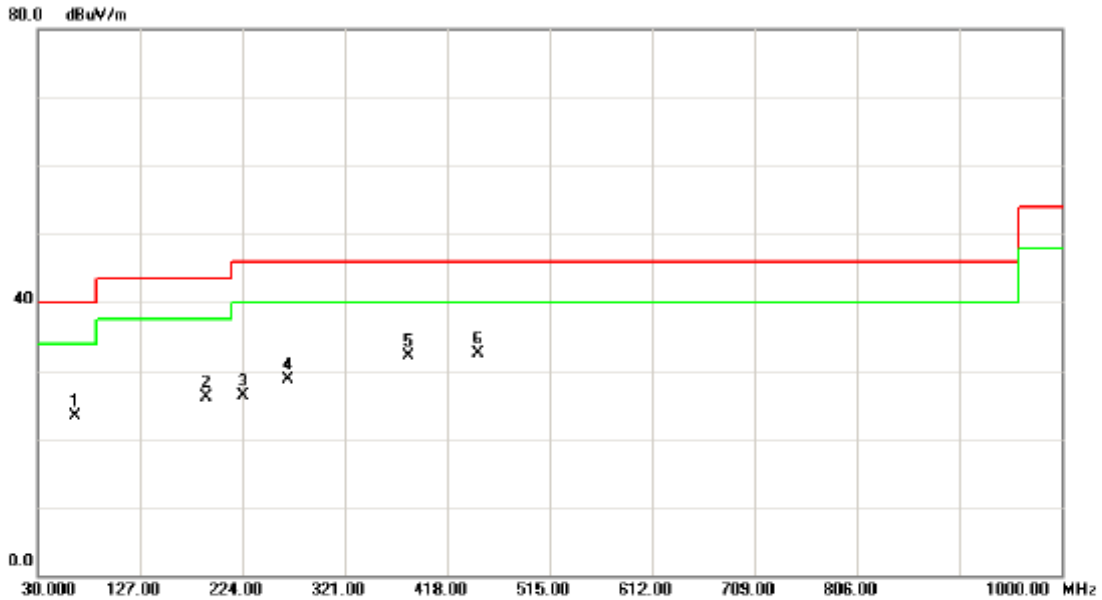

No.	Mk.	Freq. MHz	Reading Level dBuV	Correct Factor dB	Measure- ment dBuV/m	Limit dBuV/m	Over dB	Detector	Comment
1		65.4500	41.04	-17.67	23.37	40.00	-16.63	peak	
2		189.4200	42.78	-16.74	26.04	43.50	-17.46	peak	
3		225.1200	42.02	-15.73	26.29	46.00	-19.71	peak	
4		266.7200	42.25	-13.46	28.79	46.00	-17.21	peak	
5		381.7400	41.83	-9.68	32.15	46.00	-13.85	peak	
6	*	447.4800	40.73	-8.17	32.56	46.00	-13.44	peak	



EUT:	Bluetooth Module	Model Name:	BC05 ROM
Temperature:	24 °C	Relative Humidity:	56 %
Test Power:	AC120V/60Hz	Phase:	Horizontal
Test Mode:	TX 2402MHz –CH00-3Mbps		

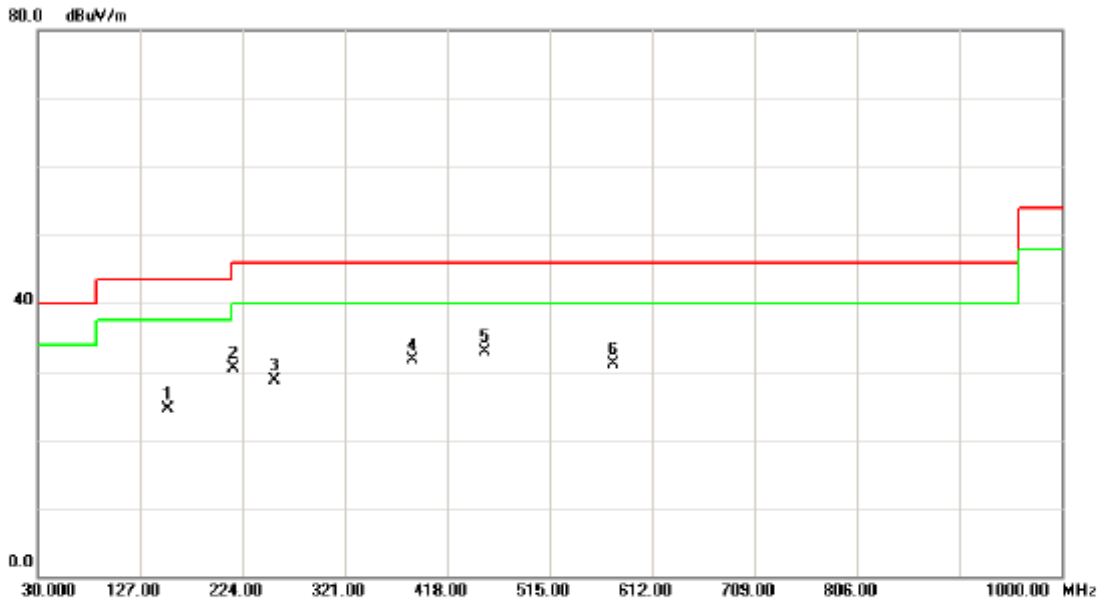

No.	Mk.	Freq. MHz	Reading Level dBuV	Correct Factor dB	Measure- ment dBuV/m	Limit dBuV/m	Over dB	Detector	Comment
1		154.1200	42.07	-17.59	24.48	43.50	-19.02	peak	
2	*	215.4700	46.56	-16.06	30.50	43.50	-13.00	peak	
3		254.4400	42.85	-14.24	28.61	46.00	-17.39	peak	
4		384.6500	41.30	-9.58	31.72	46.00	-14.28	peak	
5		453.6100	40.95	-8.05	32.90	46.00	-13.10	peak	
6		575.5500	35.91	-4.87	31.04	46.00	-14.96	peak	



EUT:	Bluetooth Module	Model Name:	BC05 ROM
Temperature:	24 °C	Relative Humidity:	56 %
Test Power:	AC120V/60Hz	Phase:	Vertical
Test Mode:	TX 2441MHz –CH39-3Mbps		

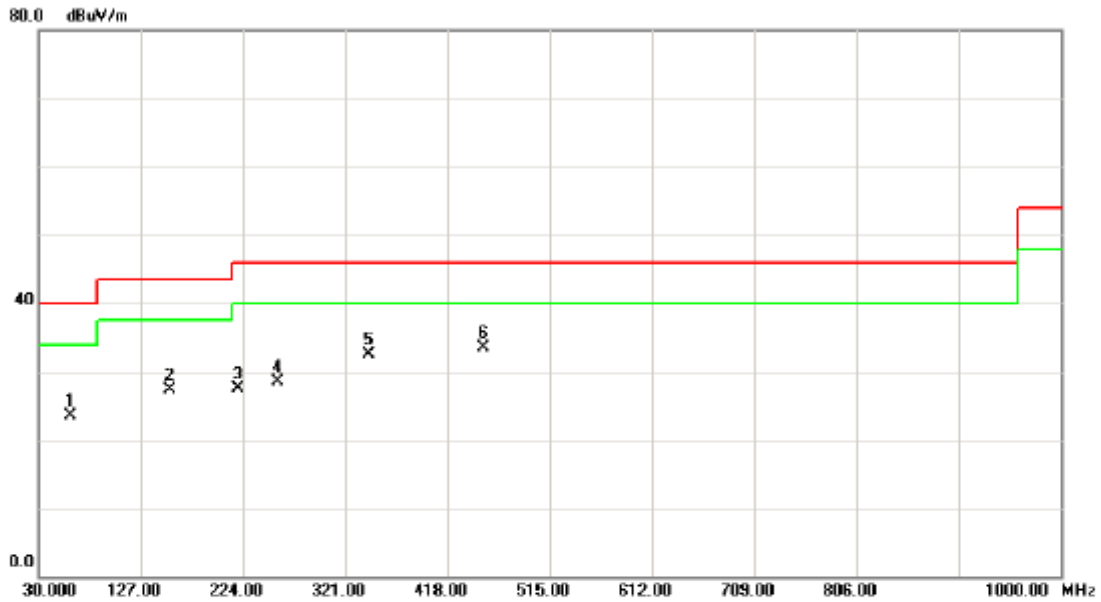

No.	Mk.	Freq. MHz	Reading Level dBuV	Correct Factor dB	Measure- ment dBuV/m	Limit dBuV/m	Over dB	Detector	Comment
1		60.1200	40.93	-17.46	23.47	40.00	-16.53	peak	
2		155.4100	44.85	-17.61	27.24	43.50	-16.26	peak	
3		219.3600	43.41	-15.89	27.52	46.00	-18.48	peak	
4		257.2600	42.48	-14.04	28.44	46.00	-17.56	peak	
5		343.6900	43.45	-11.00	32.45	46.00	-13.55	peak	
6	*	452.8200	41.63	-8.07	33.56	46.00	-12.44	peak	



EUT:	Bluetooth Module	Model Name:	BC05 ROM
Temperature:	24 °C	Relative Humidity:	56 %
Test Power:	AC120V/60Hz	Phase:	Horizontal
Test Mode:	TX 2441MHz –CH39-3Mbps		

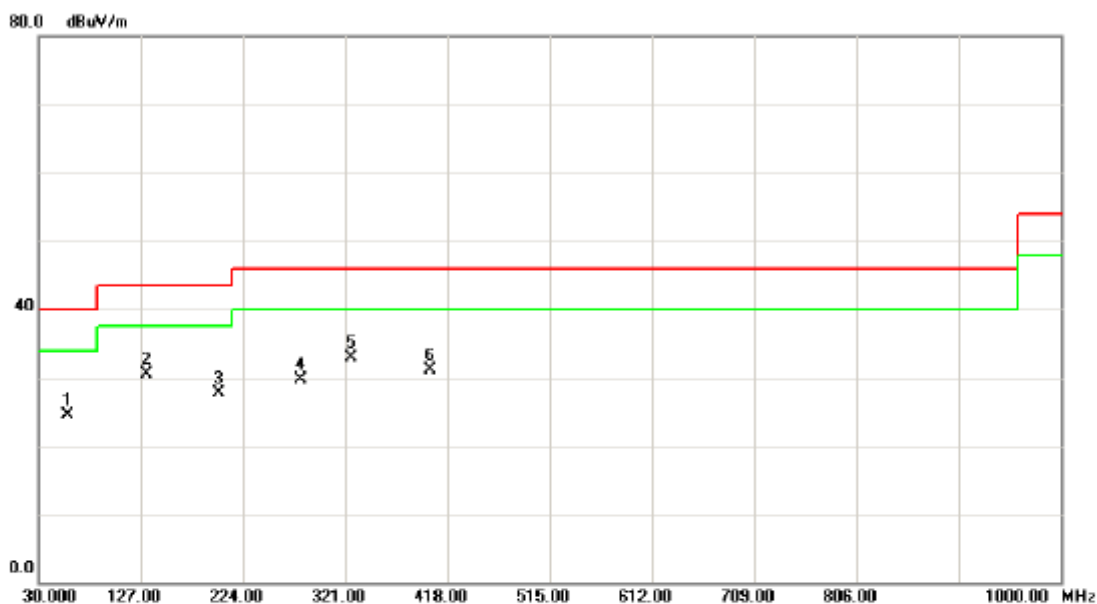

No.	Mk.	Freq. MHz	Reading Level dBuV	Correct Factor dB	Measure- ment dBuV/m	Limit dBuV/m	Over dB	Detector	Comment
1		57.5800	42.15	-17.58	24.57	40.00	-15.43	peak	
2	*	132.4400	48.52	-18.02	30.50	43.50	-13.00	peak	
3		201.2200	44.15	-16.54	27.61	43.50	-15.89	peak	
4		278.6100	42.47	-12.73	29.74	46.00	-16.26	peak	
5		327.2700	44.29	-11.39	32.90	46.00	-13.10	peak	
6		402.4300	40.02	-8.98	31.04	46.00	-14.96	peak	



EUT:	Bluetooth Module	Model Name:	BC05 ROM
Temperature:	24 °C	Relative Humidity:	56 %
Test Power:	AC120V/60Hz	Phase:	Vertical
Test Mode:	TX 2480MHz –CH78-3Mbps		

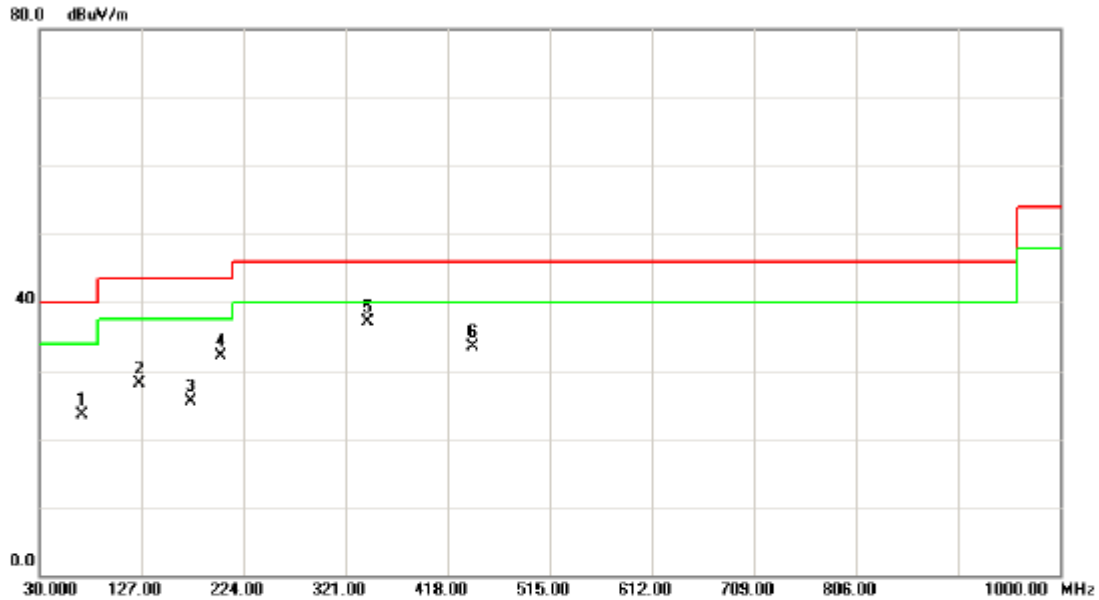

No. Mk.	Freq. MHz	Reading Level dBuV	Correct Factor dB	Measurement dBuV/m	Limit dBuV/m	Over dB	Detector	Comment
1	70.1200	41.88	-18.35	23.53	40.00	-16.47	peak	
2	125.6000	46.23	-18.19	28.04	43.50	-15.46	peak	
3	174.5000	42.67	-17.11	25.56	43.50	-17.94	peak	
4	202.5800	48.52	-16.50	32.02	43.50	-11.48	peak	
5 *	342.1500	48.19	-11.04	37.15	46.00	-8.85	peak	
6	442.5700	41.82	-8.25	33.57	46.00	-12.43	peak	



EUT:	Bluetooth Module	Model Name:	BC05 ROM
Temperature:	24 °C	Relative Humidity:	56 %
Test Power:	AC120V/60Hz	Phase:	Horizontal
Test Mode:	TX 2480MHz –CH78-3Mbps		

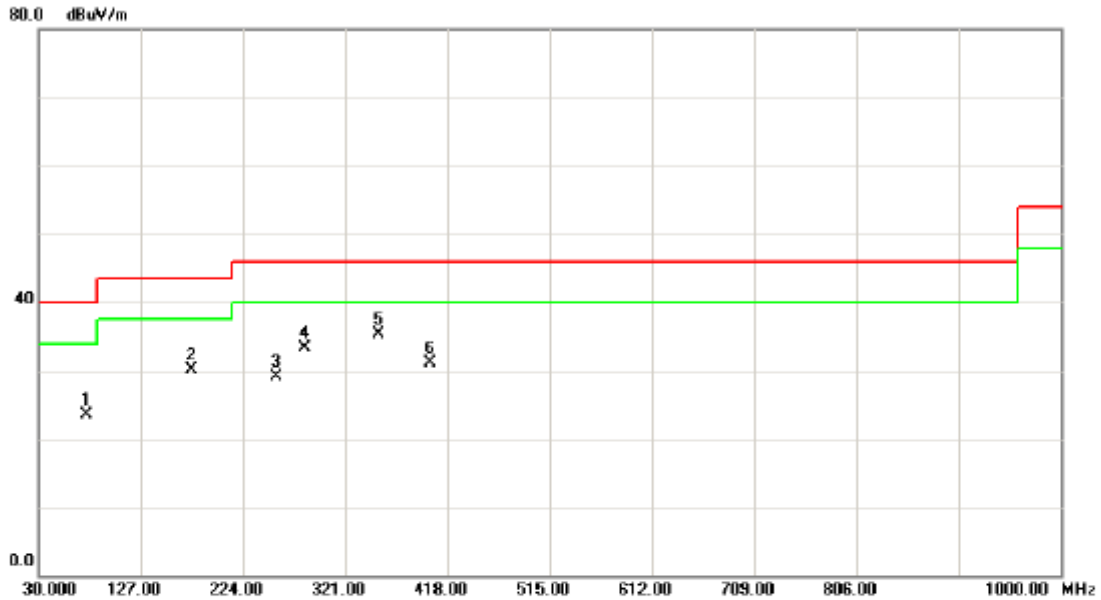

No.	Mk.	Freq. MHz	Reading Level dBuV	Correct Factor dB	Measure- ment dBuV/m	Limit dBuV/m	Over dB	Detector	Comment
1		75.3200	42.41	-18.82	23.59	40.00	-16.41	peak	
2		175.4200	47.28	-17.08	30.20	43.50	-13.30	peak	
3		255.7100	43.17	-14.16	29.01	46.00	-16.99	peak	
4		283.2500	45.78	-12.46	33.32	46.00	-12.68	peak	
5	*	352.6300	46.11	-10.75	35.36	46.00	-10.64	peak	
6		402.3200	40.02	-8.98	31.04	46.00	-14.96	peak	



4.2.9 TEST RESULTS (ABOVE 1000 MHZ)

EUT :	Bluetooth Module	Model Name :	BC05 ROM
Temperature :	24 °C	Relative Humidity :	58 %
Pressure :	1010 hPa	Test Voltage :	AC120V/60Hz
Test Mode :	TX 2402MHz – CH 00-1Mbps		

Freq. (MHz)	Ant.Pol. H/V	Reading		Ant./CF CF(dB)	Act.		Limit		Margin		Note
		Peak (dBuV)	AV (dBuV)		Peak (dBuV/m)	AV (dBuV/m)	Peak (dBuV/m)	AV (dBuV/m)	Peak (dBuV/m)	AV (dBuV/m)	
2390.00	V	24.01	10.42	31.91	55.92	42.33	74.00	54.00	-18.08	-11.67	X/E
2402.15	V	58.46	26.35	31.90	90.36	58.25					X/F
4803.98	V	52.84	37.25	5.21	58.05	42.46	74.00	54.00	-15.95	-11.54	X/H

Remark :

- (1) All readings are Peak unless otherwise stated QP in column of 『Note』 . Peak denotes that the Peak reading compliance with the QP Limits and then QP Mode measurement didn't perform.
- (2) Measuring frequency range from 30MHz to 1000MHz or the 10th harmonic of highest fundamental frequency. "F" denotes fundamental frequency; "H" denotes spurious frequency. "E" denotes band edge frequency. (This judgment method includes the Band Edge Requirement.)
- (3) Radiated emissions measured in frequency range above 1000MHz were made with an instrument using Peak detector mode and AV detector mode of the emission .
- (4) Data of measurement within this frequency range shown " * " in the table above means the reading of emissions are attenuated more than 20dB below the permissible limits or the field strength is too small to be measured.
- (5) A preamp and high pass filter were used for this test in order to provide sufficient measurement sensitivity.
- (6) EUT Orthogonal Axis :
"X" - denotes Laid on Table ; "Y" - denotes Vertical Stand ; "Z" - denotes Side Stand
- (7) During the measurements above 1 GHz it is taken care of that the EUT is always within the 3 dB cone of radiation BW of the used antenna



TX CH00(Above 1000 MHz, Vertical)

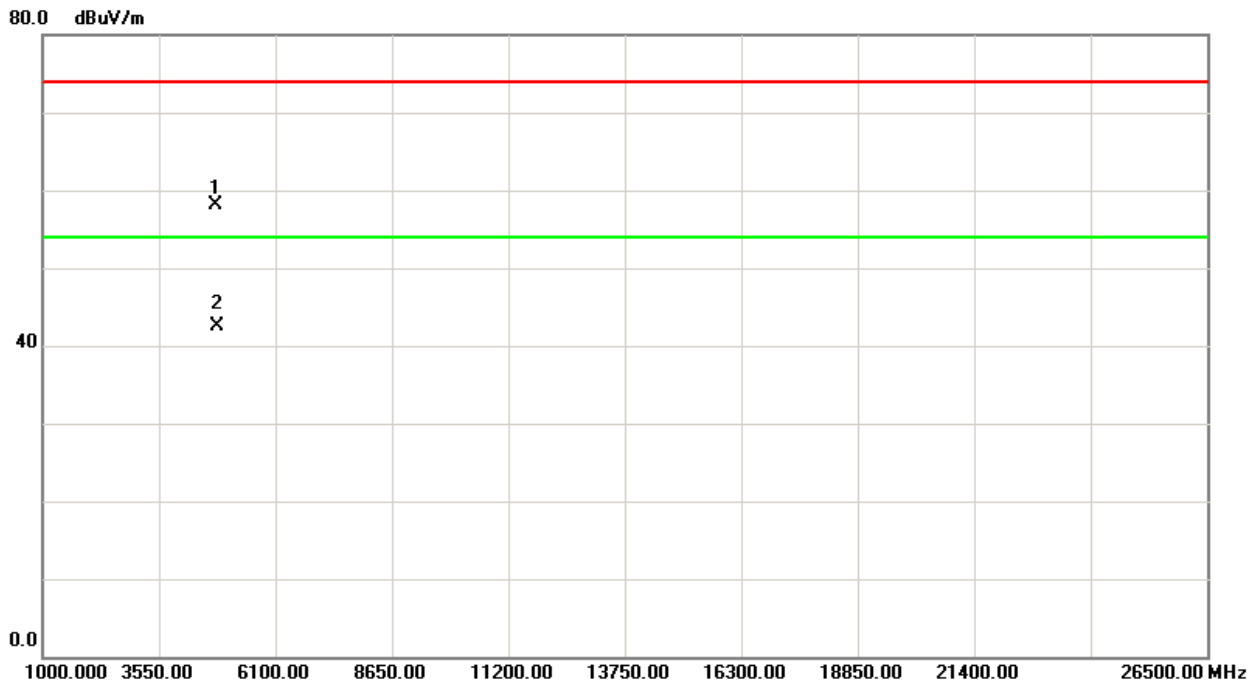
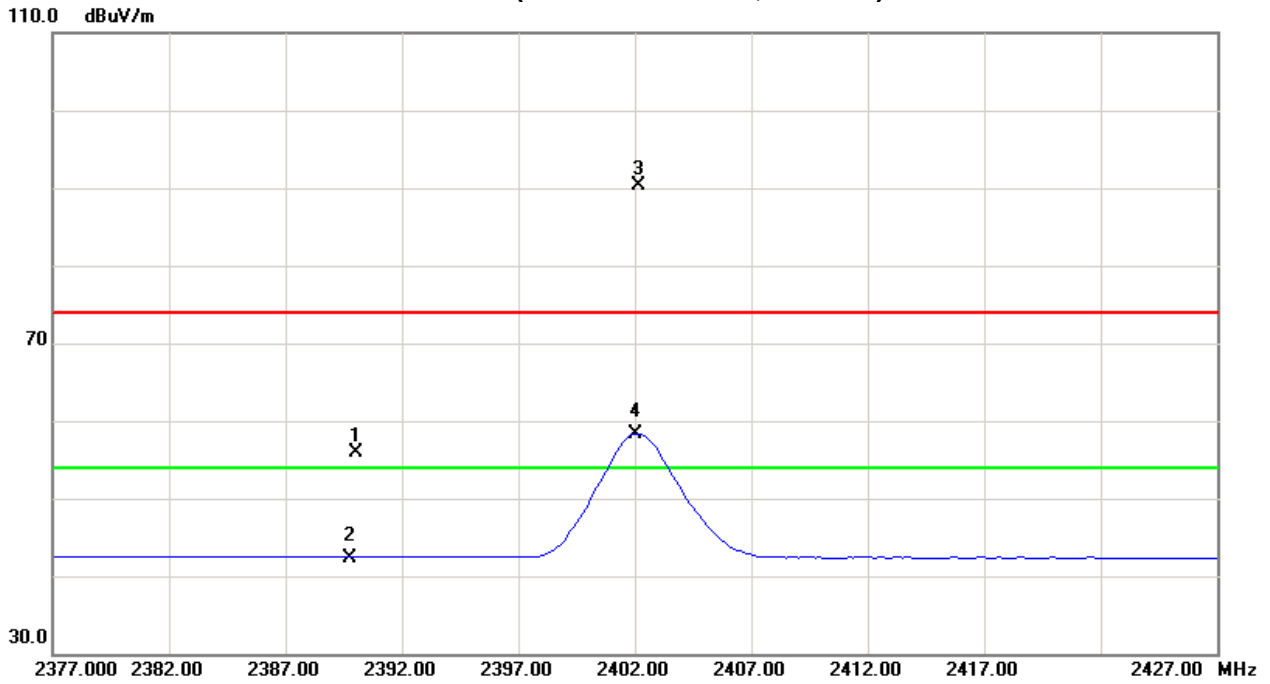



EUT :	Bluetooth Module	Model Name :	BC05 ROM
Temperature :	24 °C	Relative Humidity :	58 %
Pressure :	1010hPa	Test Voltage :	AC120V/60Hz
Test Mode :	TX 2402MHz – CH 00-1Mbps		

Freq. (MHz)	Ant.Pol. H/V	Reading		Ant./CF CF(dB)	Act.		Limit		Margin		Note
		Peak (dBuV)	AV (dBuV)		Peak (dBuV/m)	AV (dBuV/m)	Peak (dBuV/m)	AV (dBuV/m)	Peak (dBuV/m)	AV (dBuV/m)	
2390.00	H	26.75	10.62	31.91	58.66	42.53	74.00	54.00	-15.34	-11.47	X/E
2402.25	H	62.24	27.77	31.90	94.14	59.67					X/F
4803.98	H	50.12	36.47	5.21	55.33	41.68	74.00	54.00	-18.67	-12.32	X/H

Remark :

- (1) All readings are Peak unless otherwise stated QP in column of 『Note』 . Peak denotes that the Peak reading compliance with the QP Limits and then QP Mode measurement didn't perform.
- (2) Measuring frequency range from 30MHz to 1000MHz or the 10th harmonic of highest fundamental frequency. "F" denotes fundamental frequency; "H" denotes spurious frequency. "E" denotes band edge frequency. (This judgment method includes the Band Edge Requirement.)
- (3) Radiated emissions measured in frequency range above 1000MHz were made with an instrument using Peak detector mode and AV detector mode of the emission .
- (4) Data of measurement within this frequency range shown " * " in the table above means the reading of emissions are attenuated more than 20dB below the permissible limits or the field strength is too small to be measured.
- (5) A preamp and high pass filter were used for this test in order to provide sufficient measurement sensitivity.
- (6) EUT Orthogonal Axis :
"X" - denotes Laid on Table ; "Y" - denotes Vertical Stand ; "Z" - denotes Side Stand
- (7) During the measurements above 1 GHz it is taken care of that the EUT is always within the 3 dB cone of radiation BW of the used antenna



TX CH00(Above 1000 MHz, Horizontal)

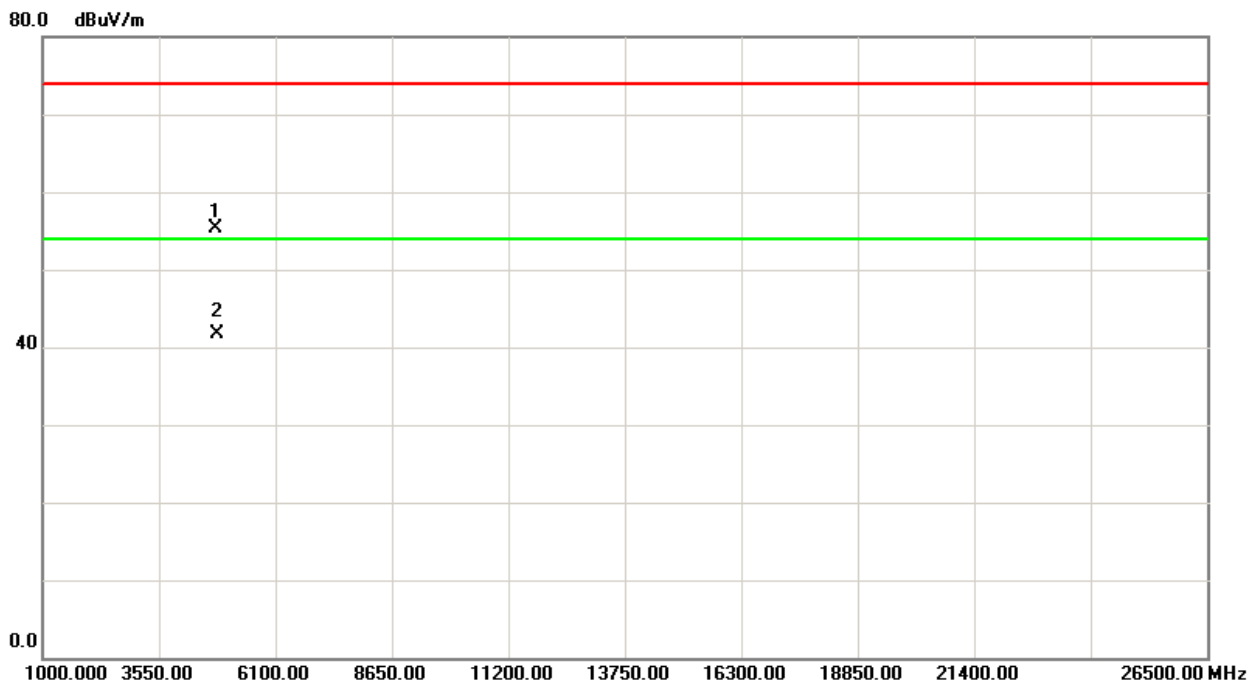
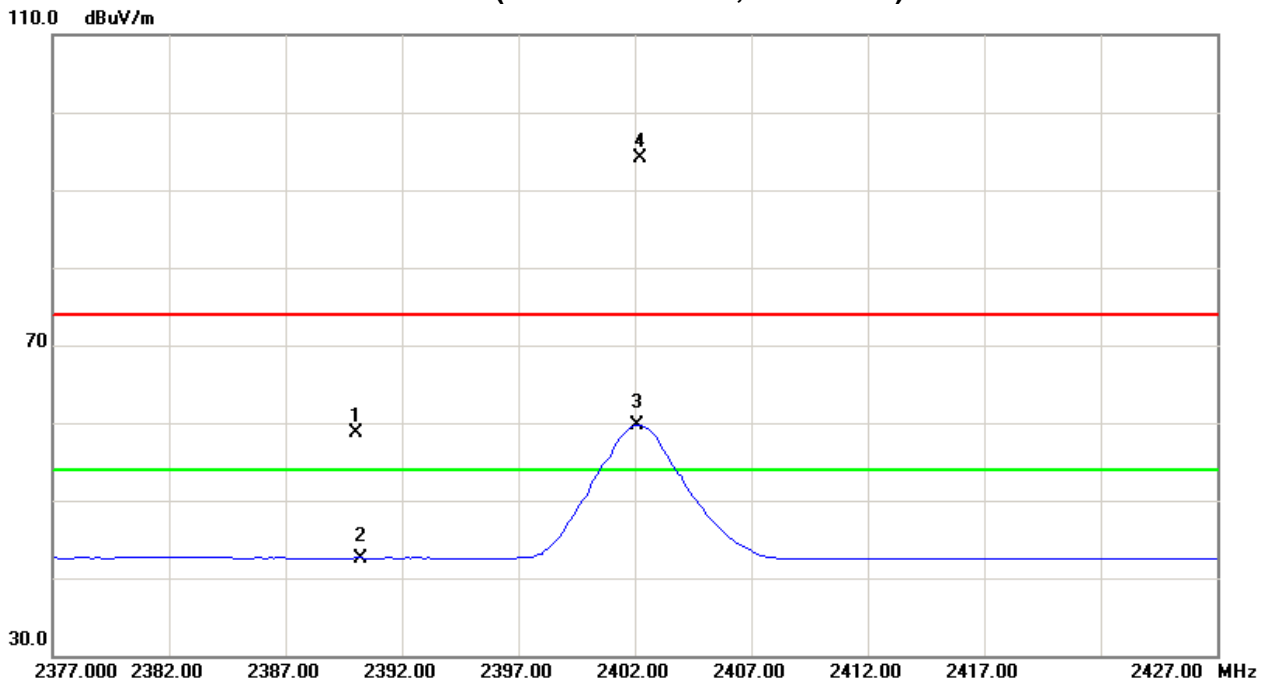



EUT :	Bluetooth Module	Model Name :	BC05 ROM
Temperature :	24 °C	Relative Humidity :	58 %
Pressure :	1010 hPa	Test Voltage :	AC120V/60Hz
Test Mode :	TX 2441MHz –CH39-1Mbps		

Freq. (MHz)	Ant.Pol. H/V	Reading		Ant./CF CF(dB)	Act.		Limit		Margin		Note
		Peak (dBuV)	AV (dBuV)		Peak (dBuV/m)	AV (dBuV/m)	Peak (dBuV/m)	AV (dBuV/m)	Peak (dBuV/m)	AV (dBuV/m)	
2441.15	V	60.02	25.99	31.85	91.87	57.84					X/F
4882.16	V	52.26	38.27	5.50	57.76	43.77	74.00	54.00	-16.24	-10.23	X/H

Remark :

- (1) All readings are Peak unless otherwise stated QP in column of 『Note』 . Peak denotes that the Peak reading compliance with the QP Limits and then QP Mode measurement didn't perform.
- (2) Measuring frequency range from 30MHz to 1000MHz or the 10th harmonic of highest fundamental frequency. "F" denotes fundamental frequency; "H" denotes spurious frequency. "E" denotes band edge frequency. (This judgment method includes the Band Edge Requirement.)
- (3) Radiated emissions measured in frequency range above 1000MHz were made with an instrument using Peak detector mode and AV detector mode of the emission .
- (4) Data of measurement within this frequency range shown " * " in the table above means the reading of emissions are attenuated more than 20dB below the permissible limits or the field strength is too small to be measured.
- (5) A preamp and high pass filter were used for this test in order to provide sufficient measurement sensitivity.
- (6) EUT Orthogonal Axis :
"X" - denotes Laid on Table ; "Y" - denotes Vertical Stand ; "Z" - denotes Side Stand
- (7) During the measurements above 1 GHz it is taken care of that the EUT is always within the 3 dB cone of radiation BW of the used antenna



TX CH39 (Above 1000 MHz, Vertical)

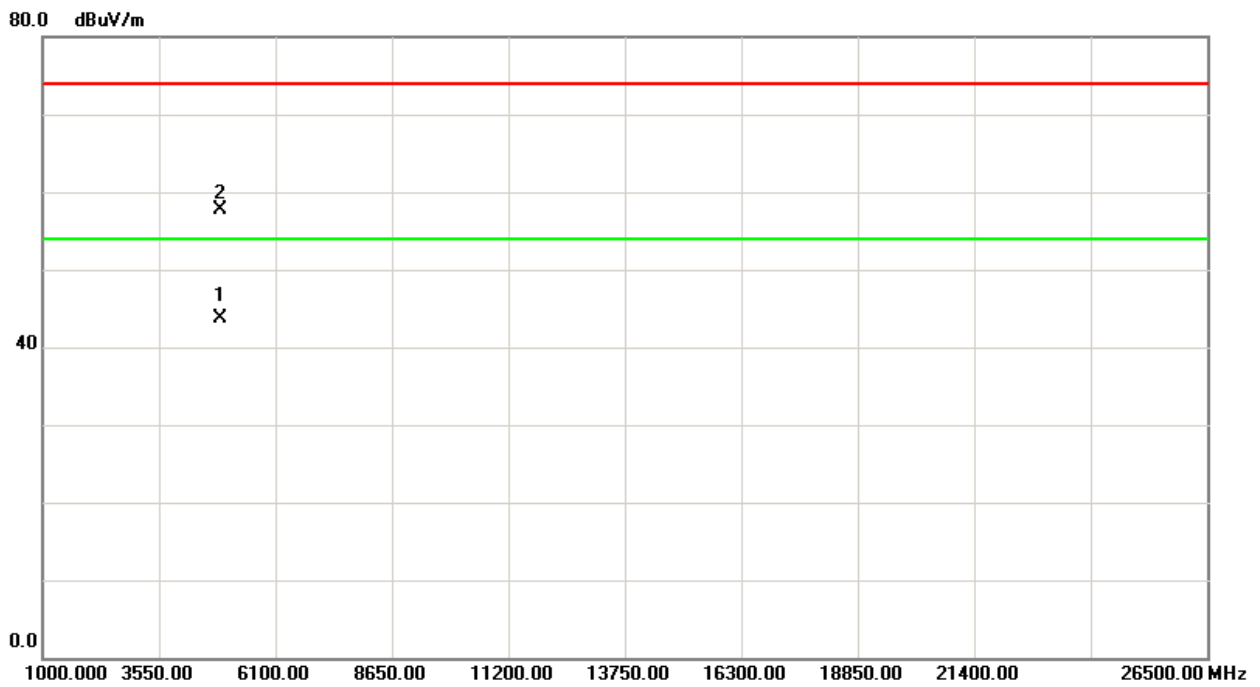
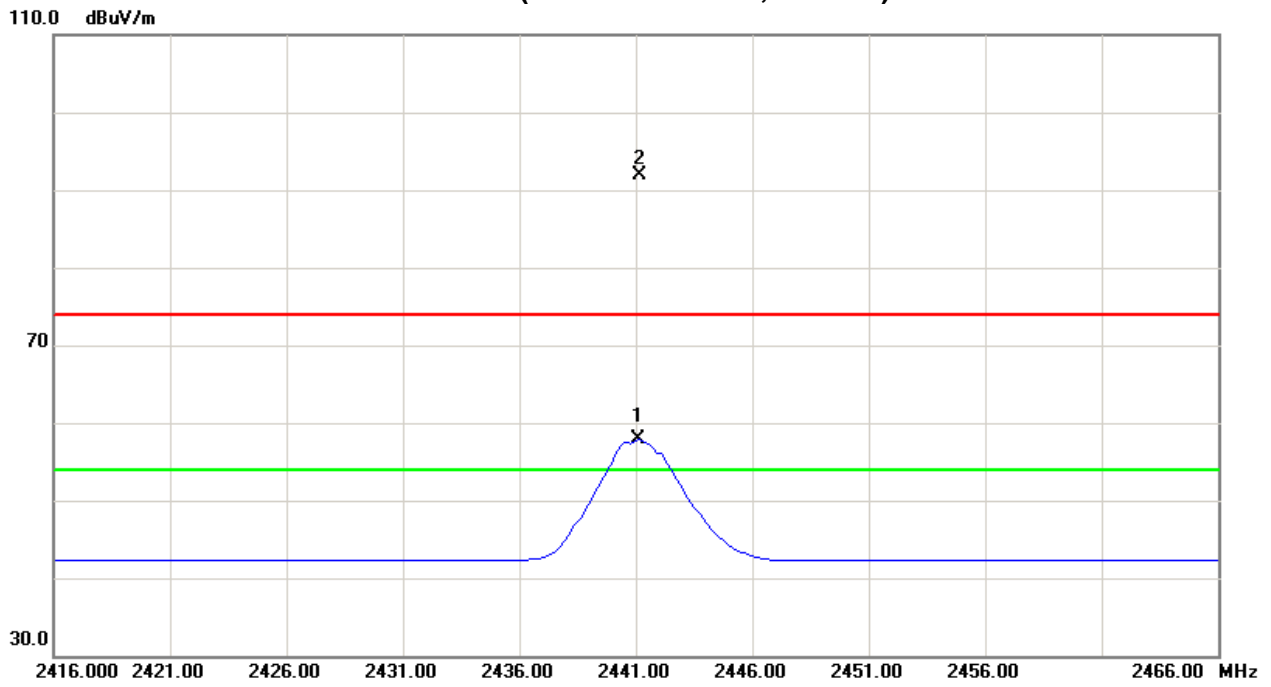



EUT :	Bluetooth Module	Model Name :	BC05 ROM
Temperature :	24 °C	Relative Humidity :	58 %
Pressure :	1010 hPa	Test Voltage :	AC120V/60Hz
Test Mode :	TX 2441MHz –CH39-1Mbps		

Freq. (MHz)	Ant.Pol. H/V	Reading		Ant./CF CF(dB)	Act.		Limit		Margin		Note
		Peak (dBuV)	AV (dBuV)		Peak (dBuV/m)	AV (dBuV/m)	Peak (dBuV/m)	AV (dBuV/m)	Peak (dBuV/m)	AV (dBuV/m)	
2441.00	H	63.67	27.80	31.85	95.52	59.65					X/F
4882.02	H	51.02	36.57	5.50	56.52	42.07	74.00	54.00	-17.48	-11.93	X/H

Remark :

- (1) All readings are Peak unless otherwise stated QP in column of 『Note』 . Peak denotes that the Peak reading compliance with the QP Limits and then QP Mode measurement didn't perform.
- (2) Measuring frequency range from 30MHz to 1000MHz or the 10th harmonic of highest fundamental frequency. "F" denotes fundamental frequency; "H" denotes spurious frequency. "E" denotes band edge frequency. (This judgment method includes the Band Edge Requirement.)
- (3) Radiated emissions measured in frequency range above 1000MHz were made with an instrument using Peak detector mode and AV detector mode of the emission .
- (4) Data of measurement within this frequency range shown " * " in the table above means the reading of emissions are attenuated more than 20dB below the permissible limits or the field strength is too small to be measured.
- (5) A preamp and high pass filter were used for this test in order to provide sufficient measurement sensitivity.
- (6) EUT Orthogonal Axis :
"X" - denotes Laid on Table ; "Y" - denotes Vertical Stand ; "Z" - denotes Side Stand
- (7) During the measurements above 1 GHz it is taken care of that the EUT is always within the 3 dB cone of radiation BW of the used antenna



TX CH39 (Above 1000 MHz, Horizontal)

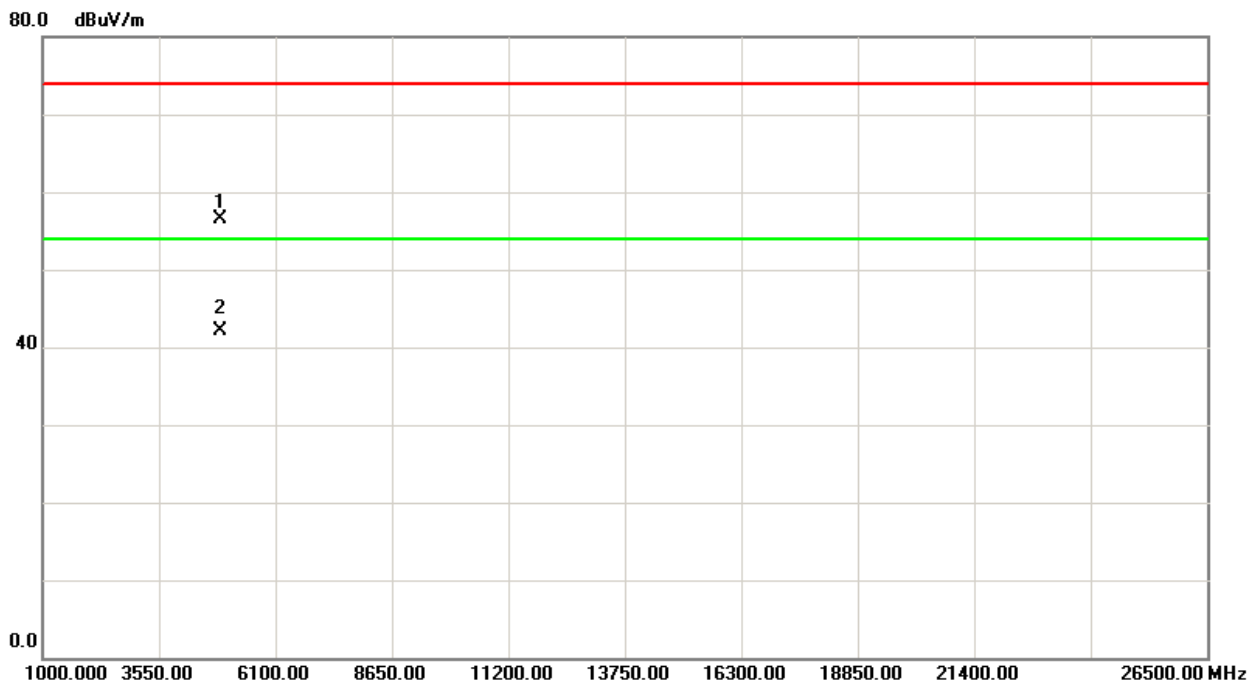
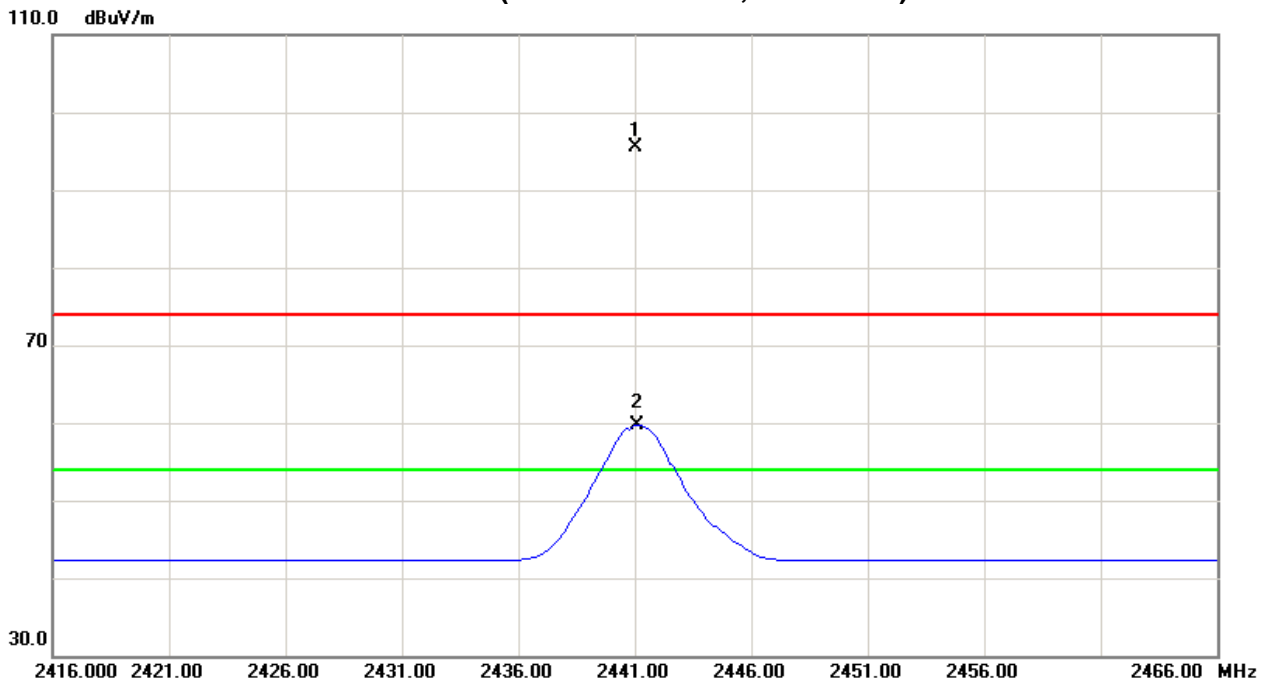



EUT :	Bluetooth Module	Model Name :	BC05 ROM
Temperature :	24 °C	Relative Humidity :	58 %
Pressure :	1010hPa	Test Voltage :	AC120V/60Hz
Test Mode :	TX 2480MHz –CH78-1Mbps		

Freq. (MHz)	Ant.Pol. H/V	Reading		Ant./CF CF(dB)	Act.		Limit		Margin		Note
		Peak (dBuV)	AV (dBuV)		Peak (dBuV/m)	AV (dBuV/m)	Peak (dBuV/m)	AV (dBuV/m)	Peak (dBuV/m)	AV (dBuV/m)	
2480.00	V	58.04	26.44	31.80	89.84	58.24					X/F
2483.50	V	32.12	13.13	31.80	63.92	44.93	74.00	54.00	-10.08	-9.07	X/E
4960.12	V	53.12	36.28	5.78	58.90	42.06	74.00	54.00	-15.10	-11.94	X/H

Remark :

- (1) All readings are Peak unless otherwise stated QP in column of 『Note』 . Peak denotes that the Peak reading compliance with the QP Limits and then QP Mode measurement didn't perform.
- (2) Measuring frequency range from 30MHz to 1000MHz or the 10th harmonic of highest fundamental frequency. "F" denotes fundamental frequency; "H" denotes spurious frequency. "E" denotes band edge frequency. (This judgment method includes the Band Edge Requirement.)
- (3) Radiated emissions measured in frequency range above 1000MHz were made with an instrument using Peak detector mode and AV detector mode of the emission .
- (4) Data of measurement within this frequency range shown " * " in the table above means the reading of emissions are attenuated more than 20dB below the permissible limits or the field strength is too small to be measured.
- (5) A preamp and high pass filter were used for this test in order to provide sufficient measurement sensitivity.
- (6) EUT Orthogonal Axis :
"X" - denotes Laid on Table ; "Y" - denotes Vertical Stand ; "Z" - denotes Side Stand
- (7) During the measurements above 1 GHz it is taken care of that the EUT is always within the 3 dB cone of radiation BW of the used antenna



TX CH78 (Above 1000 MHz, Vertical)

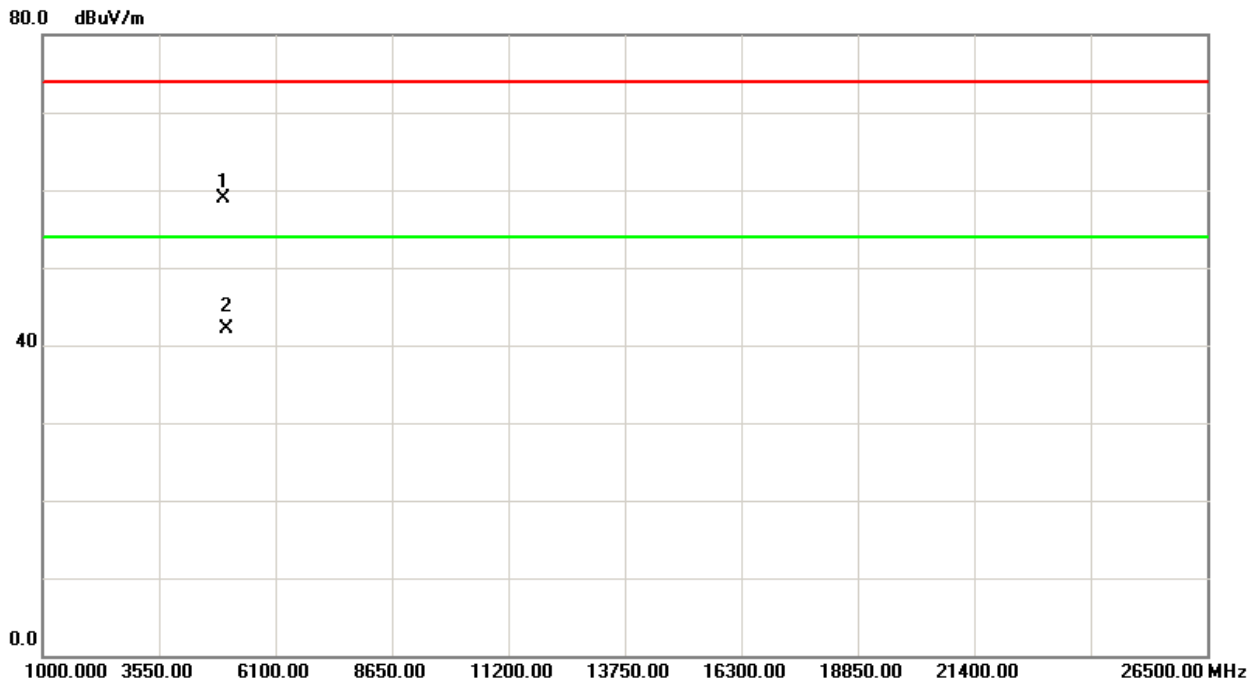
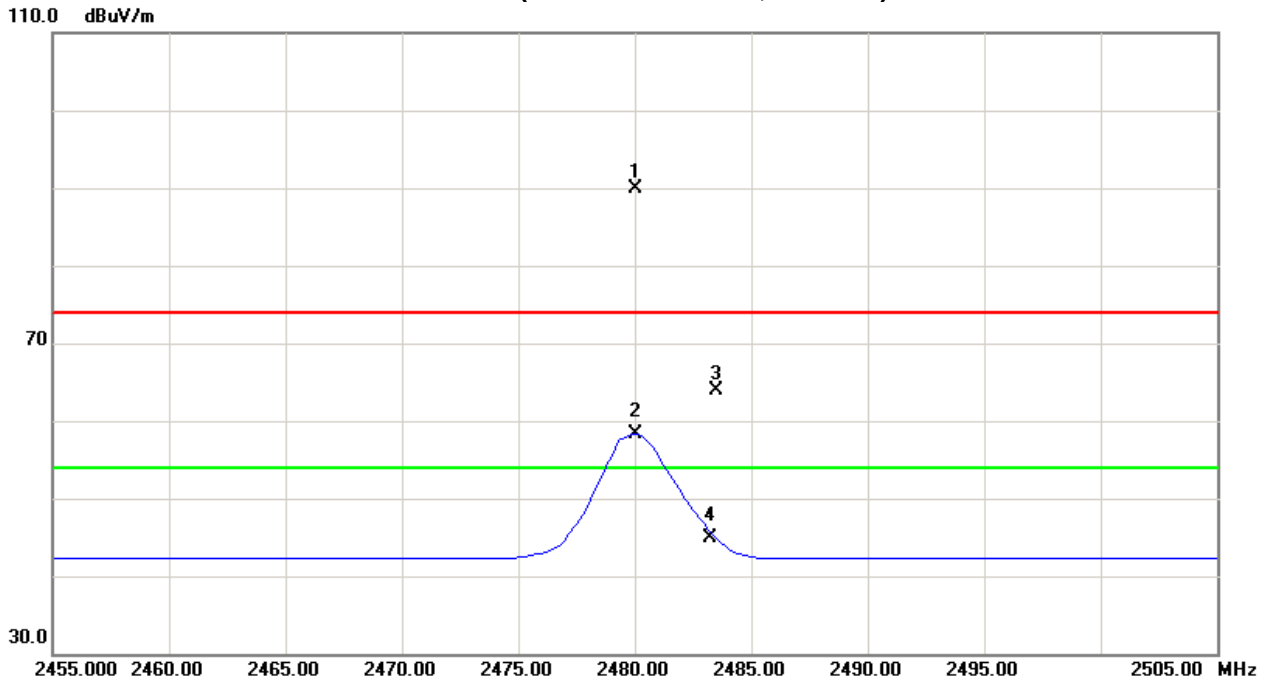



EUT :	Bluetooth Module	Model Name :	BC05 ROM
Temperature :	24 °C	Relative Humidity :	58 %
Pressure :	1010 hPa	Test Voltage :	AC120V/60Hz
Test Mode :	TX 2480MHz –CH78-1Mbps		

Freq. (MHz)	Ant.Pol. H/V	Reading		Ant./CF CF(dB)	Act.		Limit		Margin		Note
		Peak (dBuV)	AV (dBuV)		Peak (dBuV/m)	AV (dBuV/m)	Peak (dBuV/m)	AV (dBuV/m)	Peak (dBuV/m)	AV (dBuV/m)	
2479.88	H	60.01	27.16	31.80	91.81	58.96					X/F
2483.50	H	36.12	13.75	31.80	67.92	45.55	74.00	54.00	-6.08	-8.45	X/E
4960.12	H	51.59	34.57	5.78	57.37	40.35	74.00	54.00	-16.63	-13.65	X/H

Remark :

- (1) All readings are Peak unless otherwise stated QP in column of 『Note』 . Peak denotes that the Peak reading compliance with the QP Limits and then QP Mode measurement didn't perform.
- (2) Measuring frequency range from 30MHz to 1000MHz or the 10th harmonic of highest fundamental frequency."F" denotes fundamental frequency; "H" denotes spurious frequency. "E" denotes band edge frequency. (This judgment method includes the Band Edge Requirement.)
- (3) Radiated emissions measured in frequency range above 1000MHz were made with an instrument using Peak detector mode and AV detector mode of the emission .
- (4) Data of measurement within this frequency range shown " * " in the table above means the reading of emissions are attenuated more than 20dB below the permissible limits or the field strength is too small to be measured.
- (5) A preamp and high pass filter were used for this test in order to provide sufficient measurement sensitivity.
- (6) EUT Orthogonal Axis :
"X" - denotes Laid on Table ; "Y" - denotes Vertical Stand ; "Z" - denotes Side Stand
- (7) During the measurements above 1 GHz it is taken care of that the EUT is always within the 3 dB cone of radiation BW of the used antenna



TX CH78 (Above 1000 MHz, Horizontal)

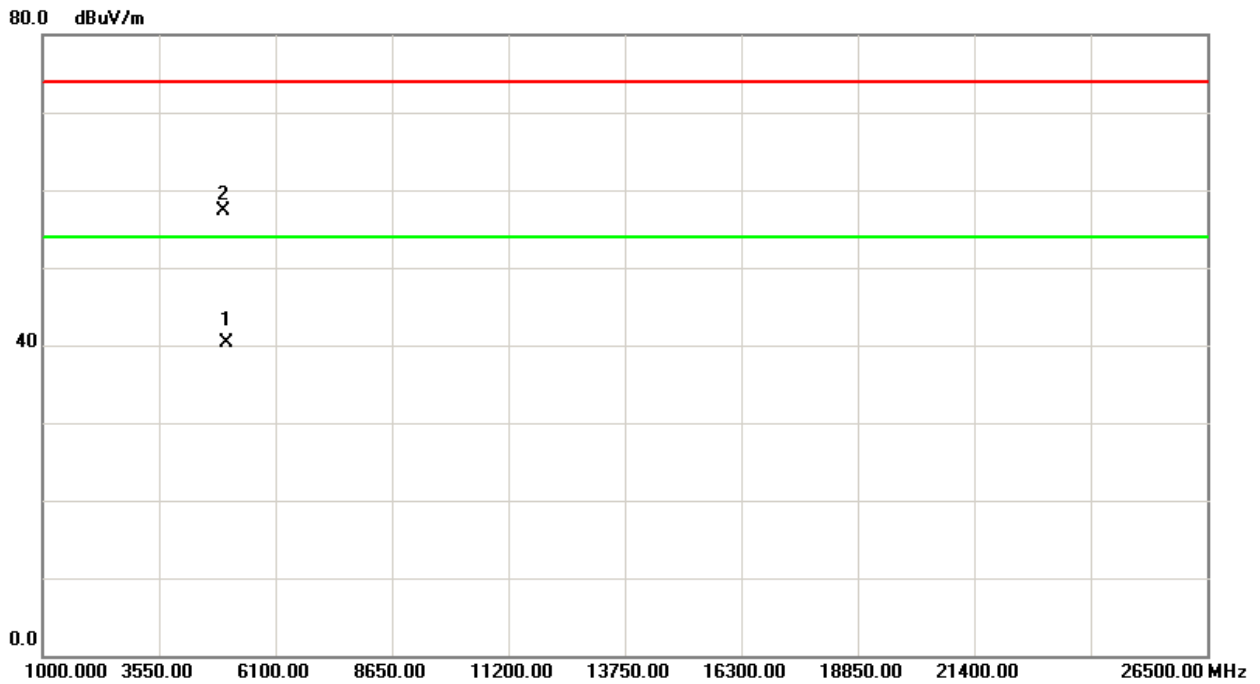
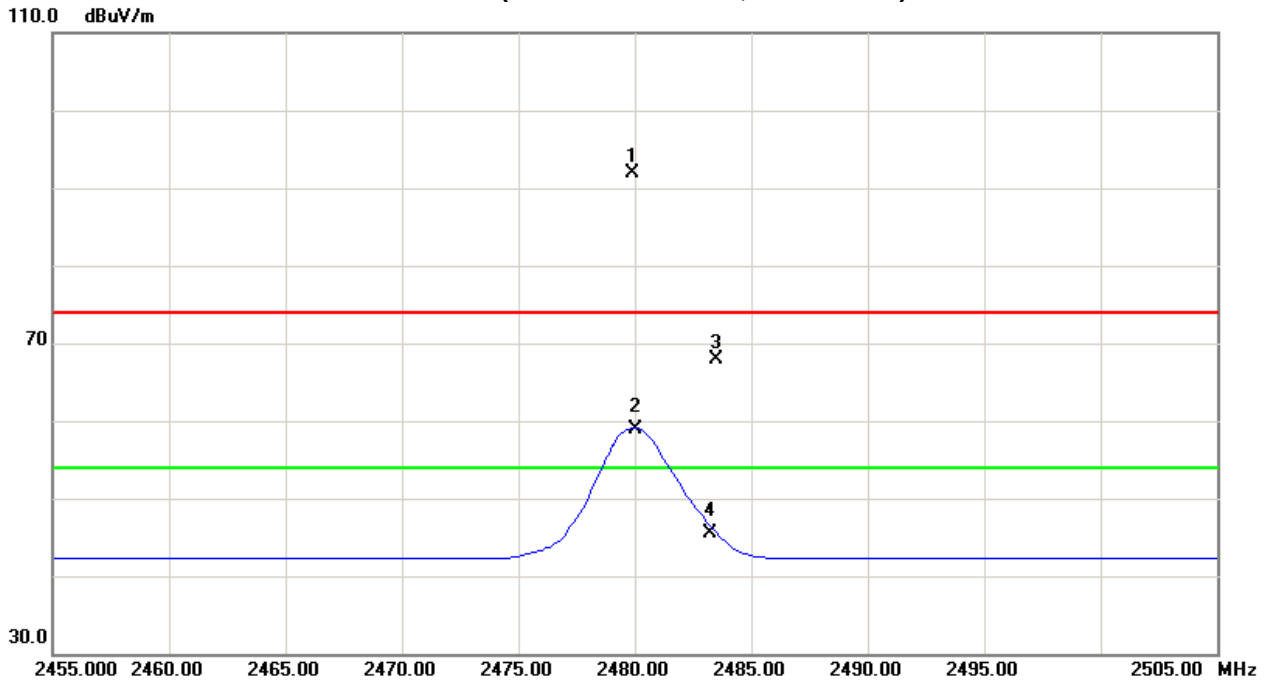



EUT :	Bluetooth Module	Model Name :	BC05 ROM
Temperature :	24 °C	Relative Humidity :	58 %
Pressure :	1010 hPa	Test Voltage :	AC120V/60Hz
Test Mode :	TX 2402MHz – CH 00-3Mbps		

Freq. (MHz)	Ant.Pol. H/V	Reading		Ant./CF CF(dB)	Act.		Limit		Margin		Note
		Peak (dBuV)	AV (dBuV)		Peak (dBuV/m)	AV (dBuV/m)	Peak (dBuV/m)	AV (dBuV/m)	Peak (dBuV/m)	AV (dBuV/m)	
2390.00	V	22.91	10.42	31.91	54.82	42.33	74.00	54.00	-19.18	-11.67	X/E
2402.13	V	56.42	24.97	31.90	88.32	56.87					X/F
4804.23	V	43.38	31.38	5.21	48.59	36.59	74.00	54.00	-25.41	-17.41	X/H

Remark :

- (1) All readings are Peak unless otherwise stated QP in column of 『Note』 . Peak denotes that the Peak reading compliance with the QP Limits and then QP Mode measurement didn't perform.
- (2) Measuring frequency range from 30MHz to 1000MHz or the 10th harmonic of highest fundamental frequency. "F" denotes fundamental frequency; "H" denotes spurious frequency. "E" denotes band edge frequency. (This judgment method includes the Band Edge Requirement.)
- (3) Radiated emissions measured in frequency range above 1000MHz were made with an instrument using Peak detector mode and AV detector mode of the emission .
- (4) Data of measurement within this frequency range shown " * " in the table above means the reading of emissions are attenuated more than 20dB below the permissible limits or the field strength is too small to be measured.
- (5) A preamp and high pass filter were used for this test in order to provide sufficient measurement sensitivity.
- (6) EUT Orthogonal Axis :
"X" - denotes Laid on Table ; "Y" - denotes Vertical Stand ; "Z" - denotes Side Stand
- (7) During the measurements above 1 GHz it is taken care of that the EUT is always within the 3 dB cone of radiation BW of the used antenna



TX CH00(Above 1000 MHz, Vertical)

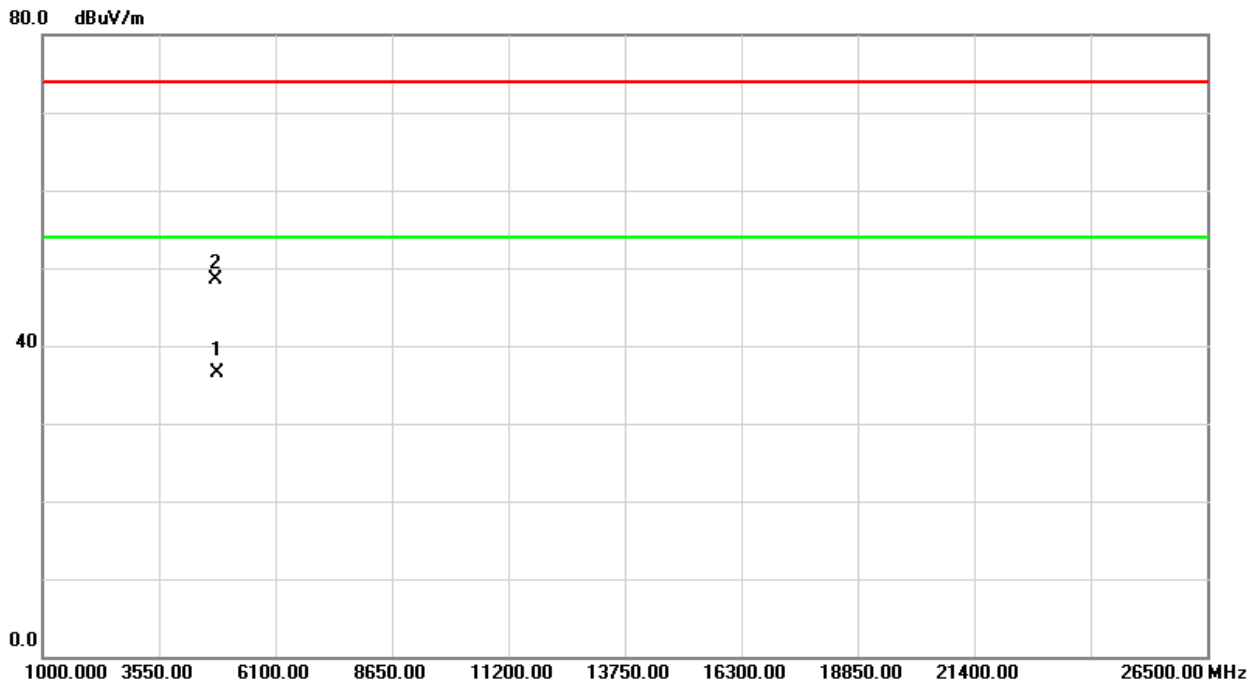
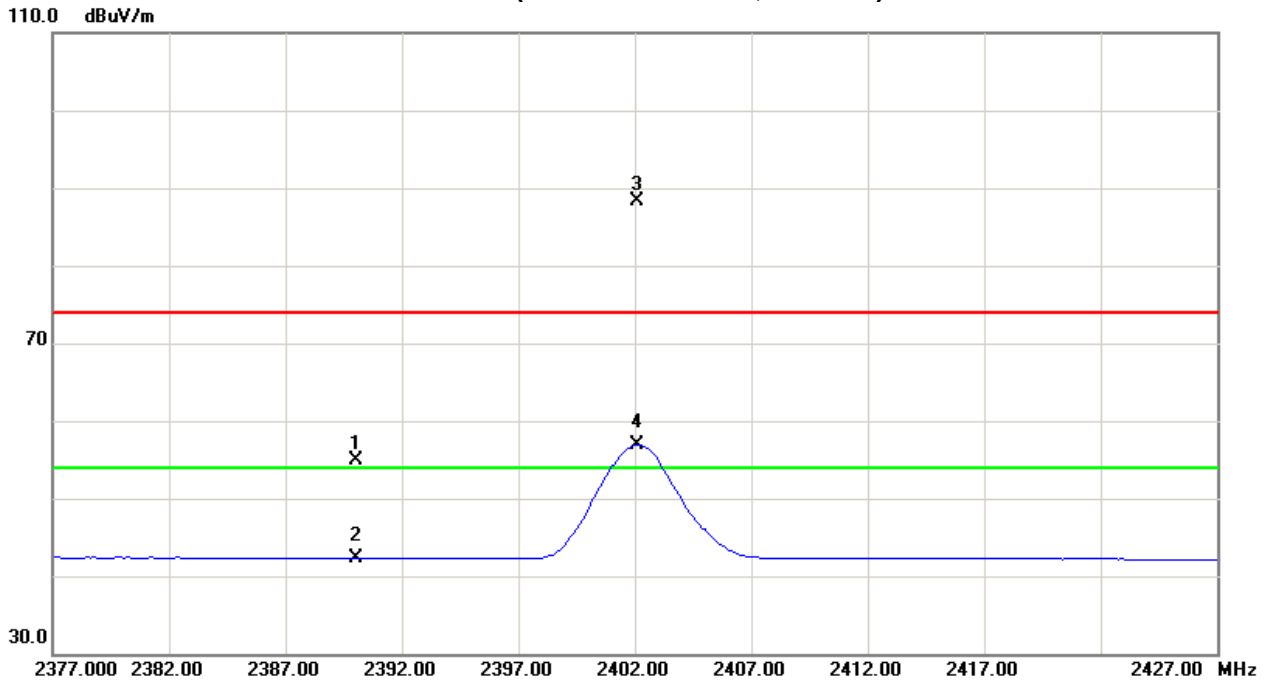



EUT :	Bluetooth Module	Model Name :	BC05 ROM
Temperature :	24 °C	Relative Humidity :	58 %
Pressure :	1010hPa	Test Voltage :	AC120V/60Hz
Test Mode :	TX 2402MHz – CH 00-3Mbps		

Freq. (MHz)	Ant.Pol. H/V	Reading		Ant./CF CF(dB)	Act.		Limit		Margin		Note
		Peak (dBuV)	AV (dBuV)		Peak (dBuV/m)	AV (dBuV/m)	Peak (dBuV/m)	AV (dBuV/m)	Peak (dBuV/m)	AV (dBuV/m)	
2390.00	H	22.11	10.41	31.91	54.02	42.32	74.00	54.00	-19.98	-11.68	X/E
2402.00	H	59.46	26.10	31.90	91.36	58.00					X/F
4804.14	H	42.14	30.16	5.21	47.35	35.37	74.00	54.00	-26.65	-18.63	X/H

Remark :

- (1) All readings are Peak unless otherwise stated QP in column of 『Note』 . Peak denotes that the Peak reading compliance with the QP Limits and then QP Mode measurement didn't perform.
- (2) Measuring frequency range from 30MHz to 1000MHz or the 10th harmonic of highest fundamental frequency. "F" denotes fundamental frequency; "H" denotes spurious frequency. "E" denotes band edge frequency. (This judgment method includes the Band Edge Requirement.)
- (3) Radiated emissions measured in frequency range above 1000MHz were made with an instrument using Peak detector mode and AV detector mode of the emission .
- (4) Data of measurement within this frequency range shown " * " in the table above means the reading of emissions are attenuated more than 20dB below the permissible limits or the field strength is too small to be measured.
- (5) A preamp and high pass filter were used for this test in order to provide sufficient measurement sensitivity.
- (6) EUT Orthogonal Axis :
"X" - denotes Laid on Table ; "Y" - denotes Vertical Stand ; "Z" - denotes Side Stand
- (7) During the measurements above 1 GHz it is taken care of that the EUT is always within the 3 dB cone of radiation BW of the used antenna



TX CH00(Above 1000 MHz, Horizontal)

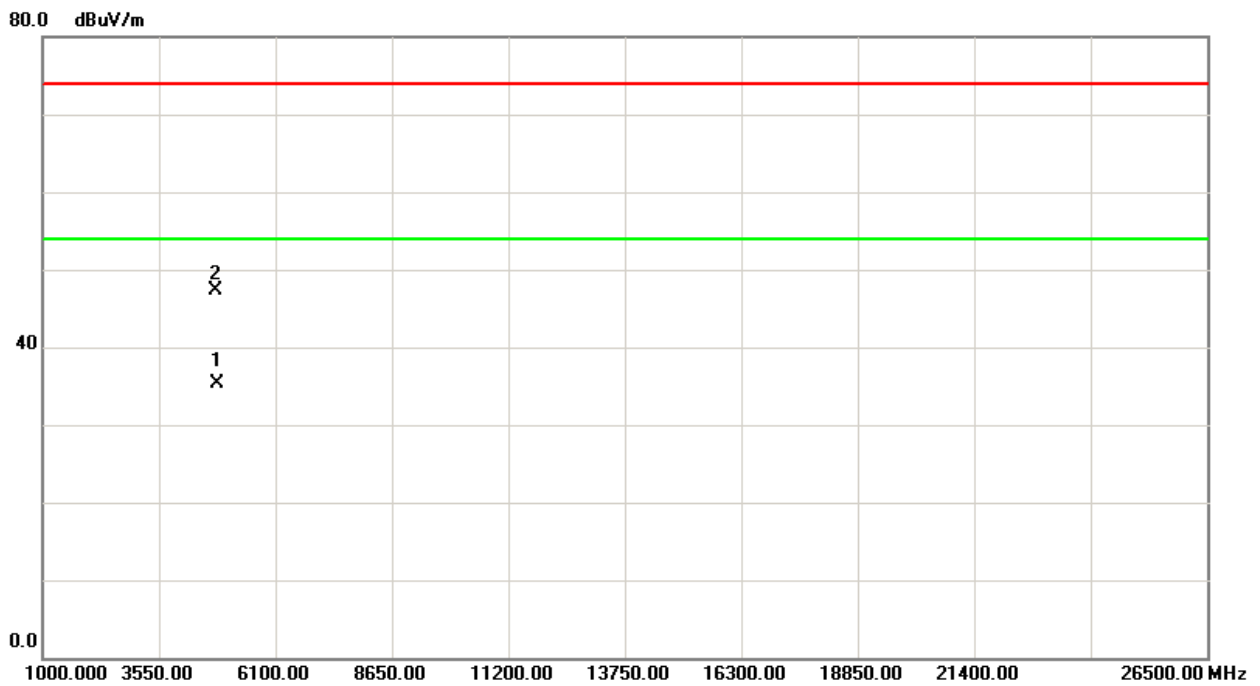
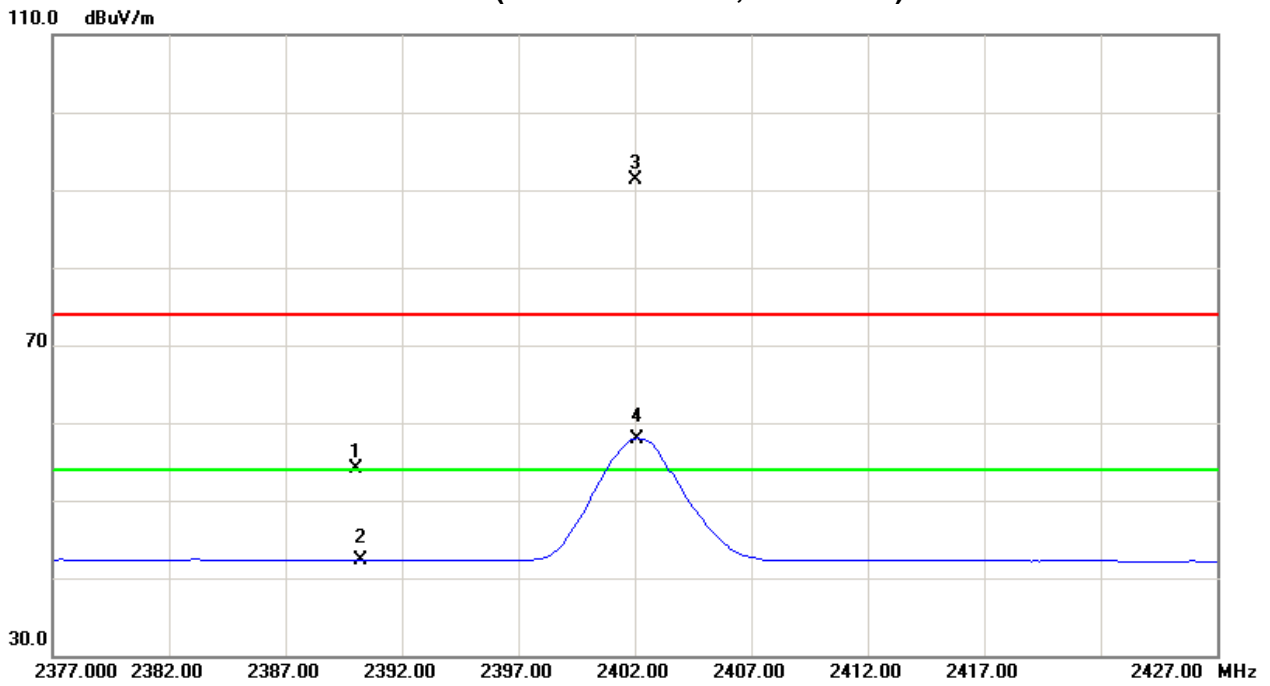



EUT :	Bluetooth Module	Model Name :	BC05 ROM
Temperature :	24 °C	Relative Humidity :	58 %
Pressure :	1010 hPa	Test Voltage :	AC120V/60Hz
Test Mode :	TX 2441MHz –CH39-3Mbps		

Freq.	Ant.Pol.	Reading		Ant./CF	Act.		Limit		Margin		Note
		Peak	AV		Peak	AV	Peak	AV	Peak	AV	
(MHz)	H/V	(dBuV)	(dBuV)	CF(dB)	(dBuV/m)	(dBuV/m)	(dBuV/m)	(dBuV/m)	(dBuV/m)	(dBuV/m)	
2441.00	V	58.74	25.82	31.85	90.59	57.67					X/F
4882.12	V	46.03	31.24	5.50	51.53	36.74	74.00	54.00	-22.47	-17.26	X/H

Remark :

- (1) All readings are Peak unless otherwise stated QP in column of 『Note』 . Peak denotes that the Peak reading compliance with the QP Limits and then QP Mode measurement didn't perform.
- (2) Measuring frequency range from 30MHz to 1000MHz or the 10th harmonic of highest fundamental frequency. "F" denotes fundamental frequency; "H" denotes spurious frequency. "E" denotes band edge frequency. (This judgment method includes the Band Edge Requirement.)
- (3) Radiated emissions measured in frequency range above 1000MHz were made with an instrument using Peak detector mode and AV detector mode of the emission .
- (4) Data of measurement within this frequency range shown " * " in the table above means the reading of emissions are attenuated more than 20dB below the permissible limits or the field strength is too small to be measured.
- (5) A preamp and high pass filter were used for this test in order to provide sufficient measurement sensitivity.
- (6) EUT Orthogonal Axis :
 "X" - denotes Laid on Table ; "Y" - denotes Vertical Stand ; "Z" - denotes Side Stand
- (7) During the measurements above 1 GHz it is taken care of that the EUT is always within the 3 dB cone of radiation BW of the used antenna



TX CH39 (Above 1000 MHz, Vertical)

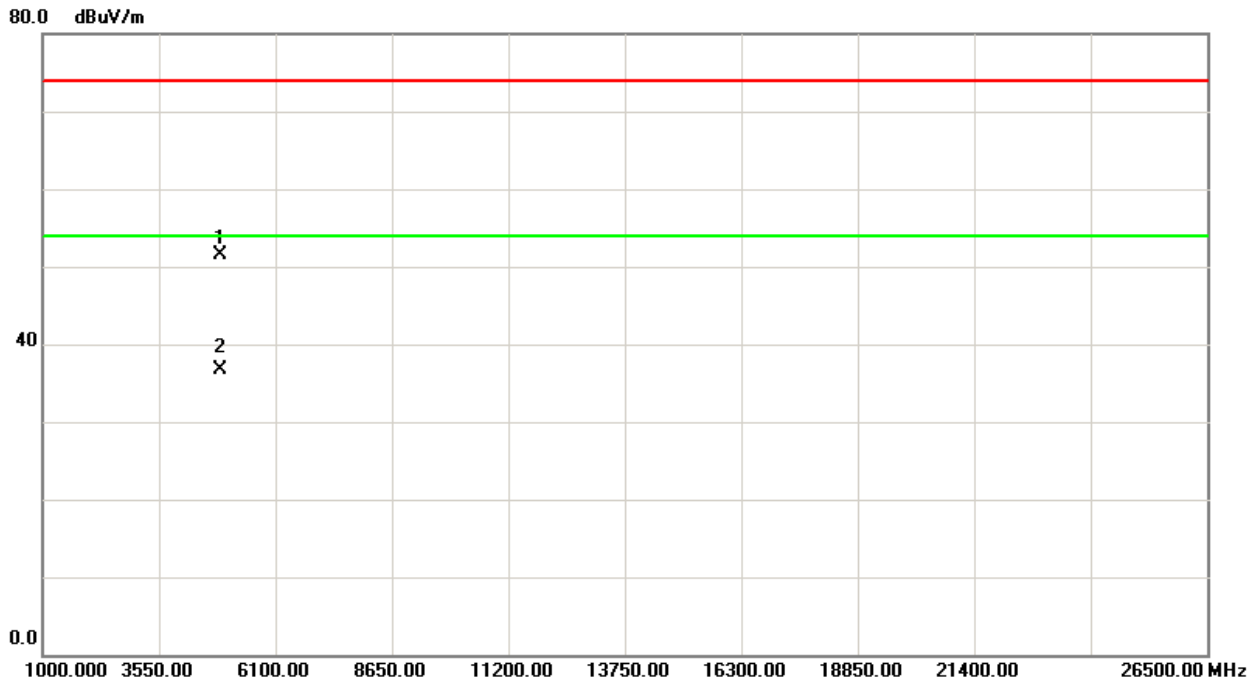
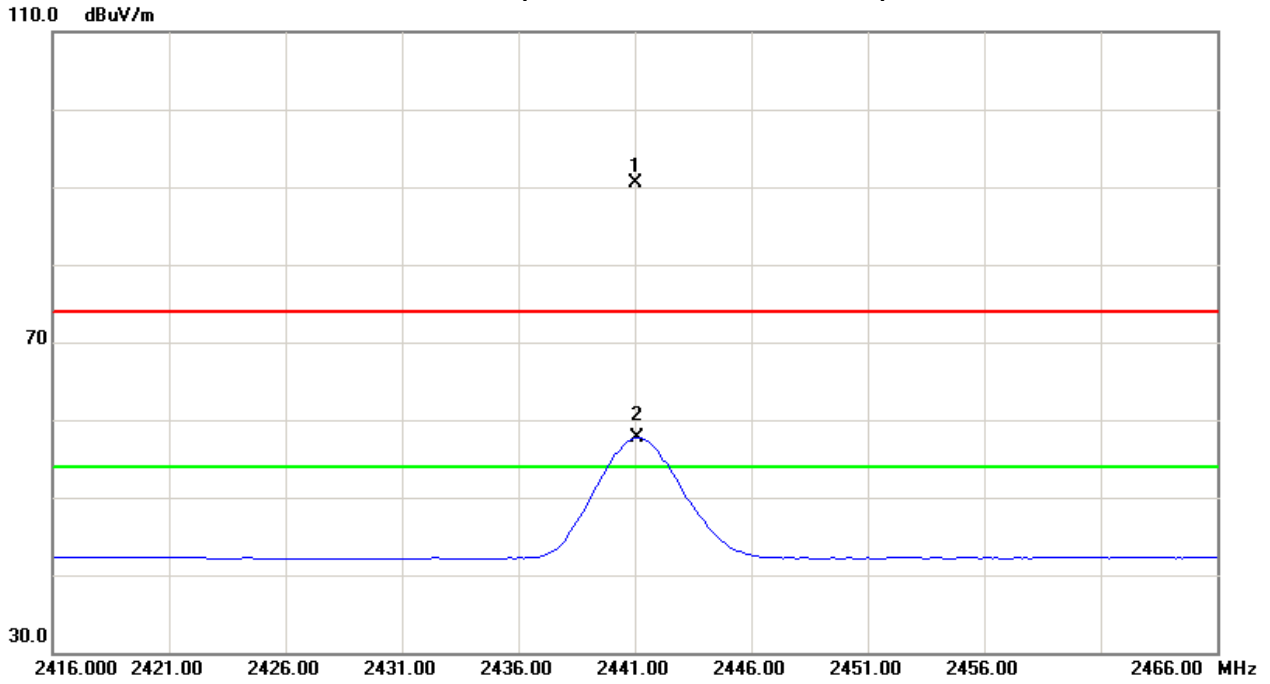



EUT :	Bluetooth Module	Model Name :	BC05 ROM
Temperature :	24 °C	Relative Humidity :	58 %
Pressure :	1010 hPa	Test Voltage :	AC120V/60Hz
Test Mode :	TX 2441MHz –CH39-3Mbps		

Freq.	Ant.Pol.	Reading		Ant./CF	Act.		Limit		Margin		Note
		Peak	AV		Peak	AV	Peak	AV	Peak	AV	
(MHz)	H/V	(dBuV)	(dBuV)	CF(dB)	(dBuV/m)	(dBuV/m)	(dBuV/m)	(dBuV/m)	(dBuV/m)	(dBuV/m)	
2441.00	H	59.75	26.17	31.85	91.60	58.02					X/F
4882.20	H	42.21	30.04	5.50	47.71	35.54	74.00	54.00	-26.29	-18.46	X/H

Remark :

- (1) All readings are Peak unless otherwise stated QP in column of 『Note』 . Peak denotes that the Peak reading compliance with the QP Limits and then QP Mode measurement didn't perform.
- (2) Measuring frequency range from 30MHz to 1000MHz or the 10th harmonic of highest fundamental frequency. "F" denotes fundamental frequency; "H" denotes spurious frequency. "E" denotes band edge frequency. (This judgment method includes the Band Edge Requirement.)
- (3) Radiated emissions measured in frequency range above 1000MHz were made with an instrument using Peak detector mode and AV detector mode of the emission .
- (4) Data of measurement within this frequency range shown " * " in the table above means the reading of emissions are attenuated more than 20dB below the permissible limits or the field strength is too small to be measured.
- (5) A preamp and high pass filter were used for this test in order to provide sufficient measurement sensitivity.
- (6) EUT Orthogonal Axis :
 "X" - denotes Laid on Table ; "Y" - denotes Vertical Stand ; "Z" - denotes Side Stand
- (7) During the measurements above 1 GHz it is taken care of that the EUT is always within the 3 dB cone of radiation BW of the used antenna



TX CH39 (Above 1000 MHz, Horizontal)

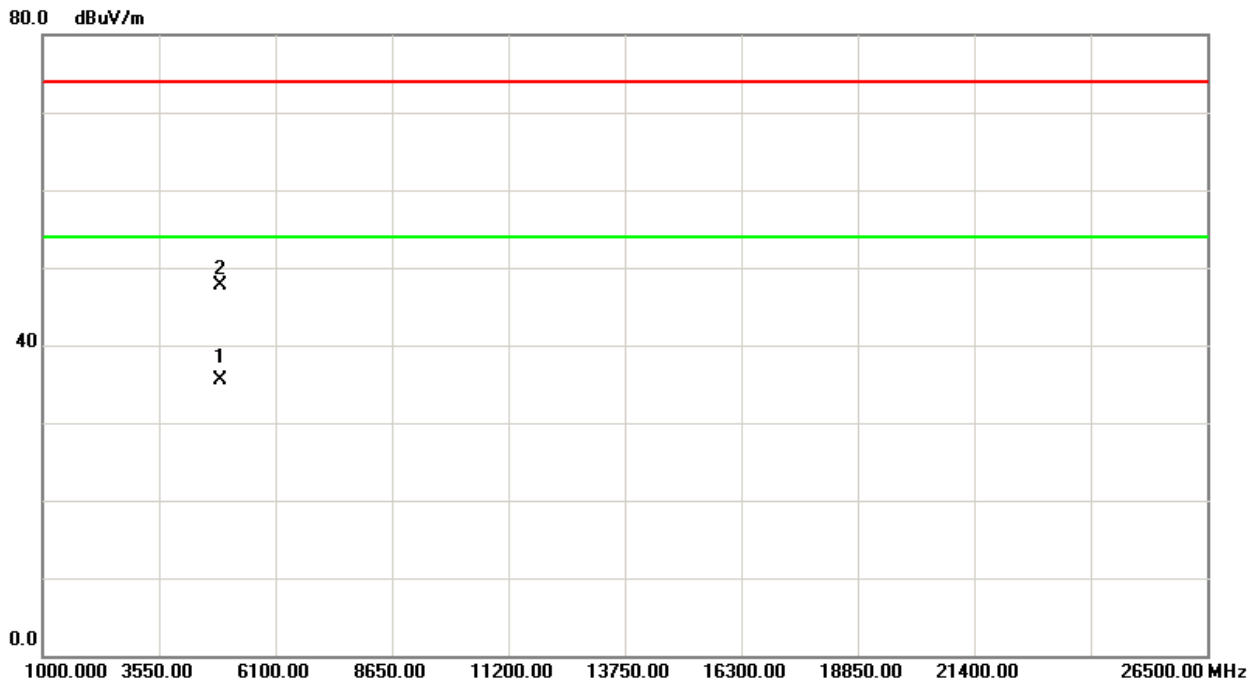
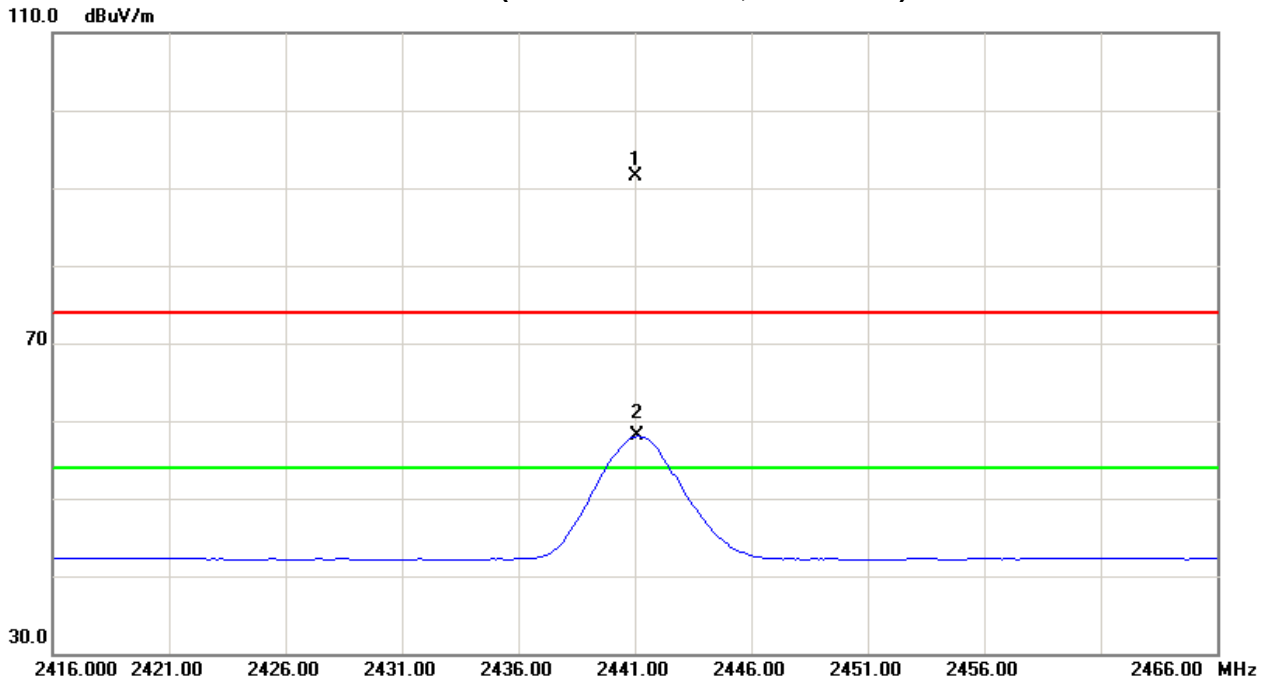



EUT :	Bluetooth Module	Model Name :	BC05 ROM
Temperature :	24 °C	Relative Humidity :	58 %
Pressure :	1010hPa	Test Voltage :	AC120V/60Hz
Test Mode :	TX 2480MHz –CH78-3Mbps		

Freq. (MHz)	Ant.Pol. H/V	Reading		Ant./CF CF(dB)	Act.		Limit		Margin		Note
		Peak (dBuV)	AV (dBuV)		Peak (dBuV/m)	AV (dBuV/m)	Peak (dBuV/m)	AV (dBuV/m)	Peak (dBuV/m)	AV (dBuV/m)	
2480.00	V	57.41	25.98	31.80	89.21	57.78					X/F
2483.50	V	25.42	12.90	31.80	57.22	44.70	74.00	54.00	-16.78	-9.30	X/E
4960.30	V	44.25	29.94	5.78	50.03	35.72	74.00	54.00	-23.97	-18.28	X/H

Remark :

- (1) All readings are Peak unless otherwise stated QP in column of 『Note』 . Peak denotes that the Peak reading compliance with the QP Limits and then QP Mode measurement didn't perform.
- (2) Measuring frequency range from 30MHz to 1000MHz or the 10th harmonic of highest fundamental frequency. "F" denotes fundamental frequency; "H" denotes spurious frequency. "E" denotes band edge frequency. (This judgment method includes the Band Edge Requirement.)
- (3) Radiated emissions measured in frequency range above 1000MHz were made with an instrument using Peak detector mode and AV detector mode of the emission .
- (4) Data of measurement within this frequency range shown " * " in the table above means the reading of emissions are attenuated more than 20dB below the permissible limits or the field strength is too small to be measured.
- (5) A preamp and high pass filter were used for this test in order to provide sufficient measurement sensitivity.
- (6) EUT Orthogonal Axis :
"X" - denotes Laid on Table ; "Y" - denotes Vertical Stand ; "Z" - denotes Side Stand
- (7) During the measurements above 1 GHz it is taken care of that the EUT is always within the 3 dB cone of radiation BW of the used antenna



TX CH78 (Above 1000 MHz, Vertical)

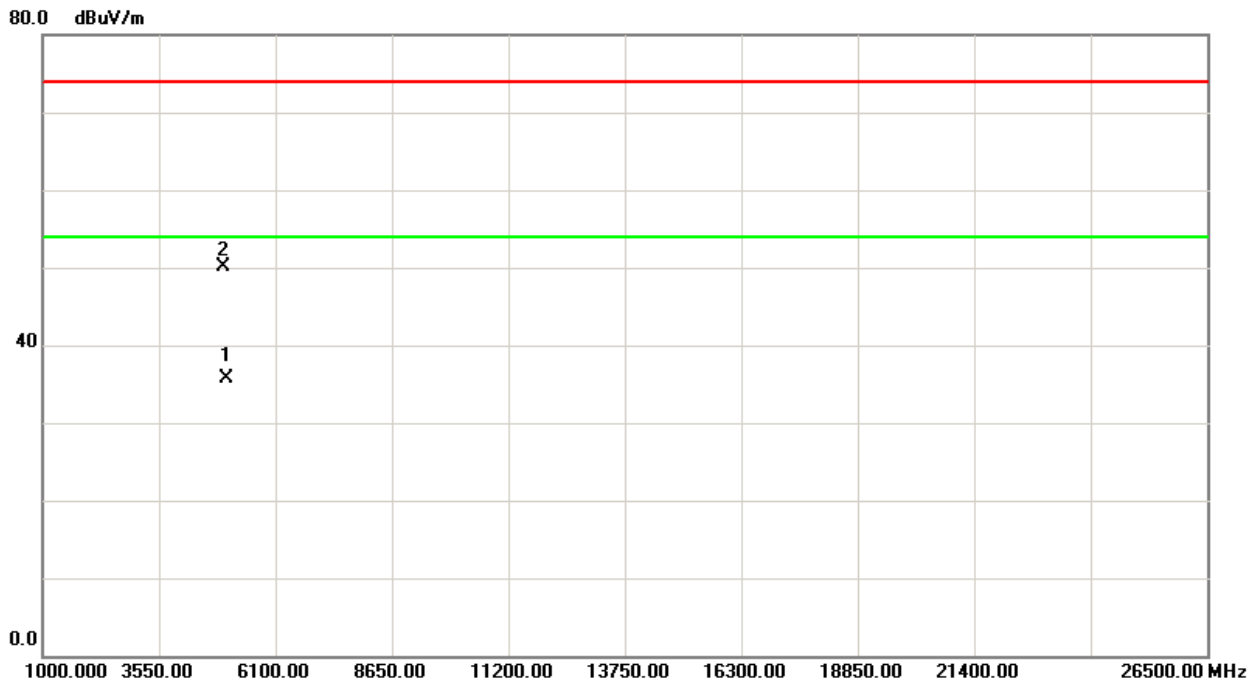
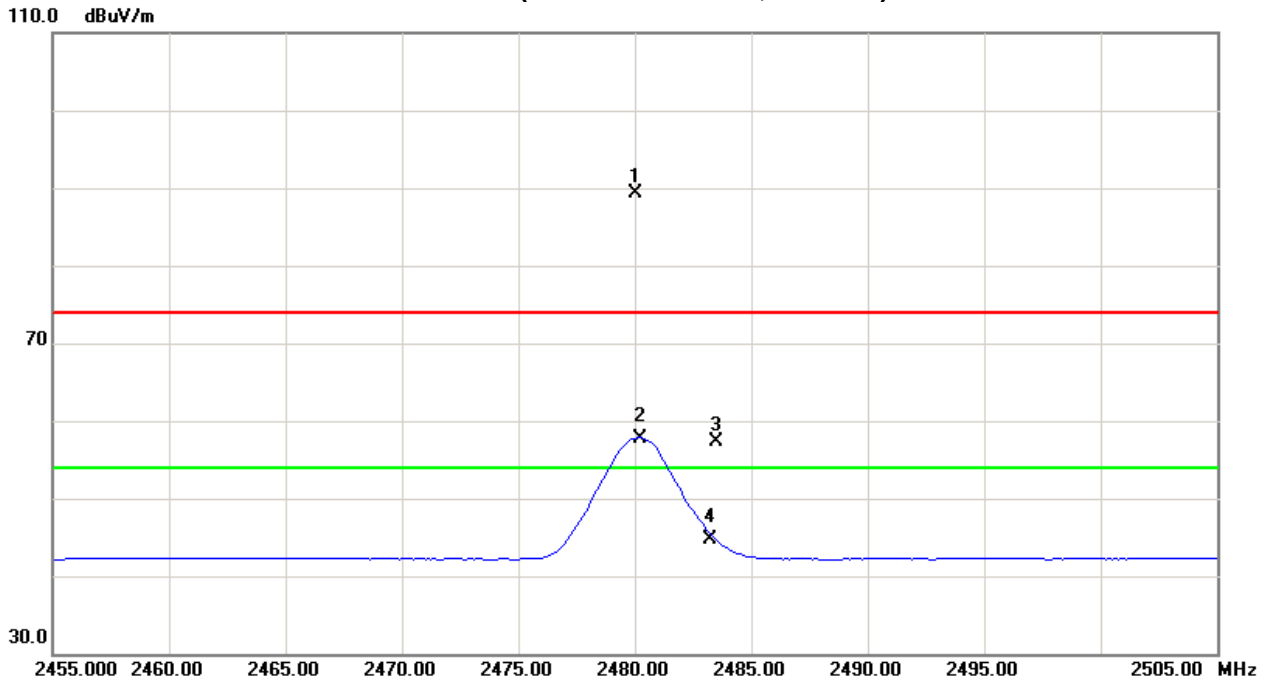



EUT :	Bluetooth Module	Model Name :	BC05 ROM
Temperature :	24 °C	Relative Humidity :	58 %
Pressure :	1010 hPa	Test Voltage :	AC120V/60Hz
Test Mode :	TX 2480MHz –CH78-3Mbps		

Freq.	Ant.Pol.	Reading		Ant./CF	Act.		Limit		Margin		Note
		Peak	AV		Peak	AV	Peak	AV	Peak	AV	
(MHz)	H/V	(dBuV)	(dBuV)	CF(dB)	(dBuV/m)	(dBuV/m)	(dBuV/m)	(dBuV/m)	(dBuV/m)	(dBuV/m)	
2480.13	H	56.46	25.62	31.80	88.26	57.42					X/F
2483.50	H	28.67	12.61	31.80	60.47	44.41	74.00	54.00	-13.53	-9.59	X/E
4960.13	H	43.15	28.86	5.78	48.93	34.64	74.00	54.00	-25.07	-19.36	X/H

Remark :

- (1) All readings are Peak unless otherwise stated QP in column of 『Note』 . Peak denotes that the Peak reading compliance with the QP Limits and then QP Mode measurement didn't perform.
- (2) Measuring frequency range from 30MHz to 1000MHz or the 10th harmonic of highest fundamental frequency. "F" denotes fundamental frequency; "H" denotes spurious frequency. "E" denotes band edge frequency. (This judgment method includes the Band Edge Requirement.)
- (3) Radiated emissions measured in frequency range above 1000MHz were made with an instrument using Peak detector mode and AV detector mode of the emission .
- (4) Data of measurement within this frequency range shown " * " in the table above means the reading of emissions are attenuated more than 20dB below the permissible limits or the field strength is too small to be measured.
- (5) A preamp and high pass filter were used for this test in order to provide sufficient measurement sensitivity.
- (6) EUT Orthogonal Axis :
"X" - denotes Laid on Table ; "Y" - denotes Vertical Stand ; "Z" - denotes Side Stand
- (7) During the measurements above 1 GHz it is taken care of that the EUT is always within the 3 dB cone of radiation BW of the used antenna



TX CH78 (Above 1000 MHz, Horizontal)

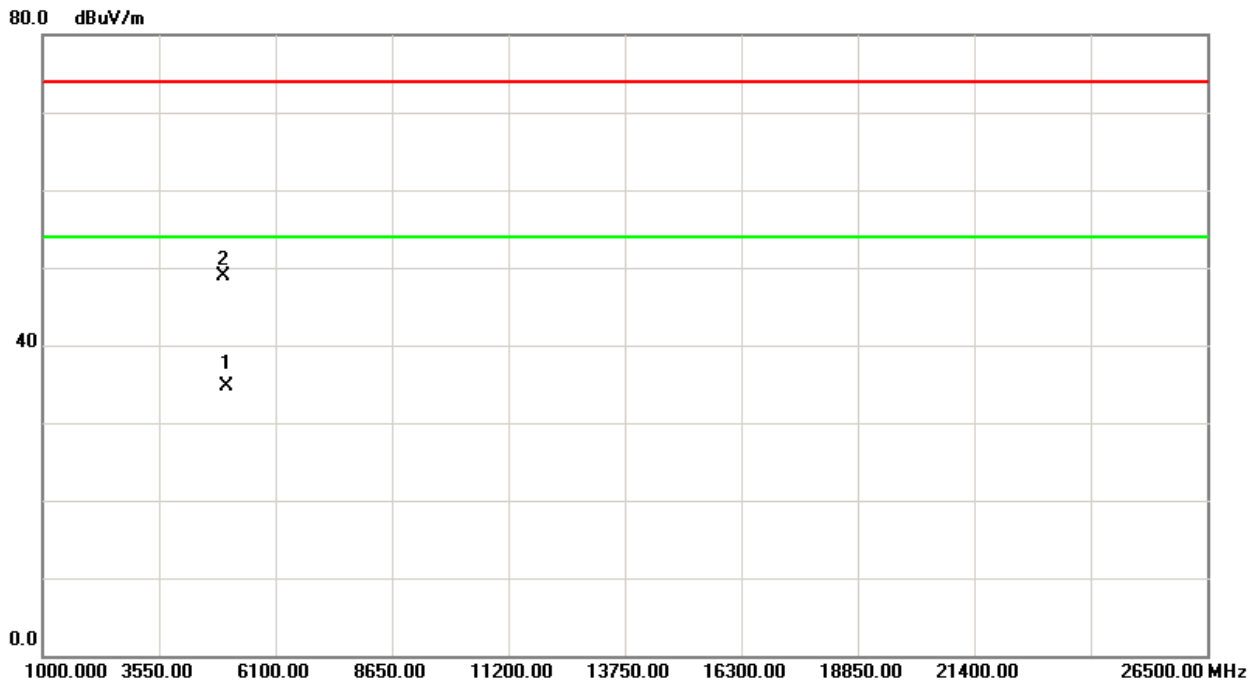
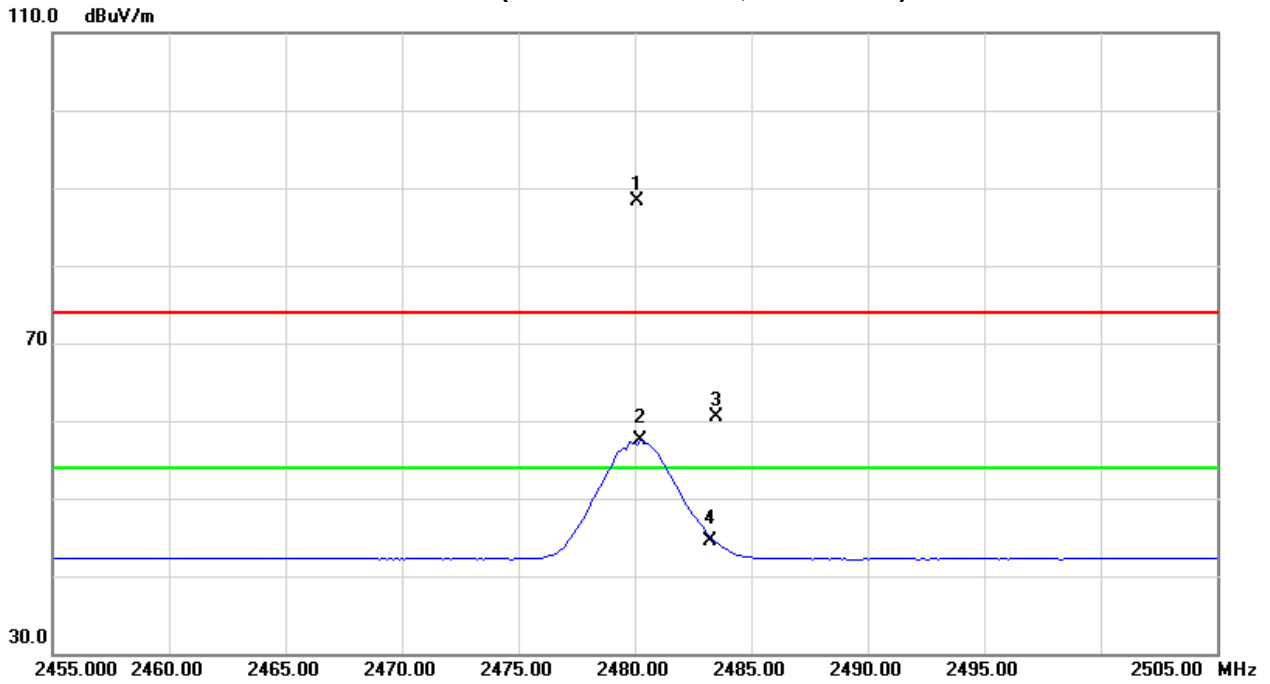



5. NUMBER OF HOPPING CHANNEL

5.1 APPLIED PROCEDURES / LIMIT

FCC Part15 (15.247) , Subpart C			
Section	Test Item	Frequency Range (MHz)	Result
15.247 (a)(1)(iii)	Number of Hopping Channel	2400-2483.5	PASS

5.1.1 MEASUREMENT INSTRUMENTS LIST AND SETTING

Item	Kind of Equipment	Manufacturer	Type No.	Serial No.	Calibrated until
1	Spectrum Analyzer	R&S	FSP 40	100185	Nov. 16.2013

Remark: "N/A" denotes no model name, serial no. or calibration specified.
All calibration period of Equipment List is One Year.

Spectrum Parameters	Setting
Attenuation	Auto
Span Frequency	> Operating Frequency Range
RB	100 kHz
VB	100 kHz
Detector	Peak
Trace	Max Hold
Sweep Time	Auto

5.1.2 TEST PROCEDURE

- a. The EUT was directly connected to the spectrum analyzer and antenna output port as show in the block diagram below,
- b. Spectrum Setting : RBW= 100KHz, VBW=100KHz, Sweep time = Auto.

5.1.3 DEVIATION FROM STANDARD

No deviation.

5.1.4 TEST SETUP

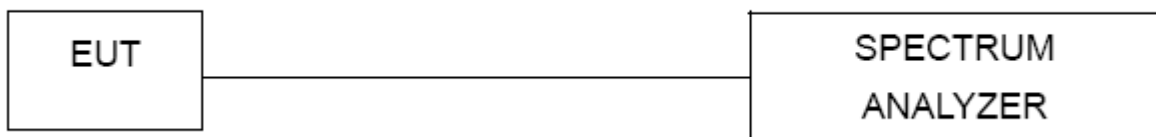

5.1.5 EUT OPERATION CONDITIONS

The EUT tested system was configured as the statements of 4.1.6 Unless otherwise a special operating condition is specified in the follows during the testing.



5.1.6 TEST RESULTS

EUT :	Bluetooth Module	Model Name :	BC05 ROM
Temperature :	24 °C	Relative Humidity :	58 %
Pressure :	1009 hPa	Test Voltage :	AC120V/60Hz
Test Mode :	Hopping Mode -1Mbps		

Number of Hopping Channel	79
---------------------------	----

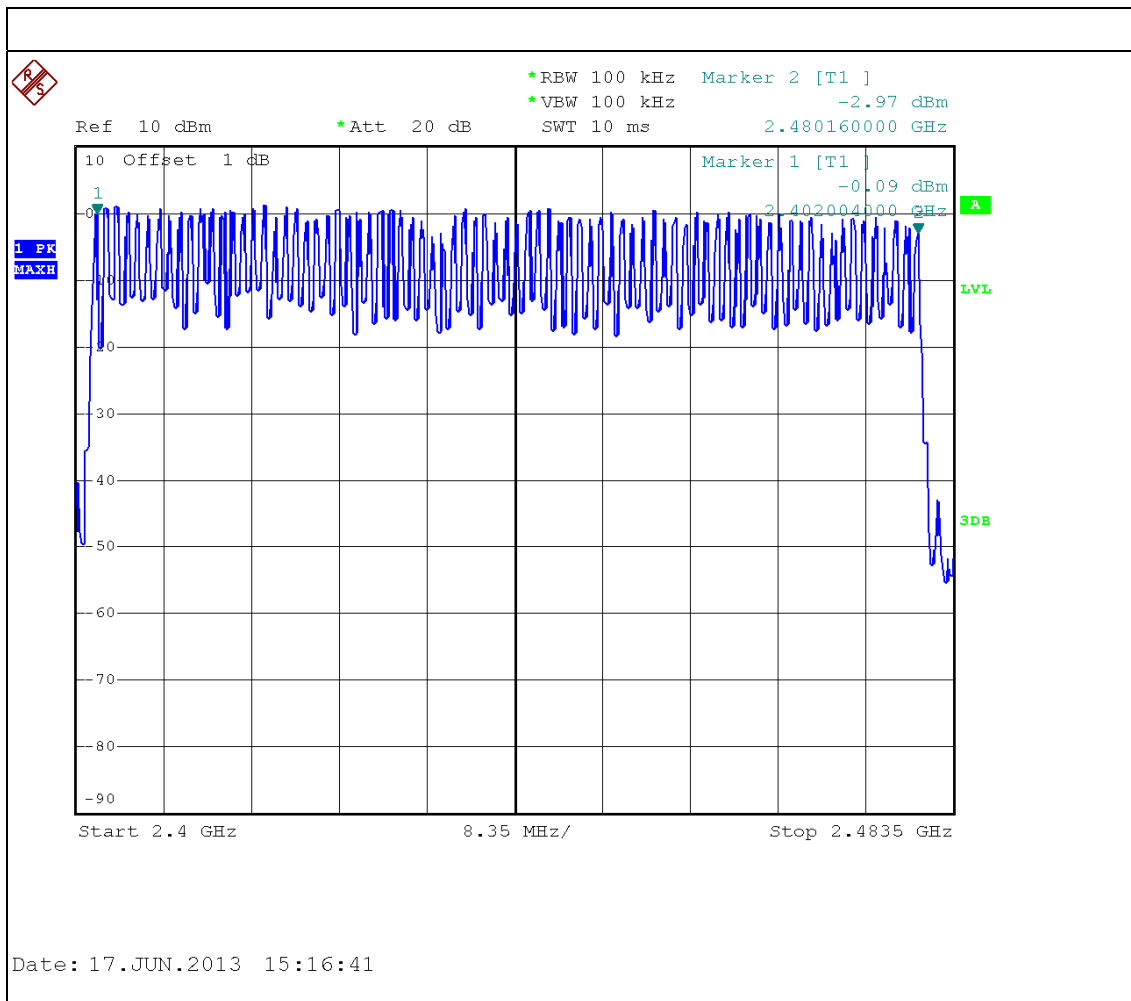



EUT :	Bluetooth Module	Model Name :	BC05 ROM
Temperature :	24 °C	Relative Humidity :	58 %
Pressure :	1009 hPa	Test Voltage :	AC120V/60Hz
Test Mode :	Hopping Mode -3Mbps		

Number of Hopping Channel	79
---------------------------	----

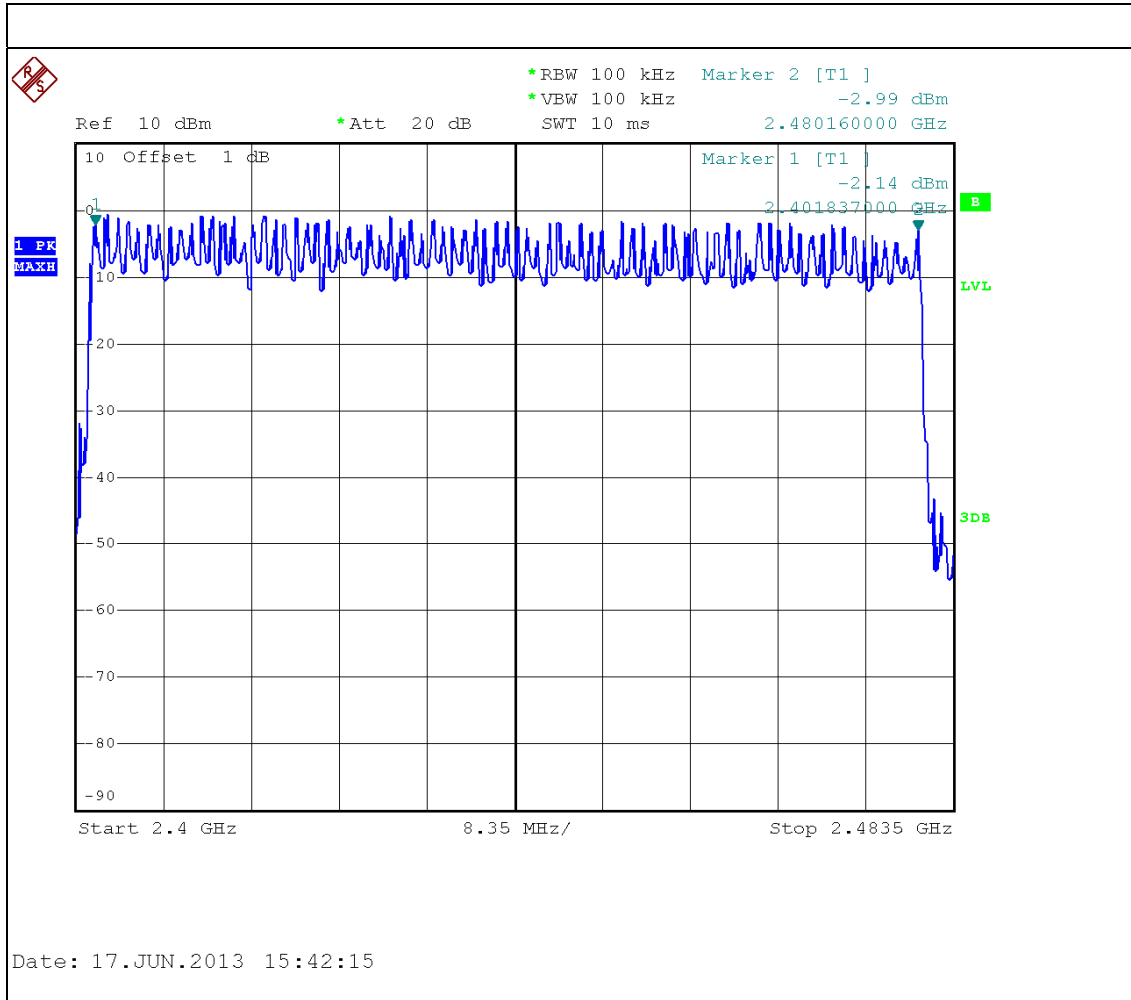



6. AVERAGE TIME OF OCCUPANCY

6.1 APPLIED PROCEDURES / LIMIT

FCC Part15 (15.247) , Subpart C				
Section	Test Item	Limit	Frequency Range (MHz)	Result
15.247 (a)(1)(iii)	Average Time of Occupancy	0.4sec	2400-2483.5	PASS

6.1.1 MEASUREMENT INSTRUMENTS LIST

Item	Kind of Equipment	Manufacturer	Type No.	Serial No.	Calibrated until
1	Spectrum Analyzer	R&S	FSP 40	100185	Nov. 16.2013

Remark: "N/A" denotes no model name, serial no. or calibration specified.

All calibration period of Equipment List is One Year.

6.1.2 TEST PROCEDURE

- a. The transmitter output (antenna port) was connected to the spectrum analyzer
- b. Set RBW of spectrum analyzer to 1MHz and VBW to 1MHz.
- c. Use a video trigger with the trigger level set to enable triggering only on full pulses.
- d. Sweep Time is more than once pulse time.
- e. Set the center frequency on any frequency would be measure and set the frequency span to zero span.
- f. Measure the maximum time duration of one single pulse.
- g. Set the EUT for DH5, DH3 and DH1 packet transmitting.
- h. Measure the maximum time duration of one single pulse.
- i. DH5 Packet permit maximum $1600 / 79 / 6 = 3.37$ hops per second in each channel (5 time slots TX, 1 time slot RX). So, the dwell time is the time duration of the pulse times $3.37 \times 31.6 = 106.6$ within 31.6 seconds.
- j. DH3 Packet permit maximum $1600 / 79 / 4 = 5.06$ hops per second in each channel (3 time slots TX, 1 time slot RX). So, the dwell time is the time duration of the pulse times $5.06 \times 31.6 = 160$ within 31.6 seconds.
- k. DH1 Packet permit maximum $1600 / 79 / 2 = 10.12$ hops per second in each channel (1 time slot RX, 1 time slot TX). So, the dwell time is the time duration of the pulse times $10.12 \times 31.6 = 320$ within 31.6 seconds.

6.1.3 DEVIATION FROM STANDARD

No deviation.



6.1.4 TEST SETUP

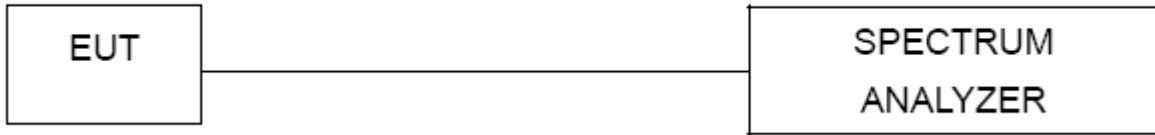

6.1.5 EUT OPERATION CONDITIONS

The EUT tested system was configured as the statements of 4.1.6 Unless otherwise a special operating condition is specified in the follows during the testing.



6.1.6 TEST RESULTS

EUT :	Bluetooth Module	Model Name :	BC05 ROM
Temperature :	24 °C	Relative Humidity :	58 %
Pressure :	1009 hPa	Test Voltage :	AC120V/60Hz
Test Mode :	CH00-DH1/DH3/DH5 -1Mbps		

Data Packet	Frequency	Pulse Duration (ms)	Dwell Time (s)	Limits (s)
DH5	2402 MHz	3.1200	0.3328	0.4000
DH3	2402 MHz	1.8300	0.2928	0.4000
DH1	2402 MHz	0.5400	0.1728	0.4000

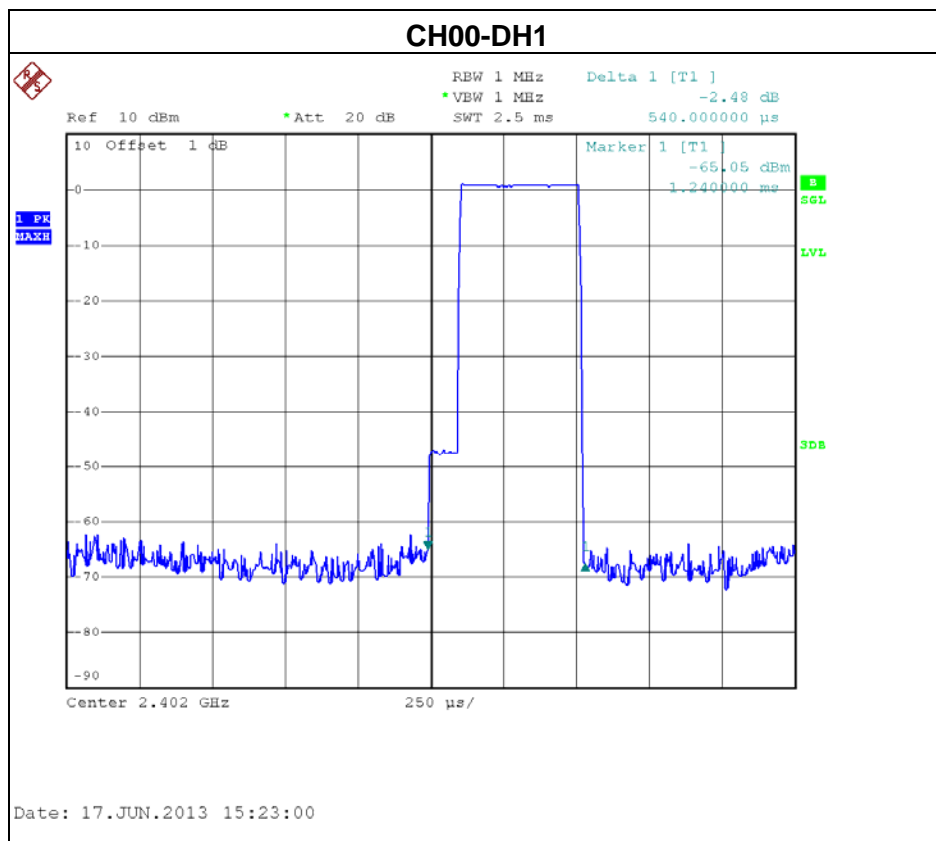

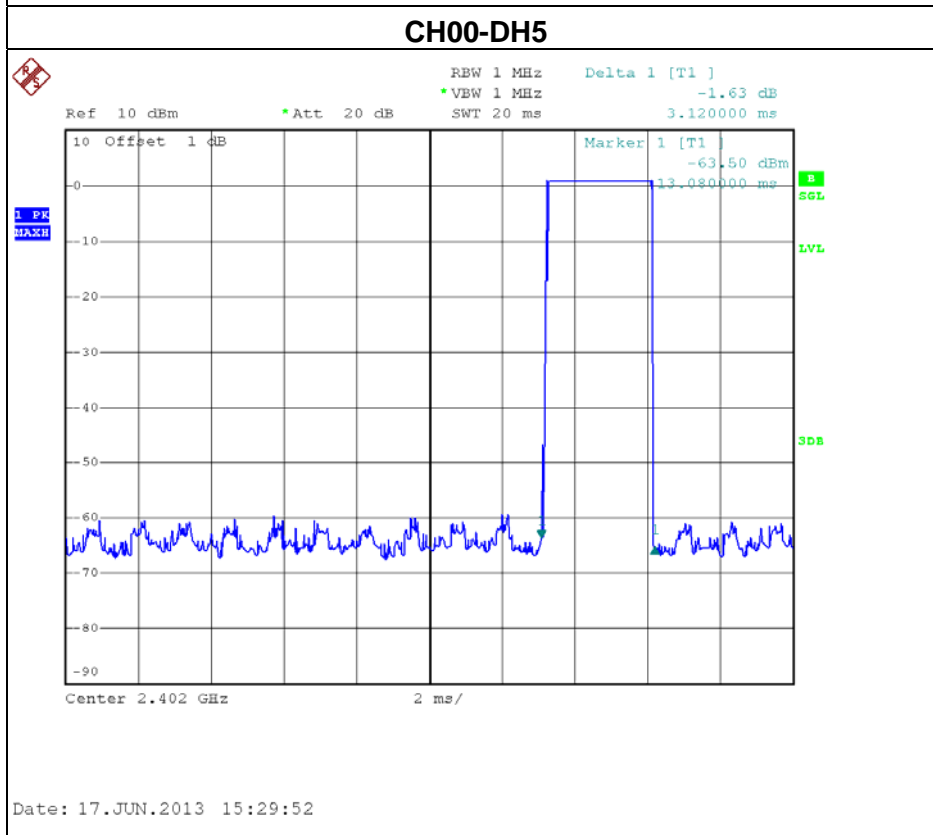
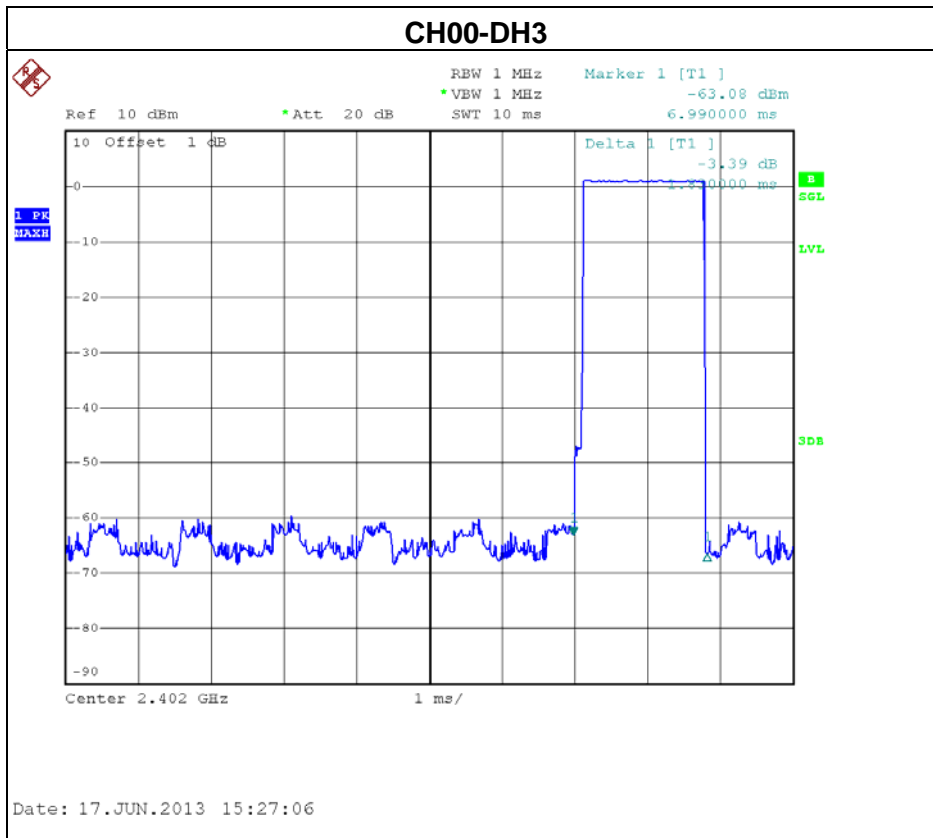



EUT :	Bluetooth Module	Model Name :	BC05 ROM
Temperature :	24 °C	Relative Humidity :	58 %
Pressure :	1009 hPa	Test Voltage :	AC120V/60Hz
Test Mode :	CH39 -DH1/DH3/DH5 -1Mbps		

Data Packet	Frequency	Pulse Duration (ms)	Dwell Time (s)	Limits (s)
DH5	2441 MHz	3.0800	0.3285	0.4000
DH3	2441 MHz	1.8400	0.2944	0.4000
DH1	2441 MHz	0.5400	0.1728	0.4000

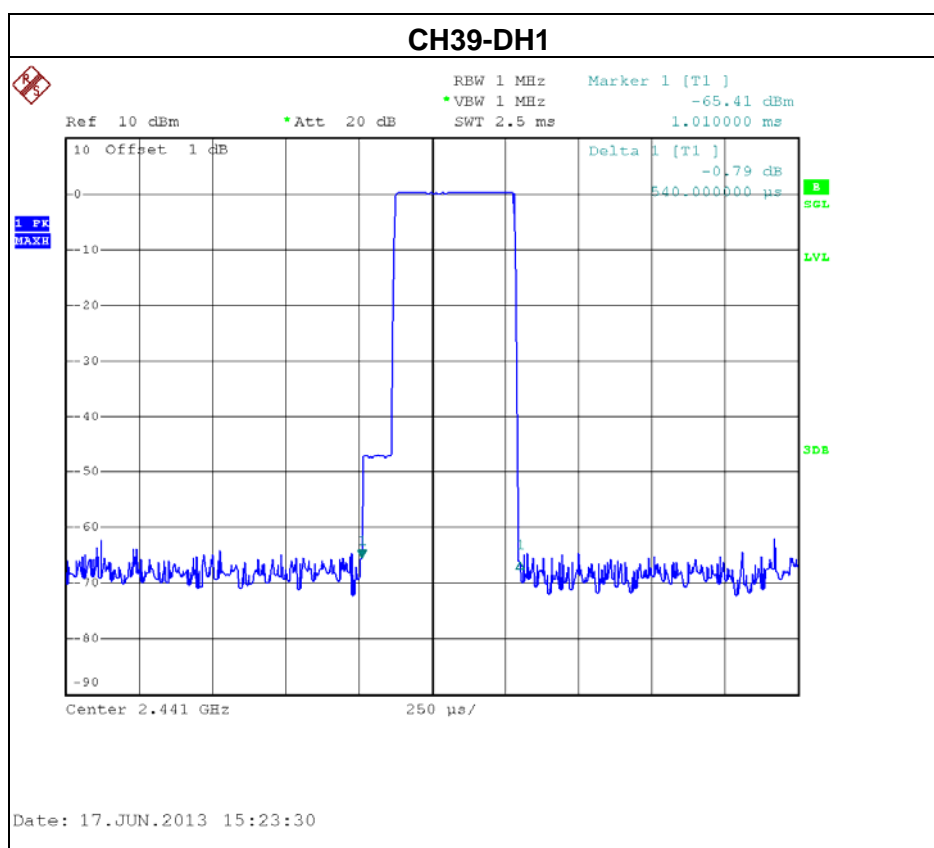

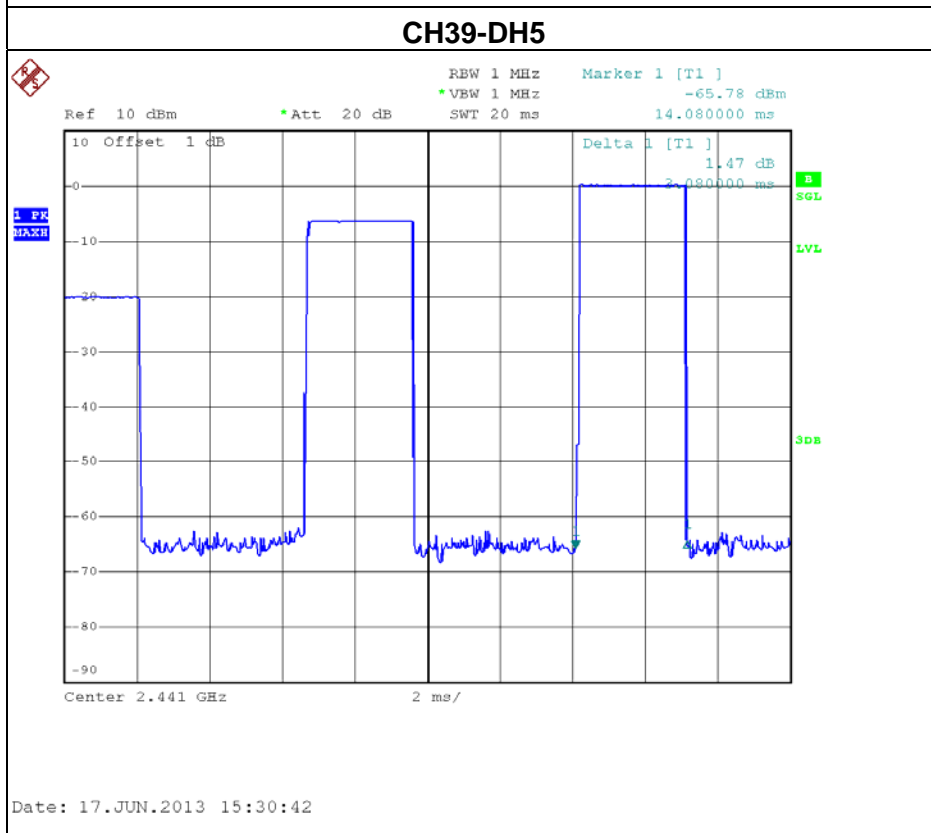
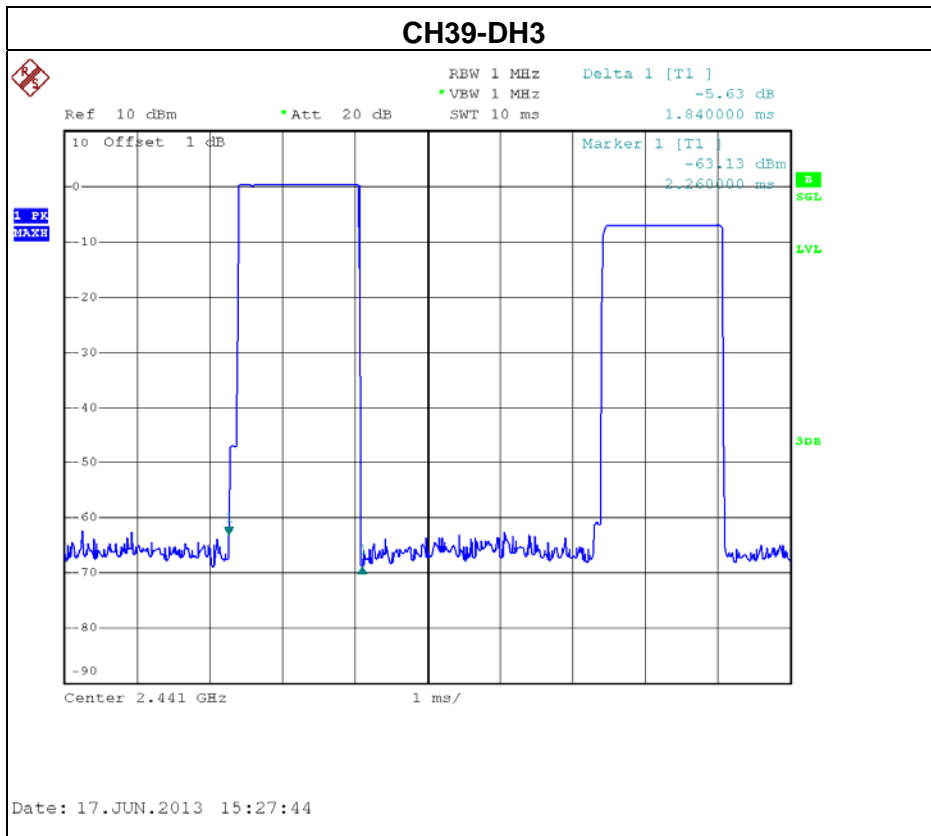



EUT :	Bluetooth Module	Model Name :	BC05 ROM
Temperature :	24 °C	Relative Humidity :	58 %
Pressure :	1009 hPa	Test Voltage :	AC120V/60Hz
Test Mode :	CH78 -DH1/DH3/DH5-1Mbps		

Data Packet	Frequency	Pulse Duration (ms)	Dwell Time (s)	Limits (s)
DH5	2480 MHz	3.1200	0.3328	0.4000
DH3	2480 MHz	1.8400	0.2944	0.4000
DH1	2480 MHz	0.5400	0.1728	0.4000

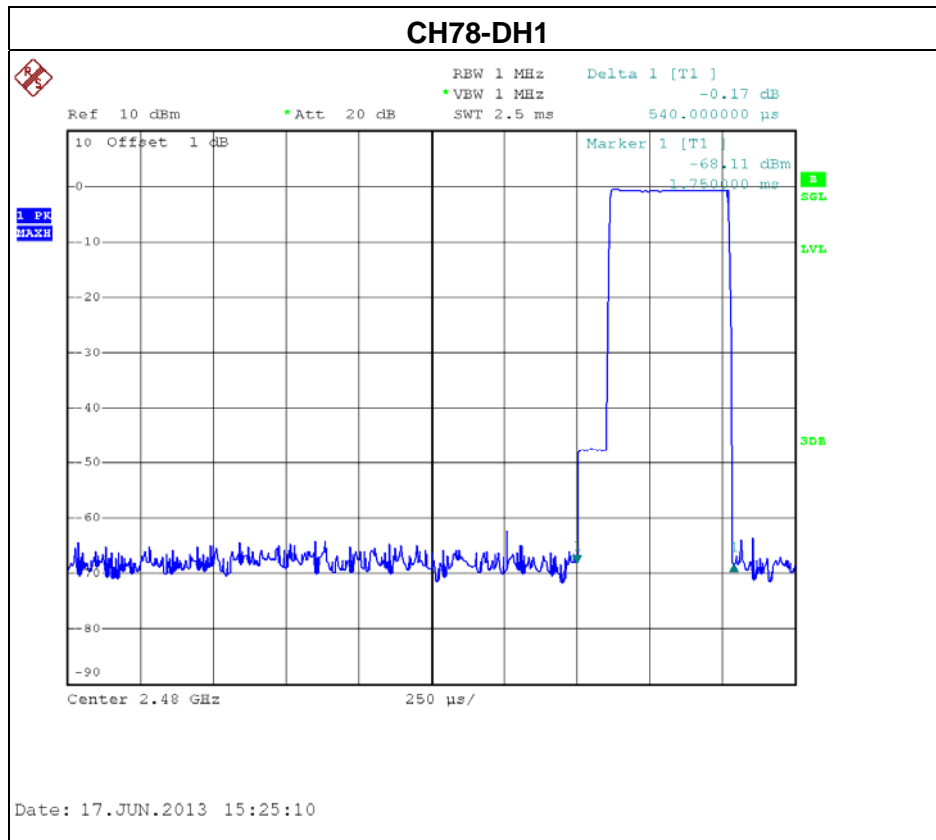

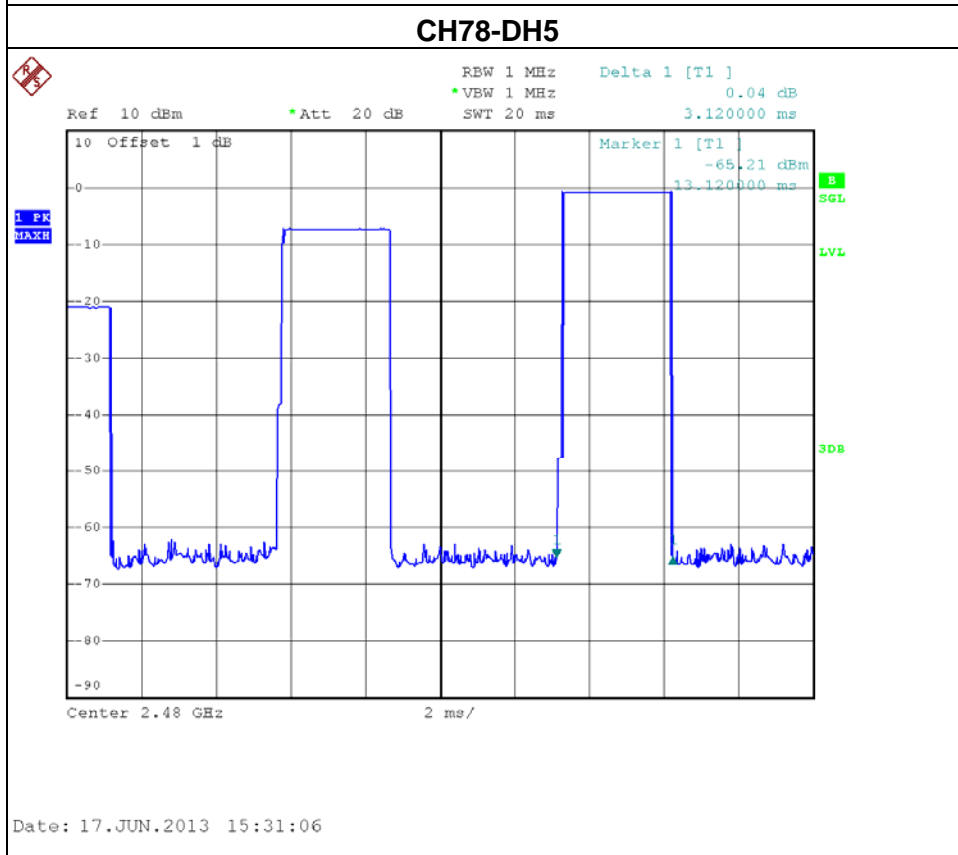
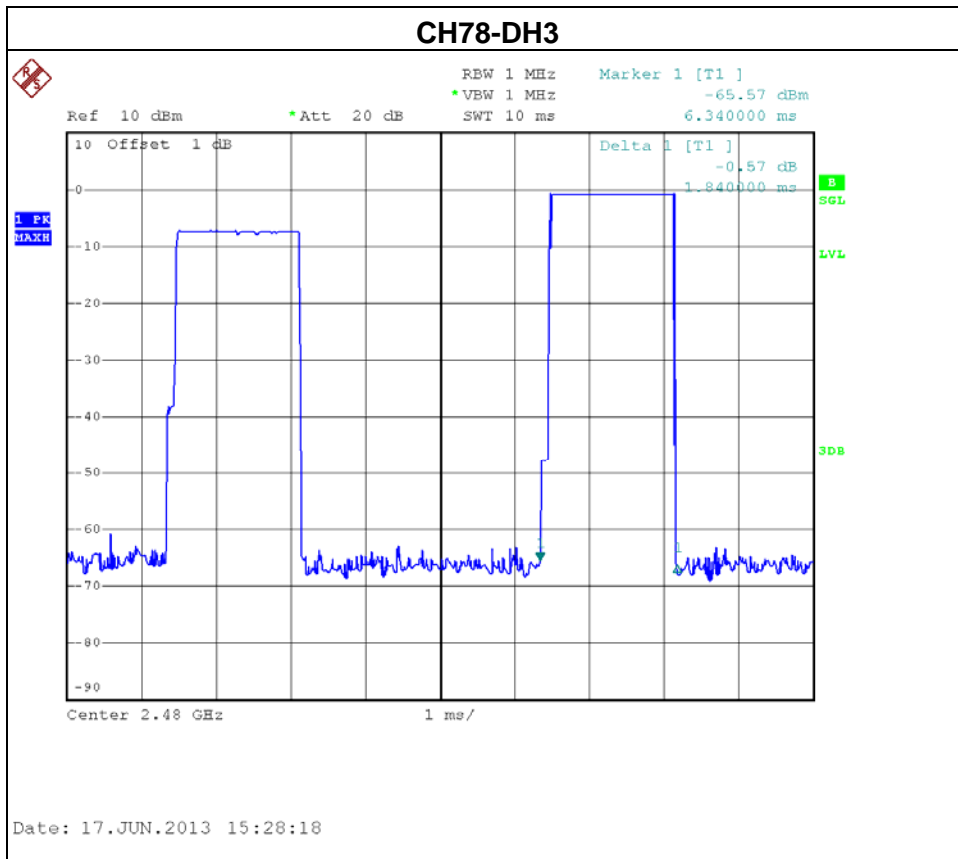



EUT :	Bluetooth Module	Model Name :	BC05 ROM
Temperature :	24 °C	Relative Humidity :	58 %
Pressure :	1009 hPa	Test Voltage :	AC120V/60Hz
Test Mode :	CH00-DH1/DH3/DH5 -3Mbps		

Data Packet	Frequency	Pulse Duration (ms)	Dwell Time (s)	Limits (s)
DH5	2402 MHz	3.1200	0.3328	0.4000
DH3	2402 MHz	1.8400	0.2944	0.4000
DH1	2402 MHz	0.5600	0.1792	0.4000

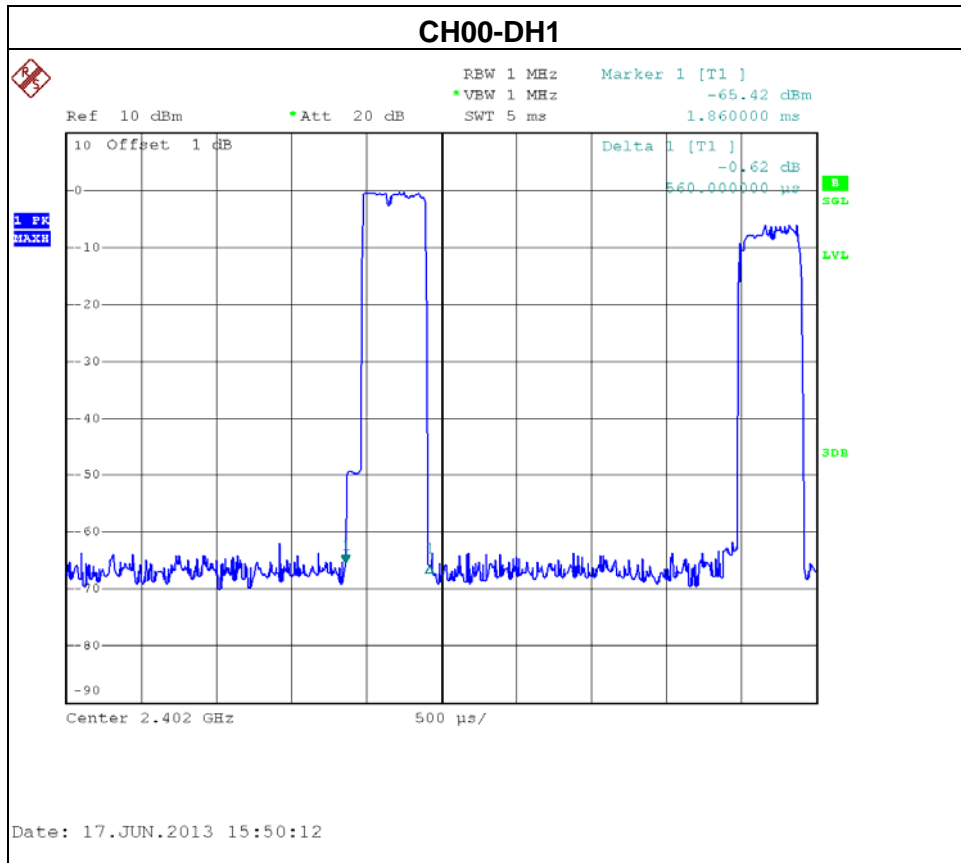

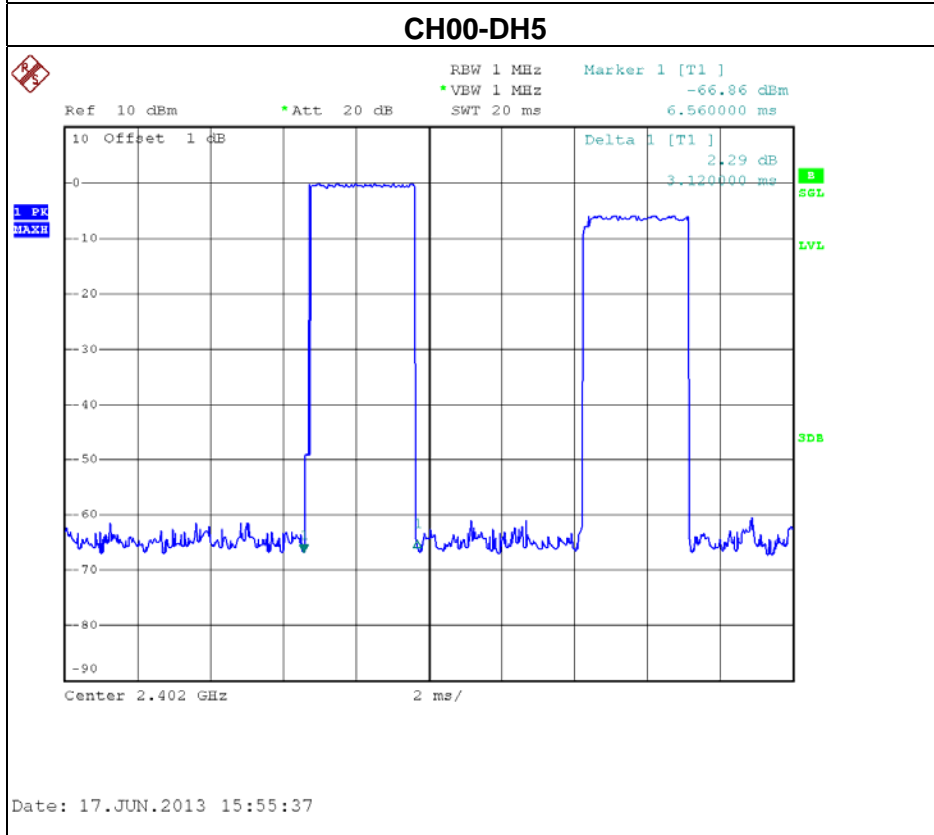
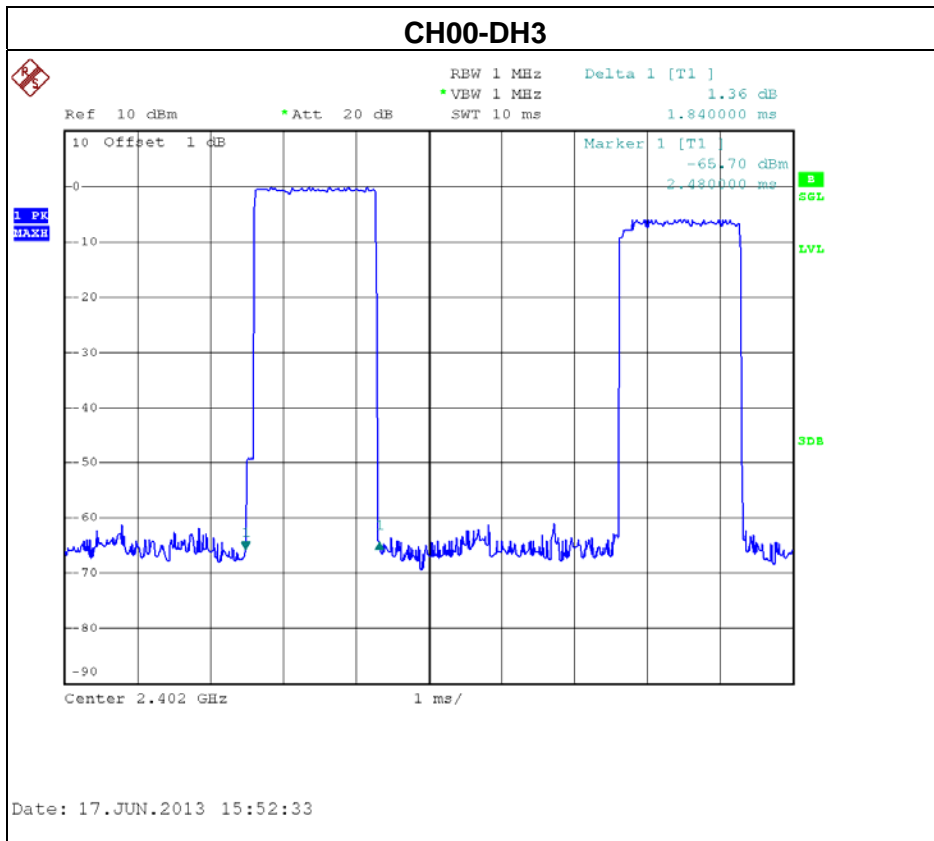



EUT :	Bluetooth Module	Model Name :	BC05 ROM
Temperature :	24 °C	Relative Humidity :	58 %
Pressure :	1009 hPa	Test Voltage :	AC120V/60Hz
Test Mode :	CH39 -DH1/DH3/DH5 -3Mbps		

Data Packet	Frequency	Pulse Duration (ms)	Dwell Time (s)	Limits (s)
DH5	2441 MHz	3.1200	0.3328	0.4000
DH3	2441 MHz	1.8200	0.2912	0.4000
DH1	2441 MHz	0.5600	0.1792	0.4000

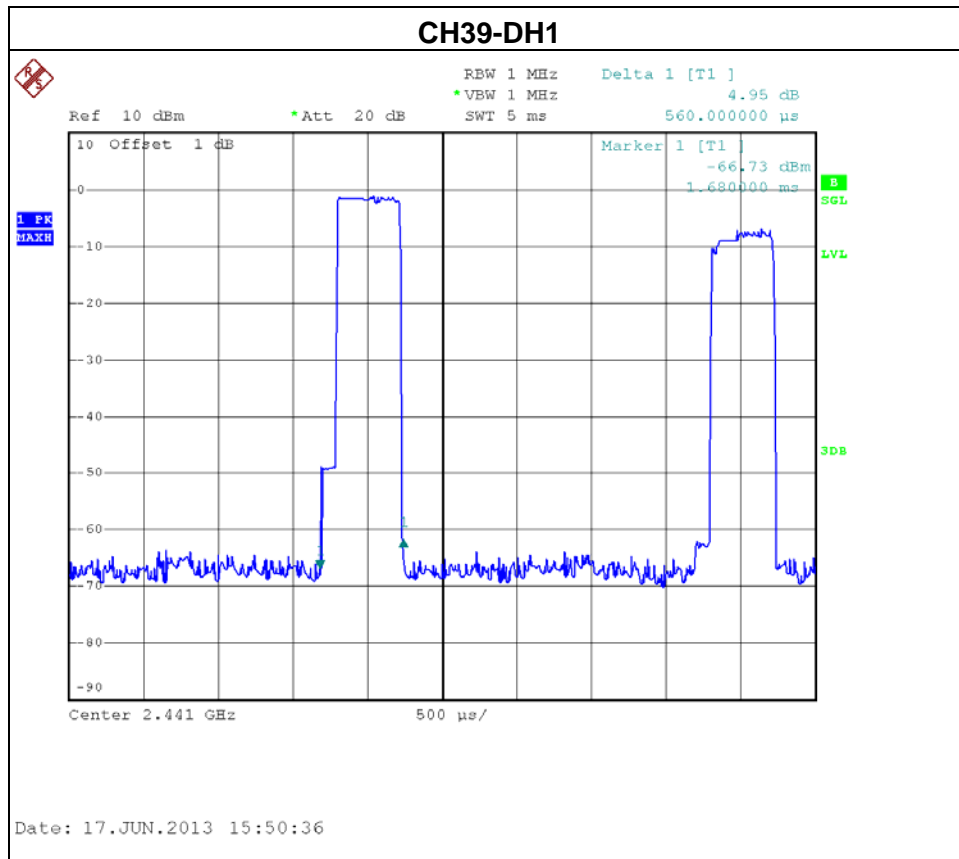

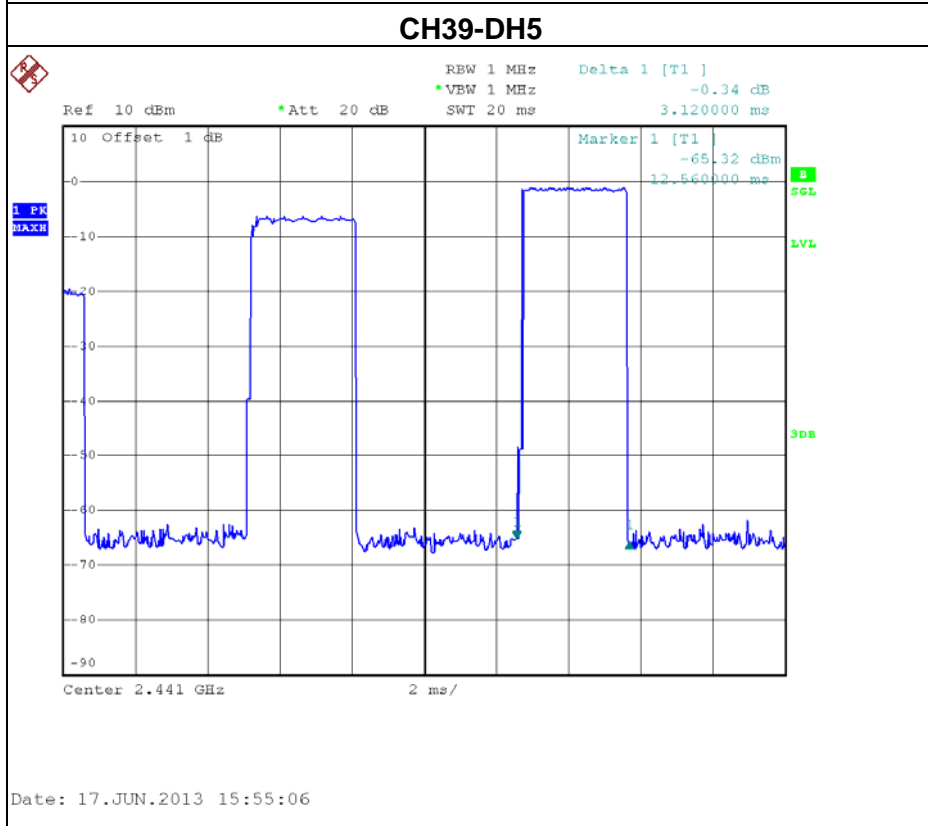
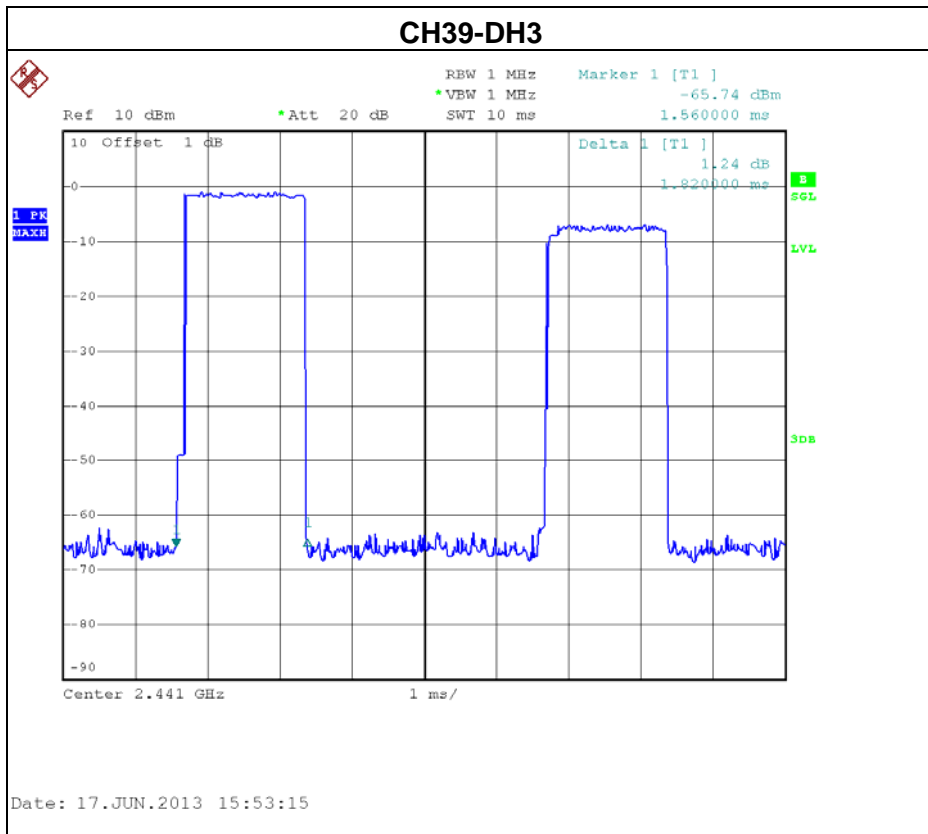



EUT :	Bluetooth Module	Model Name :	BC05 ROM
Temperature :	24 °C	Relative Humidity :	58 %
Pressure :	1009 hPa	Test Voltage :	AC120V/60Hz
Test Mode :	CH78 -DH1/DH3/DH5-3Mbps		

Data Packet	Frequency	Pulse Duration (ms)	Dwell Time (s)	Limits (s)
DH5	2480 MHz	3.1200	0.3328	0.4000
DH3	2480 MHz	1.8200	0.2912	0.4000
DH1	2480 MHz	0.5700	0.1824	0.4000

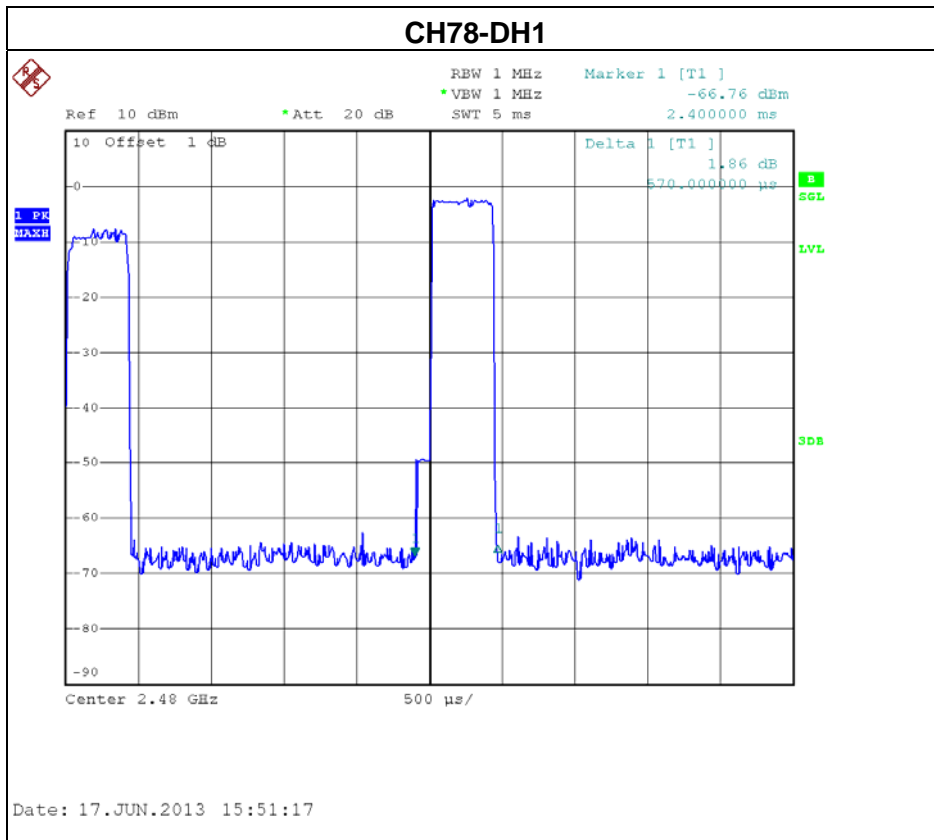

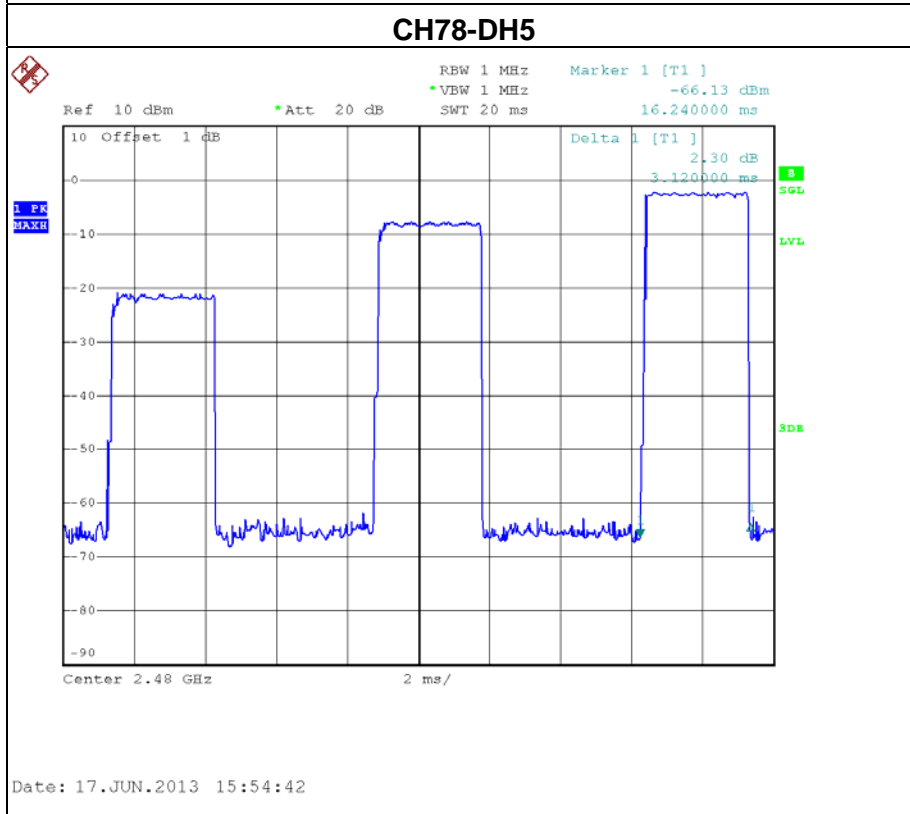
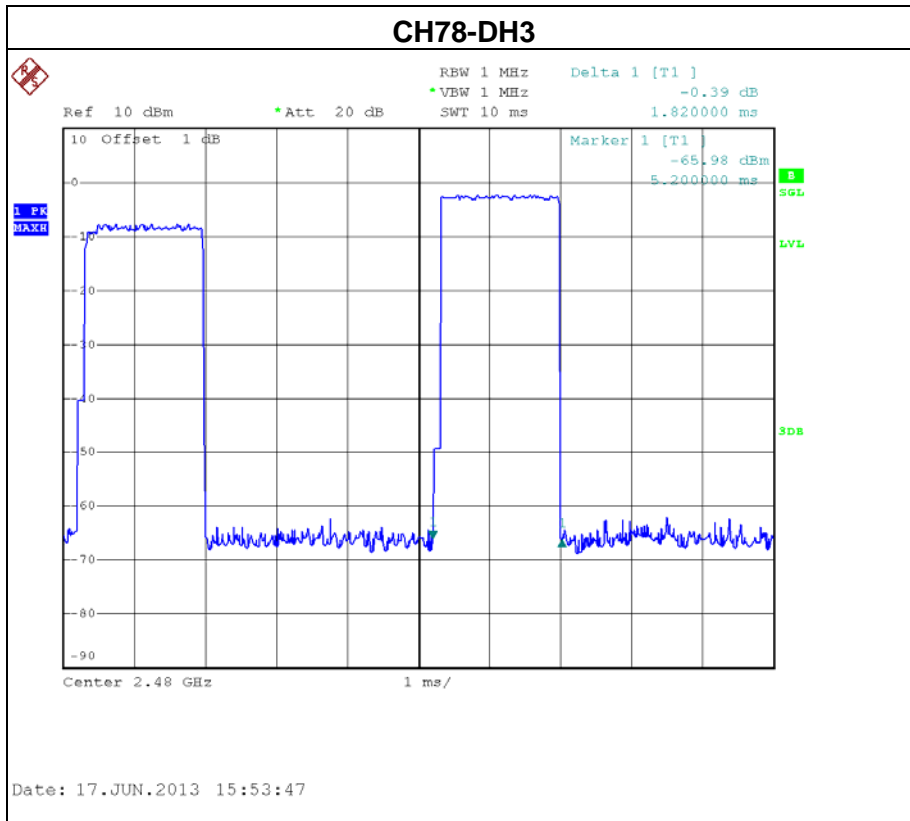

7. HOPPING CHANNEL SEPARATION MEASUREMENT

7.1 APPLIED PROCEDURES / LIMIT

Frequency hopping systems operating in the 2400-2483.5 MHz band may have hopping channel carrier frequencies that are separated by 25 kHz or two-thirds of the 20 dB bandwidth of the hopping channel, whichever is greater.

7.1.1 MEASUREMENT INSTRUMENTS LIST AND SETTING

Item	Kind of Equipment	Manufacturer	Type No.	Serial No.	Calibrated until
1	Spectrum Analyzer	R&S	FSP 40	100185	Nov. 16.2013

Remark: "N/A" denotes no model name, serial no. or calibration specified.

All calibration period of Equipment List is One Year.

Spectrum Parameter	Setting
Attenuation	Auto
Span Frequency	> Measurement Bandwidth or Channel Separation
RB	30 kHz
VB	100 kHz
Detector	Peak
Trace	Max Hold
Sweep Time	Auto

7.1.2 TEST PROCEDURE

- a. The EUT must have its hopping function enabled
- b. Span = wide enough to capture the peaks of two adjacent channels
 Resolution (or IF) Bandwidth (RBW) \geq 1% of the span
 Video (or Average) Bandwidth (VBW) \geq RBW
 Sweep = auto
 Detector function = peak
 Trace = max hold

7.1.3 DEVIATION FROM STANDARD

No deviation.

7.1.4 TEST SETUP

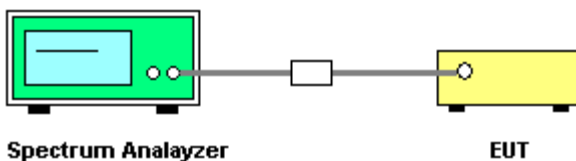

7.1.5 EUT OPERATION CONDITIONS

The EUT was programmed to be in hopping mode.



7.1.6 TEST RESULTS

EUT :	Bluetooth Module	Model Name :	BC05 ROM
Temperature :	24 °C	Relative Humidity :	58 %
Pressure :	1009 hPa	Test Voltage :	AC120V/60Hz
Test Mode :	CH00 / CH39 /CH78-1Mbps		

Frequency	Ch. Separation (MHz)	20dB Bandwidth (MHz)	Result
2402 MHz	0.978	0.890	Complies
2441 MHz	0.990	0.890	Complies
2480 MHz	1.020	0.890	Complies

Ch. Separation Limits: >20dB bandwidth or >2/3 of 20dB bandwidth

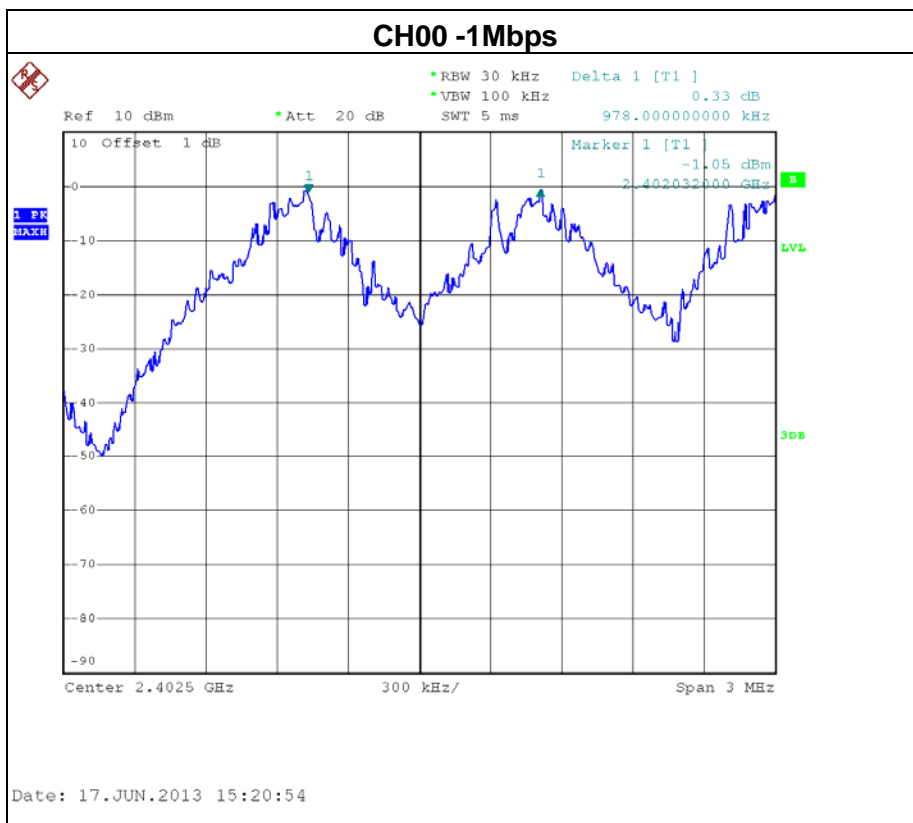

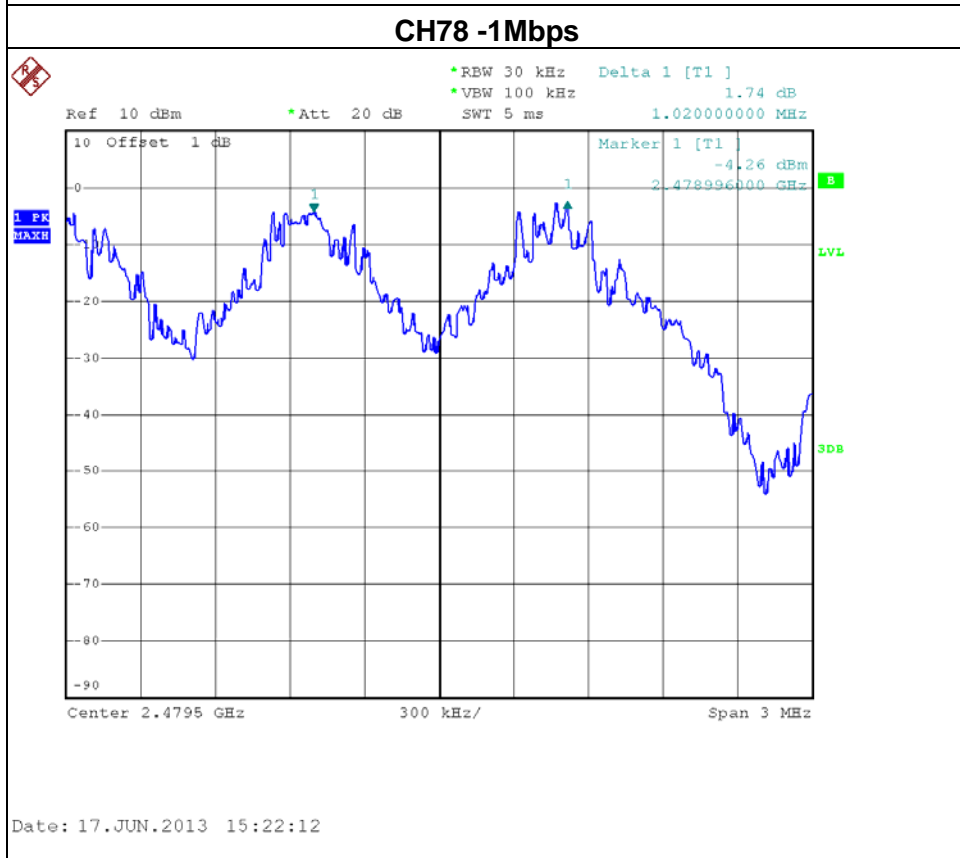
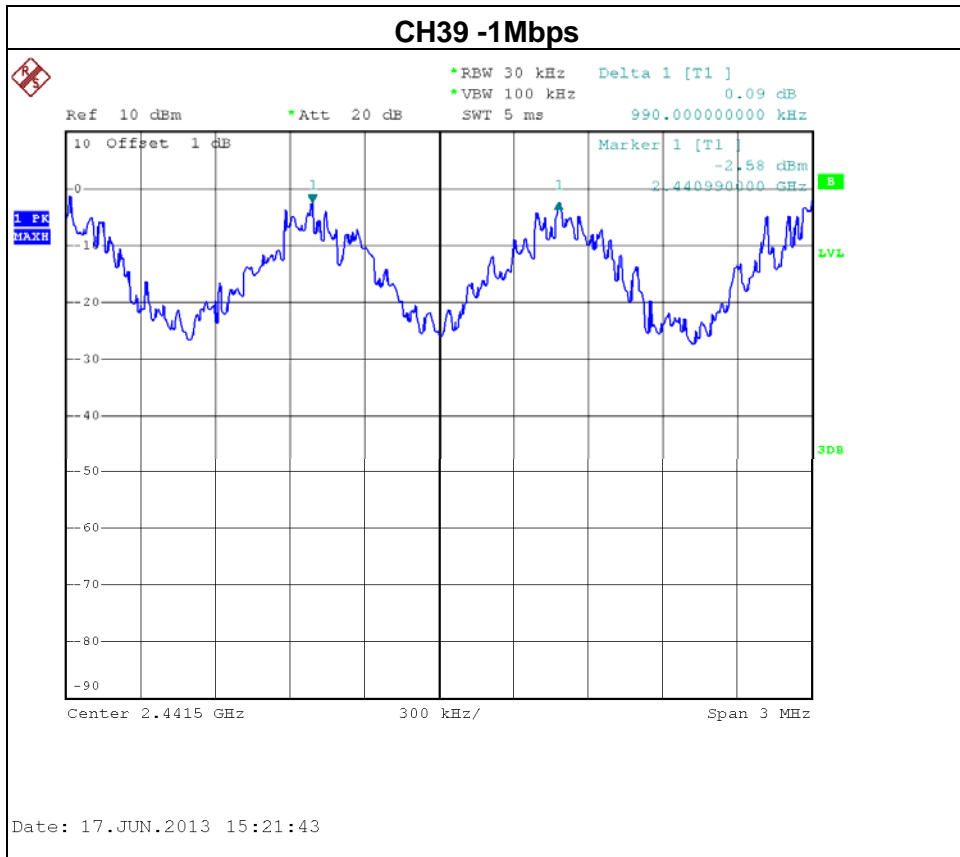



EUT :	Bluetooth Module	Model Name :	BC05 ROM
Temperature :	24 °C	Relative Humidity :	58 %
Pressure :	1009 hPa	Test Voltage :	AC120V/60Hz
Test Mode :	CH00 / CH39 /CH78-3Mbps		

Frequency	Ch. Separation (MHz)	20dB Bandwidth (MHz)	Result
2402 MHz	1.014	1.230	Complies
2441 MHz	1.044	1.230	Complies
2480 MHz	0.960	1.210	Complies

Ch. Separation Limits: >20dB bandwidth or >2/3 of 20dB bandwidth

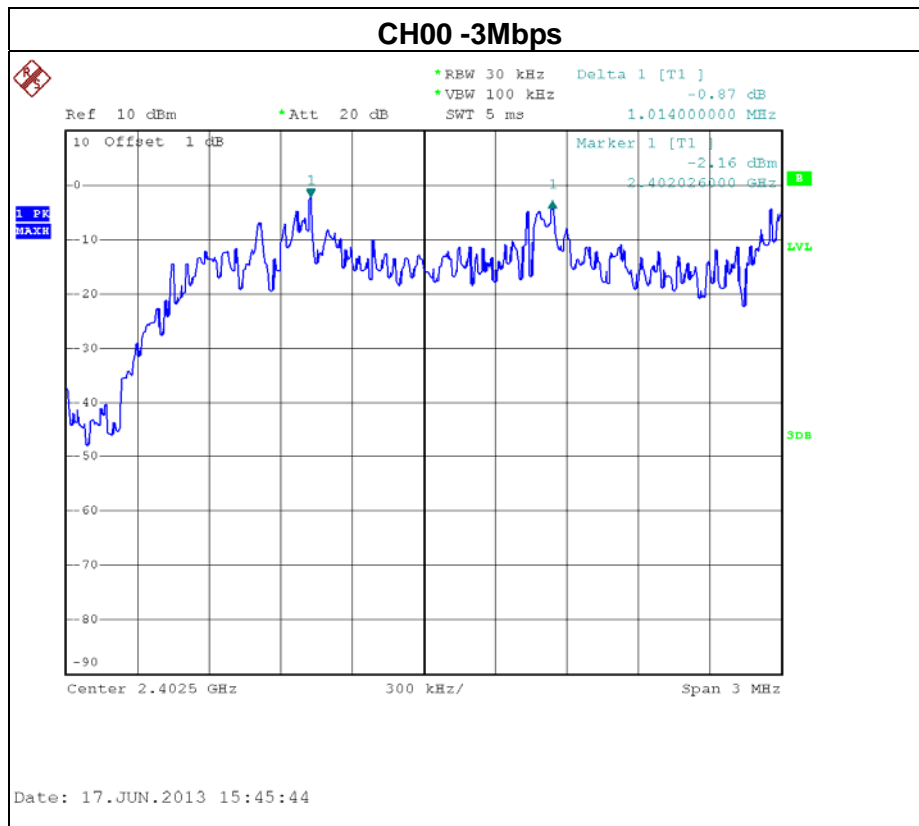

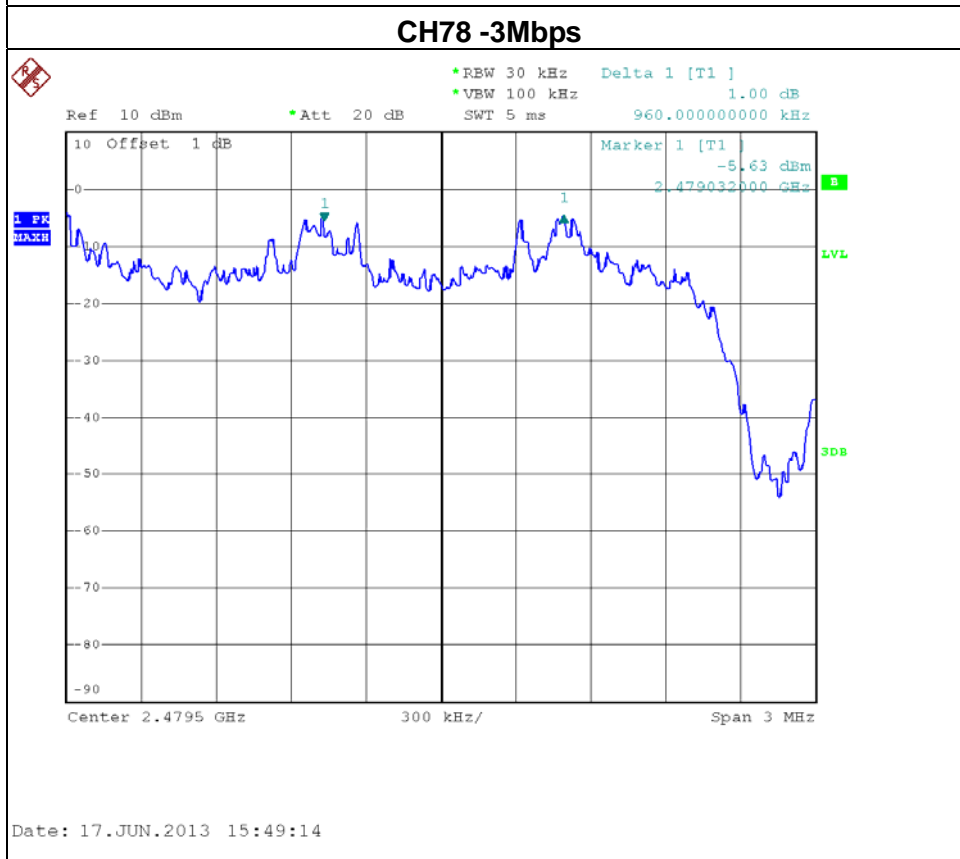
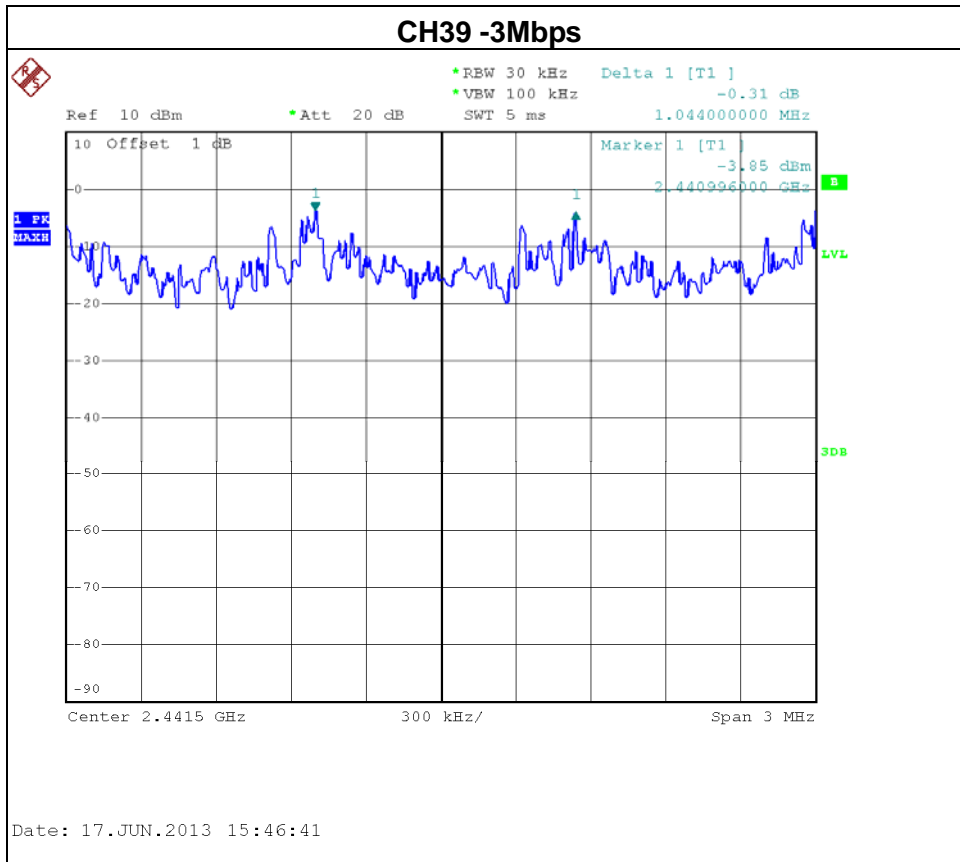



8. BANDWIDTH TEST

8.1 APPLIED PROCEDURES / LIMIT

FCC Part15 (15.247) , Subpart C		
Section	Test Item	Frequency Range (MHz)
15.247 (a)(2)	Bandwidth	2400-2483.5

8.1.1 MEASUREMENT INSTRUMENTS LIST AND SETTING

Item	Kind of Equipment	Manufacturer	Type No.	Serial No.	Calibrated until
1	Spectrum Analyzer	R&S	FSP 40	100185	Nov. 16.2013

Remark: "N/A" denotes no model name, serial no. or calibration specified.

All calibration period of Equipment List is One Year.

Spectrum Parameter	Setting
Attenuation	Auto
Span Frequency	> Measurement Bandwidth or Channel Separation
RB	30 kHz (20dB Bandwidth) / 30 kHz (Channel Separation)
VB	100 kHz (20dB Bandwidth) / 100 kHz (Channel Separation)
Detector	Peak
Trace	Max Hold
Sweep Time	Auto

8.1.2 TEST PROCEDURE

- a. The EUT was directly connected to the spectrum analyzer and antenna output port as show in the block diagram below,
- b. Spectrum Setting : RBW= 30KHz, VBW=100KHz, Sweep time = Auto.

8.1.3 DEVIATION FROM STANDARD

No deviation.

8.1.4 TEST SETUP

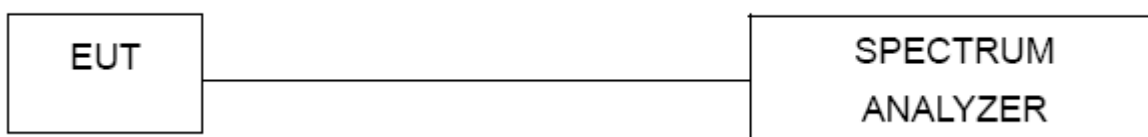

8.1.5 EUT OPERATION CONDITIONS

The EUT tested system was configured as the statements of 4.1.6 Unless otherwise a special operating condition is specified in the follows during the testing.



8.1.6 TEST RESULTS

EUT :	Bluetooth Module	Model Name :	BC05 ROM
Temperature :	24 °C	Relative Humidity :	58 %
Pressure :	1009 hPa	Test Voltage :	AC120V/60Hz
Test Mode :	CH00 / CH39 /CH78-1Mbps		

Frequency	20dB Bandwidth (MHz)	99% Occupied Bandwidth (MHz)	Result
2402 MHz	0.890	0.840	PASS
2441 MHz	0.890	0.840	PASS
2480 MHz	0.890	0.830	PASS

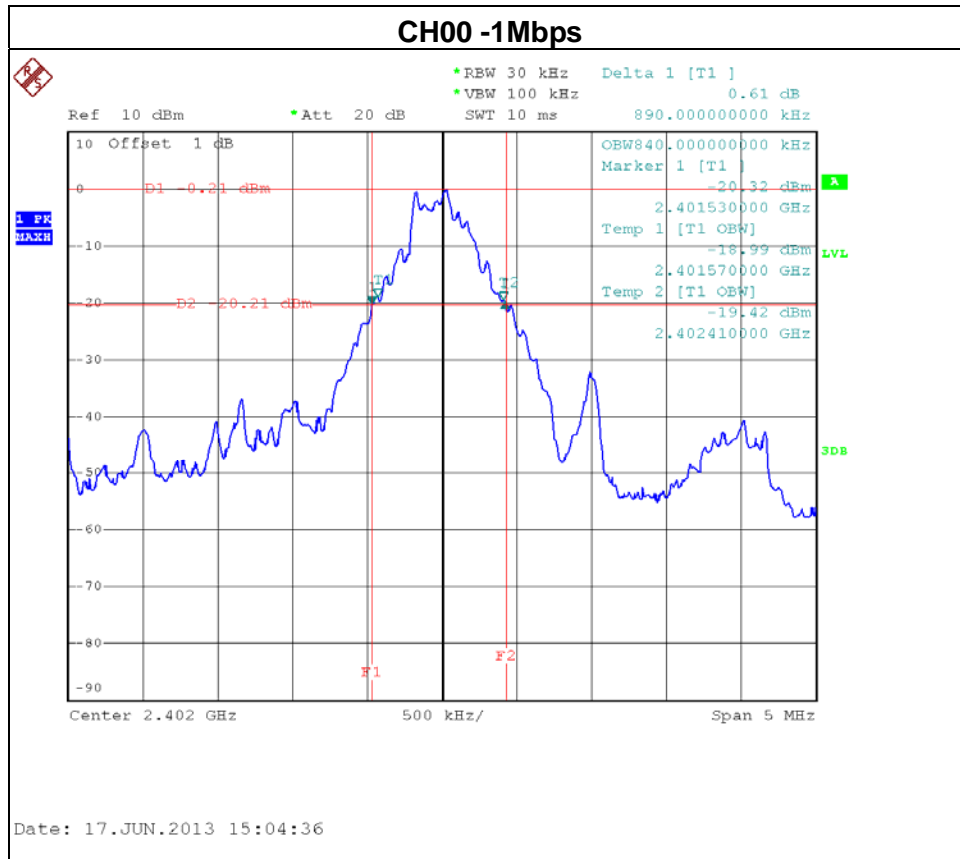

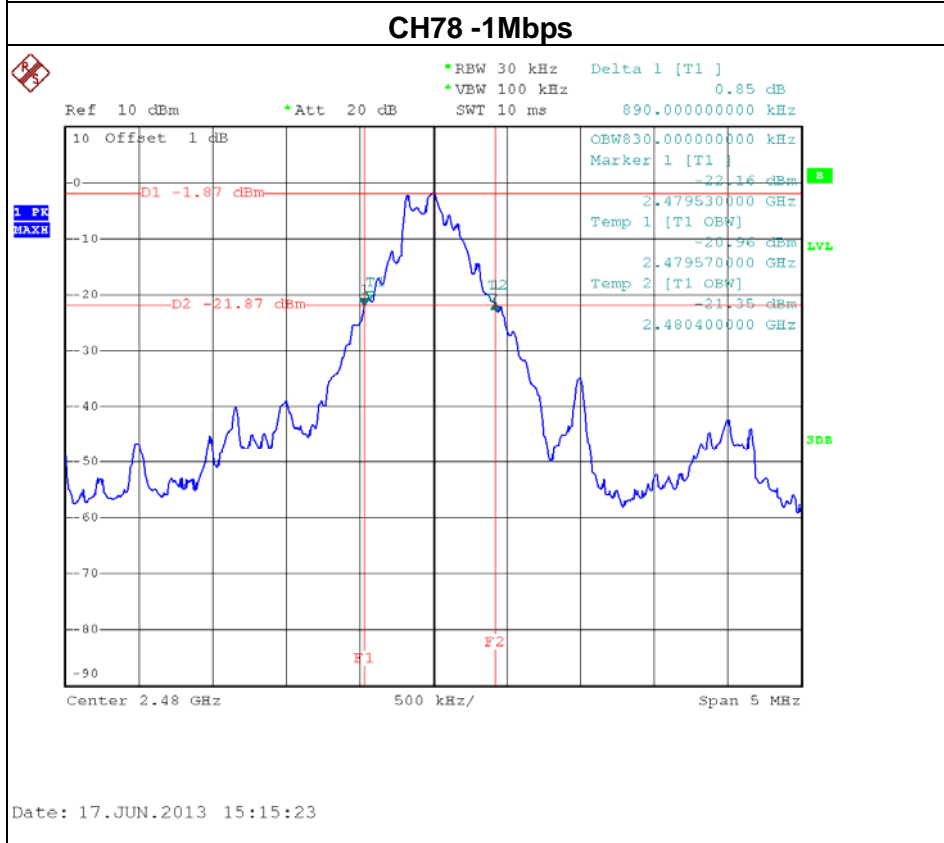
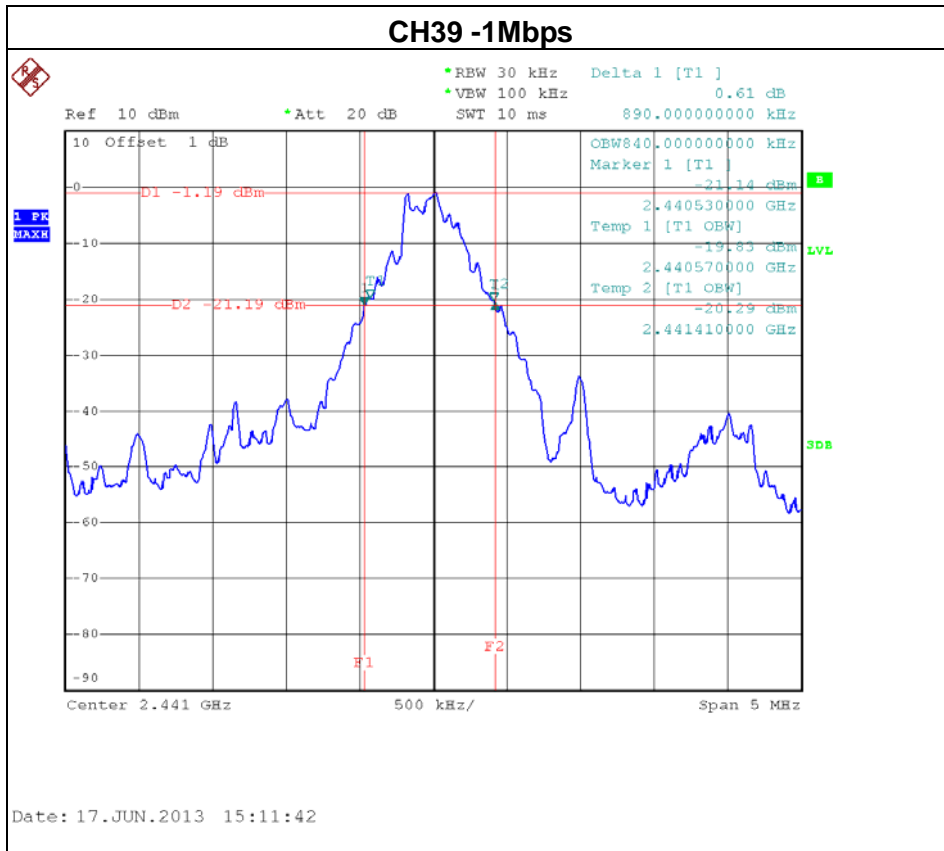

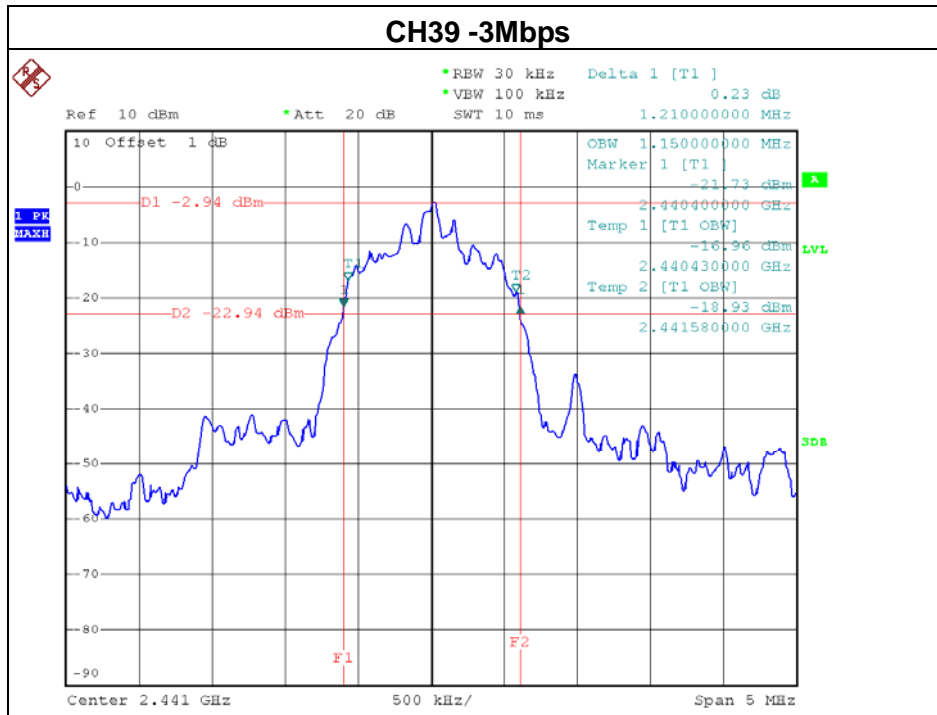

Date: 17.JUN.2013 15:36:12

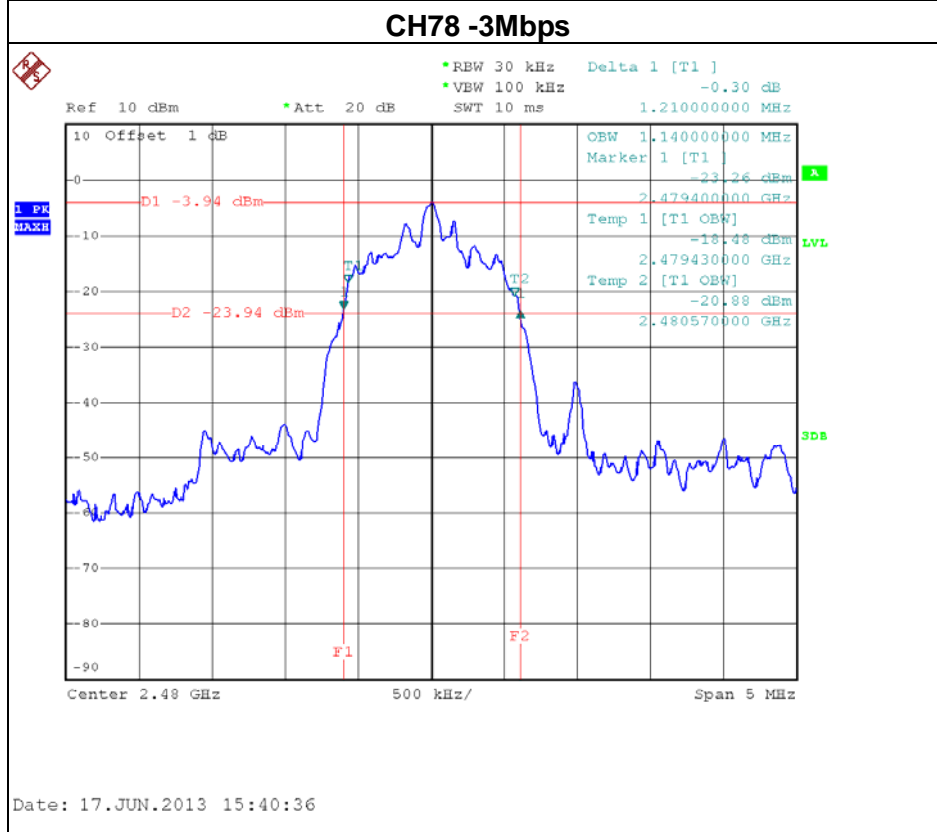

Date: 17.JUN.2013 15:40:36



9. PEAK OUTPUT POWER TEST

9.1 APPLIED PROCEDURES / LIMIT

FCC Part15 (15.247) , Subpart C				
Section	Test Item	Limit	Frequency Range (MHz)	Result
15.247 (b)(1)	Peak Output Power	0.125 watt or 21dBm	2400-2483.5	PASS

9.1.1 MEASUREMENT INSTRUMENTS LIST AND SETTING

Item	Kind of Equipment	Manufacturer	Type No.	Serial No.	Calibrated until
1	Spectrum Analyzer	R&S	FSP 40	100185	Nov. 16.2013

Remark: "N/A" denotes no model name, serial no. or calibration specified.
 All calibration period of Equipment List is One Year.

9.1.2 TEST PROCEDURE

- a. The EUT was directly connected to the spectrum analyzer and antenna output port as show in the block diagram below,
- b. Spectrum Setting : RBW= 3MHz, VBW= 3MHz, Sweep time = Auto.

9.1.3 DEVIATION FROM STANDARD

No deviation.

9.1.4 TEST SETUP

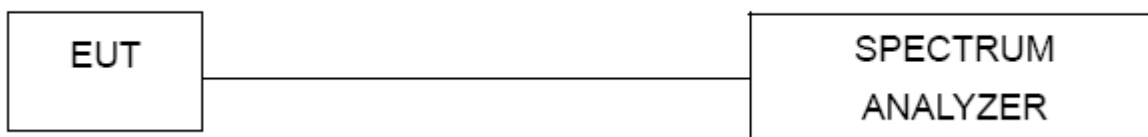

9.1.5 EUT OPERATION CONDITIONS

The EUT tested system was configured as the statements of 4.1.6 Unless otherwise a special operating condition is specified in the follows during the testing.



9.1.6 TEST RESULTS

EUT :	Bluetooth Module	Model Name :	BC05 ROM
Temperature :	24 °C	Relative Humidity :	58 %
Pressure :	1009 hPa	Test Voltage :	AC120V/60Hz
Test Mode :	CH00/ CH39 /CH78 -1Mbps		

Test Channel	Frequency (MHz)	Peak Output Power (dBm)	LIMIT (dBm)	LIMIT (W)
CH00	2402	1.24	21	0.125
CH39	2441	0.51	21	0.125
CH78	2480	-0.41	21	0.125

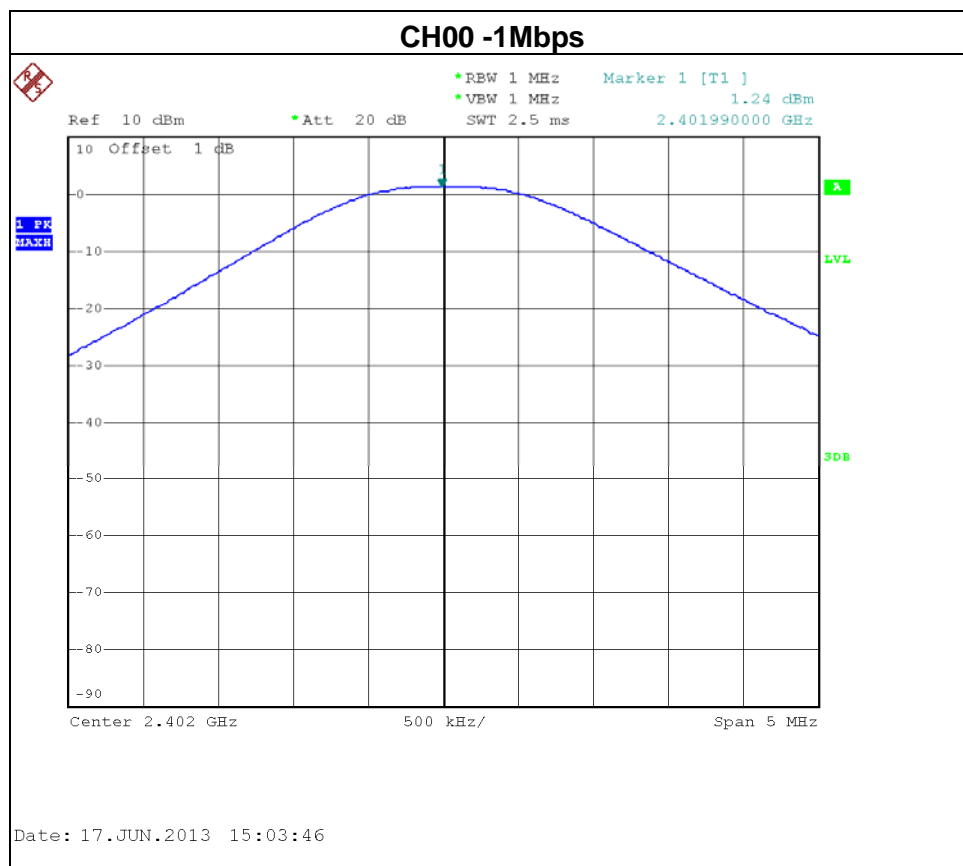

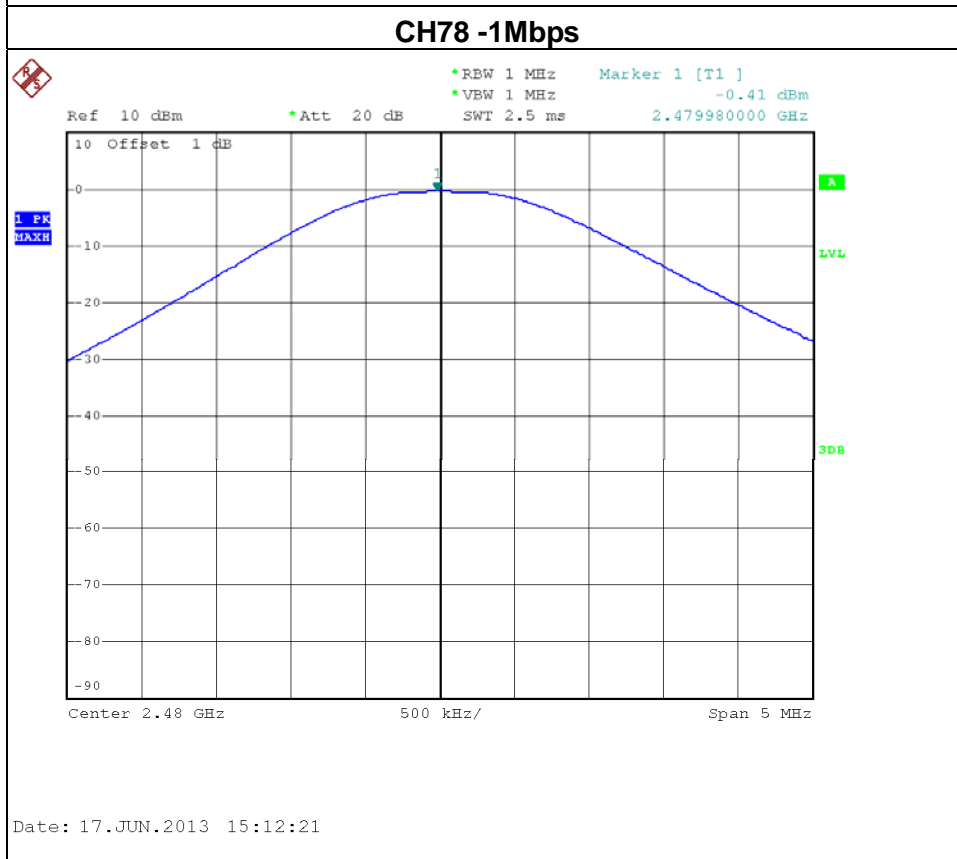
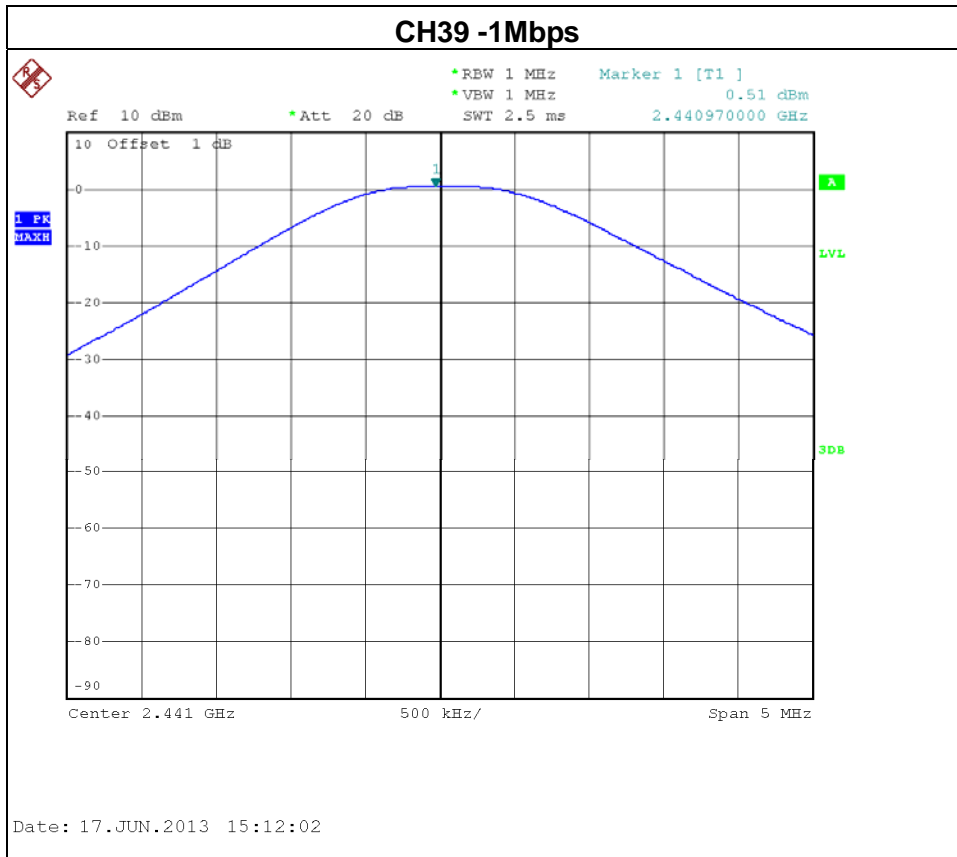



EUT :	Bluetooth Module	Model Name :	BC05 ROM
Temperature :	24 °C	Relative Humidity :	58 %
Pressure :	1009 hPa	Test Voltage :	AC120V/60Hz
Test Mode :	CH00/ CH39 /CH78 -3Mbps		

Test Channel	Frequency (MHz)	Peak Output Power (dBm)	LIMIT (dBm)	LIMIT (W)
CH00	2402	0.15	21	0.125
CH39	2441	-0.58	21	0.125
CH78	2480	-1.70	21	0.125

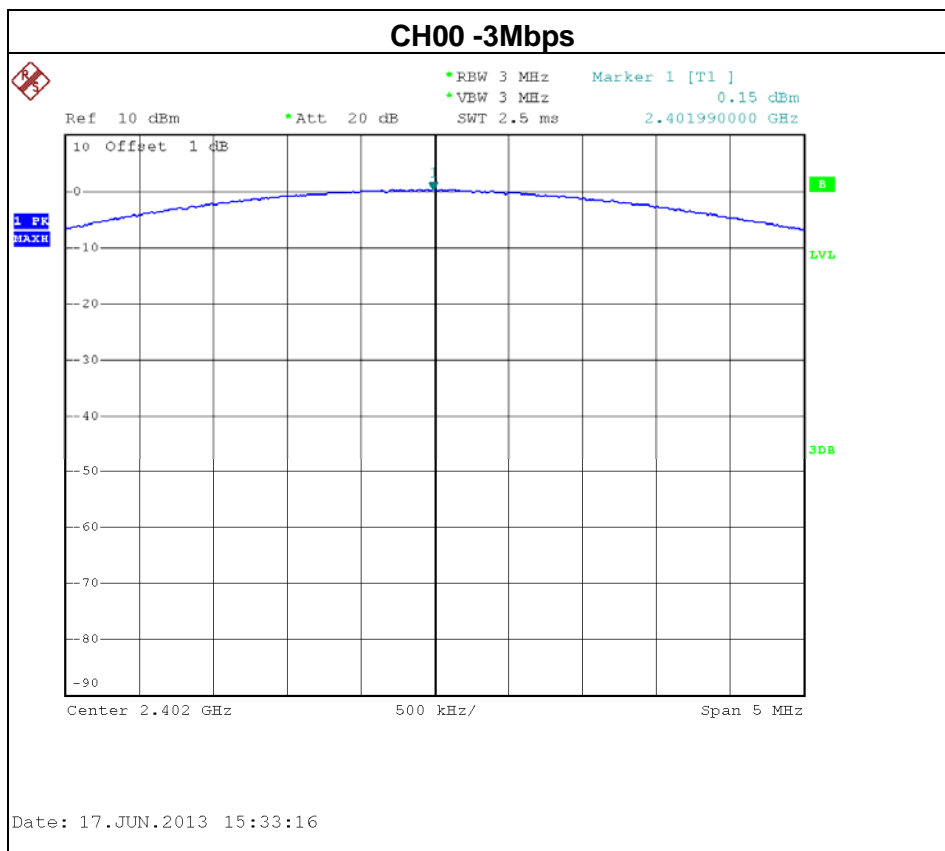

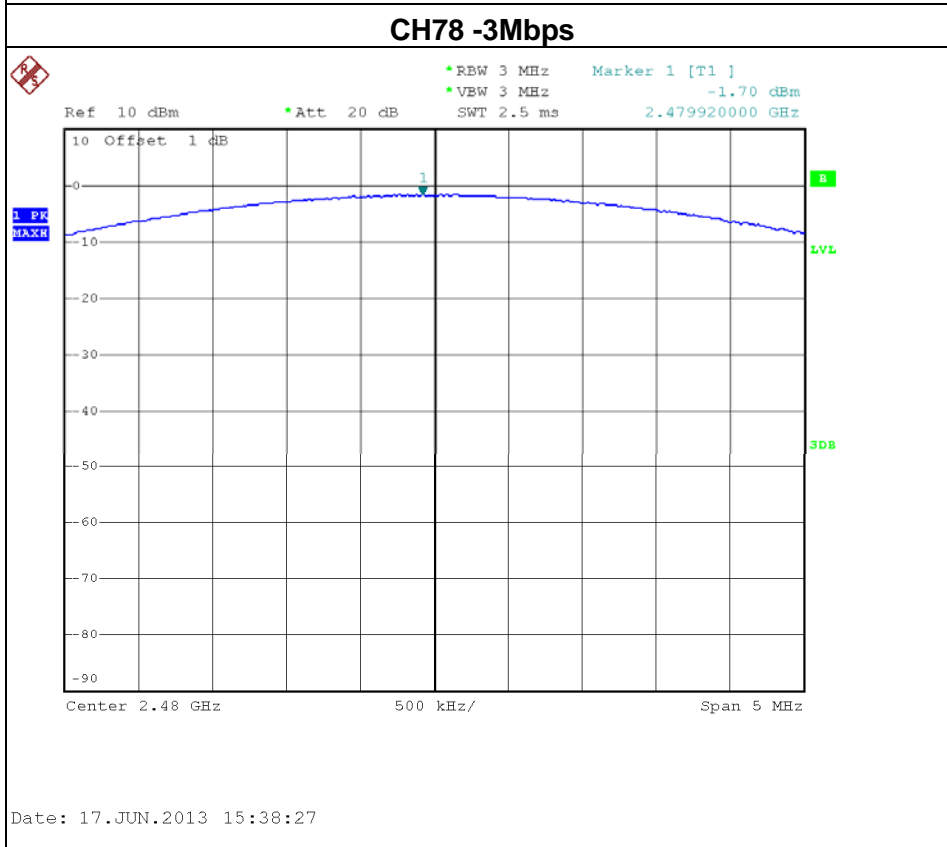
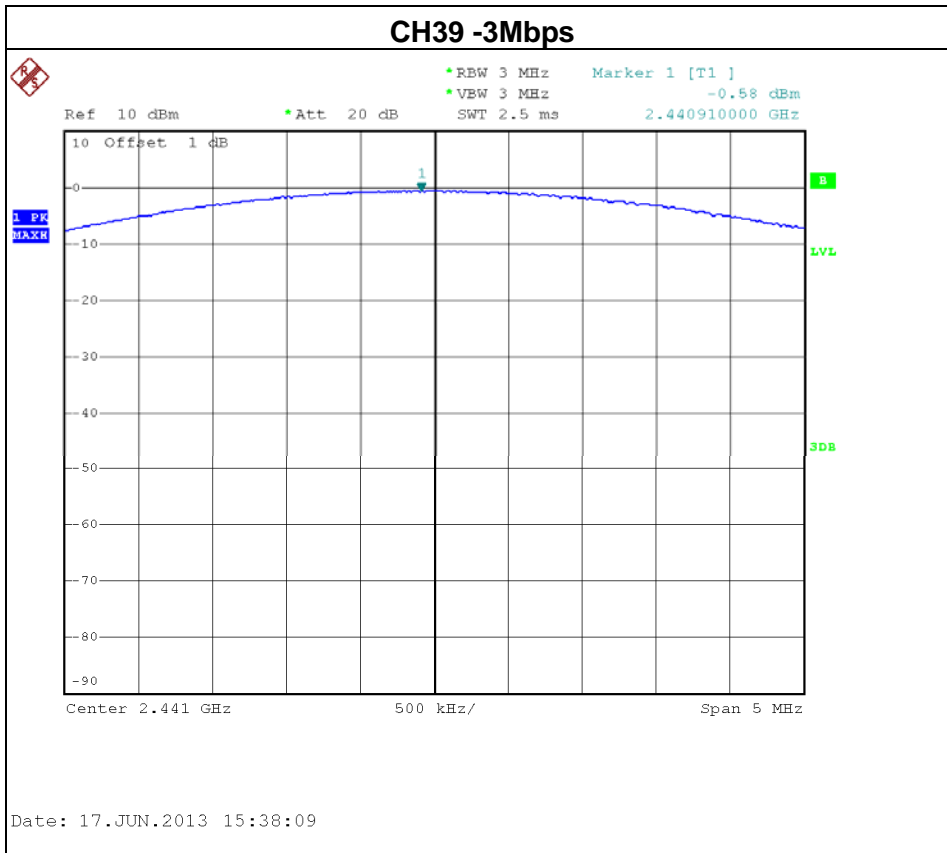



10. ANTENNA CONDUCTED SPURIOUS EMISSION

10.1 APPLIED PROCEDURES / LIMIT

20dBc in any 100 kHz bandwidth outside the operating frequency band. In case the emission fall within the restricted band specified on 15.205(a), then the 15.209(a) limit in the table below has to be followed.

Frequencies (MHz)	Field Strength (micorvolts/meter)	Measurement Distance (meters)
0.009~0.490	2400/F(KHz)	300
0.490~1.705	24000/F(KHz)	30
1.705~30.0	30	30
30~88	100	3
88~216	150	3
216~960	200	3
Above 960	500	3

10.1.1 MEASUREMENT INSTRUMENTS LIST AND SETTING

Item	Kind of Equipment	Manufacturer	Type No.	Serial No.	Calibrated until
1	Spectrum Analyzer	R&S	FSP 40	100185	Nov. 16.2013

Remark: "N/A" denotes no model name, serial no. or calibration specified.
All calibration period of Equipment List is One Year.

10.1.2 TEST PROCEDURE

- a. The EUT was directly connected to the spectrum analyzer and antenna output port as show in the block diagram below,
- b. Spectrum Setting : RBW= 100KHz, VBW=100KHz, Sweep time = Auto.

10.1.3 DEVIATION FROM STANDARD

No deviation.

10.1.4 TEST SETUP



10.1.5 EUT OPERATION CONDITIONS

The EUT tested system was configured as the statements of 4.1.6 Unless otherwise a special operating condition is specified in the follows during the testing.



10.1.6 TEST RESULTS

EUT :	Bluetooth Module	Model Name :	BC05 ROM
Temperature :	24 °C	Relative Humidity :	58 %
Pressure :	1009 hPa	Test Voltage :	AC120V/60Hz
Test Mode :	CH00 / CH39/ CH78-1Mbps & Hopping on mode (1Mbps)		

The max. radio frequency power in any 100kHz bandwidth outside the frequency band		The max. radio frequency power in any 100 kHz bandwidth within the frequency band.	
FREQUENCY(MHz)	POWER(dBm)	FREQUENCY(MHz)	POWER(dBm)
2400.00	-40.51	2484.40	-49.92

Result

In any 100kHz bandwidth outside the frequency band, the radio frequency power is at least 20dB below that in the 100kHz bandwidth within the band that contains the highest level of the desired power.



CH00 (Lower) -1Mbps

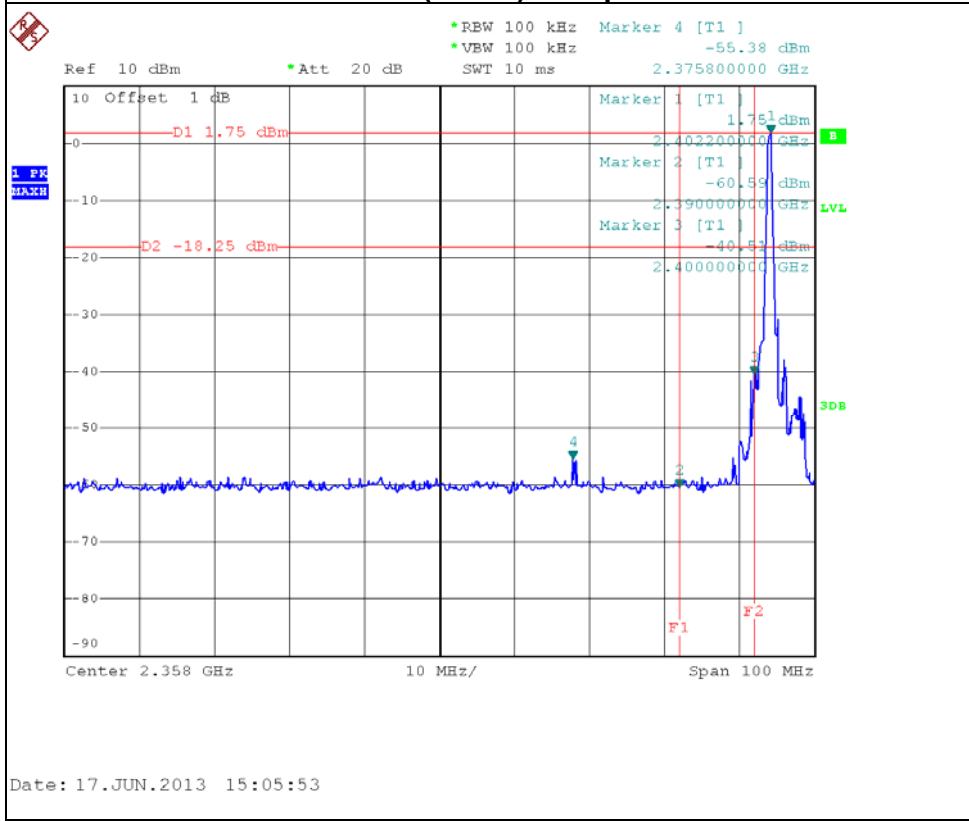

CH78 (upper) -1Mbps

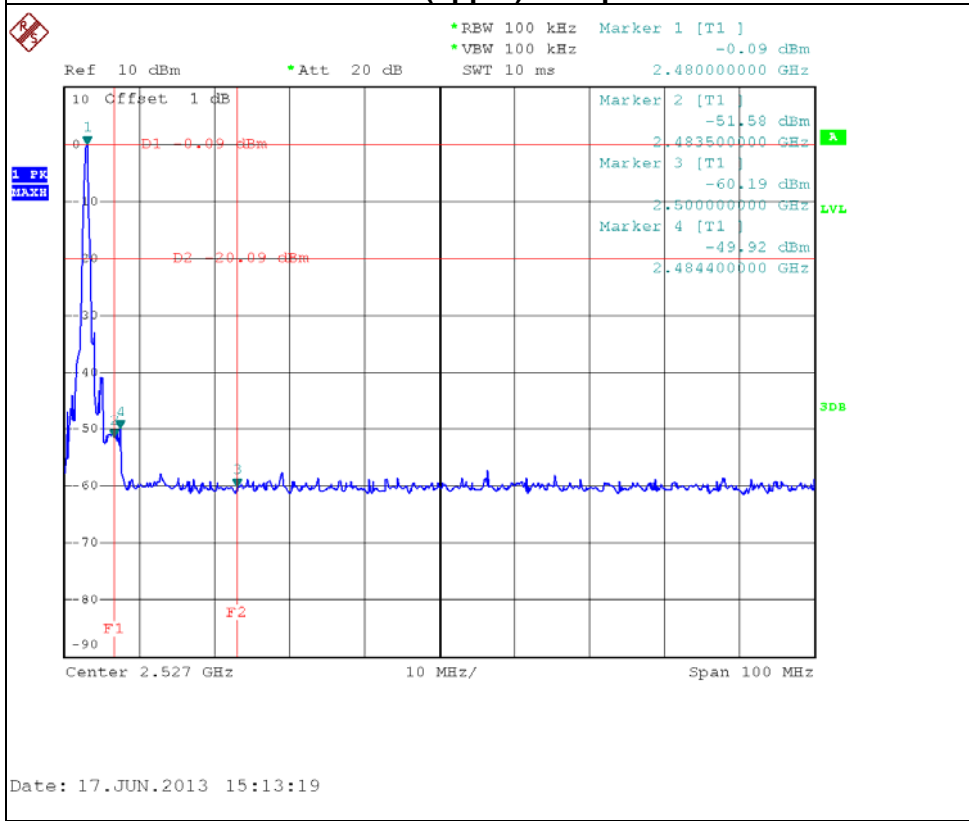



Hopping on mode (1Mbps- Lower)

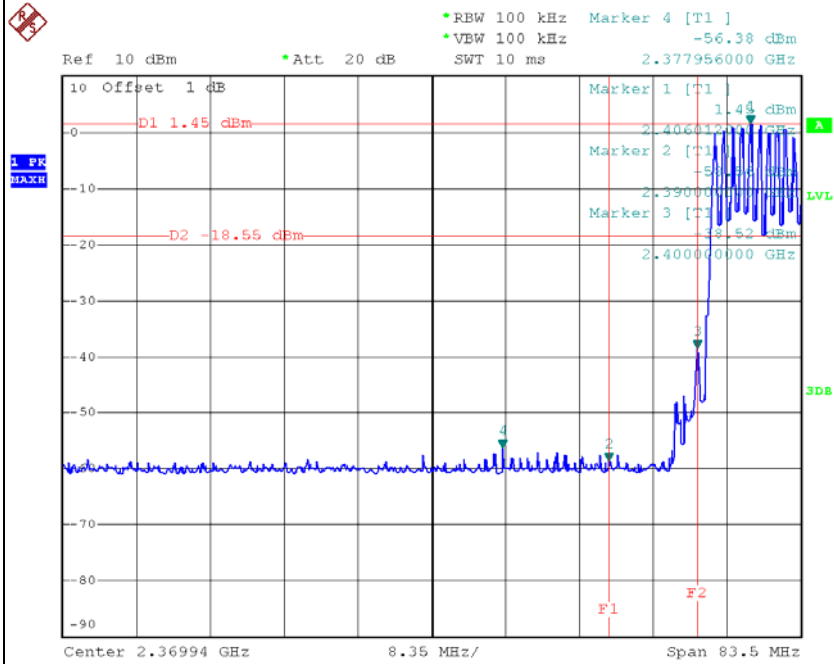

Date: 17.JUN.2013 15:17:54

Hopping on mode (1Mbps- upper)

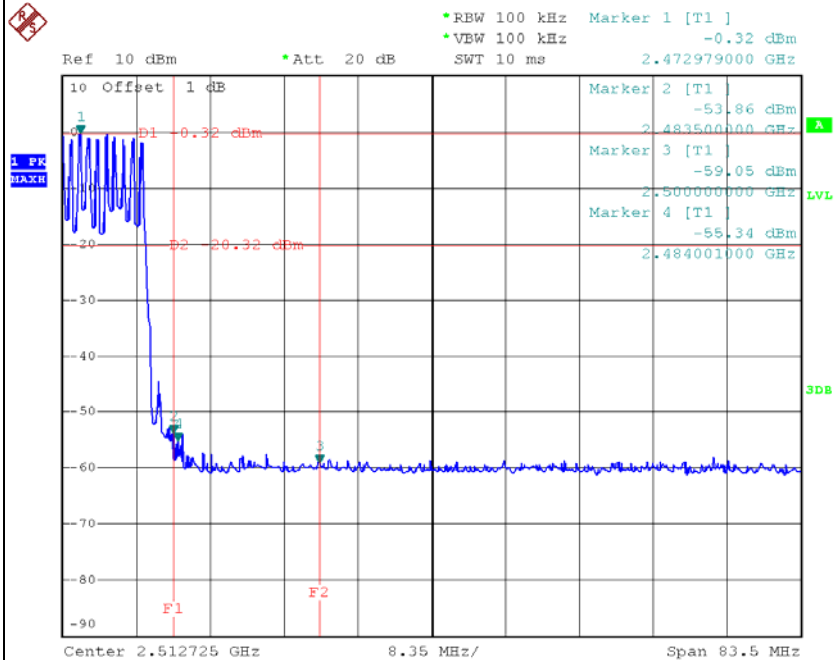

Date: 17.JUN.2013 15:19:04

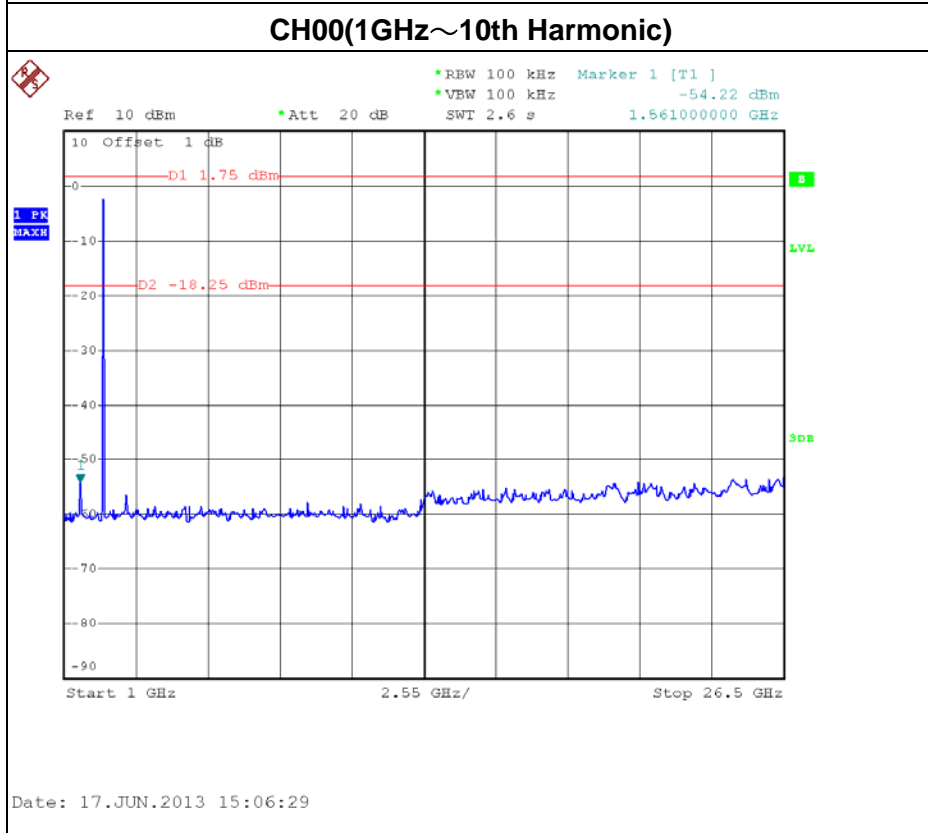
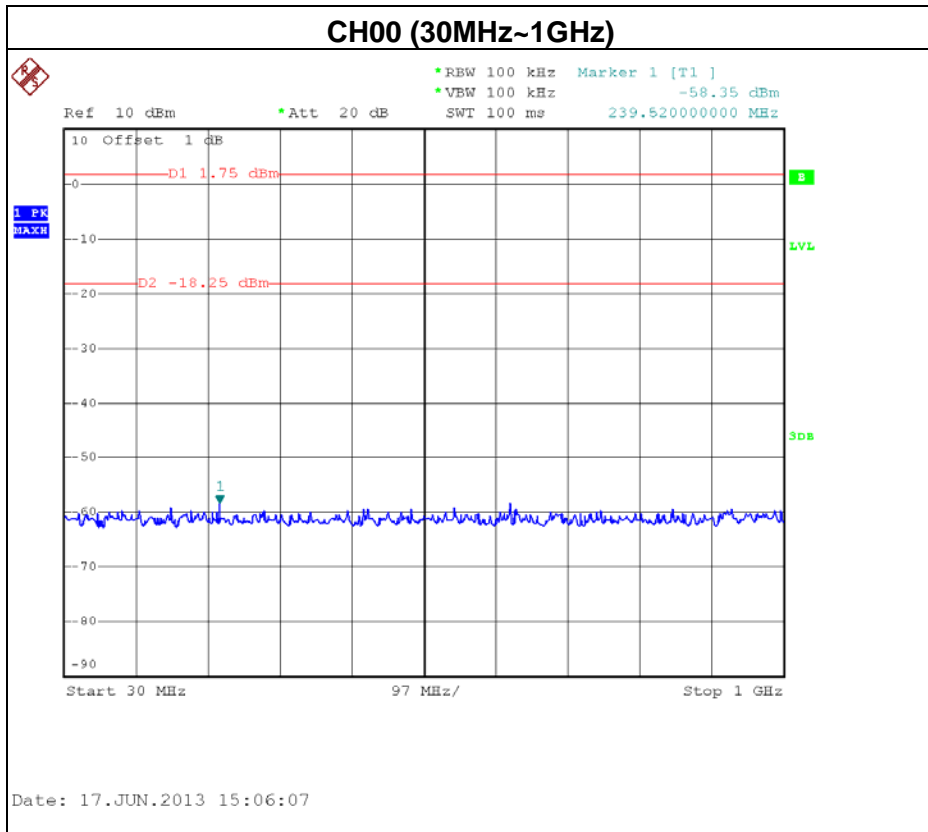

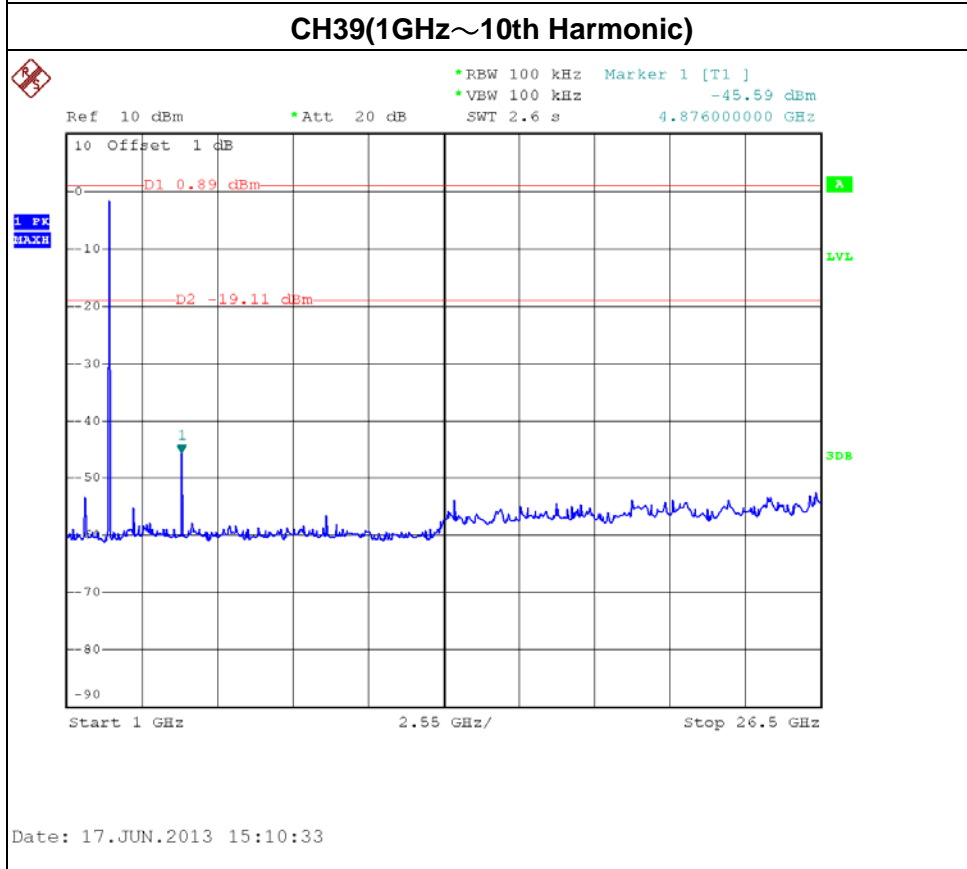
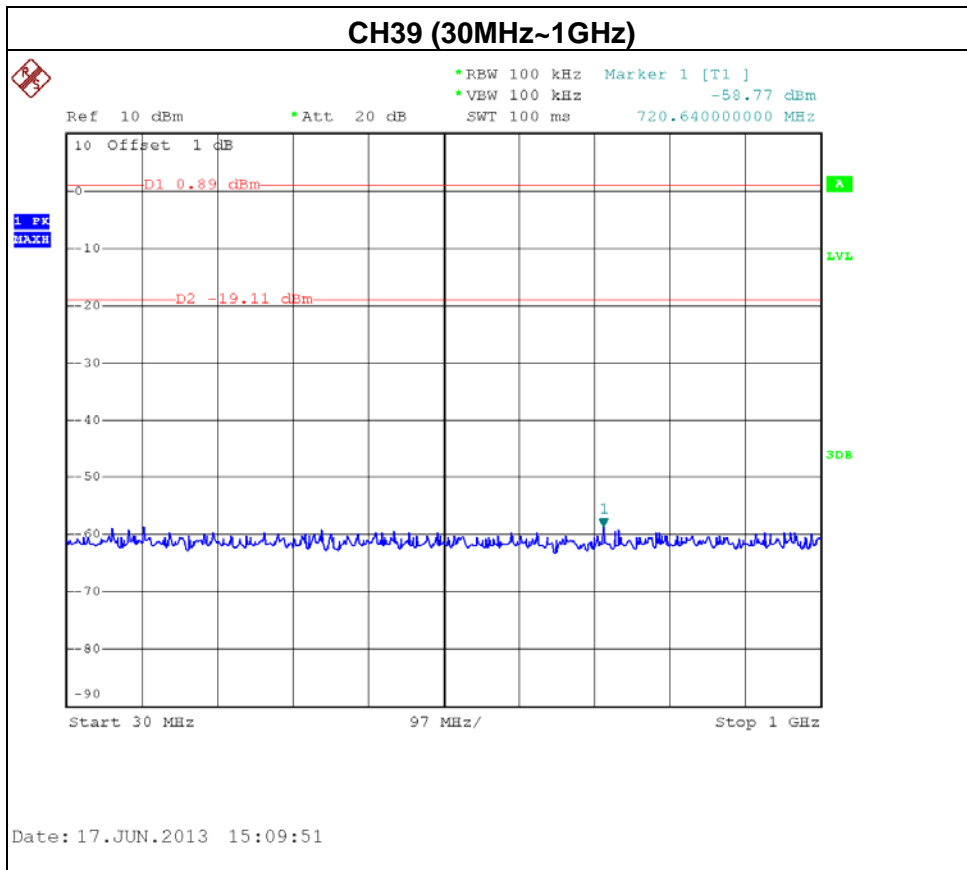



CH78 (30MHz~1GHz)

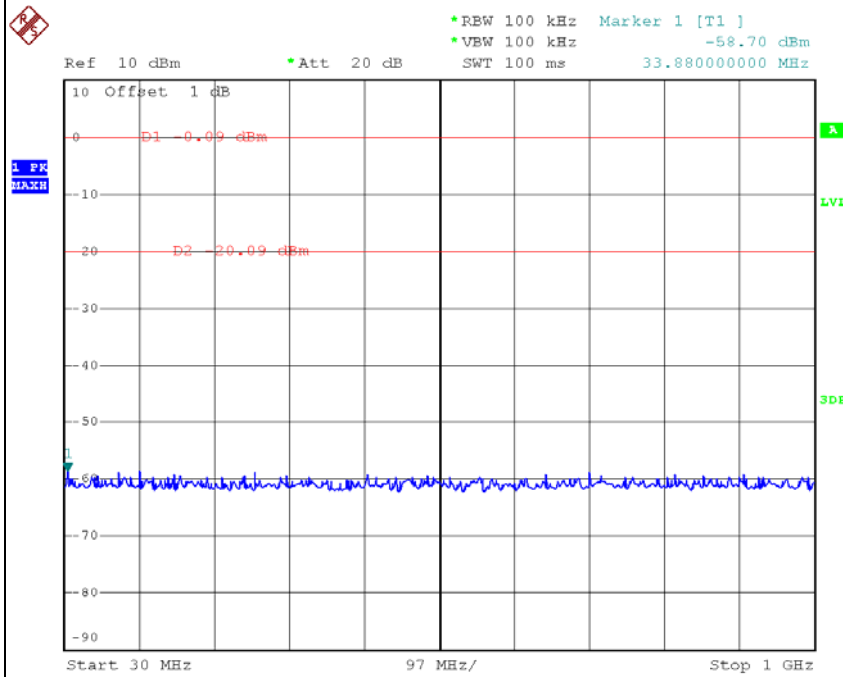

Date: 17.JUN.2013 15:13:41

CH78(1GHz~10th Harmonic)

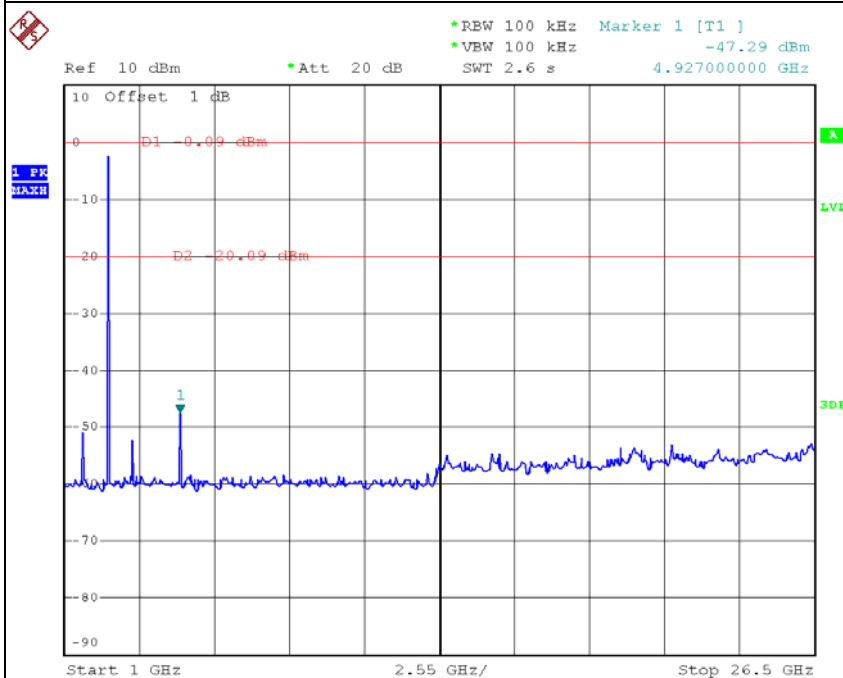

Date: 17.JUN.2013 15:14:03



EUT :	Bluetooth Module	Model Name :	BC05 ROM
Temperature :	24 °C	Relative Humidity :	58 %
Pressure :	1009 hPa	Test Voltage :	AC120V/60Hz
Test Mode :	CH00 / CH39/ CH78 -3Mbps & Hopping on mode (3Mbps)		

The max. radio frequency power in any 100kHz bandwidth outside the frequency band		The max. radio frequency power in any 100 kHz bandwidth within the frequency band.	
FREQUENCY(MHz)	POWER(dBm)	FREQUENCY(MHz)	POWER(dBm)
2400.00	-47.72	2484.00	-49.01

Result

In any 100kHz bandwidth outside the frequency band, the radio frequency power is at least 20dB below that in the 100kHz bandwidth within the band that contains the highest level of the desired power.

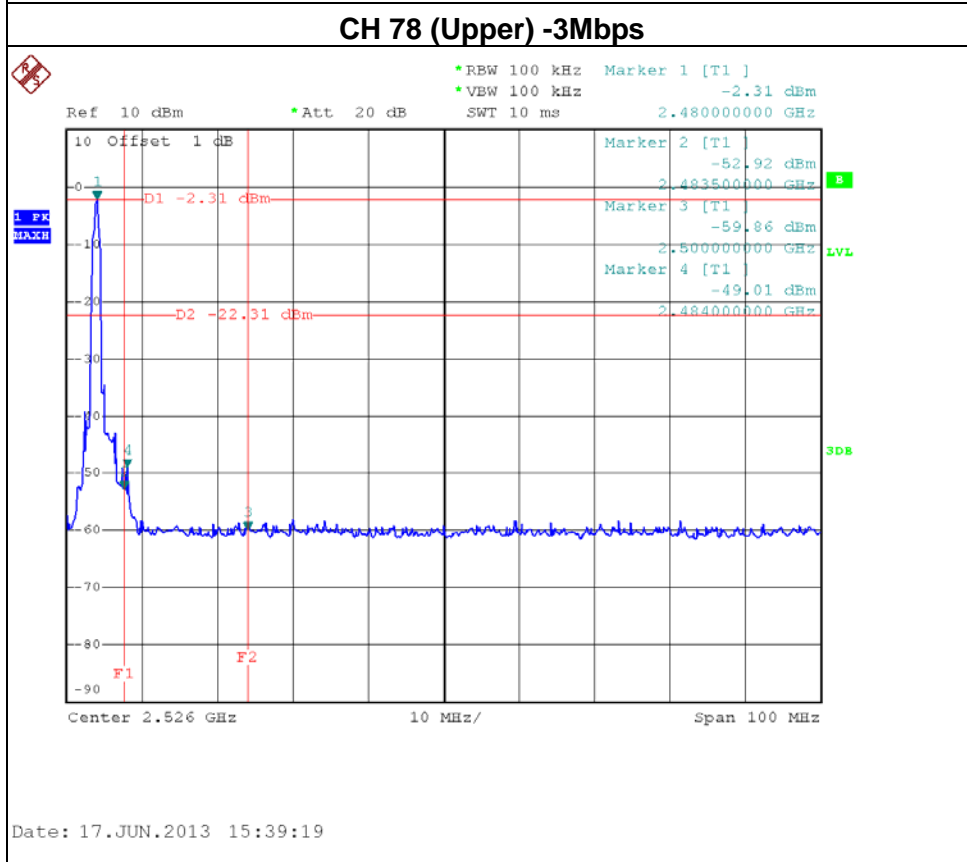
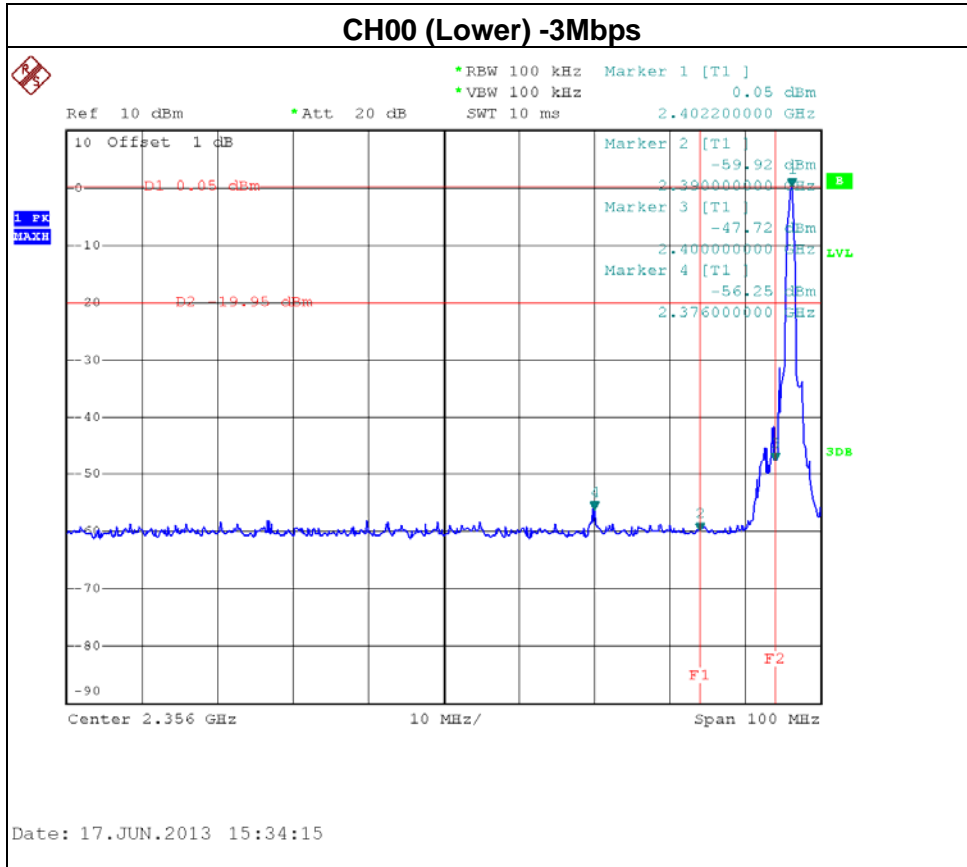



Hopping on mode (3Mbps- Lower)

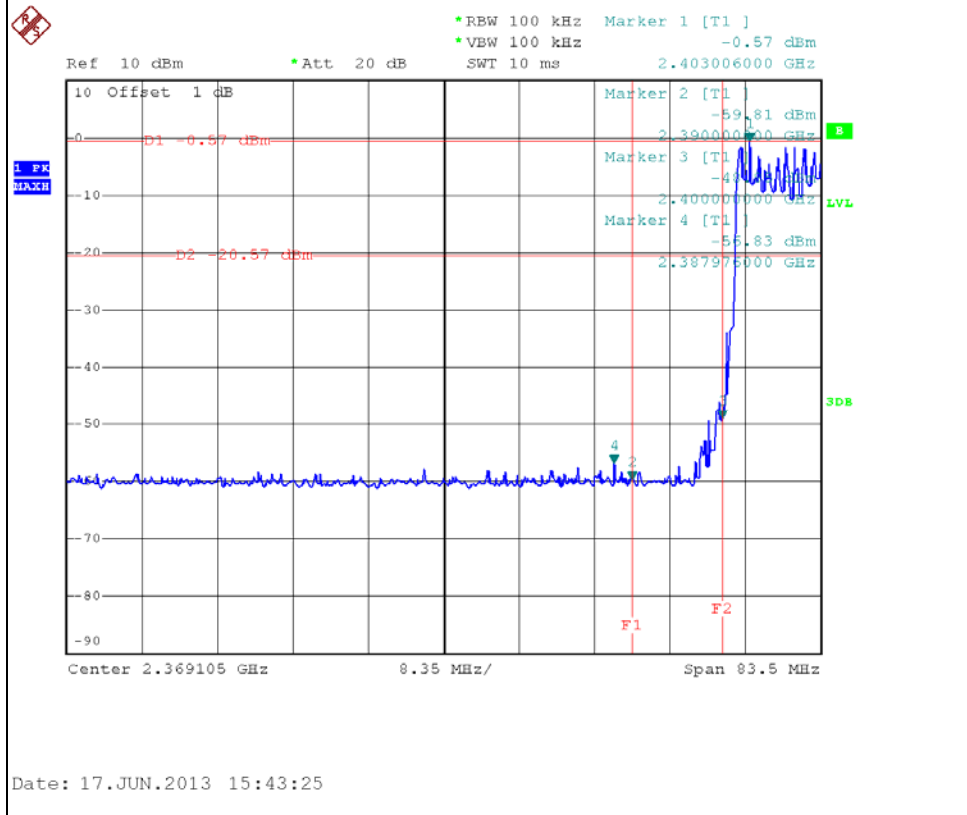

Hopping on mode (3Mbps-upper)

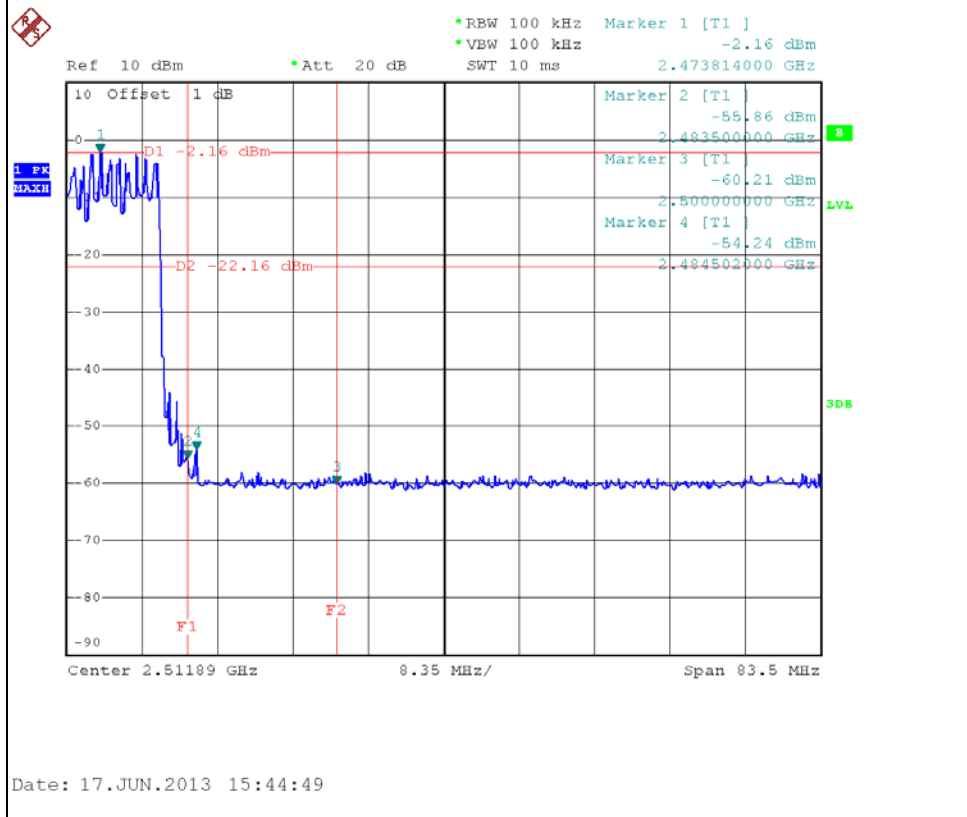

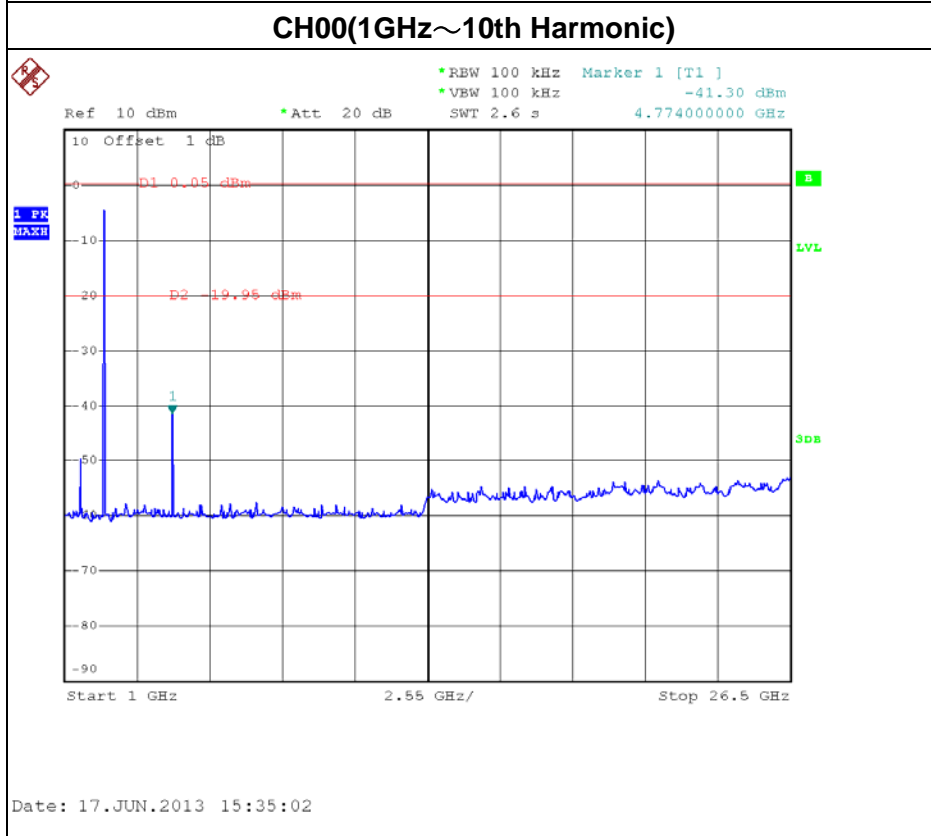
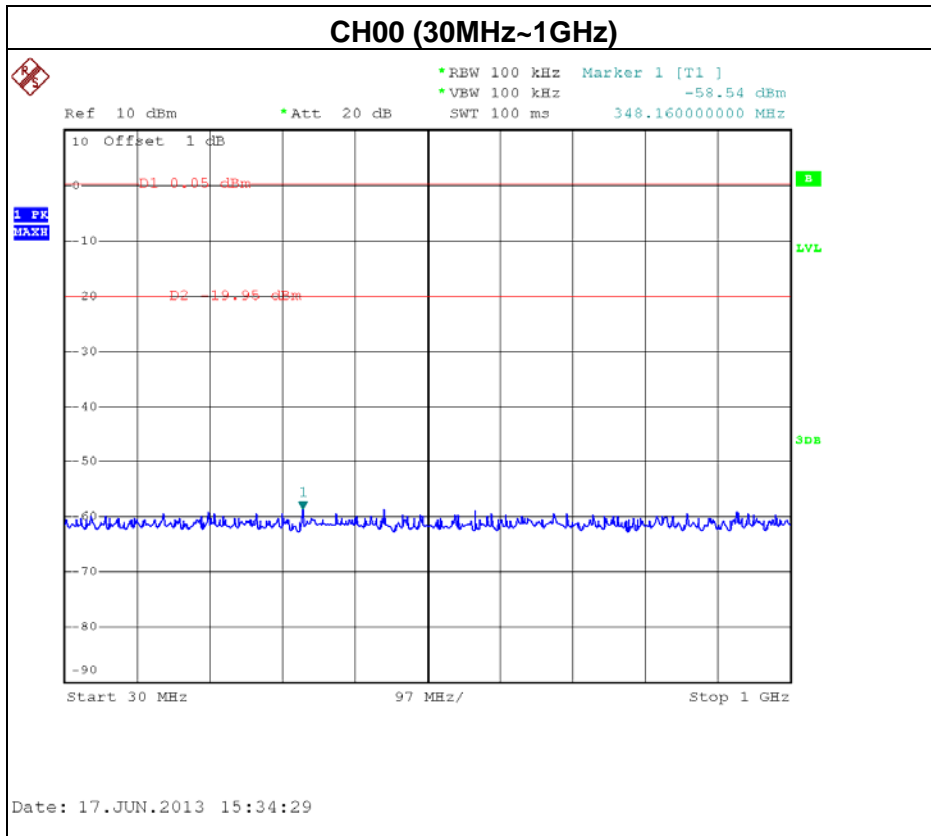

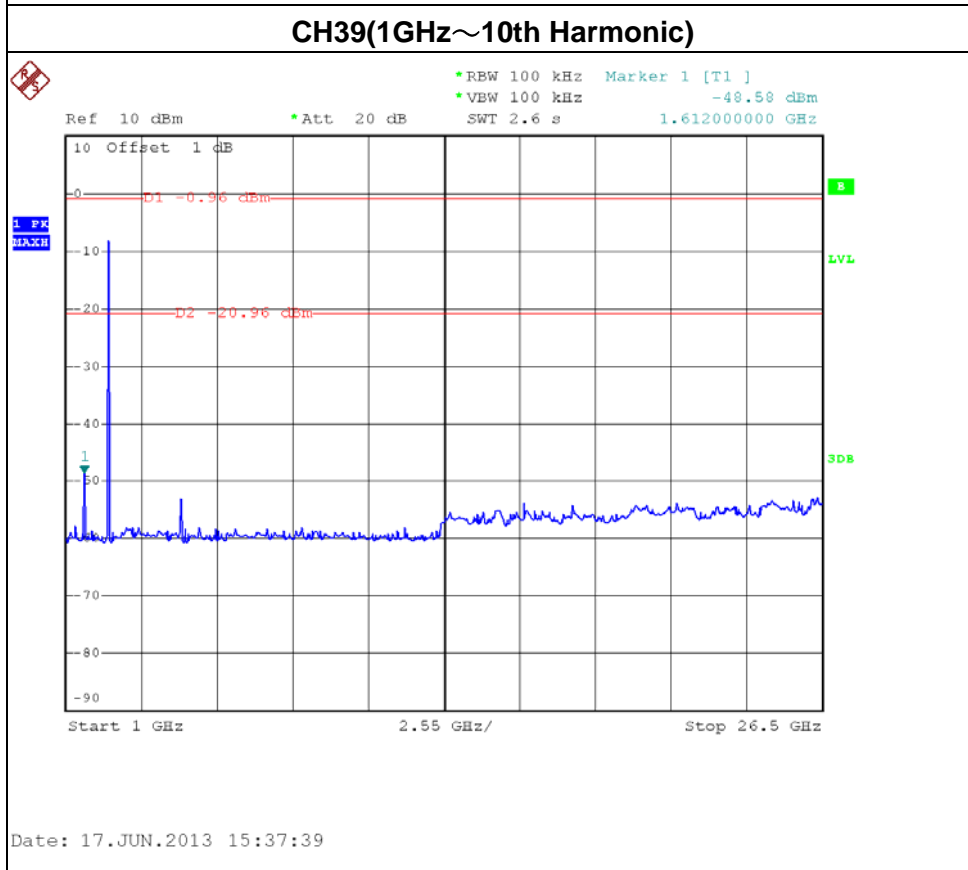
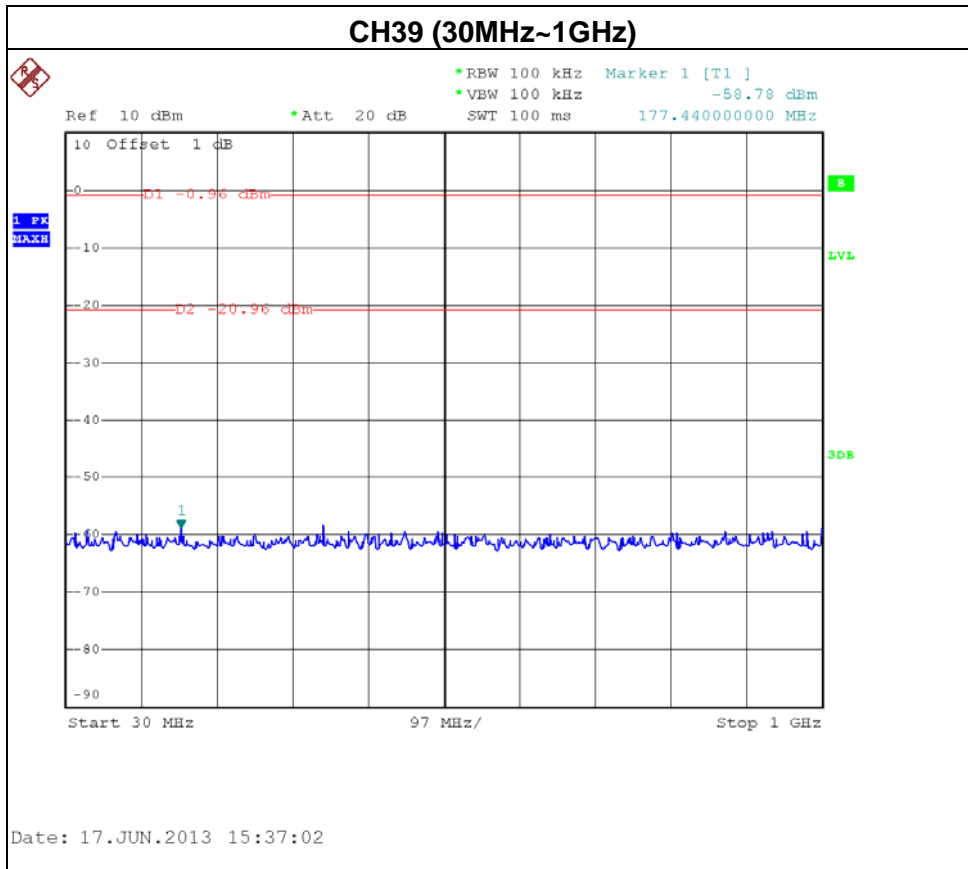

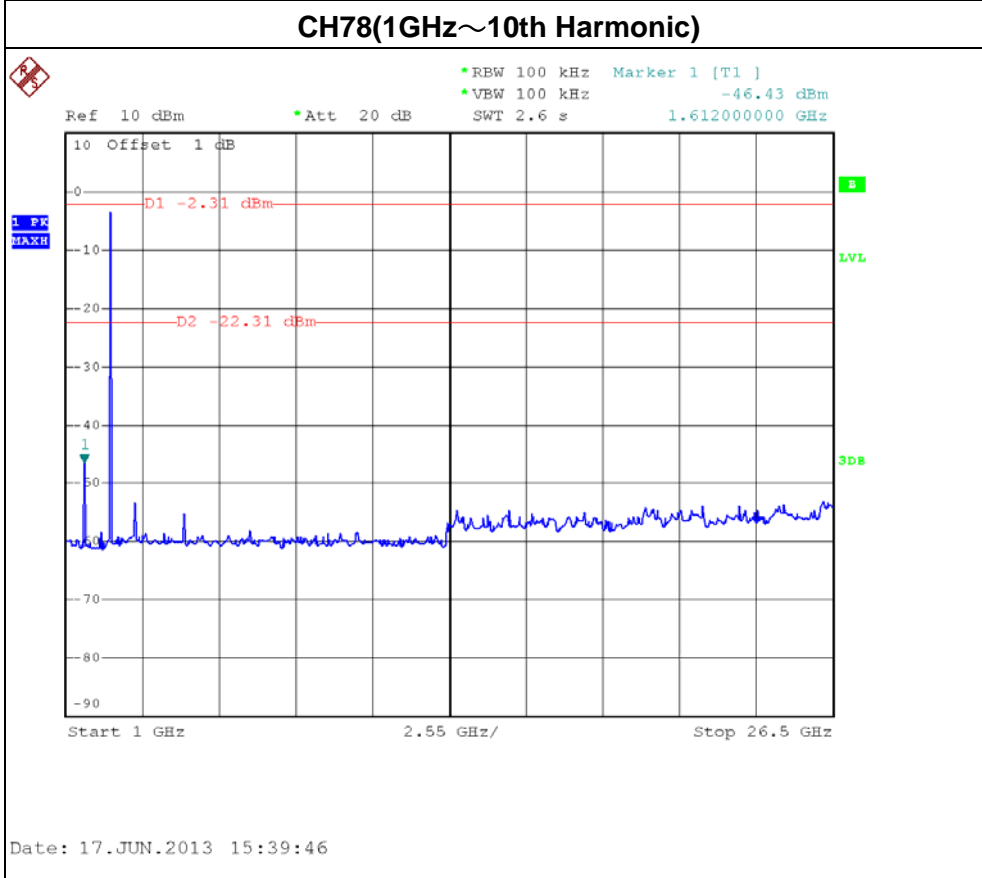
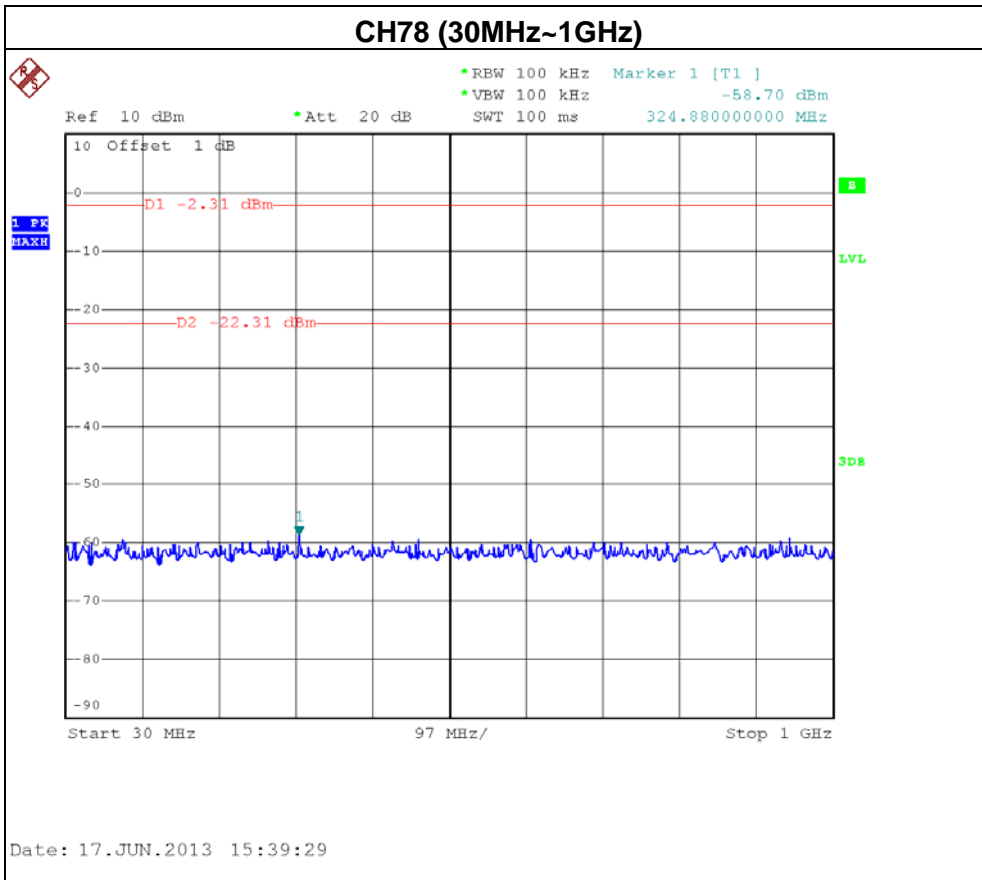



11. EUT TEST PHOTO

Conducted Measurement Photos



**Radiated Measurement Photos
9K~30MHz**

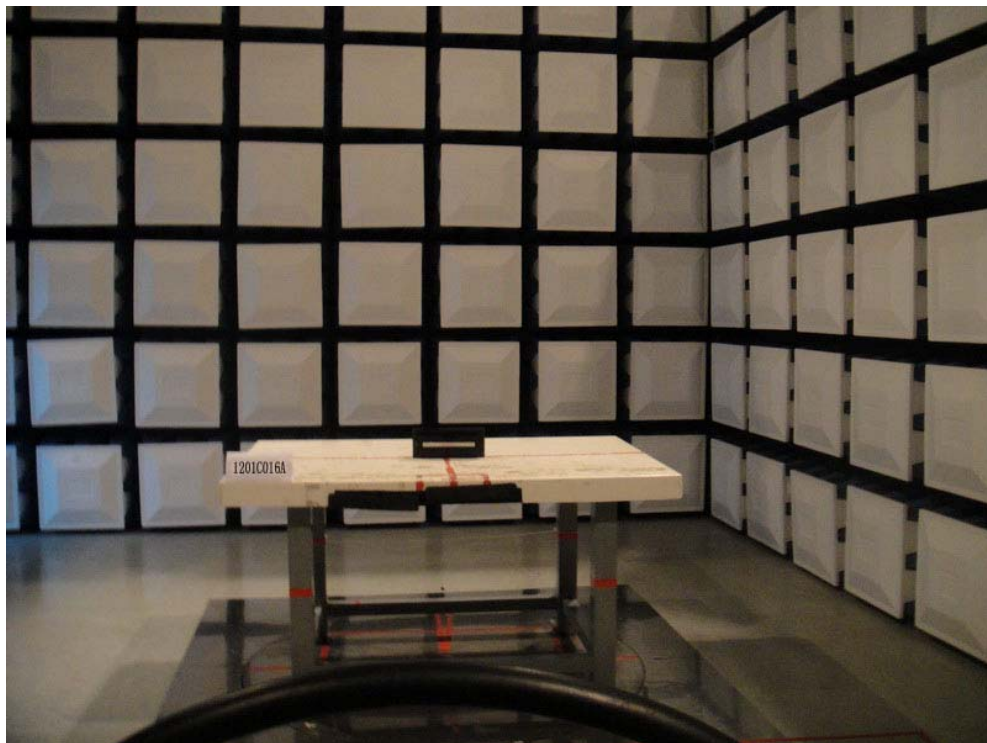
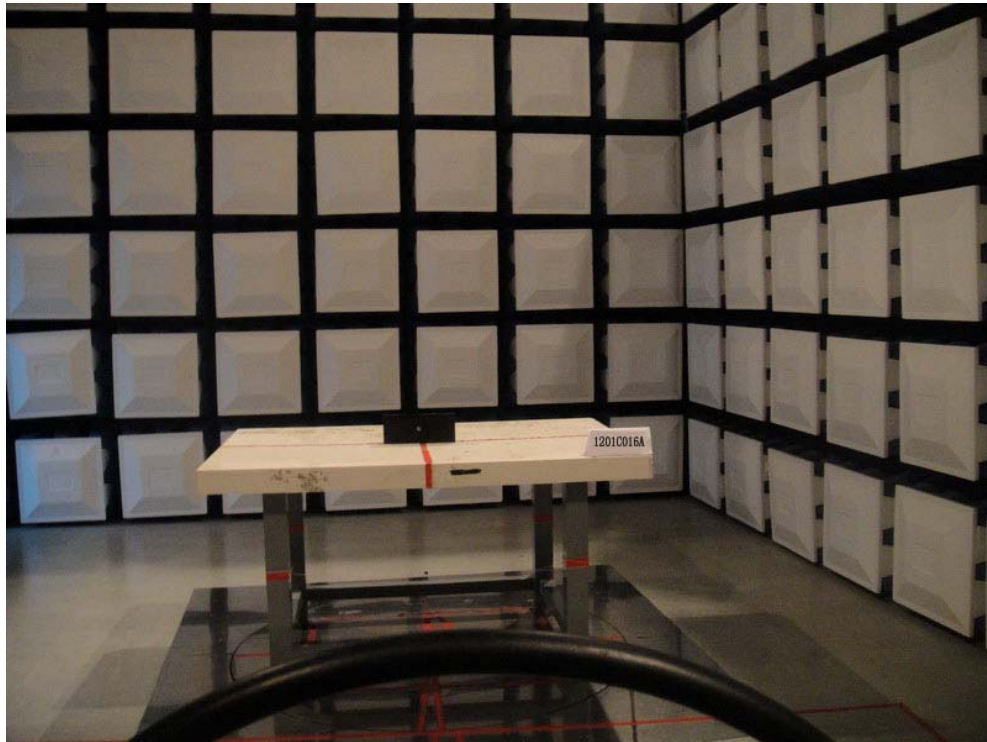

**Radiated Measurement Photos
30M~1000MHz**

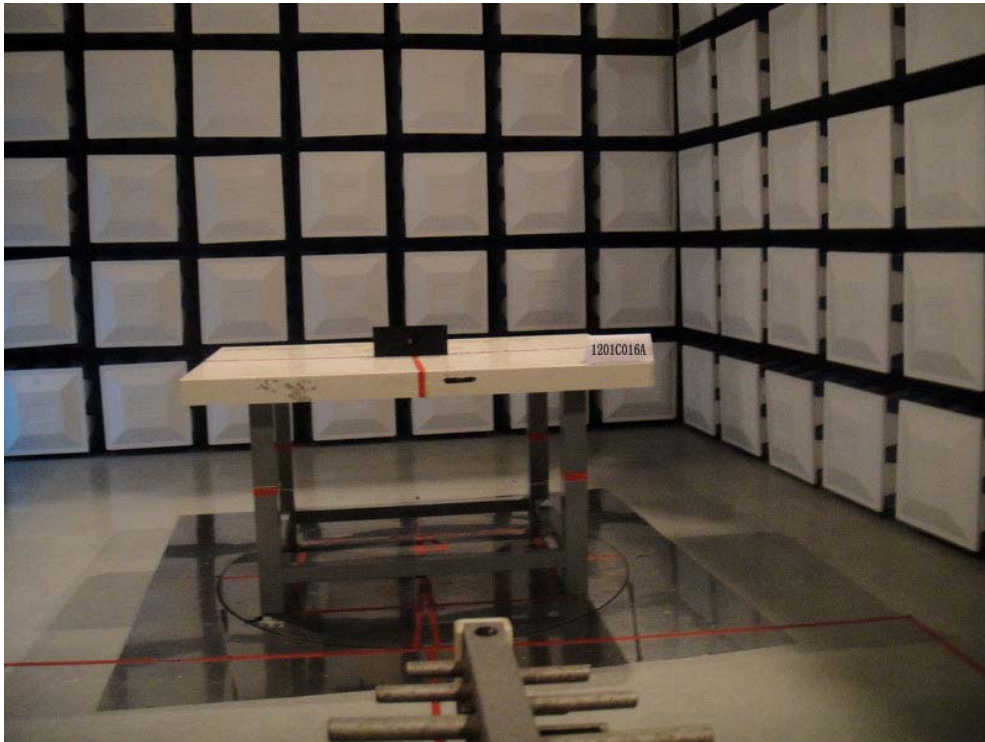

**Radiated Measurement Photos
Above 1000MHz**

