

# SOUND|FREQ<sup>®</sup>

## Sound Stack

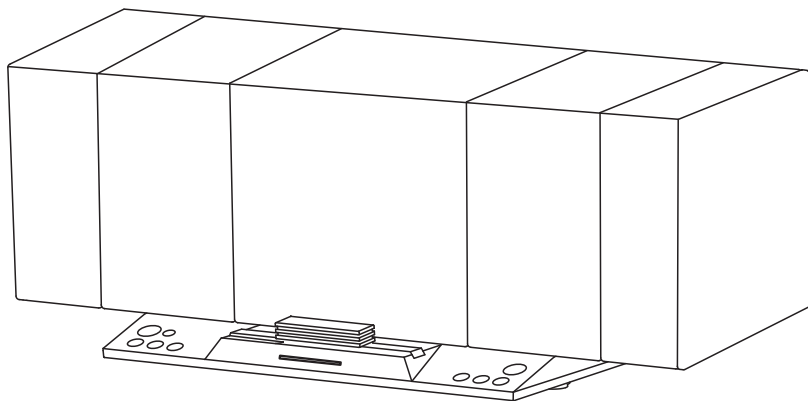



SFQ-03



Made for  
iPod iPhone iPad

## User Manual

# Safety Information

	<b>CAUTION</b> RISK OF ELECTRIC SHOCK DO NOT OPEN	
	The lightning flash with arrowhead symbol, within an equilateral triangle is intended to alert the user to the presence of uninsulated "dangerous voltage" within the product's enclosure that may be of sufficient magnitude to constitute a risk of electric shock to persons.	
	The exclamation point within an equilateral triangle is intended to alert the user to the presence of important operating and maintenance (servicing) instructions in the literature accompanying the appliance.	
<b>WARNINGS:</b> TO REDUCE THE RISK OF FIRE OR ELECTRIC SHOCK, DO NOT EXPOSE THIS APPLIANCE TO RAIN OR MOISTURE.  <b>DO NOT REMOVE COVER or OPEN THE CABINET.</b> Dangerous high voltages are present inside the enclosure. No user serviceable parts inside. Leave all servicing to qualified service personnel.		

## IMPORTANT SAFETY INSTRUCTIONS

1. Read these instructions.
2. Keep these Instructions.
3. Heed all Warnings.
4. Follow all instructions.
5. Do not use this apparatus near water.
6. Clean only with dry cloth.
7. Do not block any ventilation openings. Install in accordance with the manufacturer's instructions.
8. Do not install near any heat sources such as radiators, heat registers, stoves, or other apparatus (including amplifiers) that produce heat.
9. Do not defeat the safety purpose of the polarized or grounding - type plug. A polarized plug has two blades with one wider than the other. A grounding type plug has two blades and a third grounding prong. The wide blade or the third prong is provided for your safety. If the provided plug does not fit into your outlet, consult an electrician for replacement of the obsolete outlet.

10. Protect the power cord from being walked on or pinched particularly at plugs, convenience receptacles, and the point where they exit from the apparatus.
11. Only use attachments/accessories specified by the manufacturer.
12. Use only with the cart, stand, tripod, bracket or table specified by the manufacturer, or sold with the apparatus. When a cart is used, use caution when moving the cart/apparatus combination to avoid injury from tip-over.



PORTABLE CART WARNING  
(Symbol provided by RETAC)

13. Unplug this apparatus during lightning storms or when unused for long periods of time.
14. Refer all servicing to qualified service personnel. Servicing is required when the apparatus has been damaged in any way, such as power-supply cord or plug is damaged, liquid has been spilled or objects have fallen into the apparatus, the apparatus has been exposed to rain or moisture, does not operate normally, or has been dropped.
15. Apparatus shall not be exposed to dripping or splashing and no objects filled with liquids, such as vase, shall not be placed on the apparatus.
16. The mains plug is used as disconnect device and it shall remain readily operable during intended use. In order to disconnect the mains plug from the mains completely, the mains plug should be disconnected from the mains socket outlet completely.
17. The batteries (battery pack & batteries installed) shall not be exposed to excessive heat such as sunshine, fire or the like.

18. Do not place any naked flame sources, such as lighted candles, on the apparatus.
19. The battery used in this product must be properly recycled or disposed of. Please contact your local recycling center for proper battery handling and disposal instructions.

**FCC and IC Information:**

This device complies with Part 15 of the FCC Rules and RSS-210 of the IC Rules. Operation is subject to the following two conditions: (1) This device may not cause harmful interference, and (2) this device must accept any interference received, including interference that may cause undesired operation.

**Warning:** Changes or modifications to this unit not expressly approved by the party responsible for compliance could void the user's authority to operate the equipment.

**Note:** This equipment has been tested and found to comply with the limits for a Class B digital device, pursuant to Part 15 of the FCC Rules. These limits are designed to provide reasonable protection against harmful interference in a residential installation. This equipment generates, uses, and can radiate radio frequency energy and, if not installed and used in accordance with the instructions, may cause harmful interference to radio communications. However, there is no guarantee that interference will not occur in a particular installation. If this equipment does cause harmful interference to radio or television reception, which can be determined by turning the equipment off and on, the user is encouraged to try to correct the interference by one or more of the following measures:

- Reorient or relocate the receiving antenna.
- Increase the separation between the equipment and receiver.

- Connect the equipment into an outlet on a circuit different from that to which the receiver is connected.
- Consult the dealer or an experienced radio TV technician for help.

**Warnings:** The device meets the exemption from the routine evaluation limits in section 2.5 of RSS 102 and users can obtain Canadian information on RF exposure and compliance from the Canadian Representative Burnport Holdings Ltd. 72MT Belcher Pls, East, Calgary, Alberta, T2Z 2G1, CANADA. Tel: 403-257-4961

**FCC&IC Radiation Exposure Statement**

This equipment complies with FCC radiation exposure limits set forth for an uncontrolled environment and meets the exemption from the routine evaluation limits in section 2.5 of RSS 102.

1. This Transmitter must not be co-located or operating in conjunction with any other antenna or transmitter.
2. This equipment complies with FCC RF radiation exposure limits set forth for an uncontrolled environment. This equipment should be installed and operated with a minimum distance of 20 centimeters from user and bystanders.

For compatibility between the SFQ-03 system and another device with Bluetooth technology, consult the device's documentation and dealer. In some countries, there may be restrictions on using Bluetooth devices. Check with your local authorities.

Bluetooth is a registered trademark of Bluetooth SIG, Inc

Please read rating label at the bottom of system for power input and other safety information.

### CAUTION — Proper Installation

- Install the system in a place which is level, dry and neither too hot nor too cold. The appropriate temperature is between 5 °C and 35 °C.
- Install the system in a location with adequate ventilation to prevent internal heat from building up inside the unit.
- Leave sufficient distance between the system and TV.
- Keep the system away from TV to avoid interference with TV.

### CAUTION — Proper Ventilation

To avoid risk of electric shock and fire, and to prevent damage, locate the apparatus as follows:

**Front:** No obstructions and open spacing.

**Sides / Top / Back:** No obstructions should be placed in the areas shown by the dimensions below.

**Bottom:** Place on the level surface. Maintain an adequate air path for ventilation by placing on a stand with a height of 10 cm (3-15/16") or more.

#### Front View:

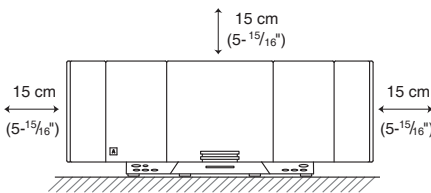

#### Side View:

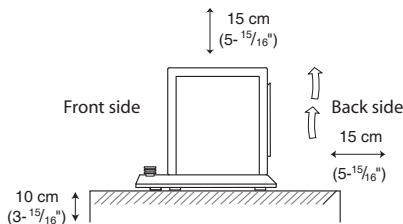

### Information for Users on Disposal of Old Equipment

#### [European Union]



This symbol indicates that the electrical and electronic equipment should not be disposed as general household waste at its end-of-life. Instead, the product should be handed over to the applicable collection point for the recycling in accordance with your national legislation.

**Attention:**  
This symbol is only valid in the European Union.

By disposing of this product correctly, you will help to conserve natural resources and will help prevent potential negative effects on the environment and human health that could otherwise be caused by inappropriate waste handling of this product. For more information about collection point and recycling of this product, please contact your local municipal office, your household waste disposal service or the shop where you purchased the product. Penalties may be applicable for incorrect disposal of this waste, in accordance with national legislation.

#### [Other Countries outside the European Union]

If you wish to dispose of this product, please do so in accordance with applicable national legislation or other rules in your country for the treatment of old electrical and electronic equipment.

QDID:

# Contents

---

<b>Getting Started</b> .....	<b>5</b>
Package Contents .....	5
Installing/Replacing the Batteries .....	5
Connecting the AC Adapter .....	6
Using the Remote Control .....	7
<b>System Overview</b> .....	<b>8</b>
Front View .....	8
Back View .....	8
Remote Control .....	9
<b>Selecting the Sound Source</b> .....	<b>9</b>
<b>Playing back from iPad/iPhone/iPod</b> .....	<b>10</b>
Setting an iPod on the Unit .....	10
Listening to an iPod .....	10
Charging an iPod .....	11
<b>Playing back via Bluetooth</b> .....	<b>12</b>
Downloading the SoundFreaq App .....	12
Using Multiple Bluetooth Devices .....	13
Playing back from Macbook or Macbook Pro .....	13
Playing back from PC/Notebook .....	13
<b>Listening to Tuner</b> .....	<b>14</b>
Listening to a Station .....	14
Presetting a Station .....	14
<b>Playing back from Optional Components</b> .....	<b>15</b>
Listening to an External Audio Device .....	15
<b>Playing back via Digital Optical Input</b> .....	<b>15</b>
Listening to an Optical Audio Device .....	15
<b>Activating "U-Cubed" Sound Effect</b> .....	<b>16</b>
<b>Troubleshooting</b> .....	<b>17</b>
<b>Technical Specifications</b> .....	<b>18</b>

# Getting Started

## Package Contents

Examine whether the following package contents are all included:

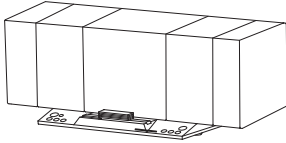

Main Unit



Remote Control



Switch Mode  
Power Supply



FM Antenna



Adapter Cable



Lithium Coin Battery  
CR2025

- It is loaded on the remote control at the factory.

## Installing/Replacing the Batteries

**CAUTION:** Danger of explosion if battery is incorrectly replaced. Replace only with the same or equivalent type.

1. Squeeze and pull to release the battery cover latch. You can remove the battery door with your fingernails by using the spaces set back in wall.

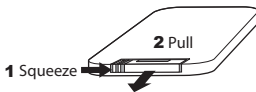

2. Match the polarity on the Lithium Cell with a plus sign (+) on the battery tray.
3. Slide the tray with new battery into the battery compartment until you hear a click sound.

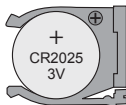

### Warning - When Using the Battery

- Store the battery in a place where children cannot reach. If a child accidentally swallows the battery, consult a doctor immediately.
- Do not recharge, short circuit, disassemble, heat the battery, or dispose the battery in fire.
- Do not leave the battery with other metallic materials.
- When throwing away or saving the battery, wrap it in tape and insulate; otherwise, the battery may start to give off heat, crack, or start a fire.
- Do not poke the battery with tweezers or similar tools.
- Dispose of battery in the proper manner, according to federal, state, and local regulations.
- This product contains a CR Coin Cell Lithium Battery that contains Perchlorate Material, so that special handling may apply.

# Connecting the AC Adapter

**WARNING!** For optimal performance, use only the supplied AC adapter.

- Ensure that power supply outlet matches with the unit AC's input 100-240V~, 50/60Hz before connection.

1. Insert the Switch Mode Power Supply into 20V/4.47A DC IN jack of the unit.
2. Insert one end of the Adapter Cable into the end of the Switch Mode Power Supply and the other end into an electrical outlet only after all other connections are completed.

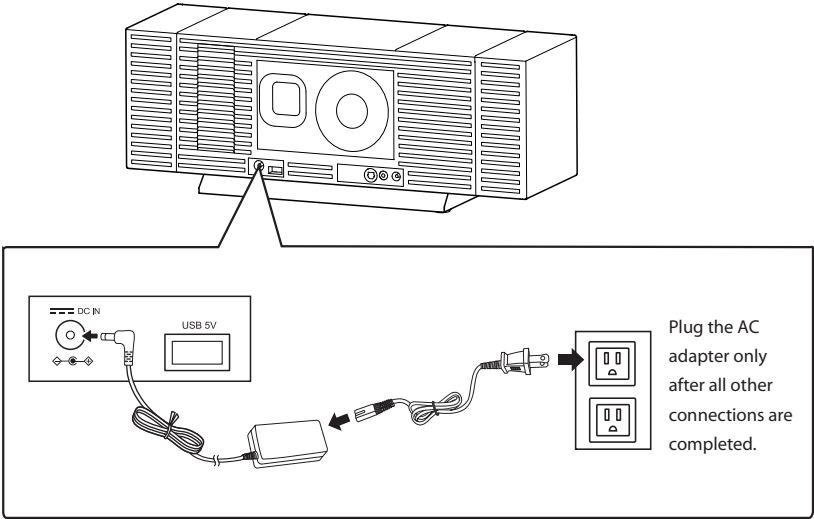

## **Using the Remote Control**

### **Using the remote control**

- Remove the insulation sheet before using for the first time.
- Aim the remote control at the IR sensor on the front lens within an approximate distance of 7m (23 feet) away.

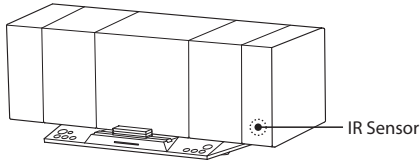

### **Storing the remote control**

A remote control storage location is designed on the back of the unit. The remote control can be magnetized into the storage location easily for your quick and convenient use.

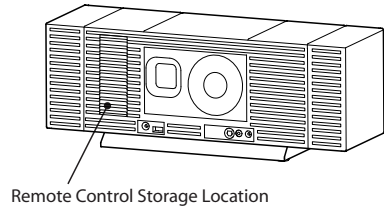

### **Handling the Remote Control**

To avoid possible failure, read the following instructions and handle the remote control properly.

- Do not drop or cause impact to the remote control.
- Do not spill water or any liquid on the remote control.
- Do not place the remote control on a wet object.
- Do not place the remote control under the direct sunlight or near sources of excessive heat.



**Note:** If you are not going to use the remote control for a long time, remove the battery to avoid any damage that may be caused by leakage and corrosion.

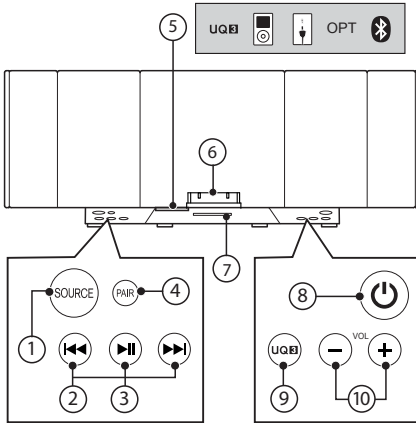

# System Overview

## Front View



1. **SOURCE** button  
Toggle among iPod, AUX, Optical and Bluetooth modes.
2. ◀◀ (Previous) / ▶▶ (Next) button  
Skip to the previous/next track in iPod and Bluetooth modes.
3. ▶◯◀ (Play/Pause) button  
Press to play or pause a track.
4. **PAIR** button  
Build a Bluetooth connection with a Bluetooth-enabled device.
5. Indicators  
 uq3 Lights when the UQ3 is activated.  
 Lights in iPod mode  
 Lights in AUX mode  
 OPT Lights in opticle mode  
 Lights in Bluetooth mode
6. 30-pin Apple connector  
Connect with iPod.
7. Pair indicator  
To indicate when building a Bluetooth connection.
8. ⏻ (on/Standby) button  
Switch between standby and power-on modes.

## Back View

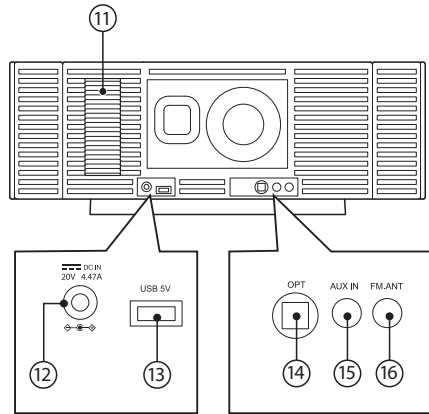

9. **U-Cubed** button  
Press to activate or deactivate the U-Cubed (High Definition Wide Stereo) sound effect.
10. **Vol +/-** button  
Press to increase (+) or decrease (-) the volume level.
11. Remote control storage location
12. **DC IN** jack
13. **USB** jack  
Charge an external device via the jack. It is used for charging purposes only.  
**Note:** With the USB connection, it can charge most devices whose power supply is possible via USB (e.g., various mobile phones).
14. **OPT** optical input jack  
For connecting an external device that has a digital optical output jack.  
**Note:** The little plastic piece swings up when you plug in the optical cable.
15. **AUX IN** jack  
For transmitting an audio input signals from auxiliary source.
16. **ANT** Antenna jack  
For FM reception, connect the FM antenna to the jack.

## Remote Control

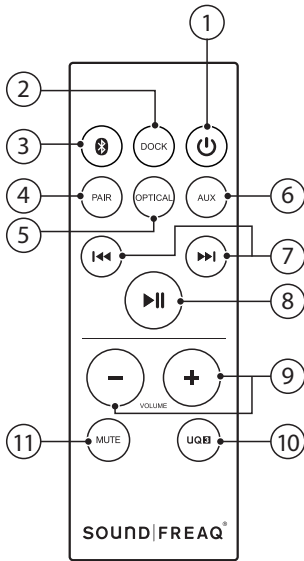

1. **⏻** (On/Standby) button  
Switch between standby mode and power-on mode.
2. **DOCK** button  
Switch to iPod mode.
3. **Bluetooth** button  
Switch to Bluetooth mode.
4. **PAIR** button  
Build a Bluetooth connection with a Bluetooth-enabled device.
5. **OPTICAL** button  
Switch to optical mode.
6. **AUX** button  
Switch to AUX mode.
7. **⏮** (Previous) / **⏭** (Next) button  
Skip to the previous/next track in iPod and Bluetooth modes.
8. **▶||** (Play/Pause) button  
Play/pause a track when listening to a track.
9. **VOLUME +/-** button  
Press to increase (+) or decrease (-) the volume level.
10. **U-Cubed** button  
Activate or deactivates U-Cubed (High Definition Wide Stereo) sound effect.
11. **MUTE** button  
Turn off the sound. Press again to restore the sound output.

## Selecting the Sound Source

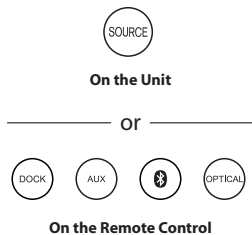

This system enables you to access one of four basic functions - iPod, AUX, Bluetooth and Optical.

Press the **SOURCE** button on the unit or the **DOCK**, **AUX**, **Bluetooth** and **OPTICAL** buttons on the remote control/remote App to select one of the sound sources.

The FM radio can only be played from an iPad, iPhone or iPod touch using the Soundfreaq App. It can be played in iPod or Bluetooth mode.

# Playing back from iPad/iPhone/iPod

**Note:** In this user manual, "iPod" is used as a general reference to functions on an iPod, iPhone or iPad, unless otherwise specified by the text or illustrations.

## Setting an iPod on the Unit

● **Compatible iPod Players:** Most Apple iPod models with 30-pin dock connectors as follows: iPad, iPod nano 6th generation, iPod nano 5th generation (video camera), iPod nano 4th generation (video), iPod nano 3rd generation (video), iPod nano 2nd generation (aluminum), iPod nano 1st generation, iPod 4th generation (color display), iPhone, iPhone 3G/3GS, iPhone 4, iPod classic, iPod 5th generation (video), iPod 4th generation, iPod touch 4th generation, iPod touch 3rd generation, iPod touch 2nd generation, iPod touch 1st generation, iPod mini.

1. Remove the rubber cover from the iPod connector.
2. Connect your iPod. Make sure the connector plug of unit is firmly inserted into the connector port of iPod.

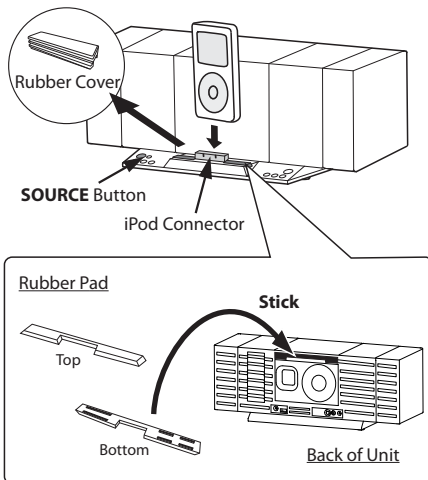

## Notes:

- If you are docking your device with a case, you can remove the rubber pad to secure a better fit and connection. Both the rubber cover and pad can be conveniently stuck along the ribs on the back of the Sound Stack.
- Always set volume to the minimum when connecting or disconnecting the other equipment.
- When you connect your iPod to unit, make sure you insert it all the way.
- When placing or removing the iPod, hold the iPod at the same angle as that of the connector on this unit, and do not twist or bend the iPod as connector damage may result.
- Before disconnecting the iPod, pause playback.
- If the battery of your iPod is extremely low, charge it for a while before operation.
- An iPod touch/iPhone/iPad will not work unless it is turned on. Be sure to turn on the power of iPod touch/iPhone/iPad before operation.

## Listening to an iPod

1. Press the "⏻" button to power on the system.
2. Set an iPod on the unit and press the **SOURCE** button on the unit or **DOCK** button on the remote control to switch to the iPod mode if the unit is not in the iPod mode.
3. Press the "▶||" button to play the track.

## **Charging an iPod**

The battery of the iPod is always charged through the unit when it is connecting to a wall outlet.

- Charging begins when the iPod is set on the dock.
- The charging status appears in the display on iPod.
- Make sure the AC adapter is connected to the unit.
- The iPod is charged regardless of the sound source selected on the unit.
- See the iPod instruction manual about the details of iPod charging.

## **Notes for Caring Your iPod:**

- The connector plug is protected with a cover when it is first purchased. Please remove the cover before operating the unit.
- Do not carry the unit with iPod connected. You might drop it down or it might cause damages to the connector part.
- Do not touch or hit the iPod terminal pins or the connector pins directly. It might cause damages to the connector part.
- If the iPod does not play correctly, please update your iPod software to the latest version. - For details about updating your iPod, check on the Apple web site <<http://www.apple.com>>.
- iPod is a trademark of Apple Inc., registered in the U.S. and other countries.
- iPhone is a trademark of Apple Inc.
- iPad is a trademark of Apple Inc.
- We are not responsible for any loss of or damage to iPod that might result from the use of this product.
- Sound distortion may occur when playing back audio sources with high recording levels. When distortion occurs, it is recommended to turn off the equalizer of the iPod. For information on operating the iPod, see the iPod instruction manual.
- "Made for iPod" and "Made for iPhone" and "Made for iPad" mean that an electronic accessory has been designed to connect specifically to iPod/iPhone/iPad and has been certified by the developer to meet Apple performance standards.
- Apple is not responsible for the operation of this device or its compliance with safety and regulatory standards.

# Playing back via Bluetooth

## Downloading the SoundFreaq App

We have developed an App to give you full control from your iPhone/iPad/iPod touch while playing audio over the Bluetooth wireless connection, please download the "SoundFreaq Remote" App for FREE.

After you build a Bluetooth connection between your iPhone/iPad/iPod touch and the Sound Stack, a prompt will be displayed on your iPhone/iPad/iPod touch asking you if you would like to install our App, click "Yes" to install the APP. After a while, "For this Accessory" page will appear on your iPhone/iPad/iPod touch. Enter the "User Name" and "Password" in the iTunes. After pressing the "FREE" button, press the "INSTALL APP" button that will appear to install the APP for your unit. When the installation is finished, you can control the playback from your iPhone/iPad/iPod touch.

**You will need the App to operate the FM radio function.**

**Warning:** Do not unplug the AC adapter from the unit when playing back a track via the Bluetooth connection.

### Notes:

- If your mobile phone supports A2DP protocol, its music will play through the unit.
  - You can build a Bluetooth connection with a mobile phone, an iPhone/iPad/iPod touch or any other Bluetooth-enabled devices.
1. Press the "  " button to power on the unit.
  - The pair indicator is solid on when the unit is powered on.
  2. Press the **PAIR** button on the unit to put the unit into the pair mode.
  - The Pair indicator starts blinking at a fast rate.
  - If you hold the **PAIR** button for more than 2 seconds during the process of pairing, the operation will be cancelled.

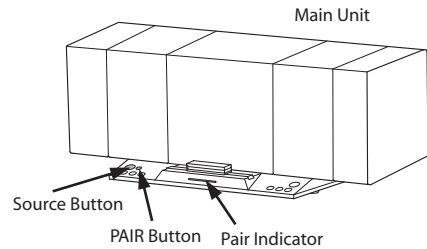

3. During this period, you can operate the mobile phone, iPad or Bluetooth-enabled device to pair with the unit within a 33 feet (10m) range.
- Please check the user manual of the iPad or Bluetooth-enabled device with which you are initiating pair to learn about Bluetooth connection with any other devices.
4. Once the unit is detected and its name "**Sound Stack**" appears on the display of your Bluetooth-enabled device, key in the default password "**1234**" if a prompt requests it.
- You may change the device name on your Bluetooth-enabled device after the pair is successfully set up.

- The pair indicator starts blinking quickly to indicate that the unit and your device have put into the connection mode.
  - When a Bluetooth connection is established successfully, the indicator will be solid on.
5. Select Bluetooth mode by repeatedly pressing the **SOURCE** button on the unit or pressing the Bluetooth button on remote control.
  6. Select the desired music and press "Play" button on your device. The unit automatically starts playing the audio.
- Try again above steps 2 to 5 if the pair indicator turns solid after blinking for 3 minutes, the pair was unsuccessful.

4. Once completed, the pairing success screen will come out.

**Note:** Don't quit the page immediately. You may notice that the previous dialog screen still shows the device not connected. Just ignore it. It's confusing to the user. In fact, it's connected already.

5. Open iTunes, play a song. Then use mouse to click the Bluetooth icon and the top right hand corner of the desktop screen, select the "Sound Stack" option and then select the "Use as Audio Device (Stereo)". After a while (a few seconds), the music will come out from the SFQ-03. If not, retry to select the "Use as Audio Device (Stereo)" once again. The Sound Quality should be good.

### **Using Multiple Bluetooth Devices**

Only one device can be used at a time, but you can switch between different Bluetooth devices. Make sure each device you want to use has already been paired, to switch devices:

1. On the Sound Stack, press the pair button.
2. On the Bluetooth device, select the connection to the Sound Stack.

This device is now the connected device to the Sound Stack, (the previous connected device is now disconnected). Repeat those steps to switch the connected device again.

**Note:** If the unit has no sound output, please check if the volume level of your Bluetooth device connected to the unit is set to the minimum, or the Bluetooth device is muted.

### **Playing back from Macbook or Macbook Pro**

1. In the desktop screen, Select the "Open Bluetooth Preference".
2. If there is any old "Sound Stack" records, remove it. And then select "Setup New Device" again.
3. Select "Sound Pla" and the type should be "Audio" in the latest SFQ-03 unit.  
Click the "Continue" to proceed pairing process.

### **Playing back from PC/Notebook**

1. Press the "Start" button to open the "Device and Printers" dialog box.
2. Turn on the SFQ-03 system and press the **PAIR** button on the unit to put the unit into the pair mode.
3. Select the "Add a device" in the "Device and Printer" dialog box. The "Sound Stack" icon will appear on the display.
4. Double click the "Sound Stack" icon and wait until the device has been added successfully.
5. Click the "Close" button to close the "Device and Printer" dialog box. A "Sound Stack" icon appears in the dialog box.
6. Double click the "Sound Stack" icon and the device connection screen will be shown.
7. Click the "Connect" button in the "Music and Audio" option.
8. Once connected, the pair indicator on the unit will be solid on and the connection success screen will be shown.

# Listening to Tuner

The FM radio function can be accessed by:

- 1) the remote App, when Bluetooth connection has been built;
- 2) the remote App, when the iPad/iPhone/iPod touch is set on the unit.

The operation interface of remote App software is similar to the remote control. You can easily operate the tuner function on the display of iPad/iPhone/iPod touch.

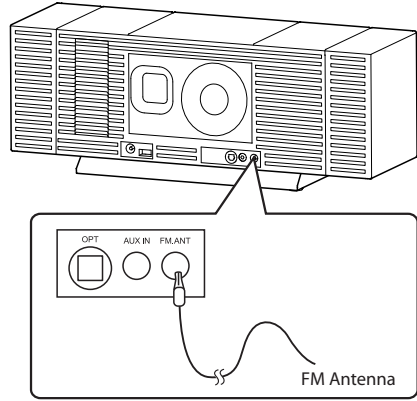

Press the Button	Functions
Remote App	
	<ul style="list-style-type: none"> <li>• Switch between the frequency display and channel number display.</li> <li>• Hold this button to enter saving mode. Press to save a channel. (see "Presetting a station")</li> </ul>
	<ul style="list-style-type: none"> <li>• Select a channel (from 01 to 20).</li> <li>• Change frequency (from 87.5 MHz to 108.0 MHz).</li> <li>• Hold for more than one second to activate the Auto Scan function, and then release the button. The frequency will be scanned automatically until a radio station is found. Or press again to quit search while searching.</li> </ul>

## Listening to a Station

**Note:** Position the antenna as far away as possible from the AC adapter, a TV, or other radiation source.

1. Plug the supplied FM antenna into the **FM.ANT** jack located on the back of unit.
2. Press the "⏻" button to power on the system.
3. Select tuner mode with the **SOURCE** button on the remote App.
4. Select a desired radio station for listening.
5. Move the antenna in various directions until the clearest signal is received.
6. If necessary, adjust the volume level.

## Presetting a Station

**Note:** Presetting station function can be completed through the Soundfreaq App, in either iPod or Bluetooth mode.

1. Select tuner mode with the **SOURCE** button on the remote App.
2. Switch to the frequency display if the display is channel number.
3. Tune a desired frequency. You can use either of the below methods to tune the frequency.

**A. Manual Tuning** - Briefly press "◀ / ▶" button repeatedly to move frequency to frequency (from 87.5 MHz to 108.0 MHz) until you find the desired station.

**B. Auto Scanning** - Hold "◀ / ▶" button until the frequency display starts flashing. The frequency will be scanned automatically until a station is found.

4. Hold "▶▶" button to start storing a station.
  - The channel number and "Select" word start blinking together on the display of the iPad/iPhone/iPod touch.
5. Use "◀ / ▶" to select the channel number (from 01 to 20) to be set.
6. Press "▶▶" button again to store the frequency. The selected frequency will then be stored with the preset channel number.

# Playing back from Optional Components

## Listening to an External Audio Device

You can enjoy the sound from an optional component such as a portable digital music player through the speakers of this unit. Be sure to turn off the power of each component before making any connections. For details, refer to the instruction manual of the component to be connected.

Connect an external device to the **AUX IN** jack on the back panel of the unit using a stereo mini plug cord (not supplied).

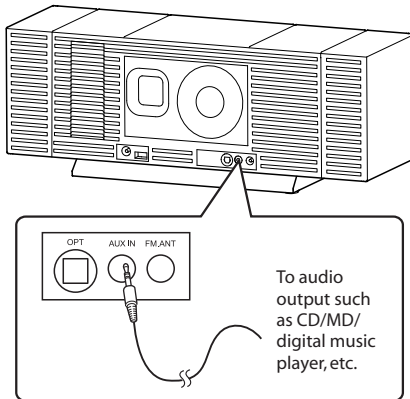

1. Turn the unit power on.
2. Set the volume to the minimum position.
3. Select AUX mode with the AUX button on the unit or the **SOURCE** button on the remote control.
4. Start playback on the external device.
5. Adjust the volume level to the level that you want to listen to.

# Playing back via Digital Optical Input

## Listening to an Optical Audio Device

You can enjoy the sound from a digital optical device (such as CD or DVD player and an AV receiver or Surround Sound Preamp/Processor), through the speakers of this unit. You can obtain better sound effect.

Connect the two ends of an optical audio cable (not supplied) separately to the **OPT** jack of the unit and an optical output jack of your digital device.

1. Turn the unit power on.
2. Set the volume to the minimum position.
3. Select optical mode with the **SOURCE** button on the unit or the **OPTICAL** button on the remote control.
4. Start playback on the optical device.
5. Adjust the volume level to the level that you want to listen to.



## Activating "U-Cubed" Sound Effect

**UQ3** "U-Cubed" is an proprietary technology designed to create an ultra wide stereo sound field in digital music systems. With exceptional natural sound reproduction of high definition and fidelity, we create a listening experience where you feel like your speakers are separated much more than they are.

**To activate UQ3 on:**

- The unit, press the " **UQ3** " button to activate, press again to deactivate.
- On the remote control or remote App, press the " **UQ3** " button to activate and deactivate..

**Note:** In tuner mode, the U-Cubed sound effect cannot be activated.

# Troubleshooting

Check this list for a possible troubleshooting solution before calling for service.

In These Cases	Check the following points
Power does not come on.	<ul style="list-style-type: none"> <li>AC adapter is not inserted securely. Plug in securely.</li> </ul>
Cannot set the iPad/iPhone/iPod.	<ul style="list-style-type: none"> <li>Is the selected dock adapter compatible to your iPad/iPhone/iPod?</li> <li>Is the dock adapter properly mounted on the unit? Make sure to mount the dock adapter properly.</li> </ul>
Cannot operate iPad/iPhone/iPod.	<ul style="list-style-type: none"> <li>Is the connector plug of the unit firmly inserted into the connector port of the iPad/iPhone/iPod?</li> <li>Is the iPad/iPhone/iPod properly functioning? Test the iPad/iPhone/iPod functions in stand-alone condition.</li> </ul>
iPad/iPhone/iPod cannot be charged.	<ul style="list-style-type: none"> <li>Is the connector plug of the unit firmly inserted into the connector port of the iPad/iPhone/iPod?</li> <li>Is the AC adapter plug firmly inserted into DC IN jack of the unit?</li> </ul>
Hard to listen to broadcasts because of noise.	<ul style="list-style-type: none"> <li>The antenna is not properly extended or positioned.</li> <li>Tune to the correct radio channel/frequency.</li> <li>Making sure the antenna is further away from any equipment that may be causing the noise or interference.</li> </ul>
Unable to operate the System from the remote control.	<ul style="list-style-type: none"> <li>The path between the remote control and the sensor on the unit is blocked.</li> <li>The battery of remote control is exhausted.</li> </ul>
No sound output.	<ul style="list-style-type: none"> <li>Check if the volume level is set to the minimum.</li> <li>Check if the volume level of your Bluetooth device connected to the system is set to the minimum.</li> <li>Check if the volume level is muted. Press <b>MUTE</b> button on the remote control again to restore the sound output.</li> <li>Check to make sure your Bluetooth device is not muted.</li> </ul>
The system does not react when the buttons are pressed.	<ul style="list-style-type: none"> <li>Remove and reconnect the AC power plug and turn on the system again.</li> </ul>
The system is suddenly powered off.	<ul style="list-style-type: none"> <li>The system enters the saving energy mode. The unit may be no sound output for more than 28 minutes. Turn on the system again and play back an audio source.</li> </ul>
All the indicators on the system start blinking quickly at the same time when iPod/iPhone is charging.	<ul style="list-style-type: none"> <li>The system enters the protection mode. The unit may have a short circuit. Unplug the AC adapter immediately. You need to consult your seller and leave all servicing to the qualified personnel.</li> </ul>
No sound output is via Bluetooth or Bluetooth connection cannot be restored automatically.	<ul style="list-style-type: none"> <li>The unit may be powered off and powered on when playing back a track via Bluetooth connection. You need to build the connection again.</li> </ul>
Bluetooth connection cannot be built.	<ul style="list-style-type: none"> <li>When building a Bluetooth connection between the unit and your device for the first time, if the connection is fail, you need to power off your device and power on again to clear the device name, and build the connection again.</li> </ul>
Bluetooth connection cannot be established between the system and your Lenovo PC with Win 7 OS.	<ol style="list-style-type: none"> <li>Right click the "Sound Stack" icon in the "Device and Printer" dialog box.</li> <li>Open the "Sound Stack Properties" dialog box and select the "Services" tab.</li> <li>Put the ticks on the "Audio Sink" and "Remote Control" boxes.</li> <li>Press the "Apply" button and the exclamation mark of the "Sound Stack" driver icon will be cleared.</li> </ol>

# Technical Specifications





Model	SFQ-03	
Type	Sound Stack	
Support Bluetooth	Bluetooth 1.2, 2.0 and 2.1 compliant	
Support Profile	A2DP	
Input Sensitivity/Impedance	AUX Input	1200 mV
Tuner	Band	FM
	Tuning Range	87.5 ~ 108.0 MHz
	Frequency Step	100 KHz
	Preset Stations	20
Input Terminal	External DC IN (for AC adapter), AUX IN	
Power Source	DC 20 V $\pm$ 4.47 A (External DC IN)	
AC Adapter	Input: AC 100-240V, 50/60Hz	
	Output: DC 20 V $\pm$ 4.47 A	
Dimensions (Approx.)	440mm (W) * 162mm (H) * 190mm (D)	
Weight	3.18Kg	

Save this manual



## Informations de sécurité

Version Canada

	<b>ATTENTION</b> <small>NE PAS OUVRIR - RISQUE D'ÉLECTROCUTION</small>	
	<p>Le symbole de l'éclair dans un triangle est destiné à mettre en garde l'utilisateur contre la présence de tensions dangereuses à l'intérieur du boîtier du produit, d'une puissance suffisante pour constituer un risque de choc électrique.</p>	
	<p>Le symbole du point d'exclamation dans un triangle est destiné à avertir l'utilisateur de la présence d'importantes instructions d'utilisation et d'entretien dans la documentation jointe à l'appareil.</p>	
<p><b>AVERTISSEMENTS :</b></p> <p>POUR RÉDUIRE LE RISQUE D'INCENDIE OU D'ÉLECTROCUTION, NE PAS EXPOSER CET APPAREIL À LA PLUIE OU À L'HUMIDITÉ.</p> <p><b>N'ENLEVEZ PAS LE COUVERCLE et N'OUVREZ PAS LE BOÎTIER.</b></p> <p>Des tensions élevées dangereuses sont présentes à l'intérieur.          Non réparable par l'utilisateur. Toutes les réparations doivent être effectuées par un personnel qualifié.</p>		

### IMPORTANTES INSTRUCTIONS DE SÉCURITÉ

1. Lisez attentivement ces instructions.
2. Conservez ces instructions.
3. Respectez tous les avertissements.
4. Suivez toutes les instructions.
5. N'utilisez pas cet appareil près de l'eau.
6. Nettoyez-le avec un linge sec uniquement.
7. Ne bloquez pas les fentes d'aération. Installez l'appareil conformément aux instructions du fabricant.
8. N'installez pas l'appareil près de sources de chaleur telles que radiateurs, registres de chaleur, poêles ou autres appareils (y compris les amplificateurs) produisant de la chaleur.
9. Ne détruisez pas la fonction de sécurité de la prise polarisée ou avec mise à la terre. Une prise polarisée comporte deux broches, l'une étant plus large que l'autre. Une prise avec mise à la terre comporte trois broches, la troisième étant la broche de terre. La broche plus large, ou la broche de terre, sont là pour votre sécurité. Si la prise fournie ne correspond pas à vos prises secteur, demandez à un électricien de la remplacer.
10. Protégez le cordon d'alimentation pour qu'il ne soit pas écrasé ou pincé, particulièrement au niveau de la prise de courant et au point où il sort de l'appareil.

11. Utilisez uniquement les accessoires spécifiés par le fabricant.
12. Utilisez uniquement avec le chariot, le pied, le trépied, le support ou la table spécifiés par le fabricant ou vendus avec l'appareil. Quand vous utilisez un chariot, soyez prudent lorsque vous déplacez l'ensemble chariot / appareil pour éviter les blessures en cas de renversement.
13. Débranchez l'appareil en cas d'orage ou si vous ne l'utilisez pas pendant une période prolongée.
14. Toutes les réparations doivent être effectuées par un personnel qualifié. Un entretien est requis lorsque l'appareil a été endommagé de quelque manière que ce soit, par exemple cordon d'alimentation ou prise de courant endommagés, liquide renversé sur l'appareil, objets tombés dans l'appareil, exposition de l'appareil à la pluie ou à l'humidité, ou si l'appareil ne fonctionne pas normalement ou est tombé.
15. L'appareil ne doit pas être exposé aux éclaboussures et aucun objet rempli de liquide ne doit être posé sur l'appareil.
16. La prise secteur est utilisée comme dispositif de déconnexion et doit rester facilement accessible pendant l'utilisation. Pour couper l'alimentation électrique de l'appareil, débranchez la fiche de la prise murale.
17. Les piles ne doivent pas être exposées à une chaleur excessive (soleil, feu, etc.).



AVERTISSEMENT RELATIF AU CHARIOT DE TRANSPORT (Symbole fourni par RETAC)

Pour assurer la compatibilité entre le système SFQ-03 et un autre appareil avec la technologie Bluetooth, consultez la documentation de l'appareil et renseignez-vous auprès du concessionnaire. Certains pays peuvent imposer des restrictions sur l'utilisation des appareils Bluetooth. Veuillez vous renseigner auprès des autorités locales.

Bluetooth est une marque déposée de Bluetooth SIG, Inc.

Veuillez lire l'étiquette apposée sous le système pour la tension d'entrée et d'autres informations de sécurité.

**Avertissement :** les changements ou modifications apportés à cet appareil sans l'approbation expresse de la partie responsable de la conformité pourraient annuler le droit de l'utilisateur à se servir l'appareil.

### Déclarations FCC et IC

Cet appareil est conforme à l'article 15 du règlement de la FCC. Son utilisation est soumise aux deux conditions suivantes : (1) cet appareil ne doit pas provoquer d'interférences préjudiciables, et (2) il doit accepter toute interférence reçue, y compris celles risquant d'engendrer un fonctionnement indésirable.

Le présent appareil est conforme aux CNR d'Industrie Canada applicables aux appareils radio exempts de licence. L'exploitation est autorisée aux deux conditions suivantes : (1) l'appareil ne doit pas produire de brouillage, et (2) l'utilisateur de l'appareil doit accepter tout brouillage radioélectrique subi, même si le brouillage est susceptible d'en compromettre le fonctionnement.

### Déclaration de la FCC et d'IC sur l'exposition aux irradiations :

Cet équipement est conforme aux limitations prévues par la FCC pour l'exposition aux irradiations dans le cadre d'un environnement d'accès libre et est en conformité avec l'exemption d'évaluation de routine des limitations de la section 2.5 de la CNR-210.

1. Cet émetteur ne doit pas être situé à proximité ou fonctionner simultanément avec une autre antenne ou émetteur.
2. Cet équipement est conforme aux limitations prévues par la FCC pour l'exposition aux irradiations RF dans le cadre d'un environnement d'accès libre. Cet équipement doit être installé et mis en fonctionnement à une distance minimale de 20 cm de l'utilisateur et des personnes qui l'entourent.

**Remarque :** ce matériel a été testé et trouvé conforme aux limites de l'article 15 de la réglementation FCC pour les appareils numériques de classe B. Ces limites sont conçues pour fournir une protection raisonnable contre les interférences nuisibles dans une installation résidentielle. Ce matériel génère, utilise et peut émettre des fréquences radio et, s'il n'est pas installé et utilisé conformément aux instructions, peut causer des interférences nuisibles aux communications radio. Toutefois, il n'existe aucune garantie que des interférences ne se produiront pas dans une installation particulière. Si ce matériel cause des interférences nuisibles à la réception radio ou télévision, ce qui peut être déterminé en éteignant l'appareil, l'utilisateur est encouragé à essayer de corriger l'interférence par une ou plusieurs des mesures suivantes :

- Réorienter ou déplacer l'antenne de réception.
- Augmenter la distance entre l'appareil et le récepteur.

- Brancher l'appareil à une prise de courant sur un circuit différent de celui auquel le récepteur est branché.
- Consulter le revendeur ou un technicien radio/ télévision expérimenté.

### ATTENTION - Installation correcte

- Installez le système sur une surface horizontale, dans un endroit sec et ni trop chaud ni trop froid. La température d'utilisation se situe entre 5°C et 35°C.
- Installez le système dans un lieu bien aéré pour éviter qu'il ne surchauffe.
- Laissez une distance suffisante entre le système et le téléviseur.
- Éloignez le système du téléviseur afin d'éviter les interférences avec ce dernier.

### ATTENTION - Ventilation correcte

Pour prévenir tout risque de choc électrique, d'incendie, ou tout autre dommage, placez l'appareil comme suit :

**Face avant :** pas d'obstructions et un espace libre.

**Côtés / dessus / arrière :** aucun obstacle dans les zones indiquées ci-dessous.

**Dessus :** posez l'appareil sur une surface horizontale. Maintenez une circulation d'air suffisante pour la ventilation en plaçant l'appareil sur un support de 10 cm (3-15/16") de haut ou plus.

**Vue de face :**

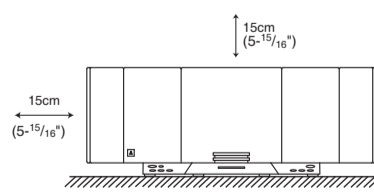

**Vue de côté :**

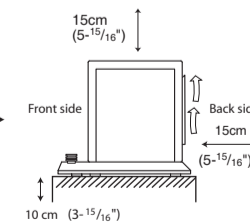





QDID:

# SOUND|FREQ<sup>®</sup>

## Safety Information

U.S. &amp; Canada Version

	<b>CAUTION</b> <small>RISK OF ELECTRIC SHOCK DO NOT OPEN</small>	
	<p>The lightning flash with arrowhead symbol, within an equilateral triangle is intended to alert the user to the presence of uninsulated "dangerous voltage" within the product's enclosure that may be of sufficient magnitude to constitute a risk of electric shock to persons.</p>	
	<p>The exclamation point within an equilateral triangle is intended to alert the user to the presence of important operating and maintenance (servicing) instructions in the literature accompanying the appliance.</p>	
<p><b>WARNINGS:</b>          TO REDUCE THE RISK OF FIRE OR ELECTRIC SHOCK, DO NOT EXPOSE THIS APPLIANCE TO RAIN OR MOISTURE.</p> <p><b>DO NOT REMOVE COVER or OPEN THE CABINET.</b>          Dangerous high voltages are present inside the enclosure. No user serviceable parts inside. Leave all servicing to qualified service personnel.</p>		

### IMPORTANT SAFETY INSTRUCTIONS

1. Read these instructions.
2. Keep these Instructions.
3. Heed all Warnings.
4. Follow all instructions.
5. Do not use this apparatus near water.
6. Clean only with dry cloth.
7. Do not block any ventilation openings. Install in accordance with the manufacturer's instructions.
8. Do not install near any heat sources such as radiators, heat registers, stoves, or other apparatus (including amplifiers) that produce heat.
9. Do not defeat the safety purpose of the polarized or grounding - type plug. A polarized plug has two blades with one wider than the other. A grounding type plug has two blades and a third grounding prong. The wide blade or the third prong is provided for your safety. If the provided plug does not fit into your outlet, consult an electrician for replacement of the obsolete outlet.
10. Protect the power cord from being walked on or pinched particularly at plugs, convenience receptacles, and the point where they exit from the apparatus.
11. Only use attachments/accessories specified by the manufacturer.

12. Use only with the cart, stand, tripod, bracket or table specified by the manufacturer, or sold with the apparatus. When a cart is used, use caution when moving the cart/apparatus combination to avoid injury from tip-over.
13. Unplug this apparatus during lightning storms or when unused for long periods of time.
14. Refer all servicing to qualified service personnel. Servicing is required when the apparatus has been damaged in any way, such as power-supply cord or plug is damaged, liquid has been spilled or objects have fallen into the apparatus, the apparatus has been exposed to rain or moisture, does not operate normally, or has been dropped.
15. Apparatus shall not be exposed to dripping or splashing and no objects filled with liquids, shall not be placed on the apparatus.
16. The mains plug is used as disconnect device and it shall remain readily operable during intended use. In order to disconnect the mains plug from the mains completely, the mains plug should be disconnected from the mains socket outlet completely.
17. The batteries (battery pack & batteries installed) shall not be exposed to excessive heat such as sunshine, fire or the like.
18. Do not place any naked flame sources, such as lighted candles, on the apparatus.
19. The battery used in this product must be properly recycled or disposed of. Please contact your local recycling center for proper battery handling and disposal instructions.



PORTABLE CART WARNING  
(Symbol provided by RETAC)

**WARNING!** Danger of explosion if battery is incorrectly replaced. Replace only with the same or equivalent type.

For compatibility between the SFQ-03 system and another device with Bluetooth technology, consult the device's documentation and dealer. In some countries, there may be restrictions on using Bluetooth devices. Check with your local authorities.

Bluetooth is a registered trademark of Bluetooth SIG, Inc

Please read rating label at the bottom of system for power input and other safety information.

**Warning:** Changes or modifications to this unit not expressly approved by the party responsible for compliance could void the user's authority to operate the equipment.

### FCC and IC Information:

This device complies with Part 15 of the FCC Rules and RSS-210 of the IC Rules. Operation is subject to the following two conditions: (1) This device may not cause harmful interference, and (2) this device must accept any interference received, including interference that may cause undesired operation.

**Warnings:** The device meets the exemption from the routine evaluation limits in section 2.5 of RSS 102 and users can obtain Canadian information on RF exposure and compliance from the Canadian Representative Burnport Holdings Ltd. 72MT Belcher Pls, East, Calgary, Alberta, T2Z 2G1, CANADA. Tel: 403-257-4961

### FCC&IC Radiation Exposure Statement

This equipment complies with FCC radiation exposure limits set forth for an uncontrolled environment and meets the exemption from the routine evaluation limits in section 2.5 of RSS 102.

1. This Transmitter must not be co-located or operating in conjunction with any other antenna or transmitter.
2. This equipment complies with FCC RF radiation exposure limits set forth for an uncontrolled environment. This equipment should be installed and operated with a minimum distance of 20 centimeters from user and bystanders.

**Note:** This equipment has been tested and found to comply with the limits for a Class B digital device, pursuant to Part 15 of the FCC Rules. These limits are designed to provide reasonable protection against harmful interference in a residential installation. This equipment generates, uses, and can radiate radio frequency energy and, if not installed and used in accordance with the instructions, may cause harmful interference to radio communications. However, there is no guarantee that interference will not occur in a particular installation. If this equipment does cause harmful interference to radio or television reception, which can be determined by turning the equipment off and on, the user is encouraged to try to correct the interference by one or more of the following measures:

- Reorient or relocate the receiving antenna.
- Increase the separation between the equipment and receiver.

- Connect the equipment into an outlet on a circuit different from that to which the receiver is connected.
- Consult the dealer or an experienced radio TV technician for help.

### CAUTION - Proper Installation

- Install the system in a place which is level, dry and neither too hot nor too cold. The appropriate temperature is between 5 °C and 35 °C.
- Install the system in a location with adequate ventilation to prevent internal heat from building up inside the unit.
- Leave sufficient distance between the system and TV.
- Keep the system away from TV to avoid interference with TV.

### CAUTION - Proper Ventilation

To avoid risk of electric shock and fire, and to prevent damage, locate the apparatus as follows:

**Front:** No obstructions and open spacing.

**Sides / Top / Back:** No obstructions should be placed in the areas shown by the dimensions.

**Bottom:** Place on the level surface. Maintain an adequate air path for ventilation by placing on a stand with a height of 10 cm (3-15/16") or more.

### Front View:

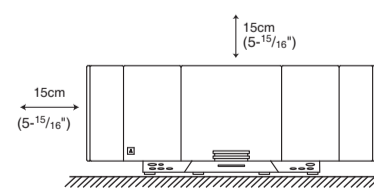

### Side View:

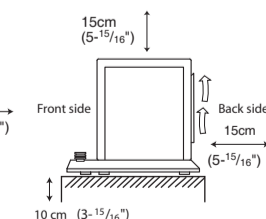

QDID: