



FCC/IC Radio Test Report

FCC ID: UZZSFQ01

IC: 7633A-SFQ01

This report concerns (check one) : Original Grant Class II Change

Issued Date : Jul. 21, 2010
Project No. : 1007C119
Equipment : Hi Fi dock with bluetooth wireless Audio system
Model Name : SFQ-01
Applicant : Beautiful Enterprise Co., Ltd
Address : 26th Floor, Beautiful Group Tower, 77 Connaught Road Central, Hong Kong

Tested by:
Neutron Engineering Inc. EMC Laboratory
Date of Receipt: Jul. 13, 2010
Date of Test:
Jul. 13, 2010 ~ Jul. 19, 2010

Testing Engineer : Jeff Yang
(Jeff Yang)
Technical Manager : Vic Chiu
(Vic Chiu)
Authorized Signatory : Steven Lu
(Steven Lu)

Neutron Engineering Inc.

No.3, Jinshagang 1st Road, ShiXia, Dalang
Town, Dong Guan, China.
TEL : (0769) 8318-3000 FAX : (0769) 8319-6000



Declaration

Neutron represents to the client that testing is done in accordance with standard procedures as applicable and that test instruments used has been calibrated with the standards traceable to National Measurement Laboratory (**NML**) of **R.O.C.**, or National Institute of Standards and Technology (**NIST**) of **U.S.A.**

Neutron's reports apply only to the specific samples tested under conditions. It is manufacture's responsibility to ensure that additional production units of this model are manufactured with the identical electrical and mechanical components. **Neutron** shall have no liability for any declarations, inferences or generalizations drawn by the client or others from **Neutron** issued reports.

Neutron's reports must not be used by the client to claim product endorsement by the authorities or any agency of the Government.

This report is the confidential property of the client. As a mutual protection to the clients, the public and **Neutron-self**, extracts from the test report shall not be reproduced except in full with **Neutron's** authorized written approval.

Neutron's laboratory quality assurance procedures are in compliance with the **ISO Guide 17025** requirements, and accredited by the conformity assessment authorities listed in this test report.

Limitation

For the use of the authority's logo is limited unless the Test Standard(s)/Scope(s)/Item(s) mentioned in this test report is (are) included in the conformity assessment authorities acceptance respective.



| Table of Contents | Page |
|---|-------------|
| 1 . CERTIFICATION | 6 |
| 2 . SUMMARY OF TEST RESULTS | 7 |
| 2.1 TEST FACILITY | 8 |
| 2.2 MEASUREMENT UNCERTAINTY | 8 |
| 3 . GENERAL INFORMATION | 9 |
| 3.1 GENERAL DESCRIPTION OF EUT | 9 |
| 3.2 DESCRIPTION OF TEST MODES | 11 |
| 3.3 TABLE OF PARAMETERS OF TEXT SOFTWARE SETTING | 12 |
| 3.4 BLOCK DIGRAM SHOWING THE CONFIGURATION OF SYSTEM TESTED | 12 |
| 3.5 DESCRIPTION OF SUPPORT UNITS | 13 |
| 4 . EMC EMISSION TEST | 14 |
| 4.1 CONDUCTED EMISSION MEASUREMENT | 14 |
| 4.1.1 POWER LINE CONDUCTED EMISSION LIMITS | 14 |
| 4.1.2 MEASUREMENT INSTRUMENTS LIST AND SETTING | 14 |
| 4.1.3 TEST PROCEDURE | 15 |
| 4.1.4 DEVIATION FROM TEST STANDARD | 15 |
| 4.1.5 TEST SETUP | 15 |
| 4.1.6 EUT OPERATING CONDITIONS | 16 |
| 4.1.7 TEST RESULTS | 17 |
| 4.2 RADIATED EMISSION MEASUREMENT | 25 |
| 4.2.1 RADIATED EMISSION LIMITS | 25 |
| 4.2.2 MEASUREMENT INSTRUMENTS LIST ANS SETTING | 26 |
| 4.2.3 TEST PROCEDURE | 27 |
| 4.2.4 DEVIATION FROM TEST STANDARD | 27 |
| 4.2.5 TEST SETUP | 28 |
| 4.2.6 EUT OPERATING CONDITIONS | 29 |
| 4.2.7 TEST RESULTS (BETWEEN 30 – 1000 MHZ) | 30 |
| 4.2.8 TEST RESULTS (ABOVE 1000 MHZ) | 34 |
| 5 . NUMBER OF HOPPING CHANNEL | 64 |
| 5.1 APPLIED PROCEDURES / LIMIT | 64 |
| 5.1.1 MEASUREMENT INSTRUMENTS LIST AND SETTING | 64 |
| 5.1.2 TEST PROCEDURE | 64 |
| 5.1.3 DEVIATION FROM STANDARD | 64 |
| 5.1.4 TEST SETUP | 64 |
| 5.1.5 EUT OPERATION CONDITIONS | 64 |
| 5.1.6 TEST RESULTS | 65 |



| Table of Contents | Page |
|---|-------------|
| 6 . AVERAGE TIME OF OCCUPANCY | 67 |
| 6.1 APPLIED PROCEDURES / LIMIT | 67 |
| 6.1.1 MEASUREMENT INSTRUMENTS LIST | 67 |
| 6.1.2 TEST PROCEDURE | 67 |
| 6.1.3 DEVIATION FROM STANDARD | 67 |
| 6.1.4 TEST SETUP | 68 |
| 6.1.5 EUT OPERATION CONDITIONS | 68 |
| 6.1.6 TEST RESULTS | 69 |
| 7 . HOPPING CHANNEL SEPARATION MEASUREMENT | 81 |
| 7.1 APPLIED PROCEDURES / LIMIT | 81 |
| 7.1.1 MEASUREMENT INSTRUMENTS LIST AND SETTING | 81 |
| 7.1.2 TEST PROCEDURE | 81 |
| 7.1.3 DEVIATION FROM STANDARD | 81 |
| 7.1.4 TEST SETUP | 81 |
| 7.1.5 EUT OPERATION CONDITIONS | 81 |
| 7.1.6 TEST RESULTS | 82 |
| 8 . BANDWIDTH TEST | 86 |
| 8.1 APPLIED PROCEDURES / LIMIT | 86 |
| 8.1.1 MEASUREMENT INSTRUMENTS LIST AND SETTING | 86 |
| 8.1.2 TEST PROCEDURE | 86 |
| 8.1.3 DEVIATION FROM STANDARD | 86 |
| 8.1.4 TEST SETUP | 86 |
| 8.1.5 EUT OPERATION CONDITIONS | 86 |
| 8.1.6 TEST RESULTS | 87 |
| 9 . PEAK OUTPUT POWER TEST | 91 |
| 9.1 APPLIED PROCEDURES / LIMIT | 91 |
| 9.1.1 MEASUREMENT INSTRUMENTS LIST AND SETTING | 91 |
| 9.1.2 TEST PROCEDURE | 91 |
| 9.1.3 DEVIATION FROM STANDARD | 91 |
| 9.1.4 TEST SETUP | 91 |
| 9.1.5 EUT OPERATION CONDITIONS | 91 |
| 9.1.6 TEST RESULTS | 92 |
| 10 . ANTENNA CONDUCTED SPURIOUS EMISSION | 96 |
| 10.1 APPLIED PROCEDURES / LIMIT | 96 |
| 10.1.1 MEASUREMENT INSTRUMENTS LIST AND SETTING | 96 |
| 10.1.2 TEST PROCEDURE | 96 |
| 10.1.3 DEVIATION FROM STANDARD | 96 |
| 10.1.4 TEST SETUP | 97 |
| 10.1.5 EUT OPERATION CONDITIONS | 97 |



| Table of Contents | Page |
|-------------------------------------|-------------|
| 10.1.6 TEST RESULTS | 98 |
| 11 . RF EXPOSURE TEST | 102 |
| 11.1 APPLIED PROCEDURES / LIMIT | 102 |
| 11.1.1 MEASUREMENT INSTRUMENTS LIST | 102 |
| 11.1.2 MPE CALCULATION METHOD | 103 |
| 11.1.3 DEVIATION FROM STANDARD | 103 |
| 11.1.4 TEST SETUP | 103 |
| 11.1.5 EUT OPERATION CONDITIONS | 103 |
| 11.1.6 TEST RESULTS | 104 |
| 12 . EUT TEST PHOTO | 105 |



1. CERTIFICATION

Equipment : Hi Fi dock with bluetooth wireless Audio system
Brand Name : N/A
Model Name : SFQ-01
Applicant : Beautiful Enterprise Co., Ltd
Factory : Shenzhen Synchron Electronics Co.,Ltd
Address : No. 9 Mei Li Road, Xia Mei Lin, Fu Tian Area, Shenzhen, China
Date of Test: Jul. 13, 2010 ~ Jul. 19, 2010
Test Item : ENGINEERING SAMPLE
Standards : FCC Part15, Subpart C(15.247) / Canada RSS-210:2007

The above equipment has been tested and found compliance with the requirement of the relative standards by Neutron Engineering Inc. EMC Laboratory.

The test data, data evaluation, and equipment configuration contained in our test report (Ref No. NEI-FICP-1-1007C119) were obtained utilizing the test procedures, test instruments, test sites that has been accredited by the Authority of NVLAP and TAF according to the ISO-17025 quality assessment standard and technical standard(s).



2. SUMMARY OF TEST RESULTS

Test procedures according to the technical standards:

| APPLIED STANDARD: 47 CFR Part 15, Subpart C; Canada RSS-210:2007 | | | | |
|---|--------------------------------------|-------------------------------------|----------|--------|
| Standard Section | | Test Item | Judgment | Remark |
| RSS-210 | 47 CFR Part 15 | | | |
| RSS-GEN 7.2.2 | 15.207 | Conducted Emission | PASS | |
| RSS-210 Annex 8 (A8.1d) | 15.247 (c) | Antenna conducted Spurious Emission | PASS | |
| RSS-210 Annex 8 (A8.1d) | 15.247 (a)(1) | Hopping Channel Separation | PASS | |
| RSS-210 Annex 8 (A8.1b) | 15.247 (b)(1) | Peak Output Power | PASS | |
| RSS-210 Annex 8 (A8.1a) | 15.247 (c) | Radiated Spurious Emission | PASS | |
| RSS-210 Annex 8 (A8.4(2)) | 15.247 (a)(1)(iii) | Number of Hopping Frequency | PASS | |
| RSS-210 Annex 8 (A8.5) | 15.247 (a)(1)(iii) | Dwell Time | PASS | |
| RSS-Gen 7.2.3 | 15.205 | Restricted Bands | PASS | |
| RSS-210 Annex 8 (A8.5) | 15.203 | Antenna Requirement | PASS | |
| | 1.1307 1.1310 2.1091 2.1093 | RF Exposure Compliance | PASS | |

NOTE:

(1) "N/A" denotes test is not applicable in this Test Report



2.1 TEST FACILITY

The test facilities used to collect the test data in this report is **DG-C03/CB03** at the location of No.3,Jinshagang 1st Road, ShiXia, Dalang Town, Dong Guan, China.523792

Neutron's test firm number for FCC 319330

Neutron's test firm number for IC 4428B-1

2.2 MEASUREMENT UNCERTAINTY

Where relevant, the following measurement uncertainty levels have been estimated for tests performed on the EUT as specified in CISPR 16-4-2:

The reported uncertainty of measurement $y \pm U$, where expanded uncertainty U is based on a standard uncertainty multiplied by a coverage factor of $k=2$, providing a level of confidence of approximately **95 %**.

A. Conducted Measurement :

| Test Site | Method | Measurement Frequency Range | U , (dB) | NOTE |
|-----------|--------|-----------------------------|----------|------|
| DG-C03 | CISPR | 150 KHz ~ 30MHz | 1.94 | |

B. Radiated Measurement :

| Test Site | Method | Measurement Frequency Range | Ant. H / V | U , (dB) | NOTE |
|-----------|--------|-----------------------------|------------|----------|------|
| CB03 | CISPR | 30MHz ~ 200MHz | V | 3.82 | |
| | | 30MHz ~ 200MHz | H | 3.60 | |
| | | 200MHz ~ 1,000MHz | V | 3.86 | |
| | | 200MHz ~ 1,000MHz | H | 3.94 | |



3. GENERAL INFORMATION

3.1 GENERAL DESCRIPTION OF EUT

| | | |
|------------------------|--|--|
| Equipment | Hi Fi dock with bluetooth wireless Audio system | |
| Brand Name | N/A | |
| Model Name | SFQ-01 | |
| OEM Brand/Model Name | N/A | |
| Model Difference | N/A | |
| Product Description | The EUT is a Hi Fi dock with bluetooth wireless Audio system | |
| | Operation Frequency: | 2402~2480 MHz |
| | Modulation Type: | GFSK(1Mbps) |
| | Bit Rate of Transmitter | π /4-DQPSK(2Mbps) 8-DPSK(3Mbps) |
| | Number Of Channel | 79 CH |
| | Antenna Designation: | Please see Note 3. |
| | Antenna Gain(Peak) | Please see Note 3. |
| | Output Power: | 3.75 dBm (1Mbps) 1.82 dBm (3Mbps) |
| | Based on the application, features, or specification exhibited in User's Manual, the EUT is considered as an ITE/Computing Device. More details of EUT technical | |
| | Channel List | Please refer to the Note 2. |
| Power Source | DC Voltage supplied from AC/DC adapter. Brand name: KINGWALL Model name:AS600-180-AA330 | |
| Power Rating | I/P AC100-240V~50/60Hz, 1.5A O/P 18V, 3.3A | |
| Connecting I/O Port(s) | Please refer to the User's Manual | |
| Products Covered | N/A | |

Note:

1. For a more detailed features description, please refer to the manufacturer's specifications or the User's Manual.



2.

| Channel List | | | | | |
|--------------|-----------------|---------|-----------------|---------|-----------------|
| Channel | Frequency (MHz) | Channel | Frequency (MHz) | Channel | Frequency (MHz) |
| 00 | 2402 | 27 | 2429 | 54 | 2456 |
| 01 | 2403 | 28 | 2430 | 55 | 2457 |
| 02 | 2404 | 29 | 2431 | 56 | 2458 |
| 03 | 2405 | 30 | 2432 | 57 | 2459 |
| 04 | 2406 | 31 | 2433 | 58 | 2460 |
| 05 | 2407 | 32 | 2434 | 59 | 2461 |
| 06 | 2408 | 33 | 2435 | 60 | 2462 |
| 07 | 2409 | 34 | 2436 | 61 | 2463 |
| 08 | 2410 | 35 | 2437 | 62 | 2464 |
| 09 | 2411 | 36 | 2438 | 63 | 2465 |
| 10 | 2412 | 37 | 2439 | 64 | 2466 |
| 11 | 2413 | 38 | 2440 | 65 | 2467 |
| 12 | 2414 | 39 | 2441 | 66 | 2468 |
| 13 | 2415 | 40 | 2442 | 67 | 2469 |
| 14 | 2416 | 41 | 2443 | 68 | 2470 |
| 15 | 2417 | 42 | 2444 | 69 | 2471 |
| 16 | 2418 | 43 | 2445 | 70 | 2472 |
| 17 | 2419 | 44 | 2446 | 71 | 2473 |
| 18 | 2420 | 45 | 2447 | 72 | 2474 |
| 19 | 2421 | 46 | 2448 | 73 | 2475 |
| 20 | 2422 | 47 | 2449 | 74 | 2476 |
| 21 | 2423 | 48 | 2450 | 75 | 2477 |
| 22 | 2424 | 49 | 2451 | 76 | 2478 |
| 23 | 2425 | 50 | 2452 | 77 | 2479 |
| 24 | 2426 | 51 | 2453 | 78 | 2480 |
| 25 | 2427 | 52 | 2454 | | |
| 26 | 2428 | 53 | 2455 | | |

3.

Table for Filed Antenna

| Ant | Brand | Model Name | Antenna Type | Connector | Gain (dBi) | NOTE |
|-----|---------|------------|--------------|-----------|------------|------------|
| 1 | AMOTECH | ALA621C4 | CHIP ANT | N/A | 3.5 | BT Antenna |



3.2 DESCRIPTION OF TEST MODES

To investigate the maximum EMI emission characteristics generated from EUT, the test system was pre-scanning tested based on the consideration of following EUT operation mode or test configuration mode which possibly have effect on EMI emission level. Each of these EUT operation mode(s) or test configuration mode(s) mentioned above was evaluated respectively.

| Pretest Mode | Description |
|--------------|--------------------|
| Mode 1 | CH00 (1Mbps/3Mbps) |
| Mode 2 | CH39 (1Mbps/3Mbps) |
| Mode 3 | CH78 (1Mbps/3Mbps) |
| Mode 4 | IPOD IN |
| Mode 5 | AUX IN |
| Mode 6 | FM 87.5MHz |
| Mode 7 | Bluetooth |

The EUT system operated these modes were found to be the worst case during the pre-scanning test as following:

| For Conducted Emission | |
|------------------------|-------------|
| Final Test Mode | Description |
| Mode 4 | IPOD IN |
| Mode 5 | AUX IN |
| Mode 6 | FM 87.5MHz |
| Mode 7 | Bluetooth |

| For Radiated Emission | |
|-----------------------|--------------------|
| Final Test Mode | Description |
| Mode 1 | CH00 (1Mbps/3Mbps) |
| Mode 2 | CH39 (1Mbps/3Mbps) |
| Mode 3 | CH78 (1Mbps/3Mbps) |

Note:

- (1) The measurements are performed at the highest, middle, lowest available channels.



3.3 TABLE OF PARAMETERS OF TEXT SOFTWARE SETTING

During testing channel & power controlling software provided by the customer was used to control the operating channel as well as the output power level. The RF output power selection is for the setting of RF output power expected by the customer and is going to be fixed on the firmware of the final end product power parameters of FHSS

| Test software Version | Test program: Bluetest.exe | | |
|-----------------------|----------------------------|----------|----------|
| Frequency | 2402 MHz | 2441 MHz | 2480 MHz |
| Parameters-1Mbps | 63 | 63 | 63 |
| Parameters-3Mbps | 100 | 100 | 100 |

3.4 BLOCK DIGRAM SHOWING THE CONFIGURATION OF SYSTEM TESTED

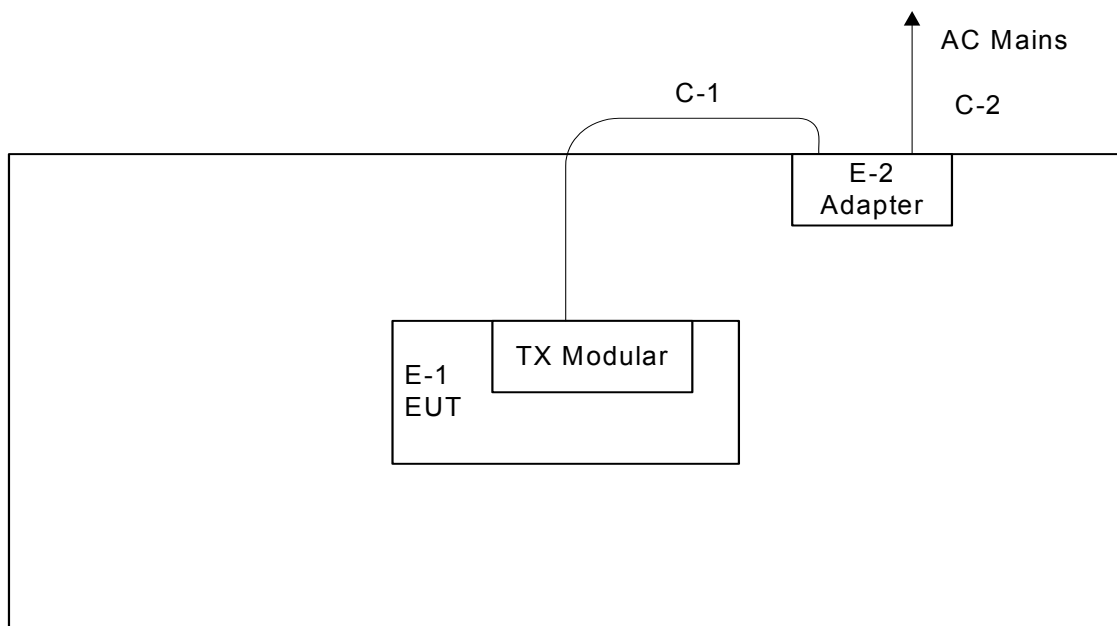

C-1: DC Cable
C-2: AC Cable



3.1 DESCRIPTION OF SUPPORT UNITS

The EUT has been tested as an independent unit together with other necessary accessories or support units. The following support units or accessories were used to form a representative test configuration during the tests.

| Item | Equipment | Mfr/Brand | Model/Type No. | FCC ID/IC | Series No. | Note |
|------|---|-----------|-----------------|-------------------------|------------|------|
| E-1 | Hi Fi dock with bluetooth wireless Audio system | N/A | SFQ-01 | UZZSFQ01 7633A-SFQ01 | N/A | EUT |
| E-2 | Adapter | KINGWALL | AS600-180-AA330 | N/A | N/A | |
| | | | | | | |
| | | | | | | |
| | | | | | | |
| | | | | | | |

| Item | Shielded Type | Ferrite Core | Length | Note |
|------|---------------|--------------|--------|------|
| C-1 | NO | YES | 1.0M | |
| C-2 | NO | NO | 1.8M | |
| | | | | |
| | | | | |
| | | | | |

Note:

- (1) The support equipment was authorized by Declaration of Confirmation.
- (2) For detachable type I/O cable should be specified the length in cm in 『Length』 column.



4. EMC EMISSION TEST

4.1 CONDUCTED EMISSION MEASUREMENT

4.1.1 POWER LINE CONDUCTED EMISSION Limits (Frequency Range 150KHz-30MHz)

| FREQUENCY (MHz) | Class A (dBuV) | | Class B (dBuV) | | Standard |
|-----------------|----------------|---------|----------------|-----------|----------|
| | Quasi-peak | Average | Quasi-peak | Average | |
| 0.15 -0.5 | 79.00 | 66.00 | 66 - 56 * | 56 - 46 * | CISPR |
| 0.50 -5.0 | 73.00 | 60.00 | 56.00 | 46.00 | CISPR |
| 5.0 -30.0 | 73.00 | 60.00 | 60.00 | 50.00 | CISPR |

| | | | | | |
|-----------|-------|-------|-----------|-----------|-----|
| 0.15 -0.5 | 79.00 | 66.00 | 66 - 56 * | 56 - 46 * | FCC |
| 0.50 -5.0 | 73.00 | 60.00 | 56.00 | 46.00 | FCC |
| 5.0 -30.0 | 73.00 | 60.00 | 60.00 | 50.00 | FCC |

Note:

- (1) The tighter limit applies at the band edges.
- (2) The limit of " * " marked band means the limitation decreases linearly with the logarithm of the frequency in the range.

4.1.2 MEASUREMENT INSTRUMENTS LIST AND SETTING

| Item | Kind of Equipment | Manufacturer | Type No. | Serial No. | Calibrated until |
|------|-------------------|--------------|-----------|------------|------------------|
| 1 | LISN | EMCO | 3816/2 | 00052765 | May.26.2011 |
| 2 | LISN | Rolf Heine | NNB-2-16Z | 99044 | May.26.2011 |
| 3 | 50Ω Terminator | SHX | TF2-3G-A | 08122901 | May.26.2011 |
| 4 | Transient Limiter | Agilent | 11947A | 3107A03668 | May.26.2011 |
| 5 | Test Cable | N/A | C-06_C03 | N/A | Nov.16.2010 |
| 6 | EMI TEST RECEIVER | R&S | ESCS30 | 8333641017 | May.26.2011 |

Remark: " N/A" denotes No Model No. , Serial No. or No Calibration specified.

The following table is the setting of the receiver

| Receiver Parameters | Setting |
|---------------------|----------|
| Attenuation | 10 dB |
| Start Frequency | 0.15 MHz |
| Stop Frequency | 30 MHz |
| IF Bandwidth | 9 kHz |

4.1.3 TEST PROCEDURE

- The EUT was placed 0.8 meters from the horizontal ground plane with EUT being connected to the power mains through a line impedance stabilization network (LISN). All other support equipments powered from additional LISN(s). The LISN provide 50 Ohm/ 50uH of coupling impedance for the measuring instrument.
- Interconnecting cables that hang closer than 40 cm to the ground plane shall be folded back and forth in the center forming a bundle 30 to 40 cm long.
- I/O cables that are not connected to a peripheral shall be bundled in the center. The end of the cable may be terminated, if required, using the correct terminating impedance. The overall length shall not exceed 1 m.
- LISN at least 80 cm from nearest part of EUT chassis.
- For the actual test configuration, please refer to the related Item –EUT Test Photos.

4.1.4 DEVIATION FROM TEST STANDARD

No deviation

4.1.5 TEST SETUP

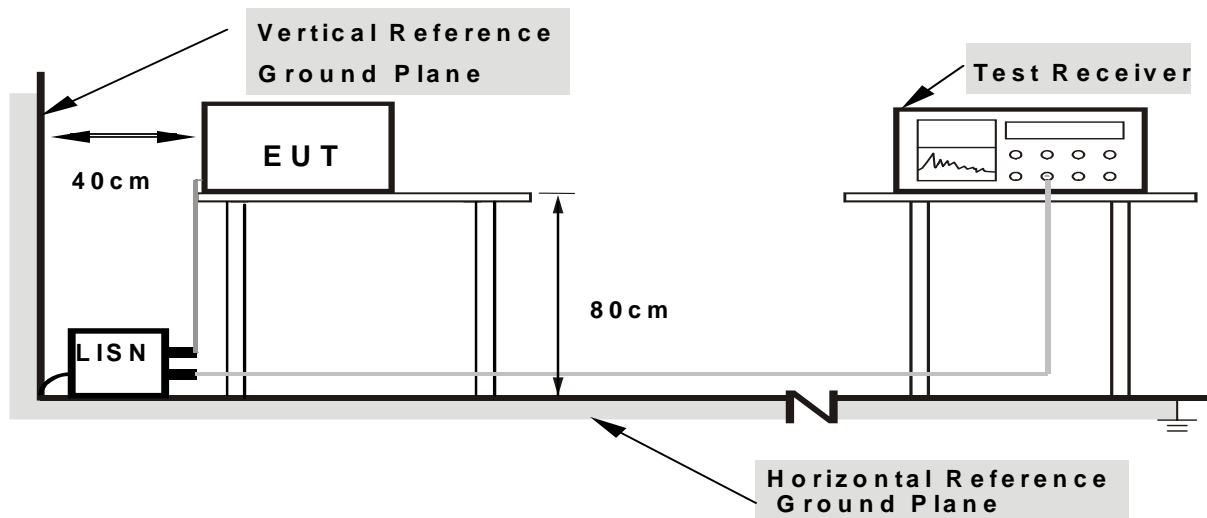

Note: 1. Support units were connected to second LISN.

2. Both of LISNs (AMN) are 80 cm from EUT and at least 80 cm from other units and other metal planes



4.1.6 EUT OPERATING CONDITIONS

The EUT was configured for testing in a typical fashion (as a customer would normally use it). The EUT has been programmed to continuously transmit during test. This operating condition was tested and used to collect the included data.



4.1.7 TEST RESULTS

| | | | |
|---------------|---|---------------------|--------------|
| EUT : | Hi Fi dock with bluetooth wireless Audio system | Model Name : | SFQ-01 |
| Temperature : | 23 °C | Relative Humidity : | 57 % |
| Pressure : | 1010hPa | Test Voltage : | AC 120V/60Hz |
| Test Mode : | IPOD IN | | |

| Freq. (MHz) | Terminal L/N | Measured(dBuV) | | Limits(dBuV) | | Margin (dB) | Note |
|-------------|--------------|----------------|---------|--------------|---------|-------------|------|
| | | QP-Mode | AV-Mode | QP-Mode | AV-Mode | | |
| 0.16 | Line | 56.88 | 36.61 | 65.52 | 55.52 | -8.64 | (QP) |
| 0.18 | Line | 54.90 | 35.32 | 64.63 | 54.63 | -9.73 | (QP) |
| 0.21 | Line | 52.14 | * | 63.09 | 53.09 | -10.95 | (QP) |
| 0.74 | Line | 27.65 | * | 56.00 | 46.00 | -28.35 | (QP) |
| 0.94 | Line | 26.56 | * | 56.00 | 46.00 | -29.44 | (QP) |
| 3.39 | Line | 26.46 | * | 56.00 | 46.00 | -29.54 | (QP) |

Remark

- (1) Reading in which marked as QP means measurements by using are Quasi-Peak Mode with Detector BW=9KHz : SPA setting in RBW=10KHz,VBW =10KHz, Swp. Time = 0.2 sec./MHz ◦ Reading in which marked as AV means measurements by using are Average Mode with instrument setting in RBW=10KHz,VBW=10KHz, Swp. Time =0.2 sec./MHz ◦
- (2) All readings are QP Mode value unless otherwise stated AVG in column of Note . If the QP Mode Measured value compliance with the QP Limits and lower than AVG Limits, the EUT shall be deemed to meet both QP & AVG Limits and then only QP Mode was measured, but AVG Mode didn't perform ◦ In this case, a " * " marked in AVG Mode column of Interference Voltage Measured ◦
- (3) Measuring frequency range from 150KHz to 30MHz ◦

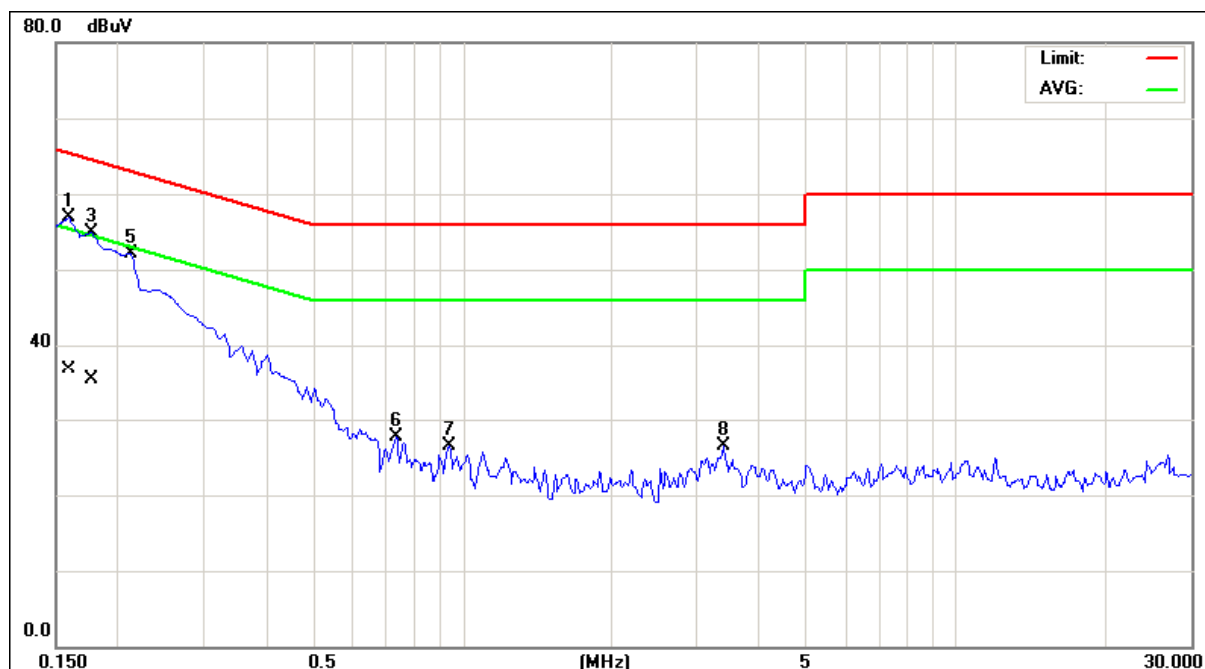



| | | | |
|---------------|---|---------------------|--------------|
| EUT : | Hi Fi dock with bluetooth wireless Audio system | Model Name : | SFQ-01 |
| Temperature : | 23 °C | Relative Humidity : | 57 % |
| Pressure : | 1010hPa | Test Voltage : | AC 120V/60Hz |
| Test Mode : | IPOD IN | | |

| Freq. (MHz) | Terminal L/N | Measured(dBuV) | | Limits(dBuV) | | Margin (dB) | Note |
|-------------|--------------|----------------|---------|--------------|---------|-------------|------|
| | | QP-Mode | AV-Mode | QP-Mode | AV-Mode | | |
| 0.15 | Neutral | 56.52 | 34.49 | 66.00 | 56.00 | -9.48 | (QP) |
| 0.19 | Neutral | 52.98 | 33.74 | 64.21 | 54.21 | -11.23 | (QP) |
| 0.69 | Neutral | 28.10 | * | 56.00 | 46.00 | -27.90 | (QP) |
| 2.54 | Neutral | 24.71 | * | 56.00 | 46.00 | -31.29 | (QP) |
| 3.19 | Neutral | 25.02 | * | 56.00 | 46.00 | -30.98 | (QP) |
| 7.04 | Neutral | 24.72 | * | 60.00 | 50.00 | -35.28 | (QP) |

Remark

- (1) Reading in which marked as QP means measurements by using are Quasi-Peak Mode with Detector BW=9KHz ; SPA setting in RBW=10KHz,VBW =10KHz, Swp. Time = 0.2 sec./MHz ◦ Reading in which marked as AV means measurements by using are Average Mode with instrument setting in RBW=10KHz,VBW=10KHz, Swp. Time =0.2 sec./MHz ◦
- (2) All readings are QP Mode value unless otherwise stated AVG in column of Note . If the QP Mode Measured value compliance with the QP Limits and lower than AVG Limits, the EUT shall be deemed to meet both QP & AVG Limits and then only QP Mode was measured, but AVG Mode didn't perform ◦ In this case, a " * " marked in AVG Mode column of Interference Voltage Measured ◦
- (3) Measuring frequency range from 150KHz to 30MHz ◦

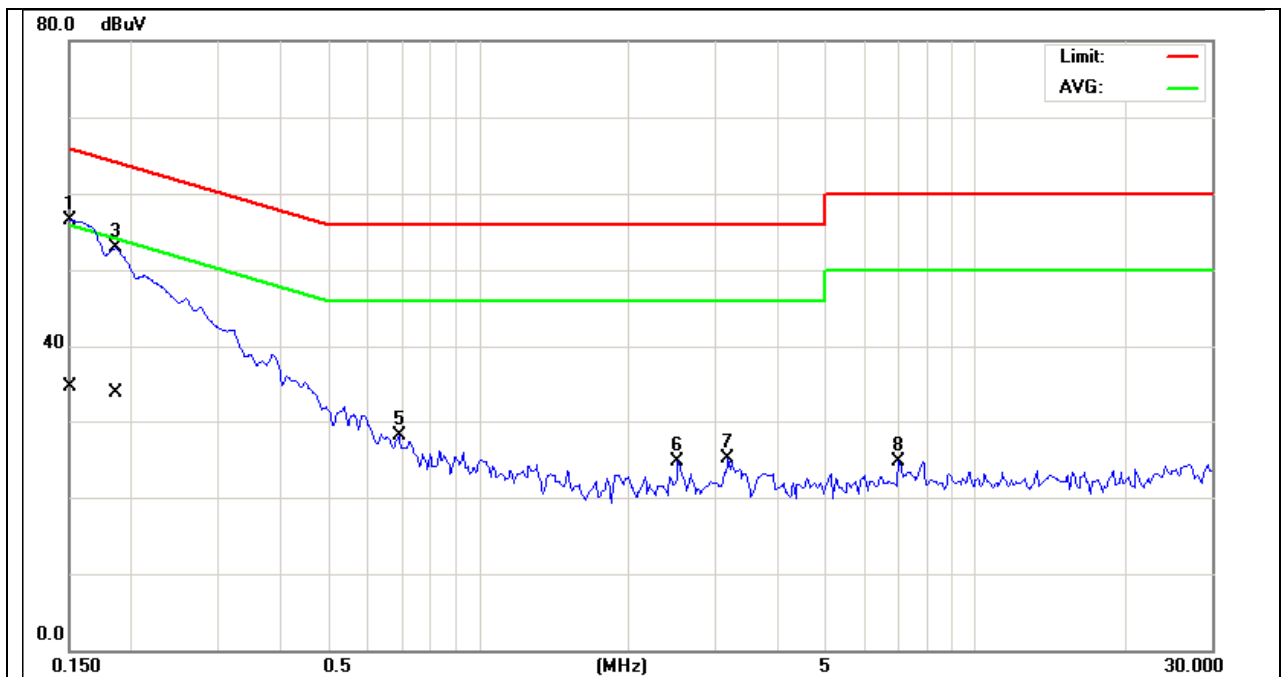



| | | | |
|---------------|---|---------------------|--------------|
| EUT : | Hi Fi dock with bluetooth wireless Audio system | Model Name : | SFQ-01 |
| Temperature : | 23 °C | Relative Humidity : | 57 % |
| Pressure : | 1010hPa | Test Voltage : | AC 120V/60Hz |
| Test Mode : | AUX IN | | |

| Freq. (MHz) | Terminal L/N | Measured(dBuV) | | Limits(dBuV) | | Margin (dB) | Note |
|-------------|--------------|----------------|---------|--------------|---------|-------------|------|
| | | QP-Mode | AV-Mode | QP-Mode | AV-Mode | | |
| 0.15 | Line | 56.62 | 36.03 | 66.00 | 56.00 | -9.38 | (QP) |
| 0.17 | Line | 54.88 | 35.22 | 65.06 | 55.06 | -10.18 | (QP) |
| 0.67 | Line | 29.27 | * | 56.00 | 46.00 | -26.73 | (QP) |
| 2.21 | Line | 25.55 | * | 56.00 | 46.00 | -30.45 | (QP) |
| 3.36 | Line | 26.09 | * | 56.00 | 46.00 | -29.91 | (QP) |
| 9.12 | Line | 24.50 | * | 60.00 | 50.00 | -35.50 | (QP) |

Remark

- (1) Reading in which marked as QP means measurements by using are Quasi-Peak Mode with Detector BW=9KHz ; SPA setting in RBW=10KHz,VBW =10KHz, Swp. Time = 0.2 sec./MHz . Reading in which marked as AV means measurements by using are Average Mode with instrument setting in RBW=10KHz,VBW=10KHz, Swp. Time =0.2 sec./MHz .
- (2) All readings are QP Mode value unless otherwise stated AVG in column of Note . If the QP Mode Measured value compliance with the QP Limits and lower than AVG Limits, the EUT shall be deemed to meet both QP & AVG Limits and then only QP Mode was measured, but AVG Mode didn't perform . In this case, a " * " marked in AVG Mode column of Interference Voltage Measured .
- (3) Measuring frequency range from 150KHz to 30MHz .

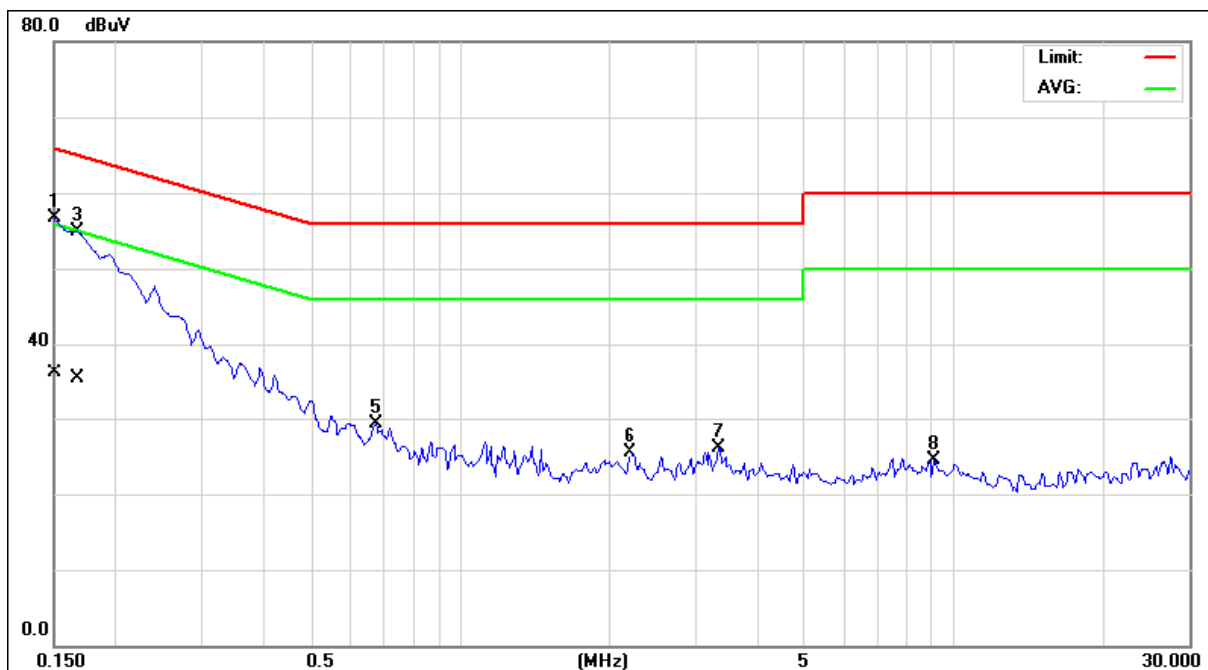



| | | | |
|---------------|---|---------------------|--------------|
| EUT : | Hi Fi dock with bluetooth wireless Audio system | Model Name : | SFQ-01 |
| Temperature : | 23 °C | Relative Humidity : | 57 % |
| Pressure : | 1010hPa | Test Voltage : | AC 120V/60Hz |
| Test Mode : | AUX IN | | |

| Freq. (MHz) | Terminal L/N | Measured(dBuV) | | Limits(dBuV) | | Margin (dB) | Note |
|-------------|--------------|----------------|---------|--------------|---------|-------------|------|
| | | QP-Mode | AV-Mode | QP-Mode | AV-Mode | | |
| 0.15 | Neutral | 55.18 | 35.23 | 66.00 | 56.00 | -10.82 | (QP) |
| 0.17 | Neutral | 53.98 | 32.17 | 65.06 | 55.06 | -11.08 | (QP) |
| 0.53 | Neutral | 30.09 | * | 56.00 | 46.00 | -25.91 | (QP) |
| 1.01 | Neutral | 27.46 | * | 56.00 | 46.00 | -28.54 | (QP) |
| 1.78 | Neutral | 25.31 | * | 56.00 | 46.00 | -30.69 | (QP) |
| 4.90 | Neutral | 25.60 | * | 56.00 | 46.00 | -30.40 | (QP) |

Remark

- (1) Reading in which marked as QP means measurements by using are Quasi-Peak Mode with Detector BW=9KHz ; SPA setting in RBW=10KHz,VBW =10KHz, Swp. Time = 0.2 sec./MHz ◦ Reading in which marked as AV means measurements by using are Average Mode with instrument setting in RBW=10KHz,VBW=10KHz, Swp. Time =0.2 sec./MHz ◦
- (2) All readings are QP Mode value unless otherwise stated AVG in column of Note . If the QP Mode Measured value compliance with the QP Limits and lower than AVG Limits, the EUT shall be deemed to meet both QP & AVG Limits and then only QP Mode was measured, but AVG Mode didn't perform ◦ In this case, a " * " marked in AVG Mode column of Interference Voltage Measured ◦
- (3) Measuring frequency range from 150KHz to 30MHz ◦

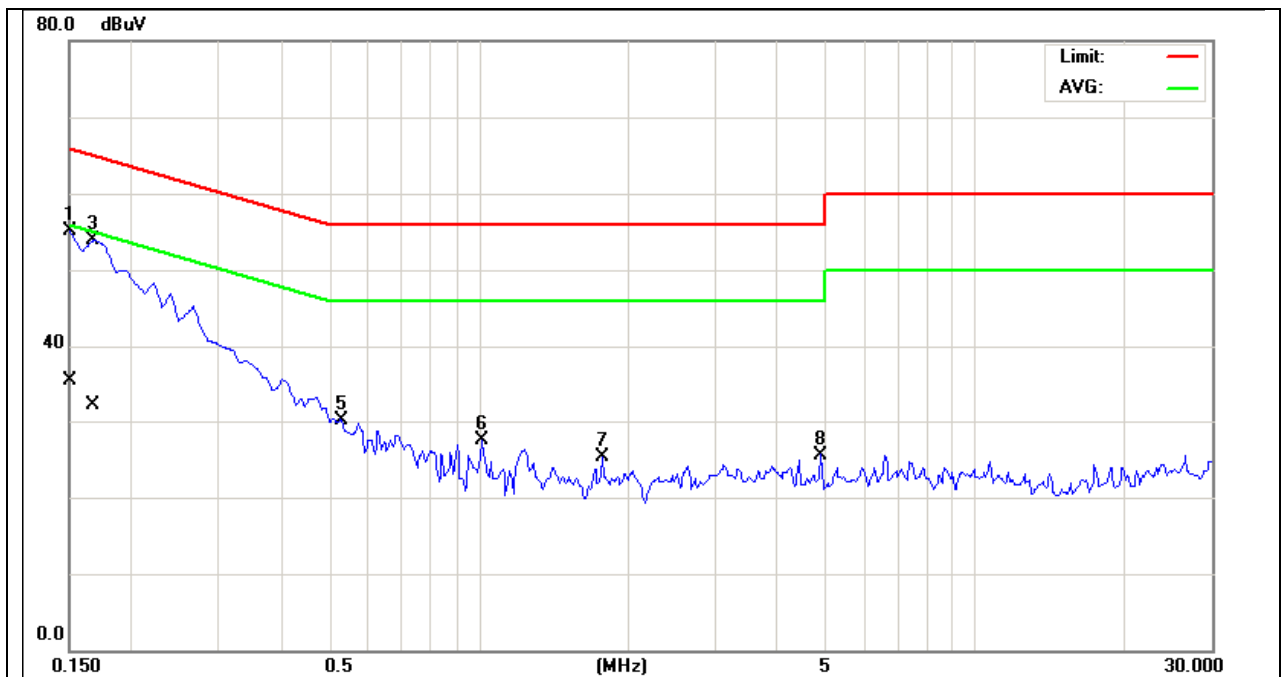



| | | | |
|---------------|---|---------------------|--------------|
| EUT : | Hi Fi dock with bluetooth wireless Audio system | Model Name : | SFQ-01 |
| Temperature : | 23 °C | Relative Humidity : | 57 % |
| Pressure : | 1010hPa | Test Voltage : | AC 120V/60Hz |
| Test Mode : | FM 87.5MHz | | |

| Freq. (MHz) | Terminal L/N | Measured(dBuV) | | Limits(dBuV) | | Margin (dB) | Note |
|-------------|--------------|----------------|---------|--------------|---------|-------------|------|
| | | QP-Mode | AV-Mode | QP-Mode | AV-Mode | | |
| 0.15 | Line | 56.13 | 38.24 | 66.00 | 56.00 | -9.87 | (QP) |
| 0.16 | Line | 56.10 | 34.04 | 65.70 | 55.70 | -9.60 | (QP) |
| 0.35 | Line | 38.49 | * | 59.01 | 49.01 | -20.52 | (QP) |
| 0.51 | Line | 30.67 | * | 56.00 | 46.00 | -25.33 | (QP) |
| 1.72 | Line | 24.75 | * | 56.00 | 46.00 | -31.25 | (QP) |
| 6.22 | Line | 23.28 | * | 60.00 | 50.00 | -36.72 | (QP) |

Remark

- (1) Reading in which marked as QP means measurements by using are Quasi-Peak Mode with Detector BW=9KHz ; SPA setting in RBW=10KHz,VBW =10KHz, Swp. Time = 0.2 sec./MHz . Reading in which marked as AV means measurements by using are Average Mode with instrument setting in RBW=10KHz,VBW=10KHz, Swp. Time =0.2 sec./MHz .
- (2) All readings are QP Mode value unless otherwise stated AVG in column of Note . If the QP Mode Measured value compliance with the QP Limits and lower than AVG Limits, the EUT shall be deemed to meet both QP & AVG Limits and then only QP Mode was measured, but AVG Mode didn't perform . In this case, a " * " marked in AVG Mode column of Interference Voltage Measured .
- (3) Measuring frequency range from 150KHz to 30MHz .

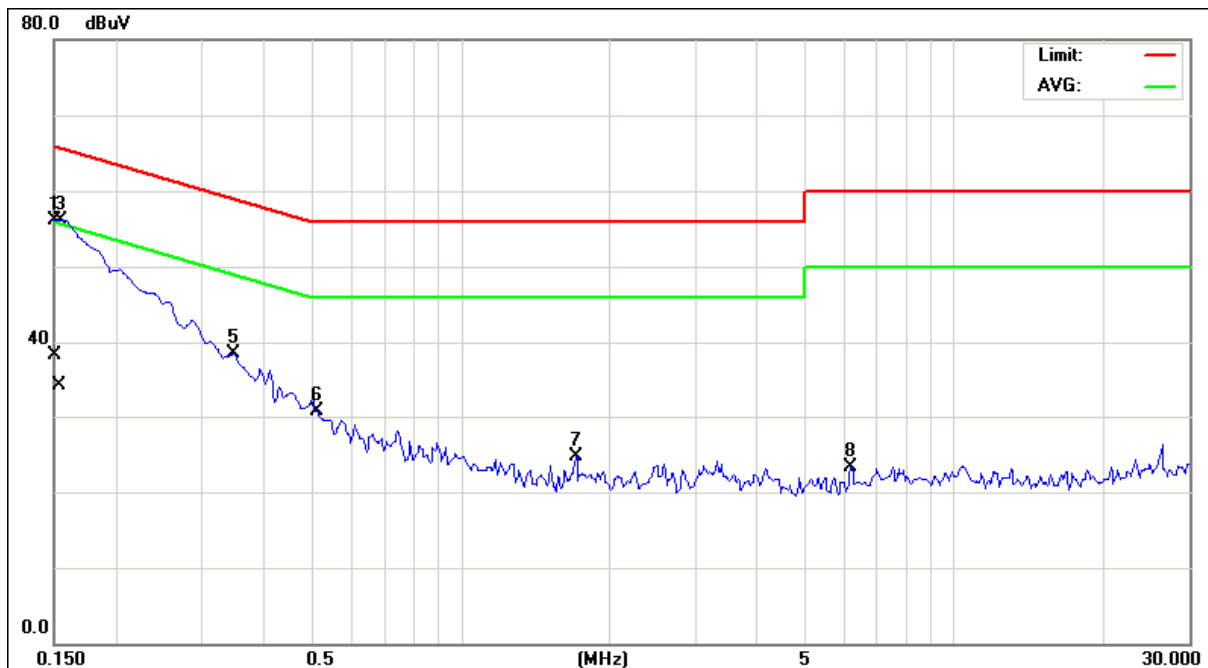



| | | | |
|---------------|---|---------------------|--------------|
| EUT : | Hi Fi dock with bluetooth wireless Audio system | Model Name : | SFQ-01 |
| Temperature : | 23 °C | Relative Humidity : | 57 % |
| Pressure : | 1010hPa | Test Voltage : | AC 120V/60Hz |
| Test Mode : | FM 87.5MHz | | |

| Freq. (MHz) | Terminal L/N | Measured(dBuV) | | Limits(dBuV) | | Margin (dB) | Note |
|-------------|--------------|----------------|---------|--------------|---------|-------------|------|
| | | QP-Mode | AV-Mode | QP-Mode | AV-Mode | | |
| 0.15 | Neutral | 56.08 | 35.43 | 66.00 | 56.00 | -9.92 | (QP) |
| 0.18 | Neutral | 53.13 | 36.50 | 64.63 | 54.63 | -11.50 | (QP) |
| 0.56 | Neutral | 30.75 | * | 56.00 | 46.00 | -25.25 | (QP) |
| 1.23 | Neutral | 24.09 | * | 56.00 | 46.00 | -31.91 | (QP) |
| 3.26 | Neutral | 23.38 | * | 56.00 | 46.00 | -32.62 | (QP) |
| 7.36 | Neutral | 24.19 | * | 60.00 | 50.00 | -35.81 | (QP) |

Remark

- (1) Reading in which marked as QP means measurements by using are Quasi-Peak Mode with Detector BW=9KHz ; SPA setting in RBW=10KHz,VBW =10KHz, Swp. Time = 0.2 sec./MHz ◦ Reading in which marked as AV means measurements by using are Average Mode with instrument setting in RBW=10KHz,VBW=10KHz, Swp. Time =0.2 sec./MHz ◦
- (2) All readings are QP Mode value unless otherwise stated AVG in column of Note . If the QP Mode Measured value compliance with the QP Limits and lower than AVG Limits, the EUT shall be deemed to meet both QP & AVG Limits and then only QP Mode was measured, but AVG Mode didn't perform ◦ In this case, a " * " marked in AVG Mode column of Interference Voltage Measured ◦
- (3) Measuring frequency range from 150KHz to 30MHz ◦

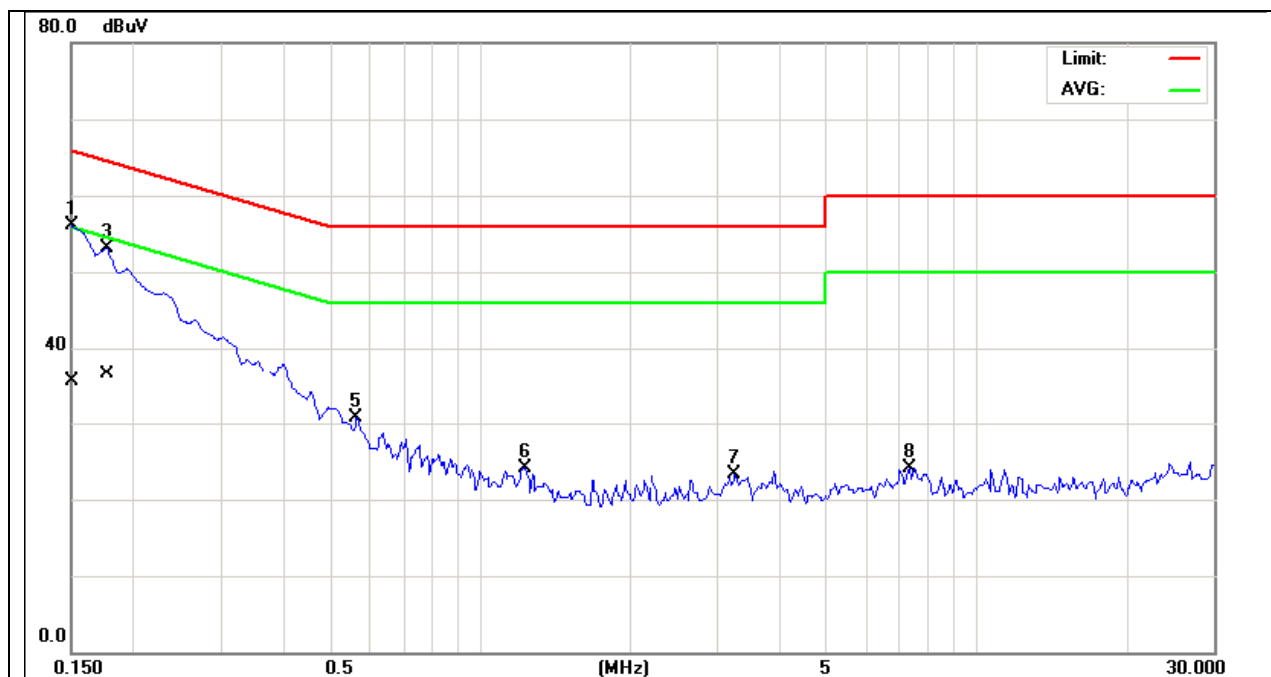



| | | | |
|---------------|---|---------------------|--------------|
| EUT : | Hi Fi dock with bluetooth wireless Audio system | Model Name : | SFQ-01 |
| Temperature : | 23 °C | Relative Humidity : | 57 % |
| Pressure : | 1010hPa | Test Voltage : | AC 120V/60Hz |
| Test Mode : | Bluetooth | | |

| Freq. (MHz) | Terminal L/N | Measured(dBuV) | | Limits(dBuV) | | Margin (dB) | Note |
|-------------|--------------|----------------|---------|--------------|---------|-------------|------|
| | | QP-Mode | AV-Mode | QP-Mode | AV-Mode | | |
| 0.15 | Line | 56.60 | 34.93 | 66.00 | 56.00 | -9.40 | (QP) |
| 0.18 | Line | 52.81 | 33.50 | 64.63 | 54.63 | -11.82 | (QP) |
| 0.40 | Line | 38.44 | * | 57.81 | 47.81 | -19.37 | (QP) |
| 1.22 | Line | 24.45 | * | 56.00 | 46.00 | -31.55 | (QP) |
| 3.35 | Line | 25.19 | * | 56.00 | 46.00 | -30.81 | (QP) |
| 6.64 | Line | 23.97 | * | 60.00 | 50.00 | -36.03 | (QP) |

Remark

- (1) Reading in which marked as QP means measurements by using are Quasi-Peak Mode with Detector BW=9KHz ; SPA setting in RBW=10KHz,VBW =10KHz, Swp. Time = 0.2 sec./MHz . Reading in which marked as AV means measurements by using are Average Mode with instrument setting in RBW=10KHz,VBW=10KHz, Swp. Time =0.2 sec./MHz .
- (2) All readings are QP Mode value unless otherwise stated AVG in column of Note . If the QP Mode Measured value compliance with the QP Limits and lower than AVG Limits, the EUT shall be deemed to meet both QP & AVG Limits and then only QP Mode was measured, but AVG Mode didn't perform . In this case, a " * " marked in AVG Mode column of Interference Voltage Measured .
- (3) Measuring frequency range from 150KHz to 30MHz .

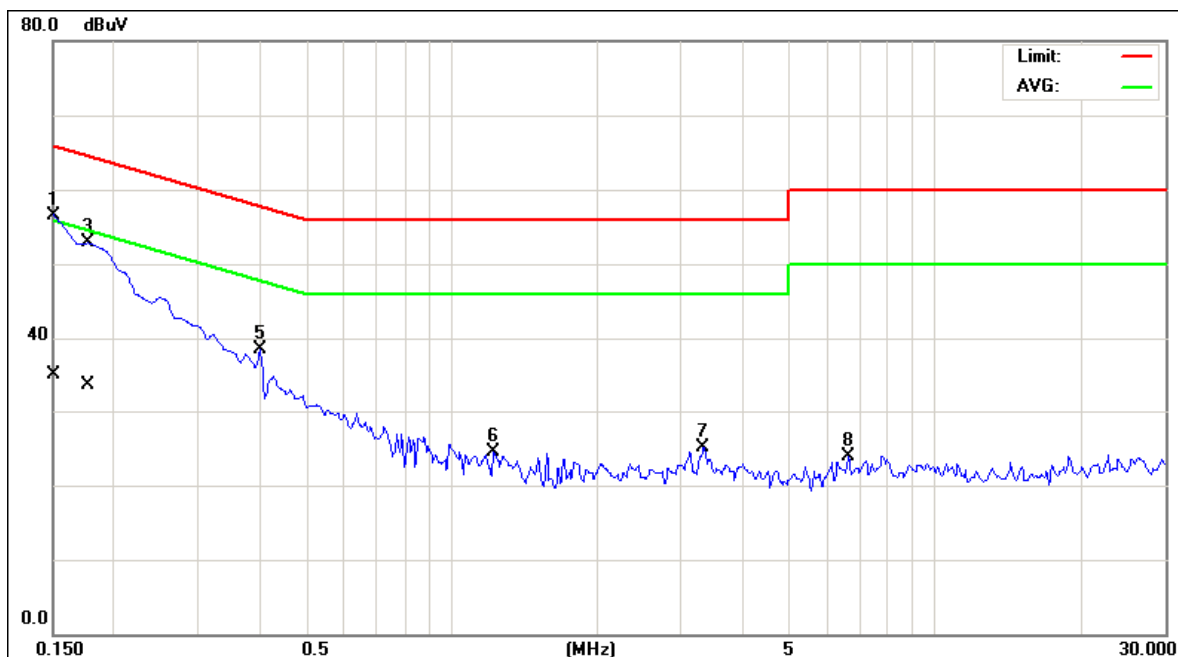



| | | | |
|---------------|---|---------------------|--------------|
| EUT : | Hi Fi dock with bluetooth wireless Audio system | Model Name : | SFQ-01 |
| Temperature : | 23 °C | Relative Humidity : | 57 % |
| Pressure : | 1010hPa | Test Voltage : | AC 120V/60Hz |
| Test Mode : | Bluetooth | | |

| Freq. (MHz) | Terminal L/N | Measured(dBuV) | | Limits(dBuV) | | Margin (dB) | Note |
|-------------|--------------|----------------|---------|--------------|---------|-------------|------|
| | | QP-Mode | AV-Mode | QP-Mode | AV-Mode | | |
| 0.15 | Neutral | 57.50 | 34.29 | 66.00 | 56.00 | -8.50 | (QP) |
| 0.17 | Neutral | 55.47 | 33.96 | 65.21 | 55.21 | -9.74 | (QP) |
| 0.61 | Neutral | 29.04 | * | 56.00 | 46.00 | -26.96 | (QP) |
| 1.19 | Neutral | 23.48 | * | 56.00 | 46.00 | -32.52 | (QP) |
| 3.35 | Neutral | 24.68 | * | 56.00 | 46.00 | -31.32 | (QP) |
| 8.98 | Neutral | 23.83 | * | 60.00 | 50.00 | -36.17 | (QP) |

Remark

- (1) Reading in which marked as QP means measurements by using are Quasi-Peak Mode with Detector BW=9KHz ; SPA setting in RBW=10KHz,VBW =10KHz, Swp. Time = 0.2 sec./MHz ◦ Reading in which marked as AV means measurements by using are Average Mode with instrument setting in RBW=10KHz,VBW=10KHz, Swp. Time =0.2 sec./MHz ◦
- (2) All readings are QP Mode value unless otherwise stated AVG in column of Note . If the QP Mode Measured value compliance with the QP Limits and lower than AVG Limits, the EUT shall be deemed to meet both QP & AVG Limits and then only QP Mode was measured, but AVG Mode didn't perform ◦ In this case, a " * " marked in AVG Mode column of Interference Voltage Measured ◦
- (3) Measuring frequency range from 150KHz to 30MHz ◦

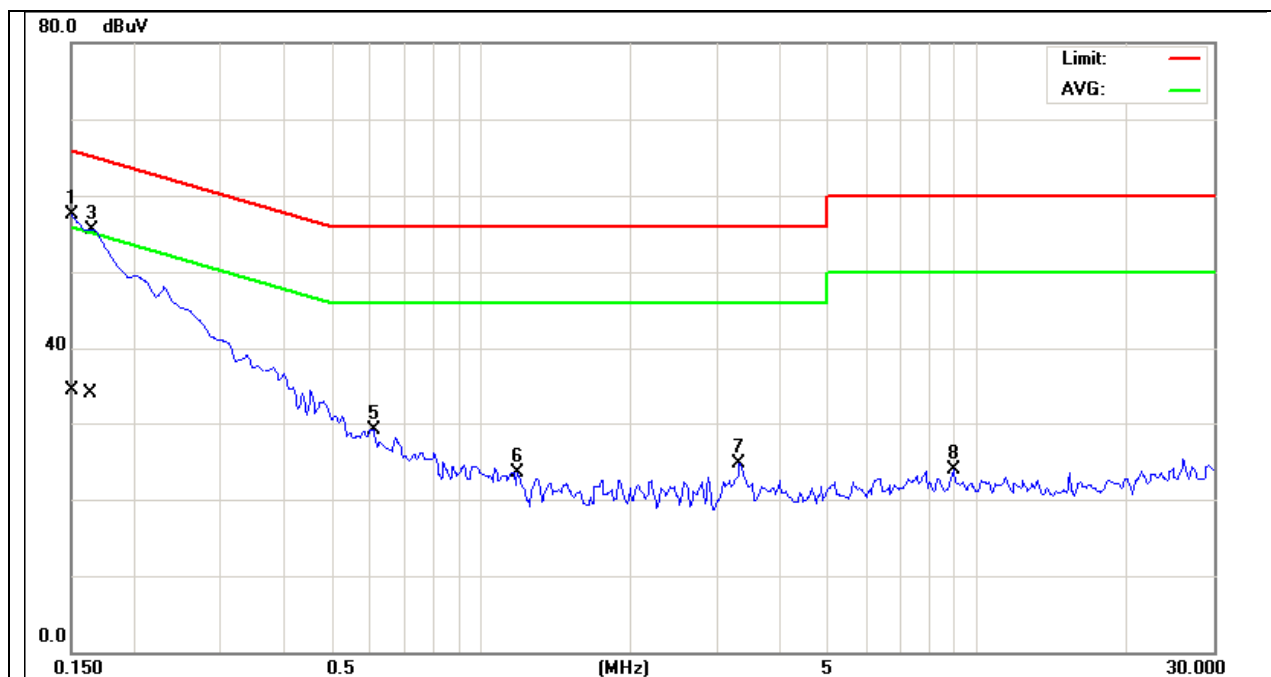



4.2 RADIATED EMISSION MEASUREMENT

4.2.1 RADIATED EMISSION LIMITS (Frequency Range 9kHz-1000MHz)

20dBc in any 100 kHz bandwidth outside the operating frequency band. In case the emission fall within the restricted band specified on 15.205(a), then the 15.209(a) limit in the table below has to be followed.

| Frequencies (MHz) | Field Strength (micorvolts/meter) | Measurement Distance (meters) |
|-------------------|-----------------------------------|-------------------------------|
| 0.009~0.490 | 2400/F(KHz) | 300 |
| 0.490~1.705 | 24000/F(KHz) | 30 |
| 1.705~30.0 | 30 | 30 |
| 30~88 | 100 | 3 |
| 88~216 | 150 | 3 |
| 216~960 | 200 | 3 |
| Above 960 | 500 | 3 |

LIMITS OF RADIATED EMISSION MEASUREMENT (Above 1000MHz)

| FREQUENCY (MHz) | Class A (dBuV/m) (at 3M) | | Class B (dBuV/m) (at 3M) | |
|-----------------|--------------------------|---------|--------------------------|---------|
| | PEAK | AVERAGE | PEAK | AVERAGE |
| Above 1000 | 80 | 60 | 74 | 54 |

Notes:

- (1) The limit for radiated test was performed according to FCC PART 15C.
- (2) The tighter limit applies at the band edges.
- (3) Emission level (dBuV/m)=20log Emission level (uV/m).

FREQUENCY RANGE OF RADIATED MEASUREMENT (For unintentional radiators)

| Highest frequency generated or Upper frequency of measurement used in the device or on which the device operates or tunes (MHz) | Range (MHz) |
|---|---|
| Below 1.705 | 30 |
| 1.705 – 108 | 1000 |
| 108 – 500 | 2000 |
| 500 – 1000 | 5000 |
| Above 1000 | 5 th harmonic of the highest frequency or 40 GHz, whichever is lower |



4.2.2 MEASUREMENT INSTRUMENTS LIST AND SETTING

| Item | Kind of Equipment | Manufacturer | Type No. | Serial No. | Calibrated until |
|------|-------------------------|--------------|---------------|------------|------------------|
| 1 | Horn Antenna | ETS | 3115 | 00075789 | May.12.2011 |
| 2 | Amplifier | Agilent | 8449B | 3008A02274 | May.26.2011 |
| 3 | Spectrum | Agilent | E4408B | US39240143 | Nov.16.2010 |
| 4 | Test Cable | HUBER+SUHNER | CB03 High Fre | N/A | May.03.2011 |
| 5 | Bi-log Antenna | Schwarzbeck | VULB9160 | 9160-3232 | May.26.2011 |
| 6 | Amplifier | HP | 8447D | 2944A09673 | May.26.2011 |
| 7 | Test Receiver | R&S | ESCI | 100895 | May.26.2011 |
| 8 | Test Cable | N/A | C-01_CB03 | N/A | Jul.05.2011 |
| 9 | Controller | CT | SC100 | N/A | N/A |
| 10 | Triple Loop Antenna | R&S | HFH2-Z2 | 830749/020 | May.27.2011 |
| 11 | Broad-Band Horn Antenna | Schwarzbeck | BBHA 9170 | 9170319 | May.12.2011 |

Remark: " N/A" denotes No Model Name / Serial No. and No Calibration specified.

| Spectrum Parameter | Setting |
|---------------------------------------|--|
| Attenuation | Auto |
| Start Frequency | 1000 MHz |
| Stop Frequency | 10th carrier harmonic |
| RB / VB (emission in restricted band) | 1 MHz / 1 MHz for Peak, 1 MHz / 10Hz for Average |

| Receiver Parameter | Setting |
|------------------------|----------------------------------|
| Attenuation | Auto |
| Start ~ Stop Frequency | 9kHz~150kHz / RB 200Hz for QP |
| Start ~ Stop Frequency | 150kHz~30MHz / RB 9kHz for QP |
| Start ~ Stop Frequency | 30MHz~1000MHz / RB 120kHz for QP |



4.2.3 TEST PROCEDURE

- a. The measuring distance of at 3 m shall be used for measurements at frequency up to 1GHz. For frequencies above 1GHz, any suitable measuring distance may be used.
- b. The EUT was placed on the top of a rotating table 0.8 meters above the ground at a 3 meter semi-anechoic chamber. The table was rotated 360 degrees to determine the position of the highest radiation.
- c. The height of the equipment or of the substitution antenna shall be 0.8 m; the height of the test antenna shall vary between 1 m to 4 m. Both horizontal and vertical polarizations of the antenna are set to make the measurement.
- d. The initial step in collecting conducted emission data is a spectrum analyzer peak detector mode pre-scanning the measurement frequency range. Significant peaks are then marked and then Quasi Peak detector mode re-measured.
- e. If the Peak Mode measured value compliance with and lower than Quasi Peak Mode Limit, the EUT shall be deemed to meet QP Limits and then no additional QP Mode measurement performed.
- f. For the actual test configuration, please refer to the related Item –EUT Test Photos.

4.2.4 DEVIATION FROM TEST STANDARD

No deviation

4.2.5 TEST SETUP

(A) Radiated Emission Test Set-Up Frequency Below 1 GHz

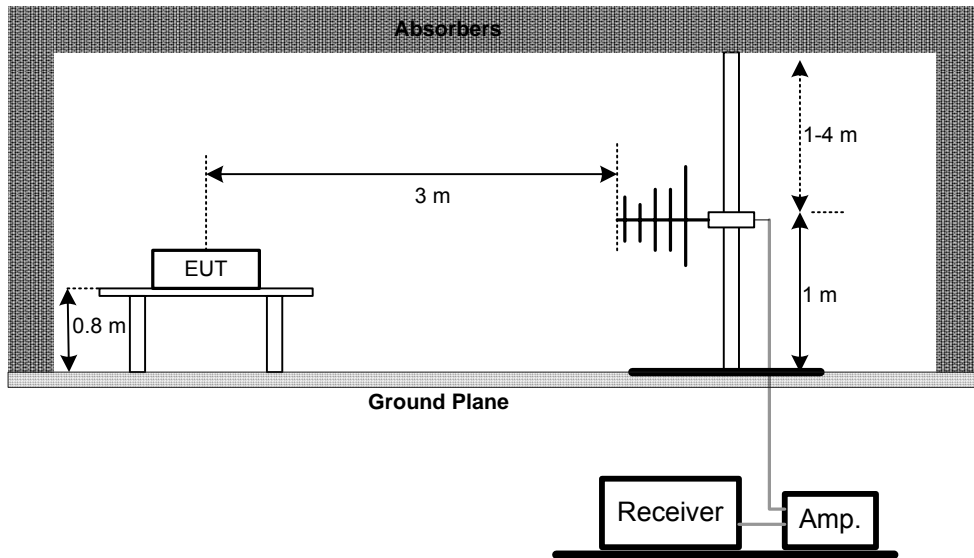

(B) Radiated Emission Test Set-Up Frequency Above 1 GHz

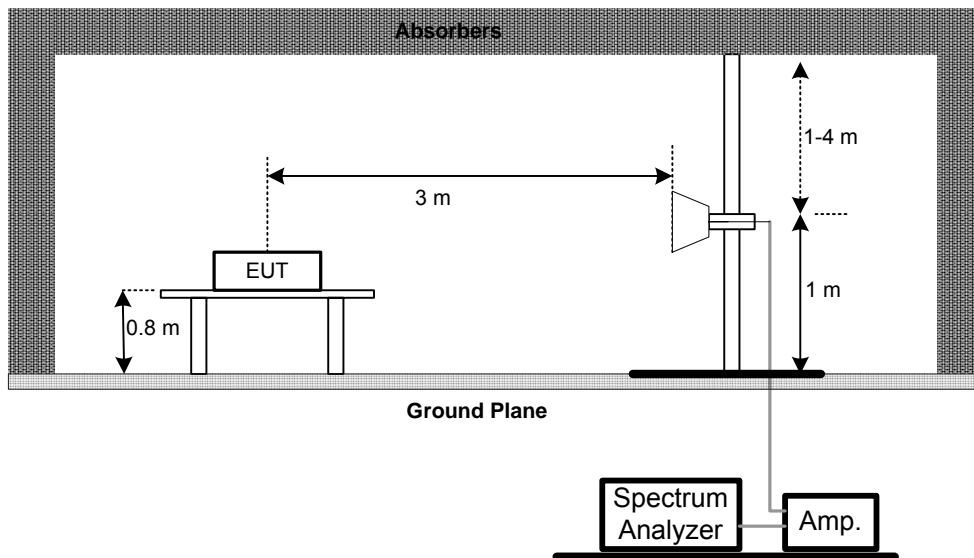

(C) For radiated emissions below 30MHz

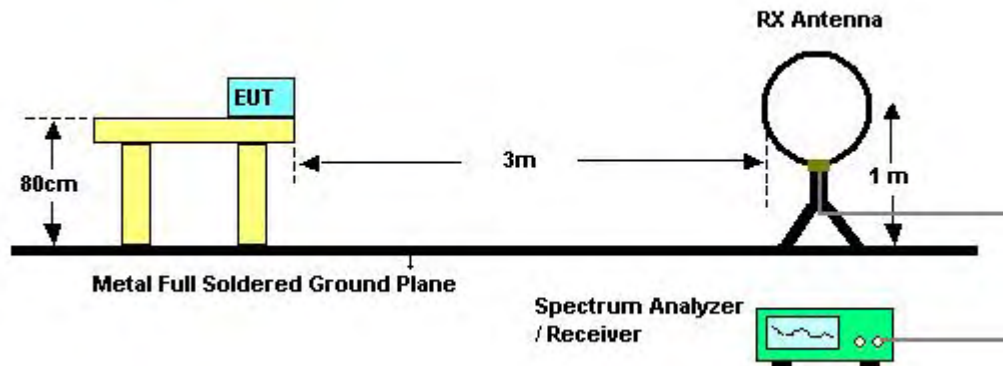

4.2.6 EUT OPERATING CONDITIONS

The EUT tested system was configured as the statements of 4.1.6 Unless otherwise a special operating condition is specified in the follows during the testing.



4.2.7 TEST RESULTS (BETWEEN 30 – 1000 MHZ)

| | | | |
|---------------|---|---------------------|--------------|
| EUT : | Hi Fi dock with bluetooth wireless Audio system | Model Name : | SFQ-01 |
| Temperature : | 23 °C | Relative Humidity : | 56 % |
| Pressure : | 1010 hPa | Test Voltage : | AC 120V/60Hz |
| Test Mode : | TX 2402MHz –CH00-1Mbps | | |

| Freq. (MHz) | Ant. H/V | Reading(RA) (dBuV) | Corr.Factor(CF) (dB) | Measured(FS) (dBuV/m) | Limits(QP) (dBuV/m) | Margin (dB) | Note |
|-------------|----------|--------------------|----------------------|-----------------------|---------------------|-------------|------|
| 56.99 | V | 46.53 | -23.67 | 22.86 | 40.00 | - 17.14 | |
| 123.35 | V | 48.99 | -20.49 | 28.50 | 43.50 | - 15.00 | |
| 187.61 | V | 43.74 | -21.92 | 21.82 | 43.50 | - 21.68 | |
| 266.93 | V | 45.66 | -17.18 | 28.48 | 46.00 | - 17.52 | |
| 387.71 | V | 39.24 | -15.16 | 24.08 | 46.00 | - 21.92 | |
| 499.82 | V | 40.88 | -15.24 | 25.64 | 46.00 | - 20.36 | |

Remark :

- (1) Reading in which marked as QP or Peak means measurements by using are Quasi-Peak Mode or Peak Mode with Detector BW=120KHz ; SPA setting in RBW=120KHz, VBW =120KHz, Swp. Time = 0.3 sec./MHz ◦
- (2) All readings are Peak unless otherwise stated QP in column of 『 Note 』 . Peak denotes that the Peak reading compliance with the QP Limits and then QP Mode measurement didn't perform ◦
- (3) Measuring frequency range from 30MHz to 1000MHz ◦
- (4) If the peak scan value lower limit more than 20dB, then this signal data does not show in table ◦

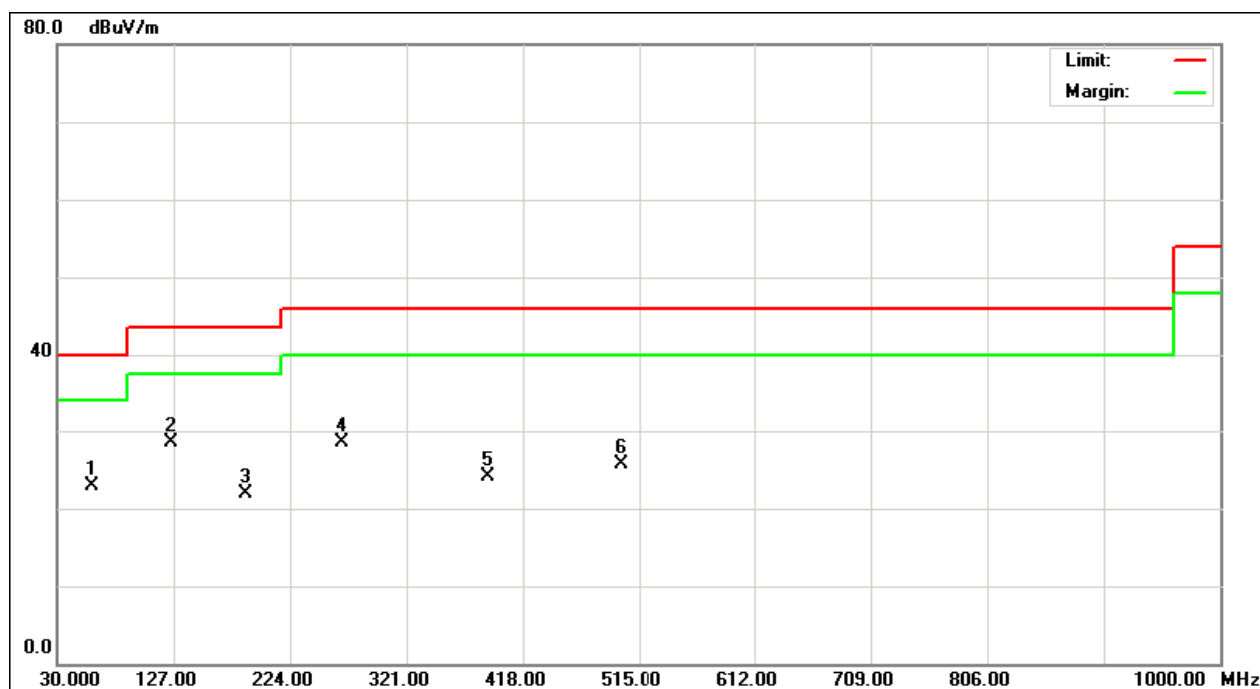



| | | | |
|---------------|---|---------------------|--------------|
| EUT : | Hi Fi dock with bluetooth wireless Audio system | Model Name : | SFQ-01 |
| Temperature : | 23 °C | Relative Humidity : | 56 % |
| Pressure : | 1010 hPa | Test Voltage : | AC 120V/60Hz |
| Test Mode : | TX 2402MHz –CH00-1Mbps | | |

| Freq. (MHz) | Ant. H/V | Reading(RA) (dBuV) | Corr.Factor(CF) (dB) | Measured(FS) (dBuV/m) | Limits(QP) (dBuV/m) | Margin (dB) | Note |
|-------------|----------|--------------------|----------------------|-----------------------|---------------------|-------------|------|
| 87.96 | H | 48.33 | -29.71 | 18.62 | 40.00 | - 21.38 | |
| 125.66 | H | 44.26 | -23.41 | 20.85 | 43.50 | - 22.65 | |
| 189.61 | H | 43.21 | -23.56 | 19.65 | 43.50 | - 23.85 | |
| 256.73 | H | 44.17 | -21.63 | 22.54 | 46.00 | - 23.46 | |
| 336.98 | H | 42.50 | -20.05 | 22.45 | 46.00 | - 23.55 | |
| 599.40 | H | 33.99 | -10.57 | 23.42 | 46.00 | - 22.58 | |

Remark :

- (1) Reading in which marked as QP or Peak means measurements by using are Quasi-Peak Mode or Peak Mode with Detector BW=120KHz ; SPA setting in RBW=120KHz, VBW =120KHz, Swp. Time = 0.3 sec./MHz .
- (2) All readings are Peak unless otherwise stated QP in column of 『 Note 』 . Peak denotes that the Peak reading compliance with the QP Limits and then QP Mode measurement didn't perform .
- (3) Measuring frequency range from 30MHz to 1000MHz .
- (4) If the peak scan value lower limit more than 20dB, then this signal data does not show in table .

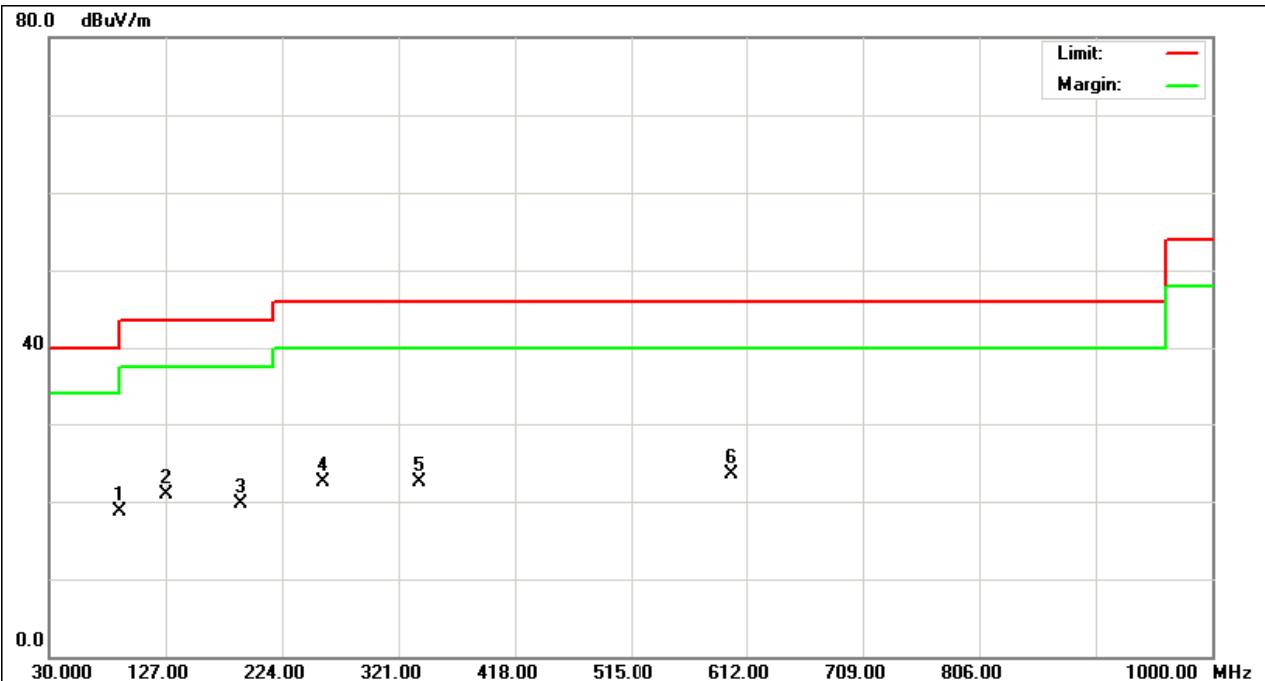



| | | | |
|---------------|---|---------------------|--------------|
| EUT : | Hi Fi dock with bluetooth wireless Audio system | Model Name : | SFQ-01 |
| Temperature : | 23 °C | Relative Humidity : | 56 % |
| Pressure : | 1010 hPa | Test Voltage : | AC 120V/60Hz |
| Test Mode : | RX 2402MHz –CH00-1Mbps | | |

| Freq. (MHz) | Ant. H/V | Reading(RA) (dBuV) | Corr.Factor(CF) (dB) | Measured(FS) (dBuV/m) | Limits(QP) (dBuV/m) | Margin (dB) | Note |
|-------------|----------|--------------------|----------------------|-----------------------|---------------------|-------------|------|
| 89.63 | V | 42.32 | -24.84 | 17.48 | 43.50 | - 26.02 | |
| 156.37 | V | 40.12 | -19.19 | 20.93 | 43.50 | - 22.57 | |
| 254.28 | V | 39.96 | -17.19 | 22.77 | 46.00 | - 23.23 | |
| 339.91 | V | 41.86 | -17.55 | 24.31 | 46.00 | - 21.69 | |
| 415.53 | V | 42.53 | -15.51 | 27.02 | 46.00 | - 18.98 | |
| 520.33 | V | 38.77 | -15.28 | 23.49 | 46.00 | - 22.51 | |

Remark :

- (1) Reading in which marked as QP or Peak means measurements by using are Quasi-Peak Mode or Peak Mode with Detector BW=120KHz ; SPA setting in RBW=120KHz, VBW =120KHz, Swp. Time = 0.3 sec./MHz ◦
- (2) All readings are Peak unless otherwise stated QP in column of 『 Note 』 . Peak denotes that the Peak reading compliance with the QP Limits and then QP Mode measurement didn't perform ◦
- (3) Measuring frequency range from 30MHz to 1000MHz ◦
- (4) If the peak scan value lower limit more than 20dB, then this signal data does not show in table ◦

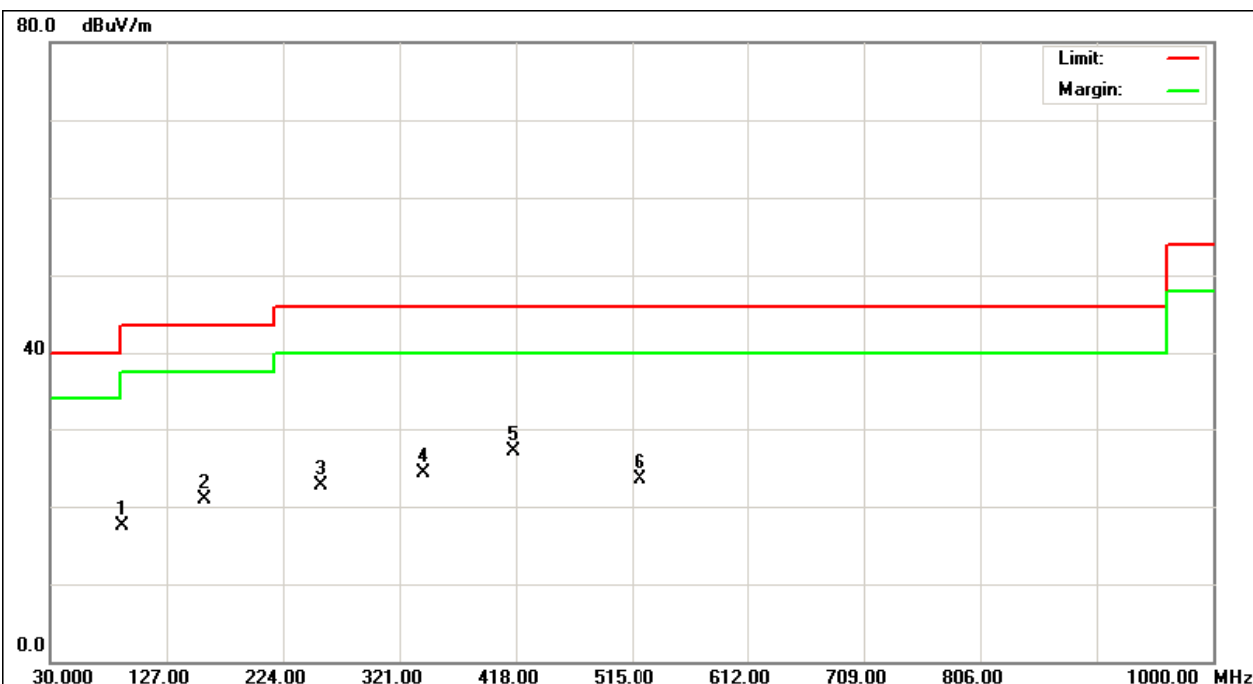



| | | | |
|---------------|---|---------------------|--------------|
| EUT : | Hi Fi dock with bluetooth wireless Audio system | Model Name : | SFQ-01 |
| Temperature : | 23 °C | Relative Humidity : | 56 % |
| Pressure : | 1010 hPa | Test Voltage : | AC 120V/60Hz |
| Test Mode : | RX 2402MHz –CH00-1Mbps | | |

| Freq. (MHz) | Ant. H/V | Reading(RA) (dBuV) | Corr.Factor(CF) (dB) | Measured(FS) (dBuV/m) | Limits(QP) (dBuV/m) | Margin (dB) | Note |
|-------------|----------|--------------------|----------------------|-----------------------|---------------------|-------------|------|
| 187.60 | H | 42.63 | -23.46 | 19.17 | 43.50 | - 24.33 | |
| 236.55 | H | 41.18 | -21.91 | 19.27 | 46.00 | - 26.73 | |
| 376.80 | H | 45.87 | -18.38 | 27.49 | 46.00 | - 18.51 | |
| 447.86 | H | 36.55 | -14.74 | 21.81 | 46.00 | - 24.19 | |
| 619.30 | H | 26.05 | -10.07 | 15.98 | 46.00 | - 30.02 | |
| 704.20 | H | 27.42 | -10.87 | 16.55 | 46.00 | - 29.45 | |

Remark :

- (1) Reading in which marked as QP or Peak means measurements by using are Quasi-Peak Mode or Peak Mode with Detector BW=120KHz ; SPA setting in RBW=120KHz, VBW =120KHz, Swp. Time = 0.3 sec./MHz ◦
- (2) All readings are Peak unless otherwise stated QP in column of 『 Note 』 . Peak denotes that the Peak reading compliance with the QP Limits and then QP Mode measurement didn't perform ◦
- (3) Measuring frequency range from 30MHz to 1000MHz ◦
- (4) If the peak scan value lower limit more than 20dB, then this signal data does not show in table ◦

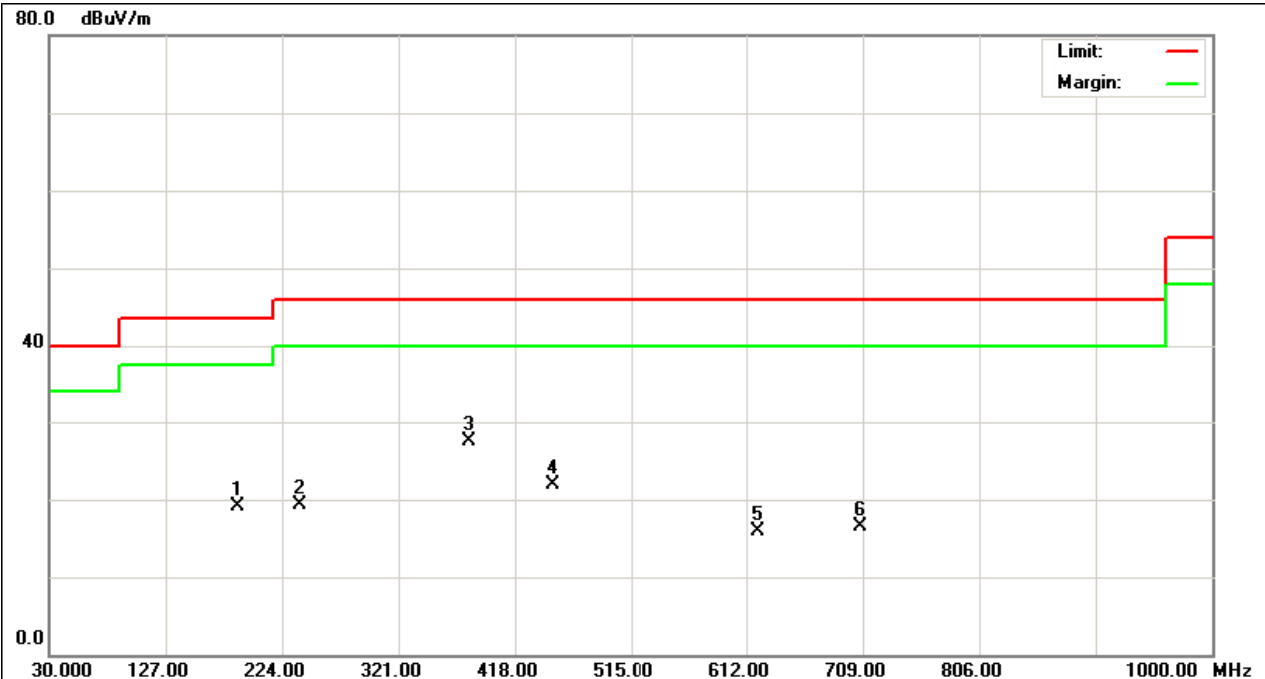



4.2.8 TEST RESULTS (ABOVE 1000 MHZ)

| | | | |
|---------------|---|---------------------|--------------|
| EUT : | Hi Fi dock with bluetooth wireless Audio system | Model Name : | SFQ-01 |
| Temperature : | 23 °C | Relative Humidity : | 56 % |
| Pressure : | 1010 hPa | Test Voltage : | AC 120V/60Hz |
| Test Mode : | TX 2402MHz – CH 00-1Mbps | | |

| Freq. (MHz) | Ant.Pol. H/V | Reading | | Ant./CF CF(dB) | Act. | | Limit | | Note |
|----------------|-----------------|----------------|--------------|-------------------|------------------|----------------|------------------|----------------|------------|
| | | Peak (dBuV) | AV (dBuV) | | Peak (dBuV/m) | AV (dBuV/m) | Peak (dBuV/m) | AV (dBuV/m) | |
| 2390.00 | V | 21.87 | 10.77 | 31.61 | 53.48 | 42.38 | 74.00 | 54.00 | X/E |
| 2402.30 | V | 62.01 | 27.59 | 31.60 | 93.61 | 59.19 | | | X/F |
| 4804.26 | V | 55.46 | 41.02 | 5.18 | 60.64 | 46.20 | 74.00 | 54.00 | X/H |

Remark :

- (1) All readings are Peak unless otherwise stated QP in column of 『Note』 . Peak denotes that the Peak reading compliance with the QP Limits and then QP Mode measurement didn't perform .
- (2) Measuring frequency range from 30MHz to 1000MHz or the 10th harmonic of highest fundamental frequency . "F" denotes fundamental frequency; "H" denotes spurious frequency. "E" denotes band edge frequency. (This judgment method includes the Band Edge Requirement.)
- (3) Radiated emissions measured in frequency range above 1000MHz were made with an instrument using Peak detector mode and AV detector mode of the emission .
- (4) Data of measurement within this frequency range shown " * " in the table above means the reading of emissions are attenuated more than 20dB below the permissible limits or the field strength is too small to be measured.
- (5) A preamp and high pass filter were used for this test in order to provide sufficient measurement sensitivity.
- (6) EUT Orthogonal Axis :
"X" - denotes Laid on Table ; "Y" - denotes Vertical Stand ; "Z" - denotes Side Stand
- (7) During the measurements above 1 GHz it is taken care of that the EUT is always within the 3 dB cone of radiation BW of the used antenna



TX CH00(Above 1000 MHz, Vertical)

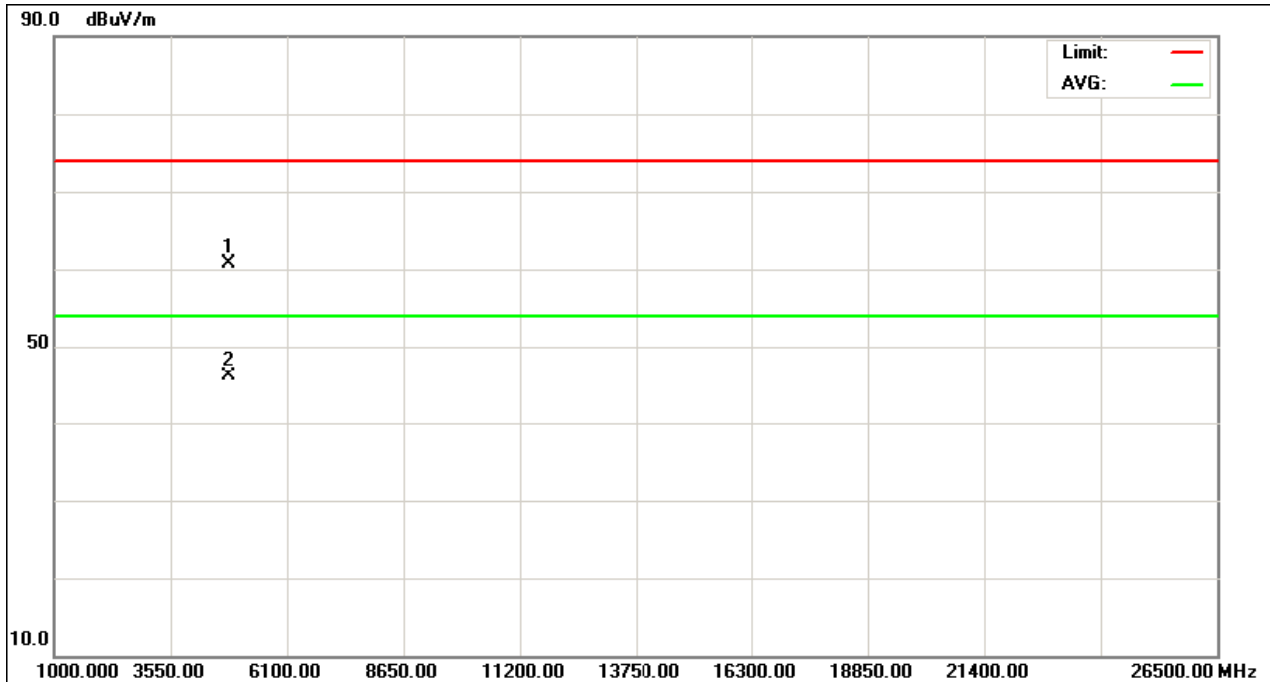
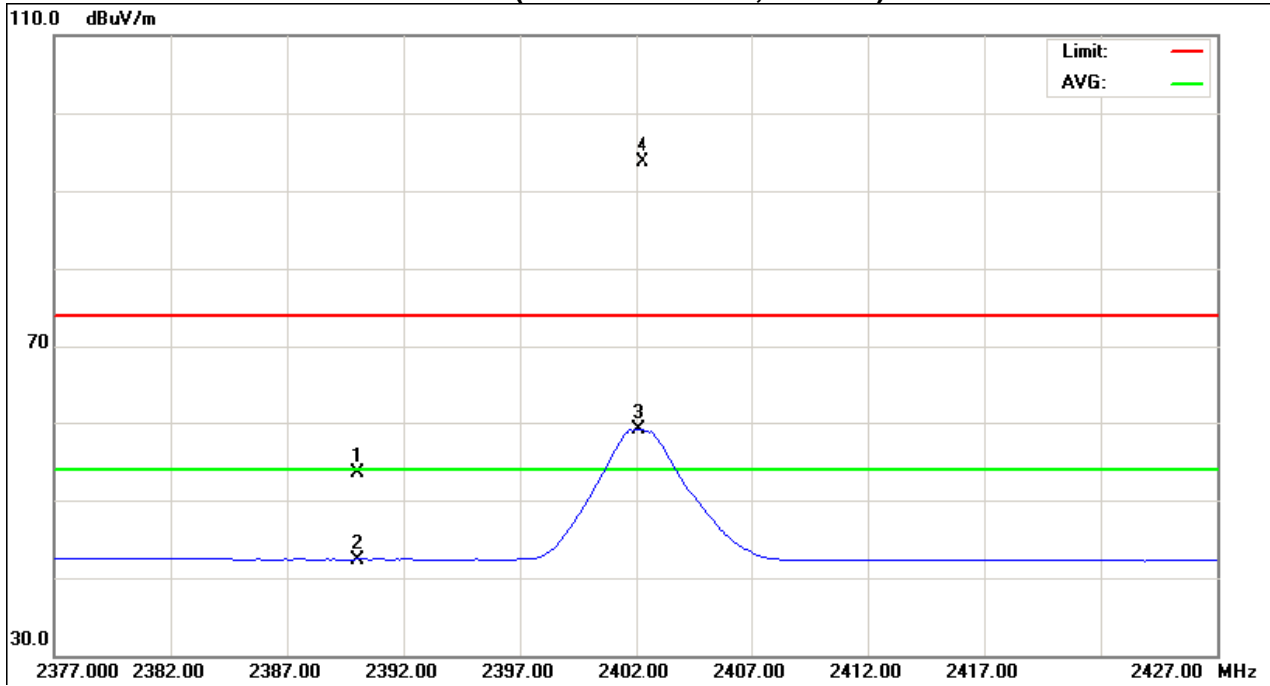



| | | | |
|---------------|---|---------------------|--------------|
| EUT : | Hi Fi dock with bluetooth wireless Audio system | Model Name : | SFQ-01 |
| Temperature : | 22 °C | Relative Humidity : | 56 % |
| Pressure : | 1010hPa | Test Voltage : | AC 120V/60Hz |
| Test Mode : | TX 2402MHz – CH 00-1Mbps | | |

| Freq. (MHz) | Ant.Pol. H/V | Reading | | Ant./CF CF(dB) | Act. | | Limit | | Note |
|----------------|-----------------|----------------|--------------|-------------------|------------------|----------------|------------------|----------------|------------|
| | | Peak (dBuV) | AV (dBuV) | | Peak (dBuV/m) | AV (dBuV/m) | Peak (dBuV/m) | AV (dBuV/m) | |
| 2390.00 | H | 22.32 | 10.74 | 31.61 | 53.93 | 42.35 | 74.00 | 54.00 | X/E |
| 2402.30 | H | 62.87 | 27.79 | 31.60 | 94.47 | 59.39 | | | X/F |
| 4803.95 | H | 48.79 | 36.19 | 5.17 | 53.96 | 41.36 | 74.00 | 54.00 | X/H |

Remark :

- (1) All readings are Peak unless otherwise stated QP in column of 『Note』 . Peak denotes that the Peak reading compliance with the QP Limits and then QP Mode measurement didn't perform ◦
- (2) Measuring frequency range from 30MHz to 1000MHz or the 10th harmonic of highest fundamental frequency ◦ “F” denotes fundamental frequency; “H” denotes spurious frequency. “E” denotes band edge frequency. (This judgment method includes the Band Edge Requirement.)
- (3) Radiated emissions measured in frequency range above 1000MHz were made with an instrument using Peak detector mode and AV detector mode of the emission ◦
- (4) Data of measurement within this frequency range shown “ * ” in the table above means the reading of emissions are attenuated more than 20dB below the permissible limits or the field strength is too small to be measured.
- (5) A preamp and high pass filter were used for this test in order to provide sufficient measurement sensitivity.
- (6) EUT Orthogonal Axis :
“X” - denotes Laid on Table ; “Y” - denotes Vertical Stand ; “Z” - denotes Side Stand
- (7) During the measurements above 1 GHz it is taken care of that the EUT is always within the 3 dB cone of radiation BW of the used antenna



TX CH00(Above 1000 MHz, Horizontal)

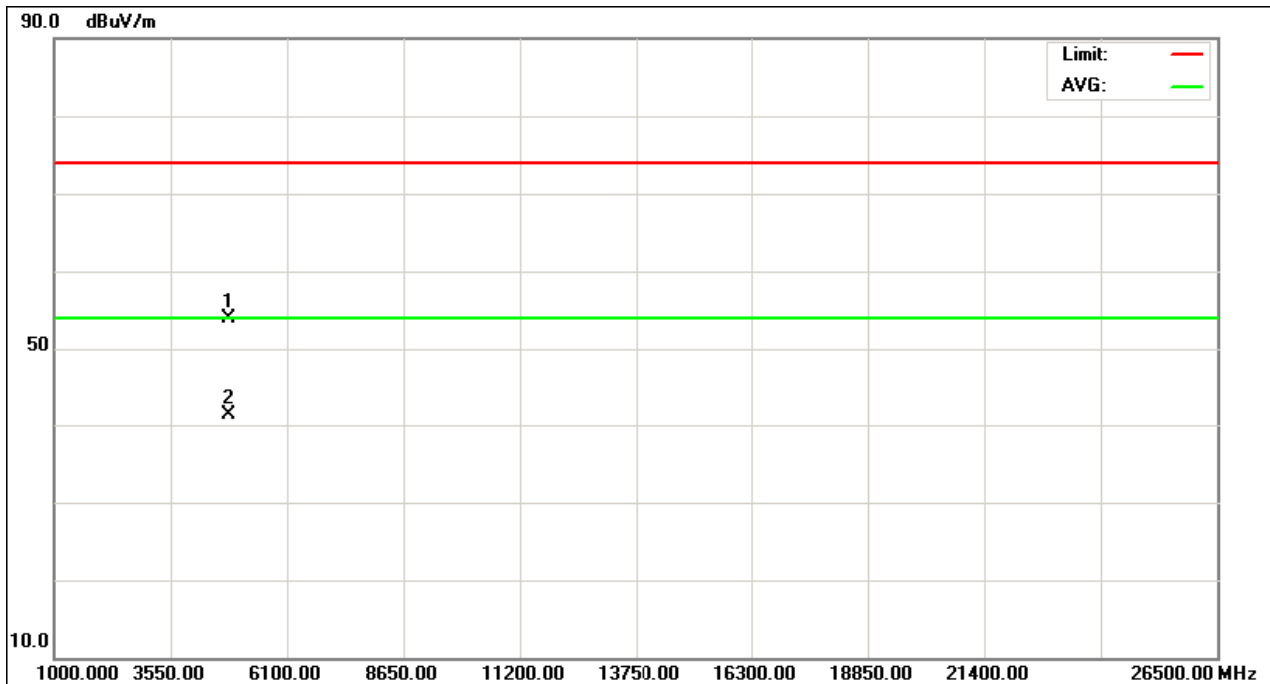
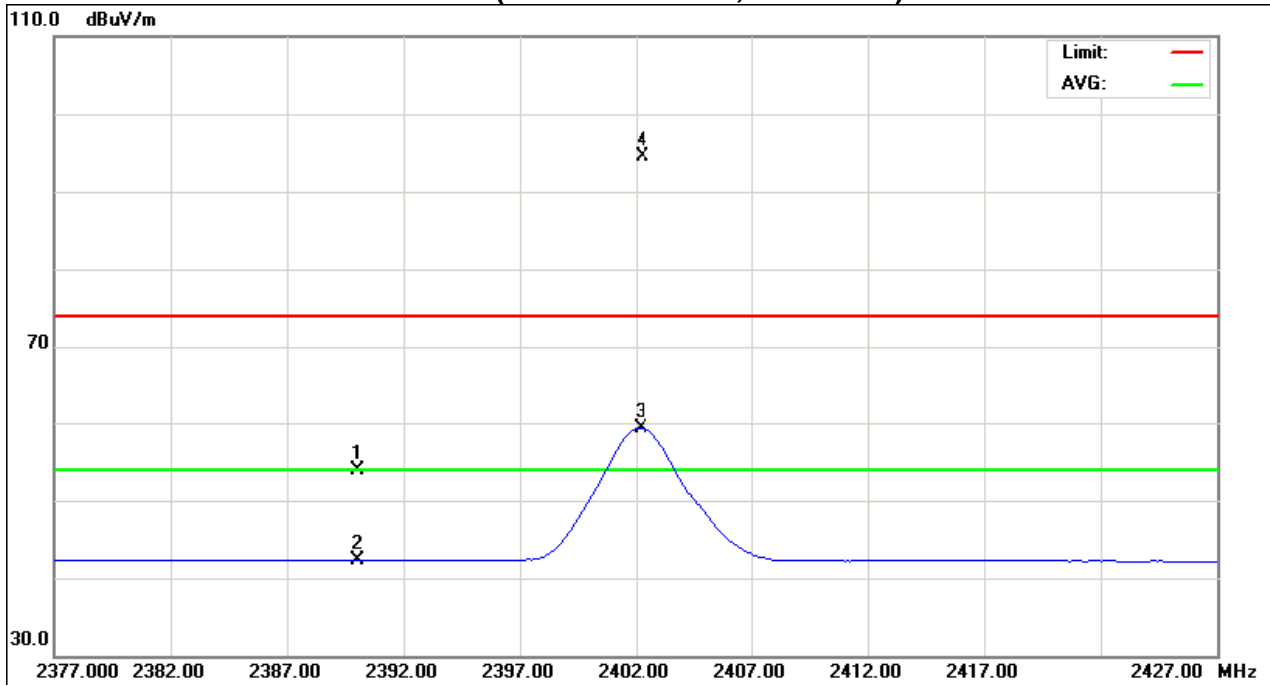



| | | | |
|---------------|---|---------------------|--------------|
| EUT : | Hi Fi dock with bluetooth wireless Audio system | Model Name : | SFQ-01 |
| Temperature : | 22 °C | Relative Humidity : | 56 % |
| Pressure : | 1010 hPa | Test Voltage : | AC 120V/60Hz |
| Test Mode : | TX 2441MHz –CH39-1Mbps | | |

| Freq. | Ant.Pol. | Reading | | Ant./CF | Act. | | Limit | | Note |
|----------------|----------|--------------|--------------|--------------|--------------|--------------|----------|----------|------------|
| | | Peak | AV | | Peak | AV | Peak | AV | |
| (MHz) | H/V | (dBUV) | (dBUV) | CF(dB) | (dBUV/m) | (dBUV/m) | (dBUV/m) | (dBUV/m) | |
| 2441.20 | V | 67.47 | 29.38 | 31.55 | 99.02 | 60.93 | | | X/F |
| 4882.05 | V | 55.63 | 41.29 | 5.56 | 61.19 | 46.85 | 74.00 | 54.00 | X/H |

Remark :

- (1) All readings are Peak unless otherwise stated QP in column of 『Note』 . Peak denotes that the Peak reading compliance with the QP Limits and then QP Mode measurement didn't perform .
- (2) Measuring frequency range from 30MHz to 1000MHz or the 10th harmonic of highest fundamental frequency .“F” denotes fundamental frequency; “H” denotes spurious frequency. “E” denotes band edge frequency. (This judgment method includes the Band Edge Requirement.)
- (3) Radiated emissions measured in frequency range above 1000MHz were made with an instrument using Peak detector mode and AV detector mode of the emission .
- (4) Data of measurement within this frequency range shown “ * ” in the table above means the reading of emissions are attenuated more than 20dB below the permissible limits or the field strength is too small to be measured.
- (5) A preamp and high pass filter were used for this test in order to provide sufficient measurement sensitivity.
- (6) EUT Orthogonal Axis :
“X” - denotes Laid on Table ; “Y” - denotes Vertical Stand ; “Z” - denotes Side Stand
- (7) During the measurements above 1 GHz it is taken care of that the EUT is always within the 3 dB cone of radiation BW of the used antenna



TX CH39 (Above 1000 MHz, Vertical)

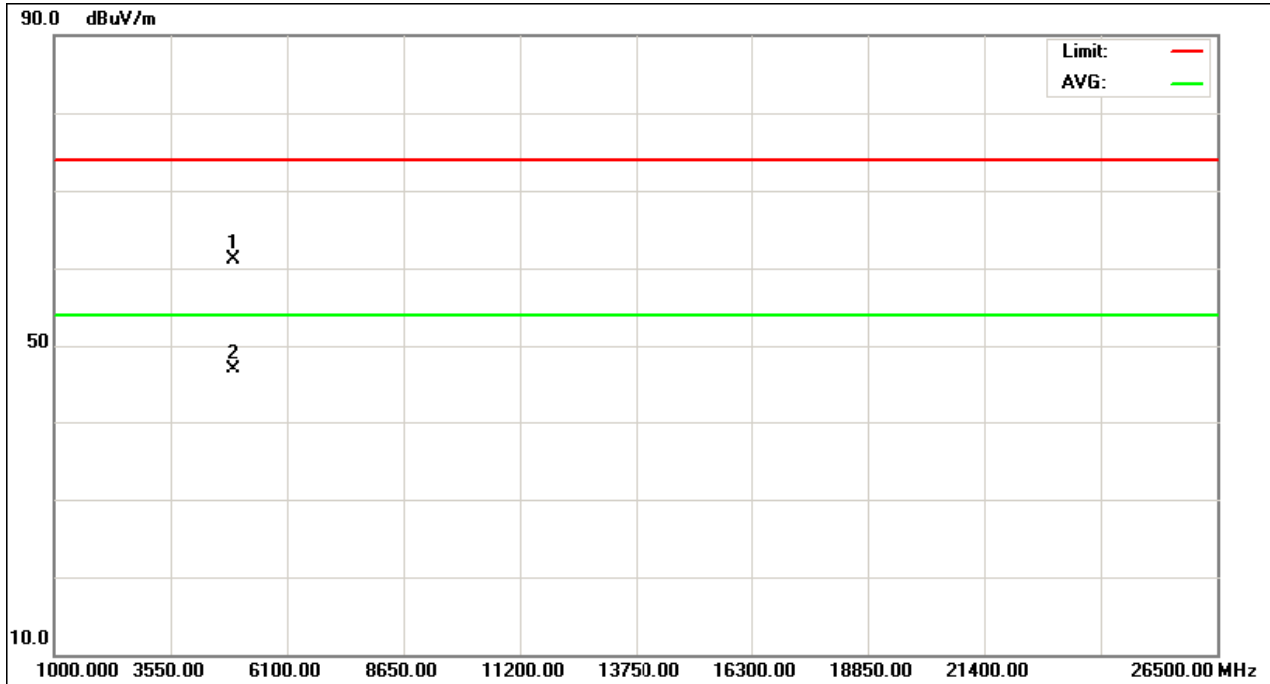
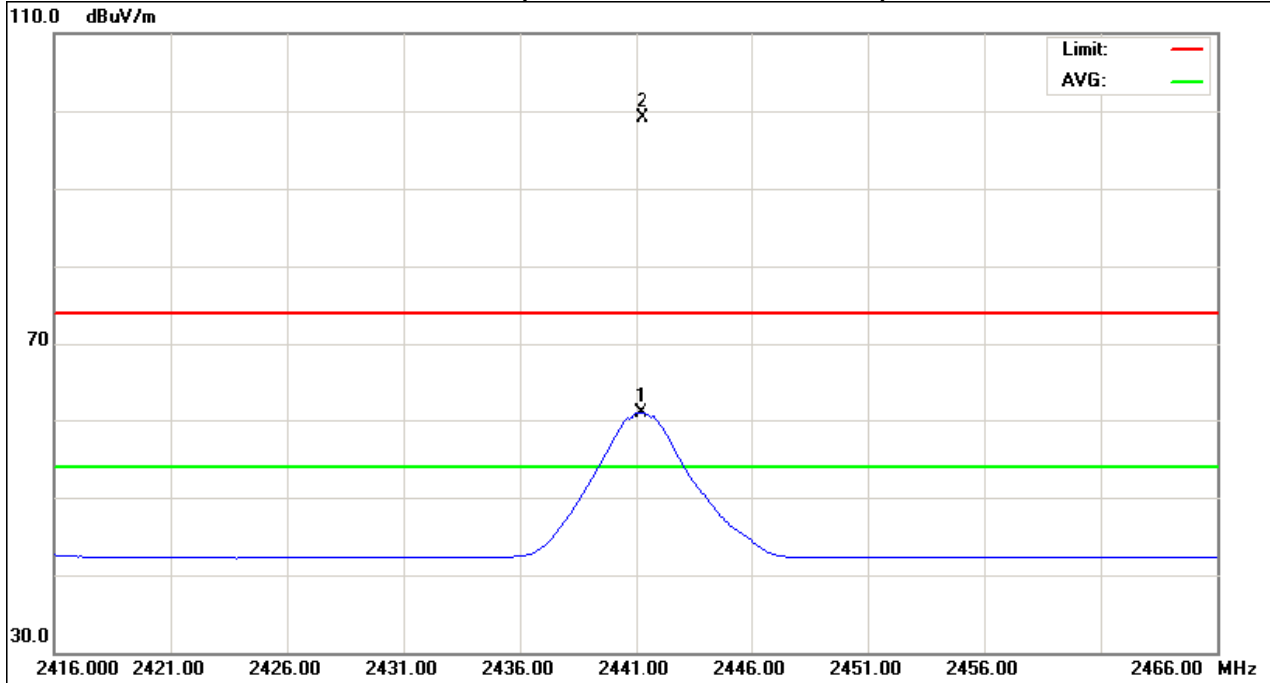



| | | | |
|---------------|---|---------------------|--------------|
| EUT : | Hi Fi dock with bluetooth wireless Audio system | Model Name : | SFQ-01 |
| Temperature : | 22 °C | Relative Humidity : | 56 % |
| Pressure : | 1010 hPa | Test Voltage : | AC 120V/60Hz |
| Test Mode : | TX 2441MHz –CH39-1Mbps | | |

| Freq. | Ant.Pol. | Reading | | Ant./CF | Act. | | Limit | | Note |
|----------------|----------|--------------|--------------|--------------|--------------|--------------|----------|----------|------------|
| | | Peak | AV | | Peak | AV | Peak | AV | |
| (MHz) | H/V | (dBuV) | (dBuV) | CF(dB) | (dBuV/m) | (dBuV/m) | (dBuV/m) | (dBuV/m) | |
| 2441.30 | H | 65.28 | 28.53 | 31.55 | 96.83 | 60.08 | | | X/F |
| 4882.74 | H | 50.31 | 38.29 | 5.56 | 55.87 | 43.85 | 74.00 | 54.00 | X/H |

Remark :

- (1) All readings are Peak unless otherwise stated QP in column of 『 Note 』 . Peak denotes that the Peak reading compliance with the QP Limits and then QP Mode measurement didn't perform .
- (2) Measuring frequency range from 30MHz to 1000MHz or the 10th harmonic of highest fundamental frequency .“F” denotes fundamental frequency; “H” denotes spurious frequency. “E” denotes band edge frequency. (This judgment method includes the Band Edge Requirement.)
- (3) Radiated emissions measured in frequency range above 1000MHz were made with an instrument using Peak detector mode and AV detector mode of the emission .
- (4) Data of measurement within this frequency range shown “ * ” in the table above means the reading of emissions are attenuated more than 20dB below the permissible limits or the field strength is too small to be measured.
- (5) A preamp and high pass filter were used for this test in order to provide sufficient measurement sensitivity.
- (6) EUT Orthogonal Axis :
“X” - denotes Laid on Table ; “Y” - denotes Vertical Stand ; “Z” - denotes Side Stand
- (7) During the measurements above 1 GHz it is taken care of that the EUT is always within the 3 dB cone of radiation BW of the used antenna



TX CH39 (Above 1000 MHz, Horizontal)

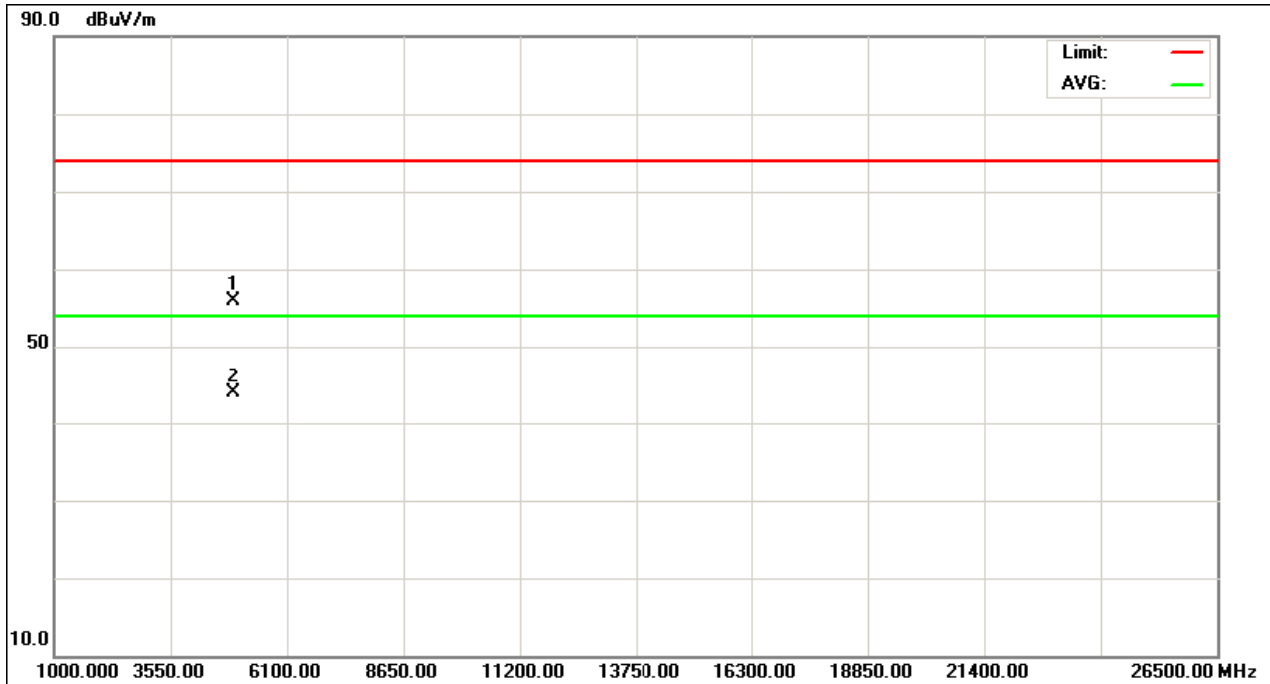
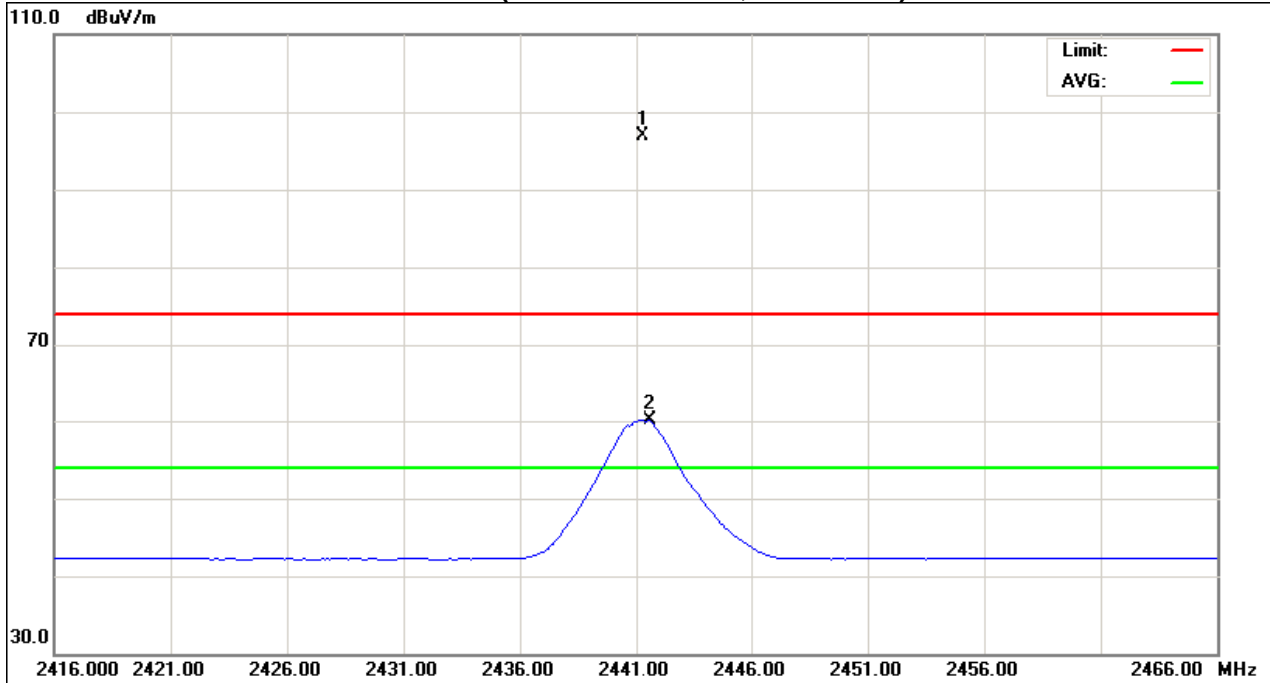



| | | | |
|---------------|---|---------------------|--------------|
| EUT : | Hi Fi dock with bluetooth wireless Audio system | Model Name : | SFQ-01 |
| Temperature : | 22 °C | Relative Humidity : | 56 % |
| Pressure : | 1010hPa | Test Voltage : | AC 120V/60Hz |
| Test Mode : | TX 2480MHz –CH78-1Mbps | | |

| Freq. | Ant.Pol. | Reading | | Ant./CF | Act. | | Limit | | Note |
|----------------|----------|--------------|--------------|--------------|--------------|--------------|----------|----------|------------|
| | | Peak | AV | | Peak | AV | Peak | AV | |
| (MHz) | H/V | (dBuV) | (dBuV) | CF(dB) | (dBuV/m) | (dBuV/m) | (dBuV/m) | (dBuV/m) | |
| 2480.20 | V | 67.03 | 29.79 | 31.50 | 98.53 | 61.29 | | | X/F |
| 2483.50 | V | 31.25 | 16.36 | 31.50 | 62.75 | 47.86 | 74.00 | 54.00 | X/E |
| 4960.87 | V | 55.39 | 40.12 | 5.94 | 61.33 | 46.06 | 74.00 | 54.00 | X/H |

Remark :

- (1) All readings are Peak unless otherwise stated QP in column of 『Note』 . Peak denotes that the Peak reading compliance with the QP Limits and then QP Mode measurement didn't perform ◦
- (2) Measuring frequency range from 30MHz to 1000MHz or the 10th harmonic of highest fundamental frequency ◦ “F” denotes fundamental frequency; “H” denotes spurious frequency. “E” denotes band edge frequency. (This judgment method includes the Band Edge Requirement.)
- (3) Radiated emissions measured in frequency range above 1000MHz were made with an instrument using Peak detector mode and AV detector mode of the emission ◦
- (4) Data of measurement within this frequency range shown “ * ” in the table above means the reading of emissions are attenuated more than 20dB below the permissible limits or the field strength is too small to be measured.
- (5) A preamp and high pass filter were used for this test in order to provide sufficient measurement sensitivity.
- (6) EUT Orthogonal Axis :
“X” - denotes Laid on Table ; “Y” - denotes Vertical Stand ; “Z” - denotes Side Stand
- (7) During the measurements above 1 GHz it is taken care of that the EUT is always within the 3 dB cone of radiation BW of the used antenna



TX CH78 (Above 1000 MHz, Vertical)

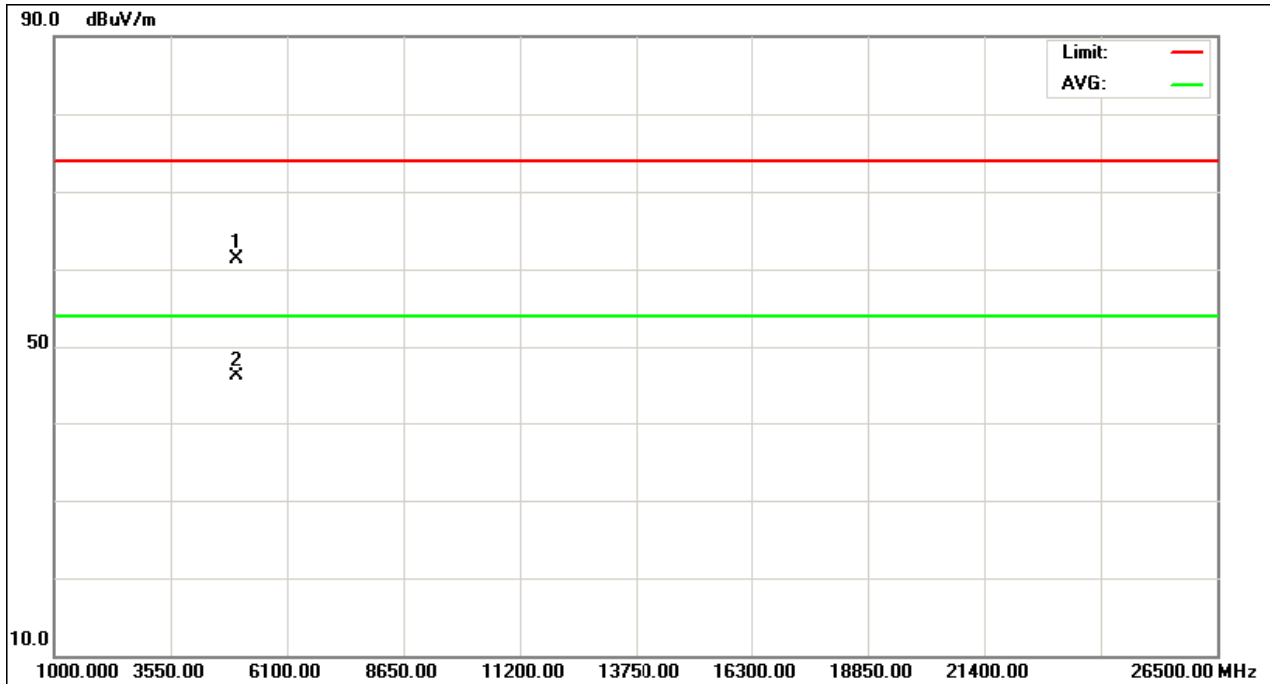
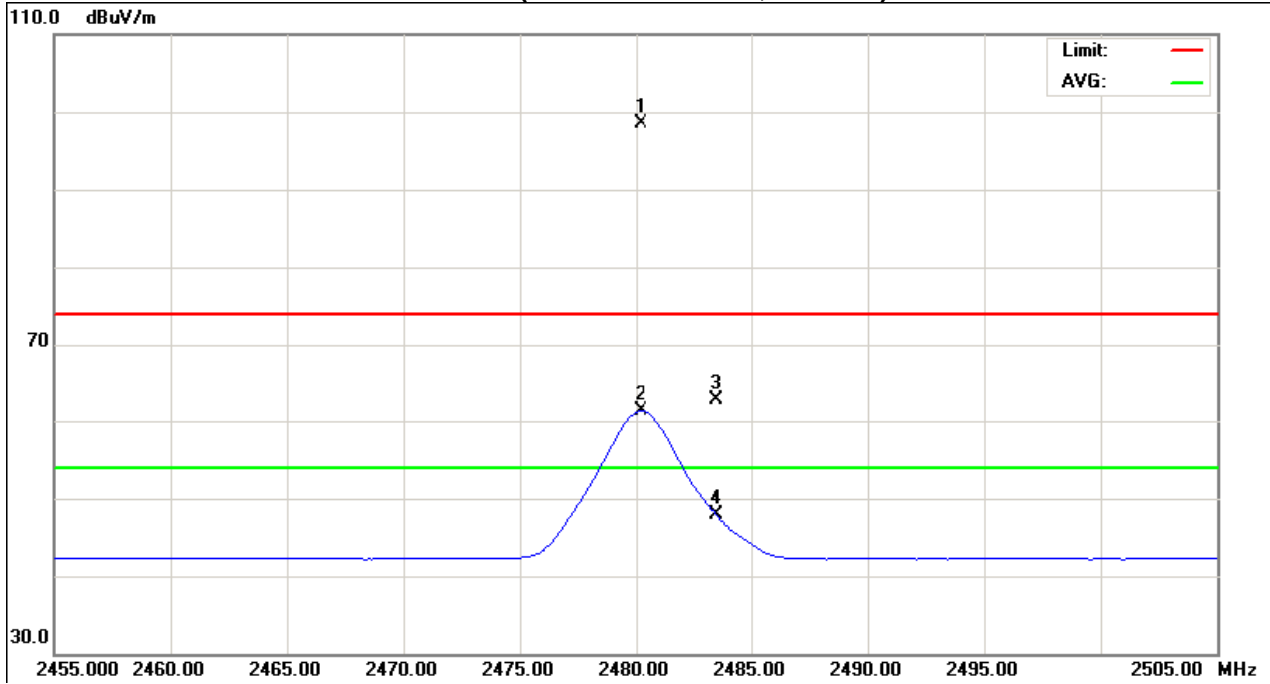



| | | | |
|---------------|---|---------------------|--------------|
| EUT : | Hi Fi dock with bluetooth wireless Audio system | Model Name : | SFQ-01 |
| Temperature : | 22 °C | Relative Humidity : | 56 % |
| Pressure : | 1010 hPa | Test Voltage : | AC 120V/60Hz |
| Test Mode : | TX 2480MHz –CH78-1Mbps | | |

| Freq. | Ant.Pol. | Reading | | Ant./CF | Act. | | Limit | | Note |
|----------------|----------|--------------|--------------|--------------|--------------|--------------|----------|----------|------------|
| | | Peak | AV | | Peak | AV | Peak | AV | |
| (MHz) | H/V | (dBuV) | (dBuV) | CF(dB) | (dBuV/m) | (dBuV/m) | (dBuV/m) | (dBuV/m) | |
| 2480.20 | H | 62.97 | 28.34 | 31.50 | 94.47 | 59.84 | | | X/F |
| 2483.50 | H | 27.54 | 15.20 | 31.50 | 59.04 | 46.70 | 74.00 | 54.00 | X/E |
| 4959.82 | H | 52.36 | 39.91 | 5.94 | 58.30 | 45.85 | 74.00 | 54.00 | X/H |

Remark :

- (1) All readings are Peak unless otherwise stated QP in column of 『 Note 』 . Peak denotes that the Peak reading compliance with the QP Limits and then QP Mode measurement didn't perform ◦
- (2) Measuring frequency range from 30MHz to 1000MHz or the 10th harmonic of highest fundamental frequency ◦ “F” denotes fundamental frequency; “H” denotes spurious frequency. “E” denotes band edge frequency. (This judgment method includes the Band Edge Requirement.)
- (3) Radiated emissions measured in frequency range above 1000MHz were made with an instrument using Peak detector mode and AV detector mode of the emission ◦
- (4) Data of measurement within this frequency range shown “ * ” in the table above means the reading of emissions are attenuated more than 20dB below the permissible limits or the field strength is too small to be measured.
- (5) A preamp and high pass filter were used for this test in order to provide sufficient measurement sensitivity.
- (6) EUT Orthogonal Axis :
 “X” - denotes Laid on Table ; “Y” - denotes Vertical Stand ; “Z” - denotes Side Stand
- (7) During the measurements above 1 GHz it is taken care of that the EUT is always within the 3 dB cone of radiation BW of the used antenna



TX CH78 (Above 1000 MHz, Horizontal)

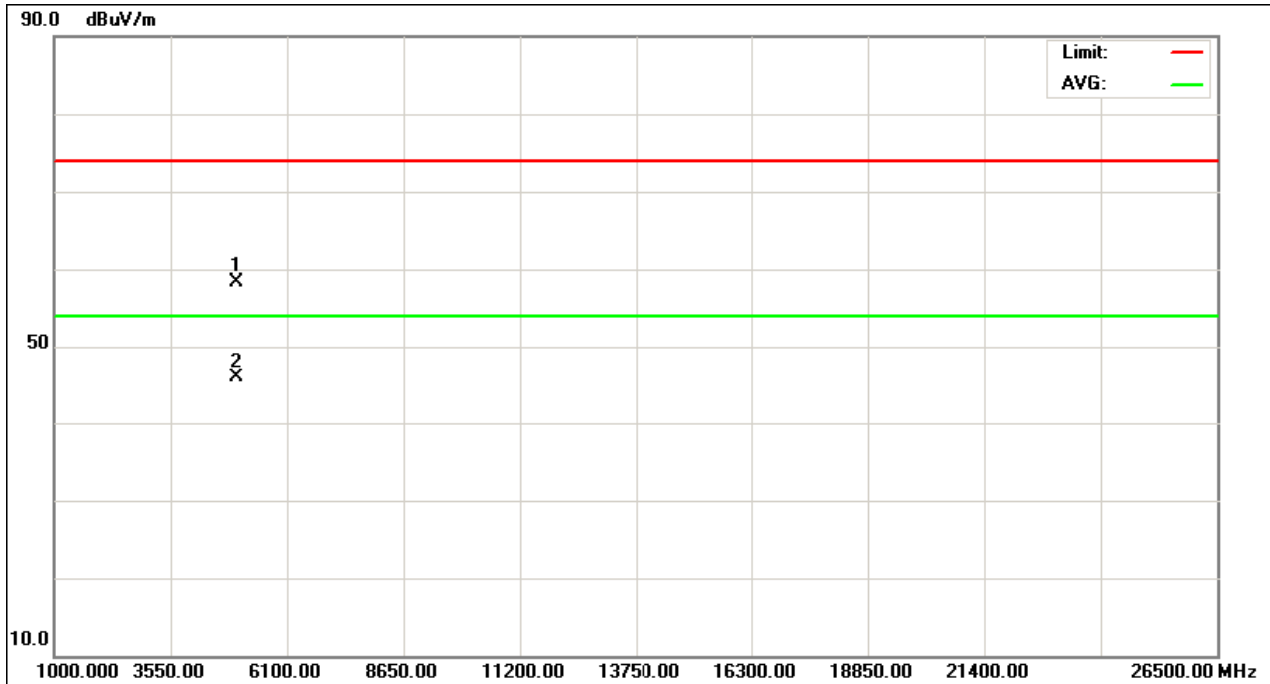
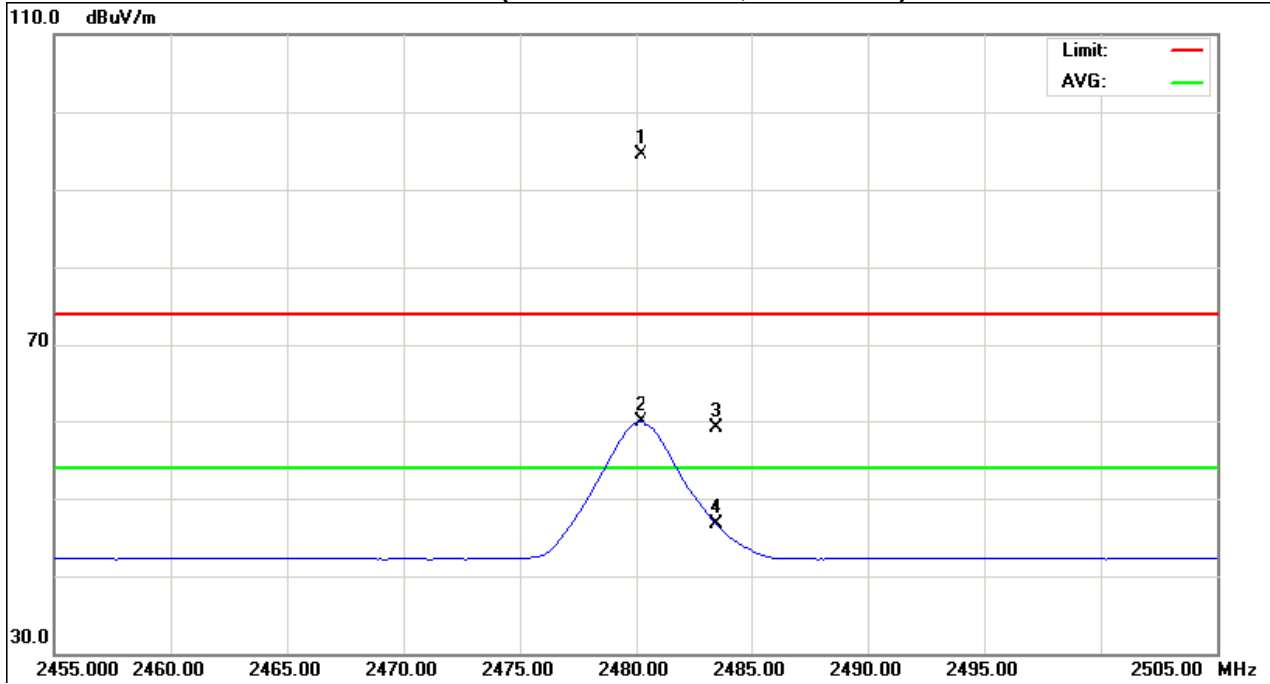



| | | | |
|---------------|---|---------------------|--------------|
| EUT : | Hi Fi dock with bluetooth wireless Audio system | Model Name : | SFQ-01 |
| Temperature : | 22 °C | Relative Humidity : | 56 % |
| Pressure : | 1010 hPa | Test Voltage : | AC 120V/60Hz |
| Test Mode : | TX 2402MHz – CH 00-3Mbps | | |

| Freq. (MHz) | Ant.Pol. H/V | Reading | | Ant./CF CF(dB) | Act. | | Limit | | Note |
|----------------|-----------------|----------------|--------------|-------------------|------------------|----------------|------------------|----------------|------------|
| | | Peak (dBuV) | AV (dBuV) | | Peak (dBuV/m) | AV (dBuV/m) | Peak (dBuV/m) | AV (dBuV/m) | |
| 2390.00 | V | 21.35 | 10.73 | 31.61 | 52.96 | 42.34 | 74.00 | 54.00 | X/E |
| 2402.10 | V | 65.03 | 26.76 | 31.60 | 96.63 | 58.36 | | | X/F |
| 4804.76 | V | 57.66 | 40.35 | 5.18 | 62.84 | 45.53 | 74.00 | 54.00 | X/H |

Remark :

- (1) All readings are Peak unless otherwise stated QP in column of 『Note』 . Peak denotes that the Peak reading compliance with the QP Limits and then QP Mode measurement didn't perform .
- (2) Measuring frequency range from 30MHz to 1000MHz or the 10th harmonic of highest fundamental frequency .“F” denotes fundamental frequency; “H” denotes spurious frequency. “E” denotes band edge frequency. (This judgment method includes the Band Edge Requirement.)
- (3) Radiated emissions measured in frequency range above 1000MHz were made with an instrument using Peak detector mode and AV detector mode of the emission .
- (4) Data of measurement within this frequency range shown “ * ” in the table above means the reading of emissions are attenuated more than 20dB below the permissible limits or the field strength is too small to be measured.
- (5) A preamp and high pass filter were used for this test in order to provide sufficient measurement sensitivity.
- (6) EUT Orthogonal Axis :
“X” - denotes Laid on Table ; “Y” - denotes Vertical Stand ; “Z” - denotes Side Stand
- (7) During the measurements above 1 GHz it is taken care of that the EUT is always within the 3 dB cone of radiation BW of the used antenna



TX CH00(Above 1000 MHz, Vertical)

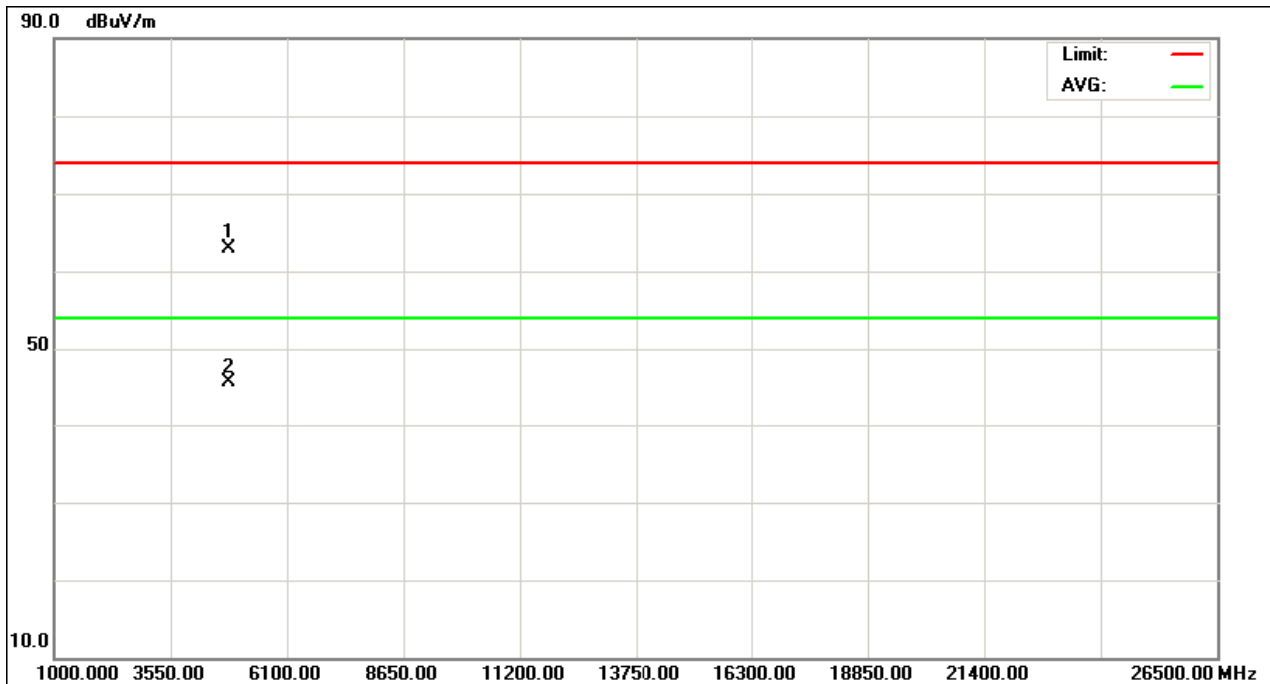
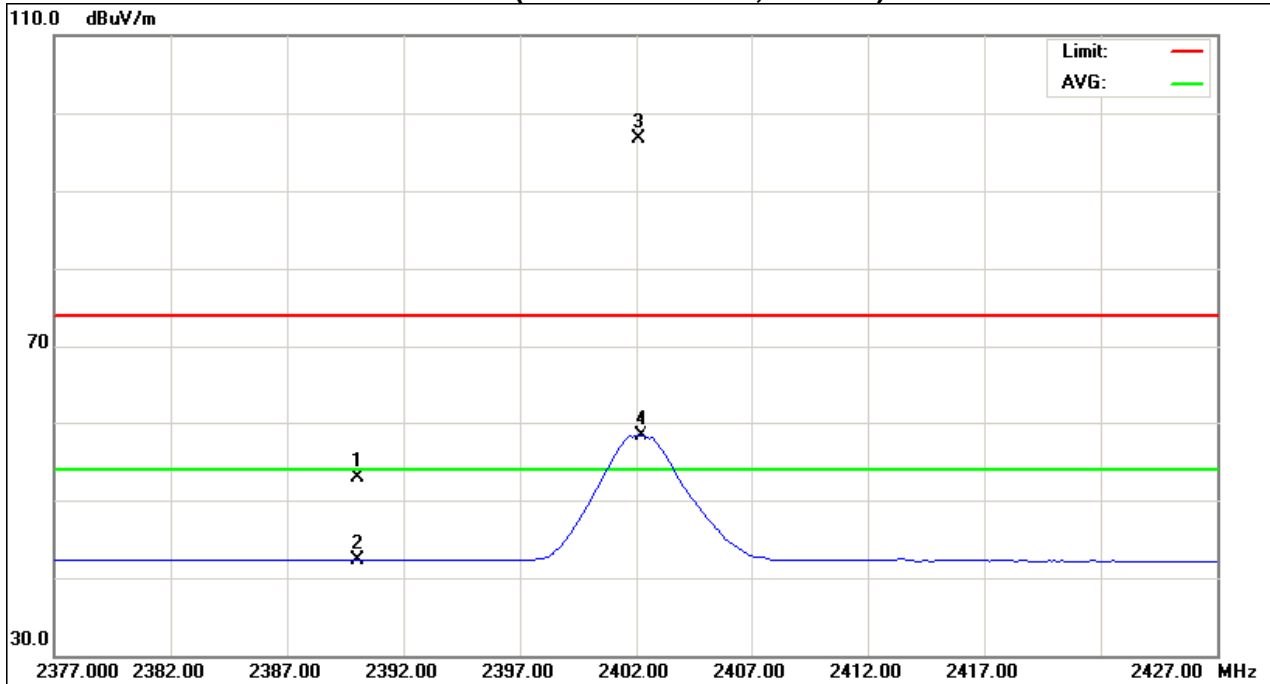



| | | | |
|---------------|---|---------------------|--------------|
| EUT : | Hi Fi dock with bluetooth wireless Audio system | Model Name : | SFQ-01 |
| Temperature : | 22 °C | Relative Humidity : | 56 % |
| Pressure : | 1010hPa | Test Voltage : | AC 120V/60Hz |
| Test Mode : | TX 2402MHz – CH 00-3Mbps | | |

| Freq. (MHz) | Ant.Pol. H/V | Reading | | Ant./CF CF(dB) | Act. | | Limit | | Note |
|----------------|-----------------|----------------|--------------|-------------------|------------------|----------------|------------------|----------------|------------|
| | | Peak (dBuV) | AV (dBuV) | | Peak (dBuV/m) | AV (dBuV/m) | Peak (dBuV/m) | AV (dBuV/m) | |
| 2390.00 | H | 20.91 | 10.69 | 31.61 | 52.52 | 42.30 | 74.00 | 54.00 | X/E |
| 2402.20 | H | 62.98 | 26.50 | 31.60 | 94.58 | 58.10 | | | X/F |
| 4804.59 | H | 52.33 | 38.47 | 5.18 | 57.51 | 43.65 | 74.00 | 54.00 | X/H |

Remark :

- (1) All readings are Peak unless otherwise stated QP in column of 『Note』 . Peak denotes that the Peak reading compliance with the QP Limits and then QP Mode measurement didn't perform ◦
- (2) Measuring frequency range from 30MHz to 1000MHz or the 10th harmonic of highest fundamental frequency ◦ "F" denotes fundamental frequency; "H" denotes spurious frequency. "E" denotes band edge frequency. (This judgment method includes the Band Edge Requirement.)
- (3) Radiated emissions measured in frequency range above 1000MHz were made with an instrument using Peak detector mode and AV detector mode of the emission ◦
- (4) Data of measurement within this frequency range shown " * " in the table above means the reading of emissions are attenuated more than 20dB below the permissible limits or the field strength is too small to be measured.
- (5) A preamp and high pass filter were used for this test in order to provide sufficient measurement sensitivity.
- (6) EUT Orthogonal Axis :
"X" - denotes Laid on Table ; "Y" - denotes Vertical Stand ; "Z" - denotes Side Stand
- (7) During the measurements above 1 GHz it is taken care of that the EUT is always within the 3 dB cone of radiation BW of the used antenna



TX CH00(Above 1000 MHz, Horizontal)

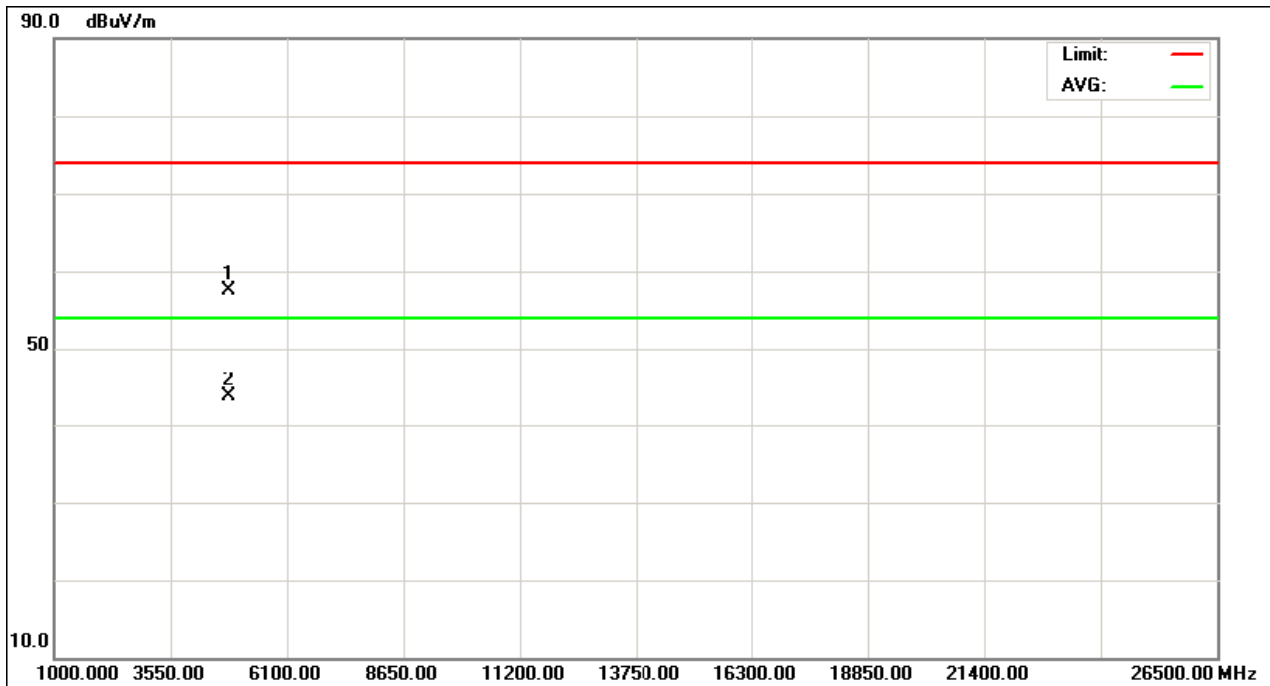
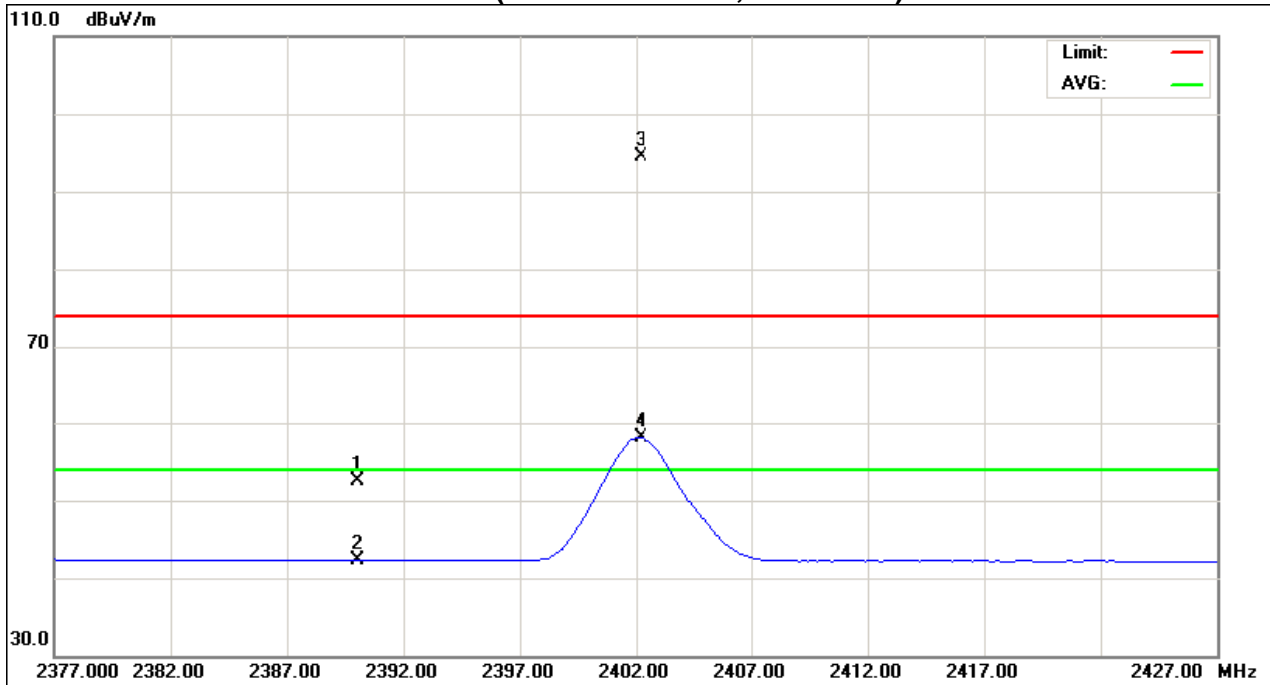



| | | | |
|---------------|---|---------------------|--------------|
| EUT : | Hi Fi dock with bluetooth wireless Audio system | Model Name : | SFQ-01 |
| Temperature : | 22 °C | Relative Humidity : | 56 % |
| Pressure : | 1010 hPa | Test Voltage : | AC 120V/60Hz |
| Test Mode : | TX 2441MHz –CH39-3Mbps | | |

| Freq. | Ant.Pol. | Reading | | Ant./CF | Act. | | Limit | | Note |
|----------------|----------|--------------|--------------|--------------|--------------|--------------|----------|----------|------------|
| | | Peak | AV | | Peak | AV | Peak | AV | |
| (MHz) | H/V | (dBuV) | (dBuV) | CF(dB) | (dBuV/m) | (dBuV/m) | (dBuV/m) | (dBuV/m) | |
| 2441.00 | V | 65.65 | 29.00 | 31.55 | 97.20 | 60.55 | | | X/F |
| 4882.36 | V | 56.55 | 41.12 | 5.56 | 62.11 | 46.68 | 74.00 | 54.00 | X/H |

Remark :

- (1) All readings are Peak unless otherwise stated QP in column of 『Note』 . Peak denotes that the Peak reading compliance with the QP Limits and then QP Mode measurement didn't perform .
- (2) Measuring frequency range from 30MHz to 1000MHz or the 10th harmonic of highest fundamental frequency .“F” denotes fundamental frequency; “H” denotes spurious frequency. “E” denotes band edge frequency. (This judgment method includes the Band Edge Requirement.)
- (3) Radiated emissions measured in frequency range above 1000MHz were made with an instrument using Peak detector mode and AV detector mode of the emission .
- (4) Data of measurement within this frequency range shown “ * ” in the table above means the reading of emissions are attenuated more than 20dB below the permissible limits or the field strength is too small to be measured.
- (5) A preamp and high pass filter were used for this test in order to provide sufficient measurement sensitivity.
- (6) EUT Orthogonal Axis :
“X” - denotes Laid on Table ; “Y” - denotes Vertical Stand ; “Z” - denotes Side Stand
- (7) During the measurements above 1 GHz it is taken care of that the EUT is always within the 3 dB cone of radiation BW of the used antenna



TX CH39 (Above 1000 MHz, Vertical)

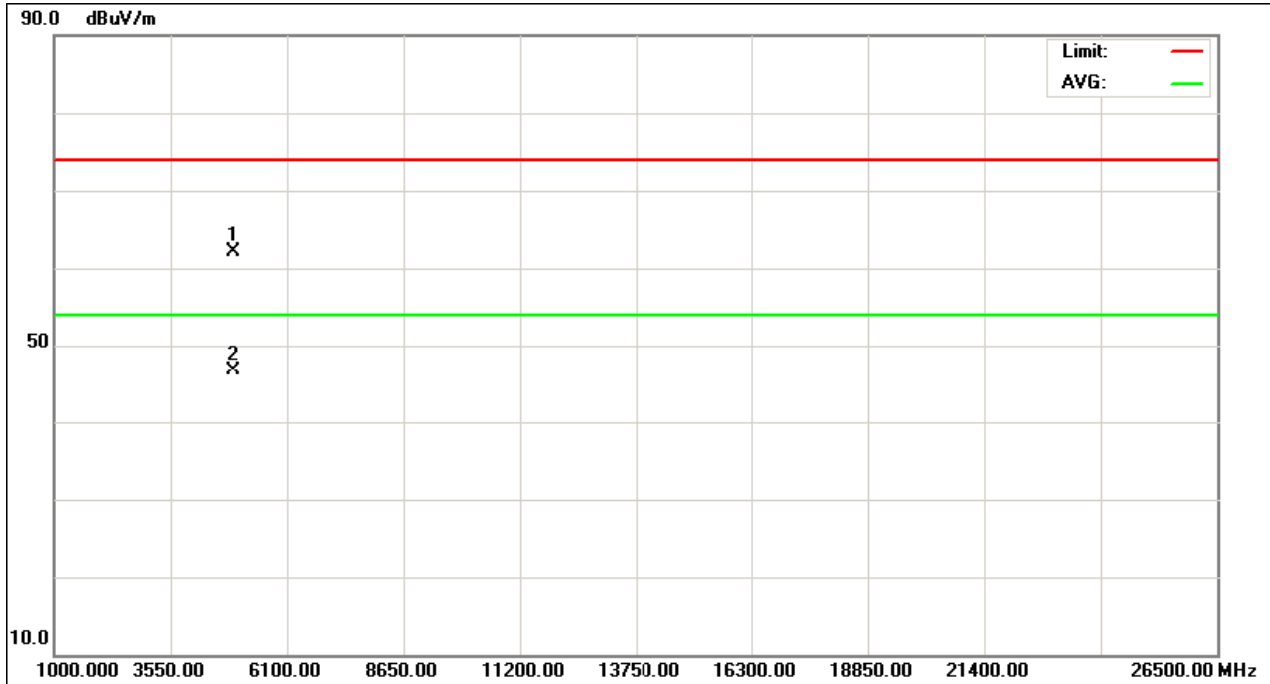
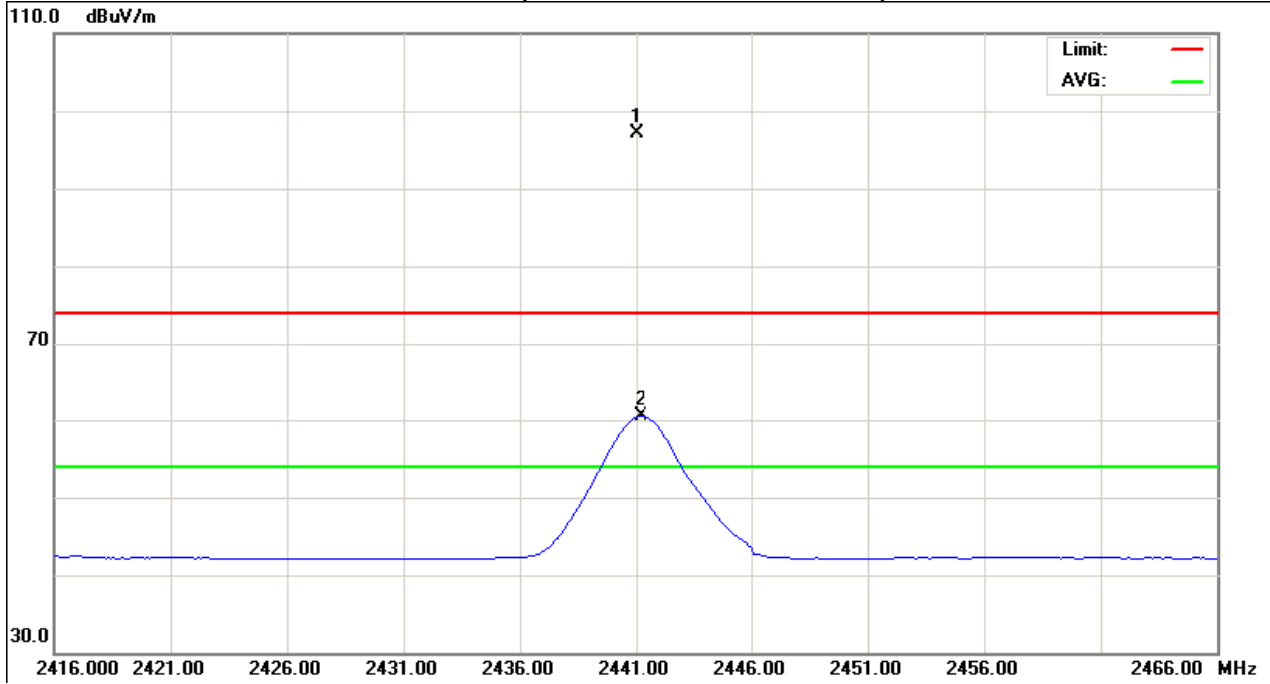



| | | | |
|---------------|---|---------------------|--------------|
| EUT : | Hi Fi dock with bluetooth wireless Audio system | Model Name : | SFQ-01 |
| Temperature : | 22 °C | Relative Humidity : | 56 % |
| Pressure : | 1010 hPa | Test Voltage : | AC 120V/60Hz |
| Test Mode : | TX 2441MHz –CH39-3Mbps | | |

| Freq. | Ant.Pol. | Reading | | Ant./CF | Act. | | Limit | | Note |
|----------------|----------|--------------|--------------|--------------|--------------|--------------|----------|----------|------------|
| | | Peak | AV | | Peak | AV | Peak | AV | |
| (MHz) | H/V | (dBuV) | (dBuV) | CF(dB) | (dBuV/m) | (dBuV/m) | (dBuV/m) | (dBuV/m) | |
| 2441.20 | H | 64.99 | 29.04 | 31.55 | 96.54 | 60.59 | | | X/F |
| 4882.76 | H | 52.36 | 37.88 | 5.56 | 57.92 | 43.44 | 74.00 | 54.00 | X/H |

Remark :

- (1) All readings are Peak unless otherwise stated QP in column of 『 Note 』 . Peak denotes that the Peak reading compliance with the QP Limits and then QP Mode measurement didn't perform .
- (2) Measuring frequency range from 30MHz to 1000MHz or the 10th harmonic of highest fundamental frequency .“F” denotes fundamental frequency; “H” denotes spurious frequency. “E” denotes band edge frequency. (This judgment method includes the Band Edge Requirement.)
- (3) Radiated emissions measured in frequency range above 1000MHz were made with an instrument using Peak detector mode and AV detector mode of the emission .
- (4) Data of measurement within this frequency range shown “ * ” in the table above means the reading of emissions are attenuated more than 20dB below the permissible limits or the field strength is too small to be measured.
- (5) A preamp and high pass filter were used for this test in order to provide sufficient measurement sensitivity.
- (6) EUT Orthogonal Axis :
“X” - denotes Laid on Table ; “Y” - denotes Vertical Stand ; “Z” - denotes Side Stand
- (7) During the measurements above 1 GHz it is taken care of that the EUT is always within the 3 dB cone of radiation BW of the used antenna



TX CH39 (Above 1000 MHz, Horizontal)

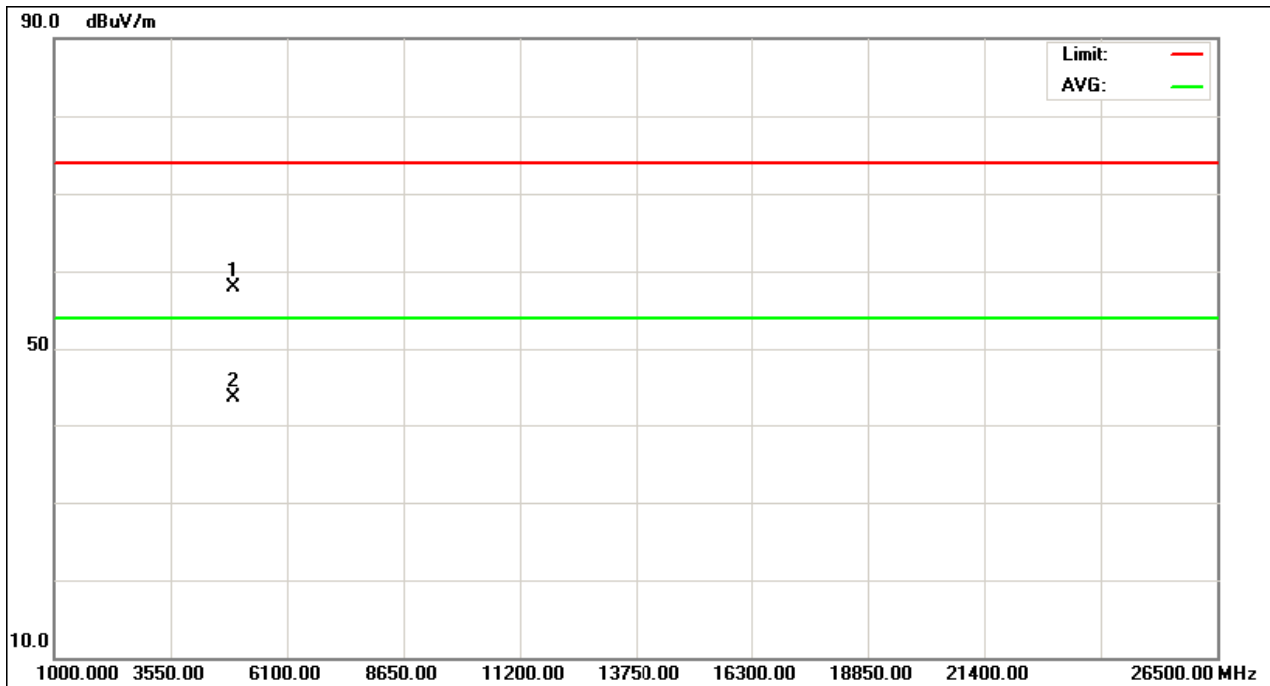
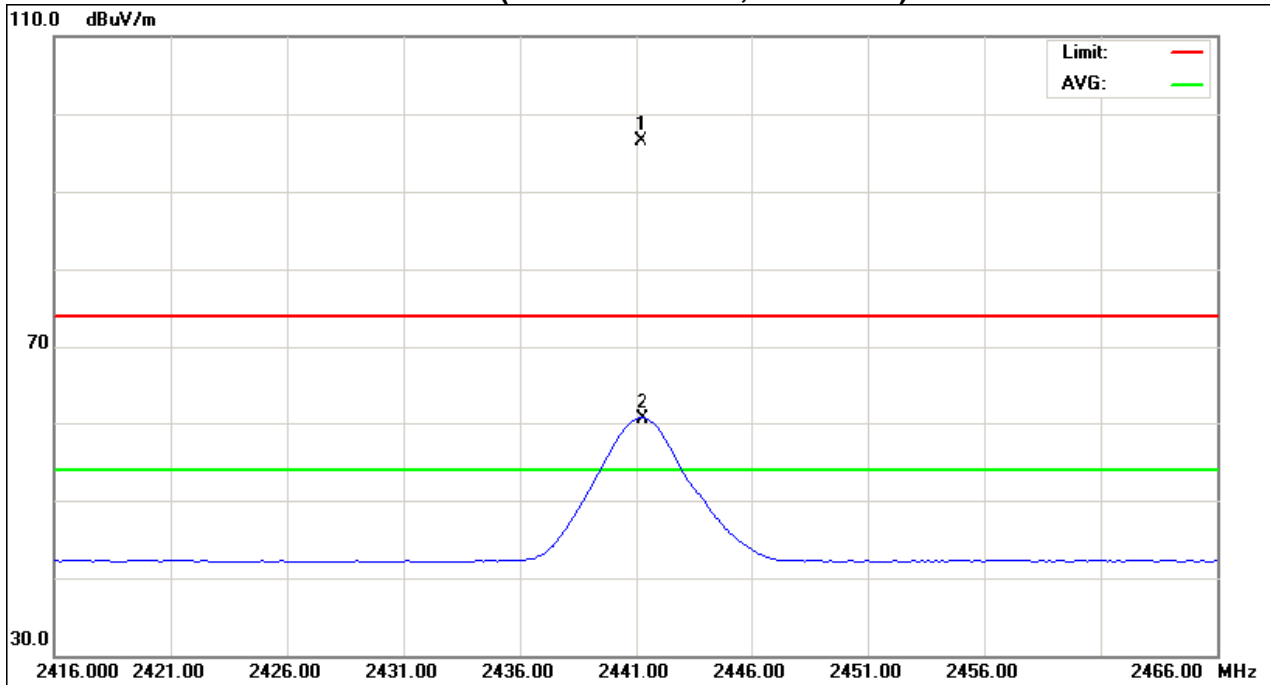



| | | | |
|---------------|---|---------------------|--------------|
| EUT : | Hi Fi dock with bluetooth wireless Audio system | Model Name : | SFQ-01 |
| Temperature : | 22 °C | Relative Humidity : | 56 % |
| Pressure : | 1010hPa | Test Voltage : | AC 120V/60Hz |
| Test Mode : | TX 2480MHz –CH78-3Mbps | | |

| Freq. | Ant.Pol. | Reading | | Ant./CF | Act. | | Limit | | Note |
|----------------|----------|--------------|--------------|--------------|--------------|--------------|----------|----------|------------|
| | | Peak | AV | | Peak | AV | Peak | AV | |
| (MHz) | H/V | (dBuV) | (dBuV) | CF(dB) | (dBuV/m) | (dBuV/m) | (dBuV/m) | (dBuV/m) | |
| 2480.10 | V | 66.52 | 29.57 | 31.50 | 98.02 | 61.07 | | | X/F |
| 2483.50 | V | 31.88 | 16.45 | 31.50 | 63.38 | 47.95 | 74.00 | 54.00 | X/E |
| 4959.68 | V | 54.76 | 39.65 | 5.93 | 60.69 | 45.58 | 74.00 | 54.00 | X/H |

Remark :

- (1) All readings are Peak unless otherwise stated QP in column of 『Note』 . Peak denotes that the Peak reading compliance with the QP Limits and then QP Mode measurement didn't perform ◦
- (2) Measuring frequency range from 30MHz to 1000MHz or the 10th harmonic of highest fundamental frequency ◦ “F” denotes fundamental frequency; “H” denotes spurious frequency. “E” denotes band edge frequency. (This judgment method includes the Band Edge Requirement.)
- (3) Radiated emissions measured in frequency range above 1000MHz were made with an instrument using Peak detector mode and AV detector mode of the emission ◦
- (4) Data of measurement within this frequency range shown “ * ” in the table above means the reading of emissions are attenuated more than 20dB below the permissible limits or the field strength is too small to be measured.
- (5) A preamp and high pass filter were used for this test in order to provide sufficient measurement sensitivity.
- (6) EUT Orthogonal Axis :
“X” - denotes Laid on Table ; “Y” - denotes Vertical Stand ; “Z” - denotes Side Stand
- (7) During the measurements above 1 GHz it is taken care of that the EUT is always within the 3 dB cone of radiation BW of the used antenna



TX CH78 (Above 1000 MHz, Vertical)

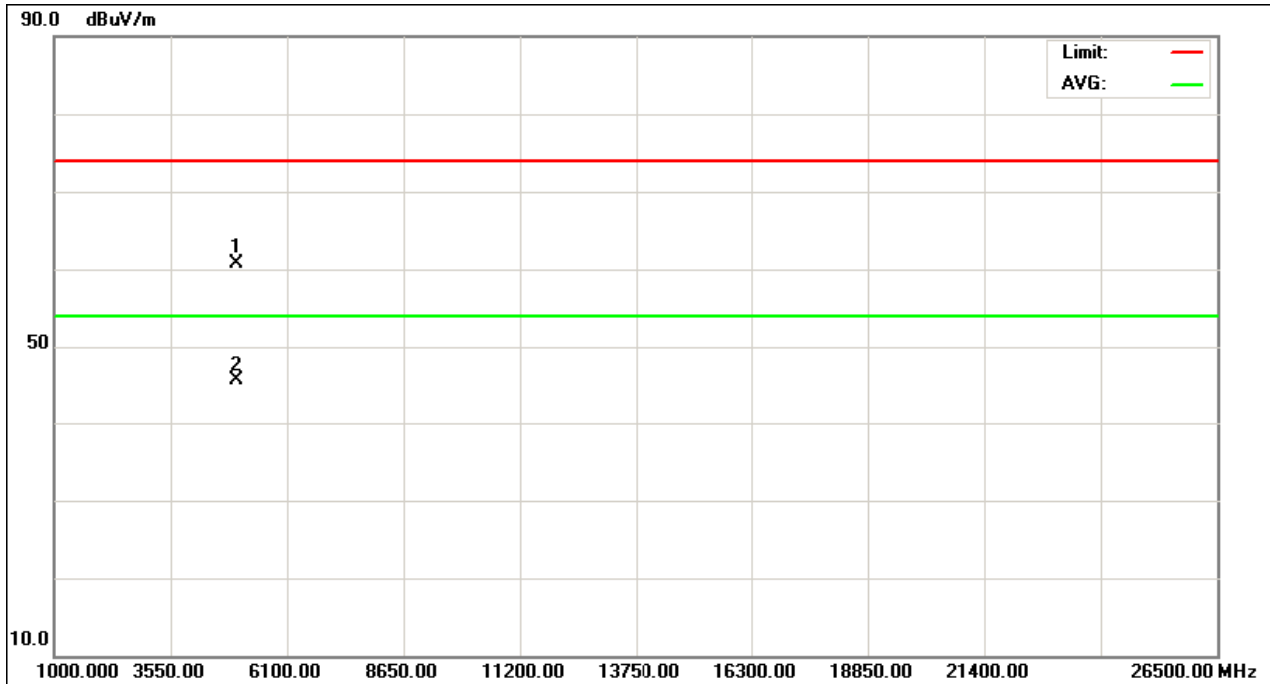
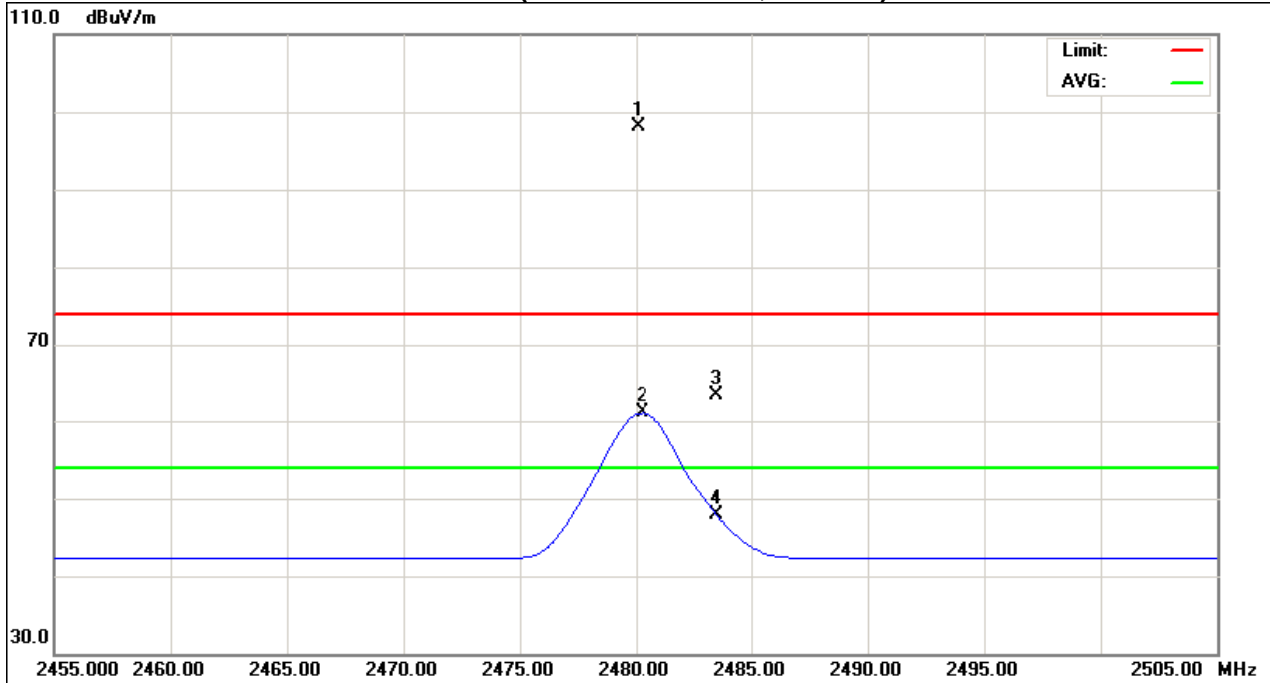



| | | | |
|---------------|---|---------------------|--------------|
| EUT : | Hi Fi dock with bluetooth wireless Audio system | Model Name : | SFQ-01 |
| Temperature : | 22 °C | Relative Humidity : | 56 % |
| Pressure : | 1010 hPa | Test Voltage : | AC 120V/60Hz |
| Test Mode : | TX 2480MHz –CH78-3Mbps | | |

| Freq. | Ant.Pol. | Reading | | Ant./CF | Act. | | Limit | | Note |
|----------------|----------|--------------|--------------|--------------|--------------|--------------|----------|----------|------------|
| | | Peak | AV | | Peak | AV | Peak | AV | |
| (MHz) | H/V | (dBuV) | (dBuV) | CF(dB) | (dBuV/m) | (dBuV/m) | (dBuV/m) | (dBuV/m) | |
| 2480.20 | H | 62.86 | 28.00 | 31.50 | 94.36 | 59.50 | | | X/F |
| 2483.50 | H | 28.96 | 15.30 | 31.50 | 60.46 | 46.80 | 74.00 | 54.00 | X/E |
| 4960.50 | H | 50.69 | 37.04 | 5.94 | 56.63 | 42.98 | 74.00 | 54.00 | X/H |

Remark :

- (1) All readings are Peak unless otherwise stated QP in column of 『 Note 』 . Peak denotes that the Peak reading compliance with the QP Limits and then QP Mode measurement didn't perform ◦
- (2) Measuring frequency range from 30MHz to 1000MHz or the 10th harmonic of highest fundamental frequency ◦ “F” denotes fundamental frequency; “H” denotes spurious frequency. “E” denotes band edge frequency. (This judgment method includes the Band Edge Requirement.)
- (3) Radiated emissions measured in frequency range above 1000MHz were made with an instrument using Peak detector mode and AV detector mode of the emission ◦
- (4) Data of measurement within this frequency range shown “ * ” in the table above means the reading of emissions are attenuated more than 20dB below the permissible limits or the field strength is too small to be measured.
- (5) A preamp and high pass filter were used for this test in order to provide sufficient measurement sensitivity.
- (6) EUT Orthogonal Axis :
 “X” - denotes Laid on Table ; “Y” - denotes Vertical Stand ; “Z” - denotes Side Stand
- (7) During the measurements above 1 GHz it is taken care of that the EUT is always within the 3 dB cone of radiation BW of the used antenna



TX CH78 (Above 1000 MHz, Horizontal)

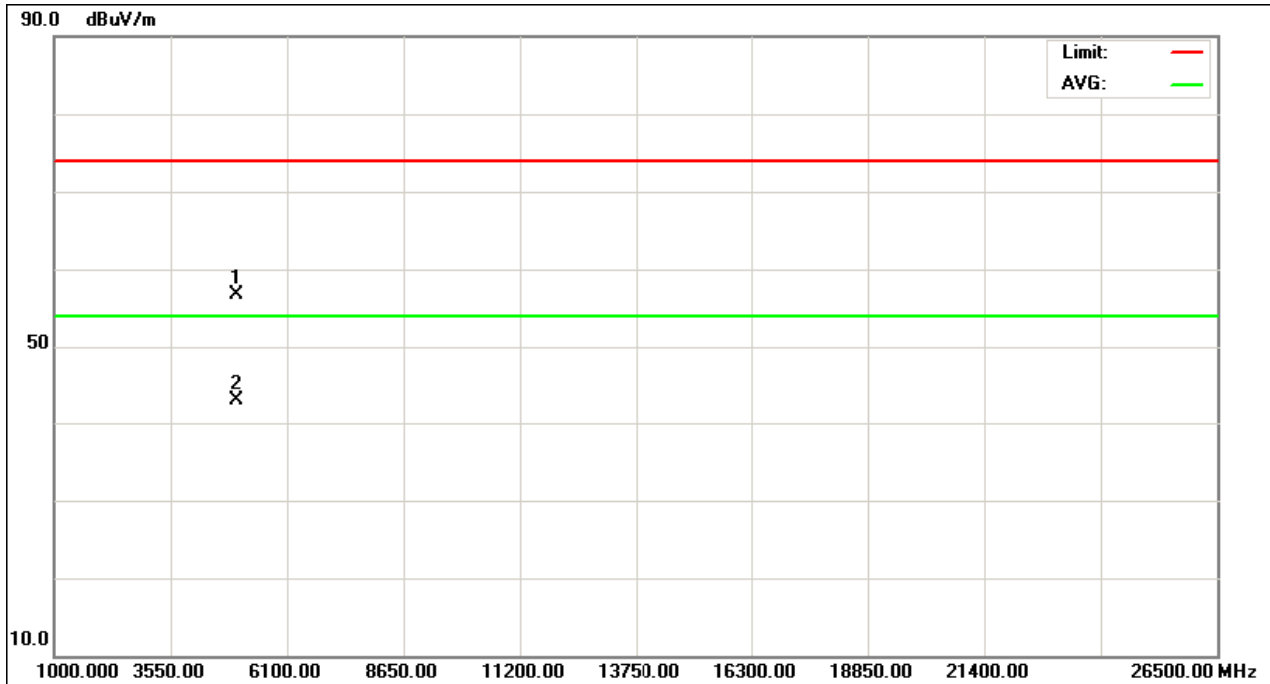
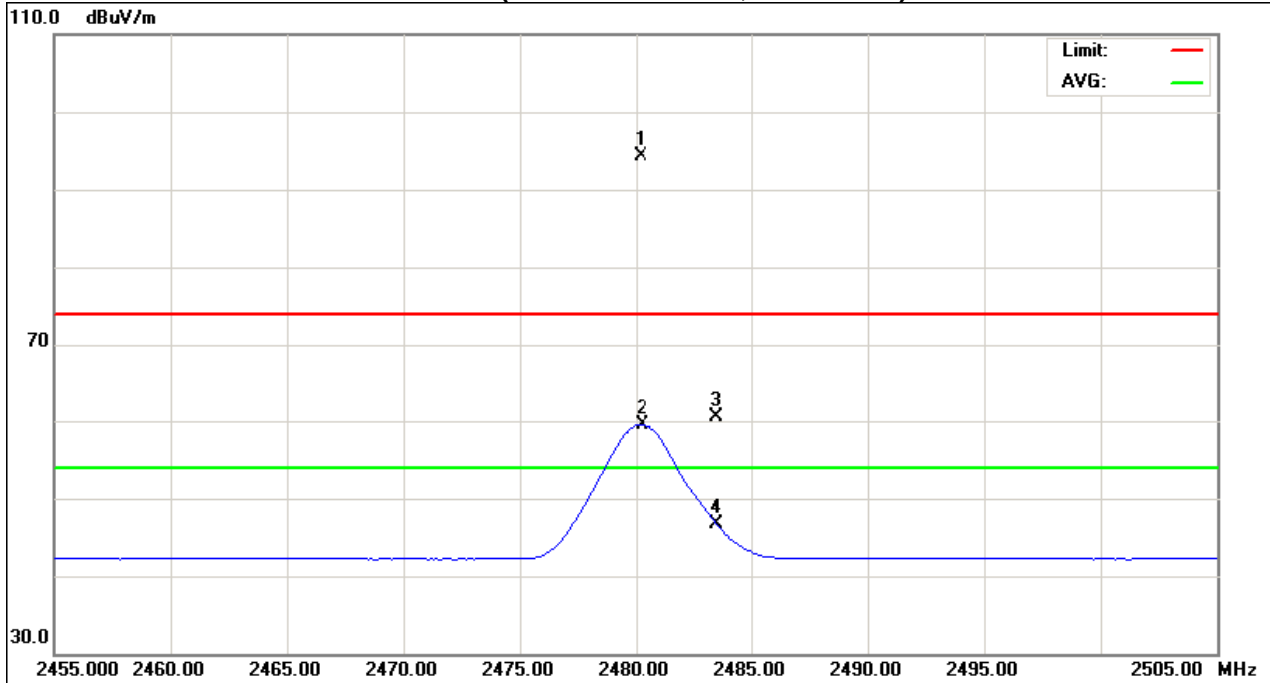



| | | | |
|---------------|---|---------------------|--------------|
| EUT : | Hi Fi dock with bluetooth wireless Audio system | Model Name. : | SFQ-01 |
| Temperature : | 26 °C | Relative Humidity : | 54 % |
| Pressure : | 1009 hPa | Test Power : | AC 120V/60Hz |
| Test Mode : | RX Mode 2441MHz | | |

| Freq. (MHz) | Ant.Pol. H/V | Reading | | Ant./CF CF(dB) | Act. | | Limit | | Note |
|----------------|-----------------|----------------|--------------|-------------------|------------------|----------------|------------------|----------------|------|
| | | Peak (dBuV) | AV (dBuV) | | Peak (dBuV/m) | AV (dBuV/m) | Peak (dBuV/m) | AV (dBuV/m) | |
| 1619.63 | V | 51.38 | 41.55 | -5.10 | 46.28 | 36.45 | 74.00 | 54.00 | X/H |

Remark :

- (1) All readings are Peak unless otherwise stated QP in column of 『 Note 』 . Peak denotes that the Peak reading compliance with the QP Limits and then QP Mode measurement didn't perform ◦
- (2) Measuring frequency range from 1000MHz to 6000MHz or the 10th harmonic of highest fundamental frequency - "F" denotes fundamental frequency; "H" denotes spurious frequency. "E" denotes band edge frequency. (This judgment method includes the Band Edge Requirement.)
- (3) Radiated emissions measured in frequency range above 1000MHz were made with an instrument using Peak detector mode and AV detector mode of the emission ◦
- (4) Data of measurement within this frequency range shown " * " in the table above means the reading of emissions are attenuated more than 20dB below the permissible limits or the field strength is too small to be measured.
- (5) A preamp and high pass filter were used for this test in order to provide sufficient measurement sensitivity.
- (6) EUT Orthogonal Axis :
 "X" - denotes Laid on Table ; "Y" - denotes Vertical Stand ; "Z" - denotes Side Stand

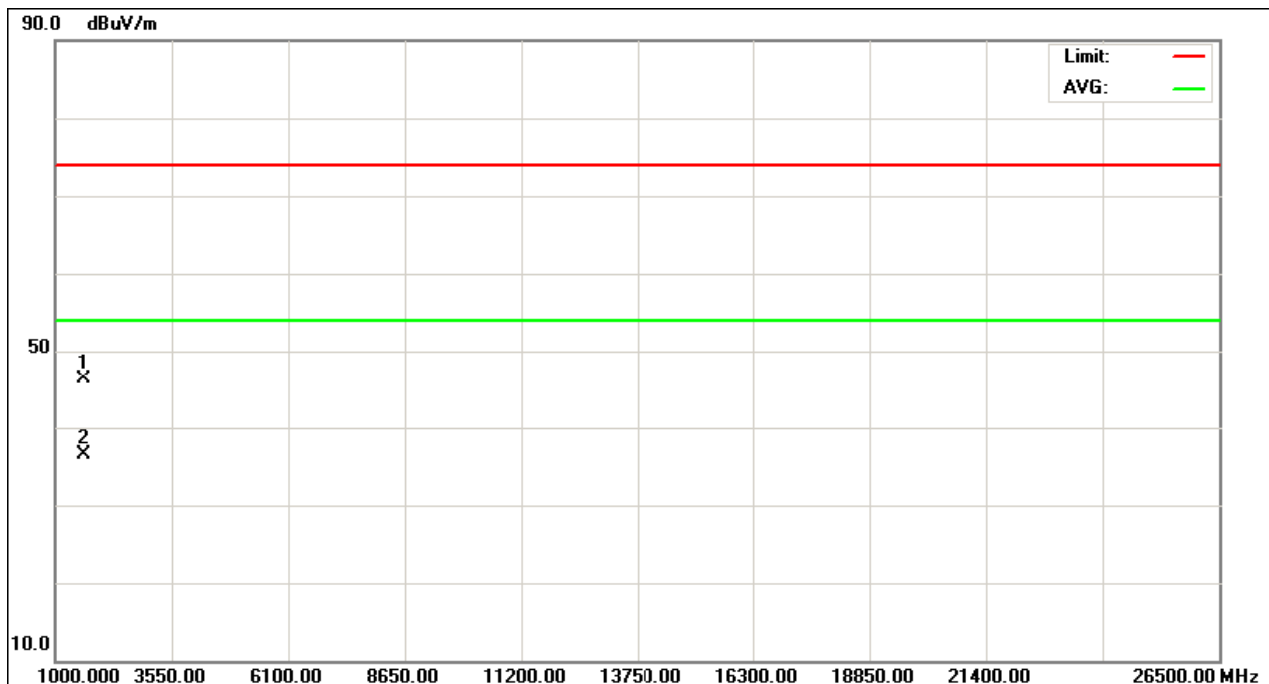



| | | | |
|---------------|---|---------------------|--------------|
| EUT : | Hi Fi dock with bluetooth wireless Audio system | Model Name. : | SFQ-01 |
| Temperature : | 26 °C | Relative Humidity : | 54 % |
| Pressure : | 1009 hPa | Test Power : | AC 120V/60Hz |
| Test Mode : | RX Mode 2441MHz | | |

| Freq. (MHz) | Ant.Pol. H/V | Reading | | Ant./CF CF(dB) | Act. | | Limit | | Note |
|----------------|-----------------|----------------|--------------|-------------------|------------------|----------------|------------------|----------------|------|
| | | Peak (dBuV) | AV (dBuV) | | Peak (dBuV/m) | AV (dBuV/m) | Peak (dBuV/m) | AV (dBuV/m) | |
| 1623.89 | H | 48.77 | 39.65 | -5.05 | 43.72 | 34.60 | 74.00 | 54.00 | X/H |

Remark :

- (1) All readings are Peak unless otherwise stated QP in column of 『Note』 . Peak denotes that the Peak reading compliance with the QP Limits and then QP Mode measurement didn't perform ◦
- (2) Measuring frequency range from 1000MHz to 6000MHz or the 10th harmonic of highest fundamental frequency ◦ "F" denotes fundamental frequency; "H" denotes spurious frequency. "E" denotes band edge frequency. (This judgment method includes the Band Edge Requirement.)
- (3) Radiated emissions measured in frequency range above 1000MHz were made with an instrument using Peak detector mode and AV detector mode of the emission ◦
- (4) Data of measurement within this frequency range shown " * " in the table above means the reading of emissions are attenuated more than 20dB below the permissible limits or the field strength is too small to be measured.
- (5) A preamp and high pass filter were used for this test in order to provide sufficient measurement sensitivity.
- (6) EUT Orthogonal Axis :
 "X" - denotes Laid on Table ; "Y" - denotes Vertical Stand ; "Z" - denotes Side Stand

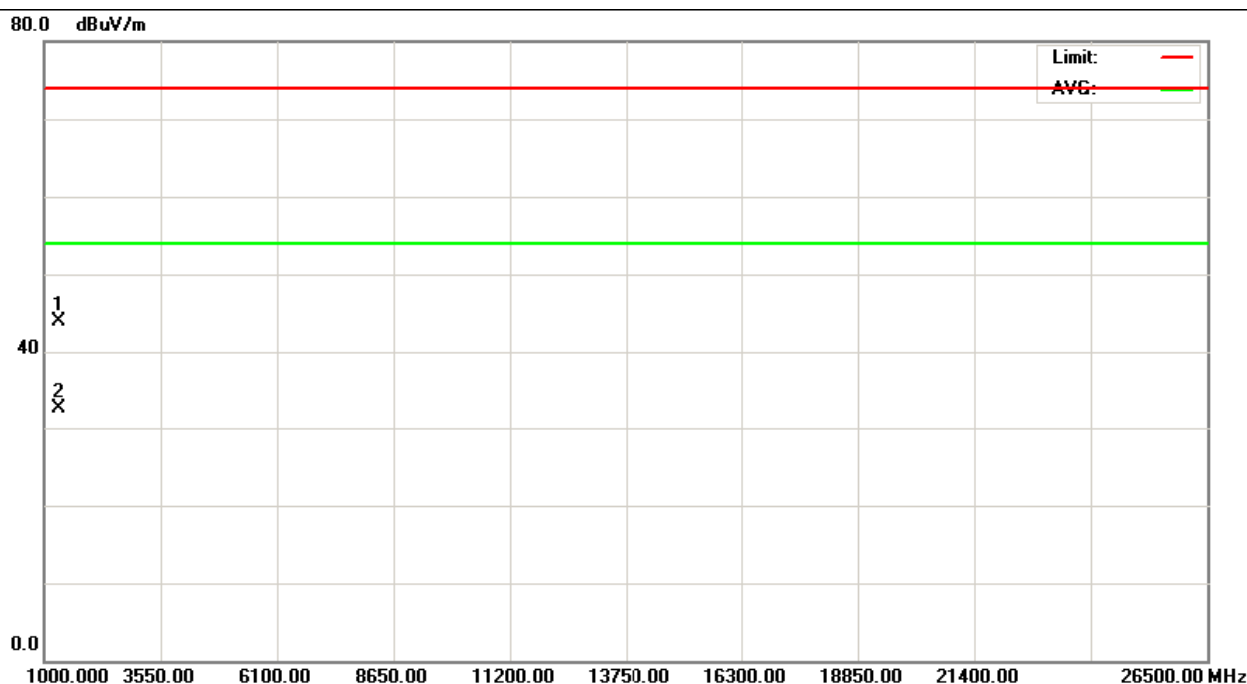



| | | | |
|---------------|---|---------------------|--------------|
| EUT : | Hi Fi dock with bluetooth wireless Audio system | Model Name. : | SFQ-01 |
| Temperature : | 23 °C | Relative Humidity : | 57 % |
| Pressure : | 1009 hPa | Test Power : | AC 120V/60Hz |
| Test Mode : | FM 87.5MHz | | |

| Freq. (MHz) | Ant.Pol. H/V | Reading (dBuV) | Ant./CF CF(dB) | Measurement (dBuV/m) | Limit (dBuV/m) | Note |
|-------------|--------------|----------------|----------------|----------------------|----------------|------|
| 81.22 | V | 47.57 | -20.32 | 27.25 | 30.00 | |
| 103.65 | V | 42.84 | -18.73 | 24.11 | 30.00 | |
| 198.62 | V | 42.03 | -15.52 | 26.51 | 30.00 | |
| 236.55 | V | 39.71 | -13.26 | 26.54 | 37.00 | |
| 325.59 | V | 39.07 | -10.05 | 29.02 | 37.00 | |
| 463.37 | V | 41.75 | -6.69 | 35.06 | 37.00 | |

Remark

- (1) All readings are Peak unless otherwise stated QP in column of 『Note』 . Peak denotes that the Peak reading compliance with the QP Limits and then QP Mode measurement didn't perform ◦
- (2) Measuring frequency range from 1000MHz to 6000MHz or the 10th harmonic of highest fundamental frequency ◦ “F” denotes fundamental frequency; “H” denotes spurious frequency. “E” denotes band edge frequency. (This judgment method includes the Band Edge Requirement.)
- (3) Radiated emissions measured in frequency range above 1000MHz were made with an instrument using Peak detector mode and AV detector mode of the emission ◦
- (4) Data of measurement within this frequency range shown “ * ” in the table above means the reading of emissions are attenuated more than 20dB below the permissible limits or the field strength is too small to be measured.
- (5) A preamp and high pass filter were used for this test in order to provide sufficient measurement sensitivity.
- (6) EUT Orthogonal Axis :
 “X” - denotes Laid on Table ; “Y” - denotes Vertical Stand ; “Z” - denotes Side Stand

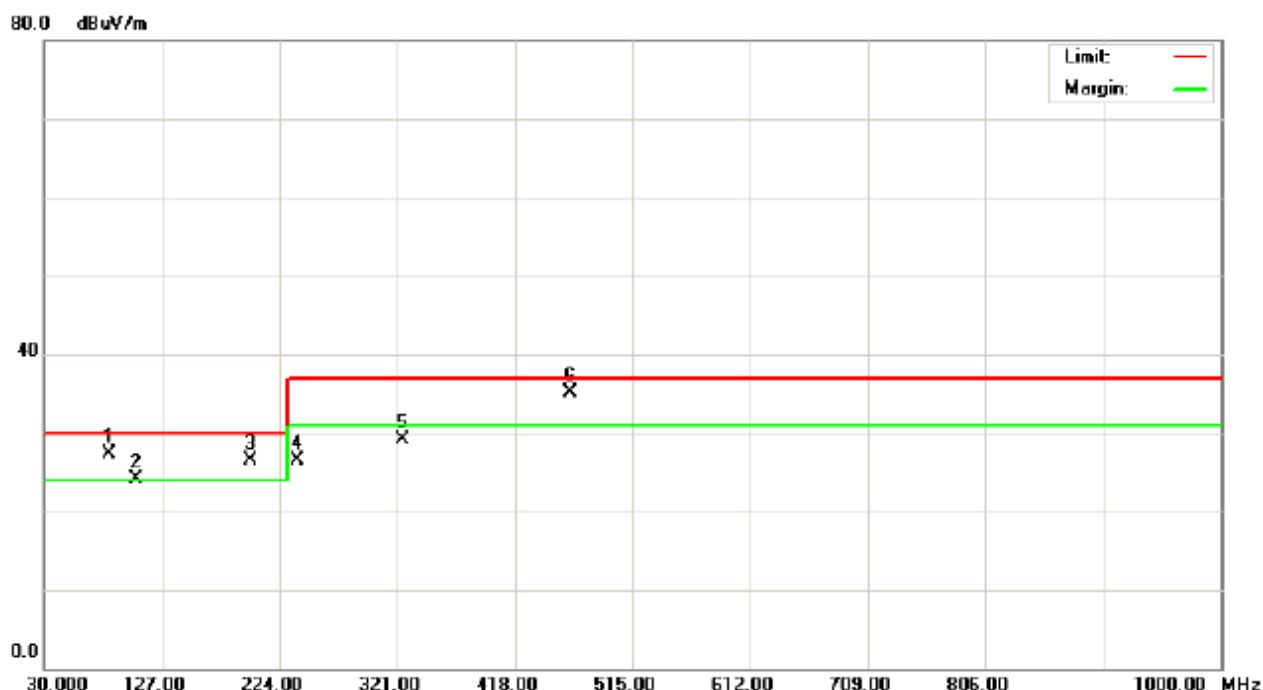



| | | | |
|---------------|---|---------------------|--------------|
| EUT : | Hi Fi dock with bluetooth wireless Audio system | Model Name. : | SFQ-01 |
| Temperature : | 23 °C | Relative Humidity : | 57 % |
| Pressure : | 1009 hPa | Test Power : | AC 120V/60Hz |
| Test Mode : | FM 87.5MHz | | |

| Freq. (MHz) | Ant.Pol. HV | Reading (dBuV) | Ant./CF CF(dB) | Measurement (dBuV/m) | Limit (dBuV/m) | Note |
|-------------|-------------|----------------|----------------|----------------------|----------------|------|
| 69.97 | H | 46.84 | -20.29 | 26.55 | 30.00 | |
| 111.32 | H | 43.01 | -18.98 | 24.03 | 30.00 | |
| 187.65 | H | 43.12 | -15.58 | 27.54 | 30.00 | |
| 254.46 | H | 42.33 | -12.45 | 29.88 | 37.00 | |
| 300.98 | H | 40.37 | -11.25 | 29.12 | 37.00 | |
| 387.56 | H | 40.69 | -8.03 | 32.66 | 37.00 | |

Remark :

- (1) All readings are Peak unless otherwise stated QP in column of 『 Note 』 . Peak denotes that the Peak reading compliance with the QP Limits and then QP Mode measurement didn't perform .
- (2) Measuring frequency range from 1000MHz to 6000MHz or the 10th harmonic of highest fundamental frequency . "F" denotes fundamental frequency; "H" denotes spurious frequency. "E" denotes band edge frequency. (This judgment method includes the Band Edge Requirement.)
- (3) Radiated emissions measured in frequency range above 1000MHz were made with an instrument using Peak detector mode and AV detector mode of the emission .
- (4) Data of measurement within this frequency range shown " * " in the table above means the reading of emissions are attenuated more than 20dB below the permissible limits or the field strength is too small to be measured.
- (5) A preamp and high pass filter were used for this test in order to provide sufficient measurement sensitivity.
- (6) EUT Orthogonal Axis :
 "X" - denotes Laid on Table ; "Y" - denotes Vertical Stand ; "Z" - denotes Side Stand

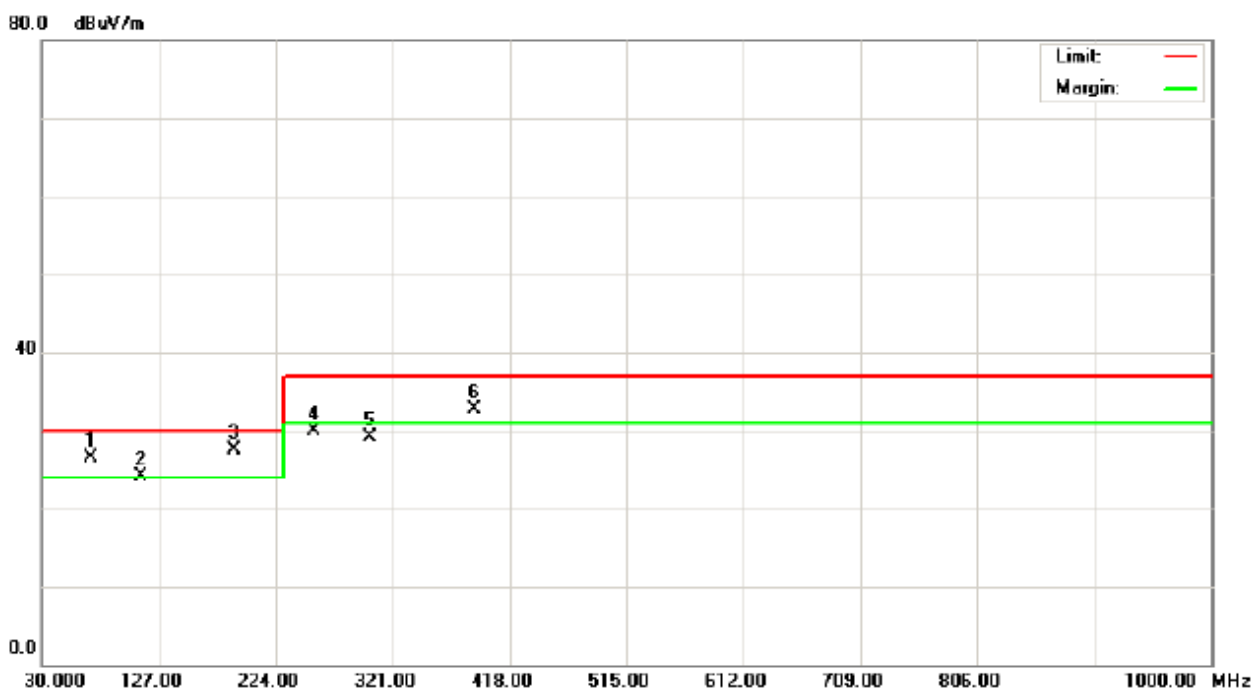



| | | | |
|---------------|---|---------------------|--------------|
| EUT : | Hi Fi dock with bluetooth wireless Audio system | Model Name. : | SFQ-01 |
| Temperature : | 23 °C | Relative Humidity : | 57 % |
| Pressure : | 1009 hPa | Test Power : | AC 120V/60Hz |
| Test Mode : | FM 97.5MHz | | |

| Freq. (MHz) | Ant.Pol. HV | Reading (dBuV) | Ant./CF CF(dB) | Measurement (dBuV/m) | Limit (dBuV/m) | Note |
|-------------|-------------|----------------|----------------|----------------------|----------------|------|
| 78.44 | V | 45.62 | -20.43 | 25.19 | 30.00 | |
| 132.56 | V | 43.23 | -19.14 | 24.09 | 30.00 | |
| 158.79 | V | 44.27 | -16.64 | 27.63 | 30.00 | |
| 210.34 | V | 39.54 | -14.82 | 24.72 | 30.00 | |
| 287.93 | V | 39.54 | -11.55 | 27.79 | 37.00 | |
| 442.33 | V | 40.56 | -7.55 | 33.01 | 37.00 | |

Remark :

- (1) All readings are Peak unless otherwise stated QP in column of 『Note』 . Peak denotes that the Peak reading compliance with the QP Limits and then QP Mode measurement didn't perform .
- (2) Measuring frequency range from 1000MHz to 6000MHz or the 10th harmonic of highest fundamental frequency . "F" denotes fundamental frequency; "H" denotes spurious frequency. "E" denotes band edge frequency. (This judgment method includes the Band Edge Requirement.)
- (3) Radiated emissions measured in frequency range above 1000MHz were made with an instrument using Peak detector mode and AV detector mode of the emission .
- (4) Data of measurement within this frequency range shown " * " in the table above means the reading of emissions are attenuated more than 20dB below the permissible limits or the field strength is too small to be measured.
- (5) A preamp and high pass filter were used for this test in order to provide sufficient measurement sensitivity.
- (6) EUT Orthogonal Axis :
 "X" - denotes Laid on Table ; "Y" - denotes Vertical Stand ; "Z" - denotes Side Stand

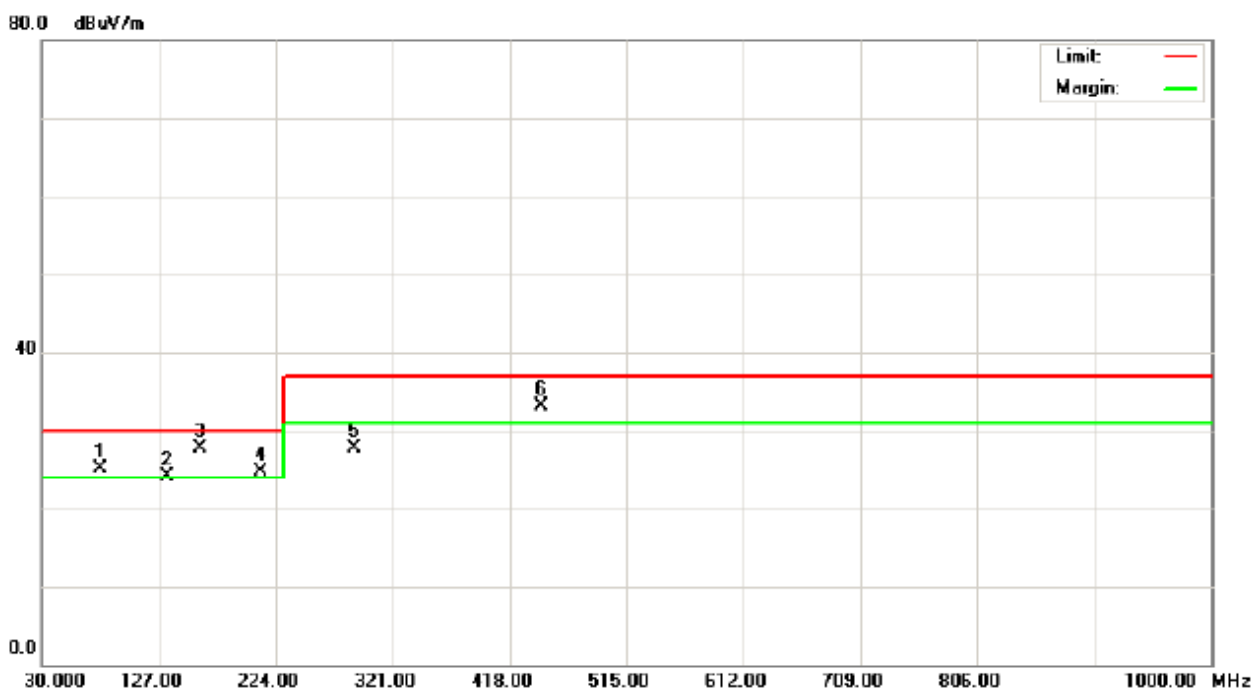



| | | | |
|---------------|---|---------------------|--------------|
| EUT : | Hi Fi dock with bluetooth wireless Audio system | Model Name. : | SFQ-01 |
| Temperature : | 23 °C | Relative Humidity : | 57 % |
| Pressure : | 1009 hPa | Test Power : | AC 120V/60Hz |
| Test Mode : | FM 107.5MHz | | |

| Freq. (MHz) | Ant. Pol. H/V | Reading (dBuV) | Ant./CF CF(dB) | Measurement (dBuV/m) | Limit (dBuV/m) | Note |
|-------------|---------------|----------------|----------------|----------------------|----------------|------|
| 56.98 | H | 42.99 | -19.24 | 23.75 | 30.00 | |
| 168.99 | H | 44.04 | -16.46 | 27.58 | 30.00 | |
| 234.76 | H | 41.95 | -13.34 | 28.61 | 30.00 | |
| 268.49 | H | 39.85 | -12.03 | 27.82 | 37.00 | |
| 369.94 | H | 35.75 | -8.14 | 27.61 | 37.00 | |
| 468.12 | H | 36.90 | -6.44 | 30.46 | 37.00 | |

Remark :

- (1) All readings are Peak unless otherwise stated QP in column of 『Note 』 . Peak denotes that the Peak reading compliance with the QP Limits and then QP Mode measurement didn't perform .
- (2) Measuring frequency range from 1000MHz to 6000MHz or the 10th harmonic of highest fundamental frequency . "F" denotes fundamental frequency; "H" denotes spurious frequency. "E" denotes band edge frequency. (This judgment method includes the Band Edge Requirement.)
- (3) Radiated emissions measured in frequency range above 1000MHz were made with an instrument using Peak detector mode and AV detector mode of the emission .
- (4) Data of measurement within this frequency range shown " * " in the table above means the reading of emissions are attenuated more than 20dB below the permissible limits or the field strength is too small to be measured.
- (5) A preamp and high pass filter were used for this test in order to provide sufficient measurement sensitivity.
- (6) EUT Orthogonal Axis :
 "X" - denotes Laid on Table ; "Y" - denotes Vertical Stand ; "Z" - denotes Side Stand

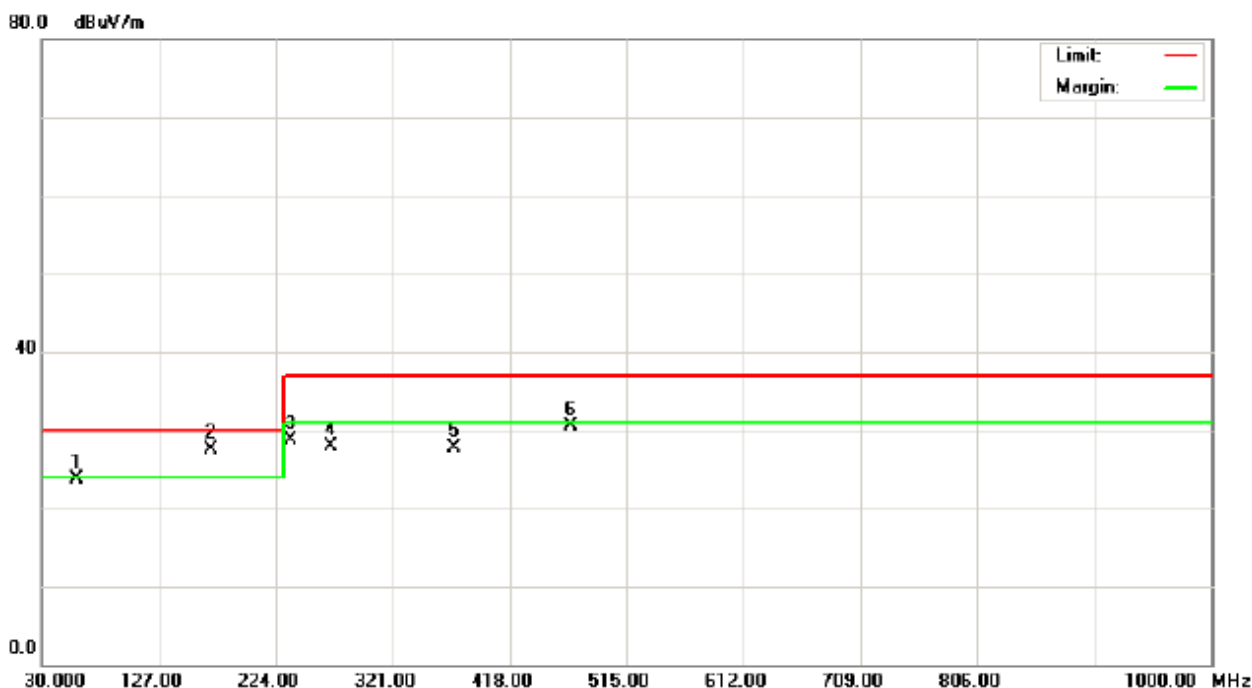



5. NUMBER OF HOPPING CHANNEL

5.1 APPLIED PROCEDURES / LIMIT

| FCC Part15 (15.247) , Subpart C | | | |
|---------------------------------|---------------------------|-----------------------|--------|
| Section | Test Item | Frequency Range (MHz) | Result |
| 15.247 (a)(1)(iii) | Number of Hopping Channel | 2400-2483.5 | PASS |

5.1.1 MEASUREMENT INSTRUMENTS LIST AND SETTING

| Item | Kind of Equipment | Manufacturer | Type No. | Serial No. | Calibrated until |
|------|-------------------|--------------|----------|------------|------------------|
| 1 | Spectrum Analyzer | R&S | FSP 40 | 100185 | Nov.27.2010 |

Remark: " N/A" denotes No Model Name , Serial No. or No Calibration specified.

| Spectrum Parameters | Setting |
|---------------------|-----------------------------|
| Attenuation | Auto |
| Span Frequency | > Operating Frequency Range |
| RB | 100 kHz |
| VB | 100 kHz |
| Detector | Peak |
| Trace | Max Hold |
| Sweep Time | Auto |

5.1.2 TEST PROCEDURE

- a. The EUT was directly connected to the spectrum analyzer and antenna output port as show in the block diagram below,
- b. Spectrum Setting : RBW= 100KHz, VBW=100KHz, Sweep time = Auto.

5.1.3 DEVIATION FROM STANDARD

No deviation.

5.1.4 TEST SETUP



5.1.5 EUT OPERATION CONDITIONS

The EUT tested system was configured as the statements of 4.1.6 Unless otherwise a special operating condition is specified in the follows during the testing.



5.1.6 TEST RESULTS

| | | | |
|---------------|---|---------------------|--------------|
| EUT : | Hi Fi dock with bluetooth wireless Audio system | Model Name : | SFQ-01 |
| Temperature : | 22 °C | Relative Humidity : | 60 % |
| Pressure : | 1010 hPa | Test Voltage : | AC 120V/60Hz |
| Test Mode : | Hopping Mode -1Mbps | | |

| | |
|---------------------------|----|
| Number of Hopping Channel | 79 |
|---------------------------|----|

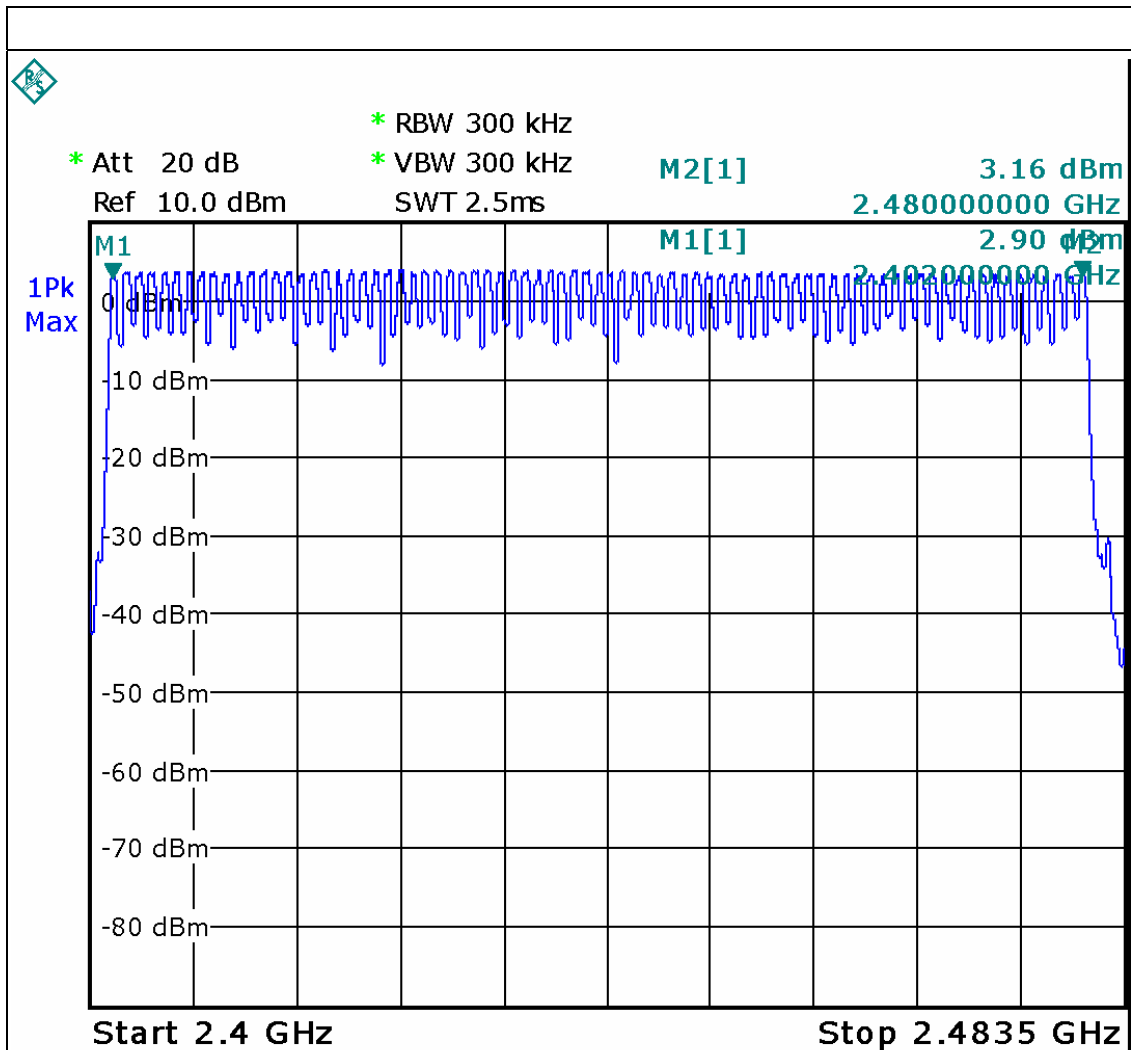

Date: 17.JUL.2010 11:00:22



| | | | |
|---------------|---|---------------------|--------------|
| EUT : | Hi Fi dock with bluetooth wireless Audio system | Model Name : | SFQ-01 |
| Temperature : | 22 °C | Relative Humidity : | 60 % |
| Pressure : | 1015 hPa | Test Voltage : | AC 120V/60Hz |
| Test Mode : | Hopping Mode -3Mbps | | |

| | |
|---------------------------|----|
| Number of Hopping Channel | 79 |
|---------------------------|----|

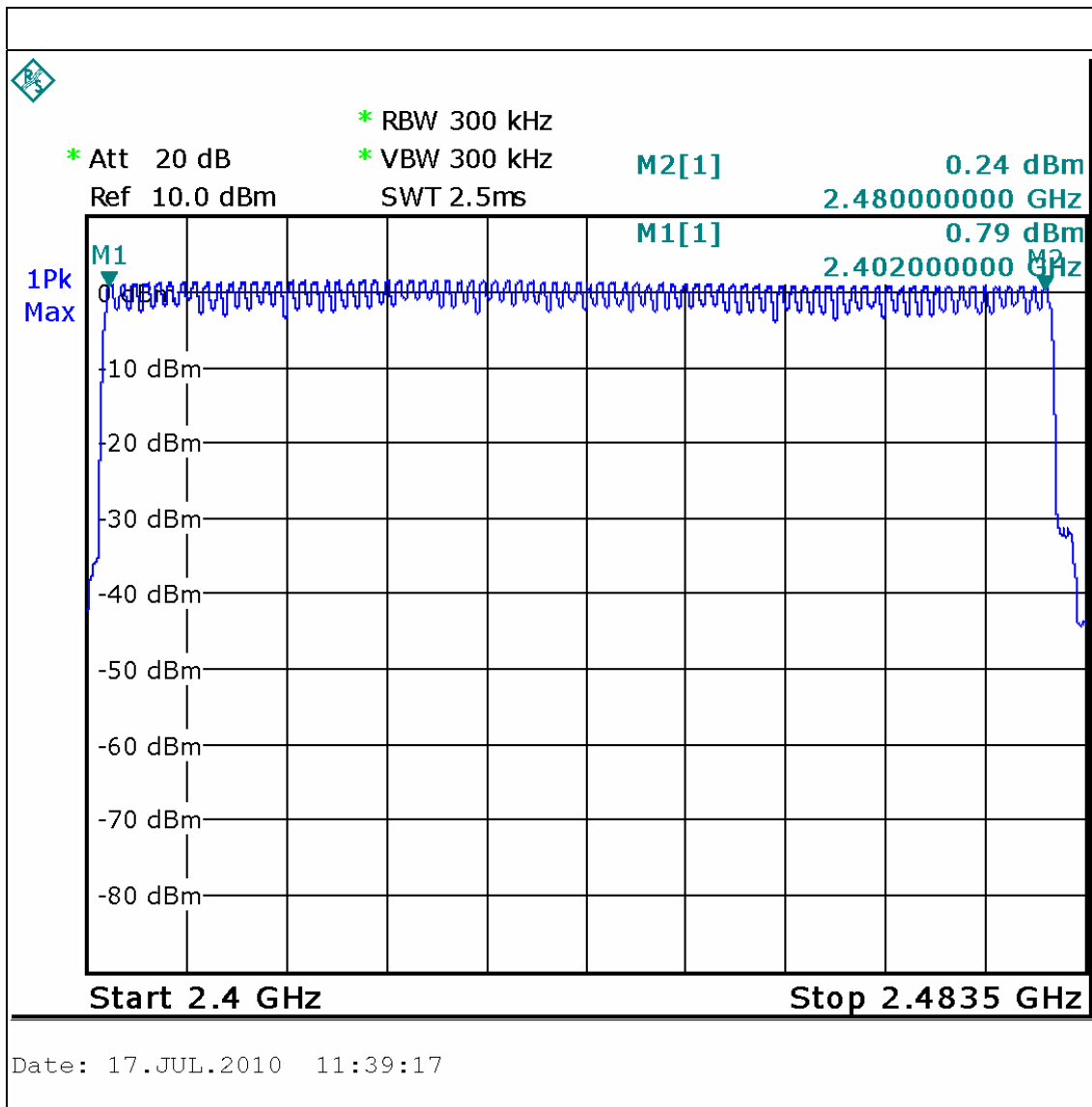



6. AVERAGE TIME OF OCCUPANCY

6.1 APPLIED PROCEDURES / LIMIT

| FCC Part15 (15.247) , Subpart C | | | | |
|---------------------------------|---------------------------|--------|-----------------------|--------|
| Section | Test Item | Limit | Frequency Range (MHz) | Result |
| 15.247 (a)(1)(iii) | Average Time of Occupancy | 0.4sec | 2400-2483.5 | PASS |

6.1.1 MEASUREMENT INSTRUMENTS LIST

| Item | Kind of Equipment | Manufacturer | Type No. | Serial No. | Calibrated until |
|------|-------------------|--------------|----------|------------|------------------|
| 1 | Spectrum Analyzer | R&S | FSP 40 | 100185 | Nov.27.2010 |

Remark: " N/A" denotes No Model Name , Serial No. or No Calibration specified.

6.1.2 TEST PROCEDURE

- a. The transmitter output (antenna port) was connected to the spectrum analyzer
- b. Set RBW of spectrum analyzer to 1MHz and VBW to 1MHz.
- c. Use a video trigger with the trigger level set to enable triggering only on full pulses.
- d. Sweep Time is more than once pulse time.
- e. Set the center frequency on any frequency would be measure and set the frequency span to zero span.
- f. Measure the maximum time duration of one single pulse.
- g. Set the EUT for DH5, DH3 and DH1 packet transmitting.
- h. Measure the maximum time duration of one single pulse.
- i. DH5 Packet permit maximum $1600 / 79 / 6 = 3.37$ hops per second in each channel (5 time slots RX, 1 time slot TX). So, the dwell time is the time duration of the pulse times $3.37 \times 31.6 = 106.6$ within 31.6 seconds.
- j. DH3 Packet permit maximum $1600 / 79 / 4 = 5.06$ hops per second in each channel (3 time slots RX, 1 time slot TX). So, the dwell time is the time duration of the pulse times $5.06 \times 31.6 = 160$ within 31.6 seconds.
- k. DH1 Packet permit maximum $1600 / 79 / 2 = 10.12$ hops per second in each channel (1 time slot RX, 1 time slot TX). So, the dwell time is the time duration of the pulse times $10.12 \times 31.6 = 320$ within 31.6 seconds.

6.1.3 DEVIATION FROM STANDARD

No deviation.



6.1.4 TEST SETUP

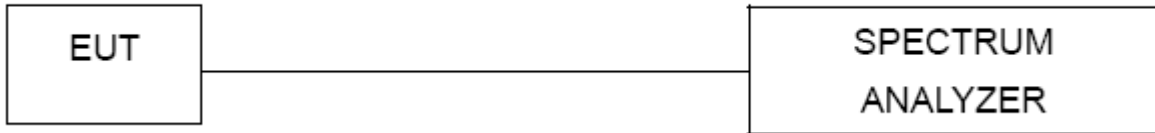

6.1.5 EUT OPERATION CONDITIONS

The EUT tested system was configured as the statements of 4.1.6 Unless otherwise a special operating condition is specified in the follows during the testing.



6.1.6 TEST RESULTS

| | | | |
|---------------|---|---------------------|--------------|
| EUT : | Hi Fi dock with bluetooth wireless Audio system | Model Name : | SFQ-01 |
| Temperature : | 22 °C | Relative Humidity : | 60 % |
| Pressure : | 1012 hPa | Test Voltage : | AC 120V/60Hz |
| Test Mode : | CH00-DH1/DH3/DH5 -1Mbps | | |

| Data Packet | Frequency | Pulse Duration (ms) | Dwell Time (s) | Limits (s) |
|-------------|-----------|---------------------|----------------|------------|
| DH5 | 2402 MHz | 3.1200 | 0.3328 | 0.4000 |
| DH3 | 2402 MHz | 1.8400 | 0.2944 | 0.4000 |
| DH1 | 2402 MHz | 0.5600 | 0.1792 | 0.4000 |

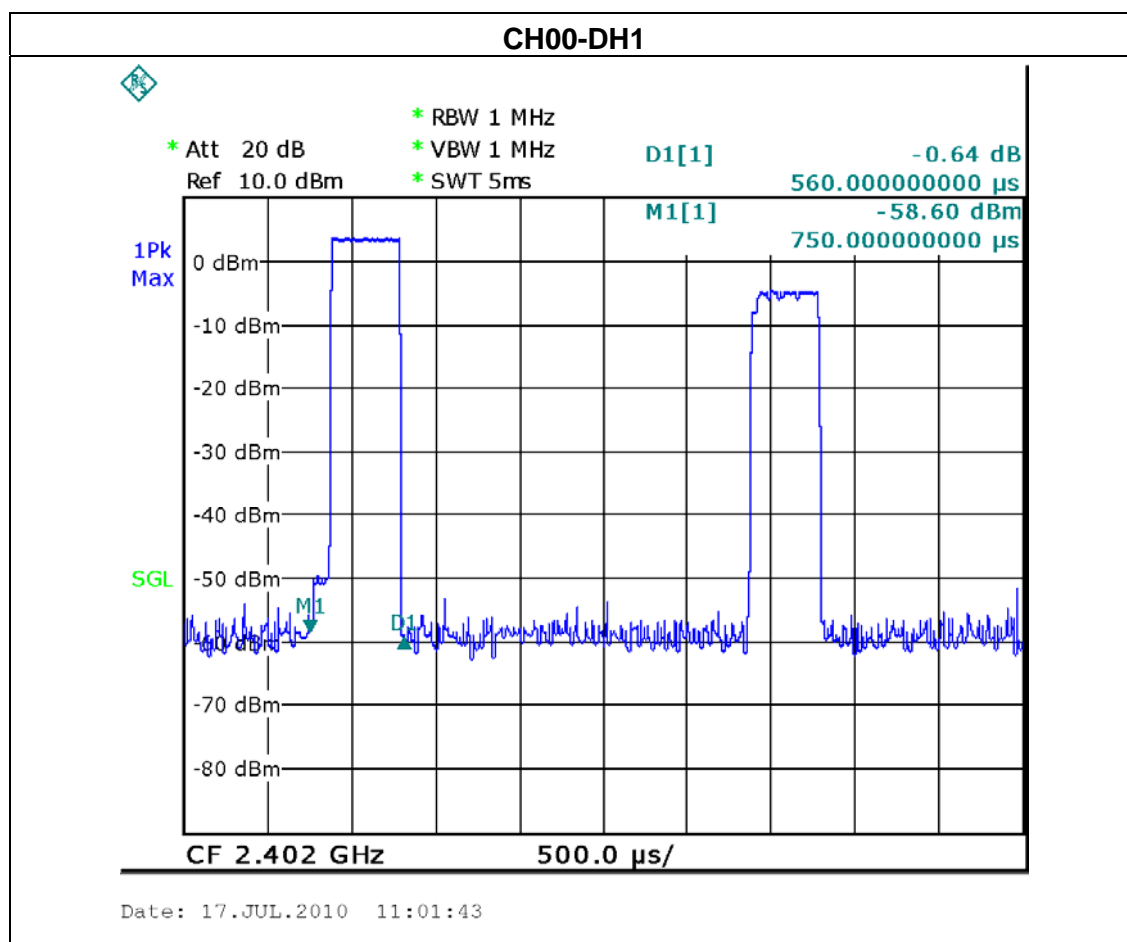

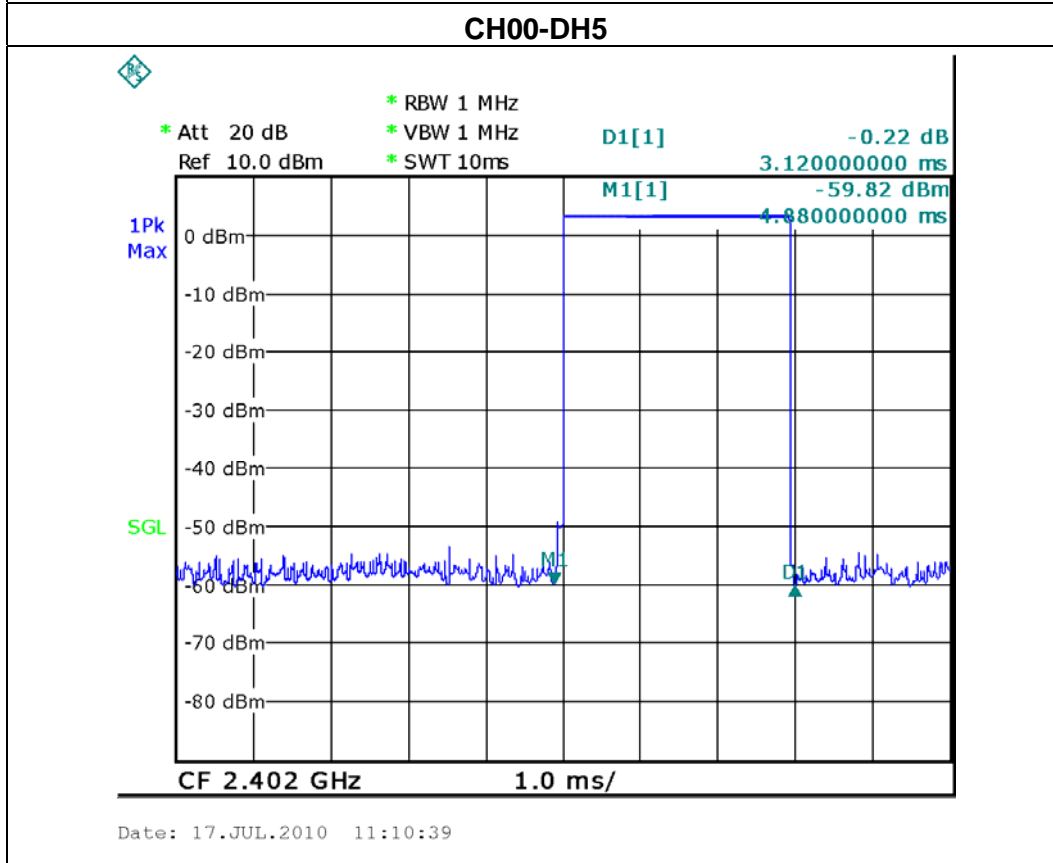
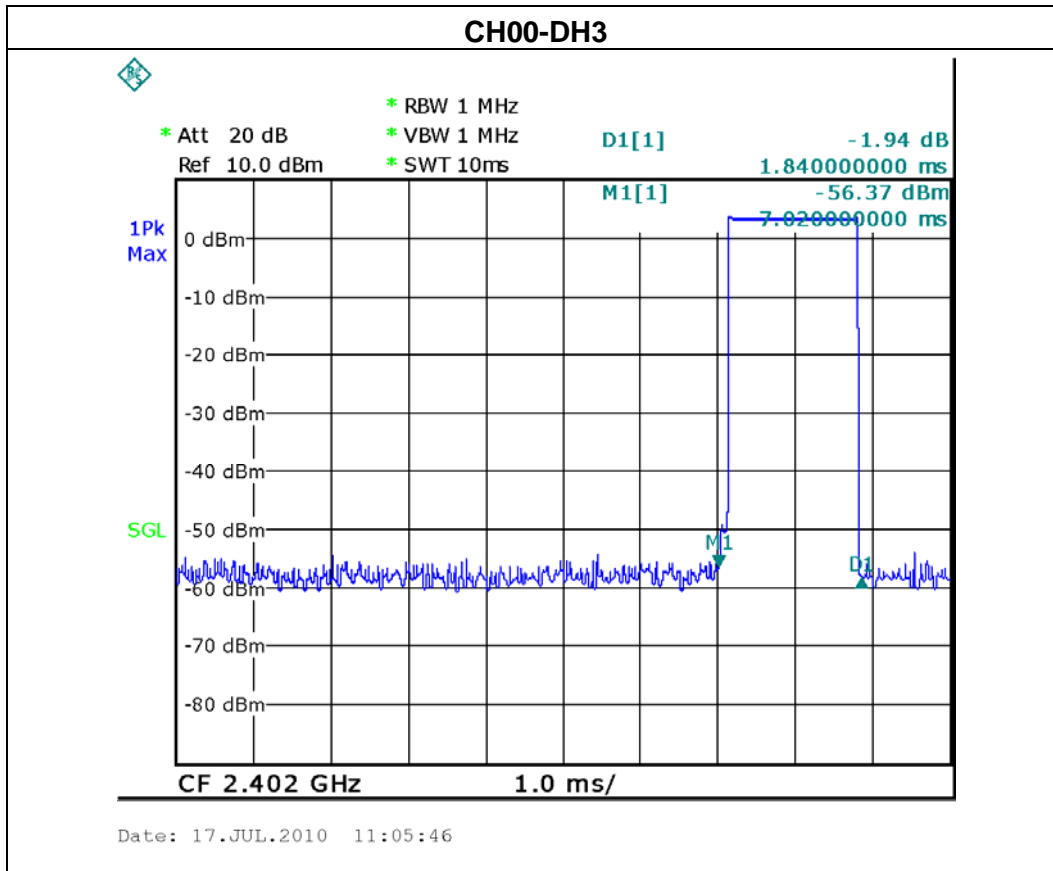



| | | | |
|---------------|---|---------------------|--------------|
| EUT : | Hi Fi dock with bluetooth wireless Audio system | Model Name : | SFQ-01 |
| Temperature : | 22 °C | Relative Humidity : | 60 % |
| Pressure : | 1012 hPa | Test Voltage : | AC 120V/60Hz |
| Test Mode : | CH39 -DH1/DH3/DH5 -1Mbps | | |

| Data Packet | Frequency | Pulse Duration (ms) | Dwell Time (s) | Limits (s) |
|-------------|-----------|---------------------|----------------|------------|
| DH5 | 2441 MHz | 3.1000 | 0.3307 | 0.4000 |
| DH3 | 2441 MHz | 1.8400 | 0.2944 | 0.4000 |
| DH1 | 2441 MHz | 0.5500 | 0.1760 | 0.4000 |

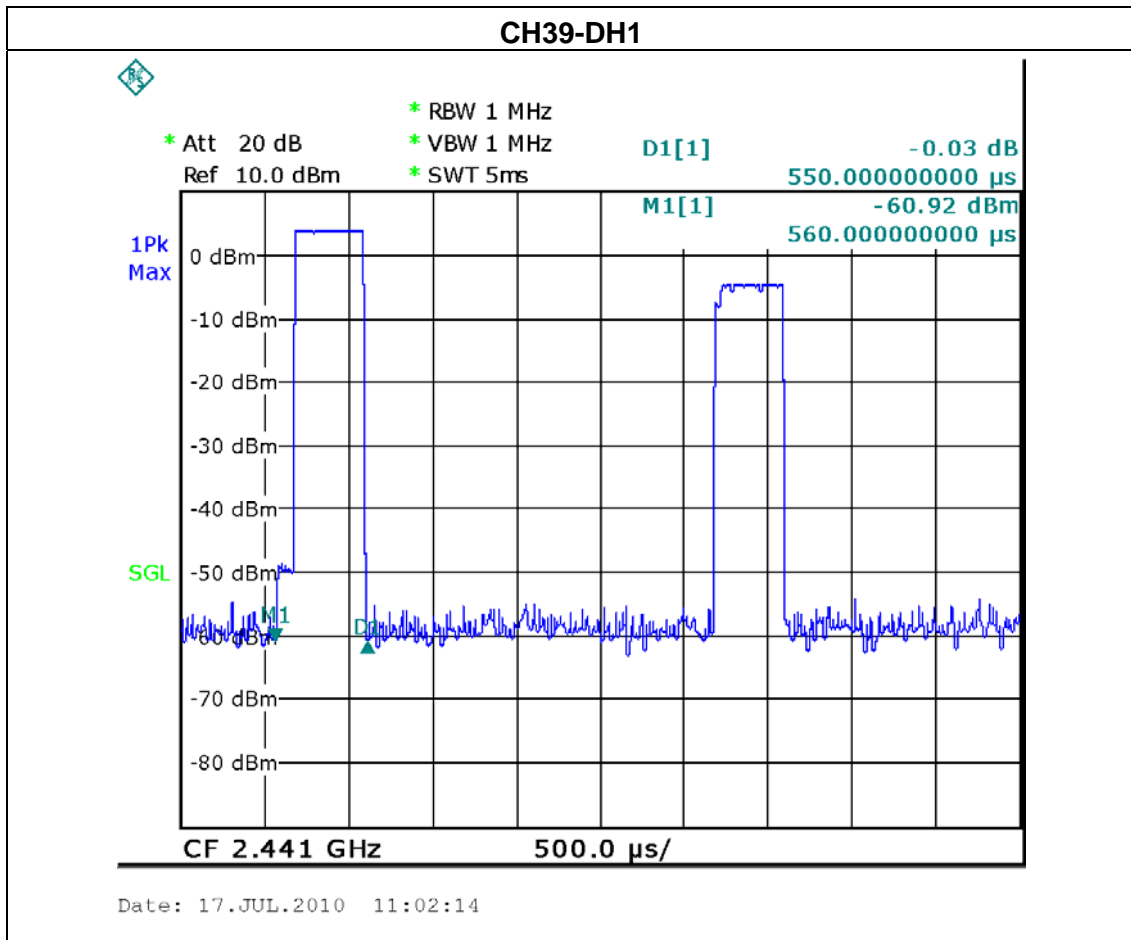

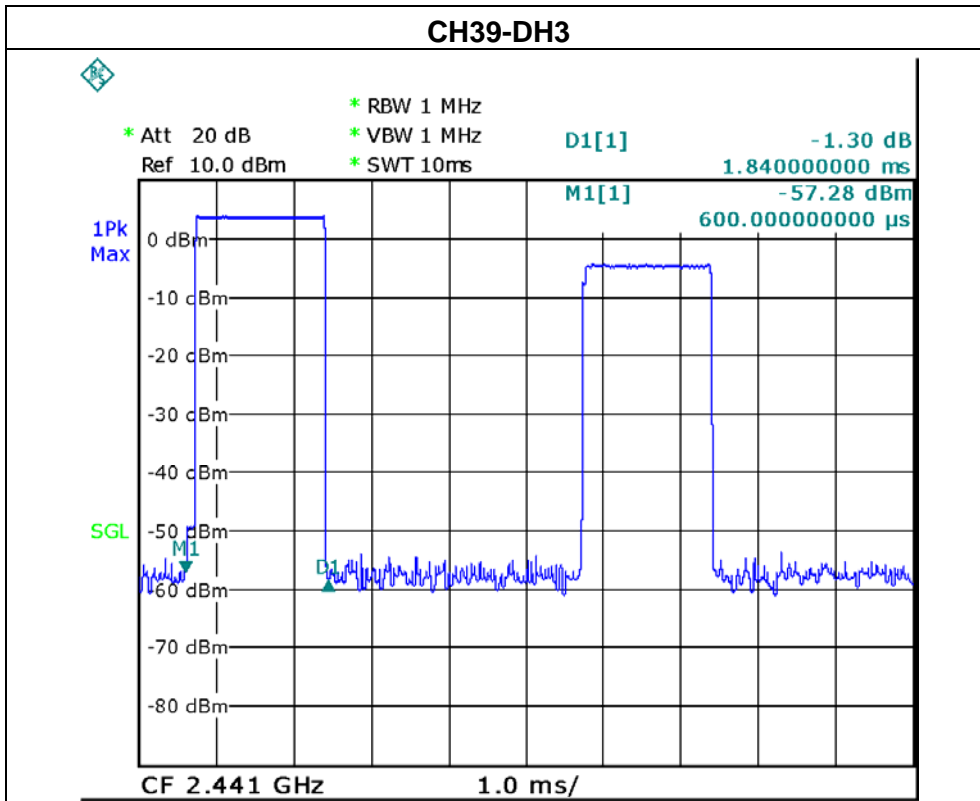

Date: 17.JUL.2010 11:06:23

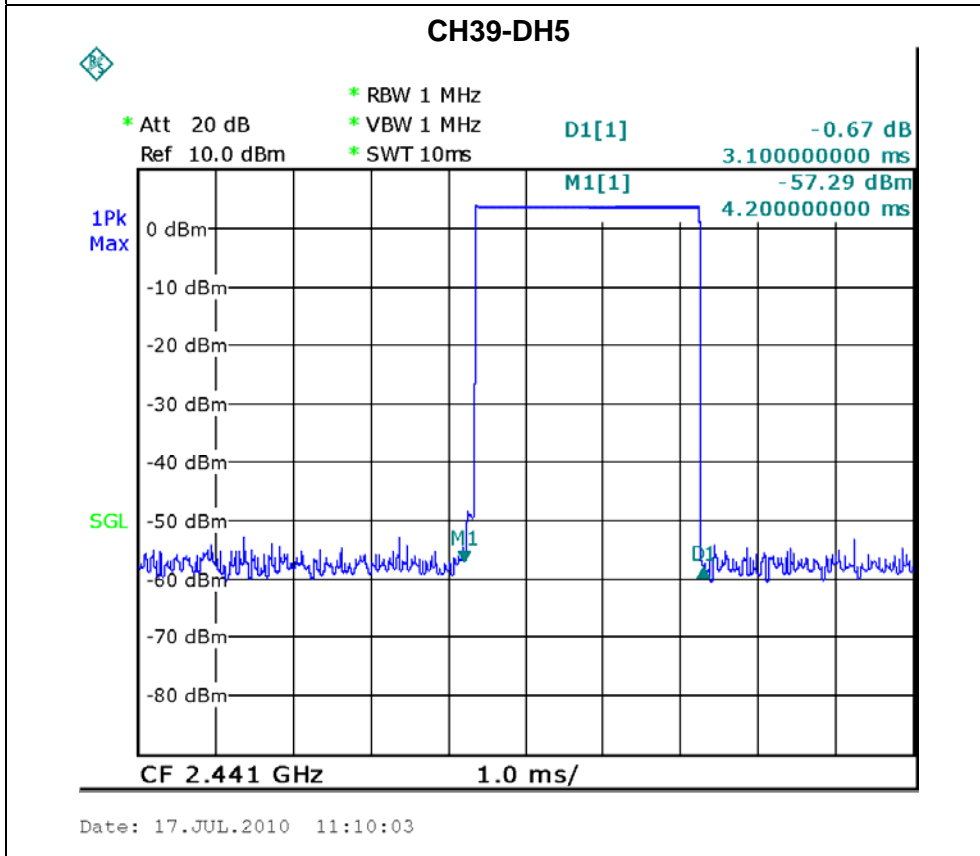

Date: 17.JUL.2010 11:10:03



| | | | |
|---------------|---|---------------------|--------------|
| EUT : | Hi Fi dock with bluetooth wireless Audio system | Model Name : | SFQ-01 |
| Temperature : | 22 °C | Relative Humidity : | 60 % |
| Pressure : | 1012 hPa | Test Voltage : | AC 120V/60Hz |
| Test Mode : | CH78 -DH1/DH3/DH5-1Mbps | | |

| Data Packet | Frequency | Pulse Duration (ms) | Dwell Time (s) | Limits (s) |
|-------------|-----------|---------------------|----------------|------------|
| DH5 | 2480 MHz | 3.0800 | 0.3285 | 0.4000 |
| DH3 | 2480 MHz | 1.8400 | 0.2944 | 0.4000 |
| DH1 | 2480 MHz | 0.5600 | 0.1792 | 0.4000 |

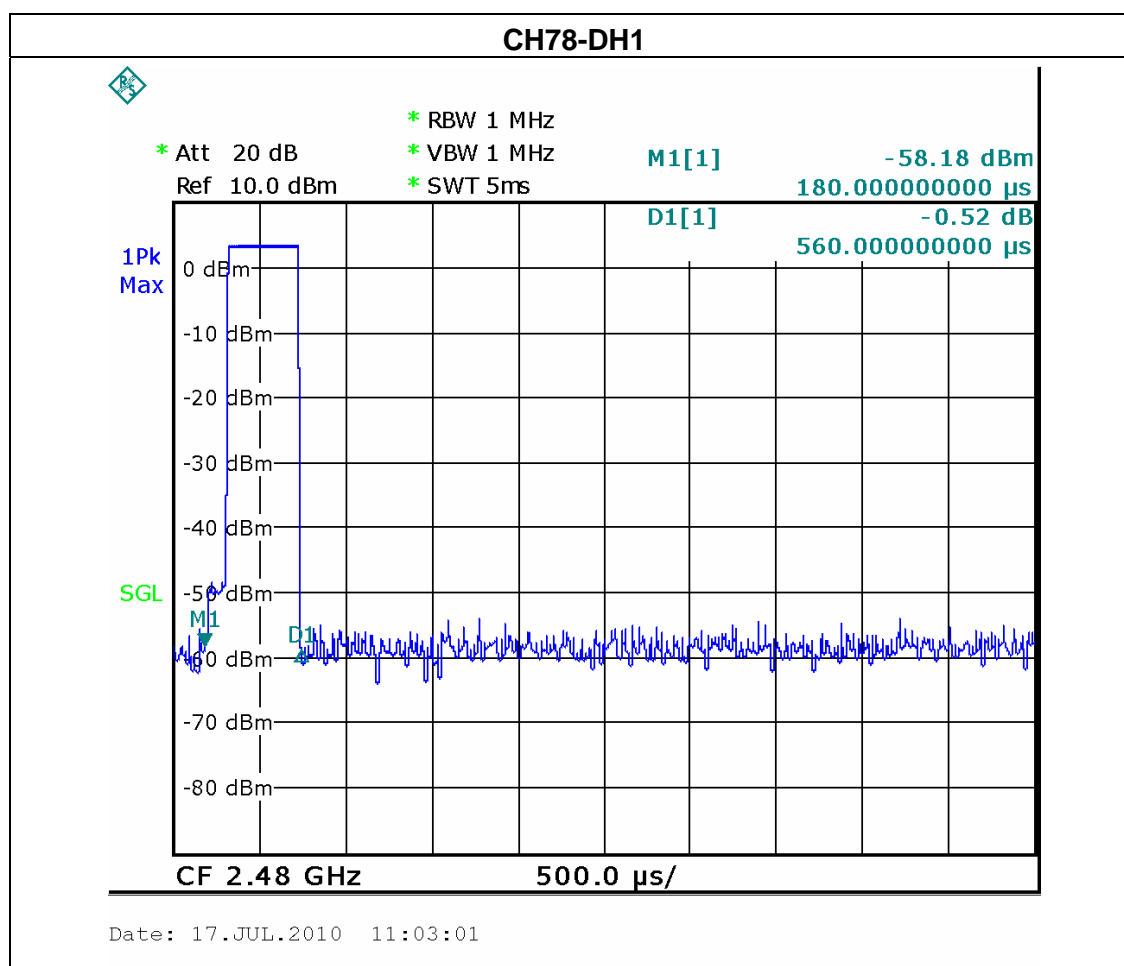

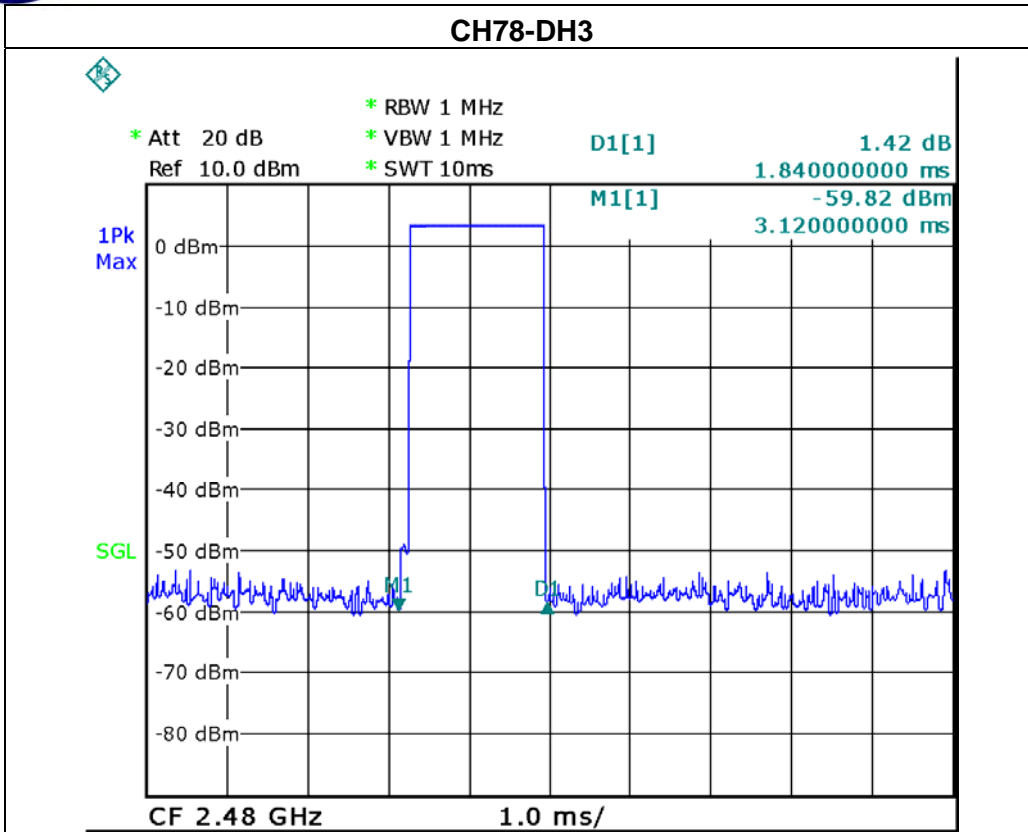

Date: 17.JUL.2010 11:06:55

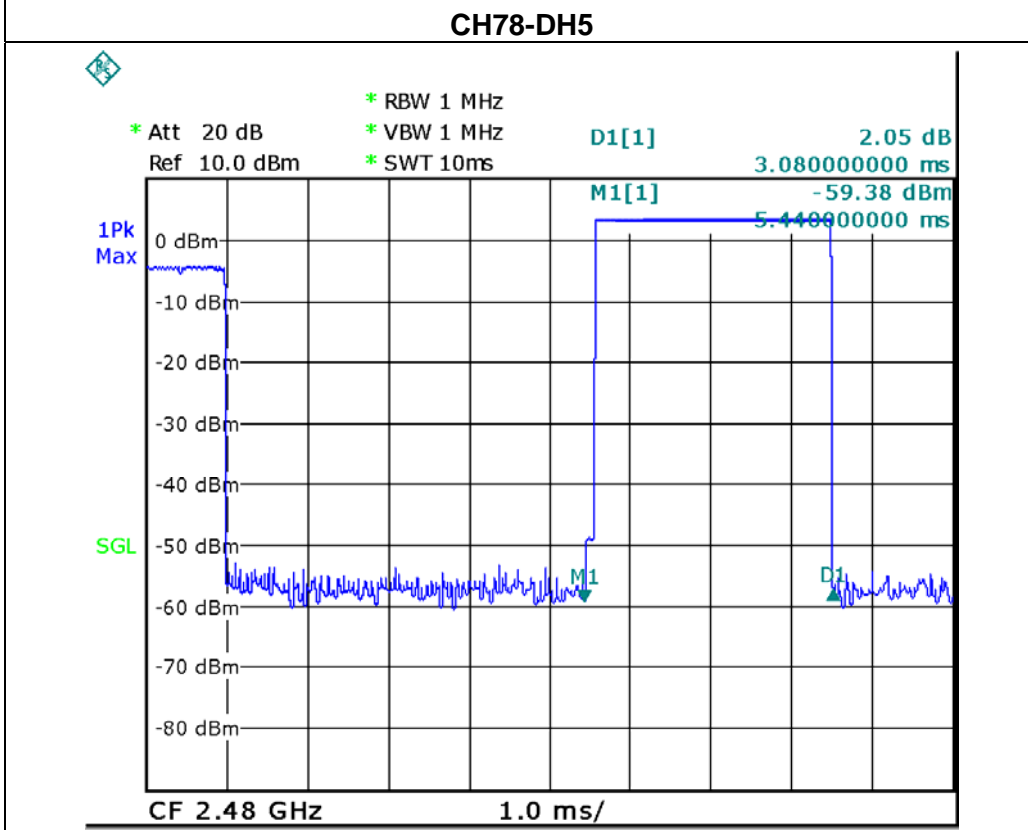

Date: 17.JUL.2010 11:07:40

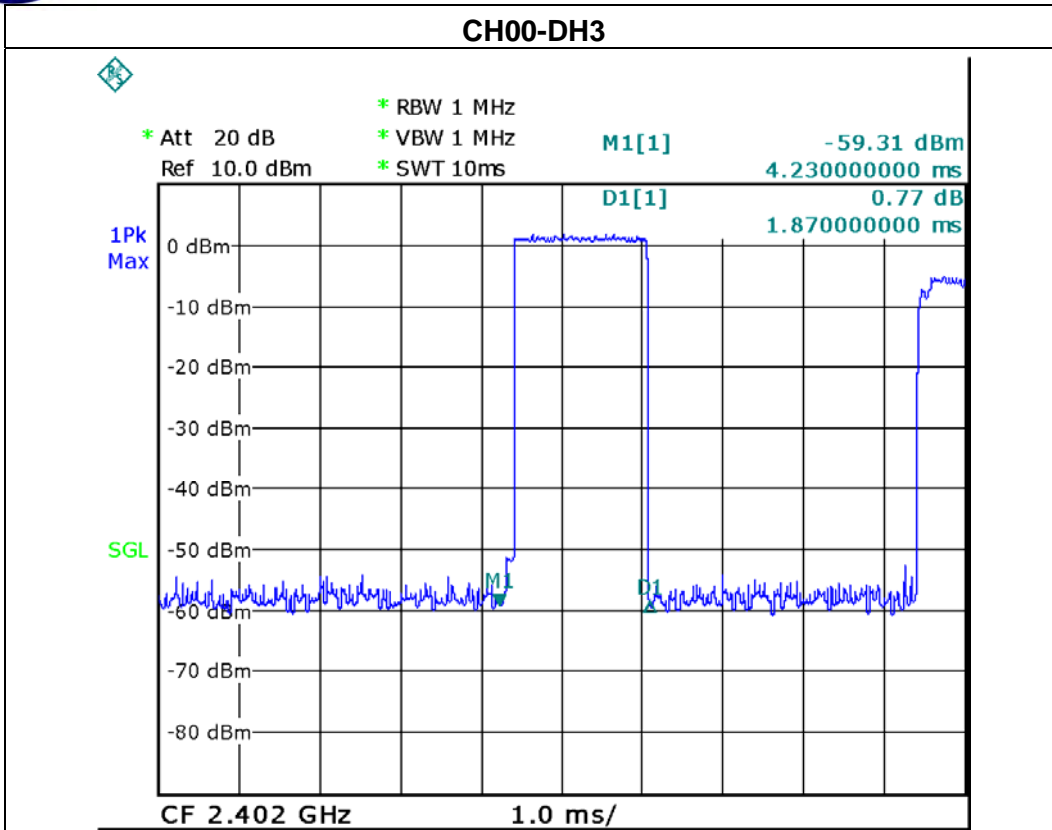

Date: 17.JUL.2010 11:42:44

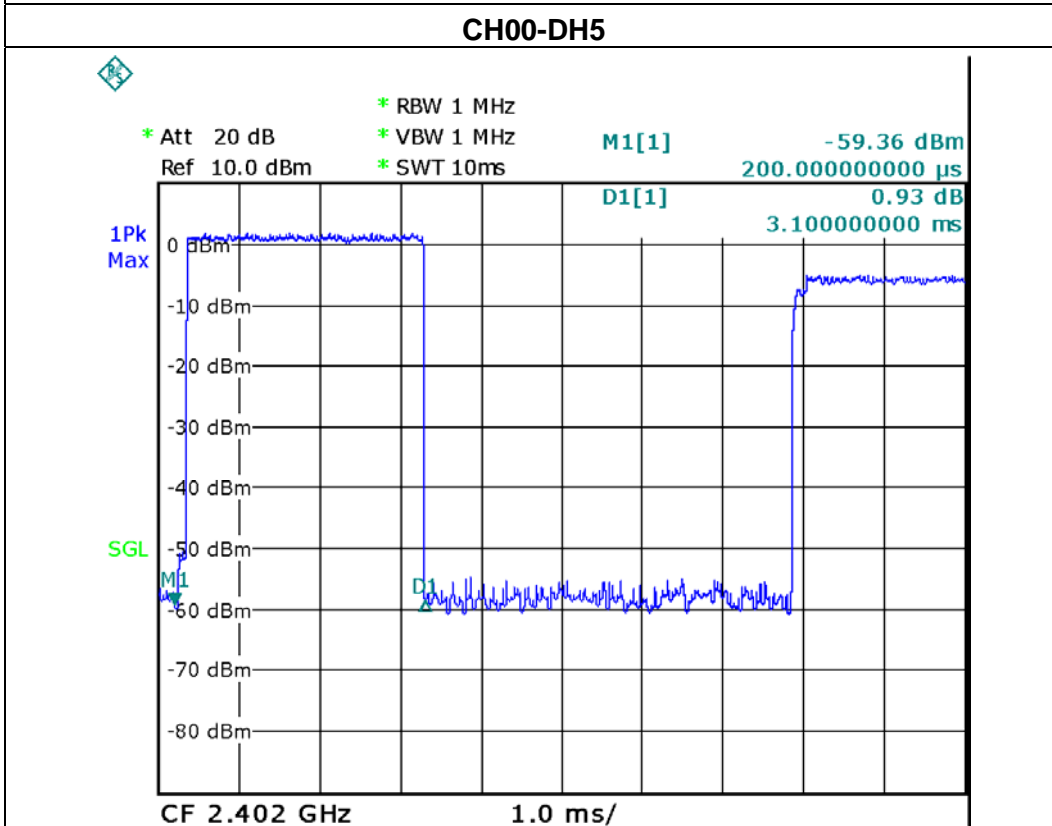

Date: 17.JUL.2010 11:44:45



| | | | |
|---------------|---|---------------------|--------------|
| EUT : | Hi Fi dock with bluetooth wireless Audio system | Model Name : | SFQ-01 |
| Temperature : | 22 °C | Relative Humidity : | 60 % |
| Pressure : | 1012 hPa | Test Voltage : | AC 120V/60Hz |
| Test Mode : | CH39 -DH1/DH3/DH5 -3Mbps | | |

| Data Packet | Frequency | Pulse Duration (ms) | Dwell Time (s) | Limits (s) |
|-------------|-----------|---------------------|----------------|------------|
| DH5 | 2441 MHz | 3.1200 | 0.3328 | 0.4000 |
| DH3 | 2441 MHz | 1.8500 | 0.2960 | 0.4000 |
| DH1 | 2441 MHz | 0.5500 | 0.1760 | 0.4000 |

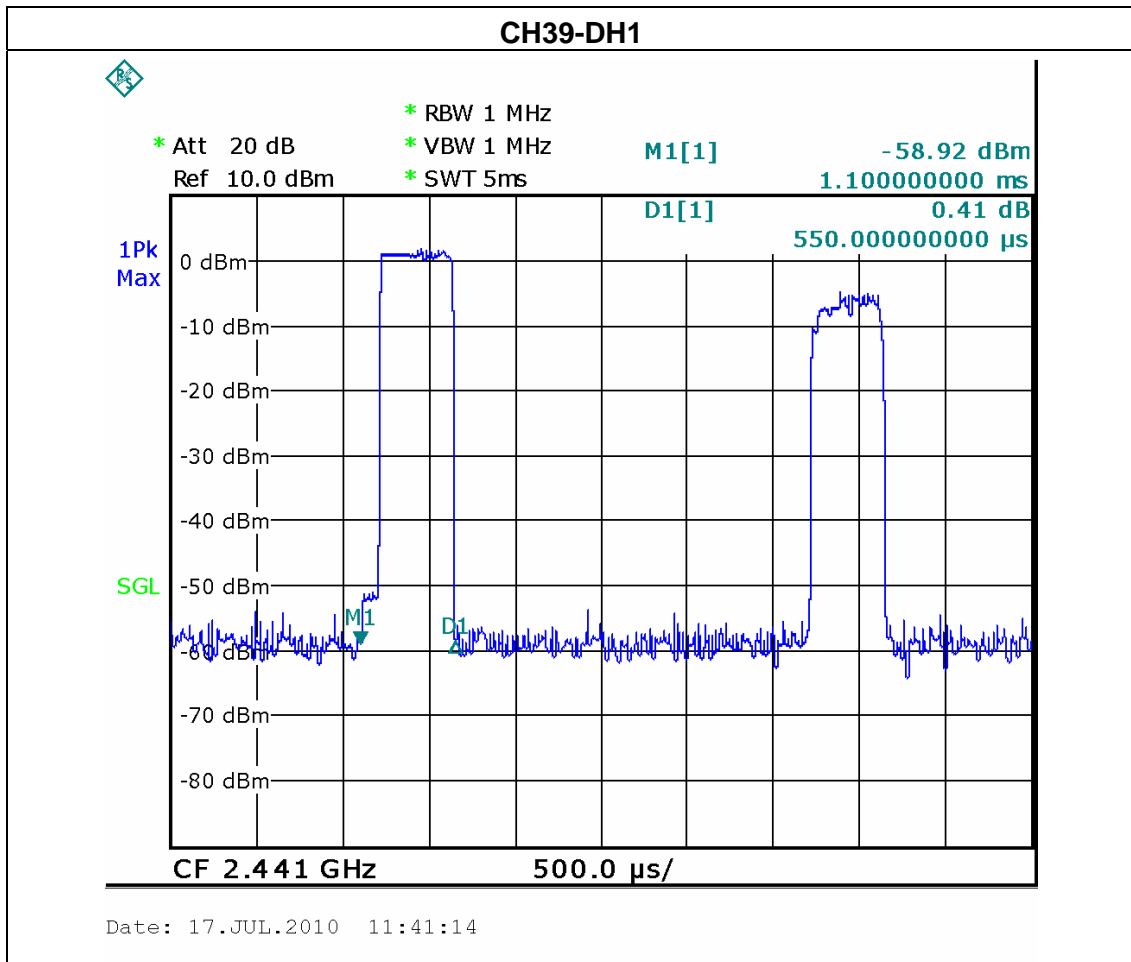

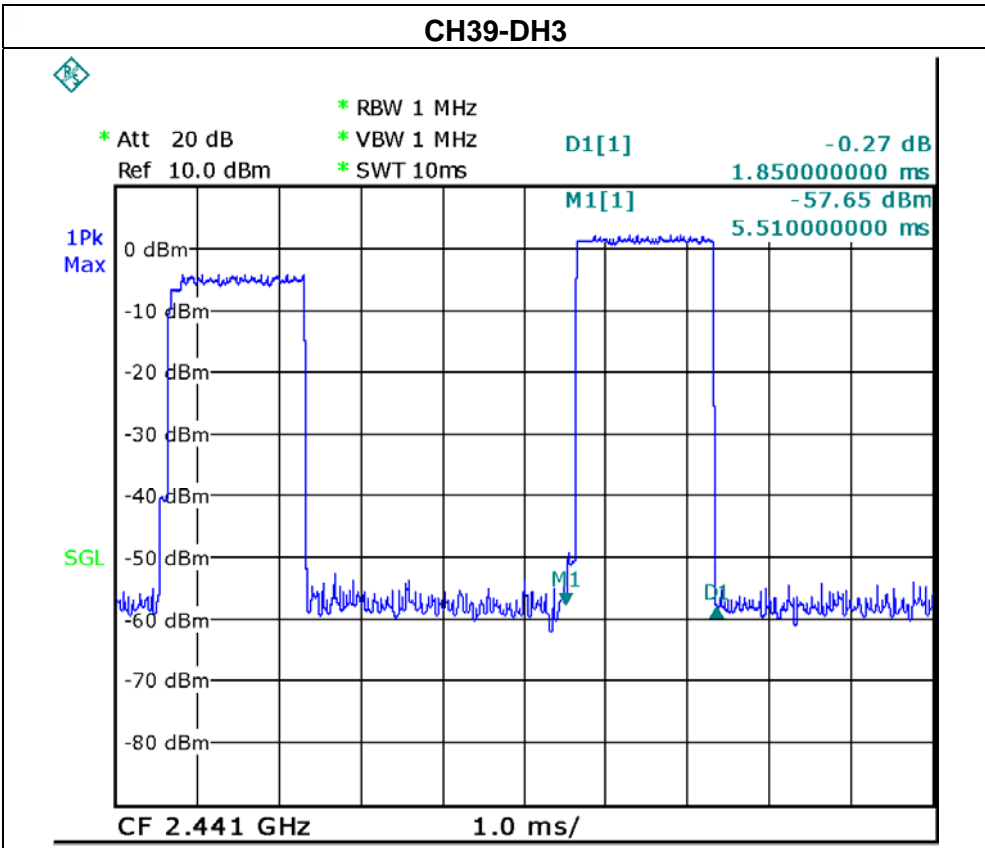

Date: 17.JUL.2010 11:43:06

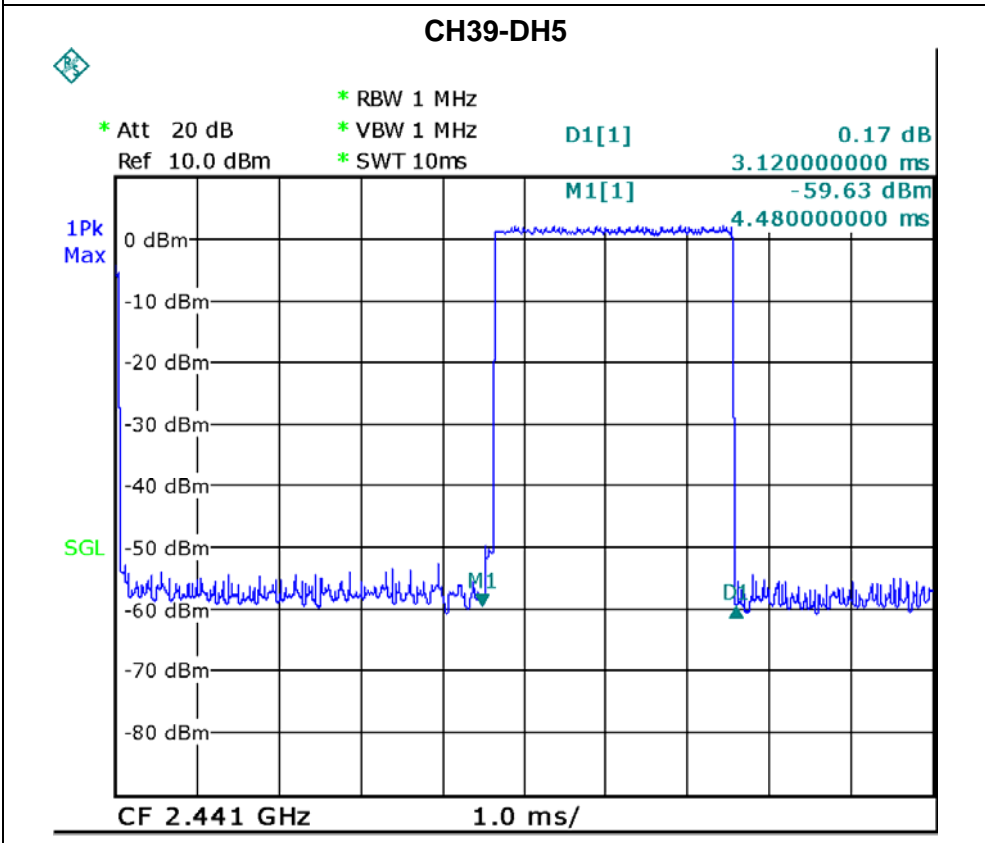

Date: 17.JUL.2010 11:45:14



| | | | |
|---------------|---|---------------------|--------------|
| EUT : | Hi Fi dock with bluetooth wireless Audio system | Model Name : | SFQ-01 |
| Temperature : | 22 °C | Relative Humidity : | 60 % |
| Pressure : | 1012 hPa | Test Voltage : | AC 120V/60Hz |
| Test Mode : | CH78 -DH1/DH3/DH5-3Mbps | | |

| Data Packet | Frequency | Pulse Duration (ms) | Dwell Time (s) | Limits (s) |
|-------------|-----------|---------------------|----------------|------------|
| DH5 | 2480 MHz | 3.1000 | 0.3307 | 0.4000 |
| DH3 | 2480 MHz | 1.8300 | 0.2928 | 0.4000 |
| DH1 | 2480 MHz | 0.5700 | 0.1824 | 0.4000 |

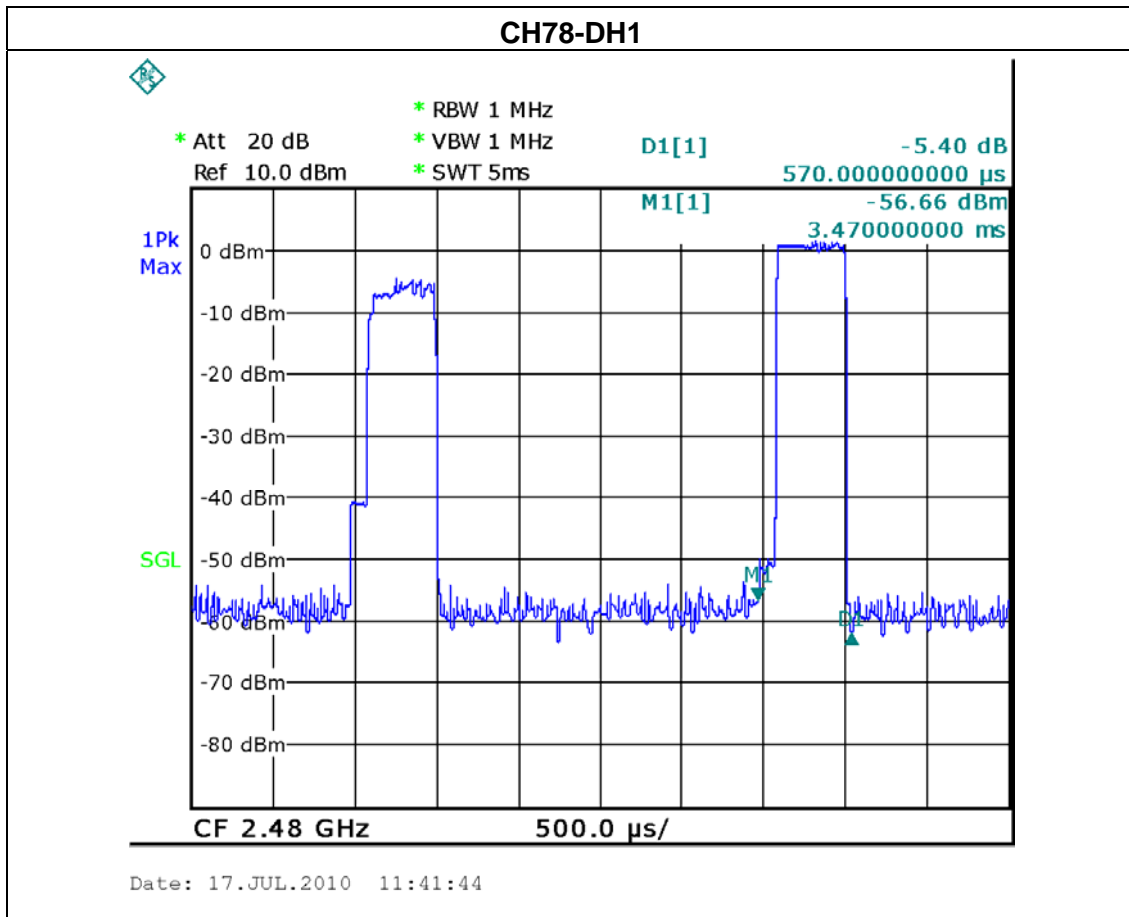

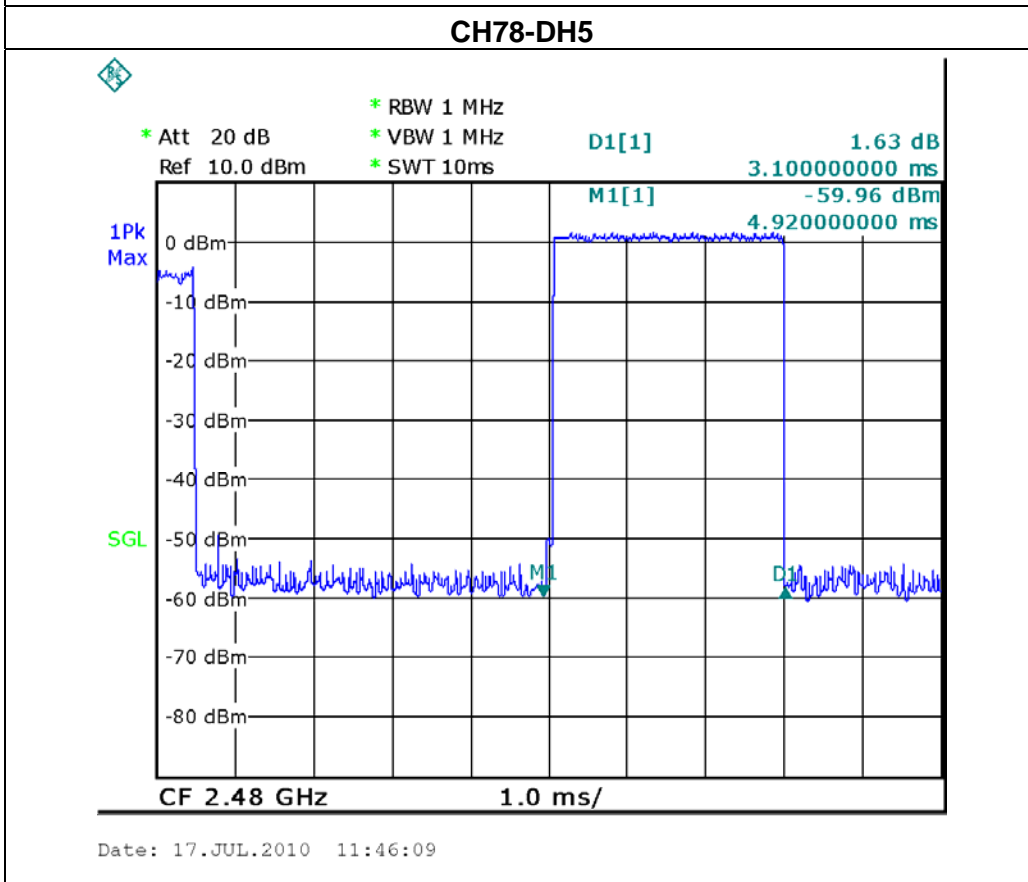
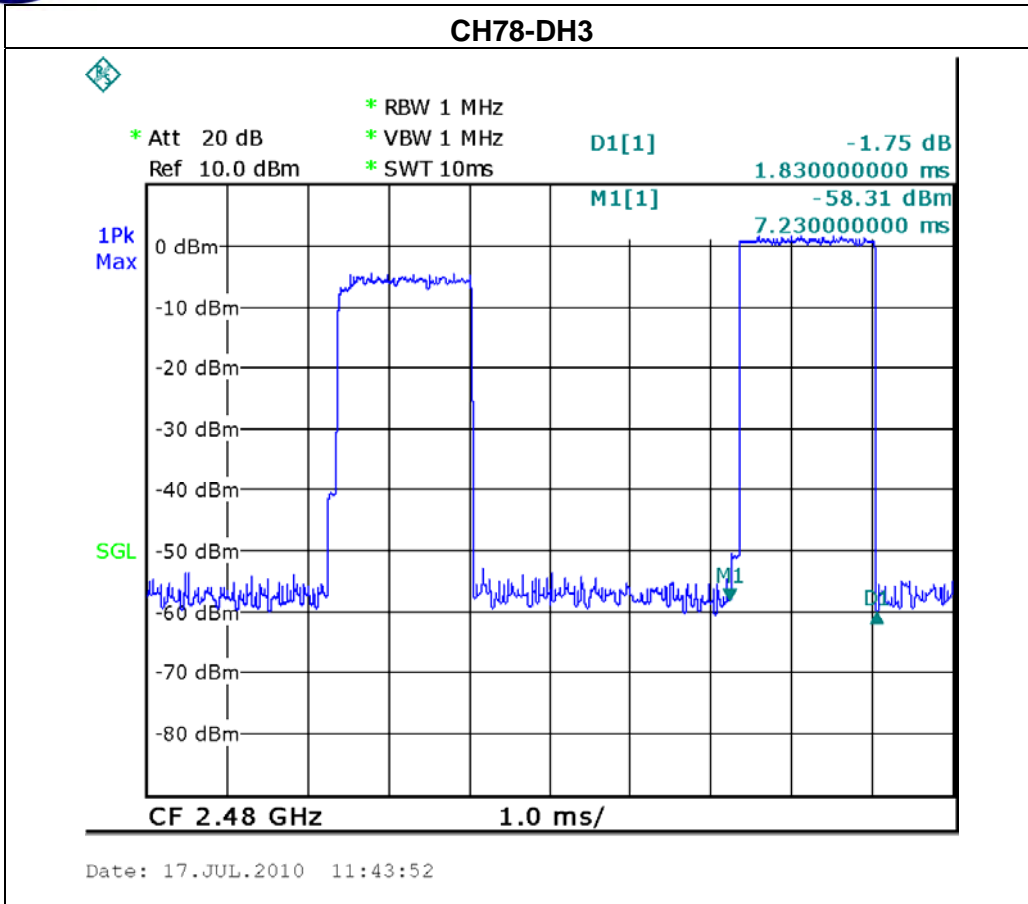

7. HOPPING CHANNEL SEPARATION MEASUREMENT

7.1 APPLIED PROCEDURES / LIMIT

Frequency hopping systems operating in the 2400-2483.5 MHz band may have hopping channel carrier frequencies that are separated by 25 kHz or two-thirds of the 20 dB bandwidth of the hopping channel, whichever is greater.

7.1.1 MEASUREMENT INSTRUMENTS LIST AND SETTING

| Item | Kind of Equipment | Manufacturer | Type No. | Serial No. | Calibrated until |
|------|-------------------|--------------|----------|------------|------------------|
| 1 | Spectrum Analyzer | R&S | FSP 40 | 100185 | Nov.27.2010 |

Remark: " N/A" denotes No Model Name , Serial No. or No Calibration specified.

| Spectrum Parameter | Setting |
|--------------------|---|
| Attenuation | Auto |
| Span Frequency | > Measurement Bandwidth or Channel Separation |
| RB | 30 kHz (20dB Bandwidth) / 100 kHz (Channel Separation) |
| VB | 100 kHz (20dB Bandwidth) / 300 kHz (Channel Separation) |
| Detector | Peak |
| Trace | Max Hold |
| Sweep Time | Auto |

7.1.2 TEST PROCEDURE

- The transmitter output (antenna port) was connected to the spectrum analyser in peak hold mode.
- The resolution bandwidth of 30 kHz and the video bandwidth of 100 kHz were utilised for 20 dB bandwidth measurement.
- The resolution bandwidth of 100 kHz and the video bandwidth of 300 kHz were utilised for channel separation measurement.

7.1.3 DEVIATION FROM STANDARD

No deviation.

7.1.4 TEST SETUP

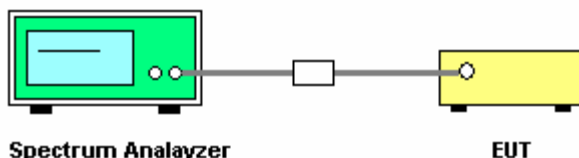

7.1.5 EUT OPERATION CONDITIONS

The EUT was programmed to be in continuously transmitting mode.



7.1.6 TEST RESULTS

| | | | |
|---------------|---|---------------------|--------------|
| EUT : | Hi Fi dock with bluetooth wireless Audio system | Model Name : | SFQ-01 |
| Temperature : | 22 °C | Relative Humidity : | 60 % |
| Pressure : | 1012 hPa | Test Voltage : | AC 120V/60Hz |
| Test Mode : | CH00 / CH39 /CH78-1Mbps | | |

| Frequency | Ch. Separation (MHz) | 20d Bandwidth B (kHz) | Result |
|-----------|----------------------|-----------------------|-----------------|
| 2402 MHz | 1 | 918.00 | Complies |
| 2441 MHz | 1 | 918.00 | Complies |
| 2480 MHz | 1 | 948.00 | Complies |

Ch. Separation Limits: >20dB bandwidth or >2/3 of 20dB bandwidth

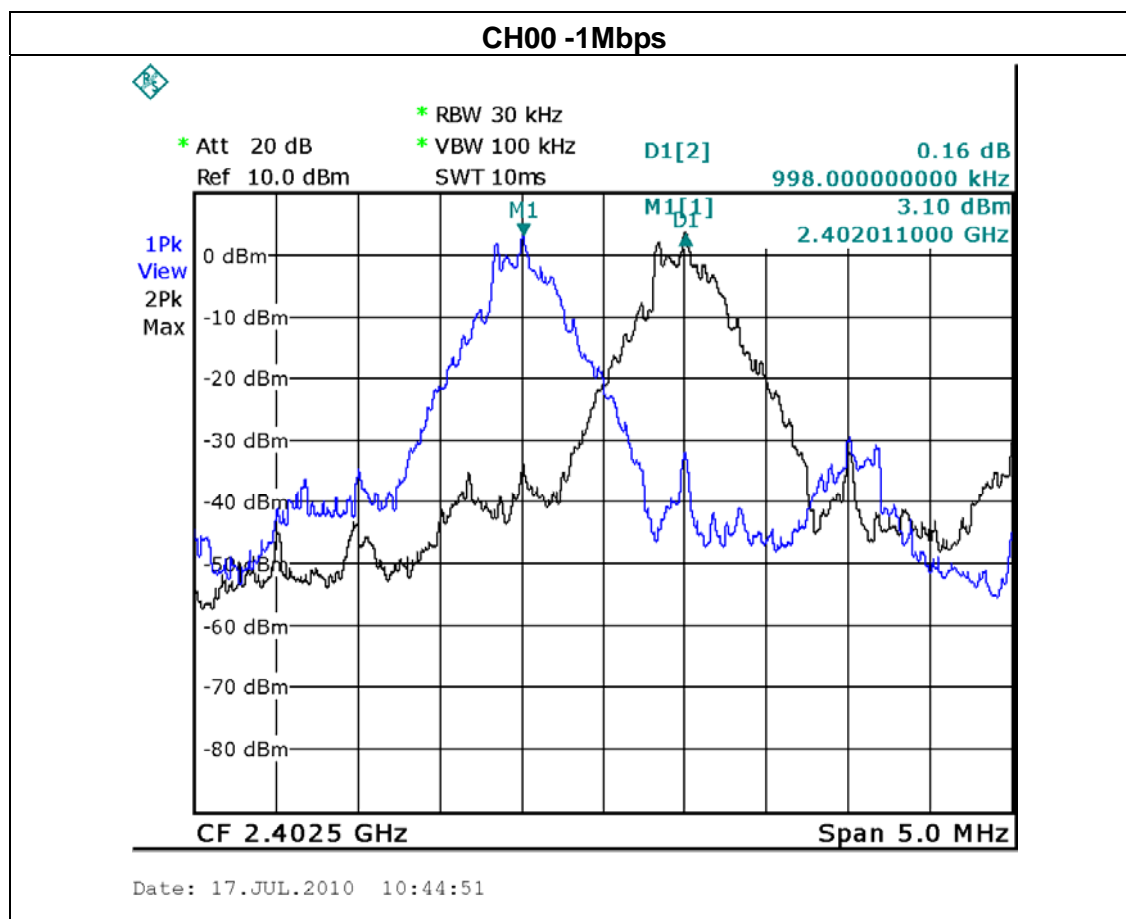

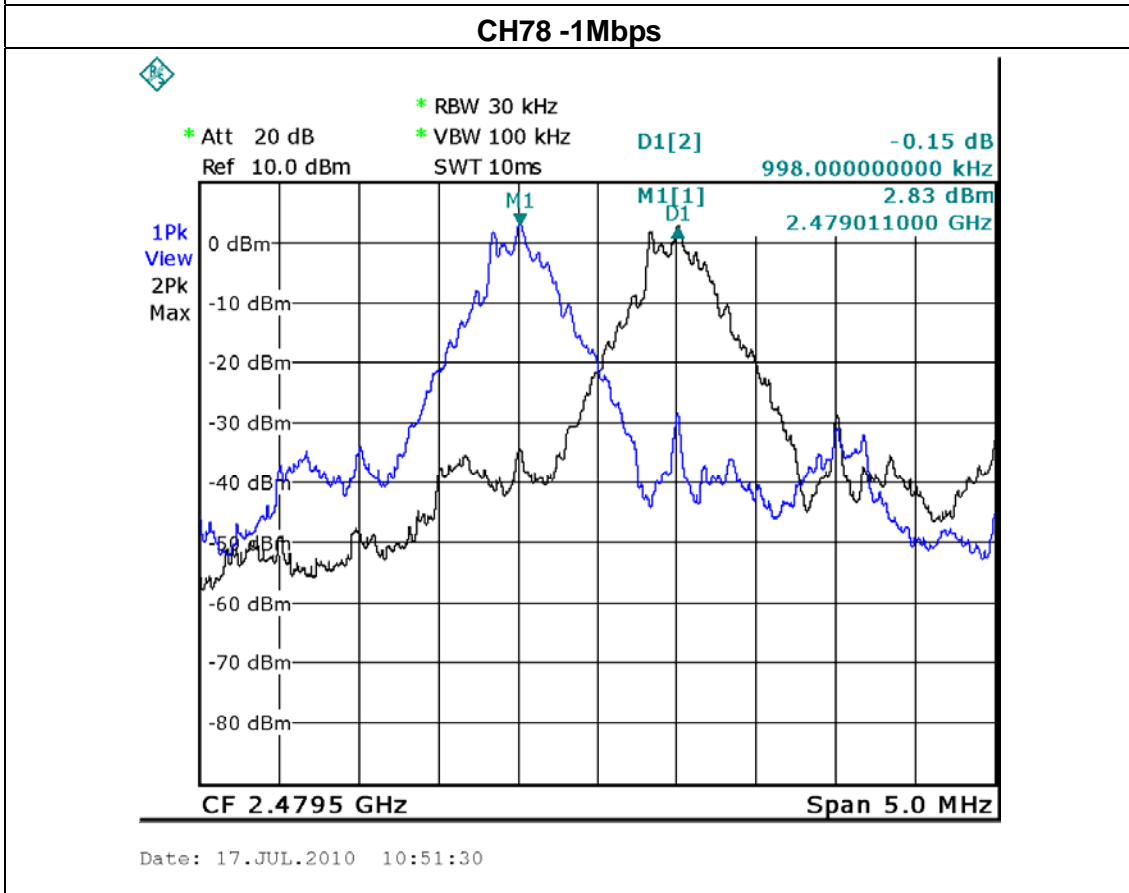
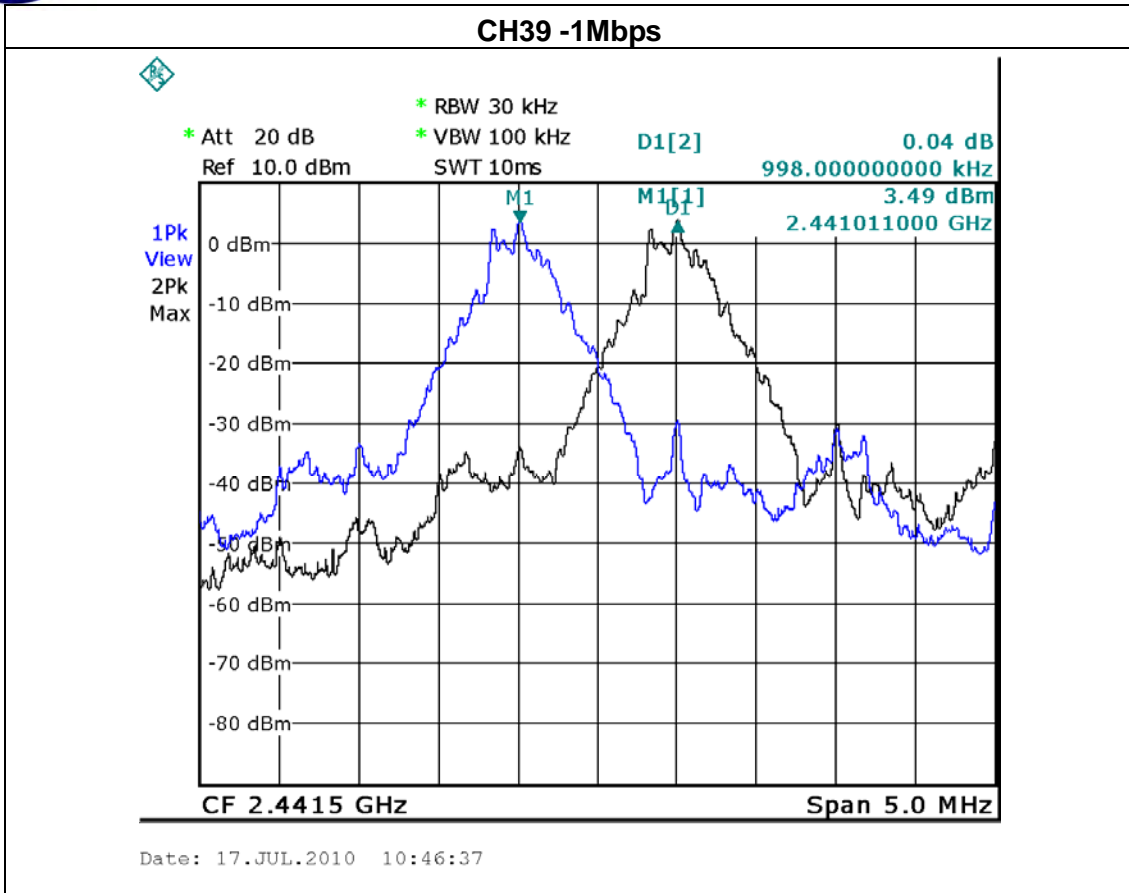



| | | | |
|---------------|---|---------------------|--------------|
| EUT : | Hi Fi dock with bluetooth wireless Audio system | Model Name : | SFQ-01 |
| Temperature : | 22 °C | Relative Humidity : | 60 % |
| Pressure : | 1012 hPa | Test Voltage : | AC 120V/60Hz |
| Test Mode : | CH00 / CH39 /CH78-3Mbps | | |

| Frequency | Ch. Separation (MHz) | 20d Bandwidth B (kHz) | Result |
|-----------|----------------------|-----------------------|-----------------|
| 2402 MHz | 1 | 1198.00 | Complies |
| 2441 MHz | 1 | 1218.00 | Complies |
| 2480 MHz | 1 | 1208.00 | Complies |

Ch. Separation Limits: >20dB bandwidth or >2/3 of 20dB bandwidth

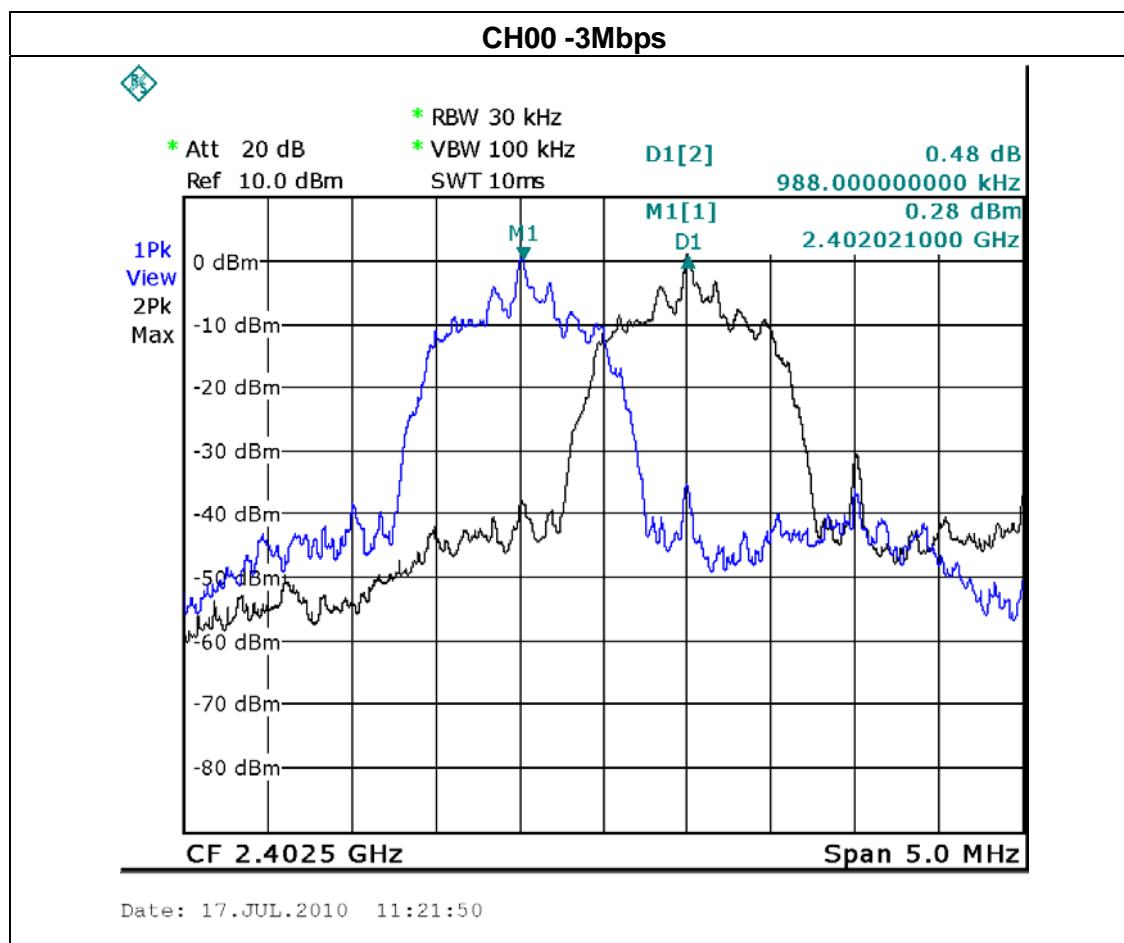

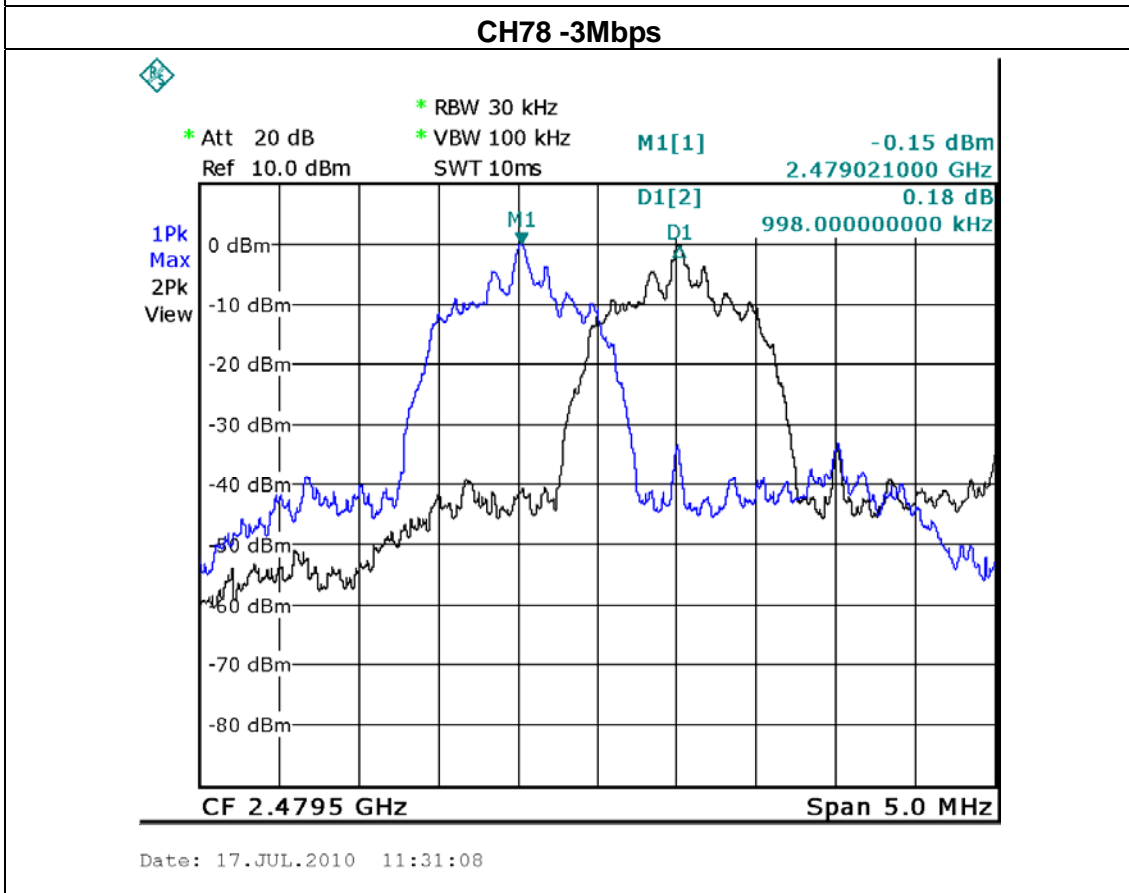
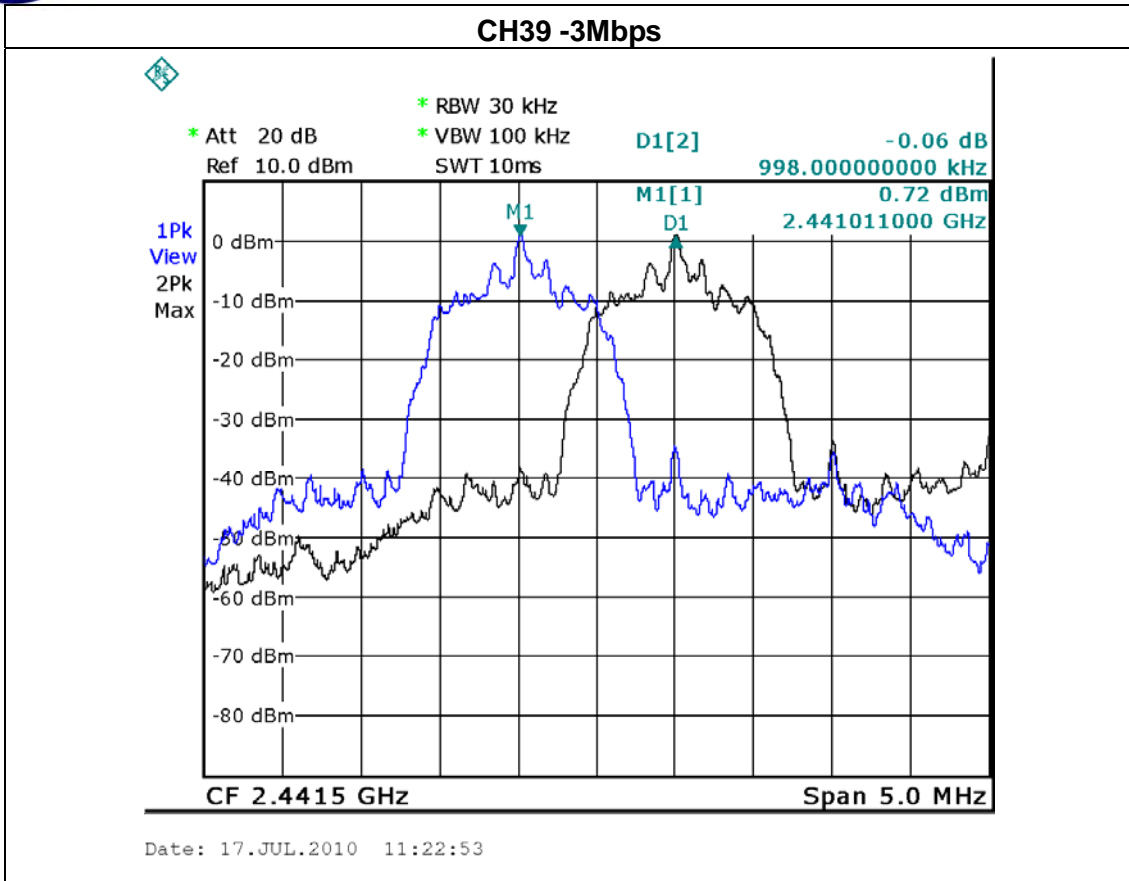



8. BANDWIDTH TEST

8.1 APPLIED PROCEDURES / LIMIT

| FCC Part15 (15.247) , Subpart C | | | | |
|---------------------------------|-----------|------------------------------|-----------------------|--------|
| Section | Test Item | Limit | Frequency Range (MHz) | Result |
| 15.247 (a)(2) | Bandwidth | <= 1 MHz (20dB bandwidth) | 2400-2483.5 | PASS |

8.1.1 MEASUREMENT INSTRUMENTS LIST AND SETTING

| Item | Kind of Equipment | Manufacturer | Type No. | Serial No. | Calibrated until |
|------|-------------------|--------------|----------|------------|------------------|
| 1 | Spectrum Analyzer | R&S | FSP 40 | 100185 | Nov.27.2010 |

Remark: " N/A" denotes No Model Name , Serial No. or No Calibration specified.

| Spectrum Parameter | Setting |
|--------------------|---|
| Attenuation | Auto |
| Span Frequency | > Measurement Bandwidth or Channel Separation |
| RB | 30 kHz (20dB Bandwidth) / 100 kHz (Channel Separation) |
| VB | 100 kHz (20dB Bandwidth) / 300 kHz (Channel Separation) |
| Detector | Peak |
| Trace | Max Hold |
| Sweep Time | Auto |

8.1.2 TEST PROCEDURE

- a. The EUT was directly connected to the spectrum analyzer and antenna output port as show in the block diagram below,
- b. Spectrum Setting : RBW= 10KHz, VBW=100KHz, Sweep time = Auto.

8.1.3 DEVIATION FROM STANDARD

No deviation.

8.1.4 TEST SETUP

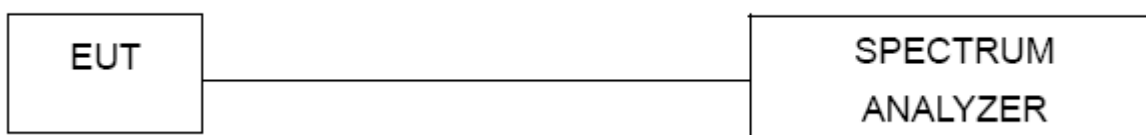

8.1.5 EUT OPERATION CONDITIONS

The EUT tested system was configured as the statements of 4.1.6 Unless otherwise a special operating condition is specified in the follows during the testing.



8.1.6 TEST RESULTS

| | | | |
|---------------|---|---------------------|--------------|
| EUT : | Hi Fi dock with bluetooth wireless Audio system | Model Name : | SFQ-01 |
| Temperature : | 22 °C | Relative Humidity : | 60 % |
| Pressure : | 1012 hPa | Test Voltage : | AC 120V/60Hz |
| Test Mode : | CH00 / CH39 /CH78-1Mbps | | |

| Frequency | 20dB Bandwidth (KHz) | 99% Occupied Bandwidth (KHz) | Channel Separation (MHz) | Result |
|-----------|----------------------|------------------------------|--------------------------|-------------|
| 2402 MHz | 918.00 | 878.24 | <= 1MHz | PASS |
| 2441 MHz | 918.00 | 878.24 | <= 1MHz | PASS |
| 2480 MHz | 948.00 | 888.22 | <= 1MHz | PASS |

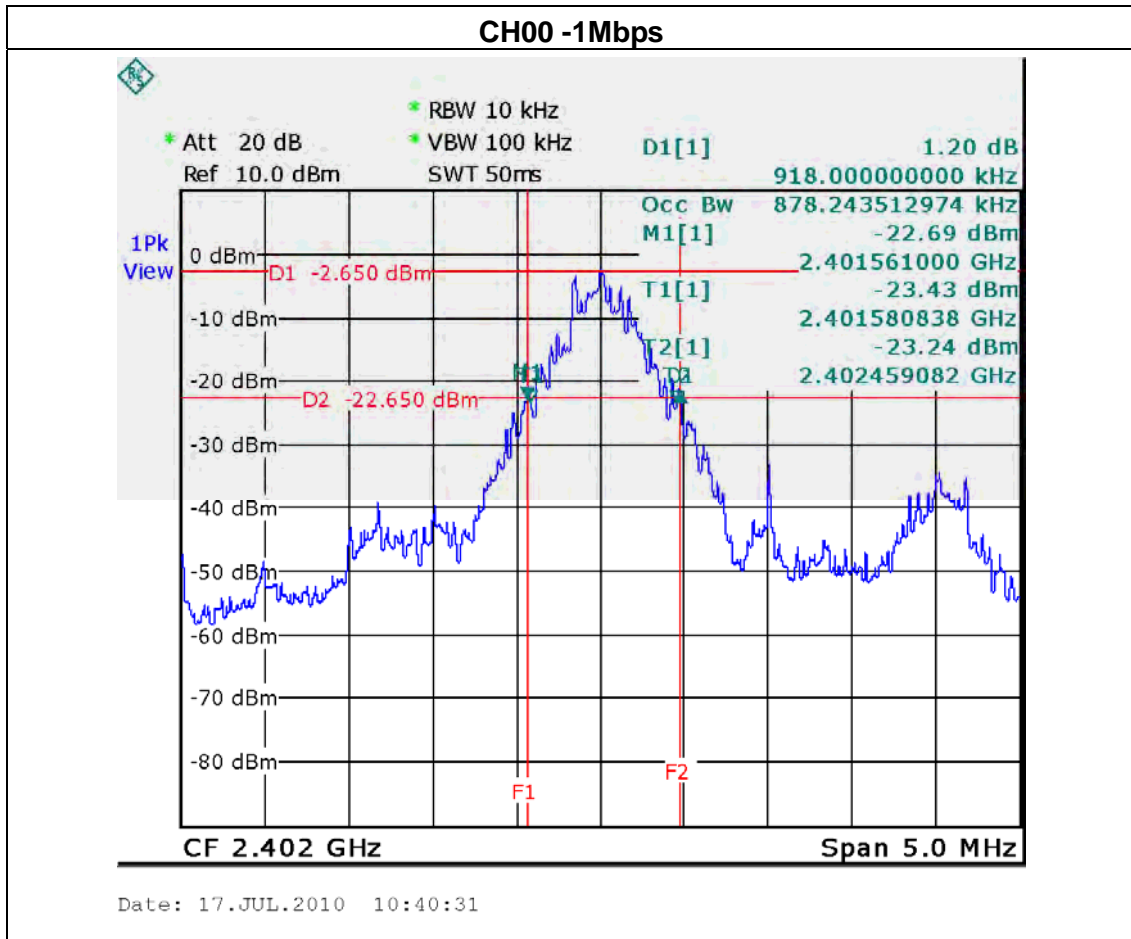



CH39 -1Mbps

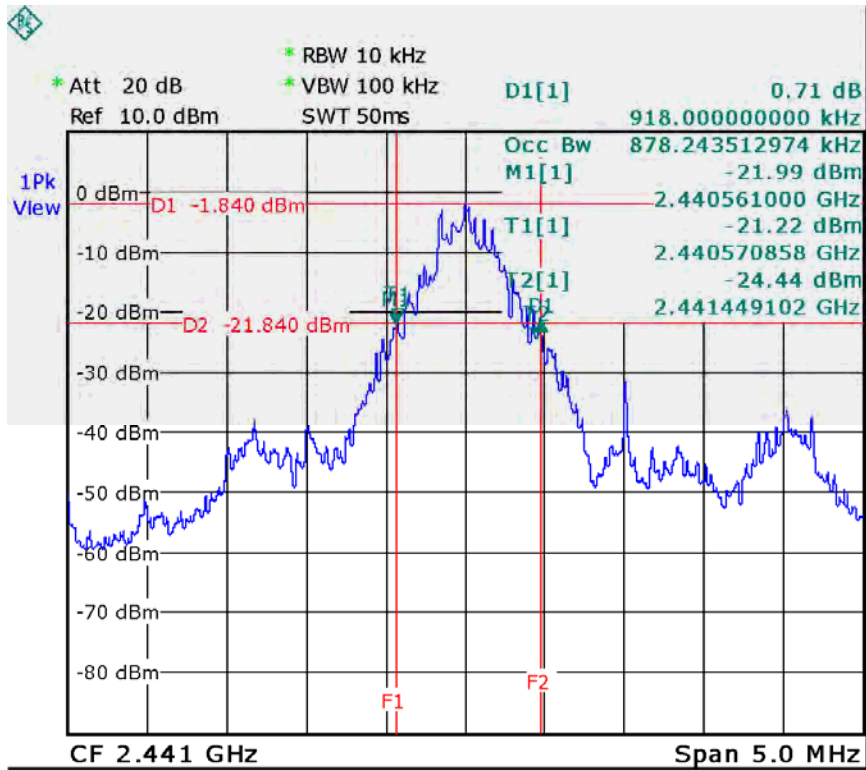

Date: 17.JUL.2010 10:49:53

CH78 -1Mbps

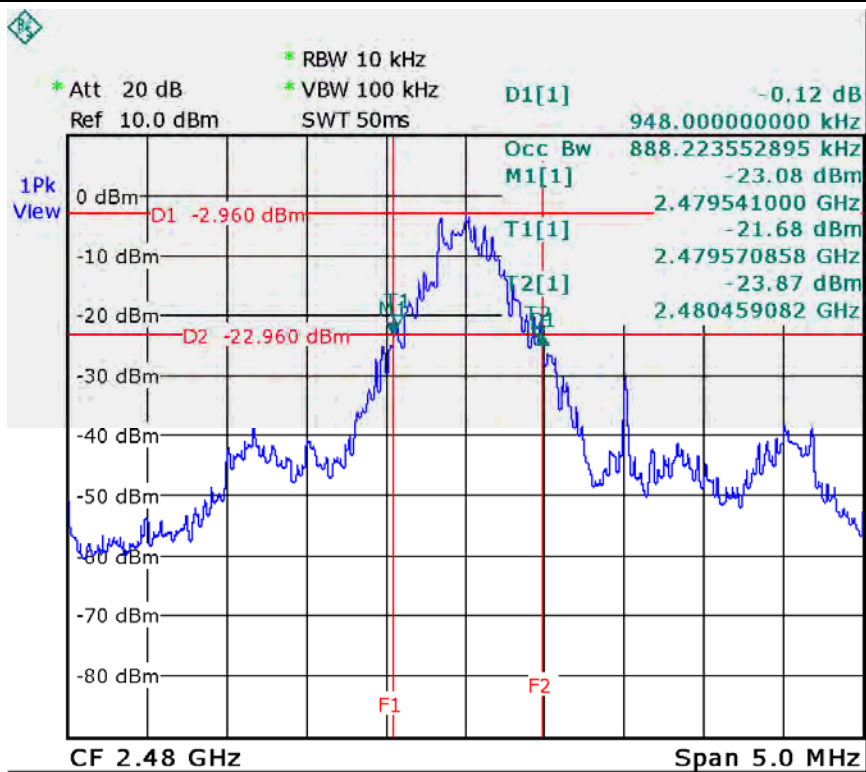

Date: 17.JUL.2010 10:54:07



| | | | |
|---------------|---|---------------------|--------------|
| EUT : | Hi Fi dock with bluetooth wireless Audio system | Model Name : | SFQ-01 |
| Temperature : | 22 °C | Relative Humidity : | 60 % |
| Pressure : | 1012 hPa | Test Voltage : | AC 120V/60Hz |
| Test Mode : | CH00 / CH39 /CH78-3Mbps | | |

| Frequency | 20dB Bandwidth (KHz) | 99% Occupied Bandwidth (KHz) | Channel Separation (MHz) | Result |
|-----------|----------------------|------------------------------|--------------------------|-------------|
| 2402 MHz | 1198.00 | 1157.68 | <= 1MHz | PASS |
| 2441 MHz | 1218.00 | 1157.68 | <= 1MHz | PASS |
| 2480 MHz | 1208.00 | 1157.68 | <= 1MHz | PASS |

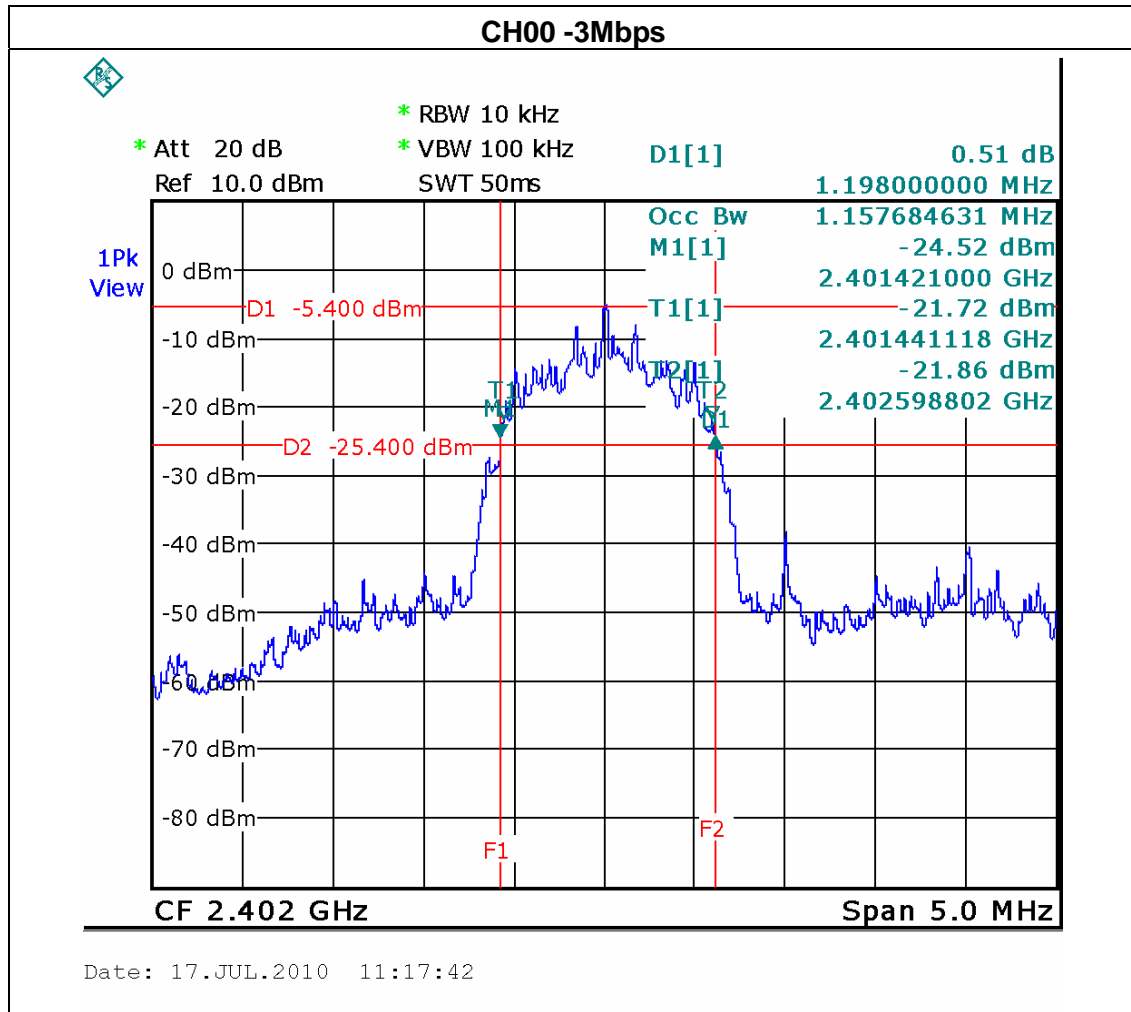



CH39 -3Mbps

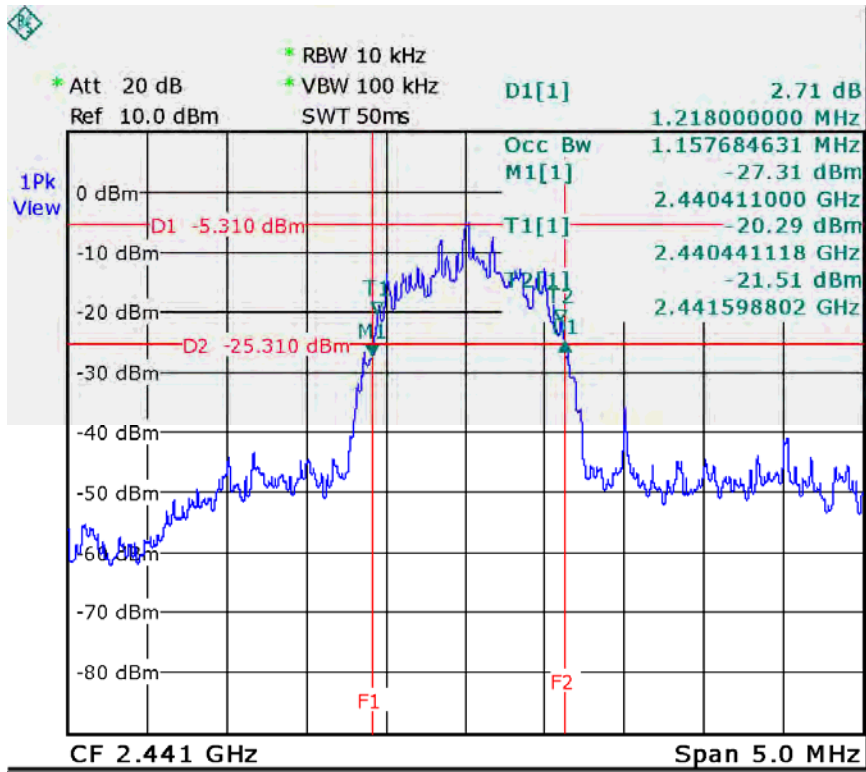

Date: 17.JUL.2010 11:25:09

CH78 -3Mbps

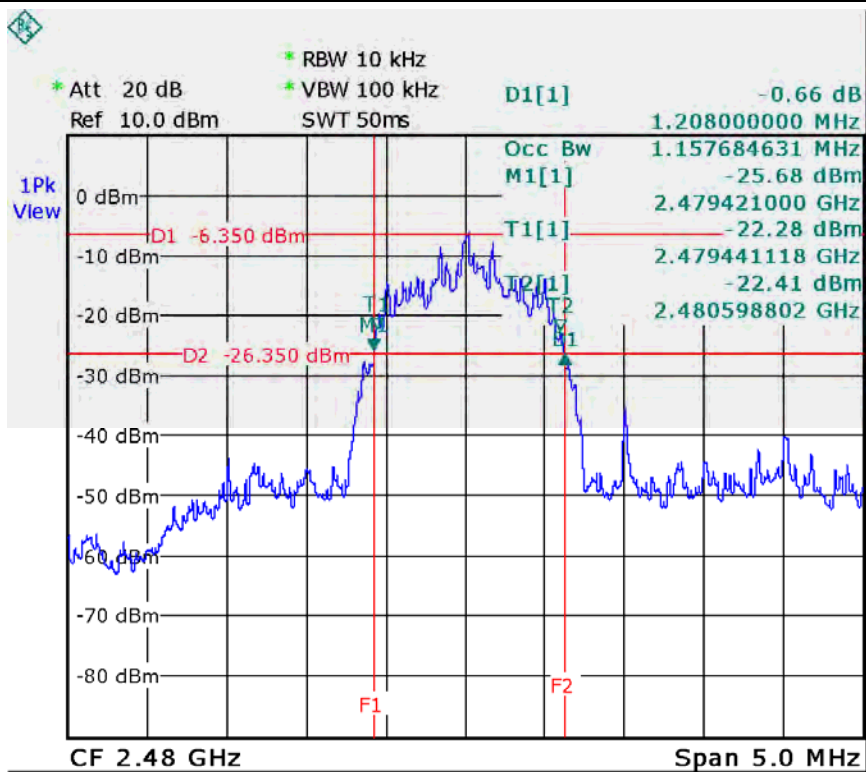

Date: 17.JUL.2010 11:26:47



9. PEAK OUTPUT POWER TEST

9.1 APPLIED PROCEDURES / LIMIT

| FCC Part15 (15.247) , Subpart C | | | | |
|---------------------------------|-------------------|-----------------|-----------------------|--------|
| Section | Test Item | Limit | Frequency Range (MHz) | Result |
| 15.247 (b)(1) | Peak Output Power | 1 watt or 30dBm | 2400-2483.5 | PASS |

9.1.1 MEASUREMENT INSTRUMENTS LIST AND SETTING

| Item | Kind of Equipment | Manufacturer | Type No. | Serial No. | Calibrated until |
|------|-------------------|--------------|----------|------------|------------------|
| 1 | Spectrum Analyzer | R&S | FSP 40 | 100185 | Nov.27.2010 |

Remark: " N/A" denotes No Model Name , Serial No. or No Calibration specified.

9.1.2 TEST PROCEDURE

- a. The EUT was directly connected to the spectrum analyzer and antenna output port as show in the block diagram below,
- b. Spectrum Setting : RBW= 1MHz, VBW= 1MHz, Sweep time = Auto.

9.1.3 DEVIATION FROM STANDARD

No deviation.

9.1.4 TEST SETUP

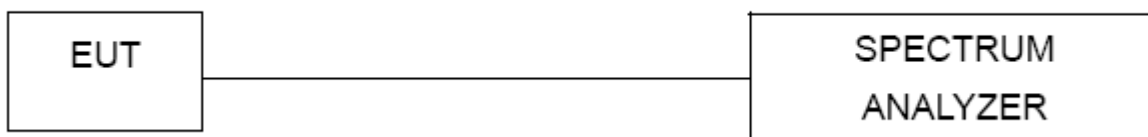

9.1.5 EUT OPERATION CONDITIONS

The EUT tested system was configured as the statements of 4.1.6 Unless otherwise a special operating condition is specified in the follows during the testing.

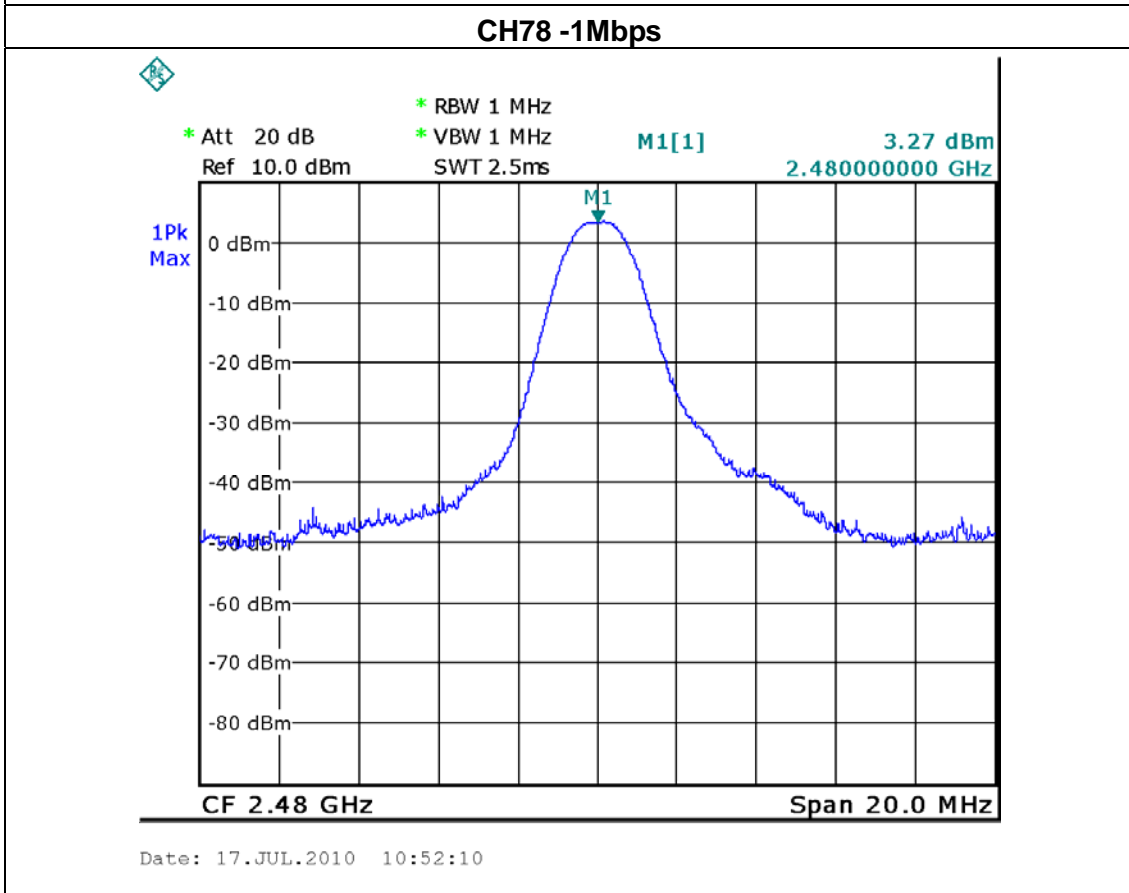
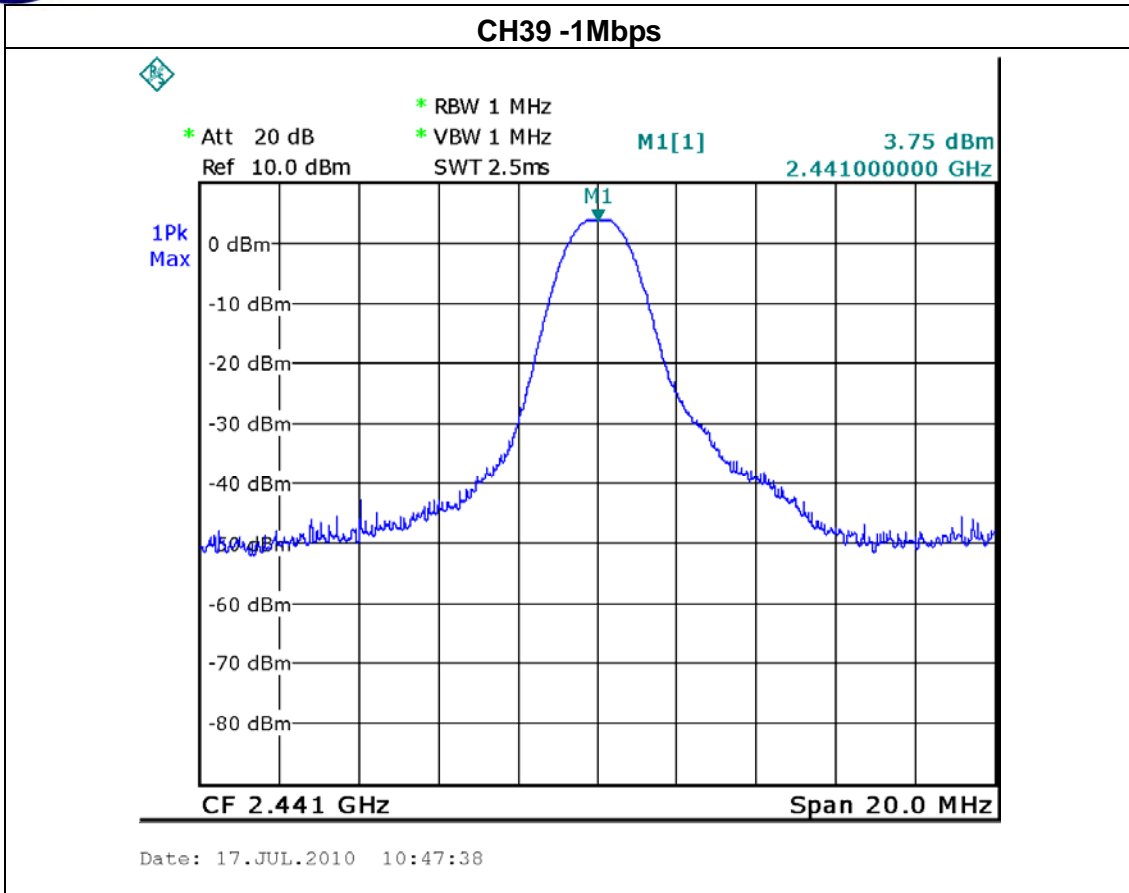



| | | | |
|---------------|---|---------------------|--------------|
| EUT : | Hi Fi dock with bluetooth wireless Audio system | Model Name : | SFQ-01 |
| Temperature : | 22 °C | Relative Humidity : | 60 % |
| Pressure : | 1012 hPa | Test Voltage : | AC 120V/60Hz |
| Test Mode : | CH00/ CH39 /CH78 -3Mbps | | |

| Test Channel | Frequency (MHz) | Peak Output Power (dBm) | LIMIT (dBm) | LIMIT (W) |
|--------------|-----------------|-------------------------|-------------|-----------|
| CH00 | 2402 | 1.63 | 30 | 1 |
| CH39 | 2441 | 1.82 | 30 | 1 |
| CH78 | 2480 | 1.29 | 30 | 1 |

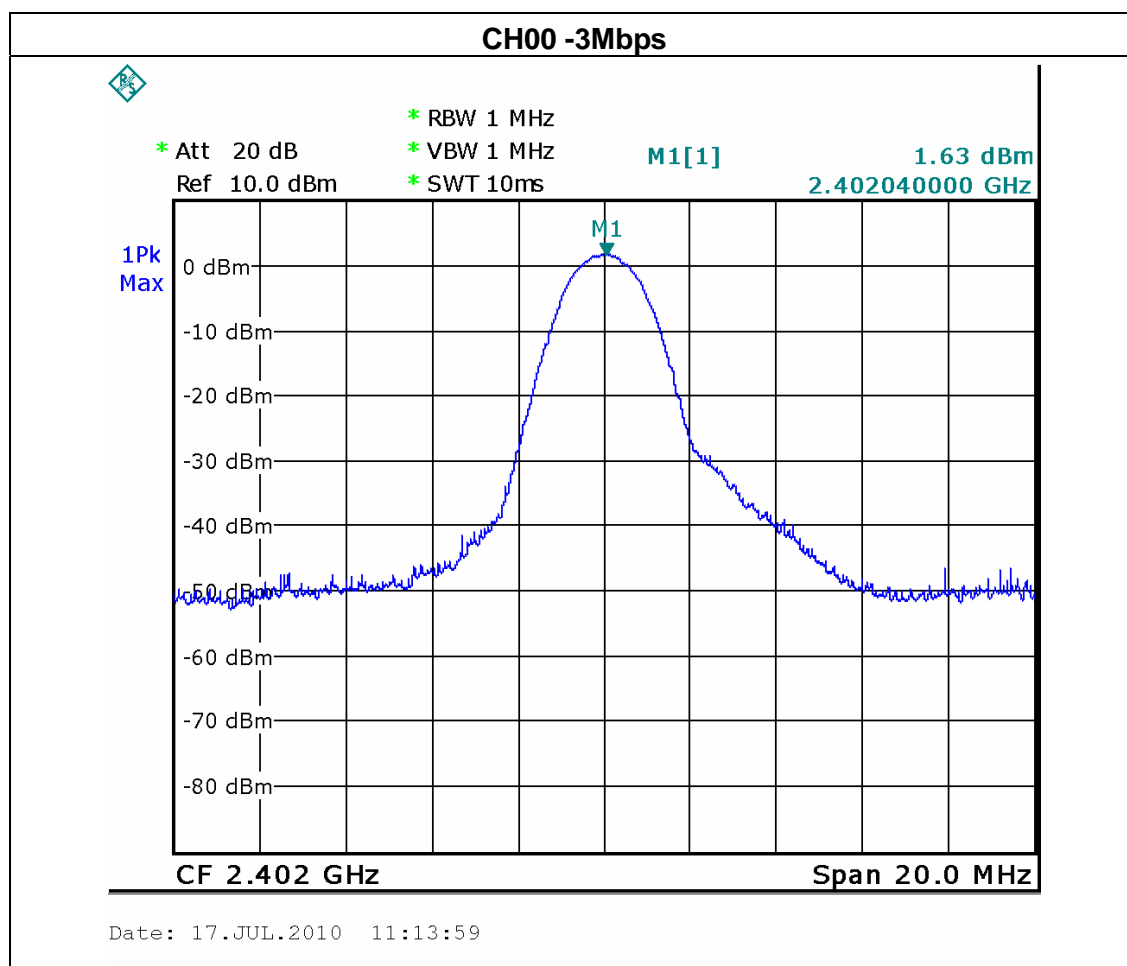

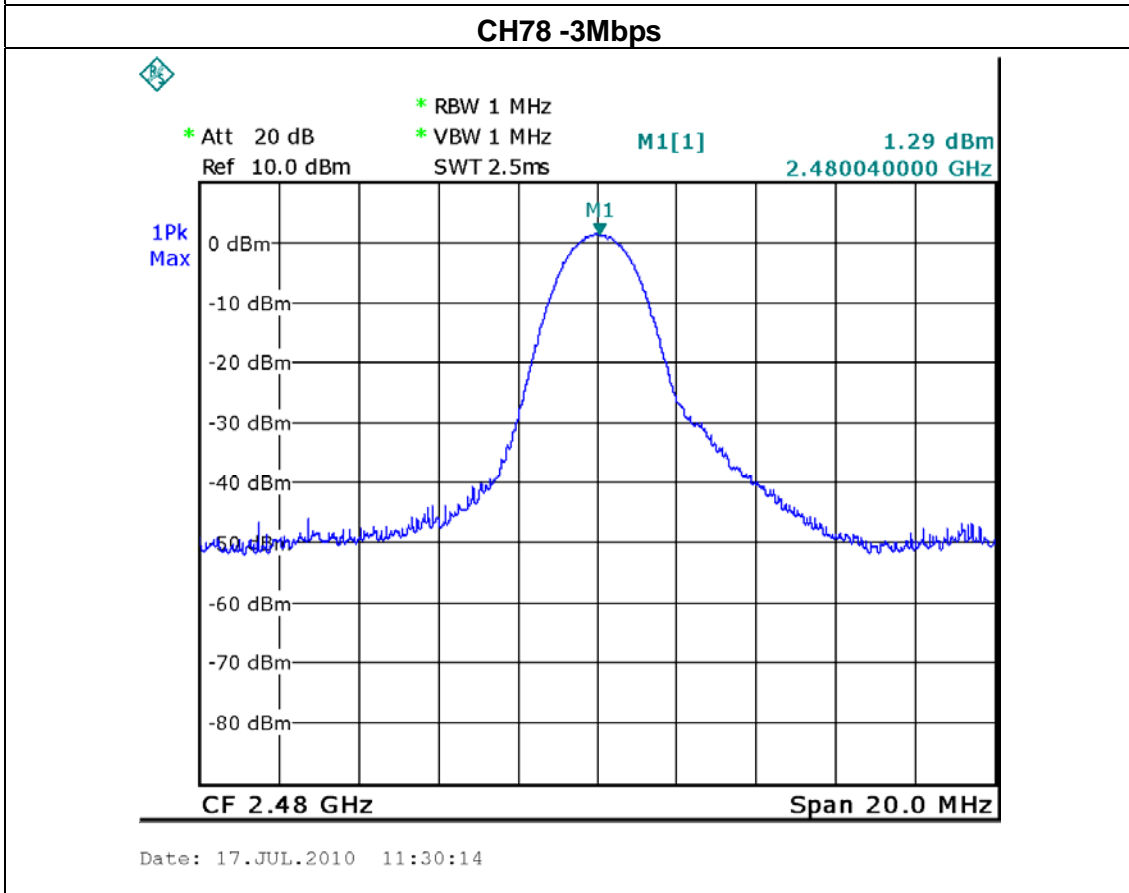
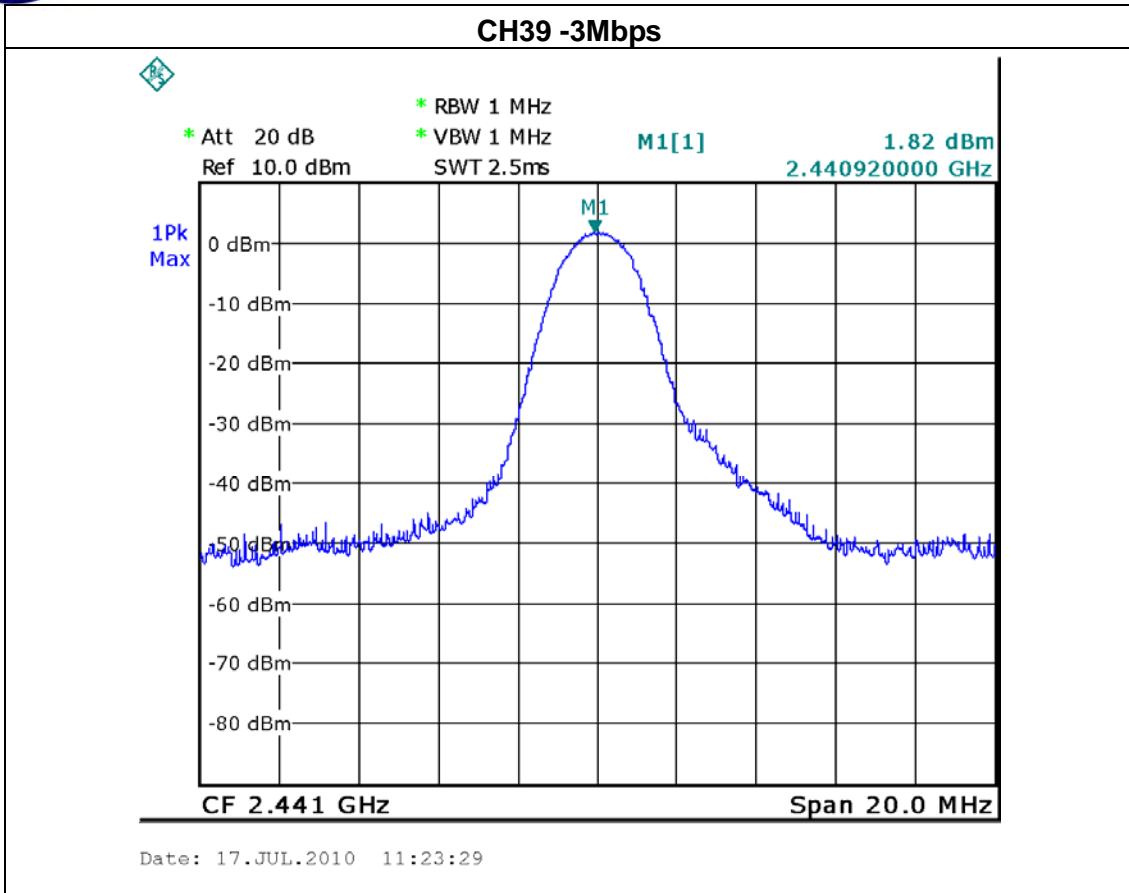



10. ANTENNA CONDUCTED SPURIOUS EMISSION

10.1 APPLIED PROCEDURES / LIMIT

20dBc in any 100 kHz bandwidth outside the operating frequency band. In case the emission fall within the restricted band specified on 15.205(a), then the 15.209(a) limit in the table below has to be followed.

| Frequencies (MHz) | Field Strength (micorvolts/meter) | Measurement Distance (meters) |
|-------------------|-----------------------------------|-------------------------------|
| 0.009~0.490 | 2400/F(KHz) | 300 |
| 0.490~1.705 | 24000/F(KHz) | 30 |
| 1.705~30.0 | 30 | 30 |
| 30~88 | 100 | 3 |
| 88~216 | 150 | 3 |
| 216~960 | 200 | 3 |
| Above 960 | 500 | 3 |

10.1.1 MEASUREMENT INSTRUMENTS LIST AND SETTING

| Item | Kind of Equipment | Manufacturer | Type No. | Serial No. | Calibrated until |
|------|-------------------|--------------|----------|------------|------------------|
| 1 | Spectrum Analyzer | R&S | FSP 40 | 100185 | Nov.27.2010 |

Remark: " N/A" denotes No Model Name , Serial No. or No Calibration specified.

The following table is the setting of the spectrum analyzer.

| Spectrum Parameter | Setting |
|---------------------------------------|--|
| Attenuation | Auto |
| Span Frequency | 100 MHz |
| RB / VB (emission in restricted band) | 1MHz / 1MHz for Peak, 1 MHz / 10Hz for Average |
| RB / VB (other emission) | 100 KHz /100 KHz for Peak |

10.1.2 TEST PROCEDURE

- a. The EUT was directly connected to the spectrum analyzer and antenna output port as show in the block diagram below,
- b. Spectrum Setting : RBW= 100KHz, VBW=100KHz, Sweep time = Auto.

10.1.3 DEVIATION FROM STANDARD

No deviation.



10.1.4 TEST SETUP

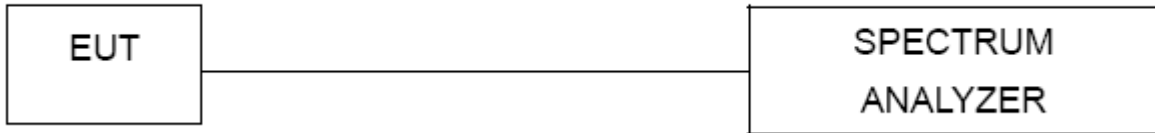

10.1.5 EUT OPERATION CONDITIONS

The EUT tested system was configured as the statements of 4.1.6 Unless otherwise a special operating condition is specified in the follows during the testing.



10.1.6 TEST RESULTS

| | | | |
|---------------|---|---------------------|--------------|
| EUT : | Hi Fi dock with bluetooth wireless Audio system | Model Name : | SFQ-01 |
| Temperature : | 22 °C | Relative Humidity : | 60 % |
| Pressure : | 1012 hPa | Test Voltage : | AC 120V/60Hz |
| Test Mode : | CH00 / CH78-1Mbps | | |

| | | | |
|---|------------|--|------------|
| The max. radio frequency power in any 100kHz bandwidth outside the frequency band | | The max. radio frequency power in any 100 kHz bandwidth within the frequency band. | |
| FREQUENCY(MHz) | POWER(dBm) | FREQUENCY(MHz) | POWER(dBm) |
| 2376.16 | -58.75 | 2484.08 | -43.14 |

Result

In any 100kHz bandwidth outside the frequency band, the radio frequency power is at least 20dB below that in the 100kHz bandwidth within the band that contains the highest level of the desired power.



| | | | |
|---------------|---|---------------------|--------------|
| EUT : | Hi Fi dock with bluetooth wireless Audio system | Model Name : | SFQ-01 |
| Temperature : | 22 °C | Relative Humidity : | 60 % |
| Pressure : | 1012 hPa | Test Voltage : | AC 120V/60Hz |
| Test Mode : | CH00 / CH78-3Mbps | | |

| | | | |
|---|------------|--|------------|
| The max. radio frequency power in any 100kHz bandwidth outside the frequency band | | The max. radio frequency power in any 100 kHz bandwidth within the frequency band. | |
| FREQUENCY(MHz) | POWER(dBm) | FREQUENCY(MHz) | POWER(dBm) |
| 2376.16 | -60.42 | 2484.08 | -45.98 |

Result

In any 100kHz bandwidth outside the frequency band, the radio frequency power is at least 20dB below that in the 100kHz bandwidth within the band that contains the highest level of the desired power.



CH00 (Lower) -3Mbps

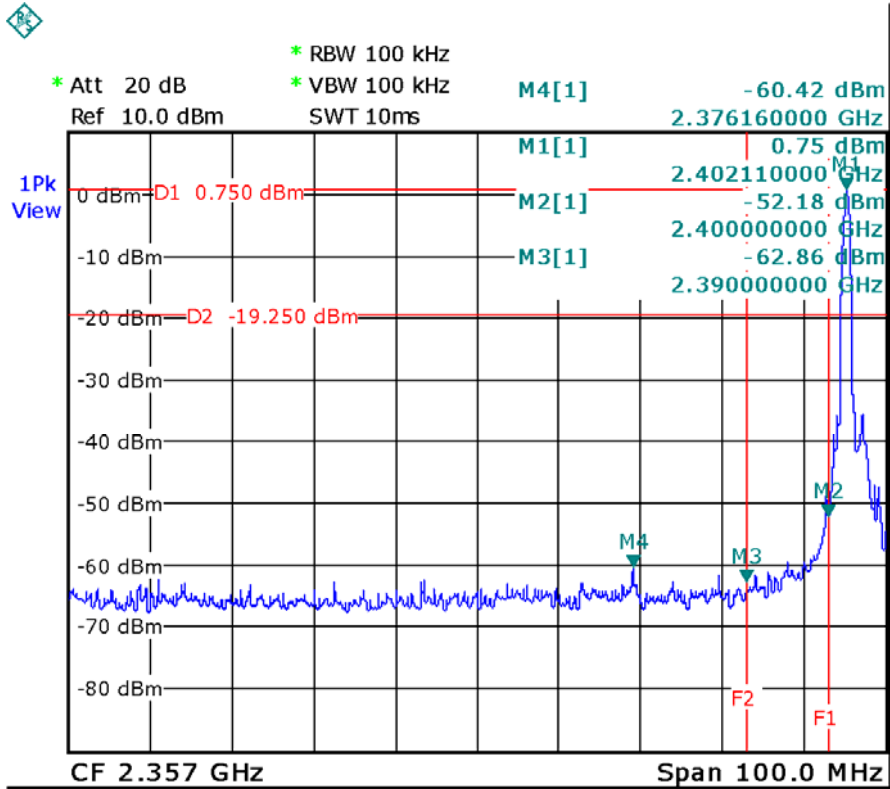

Date: 17.JUL.2010 11:19:44

CH 78 (Upper) -3Mbps

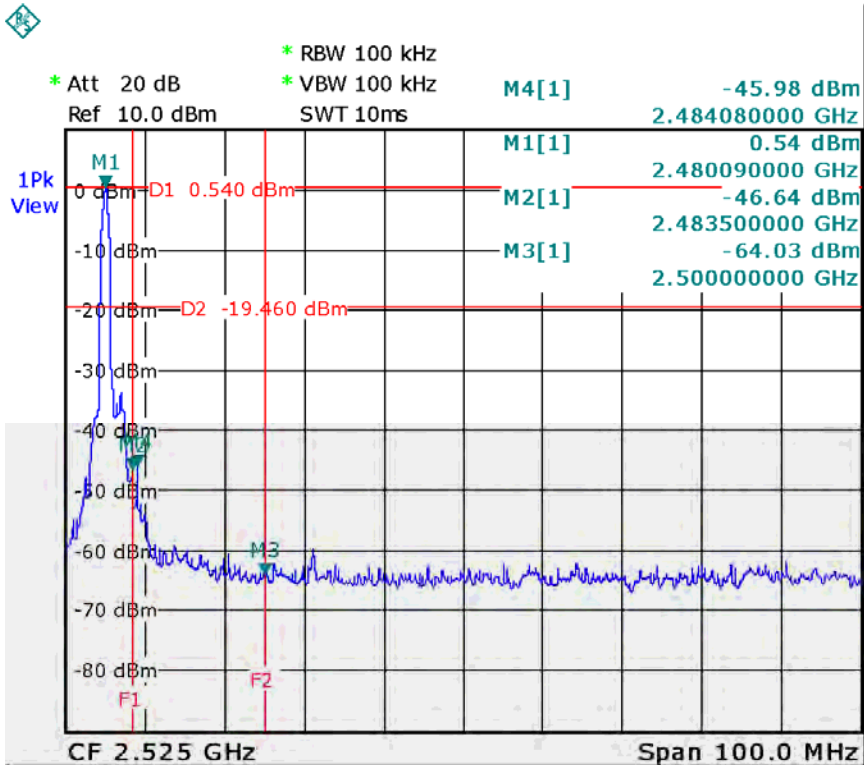

Date: 17.JUL.2010 11:29:25



11. RF EXPOSURE TEST

11.1 APPLIED PROCEDURES / LIMIT

These devices are not exempted from compliance does not exceed the Commission’s RF exposure guidelines. Unless a device operates at substantially low power levels, with a low gain antenna(s), supporting information is generally needed to establish the various potential operating configurations and exposure conditions of a transmitter and its antenna(s) in order to determine compliance with the RF exposure guidelines.

In order to demonstrate compliance with MPE requirement (see Section 2.1091), the following information is typically needed:

Calculation that estimates the minimum separation distance (20 cm or more) between an antenna and persons required to satisfy power density limits defined for free space.

Antenna installation and device operating instructions for installers (professional/unskilled users), and the parties responsible for ensuring compliance with the RF exposure requirement. Any caution statements and/or warning labels that are necessary in order to comply with the exposure limits. Any other RF exposure related issues that may affect MPE compliance.

FCC 1.1310: The criteria listed in the following table shall be used to evaluate the environmental impact of human exposure to radio-frequency (RF) radiation as specified in 1.1307(b).

(A) Limits for Occupational / Controlled Exposure

| Frequency Range (MHz) | Electric Field Strength (E) (V/m) | Magnetic Field Strength (H) (A/m) | Power Density (S) (mW/ cm ²) | Averaging Time E ² , H ² or S (minutes) |
|-----------------------|-----------------------------------|-----------------------------------|--|---|
| 0.3-3.0 | 614 | 1.63 | (100)* | 6 |
| 3.0-30 | 1842 / f | 4.89 / f | (900 / f)* | 6 |
| 30-300 | 61.4 | 0.163 | 1.0 | 6 |
| 300-1500 | | | F/300 | 6 |
| 1500-100,000 | | | 5 | 6 |

(B) Limits for General Population / Uncontrolled Exposure

| Frequency Range (MHz) | Electric Field Strength (E) (V/m) | Magnetic Field Strength (H) (A/m) | Power Density (S) (mW/ cm ²) | Averaging Time E ² , H ² or S (minutes) |
|-----------------------|-----------------------------------|-----------------------------------|--|---|
| 0.3-1.34 | 614 | 1.63 | (100)* | 30 |
| 1.34-30 | 824/f | 2.19/f | (180/f)* | 30 |
| 30-300 | 27.5 | 0.073 | 0.2 | 30 |
| 300-1500 | | | F/1500 | 30 |
| 1500-100,000 | | | 1.0 | 30 |

Note: f = frequency in MHz ; *Plane-wave equivalent power density

11.1.1 MEASUREMENT INSTRUMENTS LIST

| Item | Kind of Equipment | Manufacturer | Type No. | Serial No. | Calibrated until |
|------|-------------------|--------------|----------|------------|------------------|
| 1 | Spectrum Analyzer | R&S | FSP 40 | 100185 | Nov.27.2010 |

Remark: " N/A" denotes No Model Name , Serial No. or No Calibration specified.



11.1.2 MPE CALCULATION METHOD

Calculation Method of RF Safety Distance:

$$S = \frac{PG}{4\pi r^2} = \frac{EIRP}{4\pi r^2}$$

P :power input to the antenna in Mw

EIRP :Equivalent(effective) isotropic radiated power.

S :power density mW/ cm²

G :numeric gain of antenna relative to isotropic radiator

R :distance to centre of radiation in cm

FCC radio frequency exposure limits may be exceeded at distances closer than r cm from the antenna of this device

$$r = \sqrt{\frac{PG}{4\pi S}} = \sqrt{\frac{EIRP}{4\pi S}}$$

11.1.3 DEVIATION FROM STANDARD

No deviation.

11.1.4 TEST SETUP

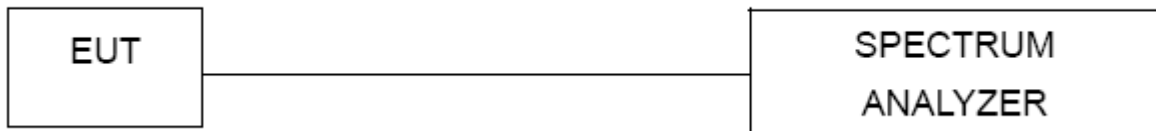

11.1.5 EUT OPERATION CONDITIONS

The EUT tested system was configured as the statements of 4.1.6 Unless otherwise a special operating condition is specified in the follows during the testing.



11.1.6 TEST RESULTS

| | | | |
|---------------|---|---------------------|--------------|
| EUT : | Hi Fi dock with bluetooth wireless Audio system | Model Name : | SFQ-01 |
| Temperature : | 22 °C | Relative Humidity : | 60 % |
| Pressure : | 1012 hPa | Test Voltage : | AC 120V/60Hz |
| Test Mode : | CH00 (2402 MHz), CH39(2441 MHz) , CH78 (2480 MHz) -1Mbps | | |

| Frequency (MHz) | Antenna Gain (dBi) | Peak Output Power (dBm) | Calculated EIRP (mW) | FCC Threshold (mW) | Test Result |
|-----------------|--------------------|-------------------------|----------------------|--------------------|-----------------|
| 2402 | 3.5 | 3.39 | 4.8865 | 24.98 | Complies |
| 2441 | 3.5 | 3.75 | 5.3088 | 24.58 | Complies |
| 2480 | 3.5 | 3.27 | 4.7534 | 24.19 | Complies |

Note: Shown calculated EIRP is "worst case" scenario (peak power value) showing definite compliance with the threshold level.

| | | | |
|---------------|---|---------------------|--------------|
| EUT : | Hi Fi dock with bluetooth wireless Audio system | Model Name : | SFQ-01 |
| Temperature : | 22 °C | Relative Humidity : | 60 % |
| Pressure : | 1012 hPa | Test Voltage : | AC 120V/60Hz |
| Test Mode : | CH00 (2402 MHz), CH39(2441 MHz) , CH78 (2480 MHz) -3Mbps | | |

| Frequency (MHz) | Antenna Gain (dBi) | Peak Output Power (dBm) | Calculated EIRP (mW) | FCC Threshold (mW) | Test Result |
|-----------------|--------------------|-------------------------|----------------------|--------------------|-----------------|
| 2402 | 3.5 | 1.63 | 3.2584 | 24.98 | Complies |
| 2441 | 3.5 | 1.82 | 3.4041 | 24.58 | Complies |
| 2480 | 3.5 | 1.29 | 3.0130 | 24.19 | Complies |

Note: Shown calculated EIRP is "worst case" scenario (peak power value) showing definite compliance with the threshold level.

12. EUT TEST PHOTO

Conducted Measurement Photos

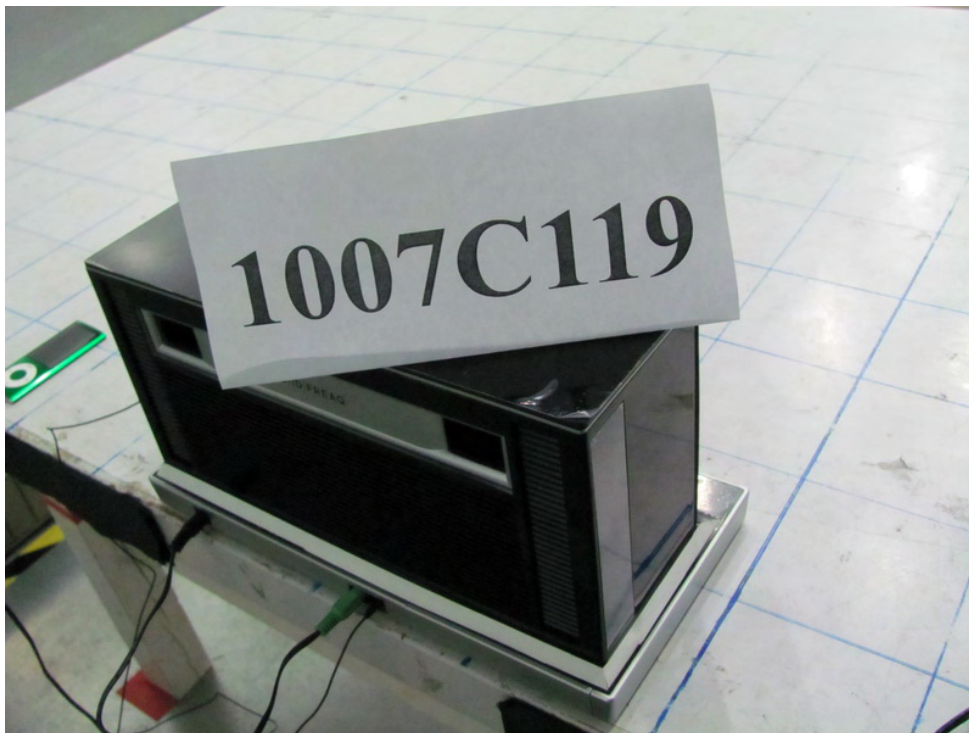
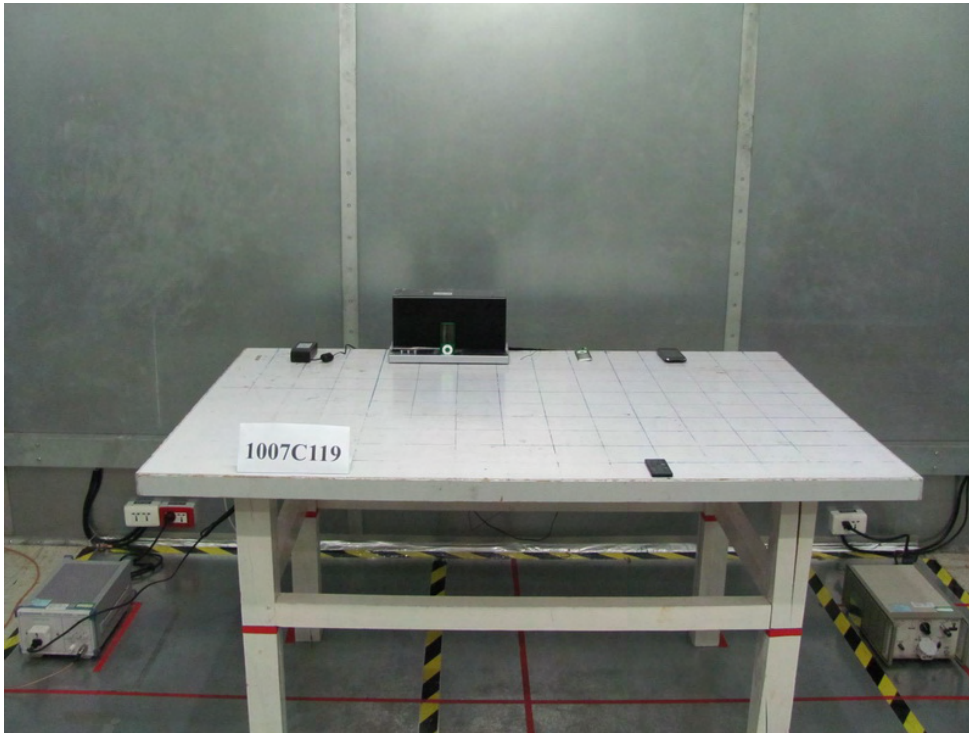



**Radiated Measurement Photos
30M~1000MHz**

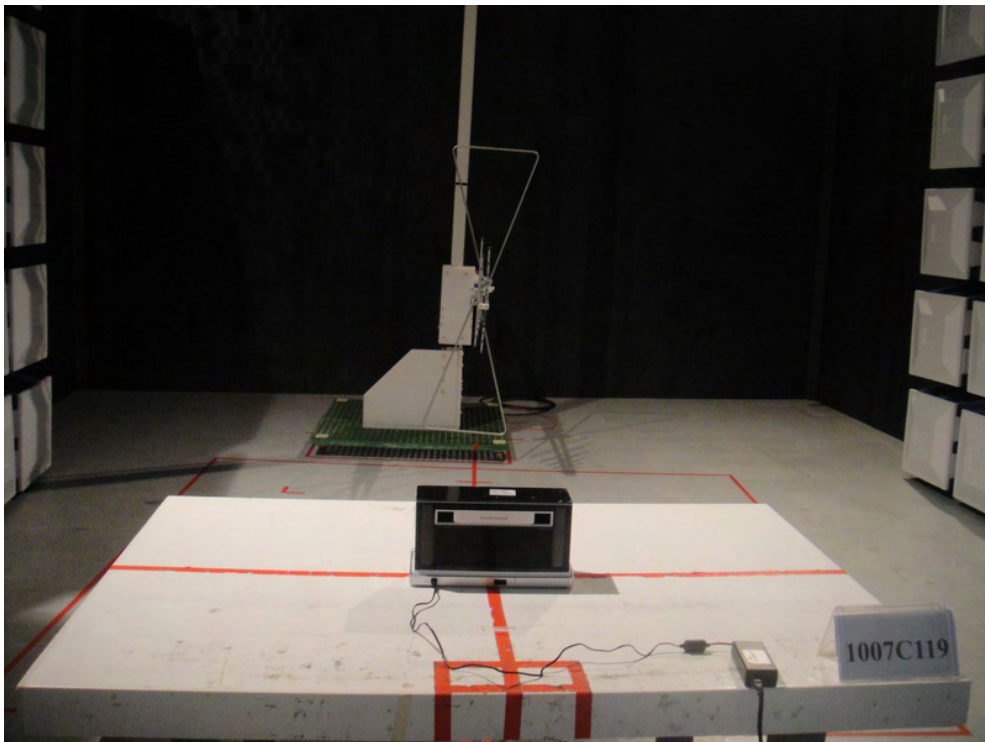
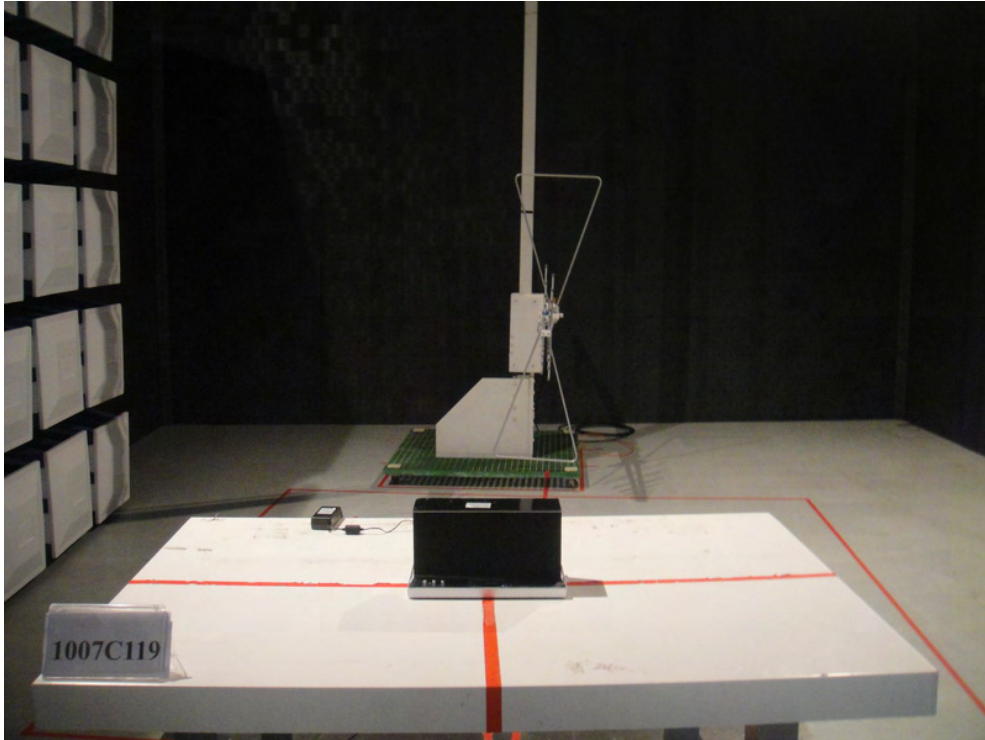

**Radiated Measurement Photos
Above 1000MHz**

