



**FCC 47 CFR PART 15 SUBPART C
INDUSTRY CANADA RSS-247 ISSUE 1**

CERTIFICATION TEST REPORT

For

**LIFEPROOF AQ11
MODEL NUMBER: LPSAN-0007-A**

**FCC ID: UZZLPSAN0007
IC: 7633A-LPSAN0007**

REPORT NUMBER: 4787565288.3.1-3

ISSUE DATE: September 29, 2016

Prepared for

**Beautiful Enterprise Co., Ltd.
27th Floor, Beautiful Group Tower, 77 Connaught Road Central, Hong Kong**

Prepared by

**UL Verification Services (Guangzhou) Co., Ltd, Song Shan Lake Branch
Room 101, Building 10, Innovation Technology Park,
Song Shan Lake Hi tech Development Zone, Dongguan, 523808, China
Tel: +86 769 33817100
Fax: +86 769 33244054
Website: www.ul.com**

The results reported herein have been performed in accordance with the laboratory's terms of accreditation. This report shall not be reproduced except in full without the written approval of the Laboratory. The results in this report apply to the test sample(s) mentioned above at the time of the testing period only and are not to be used to indicate applicability to other similar products. This report does not imply that the product(s) has met the criteria for certification.

Revision History

<u>Rev.</u>	<u>Issue Date</u>	<u>Revisions</u>	<u>Revised By</u>
--	9/29/2016	Initial Issue	

Summary of Test Results			
Clause	Test Items	FCC/IC Rules	Test Results
1	6db DTS Bandwidth	FCC 15.247 (a) (2) IC RSS-247 Clause 5.1 (1)	Complied
2	Peak Conducted Power	FCC 15.247 (b) (3) IC RSS-247 Clause 5.4 (4)	Complied
3	Power Spectral Density	FCC 15.247 (3) IC RSS-247 Clause 5.2 (2)	Complied
4	Conducted Band edge And Spurious emission	FCC 15.247 (d) IC RSS-247 Clause 5.5	Complied
5	Radiated Band edges and Spurious emission	FCC 15.247 (d) FCC 15.209 FCC 15.205 IC RSS-247 Clause 5.5 IC RSS-GEN Clause 8.9	Complied
6	Conducted Emission Test For AC Power Port	FCC 15.207 RSS-GEN Clause 8.8	Complied
7	Antenna Requirement	FCC 15.203 RSS-GEN Clause 8.3	Complied

TABLE OF CONTENTS

1. ATTESTATION OF TEST RESULTS	6
2. TEST METHODOLOGY	6
3. FACILITIES AND ACCREDITATION	7
4. CALIBRATION AND UNCERTAINTY	8
4.1. MEASURING INSTRUMENT CALIBRATION	8
4.2. MEASUREMENT UNCERTAINTY	8
5. EQUIPMENT UNDER TEST	9
5.1. DESCRIPTION OF EUT	9
5.2. MAXIMUM OUTPUT POWER	9
5.3. CHANNEL LIST.....	9
5.4. TEST CHANNEL CONFIGURATION	10
5.5. THE WORSE CASE POWER SETTING PARAMETER.....	10
5.6. DESCRIPTION OF AVAILABLE ANTENNAS	10
5.7. WORST-CASE CONFIGURATIONS.....	10
5.8. DESCRIPTION OF TEST SETUP.....	11
5.9. MEASURING INSTRUMENT AND SOFTWARE USED.....	12
6. MEASUREMENT METHODS	13
7. ANTENNA PORT TEST RESULTS	14
7.1. 6 dB DTS BANDWIDTH.....	14
7.2. 99% DTS BANDWIDTH.....	17
7.2.1. GFSK MODE.....	17
7.3. PEAK CONDUCTED OUTPUT POWER.....	20
7.4. POWER SPECTRAL DENSITY.....	23
7.5. CONDUCTED BANDEDGE AND SPURIOUS EMISSIONS.....	26
8. RADIATED TEST RESULTS	33
8.1. LIMITS AND PROCEDURE.....	33
8.2. RESTRICTED BANDEDGE.....	37
8.2.1. GFSK MODE.....	37
8.3. SPURIOUS EMISSIONS (1~25GHz)	41
8.3.1. GFSK MODE.....	41
8.4. SPURIOUS EMISSIONS 30M ~ 1 GHz.....	47
8.4.1. GFSK MODE.....	47

REPORT NO: 4787565288.3.1-3

DATE: September 29, 2016

FCC ID: UZZLPSAN0007

IC: 7633A-LPSAN0007

8.5. SPURIOUS EMISSIONS BELOW 30M 49

9. AC POWER LINE CONDUCTED EMISSIONS..... 50

10. ANTENNA REQUIREMENTS 53

1. ATTESTATION OF TEST RESULTS

Applicant Information

Company Name: Beautiful Enterprise Co., Ltd.
Address: 27th Floor, Beautiful Group Tower, 77 Connaught Road Central, Hong Kong

Manufacturer Information

Company Name: Shenzhen Synchron Electronics Co., Ltd.
Address: No. 9 Mei Li Road, Xia Mei Lin, Fu Tian Area, Shenzhen, Guangdong, P.R. China

EUT Description

Product Name: LIFEPROOF AQ11
Brand Name: LIFEPROOF
Model Name: LPSAN-0007-A
FCC ID: UZZLPSAN0007
IC: 7633A-LPSAN0007
Date Tested: September 18, 2016 ~ September 29, 2016

APPLICABLE STANDARDS	
STANDARD	TEST RESULTS
CFR 47 Part 15 Subpart C	PASS
INDUSTRY CANADA RSS-247 Issue 1	PASS
INDUSTRY CANADA RSS-GEN Issue 4	PASS

Tested By:

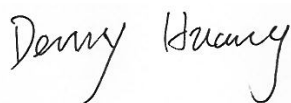

Denny Huang
Engineer Project Associate
Approved By:



Stephen Guo
Laboratory Manager

Check By:



Shawn Wen
Laboratory Leader

2. TEST METHODOLOGY

The tests documented in this report were performed in accordance with ANSI C63.10-2013, FCC CFR 47 Part 2, FCC CFR 47 Part 15, RSS-GEN Issue 4, and RSS-247 Issue 1.

3. FACILITIES AND ACCREDITATION

Test Location	Shenzhen Huatongwei International Inspection Co., Ltd.
Address	1/F, Bldg 3, Hongfa Hi-tech Industrial Park, Genyu Road, Tianliao, Gongming, Shenzhen, China Phone: 86-755-26748019 Fax: 86-755-26748089
Accreditation Certificate	<p>Shenzhen Huatongwei International Inspection Co., Ltd. EMC Laboratory has been accredited by A2LA for technical competence in the field of electrical testing, and proved to be in compliance with ISO/IEC 17025: 2005 General Requirements for the Competence of Testing and Calibration Laboratories and any additional program requirements in the identified field of testing. Valid time is until December 31, 2016.</p> <p>Shenzhen Huatongwei International Inspection Co., Ltd. EMC Laboratory has been registered and fully described in a report filed with the FCC (Federal Communications Commission). The acceptance letter from the FCC is maintained in our files. Registration 317478, Renewal date Jul. 18, 2014, valid time is until Jul. 18, 2017.</p> <p>The 3m Alternate Test Site of Shenzhen Huatongwei International Inspection Co., Ltd. has been registered by Certification and Engineering Bureau of Industry Canada for the performance of radiated measurements with Registration No. 5377A on Dec. 31, 2013, valid time is until Dec. 31, 2016.</p> <p>Two 3m Alternate Test Site of Shenzhen Huatongwei International Inspection Co., Ltd. has been registered by Certification and Engineering Bureau of Industry Canada for the performance of radiated measurements with Registration No. 5377B on Dec.03, 2014, valid time is until Dec.03, 2017.</p>

4. CALIBRATION AND UNCERTAINTY

4.1. MEASURING INSTRUMENT CALIBRATION

The measuring equipment utilized to perform the tests documented in this report has been calibrated in accordance with the manufacturer's recommendations, and is traceable to recognized national standards.

4.2. MEASUREMENT UNCERTAINTY

Where relevant, the following measurement uncertainty levels have been estimated for tests performed on the apparatus:

PARAMETER	UNCERTAINTY
Conducted Disturbance, 0.15 to 30 MHz	± 3.39 dB
Radiated Disturbance, 9k to 30 MHz	± 2.20 dB
Radiated Disturbance, 30 to 1000 MHz	± 4.24 dB
Radiated Disturbance, 1 to 18 GHz	± 5.16 dB
Radiated Disturbance, 18 to 40 GHz	± 5.54 dB

5. EQUIPMENT UNDER TEST

5.1. DESCRIPTION OF EUT

Equipment	LIFEPROOF AQ11		
Model Name	LPSAN-0007-A		
Product Description	Operation Frequency	2402 MHz ~ 2480 MHz	
	Modulation Type	Data Rate	
	GFSK	1Mbps	
Power Supply	DC 12V, 2000mA		
Battery 1	3.8V, 6000mAh		
Battery 2	3.7V, 6000mAh		
Bluetooth Version	BT 4.2		
Adapter	Input: AC 100~240V, 50/60Hz, 600mA Output: DC 12V, 2000mA		

5.2. MAXIMUM OUTPUT POWER

Frequency Range (MHz)	Number of Transmit Chains (NTX)	Bluetooth Mode	Frequency (MHz)	Channel Number	Max PK Conducted Power (dBm)	EIRP (dBm)
2400-2483.5	1	BLE	2402-2480	0-39[40]	4.06	0.44

5.3. CHANNEL LIST

Channel	Frequency (MHz)	Channel	Frequency (MHz)	Channel	Frequency (MHz)	Channel	Frequency (MHz)
00	2402	11	2424	22	2446	33	2468
01	2404	12	2426	23	2448	34	2470
02	2406	13	2428	24	2450	35	2472
03	2408	14	2430	25	2452	36	2474
04	2410	15	2432	26	2454	37	2476
05	2412	16	2434	27	2456	38	2478
06	2414	17	2436	28	2458	39	2480
07	2416	18	2438	29	2460		
08	2418	19	2440	30	2462		
09	2420	20	2442	31	2464		
10	2422	21	2444	32	2466		

5.4. TEST CHANNEL CONFIGURATION

Test Mode	Test Channel	Frequency
GFSK	CH 00, CH 19, CH 39	2402MHz, 2440MHz, 2480MHz

5.5. THE WORSE CASE POWER SETTING PARAMETER

The Worse Case Power Setting Parameter under 2400 ~ 2483.5MHz Band				
Test Software Version		ACTsBTAPP		
Modulation Type	Transmit Antenna Number	Test Channel		
		CH 00	CH 19	CH 39
GFSK	1	0X8d	0X8d	0X8d

5.6. DESCRIPTION OF AVAILABLE ANTENNAS

Ant.	Frequency (MHz)	Antenna Type	Antenna Gain (dBi)
1	2402-2480	PCB Antenna	-4.50

Test Mode	Transmit and Receive Mode	Description
GFSK	<input checked="" type="checkbox"/> 1TX, 1RX	Chain 1 can be used as transmitting/receiving antenna.

5.7. WORST-CASE CONFIGURATIONS

Bluetooth Mode	Modulation Technology	Modulation Type	Data Rate (Mbps)
BLE	DTS	GFSK	1Mbit/s

5.8. DESCRIPTION OF TEST SETUP

SUPPORT EQUIPMENT

Item	Equipment	Brand Name	Model Name	FCC ID
1	Laptop	ThinkPad	T410	N/A

I/O CABLES

Cable No	Port	Connector Type	Cable Type	Cable Length(m)	Remarks
1	AUX In 1	AUX	Unshielded	0.30	In buttom
2	AUX In 2	AUX	Unshielded	0.30	In Lateral
3	DC In	DC	Unshielded	0.90	DC 12V, 2A
4	USB out 1	USB	Unshielded	0.30	DC 5V, 1A
5	USB out 2	USB	Unshielded	0.30	DC 5V, 0.5A

ACCESSORY

Item	Accessory	Brand Name	Model Name	Description
1	Power Adapter	N/A	S024AMU1200200	Input: AC 100~240V, 50/60Hz, 600mA Output: DC 12V, 2000mA

TEST SETUP

The EUT can work in an engineer mode with a software through a Laptop.

SETUP DIAGRAM FOR TESTS

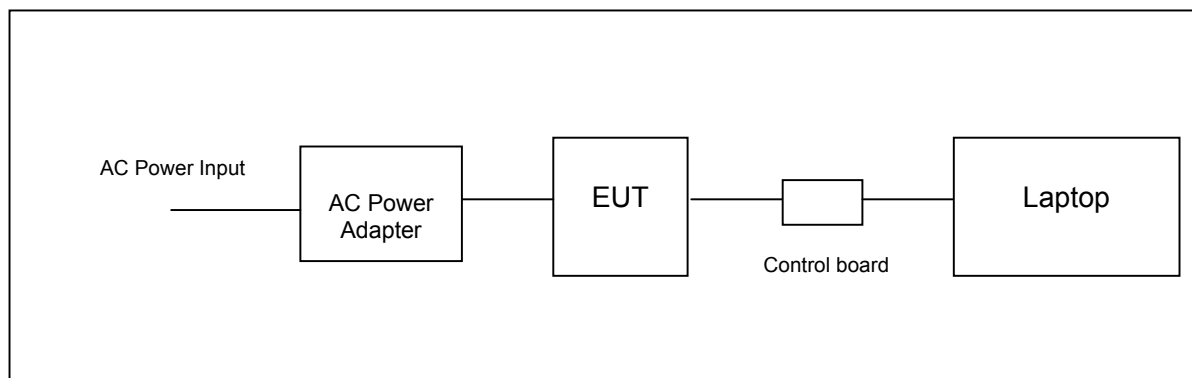

5.9. MEASURING INSTRUMENT AND SOFTWARE USED

Instrument(Conducted for RF Port)						
Used	Equipment	Manufacturer	Model No.	Serial No.	Last Cal.	Expired date
<input checked="" type="checkbox"/>	Spectrum Analyzer	R&S	FSV40	100048	Nov.3,2015	Nov.3,2016
Instrument (Line Conducted Emission (AC Main))						
Used	Equipment	Manufacturer	Model No.	Serial No.	Last Cal.	Expired date
<input checked="" type="checkbox"/>	EMI Test Receiver	R&S	ESCI	101247	Nov.3,2015	Nov.3,2016
<input checked="" type="checkbox"/>	Artificial Mains	SCHWARZBECK	NNLK 8121	573	Nov.3,2015	Nov.3,2016
<input checked="" type="checkbox"/>	Pulse Limiter	R&S	ESH3-Z2	101488	Nov.3,2015	Nov.3,2016
<input checked="" type="checkbox"/>	Test Software	R&S	ES-K1	N/A	N/A	N/A
<input checked="" type="checkbox"/>	Adapter (see note)	HUNTKEY	HW-050100C2W	HWHKAPE51309936	-	-
Instrument (Radiated Tests)						
Used	Equipment	Manufacturer	Model No.	Serial No.	Last Cal.	Expired date
<input checked="" type="checkbox"/>	EMI Test Receiver	R&S	ESI 26	100009	Nov.2,2015	Nov.2,2016
<input checked="" type="checkbox"/>	RF Test Panel	R&S	TS / RSP	335015/0017	N/A	N/A
<input checked="" type="checkbox"/>	EMI Test Software	R&S	ESK1	N/A	N/A	N/A
<input checked="" type="checkbox"/>	Ultra-Broadband Antenna	ShwarzBeck	VULB9163	538	Nov.8,2015	Nov.8,2016
<input checked="" type="checkbox"/>	Horn Antenna	ShwarzBeck	9120D	1011	Nov.8,2015	Nov.8,2016
<input checked="" type="checkbox"/>	Loop Antenna	R&S	HZ-9	838622\013	Nov.8,2015	Nov.8,2016
<input checked="" type="checkbox"/>	Broadband Horn Antenna	ShwarzBeck	BBHA9170	BBHA9170472	Nov.8,2015	Nov.8,2016
<input checked="" type="checkbox"/>	Broadband Preamplifier	ShwarzBeck	BBV 9718	9718-247	Nov.2,2015	Nov.2,2016
<input checked="" type="checkbox"/>	Broadband Preamplifier	ShwarzBeck	BBV 9721	9721-102	Nov.2,2015	Nov.2,2016
<input checked="" type="checkbox"/>	Turn Table	MATURO	TT2.0	----	N/A	N/A
<input checked="" type="checkbox"/>	Antenna Mast	MATURO	TAM-4.0-P	----	N/A	N/A
<input checked="" type="checkbox"/>	EMI Test Software	Audix	E3	N/A	N/A	N/A
<input checked="" type="checkbox"/>	Test cable	Siva Cables Italy	RG 58A/U	W14.02	Nov.5,2015	Nov.5,2016

6. MEASUREMENT METHODS

No.	Test Item	KDB Name	Section
1	6 dB Bandwidth	KDB 558074 D01 v03r05	8.2
2	Peak Output Power	KDB 558074 D01 v03r05	9.1.1
3	Power Spectral Density	KDB 558074 D01 v03r05	10.2
4	Out-of-band emissions in non-restricted bands	KDB 558074 D01 v03r05	11.0
5	Out-of-band emissions in restricted bands	KDB 558074 D01 v03r05	12.1
6	Band-edge	KDB 558074 D01 v03r05	13.3.2
7	Conducted Emission Test For AC Power Port	ANSI C63.10-2013	7.3

7. ANTENNA PORT TEST RESULTS

7.1. 6 dB DTS BANDWIDTH

LIMITS

FCC Part15 (15.247) , Subpart C IC RSS-247 ISSUE 1			
Section	Test Item	Limit	Frequency Range (MHz)
FCC 15.247(a)(2) IC RSS-247 5.1 (1)	Bandwidth	$\geq 500\text{KHz}$	2400-2483.5

TEST PROCEDURE

Connect the UUT to the spectrum analyser and use the following settings:

Center Frequency	The centre frequency of the channel under test
Detector	Peak
RBW	100K
VBW	$\geq 3 \times \text{RBW}$
Trace	Max hold
Sweep	Auto couple

Allow the trace to stabilize and measure the maximum width of the emission that is constrained by the frequencies associated with the two outermost amplitude points (upper and lower frequencies) that are attenuated by 6 dB relative to the maximum level measured in the fundamental emission.

TEST SETUP

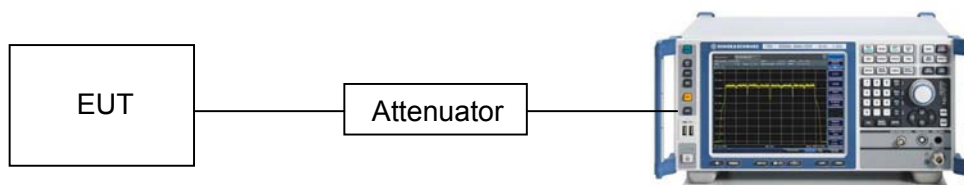

TEST CONDITIONS

Temperature: 21.0°C
 Relative Humidity: 63%
 Test Voltage: AC 120V/60Hz

RESULTS

Channel	Frequency (MHz)	6dB bandwidth (kHz)	Limit (kHz)	Result
Low	2402	548.40	500	Pass
Middle	2440	529.70	500	Pass
High	2480	534.00	500	Pass

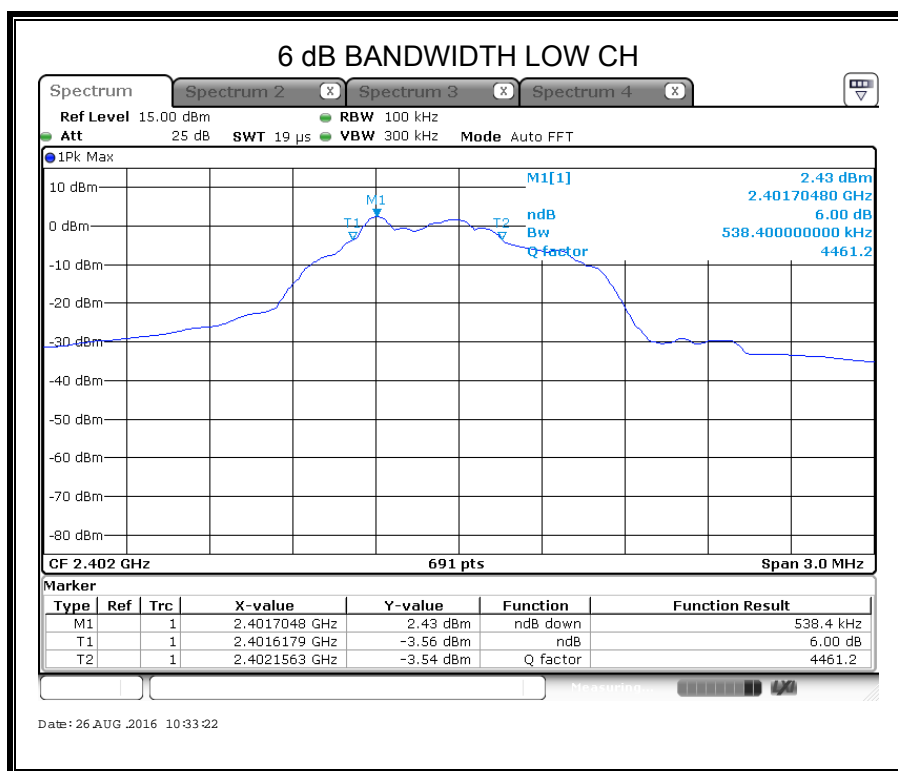

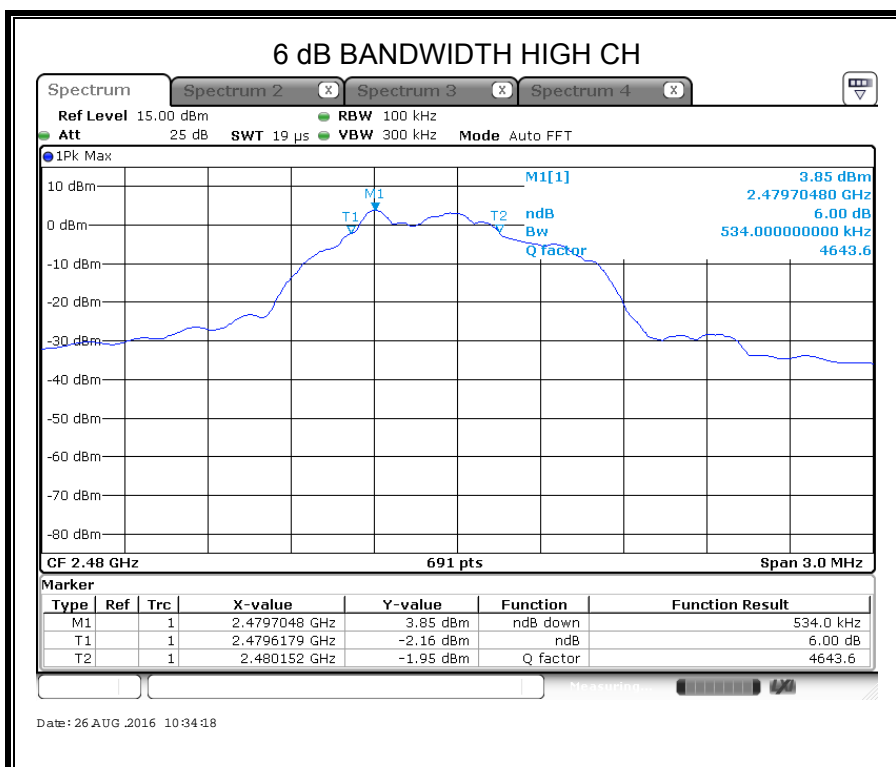
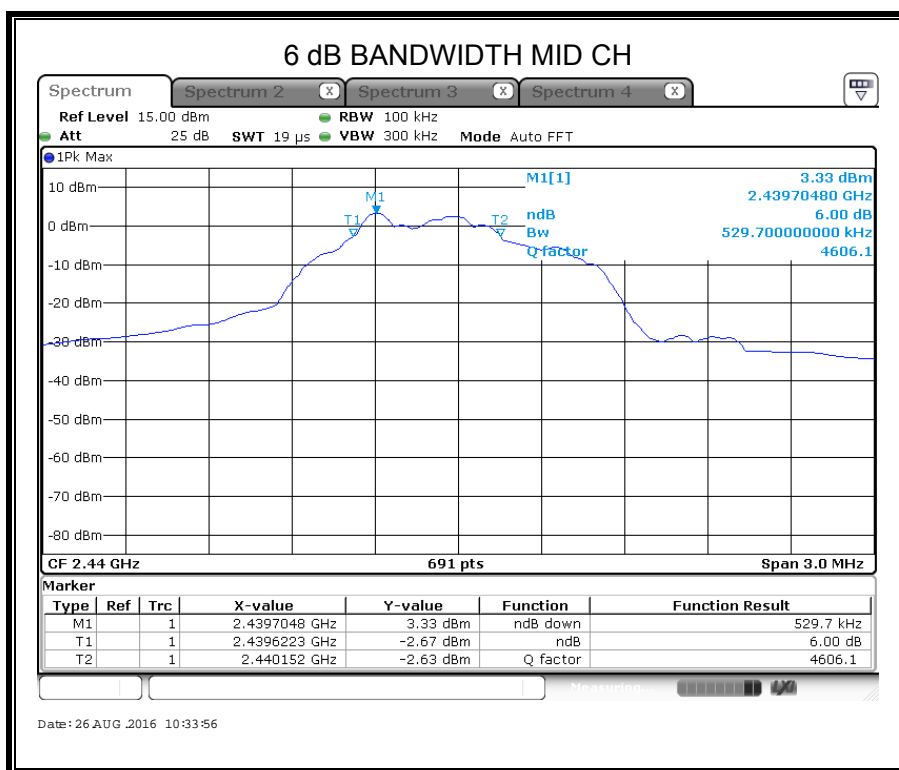

7.2. 99% DTS BANDWIDTH

LIMITS

None; for reporting purposes only.

TEST PROCEDURE

Connect the UUT to the spectrum analyser and use the following settings:

Center Frequency	The centre frequency of the channel under test
Detector	Peak
RBW	100K
VBW	$\geq 3 \times \text{RBW}$
Trace	Max hold
Sweep	Auto couple

Use the 99% bandwidth function in the spectrum analyser and allow the trace to stabilize, then recorded the measurement data.

TEST SETUP

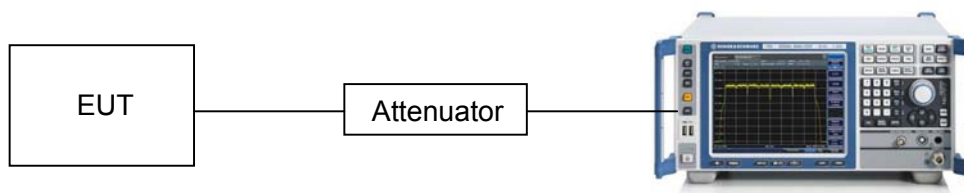

TEST CONDITIONS

Temperature: 21.0°C
 Relative Humidity: 63%
 Test Voltage: AC 120V/60Hz

RESULTS

7.2.1. GFSK MODE

Channel	Frequency (MHz)	99% Bandwidth (MHz)	Limit (kHz)	Result
Low	2402	1.211	500	Pass
Middle	2441	1.038	500	Pass
High	2480	1.042	500	Pass

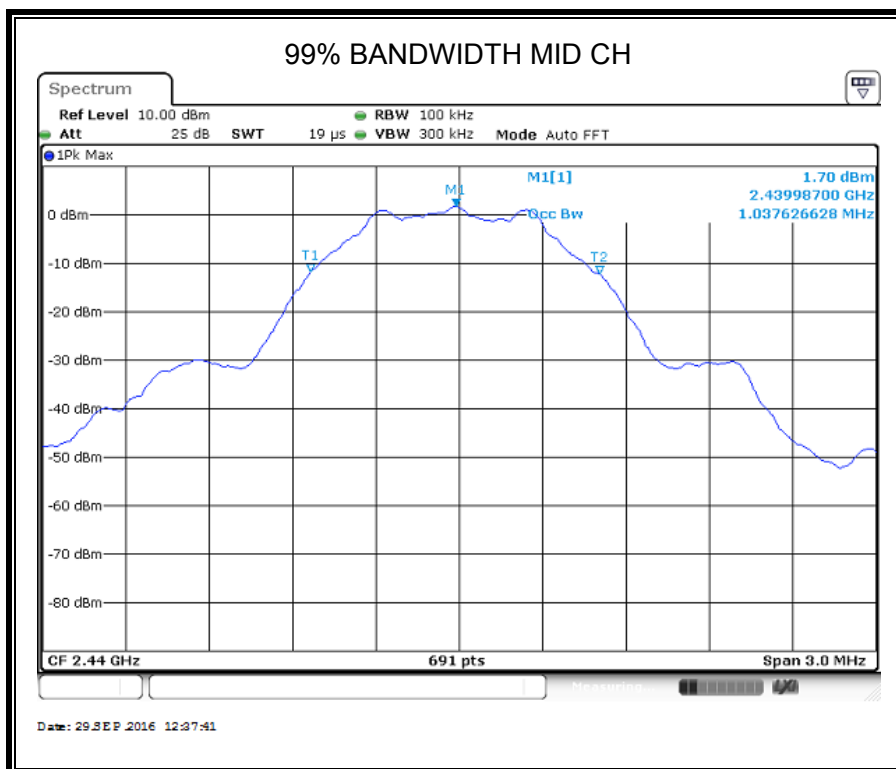
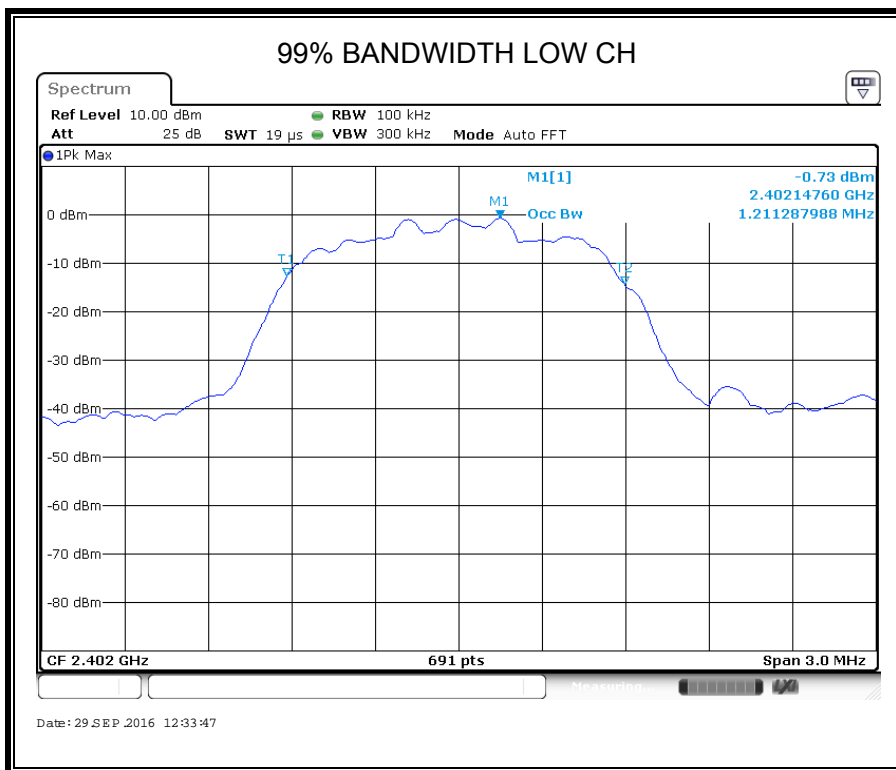

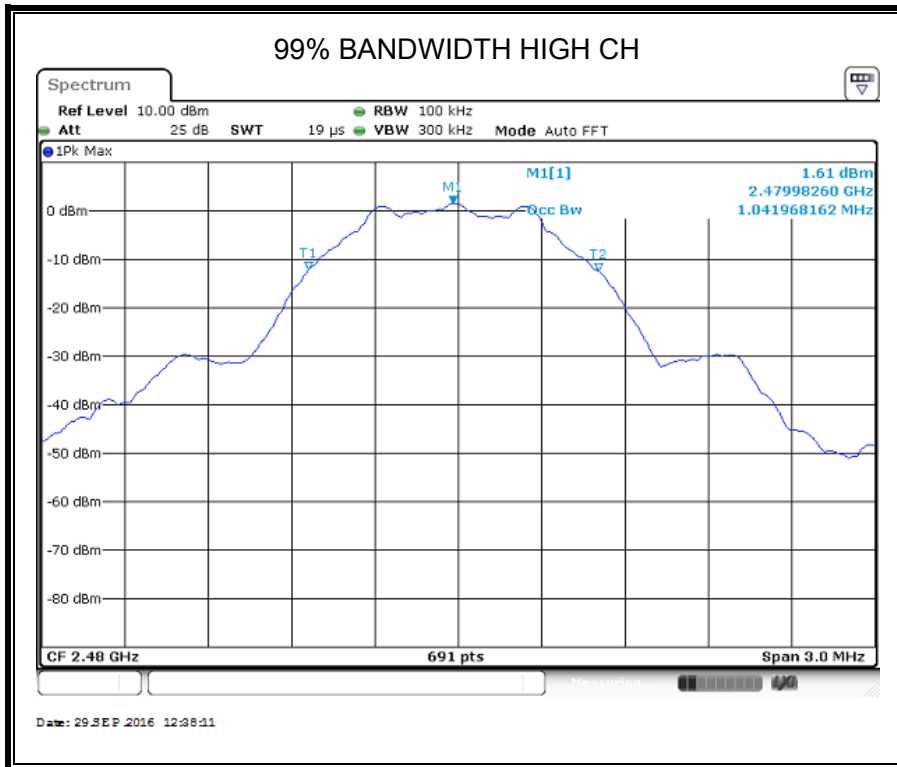

7.3. PEAK CONDUCTED OUTPUT POWER

LIMITS

FCC Part15 (15.247) , Subpart C IC RSS-247 ISSUE 1			
Section	Test Item	Limit	Frequency Range (MHz)
FCC 15.247(b)(3) IC RSS-247 5.4 (4)	Peak Output Power	1 watt or 30dBm	2400-2483.5

TEST PROCEDURE

Connect the UUT to the spectrum analyser and use the following settings:

Center Frequency	The centre frequency of the channel under test
Detector	Peak
RBW	\geq DTS bandwidth(e.g. 1 MHz for BLE)
VBW	$\geq 3 \times$ RBW
Span	3 x RBW
Trace	Max hold
Sweep time	Auto couple.

Allow trace to fully stabilize and use peak marker function to determine the peak amplitude level.

TEST SETUP

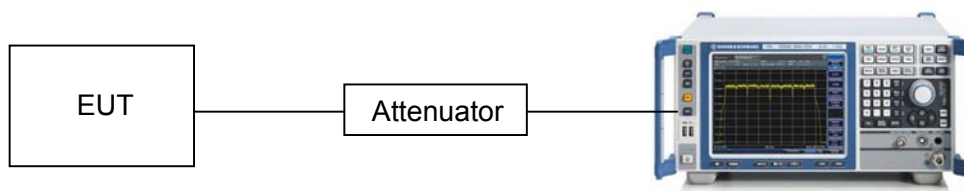

TEST CONDITIONS

Temperature: 21.0°C
 Relative Humidity: 63%
 Test Voltage: AC 120V/60Hz

RESULTS

Test Channel	Frequency	Maximum Conducted Output Power(PK)	EIRP	LIMIT
	(MHz)	(dBm)	(dBm)	dBm
CH00	2402	2.59	-1.91	30
CH19	2440	3.57	-0.93	30
CH39	2480	4.11	-0.39	30

Note: EIRP = Maximum Conducted Output Power (PK) + Antenna Gain

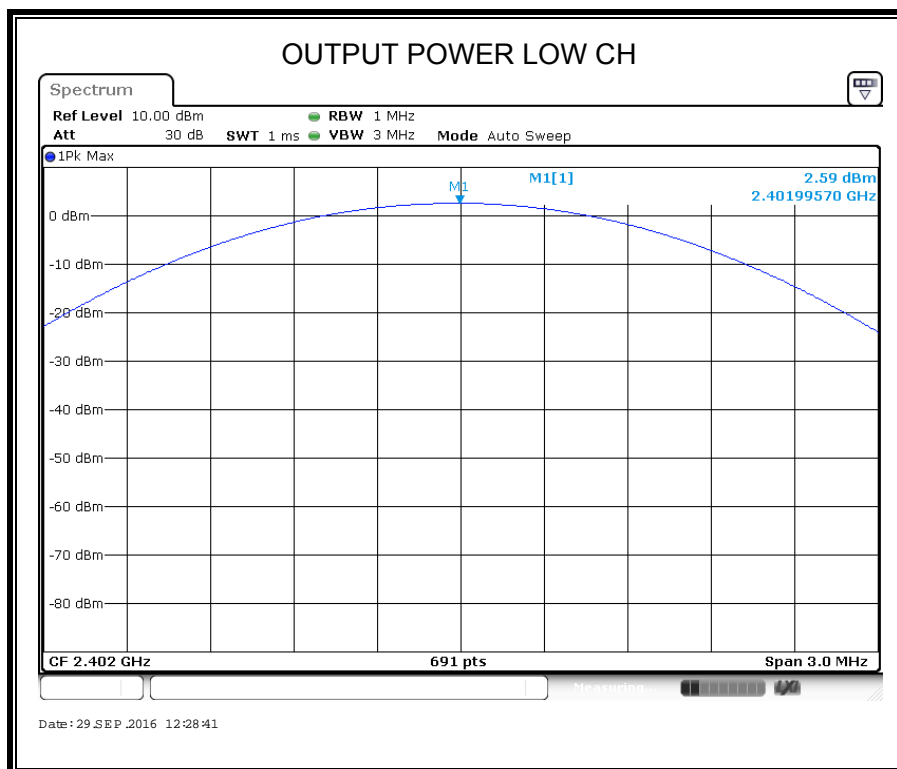

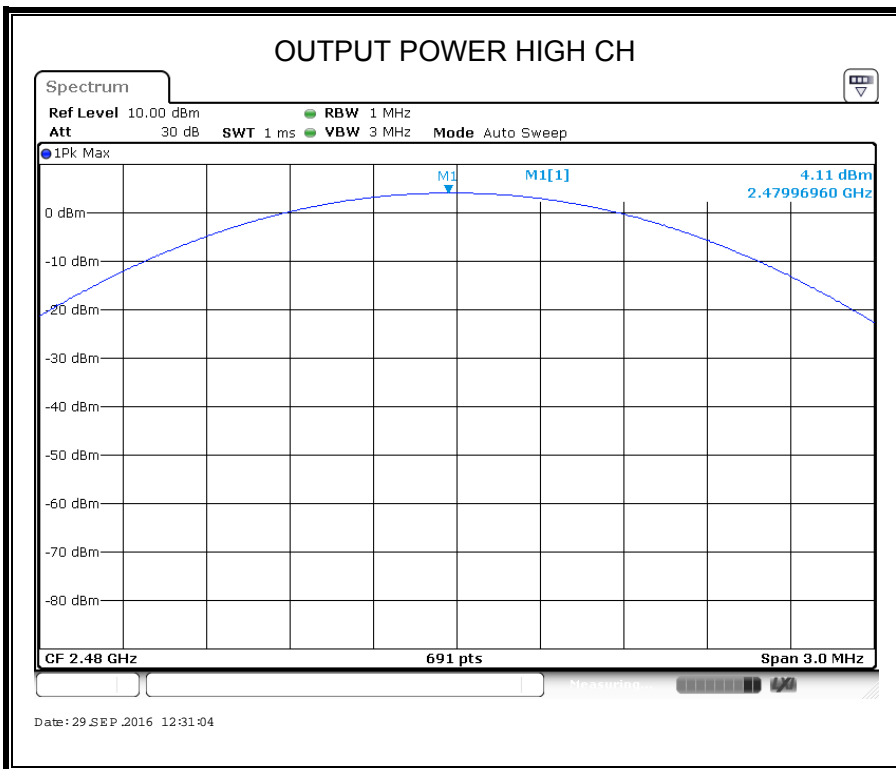
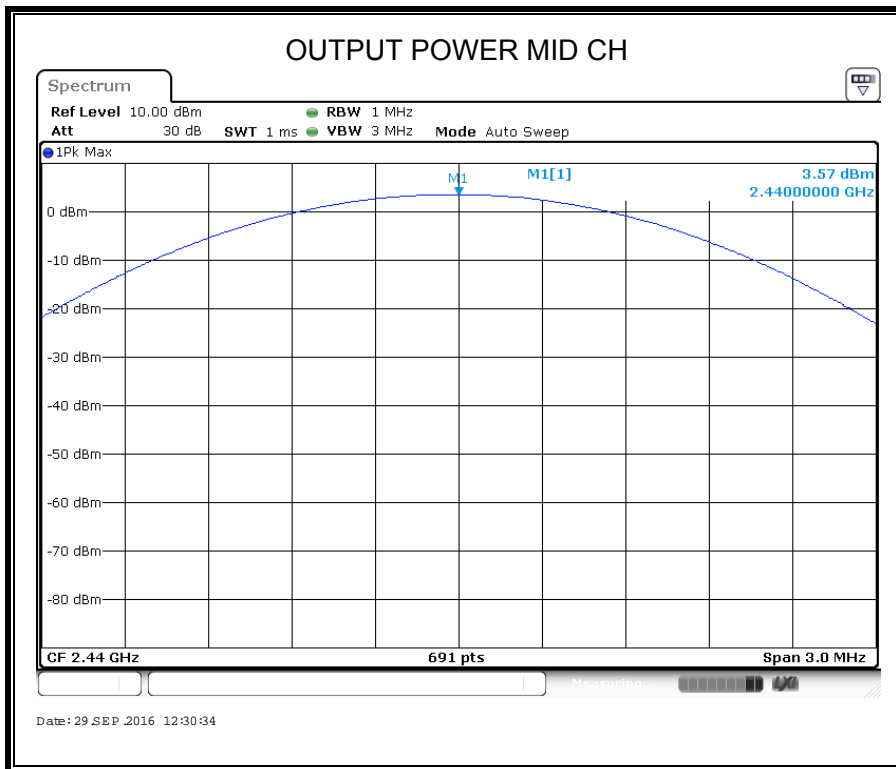

7.4. POWER SPECTRAL DENSITY

LIMITS

FCC Part15 (15.247) , Subpart C IC RSS-247 ISSUE 1			
Section	Test Item	Limit	Frequency Range (MHz)
FCC §15.247 (e) IC RSS-247 5.2 (2)	Power Spectral Density	8 dBm in any 3 kHz band	2400-2483.5

TEST PROCEDURE

Connect the UUT to the spectrum analyser and use the following settings:

Center Frequency	The centre frequency of the channel under test
Detector	Peak
RBW	$3 \text{ kHz} \leq \text{RBW} \leq 100 \text{ kHz}$
VBW	$\geq 3 \times \text{RBW}$
Span	1.5 x DTS bandwidth
Trace	Max hold
Sweep time	Auto couple.

Allow trace to fully stabilize and use the peak marker function to determine the maximum amplitude level within the RBW.

If measured value exceeds limit, reduce RBW (no less than 3 kHz) and repeat.

TEST SETUP

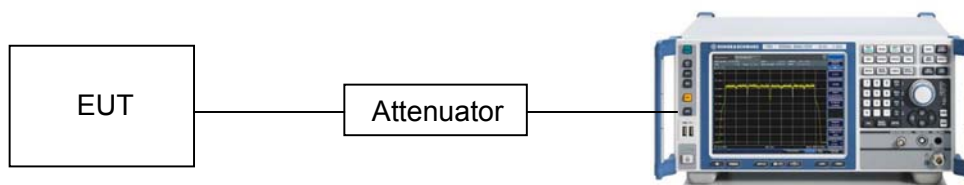

TEST CONDITIONS

Temperature: 21.0°C
 Relative Humidity: 63%
 Test Voltage: AC 120V/60Hz

RESULTS

Frequency	Power Spectral Density (dBm/3kHz)	Limit (dBm/3kHz)	Result
2402 MHz	-16.23	8	PASS
2440 MHz	-15.19	8	PASS
2480 MHz	-14.66	8	PASS

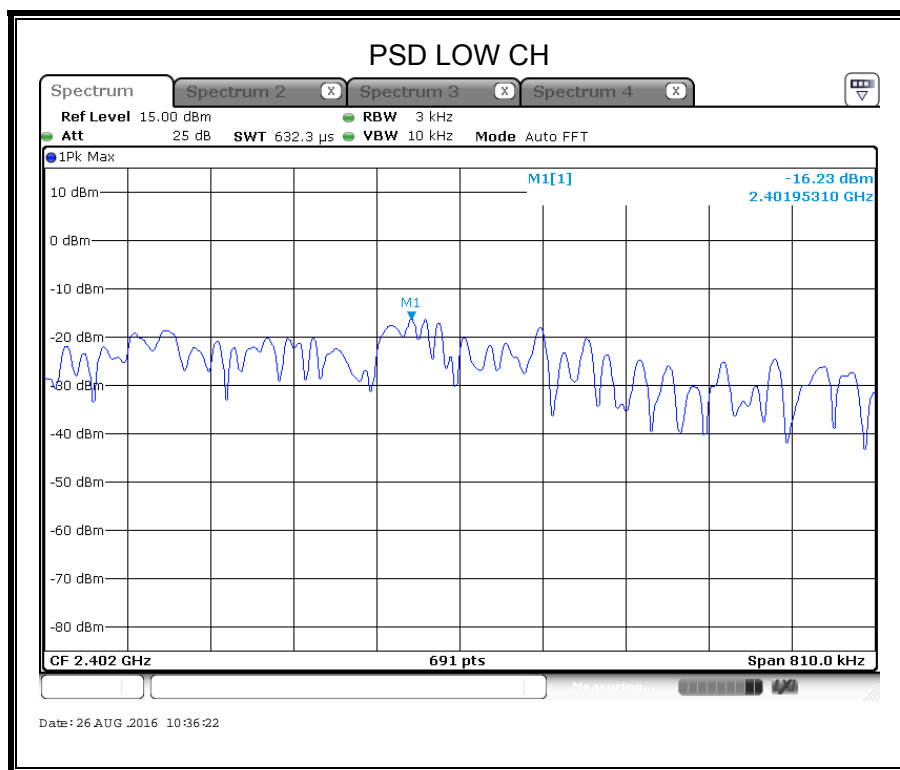

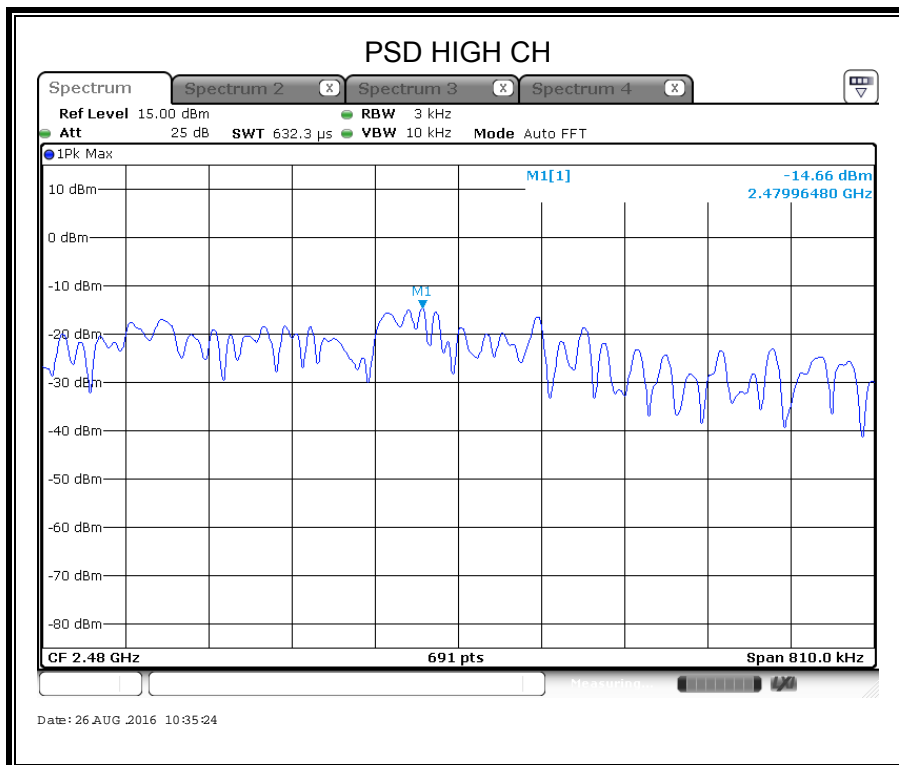
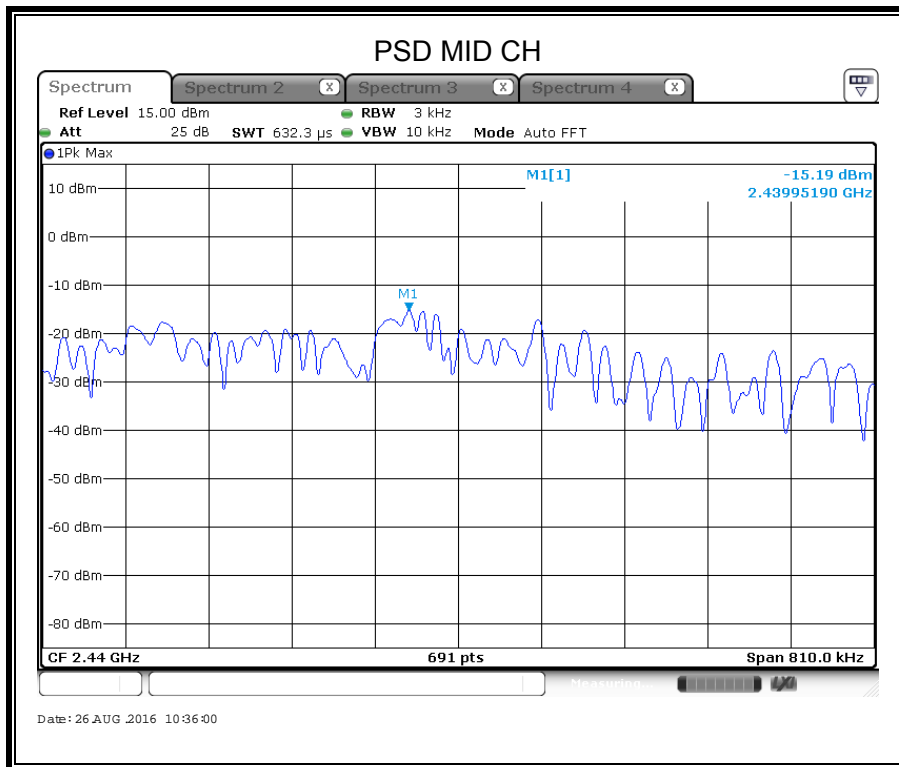

7.5. CONDUCTED BANEDGE AND SPURIOUS EMISSIONS

LIMITS

FCC Part15 (15.247) , Subpart C IC RSS-247 ISSUE 1		
Section	Test Item	Limit
FCC §15.247 (d) IC RSS-247 5.5	Conducted Bandedge and Spurious Emissions	at least 20 dB below that in the 100 kHz bandwidth within the band that contains the highest level of the desired power

TEST PROCEDURE

Connect the UUT to the spectrum analyser and use the following settings:

Center Frequency	The centre frequency of the channel under test
Detector	Peak
RBW	100K
VBW	$\geq 3 \times \text{RBW}$
Span	1.5 x DTS bandwidth
Trace	Max hold
Sweep time	Auto couple.

Use the peak marker function to determine the maximum PSD level.

Span	Set the center frequency and span to encompass frequency range to be measured
Detector	Peak
RBW	100K
VBW	$\geq 3 \times \text{RBW}$
measurement points	$\geq \text{span}/\text{RBW}$
Trace	Max hold
Sweep time	Auto couple.

Use the peak marker function to determine the maximum amplitude level.

TEST SETUP

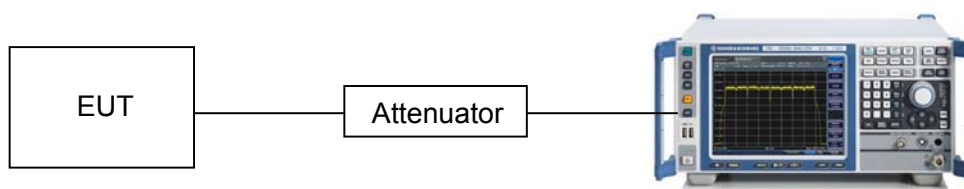

Temperature: 21.0°C
Relative Humidity: 63%
Test Voltage: AC 120V/60Hz

RESULTS

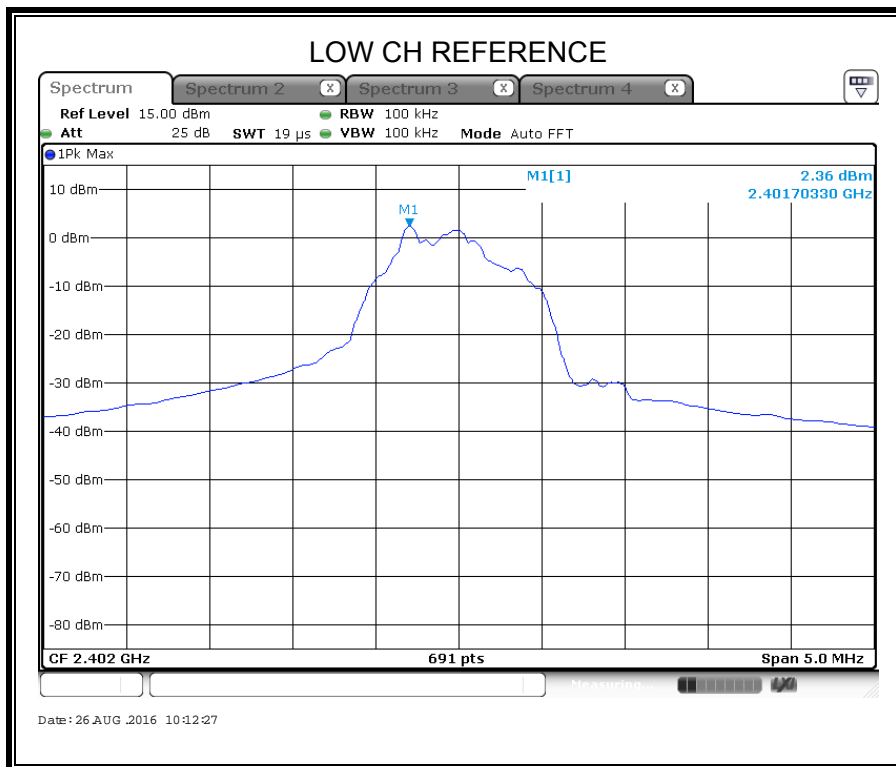

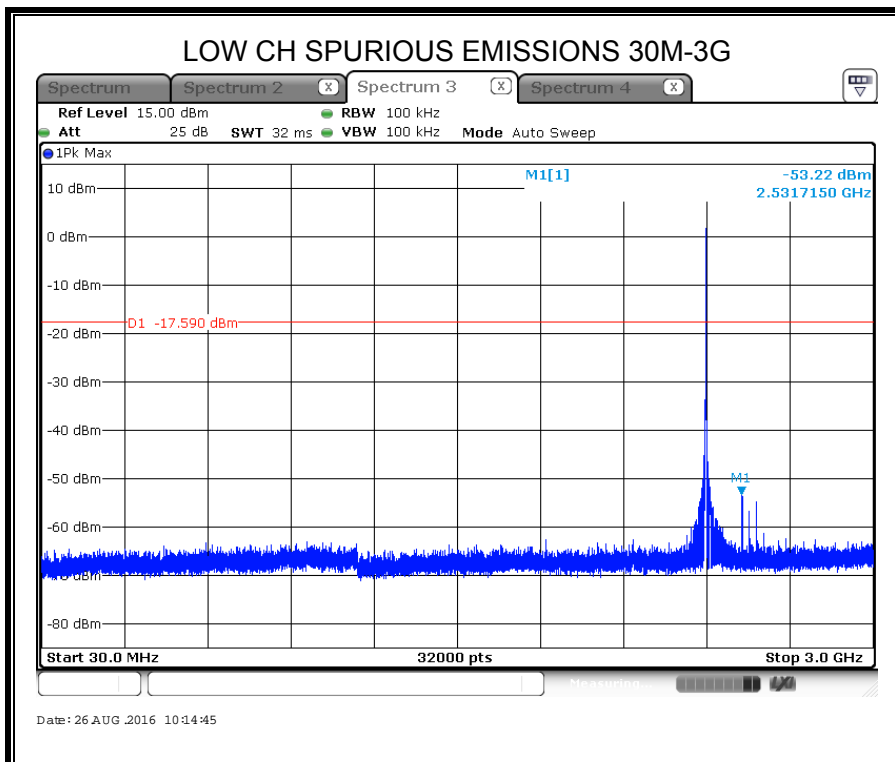
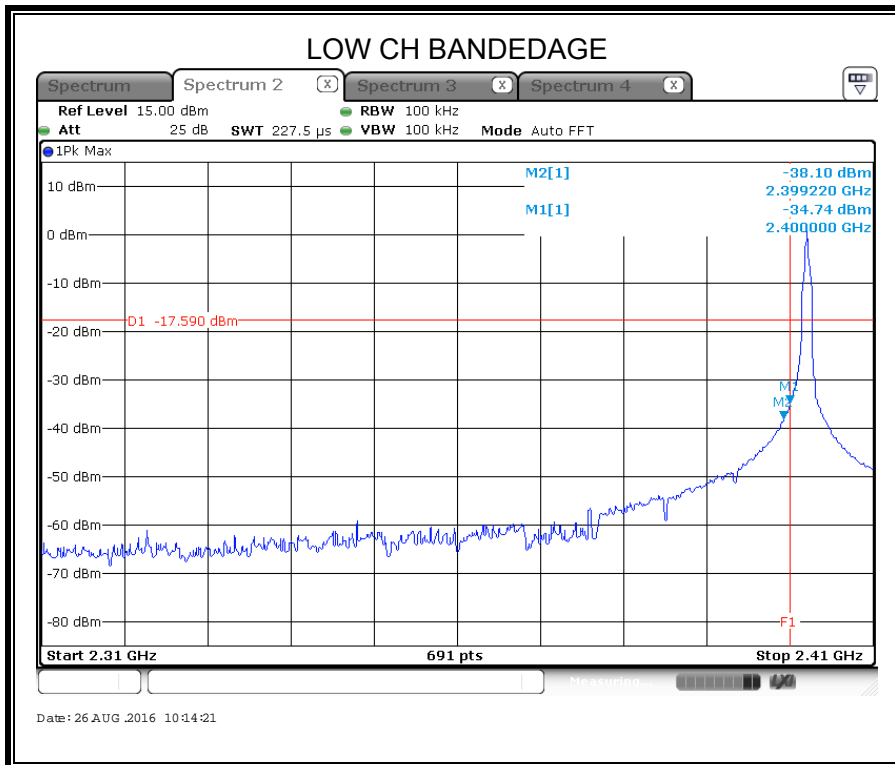

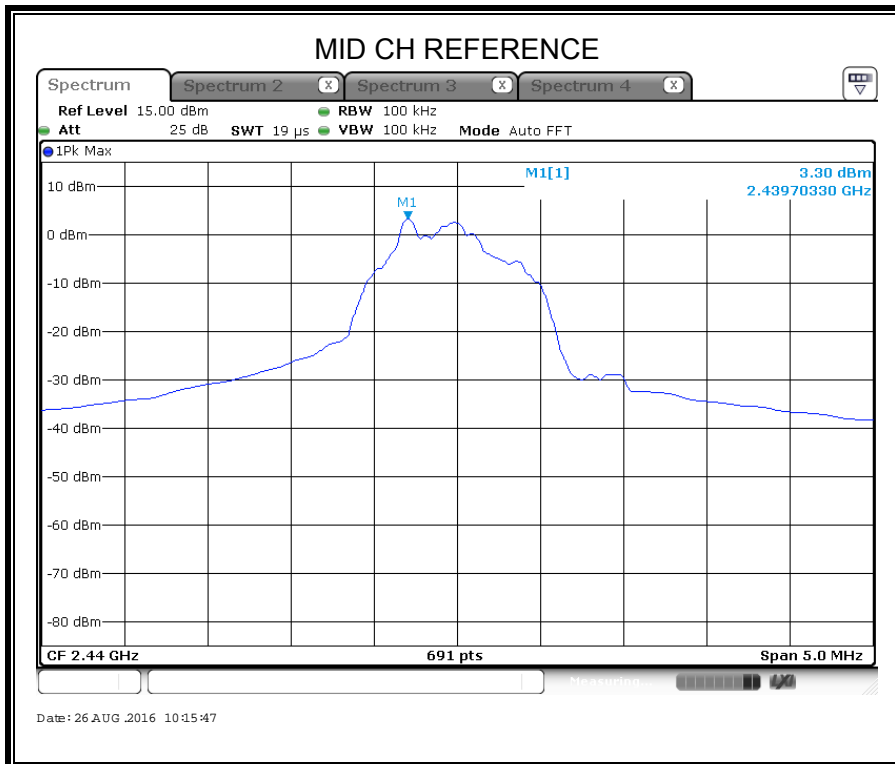
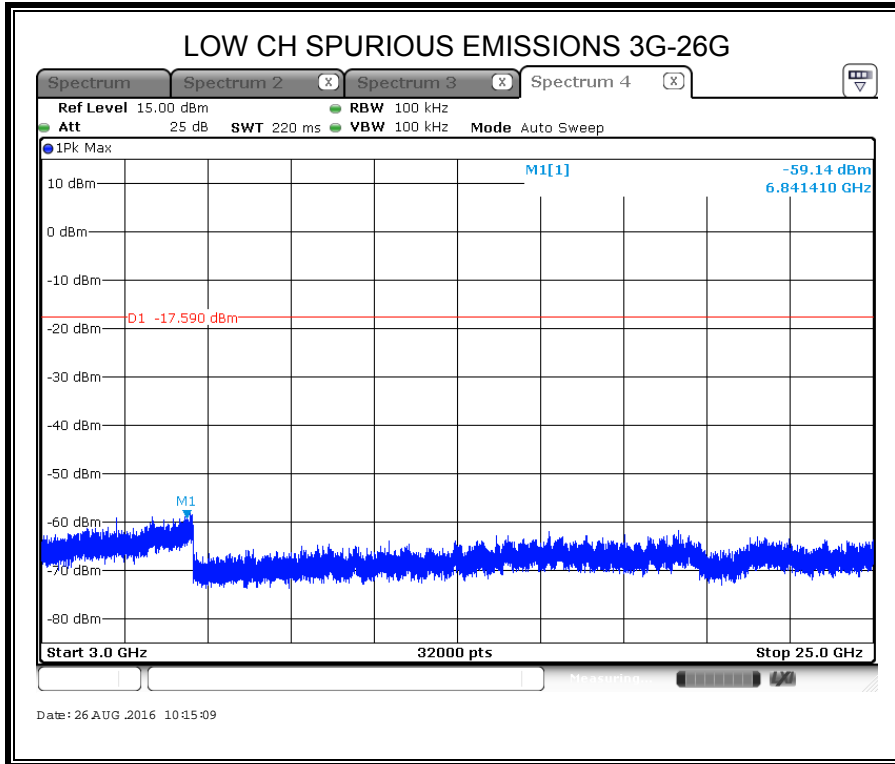

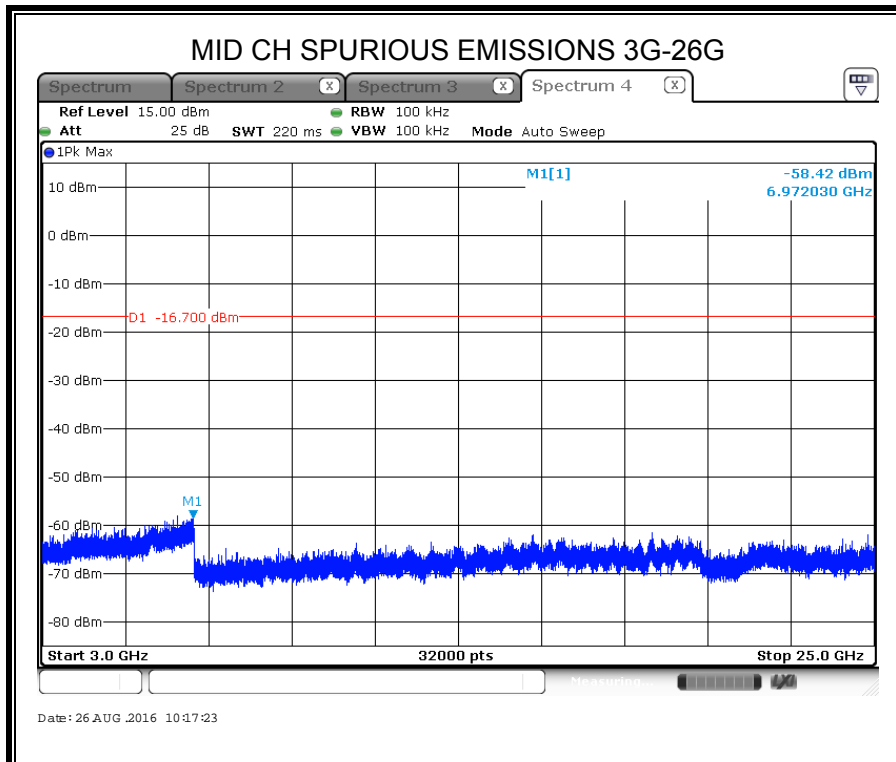
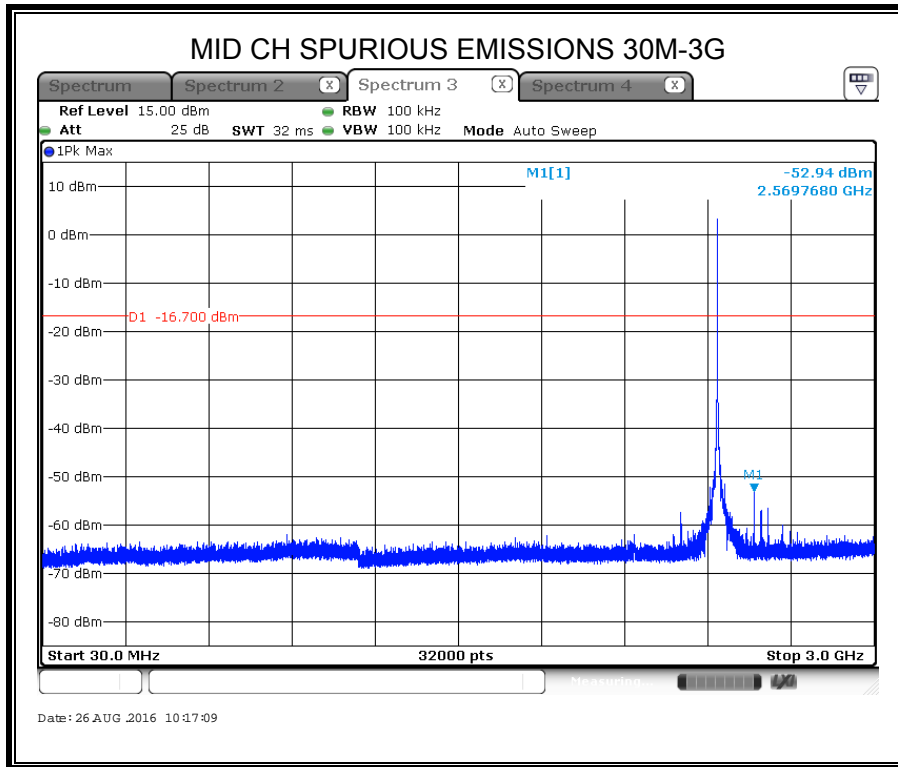

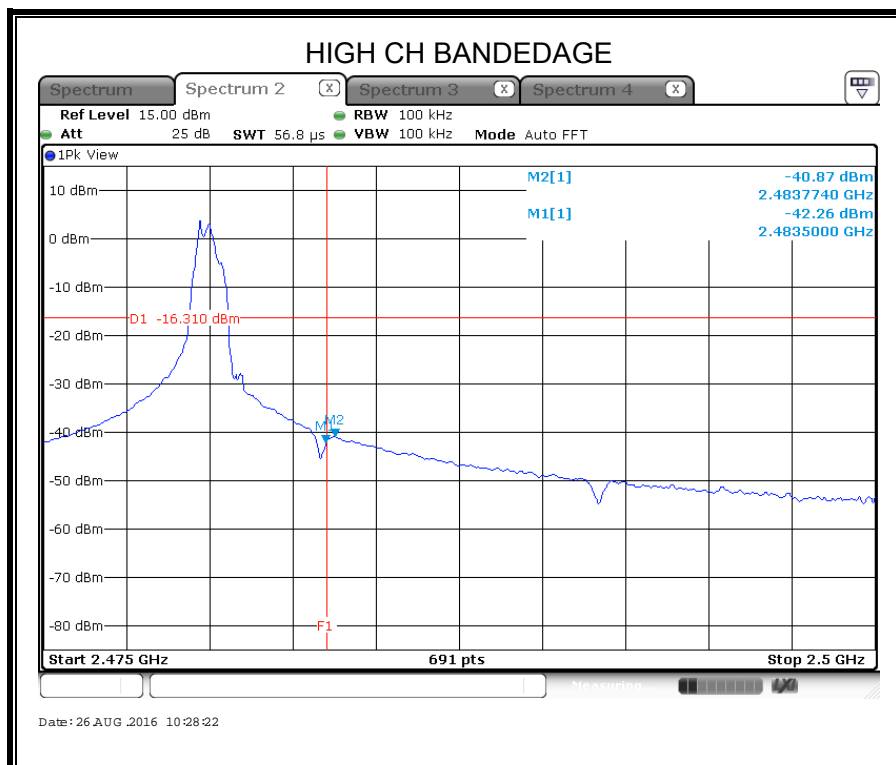
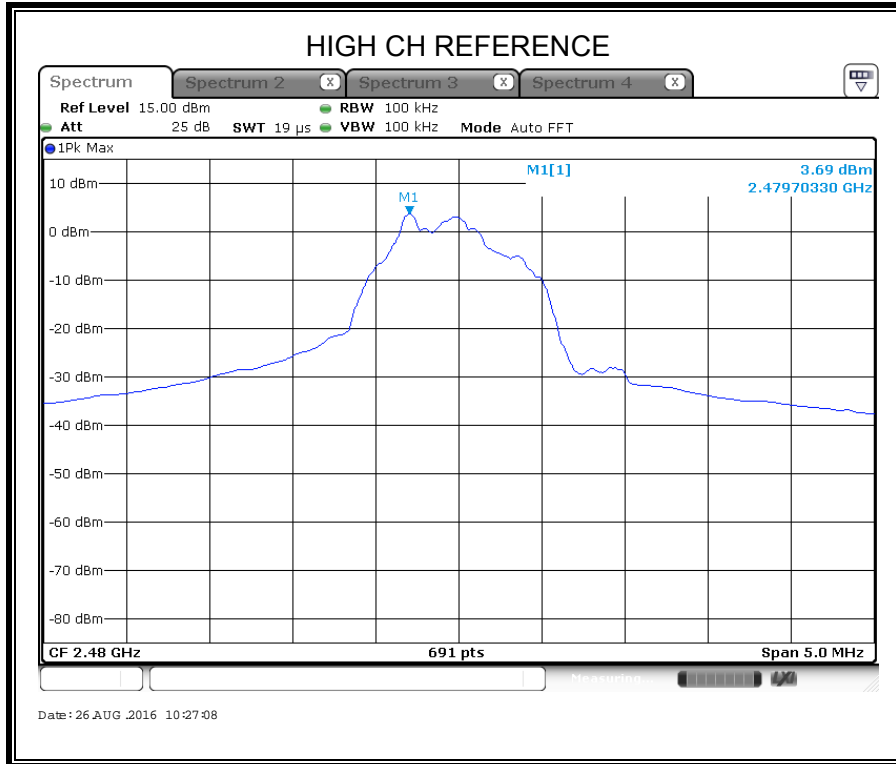

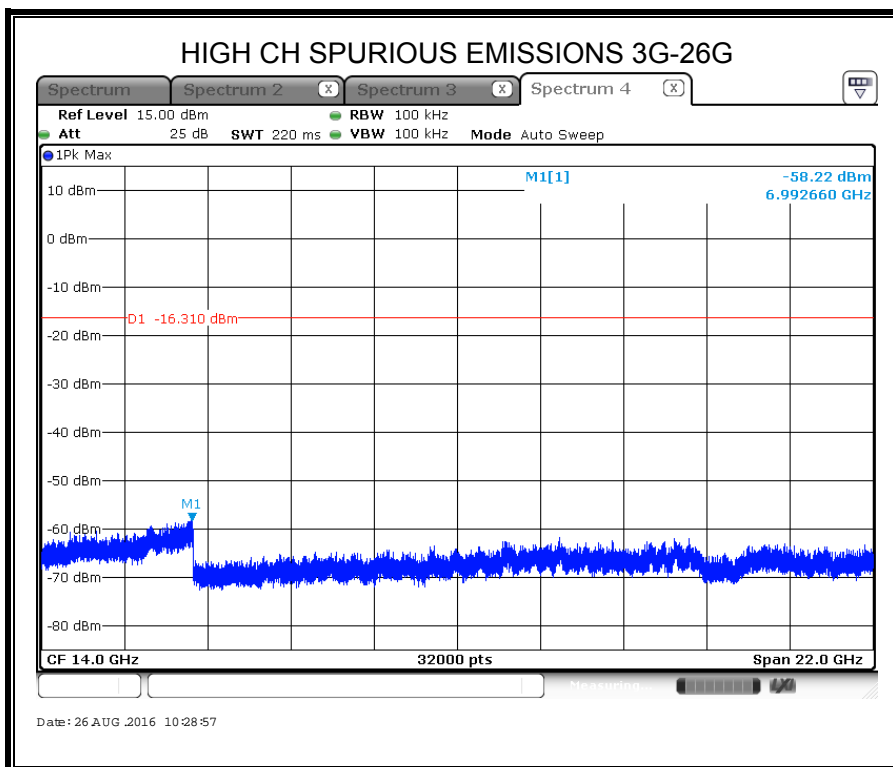
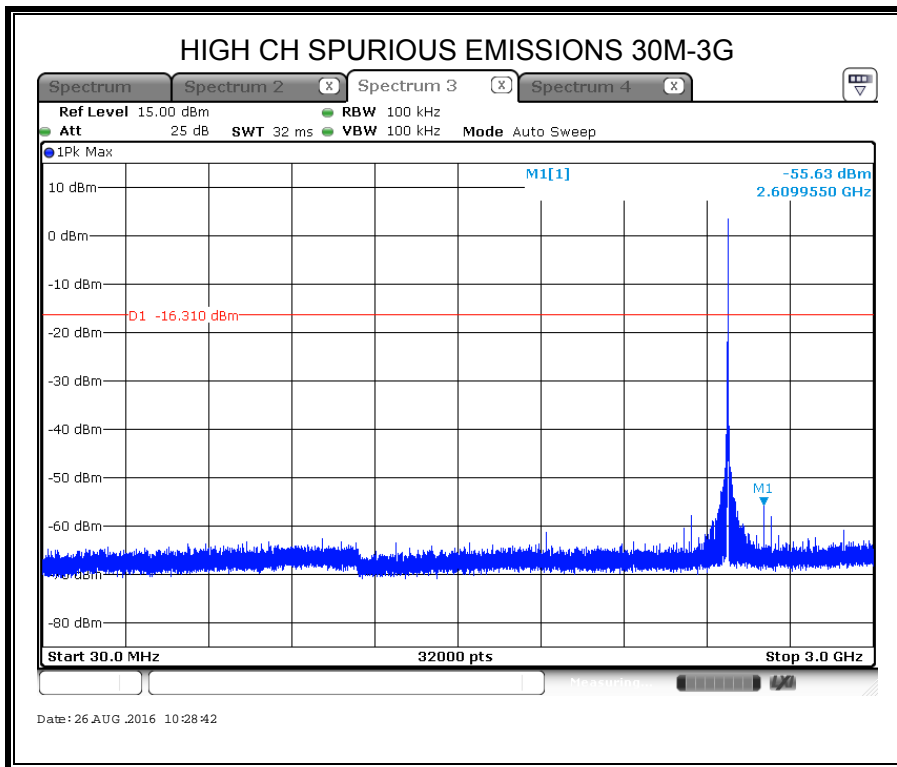

8. RADIATED TEST RESULTS

8.1. LIMITS AND PROCEDURE

LIMITS

Please refer to FCC §15.205 and §15.209

Please refer to IC RSS-GEN Clause 8.9 (Transmitter)

Radiation Disturbance Test Limit for FCC (Class B)(9KHz-1GHz)

Frequency (MHz)	Field Strength (microvolts/meter)	Measurement Distance (meters)
0.009~0.490	2400/F(KHz)	300
0.490~1.705	24000/F(KHz)	30
1.705~30.0	30	30
30~88	100	3
88~216	150	3
216~960	200	3
960~1000	500	3

Radiation Disturbance Test Limit for FCC (Above 1G)

Frequency (MHz)	dB(uV/m) (at 3 meters)	
	Peak	Average
Above 1000	74	54

TEST SETUP AND PROCEDURE

Below 30MHz

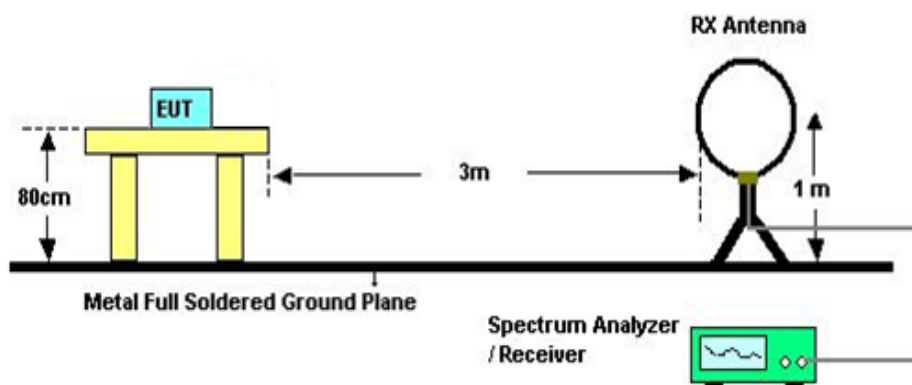

The setting of the spectrum analyser

RBW	200Hz (From 9kHz to 0.15MHz)/ 9KHz (From 0.15MHz to 30MHz)
VBW	200Hz (From 9kHz to 0.15MHz)/ 9KHz (From 0.15MHz to 30MHz)
Sweep	Auto
Detector	Peak/QP/ Average
Trace	Max hold

1. The testing follows the guidelines in ANSI C63.10-2013
2. The EUT was arranged to its worst case and then turntable (from 0 degree to 360 degrees) to find the maximum reading. A pre-amp and a high pass filter are used for the test in order to get better signal level. Both horizontal and vertical polarizations of the antenna are set to make the measurement.
3. The EUT was placed on a turntable with 0.8 meter above ground.
4. The EUT was set 3 meters from the interference receiving antenna, which was mounted on the top of a variable height antenna tower.
5. Corrected Reading: Antenna Factor + Cable Loss + Read Level - Preamp Factor = Level
6. For measurement below 1GHz, the initial step in collecting conducted emission data is a spectrum analyzer peak detector mode pre-scanning the measurement frequency range. Significant peaks are then marked and then Quasi Peak detector mode re-measured. If the emission level of the EUT measured by the peak detector is 3 dB lower than the applicable limit, the peak emission level will be reported. Otherwise, the emission measurement will be repeated using the quasi-peak detector and reported.
7. For the actual test configuration, please refer to the related item in this test report (Photographs of the Test Configuration)

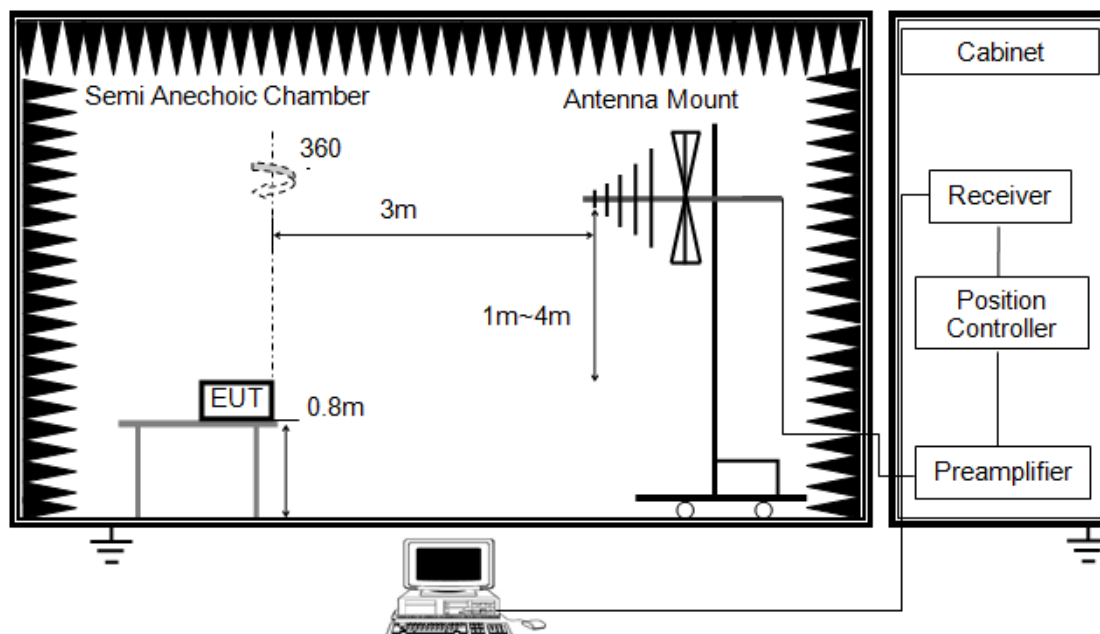

The setting of the spectrum analyser

RBW	120K
VBW	300K
Sweep	Auto
Detector	Peak/QP
Trace	Max hold

1. The testing follows the guidelines in ANSI C63.10-2013.
2. The EUT was arranged to its worst case and then tune the antenna tower (from 1 m to 4 m) and turntable (from 0 degree to 360 degrees) to find the maximum reading. A pre-amp and a high pass filter are used for the test in order to get better signal level. Both horizontal and vertical polarizations of the antenna are set to make the measurement.
3. The EUT was placed on a turntable with 0.8 meter above ground.
4. The EUT was set 3 meters from the interference receiving antenna, which was mounted on the top of a variable height antenna tower.
5. Corrected Reading: $\text{Antenna Factor} + \text{Cable Loss} + \text{Read Level} - \text{Preamp Factor} = \text{Level}$
6. For measurement below 1GHz, the initial step in collecting conducted emission data is a spectrum analyzer peak detector mode pre-scanning the measurement frequency range. Significant peaks are then marked and then Quasi Peak detector mode re-measured. If the emission level of the EUT measured by the peak detector is 3 dB lower than the applicable limit, the peak emission level will be reported. Otherwise, the emission measurement will be repeated using the quasi-peak detector and reported.
7. For the actual test configuration, please refer to the related Item in this test report (Photographs of the Test Configuration)

ABOVE 1G

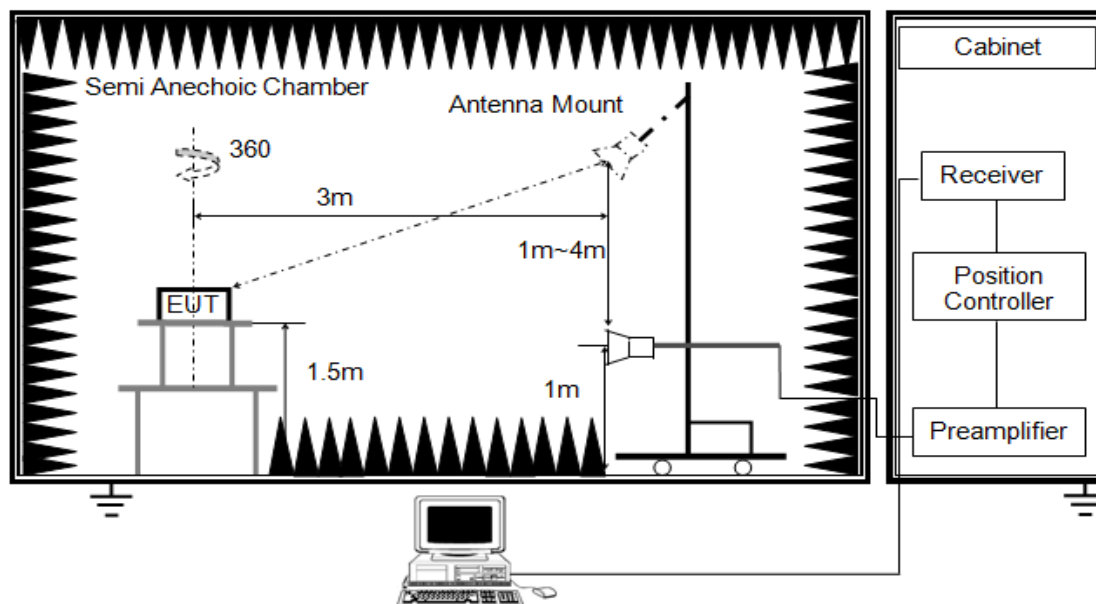

The setting of the spectrum analyser

RBW	1M
VBW	3M
Sweep	Auto
Detector	Peak and CISPR Average
Trace	Max hold

1. The testing follows the guidelines in ANSI C63.10-2013.
2. The EUT was arranged to its worst case and then tune the antenna tower (1.5 m) and turntable (from 0 degree to 360 degrees) to find the maximum reading. A pre-amp and a high pass filter are used for the test in order to get better signal level. Both horizontal and vertical polarizations of the antenna are set to make the measurement.
3. The EUT was placed on a turntable with 1.5 meter above ground.
4. The EUT was set 3 meters from the interference receiving antenna, which was mounted on the top of a variable height antenna tower.
5. Corrected Reading: Antenna Factor + Cable Loss + Read Level - Preamp Factor = Level
6. For measurement above 1GHz, the emission measurement will be measured by the peak detector and the AV detector.
7. For the actual test configuration, please refer to the related Item in this test report (Photographs of the Test Configuration)

TEST CONDITIONS

Temperature: 20.6°C
 Relative Humidity: 43.0%
 Test Voltage: AC 120V/60Hz

8.2. RESTRICTED BANDEDGE

8.2.1. GFSK MODE

RESTRICTED BANDEDGE (LOW CHANNEL, HORIZONTAL)

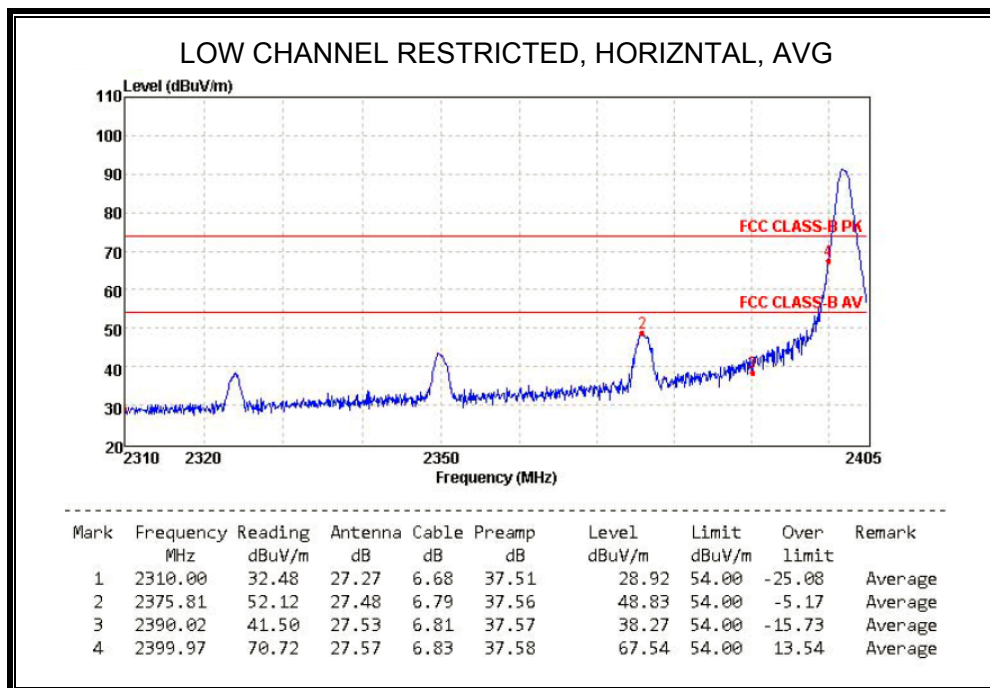
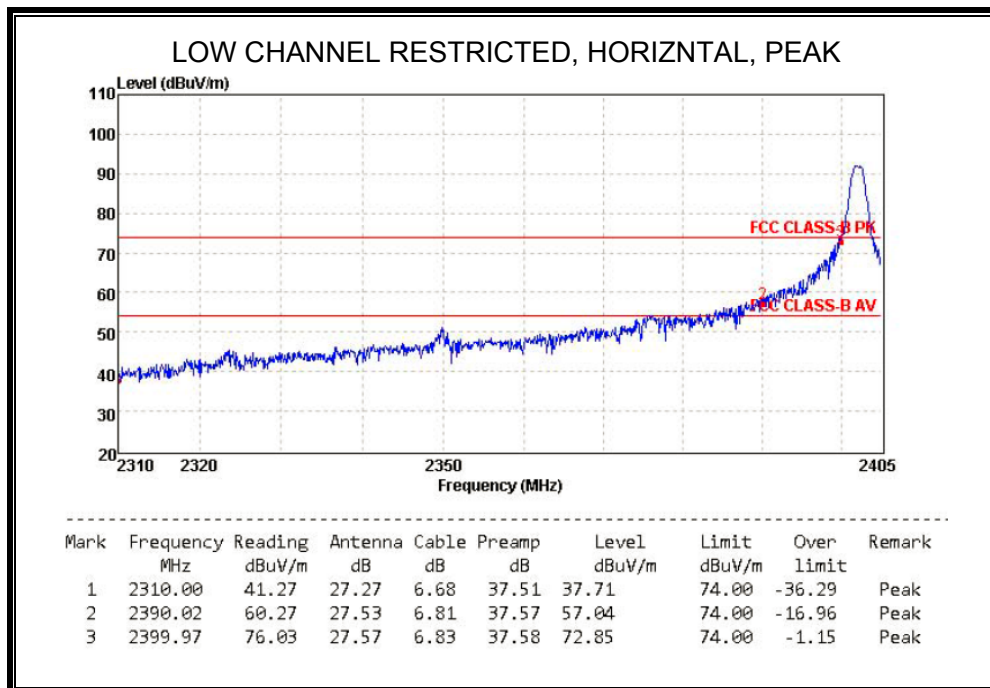

RESTRICTED BANDEDGE (LOW CHANNEL, VERTICAL)

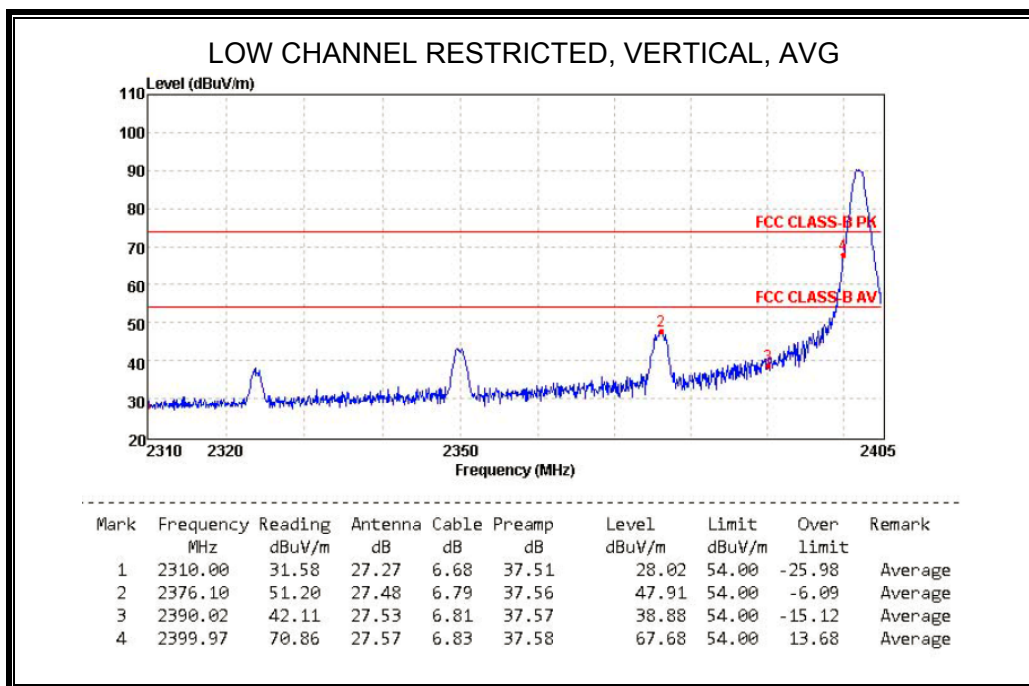
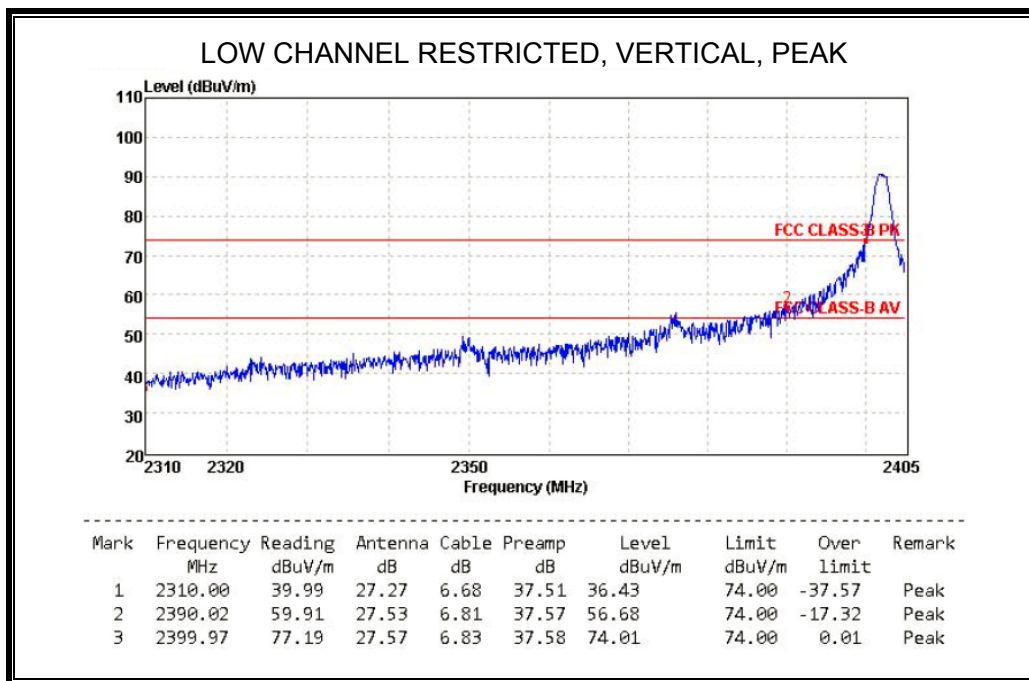

RESTRICTED BANDEDGE (HIGH CHANNEL, HORIZONTAL)

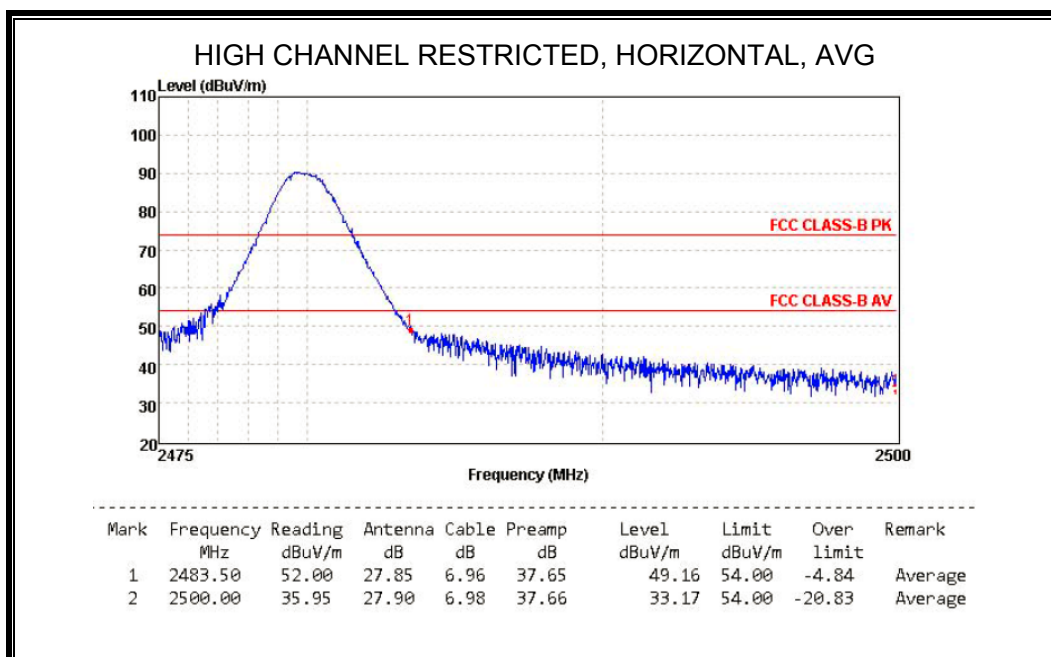
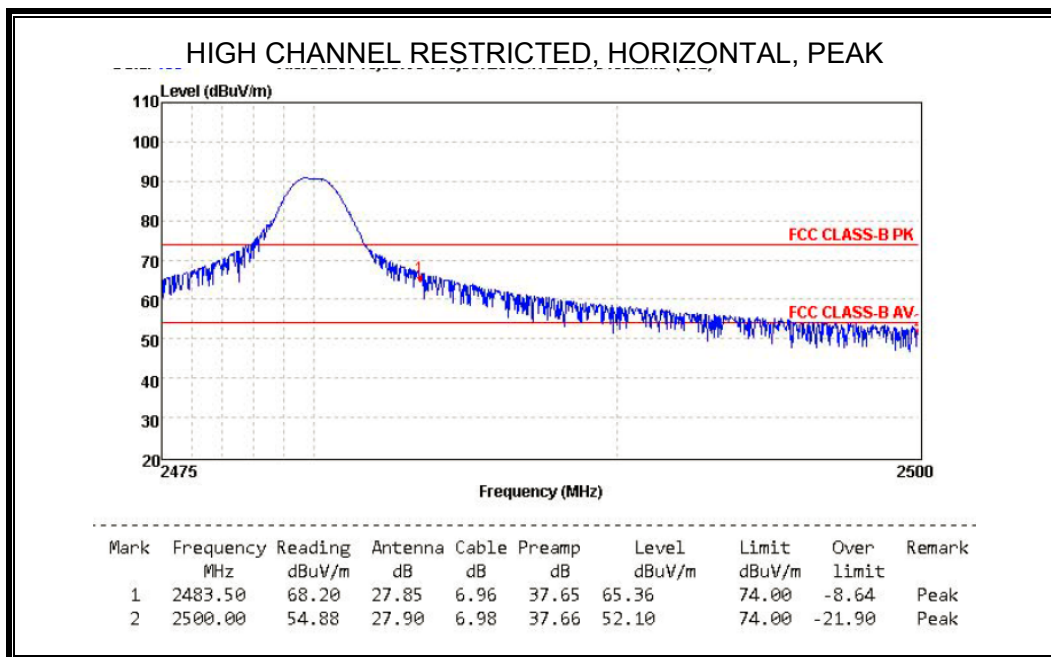

RESTRICTED BANDEDGE (HIGH CHANNEL, VERTICAL)

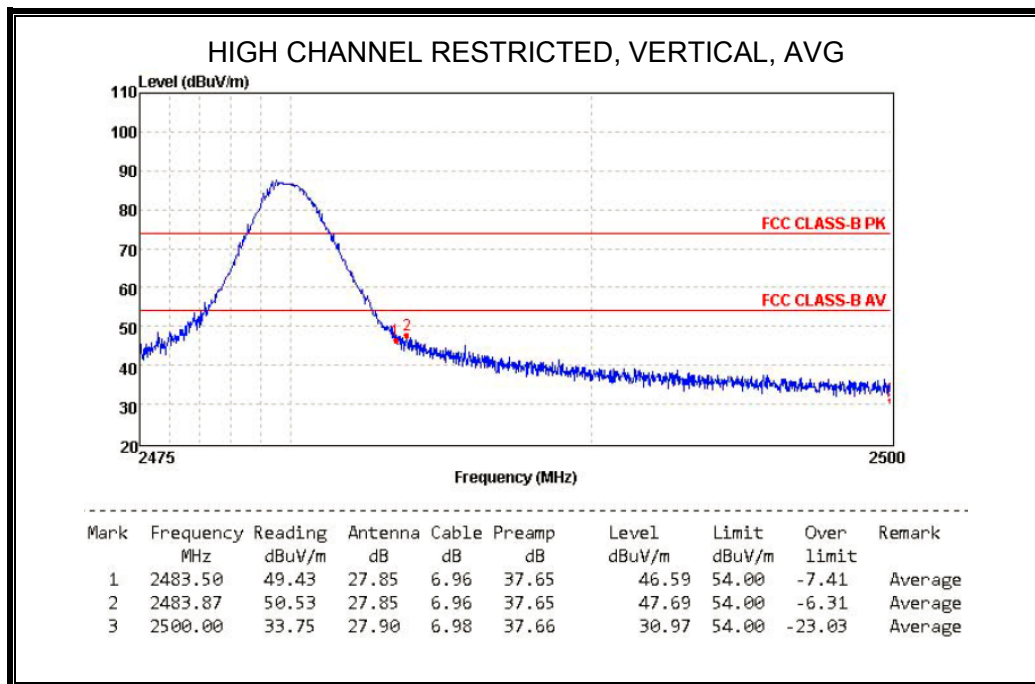
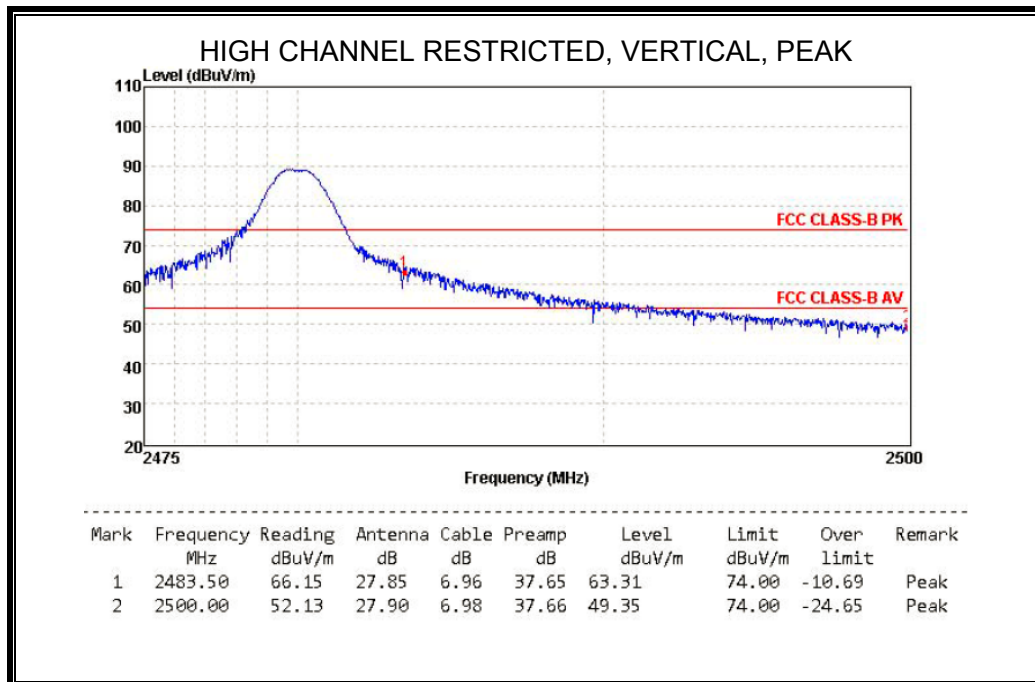

Note: EUT in each of three orthogonal axis emissions had been tested, but only the worst case (X axis) data recorded in the report.

8.3. SPURIOUS EMISSIONS (1~25GHz)

8.3.1. GFSK MODE

HARMONICS AND SPURIOUS EMISSIONS

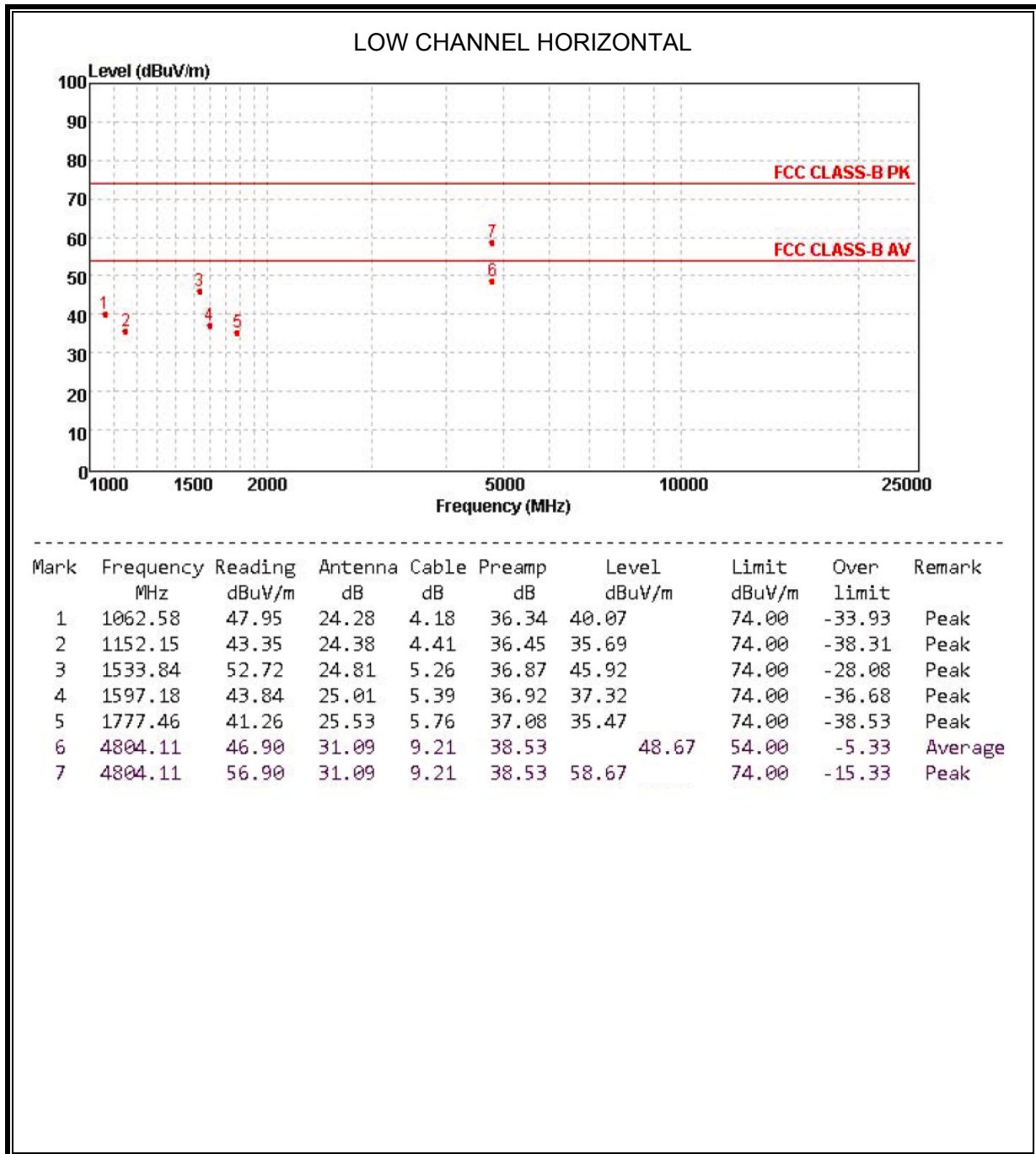

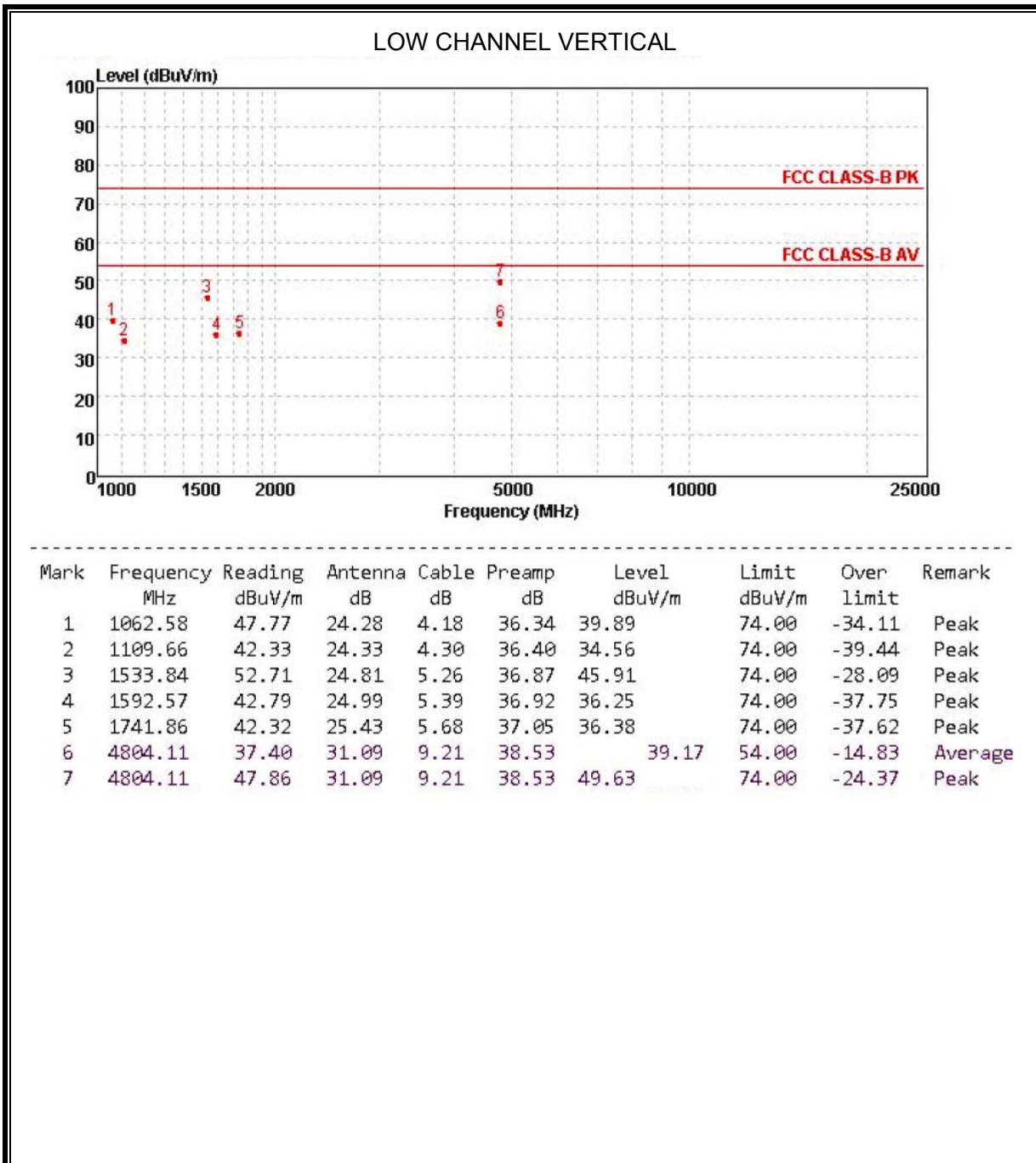

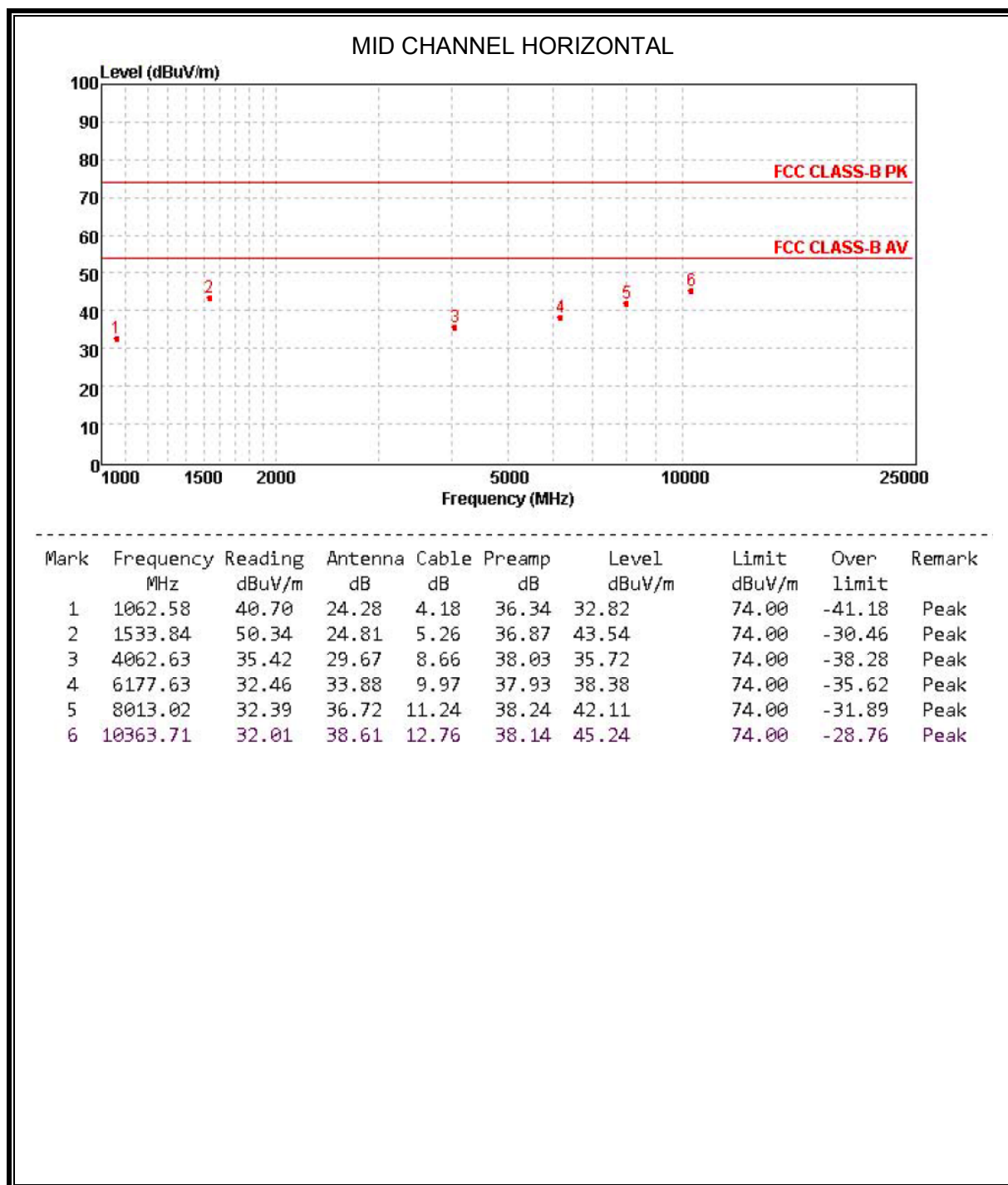

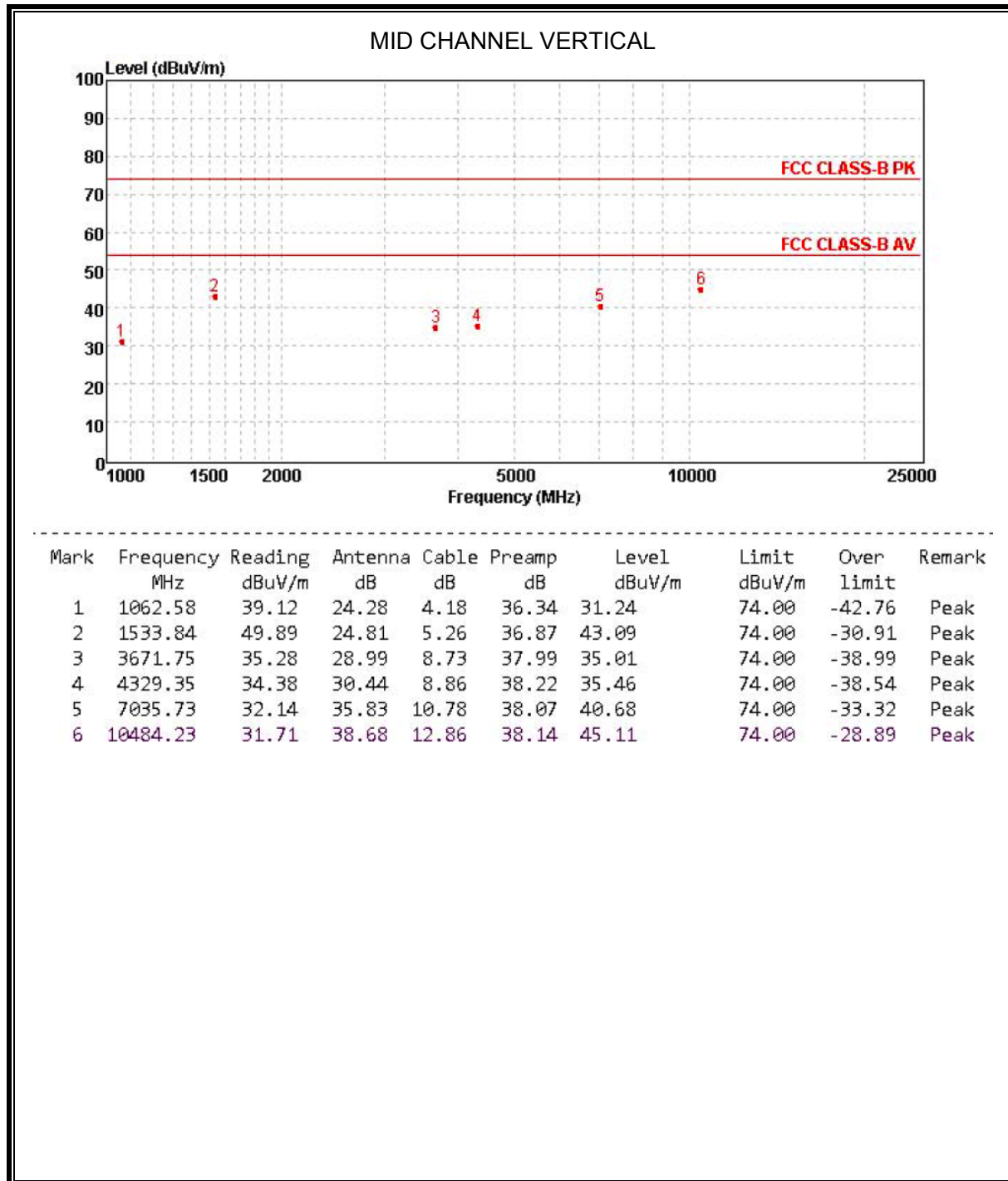

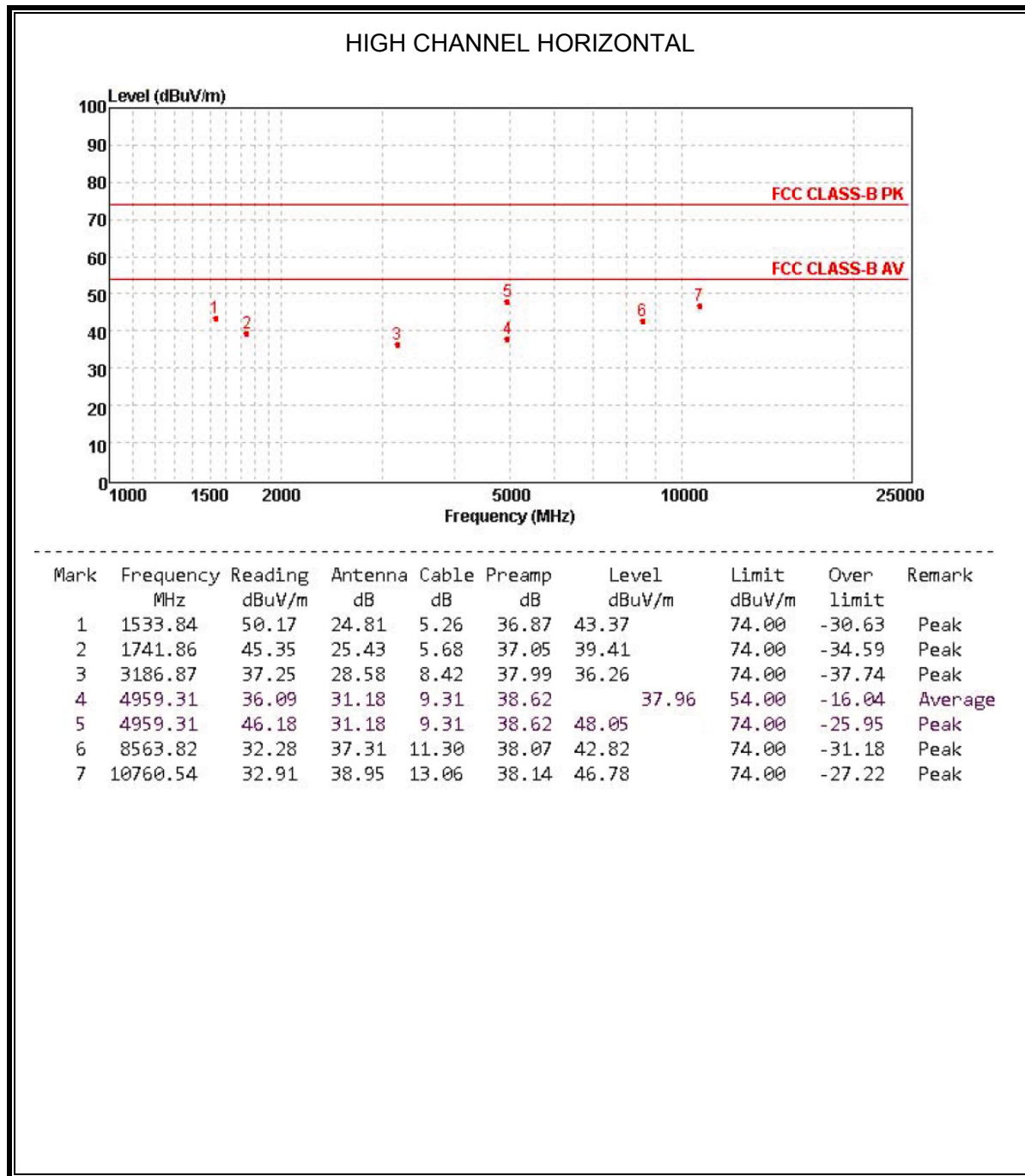

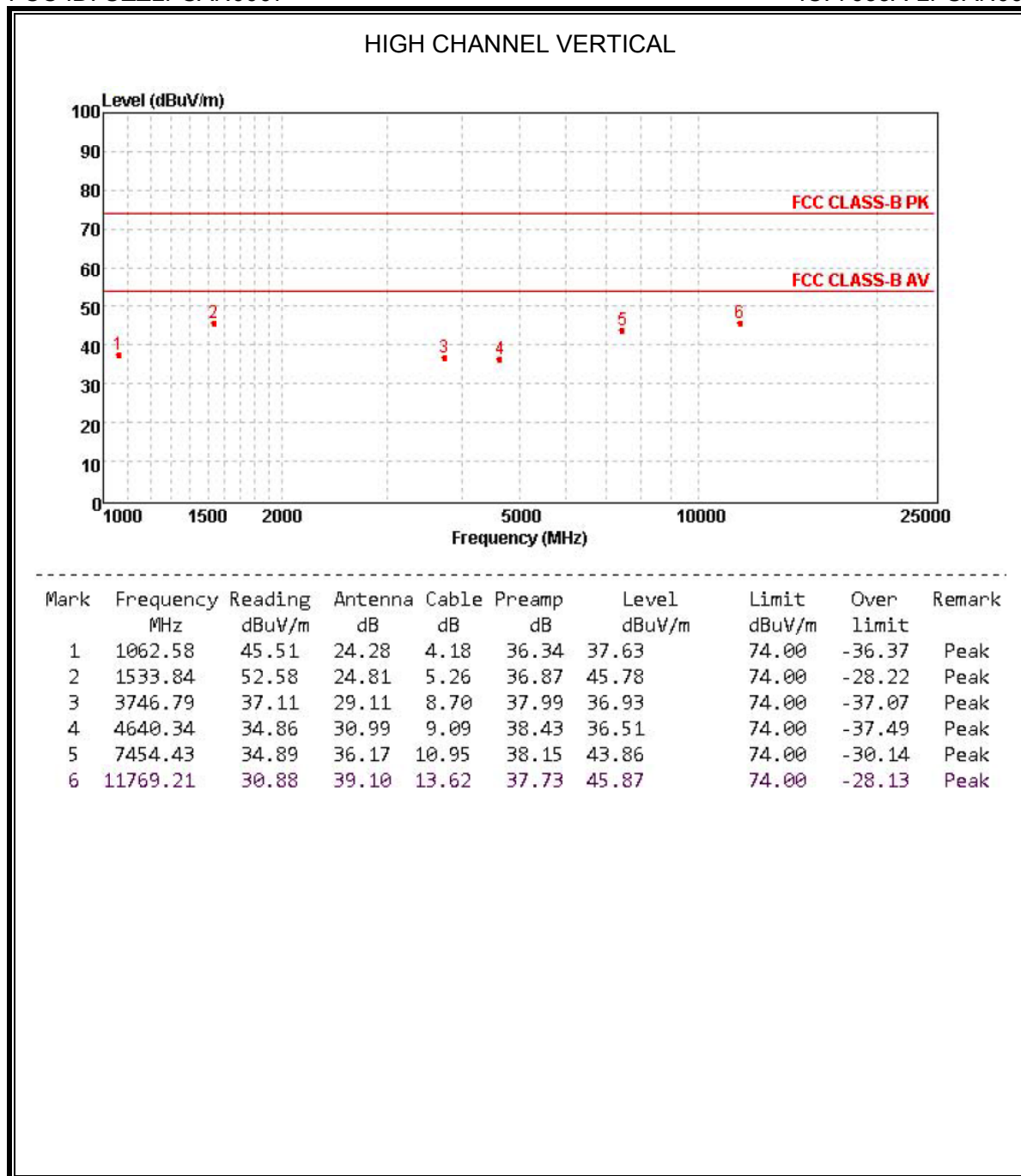

Note: EUT in each of three orthogonal axis emissions had been tested, but only the worst case (X axis) data recorded in the report.

8.4. SPURIOUS EMISSIONS 30M ~ 1 GHz

8.4.1. GFSK MODE

SPURIOUS EMISSIONS 30 TO 1000 MHz

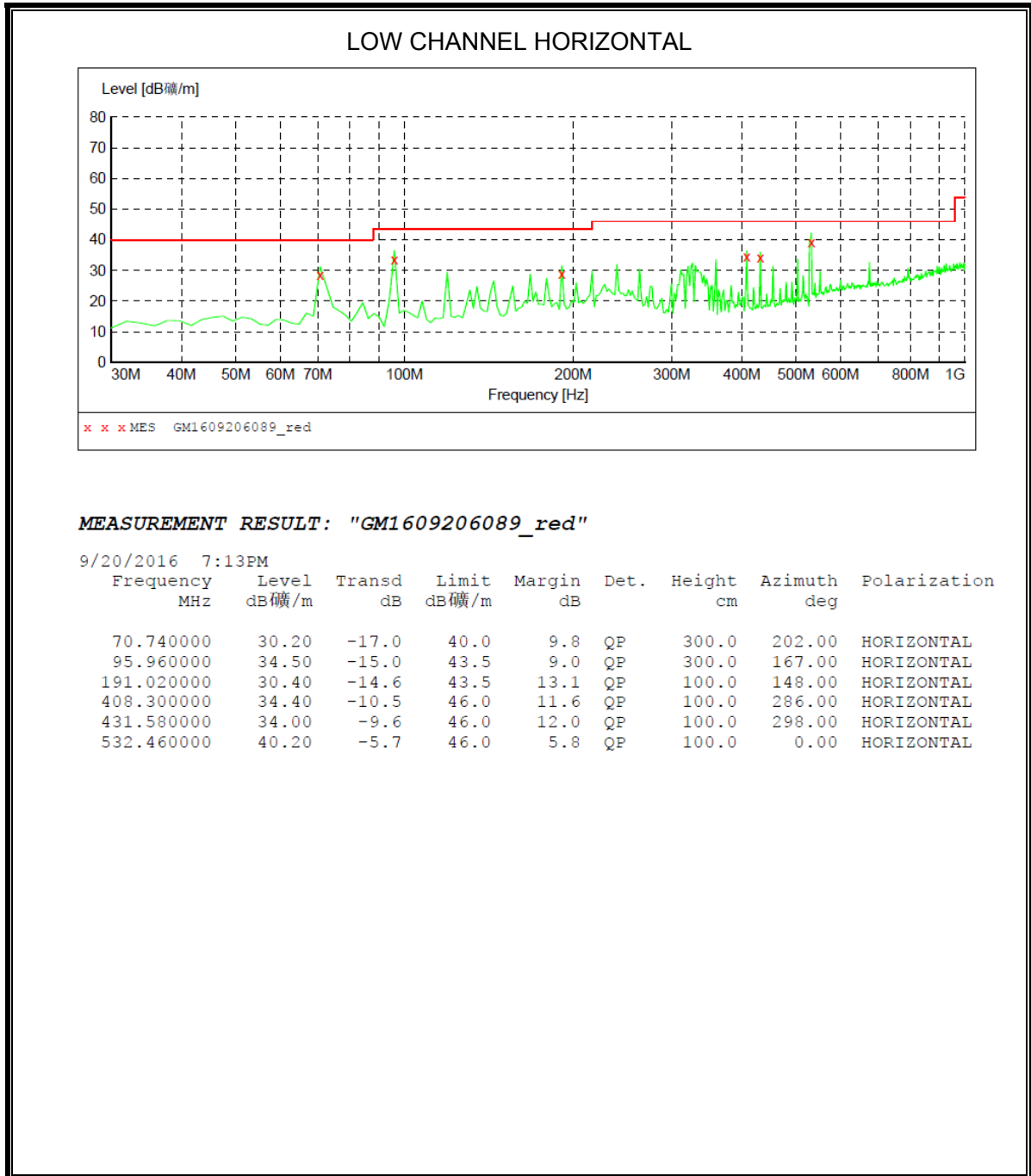

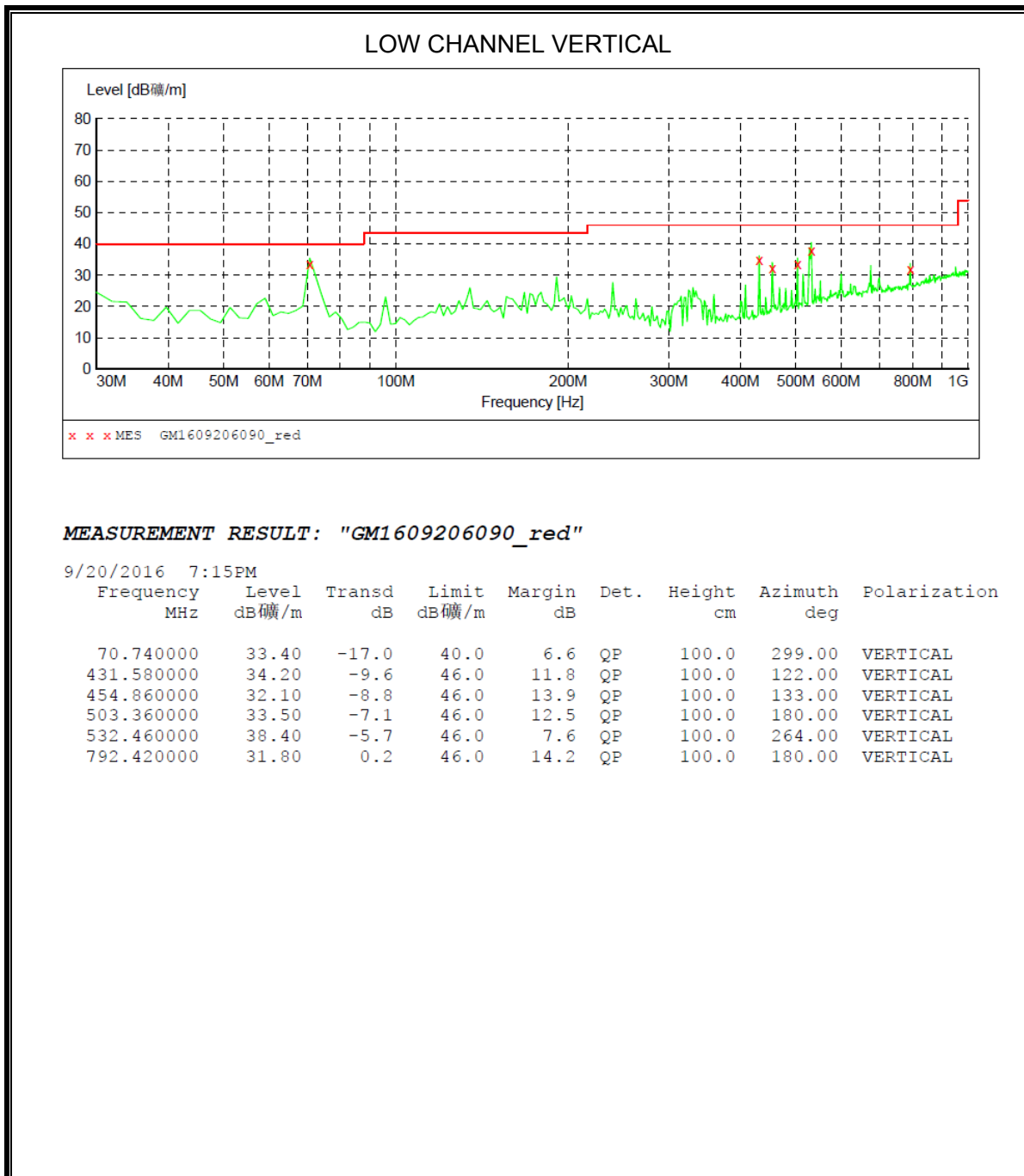

Note: EUT in each of three orthogonal axis emissions had been tested, but only the worst case (X axis) data recorded in the report.

8.5. SPURIOUS EMISSIONS BELOW 30M

Note 1: The low frequency, which started from 9 kHz to 30MHz, was pre-scanned and the result which was 20dB lower than the limit line per 15.31(o) was not reported.

Note 2: EUT in each of three orthogonal axis emissions had been tested, but only the worst case (X axis) data recorded in the report.

9. AC POWER LINE CONDUCTED EMISSIONS

LIMITS

Please refer to FCC §15.207 (a) and RSS-Gen Clause 8.8

FREQUENCY (MHz)	Class A (dBuV)		Class B (dBuV)	
	Quasi-peak	Average	Quasi-peak	Average
0.15 -0.5	79.00	66.00	66 - 56 *	56 - 46 *
0.50 -5.0	73.00	60.00	56.00	46.00
5.0 -30.0	73.00	60.00	60.00	50.00

TEST SETUP AND PROCEDURE

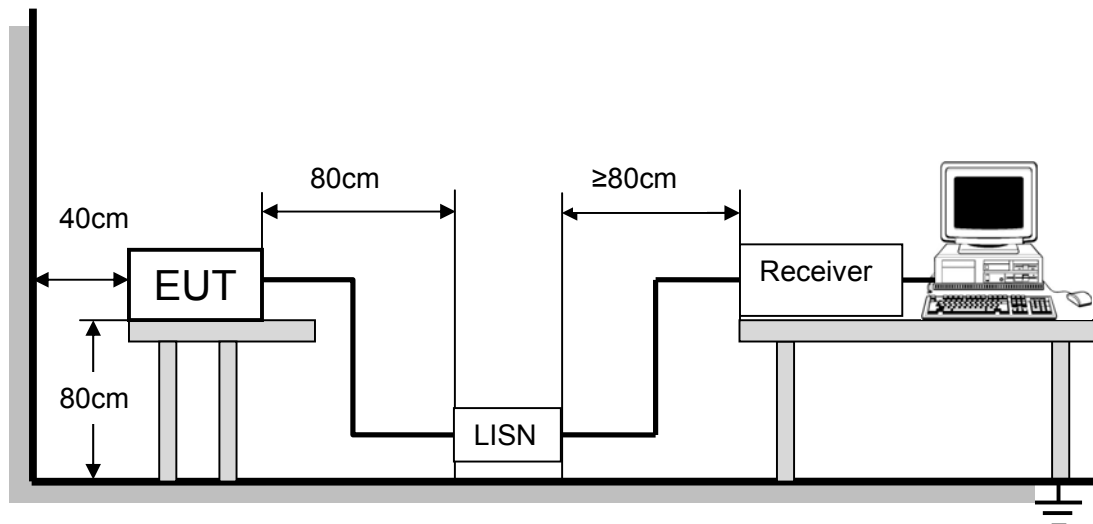

The EUT is put on a table of non-conducting material that is 80cm high. The vertical conducting wall of shielding is located 40cm to the rear of the EUT. The power line of the EUT is connected to the AC mains through a Artificial Mains Network (A.M.N.). A EMI Measurement Receiver (R&S Test Receiver ESR3) is used to test the emissions from both sides of AC line. According to the requirements in Section 7 and 13 of ANSI C63.4-2014. Conducted emissions from the EUT measured in the frequency range between 0.15 MHz and 30MHz using CISPR Quasi-Peak and average detector mode. The bandwidth of EMI test receiver is set at 9kHz.

The arrangement of the equipment is installed to meet the standards and operating in a manner, which tends to maximize its emission characteristics in a normal application.

TEST RESULTS

EUT:	LIFEPROOF AQ10	Model Name:	LPSAN-0006-A
Temperature:	24.3°C	Relative Humidity:	47.0 %
Pressure:	1012 hPa	Test Voltage:	AC 120V/60Hz
Test Mode:	GFSK Mode	Phase :	L1

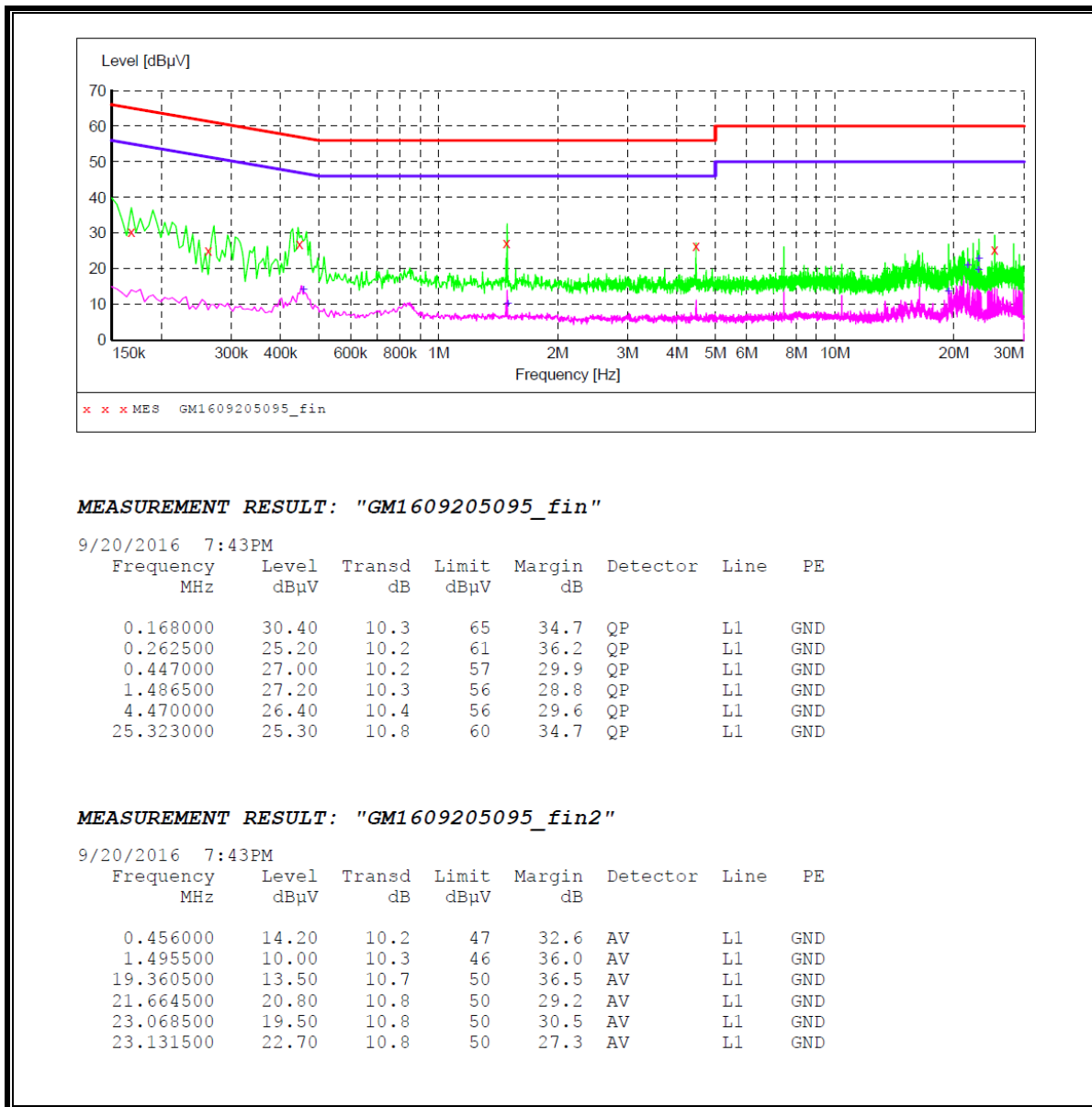

EUT:	LIFEPROOF AQ10	Model Name:	LPSAN-0006-A
Temperature:	24.3°C	Relative Humidity:	47.0 %
Pressure:	1012 hPa	Test Voltage:	AC 120V/60Hz
Test Mode:	GFSK Mode	Phase :	N

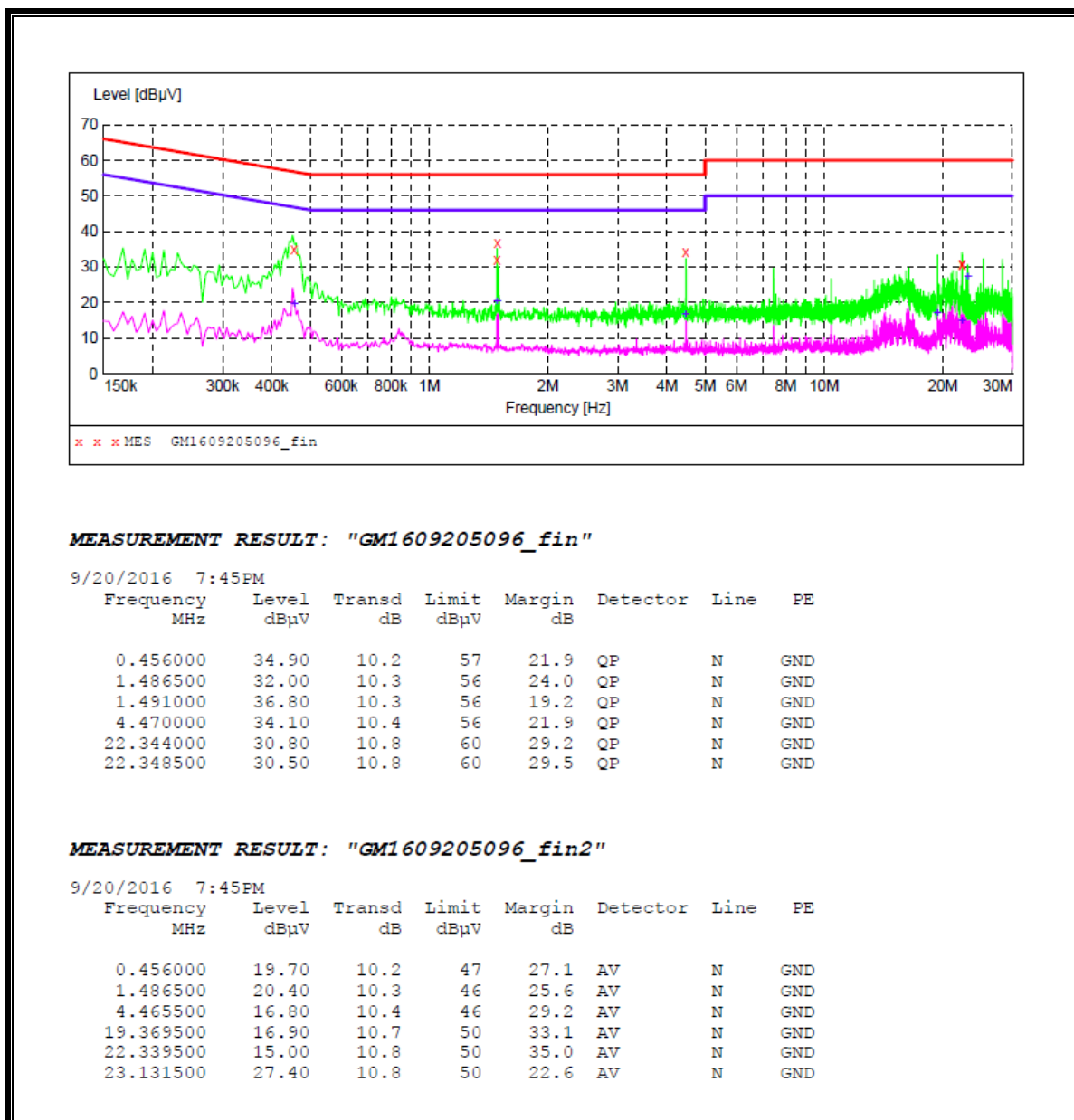

10. ANTENNA REQUIREMENTS

APPLICABLE REQUIREMENTS

Please refer to FCC §15.203

If directional gain of transmitting antennas is greater than 6dBi, the power shall be reduced by the same level in dB comparing to gain minus 6dBi. For the fixed point-to-point operation, the power shall be reduced by one dB for every 3 dB that the directional gain of the antenna exceeds 6 dBi. The use of a permanently attached antenna or of an antenna that uses a unique coupling to the intentional radiator shall be considered sufficient to comply with the FCC rule.

ANTENNA CONNECTOR

EUT has a PCB antenna without antenna connector.

ANTENNA GAIN

The antenna gain of EUT is less than 6 dBi.

END OF REPORT