



**FCC 47 CFR PART 15 SUBPART C
INDUSTRY CANADA RSS-247 ISSUE 1**

CERTIFICATION TEST REPORT

For

**LIFEPROOF AQ9
MODEL NUMBER: LPSAN-0005-A**

**FCC ID: UZZLPSAN0005
IC: 7633A-LPSAN0005**

REPORT NUMBER: 4787565292.3.1-2

ISSUE DATE: September 05, 2016

Prepared for

**Beautiful Enterprise Co., Ltd.
27th Floor, Beautiful Group Tower, 77 Connaught Road Central, Hong Kong**

Prepared by

**UL Verification Services (Guangzhou) Co., Ltd, Song Shan Lake Branch
Room 101, Building 10, Innovation Technology Park,
Song Shan Lake Hi tech Development Zone, Dongguan, 523808, China
Tel: +86 769 33817100
Fax: +86 769 33244054
Website: www.ul.com**

Revision History

<u>Rev.</u>	<u>Issue Date</u>	<u>Revisions</u>	<u>Revised By</u>
--	9/05/2016	Initial Issue	

Summary of Test Results			
Clause	Test Items	FCC/IC Rules	Test Results
1	20dB Bandwidth	FCC 15.247 (a) (1) IC RSS-247 Clause 5.1 (1)	Complied
2	Peak Conducted Output Power	FCC 15.247 (b) (1) IC RSS-247 Clause 5.4 (2)	Complied
3	Carrier Hopping Channel Separation	FCC 15.247 (a) (1) IC RSS-247 Clause 5.1 (2)	Complied
4	Number of Hopping Frequency	15.247 (a) (1) III IC RSS-247 Clause 5.1 (4)	Complied
5	Time of Occupancy (Dwell Time)	15.247 (a) (1) III IC RSS-247 Clause 5.1 (4)	Complied
6	Conducted Bandedge and Spurious	FCC 15.247 (d) IC RSS-247 Clause 5.5	Complied
7	Radiated Bandedge and Spurious	FCC 15.247 (d) FCC 15.209 FCC 15.205 IC RSS-247 Clause 5.5 IC RSS-GEN Clause 8.9	Complied
8	Conducted Emission Test For AC Power Port	FCC 15.207 RSS-GEN Clause 8.8	Complied
9	Antenna Requirement	FCC 15.203 RSS-GEN Clause 8.3	Complied

TABLE OF CONTENTS

1. ATTESTATION OF TEST RESULTS	6
2. TEST METHODOLOGY	7
3. FACILITIES AND ACCREDITATION	7
4. CALIBRATION AND UNCERTAINTY	8
4.1. MEASURING INSTRUMENT CALIBRATION	8
4.2. MEASUREMENT UNCERTAINTY	8
5. EQUIPMENT UNDER TEST	9
5.1. DESCRIPTION OF EUT	9
5.2. MAXIMUM OUTPUT POWER.....	9
5.3. PACKET TYPE CONFIGURATION.....	9
5.4. CHANNEL LIST	10
5.5. TEST CHANNEL CONFIGURATION	10
5.6. THE WORSE CASE POWER SETTING PARAMETER.....	10
5.7. DESCRIPTION OF AVAILABLE ANTENNAS	11
5.8. WORST-CASE CONFIGURATIONS.....	11
5.9. DESCRIPTION OF TEST SETUP	11
5.10. MEASURING INSTRUMENT AND SOFTWARE USED.....	13
6. MEASUREMENT METHODS	14
7. ANTENNA PORT TEST RESULTS	15
7.1. 20 dB BANDWIDTH	15
7.1.1. GFSK MODE.....	16
7.1.2. 8-DPSK MODE.....	18
7.2. 99% BANDWIDTH.....	20
7.2.1. GFSK MODE.....	21
7.2.2. 8-DQPSK MODE.....	23
7.3. PEAK CONDUCTED OUTPUT POWER.....	25
7.3.1. GFSK MODE.....	25
7.3.2. 8-DPSK MODE.....	28
7.4. CARRIER HOPPING CHANNEL SEPARATION.....	30
7.4.1. GFSK MODE.....	31
7.4.2. 8-DPSK MODE.....	Error! Bookmark not defined.
7.5. NUMBER OF HOPPING FREQUENCY	35
7.5.1. GFSK MODE.....	36
7.5.2. 8-DPSK MODE.....	37
7.6. TIME OF OCCUPANCY (DWELL TIME).....	38

7.6.1.	GFSK MODE.....	39
7.6.2.	8-DPSK MODE.....	41
7.7.	CONDUCTED BANDEDGE AND SPURIOUS EMISSIONS	43
7.7.1.	GFSK MODE.....	44
7.7.2.	8-DPSK MODE.....	50
8.	RADIATED TEST RESULTS	56
8.1.	LIMITS AND PROCEDURE	56
8.2.	RESTRICTED BANDEDGE	60
8.2.1.	GFSK MODE.....	60
8.2.2.	8-DPSK MODE.....	64
8.3.	SPURIOUS EMISSIONS (1~25GHz)	68
8.3.1.	GFSK MODE.....	68
8.3.2.	8DPSK MODE.....	74
8.4.	SPURIOUS EMISSIONS 30M ~ 1 GHz.....	80
8.4.1.	GFSK MODE.....	80
8.5.	SPURIOUS EMISSIONS BELOW 30M.....	82
9.	AC POWER LINE CONDUCTED EMISSIONS.....	83
10.	ANTENNA REQUIREMENTS.....	86

1. ATTESTATION OF TEST RESULTS

Applicant Information

Company Name: Beautiful Enterprise Co., Ltd.
Address: 27th Floor, Beautiful Group Tower, 77 Connaught Road Central, Hong Kong

Manufacturer Information

Company Name: Shenzhen Synchron Electronics Co., Ltd.
Address: No. 9 Mei Li Road, Xia Mei Lin, Fu Tian Area, Shenzhen, Guangdong, P.R. China

EUT Description

Product Name: LIFEPROOF AQ9
Brand Name: N/A
Model Name: LPSAN-0005-A
FCC ID: UZZLPSAN0005
IC: 7633A-LPSAN0005
Date Tested: August 15, 2016 ~ August 24, 2016

APPLICABLE STANDARDS	
STANDARD	TEST RESULTS
CFR 47 Part 15 Subpart C	PASS
INDUSTRY CANADA RSS-247 Issue 1	PASS
INDUSTRY CANADA RSS-GEN Issue 4	PASS

Tested By:

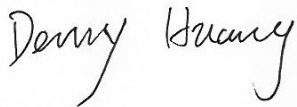

Denny Huang
Engineer Project Associate
Approved By:



Shawn Wen
Laboratory Leader

Check By:



Shawn Wen
Laboratory Leader

2. TEST METHODOLOGY

The tests documented in this report were performed in accordance with FCC CFR 47 Part 2, FCC CFR 47 Part 15, ANSI C63.10-2013, RSS-GEN Issue 4, and RSS-247 Issue 1.

3. FACILITIES AND ACCREDITATION

Test Location	Shenzhen Huatongwei International Inspection Co., Ltd.
Address	1/F, Bldg 3, Hongfa Hi-tech Industrial Park, Genyu Road, Tianliao, Gongming, Shenzhen, China Phone: 86-755-26748019 Fax: 86-755-26748089
Accreditation Certificate	<p>Shenzhen Huatongwei International Inspection Co., Ltd. EMC Laboratory has been accredited by A2LA for technical competence in the field of electrical testing, and proved to be in compliance with ISO/IEC 17025: 2005 General Requirements for the Competence of Testing and Calibration Laboratories and any additional program requirements in the identified field of testing. Valid time is until December 31, 2016.</p> <p>Shenzhen Huatongwei International Inspection Co., Ltd. EMC Laboratory has been registered and fully described in a report filed with the FCC (Federal Communications Commission). The acceptance letter from the FCC is maintained in our files. Registration 317478, Renewal date Jul. 18, 2014, valid time is until Jul. 18, 2017.</p> <p>The 3m Alternate Test Site of Shenzhen Huatongwei International Inspection Co., Ltd. has been registered by Certification and Engineering Bureau of Industry Canada for the performance of radiated measurements with Registration No. 5377A on Dec. 31, 2013, valid time is until Dec. 31, 2016.</p> <p>Two 3m Alternate Test Site of Shenzhen Huatongwei International Inspection Co., Ltd. has been registered by Certification and Engineering Bureau of Industry Canada for the performance of radiated measurements with Registration No. 5377B on Dec.03, 2014, valid time is until Dec.03, 2017.</p>
Description	Radiated tests and Conducted Emission tests for AC Power Port measurement facilities use to collect the measurement data are located at 1/F, Bldg 3, Hongfa Hi-tech Industrial Park, Genyu Road, Tianliao, Gongming, Shenzhen, China

4. CALIBRATION AND UNCERTAINTY

4.1. MEASURING INSTRUMENT CALIBRATION

The measuring equipment utilized to perform the tests documented in this report has been calibrated in accordance with the manufacturer's recommendations, and is traceable to recognized national standards.

4.2. MEASUREMENT UNCERTAINTY

Where relevant, the following measurement uncertainty levels have been estimated for tests performed on the apparatus:

PARAMETER	UNCERTAINTY
Conducted Disturbance, 0.15 to 30 MHz	± 3.39 dB
Radiated Disturbance, 9k to 30 MHz	± 2.20 dB
Radiated Disturbance, 30 to 1000 MHz	± 4.24 dB
Radiated Disturbance, 1 to 18 GHz	± 5.16 dB
Radiated Disturbance, 18 to 40 GHz	± 5.54 dB

Uncertainty figures are valid to a confidence level of 95%.

5. EQUIPMENT UNDER TEST

5.1. DESCRIPTION OF EUT

Equipment	LIFEPROOF AQ9		
Model Name	LPSAN-0005-A		
Product Description	Operation Frequency	2402 MHz ~ 2480 MHz	
	Modulation Type	Data Rate	
	GFSK	1Mbps	
	π/4-DQPSK	2Mbps	
	8-DPSK	3Mbps	
Power Supply	DC 5V, 2A		
Battery	3.7V, 1000mAh		
Bluetooth Version	BT 4.2		

5.2. MAXIMUM OUTPUT POWER

Frequency Range (MHz)	Number of Transmit Chains (NTX)	Bluetooth Mode	Frequency (MHz)	Channel Number	Max PK Conducted Power (dBm)	Max EIRP (dBm)
2400-2483.5	1	GFSK	2402-2480	0-78[79]	0.10	-1.62
2400-2483.5	1	8-DPSK	2402-2480	0-78[79]]	0.47	-1.25

5.3. PACKET TYPE CONFIGURATION

Test Mode	Packet Type	Setting
GFSK	DH1	27
	DH3	183
	DH5	339
π/4-DQPSK	2-DH1	54
	2-DH3	367
	2-DH5	679
8-DPSK	3-DH1	83
	3-DH3	552
	3-DH5	1021

5.4. CHANNEL LIST

Channel	Frequency (MHz)	Channel	Frequency (MHz)	Channel	Frequency (MHz)	Channel	Frequency (MHz)
00	2402	20	2422	40	2442	60	2462
01	2403	21	2423	41	2443	61	2463
02	2404	22	2424	42	2444	62	2464
03	2405	23	2425	43	2445	63	2465
04	2406	24	2426	44	2446	64	2466
05	2407	25	2427	45	2447	65	2467
06	2408	26	2428	46	2448	66	2468
07	2409	27	2429	47	2449	67	2469
08	2410	28	2430	48	2450	68	2470
09	2411	29	2431	49	2451	69	2471
10	2412	30	2432	50	2452	70	2472
11	2413	31	2433	51	2453	71	2473
12	2414	32	2434	52	2454	72	2474
13	2415	33	2435	53	2455	73	2475
14	2416	34	2436	54	2456	74	2476
15	2417	35	2437	55	2457	75	2477
16	2418	36	2438	56	2458	76	2478
17	2419	37	2439	57	2459	77	2479
18	2420	38	2440	58	2460	78	2480
19	2421	39	2441	59	2461		

5.5. TEST CHANNEL CONFIGURATION

Test Mode	Test Channel Number	Test Channel
GFSK	CH 00, CH 39, CH 78	Low, Middle, High
8-DPSK	CH 00, CH 39, CH 78	Low, Middle, High

5.6. THE WORSE CASE POWER SETTING PARAMETER

The Worst Case Power Setting Parameter under 2400 ~ 2483.5MHz Band				
Test Software Version		ACTsBTAPP		
Modulation Type	Transmit Antenna Number	Test Channel		
		CH 00	CH 039	CH 78
GFSK	1	N/A	N/A	N/A
8-DPSK	1	N/A	N/A	N/A

5.7. DESCRIPTION OF AVAILABLE ANTENNAS

Ant.	Frequency (MHz)	Antenna Type	Antenna Gain (dBi)
1	2402-2480	PCB Antenna	-1.72

Test Mode	Transmit and Receive Mode	Description
GFSK	<input checked="" type="checkbox"/> 1TX, 1RX	Chain 1 can be used as transmitting/receiving antenna.
8-DPSK	<input checked="" type="checkbox"/> 1TX, 1RX	Chain 1 can be used as transmitting/receiving antenna.

5.8. WORST-CASE CONFIGURATIONS

Bluetooth Mode	Modulation Technology	Modulation Type	Data Rate (Mbps)
BR	FHSS	GFSK	1Mbit/s
EDR	FHSS	8-DPSK	3Mbit/s

5.9. DESCRIPTION OF TEST SETUP

SUPPORT EQUIPMENT

Item	Equipment	Brand Name	Model Name	FCC ID
1	Laptop	ThinkPad	T410	N/A

I/O CABLES

Cable No	Port	Connector Type	Cable Type	Cable Length(m)	Remarks
1	AUX In	AUX	N/A	0.30	N/A
2	DC In	USB	Unshielded	0.92	N/A

ACCESSORY

Item	Accessory	Brand Name	Model Name	Description
1	N/A	N/A		N/A

Note: The EUT has no accessory.

TEST SETUP

The EUT can work in an engineer mode with a software through a Laptop.

SETUP DIAGRAM FOR TESTS

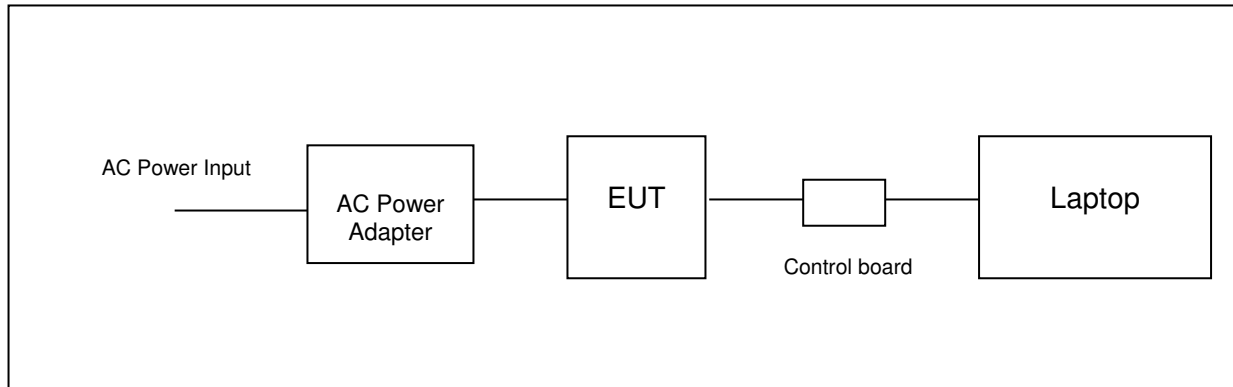

5.10. MEASURING INSTRUMENT AND SOFTWARE USED

Instrument(Conducted for RF Port)						
Used	Equipment	Manufacturer	Model No.	Serial No.	Last Cal.	Expired date
<input checked="" type="checkbox"/>	Spectrum Analyzer	R&S	FSV40	100048	Nov.3,2015	Nov.3,2016
Instrument (Line Conducted Emission (AC Main))						
Use d	Equipment	Manufacturer	Model No.	Serial No.	Last Cal.	Expired date
<input checked="" type="checkbox"/>	EMI Test Receiver	R&S	ESCI	101247	Nov.3,2015	Nov.3,2016
<input checked="" type="checkbox"/>	Artificial Mains	SCHWARZBECK	NNLK 8121	573	Nov.3,2015	Nov.3,2016
<input checked="" type="checkbox"/>	Pulse Limiter	R&S	ESH3-Z2	101488	Nov.3,2015	Nov.3,2016
<input checked="" type="checkbox"/>	Test Software	R&S	ES-K1	N/A	N/A	N/A
<input checked="" type="checkbox"/>	Adapter (see note)	HUNTKEY	HW-050100C2W	HWHKAPE51309936	-	-
Instrument (Radiated Tests)						
Use d	Equipment	Manufacturer	Model No.	Serial No.	Last Cal.	Expired date
<input checked="" type="checkbox"/>	EMI Test Receiver	R&S	ESI 26	100009	Nov.2,2015	Nov.2,2016
<input checked="" type="checkbox"/>	RF Test Panel	R&S	TS / RSP	335015/0017	N/A	N/A
<input checked="" type="checkbox"/>	EMI Test Software	R&S	ESK1	N/A	N/A	N/A
<input checked="" type="checkbox"/>	Ultra-Broadband Antenna	ShwarzBeck	VULB9163	538	Nov.8,2015	Nov.8,2016
<input checked="" type="checkbox"/>	Horn Antenna	ShwarzBeck	9120D	1011	Nov.8,2015	Nov.8,2016
<input checked="" type="checkbox"/>	Loop Antenna	R&S	HZ-9	838622\013	Nov.8,2015	Nov.8,2016
<input checked="" type="checkbox"/>	Broadband Horn Antenna	ShwarzBeck	BBHA9170	BBHA9170472	Nov.8,2015	Nov.8,2016
<input checked="" type="checkbox"/>	Broadband Preamplifier	ShwarzBeck	BBV 9718	9718-247	Nov.2,2015	Nov.2,2016
<input checked="" type="checkbox"/>	Broadband Preamplifier	ShwarzBeck	BBV 9721	9721-102	Nov.2,2015	Nov.2,2016
<input checked="" type="checkbox"/>	Turn Table	MATURO	TT2.0	----	N/A	N/A
<input checked="" type="checkbox"/>	Antenna Mast	MATURO	TAM-4.0-P	----	N/A	N/A
<input checked="" type="checkbox"/>	EMI Test Software	Audix	E3	N/A	N/A	N/A
<input checked="" type="checkbox"/>	Test cable	Siva Cables Italy	RG 58A/U	W14.02	Nov.5,2015	Nov.5,2016

6. MEASUREMENT METHODS

No.	Test Item	KDB Name
1	20 dB Bandwidth	FCC Public Notice DA 00-705
2	99% Bandwidth	ANSI C63.10-2013
3	Peak Output Power	FCC Public Notice DA 00-705
4	Power Spectral Density	FCC Public Notice DA 00-705
5	Out-of-band emissions in non-restricted bands	FCC Public Notice DA 00-705
6	Out-of-band emissions in restricted bands	FCC Public Notice DA 00-705
7	Band-edge	FCC Public Notice DA 00-705

7. ANTENNA PORT TEST RESULTS

7.1. 20 dB BANDWIDTH

LIMITS

FCC Part15 (15.247) , Subpart C IC RSS-247 ISSUE 1			
Section	Test Item	Limit	Frequency Range (MHz)
FCC 15.247 (a) (1) IC RSS-247 Clause 5.1 (1)	20dB Bandwidth	/	2400-2483.5

TEST PROCEDURE

Connect the UUT to the spectrum analyser and use the following settings:

Center Frequency	The centre frequency of the channel under test
Detector	Peak
RBW	$\geq 1\%$ of the 20 dB bandwidth
VBW	\geq RBW
Trace	Max hold
Sweep	Auto couple

Allow the trace to stabilize and measure the maximum width of the emission that is constrained by the frequencies associated with the two outermost amplitude points (upper and lower frequencies) that are attenuated by 20 dB relative to the maximum level measured in the fundamental emission.

TEST SETUP

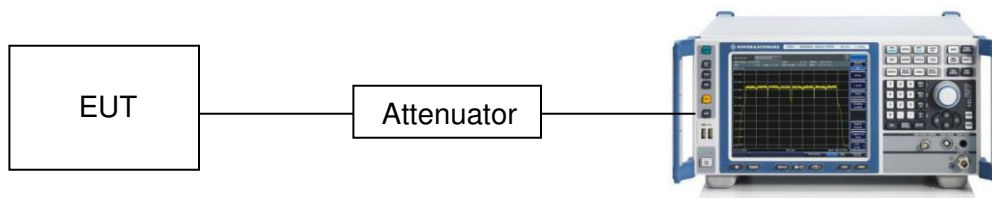

TEST CONDITIONS

Temperature: 28°C
 Relative Humidity: 60%
 Test Voltage: AC 120V/60Hz

RESULTS

7.1.1. GFSK MODE

Channel	Frequency (MHz)	20dB bandwidth (kHz)	Limit (kHz)	Result
Low	2402	916.1	500	Pass
Middle	2441	916.1	500	Pass
High	2480	916.1	500	Pass

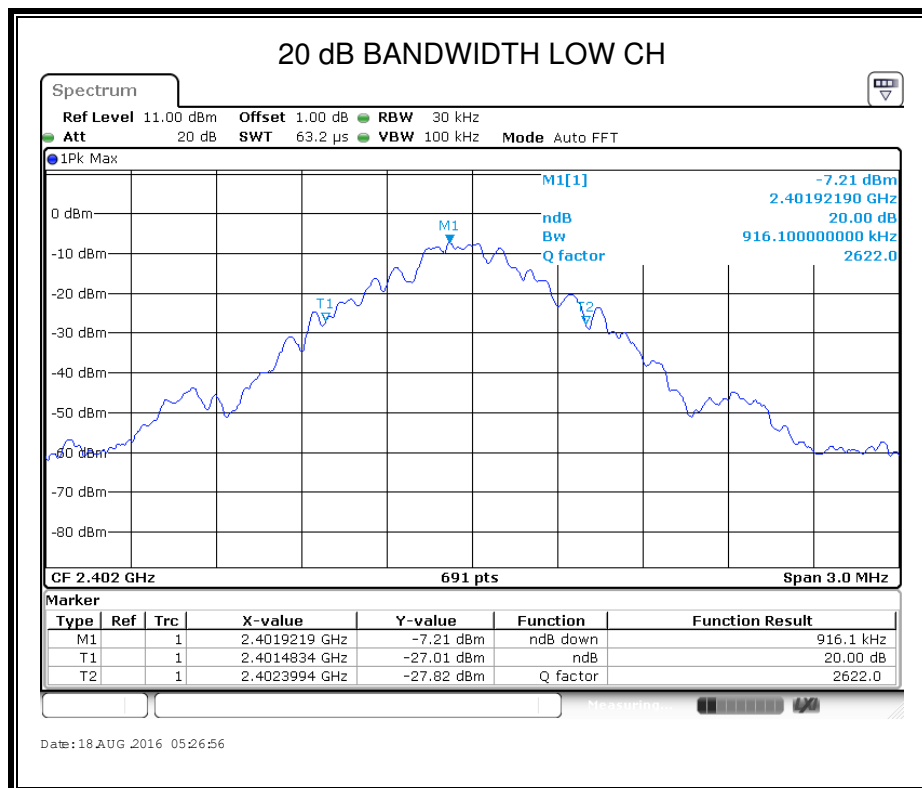

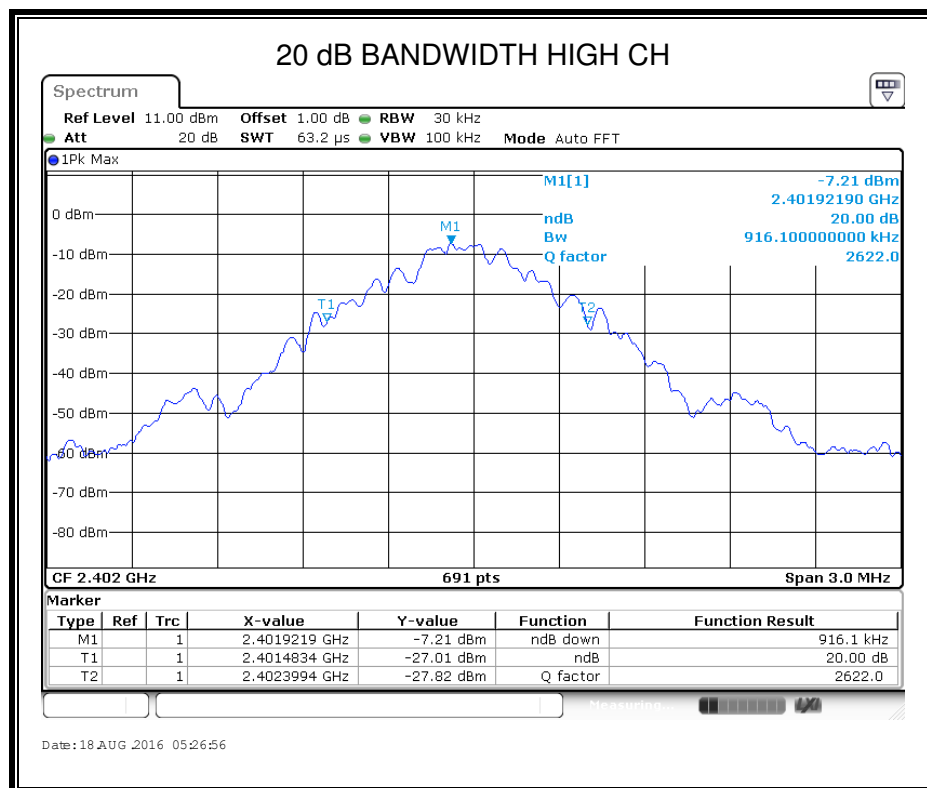
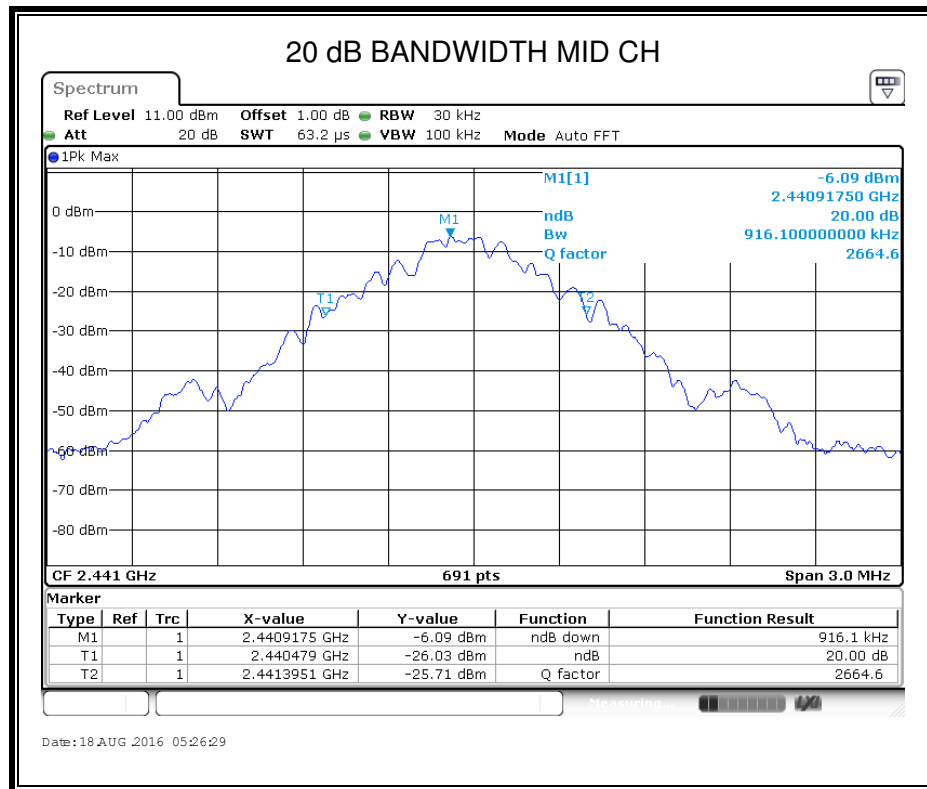

7.1.2. 8-DPSK MODE

Channel	Frequency (MHz)	20dB bandwidth (MHz)	Limit (kHz)	Result
Low	2402	1.220	500	Pass
Middle	2441	1.250	500	Pass
High	2480	1.255	500	Pass

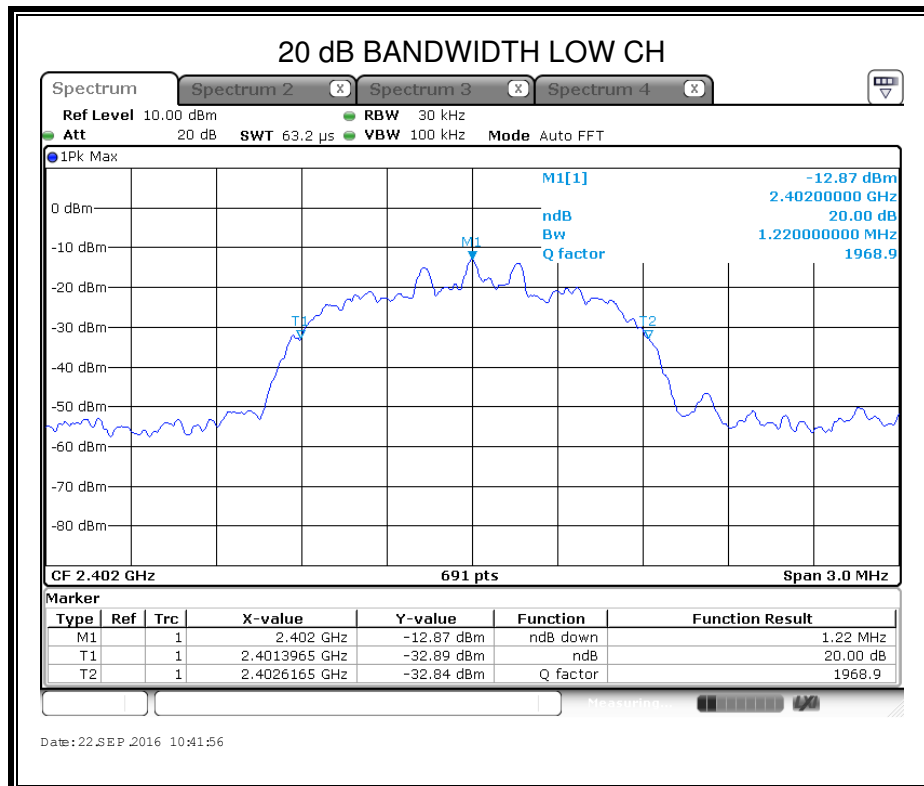

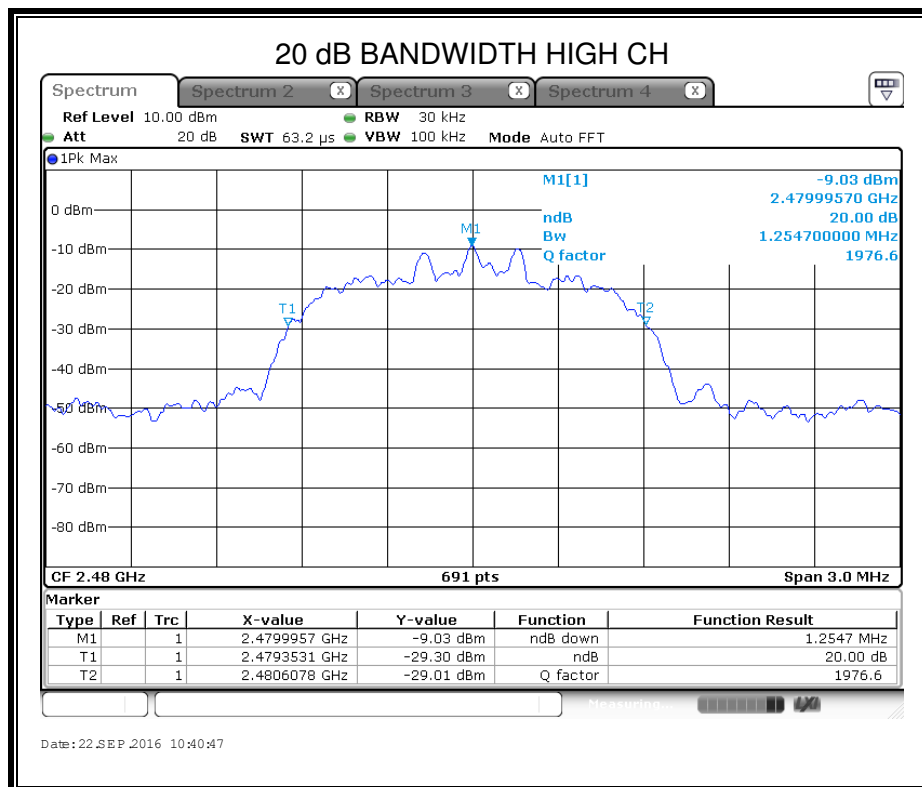
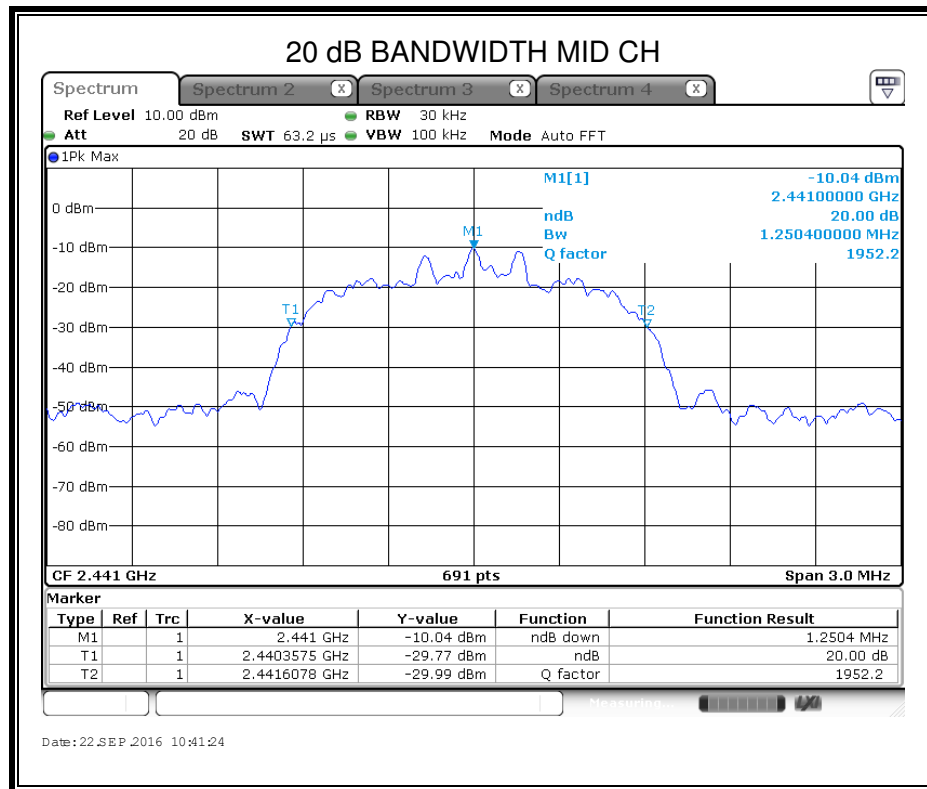

7.2. 99% BANDWIDTH

LIMITS

None; for reporting purposes only.

TEST PROCEDURE

Connect the UUT to the spectrum analyser and use the following settings:

Center Frequency	The centre frequency of the channel under test
Detector	Peak
RBW	$\geq 1\%$ of the 20 dB bandwidth (e.g. 30K for BT)
VBW	\geq RBW
Trace	Max hold
Sweep	Auto couple

Use the 99% bandwidth function in the spectrum analyser and allow the trace to stabilize, then recorded the measurement data.

TEST SETUP

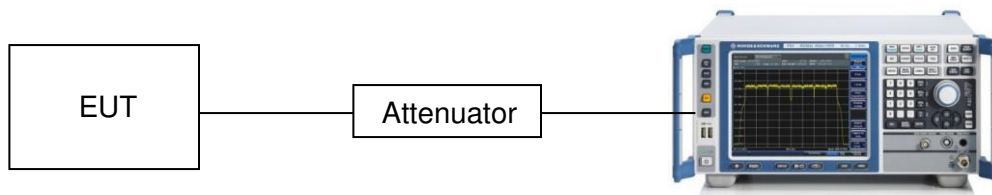

TEST CONDITIONS

Temperature: 28°C
Relative Humidity: 60%
Test Voltage: AC 120V/60Hz

RESULTS

7.2.1. GFSK MODE

Channel	Frequency (MHz)	99% Bandwidth (kHz)	Limit (kHz)	Result
Low	2402	942.113	500	Pass
Middle	2441	942.113	500	Pass
High	2480	963.821	500	Pass

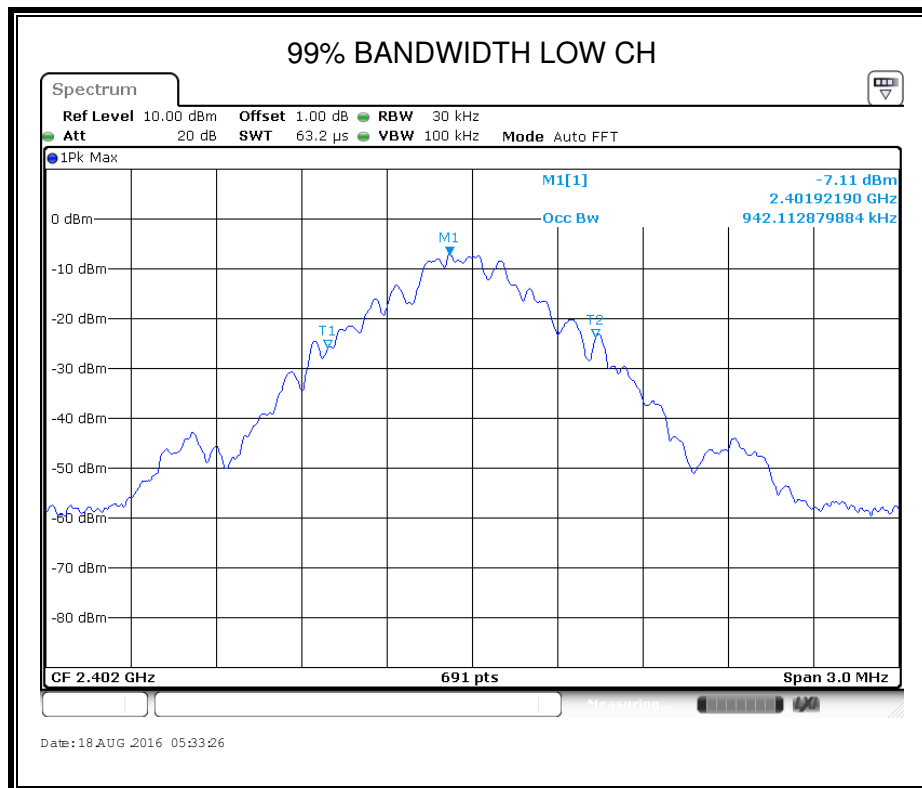

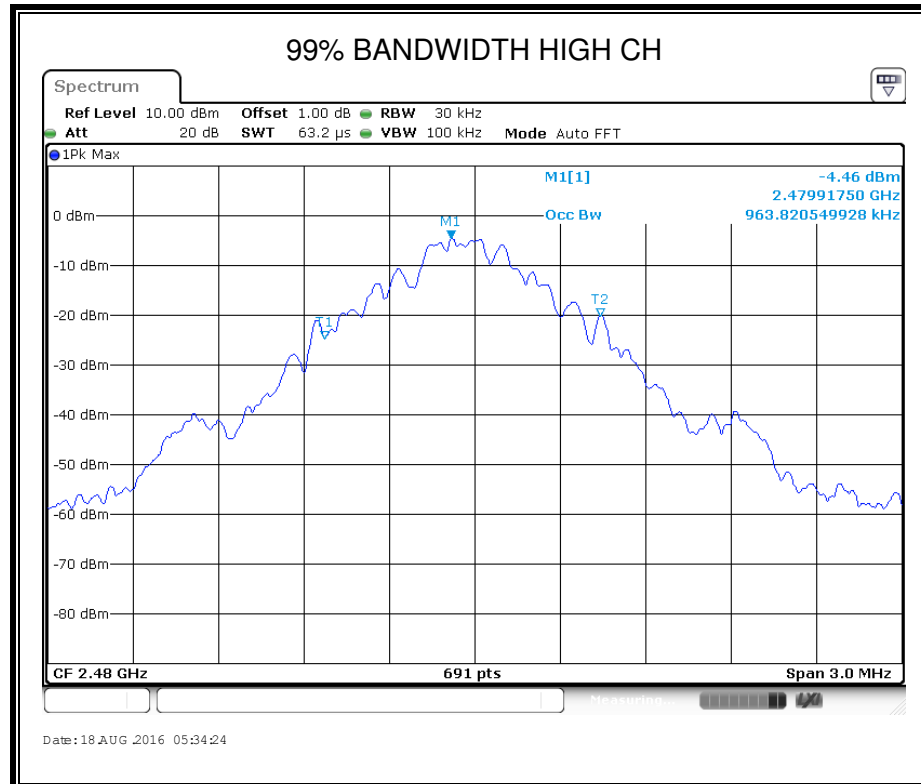
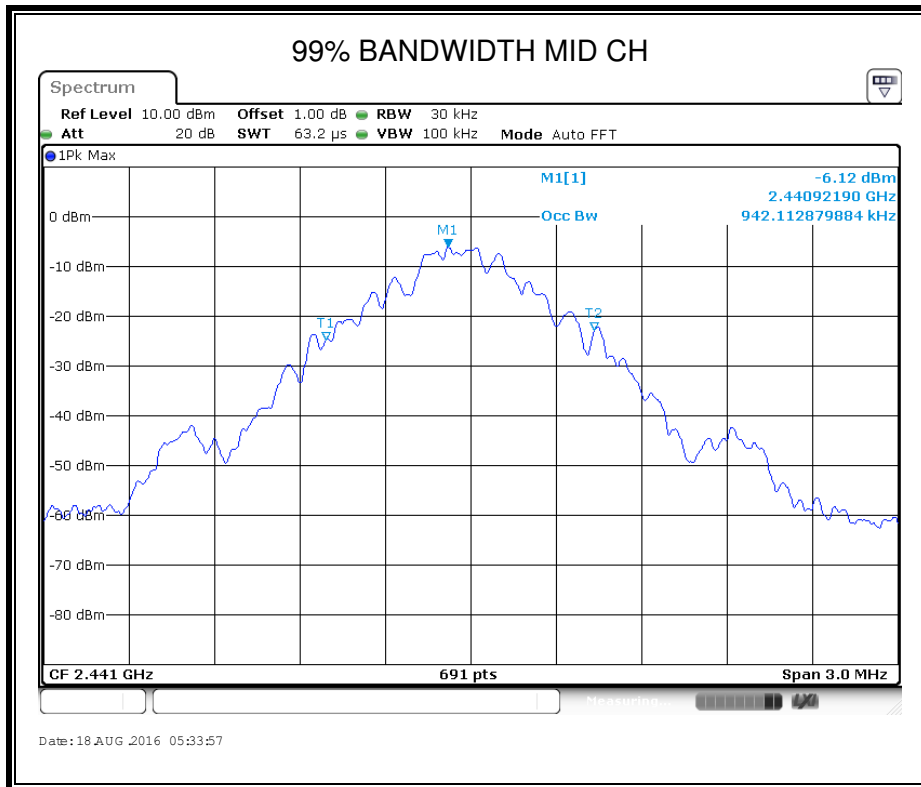

7.2.2. 8-DQPSK MODE

Channel	Frequency (MHz)	99% Bandwidth (MHz)	Limit (kHz)	Result
Low	2402	1.151	500	Pass
Middle	2441	1.155	500	Pass
High	2480	1.151	500	Pass

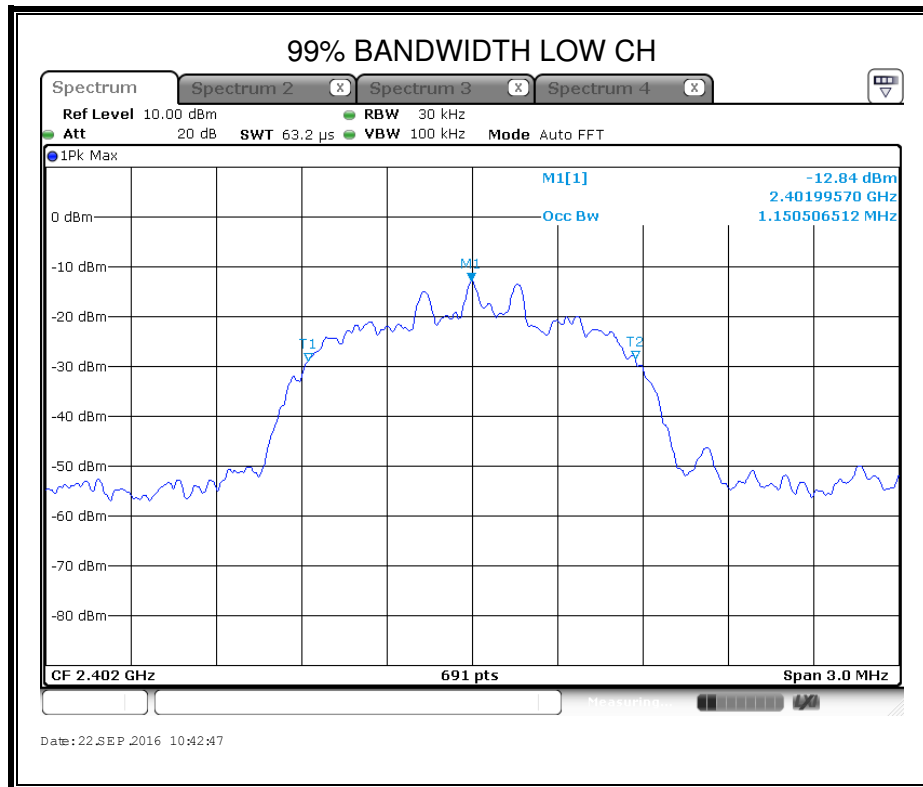

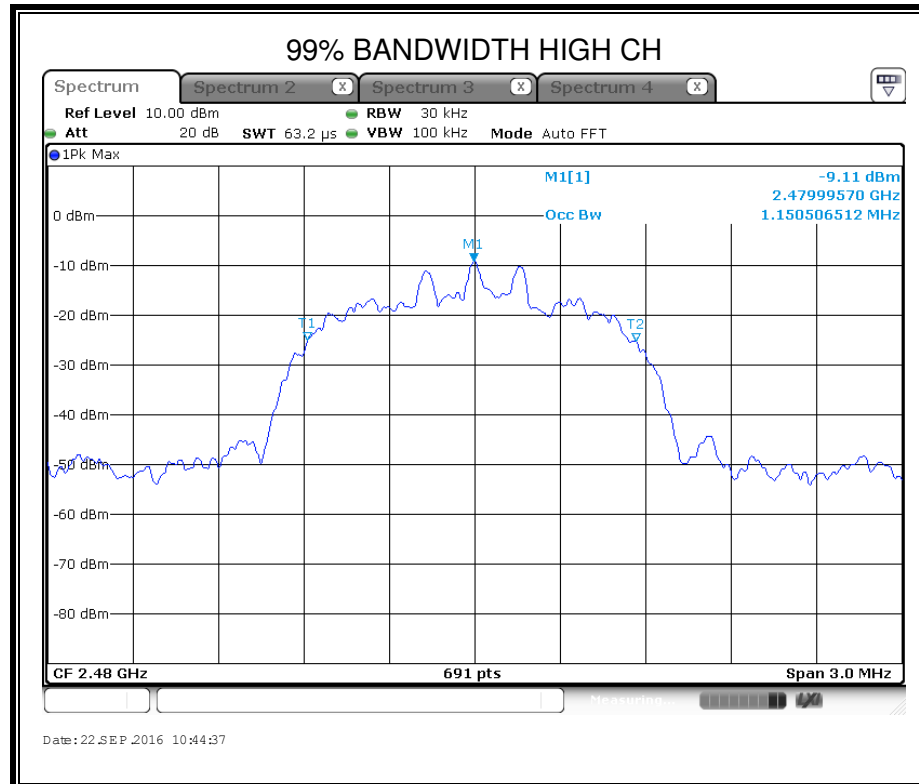
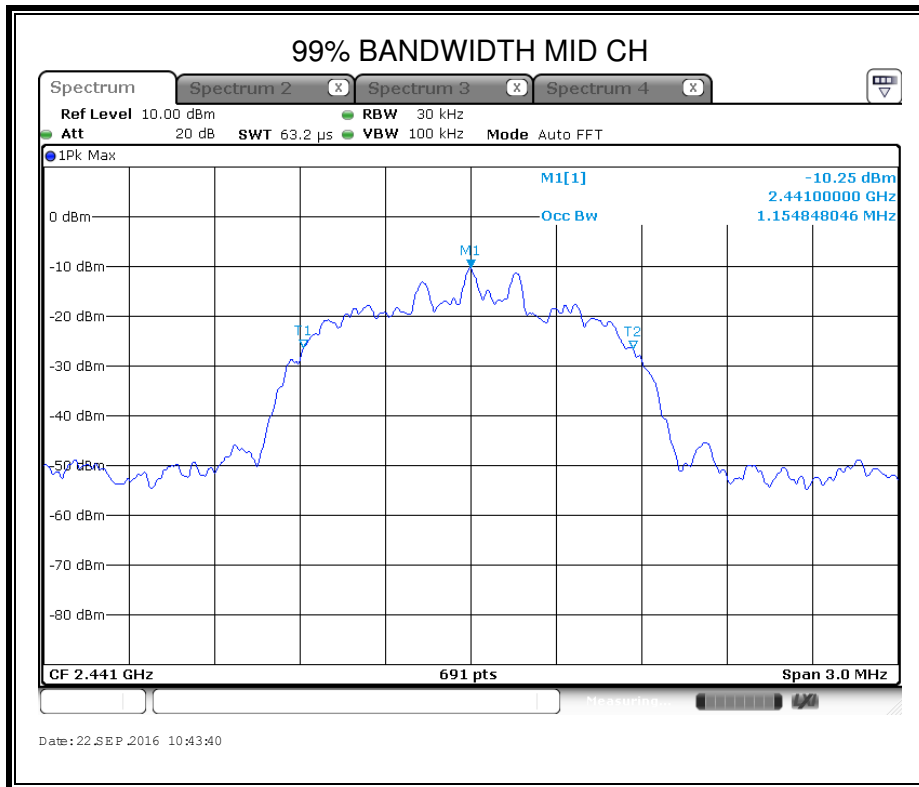

7.3. PEAK CONDUCTED OUTPUT POWER

LIMITS

FCC Part15 (15.247) , Subpart C IC RSS-247 ISSUE 1			
Section	Test Item	Limit	Frequency Range (MHz)
FCC 15.247 (b) (1) IC RSS-247 Clause 5.4 (2)	Peak Conducted Output Power	1 watt or 30dBm	2400-2483.5

TEST PROCEDURE

Connect the UUT to the spectrum analyser and use the following settings:

Center Frequency	The centre frequency of the channel under test
Detector	Peak
RBW	> the 20 dB bandwidth of the emission being measured (e.g. 1 MHz for BT)
VBW	≥RBW
Span	approximately 5 times the 20 dB bandwidth, centered on a hopping channel
Trace	Max hold
Sweep time	Auto couple

Allow trace to fully stabilize and use peak marker function to determine the peak amplitude level.

TEST SETUP

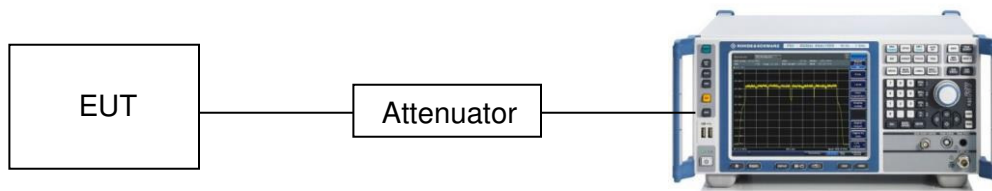

TEST CONDITIONS

Temperature: 28°C
 Relative Humidity: 60%
 Test Voltage: AC 120V/60Hz

RESULTS

7.3.1. GFSK MODE

Channel	Frequency	Maximum Conducted Output Power(PK)	EIRP	Result
	(MHz)	(dBm)	(dBm)	
Low	2402	-2.68	-4.40	Pass
Middle	2441	-1.62	-3.34	Pass
High	2480	0.10	-1.62	Pass

Note: EIRP = Maximum Conducted Output Power (PK) + Antenna Gain

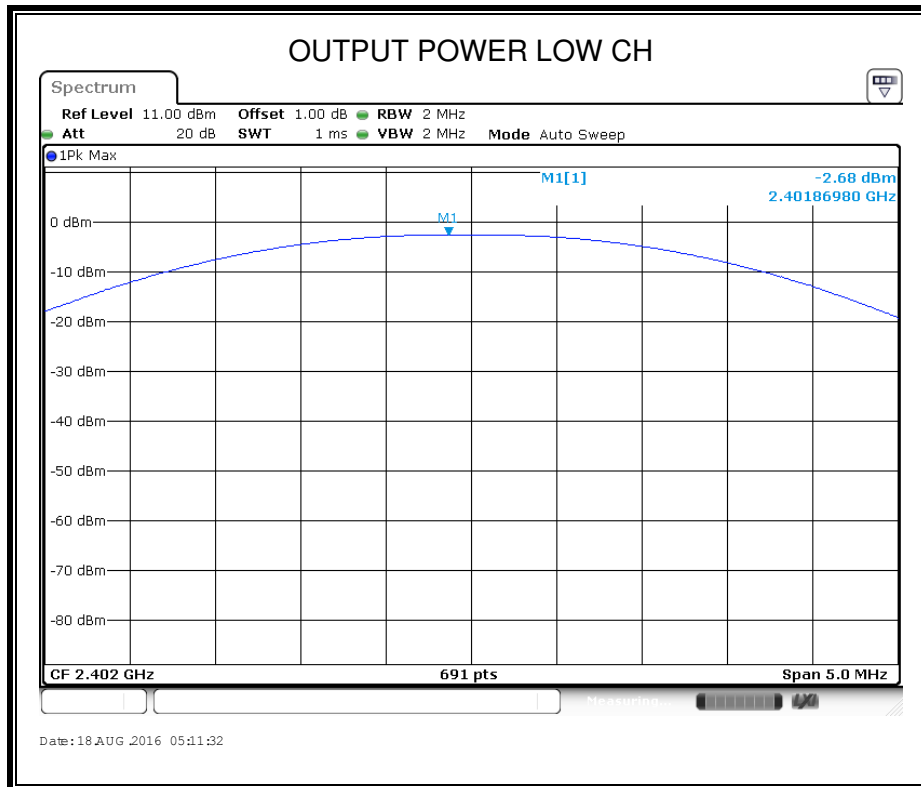

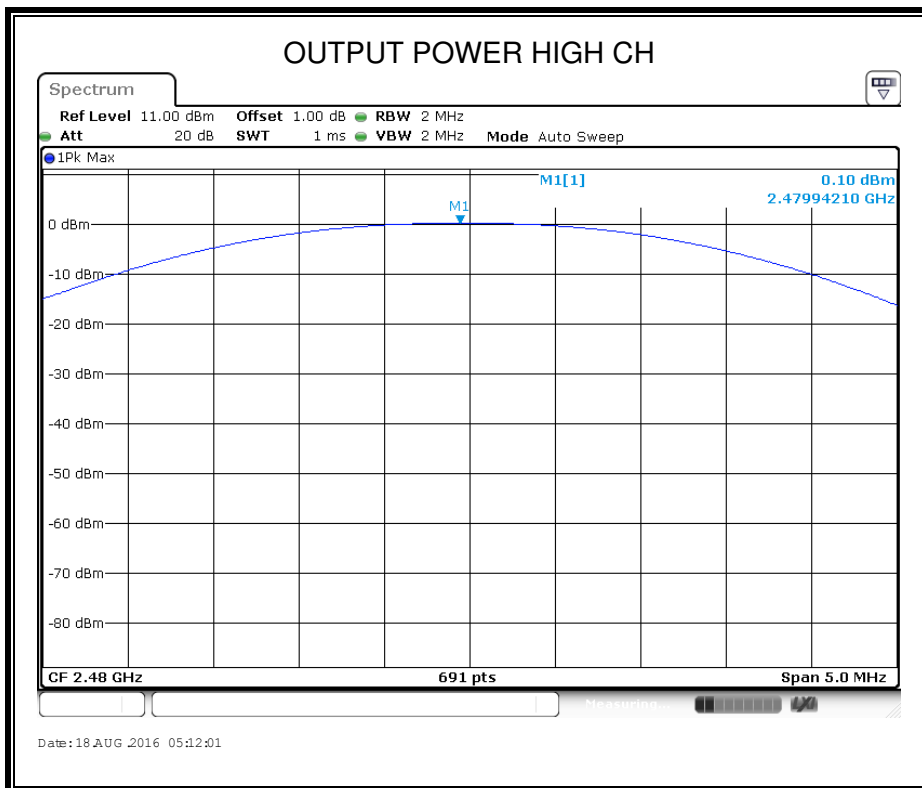
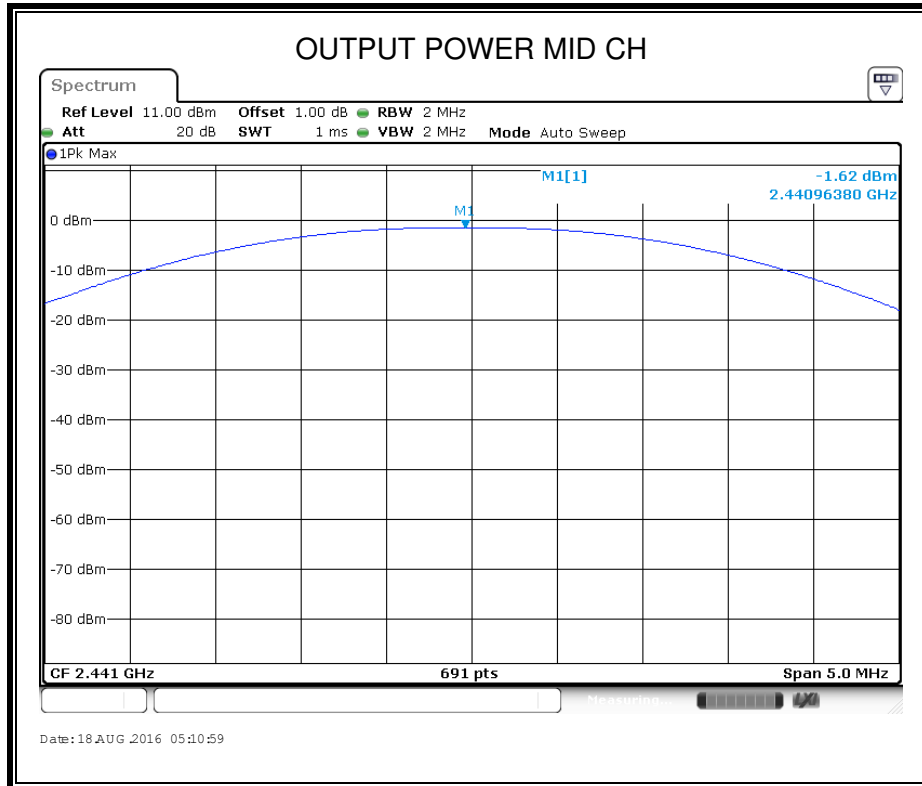

7.3.2. 8-DPSK MODE

Channel	Frequency	Maximum Conducted Output Power(PK)	EIRP	Result
	(MHz)	(dBm)	(dBm)	
Low	2402	-2.18	-3.90	Pass
Middle	2441	-1.29	-3.01	Pass
High	2480	0.47	-1.25	Pass

Note: EIRP = Maximum Conducted Output Power (PK) + Antenna Gain

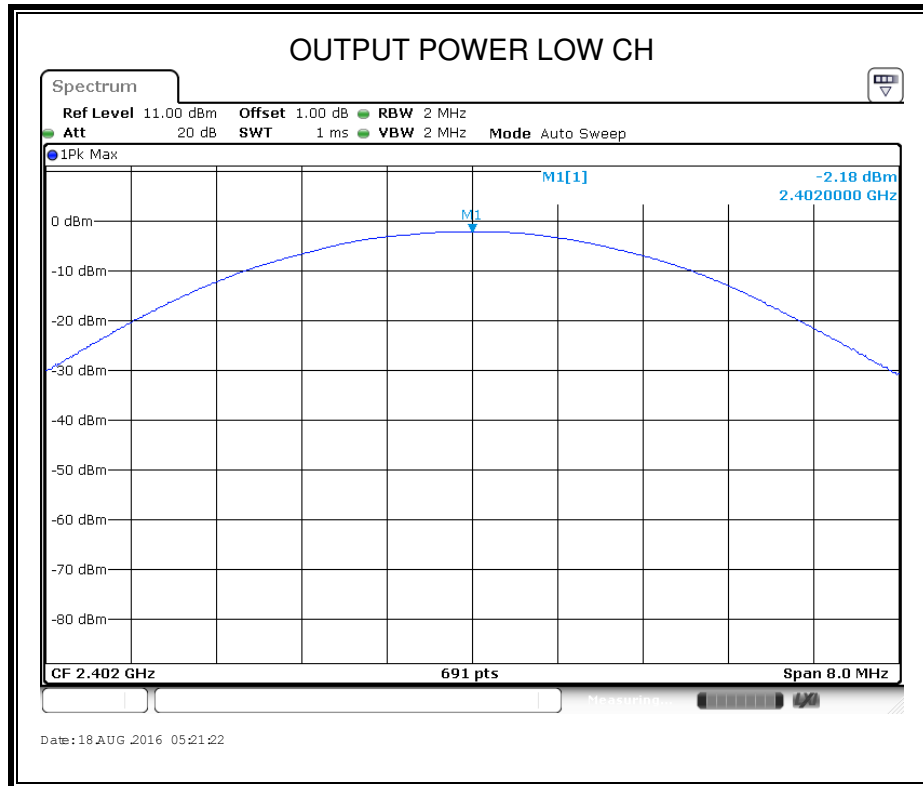

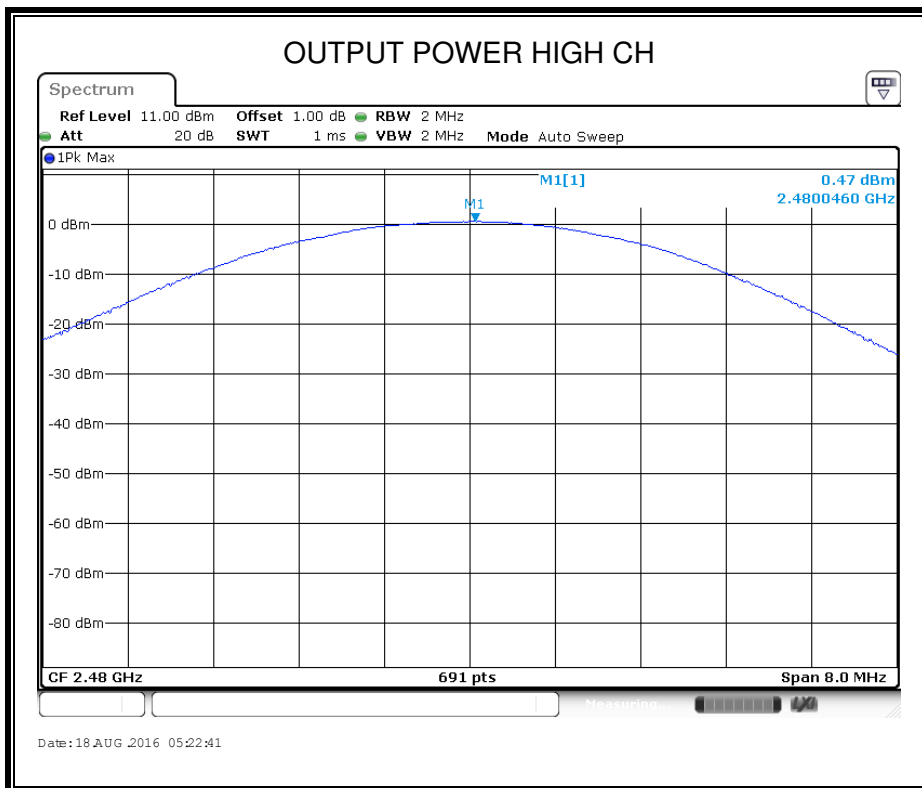
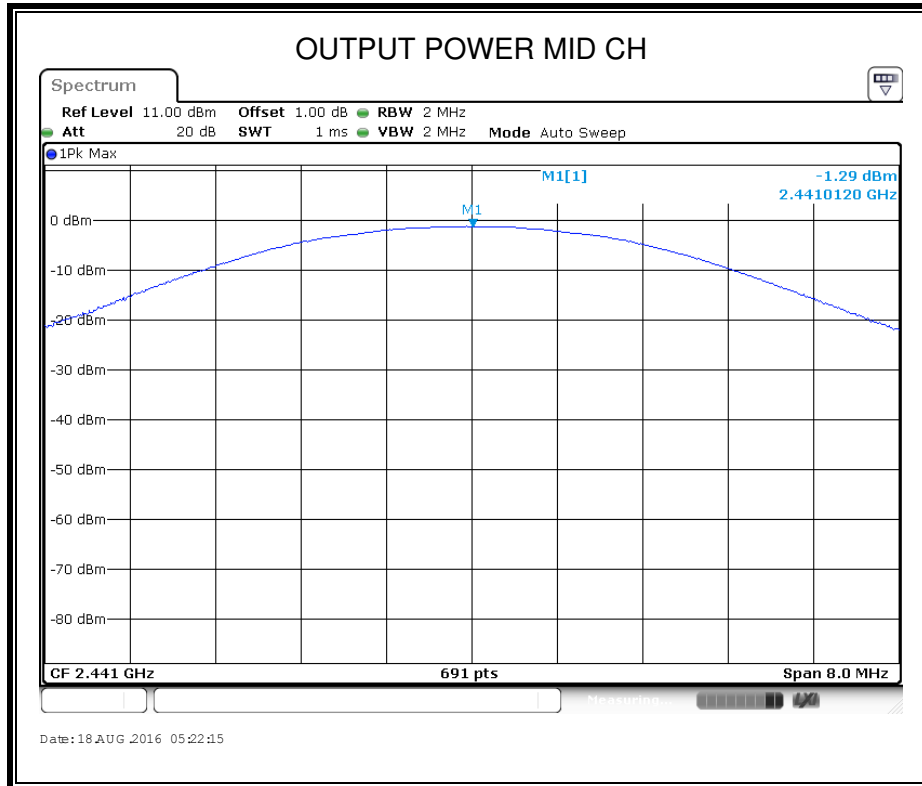

7.4. CARRIER HOPPING CHANNEL SEPARATION

LIMITS

FCC Part15 (15.247) , Subpart C IC RSS-247 ISSUE 1			
Section	Test Item	Limit	Frequency Range (MHz)
FCC 15.247 (a) (1) IC RSS-247 Clause 5.1 (2)	Carrier Hopping Channel Separation	25 kHz or two-thirds of the 20 dB bandwidth of the hopping channel, whichever is greater.	2400-2483.5

TEST PROCEDURE

Connect the UUT to the spectrum analyser and use the following settings:

Center Frequency	The centre frequency of the channel under test
Span	wide enough to capture the peaks of two adjacent channels
Detector	Peak
RBW	$\geq 1\%$ of the span
VBW	\geq RBW
Trace	Max hold
Sweep time	Auto couple

Allow the trace to stabilize. Use the marker-delta function to determine the separation between the peaks of the adjacent channels. The limit is specified in one of the subparagraphs of this Section. Submit this plot.

TEST SETUP

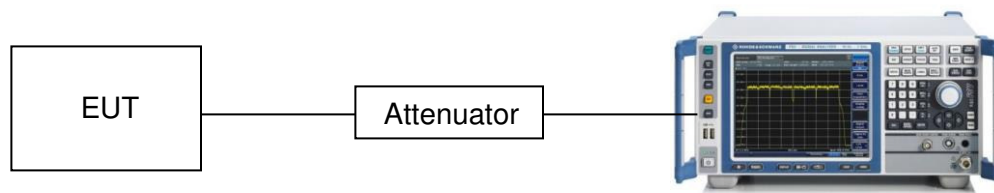

TEST CONDITIONS

Temperature: 28°C
 Relative Humidity: 60%
 Test Voltage: AC 120V/60Hz

RESULTS

7.4.1. GFSK MODE

Channel	Carrier Hopping Channel Separation (MHz)	Limit (MHz)	Result
Low	0.998	≥ two-thirds of the 20 dB Bandwidth Of The Hopping Channel	PASS
Middle	1.012	≥ two-thirds of the 20 dB Bandwidth Of The Hopping Channel	PASS
High	0.998	≥ two-thirds of the 20 dB Bandwidth Of The Hopping Channel	PASS

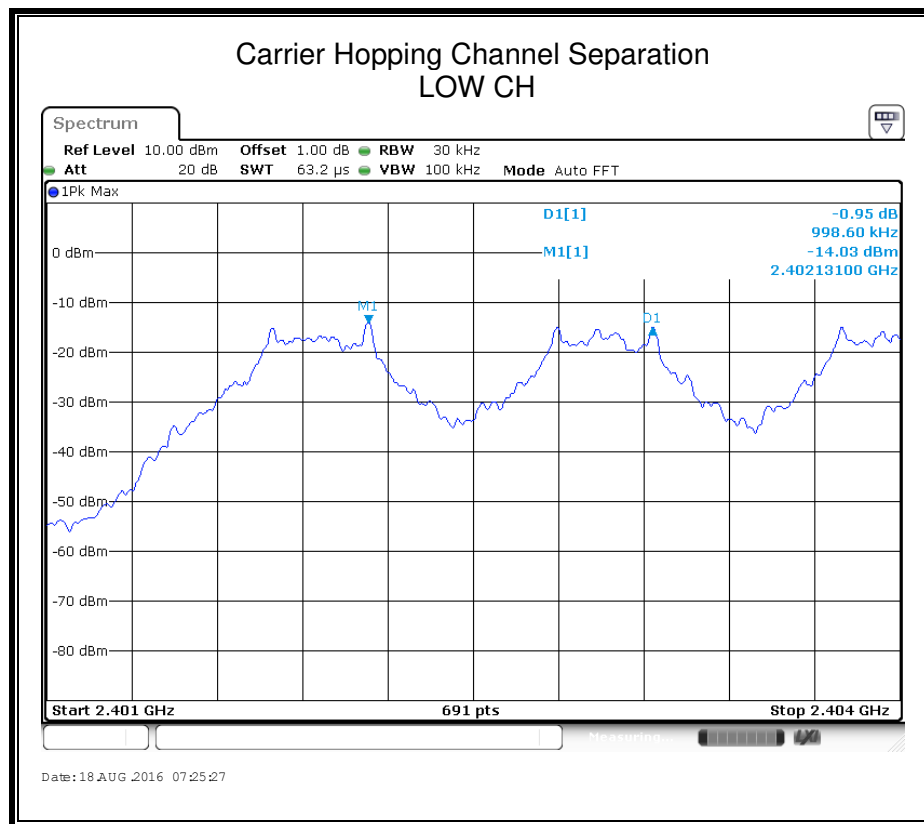

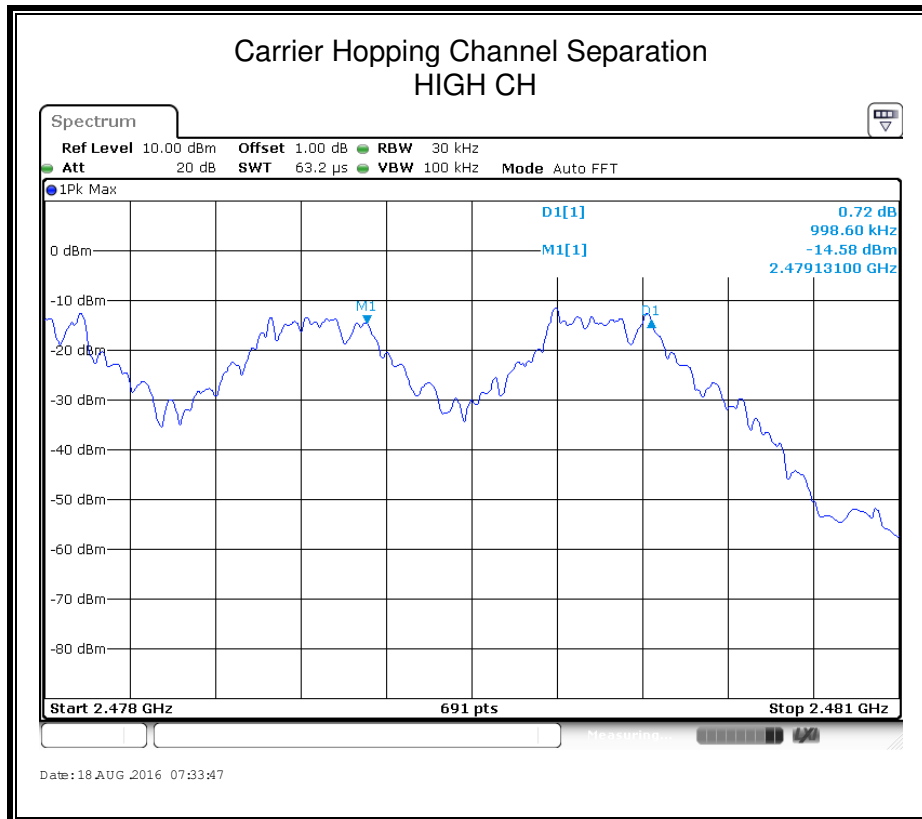
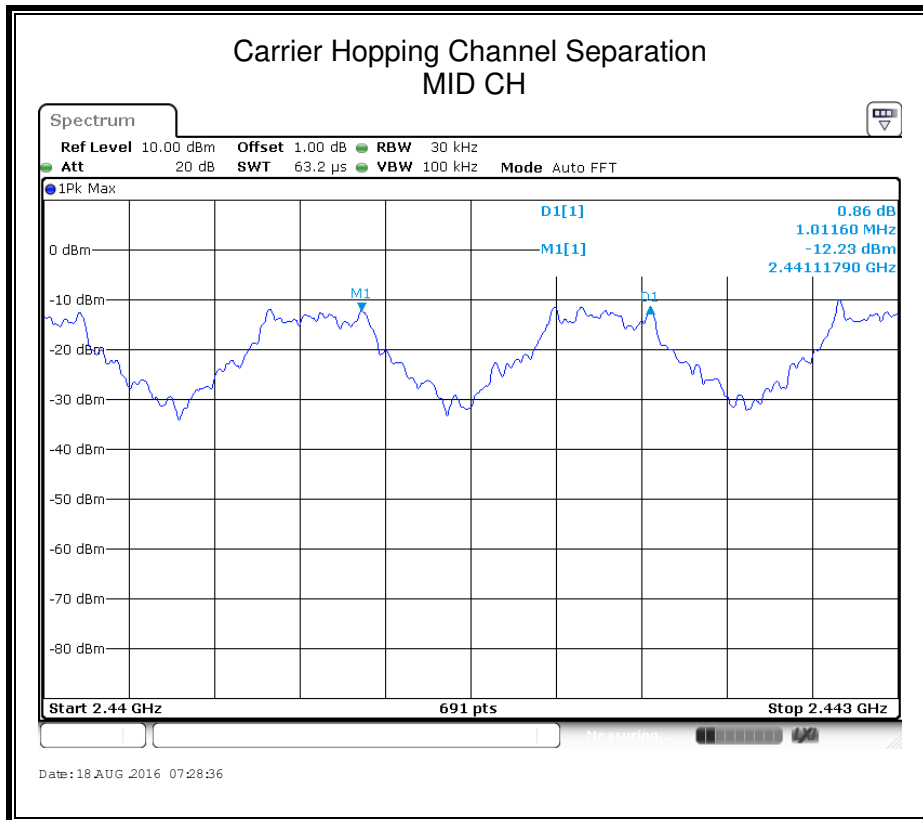

Note: For 20 dB Bandwidth of The Hopping Channel, please refer to clause 7.1.1.

7.4.2. 8-DPSK MODE

Channel	Carrier Hopping Channel Separation (MHz)	Limit (MHz)	Result
Low	1.003	≥ two-thirds of the 20 dB Bandwidth Of The Hopping Channel	PASS
Middle	0.998	≥ two-thirds of the 20 dB Bandwidth Of The Hopping Channel	PASS
High	0.998	≥ two-thirds of the 20 dB Bandwidth Of The Hopping Channel	PASS

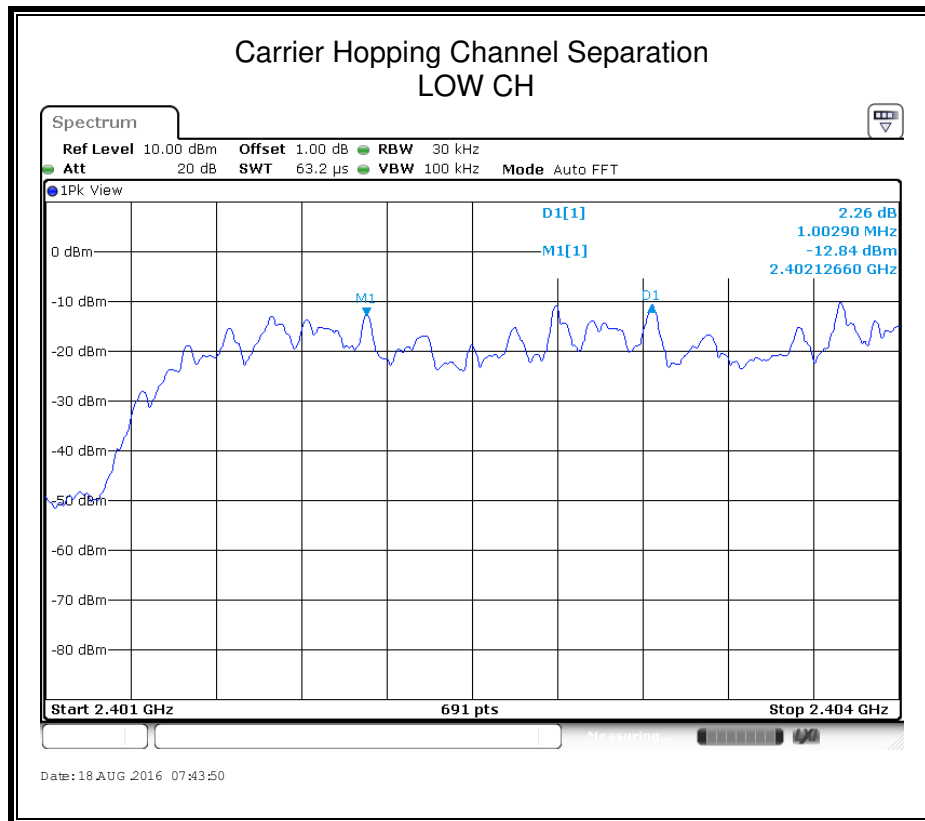

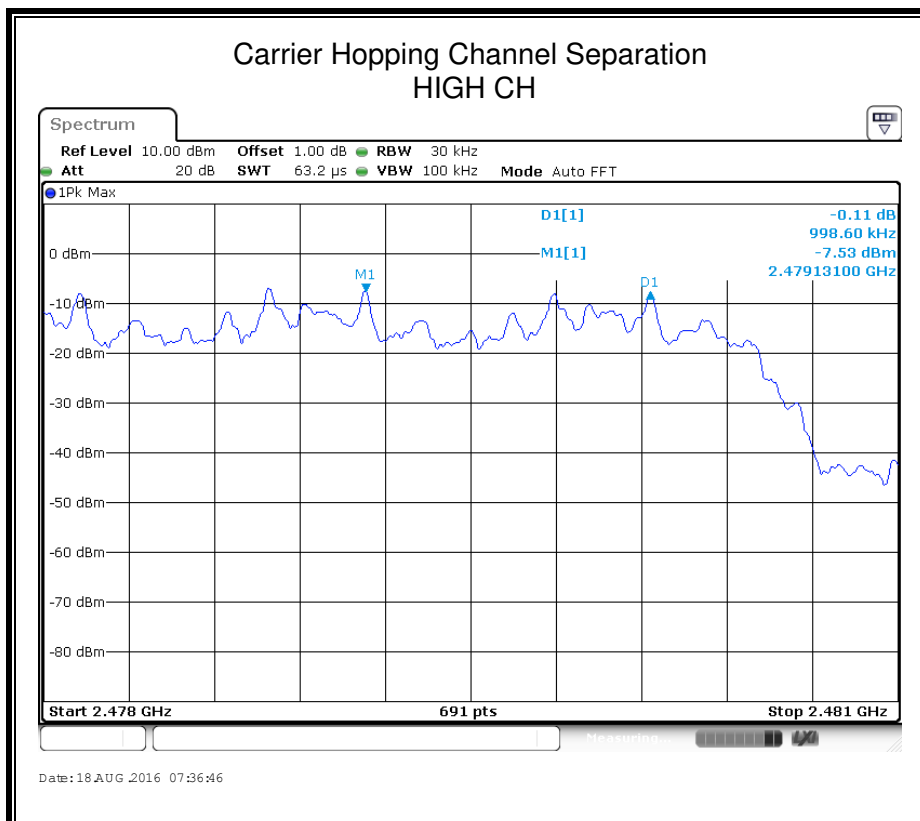
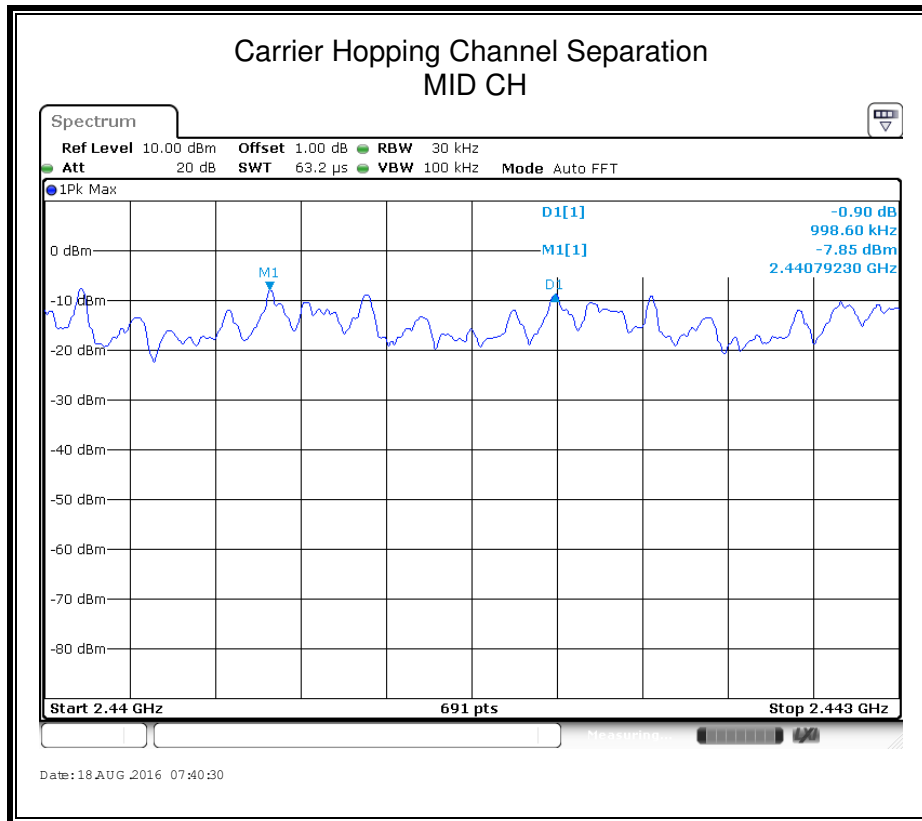

Note: For 20 dB Bandwidth of The Hopping Channel, please refer to clause 7.1.2.

7.5. NUMBER OF HOPPING FREQUENCY

LIMITS

FCC Part15 (15.247) , Subpart C IC RSS-247 ISSUE 1		
Section	Test Item	Limit
15.247 (a) (1) III IC RSS-247 Clause 5.1 (4)	Number of Hopping Frequency	at least 15 hopping channels

TEST PROCEDURE

Connect the EUT to the spectrum analyser and use the following settings:

Detector	Peak
RBW	1% of the span
VBW	≥RBW
Span	The frequency band of operation
Trace	Max hold
Sweep time	Auto couple

Set EUT to transmit maximum output power and switch on frequency hopping function. then set enough count time (larger than 5000 times) to get all the hopping frequency channel displayed on the screen of spectrum analyzer.

Count the quantity of peaks to get the number of hopping channels.

TEST SETUP

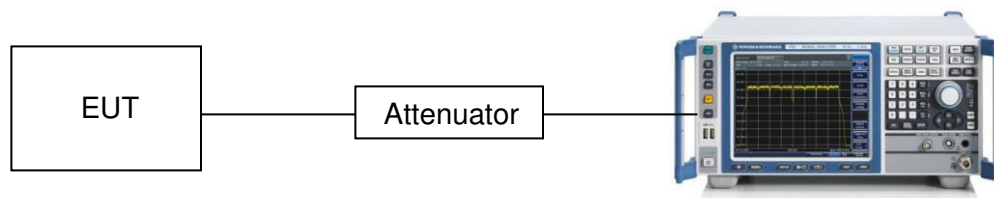

TEST CONDITIONS

Temperature: 28°C
 Relative Humidity: 60%
 Test Voltage: AC 120V/60Hz

RESULTS

7.5.1. GFSK MODE

Hopping numbers	Limit	Results
79	>15	Pass

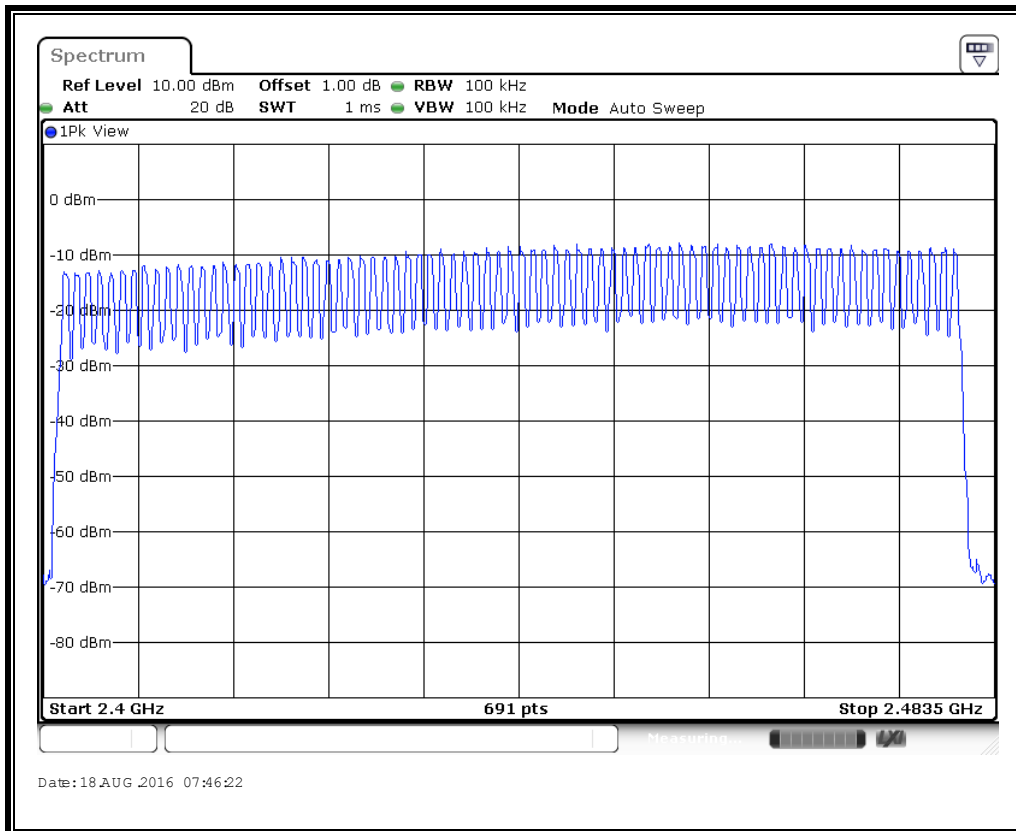

7.5.2. 8-DPSK MODE

Hopping numbers	Limit	Results
79	>15	Pass

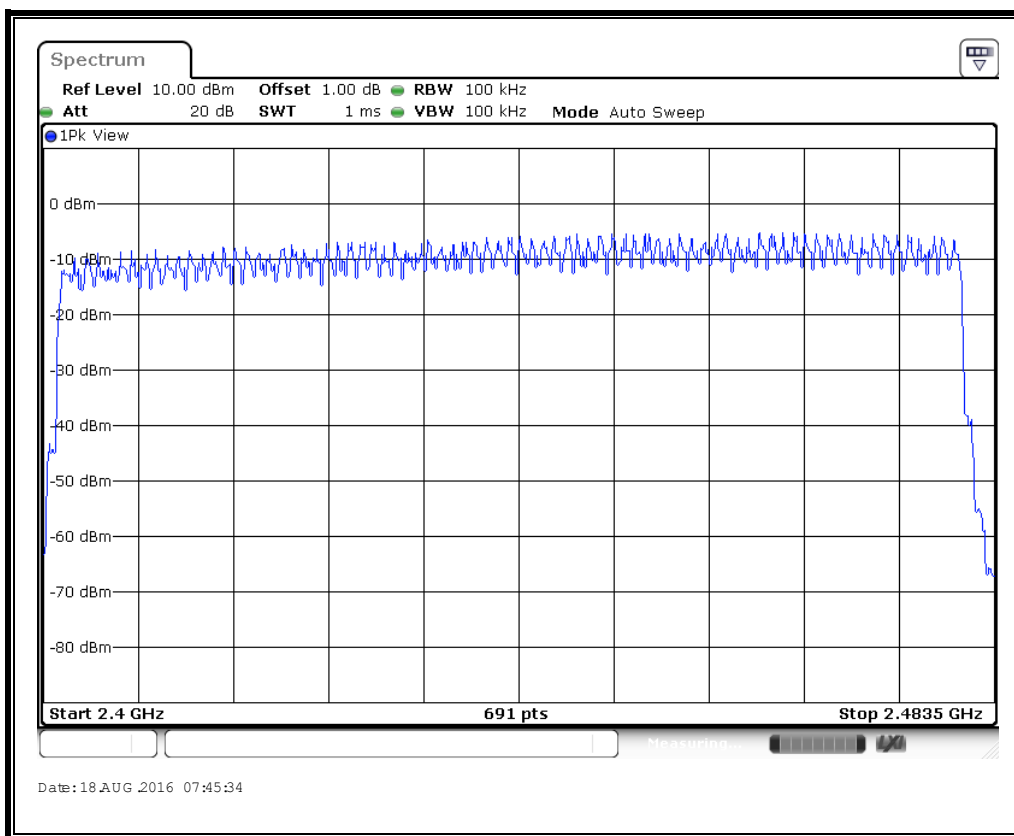

7.6. TIME OF OCCUPANCY (DWELL TIME)

LIMITS

FCC Part15 (15.247) , Subpart C IC RSS-247 ISSUE 1		
Section	Test Item	Limit
15.247 (a) (1) III IC RSS-247 Clause 5.1 (4)	Time of Occupancy (Dwell Time)	The average time of occupancy on any channel shall not be greater than 0.4 seconds within a period of 0.4 seconds, multiplied by the number of hopping channels employed.

TEST PROCEDURE

Connect the UUT to the spectrum analyser and use the following settings:

Center Frequency	The centre frequency of the channel under test
Detector	Peak
RBW	1 MHz
VBW	≥RBW
Span	zero span
Trace	Max hold
Sweep time	As necessary to capture the entire dwell time per hopping channel

- The transmitter output (antenna port) was connected to the spectrum analyzer
- Set RBW of spectrum analyzer to 1MHz and VBW to 1MHz.
- Use a video trigger with the trigger level set to enable triggering only on full pulses.
- Sweep Time is more than once pulse time.
- Set the center frequency on any frequency would be measure and set the frequency span to zero span.
- Measure the maximum time duration of one single pulse.
- Set the EUT for DH5, DH3 and DH1 packet transmitting.
- Measure the maximum time duration of one single pulse.
 A Period Time = (channel number)*0.4
 DH1 Time Slot: Reading * (1600/2)*31.6/(channel number)
 DH3 Time Slot: Reading * (1600/4)*31.6/(channel number)
 DH5 Time Slot: Reading * (1600/6)*31.6/(channel number)

TEST SETUP

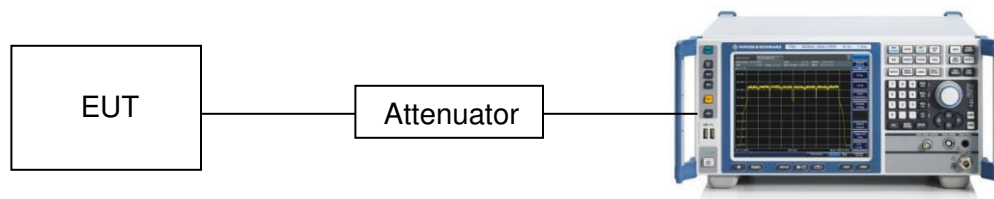

TEST CONDITIONS

Temperature: 28°C
 Relative Humidity: 60%
 Test Voltage: AC 120V/60Hz

RESULTS

7.6.1. GFSK MODE

packet type	Time of Single Slot	Time of occupied in a period	Limit	Result
	[ms]	[s]	[s]	
DH1	0.365	0.117	≤ 0.4	Pass
DH3	1.623	0.260	≤ 0.4	Pass
DH5	2.875	0.307	≤ 0.4	Pass

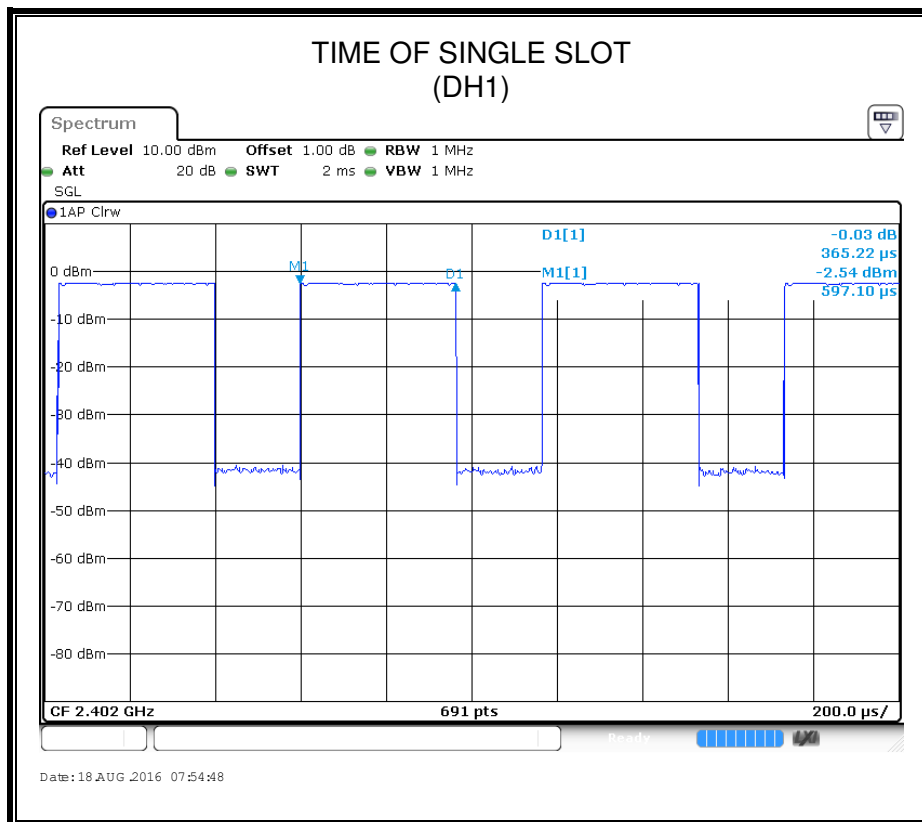

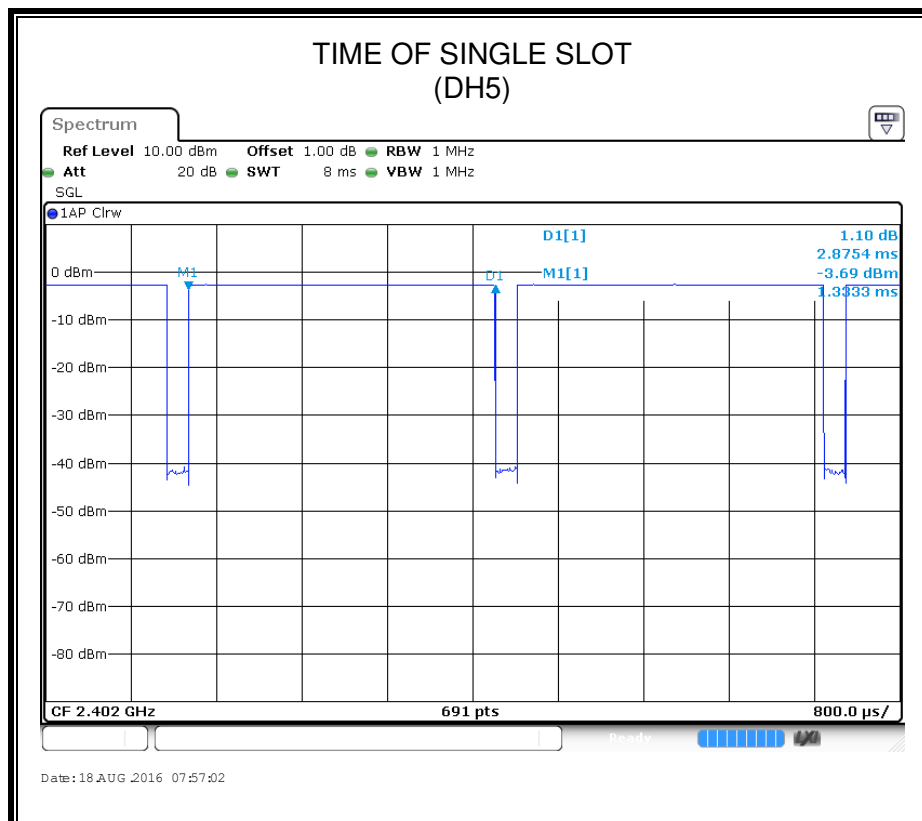
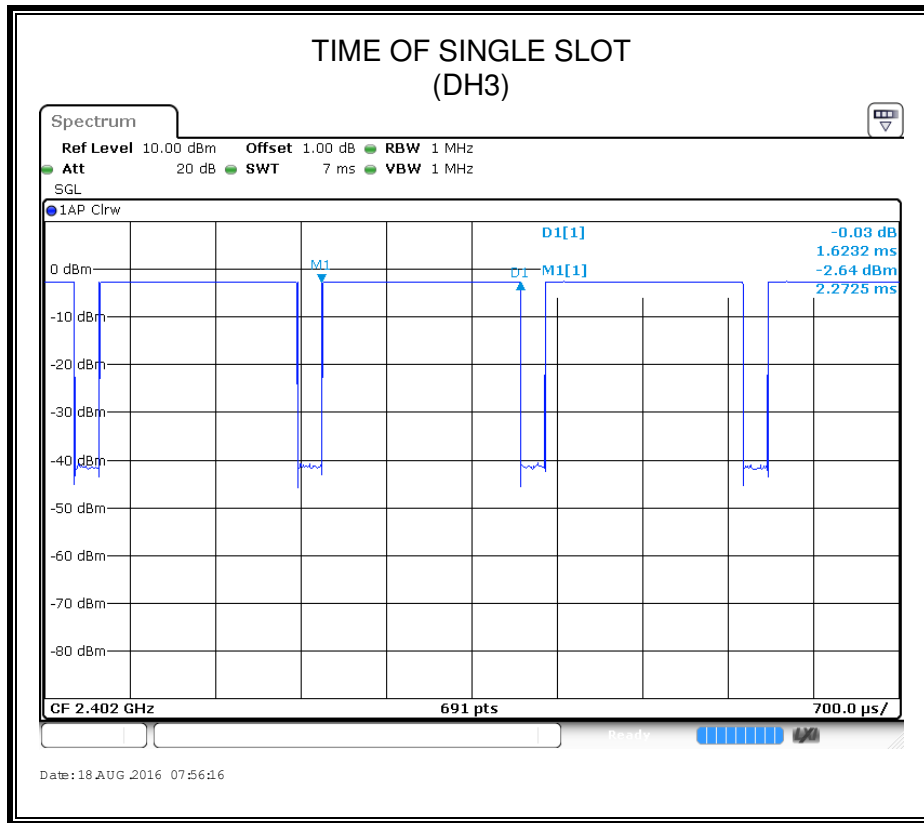

7.6.2. 8-DPSK MODE

packet type	Time of Single Slot	Time of occupied in a period	Limit	Result
	[ms]	[s]	[s]	
DH1	0.383	0.123	≤ 0.4	Pass
DH3	1.635	0.262	≤ 0.4	Pass
DH5	2.887	0.308	≤ 0.4	Pass

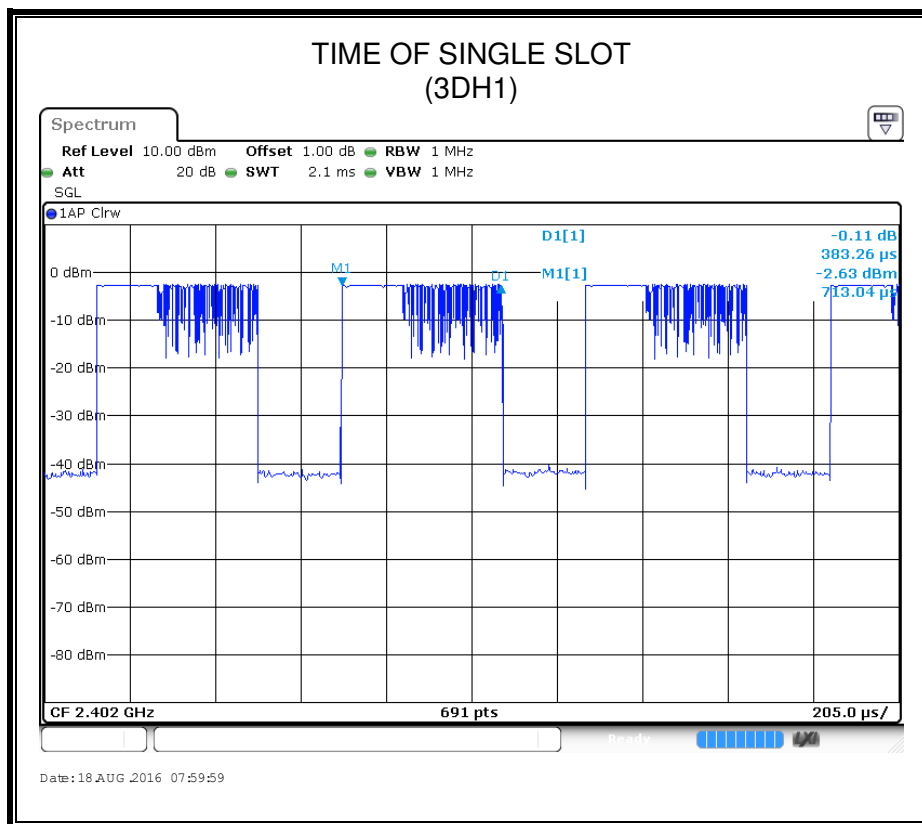

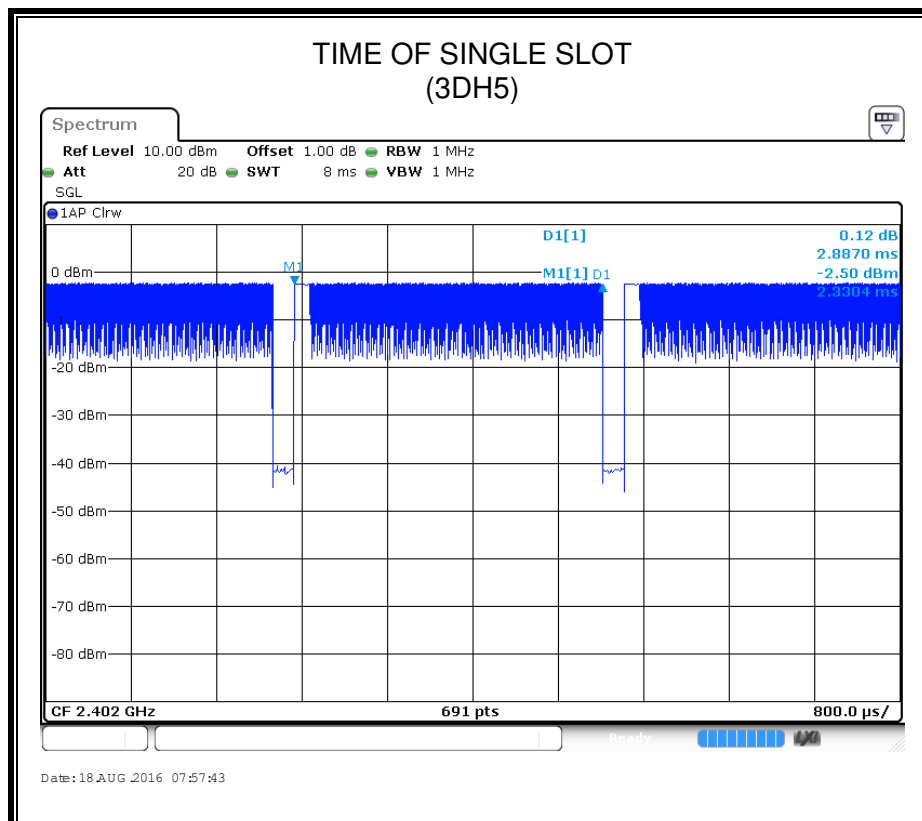
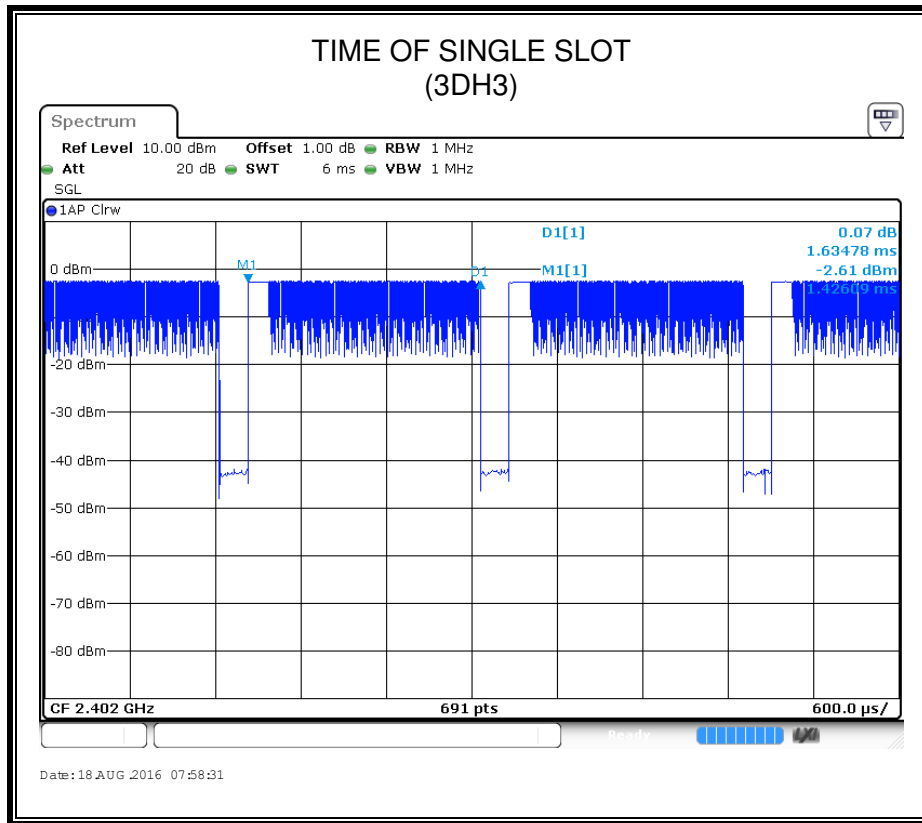

7.7. CONDUCTED BANDEGE AND SPURIOUS EMISSIONS

LIMITS

FCC Part15 (15.247) , Subpart C IC RSS-247 ISSUE 1		
Section	Test Item	Limit
FCC §15.247 (d) IC RSS-247 5.5	Conducted Bandedge and Spurious Emissions	at least 20 dB below that in the 100 kHz bandwidth within the band that contains the highest level of the desired power

TEST PROCEDURE

Connect the UUT to the spectrum analyser and use the following settings:

Center Frequency	The centre frequency of the channel under test
Detector	Peak
RBW	100K
VBW	$\geq 3 \times \text{RBW}$
Span	1.5 x DTS bandwidth
Trace	Max hold
Sweep time	Auto couple

Use the peak marker function to determine the maximum PSD level.

Span	Set the center frequency and span to encompass frequency range to be measured
Detector	Peak
RBW	100K
VBW	$\geq 3 \times \text{RBW}$
measurement points	$\geq \text{span}/\text{RBW}$
Trace	Max hold
Sweep time	Auto couple.

Use the peak marker function to determine the maximum amplitude level.

TEST SETUP

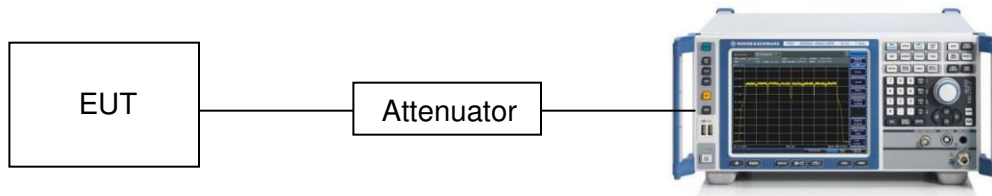

TEST CONDITIONS

Temperature: 28°C
Relative Humidity: 60%
Test Voltage: AC 120V/60Hz

RESULTS

7.7.1. GFSK MODE

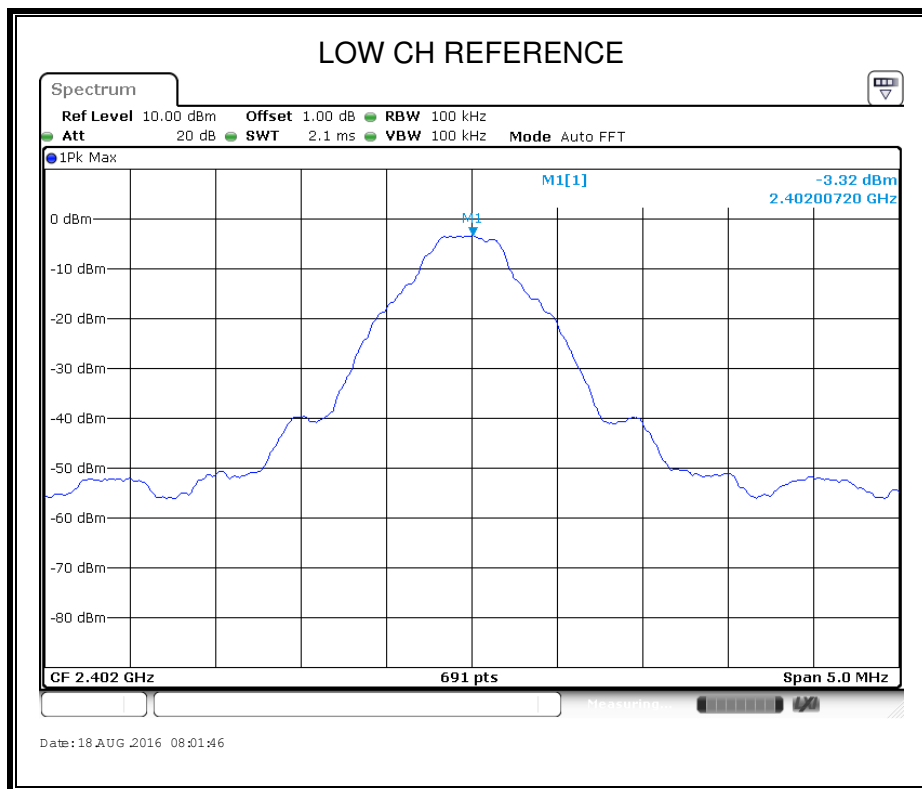

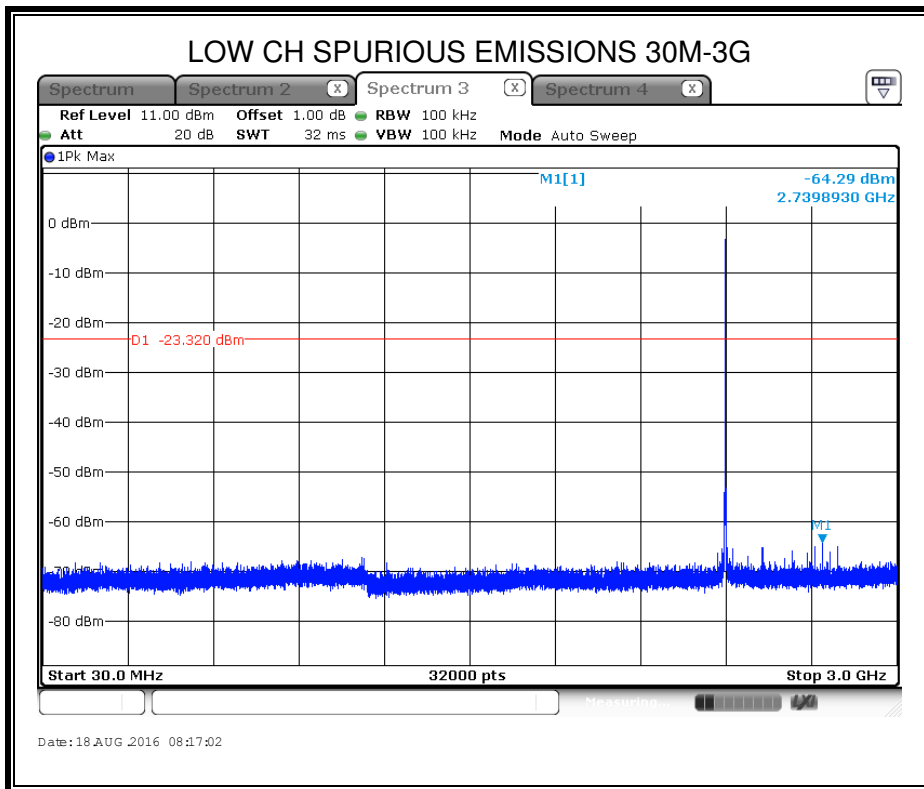
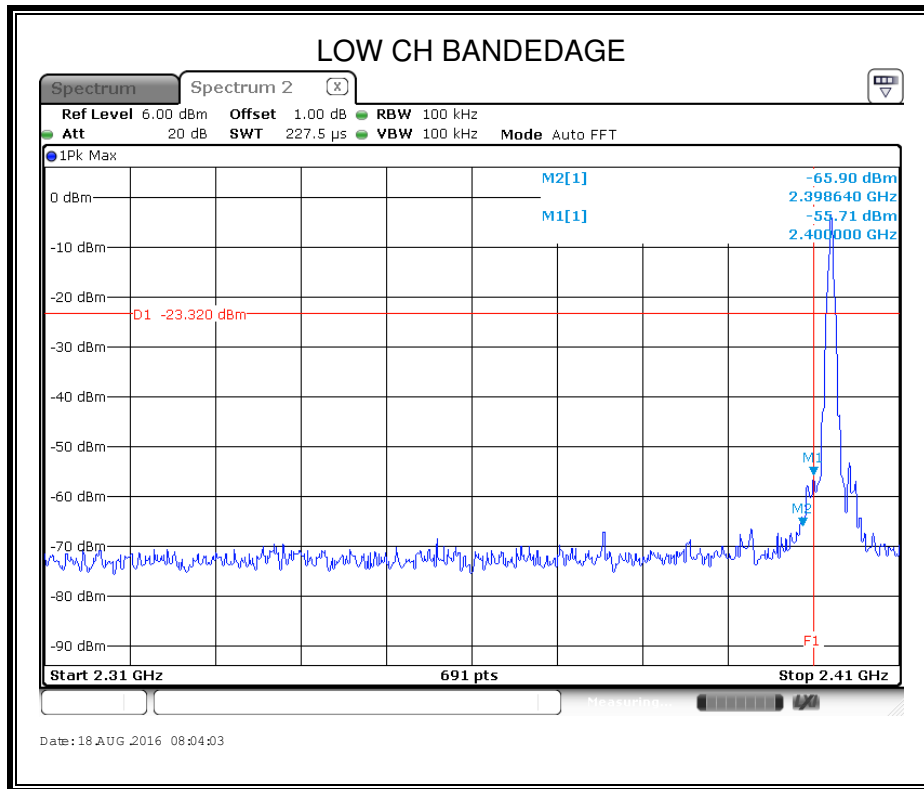

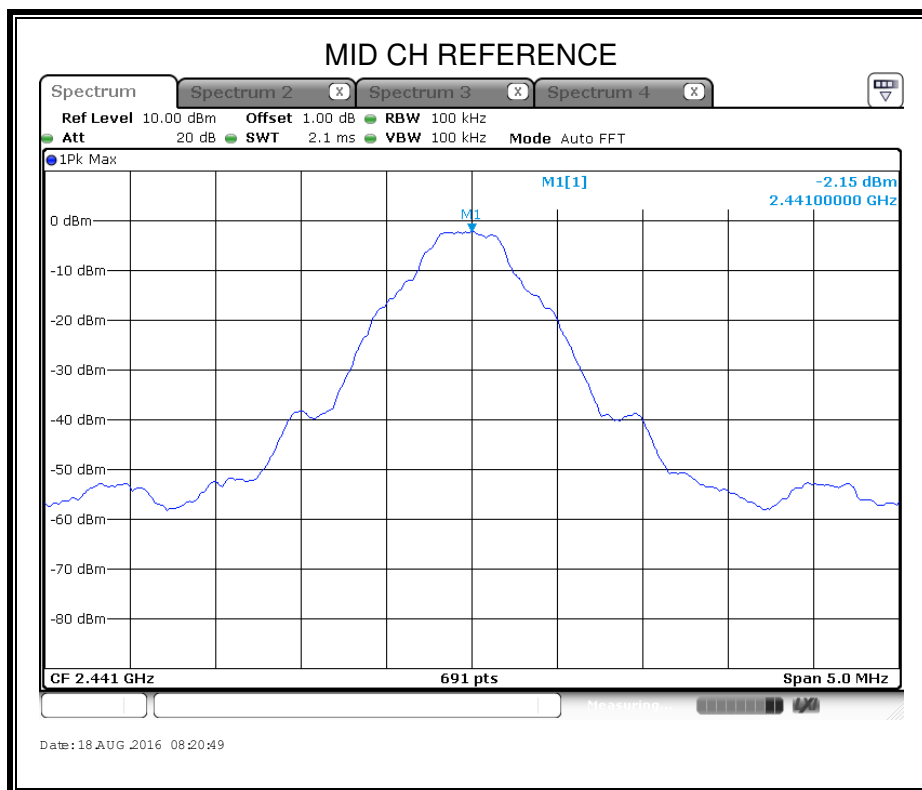
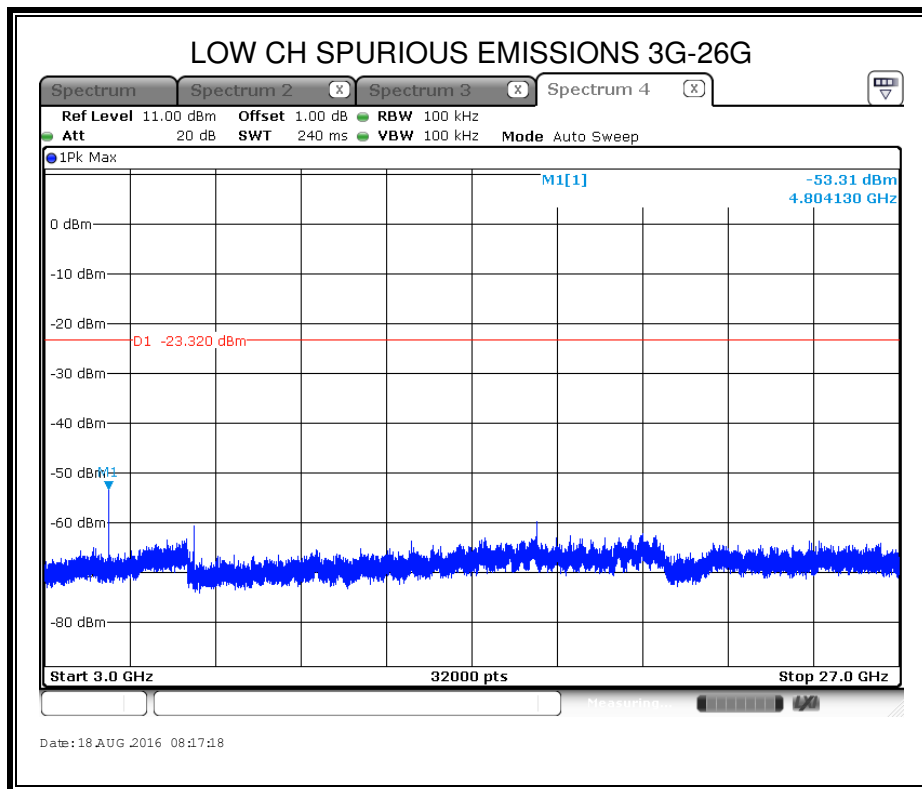

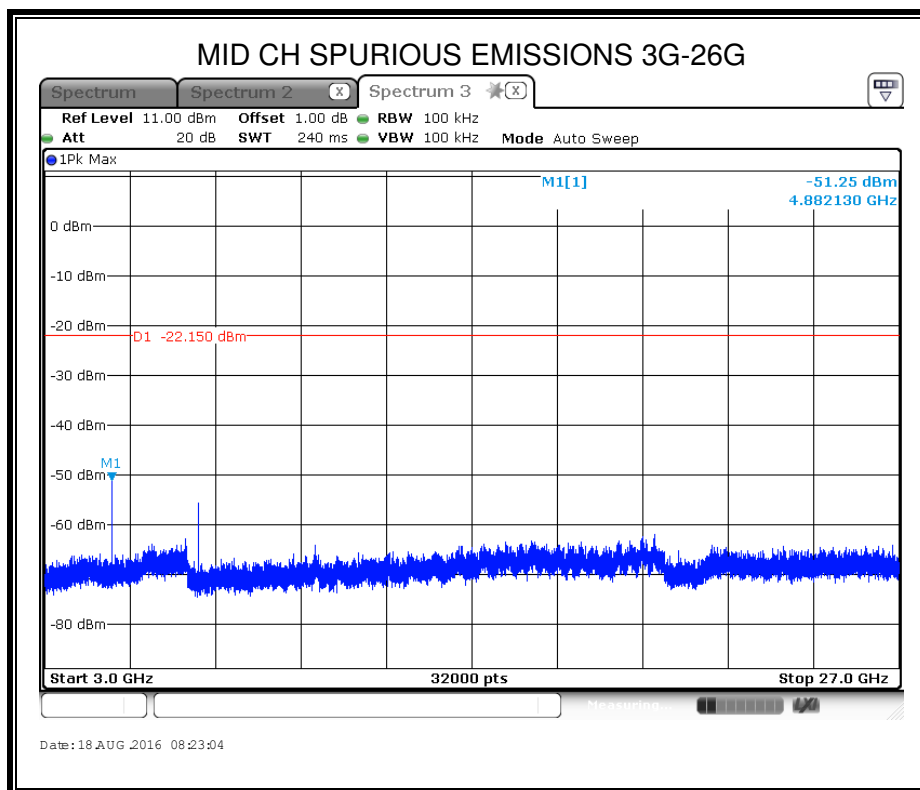
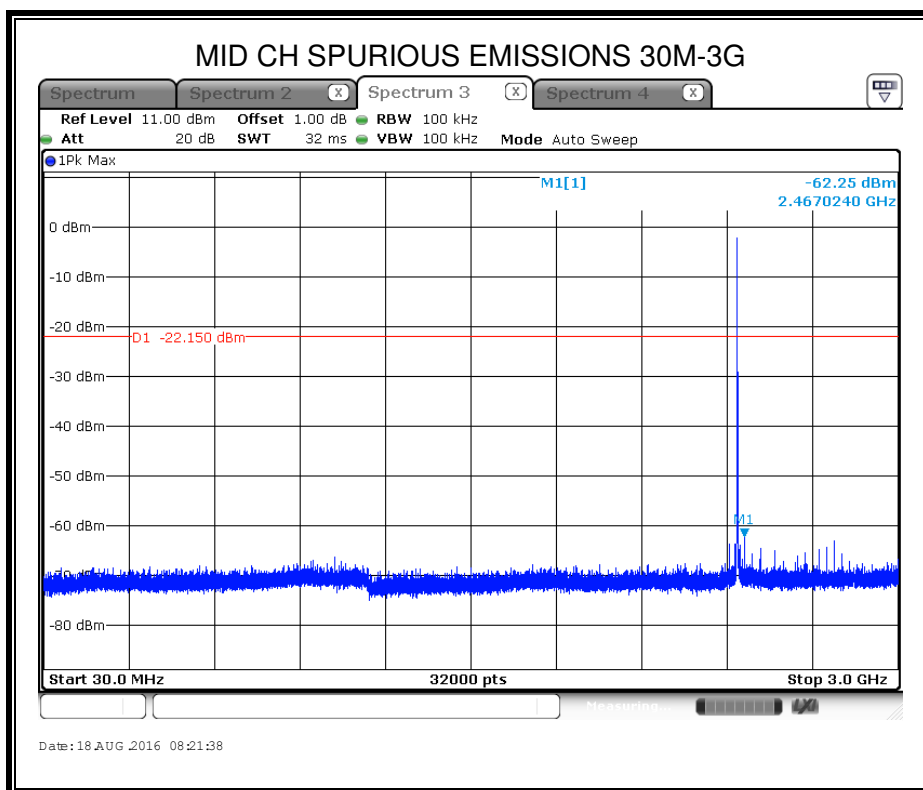

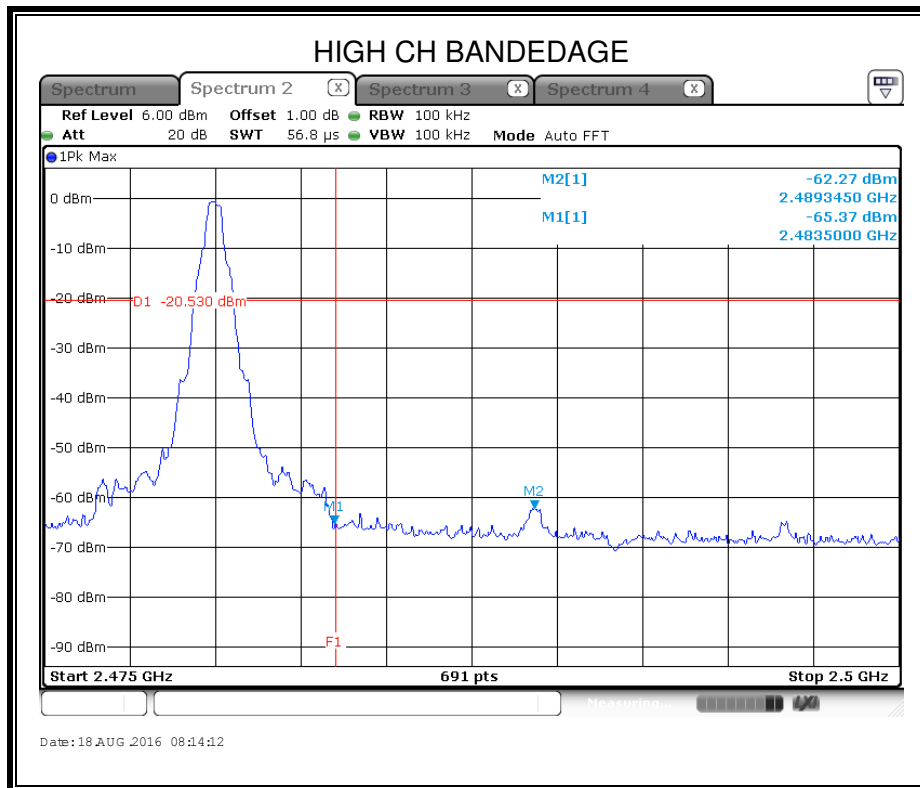
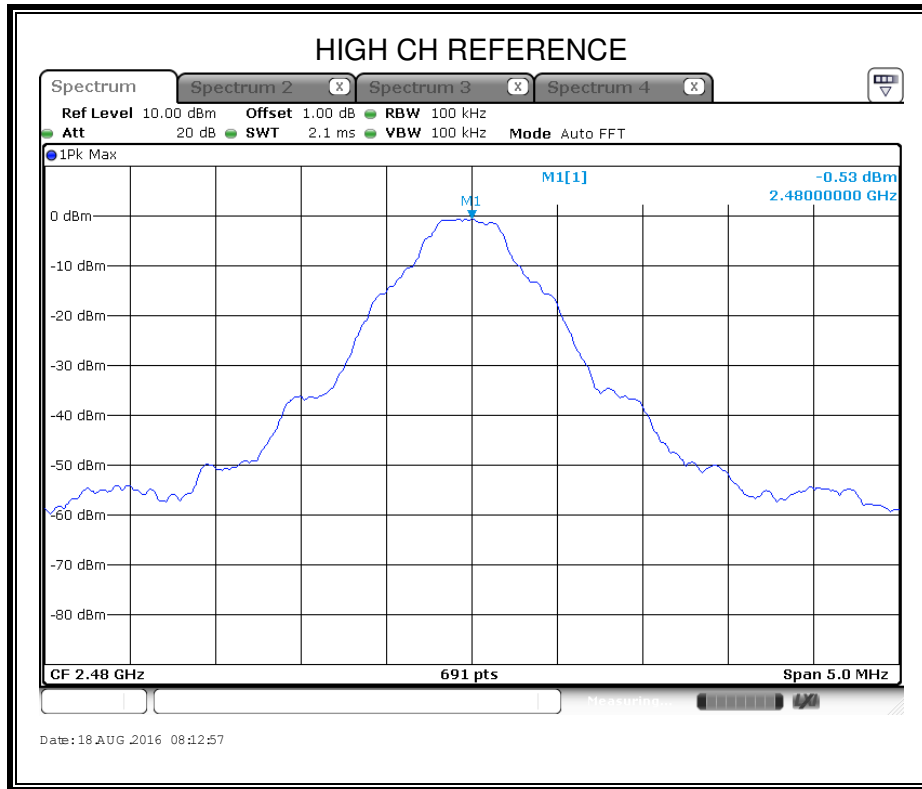

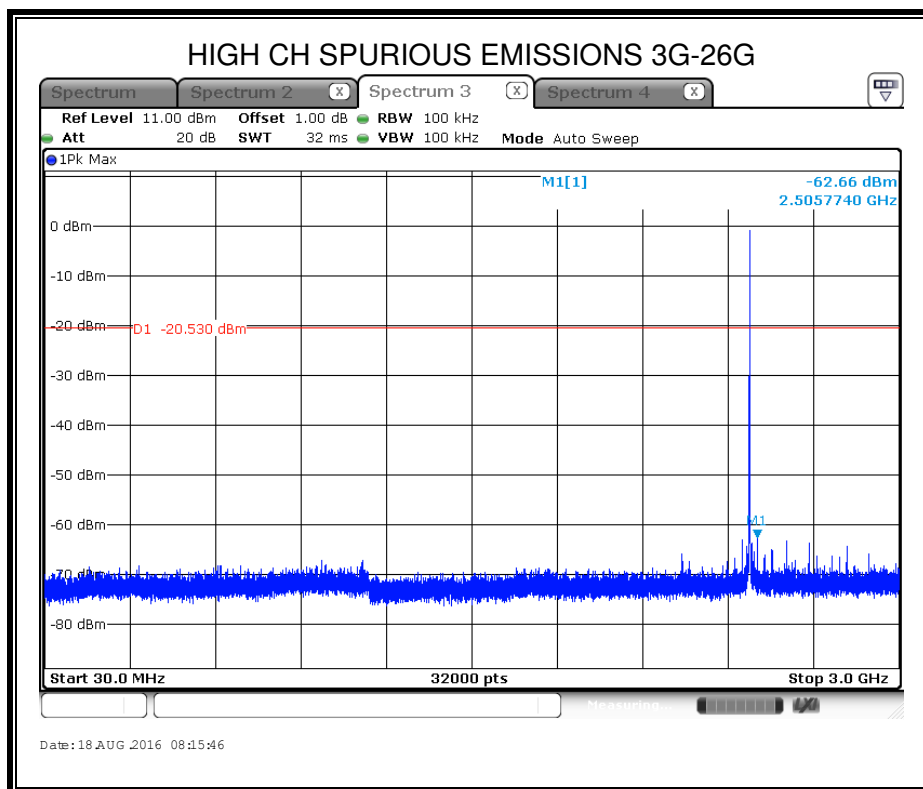
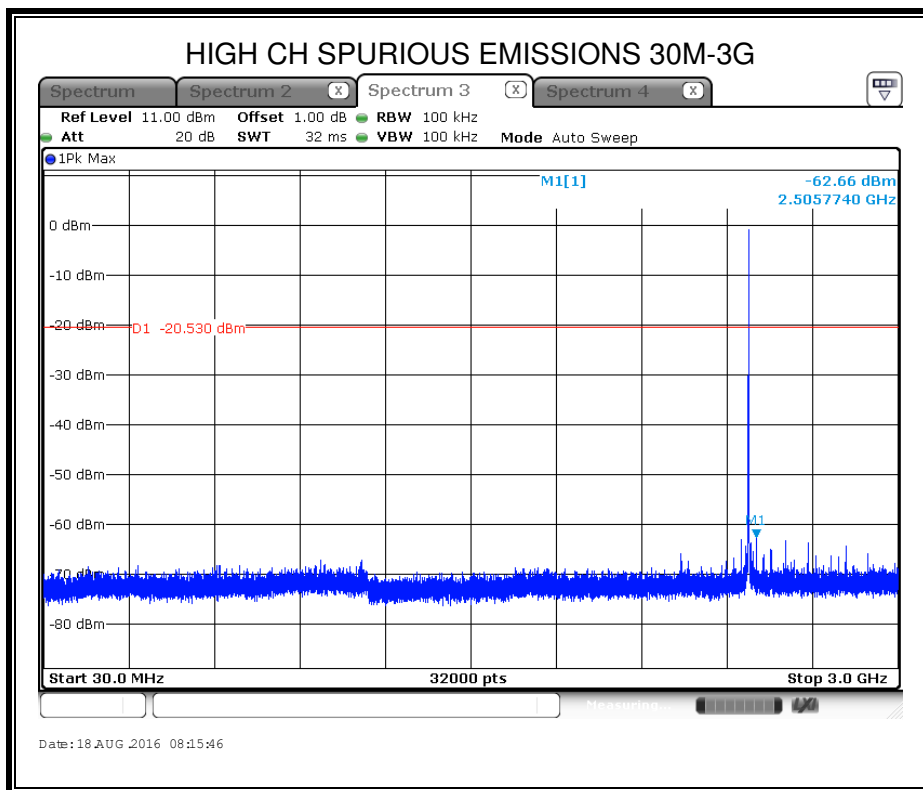

7.7.2. 8-DPSK MODE

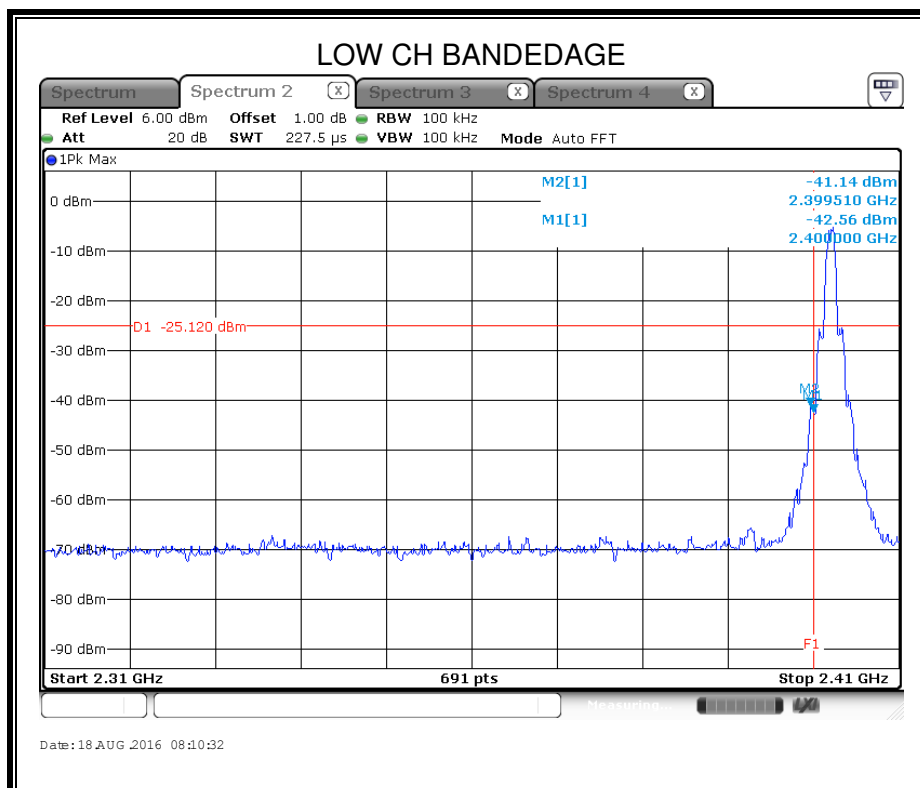
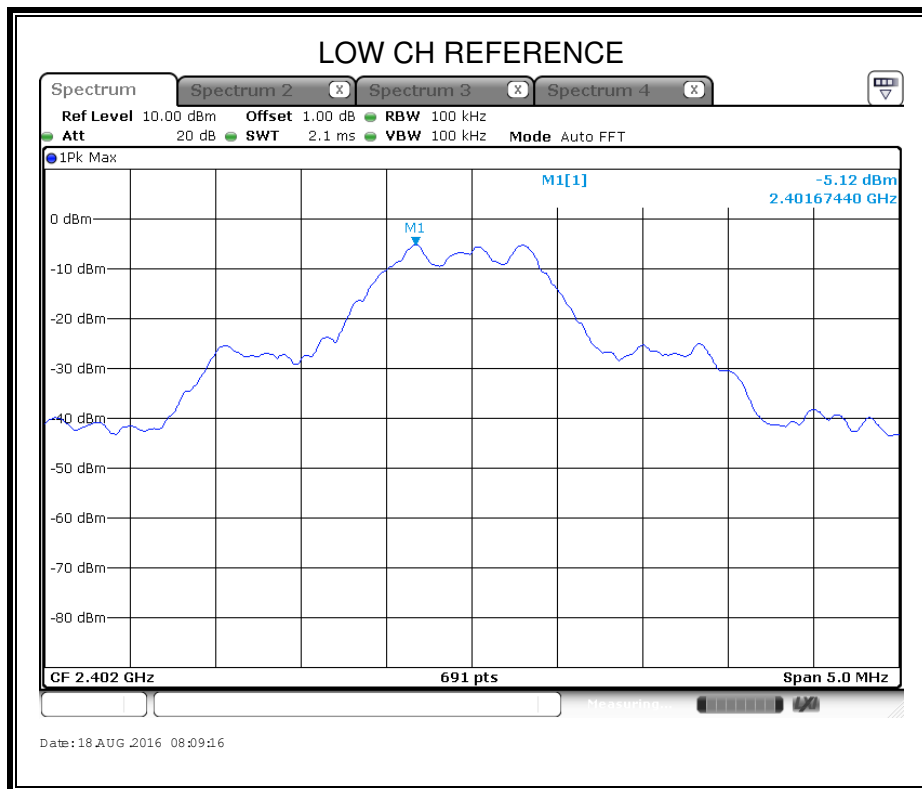

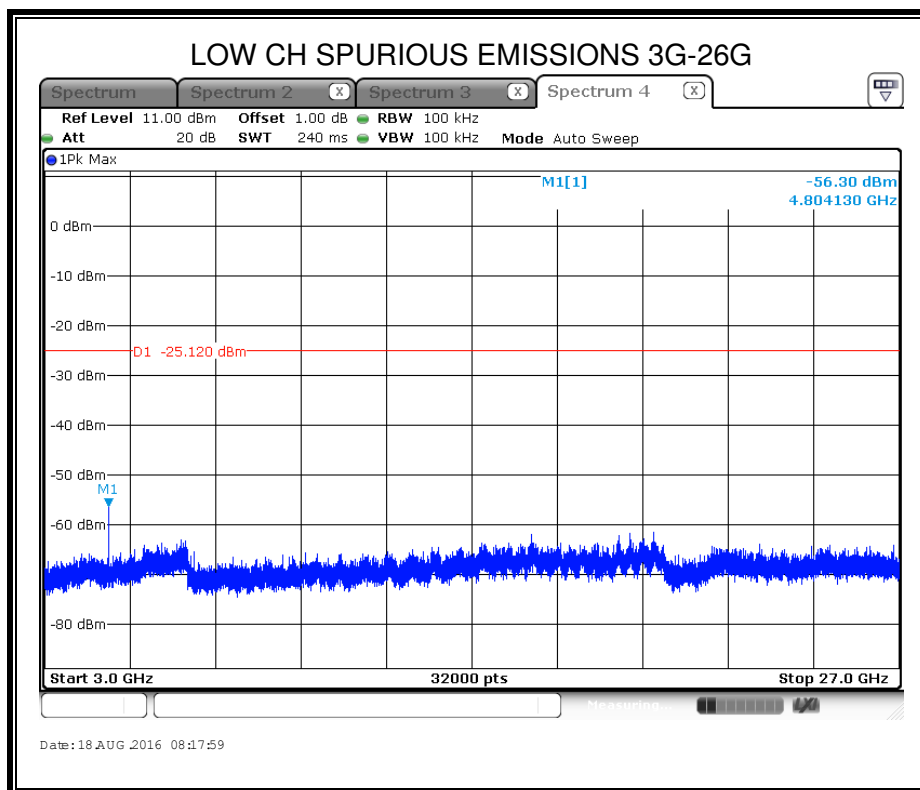
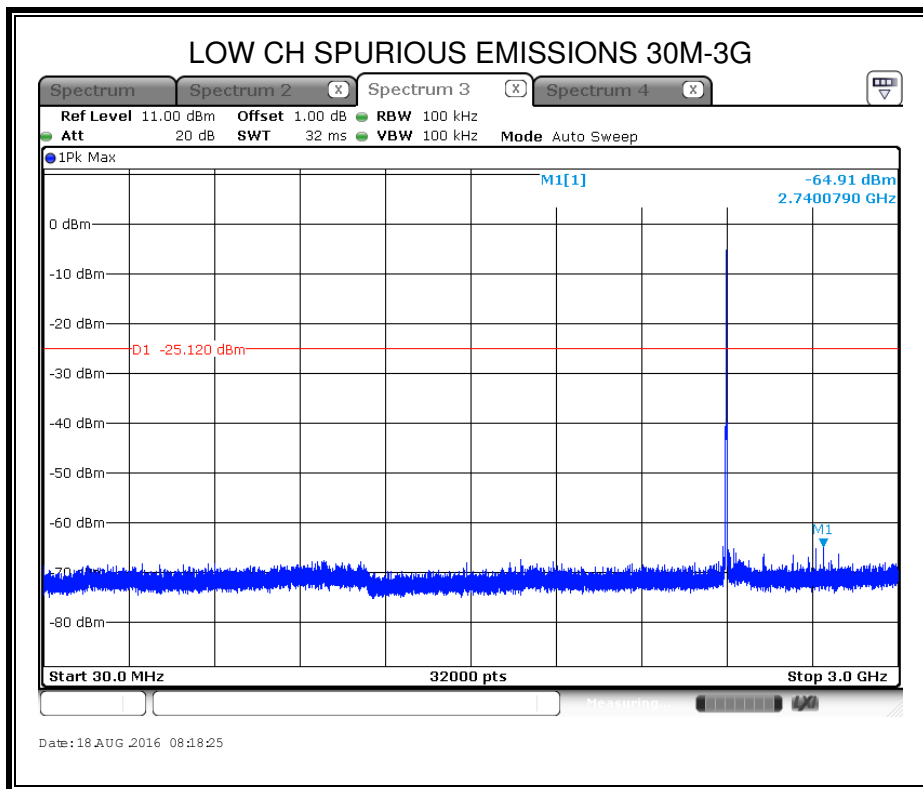

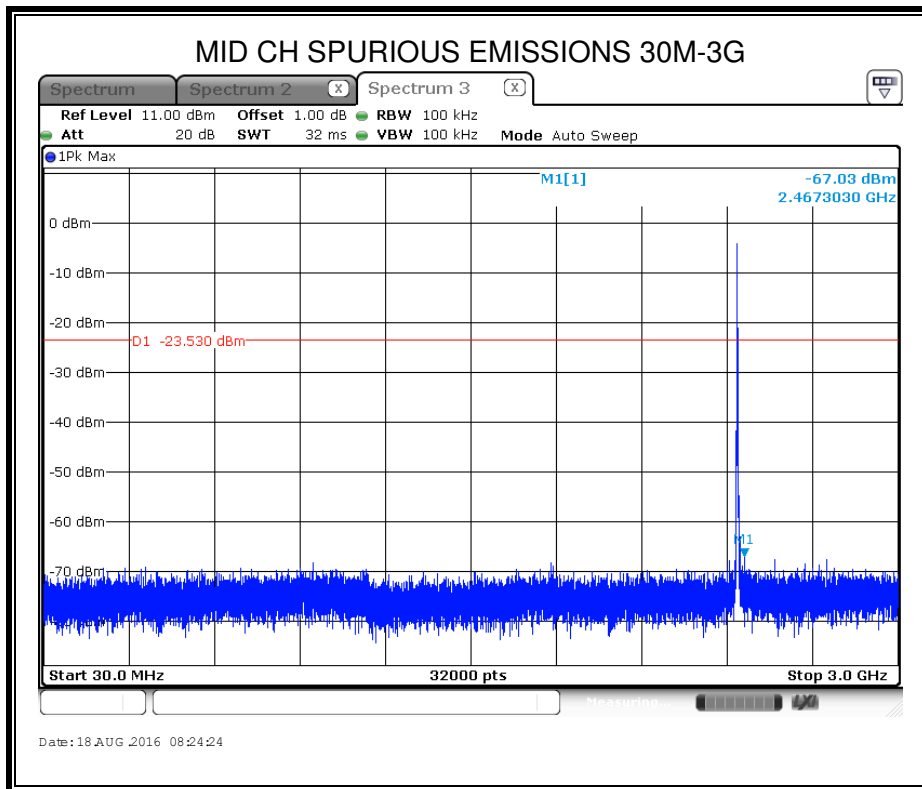
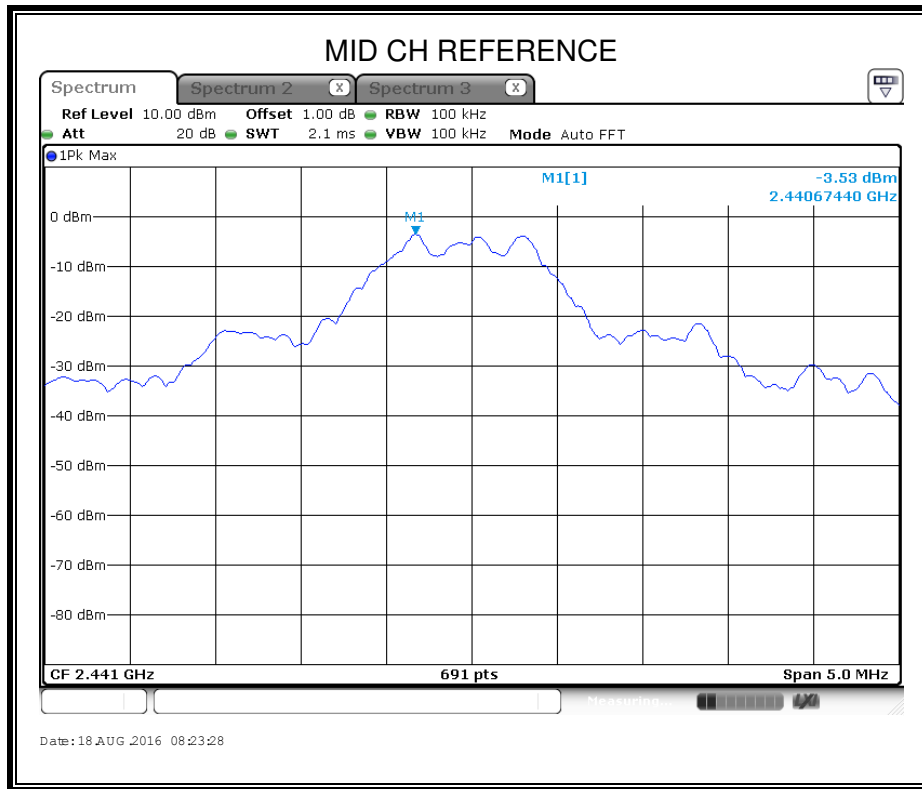

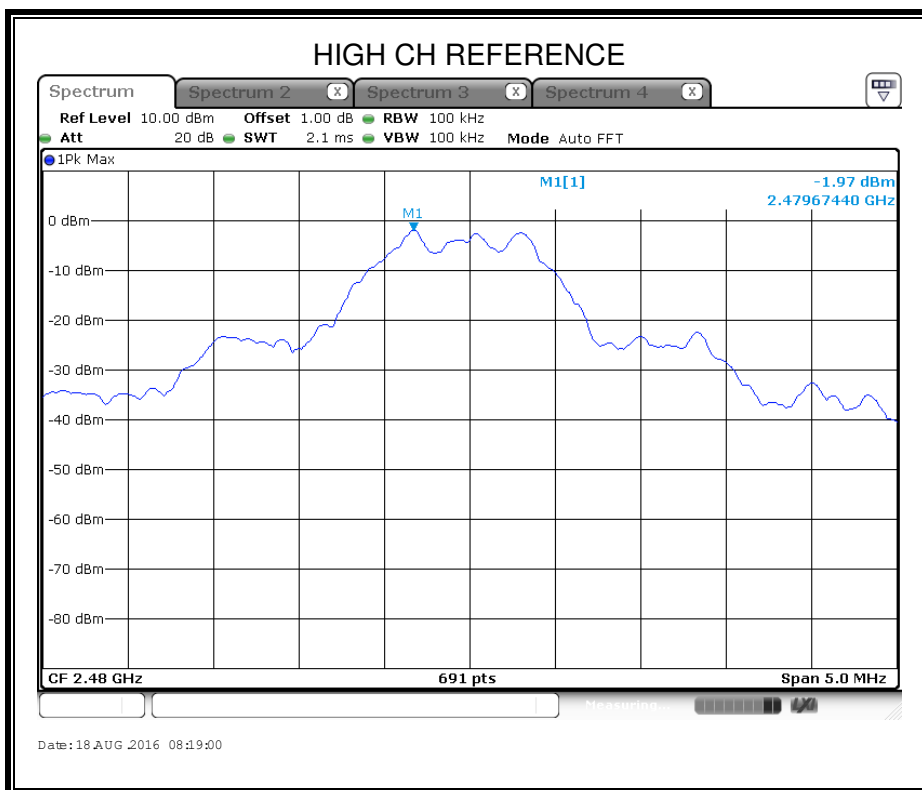
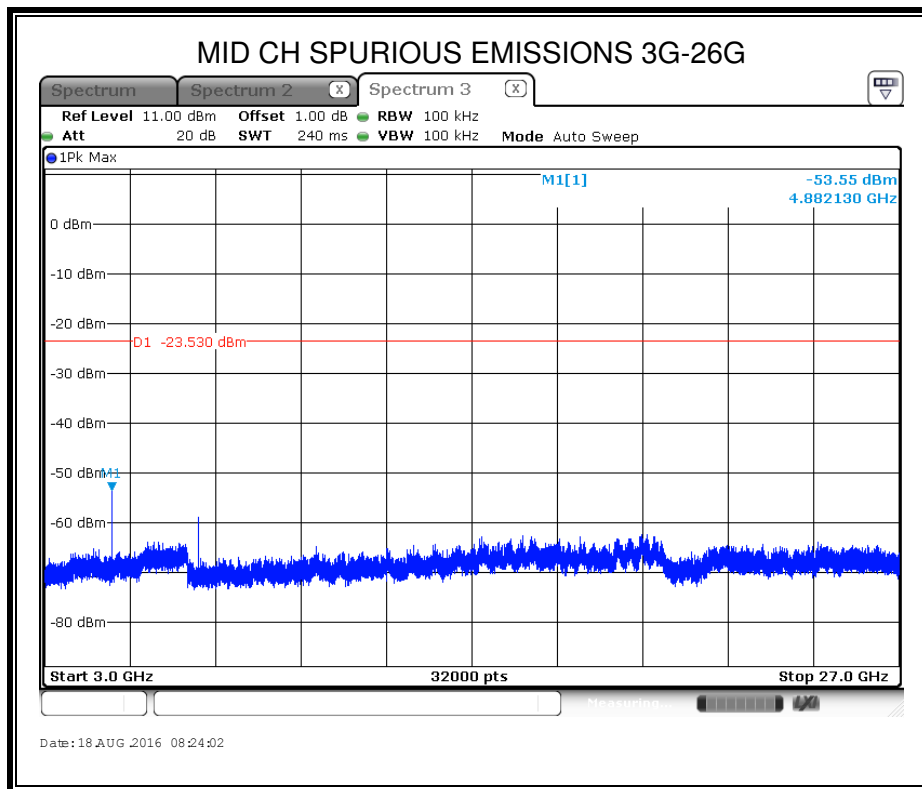

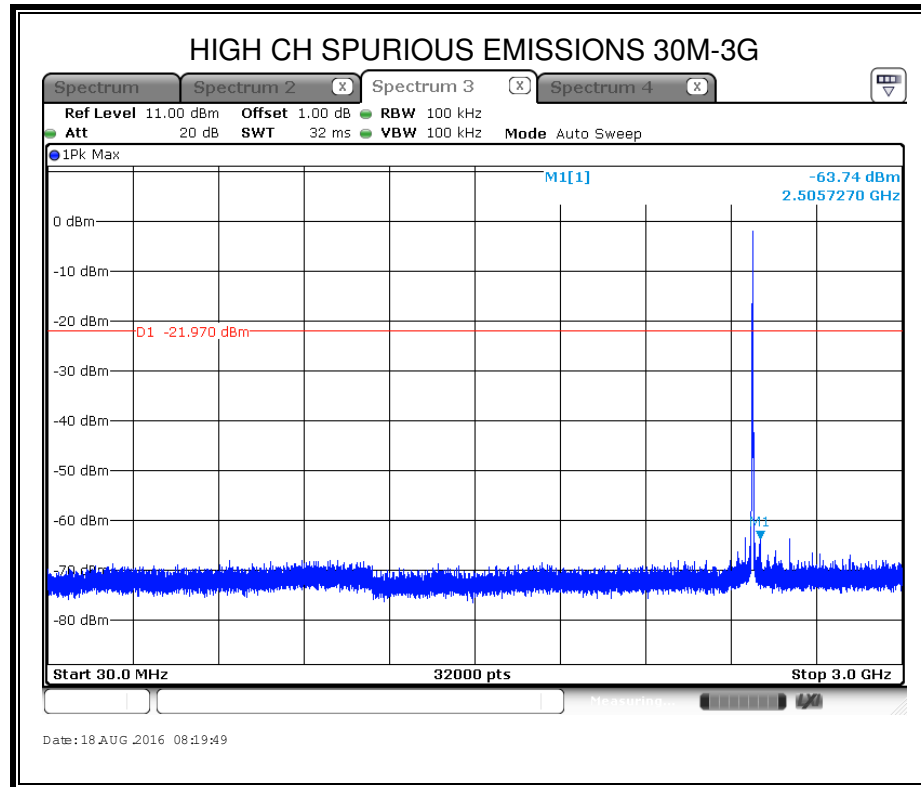
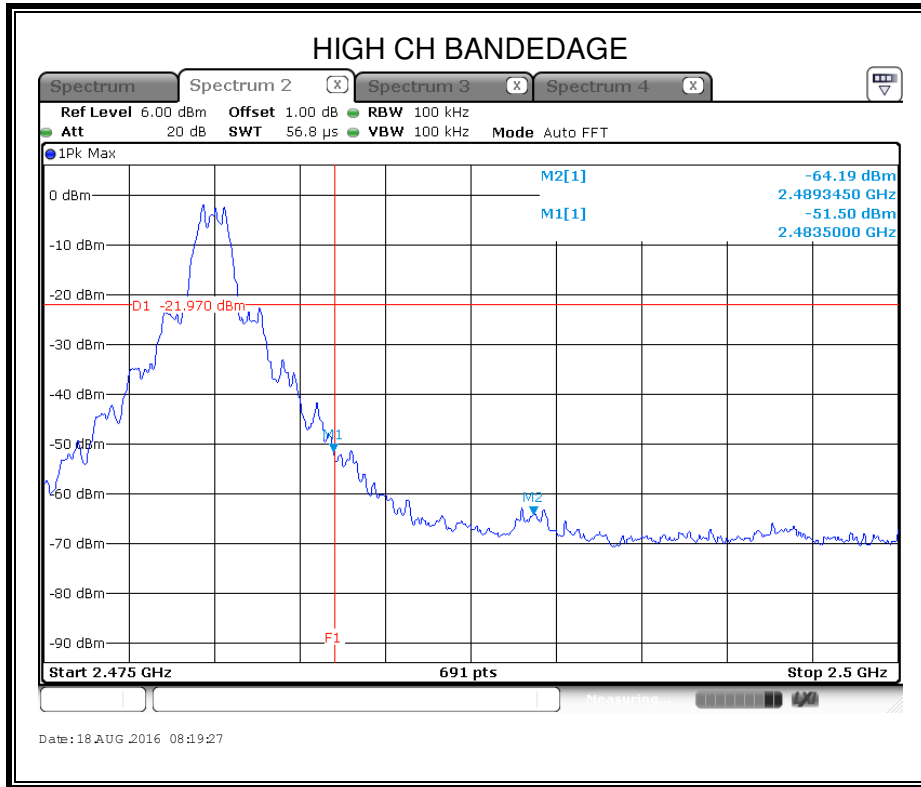

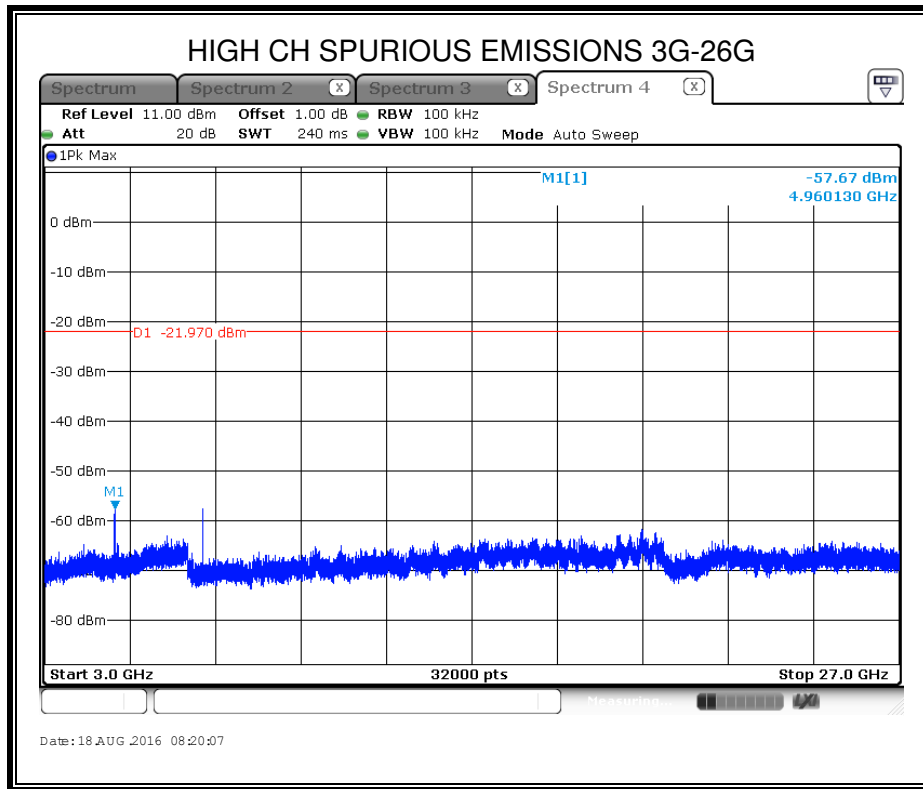

8. RADIATED TEST RESULTS

8.1. LIMITS AND PROCEDURE

LIMITS

Please refer to FCC §15.205 and §15.209

Please refer to IC RSS-GEN Clause 8.9 (Transmitter)

Radiation Disturbance Test Limit for FCC (Class B)(9KHz-1GHz)

Frequency (MHz)	Field Strength (microvolts/meter)	Measurement Distance (meters)
0.009~0.490	2400/F(KHz)	300
0.490~1.705	24000/F(KHz)	30
1.705~30.0	30	30
30~88	100	3
88~216	150	3
216~960	200	3
960~1000	500	3

Radiation Disturbance Test Limit for FCC (Above 1G)

Frequency (MHz)	dB(uV/m) (at 3 meters)	
	Peak	Average
Above 1000	74	54

TEST CONDITIONS

Temperature: 22.2°C
Relative Humidity: 61.2%
Test Voltage: AC 120V/60Hz

TEST SETUP AND PROCEDURE

Below 30MHz

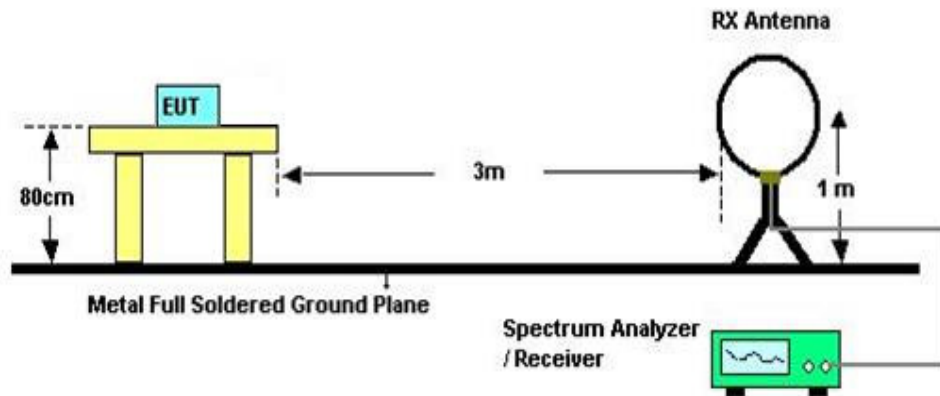

The setting of the spectrum analyser

RBW	200Hz (From 9kHz to 0.15MHz)/ 9KHz (From 0.15MHz to 30MHz)
VBW	200Hz (From 9kHz to 0.15MHz)/ 9KHz (From 0.15MHz to 30MHz)
Sweep	Auto
Detector	Peak/QP/ Average
Trace	Max hold

1. The testing follows the guidelines in ANSI C63.10-2013
2. The EUT was arranged to its worst case and then turntable (from 0 degree to 360 degrees) to find the maximum reading. A pre-amp and a high pass filter are used for the test in order to get better signal level. Both horizontal and vertical polarizations of the antenna are set to make the measurement.
3. The EUT was placed on a turntable with 0.8 meter above ground.
4. The EUT was set 3 meters from the interference receiving antenna, which was mounted on the top of a variable height antenna tower.
5. Corrected Reading: $\text{Antenna Factor} + \text{Cable Loss} + \text{Read Level} - \text{Preamp Factor} = \text{Level}$
6. For measurement below 1GHz, the initial step in collecting conducted emission data is a spectrum analyzer peak detector mode pre-scanning the measurement frequency range. Significant peaks are then marked and then Quasi Peak detector mode re-measured. If the emission level of the EUT measured by the peak detector is 3 dB lower than the applicable limit, the peak emission level will be reported. Otherwise, the emission measurement will be repeated using the quasi-peak detector and reported.
7. For the actual test configuration, please refer to the related item in this test report (Photographs of the Test Configuration)

Below 1G

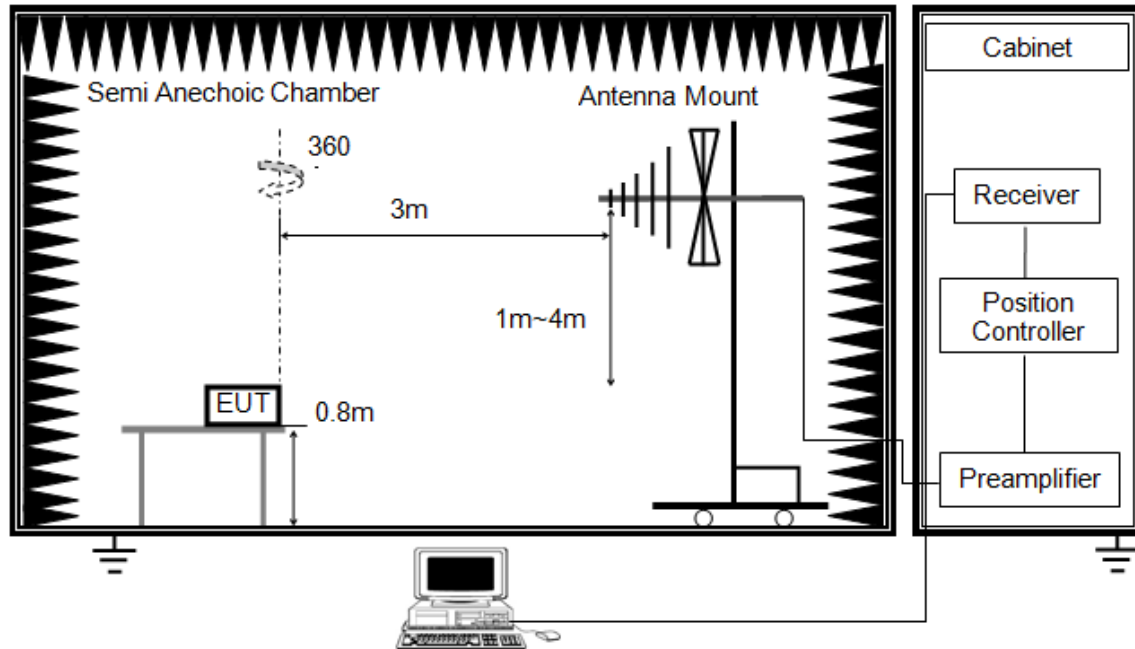

The setting of the spectrum analyser

RBW	120K
VBW	300K
Sweep	Auto
Detector	Peak/QP
Trace	Max hold

1. The testing follows the guidelines in ANSI C63.10-2013.
2. The EUT was arranged to its worst case and then tune the antenna tower (from 1 m to 4 m) and turntable (from 0 degree to 360 degrees) to find the maximum reading. A pre-amp and a high pass filter are used for the test in order to get better signal level. Both horizontal and vertical polarizations of the antenna are set to make the measurement.
3. The EUT was placed on a turntable with 0.8 meter above ground.
4. The EUT was set 3 meters from the interference receiving antenna, which was mounted on the top of a variable height antenna tower.
5. Corrected Reading: Antenna Factor + Cable Loss + Read Level - Preamp Factor = Level
6. For measurement below 1GHz, the initial step in collecting conducted emission data is a spectrum analyzer peak detector mode pre-scanning the measurement frequency range. Significant peaks are then marked and then Quasi Peak detector mode re-measured. If the emission level of the EUT measured by the peak detector is 3 dB lower than the applicable limit, the peak emission level will be reported. Otherwise, the emission measurement will be repeated using the quasi-peak detector and reported.
7. For the actual test configuration, please refer to the related Item in this test report (Photographs of the Test Configuration)

ABOVE 1G

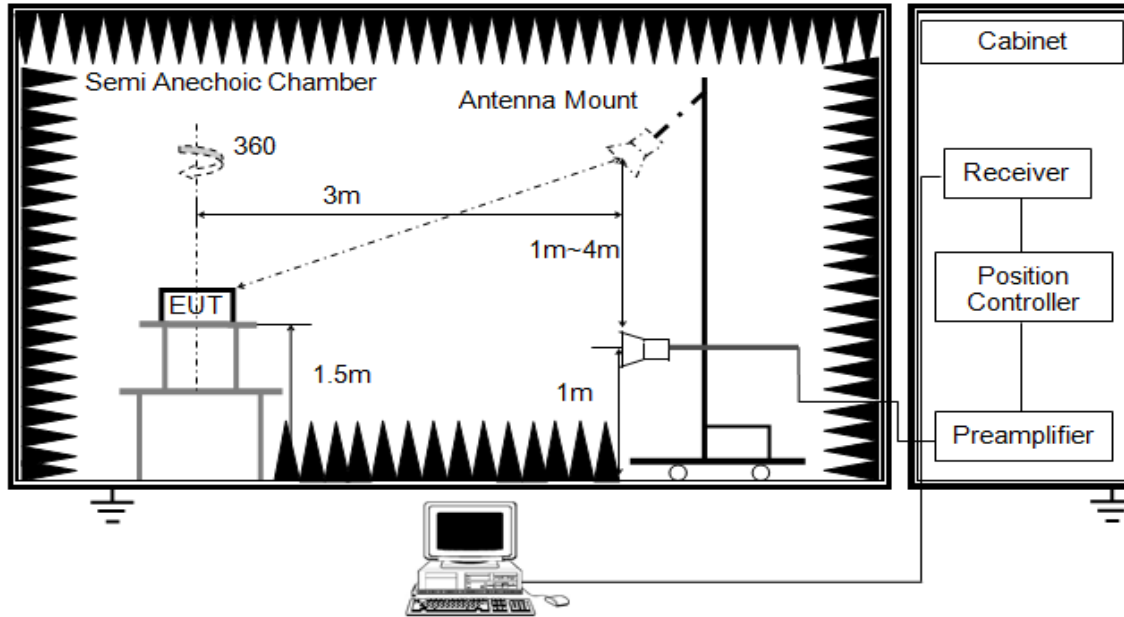

The setting of the spectrum analyser

RBW	1M
VBW	3M
Sweep	Auto
Detector	Peak and CISPR Average
Trace	Max hold

1. The testing follows the guidelines in ANSI C63.10-2013.
2. The EUT was arranged to its worst case and then tune the antenna tower (1.5 m) and turntable (from 0 degree to 360 degrees) to find the maximum reading. A pre-amp and a high pass filter are used for the test in order to get better signal level. Both horizontal and vertical polarizations of the antenna are set to make the measurement.
3. The EUT was placed on a turntable with 1.5 meter above ground.
4. The EUT was set 3 meters from the interference receiving antenna, which was mounted on the top of a variable height antenna tower.
5. Corrected Reading: $\text{Antenna Factor} + \text{Cable Loss} + \text{Read Level} - \text{Preamp Factor} = \text{Level}$
6. For measurement above 1GHz, the emission measurement will be measured by the peak detector and the AV detector.
7. For the actual test configuration, please refer to the related Item in this test report (Photographs of the Test Configuration)

TEST CONDITIONS

Temperature: 22.2°C
 Relative Humidity: 61%
 Test Voltage: AC 120V/60Hz

8.2. RESTRICTED BANDEDGE

8.2.1. GFSK MODE

RESTRICTED BANDEDGE (LOW CHANNEL, HORIZONTAL)

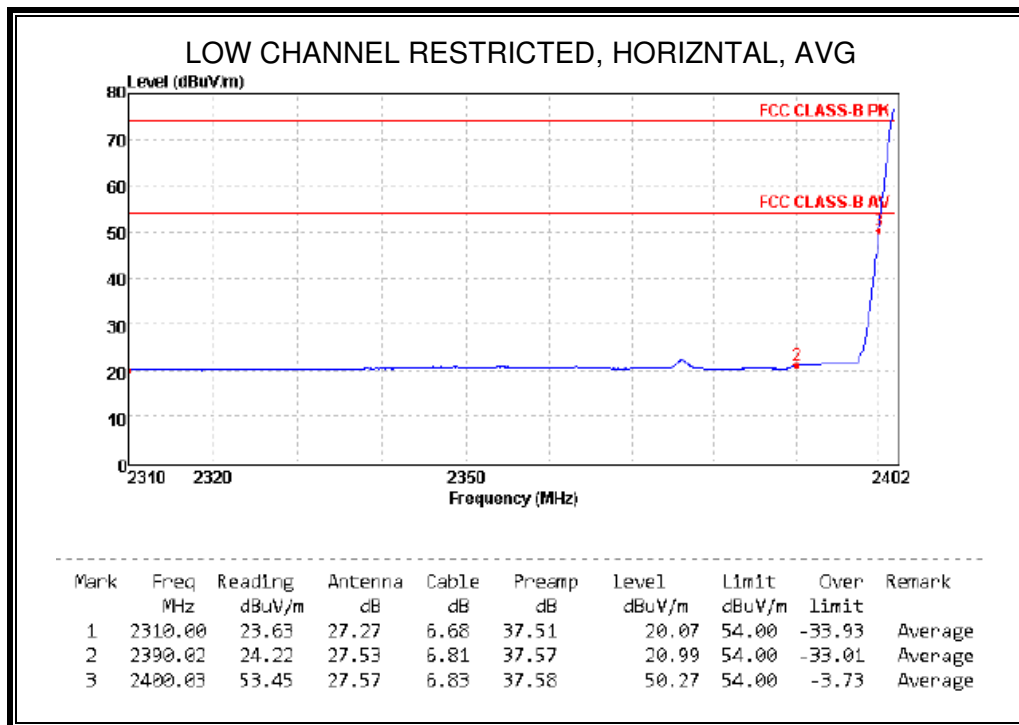
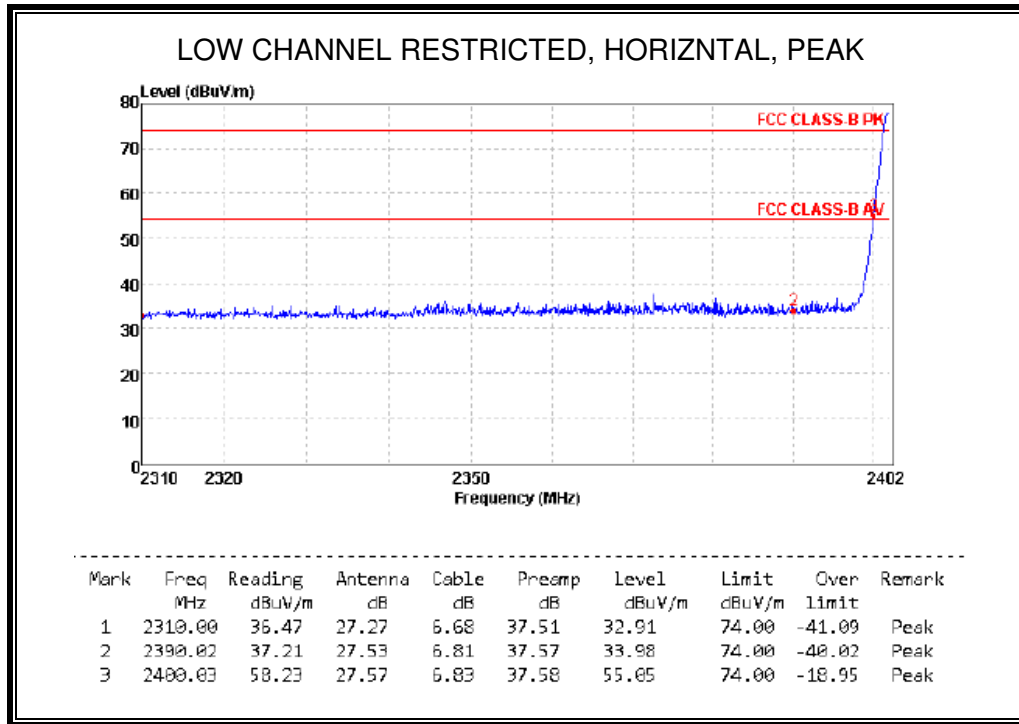

RESTRICTED BANDEDGE (LOW CHANNEL, VERTICAL)

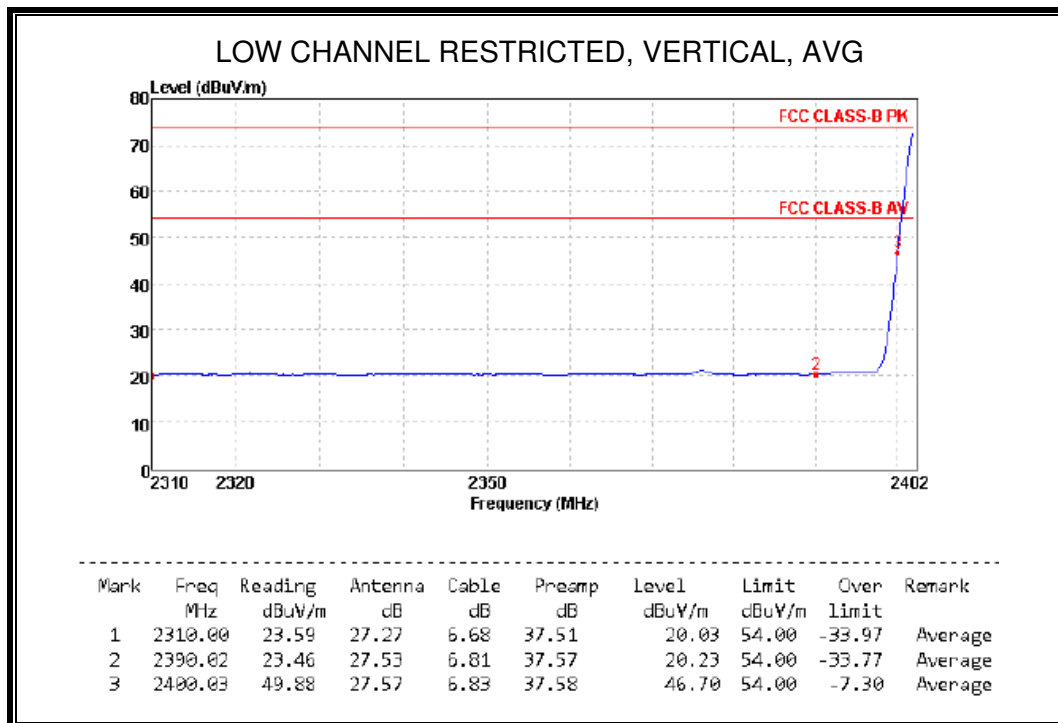
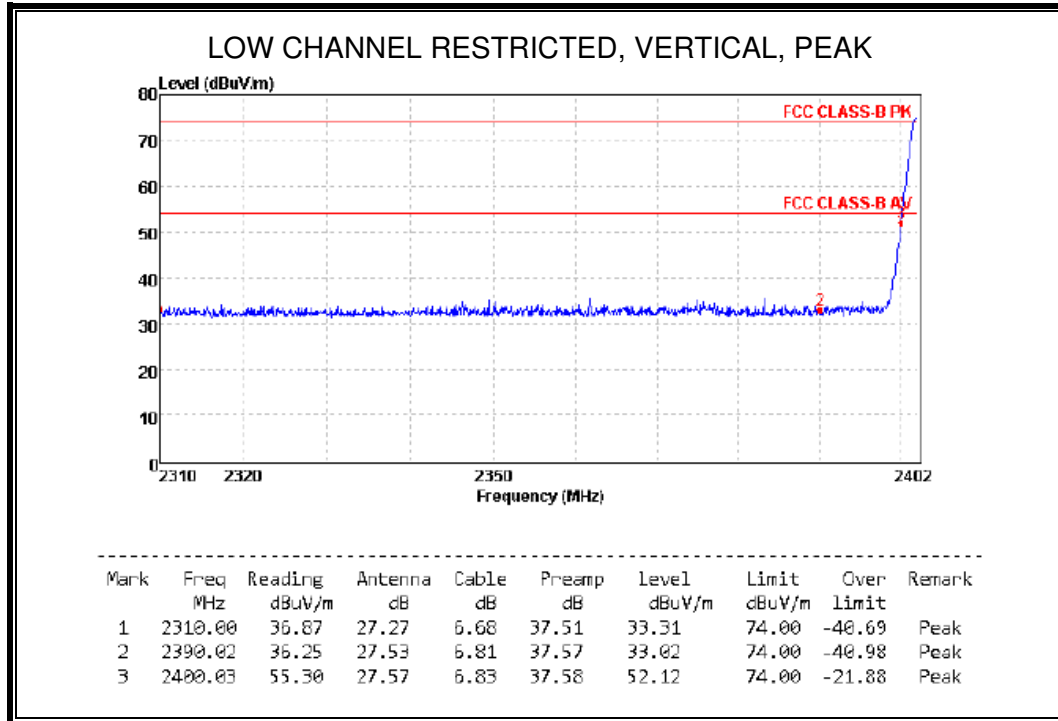

RESTRICTED BANDEDGE (HIGH CHANNEL, HORIZONTAL)

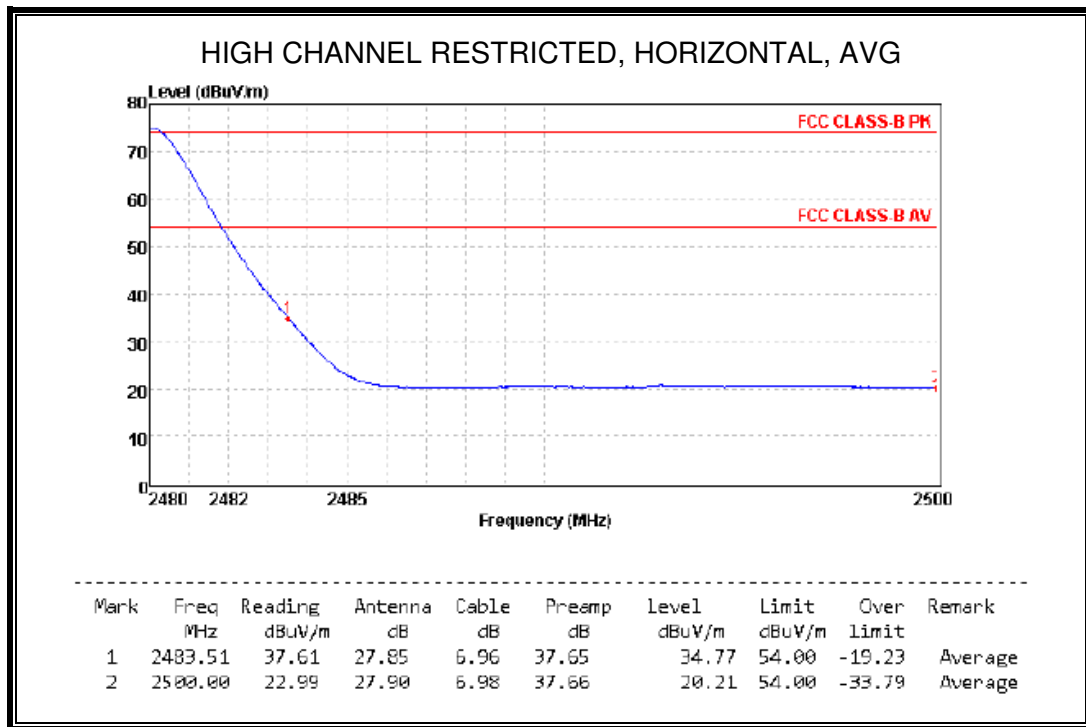
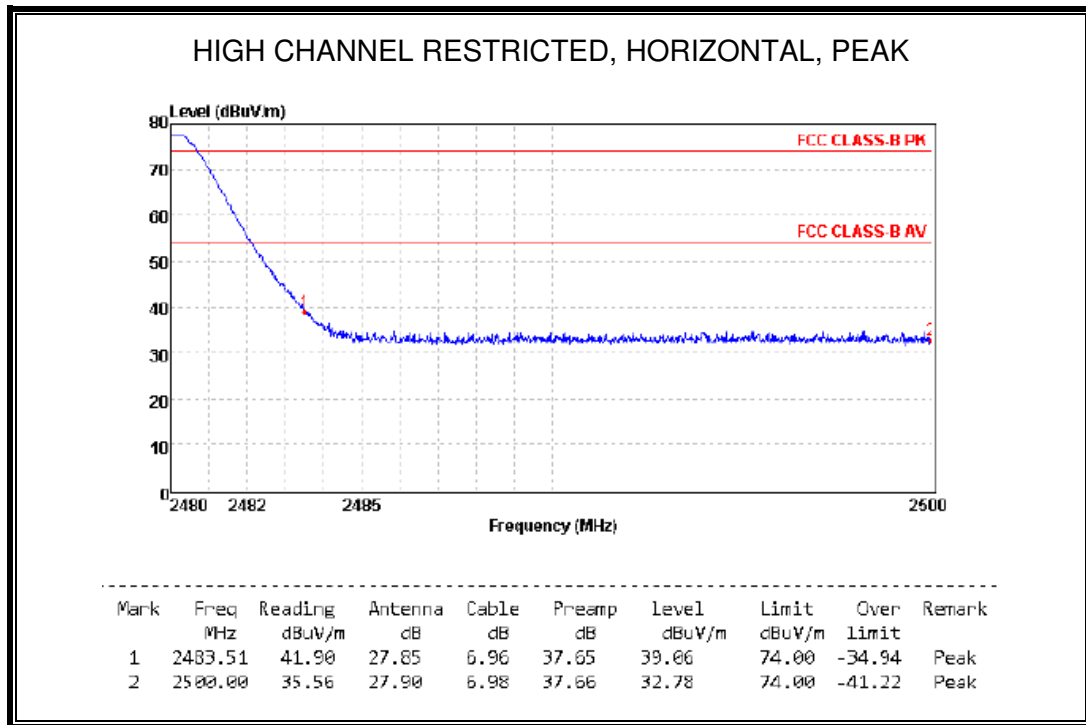

RESTRICTED BANDEDGE (HIGH CHANNEL, VERTICAL)

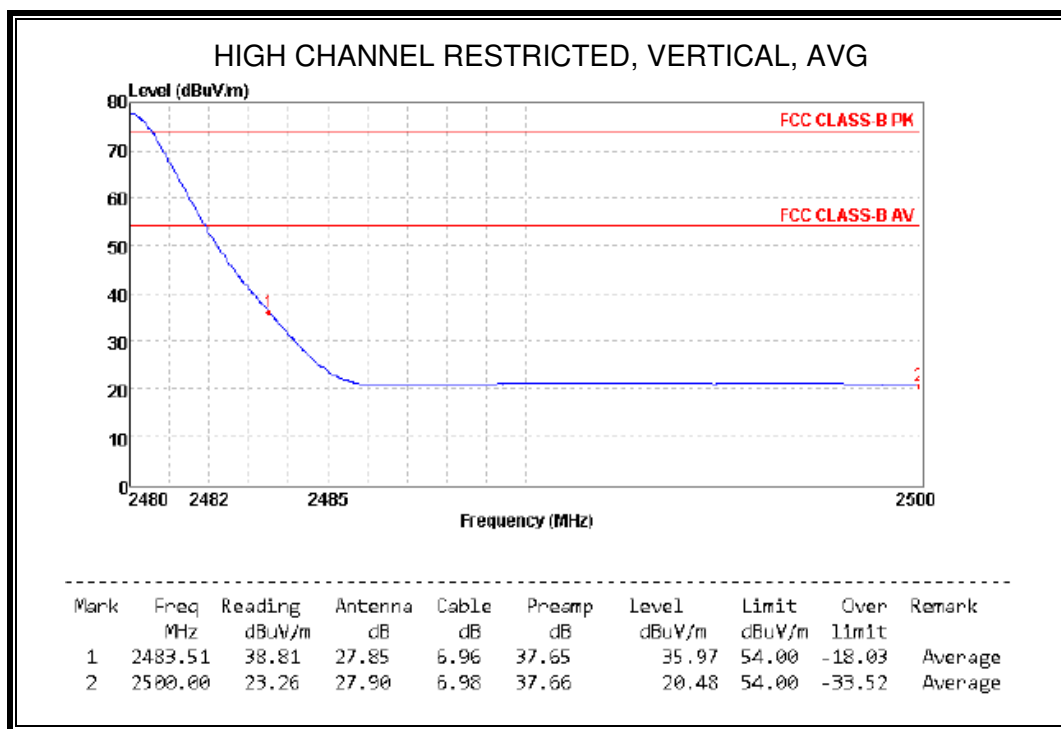
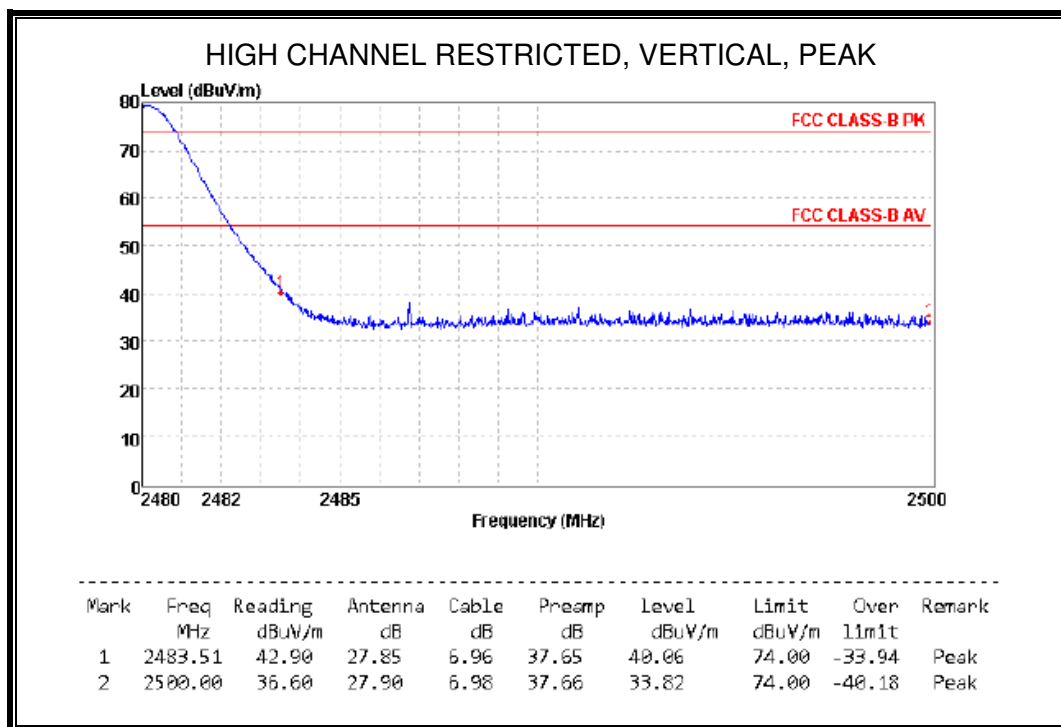

8.2.2. 8-DPSK MODE

RESTRICTED BANDEDGE (LOW CHANNEL, HORIZONTAL)

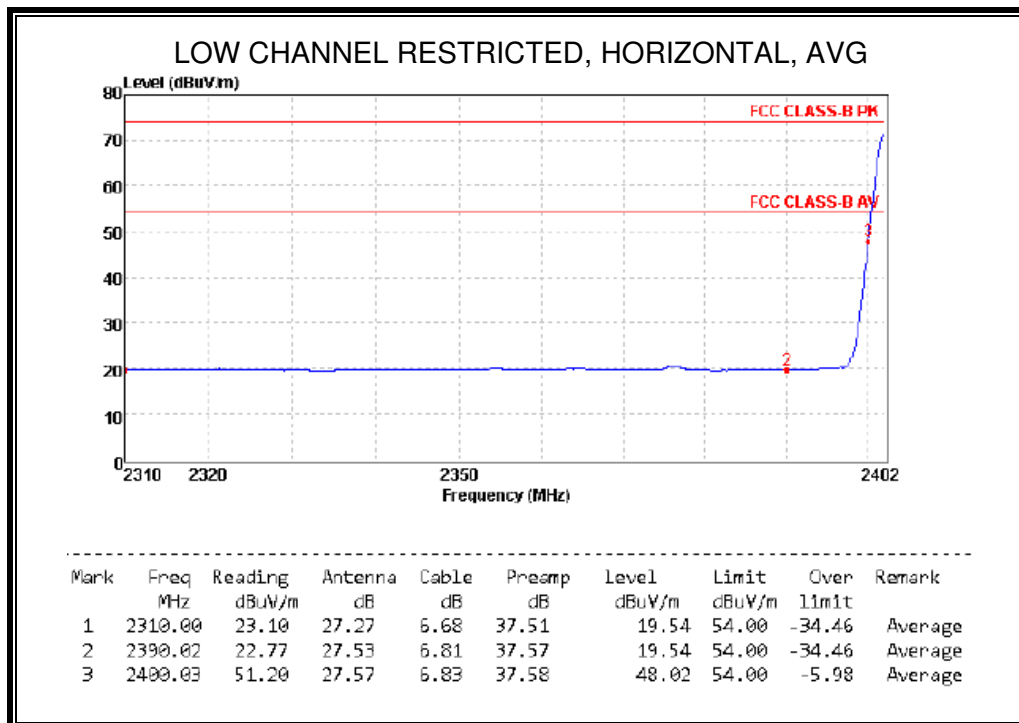
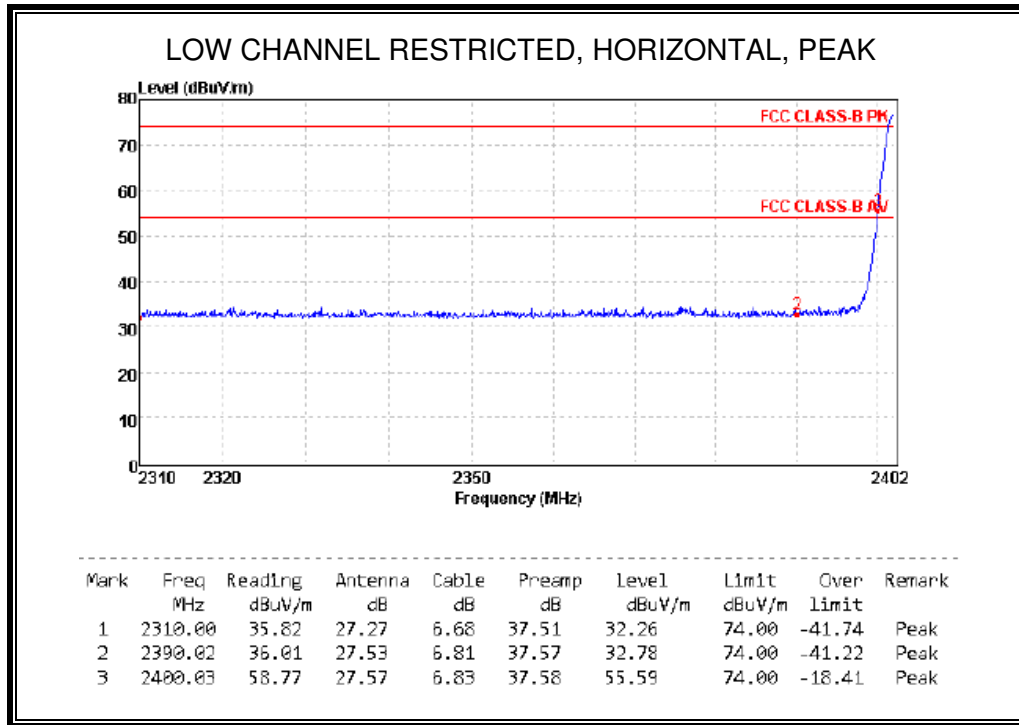

RESTRICTED BANDEDGE (LOW CHANNEL, VERTICAL)

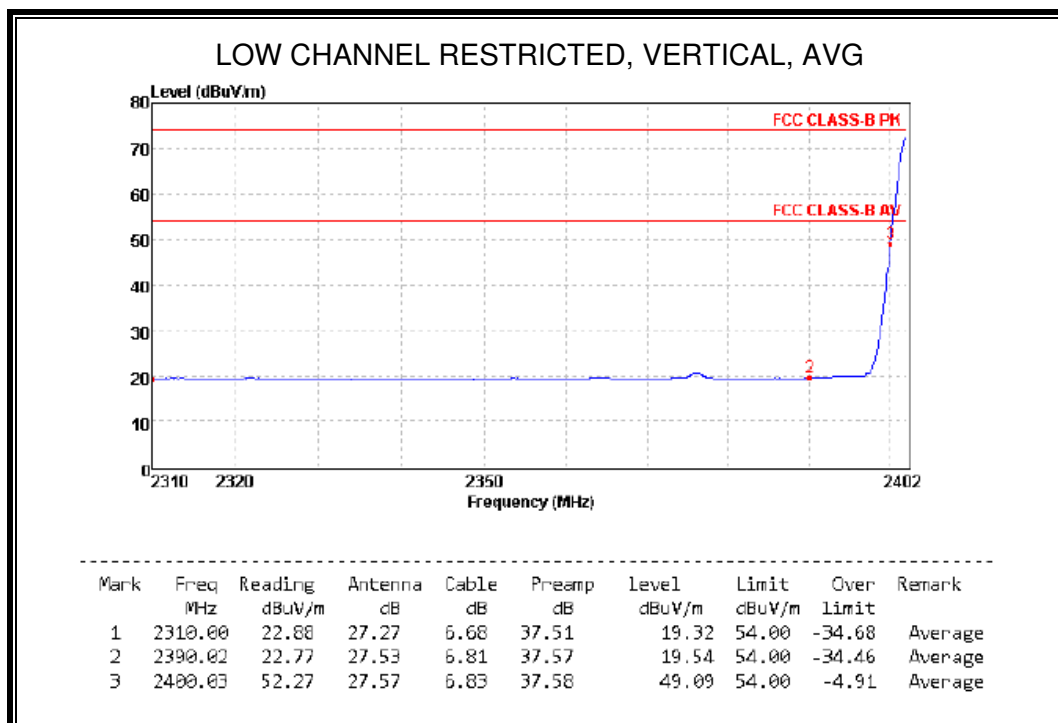
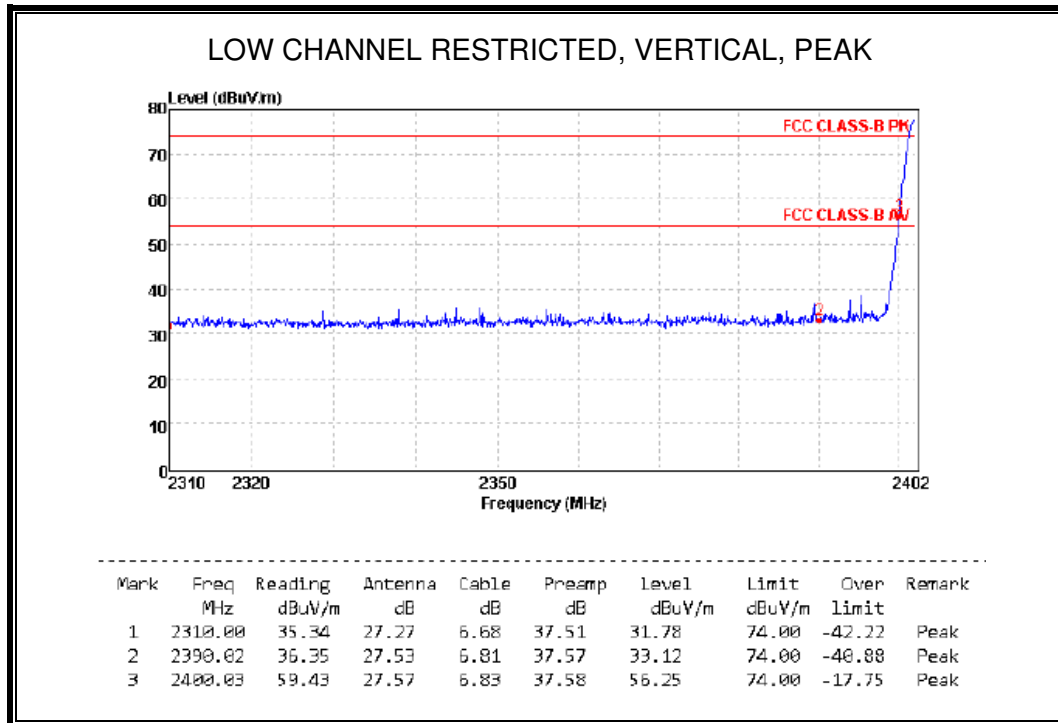

RESTRICTED BANDEDGE (HIGH CHANNEL, HORIZONTAL)

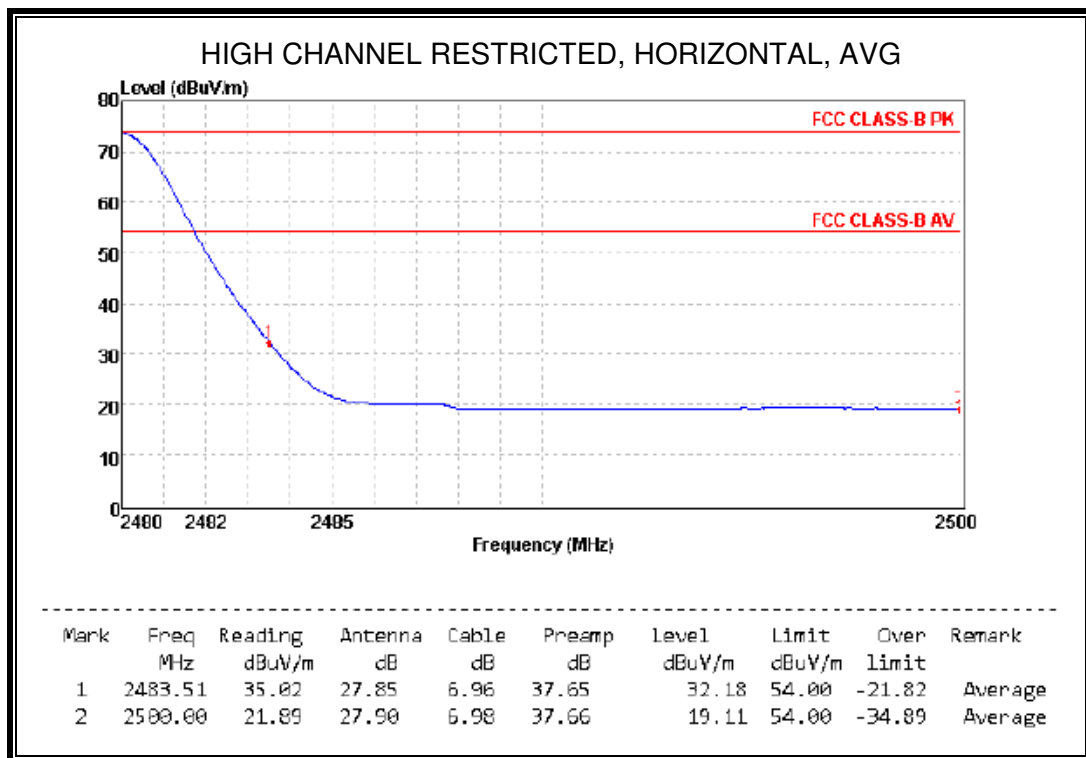
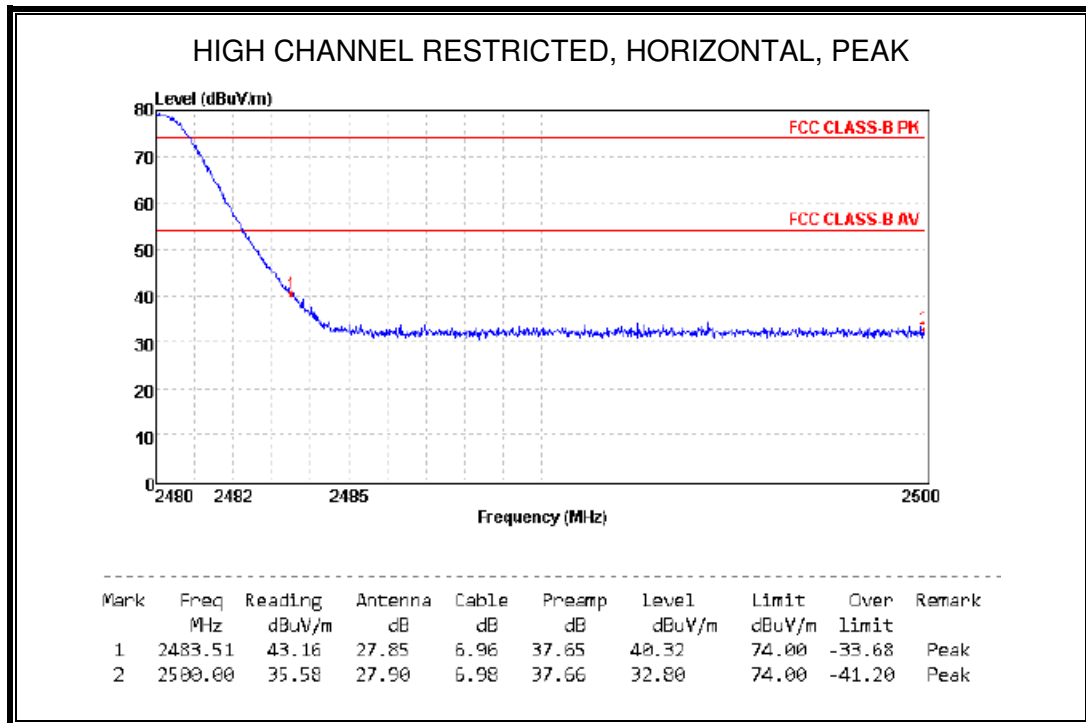

RESTRICTED BANDEDGE (HIGH CHANNEL, VERTICAL)

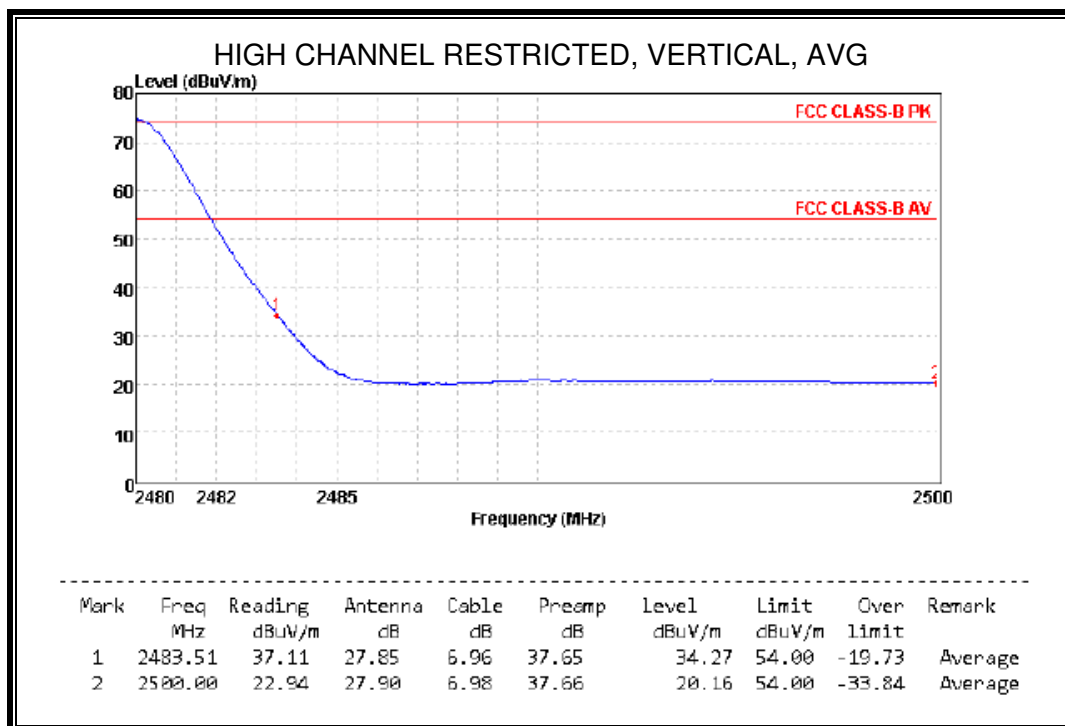
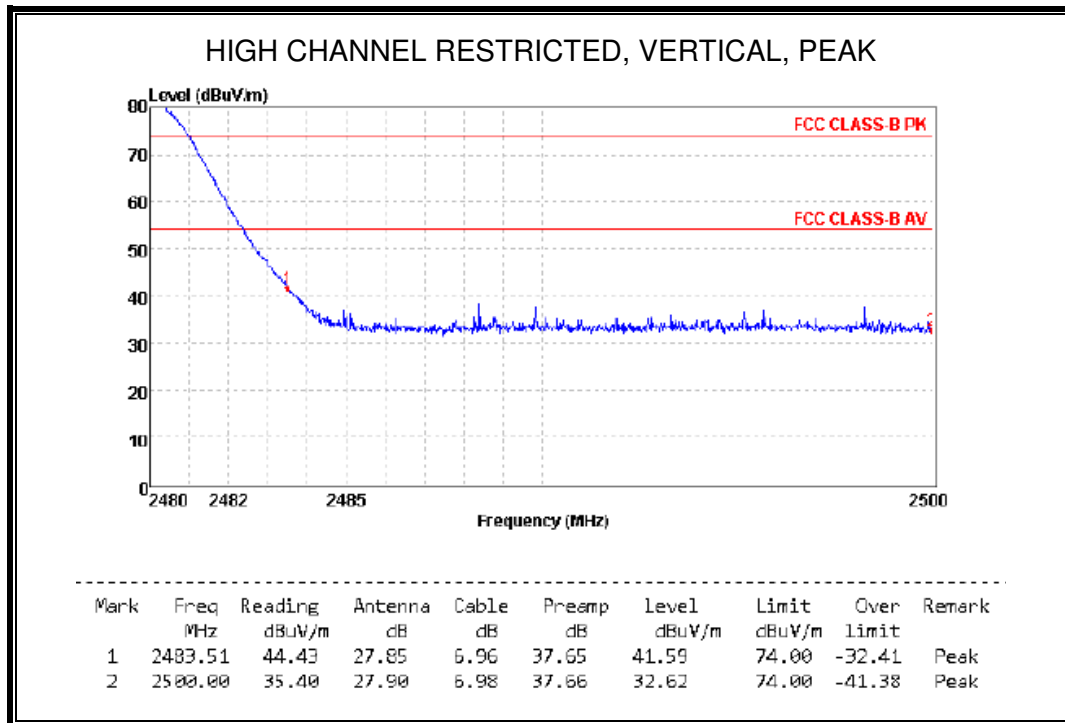

Note: EUT in each of three orthogonal axis emissions had been tested, but only the worst case (Z axis) data recorded in the report.

8.3. SPURIOUS EMISSIONS (1~25GHz)

8.3.1. GFSK MODE

HARMONICS AND SPURIOUS EMISSIONS

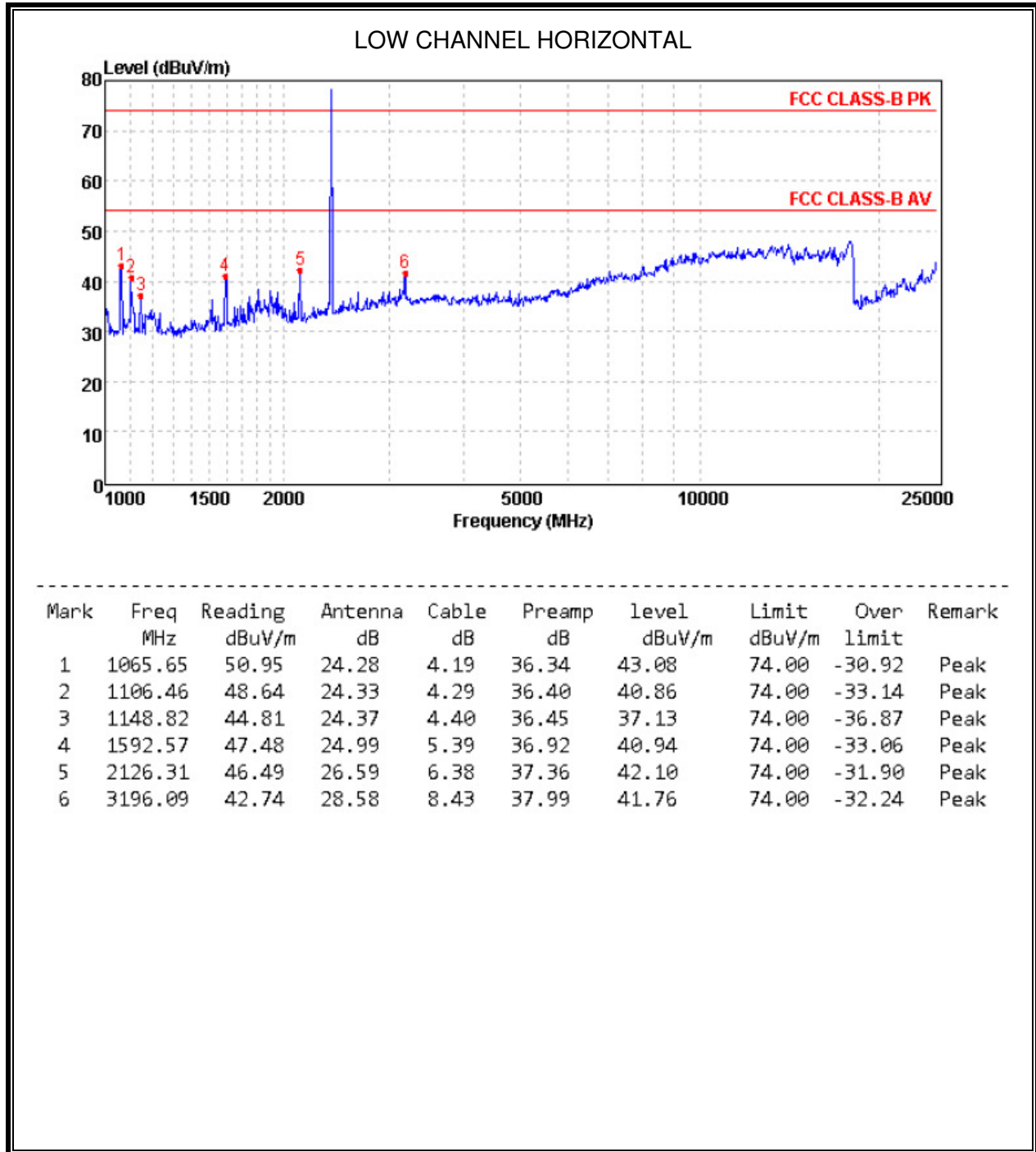

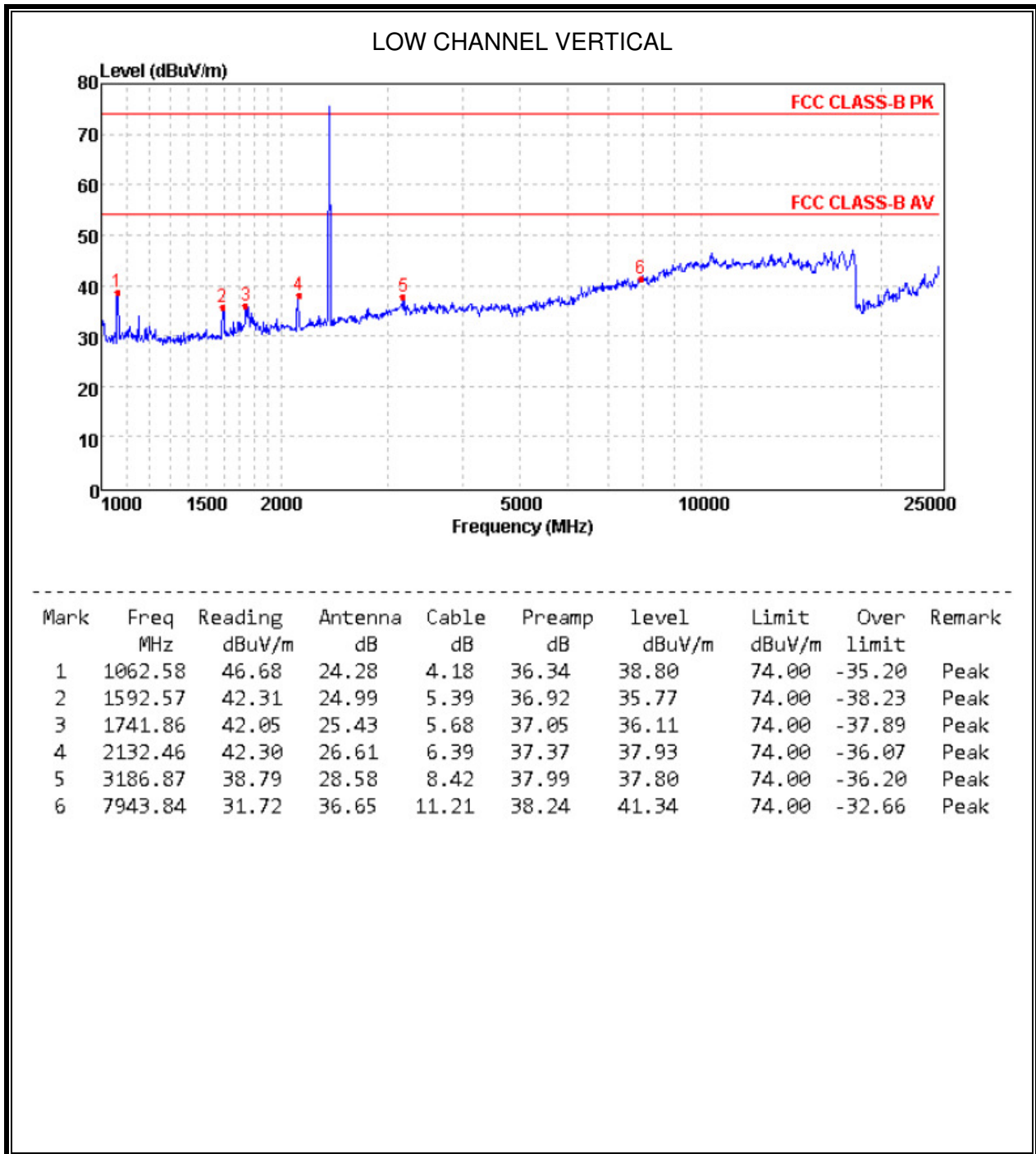

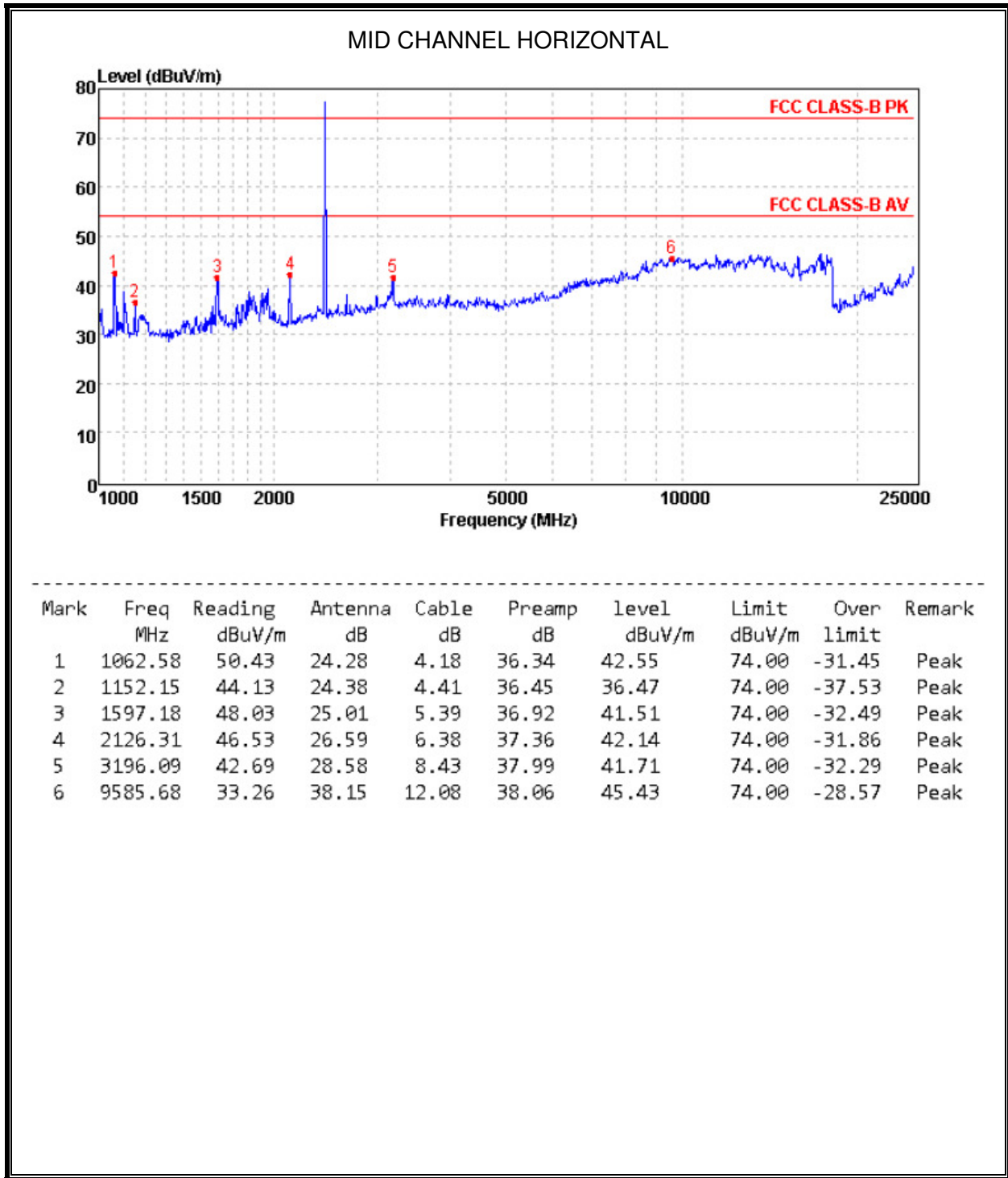

MID CHANNEL VERTICAL

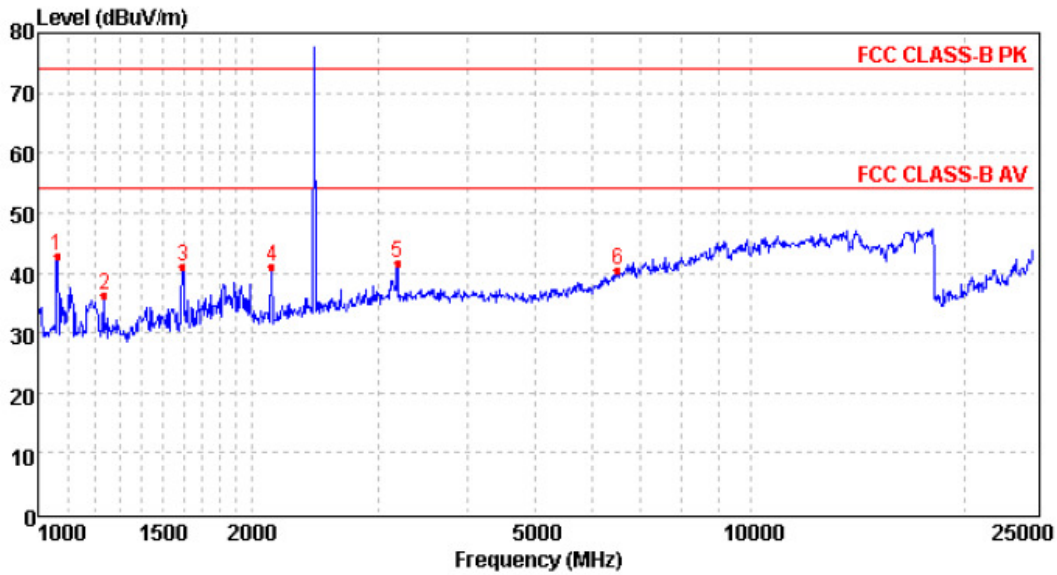

Mark	Freq MHz	Reading dBuV/m	Antenna dB	Cable dB	Preamp dB	level dBuV/m	Limit dBuV/m	Over limit	Remark
1	1062.58	50.59	24.28	4.18	36.34	42.71	74.00	-31.29	Peak
2	1238.48	43.69	24.46	4.62	36.56	36.21	74.00	-37.79	Peak
3	1597.18	47.52	25.01	5.39	36.92	41.00	74.00	-33.00	Peak
4	2126.31	45.29	26.59	6.38	37.36	40.90	74.00	-33.10	Peak
5	3196.09	42.61	28.58	8.43	37.99	41.63	74.00	-32.37	Peak
6	6507.54	32.97	35.10	10.35	37.98	40.44	74.00	-33.56	Peak

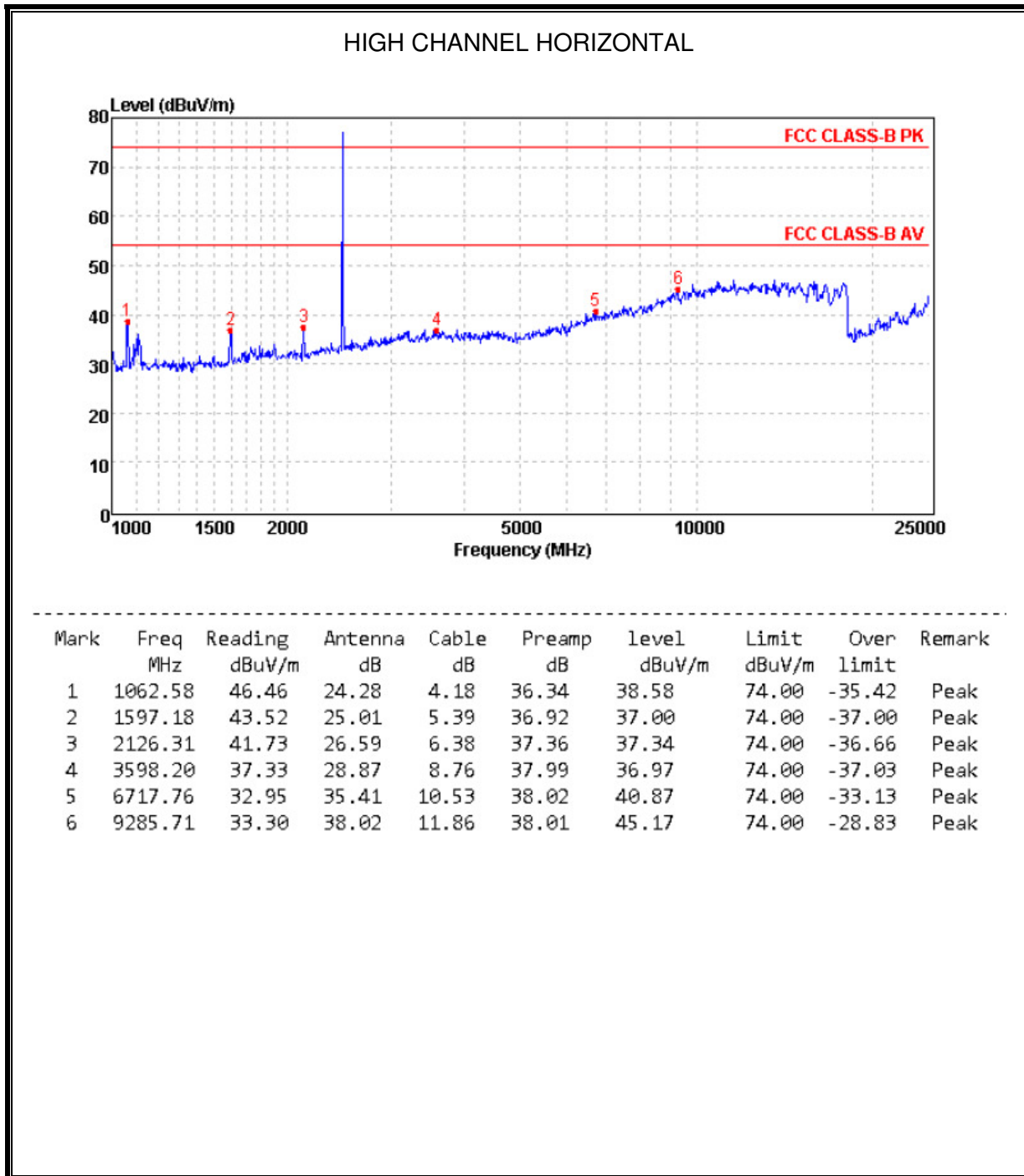

HIGH CHANNEL VERTICAL

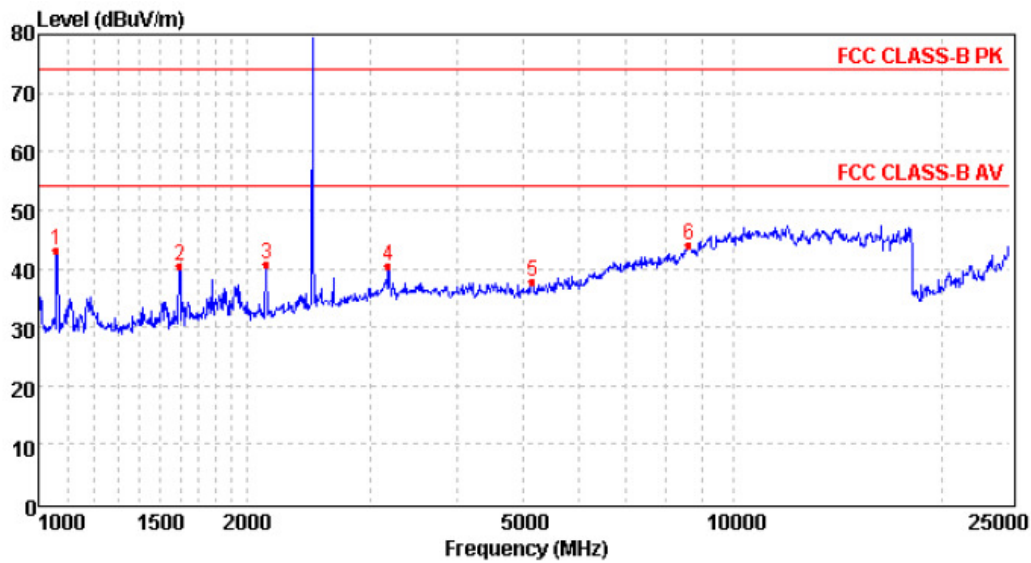

Mark	Freq MHz	Reading dBuV/m	Antenna dB	Cable dB	Preamp dB	level dBuV/m	Limit dBuV/m	Over limit	Remark
1	1059.51	51.06	24.27	4.17	36.33	43.17	74.00	-30.83	Peak
2	1597.18	47.07	25.01	5.39	36.92	40.55	74.00	-33.45	Peak
3	2126.31	45.15	26.59	6.38	37.36	40.76	74.00	-33.24	Peak
4	3186.87	41.37	28.58	8.42	37.99	40.38	74.00	-33.62	Peak
5	5134.34	35.36	31.53	9.42	38.54	37.77	74.00	-36.23	Peak
6	8638.40	33.25	37.41	11.37	38.05	43.98	74.00	-30.02	Peak

8.3.2. 8DPSK MODE

HARMONICS AND SPURIOUS EMISSIONS

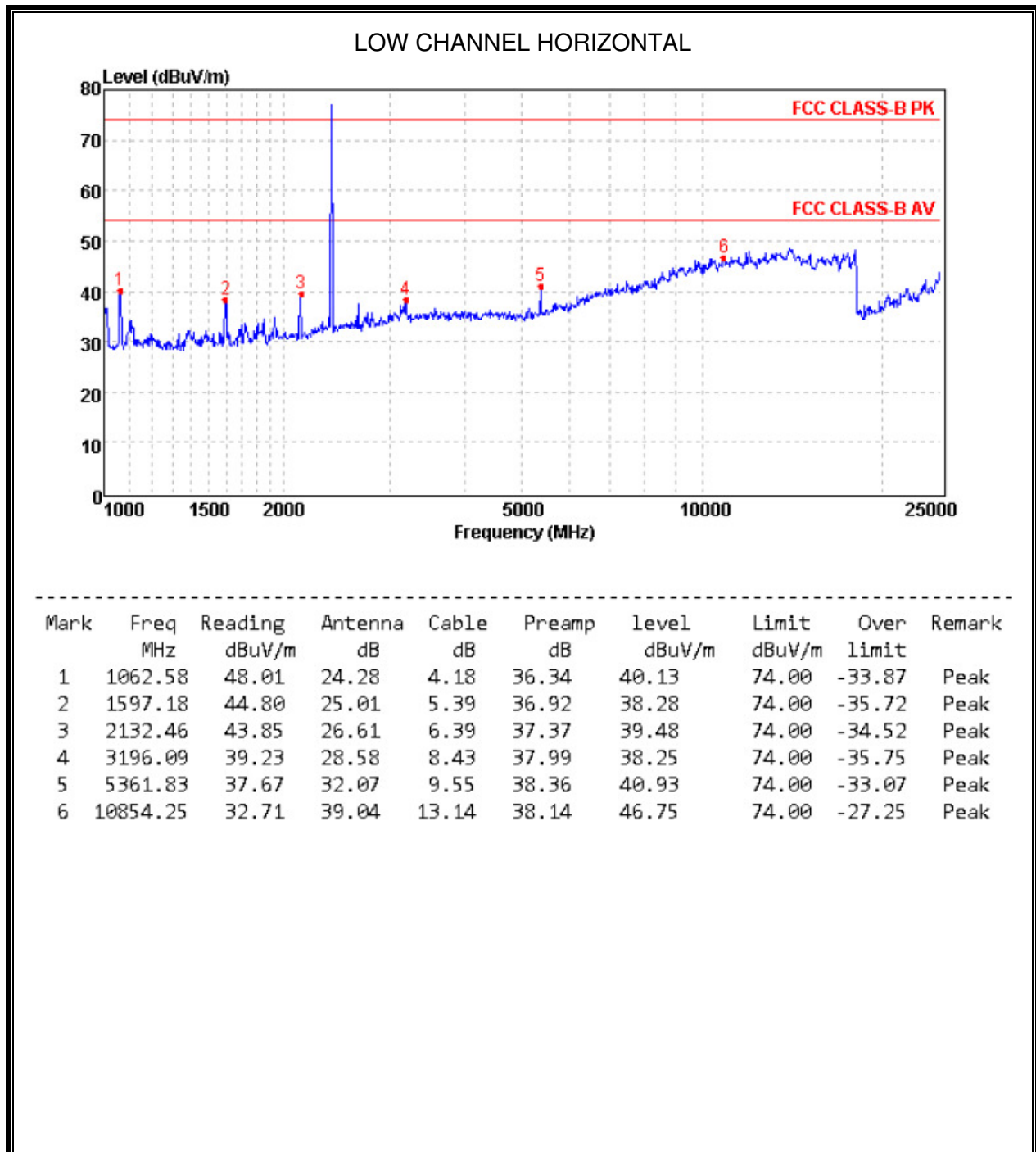

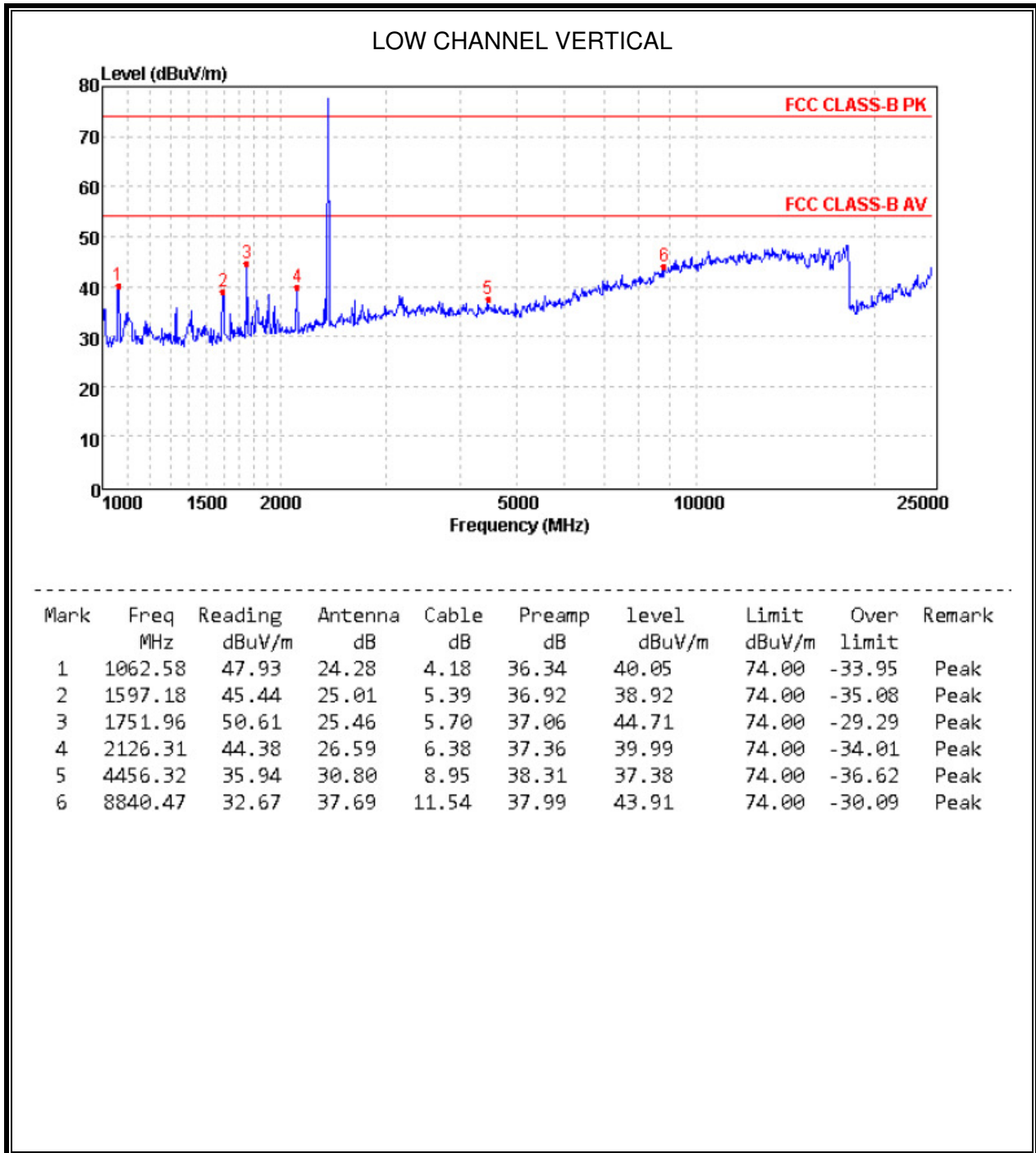

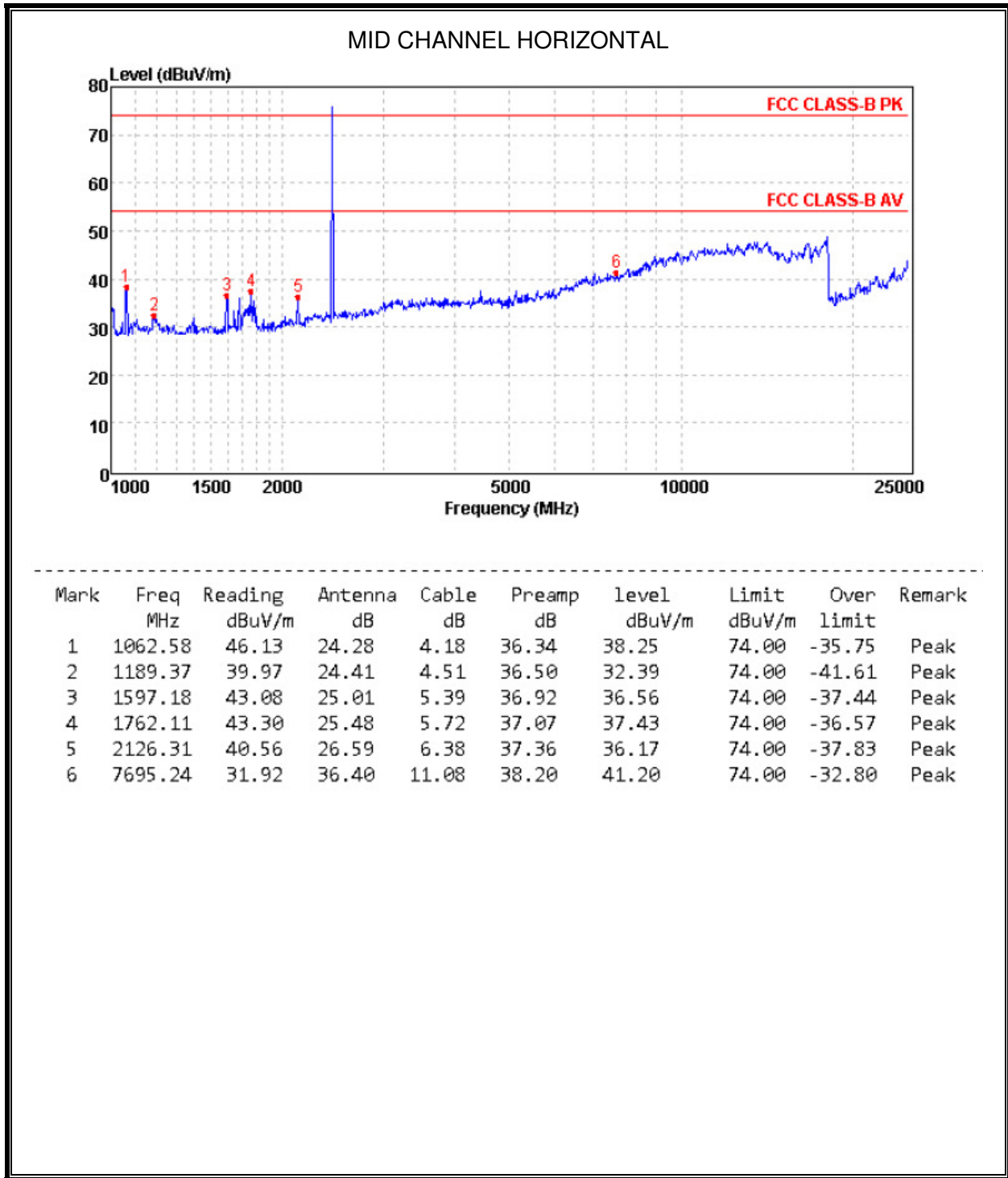

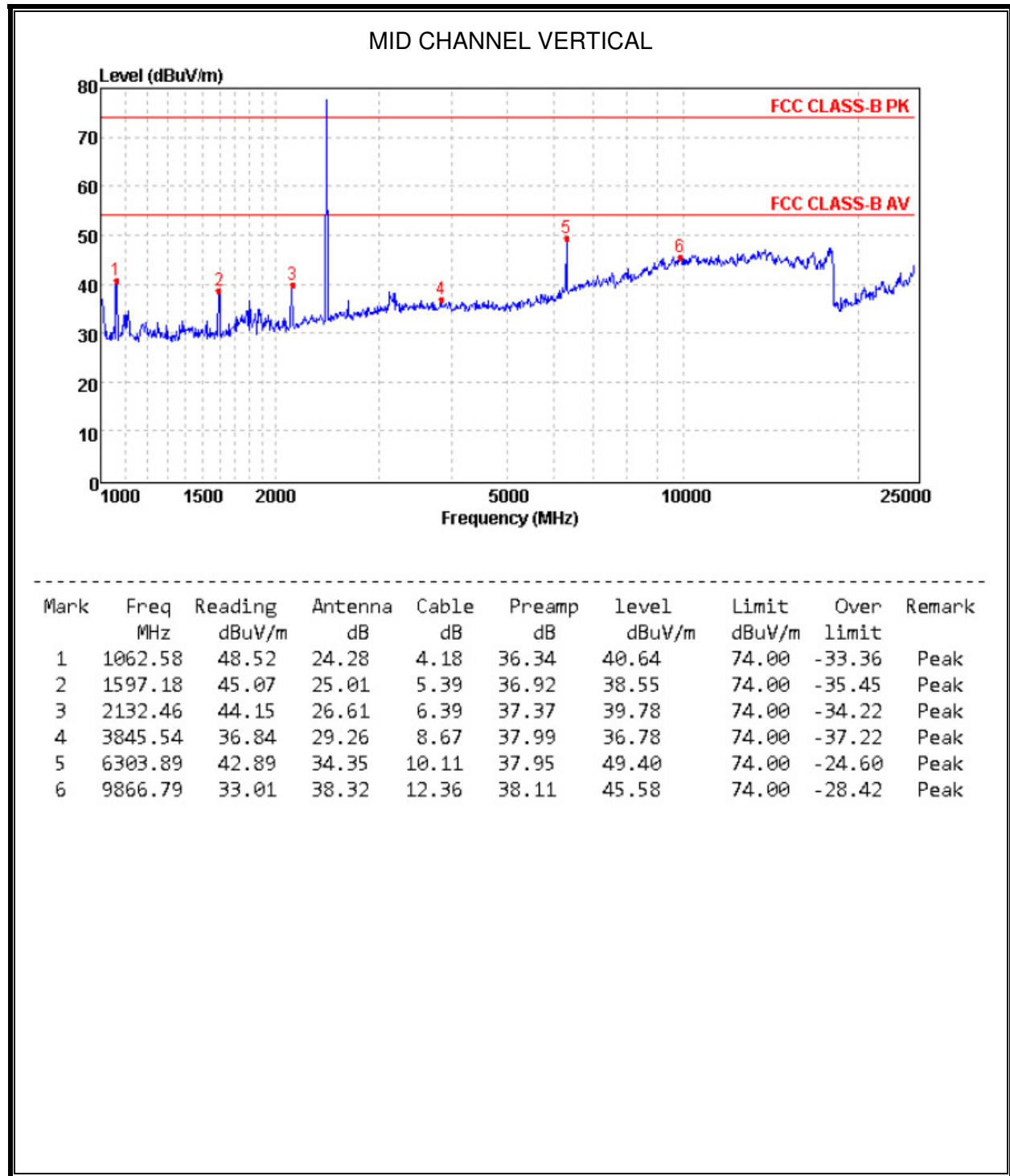

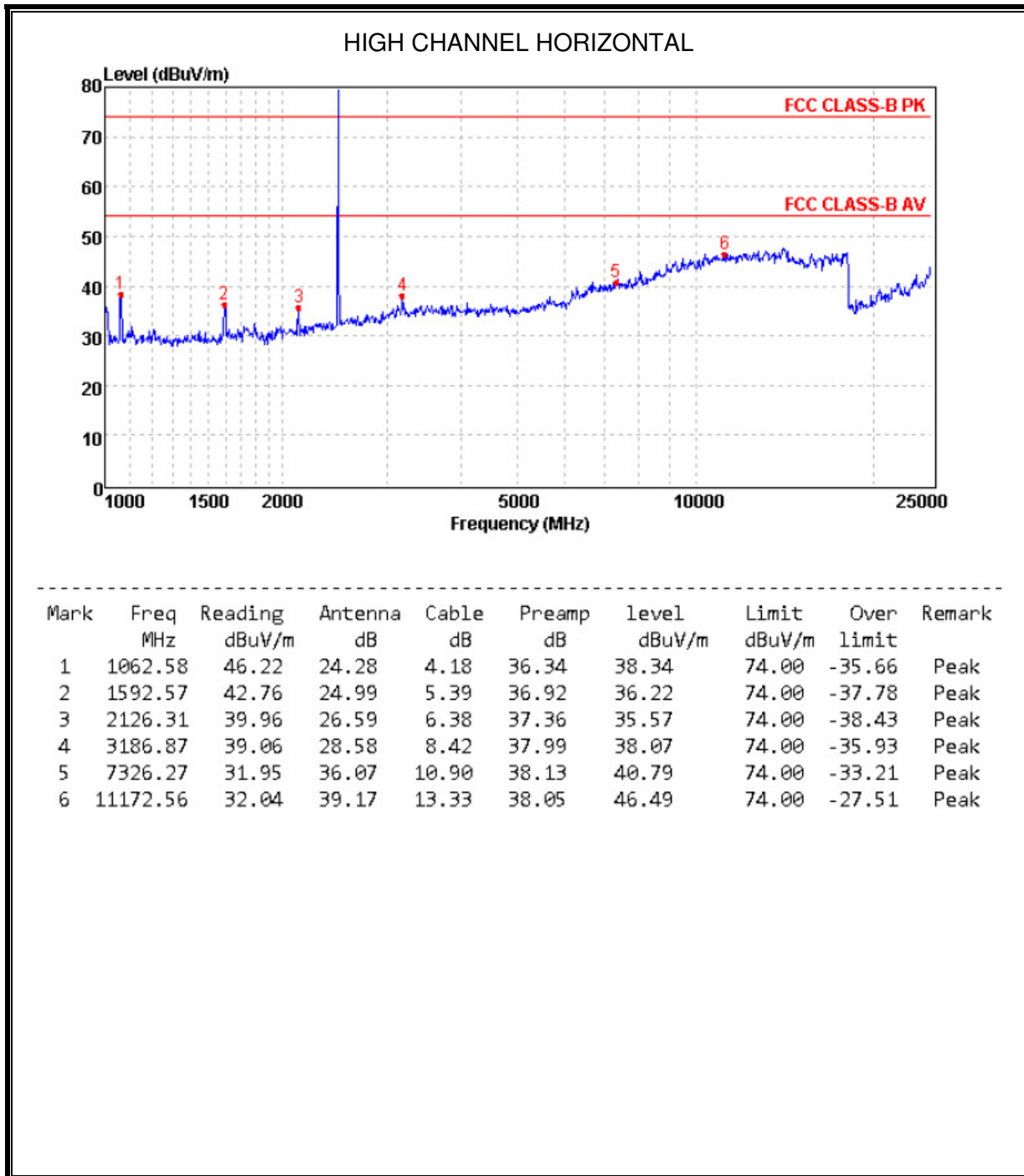

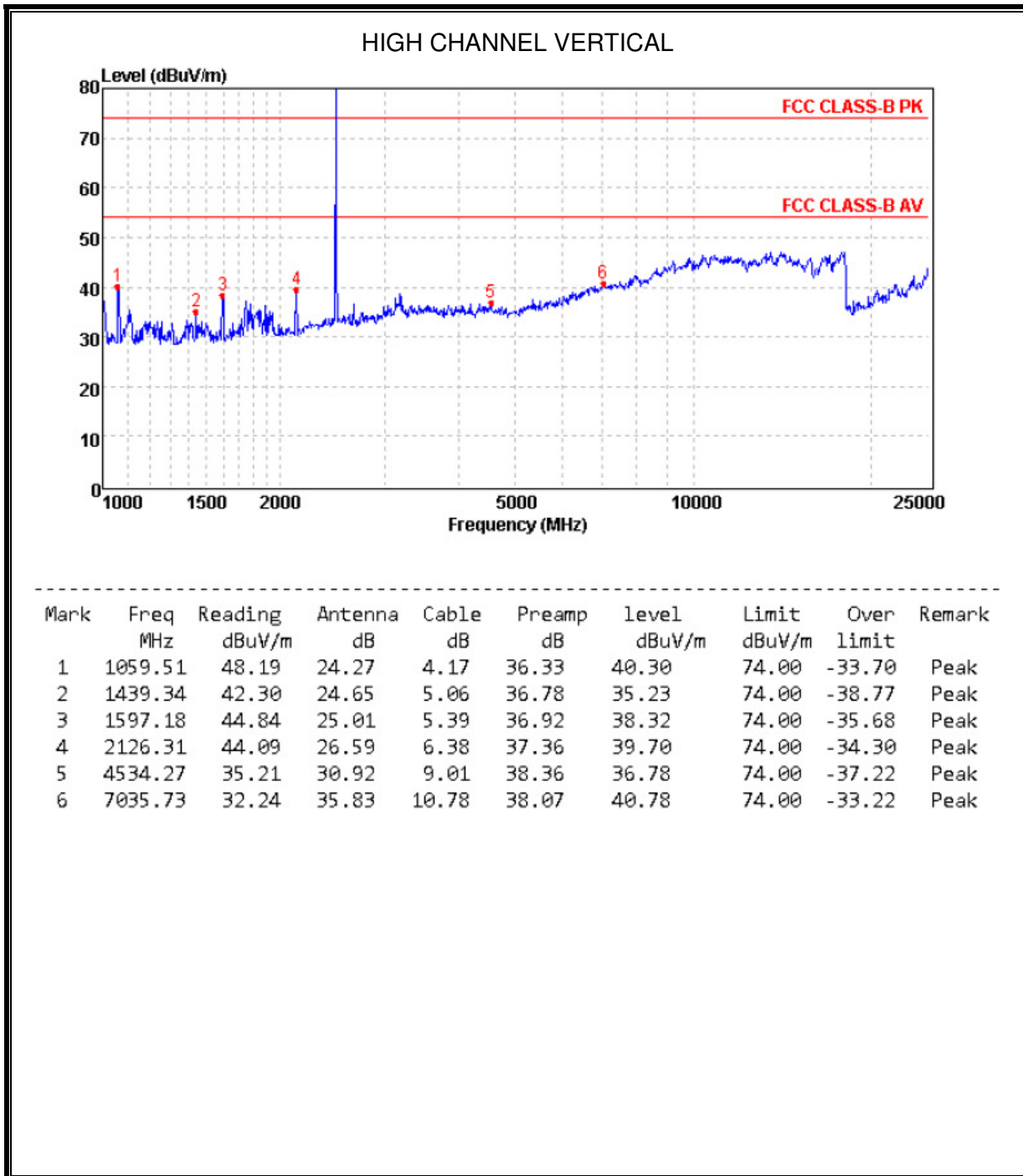

Note: EUT in each of three orthogonal axis emissions had been tested, but only the worst case(Z axis) data recorded in the report.

8.4. SPURIOUS EMISSIONS 30M ~ 1 GHz

8.4.1. GFSK MODE

SPURIOUS EMISSIONS 30 TO 1000 MHz (WORST-CASE CONFIGURATION)

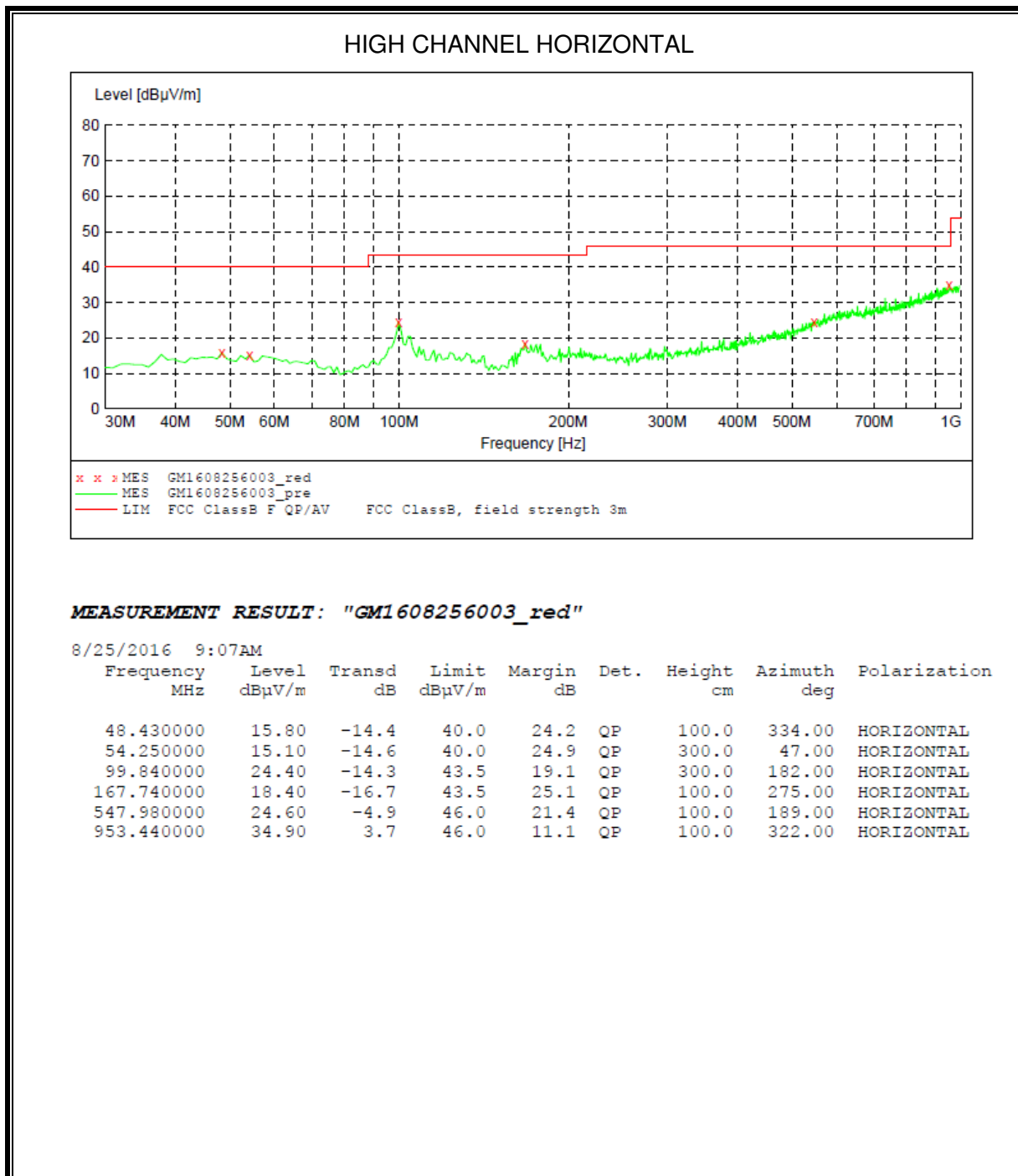

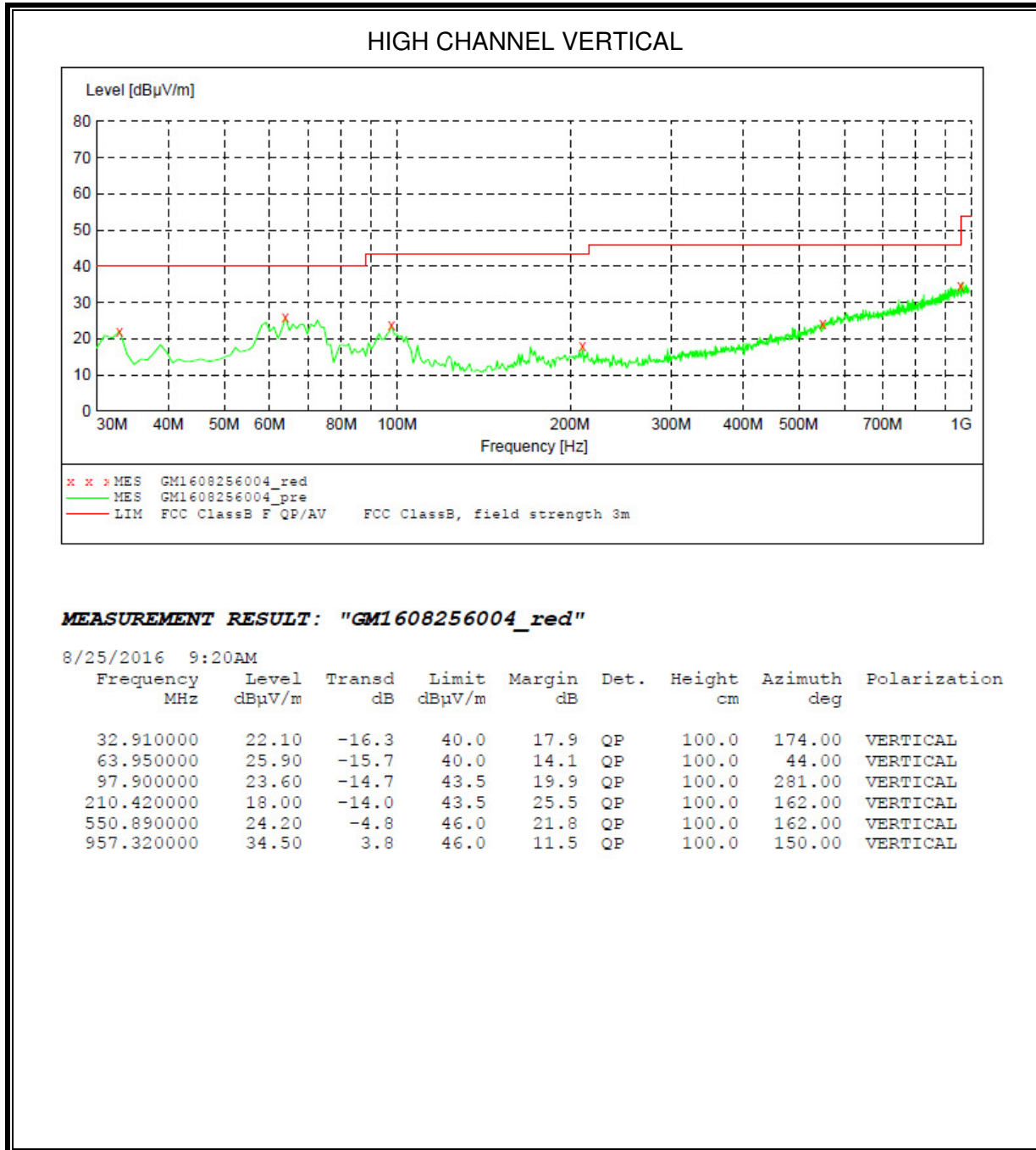

Note: EUT in each of three orthogonal axis emissions had been tested, but only the worst case (X axis) data recorded in the report.

8.5. SPURIOUS EMISSIONS BELOW 30M

Note 1: The low frequency, which started from 9 kHz to 30MHz, was pre-scanned and the result which was 20dB lower than the limit line per 15.31(o) was not reported.

Note 2: EUT in each of three orthogonal axis emissions had been tested, but only the worst case (X axis) data recorded in the report.

9. AC POWER LINE CONDUCTED EMISSIONS

LIMITS

Please refer to FCC §15.207 (a) and RSS-Gen Clause 8.8

FREQUENCY (MHz)	Class A (dBuV)		Class B (dBuV)	
	Quasi-peak	Average	Quasi-peak	Average
0.15 -0.5	79.00	66.00	66 - 56 *	56 - 46 *
0.50 -5.0	73.00	60.00	56.00	46.00
5.0 -30.0	73.00	60.00	60.00	50.00

TEST SETUP AND PROCEDURE

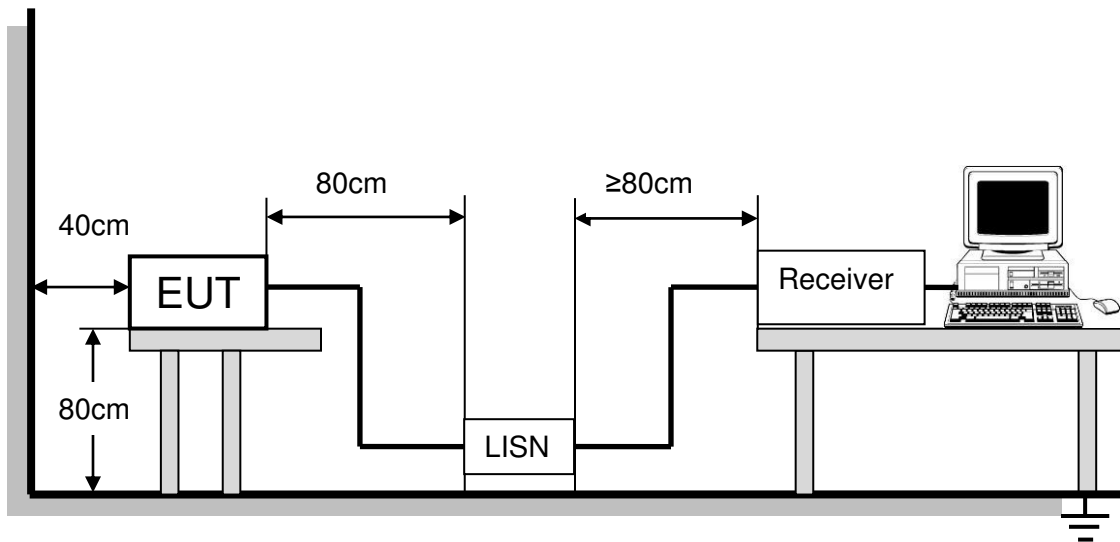

The EUT is put on a table of non-conducting material that is 80cm high. The vertical conducting wall of shielding is located 40cm to the rear of the EUT. The power line of the EUT is connected to the AC mains through a Artificial Mains Network (A.M.N.). A EMI Measurement Receiver (R&S Test Receiver ESR3) is used to test the emissions from both sides of AC line. According to the requirements in Section 7 and 13 of ANSI C63.4-2014. Conducted emissions from the EUT measured in the frequency range between 0.15 MHz and 30MHz using CISPR Quasi-Peak and average detector mode. The bandwidth of EMI test receiver is set at 9kHz.

The arrangement of the equipment is installed to meet the standards and operating in a manner, which tends to maximize its emission characteristics in a normal application.

TEST RESULTS (WORST-CASE CONFIGURATION)

EUT:	LIFEPROOF AQ9	Model Name:	LPSAN-0005-A
Temperature:	26.0°C	Relative Humidity:	43.0 %
Pressure:	1012 hPa	Test Voltage:	AC 120V/60Hz
Test Mode:	GFSK Mode	Phase :	L1

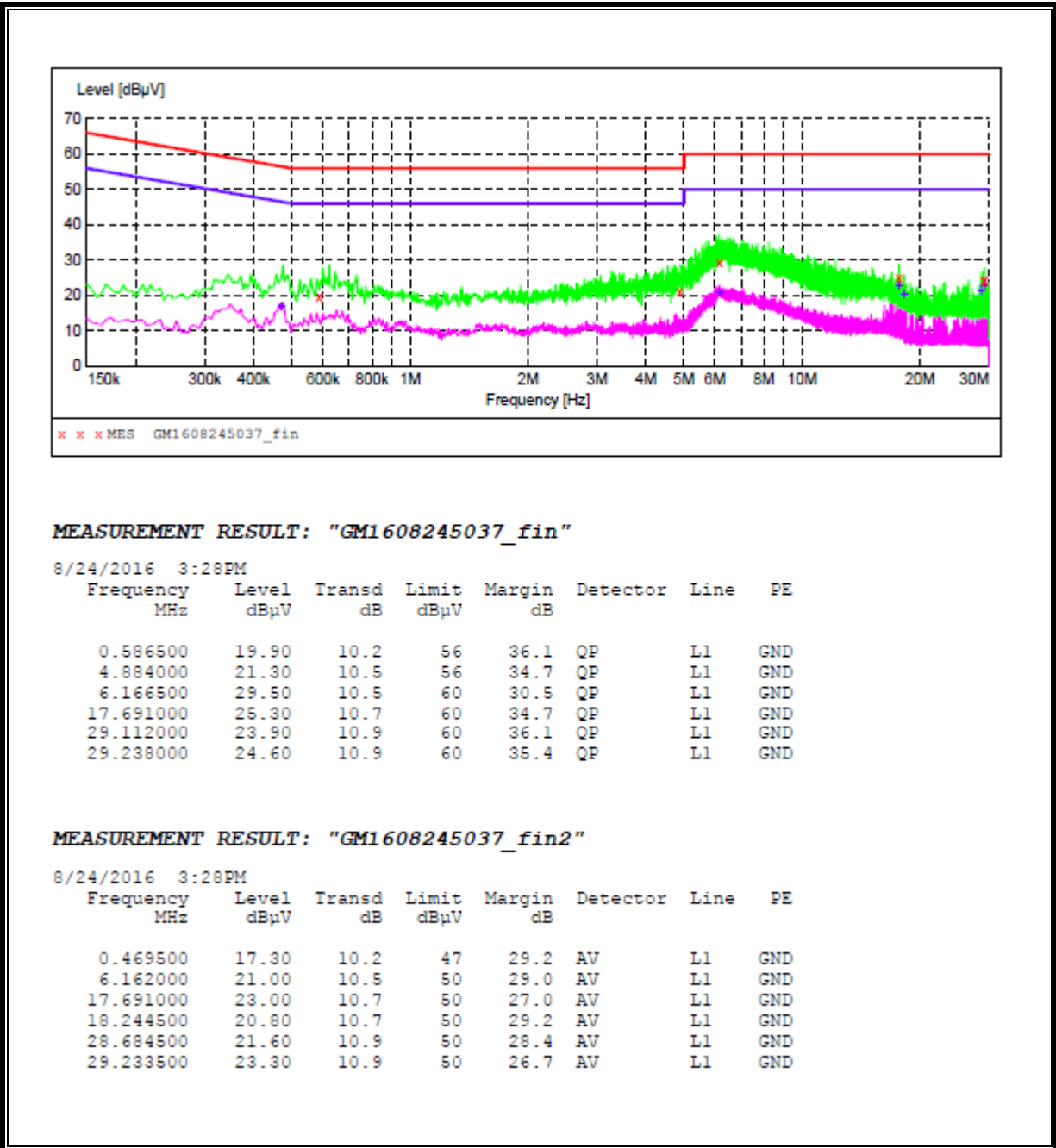

EUT:	LIFEPROOF AQ9	Model Name:	LPSAN-0005-A
Temperature:	26.0°C	Relative Humidity:	43.0 %
Pressure:	1012 hPa	Test Voltage:	AC 120V/60Hz
Test Mode:	GFSK Mode	Phase :	N

LINE N

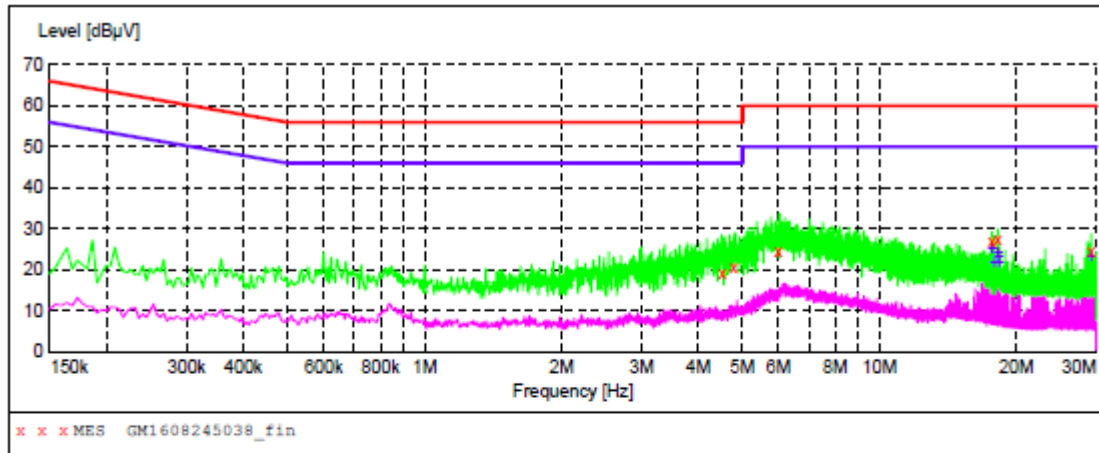

MEASUREMENT RESULT: "GM1608245038_fin"

8/24/2016 3:31PM

Frequency MHz	Level dBµV	Transd dB	Limit dBµV	Margin dB	Detector	Line	PE
4.515000	19.40	10.4	56	36.6	QP	N	GND
4.789500	20.90	10.5	56	35.1	QP	N	GND
5.995500	24.40	10.5	60	35.6	QP	N	GND
17.691000	26.90	10.7	60	33.1	QP	N	GND
18.244500	27.30	10.7	60	32.7	QP	N	GND
29.238000	24.80	10.9	60	35.2	QP	N	GND

MEASUREMENT RESULT: "GM1608245038_fin2"

8/24/2016 3:31PM

Frequency MHz	Level dBµV	Transd dB	Limit dBµV	Margin dB	Detector	Line	PE
17.691000	25.40	10.7	50	24.6	AV	N	GND
17.938500	22.30	10.7	50	27.7	AV	N	GND
18.244500	24.80	10.7	50	25.2	AV	N	GND
18.303000	23.70	10.7	50	26.3	AV	N	GND
18.366000	21.90	10.7	50	28.1	AV	N	GND
29.233500	23.60	10.9	50	26.4	AV	N	GND

10. ANTENNA REQUIREMENTS

APPLICABLE REQUIREMENTS

Please refer to FCC §15.203

If directional gain of transmitting antennas is greater than 6dBi, the power shall be reduced by the same level in dB comparing to gain minus 6dBi. For the fixed point-to-point operation, the power shall be reduced by one dB for every 3 dB that the directional gain of the antenna exceeds 6 dBi. The use of a permanently attached antenna or of an antenna that uses a unique coupling to the intentional radiator shall be considered sufficient to comply with the FCC rule.

ANTENNA CONNECTOR

EUT has a PCB antenna without antenna connector.

ANTENNA GAIN

The antenna gain of EUT is less than 6 dBi.

END OF REPORT