



FCC SAR Test Report

Report No. : SA121023C07
Applicant : BandRich Inc.
Address : 6F., NO. 71, ZHOUI ST., NEIHU DIST., TAIPEI CITY 11493, TAIWAN (R.O.C.)
Product : LTE/HSPA+ Mobile Router
FCC ID : UZI-P530A
Brand : BandLuxe
Model No. : P530A
Standards : FCC 47 CFR Part 2 (2.1093) / IEEE C95.1:1991 / IEEE 1528:2003
FCC OET Bulletin 65 Supplement C (Edition 01-01)
KDB 248227 D01 v01r02 / KDB 447498 D01 v04
KDB 941225 D01 v02 / KDB 941225 D05 v02 / KDB 941225 D06 v01
Date of Testing : Nov. 07, 2012 ~ Nov. 14, 2012

CERTIFICATION: The above equipment have been tested by **Bureau Veritas Consumer Products Services (H.K.) Ltd., Taoyuan Branch - Taiwan HwaYa Lab**, and found compliance with the requirement of the above standards. The test record, data evaluation & Equipment Under Test (EUT) configurations represented herein are true and accurate accounts of the measurements of the sample’s SAR characteristics under the conditions specified in this report. It should not be reproduced except in full, without the written approval of our laboratory. The client should not use it to claim product certification, approval, or endorsement by TAF or any government agencies.

Prepared By : Evonne Liu
Evonne Liu / Specialist

Approved By : Roy Wu
Roy Wu / Manager



This report is for your exclusive use. Any copying or replication of this report to or for any other person or entity, or use of our name or trademark, is permitted only with our prior written permission. This report sets forth our findings solely with respect to the test samples identified herein. The results set forth in this report are not indicative or representative of the quality or characteristics of the lot from which a test sample was taken or any similar or identical product unless specifically and expressly noted. Our report includes all of the tests requested by you and the results thereof based upon the information that you provided to us. You have 60 days from date of issuance of this report to notify us of any material error or omission caused by our negligence, provided, however, that such notice shall be in writing and shall specifically address the issue you wish to raise. A failure to raise such issue within the prescribed time shall constitute your unqualified acceptance of the completeness of this report, the tests conducted and the correctness of the report contents. Unless specific mention, the uncertainty of measurement has been explicitly taken into account to declare the compliance or non-compliance to the specification.



Table of Contents

Release Control Record	3
1. Summary of Maximum SAR Value	4
2. Description of Equipment Under Test	5
3. SAR Measurement System	6
3.1 Definition of Specific Absorption Rate (SAR).....	6
3.2 SPEAG DASY System	6
3.2.1 Robot.....	7
3.2.2 Probes.....	8
3.2.3 Data Acquisition Electronics (DAE)	8
3.2.4 Phantoms	9
3.2.5 Device Holder.....	10
3.2.6 System Validation Dipoles	10
3.2.7 Tissue Simulating Liquids.....	11
3.3 SAR System Verification	12
3.4 SAR Measurement Procedure	13
3.4.1 Area & Zoom Scan Procedure	13
3.4.2 Volume Scan Procedure.....	13
3.4.3 Power Drift Monitoring.....	13
3.4.4 Spatial Peak SAR Evaluation	14
3.4.5 SAR Averaged Methods	14
4. SAR Measurement Evaluation	15
4.1 EUT Configuration and Setting.....	15
4.2 EUT Testing Position	17
4.3 Tissue Verification	18
4.4 System Verification.....	18
4.5 Conducted Power Results.....	19
4.6 SAR Testing Results.....	45
4.6.1 SAR Results for Body.....	45
4.6.2 Simultaneous Multi-band Transmission Evaluation	47
5. Calibration of Test Equipment.....	49
6. Measurement Uncertainty	50
7. Information on the Testing Laboratories.....	51
Appendix A. SAR Plots of System Verification	
Appendix B. SAR Plots of SAR Measurement	
Appendix C. Calibration Certificate for Probe and Dipole	
Appendix D. Photographs of EUT and Setup	



Release Control Record

Issue No.	Reason for Change	Date Issued
R01	Original release	Dec. 19, 2012

1. Summary of Maximum SAR Value

Mode / Band	Test Position	SAR-1g (W/kg)
WCDMA Band II	Body (0.5 cm Gap)	0.652
WCDMA Band IV	Body (0.5 cm Gap)	0.66
WCDMA Band V	Body (0.5 cm Gap)	0.08
LTE Band 2	Body (0.5 cm Gap)	0.687
LTE Band 4	Body (0.5 cm Gap)	0.546
LTE Band 12	Body (0.5 cm Gap)	0.55
LTE Band 17	Body (0.5 cm Gap)	0.547
LTE Band 25	Body (0.5 cm Gap)	0.704
WLAN 2.4GHz	Body (0.5 cm Gap)	0.206

Note:

1. The SAR limit (**1.6 W/kg**) for general population/uncontrolled exposure is specified in FCC 47 CFR part 2 (2.1093) and ANSI/IEEE C95.1-1991.

2. Description of Equipment Under Test

EUT Type	LTE/HSPA+ Mobile Router
FCC ID	UZI-P530A
Brand Name	BandLuxe
Model Name	P530A
HW Version	V01
SW Version	B2031V01
Tx Frequency Bands (Unit: MHz)	WCDMA Band II : 1850 ~ 1910 WCDMA Band IV : 1712.4 ~ 1752.6 WCDMA Band V : 824 ~ 849 LTE Band 2 : 1850 ~ 1910 LTE Band 4 : 1710 ~ 1755 LTE Band 12 : 699 ~ 716 LTE Band 17 : 704 ~ 716 LTE Band 25 : 1850 ~ 1915 WLAN : 2400 ~ 2483.5
Uplink Modulations	WCDMA : QPSK LTE : QPSK, 16QAM 802.11b : DSSS 802.11g/n : OFDM
Maximum AVG Conducted Power (Unit: dBm)	WCDMA Band II : 22.93 WCDMA Band IV : 23.02 WCDMA Band V : 22.18 LTE Band 2 : 22.85 LTE Band 4 : 22.60 LTE Band 12 : 22.56 LTE Band 17 : 22.50 LTE Band 25 : 22.79 802.11b : 14.09 802.11g : 12.01 802.11n HT20 : 10.22
Antenna Type	Fixed Internal Antenna
EUT Stage	Identical Prototype

Note:

- The above EUT information is declared by manufacturer and for more detailed features description please refers to the manufacturer's specifications or User's Manual.

List of Accessory:

AC Adapter	Brand Name	PHIHONG
	Model Name	PSA05A-050Q
	Power Rating	I/P:100-240Vac, 50-60Hz, 0.2A; O/P: 5Vdc, 1A
	DC Power Cord Type	1 meter shielded cable without ferrite core

3. SAR Measurement System

3.1 Definition of Specific Absorption Rate (SAR)

SAR is related to the rate at which energy is absorbed per unit mass in an object exposed to a radio field. The SAR distribution in a biological body is complicated and is usually carried out by experimental techniques or numerical modeling. The standard recommends limits for two tiers of groups, occupational/controlled and general population/uncontrolled, based on a person's awareness and ability to exercise control over his or her exposure. In general, occupational/controlled exposure limits are higher than the limits for general population/uncontrolled.

The SAR definition is the time derivative (rate) of the incremental energy (dW) absorbed by (dissipated in) an incremental mass (dm) contained in a volume element (dv) of a given density (ρ). The equation description is as below:

$$\text{SAR} = \frac{d}{dt} \left(\frac{dW}{dm} \right) = \frac{d}{dt} \left(\frac{dW}{\rho dv} \right)$$

SAR is expressed in units of Watts per kilogram (W/kg)

SAR measurement can be related to the electrical field in the tissue by

$$\text{SAR} = \frac{\sigma |E|^2}{\rho}$$

Where: σ is the conductivity of the tissue, ρ is the mass density of the tissue and E is the RMS electrical field strength.

3.2 SPEAG DASY System

DASY system consists of high precision robot, probe alignment sensor, phantom, robot controller, controlled measurement server and near-field probe. The robot includes six axes that can move to the precision position of the DASY4/5 software defined. The DASY software can define the area that is detected by the probe. The robot is connected to controlled box. Controlled measurement server is connected to the controlled robot box. The DAE includes amplifier, signal multiplexing, AD converter, offset measurement and surface detection. It is connected to the Electro-optical coupler (ECO). The ECO performs the conversion form the optical into digital electric signal of the DAE and transfers data to the PC.

FCC SAR Test Report

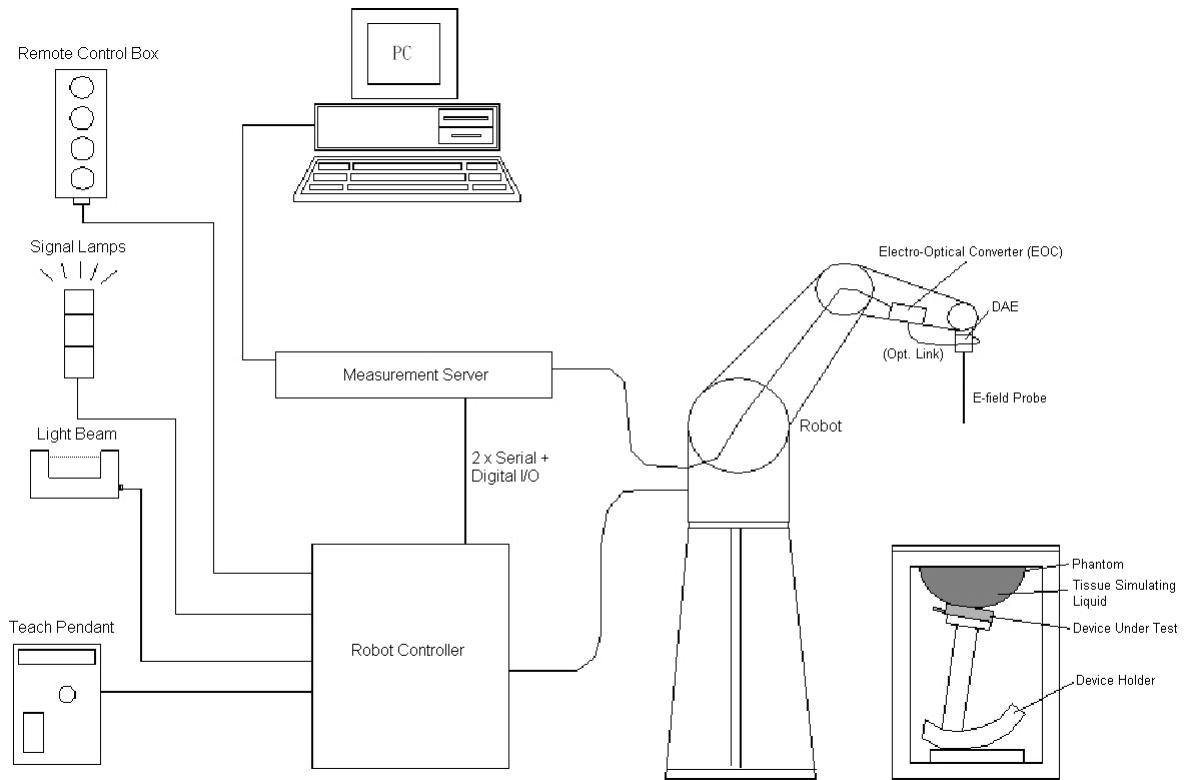

Fig-3.1 DASY System Setup

3.2.1 Robot

The DASY system uses the high precision robots from Stäubli SA (France). For the 6-axis controller system, the robot controller version (DASY4: CS7MB; DASY5: CS8c) from Stäubli is used. The Stäubli robot series have many features that are important for our application:

- High precision (repeatability ± 0.035 mm)
- High reliability (industrial design)
- Jerk-free straight movements
- Low ELF interference (the closed metallic construction shields against motor control fields)



Fig-3.2 DASY4





Fig-3.3 DASY5

FCC SAR Test Report

3.2.2 Probes

The SAR measurement is conducted with the dosimetric probe. The probe is specially designed and calibrated for use in liquid with high permittivity. The dosimetric probe has special calibration in liquid at different frequency.

Model	EX3DV4	
Construction	Symmetrical design with triangular core. Built-in shielding against static charges. PEEK enclosure material (resistant to organic solvents, e.g., DGBE).	
Frequency	10 MHz to 6 GHz Linearity: ± 0.2 dB	
Directivity	± 0.3 dB in HSL (rotation around probe axis) ± 0.5 dB in tissue material (rotation normal to probe axis)	
Dynamic Range	10 μ W/g to 100 mW/g Linearity: ± 0.2 dB (noise: typically < 1 μ W/g)	
Dimensions	Overall length: 337 mm (Tip: 20 mm) Tip diameter: 2.5 mm (Body: 12 mm) Typical distance from probe tip to dipole centers: 1 mm	

Model	ES3DV3	
Construction	Symmetrical design with triangular core. Interleaved sensors. Built-in shielding against static charges. PEEK enclosure material (resistant to organic solvents, e.g., DGBE).	
Frequency	10 MHz to 4 GHz Linearity: ± 0.2 dB	
Directivity	± 0.2 dB in HSL (rotation around probe axis) ± 0.3 dB in tissue material (rotation normal to probe axis)	
Dynamic Range	5 μ W/g to 100 mW/g Linearity: ± 0.2 dB	
Dimensions	Overall length: 337 mm (Tip: 20 mm) Tip diameter: 3.9 mm (Body: 12 mm) Distance from probe tip to dipole centers: 2.0 mm	

3.2.3 Data Acquisition Electronics (DAE)

Model	DAE3, DAE4	
Construction	Signal amplifier, multiplexer, A/D converter and control logic. Serial optical link for communication with DASY4/5 embedded system (fully remote controlled). Two step probe touch detector for mechanical surface detection and emergency robot stop.	
Measurement Range	-100 to +300 mV (16 bit resolution and two range settings: 4mV, 400mV)	
Input Offset Voltage	< 5 μ V (with auto zero)	
Input Bias Current	< 50 fA	
Dimensions	60 x 60 x 68 mm	

FCC SAR Test Report

3.2.4 Phantoms

Model	Twin SAM	
Construction	The shell corresponds to the specifications of the Specific Anthropomorphic Mannequin (SAM) phantom defined in IEEE 1528 and IEC 62209-1. It enables the dosimetric evaluation of left and right hand phone usage as well as body mounted usage at the flat phantom region. A cover prevents evaporation of the liquid. Reference markings on the phantom allow the complete setup of all predefined phantom positions and measurement grids by teaching three points with the robot.	
Material	Vinylester, glass fiber reinforced (VE-GF)	
Shell Thickness	2 ± 0.2 mm (6 ± 0.2 mm at ear point)	
Dimensions	Length: 1000 mm Width: 500 mm Height: adjustable feet	
Filling Volume	approx. 25 liters	

Model	ELI	
Construction	Phantom for compliance testing of handheld and body-mounted wireless devices in the frequency range of 30 MHz to 6 GHz. ELI is fully compatible with the IEC 62209-2 standard and all known tissue simulating liquids. ELI has been optimized regarding its performance and can be integrated into our standard phantom tables. A cover prevents evaporation of the liquid. Reference markings on the phantom allow installation of the complete setup, including all predefined phantom positions and measurement grids, by teaching three points. The phantom is compatible with all SPEAG dosimetric probes and dipoles.	
Material	Vinylester, glass fiber reinforced (VE-GF)	
Shell Thickness	2.0 ± 0.2 mm (bottom plate)	
Dimensions	Major axis: 600 mm Minor axis: 400 mm	
Filling Volume	approx. 30 liters	

FCC SAR Test Report

3.2.5 Device Holder

Model	Mounting Device	
Construction	In combination with the Twin SAM Phantom or ELI4, the Mounting Device enables the rotation of the mounted transmitter device in spherical coordinates. Rotation point is the ear opening point. Transmitter devices can be easily and accurately positioned according to IEC, IEEE, FCC or other specifications. The device holder can be locked for positioning at different phantom sections (left head, right head, flat).	
Material	POM	

Model	Laptop Extensions Kit	
Construction	Simple but effective and easy-to-use extension for Mounting Device that facilitates the testing of larger devices according to IEC 62209-2 (e.g., laptops, cameras, etc.). It is lightweight and fits easily on the upper part of the Mounting Device in place of the phone positioner.	
Material	POM, Acrylic glass, Foam	

3.2.6 System Validation Dipoles

Model	D-Serial	
Construction	Symmetrical dipole with 1/4 balun. Enables measurement of feed point impedance with NWA. Matched for use near flat phantoms filled with tissue simulating solutions.	
Frequency	750 MHz to 5800 MHz	
Return Loss	> 20 dB	
Power Capability	> 100 W (f < 1GHz), > 40 W (f > 1GHz)	

FCC SAR Test Report

3.2.7 Tissue Simulating Liquids

For SAR measurement of the field distribution inside the phantom, the phantom must be filled with homogeneous tissue simulating liquid to a depth of at least 15 cm. For head SAR testing, the liquid height from the ear reference point (ERP) of the phantom to the liquid top surface is larger than 15 cm. For body SAR testing, the liquid height from the center of the flat phantom to the liquid top surface is larger than 15 cm. The nominal dielectric values of the tissue simulating liquids in the phantom and the tolerance of 5% are listed in Table-3.1.

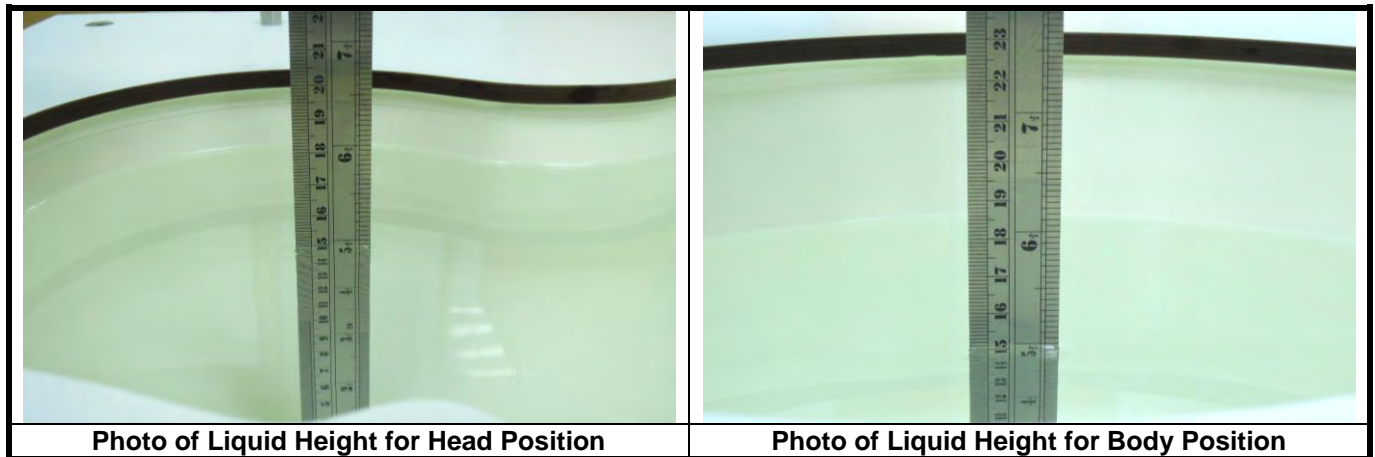

The dielectric properties of the head tissue simulating liquids are defined in IEEE 1528 and FCC OET 65 Supplement C Appendix C. For the body tissue simulating liquids, the dielectric properties are defined in FCC OET 65 Supplement C Appendix C. The dielectric properties of the tissue simulating liquids were verified prior to the SAR evaluation using an Agilent 85070D Dielectric Probe Kit and an Agilent Network Analyzer.

Table-3.1 Targets of Tissue Simulating Liquid

Frequency (MHz)	Target Permittivity	Range of $\pm 5\%$	Target Conductivity	Range of $\pm 5\%$
For Body				
750	55.5	52.7 ~ 58.3	0.96	0.91 ~ 1.01
835	55.2	52.4 ~ 58.0	0.97	0.92 ~ 1.02
1750	53.4	50.7 ~ 56.1	1.49	1.42 ~ 1.56
1900	53.3	50.6 ~ 56.0	1.52	1.44 ~ 1.60
2450	52.7	50.1 ~ 55.3	1.95	1.85 ~ 2.05

The following table gives the recipes for tissue simulating liquids.

Table-3.2 Recipes of Tissue Simulating Liquid

Tissue Type	Bactericide	DGBE	HEC	NaCl	Sucrose	Triton X-100	Water	Diethylene Glycol Mono-hexylether
B750	0.2	-	0.2	0.8	48.8	-	50.0	-
B835	0.2	-	0.2	0.9	48.5	-	50.2	-
B1750	-	31.0	-	0.2	-	-	68.8	-
B1900	-	29.5	-	0.3	-	-	70.2	-
B2450	-	31.4	-	0.1	-	-	68.5	-

3.3 SAR System Verification

The system check verifies that the system operates within its specifications. It is performed daily or before every SAR measurement. The system check uses normal SAR measurements in the flat section of the phantom with a matched dipole at a specified distance. The system verification setup is shown as below.

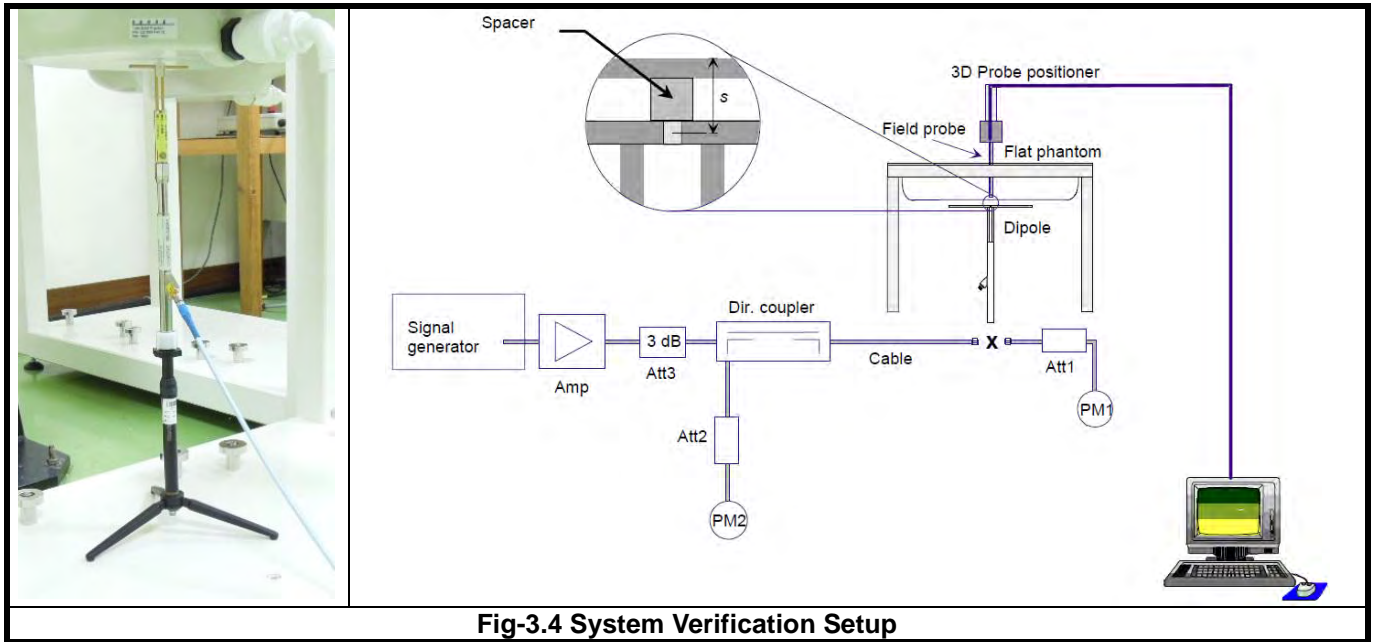

Fig-3.4 System Verification Setup

The validation dipole is placed beneath the flat phantom with the specific spacer in place. The distance spacer is touch the phantom surface with a light pressure at the reference marking and be oriented parallel to the long side of the phantom. The power meter PM1 measures the forward power at the location of the system check dipole connector. The signal generator is adjusted for the desired forward power (250 mW is used for 700 MHz to 3 GHz, 100 mW is used for 3.5 GHz to 6 GHz) at the dipole connector and the power meter PM2 is read at that level. After connecting the cable to the dipole, the signal generator is readjusted for the same reading at power meter PM2.

After system check testing, the SAR result will be normalized to 1W forward input power and compared with the reference SAR value derived from validation dipole certificate report. The deviation of system check should be within 10 %.

3.4 SAR Measurement Procedure

According to the SAR test standard, the recommended procedure for assessing the peak spatial-average SAR value consists of the following steps:

- (a) Power reference measurement
- (b) Area scan
- (c) Zoom scan
- (d) Power drift measurement

The SAR measurement procedures for each of test conditions are as follows:

- (a) Make EUT to transmit maximum output power
- (b) Measure conducted output power through RF cable
- (c) Place the EUT in the specific position of phantom
- (d) Perform SAR testing steps on the DASY system
- (e) Record the SAR value

3.4.1 Area & Zoom Scan Procedure

First Area Scan is used to locate the approximate location(s) of the local peak SAR value(s). The measurement grid within an Area Scan is defined by the grid extent, grid step size and grid offset. Next, in order to determine the EM field distribution in a three-dimensional spatial extension, Zoom Scan is required. The Zoom Scan measures 5x5x7 points with step size 8, 8 and 5 mm for below 3 GHz, and 7x7x9 points with step size 4, 4 and 2.5 mm for above 5 GHz. The Zoom Scan is performed around the highest E-field value to determine the averaged SAR-distribution over 10 g.

3.4.2 Volume Scan Procedure

The volume scan is used for assess overlapping SAR distributions for antennas transmitting in different frequency bands. It is equivalent to an oversized zoom scan used in standalone measurements. The measurement volume will be used to enclose all the simultaneous transmitting antennas. For antennas transmitting simultaneously in different frequency bands, the volume scan is measured separately in each frequency band. In order to sum correctly to compute the 1g aggregate SAR, the EUT remain in the same test position for all measurements and all volume scan use the same spatial resolution and grid spacing. When all volume scan were completed, the software, SEMCAD postprocessor can combine and subsequently superpose these measurement data to calculating the multiband SAR.

3.4.3 Power Drift Monitoring

All SAR testing is under the EUT install full charged battery and transmit maximum output power. In DASY measurement software, the power reference measurement and power drift measurement procedures are used for monitoring the power drift of EUT during SAR test. Both these procedures measure the field at a specified reference position before and after the SAR testing. The software will calculate the field difference in dB. If the power drift more than 5%, the SAR will be retested.

FCC SAR Test Report

3.4.4 Spatial Peak SAR Evaluation

The procedure for spatial peak SAR evaluation has been implemented according to the test standard. It can be conducted for 1g and 10g, as well as for user-specific masses. The DASY software includes all numerical procedures necessary to evaluate the spatial peak SAR value.

The base for the evaluation is a "cube" measurement. The measured volume must include the 1g and 10g cubes with the highest averaged SAR values. For that purpose, the center of the measured volume is aligned to the interpolated peak SAR value of a previously performed area scan.

The entire evaluation of the spatial peak values is performed within the post-processing engine (SEMCAD). The system always gives the maximum values for the 1g and 10g cubes. The algorithm to find the cube with highest averaged SAR is divided into the following stages:

- (a) Extraction of the measured data (grid and values) from the Zoom Scan
- (b) Calculation of the SAR value at every measurement point based on all stored data (A/D values and measurement parameters)
- (c) Generation of a high-resolution mesh within the measured volume
- (d) Interpolation of all measured values from the measurement grid to the high-resolution grid
- (e) Extrapolation of the entire 3-D field distribution to the phantom surface over the distance from sensor to surface
- (f) Calculation of the averaged SAR within masses of 1g and 10g

3.4.5 SAR Averaged Methods

In DASY, the interpolation and extrapolation are both based on the modified Quadratic Shepard's method. The interpolation scheme combines a least-square fitted function method and a weighted average method which are the two basic types of computational interpolation and approximation.

Extrapolation routines are used to obtain SAR values between the lowest measurement points and the inner phantom surface. The extrapolation distance is determined by the surface detection distance and the probe sensor offset. The uncertainty increases with the extrapolation distance. To keep the uncertainty within 1% for the 1 g and 10 g cubes, the extrapolation distance should not be larger than 5 mm.

4. SAR Measurement Evaluation

4.1 EUT Configuration and Setting

The EUT is a data transmitter device that contains one WCDMA/LTE transmitter. Confirming the LTE transmitter follows 3GPP standards, is category 3, BW 1.4/3/5/10/15/20 MHz, band 2/4/12/17/25, supports QPSK / 16QAM modulations, and supports data transmission only. Tested per 3GPP 36.521 maximum transmit procedures for both QPSK / 16QAM.

LTE Maximum Power Reduction in accordance with 3GPP 36.101: Power Reduction in accordance to 3GPP is active all times during LTE operation.

Modulation	Channel Bandwidth / RB Configurations						LTE MPR Setting (dB)
	BW 1.4 MHz	BW 3 MHz	BW 5 MHz	BW 10 MHz	BW 15 MHz	BW 20 MHz	
QPSK	> 5	> 4	> 8	> 12	> 16	> 18	1
16QAM	<= 5	<= 4	<= 8	<= 12	<= 16	<= 18	1
16QAM	> 5	> 4	> 8	> 12	> 16	> 18	2

Note: MPR is according to the standard and implemented in the circuit (mandatory).

In addition, the device is compliant with A-MPR requirements defined in 36.101 section 6.2.4 that may be required to meet 3GPP Adjacent Channel Leakage Ratio (“ACLR”) requirements. A-MPR was disabled for all FCC compliance testing.

<Antenna Location>

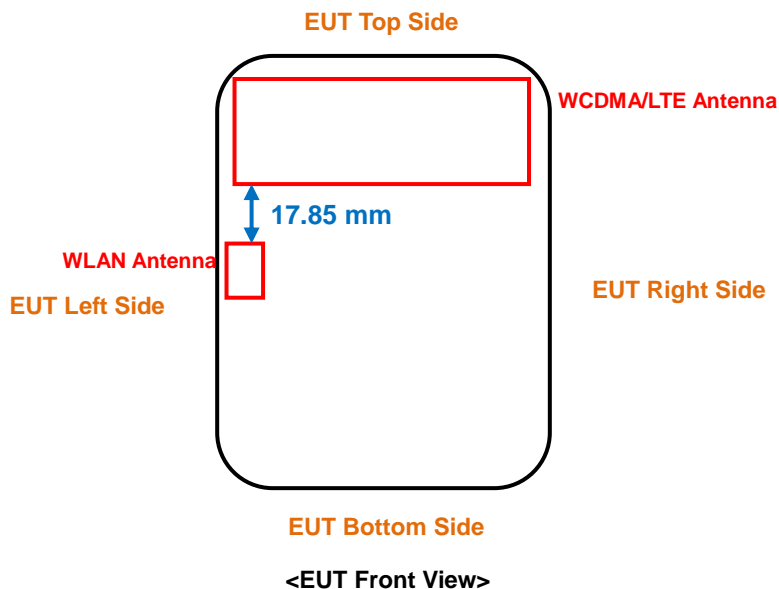



FCC SAR Test Report

This device supports WiFi hotspot function, so body SAR was tested for the surfaces / slide edges where a transmitting antenna is within 2.5 cm from the edge. Since the SAR is required for antenna located within 2.5 cm from edge, SAR testing for each antenna is listed as below.

WWAN Antenna : Front Face, Rear Face, Left Side, Right Side, Top Side

WLAN Antenna : Front Face, Rear Face, Left Side

The simultaneous transmission possibilities are listed as below.

Simultaneous TX Combination	Configuration	Head (Voice / VoIP)	Body Worn (Voice / VoIP)	Hotspot (Data)
1	WCDMA II (Data) + WLAN (Data)	No	No	Yes
2	WCDMA IV (Data) + WLAN (Data)	No	No	Yes
3	WCDMA V (Data) + WLAN (Data)	No	No	Yes
4	LTE 2 (Data) + WLAN (Data)	No	No	Yes
5	LTE 4 (Data) + WLAN (Data)	No	No	Yes
6	LTE 12 (Data) + WLAN (Data)	No	No	Yes
7	LTE 17 (Data) + WLAN (Data)	No	No	Yes
8	LTE 25 (Data) + WLAN (Data)	No	No	Yes

Note : In the SVLTE mode, WCDMA and LTE can transmit at maximum power level simultaneously.

For WWAN SAR testing, the EUT was linked and controlled by base station emulator (Agilent E5515C). Communication between the EUT and the emulator was established by air link. The distance between the EUT and the communicating antenna of the emulator is larger than 50 cm and the output power radiated from the emulator antenna is at least 30 dB smaller than the output power of EUT. The EUT was set from the emulator to radiate maximum output power during SAR testing.

For WCDMA, SAR is tested under 12.2k RMC mode with power control set all up bits. SAR for AMR is not required since its power is less than 1/4 dB higher than RMC. SAR for HSDPA/HSUPA is not required since its power is less than 1/4 dB higher than RMC without HSDPA/HSUPA and SAR for 12.2 kbps RMC is less than 75% of the SAR limit (1.2 W/kg).

FCC SAR Test Report

For LTE, set the related parameters of operating band, channel bandwidth, uplink channel number, modulation type, and RB in base station simulator. When the EUT has registered and communicated to base station simulator, set the simulator to make EUT transmitting the maximum radiated power. The steps for system simulator (Anritsu MT8820C) setup are as below.

1. Press the “Std” button to select “LTE 22.20S” function
2. Choose the “Screen Select” item to “Fundamental Measurement”
3. Enter the “Common” item
4. Set the Operating Band
5. Set the Channel Bandwidth
6. Set the UL Channel & Frequency
7. Set the Modulation
8. Set the RB number and RB shift
9. Press “Start Call” button when EUT register to the system simulator
10. Set the TX-1 Max. Power to make the EUT transmit maximum output power

For WLAN SAR testing, the EUT has installed WLAN engineering testing software which can provide continuous transmitting RF signal. This RF signal utilized in SAR measurement has almost 100% duty cycle. The data rates for WLAN SAR testing were set in 1 Mbps for 802.11b due to the highest RF output power.

4.2 EUT Testing Position

The SAR test mode has got the FCC suggestion through KDB 442220. According to KDB 941225 D06, SAR testing is required for all sides and edges with a transmitting antenna within 25 mm from that surface or edge. Based on the antenna location, the EUT was tested in some positions as **Front Face, Rear Face, Left Side, Right Side, and Top Side**. In these positions, the separation distance between EUT and phantom is 0.5 cm.

FCC SAR Test Report

4.3 Tissue Verification

The measuring results for tissue simulating liquid are shown as below.

Tissue Type	Frequency (MHz)	Liquid Temp. (°C)	Measured Conductivity (σ)	Measured Permittivity (ϵ_r)	Target Conductivity (σ)	Target Permittivity (ϵ_r)	Conductivity Deviation (%)	Permittivity Deviation (%)	Test Date
B750	750	20.5	0.965	55.172	0.96	55.5	0.52	-0.59	Nov. 13, 2012
B835	835	20.7	0.993	56.69	0.97	55.2	2.37	2.70	Nov. 13, 2012
B1750	1750	20.6	1.469	53.127	1.49	53.4	-1.41	-0.51	Nov. 07, 2012
B1750	1750	20.7	1.47	53.184	1.49	53.4	-1.34	-0.40	Nov. 08, 2012
B1750	1750	20.9	1.466	53.656	1.49	53.4	-1.61	0.48	Nov. 12, 2012
B1900	1900	20.3	1.535	51.016	1.52	53.3	0.99	-4.29	Nov. 06, 2012
B1900	1900	20.9	1.545	52.799	1.52	53.3	1.64	-0.94	Nov. 12, 2012
B1900	1900	20.7	1.535	51.016	1.52	53.3	0.99	-4.29	Nov. 13, 2012
B2450	2450	20.6	1.982	51.15	1.95	52.7	1.64	-2.94	Nov. 14, 2012

Note:

The dielectric properties of the tissue simulating liquid must be measured within 24 hours before the SAR testing and within $\pm 5\%$ of the target values. Liquid temperature during the SAR testing must be within $\pm 2^\circ\text{C}$.

4.4 System Verification

The measuring results for system check are shown as below.

Test Date	Frequency (MHz)	1W Target SAR-1g (W/kg)	Measured SAR-1g (W/kg)	Normalized to 1W SAR-1g (W/kg)	Deviation (%)	Dipole S/N	Probe S/N	DAE S/N
Nov. 13, 2012	750	8.76	2.16	8.64	-1.37	1013	3578	1277
Nov. 13, 2012	835	9.60	2.42	9.68	0.83	4d021	3578	1277
Nov. 07, 2012	1750	37.20	9.09	36.36	-2.26	1055	3590	861
Nov. 08, 2012	1750	37.20	9.48	37.92	1.94	1055	3864	915
Nov. 12, 2012	1750	37.20	9.36	37.44	0.65	1055	3864	915
Nov. 06, 2012	1900	38.90	9.38	37.52	-3.55	5d036	3590	861
Nov. 12, 2012	1900	38.90	9.66	38.64	-0.67	5d036	3864	915
Nov. 13, 2012	1900	38.90	9.38	37.52	-3.55	5d036	3578	1277
Nov. 14, 2012	2450	50.00	13.3	53.20	6.40	737	3578	1277

Note:

Comparing to the reference SAR value provided by SPEAG, the validation data should be within its specification of 10 %. The result indicates the system check can meet the variation criterion and the plots can be referred to Appendix A of this report.



4.5 Conducted Power Results

The measuring conducted power (Unit: dBm) are shown as below.

Band	WCDMA Band II			WCDMA Band V		
Channel	9262	9400	9538	4132	4182	4233
Frequency (MHz)	1852.4	1880.0	1907.6	826.4	836.4	846.6
RMC 12.2K	22.63	22.93	22.48	22.18	22.03	22.11
HSDPA Subtest-1	21.62	21.94	21.39	21.13	21.03	21.08
HSDPA Subtest-2	21.48	21.80	21.25	21.15	21.02	21.07
HSDPA Subtest-3	21.06	21.38	20.83	20.58	20.45	20.50
HSDPA Subtest-4	21.11	21.43	20.88	20.57	20.51	20.56
HSUPA Subtest-1	21.21	21.46	21.18	20.68	20.63	20.59
HSUPA Subtest-2	19.33	19.47	19.30	18.75	18.66	18.62
HSUPA Subtest-3	20.31	20.48	20.21	19.86	19.82	19.78
HSUPA Subtest-4	19.36	19.48	19.31	18.77	18.71	18.61
HSUPA Subtest-5	21.22	21.38	21.11	20.72	20.71	20.71
Maximum Power Reduction (dB)						
HSDPA Subtest-1 Target MPR = 0	0.00	0.00	0.00	0.00	0.00	0.00
HSDPA Subtest-2 Target MPR = 0	0.14	0.14	0.14	-0.02	0.01	0.01
HSDPA Subtest-3 Target MPR = 0.5	0.56	0.56	0.56	0.55	0.58	0.58
HSDPA Subtest-4 Target MPR = 0.5	0.51	0.51	0.51	0.56	0.52	0.52
HSUPA Subtest-1 Target MPR = 0	0.00	0.00	0.00	0.00	0.00	0.00
HSUPA Subtest-2 Target MPR = 2	1.88	1.99	1.88	1.93	1.97	1.97
HSUPA Subtest-3 Target MPR = 1	0.90	0.98	0.97	0.82	0.81	0.81
HSUPA Subtest-4 Target MPR = 2	1.85	1.98	1.87	1.91	1.92	1.98
HSUPA Subtest-5 Target MPR = 0	-0.01	0.08	0.07	-0.04	-0.08	-0.12



FCC SAR Test Report

Band	WCDMA Band IV		
Channel	1312	1413	1513
Frequency (MHz)	1712.4	1732.6	1752.6
RMC 12.2K	22.26	22.21	23.02
HSDPA Subtest-1	21.33	21.30	22.15
HSDPA Subtest-2	21.28	21.25	22.10
HSDPA Subtest-3	20.82	20.79	21.64
HSDPA Subtest-4	20.79	20.76	21.61
HSUPA Subtest-1	21.18	21.19	21.33
HSUPA Subtest-2	19.21	19.25	19.32
HSUPA Subtest-3	20.15	20.18	20.23
HSUPA Subtest-4	19.11	19.15	19.26
HSUPA Subtest-5	21.15	21.19	21.32
Maximum Power Reduction (dB)			
HSDPA Subtest-1 Target MPR = 0	0.00	0.00	0.00
HSDPA Subtest-2 Target MPR = 0	0.05	0.05	0.05
HSDPA Subtest-3 Target MPR = 0.5	0.51	0.51	0.51
HSDPA Subtest-4 Target MPR = 0.5	0.54	0.54	0.54
HSUPA Subtest-1 Target MPR = 0	0.00	0.00	0.00
HSUPA Subtest-2 Target MPR = 2	1.97	1.94	2.01
HSUPA Subtest-3 Target MPR = 1	1.03	1.01	1.10
HSUPA Subtest-4 Target MPR = 2	2.07	2.04	2.07
HSUPA Subtest-5 Target MPR = 0	0.03	0.00	0.01

Band	802.11b			802.11g		
Channel	1	6	11	1	6	11
Frequency (MHz)	2412	2437	2462	2412	2437	2462
Average Power	13.97	13.96	14.09	11.94	11.93	12.01

Band	802.11n (HT20)		
Channel	1	6	11
Frequency (MHz)	2412	2437	2462
Average Power	10.20	10.22	10.04



FCC SAR Test Report

LTE Band 2										
BW	Modulation	CH	Frequency (MHz)	RB	RB Offset	Target Power	MPR	Expected Power	Measured Power	Scaling Factor
1.4 MHz	QPSK	18607	1850.7	1	0	22.9	0	22.9	22.71	1.04
		18900	1880	1	0	22.9	0	22.9	22.67	1.05
		19193	1909.3	1	0	22.9	0	22.9	22.44	1.11
		18607	1850.7	1	2	22.9	0	22.9	22.72	1.04
		18900	1880	1	2	22.9	0	22.9	22.68	1.05
		19193	1909.3	1	2	22.9	0	22.9	22.45	1.11
		18607	1850.7	1	5	22.9	0	22.9	22.65	1.06
		18900	1880	1	5	22.9	0	22.9	22.61	1.07
		19193	1909.3	1	5	22.9	0	22.9	22.38	1.13
		18607	1850.7	3	0	22.9	0	22.9	22.68	1.05
		18900	1880	3	0	22.9	0	22.9	22.64	1.06
		19193	1909.3	3	0	22.9	0	22.9	22.41	1.12
		18607	1850.7	3	1	22.9	0	22.9	22.65	1.06
		18900	1880	3	1	22.9	0	22.9	22.61	1.07
		19193	1909.3	3	1	22.9	0	22.9	22.38	1.13
		18607	1850.7	3	3	22.9	0	22.9	22.62	1.07
		18900	1880	3	3	22.9	0	22.9	22.58	1.08
		19193	1909.3	3	3	22.9	0	22.9	22.35	1.14
	18607	1850.7	6	0	22.9	1	21.9	21.51	1.09	
	18900	1880	6	0	22.9	1	21.9	21.47	1.10	
	19193	1909.3	6	0	22.9	1	21.9	21.24	1.16	
	18607	1850.7	1	0	22.9	1	21.9	21.56	1.08	
	18900	1880	1	0	22.9	1	21.9	21.52	1.09	
	19193	1909.3	1	0	22.9	1	21.9	21.29	1.15	
	18607	1850.7	1	2	22.9	1	21.9	21.68	1.05	
	18900	1880	1	2	22.9	1	21.9	21.64	1.06	
	19193	1909.3	1	2	22.9	1	21.9	21.41	1.12	
	18607	1850.7	1	5	22.9	1	21.9	21.56	1.08	
	18900	1880	1	5	22.9	1	21.9	21.52	1.09	
	19193	1909.3	1	5	22.9	1	21.9	21.29	1.15	
	18607	1850.7	3	0	22.9	1	21.9	21.70	1.05	
	18900	1880	3	0	22.9	1	21.9	21.66	1.06	
	19193	1909.3	3	0	22.9	1	21.9	21.43	1.11	
	18607	1850.7	3	1	22.9	1	21.9	21.65	1.06	
	18900	1880	3	1	22.9	1	21.9	21.61	1.07	
	19193	1909.3	3	1	22.9	1	21.9	21.38	1.13	
18607	1850.7	3	3	22.9	1	21.9	21.64	1.06		
18900	1880	3	3	22.9	1	21.9	21.60	1.07		
19193	1909.3	3	3	22.9	1	21.9	21.37	1.13		
18607	1850.7	6	0	22.9	2	20.9	20.67	1.05		
18900	1880	6	0	22.9	2	20.9	20.63	1.06		
19193	1909.3	6	0	22.9	2	20.9	20.40	1.12		

Note: The Scaling Factor is $[10^{(Expected Power / 10)} / 10^{(Measured Power / 10)}]$



FCC SAR Test Report

LTE Band 2										
BW	Modulation	CH	Frequency (MHz)	RB	RB Offset	Target Power	MPR	Expected Power	Measured Power	Scaling Factor
3 MHz	QPSK	18615	1851.5	1	0	22.9	0	22.9	22.64	1.06
		18900	1880	1	0	22.9	0	22.9	22.61	1.07
		19185	1908.5	1	0	22.9	0	22.9	22.59	1.07
		18615	1851.5	1	7	22.9	0	22.9	22.75	1.04
		18900	1880	1	7	22.9	0	22.9	22.72	1.04
		19185	1908.5	1	7	22.9	0	22.9	22.70	1.05
		18615	1851.5	1	14	22.9	0	22.9	22.69	1.05
		18900	1880	1	14	22.9	0	22.9	22.66	1.06
		19185	1908.5	1	14	22.9	0	22.9	22.64	1.06
		18615	1851.5	8	0	22.9	1	21.9	21.61	1.07
		18900	1880	8	0	22.9	1	21.9	21.58	1.08
		19185	1908.5	8	0	22.9	1	21.9	21.56	1.08
		18615	1851.5	8	3	22.9	1	21.9	21.63	1.06
		18900	1880	8	3	22.9	1	21.9	21.60	1.07
		19185	1908.5	8	3	22.9	1	21.9	21.58	1.08
		18615	1851.5	8	7	22.9	1	21.9	21.64	1.06
		18900	1880	8	7	22.9	1	21.9	21.61	1.07
		19185	1908.5	8	7	22.9	1	21.9	21.59	1.07
	18615	1851.5	15	0	22.9	1	21.9	21.52	1.09	
	18900	1880	15	0	22.9	1	21.9	21.49	1.10	
	19185	1908.5	15	0	22.9	1	21.9	21.47	1.10	
	18615	1851.5	1	0	22.9	1	21.9	21.53	1.09	
	18900	1880	1	0	22.9	1	21.9	21.50	1.10	
	19185	1908.5	1	0	22.9	1	21.9	21.48	1.10	
	18615	1851.5	1	7	22.9	1	21.9	21.72	1.04	
	18900	1880	1	7	22.9	1	21.9	21.69	1.05	
	19185	1908.5	1	7	22.9	1	21.9	21.67	1.05	
	18615	1851.5	1	14	22.9	1	21.9	21.57	1.08	
	18900	1880	1	14	22.9	1	21.9	21.54	1.09	
	19185	1908.5	1	14	22.9	1	21.9	21.52	1.09	
	18615	1851.5	8	0	22.9	2	20.9	20.52	1.09	
	18900	1880	8	0	22.9	2	20.9	20.49	1.10	
	19185	1908.5	8	0	22.9	2	20.9	20.47	1.10	
	18615	1851.5	8	3	22.9	2	20.9	20.54	1.09	
	18900	1880	8	3	22.9	2	20.9	20.51	1.09	
	19185	1908.5	8	3	22.9	2	20.9	20.49	1.10	
18615	1851.5	8	7	22.9	2	20.9	20.56	1.08		
18900	1880	8	7	22.9	2	20.9	20.53	1.09		
19185	1908.5	8	7	22.9	2	20.9	20.51	1.09		
18615	1851.5	15	0	22.9	2	20.9	20.51	1.09		
18900	1880	15	0	22.9	2	20.9	20.48	1.10		
19185	1908.5	15	0	22.9	2	20.9	20.46	1.11		



FCC SAR Test Report

LTE Band 2										
BW	Modulation	CH	Frequency (MHz)	RB	RB Offset	Target Power	MPR	Expected Power	Measured Power	Scaling Factor
5 MHz	QPSK	18625	1852.5	1	0	22.9	0	22.9	22.76	1.03
		18900	1880	1	0	22.9	0	22.9	22.63	1.06
		19175	1907.5	1	0	22.9	0	22.9	22.62	1.07
		18625	1852.5	1	12	22.9	0	22.9	22.76	1.03
		18900	1880	1	12	22.9	0	22.9	22.63	1.06
		19175	1907.5	1	12	22.9	0	22.9	22.62	1.07
		18625	1852.5	1	24	22.9	0	22.9	22.66	1.06
		18900	1880	1	24	22.9	0	22.9	22.53	1.09
		19175	1907.5	1	24	22.9	0	22.9	22.52	1.09
		18625	1852.5	12	0	22.9	1	21.9	21.61	1.07
		18900	1880	12	0	22.9	1	21.9	21.48	1.10
		19175	1907.5	12	0	22.9	1	21.9	21.47	1.10
		18625	1852.5	12	6	22.9	1	21.9	21.61	1.07
		18900	1880	12	6	22.9	1	21.9	21.48	1.10
		19175	1907.5	12	6	22.9	1	21.9	21.47	1.10
		18625	1852.5	12	13	22.9	1	21.9	21.62	1.07
		18900	1880	12	13	22.9	1	21.9	21.49	1.10
		19175	1907.5	12	13	22.9	1	21.9	21.48	1.10
		18625	1852.5	25	0	22.9	1	21.9	21.48	1.10
		18900	1880	25	0	22.9	1	21.9	21.35	1.14
	19175	1907.5	25	0	22.9	1	21.9	21.34	1.14	
	16QAM	18625	1852.5	1	0	22.9	1	21.9	21.55	1.08
		18900	1880	1	0	22.9	1	21.9	21.42	1.12
		19175	1907.5	1	0	22.9	1	21.9	21.41	1.12
		18625	1852.5	1	12	22.9	1	21.9	21.73	1.04
		18900	1880	1	12	22.9	1	21.9	21.60	1.07
		19175	1907.5	1	12	22.9	1	21.9	21.59	1.07
		18625	1852.5	1	24	22.9	1	21.9	21.58	1.08
		18900	1880	1	24	22.9	1	21.9	21.45	1.11
		19175	1907.5	1	24	22.9	1	21.9	21.44	1.11
		18625	1852.5	12	0	22.9	2	20.9	20.60	1.07
		18900	1880	12	0	22.9	2	20.9	20.47	1.10
		19175	1907.5	12	0	22.9	2	20.9	20.46	1.11
		18625	1852.5	12	6	22.9	2	20.9	20.61	1.07
		18900	1880	12	6	22.9	2	20.9	20.48	1.10
		19175	1907.5	12	6	22.9	2	20.9	20.47	1.10
18625		1852.5	12	13	22.9	2	20.9	20.63	1.06	
18900	1880	12	13	22.9	2	20.9	20.50	1.10		
19175	1907.5	12	13	22.9	2	20.9	20.49	1.10		
18625	1852.5	25	0	22.9	2	20.9	20.48	1.10		
18900	1880	25	0	22.9	2	20.9	20.35	1.14		
19175	1907.5	25	0	22.9	2	20.9	20.34	1.14		



FCC SAR Test Report

A D T

LTE Band 2										
BW	Modulation	CH	Frequency (MHz)	RB	RB Offset	Target Power	MPR	Expected Power	Measured Power	Scaling Factor
10 MHz	QPSK	18650	1855	1	0	22.9	0	22.9	22.76	1.03
		18900	1880	1	0	22.9	0	22.9	22.59	1.07
		19150	1905	1	0	22.9	0	22.9	22.55	1.08
		18650	1855	1	24	22.9	0	22.9	22.77	1.03
		18900	1880	1	24	22.9	0	22.9	22.60	1.07
		19150	1905	1	24	22.9	0	22.9	22.56	1.08
		18650	1855	1	49	22.9	0	22.9	22.69	1.05
		18900	1880	1	49	22.9	0	22.9	22.52	1.09
		19150	1905	1	49	22.9	0	22.9	22.48	1.10
		18650	1855	25	0	22.9	1	21.9	21.58	1.08
		18900	1880	25	0	22.9	1	21.9	21.41	1.12
		19150	1905	25	0	22.9	1	21.9	21.37	1.13
		18650	1855	25	12	22.9	1	21.9	21.57	1.08
		18900	1880	25	12	22.9	1	21.9	21.40	1.12
		19150	1905	25	12	22.9	1	21.9	21.36	1.13
		18650	1855	25	25	22.9	1	21.9	21.55	1.08
		18900	1880	25	25	22.9	1	21.9	21.38	1.13
		19150	1905	25	25	22.9	1	21.9	21.34	1.14
	18650	1855	50	0	22.9	1	21.9	21.38	1.13	
	18900	1880	50	0	22.9	1	21.9	21.21	1.17	
	19150	1905	50	0	22.9	1	21.9	21.17	1.18	
	18650	1855	1	0	22.9	1	21.9	21.62	1.07	
	18900	1880	1	0	22.9	1	21.9	21.45	1.11	
	19150	1905	1	0	22.9	1	21.9	21.41	1.12	
	18650	1855	1	24	22.9	1	21.9	21.74	1.04	
	18900	1880	1	24	22.9	1	21.9	21.57	1.08	
	19150	1905	1	24	22.9	1	21.9	21.53	1.09	
	18650	1855	1	49	22.9	1	21.9	21.63	1.06	
	18900	1880	1	49	22.9	1	21.9	21.46	1.11	
	19150	1905	1	49	22.9	1	21.9	21.42	1.12	
	18650	1855	25	0	22.9	2	20.9	20.58	1.08	
	18900	1880	25	0	22.9	2	20.9	20.41	1.12	
	19150	1905	25	0	22.9	2	20.9	20.37	1.13	
	18650	1855	25	12	22.9	2	20.9	20.55	1.08	
	18900	1880	25	12	22.9	2	20.9	20.38	1.13	
	19150	1905	25	12	22.9	2	20.9	20.34	1.14	
18650	1855	25	25	22.9	2	20.9	20.40	1.12		
18900	1880	25	25	22.9	2	20.9	20.23	1.17		
19150	1905	25	25	22.9	2	20.9	20.19	1.18		
18650	1855	50	0	22.9	2	20.9	20.38	1.13		
18900	1880	50	0	22.9	2	20.9	20.21	1.17		
19150	1905	50	0	22.9	2	20.9	20.17	1.18		



FCC SAR Test Report

A D T

LTE Band 2										
BW	Modulation	CH	Frequency (MHz)	RB	RB Offset	Target Power	MPR	Expected Power	Measured Power	Scaling Factor
15 MHz	QPSK	18675	1857.5	1	0	22.9	0	22.9	22.70	1.05
		18900	1880	1	0	22.9	0	22.9	22.58	1.08
		19125	1902.5	1	0	22.9	0	22.9	22.48	1.10
		18675	1857.5	1	37	22.9	0	22.9	22.83	1.02
		18900	1880	1	37	22.9	0	22.9	22.71	1.04
		19125	1902.5	1	37	22.9	0	22.9	22.61	1.07
		18675	1857.5	1	74	22.9	0	22.9	22.64	1.06
		18900	1880	1	74	22.9	0	22.9	22.52	1.09
		19125	1902.5	1	74	22.9	0	22.9	22.42	1.12
		18675	1857.5	36	0	22.9	1	21.9	21.43	1.11
		18900	1880	36	0	22.9	1	21.9	21.31	1.15
		19125	1902.5	36	0	22.9	1	21.9	21.21	1.17
		18675	1857.5	36	19	22.9	1	21.9	21.42	1.12
		18900	1880	36	19	22.9	1	21.9	21.30	1.15
		19125	1902.5	36	19	22.9	1	21.9	21.20	1.17
		18675	1857.5	36	39	22.9	1	21.9	21.40	1.12
		18900	1880	36	39	22.9	1	21.9	21.28	1.15
		19125	1902.5	36	39	22.9	1	21.9	21.18	1.18
	18675	1857.5	75	0	22.9	1	21.9	21.36	1.13	
	18900	1880	75	0	22.9	1	21.9	21.24	1.16	
	19125	1902.5	75	0	22.9	1	21.9	21.14	1.19	
	18675	1857.5	1	0	22.9	1	21.9	21.51	1.09	
	18900	1880	1	0	22.9	1	21.9	21.39	1.12	
	19125	1902.5	1	0	22.9	1	21.9	21.29	1.15	
	18675	1857.5	1	37	22.9	1	21.9	21.76	1.03	
	18900	1880	1	37	22.9	1	21.9	21.64	1.06	
	19125	1902.5	1	37	22.9	1	21.9	21.54	1.09	
	18675	1857.5	1	74	22.9	1	21.9	21.60	1.07	
	18900	1880	1	74	22.9	1	21.9	21.48	1.10	
	19125	1902.5	1	74	22.9	1	21.9	21.38	1.13	
	18675	1857.5	36	0	22.9	2	20.9	20.39	1.12	
	18900	1880	36	0	22.9	2	20.9	20.27	1.16	
	19125	1902.5	36	0	22.9	2	20.9	20.17	1.18	
	18675	1857.5	36	19	22.9	2	20.9	20.24	1.16	
	18900	1880	36	19	22.9	2	20.9	20.12	1.20	
	19125	1902.5	36	19	22.9	2	20.9	20.02	1.22	
18675	1857.5	36	39	22.9	2	20.9	20.29	1.15		
18900	1880	36	39	22.9	2	20.9	20.17	1.18		
19125	1902.5	36	39	22.9	2	20.9	20.07	1.21		
18675	1857.5	75	0	22.9	2	20.9	20.28	1.15		
18900	1880	75	0	22.9	2	20.9	20.16	1.19		
19125	1902.5	75	0	22.9	2	20.9	20.06	1.21		



FCC SAR Test Report

LTE Band 2										
BW	Modulation	CH	Frequency (MHz)	RB	RB Offset	Target Power	MPR	Expected Power	Measured Power	Scaling Factor
20 MHz	QPSK	18700	1860	1	0	22.9	0	22.9	22.77	1.03
		18900	1880	1	0	22.9	0	22.9	22.65	1.06
		19100	1900	1	0	22.9	0	22.9	22.63	1.06
		18700	1860	1	50	22.9	0	22.9	22.85	1.01
		18900	1880	1	50	22.9	0	22.9	22.73	1.04
		19100	1900	1	50	22.9	0	22.9	22.71	1.04
		18700	1860	1	99	22.9	0	22.9	22.70	1.05
		18900	1880	1	99	22.9	0	22.9	22.58	1.08
		19100	1900	1	99	22.9	0	22.9	22.56	1.08
		18700	1860	50	0	22.9	1	21.9	21.51	1.09
		18900	1880	50	0	22.9	1	21.9	21.39	1.12
		19100	1900	50	0	22.9	1	21.9	21.37	1.13
		18700	1860	50	25	22.9	1	21.9	21.46	1.11
		18900	1880	50	25	22.9	1	21.9	21.34	1.14
		19100	1900	50	25	22.9	1	21.9	21.32	1.14
		18700	1860	50	50	22.9	1	21.9	21.45	1.11
		18900	1880	50	50	22.9	1	21.9	21.33	1.14
		19100	1900	50	50	22.9	1	21.9	21.31	1.15
	18700	1860	100	0	22.9	1	21.9	21.49	1.10	
	18900	1880	100	0	22.9	1	21.9	21.37	1.13	
	19100	1900	100	0	22.9	1	21.9	21.35	1.14	
	16QAM	18700	1860	1	0	22.9	1	21.9	21.68	1.05
		18900	1880	1	0	22.9	1	21.9	21.56	1.08
		19100	1900	1	0	22.9	1	21.9	21.54	1.09
		18700	1860	1	50	22.9	1	21.9	21.79	1.03
		18900	1880	1	50	22.9	1	21.9	21.67	1.05
		19100	1900	1	50	22.9	1	21.9	21.65	1.06
		18700	1860	1	99	22.9	1	21.9	21.64	1.06
		18900	1880	1	99	22.9	1	21.9	21.52	1.09
		19100	1900	1	99	22.9	1	21.9	21.50	1.10
		18700	1860	50	0	22.9	2	20.9	20.51	1.09
		18900	1880	50	0	22.9	2	20.9	20.39	1.12
		19100	1900	50	0	22.9	2	20.9	20.37	1.13
		18700	1860	50	25	22.9	2	20.9	20.46	1.11
		18900	1880	50	25	22.9	2	20.9	20.34	1.14
		19100	1900	50	25	22.9	2	20.9	20.32	1.14
18700		1860	50	50	22.9	2	20.9	20.47	1.10	
18900		1880	50	50	22.9	2	20.9	20.35	1.14	
19100		1900	50	50	22.9	2	20.9	20.33	1.14	
18700	1860	100	0	22.9	2	20.9	20.46	1.11		
18900	1880	100	0	22.9	2	20.9	20.34	1.14		
19100	1900	100	0	22.9	2	20.9	20.32	1.14		



FCC SAR Test Report

LTE Band 4										
BW	Modulation	CH	Frequency (MHz)	RB	RB Offset	Target Power	MPR	Expected Power	Measured Power	Scaling Factor
1.4 MHz	QPSK	19957	1710.7	1	0	22.6	0	22.6	22.22	1.09
		20175	1732.5	1	0	22.6	0	22.6	22.08	1.13
		20393	1754.3	1	0	22.6	0	22.6	22.43	1.04
		19957	1710.7	1	2	22.6	0	22.6	22.27	1.08
		20175	1732.5	1	2	22.6	0	22.6	22.13	1.11
		20393	1754.3	1	2	22.6	0	22.6	22.48	1.03
		19957	1710.7	1	5	22.6	0	22.6	22.15	1.11
		20175	1732.5	1	5	22.6	0	22.6	22.01	1.15
		20393	1754.3	1	5	22.6	0	22.6	22.36	1.06
		19957	1710.7	3	0	22.6	0	22.6	22.26	1.08
		20175	1732.5	3	0	22.6	0	22.6	22.12	1.12
		20393	1754.3	3	0	22.6	0	22.6	22.47	1.03
		19957	1710.7	3	1	22.6	0	22.6	22.11	1.12
		20175	1732.5	3	1	22.6	0	22.6	21.97	1.16
		20393	1754.3	3	1	22.6	0	22.6	22.32	1.07
		19957	1710.7	3	3	22.6	0	22.6	22.09	1.12
		20175	1732.5	3	3	22.6	0	22.6	21.95	1.16
		20393	1754.3	3	3	22.6	0	22.6	22.30	1.07
	19957	1710.7	6	0	22.6	1	21.6	21.08	1.13	
	20175	1732.5	6	0	22.6	1	21.6	20.94	1.16	
	20393	1754.3	6	0	22.6	1	21.6	21.29	1.07	
	16QAM	19957	1710.7	1	0	22.6	1	21.6	21.12	1.12
		20175	1732.5	1	0	22.6	1	21.6	20.98	1.15
		20393	1754.3	1	0	22.6	1	21.6	21.33	1.06
		19957	1710.7	1	2	22.6	1	21.6	21.10	1.12
		20175	1732.5	1	2	22.6	1	21.6	20.96	1.16
		20393	1754.3	1	2	22.6	1	21.6	21.31	1.07
		19957	1710.7	1	5	22.6	1	21.6	20.94	1.16
		20175	1732.5	1	5	22.6	1	21.6	20.80	1.20
		20393	1754.3	1	5	22.6	1	21.6	21.15	1.11
		19957	1710.7	3	0	22.6	1	21.6	21.26	1.08
		20175	1732.5	3	0	22.6	1	21.6	21.12	1.12
		20393	1754.3	3	0	22.6	1	21.6	21.47	1.03
		19957	1710.7	3	1	22.6	1	21.6	21.21	1.09
		20175	1732.5	3	1	22.6	1	21.6	21.07	1.13
		20393	1754.3	3	1	22.6	1	21.6	21.42	1.04
19957		1710.7	3	3	22.6	1	21.6	21.19	1.10	
20175		1732.5	3	3	22.6	1	21.6	21.05	1.14	
20393		1754.3	3	3	22.6	1	21.6	21.40	1.05	
19957	1710.7	6	0	22.6	2	20.6	20.17	1.10		
20175	1732.5	6	0	22.6	2	20.6	20.03	1.14		
20393	1754.3	6	0	22.6	2	20.6	20.38	1.05		



FCC SAR Test Report

A D T

LTE Band 4										
BW	Modulation	CH	Frequency (MHz)	RB	RB Offset	Target Power	MPR	Expected Power	Measured Power	Scaling Factor
3 MHz	QPSK	19965	1711.5	1	0	22.6	0	22.6	22.21	1.09
		20175	1732.5	1	0	22.6	0	22.6	22.05	1.14
		20385	1753.5	1	0	22.6	0	22.6	22.50	1.02
		19965	1711.5	1	7	22.6	0	22.6	22.08	1.13
		20175	1732.5	1	7	22.6	0	22.6	21.92	1.17
		20385	1753.5	1	7	22.6	0	22.6	22.37	1.05
		19965	1711.5	1	14	22.6	0	22.6	21.94	1.16
		20175	1732.5	1	14	22.6	0	22.6	21.78	1.21
		20385	1753.5	1	14	22.6	0	22.6	22.23	1.09
		19965	1711.5	8	0	22.6	1	21.6	21.15	1.11
		20175	1732.5	8	0	22.6	1	21.6	20.99	1.15
		20385	1753.5	8	0	22.6	1	21.6	21.44	1.04
		19965	1711.5	8	3	22.6	1	21.6	21.03	1.14
		20175	1732.5	8	3	22.6	1	21.6	20.87	1.18
		20385	1753.5	8	3	22.6	1	21.6	21.32	1.07
		19965	1711.5	8	7	22.6	1	21.6	20.92	1.17
		20175	1732.5	8	7	22.6	1	21.6	20.76	1.21
		20385	1753.5	8	7	22.6	1	21.6	21.21	1.09
	19965	1711.5	15	0	22.6	1	21.6	20.97	1.16	
	20175	1732.5	15	0	22.6	1	21.6	20.81	1.20	
	20385	1753.5	15	0	22.6	1	21.6	21.26	1.08	
	16QAM	19965	1711.5	1	0	22.6	1	21.6	21.21	1.09
		20175	1732.5	1	0	22.6	1	21.6	21.05	1.14
		20385	1753.5	1	0	22.6	1	21.6	21.50	1.02
		19965	1711.5	1	7	22.6	1	21.6	21.13	1.11
		20175	1732.5	1	7	22.6	1	21.6	20.97	1.16
		20385	1753.5	1	7	22.6	1	21.6	21.42	1.04
		19965	1711.5	1	14	22.6	1	21.6	20.98	1.15
		20175	1732.5	1	14	22.6	1	21.6	20.82	1.20
		20385	1753.5	1	14	22.6	1	21.6	21.27	1.08
		19965	1711.5	8	0	22.6	2	20.6	20.19	1.10
		20175	1732.5	8	0	22.6	2	20.6	20.03	1.14
		20385	1753.5	8	0	22.6	2	20.6	20.48	1.03
		19965	1711.5	8	3	22.6	2	20.6	20.16	1.11
		20175	1732.5	8	3	22.6	2	20.6	20.00	1.15
		20385	1753.5	8	3	22.6	2	20.6	20.45	1.04
19965		1711.5	8	7	22.6	2	20.6	20.02	1.14	
20175		1732.5	8	7	22.6	2	20.6	19.86	1.19	
20385		1753.5	8	7	22.6	2	20.6	20.31	1.07	
19965	1711.5	15	0	22.6	2	20.6	20.10	1.12		
20175	1732.5	15	0	22.6	2	20.6	19.94	1.16		
20385	1753.5	15	0	22.6	2	20.6	20.39	1.05		



FCC SAR Test Report

LTE Band 4										
BW	Modulation	CH	Frequency (MHz)	RB	RB Offset	Target Power	MPR	Expected Power	Measured Power	Scaling Factor
5 MHz	QPSK	19975	1712.5	1	0	22.6	0	22.6	22.52	1.02
		20175	1732.5	1	0	22.6	0	22.6	22.23	1.09
		20375	1752.5	1	0	22.6	0	22.6	22.50	1.02
		19975	1712.5	1	12	22.6	0	22.6	22.36	1.06
		20175	1732.5	1	12	22.6	0	22.6	22.07	1.13
		20375	1752.5	1	12	22.6	0	22.6	22.34	1.06
		19975	1712.5	1	24	22.6	0	22.6	22.36	1.06
		20175	1732.5	1	24	22.6	0	22.6	22.07	1.13
		20375	1752.5	1	24	22.6	0	22.6	22.34	1.06
		19975	1712.5	12	0	22.6	1	21.6	21.31	1.07
		20175	1732.5	12	0	22.6	1	21.6	21.02	1.14
		20375	1752.5	12	0	22.6	1	21.6	21.29	1.07
		19975	1712.5	12	6	22.6	1	21.6	21.20	1.10
		20175	1732.5	12	6	22.6	1	21.6	20.91	1.17
		20375	1752.5	12	6	22.6	1	21.6	21.18	1.10
		19975	1712.5	12	13	22.6	1	21.6	21.15	1.11
		20175	1732.5	12	13	22.6	1	21.6	20.86	1.19
		20375	1752.5	12	13	22.6	1	21.6	21.13	1.11
	19975	1712.5	25	0	22.6	1	21.6	21.12	1.12	
	20175	1732.5	25	0	22.6	1	21.6	20.83	1.19	
	20375	1752.5	25	0	22.6	1	21.6	21.10	1.12	
	16QAM	19975	1712.5	1	0	22.6	1	21.6	21.48	1.03
		20175	1732.5	1	0	22.6	1	21.6	21.19	1.10
		20375	1752.5	1	0	22.6	1	21.6	21.46	1.03
		19975	1712.5	1	12	22.6	1	21.6	21.51	1.02
		20175	1732.5	1	12	22.6	1	21.6	21.22	1.09
		20375	1752.5	1	12	22.6	1	21.6	21.49	1.03
		19975	1712.5	1	24	22.6	1	21.6	21.39	1.05
		20175	1732.5	1	24	22.6	1	21.6	21.10	1.12
		20375	1752.5	1	24	22.6	1	21.6	21.37	1.05
		19975	1712.5	12	0	22.6	2	20.6	20.52	1.02
		20175	1732.5	12	0	22.6	2	20.6	20.23	1.09
		20375	1752.5	12	0	22.6	2	20.6	20.50	1.02
		19975	1712.5	12	6	22.6	2	20.6	20.40	1.05
		20175	1732.5	12	6	22.6	2	20.6	20.11	1.12
		20375	1752.5	12	6	22.6	2	20.6	20.38	1.05
19975		1712.5	12	13	22.6	2	20.6	20.34	1.06	
20175		1732.5	12	13	22.6	2	20.6	20.05	1.14	
20375		1752.5	12	13	22.6	2	20.6	20.32	1.07	
19975	1712.5	25	0	22.6	2	20.6	20.35	1.06		
20175	1732.5	25	0	22.6	2	20.6	20.06	1.13		
20375	1752.5	25	0	22.6	2	20.6	20.33	1.06		



FCC SAR Test Report

A D T

LTE Band 4										
BW	Modulation	CH	Frequency (MHz)	RB	RB Offset	Target Power	MPR	Expected Power	Measured Power	Scaling Factor
10 MHz	QPSK	20000	1715	1	0	22.6	0	22.6	22.28	1.08
		20175	1732.5	1	0	22.6	0	22.6	22.02	1.14
		20350	1750	1	0	22.6	0	22.6	22.43	1.04
		20000	1715	1	24	22.6	0	22.6	22.39	1.05
		20175	1732.5	1	24	22.6	0	22.6	22.13	1.11
		20350	1750	1	24	22.6	0	22.6	22.54	1.01
		20000	1715	1	49	22.6	0	22.6	22.17	1.10
		20175	1732.5	1	49	22.6	0	22.6	21.91	1.17
		20350	1750	1	49	22.6	0	22.6	22.32	1.07
		20000	1715	25	0	22.6	1	21.6	21.14	1.11
		20175	1732.5	25	0	22.6	1	21.6	20.88	1.18
		20350	1750	25	0	22.6	1	21.6	21.29	1.07
		20000	1715	25	12	22.6	1	21.6	21.17	1.10
		20175	1732.5	25	12	22.6	1	21.6	20.91	1.17
		20350	1750	25	12	22.6	1	21.6	21.32	1.07
		20000	1715	25	25	22.6	1	21.6	21.08	1.13
		20175	1732.5	25	25	22.6	1	21.6	20.82	1.20
		20350	1750	25	25	22.6	1	21.6	21.23	1.09
	20000	1715	50	0	22.6	1	21.6	21.03	1.14	
	20175	1732.5	50	0	22.6	1	21.6	20.77	1.21	
	20350	1750	50	0	22.6	1	21.6	21.18	1.10	
	16QAM	20000	1715	1	0	22.6	1	21.6	21.14	1.11
		20175	1732.5	1	0	22.6	1	21.6	20.88	1.18
		20350	1750	1	0	22.6	1	21.6	21.29	1.07
		20000	1715	1	24	22.6	1	21.6	21.38	1.05
		20175	1732.5	1	24	22.6	1	21.6	21.12	1.12
		20350	1750	1	24	22.6	1	21.6	21.53	1.02
		20000	1715	1	49	22.6	1	21.6	21.10	1.12
		20175	1732.5	1	49	22.6	1	21.6	20.84	1.19
		20350	1750	1	49	22.6	1	21.6	21.25	1.08
20000		1715	25	0	22.6	2	20.6	20.11	1.12	
20175		1732.5	25	0	22.6	2	20.6	19.85	1.19	
20350		1750	25	0	22.6	2	20.6	20.26	1.08	
20000	1715	25	12	22.6	2	20.6	20.06	1.13		
20175	1732.5	25	12	22.6	2	20.6	19.80	1.20		
20350	1750	25	12	22.6	2	20.6	20.21	1.09		
20000	1715	25	25	22.6	2	20.6	19.98	1.15		
20175	1732.5	25	25	22.6	2	20.6	19.72	1.22		
20350	1750	25	25	22.6	2	20.6	20.13	1.11		
20000	1715	50	0	22.6	2	20.6	19.92	1.17		
20175	1732.5	50	0	22.6	2	20.6	19.66	1.24		
20350	1750	50	0	22.6	2	20.6	20.07	1.13		



FCC SAR Test Report

A D T

LTE Band 4										
BW	Modulation	CH	Frequency (MHz)	RB	RB Offset	Target Power	MPR	Expected Power	Measured Power	Scaling Factor
15 MHz	QPSK	20025	1717.5	1	0	22.6	0	22.6	22.57	1.01
		20175	1732.5	1	0	22.6	0	22.6	22.18	1.10
		20325	1747.5	1	0	22.6	0	22.6	22.50	1.02
		20025	1717.5	1	37	22.6	0	22.6	22.30	1.07
		20175	1732.5	1	37	22.6	0	22.6	21.91	1.17
		20325	1747.5	1	37	22.6	0	22.6	22.23	1.09
		20025	1717.5	1	74	22.6	0	22.6	22.01	1.15
		20175	1732.5	1	74	22.6	0	22.6	21.62	1.25
		20325	1747.5	1	74	22.6	0	22.6	21.94	1.16
		20025	1717.5	36	0	22.6	1	21.6	21.19	1.10
		20175	1732.5	36	0	22.6	1	21.6	20.80	1.20
		20325	1747.5	36	0	22.6	1	21.6	21.12	1.12
		20025	1717.5	36	19	22.6	1	21.6	21.06	1.13
		20175	1732.5	36	19	22.6	1	21.6	20.67	1.24
		20325	1747.5	36	19	22.6	1	21.6	20.99	1.15
		20025	1717.5	36	39	22.6	1	21.6	21.00	1.15
		20175	1732.5	36	39	22.6	1	21.6	20.61	1.26
		20325	1747.5	36	39	22.6	1	21.6	20.93	1.17
	20025	1717.5	75	0	22.6	1	21.6	21.05	1.14	
	20175	1732.5	75	0	22.6	1	21.6	20.66	1.24	
	20325	1747.5	75	0	22.6	1	21.6	20.98	1.15	
	16QAM	20025	1717.5	1	0	22.6	1	21.6	21.55	1.01
		20175	1732.5	1	0	22.6	1	21.6	21.03	1.14
		20325	1747.5	1	0	22.6	1	21.6	21.37	1.05
		20025	1717.5	1	37	22.6	1	21.6	21.48	1.03
		20175	1732.5	1	37	22.6	1	21.6	20.96	1.16
		20325	1747.5	1	37	22.6	1	21.6	21.30	1.07
		20025	1717.5	1	74	22.6	1	21.6	21.47	1.03
		20175	1732.5	1	74	22.6	1	21.6	20.95	1.16
		20325	1747.5	1	74	22.6	1	21.6	21.29	1.07
		20025	1717.5	36	0	22.6	2	20.6	20.49	1.03
		20175	1732.5	36	0	22.6	2	20.6	19.97	1.16
		20325	1747.5	36	0	22.6	2	20.6	20.31	1.07
		20025	1717.5	36	19	22.6	2	20.6	20.32	1.07
		20175	1732.5	36	19	22.6	2	20.6	19.80	1.20
		20325	1747.5	36	19	22.6	2	20.6	20.14	1.11
20025		1717.5	36	39	22.6	2	20.6	20.20	1.10	
20175		1732.5	36	39	22.6	2	20.6	19.68	1.24	
20325		1747.5	36	39	22.6	2	20.6	20.02	1.14	
20025	1717.5	75	0	22.6	2	20.6	20.28	1.08		
20175	1732.5	75	0	22.6	2	20.6	19.76	1.21		
20325	1747.5	75	0	22.6	2	20.6	20.10	1.12		



FCC SAR Test Report

LTE Band 4										
BW	Modulation	CH	Frequency (MHz)	RB	RB Offset	Target Power	MPR	Expected Power	Measured Power	Scaling Factor
20 MHz	QPSK	20050	1720	1	0	22.6	0	22.6	22.60	1.00
		20175	1732.5	1	0	22.6	0	22.6	22.45	1.04
		20300	1745	1	0	22.6	0	22.6	22.41	1.04
		20050	1720	1	50	22.6	0	22.6	22.46	1.03
		20175	1732.5	1	50	22.6	0	22.6	22.31	1.07
		20300	1745	1	50	22.6	0	22.6	22.27	1.08
		20050	1720	1	99	22.6	0	22.6	22.27	1.08
		20175	1732.5	1	99	22.6	0	22.6	22.12	1.12
		20300	1745	1	99	22.6	0	22.6	22.08	1.13
		20050	1720	50	0	22.6	1	21.6	21.16	1.11
		20175	1732.5	50	0	22.6	1	21.6	21.01	1.15
		20300	1745	50	0	22.6	1	21.6	20.97	1.16
		20050	1720	50	25	22.6	1	21.6	21.00	1.15
		20175	1732.5	50	25	22.6	1	21.6	20.85	1.19
		20300	1745	50	25	22.6	1	21.6	20.81	1.20
		20050	1720	50	50	22.6	1	21.6	20.88	1.18
		20175	1732.5	50	50	22.6	1	21.6	20.73	1.22
		20300	1745	50	50	22.6	1	21.6	20.69	1.23
		20050	1720	100	0	22.6	1	21.6	21.08	1.13
		20175	1732.5	100	0	22.6	1	21.6	20.93	1.17
	20300	1745	100	0	22.6	1	21.6	20.89	1.18	
	16QAM	20050	1720	1	0	22.6	1	21.6	21.58	1.00
		20175	1732.5	1	0	22.6	1	21.6	21.43	1.04
		20300	1745	1	0	22.6	1	21.6	21.39	1.05
		20050	1720	1	50	22.6	1	21.6	21.53	1.02
		20175	1732.5	1	50	22.6	1	21.6	21.38	1.05
		20300	1745	1	50	22.6	1	21.6	21.34	1.06
		20050	1720	1	99	22.6	1	21.6	21.32	1.07
		20175	1732.5	1	99	22.6	1	21.6	21.17	1.10
		20300	1745	1	99	22.6	1	21.6	21.13	1.11
		20050	1720	50	0	22.6	2	20.6	20.22	1.09
		20175	1732.5	50	0	22.6	2	20.6	20.07	1.13
20300		1745	50	0	22.6	2	20.6	20.03	1.14	
20050	1720	50	25	22.6	2	20.6	19.91	1.17		
20175	1732.5	50	25	22.6	2	20.6	19.76	1.21		
20300	1745	50	25	22.6	2	20.6	19.72	1.22		
20050	1720	50	50	22.6	2	20.6	19.83	1.19		
20175	1732.5	50	50	22.6	2	20.6	19.68	1.24		
20300	1745	50	50	22.6	2	20.6	19.64	1.25		
20050	1720	100	0	22.6	2	20.6	19.96	1.16		
20175	1732.5	100	0	22.6	2	20.6	19.81	1.20		
20300	1745	100	0	22.6	2	20.6	19.77	1.21		



FCC SAR Test Report

LTE Band 12										
BW	Modulation	CH	Frequency (MHz)	RB	RB Offset	Target Power	MPR	Expected Power	Measured Power	Scaling Factor
1.4 MHz	QPSK	23017	699.7	1	0	22.5	0	22.5	22.54	0.99
		23095	707.5	1	0	22.5	0	22.5	22.33	1.04
		23173	715.3	1	0	22.5	0	22.5	22.35	1.04
		23017	699.7	1	2	22.5	0	22.5	22.36	1.03
		23095	707.5	1	2	22.5	0	22.5	22.15	1.08
		23173	715.3	1	2	22.5	0	22.5	22.17	1.08
		23017	699.7	1	5	22.5	0	22.5	22.09	1.10
		23095	707.5	1	5	22.5	0	22.5	21.88	1.15
		23173	715.3	1	5	22.5	0	22.5	21.90	1.15
		23017	699.7	3	0	22.5	0	22.5	22.21	1.07
		23095	707.5	3	0	22.5	0	22.5	22.00	1.12
		23173	715.3	3	0	22.5	0	22.5	22.02	1.12
		23017	699.7	3	1	22.5	0	22.5	22.19	1.07
		23095	707.5	3	1	22.5	0	22.5	21.98	1.13
		23173	715.3	3	1	22.5	0	22.5	22.00	1.12
		23017	699.7	3	3	22.5	0	22.5	22.00	1.12
		23095	707.5	3	3	22.5	0	22.5	21.79	1.18
		23173	715.3	3	3	22.5	0	22.5	21.81	1.17
	23017	699.7	6	0	22.5	1	21.5	21.21	1.07	
	23095	707.5	6	0	22.5	1	21.5	21.00	1.12	
	23173	715.3	6	0	22.5	1	21.5	21.02	1.12	
	16QAM	23017	699.7	1	0	22.5	1	21.5	21.38	1.03
		23095	707.5	1	0	22.5	1	21.5	21.17	1.08
		23173	715.3	1	0	22.5	1	21.5	21.19	1.07
		23017	699.7	1	2	22.5	1	21.5	21.39	1.03
		23095	707.5	1	2	22.5	1	21.5	21.18	1.08
		23173	715.3	1	2	22.5	1	21.5	21.20	1.07
		23017	699.7	1	5	22.5	1	21.5	21.07	1.10
		23095	707.5	1	5	22.5	1	21.5	20.86	1.16
		23173	715.3	1	5	22.5	1	21.5	20.88	1.15
		23017	699.7	3	0	22.5	1	21.5	21.23	1.06
		23095	707.5	3	0	22.5	1	21.5	21.02	1.12
		23173	715.3	3	0	22.5	1	21.5	21.04	1.11
		23017	699.7	3	1	22.5	1	21.5	21.10	1.10
		23095	707.5	3	1	22.5	1	21.5	20.89	1.15
		23173	715.3	3	1	22.5	1	21.5	20.91	1.15
23017		699.7	3	3	22.5	1	21.5	21.00	1.12	
23095		707.5	3	3	22.5	1	21.5	20.79	1.18	
23173		715.3	3	3	22.5	1	21.5	20.81	1.17	
23017	699.7	6	0	22.5	2	20.5	19.99	1.12		
23095	707.5	6	0	22.5	2	20.5	19.78	1.18		
23173	715.3	6	0	22.5	2	20.5	19.80	1.17		



FCC SAR Test Report

A D T

LTE Band 12										
BW	Modulation	CH	Frequency (MHz)	RB	RB Offset	Target Power	MPR	Expected Power	Measured Power	Scaling Factor
3 MHz	QPSK	23025	700.5	1	0	22.5	0	22.5	22.56	0.99
		23095	707.5	1	0	22.5	0	22.5	22.46	1.01
		23165	714.5	1	0	22.5	0	22.5	22.35	1.04
		23025	700.5	1	7	22.5	0	22.5	22.28	1.05
		23095	707.5	1	7	22.5	0	22.5	22.18	1.08
		23165	714.5	1	7	22.5	0	22.5	22.07	1.10
		23025	700.5	1	14	22.5	0	22.5	22.47	1.01
		23095	707.5	1	14	22.5	0	22.5	22.37	1.03
		23165	714.5	1	14	22.5	0	22.5	22.26	1.06
		23025	700.5	8	0	22.5	1	21.5	21.32	1.04
		23095	707.5	8	0	22.5	1	21.5	21.22	1.07
		23165	714.5	8	0	22.5	1	21.5	21.11	1.09
		23025	700.5	8	3	22.5	1	21.5	21.22	1.07
		23095	707.5	8	3	22.5	1	21.5	21.12	1.09
		23165	714.5	8	3	22.5	1	21.5	21.01	1.12
		23025	700.5	8	7	22.5	1	21.5	21.37	1.03
		23095	707.5	8	7	22.5	1	21.5	21.27	1.05
		23165	714.5	8	7	22.5	1	21.5	21.16	1.08
	23025	700.5	15	0	22.5	1	21.5	21.16	1.08	
	23095	707.5	15	0	22.5	1	21.5	21.06	1.11	
	23165	714.5	15	0	22.5	1	21.5	20.95	1.14	
	16QAM	23025	700.5	1	0	22.5	1	21.5	21.42	1.02
		23095	707.5	1	0	22.5	1	21.5	21.32	1.04
		23165	714.5	1	0	22.5	1	21.5	21.21	1.07
		23025	700.5	1	7	22.5	1	21.5	21.22	1.07
		23095	707.5	1	7	22.5	1	21.5	21.12	1.09
		23165	714.5	1	7	22.5	1	21.5	21.01	1.12
		23025	700.5	1	14	22.5	1	21.5	21.38	1.03
		23095	707.5	1	14	22.5	1	21.5	21.28	1.05
		23165	714.5	1	14	22.5	1	21.5	21.17	1.08
		23025	700.5	8	0	22.5	2	20.5	20.07	1.10
		23095	707.5	8	0	22.5	2	20.5	19.97	1.13
		23165	714.5	8	0	22.5	2	20.5	19.86	1.16
		23025	700.5	8	3	22.5	2	20.5	20.10	1.10
		23095	707.5	8	3	22.5	2	20.5	20.00	1.12
		23165	714.5	8	3	22.5	2	20.5	19.89	1.15
23025		700.5	8	7	22.5	2	20.5	20.08	1.10	
23095		707.5	8	7	22.5	2	20.5	19.98	1.13	
23165		714.5	8	7	22.5	2	20.5	19.87	1.16	
23025	700.5	15	0	22.5	2	20.5	20.01	1.12		
23095	707.5	15	0	22.5	2	20.5	19.91	1.15		
23165	714.5	15	0	22.5	2	20.5	19.80	1.17		



FCC SAR Test Report

A D T

LTE Band 12										
BW	Modulation	CH	Frequency (MHz)	RB	RB Offset	Target Power	MPR	Expected Power	Measured Power	Scaling Factor
5 MHz	QPSK	23035	701.5	1	0	22.5	0	22.5	22.44	1.01
		23095	707.5	1	0	22.5	0	22.5	22.47	1.01
		23155	713.5	1	0	22.5	0	22.5	22.39	1.03
		23035	701.5	1	12	22.5	0	22.5	22.43	1.02
		23095	707.5	1	12	22.5	0	22.5	22.46	1.01
		23155	713.5	1	12	22.5	0	22.5	22.38	1.03
		23035	701.5	1	24	22.5	0	22.5	22.37	1.03
		23095	707.5	1	24	22.5	0	22.5	22.40	1.02
		23155	713.5	1	24	22.5	0	22.5	22.32	1.04
		23035	701.5	12	0	22.5	1	21.5	21.16	1.08
		23095	707.5	12	0	22.5	1	21.5	21.19	1.07
		23155	713.5	12	0	22.5	1	21.5	21.11	1.09
		23035	701.5	12	6	22.5	1	21.5	21.21	1.07
		23095	707.5	12	6	22.5	1	21.5	21.24	1.06
		23155	713.5	12	6	22.5	1	21.5	21.16	1.08
		23035	701.5	12	13	22.5	1	21.5	21.18	1.08
		23095	707.5	12	13	22.5	1	21.5	21.21	1.07
		23155	713.5	12	13	22.5	1	21.5	21.13	1.09
	23035	701.5	25	0	22.5	1	21.5	20.93	1.14	
	23095	707.5	25	0	22.5	1	21.5	20.96	1.13	
	23155	713.5	25	0	22.5	1	21.5	20.88	1.15	
	16QAM	23035	701.5	1	0	22.5	1	21.5	21.10	1.10
		23095	707.5	1	0	22.5	1	21.5	21.13	1.09
		23155	713.5	1	0	22.5	1	21.5	21.05	1.11
		23035	701.5	1	12	22.5	1	21.5	21.20	1.07
		23095	707.5	1	12	22.5	1	21.5	21.23	1.06
		23155	713.5	1	12	22.5	1	21.5	21.15	1.08
		23035	701.5	1	24	22.5	1	21.5	21.10	1.10
		23095	707.5	1	24	22.5	1	21.5	21.13	1.09
		23155	713.5	1	24	22.5	1	21.5	21.05	1.11
		23035	701.5	12	0	22.5	2	20.5	20.17	1.08
		23095	707.5	12	0	22.5	2	20.5	20.20	1.07
		23155	713.5	12	0	22.5	2	20.5	20.12	1.09
		23035	701.5	12	6	22.5	2	20.5	20.08	1.10
		23095	707.5	12	6	22.5	2	20.5	20.11	1.09
		23155	713.5	12	6	22.5	2	20.5	20.03	1.11
23035		701.5	12	13	22.5	2	20.5	20.06	1.11	
23095		707.5	12	13	22.5	2	20.5	20.09	1.10	
23155		713.5	12	13	22.5	2	20.5	20.01	1.12	
23035	701.5	25	0	22.5	2	20.5	19.90	1.15		
23095	707.5	25	0	22.5	2	20.5	19.93	1.14		
23155	713.5	25	0	22.5	2	20.5	19.85	1.16		



FCC SAR Test Report

LTE Band 12										
BW	Modulation	CH	Frequency (MHz)	RB	RB Offset	Target Power	MPR	Expected Power	Measured Power	Scaling Factor
10 MHz	QPSK	23060	704	1	0	22.5	0	22.5	22.36	1.03
		23095	707.5	1	0	22.5	0	22.5	22.15	1.08
		23130	711	1	0	22.5	0	22.5	22.28	1.05
		23060	704	1	24	22.5	0	22.5	22.50	1.00
		23095	707.5	1	24	22.5	0	22.5	22.29	1.05
		23130	711	1	24	22.5	0	22.5	22.42	1.02
		23060	704	1	49	22.5	0	22.5	22.32	1.04
		23095	707.5	1	49	22.5	0	22.5	22.11	1.09
		23130	711	1	49	22.5	0	22.5	22.24	1.06
		23060	704	25	0	22.5	1	21.5	20.95	1.14
		23095	707.5	25	0	22.5	1	21.5	20.74	1.19
		23130	711	25	0	22.5	1	21.5	20.87	1.16
		23060	704	25	12	22.5	1	21.5	20.93	1.14
		23095	707.5	25	12	22.5	1	21.5	20.72	1.20
		23130	711	25	12	22.5	1	21.5	20.85	1.16
		23060	704	25	25	22.5	1	21.5	20.87	1.16
		23095	707.5	25	25	22.5	1	21.5	20.66	1.21
		23130	711	25	25	22.5	1	21.5	20.79	1.18
		23060	704	50	0	22.5	1	21.5	20.72	1.20
		23095	707.5	50	0	22.5	1	21.5	20.51	1.26
	23130	711	50	0	22.5	1	21.5	20.64	1.22	
	16QAM	23060	704	1	0	22.5	1	21.5	21.11	1.09
		23095	707.5	1	0	22.5	1	21.5	20.90	1.15
		23130	711	1	0	22.5	1	21.5	21.03	1.11
		23060	704	1	24	22.5	1	21.5	21.28	1.05
		23095	707.5	1	24	22.5	1	21.5	21.07	1.10
		23130	711	1	24	22.5	1	21.5	21.20	1.07
		23060	704	1	49	22.5	1	21.5	21.06	1.11
		23095	707.5	1	49	22.5	1	21.5	20.85	1.16
		23130	711	1	49	22.5	1	21.5	20.98	1.13
23060		704	25	0	22.5	2	20.5	19.87	1.16	
23095		707.5	25	0	22.5	2	20.5	19.66	1.21	
23130		711	25	0	22.5	2	20.5	19.79	1.18	
23060	704	25	12	22.5	2	20.5	19.96	1.13		
23095	707.5	25	12	22.5	2	20.5	19.75	1.19		
23130	711	25	12	22.5	2	20.5	19.88	1.15		
23060	704	25	25	22.5	2	20.5	19.90	1.15		
23095	707.5	25	25	22.5	2	20.5	19.69	1.21		
23130	711	25	25	22.5	2	20.5	19.82	1.17		
23060	704	50	0	22.5	2	20.5	19.75	1.19		
23095	707.5	50	0	22.5	2	20.5	19.54	1.25		
23130	711	50	0	22.5	2	20.5	19.67	1.21		



FCC SAR Test Report

A D T

LTE Band 17										
BW	Modulation	CH	Frequency (MHz)	RB	RB Offset	Target Power	MPR	Expected Power	Measured Power	Scaling Factor
5 MHz	QPSK	23755	706.5	1	0	22.5	0	22.5	22.42	1.02
		23790	710	1	0	22.5	0	22.5	22.00	1.12
		23825	713.5	1	0	22.5	0	22.5	22.20	1.07
		23755	706.5	1	12	22.5	0	22.5	22.26	1.06
		23790	710	1	12	22.5	0	22.5	21.84	1.16
		23825	713.5	1	12	22.5	0	22.5	22.04	1.11
		23755	706.5	1	24	22.5	0	22.5	22.15	1.08
		23790	710	1	24	22.5	0	22.5	21.73	1.19
		23825	713.5	1	24	22.5	0	22.5	21.93	1.14
		23755	706.5	12	0	22.5	1	21.5	20.98	1.13
		23790	710	12	0	22.5	1	21.5	20.56	1.24
		23825	713.5	12	0	22.5	1	21.5	20.76	1.19
		23755	706.5	12	6	22.5	1	21.5	21.01	1.12
		23790	710	12	6	22.5	1	21.5	20.59	1.23
		23825	713.5	12	6	22.5	1	21.5	20.79	1.18
		23755	706.5	12	13	22.5	1	21.5	20.98	1.13
		23790	710	12	13	22.5	1	21.5	20.56	1.24
		23825	713.5	12	13	22.5	1	21.5	20.76	1.19
	23755	706.5	25	0	22.5	1	21.5	20.98	1.13	
	23790	710	25	0	22.5	1	21.5	20.56	1.24	
	23825	713.5	25	0	22.5	1	21.5	20.76	1.19	
	23755	706.5	1	0	22.5	1	21.5	21.38	1.03	
	23790	710	1	0	22.5	1	21.5	20.96	1.13	
	23825	713.5	1	0	22.5	1	21.5	20.74	1.19	
	23755	706.5	1	12	22.5	1	21.5	21.44	1.01	
	23790	710	1	12	22.5	1	21.5	21.02	1.12	
	23825	713.5	1	12	22.5	1	21.5	20.80	1.17	
	23755	706.5	1	24	22.5	1	21.5	21.29	1.05	
	23790	710	1	24	22.5	1	21.5	20.87	1.16	
	23825	713.5	1	24	22.5	1	21.5	20.65	1.22	
	23755	706.5	12	0	22.5	2	20.5	20.26	1.06	
	23790	710	12	0	22.5	2	20.5	19.84	1.16	
	23825	713.5	12	0	22.5	2	20.5	19.62	1.22	
	23755	706.5	12	6	22.5	2	20.5	20.21	1.07	
	23790	710	12	6	22.5	2	20.5	19.79	1.18	
	23825	713.5	12	6	22.5	2	20.5	19.57	1.24	
23755	706.5	12	13	22.5	2	20.5	20.18	1.08		
23790	710	12	13	22.5	2	20.5	19.76	1.19		
23825	713.5	12	13	22.5	2	20.5	19.54	1.25		
23755	706.5	25	0	22.5	2	20.5	20.08	1.10		
23790	710	25	0	22.5	2	20.5	19.66	1.21		
23825	713.5	25	0	22.5	2	20.5	19.54	1.25		



FCC SAR Test Report

A D T

LTE Band 17										
BW	Modulation	CH	Frequency (MHz)	RB	RB Offset	Target Power	MPR	Expected Power	Measured Power	Scaling Factor
10 MHz	QPSK	23780	709	1	0	22.5	0	22.5	22.50	1.00
		23790	710	1	0	22.5	0	22.5	22.37	1.03
		23800	711	1	0	22.5	0	22.5	22.29	1.05
		23780	709	1	24	22.5	0	22.5	22.32	1.04
		23790	710	1	24	22.5	0	22.5	22.24	1.06
		23800	711	1	24	22.5	0	22.5	22.11	1.09
		23780	709	1	49	22.5	0	22.5	22.35	1.04
		23790	710	1	49	22.5	0	22.5	22.11	1.09
		23800	711	1	49	22.5	0	22.5	22.14	1.09
		23780	709	25	0	22.5	1	21.5	20.97	1.13
		23790	710	25	0	22.5	1	21.5	21.47	1.01
		23800	711	25	0	22.5	1	21.5	20.76	1.19
		23780	709	25	12	22.5	1	21.5	20.96	1.13
		23790	710	25	12	22.5	1	21.5	21.36	1.03
		23800	711	25	12	22.5	1	21.5	20.75	1.19
		23780	709	25	25	22.5	1	21.5	20.98	1.13
		23790	710	25	25	22.5	1	21.5	21.23	1.06
		23800	711	25	25	22.5	1	21.5	20.77	1.18
	23780	709	50	0	22.5	1	21.5	20.77	1.18	
	23790	710	50	0	22.5	1	21.5	21.10	1.10	
	23800	711	50	0	22.5	1	21.5	20.56	1.24	
	16QAM	23780	709	1	0	22.5	1	21.5	21.06	1.11
		23790	710	1	0	22.5	1	21.5	21.46	1.01
		23800	711	1	0	22.5	1	21.5	20.85	1.16
		23780	709	1	24	22.5	1	21.5	21.24	1.06
		23790	710	1	24	22.5	1	21.5	21.33	1.04
		23800	711	1	24	22.5	1	21.5	21.03	1.11
		23780	709	1	49	22.5	1	21.5	21.13	1.09
		23790	710	1	49	22.5	1	21.5	21.20	1.07
		23800	711	1	49	22.5	1	21.5	20.92	1.14
		23780	709	25	0	22.5	2	20.5	20.37	1.03
		23790	710	25	0	22.5	2	20.5	20.24	1.06
		23800	711	25	0	22.5	2	20.5	20.16	1.08
		23780	709	25	12	22.5	2	20.5	20.25	1.06
		23790	710	25	12	22.5	2	20.5	20.12	1.09
		23800	711	25	12	22.5	2	20.5	20.04	1.11
23780		709	25	25	22.5	2	20.5	20.26	1.06	
23790		710	25	25	22.5	2	20.5	20.13	1.09	
23800		711	25	25	22.5	2	20.5	20.05	1.11	
23780	709	50	0	22.5	2	20.5	20.05	1.11		
23790	710	50	0	22.5	2	20.5	19.92	1.14		
23800	711	50	0	22.5	2	20.5	19.84	1.16		



FCC SAR Test Report

LTE Band 25											
BW	Modulation	CH	Frequency (MHz)	RB	RB Offset	Target Power	MPR	Expected Power	Measured Power	Scaling Factor	
1.4 MHz	QPSK	26047	1850.7	1	0	22.8	0	22.8	22.69	1.03	
		26365	1882.5	1	0	22.8	0	22.8	22.57	1.05	
		26683	1914.3	1	0	22.8	0	22.8	22.39	1.10	
		26047	1850.7	1	2	22.8	0	22.8	22.69	1.03	
		26365	1882.5	1	2	22.8	0	22.8	22.57	1.05	
		26683	1914.3	1	2	22.8	0	22.8	22.39	1.10	
		26047	1850.7	1	5	22.8	0	22.8	22.53	1.06	
		26365	1882.5	1	5	22.8	0	22.8	22.41	1.09	
		26683	1914.3	1	5	22.8	0	22.8	22.23	1.14	
		26047	1850.7	3	0	22.8	0	22.8	22.63	1.04	
		26365	1882.5	3	0	22.8	0	22.8	22.51	1.07	
		26683	1914.3	3	0	22.8	0	22.8	22.33	1.11	
		26047	1850.7	3	1	22.8	0	22.8	22.66	1.03	
		26365	1882.5	3	1	22.8	0	22.8	22.54	1.06	
		26683	1914.3	3	1	22.8	0	22.8	22.36	1.11	
		26047	1850.7	3	3	22.8	0	22.8	22.55	1.06	
		26365	1882.5	3	3	22.8	0	22.8	22.43	1.09	
		26683	1914.3	3	3	22.8	0	22.8	22.25	1.14	
	26047	1850.7	6	0	22.8	1	21.8	21.50	1.07		
	26365	1882.5	6	0	22.8	1	21.8	21.38	1.10		
	26683	1914.3	6	0	22.8	1	21.8	21.20	1.15		
	26047	16QAM	26047	1850.7	1	0	22.8	1	21.8	21.36	1.11
	26365		1882.5	1	0	22.8	1	21.8	21.24	1.14	
	26683		1914.3	1	0	22.8	1	21.8	21.06	1.19	
	26047		1850.7	1	2	22.8	1	21.8	21.51	1.07	
	26365		1882.5	1	2	22.8	1	21.8	21.39	1.10	
	26683		1914.3	1	2	22.8	1	21.8	21.21	1.15	
	26047		1850.7	1	5	22.8	1	21.8	21.32	1.12	
	26365		1882.5	1	5	22.8	1	21.8	21.20	1.15	
	26683		1914.3	1	5	22.8	1	21.8	21.02	1.20	
	26047		1850.7	3	0	22.8	1	21.8	21.47	1.08	
	26365		1882.5	3	0	22.8	1	21.8	21.35	1.11	
	26683		1914.3	3	0	22.8	1	21.8	21.17	1.16	
	26047		1850.7	3	1	22.8	1	21.8	21.47	1.08	
	26365		1882.5	3	1	22.8	1	21.8	21.35	1.11	
	26683		1914.3	3	1	22.8	1	21.8	21.17	1.16	
26047	1850.7		3	3	22.8	1	21.8	21.44	1.09		
26365	1882.5		3	3	22.8	1	21.8	21.32	1.12		
26683	1914.3		3	3	22.8	1	21.8	21.14	1.16		
26047	1850.7	6	0	22.8	2	20.8	20.49	1.07			
26365	1882.5	6	0	22.8	2	20.8	20.37	1.10			
26683	1914.3	6	0	22.8	2	20.8	20.19	1.15			



FCC SAR Test Report

A D T

LTE Band 25										
BW	Modulation	CH	Frequency (MHz)	RB	RB Offset	Target Power	MPR	Expected Power	Measured Power	Scaling Factor
3 MHz	QPSK	26055	1851.5	1	0	22.8	0	22.8	22.71	1.02
		26365	1882.5	1	0	22.8	0	22.8	22.61	1.04
		26675	1913.5	1	0	22.8	0	22.8	22.43	1.09
		26055	1851.5	1	7	22.8	0	22.8	22.68	1.03
		26365	1882.5	1	7	22.8	0	22.8	22.58	1.05
		26675	1913.5	1	7	22.8	0	22.8	22.40	1.10
		26055	1851.5	1	14	22.8	0	22.8	22.64	1.04
		26365	1882.5	1	14	22.8	0	22.8	22.54	1.06
		26675	1913.5	1	14	22.8	0	22.8	22.36	1.11
		26055	1851.5	8	0	22.8	1	21.8	21.61	1.04
		26365	1882.5	8	0	22.8	1	21.8	21.51	1.07
		26675	1913.5	8	0	22.8	1	21.8	21.33	1.11
		26055	1851.5	8	3	22.8	1	21.8	21.46	1.08
		26365	1882.5	8	3	22.8	1	21.8	21.36	1.11
		26675	1913.5	8	3	22.8	1	21.8	21.18	1.15
		26055	1851.5	8	7	22.8	1	21.8	21.51	1.07
		26365	1882.5	8	7	22.8	1	21.8	21.41	1.09
		26675	1913.5	8	7	22.8	1	21.8	21.23	1.14
	26055	1851.5	15	0	22.8	1	21.8	21.43	1.09	
	26365	1882.5	15	0	22.8	1	21.8	21.33	1.11	
	26675	1913.5	15	0	22.8	1	21.8	21.15	1.16	
	16QAM	26055	1851.5	1	0	22.8	1	21.8	21.53	1.06
		26365	1882.5	1	0	22.8	1	21.8	21.43	1.09
		26675	1913.5	1	0	22.8	1	21.8	21.25	1.14
		26055	1851.5	1	7	22.8	1	21.8	21.48	1.08
		26365	1882.5	1	7	22.8	1	21.8	21.38	1.10
		26675	1913.5	1	7	22.8	1	21.8	21.20	1.15
		26055	1851.5	1	14	22.8	1	21.8	21.39	1.10
		26365	1882.5	1	14	22.8	1	21.8	21.29	1.12
		26675	1913.5	1	14	22.8	1	21.8	21.11	1.17
		26055	1851.5	8	0	22.8	2	20.8	20.57	1.05
		26365	1882.5	8	0	22.8	2	20.8	20.47	1.08
		26675	1913.5	8	0	22.8	2	20.8	20.29	1.12
		26055	1851.5	8	3	22.8	2	20.8	20.44	1.09
		26365	1882.5	8	3	22.8	2	20.8	20.34	1.11
		26675	1913.5	8	3	22.8	2	20.8	20.16	1.16
26055		1851.5	8	7	22.8	2	20.8	20.44	1.09	
26365		1882.5	8	7	22.8	2	20.8	20.34	1.11	
26675		1913.5	8	7	22.8	2	20.8	20.16	1.16	
26055	1851.5	15	0	22.8	2	20.8	20.45	1.08		
26365	1882.5	15	0	22.8	2	20.8	20.35	1.11		
26675	1913.5	15	0	22.8	2	20.8	20.17	1.16		



FCC SAR Test Report

A D T

LTE Band 25										
BW	Modulation	CH	Frequency (MHz)	RB	RB Offset	Target Power	MPR	Expected Power	Measured Power	Scaling Factor
5 MHz	QPSK	26065	1860	1	0	22.8	0	22.8	22.73	1.02
		26365	1882.5	1	0	22.8	0	22.8	22.61	1.04
		26665	1912.5	1	0	22.8	0	22.8	22.37	1.10
		26065	1860	1	12	22.8	0	22.8	22.66	1.03
		26365	1882.5	1	12	22.8	0	22.8	22.54	1.06
		26665	1912.5	1	12	22.8	0	22.8	22.30	1.12
		26065	1860	1	24	22.8	0	22.8	22.45	1.08
		26365	1882.5	1	24	22.8	0	22.8	22.33	1.11
		26665	1912.5	1	24	22.8	0	22.8	22.09	1.18
		26065	1860	12	0	22.8	1	21.8	21.48	1.08
		26365	1882.5	12	0	22.8	1	21.8	21.36	1.11
		26665	1912.5	12	0	22.8	1	21.8	21.12	1.17
		26065	1860	12	6	22.8	1	21.8	21.47	1.08
		26365	1882.5	12	6	22.8	1	21.8	21.35	1.11
		26665	1912.5	12	6	22.8	1	21.8	21.11	1.17
		26065	1860	12	13	22.8	1	21.8	21.40	1.10
		26365	1882.5	12	13	22.8	1	21.8	21.28	1.13
		26665	1912.5	12	13	22.8	1	21.8	21.04	1.19
	26065	1860	25	0	22.8	1	21.8	21.31	1.12	
	26365	1882.5	25	0	22.8	1	21.8	21.19	1.15	
	26665	1912.5	25	0	22.8	1	21.8	20.95	1.22	
	16QAM	26065	1860	1	0	22.8	1	21.8	21.55	1.06
		26365	1882.5	1	0	22.8	1	21.8	21.43	1.09
		26665	1912.5	1	0	22.8	1	21.8	21.19	1.15
		26065	1860	1	12	22.8	1	21.8	21.50	1.07
		26365	1882.5	1	12	22.8	1	21.8	21.38	1.10
		26665	1912.5	1	12	22.8	1	21.8	21.14	1.16
		26065	1860	1	24	22.8	1	21.8	21.37	1.10
		26365	1882.5	1	24	22.8	1	21.8	21.25	1.14
		26665	1912.5	1	24	22.8	1	21.8	21.01	1.20
		26065	1860	12	0	22.8	2	20.8	20.51	1.07
		26365	1882.5	12	0	22.8	2	20.8	20.39	1.10
		26665	1912.5	12	0	22.8	2	20.8	20.15	1.16
		26065	1860	12	6	22.8	2	20.8	20.54	1.06
		26365	1882.5	12	6	22.8	2	20.8	20.42	1.09
		26665	1912.5	12	6	22.8	2	20.8	20.18	1.15
26065		1860	12	13	22.8	2	20.8	20.44	1.09	
26365		1882.5	12	13	22.8	2	20.8	20.32	1.12	
26665		1912.5	12	13	22.8	2	20.8	20.08	1.18	
26065	1860	25	0	22.8	2	20.8	20.31	1.12		
26365	1882.5	25	0	22.8	2	20.8	20.19	1.15		
26665	1912.5	25	0	22.8	2	20.8	19.95	1.22		



FCC SAR Test Report

LTE Band 25										
BW	Modulation	CH	Frequency (MHz)	RB	RB Offset	Target Power	MPR	Expected Power	Measured Power	Scaling Factor
10 MHz	QPSK	26090	1855	1	0	22.8	0	22.8	22.75	1.01
		26365	1882.5	1	0	22.8	0	22.8	22.57	1.05
		26640	1910	1	0	22.8	0	22.8	22.50	1.07
		26090	1855	1	24	22.8	0	22.8	22.69	1.03
		26365	1882.5	1	24	22.8	0	22.8	22.51	1.07
		26640	1910	1	24	22.8	0	22.8	22.44	1.09
		26090	1855	1	49	22.8	0	22.8	22.60	1.05
		26365	1882.5	1	49	22.8	0	22.8	22.42	1.09
		26640	1910	1	49	22.8	0	22.8	22.35	1.11
		26090	1855	25	0	22.8	1	21.8	21.41	1.09
		26365	1882.5	25	0	22.8	1	21.8	21.23	1.14
		26640	1910	25	0	22.8	1	21.8	21.16	1.16
		26090	1855	25	12	22.8	1	21.8	21.44	1.09
		26365	1882.5	25	12	22.8	1	21.8	21.26	1.13
		26640	1910	25	12	22.8	1	21.8	21.19	1.15
		26090	1855	25	25	22.8	1	21.8	21.38	1.10
		26365	1882.5	25	25	22.8	1	21.8	21.20	1.15
		26640	1910	25	25	22.8	1	21.8	21.13	1.17
	26090	1855	50	0	22.8	1	21.8	21.30	1.12	
	26365	1882.5	50	0	22.8	1	21.8	21.12	1.17	
	26640	1910	50	0	22.8	1	21.8	21.05	1.19	
	16QAM	26090	1855	1	0	22.8	1	21.8	21.59	1.05
		26365	1882.5	1	0	22.8	1	21.8	21.41	1.09
		26640	1910	1	0	22.8	1	21.8	21.34	1.11
		26090	1855	1	24	22.8	1	21.8	21.49	1.07
		26365	1882.5	1	24	22.8	1	21.8	21.31	1.12
		26640	1910	1	24	22.8	1	21.8	21.24	1.14
		26090	1855	1	49	22.8	1	21.8	21.41	1.09
		26365	1882.5	1	49	22.8	1	21.8	21.23	1.14
		26640	1910	1	49	22.8	1	21.8	21.16	1.16
		26090	1855	25	0	22.8	2	20.8	20.38	1.10
		26365	1882.5	25	0	22.8	2	20.8	20.20	1.15
		26640	1910	25	0	22.8	2	20.8	20.13	1.17
		26090	1855	25	12	22.8	2	20.8	20.42	1.09
		26365	1882.5	25	12	22.8	2	20.8	20.24	1.14
		26640	1910	25	12	22.8	2	20.8	20.17	1.16
26090		1855	25	25	22.8	2	20.8	20.40	1.10	
26365		1882.5	25	25	22.8	2	20.8	20.22	1.14	
26640		1910	25	25	22.8	2	20.8	20.15	1.16	
26090	1855	50	0	22.8	2	20.8	20.32	1.12		
26365	1882.5	50	0	22.8	2	20.8	20.14	1.16		
26640	1910	50	0	22.8	2	20.8	20.07	1.18		



FCC SAR Test Report

A D T

LTE Band 25										
BW	Modulation	CH	Frequency (MHz)	RB	RB Offset	Target Power	MPR	Expected Power	Measured Power	Scaling Factor
15 MHz	QPSK	26115	1857.5	1	0	22.8	0	22.8	22.76	1.01
		26365	1882.5	1	0	22.8	0	22.8	22.60	1.05
		26615	1907.5	1	0	22.8	0	22.8	22.45	1.08
		26115	1857.5	1	37	22.8	0	22.8	22.76	1.01
		26365	1882.5	1	37	22.8	0	22.8	22.60	1.05
		26615	1907.5	1	37	22.8	0	22.8	22.45	1.08
		26115	1857.5	1	74	22.8	0	22.8	22.72	1.02
		26365	1882.5	1	74	22.8	0	22.8	22.56	1.06
		26615	1907.5	1	74	22.8	0	22.8	22.41	1.09
		26115	1857.5	36	0	22.8	1	21.8	21.48	1.08
		26365	1882.5	36	0	22.8	1	21.8	21.32	1.12
		26615	1907.5	36	0	22.8	1	21.8	21.17	1.16
		26115	1857.5	36	19	22.8	1	21.8	21.56	1.06
		26365	1882.5	36	19	22.8	1	21.8	21.40	1.10
		26615	1907.5	36	19	22.8	1	21.8	21.25	1.14
		26115	1857.5	36	39	22.8	1	21.8	21.44	1.09
		26365	1882.5	36	39	22.8	1	21.8	21.28	1.13
		26615	1907.5	36	39	22.8	1	21.8	21.13	1.17
	26115	1857.5	75	0	22.8	1	21.8	21.33	1.11	
	26365	1882.5	75	0	22.8	1	21.8	21.17	1.16	
	26615	1907.5	75	0	22.8	1	21.8	21.02	1.20	
	16QAM	26115	1857.5	1	0	22.8	1	21.8	21.58	1.05
		26365	1882.5	1	0	22.8	1	21.8	21.42	1.09
		26615	1907.5	1	0	22.8	1	21.8	21.27	1.13
		26115	1857.5	1	37	22.8	1	21.8	21.62	1.04
		26365	1882.5	1	37	22.8	1	21.8	21.46	1.08
		26615	1907.5	1	37	22.8	1	21.8	21.31	1.12
		26115	1857.5	1	74	22.8	1	21.8	21.45	1.08
		26365	1882.5	1	74	22.8	1	21.8	21.29	1.12
		26615	1907.5	1	74	22.8	1	21.8	21.14	1.16
		26115	1857.5	36	0	22.8	2	20.8	20.41	1.09
		26365	1882.5	36	0	22.8	2	20.8	20.25	1.14
		26615	1907.5	36	0	22.8	2	20.8	20.10	1.17
		26115	1857.5	36	19	22.8	2	20.8	20.38	1.10
		26365	1882.5	36	19	22.8	2	20.8	20.22	1.14
		26615	1907.5	36	19	22.8	2	20.8	20.07	1.18
26115		1857.5	36	39	22.8	2	20.8	20.44	1.09	
26365		1882.5	36	39	22.8	2	20.8	20.28	1.13	
26615		1907.5	36	39	22.8	2	20.8	20.13	1.17	
26115	1857.5	75	0	22.8	2	20.8	20.37	1.10		
26365	1882.5	75	0	22.8	2	20.8	20.21	1.15		
26615	1907.5	75	0	22.8	2	20.8	20.06	1.19		



FCC SAR Test Report

A D T

LTE Band 25										
BW	Modulation	CH	Frequency (MHz)	RB	RB Offset	Target Power	MPR	Expected Power	Measured Power	Scaling Factor
20 MHz	QPSK	26140	1860	1	0	22.8	0	22.8	22.72	1.02
		26365	1882.5	1	0	22.8	0	22.8	22.67	1.03
		26590	1905	1	0	22.8	0	22.8	22.63	1.04
		26140	1860	1	50	22.8	0	22.8	22.79	1.00
		26365	1882.5	1	50	22.8	0	22.8	22.74	1.01
		26590	1905	1	50	22.8	0	22.8	22.70	1.02
		26140	1860	1	99	22.8	0	22.8	22.64	1.04
		26365	1882.5	1	99	22.8	0	22.8	22.59	1.05
		26590	1905	1	99	22.8	0	22.8	22.55	1.06
		26140	1860	50	0	22.8	1	21.8	21.47	1.08
		26365	1882.5	50	0	22.8	1	21.8	21.42	1.09
		26590	1905	50	0	22.8	1	21.8	21.38	1.10
		26140	1860	50	25	22.8	1	21.8	21.47	1.08
		26365	1882.5	50	25	22.8	1	21.8	21.42	1.09
		26590	1905	50	25	22.8	1	21.8	21.38	1.10
		26140	1860	50	50	22.8	1	21.8	21.51	1.07
		26365	1882.5	50	50	22.8	1	21.8	21.46	1.08
		26590	1905	50	50	22.8	1	21.8	21.42	1.09
		26140	1860	100	0	22.8	1	21.8	21.53	1.06
		26365	1882.5	100	0	22.8	1	21.8	21.48	1.08
	26590	1905	100	0	22.8	1	21.8	21.44	1.09	
	16QAM	26140	1860	1	0	22.8	1	21.8	21.61	1.04
		26365	1882.5	1	0	22.8	1	21.8	21.56	1.06
		26590	1905	1	0	22.8	1	21.8	21.52	1.07
		26140	1860	1	50	22.8	1	21.8	21.74	1.01
		26365	1882.5	1	50	22.8	1	21.8	21.69	1.03
		26590	1905	1	50	22.8	1	21.8	21.65	1.04
		26140	1860	1	99	22.8	1	21.8	21.62	1.04
		26365	1882.5	1	99	22.8	1	21.8	21.57	1.05
		26590	1905	1	99	22.8	1	21.8	21.53	1.06
26140		1860	50	0	22.8	2	20.8	20.48	1.08	
26365	1882.5	50	0	22.8	2	20.8	20.43	1.09		
26590	1905	50	0	22.8	2	20.8	20.39	1.10		
26140	1860	50	25	22.8	2	20.8	20.47	1.08		
26365	1882.5	50	25	22.8	2	20.8	20.42	1.09		
26590	1905	50	25	22.8	2	20.8	20.38	1.10		
26140	1860	50	50	22.8	2	20.8	20.46	1.08		
26365	1882.5	50	50	22.8	2	20.8	20.41	1.09		
26590	1905	50	50	22.8	2	20.8	20.37	1.10		
26140	1860	100	0	22.8	2	20.8	20.44	1.09		
26365	1882.5	100	0	22.8	2	20.8	20.39	1.10		
26590	1905	100	0	22.8	2	20.8	20.35	1.11		



FCC SAR Test Report

4.6 SAR Testing Results

4.6.1 SAR Results for Body

Plot No.	Band	Mode	Test Position	Separation Distance (cm)	Channel	Conducted Power (dBm)	Power Drift (dB)	SAR-1g (W/kg)
1	WCDMA II	RMC12.2K	Front Face	0.5	9400	22.93	-0.06	0.439
2	WCDMA II	RMC12.2K	Rear Face	0.5	9400	22.93	-0.05	0.652
3	WCDMA II	RMC12.2K	Left Side	0.5	9400	22.93	-0.18	0.273
4	WCDMA II	RMC12.2K	Right Side	0.5	9400	22.93	0.03	0.291
5	WCDMA II	RMC12.2K	Top Side	0.5	9400	22.93	0.13	0.119
7	WCDMA IV	RMC12.2K	Front Face	0.5	1513	23.02	0.03	0.515
8	WCDMA IV	RMC12.2K	Rear Face	0.5	1513	23.02	-0.07	0.66
9	WCDMA IV	RMC12.2K	Left Side	0.5	1513	23.02	0.09	0.273
10	WCDMA IV	RMC12.2K	Right Side	0.5	1513	23.02	-0.02	0.226
11	WCDMA IV	RMC12.2K	Top Side	0.5	1513	23.02	0.08	0.119
13	WCDMA V	RMC12.2K	Front Face	0.5	4132	22.18	-0.04	0.08
14	WCDMA V	RMC12.2K	Rear Face	0.5	4132	22.18	0.05	0.042
15	WCDMA V	RMC12.2K	Left Side	0.5	4132	22.18	0.133	0.021
16	WCDMA V	RMC12.2K	Right Side	0.5	4132	22.18	0.13	0.026
17	WCDMA V	RMC12.2K	Top Side	0.5	4132	22.18	-0.02	0.029
101	802.11b	-	Front Face	0.5	11	14.09	0.10	0.206
102	802.11b	-	Rear Face	0.5	11	14.09	-0.15	0.064
103	802.11b	-	Left Side	0.5	11	14.09	-0.16	0.168

Plot No.	Band	Mode	Test Position	Separation Distance (cm)	Channel	RB#	RB Offset	Conducted Power (dBm)	Power Drift (dB)	Measured SAR-1g (W/kg)	Scaling Factor	Scaled SAR-1g (W/kg)
234	LTE 2	QPSK_20M	Front Face	0.5	18700	1	50	22.85	-0.17	0.68	1.01	0.687
201	LTE 2	QPSK_20M	Rear Face	0.5	18700	1	50	22.85	-0.12	0.524	1.01	0.529
235	LTE 2	QPSK_20M	Left Side	0.5	18700	1	50	22.85	-0.19	0.242	1.01	0.244
236	LTE 2	QPSK_20M	Right Side	0.5	18700	1	50	22.85	-0.04	0.21	1.01	0.212
237	LTE 2	QPSK_20M	Top Side	0.5	18700	1	50	22.85	-0.04	0.1	1.01	0.101
245	LTE 2	QPSK_20M	Front Face	0.5	18700	50	0	21.51	-0.03	0.566	1.09	0.617
246	LTE 2	QPSK_20M	Rear Face	0.5	18700	50	0	21.51	-0.01	0.421	1.09	0.459
247	LTE 2	QPSK_20M	Left Side	0.5	18700	50	0	21.51	-0.00	0.198	1.09	0.216
248	LTE 2	QPSK_20M	Right Side	0.5	18700	50	0	21.51	0.02	0.169	1.09	0.184
249	LTE 2	QPSK_20M	Top Side	0.5	18700	50	0	21.51	0.01	0.067	1.09	0.073
263	LTE 4	QPSK_20M	Front Face	0.5	20050	1	0	22.60	-0.18	0.326	1.00	0.326
264	LTE 4	QPSK_20M	Rear Face	0.5	20050	1	0	22.60	-0.16	0.546	1.00	0.546
265	LTE 4	QPSK_20M	Left Side	0.5	20050	1	0	22.60	-0.13	0.134	1.00	0.134
266	LTE 4	QPSK_20M	Right Side	0.5	20050	1	0	22.60	0.09	0.096	1.00	0.096
267	LTE 4	QPSK_20M	Top Side	0.5	20050	1	0	22.60	-0.049	0.065	1.00	0.065
281	LTE 4	QPSK_20M	Front Face	0.5	20050	50	0	21.16	0.10	0.227	1.11	0.252
282	LTE 4	QPSK_20M	Rear Face	0.5	20050	50	0	21.16	0.14	0.381	1.11	0.423
283	LTE 4	QPSK_20M	Left Side	0.5	20050	50	0	21.16	0.02	0.092	1.11	0.102
284	LTE 4	QPSK_20M	Right Side	0.5	20050	50	0	21.16	0.12	0.07	1.11	0.078
285	LTE 4	QPSK_20M	Top Side	0.5	20050	50	0	21.16	0.10	0.043	1.11	0.048



FCC SAR Test Report

Plot No.	Band	Mode	Test Position	Separation Distance (cm)	Channel	RB#	RB Offset	Conducted Power (dBm)	Power Drift (dB)	Measured SAR-1g (W/kg)	Scaling Factor	Scaled SAR-1g (W/kg)
316	LTE 12	QPSK_10M	Front Face	0.5	23060	1	24	22.50	-0.16	0.55	1.00	0.550
317	LTE 12	QPSK_10M	Rear Face	0.5	23060	1	24	22.50	-0.13	0.218	1.00	0.218
318	LTE 12	QPSK_10M	Left Side	0.5	23060	1	24	22.50	-0.05	0.076	1.00	0.076
319	LTE 12	QPSK_10M	Right Side	0.5	23060	1	24	22.50	-0.14	0.265	1.00	0.265
320	LTE 12	QPSK_10M	Top Side	0.5	23060	1	24	22.50	-0.01	0.115	1.00	0.115
321	LTE 12	QPSK_10M	Front Face	0.5	23060	25	0	20.95	-0.02	0.372	1.14	0.424
322	LTE 12	QPSK_10M	Rear Face	0.5	23060	25	0	20.95	-0.09	0.177	1.14	0.202
323	LTE 12	QPSK_10M	Left Side	0.5	23060	25	0	20.95	0.04	0.05	1.14	0.057
324	LTE 12	QPSK_10M	Right Side	0.5	23060	25	0	20.95	-0.03	0.18	1.14	0.205
325	LTE 12	QPSK_10M	Top Side	0.5	23060	25	0	20.95	0.02	0.087	1.14	0.099
204	LTE 17	QPSK_10M	Front Face	0.5	23780	1	0	22.50	0.02	0.547	1.00	0.547
205	LTE 17	QPSK_10M	Rear Face	0.5	23780	1	0	22.50	0.01	0.222	1.00	0.222
206	LTE 17	QPSK_10M	Left Side	0.5	23780	1	0	22.50	-0.15	0.105	1.00	0.105
207	LTE 17	QPSK_10M	Right Side	0.5	23780	1	0	22.50	-0.01	0.174	1.00	0.174
208	LTE 17	QPSK_10M	Top Side	0.5	23780	1	0	22.50	-0.07	0.131	1.00	0.131
210	LTE 17	QPSK_10M	Front Face	0.5	23790	25	0	21.47	-0.06	0.407	1.01	0.411
211	LTE 17	QPSK_10M	Rear Face	0.5	23790	25	0	21.47	0.14	0.132	1.01	0.133
212	LTE 17	QPSK_10M	Left Side	0.5	23790	25	0	21.47	0.16	0.071	1.01	0.072
213	LTE 17	QPSK_10M	Right Side	0.5	23790	25	0	21.47	-0.02	0.148	1.01	0.149
214	LTE 17	QPSK_10M	Top Side	0.5	23790	25	0	21.47	-0.18	0.089	1.01	0.090
306	LTE 25	QPSK_20M	Front Face	0.5	26140	1	50	22.79	-0.17	0.704	1.00	0.704
307	LTE 25	QPSK_20M	Rear Face	0.5	26140	1	50	22.79	0.01	0.634	1.00	0.634
308	LTE 25	QPSK_20M	Left Side	0.5	26140	1	50	22.79	-0.02	0.283	1.00	0.283
309	LTE 25	QPSK_20M	Right Side	0.5	26140	1	50	22.79	-0.07	0.232	1.00	0.232
310	LTE 25	QPSK_20M	Top Side	0.5	26140	1	50	22.79	0.11	0.106	1.00	0.106
311	LTE 25	QPSK_20M	Front Face	0.5	26140	50	50	21.51	0.06	0.512	1.07	0.548
312	LTE 25	QPSK_20M	Rear Face	0.5	26140	50	50	21.51	0.05	0.477	1.07	0.510
313	LTE 25	QPSK_20M	Left Side	0.5	26140	50	50	21.51	0.07	0.212	1.07	0.227
314	LTE 25	QPSK_20M	Right Side	0.5	26140	50	50	21.51	0.01	0.17	1.07	0.182
315	LTE 25	QPSK_20M	Top Side	0.5	26140	50	50	21.51	0.13	0.08	1.07	0.086

Note:

- SAR is performed on the highest power channel. When the SAR value of highest power channel is less than 0.8 W/kg, SAR testing for optional channel is not required.
- According to KDB 941225, LTE SAR testing of the remaining RB offset configurations and required test channels is not required when the reported SAR of highest power 1RB configuration is less than 0.8 W/kg.
- According to KDB 941225, LTE SAR testing of the remaining RB offset configurations and required test channels is not required when the reported SAR of highest power 50% RB configuration is less than 0.8 W/kg.
- According to KDB 941225, LTE SAR testing for 100% RB is not required when the maximum power of 100% RB is less than the maximum power of 1RB and 50% RB and the highest reported SAR for 1RB and 50% RB is less than 0.8 W/kg.
- According to KDB 941225, LTE SAR testing for 100% RB is not required when the maximum power of 100% RB is less than the maximum power of 1RB and 50% RB and the highest reported SAR for 1RB and 50% RB is less than 0.8 W/kg.
- According to KDB 941225, LTE SAR testing for 16QAM is not required when the maximum power of 16QAM is less 1/2 dB higher than QPSK and the highest reported SAR of QPSK is less than 1.45 W/kg.
- According to KDB 941225, LTE SAR testing for smaller channel bandwidth is not required when the maximum power of smaller channel bandwidth is less 1/2 dB higher than largest channel bandwidth and the highest reported SAR of largest channel bandwidth is less than 1.45 W/kg.
- SAR testing for 802.11g/n is not required because its maximum power is less than 1/4 dB higher than 802.11b.

Test Engineer : Hank Wu, and Isaac Liao

4.6.2 Simultaneous Multi-band Transmission Evaluation

No.	Conditions (SAR1 + SAR2)	Mode	Position	Max. SAR1	Max. SAR2	SAR Summation	SPLSR
1	WCDMA II + WLAN	Body	Front Face	0.439	0.206	0.645	-
			Rear Face	0.652	0.064	0.716	-
			Left Side	0.273	0.168	0.441	-
			Right Side	0.291	0	0.291	-
			Top Side	0.119	0	0.119	-
			Bottom Side	0	0	0	-
2	WCDMA IV + WLAN	Body	Front Face	0.515	0.206	0.721	-
			Rear Face	0.66	0.064	0.724	-
			Left Side	0.273	0.168	0.441	-
			Right Side	0.226	0	0.226	-
			Top Side	0.119	0	0.119	-
			Bottom Side	0	0	0	-
3	WCDMA V + WLAN	Body	Front Face	0.08	0.206	0.286	-
			Rear Face	0.042	0.064	0.106	-
			Left Side	0.021	0.168	0.189	-
			Right Side	0.026	0	0.026	-
			Top Side	0.029	0	0.029	-
			Bottom Side	0	0	0	-
4	LTE 2 + WLAN	Body	Front Face	0.687	0.206	0.893	-
			Rear Face	0.529	0.064	0.593	-
			Left Side	0.244	0.168	0.412	-
			Right Side	0.212	0	0.212	-
			Top Side	0.101	0	0.101	-
			Bottom Side	0	0	0	-
5	LTE 4 + WLAN	Body	Front Face	0.326	0.206	0.532	-
			Rear Face	0.546	0.064	0.61	-
			Left Side	0.134	0.168	0.302	-
			Right Side	0.096	0	0.096	-
			Top Side	0.065	0	0.065	-
			Bottom Side	0	0	0	-
6	LTE 12 + WLAN	Body	Front Face	0.55	0.206	0.756	-
			Rear Face	0.218	0.064	0.282	-
			Left Side	0.076	0.168	0.244	-
			Right Side	0.265	0	0.265	-
			Top Side	0.115	0	0.115	-
			Bottom Side	0	0	0	-
7	LTE 17 + WLAN	Body	Front Face	0.547	0.206	0.753	-
			Rear Face	0.222	0.064	0.286	-
			Left Side	0.105	0.168	0.273	-
			Right Side	0.174	0	0.174	-
			Top Side	0.131	0	0.131	-
			Bottom Side	0	0	0	-
8	LTE 25 + WLAN	Body	Front Face	0.704	0.206	0.91	-
			Rear Face	0.634	0.064	0.698	-
			Left Side	0.283	0.168	0.451	-
			Right Side	0.232	0	0.232	-
			Top Side	0.106	0	0.106	-
			Bottom Side	0	0	0	-

Note:

1. The maximum SAR summation is calculated based on the same configuration and test position.



FCC SAR Test Report

A D T

Summary:

Since all the SAR summations are less than 1.6 W/kg, the simultaneous transmission SAR for WWAN/WLAN is not required.



5. Calibration of Test Equipment

Equipment	Manufacturer	Model	SN	Cal. Date	Cal. Interval
System Validation Kit	SPEAG	D750V3	1013	Apr. 25, 2012	Annual
System Validation Kit	SPEAG	D835V2	4d021	Apr. 20, 2012	Annual
System Validation Kit	SPEAG	D1750V2	1055	Aug. 23, 2012	Annual
System Validation Kit	SPEAG	D1900V2	5d036	Jan. 26, 2012	Annual
System Validation Kit	SPEAG	D2450V2	737	Jan. 24, 2012	Annual
Dosimetric E-Field Probe	SPEAG	EX3DV4	3578	Jun. 21, 2012	Annual
Dosimetric E-Field Probe	SPEAG	EX3DV4	3590	Feb. 23, 2012	Annual
Dosimetric E-Field Probe	SPEAG	EX3DV4	3864	Jul. 19, 2012	Annual
Data Acquisition Electronics	SPEAG	DAE4	861	Aug. 23, 2012	Annual
Data Acquisition Electronics	SPEAG	DAE4	915	Jun. 21, 2012	Annual
Data Acquisition Electronics	SPEAG	DAE4	1277	Jul. 19, 2012	Annual
SAM Phantom	SPEAG	QD000P40CD	TP-1127	N/A	N/A
SAM Phantom	SPEAG	QD000P40CD	TP-1496	N/A	N/A
ELI Phantom	SPEAG	QDOVA001B	TP-1043	N/A	N/A
Radio Communication Tester	Agilent	E5515C	MY50260642	Nov. 02, 2012	Annual
Radio Communication Analyzer	Anritsu	MT8820C	6201010284	Aug. 18, 2012	Biennial
LTE Communication Tester	R&S	CMW500	120658	Apr. 11, 2012	Biennial
ENA Series Network Analyzer	Agilent	E5071C	MY46214281	May 14, 2012	Annual
MXG Analog Signal Generator	Agilent	N5181A	MY50143868	May 06, 2012	Annual
Power Meter	Anritsu	ML2495A	1218009	May 07, 2012	Annual
Power Sensor	Anritsu	MA2411B	1207252	May 07, 2012	Annual
EXA Spectrum Analyzer	Agilent	N9010A	MY52100136	Apr. 23, 2012	Annual
Dielectric Probe Kit	Agilent	85070D	E2-020018	May 14, 2012	Annual
Thermometer	YFE	YF-160A	110600361	Feb. 21, 2012	Annual
Directional Coupler	Woken	0110A05602O-10	11122702	Apr. 19, 2012	Annual
Power Amplifier	AR	5S1G4	0339656	Apr. 23, 2012	Annual
Power Amplifier	Mini-Circuit	ZVE-8G	001000422	Apr. 23, 2012	Annual
Attenuator	Woken	00800A1G01L-03	N/A	Apr. 19, 2012	Annual

6. Measurement Uncertainty

Error Description	Uncertainty Value (±%)	Probability Distribution	Divisor	Ci (1g)	Standard Uncertainty (1g)	Vi
Measurement System						
Probe Calibration	6.0	Normal	1	1	± 6.0 %	∞
Axial Isotropy	4.7	Rectangular	√3	0.7	± 1.9 %	∞
Hemispherical Isotropy	9.6	Rectangular	√3	0.7	± 3.9 %	∞
Boundary Effects	1.0	Rectangular	√3	1	± 0.6 %	∞
Linearity	4.7	Rectangular	√3	1	± 2.7 %	∞
System Detection Limits	1.0	Rectangular	√3	1	± 0.6 %	∞
Readout Electronics	0.6	Normal	1	1	± 0.6 %	∞
Response Time	0.0	Rectangular	√3	1	± 0.0 %	∞
Integration Time	1.7	Rectangular	√3	1	± 1.0 %	∞
RF Ambient Noise	3.0	Rectangular	√3	1	± 1.7 %	∞
RF Ambient Reflections	3.0	Rectangular	√3	1	± 1.7 %	∞
Probe Positioner	0.5	Rectangular	√3	1	± 0.3 %	∞
Probe Positioning	2.9	Rectangular	√3	1	± 1.7 %	∞
Max. SAR Eval.	2.3	Rectangular	√3	1	± 1.3 %	∞
Test Sample Related						
Device Positioning	3.9	Normal	1	1	± 3.9 %	31
Device Holder	2.7	Normal	1	1	± 2.7 %	19
Power Drift	5.0	Rectangular	√3	1	± 2.9 %	∞
Phantom and Setup						
Phantom Uncertainty	4.0	Rectangular	√3	1	± 2.3 %	∞
Liquid Conductivity (Target)	5.0	Rectangular	√3	0.64	± 1.8 %	∞
Liquid Conductivity (Meas.)	5.0	Normal	1	0.64	± 3.2 %	29
Liquid Permittivity (Target)	5.0	Rectangular	√3	0.6	± 1.7 %	∞
Liquid Permittivity (Meas.)	5.0	Normal	1	0.6	± 3.0 %	29
Combined Standard Uncertainty					± 11.7 %	
Expanded Uncertainty (K=2)					± 23.4 %	

Uncertainty budget for frequency range 300 MHz to 3 GHz



7. Information on the Testing Laboratories

We, Bureau Veritas Consumer Products Services (H.K.) Ltd., Taoyuan Branch, were founded in 1988 to provide our best service in EMC, Radio, Telecom and Safety consultation. Our laboratories are accredited and approved according to ISO/IEC 17025.

If you have any comments, please feel free to contact us at the following:

Taiwan HwaYa EMC/RF/Safety/Telecom Lab:

Add: No. 19, Hwa Ya 2nd Rd, Wen Hwa Vil., Kwei Shan Hsiang, Taoyuan Hsien 333, Taiwan, R.O.C.
Tel: 886-3-318-3232
Fax: 886-3-327-0892

Taiwan LinKo EMC/RF Lab:

Add: No. 47, 14th Ling, Chia Pau Vil., Linkou Dist., New Taipei City 244, Taiwan, R.O.C.
Tel: 886-2-2605-2180
Fax: 886-2-2605-1924

Taiwan HsinChu EMC/RF Lab:

Add: No. 81-1, Lu Liao Keng, 9th Ling, Wu Lung Vil., Chiung Lin Township, Hsinchu County 307, Taiwan, R.O.C.
Tel: 886-3-593-5343
Fax: 886-3-593-5342

Email: service.adt@tw.bureauveritas.com

Web Site: www.adt.com.tw

The road map of all our labs can be found in our web site also.

---END---



Appendix A. SAR Plots of System Verification

The plots for system verification are shown as follows.

System Check_B750_121113

DUT: Dipole 750 MHz; Type: D750V3; SN: 1013

Communication System: CW; Frequency: 750 MHz; Duty Cycle: 1:1

Medium: B750_1113 Medium parameters used: $f = 750$ MHz; $\sigma = 0.965$ mho/m; $\epsilon_r = 55.172$; $\rho = 1000$ kg/m³

Ambient Temperature : 21.8 °C; Liquid Temperature : 20.5 °C

DASY5 Configuration:

- Probe: EX3DV4 - SN3578; ConvF(8.52, 8.52, 8.52); Calibrated: 2012/06/21;
- Sensor-Surface: 2mm (Mechanical Surface Detection)
- Electronics: DAE4 Sn1277; Calibrated: 2012/07/19
- Phantom: SAM Phantom_right; Type: QD000P40CC; Serial: TP:1496
- Measurement SW: DASY52, Version 52.8 (2); SEMCAD X Version 14.6.6 (6824)

Pin=250mW/Area Scan (61x131x1): Measurement grid: dx=15mm, dy=15mm

Maximum value of SAR (interpolated) = 2.66 W/kg

Pin=250mW/Zoom Scan (5x5x7)/Cube 0: Measurement grid: dx=8mm, dy=8mm, dz=5mm

Reference Value = 53.890 V/m; Power Drift = -0.01 dB

Peak SAR (extrapolated) = 3.118 mW/g

SAR(1 g) = 2.16 mW/g; SAR(10 g) = 1.45 mW/g

Maximum value of SAR (measured) = 2.69 W/kg

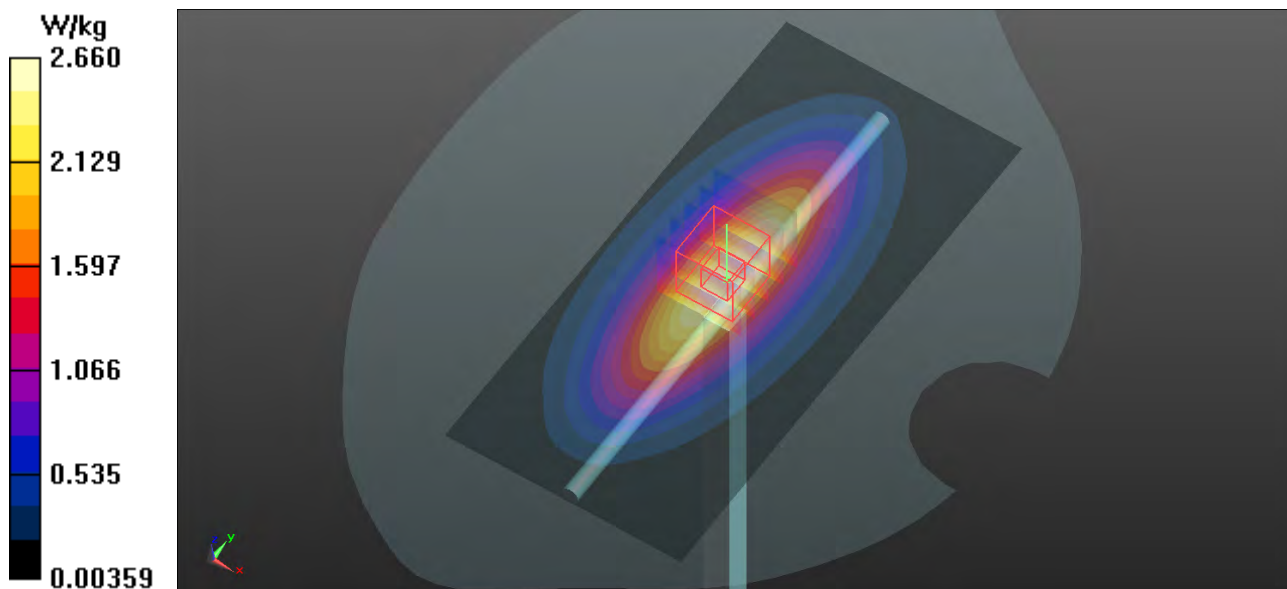

System Check_B835_121113

DUT: Dipole 835 MHz; Type: D835V2; SN: 4d021

Communication System: CW; Frequency: 835 MHz; Duty Cycle: 1:1

Medium: B835_1113 Medium parameters used: $f = 835$ MHz; $\sigma = 0.993$ mho/m; $\epsilon_r = 56.69$; $\rho = 1000$ kg/m³

Ambient Temperature : 21.9 °C; Liquid Temperature : 20.7 °C

DASY5 Configuration:

- Probe: EX3DV4 - SN3578; ConvF(8.45, 8.45, 8.45); Calibrated: 2012/06/21;
- Sensor-Surface: 2mm (Mechanical Surface Detection)
- Electronics: DAE4 Sn1277; Calibrated: 2012/07/19
- Phantom: SAM Phantom_right; Type: QD000P40CC; Serial: TP:1496
- Measurement SW: DASY52, Version 52.8 (2); SEMCAD X Version 14.6.6 (6824)

Pin=250mW/Area Scan (61x61x1): Measurement grid: dx=15mm, dy=15mm

Maximum value of SAR (interpolated) = 3.06 W/kg

Pin=250mW/Zoom Scan (5x5x7)/Cube 0: Measurement grid: dx=8mm, dy=8mm, dz=5mm

Reference Value = 53.600 V/m; Power Drift = -0.01 dB

Peak SAR (extrapolated) = 3.580 mW/g

SAR(1 g) = 2.42 mW/g; SAR(10 g) = 1.59 mW/g

Maximum value of SAR (measured) = 3.07 W/kg

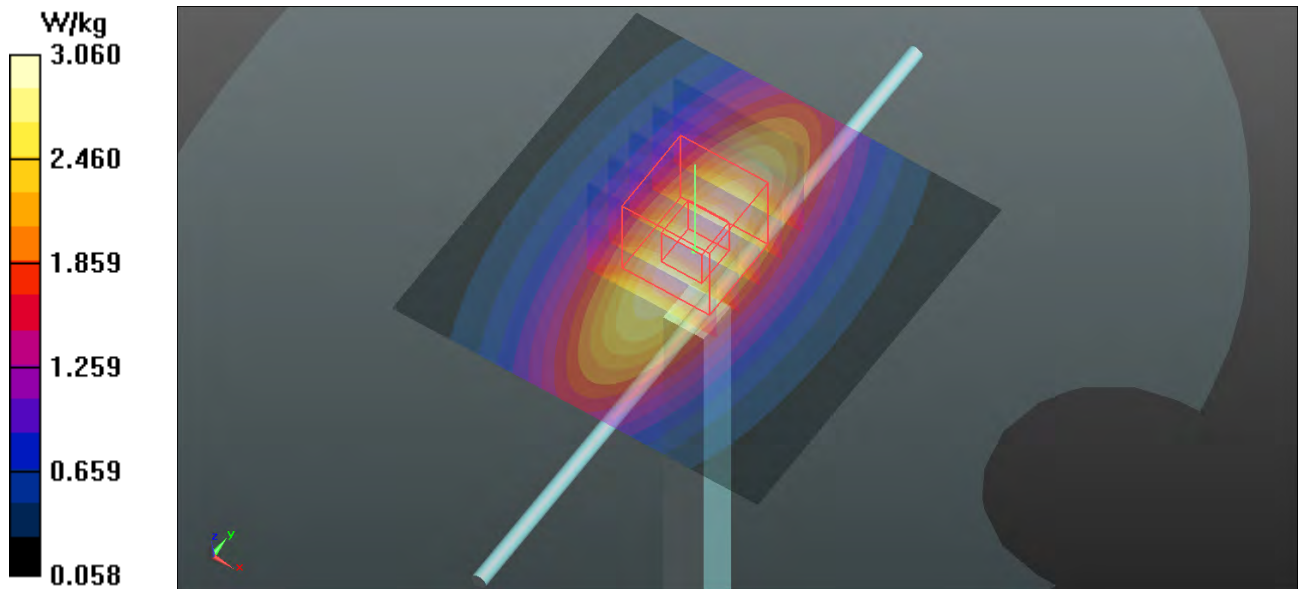

System Check_B1750_121107

DUT: Dipole 1750 MHz; Type: D1750V2; SN: 1055

Communication System: CW; Frequency: 1750 MHz; Duty Cycle: 1:1

Medium: B1750_1107 Medium parameters used: $f = 1750$ MHz; $\sigma = 1.469$ mho/m; $\epsilon_r = 53.127$; $\rho = 1000$ kg/m³

Ambient Temperature : 21.5 °C ; Liquid Temperature : 20.6 °C

DASY5 Configuration:

- Probe: EX3DV4 - SN3590; ConvF(8.64, 8.64, 8.64); Calibrated: 2012/02/23;
- Sensor-Surface: 2mm (Mechanical Surface Detection)
- Electronics: DAE4 Sn861; Calibrated: 2012/08/23
- Phantom: ELI v4.0; Type: QDOVA001BA; Serial: TP:1043
- Measurement SW: DASY52, Version 52.8 (2); SEMCAD X Version 14.6.6 (6824)

Pin=250mW/Area Scan (61x61x1): Measurement grid: dx=15mm, dy=15mm

Maximum value of SAR (interpolated) = 13.0 W/kg

Pin=250mW/Zoom Scan (5x5x7)/Cube 0: Measurement grid: dx=8mm, dy=8mm, dz=5mm

Reference Value = 95.114 V/m; Power Drift = 0.02 dB

Peak SAR (extrapolated) = 15.669 mW/g

SAR(1 g) = 9.09 mW/g; SAR(10 g) = 4.91 mW/g

Maximum value of SAR (measured) = 12.6 W/kg

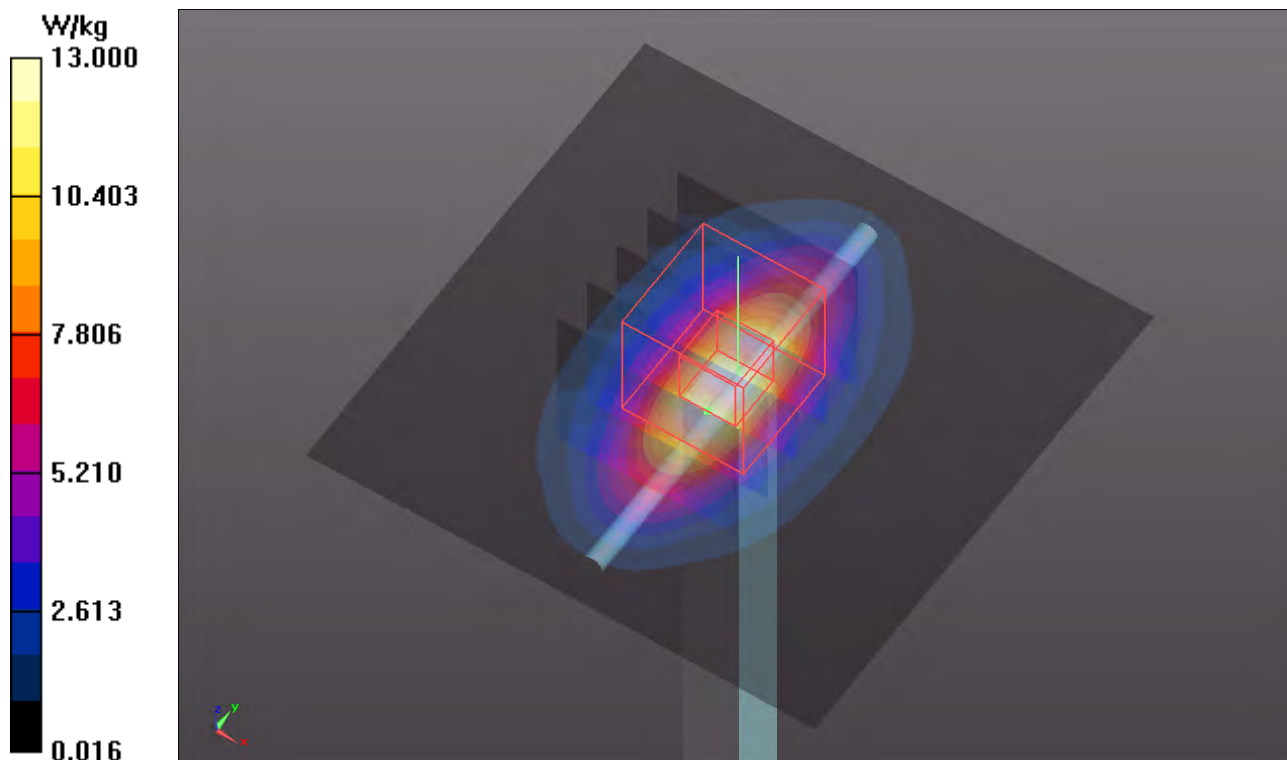

System Check_B1750_121108

DUT: Dipole 1750 MHz; Type: D1750V2; SN: 1055

Communication System: CW; Frequency: 1750 MHz; Duty Cycle: 1:1

Medium: B1750_1108 Medium parameters used: $f = 1750$ MHz; $\sigma = 1.47$ mho/m; $\epsilon_r = 53.184$; $\rho = 1000$ kg/m³

Ambient Temperature : 21.6 °C ; Liquid Temperature : 20.7 °C

DASY5 Configuration:

- Probe: EX3DV4 - SN3864; ConvF(8.45, 8.45, 8.45); Calibrated: 2012/07/19;
- Sensor-Surface: 2mm (Mechanical Surface Detection)
- Electronics: DAE4 Sn915; Calibrated: 2012/06/21
- Phantom: SAM Phantom_Front; Type: SAM V4.0; Serial: TP 1127
- Measurement SW: DASY52, Version 52.8 (2); SEMCAD X Version 14.6.6 (6824)

Pin=250mW/Area Scan (61x61x1): Measurement grid: dx=15mm, dy=15mm

Maximum value of SAR (interpolated) = 13.7 W/kg

Pin=250mW/Zoom Scan (5x5x7)/Cube 0: Measurement grid: dx=8mm, dy=8mm, dz=5mm

Reference Value = 97.246 V/m; Power Drift = -0.01 dB

Peak SAR (extrapolated) = 16.438 mW/g

SAR(1 g) = 9.48 mW/g; SAR(10 g) = 5.1 mW/g

Maximum value of SAR (measured) = 13.2 W/kg

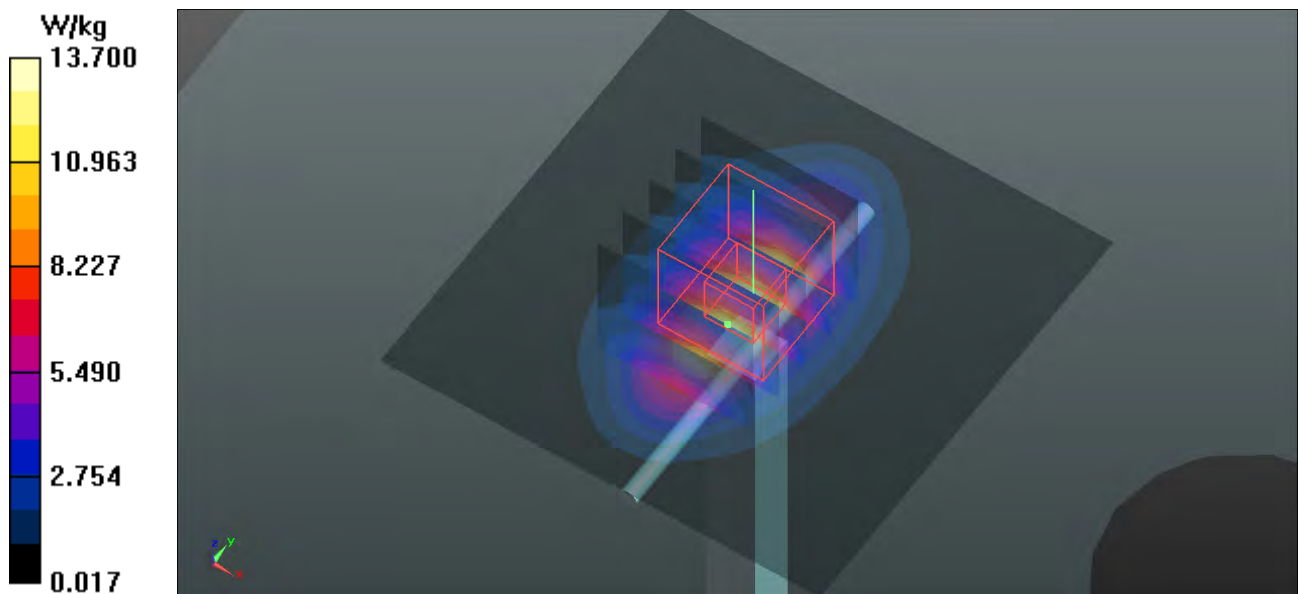

System Check_B1750_121112

DUT: Dipole 1750 MHz; Type: D1750V2; SN: 1055

Communication System: CW; Frequency: 1750 MHz; Duty Cycle: 1:1

Medium: B1750_1112 Medium parameters used: $f = 1750$ MHz; $\sigma = 1.466$ mho/m; $\epsilon_r = 53.656$; $\rho = 1000$ kg/m³

Ambient Temperature : 21.7 °C ; Liquid Temperature : 20.9 °C

DASY5 Configuration:

- Probe: EX3DV4 - SN3864; ConvF(8.45, 8.45, 8.45); Calibrated: 2012/07/19;
- Sensor-Surface: 2mm (Mechanical Surface Detection)
- Electronics: DAE4 Sn915; Calibrated: 2012/06/21
- Phantom: SAM Phantom_Front; Type: SAM V4.0; Serial: TP 1127
- Measurement SW: DASY52, Version 52.8 (2); SEMCAD X Version 14.6.6 (6824)

Pin=250mW/Area Scan (61x61x1): Measurement grid: dx=15mm, dy=15mm

Maximum value of SAR (interpolated) = 13.5 W/kg

Pin=250mW/Zoom Scan (5x5x7)/Cube 0: Measurement grid: dx=8mm, dy=8mm, dz=5mm

Reference Value = 96.958 V/m; Power Drift = -0.01 dB

Peak SAR (extrapolated) = 16.245 mW/g

SAR(1 g) = 9.36 mW/g; SAR(10 g) = 5.04 mW/g

Maximum value of SAR (measured) = 13.1 W/kg

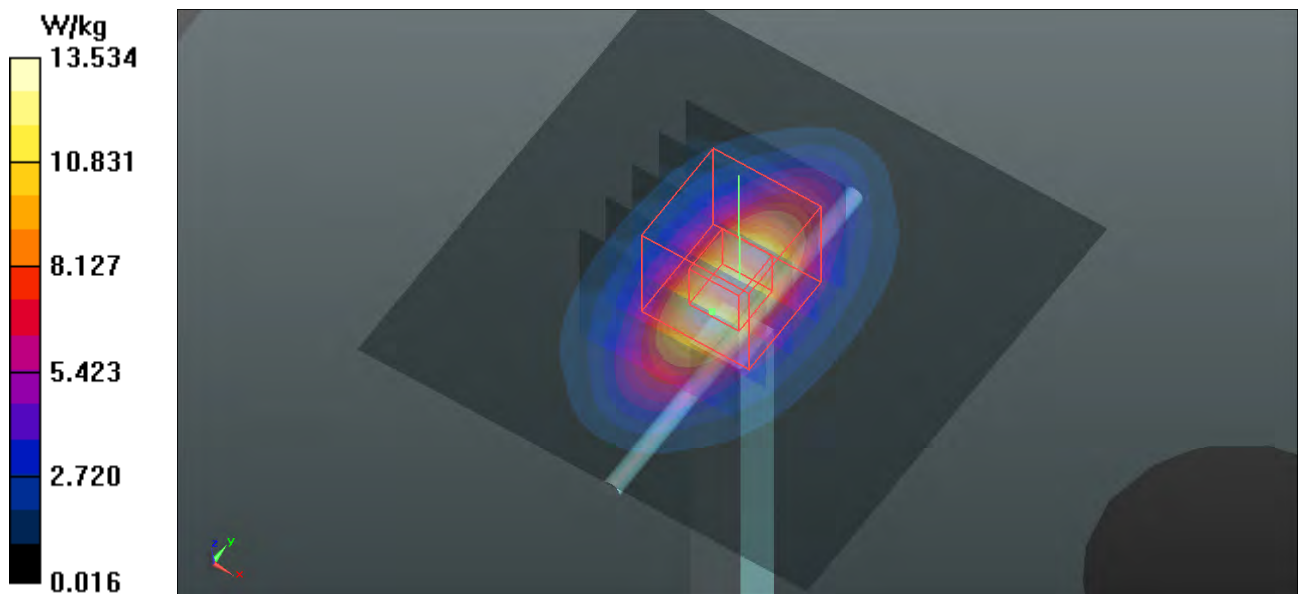

System Check_B1900_121106

DUT: Dipole 1900 MHz; Type: D1900V2; SN: 5d036

Communication System: CW; Frequency: 1900 MHz; Duty Cycle: 1:1

Medium: B1900_1106 Medium parameters used: $f = 1900$ MHz; $\sigma = 1.535$ mho/m; $\epsilon_r = 51.016$; $\rho = 1000$ kg/m³

Ambient Temperature : 21.4 °C ; Liquid Temperature : 20.3 °C

DASY5 Configuration:

- Probe: EX3DV4 - SN3590; ConvF(8.07, 8.07, 8.07); Calibrated: 2012/02/23;
- Sensor-Surface: 2mm (Mechanical Surface Detection)
- Electronics: DAE4 Sn861; Calibrated: 2012/08/23
- Phantom: ELI v4.0; Type: QDOVA001BA; Serial: TP:1043
- Measurement SW: DASY52, Version 52.8 (2); SEMCAD X Version 14.6.6 (6824)

Pin=250mW/Area Scan (61x61x1): Measurement grid: dx=15mm, dy=15mm

Maximum value of SAR (interpolated) = 13.6 W/kg

Pin=250mW/Zoom Scan (5x5x7)/Cube 0: Measurement grid: dx=8mm, dy=8mm, dz=5mm

Reference Value = 94.570 V/m; Power Drift = -0.01 dB

Peak SAR (extrapolated) = 16.545 mW/g

SAR(1 g) = 9.38 mW/g; SAR(10 g) = 4.92 mW/g

Maximum value of SAR (measured) = 13.2 W/kg

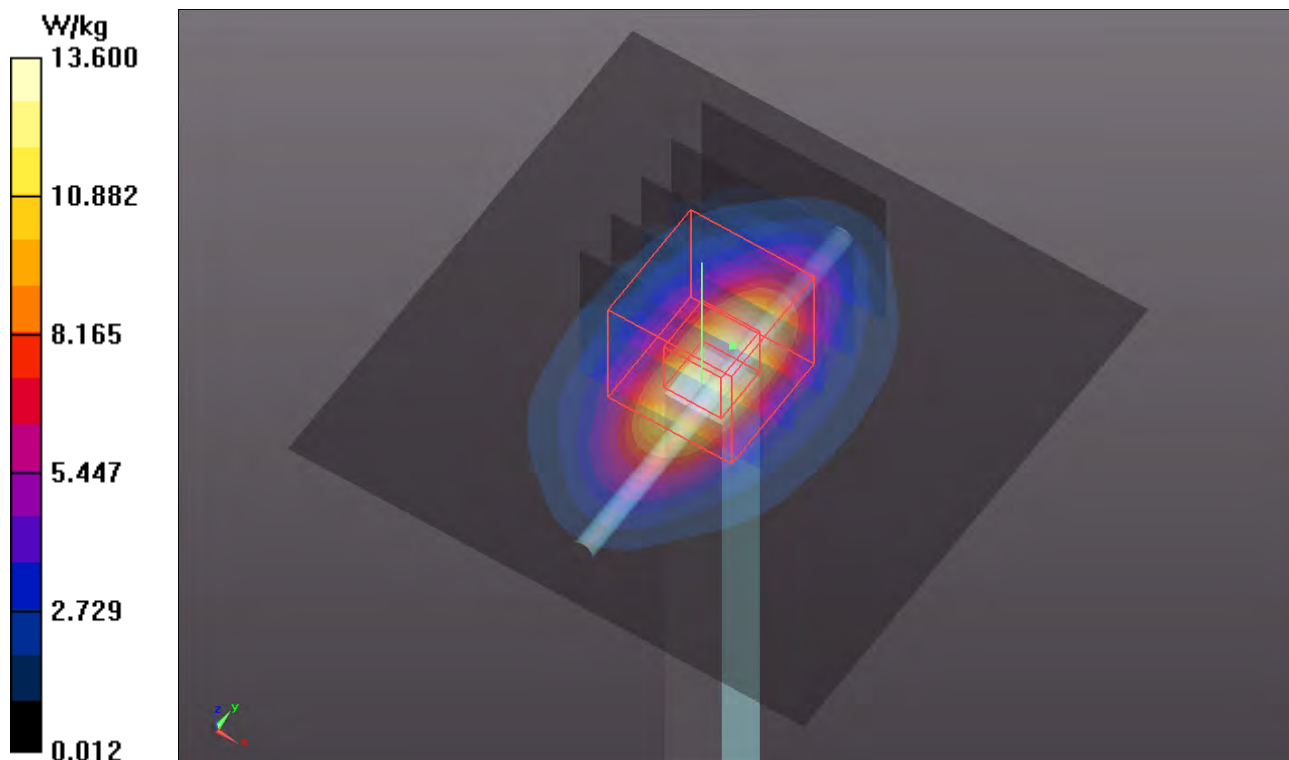

System Check_B1900_121112

DUT: Dipole 1900 MHz; Type: D1900V2; SN: 5d036

Communication System: CW; Frequency: 1900 MHz; Duty Cycle: 1:1

Medium: B1900_1112 Medium parameters used: $f = 1900$ MHz; $\sigma = 1.545$ mho/m; $\epsilon_r = 52.799$; $\rho = 1000$ kg/m³

Ambient Temperature : 21.7 °C ; Liquid Temperature : 20.9 °C

DASY5 Configuration:

- Probe: EX3DV4 - SN3864; ConvF(7.88, 7.88, 7.88); Calibrated: 2012/07/19;
- Sensor-Surface: 2mm (Mechanical Surface Detection)
- Electronics: DAE4 Sn915; Calibrated: 2012/06/21
- Phantom: SAM Phantom_Front; Type: SAM V4.0; Serial: TP 1127
- Measurement SW: DASY52, Version 52.8 (2); SEMCAD X Version 14.6.6 (6824)

Pin=250mW/Area Scan (61x61x1): Measurement grid: dx=15mm, dy=15mm

Maximum value of SAR (interpolated) = 14.5 W/kg

Pin=250mW/Zoom Scan (5x5x7)/Cube 0: Measurement grid: dx=8mm, dy=8mm, dz=5mm

Reference Value = 96.372 V/m; Power Drift = -0.01 dB

Peak SAR (extrapolated) = 17.475 mW/g

SAR(1 g) = 9.66 mW/g; SAR(10 g) = 5.01 mW/g

Maximum value of SAR (measured) = 13.6 W/kg

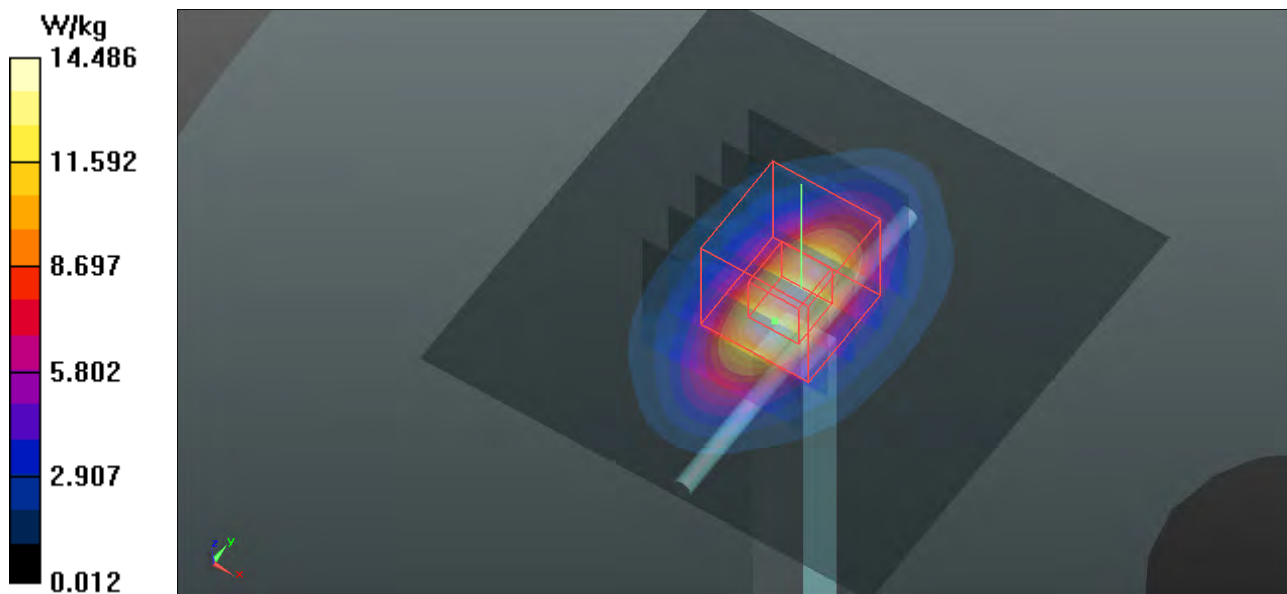

System Check_B1900_121113

DUT: Dipole 1900 MHz; Type: D1900V2; SN: 5d036

Communication System: CW; Frequency: 1900 MHz; Duty Cycle: 1:1

Medium: B1900_1113 Medium parameters used: $f = 1900$ MHz; $\sigma = 1.535$ mho/m; $\epsilon_r = 51.016$; $\rho = 1000$ kg/m³

Ambient Temperature : 21.6 °C ; Liquid Temperature : 20.7 °C

DASY5 Configuration:

- Probe: EX3DV4 - SN3578; ConvF(6.69, 6.69, 6.69); Calibrated: 2012/06/21;
- Sensor-Surface: 2mm (Mechanical Surface Detection)
- Electronics: DAE4 Sn1277; Calibrated: 2012/07/19
- Phantom: SAM Phantom_Front; Type: SAM V4.0; Serial: TP 1127
- Measurement SW: DASY52, Version 52.8 (2); SEMCAD X Version 14.6.6 (6824)

Pin=250mW/Area Scan (61x61x1): Measurement grid: dx=15mm, dy=15mm

Maximum value of SAR (interpolated) = 13.6 W/kg

Pin=250mW/Zoom Scan (5x5x7)/Cube 0: Measurement grid: dx=8mm, dy=8mm, dz=5mm

Reference Value = 94.545 V/m; Power Drift = -0.01 dB

Peak SAR (extrapolated) = 16.529 mW/g

SAR(1 g) = 9.38 mW/g; SAR(10 g) = 4.92 mW/g

Maximum value of SAR (measured) = 13.2 W/kg

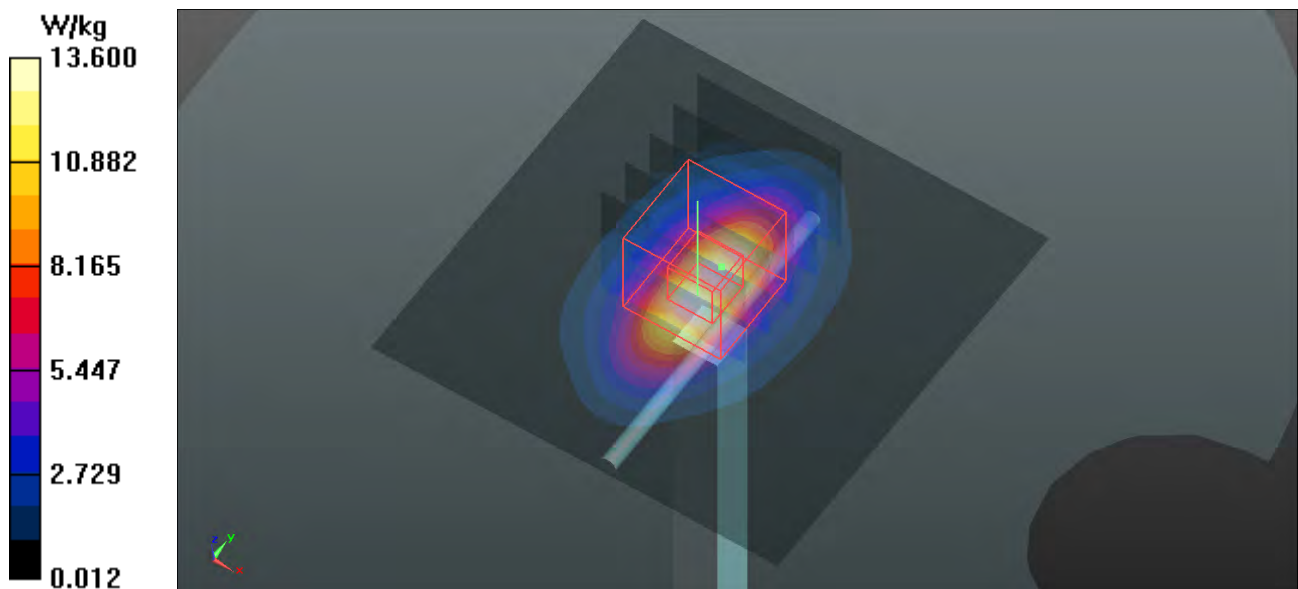

System Check_B2450_121114

DUT: Dipole 2450 MHz; Type: D2450V2; SN: 737

Communication System: CW; Frequency: 2450 MHz; Duty Cycle: 1:1

Medium: B2450_1114 Medium parameters used: $f = 2450$ MHz; $\sigma = 1.982$ mho/m; $\epsilon_r = 51.15$; $\rho = 1000$ kg/m³

Ambient Temperature : 21.6 °C ; Liquid Temperature : 20.6 °C

DASY5 Configuration:

- Probe: EX3DV4 - SN3578; ConvF(6.43, 6.43, 6.43); Calibrated: 2012/06/21;
- Sensor-Surface: 2mm (Mechanical Surface Detection)
- Electronics: DAE4 Sn1277; Calibrated: 2012/07/19
- Phantom: SAM Phantom_Front; Type: SAM V4.0; Serial: TP 1127
- Measurement SW: DASY52, Version 52.8 (2); SEMCAD X Version 14.6.6 (6824)

Pin=250mW/Area Scan (61x61x1): Measurement grid: dx=15mm, dy=15mm

Maximum value of SAR (interpolated) = 21.1 W/kg

Pin=250mW/Zoom Scan (5x5x7)/Cube 0: Measurement grid: dx=8mm, dy=8mm, dz=5mm

Reference Value = 103.2 V/m; Power Drift = -0.05 dB

Peak SAR (extrapolated) = 28.036 mW/g

SAR(1 g) = 13.3 mW/g; SAR(10 g) = 6.11 mW/g

Maximum value of SAR (measured) = 20.0 W/kg

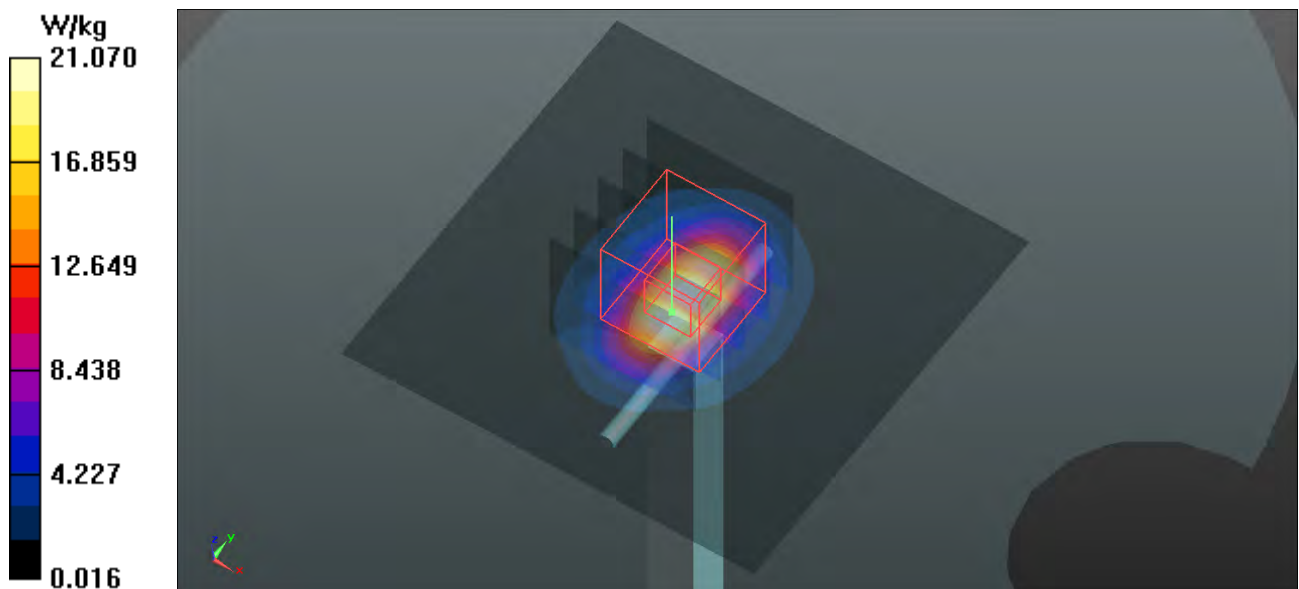



Appendix B. SAR Plots of SAR Measurement

The plots for SAR measurement are shown as follows.

P01 WCDMA II_RMC12.2k_Front Face_0.5cm_Ch9400

DUT: 121023C07

Communication System: WCDMA; Frequency: 1880 MHz; Duty Cycle: 1:1

Medium: B1900_1112 Medium parameters used: $f = 1880$ MHz; $\sigma = 1.521$ mho/m; $\epsilon_r = 52.861$; $\rho = 1000$ kg/m³

Ambient Temperature : 21.7 °C; Liquid Temperature : 20.9 °C

DASY5 Configuration:

- Probe: EX3DV4 - SN3864; ConvF(7.88, 7.88, 7.88); Calibrated: 2012/07/19;
- Sensor-Surface: 2mm (Mechanical Surface Detection)
- Electronics: DAE4 Sn915; Calibrated: 2012/06/21
- Phantom: SAM Phantom_Front; Type: SAM V4.0; Serial: TP 1127
- Measurement SW: DASY52, Version 52.8 (2); SEMCAD X Version 14.6.6 (6824)

Ch9400/Area Scan (51x71x1): Measurement grid: dx=20mm, dy=20mm

Maximum value of SAR (interpolated) = 0.609 W/kg

Ch9400/Zoom Scan (5x5x7)/Cube 0: Measurement grid: dx=8mm, dy=8mm, dz=5mm

Reference Value = 12.840 V/m; Power Drift = -0.06 dB

Peak SAR (extrapolated) = 0.848 mW/g

SAR(1 g) = 0.439 mW/g; SAR(10 g) = 0.228 mW/g

Maximum value of SAR (measured) = 0.617 W/kg

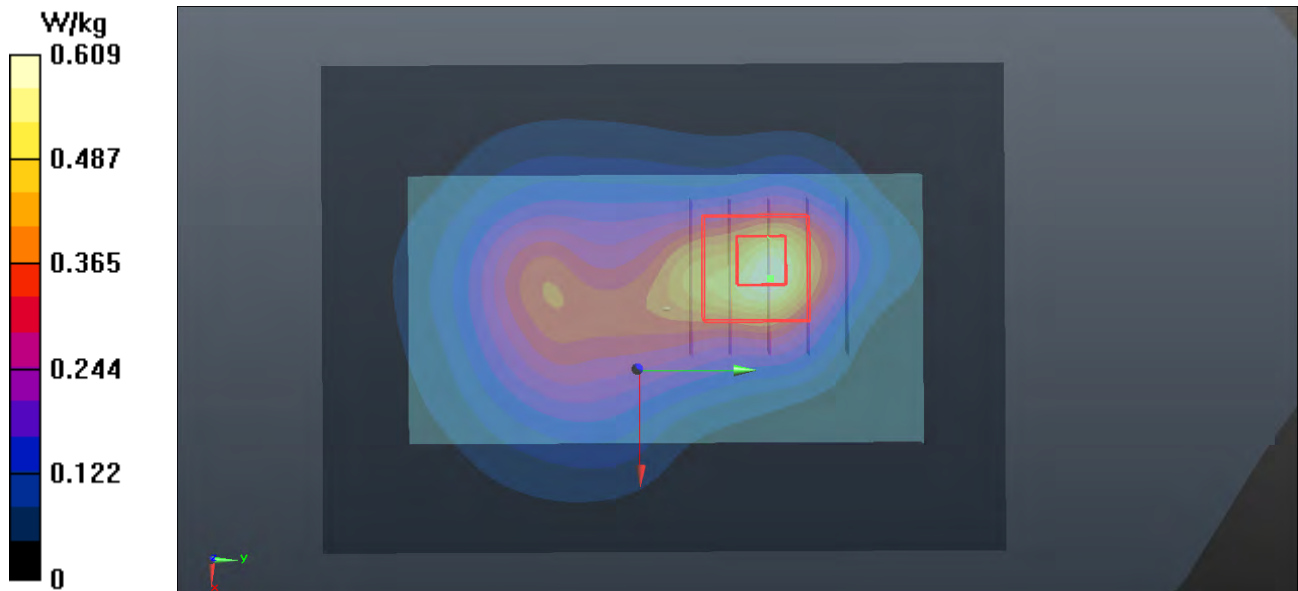

P02 WCDMA II_RMC12.2k_Rear Face_0.5cm_Ch9400

DUT: 121023C07

Communication System: WCDMA; Frequency: 1880 MHz; Duty Cycle: 1:1

Medium: B1900_1112 Medium parameters used: $f = 1880$ MHz; $\sigma = 1.521$ mho/m; $\epsilon_r = 52.861$; $\rho = 1000$ kg/m³

Ambient Temperature : 21.7 °C; Liquid Temperature : 20.9 °C

DASY5 Configuration:

- Probe: EX3DV4 - SN3864; ConvF(7.88, 7.88, 7.88); Calibrated: 2012/07/19;
- Sensor-Surface: 2mm (Mechanical Surface Detection)
- Electronics: DAE4 Sn915; Calibrated: 2012/06/21
- Phantom: SAM Phantom_Front; Type: SAM V4.0; Serial: TP 1127
- Measurement SW: DASY52, Version 52.8 (2); SEMCAD X Version 14.6.6 (6824)

Ch9400/Area Scan (51x71x1): Measurement grid: dx=20mm, dy=20mm

Maximum value of SAR (interpolated) = 1.12 W/kg

Ch9400/Zoom Scan (5x5x7)/Cube 0: Measurement grid: dx=8mm, dy=8mm, dz=5mm

Reference Value = 19.181 V/m; Power Drift = -0.05 dB

Peak SAR (extrapolated) = 0.976 mW/g

SAR(1 g) = 0.652 mW/g; SAR(10 g) = 0.399 mW/g

Maximum value of SAR (measured) = 0.792 W/kg

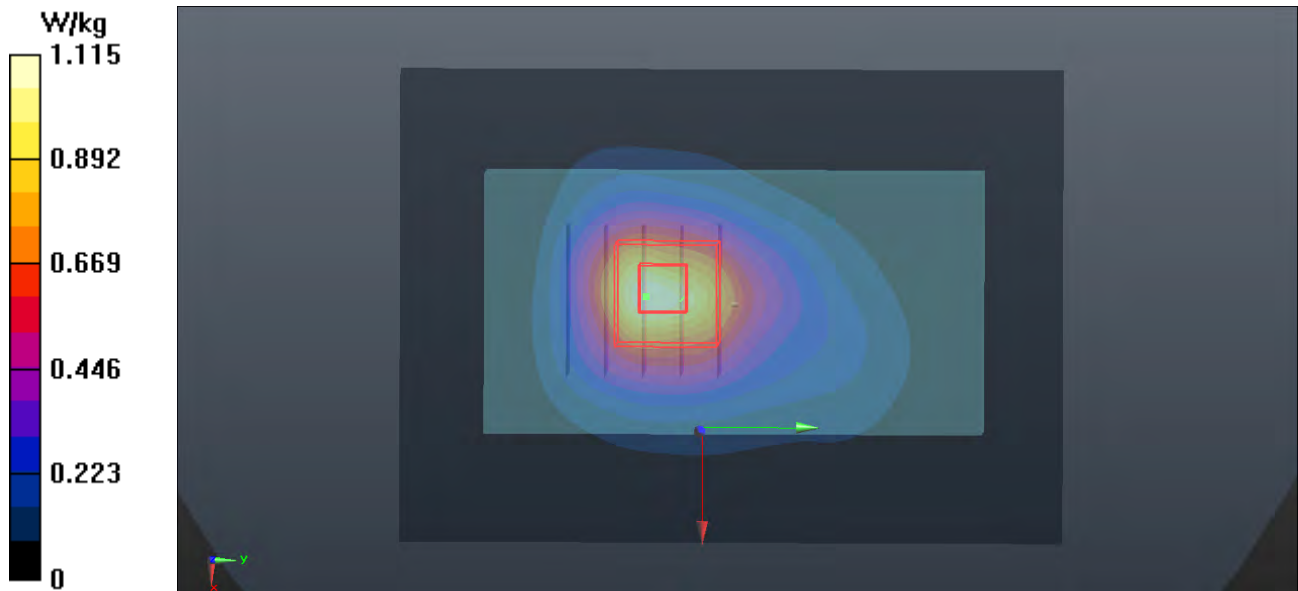

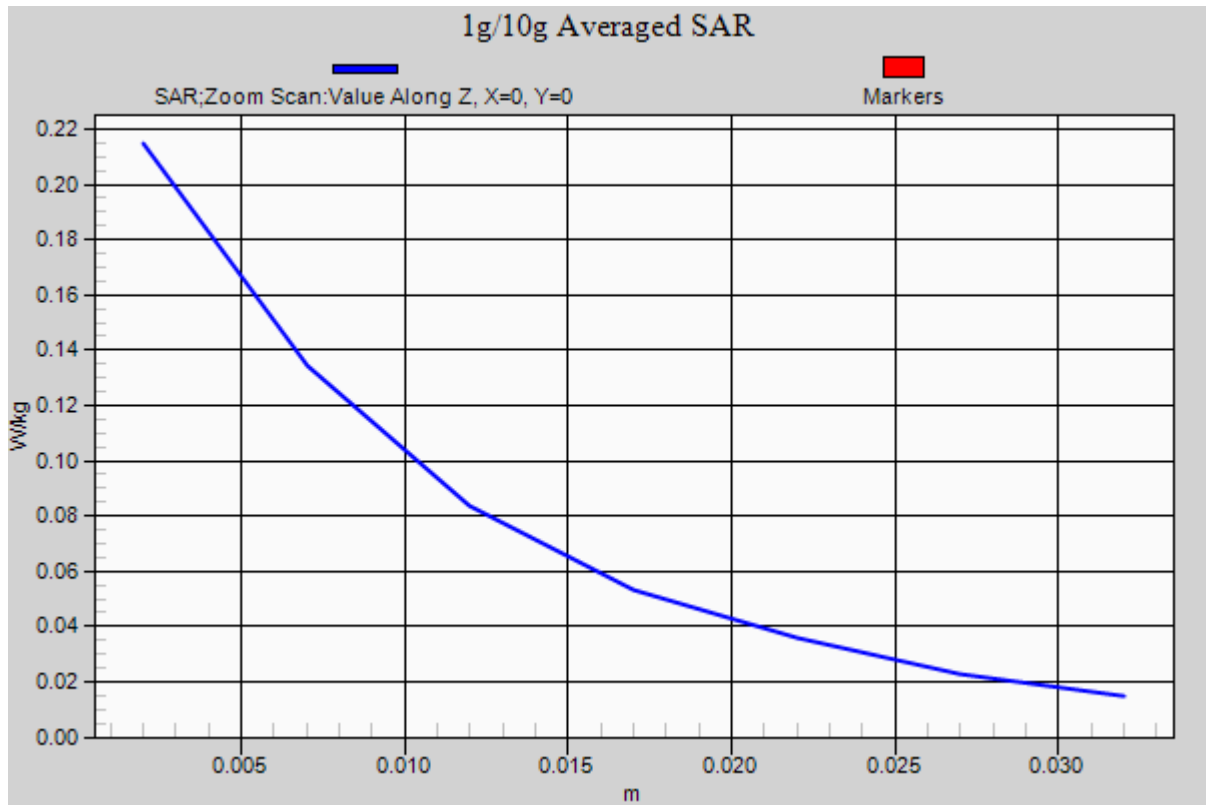

P03 WCDMA II_RMC12.2k_Left Side_0.5cm_Ch9400

DUT: 121023C07

Communication System: WCDMA; Frequency: 1880 MHz; Duty Cycle: 1:1

Medium: B1900_1112 Medium parameters used: $f = 1880$ MHz; $\sigma = 1.521$ mho/m; $\epsilon_r = 52.861$; $\rho = 1000$ kg/m³

Ambient Temperature : 21.7 °C ; Liquid Temperature : 20.9 °C

DASY5 Configuration:

- Probe: EX3DV4 - SN3864; ConvF(7.88, 7.88, 7.88); Calibrated: 2012/07/19;
- Sensor-Surface: 2mm (Mechanical Surface Detection)
- Electronics: DAE4 Sn915; Calibrated: 2012/06/21
- Phantom: SAM Phantom_Front; Type: SAM V4.0; Serial: TP 1127
- Measurement SW: DASY52, Version 52.8 (2); SEMCAD X Version 14.6.6 (6824)

Ch9400/Area Scan (31x71x1): Measurement grid: dx=20mm, dy=20mm

Maximum value of SAR (interpolated) = 0.330 W/kg

Ch9400/Zoom Scan (5x5x7)/Cube 0: Measurement grid: dx=8mm, dy=8mm, dz=5mm

Reference Value = 11.576 V/m; Power Drift = -0.18 dB

Peak SAR (extrapolated) = 0.432 mW/g

SAR(1 g) = 0.273 mW/g; SAR(10 g) = 0.161 mW/g

Maximum value of SAR (measured) = 0.358 W/kg

Ch9400/Zoom Scan (5x5x7)/Cube 1: Measurement grid: dx=8mm, dy=8mm, dz=5mm

Reference Value = 11.576 V/m; Power Drift = -0.18 dB

Peak SAR (extrapolated) = 0.394 mW/g

SAR(1 g) = 0.206 mW/g; SAR(10 g) = 0.106 mW/g

Maximum value of SAR (measured) = 0.302 W/kg

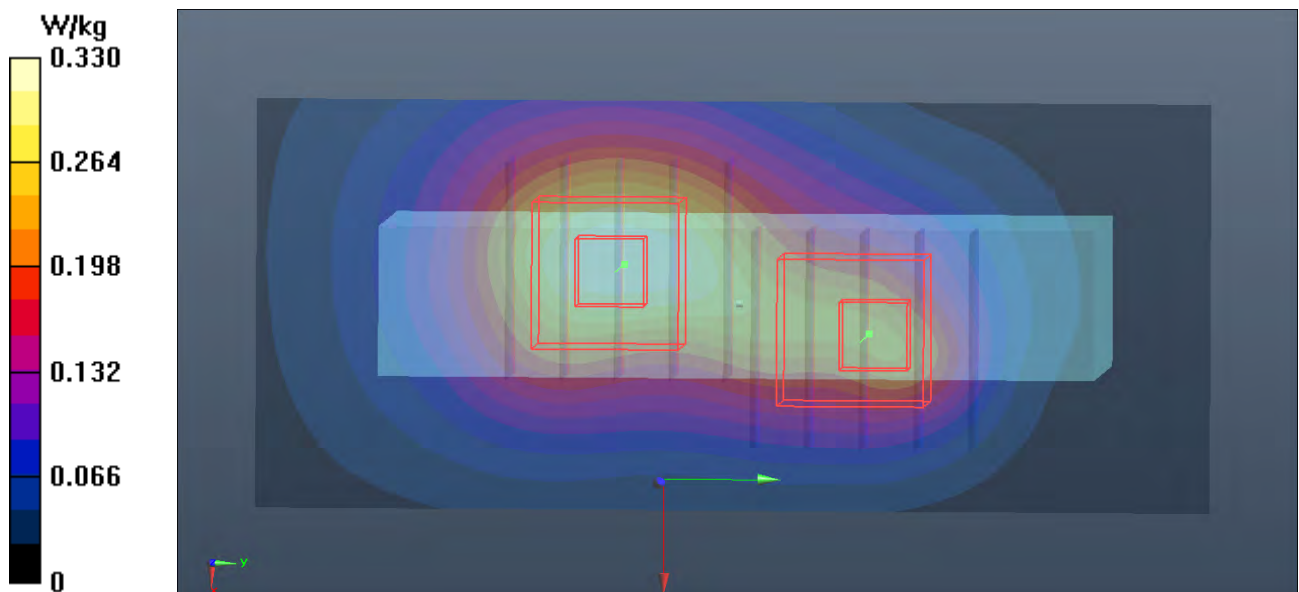

P04 WCDMA II_RMC12.2k_Right Side_0.5cm_Ch9400

DUT: 121023C07

Communication System: WCDMA; Frequency: 1880 MHz; Duty Cycle: 1:1

Medium: B1900_1112 Medium parameters used: $f = 1880$ MHz; $\sigma = 1.521$ mho/m; $\epsilon_r = 52.861$; $\rho = 1000$ kg/m³

Ambient Temperature : 21.7 °C; Liquid Temperature : 20.9 °C

DASY5 Configuration:

- Probe: EX3DV4 - SN3864; ConvF(7.88, 7.88, 7.88); Calibrated: 2012/07/19;
- Sensor-Surface: 2mm (Mechanical Surface Detection)
- Electronics: DAE4 Sn915; Calibrated: 2012/06/21
- Phantom: SAM Phantom_Front; Type: SAM V4.0; Serial: TP 1127
- Measurement SW: DASY52, Version 52.8 (2); SEMCAD X Version 14.6.6 (6824)

Ch9400/Area Scan (31x71x1): Measurement grid: dx=20mm, dy=20mm

Maximum value of SAR (interpolated) = 0.373 W/kg

Ch9400/Zoom Scan (5x5x7)/Cube 0: Measurement grid: dx=8mm, dy=8mm, dz=5mm

Reference Value = 12.979 V/m; Power Drift = 0.03 dB

Peak SAR (extrapolated) = 0.490 mW/g

SAR(1 g) = 0.291 mW/g; SAR(10 g) = 0.163 mW/g

Maximum value of SAR (measured) = 0.400 W/kg

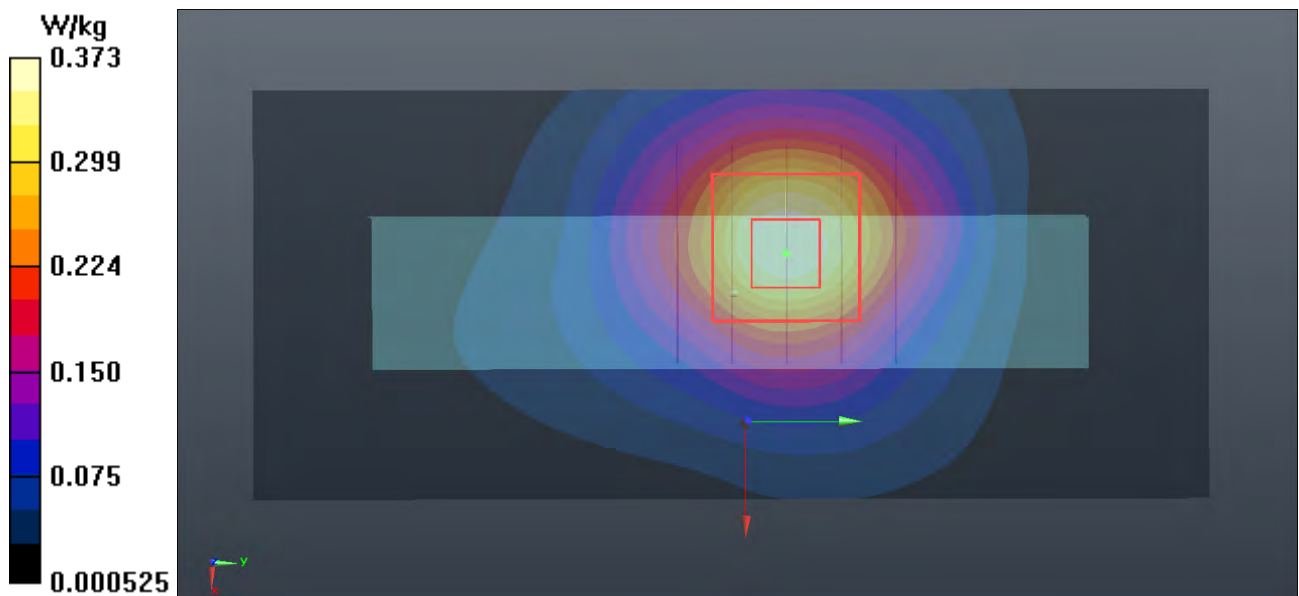

P05 WCDMA II_RMC12.2k_Top Side_0.5cm_Ch9400

DUT: 121023C07

Communication System: WCDMA; Frequency: 1880 MHz; Duty Cycle: 1:1

Medium: B1900_1112 Medium parameters used: $f = 1880$ MHz; $\sigma = 1.521$ mho/m; $\epsilon_r = 52.861$; $\rho = 1000$ kg/m³

Ambient Temperature : 21.7 °C ; Liquid Temperature : 20.9 °C

DASY5 Configuration:

- Probe: EX3DV4 - SN3864; ConvF(7.88, 7.88, 7.88); Calibrated: 2012/07/19;
- Sensor-Surface: 2mm (Mechanical Surface Detection)
- Electronics: DAE4 Sn915; Calibrated: 2012/06/21
- Phantom: SAM Phantom_Front; Type: SAM V4.0; Serial: TP 1127
- Measurement SW: DASY52, Version 52.8 (2); SEMCAD X Version 14.6.6 (6824)

Ch9400/Area Scan (31x51x1): Measurement grid: dx=20mm, dy=20mm

Maximum value of SAR (interpolated) = 0.156 W/kg

Ch9400/Zoom Scan (5x5x7)/Cube 0: Measurement grid: dx=8mm, dy=8mm, dz=5mm

Reference Value = 8.079 V/m; Power Drift = 0.13 dB

Peak SAR (extrapolated) = 0.195 mW/g

SAR(1 g) = 0.119 mW/g; SAR(10 g) = 0.067 mW/g

Maximum value of SAR (measured) = 0.162 W/kg

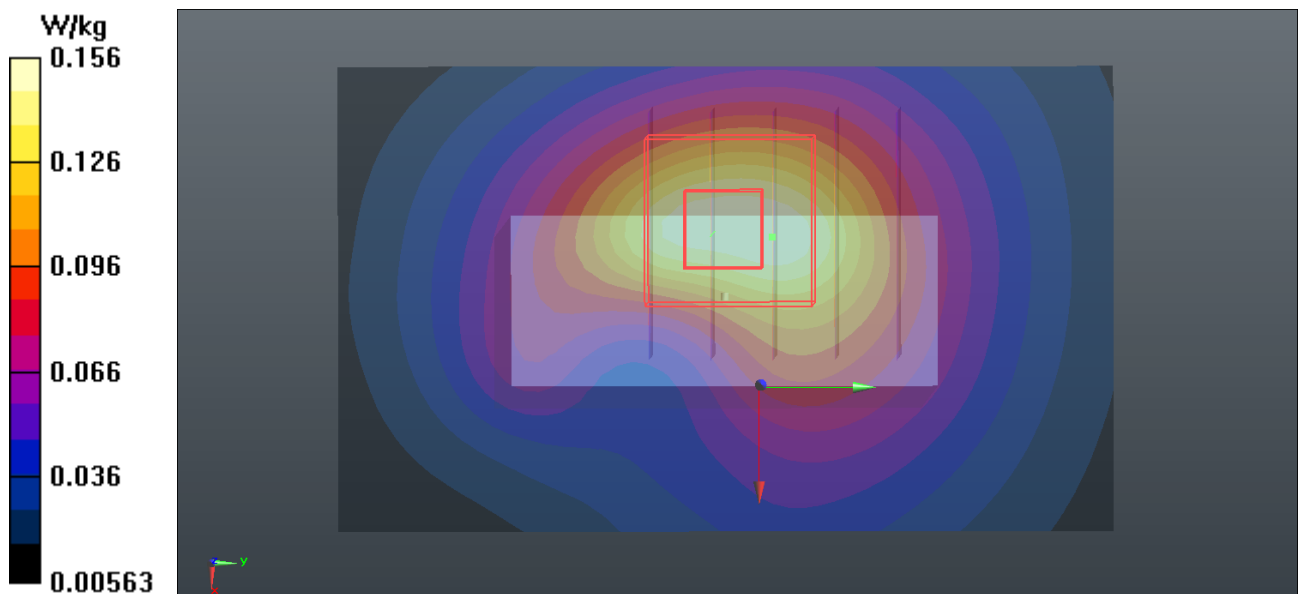

P13 WCDMA V_RMC12.2k_Front Face_0.5cm_Ch4132

DUT: 121023C07

Communication System: WCDMA; Frequency: 826.4 MHz; Duty Cycle: 1:1

Medium: B835_1113 Medium parameters used: $f = 826.4$ MHz; $\sigma = 0.985$ mho/m; $\epsilon_r = 56.732$; $\rho = 1000$ kg/m³

Ambient Temperature : 21.9 °C ; Liquid Temperature : 20.7 °C

DASY5 Configuration:

- Probe: EX3DV4 - SN3578; ConvF(8.45, 8.45, 8.45); Calibrated: 2012/06/21;
- Sensor-Surface: 2mm (Mechanical Surface Detection)
- Electronics: DAE4 Sn1277; Calibrated: 2012/07/19
- Phantom: SAM Phantom_right; Type: QD000P40CC; Serial: TP:1496
- Measurement SW: DASY52, Version 52.8 (2); SEMCAD X Version 14.6.6 (6824)

Ch4132/Area Scan (51x71x1): Measurement grid: dx=20mm, dy=20mm

Maximum value of SAR (interpolated) = 0.108 W/kg

Ch4132/Zoom Scan (5x5x7)/Cube 0: Measurement grid: dx=8mm, dy=8mm, dz=5mm

Reference Value = 8.360 V/m; Power Drift = -0.04 dB

Peak SAR (extrapolated) = 0.126 mW/g

SAR(1 g) = 0.080 mW/g; SAR(10 g) = 0.050 mW/g

Maximum value of SAR (measured) = 0.103 W/kg

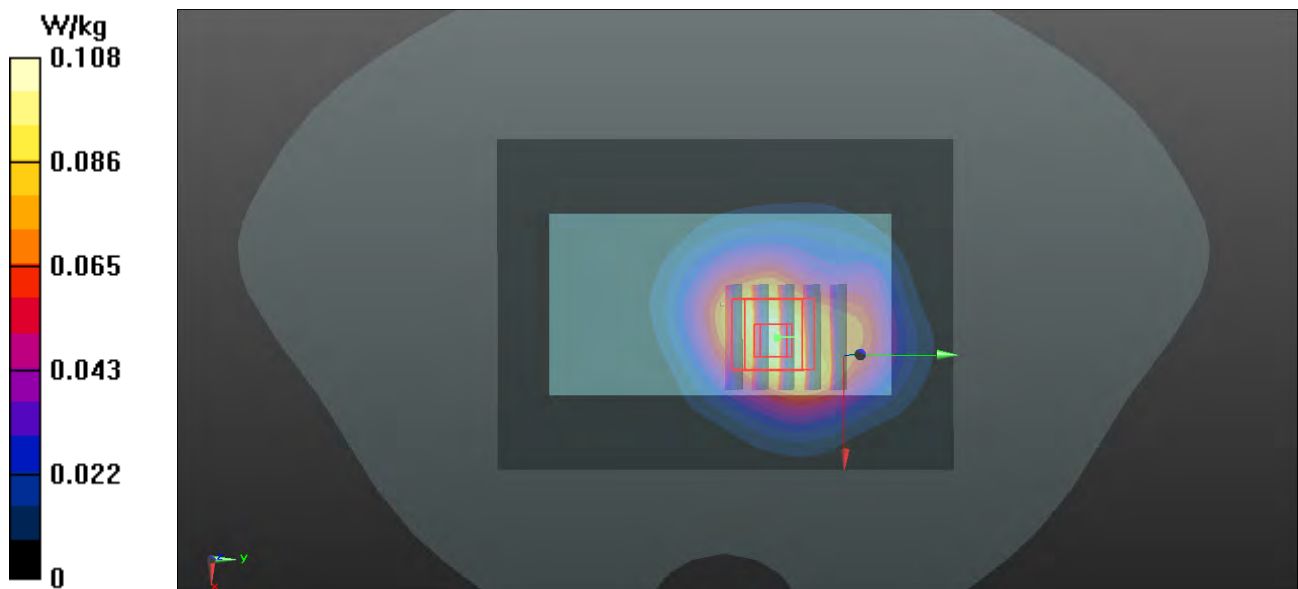

1g/10g Averaged SAR

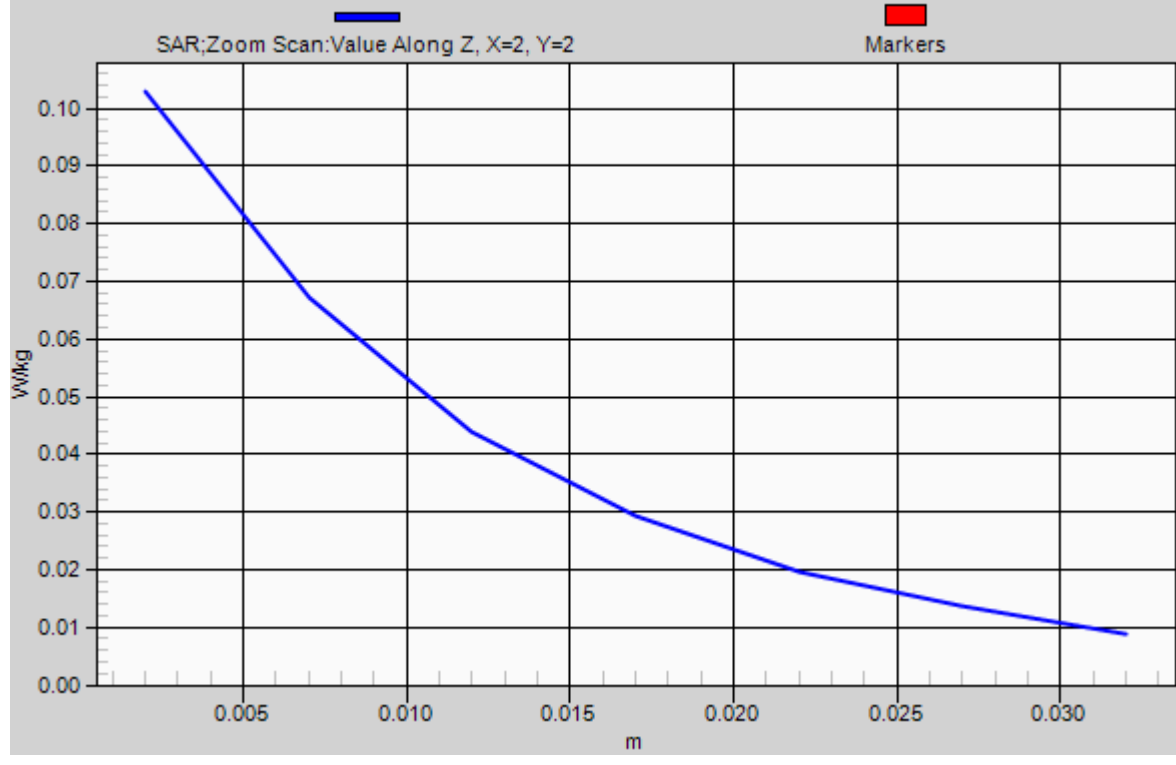

P14 WCDMA V_RMC12.2k_Rear Face_0.5cm_Ch4132

DUT: 121023C07

Communication System: WCDMA; Frequency: 826.4 MHz; Duty Cycle: 1:1

Medium: B835_1113 Medium parameters used: $f = 826.4$ MHz; $\sigma = 0.985$ mho/m; $\epsilon_r = 56.732$; $\rho = 1000$ kg/m³

Ambient Temperature : 21.9 °C; Liquid Temperature : 20.7 °C

DASY5 Configuration:

- Probe: EX3DV4 - SN3578; ConvF(8.45, 8.45, 8.45); Calibrated: 2012/06/21;
- Sensor-Surface: 2mm (Mechanical Surface Detection)
- Electronics: DAE4 Sn1277; Calibrated: 2012/07/19
- Phantom: SAM Phantom_right; Type: QD000P40CC; Serial: TP:1496
- Measurement SW: DASY52, Version 52.8 (2); SEMCAD X Version 14.6.6 (6824)

Ch4132/Area Scan (51x71x1): Measurement grid: dx=20mm, dy=20mm

Maximum value of SAR (interpolated) = 0.0517 W/kg

Ch4132/Zoom Scan (5x5x7)/Cube 0: Measurement grid: dx=8mm, dy=8mm, dz=5mm

Reference Value = 6.849 V/m; Power Drift = 0.05 dB

Peak SAR (extrapolated) = 0.059 mW/g

SAR(1 g) = 0.042 mW/g; SAR(10 g) = 0.028 mW/g

Maximum value of SAR (measured) = 0.0511 W/kg

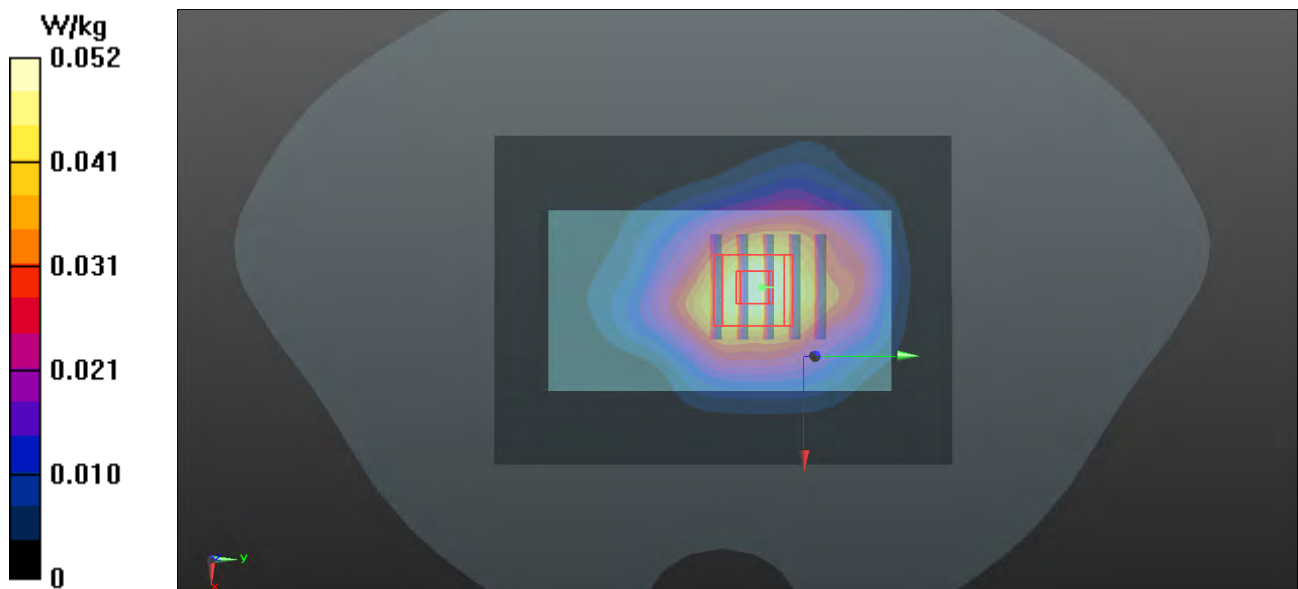

P15 WCDMA V_RMC12.2k_Left Side_0.5cm_Ch4132

DUT: 121023C07

Communication System: WCDMA; Frequency: 826.4 MHz; Duty Cycle: 1:1

Medium: B835_1113 Medium parameters used: $f = 826.4$ MHz; $\sigma = 0.985$ mho/m; $\epsilon_r = 56.732$; $\rho = 1000$ kg/m³

Ambient Temperature : 21.9 °C; Liquid Temperature : 20.7 °C

DASY5 Configuration:

- Probe: EX3DV4 - SN3578; ConvF(8.45, 8.45, 8.45); Calibrated: 2012/06/21;
- Sensor-Surface: 2mm (Mechanical Surface Detection)
- Electronics: DAE4 Sn1277; Calibrated: 2012/07/19
- Phantom: SAM Phantom_right; Type: QD000P40CC; Serial: TP:1496
- Measurement SW: DASY52, Version 52.8 (2); SEMCAD X Version 14.6.6 (6824)

Ch4132/Area Scan (41x71x1): Measurement grid: dx=20mm, dy=20mm

Maximum value of SAR (interpolated) = 0.0287 W/kg

Ch4132/Zoom Scan (5x5x7)/Cube 0: Measurement grid: dx=8mm, dy=8mm, dz=5mm

Reference Value = 4.280 V/m; Power Drift = 0.133 dB

Peak SAR (extrapolated) = 0.028 mW/g

SAR(1 g) = 0.021 mW/g; SAR(10 g) = 0.014 mW/g

Maximum value of SAR (measured) = 0.0248 W/kg

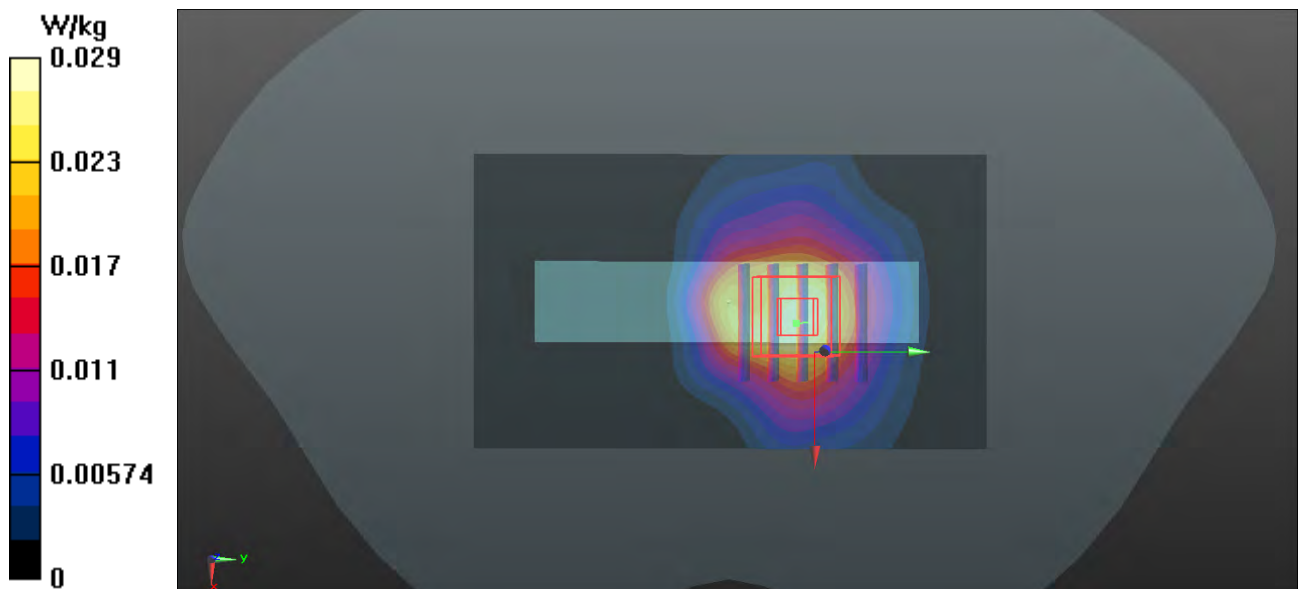

P16 WCDMA V_RMC12.2k_Right Side_0.5cm_Ch4132

DUT: 121023C07

Communication System: WCDMA; Frequency: 826.4 MHz; Duty Cycle: 1:1

Medium: B835_1113 Medium parameters used: $f = 826.4$ MHz; $\sigma = 0.985$ mho/m; $\epsilon_r = 56.732$; $\rho = 1000$ kg/m³

Ambient Temperature : 21.9 °C; Liquid Temperature : 20.7 °C

DASY5 Configuration:

- Probe: EX3DV4 - SN3578; ConvF(8.45, 8.45, 8.45); Calibrated: 2012/06/21;
- Sensor-Surface: 2mm (Mechanical Surface Detection)
- Electronics: DAE4 Sn1277; Calibrated: 2012/07/19
- Phantom: SAM Phantom_right; Type: QD000P40CC; Serial: TP:1496
- Measurement SW: DASY52, Version 52.8 (2); SEMCAD X Version 14.6.6 (6824)

Ch4132/Area Scan (41x71x1): Measurement grid: dx=20mm, dy=20mm

Maximum value of SAR (interpolated) = 0.0468 W/kg

Ch4132/Zoom Scan (5x5x7)/Cube 0: Measurement grid: dx=8mm, dy=8mm, dz=5mm

Reference Value = 3.669 V/m; Power Drift = 0.13 dB

Peak SAR (extrapolated) = 0.045 mW/g

SAR(1 g) = 0.026 mW/g; SAR(10 g) = 0.015 mW/g

Maximum value of SAR (measured) = 0.0359 W/kg

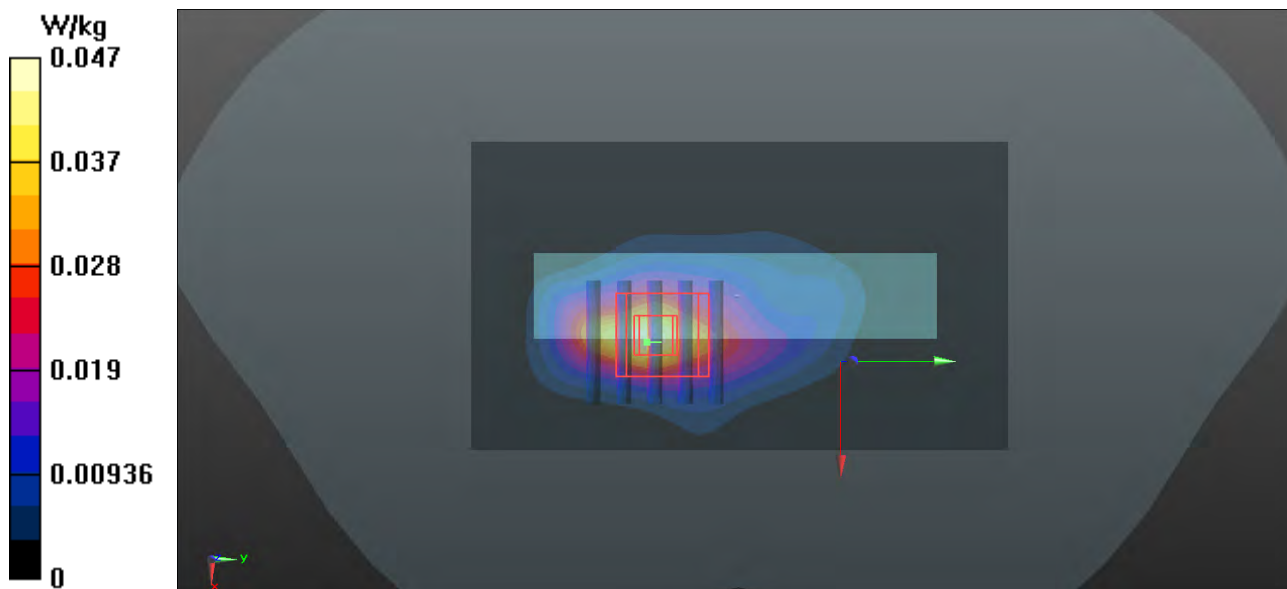

P17 WCDMA V_RMC12.2k_Top Side_0.5cm_Ch4132

DUT: 121023C07

Communication System: WCDMA; Frequency: 826.4 MHz; Duty Cycle: 1:1

Medium: B835_1113 Medium parameters used: $f = 826.4$ MHz; $\sigma = 0.985$ mho/m; $\epsilon_r = 56.732$; $\rho = 1000$ kg/m³

Ambient Temperature : 21.9 °C; Liquid Temperature : 20.7 °C

DASY5 Configuration:

- Probe: EX3DV4 - SN3578; ConvF(8.45, 8.45, 8.45); Calibrated: 2012/06/21;
- Sensor-Surface: 2mm (Mechanical Surface Detection)
- Electronics: DAE4 Sn1277; Calibrated: 2012/07/19
- Phantom: SAM Phantom_right; Type: QD000P40CC; Serial: TP:1496
- Measurement SW: DASY52, Version 52.8 (2); SEMCAD X Version 14.6.6 (6824)

Ch4132/Area Scan (41x61x1): Measurement grid: dx=20mm, dy=20mm

Maximum value of SAR (interpolated) = 0.0403 W/kg

Ch4132/Zoom Scan (5x5x7)/Cube 0: Measurement grid: dx=8mm, dy=8mm, dz=5mm

Reference Value = 6.535 V/m; Power Drift = -0.02 dB

Peak SAR (extrapolated) = 0.061 mW/g

SAR(1 g) = 0.029 mW/g; SAR(10 g) = 0.015 mW/g

Maximum value of SAR (measured) = 0.0414 W/kg

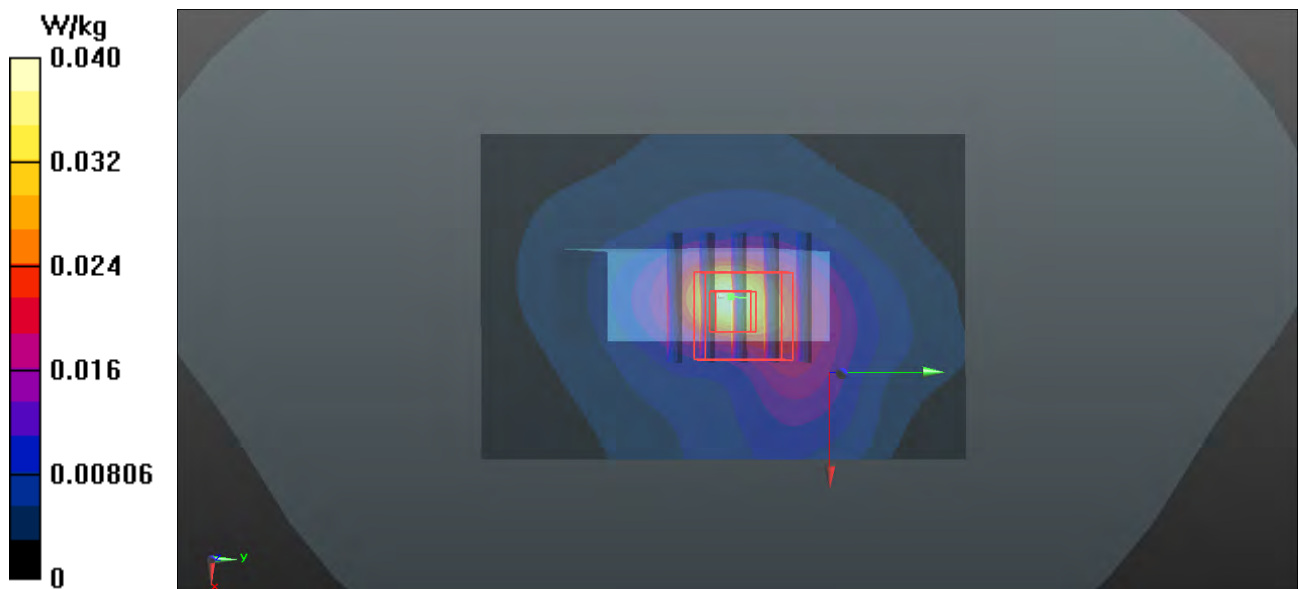

P07 WCDMA IV_RMC12.2k_Front Face_0.5cm_Ch1513

DUT: 121023C07

Communication System: WCDMA; Frequency: 1752.6 MHz; Duty Cycle: 1:1

Medium: B1750_1112 Medium parameters used: $f = 1753$ MHz; $\sigma = 1.469$ mho/m; $\epsilon_r = 53.646$; $\rho = 1000$ kg/m³

Ambient Temperature : 21.7 °C; Liquid Temperature : 20.9 °C

DASY5 Configuration:

- Probe: EX3DV4 - SN3864; ConvF(8.45, 8.45, 8.45); Calibrated: 2012/07/19;
- Sensor-Surface: 2mm (Mechanical Surface Detection)
- Electronics: DAE4 Sn915; Calibrated: 2012/06/21
- Phantom: SAM Phantom_Front; Type: SAM V4.0; Serial: TP 1127
- Measurement SW: DASY52, Version 52.8 (2); SEMCAD X Version 14.6.6 (6824)

Ch1513/Area Scan (51x71x1): Measurement grid: dx=20mm, dy=20mm

Maximum value of SAR (interpolated) = 0.758 W/kg

Ch1513/Zoom Scan (5x5x7)/Cube 0: Measurement grid: dx=8mm, dy=8mm, dz=5mm

Reference Value = 18.705 V/m; Power Drift = 0.03 dB

Peak SAR (extrapolated) = 0.843 mW/g

SAR(1 g) = 0.515 mW/g; SAR(10 g) = 0.321 mW/g

Maximum value of SAR (measured) = 0.665 W/kg

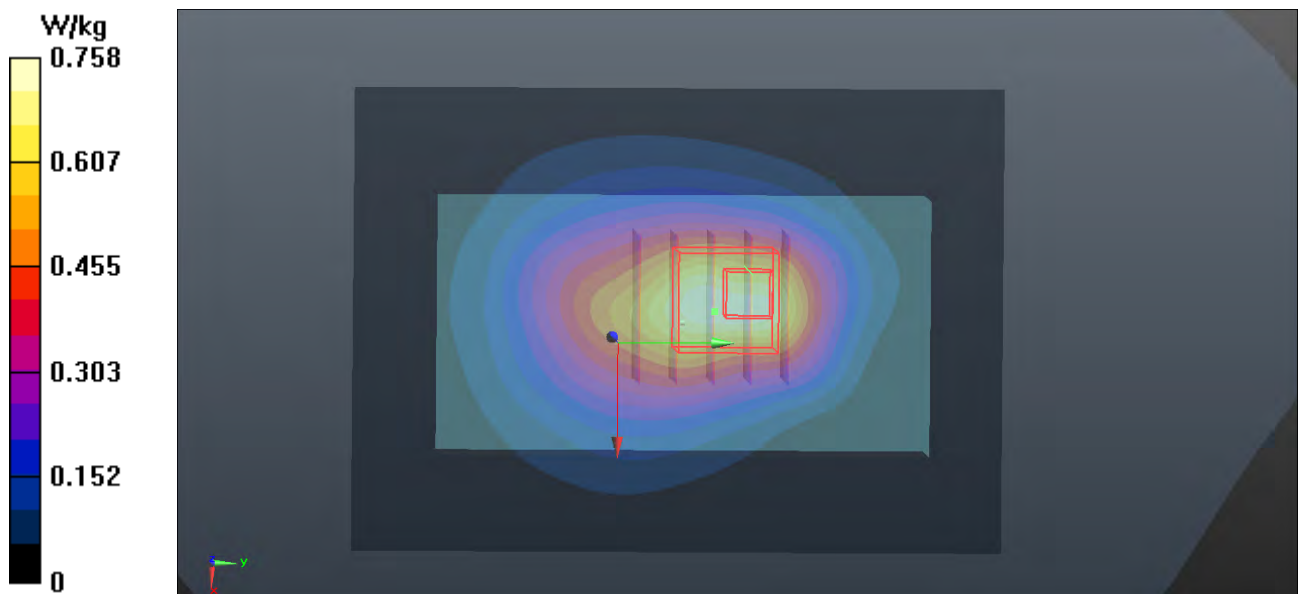

P08 WCDMA IV_RMC12.2k_Rear Face_0.5cm_Ch1513

DUT: 121023C07

Communication System: WCDMA; Frequency: 1752.6 MHz; Duty Cycle: 1:1

Medium: B1750_1112 Medium parameters used: $f = 1753$ MHz; $\sigma = 1.469$ mho/m; $\epsilon_r = 53.646$; $\rho = 1000$ kg/m³

Ambient Temperature : 21.7 °C; Liquid Temperature : 20.9 °C

DASY5 Configuration:

- Probe: EX3DV4 - SN3864; ConvF(8.45, 8.45, 8.45); Calibrated: 2012/07/19;
- Sensor-Surface: 2mm (Mechanical Surface Detection)
- Electronics: DAE4 Sn915; Calibrated: 2012/06/21
- Phantom: SAM Phantom_Front; Type: SAM V4.0; Serial: TP 1127
- Measurement SW: DASY52, Version 52.8 (2); SEMCAD X Version 14.6.6 (6824)

Ch1513/Area Scan (51x71x1): Measurement grid: dx=20mm, dy=20mm

Maximum value of SAR (interpolated) = 1.02 W/kg

Ch1513/Zoom Scan (5x5x7)/Cube 0: Measurement grid: dx=8mm, dy=8mm, dz=5mm

Reference Value = 21.875 V/m; Power Drift = -0.07 dB

Peak SAR (extrapolated) = 0.935 mW/g

SAR(1 g) = 0.660 mW/g; SAR(10 g) = 0.421 mW/g

Maximum value of SAR (measured) = 0.809 W/kg

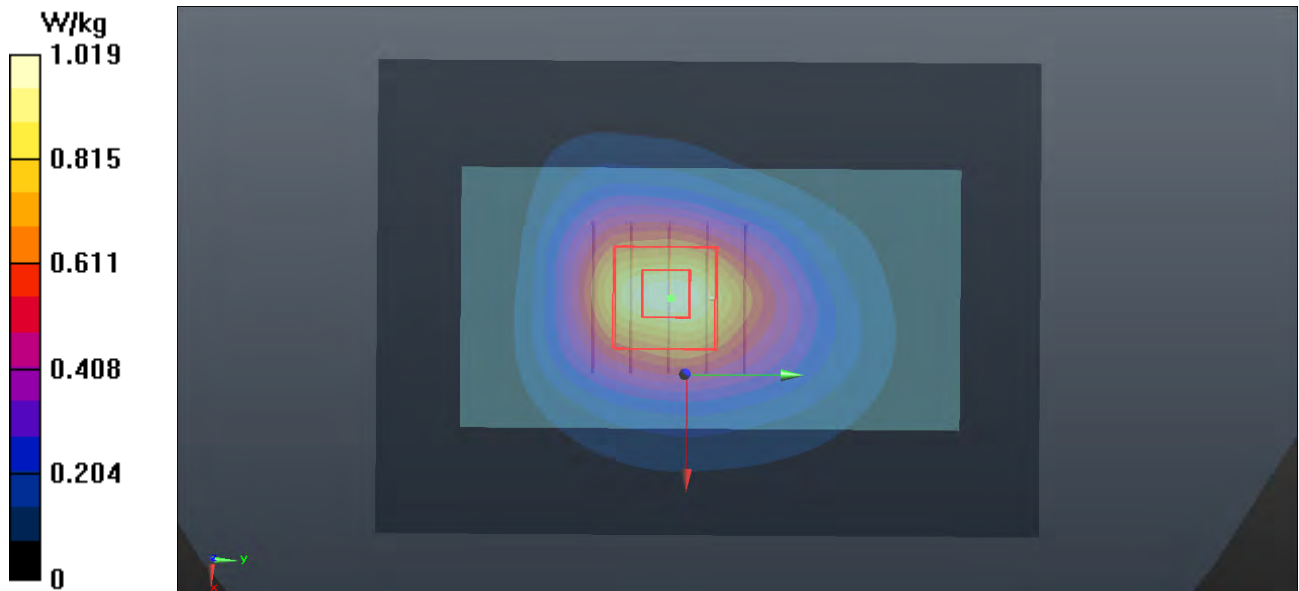

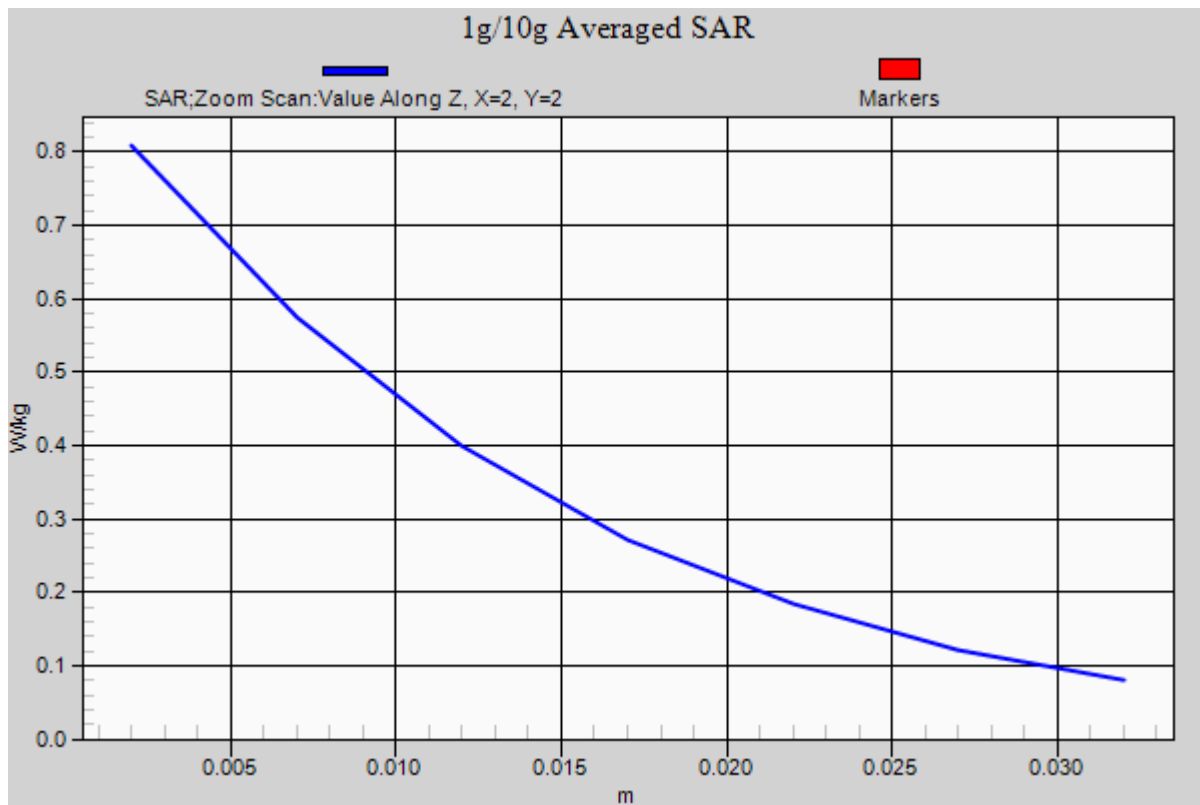

P09 WCDMA IV_RMC12.2k_Left Side_0.5cm_Ch1513

DUT: 121023C07

Communication System: WCDMA; Frequency: 1752.6 MHz; Duty Cycle: 1:1

Medium: B1750_1112 Medium parameters used: $f = 1753$ MHz; $\sigma = 1.469$ mho/m; $\epsilon_r = 53.646$; $\rho = 1000$ kg/m³

Ambient Temperature : 21.7 °C; Liquid Temperature : 20.9 °C

DASY5 Configuration:

- Probe: EX3DV4 - SN3864; ConvF(8.45, 8.45, 8.45); Calibrated: 2012/07/19;
- Sensor-Surface: 2mm (Mechanical Surface Detection)
- Electronics: DAE4 Sn915; Calibrated: 2012/06/21
- Phantom: SAM Phantom_Front; Type: SAM V4.0; Serial: TP 1127
- Measurement SW: DASY52, Version 52.8 (2); SEMCAD X Version 14.6.6 (6824)

Ch1513/Area Scan (31x71x1): Measurement grid: dx=20mm, dy=20mm

Maximum value of SAR (interpolated) = 0.367 W/kg

Ch1513/Zoom Scan (5x5x7)/Cube 0: Measurement grid: dx=8mm, dy=8mm, dz=5mm

Reference Value = 14.453 V/m; Power Drift = 0.09 dB

Peak SAR (extrapolated) = 0.411 mW/g

SAR(1 g) = 0.273 mW/g; SAR(10 g) = 0.171 mW/g

Maximum value of SAR (measured) = 0.341 W/kg

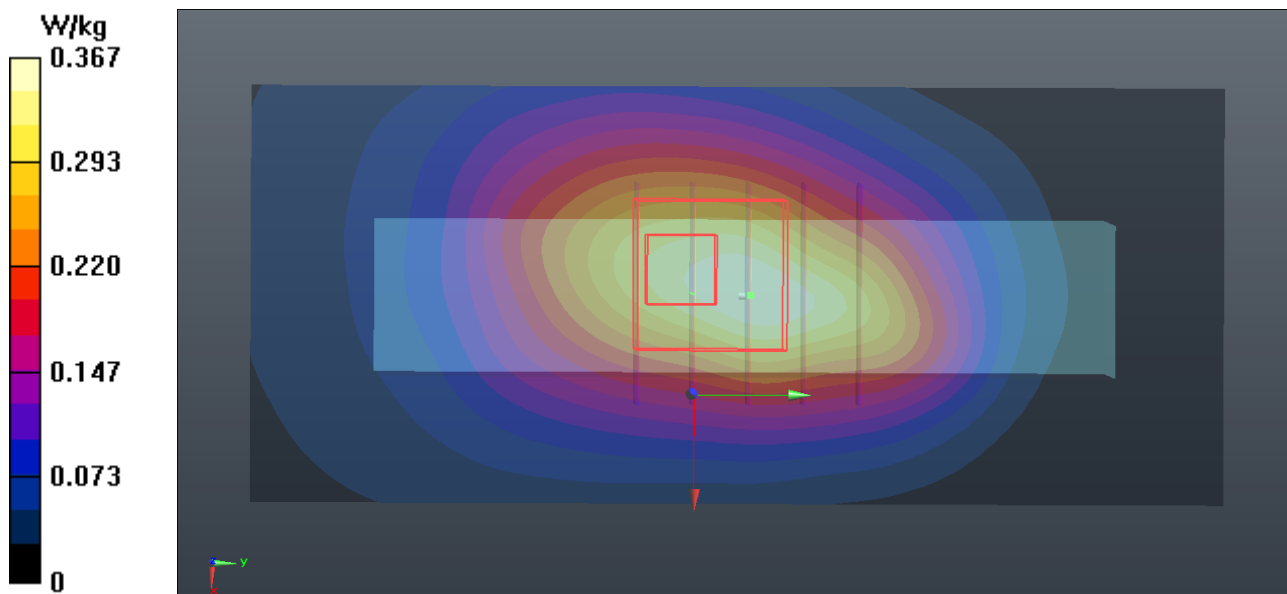

P10 WCDMA IV_RMC12.2k_Right Side_0.5cm_Ch1513

DUT: 121023C07

Communication System: WCDMA; Frequency: 1752.6 MHz; Duty Cycle: 1:1

Medium: B1750_1112 Medium parameters used: $f = 1753$ MHz; $\sigma = 1.469$ mho/m; $\epsilon_r = 53.646$; $\rho = 1000$ kg/m³

Ambient Temperature : 21.7 °C ; Liquid Temperature : 20.9 °C

DASY5 Configuration:

- Probe: EX3DV4 - SN3864; ConvF(8.45, 8.45, 8.45); Calibrated: 2012/07/19;
- Sensor-Surface: 2mm (Mechanical Surface Detection)
- Electronics: DAE4 Sn915; Calibrated: 2012/06/21
- Phantom: SAM Phantom_Front; Type: SAM V4.0; Serial: TP 1127
- Measurement SW: DASY52, Version 52.8 (2); SEMCAD X Version 14.6.6 (6824)

Ch1513/Area Scan (31x71x1): Measurement grid: dx=20mm, dy=20mm

Maximum value of SAR (interpolated) = 0.296 W/kg

Ch1513/Zoom Scan (5x5x7)/Cube 0: Measurement grid: dx=8mm, dy=8mm, dz=5mm

Reference Value = 11.852 V/m; Power Drift = -0.02 dB

Peak SAR (extrapolated) = 0.355 mW/g

SAR(1 g) = 0.226 mW/g; SAR(10 g) = 0.132 mW/g

Maximum value of SAR (measured) = 0.299 W/kg

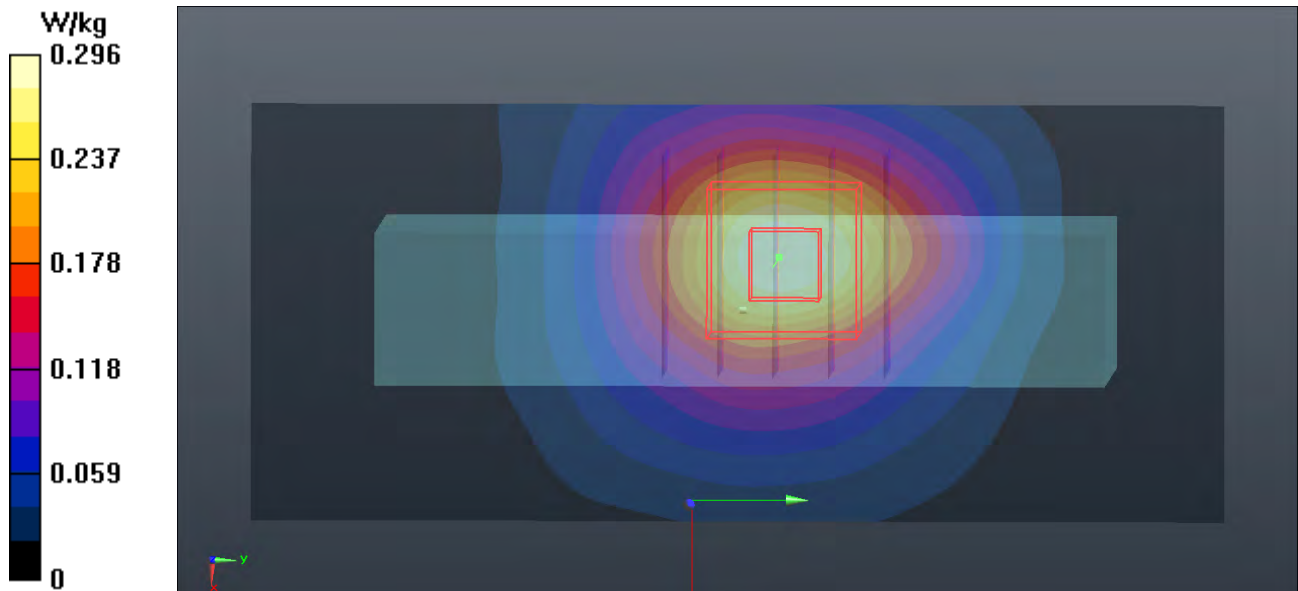

P11 WCDMA IV_RMC12.2k_Top Side_0.5cm_Ch1513

DUT: 121023C07

Communication System: WCDMA; Frequency: 1752.6 MHz; Duty Cycle: 1:1

Medium: B1750_1112 Medium parameters used: $f = 1753$ MHz; $\sigma = 1.469$ mho/m; $\epsilon_r = 53.646$; $\rho = 1000$ kg/m³

Ambient Temperature : 21.7 °C; Liquid Temperature : 20.9 °C

DASY5 Configuration:

- Probe: EX3DV4 - SN3864; ConvF(8.45, 8.45, 8.45); Calibrated: 2012/07/19;
- Sensor-Surface: 2mm (Mechanical Surface Detection)
- Electronics: DAE4 Sn915; Calibrated: 2012/06/21
- Phantom: SAM Phantom_Front; Type: SAM V4.0; Serial: TP 1127
- Measurement SW: DASY52, Version 52.8 (2); SEMCAD X Version 14.6.6 (6824)

Ch1513/Area Scan (41x51x1): Measurement grid: dx=20mm, dy=20mm

Maximum value of SAR (interpolated) = 0.119 W/kg

Ch1513/Zoom Scan (5x5x7)/Cube 0: Measurement grid: dx=8mm, dy=8mm, dz=5mm

Reference Value = 7.550 V/m; Power Drift = 0.08 dB

Peak SAR (extrapolated) = 0.191 mW/g

SAR(1 g) = 0.119 mW/g; SAR(10 g) = 0.064 mW/g

Maximum value of SAR (measured) = 0.157 W/kg

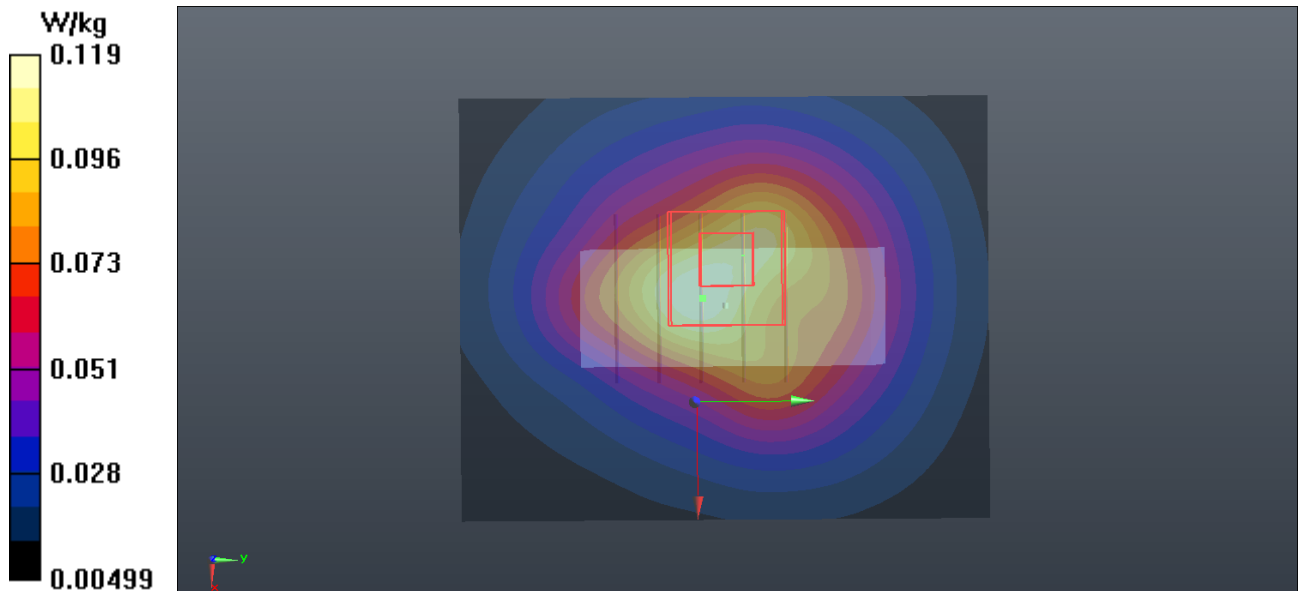

P101 802.11b_Front Face_0.5cm_Ch11

DUT: 121023C07

Communication System: WLAN_2.4G; Frequency: 2462 MHz; Duty Cycle: 1:1

Medium: B2450_1114 Medium parameters used: $f = 2462$ MHz; $\sigma = 1.998$ mho/m; $\epsilon_r = 51.123$; $\rho = 1000$ kg/m³

Ambient Temperature : 21.6 °C ; Liquid Temperature : 20.6 °C

DASY5 Configuration:

- Probe: EX3DV4 - SN3578; ConvF(6.43, 6.43, 6.43); Calibrated: 2012/06/21;
- Sensor-Surface: 2mm (Mechanical Surface Detection)
- Electronics: DAE4 Sn1277; Calibrated: 2012/07/19
- Phantom: SAM Phantom_Front; Type: SAM V4.0; Serial: TP 1127
- Measurement SW: DASY52, Version 52.8 (2); SEMCAD X Version 14.6.6 (6824)

Ch11/Area Scan (51x71x1): Measurement grid: dx=20mm, dy=20mm

Maximum value of SAR (interpolated) = 0.414 W/kg

Ch11/Zoom Scan (5x5x7)/Cube 0: Measurement grid: dx=8mm, dy=8mm, dz=5mm

Reference Value = 11.123 V/m; Power Drift = 0.10 dB

Peak SAR (extrapolated) = 0.440 mW/g

SAR(1 g) = 0.206 mW/g; SAR(10 g) = 0.103 mW/g

Maximum value of SAR (measured) = 0.309 W/kg

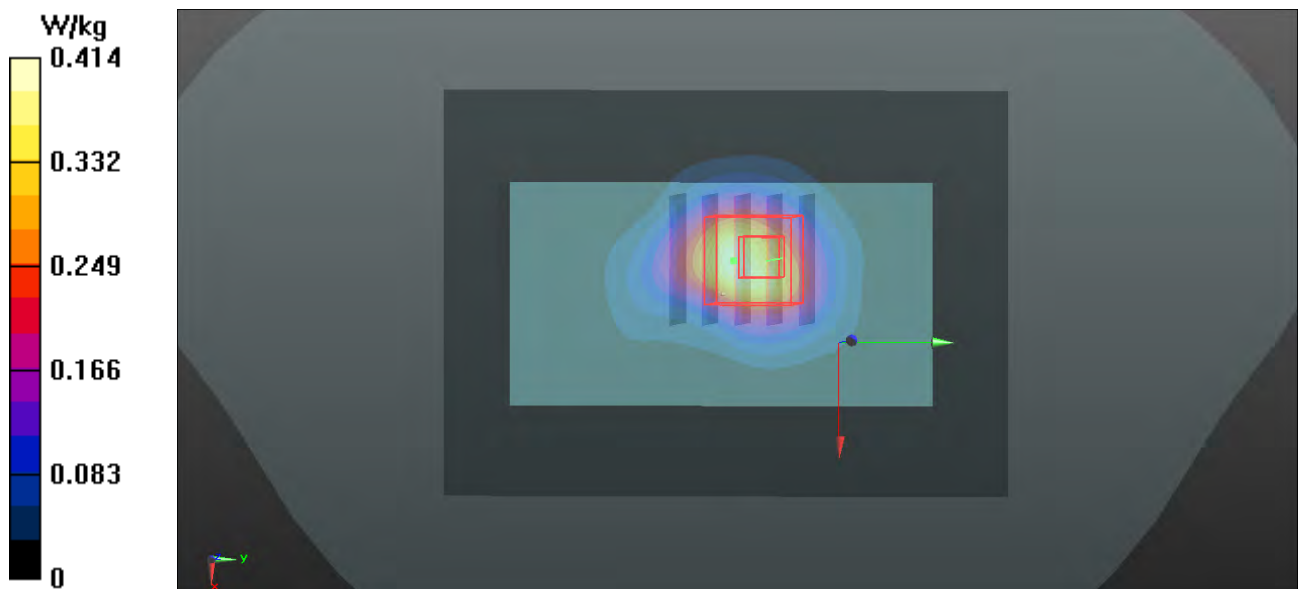

1g/10g Averaged SAR

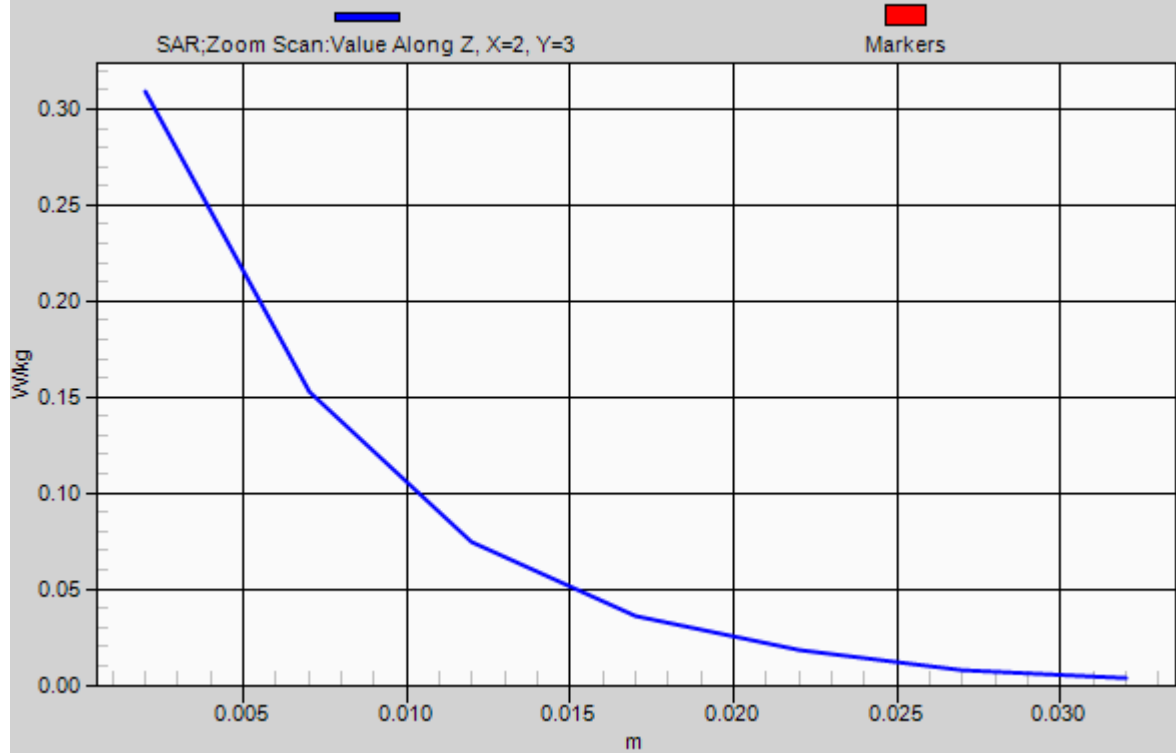

P102 802.11b_Rear Face_0.5cm_Ch11

DUT: 121023C07

Communication System: WLAN_2.4G; Frequency: 2462 MHz; Duty Cycle: 1:1

Medium: B2450_1114 Medium parameters used: $f = 2462$ MHz; $\sigma = 1.998$ mho/m; $\epsilon_r = 51.123$; $\rho = 1000$ kg/m³

Ambient Temperature : 21.6 °C; Liquid Temperature : 20.6 °C

DASY5 Configuration:

- Probe: EX3DV4 - SN3578; ConvF(6.43, 6.43, 6.43); Calibrated: 2012/06/21;
- Sensor-Surface: 2mm (Mechanical Surface Detection)
- Electronics: DAE4 Sn1277; Calibrated: 2012/07/19
- Phantom: SAM Phantom_Front; Type: SAM V4.0; Serial: TP 1127
- Measurement SW: DASY52, Version 52.8 (2); SEMCAD X Version 14.6.6 (6824)

Ch11/Area Scan (51x71x1): Measurement grid: dx=20mm, dy=20mm

Maximum value of SAR (interpolated) = 0.166 W/kg

Ch11/Zoom Scan (5x5x7)/Cube 0: Measurement grid: dx=8mm, dy=8mm, dz=5mm

Reference Value = 2.741 V/m; Power Drift = -0.15 dB

Peak SAR (extrapolated) = 0.123 mW/g

SAR(1 g) = 0.064 mW/g; SAR(10 g) = 0.032 mW/g

Maximum value of SAR (measured) = 0.0897 W/kg

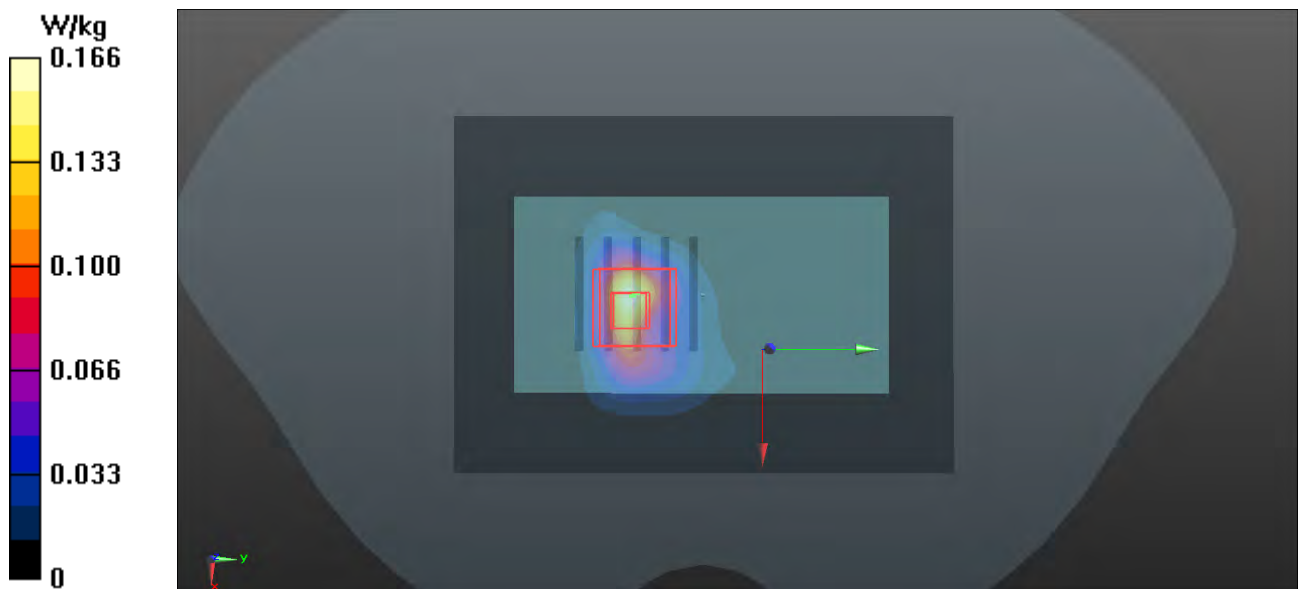

P103 802.11b_Left Side_0.5cm_Ch11

DUT: 121023C07

Communication System: WLAN_2.4G; Frequency: 2462 MHz; Duty Cycle: 1:1

Medium: B2450_1114 Medium parameters used: $f = 2462$ MHz; $\sigma = 1.998$ mho/m; $\epsilon_r = 51.123$; $\rho = 1000$ kg/m³

Ambient Temperature : 21.6 °C ; Liquid Temperature : 20.6 °C

DASY5 Configuration:

- Probe: EX3DV4 - SN3578; ConvF(6.43, 6.43, 6.43); Calibrated: 2012/06/21;
- Sensor-Surface: 2mm (Mechanical Surface Detection)
- Electronics: DAE4 Sn1277; Calibrated: 2012/07/19
- Phantom: SAM Phantom_Front; Type: SAM V4.0; Serial: TP 1127
- Measurement SW: DASY52, Version 52.8 (2); SEMCAD X Version 14.6.6 (6824)

Ch11/Area Scan (41x71x1): Measurement grid: dx=20mm, dy=20mm

Maximum value of SAR (interpolated) = 0.181 W/kg

Ch11/Zoom Scan (5x5x7)/Cube 0: Measurement grid: dx=8mm, dy=8mm, dz=5mm

Reference Value = 8.264 V/m; Power Drift = -0.16 dB

Peak SAR (extrapolated) = 0.363 mW/g

SAR(1 g) = 0.168 mW/g; SAR(10 g) = 0.073 mW/g

Maximum value of SAR (measured) = 0.264 W/kg

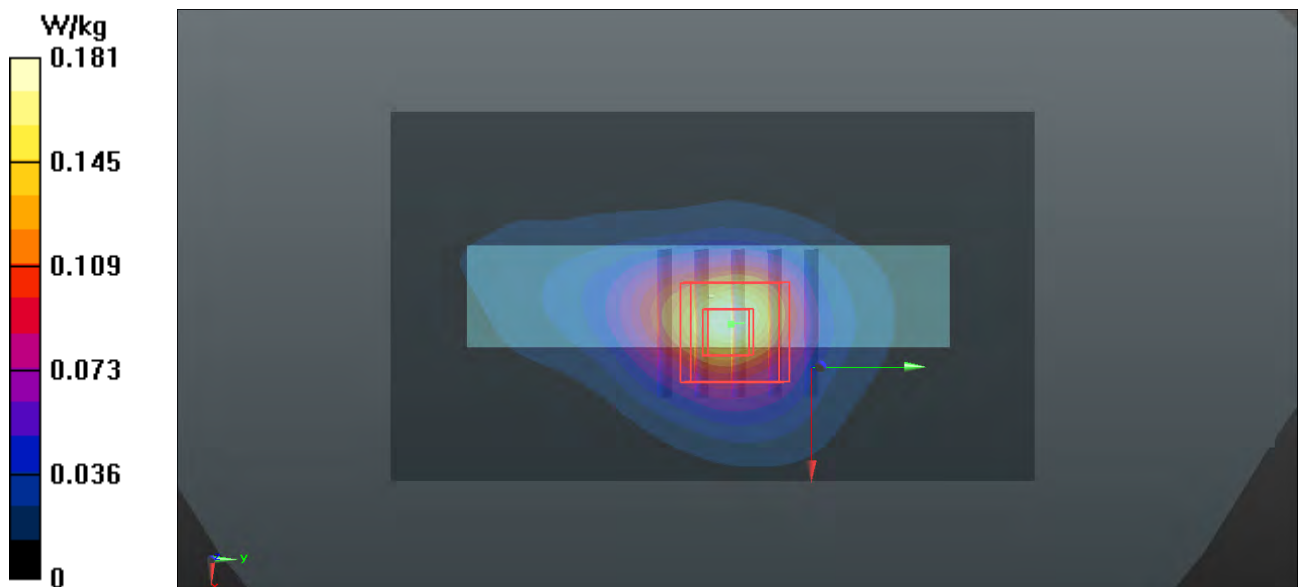

P234 LTE 2_QPSK_20M_Front Face_0.5cm_Ch18700_1 RB_offset 50

DUT: 121023C07

Communication System: LTE; Frequency: 1860 MHz; Duty Cycle: 1:1

Medium: B1900_1106 Medium parameters used: $f = 1860$ MHz; $\sigma = 1.486$ mho/m; $\epsilon_r = 51.158$; $\rho = 1000$ kg/m³

Ambient Temperature : 21.4 °C ; Liquid Temperature : 20.3 °C

DASY5 Configuration:

- Probe: EX3DV4 - SN3590; ConvF(8.07, 8.07, 8.07); Calibrated: 2012/02/23;
- Sensor-Surface: 2mm (Mechanical Surface Detection)
- Electronics: DAE4 Sn861; Calibrated: 2012/08/23
- Phantom: ELI v4.0; Type: QDOVA001BA; Serial: TP:1043
- Measurement SW: DASY52, Version 52.8 (2); SEMCAD X Version 14.6.6 (6824)

Ch18700/Area Scan (51x71x1): Measurement grid: dx=20mm, dy=20mm

Maximum value of SAR (interpolated) = 0.814 W/kg

Ch18700/Zoom Scan (5x5x7)/Cube 0: Measurement grid: dx=8mm, dy=8mm, dz=5mm

Reference Value = 12.527 V/m; Power Drift = -0.17 dB

Peak SAR (extrapolated) = 1.316 mW/g

SAR(1 g) = 0.680 mW/g; SAR(10 g) = 0.340 mW/g

Maximum value of SAR (measured) = 0.995 W/kg

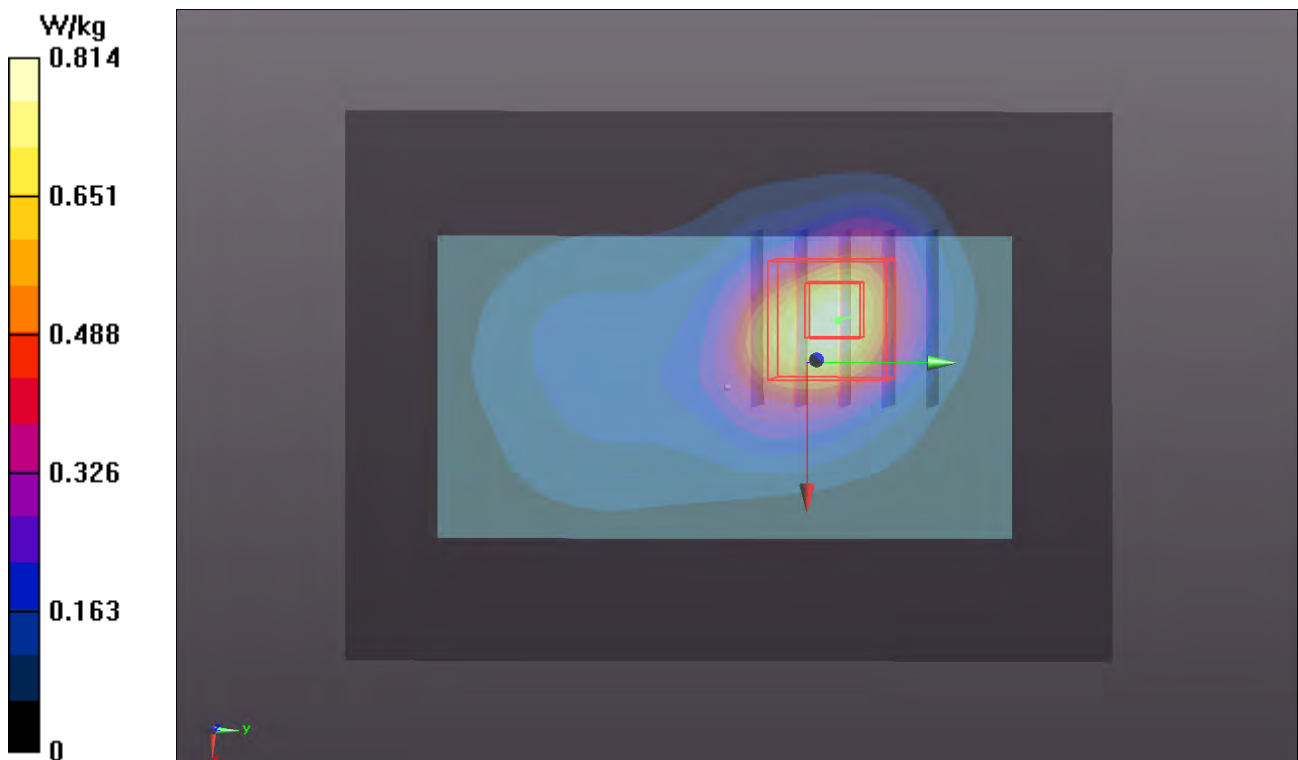

P201 LTE 2_QPSK_20M_Rear Face_0.5cm_Ch18700_1 RB_offset 50

DUT: 121023C07

Communication System: LTE; Frequency: 1860 MHz; Duty Cycle: 1:1

Medium: B1900_1106 Medium parameters used: $f = 1860$ MHz; $\sigma = 1.486$ mho/m; $\epsilon_r = 51.158$; $\rho = 1000$ kg/m³

Ambient Temperature : 21.4 °C ; Liquid Temperature : 20.3 °C

DASY5 Configuration:

- Probe: EX3DV4 - SN3590; ConvF(8.07, 8.07, 8.07); Calibrated: 2012/02/23;
- Sensor-Surface: 2mm (Mechanical Surface Detection)
- Electronics: DAE4 Sn861; Calibrated: 2012/08/23
- Phantom: ELI v4.0; Type: QDOVA001BA; Serial: TP:1043
- Measurement SW: DASY52, Version 52.8 (2); SEMCAD X Version 14.6.6 (6824)

Ch18700/Area Scan (51x71x1): Measurement grid: dx=20mm, dy=20mm

Maximum value of SAR (interpolated) = 0.880 W/kg

Ch18700/Zoom Scan (5x5x7)/Cube 0: Measurement grid: dx=8mm, dy=8mm, dz=5mm

Reference Value = 19.543 V/m; Power Drift = -0.12 dB

Peak SAR (extrapolated) = 0.773 mW/g

SAR(1 g) = 0.524 mW/g; SAR(10 g) = 0.325 mW/g

Maximum value of SAR (measured) = 0.656 W/kg

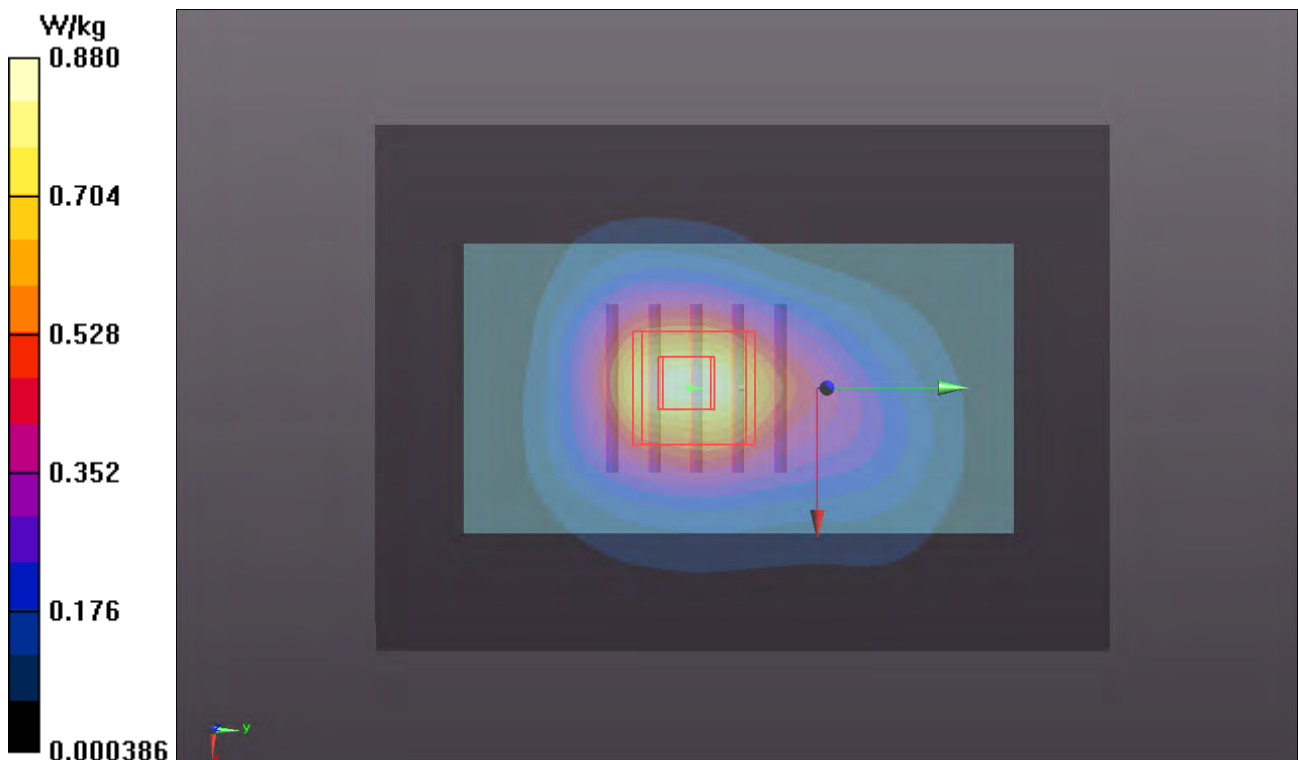

P235 LTE 2_QPSK_20M_Left Side_0.5cm_Ch18700_1 RB_offset 50**DUT: 121023C07**

Communication System: LTE; Frequency: 1860 MHz; Duty Cycle: 1:1

Medium: B1900_1106 Medium parameters used: $f = 1860$ MHz; $\sigma = 1.486$ mho/m; $\epsilon_r = 51.158$; $\rho = 1000$ kg/m³

Ambient Temperature : 21.4 °C ; Liquid Temperature : 20.3 °C

DASY5 Configuration:

- Probe: EX3DV4 - SN3590; ConvF(8.07, 8.07, 8.07); Calibrated: 2012/02/23;
- Sensor-Surface: 2mm (Mechanical Surface Detection)
- Electronics: DAE4 Sn861; Calibrated: 2012/08/23
- Phantom: ELI v4.0; Type: QDOVA001BA; Serial: TP:1043
- Measurement SW: DASY52, Version 52.8 (2); SEMCAD X Version 14.6.6 (6824)

Ch18700/Area Scan (41x71x1): Measurement grid: dx=20mm, dy=20mm

Maximum value of SAR (interpolated) = 0.306 W/kg

Ch18700/Zoom Scan (5x5x7)/Cube 0: Measurement grid: dx=8mm, dy=8mm, dz=5mm

Reference Value = 10.799 V/m; Power Drift = -0.19 dB

Peak SAR (extrapolated) = 0.465 mW/g

SAR(1 g) = 0.242 mW/g; SAR(10 g) = 0.123 mW/g

Maximum value of SAR (measured) = 0.350 W/kg

Ch18700/Zoom Scan (5x5x7)/Cube 1: Measurement grid: dx=8mm, dy=8mm, dz=5mm

Reference Value = 10.799 V/m; Power Drift = -0.19 dB

Peak SAR (extrapolated) = 0.295 mW/g

SAR(1 g) = 0.186 mW/g; SAR(10 g) = 0.111 mW/g

Maximum value of SAR (measured) = 0.241 W/kg

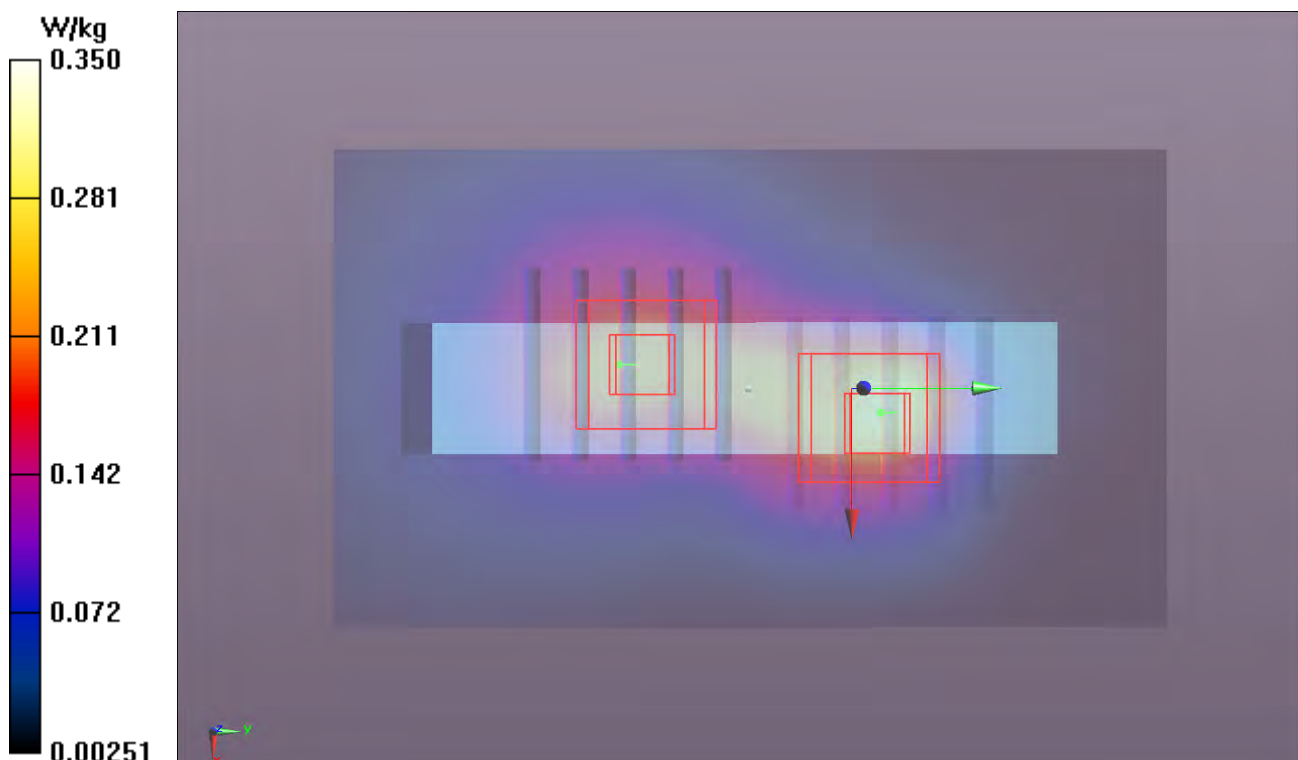

P236 LTE 2_QPSK_20M_Right Side_0.5cm_Ch18700_1 RB_offset 50

DUT: 121023C07

Communication System: LTE; Frequency: 1860 MHz; Duty Cycle: 1:1

Medium: B1900_1106 Medium parameters used: $f = 1860$ MHz; $\sigma = 1.486$ mho/m; $\epsilon_r = 51.158$; $\rho = 1000$ kg/m³

Ambient Temperature : 21.4 °C ; Liquid Temperature : 20.3 °C

DASY5 Configuration:

- Probe: EX3DV4 - SN3590; ConvF(8.07, 8.07, 8.07); Calibrated: 2012/02/23;
- Sensor-Surface: 2mm (Mechanical Surface Detection)
- Electronics: DAE4 Sn861; Calibrated: 2012/08/23
- Phantom: ELI v4.0; Type: QDOVA001BA; Serial: TP:1043
- Measurement SW: DASY52, Version 52.8 (2); SEMCAD X Version 14.6.6 (6824)

Ch18700/Area Scan (41x71x1): Measurement grid: dx=20mm, dy=20mm

Maximum value of SAR (interpolated) = 0.287 W/kg

Ch18700/Zoom Scan (5x5x7)/Cube 0: Measurement grid: dx=8mm, dy=8mm, dz=5mm

Reference Value = 10.184 V/m; Power Drift = -0.04 dB

Peak SAR (extrapolated) = 0.346 mW/g

SAR(1 g) = 0.210 mW/g; SAR(10 g) = 0.121 mW/g

Maximum value of SAR (measured) = 0.282 W/kg

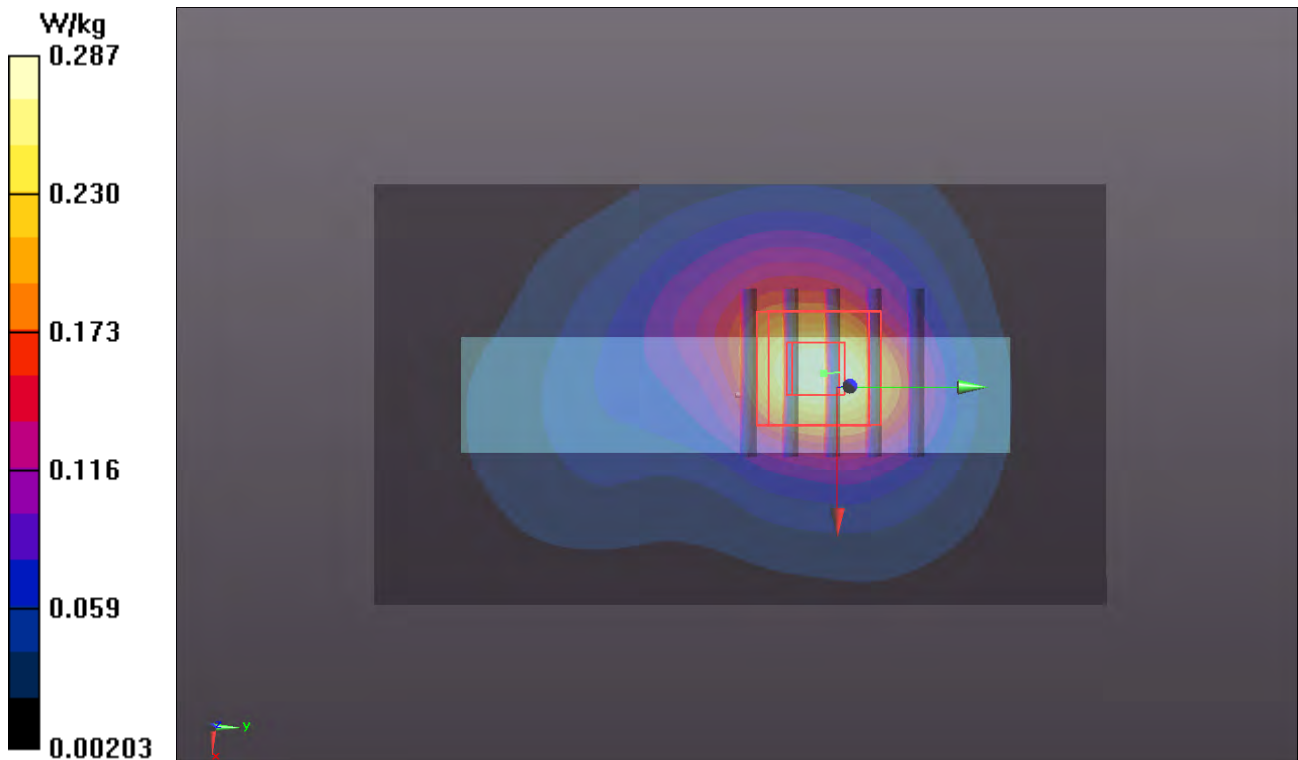

P237 LTE 2_QPSK_20M_Top Side_0.5cm_Ch18700_1 RB_offset 50

DUT: 121023C07

Communication System: LTE; Frequency: 1860 MHz; Duty Cycle: 1:1

Medium: B1900_1106 Medium parameters used: $f = 1860$ MHz; $\sigma = 1.486$ mho/m; $\epsilon_r = 51.158$; $\rho = 1000$ kg/m³

Ambient Temperature : 21.4 °C ; Liquid Temperature : 20.3 °C

DASY5 Configuration:

- Probe: EX3DV4 - SN3590; ConvF(8.07, 8.07, 8.07); Calibrated: 2012/02/23;
- Sensor-Surface: 2mm (Mechanical Surface Detection)
- Electronics: DAE4 Sn861; Calibrated: 2012/08/23
- Phantom: ELI v4.0; Type: QDOVA001BA; Serial: TP:1043
- Measurement SW: DASY52, Version 52.8 (2); SEMCAD X Version 14.6.6 (6824)

Ch18700/Area Scan (41x71x1): Measurement grid: dx=20mm, dy=20mm

Maximum value of SAR (interpolated) = 0.137 W/kg

Ch18700/Zoom Scan (5x5x7)/Cube 0: Measurement grid: dx=8mm, dy=8mm, dz=5mm

Reference Value = 8.864 V/m; Power Drift = -0.04 dB

Peak SAR (extrapolated) = 0.162 mW/g

SAR(1 g) = 0.100 mW/g; SAR(10 g) = 0.057 mW/g

Maximum value of SAR (measured) = 0.133 W/kg

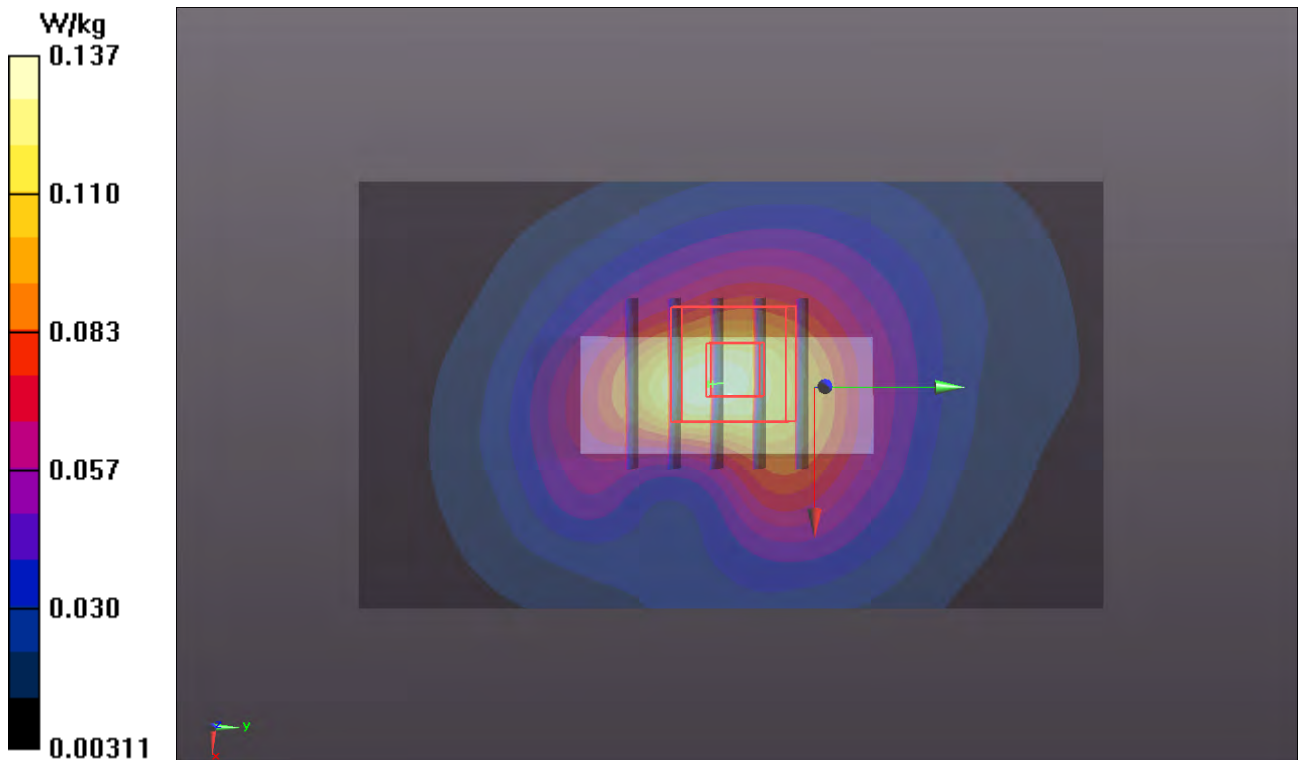

P245 LTE 2_QPSK_20M_Front Face_0.5cm_Ch18700_50 RB_offset 0

DUT: 121023C07

Communication System: LTE; Frequency: 1860 MHz; Duty Cycle: 1:1

Medium: B1900_1106 Medium parameters used: $f = 1860$ MHz; $\sigma = 1.486$ mho/m; $\epsilon_r = 51.158$; $\rho = 1000$ kg/m³

Ambient Temperature : 21.4 °C ; Liquid Temperature : 20.3 °C

DASY5 Configuration:

- Probe: EX3DV4 - SN3590; ConvF(8.07, 8.07, 8.07); Calibrated: 2012/02/23;
- Sensor-Surface: 2mm (Mechanical Surface Detection)
- Electronics: DAE4 Sn861; Calibrated: 2012/08/23
- Phantom: ELI v4.0; Type: QDOVA001BA; Serial: TP:1043
- Measurement SW: DASY52, Version 52.8 (2); SEMCAD X Version 14.6.6 (6824)

Ch18700/Area Scan (51x71x1): Measurement grid: dx=20mm, dy=20mm

Maximum value of SAR (interpolated) = 0.660 W/kg

Ch18700/Zoom Scan (5x5x7)/Cube 0: Measurement grid: dx=8mm, dy=8mm, dz=5mm

Reference Value = 10.883 V/m; Power Drift = -0.03 dB

Peak SAR (extrapolated) = 1.102 mW/g

SAR(1 g) = 0.566 mW/g; SAR(10 g) = 0.281 mW/g

Maximum value of SAR (measured) = 0.832 W/kg

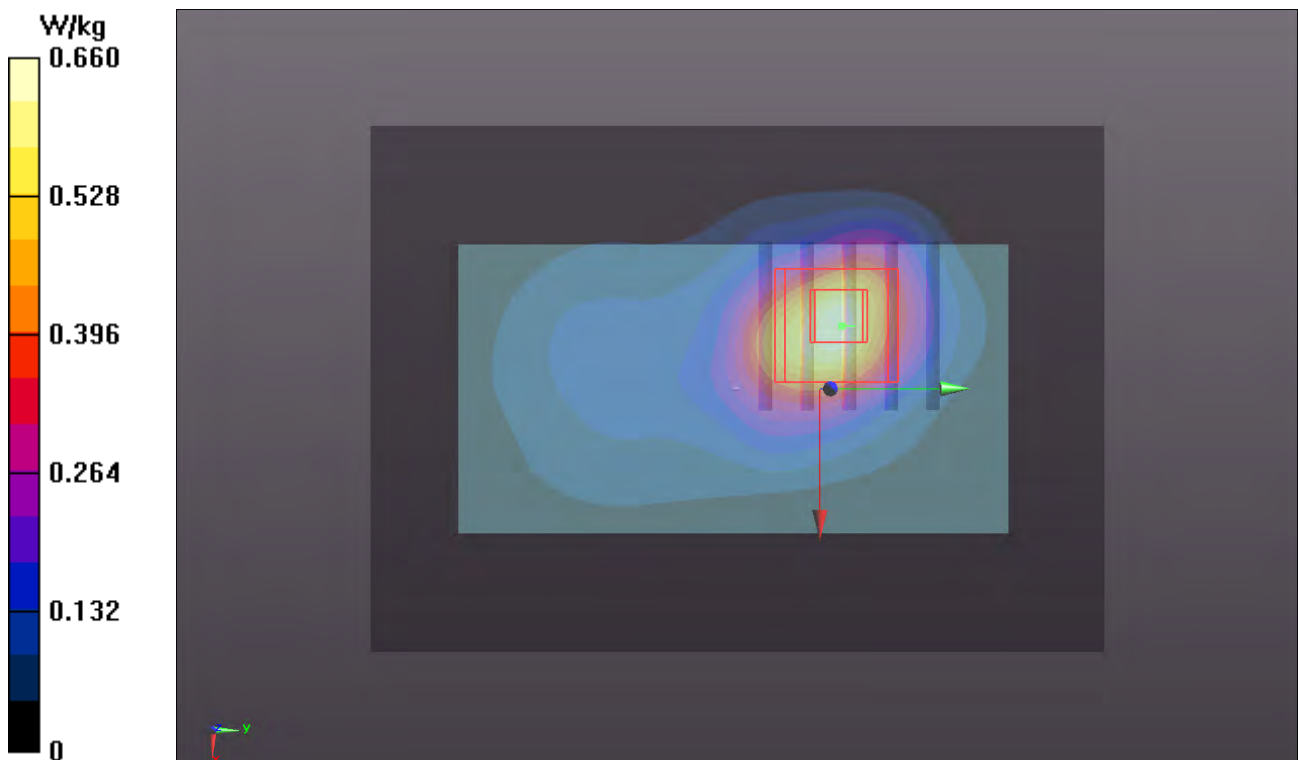

P246 LTE 2_QPSK_20M_Rear Face_0.5cm_Ch18700_50 RB_offset 0

DUT: 121023C07

Communication System: LTE; Frequency: 1860 MHz; Duty Cycle: 1:1

Medium: B1900_1106 Medium parameters used: $f = 1860$ MHz; $\sigma = 1.486$ mho/m; $\epsilon_r = 51.158$; $\rho = 1000$ kg/m³

Ambient Temperature : 21.4 °C ; Liquid Temperature : 20.3 °C

DASY5 Configuration:

- Probe: EX3DV4 - SN3590; ConvF(8.07, 8.07, 8.07); Calibrated: 2012/02/23;
- Sensor-Surface: 2mm (Mechanical Surface Detection)
- Electronics: DAE4 Sn861; Calibrated: 2012/08/23
- Phantom: ELI v4.0; Type: QDOVA001BA; Serial: TP:1043
- Measurement SW: DASY52, Version 52.8 (2); SEMCAD X Version 14.6.6 (6824)

Ch18700/Area Scan (51x71x1): Measurement grid: dx=20mm, dy=20mm

Maximum value of SAR (interpolated) = 0.684 W/kg

Ch18700/Zoom Scan (5x5x7)/Cube 0: Measurement grid: dx=8mm, dy=8mm, dz=5mm

Reference Value = 16.984 V/m; Power Drift = -0.01 dB

Peak SAR (extrapolated) = 0.631 mW/g

SAR(1 g) = 0.421 mW/g; SAR(10 g) = 0.260 mW/g

Maximum value of SAR (measured) = 0.534 W/kg

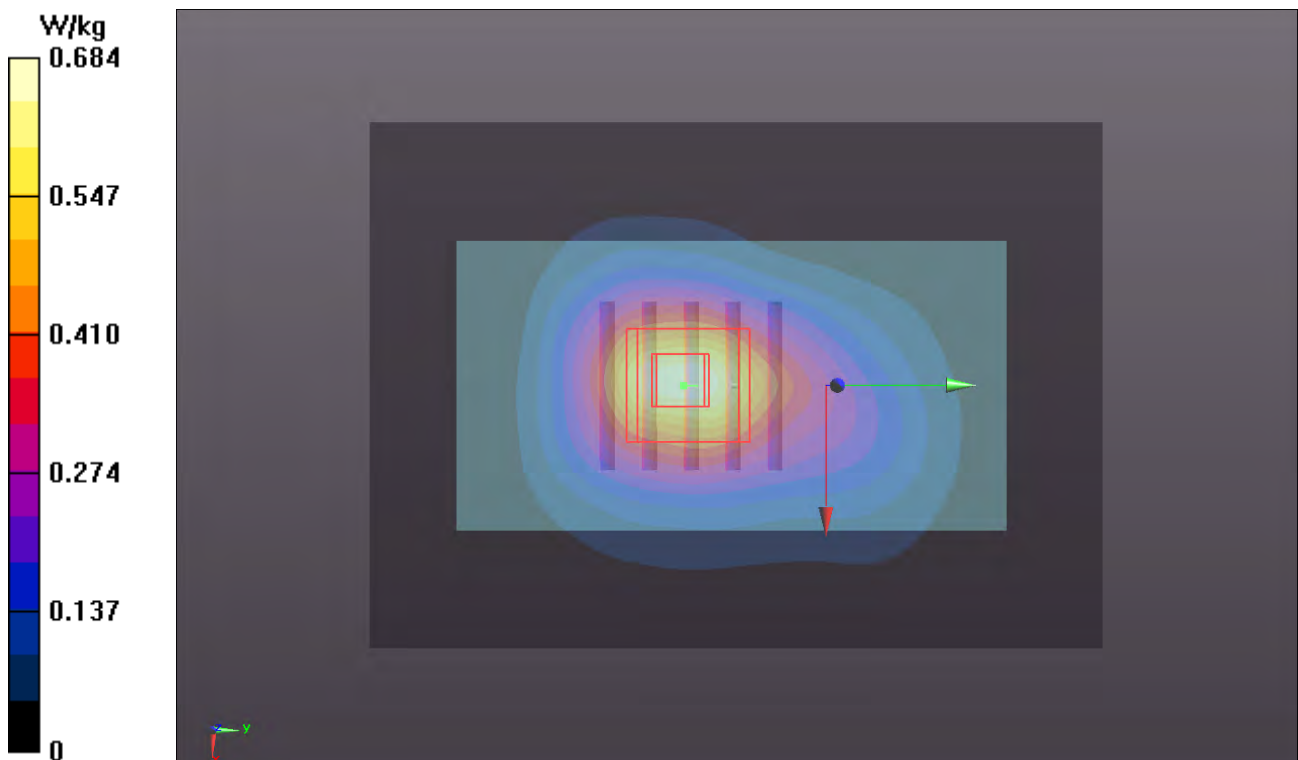

P247 LTE 2_QPSK_20M_Left Side_0.5cm_Ch18700_50 RB_offset 0

DUT: 121023C07

Communication System: LTE; Frequency: 1860 MHz; Duty Cycle: 1:1

Medium: B1900_1106 Medium parameters used: $f = 1860$ MHz; $\sigma = 1.486$ mho/m; $\epsilon_r = 51.158$; $\rho = 1000$ kg/m³

Ambient Temperature : 21.4 °C ; Liquid Temperature : 20.3 °C

DASY5 Configuration:

- Probe: EX3DV4 - SN3590; ConvF(8.07, 8.07, 8.07); Calibrated: 2012/02/23;
- Sensor-Surface: 2mm (Mechanical Surface Detection)
- Electronics: DAE4 Sn861; Calibrated: 2012/08/23
- Phantom: ELI v4.0; Type: QDOVA001BA; Serial: TP:1043
- Measurement SW: DASY52, Version 52.8 (2); SEMCAD X Version 14.6.6 (6824)

Ch18700/Area Scan (41x71x1): Measurement grid: dx=20mm, dy=20mm

Maximum value of SAR (interpolated) = 0.256 W/kg

Ch18700/Zoom Scan (5x5x7)/Cube 0: Measurement grid: dx=8mm, dy=8mm, dz=5mm

Reference Value = 9.648 V/m; Power Drift = -0.00 dB

Peak SAR (extrapolated) = 0.376 mW/g

SAR(1 g) = 0.198 mW/g; SAR(10 g) = 0.100 mW/g

Maximum value of SAR (measured) = 0.284 W/kg

Ch18700/Zoom Scan (5x5x7)/Cube 1: Measurement grid: dx=8mm, dy=8mm, dz=5mm

Reference Value = 9.648 V/m; Power Drift = -0.00 dB

Peak SAR (extrapolated) = 0.250 mW/g

SAR(1 g) = 0.157 mW/g; SAR(10 g) = 0.094 mW/g

Maximum value of SAR (measured) = 0.203 W/kg

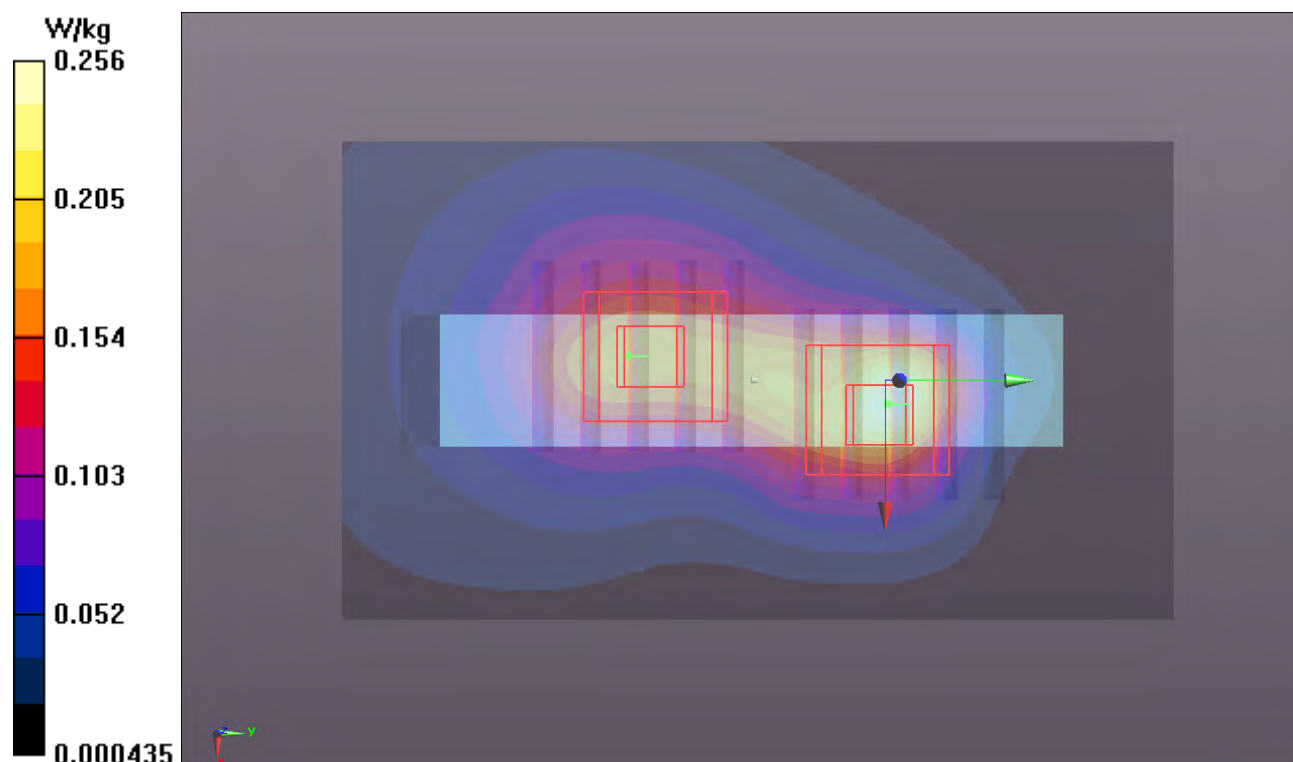

P248 LTE 2_QPSK_20M_Right Side_0.5cm_Ch18700_50 RB_offset 0

DUT: 121023C07

Communication System: LTE; Frequency: 1860 MHz; Duty Cycle: 1:1

Medium: B1900_1106 Medium parameters used: $f = 1860$ MHz; $\sigma = 1.486$ mho/m; $\epsilon_r = 51.158$; $\rho = 1000$ kg/m³

Ambient Temperature : 21.4 °C ; Liquid Temperature : 20.3 °C

DASY5 Configuration:

- Probe: EX3DV4 - SN3590; ConvF(8.07, 8.07, 8.07); Calibrated: 2012/02/23;
- Sensor-Surface: 2mm (Mechanical Surface Detection)
- Electronics: DAE4 Sn861; Calibrated: 2012/08/23
- Phantom: ELI v4.0; Type: QDOVA001BA; Serial: TP:1043
- Measurement SW: DASY52, Version 52.8 (2); SEMCAD X Version 14.6.6 (6824)

Ch18700/Area Scan (41x71x1): Measurement grid: dx=20mm, dy=20mm

Maximum value of SAR (interpolated) = 0.223 W/kg

Ch18700/Zoom Scan (5x5x7)/Cube 0: Measurement grid: dx=8mm, dy=8mm, dz=5mm

Reference Value = 8.904 V/m; Power Drift = 0.02 dB

Peak SAR (extrapolated) = 0.275 mW/g

SAR(1 g) = 0.169 mW/g; SAR(10 g) = 0.097 mW/g

Maximum value of SAR (measured) = 0.226 W/kg

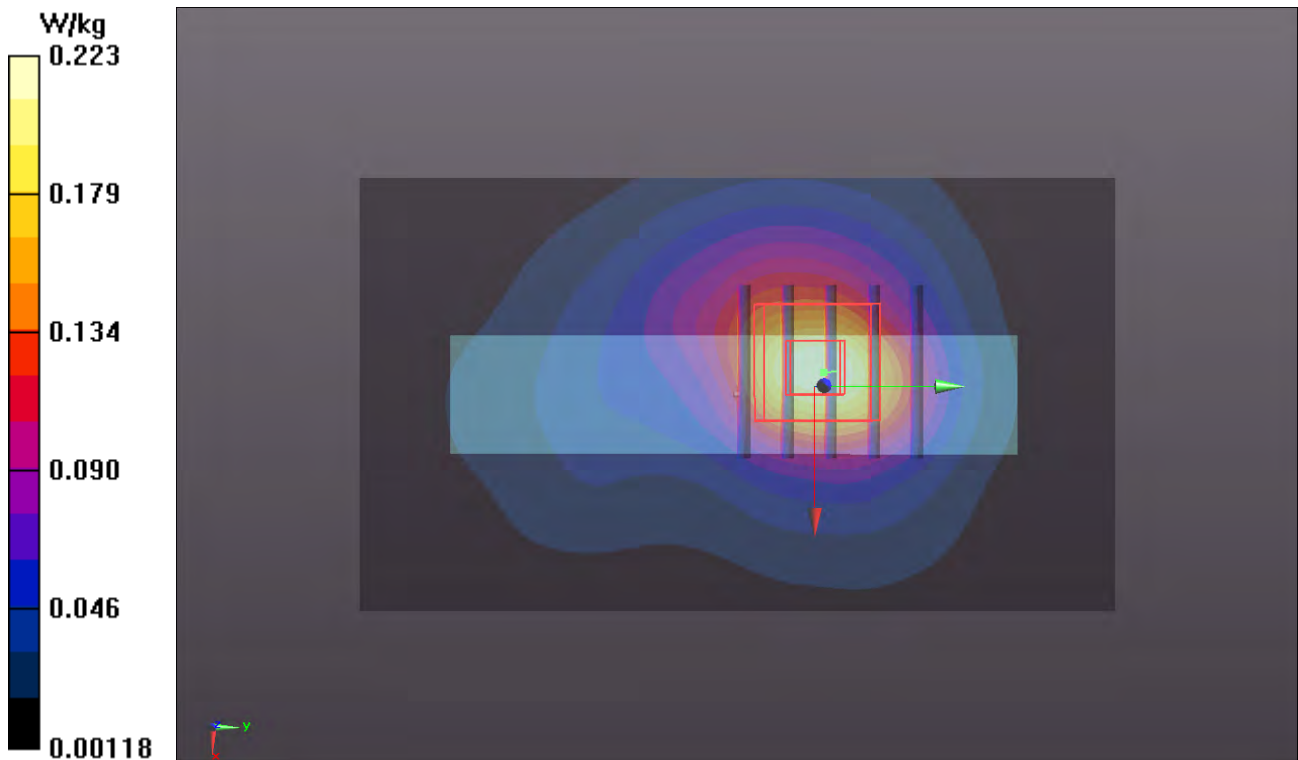

P249 LTE 2_QPSK_20M_Top Side_0.5cm_Ch18700_50 RB_offset 0

DUT: 121023C07

Communication System: LTE; Frequency: 1860 MHz; Duty Cycle: 1:1

Medium: B1900_1106 Medium parameters used: $f = 1860$ MHz; $\sigma = 1.486$ mho/m; $\epsilon_r = 51.158$; $\rho = 1000$ kg/m³

Ambient Temperature : 21.4 °C ; Liquid Temperature : 20.3 °C

DASY5 Configuration:

- Probe: EX3DV4 - SN3590; ConvF(8.07, 8.07, 8.07); Calibrated: 2012/02/23;
- Sensor-Surface: 2mm (Mechanical Surface Detection)
- Electronics: DAE4 Sn861; Calibrated: 2012/08/23
- Phantom: ELI v4.0; Type: QDOVA001BA; Serial: TP:1043
- Measurement SW: DASY52, Version 52.8 (2); SEMCAD X Version 14.6.6 (6824)

Ch18700/Area Scan (41x71x1): Measurement grid: dx=20mm, dy=20mm

Maximum value of SAR (interpolated) = 0.0887 W/kg

Ch18700/Zoom Scan (5x5x7)/Cube 0: Measurement grid: dx=8mm, dy=8mm, dz=5mm

Reference Value = 6.609 V/m; Power Drift = 0.01 dB

Peak SAR (extrapolated) = 0.108 mW/g

SAR(1 g) = 0.067 mW/g; SAR(10 g) = 0.039 mW/g

Maximum value of SAR (measured) = 0.0861 W/kg

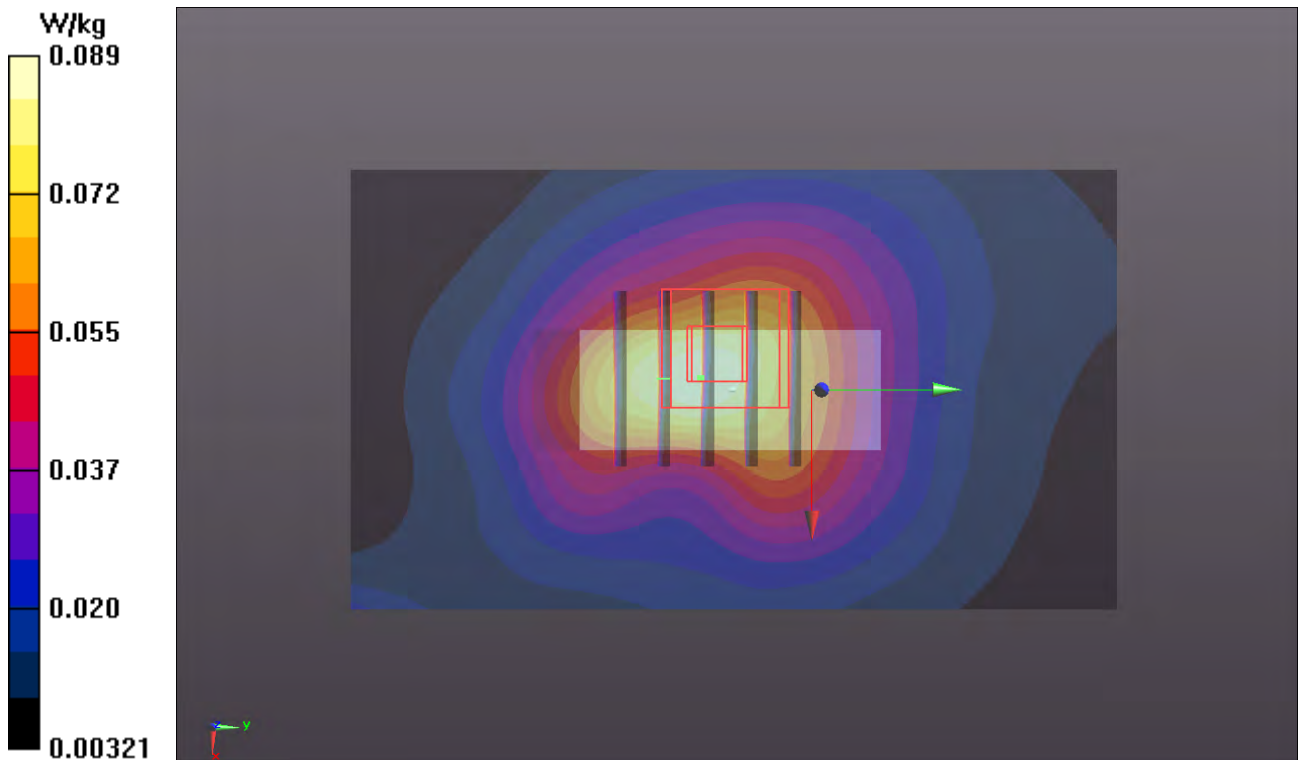

P263 LTE 4_QPSK_20M_Front Face_0.5cm_Ch20050_1 RB_offset 0

DUT: 121023C07

Communication System: LTE; Frequency: 1720 MHz; Duty Cycle: 1:1

Medium: B1750_1107 Medium parameters used: $f = 1720$ MHz; $\sigma = 1.434$ mho/m; $\epsilon_r = 53.251$; $\rho = 1000$ kg/m³

Ambient Temperature : 21.5 °C ; Liquid Temperature : 20.6 °C

DASY5 Configuration:

- Probe: EX3DV4 - SN3590; ConvF(8.64, 8.64, 8.64); Calibrated: 2012/02/23;
- Sensor-Surface: 2mm (Mechanical Surface Detection)
- Electronics: DAE4 Sn861; Calibrated: 2012/08/23
- Phantom: ELI v4.0; Type: QDOVA001BA; Serial: TP:1043
- Measurement SW: DASY52, Version 52.8 (2); SEMCAD X Version 14.6.6 (6824)

Ch20050/Area Scan (51x71x1): Measurement grid: dx=20mm, dy=20mm

Maximum value of SAR (interpolated) = 0.508 W/kg

Ch20050/Zoom Scan (5x5x7)/Cube 0: Measurement grid: dx=8mm, dy=8mm, dz=5mm

Reference Value = 16.050 V/m; Power Drift = -0.18 dB

Peak SAR (extrapolated) = 0.527 mW/g

SAR(1 g) = 0.326 mW/g; SAR(10 g) = 0.211 mW/g

Maximum value of SAR (measured) = 0.418 W/kg

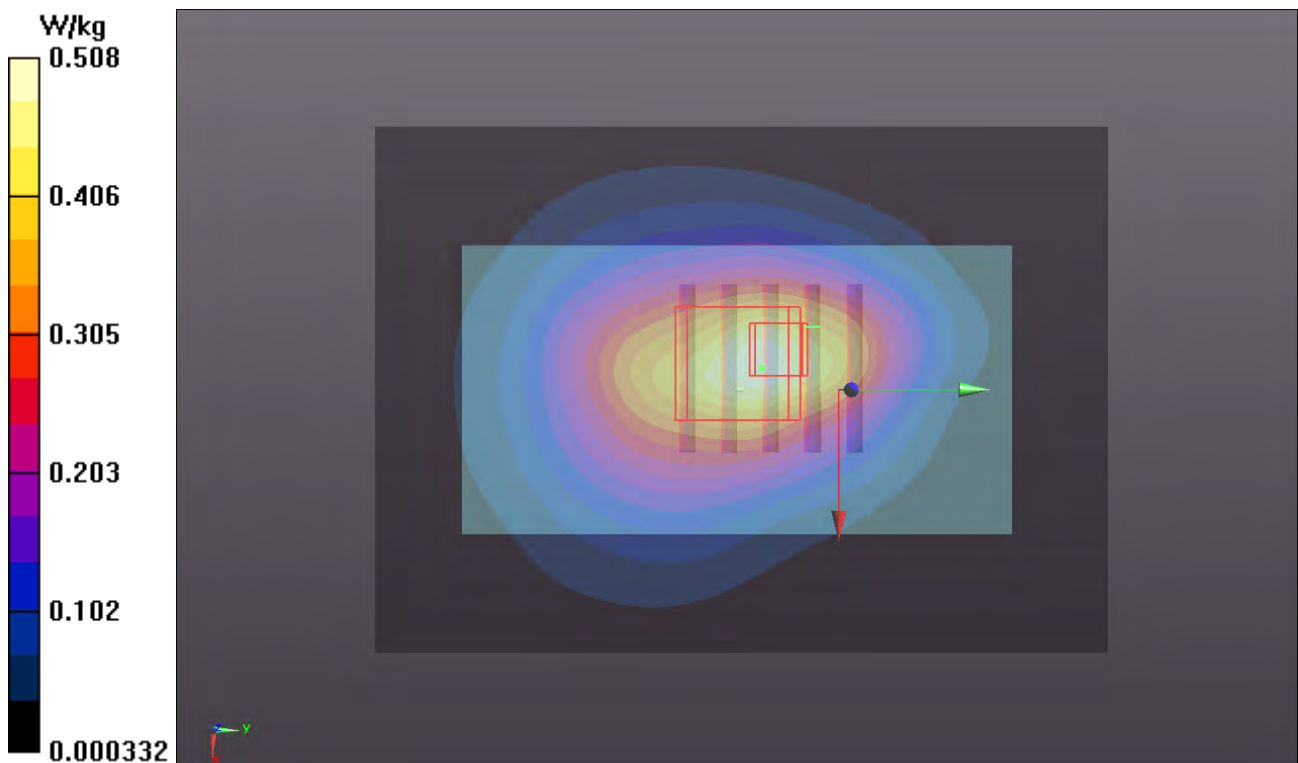

P264 LTE 4_QPSK_20M_Rear Face_0.5cm_Ch20050_1 RB_offset 0

DUT: 121023C07

Communication System: LTE; Frequency: 1720 MHz; Duty Cycle: 1:1

Medium: B1750_1107 Medium parameters used: $f = 1720$ MHz; $\sigma = 1.434$ mho/m; $\epsilon_r = 53.251$; $\rho = 1000$ kg/m³

Ambient Temperature : 21.5 °C ; Liquid Temperature : 20.6 °C

DASY5 Configuration:

- Probe: EX3DV4 - SN3590; ConvF(8.64, 8.64, 8.64); Calibrated: 2012/02/23;
- Sensor-Surface: 2mm (Mechanical Surface Detection)
- Electronics: DAE4 Sn861; Calibrated: 2012/08/23
- Phantom: ELI v4.0; Type: QDOVA001BA; Serial: TP:1043
- Measurement SW: DASY52, Version 52.8 (2); SEMCAD X Version 14.6.6 (6824)

Ch20050/Area Scan (51x71x1): Measurement grid: dx=20mm, dy=20mm

Maximum value of SAR (interpolated) = 0.879 W/kg

Ch20050/Zoom Scan (5x5x7)/Cube 0: Measurement grid: dx=8mm, dy=8mm, dz=5mm

Reference Value = 21.464 V/m; Power Drift = -0.16 dB

Peak SAR (extrapolated) = 0.782 mW/g

SAR(1 g) = 0.546 mW/g; SAR(10 g) = 0.346 mW/g

Maximum value of SAR (measured) = 0.676 W/kg

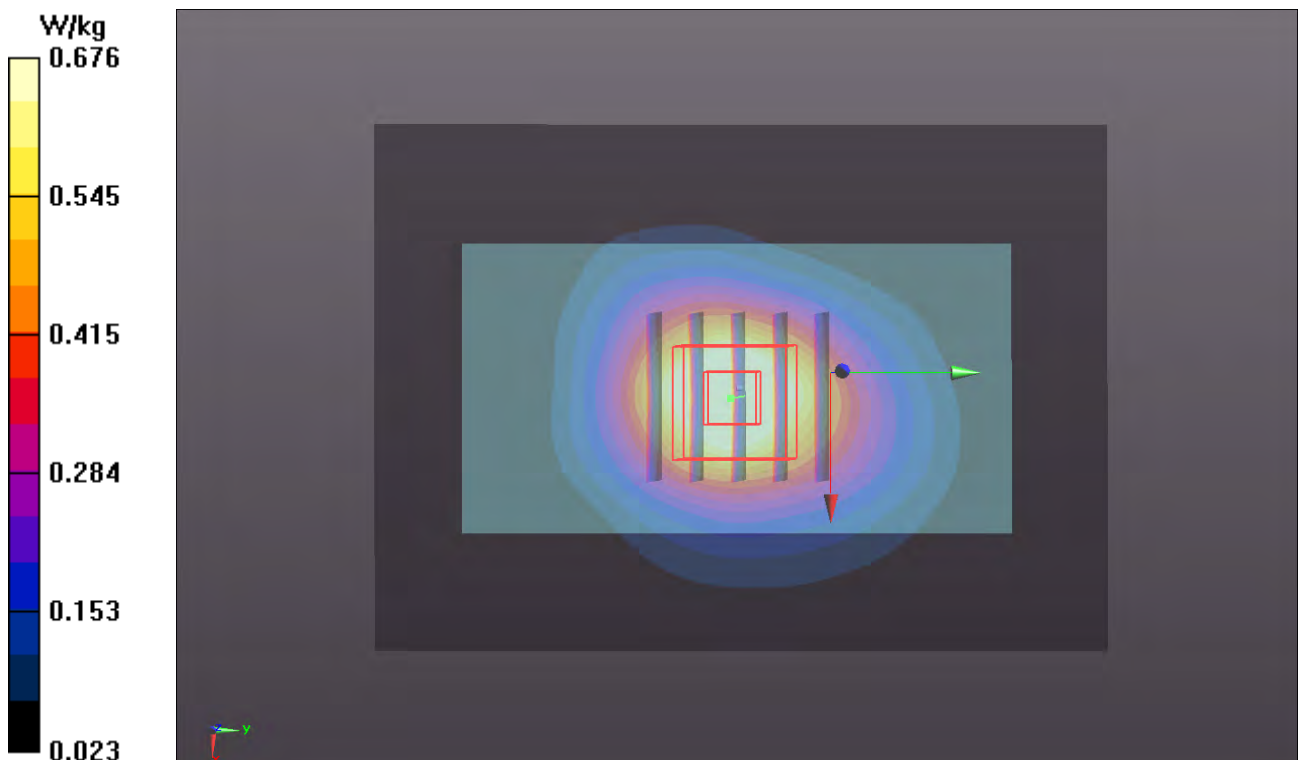

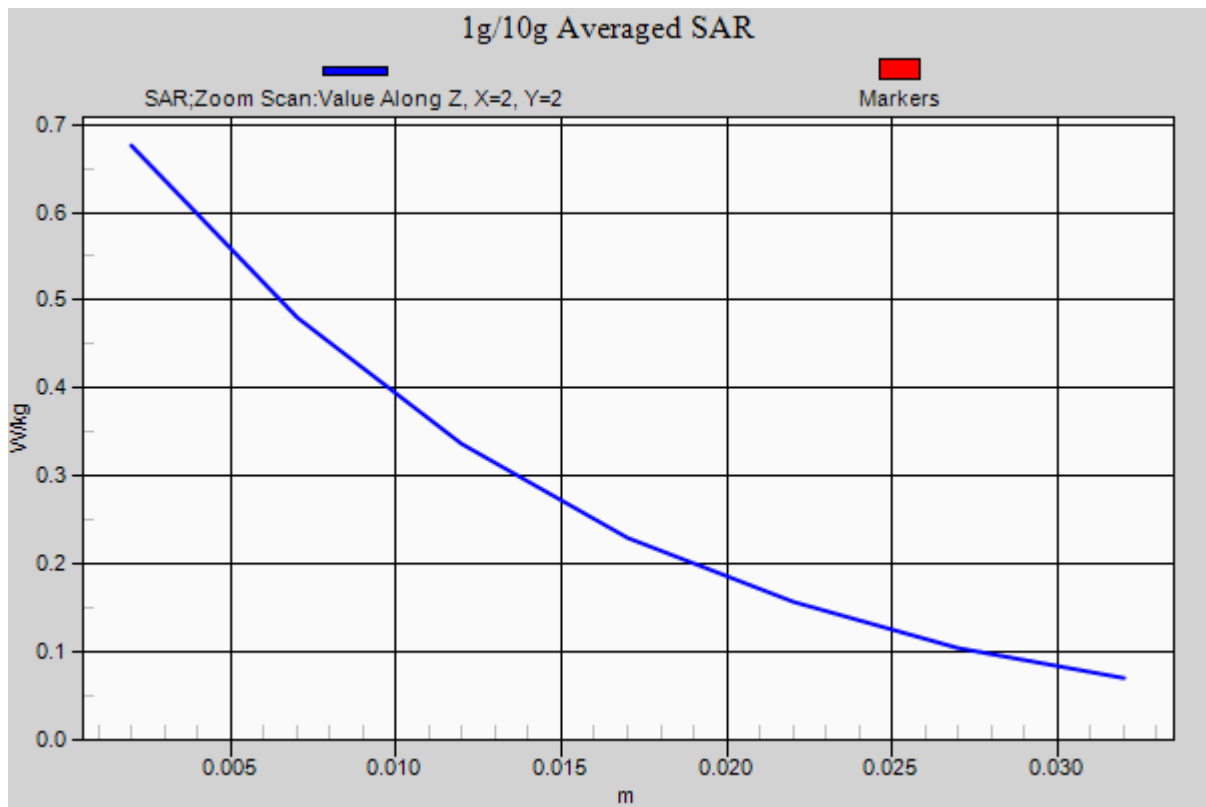

P265 LTE 4_QPSK_20M_Left Side_0.5cm_Ch20050_1 RB_offset 0

DUT: 121023C07

Communication System: LTE; Frequency: 1720 MHz; Duty Cycle: 1:1

Medium: B1750_1108 Medium parameters used: $f = 1720$ MHz; $\sigma = 1.435$ mho/m; $\epsilon_r = 53.313$; $\rho = 1000$ kg/m³

Ambient Temperature : 21.6 °C; Liquid Temperature : 20.7 °C

DASY5 Configuration:

- Probe: EX3DV4 - SN3864; ConvF(8.45, 8.45, 8.45); Calibrated: 2012/07/19;
- Sensor-Surface: 2mm (Mechanical Surface Detection)
- Electronics: DAE4 Sn915; Calibrated: 2012/06/21
- Phantom: SAM Phantom_Front; Type: SAM V4.0; Serial: TP 1127
- Measurement SW: DASY52, Version 52.8 (2); SEMCAD X Version 14.6.6 (6824)

Ch20050/Area Scan (51x71x1): Measurement grid: dx=20mm, dy=20mm

Maximum value of SAR (interpolated) = 0.188 W/kg

Ch20050/Zoom Scan (5x5x7)/Cube 0: Measurement grid: dx=8mm, dy=8mm, dz=5mm

Reference Value = 10.805 V/m; Power Drift = -0.13 dB

Peak SAR (extrapolated) = 0.199 mW/g

SAR(1 g) = 0.134 mW/g; SAR(10 g) = 0.084 mW/g

Maximum value of SAR (measured) = 0.164 W/kg

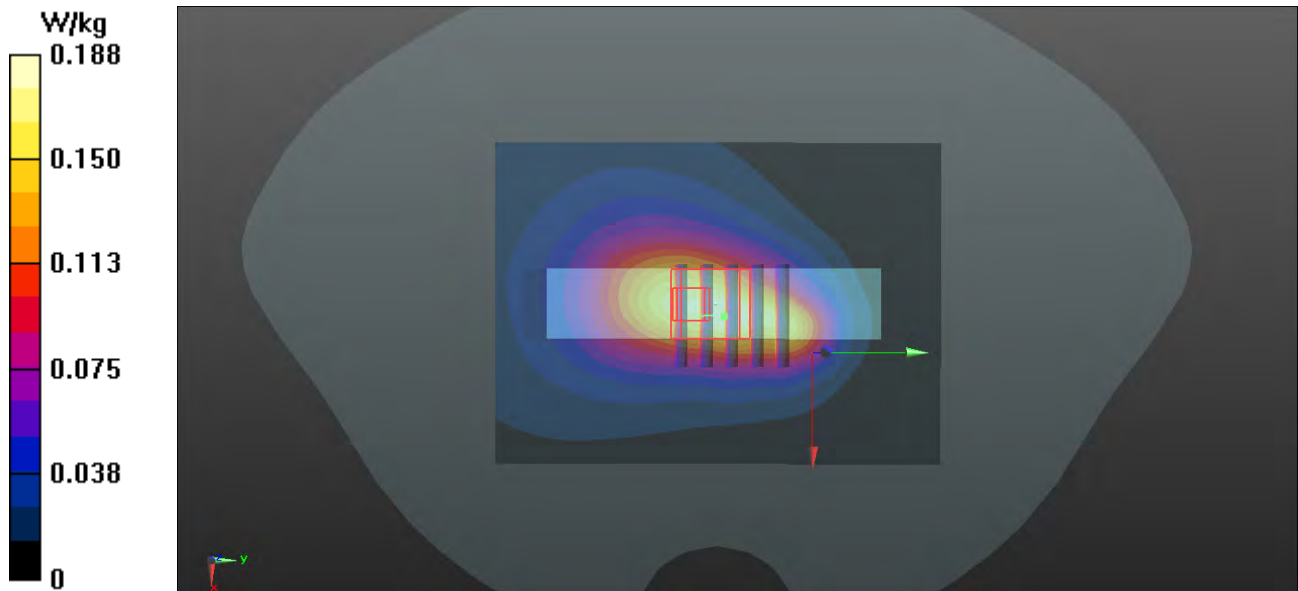

P266 LTE 4_QPSK_20M_Right Side_0.5cm_Ch20050_1 RB_offset 0

DUT: 121023C07

Communication System: LTE; Frequency: 1720 MHz; Duty Cycle: 1:1

Medium: B1750_1108 Medium parameters used: $f = 1720$ MHz; $\sigma = 1.435$ mho/m; $\epsilon_r = 53.313$; $\rho = 1000$ kg/m³

Ambient Temperature : 21.6 °C; Liquid Temperature : 20.7 °C

DASY5 Configuration:

- Probe: EX3DV4 - SN3864; ConvF(8.45, 8.45, 8.45); Calibrated: 2012/07/19;
- Sensor-Surface: 2mm (Mechanical Surface Detection)
- Electronics: DAE4 Sn915; Calibrated: 2012/06/21
- Phantom: SAM Phantom_Front; Type: SAM V4.0; Serial: TP 1127
- Measurement SW: DASY52, Version 52.8 (2); SEMCAD X Version 14.6.6 (6824)

Ch20050/Area Scan (51x71x1): Measurement grid: dx=20mm, dy=20mm

Maximum value of SAR (interpolated) = 0.113 W/kg

Ch20050/Zoom Scan (5x5x7)/Cube 0: Measurement grid: dx=8mm, dy=8mm, dz=5mm

Reference Value = 9.000 V/m; Power Drift = 0.09 dB

Peak SAR (extrapolated) = 0.150 mW/g

SAR(1 g) = 0.096 mW/g; SAR(10 g) = 0.057 mW/g

Maximum value of SAR (measured) = 0.124 W/kg

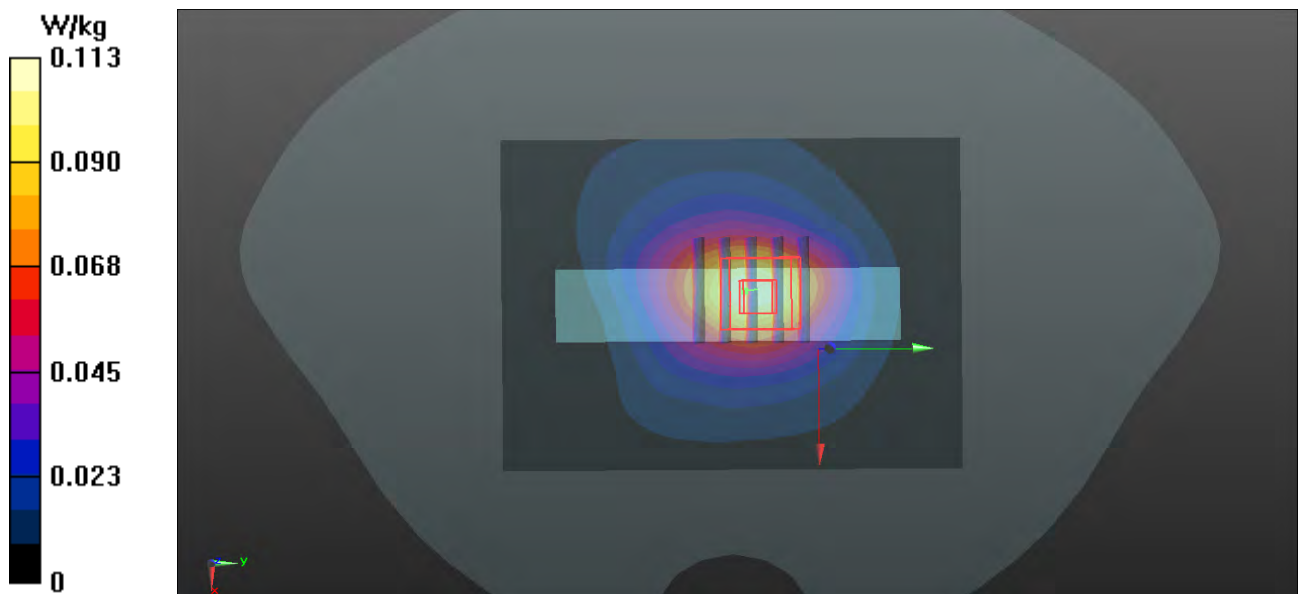

P267 LTE 4_QPSK_20M_Top Side_0.5cm_Ch20050_1 RB_offset 0

DUT: 121023C07

Communication System: LTE; Frequency: 1720 MHz; Duty Cycle: 1:1

Medium: B1750_1108 Medium parameters used: $f = 1720$ MHz; $\sigma = 1.435$ mho/m; $\epsilon_r = 53.313$; $\rho = 1000$ kg/m³

Ambient Temperature : 21.6 °C ; Liquid Temperature : 20.7 °C

DASY5 Configuration:

- Probe: EX3DV4 - SN3864; ConvF(8.45, 8.45, 8.45); Calibrated: 2012/07/19;
- Sensor-Surface: 2mm (Mechanical Surface Detection)
- Electronics: DAE4 Sn915; Calibrated: 2012/06/21
- Phantom: SAM Phantom_Front; Type: SAM V4.0; Serial: TP 1127
- Measurement SW: DASY52, Version 52.8 (2); SEMCAD X Version 14.6.6 (6824)

Ch20050/Area Scan (51x71x1): Measurement grid: dx=20mm, dy=20mm

Maximum value of SAR (interpolated) = 0.0629 W/kg

Ch20050/Zoom Scan (5x5x7)/Cube 0: Measurement grid: dx=8mm, dy=8mm, dz=5mm

Reference Value = 8.506 V/m; Power Drift = -0.049 dB

Peak SAR (extrapolated) = 0.116 mW/g

SAR(1 g) = 0.065 mW/g; SAR(10 g) = 0.034 mW/g

Maximum value of SAR (measured) = 0.0859 W/kg

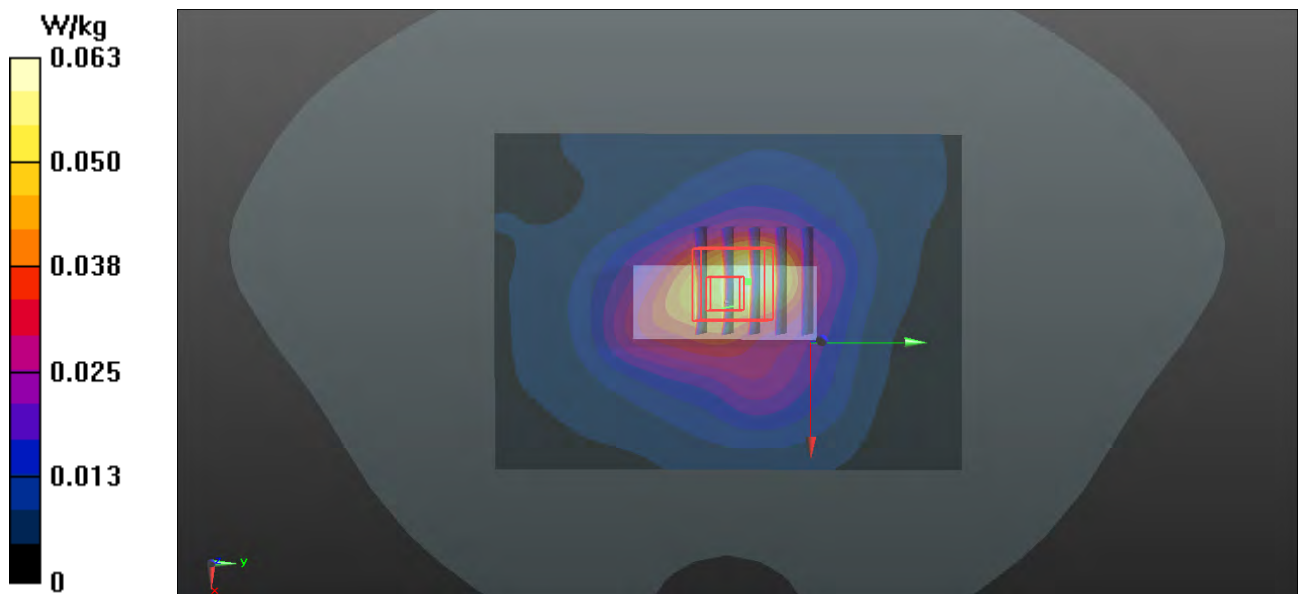

P281 LTE 4_QPSK_20M_Front Face_0.5cm_Ch20050_50 RB_offset 0

DUT: 121023C07

Communication System: LTE; Frequency: 1720 MHz; Duty Cycle: 1:1

Medium: B1750_1107 Medium parameters used: $f = 1720$ MHz; $\sigma = 1.434$ mho/m; $\epsilon_r = 53.251$; $\rho = 1000$ kg/m³

Ambient Temperature : 21.5 °C ; Liquid Temperature : 20.6 °C

DASY5 Configuration:

- Probe: EX3DV4 - SN3590; ConvF(8.64, 8.64, 8.64); Calibrated: 2012/02/23;
- Sensor-Surface: 2mm (Mechanical Surface Detection)
- Electronics: DAE4 Sn861; Calibrated: 2012/08/23
- Phantom: ELI v4.0; Type: QDOVA001BA; Serial: TP:1043
- Measurement SW: DASY52, Version 52.8 (2); SEMCAD X Version 14.6.6 (6824)

Ch20050/Area Scan (51x71x1): Measurement grid: dx=20mm, dy=20mm

Maximum value of SAR (interpolated) = 0.348 W/kg

Ch20050/Zoom Scan (5x5x7)/Cube 0: Measurement grid: dx=8mm, dy=8mm, dz=5mm

Reference Value = 12.854 V/m; Power Drift = 0.10 dB

Peak SAR (extrapolated) = 0.369 mW/g

SAR(1 g) = 0.227 mW/g; SAR(10 g) = 0.146 mW/g

Maximum value of SAR (measured) = 0.289 W/kg

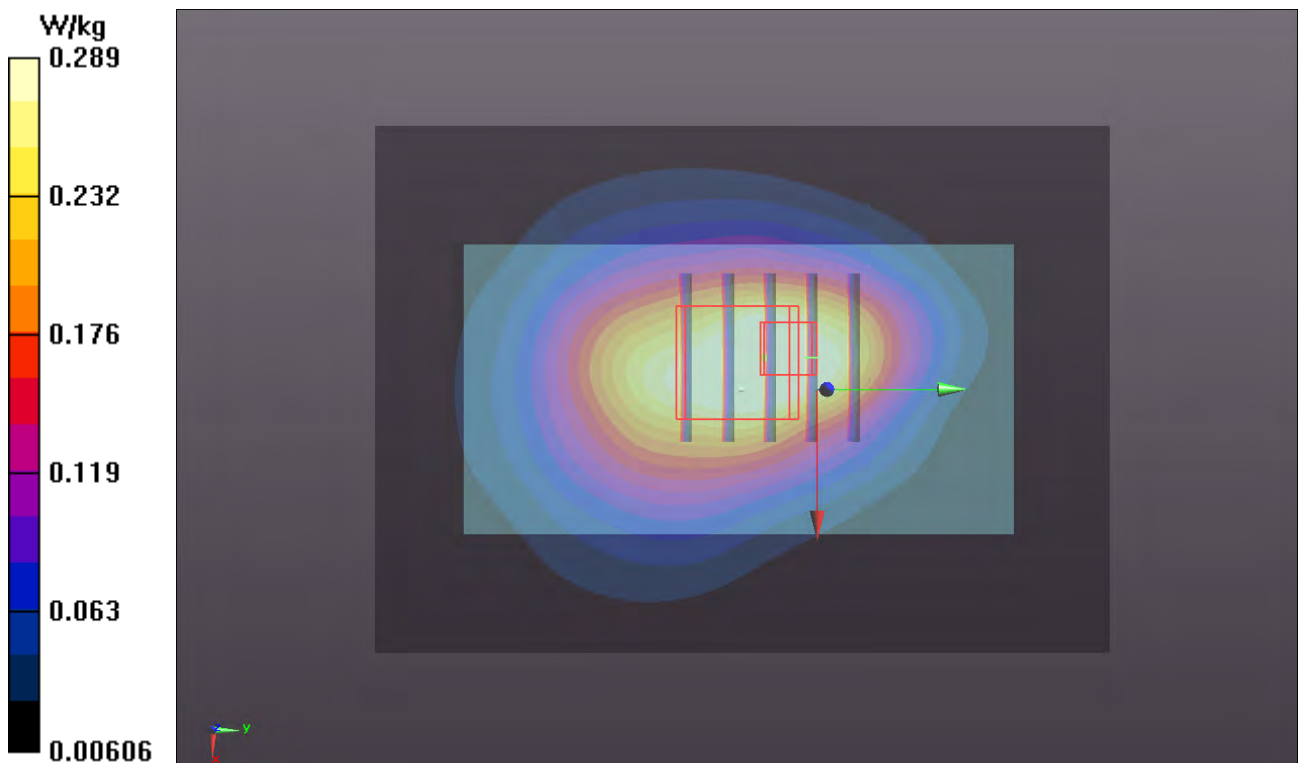

P282 LTE 4_QPSK_20M_Rear Face_0.5cm_Ch20050_50 RB_offset 0

DUT: 121023C07

Communication System: LTE; Frequency: 1720 MHz; Duty Cycle: 1:1

Medium: B1750_1107 Medium parameters used: $f = 1720$ MHz; $\sigma = 1.434$ mho/m; $\epsilon_r = 53.251$; $\rho = 1000$ kg/m³

Ambient Temperature : 21.5 °C ; Liquid Temperature : 20.6 °C

DASY5 Configuration:

- Probe: EX3DV4 - SN3590; ConvF(8.64, 8.64, 8.64); Calibrated: 2012/02/23;
- Sensor-Surface: 2mm (Mechanical Surface Detection)
- Electronics: DAE4 Sn861; Calibrated: 2012/08/23
- Phantom: ELI v4.0; Type: QDOVA001BA; Serial: TP:1043
- Measurement SW: DASY52, Version 52.8 (2); SEMCAD X Version 14.6.6 (6824)

Ch20050/Area Scan (51x71x1): Measurement grid: dx=20mm, dy=20mm

Maximum value of SAR (interpolated) = 0.596 W/kg

Ch20050/Zoom Scan (5x5x7)/Cube 0: Measurement grid: dx=8mm, dy=8mm, dz=5mm

Reference Value = 17.177 V/m; Power Drift = 0.14 dB

Peak SAR (extrapolated) = 0.546 mW/g

SAR(1 g) = 0.381 mW/g; SAR(10 g) = 0.242 mW/g

Maximum value of SAR (measured) = 0.466 W/kg

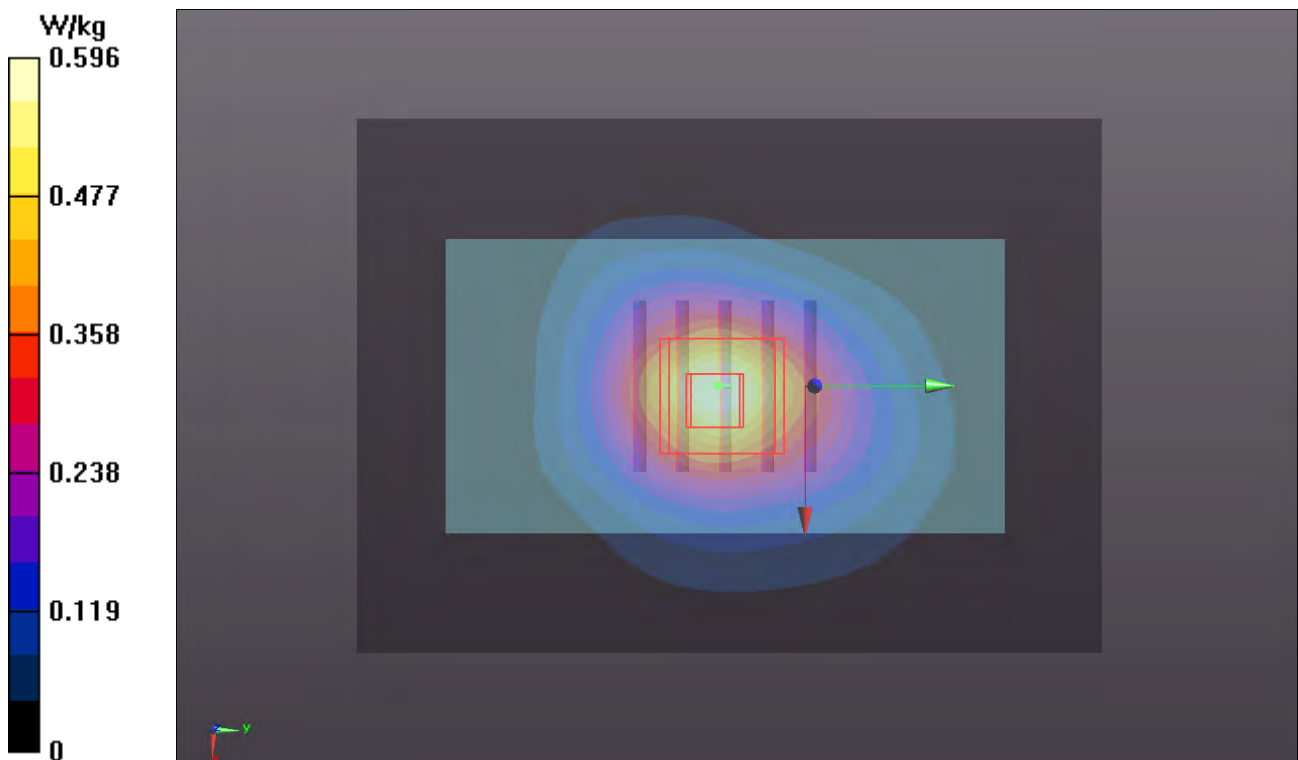

P283 LTE 4_QPSK_20M_Left Side_0.5cm_Ch20050_50 RB_offset 0

DUT: 121023C07

Communication System: LTE; Frequency: 1720 MHz; Duty Cycle: 1:1

Medium: B1750_1108 Medium parameters used: $f = 1720$ MHz; $\sigma = 1.435$ mho/m; $\epsilon_r = 53.313$; $\rho = 1000$ kg/m³

Ambient Temperature : 21.6 °C; Liquid Temperature : 20.7 °C

DASY5 Configuration:

- Probe: EX3DV4 - SN3864; ConvF(8.45, 8.45, 8.45); Calibrated: 2012/07/19;
- Sensor-Surface: 2mm (Mechanical Surface Detection)
- Electronics: DAE4 Sn915; Calibrated: 2012/06/21
- Phantom: SAM Phantom_Front; Type: SAM V4.0; Serial: TP 1127
- Measurement SW: DASY52, Version 52.8 (2); SEMCAD X Version 14.6.6 (6824)

Ch20050/Area Scan (51x71x1): Measurement grid: dx=20mm, dy=20mm

Maximum value of SAR (interpolated) = 0.125 W/kg

Ch20050/Zoom Scan (5x5x7)/Cube 0: Measurement grid: dx=8mm, dy=8mm, dz=5mm

Reference Value = 8.853 V/m; Power Drift = 0.02 dB

Peak SAR (extrapolated) = 0.142 mW/g

SAR(1 g) = 0.092 mW/g; SAR(10 g) = 0.057 mW/g

Maximum value of SAR (measured) = 0.114 W/kg

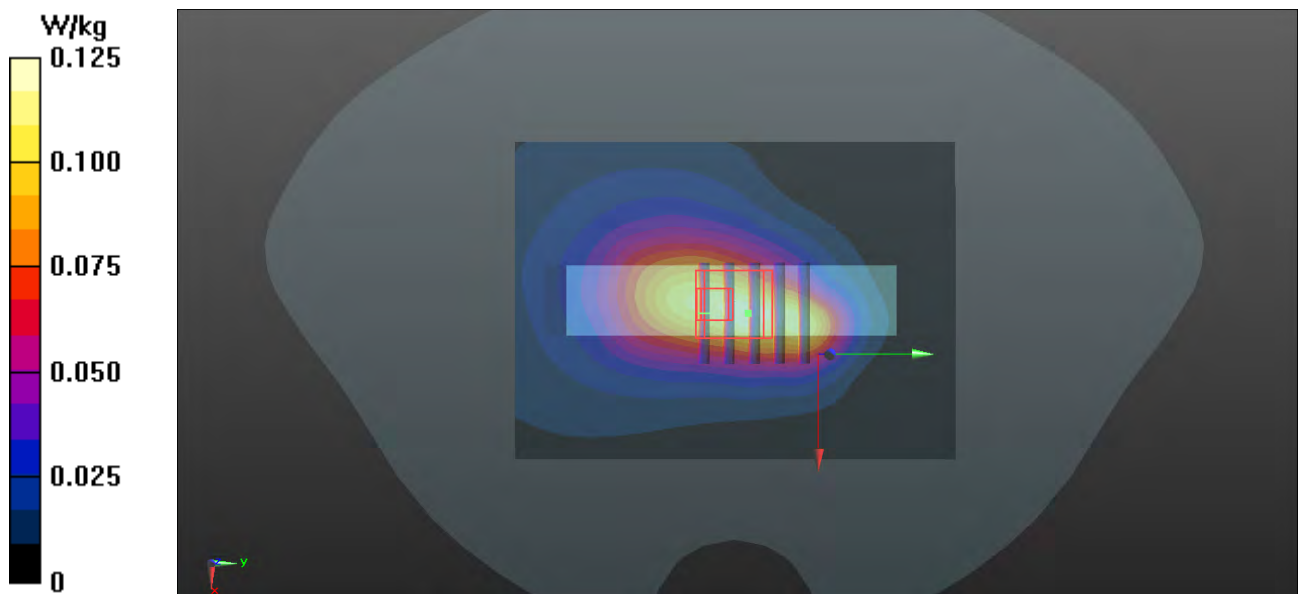

P284 LTE 4_QPSK_20M_Right Side_0.5cm_Ch20050_50 RB_offset 0

DUT: 121023C07

Communication System: LTE; Frequency: 1720 MHz; Duty Cycle: 1:1

Medium: B1750_1108 Medium parameters used: $f = 1720$ MHz; $\sigma = 1.435$ mho/m; $\epsilon_r = 53.313$; $\rho = 1000$ kg/m³

Ambient Temperature : 21.6 °C; Liquid Temperature : 20.7 °C

DASY5 Configuration:

- Probe: EX3DV4 - SN3864; ConvF(8.45, 8.45, 8.45); Calibrated: 2012/07/19;
- Sensor-Surface: 2mm (Mechanical Surface Detection)
- Electronics: DAE4 Sn915; Calibrated: 2012/06/21
- Phantom: SAM Phantom_Front; Type: SAM V4.0; Serial: TP 1127
- Measurement SW: DASY52, Version 52.8 (2); SEMCAD X Version 14.6.6 (6824)

Ch20050/Area Scan (51x71x1): Measurement grid: dx=20mm, dy=20mm

Maximum value of SAR (interpolated) = 0.0839 W/kg

Ch20050/Zoom Scan (5x5x7)/Cube 0: Measurement grid: dx=8mm, dy=8mm, dz=5mm

Reference Value = 7.704 V/m; Power Drift = 0.12 dB

Peak SAR (extrapolated) = 0.111 mW/g

SAR(1 g) = 0.070 mW/g; SAR(10 g) = 0.041 mW/g

Maximum value of SAR (measured) = 0.0916 W/kg

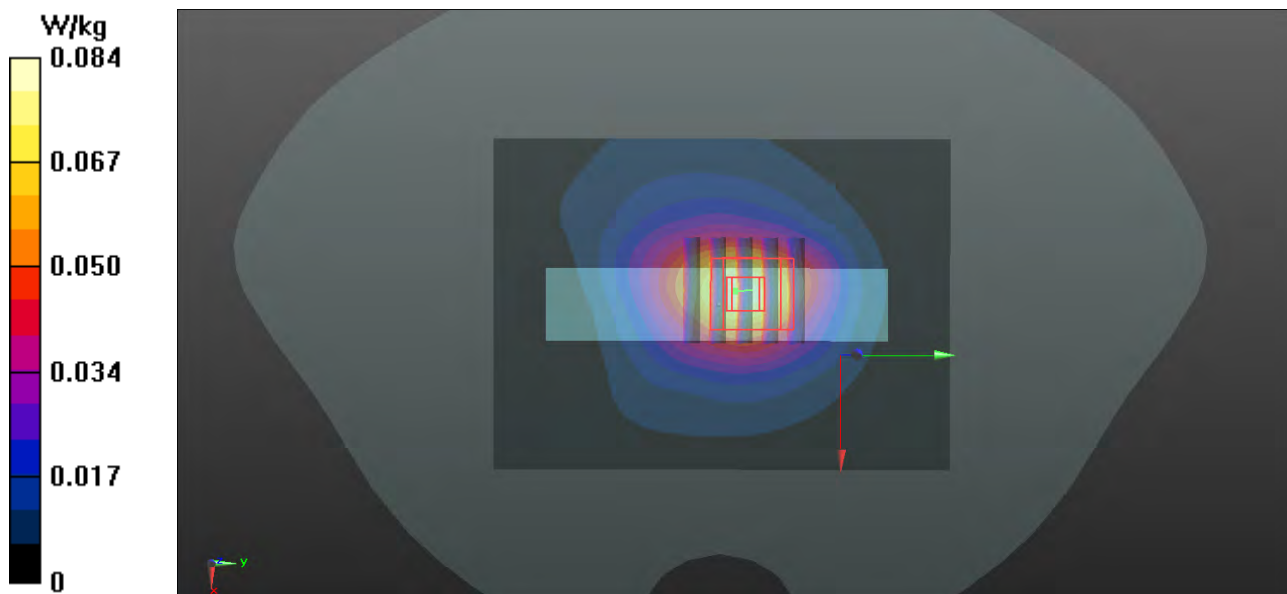

P285 LTE 4_QPSK_20M_Top Side_0.5cm_Ch20050_50 RB_offset 0

DUT: 121023C07

Communication System: LTE; Frequency: 1720 MHz; Duty Cycle: 1:1

Medium: B1750_1108 Medium parameters used: $f = 1720$ MHz; $\sigma = 1.435$ mho/m; $\epsilon_r = 53.313$; $\rho = 1000$ kg/m³

Ambient Temperature : 21.6 °C; Liquid Temperature : 20.7 °C

DASY5 Configuration:

- Probe: EX3DV4 - SN3864; ConvF(8.45, 8.45, 8.45); Calibrated: 2012/07/19;
- Sensor-Surface: 2mm (Mechanical Surface Detection)
- Electronics: DAE4 Sn915; Calibrated: 2012/06/21
- Phantom: SAM Phantom_Front; Type: SAM V4.0; Serial: TP 1127
- Measurement SW: DASY52, Version 52.8 (2); SEMCAD X Version 14.6.6 (6824)

Ch20050/Area Scan (51x71x1): Measurement grid: dx=20mm, dy=20mm

Maximum value of SAR (interpolated) = 0.0410 W/kg

Ch20050/Zoom Scan (5x5x7)/Cube 0: Measurement grid: dx=8mm, dy=8mm, dz=5mm

Reference Value = 6.558 V/m; Power Drift = 0.10 dB

Peak SAR (extrapolated) = 0.076 mW/g

SAR(1 g) = 0.043 mW/g; SAR(10 g) = 0.022 mW/g

Maximum value of SAR (measured) = 0.0604 W/kg

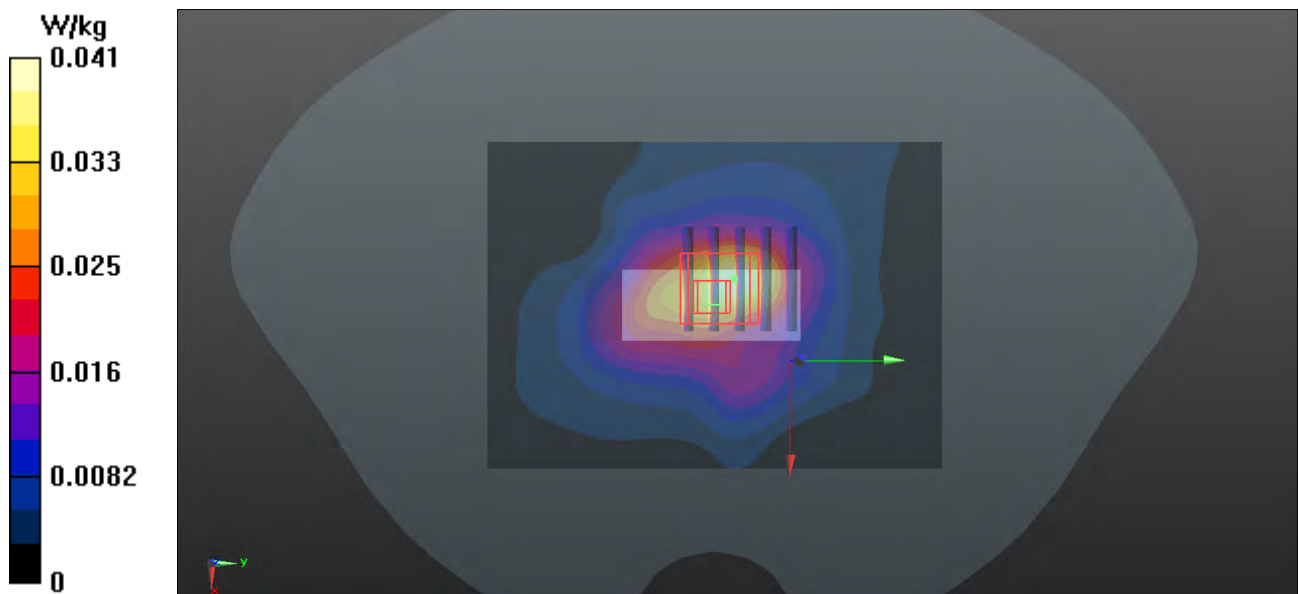

P316 LTE 12_QPSK_10M_Front Face_0.5cm_Ch23060_1 RB_offset 24

DUT: 121023C07

Communication System: LTE; Frequency: 704 MHz; Duty Cycle: 1:1

Medium: B750_1113 Medium parameters used: $f = 704$ MHz; $\sigma = 0.927$ mho/m; $\epsilon_r = 55.552$; $\rho = 1000$ kg/m³

Ambient Temperature : 21.8 °C; Liquid Temperature : 20.5 °C

DASY5 Configuration:

- Probe: EX3DV4 - SN3578; ConvF(8.52, 8.52, 8.52); Calibrated: 2012/06/21;
- Sensor-Surface: 2mm (Mechanical Surface Detection)
- Electronics: DAE4 Sn1277; Calibrated: 2012/07/19
- Phantom: SAM Phantom_right; Type: QD000P40CC; Serial: TP:1496
- Measurement SW: DASY52, Version 52.8 (2); SEMCAD X Version 14.6.6 (6824)

Ch23060/Area Scan (41x71x1): Measurement grid: dx=20mm, dy=20mm

Maximum value of SAR (interpolated) = 0.789 W/kg

Ch23060/Zoom Scan (5x5x7)/Cube 0: Measurement grid: dx=8mm, dy=8mm, dz=5mm

Reference Value = 18.774 V/m; Power Drift = -0.16 dB

Peak SAR (extrapolated) = 0.981 mW/g

SAR(1 g) = 0.550 mW/g; SAR(10 g) = 0.314 mW/g

Maximum value of SAR (measured) = 0.756 W/kg

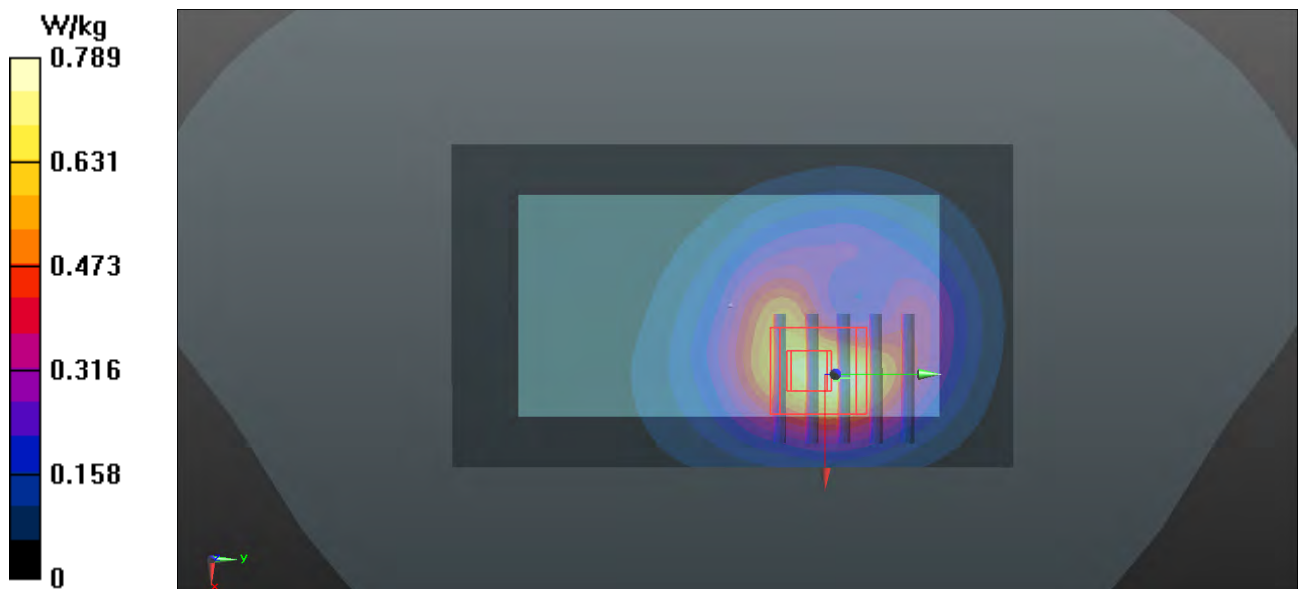

1g/10g Averaged SAR

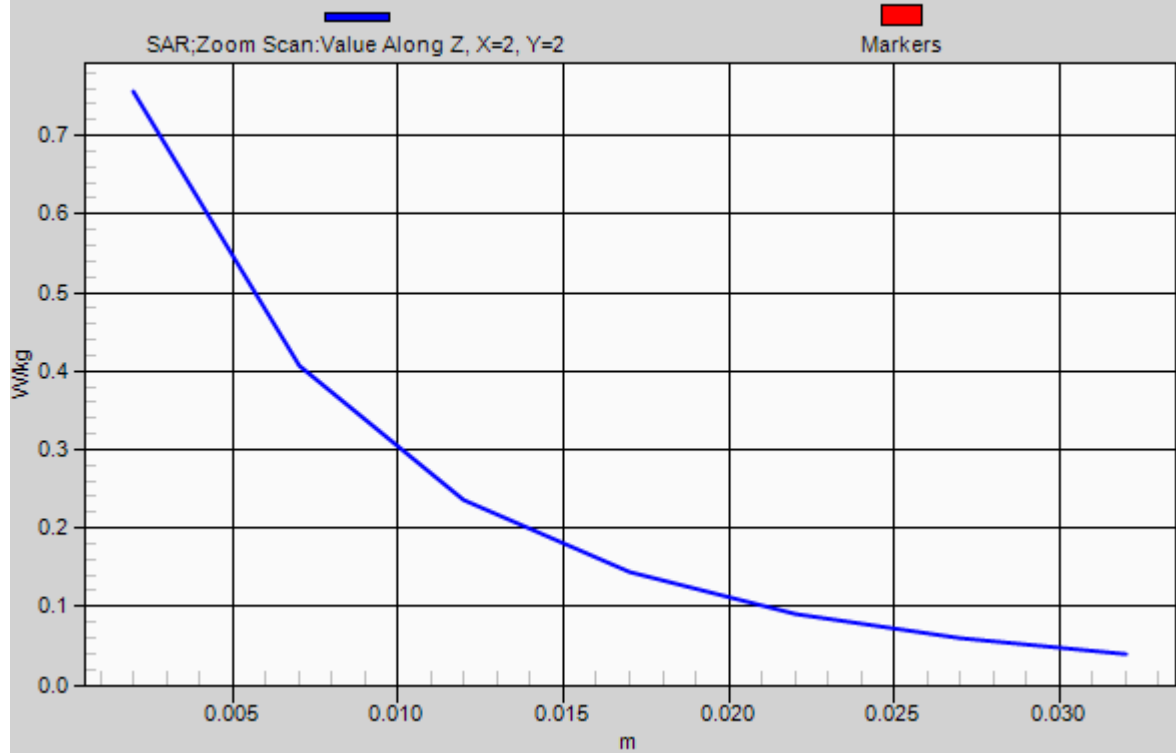

P317 LTE 12_QPSK_10M_Rear Face_0.5cm_Ch23060_1 RB_offset 24

DUT: 121023C07

Communication System: LTE; Frequency: 704 MHz; Duty Cycle: 1:1

Medium: B750_1113 Medium parameters used: $f = 704 \text{ MHz}$; $\sigma = 0.927 \text{ mho/m}$; $\epsilon_r = 55.552$; $\rho = 1000 \text{ kg/m}^3$

Ambient Temperature : 21.8 °C ; Liquid Temperature : 20.5 °C

DASY5 Configuration:

- Probe: EX3DV4 - SN3578; ConvF(8.52, 8.52, 8.52); Calibrated: 2012/06/21;
- Sensor-Surface: 2mm (Mechanical Surface Detection)
- Electronics: DAE4 Sn1277; Calibrated: 2012/07/19
- Phantom: SAM Phantom_right; Type: QD000P40CC; Serial: TP:1496
- Measurement SW: DASY52, Version 52.8 (2); SEMCAD X Version 14.6.6 (6824)

Ch23060/Area Scan (41x71x1): Measurement grid: $dx=20\text{mm}$, $dy=2.0\text{mm}$

Maximum value of SAR (interpolated) = 0.269 W/kg

Ch23060/Zoom Scan (5x5x7)/Cube 0: Measurement grid: $dx=8\text{mm}$, $dy=8\text{mm}$, $dz=5\text{mm}$

Reference Value = 14.602 V/m; Power Drift = -0.13 dB

Peak SAR (extrapolated) = 0.294 mW/g

SAR(1 g) = 0.218 mW/g; SAR(10 g) = 0.157 mW/g

Maximum value of SAR (measured) = 0.258 W/k

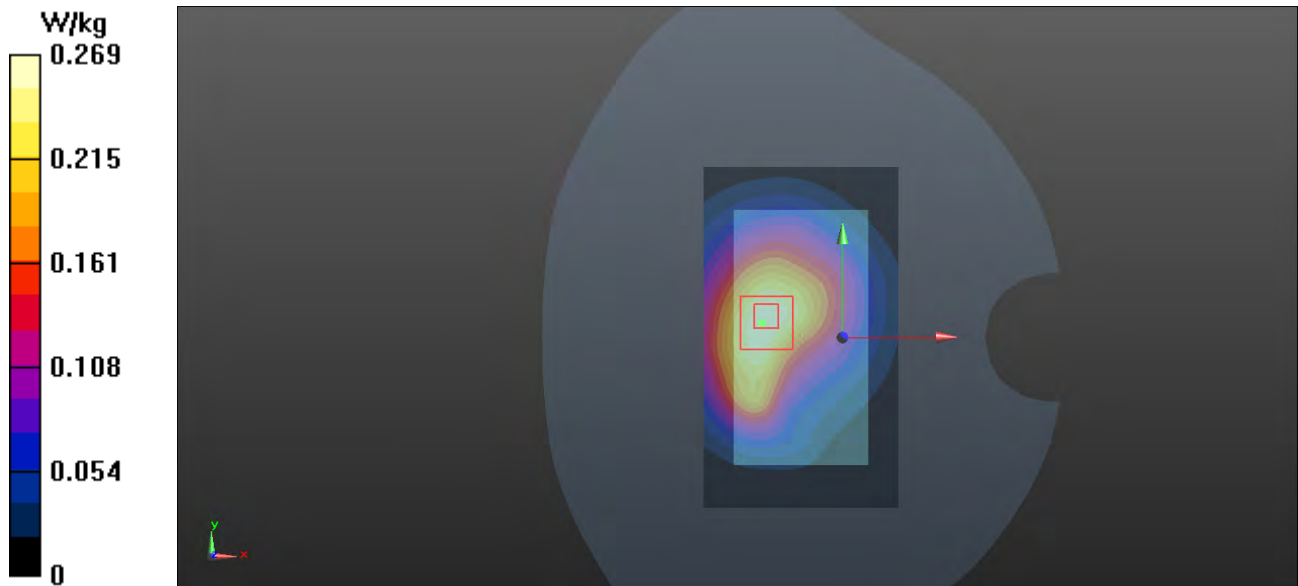

P318 LTE 12_QPSK_10M_Left Side_0.5cm_Ch23060_1 RB_offset 24

DUT: 121023C07

Communication System: LTE; Frequency: 704 MHz; Duty Cycle: 1:1

Medium: B750_1113 Medium parameters used: $f = 704$ MHz; $\sigma = 0.927$ mho/m; $\epsilon_r = 55.552$; $\rho = 1000$ kg/m³

Ambient Temperature : 21.8 °C ; Liquid Temperature : 20.5 °C

DASY5 Configuration:

- Probe: EX3DV4 - SN3578; ConvF(8.52, 8.52, 8.52); Calibrated: 2012/06/21;
- Sensor-Surface: 2mm (Mechanical Surface Detection)
- Electronics: DAE4 Sn1277; Calibrated: 2012/07/19
- Phantom: SAM Phantom_right; Type: QD000P40CC; Serial: TP:1496
- Measurement SW: DASY52, Version 52.8 (2); SEMCAD X Version 14.6.6 (6824)

Ch23060/Area Scan (41x71x1): Measurement grid: dx=20mm, dy=20mm

Maximum value of SAR (interpolated) = 0.102 W/kg

Ch23060/Zoom Scan (5x5x7)/Cube 0: Measurement grid: dx=8mm, dy=8mm, dz=5mm

Reference Value = 9.214 V/m; Power Drift = -0.05 dB

Peak SAR (extrapolated) = 0.104 mW/g

SAR(1 g) = 0.076 mW/g; SAR(10 g) = 0.054 mW/g

Maximum value of SAR (measured) = 0.0878 W/kg

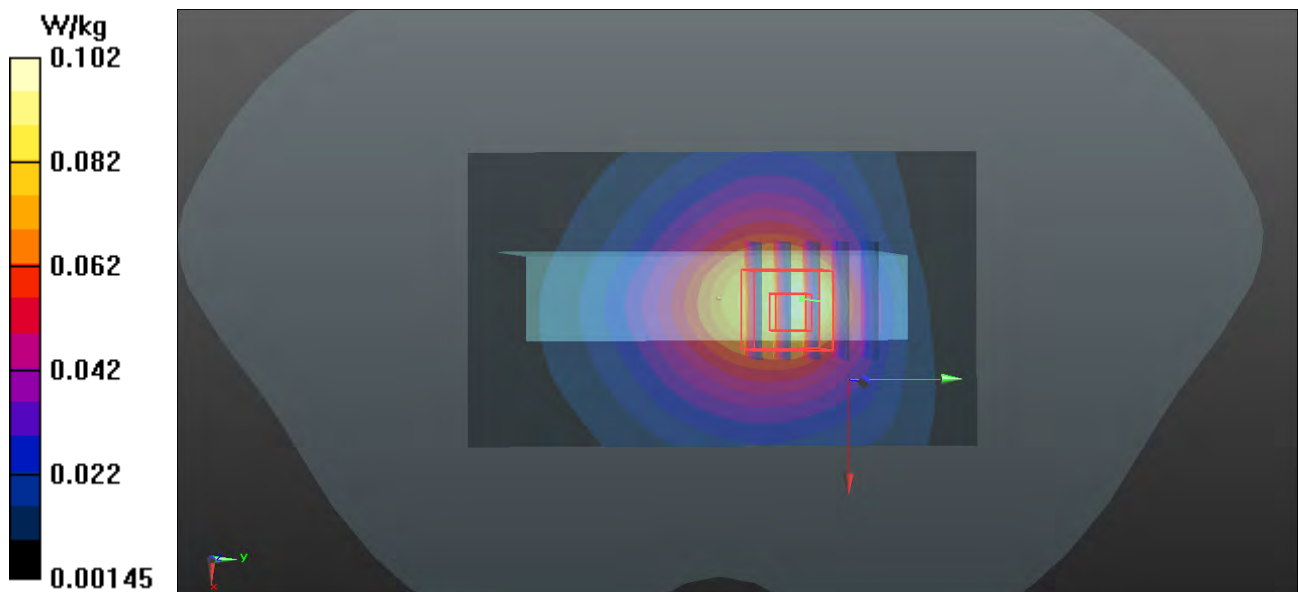

P319 LTE 12_QPSK_10M_Right Side_0.5cm_Ch23060_1 RB_offset 24

DUT: 121023C07

Communication System: LTE; Frequency: 704 MHz; Duty Cycle: 1:1

Medium: B750_1113 Medium parameters used: $f = 704$ MHz; $\sigma = 0.927$ mho/m; $\epsilon_r = 55.552$; $\rho = 1000$ kg/m³

Ambient Temperature : 21.8 °C ; Liquid Temperature : 20.5 °C

DASY5 Configuration:

- Probe: EX3DV4 - SN3578; ConvF(8.52, 8.52, 8.52); Calibrated: 2012/06/21;
- Sensor-Surface: 2mm (Mechanical Surface Detection)
- Electronics: DAE4 Sn1277; Calibrated: 2012/07/19
- Phantom: SAM Phantom_right; Type: QD000P40CC; Serial: TP:1496
- Measurement SW: DASY52, Version 52.8 (2); SEMCAD X Version 14.6.6 (6824)

Ch23060/Area Scan (41x71x1): Measurement grid: dx=20mm, dy=20mm

Maximum value of SAR (interpolated) = 0.366 W/kg

Ch23060/Zoom Scan (5x5x7)/Cube 0: Measurement grid: dx=8mm, dy=8mm, dz=5mm

Reference Value = 18.864 V/m; Power Drift = -0.14 dB

Peak SAR (extrapolated) = 0.405 mW/g

SAR(1 g) = 0.265 mW/g; SAR(10 g) = 0.174 mW/g

Maximum value of SAR (measured) = 0.333 W/kg

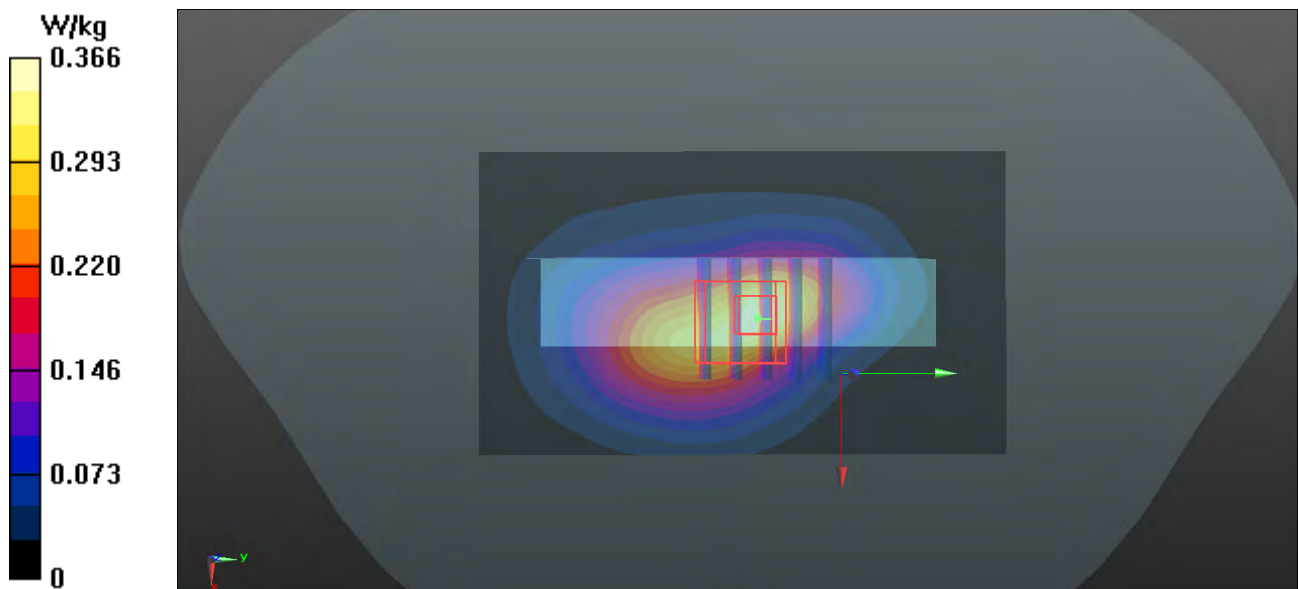

P320 LTE 12_QPSK_10M_Top Side_0.5cm_Ch23060_1 RB_offset 24

DUT: 121023C07

Communication System: LTE; Frequency: 704 MHz; Duty Cycle: 1:1

Medium: B750_1113 Medium parameters used: $f = 704 \text{ MHz}$; $\sigma = 0.927 \text{ mho/m}$; $\epsilon_r = 55.552$; $\rho = 1000 \text{ kg/m}^3$

Ambient Temperature : 21.8 °C ; Liquid Temperature : 20.5 °C

DASY5 Configuration:

- Probe: EX3DV4 - SN3578; ConvF(8.52, 8.52, 8.52); Calibrated: 2012/06/21;
- Sensor-Surface: 2mm (Mechanical Surface Detection)
- Electronics: DAE4 Sn1277; Calibrated: 2012/07/19
- Phantom: SAM Phantom_right; Type: QD000P40CC; Serial: TP:1496
- Measurement SW: DASY52, Version 52.8 (2); SEMCAD X Version 14.6.6 (6824)

Ch23060/Area Scan (41x61x1): Measurement grid: $dx=20\text{mm}$, $dy=20\text{mm}$

Maximum value of SAR (interpolated) = 0.166 W/kg

Ch23060/Zoom Scan (5x5x7)/Cube 0: Measurement grid: $dx=8\text{mm}$, $dy=8\text{mm}$, $dz=5\text{mm}$

Reference Value = 13.562 V/m; Power Drift = -0.01 dB

Peak SAR (extrapolated) = 0.240 mW/g

SAR(1 g) = 0.115 mW/g; SAR(10 g) = 0.058 mW/g

Maximum value of SAR (measured) = 0.165 W/kg

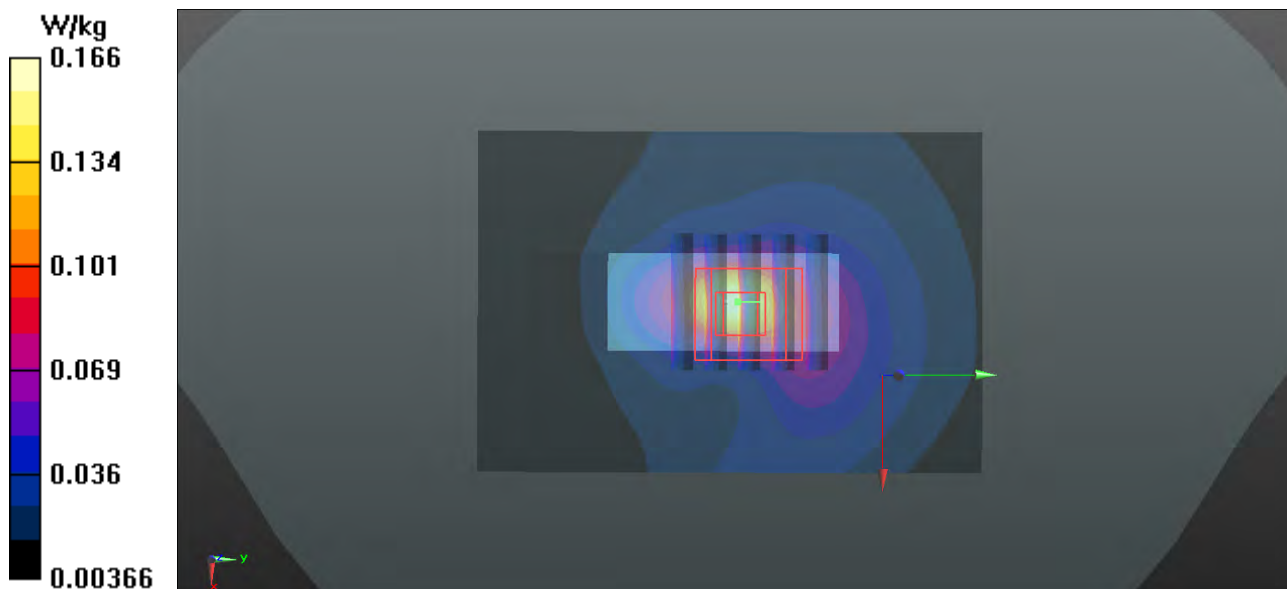

P321 LTE 12_QPSK_10M_Front Face_0.5cm_Ch23060_25 RB_offset 0

DUT: 121023C07

Communication System: LTE; Frequency: 704 MHz; Duty Cycle: 1:1

Medium: B750_1113 Medium parameters used: $f = 704$ MHz; $\sigma = 0.927$ mho/m; $\epsilon_r = 55.552$; $\rho = 1000$ kg/m³

Ambient Temperature : 21.8 °C ; Liquid Temperature : 20.5 °C

DASY5 Configuration:

- Probe: EX3DV4 - SN3578; ConvF(8.52, 8.52, 8.52); Calibrated: 2012/06/21;
- Sensor-Surface: 2mm (Mechanical Surface Detection)
- Electronics: DAE4 Sn1277; Calibrated: 2012/07/19
- Phantom: SAM Phantom_right; Type: QD000P40CC; Serial: TP:1496
- Measurement SW: DASY52, Version 52.8 (2); SEMCAD X Version 14.6.6 (6824)

Ch23060/Area Scan (41x71x1): Measurement grid: dx=20mm, dy=20mm

Maximum value of SAR (interpolated) = 0.513 W/kg

Ch23060/Zoom Scan (5x5x7)/Cube 0: Measurement grid: dx=8mm, dy=8mm, dz=5mm

Reference Value = 14.975 V/m; Power Drift = -0.02 dB

Peak SAR (extrapolated) = 0.679 mW/g

SAR(1 g) = 0.372 mW/g; SAR(10 g) = 0.209 mW/g

Maximum value of SAR (measured) = 0.521 W/kg

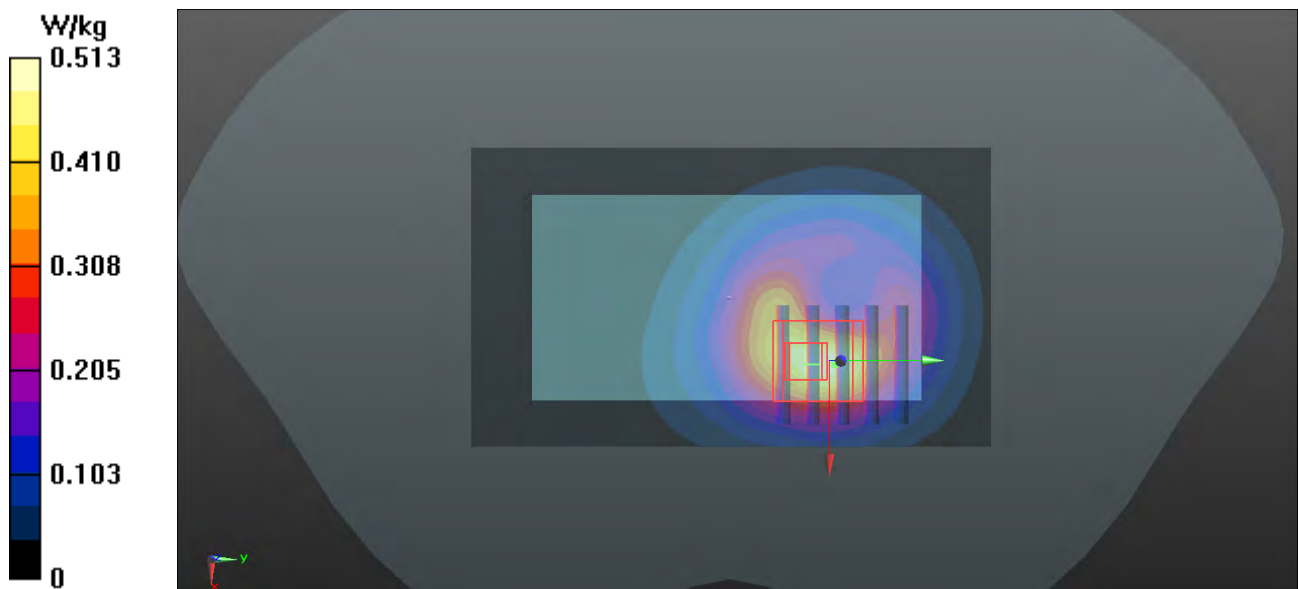

P322 LTE 12_QPSK_10M_Rear Face_0.5cm_Ch23060_25 RB_offset 0

DUT: 121023C07

Communication System: LTE; Frequency: 704 MHz; Duty Cycle: 1:1

Medium: B750_1113 Medium parameters used: $f = 704$ MHz; $\sigma = 0.927$ mho/m; $\epsilon_r = 55.552$; $\rho = 1000$ kg/m³

Ambient Temperature : 21.8 °C ; Liquid Temperature : 20.5 °C

DASY5 Configuration:

- Probe: EX3DV4 - SN3578; ConvF(8.52, 8.52, 8.52); Calibrated: 2012/06/21;
- Sensor-Surface: 2mm (Mechanical Surface Detection)
- Electronics: DAE4 Sn1277; Calibrated: 2012/07/19
- Phantom: SAM Phantom_right; Type: QD000P40CC; Serial: TP:1496
- Measurement SW: DASY52, Version 52.8 (2); SEMCAD X Version 14.6.6 (6824)

Ch23060/Area Scan (41x71x1): Measurement grid: dx=20mm, dy=20mm

Maximum value of SAR (interpolated) = 0.223 W/kg

Ch23060/Zoom Scan (5x5x7)/Cube 0: Measurement grid: dx=8mm, dy=8mm, dz=5mm

Reference Value = 13.529 V/m; Power Drift = -0.09 dB

Peak SAR (extrapolated) = 0.239 mW/g

SAR(1 g) = 0.177 mW/g; SAR(10 g) = 0.128 mW/g

Maximum value of SAR (measured) = 0.207 W/kg

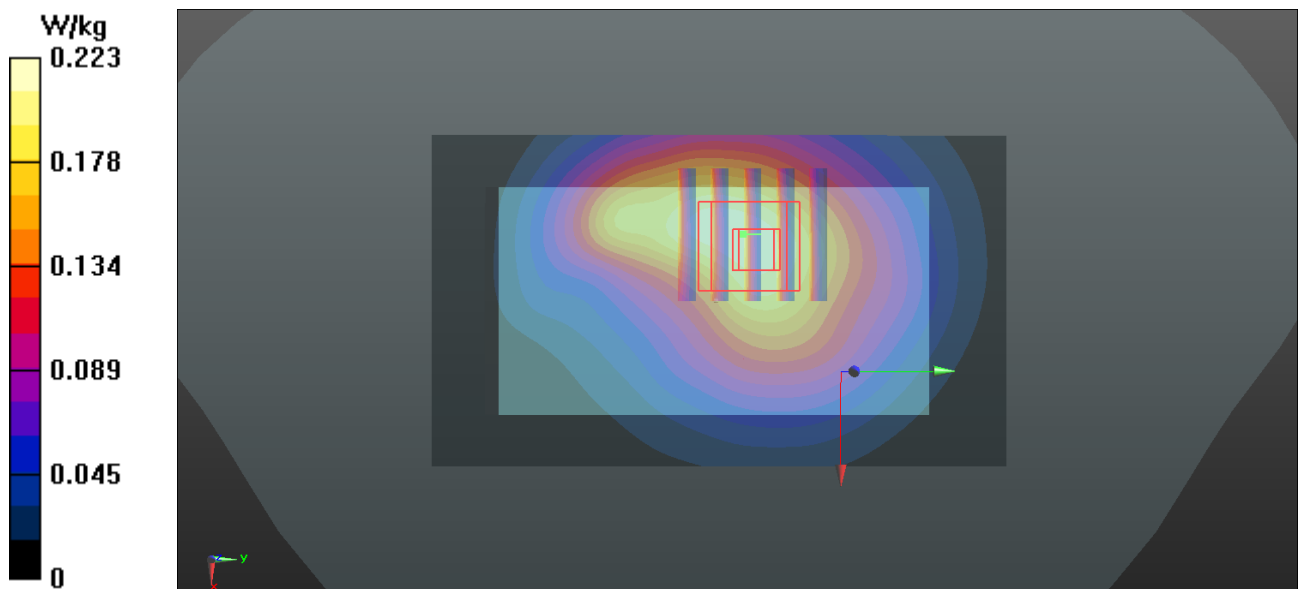

P323 LTE 12_QPSK_10M_Left Side_0.5cm_Ch23060_25 RB_offset 0

DUT: 121023C07

Communication System: LTE; Frequency: 704 MHz; Duty Cycle: 1:1

Medium: B750_1113 Medium parameters used: $f = 704 \text{ MHz}$; $\sigma = 0.927 \text{ mho/m}$; $\epsilon_r = 55.552$; $\rho = 1000 \text{ kg/m}^3$

Ambient Temperature : 21.8 °C ; Liquid Temperature : 20.5 °C

DASY5 Configuration:

- Probe: EX3DV4 - SN3578; ConvF(8.52, 8.52, 8.52); Calibrated: 2012/06/21;
- Sensor-Surface: 2mm (Mechanical Surface Detection)
- Electronics: DAE4 Sn1277; Calibrated: 2012/07/19
- Phantom: SAM Phantom_right; Type: QD000P40CC; Serial: TP:1496
- Measurement SW: DASY52, Version 52.8 (2); SEMCAD X Version 14.6.6 (6824)

Ch23060/Area Scan (41x71x1): Measurement grid: $dx=20\text{mm}$, $dy=20\text{mm}$

Maximum value of SAR (interpolated) = 0.0654 W/kg

Ch23060/Zoom Scan (5x5x7)/Cube 0: Measurement grid: $dx=8\text{mm}$, $dy=8\text{mm}$, $dz=5\text{mm}$

Reference Value = 7.463 V/m; Power Drift = 0.04 dB

Peak SAR (extrapolated) = 0.070 mW/g

SAR(1 g) = 0.050 mW/g; SAR(10 g) = 0.036 mW/g

Maximum value of SAR (measured) = 0.0588 W/kg

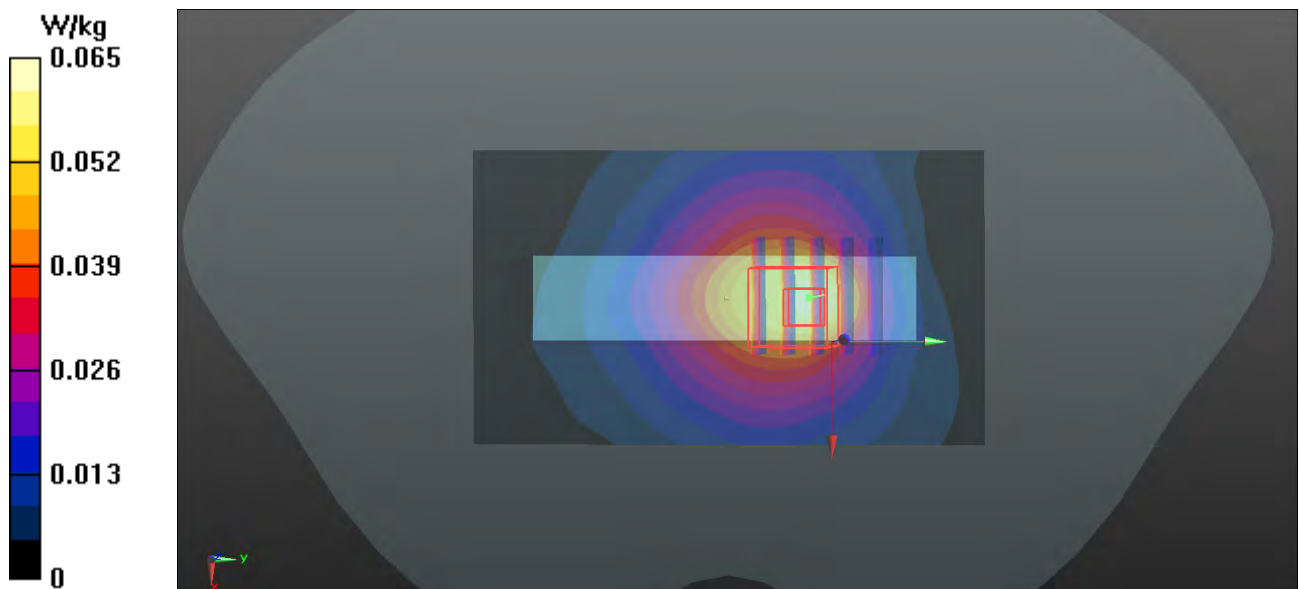

P324 LTE 12_QPSK_10M_Right Side_0.5cm_Ch23060_25 RB_offset 0

DUT: 121023C07

Communication System: LTE; Frequency: 704 MHz; Duty Cycle: 1:1

Medium: B750_1113 Medium parameters used: $f = 704$ MHz; $\sigma = 0.927$ mho/m; $\epsilon_r = 55.552$; $\rho = 1000$ kg/m³

Ambient Temperature : 21.8 °C ; Liquid Temperature : 20.5 °C

DASY5 Configuration:

- Probe: EX3DV4 - SN3578; ConvF(8.52, 8.52, 8.52); Calibrated: 2012/06/21;
- Sensor-Surface: 2mm (Mechanical Surface Detection)
- Electronics: DAE4 Sn1277; Calibrated: 2012/07/19
- Phantom: SAM Phantom_right; Type: QD000P40CC; Serial: TP:1496
- Measurement SW: DASY52, Version 52.8 (2); SEMCAD X Version 14.6.6 (6824)

Ch23060/Area Scan (41x71x1): Measurement grid: dx=20mm, dy=20mm

Maximum value of SAR (interpolated) = 0.244 W/kg

Ch23060/Zoom Scan (5x5x7)/Cube 0: Measurement grid: dx=8mm, dy=8mm, dz=5mm

Reference Value = 15.329 V/m; Power Drift = -0.03 dB

Peak SAR (extrapolated) = 0.277 mW/g

SAR(1 g) = 0.180 mW/g; SAR(10 g) = 0.118 mW/g

Maximum value of SAR (measured) = 0.227 W/kg

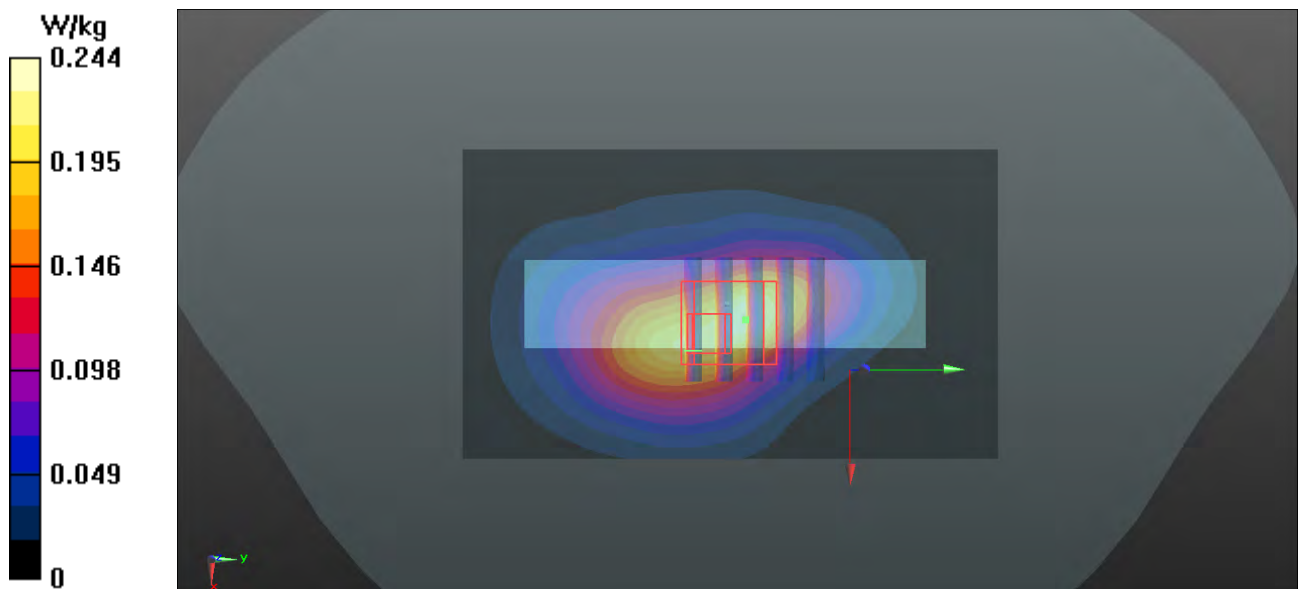

P325 LTE 12_QPSK_10M_Top Side_0.5cm_Ch23060_25 RB_offset 0

DUT: 121023C07

Communication System: LTE; Frequency: 704 MHz; Duty Cycle: 1:1

Medium: B750_1113 Medium parameters used: $f = 704$ MHz; $\sigma = 0.927$ mho/m; $\epsilon_r = 55.552$; $\rho = 1000$ kg/m³

Ambient Temperature : 21.8 °C ; Liquid Temperature : 20.5 °C

DASY5 Configuration:

- Probe: EX3DV4 - SN3578; ConvF(8.52, 8.52, 8.52); Calibrated: 2012/06/21;
- Sensor-Surface: 2mm (Mechanical Surface Detection)
- Electronics: DAE4 Sn1277; Calibrated: 2012/07/19
- Phantom: SAM Phantom_right; Type: QD000P40CC; Serial: TP:1496
- Measurement SW: DASY52, Version 52.8 (2); SEMCAD X Version 14.6.6 (6824)

Ch23060/Area Scan (41x61x1): Measurement grid: dx=20mm, dy=20mm

Maximum value of SAR (interpolated) = 0.125 W/kg

Ch23060/Zoom Scan (5x5x7)/Cube 0: Measurement grid: dx=8mm, dy=8mm, dz=5mm

Reference Value = 11.754 V/m; Power Drift = 0.02 dB

Peak SAR (extrapolated) = 0.183 mW/g

SAR(1 g) = 0.087 mW/g; SAR(10 g) = 0.044 mW/g

Maximum value of SAR (measured) = 0.126 W/kg

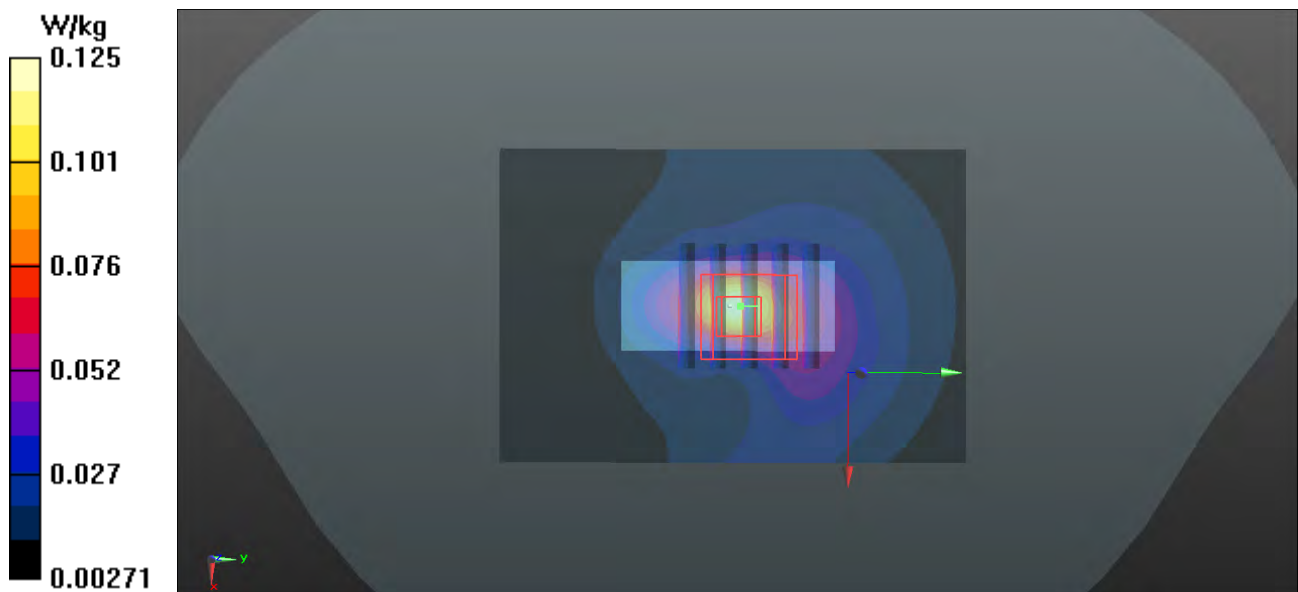

P204 LTE 17_QPSK_10M_Front Face_0.5cm_Ch23780_1 RB_offset 0

DUT: 121023C07

Communication System: LTE; Frequency: 709 MHz; Duty Cycle: 1:1

Medium: B750_1113 Medium parameters used: $f = 709 \text{ MHz}$; $\sigma = 0.931 \text{ mho/m}$; $\epsilon_r = 55.514$; $\rho = 1000 \text{ kg/m}^3$

Ambient Temperature : 21.8 °C ; Liquid Temperature : 20.5 °C

DASY5 Configuration:

- Probe: EX3DV4 - SN3578; ConvF(8.52, 8.52, 8.52); Calibrated: 2012/06/21;
- Sensor-Surface: 2mm (Mechanical Surface Detection)
- Electronics: DAE4 Sn1277; Calibrated: 2012/07/19
- Phantom: SAM Phantom_right; Type: QD000P40CC; Serial: TP:1496
- Measurement SW: DASY52, Version 52.8 (2); SEMCAD X Version 14.6.6 (6824)

Ch23780/Area Scan (51x71x1): Measurement grid: $dx=20\text{mm}$, $dy=20\text{mm}$

Maximum value of SAR (interpolated) = 0.688 W/kg

Ch23780/Zoom Scan (5x5x7)/Cube 0: Measurement grid: $dx=8\text{mm}$, $dy=8\text{mm}$, $dz=5\text{mm}$

Reference Value = 18.255 V/m; Power Drift = 0.02 dB

Peak SAR (extrapolated) = 0.975 mW/g

SAR(1 g) = 0.547 mW/g; SAR(10 g) = 0.315 mW/g

Maximum value of SAR (measured) = 0.757 W/kg

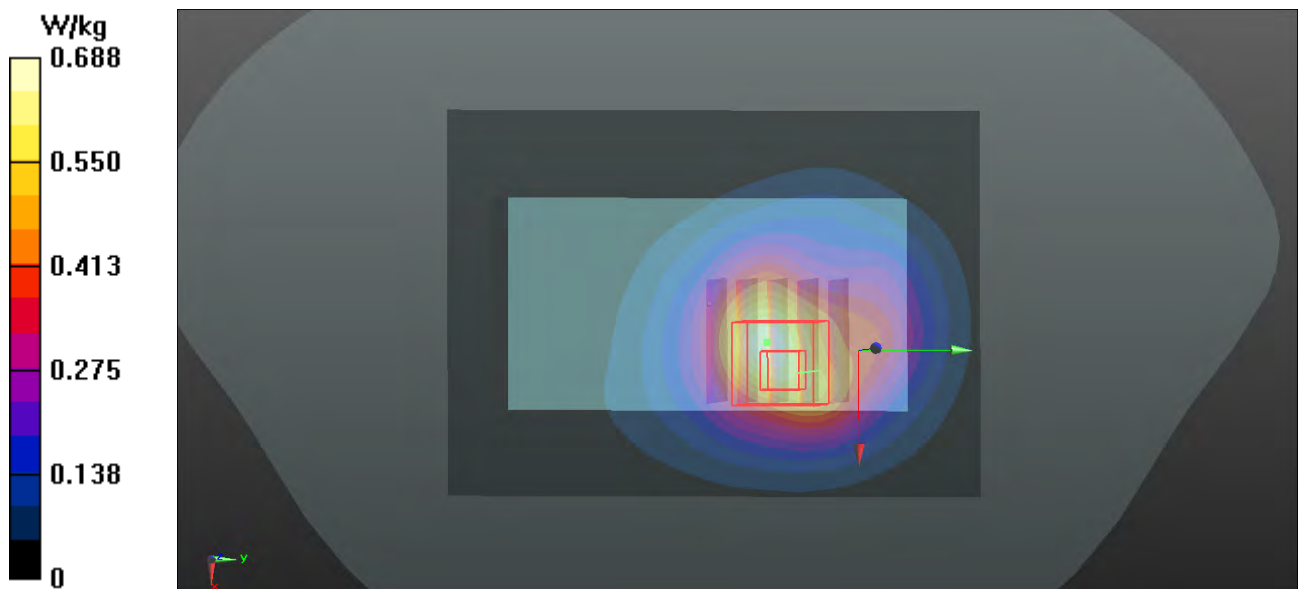

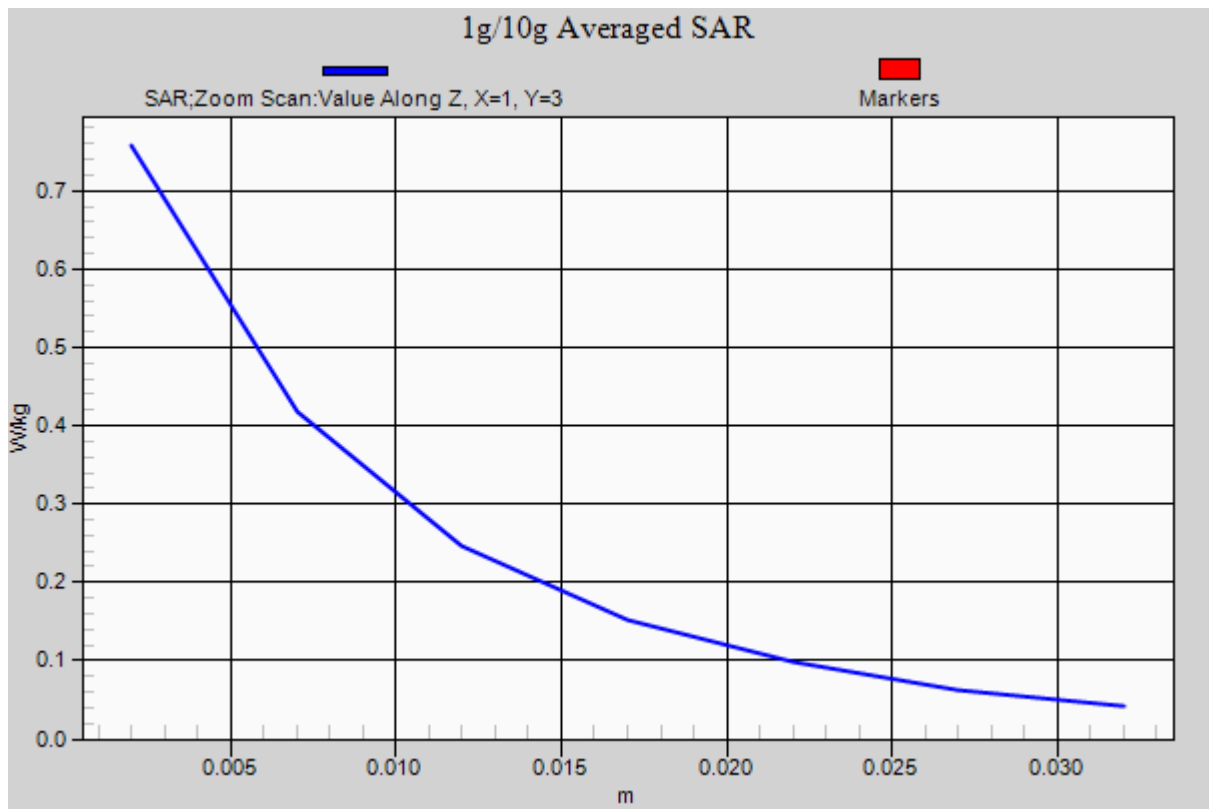

P205 LTE 17_QPSK_10M_Rear Face_0.5cm_Ch23780_1 RB_offset 0

DUT: 121023C07

Communication System: LTE; Frequency: 709 MHz; Duty Cycle: 1:1

Medium: B750_1113 Medium parameters used: $f = 709$ MHz; $\sigma = 0.931$ mho/m; $\epsilon_r = 55.514$; $\rho = 1000$ kg/m³

Ambient Temperature : 21.8 °C ; Liquid Temperature : 20.5 °C

DASY5 Configuration:

- Probe: EX3DV4 - SN3578; ConvF(8.52, 8.52, 8.52); Calibrated: 2012/06/21;
- Sensor-Surface: 2mm (Mechanical Surface Detection)
- Electronics: DAE4 Sn1277; Calibrated: 2012/07/19
- Phantom: SAM Phantom_right; Type: QD000P40CC; Serial: TP:1496
- Measurement SW: DASY52, Version 52.8 (2); SEMCAD X Version 14.6.6 (6824)

Ch23780/Area Scan (51x71x1): Measurement grid: dx=20mm, dy=20mm

Maximum value of SAR (interpolated) = 0.265 W/kg

Ch23780/Zoom Scan (5x5x7)/Cube 0: Measurement grid: dx=8mm, dy=8mm, dz=5mm

Reference Value = 14.416 V/m; Power Drift = 0.01 dB

Peak SAR (extrapolated) = 0.319 mW/g

SAR(1 g) = 0.222 mW/g; SAR(10 g) = 0.162 mW/g

Maximum value of SAR (measured) = 0.277 W/kg

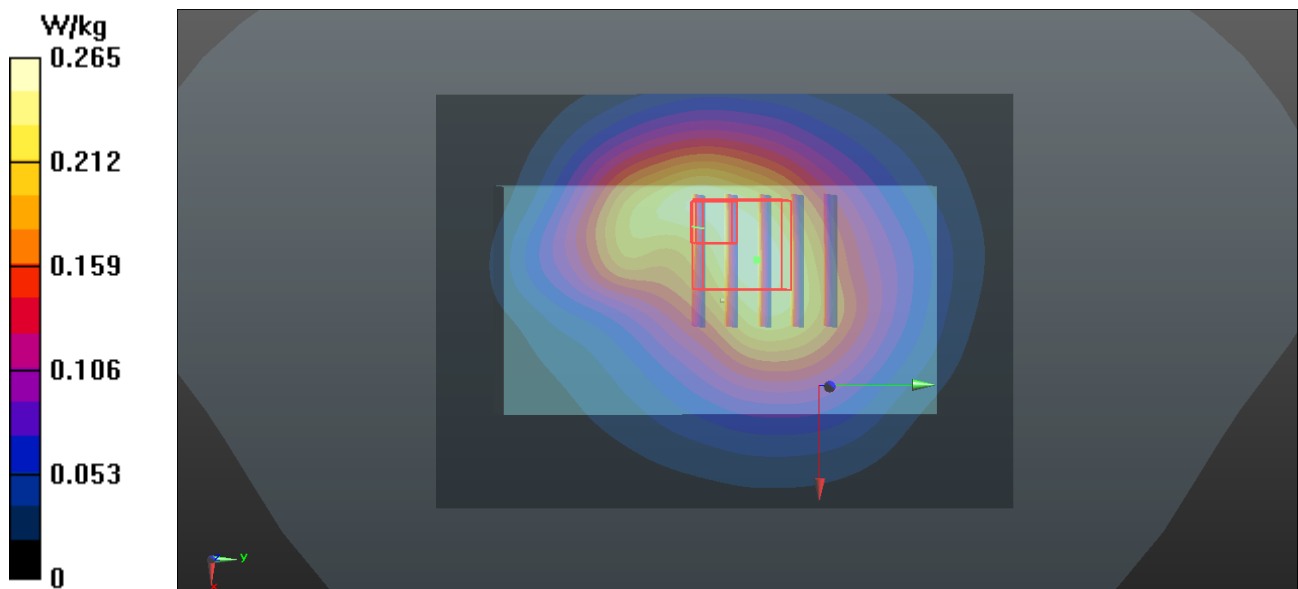

P206 LTE 17_QPSK_10M_Left Side_0.5cm_Ch23780_1 RB_offset 0

DUT: 121023C07

Communication System: LTE; Frequency: 709 MHz; Duty Cycle: 1:1

Medium: B750_1113 Medium parameters used: $f = 709$ MHz; $\sigma = 0.931$ mho/m; $\epsilon_r = 55.514$; $\rho = 1000$ kg/m³

Ambient Temperature : 21.8 °C ; Liquid Temperature : 20.5 °C

DASY5 Configuration:

- Probe: EX3DV4 - SN3578; ConvF(8.52, 8.52, 8.52); Calibrated: 2012/06/21;
- Sensor-Surface: 2mm (Mechanical Surface Detection)
- Electronics: DAE4 Sn1277; Calibrated: 2012/07/19
- Phantom: SAM Phantom_right; Type: QD000P40CC; Serial: TP:1496
- Measurement SW: DASY52, Version 52.8 (2); SEMCAD X Version 14.6.6 (6824)

Ch23780/Area Scan (41x71x1): Measurement grid: dx=20mm, dy=20mm

Maximum value of SAR (interpolated) = 0.153 W/kg

Ch23780/Zoom Scan (5x5x7)/Cube 0: Measurement grid: dx=8mm, dy=8mm, dz=5mm

Reference Value = 10.062 V/m; Power Drift = -0.15 dB

Peak SAR (extrapolated) = 0.160 mW/g

SAR(1 g) = 0.105 mW/g; SAR(10 g) = 0.073 mW/g

Maximum value of SAR (measured) = 0.127 W/kg

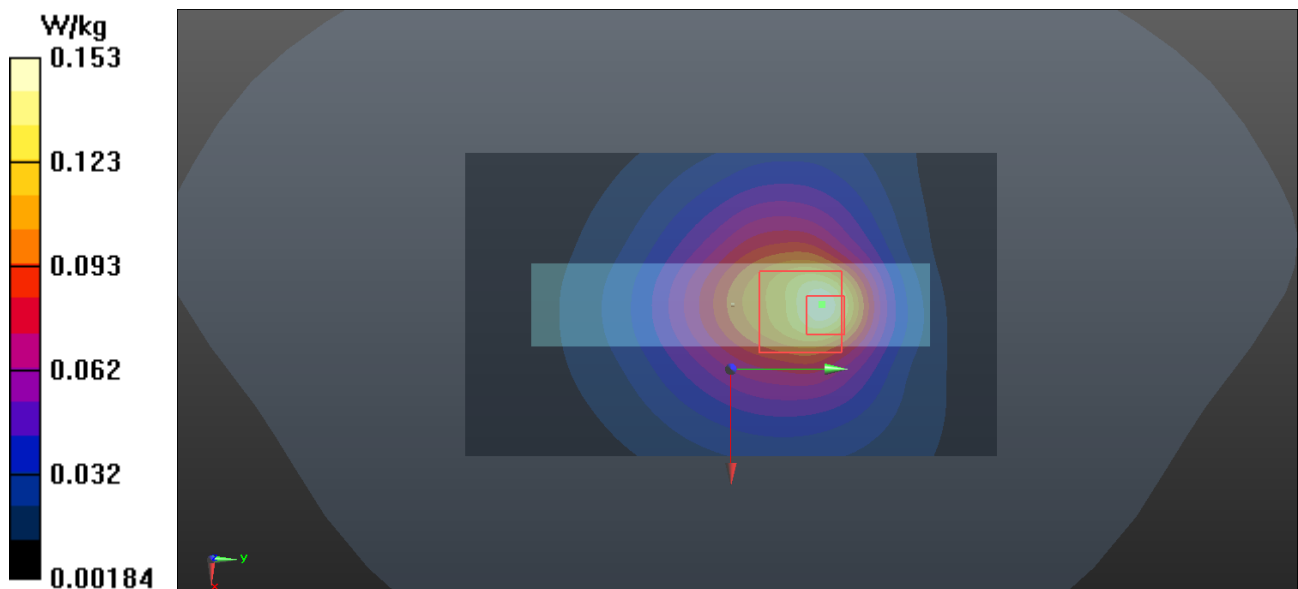

P207 LTE 17_QPSK_10M_Right Side_0.5cm_Ch23780_1 RB_offset 0

DUT: 121023C07

Communication System: LTE; Frequency: 709 MHz; Duty Cycle: 1:1

Medium: B750_1113 Medium parameters used: $f = 709 \text{ MHz}$; $\sigma = 0.931 \text{ mho/m}$; $\epsilon_r = 55.514$; $\rho = 1000 \text{ kg/m}^3$

Ambient Temperature : 21.8 °C ; Liquid Temperature : 20.5 °C

DASY5 Configuration:

- Probe: EX3DV4 - SN3578; ConvF(8.52, 8.52, 8.52); Calibrated: 2012/06/21;
- Sensor-Surface: 2mm (Mechanical Surface Detection)
- Electronics: DAE4 Sn1277; Calibrated: 2012/07/19
- Phantom: SAM Phantom_right; Type: QD000P40CC; Serial: TP:1496
- Measurement SW: DASY52, Version 52.8 (2); SEMCAD X Version 14.6.6 (6824)

Ch23780/Area Scan (41x71x1): Measurement grid: $dx=20\text{mm}$, $dy=20\text{mm}$

Maximum value of SAR (interpolated) = 0.210 W/kg

Ch23780/Zoom Scan (5x5x7)/Cube 0: Measurement grid: $dx=8\text{mm}$, $dy=8\text{mm}$, $dz=5\text{mm}$

Reference Value = 10.908 V/m; Power Drift = -0.01 dB

Peak SAR (extrapolated) = 0.297 mW/g

SAR(1 g) = 0.174 mW/g; SAR(10 g) = 0.102 mW/g

Maximum value of SAR (measured) = 0.238 W/kg

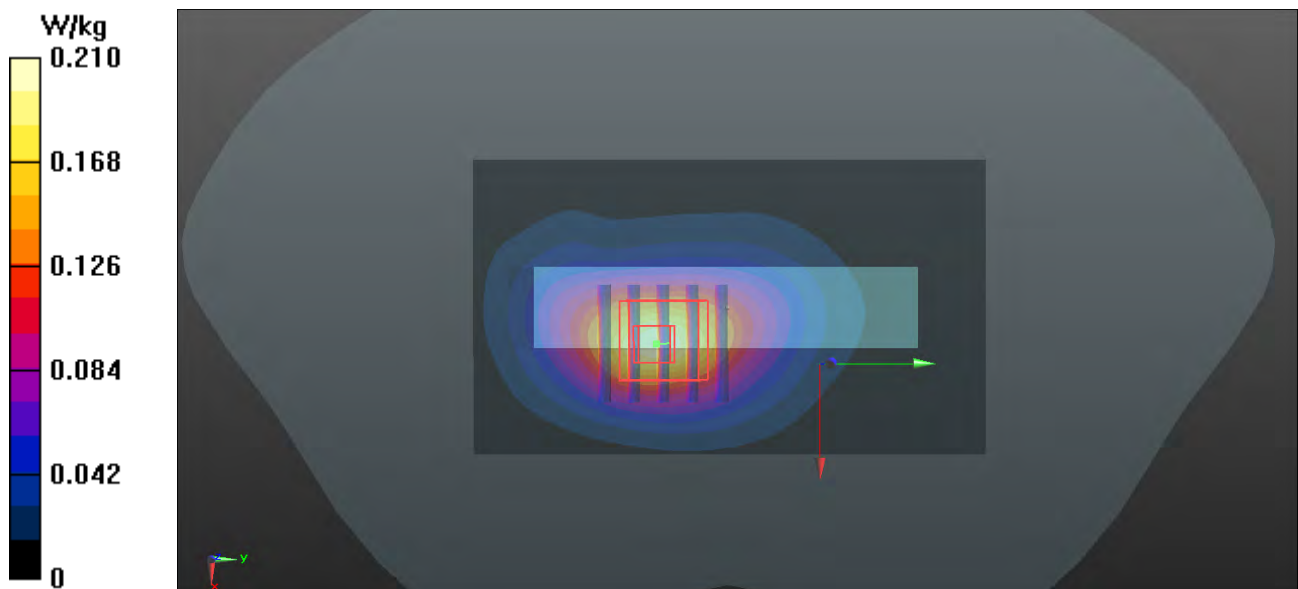

P208 LTE 17_QPSK_10M_Top Side_0.5cm_Ch23780_1 RB_offset 0

DUT: 121023C07

Communication System: LTE; Frequency: 709 MHz; Duty Cycle: 1:1

Medium: B750_1113 Medium parameters used: $f = 709$ MHz; $\sigma = 0.931$ mho/m; $\epsilon_r = 55.514$; $\rho = 1000$ kg/m³

Ambient Temperature : 21.8 °C ; Liquid Temperature : 20.5 °C

DASY5 Configuration:

- Probe: EX3DV4 - SN3578; ConvF(8.52, 8.52, 8.52); Calibrated: 2012/06/21;
- Sensor-Surface: 2mm (Mechanical Surface Detection)
- Electronics: DAE4 Sn1277; Calibrated: 2012/07/19
- Phantom: SAM Phantom_right; Type: QD000P40CC; Serial: TP:1496
- Measurement SW: DASY52, Version 52.8 (2); SEMCAD X Version 14.6.6 (6824)

Ch23780/Area Scan (41x61x1): Measurement grid: dx=20mm, dy=20mm

Maximum value of SAR (interpolated) = 0.196 W/kg

Ch23780/Zoom Scan (5x5x7)/Cube 0: Measurement grid: dx=8mm, dy=8mm, dz=5mm

Reference Value = 13.284 V/m; Power Drift = -0.07 dB

Peak SAR (extrapolated) = 0.275 mW/g

SAR(1 g) = 0.131 mW/g; SAR(10 g) = 0.067 mW/g

Maximum value of SAR (measured) = 0.194 W/kg

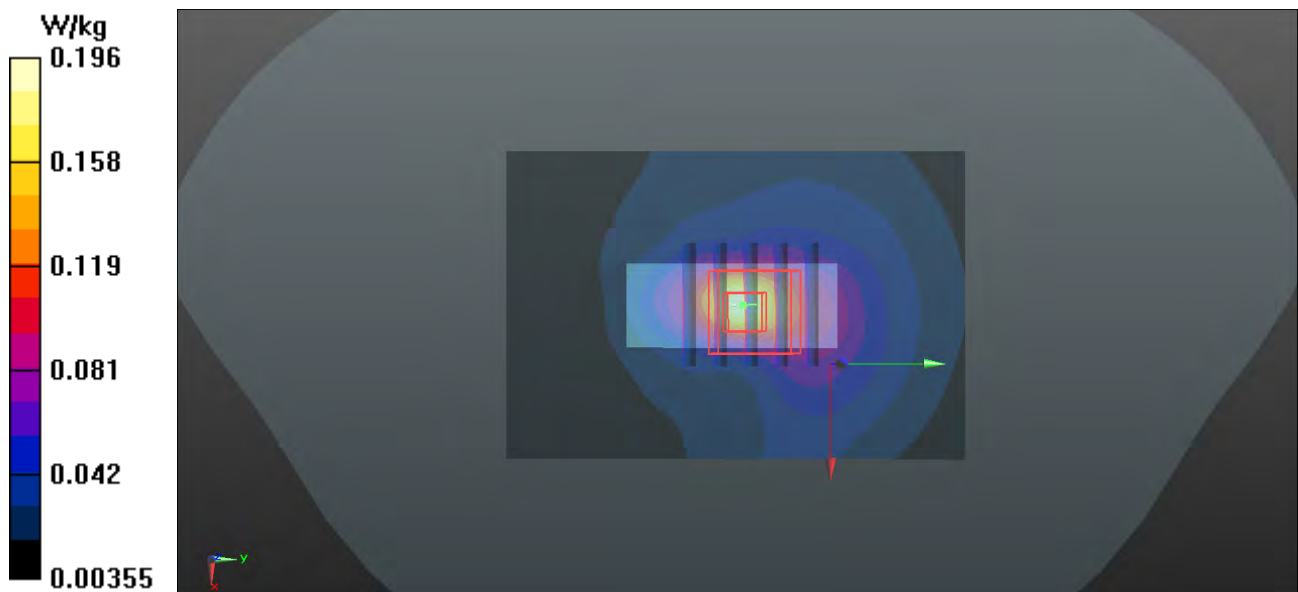

P210 LTE 17_QPSK_10M_Front Face_0.5cm_Ch23790_25 RB_offset 0

DUT: 121023C07

Communication System: LTE; Frequency: 710 MHz; Duty Cycle: 1:1

Medium: B750_1113 Medium parameters used: $f = 710$ MHz; $\sigma = 0.932$ mho/m; $\epsilon_r = 55.507$; $\rho = 1000$ kg/m³

Ambient Temperature : 21.8 °C ; Liquid Temperature : 20.5 °C

DASY5 Configuration:

- Probe: EX3DV4 - SN3578; ConvF(8.52, 8.52, 8.52); Calibrated: 2012/06/21;
- Sensor-Surface: 2mm (Mechanical Surface Detection)
- Electronics: DAE4 Sn1277; Calibrated: 2012/07/19
- Phantom: SAM Phantom_right; Type: QD000P40CC; Serial: TP:1496
- Measurement SW: DASY52, Version 52.8 (2); SEMCAD X Version 14.6.6 (6824)

Ch23790/Area Scan (51x71x1): Measurement grid: dx=20mm, dy=20mm

Maximum value of SAR (interpolated) = 0.519 W/kg

Ch23790/Zoom Scan (5x5x7)/Cube 0: Measurement grid: dx=8mm, dy=8mm, dz=5mm

Reference Value = 15.884 V/m; Power Drift = -0.06 dB

Peak SAR (extrapolated) = 0.722 mW/g

SAR(1 g) = 0.407 mW/g; SAR(10 g) = 0.235 mW/g

Maximum value of SAR (measured) = 0.558 W/kg

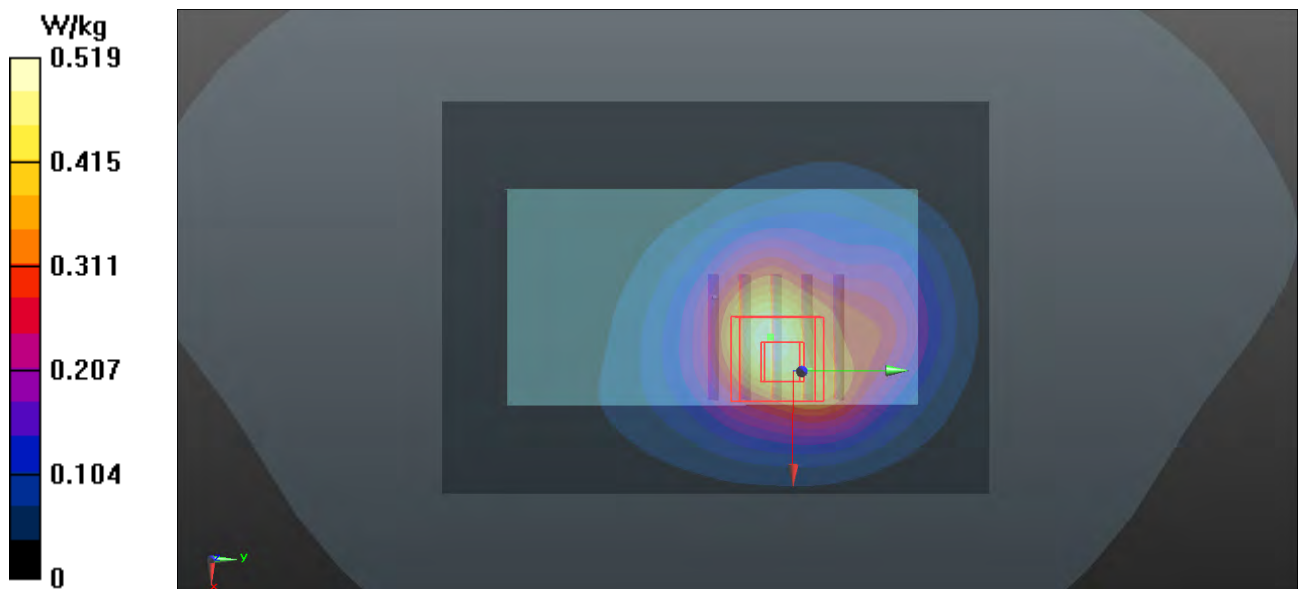

P211 LTE 17_QPSK_10M_Rear Face_0.5cm_Ch23790_25 RB_offset 0

DUT: 121023C07

Communication System: LTE; Frequency: 710 MHz; Duty Cycle: 1:1

Medium: B750_1113 Medium parameters used: $f = 710 \text{ MHz}$; $\sigma = 0.932 \text{ mho/m}$; $\epsilon_r = 55.507$; $\rho = 1000 \text{ kg/m}^3$

Ambient Temperature : 21.8 °C ; Liquid Temperature : 20.5 °C

DASY5 Configuration:

- Probe: EX3DV4 - SN3578; ConvF(8.52, 8.52, 8.52); Calibrated: 2012/06/21;
- Sensor-Surface: 2mm (Mechanical Surface Detection)
- Electronics: DAE4 Sn1277; Calibrated: 2012/07/19
- Phantom: SAM Phantom_right; Type: QD000P40CC; Serial: TP:1496
- Measurement SW: DASY52, Version 52.8 (2); SEMCAD X Version 14.6.6 (6824)

Ch23790/Area Scan (51x71x1): Measurement grid: $dx=20\text{mm}$, $dy=20\text{mm}$

Maximum value of SAR (interpolated) = 0.157 W/kg

Ch23790/Zoom Scan (5x5x7)/Cube 0: Measurement grid: $dx=8\text{mm}$, $dy=8\text{mm}$, $dz=5\text{mm}$

Reference Value = 11.052 V/m; Power Drift = 0.14 dB

Peak SAR (extrapolated) = 0.204 mW/g

SAR(1 g) = 0.132 mW/g; SAR(10 g) = 0.095 mW/g

Maximum value of SAR (measured) = 0.171 W/kg

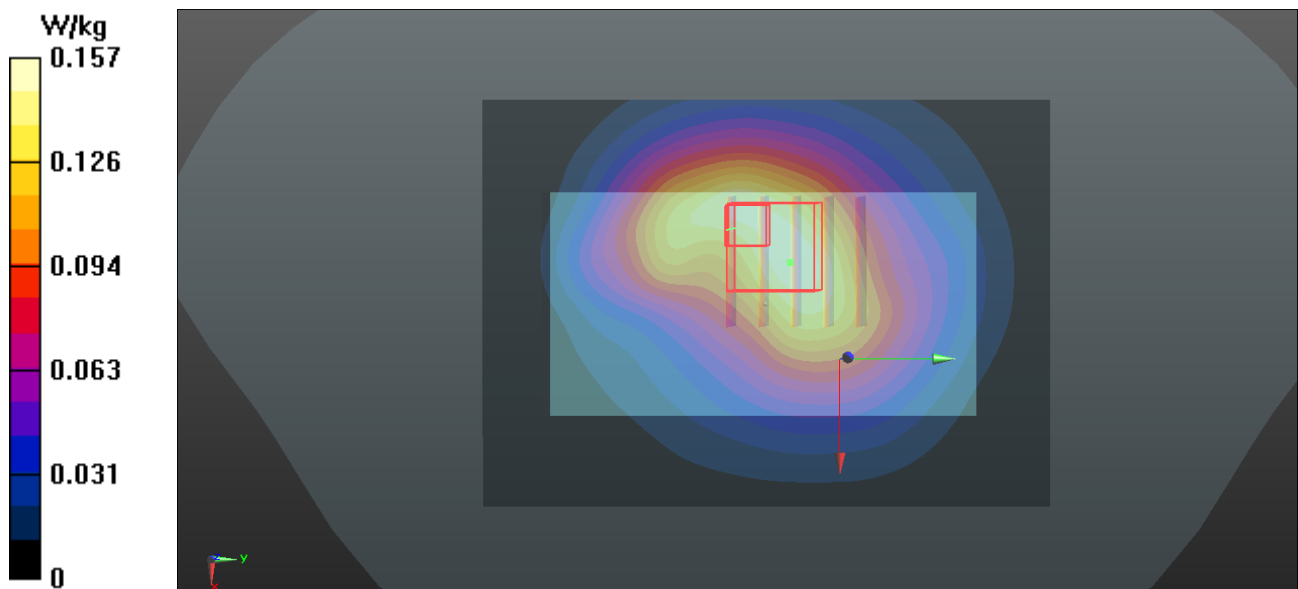

P212 LTE 17_QPSK_10M_Left Side_0.5cm_Ch23790_25 RB_offset 0

DUT: 121023C07

Communication System: LTE; Frequency: 710 MHz; Duty Cycle: 1:1

Medium: B750_1113 Medium parameters used: $f = 710$ MHz; $\sigma = 0.932$ mho/m; $\epsilon_r = 55.507$; $\rho = 1000$ kg/m³

Ambient Temperature : 21.8 °C; Liquid Temperature : 20.5 °C

DASY5 Configuration:

- Probe: EX3DV4 - SN3578; ConvF(8.52, 8.52, 8.52); Calibrated: 2012/06/21;
- Sensor-Surface: 2mm (Mechanical Surface Detection)
- Electronics: DAE4 Sn1277; Calibrated: 2012/07/19
- Phantom: SAM Phantom_right; Type: QD000P40CC; Serial: TP:1496
- Measurement SW: DASY52, Version 52.8 (2); SEMCAD X Version 14.6.6 (6824)

Ch23790/Area Scan (41x71x1): Measurement grid: dx=20mm, dy=20mm

Maximum value of SAR (interpolated) = 0.102 W/kg

Ch23790/Zoom Scan (5x5x7)/Cube 0: Measurement grid: dx=8mm, dy=8mm, dz=5mm

Reference Value = 8.156 V/m; Power Drift = 0.16 dB

Peak SAR (extrapolated) = 0.109 mW/g

SAR(1 g) = 0.071 mW/g; SAR(10 g) = 0.049 mW/g

Maximum value of SAR (measured) = 0.0857 W/kg

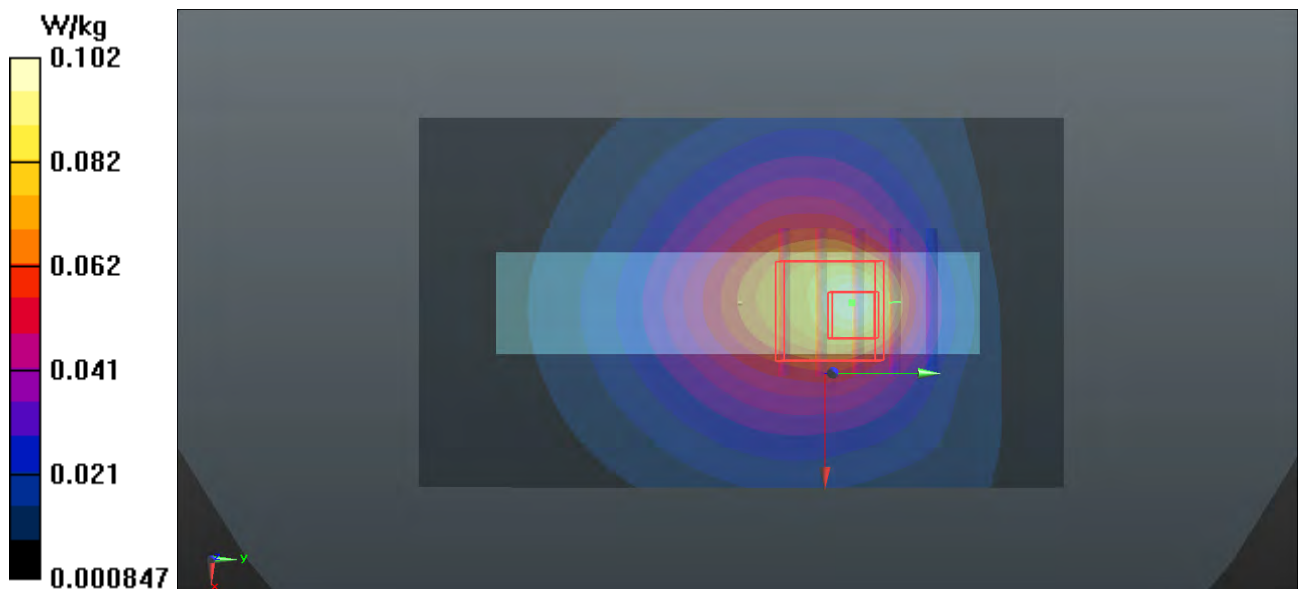

P213 LTE 17_QPSK_10M_Right Side_0.5cm_Ch23790_25 RB_offset 0

DUT: 121023C07

Communication System: LTE; Frequency: 710 MHz; Duty Cycle: 1:1

Medium: B750_1113 Medium parameters used: $f = 710 \text{ MHz}$; $\sigma = 0.932 \text{ mho/m}$; $\epsilon_r = 55.507$; $\rho = 1000 \text{ kg/m}^3$

Ambient Temperature : 21.8 °C ; Liquid Temperature : 20.5 °C

DASY5 Configuration:

- Probe: EX3DV4 - SN3578; ConvF(8.52, 8.52, 8.52); Calibrated: 2012/06/21;
- Sensor-Surface: 2mm (Mechanical Surface Detection)
- Electronics: DAE4 Sn1277; Calibrated: 2012/07/19
- Phantom: SAM Phantom_right; Type: QD000P40CC; Serial: TP:1496
- Measurement SW: DASY52, Version 52.8 (2); SEMCAD X Version 14.6.6 (6824)

Ch23790/Area Scan (41x71x1): Measurement grid: $dx=20\text{mm}$, $dy=20\text{mm}$

Maximum value of SAR (interpolated) = 0.176 W/kg

Ch23790/Zoom Scan (5x5x7)/Cube 0: Measurement grid: $dx=8\text{mm}$, $dy=8\text{mm}$, $dz=5\text{mm}$

Reference Value = 10.069 V/m; Power Drift = -0.02 dB

Peak SAR (extrapolated) = 0.251 mW/g

SAR(1 g) = 0.148 mW/g; SAR(10 g) = 0.087 mW/g

Maximum value of SAR (measured) = 0.201 W/kg

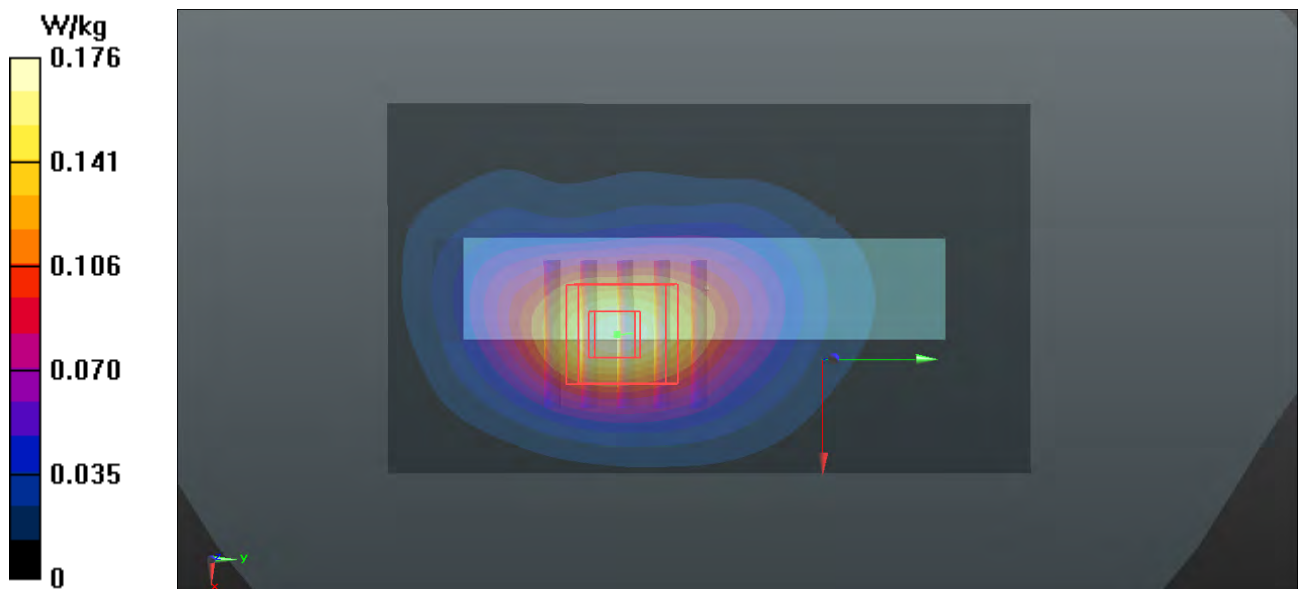

P214 LTE 17_QPSK_10M_Top Side_0.5cm_Ch23790_25 RB_offset 0

DUT: 121023C07

Communication System: LTE; Frequency: 710 MHz; Duty Cycle: 1:1

Medium: B750_1113 Medium parameters used: $f = 710 \text{ MHz}$; $\sigma = 0.932 \text{ mho/m}$; $\epsilon_r = 55.507$; $\rho = 1000 \text{ kg/m}^3$

Ambient Temperature : 21.8 °C ; Liquid Temperature : 20.5 °C

DASY5 Configuration:

- Probe: EX3DV4 - SN3578; ConvF(8.52, 8.52, 8.52); Calibrated: 2012/06/21;
- Sensor-Surface: 2mm (Mechanical Surface Detection)
- Electronics: DAE4 Sn1277; Calibrated: 2012/07/19
- Phantom: SAM Phantom_right; Type: QD000P40CC; Serial: TP:1496
- Measurement SW: DASY52, Version 52.8 (2); SEMCAD X Version 14.6.6 (6824)

Ch23790/Area Scan (41x61x1): Measurement grid: $dx=20\text{mm}$, $dy=20\text{mm}$

Maximum value of SAR (interpolated) = 0.141 W/kg

Ch23790/Zoom Scan (5x5x7)/Cube 0: Measurement grid: $dx=8\text{mm}$, $dy=8\text{mm}$, $dz=5\text{mm}$

Reference Value = 11.613 V/m; Power Drift = -0.18 dB

Peak SAR (extrapolated) = 0.187 mW/g

SAR(1 g) = 0.089 mW/g; SAR(10 g) = 0.045 mW/g

Maximum value of SAR (measured) = 0.132 W/kg

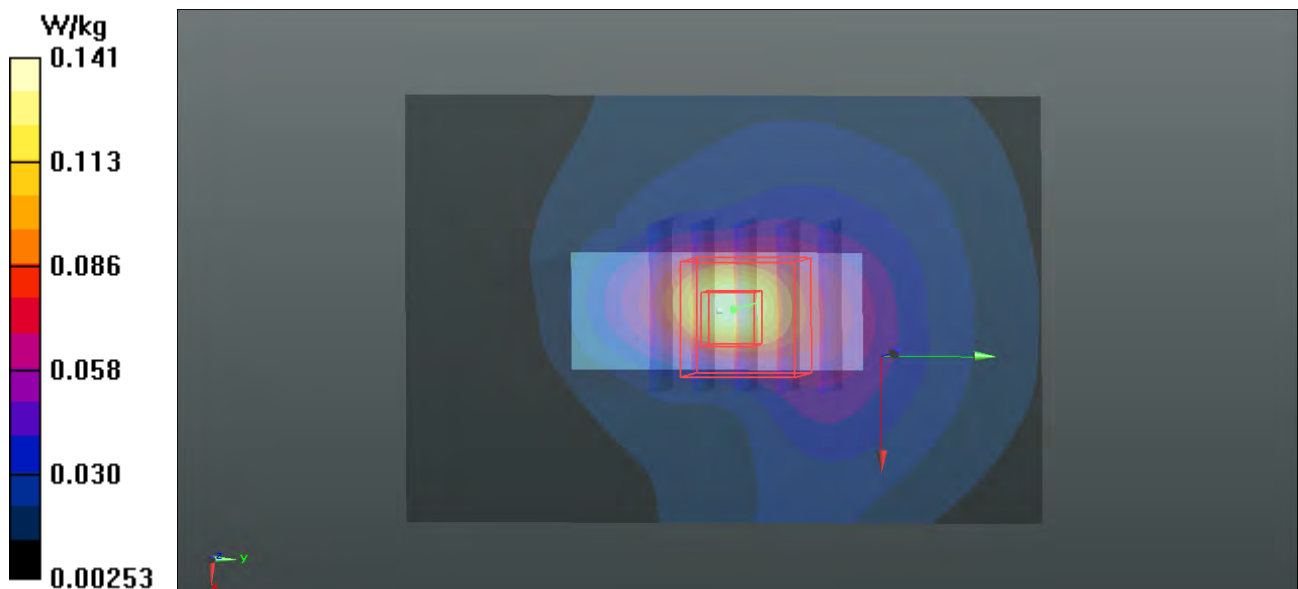

P306 LTE 25_QPSK_20M_Front Face_0.5cm_Ch26140_1 RB_offset 50

DUT: 121023C07

Communication System: LTE; Frequency: 1860 MHz; Duty Cycle: 1:1

Medium: B1900_1113 Medium parameters used: $f = 1860$ MHz; $\sigma = 1.486$ mho/m; $\epsilon_r = 51.158$; $\rho = 1000$ kg/m³

Ambient Temperature : 21.6 °C ; Liquid Temperature : 20.7 °C

DASY5 Configuration:

- Probe: EX3DV4 - SN3578; ConvF(6.69, 6.69, 6.69); Calibrated: 2012/06/21;
- Sensor-Surface: 2mm (Mechanical Surface Detection)
- Electronics: DAE4 Sn1277; Calibrated: 2012/07/19
- Phantom: SAM Phantom_Front; Type: SAM V4.0; Serial: TP 1127
- Measurement SW: DASY52, Version 52.8 (2); SEMCAD X Version 14.6.6 (6824)

Ch26140/Area Scan (51x71x1): Measurement grid: dx=20mm, dy=20mm

Maximum value of SAR (interpolated) = 0.893 W/kg

Ch26140/Zoom Scan (5x5x7)/Cube 0: Measurement grid: dx=8mm, dy=8mm, dz=5mm

Reference Value = 16.006 V/m; Power Drift = -0.17 dB

Peak SAR (extrapolated) = 1.365 mW/g

SAR(1 g) = 0.704 mW/g; SAR(10 g) = 0.370 mW/g

Maximum value of SAR (measured) = 0.985 W/kg

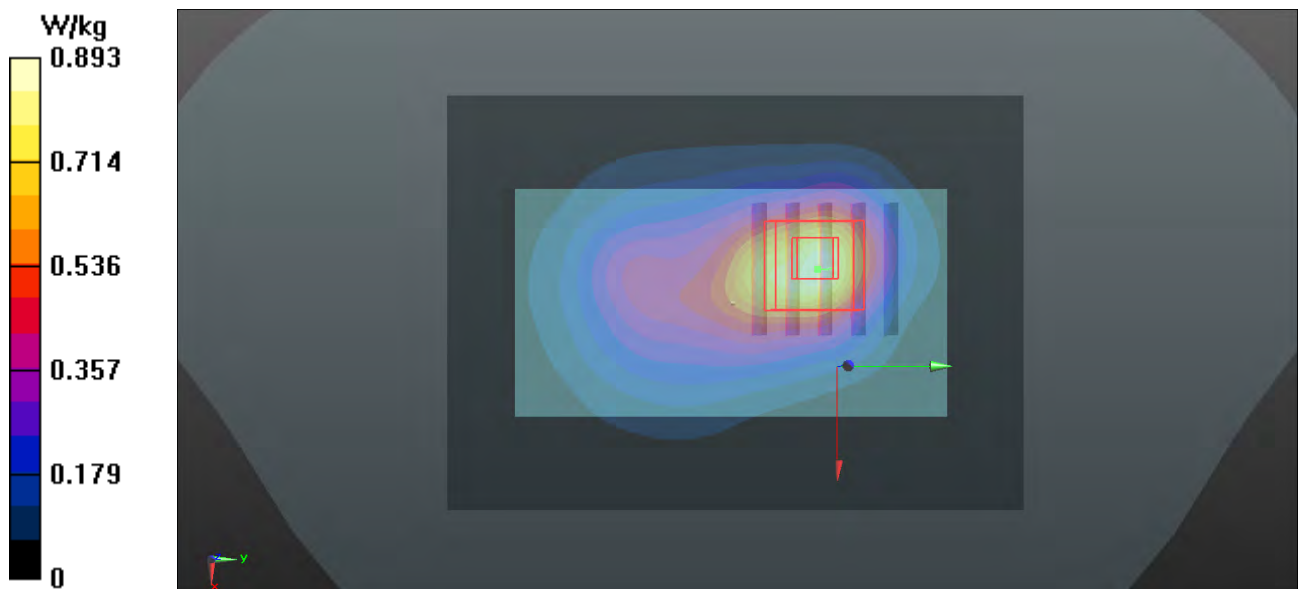

1g/10g Averaged SAR

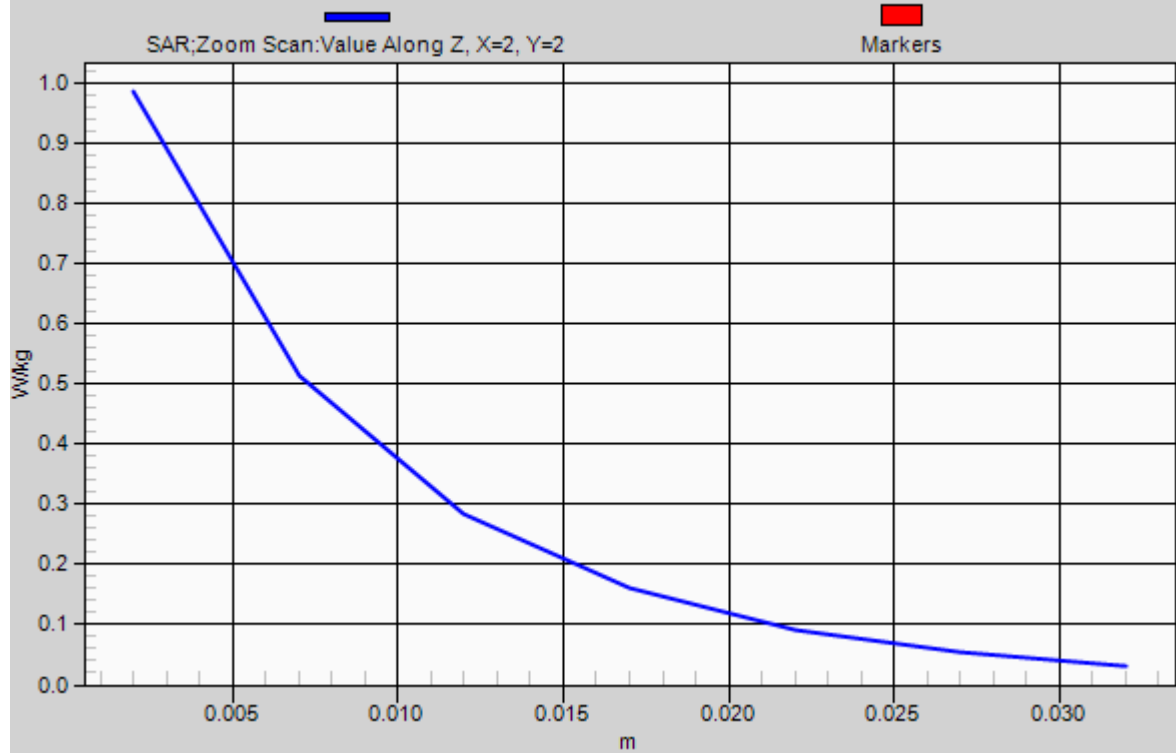

P307 LTE 25_QPSK_20M_Rear Face_0.5cm_Ch26140_1 RB_offset 50

DUT: 121023C07

Communication System: LTE; Frequency: 1860 MHz; Duty Cycle: 1:1

Medium: B1900_1113 Medium parameters used: $f = 1860$ MHz; $\sigma = 1.486$ mho/m; $\epsilon_r = 51.158$; $\rho = 1000$ kg/m³

Ambient Temperature : 21.6 °C ; Liquid Temperature : 20.7 °C

DASY5 Configuration:

- Probe: EX3DV4 - SN3578; ConvF(6.69, 6.69, 6.69); Calibrated: 2012/06/21;
- Sensor-Surface: 2mm (Mechanical Surface Detection)
- Electronics: DAE4 Sn1277; Calibrated: 2012/07/19
- Phantom: SAM Phantom_Front; Type: SAM V4.0; Serial: TP 1127
- Measurement SW: DASY52, Version 52.8 (2); SEMCAD X Version 14.6.6 (6824)

Ch26140/Area Scan (51x71x1): Measurement grid: dx=20mm, dy=20mm

Maximum value of SAR (interpolated) = 1.04 W/kg

Ch26140/Zoom Scan (5x5x7)/Cube 0: Measurement grid: dx=8mm, dy=8mm, dz=5mm

Reference Value = 21.738 V/m; Power Drift = 0.01 dB

Peak SAR (extrapolated) = 0.933 mW/g

SAR(1 g) = 0.634 mW/g; SAR(10 g) = 0.398 mW/g

Maximum value of SAR (measured) = 0.793 W/kg

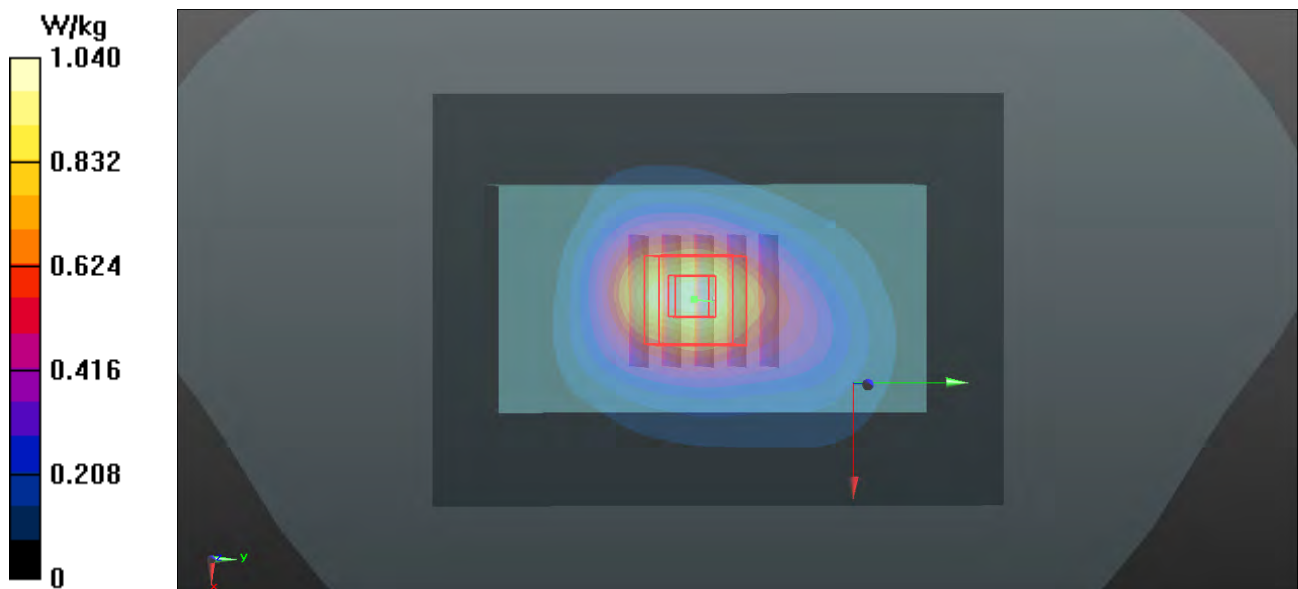

P308 LTE 25_QPSK_20M_Left Side_0.5cm_Ch26140_1 RB_offset 50

DUT: 121023C07

Communication System: LTE; Frequency: 1860 MHz; Duty Cycle: 1:1

Medium: B1900_1113 Medium parameters used: $f = 1860$ MHz; $\sigma = 1.486$ mho/m; $\epsilon_r = 51.158$; $\rho = 1000$ kg/m³

Ambient Temperature : 21.6 °C ; Liquid Temperature : 20.7 °C

DASY5 Configuration:

- Probe: EX3DV4 - SN3578; ConvF(6.69, 6.69, 6.69); Calibrated: 2012/06/21;
- Sensor-Surface: 2mm (Mechanical Surface Detection)
- Electronics: DAE4 Sn1277; Calibrated: 2012/07/19
- Phantom: SAM Phantom_Front; Type: SAM V4.0; Serial: TP 1127
- Measurement SW: DASY52, Version 52.8 (2); SEMCAD X Version 14.6.6 (6824)

Ch26140/Area Scan (41x71x1): Measurement grid: dx=20mm, dy=20mm

Maximum value of SAR (interpolated) = 0.359 W/kg

Ch26140/Zoom Scan (5x5x7)/Cube 0: Measurement grid: dx=8mm, dy=8mm, dz=5mm

Reference Value = 13.881 V/m; Power Drift = -0.02 dB

Peak SAR (extrapolated) = 0.444 mW/g

SAR(1 g) = 0.283 mW/g; SAR(10 g) = 0.170 mW/g

Maximum value of SAR (measured) = 0.369 W/kg

Ch26140/Zoom Scan (5x5x7)/Cube 1: Measurement grid: dx=8mm, dy=8mm, dz=5mm

Reference Value = 13.881 V/m; Power Drift = -0.02 dB

Peak SAR (extrapolated) = 0.476 mW/g

SAR(1 g) = 0.251 mW/g; SAR(10 g) = 0.138 mW/g

Maximum value of SAR (measured) = 0.360 W/kg

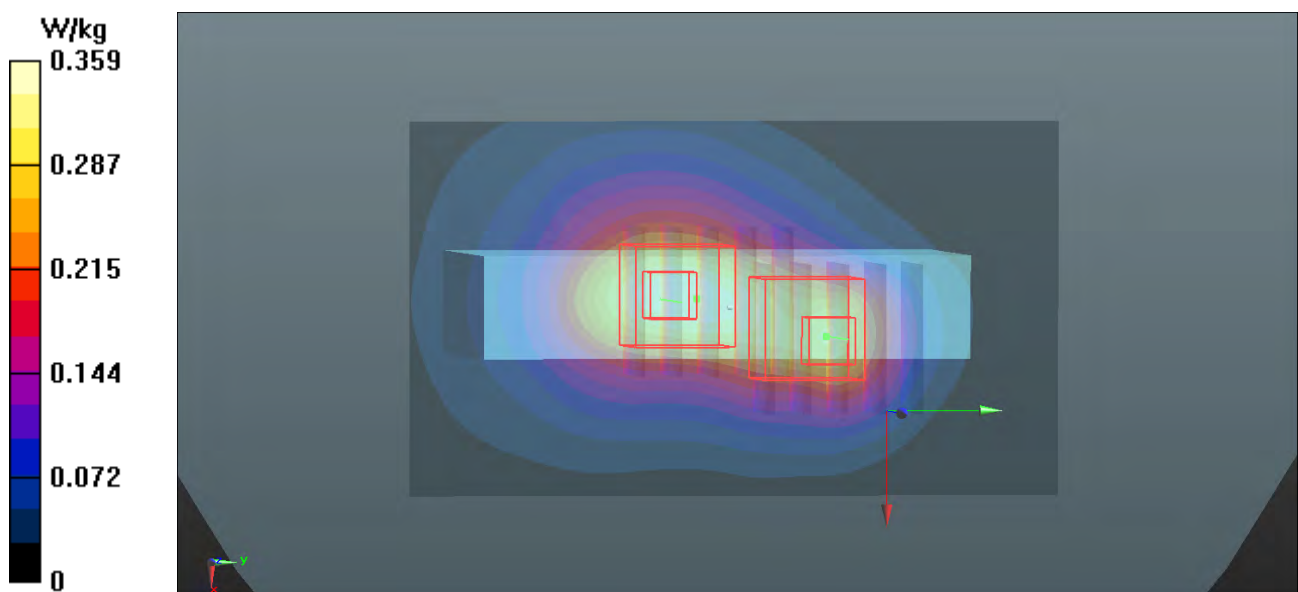

P309 LTE 25_QPSK_20M_Right Side_0.5cm_Ch26140_1 RB_offset 50

DUT: 121023C07

Communication System: LTE; Frequency: 1860 MHz; Duty Cycle: 1:1

Medium: B1900_1113 Medium parameters used: $f = 1860$ MHz; $\sigma = 1.486$ mho/m; $\epsilon_r = 51.158$; $\rho = 1000$ kg/m³

Ambient Temperature : 21.6 °C ; Liquid Temperature : 20.7 °C

DASY5 Configuration:

- Probe: EX3DV4 - SN3578; ConvF(6.69, 6.69, 6.69); Calibrated: 2012/06/21;
- Sensor-Surface: 2mm (Mechanical Surface Detection)
- Electronics: DAE4 Sn1277; Calibrated: 2012/07/19
- Phantom: SAM Phantom_Front; Type: SAM V4.0; Serial: TP 1127
- Measurement SW: DASY52, Version 52.8 (2); SEMCAD X Version 14.6.6 (6824)

Ch26140/Area Scan (41x71x1): Measurement grid: dx=20mm, dy=20mm

Maximum value of SAR (interpolated) = 0.314 W/kg

Ch26140/Zoom Scan (5x5x7)/Cube 0: Measurement grid: dx=8mm, dy=8mm, dz=5mm

Reference Value = 12.338 V/m; Power Drift = -0.07 dB

Peak SAR (extrapolated) = 0.372 mW/g

SAR(1 g) = 0.232 mW/g; SAR(10 g) = 0.136 mW/g

Maximum value of SAR (measured) = 0.307 W/kg

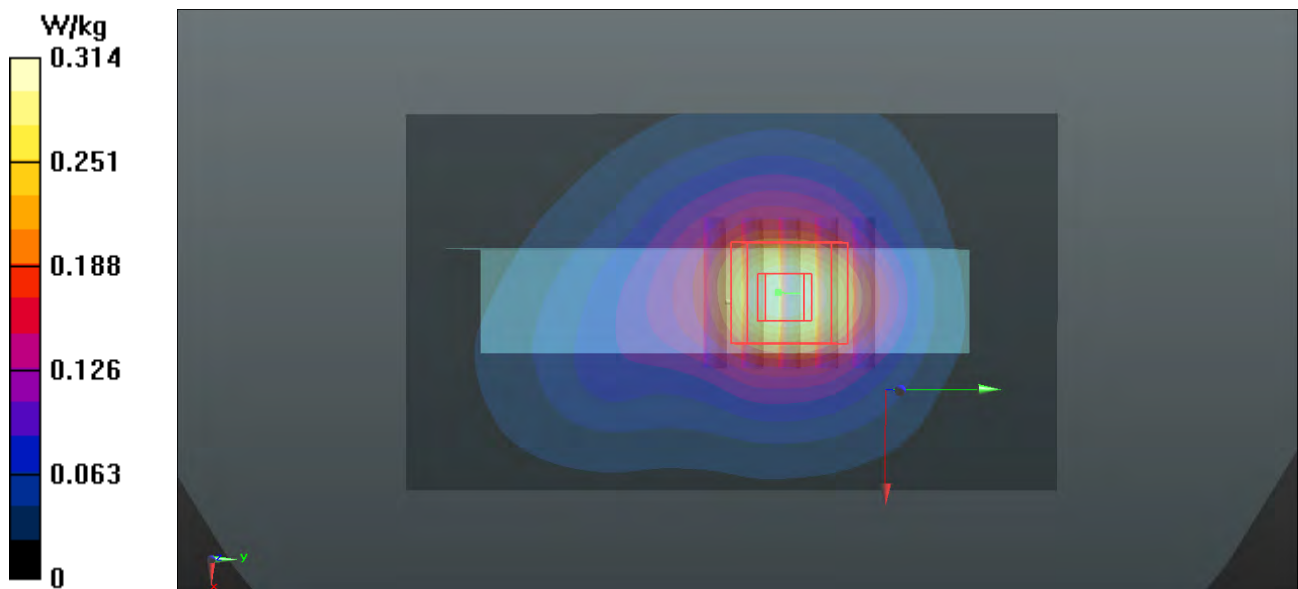

P310 LTE 25_QPSK_20M_Top Side_0.5cm_Ch26140_1 RB_offset 50

DUT: 121023C07

Communication System: LTE; Frequency: 1860 MHz; Duty Cycle: 1:1

Medium: B1900_1113 Medium parameters used: $f = 1860$ MHz; $\sigma = 1.486$ mho/m; $\epsilon_r = 51.158$; $\rho = 1000$ kg/m³

Ambient Temperature : 21.6 °C; Liquid Temperature : 20.7 °C

DASY5 Configuration:

- Probe: EX3DV4 - SN3578; ConvF(6.69, 6.69, 6.69); Calibrated: 2012/06/21;
- Sensor-Surface: 2mm (Mechanical Surface Detection)
- Electronics: DAE4 Sn1277; Calibrated: 2012/07/19
- Phantom: SAM Phantom_Front; Type: SAM V4.0; Serial: TP 1127
- Measurement SW: DASY52, Version 52.8 (2); SEMCAD X Version 14.6.6 (6824)

Ch26140/Area Scan (41x51x1): Measurement grid: dx=20mm, dy=20mm

Maximum value of SAR (interpolated) = 0.144 W/kg

Ch26140/Zoom Scan (5x5x7)/Cube 0: Measurement grid: dx=8mm, dy=8mm, dz=5mm

Reference Value = 8.391 V/m; Power Drift = 0.11 dB

Peak SAR (extrapolated) = 0.182 mW/g

SAR(1 g) = 0.106 mW/g; SAR(10 g) = 0.060 mW/g

Maximum value of SAR (measured) = 0.142 W/kg

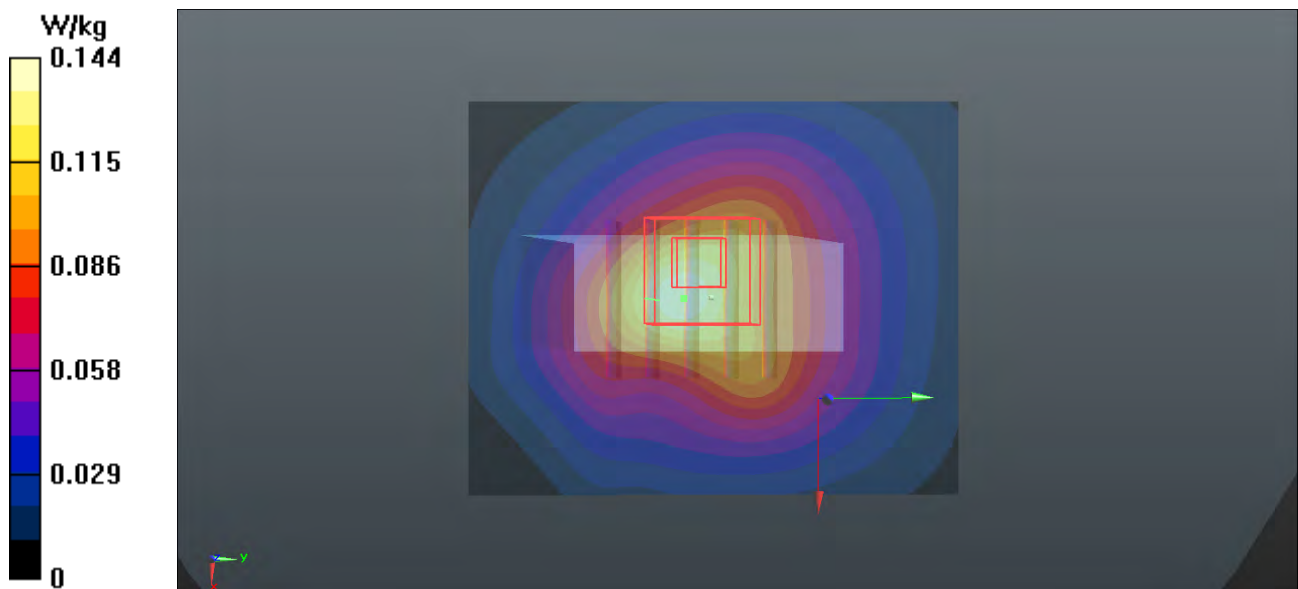

P311 LTE 25_QPSK_20M_Front Face_0.5cm_Ch26140_50 RB_offset 50

DUT: 121023C07

Communication System: LTE; Frequency: 1860 MHz; Duty Cycle: 1:1

Medium: B1900_1113 Medium parameters used: $f = 1860$ MHz; $\sigma = 1.486$ mho/m; $\epsilon_r = 51.158$; $\rho = 1000$ kg/m³

Ambient Temperature : 21.6 °C; Liquid Temperature : 20.7 °C

DASY5 Configuration:

- Probe: EX3DV4 - SN3578; ConvF(6.69, 6.69, 6.69); Calibrated: 2012/06/21;
- Sensor-Surface: 2mm (Mechanical Surface Detection)
- Electronics: DAE4 Sn1277; Calibrated: 2012/07/19
- Phantom: SAM Phantom_Front; Type: SAM V4.0; Serial: TP 1127
- Measurement SW: DASY52, Version 52.8 (2); SEMCAD X Version 14.6.6 (6824)

Ch26140/Area Scan (51x71x1): Measurement grid: dx=20mm, dy=20mm

Maximum value of SAR (interpolated) = 0.632 W/kg

Ch26140/Zoom Scan (5x5x7)/Cube 0: Measurement grid: dx=8mm, dy=8mm, dz=5mm

Reference Value = 13.135 V/m; Power Drift = 0.06 dB

Peak SAR (extrapolated) = 0.983 mW/g

SAR(1 g) = 0.512 mW/g; SAR(10 g) = 0.268 mW/g

Maximum value of SAR (measured) = 0.720 W/kg

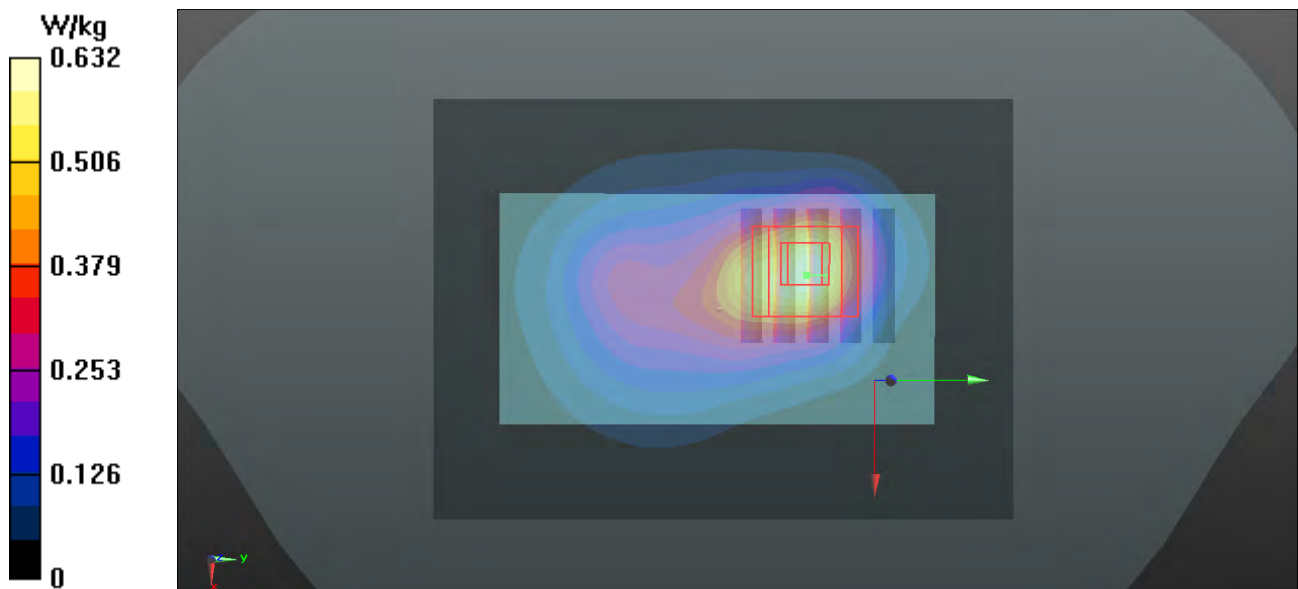

P312 LTE 25_QPSK_20M_Rear Face_0.5cm_Ch26140_50 RB_offset 50

DUT: 121023C07

Communication System: LTE; Frequency: 1860 MHz; Duty Cycle: 1:1

Medium: B1900_1113 Medium parameters used: $f = 1860$ MHz; $\sigma = 1.486$ mho/m; $\epsilon_r = 51.158$; $\rho = 1000$ kg/m³

Ambient Temperature : 21.6 °C ; Liquid Temperature : 20.7 °C

DASY5 Configuration:

- Probe: EX3DV4 - SN3578; ConvF(6.69, 6.69, 6.69); Calibrated: 2012/06/21;
- Sensor-Surface: 2mm (Mechanical Surface Detection)
- Electronics: DAE4 Sn1277; Calibrated: 2012/07/19
- Phantom: SAM Phantom_Front; Type: SAM V4.0; Serial: TP 1127
- Measurement SW: DASY52, Version 52.8 (2); SEMCAD X Version 14.6.6 (6824)

Ch26140/Area Scan (51x71x1): Measurement grid: dx=20mm, dy=20mm

Maximum value of SAR (interpolated) = 0.786 W/kg

Ch26140/Zoom Scan (5x5x7)/Cube 0: Measurement grid: dx=8mm, dy=8mm, dz=5mm

Reference Value = 18.706 V/m; Power Drift = 0.05 dB

Peak SAR (extrapolated) = 0.705 mW/g

SAR(1 g) = 0.477 mW/g; SAR(10 g) = 0.298 mW/g

Maximum value of SAR (measured) = 0.600 W/kg

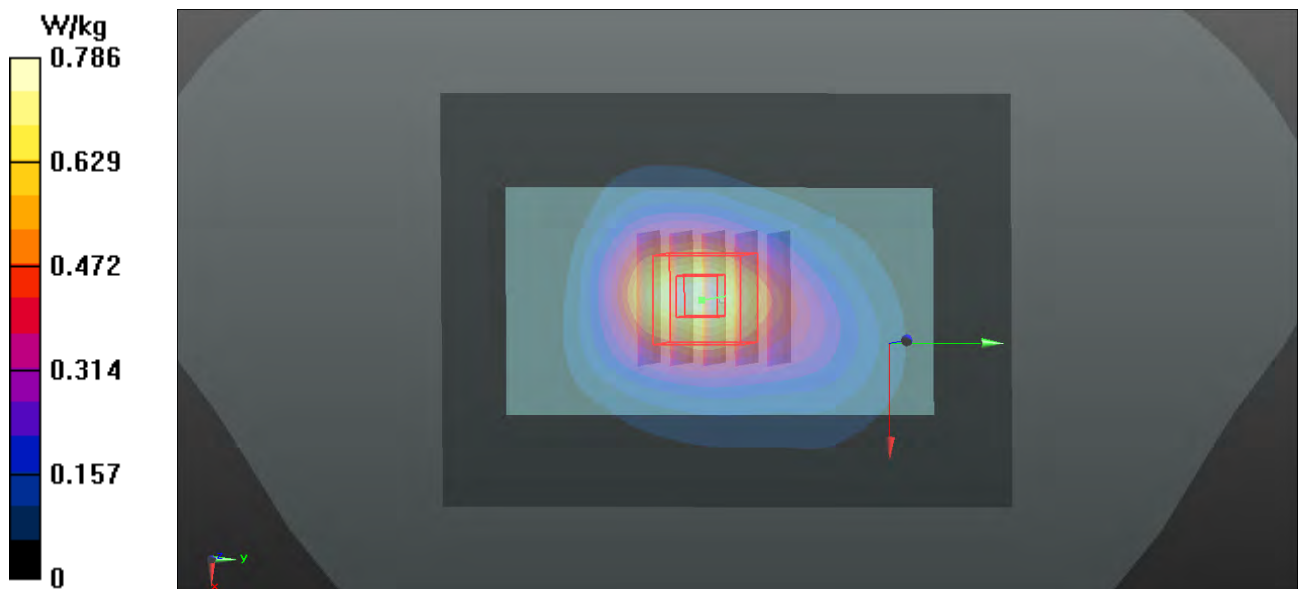

P313 LTE 25_QPSK_20M_Left Side_0.5cm_Ch26140_50 RB_offset 50

DUT: 121023C07

Communication System: LTE; Frequency: 1860 MHz; Duty Cycle: 1:1

Medium: B1900_1113 Medium parameters used: $f = 1860$ MHz; $\sigma = 1.486$ mho/m; $\epsilon_r = 51.158$; $\rho = 1000$ kg/m³

Ambient Temperature : 21.6 °C ; Liquid Temperature : 20.7 °C

DASY5 Configuration:

- Probe: EX3DV4 - SN3578; ConvF(6.69, 6.69, 6.69); Calibrated: 2012/06/21;
- Sensor-Surface: 2mm (Mechanical Surface Detection)
- Electronics: DAE4 Sn1277; Calibrated: 2012/07/19
- Phantom: SAM Phantom_Front; Type: SAM V4.0; Serial: TP 1127
- Measurement SW: DASY52, Version 52.8 (2); SEMCAD X Version 14.6.6 (6824)

Ch26140/Area Scan (41x71x1): Measurement grid: dx=20mm, dy=20mm

Maximum value of SAR (interpolated) = 0.267 W/kg

Ch26140/Zoom Scan (5x5x7)/Cube 0: Measurement grid: dx=8mm, dy=8mm, dz=5mm

Reference Value = 11.756 V/m; Power Drift = 0.07 dB

Peak SAR (extrapolated) = 0.336 mW/g

SAR(1 g) = 0.212 mW/g; SAR(10 g) = 0.127 mW/g

Maximum value of SAR (measured) = 0.276 W/kg

Ch26140/Zoom Scan (5x5x7)/Cube 1: Measurement grid: dx=8mm, dy=8mm, dz=5mm

Reference Value = 11.756 V/m; Power Drift = 0.07 dB

Peak SAR (extrapolated) = 0.358 mW/g

SAR(1 g) = 0.187 mW/g; SAR(10 g) = 0.101 mW/g

Maximum value of SAR (measured) = 0.267 W/kg

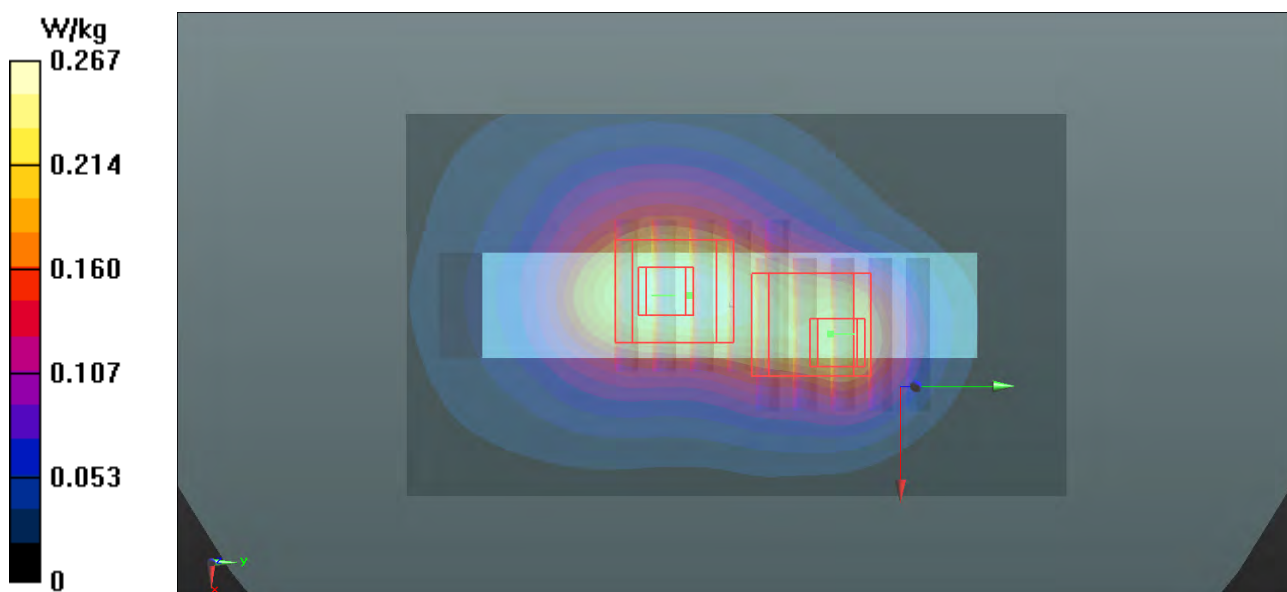

P314 LTE 25_QPSK_20M_Right Side_0.5cm_Ch26140_50 RB_offset 50

DUT: 121023C07

Communication System: LTE; Frequency: 1860 MHz; Duty Cycle: 1:1

Medium: B1900_1113 Medium parameters used: $f = 1860$ MHz; $\sigma = 1.486$ mho/m; $\epsilon_r = 51.158$; $\rho = 1000$ kg/m³

Ambient Temperature : 21.6 °C ; Liquid Temperature : 20.7 °C

DASY5 Configuration:

- Probe: EX3DV4 - SN3578; ConvF(6.69, 6.69, 6.69); Calibrated: 2012/06/21;
- Sensor-Surface: 2mm (Mechanical Surface Detection)
- Electronics: DAE4 Sn1277; Calibrated: 2012/07/19
- Phantom: SAM Phantom_Front; Type: SAM V4.0; Serial: TP 1127
- Measurement SW: DASY52, Version 52.8 (2); SEMCAD X Version 14.6.6 (6824)

Ch26140/Area Scan (41x71x1): Measurement grid: dx=20mm, dy=20mm

Maximum value of SAR (interpolated) = 0.224 W/kg

Ch26140/Zoom Scan (5x5x7)/Cube 0: Measurement grid: dx=8mm, dy=8mm, dz=5mm

Reference Value = 10.395 V/m; Power Drift = 0.01 dB

Peak SAR (extrapolated) = 0.275 mW/g

SAR(1 g) = 0.170 mW/g; SAR(10 g) = 0.099 mW/g

Maximum value of SAR (measured) = 0.227 W/kg

