



# FCC TEST REPORT (PART 90S)

**REPORT NO.:** RF130627C19-3  
**MODEL NO.:** M530S  
**FCC ID:** UZI-M30S58  
**RECEIVED:** Jun. 27, 2013  
**TESTED:** Jul. 15 ~ Aug. 08, 2013  
**ISSUED:** Aug. 12, 2013

**APPLICANT:** BandRich Inc.

**ADDRESS:** 6F., No. 71, Zhouzi St., Neihu Dist., Taipei City  
11493, Taiwan (R.O.C.)

**ISSUED BY:** Bureau Veritas Consumer Products Services  
(H.K.) Ltd., Taoyuan Branch

**LAB ADDRESS:** No. 47, 14th Ling, Chia Pau Vil., Lin Kou Dist.,  
New Taipei City, Taiwan (R.O.C)

**TEST LOCATION:** No. 19, Hwa Ya 2nd Rd, Wen Hwa Tsuen, Kwei  
Shan Hsiang, Taoyuan Hsien 333, Taiwan, R.O.C.

This report should not be used by the client to claim product certification, approval, or endorsement by any government agencies.

This report is for your exclusive use. Any copying or replication of this report to or for any other person or entity, or use of our name or trademark, is permitted only with our prior written permission. This report sets forth our findings solely with respect to the test samples identified herein. The results set forth in this report are not indicative or representative of the quality or characteristics of the lot from which a test sample was taken or any similar or identical product unless specifically and expressly noted. Our report includes all of the tests requested by you and the results thereof based upon the information that you provided to us. You have 60 days from date of issuance of this report to notify us of any material error or omission caused by our negligence, provided, however, that such notice shall be in writing and shall specifically address the issue you wish to raise. A failure to raise such issue within the prescribed time shall constitute your unqualified acceptance of the completeness of this report, the tests conducted and the correctness of the report contents. Unless specific mention, the uncertainty of measurement has been explicitly taken into account to declare the compliance or non-compliance to the specification.

## TABLE OF CONTENTS

RELEASE CONTROL RECORD .....	3
1 CERTIFICATION .....	4
2 SUMMARY OF TEST RESULTS .....	5
2.1 MEASUREMENT UNCERTAINTY .....	5
2.2 TEST SITE AND INSTRUMENTS .....	6
3 GENERAL INFORMATION.....	7
3.1 GENERAL DESCRIPTION OF EUT.....	7
3.2 CONFIGURATION OF SYSTEM UNDER TEST.....	9
3.3 DESCRIPTION OF SUPPORT UNITS.....	9
3.4 DESCRIPTION OF TEST MODES.....	10
3.5 GENERAL DESCRIPTION OF APPLIED STANDARDS.....	13
4 TEST TYPES AND RESULTS.....	14
4.1 OUTPUT POWER MEASUREMENT .....	14
4.1.1 LIMITS OF OUTPUT POWER MEASUREMENT.....	14
4.1.2 TEST PROCEDURES.....	14
4.1.3 TEST SETUP .....	15
4.1.4 TEST RESULTS.....	16
4.2 FREQUENCY STABILITY MEASUREMENT .....	26
4.2.1 LIMITS OF FREQUENCY STABILITY MEASUREMENT.....	26
4.2.2 TEST PROCEDURE .....	26
4.2.3 TEST SETUP .....	26
4.2.4 TEST RESULTS.....	27
4.3 OCCUPIED BANDWIDTH MEASUREMENT.....	29
4.3.1 LIMITS OF OCCUPIED BANDWIDTH MEASUREMENT.....	29
4.3.2 TEST SETUP .....	29
4.3.3 TEST PROCEDURES.....	29
4.3.4 TEST RESULTS.....	30
4.4 EMISSION MASK MEASUREMENT.....	33
4.4.1 LIMITS OF BAND EDGE MEASUREMENT.....	33
4.4.2 TEST SETUP .....	33
4.4.3 TEST PROCEDURES.....	33
4.4.4 TEST RESULTS.....	34
4.5 CONDUCTED SPURIOUS EMISSIONS.....	40
4.5.1 LIMITS OF CONDUCTED SPURIOUS EMISSIONS MEASUREMENT.....	40
4.5.2 TEST PROCEDURE .....	40
4.5.3 TEST SETUP .....	40
4.5.4 TEST RESULTS.....	41
4.6 RADIATED EMISSION MEASUREMENT.....	57
4.6.1 LIMITS OF RADIATED EMISSION MEASUREMENT.....	57
4.6.2 TEST PROCEDURES.....	57
4.6.3 DEVIATION FROM TEST STANDARD.....	57
4.6.4 TEST SETUP .....	58
4.6.5 TEST RESULTS.....	59
5 PHOTOGRAPHS OF THE TEST CONFIGURATION.....	77
6 INFORMATION ON THE TESTING LABORATORIES.....	78
7 APPENDIX A – MODIFICATIONS RECORDERS FOR ENGINEERING CHANGES TO THE EUT BY THE LAB.....	79



A D T

## RELEASE CONTROL RECORD

ISSUE NO.	REASON FOR CHANGE	DATE ISSUED
RF130627C19-3	Original release	Aug. 12, 2013



# 1 CERTIFICATION

**PRODUCT:** LTE/CDMA module  
**MODEL:** M530S  
**BRAND:** BandLuxe  
**APPLICANT:** BandRich Inc.  
**TESTED :** Jul. 15 ~ Aug. 08, 2013  
**TEST SAMPLE:** ENGINEERING SAMPLE  
**STANDARDS :** **FCC Part 90, Subpart S**  
**FCC Part 2**

The above equipment (model: M530S) has been tested by **Bureau Veritas Consumer Products Services (H.K.) Ltd., Taoyuan Branch**, and found compliance with the requirement of the above standards. The test record, data evaluation & Equipment Under Test (EUT) configurations represented herein are true and accurate accounts of the measurements of the sample's EMC characteristics under the conditions specified in this report.

**PREPARED BY :** Celine Chou , **DATE:** Aug. 12, 2013  
Celine Chou / Specialist

**APPROVED BY :** Anderson Chiu , **DATE:** Aug. 12, 2013  
Anderson Chiu / Senior Engineer

## 2 SUMMARY OF TEST RESULTS

The EUT has been tested according to the following specifications:

APPLIED STANDARD: FCC Part 90 & Part 2			
STANDARD SECTION	TEST TYPE AND LIMIT	RESULT	REMARK
2.1046 90.635 (b)	Maximum Peak Output Power	PASS	Meet the requirement of limit.
2.1055 90.213	Frequency Stability	PASS	Meet the requirement of limit.
2.1049 90.209	Occupied Bandwidth	PASS	Meet the requirement of limit.
2.1051 90.691	Emission Masks	PASS	Meet the requirement of limit.
2.1051 90.691	Conducted Spurious Emissions	PASS	Meet the requirement of limit.
2.1053 90.691	Radiated Spurious Emissions	PASS	Meet the requirement of limit. Minimum passing margin is -31.06dB at 1645.50MHz.

### 2.1 MEASUREMENT UNCERTAINTY

Where relevant, the following measurement uncertainty levels have been estimated for tests performed on the EUT as specified in CISPR 16-4-2:

MEASUREMENT	FREQUENCY	UNCERTAINTY
Conducted emissions	9kHz~30MHz	2.44 dB
Radiated emissions	30MHz ~ 200MHz	3.34 dB
	200MHz ~1000MHz	3.35 dB
	1GHz ~ 18GHz	2.26 dB
	18GHz ~ 40GHz	1.94 dB

This uncertainty represents an expanded uncertainty expressed at approximately the 95% confidence level using a coverage factor of k=2.



## 2.2 TEST SITE AND INSTRUMENTS

DESCRIPTION & MANUFACTURER	MODEL NO.	SERIAL NO.	DATE OF CALIBRATION	DUE DATE OF CALIBRATION
Test Receiver ROHDE & SCHWARZ	ESI7	838496/016	Dec. 25, 2012	Dec. 24, 2013
Spectrum Analyzer ROHDE & SCHWARZ	FSP40	100039	Jan. 31, 2013	Jan. 30, 2014
BILOG Antenna SCHWARZBECK	VULB9168	9168-160	Mar. 20, 2013	Mar. 19, 2014
HORN Antenna SCHWARZBECK	9120D	209	Sep. 03, 2012	Sep. 02, 2013
HORN Antenna SCHWARZBECK	BBHA 9170	148	Jul. 15, 2013	Jul. 14, 2014
Preamplifier Agilent	8447D	2944A10633	Oct. 25, 2012	Oct. 24, 2013
Preamplifier Agilent	8449B	3008A01964	Oct. 25, 2012	Oct. 24, 2013
RF signal cable HUBER+SUHNNER	SUCOFLEX 104	250723/4	Aug. 28, 2012	Aug. 27, 2013
RF signal cable HUBER+SUHNNER	SUCOFLEX 106	12738/6+309224/4	Aug. 28, 2012	Aug. 27, 2013
Software BV ADT	ADT_Radiated_ V7.6.15.9.4	NA	NA	NA
Antenna Tower inn-co GmbH	MA 4000	013303	NA	NA
Antenna Tower Controller inn-co GmbH	CO2000	017303	NA	NA
Turn Table BV ADT	TT100	TT93021703	NA	NA
Turn Table Controller BV ADT	SC100	SC93021703	NA	NA
Mini-Circuits Power Splitter	ZN2PD-9G	NA	Jun. 13, 2013	Jun. 12, 2014
JFW 20dB attenuation	50HF-020-SMA	NA	NA	NA
Communications Tester-Wireless	E5515C	MY50266653	Oct. 08, 2012	Oct. 09, 2013

- NOTE:**
1. The calibration interval of the above test instruments is 12 months and the calibrations are traceable to NML/ROC and NIST/USA.
  2. The test was performed in HwaYa Chamber 3.
  3. The horn antenna and HP preamplifier (model: 8449B) are used only for the measurement of emission frequency above 1GHz if tested.
  4. The FCC Site Registration No. is 988962.
  5. The IC Site Registration No. is IC 7450F-3.

### 3 GENERAL INFORMATION

#### 3.1 GENERAL DESCRIPTION OF EUT

<b>EUT</b>	LTE/CDMA module		
<b>MODEL NO.</b>	M530S		
<b>POWER SUPPLY</b>	3.7Vdc (host equipment)		
<b>MODULATION TYPE</b>	<b>CDMA, EVDO</b>	QPSK, OQPSK, HPSK	
	<b>LTE BAND 26</b>	QPSK, 16QAM	
<b>FREQUENCY RANGE</b>	<b>CDMA, EVDO</b>	817.9MHz ~ 822.75MHz	
	<b>LTE BAND 26</b>	<b>Channel Bandwidth 1.4MHz:</b>	814.7MHz ~ 823.3MHz
		<b>Channel Bandwidth 3MHz:</b>	815.5MHz ~ 822.5MHz
		<b>Channel Bandwidth 5MHz:</b>	816.5MHz ~ 821.5MHz
		<b>Channel Bandwidth 10MHz:</b>	819MHz
<b>MAX. ERP POWER</b>	<b>CDMA</b>	0.259Watts (24.13dBm)	
	<b>LTE BAND 26</b>	<b>Channel Bandwidth 1.4MHz:</b>	0.233W (23.67dBm)
		<b>Channel Bandwidth 3MHz:</b>	0.235W (23.71dBm)
		<b>Channel Bandwidth 5MHz:</b>	0.230W (23.61dBm)
		<b>Channel Bandwidth 10MHz:</b>	0.203W (23.07dBm)
<b>EMISSION DESIGNATOR</b>	<b>CDMA</b>	1M28F9W	
	<b>LTE BAND 26</b>	<b>Channel Bandwidth 1.4MHz:</b>	1M24G7D (QPSK)
			1M25W7D (16QAM)
		<b>Channel Bandwidth 3MHz:</b>	2M73G7D (QPSK)
			2M73W7D (16QAM)
		<b>Channel Bandwidth 5MHz:</b>	4M50G7D (QPSK)
			4M52W7D (16QAM)
		<b>Channel Bandwidth 10MHz:</b>	9M03G7D (QPSK)
			9M00W7D (16QAM)
<b>ANTENNA TYPE</b>	Dipole antenna with 0.57dBi gain		
<b>ANTENNA CONNECTOR</b>	IPEX 20279		
<b>I/O PORTS</b>	Refer to users' manual		
<b>DATA CABLE</b>	NA		
<b>ACCESSORY DEVICES</b>	NA		

**NOTE:**

1. The convertible Board consumes power from the following adapter (for support unit only).

<b>Brand</b>	TPT
<b>Model</b>	FSY050200UU12-2
<b>Input Power</b>	100-240Vac, 50/60Hz, 0.6A
<b>Output Power</b>	5Vdc, 2A
<b>Power Line</b>	1.8m cable without core attached on adapter

2. The above EUT information was declared by manufacturer and for more detailed features description, please refer to the manufacturer's specifications or User's Manual.



### 3.2 CONFIGURATION OF SYSTEM UNDER TEST

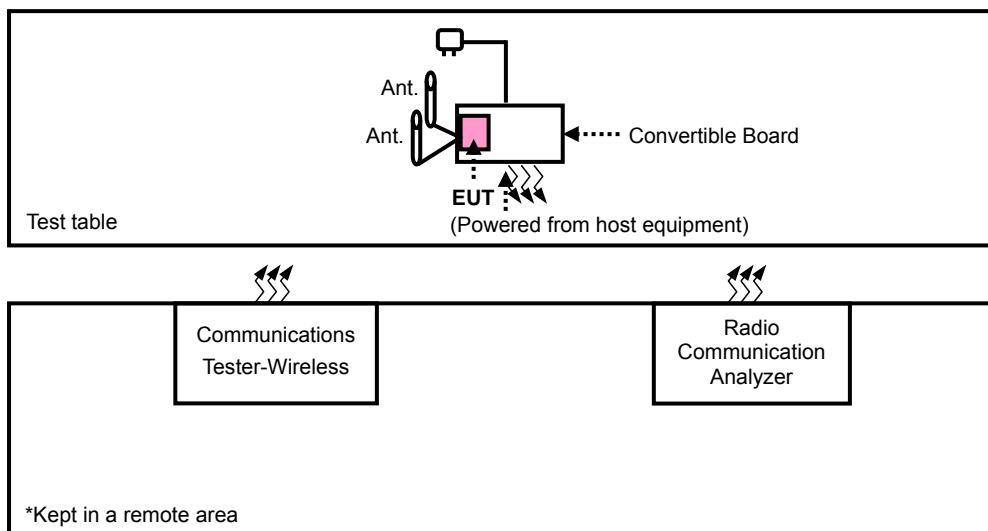

### 3.3 DESCRIPTION OF SUPPORT UNITS

The EUT has been tested as an independent unit together with other necessary accessories or support units. The following support units or accessories were used to form a representative test configuration during the tests.

NO.	PRODUCT	BRAND	MODEL NO.	SERIAL NO.	FCC ID
1	Antenna x2	NA	NA	NA	NA
2	Convertible Board	BandLuxe	PCIe Mini Card evaluation board 1.0	NA	NA
3	Communications Tester-Wireless	Agilent	8960 Series 10	MY50260642	NA
4	Radio Communication Analyzer	Anritsu	MT8820C	6201010284	NA

NO.	SIGNAL CABLE DESCRIPTION OF THE ABOVE SUPPORT UNITS
1	NA
2	NA
3	NA
4	NA

**NOTE:**

1. All power cords of the above support units are non-shielded (1.8m).
2. Items 2-3 act as communication partners to transfer data.
3. Item 1, 2 were provided by the client.

### 3.4 DESCRIPTION OF TEST MODES

Pre-Scan has been conducted to determine the worst-case mode from all possible combinations between available modulations, data rates, XYZ axis and antenna ports. The worst case was found when positioned on Z-plane. Following channel(s) was (were) selected for the final test as listed below:

#### For CDMA

TEST ITEM	AVAILABLE CHANNEL	TESTED CHANNEL	MODE
OUTPUT POWER	476 to 670	476, 580, 670	CDMA
FREQUENCY STABILITY	476 to 670	580	CDMA
OCCUPIED BANDWIDTH	476 to 670	476, 580, 670	CDMA, EVDO
EMISSION MASKS	476 to 670	476, 580, 670	CDMA, EVDO
CONDUCTED EMISSION	476 to 670	476, 580, 670	CDMA, EVDO
RADIATED EMISSION Below 1GHz	476 to 670	670	CDMA
RADIATED EMISSION Above 1GHz	476 to 670	476, 580, 670	CDMA

#### NOTE:

1. For radiated emission below 1 GHz, the channel 476, 580 and 670 were pre-tested in chamber. The channel 670 was the worst case and chosen for final test.
2. The conducted output power for CDMA and EVDO, measured value of CDMA is higher than EVDO mode. Therefore, the ERP power, FREQUENCY STABILITY and RADIATED EMISSION were performed under CDMA mode only.

#### TEST CONDITION:

TEST ITEM	ENVIRONMENTAL CONDITIONS	INPUT POWER (SYSTEM)	TESTED BY
OUTPUT POWER	24deg. C, 64%RH	120Vac, 60Hz	Ted Chang
FREQUENCY STABILITY	24deg. C, 64%RH	120Vac, 60Hz	Match Tsui
OCCUPIED BANDWIDTH	24deg. C, 64%RH	120Vac, 60Hz	Match Tsui
EMISSION MASKS	24deg. C, 64%RH	120Vac, 60Hz	Match Tsui
CONDUCTED EMISSION	24deg. C, 64%RH	120Vac, 60Hz	Match Tsui
RADIATED EMISSION	24deg. C, 64%RH	120Vac, 60Hz	Ted Chang

**For LTE BAND 26**

TEST ITEM	AVAILABLE CHANNEL	TESTED CHANNEL	CHANNEL BANDWIDTH	MODULATION	MODE
OUTPUT POWER	26697 to 26783	26697, 26740, 26783	1.4MHz	QPSK	1 RB / 0 RB Offset
	26705 to 26775	26705, 26740, 26775	3MHz	QPSK	1 RB / 0 RB Offset
	26715 to 26765	26715, 26740, 26765	5MHz	QPSK	1 RB / 0 RB Offset
	26740	26740	10MHz	QPSK	1 RB / 0 RB Offset
FREQUENCY STABILITY	26697 to 26783	26697	1.4MHz	QPSK	1 RB / 0 RB Offset
	26705 to 26775	26705	3MHz	QPSK	1 RB / 0 RB Offset
	26715 to 26765	26715	5MHz	QPSK	1 RB / 0 RB Offset
	26740	26740	10MHz	QPSK	1 RB / 0 RB Offset
OCCUPIED BANDWIDTH	26697 to 26783	26697, 26740, 26783	1.4MHz	QPSK, 16QAM	6 RB / 0 RB Offset
	26705 to 26775	26705, 26740, 26775	3MHz	QPSK, 16QAM	15 RB / 0 RB Offset
	26715 to 26765	26715, 26740, 26765	5MHz	QPSK, 16QAM	25 RB / 0 RB Offset
	26740	26740	10MHz	QPSK, 16QAM	50 RB / 0 RB Offset
EMISSION MASKS	26697 to 26783	26697, 26783	1.4MHz	QPSK, 16QAM	1 RB / 0 RB Offset
					1 RB / 6 RB Offset
					6 RB / 0 RB Offset
	26705 to 26775	26705, 26775	3MHz	QPSK, 16QAM	1 RB / 0 RB Offset
					1 RB / 14 RB Offset
					15 RB / 0 RB Offset
	26715 to 26765	26715, 26765	5MHz	QPSK, 16QAM	1 RB / 0 RB Offset
					1 RB / 24 RB Offset
					25 RB / 0 RB Offset
	26740	26740	10MHz	QPSK, 16QAM	1 RB / 0 RB Offset
					1 RB / 49 RB Offset
					50 RB / 0 RB Offset
CONDUCTED EMISSION	26697 to 26783	26697, 26740, 26783	1.4MHz	QPSK, 16QAM	1 RB / 0 RB Offset
	26705 to 26775	26705, 26740, 26775	3MHz	QPSK, 16QAM	1 RB / 0 RB Offset
	26715 to 26765	26715, 26740, 26765	5MHz	QPSK, 16QAM	1 RB / 0 RB Offset
	26740	26740	10MHz	QPSK, 16QAM	1 RB / 0 RB Offset
RADIATED EMISSION Below 1GHz	26697 to 26783	26783	1.4MHz	QPSK	1 RB / 0 RB Offset
	26705 to 26775	26775	3MHz	QPSK	1 RB / 0 RB Offset
	26715 to 26765	26765	5MHz	QPSK	1 RB / 0 RB Offset
	26740	26740	10MHz	QPSK	1 RB / 0 RB Offset
RADIATED EMISSION Above 1GHz	26697 to 26783	26697, 26740, 26783	1.4MHz	QPSK	1 RB / 0 RB Offset
	26705 to 26775	26705, 26740, 26775	3MHz	QPSK	1 RB / 0 RB Offset
	26715 to 26765	26715, 26740, 26765	5MHz	QPSK	1 RB / 0 RB Offset
	26740	26740	10MHz	QPSK	1 RB / 0 RB Offset

**NOTE:** The conducted output power for QPSK and 16QAM, measured value of QPSK is higher than 16QAM mode. Therefore, the ERP power, FREQUENCY STABILITY and RADIATED EMISSION were performed under QPSK mode only.



A D T

**TEST CONDITION:**

TEST ITEM	ENVIRONMENTAL CONDITIONS	INPUT POWER (SYSTEM)	TESTED BY
OUTPUT POWER	28deg. C, 68%RH	120Vac, 60Hz	Alan Wu
FREQUENCY STABILITY	24deg. C, 64%RH	120Vac, 60Hz	Match Tsui
OCCUPIED BANDWIDTH	24deg. C, 64%RH	120Vac, 60Hz	Match Tsui
EMISSION MASKS	24deg. C, 64%RH	120Vac, 60Hz	Match Tsui
CONDCUDETED EMISSION	24deg. C, 64%RH	120Vac, 60Hz	Match Tsui
RADIATED EMISSION	25deg. C, 65%RH	120Vac, 60Hz	Ted Chang



### **3.5 GENERAL DESCRIPTION OF APPLIED STANDARDS**

The EUT is a RF product. According to the specifications of the manufacturer, it must comply with the requirements of the following standards:

**FCC 47 CFR Part 2**

**FCC 47 CFR Part 90**

**ANSI/TIA/EIA-603-C 2004**

**NOTE:** All test items have been performed and recorded as per the above standards.

## 4 TEST TYPES AND RESULTS

### 4.1 OUTPUT POWER MEASUREMENT

#### 4.1.1 LIMITS OF OUTPUT POWER MEASUREMENT

The radiated peak output power shall be according to the specific rule Part 90.635 that “Mobile station are limited to 100 watts e.r.p”.

#### 4.1.2 TEST PROCEDURES

##### EIRP / ERP MEASUREMENT:

- a. The power was measured with R&S Spectrum Analyzer. All measurements were done at low, middle and high channels.
- b. Substitution method is used for E.I.R.P measurement. In the semi-anechoic chamber, EUT placed on the 0.8m height of Turn Table, rotated the table around 360 degrees to search the maximum radiation power and receiver antenna shall be rotated vertical and horizontal polarization and moved height from 1m to 4m to find the maximum polar radiated power. The “Read Value” is the spectrum reading the maximum power value.
- c. The substitution horn antenna is substituted for EUT at the same position and signals generator export the CW signal to the substitution antenna via a tx cable. Rotated the Turn Table and moved receiving antenna to find the maximum radiation power. Adjust output power level of S.G to get a Value of spectrum reading equal to “Read Value“ of step c. Record the power level of S.G
- d.  $EIRP = \text{Output power level of S.G} - \text{TX cable loss} + \text{Antenna gain of substitution horn}$ .
- e. E.R.P power can be calculated form E.I.R.P power by subtracting the gain of dipole,  
 $E.R.P \text{ power} = E.I.P.R \text{ power} - 2.15\text{dBi}$ .

##### CONDUCTED POWER MEASUREMENT:

- a. The EUT was set up for the maximum power with CDMA link data modulation and link up with simulator.
- b. Set the EUT to transmit under low, middle and high channel and record the power level shown on simulator.

### 4.1.3 TEST SETUP

#### EIRP / ERP MEASUREMENT:

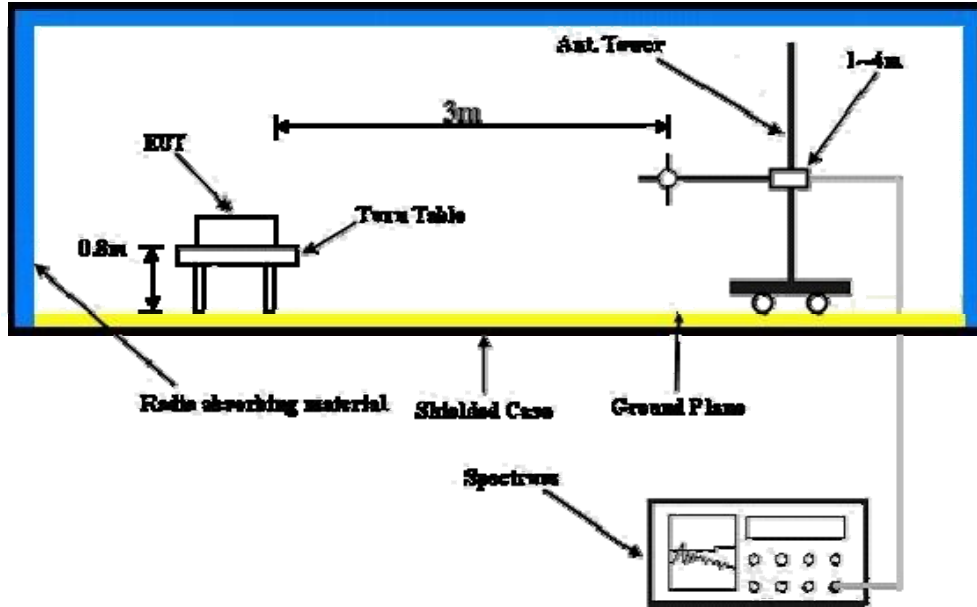

For the actual test configuration, please refer to the attached file (Test Setup Photo).

#### CONDUCTED POWER MEASUREMENT:

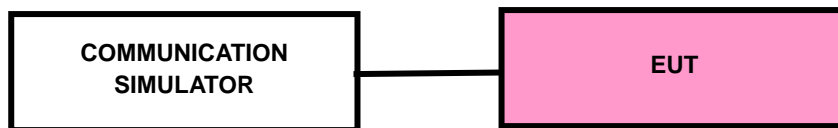

For the actual test configuration, please refer to the attached file (Test Setup Photo).



A D T

#### 4.1.4 TEST RESULTS

##### CONDUCTED OUTPUT POWER (dBm)

Band	CDMA2000 BC10		
Channel	476	580	670
Frequency	817.9	820.5	822.75
RC1+SO55	24.45	24.52	24.34
RC3+SO55	24.49	24.51	24.36
RC3+SO32(+ F-SCH)	24.48	24.47	24.33
RC3+SO32(+SCH)	24.44	24.51	24.32
RTAP 153.6	24.43	24.42	24.38
RETAP 4096	24.47	24.49	24.32





A D T

LTE Band 26								
BW	Modulation	CH	Frequency	RB	RB Offset	MPR	Target	Measured
			(MHz)				Power	Power
1.4 MHz	QPSK	26697	814.70	1	0	0	23	22.54
		26740	819.00	1	0	0	23	22.38
		26783	823.30	1	0	0	23	22.31
		26697	814.70	1	2	0	23	22.50
		26740	819.00	1	2	0	23	22.43
		26783	823.30	1	2	0	23	22.37
		26697	814.70	1	5	0	23	22.11
		26740	819.00	1	5	0	23	22.10
		26783	823.30	1	5	0	23	22.07
		26697	814.70	3	0	0	23	22.30
		26740	819.00	3	0	0	23	22.24
		26783	823.30	3	0	0	23	22.18
		26697	814.70	3	1	0	23	22.42
		26740	819.00	3	1	0	23	22.39
		26783	823.30	3	1	0	23	22.31
		26697	814.70	3	3	0	23	22.31
		26740	819.00	3	3	0	23	22.29
		26783	823.30	3	3	0	23	22.21
	26697	814.70	6	0	1	23	21.27	
	26740	819.00	6	0	1	23	21.21	
	26783	823.30	6	0	1	23	21.19	
	26697	814.70	1	0	1	23	21.54	
	26740	819.00	1	0	1	23	21.51	
	26783	823.30	1	0	1	23	21.44	
	26697	814.70	1	2	1	23	21.50	
	26740	819.00	1	2	1	23	21.44	
	26783	823.30	1	2	1	23	21.38	
	26697	814.70	1	5	1	23	21.11	
	26740	819.00	1	5	1	23	21.10	
	26783	823.30	1	5	1	23	21.08	
	26697	814.70	3	0	1	23	21.30	
	26740	819.00	3	0	1	23	21.24	
	26783	823.30	3	0	1	23	21.20	
	26697	814.70	3	1	1	23	21.42	
	26740	819.00	3	1	1	23	21.34	
	26783	823.30	3	1	1	23	21.26	
26697	814.70	3	3	1	23	21.31		
26740	819.00	3	3	1	23	21.26		
26783	823.30	3	3	1	23	21.20		
26697	814.70	6	0	2	23	20.27		
26740	819.00	6	0	2	23	20.24		
26783	823.30	6	0	2	23	20.17		



A D T

LTE Band 26								
BW	Modulation	CH	Frequency	RB	RB Offset	MPR	Target	Measured
			(MHz)				Power	Power
3 MHz	QPSK	26705	815.50	1	0	0	23	22.55
		26740	819.00	1	0	0	23	22.47
		26775	822.50	1	0	0	23	22.38
		26705	815.50	1	7	0	23	22.51
		26740	819.00	1	7	0	23	22.46
		26775	822.50	1	7	0	23	22.42
		26705	815.50	1	14	0	23	22.12
		26740	819.00	1	14	0	23	22.11
		26775	822.50	1	14	0	23	22.09
		26705	815.50	8	0	1	23	21.21
		26740	819.00	8	0	1	23	21.19
		26775	822.50	8	0	1	23	21.15
		26705	815.50	8	3	1	23	21.33
		26740	819.00	8	3	1	23	21.24
		26775	822.50	8	3	1	23	21.21
		26705	815.50	8	7	1	23	21.22
		26740	819.00	8	7	1	23	21.19
		26775	822.50	8	7	1	23	21.15
	26705	815.50	15	0	1	23	21.28	
	26740	819.00	15	0	1	23	21.24	
	26775	822.50	15	0	1	23	21.19	
	26705	815.50	1	0	1	23	21.55	
	26740	819.00	1	0	1	23	21.49	
	26775	822.50	1	0	1	23	21.42	
	26705	815.50	1	7	1	23	21.51	
	26740	819.00	1	7	1	23	21.42	
	26775	822.50	1	7	1	23	21.37	
	26705	815.50	1	14	1	23	21.12	
	26740	819.00	1	14	1	23	21.11	
	26775	822.50	1	14	1	23	21.11	
	26705	815.50	8	0	2	23	20.21	
	26740	819.00	8	0	2	23	20.18	
	26775	822.50	8	0	2	23	20.14	
	26705	815.50	8	3	2	23	20.33	
	26740	819.00	8	3	2	23	20.21	
	26775	822.50	8	3	2	23	20.17	
26705	815.50	8	7	2	23	20.22		
26740	819.00	8	7	2	23	20.17		
26775	822.50	8	7	2	23	20.11		
26705	815.50	15	0	2	23	20.28		
26740	819.00	15	0	2	23	20.24		
26775	822.50	15	0	2	23	20.21		



A D T

LTE Band 26								
BW	Modulation	CH	Frequency	RB	RB Offset	MPR	Target	Measured
			(MHz)				Power	Power
5 MHz	QPSK	26715	816.50	1	0	0	23	22.57
		26740	819.00	1	0	0	23	22.51
		26765	821.50	1	0	0	23	22.43
		26715	816.50	1	12	0	23	22.53
		26740	819.00	1	12	0	23	22.45
		26765	821.50	1	12	0	23	22.36
		26715	816.50	1	24	0	23	22.14
		26740	819.00	1	24	0	23	22.11
		26765	821.50	1	24	0	23	22.10
		26715	816.50	12	0	1	23	21.23
		26740	819.00	12	0	1	23	21.21
		26765	821.50	12	0	1	23	21.20
		26715	816.50	12	6	1	23	21.35
		26740	819.00	12	6	1	23	21.29
		26765	821.50	12	6	1	23	21.22
		26715	816.50	12	13	1	23	21.24
		26740	819.00	12	13	1	23	21.20
		26765	821.50	12	13	1	23	21.17
	26715	816.50	25	0	1	23	21.30	
	26740	819.00	25	0	1	23	21.24	
	26765	821.50	25	0	1	23	21.21	
	26715	816.50	1	0	1	23	21.57	
	26740	819.00	1	0	1	23	21.51	
	26765	821.50	1	0	1	23	21.43	
	26715	816.50	1	12	1	23	21.53	
	26740	819.00	1	12	1	23	21.49	
	26765	821.50	1	12	1	23	21.41	
	26715	816.50	1	24	1	23	21.14	
	26740	819.00	1	24	1	23	21.10	
	26765	821.50	1	24	1	23	21.09	
	26715	816.50	12	0	2	23	20.23	
	26740	819.00	12	0	2	23	20.19	
	26765	821.50	12	0	2	23	20.14	
	26715	816.50	12	6	2	23	20.35	
	26740	819.00	12	6	2	23	20.31	
	26765	821.50	12	6	2	23	20.27	
26715	816.50	12	13	2	23	20.24		
26740	819.00	12	13	2	23	20.20		
26765	821.50	12	13	2	23	20.18		
26715	816.50	25	0	2	23	20.30		
26740	819.00	25	0	2	23	20.24		
26765	821.50	25	0	2	23	20.21		



A D T

LTE Band 26								
BW	Modulation	CH	Frequency	RB	RB Offset	MPR	Target	Measured
			(MHz)				Power	Power
10 MHz	QPSK	26740	819.00	1	0	0	23	22.60
		26740	819.00	1	24	0	23	22.56
		26740	819.00	1	49	0	23	22.17
		26740	819.00	25	0	1	23	21.26
		26740	819.00	25	12	1	23	21.38
		26740	819.00	25	25	1	23	21.27
		26740	819.00	50	0	1	23	21.33
	16QAM	26740	819.00	1	0	1	23	21.60
		26740	819.00	1	24	1	23	21.56
		26740	819.00	1	49	1	23	21.17
		26740	819.00	25	0	2	23	20.26
		26740	819.00	25	12	2	23	20.38
		26740	819.00	25	25	2	23	20.27
		26740	819.00	50	0	2	23	20.33

## ERP POWER

### For CDMA

MODE		TX channel 476					
ANTENNA POLARITY & TEST DISTANCE: HORIZONTAL AT 3 M							
No.	Freq. (MHz)	Reading (dBm)	S.G Power Value (dBm)	Correction Factor (dB)	ERP (dBm)	Limit (dBm)	Margin (dB)
1	817.90	-16.15	14.10	-0.15	13.95	50.00	-36.05
ANTENNA POLARITY & TEST DISTANCE: VERTICAL AT 3 M							
No.	Freq. (MHz)	Reading (dBm)	S.G Power Value (dBm)	Correction Factor (dB)	ERP (dBm)	Limit (dBm)	Margin (dB)
1	817.90	-5.97	24.28	-0.15	<b>24.13</b>	50.00	-25.87

MODE		TX channel 580					
ANTENNA POLARITY & TEST DISTANCE: HORIZONTAL AT 3 M							
No.	Freq. (MHz)	Reading (dBm)	S.G Power Value (dBm)	Correction Factor (dB)	ERP (dBm)	Limit (dBm)	Margin (dB)
1	820.50	-16.33	13.98	-0.08	13.90	50.00	-36.10
ANTENNA POLARITY & TEST DISTANCE: VERTICAL AT 3 M							
No.	Freq. (MHz)	Reading (dBm)	S.G Power Value (dBm)	Correction Factor (dB)	ERP (dBm)	Limit (dBm)	Margin (dB)
1	820.50	-6.42	23.89	-0.08	23.81	50.00	-26.19

MODE		TX channel 670					
ANTENNA POLARITY & TEST DISTANCE: HORIZONTAL AT 3 M							
No.	Freq. (MHz)	Reading (dBm)	S.G Power Value (dBm)	Correction Factor (dB)	ERP (dBm)	Limit (dBm)	Margin (dB)
1	822.75	-16.25	14.12	-0.03	14.09	50.00	-35.91
ANTENNA POLARITY & TEST DISTANCE: VERTICAL AT 3 M							
No.	Freq. (MHz)	Reading (dBm)	S.G Power Value (dBm)	Correction Factor (dB)	ERP (dBm)	Limit (dBm)	Margin (dB)
1	822.75	-6.50	23.87	-0.03	23.84	50.00	-26.16

**NOTE:** ERP (dBm) = S.G Power Value (dBm) + Correction Factor (dB).

For LTE BAND 26

CHANNEL BANDWIDTH: 1.4MHz

MODE		TX channel 26697					
ANTENNA POLARITY & TEST DISTANCE: HORIZONTAL AT 3 M							
No.	Freq. (MHz)	Reading (dBm)	S.G Power Value (dBm)	Correction Factor (dB)	ERP (dBm)	Limit (dBm)	Margin (dB)
1	814.70	-13.88	16.29	-0.23	16.06	50.00	-33.94
ANTENNA POLARITY & TEST DISTANCE: VERTICAL AT 3 M							
No.	Freq. (MHz)	Reading (dBm)	S.G Power Value (dBm)	Correction Factor (dB)	ERP (dBm)	Limit (dBm)	Margin (dB)
1	814.70	-6.71	22.37	-0.23	22.14	50.00	-27.86

MODE		TX channel 26740					
ANTENNA POLARITY & TEST DISTANCE: HORIZONTAL AT 3 M							
No.	Freq. (MHz)	Reading (dBm)	S.G Power Value (dBm)	Correction Factor (dB)	ERP (dBm)	Limit (dBm)	Margin (dB)
1	819.00	-14.13	16.94	-0.12	16.82	50.00	-33.18
ANTENNA POLARITY & TEST DISTANCE: VERTICAL AT 3 M							
No.	Freq. (MHz)	Reading (dBm)	S.G Power Value (dBm)	Correction Factor (dB)	ERP (dBm)	Limit (dBm)	Margin (dB)
1	819.00	-5.50	23.53	-0.12	23.41	50.00	-26.59

MODE		TX channel 26783					
ANTENNA POLARITY & TEST DISTANCE: HORIZONTAL AT 3 M							
No.	Freq. (MHz)	Reading (dBm)	S.G Power Value (dBm)	Correction Factor (dB)	ERP (dBm)	Limit (dBm)	Margin (dB)
1	823.30	-13.75	17.43	-0.01	17.42	50.00	-32.58
ANTENNA POLARITY & TEST DISTANCE: VERTICAL AT 3 M							
No.	Freq. (MHz)	Reading (dBm)	S.G Power Value (dBm)	Correction Factor (dB)	ERP (dBm)	Limit (dBm)	Margin (dB)
1	823.30	-5.58	23.68	-0.01	23.67	50.00	-26.33

NOTE: ERP (dBm) = S.G Power Value (dBm) + Correction Factor (dB).



A D T

**CHANNEL BANDWIDTH: 3MHz**

MODE		TX channel 26705					
ANTENNA POLARITY & TEST DISTANCE: HORIZONTAL AT 3 M							
No.	Freq. (MHz)	Reading (dBm)	S.G Power Value (dBm)	Correction Factor (dB)	ERP (dBm)	Limit (dBm)	Margin (dB)
1	815.50	-14.02	16.17	-0.21	15.96	50.00	-34.04
ANTENNA POLARITY & TEST DISTANCE: VERTICAL AT 3 M							
No.	Freq. (MHz)	Reading (dBm)	S.G Power Value (dBm)	Correction Factor (dB)	ERP (dBm)	Limit (dBm)	Margin (dB)
1	815.50	-5.69	23.38	-0.21	23.17	50.00	-26.83

MODE		TX channel 26740					
ANTENNA POLARITY & TEST DISTANCE: HORIZONTAL AT 3 M							
No.	Freq. (MHz)	Reading (dBm)	S.G Power Value (dBm)	Correction Factor (dB)	ERP (dBm)	Limit (dBm)	Margin (dB)
1	819.00	-14.23	16.84	-0.12	16.72	50.00	-33.28
ANTENNA POLARITY & TEST DISTANCE: VERTICAL AT 3 M							
No.	Freq. (MHz)	Reading (dBm)	S.G Power Value (dBm)	Correction Factor (dB)	ERP (dBm)	Limit (dBm)	Margin (dB)
1	819.00	-5.47	23.56	-0.12	23.44	50.00	-26.56

MODE		TX channel 26775					
ANTENNA POLARITY & TEST DISTANCE: HORIZONTAL AT 3 M							
No.	Freq. (MHz)	Reading (dBm)	S.G Power Value (dBm)	Correction Factor (dB)	ERP (dBm)	Limit (dBm)	Margin (dB)
1	822.50	-14.12	17.04	-0.03	17.01	50.00	-32.99
ANTENNA POLARITY & TEST DISTANCE: VERTICAL AT 3 M							
No.	Freq. (MHz)	Reading (dBm)	S.G Power Value (dBm)	Correction Factor (dB)	ERP (dBm)	Limit (dBm)	Margin (dB)
1	822.50	-5.48	23.74	-0.03	23.71	50.00	-26.29

**NOTE:** ERP (dBm) = S.G Power Value (dBm) + Correction Factor (dB).



A D T

**CHANNEL BANDWIDTH: 5MHz**

MODE		TX channel 26715					
ANTENNA POLARITY & TEST DISTANCE: HORIZONTAL AT 3 M							
No.	Freq. (MHz)	Reading (dBm)	S.G Power Value (dBm)	Correction Factor (dB)	ERP (dBm)	Limit (dBm)	Margin (dB)
1	816.50	-13.56	16.66	-0.19	16.47	50.00	-33.53
ANTENNA POLARITY & TEST DISTANCE: VERTICAL AT 3 M							
No.	Freq. (MHz)	Reading (dBm)	S.G Power Value (dBm)	Correction Factor (dB)	ERP (dBm)	Limit (dBm)	Margin (dB)
1	816.50	-6.65	22.42	-0.19	22.23	50.00	-27.77

MODE		TX channel 26740					
ANTENNA POLARITY & TEST DISTANCE: HORIZONTAL AT 3 M							
No.	Freq. (MHz)	Reading (dBm)	S.G Power Value (dBm)	Correction Factor (dB)	ERP (dBm)	Limit (dBm)	Margin (dB)
1	819.00	-14.18	16.89	-0.12	16.77	50.00	-33.23
ANTENNA POLARITY & TEST DISTANCE: VERTICAL AT 3 M							
No.	Freq. (MHz)	Reading (dBm)	S.G Power Value (dBm)	Correction Factor (dB)	ERP (dBm)	Limit (dBm)	Margin (dB)
1	819.00	-5.40	23.63	-0.12	23.51	50.00	-26.49

MODE		TX channel 26765					
ANTENNA POLARITY & TEST DISTANCE: HORIZONTAL AT 3 M							
No.	Freq. (MHz)	Reading (dBm)	S.G Power Value (dBm)	Correction Factor (dB)	ERP (dBm)	Limit (dBm)	Margin (dB)
1	821.50	-13.86	17.28	-0.06	17.22	50.00	-32.78
ANTENNA POLARITY & TEST DISTANCE: VERTICAL AT 3 M							
No.	Freq. (MHz)	Reading (dBm)	S.G Power Value (dBm)	Correction Factor (dB)	ERP (dBm)	Limit (dBm)	Margin (dB)
1	821.50	-5.50	23.67	-0.06	23.61	50.00	-26.39

**NOTE:** ERP (dBm) = S.G Power Value (dBm) + Correction Factor (dB).





A D T

**CHANNEL BANDWIDTH: 10MHz**

MODE		TX channel 26740					
ANTENNA POLARITY & TEST DISTANCE: HORIZONTAL AT 3 M							
No.	Freq. (MHz)	Reading (dBm)	S.G Power Value (dBm)	Correction Factor (dB)	ERP (dBm)	Limit (dBm)	Margin (dB)
1	819.00	-13.59	16.68	-0.12	16.56	50.00	-33.44
ANTENNA POLARITY & TEST DISTANCE: VERTICAL AT 3 M							
No.	Freq. (MHz)	Reading (dBm)	S.G Power Value (dBm)	Correction Factor (dB)	ERP (dBm)	Limit (dBm)	Margin (dB)
1	819.00	-5.86	23.19	-0.12	<b>23.07</b>	50.00	-26.93

**NOTE:** ERP (dBm) = S.G Power Value (dBm) + Correction Factor (dB).

## 4.2 FREQUENCY STABILITY MEASUREMENT

### 4.2.1 LIMITS OF FREQUENCY STABILITY MEASUREMENT

1.5 ppm for fixed and base station. 2.5 ppm is for mobile station

### 4.2.2 TEST PROCEDURE

- Because of the measure the carrier frequency under the condition of the AFC lock, it shall be used the mobile station in the CDMA and LTE link mode. This is accomplished with the use of the R&S CMU200 simulator station. The oven room could control the temperatures and humidity. The CDMA link channel is the 573.
- Power must be removed when changing from one temperature to another or one voltage to another voltage. Power warm up is at least 15 min and power applied should perform before recording frequency error.
- EUT is connected the external power supply to control the AC input power. The various Volts from the minimum 108Volts to 132Volts. Each step shall be record the frequency error rate.
- The temperature range step is 10 degrees in this test items. All temperature levels shall be hold the  $\pm 0.5^{\circ}\text{C}$  during the measurement testing.
- The each temperature step shall be at least 0.5 hours, consider the EUT could be test under the stability condition.

**NOTE:** The frequency error was recorded frequency error from the communication simulator.

### 4.2.3 TEST SETUP

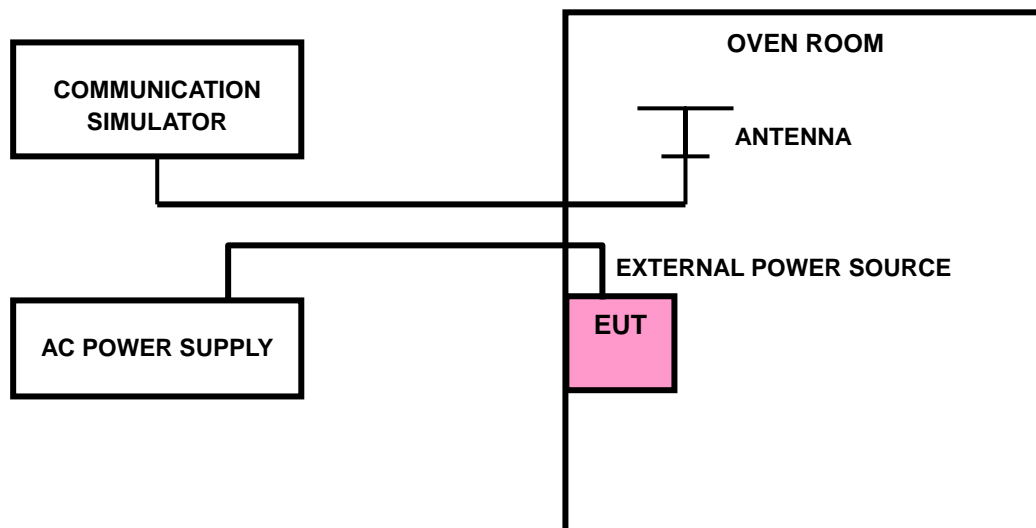

#### 4.2.4 TEST RESULTS

##### For CDMA

AFC FREQUENCY ERROR vs. VOLTAGE		
VOLTAGE (Volts)	FREQUENCY ERROR (ppm)	LIMIT (ppm)
132	-0.032	2.5
120	-0.023	2.5
108	-0.029	2.5

**NOTE:** The applicant defined the normal working voltage of the adapter is from 108Vac to 132Vac.

AFC FREQUENCY ERROR vs. TEMP.		
TEMP. (°C)	FREQUENCY ERROR (ppm)	LIMIT (ppm)
50	-0.038	2.5
40	-0.033	2.5
30	-0.028	2.5
20	-0.023	2.5
10	-0.030	2.5
0	-0.038	2.5
-10	-0.045	2.5
-20	-0.054	2.5
-30	-0.052	2.5

**For LTE BAND 26**

AFC FREQUENCY ERROR vs. VOLTAGE					
VOLTAGE (Volts)	FREQUENCY ERROR (ppm)				LIMIT (ppm)
	1.4M	3M	5M	10M	
132	-0.023	-0.025	-0.024	-0.027	2.5
120	-0.016	-0.020	-0.018	-0.023	2.5
108	-0.020	-0.023	-0.021	-0.021	2.5

**NOTE:** The applicant defined the normal working voltage of the adapter is from 108Vac to 132Vac.

AFC FREQUENCY ERROR vs. VOLTAGE					
TEMP. (°C)	FREQUENCY ERROR (ppm)				LIMIT (ppm)
	1.4M	3M	5M	10M	
50	-0.029	-0.031	-0.031	-0.037	2.5
40	-0.023	-0.028	-0.029	-0.033	2.5
30	-0.018	-0.023	-0.021	-0.028	2.5
20	-0.016	-0.020	-0.018	-0.023	2.5
10	-0.026	-0.023	-0.023	-0.024	2.5
0	-0.034	-0.027	-0.033	-0.038	2.5
-10	-0.041	-0.036	-0.045	-0.048	2.5
-20	-0.048	-0.042	-0.056	-0.054	2.5
-30	-0.055	-0.048	-0.054	-0.057	2.5

### 4.3 OCCUPIED BANDWIDTH MEASUREMENT

#### 4.3.1 LIMITS OF OCCUPIED BANDWIDTH MEASUREMENT

The width of a frequency band such that, below the lower and above the upper frequency limits, the mean powers emitted are each equal to a specified percentage 0.5 %of the total mean power of a given emission.

#### 4.3.2 TEST SETUP

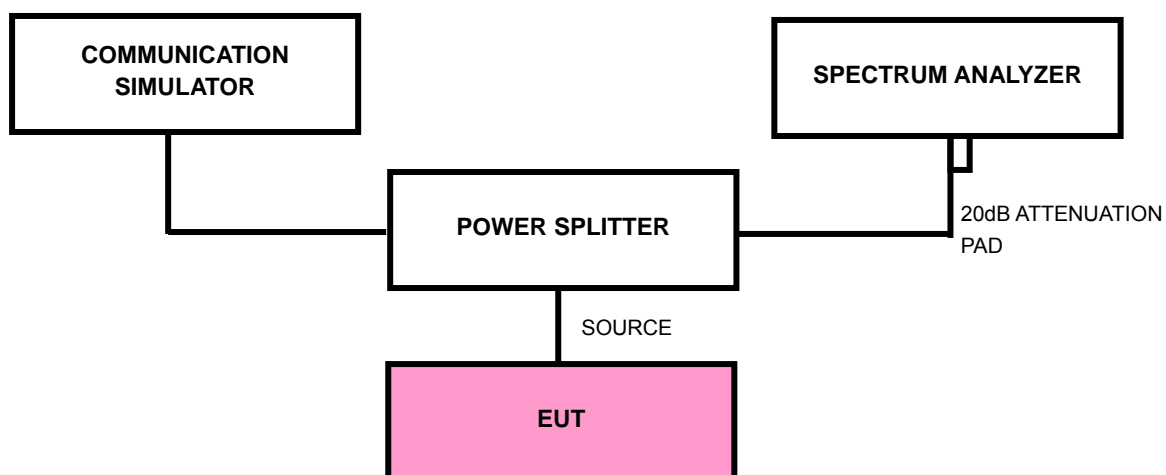

#### 4.3.3 TEST PROCEDURES

- a. The EUT makes a call to the communication simulator. The power was measured with R&S Spectrum Analyzer. All measurements were done at low, middle and high channels.
- b. The conducted occupied bandwidth used the power splitter via EUT RF power connector between simulation base station and spectrum analyzer.
- c. The communication simulator station system controlled a EUT to export maximum output power under transmission mode and specific channel frequency. Use OBW measurement function of Spectrum analyzer to measure 99 % occupied bandwidth.

### 4.3.4 TEST RESULTS

#### For CDMA

CHANNEL	FREQUENCY (MHz)	99% OCCUPIED BANDWIDTH (MHz)	
		CDMA	EVDO
476	817.90	1.28	1.27
580	820.50	1.27	1.27
670	822.75	1.28	1.27

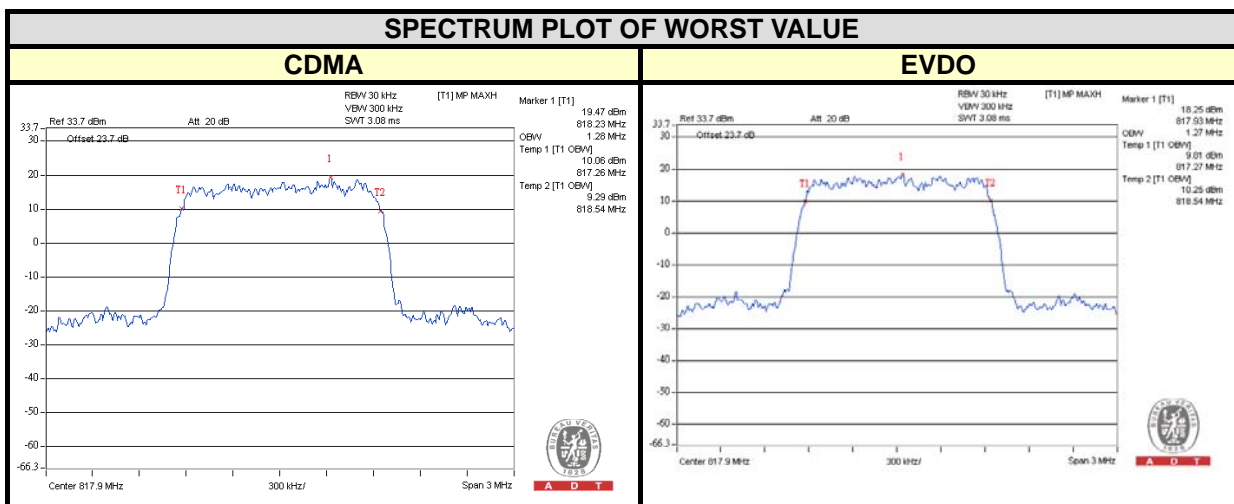



A D T

For LTE BAND 26

CHANNEL BANDWIDTH: 1.4MHz

CHANNEL	FREQUENCY (MHz)	99% OCCUPIED BANDWIDTH (MHz)	
		QPSK	16QAM
26697	814.70	1.23	1.22
26740	819.00	1.24	1.24
26783	823.30	1.24	1.25

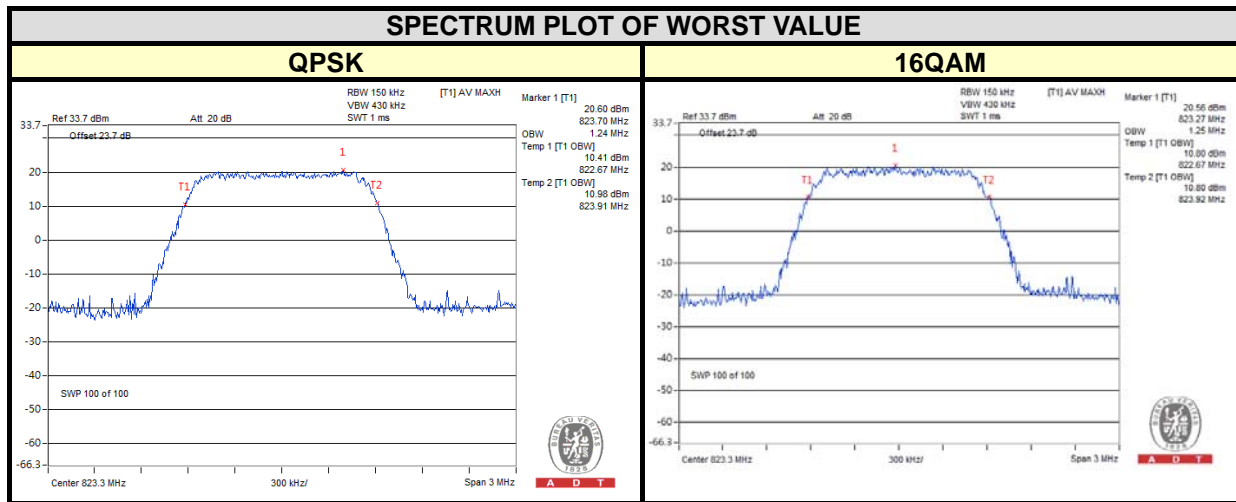

CHANNEL BANDWIDTH: 3MHz

CHANNEL	FREQUENCY (MHz)	99% OCCUPIED BANDWIDTH (MHz)	
		QPSK	16QAM
26705	815.50	2.72	2.73
26740	819.00	2.73	2.73
26775	822.50	2.73	2.73

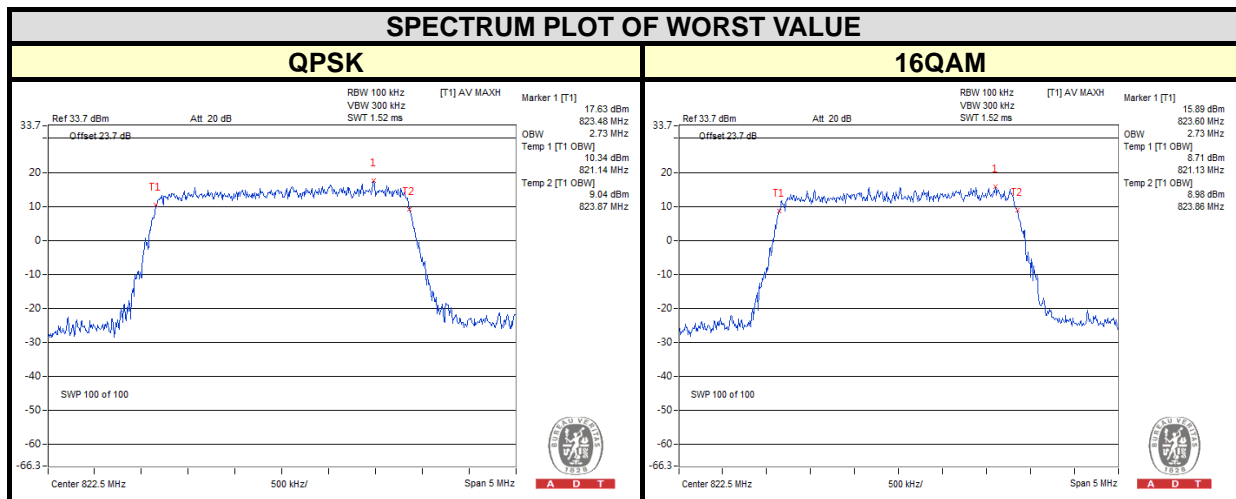



A D T

**CHANNEL BANDWIDTH: 5MHz**

CHANNEL	FREQUENCY (MHz)	99% OCCUPIED BANDWIDTH (MHz)	
		QPSK	16QAM
26715	816.50	4.50	4.52
26740	819.00	4.48	4.48
26765	821.50	4.50	4.48

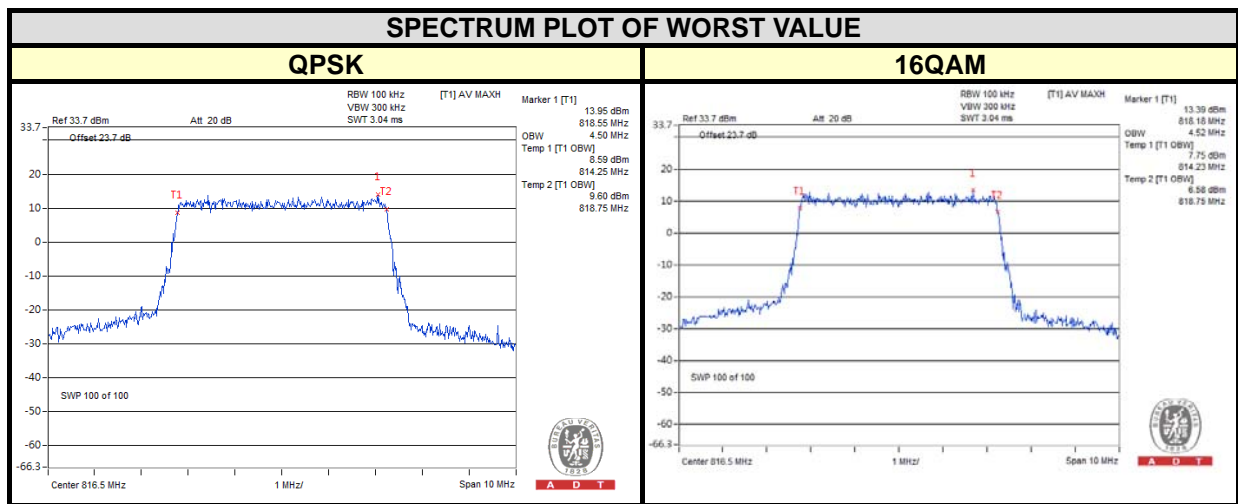

**CHANNEL BANDWIDTH: 10MHz**

CHANNEL	FREQUENCY (MHz)	99% OCCUPIED BANDWIDTH (MHz)	
		QPSK	16QAM
26740	819.00	9.03	9.00

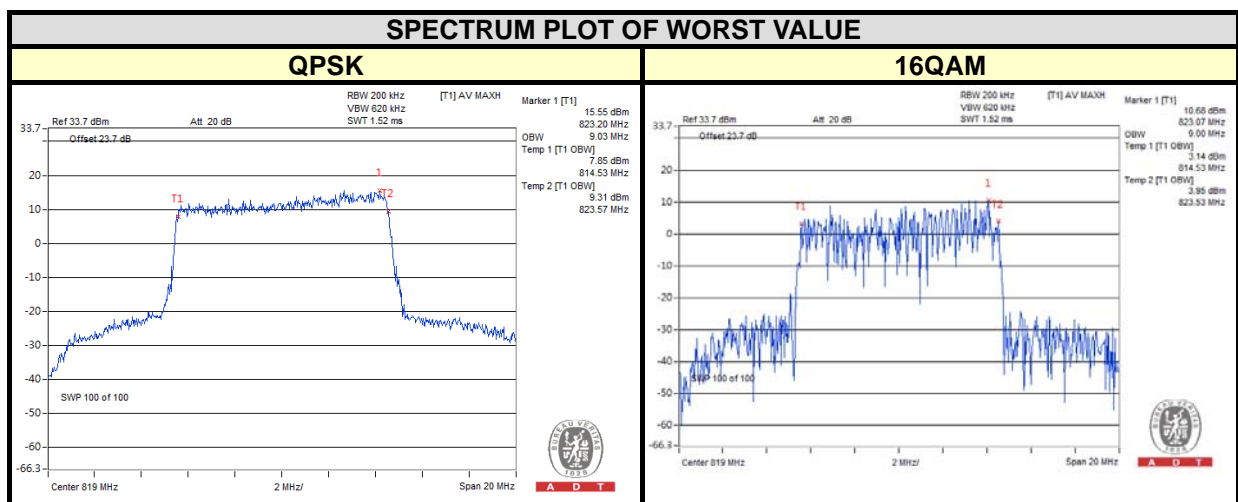



## 4.4 EMISSION MASK MEASUREMENT

### 4.4.1 LIMITS OF BAND EDGE MEASUREMENT

According to FCC part 90.691 shall be tested the emission mask. For any frequency removed from the EA licensee’s frequency block by up to and including 37.5 kHz, the power of any emission shall be attenuated below the transmitter power (P) in watts by at least  $116 \text{ Log}_{10}(f/6.1)$  decibels or  $50 + 10 \text{ Log}_{10}(P)$  decibels or 80 decibels, whichever is the lesser attenuation, where f is the frequency removed from the center of the outer channel in the block in kilohertz and where f is greater than 12.5 kHz.

### 4.4.2 TEST SETUP

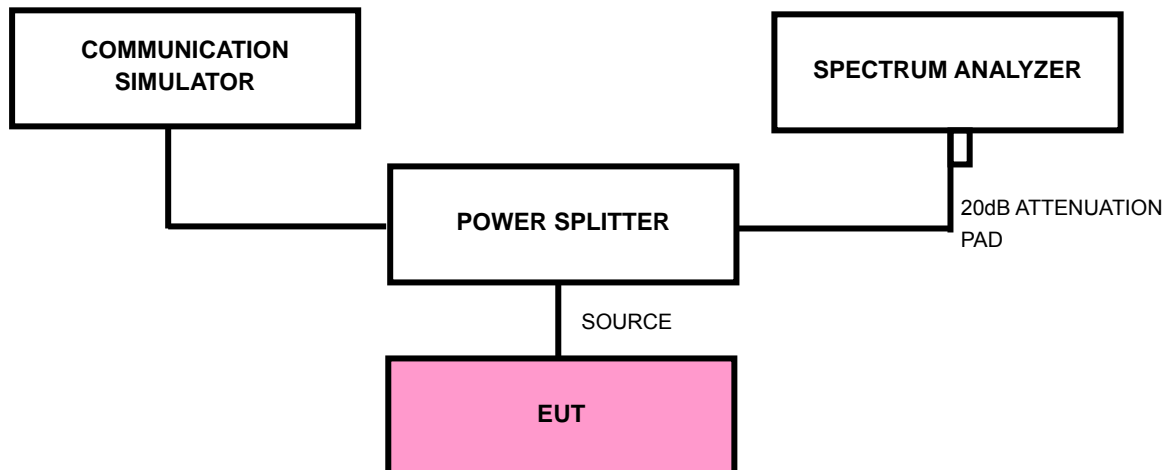

### 4.4.3 TEST PROCEDURES

- a. The measurement used the power splitter via EUT RF power connector between simulation base station and spectrum analyzer.
- b. Record the test plot.



A D T

### 4.4.4 TEST RESULTS

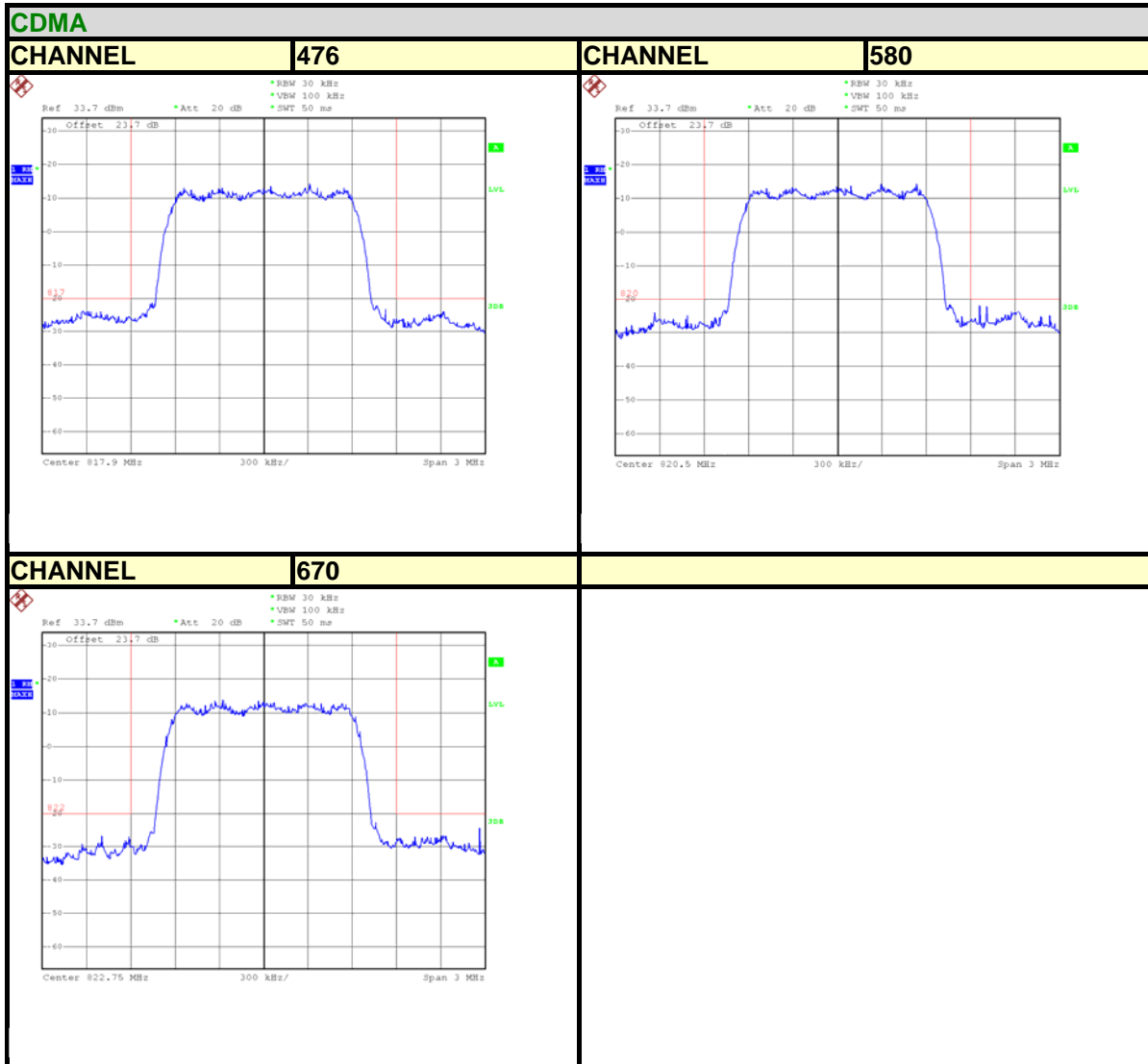



A D T

### EVDO

#### CHANNEL 476 CHANNEL 580

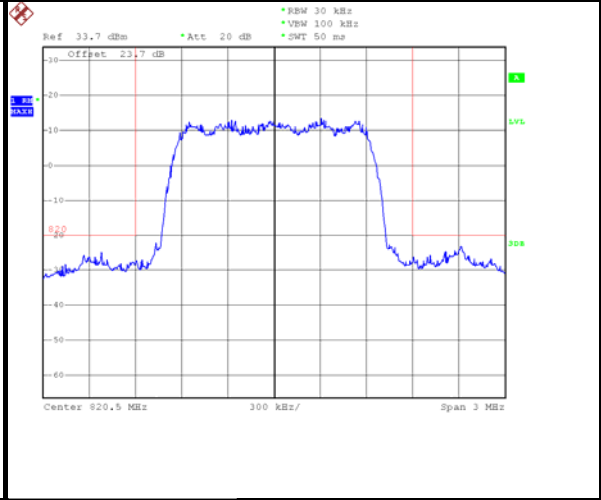
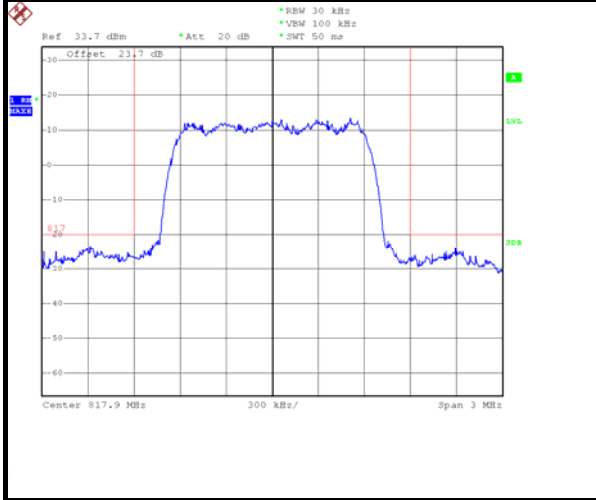

#### CHANNEL 670

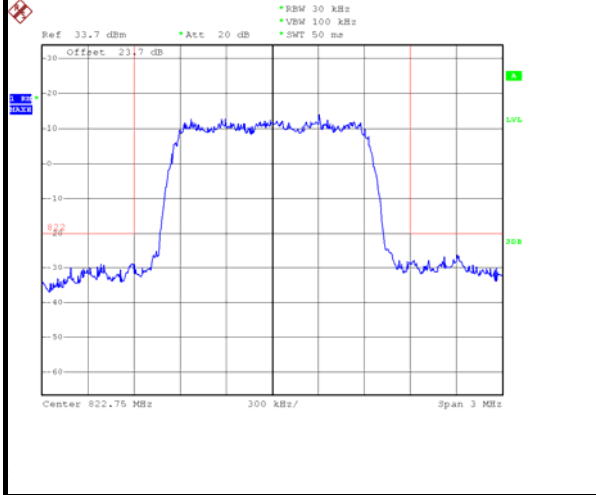



A D T

### LTE BAND 26 - CHANNEL BANDWIDTH: 1.4MHz

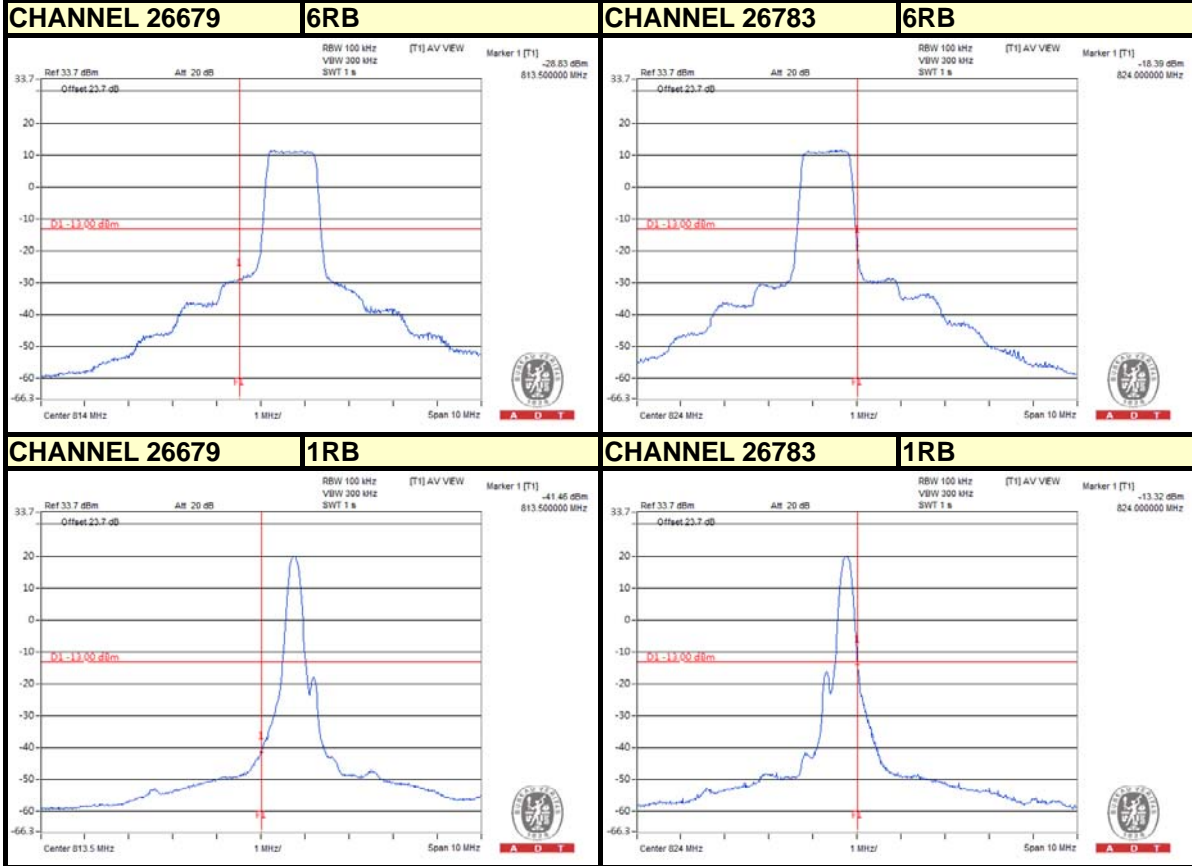



A D T

### LTE BAND 26 - CHANNEL BANDWIDTH: 3MHz

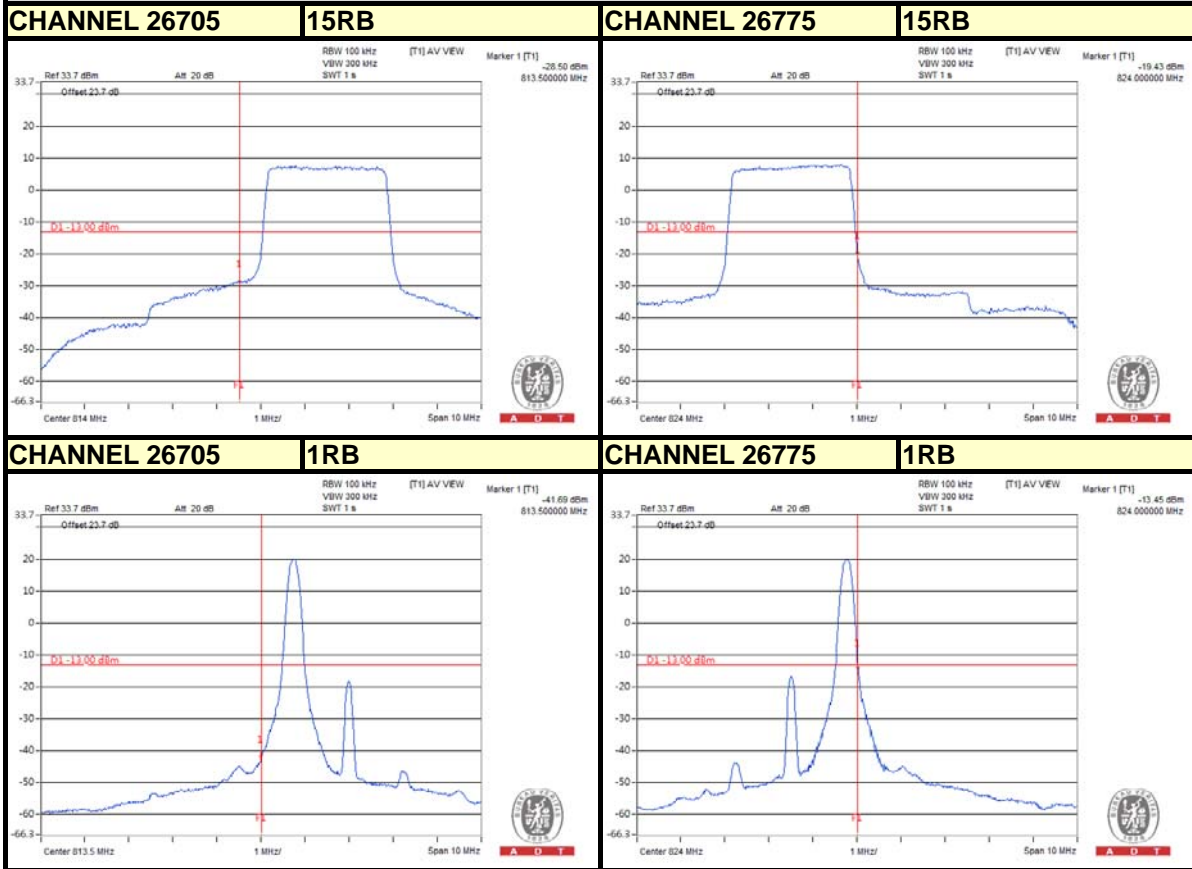



A D T

### LTE BAND 26 - CHANNEL BANDWIDTH: 5MHz

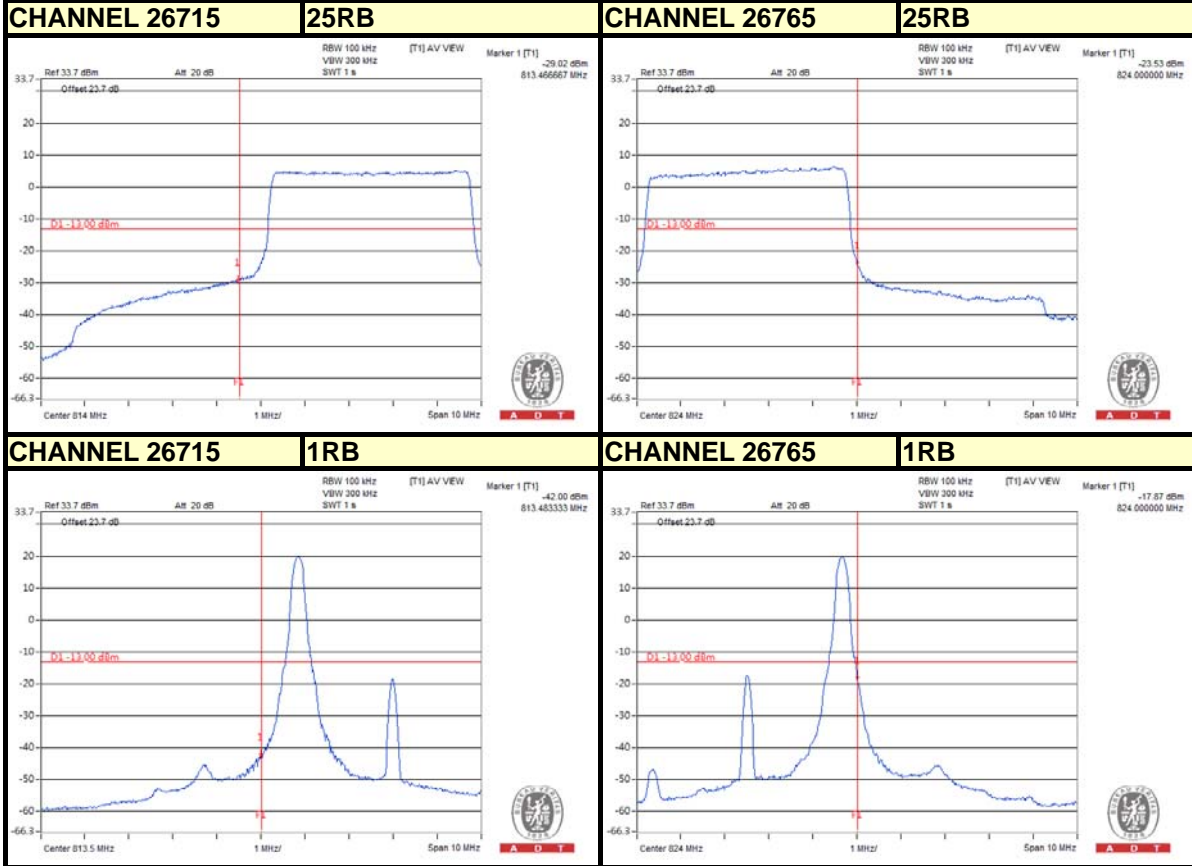



A D T

**LTE BAND 26 - CHANNEL BANDWIDTH: 10MHz**

**CHANNEL 26740**

**50RB**

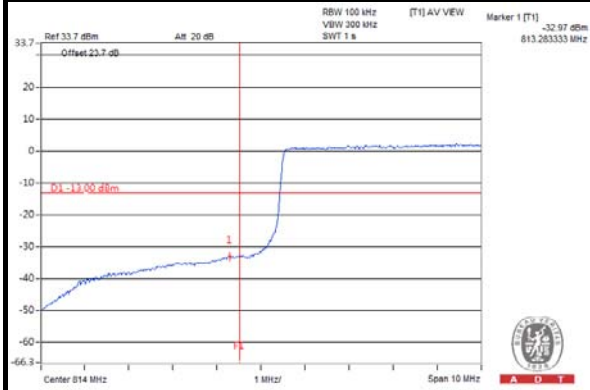

**CHANNEL 26740**

**50RB**

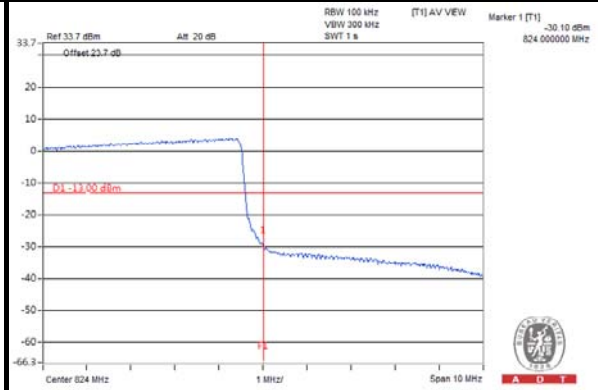

**CHANNEL 26740**

**1RB**

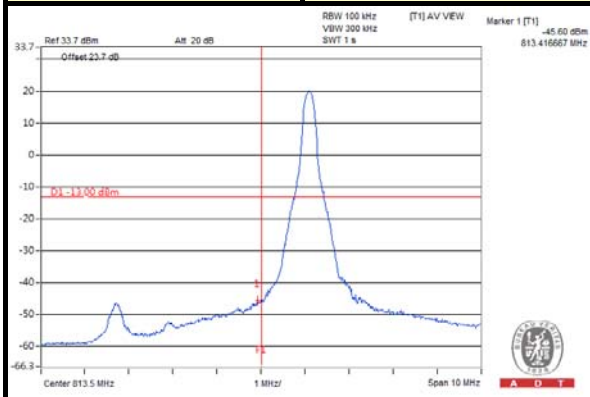

**CHANNEL 26740**

**1RB**

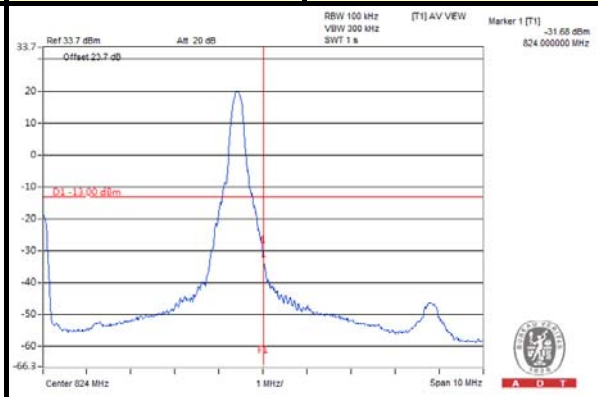

## 4.5 CONDUCTED SPURIOUS EMISSIONS

### 4.5.1 LIMITS OF CONDUCTED SPURIOUS EMISSIONS MEASUREMENT

The power of any emission shall be attenuated below the transmitter power (P) by at least  $43 + 10 \log (P)$  dB. The emission limit equal to  $-13$ dBm.

### 4.5.2 TEST PROCEDURE

- a. All measurements were done at low, middle and high channels.
- b. The conducted spurious emission used the power splitter via EUT RF power connector between simulation base station and spectrum analyzer.
- c. Measuring frequency range is from 30 MHz to 9GHz. RBW=1MHz and VBW=3MHz is used for conducted emission measurement.

### 4.5.3 TEST SETUP

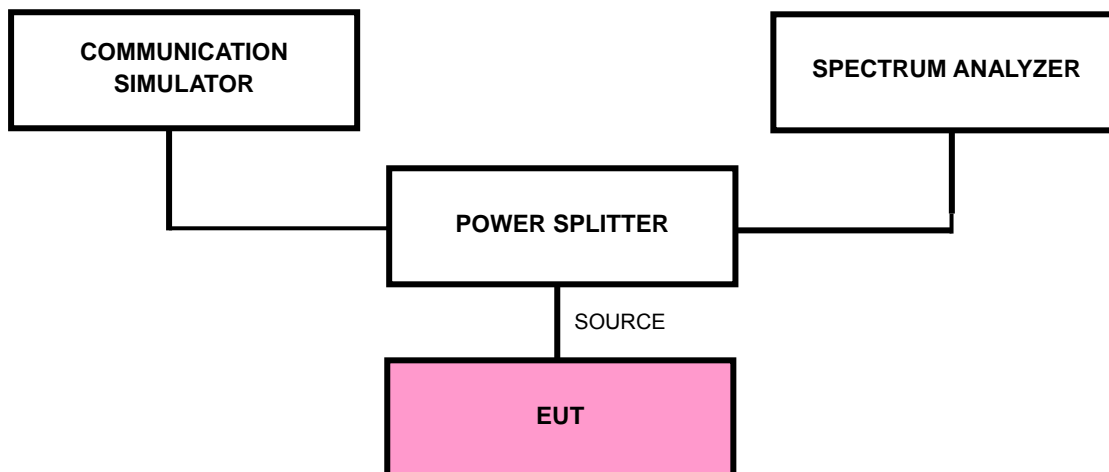





A D T

## 4.5.4 TEST RESULTS

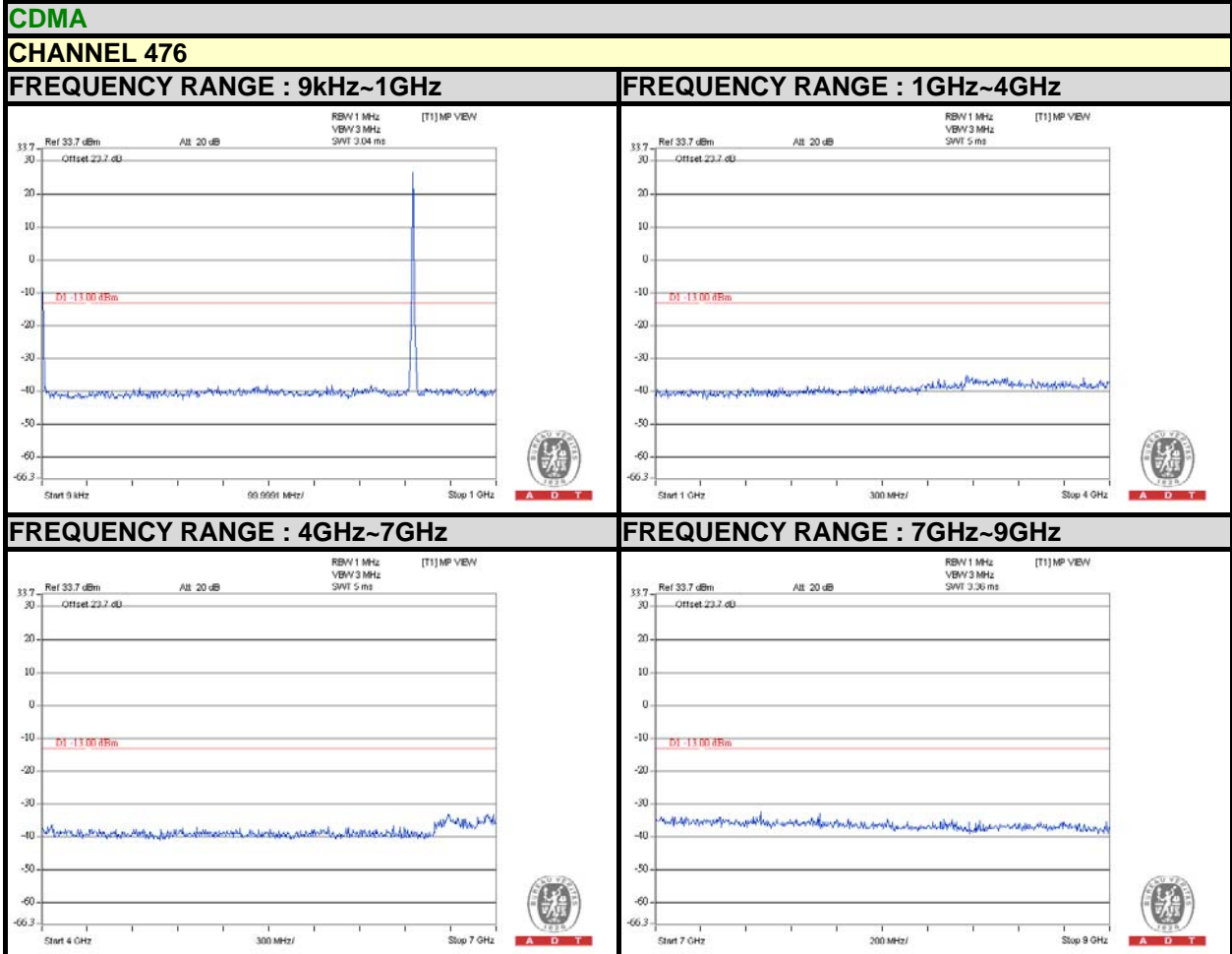



A D T

**CDMA**

**CHANNEL 580**

**FREQUENCY RANGE : 9kHz~1GHz**

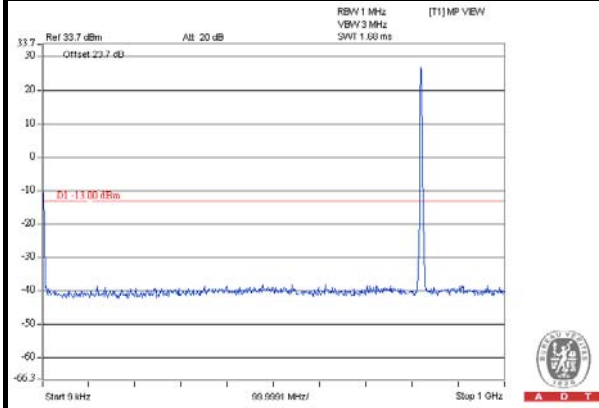

**FREQUENCY RANGE : 1GHz~4GHz**

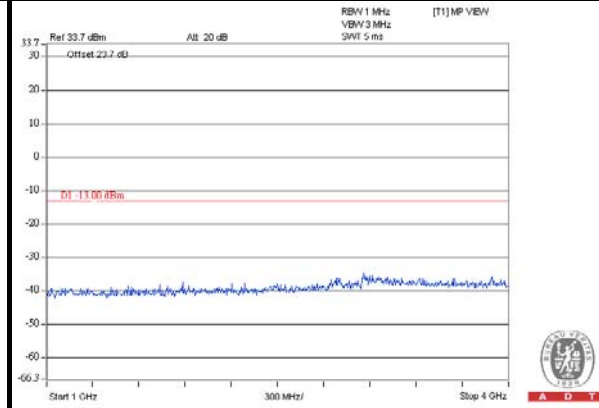

**FREQUENCY RANGE : 4GHz~7GHz**

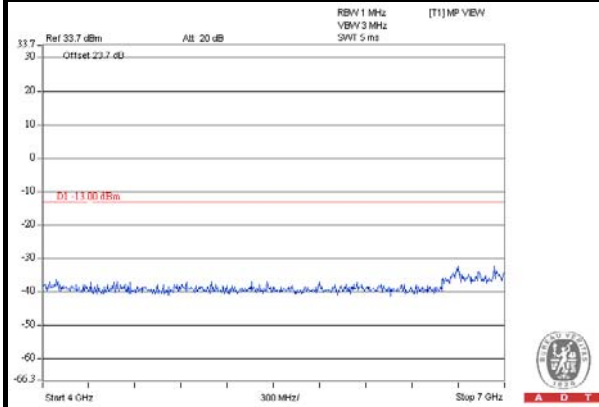

**FREQUENCY RANGE : 7GHz~9GHz**

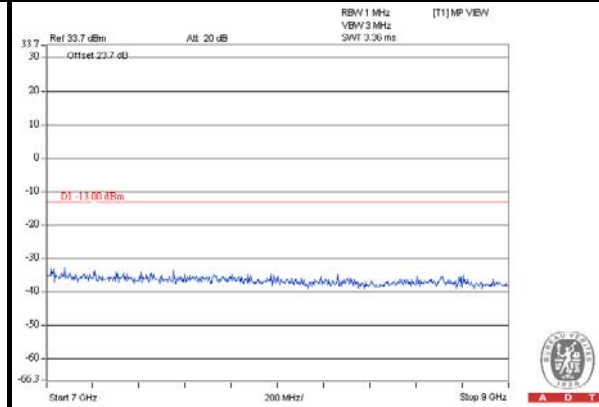



A D T

**CDMA**

**CHANNEL 670**

**FREQUENCY RANGE : 9kHz~1GHz**

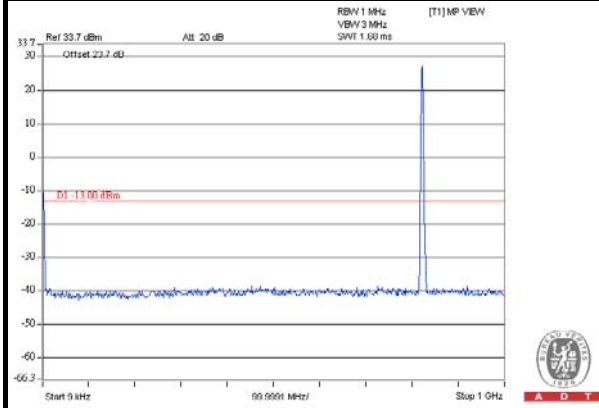

**FREQUENCY RANGE : 1GHz~4GHz**

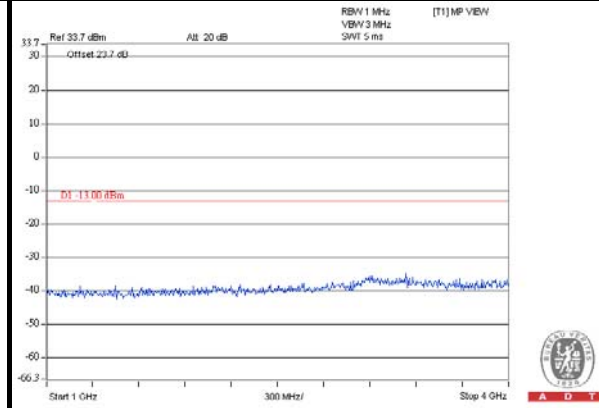

**FREQUENCY RANGE : 4GHz~7GHz**

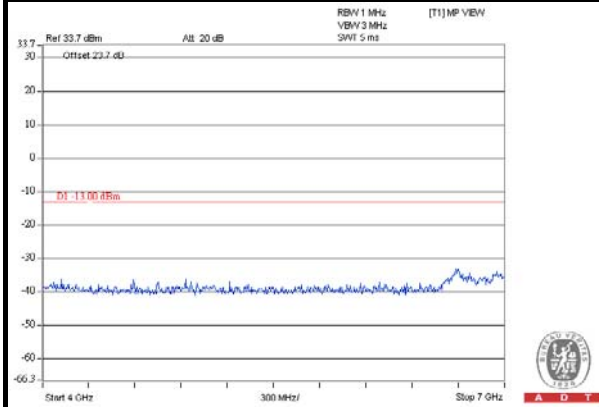

**FREQUENCY RANGE : 7GHz~9GHz**

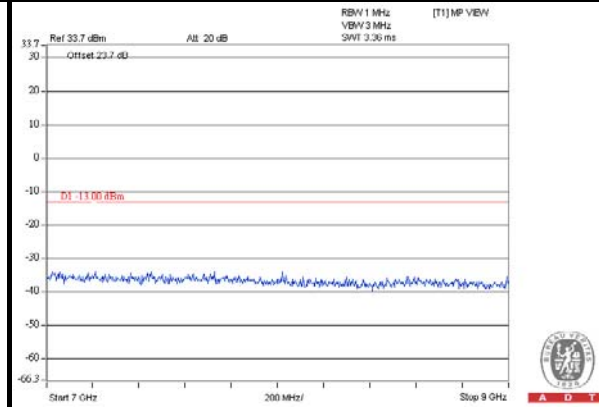



A D T

**EVDO**

**CHANNEL 476**

**FREQUENCY RANGE : 9kHz~1GHz**

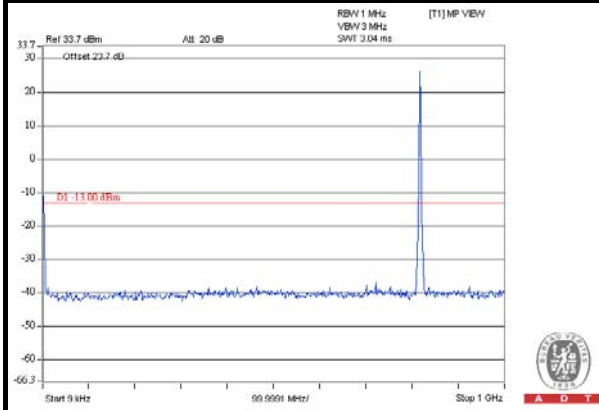

**FREQUENCY RANGE : 1GHz~4GHz**

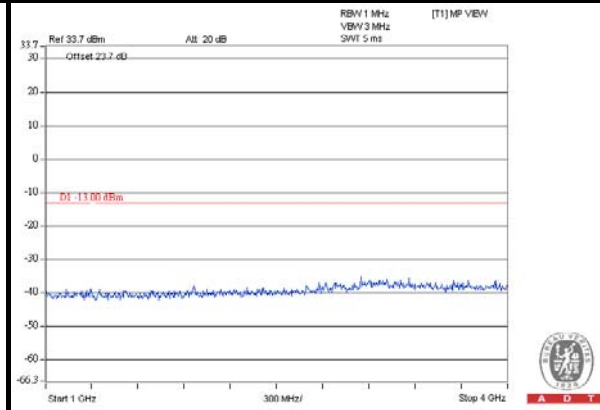

**FREQUENCY RANGE : 4GHz~7GHz**

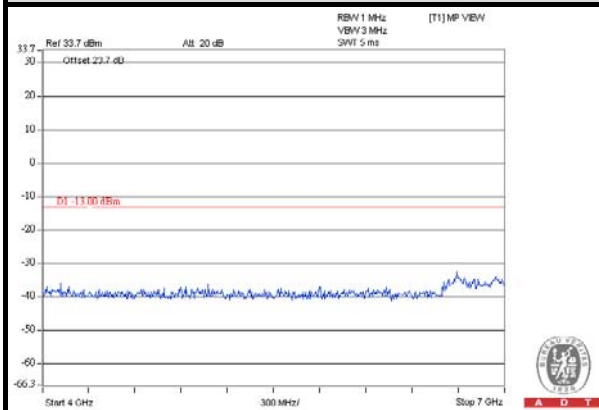

**FREQUENCY RANGE : 7GHz~9GHz**

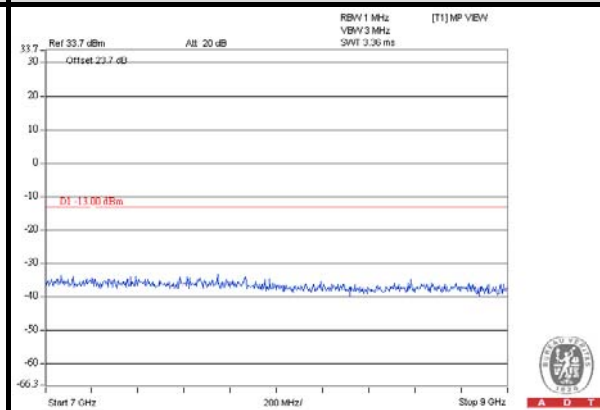



A D T

**EVDO**

**CHANNEL 580**

**FREQUENCY RANGE : 9kHz~1GHz**

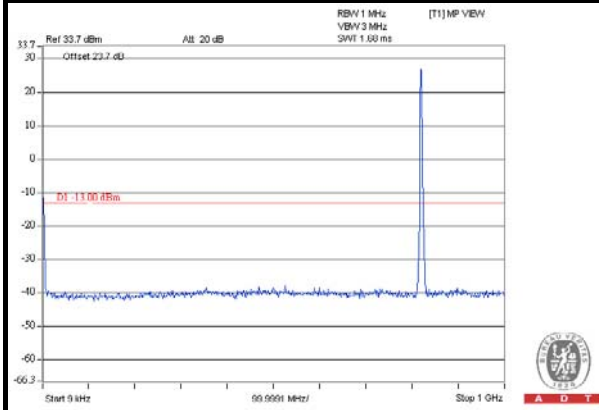

**FREQUENCY RANGE : 1GHz~4GHz**

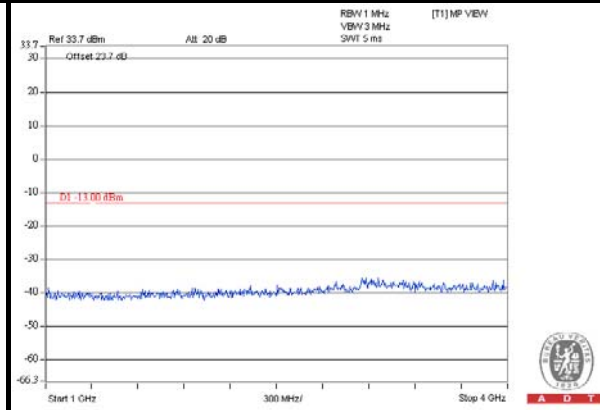

**FREQUENCY RANGE : 4GHz~7GHz**

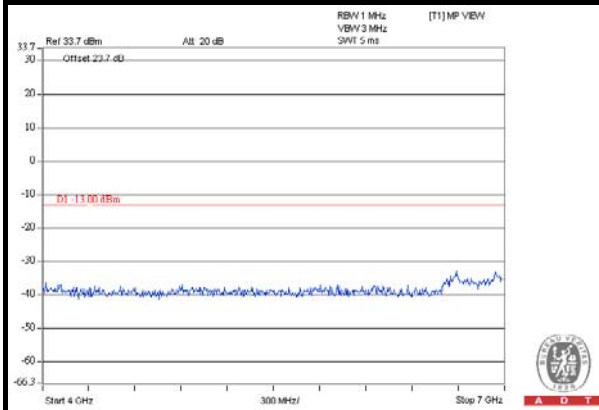

**FREQUENCY RANGE : 7GHz~9GHz**

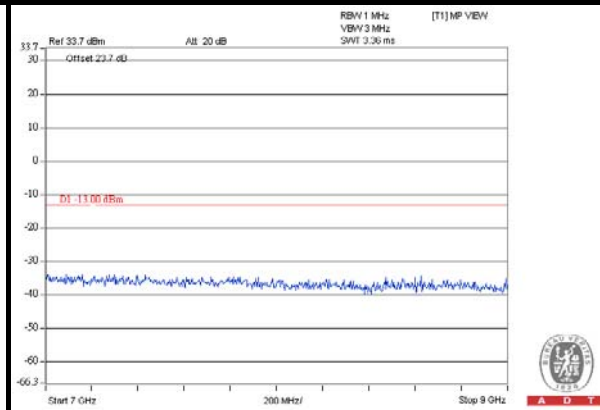



A D T

**EVDO**

**CHANNEL 670**

**FREQUENCY RANGE : 9kHz~1GHz**

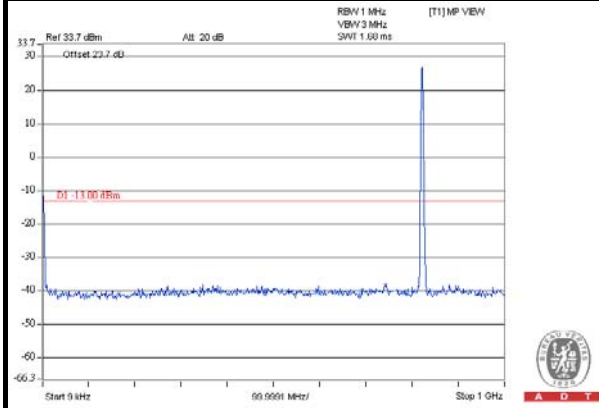

**FREQUENCY RANGE : 1GHz~4GHz**

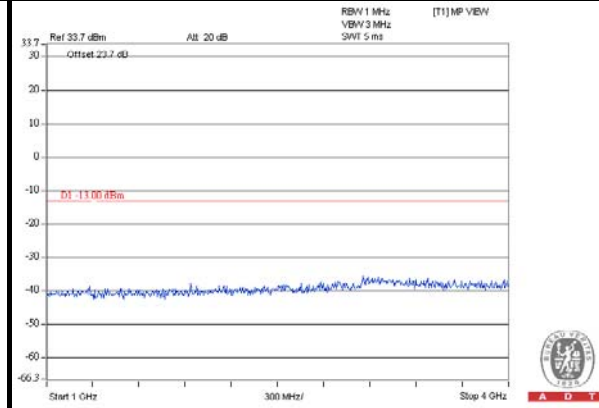

**FREQUENCY RANGE : 4GHz~7GHz**

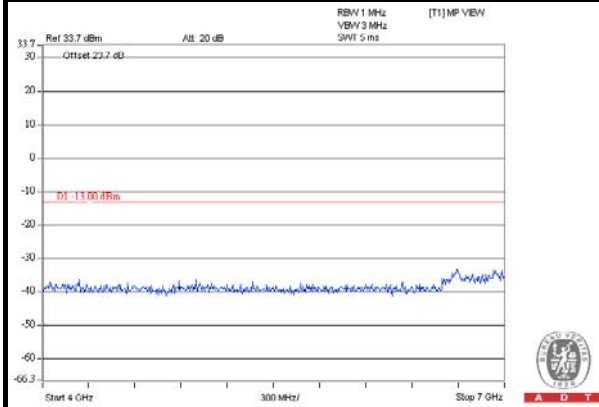

**FREQUENCY RANGE : 7GHz~9GHz**

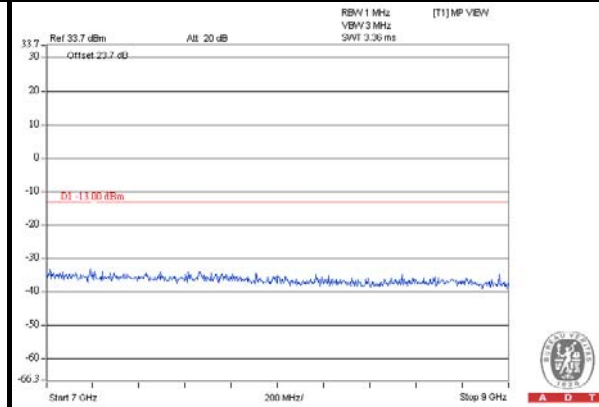



A D T

**LTE BAND 26 - CHANNEL BANDWIDTH: 1.4MHz**

**CHANNEL 26697**

**FREQUENCY RANGE : 9kHz~1GHz**

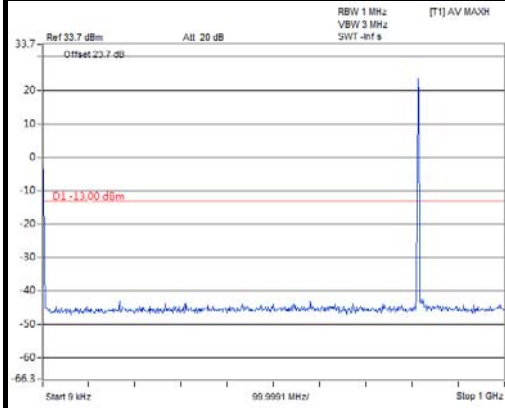

**FREQUENCY RANGE : 1GHz~4GHz**

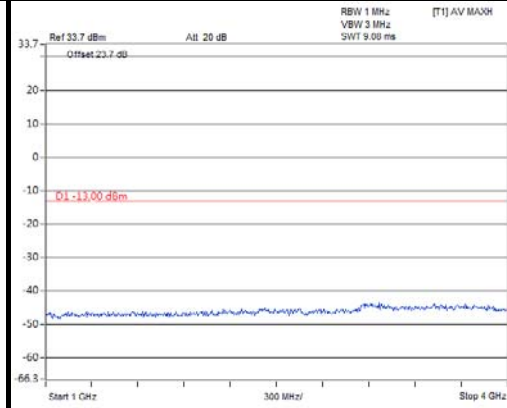

**FREQUENCY RANGE : 4GHz~7GHz**

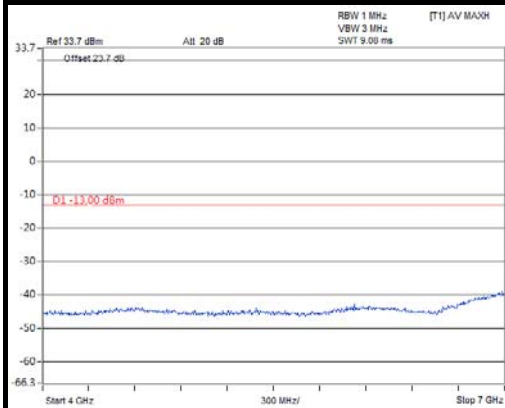

**FREQUENCY RANGE : 7GHz~9GHz**

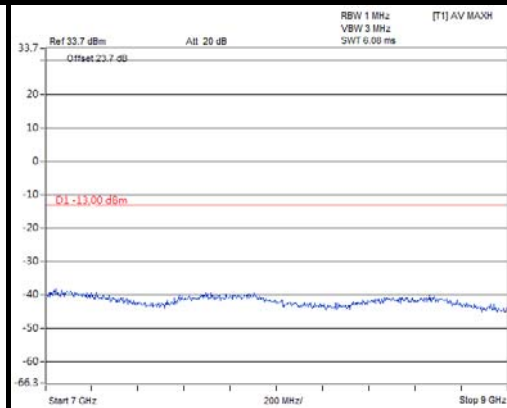



A D T

**LTE BAND 26 - CHANNEL BANDWIDTH: 1.4MHz**

**CHANNEL 26740**

**FREQUENCY RANGE : 9kHz~1GHz**

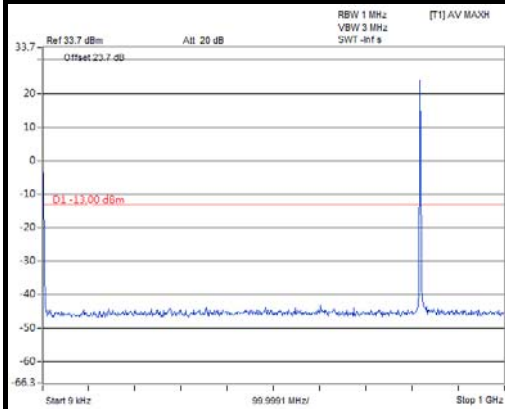

**FREQUENCY RANGE : 1GHz~4GHz**

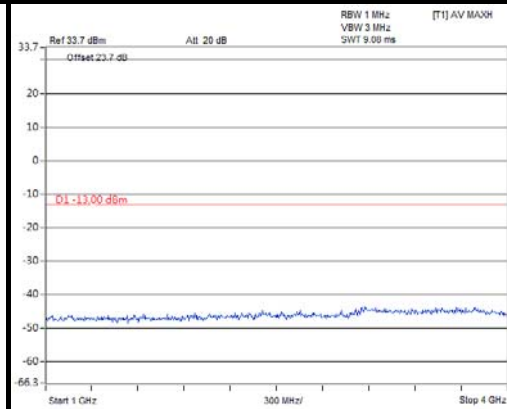

**FREQUENCY RANGE : 4GHz~7GHz**

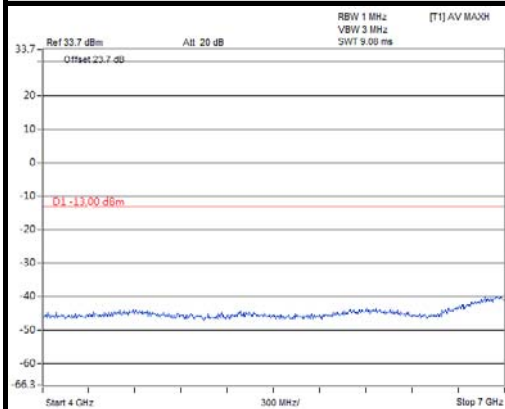

**FREQUENCY RANGE : 7GHz~9GHz**

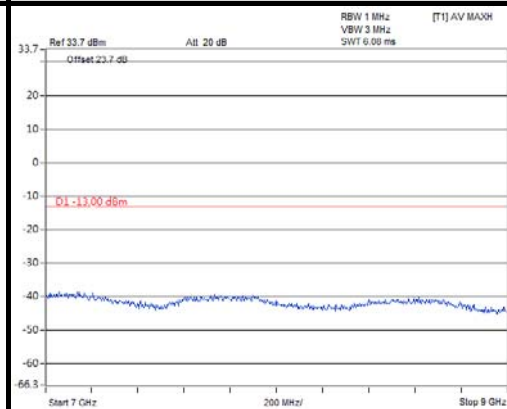





A D T

**LTE BAND 26 - CHANNEL BANDWIDTH: 1.4MHz**

**CHANNEL 26783**

**FREQUENCY RANGE : 9kHz~1GHz**

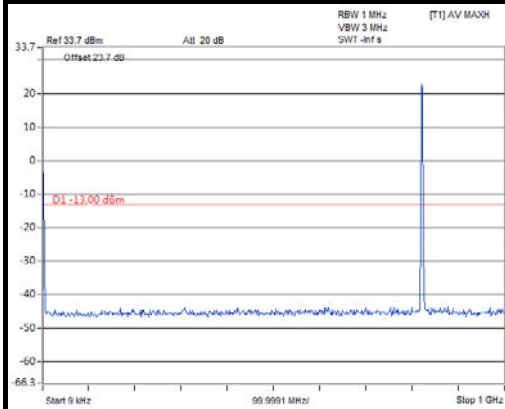

**FREQUENCY RANGE : 1GHz~4GHz**

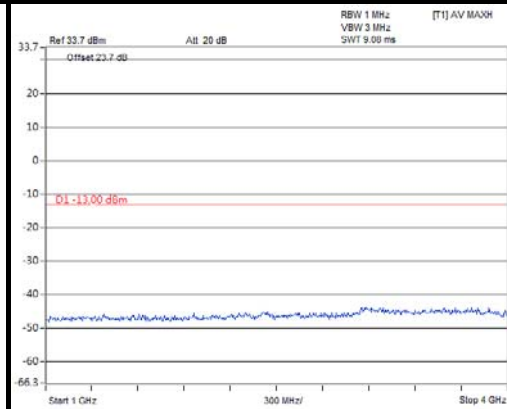

**FREQUENCY RANGE : 4GHz~7GHz**

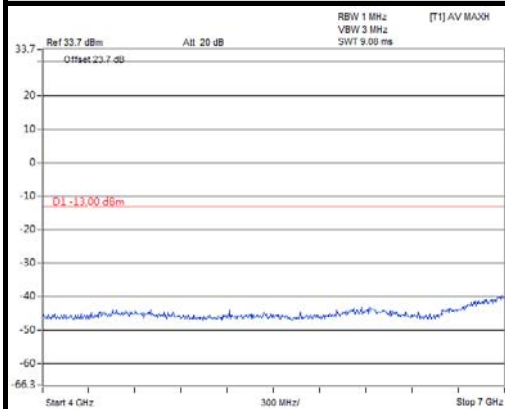

**FREQUENCY RANGE : 7GHz~9GHz**

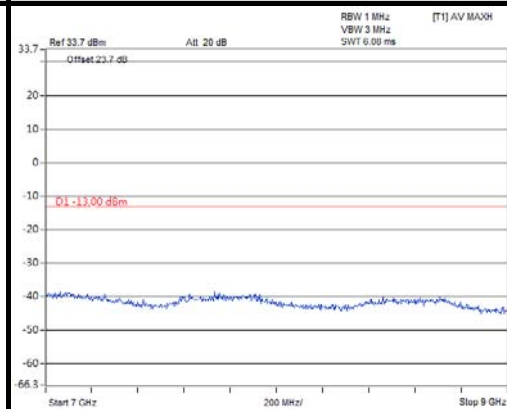



A D T

**LTE BAND 26 - CHANNEL BANDWIDTH: 3MHz**

**CHANNEL 26705**

**FREQUENCY RANGE : 9kHz~1GHz**

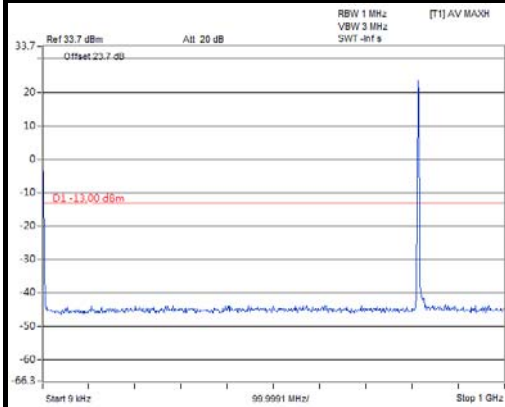

**FREQUENCY RANGE : 1GHz~4GHz**

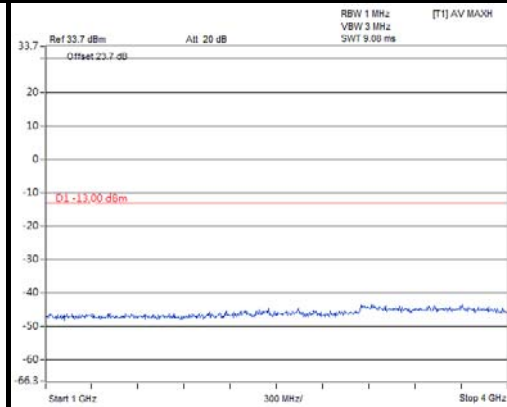

**FREQUENCY RANGE : 4GHz~7GHz**

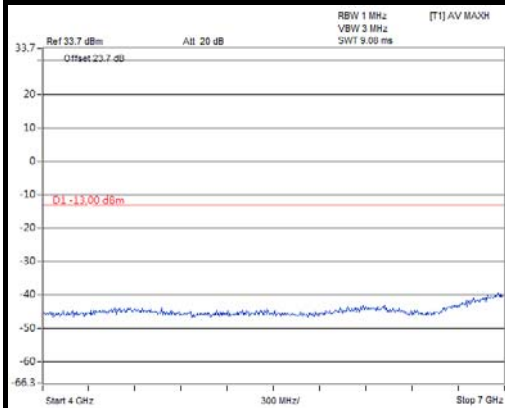

**FREQUENCY RANGE : 7GHz~9GHz**

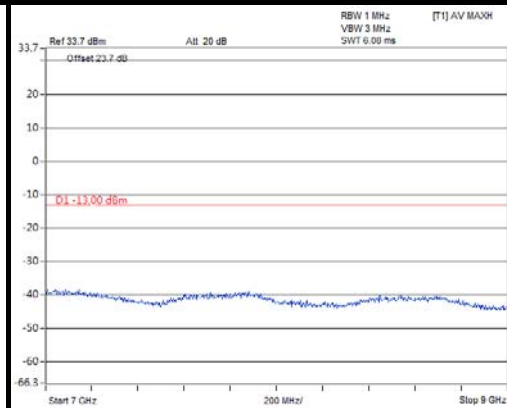



A D T

**LTE BAND 26 - CHANNEL BANDWIDTH: 3MHz**

**CHANNEL 26740**

**FREQUENCY RANGE : 9kHz~1GHz**

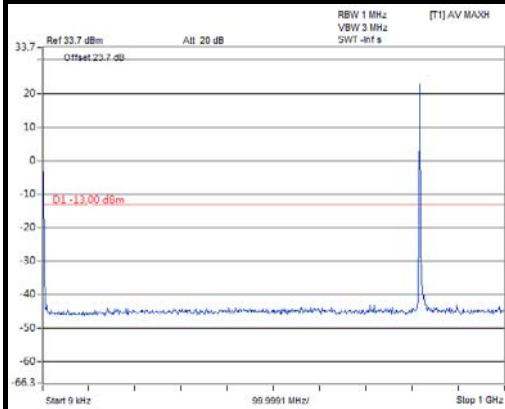

**FREQUENCY RANGE : 1GHz~4GHz**

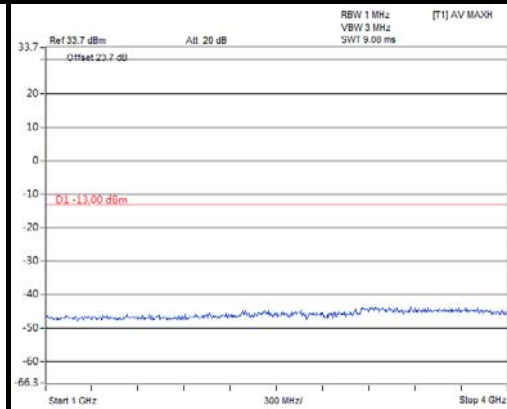

**FREQUENCY RANGE : 4GHz~7GHz**

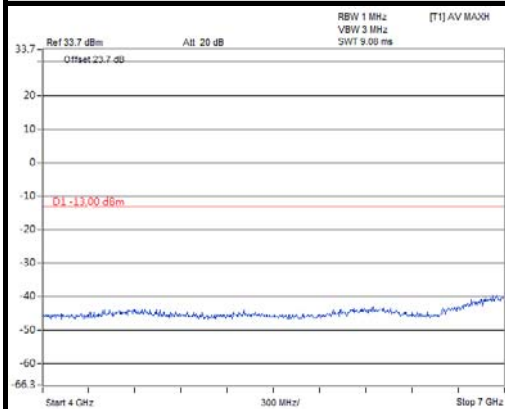

**FREQUENCY RANGE : 7GHz~9GHz**

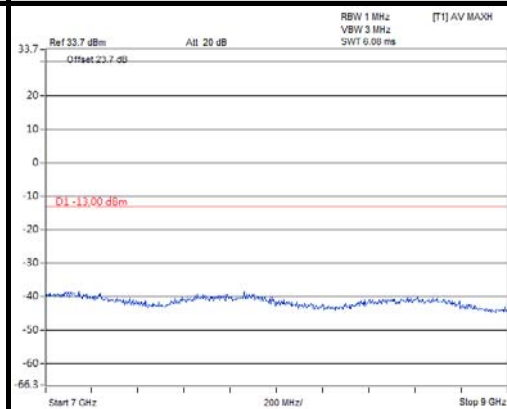



A D T

**LTE BAND 26 - CHANNEL BANDWIDTH: 3MHz**

**CHANNEL 26775**

**FREQUENCY RANGE : 9kHz~1GHz**

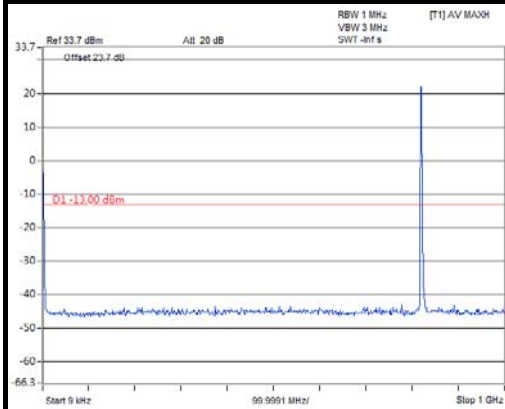

**FREQUENCY RANGE : 1GHz~4GHz**

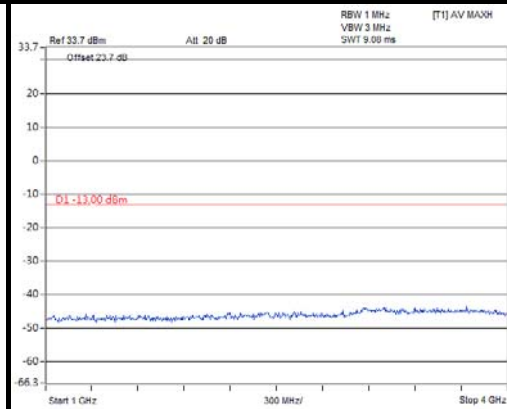

**FREQUENCY RANGE : 4GHz~7GHz**

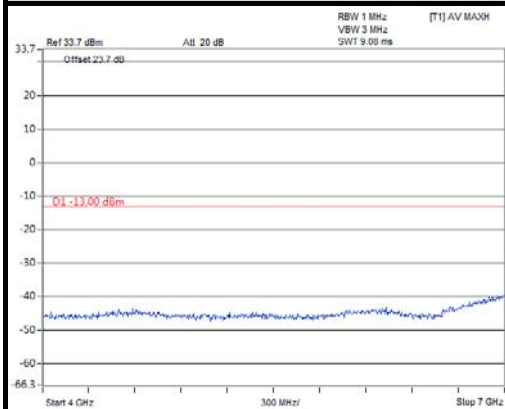

**FREQUENCY RANGE : 7GHz~9GHz**

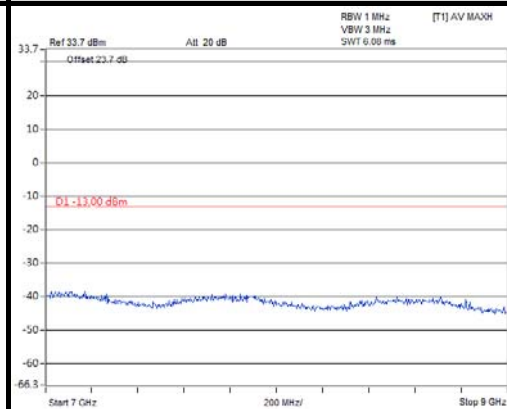



A D T

**LTE BAND 26 - CHANNEL BANDWIDTH: 5MHz**

**CHANNEL 26715**

**FREQUENCY RANGE : 9kHz~1GHz**

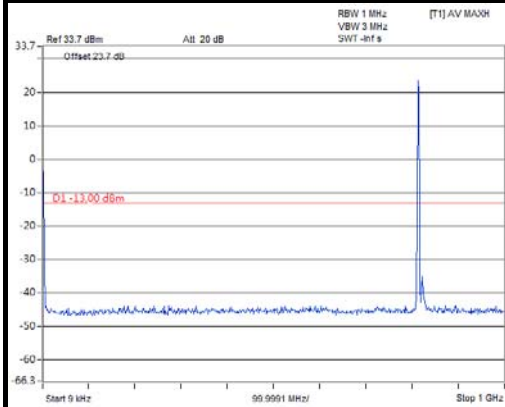

**FREQUENCY RANGE : 1GHz~4GHz**

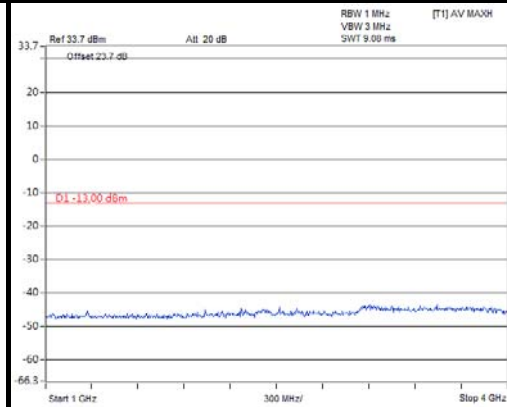

**FREQUENCY RANGE : 4GHz~7GHz**

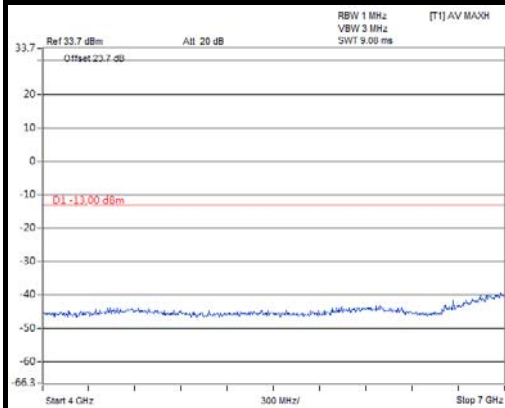

**FREQUENCY RANGE : 7GHz~9GHz**

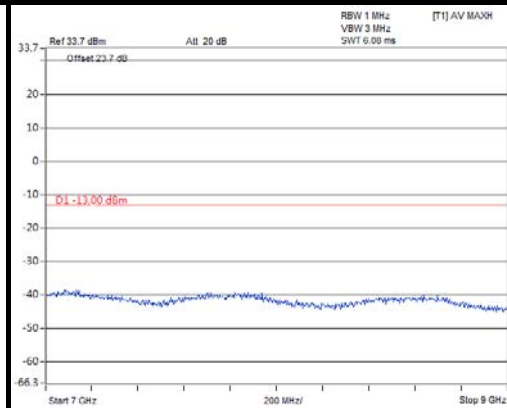



A D T

**LTE BAND 26 - CHANNEL BANDWIDTH: 5MHz**

**CHANNEL 26740**

**FREQUENCY RANGE : 9kHz~1GHz**

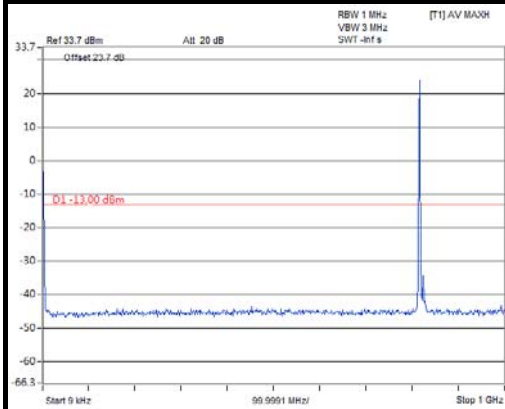

**FREQUENCY RANGE : 1GHz~4GHz**

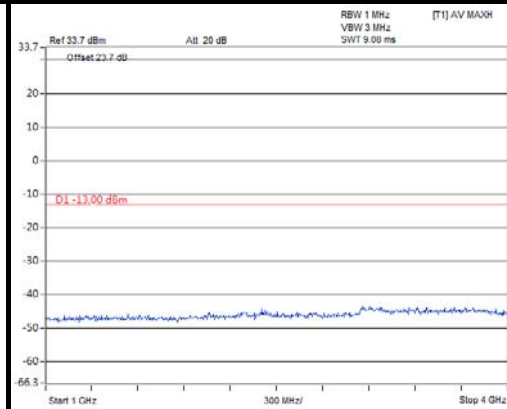

**FREQUENCY RANGE : 4GHz~7GHz**

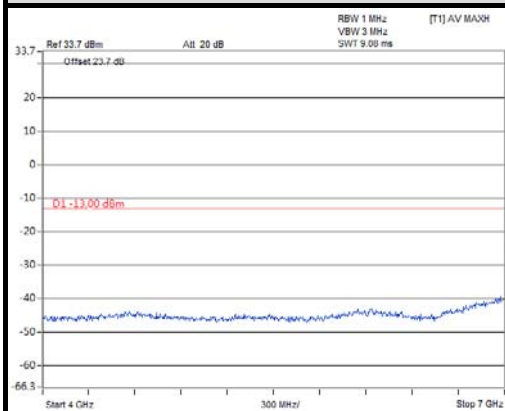

**FREQUENCY RANGE : 7GHz~9GHz**

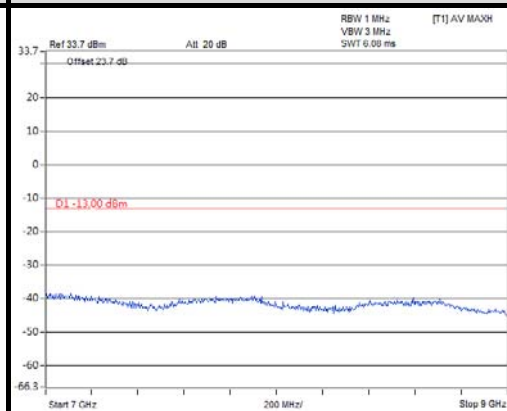



A D T

**LTE BAND 26 - CHANNEL BANDWIDTH: 5MHz**

**CHANNEL 26765**

**FREQUENCY RANGE : 9kHz~1GHz**

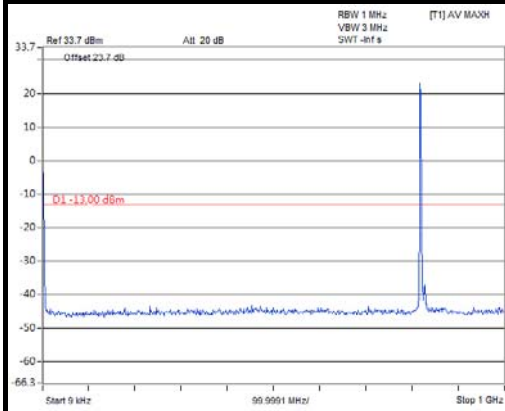

**FREQUENCY RANGE : 1GHz~4GHz**

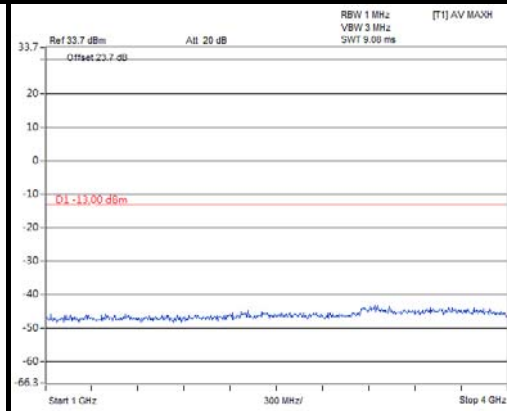

**FREQUENCY RANGE : 4GHz~7GHz**

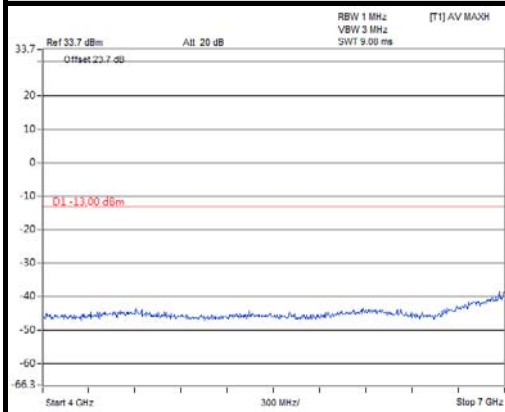

**FREQUENCY RANGE : 7GHz~9GHz**

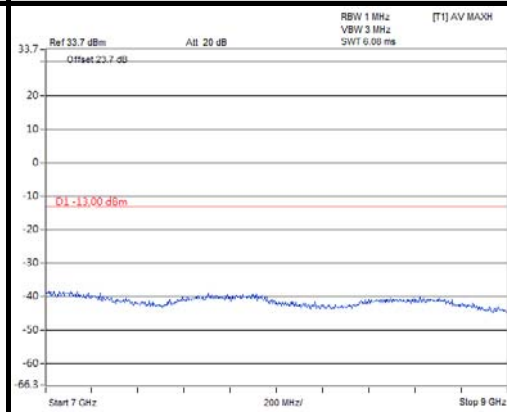



A D T

**LTE BAND 26 - CHANNEL BANDWIDTH: 10MHz**

**CHANNEL 26740**

**FREQUENCY RANGE : 9kHz~1GHz**

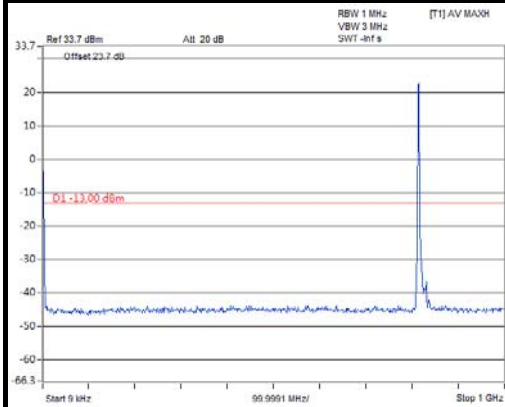

A D T

**FREQUENCY RANGE : 1GHz~4GHz**

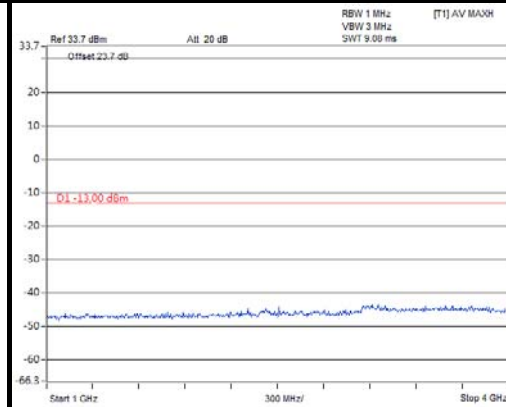

A D T

**FREQUENCY RANGE : 4GHz~7GHz**

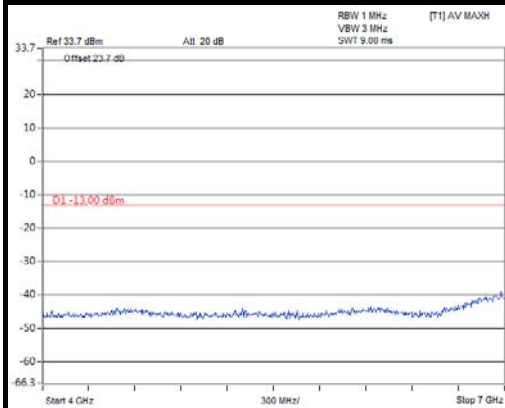

A D T

**FREQUENCY RANGE : 7GHz~9GHz**

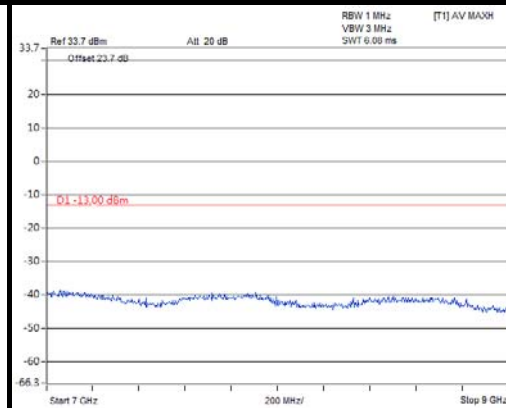

A D T



## 4.6 RADIATED EMISSION MEASUREMENT

### 4.6.1 LIMITS OF RADIATED EMISSION MEASUREMENT

The power of any emission shall be attenuated below the transmitter power (P) by at least  $43 + 10 \log (P)$  dB. The emission limit equal to  $-13\text{dBm}$ .

### 4.6.2 TEST PROCEDURES

- a. Substitution method is used for E.I.R.P measurement. In the semi-anechoic chamber, EUT placed on the 0.8m height of Turn Table, rotated the table around 360 degrees to search the maximum radiation power and receiver antenna shall be rotated vertical and horizontal polarization and moved height from 1m to 4m to find the maximum polar radiated power. The “Read Value” is the spectrum reading the maximum power value.
- b. The substitution horn antenna is substituted for EUT at the same position and signals generator export the CW signal to the substitution antenna via a TX cable. Rotated the Turn Table and moved receiving antenna to find the maximum radiation power. Adjust output power level of S.G to get a Value of spectrum reading equal to “Read Value” of step a. Record the power level of S.G
- c.  $\text{EIRP} = \text{Output power level of S.G} - \text{TX cable loss} + \text{Antenna gain of substitution horn}$ .
- d. E.R.P power can be calculated from E.I.R.P power by subtracting the gain of dipole,  $\text{E.R.P power} = \text{E.I.P.R power} - 2.15\text{dBi}$ .

**NOTE:** The resolution bandwidth and video bandwidth of test receiver/spectrum analyzer is 1MHz/3MHz.

### 4.6.3 DEVIATION FROM TEST STANDARD

No deviation

#### 4.6.4 TEST SETUP

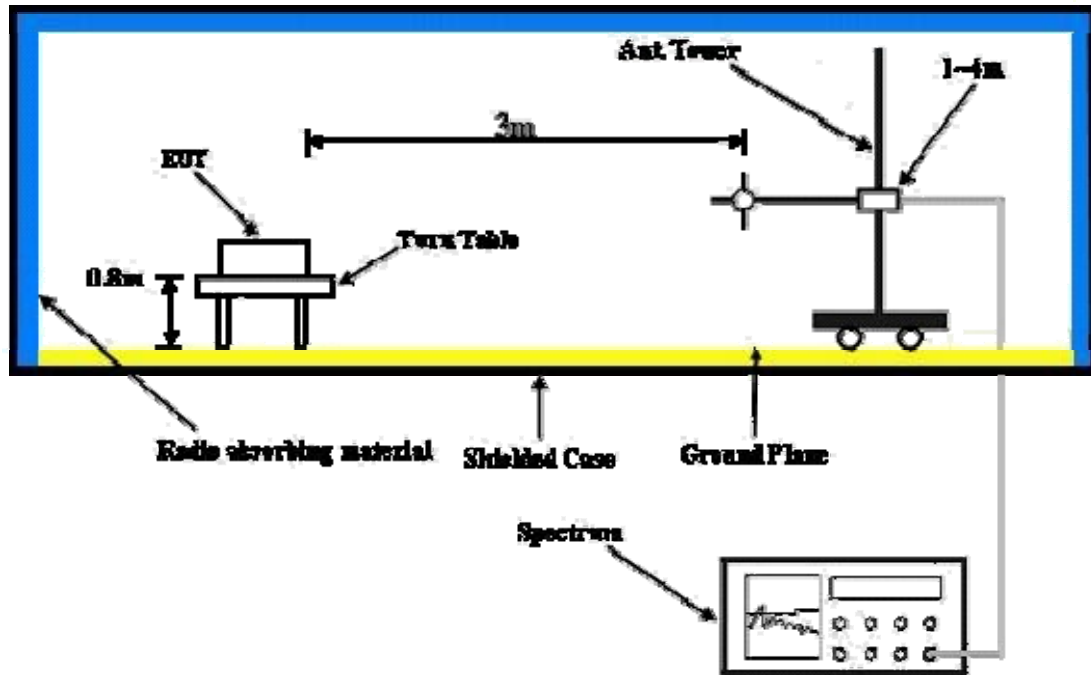

For the actual test configuration, please refer to the attached file (Test Setup Photo).

## 4.6.5 TEST RESULTS

### For CDMA

#### BELOW 1GHz

<b>MODE</b>	TX channel 670	<b>FREQUENCY RANGE</b>	Below 1000MHz
<b>ENVIRONMENTAL CONDITIONS</b>	24deg. C, 64%RH	<b>INPUT POWER</b>	120Vac, 60 Hz
<b>TESTED BY</b>	Ted Chang		

ANTENNA POLARITY & TEST DISTANCE: HORIZONTAL AT 3 M							
No.	Freq. (MHz)	Reading (dBm)	S.G Power Value (dBm)	Correction Factor (dB)	ERP (dBm)	Limit (dBm)	Margin (dB)
1	45.55	-70.00	-59.41	-9.97	-69.38	-13.00	-56.38
2	107.76	-67.29	-76.59	0.57	-76.02	-13.00	-63.02
3	146.63	-67.29	-73.65	-0.21	-73.86	-13.00	-60.86
4	306.03	-75.46	-86.62	5.14	-81.48	-13.00	-68.48
5	479.04	-76.94	-84.11	4.96	-79.15	-13.00	-66.15
6	613.17	-77.61	-82.69	4.53	-78.16	-13.00	-65.16
ANTENNA POLARITY & TEST DISTANCE: VERTICAL AT 3 M							
No.	Freq. (MHz)	Reading (dBm)	S.G Power Value (dBm)	Correction Factor (dB)	ERP (dBm)	Limit (dBm)	Margin (dB)
1	45.55	-58.48	-56.57	-9.97	-66.54	-13.00	-53.54
2	105.81	-62.64	-70.93	0.64	-70.29	-13.00	-57.29
3	187.45	-60.32	-67.85	3.88	-63.97	-13.00	-50.97
4	405.17	-77.96	-84.48	5.26	-79.22	-13.00	-66.22
5	574.29	-77.61	-81.03	4.54	-76.49	-13.00	-63.49
6	723.97	-76.94	-77.09	4.95	-72.14	-13.00	-59.14

#### REMARKS:

1.  $ERP(dBm) = S.G \text{ Power Value (dBm)} + \text{Correction Factor (dB)}$ .
2. Correction Factor = gain of substitution antenna + cable loss



A D T

**ABOVE 1GHz**

<b>MODE</b>	TX channel 476	<b>FREQUENCY RANGE</b>	Above 1000MHz
<b>ENVIRONMENTAL CONDITIONS</b>	24deg. C, 64%RH	<b>INPUT POWER</b>	120Vac, 60 Hz
<b>TESTED BY</b>	Ted Chang		

<b>ANTENNA POLARITY &amp; TEST DISTANCE: HORIZONTAL AT 3 M</b>							
No.	Freq. (MHz)	Reading (dBm)	S.G Power Value (dBm)	Correction Factor (dB)	ERP (dBm)	Limit (dBm)	Margin (dB)
1	1635.80	-55.19	-57.87	5.45	-52.42	-13.00	-39.42
2	2453.70	-58.75	-58.78	6.42	-52.36	-13.00	-39.36
<b>ANTENNA POLARITY &amp; TEST DISTANCE: VERTICAL AT 3 M</b>							
No.	Freq. (MHz)	Reading (dBm)	S.G Power Value (dBm)	Correction Factor (dB)	ERP (dBm)	Limit (dBm)	Margin (dB)
1	1635.80	-51.91	-56.59	5.45	-51.14	-13.00	-38.14
2	2453.70	-56.51	-56.36	6.42	-49.94	-13.00	-36.94

**REMARKS:**

1.  $ERP(dBm) = S.G\ Power\ Value\ (dBm) + Correction\ Factor\ (dB)$ .
2. Correction Factor = gain of substitution antenna + cable loss



A D T

<b>MODE</b>	TX channel 580	<b>FREQUENCY RANGE</b>	Above 1000MHz
<b>ENVIRONMENTAL CONDITIONS</b>	24deg. C, 64%RH	<b>INPUT POWER</b>	120Vac, 60 Hz
<b>TESTED BY</b>	Ted Chang		

<b>ANTENNA POLARITY &amp; TEST DISTANCE: HORIZONTAL AT 3 M</b>							
No.	Freq. (MHz)	Reading (dBm)	S.G Power Value (dBm)	Correction Factor (dB)	ERP (dBm)	Limit (dBm)	Margin (dB)
1	1641.00	-57.09	-59.79	5.46	-54.33	-13.00	-41.33
2	2461.50	-58.52	-58.53	6.43	-52.10	-13.00	-39.10

<b>ANTENNA POLARITY &amp; TEST DISTANCE: VERTICAL AT 3 M</b>							
No.	Freq. (MHz)	Reading (dBm)	S.G Power Value (dBm)	Correction Factor (dB)	ERP (dBm)	Limit (dBm)	Margin (dB)
1	1641.00	-53.90	-58.57	5.46	-53.11	-13.00	-40.11
2	2461.50	-57.51	-57.34	6.43	-50.91	-13.00	-37.91

**REMARKS:**

1.  $ERP(dBm) = S.G \text{ Power Value (dBm)} + \text{Correction Factor (dB)}$ .
2. Correction Factor = gain of substitution antenna + cable loss



A D T

<b>MODE</b>	TX channel 670	<b>FREQUENCY RANGE</b>	Above 1000MHz
<b>ENVIRONMENTAL CONDITIONS</b>	24deg. C, 64%RH	<b>INPUT POWER</b>	120Vac, 60 Hz
<b>TESTED BY</b>	Ted Chang		

<b>ANTENNA POLARITY &amp; TEST DISTANCE: HORIZONTAL AT 3 M</b>							
No.	Freq. (MHz)	Reading (dBm)	S.G Power Value (dBm)	Correction Factor (dB)	ERP (dBm)	Limit (dBm)	Margin (dB)
1	1645.50	-58.33	-58.36	5.47	-52.89	-13.00	-39.89
2	2468.25	-61.44	-62.43	6.43	-56.00	-13.00	-43.00
3	3291.00	-60.74	-62.16	6.86	-55.30	-13.00	-42.30
<b>ANTENNA POLARITY &amp; TEST DISTANCE: VERTICAL AT 3 M</b>							
No.	Freq. (MHz)	Reading (dBm)	S.G Power Value (dBm)	Correction Factor (dB)	ERP (dBm)	Limit (dBm)	Margin (dB)
1	1645.50	-52.67	-49.53	5.47	-44.06	-13.00	-31.06
2	2468.25	-58.70	-56.52	6.43	-50.09	-13.00	-37.09
3	3291.00	-59.25	-57.50	6.86	-50.64	-13.00	-37.64

**REMARKS:**

1.  $ERP(dBm) = S.G \text{ Power Value (dBm)} + \text{Correction Factor (dB)}$ .
2. Correction Factor = gain of substitution antenna + cable loss

For LTE BAND 26

BELOW 1GHz

CHANNEL BANDWIDTH: 1.4MHz

<b>MODE</b>	TX channel 26783	<b>FREQUENCY RANGE</b>	Below 1000MHz
<b>ENVIRONMENTAL CONDITIONS</b>	25deg. C, 65%RH	<b>INPUT POWER</b>	120Vac, 60 Hz
<b>TESTED BY</b>	Chris Lin		

ANTENNA POLARITY & TEST DISTANCE: HORIZONTAL AT 3 M							
No.	Freq. (MHz)	Reading (dBm)	S.G Power Value (dBm)	Correction Factor (dB)	ERP (dBm)	Limit (dBm)	Margin (dB)
1	105.81	-60.29	-69.76	0.64	-69.12	-13.00	-56.12
2	187.45	-58.91	-70.95	3.88	-67.07	-13.00	-54.07
3	296.31	-67.31	-78.79	5.15	-73.64	-13.00	-60.64
4	461.54	-73.33	-80.40	5.04	-75.36	-13.00	-62.36
5	757.01	-74.66	-75.88	4.55	-71.33	-13.00	-58.33
6	990.28	-72.68	-71.25	3.90	-67.35	-13.00	-54.35
ANTENNA POLARITY & TEST DISTANCE: VERTICAL AT 3 M							
No.	Freq. (MHz)	Reading (dBm)	S.G Power Value (dBm)	Correction Factor (dB)	ERP (dBm)	Limit (dBm)	Margin (dB)
1	45.55	-55.01	-44.42	-9.97	-54.39	-13.00	-41.39
2	187.45	-61.92	-73.96	3.88	-70.08	-13.00	-57.08
3	296.31	-59.35	-70.83	5.15	-65.68	-13.00	-52.68
4	362.40	-66.47	-75.55	5.22	-70.33	-13.00	-57.33
5	527.64	-69.83	-76.57	4.76	-71.81	-13.00	-58.81
6	659.82	-71.43	-75.88	4.92	-70.96	-13.00	-57.96

**REMARKS:**

1. ERP(dBm) = S.G Power Value (dBm) + Correction Factor (dB).
2. Correction Factor = gain of substitution antenna + cable loss



A D T

**CHANNEL BANDWIDTH: 3MHz**

<b>MODE</b>	TX channel 26775	<b>FREQUENCY RANGE</b>	Below 1000MHz
<b>ENVIRONMENTAL CONDITIONS</b>	25deg. C, 65%RH	<b>INPUT POWER</b>	120Vac, 60 Hz
<b>TESTED BY</b>	Chris Lin		

**ANTENNA POLARITY & TEST DISTANCE: HORIZONTAL AT 3 M**

No.	Freq. (MHz)	Reading (dBm)	S.G Power Value (dBm)	Correction Factor (dB)	ERP (dBm)	Limit (dBm)	Margin (dB)
1	45.55	-69.41	-58.82	-9.97	-68.79	-13.00	-55.79
2	185.51	-58.69	-70.35	3.62	-66.73	-13.00	-53.73
3	296.31	-67.86	-79.34	5.15	-74.19	-13.00	-61.19
4	461.54	-73.12	-80.19	5.04	-75.15	-13.00	-62.15
5	757.01	-74.92	-76.14	4.55	-71.59	-13.00	-58.59
6	959.18	-77.28	-76.23	3.91	-72.32	-13.00	-59.32

**ANTENNA POLARITY & TEST DISTANCE: VERTICAL AT 3 M**

No.	Freq. (MHz)	Reading (dBm)	S.G Power Value (dBm)	Correction Factor (dB)	ERP (dBm)	Limit (dBm)	Margin (dB)
1	43.61	-56.38	-45.00	-10.29	-55.29	-13.00	-42.29
2	187.45	-62.10	-74.14	3.88	-70.26	-13.00	-57.26
3	296.31	-60.13	-71.61	5.15	-66.46	-13.00	-53.46
4	362.40	-66.01	-75.09	5.22	-69.87	-13.00	-56.87
5	521.80	-71.25	-77.99	4.78	-73.21	-13.00	-60.21
6	801.72	-73.74	-74.61	4.02	-70.59	-13.00	-57.59

**REMARKS:**

1.  $ERP(dBm) = S.G\ Power\ Value\ (dBm) + Correction\ Factor\ (dB)$ .
2. Correction Factor = gain of substitution antenna + cable loss





A D T

**CHANNEL BANDWIDTH: 5MHz**

<b>MODE</b>	TX channel 26765	<b>FREQUENCY RANGE</b>	Below 1000MHz
<b>ENVIRONMENTAL CONDITIONS</b>	25deg. C, 65%RH	<b>INPUT POWER</b>	120Vac, 60 Hz
<b>TESTED BY</b>	Chris Lin		

**ANTENNA POLARITY & TEST DISTANCE: HORIZONTAL AT 3 M**

No.	Freq. (MHz)	Reading (dBm)	S.G Power Value (dBm)	Correction Factor (dB)	ERP (dBm)	Limit (dBm)	Margin (dB)
1	109.70	-61.11	-70.24	0.49	-69.75	-13.00	-56.75
2	187.45	-59.12	-71.16	3.88	-67.28	-13.00	-54.28
3	296.31	-67.95	-79.43	5.15	-74.28	-13.00	-61.28
4	700.64	-74.94	-78.79	5.24	-73.55	-13.00	-60.55
5	801.72	-74.20	-75.07	4.02	-71.05	-13.00	-58.05
6	990.28	-73.97	-72.54	3.90	-68.64	-13.00	-55.64

**ANTENNA POLARITY & TEST DISTANCE: VERTICAL AT 3 M**

No.	Freq. (MHz)	Reading (dBm)	S.G Power Value (dBm)	Correction Factor (dB)	ERP (dBm)	Limit (dBm)	Margin (dB)
1	45.55	-56.17	-45.58	-9.97	-55.55	-13.00	-42.55
2	187.45	-62.83	-74.87	3.88	-70.99	-13.00	-57.99
3	296.31	-60.75	-72.23	5.15	-67.08	-13.00	-54.08
4	527.64	-70.76	-77.50	4.76	-72.74	-13.00	-59.74
5	757.01	-74.20	-75.42	4.55	-70.87	-13.00	-57.87
6	990.28	-76.02	-74.59	3.90	-70.69	-13.00	-57.69

**REMARKS:**

1.  $ERP(dBm) = S.G\ Power\ Value\ (dBm) + Correction\ Factor\ (dB)$ .
2. Correction Factor = gain of substitution antenna + cable loss



A D T

**CHANNEL BANDWIDTH: 10MHz**

<b>MODE</b>	TX channel 26740	<b>FREQUENCY RANGE</b>	Below 1000MHz
<b>ENVIRONMENTAL CONDITIONS</b>	25deg. C, 65%RH	<b>INPUT POWER</b>	120Vac, 60 Hz
<b>TESTED BY</b>	Chris Lin		

**ANTENNA POLARITY & TEST DISTANCE: HORIZONTAL AT 3 M**

No.	Freq. (MHz)	Reading (dBm)	S.G Power Value (dBm)	Correction Factor (dB)	ERP (dBm)	Limit (dBm)	Margin (dB)
1	45.55	-69.72	-59.13	-9.97	-69.10	-13.00	-56.10
2	109.70	-60.96	-70.09	0.49	-69.60	-13.00	-56.60
3	187.45	-59.68	-71.72	3.88	-67.84	-13.00	-54.84
4	362.40	-71.41	-80.49	5.22	-75.27	-13.00	-62.27
5	757.01	-75.46	-76.68	4.55	-72.13	-13.00	-59.13
6	990.28	-74.68	-73.25	3.90	-69.35	-13.00	-56.35

**ANTENNA POLARITY & TEST DISTANCE: VERTICAL AT 3 M**

No.	Freq. (MHz)	Reading (dBm)	S.G Power Value (dBm)	Correction Factor (dB)	ERP (dBm)	Limit (dBm)	Margin (dB)
1	43.61	-56.81	-45.43	-10.29	-55.72	-13.00	-42.72
2	187.45	-63.77	-75.81	3.88	-71.93	-13.00	-58.93
3	230.22	-63.42	-76.95	5.43	-71.52	-13.00	-58.52
4	296.31	-59.99	-71.47	5.15	-66.32	-13.00	-53.32
5	362.40	-65.83	-74.91	5.22	-69.69	-13.00	-56.69
6	521.80	-71.25	-77.99	4.78	-73.21	-13.00	-60.21

**REMARKS:**

1.  $ERP(dBm) = S.G\ Power\ Value\ (dBm) + Correction\ Factor\ (dB)$ .
2. Correction Factor = gain of substitution antenna + cable loss



**ABOVE 1GHz**

**CHANNEL BANDWIDTH: 1.4MHz**

<b>MODE</b>	TX channel 26697	<b>FREQUENCY RANGE</b>	Above 1000MHz
<b>ENVIRONMENTAL CONDITIONS</b>	25deg. C, 65%RH	<b>INPUT POWER</b>	120Vac, 60 Hz
<b>TESTED BY</b>	Ted Chang		

<b>ANTENNA POLARITY &amp; TEST DISTANCE: HORIZONTAL AT 3 M</b>							
No.	Freq. (MHz)	Reading (dBm)	S.G Power Value (dBm)	Correction Factor (dB)	ERP (dBm)	Limit (dBm)	Margin (dB)
1	1629.40	-60.50	-63.10	5.40	-57.70	-13.00	-44.70
2	2444.10	-51.10	-51.20	6.40	-44.80	-13.00	-31.80
3	3258.80	-61.20	-59.50	6.80	-52.70	-13.00	-39.70
<b>ANTENNA POLARITY &amp; TEST DISTANCE: VERTICAL AT 3 M</b>							
No.	Freq. (MHz)	Reading (dBm)	S.G Power Value (dBm)	Correction Factor (dB)	ERP (dBm)	Limit (dBm)	Margin (dB)
1	1629.40	-47.50	-52.10	5.40	-46.70	-13.00	-33.70
2	2444.10	-51.10	-51.00	6.40	-44.60	-13.00	-31.60
3	3258.80	-62.80	-61.70	6.80	-54.90	-13.00	-41.90

**REMARKS:**

1. ERP(dBm) = S.G Power Value (dBm) + Correction Factor (dB).
2. Correction Factor = gain of substitution antenna + cable loss



A D T

<b>MODE</b>	TX channel 26740	<b>FREQUENCY RANGE</b>	Above 1000MHz
<b>ENVIRONMENTAL CONDITIONS</b>	25deg. C, 65%RH	<b>INPUT POWER</b>	120Vac, 60 Hz
<b>TESTED BY</b>	Ted Chang		

<b>ANTENNA POLARITY &amp; TEST DISTANCE: HORIZONTAL AT 3 M</b>							
No.	Freq. (MHz)	Reading (dBm)	S.G Power Value (dBm)	Correction Factor (dB)	ERP (dBm)	Limit (dBm)	Margin (dB)
1	1638.00	-49.50	-52.19	5.46	-46.73	-13.00	-33.73
2	2457.00	-61.50	-61.53	6.43	-55.10	-13.00	-42.10

<b>ANTENNA POLARITY &amp; TEST DISTANCE: VERTICAL AT 3 M</b>							
No.	Freq. (MHz)	Reading (dBm)	S.G Power Value (dBm)	Correction Factor (dB)	ERP (dBm)	Limit (dBm)	Margin (dB)
1	1638.00	-46.50	-51.19	5.46	-45.73	-13.00	-32.73
2	2457.00	-60.51	-60.36	6.43	-53.93	-13.00	-40.93

**REMARKS:**

1.  $ERP(dBm) = S.G \text{ Power Value (dBm)} + \text{Correction Factor (dB)}$ .
2. Correction Factor = gain of substitution antenna + cable loss



A D T

<b>MODE</b>	TX channel 26783	<b>FREQUENCY RANGE</b>	Above 1000MHz
<b>ENVIRONMENTAL CONDITIONS</b>	25deg. C, 65%RH	<b>INPUT POWER</b>	120Vac, 60 Hz
<b>TESTED BY</b>	Ted Chang		

<b>ANTENNA POLARITY &amp; TEST DISTANCE: HORIZONTAL AT 3 M</b>							
No.	Freq. (MHz)	Reading (dBm)	S.G Power Value (dBm)	Correction Factor (dB)	ERP (dBm)	Limit (dBm)	Margin (dB)
1	1646.60	-51.57	-54.30	5.48	-48.82	-13.00	-35.82
2	2469.90	-63.50	-63.47	6.43	-57.04	-13.00	-44.04

<b>ANTENNA POLARITY &amp; TEST DISTANCE: VERTICAL AT 3 M</b>							
No.	Freq. (MHz)	Reading (dBm)	S.G Power Value (dBm)	Correction Factor (dB)	ERP (dBm)	Limit (dBm)	Margin (dB)
1	1646.60	-47.55	-52.22	5.48	-46.74	-13.00	-33.74
2	2469.90	-60.50	-60.31	6.43	-53.88	-13.00	-40.88

**REMARKS:**

1.  $ERP(dBm) = S.G \text{ Power Value (dBm)} + \text{Correction Factor (dB)}$ .
2. Correction Factor = gain of substitution antenna + cable loss



A D T

**CHANNEL BANDWIDTH: 3MHz**

<b>MODE</b>	TX channel 26705	<b>FREQUENCY RANGE</b>	Above 1000MHz
<b>ENVIRONMENTAL CONDITIONS</b>	25deg. C, 65%RH	<b>INPUT POWER</b>	120Vac, 60 Hz
<b>TESTED BY</b>	Ted Chang		

<b>ANTENNA POLARITY &amp; TEST DISTANCE: HORIZONTAL AT 3 M</b>							
No.	Freq. (MHz)	Reading (dBm)	S.G Power Value (dBm)	Correction Factor (dB)	ERP (dBm)	Limit (dBm)	Margin (dB)
1	1631.00	-55.80	-58.40	5.40	-53.00	-13.00	-40.00
2	2446.50	-58.60	-58.60	6.40	-52.20	-13.00	-39.20
3	3262.00	-60.50	-58.80	6.80	-52.00	-13.00	-39.00
<b>ANTENNA POLARITY &amp; TEST DISTANCE: VERTICAL AT 3 M</b>							
No.	Freq. (MHz)	Reading (dBm)	S.G Power Value (dBm)	Correction Factor (dB)	ERP (dBm)	Limit (dBm)	Margin (dB)
1	1631.00	-48.40	-53.00	5.40	-47.60	-13.00	-34.60
2	2446.50	-53.90	-53.80	6.40	-47.40	-13.00	-34.40
3	3262.00	-63.50	-62.30	6.80	-55.50	-13.00	-42.50

**REMARKS:**

1. ERP(dBm) = S.G Power Value (dBm) + Correction Factor (dB).
2. Correction Factor = gain of substitution antenna + cable loss



A D T

<b>MODE</b>	TX channel 26740	<b>FREQUENCY RANGE</b>	Above 1000MHz
<b>ENVIRONMENTAL CONDITIONS</b>	25deg. C, 65%RH	<b>INPUT POWER</b>	120Vac, 60 Hz
<b>TESTED BY</b>	Ted Chang		

ANTENNA POLARITY & TEST DISTANCE: HORIZONTAL AT 3 M							
No.	Freq. (MHz)	Reading (dBm)	S.G Power Value (dBm)	Correction Factor (dB)	ERP (dBm)	Limit (dBm)	Margin (dB)
1	1638.00	-53.55	-56.24	5.46	-50.78	-13.00	-37.78
2	2457.00	-62.74	-62.77	6.43	-56.34	-13.00	-43.34

ANTENNA POLARITY & TEST DISTANCE: VERTICAL AT 3 M							
No.	Freq. (MHz)	Reading (dBm)	S.G Power Value (dBm)	Correction Factor (dB)	ERP (dBm)	Limit (dBm)	Margin (dB)
1	1638.00	-48.66	-53.35	5.46	-47.89	-13.00	-34.89
2	2457.00	-61.55	-61.40	6.43	-54.97	-13.00	-41.97

**REMARKS:**

1.  $ERP(dBm) = S.G \text{ Power Value (dBm)} + \text{Correction Factor (dB)}$ .
2. Correction Factor = gain of substitution antenna + cable loss



A D T

<b>MODE</b>	TX channel 26775	<b>FREQUENCY RANGE</b>	Above 1000MHz
<b>ENVIRONMENTAL CONDITIONS</b>	25deg. C, 65%RH	<b>INPUT POWER</b>	120Vac, 60 Hz
<b>TESTED BY</b>	Ted Chang		

<b>ANTENNA POLARITY &amp; TEST DISTANCE: HORIZONTAL AT 3 M</b>							
No.	Freq. (MHz)	Reading (dBm)	S.G Power Value (dBm)	Correction Factor (dB)	ERP (dBm)	Limit (dBm)	Margin (dB)
1	1645.00	-52.66	-55.38	5.47	-49.91	-13.00	-36.91
2	3290.00	-61.99	-60.37	6.86	-53.51	-13.00	-40.51

<b>ANTENNA POLARITY &amp; TEST DISTANCE: VERTICAL AT 3 M</b>							
No.	Freq. (MHz)	Reading (dBm)	S.G Power Value (dBm)	Correction Factor (dB)	ERP (dBm)	Limit (dBm)	Margin (dB)
1	1645.00	-47.00	-51.67	5.47	-46.20	-13.00	-33.20
2	3290.00	-60.53	-59.33	6.86	-52.47	-13.00	-39.47

**REMARKS:**

1.  $ERP(dBm) = S.G \text{ Power Value (dBm)} + \text{Correction Factor (dB)}$ .
2. Correction Factor = gain of substitution antenna + cable loss





A D T

**CHANNEL BANDWIDTH: 5MHz**

<b>MODE</b>	TX channel 26715	<b>FREQUENCY RANGE</b>	Above 1000MHz
<b>ENVIRONMENTAL CONDITIONS</b>	25deg. C, 65%RH	<b>INPUT POWER</b>	120Vac, 60 Hz
<b>TESTED BY</b>	Ted Chang		

**ANTENNA POLARITY & TEST DISTANCE: HORIZONTAL AT 3 M**

No.	Freq. (MHz)	Reading (dBm)	S.G Power Value (dBm)	Correction Factor (dB)	ERP (dBm)	Limit (dBm)	Margin (dB)
1	1633.00	-57.50	-60.20	5.50	-54.70	-13.00	-41.70
2	2449.50	-57.60	-57.70	6.40	-51.30	-13.00	-38.30
3	3266.00	-61.70	-60.00	6.80	-53.20	-13.00	-40.20

**ANTENNA POLARITY & TEST DISTANCE: VERTICAL AT 3 M**

No.	Freq. (MHz)	Reading (dBm)	S.G Power Value (dBm)	Correction Factor (dB)	ERP (dBm)	Limit (dBm)	Margin (dB)
1	1633.00	-49.90	-54.60	5.50	-49.10	-13.00	-36.10
2	2449.50	-58.80	-58.60	6.40	-52.20	-13.00	-39.20
3	3266.00	-61.50	-60.30	6.80	-53.50	-13.00	-40.50

**REMARKS:**

1. ERP(dBm) = S.G Power Value (dBm) + Correction Factor (dB).
2. Correction Factor = gain of substitution antenna + cable loss



A D T

<b>MODE</b>	TX channel 26740	<b>FREQUENCY RANGE</b>	Above 1000MHz
<b>ENVIRONMENTAL CONDITIONS</b>	25deg. C, 65%RH	<b>INPUT POWER</b>	120Vac, 60 Hz
<b>TESTED BY</b>	Ted Chang		

<b>ANTENNA POLARITY &amp; TEST DISTANCE: HORIZONTAL AT 3 M</b>							
No.	Freq. (MHz)	Reading (dBm)	S.G Power Value (dBm)	Correction Factor (dB)	ERP (dBm)	Limit (dBm)	Margin (dB)
1	1638.00	-51.92	-54.61	5.46	-49.15	-13.00	-36.15
2	2457.00	-63.22	-63.25	6.43	-56.82	-13.00	-43.82

<b>ANTENNA POLARITY &amp; TEST DISTANCE: VERTICAL AT 3 M</b>							
No.	Freq. (MHz)	Reading (dBm)	S.G Power Value (dBm)	Correction Factor (dB)	ERP (dBm)	Limit (dBm)	Margin (dB)
1	1638.00	-48.62	-53.31	5.46	-47.85	-13.00	-34.85
2	2457.00	-62.58	-62.43	6.43	-56.00	-13.00	-43.00

**REMARKS:**

1.  $ERP(dBm) = S.G \text{ Power Value (dBm)} + \text{Correction Factor (dB)}$ .
2. Correction Factor = gain of substitution antenna + cable loss



A D T

<b>MODE</b>	TX channel 26765	<b>FREQUENCY RANGE</b>	Above 1000MHz
<b>ENVIRONMENTAL CONDITIONS</b>	25deg. C, 65%RH	<b>INPUT POWER</b>	120Vac, 60 Hz
<b>TESTED BY</b>	Ted Chang		

<b>ANTENNA POLARITY &amp; TEST DISTANCE: HORIZONTAL AT 3 M</b>							
No.	Freq. (MHz)	Reading (dBm)	S.G Power Value (dBm)	Correction Factor (dB)	ERP (dBm)	Limit (dBm)	Margin (dB)
1	1643.00	-52.15	-54.86	5.47	-49.39	-13.00	-36.39
2	2464.50	-63.74	-63.73	6.42	-57.31	-13.00	-44.31
<b>ANTENNA POLARITY &amp; TEST DISTANCE: VERTICAL AT 3 M</b>							
No.	Freq. (MHz)	Reading (dBm)	S.G Power Value (dBm)	Correction Factor (dB)	ERP (dBm)	Limit (dBm)	Margin (dB)
1	1643.00	-48.55	-53.23	5.47	-47.76	-13.00	-34.76
2	2464.50	-64.59	-64.41	6.42	-57.99	-13.00	-44.99

**REMARKS:**

1.  $ERP(dBm) = S.G \text{ Power Value (dBm)} + \text{Correction Factor (dB)}$ .
2. Correction Factor = gain of substitution antenna + cable loss



A D T

**CHANNEL BANDWIDTH: 10MHz**

<b>MODE</b>	TX channel 26740	<b>FREQUENCY RANGE</b>	Above 1000MHz
<b>ENVIRONMENTAL CONDITIONS</b>	25deg. C, 65%RH	<b>INPUT POWER</b>	120Vac, 60 Hz
<b>TESTED BY</b>	Ted Chang		

**ANTENNA POLARITY & TEST DISTANCE: HORIZONTAL AT 3 M**

No.	Freq. (MHz)	Reading (dBm)	S.G Power Value (dBm)	Correction Factor (dB)	ERP (dBm)	Limit (dBm)	Margin (dB)
1	1638.00	-57.40	-60.10	5.50	-54.60	-13.00	-41.60
2	2457.00	-63.50	-63.60	6.50	-57.10	-13.00	-44.10
3	3276.00	-62.80	-61.30	6.90	-54.40	-13.00	-41.40

**ANTENNA POLARITY & TEST DISTANCE: VERTICAL AT 3 M**

No.	Freq. (MHz)	Reading (dBm)	S.G Power Value (dBm)	Correction Factor (dB)	ERP (dBm)	Limit (dBm)	Margin (dB)
1	1638.00	-49.90	-54.60	5.50	-49.10	-13.00	-36.10
2	2547.00	-60.80	-60.60	6.40	-54.20	-13.00	-41.20
3	3276.00	-62.80	-61.70	6.90	-54.80	-13.00	-41.80

**REMARKS:**

1. ERP(dBm) = S.G Power Value (dBm) + Correction Factor (dB).
2. Correction Factor = gain of substitution antenna + cable loss



## 5 PHOTOGRAPHS OF THE TEST CONFIGURATION

Please refer to the attached file (Test Setup Photo).





## 6 INFORMATION ON THE TESTING LABORATORIES

We, Bureau Veritas Consumer Products Services (H.K.) Ltd., Taoyuan Branch, were founded in 1988 to provide our best service in EMC, Radio, Telecom and Safety consultation. Our laboratories are accredited and approved according to ISO/IEC 17025.

If you have any comments, please feel free to contact us at the following:

**Linko EMC/RF Lab:**

Tel: 886-2-26052180

Fax: 886-2-26051924

**Hsin Chu EMC/RF Lab:**

Tel: 886-3-5935343

Fax: 886-3-5935342

**Hwa Ya EMC/RF/Safety/Telecom Lab:**

Tel: 886-3-3183232

Fax: 886-3-3270892

**Email:** [service.adt@tw.bureauveritas.com](mailto:service.adt@tw.bureauveritas.com)

**Web Site:** [www.bureauveritas-adt.com](http://www.bureauveritas-adt.com)

The address and road map of all our labs can be found in our web site also.



A D T

## **7 APPENDIX A – MODIFICATIONS RECORDERS FOR ENGINEERING CHANGES TO THE EUT BY THE LAB**

No any modifications were made to the EUT by the lab during the test.

---END---