



FCC TEST REPORT (PART 22)

REPORT NO.: RF130627C19

MODEL NO.: M530S

FCC ID: UZI-M30S58

RECEIVED: Jun. 27, 2013

TESTED: Jul. 03 ~ Aug. 20, 2013

ISSUED: Aug. 21, 2013

APPLICANT: BandRich Inc.

ADDRESS: 6F., No. 71, Zhouzi St., Neihu Dist., Taipei City
11493, Taiwan (R.O.C.)

ISSUED BY: Bureau Veritas Consumer Products Services
(H.K.) Ltd., Taoyuan Branch

LAB ADDRESS: No. 47, 14th Ling, Chia Pau Ml., Lin Kou Dist., New
Taipei City, Taiwan (R.O.C.)

TEST LOCATION: No. 19, Hwa Ya 2nd Rd, Wen Hwa Tsuen, Kwei
Shan Hsiang, Taoyuan Hsien 333, Taiwan, R.O.C.

This report should not be used by the client to claim product certification, approval, or endorsement by TAF or any government agencies.



This report is for your exclusive use. Any copying or replication of this report to or for any other person or entity, or use of our name or trademark, is permitted only with our prior written permission. This report sets forth our findings solely with respect to the test samples identified herein. The results set forth in this report are not indicative or representative of the quality or characteristics of the lot from which a test sample was taken or any similar or identical product unless specifically and expressly noted. Our report includes all of the tests requested by you and the results thereof based upon the information that you provided to us. You have 60 days from date of issuance of this report to notify us of any material error or omission caused by our negligence, provided, however, that such notice shall be in writing and shall specifically address the issue you wish to raise. A failure to raise such issue within the prescribed time shall constitute your unqualified acceptance of the completeness of this report, the tests conducted and the correctness of the report contents. Unless specific mention, the uncertainty of measurement has been explicitly taken into account to declare the compliance or non-compliance to the specification

TABLE OF CONTENTS

RELEASE CONTROL RECORD	3
1 CERTIFICATION	4
2 SUMMARY OF TEST RESULTS	5
2.1 MEASUREMENT UNCERTAINTY	5
2.2 TEST SITE AND INSTRUMENTS	6
3 GENERAL INFORMATION	7
3.1 GENERAL DESCRIPTION OF EUT	7
3.2 CONFIGURATION OF SYSTEM UNDER TEST	9
3.3 DESCRIPTION OF SUPPORT UNITS	9
3.4 TEST ITEM AND TEST CONFIGURATION	10
3.5 EUT OPERATING CONDITIONS	12
3.6 GENERAL DESCRIPTION OF APPLIED STANDARDS	12
4 TEST TYPES AND RESULTS	13
4.1 OUTPUT POWER MEASUREMENT	13
4.1.1 LIMITS OF OUTPUT POWER MEASUREMENT	13
4.1.2 TEST PROCEDURES	13
4.1.3 TEST SETUP	14
4.1.4 TEST RESULTS	15
4.2 FREQUENCY STABILITY MEASUREMENT	25
4.2.1 LIMITS OF FREQUENCY STABILITY MEASUREMENT	25
4.2.2 TEST PROCEDURE	25
4.2.3 TEST SETUP	25
4.2.4 TEST RESULTS	26
4.3 OCCUPIED BANDWIDTH MEASUREMENT	27
4.3.1 TEST PROCEDURES	27
4.3.2 TEST SETUP	27
4.3.3 TEST RESULTS	28
4.4 BAND EDGE MEASUREMENT	31
4.4.1 LIMITS OF BAND EDGE MEASUREMENT	31
4.4.2 TEST SETUP	31
4.4.3 TEST PROCEDURES	31
4.4.4 TEST RESULTS	32
4.5 CONDUCTED SPURIOUS EMISSIONS	37
4.5.1 LIMITS OF CONDUCTED SPURIOUS EMISSIONS MEASUREMENT	37
4.5.2 TEST PROCEDURE	37
4.5.3 TEST SETUP	37
4.5.4 TEST RESULTS	38
4.6 RADIATED EMISSION MEASUREMENT	56
4.6.1 LIMITS OF RADIATED EMISSION MEASUREMENT	56
4.6.2 TEST PROCEDURES	56
4.6.3 DEVIATION FROM TEST STANDARD	56
4.6.4 TEST SETUP	57
4.6.5 TEST RESULTS	58
5 PHOTOGRAPHS OF THE TEST CONFIGURATION	73
6 INFORMATION ON THE TESTING LABORATORIES	74
7 APPENDIX A – MODIFICATIONS RECORDERS FOR ENGINEERING CHANGES TO THE EUT BY THE LAB	75



A D T

RELEASE CONTROL RECORD

ISSUE NO.	REASON FOR CHANGE	DATE ISSUED
RF130627C19	Original release.	Aug. 21, 2013



A D T

1 CERTIFICATION

PRODUCT: LTE/CDMA module
MODEL: M530S
BRAND: BandLuxe
APPLICANT: BandRich Inc.
TESTED: Jul. 03 ~ Aug. 20, 2013
TEST SAMPLE: ENGINEERING SAMPLE
STANDARDS: **FCC PART 22, Subpart H**
FCC Part 2

The above equipment (model: M530S) has been tested by **Bureau Veritas Consumer Products Services (H.K.) Ltd., Taoyuan Branch**, and found compliance with the requirement of the above standards. The test record, data evaluation & Equipment Under Test (EUT) configurations represented herein are true and accurate accounts of the measurements of the sample's EMC characteristics under the conditions specified in this report.

PREPARED BY : Polly Chien , **DATE :** Aug. 21, 2013
Polly Chien / Specialist

APPROVED BY : Anderson Chiu , **DATE :** Aug. 21, 2013
Anderson Chiu / Senior Engineer

2 SUMMARY OF TEST RESULTS

The EUT has been tested according to the following specifications:

APPLIED STANDARD: FCC Part 22 & Part 2			
STANDARD SECTION	TEST TYPE	RESULT	REMARK
2.1046 22.913 (a)	Effective radiated power	PASS	Meet the requirement of limit.
2.1055 22.355	Frequency Stability	PASS	Meet the requirement of limit.
2.1049	Occupied Bandwidth	PASS	Meet the requirement of limit.
22.917	Band Edge Measurements	PASS	Meet the requirement of limit.
2.1051 22.917	Conducted Spurious Emissions	PASS	Meet the requirement of limit.
2.1053 22.917	Radiated Spurious Emissions	PASS	Meet the requirement of limit. Minimum passing margin is -32.34dB at 1673.00MHz.

2.1 MEASUREMENT UNCERTAINTY

Where relevant, the following measurement uncertainty levels have been estimated for tests performed on the EUT as specified in CISPR 16-4-2:

MEASUREMENT	FREQUENCY	UNCERTAINTY
Conducted emissions	150kHz~30MHz	2.44 dB
Radiated emissions	30MHz ~ 200MHz	3.34 dB
	200MHz ~1000MHz	3.35 dB
	1GHz ~ 18GHz	2.26 dB
	18GHz ~ 40GHz	1.94 dB

This uncertainty represents an expanded uncertainty expressed at approximately the 95% confidence level using a coverage factor of k=2.



2.2 TEST SITE AND INSTRUMENTS

DESCRIPTION & MANUFACTURER	MODEL NO.	SERIAL NO.	DATE OF CALIBRATION	DUE DATE OF CALIBRATION
Test Receiver ROHDE & SCHWARZ	ESI7	838496/016	Dec. 25, 2012	Dec. 24, 2013
Spectrum Analyzer ROHDE & SCHWARZ	FSP40	100039	Jan. 31, 2013	Jan. 30, 2014
BILOG Antenna SCHWARZBECK	VULB9168	9168-160	Mar. 20, 2013	Mar. 19, 2014
HORN Antenna SCHWARZBECK	9120D	209	Sep. 03, 2012	Sep. 02, 2013
HORN Antenna SCHWARZBECK	BBHA 9170	148	Jul. 15, 2013	Jul. 14, 2014
Loop Antenna	HFH2-Z2	100070	Jan. 31, 2012	Jan. 30, 2014
Preamplifier Agilent	8447D	2944A10633	Oct. 25, 2012	Oct. 24, 2013
Preamplifier Agilent	8449B	3008A01964	Oct. 25, 2012	Oct. 24, 2013
RF signal cable HUBER+SUHNNER	SUCOFLEX 104	250723/4	Aug. 28, 2012	Aug. 27, 2013
RF signal cable HUBER+SUHNNER	SUCOFLEX 106	12738/6+309224/ 4	Aug. 28, 2012	Aug. 27, 2013
Software BV ADT	ADT_Radiated_ V7.6.15.9.4	NA	NA	NA
Antenna Tower inn-co GmbH	MA 4000	013303	NA	NA
Antenna Tower Controller inn-co GmbH	CO2000	017303	NA	NA
Turn Table BV ADT	TT100	TT93021703	NA	NA
Turn Table Controller BV ADT	SC100	SC93021703	NA	NA
Mini-Circuits Power Splitter	ZN2PD-9G	NA	Mar. 22, 2013	Mar. 21, 2014
JFW 20dB attenuation	50HF-020-SMA	NA	NA	NA
Communications Tester-Wireless	E5515C	MY50266653	Oct. 08, 2012	Oct. 09, 2013

- NOTE:**
1. The calibration interval of the above test instruments is 12 months and the calibrations are traceable to NML/ROC and NIST/USA.
 2. The calibration interval of the loop antenna is 24 months and the calibrations are traceable to NML/ROC and NIST/USA.
 3. The test was performed in HwaYa Chamber 3.
 4. The horn antenna and HP preamplifier (model: 8449B) are used only for the measurement of emission frequency above 1GHz if tested.
 5. The FCC Site Registration No. is 988962.
 6. The IC Site Registration No. is IC 7450F-3.

3 GENERAL INFORMATION

3.1 GENERAL DESCRIPTION OF EUT

EUT	LTE/CDMA module	
MODEL NO.	M530S	
POWER SUPPLY	3.7Vdc (host equipment)	
HW VERSION	HW81012D01	
SW VERSION	00016739_0001	
MODULATION TYPE	CDMA, EVDO	QPSK, OQPSK, HPSK
	LTE	QPSK, 16QAM
FREQUENCY RANGE	CDMA, EVDO	824.7MHz ~ 848.31MHz
	LTE Band 26 (Channel Bandwidth 1.4MHz)	824.7MHz ~ 848.3MHz
	LTE Band 26 (Channel Bandwidth 3MHz)	825.5MHz ~ 847.5MHz
	LTE Band 26 (Channel Bandwidth 5MHz)	826.5MHz ~ 846.5MHz
	LTE Band 26 (Channel Bandwidth 10MHz)	829.00MHz ~ 844.0MHz
MAX. ERP POWER	CDMA	224.39mW (23.51dBm)
	LTE Band 26 (Channel Bandwidth 1.4MHz)	222.84mW (23.48dBm)
	LTE Band 26 (Channel Bandwidth 3MHz)	224.39mW (23.51dBm)
	LTE Band 26 (Channel Bandwidth 5MHz)	226.46mW (23.55dBm)
	LTE Band 26 (Channel Bandwidth 10MHz)	243.78mW (23.87dBm)
EMISSION DESIGNATOR	CDMA, EVDO	1M28F9W
	LTE Band 26 (Channel Bandwidth 1.4MHz)	QPSK: 1M23G7D
		16QAM: 1M23W7D
	LTE Band 26 (Channel Bandwidth 3MHz)	QPSK: 2M73G7D
		16QAM: 2M74W7D
	LTE Band 26 (Channel Bandwidth 5MHz)	QPSK: 4M50G7D
16QAM: 4M50W7D		
LTE Band 26 (Channel Bandwidth 10MHz)	QPSK: 9M00G7D	
	16QAM: 9M00W7D	
CATEGORY	LTE: 3	
ANTENNA TYPE	Dipole antenna with 0.57dBi gain	
ANTENNA CONNECTOR	IPEX 20279	
I/O PORTS	Refer to users' manual	
DATA CABLE	NA	
ACCESSORY DEVICES	NA	

NOTE:

1. The convertible Board consumes power from the following adapter (for support unit only).

Brand	TPT
Model	FSY050200UU12-2
Input Power	100-240Vac, 50/60Hz, 0.6A
Output Power	5Vdc, 2A
Power Line	1.8m cable without core attached on adapter

2. The above EUT information was declared by manufacturer and for more detailed features description, please refer to the manufacturer's specifications or User's Manual.

3.2 CONFIGURATION OF SYSTEM UNDER TEST

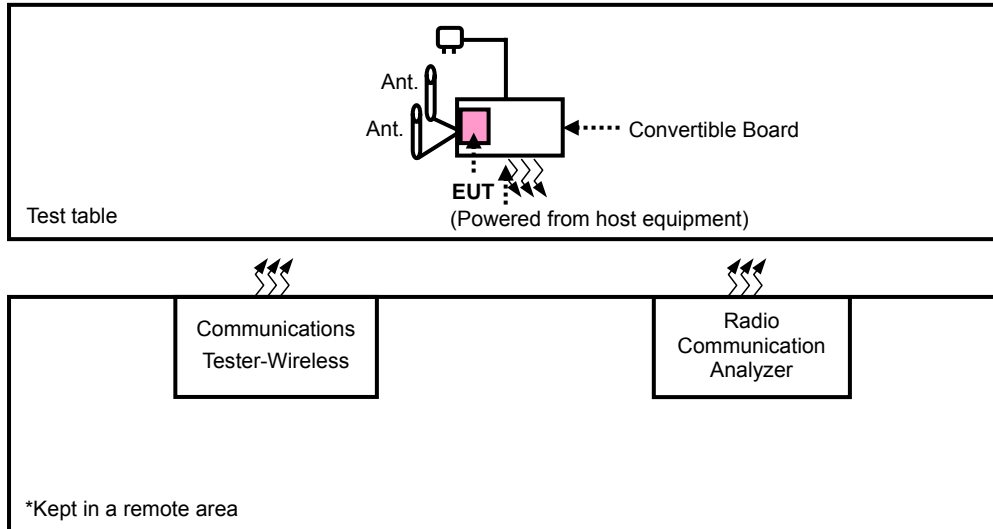

3.3 DESCRIPTION OF SUPPORT UNITS

The EUT has been tested as an independent unit together with other necessary accessories or support units. The following support units or accessories were used to form a representative test configuration during the tests.

NO.	PRODUCT	BRAND	MODEL NO.	SERIAL NO.	FCC ID
1	Antenna x2	NA	NA	NA	NA
2	Convertible Board	BandLuxe	PCIe Mini Card evaluation board 1.0	NA	NA
3	Communications Tester-Wireless	Agilent	8960 Series 10	MY50260642	NA
4	Radio Communication Analyzer	Anritsu	MT8820C	6201010284	NA

NO.	SIGNAL CABLE DESCRIPTION OF THE ABOVE SUPPORT UNITS
1	NA
2	NA
3	NA
4	NA

NOTE:

1. All power cords of the above support units are non-shielded (1.8m).
2. Items 3-4 act as communication partners to transfer data.
3. Items 1 -2 were provided by the client.

3.4 TEST ITEM AND TEST CONFIGURATION

Pre-Scan has been conducted to determine the worst-case mode from all possible combinations between available modulations, data rates, XYZ axis and antenna ports. The worst cases were found when positioned on **Z-plane** for antenna. Following channel(s) was (were) selected for the final test as listed below:

CDMA

EUT CONFIGURE MODE	TEST ITEM	AVAILABLE CHANNEL	TESTED CHANNEL	MODE
-	ERP	1013 to 777	1013, 384, 777	CDMA
-	FREQUENCY STABILITY	1013 to 777	384	CDMA
-	OCCUPIED BANDWIDTH	1013 to 777	1013, 384, 777	CDMA, EVDO
-	BAND EDGE	1013 to 777	1013, 777	CDMA, EVDO
-	CONDCUDED EMISSION	1013 to 777	384	CDMA, EVDO
-	RADIATED EMISSION Below 1GHz	1013 to 777	1013	CDMA
-	RADIATED EMISSION Above 1GHz	1013 to 777	1013, 384, 777	CDMA

LTE Band 26

TEST ITEM	AVAILABLE CHANNEL	TESTED CHANNEL	CHANNEL BANDWIDTH	MODULATION	MODE
ERP	26797 to 27033	26797, 26915, 27033	1.4MHz	QPSK	1 RB / 0 RB Offset
	26805 to 27025	26805, 26915, 27025	3MHz	QPSK	1 RB / 0 RB Offset
	26815 to 27015	26815, 26915, 27015	5MHz	QPSK	1 RB / 0 RB Offset
	26840 to 26990	26840, 26915, 26990	10MHz	QPSK	1 RB / 0 RB Offset
FREQUENCY STABILITY	26797 to 27033	26915	1.4MHz	QPSK	1 RB / 0 RB Offset
	26805 to 27025	26915	3MHz	QPSK	1 RB / 0 RB Offset
	26815 to 27015	26815	5MHz	QPSK	1 RB / 0 RB Offset
	26840 to 26990	26915	10MHz	QPSK	1 RB / 0 RB Offset
OCCUPIED BANDWIDTH	26797 to 27033	26797, 27033	1.4MHz	QPSK/16QAM	7 RB / 0 RB Offset
	26805 to 27025	26805, 27025	3MHz	QPSK/16QAM	15 RB / 0 RB Offset
	26815 to 27015	26815, 27015	5MHz	QPSK/16QAM	25 RB / 0 RB Offset
	26840 to 26990	26840, 26990	10MHz	QPSK/16QAM	50 RB / 0 RB Offset
BAND EDGE	26797 to 27033	26797, 27033	1.4MHz	QPSK	7 RB / 0 RB Offset 1 RB / 0 RB Offset
	26805 to 27025	26805, 27025	3MHz	QPSK	15 RB / 0 RB Offset 1 RB / 0 RB Offset
	26815 to 27015	26815, 27015	5MHz	QPSK	25 RB / 0 RB Offset 1 RB / 0 RB Offset
	26840 to 26990	26840, 26990	10MHz	QPSK	50 RB / 0 RB Offset 1 RB / 0 RB Offset
CONDCUETED EMISSION	26797 to 27033	26797, 26915, 27033	1.4MHz	QPSK	1 RB / 0 RB Offset
	26805 to 27025	26805, 26915, 27025	3MHz	QPSK	1 RB / 0 RB Offset
	26815 to 27015	26815, 26915, 27015	5MHz	QPSK	1 RB / 0 RB Offset
	26840 to 26990	26840, 26915, 26990	10MHz	QPSK	1 RB / 0 RB Offset
RADIATED EMISSION BELOW 1GHz	26797 to 27033	26915	1.4MHz	QPSK	1 RB / 0 RB Offset
	26805 to 27025	26915	3MHz	QPSK	1 RB / 0 RB Offset
	26815 to 27015	26815	5MHz	QPSK	1 RB / 0 RB Offset
	26840 to 26990	26915	10MHz	QPSK	1 RB / 0 RB Offset
RADIATED EMISSION ABOVE 1GHz	26797 to 27033	26797, 26915, 27033	1.4MHz	QPSK	1 RB / 0 RB Offset
	26805 to 27025	26805, 26915, 27025	3MHz	QPSK	1 RB / 0 RB Offset
	26815 to 27015	26815, 26915, 27015	5MHz	QPSK	1 RB / 0 RB Offset
	26840 to 26990	26840, 26915, 26990	10MHz	QPSK	1 RB / 0 RB Offset

TEST CONDITION:

TEST ITEM	ENVIRONMENTAL CONDITIONS	INPUT POWER (SYSTEM)	TESTED BY
ERP	27deg. C, 66%RH	120Vac, 60Hz	Martin Lee
	25deg. C, 65%RH	120Vac, 60Hz	Ted Chang
FREQUENCY STABILITY	25deg. C, 65%RH	120Vac, 60Hz	Ted Chang
OCCUPIED BANDWIDTH	24deg. C, 64%RH	120Vac, 60Hz	Match Tsui
BAND EDGE	24deg. C, 64%RH	120Vac, 60Hz	Match Tsui
CONDCUDED EMISSION	24deg. C, 64%RH	120Vac, 60Hz	Match Tsui
RADIATED EMISSION BELOW 1GHz	24deg. C, 64%RH (CDMA)	120Vac, 60Hz	Ted Chang
	25deg. C, 65%RH (LTE)	120Vac, 60Hz	Chris Lin
RADIATED EMISSION ABOVE 1GHz	24deg. C, 64%RH (CDMA)	120Vac, 60Hz	Ted Chang
	25deg. C, 65%RH (LTE)	120Vac, 60Hz	Ted Chang

3.5 EUT OPERATING CONDITIONS

The EUT makes a call to the communication simulator. The communication simulator station system controlled a EUT to export maximum output power under transmission mode and specific channel frequency

3.6 GENERAL DESCRIPTION OF APPLIED STANDARDS

The EUT is a RF product. According to the specifications of the manufacturer, it must comply with the requirements of the following standards:

FCC 47 CFR Part 2

FCC 47 CFR Part 22

ANSI/TIA/EIA-603-C 2004

NOTE: All test items have been performed and recorded as per the above standards.



A D T

4 TEST TYPES AND RESULTS

4.1 OUTPUT POWER MEASUREMENT

4.1.1 LIMITS OF OUTPUT POWER MEASUREMENT

Mobile / Portable station are limited to 7 watts e.r.p.

4.1.2 TEST PROCEDURES

EIRP / ERP MEASUREMENT:

- a. All measurements were done at low, middle and high operational frequency range. RBW and VBW is 1MHz, 5MHz for CDMA, EVDO mode and 10MHz for LTE mode.
- b. Substitution method is used for E.I.R.P measurement. In the semi-anechoic chamber, EUT placed on the 0.8m height of Turn Table, rotated the table around 360 degrees to search the maximum radiation power and receiver antenna shall be rotated vertical and horizontal polarization and moved height from 1m to 4m to find the maximum polar radiated power. The “Read Value” is the spectrum reading the maximum power value.
- c. The substitution horn antenna is substituted for EUT at the same position and signals generator export the CW signal to the substitution antenna via a tx cable. Rotated the Turn Table and moved receiving antenna to find the maximum radiation power. Adjust output power level of S.G to get a Value of spectrum reading equal to “Read Value” of step b. Record the power level of S.G
- d. $EIRP = \text{Output power level of S.G} - \text{TX cable loss} + \text{Antenna gain of substitution horn.}$
 $E.R.P \text{ power can be calculated form E.I.R.P power by subtracting the gain of dipole, } E.R.P \text{ power} = E.I.R.P \text{ power} - 2.15\text{dBi.}$

CONDUCTED POWER MEASUREMENT:

The EUT was set up for the maximum power with EVDO/ LTE link data modulation and link up with simulator. Set the EUT to transmit under low, middle and high channel and record the power level shown on simulator.

4.1.3 TEST SETUP

EIRP / ERP MEASUREMENT:

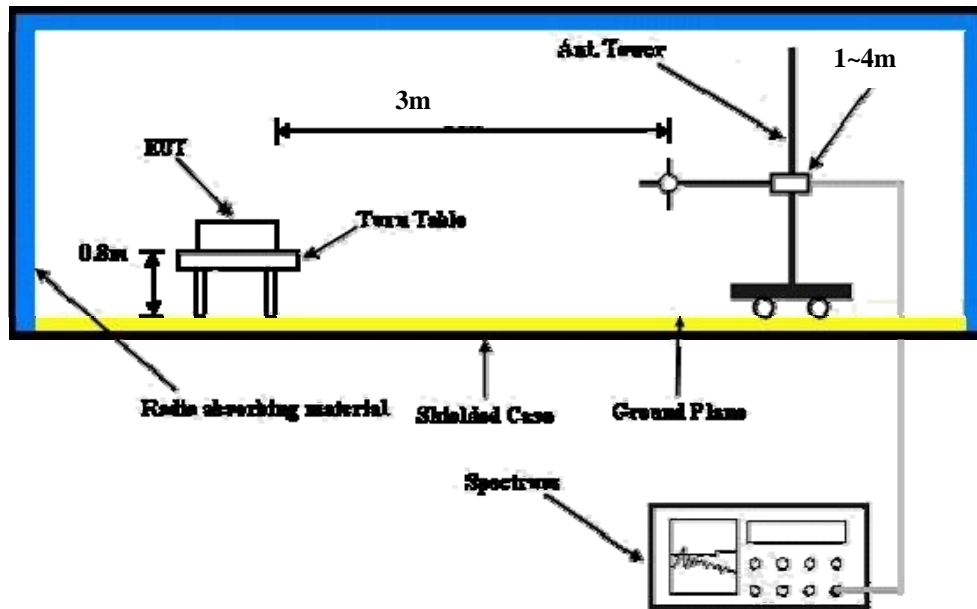

For the actual test configuration, please refer to the attached file (Test Setup Photo).

CONDUCTED POWER MEASUREMENT:

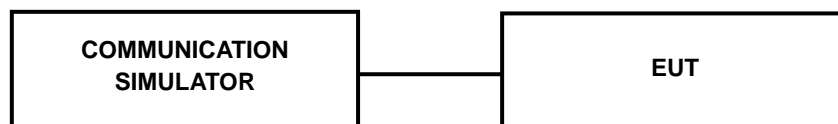

For the actual test configuration, please refer to the attached file (Test Setup Photo).



A D T

4.1.4 TEST RESULTS

CONDUCTED OUTPUT POWER (dBm)

Band	CDMA2000 BC0		
Channel	1013	384	777
Frequency (MHz)	824.7	836.52	848.31
RC1+SO55	24.22	24.18	23.93
RC3+SO55	24.27	24.24	23.92
RC3+SO32(+ F-SCH)	24.21	24.18	23.87
RC3+SO32(+SCH)	24.20	24.19	23.90
RTAP 153.6	23.51	23.50	23.22
RETAP 4096	23.48	23.45	23.33



A D T

LTE Band 26								
BW	Modulation	CH	Frequency	RB	RB Offset	MPR	Target	Measured
			(MHz)				Power	Power
1.4 MHz	QPSK	26797	824.7	1	0 0		23	22.28
		26915	836.5	1	0 0		23	22.2
		27033	848.3	1	0 0		23	22.18
		26797	824.7	1	2 0		23	22.26
		26915	836.5	1	2 0		23	22.18
		27033	848.3	1	2 0		23	22.12
		26797	824.7	1	5 0		23	22.04
		26915	836.5	1	5 0		23	22.08
		27033	848.3	1	5 0		23	22.04
		26797	824.7	3	0 0		23	22.14
		26915	836.5	3	0 0		23	22.14
		27033	848.3	3	0 0		23	22.15
		26797	824.7	3	1 0		23	22.27
		26915	836.5	3	1 0		23	22.16
		27033	848.3	3	1 0		23	22.1
		26797	824.7	3	3 0		23	22.18
		26915	836.5	3	3 0		23	22.14
		27033	848.3	3	3 0		23	22.1
		26797	824.7	6	0 1		23	21.14
		26915	836.5	6	0 1		23	21.08
		27033	848.3	6	0 1		23	21.05
1.4 MHz	16QAM	26797	824.7	1	0 1		23	21.37
		26915	836.5	1	0 1		23	21.24
		27033	848.3	1	0 1		23	21.18
		26797	824.7	1	2 1		23	21.31
		26915	836.5	1	2 1		23	21.24
		27033	848.3	1	2 1		23	21.12
		26797	824.7	1	5 1		23	21.05
		26915	836.5	1	5 1		23	21.05
		27033	848.3	1	5 1		23	21.04
		26797	824.7	3	0 1		23	21.19
		26915	836.5	3	0 1		23	21.17
		27033	848.3	3	0 1		23	21.15
		26797	824.7	3	1 1		23	21.21
		26915	836.5	3	1 1		23	21.14
		27033	848.3	3	1 1		23	21.1
		26797	824.7	3	3 1		23	21.14
		26915	836.5	3	3 1		23	21.13
		27033	848.3	3	3 1		23	21.1
		26797	824.7	6	0 2		23	20.11
		26915	836.5	6	0 2		23	20.08
		27033	848.3	6	0 2		23	20.05



A D T

LTE Band 26								
BW	Modulation	CH	Frequency	RB	RB Offset	MPR	Target	Measured
			(MHz)				Power	Power
3 MHz	QPSK	26805	825.5	1	0 0		23	22.31
		26915	836.5	1	0 0		23	22.25
		27025	847.5	1	0 0		23	22.19
		26805	825.5	1	7 0		23	22.38
		26915	836.5	1	7 0		23	22.21
		27025	847.5	1	7 0		23	22.13
		26805	825.5	1	14	0	23	22.07
		26915	836.5	1	14	0	23	22.07
		27025	847.5	1	14	0	23	22.05
		26805	825.5	8	0 1		23	21.1
		26915	836.5	8	0 1		23	21.08
		27025	847.5	8	0 1		23	21.06
		26805	825.5	8	3 1		23	21.17
		26915	836.5	8	3 1		23	21.08
		27025	847.5	8	3 1		23	21.01
		26805	825.5	8	7 1		23	21.09
		26915	836.5	8	7 1		23	21.05
		27025	847.5	8	7 1		23	21.01
		26805	825.5	15	0	1	23	21.12
		26915	836.5	15	0	1	23	21.08
		27025	847.5	15	0	1	23	21.06
3 MHz	16QAM	26805	825.5	1	0 1		23	21.34
		26915	836.5	1	0 1		23	21.26
		27025	847.5	1	0 1		23	21.19
		26805	825.5	1	7 1		23	21.31
		26915	836.5	1	7 1		23	21.24
		27025	847.5	1	7 1		23	21.13
		26805	825.5	1	14	1	23	21.08
		26915	836.5	1	14	1	23	21.06
		27025	847.5	1	14	1	23	21.05
		26805	825.5	8	0 2		23	20.11
		26915	836.5	8	0 2		23	20.08
		27025	847.5	8	0 2		23	20.06
		26805	825.5	8	3 2		23	20.11
		26915	836.5	8	3 2		23	20.04
		27025	847.5	8	3 2		23	20.01
		26805	825.5	8	7 2		23	20.08
		26915	836.5	8	7 2		23	20.04
		27025	847.5	8	7 2		23	20.01
		26805	825.5	15	0	2	23	20.17
		26915	836.5	15	0	2	23	20.11
		27025	847.5	15	0	2	23	20.06



A D T

LTE Band 26								
BW	Modulation	CH	Frequency	RB	RB Offset	MPR	Target	Measured
			(MHz)				Power	Power
5 MHz	QPSK	26815	826.5	1	0 0		23	22.38
		26915	836.5	1	0 0		23	22.29
		27015	846.5	1	0 0		23	22.21
		26815	826.5	1	12	0	23	22.24
		26915	836.5	1	12	0	23	22.19
		27015	846.5	1	12	0	23	22.15
		26815	826.5	1	24	0	23	22.08
		26915	836.5	1	24	0	23	22.07
		27015	846.5	1	24	0	23	22.07
		26815	826.5	12	0	1	23	21.17
		26915	836.5	12	0	1	23	21.11
		27015	846.5	12	0	1	23	21.08
		26815	826.5	12	6	1	23	21.14
		26915	836.5	12	6	1	23	21.08
		27015	846.5	12	6	1	23	21.03
		26815	826.5	12	13	1	23	21.14
		26915	836.5	12	13	1	23	21.06
		27015	846.5	12	13	1	23	21.03
		26815	826.5	25	0	1	23	21.16
		26915	836.5	25	0	1	23	21.13
		27015	846.5	25	0	1	23	21.08
5 MHz	16QAM	26815	826.5	1	0 1		23	21.34
		26915	836.5	1	0 1		23	21.27
		27015	846.5	1	0 1		23	21.21
		26815	826.5	1	12	1	23	21.31
		26915	836.5	1	12	1	23	21.24
		27015	846.5	1	12	1	23	21.15
		26815	826.5	1	24	1	23	21.09
		26915	836.5	1	24	1	23	21.08
		27015	846.5	1	24	1	23	21.07
		26815	826.5	12	0	2	23	20.1
		26915	836.5	12	0	2	23	20.1
		27015	846.5	12	0	2	23	20.08
		26815	826.5	12	6	2	23	20.19
		26915	836.5	12	6	2	23	20.11
		27015	846.5	12	6	2	23	20.03
		26815	826.5	12	13	2	23	20.15
		26915	836.5	12	13	2	23	20.1
		27015	846.5	12	13	2	23	20.03
		26815	826.5	25	0	2	23	20.17
		26915	836.5	25	0	2	23	20.11
		27015	846.5	25	0	2	23	20.08



A D T

LTE Band 26								
BW	Modulation	CH	Frequency	RB	RB Offset	MPR	Target	Measured
			(MHz)				Power	Power
10 MHz	QPSK	26840	829	1	0 0		23	22.51
		26915	836.5	1	0 0		23	22.34
		26990	844	1	0 0		23	22.24
		26840	829	1	24	0	23	22.5
		26915	836.5	1	24	0	23	22.27
		26990	844	1	24	0	23	22.18
		26840	829	1	49	0	23	22.17
		26915	836.5	1	49	0	23	22.14
		26990	844	1	49	0	23	22.1
		26840	829	25	0	1	23	21.21
		26915	836.5	25	0	1	23	21.14
		26990	844	25	0	1	23	21.11
		26840	829	25	12	1	23	21.31
		26915	836.5	25	12	1	23	21.24
		26990	844	25	12	1	23	21.01
		26840	829	25	25	1	23	21.21
		26915	836.5	25	25	1	23	21.14
		26990	844	25	25	1	23	21.06
		26840	829	50	0	1	23	21.24
		26915	836.5	50	0	1	23	21.15
		26990	844	50	0	1	23	21.11
10 MHz	16QAM	26840	829	1	0 1		23	21.52
		26915	836.5	1	0 1		23	21.35
		26990	844	1	0 1		23	21.24
		26840	829	1	24	1	23	21.46
		26915	836.5	1	24	1	23	21.31
		26990	844	1	24	1	23	21.18
		26840	829	1	49	1	23	21.14
		26915	836.5	1	49	1	23	20.13
		26990	844	1	49	1	23	21.1
		26840	829	25	0	2	23	20.24
		26915	836.5	25	0	2	23	20.19
		26990	844	25	0	2	23	20.11
		26840	829	25	12	2	23	20.24
		26915	836.5	25	12	2	23	20.13
		26990	844	25	12	2	23	20.01
		26840	829	25	25	2	23	20.21
		26915	836.5	25	25	2	23	20.16
		26990	844	25	25	2	23	20.06
		26840	829	50	0	2	23	20.21
		26915	836.5	50	0	2	23	20.16
		26990	844	50	0	2	23	20.11



A D T

ERP POWER (dBm)

CDMA

MODE		TX channel 1013					
ANTENNA POLARITY & TEST DISTANCE: HORIZONTAL AT 3 M							
No.	Freq. (MHz)	Reading (dBm)	S.G Power Value (dBm)	Correction Factor (dB)	ERP (dBm)	Limit (dBm)	Margin (dB)
1	824.70	-15.41	14.95	0.02	14.97	38.45	-23.48
ANTENNA POLARITY & TEST DISTANCE: VERTICAL AT 3 M							
No.	Freq. (MHz)	Reading (dBm)	S.G Power Value (dBm)	Correction Factor (dB)	ERP (dBm)	Limit (dBm)	Margin (dB)
1	824.70	-6.87	23.49	0.02	23.51	38.45	-14.94

MODE		TX channel 384					
ANTENNA POLARITY & TEST DISTANCE: HORIZONTAL AT 3 M							
No.	Freq. (MHz)	Reading (dBm)	S.G Power Value (dBm)	Correction Factor (dB)	ERP (dBm)	Limit (dBm)	Margin (dB)
1	836.52	-14.91	14.40	0.29	14.69	38.45	-23.76
ANTENNA POLARITY & TEST DISTANCE: VERTICAL AT 3 M							
No.	Freq. (MHz)	Reading (dBm)	S.G Power Value (dBm)	Correction Factor (dB)	ERP (dBm)	Limit (dBm)	Margin (dB)
1	836.52	-6.29	23.02	0.29	23.31	38.45	-15.14

MODE		TX channel 777					
ANTENNA POLARITY & TEST DISTANCE: HORIZONTAL AT 3 M							
No.	Freq. (MHz)	Reading (dBm)	S.G Power Value (dBm)	Correction Factor (dB)	ERP (dBm)	Limit (dBm)	Margin (dB)
1	848.31	-15.52	13.63	0.50	14.13	38.45	-24.32
ANTENNA POLARITY & TEST DISTANCE: VERTICAL AT 3 M							
No.	Freq. (MHz)	Reading (dBm)	S.G Power Value (dBm)	Correction Factor (dB)	ERP (dBm)	Limit (dBm)	Margin (dB)
1	848.31	-6.60	22.55	0.50	23.05	38.45	-15.40

NOTE: ERP (dBm) = S.G Power Value (dBm) + Correction Factor (dB).

LTE Band 26 (Channel Bandwidth 1.4MHz)

MODE		TX channel 26797					
ANTENNA POLARITY & TEST DISTANCE: HORIZONTAL AT 3 M							
No.	Freq. (MHz)	Reading (dBm)	S.G Power Value (dBm)	Correction Factor (dB)	ERP (dBm)	Limit (dBm)	Margin (dB)
1	824.70	-14.95	16.22	0.02	16.24	38.45	-22.21
ANTENNA POLARITY & TEST DISTANCE: VERTICAL AT 3 M							
No.	Freq. (MHz)	Reading (dBm)	S.G Power Value (dBm)	Correction Factor (dB)	ERP (dBm)	Limit (dBm)	Margin (dB)
1	824.70	-6.24	23.09	0.02	23.11	38.45	-15.34

MODE		TX channel 26915					
ANTENNA POLARITY & TEST DISTANCE: HORIZONTAL AT 3 M							
No.	Freq. (MHz)	Reading (dBm)	S.G Power Value (dBm)	Correction Factor (dB)	ERP (dBm)	Limit (dBm)	Margin (dB)
1	836.50	-14.16	16.14	0.29	16.43	38.45	-22.02
ANTENNA POLARITY & TEST DISTANCE: VERTICAL AT 3 M							
No.	Freq. (MHz)	Reading (dBm)	S.G Power Value (dBm)	Correction Factor (dB)	ERP (dBm)	Limit (dBm)	Margin (dB)
1	836.50	-6.65	23.19	0.29	23.48	38.45	-14.97

MODE		TX channel 27033					
ANTENNA POLARITY & TEST DISTANCE: HORIZONTAL AT 3 M							
No.	Freq. (MHz)	Reading (dBm)	S.G Power Value (dBm)	Correction Factor (dB)	ERP (dBm)	Limit (dBm)	Margin (dB)
1	848.30	-13.88	15.27	0.50	15.77	38.45	-22.68
ANTENNA POLARITY & TEST DISTANCE: VERTICAL AT 3 M							
No.	Freq. (MHz)	Reading (dBm)	S.G Power Value (dBm)	Correction Factor (dB)	ERP (dBm)	Limit (dBm)	Margin (dB)
1	848.30	-6.71	22.71	0.50	23.21	38.45	-15.24

NOTE: ERP (dBm) = S.G Power Value (dBm) + Correction Factor (dB).

LTE Band 26 (Channel Bandwidth 3MHz)

MODE		TX channel 26805					
ANTENNA POLARITY & TEST DISTANCE: HORIZONTAL AT 3 M							
No.	Freq. (MHz)	Reading (dBm)	S.G Power Value (dBm)	Correction Factor (dB)	ERP (dBm)	Limit (dBm)	Margin (dB)
1	825.50	-14.81	16.30	0.04	16.34	38.45	-22.11
ANTENNA POLARITY & TEST DISTANCE: VERTICAL AT 3 M							
No.	Freq. (MHz)	Reading (dBm)	S.G Power Value (dBm)	Correction Factor (dB)	ERP (dBm)	Limit (dBm)	Margin (dB)
1	825.50	-6.37	23.00	0.04	23.04	38.45	-15.41

MODE		TX channel 26915					
ANTENNA POLARITY & TEST DISTANCE: HORIZONTAL AT 3 M							
No.	Freq. (MHz)	Reading (dBm)	S.G Power Value (dBm)	Correction Factor (dB)	ERP (dBm)	Limit (dBm)	Margin (dB)
1	836.50	-14.03	16.27	0.29	16.56	38.45	-21.89
ANTENNA POLARITY & TEST DISTANCE: VERTICAL AT 3 M							
No.	Freq. (MHz)	Reading (dBm)	S.G Power Value (dBm)	Correction Factor (dB)	ERP (dBm)	Limit (dBm)	Margin (dB)
1	836.50	-6.62	23.22	0.29	23.51	38.45	-14.94

MODE		TX channel 27025					
ANTENNA POLARITY & TEST DISTANCE: HORIZONTAL AT 3 M							
No.	Freq. (MHz)	Reading (dBm)	S.G Power Value (dBm)	Correction Factor (dB)	ERP (dBm)	Limit (dBm)	Margin (dB)
1	847.50	-13.32	15.83	0.49	16.32	38.45	-22.13
ANTENNA POLARITY & TEST DISTANCE: VERTICAL AT 3 M							
No.	Freq. (MHz)	Reading (dBm)	S.G Power Value (dBm)	Correction Factor (dB)	ERP (dBm)	Limit (dBm)	Margin (dB)
1	847.50	-6.69	22.73	0.49	23.22	38.45	-15.23

NOTE: ERP (dBm) = S.G Power Value (dBm) + Correction Factor (dB).

LTE Band 26 (Channel Bandwidth 5MHz)

MODE		TX channel 26815					
ANTENNA POLARITY & TEST DISTANCE: HORIZONTAL AT 3 M							
No.	Freq. (MHz)	Reading (dBm)	S.G Power Value (dBm)	Correction Factor (dB)	ERP (dBm)	Limit (dBm)	Margin (dB)
1	826.50	-14.77	16.27	0.06	16.33	38.45	-22.12
ANTENNA POLARITY & TEST DISTANCE: VERTICAL AT 3 M							
No.	Freq. (MHz)	Reading (dBm)	S.G Power Value (dBm)	Correction Factor (dB)	ERP (dBm)	Limit (dBm)	Margin (dB)
1	826.50	-6.30	23.11	0.06	23.17	38.45	-15.28

MODE		TX channel 26915					
ANTENNA POLARITY & TEST DISTANCE: HORIZONTAL AT 3 M							
No.	Freq. (MHz)	Reading (dBm)	S.G Power Value (dBm)	Correction Factor (dB)	ERP (dBm)	Limit (dBm)	Margin (dB)
1	836.50	-14.21	16.09	0.29	16.38	38.45	-22.07
ANTENNA POLARITY & TEST DISTANCE: VERTICAL AT 3 M							
No.	Freq. (MHz)	Reading (dBm)	S.G Power Value (dBm)	Correction Factor (dB)	ERP (dBm)	Limit (dBm)	Margin (dB)
1	836.50	-6.58	23.26	0.29	23.55	38.45	-14.90

MODE		TX channel 27015					
ANTENNA POLARITY & TEST DISTANCE: HORIZONTAL AT 3 M							
No.	Freq. (MHz)	Reading (dBm)	S.G Power Value (dBm)	Correction Factor (dB)	ERP (dBm)	Limit (dBm)	Margin (dB)
1	846.50	-12.92	16.25	0.47	16.72	38.45	-21.73
ANTENNA POLARITY & TEST DISTANCE: VERTICAL AT 3 M							
No.	Freq. (MHz)	Reading (dBm)	S.G Power Value (dBm)	Correction Factor (dB)	ERP (dBm)	Limit (dBm)	Margin (dB)
1	846.50	-6.58	22.84	0.47	23.31	38.45	-15.14

NOTE: ERP (dBm) = S.G Power Value (dBm) + Correction Factor (dB).

LTE Band 26 (Channel Bandwidth 10MHz)

MODE		TX channel 26840					
ANTENNA POLARITY & TEST DISTANCE: HORIZONTAL AT 3 M							
No.	Freq. (MHz)	Reading (dBm)	S.G Power Value (dBm)	Correction Factor (dB)	ERP (dBm)	Limit (dBm)	Margin (dB)
1	829.00	-14.37	16.10	0.12	16.22	38.45	-22.23
ANTENNA POLARITY & TEST DISTANCE: VERTICAL AT 3 M							
No.	Freq. (MHz)	Reading (dBm)	S.G Power Value (dBm)	Correction Factor (dB)	ERP (dBm)	Limit (dBm)	Margin (dB)
1	829.00	-6.48	23.03	0.12	23.15	38.45	-15.30

MODE		TX channel 26915					
ANTENNA POLARITY & TEST DISTANCE: HORIZONTAL AT 3 M							
No.	Freq. (MHz)	Reading (dBm)	S.G Power Value (dBm)	Correction Factor (dB)	ERP (dBm)	Limit (dBm)	Margin (dB)
1	836.50	-14.08	16.22	0.29	16.51	38.45	-21.94
ANTENNA POLARITY & TEST DISTANCE: VERTICAL AT 3 M							
No.	Freq. (MHz)	Reading (dBm)	S.G Power Value (dBm)	Correction Factor (dB)	ERP (dBm)	Limit (dBm)	Margin (dB)
1	836.50	-6.64	23.20	0.29	23.49	38.45	-14.96

MODE		TX channel 26990					
ANTENNA POLARITY & TEST DISTANCE: HORIZONTAL AT 3 M							
No.	Freq. (MHz)	Reading (dBm)	S.G Power Value (dBm)	Correction Factor (dB)	ERP (dBm)	Limit (dBm)	Margin (dB)
1	844.00	-13.26	15.95	0.42	16.37	38.45	-22.08
ANTENNA POLARITY & TEST DISTANCE: VERTICAL AT 3 M							
No.	Freq. (MHz)	Reading (dBm)	S.G Power Value (dBm)	Correction Factor (dB)	ERP (dBm)	Limit (dBm)	Margin (dB)
1	844.00	-5.99	23.45	0.42	23.87	38.45	-14.58

NOTE: ERP (dBm) = S.G Power Value (dBm) + Correction Factor (dB).

4.2 FREQUENCY STABILITY MEASUREMENT

4.2.1 LIMITS OF FREQUENCY STABILITY MEASUREMENT

1.5 ppm is for base and fixed station. 2.5 ppm is for mobile station.

4.2.2 TEST PROCEDURE

- a. Device is placed at the oven room. The oven room could control the temperatures and humidity. Power warm up is at least 15 min and power applied should perform before recording frequency error.
- b. EUT is connected the external power supply to control the AC input power. The test voltage range is from minimum to maximum working voltage. Each step shall be record the frequency error rate.
- c. The temperature range step is 10 degrees in this test items. All temperature levels shall be hold the $\pm 0.5^{\circ}\text{C}$ during the measurement testing. The each temperature step shall be at least 0.5 hours, consider the EUT could be test under the stability condition.

NOTE: The frequency error was recorded frequency error from the communication simulator.

4.2.3 TEST SETUP

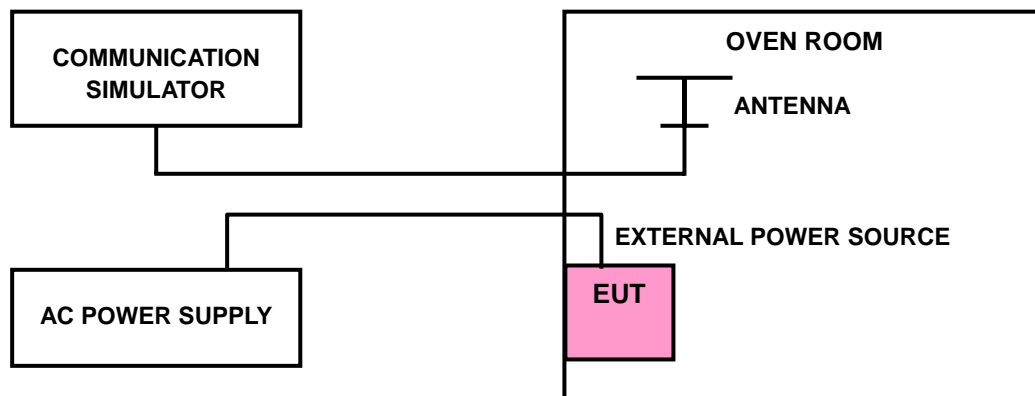

4.2.4 TEST RESULTS

FREQUENCY ERROR VS. VOLTAGE

VOLTAGE (Volts)	FREQUENCY ERROR (ppm)					LIMIT (ppm)
	CDMA	LTE Band 26				
		1.4MHz	3MHz	5MHz	10MHz	
132	-0.029	-0.026	-0.028	-0.024	-0.023	2.5
120	-0.020	-0.019	-0.023	-0.019	-0.013	2.5
108	-0.023	-0.023	-0.020	-0.020	-0.020	2.5

NOTE: The applicant defined the normal working voltage of the battery is from 108Vac to 132Vac.

FREQUENCY ERROR vs. TEMPERATURE.

TEMP. (°C)	FREQUENCY ERROR (ppm)					LIMIT (ppm)
	CDMA	LTE Band 26				
		1.4MHz	3MHz	5MHz	10MHz	
50	-0.038	-0.040	-0.038	-0.036	-0.029	2.5
40	-0.033	-0.032	-0.035	-0.032	-0.024	2.5
30	-0.025	-0.025	-0.029	-0.026	-0.020	2.5
20	-0.020	-0.019	-0.023	-0.019	-0.013	2.5
10	-0.029	-0.032	-0.024	-0.023	-0.018	2.5
0	-0.035	-0.041	-0.032	-0.029	-0.029	2.5
-10	-0.044	-0.047	-0.041	-0.035	-0.040	2.5
-20	-0.050	-0.054	-0.047	-0.037	-0.044	2.5
-30	-0.055	-0.055	-0.049	-0.044	-0.054	2.5

4.3 OCCUPIED BANDWIDTH MEASUREMENT

4.3.1 TEST PROCEDURES

The EUT makes a call to the communication simulator. All measurements were done at low, middle and high operational frequency range. The communication simulator station system controlled a EUT to export maximum output power under transmission mode and specific channel frequency. Use OBW measurement function of Spectrum analyzer to measure 99 % occupied bandwidth.

4.3.2 TEST SETUP

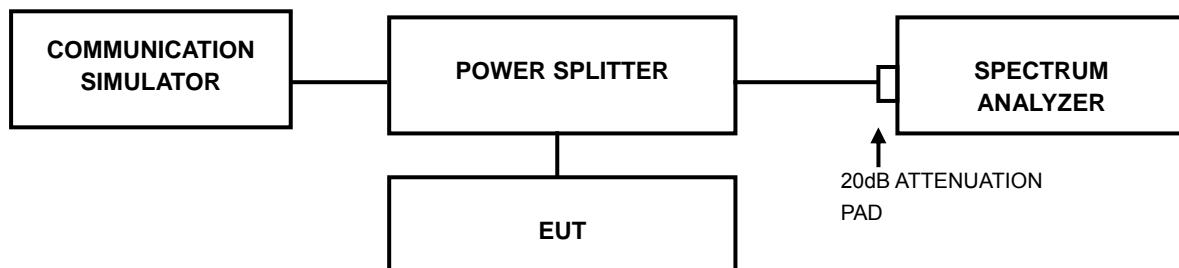



A D T

4.3.3 TEST RESULTS

CDMA

CHANNEL	FREQUENCY (MHz)	99% OCCUPIED BANDWIDTH (MHz)	
		CDMA	EVDO
1013	824.70	1.27	1.27
384	836.52	1.27	1.28
777	848.31	1.28	1.27

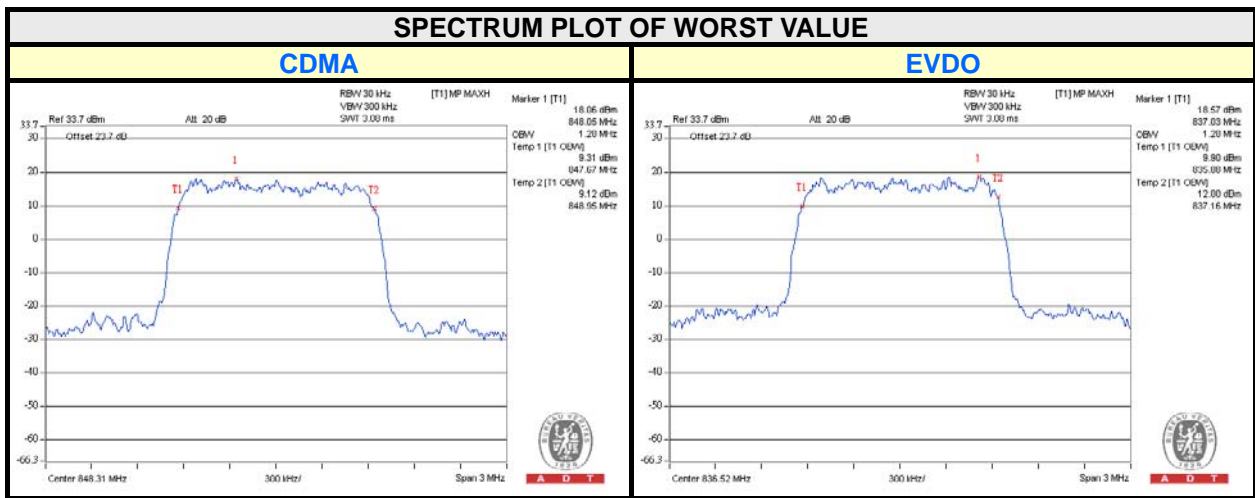



A D T

LTE Band 26 (Channel Bandwidth 1.4MHz)

CHANNEL	FREQUENCY (MHz)	99% OCCUPIED BANDWIDTH (MHz)	
		QPSK	16QAM
26797	824.70	1.23	1.23
26915	836.50	1.23	1.23
27033	848.30	1.23	1.22

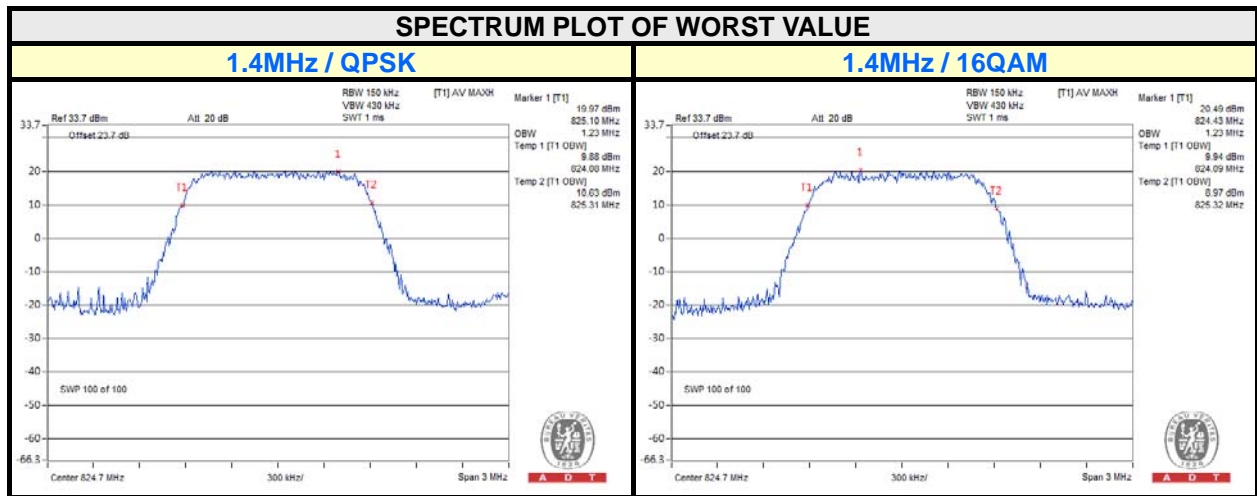

LTE Band 26 (Channel Bandwidth 3MHz)

CHANNEL	FREQUENCY (MHz)	99% OCCUPIED BANDWIDTH (MHz)	
		QPSK	16QAM
26805	825.50	2.73	2.73
26915	836.50	2.73	2.74
27025	847.50	2.72	2.73

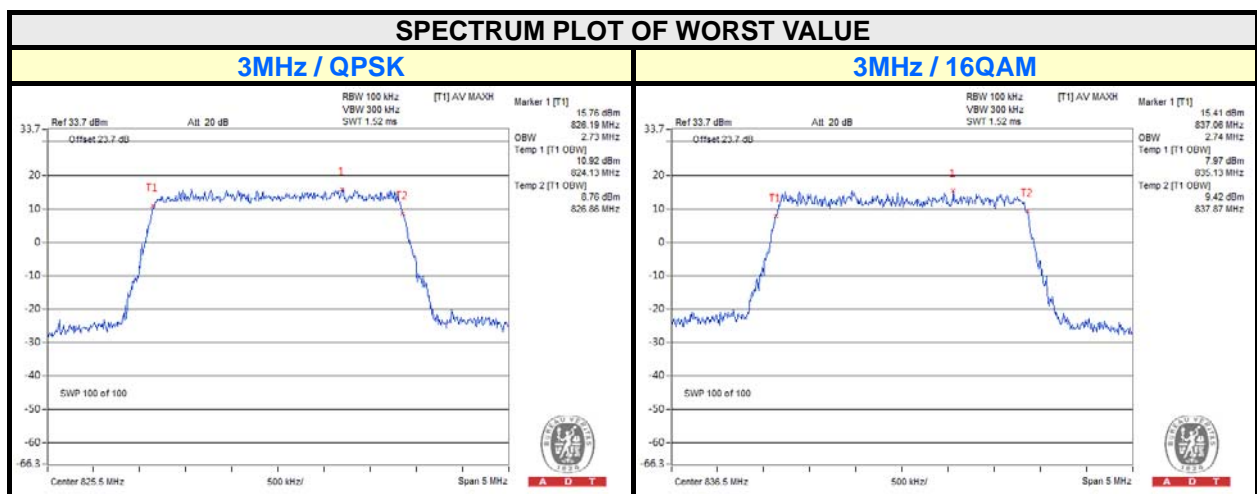

LTE Band 26 (Channel Bandwidth 5MHz)

CHANNEL	FREQUENCY (MHz)	99% OCCUPIED BANDWIDTH (MHz)	
		QPSK	16QAM
26815	826.50	4.50	4.48
26915	836.50	4.50	4.50
27015	846.50	4.48	4.50

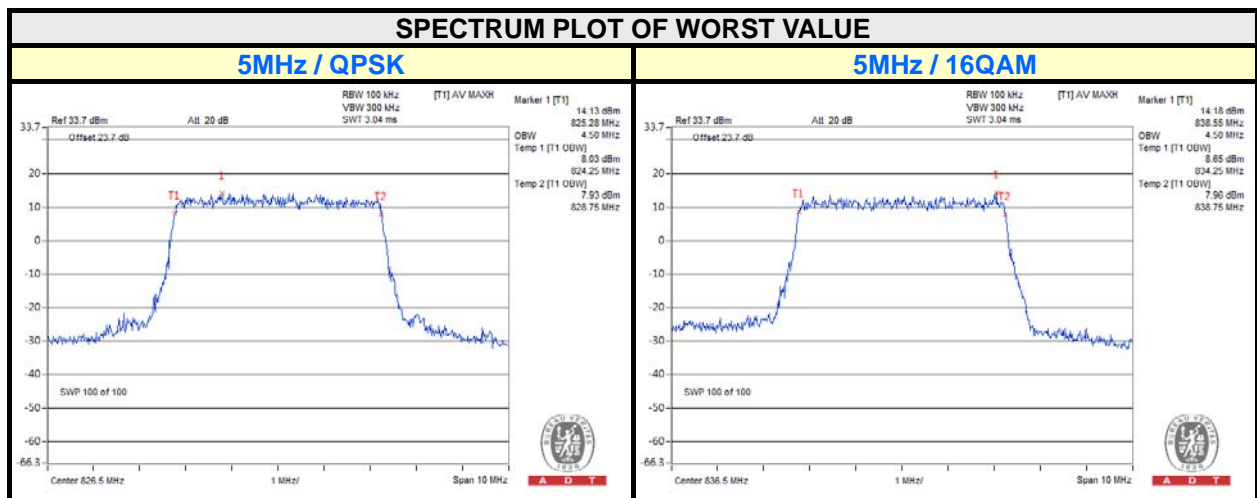

LTE Band 26 (Channel Bandwidth 10MHz)

CHANNEL	FREQUENCY (MHz)	99% OCCUPIED BANDWIDTH (MHz)	
		QPSK	16QAM
26840	829.00	8.93	8.93
26915	836.50	9.00	9.00
26990	844.00	8.97	8.93

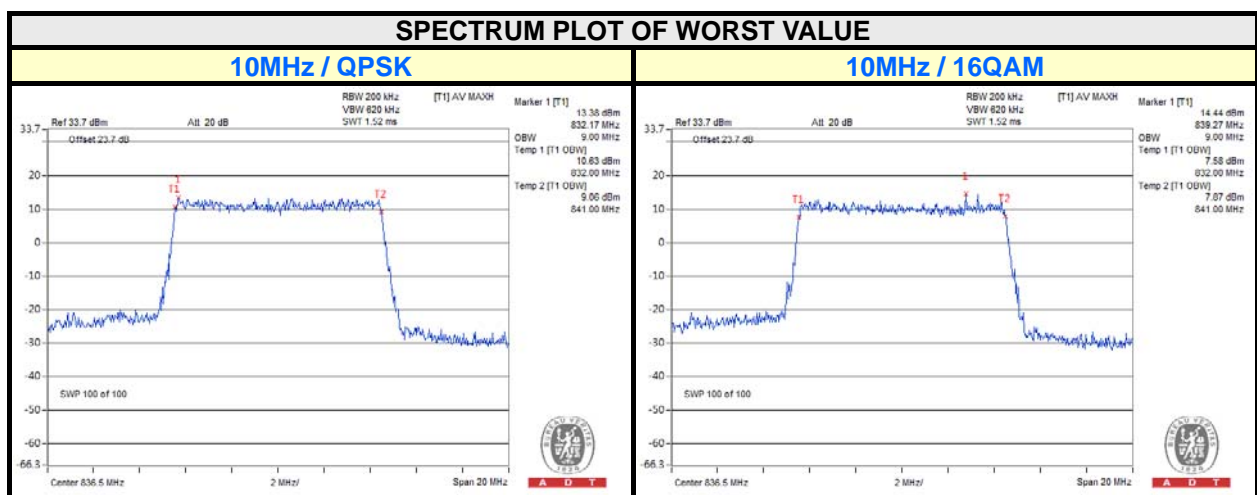

4.4 BAND EDGE MEASUREMENT

4.4.1 LIMITS OF BAND EDGE MEASUREMENT

Power of any emission outside of the authorized operating frequency ranges must be attenuated below the transmitting power (P) by a factor of at least $43 + 10 \log(P)$ dB. In the 1 MHz bands immediately outside and adjacent to the frequency block a resolution bandwidth of at least one percent of the emission bandwidth of the fundamental emission of the transmitter may be employed.

4.4.2 TEST SETUP

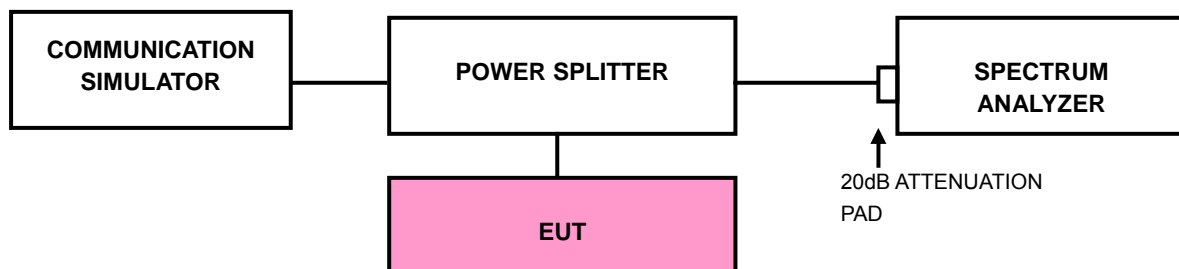

4.4.3 TEST PROCEDURES

- All measurements were done at low and high operational frequency range.
- The center frequency of spectrum is the band edge frequency and span is 3MHz. RB of the spectrum is 15kHz and VB of the spectrum is 15kHz (CDMA, EVDO).
- The center frequency of spectrum is the band edge frequency and span is 10MHz. RB of the spectrum is 100kHz and VB of the spectrum is 300kHz (LTE).
- Record the max trace plot into the test report.



A D T

4.4.4 TEST RESULTS

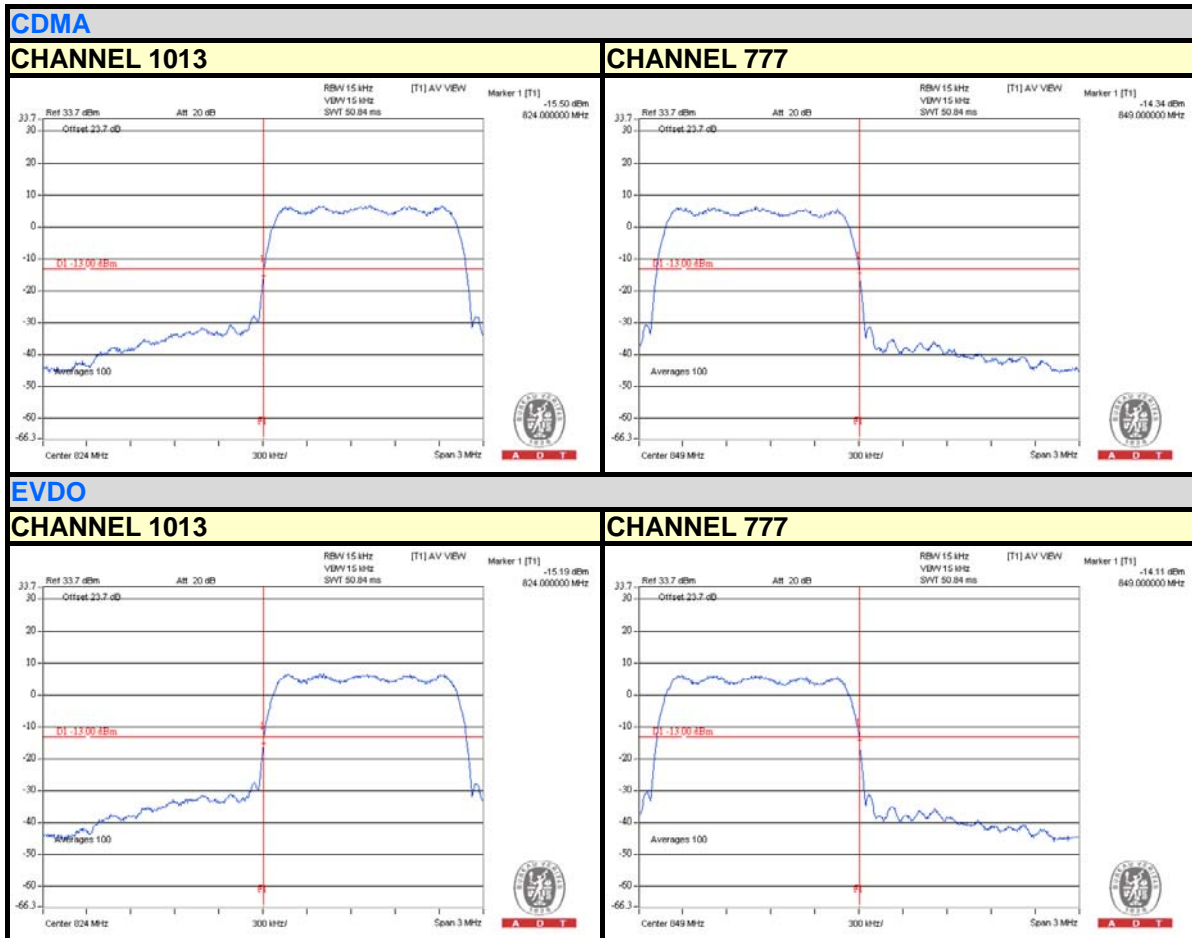



A D T

LTE Band 26 (Channel Bandwidth 1.4MHz)

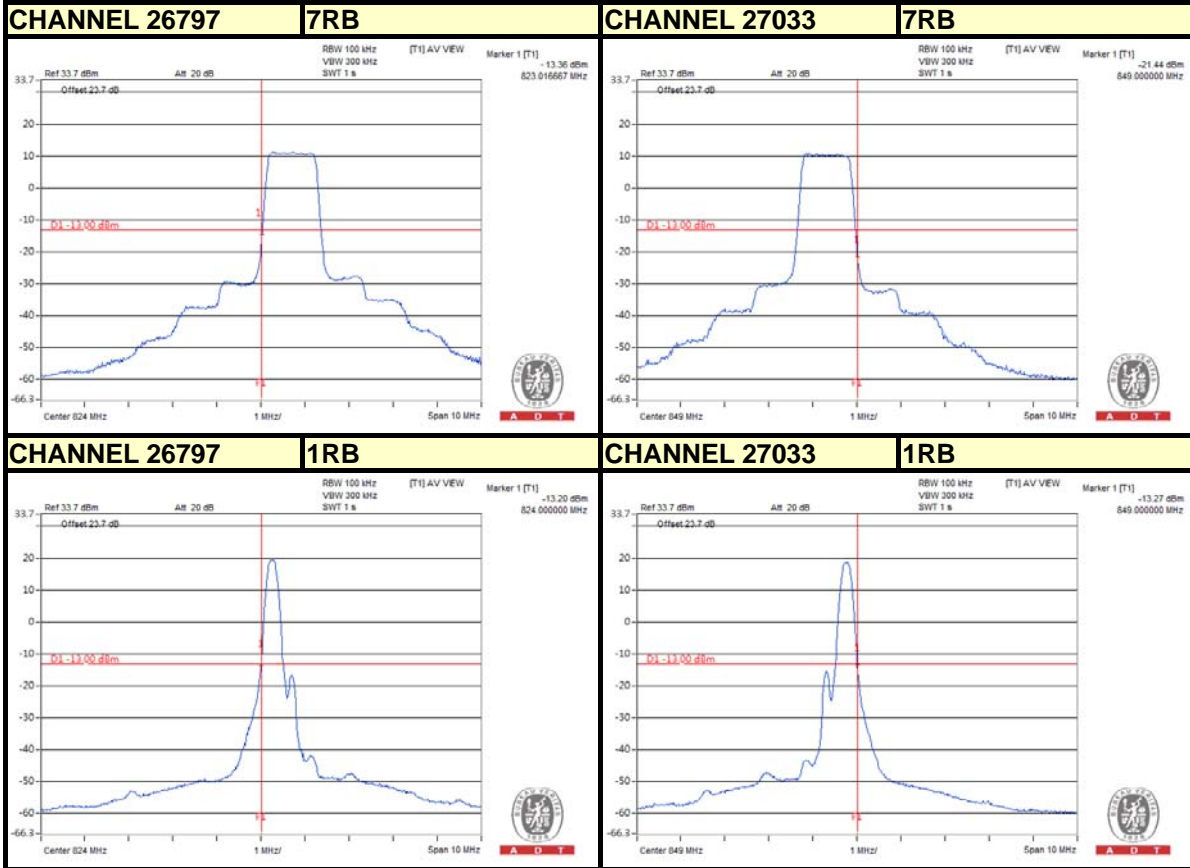



A D T

LTE Band 26 (Channel Bandwidth 3MHz)

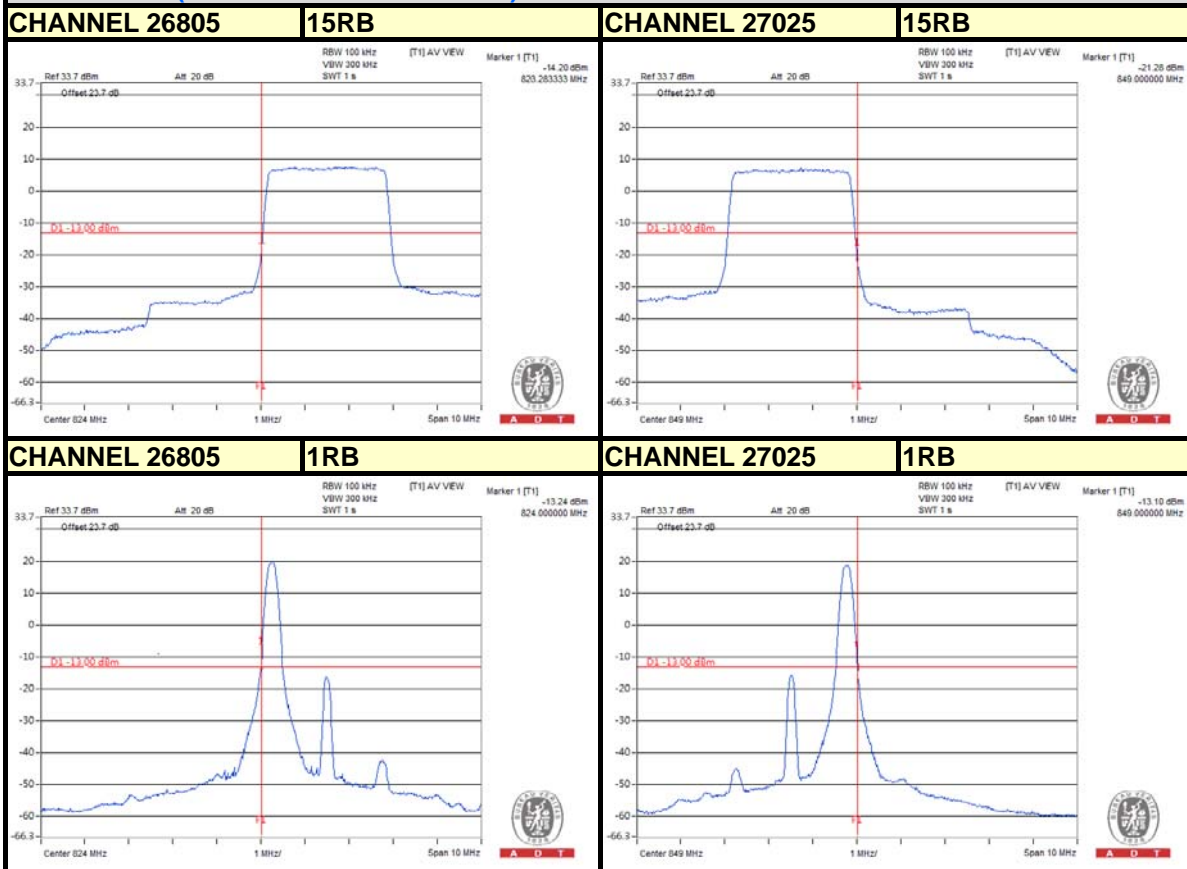



A D T

LTE Band 26 (Channel Bandwidth 5MHz)

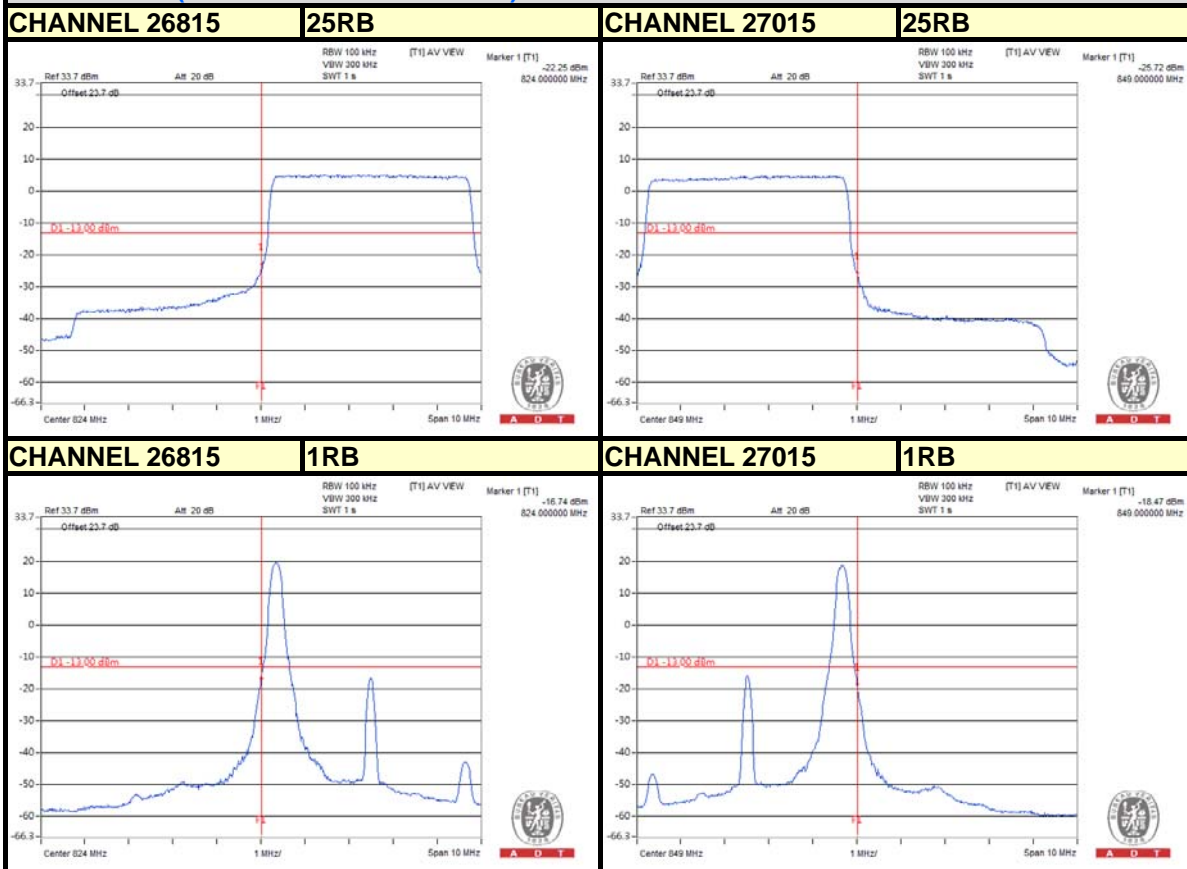



A D T

LTE Band 26 (Channel Bandwidth 10MHz)

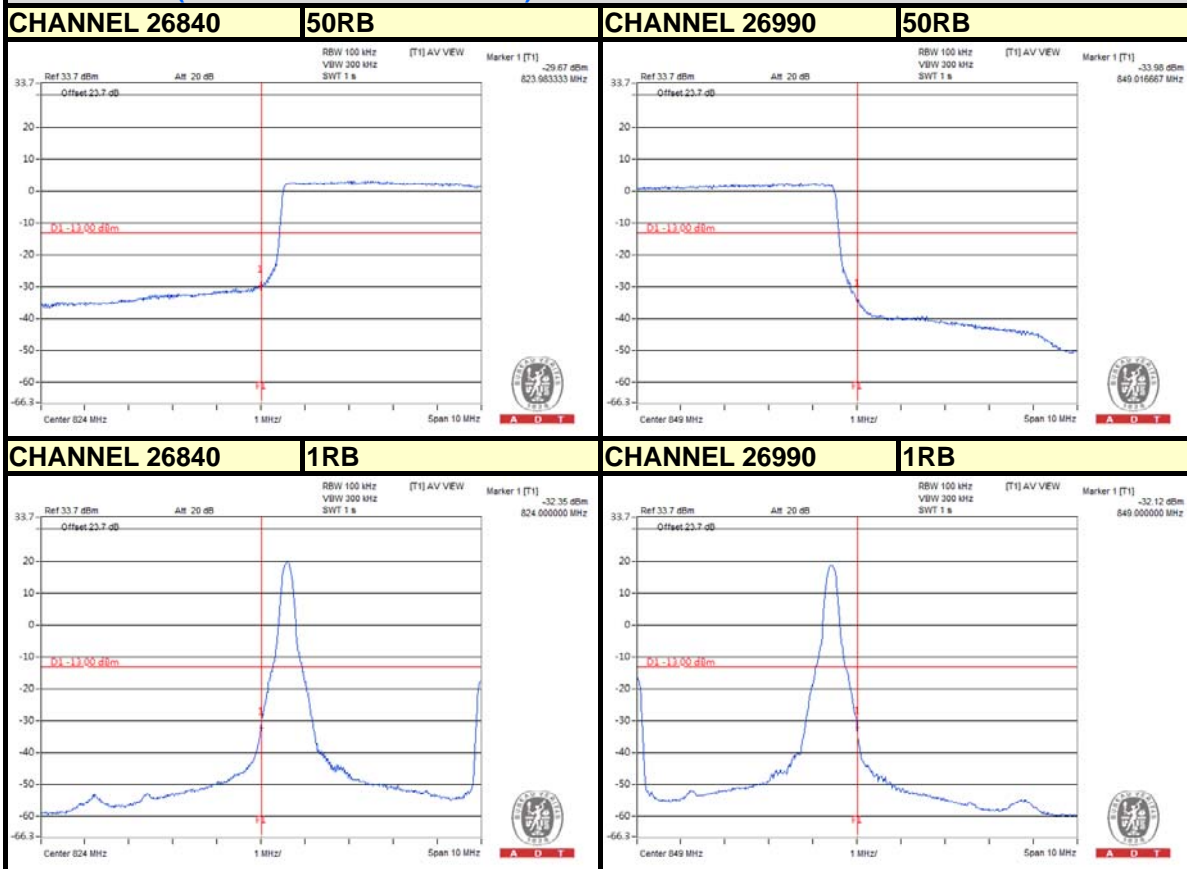

4.5 CONDUCTED SPURIOUS EMISSIONS

4.5.1 LIMITS OF CONDUCTED SPURIOUS EMISSIONS MEASUREMENT

The power of any emission outside of the authorized operating frequency ranges must be attenuated below the transmitting power (P) by a factor of at least $43 + 10 \log(P)$ dB. The emission limit equal to -13dBm .

4.5.2 TEST PROCEDURE

- The EUT makes a phone call to the communication simulator. All measurements were done at low, middle and high operational frequency range.
- Measuring frequency range is from 9kHz to 9GHz (CDMA/EVDO/ LTE). 20dB attenuation pad is connected with spectrum. RBW=1MHz and VBW=3MHz is used for conducted emission measurement.

4.5.3 TEST SETUP

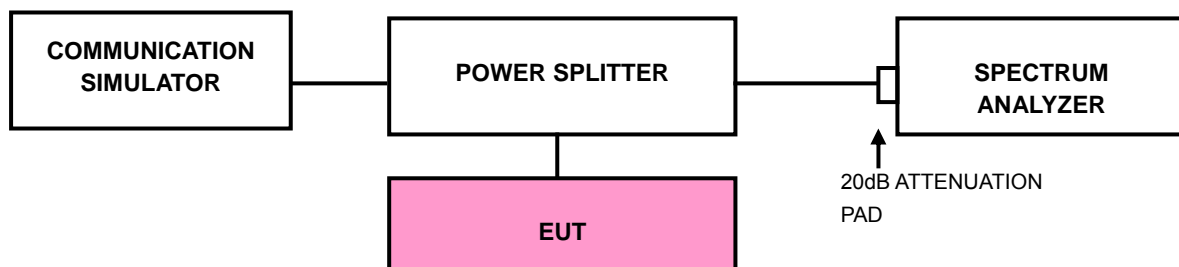



A D T

4.5.4 TEST RESULTS





A D T

CDMA

CHANNEL 384

FREQUENCY RANGE : 9kHz~1GHz

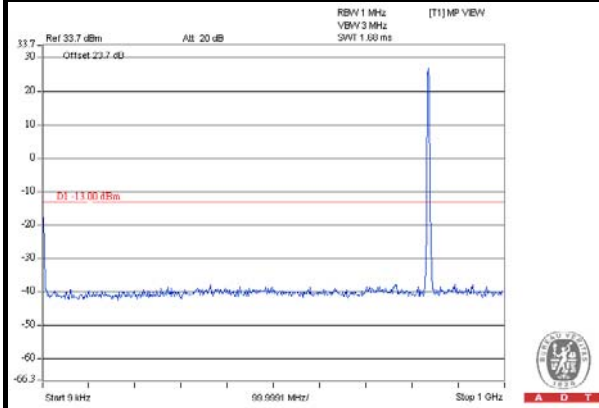

FREQUENCY RANGE : 1GHz~4GHz

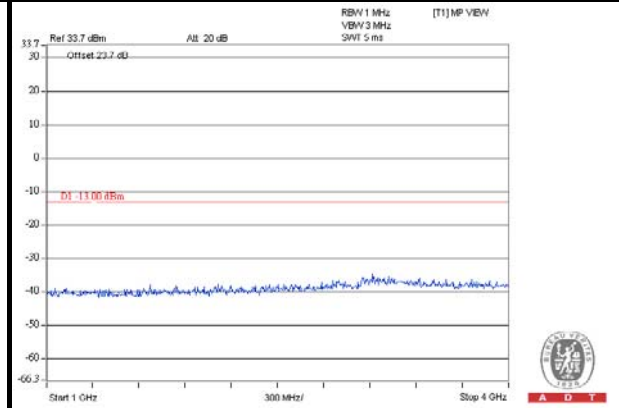

FREQUENCY RANGE : 4GHz~7GHz

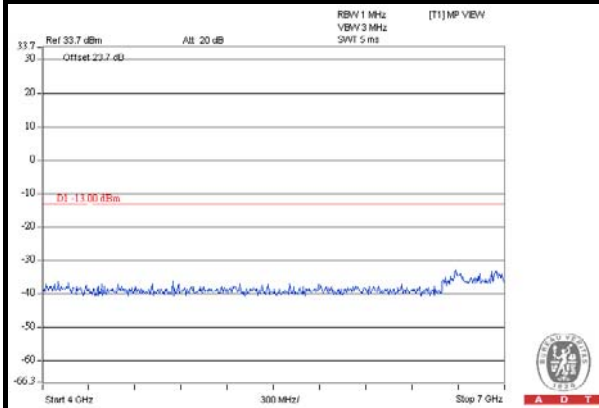

FREQUENCY RANGE : 7GHz~9GHz

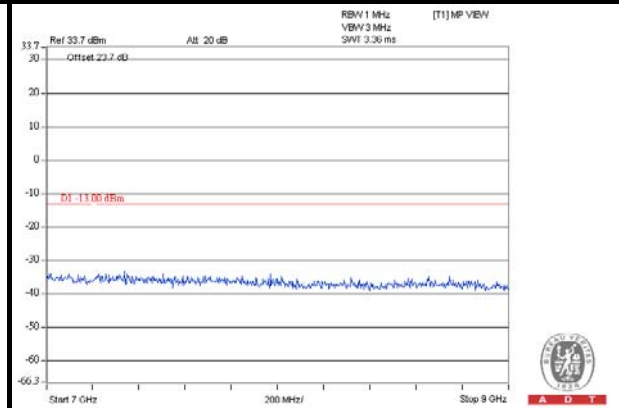



A D T

CDMA

CHANNEL 777

FREQUENCY RANGE : 9kHz~1GHz

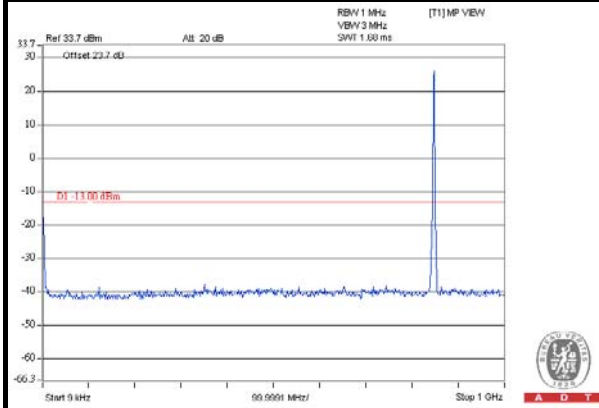

FREQUENCY RANGE : 1GHz~4GHz

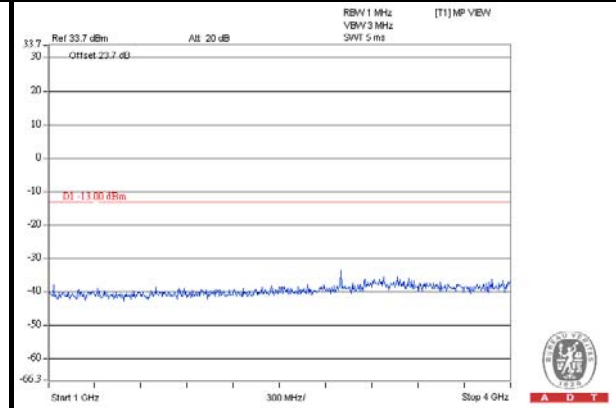

FREQUENCY RANGE : 4GHz~7GHz

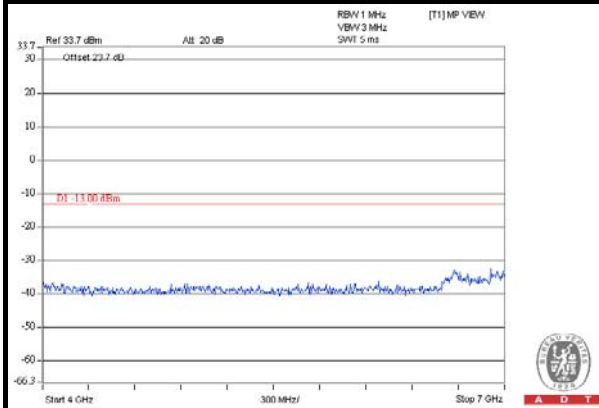

FREQUENCY RANGE : 7GHz~9GHz

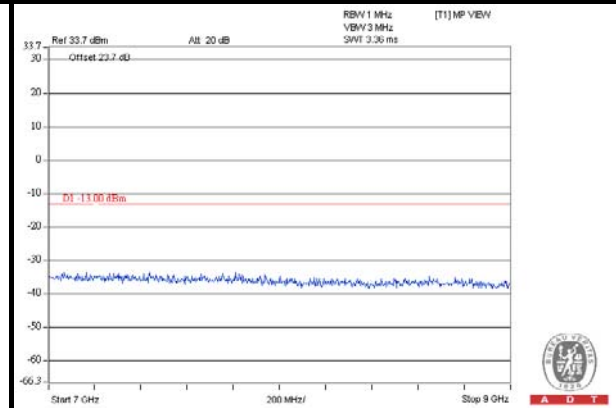



A D T

EVDO

CHANNEL 1013

FREQUENCY RANGE : 9kHz~1GHz

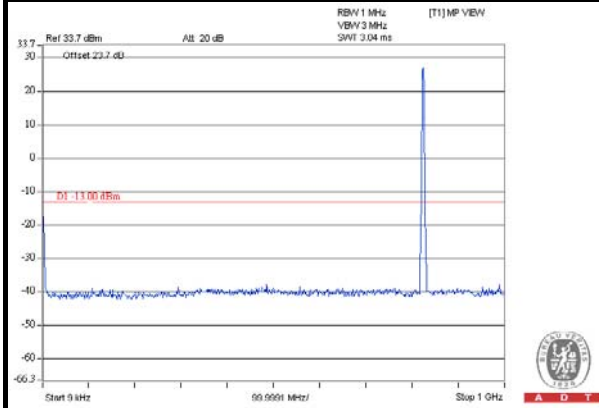

FREQUENCY RANGE : 1GHz~4GHz

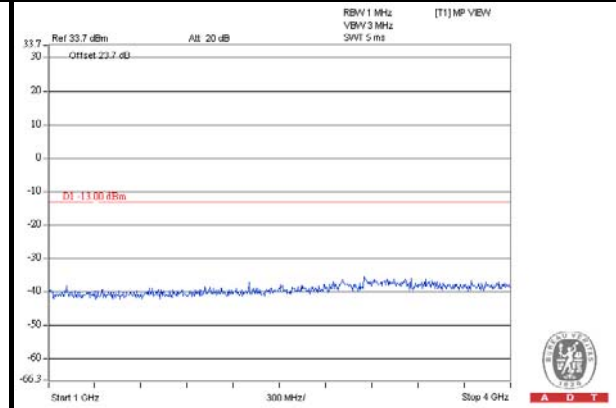

FREQUENCY RANGE : 4GHz~7GHz

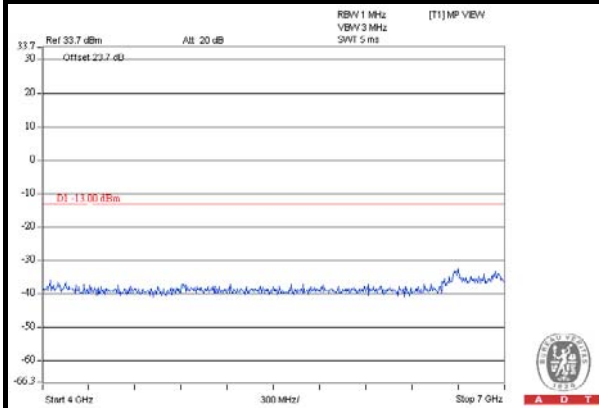

FREQUENCY RANGE : 7GHz~9GHz

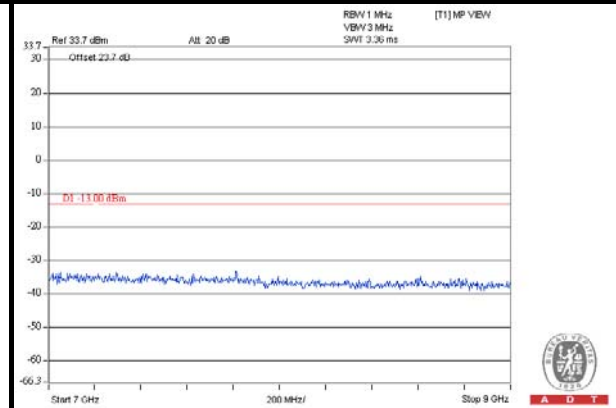



A D T

EVDO

CHANNEL 384

FREQUENCY RANGE : 9kHz~1GHz

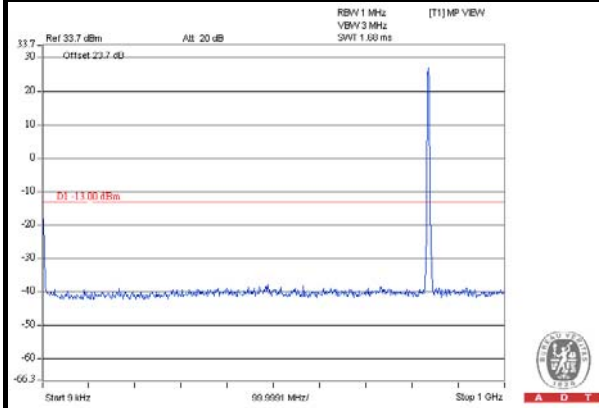

FREQUENCY RANGE : 1GHz~4GHz

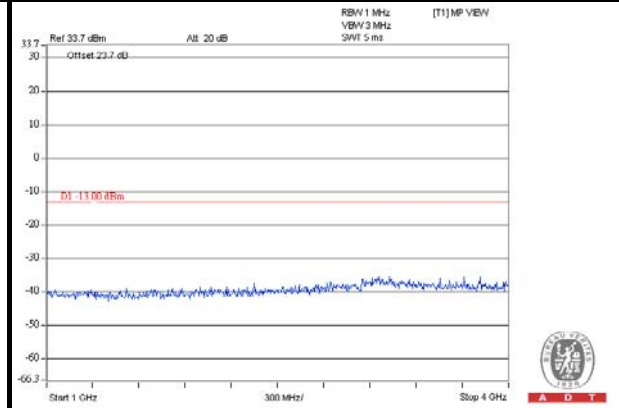

FREQUENCY RANGE : 4GHz~7GHz

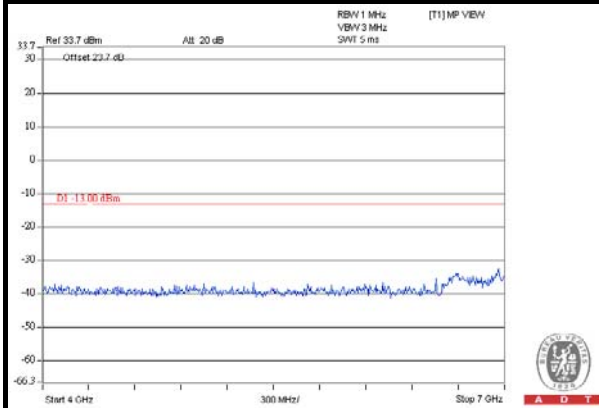

FREQUENCY RANGE : 7GHz~9GHz

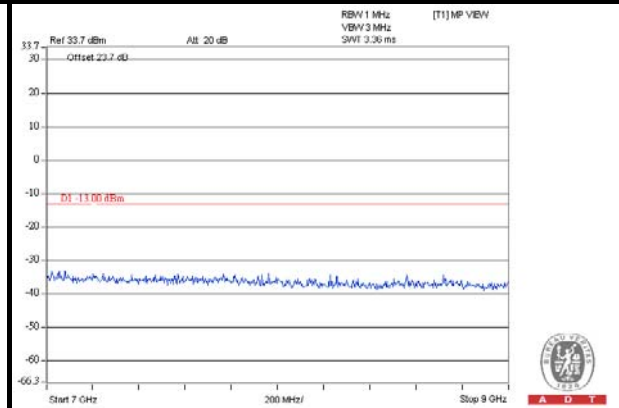



A D T

EVDO

CHANNEL 777

FREQUENCY RANGE : 9kHz~1GHz

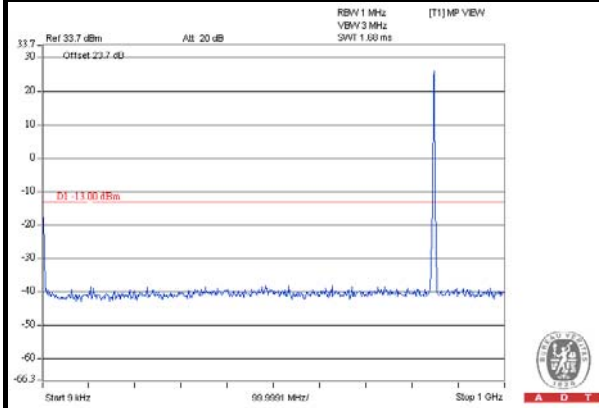

FREQUENCY RANGE : 1GHz~4GHz

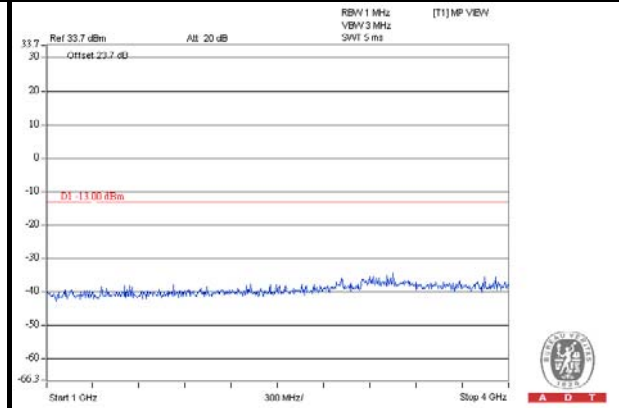

FREQUENCY RANGE : 4GHz~7GHz

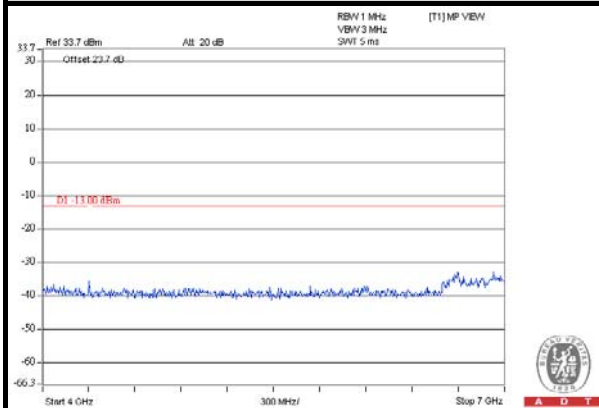

FREQUENCY RANGE : 7GHz~9GHz

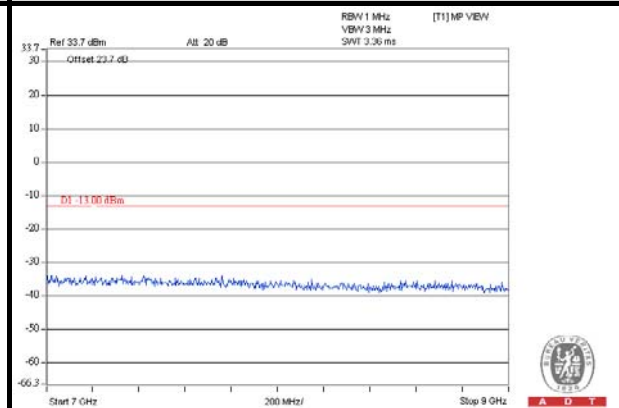



A D T

LTE Band 26 (Channel Bandwidth 1.4MHz)

CHANNEL 26797

FREQUENCY RANGE : 9kHz~1GHz

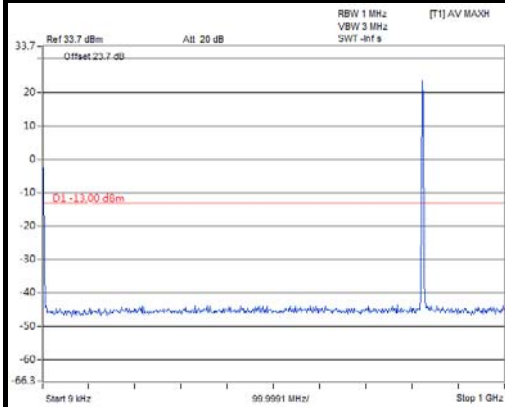

FREQUENCY RANGE : 1GHz~4GHz

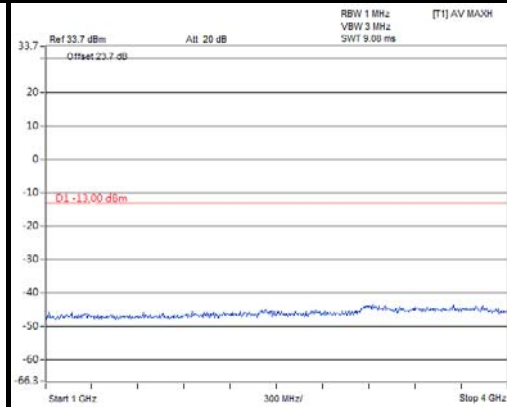

FREQUENCY RANGE : 4GHz~7GHz

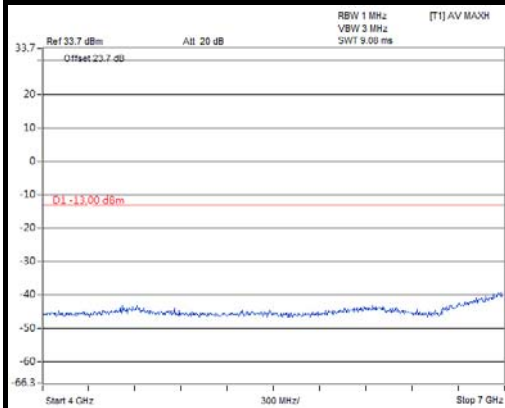

FREQUENCY RANGE : 7GHz~9GHz

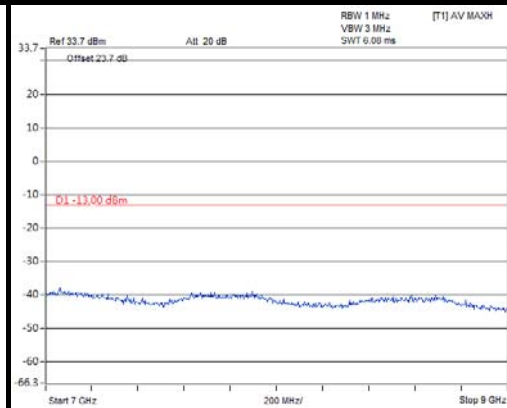



A D T

LTE Band 26 (Channel Bandwidth 1.4MHz)

CHANNEL 26915

FREQUENCY RANGE : 9kHz~1GHz

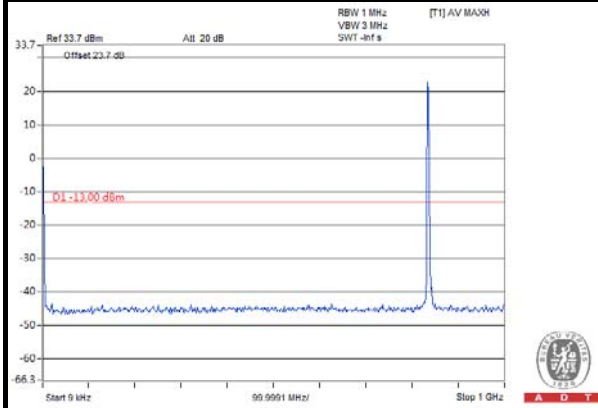

FREQUENCY RANGE : 1GHz~4GHz

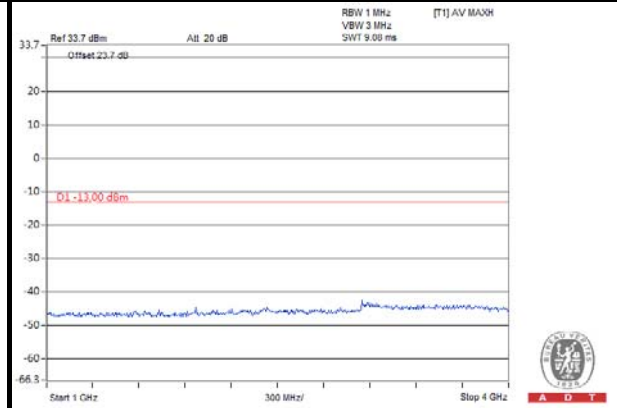

FREQUENCY RANGE : 4GHz~7GHz

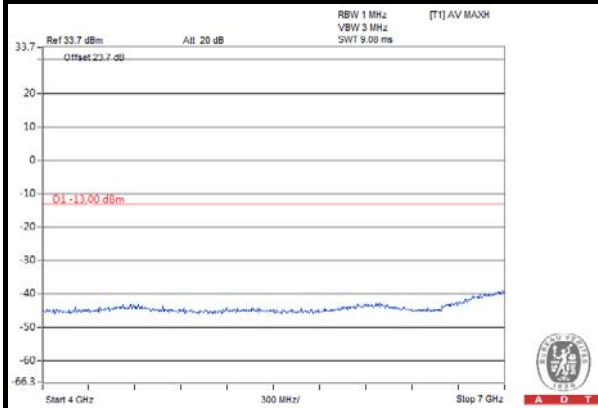

FREQUENCY RANGE : 7GHz~9GHz

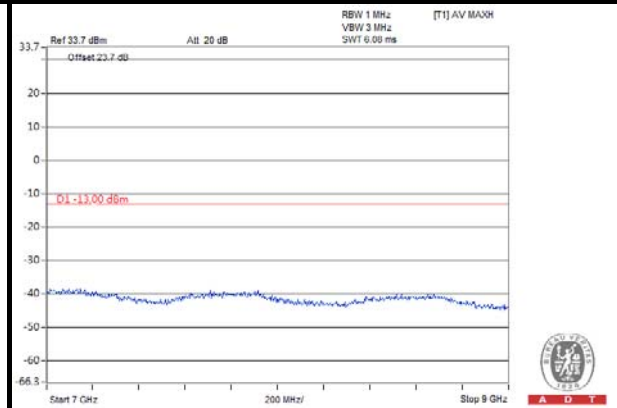



A D T

LTE Band 26 (Channel Bandwidth 1.4MHz)

CHANNEL 27033

FREQUENCY RANGE : 9kHz~1GHz

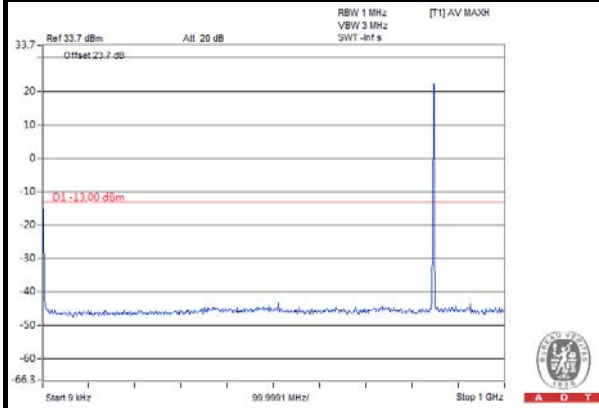

FREQUENCY RANGE : 1GHz~4GHz

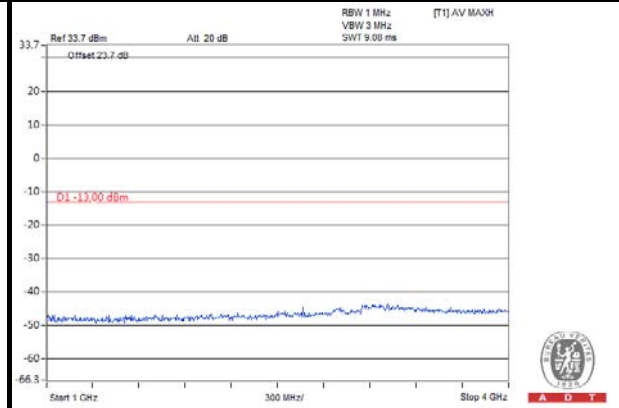

FREQUENCY RANGE : 4GHz~7GHz

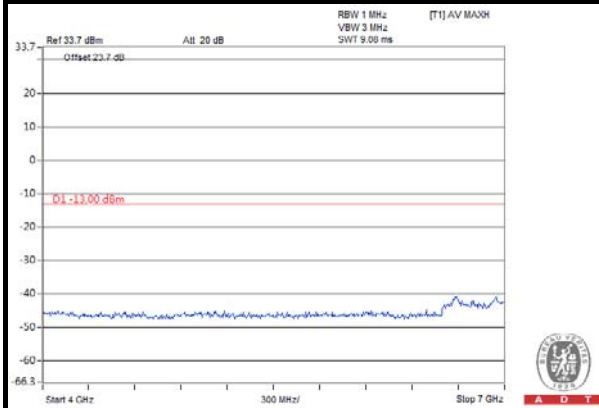

FREQUENCY RANGE : 7GHz~9GHz

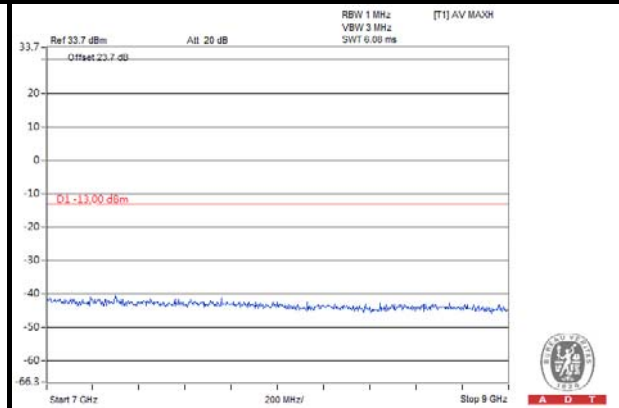



A D T

LTE Band 26 (Channel Bandwidth 3MHz)

CHANNEL 26805

FREQUENCY RANGE : 9kHz~1GHz

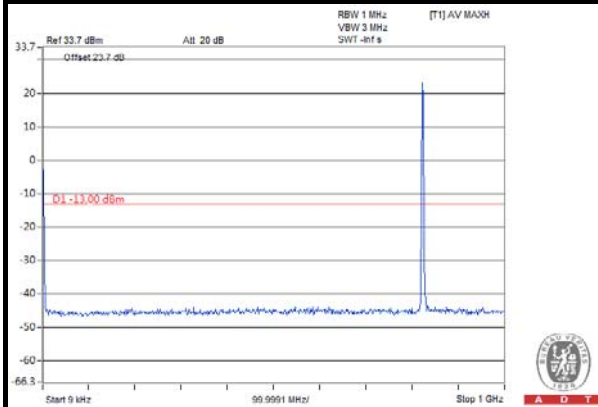

FREQUENCY RANGE : 1GHz~4GHz

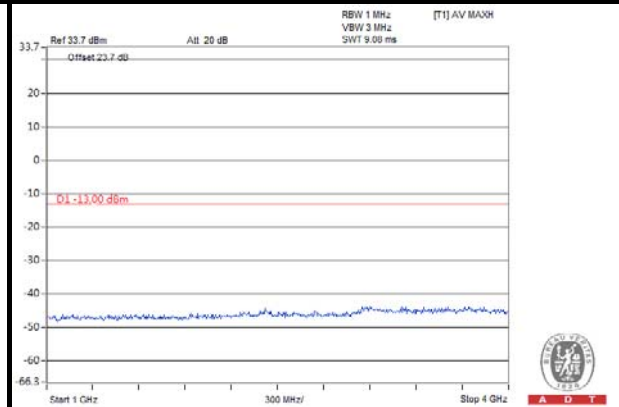

FREQUENCY RANGE : 4GHz~7GHz

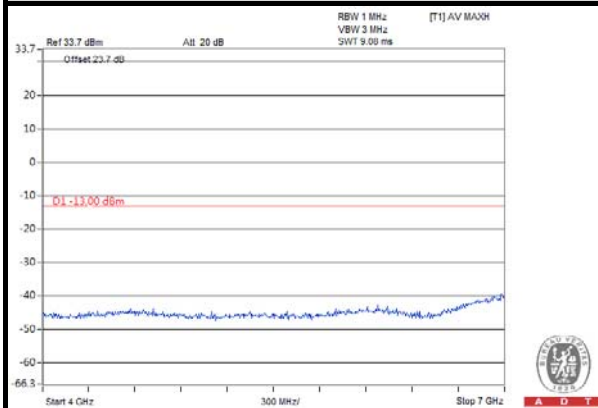

FREQUENCY RANGE : 7GHz~9GHz

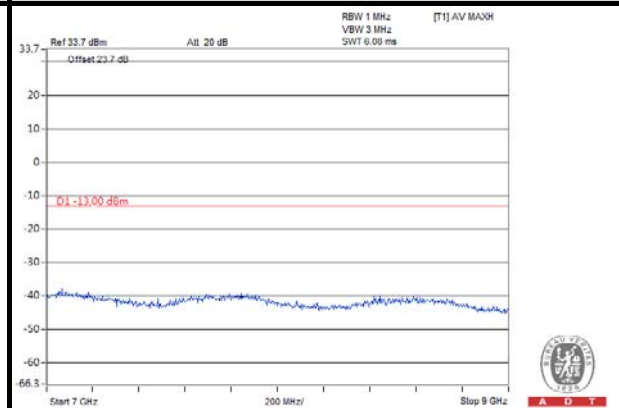



A D T

LTE Band 26 (Channel Bandwidth 3MHz)

CHANNEL 26915

FREQUENCY RANGE : 9kHz~1GHz

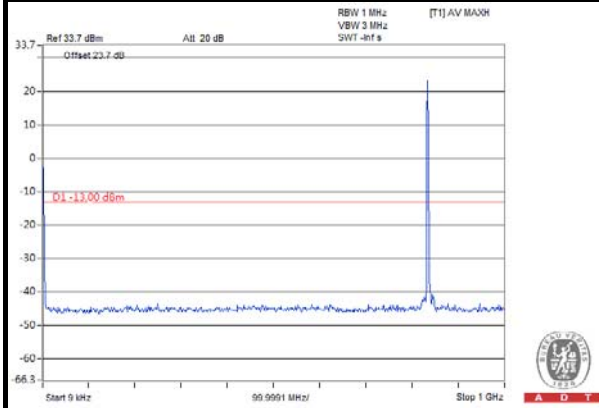

FREQUENCY RANGE : 1GHz~4GHz

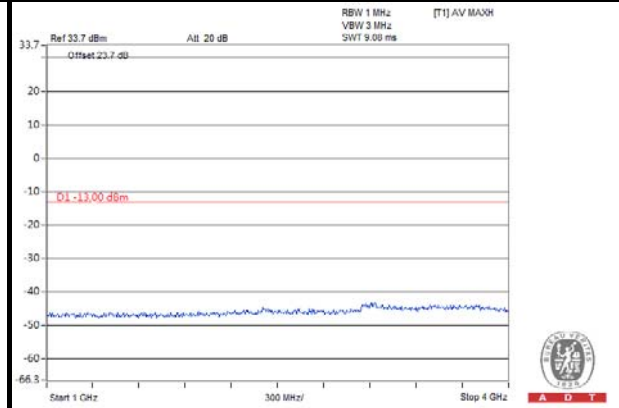

FREQUENCY RANGE : 4GHz~7GHz

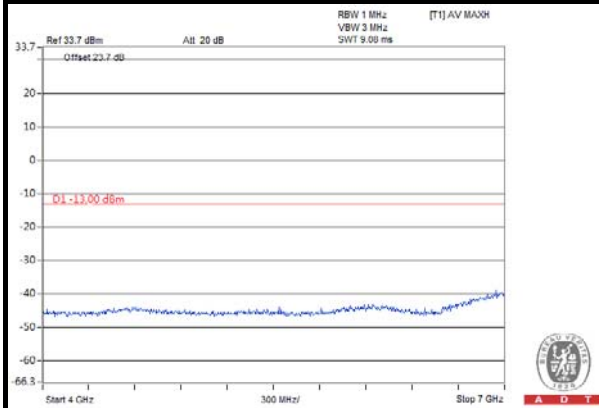

FREQUENCY RANGE : 7GHz~9GHz

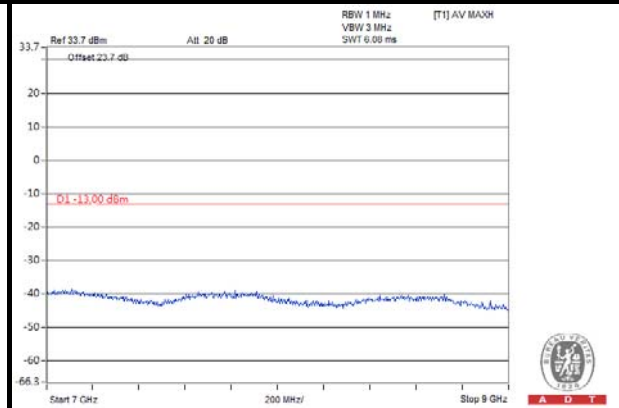



A D T

LTE Band 26 (Channel Bandwidth 3MHz)

CHANNEL 27025

FREQUENCY RANGE : 9kHz~1GHz

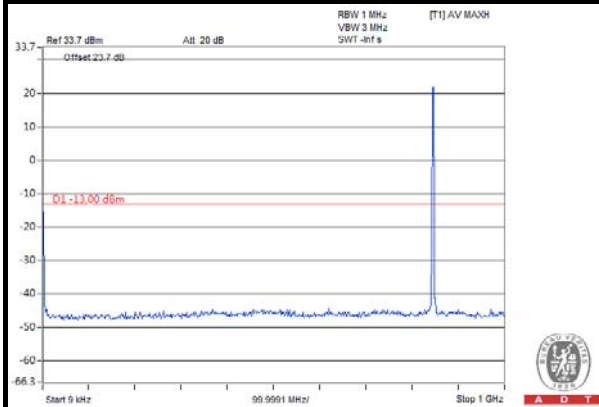

FREQUENCY RANGE : 1GHz~4GHz

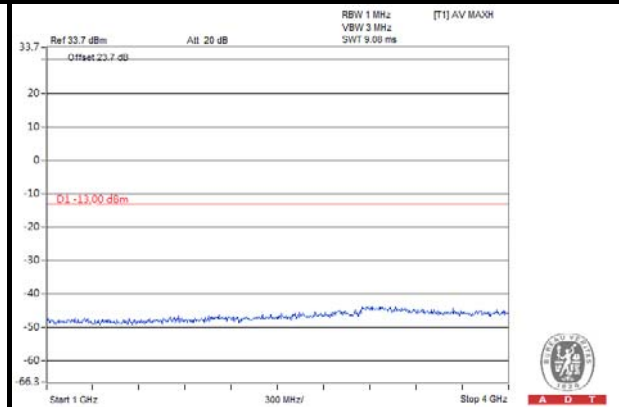

FREQUENCY RANGE : 4GHz~7GHz

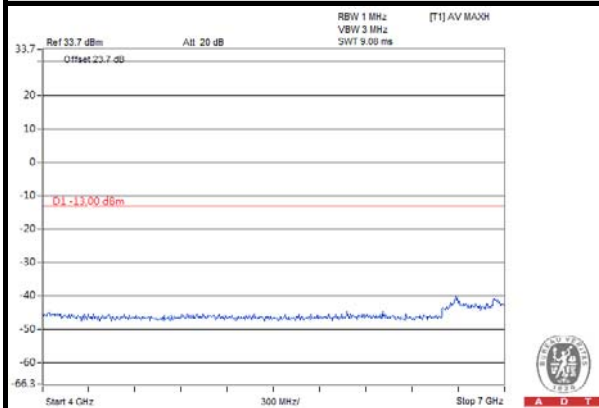

FREQUENCY RANGE : 7GHz~9GHz

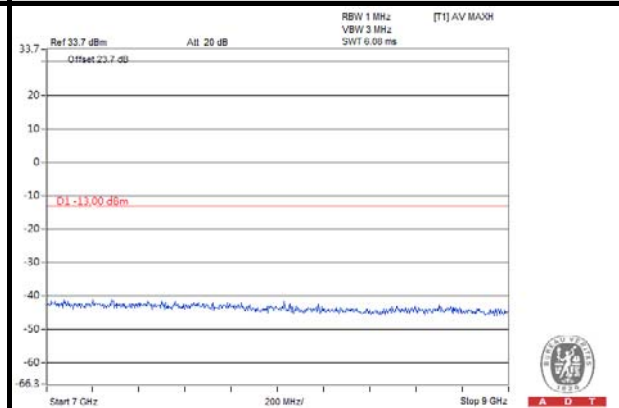



A D T

LTE Band 26 (Channel Bandwidth 5MHz)

CHANNEL 26815

FREQUENCY RANGE : 9kHz~1GHz

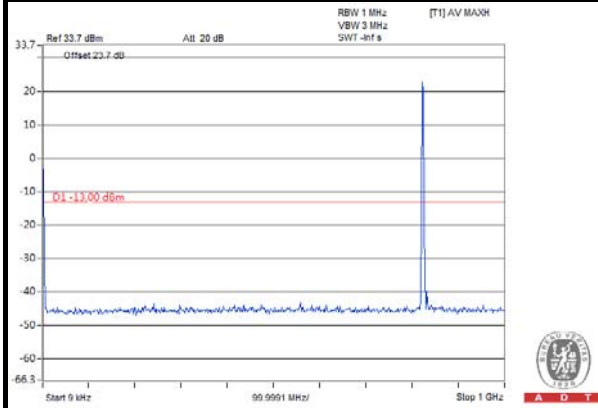

FREQUENCY RANGE : 1GHz~4GHz

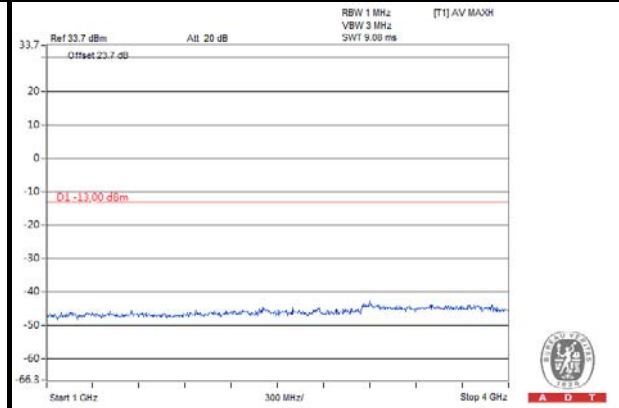

FREQUENCY RANGE : 4GHz~7GHz

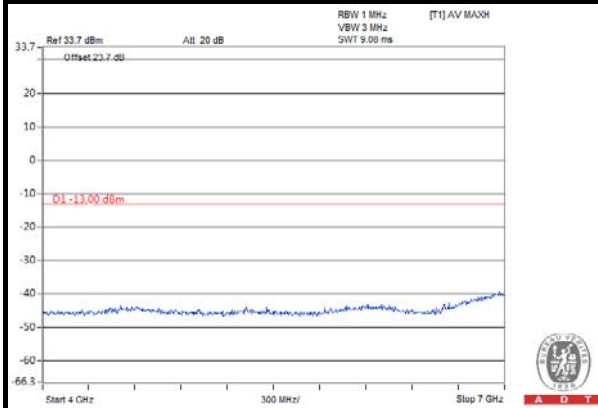

FREQUENCY RANGE : 7GHz~9GHz

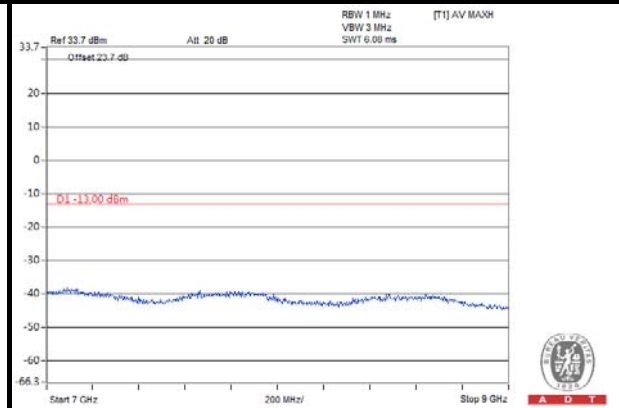



A D T

LTE Band 26 (Channel Bandwidth 5MHz)

CHANNEL 26915

FREQUENCY RANGE : 9kHz~1GHz

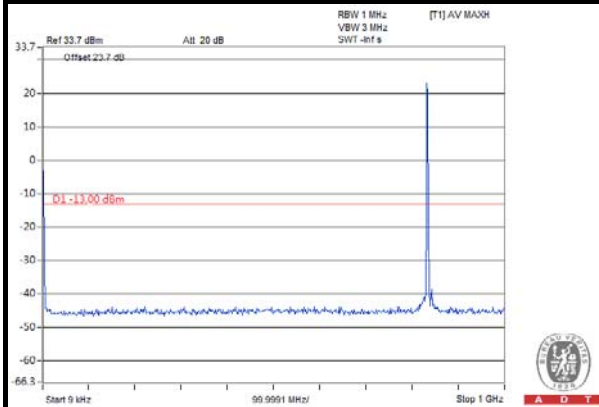

FREQUENCY RANGE : 1GHz~4GHz

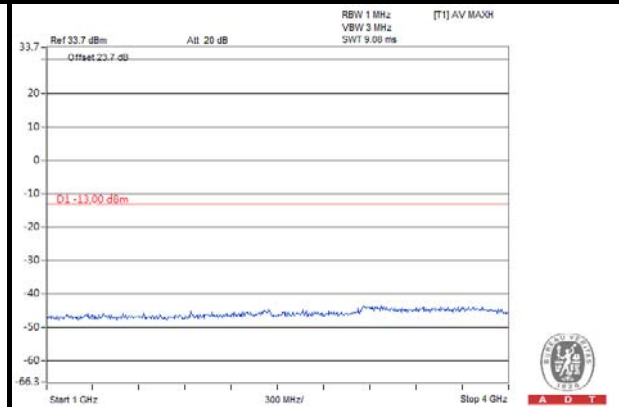

FREQUENCY RANGE : 4GHz~7GHz

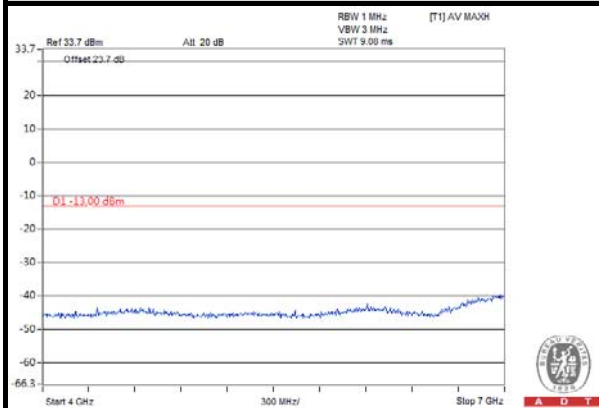

FREQUENCY RANGE : 7GHz~9GHz

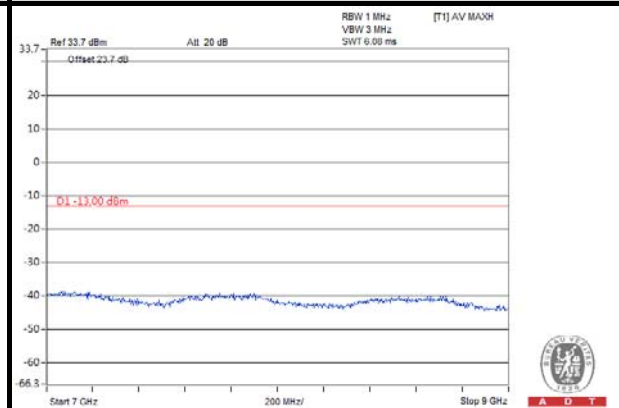



A D T

LTE Band 26 (Channel Bandwidth 5MHz)

CHANNEL 27015

FREQUENCY RANGE : 9kHz~1GHz

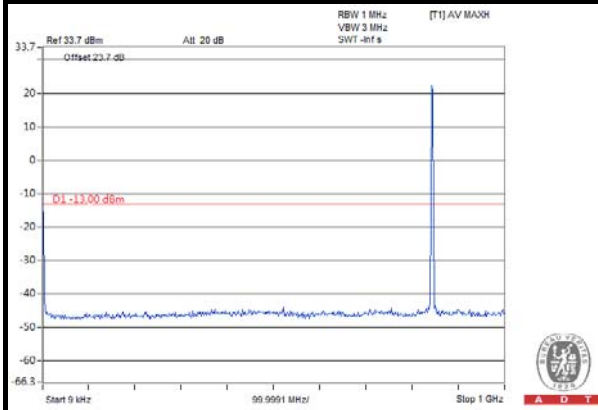

FREQUENCY RANGE : 1GHz~4GHz

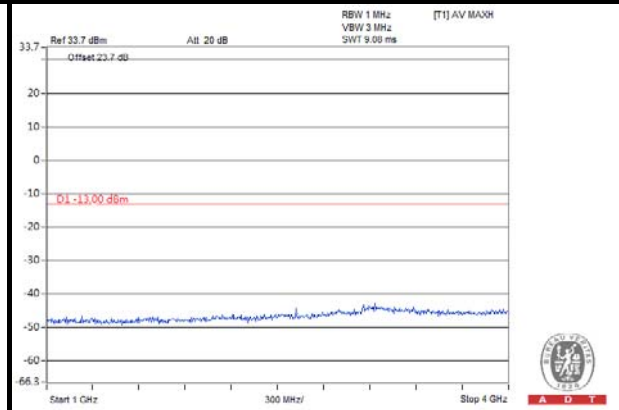

FREQUENCY RANGE : 4GHz~7GHz

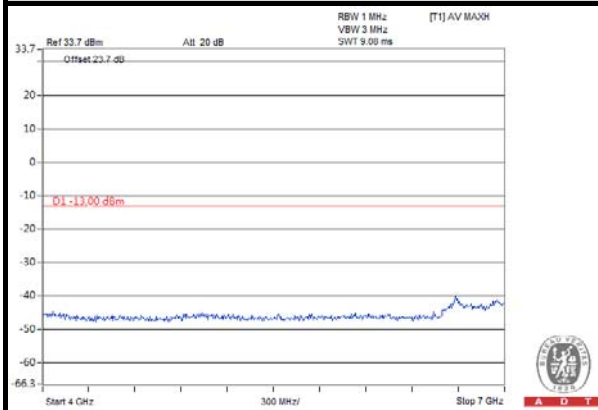

FREQUENCY RANGE : 7GHz~9GHz

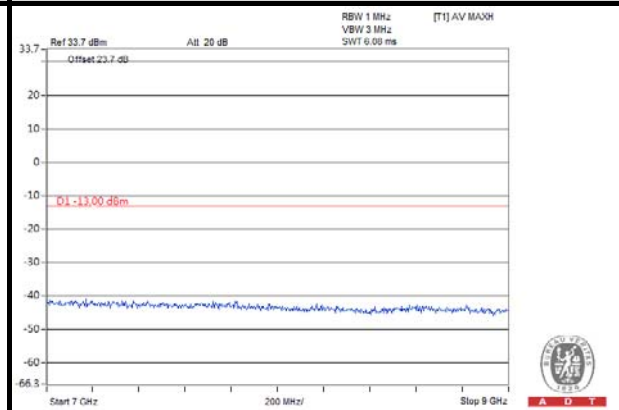



A D T

LTE Band 26 (Channel Bandwidth 10MHz)

CHANNEL 26840

FREQUENCY RANGE : 9kHz~1GHz

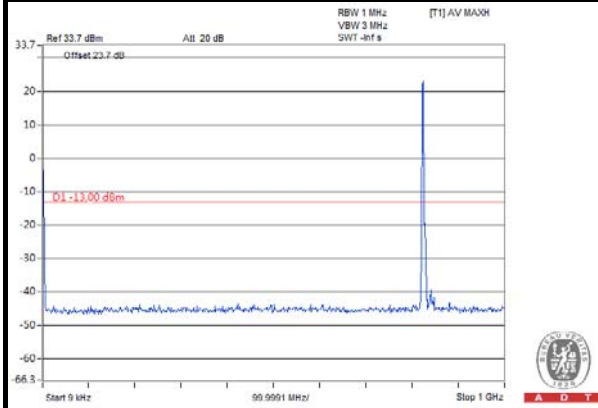

FREQUENCY RANGE : 1GHz~4GHz

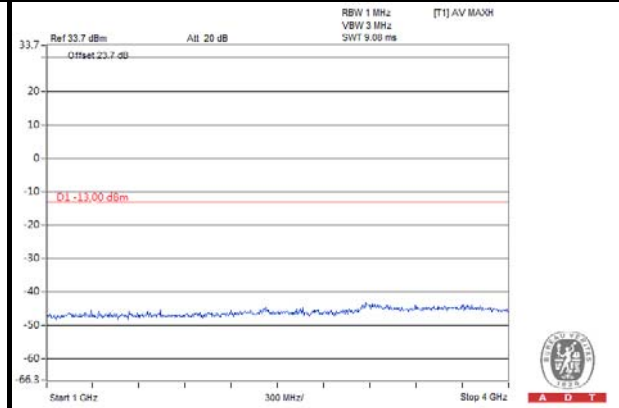

FREQUENCY RANGE : 4GHz~7GHz

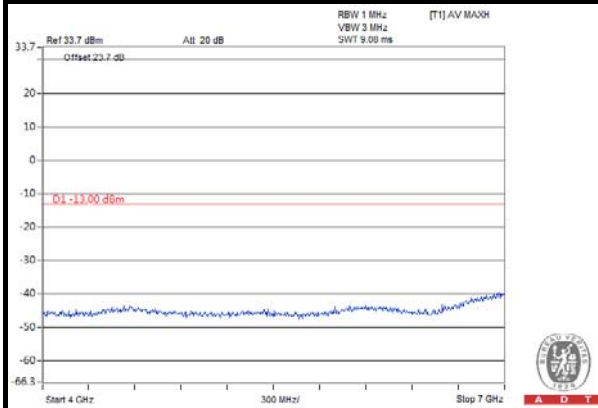

FREQUENCY RANGE : 7GHz~9GHz

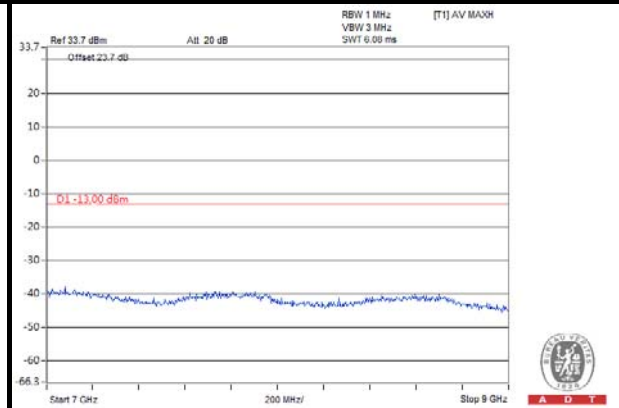



A D T

LTE Band 26 (Channel Bandwidth 10MHz)

CHANNEL 26915

FREQUENCY RANGE : 9kHz~1GHz

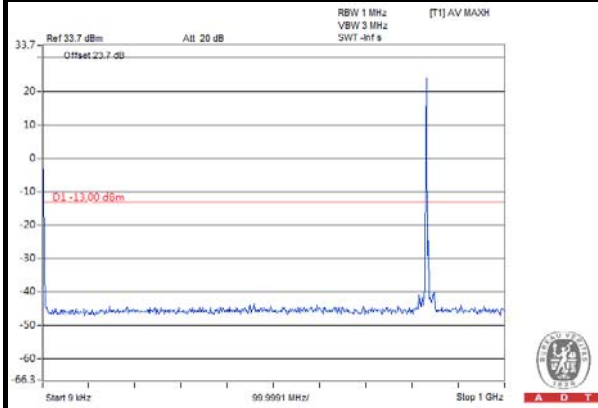

FREQUENCY RANGE : 1GHz~4GHz

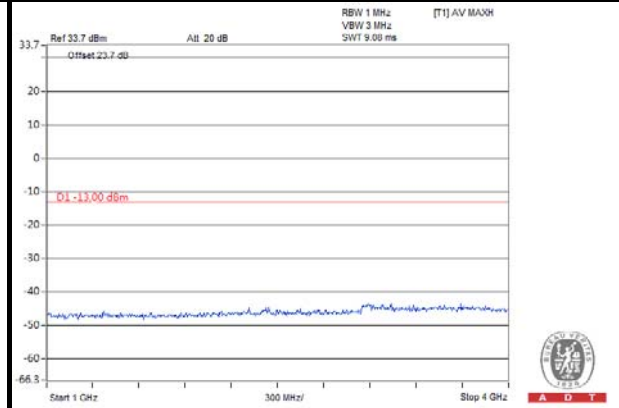

FREQUENCY RANGE : 4GHz~7GHz

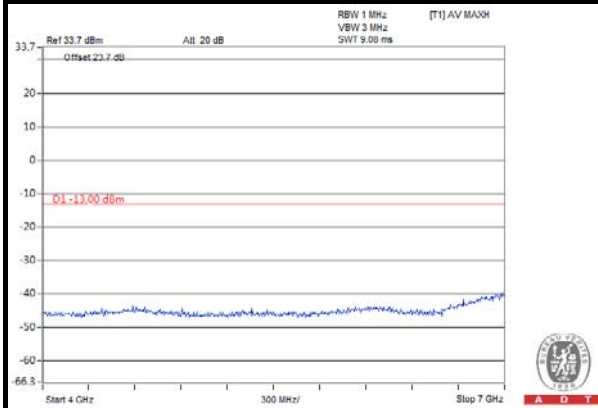

FREQUENCY RANGE : 7GHz~9GHz

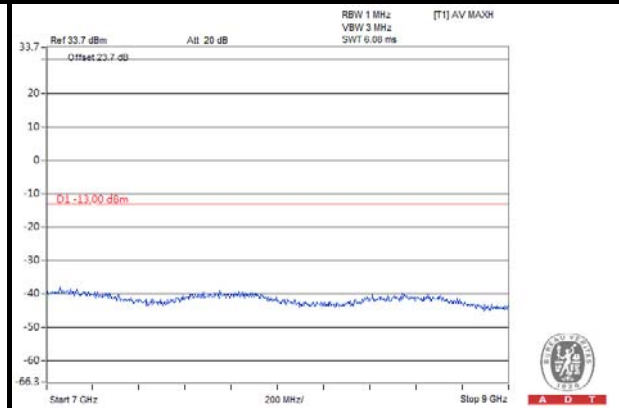



A D T

LTE Band 26 (Channel Bandwidth 10MHz)

CHANNEL 26990

FREQUENCY RANGE : 9kHz~1GHz

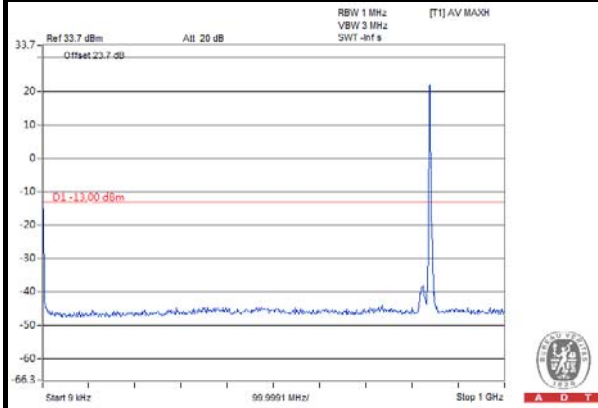

FREQUENCY RANGE : 1GHz~4GHz

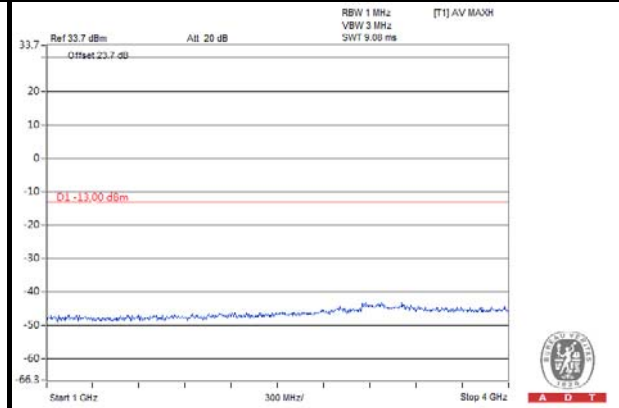

FREQUENCY RANGE : 4GHz~7GHz

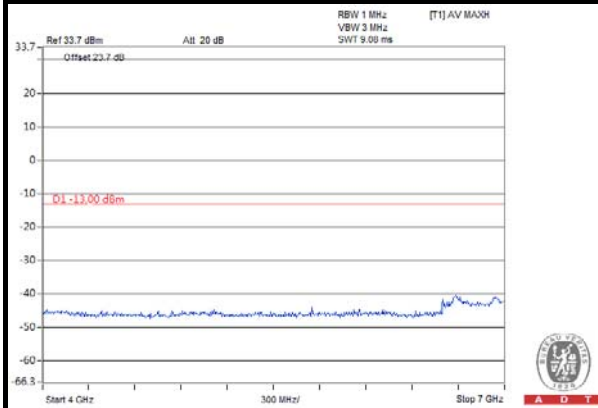

FREQUENCY RANGE : 7GHz~9GHz

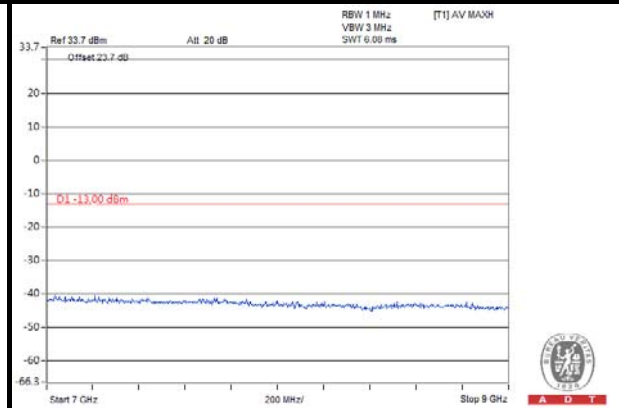



4.6 RADIATED EMISSION MEASUREMENT

4.6.1 LIMITS OF RADIATED EMISSION MEASUREMENT

The power of any emission outside of the authorized operating frequency ranges must be attenuated below the transmitting power (P) by a factor of at least $43 + 10 \log(P)$ dB. The emission limit equal to -13dBm .

4.6.2 TEST PROCEDURES

- a. Substitution method is used for E.I.R.P measurement. In the semi-anechoic chamber, EUT placed on the 0.8m height of Turn Table, rotated the table around 360 degrees to search the maximum radiation power and receiver antenna shall be rotated vertical and horizontal polarization and moved height from 1m to 4m to find the maximum polar radiated power. The "Read Value" is the spectrum reading the maximum power value.
- b. The substitution horn antenna is substituted for EUT at the same position and signals generator export the CW signal to the substitution antenna via a TX cable. Rotated the Turn Table and moved receiving antenna to find the maximum radiation power. Adjust output power level of S.G to get a Value of spectrum reading equal to "Read Value" of step a. Record the power level of S.G
- c. $\text{EIRP} = \text{Output power level of S.G} - \text{TX cable loss} + \text{Antenna gain of substitution horn}$.
- d. E.R.P power can be calculated form E.I.R.P power by subtracting the gain of dipole, $\text{E.R.P power} = \text{E.I.R.P power} - 2.15\text{dBi}$.

NOTE: The resolution bandwidth and video bandwidth of test receiver/spectrum analyzer is 1MHz/3MHz.

4.6.3 DEVIATION FROM TEST STANDARD

No deviation

4.6.4 TEST SETUP

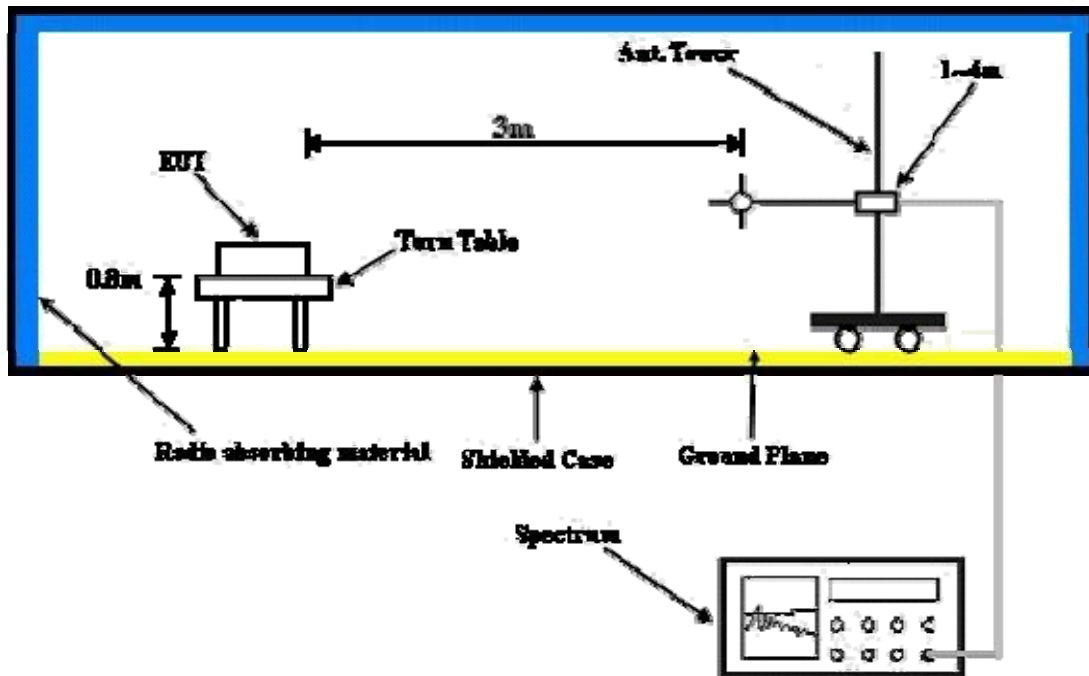

For the actual test configuration, please refer to the attached file (Test Setup Photo).



4.6.5 TEST RESULTS

CDMA

MODE	TX channel 1013	FREQUENCY RANGE	Below 1000MHz
ENVIRONMENTAL CONDITIONS	24deg. C, 64%RH	INPUT POWER	120Vac, 60Hz
TESTED BY	Ted Chang		

ANTENNA POLARITY & TEST DISTANCE: HORIZONTAL AT 3 M							
No.	Freq. (MHz)	Reading (dBm)	S.G Power Value (dBm)	Correction Factor (dB)	ERP (dBm)	Limit (dBm)	Margin (dB)
1	57.21	-63.42	-59.16	-8.20	-67.36	-13.00	-54.36
2	144.69	-66.38	-72.98	-0.24	-73.22	-13.00	-60.22
3	197.17	-63.63	-76.69	5.11	-71.58	-13.00	-58.58
4	401.28	-76.94	-84.40	5.28	-79.12	-13.00	-66.12
5	556.79	-76.62	-83.14	4.62	-78.52	-13.00	-65.52
6	712.30	-77.27	-80.52	5.10	-75.42	-13.00	-62.42
ANTENNA POLARITY & TEST DISTANCE: VERTICAL AT 3 M							
No.	Freq. (MHz)	Reading (dBm)	S.G Power Value (dBm)	Correction Factor (dB)	ERP (dBm)	Limit (dBm)	Margin (dB)
1	45.55	-58.72	-56.81	-9.97	-66.78	-13.00	-53.78
2	105.81	-61.54	-69.83	0.64	-69.19	-13.00	-56.19
3	166.07	-68.18	-70.28	1.15	-69.13	-13.00	-56.13
4	379.90	-77.61	-84.69	5.25	-79.44	-13.00	-66.44
5	523.75	-76.62	-81.48	4.78	-76.70	-13.00	-63.70
6	679.26	-77.27	-78.58	5.07	-73.51	-13.00	-60.51

REMARKS:

1. ERP(dBm) = S.G Power Value (dBm) + Correction Factor (dB).
2. Correction Factor = gain of substitution antenna + cable loss



MODE	TX channel 1013	FREQUENCY RANGE	Above 1000MHz
ENVIRONMENTAL CONDITIONS	24deg. C, 64%RH	INPUT POWER	120Vac, 60Hz
TESTED BY	Ted Chang		

ANTENNA POLARITY & TEST DISTANCE: HORIZONTAL AT 3 M							
No.	Freq. (MHz)	Reading (dBm)	S.G Power Value (dBm)	Correction Factor (dB)	ERP (dBm)	Limit (dBm)	Margin (dB)
1	1649.40	-54.79	-57.53	5.49	-52.04	-13.00	-39.04
2	2474.10	-58.94	-58.89	6.43	-52.46	-13.00	-39.46
ANTENNA POLARITY & TEST DISTANCE: VERTICAL AT 3 M							
No.	Freq. (MHz)	Reading (dBm)	S.G Power Value (dBm)	Correction Factor (dB)	ERP (dBm)	Limit (dBm)	Margin (dB)
1	1649.40	-49.80	-54.47	5.49	-48.98	-13.00	-35.98
2	2474.10	-57.11	-56.91	6.43	-50.48	-13.00	-37.48

REMARKS:

1. ERP(dBm) = S.G Power Value (dBm) + Correction Factor (dB).
2. Correction Factor = gain of substitution antenna + cable loss

MODE	TX channel 384	FREQUENCY RANGE	Above 1000MHz
ENVIRONMENTAL CONDITIONS	24deg. C, 64%RH	INPUT POWER	120Vac, 60Hz
TESTED BY	Ted Chang		

ANTENNA POLARITY & TEST DISTANCE: HORIZONTAL AT 3 M							
No.	Freq. (MHz)	Reading (dBm)	S.G Power Value (dBm)	Correction Factor (dB)	ERP (dBm)	Limit (dBm)	Margin (dB)
1	1673.04	-58.13	-60.96	5.54	-55.42	-13.00	-42.42
2	2509.56	-56.16	-55.96	6.45	-49.51	-13.00	-36.51
ANTENNA POLARITY & TEST DISTANCE: VERTICAL AT 3 M							
No.	Freq. (MHz)	Reading (dBm)	S.G Power Value (dBm)	Correction Factor (dB)	ERP (dBm)	Limit (dBm)	Margin (dB)
1	1673.04	-55.05	-59.68	5.54	-54.14	-13.00	-41.14
2	2509.56	-57.12	-56.89	6.45	-50.44	-13.00	-37.44

REMARKS:

1. ERP(dBm) = S.G Power Value (dBm) + Correction Factor (dB).
2. Correction Factor = gain of substitution antenna + cable loss



A D T

MODE	TX channel 777	FREQUENCY RANGE	Above 1000MHz
ENVIRONMENTAL CONDITIONS	24deg. C, 64%RH	INPUT POWER	120Vac, 60Hz
TESTED BY	Ted Chang		

ANTENNA POLARITY & TEST DISTANCE: HORIZONTAL AT 3 M							
No.	Freq. (MHz)	Reading (dBm)	S.G Power Value (dBm)	Correction Factor (dB)	ERP (dBm)	Limit (dBm)	Margin (dB)
1	1696.62	-55.84	-58.76	5.59	-53.17	-13.00	-40.17
2	2544.93	-55.79	-55.34	6.44	-48.90	-13.00	-35.90

ANTENNA POLARITY & TEST DISTANCE: VERTICAL AT 3 M							
No.	Freq. (MHz)	Reading (dBm)	S.G Power Value (dBm)	Correction Factor (dB)	ERP (dBm)	Limit (dBm)	Margin (dB)
1	1696.62	-51.26	-55.85	5.59	-50.26	-13.00	-37.26
2	2544.93	-58.39	-58.23	6.44	-51.79	-13.00	-38.79

REMARKS:

1. $ERP(dBm) = S.G \text{ Power Value (dBm)} + \text{Correction Factor (dB)}$.
2. Correction Factor = gain of substitution antenna + cable loss



A D T

LTE Band 26 (Channel Bandwidth 1.4MHz)

MODE	TX channel 26915	FREQUENCY RANGE	Below 1000MHz
ENVIRONMENTAL CONDITIONS	25deg. C, 65%RH	INPUT POWER	120Vac, 60Hz
TESTED BY	Chris Lin		

ANTENNA POLARITY & TEST DISTANCE: HORIZONTAL AT 3 M							
No.	Freq. (MHz)	Reading (dBm)	S.G Power Value (dBm)	Correction Factor (dB)	ERP (dBm)	Limit (dBm)	Margin (dB)
1	105.81	-60.29	-69.76	0.64	-69.12	-13.00	-56.12
2	187.45	-58.91	-70.95	3.88	-67.07	-13.00	-54.07
3	296.31	-67.31	-78.79	5.15	-73.64	-13.00	-60.64
4	461.54	-73.33	-80.40	5.04	-75.36	-13.00	-62.36
5	757.01	-74.66	-75.88	4.55	-71.33	-13.00	-58.33
6	990.28	-72.68	-71.25	3.90	-67.35	-13.00	-54.35

ANTENNA POLARITY & TEST DISTANCE: VERTICAL AT 3 M							
No.	Freq. (MHz)	Reading (dBm)	S.G Power Value (dBm)	Correction Factor (dB)	ERP (dBm)	Limit (dBm)	Margin (dB)
1	45.55	-55.01	-44.42	-9.97	-54.39	-13.00	-41.39
2	187.45	-61.92	-73.96	3.88	-70.08	-13.00	-57.08
3	296.31	-59.35	-70.83	5.15	-65.68	-13.00	-52.68
4	362.40	-66.47	-75.55	5.22	-70.33	-13.00	-57.33
5	527.64	-69.83	-76.57	4.76	-71.81	-13.00	-58.81
6	659.82	-71.43	-75.88	4.92	-70.96	-13.00	-57.96

REMARKS:

1. $ERP(dBm) = S.G\ Power\ Value\ (dBm) + Correction\ Factor\ (dB)$.
2. Correction Factor = gain of substitution antenna + cable loss



A D T

MODE	TX channel 26797	FREQUENCY RANGE	Above 1000MHz
ENVIRONMENTAL CONDITIONS	25deg. C, 65%RH	INPUT POWER	120Vac, 60Hz
TESTED BY	Ted Chang		

ANTENNA POLARITY & TEST DISTANCE: HORIZONTAL AT 3 M							
No.	Freq. (MHz)	Reading (dBm)	S.G Power Value (dBm)	Correction Factor (dB)	ERP (dBm)	Limit (dBm)	Margin (dB)
1	1649.40	-52.93	-55.67	5.49	-50.18	-13.00	-37.18
2	2474.10	-63.33	-63.28	6.43	-56.85	-13.00	-43.85
ANTENNA POLARITY & TEST DISTANCE: VERTICAL AT 3 M							
No.	Freq. (MHz)	Reading (dBm)	S.G Power Value (dBm)	Correction Factor (dB)	ERP (dBm)	Limit (dBm)	Margin (dB)
1	1649.40	-47.50	-52.17	5.49	-46.68	-13.00	-33.68
2	2474.10	-62.88	-62.68	6.43	-56.25	-13.00	-43.25

REMARKS:

1. $ERP(dBm) = S.G \text{ Power Value (dBm)} + \text{Correction Factor (dB)}$.
2. Correction Factor = gain of substitution antenna + cable loss

MODE	TX channel 26915	FREQUENCY RANGE	Above 1000MHz
ENVIRONMENTAL CONDITIONS	25deg. C, 65%RH	INPUT POWER	120Vac, 60Hz
TESTED BY	Ted Chang		

ANTENNA POLARITY & TEST DISTANCE: HORIZONTAL AT 3 M							
No.	Freq. (MHz)	Reading (dBm)	S.G Power Value (dBm)	Correction Factor (dB)	ERP (dBm)	Limit (dBm)	Margin (dB)
1	1673.00	-54.51	-57.34	5.54	-51.80	-13.00	-38.80
2	2509.50	-61.49	-61.29	6.45	-54.84	-13.00	-41.84
ANTENNA POLARITY & TEST DISTANCE: VERTICAL AT 3 M							
No.	Freq. (MHz)	Reading (dBm)	S.G Power Value (dBm)	Correction Factor (dB)	ERP (dBm)	Limit (dBm)	Margin (dB)
1	1673.00	-46.80	-51.43	5.54	-45.89	-13.00	-32.89
2	2509.50	-62.40	-62.17	6.45	-55.72	-13.00	-42.72

REMARKS:

1. $ERP(dBm) = S.G \text{ Power Value (dBm)} + \text{Correction Factor (dB)}$.
2. Correction Factor = gain of substitution antenna + cable loss



A D T

MODE	TX channel 27033	FREQUENCY RANGE	Above 1000MHz
ENVIRONMENTAL CONDITIONS	25deg. C, 65%RH	INPUT POWER	120Vac, 60Hz
TESTED BY	Ted Chang		

ANTENNA POLARITY & TEST DISTANCE: HORIZONTAL AT 3 M							
No.	Freq. (MHz)	Reading (dBm)	S.G Power Value (dBm)	Correction Factor (dB)	ERP (dBm)	Limit (dBm)	Margin (dB)
1	1696.60	-58.96	-61.88	5.59	-56.29	-13.00	-43.29
2	2544.90	-60.63	-60.18	6.44	-53.74	-13.00	-40.74
3	3393.20	-60.78	-59.35	7.02	-52.33	-13.00	-39.33
ANTENNA POLARITY & TEST DISTANCE: VERTICAL AT 3 M							
No.	Freq. (MHz)	Reading (dBm)	S.G Power Value (dBm)	Correction Factor (dB)	ERP (dBm)	Limit (dBm)	Margin (dB)
1	1696.60	-55.76	-60.35	5.59	-54.76	-13.00	-41.76
2	2544.90	-61.75	-61.59	6.44	-55.15	-13.00	-42.15
3	3393.20	-62.87	-61.56	7.02	-54.54	-13.00	-41.54

REMARKS:

1. $ERP(dBm) = S.G\ Power\ Value\ (dBm) + Correction\ Factor\ (dB)$.
2. Correction Factor = gain of substitution antenna + cable loss



LTE Band 26 (Channel Bandwidth 3MHz)

MODE	TX channel 26915	FREQUENCY RANGE	Below 1000MHz
ENVIRONMENTAL CONDITIONS	25deg. C, 65%RH	INPUT POWER	120Vac, 60Hz
TESTED BY	Chris Lin		

ANTENNA POLARITY & TEST DISTANCE: HORIZONTAL AT 3 M							
No.	Freq. (MHz)	Reading (dBm)	S.G Power Value (dBm)	Correction Factor (dB)	ERP (dBm)	Limit (dBm)	Margin (dB)
1	45.55	-69.41	-58.82	-9.97	-68.79	-13.00	-55.79
2	185.51	-58.69	-70.35	3.62	-66.73	-13.00	-53.73
3	296.31	-67.86	-79.34	5.15	-74.19	-13.00	-61.19
4	461.54	-73.12	-80.19	5.04	-75.15	-13.00	-62.15
5	757.01	-74.92	-76.14	4.55	-71.59	-13.00	-58.59
6	959.18	-77.28	-76.23	3.91	-72.32	-13.00	-59.32

ANTENNA POLARITY & TEST DISTANCE: VERTICAL AT 3 M							
No.	Freq. (MHz)	Reading (dBm)	S.G Power Value (dBm)	Correction Factor (dB)	ERP (dBm)	Limit (dBm)	Margin (dB)
1	43.61	-56.38	-45.00	-10.29	-55.29	-13.00	-42.29
2	187.45	-62.10	-74.14	3.88	-70.26	-13.00	-57.26
3	296.31	-60.13	-71.61	5.15	-66.46	-13.00	-53.46
4	362.40	-66.01	-75.09	5.22	-69.87	-13.00	-56.87
5	521.80	-71.25	-77.99	4.78	-73.21	-13.00	-60.21
6	801.72	-73.74	-74.61	4.02	-70.59	-13.00	-57.59

REMARKS:

- 1. $ERP(dBm) = S.G\ Power\ Value\ (dBm) + Correction\ Factor\ (dB)$.
- 2. Correction Factor = gain of substitution antenna + cable loss



A D T

MODE	TX channel 26805	FREQUENCY RANGE	Above 1000MHz
ENVIRONMENTAL CONDITIONS	25deg. C, 65%RH	INPUT POWER	120Vac, 60Hz
TESTED BY	Ted Chang		

ANTENNA POLARITY & TEST DISTANCE: HORIZONTAL AT 3 M							
No.	Freq. (MHz)	Reading (dBm)	S.G Power Value (dBm)	Correction Factor (dB)	ERP (dBm)	Limit (dBm)	Margin (dB)
1	1651.00	-54.53	-57.27	5.48	-51.79	-13.00	-38.79
2	2476.50	-62.82	-62.77	6.44	-56.33	-13.00	-43.33
ANTENNA POLARITY & TEST DISTANCE: VERTICAL AT 3 M							
No.	Freq. (MHz)	Reading (dBm)	S.G Power Value (dBm)	Correction Factor (dB)	ERP (dBm)	Limit (dBm)	Margin (dB)
1	1651.00	-47.11	-51.77	5.48	-46.29	-13.00	-33.29
2	2476.50	-60.55	-60.35	6.44	-53.91	-13.00	-40.91

REMARKS:

1. ERP(dBm) = S.G Power Value (dBm) + Correction Factor (dB).
2. Correction Factor = gain of substitution antenna + cable loss

MODE	TX channel 26915	FREQUENCY RANGE	Above 1000MHz
ENVIRONMENTAL CONDITIONS	25deg. C, 65%RH	INPUT POWER	120Vac, 60Hz
TESTED BY	Ted Chang		

ANTENNA POLARITY & TEST DISTANCE: HORIZONTAL AT 3 M							
No.	Freq. (MHz)	Reading (dBm)	S.G Power Value (dBm)	Correction Factor (dB)	ERP (dBm)	Limit (dBm)	Margin (dB)
1	1673.00	-55.51	-58.34	5.54	-52.80	-13.00	-39.80
2	2509.50	-61.66	-61.46	6.45	-55.01	-13.00	-42.01
ANTENNA POLARITY & TEST DISTANCE: VERTICAL AT 3 M							
No.	Freq. (MHz)	Reading (dBm)	S.G Power Value (dBm)	Correction Factor (dB)	ERP (dBm)	Limit (dBm)	Margin (dB)
1	1673.00	-46.25	-50.88	5.54	-45.34	-13.00	-32.34
2	2509.50	-60.89	-60.66	6.45	-54.21	-13.00	-41.21

REMARKS:

1. ERP(dBm) = S.G Power Value (dBm) + Correction Factor (dB).
2. Correction Factor = gain of substitution antenna + cable loss



A D T

MODE	TX channel 27025	FREQUENCY RANGE	Above 1000MHz
ENVIRONMENTAL CONDITIONS	25deg. C, 65%RH	INPUT POWER	120Vac, 60Hz
TESTED BY	Ted Chang		

ANTENNA POLARITY & TEST DISTANCE: HORIZONTAL AT 3 M							
No.	Freq. (MHz)	Reading (dBm)	S.G Power Value (dBm)	Correction Factor (dB)	ERP (dBm)	Limit (dBm)	Margin (dB)
1	1695.00	-57.65	-60.57	5.59	-54.98	-13.00	-41.98
2	2542.50	-60.88	-60.45	6.44	-54.01	-13.00	-41.01
3	3390.00	-64.52	-63.09	7.02	-56.07	-13.00	-43.07
ANTENNA POLARITY & TEST DISTANCE: VERTICAL AT 3 M							
No.	Freq. (MHz)	Reading (dBm)	S.G Power Value (dBm)	Correction Factor (dB)	ERP (dBm)	Limit (dBm)	Margin (dB)
1	1695.00	-48.74	-53.34	5.59	-47.75	-13.00	-34.75
2	2542.50	-60.41	-60.25	6.44	-53.81	-13.00	-40.81
3	3390.00	-63.74	-62.44	7.02	-55.42	-13.00	-42.42

REMARKS:

1. $ERP(dBm) = S.G \text{ Power Value (dBm)} + \text{Correction Factor (dB)}$.
2. Correction Factor = gain of substitution antenna + cable loss



LTE Band 26 (Channel Bandwidth 5MHz)

MODE	TX channel 26815	FREQUENCY RANGE	Below 1000MHz
ENVIRONMENTAL CONDITIONS	25deg. C, 65%RH	INPUT POWER	120Vac, 60Hz
TESTED BY	Chris Lin		

ANTENNA POLARITY & TEST DISTANCE: HORIZONTAL AT 3 M							
No.	Freq. (MHz)	Reading (dBm)	S.G Power Value (dBm)	Correction Factor (dB)	ERP (dBm)	Limit (dBm)	Margin (dB)
1	109.70	-61.11	-70.24	0.49	-69.75	-13.00	-56.75
2	187.45	-59.12	-71.16	3.88	-67.28	-13.00	-54.28
3	296.31	-67.95	-79.43	5.15	-74.28	-13.00	-61.28
4	700.64	-74.94	-78.79	5.24	-73.55	-13.00	-60.55
5	801.72	-74.20	-75.07	4.02	-71.05	-13.00	-58.05
6	990.28	-73.97	-72.54	3.90	-68.64	-13.00	-55.64

ANTENNA POLARITY & TEST DISTANCE: VERTICAL AT 3 M							
No.	Freq. (MHz)	Reading (dBm)	S.G Power Value (dBm)	Correction Factor (dB)	ERP (dBm)	Limit (dBm)	Margin (dB)
1	45.55	-56.17	-45.58	-9.97	-55.55	-13.00	-42.55
2	187.45	-62.83	-74.87	3.88	-70.99	-13.00	-57.99
3	296.31	-60.75	-72.23	5.15	-67.08	-13.00	-54.08
4	527.64	-70.76	-77.50	4.76	-72.74	-13.00	-59.74
5	757.01	-74.20	-75.42	4.55	-70.87	-13.00	-57.87
6	990.28	-76.02	-74.59	3.90	-70.69	-13.00	-57.69

REMARKS:

1. $ERP(dBm) = S.G\ Power\ Value\ (dBm) + Correction\ Factor\ (dB)$.
2. Correction Factor = gain of substitution antenna + cable loss



MODE	TX channel 26815	FREQUENCY RANGE	Above 1000MHz
ENVIRONMENTAL CONDITIONS	25deg. C, 65%RH	INPUT POWER	120Vac, 60Hz
TESTED BY	Ted Chang		

ANTENNA POLARITY & TEST DISTANCE: HORIZONTAL AT 3 M							
No.	Freq. (MHz)	Reading (dBm)	S.G Power Value (dBm)	Correction Factor (dB)	ERP (dBm)	Limit (dBm)	Margin (dB)
1	1653.00	-53.57	-56.32	5.49	-50.83	-13.00	-37.83
2	2479.50	-62.31	-62.25	6.44	-55.81	-13.00	-42.81
ANTENNA POLARITY & TEST DISTANCE: VERTICAL AT 3 M							
No.	Freq. (MHz)	Reading (dBm)	S.G Power Value (dBm)	Correction Factor (dB)	ERP (dBm)	Limit (dBm)	Margin (dB)
1	1653.00	-47.11	-51.77	5.49	-46.28	-13.00	-33.28
2	2479.50	-60.22	-60.02	6.44	-53.58	-13.00	-40.58

REMARKS:

1. $ERP(dBm) = S.G\ Power\ Value\ (dBm) + Correction\ Factor\ (dB)$.
2. Correction Factor = gain of substitution antenna + cable loss

MODE	TX channel 26915	FREQUENCY RANGE	Above 1000MHz
ENVIRONMENTAL CONDITIONS	25deg. C, 65%RH	INPUT POWER	120Vac, 60Hz
TESTED BY	Ted Chang		

ANTENNA POLARITY & TEST DISTANCE: HORIZONTAL AT 3 M							
No.	Freq. (MHz)	Reading (dBm)	S.G Power Value (dBm)	Correction Factor (dB)	ERP (dBm)	Limit (dBm)	Margin (dB)
1	1673.00	-54.22	-57.05	5.54	-51.51	-13.00	-38.51
2	2509.50	-64.95	-64.75	6.45	-58.30	-13.00	-45.30
ANTENNA POLARITY & TEST DISTANCE: VERTICAL AT 3 M							
No.	Freq. (MHz)	Reading (dBm)	S.G Power Value (dBm)	Correction Factor (dB)	ERP (dBm)	Limit (dBm)	Margin (dB)
1	1673.00	-49.82	-54.45	5.54	-48.91	-13.00	-35.91
2	2509.50	-61.51	-61.28	6.45	-54.83	-13.00	-41.83

REMARKS:

1. $ERP(dBm) = S.G\ Power\ Value\ (dBm) + Correction\ Factor\ (dB)$.
2. Correction Factor = gain of substitution antenna + cable loss



A D T

MODE	TX channel 27015	FREQUENCY RANGE	Above 1000MHz
ENVIRONMENTAL CONDITIONS	25deg. C, 65%RH	INPUT POWER	120Vac, 60Hz
TESTED BY	Ted Chang		

ANTENNA POLARITY & TEST DISTANCE: HORIZONTAL AT 3 M							
No.	Freq. (MHz)	Reading (dBm)	S.G Power Value (dBm)	Correction Factor (dB)	ERP (dBm)	Limit (dBm)	Margin (dB)
1	1693.00	-49.87	-52.79	5.59	-47.20	-13.00	-34.20
2	2539.50	-60.41	-59.99	6.43	-53.56	-13.00	-40.56
3	3386.00	-62.36	-60.92	7.01	-53.91	-13.00	-40.91
ANTENNA POLARITY & TEST DISTANCE: VERTICAL AT 3 M							
No.	Freq. (MHz)	Reading (dBm)	S.G Power Value (dBm)	Correction Factor (dB)	ERP (dBm)	Limit (dBm)	Margin (dB)
1	1693.00	-50.87	-55.48	5.59	-49.89	-13.00	-36.89
2	2539.50	-61.74	-61.56	6.43	-55.13	-13.00	-42.13
3	3386.00	-63.47	-62.17	7.01	-55.16	-13.00	-42.16

REMARKS:

1. $ERP(dBm) = S.G\ Power\ Value\ (dBm) + Correction\ Factor\ (dB)$.
2. Correction Factor = gain of substitution antenna + cable loss



A D T

LTE Band 26 (Channel Bandwidth 10MHz)

MODE	TX channel 26915	FREQUENCY RANGE	Below 1000MHz
ENVIRONMENTAL CONDITIONS	25deg. C, 65%RH	INPUT POWER	120Vac, 60Hz
TESTED BY	Chris Lin		

ANTENNA POLARITY & TEST DISTANCE: HORIZONTAL AT 3 M

No.	Freq. (MHz)	Reading (dBm)	S.G Power Value (dBm)	Correction Factor (dB)	ERP (dBm)	Limit (dBm)	Margin (dB)
1	45.55	-69.72	-59.13	-9.97	-69.10	-13.00	-56.10
2	109.70	-60.96	-70.09	0.49	-69.60	-13.00	-56.60
3	187.45	-59.68	-71.72	3.88	-67.84	-13.00	-54.84
4	362.40	-71.41	-80.49	5.22	-75.27	-13.00	-62.27
5	757.01	-75.46	-76.68	4.55	-72.13	-13.00	-59.13
6	990.28	-74.68	-73.25	3.90	-69.35	-13.00	-56.35

ANTENNA POLARITY & TEST DISTANCE: VERTICAL AT 3 M

No.	Freq. (MHz)	Reading (dBm)	S.G Power Value (dBm)	Correction Factor (dB)	ERP (dBm)	Limit (dBm)	Margin (dB)
1	43.61	-56.81	-45.43	-10.29	-55.72	-13.00	-42.72
2	187.45	-63.77	-75.81	3.88	-71.93	-13.00	-58.93
3	230.22	-63.42	-76.95	5.43	-71.52	-13.00	-58.52
4	296.31	-59.99	-71.47	5.15	-66.32	-13.00	-53.32
5	362.40	-65.83	-74.91	5.22	-69.69	-13.00	-56.69
6	521.80	-71.25	-77.99	4.78	-73.21	-13.00	-60.21

REMARKS:

1. $ERP(dBm) = S.G\ Power\ Value\ (dBm) + Correction\ Factor\ (dB).$
2. Correction Factor = gain of substitution antenna + cable loss



A D T

MODE	TX channel 26840	FREQUENCY RANGE	Above 1000MHz
ENVIRONMENTAL CONDITIONS	25deg. C, 65%RH	INPUT POWER	120Vac, 60Hz
TESTED BY	Ted Chang		

ANTENNA POLARITY & TEST DISTANCE: HORIZONTAL AT 3 M							
No.	Freq. (MHz)	Reading (dBm)	S.G Power Value (dBm)	Correction Factor (dB)	ERP (dBm)	Limit (dBm)	Margin (dB)
1	1658.00	-52.15	-54.93	5.51	-49.42	-13.00	-36.42
2	2487.00	-63.55	-63.47	6.45	-57.02	-13.00	-44.02
ANTENNA POLARITY & TEST DISTANCE: VERTICAL AT 3 M							
No.	Freq. (MHz)	Reading (dBm)	S.G Power Value (dBm)	Correction Factor (dB)	ERP (dBm)	Limit (dBm)	Margin (dB)
1	1658.00	-49.66	-54.32	5.51	-48.81	-13.00	-35.81
2	2487.00	-60.33	-60.12	6.45	-53.67	-13.00	-40.67

REMARKS:

1. ERP(dBm) = S.G Power Value (dBm) + Correction Factor (dB).
2. Correction Factor = gain of substitution antenna + cable loss

MODE	TX channel 26915	FREQUENCY RANGE	Above 1000MHz
ENVIRONMENTAL CONDITIONS	25deg. C, 65%RH	INPUT POWER	120Vac, 60Hz
TESTED BY	Ted Chang		

ANTENNA POLARITY & TEST DISTANCE: HORIZONTAL AT 3 M							
No.	Freq. (MHz)	Reading (dBm)	S.G Power Value (dBm)	Correction Factor (dB)	ERP (dBm)	Limit (dBm)	Margin (dB)
1	1673.00	-51.59	-54.42	5.54	-48.88	-13.00	-35.88
2	2509.50	-63.57	-63.37	6.45	-56.92	-13.00	-43.92
ANTENNA POLARITY & TEST DISTANCE: VERTICAL AT 3 M							
No.	Freq. (MHz)	Reading (dBm)	S.G Power Value (dBm)	Correction Factor (dB)	ERP (dBm)	Limit (dBm)	Margin (dB)
1	1673.00	-47.58	-52.21	5.54	-46.67	-13.00	-33.67
2	2509.50	-59.71	-59.48	6.45	-53.03	-13.00	-40.03

REMARKS:

1. ERP(dBm) = S.G Power Value (dBm) + Correction Factor (dB).
2. Correction Factor = gain of substitution antenna + cable loss



A D T

MODE	TX channel 26990	FREQUENCY RANGE	Above 1000MHz
ENVIRONMENTAL CONDITIONS	25deg. C, 65%RH	INPUT POWER	120Vac, 60Hz
TESTED BY	Ted Chang		

ANTENNA POLARITY & TEST DISTANCE: HORIZONTAL AT 3 M							
No.	Freq. (MHz)	Reading (dBm)	S.G Power Value (dBm)	Correction Factor (dB)	ERP (dBm)	Limit (dBm)	Margin (dB)
1	1688.00	-57.95	-60.84	5.57	-55.27	-13.00	-42.27
2	2532.00	-60.74	-60.38	6.44	-53.94	-13.00	-40.94
3	3376.00	-62.47	-61.01	6.99	-54.02	-13.00	-41.02
ANTENNA POLARITY & TEST DISTANCE: VERTICAL AT 3 M							
No.	Freq. (MHz)	Reading (dBm)	S.G Power Value (dBm)	Correction Factor (dB)	ERP (dBm)	Limit (dBm)	Margin (dB)
1	1688.00	-49.87	-54.48	5.57	-48.91	-13.00	-35.91
2	2532.00	-60.47	-60.28	6.44	-53.84	-13.00	-40.84
3	3376.00	-62.85	-61.55	6.99	-54.56	-13.00	-41.56

REMARKS:

1. $ERP(dBm) = S.G\ Power\ Value\ (dBm) + Correction\ Factor\ (dB)$.
2. Correction Factor = gain of substitution antenna + cable loss



A D T

5 PHOTOGRAPHS OF THE TEST CONFIGURATION

Please refer to the attached file (Test Setup Photo).



6 INFORMATION ON THE TESTING LABORATORIES

We, Bureau Veritas Consumer Products Services (H.K.) Ltd., Taoyuan Branch, were founded in 1988 to provide our best service in EMC, Radio, Telecom and Safety consultation. Our laboratories are accredited and approved according to ISO/IEC 17025.

If you have any comments, please feel free to contact us at the following:

Linko EMC/RF Lab:

Tel: 886-2-26052180

Fax: 886-2-26051924

Hsin Chu EMC/RF Lab:

Tel: 886-3-5935343

Fax: 886-3-5935342

Hwa Ya EMC/RF/Safety/Telecom Lab:

Tel: 886-3-3183232

Fax: 886-3-3270892

Email: service.adt@tw.bureauveritas.com

Web Site: www.bureauveritas-adt.com

The address and road map of all our labs can be found in our web site also.



A D T

7 APPENDIX A – MODIFICATIONS RECORDERS FOR ENGINEERING CHANGES TO THE EUT BY THE LAB

No any modifications were made to the EUT by the lab during the test.

---END---