



FCC TEST REPORT (PART 27)

REPORT NO.: RF991230C03-2

MODEL NO.: C505

FCC ID: UZI-C505

RECEIVED: Dec. 30, 2010

TESTED: Jan. 05 ~ Jan. 25, 2011

ISSUED: Jan. 27, 2011

APPLICANT: BandRich Inc.

ADDRESS: 7F., No. 188, Baociao Rd., Sindian City, Taipei
County 23146, Taiwan (R.O.C.)

ISSUED BY: Bureau Veritas Consumer Products Services
(H.K.) Ltd., Taoyuan Branch

LAB ADDRESS: No. 47, 14th Ling, Chia Pau Tsuen, Lin Kou
Hsiang, Taipei Hsien 244, Taiwan, R.O.C.

TEST LOCATION: No. 19, Hwa Ya 2nd Rd, Wen Hwa Tsuen, Kwei
Shan Hsiang, Taoyuan Hsien 333, Taiwan, R.O.C.

This test report consists of 131 pages in total. It may be duplicated completely for legal use with the approval of the applicant. It should not be reproduced except in full, without the written approval of our laboratory. The client should not use it to claim product, certification, approval or endorsement by TAF or any government agency. The test results in the report only apply to the tested sample.





TABLE OF CONTENTS

RELEASE CONTROL RECORD.....	4
1 CERTIFICATION	5
2 SUMMARY OF TEST RESULTS	6
2.1 MEASUREMENT UNCERTAINTY	7
3 GENERAL INFORMATION.....	8
3.1 GENERAL DESCRIPTION OF EUT.....	8
3.2 DESCRIPTION OF TEST MODES.....	9
3.2.1 CONFIGURATION OF SYSTEM UNDER TEST	10
3.2.2 TEST MODE APPLICABILITY AND TESTED CHANNEL DETAIL.....	11
3.3 GENERAL DESCRIPTION OF APPLIED STANDARDS	15
3.4 DESCRIPTION OF SUPPORT UNITS	15
4 TEST TYPES AND RESULTS	16
4.1 OUTPUT POWER MEASUREMENT	16
4.1.1 LIMITS OF OUTPUT POWER MEASUREMENT	16
4.1.2 TEST INSTRUMENTS	17
4.1.3 TEST PROCEDURES	18
4.1.4 TEST SETUP	19
4.1.5 EUT OPERATING CONDITIONS	19
4.1.6 TEST RESULTS	20
4.2 FREQUENCY STABILITY MEASUREMENT	35
4.2.1 LIMITS OF FREQUENCY STABILITY MEASUREMENT	35
4.2.2 TEST INSTRUMENTS	35
4.2.3 TEST PROCEDURE	36
4.2.4 TEST SETUP	36
4.2.5 TEST RESULTS	37
4.3 OCCUPIED BANDWIDTH MEASUREMENT	38
4.3.1 LIMITS OF OCCUPIED BANDWIDTH MEASUREMENT	38
4.3.2 TEST INSTRUMENTS	38
4.3.3 TEST SETUP	38
4.3.4 TEST PROCEDURES	39
4.3.5 TEST RESULTS	40
4.4 PEAK TO AVERAGE RATIO	51
4.4.1 LIMITS OF PEAK TO AVERAGE RATIO MEASUREMENT	51
4.4.2 TEST INSTRUMENTS	51
4.4.3 TEST SETUP	51
4.4.4 TEST PROCEDURES	52
4.4.5 EUT OPERATING CONDITION	52
4.4.6 TEST RESULTS	53
4.5 BAND EDGE MEASUREMENT	64



A D T

4.5.1	LIMITS OF BAND EDGE MEASUREMENT	64
4.5.2	TEST INSTRUMENTS	65
4.5.3	TEST SETUP	65
4.5.4	TEST PROCEDURES	66
4.5.5	EUT OPERATING CONDITION	66
4.5.6	TEST RESULTS	67
4.6	CONDUCTED SPURIOUS EMISSIONS	82
4.6.1	LIMITS OF CONDUCTED SPURIOUS EMISSIONS MEASUREMENT	82
4.6.2	TEST INSTRUMENTS	82
4.6.3	TEST PROCEDURE	83
4.6.4	TEST SETUP	83
4.6.5	EUT OPERATING CONDITIONS	83
4.6.6	TEST RESULTS	84
4.7	RADIATED EMISSION MEASUREMENT	111
4.7.1	LIMITS OF RADIATED EMISSION MEASUREMENT	111
4.7.2	TEST INSTRUMENTS	112
4.7.3	TEST PROCEDURES	113
4.7.4	DEVIATION FROM TEST STANDARD	113
4.7.5	TEST SETUP	114
4.7.6	EUT OPERATING CONDITIONS	114
4.7.7	TEST RESULTS (BELOW 1GHz)	115
4.7.8	TEST RESULTS (ABOVE 1GHz)	120
5	INFORMATION ON THE TESTING LABORATORIES	130
6	APPENDIX A – MODIFICATIONS RECORDERS FOR ENGINEERING CHANGES TO THE EUT BY THE LAB.....	131



A D T

RELEASE CONTROL RECORD

ISSUE NO.	REASON FOR CHANGE	DATE ISSUED
Original release	N/A	Jan. 27, 2011



1 CERTIFICATION

PRODUCT : LTE USB Modem

BRAND : BandLuxe

MODEL : C505

APPLICANT : BandRich Inc.

TESTED : Jan. 05 ~ Jan. 25, 2011

TEST SAMPLE : ENGINEERING SAMPLE

TEST STANDARDS : FCC Part 27, Subpart C, L

FCC Part 2

ANSI C63.4-2003

The above equipment (model: C505) has been tested by **Bureau Veritas Consumer Products Services (H.K.) Ltd., Taoyuan Branch**, and found compliance with the requirement of the above standards. The test record, data evaluation & Equipment Under Test (EUT) configurations represented herein are true and accurate accounts of the measurements of the sample's EMC characteristics under the conditions specified in this report.

PREPARED BY :  , **DATE**: Jan. 27, 2011
Pettie Chen / Specialist

APPROVED BY :  , **DATE**: Jan. 27, 2011
Gary Chang / Assistant Manager

2 SUMMARY OF TEST RESULTS

The EUT has been tested according to the following specifications:

OPERATING BAND: 704~716 MHz			
STANDARD SECTION	TEST TYPE AND LIMIT	RESULT	REMARK
2.1046 27.50(C)(10)	Maximum Peak Output Power Limit: max. 3 watts e.r.p peak power	PASS	Meet the requirement of limit. Minimum passing margin is 19.0dBm at 711.0MHz.
2.1055 27.54	Frequency Stability	PASS	Meet the requirement of limit.
2.1049 27.53(g)	Occupied Bandwidth	PASS	Meet the requirement of limit.
27.50(d)(5)	Peak to average ratio	PASS	Meet the requirement of limit.
27.53(g)	Band Edge Measurements	PASS	Meet the requirement of limit.
2.1051 27.53(g)	Conducted Spurious Emissions	PASS	Meet the requirement of limit.
2.1053 27.53(g)	Radiated Spurious Emissions	PASS	Meet the requirement of limit. Minimum passing margin is -32.0dB at 1415.68MHz.

OPERATING BAND: 1710~1755 MHz			
STANDARD SECTION	TEST TYPE AND LIMIT	RESULT	REMARK
2.1046 27.50(d)(4)	Maximum Peak Output Power Limit: max. 1 watts e.i.r.p peak power	PASS	Meet the requirement of limit. Minimum passing margin is 17.2dBm at 1732.4MHz.
2.1055 27.54	Frequency Stability	PASS	Meet the requirement of limit.
2.1049 27.53(h)	Occupied Bandwidth	PASS	Meet the requirement of limit.
27.50(d)(5)	Peak to average ratio	PASS	Meet the requirement of limit.
27.53(h)	Band Edge Measurements	PASS	Meet the requirement of limit.
2.1051 27.53(h)	Conducted Spurious Emissions	PASS	Meet the requirement of limit.
2.1053 27.53(h)	Radiated Spurious Emissions	PASS	Meet the requirement of limit. Minimum passing margin is -20.0dB at 3505.2MHz.

2.1 MEASUREMENT UNCERTAINTY

Where relevant, the following measurement uncertainty levels have been estimated for tests performed on the EUT as specified in CISPR 16-4-2:

MEASUREMENT	FREQUENCY	UNCERTAINTY
Conducted emissions	9kHz~30MHz	2.44 dB
Radiated emissions	30MHz ~ 200MHz	2.93 dB
	200MHz ~1000MHz	2.95 dB
	1GHz ~ 18GHz	2.26 dB
	18GHz ~ 40GHz	1.94 dB

This uncertainty represents an expanded uncertainty expressed at approximately the 95% confidence level using a coverage factor of k=2.

3 GENERAL INFORMATION

3.1 GENERAL DESCRIPTION OF EUT

PRODUCT	LTE USB Modem	
MODEL NO.	C505	
FCC ID	UZI-C505	
POWER SUPPLY	5.0Vdc from host equipment	
OPERATION TEMPERATURE RANGE	-20°C ~ 55°C	
MODULATION TECHNOLOGY	LTE Band 17	QPSK, 16QAM
	LTE Band 4	QPSK, 16QAM
	WCDMA AWS Band	BPSK
FREQUENCY RANGE	LTE Band 17 Channel Bandwidth: 5MHz	706.5MHz ~ 713.5MHz
	LTE Band 17 Channel Bandwidth: 10MHz	709MHz ~ 711MHz
	LTE Band 4 Channel Bandwidth: 5MHz	1712.5MHz ~1752.5MHz
	LTE Band 4 Channel Bandwidth: 10MHz	1715.0MHz ~1750.0MHz
	WCDMA AWS Band	1712.4MHz ~1752.6MHz
MAX. ERP POWER (W)	LTE Band 17 Channel Bandwidth: 5MHz	0.064W
	LTE Band 17 Channel Bandwidth: 10MHz	0.079W
MAX. EIRP POWER (W)	LTE Band 4 Channel Bandwidth: 5MHz	0.051W
	LTE Band 4 Channel Bandwidth: 10MHz	0.037W
	WCDMA AWS Band	0.053W
CATEGORY	LTE: 3	
RELEASE VERSION	WCDMA: Release 5 / 6	
ANTENNA TYPE	Refer to Note	
DATA CABLE	0.5m non-shielded USB cable without core	
I/O PORTS	Refer to user's manual	
ACCESSORY DEVICES	NA	

NOTE:

1. The EUT is a LTE USB Modem. The test data are separated into following test reports.

	TEST STANDARD	REFERENCE REPORT
GPRS/EGPRS/WCDMA 850	FCC Part 22	RF991230C03
GPRS/EGPRS/WCDMA 1900	FCC Part 24	RF991230C03-1
LTE band 17 & band 4 / WCDMA AWS Band	FCC Part 27	RF991230C03-2

2. The antennas used in this EUT are listed as below table:

Frequency Band	Embedded Monopole Antenna	Chip Antenna	Printed Antenna
LTE band 17	TX/ RX (Gain: -3dBi)	Not support	RX only
GPRS/EGPRS/WCDMA 850	TX/ RX (Gain: -2dBi)		Not support
GPRS/EGPRS/WCDMA 1900	TX/ RX (Gain: -3dBi)		
LTE band 4 / WCDMA AWS Band	TX/ RX (Gain: -7dBi)	RX only	

3. The above EUT information is declared by manufacturer and for more detailed features description, please refer to the manufacturer's specifications or User's Manual.

3.2 DESCRIPTION OF TEST MODES

LTE Band 17: 704MHz ~ 716MHz

Three channels had been tested for each channel bandwidth.

CHANNEL BANDWIDTH	5MHz		10MHz	
	Channel	Frequency(MHz)	Channel	Frequency(MHz)
Low channel (L)	23755	706.5	23780	709.0
Middle channel (M)	23790	710.0	23790	710.0
High channel (H)	23825	713.5	23800	711.0

LTE Band 4: 1710MHz ~ 1755MHz

Three channels had been tested for each channel bandwidth.

CHANNEL BANDWIDTH	5MHz		10MHz	
	Channel	Frequency(MHz)	Channel	Frequency(MHz)
Low channel (L)	19975	1712.5	20000	1715.0
Middle channel (M)	20175	1732.5	20175	1732.5
High channel (H)	20375	1752.5	20350	1750.0

WCDMA AWS Band

Three channels had been tested for each channel bandwidth.

	Channel	Frequency(MHz)
Low channel (L)	1312	1712.4
Middle channel (M)	1412	1732.4
High channel (H)	1513	1752.6

3.2.1 CONFIGURATION OF SYSTEM UNDER TEST

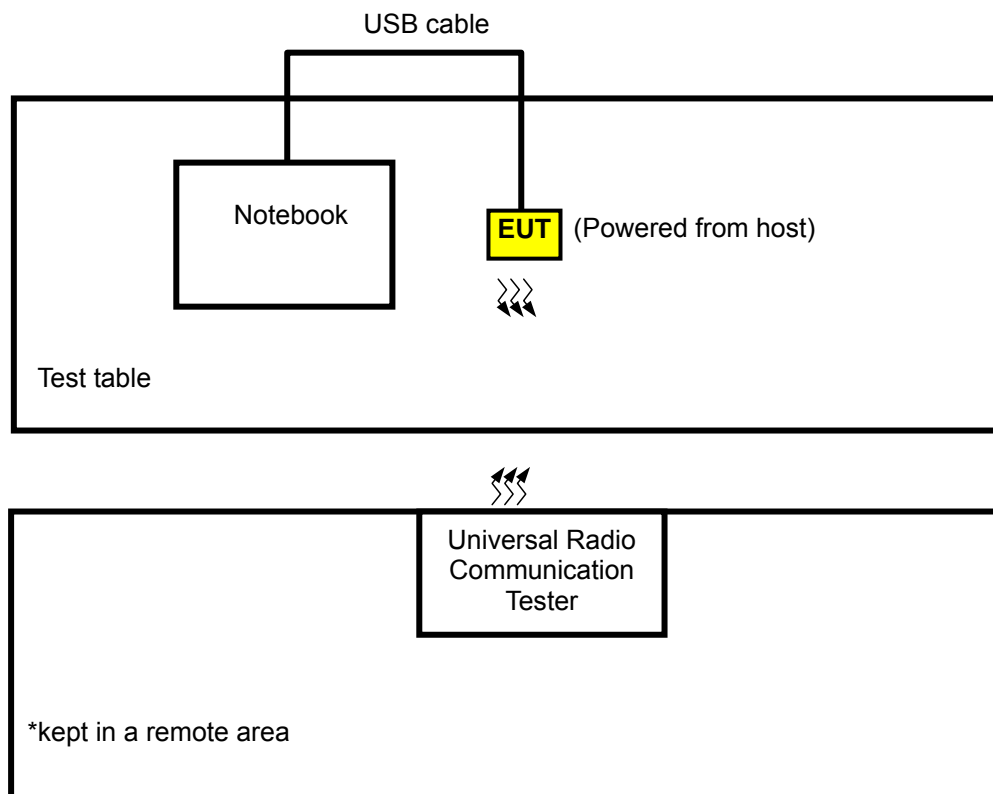

3.2.2 TEST MODE APPLICABILITY AND TESTED CHANNEL DETAIL

EUT CONFIGURE MODE	APPLICABLE TO								DESCRIPTION
	OP	FS	OB	PA	BE	CE	RE<1G	RE≥1G	
-	V	V	V	V	V	V	V	V	-

Where **OP**: Output power **FS**: Frequency stability
OB: Occupied bandwidth **PA**: Peak to Average Ratio
BE: Band edge **CE**: Conducted spurious emissions
RE<1G: Radiated emission below 1GHz **RE≥1G**: Radiated emission above 1GHz

OUTPUT POWER MEASUREMENT:

- Pre-Scan has been conducted to determine the worst-case mode from all possible combinations between available modulations, XYZ axis and antenna ports (if EUT with antenna diversity architecture).
- Following channel(s) was (were) selected for the final test as listed below.

EUT CONFIGURE MODE	OPERATING BAND	AVAILABLE CHANNEL	TESTED CHANNEL	MODULATION TECHNOLOGY	AXIS
-	LTE Band 17	23755 to 23825	23755, 23790, 23825	QPSK, 16QAM	X
-		23780 to 23800	23780, 23790, 23800	QPSK, 16QAM	X
-	LTE Band 4	19975 to 20375	19975, 20175, 20375	QPSK, 16QAM	Z
-		20000 to 20350	20000, 20175, 20350	QPSK, 16QAM	Z
-	WCDMA AWS Band	1312 to 1513	1312, 1412, 1513	BPSK	Z

FREQUENCY STABILITY MEASUREMENT:

- Pre-Scan has been conducted to determine the worst-case mode from all possible combinations between available modulations and antenna ports (if EUT with antenna diversity architecture).
- Following channel(s) was (were) selected for the final test as listed below.

EUT CONFIGURE MODE	OPERATING BAND	AVAILABLE CHANNEL	TESTED CHANNEL	MODULATION TECHNOLOGY
-	LTE Band 17	23755 to 23825	23790	QPSK
-		23780 to 23800	23790	QPSK
-	LTE Band 4	19975 to 20375	20175	QPSK
-		20000 to 20350	20175	QPSK
-	WCDMA AWS Band	1312 to 1513	1412	BPSK

OCCUPIED BANDWIDTH MEASUREMENT:

- This item includes all test value of each mode, but only includes spectrum plot of worst value of each mode.
- Pre-Scan has been conducted to determine the worst-case mode from all possible combinations between available modulations and antenna ports (if EUT with antenna diversity architecture).
- Following channel(s) was (were) selected for the final test as listed below.

EUT CONFIGURE MODE	OPERATING BAND	AVAILABLE CHANNEL	TESTED CHANNEL	MODULATION TECHNOLOGY
-	LTE Band 17	23755 to 23825	23755, 23790, 23825	QPSK, 16QAM
-		23780 to 23800	23780, 23790, 23800	QPSK, 16QAM
-	LTE Band 4	19975 to 20375	19975, 20175, 20375	QPSK, 16QAM
-		20000 to 20350	20000, 20175, 20350	QPSK, 16QAM
-	WCDMA AWS Band	1312 to 1513	1312, 1412, 1513	BPSK

PEAK TO AVERAGE RATIO:

- This item includes all test value of each mode, but only includes spectrum plot of worst value of each mode.
- Pre-Scan has been conducted to determine the worst-case mode from all possible combinations between available modulations, XYZ axis and antenna ports (if EUT with antenna diversity architecture).
- Following channel(s) was (were) selected for the final test as listed below.

EUT CONFIGURE MODE	OPERATING BAND	AVAILABLE CHANNEL	TESTED CHANNEL	MODULATION TECHNOLOGY
-	LTE Band 17	23755 to 23825	23755, 23790, 23825	QPSK, 16QAM
-		23780 to 23800	23780, 23790, 23800	QPSK, 16QAM
-	LTE Band 4	19975 to 20375	19975, 20175, 20375	QPSK, 16QAM
-		20000 to 20350	20000, 20175, 20350	QPSK, 16QAM
-	WCDMA AWS Band	1312 to 1513	1312, 1412, 1513	BPSK

BAND EDGE MEASUREMENT:

- Pre-Scan has been conducted to determine the worst-case mode from all possible combinations between available modulations, XYZ axis and antenna ports (if EUT with antenna diversity architecture).
- Following channel(s) was (were) selected for the final test as listed below.

EUT CONFIGURE MODE	OPERATING BAND	AVAILABLE CHANNEL	TESTED CHANNEL	MODULATION TECHNOLOGY
-	LTE Band 17	23755 to 23825	23755, 23825	QPSK
-		23780 to 23800	23780, 23800	QPSK
-	LTE Band 4	19975 to 20375	19975, 20375	QPSK
-		20000 to 20350	20000, 20350	QPSK
-	WCDMA AWS Band	1312 to 1513	1312, 1513	BPSK

CONDUCTED SPURIOUS EMISSIONS MEASUREMENT:

- Pre-Scan has been conducted to determine the worst-case mode from all possible combinations between available modulations and antenna ports (if EUT with antenna diversity architecture).
- Following channel(s) was (were) selected for the final test as listed below.

EUT CONFIGURE MODE	OPERATING BAND	AVAILABLE CHANNEL	TESTED CHANNEL	MODULATION TECHNOLOGY
-	LTE Band 17	23755 to 23825	23755, 23790, 23825	QPSK
-		23780 to 23800	23780, 23790, 23800	QPSK
-	LTE Band 4	19975 to 20375	19975, 20175, 20375	QPSK
-		20000 to 20350	20000, 20175, 20350	QPSK
-	WCDMA AWS Band	1312 to 1513	1312, 1412, 1513	BPSK

RADIATED EMISSION MEASUREMENT (BELOW 1 GHz):

- Pre-Scan has been conducted to determine the worst-case mode from all possible combinations between available modulations, XYZ axis and antenna ports (if EUT with antenna diversity architecture).
- Following channel(s) was (were) selected for the final test as listed below.

EUT CONFIGURE MODE	OPERATING BAND	AVAILABLE CHANNEL	TESTED CHANNEL	MODULATION TECHNOLOGY	AXIS
-	LTE Band 17	23755 to 23825	23755	QPSK	X
-		23780 to 23800	23780	QPSK	X
-	LTE Band 4	19975 to 20375	19975	QPSK	Z
-		20000 to 20350	20000	QPSK	Z
-	WCDMA AWS Band	1312 to 1513	1312	BPSK	Z

RADIATED EMISSION MEASUREMENT (ABOVE 1 GHz):

- Pre-Scan has been conducted to determine the worst-case mode from all possible combinations between available modulations, XYZ axis and antenna ports (if EUT with antenna diversity architecture).
- Following channel(s) was (were) selected for the final test as listed below.

EUT CONFIGURE MODE	OPERATING BAND	AVAILABLE CHANNEL	TESTED CHANNEL	MODULATION TECHNOLOGY	AXIS
-	LTE Band 17	23755 to 23825	23755, 23790, 23825	QPSK	X
-		23780 to 23800	23780, 23790, 23800	QPSK	X
-	LTE Band 4	19975 to 20375	19975, 20175, 20375	QPSK	Z
-		20000 to 20350	20000, 20175, 20350	QPSK	Z
-	WCDMA AWS Band	1312 to 1513	1312, 1412, 1513	BPSK	Z

TEST CONDITION:

APPLICABLE TO	ENVIRONMENTAL CONDITIONS	INPUT POWER (SYSTEM)	TESTED BY
OP	23deg. C, 65%RH, 1010 hPa	120Vac, 60Hz	David Huang
FS	23deg. C, 65%RH, 1010 hPa	120Vac, 60Hz	David Huang
OB	23deg. C, 65%RH, 1010 hPa	120Vac, 60Hz	David Huang
PA	23deg. C, 65%RH, 1010 hPa	120Vac, 60Hz	David Huang
BE	23deg. C, 65%RH, 1010 hPa	120Vac, 60Hz	David Huang
CE	23deg. C, 65%RH, 1010 hPa	120Vac, 60Hz	David Huang
RE < 1G	23deg. C, 65%RH, 1010 hPa	120Vac, 60Hz	David Huang
RE ≥ 1G	23deg. C, 65%RH, 1010 hPa	120Vac, 60Hz	David Huang

3.3 GENERAL DESCRIPTION OF APPLIED STANDARDS

The EUT is a RF product. According to the specifications of the manufacturer, it must comply with the requirements of the following standards:

FCC 47 CFR Part 2

FCC 47 CFR Part 27

ANSI C63.4-2003

ANSI/TIA/EIA-603-C 2004

NOTE: All test items have been performed and recorded as per the above standards.

3.4 DESCRIPTION OF SUPPORT UNITS

The EUT has been tested as an independent unit together with other necessary accessories or support units. The following support units or accessories were used to form a representative test configuration during the tests.

NO.	PRODUCT	BRAND	MODEL NO.	SERIAL NO.	FCC ID
1	Notebook	DELL	D600	N09-00319	QDS-BRCM1005-D
2	Universal Radio Communication Tester	R&S	CMU200	104484	NA
3	Universal Radio Communication Tester	Anritsu	MT8820C	NA	NA

NO.	SIGNAL CABLE DESCRIPTION OF THE ABOVE SUPPORT UNITS
1	1.8m USB cable
2	NA
3	NA

NOTE:

1. All power cords of the above support units are non shielded (1.8m).
2. Item 2, 3 acted as a communication partners to transfer data.
3. Item 2 was for WCDMA AWS Band test only.
4. Item 3 was for LTE Band 17 & LTE Band 4 test only.

4 TEST TYPES AND RESULTS

4.1 OUTPUT POWER MEASUREMENT

4.1.1 LIMITS OF OUTPUT POWER MEASUREMENT

Fixed, mobile, and portable (hand-held) stations operating in the 1710–1755 MHz band are limited to 1 watt EIRP.

Portable stations (hand-held devices) operating in the 698–746 MHz band are limited to 3 watts ERP

4.1.2 TEST INSTRUMENTS

DESCRIPTION & MANUFACTURER	MODEL NO.	SERIAL NO.	DATE OF CALIBRATION	DUE DATE OF CALIBRATION
Test Receiver ROHDE & SCHWARZ	ESCI	100424	Aug. 04, 2010	Aug. 03, 2011
Spectrum Analyzer ROHDE & SCHWARZ	FSP40	100041	Jul. 09, 2010	Jul. 08, 2011
BILOG Antenna SCHWARZBECK	VULB9168	9168-156	Apr. 30, 2010	Apr. 29, 2011
HORN Antenna SCHWARZBECK	BBHA 9120 D	9120D-209	Aug. 02, 2010	Aug. 01, 2011
HORN Antenna SCHWARZBECK	BBHA 9170	BBHA9170243	Dec. 27, 2010	Dec. 26, 2011
Preamplifier Agilent	8449B	3008A01910	Sep. 09, 2010	Sep. 08, 2011
Preamplifier Agilent	8447D	2944A10638	Nov. 03, 2010	Nov. 02, 2011
RF signal cable HUBER+SUHNNER	SUCOFLEX 104	218190/4 231241/4	May 14, 2010	May 13, 2011
RF signal cable Worken	8D-FB	Cable-HYCH9-01	Aug. 20, 2010	Aug. 19, 2011
Software	ADT_Radiated_ V7.6.15.9.2	NA	NA	NA
Antenna Tower EMCO	2070/2080	512.835.4684	NA	NA
Turn Table EMCO	2087-2.03	NA	NA	NA
Antenna Tower & Turn Table Controller EMCO	2090	NA	NA	NA

- NOTE:**
1. The calibration interval of the above test instruments is 12 months and the calibrations are traceable to NML/ROC and NIST/USA.
 2. The test was performed in HwaYa Chamber 9.
 3. The horn antenna and HP preamplifier (model: 8449B) are used only for the measurement of emission frequency above 1GHz if tested.
 4. The FCC Site Registration No. is 460141.
 5. The IC Site Registration No. is IC 7450F-4.

4.1.3 TEST PROCEDURES

EIRP / ERP MEASUREMENT:

- a. The EUT was set up for the maximum power with LTE/WCDMA link data modulation. The power was measured with R&S Spectrum Analyzer. All measurements were done at 3 channels (low, middle and high operational frequency range). RWB and VBW is 10MHz for LTE and 5MHz for WCDMA mode.
- b. E.I.R.P power measurement. In the semi-anechoic chamber, EUT placed on the 0.8m height of Turn Table, rotated the table around 360 degrees to search the maximum radiation power and receiver antenna shall be rotated vertical and horizontal polarization and moved height from 1m to 4m to find the maximum polar radiated power. The "Read Value" is the spectrum reading the maximum power value.
- c. The substitution horn antenna is substituted for EUT at the same position and signals generator export the CW signal to the substitution antenna via a TX cable. Rotated the Turn Table and moved receiving antenna to find the maximum radiation power. Adjust output power level of S.G to get a Value of spectrum reading equal to "Read Value" of step a. Record the power level of S.G
- d. $EIRP = \text{Output power level of S.G} - \text{TX cable loss} + \text{Antenna gain of substitution horn}$
- e. $E.R.P = E.I.R.P - 2.15 \text{ dB}$

CONDUCTED POWER MEASUREMENT:

- a. The EUT was set up for the maximum power with LTE/WCDMA link data modulation and link up with simulator.
- b. Set the EUT to transmit under low, middle and high channel and record the power level shown on simulator.

4.1.4 TEST SETUP EIRP / ERP MEASUREMENT:

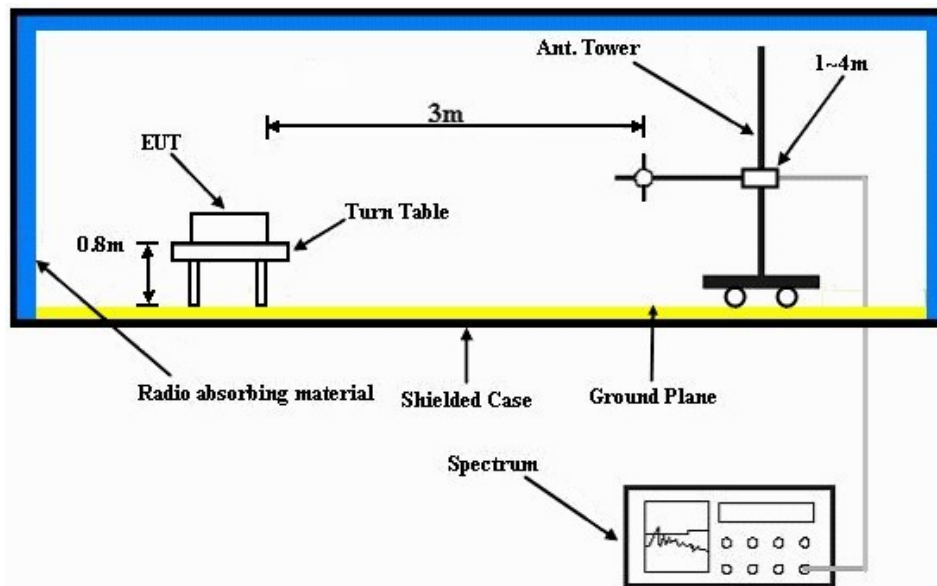

For the actual test configuration, please refer to the attached file (Test Setup Photo).

CONDUCTED POWER MEASUREMENT:

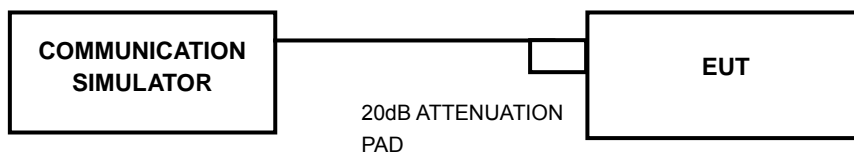

For the actual test configuration, please refer to the attached file (Test Setup Photo).

4.1.5 EUT OPERATING CONDITIONS

- a. The EUT makes a call to the communication simulator.
- b. The communication simulator station system controlled an EUT to export maximum output power under transmission mode and specific channel frequency.

4.1.6 TEST RESULTS

LTE Band 17

CHANNEL BANDWIDTH: 5MHz

CONDUCTED OUTPUT POWER (QPSK 1 RB ALLOCATED AT THE LOWER EDGE)					
CHANNEL NO.	FREQUENCY (MHz)	RAW VALUE (dBm)	CORRECTION FACTOR (dB)	OUTPUT POWER	
				dBm	mW
23755	706.5	-0.72	23.80	23.08	203.2
23790	710.0	-0.80	23.80	23.00	199.5
23825	713.5	-0.99	23.80	22.81	191.0

CONDUCTED OUTPUT POWER (QPSK 1 RB ALLOCATED AT THE UPPER EDGE)					
CHANNEL NO.	FREQUENCY (MHz)	RAW VALUE (dBm)	CORRECTION FACTOR (dB)	OUTPUT POWER	
				dBm	mW
23755	706.5	-1.04	23.80	22.76	188.8
23790	710.0	-1.08	23.80	22.72	187.1
23825	713.5	-1.28	23.80	22.52	178.6

CONDUCTED OUTPUT POWER (QPSK 50% RB ALLOCATION CENTERED)					
CHANNEL NO.	FREQUENCY (MHz)	RAW VALUE (dBm)	CORRECTION FACTOR (dB)	OUTPUT POWER	
				dBm	mW
23755	706.5	-1.87	23.80	21.93	156.0
23790	710.0	-1.65	23.80	22.15	164.1
23825	713.5	-1.98	23.80	21.82	152.1

CONDUCTED OUTPUT POWER (QPSK 100% RB ALLOCATION)					
CHANNEL NO.	FREQUENCY (MHz)	RAW VALUE (dBm)	CORRECTION FACTOR (dB)	OUTPUT POWER	
				dBm	mW
23755	706.5	-2.00	23.80	21.80	151.4
23790	710.0	-2.07	23.80	21.73	148.9
23825	713.5	-2.31	23.80	21.49	140.9

CONDUCTED OUTPUT POWER (16QAM 1 RB ALLOCATED AT THE LOWER EDGE)					
CHANNEL NO.	FREQUENCY (MHz)	RAW VALUE (dBm)	CORRECTION FACTOR (dB)	OUTPUT POWER	
				dBm	mW
23755	706.5	-1.29	23.80	22.51	178.2
23790	710.0	-1.38	23.80	22.42	174.6
23825	713.5	-1.56	23.80	22.24	167.5

CONDUCTED OUTPUT POWER (16QAM 1 RB ALLOCATED AT THE UPPER EDGE)					
CHANNEL NO.	FREQUENCY (MHz)	RAW VALUE (dBm)	CORRECTION FACTOR (dB)	OUTPUT POWER	
				dBm	mW
23755	706.5	-1.69	23.80	22.11	162.6
23790	710.0	-1.79	23.80	22.01	158.9
23825	713.5	-1.97	23.80	21.83	152.4

CONDUCTED OUTPUT POWER (16QAM 50% RB ALLOCATION CENTERED)					
CHANNEL NO.	FREQUENCY (MHz)	RAW VALUE (dBm)	CORRECTION FACTOR (dB)	OUTPUT POWER	
				dBm	mW
23755	706.5	-2.02	23.80	21.78	150.7
23790	710.0	-2.49	23.80	21.31	135.2
23825	713.5	-2.42	23.80	21.38	137.4

CONDUCTED OUTPUT POWER (16QAM 100% RB ALLOCATION)					
CHANNEL NO.	FREQUENCY (MHz)	RAW VALUE (dBm)	CORRECTION FACTOR (dB)	OUTPUT POWER	
				dBm	mW
23755	706.5	-2.35	23.80	21.45	139.6
23790	710.0	-2.25	23.80	21.55	142.9
23825	713.5	-2.58	23.80	21.22	132.4

- REMARKS:** 1. Output Power (dBm) = Raw Value (dBm) + Correction Factor (dB).
 2. Correction Factor (dB) = Power Splitter Loss (dB) + Cable Loss (dB) + 20dB Attenuator.
 3. The value in bold is the worst.



A D T

LTE Band 17

CHANNEL BANDWIDTH: 5MHz

ERP POWER (QPSK 1 RB ALLOCATED AT THE LOWER EDGE)					
CHANNEL NO.	FREQUENCY (MHz)	S.G LEVEL (dBm)	CORRECTION FACTOR (dB)	OUTPUT POWER	
				dBm	mW
23755	706.5	25.4	-8.3	17.1	50.7
23790	710.0	26.4	-8.3	18.1	63.8
23825	713.5	26.3	-8.3	18.0	62.4

- REMARKS:** 1. Output Power (dBm) = Raw Value (dBm) + Correction Factor (dB).
2. Correction Factor (dB) = S.G Level + Gain of Substitution horn + TX cable loss.
3. The value in bold is the worst.

LTE Band 17
CHANNEL BANDWIDTH: 10MHz

CONDUCTED OUTPUT POWER (QPSK 1 RB ALLOCATED AT THE LOWER EDGE)					
CHANNEL NO.	FREQUENCY (MHz)	RAW VALUE (dBm)	CORRECTION FACTOR (dB)	OUTPUT POWER	
				dBm	mW
23780	709.0	-1.05	23.80	22.75	188.4
23790	710.0	-1.23	23.80	22.57	180.7
23800	711.0	-1.28	23.80	22.52	178.6

CONDUCTED OUTPUT POWER (QPSK 1 RB ALLOCATED AT THE UPPER EDGE)					
CHANNEL NO.	FREQUENCY (MHz)	RAW VALUE (dBm)	CORRECTION FACTOR (dB)	OUTPUT POWER	
				dBm	mW
23780	709.0	-1.40	23.80	22.40	173.8
23790	710.0	-1.55	23.80	22.25	167.9
23800	711.0	-1.59	23.80	22.21	166.3

CONDUCTED OUTPUT POWER (QPSK 50% RB ALLOCATION CENTERED)					
CHANNEL NO.	FREQUENCY (MHz)	RAW VALUE (dBm)	CORRECTION FACTOR (dB)	OUTPUT POWER	
				dBm	mW
23780	709.0	-1.89	23.80	21.91	155.2
23790	710.0	-1.90	23.80	21.90	154.9
23800	711.0	-2.11	23.80	21.69	147.6

CONDUCTED OUTPUT POWER (QPSK 100% RB ALLOCATION)					
CHANNEL NO.	FREQUENCY (MHz)	RAW VALUE (dBm)	CORRECTION FACTOR (dB)	OUTPUT POWER	
				dBm	mW
23780	709.0	-2.08	23.80	21.72	148.6
23790	710.0	-2.16	23.80	21.64	145.9
23800	711.0	-2.28	23.80	21.52	141.9



CONDUCTED OUTPUT POWER (16QAM 1 RB ALLOCATED AT THE LOWER EDGE)					
CHANNEL NO.	FREQUENCY (MHz)	RAW VALUE (dBm)	CORRECTION FACTOR (dB)	OUTPUT POWER	
				dBm	mW
23780	709.0	-1.91	23.80	21.89	154.5
23790	710.0	-2.01	23.80	21.79	151.0
23800	711.0	-2.27	23.80	21.53	142.2

CONDUCTED OUTPUT POWER (16QAM 1 RB ALLOCATED AT THE UPPER EDGE)					
CHANNEL NO.	FREQUENCY (MHz)	RAW VALUE (dBm)	CORRECTION FACTOR (dB)	OUTPUT POWER	
				dBm	mW
23780	709.0	-2.27	23.80	21.53	142.2
23790	710.0	-2.34	23.80	21.46	140.0
23800	711.0	-1.50	23.80	22.30	169.8

CONDUCTED OUTPUT POWER (16QAM 50% RB ALLOCATION CENTERED)					
CHANNEL NO.	FREQUENCY (MHz)	RAW VALUE (dBm)	CORRECTION FACTOR (dB)	OUTPUT POWER	
				dBm	mW
23780	709.0	-2.34	23.80	21.46	140.0
23790	710.0	-2.43	23.80	21.37	137.1
23800	711.0	-2.63	23.80	21.17	130.9

CONDUCTED OUTPUT POWER (16QAM 100% RB ALLOCATION)					
CHANNEL NO.	FREQUENCY (MHz)	RAW VALUE (dBm)	CORRECTION FACTOR (dB)	OUTPUT POWER	
				dBm	mW
23780	709.0	-2.57	23.80	21.23	132.7
23790	710.0	-2.79	23.80	21.01	126.2
23800	711.0	-2.75	23.80	21.05	127.4

- REMARKS:** 1. Output Power (dBm) = Raw Value (dBm) + Correction Factor (dB).
 2. Correction Factor (dB) = Power Splitter Loss (dB) + Cable Loss (dB) + 20dB Attenuator.
 3. The value in bold is the worst.



A D T

LTE Band 17

CHANNEL BANDWIDTH: 10MHz

ERP POWER (QPSK 1 RB ALLOCATED AT THE LOWER EDGE)					
CHANNEL NO.	FREQUENCY (MHz)	S.G LEVEL (dBm)	CORRECTION FACTOR (dB)	OUTPUT POWER	
				dBm	mW
23780	709.0	26.8	-8.3	18.5	70.0
23790	710.0	27.1	-8.3	18.8	75.0
23800	711.0	27.3	-8.3	19.0	78.5

- REMARKS:**
1. Output Power (dBm) = Raw Value (dBm) + Correction Factor (dB).
 2. Correction Factor (dB) = S.G Level + Gain of Substitution horn + TX cable loss.
 3. The value in bold is the worst.

LTE Band 4

CHANNEL BANDWIDTH: 5MHz

CONDUCTED OUTPUT POWER (QPSK 1 RB ALLOCATED AT THE LOWER EDGE)					
CHANNEL NO.	FREQUENCY (MHz)	RAW VALUE (dBm)	CORRECTION FACTOR (dB)	OUTPUT POWER	
				dBm	mW
19975	1712.5	-1.47	24.30	22.83	191.9
20175	1732.5	-1.66	24.30	22.64	183.7
20375	1752.5	-1.70	24.30	22.60	182.0

CONDUCTED OUTPUT POWER (QPSK 1 RB ALLOCATED AT THE UPPER EDGE)					
CHANNEL NO.	FREQUENCY (MHz)	RAW VALUE (dBm)	CORRECTION FACTOR (dB)	OUTPUT POWER	
				dBm	mW
19975	1712.5	-1.23	24.30	23.07	202.8
20175	1732.5	-1.63	24.30	22.67	184.9
20375	1752.5	-1.68	24.30	22.62	182.8

CONDUCTED OUTPUT POWER (QPSK 50% RB ALLOCATION CENTERED)					
CHANNEL NO.	FREQUENCY (MHz)	RAW VALUE (dBm)	CORRECTION FACTOR (dB)	OUTPUT POWER	
				dBm	mW
19975	1712.5	-2.54	24.30	21.76	150.0
20175	1732.5	-2.94	24.30	21.36	136.8
20375	1752.5	-2.52	24.30	21.78	150.7

CONDUCTED OUTPUT POWER (QPSK 100% RB ALLOCATION)					
CHANNEL NO.	FREQUENCY (MHz)	RAW VALUE (dBm)	CORRECTION FACTOR (dB)	OUTPUT POWER	
				dBm	mW
19975	1712.5	-2.55	24.30	21.75	149.6
20175	1732.5	-2.84	24.30	21.46	140.0
20375	1752.5	-2.64	24.30	21.66	146.6



A D T

CONDUCTED OUTPUT POWER (16QAM 1 RB ALLOCATED AT THE LOWER EDGE)					
CHANNEL NO.	FREQUENCY (MHz)	RAW VALUE (dBm)	CORRECTION FACTOR (dB)	OUTPUT POWER	
				dBm	mW
19975	1712.5	-2.18	24.30	22.12	162.9
20175	1732.5	-2.51	24.30	21.79	151.0
20375	1752.5	-2.45	24.30	21.85	153.1

CONDUCTED OUTPUT POWER (16QAM 1 RB ALLOCATED AT THE UPPER EDGE)					
CHANNEL NO.	FREQUENCY (MHz)	RAW VALUE (dBm)	CORRECTION FACTOR (dB)	OUTPUT POWER	
				dBm	mW
19975	1712.5	-2.11	24.30	22.19	165.6
20175	1732.5	-2.49	24.30	21.81	151.7
20375	1752.5	-2.36	24.30	21.94	156.3

CONDUCTED OUTPUT POWER (16QAM 50% RB ALLOCATION CENTERED)					
CHANNEL NO.	FREQUENCY (MHz)	RAW VALUE (dBm)	CORRECTION FACTOR (dB)	OUTPUT POWER	
				dBm	mW
19975	1712.5	-3.00	24.30	21.30	134.9
20175	1732.5	-3.17	24.30	21.13	129.7
20375	1752.5	-3.05	24.30	21.25	133.4

CONDUCTED OUTPUT POWER (16QAM 100% RB ALLOCATION)					
CHANNEL NO.	FREQUENCY (MHz)	RAW VALUE (dBm)	CORRECTION FACTOR (dB)	OUTPUT POWER	
				dBm	mW
19975	1712.5	-2.82	24.30	21.48	140.6
20175	1732.5	-3.08	24.30	21.22	132.4
20375	1752.5	-2.93	24.30	21.37	137.1

- REMARKS:**
1. Output Power (dBm) = Raw Value (dBm) + Correction Factor (dB).
 2. Correction Factor (dB) = Power Splitter Loss (dB) + Cable Loss (dB) + 20dB Attenuator.
 3. The value in bold is the worst.



A D T

LTE Band 4

CHANNEL BANDWIDTH: 5MHz

EIRP POWER (QPSK 1 RB ALLOCATED AT THE UPPER EDGE)					
CHANNEL NO.	FREQUENCY (MHz)	S.G LEVEL (dBm)	CORRECTION FACTOR (dB)	OUTPUT POWER	
				dBm	mW
19975	1712.5	8.2	8.0	16.2	41.7
20175	1732.5	6.5	8.1	14.6	28.8
20375	1752.5	8.9	8.2	17.1	51.3

- REMARKS:** 1. Output Power (dBm) = Raw Value (dBm) + Correction Factor (dB).
2. Correction Factor (dB) = S.G Level + Gain of Substitution horn + TX cable loss.
3. The value in bold is the worst.

**LTE Band 4****CHANNEL BANDWIDTH: 10MHz**

CONDUCTED OUTPUT POWER (QPSK 1 RB ALLOCATED AT THE LOWER EDGE)					
CHANNEL NO.	FREQUENCY (MHz)	RAW VALUE (dBm)	CORRECTION FACTOR (dB)	OUTPUT POWER	
				dBm	mW
20000	1715.0	-1.39	24.30	22.91	195.4
20175	1732.5	-1.51	24.30	22.79	190.1
20350	1750.0	-1.65	24.30	22.65	184.1

CONDUCTED OUTPUT POWER (QPSK 1 RB ALLOCATED AT THE UPPER EDGE)					
CHANNEL NO.	FREQUENCY (MHz)	RAW VALUE (dBm)	CORRECTION FACTOR (dB)	OUTPUT POWER	
				dBm	mW
20000	1715.0	-0.84	24.30	23.46	221.8
20175	1732.5	-1.08	24.30	23.22	209.9
20350	1750.0	-1.17	24.30	23.13	205.6

CONDUCTED OUTPUT POWER (QPSK 50% RB ALLOCATION CENTERED)					
CHANNEL NO.	FREQUENCY (MHz)	RAW VALUE (dBm)	CORRECTION FACTOR (dB)	OUTPUT POWER	
				dBm	mW
20000	1715.0	-2.06	24.30	22.24	167.5
20175	1732.5	-2.42	24.30	21.88	154.2
20350	1750.0	-2.34	24.30	21.96	157.0

CONDUCTED OUTPUT POWER (QPSK 100% RB ALLOCATION)					
CHANNEL NO.	FREQUENCY (MHz)	RAW VALUE (dBm)	CORRECTION FACTOR (dB)	OUTPUT POWER	
				dBm	mW
20000	1715.0	-2.08	24.30	22.22	166.7
20175	1732.5	-2.46	24.30	21.84	152.8
20350	1750.0	-2.38	24.30	21.92	155.6

CONDUCTED OUTPUT POWER (16QAM 1 RB ALLOCATED AT THE LOWER EDGE)					
CHANNEL NO.	FREQUENCY (MHz)	RAW VALUE (dBm)	CORRECTION FACTOR (dB)	OUTPUT POWER	
				dBm	mW
20000	1715.0	-1.85	24.30	22.45	175.8
20175	1732.5	-2.20	24.30	22.10	162.2
20350	1750.0	-2.09	24.30	22.21	166.3

CONDUCTED OUTPUT POWER (16QAM 1 RB ALLOCATED AT THE UPPER EDGE)					
CHANNEL NO.	FREQUENCY (MHz)	RAW VALUE (dBm)	CORRECTION FACTOR (dB)	OUTPUT POWER	
				dBm	mW
20000	1715.0	-1.24	24.30	23.06	202.3
20175	1732.5	-1.56	24.30	22.74	187.9
20350	1750.0	-1.47	24.30	22.83	191.9

CONDUCTED OUTPUT POWER (16QAM 50% RB ALLOCATION CENTERED)					
CHANNEL NO.	FREQUENCY (MHz)	RAW VALUE (dBm)	CORRECTION FACTOR (dB)	OUTPUT POWER	
				dBm	mW
20000	1715.0	-2.60	24.30	21.70	147.9
20175	1732.5	-2.98	24.30	21.32	135.5
20350	1750.0	-2.85	24.30	21.45	139.6

CONDUCTED OUTPUT POWER (16QAM 100% RB ALLOCATION)					
CHANNEL NO.	FREQUENCY (MHz)	RAW VALUE (dBm)	CORRECTION FACTOR (dB)	OUTPUT POWER	
				dBm	mW
20000	1715.0	-2.62	24.30	21.68	147.2
20175	1732.5	-3.05	24.30	21.25	133.4
20350	1750.0	-3.02	24.30	21.28	134.3

- REMARKS:** 1. Output Power (dBm) = Raw Value (dBm) + Correction Factor (dB).
 2. Correction Factor (dB) = Power Splitter Loss (dB) + Cable Loss (dB) + 20dB Attenuator.
 3. The value in bold is the worst.

LTE Band 4

CHANNEL BANDWIDTH: 10MHz

EIRP POWER (QPSK 1 RB ALLOCATED AT THE UPPER EDGE)					
CHANNEL NO.	FREQUENCY (MHz)	S.G LEVEL (dBm)	CORRECTION FACTOR (dB)	OUTPUT POWER	
				dBm	mW
20000	1715.0	7.7	8.0	15.7	37.2
20175	1732.5	6.6	8.1	14.7	29.5
20350	1750.0	7.3	8.2	15.5	35.5

REMARKS: 1. Output Power (dBm) = Raw Value (dBm) + Correction Factor (dB).
 2. Correction Factor (dB) = S.G Level + Gain of Substitution horn + TX cable loss.
 3. The value in bold is the worst.

**WCDMA AWS Band**

CONDUCTED OUTPUT POWER (WCDMA-RMC)					
CHANNEL NO.	FREQUENCY (MHz)	RAW VALUE (dBm)	CORRECTION FACTOR (dB)	OUTPUT POWER	
				dBm	mW
1312	1712.4	-0.98	24.30	23.32	214.8
1412	1732.4	-0.83	24.30	23.47	222.3
1513	1752.6	-1.04	24.30	23.26	211.8

CONDUCTED OUTPUT POWER (HSDPA-R5 SUBTEST 1)					
CHANNEL NO.	FREQUENCY (MHz)	RAW VALUE (dBm)	CORRECTION FACTOR (dB)	OUTPUT POWER	
				dBm	mW
1312	1712.4	-1.05	24.30	23.25	211.3
1412	1732.4	-0.85	24.30	23.45	221.3
1513	1752.6	-1.11	24.30	23.19	208.4

CONDUCTED OUTPUT POWER (HSDPA-R5 SUBTEST 2)					
CHANNEL NO.	FREQUENCY (MHz)	RAW VALUE (dBm)	CORRECTION FACTOR (dB)	OUTPUT POWER	
				dBm	mW
1312	1712.4	-0.98	24.30	23.32	214.8
1412	1732.4	-0.86	24.30	23.44	220.8
1513	1752.6	-1.12	24.30	23.18	208.0

CONDUCTED OUTPUT POWER (HSDPA-R5 SUBTEST 3)					
CHANNEL NO.	FREQUENCY (MHz)	RAW VALUE (dBm)	CORRECTION FACTOR (dB)	OUTPUT POWER	
				dBm	mW
1312	1712.4	-1.03	24.30	23.27	212.3
1412	1732.4	-0.88	24.30	23.42	219.8
1513	1752.6	-1.14	24.30	23.16	207.0



CONDUCTED OUTPUT POWER (HSDPA-R5 SUBTEST 4)					
CHANNEL NO.	FREQUENCY (MHz)	RAW VALUE (dBm)	CORRECTION FACTOR (dB)	OUTPUT POWER	
				dBm	mW
1312	1712.4	-1.04	24.30	23.26	211.8
1412	1732.4	-0.82	24.30	23.48	222.8
1513	1752.6	-1.00	24.30	23.30	213.8

CONDUCTED OUTPUT POWER (HSUPA-R6 SUBTEST 1)					
CHANNEL NO.	FREQUENCY (MHz)	RAW VALUE (dBm)	CORRECTION FACTOR (dB)	OUTPUT POWER	
				dBm	mW
1312	1712.4	-1.71	24.30	22.59	181.55
1412	1732.4	-1.52	24.30	22.78	189.67
1513	1752.6	-1.68	24.30	22.62	182.81

CONDUCTED OUTPUT POWER (HSUPA-R6 SUBTEST 2)					
CHANNEL NO.	FREQUENCY (MHz)	RAW VALUE (dBm)	CORRECTION FACTOR (dB)	OUTPUT POWER	
				dBm	mW
1312	1712.4	-3.17	24.30	21.13	129.72
1412	1732.4	-2.87	24.30	21.43	139.00
1513	1752.6	-3.12	24.30	21.18	131.22

CONDUCTED OUTPUT POWER (HSUPA-R6 SUBTEST 3)					
CHANNEL NO.	FREQUENCY (MHz)	RAW VALUE (dBm)	CORRECTION FACTOR (dB)	OUTPUT POWER	
				dBm	mW
1312	1712.4	-1.99	24.30	22.31	170.2
1412	1732.4	-1.69	24.30	22.61	182.4
1513	1752.6	-1.95	24.30	22.35	171.8



A D T

CONDUCTED OUTPUT POWER (HSUPA-R6 SUBTEST 4)					
CHANNEL NO.	FREQUENCY (MHz)	RAW VALUE (dBm)	CORRECTION FACTOR (dB)	OUTPUT POWER	
				dBm	mW
1312	1712.4	-1.36	24.30	22.94	196.8
1412	1732.4	-2.16	24.30	22.14	163.7
1513	1752.6	-2.32	24.30	21.98	157.8

CONDUCTED OUTPUT POWER (HSUPA-R6 SUBTEST 5)					
CHANNEL NO.	FREQUENCY (MHz)	RAW VALUE (dBm)	CORRECTION FACTOR (dB)	OUTPUT POWER	
				dBm	mW
1312	1712.4	-2.26	24.30	22.04	160.0
1412	1732.4	-1.95	24.30	22.35	171.8
1513	1752.6	-2.20	24.30	22.10	162.2

- REMARKS:** 1. Output Power (dBm) = Raw Value (dBm) + Correction Factor (dB).
2. Correction Factor (dB) = Power Splitter Loss (dB) + Cable Loss (dB) + 20dB Attenuator.
3. The value in bold is the worst.

WCDMA AWS Band

EIRP POWER (WCDMA-RMC)					
CHANNEL NO.	FREQUENCY (MHz)	S.G LEVEL (dBm)	CORRECTION FACTOR (dB)	OUTPUT POWER	
				dBm	mW
1312	1712.4	8.8	8.0	16.8	47.9
1412	1732.4	9.1	8.1	17.2	52.5
1513	1752.6	8.7	8.2	16.9	49.0

- REMARKS:** 1. Output Power (dBm) = Raw Value (dBm) + Correction Factor (dB).
2. Correction Factor (dB) = S.G Level + Gain of Substitution horn + TX cable loss.
3. The value in bold is the worst.

4.2 FREQUENCY STABILITY MEASUREMENT

4.2.1 LIMITS OF FREQUENCY STABILITY MEASUREMENT

According to the FCC part 27.54 shall be tested the frequency stability. The rule is defined that” The frequency stability shall be sufficient to ensure that the fundamental emissions stay within the authorized bands of operation. The test extreme voltage is according to the 2.1055(d)(1) Vary primary supply voltage from 85 to 115 percent of the nominal value for other than hand carried battery equipment and the extreme temperature rule is comply with the 2.1055(a)(1) $-30^{\circ}\text{C} \sim 50^{\circ}\text{C}$.

4.2.2 TEST INSTRUMENTS

DESCRIPTION & MANUFACTURER	MODEL NO.	SERIAL NO.	DATE OF CALIBRATION	DUE DATE OF CALIBRATION
* Hewlett Packard RF cable	8120-6192	274388	Oct. 22, 2010	Oct. 21, 2011
* Suhner RF cable	Sucoflex104	246272	May 14, 2010	May 13, 2011
* WIT Standard Temperature & Humidity Chamber	TH-4S-C	W981030	Jun. 28, 2010	Jun. 27, 2011

- NOTE:**
1. The calibration interval of the above test instruments is 12 months. And the calibrations are traceable to NML/ROC and NIST/USA.
 2. “*” = These equipments are used for the final measurement.
 3. The test was performed in ADT RF OVEN room.

4.2.3 TEST PROCEDURE

- a. Because of the measure the carrier frequency under the condition of the AFC lock, it shall be used the mobile station in the LTE/WCDMA link mode. This is accomplished with the use of the communication simulator station. The oven room could control the temperatures and humidity.
- b. Power must be removed when changing from one temperature to another or one voltage to another voltage. Power warm up is at least 15 min and power applied should perform before recording frequency error.
- c. Laptop pc is connected the external power supply to control the AC input power. The various Volts from the minimum 126.5 Volts to 93.5 Volts. Each step shall be record the frequency error rate.
- d. The temperature range step is 10 degrees in this test items. All temperature levels shall be hold the $\pm 0.5^{\circ}\text{C}$ during the measurement testing.
- e. The each temperature step shall be at least 0.5 hours, consider the EUT could be test under the stability condition.

NOTE: The frequency error was recorded frequency error from the communication simulator.

4.2.4 TEST SETUP

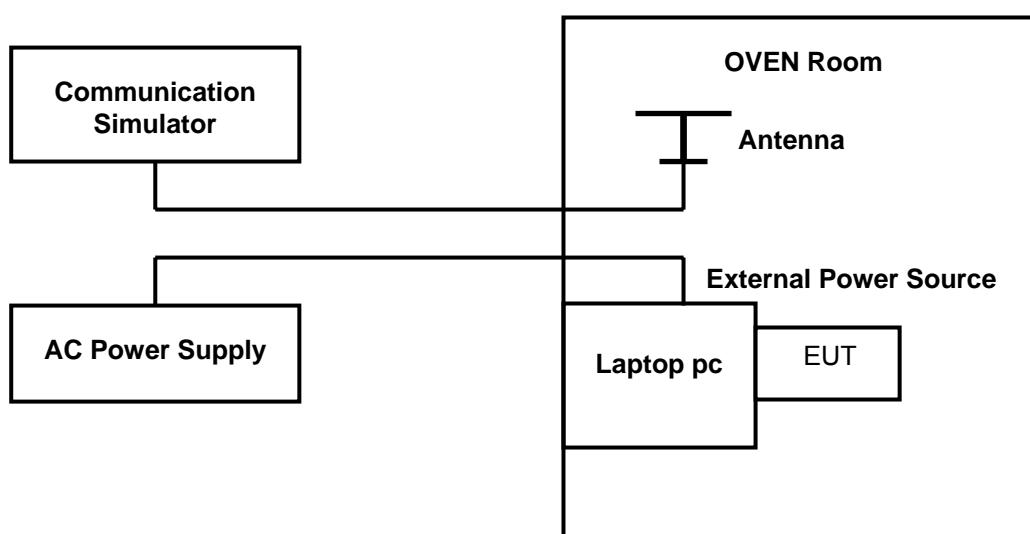

4.2.5 TEST RESULTS

AFC FREQUENCY ERROR vs. VOLTAGE						
FREQUENCY ERROR (ppm)						
Band	LTE Band 17		LTE Band 4		WCDMA AWS Band	LIMIT (ppm)
Channel bandwidth	5MHz	10MHz	5MHz	10MHz	5MHz	
VOLTAGE (Volts)	Channel 23790	Channel 23790	Channel 20175	Channel 20175	Channel 1412	
126.5	-0.003	-0.003	-0.001	-0.001	-0.002	2.5
93.5	-0.004	-0.001	-0.001	-0.002	-0.002	2.5

AFC FREQUENCY ERROR vs. TEMP.						
FREQUENCY ERROR (ppm)						
Band	LTE Band 17		LTE Band 4		WCDMA AWS Band	LIMIT (ppm)
Channel bandwidth	5MHz	10MHz	5MHz	10MHz	5MHz	
TEMP. (°C)	Channel 23790	Channel 23790	Channel 20175	Channel 20175	Channel 1412	
50	-0.003	-0.001	-0.001	-0.001	0.007	2.5
40	-0.004	-0.003	-0.001	-0.002	0.005	2.5
30	-0.003	-0.003	-0.001	-0.001	-0.002	2.5
20	-0.004	-0.001	-0.001	-0.002	-0.002	2.5
10	-0.003	-0.003	-0.001	-0.001	-0.002	2.5
0	-0.001	-0.004	-0.001	-0.002	0.005	2.5
-10	-0.004	-0.003	-0.001	-0.001	-0.003	2.5
-20	-0.003	-0.001	-0.001	-0.002	-0.002	2.5
-30	-0.003	-0.003	-0.001	-0.002	0.005	2.5

4.3 OCCUPIED BANDWIDTH MEASUREMENT

4.3.1 LIMITS OF OCCUPIED BANDWIDTH MEASUREMENT

The width of a frequency band such that, below the lower and above the upper frequency limits, the mean powers emitted are each equal to a specified percentage 0.5 %of the total mean power of a given emission.

4.3.2 TEST INSTRUMENTS

DESCRIPTION & MANUFACTURER	MODEL NO.	SERIAL NO.	DATE OF CALIBRATION	DUE DATE OF CALIBRATION
* Mini-Circuits Power Splitter	ZAPD-4	NA	Jun. 29, 2010	Jun. 28, 2011
* Hewlett Packard RF cable	8120-6192	274388	Oct. 22, 2010	Oct. 21, 2011
* JFW 20dB attenuation	50HF-020-SMA	NA	NA	NA
* Suhner RF cable	Sucoflex104	246272	May 14, 2010	May 13, 2011
* ROHDE & SCHWARZ Spectrum Analyzer	E4446A	MY44360128	Feb. 23, 2010	Feb. 22, 2011

NOTE: 1. The calibration interval of the above test instruments is 12 months. And the calibrations are traceable to NML/ROC and NIST/USA.

2. "*" = These equipments are used for the final measurement.

4.3.3 TEST SETUP

Same as Item 4.1.4 (Conducted Power Setup)

4.3.4 TEST PROCEDURES

- a. The EUT makes a phone call to the communication simulator. The power was measured with R&S Spectrum Analyzer. All measurements were done at 3 channels. (low, middle and high operational frequency range.)
- b. The conducted occupied bandwidth used the power splitter via EUT RF power connector between simulation base station and spectrum analyzer.
- c. The communication simulator station system controlled a EUT to export maximum output power under transmission mode and specific channel frequency. Use OBW measurement function of Spectrum analyzer to measure 99 % occupied bandwidth.



A D T

4.3.5 TEST RESULTS

LTE Band 17

CHANNEL BANDWIDTH: 5MHz / QPSK

FREQUENCY (MHz)	MAX. OUTPUT POWER -26 dBc BANDWIDTH (MHz)
706.5	4.52
710.0	4.52
713.5	4.52

CH 23755

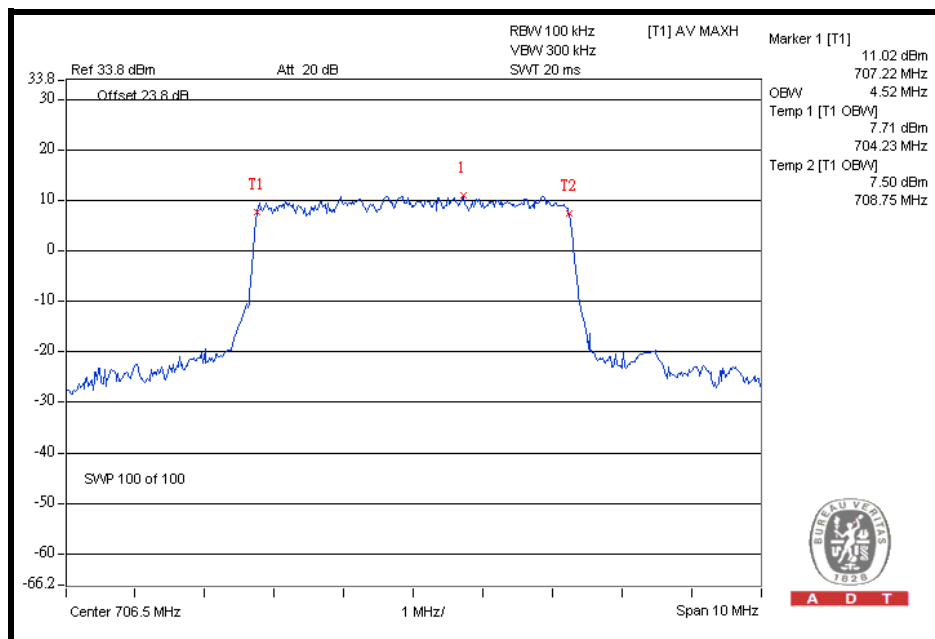



A D T

LTE Band 17

CHANNEL BANDWIDTH: 5MHz / 16QAM

FREQUENCY (MHz)	MAX. OUTPUT POWER -26 dBc BANDWIDTH (MHz)
706.5	4.50
710.0	4.48
713.5	4.48

CH 23755

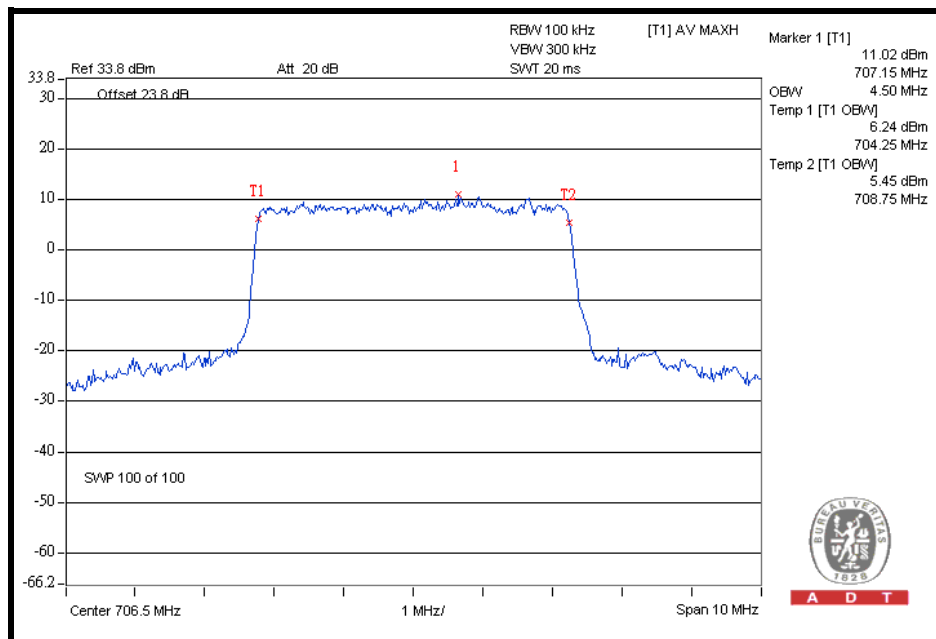



A D T

LTE Band 17

CHANNEL BANDWIDTH: 10MHz / QPSK

FREQUENCY (MHz)	MAX. OUTPUT POWER -26 dBc BANDWIDTH (MHz)
709.0	9.00
710.0	8.97
711.0	8.97

CH 23780

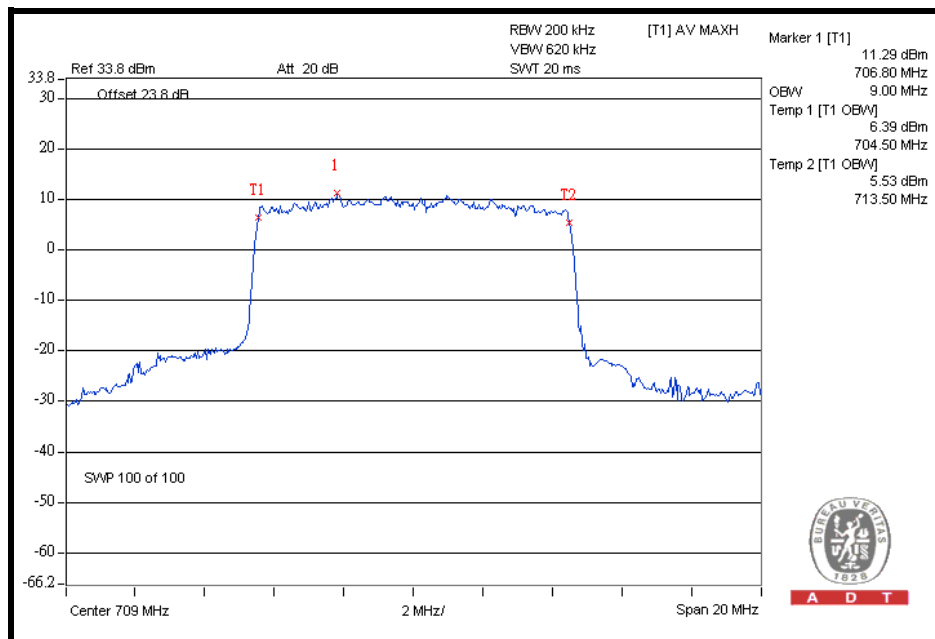



A D T

LTE Band 17

CHANNEL BANDWIDTH: 10MHz / 16QAM

FREQUENCY (MHz)	MAX. OUTPUT POWER -26 dBc BANDWIDTH (MHz)
709.0	8.97
710.0	8.93
711.0	8.97

CH 23780

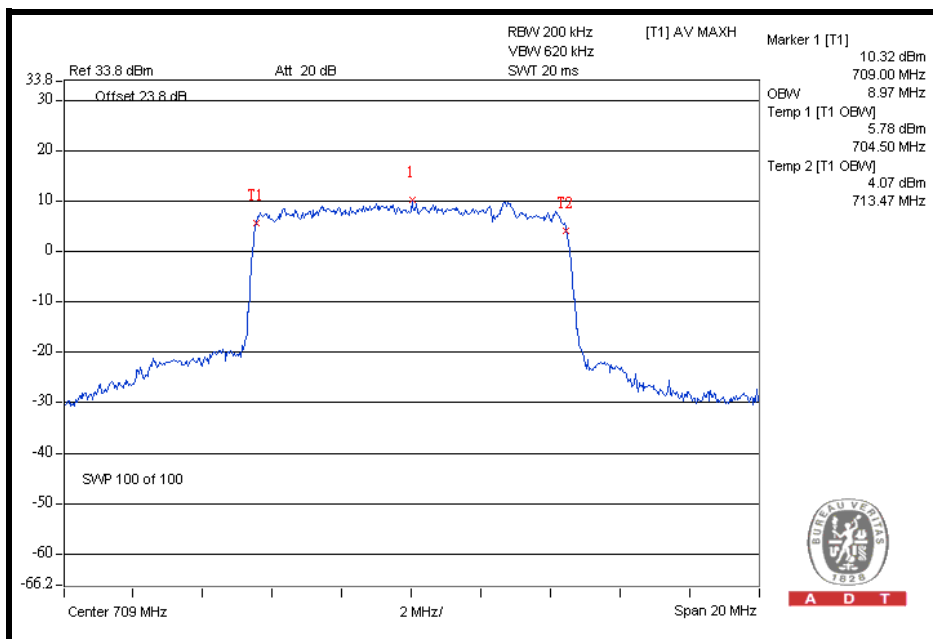



A D T

LTE Band 4

CHANNEL BANDWIDTH: 5MHz / QPSK

FREQUENCY (MHz)	MAX. OUTPUT POWER -26 dBc BANDWIDTH (MHz)
1712.5	4.50
1732.5	4.52
1752.5	4.52

CH 20375

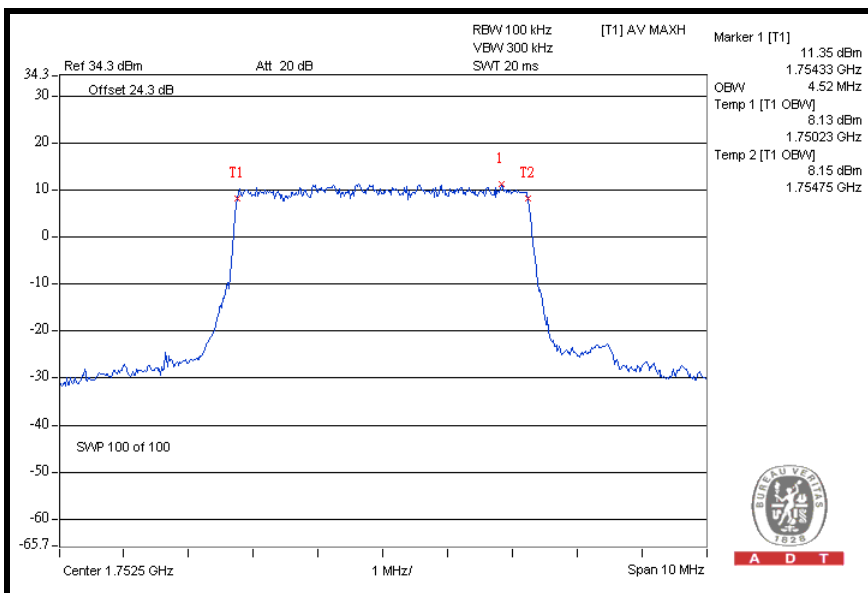



A D T

LTE Band 4

CHANNEL BANDWIDTH: 5MHz / 16QAM

FREQUENCY (MHz)	MAX. OUTPUT POWER -26 dBc BANDWIDTH (MHz)
1712.5	4.48
1732.5	4.48
1752.5	4.50

CH 20375

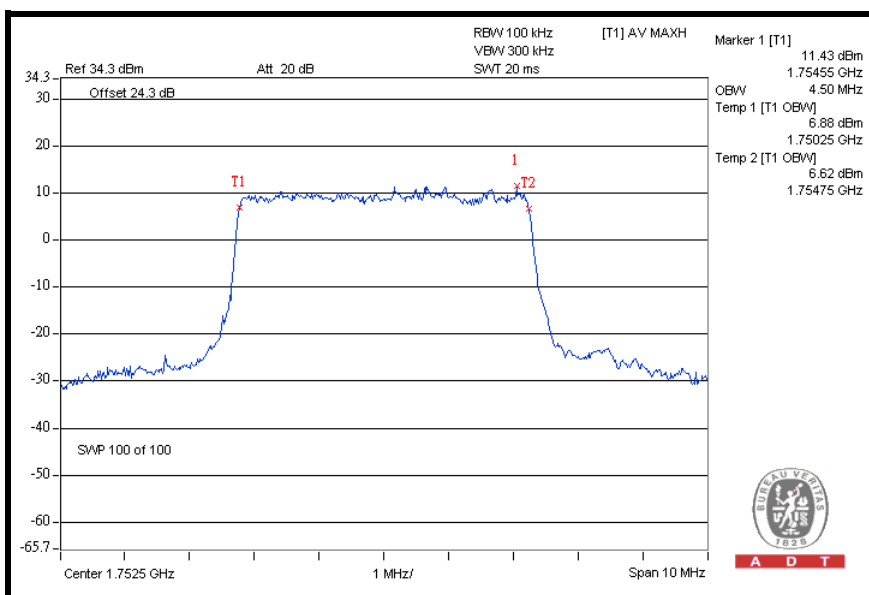



A D T

LTE Band 4

CHANNEL BANDWIDTH: 10MHz / QPSK

FREQUENCY (MHz)	MAX. OUTPUT POWER -26 dBc BANDWIDTH (MHz)
1715.0	9.00
1732.5	8.97
1750.0	9.00

CH 20000

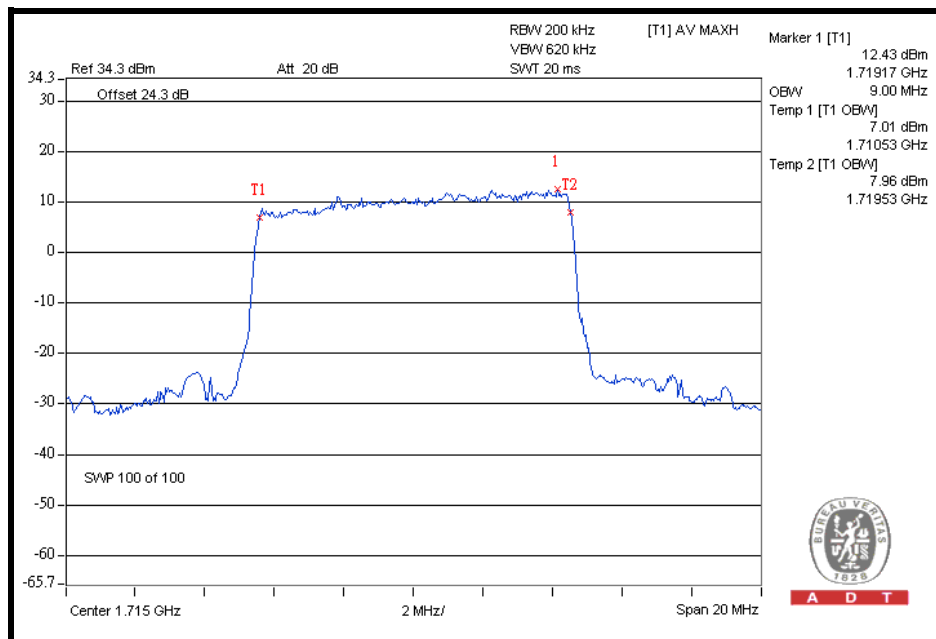



A D T

LTE Band 4

CHANNEL BANDWIDTH: 10MHz / 16QAM

FREQUENCY (MHz)	MAX. OUTPUT POWER -26 dBc BANDWIDTH (MHz)
1715.0	8.97
1732.5	8.97
1750.0	9.00

CH 20350

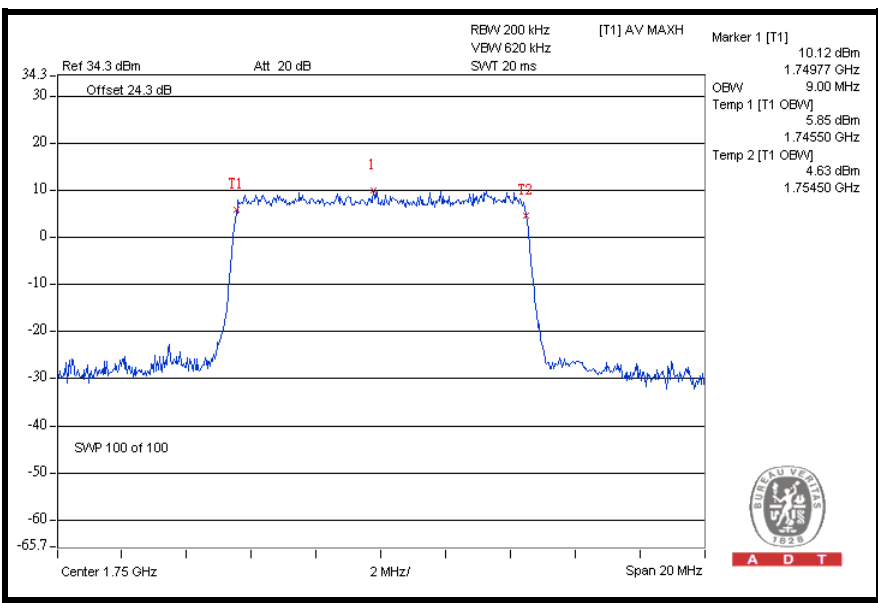



A D T

WCDMA AWS Band

WCDMA

FREQUENCY (MHz)	MAX. OUTPUT POWER -26 dBc BANDWIDTH (MHz)
1712.4	4.16
1732.4	4.18
1752.6	4.16

CH1412

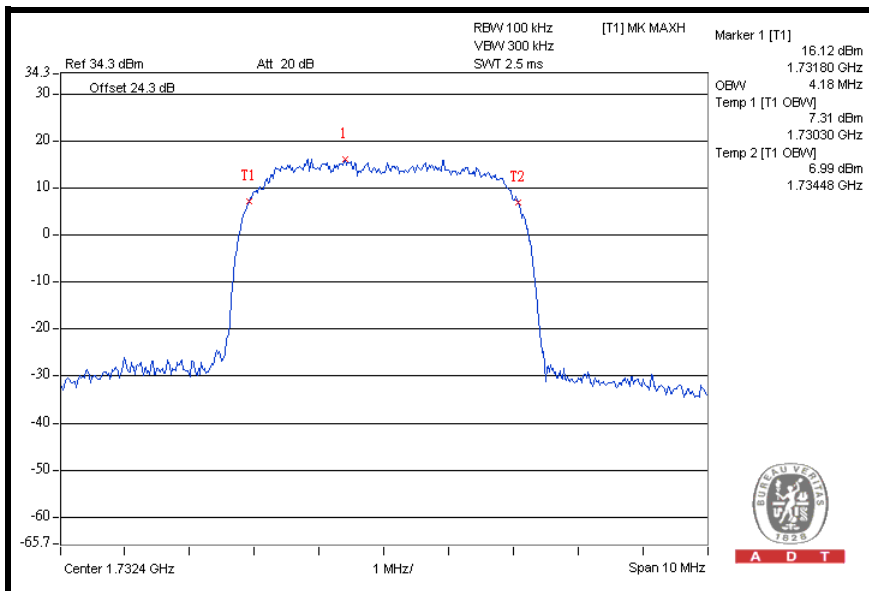

A D T



A D T

WCDMA AWS Band HSDPA

FREQUENCY (MHz)	MAX. OUTPUT POWER -26 dBc BANDWIDTH (MHz)
1712.4	4.16
1732.4	4.16
1752.6	4.16

CH 1513

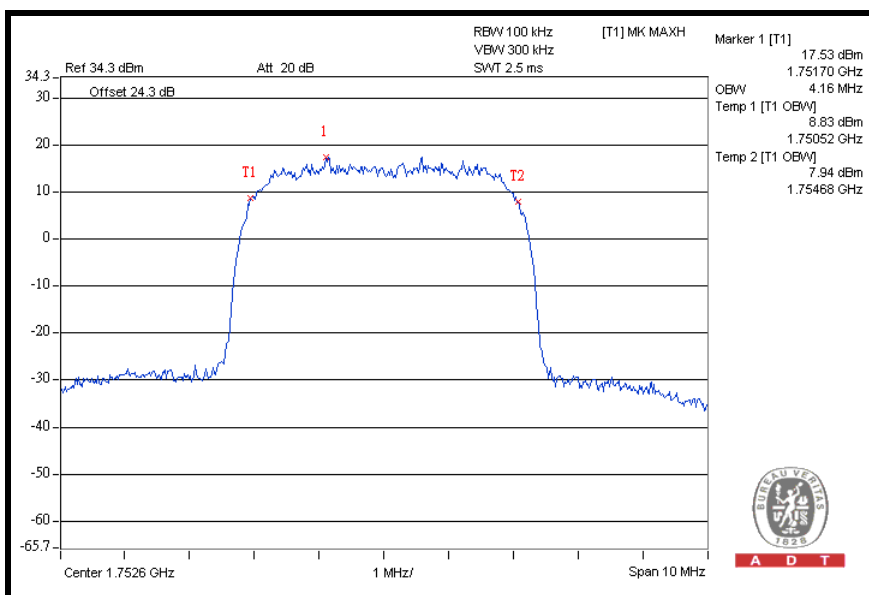



A D T

WCDMA AWS Band HSUPA

FREQUENCY (MHz)	MAX. OUTPUT POWER -26 dBc BANDWIDTH (MHz)
1712.4	4.16
1732.4	4.16
1752.6	4.14

CH 1312

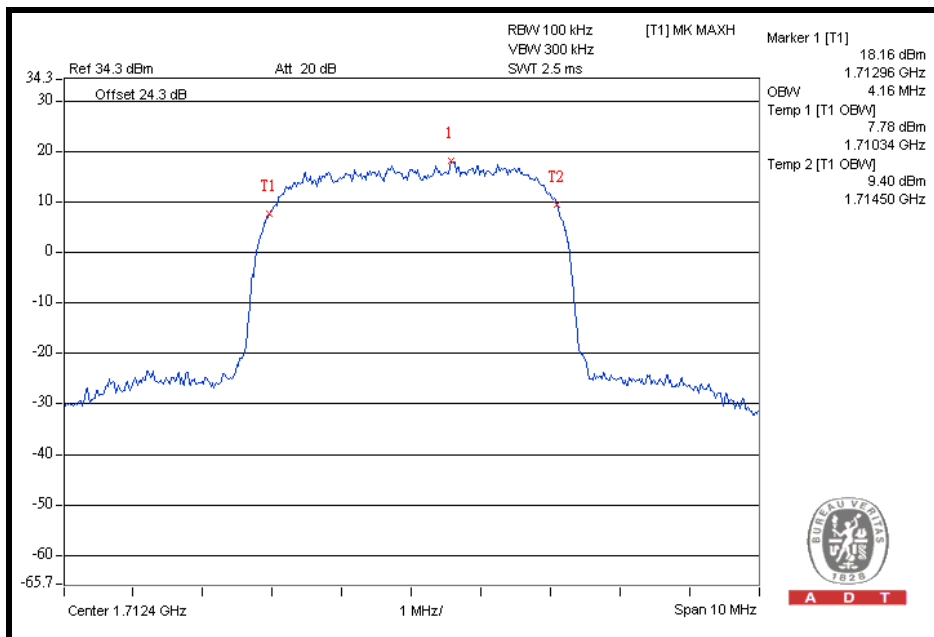

A D T

4.4 PEAK TO AVERAGE RATIO

4.4.1 LIMITS OF PEAK TO AVERAGE RATIO MEASUREMENT

In measuring transmissions in this band using an average power technique, the peak to-average ratio (PAR) of the transmission may not exceed 13 dB

4.4.2 TEST INSTRUMENTS

DESCRIPTION & MANUFACTURER	MODEL NO.	SERIAL NO.	DATE OF CALIBRATION	DUE DATE OF CALIBRATION
* ROHDE & SCHWARZ Spectrum Analyzer	FSP40	100041	Jul. 09, 2010	Jul. 08, 2011
* Mini-Circuits Power Splitter	ZN2PD-9G	NA	Mar. 29, 2010	Mar. 28, 2011
* Hewlett Packard RF cable	8120-6192	274388	Oct. 22, 2010	Oct. 21, 2011
* JFW 20dB attenuation	50HF-020-SMA	NA	NA	NA
* Suhner RF cable	Sucoflex104	246272	May 14, 2010	May 13, 2011

NOTE: 1. The calibration interval of the above test instruments is 12 months. And the calibrations are traceable to NML/ROC and NIST/USA.

2. "*" = These equipments are used for the final measurement.

4.4.3 TEST SETUP

Same as Item 4.2.4 (Conducted Power Setup)

4.4.4 TEST PROCEDURES

1. Set resolution/measurement bandwidth \geq signal's occupied bandwidth;
2. Set the number of counts to a value that stabilizes the measured CCDF curve;
3. Record the maximum PAPR level associated with a probability of 0.1%.

4.4.5 EUT OPERATING CONDITION

Same as Item 4.1.5

Note: All different RB configurations have been pre-evaluated and the 100% RB is the worst case and recorded in this report.

4.4.6 TEST RESULTS

LTE Band 17

CHANNEL BANDWIDTH: 5MHz / QPSK / 100%RB

FREQUENCY (MHz)	PEAK TO AVERAGE RATIO (dB)
706.5	5.90
710.0	5.96
713.5	5.90

CH 23790

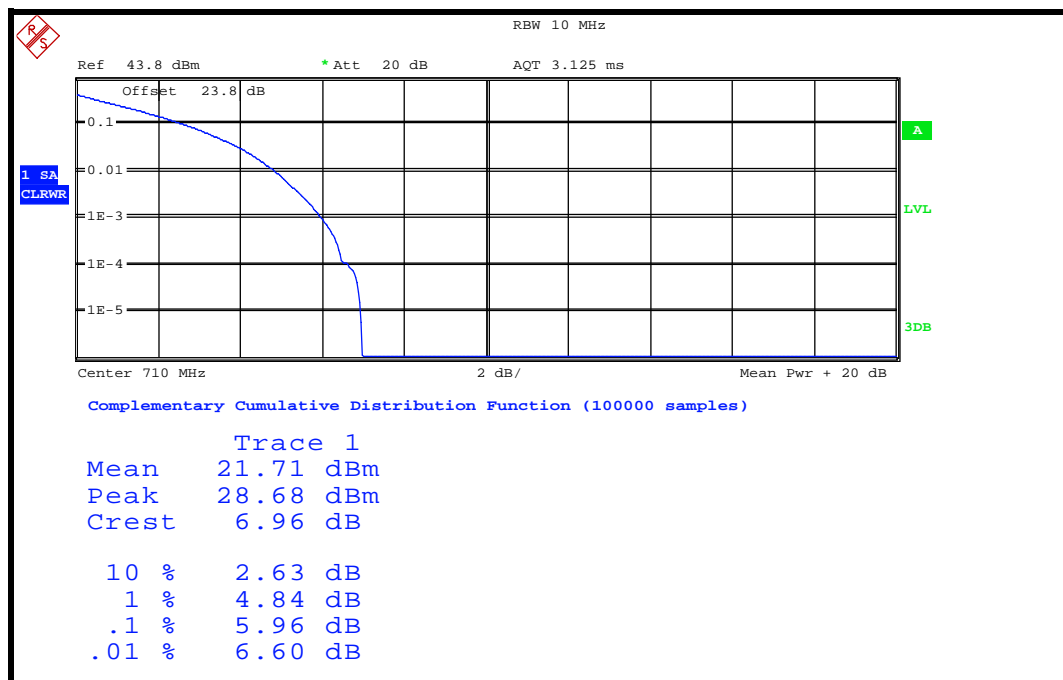



A D T

LTE Band 17

CHANNEL BANDWIDTH: 5MHz / 16QAM / 100%RB

FREQUENCY (MHz)	PEAK TO AVERAGE RATIO (dB)
706.5	6.63
710.0	6.54
713.5	6.41

CH 23755

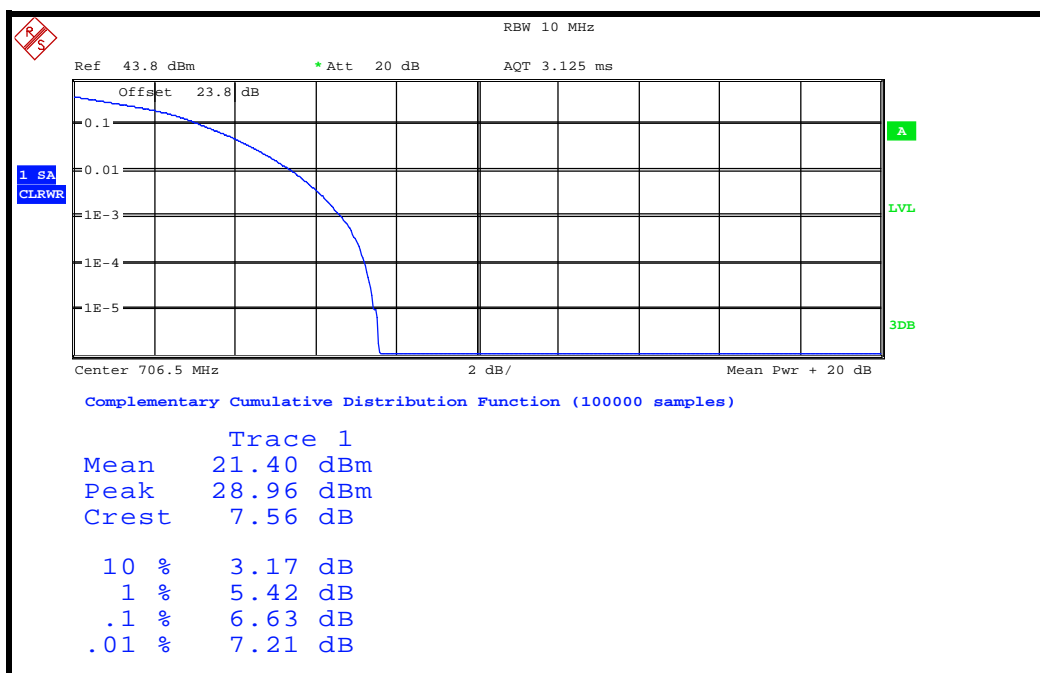



A D T

LTE Band 17

CHANNEL BANDWIDTH: 10MHz / QPSK / 100%RB

FREQUENCY (MHz)	PEAK TO AVERAGE RATIO (dB)
709.0	5.58
710.0	5.51
711.0	5.51

CH 23780

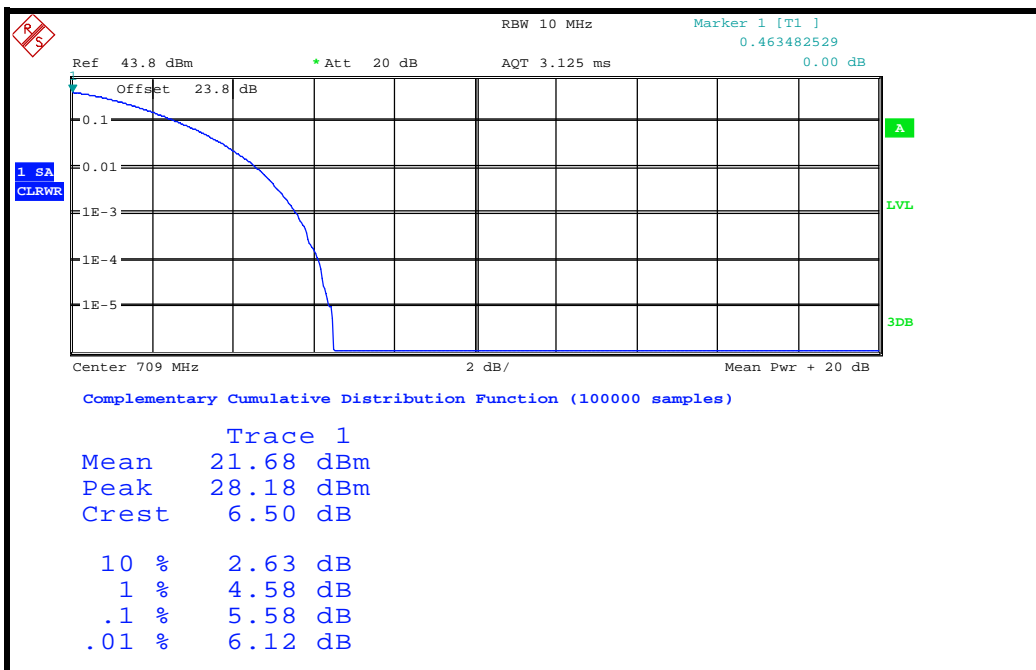



A D T

LTE Band 17

CHANNEL BANDWIDTH: 10MHz / 16QAM / 100%RB

FREQUENCY (MHz)	PEAK TO AVERAGE RATIO (dB)
709.0	6.54
710.0	6.60
711.0	6.44

CH 23790

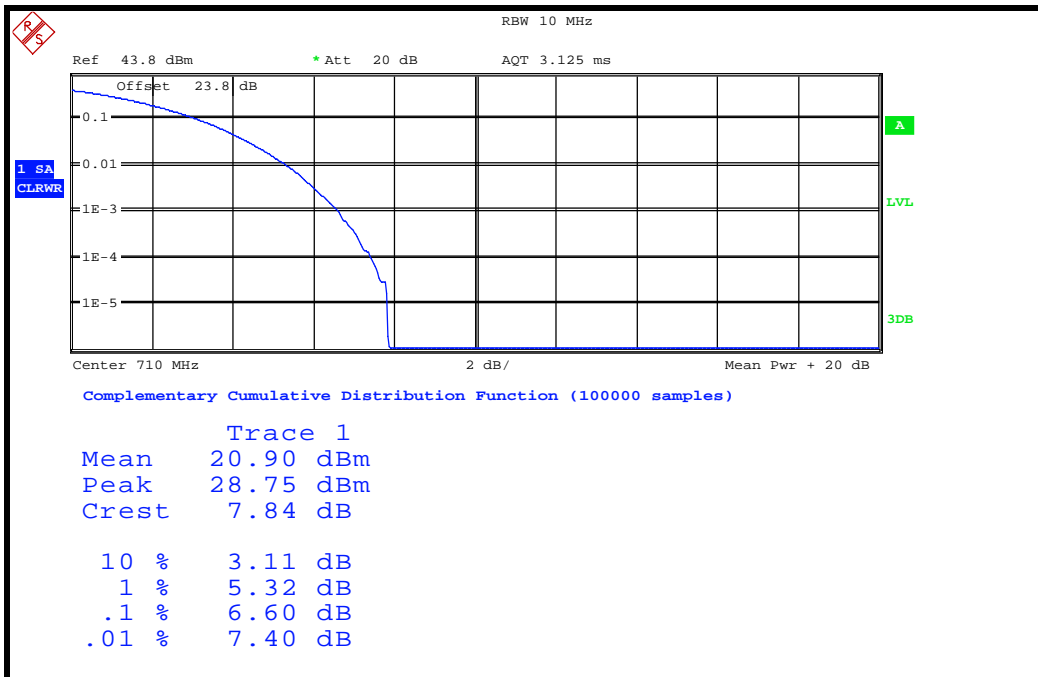



A D T

LTE Band 4

CHANNEL BANDWIDTH: 5MHz / QPSK / 100%RB

FREQUENCY (MHz)	PEAK TO AVERAGE RATIO (dB)
1712.5	5.48
1732.5	5.26
1752.5	5.10

CH 19975

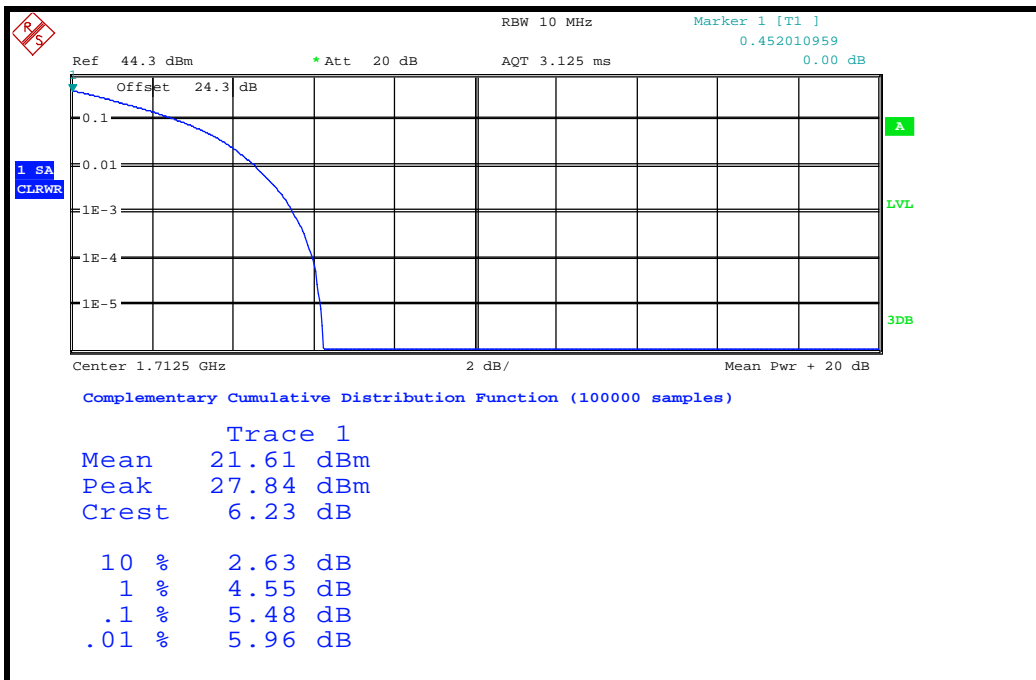



A D T

LTE Band 4

CHANNEL BANDWIDTH: 5MHz / 16QAM / 100%RB

FREQUENCY (MHz)	PEAK TO AVERAGE RATIO (dB)
1712.5	6.03
1732.5	5.64
1752.5	5.71

CH 19975

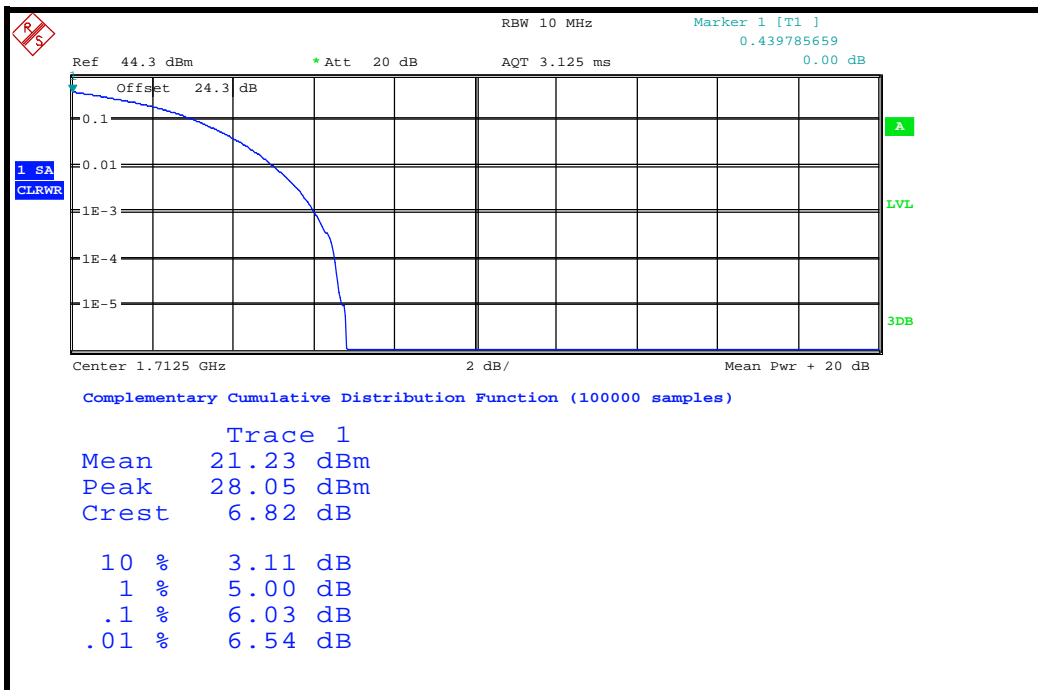



A D T

LTE Band 4 CHANNEL BANDWIDTH: 10MHz / QPSK / 100%RB

FREQUENCY (MHz)	PEAK TO AVERAGE RATIO (dB)
1715.0	5.48
1732.5	5.26
1750.0	5.10

CH 20000

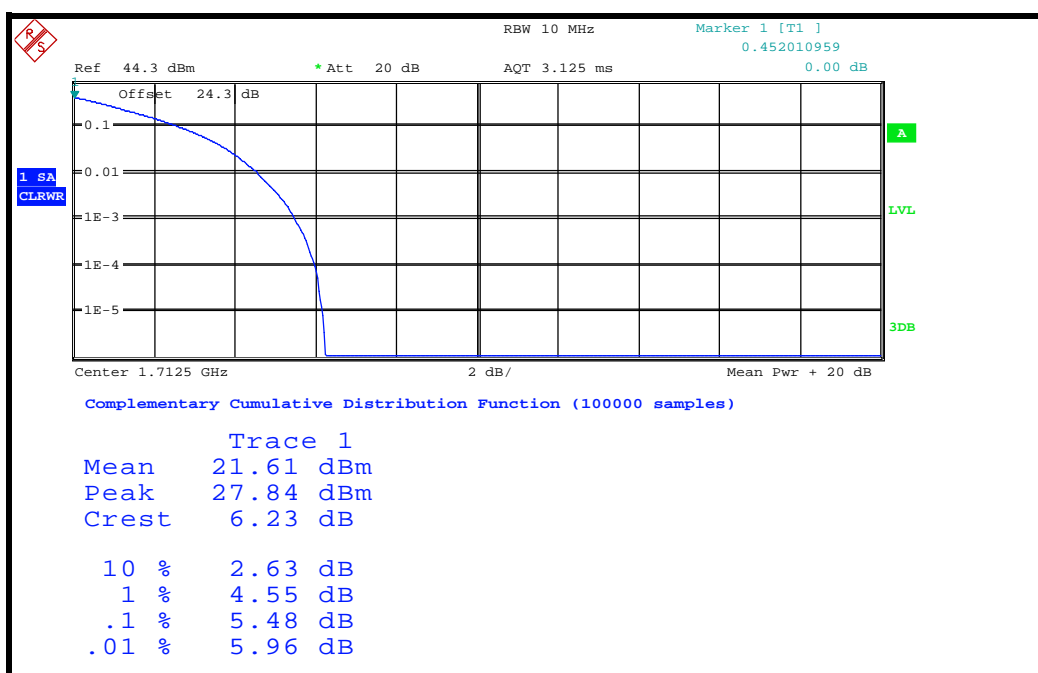



A D T

LTE Band 4

CHANNEL BANDWIDTH: 10MHz / 16QAM / 100%RB

FREQUENCY (MHz)	PEAK TO AVERAGE RATIO (dB)
1715.0	6.41
1732.5	6.09
1750.0	6.12

CH 20000

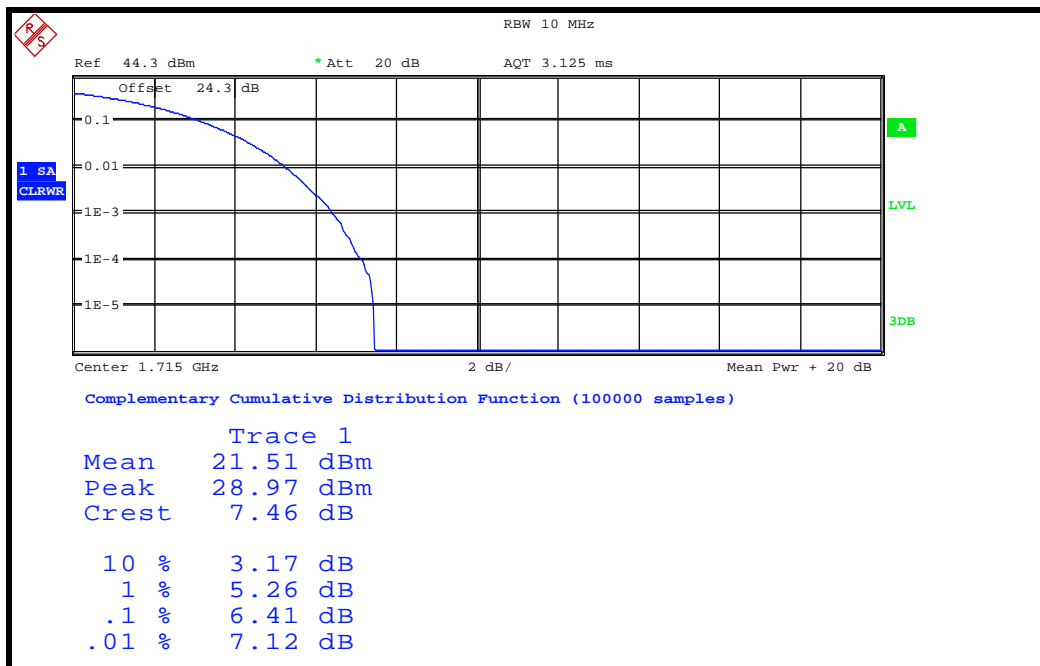



A D T

WCDMA AWS Band WCDMA

FREQUENCY (MHz)	PEAK TO AVERAGE RATIO (dB)
1712.4	3.28
1732.4	3.00
1752.6	3.12

CH 1312

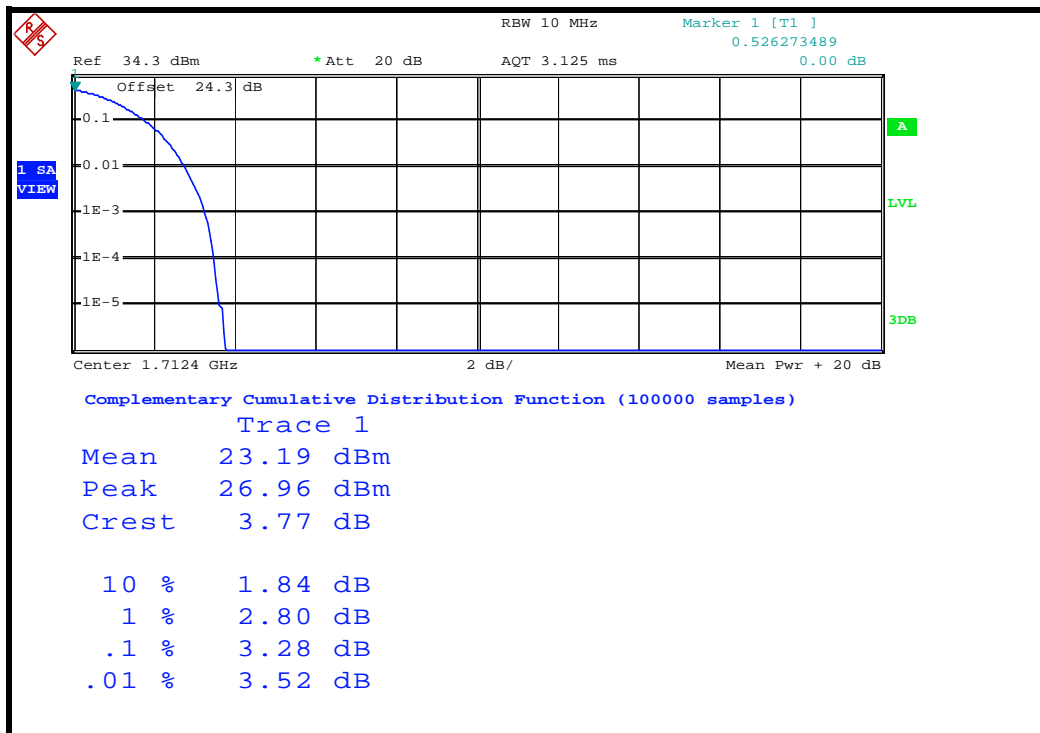



A D T

WCDMA AWS Band HSDPA

FREQUENCY (MHz)	PEAK TO AVERAGE RATIO (dB)
1712.4	3.24
1732.4	2.96
1752.6	3.12

CH 1312

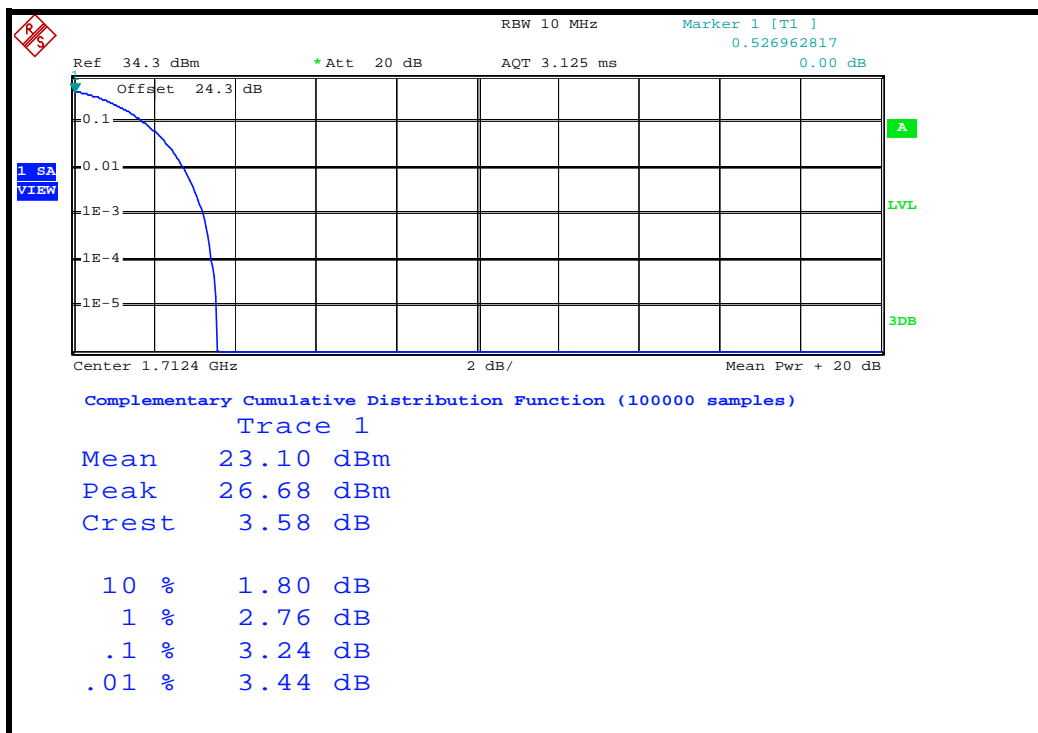



A D T

WCDMA AWS Band HSUPA

FREQUENCY (MHz)	PEAK TO AVERAGE RATIO (dB)
1712.4	3.28
1732.4	2.96
1752.6	3.16

CH 1312

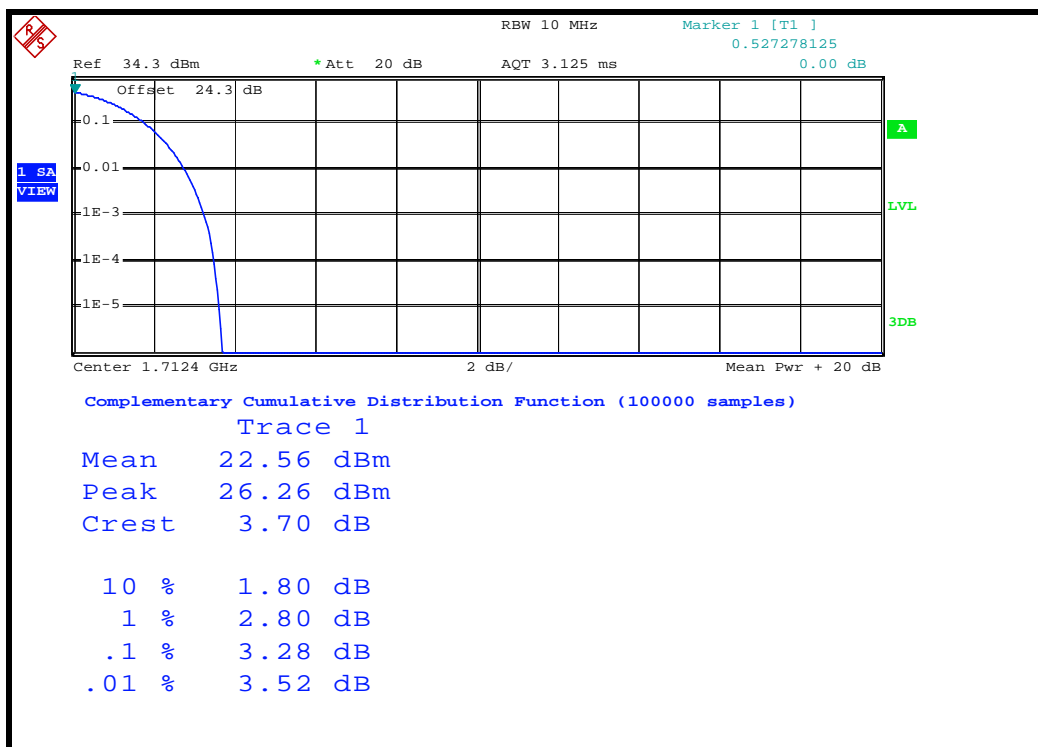

4.5 BAND EDGE MEASUREMENT

4.5.1 LIMITS OF BAND EDGE MEASUREMENT

For operations in the 698–746 MHz band, the power of any emission outside a licensee's frequency band(s) of operation shall be attenuated below the transmitter power (P) within the licensed band(s) of operation, measured in watts, by at least $43 + 10 \log (P)$ dB. Compliance with this provision is based on the use of measurement instrumentation employing a resolution bandwidth of 100 kilohertz or greater. However, in the 100 kilohertz bands immediately outside and adjacent to a licensee's frequency block, a resolution bandwidth of at least 30 kHz may be employed.

For operations in the 1710–1755 MHz and 2110–2155 MHz bands, the power of any emission outside a licensee's frequency block shall be attenuated below the transmitter power (P) by at least $43 + 10 \log_{10}(P)$ dB. The limit of emission equal to -13dBm . In the 1 MHz bands immediately outside and adjacent to the frequency block a resolution bandwidth of at least one percent of the emission bandwidth of the fundamental emission of the transmitter may be employed.

4.5.2 TEST INSTRUMENTS

DESCRIPTION & MANUFACTURER	MODEL NO.	SERIAL NO.	DATE OF CALIBRATION	DUE DATE OF CALIBRATION
* ROHDE & SCHWARZ Spectrum Analyzer	FSP40	100041	Jul. 09, 2010	Jul. 08, 2011
* Mini-Circuits Power Splitter	ZN2PD-9G	NA	Mar. 29, 2010	Mar. 28, 2011
* Hewlett Packard RF cable	8120-6192	274388	Oct. 22, 2010	Oct. 21, 2011
* JFW 20dB attenuation	50HF-020-SMA	NA	NA	NA
* Suhner RF cable	Sucoflex104	246272	May 14, 2010	May 13, 2011

NOTE: 1. The calibration interval of the above test instruments is 12 months. And the calibrations are traceable to NML/ROC and NIST/USA.

2. "*" = These equipments are used for the final measurement.

4.5.3 TEST SETUP

Same as Item 4.1.4 (Conducted Power Setup)

4.5.4 TEST PROCEDURES

- a. The EUT was set up for the maximum peak power with LTE/WCDMA link data modulation. The power was measured with R&S Spectrum Analyzer. All measurements were done at 2 channels (low and high operational frequency range.).
- b. The band edge measurement used the power splitter via EUT RF power connector between simulation base station and spectrum analyzer. This splitter loss and cable loss are the worst loss 7.2 dB in the transmitted path track.
- c. The center frequency of spectrum is the band edge frequency and span is 1 MHz. RB of the spectrum is 50kHz and VB of the spectrum is 200kHz.
- d. Record the max trace plot into the test report.

4.5.5 EUT OPERATING CONDITION

- a. The EUT makes a call to the communication simulator.
- b. The communication simulator station system controlled an EUT to export maximum output power under transmission mode and specific channel frequency.



A D T

4.5.6 TEST RESULTS

LTE Band 17

CHANNEL BANDWIDTH: 5MHz / 1RB ALLOCATED

LOWER BAND EDGE

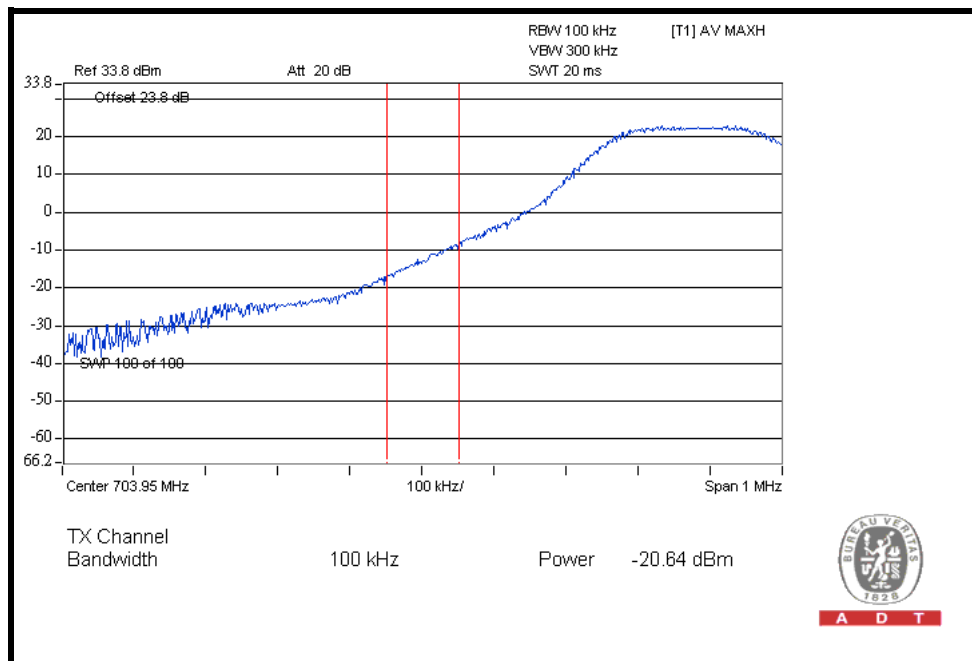

HIGHER BAND EDGE

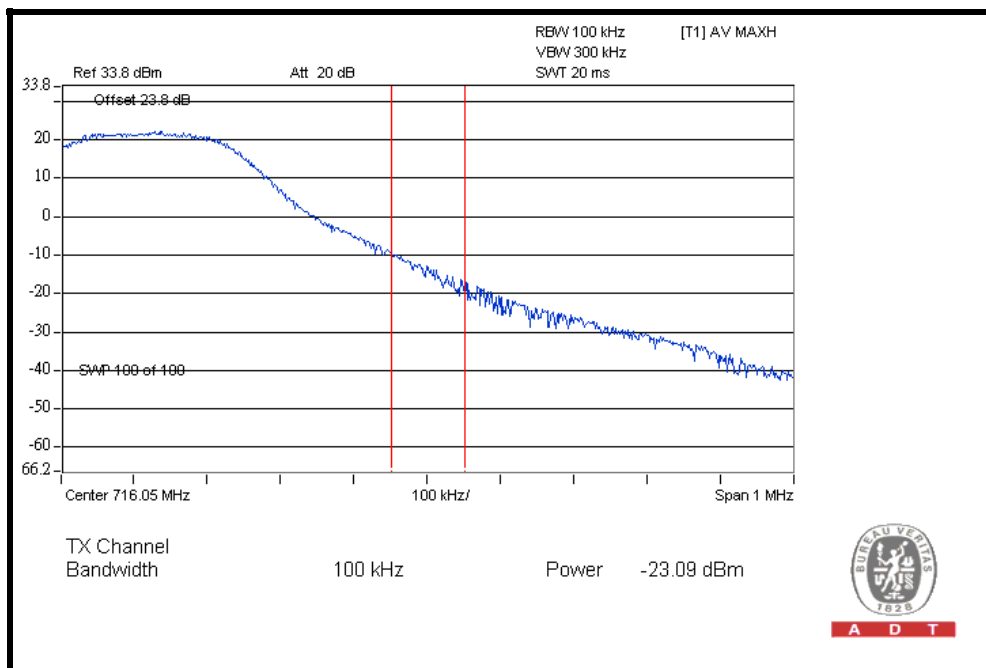



A D T

CHANNEL BANDWIDTH: 5MHz / FULL RB ALLOCATED

LOWER BAND EDGE

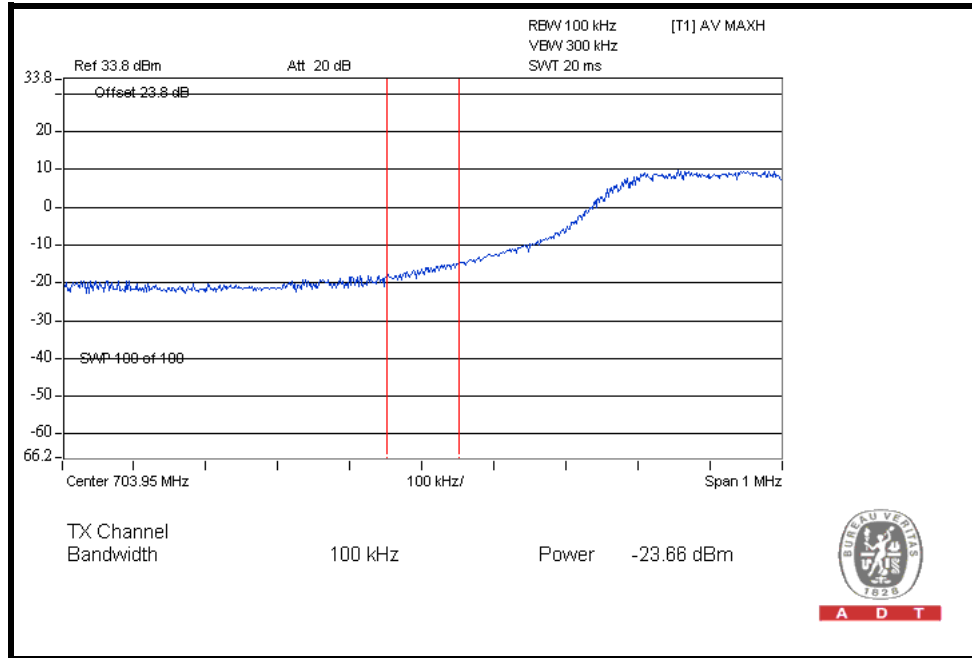

HIGHER BAND EDGE

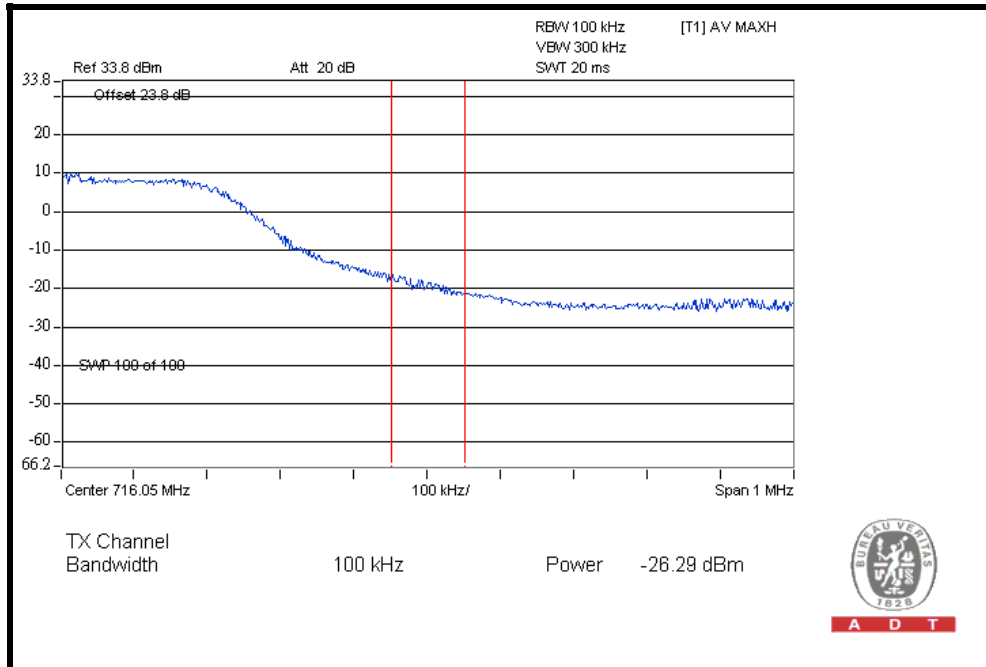



A D T

LTE Band 17

CHANNEL BANDWIDTH: 10MHz / 1RB ALLOCATED

LOWER BAND EDGE

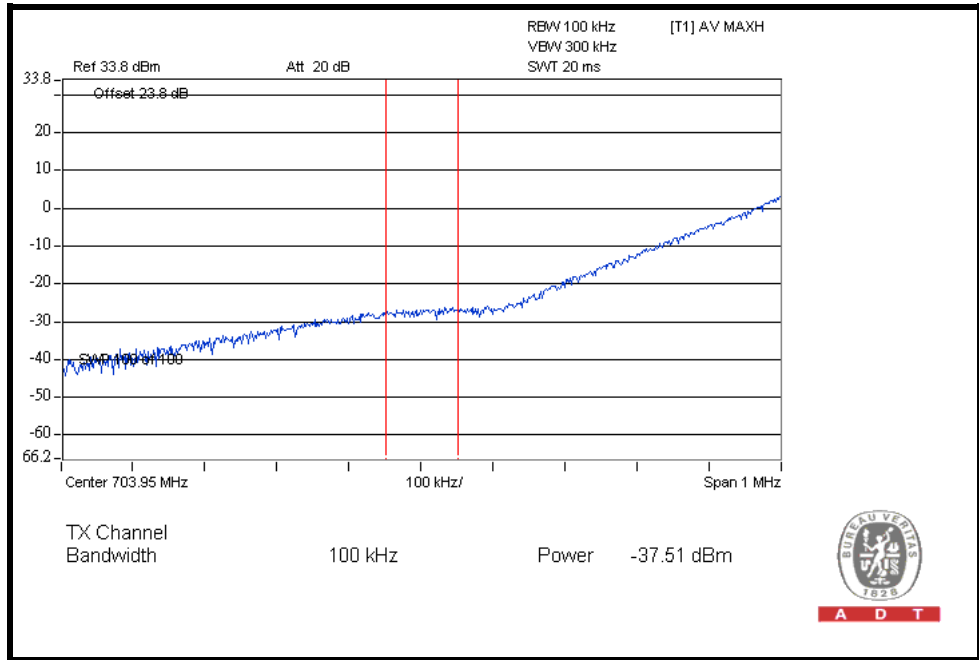

HIGHER BAND EDGE

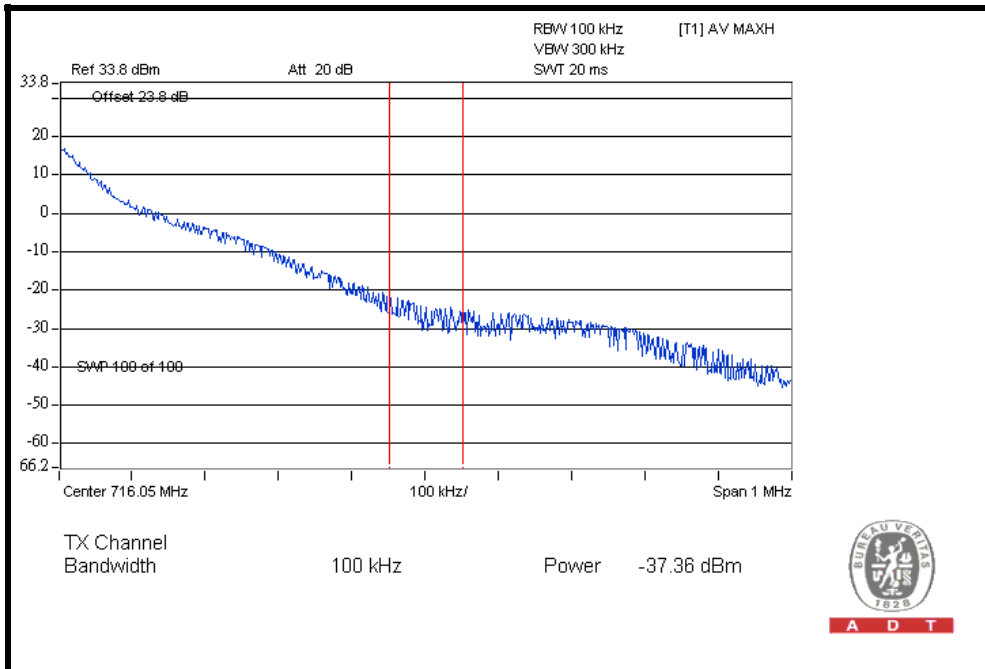



A D T

CHANNEL BANDWIDTH: 10MHz / FULL RB ALLOCATED

LOWER BAND EDGE

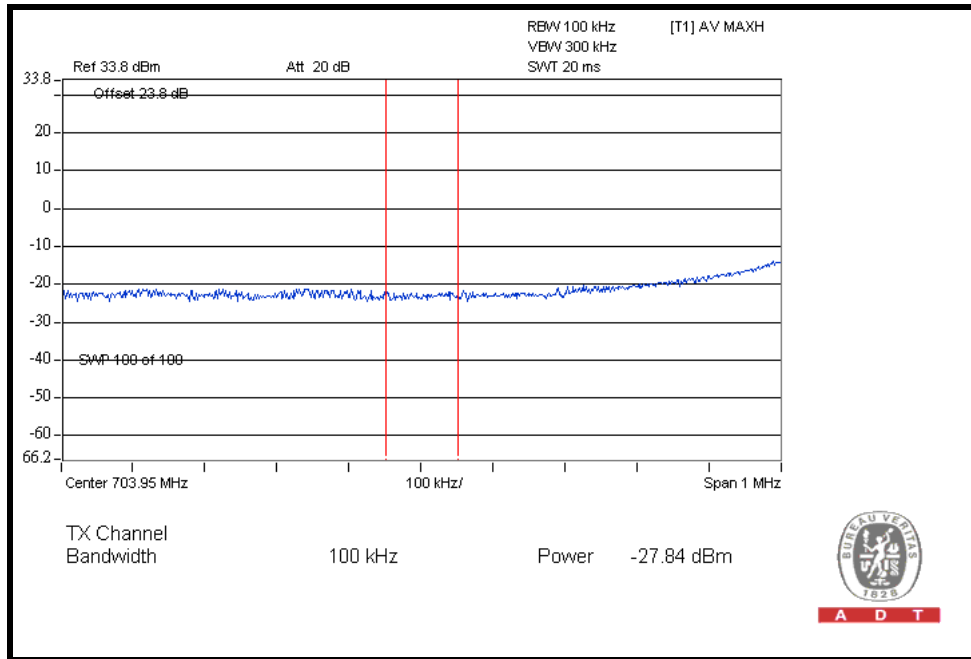

HIGHER BAND EDGE

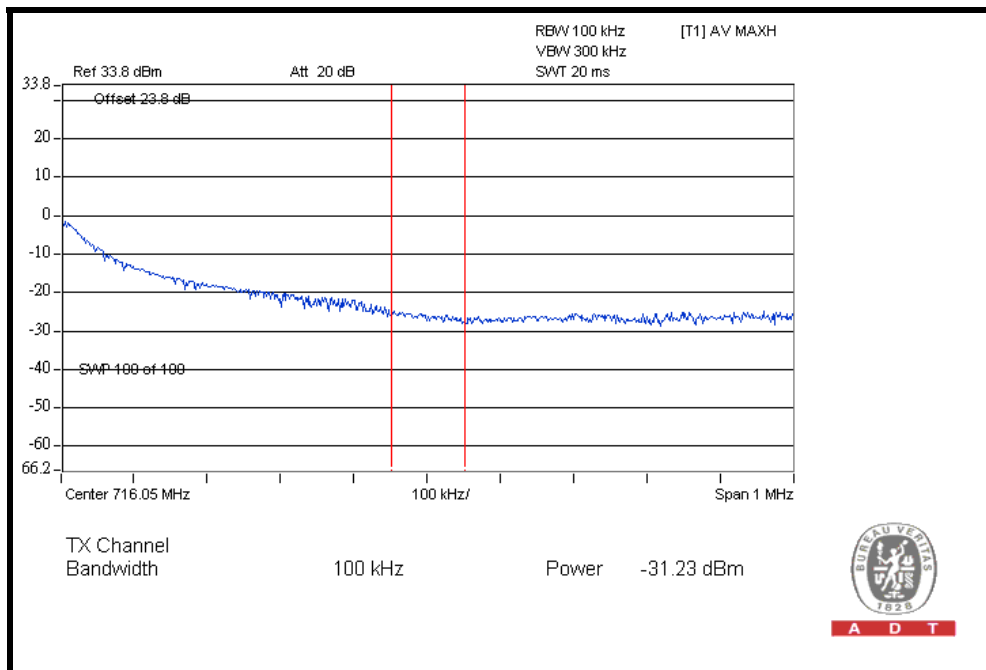



A D T

LTE Band 4

CHANNEL BANDWIDTH: 5MHz / 1 RB ALLOCATED AT THE LOWER EDGE

LOWER BAND EDGE

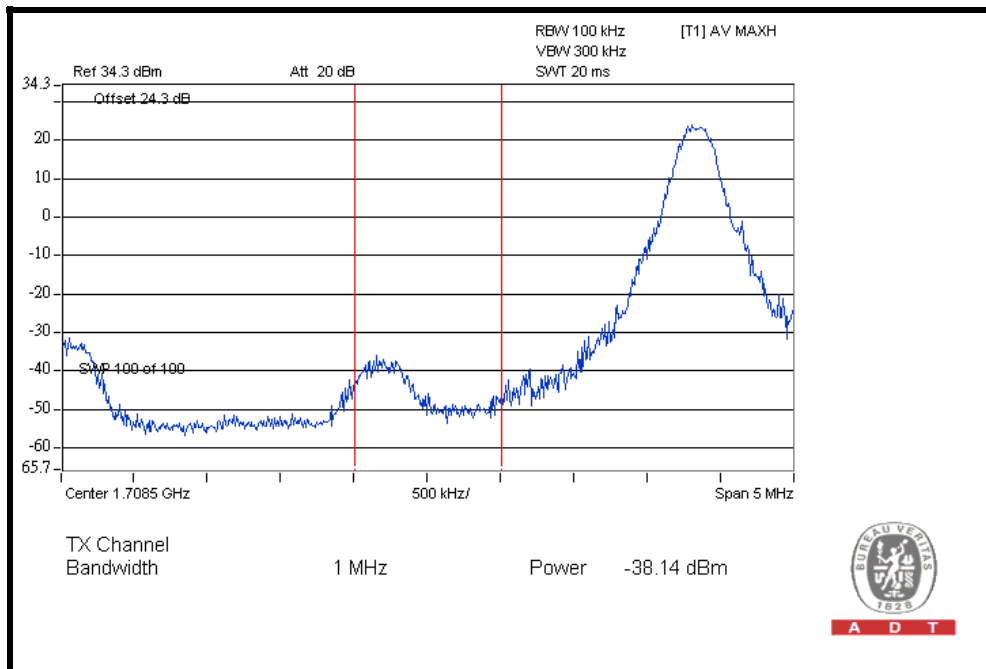
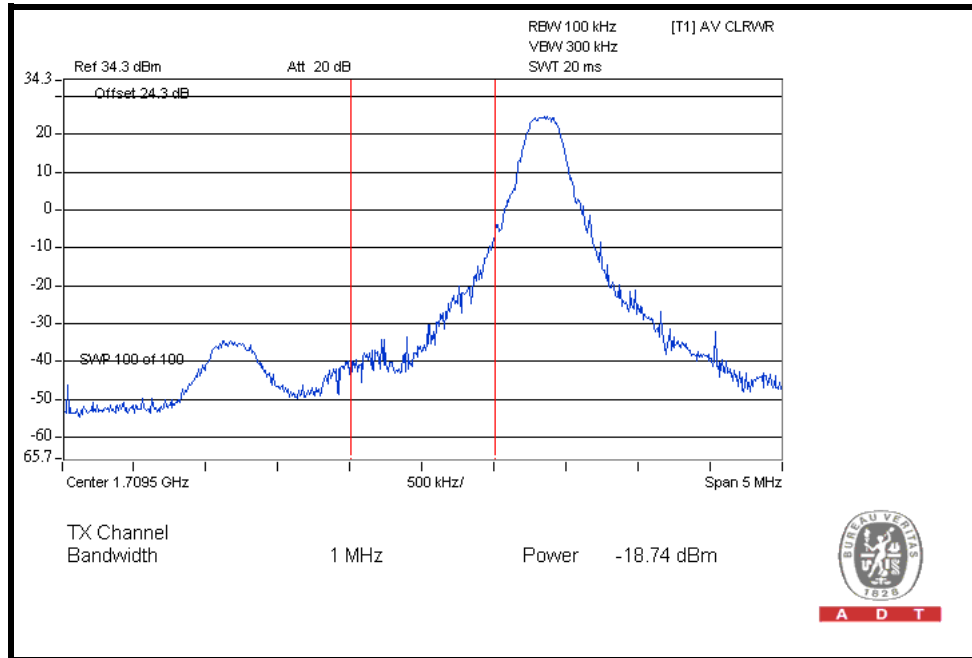

CHANNEL BANDWIDTH: 5MHz / 1 RB ALLOCATED AT THE UPPER EDGE

HIGHER BAND EDGE

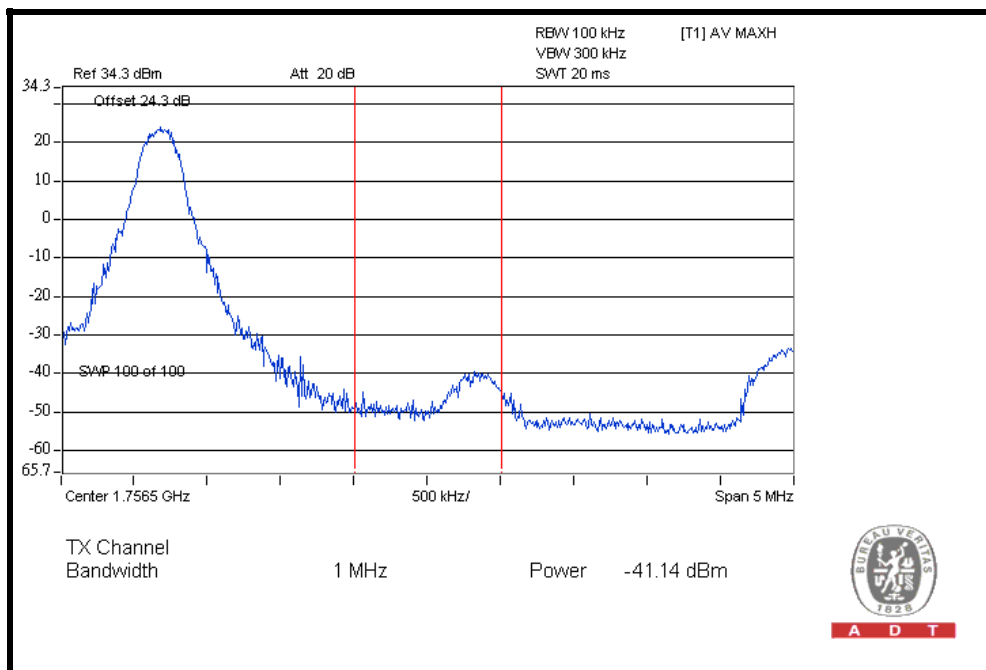
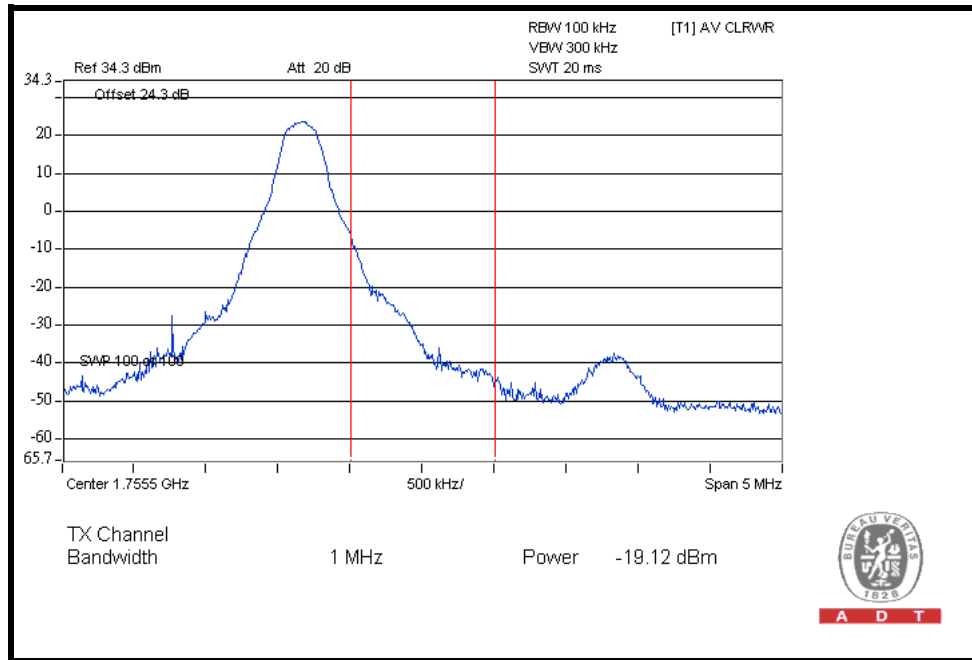



A D T

CHANNEL BANDWIDTH: 5MHz / FULL RB ALLOCATION

LOWER BAND EDGE

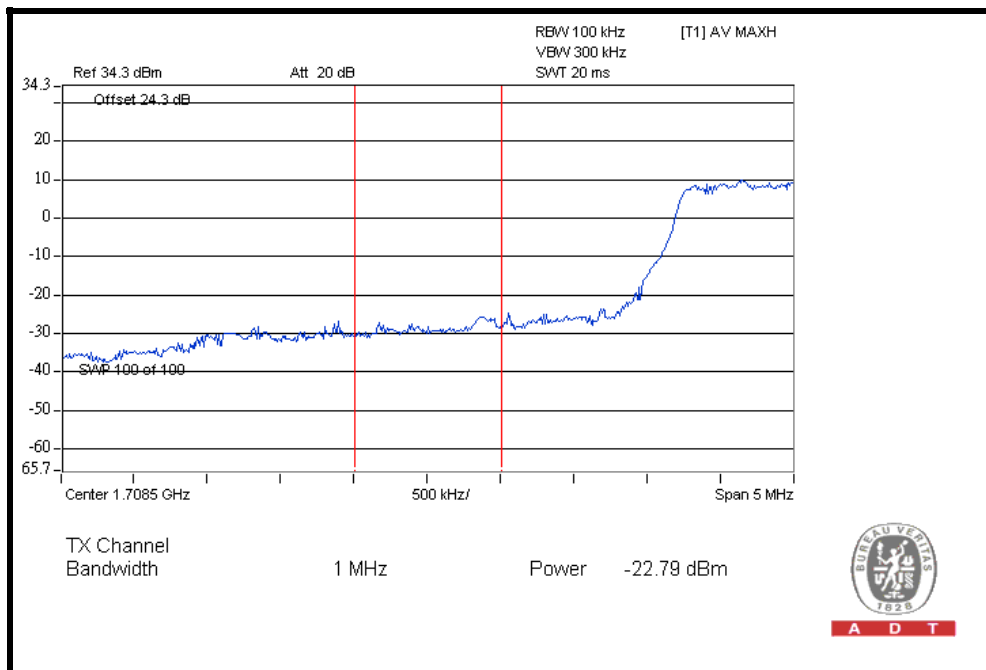
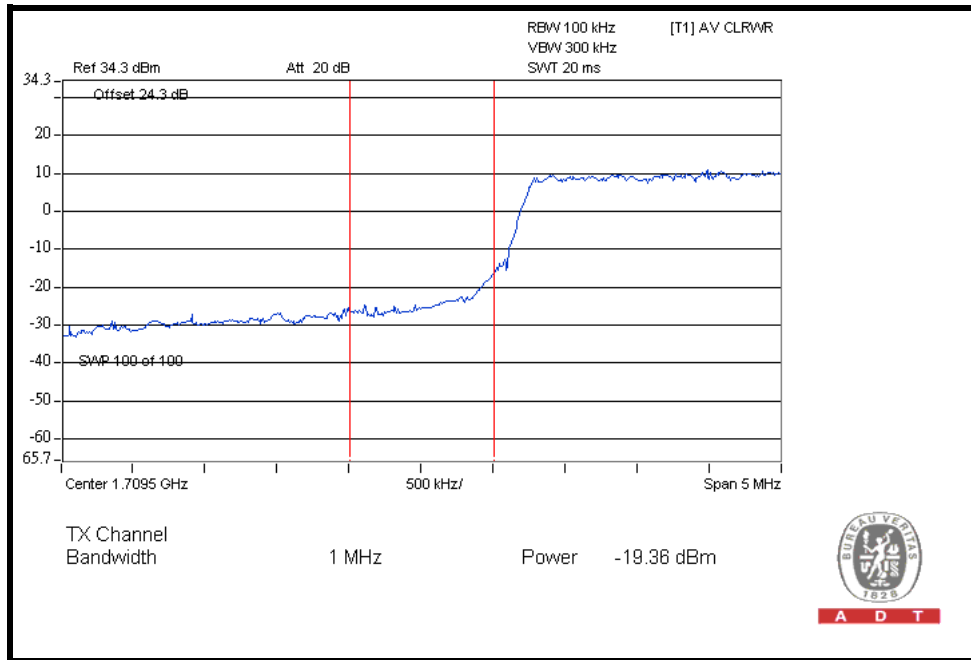



A D T

HIGHER BAND EDGE

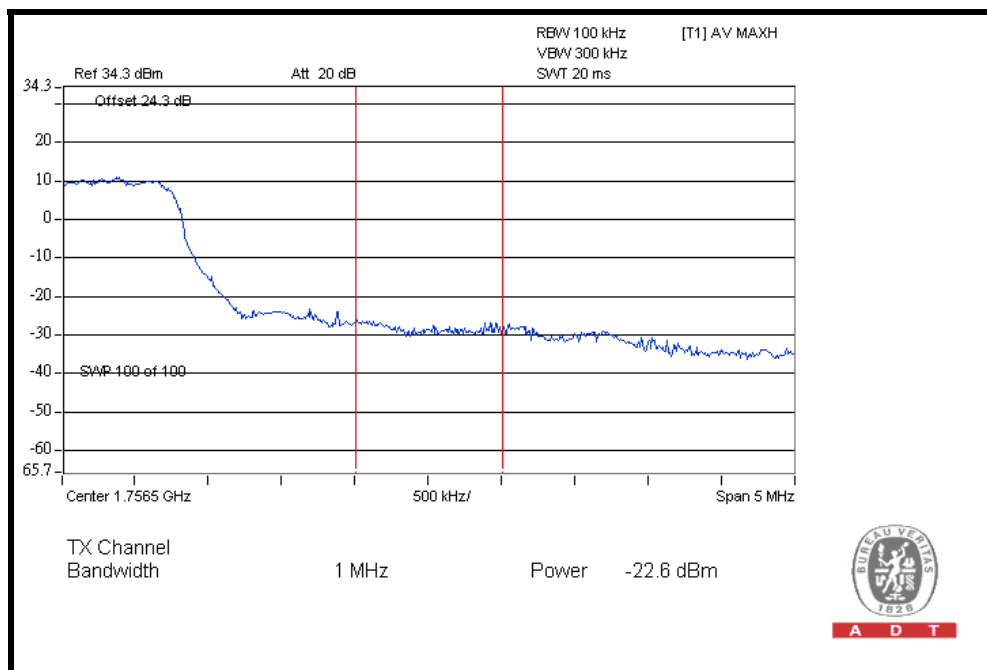
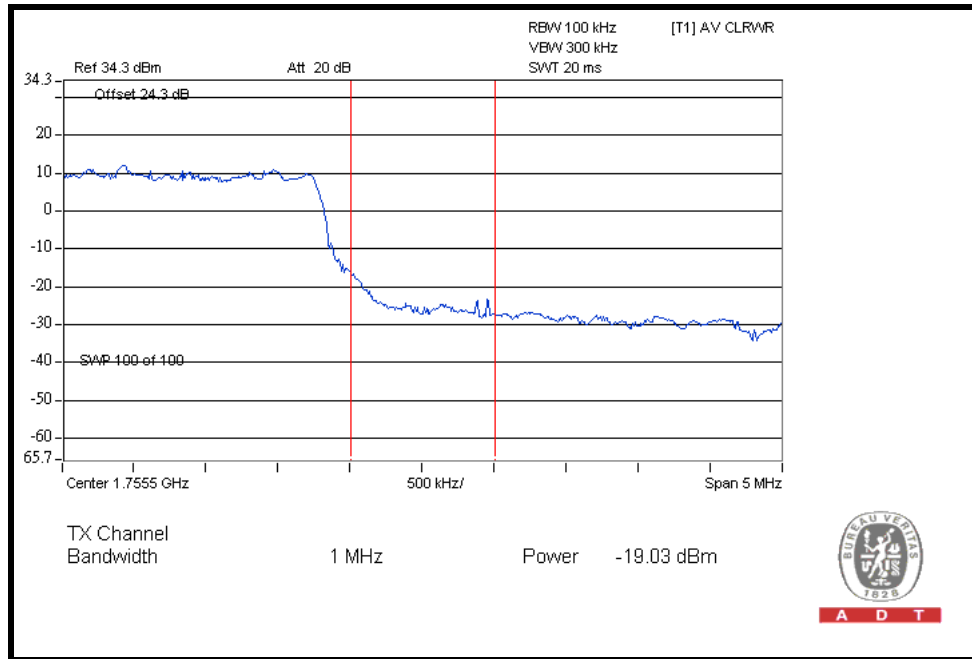



A D T

LTE Band 4

CHANNEL BANDWIDTH: 10MHz / 1 RB ALLOCATED AT THE LOWER EDGE

LOWER BAND EDGE

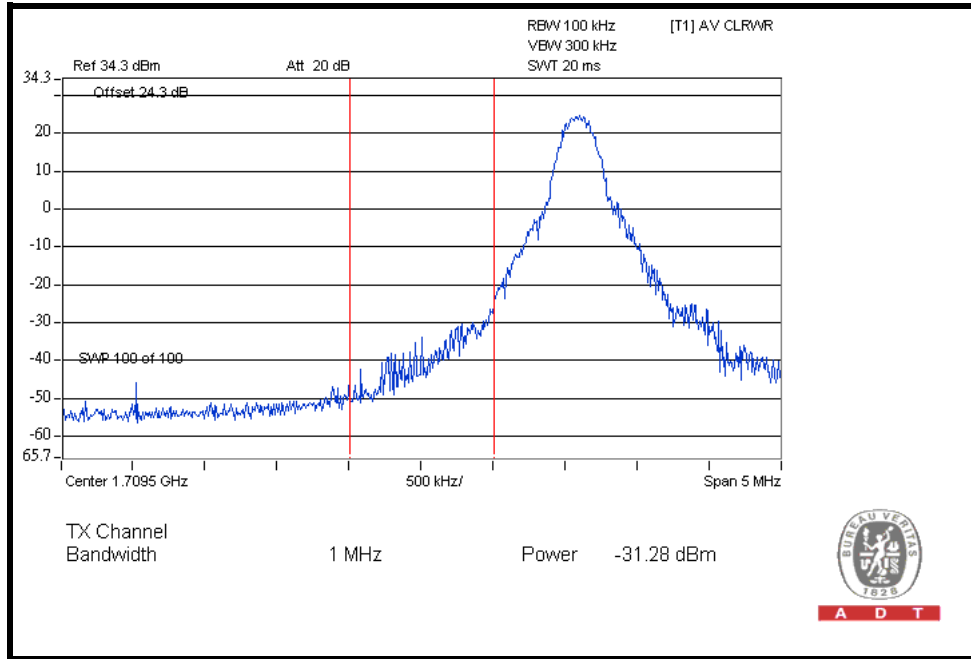

A D T

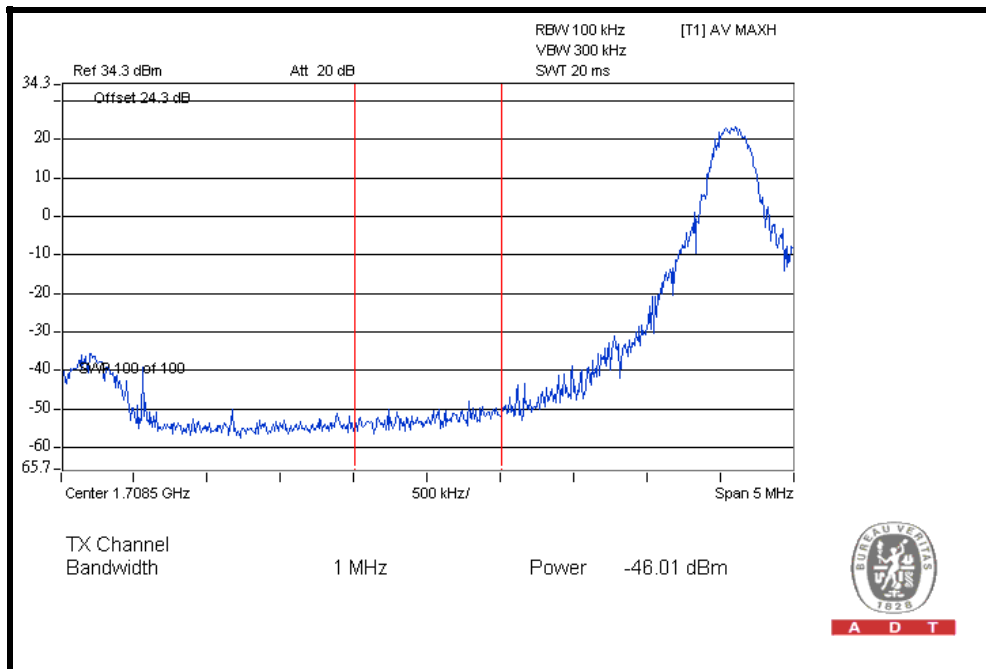

A D T



A D T

CHANNEL BANDWIDTH: 10MHz / 1 RB ALLOCATED AT THE UPPER EDGE

HIGHER BAND EDGE

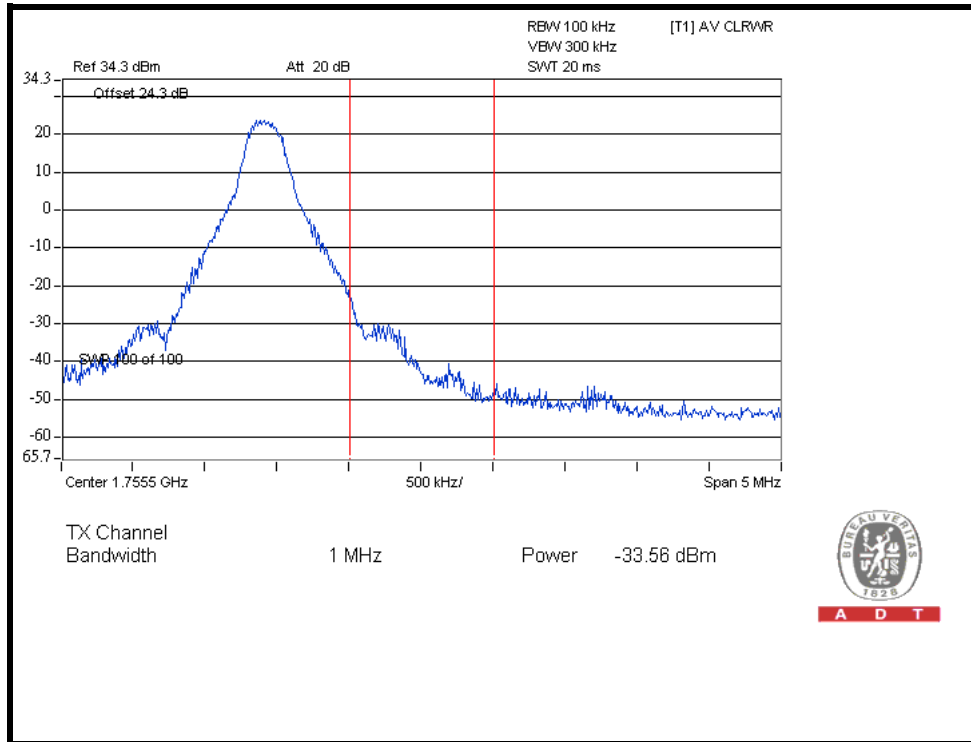

A D T

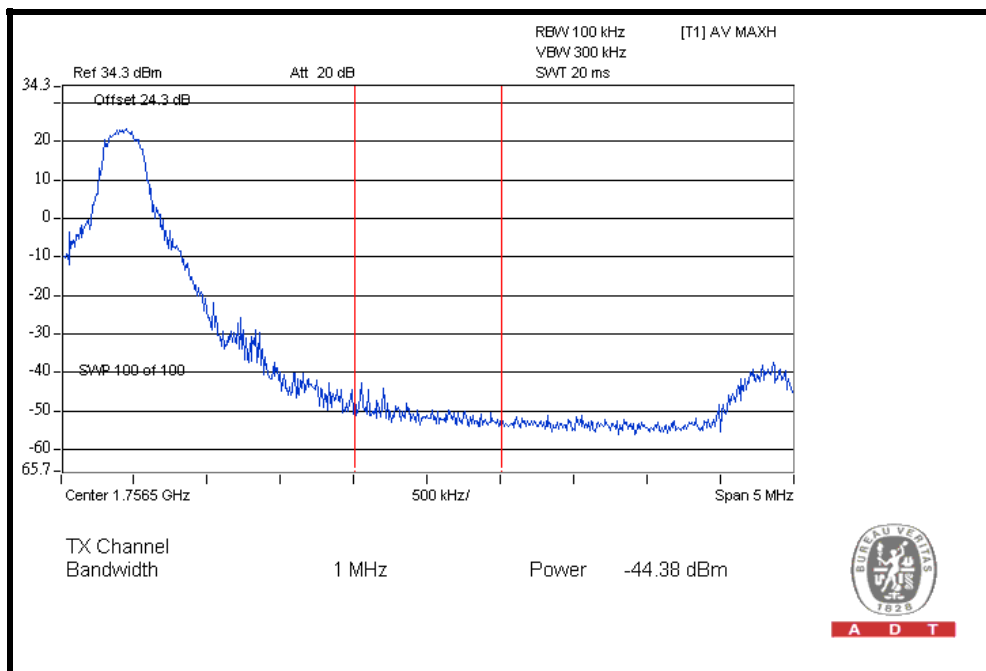

A D T



A D T

CHANNEL BANDWIDTH: 10MHz / FULL RB ALLOCATION

LOWER BAND EDGE

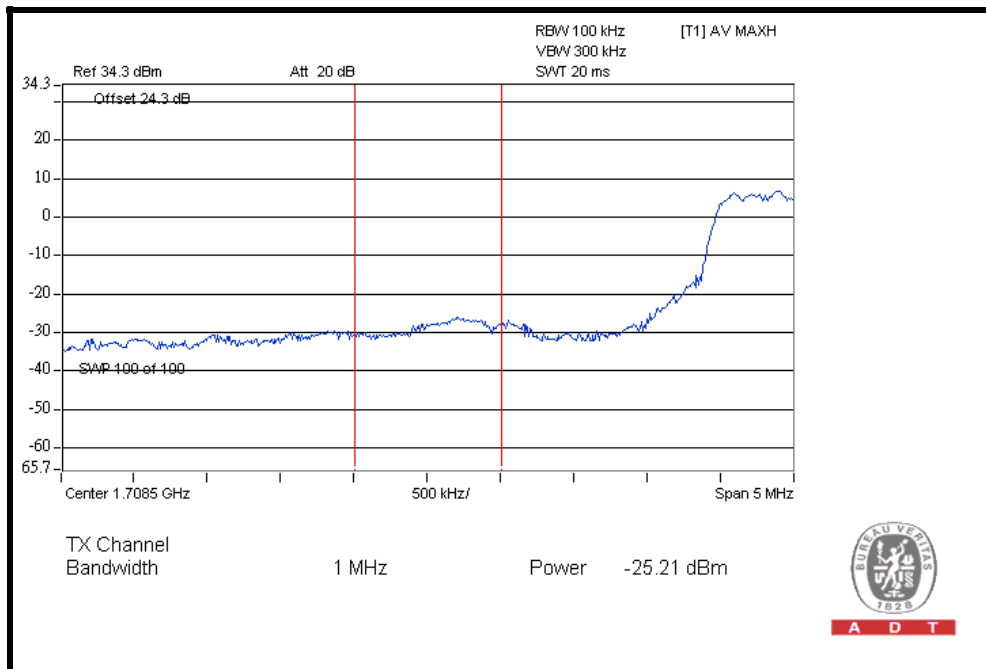
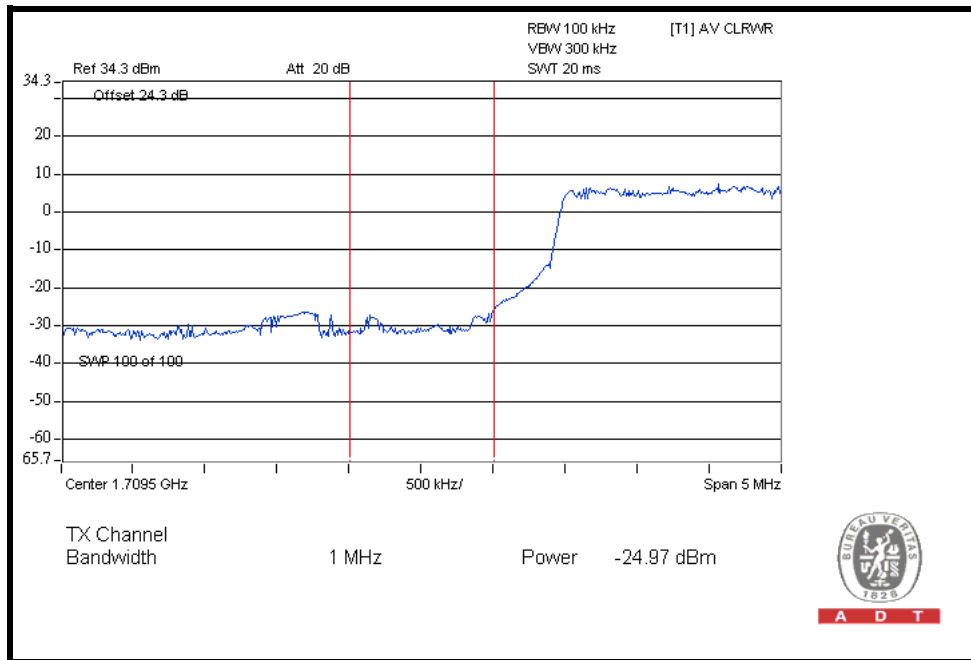



A D T

HIGHER BAND EDGE

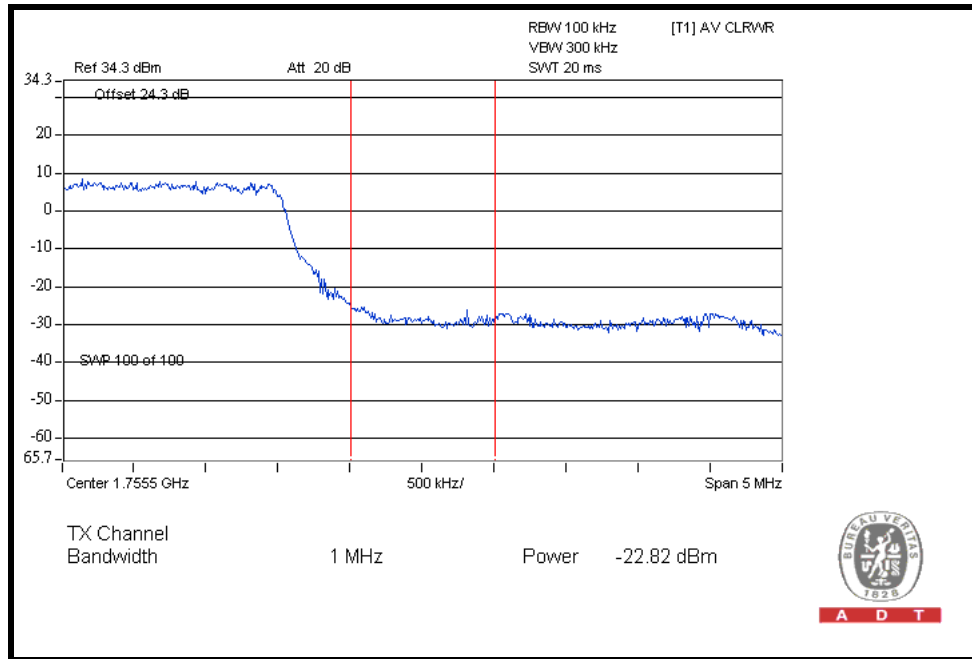

A D T

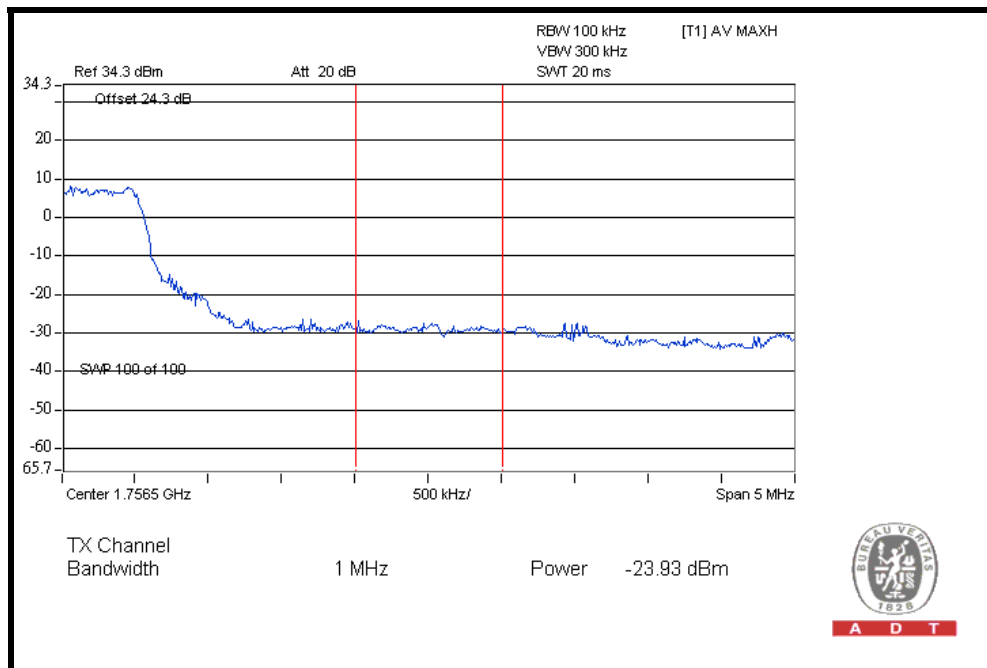

A D T



A D T

WCDMA AWS Band WCDMA

LOWER BAND EDGE

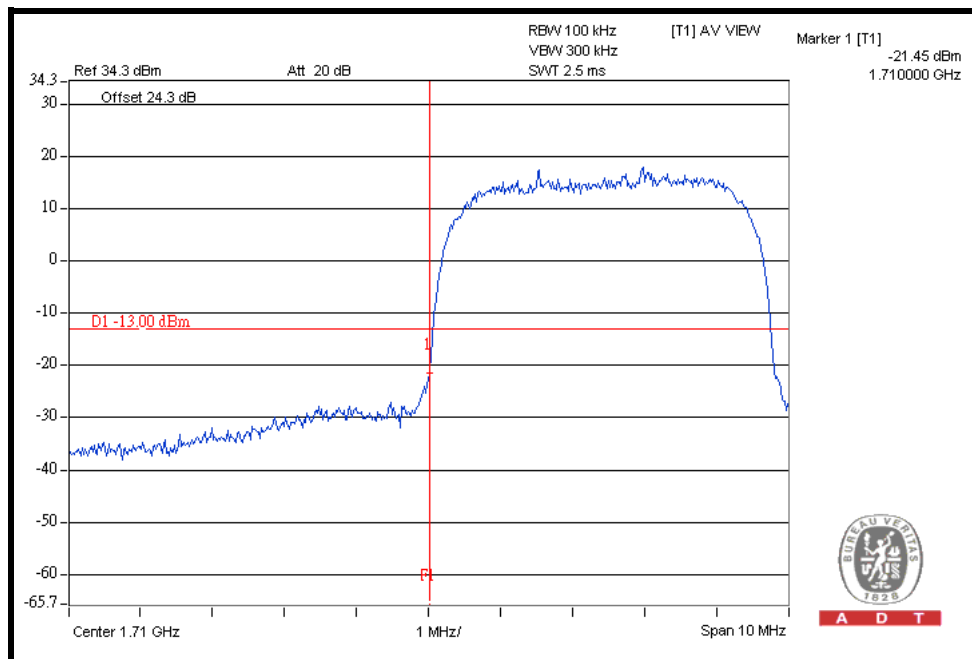

HIGHER BAND EDGE

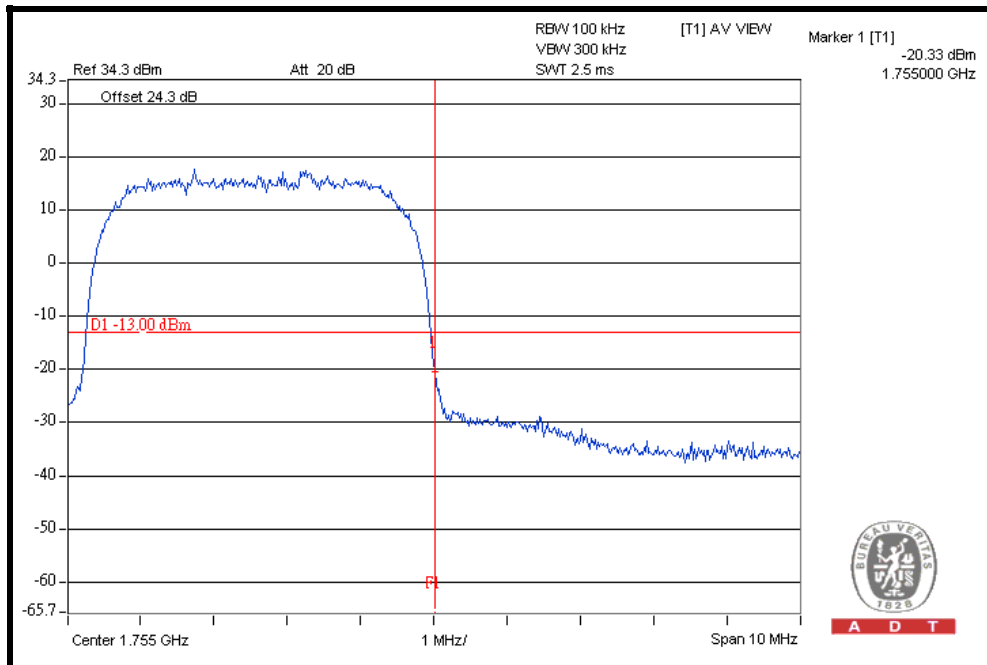



A D T

WCDMA AWS Band HSDPA

LOWER BAND EDGE

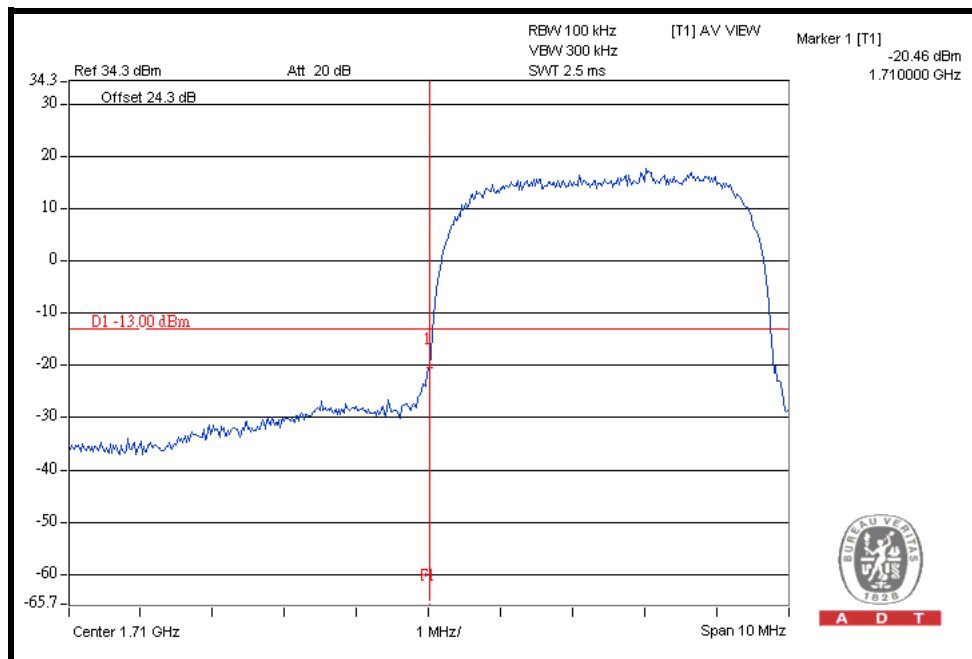

A D T

HIGHER BAND EDGE

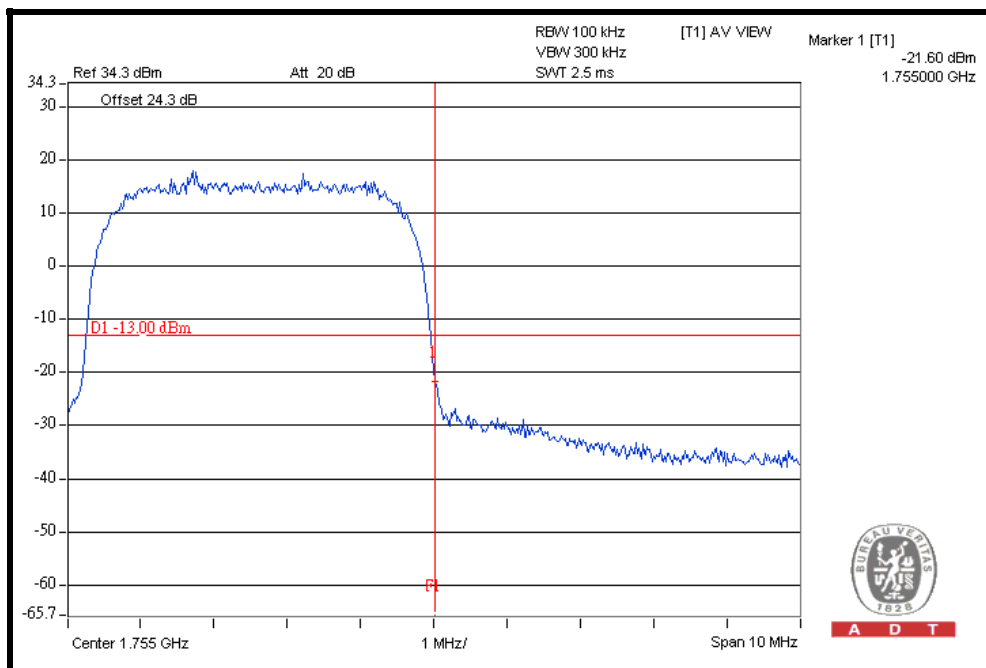

A D T



A D T

WCDMA AWS Band HSUPA

LOWER BAND EDGE

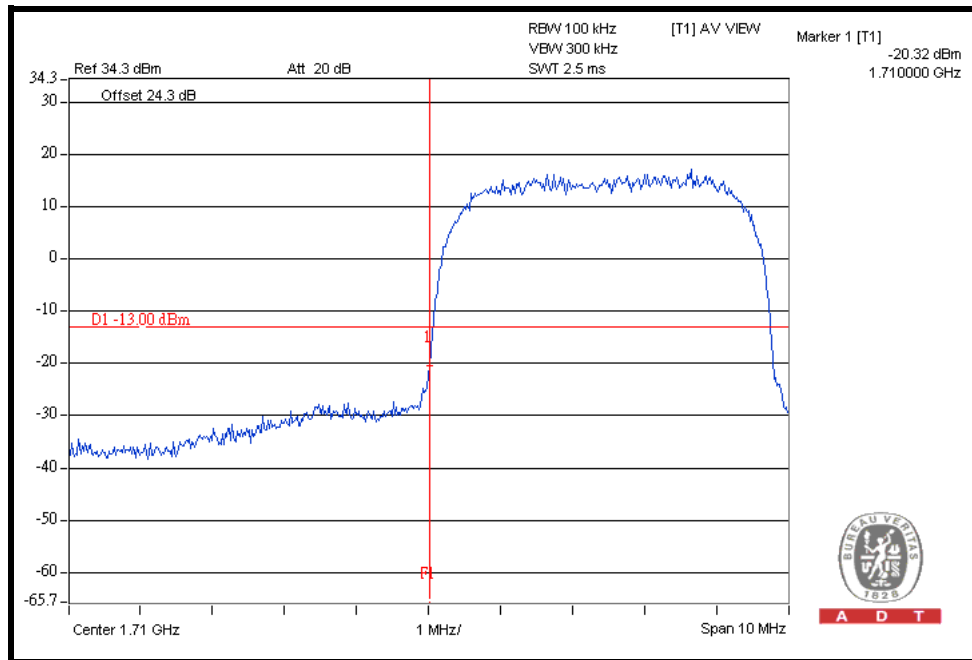

HIGHER BAND EDGE

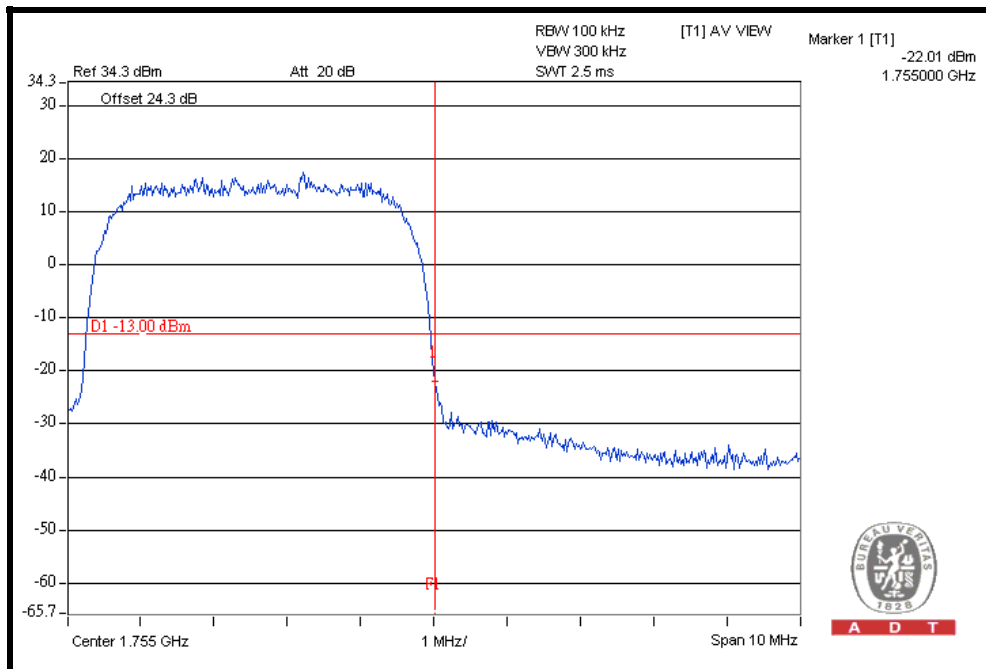

4.6 CONDUCTED SPURIOUS EMISSIONS

4.6.1 LIMITS OF CONDUCTED SPURIOUS EMISSIONS MEASUREMENT

The power of any emission outside a licensee's frequency block shall be attenuated below the transmitter power (P) by at least $43 + 10 \log_{10}(P)$ dB. The limit of emission equal to -13dBm

4.6.2 TEST INSTRUMENTS

DESCRIPTION & MANUFACTURER	MODEL NO.	SERIAL NO.	DATE OF CALIBRATION	DUE DATE OF CALIBRATION
* ROHDE & SCHWARZ Spectrum Analyzer	FSP40	100041	Jul. 09, 2010	Jul. 08, 2011
* Wainwright Instruments Band Reject Filter	WRCG1850/1910-1 830/1930-60/10SS	SN1	Mar. 25, 2010	Mar. 24, 2011
* Wainwright Instruments High Pass Filter	WHK3.1/18G-10SS	SN3	Jun. 29, 2010	Jun. 28, 2011
* Mini-Circuits Power Splitter	ZAPD-4	NA	Jun. 29, 2010	Jun. 28, 2011
* Hewlett Packard RF cable	8120-6192	274388	Oct. 22, 2010	Oct. 21, 2011
* JFW 20dB attenuation	50HF-020-SMA	NA	NA	NA
* Suhner RF cable	Sucoflex104	246272	May 14, 2010	May 13, 2011

- NOTE:**
1. The calibration interval of the above test instruments is 12 months. And the calibrations are traceable to NML/ROC and NIST/USA.
 2. "*" = These equipments are used for the final measurement.

4.6.3 TEST PROCEDURE

- a. The EUT was set up for the maximum peak power with LTE / WCDMA link data modulation. The power was measured with R&S Spectrum Analyzer. All measurements were done at 3 channels (low, middle and high operational frequency range.).
- b. The conducted spurious emission used the power splitter via EUT RF power connector between simulation base station and spectrum analyzer.
- c. When the spectrum scanned from 30MHz to 3GHz, it shall be connected to the band reject filter attenuated the carried frequency. The spectrum set RB=1MHz, VB=3MHz.
- d. When the spectrum scanned from 3GHz to 20GHz, it shall be connected to the high pass filter attenuated the carried frequency. The spectrum set RB=1MHz, VB=3MHz.

4.6.4 TEST SETUP

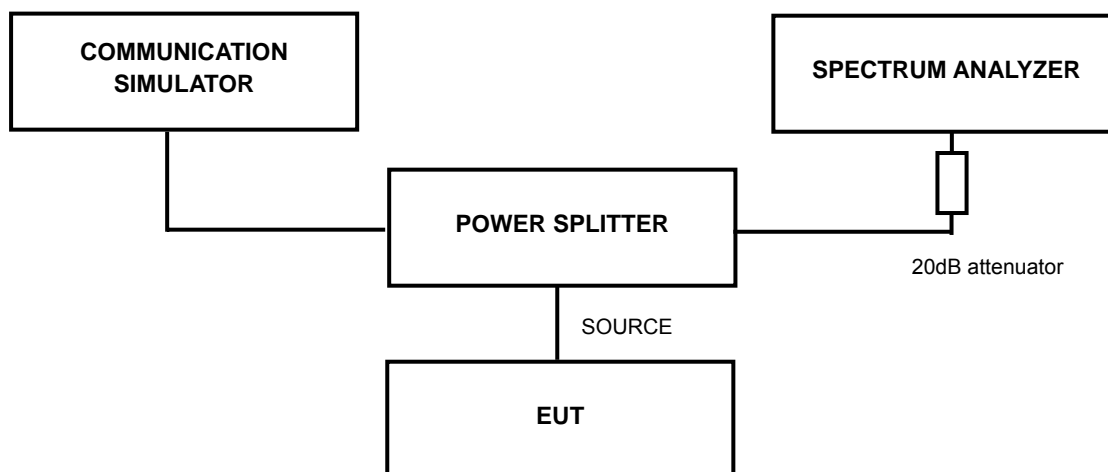

4.6.5 EUT OPERATING CONDITIONS

- a. The EUT makes a phone call to the communication simulator.
- b. The communication simulator station system controlled a EUT to export maximum output power under transmission mode and specific channel frequency.

4.6.6 TEST RESULTS

LTE Band 17

CHANNEL BANDWIDTH: 5MHz / 1 RB ALLOCATED AT THE LOWER EDGE

CH 23755: 9kHz ~ 1GHz

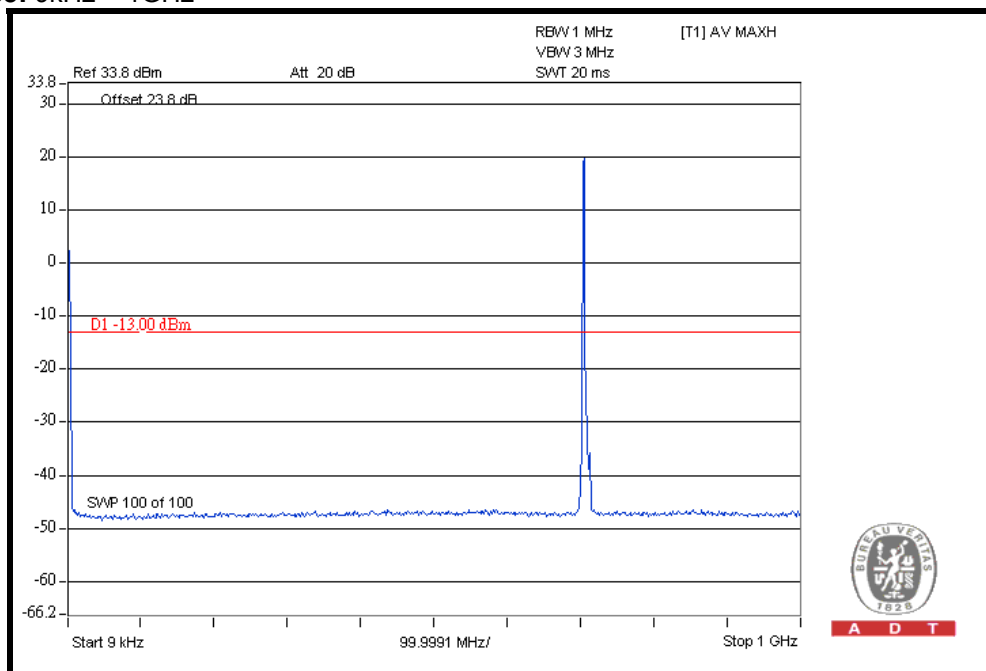

CH 23755: 1GHz ~ 4GHz

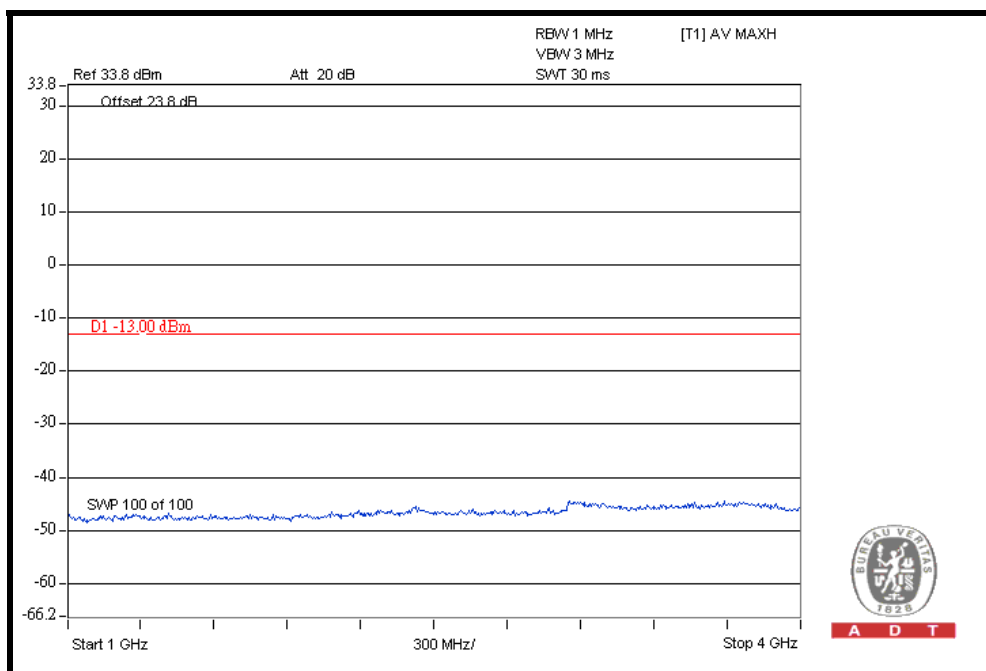



A D T

CH 23755: 4GHz ~ 7GHz

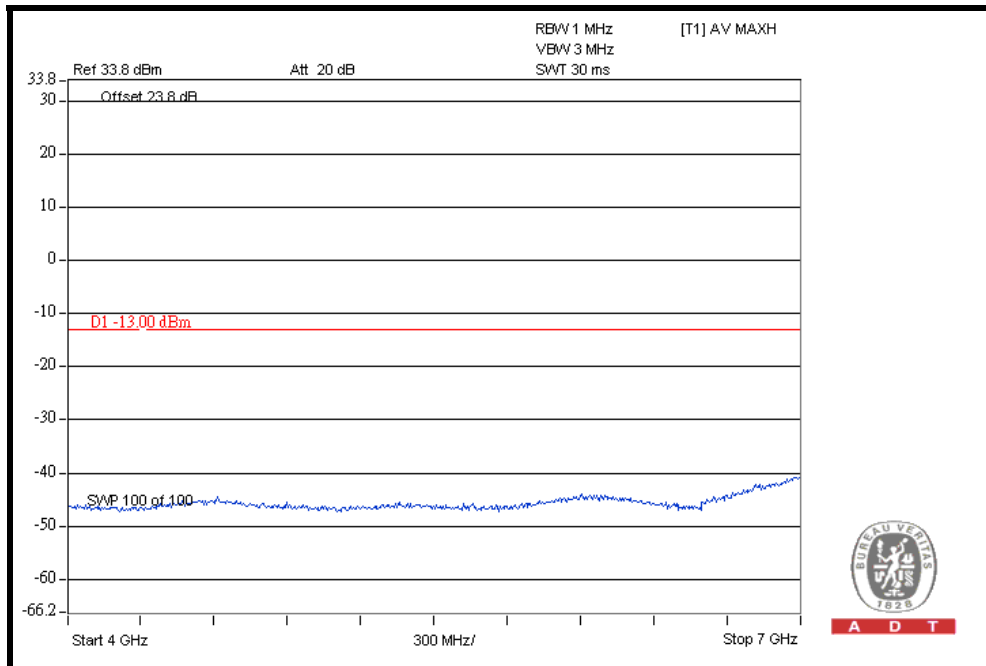

CH 23755: 7GHz ~ 9GHz

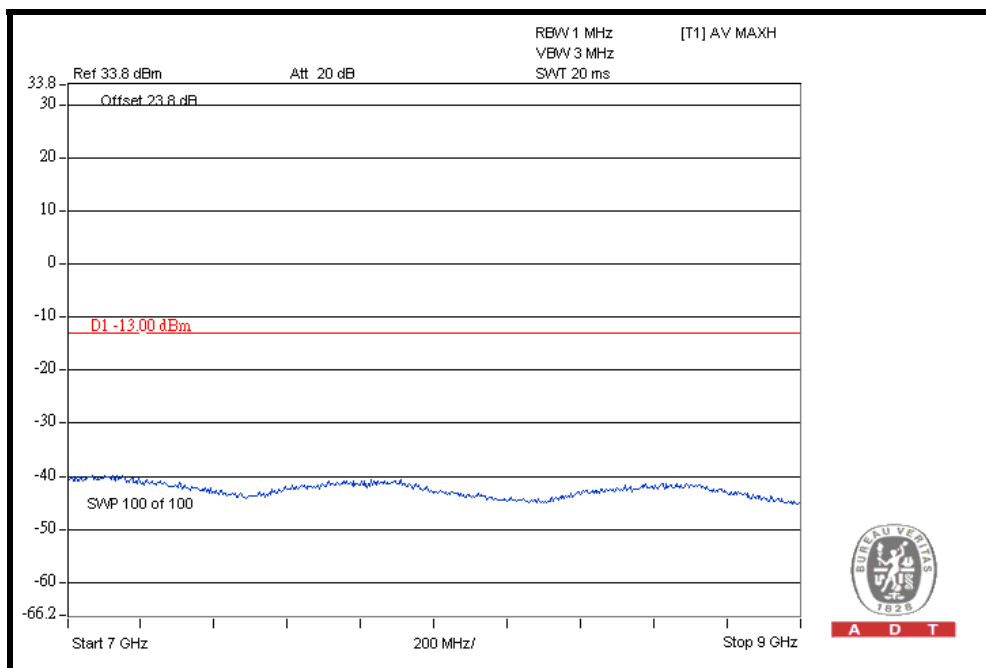



A D T

CH 23790: 9kHz ~ 1GHz

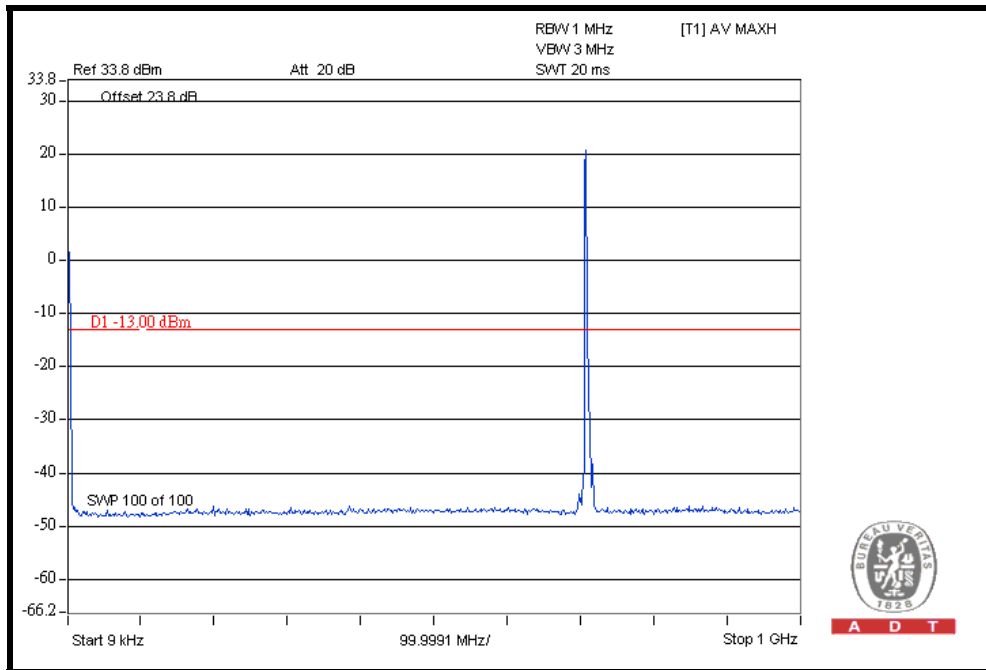

CH 23790: 1GHz ~ 4GHz

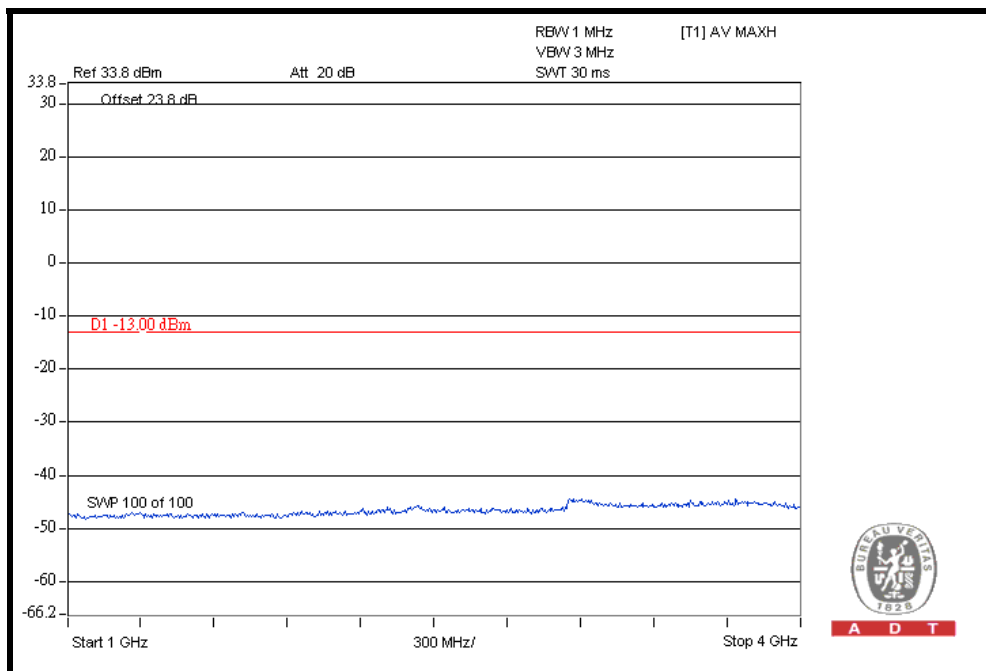



A D T

CH 23790: 4GHz ~ 7GHz

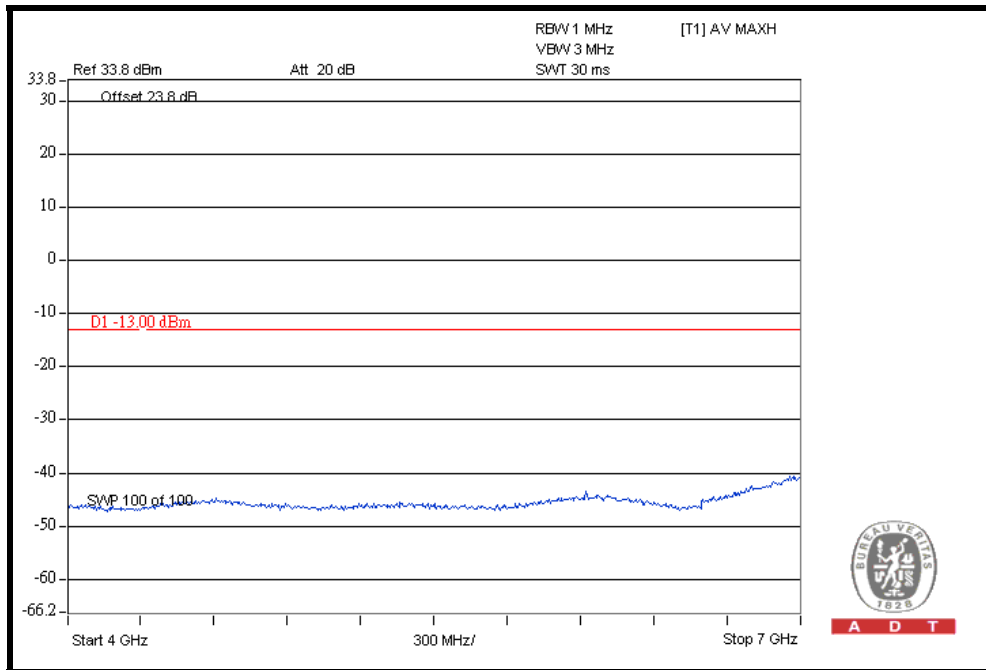

CH 23790: 7GHz ~ 9GHz

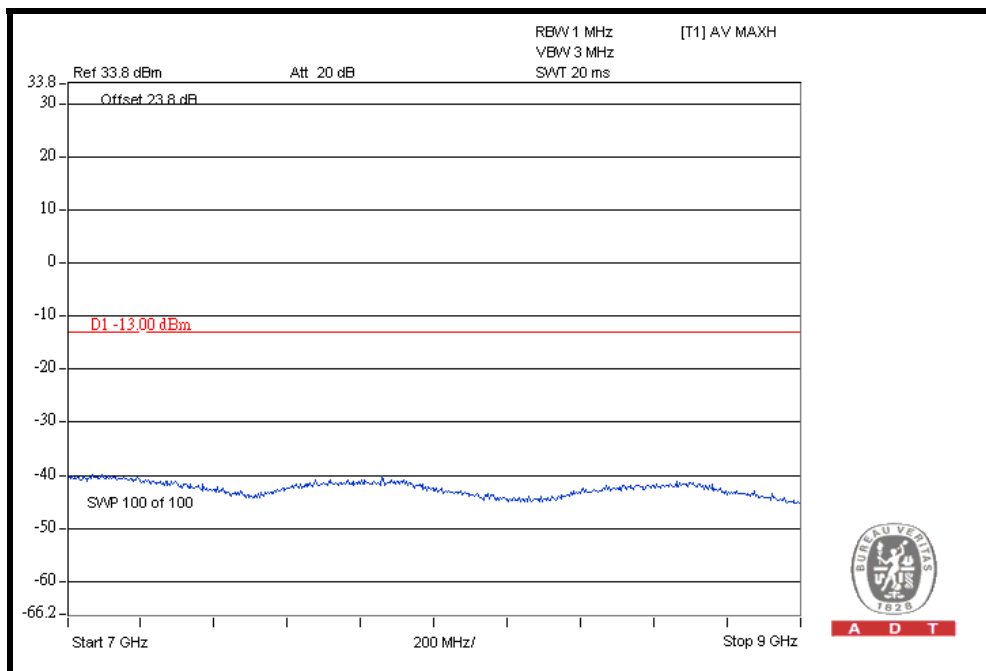



A D T

CH 23825: 9kHz ~ 1GHz

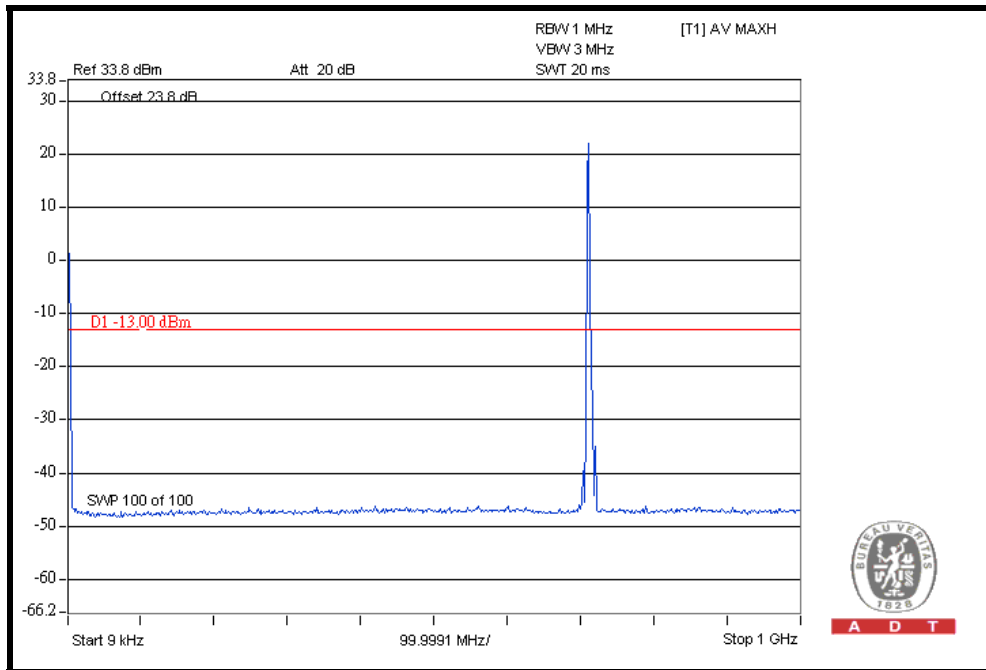

CH 23825: 1GHz ~ 4GHz

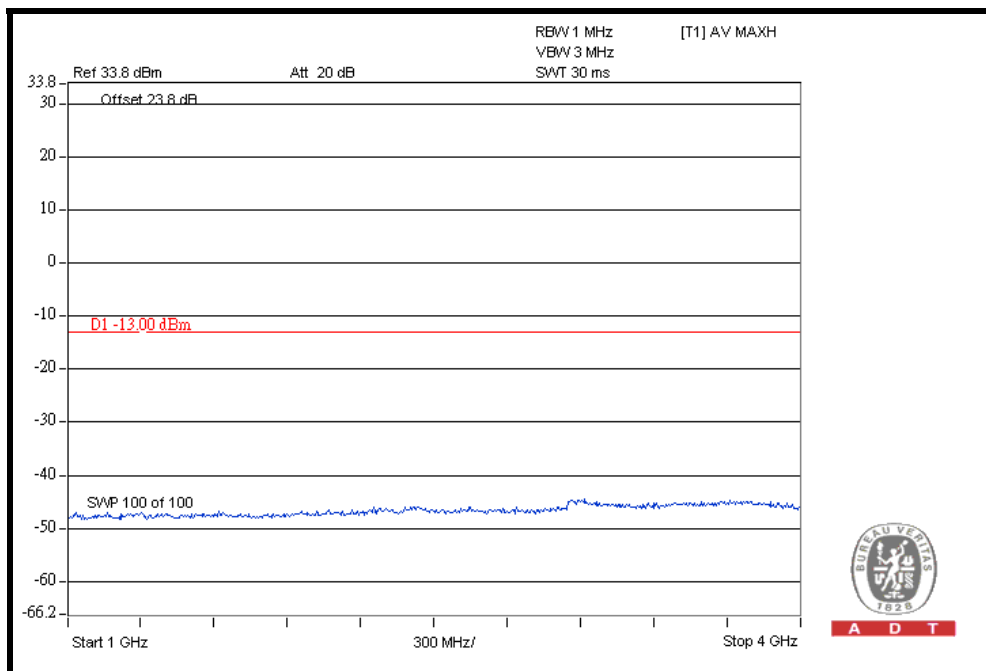



A D T

CH 23825: 4GHz ~ 7GHz

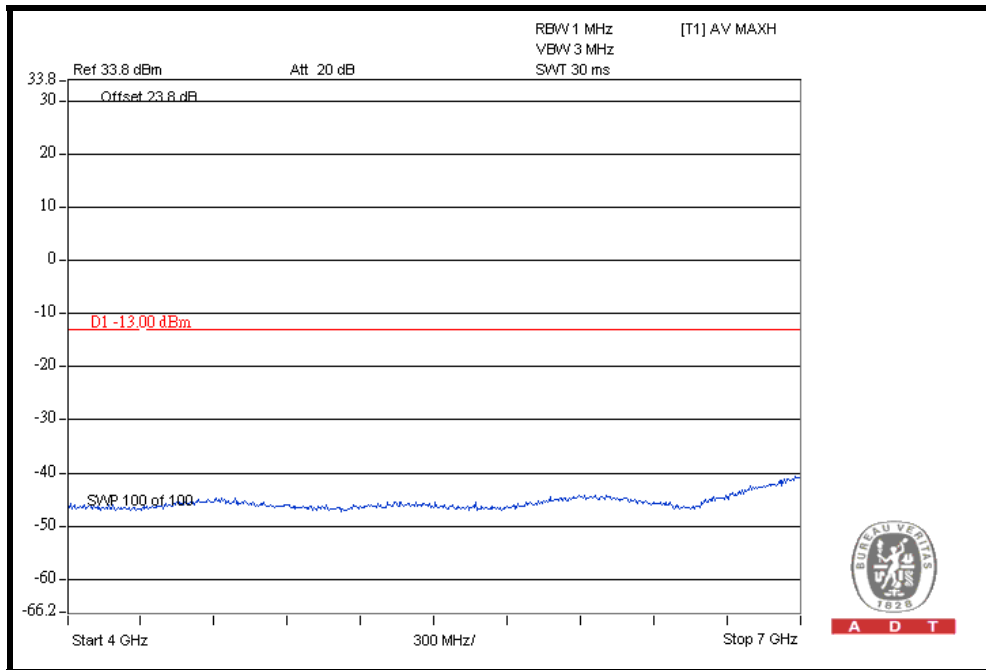

CH 23825: 7GHz ~ 9GHz

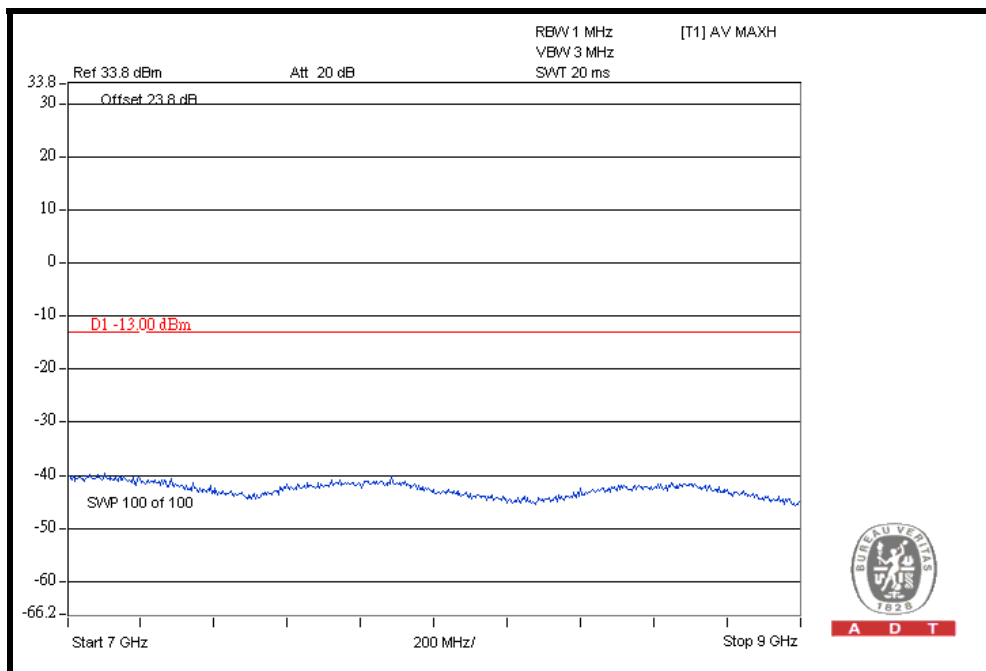

LTE Band 17

CHANNEL BANDWIDTH: 10MHz / 1 RB ALLOCATED AT THE LOWER EDGE

CH 23780: 9kHz ~ 1GHz

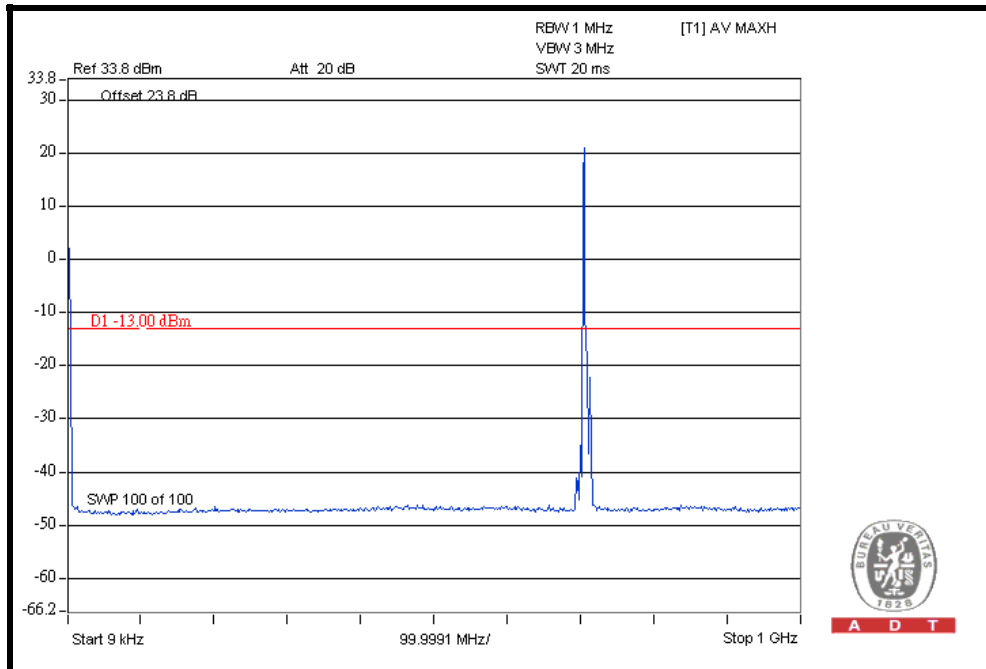

CH 23780: 1GHz ~ 4GHz

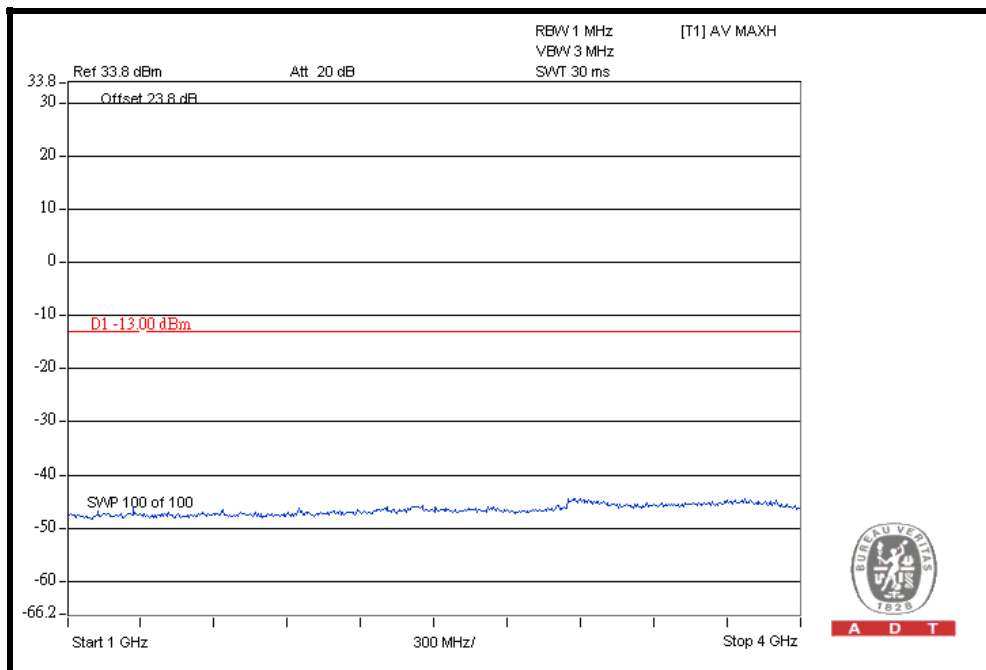



A D T

CH 23780: 4GHz ~ 7GHz

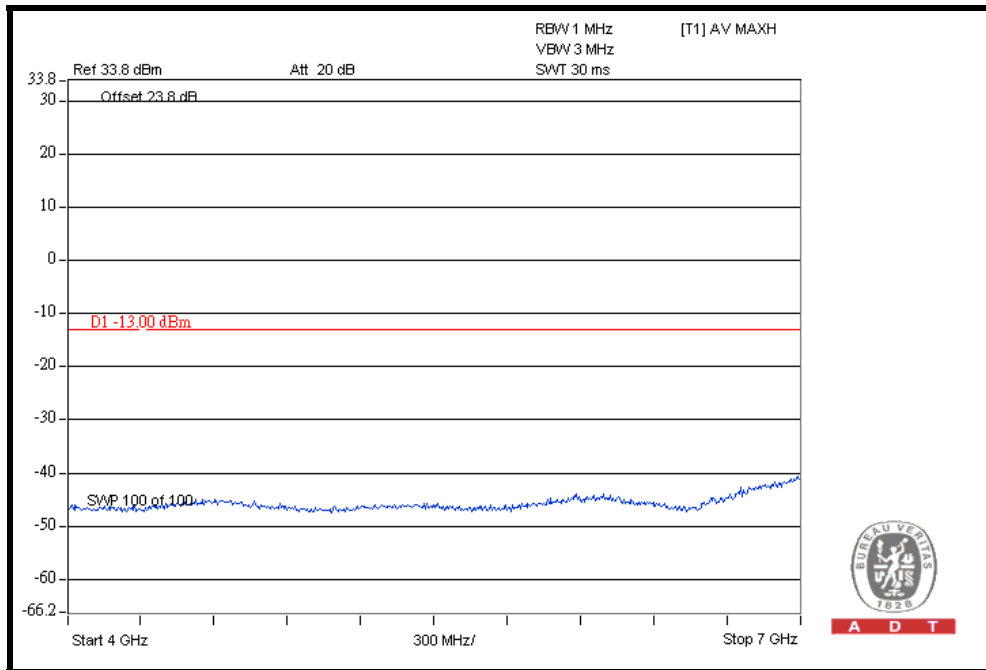

CH 23780: 7GHz ~ 9GHz

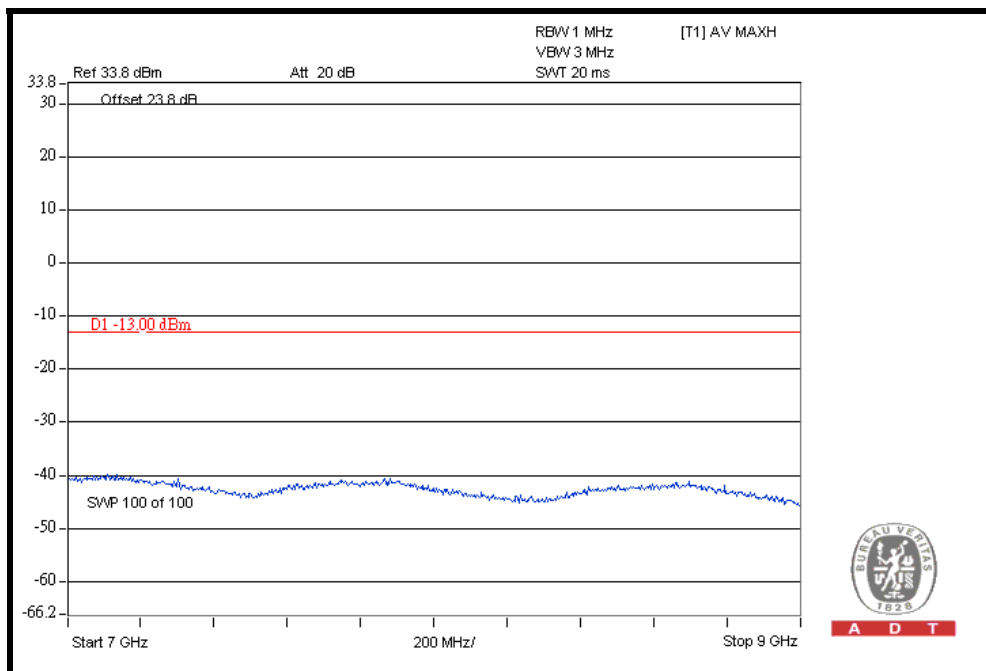



A D T

CH 23790: 9kHz ~ 1GHz

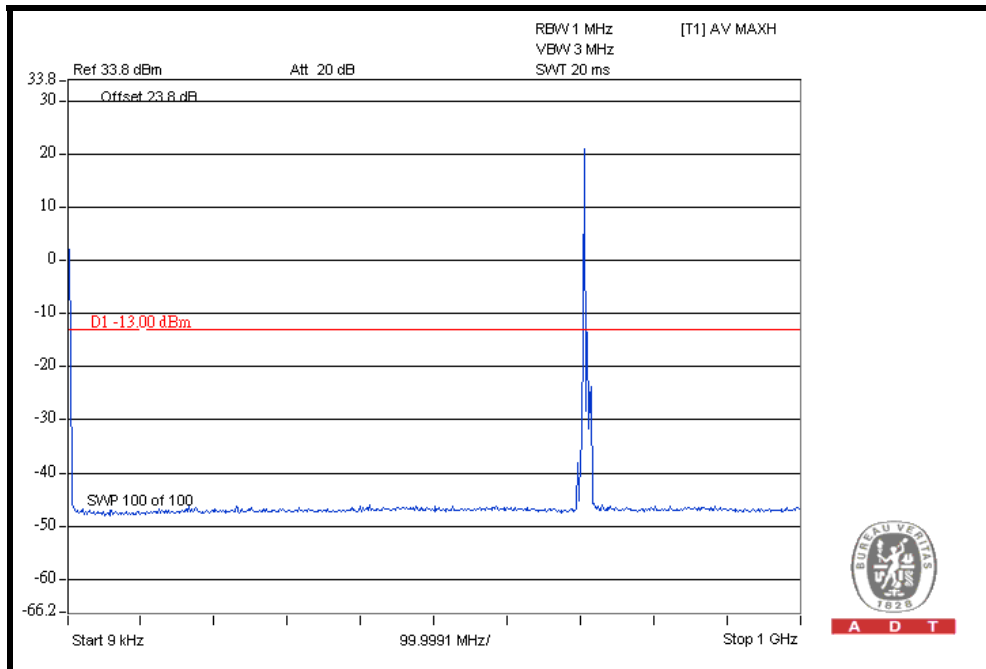

CH 23790: 1GHz ~ 4GHz

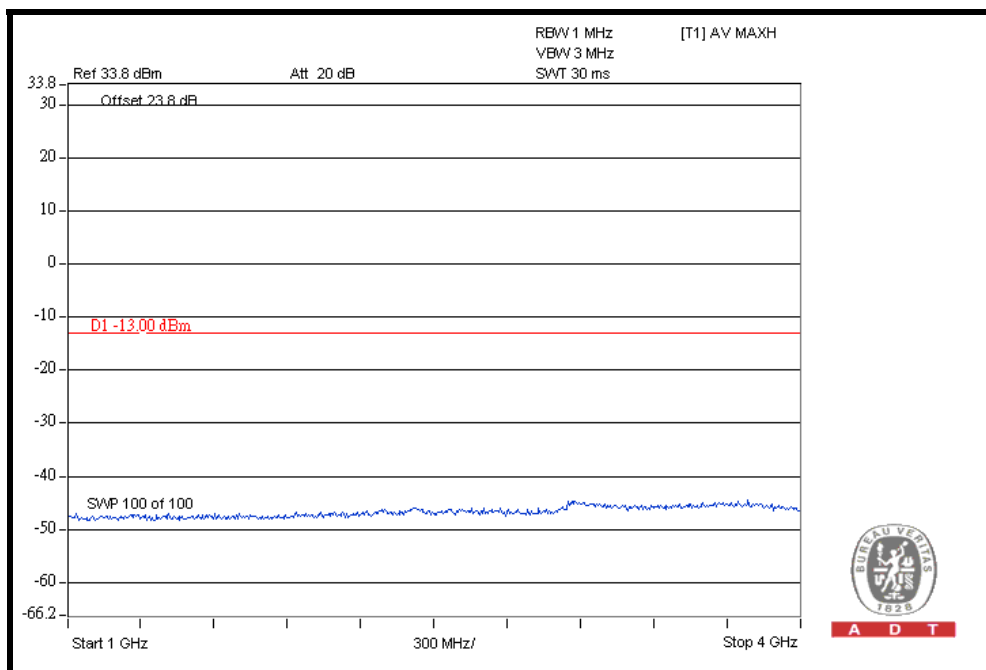



A D T

CH 23790: 4GHz ~ 7GHz

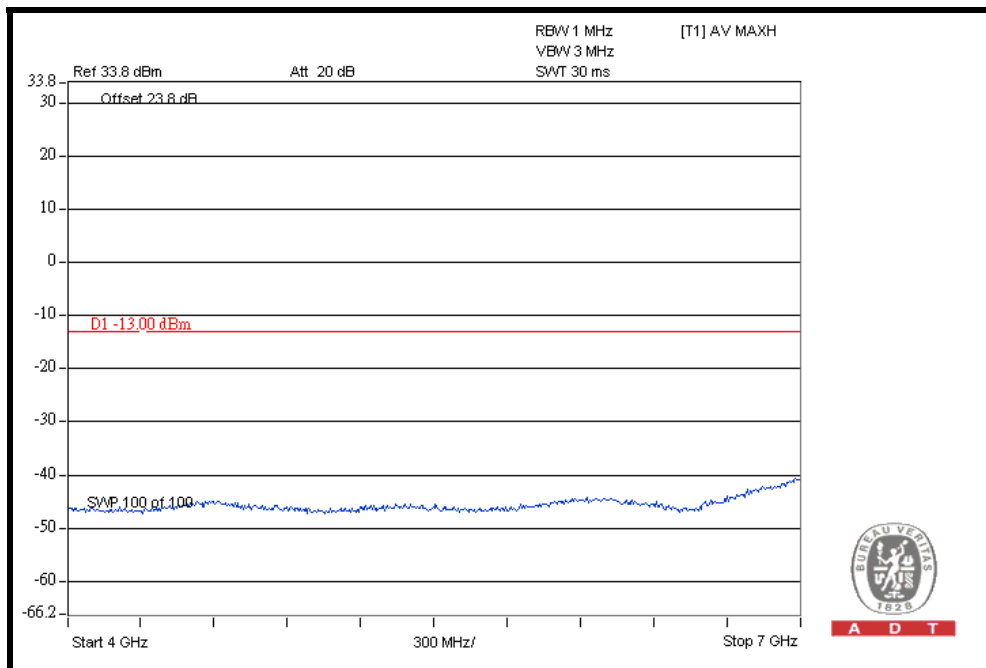

CH 23790: 7GHz ~ 9GHz

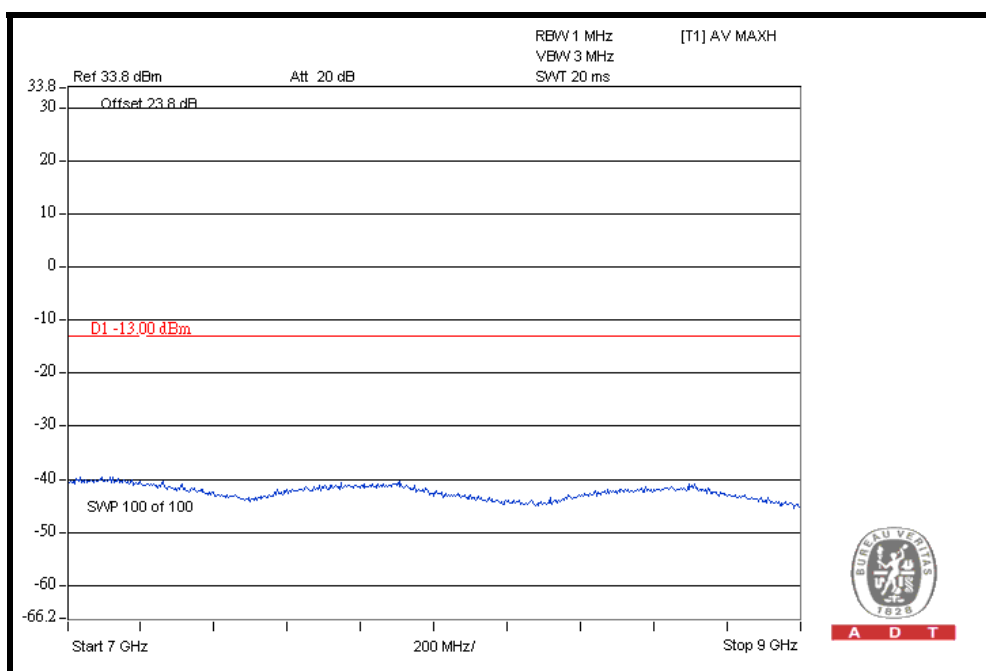



A D T

CH 23800: 9kHz ~ 1GHz

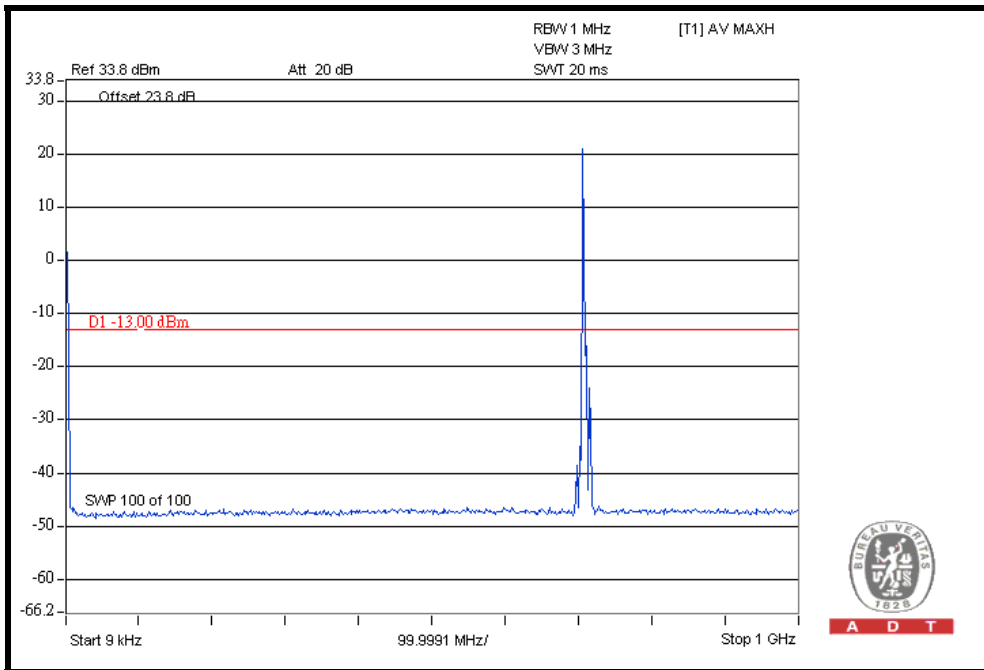

CH 23800: 1GHz ~ 4GHz

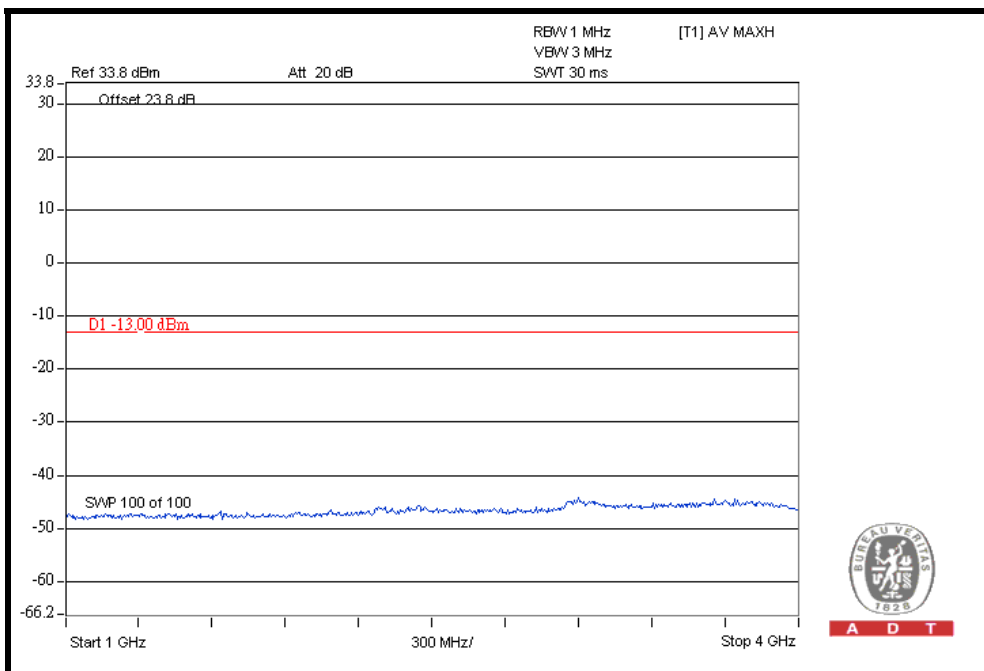



A D T

CH 23800: 4GHz ~ 7GHz

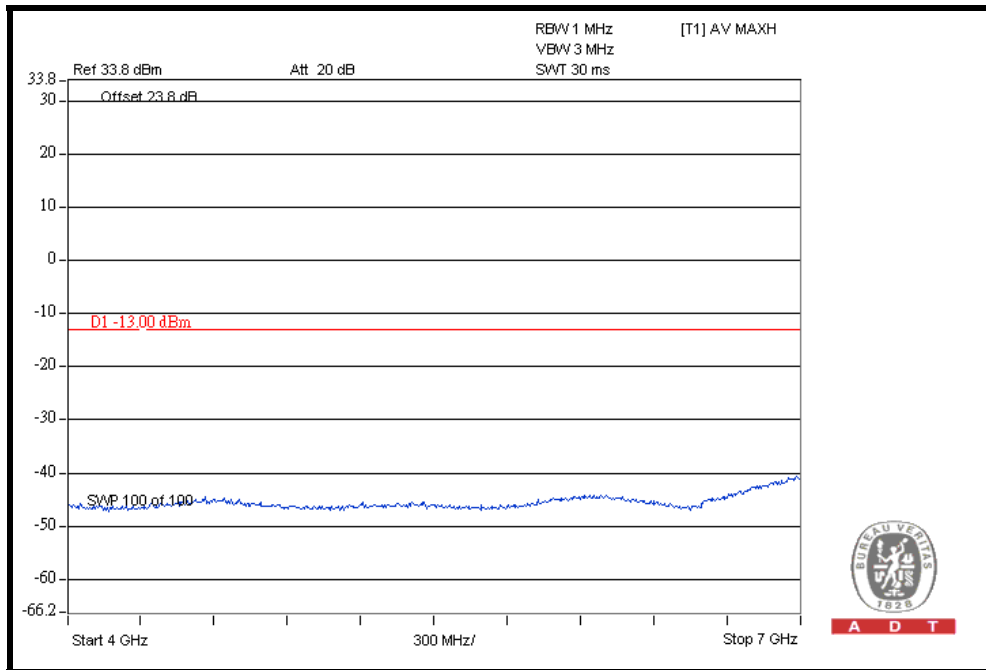

CH 23800: 7GHz ~ 9GHz

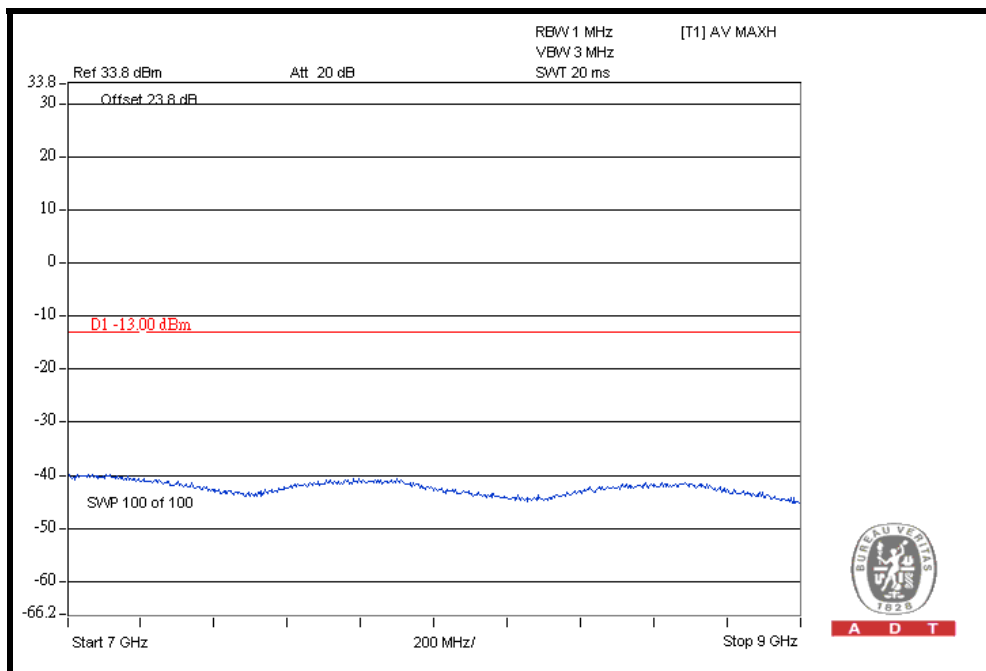



A D T

LTE Band 4

CHANNEL BANDWIDTH: 5MHz / 1 RB ALLOCATED AT THE UPPER EDGE

CH 19975: 9kHz ~ 3GHz

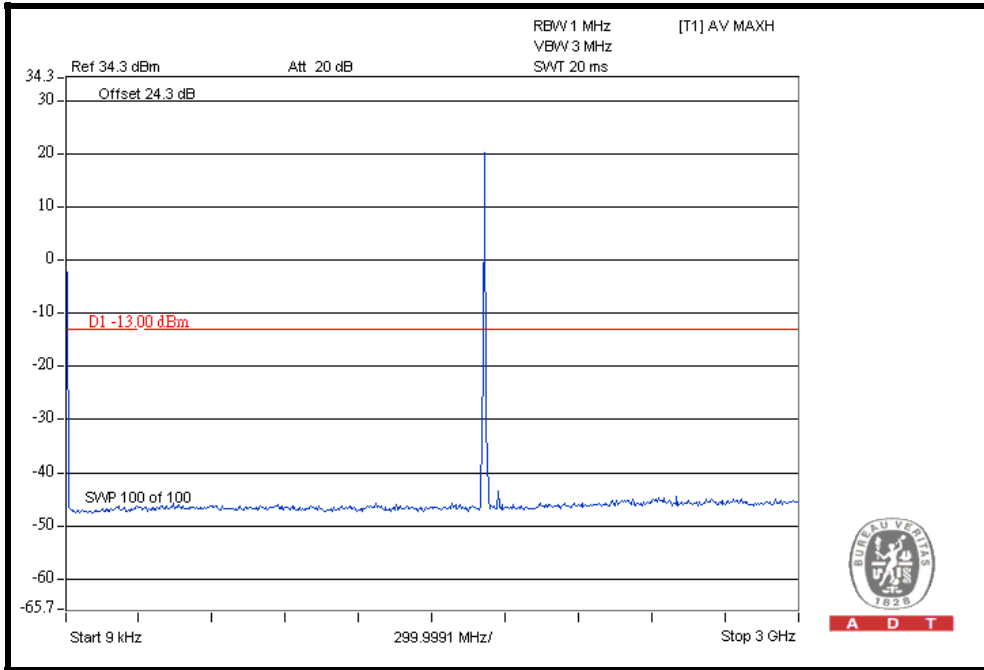

CH 19975: 3GHz ~ 10GHz

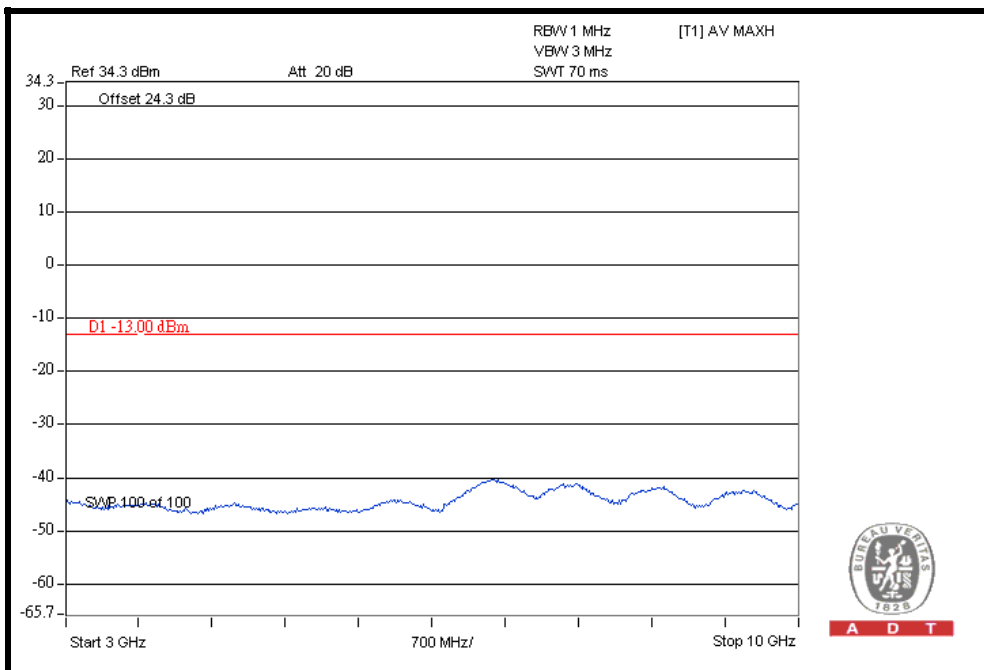



A D T

CH 19975: 10GHz ~ 20GHz

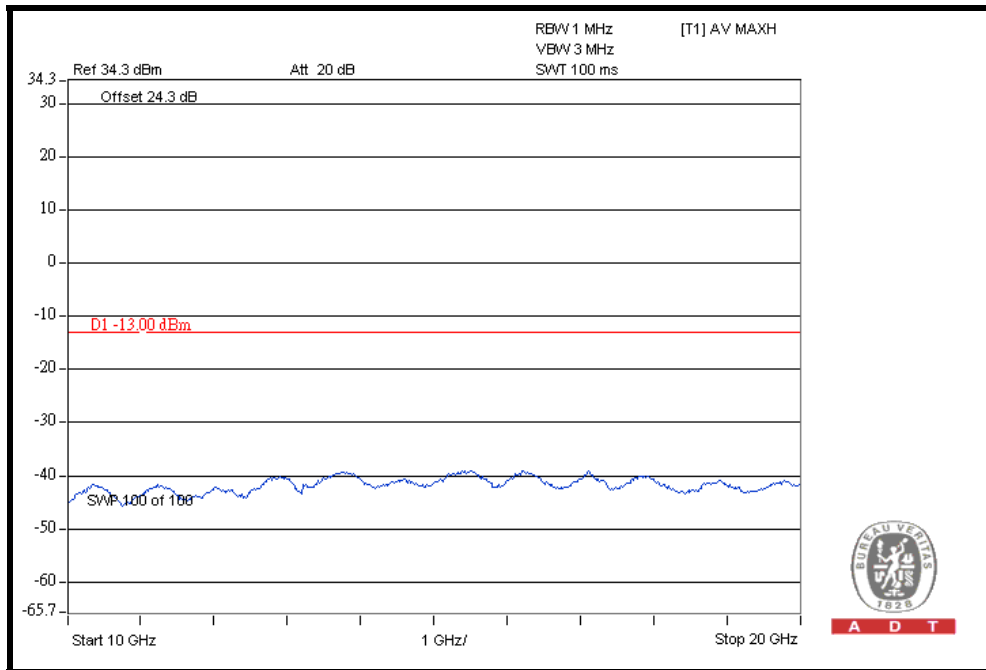

CH 20175: 9kHz ~ 3GHz

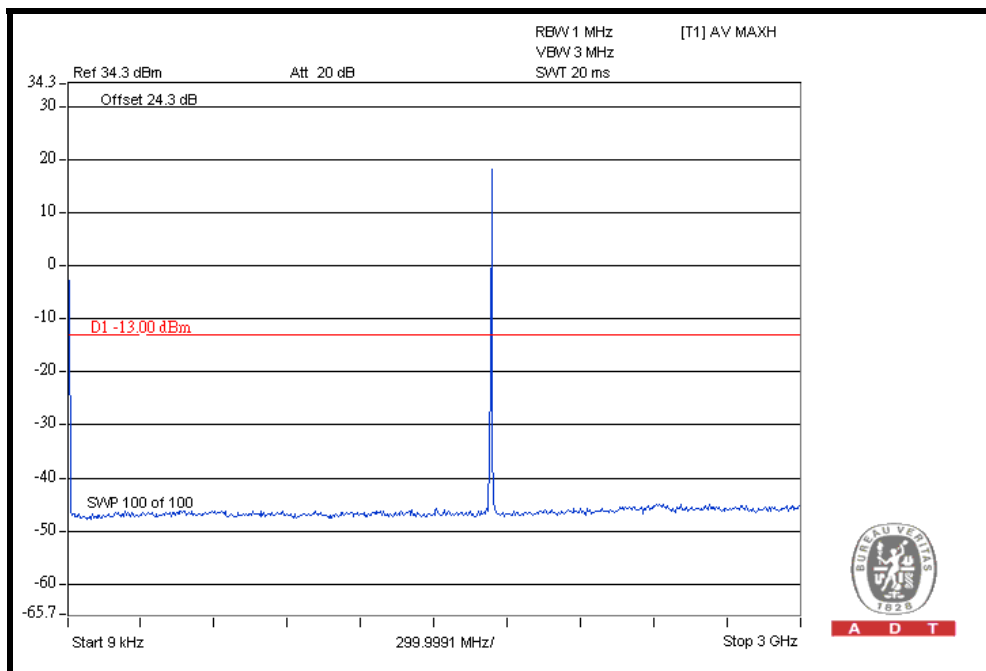



A D T

CH 20175: 3GHz ~ 10GHz

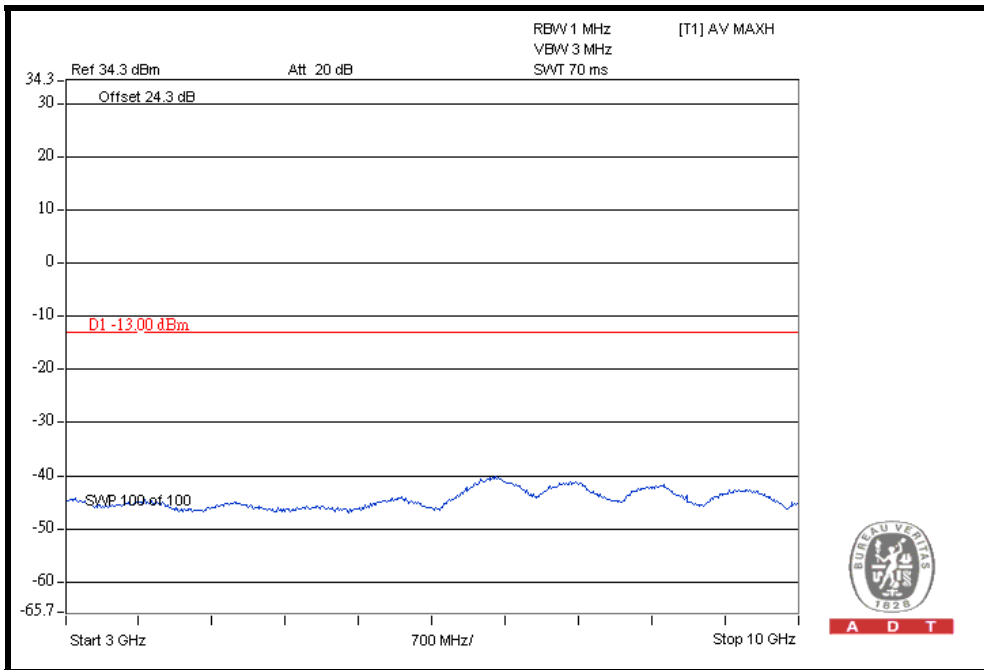

CH 20175: 10GHz ~ 20GHz

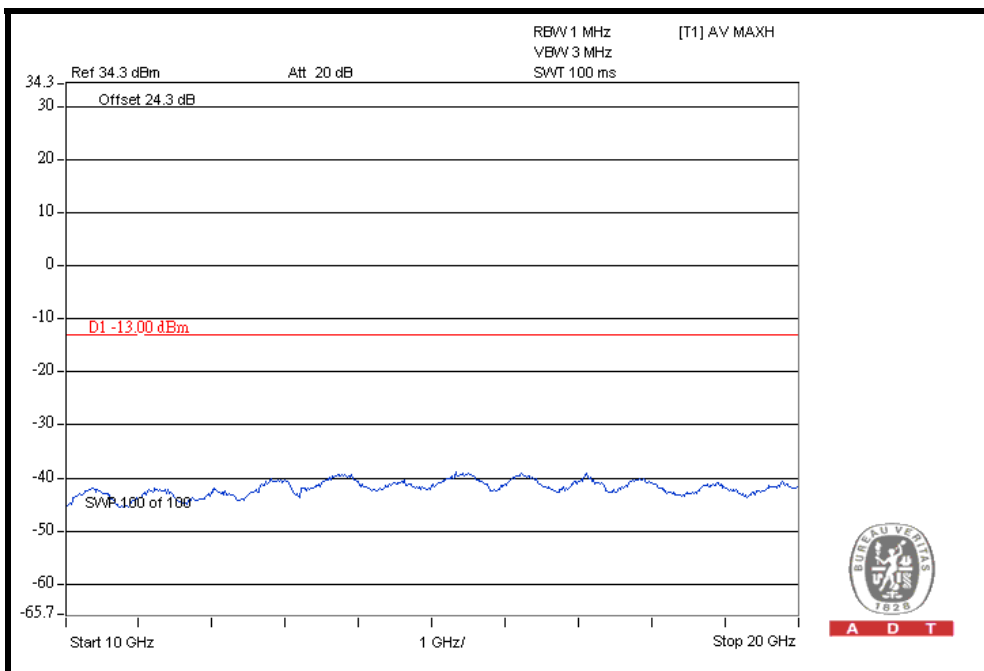



A D T

CH 20375: 9kHz ~ 3GHz

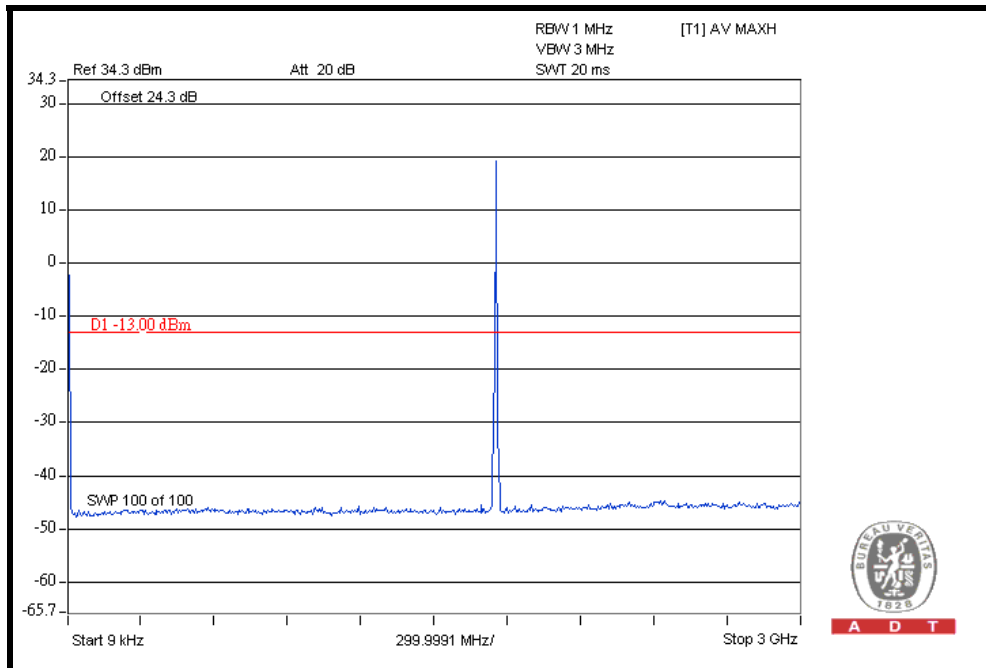

CH 20375: 3GHz ~ 10GHz

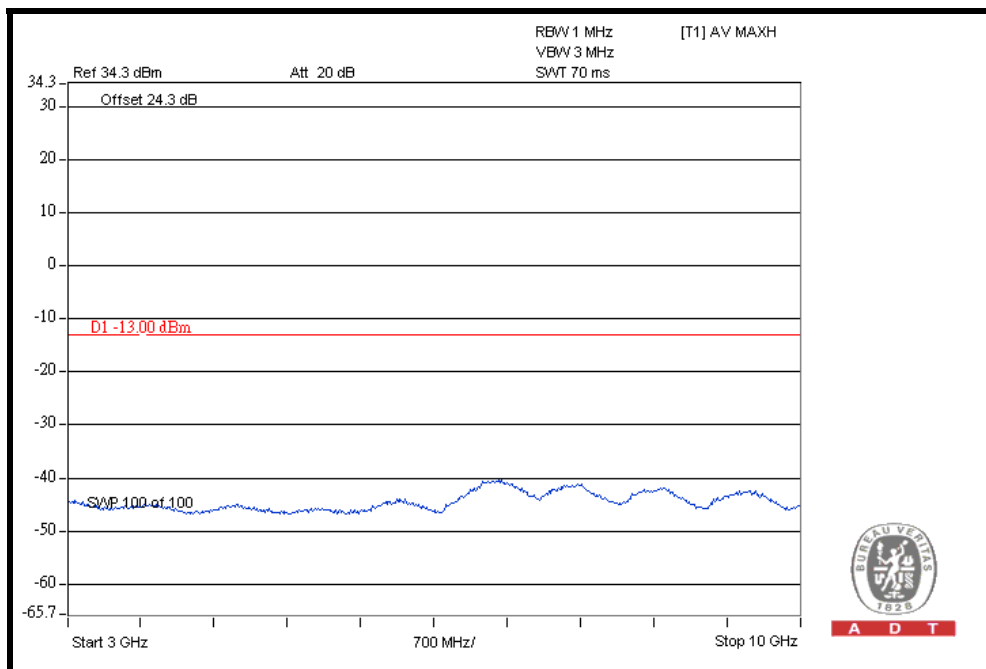



A D T

CH 20375: 10GHz ~ 20GHz

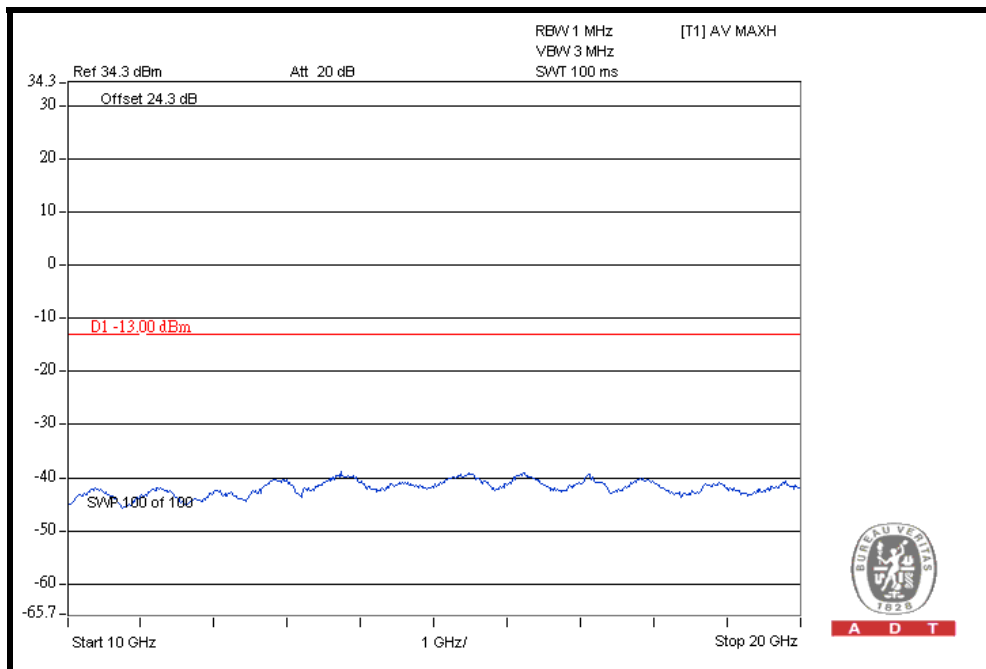



A D T

LTE Band 4

CHANNEL BANDWIDTH: 10MHz / 1 RB ALLOCATED AT THE UPPER EDGE

CH 20000: 9kHz ~ 3GHz

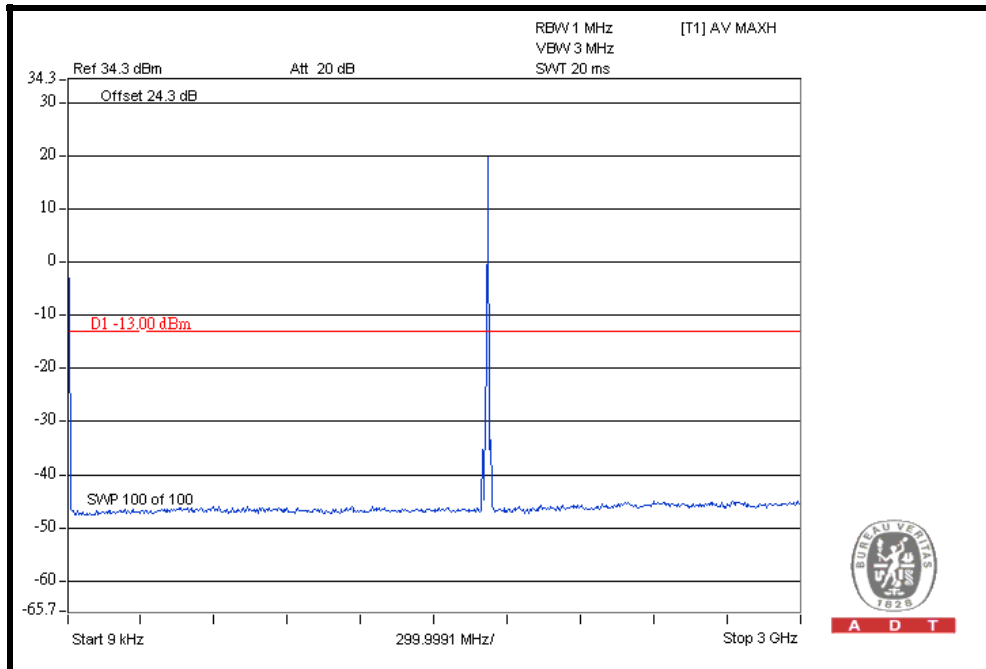

CH 20000: 3GHz ~ 10GHz

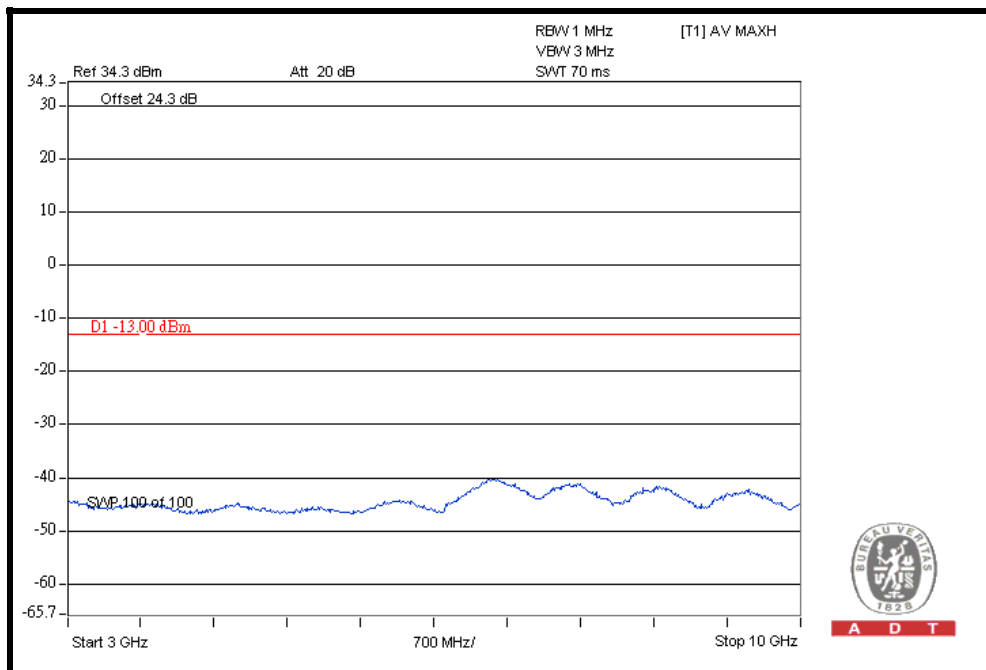



A D T

CH 20000: 10GHz ~ 20GHz

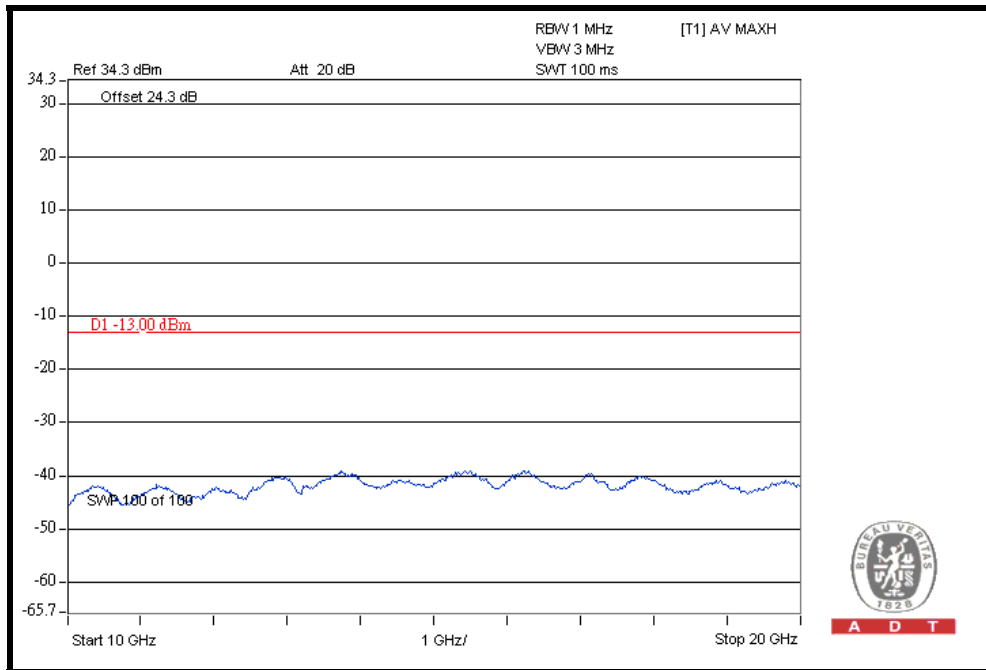

CH 20175: 9kHz ~ 3GHz

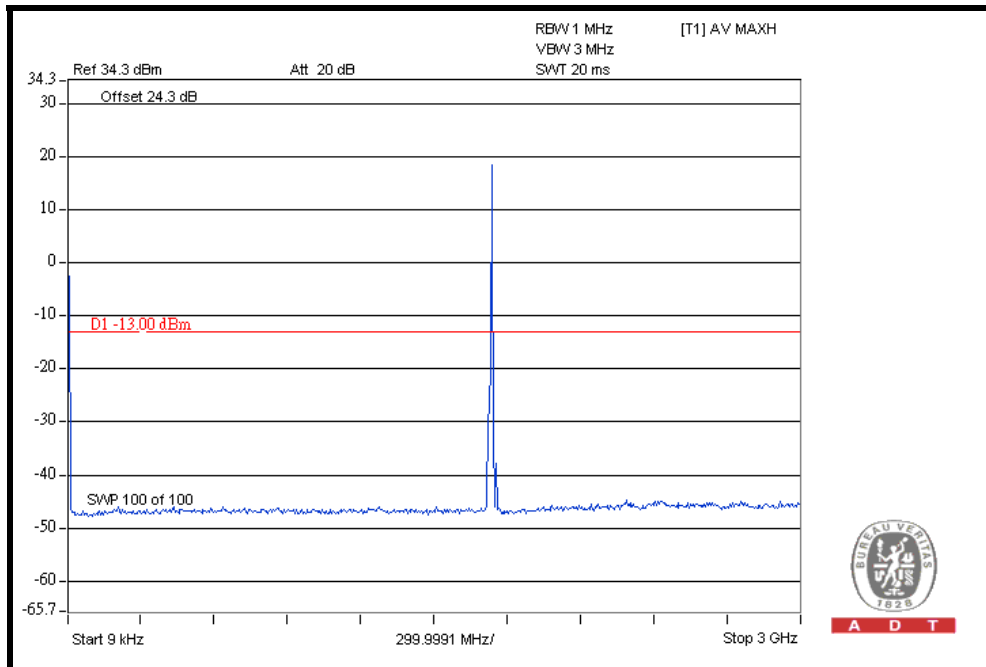



A D T

CH 20175: 3GHz ~ 10GHz

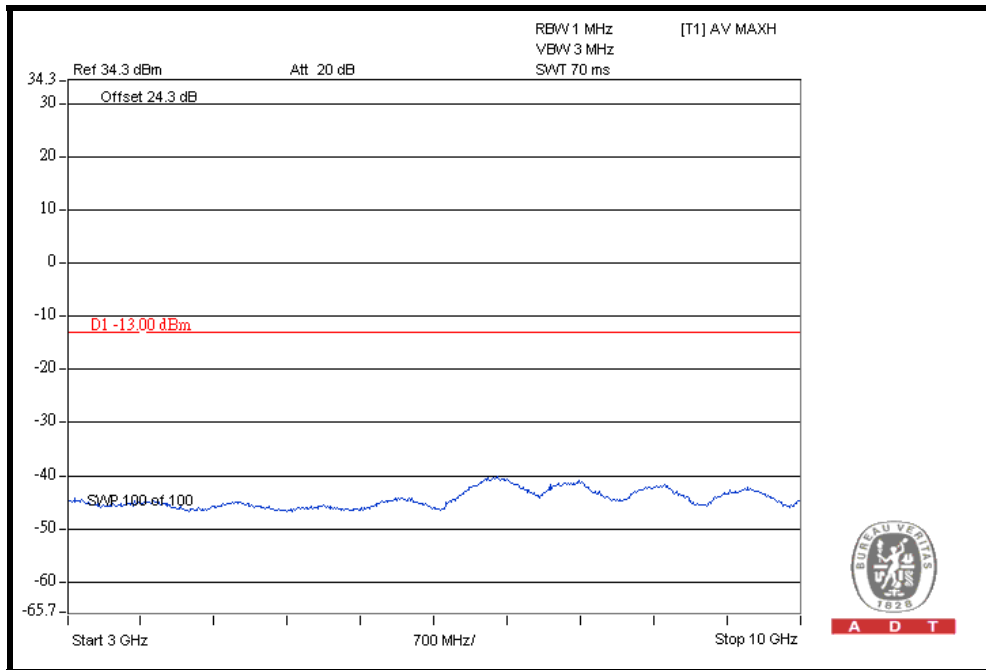

CH 20175: 10GHz ~ 20GHz

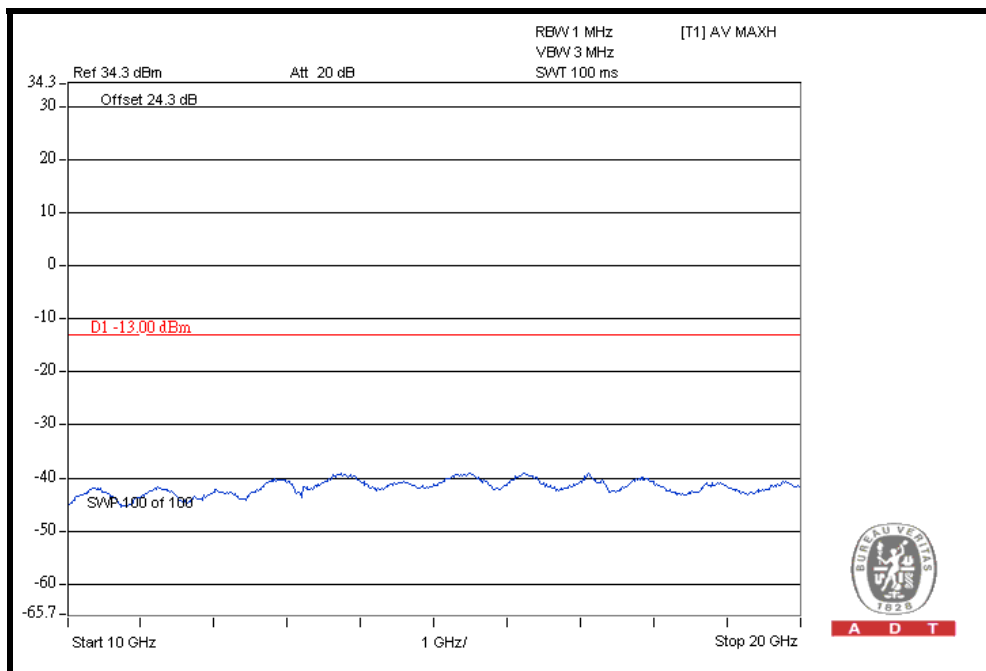



A D T

CH 20350: 9kHz ~ 3GHz

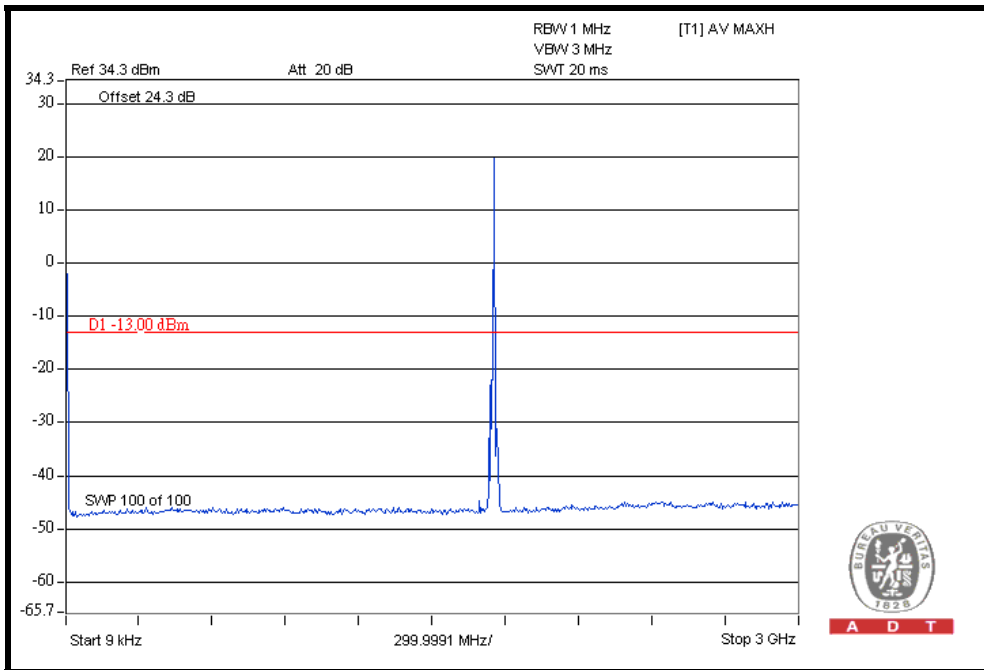

CH 20350: 3GHz ~ 10GHz

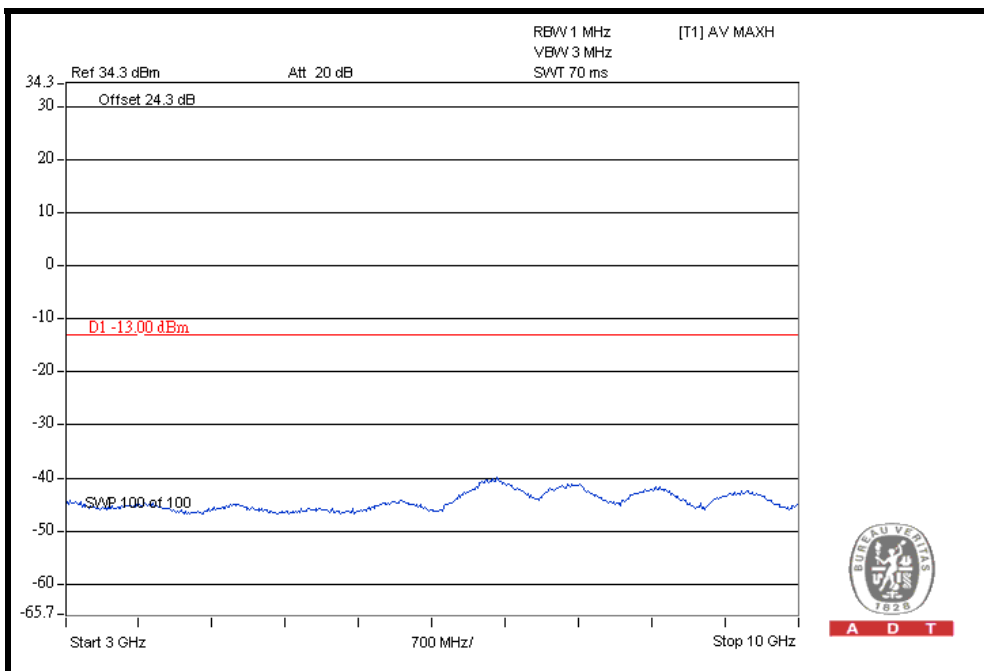



A D T

CH 20350: 10GHz ~ 20GHz

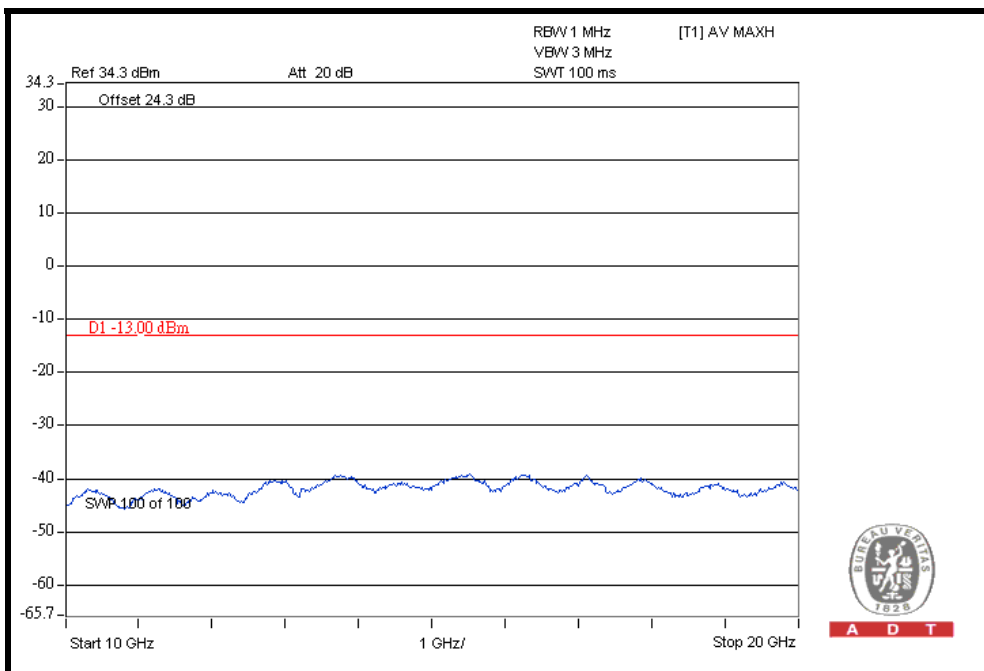



A D T

WCDMA AWS Band

WCDMA

CH 1312: 9kHz ~ 3GHz

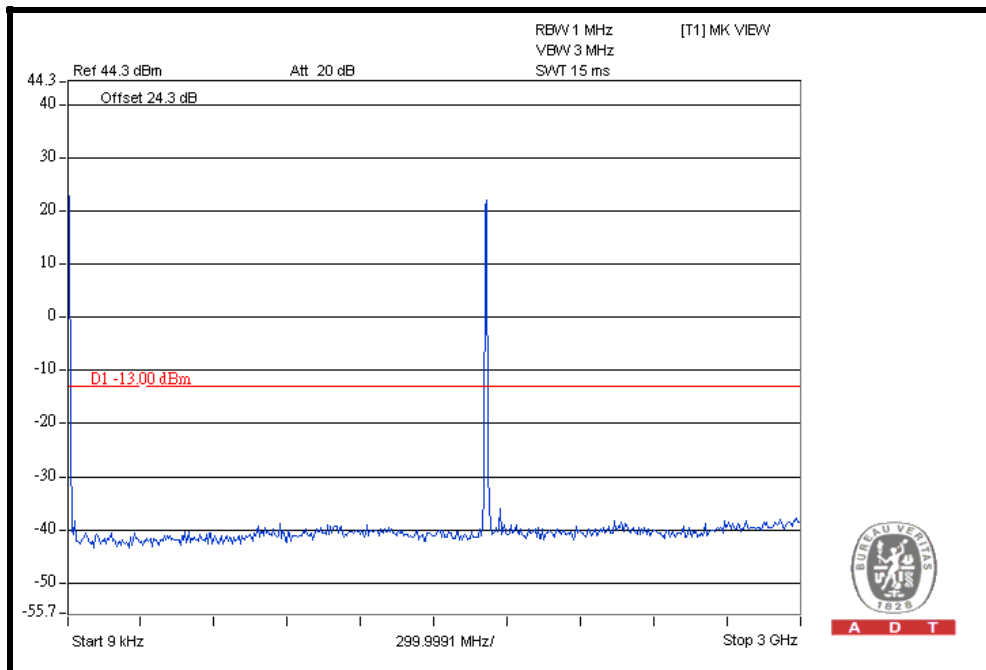

CH 1312: 3GHz ~ 10GHz

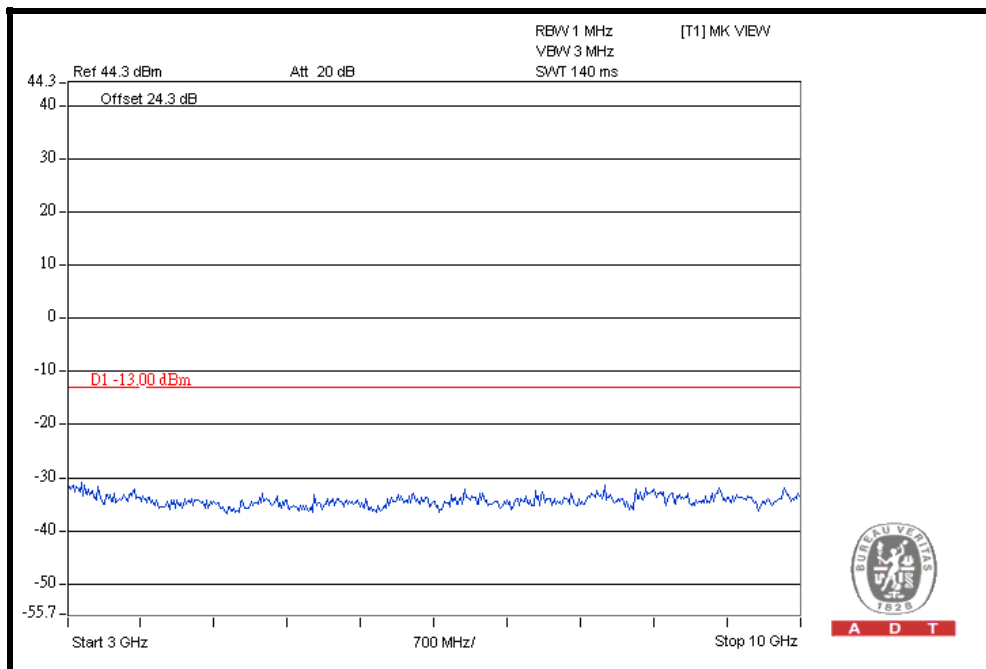



A D T

CH 1312: 10GHz ~ 20GHz

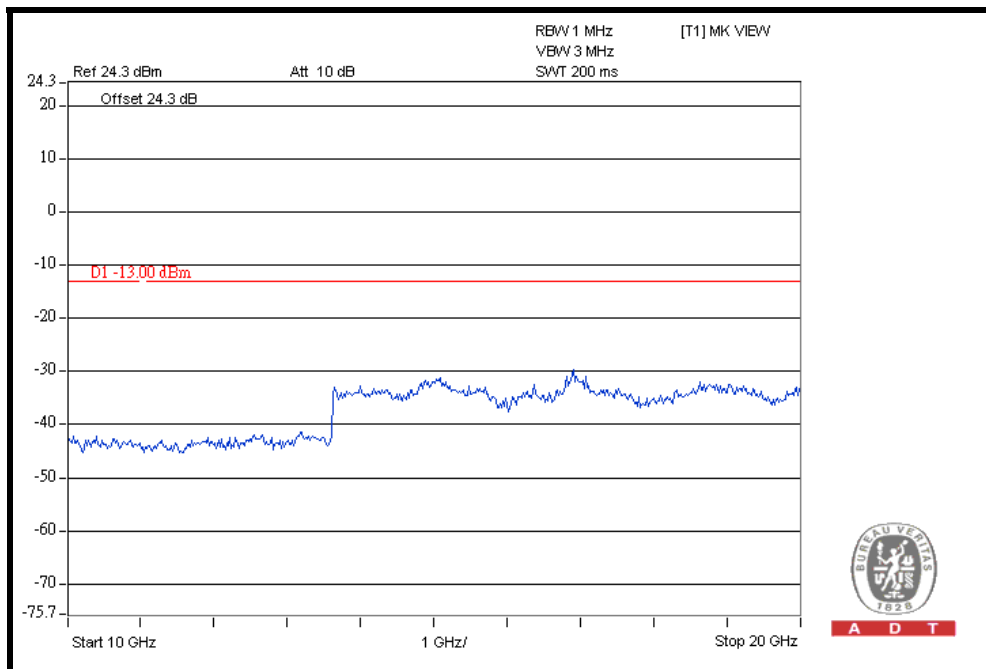

CH 1412: 9kHz ~ 3GHz

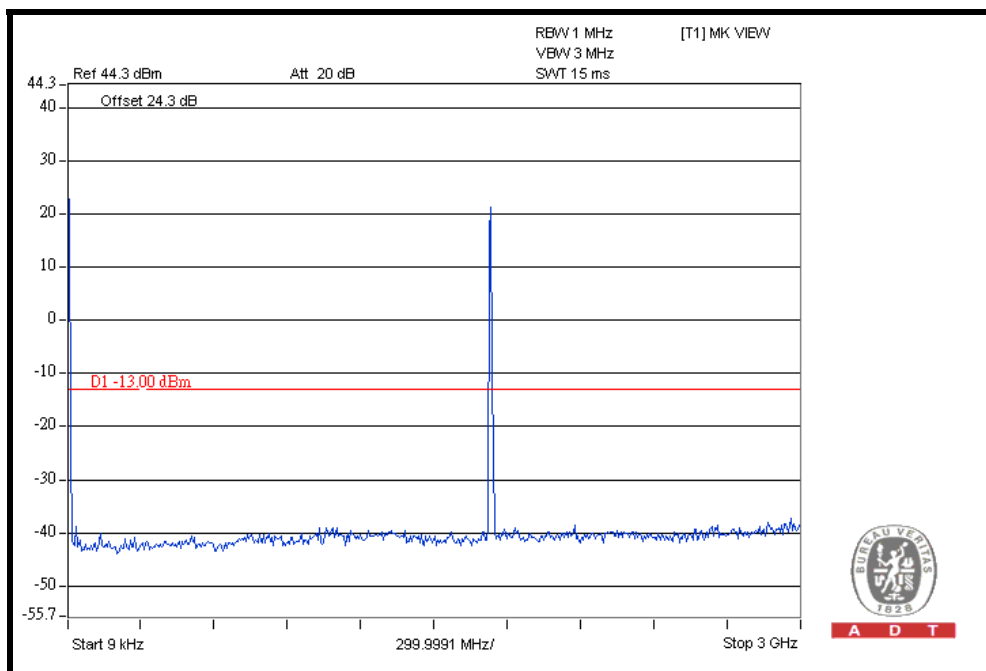



A D T

CH 1412: 3GHz ~ 10GHz

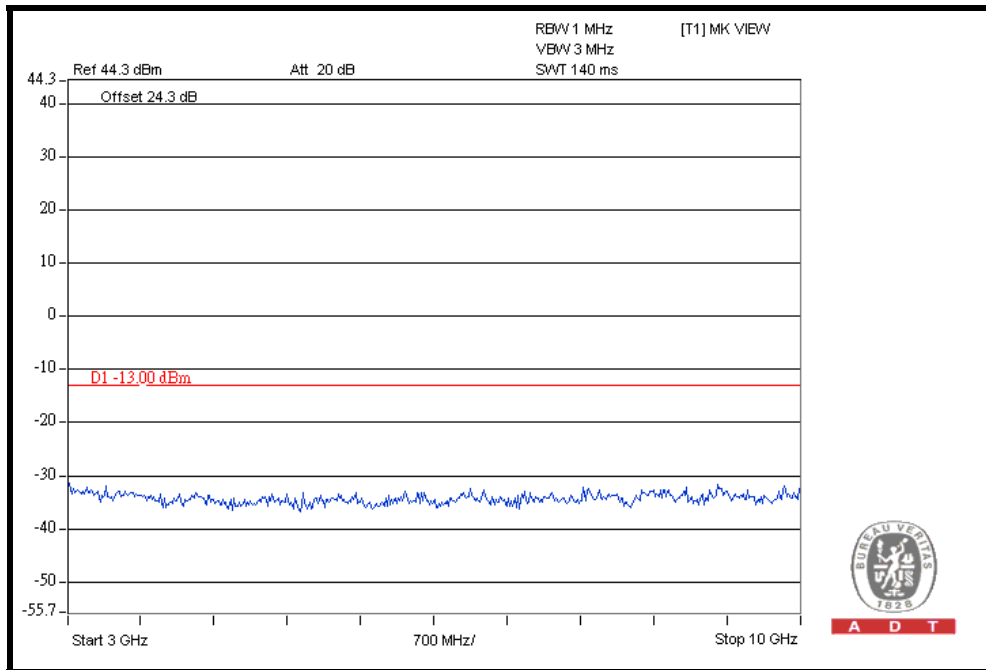

CH 1412: 10GHz ~ 20GHz

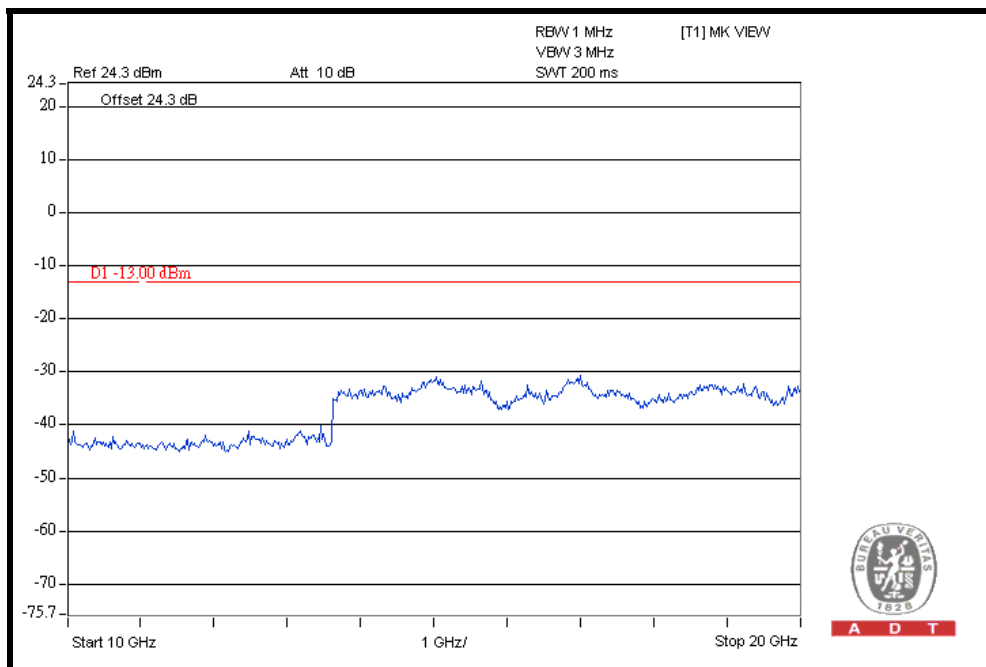



A D T

CH 1513: 9kHz ~ 3GHz

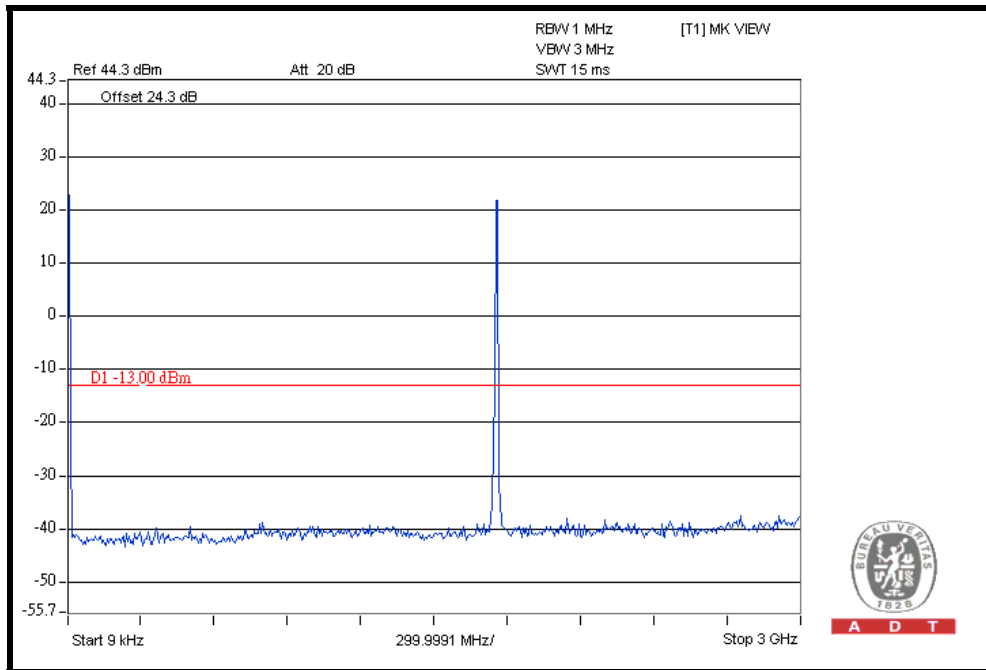

CH 1513: 3GHz ~ 10GHz

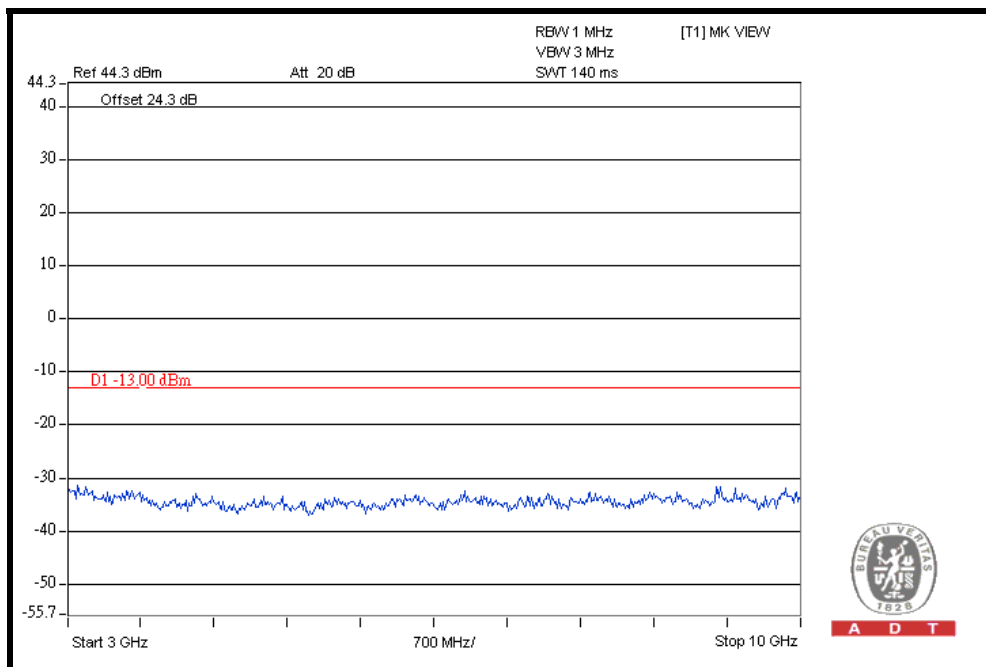



A D T

CH 1513: 10GHz ~ 20GHz

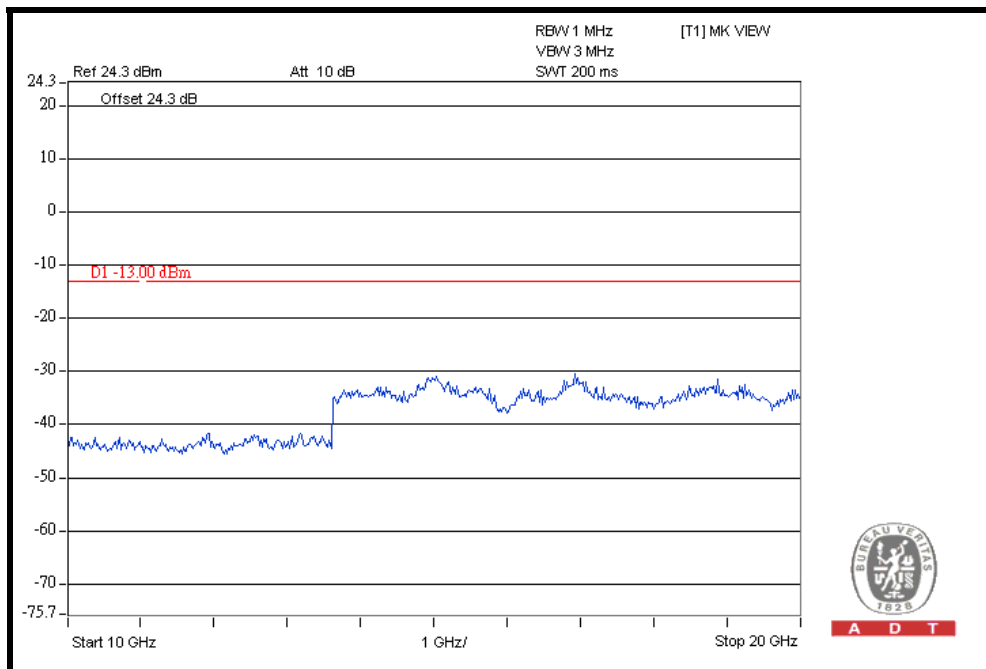

4.7 RADIATED EMISSION MEASUREMENT

4.7.1 LIMITS OF RADIATED EMISSION MEASUREMENT

The power of any emission outside a licensee's frequency block shall be attenuated below the transmitter power (P) by at least $43 + 10 \log_{10}(P)$ dB. The limit of emission equal to -13dBm

So the limit of emission is the same absolute specified line.

LIMIT (dBm)	EQUIVALENT FIELD STRENGTH AT 3m (dBuV/m) (NOTE)
-13	82.22

NOTE: The following formula is used to convert the equipment radiated power to field strength.

$$E = [1000000 \sqrt{(30P)}] / 3 \text{ uV/m, where P is Watts.}$$

4.7.2 TEST INSTRUMENTS

DESCRIPTION & MANUFACTURER	MODEL NO.	SERIAL NO.	DATE OF CALIBRATION	DUE DATE OF CALIBRATION
Test Receiver ROHDE & SCHWARZ	ESCI	100424	Aug. 04, 2010	Aug. 03, 2011
Spectrum Analyzer ROHDE & SCHWARZ	FSP40	100041	Jul. 09, 2010	Jul. 08, 2011
BILOG Antenna SCHWARZBECK	VULB9168	9168-156	Apr. 30, 2010	Apr. 29, 2011
HORN Antenna SCHWARZBECK	BBHA 9120 D	9120D-209	Aug. 02, 2010	Aug. 01, 2011
HORN Antenna SCHWARZBECK	BBHA 9170	BBHA9170243	Dec. 27, 2010	Dec. 26, 2011
Preamplifier Agilent	8449B	3008A01910	Sep. 09, 2010	Sep. 08, 2011
Preamplifier Agilent	8447D	2944A10638	Nov. 03, 2010	Nov. 02, 2011
RF signal cable HUBER+SUHNNER	SUCOFLEX 104	218190/4 231241/4	May 14, 2010	May 13, 2011
RF signal cable Worken	8D-FB	Cable-HYCH9-01	Aug. 20, 2010	Aug. 19, 2011
Software	ADT_Radiated_ V7.6.15.9.2	NA	NA	NA
Antenna Tower EMCO	2070/2080	512.835.4684	NA	NA
Turn Table EMCO	2087-2.03	NA	NA	NA
Antenna Tower & Turn Table Controller EMCO	2090	NA	NA	NA
Turn Table Controller ADT.	SC100.	SC93021703	NA	NA

- NOTE:**
1. The calibration interval of the above test instruments is 12 months and the calibrations are traceable to NML/ROC and NIST/USA.
 2. The test was performed in HwaYa Chamber 9.
 3. The horn antenna and HP preamplifier (model: 8449B) are used only for the measurement of emission frequency above 1GHz if tested.
 4. The FCC Site Registration No. is 460141.
 5. The IC Site Registration No. is IC 7450F-4.

4.7.3 TEST PROCEDURES

- a. The EUT was placed on the top of a rotating table 0.8 meters above the ground. The table was rotated 360 degrees to determine the position of the highest radiation.
- b. The EUT was set 3 meters away from the receiving antenna, which was mounted on antenna tower and its position at 0.8 m above the ground.
- c. For each suspected emission, the EUT was arranged to its worst case and the rotatable table was turned from 0 degrees to 360 degrees to find the maximum reading and recorded the value.
- d. Repeat step a ~ c for horizontal polarization.

NOTE: The resolution bandwidth of spectrum analyzer is 1 MHz and the video bandwidth is 3 MHz.

4.7.4 DEVIATION FROM TEST STANDARD

No deviation

4.7.5 TEST SETUP

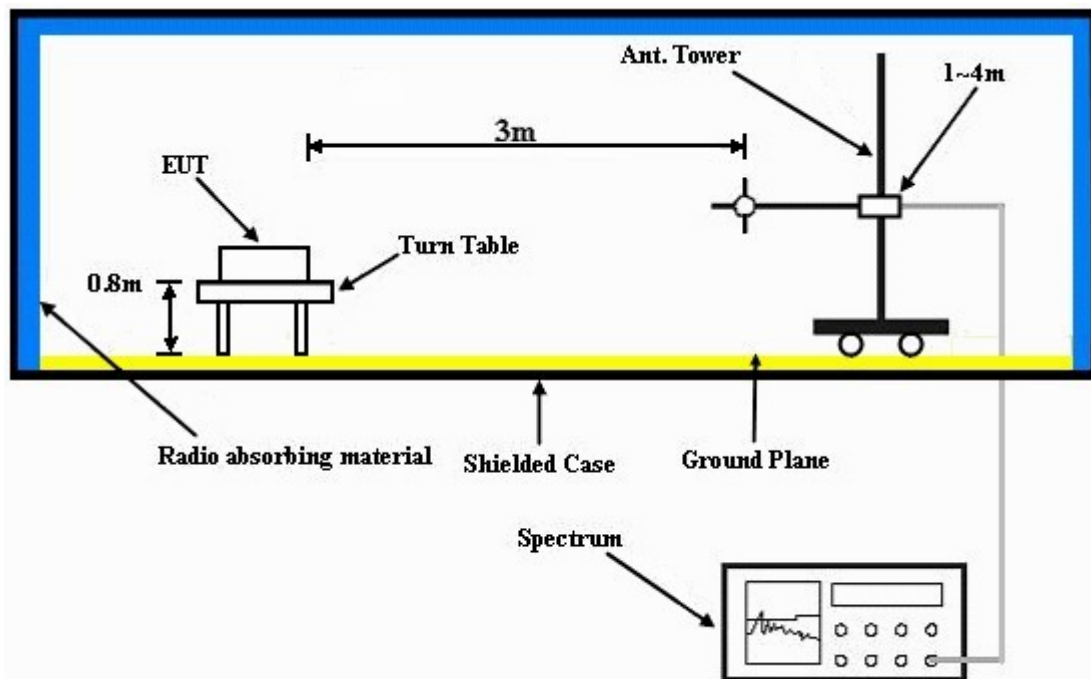

For the actual test configuration, please refer to the attached file (Test Setup Photo).

4.7.6 EUT OPERATING CONDITIONS

- a. The EUT makes a call to the communication simulator.
- b. The communication simulator station system controlled an EUT to export maximum output power under transmission mode and specific channel frequency.

4.7.7 TEST RESULTS (Below 1GHz)

LTE Band 17

CHANNEL BANDWIDTH: 5MHz

MODE	Low channel	FREQUENCY RANGE	Below 1000MHz
-------------	-------------	------------------------	---------------

ANTENNA POLARITY & TEST DISTANCE: HORIZONTAL AT 3 M								
NO.	FREQ. (MHz)	EMISSION LEVEL (dBuV/m)	LIMIT (dBuV/m)	MARGIN (dB)	ANTENNA HEIGHT (m)	TABLE ANGLE (Degree)	RAW VALUE (dBuV)	CORRECTION FACTOR (dB/m)
1	134.97	37.6	82.2	-44.7	2.00 H	10	25.20	12.40
2	166.07	33.0	82.2	-49.3	1.75 H	109	19.70	13.30
3	333.25	34.7	82.2	-47.6	1.00 H	196	20.20	14.50
4	465.43	37.8	82.2	-44.5	1.50 H	289	19.60	18.20
5	599.56	35.1	82.2	-47.2	1.25 H	250	13.20	21.90
6	832.83	33.5	82.2	-48.8	1.50 H	268	7.90	25.60
ANTENNA POLARITY & TEST DISTANCE: VERTICAL AT 3 M								
NO.	FREQ. (MHz)	EMISSION LEVEL (dBuV/m)	LIMIT (dBuV/m)	MARGIN (dB)	ANTENNA HEIGHT (m)	TABLE ANGLE (Degree)	RAW VALUE (dBuV)	CORRECTION FACTOR (dB/m)
1	119.42	31.3	82.2	-51.0	1.25 V	10	19.60	11.70
2	199.12	30.5	82.2	-51.8	1.25 V	310	19.80	10.70
3	333.25	32.8	82.2	-49.5	1.75 V	277	18.30	14.50
4	465.43	35.7	82.2	-46.6	1.00 V	310	17.50	18.20
5	597.62	34.0	82.2	-48.3	1.00 V	328	12.10	21.90
6	832.83	34.4	82.2	-47.9	1.25 V	211	8.80	25.60

NOTE:

1. Emission level (dBuV/m) = Raw Value (dBuV) + Correction Factor (dB).
2. Correction Factor (dB/m) = Antenna Factor (dB/m) + Cable Factor (dB).
3. The other emission levels were very low against the limit.
4. Margin value = Emission level – Limit value.
5. This is valid for all 3 channels.

LTE Band 17

CHANNEL BANDWIDTH: 10MHz

MODE	Low channel	FREQUENCY RANGE	Below 1000MHz
------	-------------	-----------------	---------------

ANTENNA POLARITY & TEST DISTANCE: HORIZONTAL AT 3 M								
NO.	FREQ. (MHz)	EMISSION LEVEL (dBuV/m)	LIMIT (dBuV/m)	MARGIN (dB)	ANTENNA HEIGHT (m)	TABLE ANGLE (Degree)	RAW VALUE (dBuV)	CORRECTION FACTOR (dB/m)
1	134.97	31.6	82.2	-50.7	1.00 H	226	19.20	12.40
2	201.06	30.2	82.2	-52.1	1.00 H	277	19.50	10.70
3	331.30	34.3	82.2	-48.0	1.00 H	190	19.80	14.50
4	465.43	29.6	82.2	-52.7	1.00 H	169	11.40	18.20
5	599.56	31.4	82.2	-50.9	1.00 H	241	9.50	21.90
6	830.88	35.7	82.2	-46.6	1.00 H	235	10.10	25.60
ANTENNA POLARITY & TEST DISTANCE: VERTICAL AT 3 M								
NO.	FREQ. (MHz)	EMISSION LEVEL (dBuV/m)	LIMIT (dBuV/m)	MARGIN (dB)	ANTENNA HEIGHT (m)	TABLE ANGLE (Degree)	RAW VALUE (dBuV)	CORRECTION FACTOR (dB/m)
1	45.55	30.9	82.2	-51.4	1.00 V	271	18.20	12.70
2	199.12	31.3	82.2	-51.0	1.00 V	280	20.60	10.70
3	331.30	29.4	82.2	-52.9	1.00 V	292	14.90	14.50
4	465.43	35.9	82.2	-46.4	1.00 V	352	17.70	18.20
5	599.56	35.7	82.2	-46.6	1.00 V	340	13.80	21.90
6	865.87	33.0	82.2	-49.3	1.00 V	292	7.20	25.80

NOTE:

1. Emission level (dBuV/m) = Raw Value (dBuV) + Correction Factor (dB).
2. Correction Factor (dB/m) = Antenna Factor (dB/m) + Cable Factor (dB).
3. The other emission levels were very low against the limit.
4. Margin value = Emission level – Limit value.
5. This is valid for all 3 channels.

LTE Band 4

CHANNEL BANDWIDTH: 5MHz

MODE	Low channel	FREQUENCY RANGE	Below 1000MHz
------	-------------	-----------------	---------------

ANTENNA POLARITY & TEST DISTANCE: HORIZONTAL AT 3 M								
NO.	FREQ. (MHz)	EMISSION LEVEL (dBuV/m)	LIMIT (dBuV/m)	MARGIN (dB)	ANTENNA HEIGHT (m)	TABLE ANGLE (Degree)	RAW VALUE (dBuV)	CORRECTION FACTOR (dB/m)
1	131.08	38.4	82.2	-43.9	2.00 H	355	26.20	12.20
2	199.12	32.3	82.2	-50.0	1.25 H	319	21.60	10.70
3	333.25	34.8	82.2	-47.5	1.25 H	337	20.30	14.50
4	465.43	37.0	82.2	-45.3	1.75 H	307	18.80	18.20
5	597.62	33.7	82.2	-48.6	1.25 H	250	11.80	21.90
6	832.83	32.4	82.2	-49.9	1.00 H	145	6.80	25.60
ANTENNA POLARITY & TEST DISTANCE: VERTICAL AT 3 M								
NO.	FREQ. (MHz)	EMISSION LEVEL (dBuV/m)	LIMIT (dBuV/m)	MARGIN (dB)	ANTENNA HEIGHT (m)	TABLE ANGLE (Degree)	RAW VALUE (dBuV)	CORRECTION FACTOR (dB/m)
1	119.42	33.3	82.2	-49.0	1.50 V	10	21.60	11.70
2	216.61	28.6	82.2	-53.7	1.00 V	322	17.20	11.40
3	331.30	31.7	82.2	-50.6	1.50 V	289	17.20	14.50
4	498.48	34.1	82.2	-48.2	1.00 V	238	14.90	19.20
5	599.56	35.5	82.2	-46.8	1.00 V	331	13.60	21.90
6	830.88	36.1	82.2	-46.2	1.50 V	325	10.50	25.60

NOTE:

1. Emission level (dBuV/m) = Raw Value (dBuV) + Correction Factor (dB).
2. Correction Factor (dB/m) = Antenna Factor (dB/m) + Cable Factor (dB).
3. The other emission levels were very low against the limit.
4. Margin value = Emission level – Limit value.
5. This is valid for all 3 channels.

LTE Band 4

CHANNEL BANDWIDTH: 10MHz

MODE	Low channel	FREQUENCY RANGE	Below 1000MHz
------	-------------	-----------------	---------------

ANTENNA POLARITY & TEST DISTANCE: HORIZONTAL AT 3 M								
NO.	FREQ. (MHz)	EMISSION LEVEL (dBuV/m)	LIMIT (dBuV/m)	MARGIN (dB)	ANTENNA HEIGHT (m)	TABLE ANGLE (Degree)	RAW VALUE (dBuV)	CORRECTION FACTOR (dB/m)
1	134.97	32.4	82.2	-49.9	1.00 H	10	20.00	12.40
2	199.12	27.8	82.2	-54.5	1.00 H	280	17.10	10.70
3	331.30	34.9	82.2	-47.4	1.00 H	334	20.40	14.50
4	465.43	29.5	82.2	-52.8	1.00 H	184	11.30	18.20
5	597.62	31.3	82.2	-51.0	1.00 H	259	9.40	21.90
6	830.88	37.8	82.2	-44.5	1.00 H	163	12.20	25.60
ANTENNA POLARITY & TEST DISTANCE: VERTICAL AT 3 M								
NO.	FREQ. (MHz)	EMISSION LEVEL (dBuV/m)	LIMIT (dBuV/m)	MARGIN (dB)	ANTENNA HEIGHT (m)	TABLE ANGLE (Degree)	RAW VALUE (dBuV)	CORRECTION FACTOR (dB/m)
1	45.55	32.9	82.2	-49.4	1.00 V	184	20.20	12.70
2	199.12	31.1	82.2	-51.2	1.00 V	277	20.40	10.70
3	331.30	30.0	82.2	-52.3	1.00 V	73	15.50	14.50
4	465.43	36.6	82.2	-45.7	1.00 V	316	18.40	18.20
5	597.62	34.0	82.2	-48.3	1.00 V	109	12.10	21.90
6	916.41	33.9	82.2	-48.4	1.00 V	265	7.60	26.30

NOTE:

1. Emission level (dBuV/m) = Raw Value (dBuV) + Correction Factor (dB).
2. Correction Factor (dB/m) = Antenna Factor (dB/m) + Cable Factor (dB).
3. The other emission levels were very low against the limit.
4. Margin value = Emission level – Limit value.
5. This is valid for all 3 channels.

WCDMA AWS Band

MODE	Low channel	FREQUENCY RANGE	Below 1000MHz
-------------	-------------	------------------------	---------------

ANTENNA POLARITY & TEST DISTANCE: HORIZONTAL AT 3 M								
NO.	FREQ. (MHz)	EMISSION LEVEL (dBuV/m)	LIMIT (dBuV/m)	MARGIN (dB)	ANTENNA HEIGHT (m)	TABLE ANGLE (Degree)	RAW VALUE (dBuV)	CORRECTION FACTOR (dB/m)
1	45.55	34.1	82.2	-48.2	1.25 H	343	21.40	12.70
2	146.63	23.7	82.2	-58.6	1.25 H	187	10.20	13.50
3	372.12	25.3	82.2	-57.0	1.25 H	244	9.90	15.40
4	576.23	30.9	82.2	-51.4	1.50 H	193	9.50	21.40
5	776.45	35.1	82.2	-47.2	1.25 H	10	10.40	24.70
6	898.92	36.8	82.2	-45.5	1.50 H	19	10.70	26.10
ANTENNA POLARITY & TEST DISTANCE: VERTICAL AT 3 M								
NO.	FREQ. (MHz)	EMISSION LEVEL (dBuV/m)	LIMIT (dBuV/m)	MARGIN (dB)	ANTENNA HEIGHT (m)	TABLE ANGLE (Degree)	RAW VALUE (dBuV)	CORRECTION FACTOR (dB/m)
1	45.55	42.9	82.2	-39.4	1.25 V	82	30.20	12.70
2	123.31	32.3	82.2	-50.0	2.00 V	280	20.40	11.90
3	403.23	36.7	82.2	-45.6	1.00 V	199	20.50	16.20
4	593.73	42.2	82.2	-40.1	2.00 V	46	20.40	21.80
5	832.83	47.3	82.2	-35.0	1.00 V	64	21.70	25.60
6	963.07	46.7	82.2	-35.6	1.50 V	334	20.10	26.60

NOTE:

1. Emission level (dBuV/m) = Raw Value (dBuV) + Correction Factor (dB).
2. Correction Factor (dB/m) = Antenna Factor (dB/m) + Cable Factor (dB).
3. The other emission levels were very low against the limit.
4. Margin value = Emission level – Limit value.
5. This is valid for all 3 channels.

4.7.8 TEST RESULTS (Above 1GHz)

LTE Band 17

CHANNEL BANDWIDTH: 5MHz

Test channel		Low channel				
ANTENNA POLARITY & TEST DISTANCE: HORIZONTAL AT 3m						
NO.	FREQ. (MHz)	EMISSION LEVEL (dBuV)	LIMIT (dBm)	S.G POWER VALUE (dBm)	CORRECTION FACTOR (dB)	POWER VALUE (dBm)
1	1408.68	42.2	-13.0	-58.2	6.1	-52.1
2	2113.02	38.8	-13.0	-64.2	8.4	-55.8
3	2817.36	40.7	-13.0	-62.4	8.7	-53.7
ANTENNA POLARITY & TEST DISTANCE: VERTICAL AT 3m						
NO.	FREQ. (MHz)	EMISSION LEVEL (dBuV)	LIMIT (dBm)	S.G POWER VALUE (dBm)	CORRECTION FACTOR (dB)	POWER VALUE (dBm)
1	1408.68	43.1	-13.0	-57.3	6.1	-51.2
2	2113.02	41.5	-13.0	-61.5	8.4	-53.1
3	2817.36	40.7	-13.0	-62.4	8.7	-53.7

Test channel		Middle channel				
ANTENNA POLARITY & TEST DISTANCE: HORIZONTAL AT 3m						
NO.	FREQ. (MHz)	EMISSION LEVEL (dBuV)	LIMIT (dBm)	S.G POWER VALUE (dBm)	CORRECTION FACTOR (dB)	POWER VALUE (dBm)
1	1415.68	45.7	-13.0	-54.4	6.1	-48.3
2	2123.52	36.4	-13.0	-66.4	8.4	-58.0
3	2831.36	41.7	-13.0	-61.1	8.7	-52.4
ANTENNA POLARITY & TEST DISTANCE: VERTICAL AT 3m						
NO.	FREQ. (MHz)	EMISSION LEVEL (dBuV)	LIMIT (dBm)	S.G POWER VALUE (dBm)	CORRECTION FACTOR (dB)	POWER VALUE (dBm)
1	1415.68	49.0	-13.0	-51.1	6.1	-45.0
2	2123.52	38.0	-13.0	-64.8	8.4	-56.4
3	2831.36	44.5	-13.0	-58.3	8.7	-49.6

NOTE: ERP(dBm) = S.G Power Value (dBm) + Correction Factor (dB).
Correction Factor = gain of substitution antenna + cable loss

Test channel		High channel				
ANTENNA POLARITY & TEST DISTANCE: HORIZONTAL AT 3m						
NO.	FREQ. (MHz)	EMISSION LEVEL (dBuV)	LIMIT (dBm)	S.G POWER VALUE (dBm)	CORRECTION FACTOR (dB)	POWER VALUE (dBm)
1	1422.68	44.3	-13.0	-56.0	6.1	-49.9
2	2134.02	35.6	-13.0	-67.2	8.4	-58.8
3	2845.36	41.2	-13.0	-61.9	8.7	-53.2
ANTENNA POLARITY & TEST DISTANCE: VERTICAL AT 3m						
NO.	FREQ. (MHz)	EMISSION LEVEL (dBuV)	LIMIT (dBm)	S.G POWER VALUE (dBm)	CORRECTION FACTOR (dB)	POWER VALUE (dBm)
1	1422.68	48.8	-13.0	-51.5	6.1	-45.4
2	2134.02	39.3	-13.0	-63.5	8.4	-55.1
3	2845.36	44.7	-13.0	-58.4	8.7	-49.7

NOTE: ERP(dBm) = S.G Power Value (dBm) + Correction Factor (dB).
 Correction Factor = gain of substitution antenna + cable loss

LTE Band 17

CHANNEL BANDWIDTH: 10MHz

Test channel		Low channel				
ANTENNA POLARITY & TEST DISTANCE: HORIZONTAL AT 3m						
NO.	FREQ. (MHz)	EMISSION LEVEL (dBuV)	LIMIT (dBm)	S.G POWER VALUE (dBm)	CORRECTION FACTOR (dB)	POWER VALUE (dBm)
1	1409.18	39.0	-13.0	-61.4	6.1	-55.3
2	2113.77	39.5	-13.0	-63.5	8.4	-55.1
3	2818.36	38.4	-13.0	-64.7	8.7	-56.0
ANTENNA POLARITY & TEST DISTANCE: VERTICAL AT 3m						
NO.	FREQ. (MHz)	EMISSION LEVEL (dBuV)	LIMIT (dBm)	S.G POWER VALUE (dBm)	CORRECTION FACTOR (dB)	POWER VALUE (dBm)
1	1409.18	38.8	-13.0	-61.6	6.1	-55.5
2	2113.77	38.7	-13.0	-64.3	8.4	-55.9
3	2818.36	38.5	-13.0	-64.6	8.7	-55.9

Test channel		Middle channel				
ANTENNA POLARITY & TEST DISTANCE: HORIZONTAL AT 3m						
NO.	FREQ. (MHz)	EMISSION LEVEL (dBuV)	LIMIT (dBm)	S.G POWER VALUE (dBm)	CORRECTION FACTOR (dB)	POWER VALUE (dBm)
1	1411.18	37.9	-13.0	-62.2	6.1	-56.1
2	2116.77	36.7	-13.0	-66.1	8.4	-57.7
3	2822.36	41.4	-13.0	-61.4	8.7	-52.7
ANTENNA POLARITY & TEST DISTANCE: VERTICAL AT 3m						
NO.	FREQ. (MHz)	EMISSION LEVEL (dBuV)	LIMIT (dBm)	S.G POWER VALUE (dBm)	CORRECTION FACTOR (dB)	POWER VALUE (dBm)
1	1411.18	34.7	-13.0	-65.4	6.1	-59.3
2	2116.77	33.4	-13.0	-69.4	8.4	-61.0
3	2822.36	39.7	-13.0	-63.1	8.7	-54.4

NOTE: ERP(dBm) = S.G Power Value (dBm) + Correction Factor (dB).
Correction Factor = gain of substitution antenna + cable loss



A D T

Test channel		High channel				
ANTENNA POLARITY & TEST DISTANCE: HORIZONTAL AT 3m						
NO.	FREQ. (MHz)	EMISSION LEVEL (dBuV)	LIMIT (dBm)	S.G POWER VALUE (dBm)	CORRECTION FACTOR (dB)	POWER VALUE (dBm)
1	1413.18	36.4	-13.0	-63.9	6.1	-57.8
2	2119.77	49.0	-13.0	-53.8	8.4	-45.4
3	2826.36	39.0	-13.0	-64.1	8.7	-55.4
ANTENNA POLARITY & TEST DISTANCE: VERTICAL AT 3m						
NO.	FREQ. (MHz)	EMISSION LEVEL (dBuV)	LIMIT (dBm)	S.G POWER VALUE (dBm)	CORRECTION FACTOR (dB)	POWER VALUE (dBm)
1	1413.18	33.7	-13.0	-66.6	6.1	-60.5
2	2119.77	46.5	-13.0	-56.3	8.4	-47.9
3	2826.36	35.2	-13.0	-67.9	8.7	-59.2

NOTE: ERP(dBm) = S.G Power Value (dBm) + Correction Factor (dB).
Correction Factor = gain of substitution antenna + cable loss



A D T

LTE Band 4

CHANNEL BANDWIDTH: 5MHz

Test channel		Low channel				
ANTENNA POLARITY & TEST DISTANCE: HORIZONTAL AT 3m						
NO.	FREQ. (MHz)	EMISSION LEVEL (dBuV)	LIMIT (dBm)	S.G POWER VALUE (dBm)	CORRECTION FACTOR (dB)	POWER VALUE (dBm)
1	3429.32	60.9	-13.0	-43.1	9.9	-33.2
2	5143.98	43.0	-13.0	-61.0	9.7	-51.3
3	6858.64	49.0	-13.0	-53.9	8.3	-45.6
ANTENNA POLARITY & TEST DISTANCE: VERTICAL AT 3m						
NO.	FREQ. (MHz)	EMISSION LEVEL (dBuV)	LIMIT (dBm)	S.G POWER VALUE (dBm)	CORRECTION FACTOR (dB)	POWER VALUE (dBm)
1	3429.32	52.0	-13.0	-52.0	9.9	-42.1
2	5143.98	46.9	-13.0	-57.1	9.7	-47.4
3	6858.64	51.5	-13.0	-51.4	8.3	-43.1

Test channel		Middle channel				
ANTENNA POLARITY & TEST DISTANCE: HORIZONTAL AT 3m						
NO.	FREQ. (MHz)	EMISSION LEVEL (dBuV)	LIMIT (dBm)	S.G POWER VALUE (dBm)	CORRECTION FACTOR (dB)	POWER VALUE (dBm)
1	3469.32	57.4	-13.0	-46.9	9.9	-37.0
2	5203.98	43.8	-13.0	-60.5	9.7	-50.8
3	6938.64	47.3	-13.0	-55.4	8.0	-47.4
ANTENNA POLARITY & TEST DISTANCE: VERTICAL AT 3m						
NO.	FREQ. (MHz)	EMISSION LEVEL (dBuV)	LIMIT (dBm)	S.G POWER VALUE (dBm)	CORRECTION FACTOR (dB)	POWER VALUE (dBm)
1	3469.32	51.6	-13.0	-52.7	9.9	-42.8
2	5203.98	43.7	-13.0	-60.6	9.7	-50.9
3	6938.64	48.4	-13.0	-54.3	8.0	-46.3

NOTE: EIRP(dBm) = S.G Power Value (dBm) + Correction Factor (dB).
Correction Factor = gain of substitution antenna + cable loss



A D T

Test channel		High channel				
ANTENNA POLARITY & TEST DISTANCE: HORIZONTAL AT 3m						
NO.	FREQ. (MHz)	EMISSION LEVEL (dBuV)	LIMIT (dBm)	S.G POWER VALUE (dBm)	CORRECTION FACTOR (dB)	POWER VALUE (dBm)
1	3509.32	59.0	-13.0	-45.4	10.0	-35.4
2	5263.98	44.8	-13.0	-59.6	9.7	-49.9
3	7018.64	47.7	-13.0	-54.8	7.9	-46.9
ANTENNA POLARITY & TEST DISTANCE: VERTICAL AT 3m						
NO.	FREQ. (MHz)	EMISSION LEVEL (dBuV)	LIMIT (dBm)	S.G POWER VALUE (dBm)	CORRECTION FACTOR (dB)	POWER VALUE (dBm)
1	3509.32	51.1	-13.0	-53.3	10.0	-43.3
2	5263.98	44.2	-13.0	-60.2	9.7	-50.5
3	7018.64	48.2	-13.0	-54.3	7.9	-46.4

NOTE: EIRP(dBm) = S.G Power Value (dBm) + Correction Factor (dB).
Correction Factor = gain of substitution antenna + cable loss



A D T

LTE Band 4

CHANNEL BANDWIDTH: 10MHz

Test channel		Low channel				
ANTENNA POLARITY & TEST DISTANCE: HORIZONTAL AT 3m						
NO.	FREQ. (MHz)	EMISSION LEVEL (dBuV)	LIMIT (dBm)	S.G POWER VALUE (dBm)	CORRECTION FACTOR (dB)	POWER VALUE (dBm)
1	3438.8	58.8	-13.0	-45.2	9.9	-35.3
2	5158.2	44.3	-13.0	-59.7	9.7	-50.0
3	6877.6	47.9	-13.0	-55.0	8.3	-46.7
ANTENNA POLARITY & TEST DISTANCE: VERTICAL AT 3m						
NO.	FREQ. (MHz)	EMISSION LEVEL (dBuV)	LIMIT (dBm)	S.G POWER VALUE (dBm)	CORRECTION FACTOR (dB)	POWER VALUE (dBm)
1	3438.8	51.8	-13.0	-52.2	9.9	-42.3
2	5158.2	43.6	-13.0	-60.4	9.7	-50.7
3	6877.6	48.9	-13.0	-54.0	8.3	-45.7

Test channel		Middle channel				
ANTENNA POLARITY & TEST DISTANCE: HORIZONTAL AT 3m						
NO.	FREQ. (MHz)	EMISSION LEVEL (dBuV)	LIMIT (dBm)	S.G POWER VALUE (dBm)	CORRECTION FACTOR (dB)	POWER VALUE (dBm)
1	3473.82	59.4	-13.0	-44.9	9.9	-35.0
2	5210.73	46.7	-13.0	-57.6	9.7	-47.9
3	6947.64	46.6	-13.0	-56.1	8.0	-48.1
ANTENNA POLARITY & TEST DISTANCE: VERTICAL AT 3m						
NO.	FREQ. (MHz)	EMISSION LEVEL (dBuV)	LIMIT (dBm)	S.G POWER VALUE (dBm)	CORRECTION FACTOR (dB)	POWER VALUE (dBm)
1	3473.82	52.4	-13.0	-51.9	9.9	-42.0
2	5210.73	44.7	-13.0	-59.6	9.7	-49.9
3	6947.64	49.6	-13.0	-53.1	8.0	-45.1

NOTE: EIRP(dBm) = S.G Power Value (dBm) + Correction Factor (dB).
Correction Factor = gain of substitution antenna + cable loss



A D T

Test channel		High channel				
ANTENNA POLARITY & TEST DISTANCE: HORIZONTAL AT 3m						
NO.	FREQ. (MHz)	EMISSION LEVEL (dBuV)	LIMIT (dBm)	S.G POWER VALUE (dBm)	CORRECTION FACTOR (dB)	POWER VALUE (dBm)
1	3513.82	59.1	-13.0	-45.3	10.0	-35.3
2	5270.73	43.0	-13.0	-61.4	9.7	-51.7
3	7027.64	50.3	-13.0	-52.2	7.9	-44.3
ANTENNA POLARITY & TEST DISTANCE: VERTICAL AT 3m						
NO.	FREQ. (MHz)	EMISSION LEVEL (dBuV)	LIMIT (dBm)	S.G POWER VALUE (dBm)	CORRECTION FACTOR (dB)	POWER VALUE (dBm)
1	3513.82	55.6	-13.0	-48.8	10.0	-38.8
2	5270.73	41.2	-13.0	-63.2	9.7	-53.5
3	7027.64	46.5	-13.0	-56.0	7.9	-48.1

NOTE: EIRP(dBm) = S.G Power Value (dBm) + Correction Factor (dB).
Correction Factor = gain of substitution antenna + cable loss



A D T

WCDMA AWS Band

Test channel		Low channel				
ANTENNA POLARITY & TEST DISTANCE: HORIZONTAL AT 3m						
NO.	FREQ. (MHz)	EMISSION LEVEL (dBuV)	LIMIT (dBm)	S.G POWER VALUE (dBm)	CORRECTION FACTOR (dB)	POWER VALUE (dBm)
1	3424.8	54.8	-13.0	-49.2	9.9	-39.3
2	5137.2	40.3	-13.0	-63.7	9.7	-54.0
3	6849.6	46.3	-13.0	-56.6	8.3	-48.3
ANTENNA POLARITY & TEST DISTANCE: VERTICAL AT 3m						
NO.	FREQ. (MHz)	EMISSION LEVEL (dBuV)	LIMIT (dBm)	S.G POWER VALUE (dBm)	CORRECTION FACTOR (dB)	POWER VALUE (dBm)
1	3424.8	52.3	-13.0	-51.7	9.9	-41.8
2	5137.2	41.2	-13.0	-62.8	9.7	-53.1
3	6849.6	47.5	-13.0	-55.4	8.3	-47.1

Test channel		Middle channel				
ANTENNA POLARITY & TEST DISTANCE: HORIZONTAL AT 3m						
NO.	FREQ. (MHz)	EMISSION LEVEL (dBuV)	LIMIT (dBm)	S.G POWER VALUE (dBm)	CORRECTION FACTOR (dB)	POWER VALUE (dBm)
1	3464.8	52.4	-13.0	-51.9	9.9	-42.0
2	5197.2	40.7	-13.0	-63.6	9.7	-53.9
3	6929.6	46.1	-13.0	-56.6	8.0	-48.6
ANTENNA POLARITY & TEST DISTANCE: VERTICAL AT 3m						
NO.	FREQ. (MHz)	EMISSION LEVEL (dBuV)	LIMIT (dBm)	S.G POWER VALUE (dBm)	CORRECTION FACTOR (dB)	POWER VALUE (dBm)
1	3464.8	60.4	-13.0	-43.9	9.9	-34.0
2	5197.2	41.9	-13.0	-62.4	9.7	-52.7
3	6929.6	46.2	-13.0	-56.5	8.0	-48.5

NOTE: EIRP(dBm) = S.G Power Value (dBm) + Correction Factor (dB).
Correction Factor = gain of substitution antenna + cable loss



A D T

Test channel		High channel				
ANTENNA POLARITY & TEST DISTANCE: HORIZONTAL AT 3m						
NO.	FREQ. (MHz)	EMISSION LEVEL (dBuV)	LIMIT (dBm)	S.G POWER VALUE (dBm)	CORRECTION FACTOR (dB)	POWER VALUE (dBm)
1	3505.2	57.8	-13.0	-46.6	10.0	-36.6
2	5257.8	40.7	-13.0	-63.7	9.7	-54.0
3	7010.4	45.6	-13.0	-56.9	7.9	-49.0
ANTENNA POLARITY & TEST DISTANCE: VERTICAL AT 3m						
NO.	FREQ. (MHz)	EMISSION LEVEL (dBuV)	LIMIT (dBm)	S.G POWER VALUE (dBm)	CORRECTION FACTOR (dB)	POWER VALUE (dBm)
1	3505.2	61.4	-13.0	-43.0	10.0	-33.0
2	5257.8	42.5	-13.0	-61.9	9.7	-52.2
3	7010.4	47.7	-13.0	-54.8	7.9	-46.9

NOTE: EIRP(dBm) = S.G Power Value (dBm) + Correction Factor (dB).
Correction Factor = gain of substitution antenna + cable loss



5 INFORMATION ON THE TESTING LABORATORIES

We, Bureau Veritas Consumer Products Services (H.K.) Ltd., Taoyuan Branch, were founded in 1988 to provide our best service in EMC, Radio, Telecom and Safety consultation. Our laboratories are accredited and approved according to ISO/IEC 17025.

Copies of accreditation certificates of our laboratories obtained from approval agencies can be downloaded from our web site: www.adt.com.tw/index.5.phtml.
If you have any comments, please feel free to contact us at the following:

Linko EMC/RF Lab:

Tel: 886-2-26052180

Fax: 886-2-26051924

Hsin Chu EMC/RF Lab:

Tel: 886-3-5935343

Fax: 886-3-5935342

Hwa Ya EMC/RF/Safety/Telecom Lab: Web Site: www.adt.com.tw

Tel: 886-3-3183232

Fax: 886-3-3185050

The address and road map of all our labs can be found in our web site also.

6 APPENDIX A – MODIFICATIONS RECORDERS FOR ENGINEERING CHANGES TO THE EUT BY THE LAB

No any modifications are made to the EUT by the lab during the test.

---END---