



SAR TEST REPORT

REPORT NO.: SA991230C03

MODEL NO.: C505

FCC ID: UZI-C505

RECEIVED: Dec. 28, 2010

TESTED: Jan. 12 ~ Mar. 02, 2011

ISSUED: Mar. 04, 2011

APPLICANT: BandRich Inc.

ADDRESS: 7F., No. 188, Baociao Rd., Sindian City, Taipei
County 23146, Taiwan

ISSUED BY: Bureau Veritas Consumer Products Services (H.K.)
Ltd., Taoyuan Branch

LAB ADDRESS: No. 47, 14th Ling, Chia Pau Tsuen, Lin Kou Hsiang,
Taipei Hsien 244, Taiwan, R.O.C.

TEST LOCATION: No. 19, Hwa Ya 2nd Rd, Wen Hwa Tsuen, Kwei
Shan Hsiang, Taoyuan Hsien 333, Taiwan, R.O.C.

This test report consists of 62 pages in total except Appendix. It may be duplicated completely for legal use with the approval of the applicant. It should not be reproduced except in full, without the written approval of our laboratory. The client should not use it to claim product certification, approval or endorsement by TAF or any government agency. The test results in the report only apply to the tested sample.





TABLE OF CONTENTS

RELEASE CONTROL RECORD	3
1. CERTIFICATION.....	4
2. GENERAL INFORMATION	5
2.1 GENERAL DESCRIPTION OF EUT	5
2.2 GENERAL DESCRIPTION OF APPLIED STANDARDS	7
2.3 GENERAL INFORMATION OF THE SAR SYSTEM	8
2.4 TEST EQUIPMENT	12
2.5 GENERAL DESCRIPTION OF THE SPATIAL PEAK SAR EVALUATION	13
3. DESCRIPTION OF SUPPORT UNITS	16
4. SAR TEST CONSIDERATIONS	17
4.1. SUMMARY INFORMATION OF LTE	17
4.2. OTHER U.S. WIRELESS OPERATING MODES	17
4.3. CONDUCTED OUTPUT POWER	18
4.4. MPR AND A-MPR	28
4.5. ANTENNA LOCATION AND FUNCTION	29
4.6. TEST SETUP	30
4.7. TEST INSTRUMENTS	31
4.8. TEST SOFTWARE	32
4.9. TEST LAPTOP	33
4.10. TEST MODE AND TEST REDUCTION	34
4.11. NO SIMULTANEOUS TRANSMISSION SAR JUSTIFICATION	37
4.12. LINEARITY CONSIDERATION	38
5. RECIPES FOR TISSUE SIMULATING LIQUIDS	41
5. SYSTEM VALIDATION	47
5.1 TEST PROCEDURE	47
5.2 VALIDATION RESULTS	49
5.3 SYSTEM VALIDATION UNCERTAINTIES	50
6. TEST RESULTS	51
6.1 TEST PROCEDURES	51
6.2 DESCRIPTION OF TEST CONDITION	52
6.3 MEASURED SAR RESULT	53
6.4 POWER DRIFT TABLE	56
6.5 SAR LIMITS	61
7. INFORMATION ON THE TESTING LABORATORIES	62
APPENDIX A: TEST CONFIGURATIONS AND TEST DATA	
APPENDIX B: ADT SAR MEASUREMENT SYSTEM	
APPENDIX C: PHOTOGRAPHS OF SYSTEM VALIDATION	
APPENDIX D: SYSTEM CERTIFICATE & CALIBRATION	



A D T

RELEASE CONTROL RECORD

ISSUE NO.	REASON FOR CHANGE	DATE ISSUED
Original release	N/A	Mar. 04, 2011



1. CERTIFICATION

PRODUCT: LTE USB Modem

MODEL NO.: C505

BRAND: BandLuxe

APPLICANT: BandRich Inc.

TESTED: Jan. 12 ~ Mar. 02, 2011

TEST SAMPLE: ENGINEERING SAMPLE

STANDARDS: FCC Part 2 (Section 2.1093)

FCC OET Bulletin 65, Supplement C (01-01)

RSS-102 Issue 4 (2010-03)

The above equipment (model: C505) has been tested by **Bureau Veritas Consumer Products Services (H.K.) Ltd., Taoyuan Branch**, and found compliance with the requirement of the above standards. The test record, data evaluation & Equipment Under Test (EUT) configurations represented herein are true and accurate accounts of the measurements of the sample's EMC characteristics under the conditions specified in this report.

PREPARED BY :

Andrea Hsia / Specialist

, DATE: Mar. 04, 2011

APPROVED BY :

Gary Chang / Assistant Manager

, DATE: Mar. 04, 2011



2. GENERAL INFORMATION

2.1 GENERAL DESCRIPTION OF EUT

PRODUCT	LTE USB Modem	
MODEL NO.	C505	
FCC ID	UZI-C505	
NOMINAL VOLTAGE	5.0Vdc from host equipment	
MODULATION TYPE	GPRS, E-GPRS	GMSK, 8PSK
	WCDMA	BPSK
	LTE Band 17	QPSK, 16QAM
	LTE Band 4	QPSK, 16QAM
	WCDMA AWS Band	BPSK
FREQUENCY RANGE	GPRS, E-GPRS	824.2MHz ~ 848.8MHz 1850.2MHz ~ 1909.8MHz
	WCDMA	826.4MHz ~ 846.6MHz 1852.4MHz ~ 1907.6MHz
	LTE Band 17 Channel Bandwidth: 5MHz	706.5MHz ~ 713.5MHz
	LTE Band 17 Channel Bandwidth: 10MHz	709MHz ~ 711MHz
	LTE Band 4 Channel Bandwidth: 5MHz	1712.5MHz ~ 1752.5MHz
	LTE Band 4 Channel Bandwidth: 10MHz	1715.0MHz ~ 1750.0MHz
	WCDMA AWS Band	1712.4MHz ~ 1752.6MHz
MAXIMUM SAR (1g)	LTE band 17	0.334W/kg
	GPRS/EGPRS/WCDMA 850	0.676W/kg
	LTE band 4 / WCDMA AWS Band	0.702W/kg
	GPRS/EGPRS/WCDMA 1900	0.694W/kg
CATEGORY	LTE: 3	
RELEASE VERSION	WCDMA: Release 5 / 6	
ANTENNA TYPE	Refer to Note	
DATA CABLE	0.5m non-shielded USB cable without core	
I/O PORTS	Refer to user's manual	
ACCESSORY DEVICES	NA	

NOTE:

1. The antennas used in this EUT are listed as below table:

Frequency Band	Embedded Monopole Antenna	Chip Antenna	Printed Antenna
LTE band 17	TX/ RX (Gain: -3dBi)	Not support	RX only
GPRS/EGPRS/WCDMA 850	TX/ RX (Gain: -2dBi)		Not support
GPRS/EGPRS/WCDMA 1900	TX/ RX (Gain: -3dBi)		
LTE band 4 / WCDMA AWS Band	TX/ RX (Gain: -7dBi)	RX only	

2. The EUT has no voice function.
3. Hardware version: V1.0.3
4. Software version: 1034 001 0310
5. IMEI Code: 35673404*****.
6. The above EUT information was declared by manufacturer and for more detailed features description, please refer to the manufacturer's specifications or User's Manual.



2.2 GENERAL DESCRIPTION OF APPLIED STANDARDS

According to the specifications of the manufacturer, this product must comply with the requirements of the following standards:

FCC Part 2 (2.1093)

FCC OET Bulletin 65, Supplement C (01- 01)

RSS-102 Issue 4 (2010-03)

IEEE 1528-2003

All test items have been performed and recorded as per the above standards.



2.3 GENERAL INFORMATION OF THE SAR SYSTEM

DASY4 (**Software 4.7 Build 80**) consists of high precision robot, probe alignment sensor, phantom, robot controller, controlled measurement server and near-field probe. The robot includes six axes that can move to the precision position of the DASY4 software defined. The DASY4 software can define the area that is detected by the probe. The robot is connected to controlled box. Controlled measurement server is connected to the controlled robot box. The DAE includes amplifier, signal multiplexing, AD converter, offset measurement and surface detection. It is connected to the Electro-optical coupler (ECO). The ECO performs the conversion from the optical into digital electric signal of the DAE and transfers data to the PC.

ES3DV3 ISOTROPIC E-FIELD PROBE

CONSTRUCTION	Symmetrical design with triangular core Interleaved sensors Built-in shielding against static charges PEEK enclosure material (resistant to organic solvents, e.g., DGBE)
FREQUENCY	10 MHz to 4 GHz; Linearity: ± 0.2 dB (30 MHz to 4 GHz)
DIRECTIVITY	± 0.2 dB in HSL (rotation around probe axis) ± 0.3 dB in tissue material (rotation normal to probe axis)
DYNAMIC RANGE	5 μ W/g to > 100 mW/g; Linearity: ± 0.2 dB
DIMENSIONS	Overall length: 337 mm (Tip: 20 mm) Tip diameter: 3.9 mm (Body: 12 mm) Distance from probe tip to dipole centers: 2.0 mm
APPLICATION	General dosimetry up to 4 GHz Dosimetry in strong gradient fields Compliance tests of mobile phones

NOTE

1. The Probe parameters have been calibrated by the SPEAG. Please reference "APPENDIX D" for the Calibration Certification Report.



EX3DV4 ISOTROPIC E-FIELD PROBE

CONSTRUCTION	Symmetrical design with triangular core Built-in shielding against static charges PEEK enclosure material (resistant to organic solvents, e.g., DGBE)
FREQUENCY	10 MHz to > 6 GHz Linearity: ± 0.2 dB (30 MHz to 6 GHz)
DIRECTIVITY	± 0.3 dB in HSL (rotation around probe axis) ± 0.5 dB in tissue material (rotation normal to probe axis)
DYNAMIC RANGE	10 μ W/g to > 100 mW/g Linearity: ± 0.2 dB (noise: typically < 1 μ W/g)
DIMENSIONS	Overall length: 330 mm (Tip: 20 mm) Tip diameter: 2.5 mm (Body: 12 mm) Typical distance from probe tip to dipole centers: 1 mm
APPLICATION	High precision dosimetric measurements in any exposure scenario (e.g., very strong gradient fields). Only probe which enables compliance testing for frequencies up to 6 GHz with precision of better 30%.

NOTE

1. The Probe parameters have been calibrated by the SPEAG. Please reference "APPENDIX D" for the Calibration Certification Report.
2. For frequencies above 800MHz, calibration in a rectangular wave-guide is used, because wave-guide size is manageable.
3. For frequencies below 800MHz, temperature transfer calibration is used because the wave-guide size becomes relatively large.

TWIN SAM V4.0

CONSTRUCTION	The shell corresponds to the specifications of the Specific Anthropomorphic Mannequin (SAM) phantom defined in IEEE 1528-2003, EN 62209-1 and IEC 62209. It enables the dosimetric evaluation of left and right hand phone usage as well as body mounted usage at the flat phantom region. A cover prevents evaporation of the liquid. Reference markings on the phantom allow the complete setup of all predefined phantom positions and measurement grids by manually teaching three points with the robot.
SHELL THICKNESS	2 ± 0.2 mm
FILLING VOLUME	Approx. 25liters
DIMENSIONS	Height: 810mm; Length: 1000mm; Width: 500mm

SYSTEM VALIDATION KITS:

CONSTRUCTION	Symmetrical dipole with 1/4 balun enables measurement of feedpoint impedance with NWA matched for use near flat phantoms filled with brain simulating solutions. Includes distance holder and tripod adaptor
CALIBRATION	Calibrated SAR value for specified position and input power at the flat phantom in brain simulating solutions
FREQUENCY	750, 835, 1700, 1900MHz
RETURN LOSS	> 20dB at specified validation position
POWER CAPABILITY	> 100W (f < 1GHz); > 40W (f > 1GHz)
OPTIONS	Dipoles for other frequencies or solutions and other calibration conditions upon request

DEVICE HOLDER FOR SAM TWIN PHANTOM

CONSTRUCTION	The device holder for the mobile phone device is designed to cope with different positions given in the standard. It has two scales for the device rotation (with respect to the body axis) and the device inclination (with respect to the line between the ear reference points). The rotation centers for both scales is the ear reference point (ERP). Thus the device needs no repositioning when changing the angles. The holder has been made out of low-loss POM material having the following dielectric parameters: relative permittivity =3 and loss tangent =0.02. The amount of dielectric material has been reduced in the closest vicinity of the device, since measurements have suggested that the influence of the clamp on the test results could thus be lowered. The device holder for the portable device makes up of the polyethylene foam. The dielectric parameters of material close to the dielectric parameters of the air.
---------------------	---



DATA ACQUISITION ELECTRONICS

CONSTRUCTION

The data acquisition electronics (DAE3) consists of a highly sensitive electrometer grade preamplifier with auto-zeroing, a channel and gain-switching multiplex, a fast 16 bit AD converter and a command decoder and control logic unit. Transmission to the measurement server is accomplished through an optical downlink for data and status information as well as an optical uplink for commands and the clock. The mechanical probe is mounting device includes two different sensor systems for frontal and sideways probe contacts. They are used for mechanical surface detection and probe collision detection. The input impedance of the DAE3 box is 200M Ω ; the inputs are symmetrical and floating. Common mode rejection is above 80 dB.



2.4 TEST EQUIPMENT

FOR SAR MEASUREMENT

ITEM	NAME	BRAND	TYPE	SERIES NO.	DATE OF CALIBRATION	DUE DATE OF CALIBRATION
1	SAM Phantom	S & P	QD000 P40 CA	TP 1202	NA	NA
2	Signal Generator	Agilent	E8257C	MY43321031	Aug. 30, 2010	Aug. 29, 2011
3	E-Field Probe	S & P	EX3DV4	3578	Jun. 22, 2010	Jun. 21, 2011
4	E-Field Probe	S & P	ES3DV3	3177	Aug. 24, 2010	Aug. 23, 2011
5	E-Field Probe	S & P	EX3DV4	3753	Dec.13, 2010	Dec.12, 2011
6	DAE	S & P	DAE 3	579	Sep. 20, 2010	Sep. 19, 2011
7	Robot Positioner	Staubli Unimation	NA	NA	NA	NA
8	Validation Dipole	S & P	D750V.	1013	Jun. 11, 2010	Jun. 10, 2011
9			D835V2	4d021	Apr. 29, 2010	Apr. 28, 2011
10			D1800V2	2d077	Feb. 23, 2010	Feb. 22, 2011
11			D1900V2	5d036	Feb. 23, 2010	Feb. 22, 2011
12			D1800V2	2d041	Jan.26, 2011	Jan.25, 2012
13			D1750v2	1003	Sep.29, 2010	Sep.28, 2011

NOTE: Before starting, all test equipment shall be warmed up for 30min.

FOR TISSUE PROPERTY

ITEM	NAME	BRAND	TYPE	SERIES NO.	DATE OF CALIBRATION	DUE DATE OF CALIBRATION
1	Network Analyzer	Agilent	E5071C	MY46104190	Apr. 06, 2010	Apr. 05, 2011
2	Dielectric Probe	Agilent	85070D	US01440176	NA	NA

NOTE:

1. Before starting, all test equipment shall be warmed up for 30min.
2. The tolerance (k=1) specified by Agilent for general dielectric measurements, deriving from inaccuracies in the calibration data, analyzer drift, and random errors, are usually $\pm 2.5\%$ and $\pm 5\%$ for measured permittivity and conductivity, respectively. However, the tolerances for the conductivity is smaller for material with large loss tangents, i.e., less than $\pm 2.5\%$ (k=1). It can be substantially smaller if more accurate methods are applied

2.5 GENERAL DESCRIPTION OF THE SPATIAL PEAK SAR EVALUATION

The DASY4 post-processing software (SEMCAD) automatically executes the following procedures to calculate the field units from the micro-volt readings at the probe connector. The parameters used in the evaluation are stored in the configuration modules of the software:

Probe parameters:	- Sensitivity	Norm _i , a _{i0} , a _{i1} , a _{i2}
	- Conversion factor	ConvF _i
	- Diode compression point	dcp _i
Device parameters:	- Frequency	F
	- Crest factor	Cf
Media parameters:	- Conductivity	
	- Density	

The first step of the evaluation is a linearization of the filtered input signal to account for the compression characteristics of the detector diode. The compensation depends on the input signal, the diode type and the DC-transmission factor from the diode to the evaluation electronics. If the exciting field is pulsed, the crest factor of the signal must be known to correctly compensate for peak power. The formula for each channel can be given as:

$$V_i = U_i + U_i^2 \cdot \frac{cf}{dcp_i}$$

V _i	=compensated signal of channel i	(i = x, y, z)
U _i	=input signal of channel i	(i = x, y, z)
Cf	=crest factor of exciting field	(DASY parameter)
dcp _i	=diode compression point	(DASY parameter)

From the compensated input signals the primary field data for each channel can be evaluated:

$$\text{E-fieldprobes: } E_i = \sqrt{\frac{V_i}{\text{Norm}_i \cdot \text{ConvF}}}$$

$$\text{H-fieldprobes: } H_i = \sqrt{V_i} \cdot \frac{a_{i0} + a_{i1}f + a_{i2}f^2}{f}$$

- V_i = compensated signal of channel I (i = x, y, z)
- Norm_i = sensor sensitivity of channel i $\mu\text{V}/(\text{V/m})^2$ for E-field Probes (i = x, y, z)
- ConvF = sensitivity enhancement in solution
- a_{ij} = sensor sensitivity factors for H-field probes
- F = carrier frequency [GHz]
- E_i = electric field strength of channel i in V/m
- H_i = magnetic field strength of channel i in A/m

The RSS value of the field components gives the total field strength (Hermitian magnitude):

$$E_{tot} = \sqrt{E_x^2 + E_y^2 + E_z^2}$$

The primary field data are used to calculate the derived field units.

$$SAR = E_{tot}^2 \cdot \frac{\sigma}{\rho \cdot 1'000}$$

- SAR = local specific absorption rate in mW/g
- E_{tot} = total field strength in V/m
- = conductivity in [mho/m] or [Siemens/m]
- = equivalent tissue density in g/cm³



Note that the density is set to 1, to account for actual head tissue density rather than the density of the tissue simulating liquid. The entire evaluation of the spatial peak values is performed within the Post-processing engine (SEMCAD). The system always gives the maximum values for the 1g and 10g cubes. The algorithm to find the cube with highest averaged SAR is divided into the following stages:

1. The extraction of the measured data (grid and values) from the Zoom Scan
2. The calculation of the SAR value at every measurement point based on all stored data (A/D values and measurement parameters)
3. The generation of a high-resolution mesh within the measured volume
4. The interpolation of all measured values from the measurement grid to the high-resolution grid
5. The extrapolation of the entire 3-D field distribution to the phantom surface over the distance from sensor to surface
6. The calculation of the averaged SAR within masses of 1g and 10g.

The probe is calibrated at the center of the dipole sensors that is located 1 to 2.7mm away from the probe tip. During measurements, the probe stops shortly above the phantom surface, depending on the probe and the surface detecting system. Both distances are included as parameters in the probe configuration file. The software always knows exactly how far away the measured point is from the surface. As the probe cannot directly measure at the surface, the values between the deepest measured point and the surface must be extrapolated. The angle between the probe axis and the surface normal line is less than 30 degree.



The maximum search is automatically performed after each area scan measurement. It is based on splines in two or three dimensions. The procedure can find the maximum for most SAR distributions even with relatively large grid spacing. After the area scanning measurement, the probe is automatically moved to a position at the interpolated maximum. The following scan can directly use this position for reference, e.g., for a finer resolution grid or the cube evaluations. The 1g and 10g peak evaluations are only available for the predefined cube 7 x 7 x 7 scans. The routines are verified and optimized for the grid dimensions used in these cube measurements. The measured volume of 30 x 30 x 30mm contains about 30g of tissue. The first procedure is an extrapolation (incl. boundary correction) to get the points between the lowest measured plane and the surface. The next step uses 3D interpolation to get all points within the measured volume in a 1mm grid (42875 points). In the last step, a 1g cube is placed numerically into the volume and its averaged SAR is calculated. This cube is the moved around until the highest averaged SAR is found. If the highest SAR is found at the edge of the measured volume, the system will issue a warning: higher SAR values might be found outside of the measured volume. In that case the cube measurement can be repeated, using the new interpolated maximum as the center.

3. DESCRIPTION OF SUPPORT UNITS

NO.	PRODUCT	BRAND	MODEL NO.	SERIAL NO.
1	LTE	Anritsu	MT8820C	6200910015
2	Universal Radio Communication Tester	R&S	CMU200	104484

NO.	SIGNAL CABLE DESCRIPTION OF THE ABOVE SUPPORT UNITS
1	NA
2	NA

NOTE: All power cords of the above support units are non shielded (1.8m).



4. SAR TEST CONSIDERATIONS

4.1. SUMMARY INFORMATION OF LTE

Operating frequency range of each LTE transmission band	Band 4 : 1710~1755MHz Band 17: 704~716 MHz																																																
Channel bandwidths	5 and 10MHz is used for Band 4 /17																																																
High, middle and low (H, M, L) channel numbers and frequencies in each LTE frequency band																																																	
704~716MHz Band	1710~1755 MHz band																																																
<table border="1"> <thead> <tr> <th>Channel bandwidth (MHz)</th> <th>Channel</th> <th>Channel No.</th> <th>Frequency (MHz)</th> </tr> </thead> <tbody> <tr> <td rowspan="3">5</td> <td>Low</td> <td>23755</td> <td>706.5</td> </tr> <tr> <td>Middle</td> <td>23790</td> <td>710</td> </tr> <tr> <td>High</td> <td>23825</td> <td>713.5</td> </tr> <tr> <td rowspan="3">10</td> <td>Low</td> <td>23780</td> <td>709</td> </tr> <tr> <td>Middle</td> <td>23790</td> <td>710</td> </tr> <tr> <td>High</td> <td>23800</td> <td>711</td> </tr> </tbody> </table>	Channel bandwidth (MHz)	Channel	Channel No.	Frequency (MHz)	5	Low	23755	706.5	Middle	23790	710	High	23825	713.5	10	Low	23780	709	Middle	23790	710	High	23800	711	<table border="1"> <thead> <tr> <th>Channel bandwidth (MHz)</th> <th>Channel</th> <th>Channel No.</th> <th>Frequency (MHz)</th> </tr> </thead> <tbody> <tr> <td rowspan="3">5</td> <td>Low</td> <td>19975</td> <td>1712.5</td> </tr> <tr> <td>Middle</td> <td>20175</td> <td>1732.5</td> </tr> <tr> <td>High</td> <td>20375</td> <td>1752.5</td> </tr> <tr> <td rowspan="3">10</td> <td>Low</td> <td>20000</td> <td>1715</td> </tr> <tr> <td>Middle</td> <td>20175</td> <td>1732.5</td> </tr> <tr> <td>High</td> <td>20350</td> <td>1750</td> </tr> </tbody> </table>	Channel bandwidth (MHz)	Channel	Channel No.	Frequency (MHz)	5	Low	19975	1712.5	Middle	20175	1732.5	High	20375	1752.5	10	Low	20000	1715	Middle	20175	1732.5	High	20350	1750
Channel bandwidth (MHz)	Channel	Channel No.	Frequency (MHz)																																														
5	Low	23755	706.5																																														
	Middle	23790	710																																														
	High	23825	713.5																																														
10	Low	23780	709																																														
	Middle	23790	710																																														
	High	23800	711																																														
Channel bandwidth (MHz)	Channel	Channel No.	Frequency (MHz)																																														
5	Low	19975	1712.5																																														
	Middle	20175	1732.5																																														
	High	20375	1752.5																																														
10	Low	20000	1715																																														
	Middle	20175	1732.5																																														
	High	20350	1750																																														
UE category	3																																																
Uplink modulations	QPSK , 16QAM																																																
LTE transmitter and antenna implementation	1Tx 2Rx, please see section 4.5 for detail																																																
LTE antenna function	Only one monopole ant can transmit																																																
Maximum Power Reduction (MPR) is optional or mandatory	MPR is Mandatory, please see section 4.4																																																
A-MPR (additional MPR) is disabled or not	A-MPR was Disabled, not available to the EUT.																																																
Conducted output power for 1RB Upper, 1RB lower , 50% RB centered, 100 % RB	Average conducted power and RB configuration plots included in section 4.3																																																
Other U.S. wireless operating modes	Include GPRS/EGPRS/WCDMA please See section 4.2 and 4.3 for detail																																																
Simultaneous transmission conditions	No, only 1Tx can on at a time. see section 4.11																																																
Power reduction for SAR	No																																																

4.2. OTHER U.S. WIRELESS OPERATING MODES

Frequency band (MHz)	Operating mode
704~716	LTE: Category 3
824~849	GPRS: Class 12 EGPRS: Class 12 WCDMA:HSPA/release5/6
1710~1755	WCDMA:HSPA,release5/6 LTE: Category 3
1850~1910	GPRS: Class 12 EGPRS: Class 12 WCDMA:HSPA/release5/6

4.3. CONDUCTED OUTPUT POWER AND RB CONFIGURATION

LTE MODE

Frequency band: 704~716MHz (dBm)

BW (MHz)	Modulation	Channel	Frequency (MHz)	RB size	RB Offset	Conducted power (dBm)	Target power (dBm)	MPR target (dB)
5	QPSK	23755	706.5	1	0	23.08	22.5	0
				1	24	22.76	22.5	0
				12	6	21.93	22.5	0.5
				25	0	21.8	22.5	0.5
		23790	710	1	0	23	22.5	0
				1	24	22.72	22.5	0
				12	6	22.15	22.5	0.5
				25	0	21.73	22.5	0.5
		23825	713.5	1	0	22.81	22.5	0
				1	24	22.52	22.5	0
				12	6	21.82	22.5	0.5
				25	0	21.49	22.5	0.5

BW (MHz)	Modulation	Channel	Frequency (MHz)	RB size	RB Offset	Conducted power (dBm)	Target power (dBm)	MPR target (dB)
5	16QAM	23755	706.5	1	0	22.51	22.5	0.5
				1	24	22.11	22.5	0.5
				12	6	21.78	22.5	1
				25	0	21.45	22.5	1
		23790	710	1	0	22.42	22.5	0.5
				1	24	22.01	22.5	0.5
				12	6	21.31	22.5	1
				25	0	21.55	22.5	1
		23825	713.5	1	0	22.24	22.5	0.5
				1	24	21.83	22.5	0.5
				12	6	21.38	22.5	1
				25	0	21.22	22.5	1

Note:

- 1) The differences from expected MPR levels are a result of measurement uncertainty and product hardware characteristic. The maximum output power will be tuned individually for not exceed tested maximum as indicated in the SAR report.
- 2) SAR for 5MHz is not required since the test reduced condition is satisfied. Please check P35 for detail information.

BW (MHz)	Modulation	Channel	Frequency (MHz)	RB size	RB Offset	Conducte d power (dBm)	Target power (dBm)	MPR target (dB)	Max SAR value (W/kg)
10	QPSK	23780	709	1	0	22.75	22.5	0	Not test
				1	49	22.4	22.5	0	
				25	13	21.91	22.5	0.5	
				50	0	21.72	22.5	0.5	
		23790	710	1	0	22.57	22.5	0	0.202
				1	49	22.25	22.5	0	0.218
				25	13	21.9	22.5	0.5	0.334
				50	0	21.64	22.5	0.5	Not test
		23800	711	1	0	22.52	22.5	0	
				1	49	22.21	22.5	0	
				25	13	21.69	22.5	0.5	
				50	0	21.52	22.5	0.5	

BW (MHz)	Modulation	Channel	Frequency (MHz)	RB size	RB Offset	Conducte d power (dBm)	Target power (dBm)	MPR target (dB)	Max SAR value (W/kg)
10	16QAM	23780	709	1	0	21.89	22.5	0.5	Not test
				1	49	21.53	22.5	0.5	
				25	13	21.46	22.5	1	
				50	0	21.23	22.5	1	
		23790	710	1	0	21.79	22.5	0.5	0.254
				1	49	21.46	22.5	0.5	0.221
				25	13	21.37	22.5	1	0.267
				50	0	21.01	22.5	1	Not test
		23800	711	1	0	21.53	22.5	0.5	
				1	49	22.3	22.5	0.5	
				25	13	21.17	22.5	1	
				50	0	21.05	22.5	1	

Note:

- 1) The differences from expected MPR levels are a result of measurement uncertainty and product hardware characteristic. The maximum output power will be tuned individually for not exceed tested maximum as indicated in the SAR report.
- 2) Not all channels and configurations are tested since the test reduced condition is satisfied. Please check P35 for detail information.



Frequency band: 1710~1755MHz (dBm)

BW (MHz)	Modulation	Channel	Frequency (MHz)	RB size	RB Offset	Conducted power (dBm)	Target power (dBm)	MPR target (dB)
5	QPSK	19975	1712.5	1	0	22.83	22.5	0
				1	24	23.07	22.5	0
				12	6	21.76	22.5	0.5
				25	0	21.75	22.5	0.5
		20175	1732.5	1	0	22.64	22.5	0
				1	24	22.67	22.5	0
				12	6	21.36	22.5	0.5
				25	0	21.46	22.5	0.5
		20375	1752.5	1	0	22.6	22.5	0
				1	24	22.62	22.5	0
				12	6	21.78	22.5	0.5
				25	0	21.66	22.5	0.5

BW (MHz)	Modulation	Channel	Frequency (MHz)	RB size	RB Offset	Conducted power (dBm)	Target power (dBm)	MPR target (dB)
5	16QAM	19975	1712.5	1	0	22.12	22.5	0.5
				1	24	22.19	22.5	0.5
				12	6	21.3	22.5	1
				25	0	21.48	22.5	1
		20175	1732.5	1	0	21.79	22.5	0.5
				1	24	21.81	22.5	0.5
				12	6	21.13	22.5	1
				25	0	21.22	22.5	1
		20375	1752.5	1	0	21.85	22.5	0.5
				1	24	21.94	22.5	0.5
				12	6	21.25	22.5	1
				25	0	21.37	22.5	1

Note:

- 1) The differences from expected MPR levels are a result of measurement uncertainty and product hardware characteristic. The maximum output power will be tuned individually for not exceed tested maximum as indicated in the SAR report.
- 2) SAR for 5MHz is not required since the test reduced condition is satisfied. Please check P35 for detail information.



BW (MHz)	Modulation	Channel	Frequency (MHz)	RB size	RB Offset	Conducted power (dBm)	Target power (dBm)	MPR target (dB)	Max SAR value (W/kg)
10	QPSK	20000	1715	1	0	22.91	22.5	0	Not test
				1	49	23.46	22.5	0	
				25	13	22.24	22.5	0.5	
				50	0	22.22	22.5	0.5	
		20175	1732.5	1	0	22.79	22.5	0	0.638
				1	49	23.22	22.5	0	0.702
				25	13	21.88	22.5	0.5	0.653
				50	0	21.84	22.5	0.5	
		20350	1750	1	0	22.65	22.5	0	Not test
				1	49	23.13	22.5	0	
				25	13	21.96	22.5	0.5	
				50	0	21.92	22.5	0.5	

BW (MHz)	Modulation	Channel	Frequency (MHz)	RB size	RB Offset	Conducted power (dBm)	Target power (dBm)	MPR target (dB)	Max SAR value (W/kg)
10	16QAM	20000	1715	1	0	22.45	22.5	0.5	Not test
				1	49	23.06	22.5	0.5	
				25	13	21.7	22.5	1	
				50	0	21.68	22.5	1	
		20175	1732.5	1	0	22.1	22.5	0.5	0.546
				1	49	22.74	22.5	0.5	0.639
				25	13	21.32	22.5	1	0.498
				50	0	21.25	22.5	1	
		20350	1750	1	0	22.21	22.5	0.5	Not test
				1	49	22.83	22.5	0.5	
				25	13	21.45	22.5	1	
				50	0	21.28	22.5	1	

Note:

- 1) The differences from expected MPR levels are a result of measurement uncertainty and product hardware characteristic. The maximum output power will be tuned individually for not exceed tested maximum as indicated in the SAR report.
- 2) Not all channels and configurations are tested since the test reduced condition is satisfied. Please check P35 for detail information.

Below are different RB configuration plots (1 RB at low end, 1 RB at high end and 50% RB centered for demonstrating that the RB was configured correctly during the test



A D T

Test plot of middle channel for Frequency band: 704~716MHz

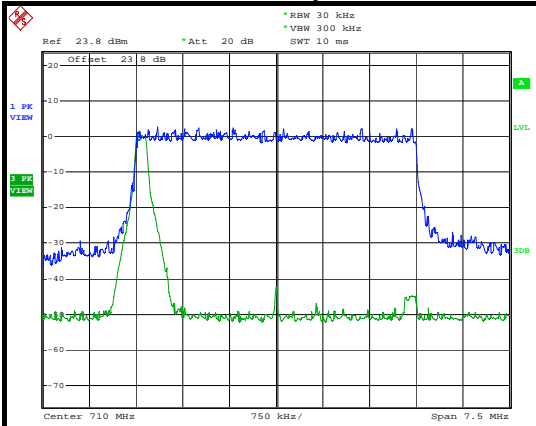

Date: 2.MAR.2011 16:21:23

5MHz / QPSK / 1RB LOWER

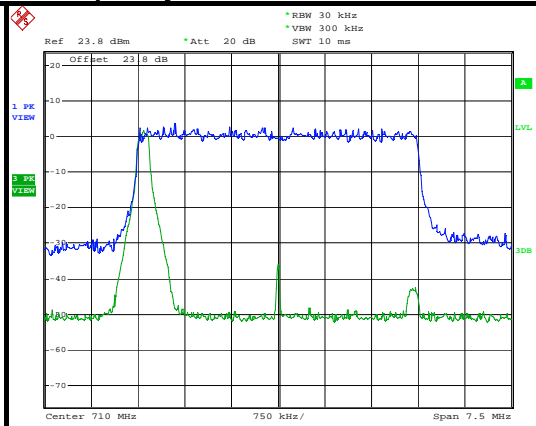

Date: 2.MAR.2011 16:19:32

5MHz / 16QAM / 1RB LOWER

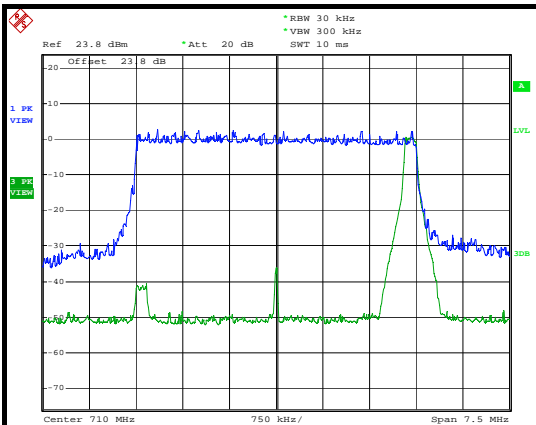

Date: 2.MAR.2011 16:22:00

5MHz / QPSK / 1RB UPPER

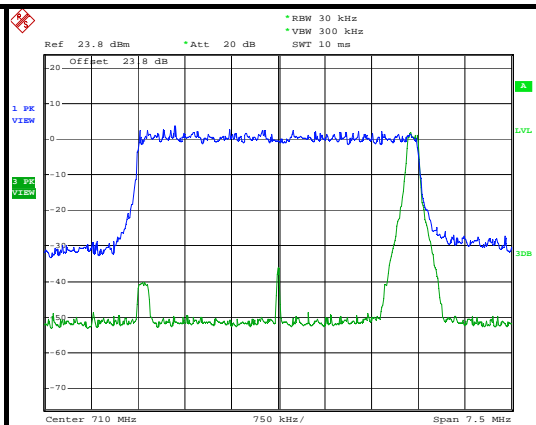

Date: 2.MAR.2011 16:20:00

5MHz / 16QAM / 1RB UPPER

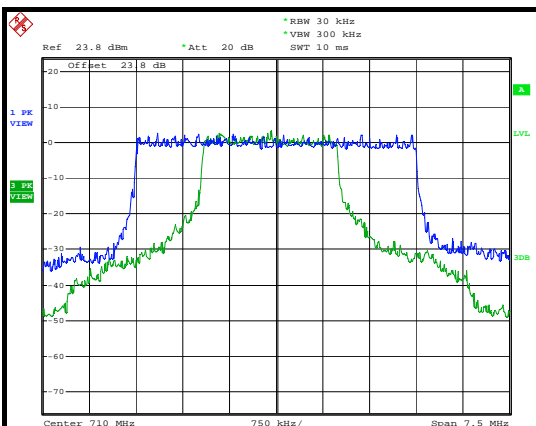

Date: 2.MAR.2011 16:20:47

5MHz / QPSK / 12 RB CENTERED

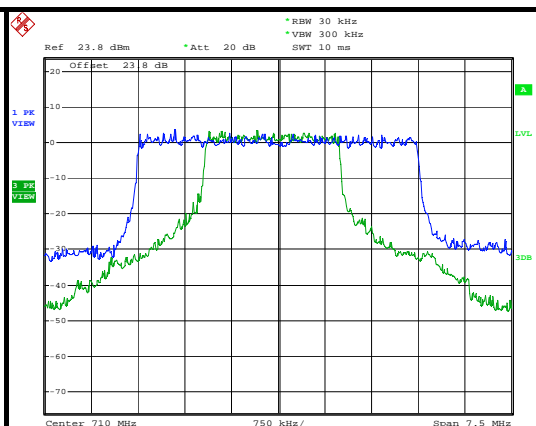

Date: 2.MAR.2011 16:18:47

5MHz / 16QAM / 12 RB CENTERED



A D T

Test plot of middle channel for Frequency band: 704~716MHz

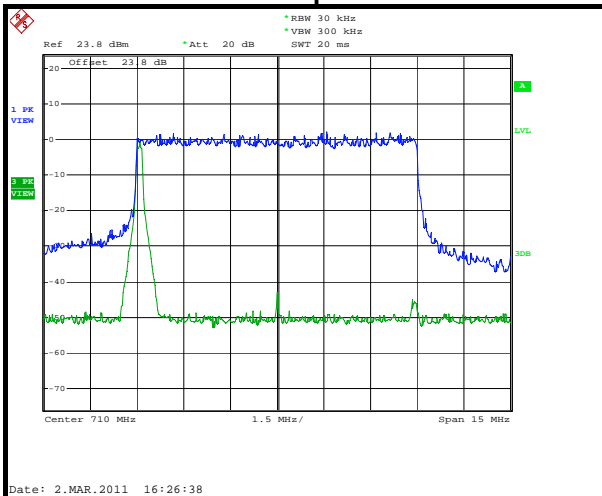

10MHz / QPSK / 1RB LOWER

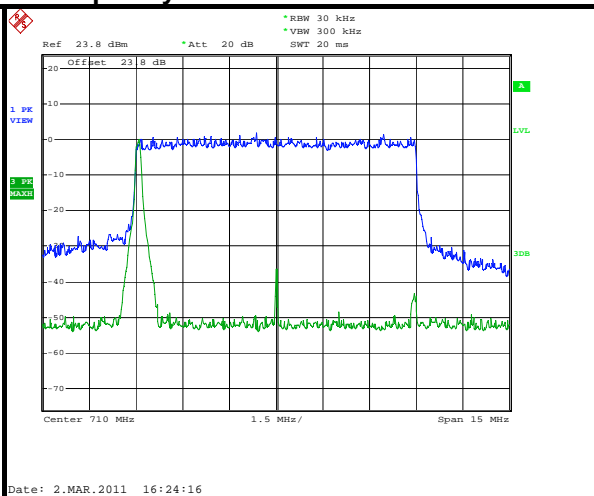

10MHz / 16QAM / 1RB LOWER

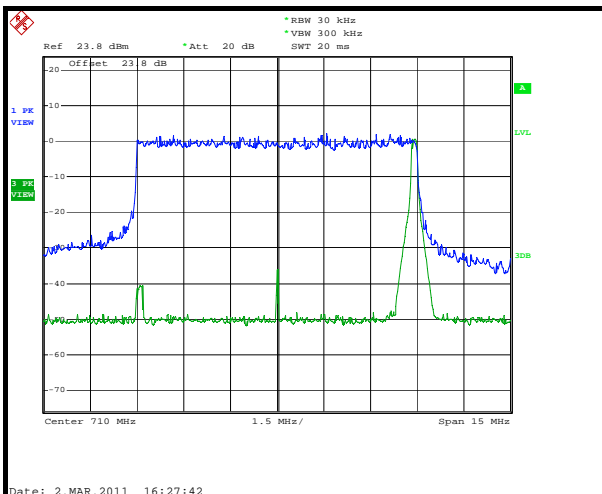

10MHz / QPSK / 1RB UPPER

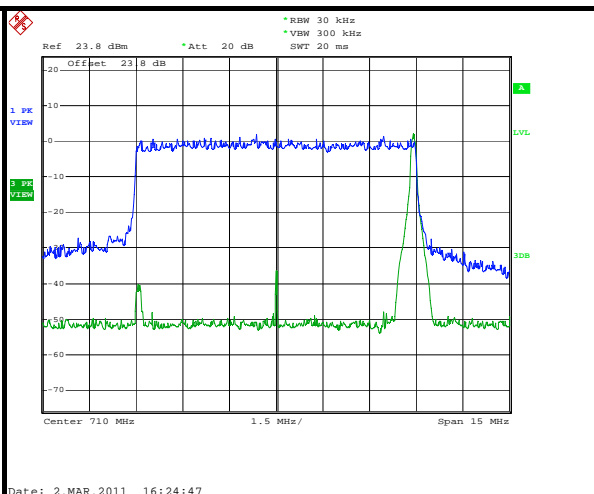

10MHz / 16QAM / 1RB UPPER

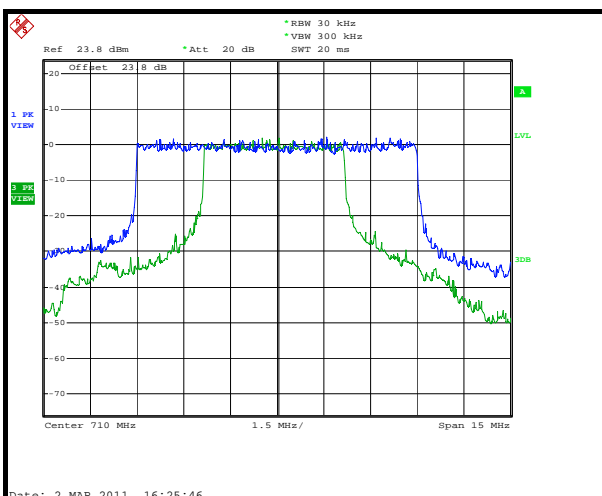

10MHz / QPSK / 25 RB CENTERED

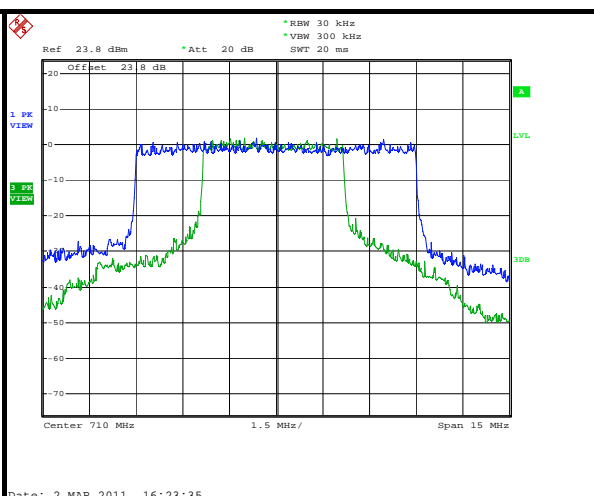

10MHz / 16QAM / 25 RB CENTERED



A D T

Test plot of middle channel for Frequency band: 1710~1755MHz

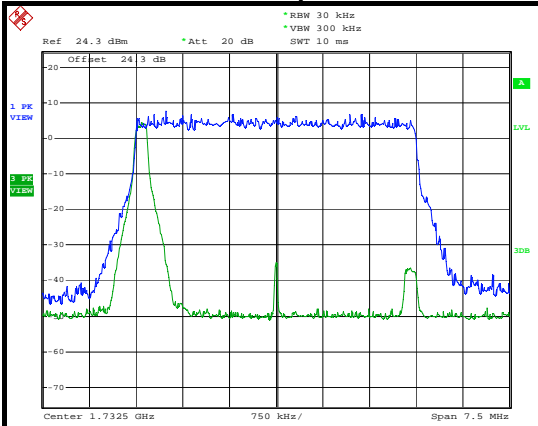

Date: 2.MAR.2011 16:13:20

5MHz / QPSK / 1RB LOWER

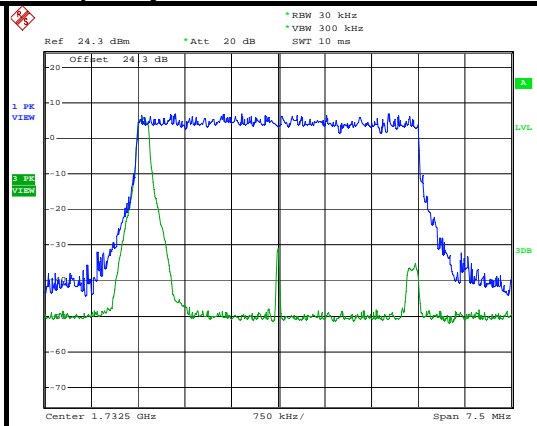

Date: 2.MAR.2011 16:15:39

5MHz / 16QAM / 1RB LOWER

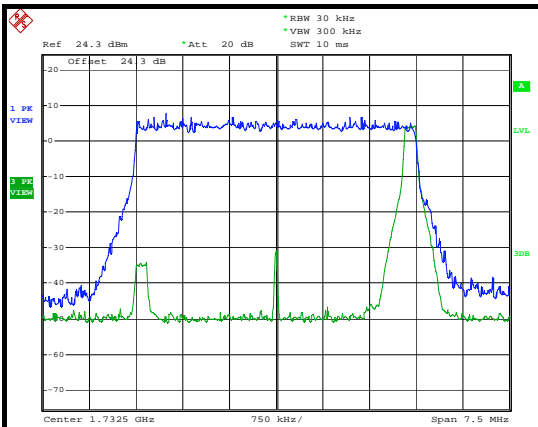

Date: 2.MAR.2011 16:14:11

5MHz / QPSK / 1RB UPPER

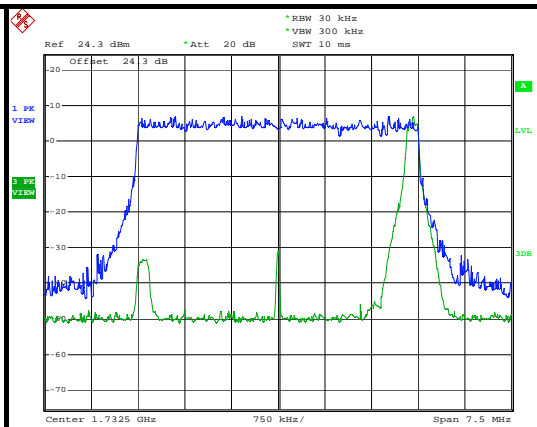

Date: 2.MAR.2011 16:16:24

5MHz / 16QAM / 1RB UPPER

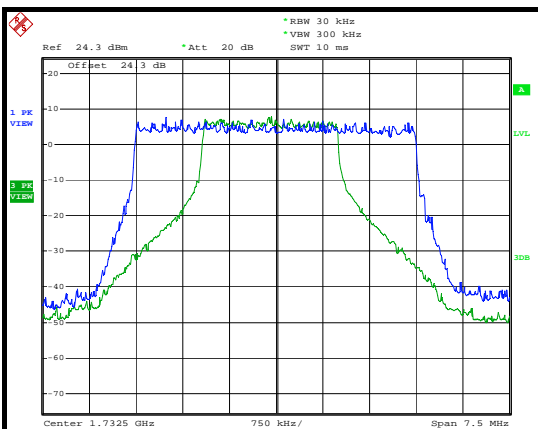

Date: 2.MAR.2011 16:10:27

5MHz / QPSK / 12 RB CENTERED

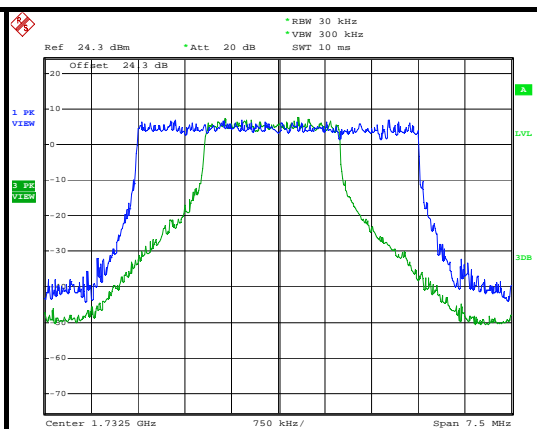

Date: 2.MAR.2011 16:15:06

5MHz / 16QAM / 12 RB CENTERED

Test plot of middle channel for Frequency band: 1710~1755MHz

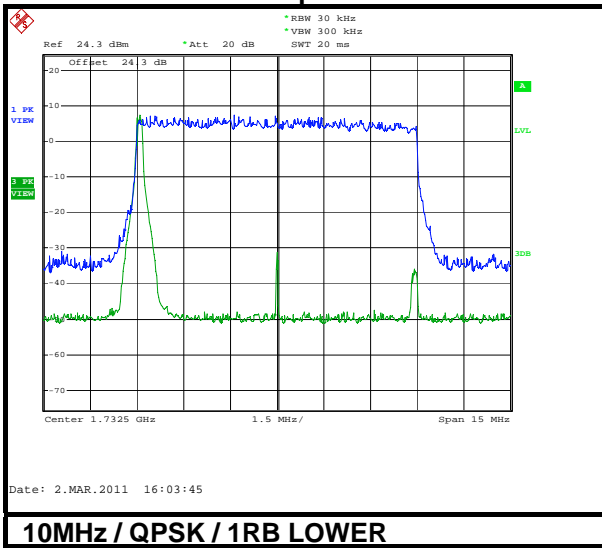

10MHz / QPSK / 1RB LOWER

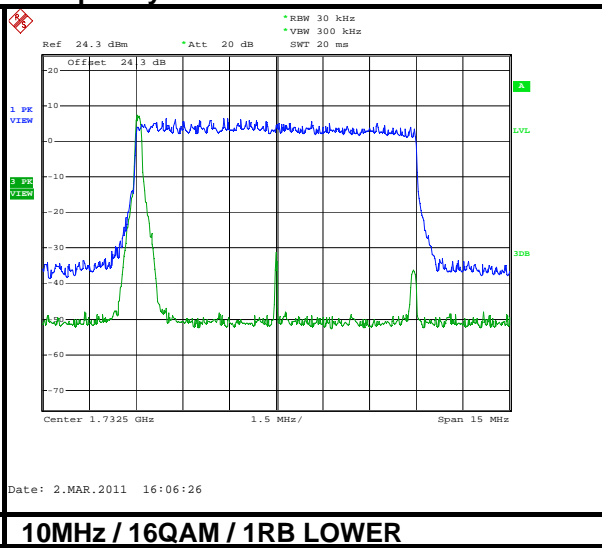

10MHz / 16QAM / 1RB LOWER

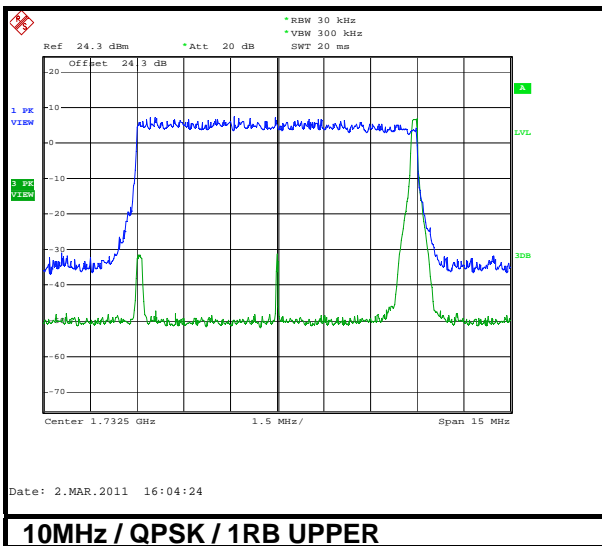

10MHz / QPSK / 1RB UPPER

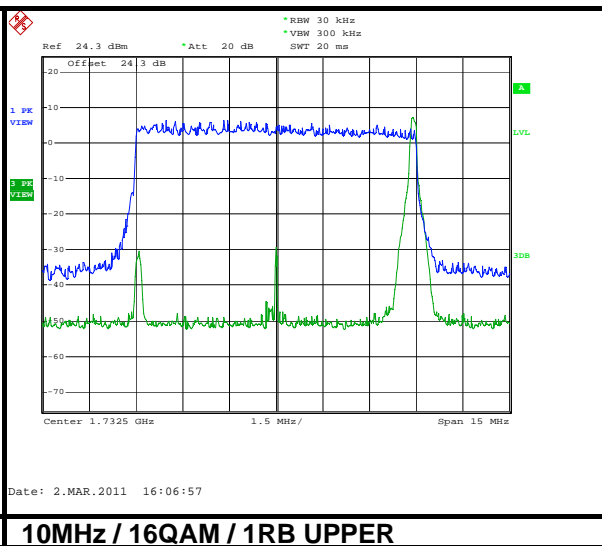

10MHz / 16QAM / 1RB UPPER

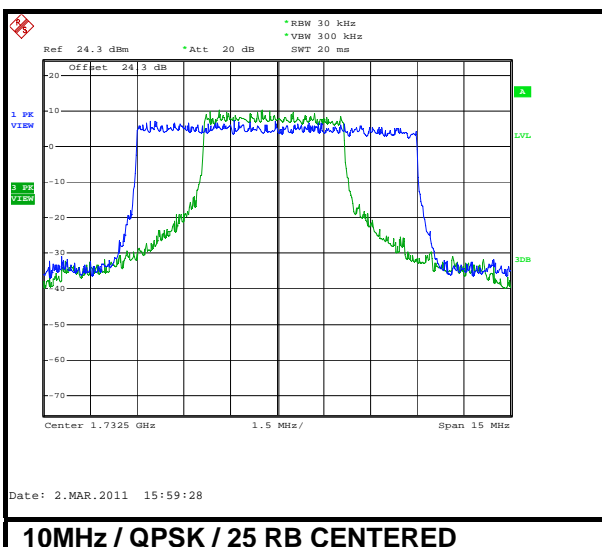

10MHz / QPSK / 25 RB CENTERED

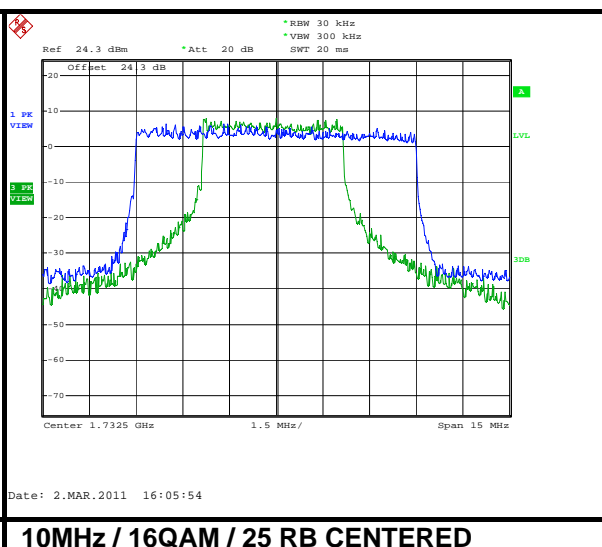

10MHz / 16QAM / 25 RB CENTERED



A D T

GPRS / EGPRS MODE conducted average power (dBm)

Band	Channel	Frequency (MHz)	GPRS mode				EGPRS mode			
			TS1	TS2	TS3	TS4	TS1	TS2	TS3	TS4
850	128	824.2	32.13	30.87	29.24	27.56	26.71	25.02	23.71	21.72
	190	836.6	32.23	31.08	29.32	27.70	26.85	25.23	23.95	21.90
	251	848.8	32.18	30.92	29.21	27.61	26.75	25.08	23.88	21.87
1900	512	1850.2	29.84	28.95	26.98	24.93	24.86	23.07	21.93	19.92
	661	1880	30.48	29.22	27.31	25.21	25.23	23.47	22.24	20.35
	128	824.2	30.24	29.08	27.20	25.10	25.08	23.11	22.07	20.02

Note: TS=Time slot

WCDMA conducted average power (dBm)

Mode	Channel	Frequency (MHz)	Conducted power (dBm)
WCDMA 850	4132	826.4	23.08
	4182	836.4	23.37
	4233	846.6	23.12
WCDMA1900	9262	1852.4	22.32
	9400	1880	22.89
	9538	1907.6	22.31
WCDMA AWS	1312	1712.4	23.32
	1412	1732.4	23.47
	1513	1752.6	23.26

HSDPA conducted average power (dBm)

Mode	Channel	Frequency (MHz)	H-set 1			
			SUBTEST 1	SUBTEST 2	SUBTEST 3	SUBTEST 4
HSDPA 850	4132	826.4	22.41	22.23	21.23	21.05
	4182	836.4	22.68	22.63	21.34	21.33
	4233	846.6	22.59	22.54	21.16	21.25
HSDPA 1900	9262	1852.4	21.91	22.03	20.81	21.01
	9400	1880	22.29	22.23	21.15	21.15
	9538	1907.6	21.93	22.15	21.01	20.93
HSDPA AWS	1312	1712.4	23.25	23.32	23.27	23.26
	1412	1732.4	23.45	23.44	23.42	23.48
	1513	1752.6	23.19	23.18	23.16	23.3



HSUPA conducted average power (dBm)

Mode	Channel	Frequency (MHz)	H-set 1				
			SUBTEST 1	SUBTEST 2	SUBTEST 3	SUBTEST 4	SUBTEST 5
HSUPA 850	4132	826.4	22.46	21.27	21.72	21.81	22.48
	4182	836.4	22.63	21.49	21.82	22.09	22.63
	4233	846.6	22.53	21.33	21.75	21.89	22.49
HSUPA 1900	9262	1852.4	22.06	20.46	21.89	21.62	22.47
	9400	1880	22.42	20.84	21.93	21.95	22.88
	9538	1907.6	21.93	20.23	21.52	21.39	22.43
HSUPA AWS	1312	1712.4	22.59	21.13	22.31	22.94	22.04
	1412	1732.4	22.78	21.43	22.61	22.14	22.35
	1513	1752.6	22.62	21.18	22.35	21.98	22.10

4.4. MPR AND A-MPR IMPLEMENTATION INFO

Modulation	Channel bandwidth / Transmission bandwidth configuration (RB)	MPR (dB)
	5MHz	
QPSK	> 8	0
16QAM	<=8	0
16QAM	> 8	1

Modulation	Channel bandwidth / Transmission bandwidth configuration (RB)	MPR (dB)
	10MHz	
QPSK	> 12	0
16QAM	< 12	0
16QAM	> 12	1

MPR is according to the standard and implemented in the circuit (mandatory). A-MPR is disabled by hard-coded in the software and is not available to the device.

4.5. ANTENNA LOCATION AND FUNCTION

3 Antennas are used for the device. But only monopole antenna can transmit and receive signal for all 4 bands, chip and printed can only receive signal on LTE band 4 and LTE band 17 respectively.

Antenna location

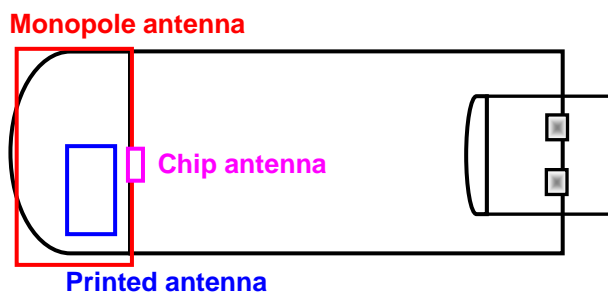

Antenna function and operating bands

Frequency Band	Embedded Monopole Antenna	Chip Antenna	Printed Antenna
LTE band 17	TX/ RX (Gain: -3dBi)	Not support	RX only
GPRS/EGPRS/WCDMA 850	TX/ RX (Gain: -2dBi)		Not support
GPRS/EGPRS/WCDMA 1900	TX/ RX (Gain: -3dBi)		
LTE band 4 / WCDMA AWS Band	TX/ RX (Gain: -7dBi)	RX only	

4.6. TEST SETUP

EUT was connected to NB directly for Horizontal-Down and Vertical-Front test position

EUT was connected to NB via a short usb cable for Horizontal-Down, Vertical-Back and Top edge position.

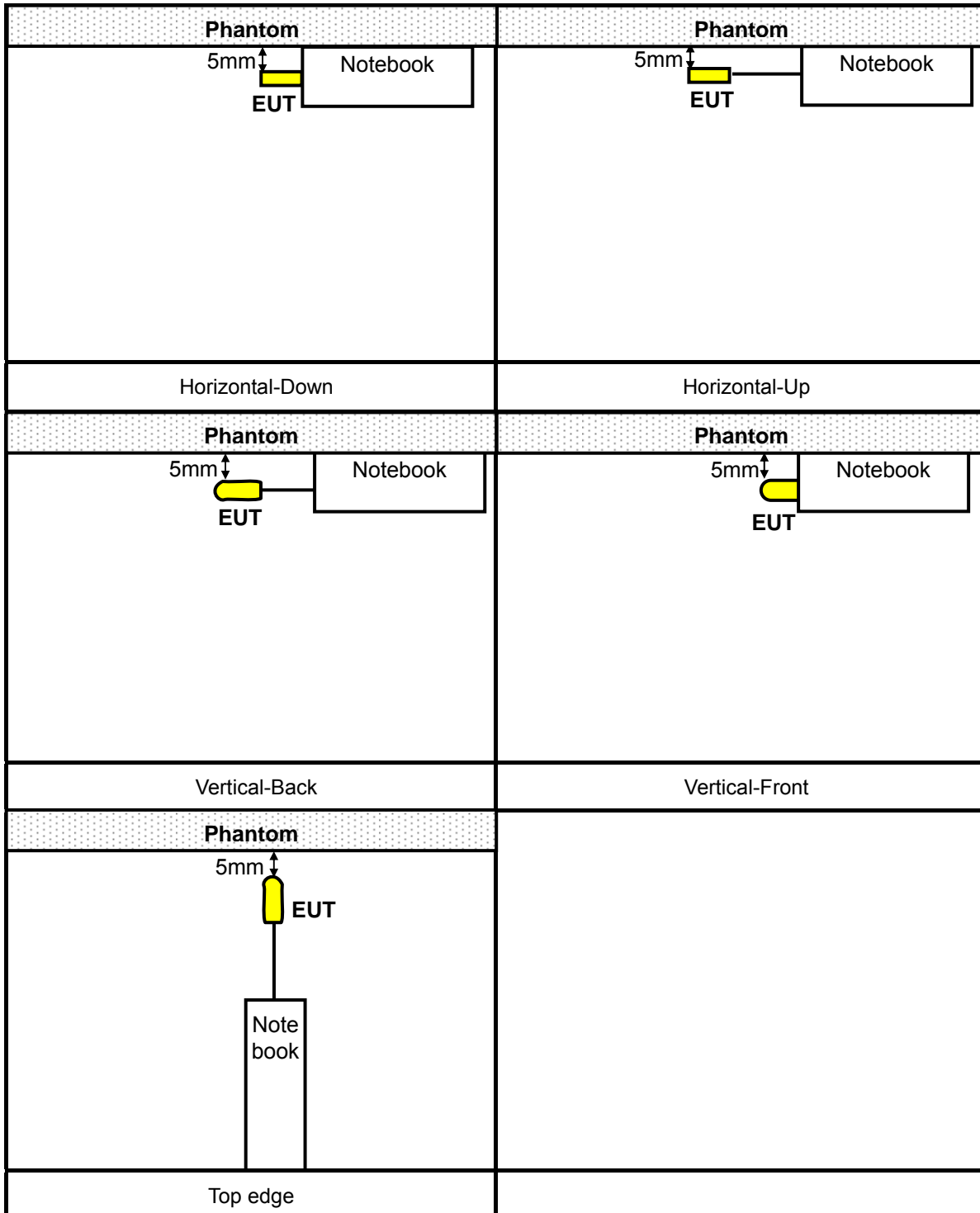

4.7. TEST INSTRUMENTS

Different simulator was used during the test for GPRS/EGPRS/WCDMA and LTE mode:

R&S CMU 200 is used for GPRS/EGPRS and WCDMA mode.

Test mode	Instrument		
	Brand	Model	SW version
GPRS/EGPRS/WCDMA	R&S	CMU 200 -1100.0008.02	V5.04

Information of R&S CMU 200

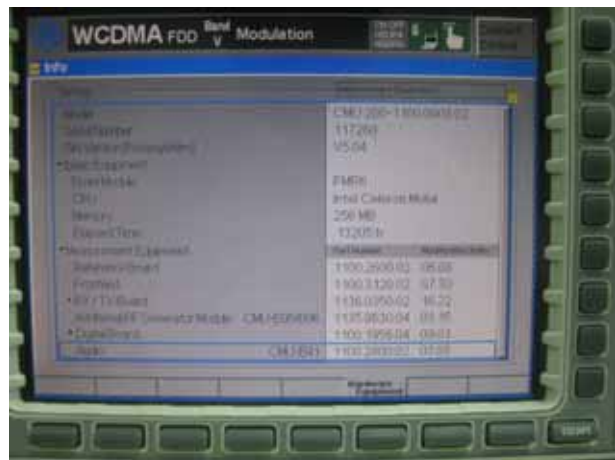
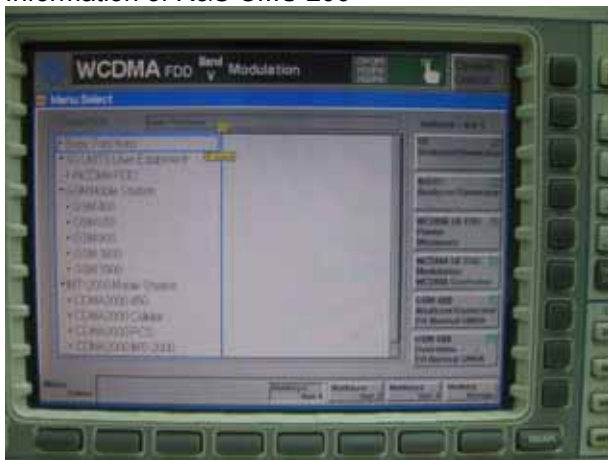

Anritsu MT8820C is used for LTE mode

Test mode	Instrument		
	Brand	Model	SW version
LTE	Anritsu	MT8820C	21.03 #003

Information of Anritsu MT8820C



4.8. TEST SOFTWARE

EUT was plugged into laptop pc and a special test mode software which supplied by the manufacture was loaded into the host NB. The software configures the EUT for each intended test mode.

Software version:1.03.010 Build010

Firmware version:1034_001_0310



Test tool can control EUT operating mode only and the detail output parameters was controlled by the correspondent simulator as explained in the previous section.

Select **setting item** → **network type** to choose operating mode.



4.9. TEST LAPTOP

Brand name: Dell
Model name: D820

The laptop pc has horizontal and vertical USB ports

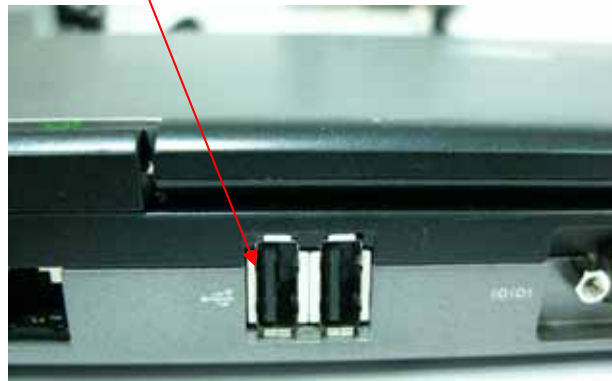
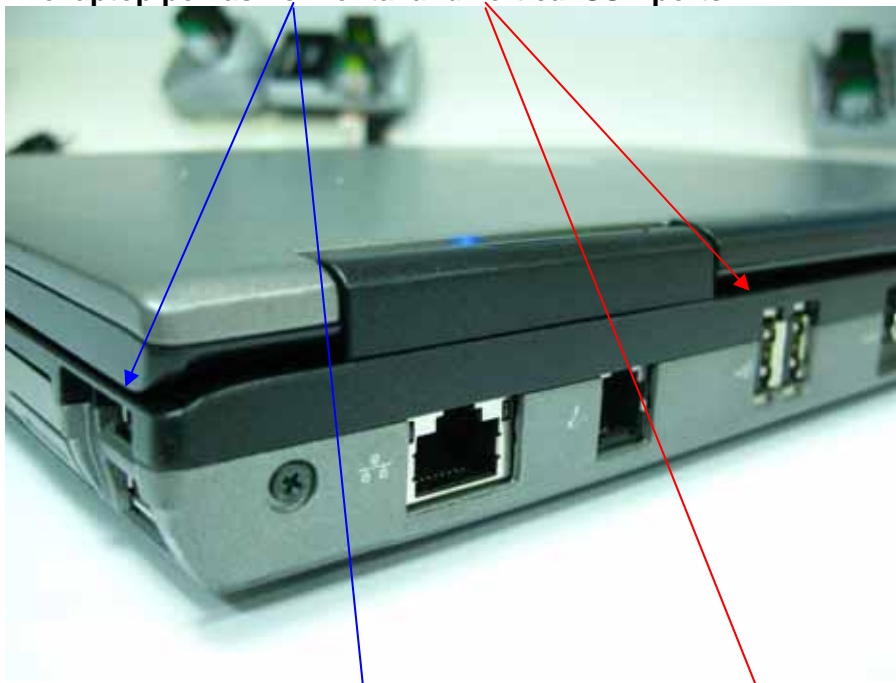

4.10. TEST MODE AND TEST REDUCTION

Test mode and test reduction is according to the “KDB 941225 D05 SAR for LTE Devices v01” and “KDB 941225 D01-3 for GSM/GPRS/WCDMA 3G device”. Also test plan had been accepted by FCC in Lab pre-TCB KDB tracking no. 765203. The device supports 3 air interface modes

GPRS / EGPRS

WCDMA

LTE

GRPS and EGPRS mode

Middle channel will be tested first. Other channels will be reduced if SAR of middle channel is < 0.8 W/kg
Time slot 1/2/3/4 will be tested

WCDMA mode

1. Middle channel will be tested first. Other channels will be reduced if SAR of middle channel is < 0.8 W/kg
2.

- 1) Please check power table of p23 and 24, power of HSDPA and HSUPA mode is not higher 1/4dB than that measured without HSPA using 12.2kbps RMC
- 2) Please check below SAR test result table, max SAR value of each mode is less than 0.75 % of SAR limit

Mode	Channel	Frequency (MHz)	Horizontal-Down	Horizontal-Up	Vertical-Back	Vertical-Front	Tip
WCDMA 850	4182	836.4	0.500	0.380	0.280	0.279	0.033
WCDMA 1900	9400	1800	0.694	0.586	0.489	0.528	0.051
WCDMA 1700	1412	1732.4	0.362	0.423	0.204	0.396	0.071

Therefore, only WCDMA-RMC will be tested, HSDPA and HSUPA are not required.

LTE mode

1. Middle channel will be tested first. Other channels will be reduced if SAR of middle channel is < 0.8 W/kg
2. 5 & 10MHz bandwidth is used for LTE mode. The highest BW (10MHz bandwidth) with QPSK modulation was tested at 3 different RB configurations first as required by the KDB 941225 D05. The SAR result tabulated in following tables:

LTE Band 17 (704~716MHz) / Bandwidth: 10MHz/ Modulation QPSK

Channel	Frequency (MHz)	RB size and allocation	Horizontal-Down	Horizontal-Up	Vertical-Back	Vertical-Front	Tip
23790	710	50% centered	0.334	0.215	0.108	0.169	0.023
		1 RB , lower edge	0.202	0.125	0.074	0.12	0.018
		1 RB , upper edge	0.218	0.137	0.075	0.113	0.017

LTE Band 4 (1710~1755MHz) / Bandwidth: 10MHz/ Modulation QPSK

Channel	Frequency (MHz)	RB size and allocation	Horizontal-Down	Horizontal-Up	Vertical-Back	Vertical-Front	Tip
20175	1732.5	50% centered	0.336	0.653	0.392	0.446	0.129
		1 RB , lower edge	0.340	0.638	0.358	0.449	0.127
		1 RB , upper edge	0.376	0.702	0.379	0.531	0.142

Per KDB 941225 D05

- 1) SAR of QPSK with 50% RB (10MHz) is < 1.45 W/kg → SAR for QPSK with 100 % is not required
- 2) Measured SAR in QPSK with 1 RB is < 1.45 W/kg→ Test 1RB configuration on other channels is not required.
- 3) Per section 5)B), SAR for 5MHz is not required due to following 2 conditions
 - (a) Max average conducted power of 5MHz BW is within +/- 1/2dB of 10MHz BW

BANDWIDTH (MHz)	704~716MHz	1710~1755MHz
5	23.08	23.07
10	22.75	23.46

- (b) SAR of QPSK with 50% RB (10MHz) is < 1.45 W/kg

According to above explanation, we conclude that only following configurations are required for this specific device:

BANDWIDTH (MHz)	10
MODULATION TYPE	QPSK / 16QAM
RB SIZE AND ALLOCATION	1RB lower edge 1RB upper edge 50 % RB centered
TEST CHANNEL	Middle channel

Final test configuration

Per pretest data and valid test reductions items as discussed in previous section, below are final test configurations for each air interface mode.

GPRS / EGPRS	Time slot 1/2/3/4	4 configurations need to be tested
	LOW CHANNEL	Not TEST *
	MIDDLE CHANNEL	TEST*
	HIGH CHANNEL	Not TEST *

*Please check SAR test result table of P49. SAR of middle channel is <0.8 W/kg, other channels are not required.

WCDMA	WCDMA-RMC	TEST
	HSDPA	Not TEST
	HSUPA	Not TEST
	LOW CHANNEL	Not TEST *
	MIDDLE CHANNEL	TEST*
	HIGH CHANNEL	Not TEST *

*Please check SAR test result table of P49. SAR of middle channel is <0.8 W/kg, other channels are not required.

LTE	BANDWIDTH (MHZ)	5	Not test
		10	TEST
	MODULATION TYPE	QPSK	TEST
		16QAM	TEST
		1RB LOWER EDGE	TEST
	RB SIZE AND ALLOCATION	1RB UPPER EDGE	TEST
		50% CENTERED	TEST
		100 % RB	Not TEST
		LOW CHANNEL	Not TEST*
	TEST CHANNEL	MIDDLE CHANNEL	TEST*/
		HIGH CHANNEL	Not TEST*

*Please check SAR test result table of P50. SAR of middle channel is <0.8 W/kg, other channels are not required.



4.11. NO SIMULTANEOUS TRANSMISSION SAR JUSTIFICATION

GPRS / WCDMA / LTE mode can not work at the same time. Only one mode can work at a time. No Simultaneous transmission mode is provided for the device. Therefore, simultaneous transmission SAR is not required

4.12. LINEARITY CONSIDERATION

In order to estimate the measurement error due to PAR issues, the configuration with the highest SAR in each channel bandwidth and frequency band is measured at various power level. Test conditions are as below

Test position	Horizontal Down for Band 17 (worst SAR configuration for this band) Horizontal Up for Band 4 (worst SAR configuration for this band)
Test mode	LTE
Test frequency	710MHz for Band 17 1732.5MHz for Band 4
TX antenna	Main antenna
Bandwidth	10MHz
Modulation	QPSK 16QAM

By tuning different power on this EUT and measuring the relative SAR to verify the high PAR of LTE is as below:

QPSK / 1732.5 MHz / RB Size: 1 / RB offset: 49

SAR (W/kg)	Power (mW)	13.24	26.42	52.72	105.20	209.89
5MHz	Point SAR	0.071	0.145	0.294	0.59	1.21
	Linear line	0.071	0.142	0.283	0.564	1.126
	Deviation(%)	0.00%	2.11	3.89	4.61	7.46

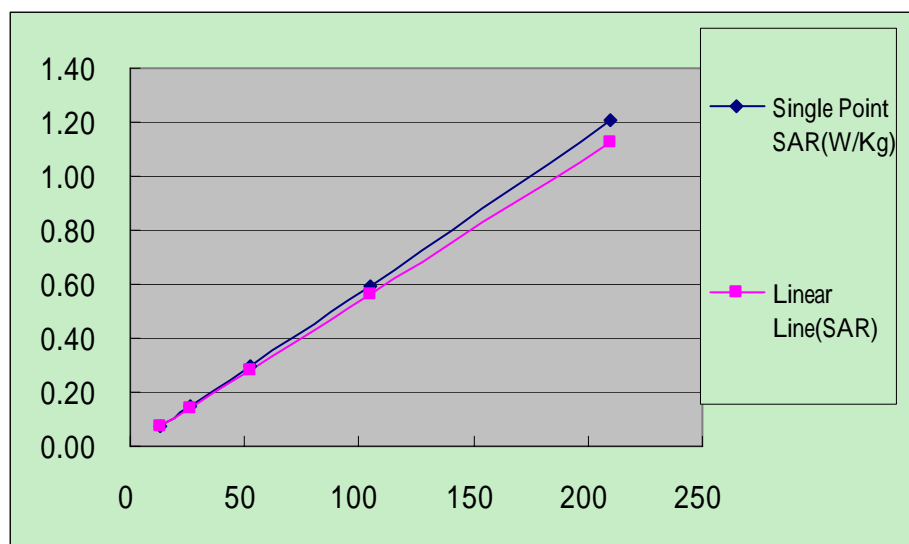



A D T

QPSK / 710 MHz / RB Size: 25 / RB offset: 13

SAR (W/kg)	Power (mW)	9.77	19.50	38.90	77.62	154.88
5MHz	Point SAR	0.037	0.076	0.151	0.304	0.613
	Linear line	0.037	0.074	0.147	0.294	0.587
	Deviation(%)	0	2.70	2.72	3.40	4.43

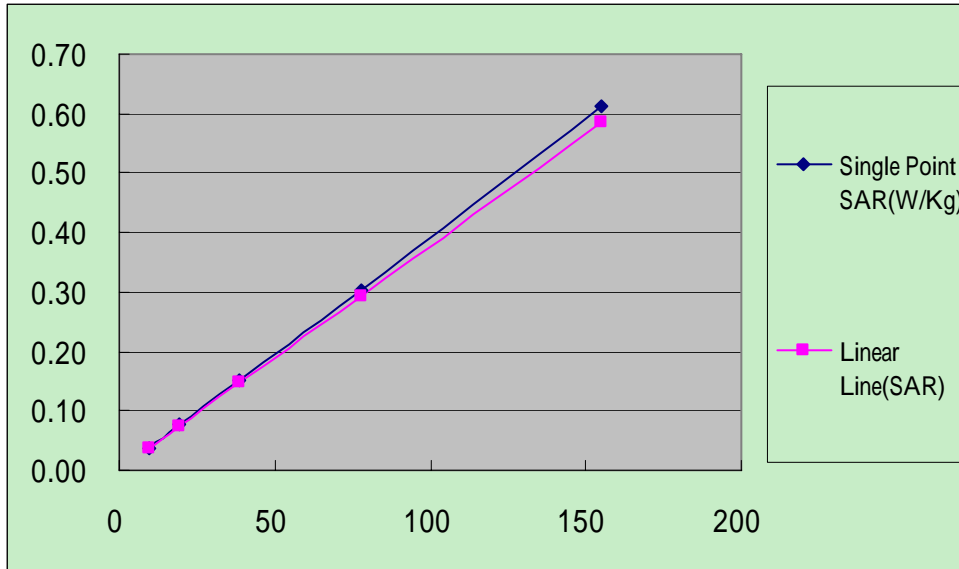

16QAM / 1732.5 MHz / RB Size: 1 / RB offset: 49

SAR (W/kg)	Power (mW)	11.86	23.66	47.20	94.19	187.93
5MHz	Point SAR	0.068	0.141	0.283	0.571	1.172
	Linear line	0.068	0.136	0.271	0.54	1.078
	Deviation(%)	0	3.68	4.43	5.74	8.72

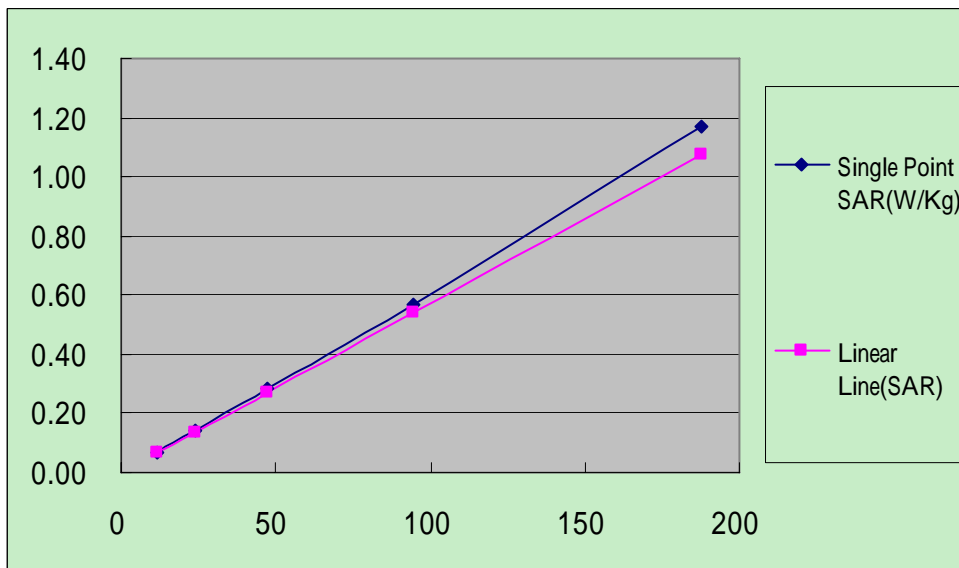



A D T

16QAM / 710 MHz / RB Size: 25 / RB offset: 13

SAR (W/kg)	Power (mW)	8.65	17.26	34.43	68.70	137.09
5MHz	Point SAR	0.029	0.06	0.117	0.241	0.474
	Linear line	0.029	0.058	0.115	0.23	0.46
	Deviation(%)	0	3.45	1.74	4.78	3.04

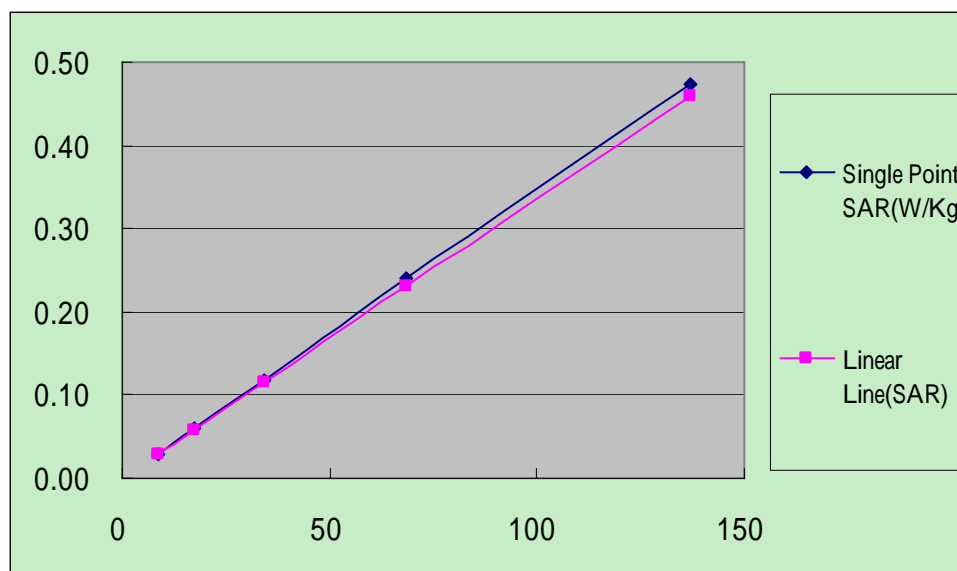

5. RECIPES FOR TISSUE SIMULATING LIQUIDS

For the measurement of the field distribution inside the SAM phantom, the phantom must be filled with 25 liters of tissue simulation liquid.

The following are some common ingredients :

- **WATER-** Deionized water (pure H₂O), resistivity ≥ 16 M - as basis for the liquid
- **SUGAR-** Refined sugar in crystals, as available in food shops - to reduce relative permittivity
- **SALT-** Pure NaCl - to increase conductivity
- **CELLULOSE-** Hydroxyethyl-cellulose, medium viscosity (75-125mPa.s, 2% in water, 20_C),
CAS # 54290 - to increase viscosity and to keep sugar in solution
- **PRESERVATIVE-** Preventol D-7 Bayer AG, D-51368 Leverkusen, CAS # 55965-84-9 - to prevent the spread of bacteria and molds
- **DGMBE-** Diethylenglycol-monobuthyl ether (DGMBE), Fluka Chemie GmbH, CAS # 112-34-5 - to reduce relative permittivity

THE RECIPES FOR 700MHz SIMULATING LIQUID TABLE

INGREDIENT	BODY SIMULATING LIQUID 700MHz (MSL-700)
Water	49%
Sugar	49.58%
Cellulose	0.12%
Salt	1.2%
Preventol	0.1%

THE RECIPES FOR 835MHz SIMULATING LIQUID TABLE

INGREDIENT	MUSCLE SIMULATING LIQUID 835MHz (MSL-835)
Water	50.07%
Cellulose	NA
Salt	0.94%
Preventtol D-7	0.09%
Sugar	48.2%

THE RECIPES FOR 1700MHz SIMULATING LIQUID TABLE

Ingredient	Muscle Simulating Liquid 1700MHz (MSL-1700)
Water	70.53%
Sugar	29.12%
Cellulose	0.35%

THE RECIPES FOR 1900MHz SIMULATING LIQUID TABLE

INGREDIENT	MUSCLE SIMULATING LIQUID 1900MHz (MSL-1900)
Water	70.16%
DGMBE	29.44%
Salt	00.39%
Dielectric Parameters at 22	$f = 1900\text{MHz}$ $\epsilon = 53.3 \pm 5\%$ $\sigma = 1.52 \pm 5\% \text{ S/m}$

Testing the liquids using the Agilent Network Analyzer E8358A and Agilent Dielectric Probe Kit 85070D. The testing procedure is following as

1. Turn Network Analyzer on and allow at least 30min. warm up.
2. Mount dielectric probe kit so that interconnecting cable to Network Analyzer will not be moved during measurements or calibration.
3. Pour de-ionized water and measure water temperature ($\pm 1^\circ$).
4. Set water temperature in Agilent-Software (Calibration Setup).
5. Perform calibration.
6. Validate calibration with dielectric material of known properties (e.g. polished ceramic slab with $>8\text{mm}$ thickness $\epsilon' = 10.0$, $\epsilon'' = 0.0$). If measured parameters do not fit within tolerance, repeat calibration (± 0.2 for ϵ' : ± 0.1 for ϵ'').
7. Conductivity can be calculated from ϵ'' by $\sigma = \omega \epsilon_0 \epsilon'' = \epsilon'' f [\text{GHz}] / 18$.
8. Measure liquid shortly after calibration. Repeat calibration every hour.
9. Stir the liquid to be measured. Take a sample ($\sim 50\text{ml}$) with a syringe from the center of the liquid container.
10. Pour the liquid into a small glass flask. Hold the syringe at the bottom of the flask to avoid air bubbles.
11. Put the dielectric probe in the glass flask. Check that there are no air bubbles in front of the opening in the dielectric probe kit.
12. Perform measurements.
13. Adjust medium parameters in DASY4 for the frequencies necessary for the measurements ('Setup Config', select medium (e.g. Brain 900MHz) and press 'Option'-button.
14. Select the current medium for the frequency of the validation (e.g. Setup Medium Brain 900MHz).



FOR BAND SIMULATING LIQUID

LIQUID TYPE		MSL-750			
SIMULATING LIQUID TEMP.		21.2			
TEST DATE		Jan. 24, 2011			
TESTED BY		Sam Onn			
FREQ. (MHz)	LIQUID PARAMETER	STANDARD VALUE	MEASUREMENT VALUE	ERROR PERCENTAGE (%)	LIMIT(%)
710	Permittivity	55.69	55.86	0.31	±5
750	()	55.53	55.84	0.56	
710	Conductivity	0.96	0.95	-1.04	
750	() S/m	0.96	0.98	2.08	

LIQUID TYPE		MSL-750			
SIMULATING LIQUID TEMP.		21.6			
TEST DATE		Mar. 02, 2011			
TESTED BY		Sam Onn			
FREQ. (MHz)	LIQUID PARAMETER	STANDARD VALUE	MEASUREMENT VALUE	ERROR PERCENTAGE (%)	LIMIT(%)
710	Permittivity	55.69	56.11	0.75	±5
750	()	55.53	56.06	0.95	
710	Conductivity	0.96	0.96	0.00	
750	() S/m	0.96	0.99	3.13	



LIQUID TYPE		MSL-835			
SIMULATING LIQUID TEMP.		21.6			
TEST DATE		Jan. 12, 2011			
TESTED BY		Sam Onn			
FREQ. (MHz)	LIQUID PARAMETER	STANDARD VALUE	MEASUREMENT VALUE	ERROR PERCENTAGE (%)	LIMIT(%)
835.0	Permittivity ()	55.20	55.86	1.20	±5
836.4		55.20	55.84	1.16	
836.6		55.20	55.84	1.16	
835.0	Conductivity () S/m	0.97	0.98	1.03	
836.4		0.97	0.98	1.03	
836.6		0.97	0.98	1.03	

LIQUID TYPE		MSL-1700			
SIMULATING LIQUID TEMP.		21.3			
TEST DATE		Jan. 21, 2011			
TESTED BY		Sam Onn			
FREQ. (MHz)	LIQUID PARAMETER	STANDARD VALUE	MEASUREMENT VALUE	ERROR PERCENTAGE (%)	LIMIT(%)
1732.4	Permittivity ()	53.48	54.38	1.68	±5
1732.5		53.48	54.38	1.68	
1750.0		53.43	54.15	1.35	
1800.0		53.30	53.85	1.03	
1732.4	Conductivity () S/m	1.48	1.49	0.68	
1732.5		1.48	1.49	0.68	
1750.0		1.49	1.51	1.34	
1800.0		1.52	1.54	1.32	



LIQUID TYPE		MSL-1700			
SIMULATING LIQUID TEMP.		21.2			
TEST DATE		Mar. 01, 2011			
TESTED BY		Sam Onn			
FREQ. (MHz)	LIQUID PARAMETER	STANDARD VALUE	MEASUREMENT VALUE	ERROR PERCENTAGE (%)	LIMIT(%)
1732.4	Permittivity ()	53.52	53.76	0.45	±5
1732.5		53.48	53.65	0.32	
1750.0		53.43	54.01	1.09	
1800.0		53.30	54.21	1.71	
1732.4	Conductivity () S/m	1.47	1.48	0.68	
1732.5		1.48	1.5	1.35	
1750.0		1.49	1.51	1.34	
1800.0		1.52	1.55	1.97	

LIQUID TYPE		MSL-1900			
SIMULATING LIQUID TEMP.		21.6			
TEST DATE		Jan. 13, 2011			
TESTED BY		Sam Onn			
FREQ. (MHz)	LIQUID PARAMETER	STANDARD VALUE	MEASUREMENT VALUE	ERROR PERCENTAGE (%)	LIMIT(%)
1880.00	Permittivity ()	53.30	54.64	2.51	±5
1900.00		53.30	54.50	2.25	
1880.00	Conductivity () S/m	1.52	1.54	1.32	
1900.00		1.52	1.56	2.63	



5. SYSTEM VALIDATION

The system validation was performed in the flat phantom with equipment listed in the following table. Since the SAR value is calculated from the measured electric field, dielectric constant and conductivity of the body tissue and the SAR is proportional to the square of the electric field. So, the SAR value will be also proportional to the RF power input to the system validation dipole under the same test environment. In our system validation test, 250mW RF input power was used.

5.1 TEST PROCEDURE

Before the system performance check, we need only to tell the system which components (probe, medium, and device) are used for the system performance check; the system will take care of all parameters. The dipole must be placed beneath the flat section of the SAM Twin Phantom with the correct distance holder in place. The distance holder should touch the phantom surface with a light pressure at the reference marking (little cross) and be oriented parallel to the long side of the phantom. Accurate positioning is not necessary, since the system will search for the peak SAR location, except that the dipole arms should be parallel to the surface. The device holder for mobile phones can be left in place but should be rotated away from the dipole.

1. The "Power Reference Measurement" and "Power Drift Measurement" jobs are located at the beginning and end of the batch process. They measure the field drift at one single point in the liquid over the complete procedure. The indicated drift is mainly the variation of the amplifier output power. If it is too high (above ± 0.1 dB), the system performance check should be repeated; some amplifiers have very high drift during warm-up. A stable amplifier gives drift results in the DASY system below ± 0.02 dB.
2. The "Surface Check" job tests the optical surface detection system of the DASY system by repeatedly detecting the surface with the optical and mechanical surface detector and comparing the results. The output gives the detecting heights of both systems, the difference between the two systems and the standard deviation of the detection repeatability. Air bubbles or refraction in the liquid due to separation of the sugar-water mixture gives poor repeatability (above ± 0.1 mm). In that case it is better to abort the system performance check and stir the liquid.

3. The "Area Scan" job measures the SAR above the dipole on a plane parallel to the surface. It is used to locate the approximate location of the peak SAR. The proposed scan uses large grid spacing for faster measurement; due to the symmetric field, the peak detection is reliable. If a finer graphic is desired, the grid spacing can be reduced. Grid spacing and orientation have no influence on the SAR result.
4. The "Zoom Scan" job measures the field in a volume around the peak SAR value assessed in the previous "Area Scan" job (for more information see the application note on SAR evaluation).

About the validation dipole positioning uncertainty, the constant and low loss dielectric spacer is used to establish the correct distance between the top surface of the dipole and the bottom surface of the phantom, the error component introduced by the uncertainty of the distance between the liquid (i.e., phantom shell) and the validation dipole in the DASY4 system is less than $\pm 0.1\text{mm}$.

$$SAR_{tolerance} [\%] = 100 \times \left(\frac{(a + d)^2}{a^2} - 1 \right)$$

As the closest distance is 10mm, the resulting tolerance $SAR_{tolerance}[\%]$ is <2%.

5.2 VALIDATION RESULTS

SYSTEM VALIDATION TEST OF SIMULATING LIQUID					
FREQUENCY (MHz)	REQUIRED SAR (mW/g)	MEASURED SAR (mW/g)	DEVIATION (%)	SEPARATION DISTANCE	TESTED DATE
MSL 750	2.23 (1g)	2.09	-6.28	10mm	Jan. 24, 2011
MSL 750	2.23 (1g)	2.06	-7.62	10mm	Mar. 02, 2011
MSL 835	2.52 (1g)	2.45	-2.78	15mm	Jan. 12, 2011
MSL 1800	9.58 (1g)	9.39	-1.98	10mm	Jan. 21, 2011
MSL 1800	9.70 (1g)	9.60	-1.03	10mm	Mar. 01, 2011
MSL 1900	10.3 (1g)	9.69	-5.92	10mm	Jan. 13, 2011
TESTED BY	Sam Onn				

NOTE: Please see Appendix for the photo of system validation test.

5.3 SYSTEM VALIDATION UNCERTAINTIES

In the table below, the system validation uncertainty with respect to the analytically assessed SAR value of a dipole source as given in the IEEE 1528 standard is given. This uncertainty is smaller than the expected uncertainty for mobile phone measurements due to the simplified setup and the symmetric field distribution.

Error Description	Tolerance (±%)	Probability Distribution	Divisor	(C _i)		Standard Uncertainty (±%)		(V _i)
				(1g)	(10g)	(1g)	(10g)	
Measurement System								
Probe Calibration	5.50	Normal	1	1	1	5.50	5.50	
Axial Isotropy	0.25	Rectangular	3	0.7	0.7	0.10	0.10	
Hemispherical Isotropy	1.30	Rectangular	3	0.7	0.7	0.53	0.53	
Boundary effects	1.00	Rectangular	3	1	1	0.58	0.58	
Linearity	0.30	Rectangular	3	1	1	0.17	0.17	
System Detection Limits	1.00	Rectangular	3	1	1	0.58	0.58	
Readout Electronics	0.30	Normal	1	1	1	0.30	0.30	
Response Time	0.80	Rectangular	3	1	1	0.46	0.46	
Integration Time	2.60	Rectangular	3	1	1	1.50	1.50	
RF Ambient Noise	3.00	Rectangular	3	1	1	1.73	1.73	9
RF Ambient Reflections	3.00	Rectangular	3	1	1	1.73	1.73	9
Probe Positioner	0.40	Rectangular	3	1	1	0.23	0.23	
Probe Positioning	2.90	Rectangular	3	1	1	1.67	1.67	
Max. SAR Eval.	1.00	Rectangular	3	1	1	0.58	0.58	
Test sample related								
Sample positioning	1.90	Normal	1	1	1	1.90	1.90	4
Device holder uncertainty	2.80	Normal	1	1	1	2.80	2.80	4
Output power variation-SAR drift measurement	4.50	Rectangular	3	1	1	2.60	2.60	1
Dipole Related								
Dipole Axis to Liquid Distance	1.60	Rectangular	3	1	1	0.92	0.92	4
Input Power Drift	1.93	Rectangular	3	1	1	1.11	1.11	1
Phantom and Tissue parameters								
Phantom Uncertainty	4.00	Rectangular	3	1	1	2.31	2.31	
Liquid Conductivity (target)	5.00	Rectangular	3	0.64	0.43	1.85	1.24	
Liquid Conductivity (measurement)	2.63	Normal	1	0.64	0.43	1.68	1.13	9
Liquid Permittivity (target)	5.00	Rectangular	3	0.6	0.49	1.73	1.41	
Liquid Permittivity (measurement)	2.51	Normal	1	0.6	0.49	1.51	1.23	9
Combined Standard Uncertainty						8.95	8.66	
Coverage Factor for 95%						Kp=2		
Expanded Uncertainty (K=2)						17.90	17.31	

NOTE: About the system validation uncertainty assessment, please reference the section 7.

6. TEST RESULTS

6.1 TEST PROCEDURES

The EUT makes a phone call to the communication simulator station. Establish the simulation communication configuration rather the actual communication. Then the EUT could continuous the transmission mode. Adjust the PCL of the base station could controlled the EUT to transmitted the maximum output power. The base station also could control the transmission channel. The SAR value was calculated via the 3D spline interpolation algorithm that has been implemented in the software of DASY4 SAR measurement system manufactured and calibrated by SPEAG. According to the IEEE 1528 / EN 62209-1, the recommended procedure for assessing the peak spatial-average SAR value consists of the following steps:

- Power reference measurement
- Verification of the power reference measurement
- Area scan
- Zoom scan
- Power reference measurement

The area scan was performed for the highest spatial SAR location. The zoom scan was performed for SAR value averaged over 1g and 10g spatial volumes.

In the zoom scan, the distance between the measurement point at the probe sensor location (geometric center behind the probe tip) and the phantom surface is 3mm and maintained at a constant distance of ± 0.5 mm during a zoom scan to determine peak SAR locations. The distance is 2mm between the first measurement point and the bottom surface of the phantom. The secondary measurement point to the bottom surface of the phantom is with 7mm separation distance. The cube size is 7 x 7 x 7 points consists of 343 points and the grid space is 5mm.



The measurement time is 0.5s at each point of the zoom scan. The probe boundary effect compensation shall be applied during the SAR test. Because of the tip of the probe to the Phantom surface separated distances are longer than half a tip probe diameter.

In the area scan, the separation distance is 2mm between the each measurement point and the phantom surface. The scan size shall be included the transmission portion of the EUT. The measurement time is the same as the zoom scan. At last the reference power drift shall be less than $\pm 5\%$.

6.2 DESCRIPTION OF TEST CONDITION

TEST DATE	TISSUE TYPE / FREQ.	TEMPERATURE (°C)		HUMIDITY (%RH)	TESTED BY
		AIRBENT	LIQUID		
Jan. 24, 2011	MSL 750	22.3	21.2	52	Sam Onn
Mar. 02, 2011	MSL 750	22.7	21.6	58	Sam Onn
Jan. 12, 2011	MSL 835	22.7	21.6	52	Sam Onn
Jan. 12, 2011	MSL 1700	22.1	21.3	54	Sam Onn
Mar. 01, 2011	MSL 1700	22.4	21.2	56	Sam Onn
Jan. 13, 2011	MSL 1900	22.5	21.6	54	Sam Onn

6.3 MEASURED SAR RESULT

GPRS 850

Channel	Frequency (MHz)	Time slot	Horizontal-Down	Horizontal-Up	Vertical-Back	Vertical-Front	Tip
190	836.6	1	0.505	0.435	0.275	0.255	0.02
		2	0.624	0.519	0.346	0.327	0.025
		3	0.586	0.493	0.326	0.315	0.024
		4	0.676	0.534	0.352	0.344	0.026

EGPRS 850

Channel	Frequency (MHz)	Time slot	Horizontal-Down	Horizontal-Up	Vertical-Back	Vertical-Front	Tip
190	836.6	1	0.143	0.113	0.083	0.093	0.00753
		2	0.249	0.198	0.148	0.165	0.012
		3	0.321	0.257	0.194	0.216	0.015
		4	0.435	0.301	0.23	0.259	0.018

Note: GMSK was tested for EGPRS.

GPRS 1900

Channel	Frequency (MHz)	Time slot	Horizontal-Down	Horizontal-Up	Vertical-Back	Vertical-Front	Tip
661	1880	1	0.514	0.266	0.222	0.183	0.045
		2	0.610	0.526	0.233	0.213	0.049
		3	0.543	0.392	0.233	0.210	0.052
		4	0.365	0.365	0.173	0.161	0.038

EGPRS 1900

Channel	Frequency (MHz)	Time slot	Horizontal-Down	Horizontal-Up	Vertical-Back	Vertical-Front	Tip
661	1880	1	0.181	0.168	0.087	0.075	0.019
		2	0.317	0.299	0.134	0.122	0.033
		3	0.394	0.359	0.168	0.155	0.036
		4	0.426	0.390	0.173	0.160	0.035

Note: GMSK was tested for EGPRS.

WCDMA 850 / 1900 / AWS

Mode	Channel	Frequency (MHz)	Horizontal-Down	Horizontal-Up	Vertical-Back	Vertical-Front	Tip
WCDMA 850	4182	836.4	0.500	0.380	0.280	0.279	0.033
WCDMA 1900	9400	1800	0.694	0.586	0.489	0.528	0.051
WCDMA AWS	1412	1732.4	0.362	0.423	0.204	0.396	0.071



A D T

LTE Band 17 (704~716MHz) / Bandwidth: 10MHz / Modulation: QPSK

Channel	Freq (MHz)	C.P (dBm)	Target power (dBm)	MPR target (dB)	RB Size	RB Offset	SAR value of each test position (W/ Kg)				
							H-D	H-U	V-B	V-F	Tip
23790	710	21.9	22.5	0.5	25	13	0.334	0.215	0.108	0.169	0.023
		22.57	22.5	0	1	0	0.202	0.125	0.074	0.12	0.018
		22.25	22.5	0	1	49	0.218	0.137	0.075	0.113	0.017

LTE Band 17 (704~716MHz) / Bandwidth: 10MHz / Modulation: 16QAM

Channel	Freq (MHz)	C.P (dBm)	Target power (dBm)	MPR target (dB)	RB Size	RB Offset	SAR value of each test position (W/ Kg)				
							H-D	H-U	V-B	V-F	Tip
23790	710	21.37	22.5	1	25	13	0.267	0.213	0.118	0.135	0.018
		21.79	22.5	0.5	1	0	0.254	0.195	0.102	0.117	0.011
		21.46	22.5	0.5	1	49	0.221	0.163	0.096	0.104	0.013

NOTE:

1. Please see the Appendix A for the data.
2. The variation of the EUT conducted power measured before and after SAR testing should not over 5%.
3. Distance between EUT and phantom is 5mm for test of body position.
4. Per DA-02-1438A1, when 1-g SAR for the middle channel is less than 0.8 W/kg, testing for the other channels is not required
5. C.P: Conducted power
 H-D: Horizontal Down
 H-U: horizontal Up
 V-B: Vertical Back
 V-F: Vertical Front



LTE Band 4 (1710~1755MHz) / Bandwidth: 10MHz / Modulation: QPSK

Channel	Freq (MHz)	C.P (dBm)	Target power (dBm)	MPR target (dB)	RB Size	RB Offset	SAR value of each test position (W/ Kg)				
							H-D	H-U	V-B	V-F	Tip
20175	1732.5	21.88	22.5	0.5	25	13	0.336	0.653	0.392	0.446	0.129
		22.79	22.5	0	1	0	0.340	0.638	0.358	0.449	0.127
		23.22	22.5	0	1	49	0.376	0.702	0.379	0.531	0.142

LTE Band 4 (1710~1755MHz) / Bandwidth: 10MHz / Modulation: 16QAM

Channel	Freq (MHz)	C.P (dBm)	Target power (dBm)	MPR target (dB)	RB Size	RB Offset	SAR value of each test position (W/ Kg)				
							H-D	H-U	V-B	V-F	Tip
20175	1732.5	21.32	22.5	1	25	13	0.306	0.498	0.198	0.397	0.112
		22.1	22.5	0.5	1	0	0.342	0.546	0.26	0.469	0.128
		22.74	22.5	0.5	1	49	0.369	0.639	0.272	0.517	0.130

NOTE:

1. Please see the Appendix A for the data.
2. The variation of the EUT conducted power measured before and after SAR testing should not over 5%.
3. Distance between EUT and phantom is 5mm for test of body position.
4. Per DA-02-1438A1, when 1-g SAR for the middle channel is less than 0.8 W/kg, testing for the other channels is not required
5. C.P: Conducted power
 H-D: Horizontal Down
 H-U: horizontal Up
 V-B: Vertical Back
 V-F: Vertical Front

6.4 POWER DRIFT TABLE

850MHz Band

Test Mode	Test Position	Communication Mode	Test Channel	Test Frequency	Power (dBm)		Power Drift (%)
					Begin	After	
1	Horizontal-Down	GPRS850 TS1	190	836.6MHz	32.23	32.17	-1.37
2		GPRS850 TS2	190	836.6MHz	31.08	31.01	-1.60
3		GPRS850 TS3	190	836.6MHz	29.32	29.23	-2.05
4		GPRS850 TS4	190	836.6MHz	27.70	27.59	-2.50
5	Vertical-Front	GPRS850 TS1	190	836.6MHz	32.23	32.10	-2.95
6		GPRS850 TS2	190	836.6MHz	31.08	31.05	-0.69
7		GPRS850 TS3	190	836.6MHz	29.32	29.28	-0.92
8		GPRS850 TS4	190	836.6MHz	27.70	27.65	-1.14
9	Horizontal-Up	GPRS850 TS1	190	836.6MHz	32.23	32.17	-1.37
10		GPRS850 TS2	190	836.6MHz	31.08	31.01	-1.60
11		GPRS850 TS3	190	836.6MHz	29.32	29.24	-1.83
12		GPRS850 TS4	190	836.6MHz	27.70	27.60	-2.28
13	Vertical-Back	GPRS850 TS1	190	836.6MHz	32.23	32.11	-2.73
14		GPRS850 TS2	190	836.6MHz	31.08	30.95	-2.95
15		GPRS850 TS3	190	836.6MHz	29.32	29.18	-3.17
16		GPRS850 TS4	190	836.6MHz	27.70	27.55	-3.39
17	Tip	GPRS850 TS1	190	836.6MHz	32.23	32.07	-3.62
18		GPRS850 TS2	190	836.6MHz	31.08	30.91	-3.84
19		GPRS850 TS3	190	836.6MHz	29.32	29.14	-4.06
20		GPRS850 TS4	190	836.6MHz	27.70	27.50	-4.50
21	Horizontal-Down	E-GPRS850 TS1	190	836.6MHz	26.85	26.83	-0.46
22		E-GPRS850 TS2	190	836.6MHz	25.23	25.20	-0.69
23		E-GPRS850 TS3	190	836.6MHz	23.95	23.91	-0.92
24		E-GPRS850 TS4	190	836.6MHz	21.90	21.85	-1.14
25	Vertical-Front	E-GPRS850 TS1	190	836.6MHz	26.85	26.79	-1.37
26		E-GPRS850 TS2	190	836.6MHz	25.23	25.16	-1.60
27		E-GPRS850 TS3	190	836.6MHz	23.95	23.87	-1.83
28		E-GPRS850 TS4	190	836.6MHz	21.90	21.80	-2.28
29	Horizontal-Up	E-GPRS850 TS1	190	836.6MHz	26.85	26.74	-2.50
30		E-GPRS850 TS2	190	836.6MHz	25.23	25.11	-2.73
31		E-GPRS850 TS3	190	836.6MHz	23.95	23.81	-3.17
32		E-GPRS850 TS4	190	836.6MHz	21.90	21.74	-3.62
33	Vertical-Back	E-GPRS850 TS1	190	836.6MHz	26.85	26.68	-3.84
34		E-GPRS850 TS2	190	836.6MHz	25.23	25.05	-4.06
35		E-GPRS850 TS3	190	836.6MHz	23.95	23.76	-4.28
36		E-GPRS850 TS4	190	836.6MHz	21.90	21.70	-4.50
37	Tip	E-GPRS850 TS1	190	836.6MHz	26.85	26.82	-0.69
38		E-GPRS850 TS2	190	836.6MHz	25.23	25.19	-0.92
39		E-GPRS850 TS3	190	836.6MHz	23.95	23.90	-1.14
40		E-GPRS850 TS4	190	836.6MHz	21.90	21.84	-1.37
41	Horizontal-Down	WCDMA 850	4182	836.4MHz	23.37	23.29	-1.83
42	Vertical-Front	WCDMA 850	4182	836.4MHz	23.37	23.28	-2.05
43	Horizontal-Up	WCDMA 850	4182	836.4MHz	23.37	23.25	-2.73
44	Vertical-Back	WCDMA 850	4182	836.4MHz	23.37	23.23	-3.17



A D T

45	Tip	WCDMA 850	4182	836.4MHz	23.37	23.21	-3.62
----	-----	-----------	------	----------	-------	-------	-------

1900 MHz Band

Test Mode	Test Position	Communication Mode	Test Channel	Test Frequency	Power (dBm)		Power Drift (%)
					Begin	After	
46	Horizontal-Down	GPRS1900 TS1	661	1800MHz	30.48	30.46	-0.46
47		GPRS1900 TS2	661	1800MHz	29.22	29.19	-0.69
48		GPRS1900 TS3	661	1800MHz	27.31	27.26	-1.14
49		GPRS1900 TS4	661	1800MHz	25.21	25.15	-1.37
50	Vertical-Front	GPRS1900 TS1	661	1800MHz	30.48	30.40	-1.83
51		GPRS1900 TS2	661	1800MHz	29.22	29.12	-2.28
52		GPRS1900 TS3	661	1800MHz	27.31	27.20	-2.50
53		GPRS1900 TS4	661	1800MHz	25.21	25.09	-2.73
54	Horizontal-Up	GPRS1900 TS1	661	1800MHz	30.48	30.35	-2.95
55		GPRS1900 TS2	661	1800MHz	29.22	29.08	-3.17
56		GPRS1900 TS3	661	1800MHz	27.31	27.16	-3.39
57		GPRS1900 TS4	661	1800MHz	25.21	25.05	-3.62
58	Vertical-Back	GPRS1900 TS1	661	1800MHz	30.48	30.31	-3.84
59		GPRS1900 TS2	661	1800MHz	29.22	29.04	-4.06
60		GPRS1900 TS3	661	1800MHz	27.31	27.12	-4.28
61		GPRS1900 TS4	661	1800MHz	25.21	25.01	-4.50
62	Tip	GPRS1900 TS1	661	1800MHz	30.48	30.45	-0.69
63		GPRS1900 TS2	661	1800MHz	29.22	29.18	-0.92
64		GPRS1900 TS3	661	1800MHz	27.31	27.25	-1.37
65		GPRS1900 TS4	661	1800MHz	25.21	25.14	-1.60
66	Horizontal-Down	E-GPRS1900 TS1	661	1800MHz	25.23	25.15	-1.83
67		E-GPRS1900 TS2	661	1800MHz	23.47	23.38	-2.05
68		E-GPRS1900 TS3	661	1800MHz	22.24	22.14	-2.28
69		E-GPRS1900 TS4	661	1800MHz	20.35	20.24	-2.50
70	Vertical-Front	E-GPRS1900 TS1	661	1800MHz	25.23	25.10	-2.95
71		E-GPRS1900 TS2	661	1800MHz	23.47	23.32	-3.39
72		E-GPRS1900 TS3	661	1800MHz	22.24	22.08	-3.62
73		E-GPRS1900 TS4	661	1800MHz	20.35	20.18	-3.84
74	Horizontal-Up	E-GPRS1900 TS1	661	1800MHz	25.23	25.21	-0.46
75		E-GPRS1900 TS2	661	1800MHz	23.47	23.44	-0.69
76		E-GPRS1900 TS3	661	1800MHz	22.24	22.20	-0.92
77		E-GPRS1900 TS4	661	1800MHz	20.35	20.30	-1.14
78	Vertical-Back	E-GPRS1900 TS1	661	1800MHz	25.23	25.17	-1.37
79		E-GPRS1900 TS2	661	1800MHz	23.47	23.40	-1.60
80		E-GPRS1900 TS3	661	1800MHz	22.24	22.16	-1.83
81		E-GPRS1900 TS4	661	1800MHz	20.35	20.26	-2.05
82	Tip	E-GPRS1900 TS1	661	1800MHz	25.23	25.13	-2.28
83		E-GPRS1900 TS2	661	1800MHz	23.47	23.35	-2.73
84		E-GPRS1900 TS3	661	1800MHz	22.24	22.11	-2.95
85		E-GPRS1900 TS4	661	1800MHz	20.35	20.21	-3.17
86	Horizontal-Down	WCDMA1900	9400	1800MHz	22.89	22.74	-3.39
87	Vertical-Front	WCDMA1900	9400	1800MHz	22.89	22.73	-3.62
88	Horizontal-Up	WCDMA1900	9400	1800MHz	22.89	22.72	-3.84
89	Vertical-Back	WCDMA1900	9400	1800MHz	22.89	22.71	-4.06
90	Tip	WCDMA1900	9400	1800MHz	22.89	22.69	-4.50



A D T



LTE Band 4 and Band 17 / QPSK modulation

Test Mode	Test Position	RB Size	RB offset	Test Channel	Test Frequency	Power (dBm)		Power Drift (%)
						Begin	After	
1	Horizontal-Down	25	13	23790	710MHz	21.90	21.84	-1.37
2		1	0	23790	710MHz	22.57	22.50	-1.60
3		1	49	23790	710MHz	22.25	22.17	-1.83
4	Vertical-Front	25	13	23790	710MHz	21.90	21.81	-2.05
5		1	0	23790	710MHz	22.57	22.47	-2.28
6		1	49	23790	710MHz	22.25	22.14	-2.50
7	Horizontal-Up	25	13	23790	710MHz	21.90	21.78	-2.73
8		1	0	23790	710MHz	22.57	22.44	-2.95
9		1	49	23790	710MHz	22.25	22.11	-3.17
10	Vertical-Back	25	13	23790	710MHz	21.90	21.75	-3.39
11		1	0	23790	710MHz	22.57	22.41	-3.62
12		1	49	23790	710MHz	22.25	22.08	-3.84
13	Tip	25	13	23790	710MHz	21.90	21.72	-4.06
14		1	0	23790	710MHz	22.57	22.38	-4.28
15		1	49	23790	710MHz	22.25	22.05	-4.50
16	Horizontal-Down	25	13	20175	1732.5MHz	21.88	21.85	-0.69
17		1	0	20175	1732.5MHz	22.79	22.75	-0.92
18		1	49	20175	1732.5MHz	23.22	23.17	-1.14
19	Vertical-Front	25	13	20175	1732.5MHz	21.88	21.82	-1.37
20		1	0	20175	1732.5MHz	22.79	22.72	-1.60
21		1	49	20175	1732.5MHz	23.22	23.14	-1.83
22	Horizontal-Up	25	13	20175	1732.5MHz	21.88	21.79	-2.05
23		1	0	20175	1732.5MHz	22.79	22.69	-2.28
24		1	49	20175	1732.5MHz	23.22	23.11	-2.50
25	Vertical-Back	25	13	20175	1732.5MHz	21.88	21.76	-2.73
26		1	0	20175	1732.5MHz	22.79	22.66	-2.95
27		1	49	20175	1732.5MHz	23.22	23.08	-3.17
28	Tip	25	13	20175	1732.5MHz	21.88	21.73	-3.39
29		1	0	20175	1732.5MHz	22.79	22.63	-3.62
30		1	49	20175	1732.5MHz	23.22	23.05	-3.84

WCDMA AWS Band

Test Mode	Test Position	Communication Mode	Test Channel	Test Frequency	Power (dBm)		Power Drift (%)
					Begin	After	
31	Horizontal-Down	WCDMA AWS	1412	1732.4MHz	23.47	23.35	-2.73
32	Vertical-Front	WCDMA AWS	1412	1732.4MHz	23.47	23.34	-2.95
33	Horizontal-Up	WCDMA AWS	1412	1732.4MHz	23.47	23.33	-3.17
34	Vertical-Back	WCDMA AWS	1412	1732.4MHz	23.47	23.32	-3.39
35	Tip	WCDMA AWS	1412	1732.4MHz	23.47	23.31	-3.62



A D T

LTE Band 4 and Band 17 / 16QAM modulation

Test Mode	Test Position	RB Size	RB offset	Test Channel	Test Frequency	Power (dBm)		Power Drift (%)
						Begin	After	
36	Horizontal-Down	25	13	23790	710MHz	21.37	21.31	-1.37
37		1	0	23790	710MHz	21.79	21.72	-1.60
38		1	49	23790	710MHz	21.46	21.38	-1.83
39	Vertical-Front	25	13	23790	710MHz	21.37	21.28	-2.05
40		1	0	23790	710MHz	21.79	21.69	-2.28
41		1	49	23790	710MHz	21.46	21.35	-2.50
42	Horizontal-Up	25	13	23790	710MHz	21.37	21.25	-2.73
43		1	0	23790	710MHz	21.79	21.66	-2.95
44		1	49	23790	710MHz	21.46	21.32	-3.17
45	Vertical-Back	25	13	23790	710MHz	21.37	21.22	-3.39
46		1	0	23790	710MHz	21.79	21.63	-3.62
47		1	49	23790	710MHz	21.46	21.29	-3.84
48	Tip	25	13	23790	710MHz	21.37	21.19	-4.06
49		1	0	23790	710MHz	21.79	21.60	-4.28
50		1	49	23790	710MHz	21.46	21.26	-4.50
51	Horizontal-Down	25	13	20175	1732.5MHz	21.32	21.29	-0.69
52		1	0	20175	1732.5MHz	22.10	22.06	-0.92
53		1	49	20175	1732.5MHz	22.74	22.69	-1.14
54	Vertical-Front	25	13	20175	1732.5MHz	21.32	21.26	-1.37
55		1	0	20175	1732.5MHz	22.10	22.03	-1.60
56		1	49	20175	1732.5MHz	22.74	22.66	-1.83
57	Horizontal-Up	25	13	20175	1732.5MHz	21.32	21.23	-2.05
58		1	0	20175	1732.5MHz	22.10	22.00	-2.28
59		1	49	20175	1732.5MHz	22.74	22.63	-2.50
60	Vertical-Back	25	13	20175	1732.5MHz	21.32	21.20	-2.73
61		1	0	20175	1732.5MHz	22.10	21.97	-2.95
62		1	49	20175	1732.5MHz	22.74	22.60	-3.17
63	Tip	25	13	20175	1732.5MHz	21.32	21.17	-3.39
64		1	0	20175	1732.5MHz	22.10	21.94	-3.62
65		1	49	20175	1732.5MHz	22.74	22.57	-3.84



6.5 SAR LIMITS

HUMAN EXPOSURE	SAR (W/kg)	
	(GENERAL POPULATION / UNCONTROLLED EXPOSURE ENVIRONMENT)	(OCCUPATIONAL / CONTROLLED EXPOSURE ENVIRONMENT)
Spatial Peak (averaged over 1 g)	1.6	8.0

NOTE: This limits accord to 47 CFR 2.1093 – Safety Limit.



7. INFORMATION ON THE TESTING LABORATORIES

We, Bureau Veritas Consumer Products Services (H.K.) Ltd., Taoyuan Branch, were founded in 1988 to provide our best service in EMC, Radio, Telecom and Safety consultation. Our laboratories are accredited and approved according to ISO/IEC 17025.

Copies of accreditation certificates of our laboratories obtained from approval agencies can be downloaded from our web site: www.adt.com.tw/index.5.phtml. If you have any comments, please feel free to contact us at the following:

Linko EMC/RF Lab:

Tel: 886-2-26052180

Fax: 886-2-26051924

Hsin Chu EMC/RF Lab:

Tel: 886-3-5935343

Fax: 886-3-5935342

Hwa Ya EMC/RF/Safety/Telecom Lab:

Tel: 886-3-3183232

Fax: 886-3-3185050

Web Site: www.adt.com.tw

The address and road map of all our labs can be found in our web site also.

---END---



香港商立德國際商品試驗有限公司桃園分公司

Bureau Veritas Consumer Products Services (H.K.) Ltd., Taoyuan Branch

APPENDIX A: TEST DATA

Product Name: LTE USB Modem ; Model Name: C505

Liquid Level Photo

Tissue 835MHz D=150mm



Tissue 1900MHz D=150mm



M01-GPRS850 TS1-Ch190

Communication System: GPRS850 ; Frequency: 836.6 MHz ; Duty Cycle: 1:8.3 ; Modulation Type: GMSK / UL 1 time slot

Medium: MSL835 Medium parameters used: $f = 836.6$ MHz; $\sigma = 0.98$ mho/m; $\epsilon_r = 55.84$; $\rho = 1000$ kg/m³

Phantom section: Flat Section ; Separation distance : 5 mm (The Horizontal-Down side of the EUT to the Phantom)

DASY4 Configuration:

- Probe: EX3DV4 - SN3578; ConvF(8.55, 8.55, 8.55); Calibrated: 2010/6/22
- Sensor-Surface: 2mm (Mechanical Surface Detection)
- Electronics: DAE3 Sn579; Calibrated: 2010/9/20
- Phantom: SAM 12; Type: SAM V4.0; Serial: TP 1202
- Measurement SW: DASY4, V4.7 Build 80; Postprocessing SW: SEMCAD, V1.8 Build 186

Body Position - Mid/Area Scan (7x15x1): Measurement grid: dx=8mm, dy=8mm

Maximum value of SAR (measured) = 0.653 mW/g

Body Position - Mid/Zoom Scan (7x7x7)/Cube 0: Measurement grid: dx=5mm, dy=5mm, dz=5mm

Reference Value = 9.66 V/m; Power Drift = -0.133 dB

Peak SAR (extrapolated) = 0.757 W/kg

SAR(1 g) = 0.505 mW/g; SAR(10 g) = 0.325 mW/g

Maximum value of SAR (measured) = 0.638 mW/g

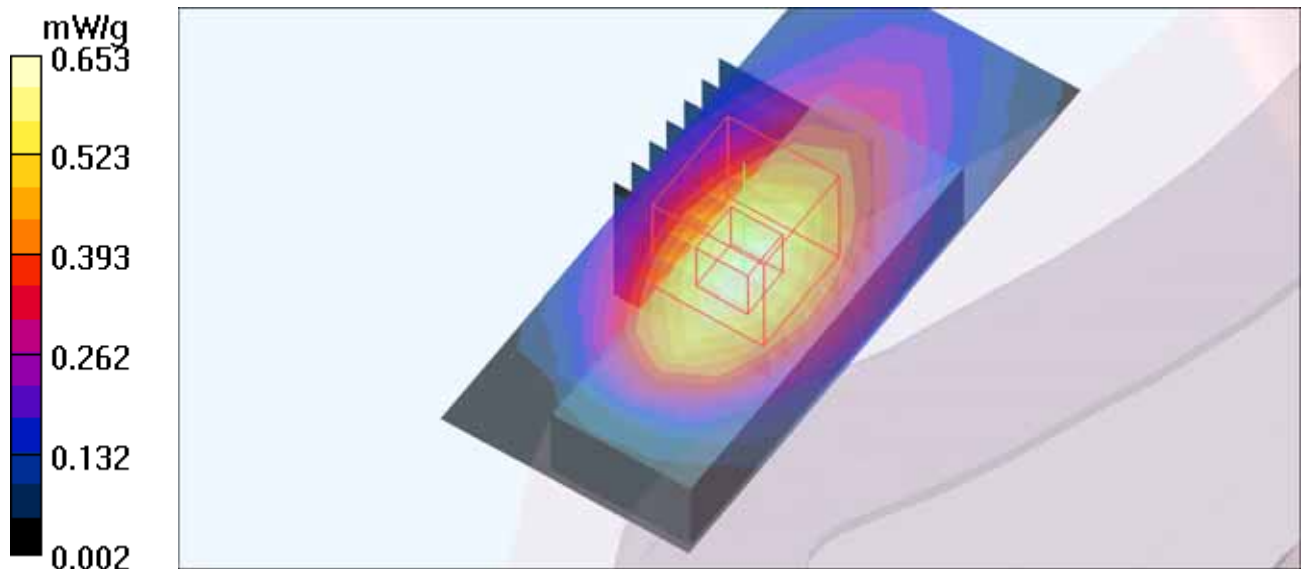

M02-GPRS850 TS2-Ch190

Communication System: GPRS850 ; Frequency: 836.6 MHz ; Duty Cycle: 1:4 ; Modulation Type: GMSK / UL 2 time slots

Medium: MSL835 Medium parameters used: $f = 836.6$ MHz; $\sigma = 0.98$ mho/m; $\epsilon_r = 55.84$; $\rho = 1000$ kg/m³

Phantom section: Flat Section ; Separation distance : 5 mm (The Horizontal-Down side of the EUT to the Phantom)

DASY4 Configuration:

- Probe: EX3DV4 - SN3578; ConvF(8.55, 8.55, 8.55); Calibrated: 2010/6/22
- Sensor-Surface: 2mm (Mechanical Surface Detection)
- Electronics: DAE3 Sn579; Calibrated: 2010/9/20
- Phantom: SAM 12; Type: SAM V4.0; Serial: TP 1202
- Measurement SW: DASY4, V4.7 Build 80; Postprocessing SW: SEMCAD, V1.8 Build 186

Body Position - Mid/Area Scan (7x15x1): Measurement grid: dx=8mm, dy=8mm

Maximum value of SAR (measured) = 0.819 mW/g

Body Position - Mid/Zoom Scan (7x7x7)/Cube 0: Measurement grid: dx=5mm, dy=5mm, dz=5mm

Reference Value = 11.0 V/m; Power Drift = -0.172 dB

Peak SAR (extrapolated) = 0.944 W/kg

SAR(1 g) = 0.624 mW/g; SAR(10 g) = 0.399 mW/g

Maximum value of SAR (measured) = 0.801 mW/g

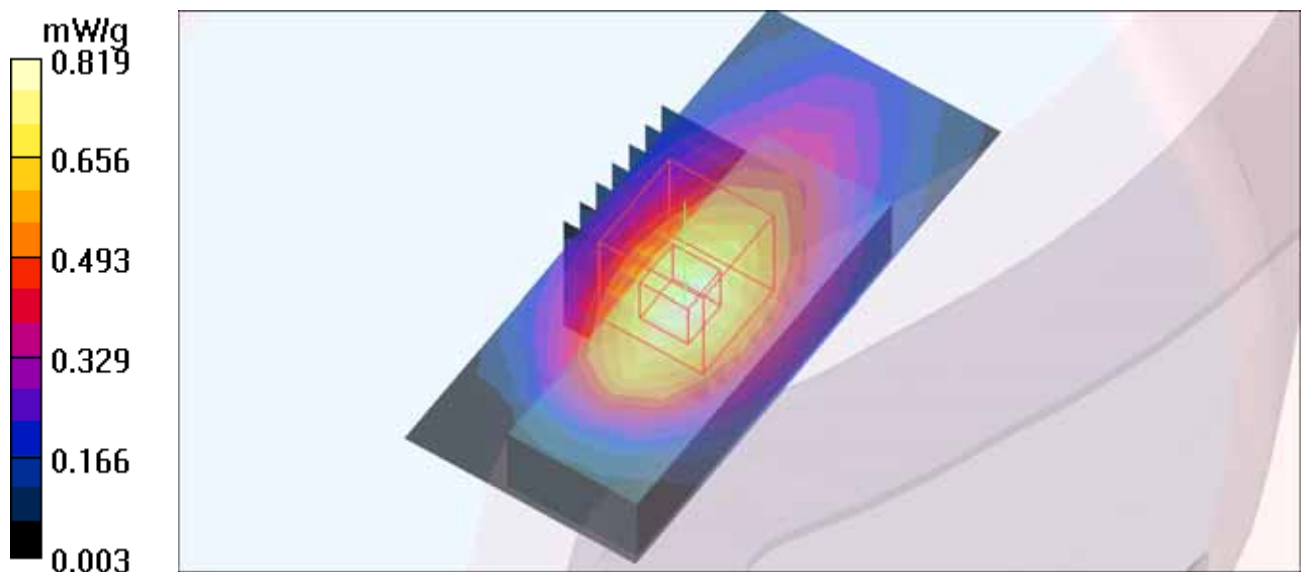

M03-GPRS850 TS3-Ch190-Ch190

Communication System: GPRS850 ; Frequency: 836.6 MHz ; Duty Cycle: 1:2.67 ; Modulation Type: GMSK / UL 3 time slots

Medium: MSL835 Medium parameters used: $f = 836.6 \text{ MHz}$; $\sigma = 0.98 \text{ mho/m}$; $\epsilon_r = 55.84$; $\rho = 1000 \text{ kg/m}^3$

Phantom section: Flat Section ; Separation distance : 5 mm (The Horizontal-Down side of the EUT to the Phantom)

DASY4 Configuration:

- Probe: EX3DV4 - SN3578; ConvF(8.55, 8.55, 8.55); Calibrated: 2010/6/22
- Sensor-Surface: 2mm (Mechanical Surface Detection)
- Electronics: DAE3 Sn579; Calibrated: 2010/9/20
- Phantom: SAM 12; Type: SAM V4.0; Serial: TP 1202
- Measurement SW: DASY4, V4.7 Build 80; Postprocessing SW: SEMCAD, V1.8 Build 186

Body Position - Mid/Area Scan (7x15x1): Measurement grid: $dx=8\text{mm}$, $dy=8\text{mm}$

Maximum value of SAR (measured) = 0.766 mW/g

Body Position - Mid/Zoom Scan (7x7x7)/Cube 0: Measurement grid: $dx=5\text{mm}$, $dy=5\text{mm}$, $dz=5\text{mm}$

Reference Value = 10.6 V/m; Power Drift = -0.195 dB

Peak SAR (extrapolated) = 0.879 W/kg

SAR(1 g) = 0.586 mW/g; SAR(10 g) = 0.375 mW/g

Maximum value of SAR (measured) = 0.745 mW/g

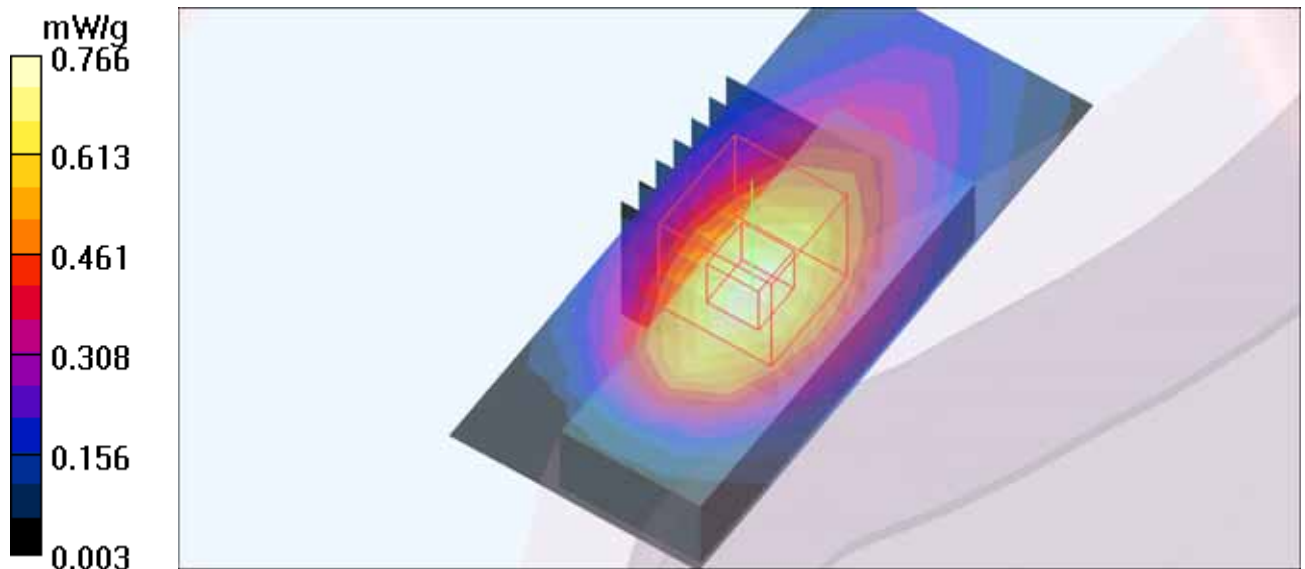

M04-GPRS850 TS4-Ch190

Communication System: GPRS850 ; Frequency: 836.6 MHz ; Duty Cycle: 1:2 ; Modulation Type: GMSK / UL 4 time slots

Medium: MSL835 Medium parameters used: $f = 836.6$ MHz; $\sigma = 0.98$ mho/m; $\epsilon_r = 55.84$; $\rho = 1000$ kg/m³

Phantom section: Flat Section ; Separation distance : 5 mm (The Horizontal-Down side of the EUT to the Phantom)

DASY4 Configuration:

- Probe: EX3DV4 - SN3578; ConvF(8.55, 8.55, 8.55); Calibrated: 2010/6/22
- Sensor-Surface: 2mm (Mechanical Surface Detection)
- Electronics: DAE3 Sn579; Calibrated: 2010/9/20
- Phantom: SAM 12; Type: SAM V4.0; Serial: TP 1202
- Measurement SW: DASY4, V4.7 Build 80; Postprocessing SW: SEMCAD, V1.8 Build 186

Body Position - Mid/Area Scan (7x15x1): Measurement grid: dx=8mm, dy=8mm

Maximum value of SAR (measured) = 0.886 mW/g

Body Position - Mid/Zoom Scan (7x7x7)/Cube 0: Measurement grid: dx=5mm, dy=5mm, dz=5mm

Reference Value = 11.1 V/m; Power Drift = -0.118 dB

Peak SAR (extrapolated) = 1.03 W/kg

SAR(1 g) = 0.676 mW/g; SAR(10 g) = 0.432 mW/g

Maximum value of SAR (measured) = 0.869 mW/g

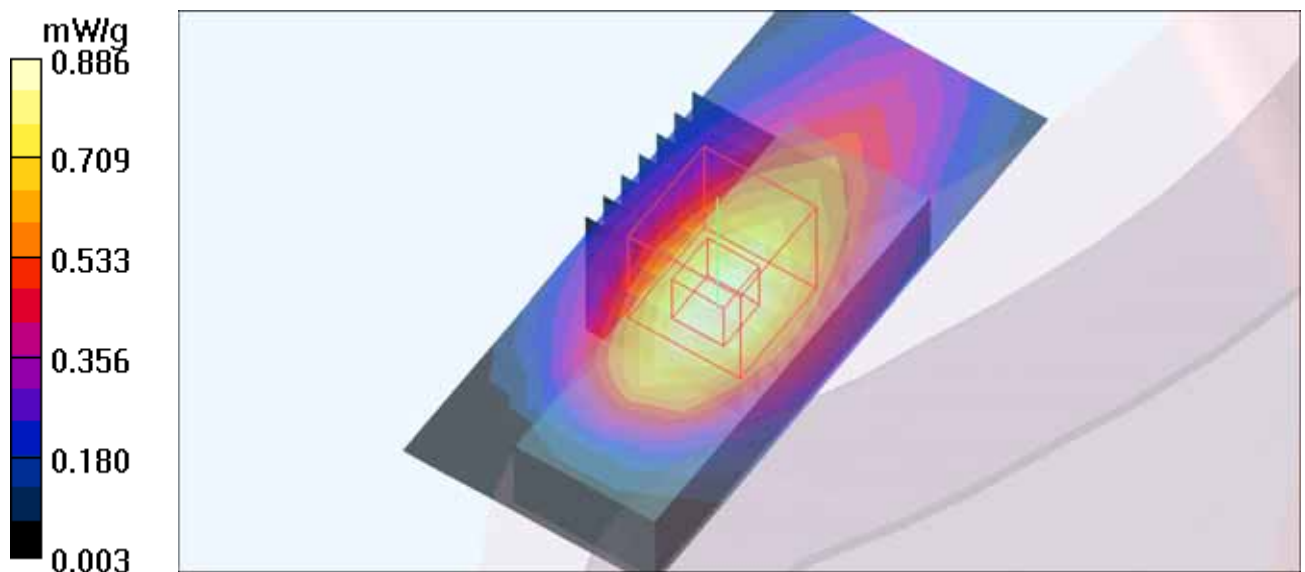

M05-GPRS850 TS1-Ch190

Communication System: GPRS850 ; Frequency: 836.6 MHz ; Duty Cycle: 1:8.3 ; Modulation Type: GMSK / UL 1 time slot

Medium: MSL835 Medium parameters used: $f = 836.6$ MHz; $\sigma = 0.98$ mho/m; $\epsilon_r = 55.84$; $\rho = 1000$ kg/m³

Phantom section: Flat Section ; Separation distance : 5 mm (The Vertical-Front side of the EUT to the Phantom)

DASY4 Configuration:

- Probe: EX3DV4 - SN3578; ConvF(8.55, 8.55, 8.55); Calibrated: 2010/6/22
- Sensor-Surface: 2mm (Mechanical Surface Detection)
- Electronics: DAE3 Sn579; Calibrated: 2010/9/20
- Phantom: SAM 12; Type: SAM V4.0; Serial: TP 1202
- Measurement SW: DASY4, V4.7 Build 80; Postprocessing SW: SEMCAD, V1.8 Build 186

Body Position - Mid/Area Scan (7x15x1): Measurement grid: dx=8mm, dy=8mm

Maximum value of SAR (measured) = 0.315 mW/g

Body Position - Mid/Zoom Scan (7x7x7)/Cube 0: Measurement grid: dx=5mm, dy=5mm, dz=5mm

Reference Value = 8.68 V/m; Power Drift = 0.106 dB

Peak SAR (extrapolated) = 0.417 W/kg

SAR(1 g) = 0.255 mW/g; SAR(10 g) = 0.156 mW/g

Maximum value of SAR (measured) = 0.338 mW/g

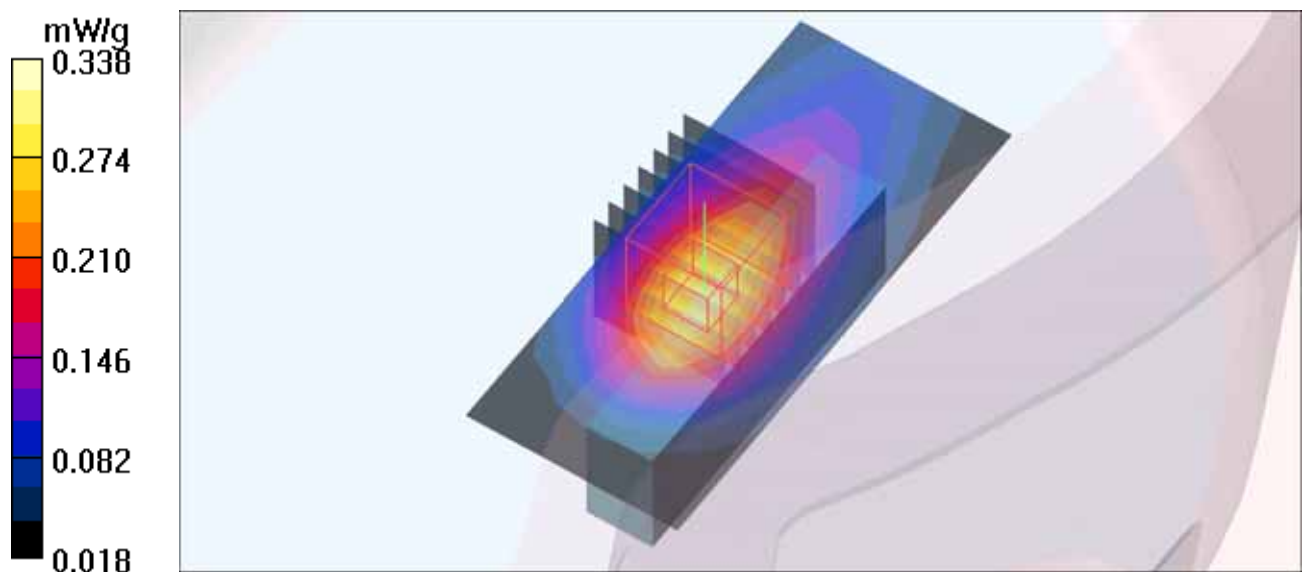

M06-GPRS850 TS2-Ch190

Communication System: GPRS850 ; Frequency: 836.6 MHz ; Duty Cycle: 1:4 ; Modulation Type: GMSK / UL 2 time slots

Medium: MSL835 Medium parameters used: $f = 836.6$ MHz; $\sigma = 0.98$ mho/m; $\epsilon_r = 55.84$; $\rho = 1000$ kg/m³

Phantom section: Flat Section ; Separation distance : 5 mm (The Vertical-Front side of the EUT to the Phantom)

DASY4 Configuration:

- Probe: EX3DV4 - SN3578; ConvF(8.55, 8.55, 8.55); Calibrated: 2010/6/22
- Sensor-Surface: 2mm (Mechanical Surface Detection)
- Electronics: DAE3 Sn579; Calibrated: 2010/9/20
- Phantom: SAM 12; Type: SAM V4.0; Serial: TP 1202
- Measurement SW: DASY4, V4.7 Build 80; Postprocessing SW: SEMCAD, V1.8 Build 186

Body Position - Mid/Area Scan (7x15x1): Measurement grid: dx=8mm, dy=8mm

Maximum value of SAR (measured) = 0.433 mW/g

Body Position - Mid/Zoom Scan (7x7x7)/Cube 0: Measurement grid: dx=5mm, dy=5mm, dz=5mm

Reference Value = 10.7 V/m; Power Drift = -0.160 dB

Peak SAR (extrapolated) = 0.532 W/kg

SAR(1 g) = 0.327 mW/g; SAR(10 g) = 0.201 mW/g

Maximum value of SAR (measured) = 0.434 mW/g

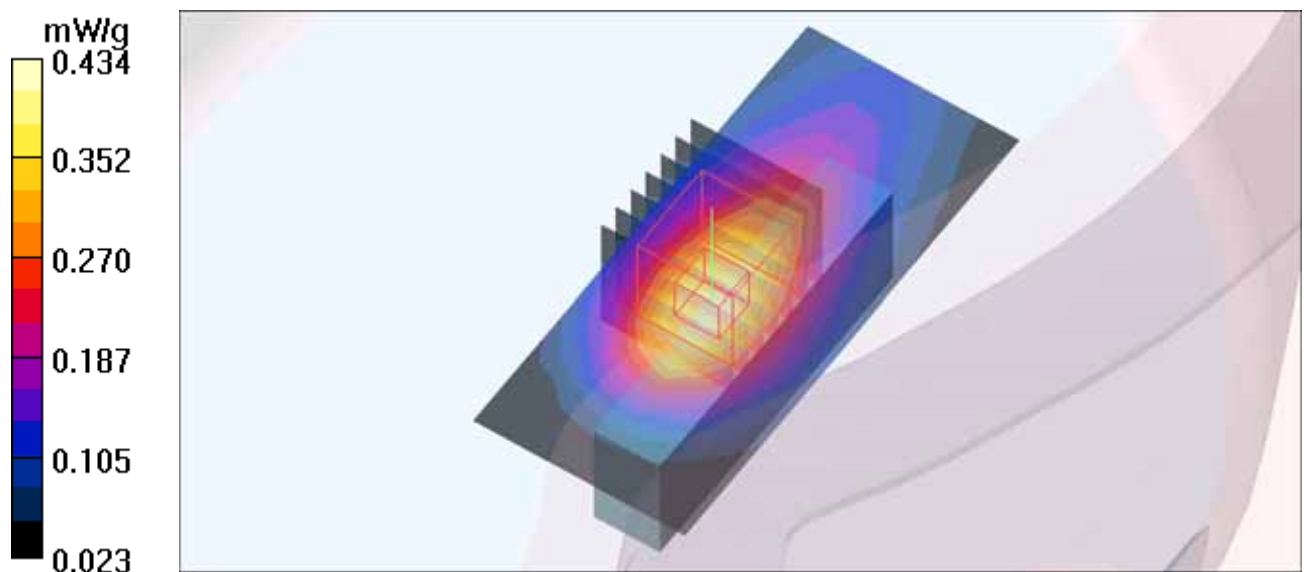

M07-GPRS850 TS3-Ch190

Communication System: GPRS850 ; Frequency: 836.6 MHz ; Duty Cycle: 1:2.67 ; Modulation Type: GMSK / UL 3 time slots

Medium: MSL835 Medium parameters used: $f = 836.6$ MHz; $\sigma = 0.98$ mho/m; $\epsilon_r = 55.84$; $\rho = 1000$ kg/m³

Phantom section: Flat Section ; Separation distance : 5 mm (The Vertical-Front side of the EUT to the Phantom)

DASY4 Configuration:

- Probe: EX3DV4 - SN3578; ConvF(8.55, 8.55, 8.55); Calibrated: 2010/6/22
- Sensor-Surface: 2mm (Mechanical Surface Detection)
- Electronics: DAE3 Sn579; Calibrated: 2010/9/20
- Phantom: SAM 12; Type: SAM V4.0; Serial: TP 1202
- Measurement SW: DASY4, V4.7 Build 80; Postprocessing SW: SEMCAD, V1.8 Build 186

Body Position - Mid/Area Scan (7x15x1): Measurement grid: dx=8mm, dy=8mm

Maximum value of SAR (measured) = 0.419 mW/g

Body Position - Mid/Zoom Scan (7x7x7)/Cube 0: Measurement grid: dx=5mm, dy=5mm, dz=5mm

Reference Value = 10.4 V/m; Power Drift = -0.109 dB

Peak SAR (extrapolated) = 0.507 W/kg

SAR(1 g) = 0.315 mW/g; SAR(10 g) = 0.193 mW/g

Maximum value of SAR (measured) = 0.414 mW/g

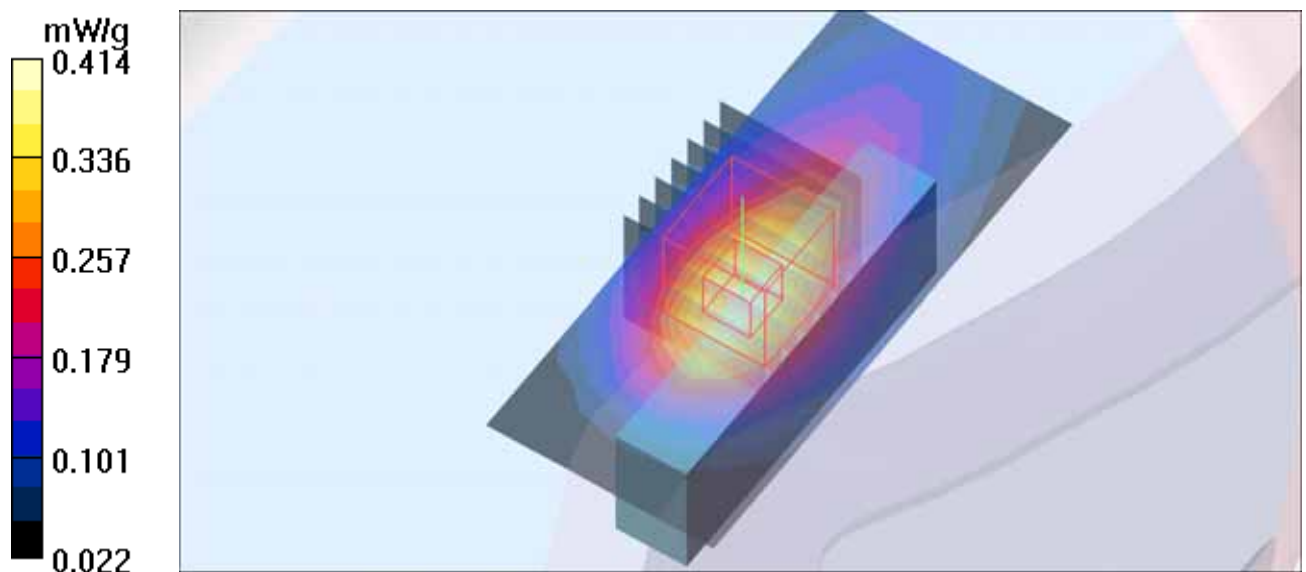

M08-GPRS850 TS4-Ch190

Communication System: GPRS850 ; Frequency: 836.6 MHz ; Duty Cycle: 1:2 ; Modulation Type: GMSK / UL 4 time slots

Medium: MSL835 Medium parameters used: $f = 836.6$ MHz; $\sigma = 0.98$ mho/m; $\epsilon_r = 55.84$; $\rho = 1000$ kg/m³

Phantom section: Flat Section ; Separation distance : 5 mm (The Vertical-Front side of the EUT to the Phantom)

DASY4 Configuration:

- Probe: EX3DV4 - SN3578; ConvF(8.55, 8.55, 8.55); Calibrated: 2010/6/22
- Sensor-Surface: 2mm (Mechanical Surface Detection)
- Electronics: DAE3 Sn579; Calibrated: 2010/9/20
- Phantom: SAM 12; Type: SAM V4.0; Serial: TP 1202
- Measurement SW: DASY4, V4.7 Build 80; Postprocessing SW: SEMCAD, V1.8 Build 186

Body Position - Mid/Area Scan (7x15x1): Measurement grid: dx=8mm, dy=8mm

Maximum value of SAR (measured) = 0.443 mW/g

Body Position - Mid/Zoom Scan (7x7x7)/Cube 0: Measurement grid: dx=5mm, dy=5mm, dz=5mm

Reference Value = 10.5 V/m; Power Drift = 0.025 dB

Peak SAR (extrapolated) = 0.558 W/kg

SAR(1 g) = 0.344 mW/g; SAR(10 g) = 0.211 mW/g

Maximum value of SAR (measured) = 0.455 mW/g

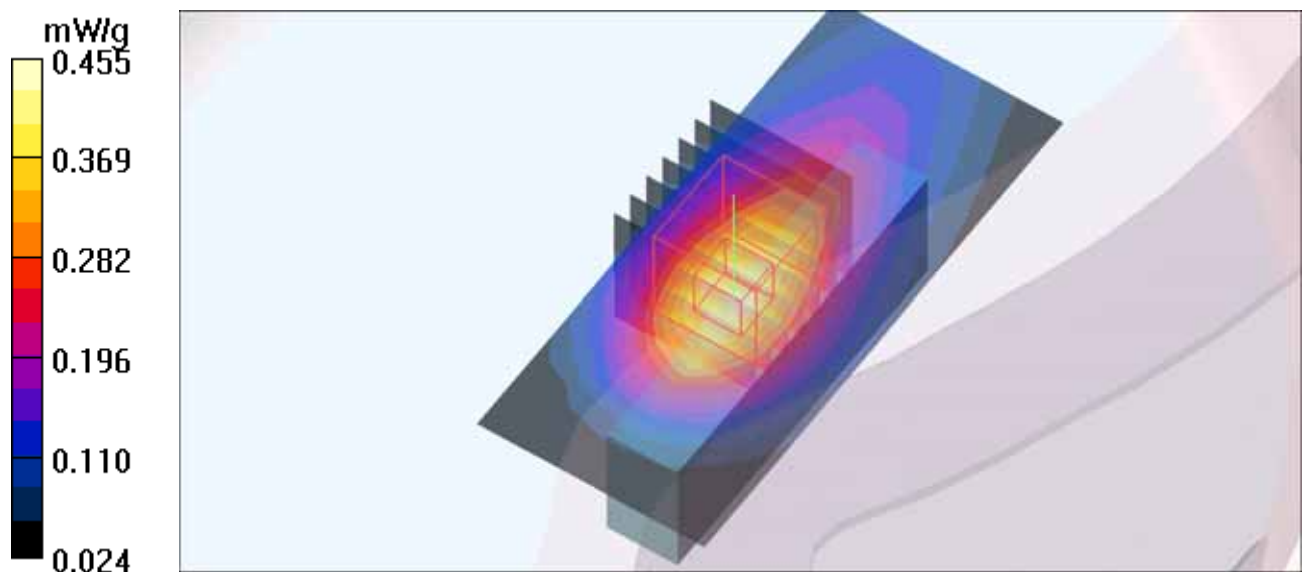

M09-GPRS850 TS1-Ch190

Communication System: GPRS850 ; Frequency: 836.6 MHz ; Duty Cycle: 1:8.3 ; Modulation Type: GMSK / UL 1 time slot

Medium: MSL835 Medium parameters used: $f = 836.6$ MHz; $\sigma = 0.98$ mho/m; $\epsilon_r = 55.84$; $\rho = 1000$ kg/m³

Phantom section: Flat Section ; Separation distance : 5 mm (The Horizontal-Up side of the EUT to the Phantom)

DASY4 Configuration:

- Probe: EX3DV4 - SN3578; ConvF(8.55, 8.55, 8.55); Calibrated: 2010/6/22
- Sensor-Surface: 2mm (Mechanical Surface Detection)
- Electronics: DAE3 Sn579; Calibrated: 2010/9/20
- Phantom: SAM 12; Type: SAM V4.0; Serial: TP 1202
- Measurement SW: DASY4, V4.7 Build 80; Postprocessing SW: SEMCAD, V1.8 Build 186

Body Position - Mid/Area Scan (7x15x1): Measurement grid: dx=8mm, dy=8mm

Maximum value of SAR (measured) = 0.551 mW/g

Body Position - Mid/Zoom Scan (7x7x7)/Cube 0: Measurement grid: dx=5mm, dy=5mm, dz=5mm

Reference Value = 10.5 V/m; Power Drift = 0.181 dB

Peak SAR (extrapolated) = 0.683 W/kg

SAR(1 g) = 0.435 mW/g; SAR(10 g) = 0.278 mW/g

Maximum value of SAR (measured) = 0.561 mW/g

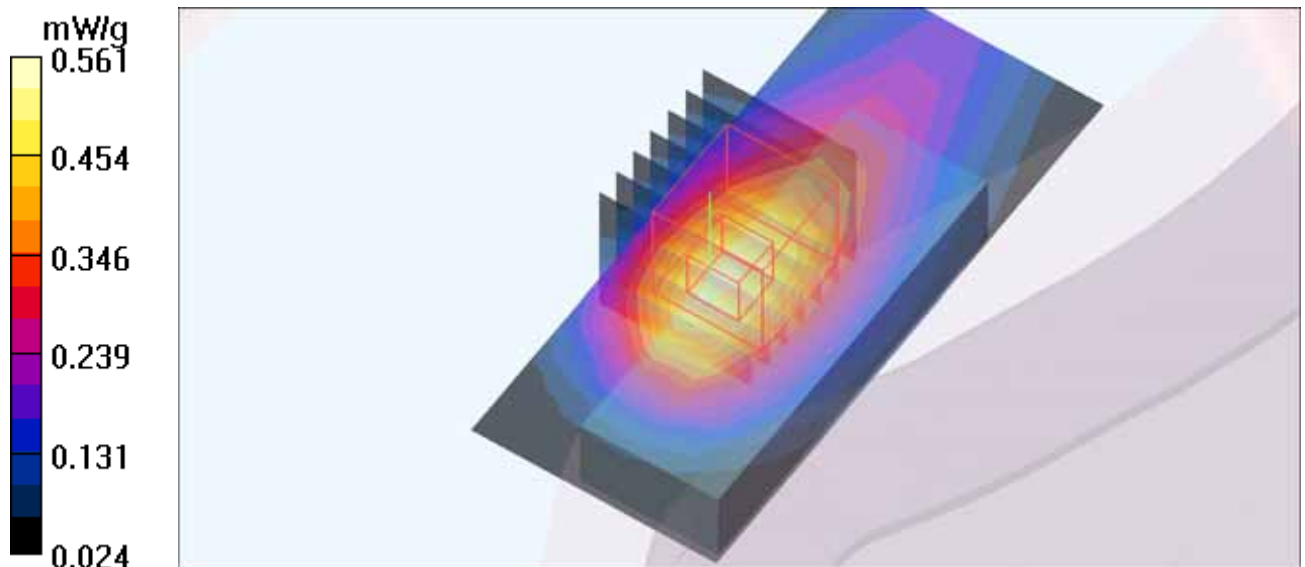

M10-GPRS850 TS2-Ch190

Communication System: GPRS850 ; Frequency: 836.6 MHz ; Duty Cycle: 1:4 ; Modulation Type: GMSK / UL 2 time slots

Medium: MSL835 Medium parameters used: $f = 836.6$ MHz; $\sigma = 0.98$ mho/m; $\epsilon_r = 55.84$; $\rho = 1000$ kg/m³

Phantom section: Flat Section ; Separation distance : 5 mm (The Horizontal-Up side of the EUT to the Phantom)

DASY4 Configuration:

- Probe: EX3DV4 - SN3578; ConvF(8.55, 8.55, 8.55); Calibrated: 2010/6/22
- Sensor-Surface: 2mm (Mechanical Surface Detection)
- Electronics: DAE3 Sn579; Calibrated: 2010/9/20
- Phantom: SAM 12; Type: SAM V4.0; Serial: TP 1202
- Measurement SW: DASY4, V4.7 Build 80; Postprocessing SW: SEMCAD, V1.8 Build 186

Body Position - Mid/Area Scan (7x15x1): Measurement grid: dx=8mm, dy=8mm

Maximum value of SAR (measured) = 0.685 mW/g

Body Position - Mid/Zoom Scan (7x7x7)/Cube 0: Measurement grid: dx=5mm, dy=5mm, dz=5mm

Reference Value = 12.7 V/m; Power Drift = -0.114 dB

Peak SAR (extrapolated) = 0.811 W/kg

SAR(1 g) = 0.519 mW/g; SAR(10 g) = 0.331 mW/g

Maximum value of SAR (measured) = 0.675 mW/g

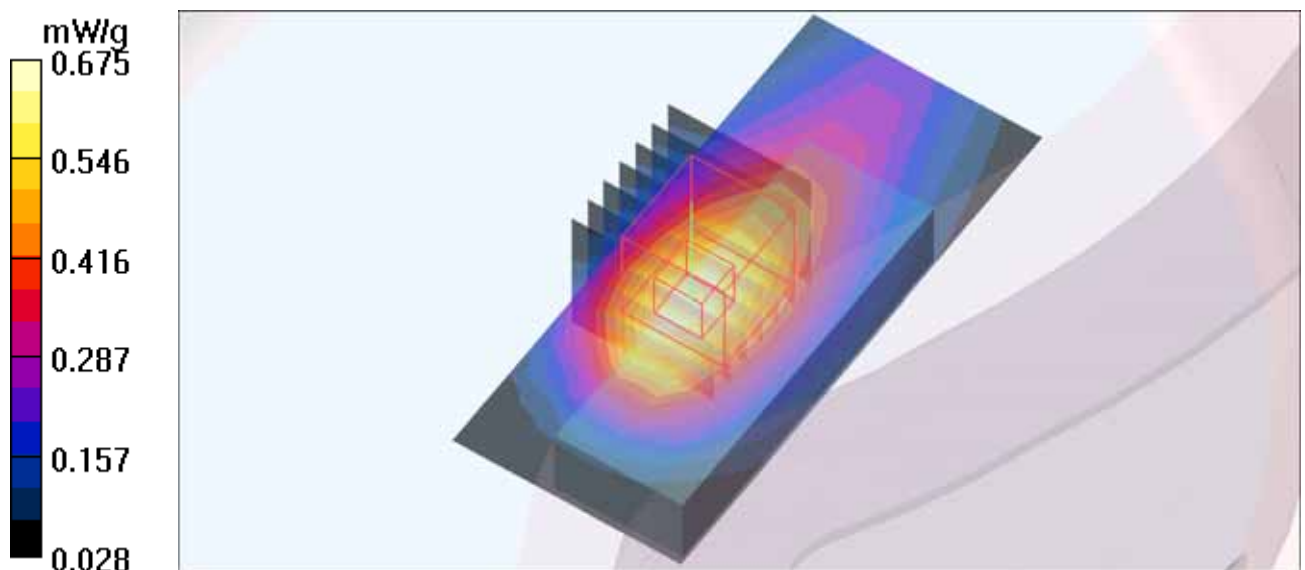

M11-GPRS850 TS3-Ch190

Communication System: GPRS850 ; Frequency: 836.6 MHz ; Duty Cycle: 1:2.67 ; Modulation Type: GMSK / UL 3 time slots

Medium: MSL835 Medium parameters used: $f = 836.6$ MHz; $\sigma = 0.98$ mho/m; $\epsilon_r = 55.84$; $\rho = 1000$ kg/m³

Phantom section: Flat Section ; Separation distance : 5 mm (The Horizontal-Up side of the EUT to the Phantom)

DASY4 Configuration:

- Probe: EX3DV4 - SN3578; ConvF(8.55, 8.55, 8.55); Calibrated: 2010/6/22
- Sensor-Surface: 2mm (Mechanical Surface Detection)
- Electronics: DAE3 Sn579; Calibrated: 2010/9/20
- Phantom: SAM 12; Type: SAM V4.0; Serial: TP 1202
- Measurement SW: DASY4, V4.7 Build 80; Postprocessing SW: SEMCAD, V1.8 Build 186

Body Position - Mid/Area Scan (7x15x1): Measurement grid: dx=8mm, dy=8mm

Maximum value of SAR (measured) = 0.644 mW/g

Body Position - Mid/Zoom Scan (7x7x7)/Cube 0: Measurement grid: dx=5mm, dy=5mm, dz=5mm

Reference Value = 12.1 V/m; Power Drift = -0.136 dB

Peak SAR (extrapolated) = 0.770 W/kg

SAR(1 g) = 0.493 mW/g; SAR(10 g) = 0.315 mW/g

Maximum value of SAR (measured) = 0.633 mW/g

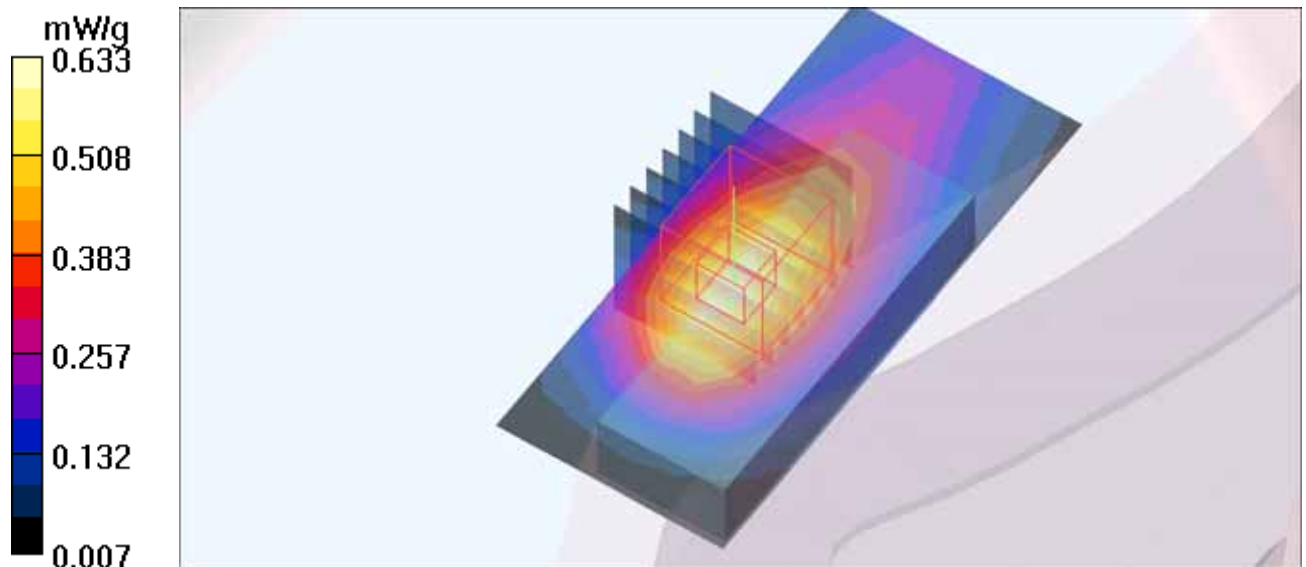

M12-GPRS850 TS4-Ch190

Communication System: GPRS850 ; Frequency: 836.6 MHz ; Duty Cycle: 1:2 ; Modulation Type: GMSK / UL 4 time slots

Medium: MSL835 Medium parameters used: $f = 836.6$ MHz; $\sigma = 0.98$ mho/m; $\epsilon_r = 55.84$; $\rho = 1000$ kg/m³

Phantom section: Flat Section ; Separation distance : 5 mm (The Horizontal-Up side of the EUT to the Phantom)

DASY4 Configuration:

- Probe: EX3DV4 - SN3578; ConvF(8.55, 8.55, 8.55); Calibrated: 2010/6/22
- Sensor-Surface: 2mm (Mechanical Surface Detection)
- Electronics: DAE3 Sn579; Calibrated: 2010/9/20
- Phantom: SAM 12; Type: SAM V4.0; Serial: TP 1202
- Measurement SW: DASY4, V4.7 Build 80; Postprocessing SW: SEMCAD, V1.8 Build 186

Body Position - Mid/Area Scan (7x15x1): Measurement grid: dx=8mm, dy=8mm

Maximum value of SAR (measured) = 0.683 mW/g

Body Position - Mid/Zoom Scan (7x7x7)/Cube 0: Measurement grid: dx=5mm, dy=5mm, dz=5mm

Reference Value = 12.2 V/m; Power Drift = 0.062 dB

Peak SAR (extrapolated) = 0.827 W/kg

SAR(1 g) = 0.534 mW/g; SAR(10 g) = 0.340 mW/g

Maximum value of SAR (measured) = 0.688 mW/g

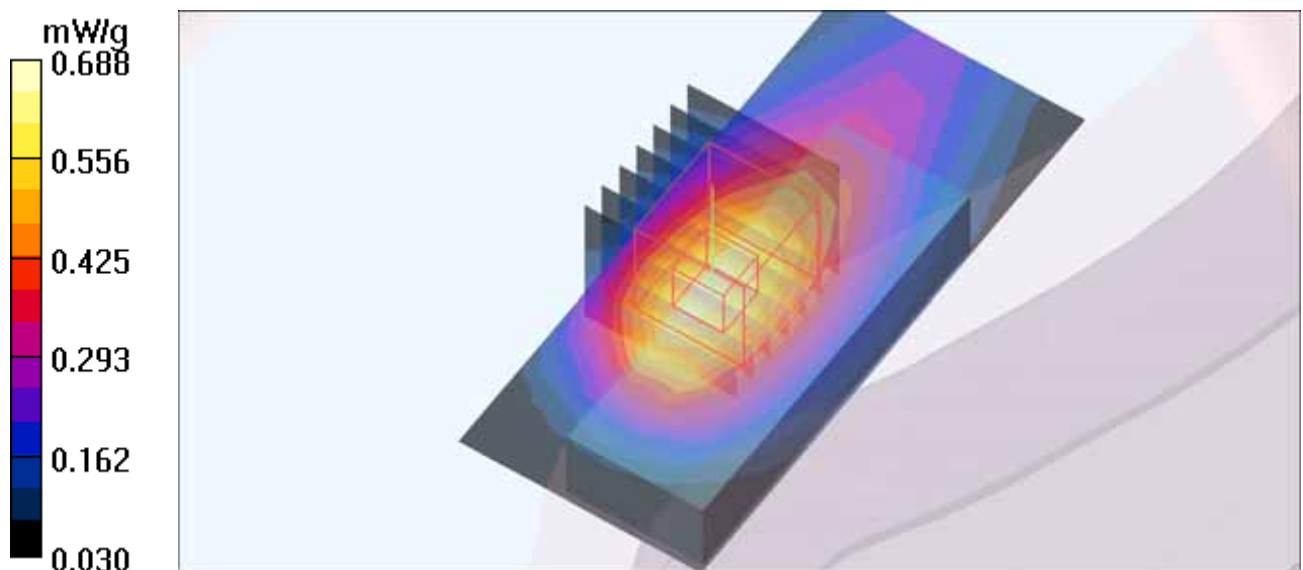

M13-GPRS850 TS1-Ch190

Communication System: GPRS850 ; Frequency: 836.6 MHz ; Duty Cycle: 1:8.3 ; Modulation Type: GMSK / UL 1 time slot

Medium: MSL835 Medium parameters used: $f = 836.6$ MHz; $\sigma = 0.98$ mho/m; $\epsilon_r = 55.84$; $\rho = 1000$ kg/m³

Phantom section: Flat Section ; Separation distance : 5 mm (The Vertical-Back side of the EUT to the Phantom)

DASY4 Configuration:

- Probe: EX3DV4 - SN3578; ConvF(8.55, 8.55, 8.55); Calibrated: 2010/6/22
- Sensor-Surface: 2mm (Mechanical Surface Detection)
- Electronics: DAE3 Sn579; Calibrated: 2010/9/20
- Phantom: SAM 12; Type: SAM V4.0; Serial: TP 1202
- Measurement SW: DASY4, V4.7 Build 80; Postprocessing SW: SEMCAD, V1.8 Build 186

Body Position - Mid/Area Scan (7x15x1): Measurement grid: dx=8mm, dy=8mm

Maximum value of SAR (measured) = 0.335 mW/g

Body Position - Mid/Zoom Scan (7x7x7)/Cube 0: Measurement grid: dx=5mm, dy=5mm, dz=5mm

Reference Value = 7.03 V/m; Power Drift = 0.156 dB

Peak SAR (extrapolated) = 0.415 W/kg

SAR(1 g) = 0.275 mW/g; SAR(10 g) = 0.180 mW/g

Maximum value of SAR (measured) = 0.349 mW/g

Body Position - Mid/Zoom Scan (7x7x7)/Cube 1: Measurement grid: dx=5mm, dy=5mm, dz=5mm

Reference Value = 7.03 V/m; Power Drift = 0.156 dB

Peak SAR (extrapolated) = 0.407 W/kg

SAR(1 g) = 0.262 mW/g; SAR(10 g) = 0.151 mW/g

Maximum value of SAR (measured) = 0.346 mW/g

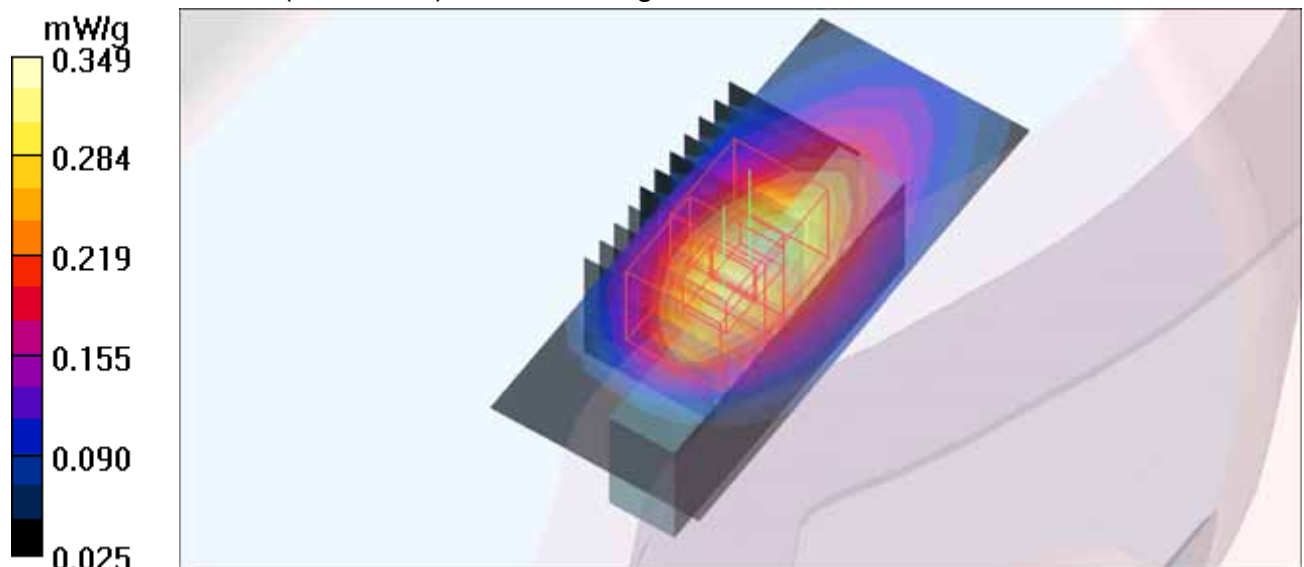

M14-GPRS850 TS2-Ch190

Communication System: GPRS850 ; Frequency: 836.6 MHz ; Duty Cycle: 1:4 ; Modulation Type: GMSK / UL 2 time slots

Medium: MSL835 Medium parameters used: $f = 836.6$ MHz; $\sigma = 0.98$ mho/m; $\epsilon_r = 55.84$; $\rho = 1000$ kg/m³

Phantom section: Flat Section ; Separation distance : 5 mm (The Vertical-Back side of the EUT to the Phantom)

DASY4 Configuration:

- Probe: EX3DV4 - SN3578; ConvF(8.55, 8.55, 8.55); Calibrated: 2010/6/22
- Sensor-Surface: 2mm (Mechanical Surface Detection)
- Electronics: DAE3 Sn579; Calibrated: 2010/9/20
- Phantom: SAM 12; Type: SAM V4.0; Serial: TP 1202
- Measurement SW: DASY4, V4.7 Build 80; Postprocessing SW: SEMCAD, V1.8 Build 186

Body Position - Mid/Area Scan (7x15x1): Measurement grid: dx=8mm, dy=8mm

Maximum value of SAR (measured) = 0.455 mW/g

Body Position - Mid/Zoom Scan (7x7x7)/Cube 0: Measurement grid: dx=5mm, dy=5mm, dz=5mm

Reference Value = 8.88 V/m; Power Drift = -0.181 dB

Peak SAR (extrapolated) = 0.519 W/kg

SAR(1 g) = 0.346 mW/g; SAR(10 g) = 0.226 mW/g

Maximum value of SAR (measured) = 0.437 mW/g

Body Position - Mid/Zoom Scan (7x7x7)/Cube 1: Measurement grid: dx=5mm, dy=5mm, dz=5mm

Reference Value = 8.88 V/m; Power Drift = -0.181 dB

Peak SAR (extrapolated) = 0.506 W/kg

SAR(1 g) = 0.318 mW/g; SAR(10 g) = 0.186 mW/g

Maximum value of SAR (measured) = 0.425 mW/g

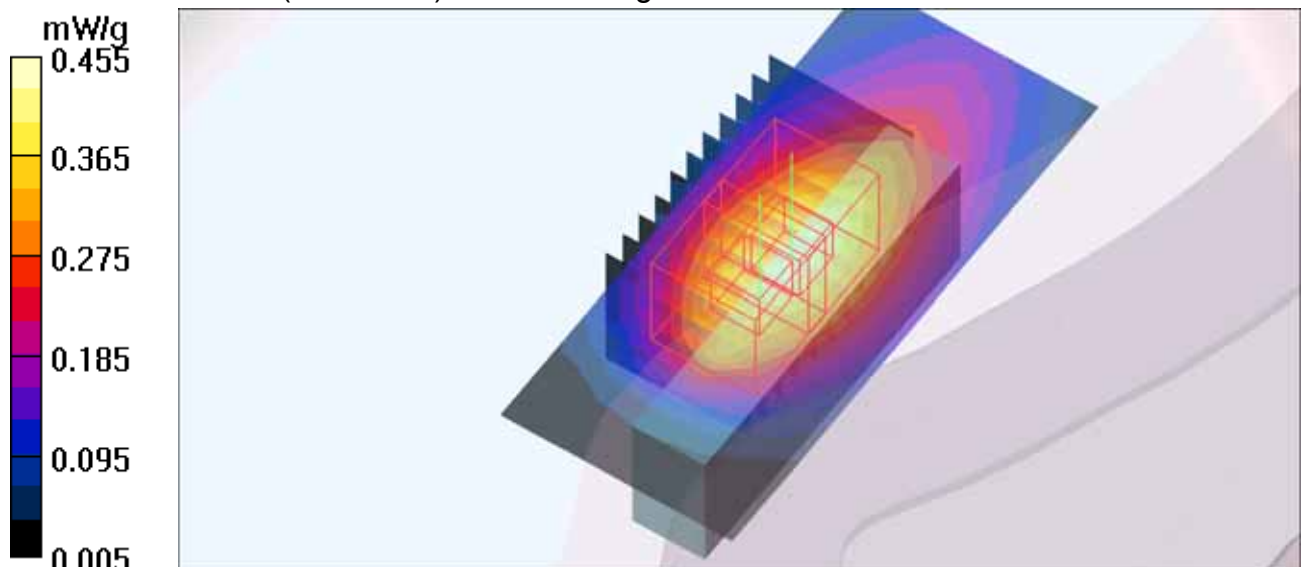

M15-GPRS850 TS3-Ch190

Communication System: GPRS850 ; Frequency: 836.6 MHz ; Duty Cycle: 1:2.67 ; Modulation Type: GMSK / UL 3 time slots

Medium: MSL835 Medium parameters used: $f = 836.6 \text{ MHz}$; $\sigma = 0.98 \text{ mho/m}$; $\epsilon_r = 55.84$; $\rho = 1000 \text{ kg/m}^3$

Phantom section: Flat Section ; Separation distance : 5 mm (The Vertical-Back side of the EUT to the Phantom)

DASY4 Configuration:

- Probe: EX3DV4 - SN3578; ConvF(8.55, 8.55, 8.55); Calibrated: 2010/6/22
- Sensor-Surface: 2mm (Mechanical Surface Detection)
- Electronics: DAE3 Sn579; Calibrated: 2010/9/20
- Phantom: SAM 12; Type: SAM V4.0; Serial: TP 1202
- Measurement SW: DASY4, V4.7 Build 80; Postprocessing SW: SEMCAD, V1.8 Build 186

Body Position - Mid/Area Scan (7x15x1): Measurement grid: $dx=8\text{mm}$, $dy=8\text{mm}$

Maximum value of SAR (measured) = 0.422 mW/g

Body Position - Mid/Zoom Scan (7x7x7)/Cube 0: Measurement grid: $dx=5\text{mm}$, $dy=5\text{mm}$, $dz=5\text{mm}$

Reference Value = 8.45 V/m; Power Drift = -0.131 dB

Peak SAR (extrapolated) = 0.488 W/kg

SAR(1 g) = 0.326 mW/g; SAR(10 g) = 0.214 mW/g

Maximum value of SAR (measured) = 0.411 mW/g

Body Position - Mid/Zoom Scan (7x7x7)/Cube 1: Measurement grid: $dx=5\text{mm}$, $dy=5\text{mm}$, $dz=5\text{mm}$

Reference Value = 8.45 V/m; Power Drift = -0.131 dB

Peak SAR (extrapolated) = 0.485 W/kg

SAR(1 g) = 0.303 mW/g; SAR(10 g) = 0.178 mW/g

Maximum value of SAR (measured) = 0.407 mW/g

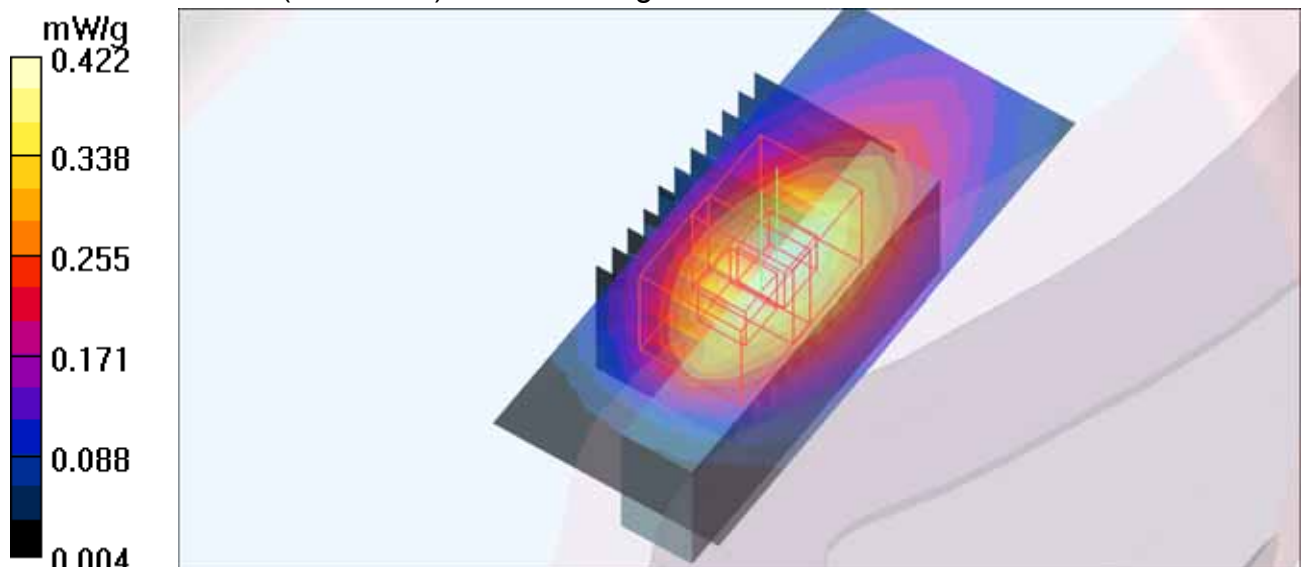

M16-GPRS850 TS4-Ch190

Communication System: GPRS850 ; Frequency: 836.6 MHz ; Duty Cycle: 1:2 ; Modulation Type: GMSK / UL 4 time slots

Medium: MSL835 Medium parameters used: $f = 836.6$ MHz; $\sigma = 0.98$ mho/m; $\epsilon_r = 55.84$; $\rho = 1000$ kg/m³

Phantom section: Flat Section ; Separation distance : 5 mm (The Vertical-Back side of the EUT to the Phantom)

DASY4 Configuration:

- Probe: EX3DV4 - SN3578; ConvF(8.55, 8.55, 8.55); Calibrated: 2010/6/22
- Sensor-Surface: 2mm (Mechanical Surface Detection)
- Electronics: DAE3 Sn579; Calibrated: 2010/9/20
- Phantom: SAM 12; Type: SAM V4.0; Serial: TP 1202
- Measurement SW: DASY4, V4.7 Build 80; Postprocessing SW: SEMCAD, V1.8 Build 186

Body Position - Mid/Area Scan (7x15x1): Measurement grid: dx=8mm, dy=8mm

Maximum value of SAR (measured) = 0.441 mW/g

Body Position - Mid/Zoom Scan (7x7x7)/Cube 0: Measurement grid: dx=5mm, dy=5mm, dz=5mm

Reference Value = 8.46 V/m; Power Drift = -0.054 dB

Peak SAR (extrapolated) = 0.528 W/kg

SAR(1 g) = 0.352 mW/g; SAR(10 g) = 0.229 mW/g

Maximum value of SAR (measured) = 0.444 mW/g

Body Position - Mid/Zoom Scan (7x7x7)/Cube 1: Measurement grid: dx=5mm, dy=5mm, dz=5mm

Reference Value = 8.46 V/m; Power Drift = -0.054 dB

Peak SAR (extrapolated) = 0.511 W/kg

SAR(1 g) = 0.326 mW/g; SAR(10 g) = 0.192 mW/g

Maximum value of SAR (measured) = 0.431 mW/g

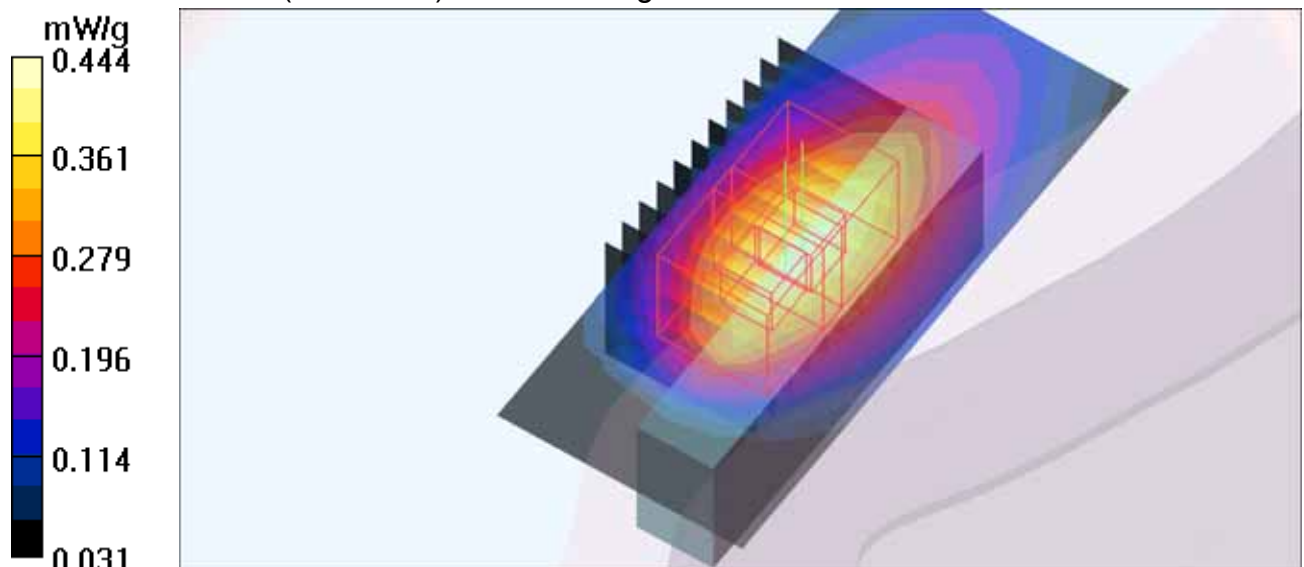

M17-GPRS850 TS1-Ch190

Communication System: GPRS850 ; Frequency: 836.6 MHz ; Duty Cycle: 1:8.3 ; Modulation Type: GMSK / UL 1 time slot

Medium: MSL835 Medium parameters used: $f = 836.6$ MHz; $\sigma = 0.98$ mho/m; $\epsilon_r = 55.84$; $\rho = 1000$ kg/m³

Phantom section: Flat Section ; Separation distance : 5 mm (The top side of the EUT to the Phantom)

DASY4 Configuration:

- Probe: EX3DV4 - SN3578; ConvF(8.55, 8.55, 8.55); Calibrated: 2010/6/22
- Sensor-Surface: 2mm (Mechanical Surface Detection)
- Electronics: DAE3 Sn579; Calibrated: 2010/9/20
- Phantom: SAM 12; Type: SAM V4.0; Serial: TP 1202
- Measurement SW: DASY4, V4.7 Build 80; Postprocessing SW: SEMCAD, V1.8 Build 186

Body Position - Mid/Area Scan (7x8x1): Measurement grid: dx=8mm, dy=8mm

Maximum value of SAR (measured) = 0.030 mW/g

Body Position - Mid/Zoom Scan (7x7x7)/Cube 0: Measurement grid: dx=5mm, dy=5mm, dz=5mm

Reference Value = 5.75 V/m; Power Drift = -0.139 dB

Peak SAR (extrapolated) = 0.036 W/kg

SAR(1 g) = 0.020 mW/g; SAR(10 g) = 0.013 mW/g

Maximum value of SAR (measured) = 0.027 mW/g

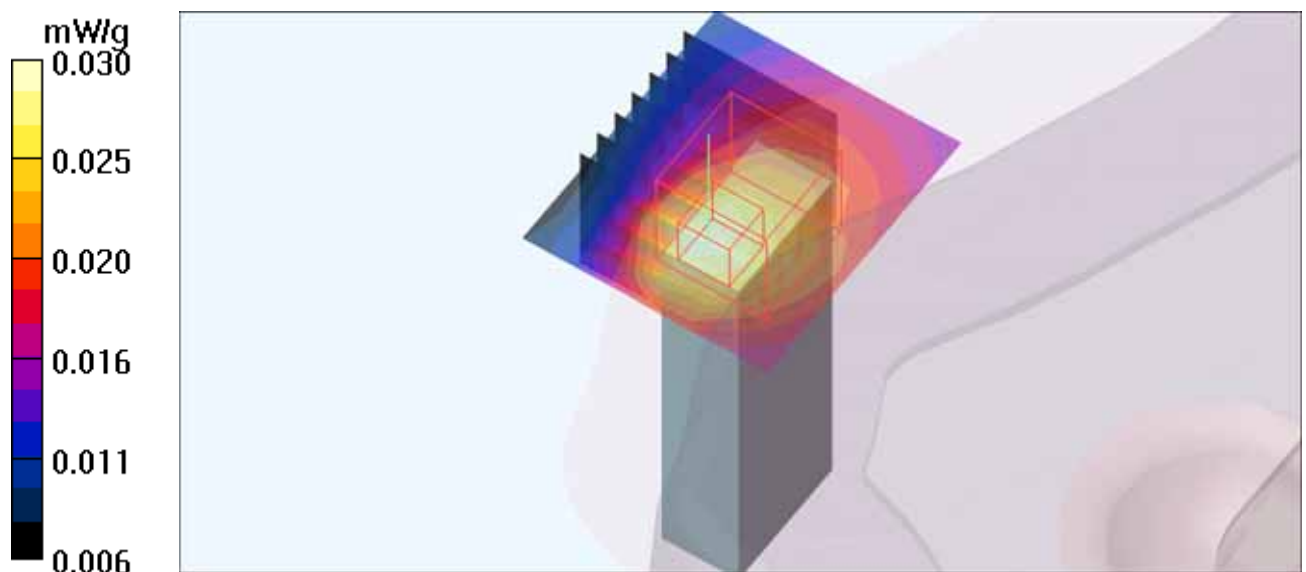

M18-GPRS850 TS2-Ch190

Communication System: GPRS850 ; Frequency: 836.6 MHz ; Duty Cycle: 1:4 ; Modulation Type: GMSK / UL 2 time slots

Medium: MSL835 Medium parameters used: $f = 836.6$ MHz; $\sigma = 0.98$ mho/m; $\epsilon_r = 55.84$; $\rho = 1000$ kg/m³

Phantom section: Flat Section ; Separation distance : 5 mm (The top side of the EUT to the Phantom)

DASY4 Configuration:

- Probe: EX3DV4 - SN3578; ConvF(8.55, 8.55, 8.55); Calibrated: 2010/6/22
- Sensor-Surface: 2mm (Mechanical Surface Detection)
- Electronics: DAE3 Sn579; Calibrated: 2010/9/20
- Phantom: SAM 12; Type: SAM V4.0; Serial: TP 1202
- Measurement SW: DASY4, V4.7 Build 80; Postprocessing SW: SEMCAD, V1.8 Build 186

Body Position - Mid/Area Scan (7x8x1): Measurement grid: dx=8mm, dy=8mm
Maximum value of SAR (measured) = 0.036 mW/g

Body Position - Mid/Zoom Scan (7x7x7)/Cube 0: Measurement grid: dx=5mm, dy=5mm, dz=5mm

Reference Value = 6.46 V/m; Power Drift = -0.135 dB

Peak SAR (extrapolated) = 0.046 W/kg

SAR(1 g) = 0.025 mW/g; SAR(10 g) = 0.016 mW/g

Maximum value of SAR (measured) = 0.035 mW/g

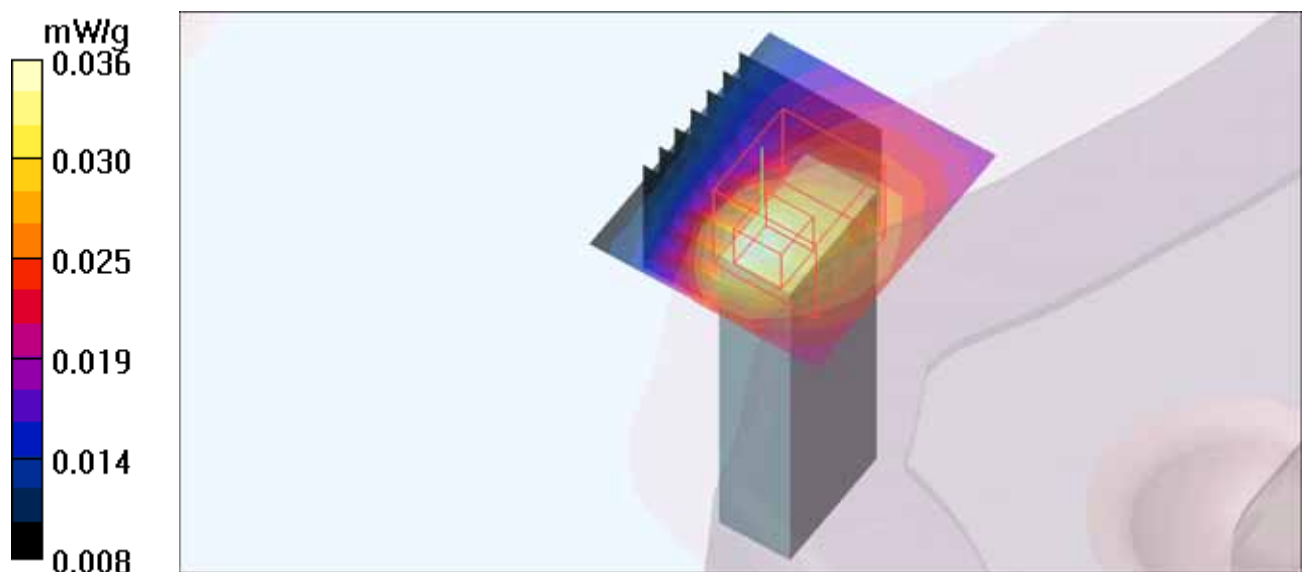

M19-GPRS850 TS3-Ch190

Communication System: GPRS850 ; Frequency: 836.6 MHz ; Duty Cycle: 1:2.67 ; Modulation Type: GMSK / UL 3 time slots

Medium: MSL835 Medium parameters used: $f = 836.6$ MHz; $\sigma = 0.98$ mho/m; $\epsilon_r = 55.84$; $\rho = 1000$ kg/m³

Phantom section: Flat Section ; Separation distance : 5 mm (The top side of the EUT to the Phantom)

DASY4 Configuration:

- Probe: EX3DV4 - SN3578; ConvF(8.55, 8.55, 8.55); Calibrated: 2010/6/22
- Sensor-Surface: 2mm (Mechanical Surface Detection)
- Electronics: DAE3 Sn579; Calibrated: 2010/9/20
- Phantom: SAM 12; Type: SAM V4.0; Serial: TP 1202
- Measurement SW: DASY4, V4.7 Build 80; Postprocessing SW: SEMCAD, V1.8 Build 186

Body Position - Mid/Area Scan (7x8x1): Measurement grid: dx=8mm, dy=8mm
Maximum value of SAR (measured) = 0.037 mW/g

Body Position - Mid/Zoom Scan (7x7x7)/Cube 0: Measurement grid: dx=5mm, dy=5mm, dz=5mm

Reference Value = 6.39 V/m; Power Drift = -0.121 dB

Peak SAR (extrapolated) = 0.044 W/kg

SAR(1 g) = 0.024 mW/g; SAR(10 g) = 0.015 mW/g

Maximum value of SAR (measured) = 0.033 mW/g

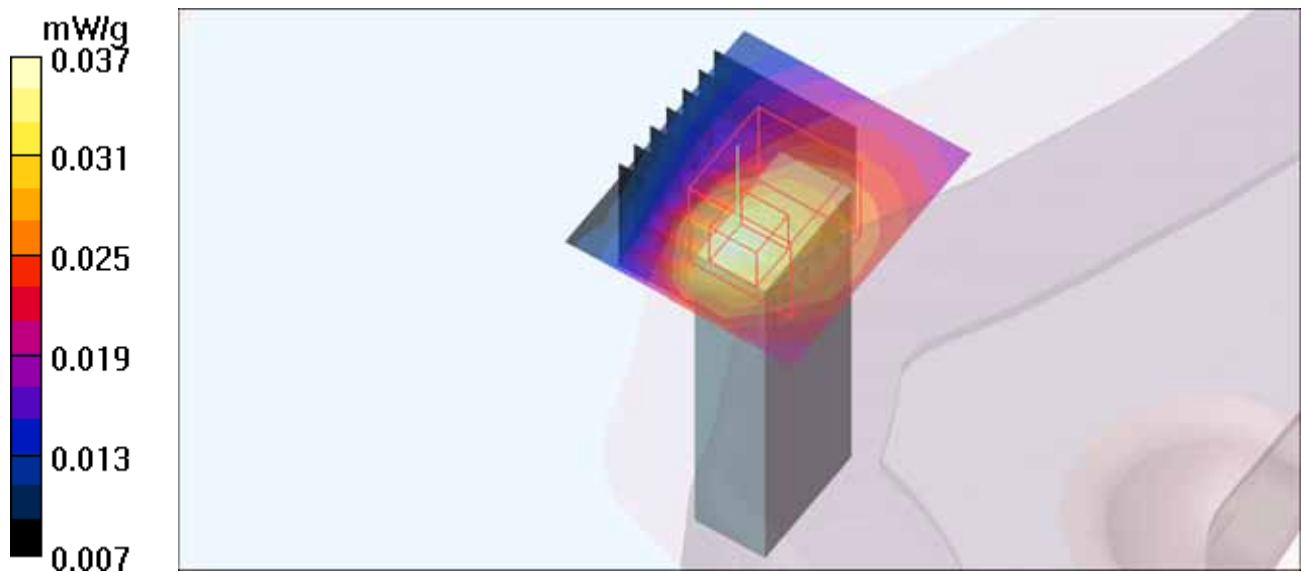

M20-GPRS850 TS4-Ch190

Communication System: GPRS850 ; Frequency: 836.6 MHz ; Duty Cycle: 1:2 ; Modulation Type: GMSK / UL 4 time slots

Medium: MSL835 Medium parameters used: $f = 836.6$ MHz; $\sigma = 0.98$ mho/m; $\epsilon_r = 55.84$; $\rho = 1000$ kg/m³

Phantom section: Flat Section ; Separation distance : 5 mm (The top side of the EUT to the Phantom)

DASY4 Configuration:

- Probe: EX3DV4 - SN3578; ConvF(8.55, 8.55, 8.55); Calibrated: 2010/6/22
- Sensor-Surface: 2mm (Mechanical Surface Detection)
- Electronics: DAE3 Sn579; Calibrated: 2010/9/20
- Phantom: SAM 12; Type: SAM V4.0; Serial: TP 1202
- Measurement SW: DASY4, V4.7 Build 80; Postprocessing SW: SEMCAD, V1.8 Build 186

Body Position - Mid/Area Scan (7x8x1): Measurement grid: dx=8mm, dy=8mm

Maximum value of SAR (measured) = 0.037 mW/g

Body Position - Mid/Zoom Scan (7x7x7)/Cube 0: Measurement grid: dx=5mm, dy=5mm, dz=5mm

Reference Value = 6.45 V/m; Power Drift = -0.149 dB

Peak SAR (extrapolated) = 0.050 W/kg

SAR(1 g) = 0.026 mW/g; SAR(10 g) = 0.017 mW/g

Maximum value of SAR (measured) = 0.036 mW/g

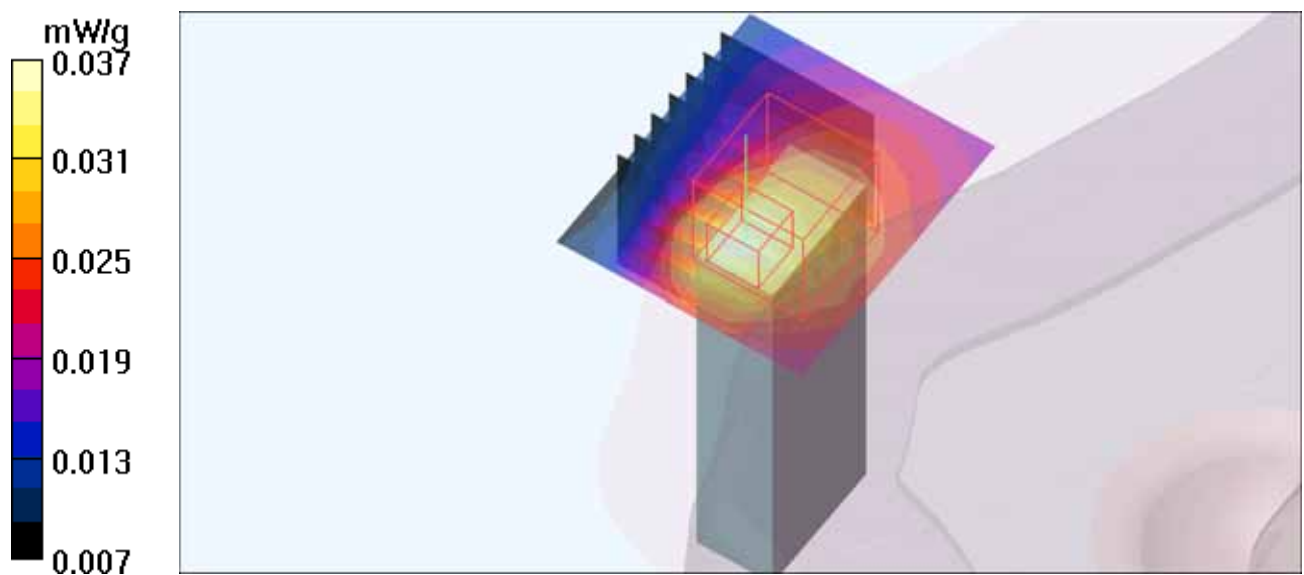

M21-E-GPRS850 TS1-Ch190

Communication System: E-GPRS850 ; Frequency: 836.6 MHz ; Duty Cycle: 1:8.3 ; Modulation Type: 8PSK / UL 1 time slot

Medium: MSL835 Medium parameters used: $f = 836.6$ MHz; $\sigma = 0.98$ mho/m; $\epsilon_r = 55.84$; $\rho = 1000$ kg/m³

Phantom section: Flat Section ; Separation distance : 5 mm (The Horizontal-Down side of the EUT to the Phantom)

DASY4 Configuration:

- Probe: EX3DV4 - SN3578; ConvF(8.55, 8.55, 8.55); Calibrated: 2010/6/22
- Sensor-Surface: 2mm (Mechanical Surface Detection)
- Electronics: DAE3 Sn579; Calibrated: 2010/9/20
- Phantom: SAM 12; Type: SAM V4.0; Serial: TP 1202
- Measurement SW: DASY4, V4.7 Build 80; Postprocessing SW: SEMCAD, V1.8 Build 186

Body Position - Mid/Area Scan (7x15x1): Measurement grid: dx=8mm, dy=8mm

Maximum value of SAR (measured) = 0.181 mW/g

Body Position - Mid/Zoom Scan (7x7x7)/Cube 0: Measurement grid: dx=5mm, dy=5mm, dz=5mm

Reference Value = 6.98 V/m; Power Drift = -0.171 dB

Peak SAR (extrapolated) = 0.217 W/kg

SAR(1 g) = 0.143 mW/g; SAR(10 g) = 0.092 mW/g

Maximum value of SAR (measured) = 0.183 mW/g

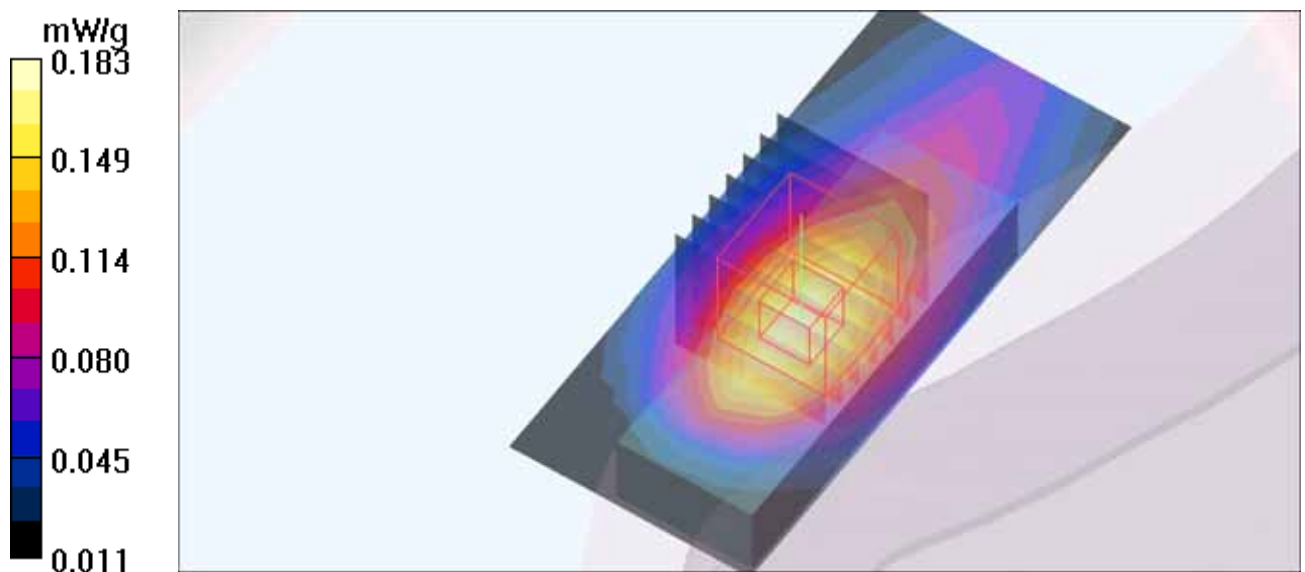

M22-E-GPRS850 TS2-Ch190

Communication System: E-GPRS850 ; Frequency: 836.6 MHz ; Duty Cycle: 1:4 ; Modulation Type: 8PSK / UL 2 time slots

Medium: MSL835 Medium parameters used: $f = 836.6$ MHz; $\sigma = 0.98$ mho/m; $\epsilon_r = 55.84$; $\rho = 1000$ kg/m³

Phantom section: Flat Section ; Separation distance : 5 mm (The Horizontal-Down side of the EUT to the Phantom)

DASY4 Configuration:

- Probe: EX3DV4 - SN3578; ConvF(8.55, 8.55, 8.55); Calibrated: 2010/6/22
- Sensor-Surface: 2mm (Mechanical Surface Detection)
- Electronics: DAE3 Sn579; Calibrated: 2010/9/20
- Phantom: SAM 12; Type: SAM V4.0; Serial: TP 1202
- Measurement SW: DASY4, V4.7 Build 80; Postprocessing SW: SEMCAD, V1.8 Build 186

Body Position - Mid/Area Scan (7x15x1): Measurement grid: dx=8mm, dy=8mm

Maximum value of SAR (measured) = 0.320 mW/g

Body Position - Mid/Zoom Scan (7x7x7)/Cube 0: Measurement grid: dx=5mm, dy=5mm, dz=5mm

Reference Value = 7.00 V/m; Power Drift = -0.155 dB

Peak SAR (extrapolated) = 0.370 W/kg

SAR(1 g) = 0.249 mW/g; SAR(10 g) = 0.160 mW/g

Maximum value of SAR (measured) = 0.310 mW/g

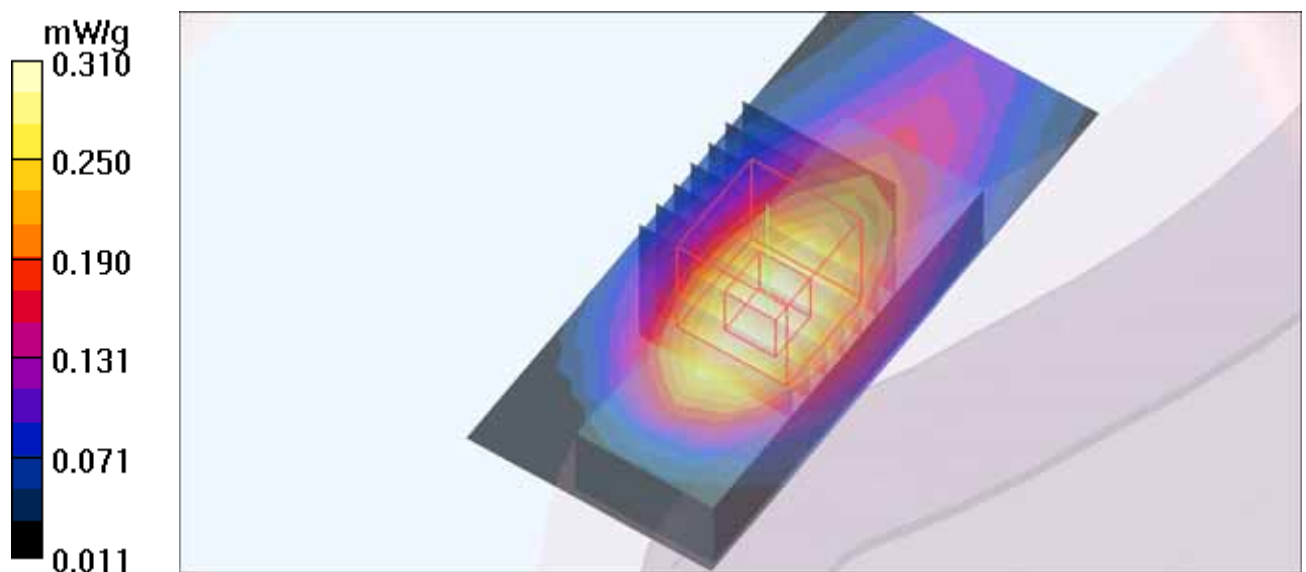

M23-E-GPRS850 TS3-Ch190

Communication System: E-GPRS850 ; Frequency: 836.6 MHz ; Duty Cycle: 1:2.67 ; Modulation Type: 8PSK / UL 3 time slots

Medium: MSL835 Medium parameters used: $f = 836.6$ MHz; $\sigma = 0.98$ mho/m; $\epsilon_r = 55.84$; $\rho = 1000$ kg/m³

Phantom section: Flat Section ; Separation distance : 5 mm (The Horizontal-Down side of the EUT to the Phantom)

DASY4 Configuration:

- Probe: EX3DV4 - SN3578; ConvF(8.55, 8.55, 8.55); Calibrated: 2010/6/22
- Sensor-Surface: 2mm (Mechanical Surface Detection)
- Electronics: DAE3 Sn579; Calibrated: 2010/9/20
- Phantom: SAM 12; Type: SAM V4.0; Serial: TP 1202
- Measurement SW: DASY4, V4.7 Build 80; Postprocessing SW: SEMCAD, V1.8 Build 186

Body Position - Mid/Area Scan (7x15x1): Measurement grid: dx=8mm, dy=8mm

Maximum value of SAR (measured) = 0.435 mW/g

Body Position - Mid/Zoom Scan (7x7x7)/Cube 0: Measurement grid: dx=5mm, dy=5mm, dz=5mm

Reference Value = 7.50 V/m; Power Drift = -0.117 dB

Peak SAR (extrapolated) = 0.486 W/kg

SAR(1 g) = 0.321 mW/g; SAR(10 g) = 0.205 mW/g

Maximum value of SAR (measured) = 0.406 mW/g

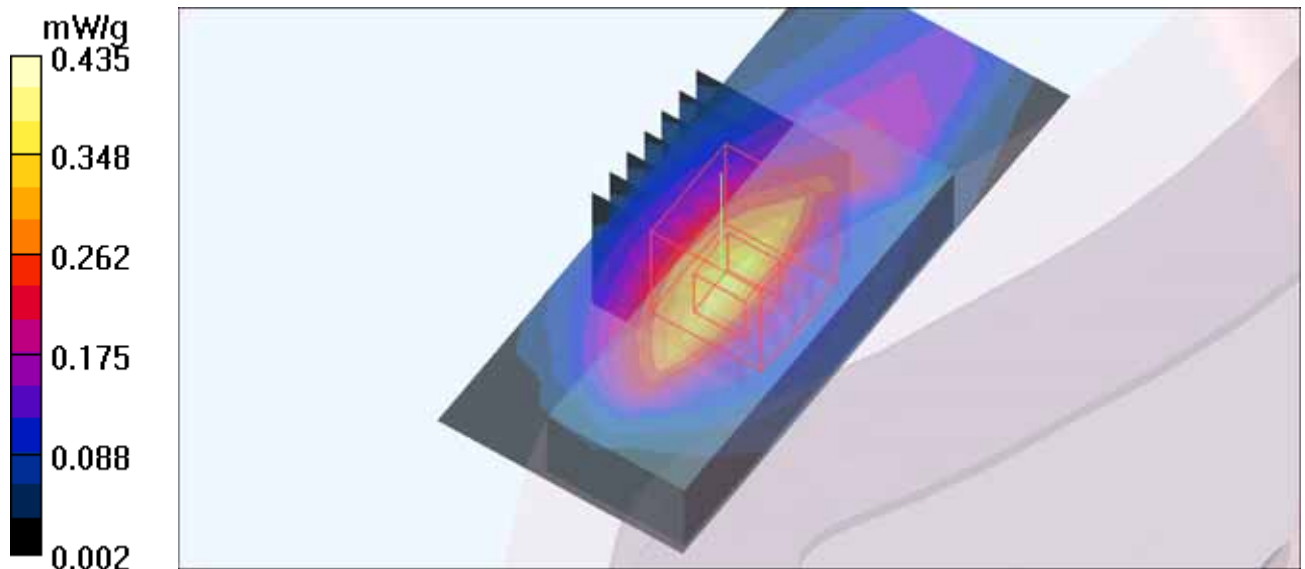

M24-E-GPRS850 TS4-Ch190

Communication System: E-GPRS850 ; Frequency: 836.6 MHz ; Duty Cycle: 1:2 ; Modulation Type: 8PSK / UL 4 time slots

Medium: MSL835 Medium parameters used: $f = 836.6$ MHz; $\sigma = 0.98$ mho/m; $\epsilon_r = 55.84$; $\rho = 1000$ kg/m³

Phantom section: Flat Section ; Separation distance : 5 mm (The Horizontal-Down side of the EUT to the Phantom)

DASY4 Configuration:

- Probe: EX3DV4 - SN3578; ConvF(8.55, 8.55, 8.55); Calibrated: 2010/6/22
- Sensor-Surface: 2mm (Mechanical Surface Detection)
- Electronics: DAE3 Sn579; Calibrated: 2010/9/20
- Phantom: SAM 12; Type: SAM V4.0; Serial: TP 1202
- Measurement SW: DASY4, V4.7 Build 80; Postprocessing SW: SEMCAD, V1.8 Build 186

Body Position - Mid/Area Scan (7x15x1): Measurement grid: dx=8mm, dy=8mm

Maximum value of SAR (measured) = 0.596 mW/g

Body Position - Mid/Zoom Scan (7x7x7)/Cube 0: Measurement grid: dx=5mm, dy=5mm, dz=5mm

Reference Value = 6.40 V/m; Power Drift = 0.119 dB

Peak SAR (extrapolated) = 0.660 W/kg

SAR(1 g) = 0.435 mW/g; SAR(10 g) = 0.280 mW/g

Maximum value of SAR (measured) = 0.549 mW/g

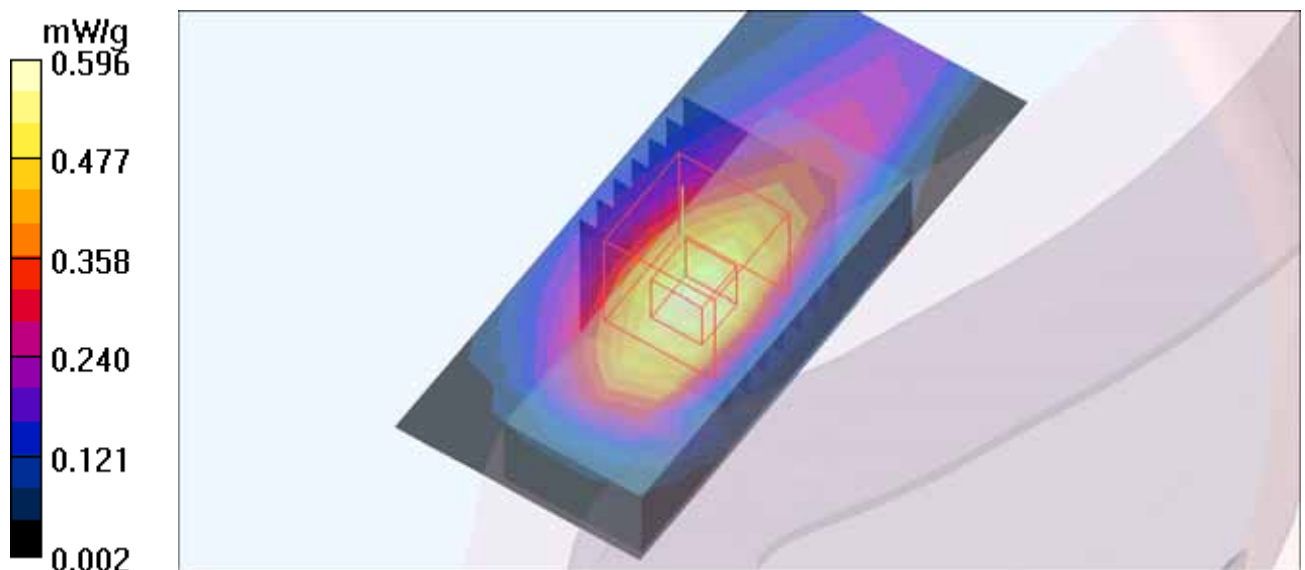

M25-E-GPRS850 TS1-Ch190

Communication System: E-GPRS850 ; Frequency: 836.6 MHz ; Duty Cycle: 1:8.3 ; Modulation Type: 8PSK / UL 1 time slot

Medium: MSL835 Medium parameters used: $f = 836.6$ MHz; $\sigma = 0.98$ mho/m; $\epsilon_r = 55.84$; $\rho = 1000$ kg/m³

Phantom section: Flat Section ; Separation distance : 5 mm (The Vertical-Front side of the EUT to the Phantom)

DASY4 Configuration:

- Probe: EX3DV4 - SN3578; ConvF(8.55, 8.55, 8.55); Calibrated: 2010/6/22
- Sensor-Surface: 2mm (Mechanical Surface Detection)
- Electronics: DAE3 Sn579; Calibrated: 2010/9/20
- Phantom: SAM 12; Type: SAM V4.0; Serial: TP 1202
- Measurement SW: DASY4, V4.7 Build 80; Postprocessing SW: SEMCAD, V1.8 Build 186

Body Position - Mid/Area Scan (7x15x1): Measurement grid: dx=8mm, dy=8mm

Maximum value of SAR (measured) = 0.106 mW/g

Body Position - Mid/Zoom Scan (7x7x7)/Cube 0: Measurement grid: dx=5mm, dy=5mm, dz=5mm

Reference Value = 4.28 V/m; Power Drift = -0.165 dB

Peak SAR (extrapolated) = 0.152 W/kg

SAR(1 g) = 0.093 mW/g; SAR(10 g) = 0.057 mW/g

Maximum value of SAR (measured) = 0.123 mW/g

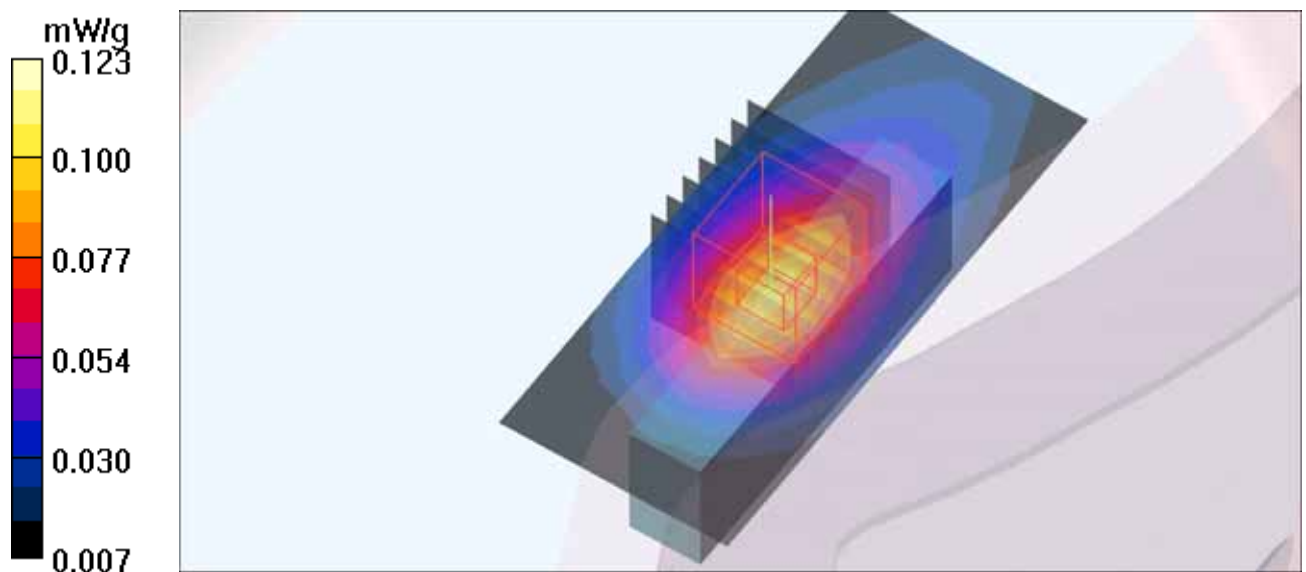

M26-E-GPRS850 TS2-Ch190

Communication System: E-GPRS850 ; Frequency: 836.6 MHz ; Duty Cycle: 1:4 ; Modulation Type: 8PSK / UL 2 time slots

Medium: MSL835 Medium parameters used: $f = 836.6$ MHz; $\sigma = 0.98$ mho/m; $\epsilon_r = 55.84$; $\rho = 1000$ kg/m³

Phantom section: Flat Section ; Separation distance : 5 mm (The Vertical-Front side of the EUT to the Phantom)

DASY4 Configuration:

- Probe: EX3DV4 - SN3578; ConvF(8.55, 8.55, 8.55); Calibrated: 2010/6/22
- Sensor-Surface: 2mm (Mechanical Surface Detection)
- Electronics: DAE3 Sn579; Calibrated: 2010/9/20
- Phantom: SAM 12; Type: SAM V4.0; Serial: TP 1202
- Measurement SW: DASY4, V4.7 Build 80; Postprocessing SW: SEMCAD, V1.8 Build 186

Body Position - Mid/Area Scan (7x15x1): Measurement grid: dx=8mm, dy=8mm

Maximum value of SAR (measured) = 0.223 mW/g

Body Position - Mid/Zoom Scan (7x7x7)/Cube 0: Measurement grid: dx=5mm, dy=5mm, dz=5mm

Reference Value = 7.04 V/m; Power Drift = -0.134 dB

Peak SAR (extrapolated) = 0.267 W/kg

SAR(1 g) = 0.165 mW/g; SAR(10 g) = 0.102 mW/g

Maximum value of SAR (measured) = 0.218 mW/g

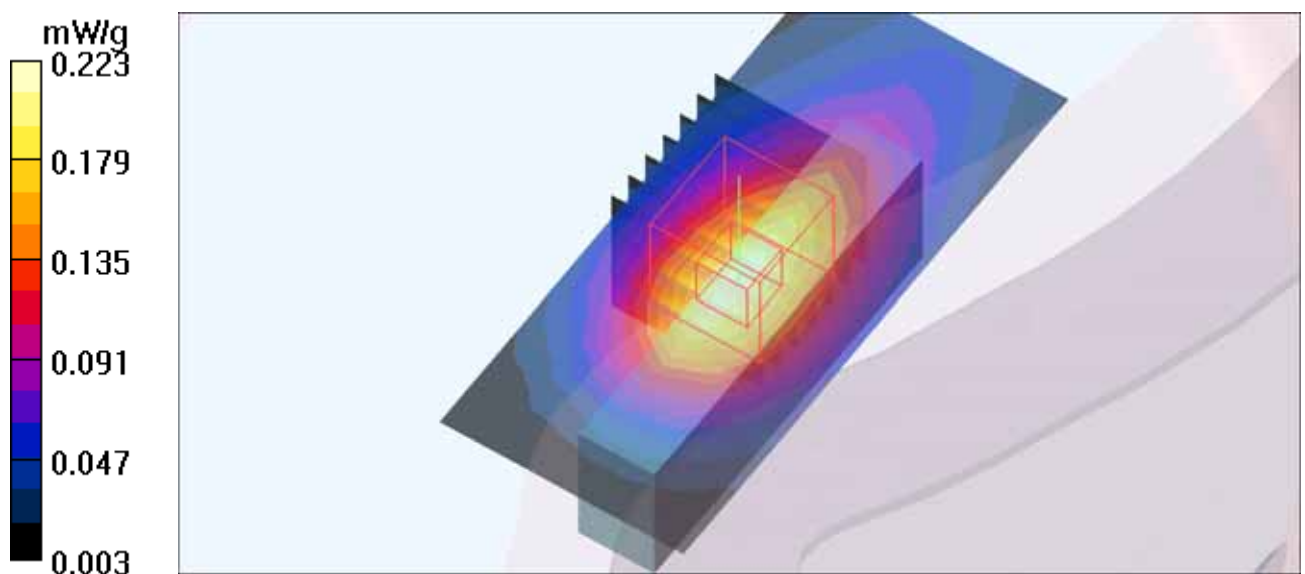

M27-E-GPRS850 TS3-Ch190

Communication System: E-GPRS850 ; Frequency: 836.6 MHz ; Duty Cycle: 1:2.67 ; Modulation Type: 8PSK / UL 3 time slots

Medium: MSL835 Medium parameters used: $f = 836.6$ MHz; $\sigma = 0.98$ mho/m; $\epsilon_r = 55.84$; $\rho = 1000$ kg/m³

Phantom section: Flat Section ; Separation distance : 5 mm (The Vertical-Front side of the EUT to the Phantom)

DASY4 Configuration:

- Probe: EX3DV4 - SN3578; ConvF(8.55, 8.55, 8.55); Calibrated: 2010/6/22
- Sensor-Surface: 2mm (Mechanical Surface Detection)
- Electronics: DAE3 Sn579; Calibrated: 2010/9/20
- Phantom: SAM 12; Type: SAM V4.0; Serial: TP 1202
- Measurement SW: DASY4, V4.7 Build 80; Postprocessing SW: SEMCAD, V1.8 Build 186

Body Position - Mid/Area Scan (7x15x1): Measurement grid: dx=8mm, dy=8mm

Maximum value of SAR (measured) = 0.291 mW/g

Body Position - Mid/Zoom Scan (7x7x7)/Cube 0: Measurement grid: dx=5mm, dy=5mm, dz=5mm

Reference Value = 8.22 V/m; Power Drift = -0.145 dB

Peak SAR (extrapolated) = 0.349 W/kg

SAR(1 g) = 0.216 mW/g; SAR(10 g) = 0.133 mW/g

Maximum value of SAR (measured) = 0.285 mW/g

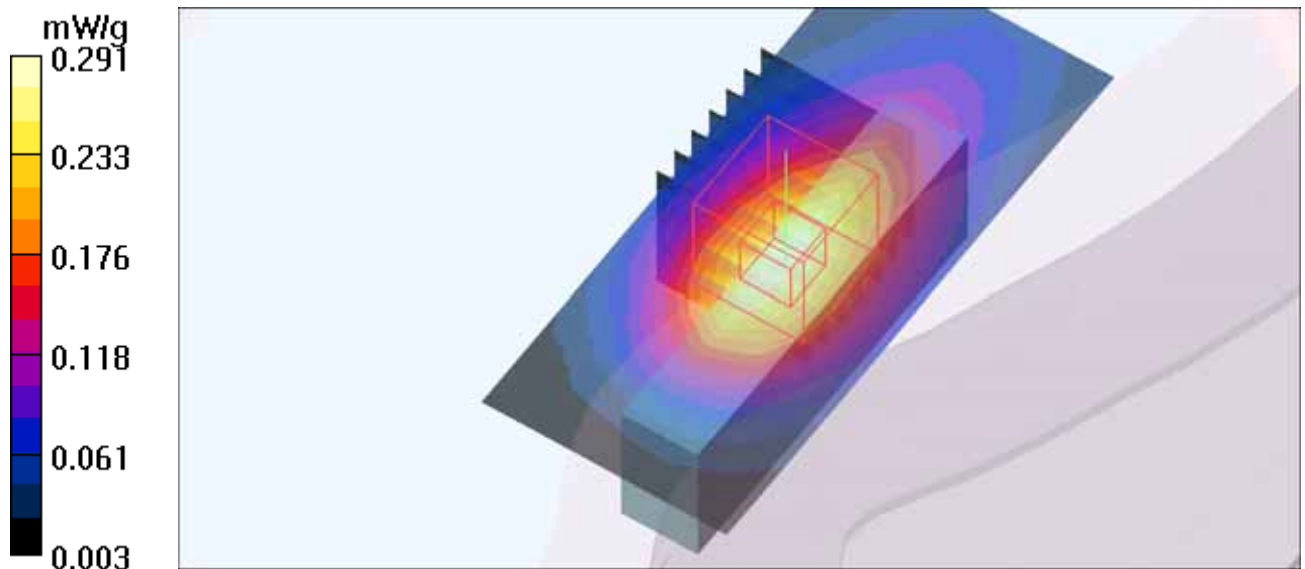

M28-E-GPRS850 TS4-Ch190

Communication System: E-GPRS850 ; Frequency: 836.6 MHz ; Duty Cycle: 1:2 ; Modulation Type: 8PSK / UL 4 time slots

Medium: MSL835 Medium parameters used: $f = 836.6$ MHz; $\sigma = 0.98$ mho/m; $\epsilon_r = 55.84$; $\rho = 1000$ kg/m³

Phantom section: Flat Section ; Separation distance : 5 mm (The Vertical-Front side of the EUT to the Phantom)

DASY4 Configuration:

- Probe: EX3DV4 - SN3578; ConvF(8.55, 8.55, 8.55); Calibrated: 2010/6/22
- Sensor-Surface: 2mm (Mechanical Surface Detection)
- Electronics: DAE3 Sn579; Calibrated: 2010/9/20
- Phantom: SAM 12; Type: SAM V4.0; Serial: TP 1202
- Measurement SW: DASY4, V4.7 Build 80; Postprocessing SW: SEMCAD, V1.8 Build 186

Body Position - Mid/Area Scan (7x15x1): Measurement grid: dx=8mm, dy=8mm

Maximum value of SAR (measured) = 0.347 mW/g

Body Position - Mid/Zoom Scan (7x7x7)/Cube 0: Measurement grid: dx=5mm, dy=5mm, dz=5mm

Reference Value = 8.86 V/m; Power Drift = -0.178 dB

Peak SAR (extrapolated) = 0.420 W/kg

SAR(1 g) = 0.259 mW/g; SAR(10 g) = 0.159 mW/g

Maximum value of SAR (measured) = 0.341 mW/g

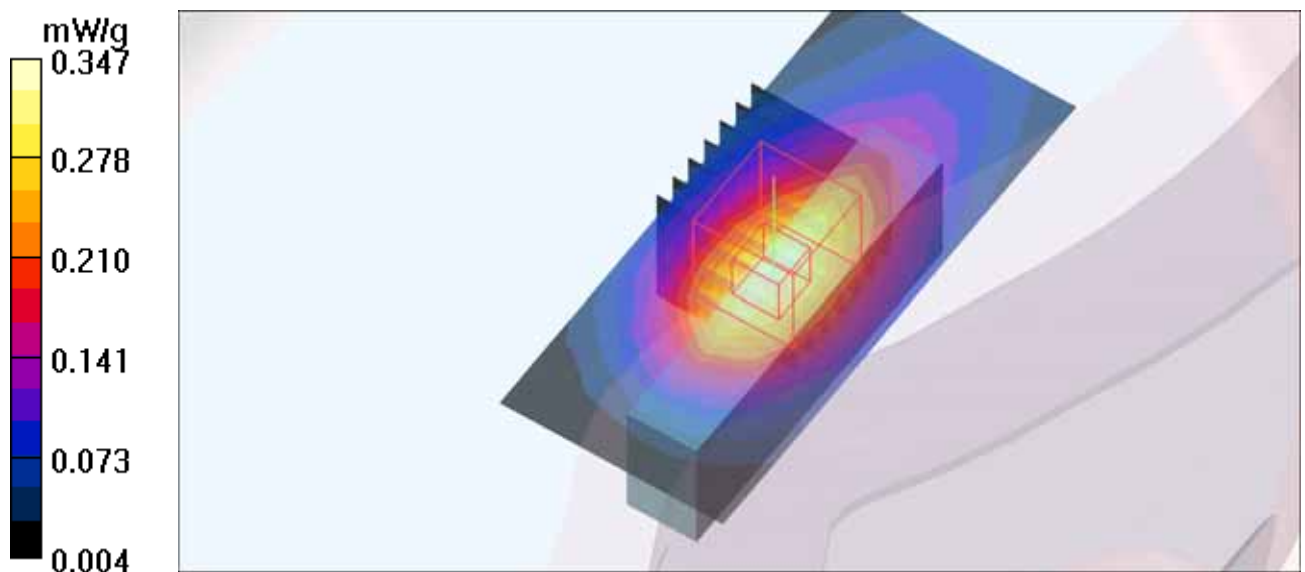

M29-E-GPRS850 TS1-Ch190

Communication System: E-GPRS850 ; Frequency: 836.6 MHz ; Duty Cycle: 1:8.3 ; Modulation Type: 8PSK / UL 1 time slot

Medium: MSL835 Medium parameters used: $f = 836.6$ MHz; $\sigma = 0.98$ mho/m; $\epsilon_r = 55.84$; $\rho = 1000$ kg/m³

Phantom section: Flat Section ; Separation distance : 5 mm (The Horizontal-Up side of the EUT to the Phantom)

DASY4 Configuration:

- Probe: EX3DV4 - SN3578; ConvF(8.55, 8.55, 8.55); Calibrated: 2010/6/22
- Sensor-Surface: 2mm (Mechanical Surface Detection)
- Electronics: DAE3 Sn579; Calibrated: 2010/9/20
- Phantom: SAM 12; Type: SAM V4.0; Serial: TP 1202
- Measurement SW: DASY4, V4.7 Build 80; Postprocessing SW: SEMCAD, V1.8 Build 186

Body Position - Mid/Area Scan (7x15x1): Measurement grid: dx=8mm, dy=8mm

Maximum value of SAR (measured) = 0.138 mW/g

Body Position - Mid/Zoom Scan (7x7x7)/Cube 0: Measurement grid: dx=5mm, dy=5mm, dz=5mm

Reference Value = 6.39 V/m; Power Drift = 0.182 dB

Peak SAR (extrapolated) = 0.178 W/kg

SAR(1 g) = 0.113 mW/g; SAR(10 g) = 0.071 mW/g

Maximum value of SAR (measured) = 0.146 mW/g

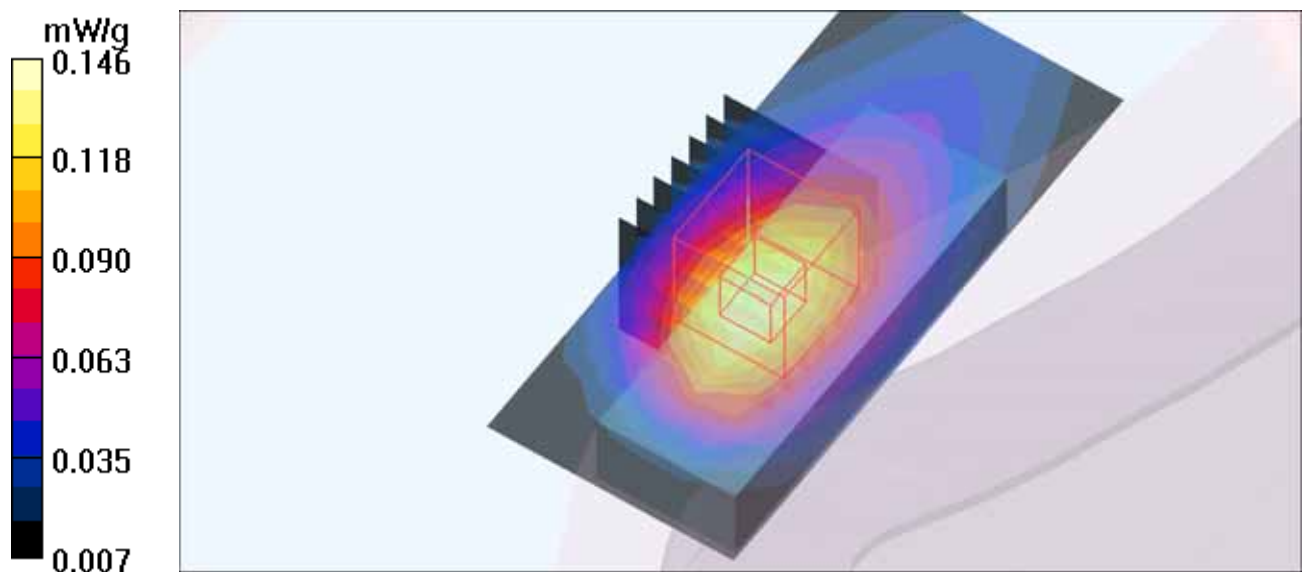

M30-E-GPRS850 TS2-Ch190

Communication System: E-GPRS850 ; Frequency: 836.6 MHz ; Duty Cycle: 1:4 ; Modulation Type: 8PSK / UL 2 time slots

Medium: MSL835 Medium parameters used: $f = 836.6$ MHz; $\sigma = 0.98$ mho/m; $\epsilon_r = 55.84$; $\rho = 1000$ kg/m³

Phantom section: Flat Section ; Separation distance : 5 mm (The Horizontal-Up side of the EUT to the Phantom)

DASY4 Configuration:

- Probe: EX3DV4 - SN3578; ConvF(8.55, 8.55, 8.55); Calibrated: 2010/6/22
- Sensor-Surface: 2mm (Mechanical Surface Detection)
- Electronics: DAE3 Sn579; Calibrated: 2010/9/20
- Phantom: SAM 12; Type: SAM V4.0; Serial: TP 1202
- Measurement SW: DASY4, V4.7 Build 80; Postprocessing SW: SEMCAD, V1.8 Build 186

Body Position - Mid/Area Scan (7x15x1): Measurement grid: dx=8mm, dy=8mm

Maximum value of SAR (measured) = 0.261 mW/g

Body Position - Mid/Zoom Scan (7x7x7)/Cube 0: Measurement grid: dx=5mm, dy=5mm, dz=5mm

Reference Value = 9.39 V/m; Power Drift = -0.107 dB

Peak SAR (extrapolated) = 0.310 W/kg

SAR(1 g) = 0.198 mW/g; SAR(10 g) = 0.125 mW/g

Maximum value of SAR (measured) = 0.257 mW/g

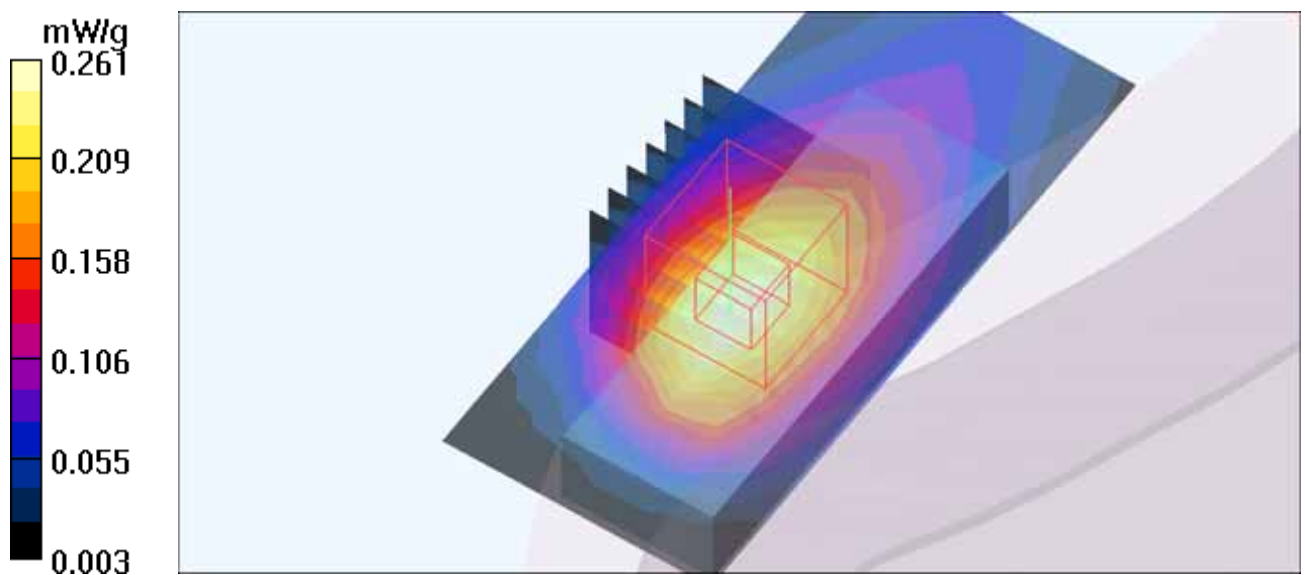

M31-E-GPRS850 TS3-Ch190

Communication System: E-GPRS850 ; Frequency: 836.6 MHz ; Duty Cycle: 1:2.67 ; Modulation Type: 8PSK / UL 3 time slots

Medium: MSL835 Medium parameters used: $f = 836.6$ MHz; $\sigma = 0.98$ mho/m; $\epsilon_r = 55.84$; $\rho = 1000$ kg/m³

Phantom section: Flat Section ; Separation distance : 5 mm (The Horizontal-Up side of the EUT to the Phantom)

DASY4 Configuration:

- Probe: EX3DV4 - SN3578; ConvF(8.55, 8.55, 8.55); Calibrated: 2010/6/22
- Sensor-Surface: 2mm (Mechanical Surface Detection)
- Electronics: DAE3 Sn579; Calibrated: 2010/9/20
- Phantom: SAM 12; Type: SAM V4.0; Serial: TP 1202
- Measurement SW: DASY4, V4.7 Build 80; Postprocessing SW: SEMCAD, V1.8 Build 186

Body Position - Mid/Area Scan (7x15x1): Measurement grid: dx=8mm, dy=8mm

Maximum value of SAR (measured) = 0.338 mW/g

Body Position - Mid/Zoom Scan (7x7x7)/Cube 0: Measurement grid: dx=5mm, dy=5mm, dz=5mm

Reference Value = 10.8 V/m; Power Drift = -0.106 dB

Peak SAR (extrapolated) = 0.400 W/kg

SAR(1 g) = 0.257 mW/g; SAR(10 g) = 0.162 mW/g

Maximum value of SAR (measured) = 0.332 mW/g

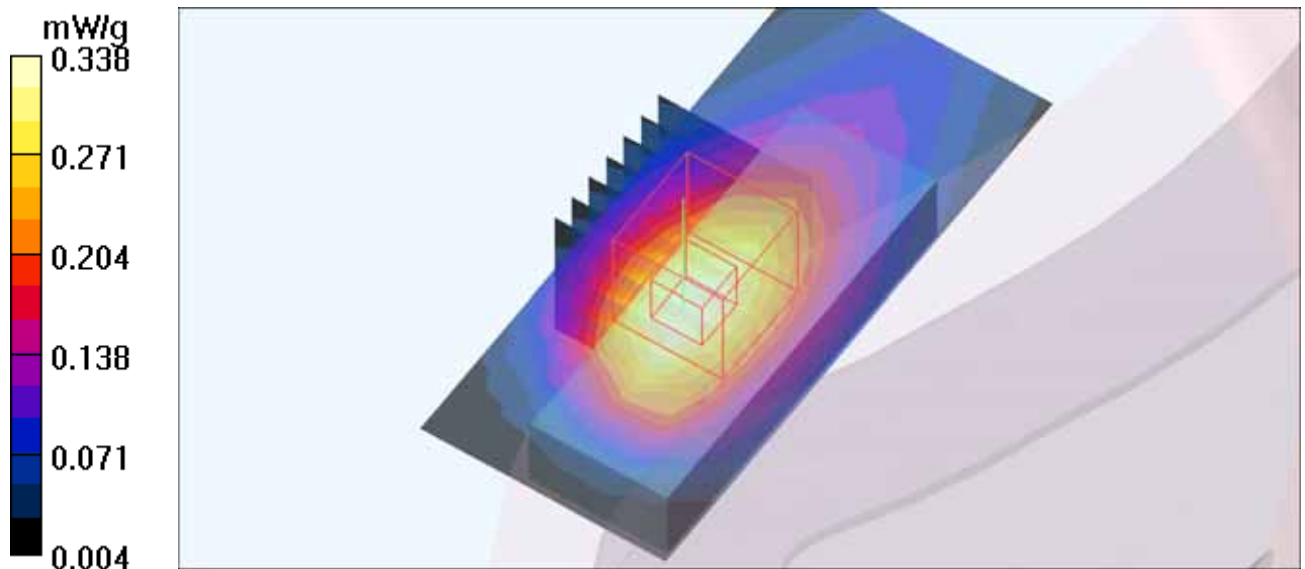

M32-E-GPRS850 TS4-Ch190

Communication System: E-GPRS850 ; Frequency: 836.6 MHz ; Duty Cycle: 1:2 ; Modulation Type: 8PSK / UL 4 time slots

Medium: MSL835 Medium parameters used: $f = 836.6$ MHz; $\sigma = 0.98$ mho/m; $\epsilon_r = 55.84$; $\rho = 1000$ kg/m³

Phantom section: Flat Section ; Separation distance : 5 mm (The Horizontal-Up side of the EUT to the Phantom)

DASY4 Configuration:

- Probe: EX3DV4 - SN3578; ConvF(8.55, 8.55, 8.55); Calibrated: 2010/6/22
- Sensor-Surface: 2mm (Mechanical Surface Detection)
- Electronics: DAE3 Sn579; Calibrated: 2010/9/20
- Phantom: SAM 12; Type: SAM V4.0; Serial: TP 1202
- Measurement SW: DASY4, V4.7 Build 80; Postprocessing SW: SEMCAD, V1.8 Build 186

Body Position - Mid/Area Scan (7x15x1): Measurement grid: dx=8mm, dy=8mm

Maximum value of SAR (measured) = 0.391 mW/g

Body Position - Mid/Zoom Scan (7x7x7)/Cube 0: Measurement grid: dx=5mm, dy=5mm, dz=5mm

Reference Value = 11.4 V/m; Power Drift = -0.183 dB

Peak SAR (extrapolated) = 0.468 W/kg

SAR(1 g) = 0.301 mW/g; SAR(10 g) = 0.190 mW/g

Maximum value of SAR (measured) = 0.389 mW/g

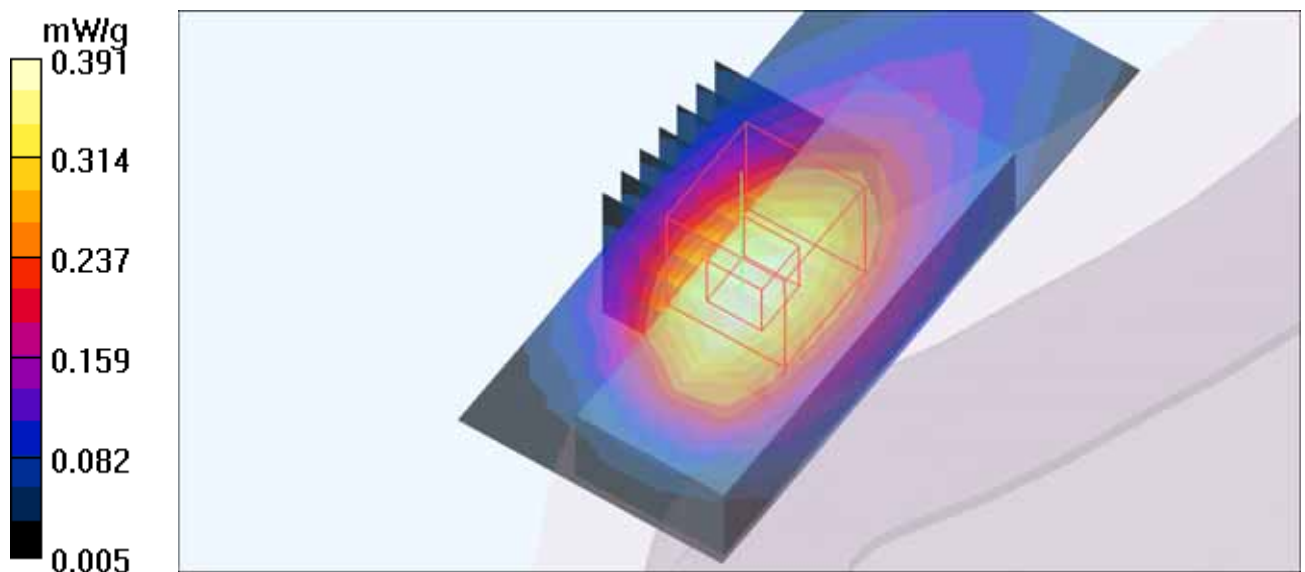

M33-E-GPRS850 TS1-Ch190

Communication System: E-GPRS850 ; Frequency: 836.6 MHz ; Duty Cycle: 1:8.3 ; Modulation Type: 8PSK / UL 1 time slot

Medium: MSL835 Medium parameters used: $f = 836.6$ MHz; $\sigma = 0.98$ mho/m; $\epsilon_r = 55.84$; $\rho = 1000$ kg/m³

Phantom section: Flat Section ; Separation distance : 5 mm (The Vertical-Back side of the EUT to the Phantom)

DASY4 Configuration:

- Probe: EX3DV4 - SN3578; ConvF(8.55, 8.55, 8.55); Calibrated: 2010/6/22
- Sensor-Surface: 2mm (Mechanical Surface Detection)
- Electronics: DAE3 Sn579; Calibrated: 2010/9/20
- Phantom: SAM 12; Type: SAM V4.0; Serial: TP 1202
- Measurement SW: DASY4, V4.7 Build 80; Postprocessing SW: SEMCAD, V1.8 Build 186

Body Position - Mid/Area Scan (7x15x1): Measurement grid: dx=8mm, dy=8mm

Maximum value of SAR (measured) = 0.087 mW/g

Body Position - Mid/Zoom Scan (7x7x7)/Cube 0: Measurement grid: dx=5mm, dy=5mm, dz=5mm

Reference Value = 4.42 V/m; Power Drift = -0.164 dB

Peak SAR (extrapolated) = 0.127 W/kg

SAR(1 g) = 0.083 mW/g; SAR(10 g) = 0.054 mW/g

Maximum value of SAR (measured) = 0.107 mW/g

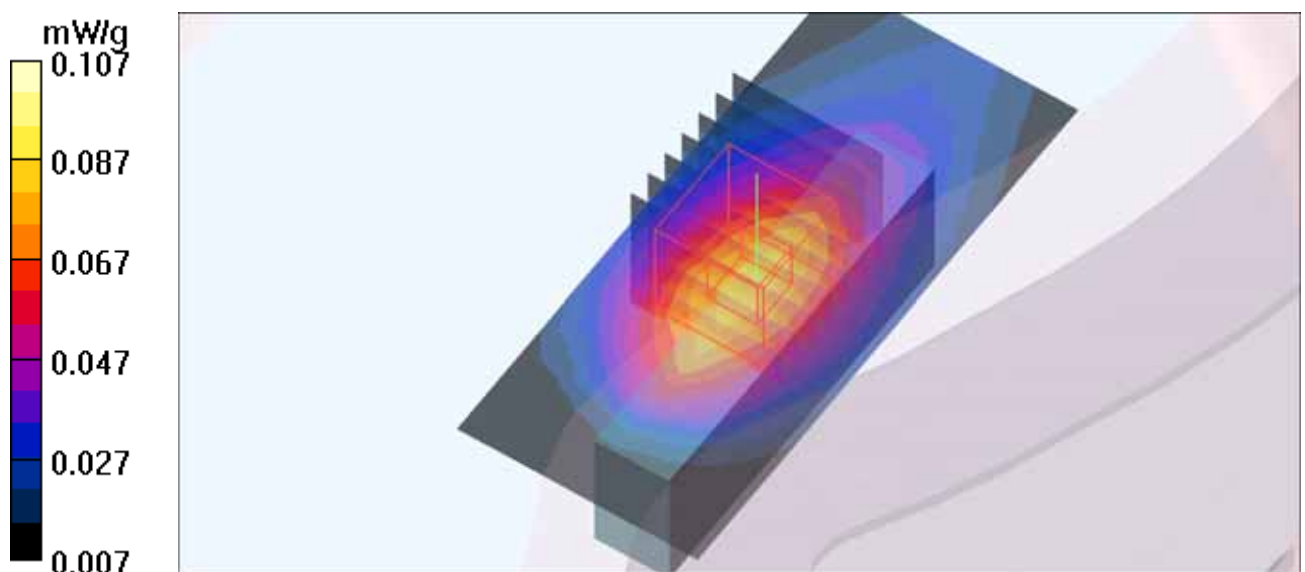

M34-E-GPRS850 TS2-Ch190

Communication System: E-GPRS850 ; Frequency: 836.6 MHz ; Duty Cycle: 1:4 ; Modulation Type: 8PSK / UL 2 time slots

Medium: MSL835 Medium parameters used: $f = 836.6$ MHz; $\sigma = 0.98$ mho/m; $\epsilon_r = 55.84$; $\rho = 1000$ kg/m³

Phantom section: Flat Section ; Separation distance : 5 mm (The Vertical-Back side of the EUT to the Phantom)

DASY4 Configuration:

- Probe: EX3DV4 - SN3578; ConvF(8.55, 8.55, 8.55); Calibrated: 2010/6/22
- Sensor-Surface: 2mm (Mechanical Surface Detection)
- Electronics: DAE3 Sn579; Calibrated: 2010/9/20
- Phantom: SAM 12; Type: SAM V4.0; Serial: TP 1202
- Measurement SW: DASY4, V4.7 Build 80; Postprocessing SW: SEMCAD, V1.8 Build 186

Body Position - Mid/Area Scan (7x15x1): Measurement grid: dx=8mm, dy=8mm

Maximum value of SAR (measured) = 0.195 mW/g

Body Position - Mid/Zoom Scan (7x7x7)/Cube 0: Measurement grid: dx=5mm, dy=5mm, dz=5mm

Reference Value = 7.25 V/m; Power Drift = -0.135 dB

Peak SAR (extrapolated) = 0.226 W/kg

SAR(1 g) = 0.148 mW/g; SAR(10 g) = 0.096 mW/g

Maximum value of SAR (measured) = 0.188 mW/g

Body Position - Mid/Zoom Scan (7x7x7)/Cube 1: Measurement grid: dx=5mm, dy=5mm, dz=5mm

Reference Value = 7.25 V/m; Power Drift = -0.135 dB

Peak SAR (extrapolated) = 0.223 W/kg

SAR(1 g) = 0.143 mW/g; SAR(10 g) = 0.086 mW/g

Maximum value of SAR (measured) = 0.187 mW/g

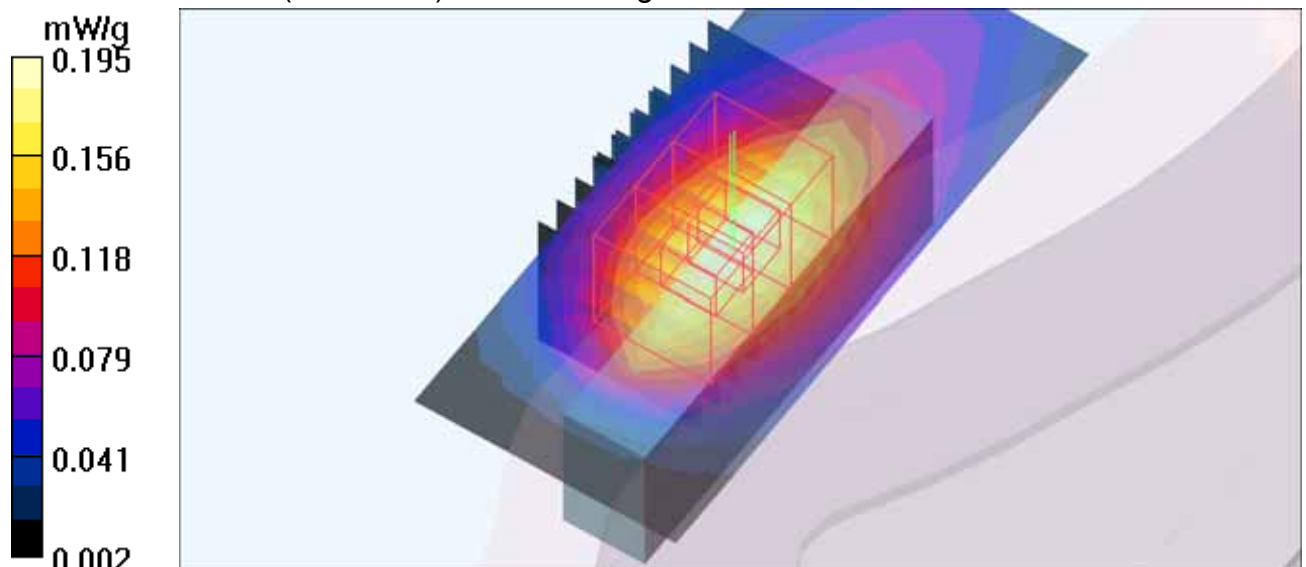

M35-E-GPRS850 TS3-Ch190

Communication System: E-GPRS850 ; Frequency: 836.6 MHz ; Duty Cycle: 1:2.67 ; Modulation Type: 8PSK / UL 3 time slots

Medium: MSL835 Medium parameters used: $f = 836.6$ MHz; $\sigma = 0.98$ mho/m; $\epsilon_r = 55.84$; $\rho = 1000$ kg/m³

Phantom section: Flat Section ; Separation distance : 5 mm (The Vertical-Back side of the EUT to the Phantom)

DASY4 Configuration:

- Probe: EX3DV4 - SN3578; ConvF(8.55, 8.55, 8.55); Calibrated: 2010/6/22
- Sensor-Surface: 2mm (Mechanical Surface Detection)
- Electronics: DAE3 Sn579; Calibrated: 2010/9/20
- Phantom: SAM 12; Type: SAM V4.0; Serial: TP 1202
- Measurement SW: DASY4, V4.7 Build 80; Postprocessing SW: SEMCAD, V1.8 Build 186

Body Position - Mid/Area Scan (7x15x1): Measurement grid: dx=8mm, dy=8mm

Maximum value of SAR (measured) = 0.253 mW/g

Body Position - Mid/Zoom Scan (7x7x7)/Cube 0: Measurement grid: dx=5mm, dy=5mm, dz=5mm

Reference Value = 8.44 V/m; Power Drift = -0.167 dB

Peak SAR (extrapolated) = 0.296 W/kg

SAR(1 g) = 0.194 mW/g; SAR(10 g) = 0.125 mW/g

Maximum value of SAR (measured) = 0.247 mW/g

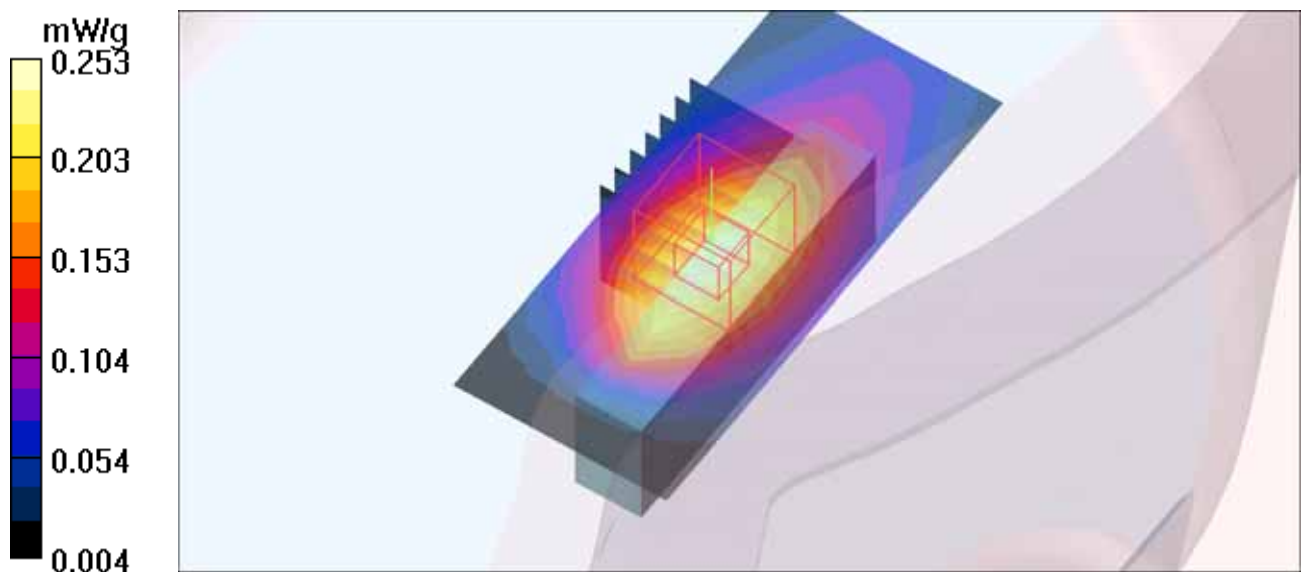

M36-E-GPRS850 TS4-Ch190

Communication System: E-GPRS850 ; Frequency: 836.6 MHz ; Duty Cycle: 1:2 ; Modulation Type: 8PSK / UL 4 time slots

Medium: MSL835 Medium parameters used: $f = 836.6$ MHz; $\sigma = 0.98$ mho/m; $\epsilon_r = 55.84$; $\rho = 1000$ kg/m³

Phantom section: Flat Section ; Separation distance : 5 mm (The Vertical-Back side of the EUT to the Phantom)

DASY4 Configuration:

- Probe: EX3DV4 - SN3578; ConvF(8.55, 8.55, 8.55); Calibrated: 2010/6/22
- Sensor-Surface: 2mm (Mechanical Surface Detection)
- Electronics: DAE3 Sn579; Calibrated: 2010/9/20
- Phantom: SAM 12; Type: SAM V4.0; Serial: TP 1202
- Measurement SW: DASY4, V4.7 Build 80; Postprocessing SW: SEMCAD, V1.8 Build 186

Body Position - Mid/Area Scan (7x15x1): Measurement grid: dx=8mm, dy=8mm

Maximum value of SAR (measured) = 0.303 mW/g

Body Position - Mid/Zoom Scan (7x7x7)/Cube 0: Measurement grid: dx=5mm, dy=5mm, dz=5mm

Reference Value = 9.19 V/m; Power Drift = -0.123 dB

Peak SAR (extrapolated) = 0.352 W/kg

SAR(1 g) = 0.230 mW/g; SAR(10 g) = 0.149 mW/g

Maximum value of SAR (measured) = 0.293 mW/g

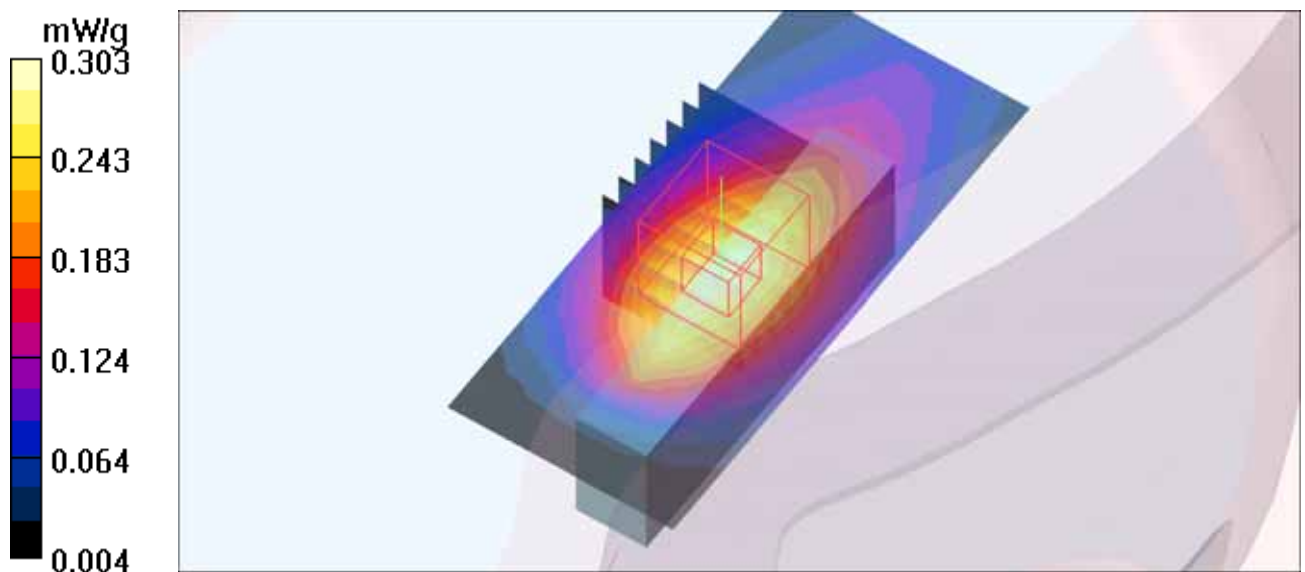

M37-E-GPRS850 TS1-Ch190

Communication System: E-GPRS850 ; Frequency: 836.6 MHz ; Duty Cycle: 1:8.3 ; Modulation Type: 8PSK / UL 1 time slot

Medium: MSL835 Medium parameters used: $f = 836.6$ MHz; $\sigma = 0.98$ mho/m; $\epsilon_r = 55.84$; $\rho = 1000$ kg/m³

Phantom section: Flat Section ; Separation distance : 5 mm (The top side of the EUT to the Phantom)

DASY4 Configuration:

- Probe: EX3DV4 - SN3578; ConvF(8.55, 8.55, 8.55); Calibrated: 2010/6/22
- Sensor-Surface: 2mm (Mechanical Surface Detection)
- Electronics: DAE3 Sn579; Calibrated: 2010/9/20
- Phantom: SAM 12; Type: SAM V4.0; Serial: TP 1202
- Measurement SW: DASY4, V4.7 Build 80; Postprocessing SW: SEMCAD, V1.8 Build 186

Body Position - Mid/Area Scan (7x8x1): Measurement grid: dx=8mm, dy=8mm

Maximum value of SAR (measured) = 0.011 mW/g

Body Position - Mid/Zoom Scan (7x7x7)/Cube 0: Measurement grid: dx=5mm, dy=5mm, dz=5mm

Reference Value = 3.58 V/m; Power Drift = -0.133 dB

Peak SAR (extrapolated) = 0.013 W/kg

SAR(1 g) = 0.00753 mW/g; SAR(10 g) = 0.00502 mW/g

Maximum value of SAR (measured) = 0.010 mW/g

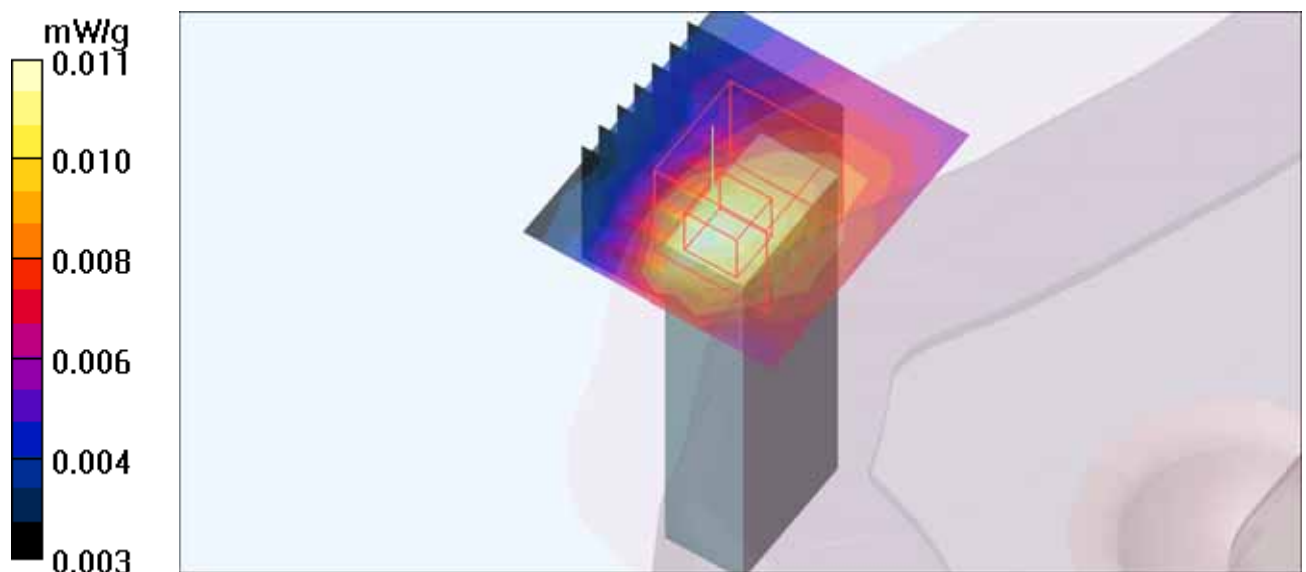

M38-E-GPRS850 TS2-Ch190

Communication System: E-GPRS850 ; Frequency: 836.6 MHz ; Duty Cycle: 1:4 ; Modulation Type: 8PSK / UL 2 time slots

Medium: MSL835 Medium parameters used: $f = 836.6$ MHz; $\sigma = 0.98$ mho/m; $\epsilon_r = 55.84$; $\rho = 1000$ kg/m³

Phantom section: Flat Section ; Separation distance : 5 mm (The top side of the EUT to the Phantom)

DASY4 Configuration:

- Probe: EX3DV4 - SN3578; ConvF(8.55, 8.55, 8.55); Calibrated: 2010/6/22
- Sensor-Surface: 2mm (Mechanical Surface Detection)
- Electronics: DAE3 Sn579; Calibrated: 2010/9/20
- Phantom: SAM 12; Type: SAM V4.0; Serial: TP 1202
- Measurement SW: DASY4, V4.7 Build 80; Postprocessing SW: SEMCAD, V1.8 Build 186

Body Position - Mid/Area Scan (7x8x1): Measurement grid: dx=8mm, dy=8mm

Maximum value of SAR (measured) = 0.014 mW/g

Body Position - Mid/Zoom Scan (7x7x7)/Cube 0: Measurement grid: dx=5mm, dy=5mm, dz=5mm

Reference Value = 3.82 V/m; Power Drift = 0.188 dB

Peak SAR (extrapolated) = 0.022 W/kg

SAR(1 g) = 0.012 mW/g; SAR(10 g) = 0.00749 mW/g

Maximum value of SAR (measured) = 0.016 mW/g

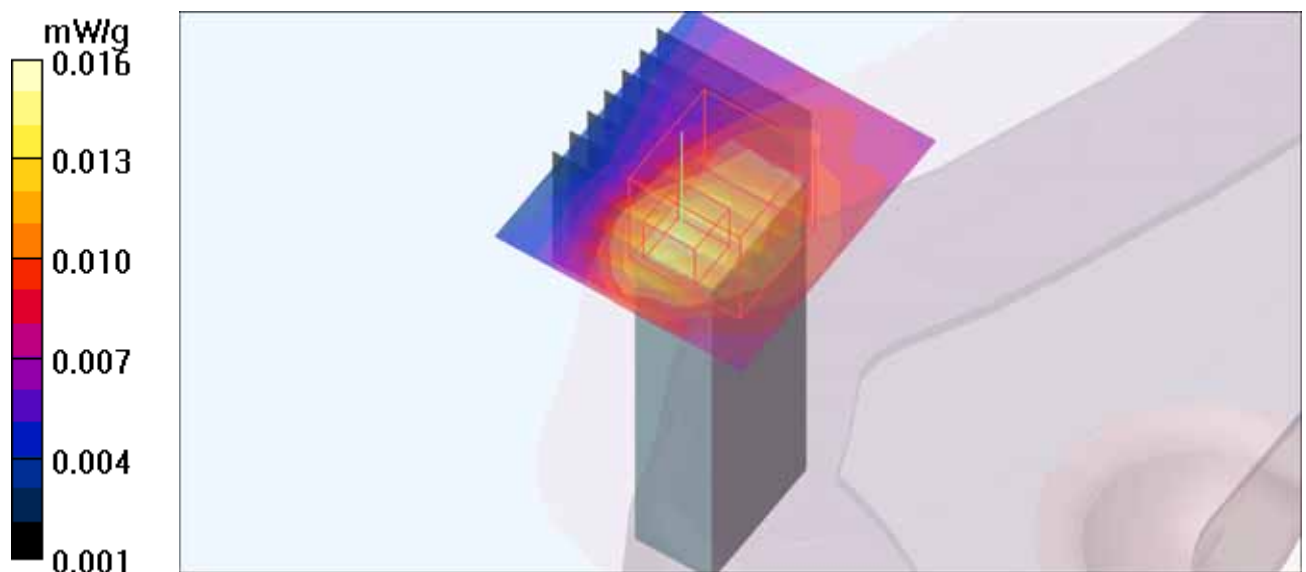

M39-E-GPRS850 TS3-Ch190

Communication System: E-GPRS850 ; Frequency: 836.6 MHz ; Duty Cycle: 1:2.67 ; Modulation Type: 8PSK / UL 3 time slots

Medium: MSL835 Medium parameters used: $f = 836.6$ MHz; $\sigma = 0.98$ mho/m; $\epsilon_r = 55.84$; $\rho = 1000$ kg/m³

Phantom section: Flat Section ; Separation distance : 5 mm (The top side of the EUT to the Phantom)

DASY4 Configuration:

- Probe: EX3DV4 - SN3578; ConvF(8.55, 8.55, 8.55); Calibrated: 2010/6/22
- Sensor-Surface: 2mm (Mechanical Surface Detection)
- Electronics: DAE3 Sn579; Calibrated: 2010/9/20
- Phantom: SAM 12; Type: SAM V4.0; Serial: TP 1202
- Measurement SW: DASY4, V4.7 Build 80; Postprocessing SW: SEMCAD, V1.8 Build 186

Body Position - Mid/Area Scan (7x8x1): Measurement grid: dx=8mm, dy=8mm
Maximum value of SAR (measured) = 0.018 mW/g

Body Position - Mid/Zoom Scan (7x7x7)/Cube 0: Measurement grid: dx=5mm, dy=5mm, dz=5mm

Reference Value = 4.34 V/m; Power Drift = 0.174 dB

Peak SAR (extrapolated) = 0.027 W/kg

SAR(1 g) = 0.015 mW/g; SAR(10 g) = 0.00932 mW/g

Maximum value of SAR (measured) = 0.020 mW/g

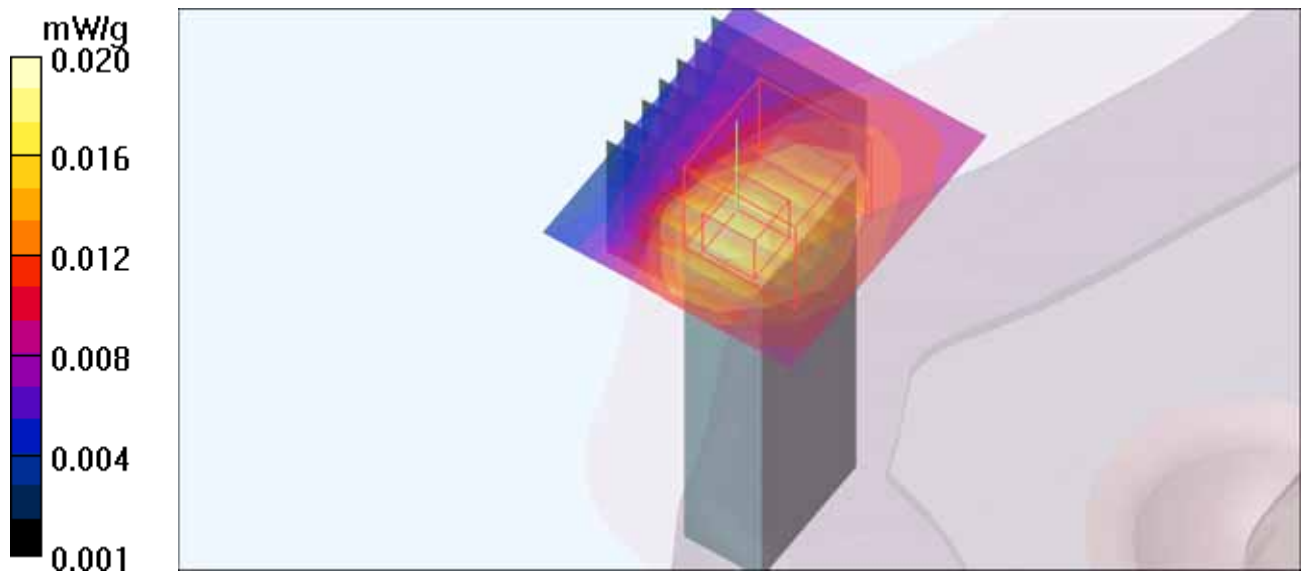

M40-E-GPRS850 TS4-Ch190

Communication System: E-GPRS850 ; Frequency: 836.6 MHz ; Duty Cycle: 1:2 ; Modulation Type: 8PSK / UL 4 time slots

Medium: MSL835 Medium parameters used: $f = 836.6$ MHz; $\sigma = 0.98$ mho/m; $\epsilon_r = 55.84$; $\rho = 1000$ kg/m³

Phantom section: Flat Section ; Separation distance : 5 mm (The top side of the EUT to the Phantom)

DASY4 Configuration:

- Probe: EX3DV4 - SN3578; ConvF(8.55, 8.55, 8.55); Calibrated: 2010/6/22
- Sensor-Surface: 2mm (Mechanical Surface Detection)
- Electronics: DAE3 Sn579; Calibrated: 2010/9/20
- Phantom: SAM 12; Type: SAM V4.0; Serial: TP 1202
- Measurement SW: DASY4, V4.7 Build 80; Postprocessing SW: SEMCAD, V1.8 Build 186

Body Position - Mid/Area Scan (7x8x1): Measurement grid: dx=8mm, dy=8mm

Maximum value of SAR (measured) = 0.023 mW/g

Body Position - Mid/Zoom Scan (7x7x7)/Cube 0: Measurement grid: dx=5mm, dy=5mm, dz=5mm

Reference Value = 4.93 V/m; Power Drift = 0.185 dB

Peak SAR (extrapolated) = 0.034 W/kg

SAR(1 g) = 0.018 mW/g; SAR(10 g) = 0.011 mW/g

Maximum value of SAR (measured) = 0.025 mW/g

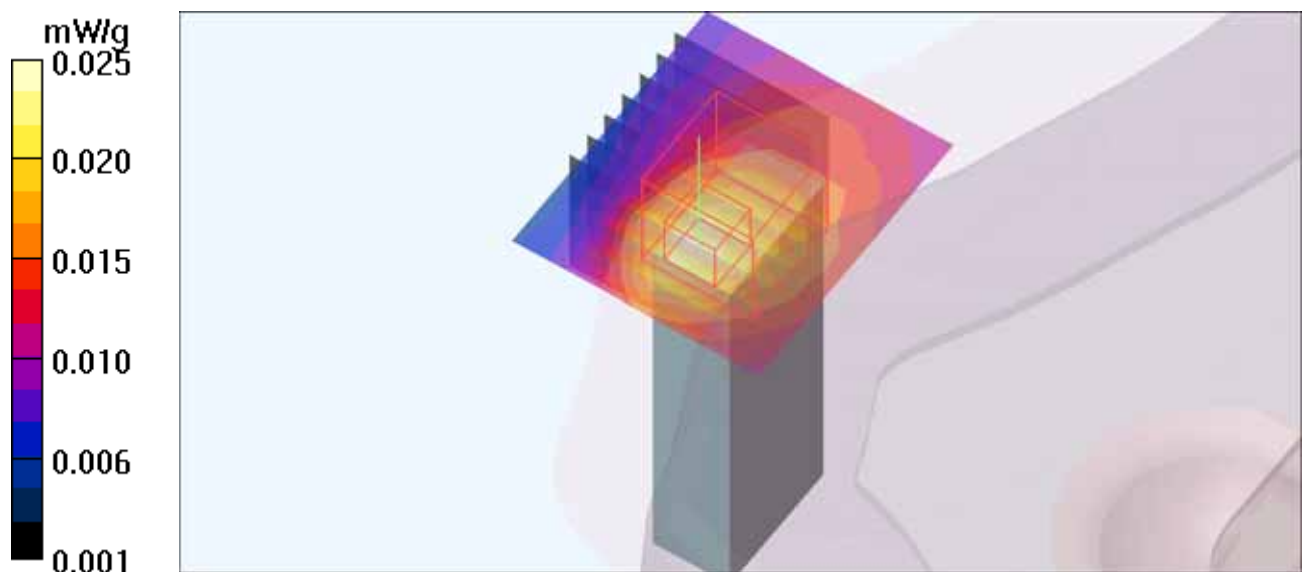

M41-WCDMA850-Ch4182

Communication System: WCDMA850 ; Frequency: 836.4 MHz ; Duty Cycle: 1:1 ; Modulation Type: BPSK

Medium: MSL835 Medium parameters used: $f = 836.4$ MHz; $\sigma = 0.98$ mho/m; $\epsilon_r = 55.84$; $\rho = 1000$ kg/m³

Phantom section: Flat Section ; Separation distance : 5 mm (The Horizontal-Down side of the EUT to the Phantom)

DASY4 Configuration:

- Probe: EX3DV4 - SN3578; ConvF(8.55, 8.55, 8.55); Calibrated: 2010/6/22
- Sensor-Surface: 2mm (Mechanical Surface Detection)
- Electronics: DAE3 Sn579; Calibrated: 2010/9/20
- Phantom: SAM 12; Type: SAM V4.0; Serial: TP 1202
- Measurement SW: DASY4, V4.7 Build 80; Postprocessing SW: SEMCAD, V1.8 Build 186

Body Position - Mid/Area Scan (7x15x1): Measurement grid: dx=8mm, dy=8mm

Maximum value of SAR (measured) = 0.620 mW/g

Body Position - Mid/Zoom Scan (7x7x7)/Cube 0: Measurement grid: dx=5mm, dy=5mm, dz=5mm

Reference Value = 10.2 V/m; Power Drift = 0.140 dB

Peak SAR (extrapolated) = 0.771 W/kg

SAR(1 g) = 0.500 mW/g; SAR(10 g) = 0.315 mW/g

Maximum value of SAR (measured) = 0.649 mW/g

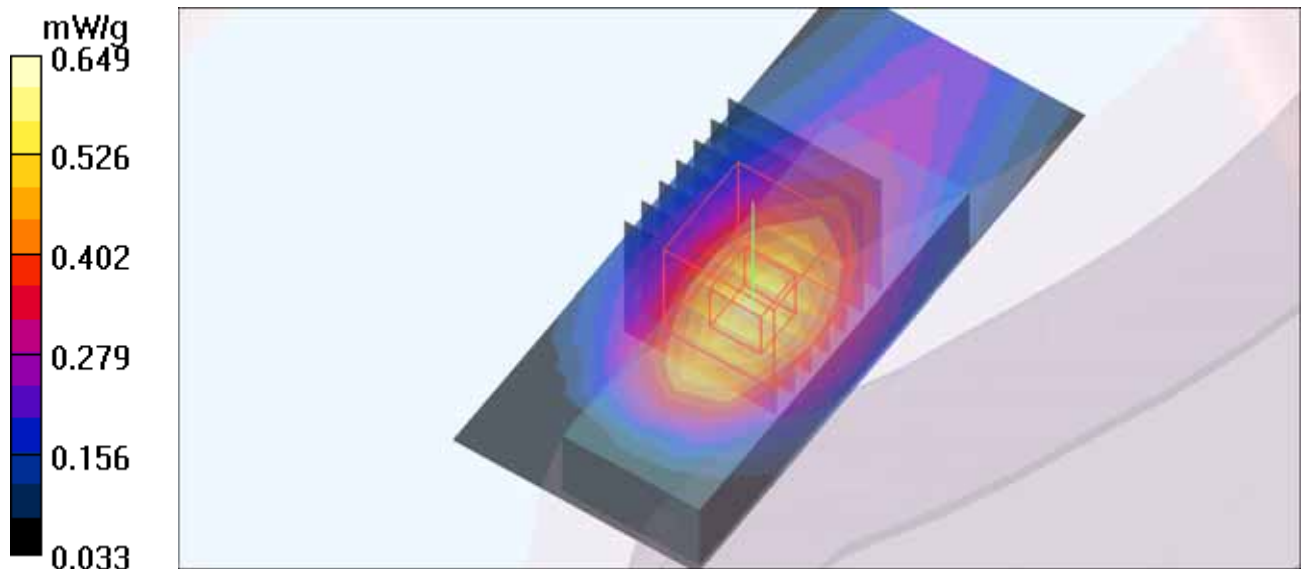

M42-WCDMA850-Ch4182

Communication System: WCDMA850 ; Frequency: 836.4 MHz ; Duty Cycle: 1:1 ; Modulation Type: BPSK

Medium: MSL835 Medium parameters used: $f = 836.4$ MHz; $\sigma = 0.98$ mho/m; $\epsilon_r = 55.84$; $\rho = 1000$ kg/m³

Phantom section: Flat Section ; Separation distance : 5 mm (The Vertical-Front side of the EUT to the Phantom)

DASY4 Configuration:

- Probe: EX3DV4 - SN3578; ConvF(8.55, 8.55, 8.55); Calibrated: 2010/6/22
- Sensor-Surface: 2mm (Mechanical Surface Detection)
- Electronics: DAE3 Sn579; Calibrated: 2010/9/20
- Phantom: SAM 12; Type: SAM V4.0; Serial: TP 1202
- Measurement SW: DASY4, V4.7 Build 80; Postprocessing SW: SEMCAD, V1.8 Build 186

Body Position - Mid/Area Scan (7x15x1): Measurement grid: dx=8mm, dy=8mm

Maximum value of SAR (measured) = 0.369 mW/g

Body Position - Mid/Zoom Scan (7x7x7)/Cube 0: Measurement grid: dx=5mm, dy=5mm, dz=5mm

Reference Value = 9.43 V/m; Power Drift = 0.173 dB

Peak SAR (extrapolated) = 0.456 W/kg

SAR(1 g) = 0.279 mW/g; SAR(10 g) = 0.169 mW/g

Maximum value of SAR (measured) = 0.371 mW/g

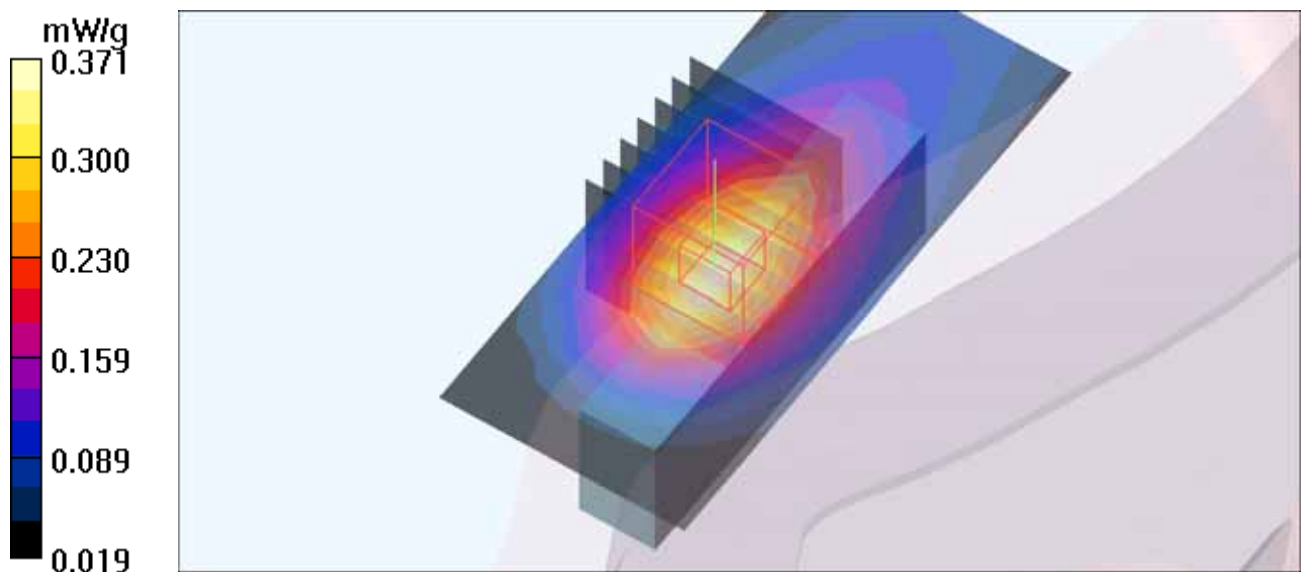

M43-WCDMA850-Ch4182

Communication System: WCDMA850 ; Frequency: 836.4 MHz ; Duty Cycle: 1:1 ; Modulation Type: BPSK

Medium: MSL835 Medium parameters used: $f = 836.4\text{MHz}$; $\sigma = 0.98\text{ mho/m}$; $\epsilon_r = 55.84$; $\rho = 1000\text{ kg/m}^3$

Phantom section: Flat Section ; Separation distance : 5 mm (The Horizontal-Up side of the EUT to the Phantom)

DASY4 Configuration:

- Probe: EX3DV4 - SN3578; ConvF(8.55, 8.55, 8.55); Calibrated: 2010/6/22
- Sensor-Surface: 2mm (Mechanical Surface Detection)
- Electronics: DAE3 Sn579; Calibrated: 2010/9/20
- Phantom: SAM 12; Type: SAM V4.0; Serial: TP 1202
- Measurement SW: DASY4, V4.7 Build 80; Postprocessing SW: SEMCAD, V1.8 Build 186

Body Position - Mid/Area Scan (7x15x1): Measurement grid: $dx=8\text{mm}$, $dy=8\text{mm}$

Maximum value of SAR (measured) = 0.464 mW/g

Body Position - Mid/Zoom Scan (7x7x7)/Cube 0: Measurement grid: $dx=5\text{mm}$, $dy=5\text{mm}$, $dz=5\text{mm}$

Reference Value = 8.50 V/m; Power Drift = 0.105 dB

Peak SAR (extrapolated) = 0.600 W/kg

SAR(1 g) = 0.380 mW/g; SAR(10 g) = 0.238 mW/g

Maximum value of SAR (measured) = 0.494 mW/g

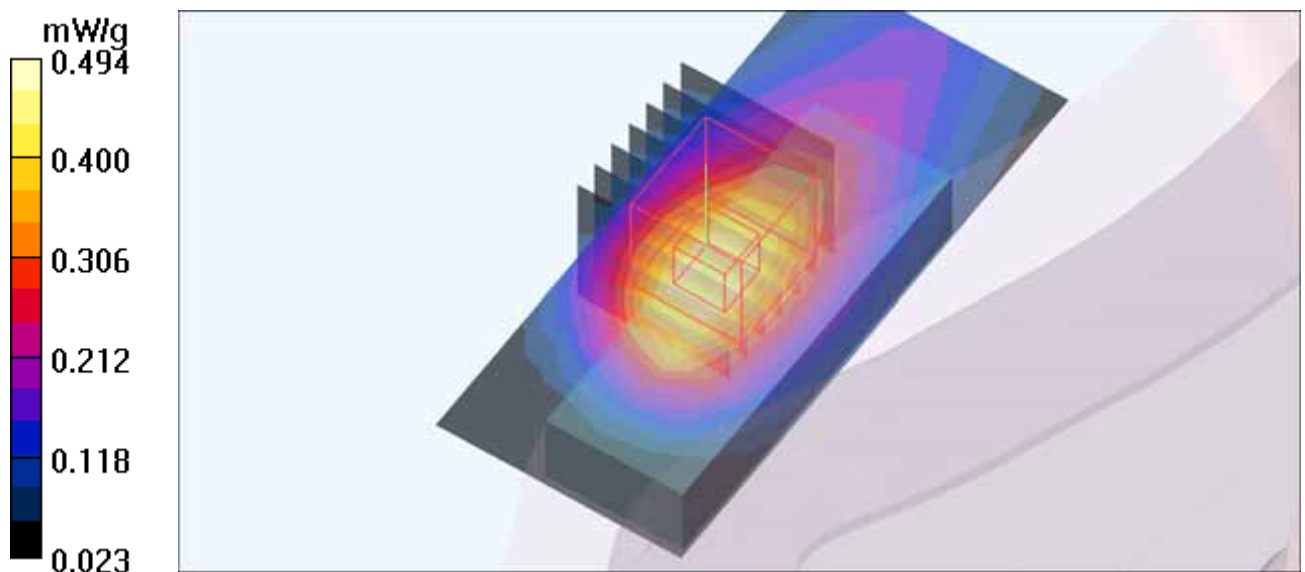

M44-WCDMA850-Ch4182

Communication System: WCDMA850 ; Frequency: 836.4 MHz ; Duty Cycle: 1:1 ; Modulation Type: BPSK

Medium: MSL835 Medium parameters used: $f = 836.4$ MHz; $\sigma = 0.98$ mho/m; $\epsilon_r = 55.84$; $\rho = 1000$ kg/m³

Phantom section: Flat Section ; Separation distance : 5 mm (The Vertical-Back side of the EUT to the Phantom)

DASY4 Configuration:

- Probe: EX3DV4 - SN3578; ConvF(8.55, 8.55, 8.55); Calibrated: 2010/6/22
- Sensor-Surface: 2mm (Mechanical Surface Detection)
- Electronics: DAE3 Sn579; Calibrated: 2010/9/20
- Phantom: SAM 12; Type: SAM V4.0; Serial: TP 1202
- Measurement SW: DASY4, V4.7 Build 80; Postprocessing SW: SEMCAD, V1.8 Build 186

Body Position - Mid/Area Scan (7x15x1): Measurement grid: dx=8mm, dy=8mm

Maximum value of SAR (measured) = 0.355 mW/g

Body Position - Mid/Zoom Scan (7x7x7)/Cube 0: Measurement grid: dx=5mm, dy=5mm, dz=5mm

Reference Value = 7.32 V/m; Power Drift = -0.014 dB

Peak SAR (extrapolated) = 0.418 W/kg

SAR(1 g) = 0.280 mW/g; SAR(10 g) = 0.184 mW/g

Maximum value of SAR (measured) = 0.353 mW/g

Body Position - Mid/Zoom Scan (7x7x7)/Cube 1: Measurement grid: dx=5mm, dy=5mm, dz=5mm

Reference Value = 7.32 V/m; Power Drift = -0.014 dB

Peak SAR (extrapolated) = 0.422 W/kg

SAR(1 g) = 0.262 mW/g; SAR(10 g) = 0.153 mW/g

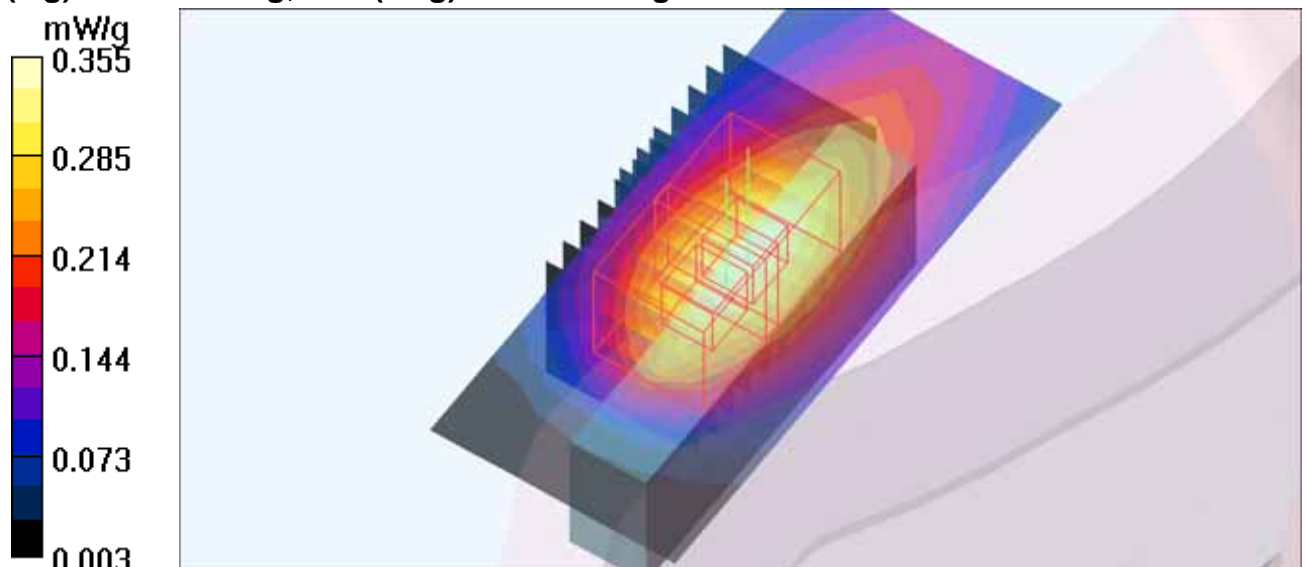

M45-WCDMA850-Ch4182

Communication System: WCDMA850 ; Frequency: 836.4 MHz ; Duty Cycle: 1:1 ; Modulation Type: BPSK

Medium: MSL835 Medium parameters used: $f = 836.4$ MHz; $\sigma = 0.98$ mho/m; $\epsilon_r = 55.84$; $\rho = 1000$ kg/m³

Phantom section: Flat Section ; Separation distance : 5 mm (The top side of the EUT to the Phantom)

DASY4 Configuration:

- Probe: EX3DV4 - SN3578; ConvF(8.55, 8.55, 8.55); Calibrated: 2010/6/22
- Sensor-Surface: 2mm (Mechanical Surface Detection)
- Electronics: DAE3 Sn579; Calibrated: 2010/9/20
- Phantom: SAM 12; Type: SAM V4.0; Serial: TP 1202
- Measurement SW: DASY4, V4.7 Build 80; Postprocessing SW: SEMCAD, V1.8 Build 186

Body Position - Mid/Area Scan (7x8x1): Measurement grid: dx=8mm, dy=8mm

Maximum value of SAR (measured) = 0.049 mW/g

Body Position - Mid/Zoom Scan (7x7x7)/Cube 0: Measurement grid: dx=5mm, dy=5mm, dz=5mm

Reference Value = 5.37 V/m; Power Drift = 0.135 dB

Peak SAR (extrapolated) = 0.066 W/kg

SAR(1 g) = 0.033 mW/g; SAR(10 g) = 0.020 mW/g

Maximum value of SAR (measured) = 0.048 mW/g

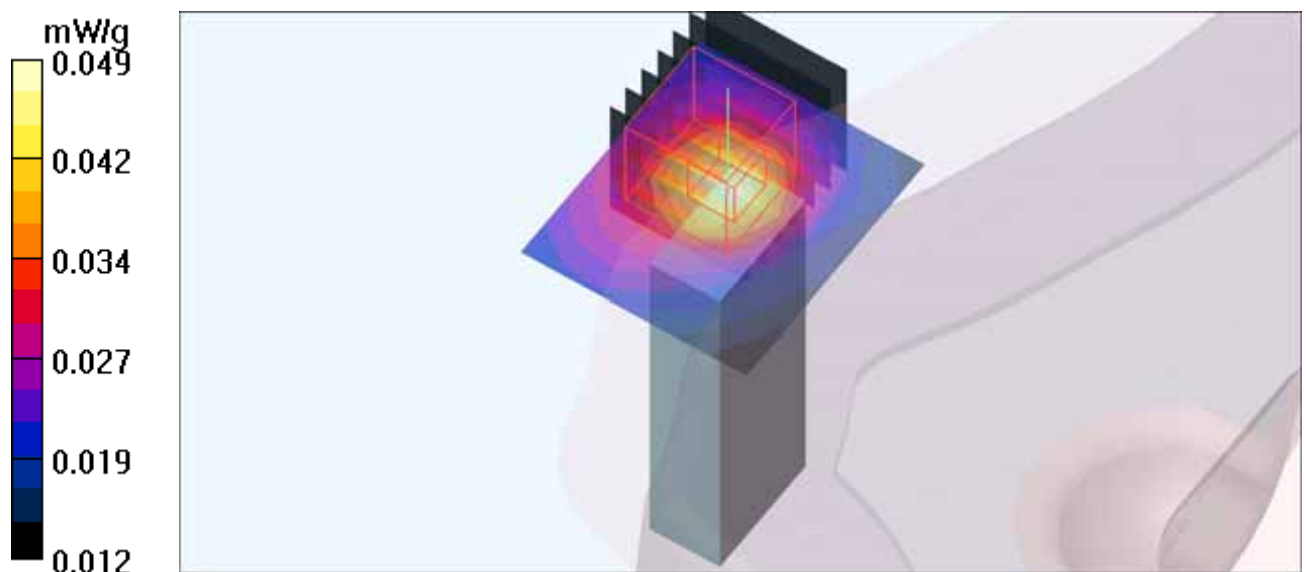

M46-GPRS1900 TS1-Ch661

Communication System: GPRS1900 ; Frequency: 1880 MHz ; Duty Cycle: 1:8.3 ; Modulation Type: GMSK / UL 1 time slot

Medium: MSL1900 Medium parameters used: $f = 1880$ MHz; $\sigma = 1.54$ mho/m; $\epsilon_r = 54.64$; $\rho = 1000$ kg/m³

Phantom section: Flat Section ; Separation Distance : 5 mm (The Horizontal-Down side of the EUT to the Phantom)

DASY4 Configuration:

- Probe: EX3DV4 - SN3578; ConvF(6.7, 6.7, 6.7); Calibrated: 2010/6/22
- Sensor-Surface: 2mm (Mechanical Surface Detection)
- Electronics: DAE3 Sn579; Calibrated: 2010/9/20
- Phantom: SAM 12; Type: SAM V4.0; Serial: TP 1202
- Measurement SW: DASY4, V4.7 Build 80; Postprocessing SW: SEMCAD, V1.8 Build 186

Body Position - Mid/Area Scan (7x15x1): Measurement grid: dx=8mm, dy=8mm

Maximum value of SAR (measured) = 0.740 mW/g

Body Position - Mid/Zoom Scan (7x7x7)/Cube 0: Measurement grid: dx=5mm, dy=5mm, dz=5mm

Reference Value = 12.3 V/m; Power Drift = -0.146 dB

Peak SAR (extrapolated) = 0.926 W/kg

SAR(1 g) = 0.514 mW/g; SAR(10 g) = 0.283 mW/g

Maximum value of SAR (measured) = 0.708 mW/g

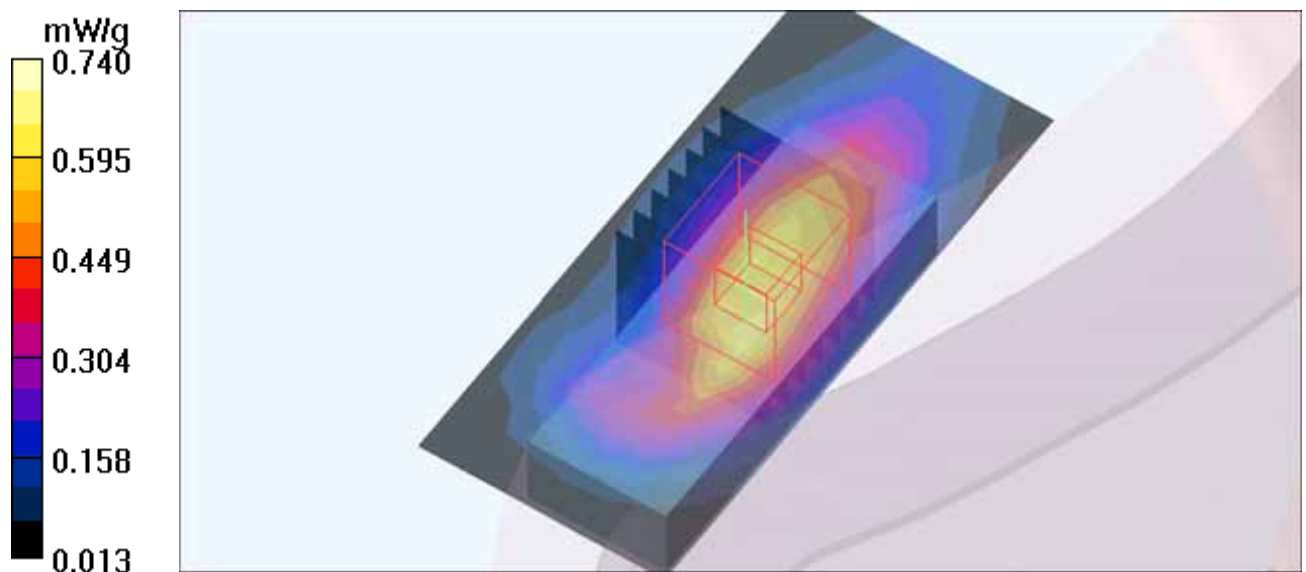

M47-GPRS1900 TS2-Ch661

Communication System: GPRS1900 ; Frequency: 1880 MHz ; Duty Cycle: 1:4 ; Modulation Type: GMSK / UL 2 time slots

Medium: MSL1900 Medium parameters used: $f = 1880$ MHz; $\sigma = 1.54$ mho/m; $\epsilon_r = 54.64$; $\rho = 1000$ kg/m³

Phantom section: Flat Section ; Separation Distance : 5 mm (The Horizontal-Down side of the EUT to the Phantom)

DASY4 Configuration:

- Probe: EX3DV4 - SN3578; ConvF(6.7, 6.7, 6.7); Calibrated: 2010/6/22
- Sensor-Surface: 2mm (Mechanical Surface Detection)
- Electronics: DAE3 Sn579; Calibrated: 2010/9/20
- Phantom: SAM 12; Type: SAM V4.0; Serial: TP 1202
- Measurement SW: DASY4, V4.7 Build 80; Postprocessing SW: SEMCAD, V1.8 Build 186

Body Position - Mid/Area Scan (7x15x1): Measurement grid: dx=8mm, dy=8mm

Maximum value of SAR (measured) = 0.897 mW/g

Body Position - Mid/Zoom Scan (7x7x7)/Cube 0: Measurement grid: dx=5mm, dy=5mm, dz=5mm

Reference Value = 14.6 V/m; Power Drift = -0.103 dB

Peak SAR (extrapolated) = 1.65 W/kg

SAR(1 g) = 0.610 mW/g; SAR(10 g) = 0.248 mW/g.

Maximum value of SAR (measured) = 0.759 mW/g

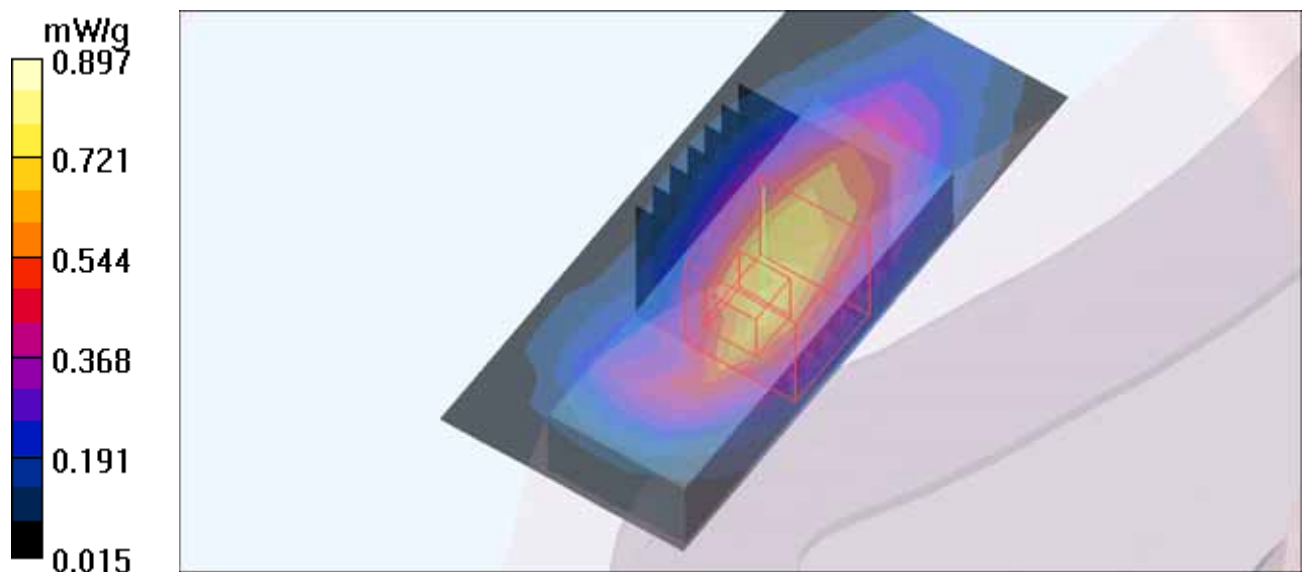

M48-GPRS1900 TS3-Ch661

Communication System: GPRS1900 ; Frequency: 1880 MHz ; Duty Cycle: 1:2.67 ; Modulation Type: GMSK / UL 3 time slots

Medium: MSL1900 Medium parameters used: $f = 1880$ MHz; $\sigma = 1.54$ mho/m; $\epsilon_r = 54.64$; $\rho = 1000$ kg/m³

Phantom section: Flat Section ; Separation Distance : 5 mm (The Horizontal-Down side of the EUT to the Phantom)

DASY4 Configuration:

- Probe: EX3DV4 - SN3578; ConvF(6.7, 6.7, 6.7); Calibrated: 2010/6/22
- Sensor-Surface: 2mm (Mechanical Surface Detection)
- Electronics: DAE3 Sn579; Calibrated: 2010/9/20
- Phantom: SAM 12; Type: SAM V4.0; Serial: TP 1202
- Measurement SW: DASY4, V4.7 Build 80; Postprocessing SW: SEMCAD, V1.8 Build 186

Body Position - Mid/Area Scan (7x15x1): Measurement grid: dx=8mm, dy=8mm

Maximum value of SAR (measured) = 0.889 mW/g

Body Position - Mid/Zoom Scan (7x7x7)/Cube 0: Measurement grid: dx=5mm, dy=5mm, dz=5mm

Reference Value = 14.6 V/m; Power Drift = -0.174 dB

Peak SAR (extrapolated) = 0.994 W/kg

SAR(1 g) = 0.543 mW/g; SAR(10 g) = 0.299 mW/g

Maximum value of SAR (measured) = 0.759 mW/g

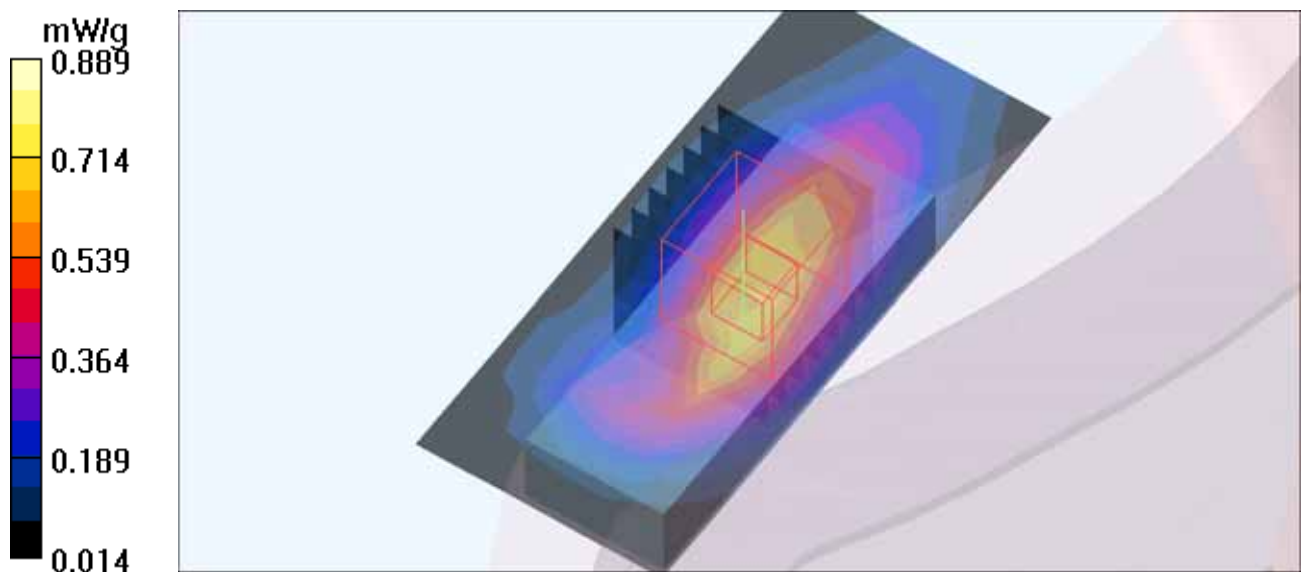

M49-GPRS1900 TS4-Ch661

Communication System: GPRS1900 ; Frequency: 1880 MHz ; Duty Cycle: 1:2 ; Modulation Type: GMSK / UL 4 time slots

Medium: MSL1900 Medium parameters used: $f = 1880$ MHz; $\sigma = 1.54$ mho/m; $\epsilon_r = 54.64$; $\rho = 1000$ kg/m³

Phantom section: Flat Section ; Separation Distance : 5 mm (The Horizontal-Down side of the EUT to the Phantom)

DASY4 Configuration:

- Probe: EX3DV4 - SN3578; ConvF(6.7, 6.7, 6.7); Calibrated: 2010/6/22
- Sensor-Surface: 2mm (Mechanical Surface Detection)
- Electronics: DAE3 Sn579; Calibrated: 2010/9/20
- Phantom: SAM 12; Type: SAM V4.0; Serial: TP 1202
- Measurement SW: DASY4, V4.7 Build 80; Postprocessing SW: SEMCAD, V1.8 Build 186

Body Position - Mid/Area Scan (7x15x1): Measurement grid: dx=8mm, dy=8mm

Maximum value of SAR (measured) = 0.492 mW/g

Body Position - Mid/Zoom Scan (7x7x7)/Cube 0: Measurement grid: dx=5mm, dy=5mm, dz=5mm

Reference Value = 9.97 V/m; Power Drift = 0.033 dB

Peak SAR (extrapolated) = 0.668 W/kg

SAR(1 g) = 0.365 mW/g; SAR(10 g) = 0.201 mW/g

Maximum value of SAR (measured) = 0.506 mW/g

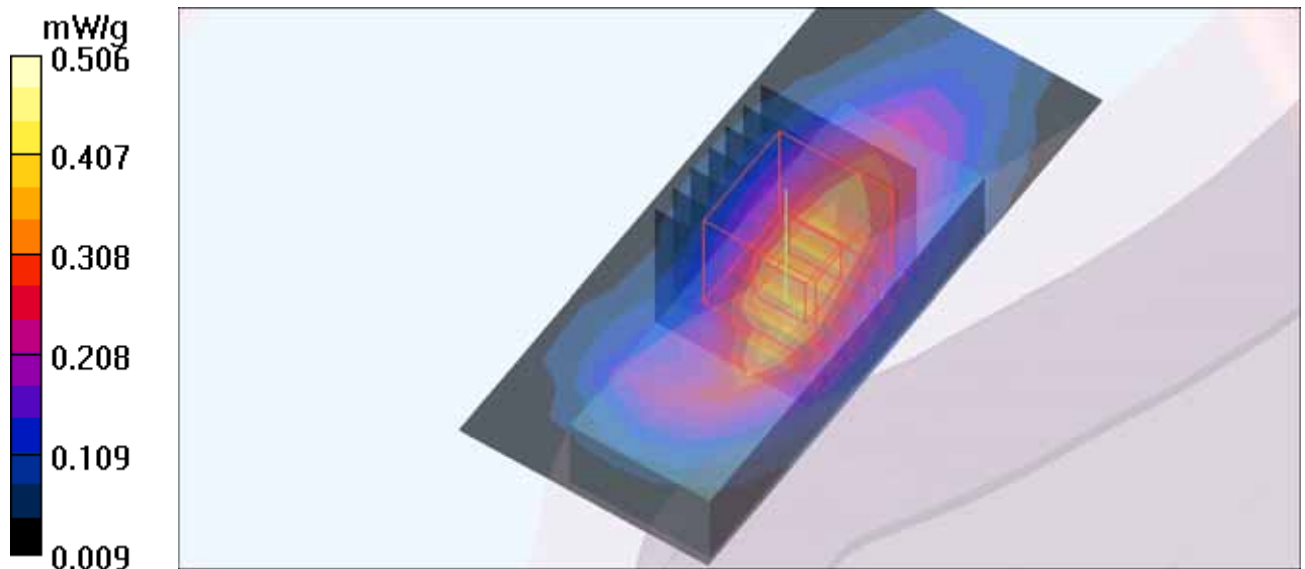

M50-GPRS1900 TS1-Ch661

Communication System: GPRS1900 ; Frequency: 1880 MHz ; Duty Cycle: 1:8.3 ; Modulation Type: GMSK / UL 1 time slot

Medium: MSL1900 Medium parameters used: $f = 1880$ MHz; $\sigma = 1.54$ mho/m; $\epsilon_r = 54.64$; $\rho = 1000$ kg/m³

Phantom section: Flat Section ; Separation Distance : 5 mm (The Vertical-Front side of the EUT to the Phantom)

DASY4 Configuration:

- Probe: EX3DV4 - SN3578; ConvF(6.7, 6.7, 6.7); Calibrated: 2010/6/22
- Sensor-Surface: 2mm (Mechanical Surface Detection)
- Electronics: DAE3 Sn579; Calibrated: 2010/9/20
- Phantom: SAM 12; Type: SAM V4.0; Serial: TP 1202
- Measurement SW: DASY4, V4.7 Build 80; Postprocessing SW: SEMCAD, V1.8 Build 186

Body Position - Mid/Area Scan (7x15x1): Measurement grid: dx=8mm, dy=8mm

Maximum value of SAR (measured) = 0.226 mW/g

Body Position - Mid/Zoom Scan (7x7x7)/Cube 0: Measurement grid: dx=5mm, dy=5mm, dz=5mm

Reference Value = 3.62 V/m; Power Drift = 0.145 dB

Peak SAR (extrapolated) = 0.317 W/kg

SAR(1 g) = 0.183 mW/g; SAR(10 g) = 0.101 mW/g

Maximum value of SAR (measured) = 0.250 mW/g

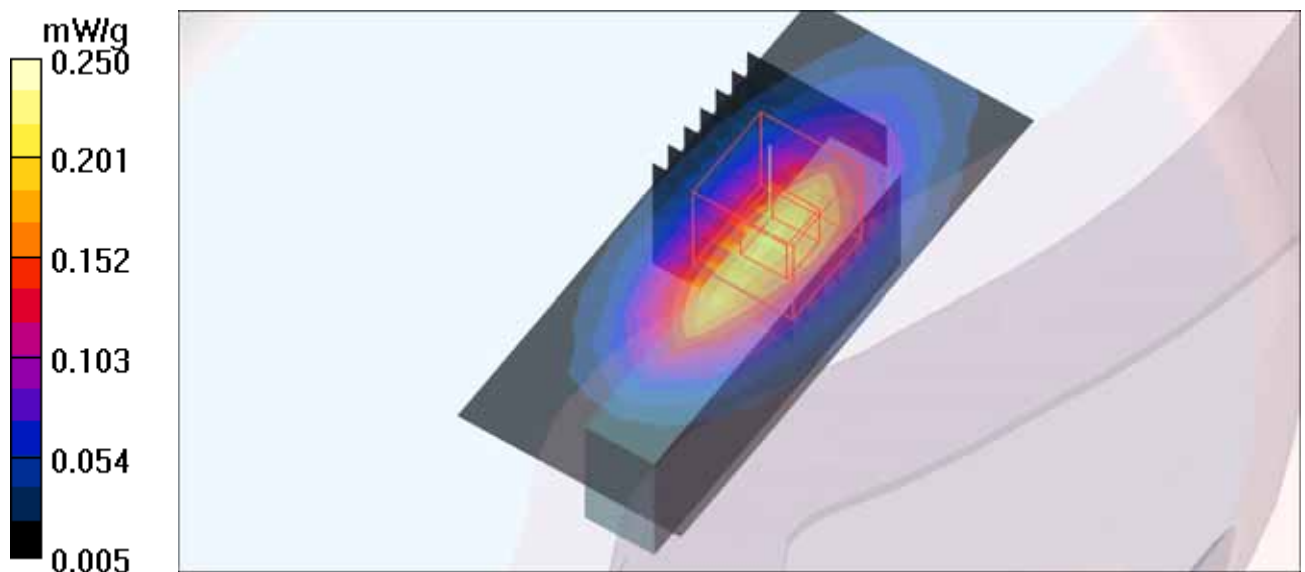

M51-GPRS1900 TS2-Ch190-Ch661

Communication System: GPRS1900 ; Frequency: 1880 MHz ; Duty Cycle: 1:4 ; Modulation Type: GMSK / UL 2 time slots

Medium: MSL1900 Medium parameters used: $f = 1880$ MHz; $\sigma = 1.54$ mho/m; $\epsilon_r = 54.64$; $\rho = 1000$ kg/m³

Phantom section: Flat Section ; Separation Distance : 5 mm (The Vertical-Front side of the EUT to the Phantom)

DASY4 Configuration:

- Probe: EX3DV4 - SN3578; ConvF(6.7, 6.7, 6.7); Calibrated: 2010/6/22
- Sensor-Surface: 2mm (Mechanical Surface Detection)
- Electronics: DAE3 Sn579; Calibrated: 2010/9/20
- Phantom: SAM 12; Type: SAM V4.0; Serial: TP 1202
- Measurement SW: DASY4, V4.7 Build 80; Postprocessing SW: SEMCAD, V1.8 Build 186

Body Position - Mid/Area Scan (7x15x1): Measurement grid: dx=8mm, dy=8mm

Maximum value of SAR (measured) = 0.309 mW/g

Body Position - Mid/Zoom Scan (7x7x7)/Cube 0: Measurement grid: dx=5mm, dy=5mm, dz=5mm

Reference Value = 4.99 V/m; Power Drift = -0.144 dB

Peak SAR (extrapolated) = 0.368 W/kg

SAR(1 g) = 0.213 mW/g; SAR(10 g) = 0.119 mW/g

Maximum value of SAR (measured) = 0.293 mW/g

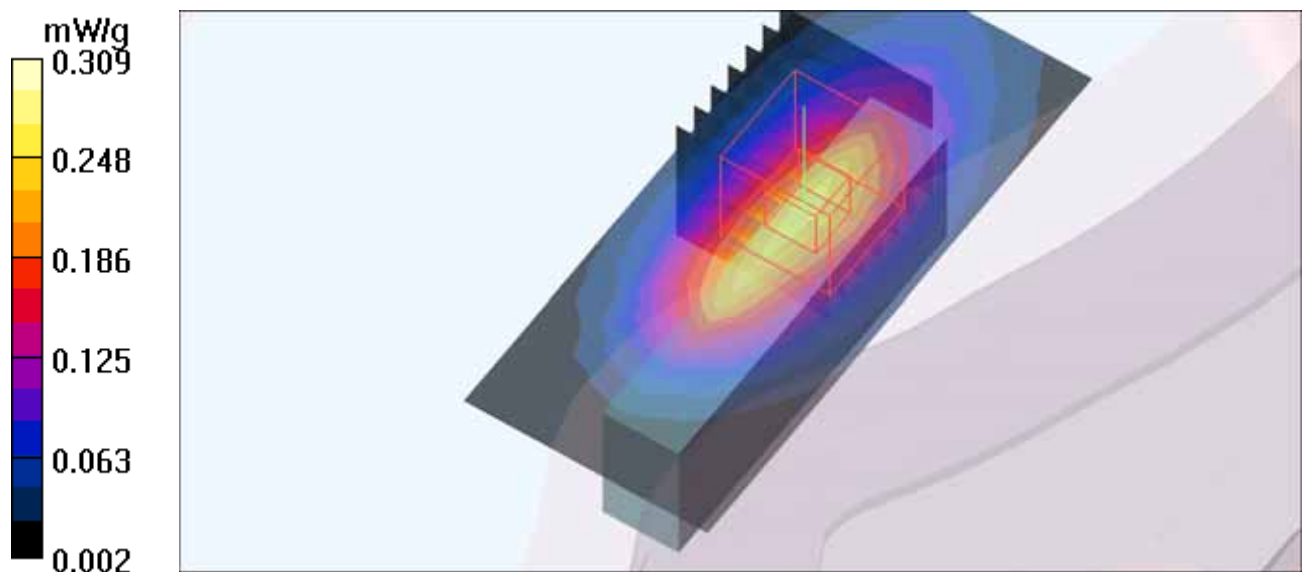

M52-GPRS1900 TS3-Ch190-Ch661

Communication System: GPRS1900 ; Frequency: 1880 MHz ; Duty Cycle: 1:2.67 ; Modulation Type: GMSK / UL 3 time slots

Medium: MSL1900 Medium parameters used: $f = 1880$ MHz; $\sigma = 1.54$ mho/m; $\epsilon_r = 54.64$; $\rho = 1000$ kg/m³

Phantom section: Flat Section ; Separation distance : 5 mm (The Vertical-Front side of the EUT to the Phantom)

DASY4 Configuration:

- Probe: EX3DV4 - SN3578; ConvF(6.7, 6.7, 6.7); Calibrated: 2010/6/22
- Sensor-Surface: 2mm (Mechanical Surface Detection)
- Electronics: DAE3 Sn579; Calibrated: 2010/9/20
- Phantom: SAM 12; Type: SAM V4.0; Serial: TP 1202
- Measurement SW: DASY4, V4.7 Build 80; Postprocessing SW: SEMCAD, V1.8 Build 186

Body Position - Mid/Area Scan (7x15x1): Measurement grid: dx=8mm, dy=8mm

Maximum value of SAR (measured) = 0.313 mW/g

Body Position - Mid/Zoom Scan (7x7x7)/Cube 0: Measurement grid: dx=5mm, dy=5mm, dz=5mm

Reference Value = 5.19 V/m; Power Drift = -0.190 dB

Peak SAR (extrapolated) = 0.364 W/kg

SAR(1 g) = 0.210 mW/g; SAR(10 g) = 0.117 mW/g

Maximum value of SAR (measured) = 0.291 mW/g

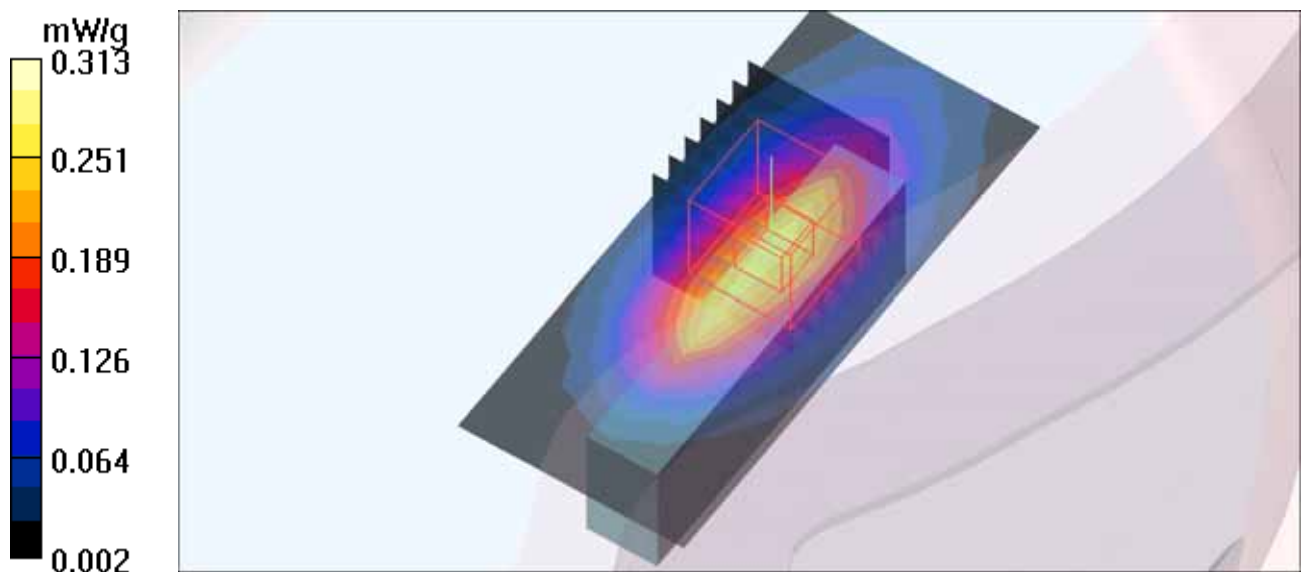

M53-GPRS1900 TS4-Ch661

Communication System: GPRS1900 ; Frequency: 1880 MHz ; Duty Cycle: 1:2 ; Modulation Type: GMSK / UL 4 time slots

Medium: MSL1900 Medium parameters used: $f = 1880$ MHz; $\sigma = 1.54$ mho/m; $\epsilon_r = 54.64$; $\rho = 1000$ kg/m³

Phantom section: Flat Section ; Separation distance : 5 mm (The Vertical-Front side of the EUT to the Phantom)

DASY4 Configuration:

- Probe: EX3DV4 - SN3578; ConvF(6.7, 6.7, 6.7); Calibrated: 2010/6/22
- Sensor-Surface: 2mm (Mechanical Surface Detection)
- Electronics: DAE3 Sn579; Calibrated: 2010/9/20
- Phantom: SAM 12; Type: SAM V4.0; Serial: TP 1202
- Measurement SW: DASY4, V4.7 Build 80; Postprocessing SW: SEMCAD, V1.8 Build 186

Body Position - Mid/Area Scan (7x15x1): Measurement grid: dx=8mm, dy=8mm

Maximum value of SAR (measured) = 0.225 mW/g

Body Position - Mid/Zoom Scan (7x7x7)/Cube 0: Measurement grid: dx=5mm, dy=5mm, dz=5mm

Reference Value = 4.21 V/m; Power Drift = -0.193 dB

Peak SAR (extrapolated) = 0.280 W/kg

SAR(1 g) = 0.161 mW/g; SAR(10 g) = 0.090 mW/g

Maximum value of SAR (measured) = 0.223 mW/g

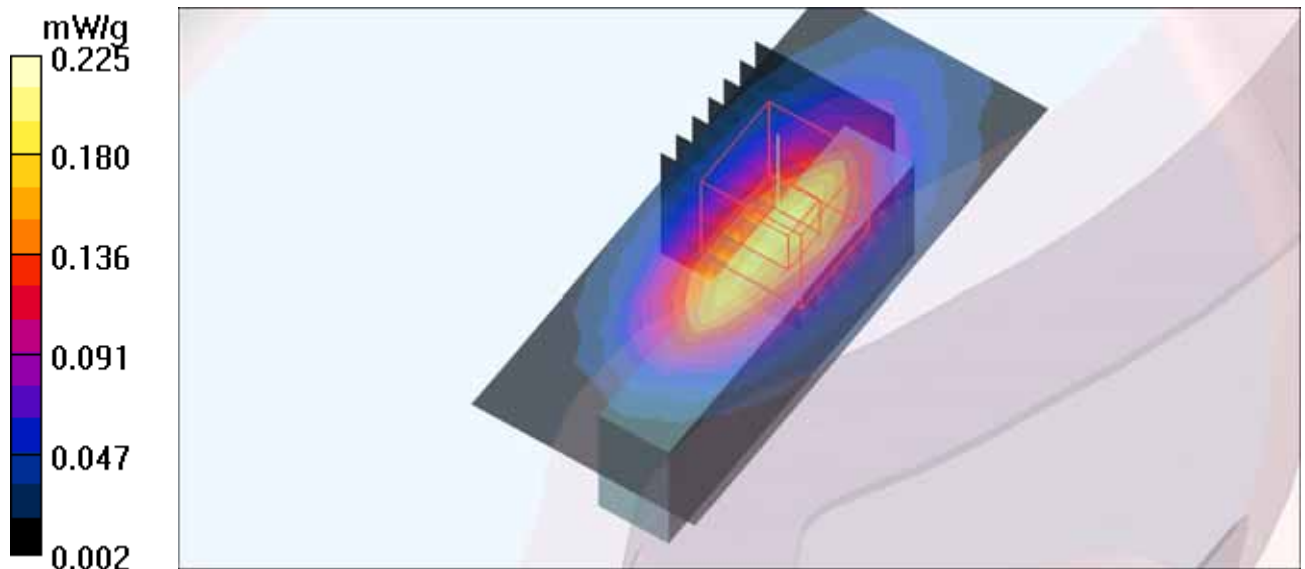

M54-GPRS1900 TS1-Ch661

Communication System: GPRS1900 ; Frequency: 1880 MHz ; Duty Cycle: 1:8.3 ; Modulation Type: GMSK / UL 1 time slot

Medium: MSL1900 Medium parameters used: $f = 1880$ MHz; $\sigma = 1.54$ mho/m; $\epsilon_r = 54.64$; $\rho = 1000$ kg/m³

Phantom section: Flat Section ; Separation Distance : 5 mm (The Horizontal-Up side of the EUT to the Phantom)

DASY4 Configuration:

- Probe: EX3DV4 - SN3578; ConvF(6.7, 6.7, 6.7); Calibrated: 2010/6/22
- Sensor-Surface: 2mm (Mechanical Surface Detection)
- Electronics: DAE3 Sn579; Calibrated: 2010/9/20
- Phantom: SAM 12; Type: SAM V4.0; Serial: TP 1202
- Measurement SW: DASY4, V4.7 Build 80; Postprocessing SW: SEMCAD, V1.8 Build 186

Body Position - Mid/Area Scan (7x15x1): Measurement grid: dx=8mm, dy=8mm

Maximum value of SAR (measured) = 0.331 mW/g

Body Position - Mid/Zoom Scan (7x7x7)/Cube 0: Measurement grid: dx=5mm, dy=5mm, dz=5mm

Reference Value = 3.07 V/m; Power Drift = 0.170 dB

Peak SAR (extrapolated) = 0.427 W/kg

SAR(1 g) = 0.266 mW/g; SAR(10 g) = 0.157 mW/g.

Maximum value of SAR (measured) = 0.348 mW/g

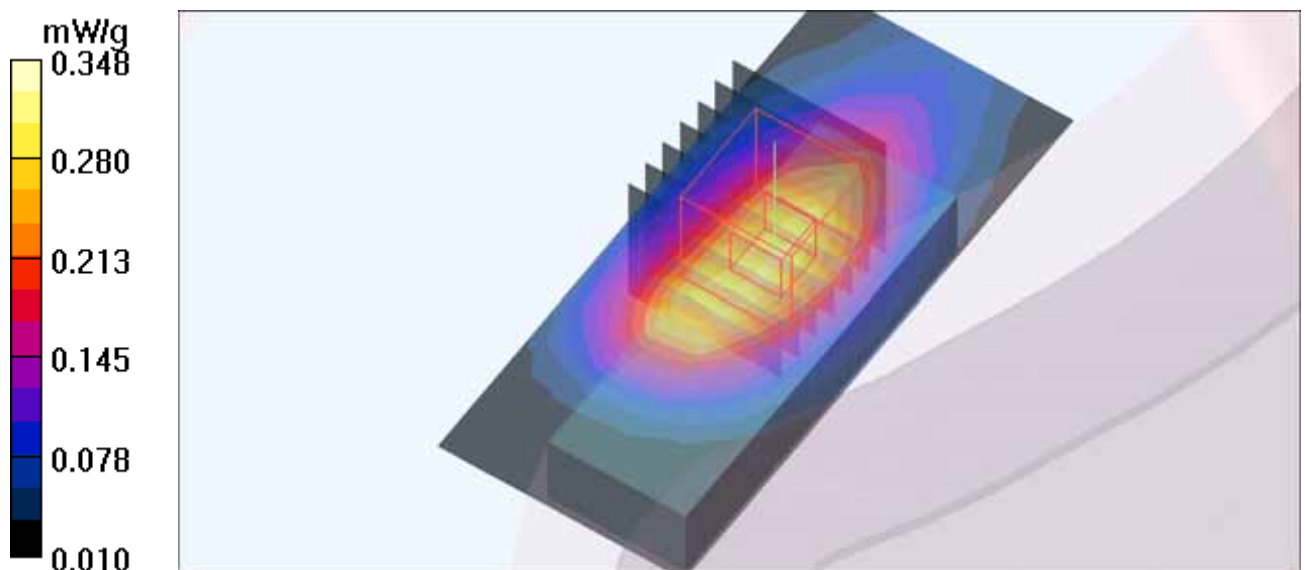

M55-GPRS1900 TS2-Ch661

Communication System: GPRS1900 ; Frequency: 1880 MHz ; Duty Cycle: 1:4 ; Modulation Type: GMSK / UL 2 time slots

Medium: MSL1900 Medium parameters used: $f = 1880$ MHz; $\sigma = 1.54$ mho/m; $\epsilon_r = 54.64$; $\rho = 1000$ kg/m³

Phantom section: Flat Section ; Separation Distance : 5 mm (The Horizontal-Up side of the EUT to the Phantom)

DASY4 Configuration:

- Probe: EX3DV4 - SN3578; ConvF(6.7, 6.7, 6.7); Calibrated: 2010/6/22
- Sensor-Surface: 2mm (Mechanical Surface Detection)
- Electronics: DAE3 Sn579; Calibrated: 2010/9/20
- Phantom: SAM 12; Type: SAM V4.0; Serial: TP 1202
- Measurement SW: DASY4, V4.7 Build 80; Postprocessing SW: SEMCAD, V1.8 Build 186

Body Position - Mid/Area Scan (7x15x1): Measurement grid: dx=8mm, dy=8mm

Maximum value of SAR (measured) = 0.731 mW/g

Body Position - Mid/Zoom Scan (7x7x7)/Cube 0: Measurement grid: dx=5mm, dy=5mm, dz=5mm

Reference Value = 4.00 V/m; Power Drift = -0.171 dB

Peak SAR (extrapolated) = 0.846 W/kg

SAR(1 g) = 0.526 mW/g; SAR(10 g) = 0.310 mW/g

Maximum value of SAR (measured) = 0.687 mW/g

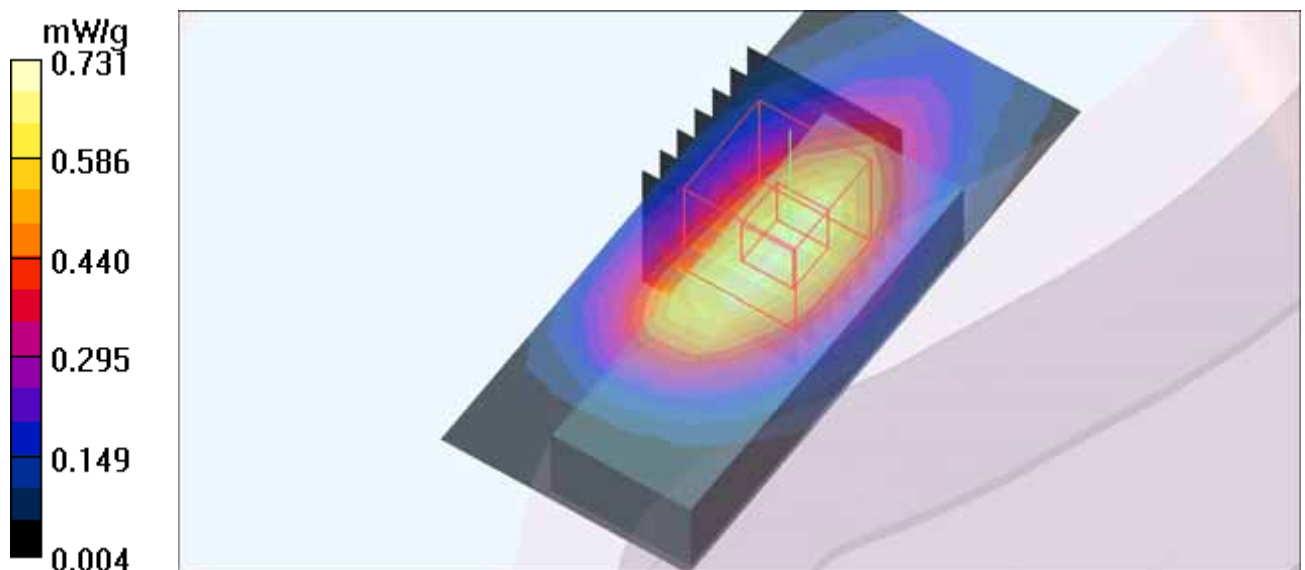

M56-GPRS1900 TS3-Ch661

Communication System: GPRS1900 ; Frequency: 1880 MHz ; Duty Cycle: 1:2.67 ; Modulation Type: GMSK / UL 3 time slots

Medium: MSL1900 Medium parameters used: $f = 1880$ MHz; $\sigma = 1.54$ mho/m; $\epsilon_r = 54.64$; $\rho = 1000$ kg/m³

Phantom section: Flat Section ; Separation Distance : 5 mm (The Horizontal-Up side of the EUT to the Phantom)

DASY4 Configuration:

- Probe: EX3DV4 - SN3578; ConvF(6.7, 6.7, 6.7); Calibrated: 2010/6/22
- Sensor-Surface: 2mm (Mechanical Surface Detection)
- Electronics: DAE3 Sn579; Calibrated: 2010/9/20
- Phantom: SAM 12; Type: SAM V4.0; Serial: TP 1202
- Measurement SW: DASY4, V4.7 Build 80; Postprocessing SW: SEMCAD, V1.8 Build 186

Body Position - Mid/Area Scan (7x15x1): Measurement grid: dx=8mm, dy=8mm

Maximum value of SAR (measured) = 0.536 mW/g

Body Position - Mid/Zoom Scan (7x7x7)/Cube 0: Measurement grid: dx=5mm, dy=5mm, dz=5mm

Reference Value = 4.02 V/m; Power Drift = -0.191 dB

Peak SAR (extrapolated) = 0.634 W/kg

SAR(1 g) = 0.392 mW/g; SAR(10 g) = 0.230 mW/g

Maximum value of SAR (measured) = 0.512 mW/g

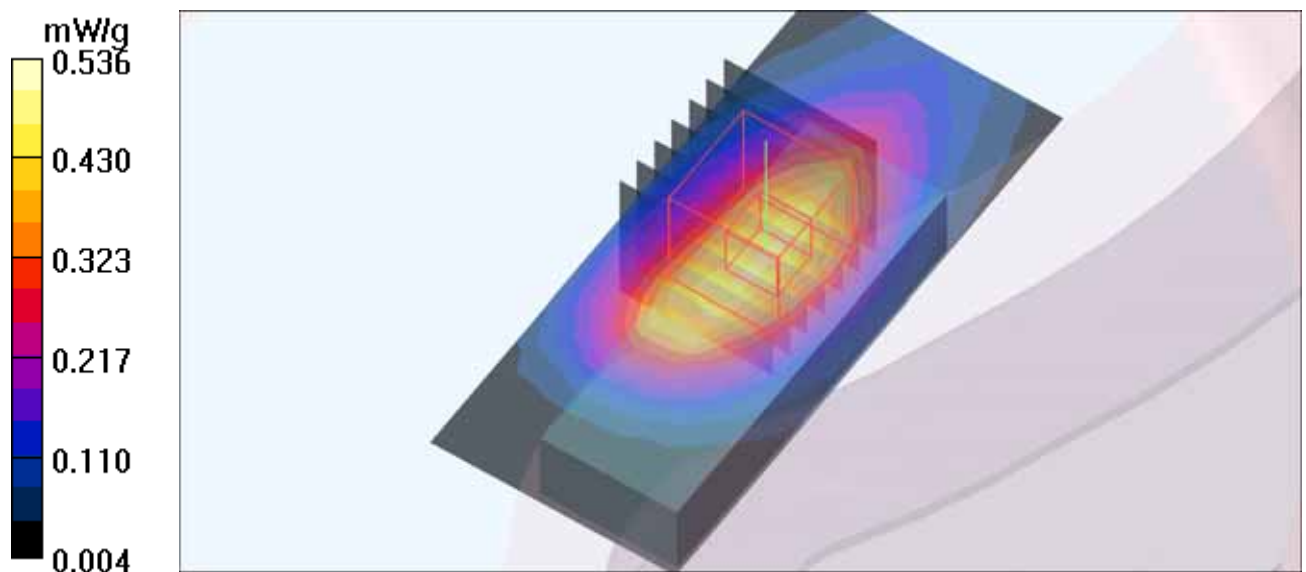

M57-GPRS1900 TS4-Ch661

Communication System: GPRS1900 ; Frequency: 1880 MHz ; Duty Cycle: 1:2 ; Modulation Type: GMSK / UL 4 time slots

Medium: MSL1900 Medium parameters used: $f = 1880$ MHz; $\sigma = 1.54$ mho/m; $\epsilon_r = 54.64$; $\rho = 1000$ kg/m³

Phantom section: Flat Section ; Separation Distance : 5 mm (The Horizontal-Up side of the EUT to the Phantom)

DASY4 Configuration:

- Probe: EX3DV4 - SN3578; ConvF(6.7, 6.7, 6.7); Calibrated: 2010/6/22
- Sensor-Surface: 2mm (Mechanical Surface Detection)
- Electronics: DAE3 Sn579; Calibrated: 2010/9/20
- Phantom: SAM 12; Type: SAM V4.0; Serial: TP 1202
- Measurement SW: DASY4, V4.7 Build 80; Postprocessing SW: SEMCAD, V1.8 Build 186

Body Position - Mid/Area Scan (7x15x1): Measurement grid: dx=8mm, dy=8mm

Maximum value of SAR (measured) = 0.481 mW/g

Body Position - Mid/Zoom Scan (7x7x7)/Cube 0: Measurement grid: dx=5mm, dy=5mm, dz=5mm

Reference Value = 3.38 V/m; Power Drift = -0.164 dB

Peak SAR (extrapolated) = 0.588 W/kg

SAR(1 g) = 0.365 mW/g; SAR(10 g) = 0.214 mW/g

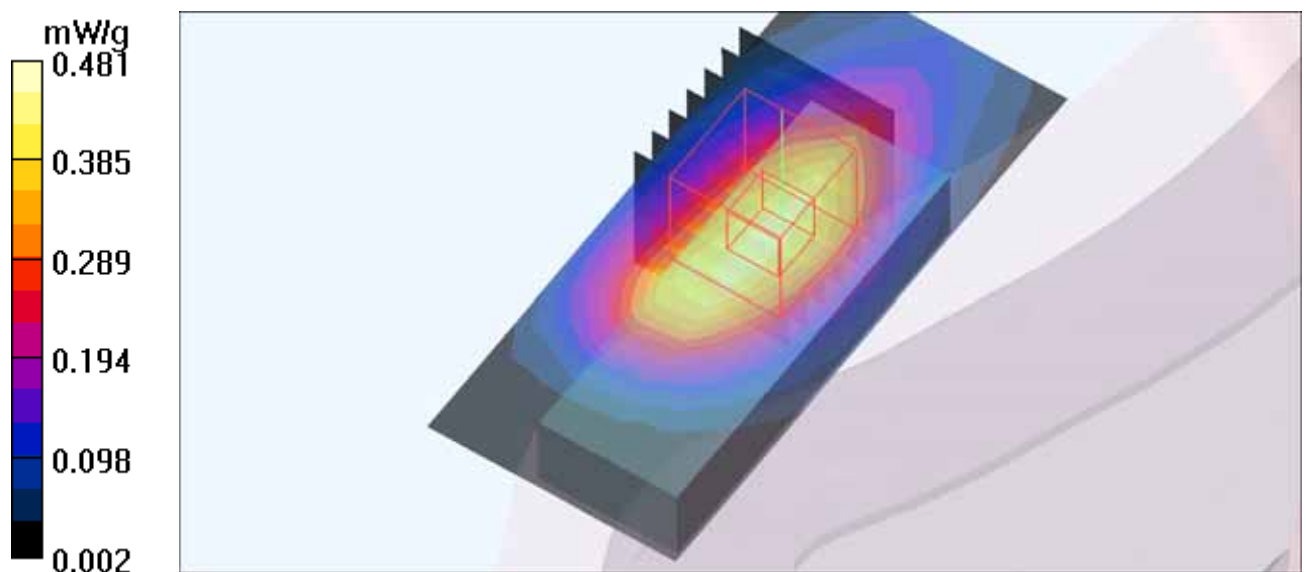

M58-GPRS1900 TS1-Ch661

Communication System: GPRS1900 ; Frequency: 1880 MHz ; Duty Cycle: 1:8.3 ; Modulation Type: GMSK / UL 1 time slot

Medium: MSL1900 Medium parameters used: $f = 1880$ MHz; $\sigma = 1.54$ mho/m; $\epsilon_r = 54.64$; $\rho = 1000$ kg/m³

Phantom section: Flat Section ; Separation distance : 5 mm (The Vertical-Back side of the EUT to the Phantom)

DASY4 Configuration:

- Probe: EX3DV4 - SN3578; ConvF(6.7, 6.7, 6.7); Calibrated: 2010/6/22
- Sensor-Surface: 2mm (Mechanical Surface Detection)
- Electronics: DAE3 Sn579; Calibrated: 2010/9/20
- Phantom: SAM 12; Type: SAM V4.0; Serial: TP 1202
- Measurement SW: DASY4, V4.7 Build 80; Postprocessing SW: SEMCAD, V1.8 Build 186

Body Position - Mid/Area Scan (7x15x1): Measurement grid: dx=8mm, dy=8mm

Maximum value of SAR (measured) = 0.284 mW/g

Body Position - Mid/Zoom Scan (7x7x7)/Cube 0: Measurement grid: dx=5mm, dy=5mm, dz=5mm

Reference Value = 3.93 V/m; Power Drift = 0.123 dB

Peak SAR (extrapolated) = 0.384 W/kg

SAR(1 g) = 0.222 mW/g; SAR(10 g) = 0.125 mW/g

Maximum value of SAR (measured) = 0.308 mW/g

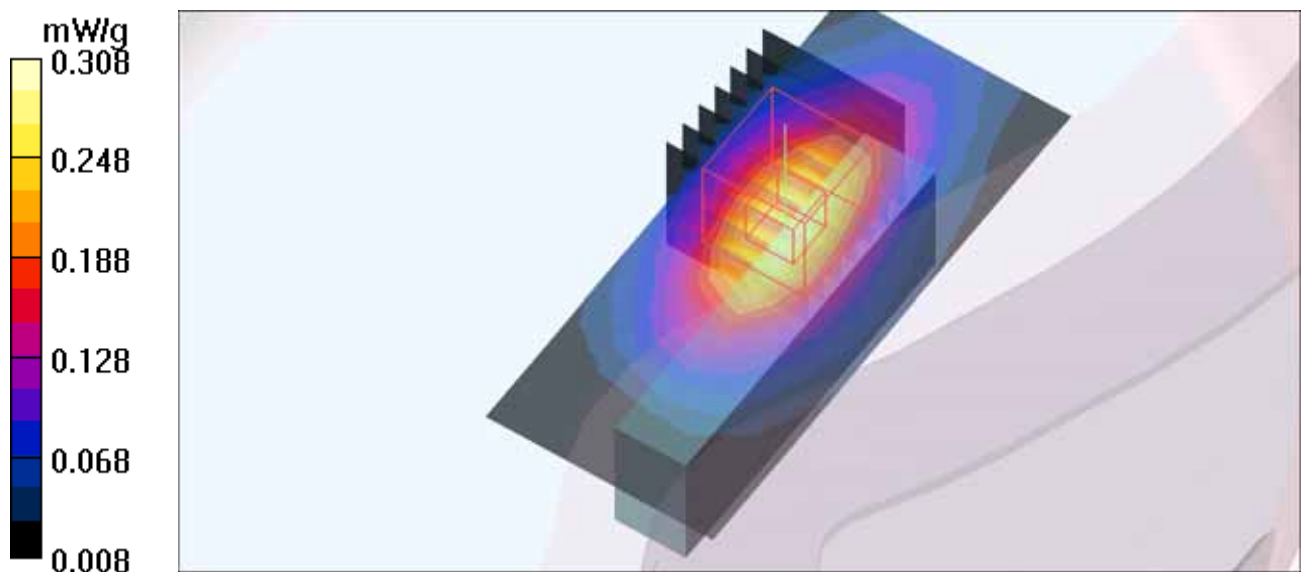

M59-GPRS1900 TS2-Ch661

Communication System: GPRS1900 ; Frequency: 1880 MHz ; Duty Cycle: 1:4 ; Modulation Type: GMSK / UL 2 time slots

Medium: MSL1900 Medium parameters used: $f = 1880$ MHz; $\sigma = 1.54$ mho/m; $\epsilon_r = 54.64$; $\rho = 1000$ kg/m³

Phantom section: Flat Section ; Separation distance : 5 mm (The Vertical-Back side of the EUT to the Phantom)

DASY4 Configuration:

- Probe: EX3DV4 - SN3578; ConvF(6.7, 6.7, 6.7); Calibrated: 2010/6/22
- Sensor-Surface: 2mm (Mechanical Surface Detection)
- Electronics: DAE3 Sn579; Calibrated: 2010/9/20
- Phantom: SAM 12; Type: SAM V4.0; Serial: TP 1202
- Measurement SW: DASY4, V4.7 Build 80; Postprocessing SW: SEMCAD, V1.8 Build 186

Body Position - Mid/Area Scan (7x15x1): Measurement grid: dx=8mm, dy=8mm

Maximum value of SAR (measured) = 0.328 mW/g

Body Position - Mid/Zoom Scan (7x7x7)/Cube 0: Measurement grid: dx=5mm, dy=5mm, dz=5mm

Reference Value = 4.77 V/m; Power Drift = -0.122 dB

Peak SAR (extrapolated) = 0.402 W/kg

SAR(1 g) = 0.233 mW/g; SAR(10 g) = 0.132 mW/g

Maximum value of SAR (measured) = 0.322 mW/g

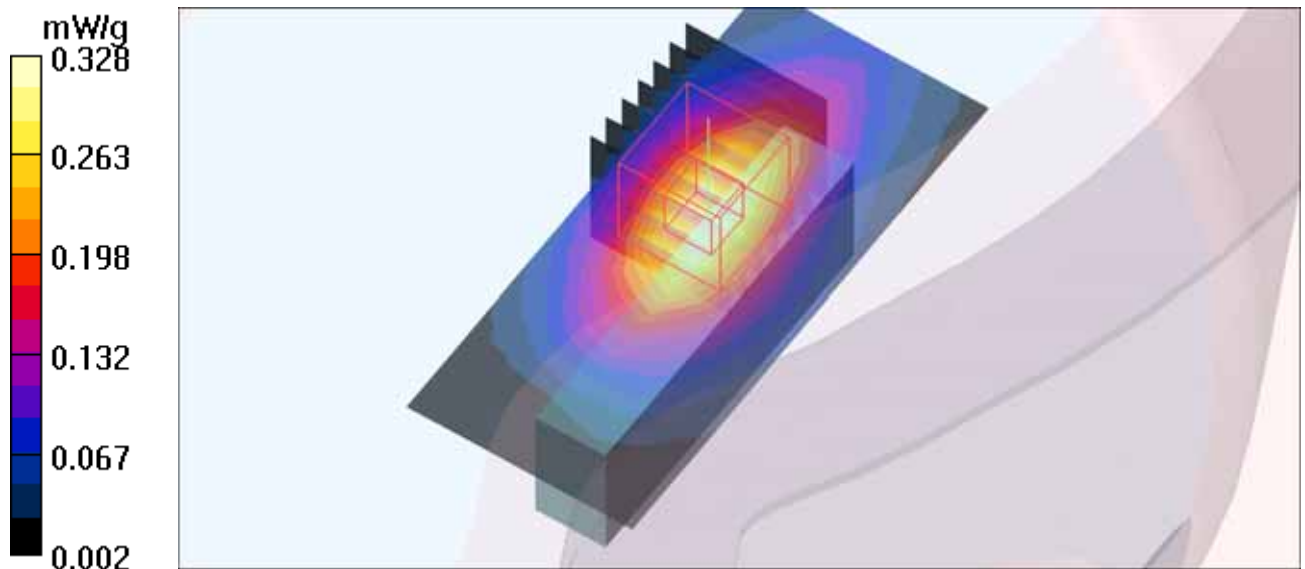

M60-GPRS1900 TS3-Ch661

Communication System: GPRS1900 ; Frequency: 1880 MHz ; Duty Cycle: 1:2.67 ; Modulation Type: GMSK / UL 3 time slots

Medium: MSL1900 Medium parameters used: $f = 1880$ MHz; $\sigma = 1.54$ mho/m; $\epsilon_r = 54.64$; $\rho = 1000$ kg/m³

Phantom section: Flat Section ; Separation distance : 5 mm (The Vertical-Back side of the EUT to the Phantom)

DASY4 Configuration:

- Probe: EX3DV4 - SN3578; ConvF(6.7, 6.7, 6.7); Calibrated: 2010/6/22
- Sensor-Surface: 2mm (Mechanical Surface Detection)
- Electronics: DAE3 Sn579; Calibrated: 2010/9/20
- Phantom: SAM 12; Type: SAM V4.0; Serial: TP 1202
- Measurement SW: DASY4, V4.7 Build 80; Postprocessing SW: SEMCAD, V1.8 Build 186

Body Position - Mid/Area Scan (7x15x1): Measurement grid: dx=8mm, dy=8mm

Maximum value of SAR (measured) = 0.313 mW/g

Body Position - Mid/Zoom Scan (7x7x7)/Cube 0: Measurement grid: dx=5mm, dy=5mm, dz=5mm

Reference Value = 4.43 V/m; Power Drift = -0.145 dB

Peak SAR (extrapolated) = 0.398 W/kg

SAR(1 g) = 0.233 mW/g; SAR(10 g) = 0.131 mW/g

Maximum value of SAR (measured) = 0.319 mW/g

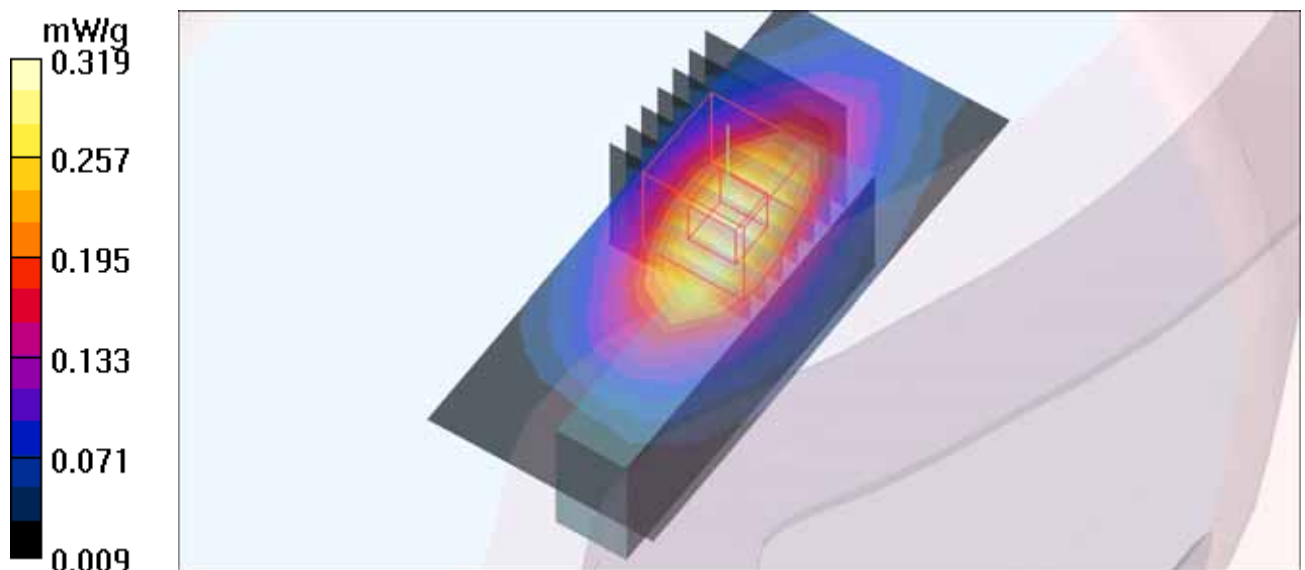

M61-GPRS1900 TS4-Ch661

Communication System: GPRS1900 ; Frequency: 1880 MHz ; Duty Cycle: 1:2 ; Modulation Type: GMSK / UL 4 time slots

Medium: MSL1900 Medium parameters used: $f = 1880$ MHz; $\sigma = 1.54$ mho/m; $\epsilon_r = 54.64$; $\rho = 1000$ kg/m³

Phantom section: Flat Section ; Separation distance : 5 mm (The Vertical-Back side of the EUT to the Phantom)

DASY4 Configuration:

- Probe: EX3DV4 - SN3578; ConvF(6.7, 6.7, 6.7); Calibrated: 2010/6/22
- Sensor-Surface: 2mm (Mechanical Surface Detection)
- Electronics: DAE3 Sn579; Calibrated: 2010/9/20
- Phantom: SAM 12; Type: SAM V4.0; Serial: TP 1202
- Measurement SW: DASY4, V4.7 Build 80; Postprocessing SW: SEMCAD, V1.8 Build 186

Body Position - Mid/Area Scan (7x15x1): Measurement grid: dx=8mm, dy=8mm

Maximum value of SAR (measured) = 0.224 mW/g

Body Position - Mid/Zoom Scan (7x7x7)/Cube 0: Measurement grid: dx=5mm, dy=5mm, dz=5mm

Reference Value = 3.70 V/m; Power Drift = -0.195 dB

Peak SAR (extrapolated) = 0.293 W/kg

SAR(1 g) = 0.173 mW/g; SAR(10 g) = 0.098 mW/g

Maximum value of SAR (measured) = 0.235 mW/g

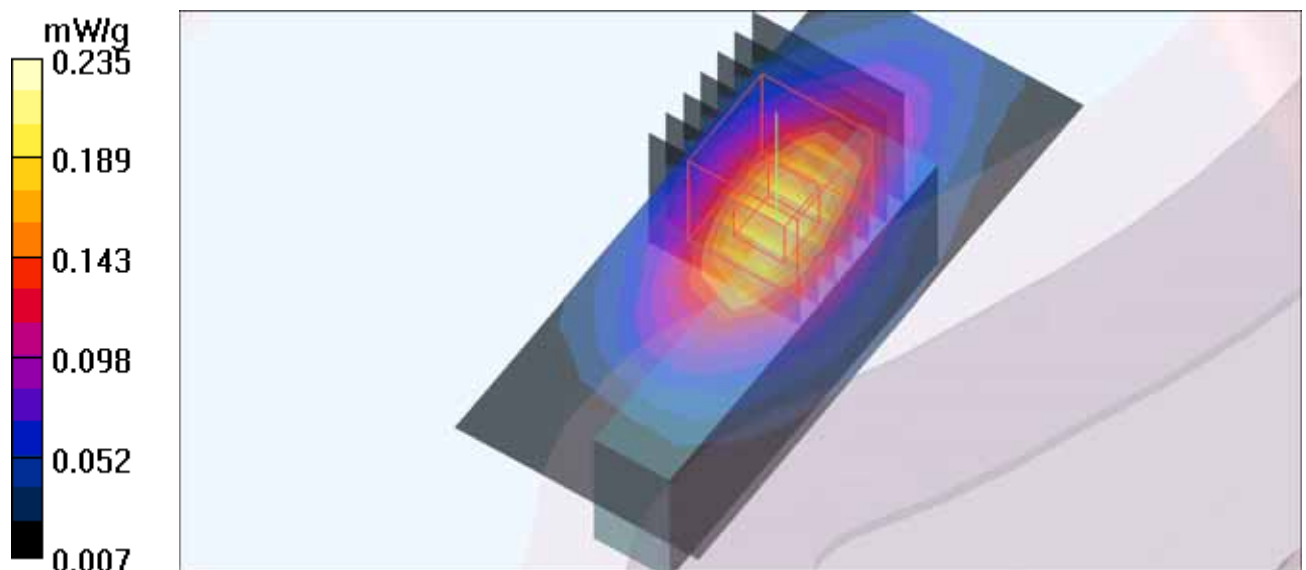

M62-GPRS1900 TS1-Ch661

Communication System: GPRS1900 ; Frequency: 1880 MHz ; Duty Cycle: 1:8.3 ; Modulation Type: GMSK / UL 1 time slot

Medium: MSL1900 Medium parameters used: $f = 1880$ MHz; $\sigma = 1.54$ mho/m; $\epsilon_r = 54.64$; $\rho = 1000$ kg/m³

Phantom section: Flat Section ; Separation distance : 5 mm (The top side of the EUT to the Phantom)

DASY4 Configuration:

- Probe: EX3DV4 - SN3578; ConvF(6.7, 6.7, 6.7); Calibrated: 2010/6/22
- Sensor-Surface: 2mm (Mechanical Surface Detection)
- Electronics: DAE3 Sn579; Calibrated: 2010/9/20
- Phantom: SAM 12; Type: SAM V4.0; Serial: TP 1202
- Measurement SW: DASY4, V4.7 Build 80; Postprocessing SW: SEMCAD, V1.8 Build 186

Body Position - Mid/Area Scan (8x10x1): Measurement grid: dx=8mm, dy=8mm

Maximum value of SAR (measured) = 0.061 mW/g

Body Position - Mid/Zoom Scan (7x7x7)/Cube 0: Measurement grid: dx=5mm, dy=5mm, dz=5mm

Reference Value = 4.23 V/m; Power Drift = -0.041 dB

Peak SAR (extrapolated) = 0.075 W/kg

SAR(1 g) = 0.045 mW/g; SAR(10 g) = 0.025 mW/g

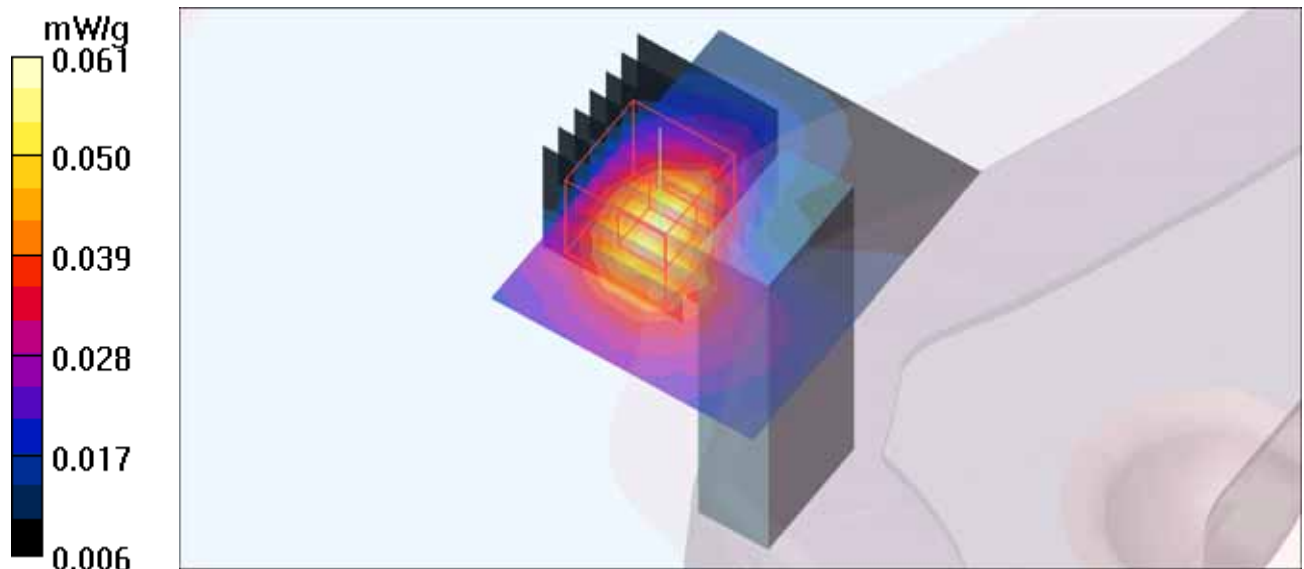

M63-GPRS1900 TS2-Ch661

Communication System: GPRS1900 ; Frequency: 1880 MHz ; Duty Cycle: 1:4 ; Modulation Type: GMSK / UL 2 time slots

Medium: MSL1900 Medium parameters used: $f = 1880$ MHz; $\sigma = 1.54$ mho/m; $\epsilon_r = 54.64$; $\rho = 1000$ kg/m³

Phantom section: Flat Section ; Separation Distance : 5 mm (The top side of the EUT to the Phantom)

DASY4 Configuration:

- Probe: EX3DV4 - SN3578; ConvF(6.7, 6.7, 6.7); Calibrated: 2010/6/22
- Sensor-Surface: 2mm (Mechanical Surface Detection)
- Electronics: DAE3 Sn579; Calibrated: 2010/9/20
- Phantom: SAM 12; Type: SAM V4.0; Serial: TP 1202
- Measurement SW: DASY4, V4.7 Build 80; Postprocessing SW: SEMCAD, V1.8 Build 186

Body Position - Mid/Area Scan (8x10x1): Measurement grid: dx=8mm, dy=8mm

Maximum value of SAR (measured) = 0.072 mW/g

Body Position - Mid/Zoom Scan (7x7x7)/Cube 0: Measurement grid: dx=5mm, dy=5mm, dz=5mm

Reference Value = 4.82 V/m; Power Drift = -0.185 dB

Peak SAR (extrapolated) = 0.085 W/kg

SAR(1 g) = 0.049 mW/g; SAR(10 g) = 0.027 mW/g

Maximum value of SAR (measured) = 0.068 mW/g

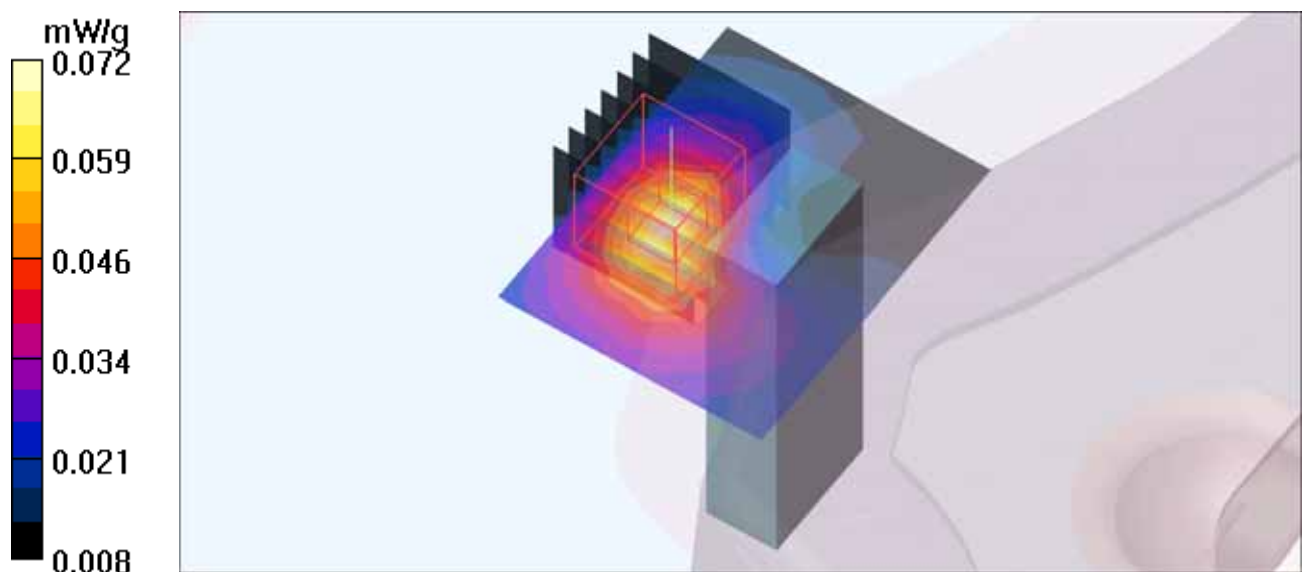

M64-GPRS1900 TS3-Ch661

Communication System: GPRS1900 ; Frequency: 1880 MHz ; Duty Cycle: 1:2.67 ; Modulation Type: GMSK / UL 3 time slots
Medium: MSL1900 Medium parameters used: $f = 1880$ MHz; $\sigma = 1.54$ mho/m; $\epsilon_r = 54.64$; $\rho = 1000$ kg/m³
Phantom section: Flat Section ; Separation Distance : 5 mm (The top side of the EUT to the Phantom)

DASY4 Configuration:

- Probe: EX3DV4 - SN3578; ConvF(6.7, 6.7, 6.7); Calibrated: 2010/6/22
- Sensor-Surface: 2mm (Mechanical Surface Detection)
- Electronics: DAE3 Sn579; Calibrated: 2010/9/20
- Phantom: SAM 12; Type: SAM V4.0; Serial: TP 1202
- Measurement SW: DASY4, V4.7 Build 80; Postprocessing SW: SEMCAD, V1.8 Build 186

Body Position - Mid/Area Scan (8x10x1): Measurement grid: dx=8mm, dy=8mm
Maximum value of SAR (measured) = 0.079 mW/g

Body Position - Mid/Zoom Scan (7x7x7)/Cube 0: Measurement grid: dx=5mm, dy=5mm, dz=5mm

Reference Value = 5.35 V/m; Power Drift = -0.154 dB

Peak SAR (extrapolated) = 0.090 W/kg

SAR(1 g) = 0.052 mW/g; SAR(10 g) = 0.029 mW/g

Maximum value of SAR (measured) = 0.072 mW/g

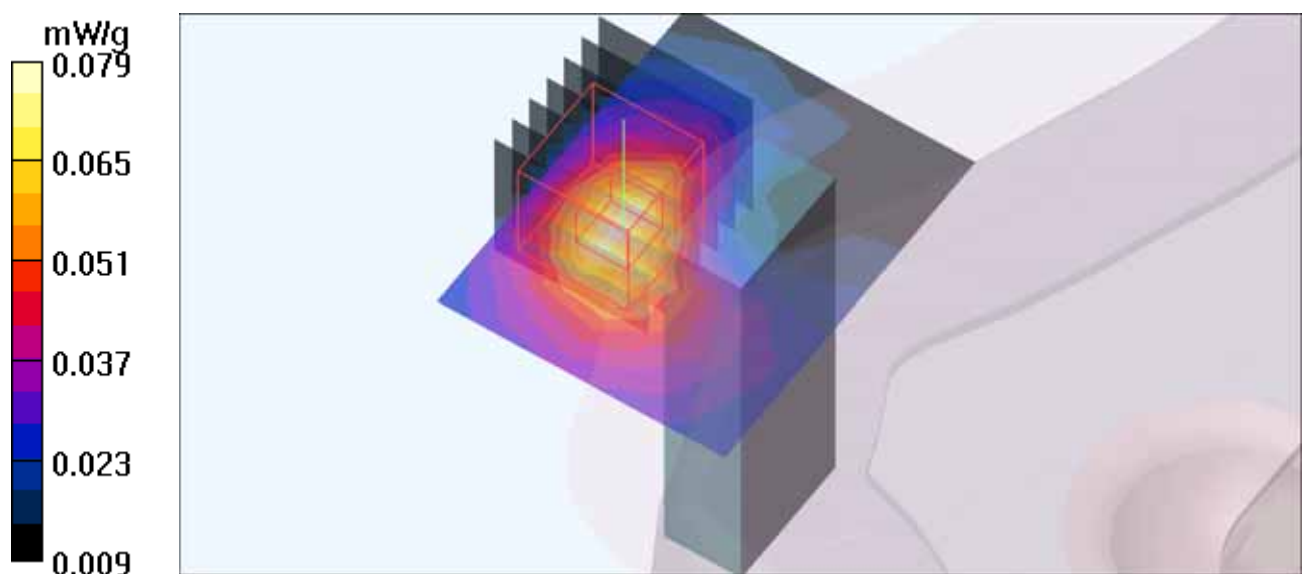

M65-GPRS1900 TS4-Ch661

Communication System: GPRS1900 ; Frequency: 1880 MHz ; Duty Cycle: 1:2 ; Modulation Type: GMSK / UL 4 time slots

Medium: MSL1900 Medium parameters used: $f = 1880$ MHz; $\sigma = 1.54$ mho/m; $\epsilon_r = 54.64$; $\rho = 1000$ kg/m³

Phantom section: Flat Section ; Separation Distance : 5 mm (The top side of the EUT to the Phantom)

DASY4 Configuration:

- Probe: EX3DV4 - SN3578; ConvF(6.7, 6.7, 6.7); Calibrated: 2010/6/22
- Sensor-Surface: 2mm (Mechanical Surface Detection)
- Electronics: DAE3 Sn579; Calibrated: 2010/9/20
- Phantom: SAM 12; Type: SAM V4.0; Serial: TP 1202
- Measurement SW: DASY4, V4.7 Build 80; Postprocessing SW: SEMCAD, V1.8 Build 186

Body Position - Mid/Area Scan (8x10x1): Measurement grid: dx=8mm, dy=8mm
Maximum value of SAR (measured) = 0.051 mW/g

Body Position - Mid/Zoom Scan (7x7x7)/Cube 0: Measurement grid: dx=5mm, dy=5mm, dz=5mm

Reference Value = 3.74 V/m; Power Drift = 0.127 dB

Peak SAR (extrapolated) = 0.065 W/kg

SAR(1 g) = 0.038 mW/g; SAR(10 g) = 0.021 mW/g

Maximum value of SAR (measured) = 0.053 mW/g

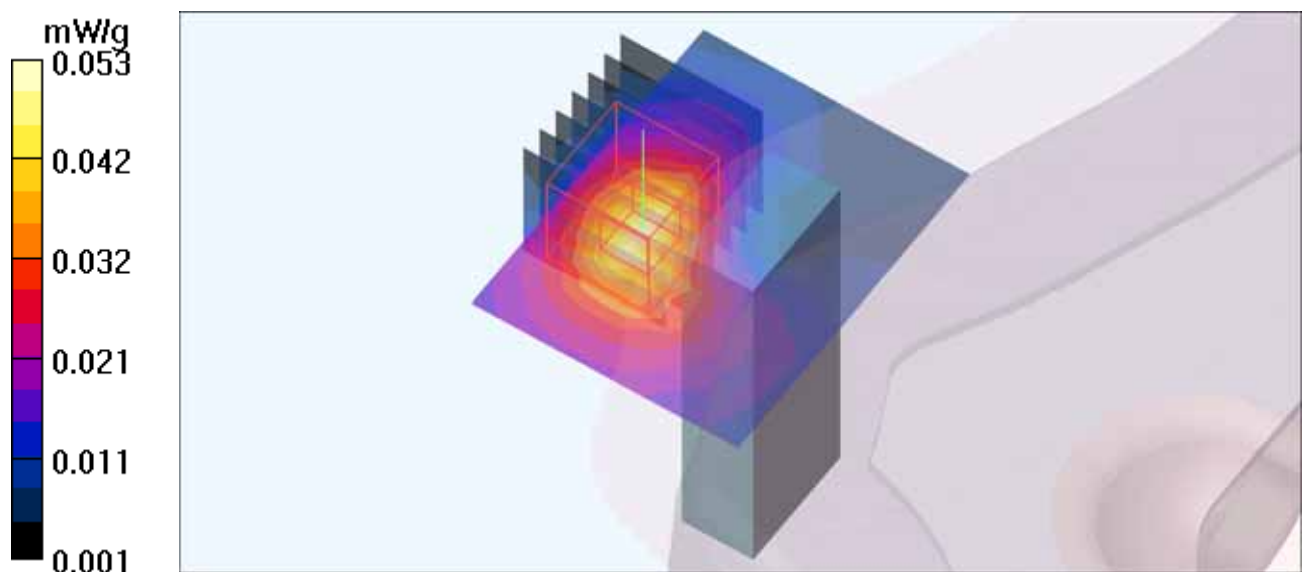

M66-E-GPRS1900 TS1-Ch661

Communication System: E-GPRS1900 ; Frequency: 1880 MHz ; Duty Cycle: 1:8.3 ; Modulation Type: 8PSK / UL 1 time slot

Medium: MSL1900 Medium parameters used: $f = 1880$ MHz; $\sigma = 1.54$ mho/m; $\epsilon_r = 54.64$; $\rho = 1000$ kg/m³

Phantom section: Flat Section ; Separation Distance : 5 mm (The Horizontal-Down side of the EUT to the Phantom)

DASY4 Configuration:

- Probe: EX3DV4 - SN3578; ConvF(6.7, 6.7, 6.7); Calibrated: 2010/6/22
- Sensor-Surface: 2mm (Mechanical Surface Detection)
- Electronics: DAE3 Sn579; Calibrated: 2010/9/20
- Phantom: SAM 12; Type: SAM V4.0; Serial: TP 1202
- Measurement SW: DASY4, V4.7 Build 80; Postprocessing SW: SEMCAD, V1.8 Build 186

Body Position - Mid/Area Scan (7x15x1): Measurement grid: dx=8mm, dy=8mm

Maximum value of SAR (measured) = 0.237 mW/g

Body Position - Mid/Zoom Scan (7x7x7)/Cube 0: Measurement grid: dx=5mm, dy=5mm, dz=5mm

Reference Value = 8.65 V/m; Power Drift = 0.073 dB

Peak SAR (extrapolated) = 0.304 W/kg

SAR(1 g) = 0.181 mW/g; SAR(10 g) = 0.104 mW/g

Maximum value of SAR (measured) = 0.241 mW/g

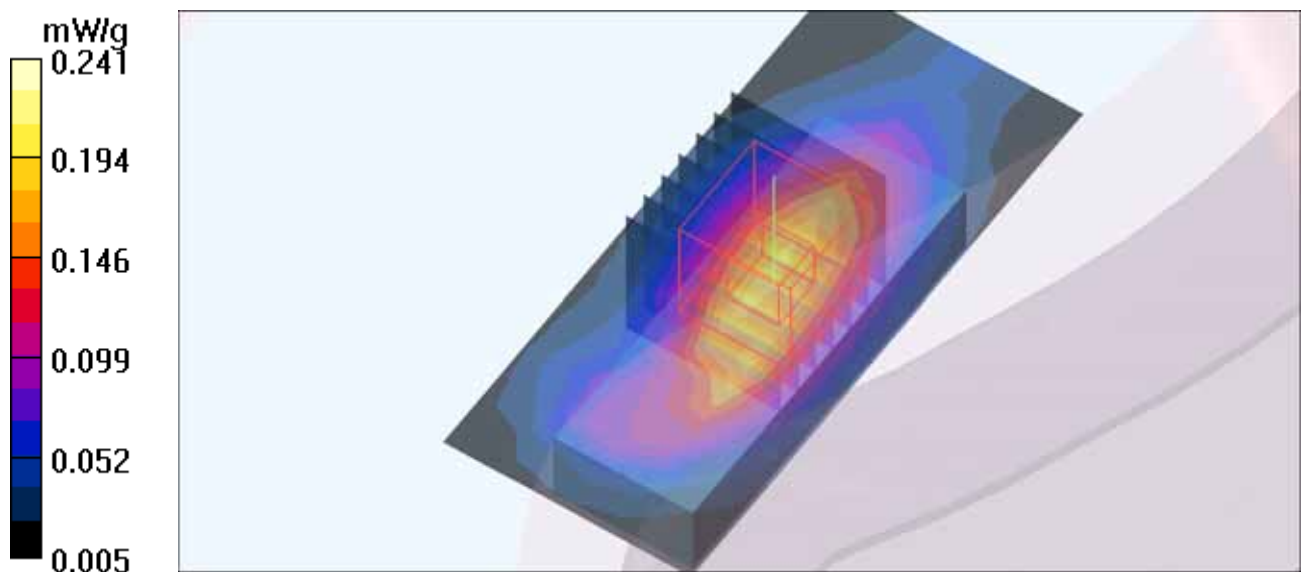

M67-E-GPRS1900 TS2-Ch661

Communication System: E-GPRS1900 ; Frequency: 1880 MHz ; Duty Cycle: 1:4 ; Modulation Type: 8PSK / UL 2 time slots

Medium: MSL1900 Medium parameters used: $f = 1880$ MHz; $\sigma = 1.54$ mho/m; $\epsilon_r = 54.64$; $\rho = 1000$ kg/m³

Phantom section: Flat Section ; Separation Distance : 5 mm (The Horizontal-Down side of the EUT to the Phantom)

DASY4 Configuration:

- Probe: EX3DV4 - SN3578; ConvF(6.7, 6.7, 6.7); Calibrated: 2010/6/22
- Sensor-Surface: 2mm (Mechanical Surface Detection)
- Electronics: DAE3 Sn579; Calibrated: 2010/9/20
- Phantom: SAM 12; Type: SAM V4.0; Serial: TP 1202
- Measurement SW: DASY4, V4.7 Build 80; Postprocessing SW: SEMCAD, V1.8 Build 186

Body Position - Mid/Area Scan (7x15x1): Measurement grid: dx=8mm, dy=8mm

Maximum value of SAR (measured) = 0.416 mW/g

Body Position - Mid/Zoom Scan (7x7x7)/Cube 0: Measurement grid: dx=5mm, dy=5mm, dz=5mm

Reference Value = 12.4 V/m; Power Drift = -0.127 dB

Peak SAR (extrapolated) = 0.540 W/kg

SAR(1 g) = 0.317 mW/g; SAR(10 g) = 0.182 mW/g

Maximum value of SAR (measured) = 0.429 mW/g

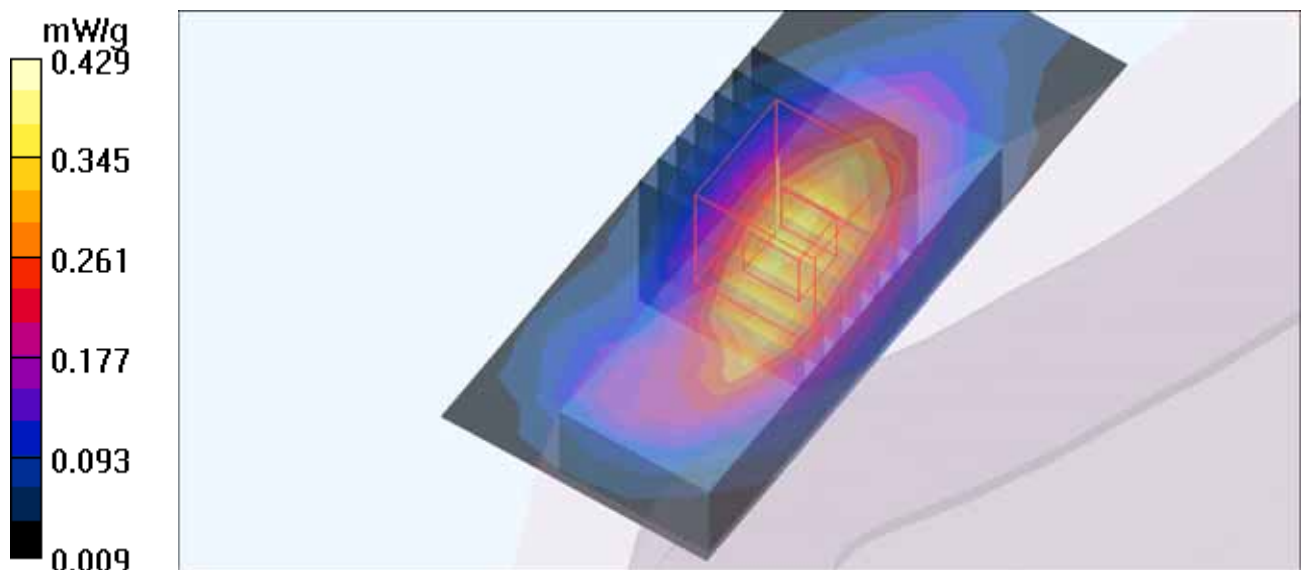

M68-E-GPRS1900 TS3-Ch661

Communication System: E-GPRS1900 ; Frequency: 1880 MHz ; Duty Cycle: 1:2.67 ; Modulation Type: 8PSK / UL 3 time slots

Medium: MSL1900 Medium parameters used: $f = 1880$ MHz; $\sigma = 1.54$ mho/m; $\epsilon_r = 54.64$; $\rho = 1000$ kg/m³

Phantom section: Flat Section ; Separation Distance : 5 mm (The Horizontal-Down side of the EUT to the Phantom)

DASY4 Configuration:

- Probe: EX3DV4 - SN3578; ConvF(6.7, 6.7, 6.7); Calibrated: 2010/6/22
- Sensor-Surface: 2mm (Mechanical Surface Detection)
- Electronics: DAE3 Sn579; Calibrated: 2010/9/20
- Phantom: SAM 12; Type: SAM V4.0; Serial: TP 1202
- Measurement SW: DASY4, V4.7 Build 80; Postprocessing SW: SEMCAD, V1.8 Build 186

Body Position - Mid/Area Scan (7x15x1): Measurement grid: dx=8mm, dy=8mm

Maximum value of SAR (measured) = 0.568 mW/g

Body Position - Mid/Zoom Scan (7x7x7)/Cube 0: Measurement grid: dx=5mm, dy=5mm, dz=5mm

Reference Value = 13.5 V/m; Power Drift = -0.118 dB

Peak SAR (extrapolated) = 0.673 W/kg

SAR(1 g) = 0.394 mW/g; SAR(10 g) = 0.225 mW/g

Maximum value of SAR (measured) = 0.526 mW/g

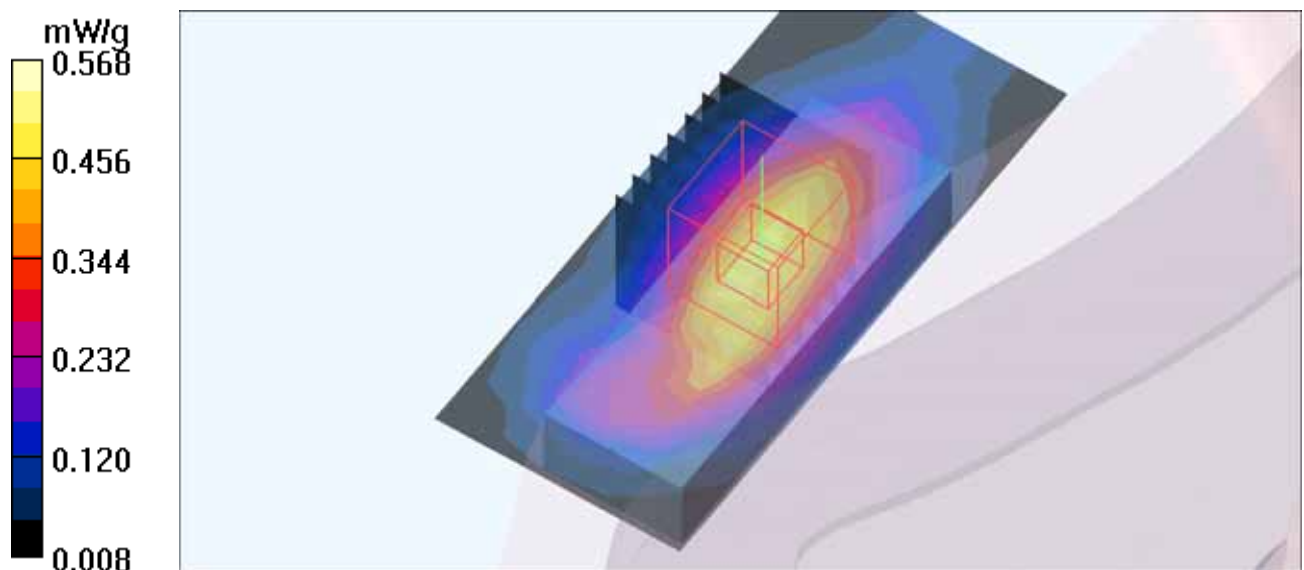

M69-E-GPRS1900 TS4-Ch661

Communication System: E-GPRS1900 ; Frequency: 1880 MHz ; Duty Cycle: 1:2 ; Modulation Type: 8PSK / UL 4 time slots

Medium: MSL1900 Medium parameters used: $f = 1880$ MHz; $\sigma = 1.54$ mho/m; $\epsilon_r = 54.64$; $\rho = 1000$ kg/m³

Phantom section: Flat Section ; Separation Distance : 5 mm (The Horizontal-Down side of the EUT to the Phantom)

DASY4 Configuration:

- Probe: EX3DV4 - SN3578; ConvF(6.7, 6.7, 6.7); Calibrated: 2010/6/22
- Sensor-Surface: 2mm (Mechanical Surface Detection)
- Electronics: DAE3 Sn579; Calibrated: 2010/9/20
- Phantom: SAM 12; Type: SAM V4.0; Serial: TP 1202
- Measurement SW: DASY4, V4.7 Build 80; Postprocessing SW: SEMCAD, V1.8 Build 186

Body Position - Mid/Area Scan (7x15x1): Measurement grid: dx=8mm, dy=8mm

Maximum value of SAR (measured) = 0.569 mW/g

Body Position - Mid/Zoom Scan (7x7x7)/Cube 0: Measurement grid: dx=5mm, dy=5mm, dz=5mm

Reference Value = 12.7 V/m; Power Drift = -0.183 dB

Peak SAR (extrapolated) = 0.730 W/kg

SAR(1 g) = 0.426 mW/g; SAR(10 g) = 0.244 mW/g

Maximum value of SAR (measured) = 0.566 mW/g

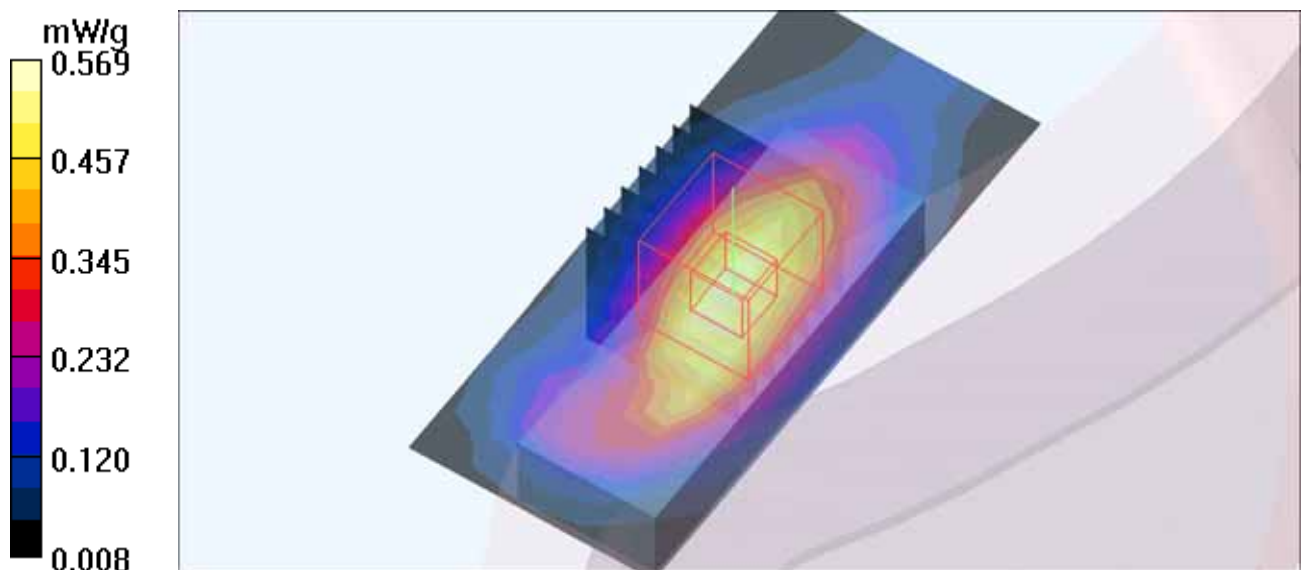

M70-E-GPRS1900 TS1-Ch661

Communication System: E-GPRS1900 ; Frequency: 1880 MHz ; Duty Cycle: 1:8.3 ; Modulation Type: 8PSK / UL 1 time slot

Medium: MSL1900 Medium parameters used: $f = 1880$ MHz; $\sigma = 1.54$ mho/m; $\epsilon_r = 54.64$; $\rho = 1000$ kg/m³

Phantom section: Flat Section ; Separation Distance : 5 mm (The Vertical-Front side of the EUT to the Phantom)

DASY4 Configuration:

- Probe: EX3DV4 - SN3578; ConvF(6.7, 6.7, 6.7); Calibrated: 2010/6/22
- Sensor-Surface: 2mm (Mechanical Surface Detection)
- Electronics: DAE3 Sn579; Calibrated: 2010/9/20
- Phantom: SAM 12; Type: SAM V4.0; Serial: TP 1202
- Measurement SW: DASY4, V4.7 Build 80; Postprocessing SW: SEMCAD, V1.8 Build 186

Body Position - Mid/Area Scan (7x15x1): Measurement grid: dx=8mm, dy=8mm

Maximum value of SAR (measured) = 0.105 mW/g

Body Position - Mid/Zoom Scan (7x7x7)/Cube 0: Measurement grid: dx=5mm, dy=5mm, dz=5mm

Reference Value = 2.63 V/m; Power Drift = 0.118 dB

Peak SAR (extrapolated) = 0.130 W/kg

SAR(1 g) = 0.075 mW/g; SAR(10 g) = 0.042 mW/g

Maximum value of SAR (measured) = 0.104 mW/g

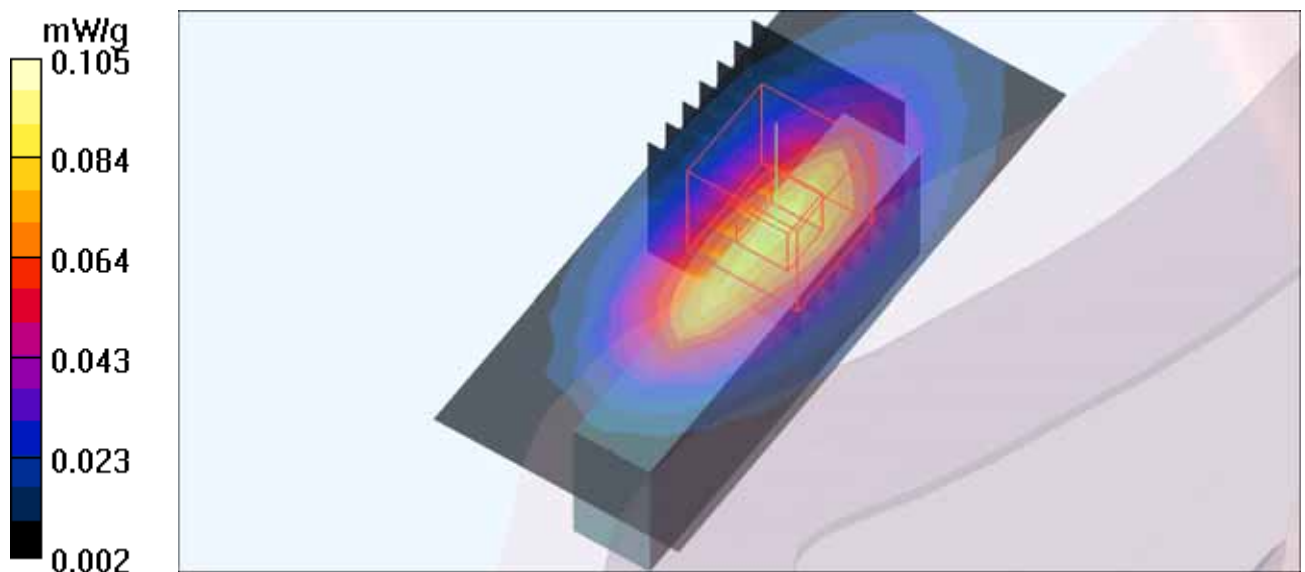

M71-E-GPRS1900 TS2-Ch661

Communication System: E-GPRS1900 ; Frequency: 1880 MHz ; Duty Cycle: 1:4 ; Modulation Type: 8PSK / UL 2 time slots

Medium: MSL1900 Medium parameters used: $f = 1880$ MHz; $\sigma = 1.54$ mho/m; $\epsilon_r = 54.64$; $\rho = 1000$ kg/m³

Phantom section: Flat Section ; Separation distance : 5 mm (The Vertical-Front side of the EUT to the Phantom)

DASY4 Configuration:

- Probe: EX3DV4 - SN3578; ConvF(6.7, 6.7, 6.7); Calibrated: 2010/6/22
- Sensor-Surface: 2mm (Mechanical Surface Detection)
- Electronics: DAE3 Sn579; Calibrated: 2010/9/20
- Phantom: SAM 12; Type: SAM V4.0; Serial: TP 1202
- Measurement SW: DASY4, V4.7 Build 80; Postprocessing SW: SEMCAD, V1.8 Build 186

Body Position - Mid/Area Scan (7x15x1): Measurement grid: dx=8mm, dy=8mm

Maximum value of SAR (measured) = 0.164 mW/g

Body Position - Mid/Zoom Scan (7x7x7)/Cube 0: Measurement grid: dx=5mm, dy=5mm, dz=5mm

Reference Value = 3.52 V/m; Power Drift = 0.151 dB

Peak SAR (extrapolated) = 0.209 W/kg

SAR(1 g) = 0.122 mW/g; SAR(10 g) = 0.068 mW/g

Maximum value of SAR (measured) = 0.167 mW/g

Body Position - Mid/Zoom Scan (7x7x7)/Cube 1: Measurement grid: dx=5mm, dy=5mm, dz=5mm

Reference Value = 3.52 V/m; Power Drift = 0.151 dB

Peak SAR (extrapolated) = 0.207 W/kg

SAR(1 g) = 0.117 mW/g; SAR(10 g) = 0.061 mW/g

Maximum value of SAR (measured) = 0.165 mW/g

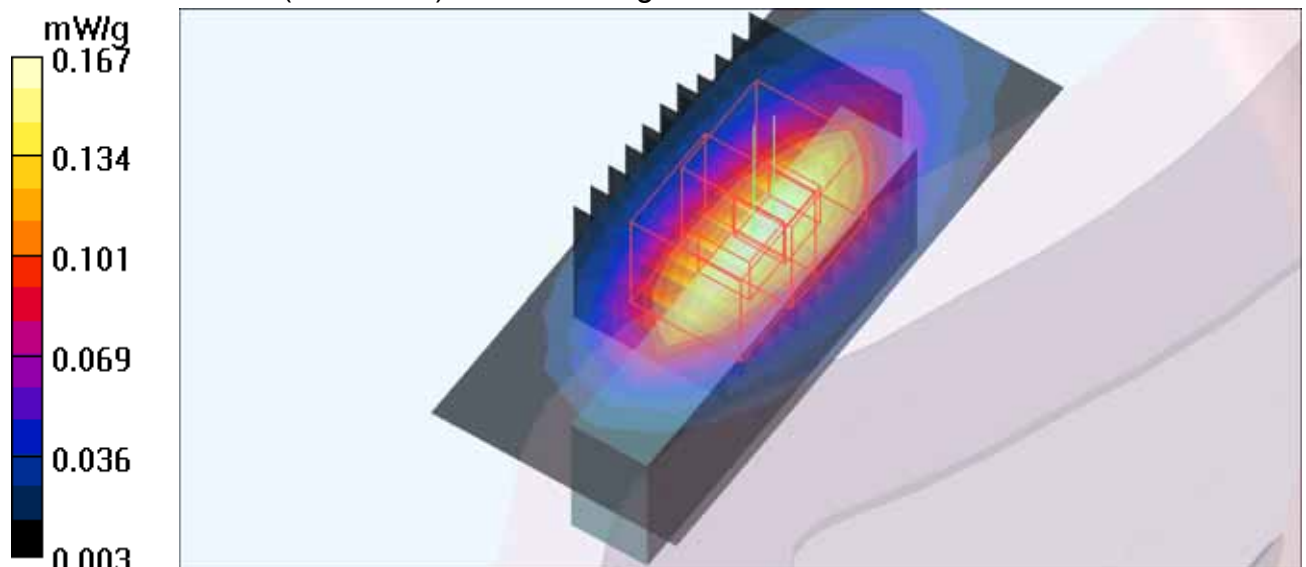

M72-E-GPRS1900 TS3-Ch661

Communication System: E-GPRS1900 ; Frequency: 1880 MHz ; Duty Cycle: 1:2.67 ; Modulation Type: 8PSK / UL 3 time slots

Medium: MSL1900 Medium parameters used: $f = 1880$ MHz; $\sigma = 1.54$ mho/m; $\epsilon_r = 54.64$; $\rho = 1000$ kg/m³

Phantom section: Flat Section ; Separation distance : 5 mm (The Vertical-Front side of the EUT to the Phantom)

DASY4 Configuration:

- Probe: EX3DV4 - SN3578; ConvF(6.7, 6.7, 6.7); Calibrated: 2010/6/22
- Sensor-Surface: 2mm (Mechanical Surface Detection)
- Electronics: DAE3 Sn579; Calibrated: 2010/9/20
- Phantom: SAM 12; Type: SAM V4.0; Serial: TP 1202
- Measurement SW: DASY4, V4.7 Build 80; Postprocessing SW: SEMCAD, V1.8 Build 186

Body Position - Mid/Area Scan (7x15x1): Measurement grid: dx=8mm, dy=8mm

Maximum value of SAR (measured) = 0.211 mW/g

Body Position – Mid/Zoom Scan (7x7x7)/Cube 0: Measurement grid: dx=5mm, dy=5mm, dz=5mm

Reference Value = 3.93 V/m; Power Drift = 0.145 dB

Peak SAR (extrapolated) = 0.268 W/kg

SAR(1 g) = 0.155 mW/g; SAR(10 g) = 0.086 mW/g

Maximum value of SAR (measured) = 0.213 mW/g

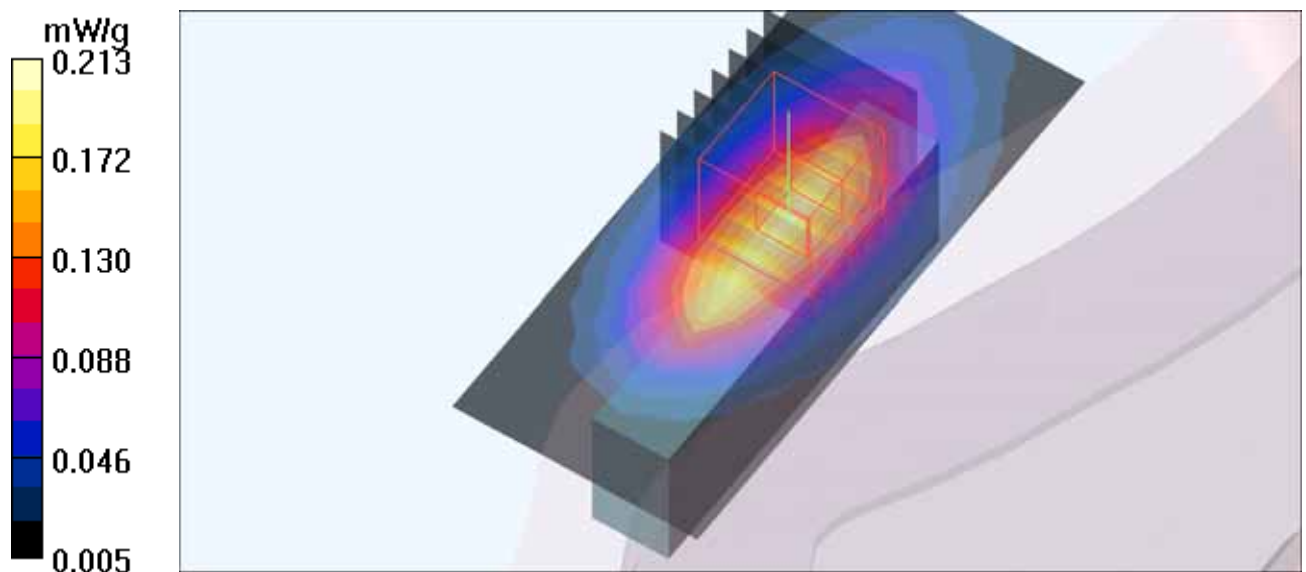

M73-E-GPRS1900 TS4-Ch661

Communication System: E-GPRS1900 ; Frequency: 1880 MHz ; Duty Cycle: 1:2 ; Modulation Type: 8PSK / UL 4 time slots

Medium: MSL1900 Medium parameters used: $f = 1880$ MHz; $\sigma = 1.54$ mho/m; $\epsilon_r = 54.64$; $\rho = 1000$ kg/m³

Phantom section: Flat Section ; Separation distance : 5 mm (The Vertical-Front side of the EUT to the Phantom)

DASY4 Configuration:

- Probe: EX3DV4 - SN3578; ConvF(6.7, 6.7, 6.7); Calibrated: 2010/6/22
- Sensor-Surface: 2mm (Mechanical Surface Detection)
- Electronics: DAE3 Sn579; Calibrated: 2010/9/20
- Phantom: SAM 12; Type: SAM V4.0; Serial: TP 1202
- Measurement SW: DASY4, V4.7 Build 80; Postprocessing SW: SEMCAD, V1.8 Build 186

Body Position - Mid/Area Scan (7x15x1): Measurement grid: dx=8mm, dy=8mm

Maximum value of SAR (measured) = 0.223 mW/g

Body Position - Mid/Zoom Scan (7x7x7)/Cube 0: Measurement grid: dx=5mm, dy=5mm, dz=5mm

Reference Value = 4.19 V/m; Power Drift = -0.134 dB

Peak SAR (extrapolated) = 0.277 W/kg

SAR(1 g) = 0.160 mW/g; SAR(10 g) = 0.089 mW/g

Maximum value of SAR (measured) = 0.221 mW/g

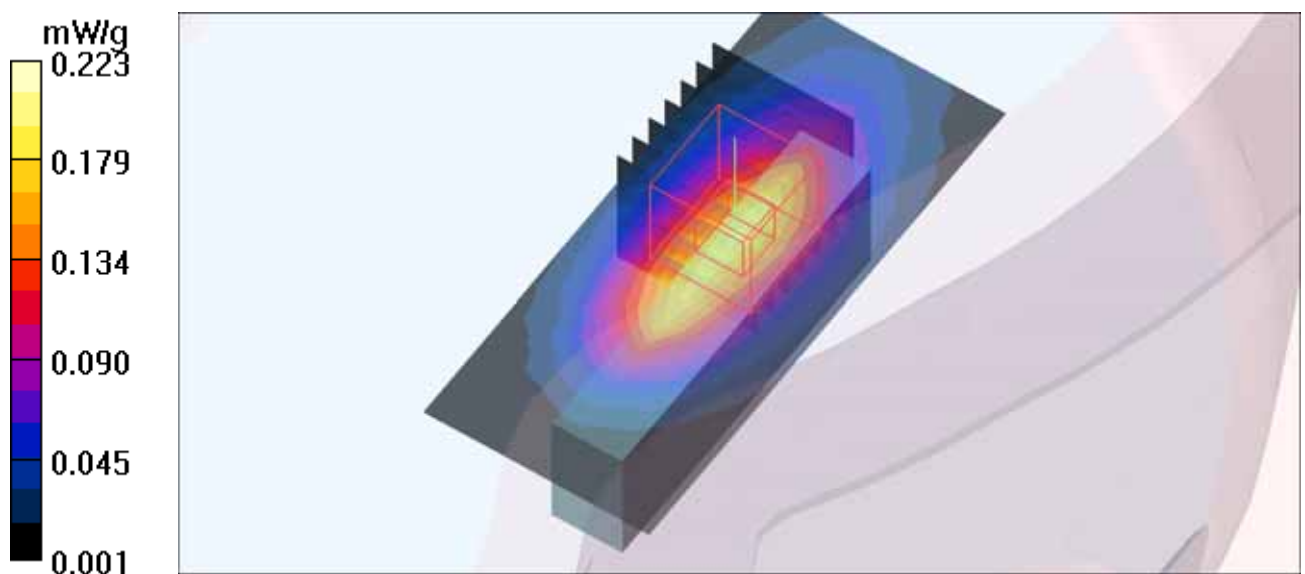

M74-E-GPRS1900 TS1-Ch661

Communication System: E-GPRS1900 ; Frequency: 1880 MHz ; Duty Cycle: 1:8.3 ; Modulation Type: 8PSK / UL 1 time slot

Medium: MSL1900 Medium parameters used: $f = 1880$ MHz; $\sigma = 1.54$ mho/m; $\epsilon_r = 54.64$; $\rho = 1000$ kg/m³

Phantom section: Flat Section ; Separation Distance : 5 mm (The Horizontal-Up side of the EUT to the Phantom)

DASY4 Configuration:

- Probe: EX3DV4 - SN3578; ConvF(6.7, 6.7, 6.7); Calibrated: 2010/6/22
- Sensor-Surface: 2mm (Mechanical Surface Detection)
- Electronics: DAE3 Sn579; Calibrated: 2010/9/20
- Phantom: SAM 12; Type: SAM V4.0; Serial: TP 1202
- Measurement SW: DASY4, V4.7 Build 80; Postprocessing SW: SEMCAD, V1.8 Build 186

Body Position - Mid/Area Scan (7x15x1): Measurement grid: dx=8mm, dy=8mm

Maximum value of SAR (measured) = 0.201 mW/g

Body Position - Mid/Zoom Scan (7x7x7)/Cube 0: Measurement grid: dx=5mm, dy=5mm, dz=5mm

Reference Value = 2.29 V/m; Power Drift = 0.133 dB

Peak SAR (extrapolated) = 0.287 W/kg

SAR(1 g) = 0.168 mW/g; SAR(10 g) = 0.100 mW/g

Maximum value of SAR (measured) = 0.229 mW/g

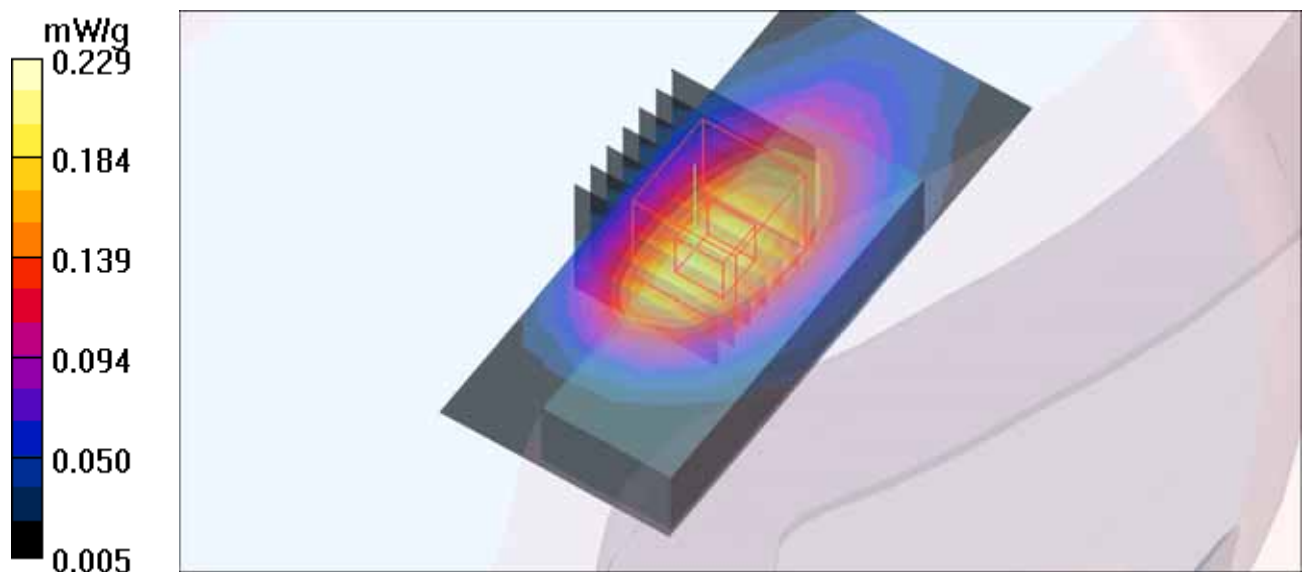

M75-E-GPRS1900 TS2-Ch661

Communication System: E-GPRS1900 ; Frequency: 1880 MHz ; Duty Cycle: 1:4 ; Modulation Type: 8PSK / UL 2 time slots

Medium: MSL1900 Medium parameters used: $f = 1880$ MHz; $\sigma = 1.54$ mho/m; $\epsilon_r = 54.64$; $\rho = 1000$ kg/m³

Phantom section: Flat Section ; Separation Distance : 5 mm (The Horizontal-Up side of the EUT to the Phantom)

DASY4 Configuration:

- Probe: EX3DV4 - SN3578; ConvF(6.7, 6.7, 6.7); Calibrated: 2010/6/22
- Sensor-Surface: 2mm (Mechanical Surface Detection)
- Electronics: DAE3 Sn579; Calibrated: 2010/9/20
- Phantom: SAM 12; Type: SAM V4.0; Serial: TP 1202
- Measurement SW: DASY4, V4.7 Build 80; Postprocessing SW: SEMCAD, V1.8 Build 186

Body Position - Mid/Area Scan (7x15x1): Measurement grid: dx=8mm, dy=8mm

Maximum value of SAR (measured) = 0.412 mW/g

Body Position - Mid/Zoom Scan (7x7x7)/Cube 0: Measurement grid: dx=5mm, dy=5mm, dz=5mm

Reference Value = 3.71 V/m; Power Drift = -0.097 dB

Peak SAR (extrapolated) = 0.503 W/kg

SAR(1 g) = 0.299 mW/g; SAR(10 g) = 0.178 mW/g.

Maximum value of SAR (measured) = 0.401 mW/g

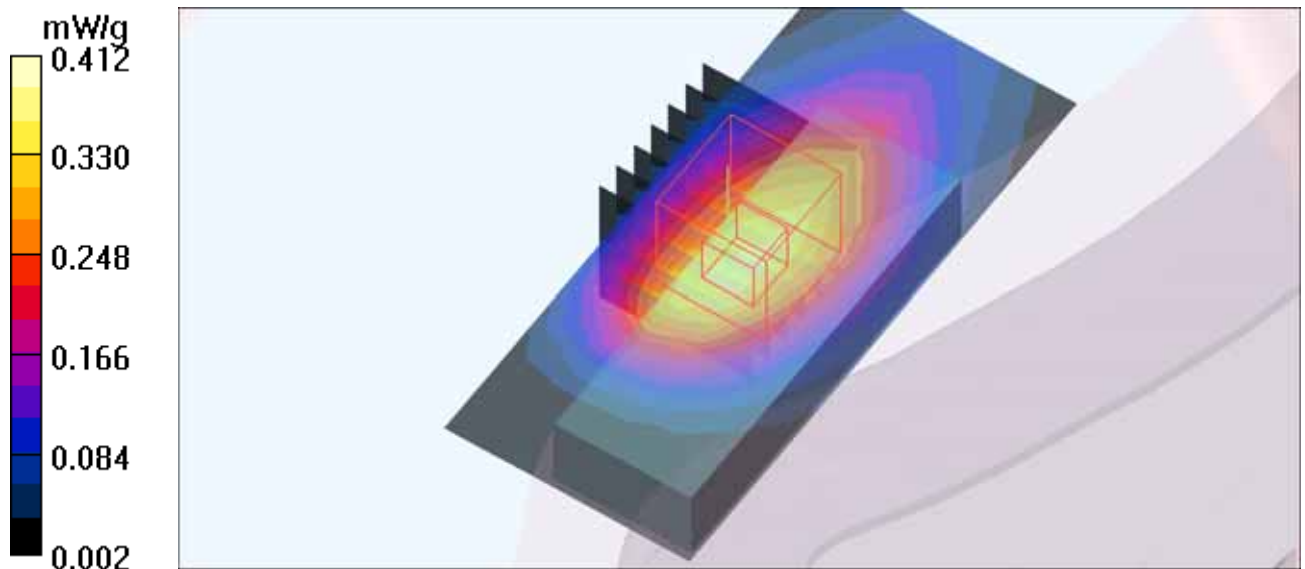

M76-E-GPRS1900 TS3-Ch661

Communication System: E-GPRS1900 ; Frequency: 1880 MHz ; Duty Cycle: 1:2.67 ; Modulation Type: 8PSK / UL 3 time slots

Medium: MSL1900 Medium parameters used: $f = 1880$ MHz; $\sigma = 1.54$ mho/m; $\epsilon_r = 54.64$; $\rho = 1000$ kg/m³

Phantom section: Flat Section ; Separation Distance : 5 mm (The Horizontal-Up side of the EUT to the Phantom)

DASY4 Configuration:

- Probe: EX3DV4 - SN3578; ConvF(6.7, 6.7, 6.7); Calibrated: 2010/6/22
- Sensor-Surface: 2mm (Mechanical Surface Detection)
- Electronics: DAE3 Sn579; Calibrated: 2010/9/20
- Phantom: SAM 12; Type: SAM V4.0; Serial: TP 1202
- Measurement SW: DASY4, V4.7 Build 80; Postprocessing SW: SEMCAD, V1.8 Build 186

Body Position - Mid/Area Scan (7x15x1): Measurement grid: dx=8mm, dy=8mm

Maximum value of SAR (measured) = 0.490 mW/g

Body Position - Mid/Zoom Scan (7x7x7)/Cube 0: Measurement grid: dx=5mm, dy=5mm, dz=5mm

Reference Value = 4.12 V/m; Power Drift = -0.135 dB

Peak SAR (extrapolated) = 0.600 W/kg

SAR(1 g) = 0.359 mW/g; SAR(10 g) = 0.213 mW/g

Maximum value of SAR (measured) = 0.478 mW/g

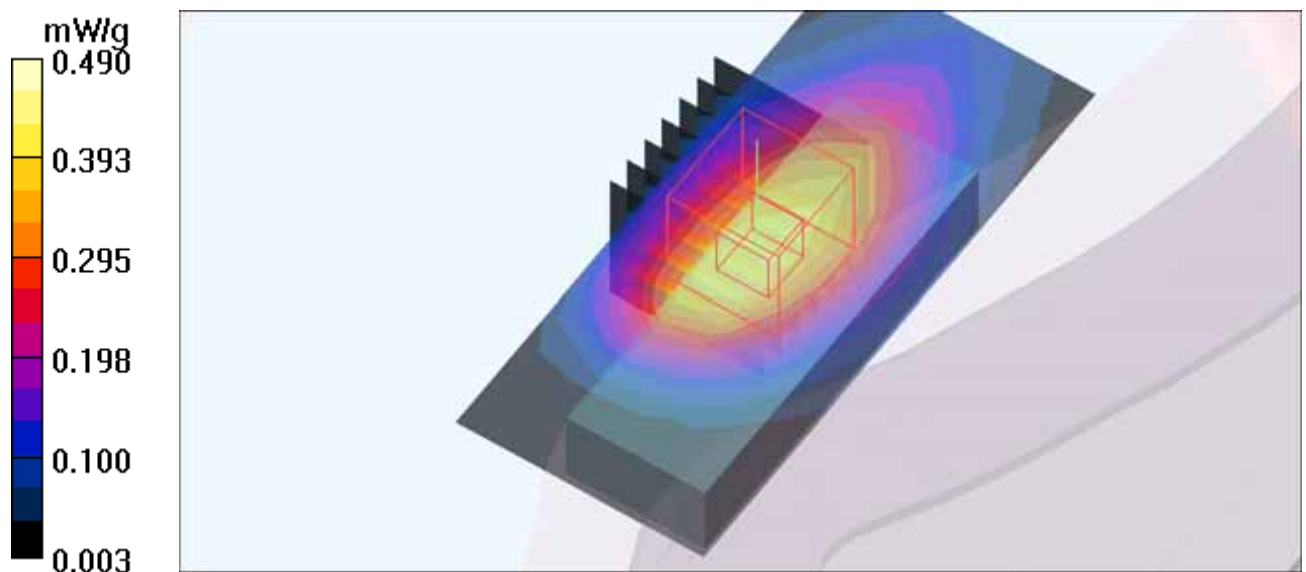

M77-E-GPRS1900 TS4-Ch661

Communication System: E-GPRS1900 ; Frequency: 1880 MHz ; Duty Cycle: 1:2 ; Modulation Type: 8PSK / UL 4 time slots

Medium: MSL1900 Medium parameters used: $f = 1880$ MHz; $\sigma = 1.54$ mho/m; $\epsilon_r = 54.64$; $\rho = 1000$ kg/m³

Phantom section: Flat Section ; Separation Distance : 5 mm (The Horizontal-Up side of the EUT to the Phantom)

DASY4 Configuration:

- Probe: EX3DV4 - SN3578; ConvF(6.7, 6.7, 6.7); Calibrated: 2010/6/22
- Sensor-Surface: 2mm (Mechanical Surface Detection)
- Electronics: DAE3 Sn579; Calibrated: 2010/9/20
- Phantom: SAM 12; Type: SAM V4.0; Serial: TP 1202
- Measurement SW: DASY4, V4.7 Build 80; Postprocessing SW: SEMCAD, V1.8 Build 186

Body Position - Mid/Area Scan (7x15x1): Measurement grid: dx=8mm, dy=8mm

Maximum value of SAR (measured) = 0.523 mW/g

Body Position - Mid/Zoom Scan (7x7x7)/Cube 0: Measurement grid: dx=5mm, dy=5mm, dz=5mm

Reference Value = 3.96 V/m; Power Drift = -0.136 dB

Peak SAR (extrapolated) = 0.661 W/kg

SAR(1 g) = 0.39 mW/g; SAR(10 g) = 0.232 mW/g

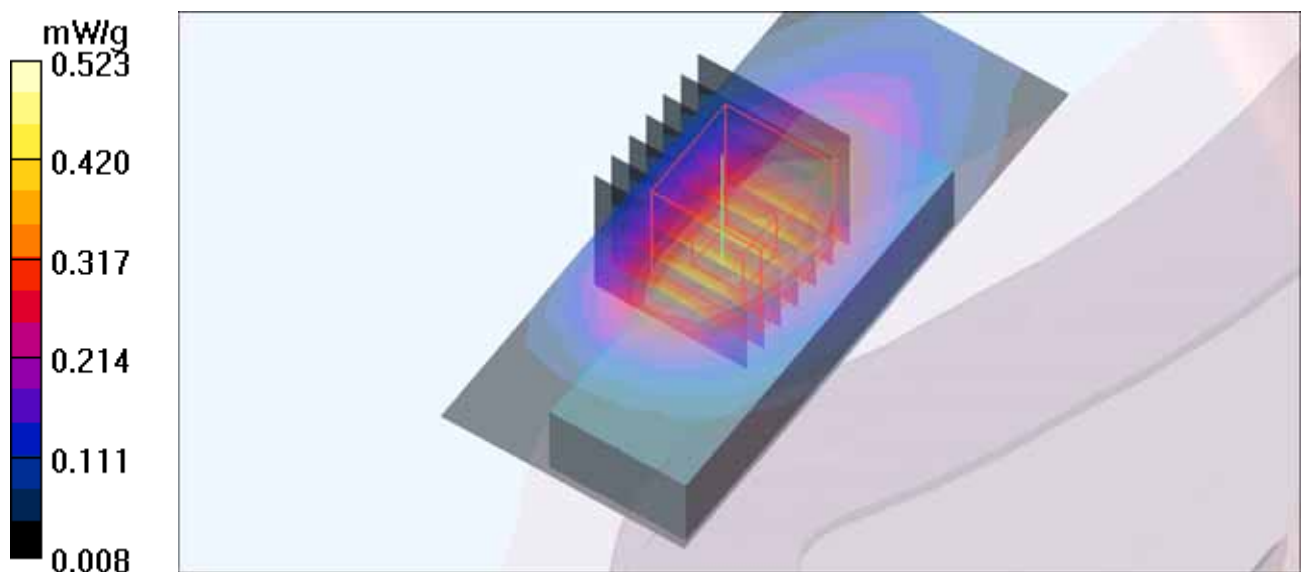

M78-E-GPRS1900 TS1-Ch661

Communication System: E-GPRS1900 ; Frequency: 1880 MHz ; Duty Cycle: 1:8.3 ; Modulation Type: 8PSK / UL 1 time slot

Medium: MSL1900 Medium parameters used: $f = 1880$ MHz; $\sigma = 1.54$ mho/m; $\epsilon_r = 54.64$; $\rho = 1000$ kg/m³

Phantom section: Flat Section ; Separation distance : 5 mm (The Vertical-Back side of the EUT to the Phantom)

DASY4 Configuration:

- Probe: EX3DV4 - SN3578; ConvF(6.7, 6.7, 6.7); Calibrated: 2010/6/22
- Sensor-Surface: 2mm (Mechanical Surface Detection)
- Electronics: DAE3 Sn579; Calibrated: 2010/9/20
- Phantom: SAM 12; Type: SAM V4.0; Serial: TP 1202
- Measurement SW: DASY4, V4.7 Build 80; Postprocessing SW: SEMCAD, V1.8 Build 186

Body Position - Mid/Area Scan (7x15x1): Measurement grid: dx=8mm, dy=8mm

Maximum value of SAR (measured) = 0.111 mW/g

Body Position - Mid/Zoom Scan (7x7x7)/Cube 0: Measurement grid: dx=5mm, dy=5mm, dz=5mm

Reference Value = 2.76 V/m; Power Drift = -0.141 dB

Peak SAR (extrapolated) = 0.152 W/kg

SAR(1 g) = 0.087 mW/g; SAR(10 g) = 0.049 mW/g

Maximum value of SAR (measured) = 0.121 mW/g

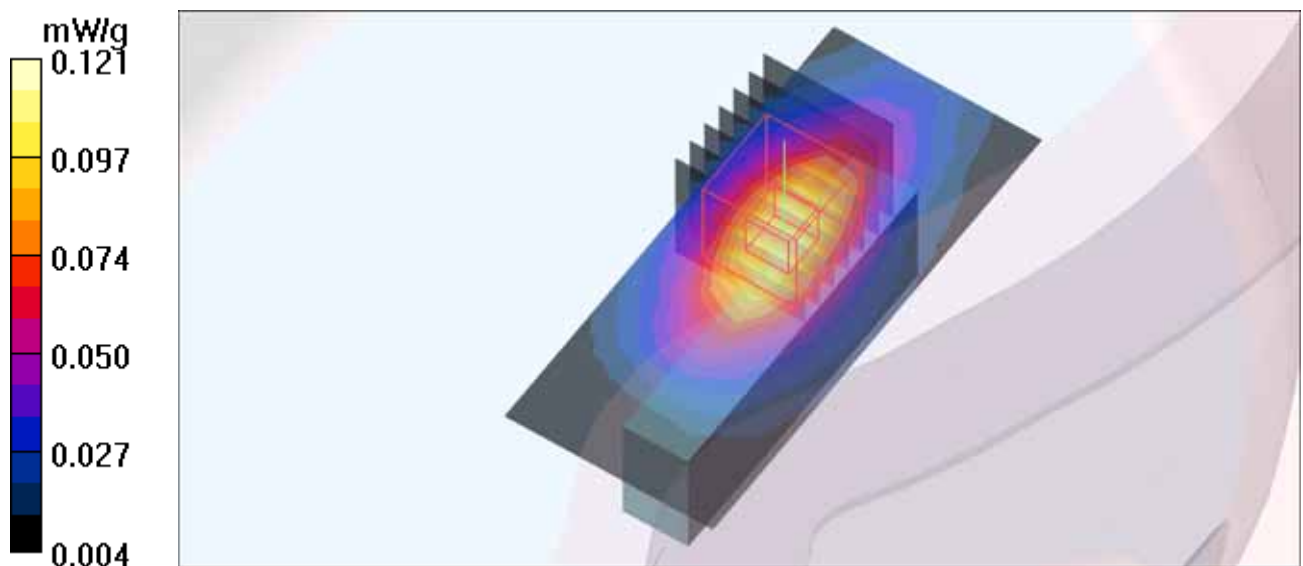

M79-E-GPRS1900 TS2-Ch661

Communication System: E-GPRS1900 ; Frequency: 1880 MHz ; Duty Cycle: 1:4 ; Modulation Type: 8PSK / UL 2 time slots

Medium: MSL1900 Medium parameters used: $f = 1880$ MHz; $\sigma = 1.54$ mho/m; $\epsilon_r = 54.64$; $\rho = 1000$ kg/m³

Phantom section: Flat Section ; Separation distance : 5 mm (The Vertical-Back side of the EUT to the Phantom)

DASY4 Configuration:

- Probe: EX3DV4 - SN3578; ConvF(6.7, 6.7, 6.7); Calibrated: 2010/6/22
- Sensor-Surface: 2mm (Mechanical Surface Detection)
- Electronics: DAE3 Sn579; Calibrated: 2010/9/20
- Phantom: SAM 12; Type: SAM V4.0; Serial: TP 1202
- Measurement SW: DASY4, V4.7 Build 80; Postprocessing SW: SEMCAD, V1.8 Build 186

Body Position - Mid/Area Scan (7x15x1): Measurement grid: dx=8mm, dy=8mm

Maximum value of SAR (measured) = 0.168 mW/g

Body Position - Mid/Zoom Scan (7x7x7)/Cube 0: Measurement grid: dx=5mm, dy=5mm, dz=5mm

Reference Value = 3.04 V/m; Power Drift = 0.121 dB

Peak SAR (extrapolated) = 0.231 W/kg

SAR(1 g) = 0.134 mW/g; SAR(10 g) = 0.076 mW/g

Maximum value of SAR (measured) = 0.184 mW/g

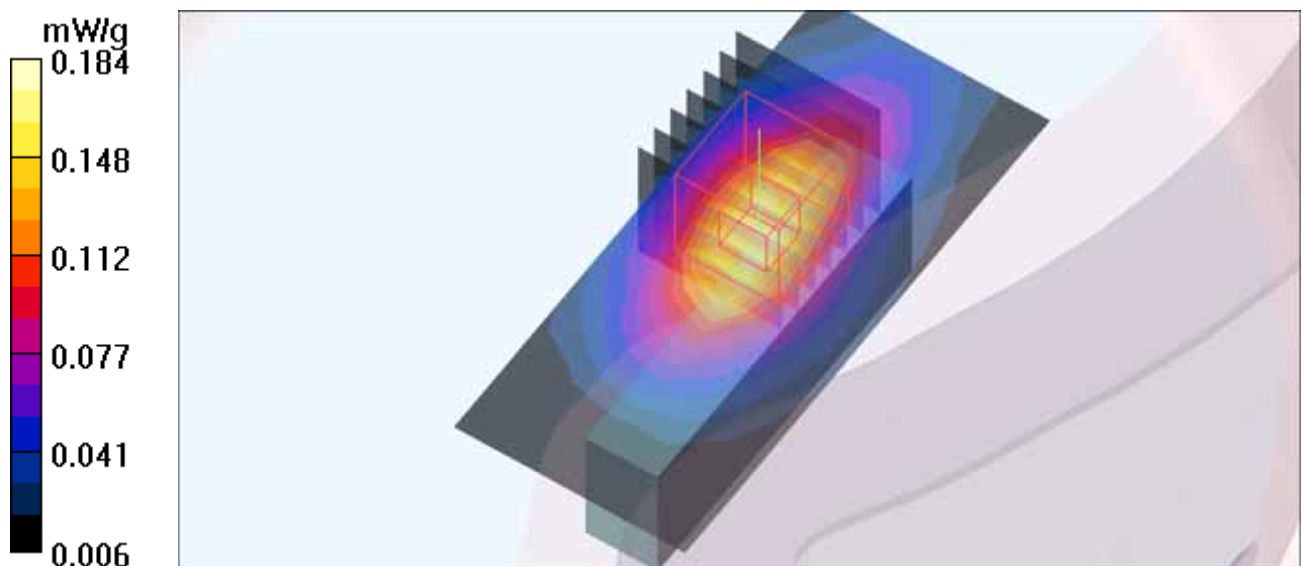

M80-E-GPRS1900 TS3-Ch661

Communication System: E-GPRS1900 ; Frequency: 1880 MHz ; Duty Cycle: 1:2.67 ; Modulation Type: 8PSK / UL 3 time slots

Medium: MSL1900 Medium parameters used: $f = 1880$ MHz; $\sigma = 1.54$ mho/m; $\epsilon_r = 54.64$; $\rho = 1000$ kg/m³

Phantom section: Flat Section ; Separation distance : 5 mm (The Vertical-Back side of the EUT to the Phantom)

DASY4 Configuration:

- Probe: EX3DV4 - SN3578; ConvF(6.7, 6.7, 6.7); Calibrated: 2010/6/22
- Sensor-Surface: 2mm (Mechanical Surface Detection)
- Electronics: DAE3 Sn579; Calibrated: 2010/9/20
- Phantom: SAM 12; Type: SAM V4.0; Serial: TP 1202
- Measurement SW: DASY4, V4.7 Build 80; Postprocessing SW: SEMCAD, V1.8 Build 186

Body Position - Mid/Area Scan (7x15x1): Measurement grid: dx=8mm, dy=8mm

Maximum value of SAR (measured) = 0.212 mW/g

Body Position - Mid/Zoom Scan (7x7x7)/Cube 0: Measurement grid: dx=5mm, dy=5mm, dz=5mm

Reference Value = 3.48 V/m; Power Drift = -0.047 dB

Peak SAR (extrapolated) = 0.288 W/kg

SAR(1 g) = 0.168 mW/g; SAR(10 g) = 0.095 mW/g

Maximum value of SAR (measured) = 0.230 mW/g

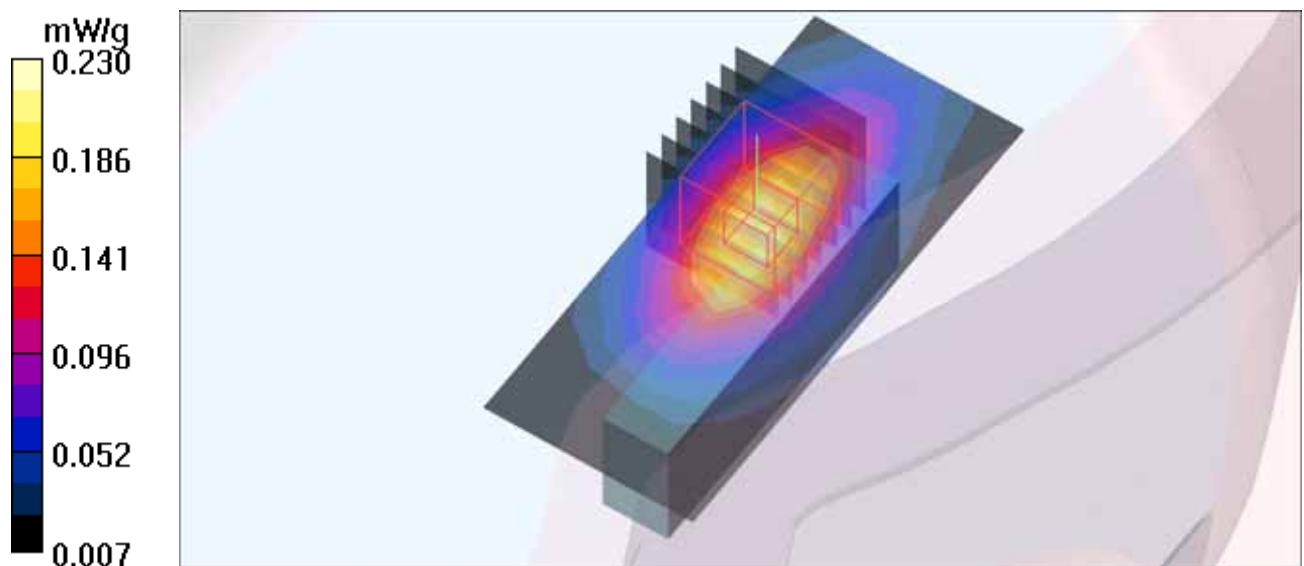

M81-E-GPRS1900 TS4-Ch661

Communication System: E-GPRS1900 ; Frequency: 1880 MHz ; Duty Cycle: 1:2 ; Modulation Type: 8PSK / UL 4 time slots

Medium: MSL1900 Medium parameters used: $f = 1880$ MHz; $\sigma = 1.54$ mho/m; $\epsilon_r = 54.64$; $\rho = 1000$ kg/m³

Phantom section: Flat Section ; Separation distance : 5 mm (The Vertical-Back side of the EUT to the Phantom)

DASY4 Configuration:

- Probe: EX3DV4 - SN3578; ConvF(6.7, 6.7, 6.7); Calibrated: 2010/6/22
- Sensor-Surface: 2mm (Mechanical Surface Detection)
- Electronics: DAE3 Sn579; Calibrated: 2010/9/20
- Phantom: SAM 12; Type: SAM V4.0; Serial: TP 1202
- Measurement SW: DASY4, V4.7 Build 80; Postprocessing SW: SEMCAD, V1.8 Build 186

Body Position - Mid/Area Scan (7x15x1): Measurement grid: dx=8mm, dy=8mm

Maximum value of SAR (measured) = 0.221 mW/g

Body Position - Mid/Zoom Scan (7x7x7)/Cube 0: Measurement grid: dx=5mm, dy=5mm, dz=5mm

Reference Value = 3.60 V/m; Power Drift = -0.072 dB

Peak SAR (extrapolated) = 0.301 W/kg

SAR(1 g) = 0.173 mW/g; SAR(10 g) = 0.097 mW/g

Maximum value of SAR (measured) = 0.240 mW/g

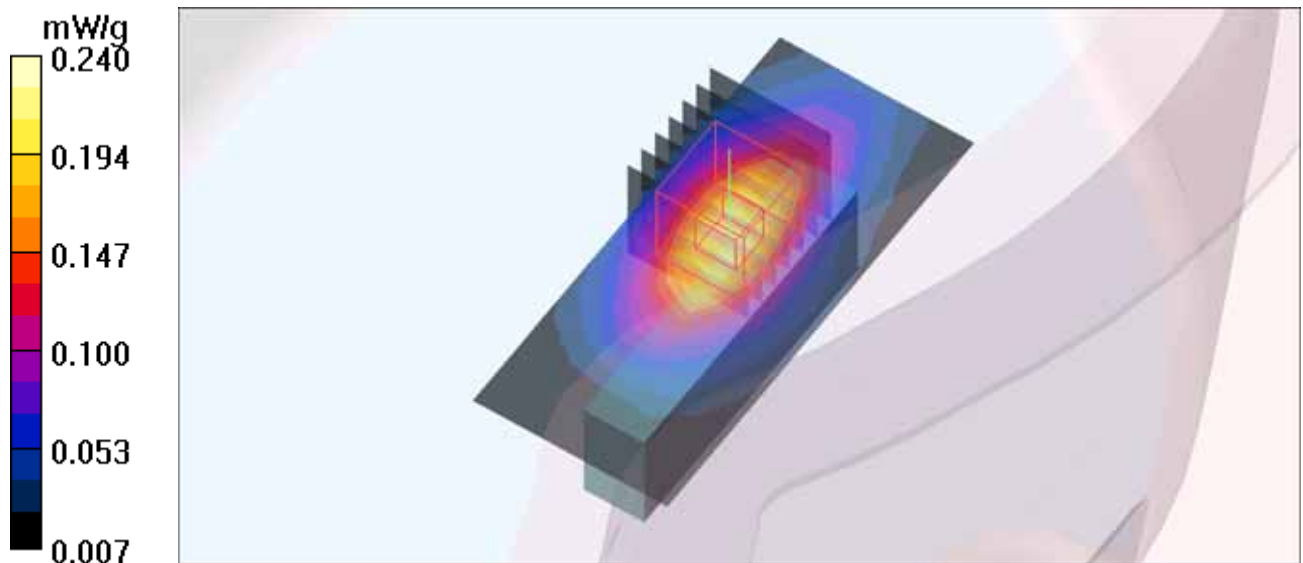

M82-E-GPRS1900 TS1-Ch661

Communication System: E-GPRS1900 ; Frequency: 1880 MHz ; Duty Cycle: 1:8.3 ; Modulation Type: 8PSK / UL 1 time slot

Medium: MSL1900 Medium parameters used: $f = 1880$ MHz; $\sigma = 1.54$ mho/m; $\epsilon_r = 54.64$; $\rho = 1000$ kg/m³

Phantom section: Flat Section ; Separation distance : 5 mm (The top side of the EUT to the Phantom)

DASY4 Configuration:

- Probe: EX3DV4 - SN3578; ConvF(6.7, 6.7, 6.7); Calibrated: 2010/6/22
- Sensor-Surface: 2mm (Mechanical Surface Detection)
- Electronics: DAE3 Sn579; Calibrated: 2010/9/20
- Phantom: SAM 12; Type: SAM V4.0; Serial: TP 1202
- Measurement SW: DASY4, V4.7 Build 80; Postprocessing SW: SEMCAD, V1.8 Build 186

Body Position - Mid/Area Scan (8x10x1): Measurement grid: dx=8mm, dy=8mm

Maximum value of SAR (measured) = 0.024 mW/g

Body Position - Mid/Zoom Scan (7x7x7)/Cube 0: Measurement grid: dx=5mm, dy=5mm, dz=5mm

Reference Value = 2.51 V/m; Power Drift = 0.118 dB

Peak SAR (extrapolated) = 0.032 W/kg

SAR(1 g) = 0.019 mW/g; SAR(10 g) = 0.011 mW/g

Maximum value of SAR (measured) = 0.026 mW/g

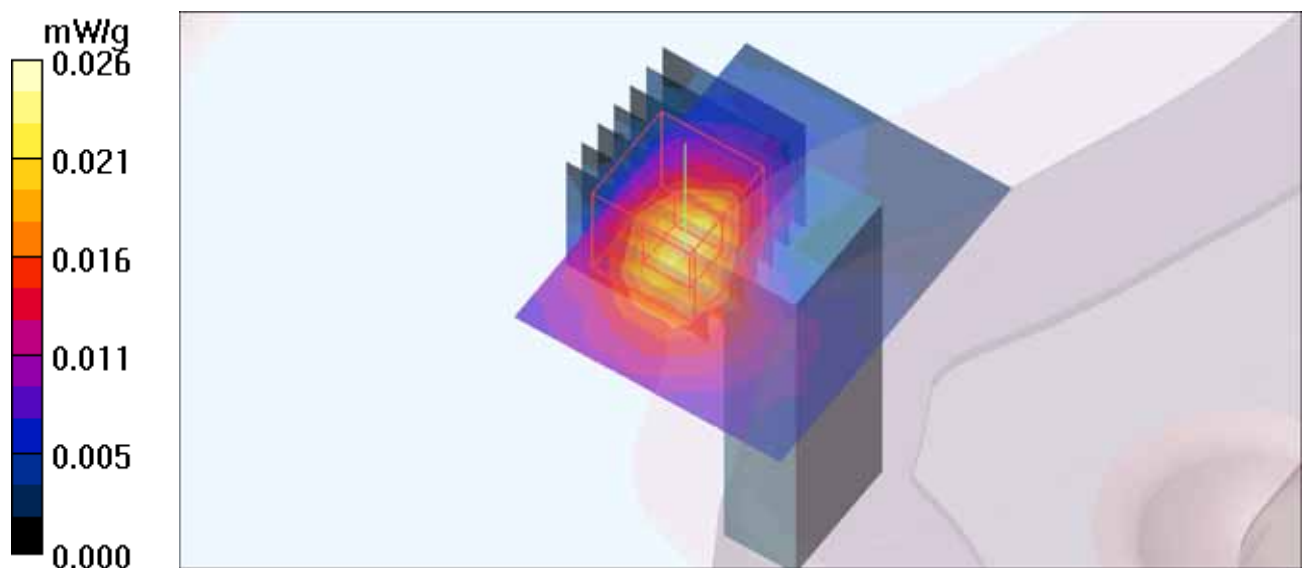

M83-E-GPRS1900 TS2-Ch661

Communication System: E-GPRS1900 ; Frequency: 1880 MHz ; Duty Cycle: 1:4 ; Modulation Type: 8PSK / UL 2 time slots

Medium: MSL1900 Medium parameters used: $f = 1880$ MHz; $\sigma = 1.54$ mho/m; $\epsilon_r = 54.64$; $\rho = 1000$ kg/m³

Phantom section: Flat Section ; Separation Distance : 5 mm (The top side of the EUT to the Phantom)

DASY4 Configuration:

- Probe: EX3DV4 - SN3578; ConvF(6.7, 6.7, 6.7); Calibrated: 2010/6/22
- Sensor-Surface: 2mm (Mechanical Surface Detection)
- Electronics: DAE3 Sn579; Calibrated: 2010/9/20
- Phantom: SAM 12; Type: SAM V4.0; Serial: TP 1202
- Measurement SW: DASY4, V4.7 Build 80; Postprocessing SW: SEMCAD, V1.8 Build 186

Body Position - Mid/Area Scan (8x10x1): Measurement grid: dx=8mm, dy=8mm

Maximum value of SAR (measured) = 0.037 mW/g

Body Position - Mid/Zoom Scan (7x7x7)/Cube 0: Measurement grid: dx=5mm, dy=5mm, dz=5mm

Reference Value = 2.89 V/m; Power Drift = 0.178 dB

Peak SAR (extrapolated) = 0.056 W/kg

SAR(1 g) = 0.033 mW/g; SAR(10 g) = 0.018 mW/g

Maximum value of SAR (measured) = 0.045 mW/g

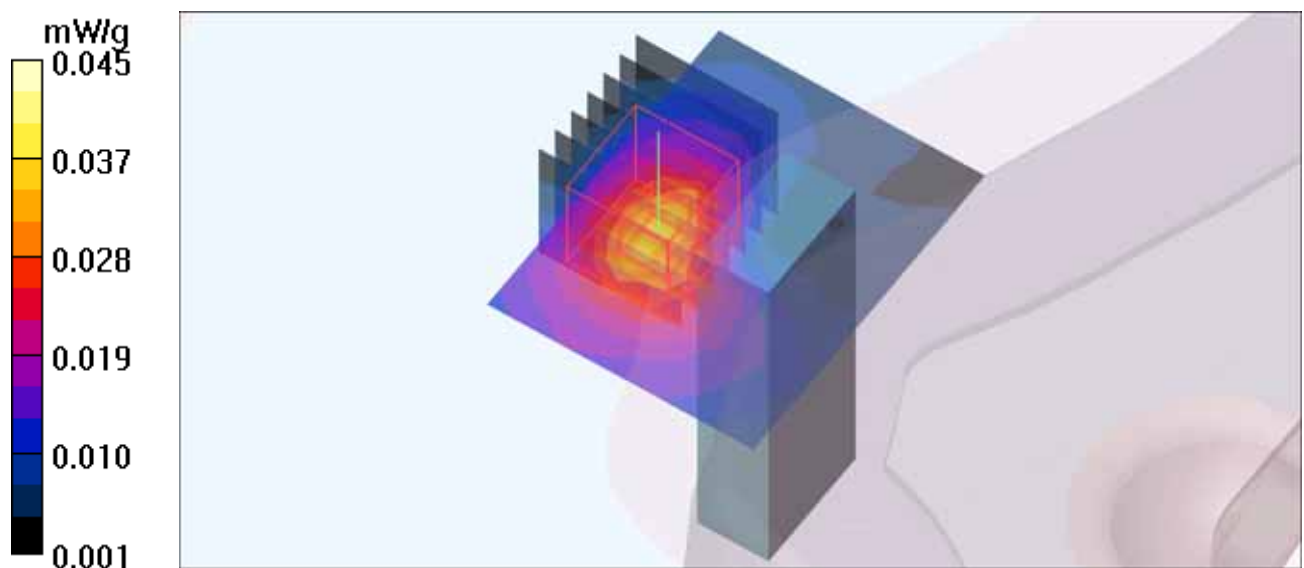

M84-E-GPRS1900 TS3-Ch661

Communication System: E-GPRS1900 ; Frequency: 1880 MHz ; Duty Cycle: 1:2.67 ; Modulation Type: 8PSK / UL 3 time slots

Medium: MSL1900 Medium parameters used: $f = 1880$ MHz; $\sigma = 1.54$ mho/m; $\epsilon_r = 54.64$; $\rho = 1000$ kg/m³

Phantom section: Flat Section ; Separation Distance : 5 mm (The top side of the EUT to the Phantom)

DASY4 Configuration:

- Probe: EX3DV4 - SN3578; ConvF(6.7, 6.7, 6.7); Calibrated: 2010/6/22
- Sensor-Surface: 2mm (Mechanical Surface Detection)
- Electronics: DAE3 Sn579; Calibrated: 2010/9/20
- Phantom: SAM 12; Type: SAM V4.0; Serial: TP 1202
- Measurement SW: DASY4, V4.7 Build 80; Postprocessing SW: SEMCAD, V1.8 Build 186

Body Position - Mid/Area Scan (8x10x1): Measurement grid: dx=8mm, dy=8mm

Maximum value of SAR (measured) = 0.051 mW/g

Body Position - Mid/Zoom Scan (7x7x7)/Cube 0: Measurement grid: dx=5mm, dy=5mm, dz=5mm

Reference Value = 3.92 V/m; Power Drift = -0.170 dB

Peak SAR (extrapolated) = 0.063 W/kg

SAR(1 g) = 0.036 mW/g; SAR(10 g) = 0.020 mW/g

Maximum value of SAR (measured) = 0.050 mW/g

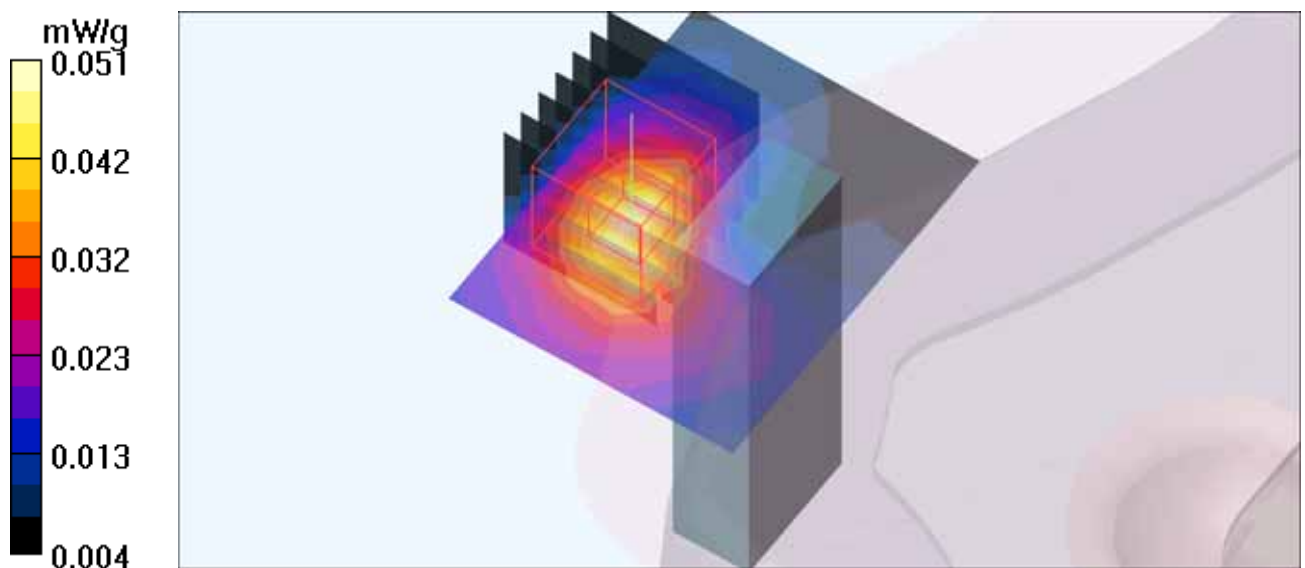

M85-E-GPRS1900 TS4-Ch661

Communication System: E-GPRS1900 ; Frequency: 1880 MHz ; Duty Cycle: 1:2 ; Modulation Type: 8PSK / UL 4 time slots

Medium: MSL1900 Medium parameters used: $f = 1880$ MHz; $\sigma = 1.54$ mho/m; $\epsilon_r = 54.64$; $\rho = 1000$ kg/m³

Phantom section: Flat Section ; Separation Distance : 5 mm (The top side of the EUT to the Phantom)

DASY4 Configuration:

- Probe: EX3DV4 - SN3578; ConvF(6.7, 6.7, 6.7); Calibrated: 2010/6/22
- Sensor-Surface: 2mm (Mechanical Surface Detection)
- Electronics: DAE3 Sn579; Calibrated: 2010/9/20
- Phantom: SAM 12; Type: SAM V4.0; Serial: TP 1202
- Measurement SW: DASY4, V4.7 Build 80; Postprocessing SW: SEMCAD, V1.8 Build 186

Body Position - Mid/Area Scan (8x10x1): Measurement grid: dx=8mm, dy=8mm

Maximum value of SAR (measured) = 0.049 mW/g

Body Position - Mid/Zoom Scan (7x7x7)/Cube 0: Measurement grid: dx=5mm, dy=5mm, dz=5mm

Reference Value = 3.80 V/m; Power Drift = -0.045 dB

Peak SAR (extrapolated) = 0.059 W/kg

SAR(1 g) = 0.035 mW/g; SAR(10 g) = 0.020 mW/g

Maximum value of SAR (measured) = 0.048 mW/g

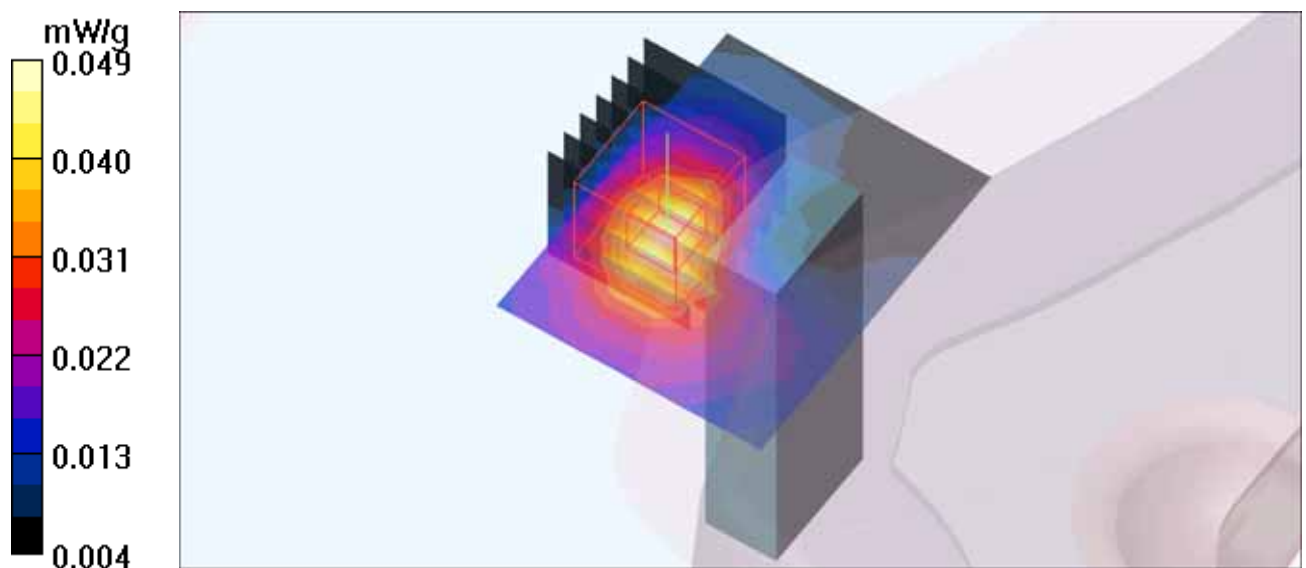

M86-WCDMA1900-Ch9400

Communication System: WCDMA1900 ; Frequency: 1880 MHz ; Duty Cycle: 1:1 ; Modulation Type: BPSK

Medium: MSL1900 Medium parameters used: $f = 1880$ MHz; $\sigma = 1.54$ mho/m; $\epsilon_r = 54.64$; $\rho = 1000$ kg/m³

Phantom section: Flat Section ; Separation Distance : 5 mm (The Horizontal-Down side of the EUT to the Phantom)

DASY4 Configuration:

- Probe: EX3DV4 - SN3578; ConvF(6.7, 6.7, 6.7); Calibrated: 2010/6/22
- Sensor-Surface: 2mm (Mechanical Surface Detection)
- Electronics: DAE3 Sn579; Calibrated: 2010/9/20
- Phantom: SAM 12; Type: SAM V4.0; Serial: TP 1202
- Measurement SW: DASY4, V4.7 Build 80; Postprocessing SW: SEMCAD, V1.8 Build 186

Body Position - Mid/Area Scan (7x15x1): Measurement grid: dx=8mm, dy=8mm

Maximum value of SAR (measured) = 0.926 mW/g

Body Position - Mid/Zoom Scan (7x7x7)/Cube 0: Measurement grid: dx=5mm, dy=5mm, dz=5mm

Reference Value = 10.3 V/m; Power Drift = 0.123 dB

Peak SAR (extrapolated) = 1.27 W/kg

SAR(1 g) = 0.694 mW/g; SAR(10 g) = 0.378 mW/g

Maximum value of SAR (measured) = 0.969 mW/g

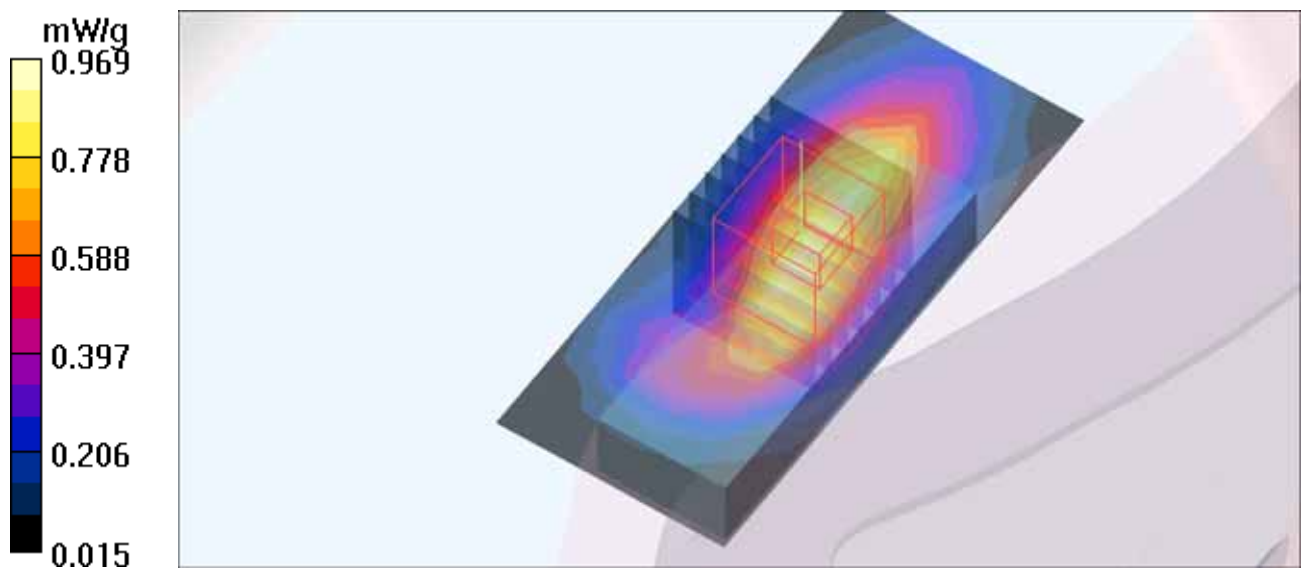

M87-WCDMA1900-Ch9400

Communication System: WCDMA1900 ; Frequency: 1880 MHz ; Duty Cycle: 1:1 ; Modulation Type: BPSK

Medium: MSL1900 Medium parameters used: $f = 1880$ MHz; $\sigma = 1.54$ mho/m; $\epsilon_r = 54.64$; $\rho = 1000$ kg/m³

Phantom section: Flat Section ; Separation Distance : 5 mm (The Vertical-Front side of the EUT to the Phantom)

DASY4 Configuration:

- Probe: EX3DV4 - SN3578; ConvF(6.7, 6.7, 6.7); Calibrated: 2010/6/22
- Sensor-Surface: 2mm (Mechanical Surface Detection)
- Electronics: DAE3 Sn579; Calibrated: 2010/9/20
- Phantom: SAM 12; Type: SAM V4.0; Serial: TP 1202
- Measurement SW: DASY4, V4.7 Build 80; Postprocessing SW: SEMCAD, V1.8 Build 186

Body Position - Mid/Area Scan (7x15x1): Measurement grid: dx=8mm, dy=8mm

Maximum value of SAR (measured) = 0.689 mW/g

Body Position - Mid/Zoom Scan (7x7x7)/Cube 0: Measurement grid: dx=5mm, dy=5mm, dz=5mm

Reference Value = 6.36 V/m; Power Drift = 0.182 dB

Peak SAR (extrapolated) = 0.967 W/kg

SAR(1 g) = 0.528 mW/g; SAR(10 g) = 0.279 mW/g

Maximum value of SAR (measured) = 0.755 mW/g

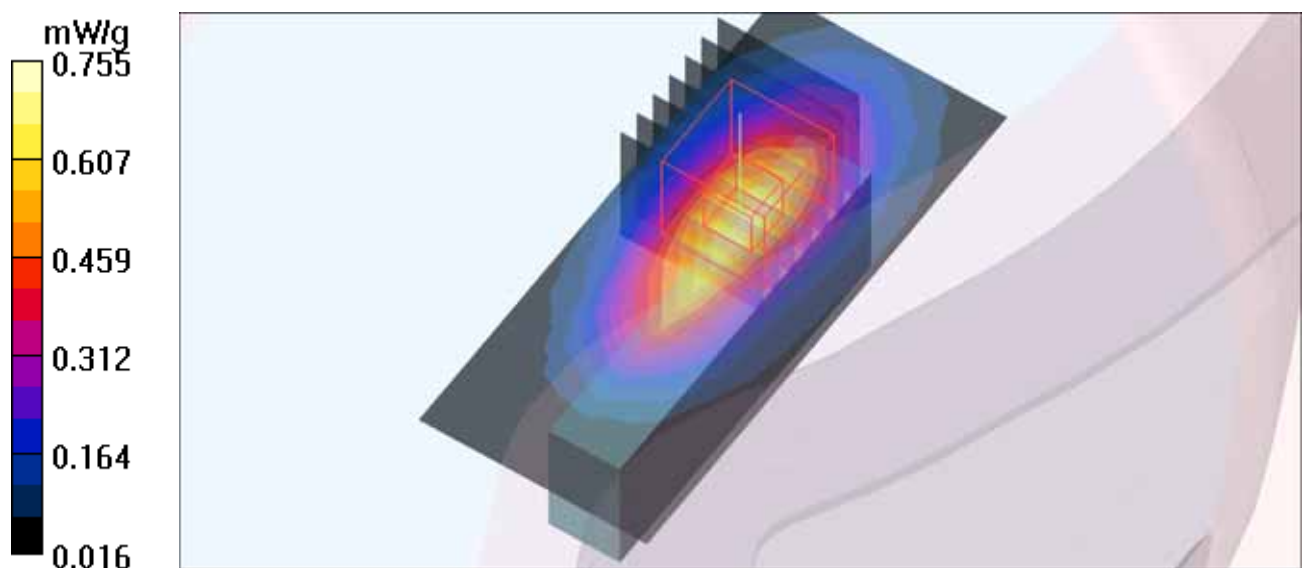

M88-WCDMA1900-Ch9400

Communication System: WCDMA1900 ; Frequency: 1880 MHz ; Duty Cycle: 1:1 ; Modulation Type: BPSK

Medium: MSL1900 Medium parameters used: $f = 1880$ MHz; $\sigma = 1.54$ mho/m; $\epsilon_r = 54.64$; $\rho = 1000$ kg/m³

Phantom section: Flat Section ; Separation Distance : 5 mm (The Horizontal-Up side of the EUT to the Phantom)

DASY4 Configuration:

- Probe: EX3DV4 - SN3578; ConvF(6.7, 6.7, 6.7); Calibrated: 2010/6/22
- Sensor-Surface: 2mm (Mechanical Surface Detection)
- Electronics: DAE3 Sn579; Calibrated: 2010/9/20
- Phantom: SAM 12; Type: SAM V4.0; Serial: TP 1202
- Measurement SW: DASY4, V4.7 Build 80; Postprocessing SW: SEMCAD, V1.8 Build 186

Body Position - Mid/Area Scan (7x15x1): Measurement grid: dx=8mm, dy=8mm

Maximum value of SAR (measured) = 0.812 mW/g

Body Position - Mid/Zoom Scan (7x7x7)/Cube 0: Measurement grid: dx=5mm, dy=5mm, dz=5mm

Reference Value = 4.90 V/m; Power Drift = 0.039 dB

Peak SAR (extrapolated) = 0.995 W/kg

SAR(1 g) = 0.586 mW/g; SAR(10 g) = 0.346 mW/g

Maximum value of SAR (measured) = 0.778 mW/g

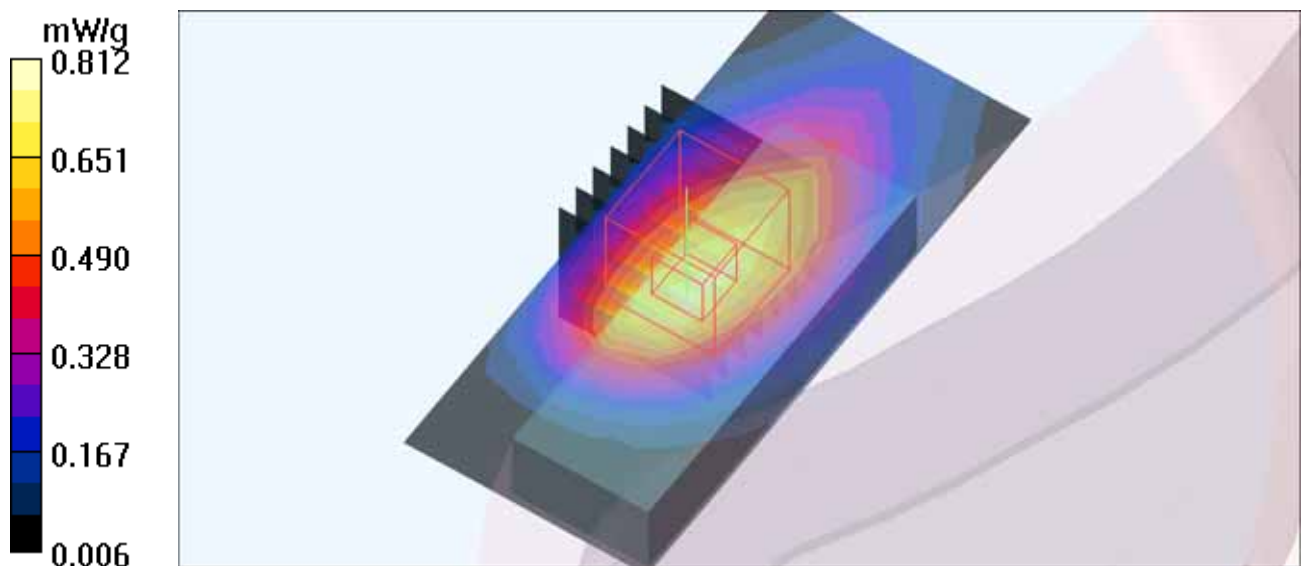

M89-WCDMA1900-Ch9400

Communication System: WCDMA1900 ; Frequency: 1880 MHz ; Duty Cycle: 1:1 ; Modulation Type: BPSK

Medium: MSL1900 Medium parameters used: $f = 1880$ MHz; $\sigma = 1.54$ mho/m; $\epsilon_r = 54.64$; $\rho = 1000$ kg/m³

Phantom section: Flat Section ; Separation Distance : 5 mm (The Vertical-Back side of the EUT to the Phantom)

DASY4 Configuration:

- Probe: EX3DV4 - SN3578; ConvF(6.7, 6.7, 6.7); Calibrated: 2010/6/22
- Sensor-Surface: 2mm (Mechanical Surface Detection)
- Electronics: DAE3 Sn579; Calibrated: 2010/9/20
- Phantom: SAM 12; Type: SAM V4.0; Serial: TP 1202
- Measurement SW: DASY4, V4.7 Build 80; Postprocessing SW: SEMCAD, V1.8 Build 186

Body Position - Mid/Area Scan (7x15x1): Measurement grid: dx=8mm, dy=8mm

Maximum value of SAR (measured) = 0.673 mW/g

Body Position - Mid/Zoom Scan (7x7x7)/Cube 0: Measurement grid: dx=5mm, dy=5mm, dz=5mm

Reference Value = 7.14 V/m; Power Drift = -0.122 dB

Peak SAR (extrapolated) = 0.848 W/kg

SAR(1 g) = 0.489 mW/g; SAR(10 g) = 0.275 mW/g

Maximum value of SAR (measured) = 0.675 mW/g

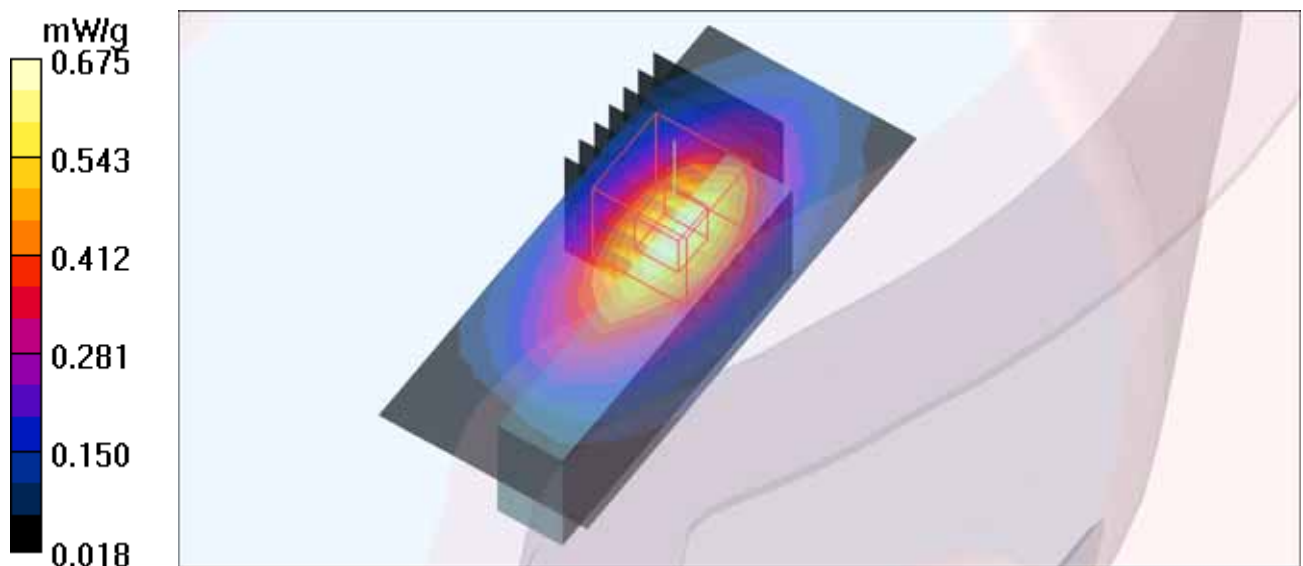

M90-WCDMA1900-Ch9400

Communication System: WCDMA1900 ; Frequency: 1880 MHz ; Duty Cycle: 1:1 ; Modulation Type: BPSK

Medium: MSL1900 Medium parameters used: $f = 1880$ MHz; $\sigma = 1.54$ mho/m; $\epsilon_r = 54.64$; $\rho = 1000$ kg/m³

Phantom section: Flat Section ; Separation Distance : 5 mm (The top side of the EUT to the Phantom)

DASY4 Configuration:

- Probe: EX3DV4 - SN3578; ConvF(6.7, 6.7, 6.7); Calibrated: 2010/6/22
- Sensor-Surface: 2mm (Mechanical Surface Detection)
- Electronics: DAE3 Sn579; Calibrated: 2010/9/20
- Phantom: SAM 12; Type: SAM V4.0; Serial: TP 1202
- Measurement SW: DASY4, V4.7 Build 80; Postprocessing SW: SEMCAD, V1.8 Build 186

Body Position - Mid/Area Scan (8x10x1): Measurement grid: dx=8mm, dy=8mm

Maximum value of SAR (measured) = 0.069 mW/g

Body Position - Mid/Zoom Scan (7x7x7)/Cube 0: Measurement grid: dx=5mm, dy=5mm, dz=5mm

Reference Value = 6.09 V/m; Power Drift = 0.041 dB

Peak SAR (extrapolated) = 0.091 W/kg

SAR(1 g) = 0.051 mW/g; SAR(10 g) = 0.027 mW/g

Maximum value of SAR (measured) = 0.072 mW/g

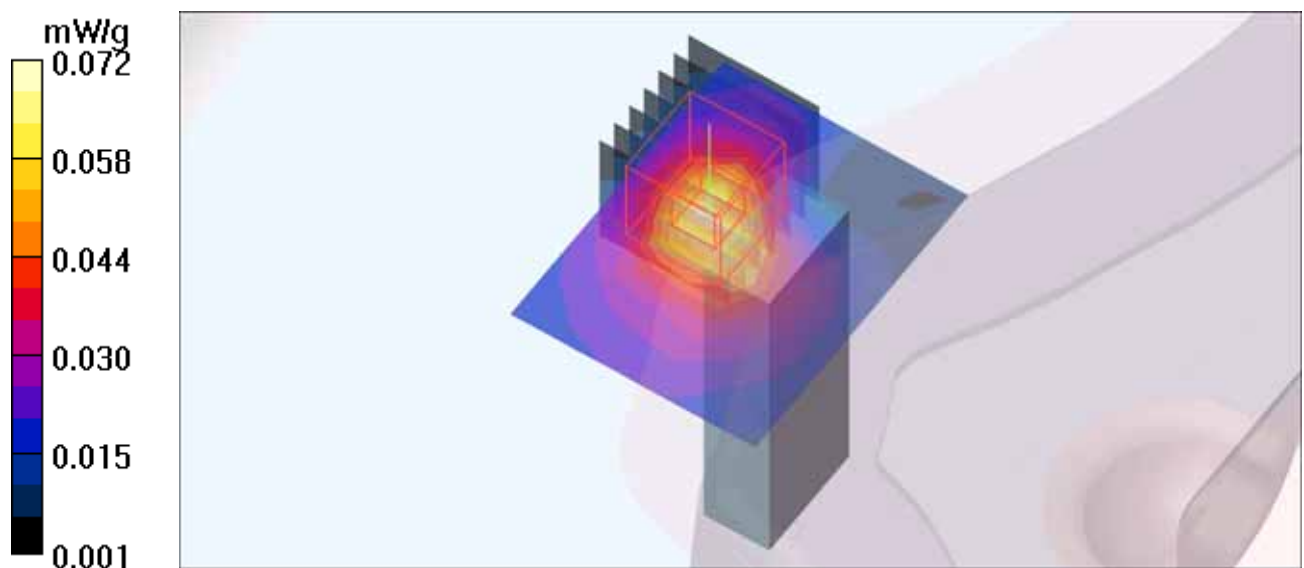

SystemPerformanceCheck-D835V2-MSL835 MHz

DUT: Dipole 835 MHz ; Type: D835V2 ; Serial: D835V2 - SN:4d021 ; Test Frequency: 835 MHz

Communication System: CW ; Frequency: 835 MHz; Duty Cycle: 1:1; Modulation Type: CW
Medium: MSL835; Medium parameters used: $f = 835 \text{ MHz}$; $\sigma = 0.98 \text{ mho/m}$; $\epsilon_r = 55.86$; $\rho = 1000 \text{ kg/m}^3$; Liquid level : 150 mm

Phantom section: Flat Section ; Separation Distance : 15 mm (The feet point of the dipole to the Phantom) Air temp. : 22.7 degrees ; Liquid temp. : 21.6 degrees

DASY4 Configuration:

- Probe: EX3DV4 - SN3578; ConvF(8.55, 8.55, 8.55); Calibrated: 2010/6/22
- Sensor-Surface: 2mm (Mechanical Surface Detection)
- Electronics: DAE3 Sn579; Calibrated: 2010/9/20
- Phantom: SAM 12; Type: SAM V4.0; Serial: TP 1202
- Measurement SW: DASY4, V4.7 Build 80; Postprocessing SW: SEMCAD, V1.8 Build 186

d=15mm, Pin=250mW/Area Scan (7x9x1): Measurement grid: dx=15mm, dy=15mm
Maximum value of SAR (measured) = 3.12 mW/g

d=15mm, Pin=250mW/Zoom Scan (7x7x7)/Cube 0: Measurement grid: dx=5mm, dy=5mm, dz=5mm

Reference Value = 55.2 V/m; Power Drift = -0.083 dB

Peak SAR (extrapolated) = 3.72 W/kg

SAR(1 g) = 2.45 mW/g; SAR(10 g) = 1.59 mW/g

Maximum value of SAR (measured) = 3.17 mW/g

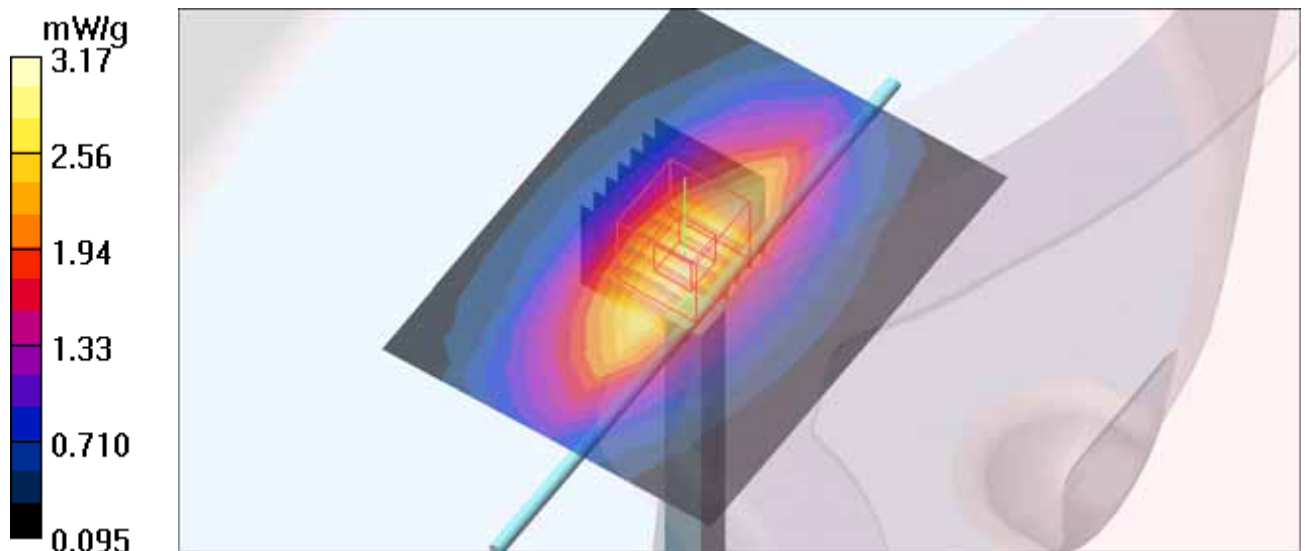

System Performance Check-D1900V2-MSL1900 MHz

DUT: Dipole 1900 MHz ; Type: D1900V2 ; Serial: D1900V2 - SN:5d036 ; Test Frequency: 1900 MHz

Communication System: CW ; Frequency: 1900 MHz; Duty Cycle: 1:1; Modulation Type: CW
Medium: MSL1900; Medium parameters used: $f = 1900$ MHz; $\sigma = 1.56$ mho/m; $\epsilon_r = 54.5$; $\rho = 1000$ kg/m³ ; Liquid level : 150 mm

Phantom section: Flat Section ; Separation distance : 10 mm (The feet point of the dipole to the Phantom) Air temp. : 22.5 degrees ; Liquid temp. : 21.6 degrees

DASY4 Configuration:

- Probe: EX3DV4 - SN3578; ConvF(6.7, 6.7, 6.7); Calibrated: 2010/6/22
- Sensor-Surface: 2mm (Mechanical Surface Detection)
- Electronics: DAE3 Sn579; Calibrated: 2010/9/20
- Phantom: SAM 12; Type: SAM V4.0; Serial: TP 1202
- Measurement SW: DASY4, V4.7 Build 80; Postprocessing SW: SEMCAD, V1.8 Build 186

d=10mm, Pin=250mW/Area Scan (7x7x1): Measurement grid: dx=15mm, dy=15mm

Maximum value of SAR (measured) = 14.1 mW/g

d=10mm, Pin=250mW/Zoom Scan (7x7x7)/Cube 0: Measurement grid: dx=5mm, dy=5mm, dz=5mm

Reference Value = 95.4 V/m; Power Drift = 0.021 dB

Peak SAR (extrapolated) = 18.5 W/kg

SAR(1 g) = 9.69 mW/g; SAR(10 g) = 5.05 mW/g

Maximum value of SAR (measured) = 14.3 mW/g

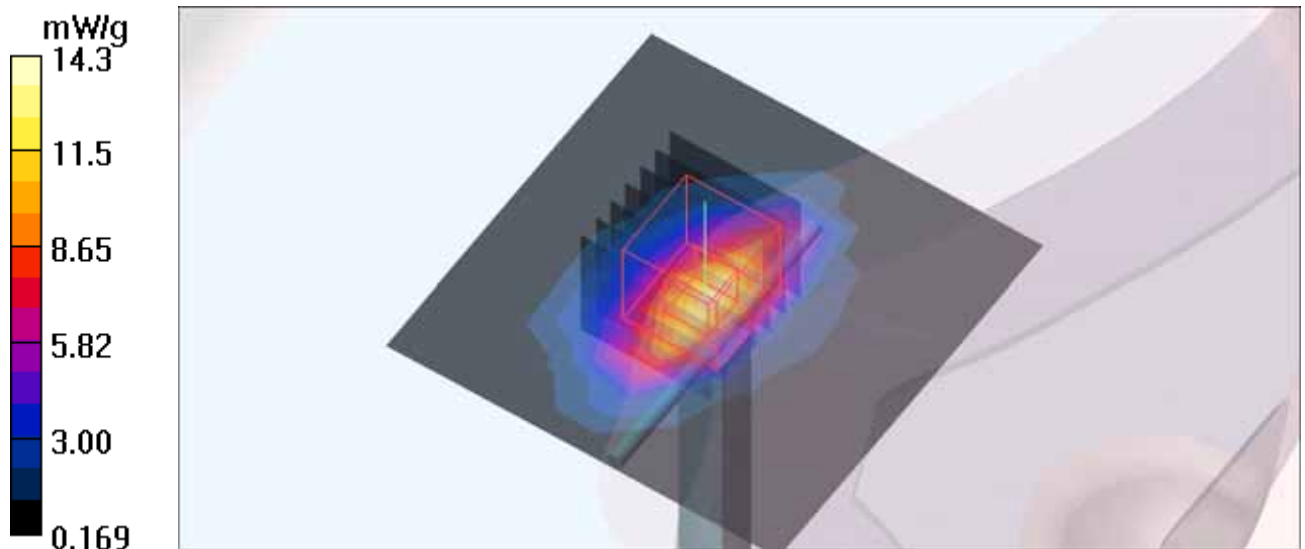



香港商立德國際商品試驗有限公司桃園分公司

Bureau Veritas Consumer Products Services (H.K.) Ltd., Taoyuan Branch

APPENDIX A: TEST DATA

Product Name: LTE USB Modem; Model Name: C505

Liquid Level Photo

Tissue 750 MHz D=150mm

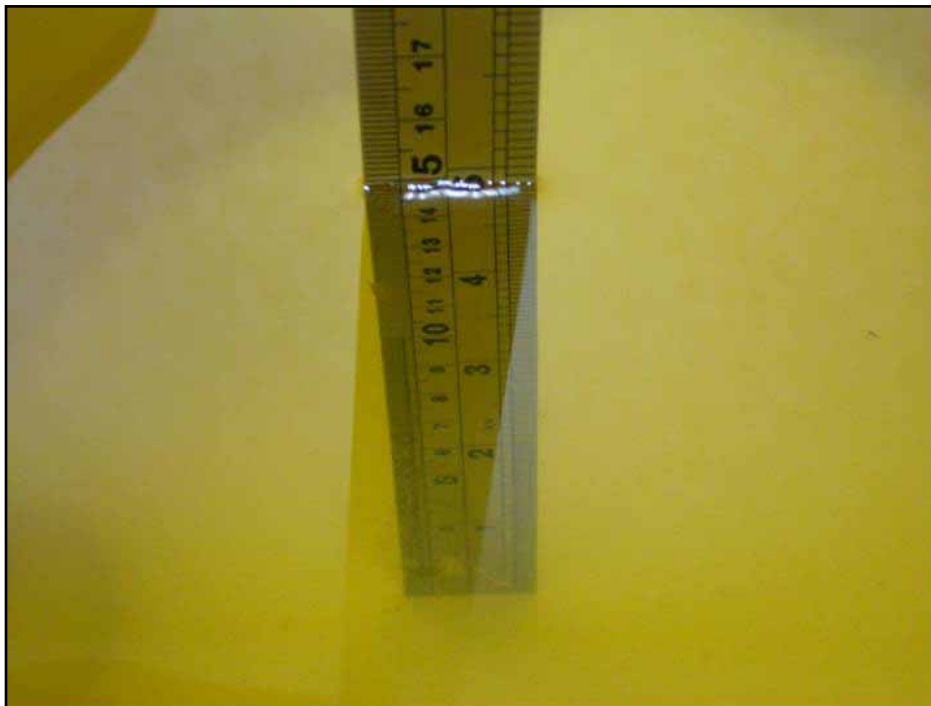

Tissue 1700MHz D=150mm



M01-LTE BAND 17-Ch23790 (50% RB centered)

Communication System: LTE band17 (700) ; Frequency: 710 MHz ; Duty Cycle: 1:1 ; Modulation type: QPSK

Medium: MSL750 Medium parameters used: $f = 710 \text{ MHz}$; $\sigma = 0.95 \text{ mho/m}$; $\epsilon_r = 55.86$; $\rho = 1000 \text{ kg/m}^3$

Phantom section: Flat Section ; Separation distance : 5 mm (The Horizontal-Down side of the EUT to the Phantom)

DASY4 Configuration:

- Probe: ES3DV3 - SN3177; ConvF(6.18, 6.18, 6.18); Calibrated: 2010/8/24
- Sensor-Surface: 3mm (Mechanical Surface Detection)
- Electronics: DAE3 Sn579; Calibrated: 2010/9/20
- Phantom: SAM Twin Phantom V4.0; Type: QD 000 P40 CA; Serial: TP-1202
- Measurement SW: DASY4, V4.7 Build 80; Postprocessing SW: SEMCAD, V1.8 Build 186

Body Position - Mid/Area Scan (7x15x1): Measurement grid: dx=8mm, dy=8mm

Maximum value of SAR (measured) = 0.378 mW/g

Body Position - Mid/Zoom Scan (7x7x7)/Cube 0: Measurement grid: dx=5mm, dy=5mm, dz=5mm

Reference Value = 19.9 V/m; Power Drift = 0.071 dB

Peak SAR (extrapolated) = 0.517 W/kg

SAR(1 g) = 0.334 mW/g; SAR(10 g) = 0.212 mW/g

Maximum value of SAR (measured) = 0.399 mW/g

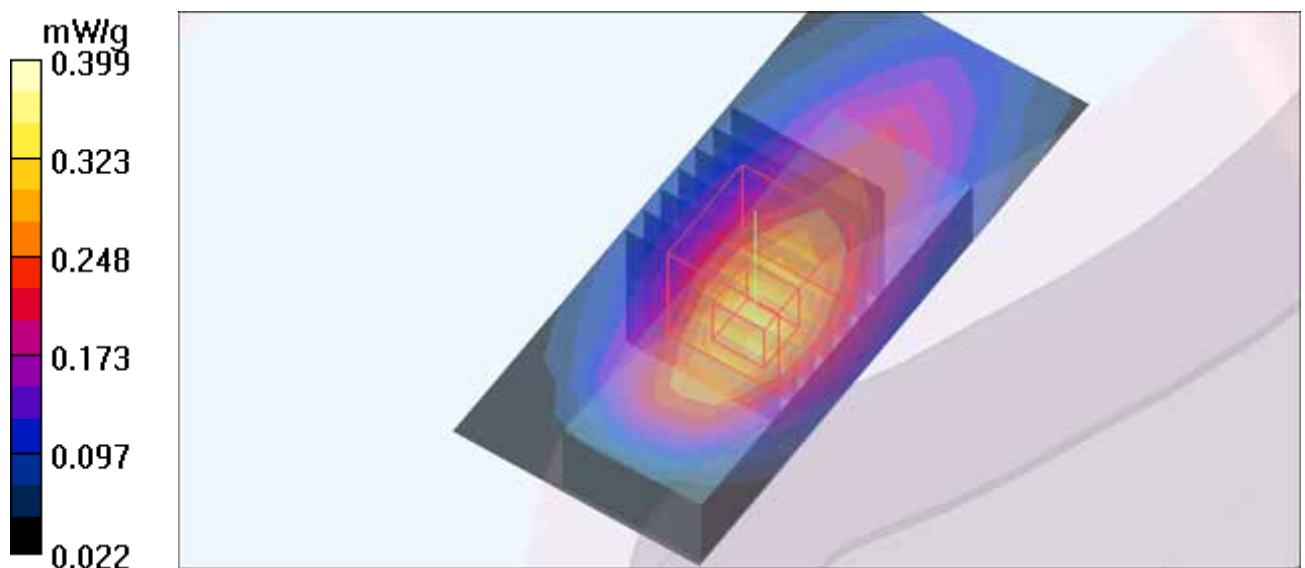

M02-LTE BAND 17-Ch23790 (1RB, Lower edge)

Communication System: LTE band17 (700) ; Frequency: 710 MHz ; Duty Cycle: 1:1 ; Modulation type: QPSK

Medium: MSL750 Medium parameters used: $f = 710 \text{ MHz}$; $\sigma = 0.95 \text{ mho/m}$; $\epsilon_r = 55.86$; $\rho = 1000 \text{ kg/m}^3$

Phantom section: Flat Section ; Separation distance : 5 mm (The Horizontal-Down side of the EUT to the Phantom)

DASY4 Configuration:

- Probe: ES3DV3 - SN3177; ConvF(6.18, 6.18, 6.18); Calibrated: 2010/8/24
- Sensor-Surface: 3mm (Mechanical Surface Detection)
- Electronics: DAE3 Sn579; Calibrated: 2010/9/20
- Phantom: SAM Twin Phantom V4.0; Type: QD 000 P40 CA; Serial: TP-1202
- Measurement SW: DASY4, V4.7 Build 80; Postprocessing SW: SEMCAD, V1.8 Build 186

Body Position - Mid/Area Scan (7x15x1): Measurement grid: dx=8mm, dy=8mm

Maximum value of SAR (measured) = 0.256 mW/g

Body Position - Mid/Zoom Scan (7x7x7)/Cube 0: Measurement grid: dx=5mm, dy=5mm, dz=5mm

Reference Value = 12.7 V/m; Power Drift = -0.184 dB

Peak SAR (extrapolated) = 0.542 W/kg

SAR(1 g) = 0.202 mW/g; SAR(10 g) = 0.123 mW/g

Maximum value of SAR (measured) = 0.304 mW/g

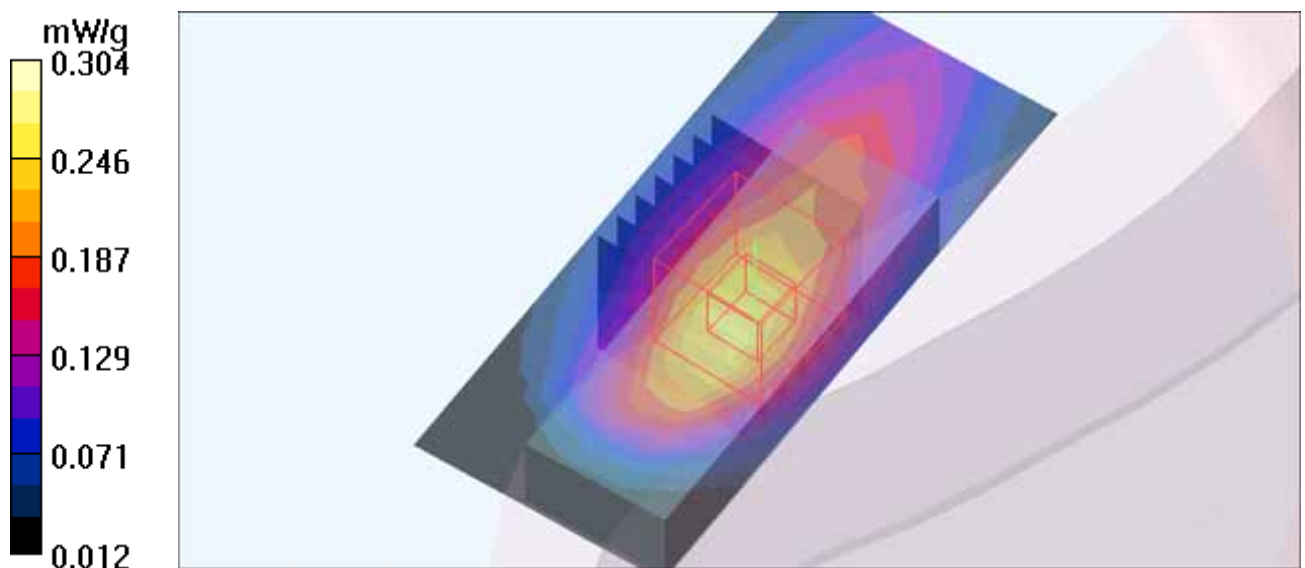

M03-LTE BAND 17-Ch23790 (1RB, Upper edge)

Communication System: LTE band17 (700) ; Frequency: 710 MHz ; Duty Cycle: 1:1 ; Modulation type: QPSK

Medium: MSL750 Medium parameters used: $f = 710 \text{ MHz}$; $\sigma = 0.95 \text{ mho/m}$; $\epsilon_r = 55.86$; $\rho = 1000 \text{ kg/m}^3$

Phantom section: Flat Section ; Separation distance : 5 mm (The Horizontal-Down side of the EUT to the Phantom)

DASY4 Configuration:

- Probe: ES3DV3 - SN3177; ConvF(6.18, 6.18, 6.18); Calibrated: 2010/8/24
- Sensor-Surface: 3mm (Mechanical Surface Detection)
- Electronics: DAE3 Sn579; Calibrated: 2010/9/20
- Phantom: SAM Twin Phantom V4.0; Type: QD 000 P40 CA; Serial: TP-1202
- Measurement SW: DASY4, V4.7 Build 80; Postprocessing SW: SEMCAD, V1.8 Build 186

Body Position - Mid/Area Scan (7x15x1): Measurement grid: dx=8mm, dy=8mm

Maximum value of SAR (measured) = 0.287 mW/g

Body Position - Mid/Zoom Scan (7x7x7)/Cube 0: Measurement grid: dx=5mm, dy=5mm, dz=5mm

Reference Value = 14.3 V/m; Power Drift = -0.157 dB

Peak SAR (extrapolated) = 0.334 W/kg

SAR(1 g) = 0.218 mW/g; SAR(10 g) = 0.139 mW/g

Maximum value of SAR (measured) = 0.258 mW/g

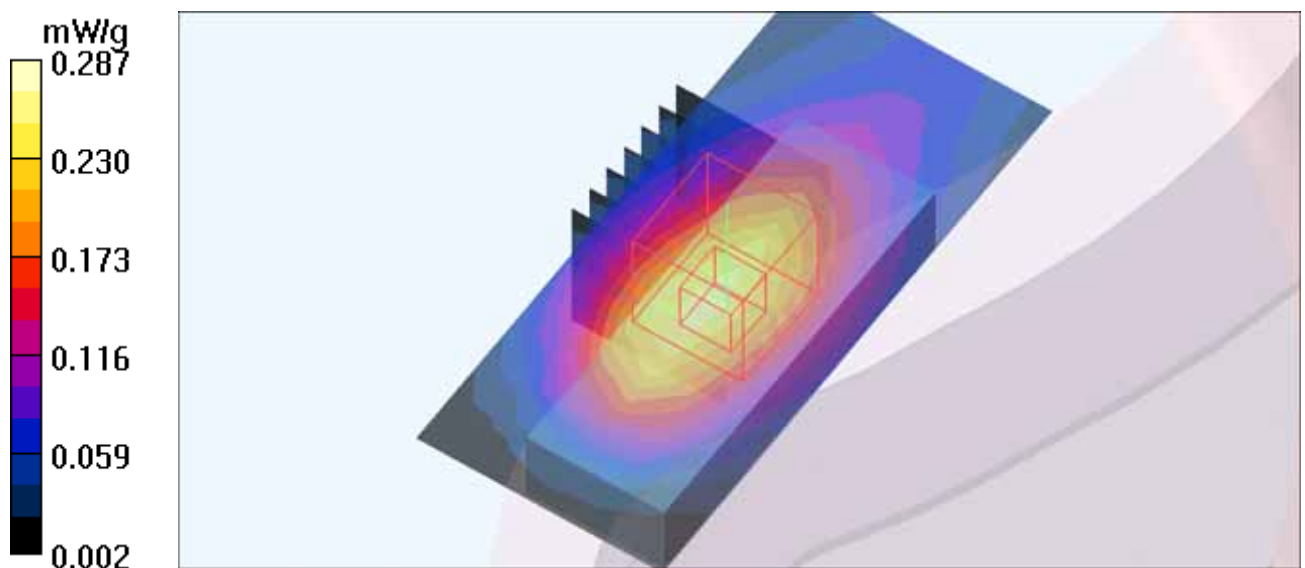

M04-LTE BAND 17-Ch23790 (50% RB centered)

Communication System: LTE band17 (700) ; Frequency: 710 MHz ; Duty Cycle: 1:1 ; Modulation Type: QPSK

Medium: MSL750 Medium parameters used: $f = 710$ MHz; $\sigma = 0.95$ mho/m; $\epsilon_r = 55.86$; $\rho = 1000$ kg/m³
Phantom section: Flat Section ; Separation Distance : 5 mm (The Vertical-Front side of the EUT to the Phantom)

DASY4 Configuration:

- Probe: ES3DV3 - SN3177; ConvF(6.18, 6.18, 6.18); Calibrated: 2010/8/24
- Sensor-Surface: 3mm (Mechanical Surface Detection)
- Electronics: DAE3 Sn579; Calibrated: 2010/9/20
- Phantom: SAM Twin Phantom V4.0; Type: QD 000 P40 CA; Serial: TP-1202
- Measurement SW: DASY4, V4.7 Build 80; Postprocessing SW: SEMCAD, V1.8 Build 186

Body Position - Mid/Area Scan (7x15x1): Measurement grid: dx=8mm, dy=8mm

Maximum value of SAR (measured) = 0.199 mW/g

Body Position - Mid/Zoom Scan (7x7x7)/Cube 0: Measurement grid: dx=5mm, dy=5mm, dz=5mm

Reference Value = 11.4 V/m; Power Drift = 0.004 dB

Peak SAR (extrapolated) = 0.268 W/kg

SAR(1 g) = 0.169 mW/g; SAR(10 g) = 0.105 mW/g

Maximum value of SAR (measured) = 0.203 mW/g

Body Position - Mid/Zoom Scan (7x7x7)/Cube 1: Measurement grid: dx=5mm, dy=5mm, dz=5mm

Reference Value = 11.4 V/m; Power Drift = 0.004 dB

Peak SAR (extrapolated) = 0.226 W/kg

SAR(1 g) = 0.134 mW/g; SAR(10 g) = 0.082 mW/g

Maximum value of SAR (measured) = 0.170 mW/g

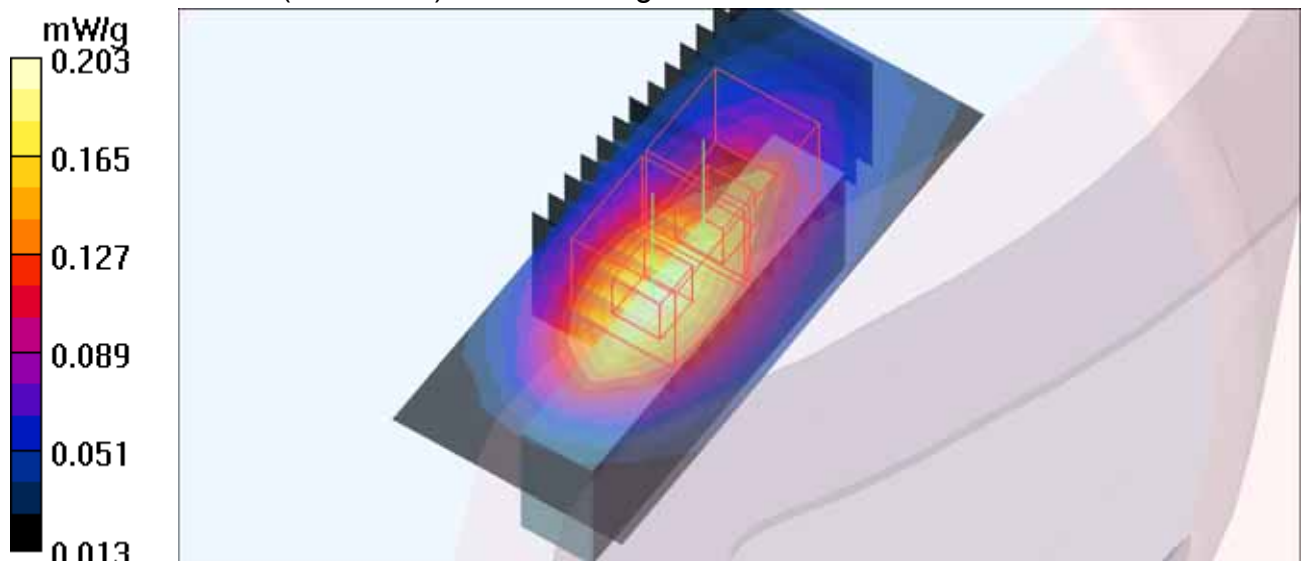

M05-LTE BAND 17-Ch23790 (1RB, Lower edge)

Communication System: LTE band17 (700) ; Frequency: 710 MHz ; Duty Cycle: 1:1 ; Modulation Type: QPSK

Medium: MSL750 Medium parameters used: $f = 710$ MHz; $\sigma = 0.95$ mho/m; $\epsilon_r = 55.86$; $\rho = 1000$ kg/m³
Phantom section: Flat Section ; Separation Distance : 5 mm (The Vertical-Front side of the EUT to the Phantom)

DASY4 Configuration:

- Probe: ES3DV3 - SN3177; ConvF(6.18, 6.18, 6.18); Calibrated: 2010/8/24
- Sensor-Surface: 3mm (Mechanical Surface Detection)
- Electronics: DAE3 Sn579; Calibrated: 2010/9/20
- Phantom: SAM Twin Phantom V4.0; Type: QD 000 P40 CA; Serial: TP-1202
- Measurement SW: DASY4, V4.7 Build 80; Postprocessing SW: SEMCAD, V1.8 Build 186

Body Position - Mid/Area Scan (7x15x1): Measurement grid: dx=8mm, dy=8mm

Maximum value of SAR (measured) = 0.161 mW/g

Body Position - Mid/Zoom Scan (7x7x7)/Cube 0: Measurement grid: dx=5mm, dy=5mm, dz=5mm

Reference Value = 10.1 V/m; Power Drift = -0.161 dB

Peak SAR (extrapolated) = 0.189 W/kg

SAR(1 g) = 0.120 mW/g; SAR(10 g) = 0.075 mW/g

Maximum value of SAR (measured) = 0.144 mW/g

Body Position - Mid/Zoom Scan (7x7x7)/Cube 1: Measurement grid: dx=5mm, dy=5mm, dz=5mm

Reference Value = 10.1 V/m; Power Drift = -0.161 dB

Peak SAR (extrapolated) = 0.160 W/kg

SAR(1 g) = 0.096 mW/g; SAR(10 g) = 0.059 mW/g

Maximum value of SAR (measured) = 0.122 mW/g

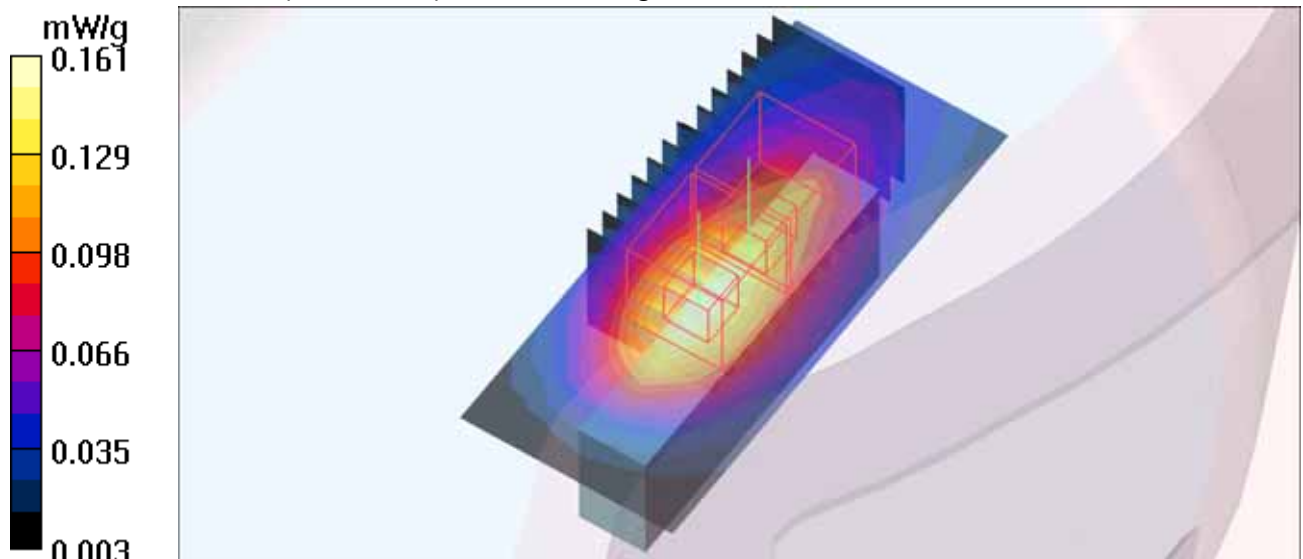

M06-LTE BAND 17-Ch23790 (1RB, Upper edge)

Communication System: LTE band17 (700) ; Frequency: 710 MHz ; Duty Cycle: 1:1 ; Modulation Type: QPSK

Medium: MSL750 Medium parameters used: $f = 710$ MHz; $\sigma = 0.95$ mho/m; $\epsilon_r = 55.86$; $\rho = 1000$ kg/m³
Phantom section: Flat Section ; Separation Distance : 5 mm (The Vertical-Front side of the EUT to the Phantom)

DASY4 Configuration:

- Probe: ES3DV3 - SN3177; ConvF(6.18, 6.18, 6.18); Calibrated: 2010/8/24
- Sensor-Surface: 3mm (Mechanical Surface Detection)
- Electronics: DAE3 Sn579; Calibrated: 2010/9/20
- Phantom: SAM Twin Phantom V4.0; Type: QD 000 P40 CA; Serial: TP-1202
- Measurement SW: DASY4, V4.7 Build 80; Postprocessing SW: SEMCAD, V1.8 Build 186

Body Position - Mid/Area Scan (7x15x1): Measurement grid: dx=8mm, dy=8mm

Maximum value of SAR (measured) = 0.146 mW/g

Body Position - Mid/Zoom Scan (7x7x7)/Cube 0: Measurement grid: dx=5mm, dy=5mm, dz=5mm

Reference Value = 10.2 V/m; Power Drift = -0.125 dB

Peak SAR (extrapolated) = 0.179 W/kg

SAR(1 g) = 0.113 mW/g; SAR(10 g) = 0.071 mW/g

Maximum value of SAR (measured) = 0.136 mW/g

Body Position - Mid/Zoom Scan (7x7x7)/Cube 1: Measurement grid: dx=5mm, dy=5mm, dz=5mm

Reference Value = 10.2 V/m; Power Drift = -0.125 dB

Peak SAR (extrapolated) = 0.149 W/kg

SAR(1 g) = 0.088 mW/g; SAR(10 g) = 0.054 mW/g

Maximum value of SAR (measured) = 0.113 mW/g

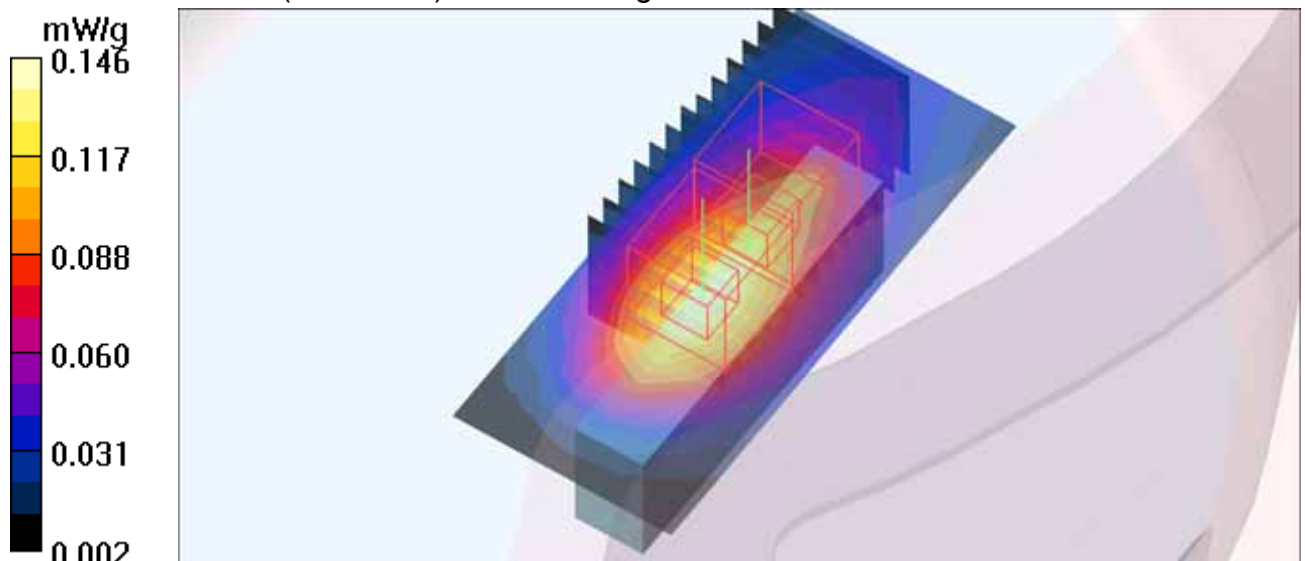

M07-LTE BAND 17-Ch23790 (50% RB centered)

Communication System: LTE band17 (700) ; Frequency: 710 MHz ; Duty Cycle: 1:1; Modulation Type: QPSK

Medium: MSL750 Medium parameters used: $f = 710 \text{ MHz}$; $\sigma = 0.95 \text{ mho/m}$; $\epsilon_r = 55.86$; $\rho = 1000 \text{ kg/m}^3$
Phantom section: Flat Section ; Separation Distance : 5 mm (The Horizontal-Up side of the EUT to the Phantom)

DASY4 Configuration:

- Probe: ES3DV3 - SN3177; ConvF(6.18, 6.18, 6.18); Calibrated: 2010/8/24
- Sensor-Surface: 3mm (Mechanical Surface Detection)
- Electronics: DAE3 Sn579; Calibrated: 2010/9/20
- Phantom: SAM Twin Phantom V4.0; Type: QD 000 P40 CA; Serial: TP-1202
- Measurement SW: DASY4, V4.7 Build 80; Postprocessing SW: SEMCAD, V1.8 Build 186

Body Position - Mid/Area Scan (7x15x1): Measurement grid: dx=8mm, dy=8mm
Maximum value of SAR (measured) = 0.254 mW/g

Body Position - Mid/Zoom Scan (7x7x7)/Cube 0: Measurement grid: dx=5mm, dy=5mm, dz=5mm

Reference Value = 13.7 V/m; Power Drift = -0.023 dB

Peak SAR (extrapolated) = 0.319 W/kg

SAR(1 g) = 0.215 mW/g; SAR(10 g) = 0.140 mW/g

Maximum value of SAR (measured) = 0.251 mW/g

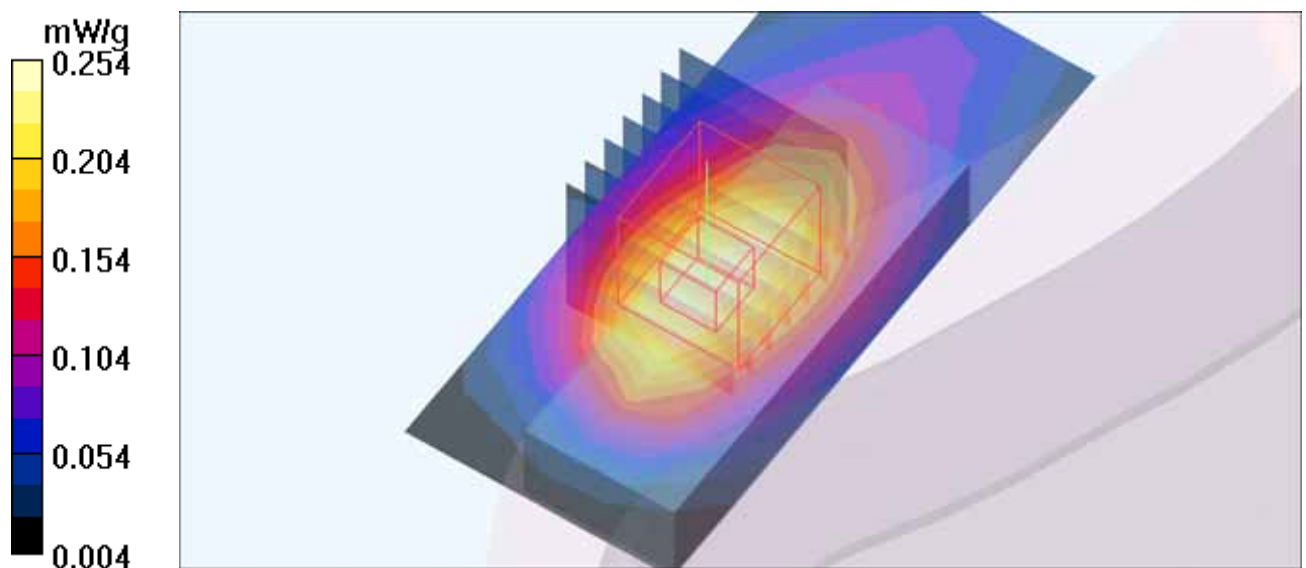

M08-LTE BAND 17-Ch23790 (1RB, Lower edge)

Communication System: LTE band17 (700) ; Frequency: 710 MHz ; Duty Cycle: 1:1 ; Modulation Type: QPSK

Medium: MSL750 Medium parameters used: $f = 710$ MHz; $\sigma = 0.95$ mho/m; $\epsilon_r = 55.86$; $\rho = 1000$ kg/m³
Phantom section: Flat Section ; Separation Distance : 5 mm (The Horizontal-Up side of the EUT to the Phantom)

DASY4 Configuration:

- Probe: ES3DV3 - SN3177; ConvF(6.18, 6.18, 6.18); Calibrated: 2010/8/24
- Sensor-Surface: 3mm (Mechanical Surface Detection)
- Electronics: DAE3 Sn579; Calibrated: 2010/9/20
- Phantom: SAM Twin Phantom V4.0; Type: QD 000 P40 CA; Serial: TP-1202
- Measurement SW: DASY4, V4.7 Build 80; Postprocessing SW: SEMCAD, V1.8 Build 186

Body Position - Mid/Area Scan (7x15x1): Measurement grid: dx=8mm, dy=8mm
Maximum value of SAR (measured) = 0.163 mW/g

Body Position - Mid/Zoom Scan (7x7x7)/Cube 0: Measurement grid: dx=5mm, dy=5mm, dz=5mm

Reference Value = 12.3 V/m; Power Drift = -0.144 dB

Peak SAR (extrapolated) = 0.183 W/kg

SAR(1 g) = 0.125 mW/g; SAR(10 g) = 0.081 mW/g

Maximum value of SAR (measured) = 0.145 mW/g

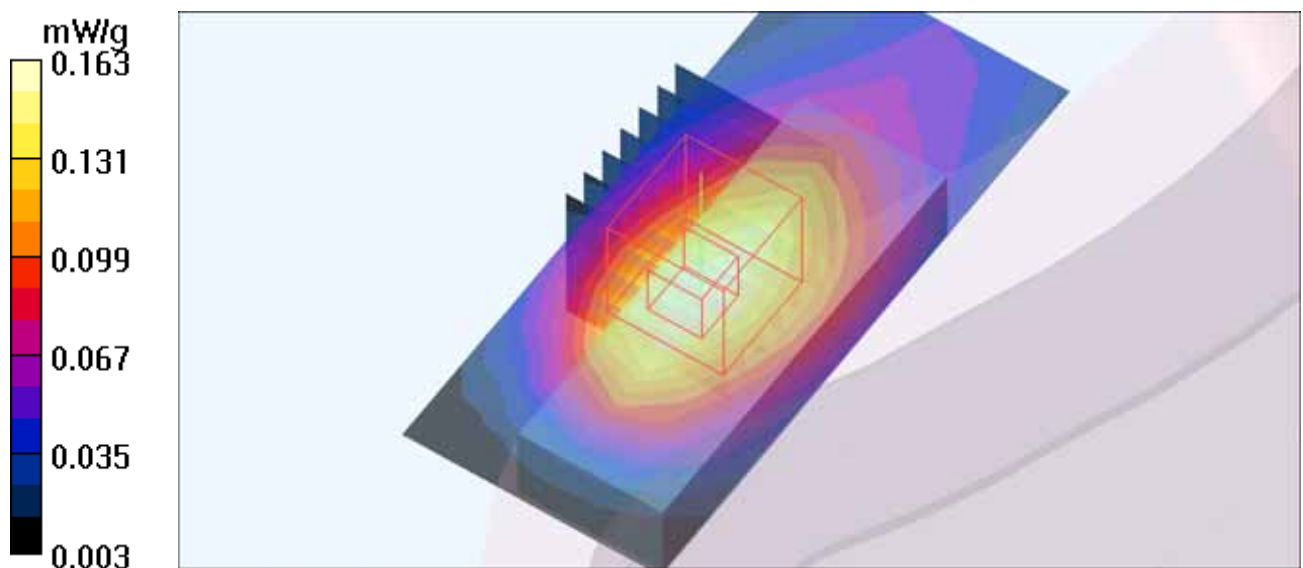

M09-LTE BAND 17-Ch23790 (1RB, Upper edge)

Communication System: LTE band17 (700) ; Frequency: 710 MHz ; Duty Cycle: 1:1 ; Modulation Type: QPSK

Medium: MSL750 Medium parameters used: $f = 710$ MHz; $\sigma = 0.95$ mho/m; $\epsilon_r = 55.86$; $\rho = 1000$ kg/m³
Phantom section: Flat Section ; Separation Distance : 5 mm (The Horizontal-Up side of the EUT to the Phantom)

DASY4 Configuration:

- Probe: ES3DV3 - SN3177; ConvF(6.18, 6.18, 6.18); Calibrated: 2010/8/24
- Sensor-Surface: 3mm (Mechanical Surface Detection)
- Electronics: DAE3 Sn579; Calibrated: 2010/9/20
- Phantom: SAM Twin Phantom V4.0; Type: QD 000 P40 CA; Serial: TP-1202
- Measurement SW: DASY4, V4.7 Build 80; Postprocessing SW: SEMCAD, V1.8 Build 186

Body Position - Mid/Area Scan (7x15x1): Measurement grid: dx=8mm, dy=8mm
Maximum value of SAR (measured) = 0.191 mW/g

Body Position - Mid/Zoom Scan (7x7x7)/Cube 0: Measurement grid: dx=5mm, dy=5mm, dz=5mm

Reference Value = 12.6 V/m; Power Drift = -0.158 dB

Peak SAR (extrapolated) = 0.198 W/kg

SAR(1 g) = 0.137 mW/g; SAR(10 g) = 0.091 mW/g

Maximum value of SAR (measured) = 0.156 mW/g

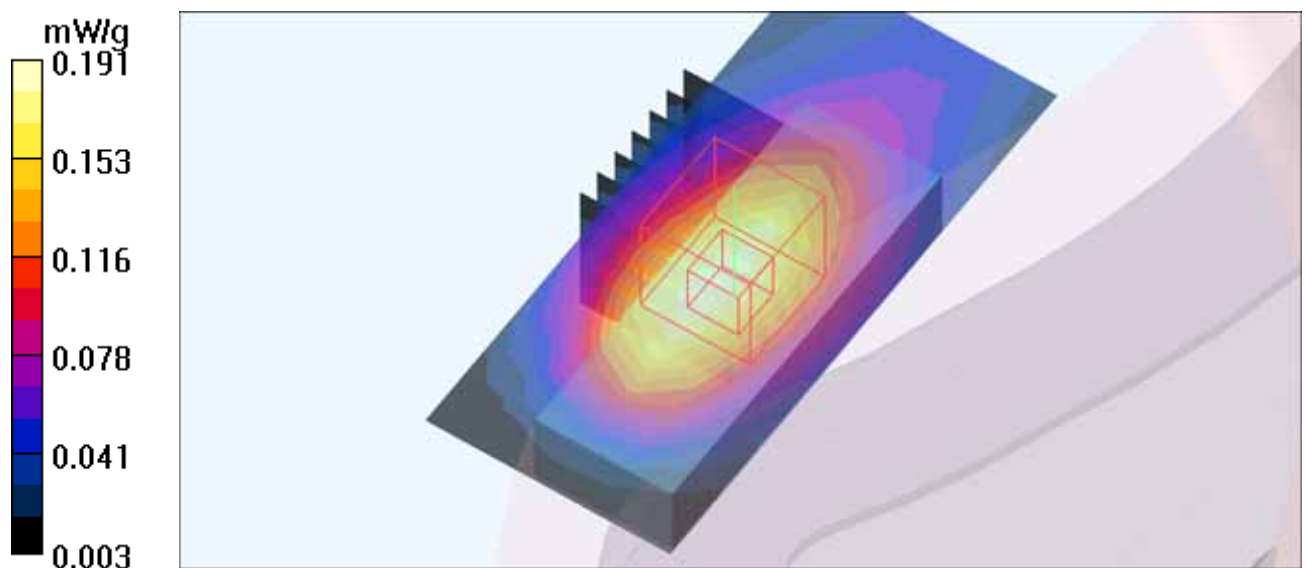

M10-LTE BAND 17-Ch23790 (50% RB centered)

Communication System: LTE band17 (700) ; Frequency: 710 MHz ; Duty Cycle: 1:1 ; Modulation Type: QPSK

Medium: MSL750 Medium parameters used: $f = 710$ MHz; $\sigma = 0.95$ mho/m; $\epsilon_r = 55.86$; $\rho = 1000$ kg/m³
Phantom section: Flat Section ; Separation Distance : 5 mm (The Vertical-Back side of the EUT to the Phantom)

DASY4 Configuration:

- Probe: ES3DV3 - SN3177; ConvF(6.18, 6.18, 6.18); Calibrated: 2010/8/24
- Sensor-Surface: 3mm (Mechanical Surface Detection)
- Electronics: DAE3 Sn579; Calibrated: 2010/9/20
- Phantom: SAM Twin Phantom V4.0; Type: QD 000 P40 CA; Serial: TP-1202
- Measurement SW: DASY4, V4.7 Build 80; Postprocessing SW: SEMCAD, V1.8 Build 186

Body Position - Mid/Area Scan (7x15x1): Measurement grid: dx=8mm, dy=8mm
Maximum value of SAR (measured) = 0.134 mW/g

Body Position - Mid/Zoom Scan (7x7x7)/Cube 0: Measurement grid: dx=5mm, dy=5mm, dz=5mm

Reference Value = 9.18 V/m; Power Drift = 0.108 dB

Peak SAR (extrapolated) = 0.167 W/kg

SAR(1 g) = 0.108 mW/g; SAR(10 g) = 0.071 mW/g

Maximum value of SAR (measured) = 0.127 mW/g

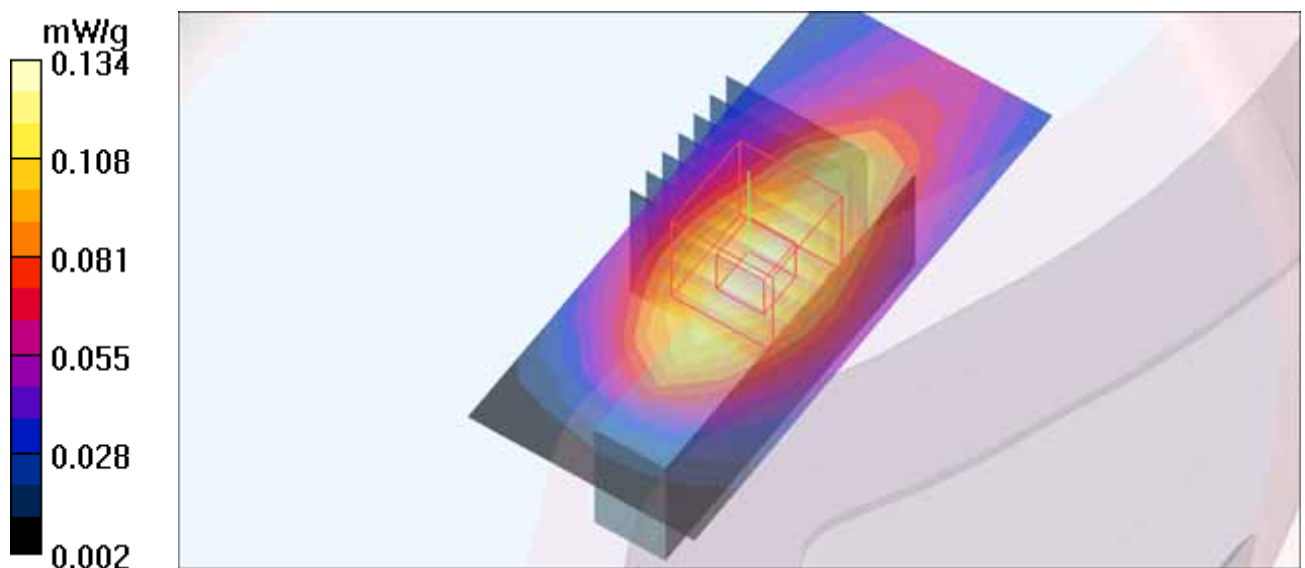

M11-LTE BAND 17-Ch23790 (1RB, Lower edge)

Communication System: LTE band17 (700) ; Frequency: 710 MHz ; Duty Cycle: 1:1 ; Modulation Type: QPSK

Medium: MSL750 Medium parameters used: $f = 710$ MHz; $\sigma = 0.95$ mho/m; $\epsilon_r = 55.86$; $\rho = 1000$ kg/m³
Phantom section: Flat Section ; Separation Distance : 5 mm (The Vertical-Back side of the EUT to the Phantom)

DASY4 Configuration:

- Probe: ES3DV3 - SN3177; ConvF(6.18, 6.18, 6.18); Calibrated: 2010/8/24
- Sensor-Surface: 3mm (Mechanical Surface Detection)
- Electronics: DAE3 Sn579; Calibrated: 2010/9/20
- Phantom: SAM Twin Phantom V4.0; Type: QD 000 P40 CA; Serial: TP-1202
- Measurement SW: DASY4, V4.7 Build 80; Postprocessing SW: SEMCAD, V1.8 Build 186

Body Position - Mid/Area Scan (7x15x1): Measurement grid: dx=8mm, dy=8mm

Maximum value of SAR (measured) = 0.099 mW/g

Body Position - Mid/Zoom Scan (7x7x7)/Cube 0: Measurement grid: dx=5mm, dy=5mm, dz=5mm

Reference Value = 8.07 V/m; Power Drift = -0.185 dB

Peak SAR (extrapolated) = 0.114 W/kg

SAR(1 g) = 0.074 mW/g; SAR(10 g) = 0.048 mW/g

Maximum value of SAR (measured) = 0.087 mW/g

Body Position - Mid/Zoom Scan (7x7x7)/Cube 1: Measurement grid: dx=5mm, dy=5mm, dz=5mm

Reference Value = 8.07 V/m; Power Drift = -0.185 dB

Peak SAR (extrapolated) = 0.113 W/kg

SAR(1 g) = 0.069 mW/g; SAR(10 g) = 0.042 mW/g

Maximum value of SAR (measured) = 0.086 mW/g

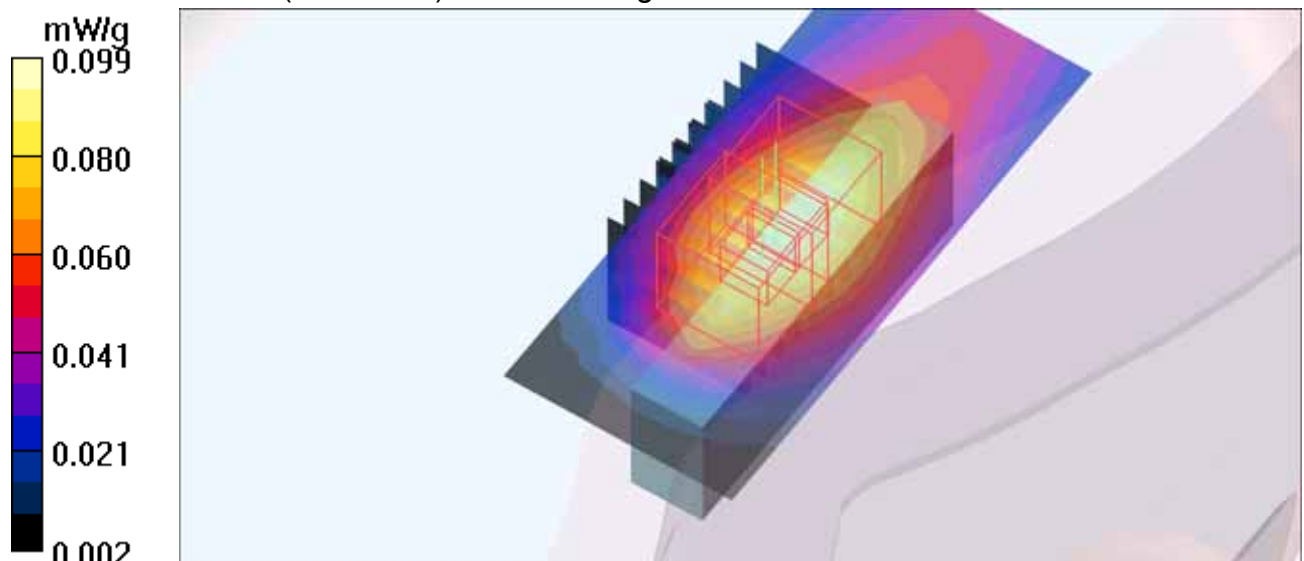

M12-LTE BAND 17-Ch23790 (1RB, Upper edge)

Communication System: LTE band17 (700) ; Frequency: 710 MHz ; Duty Cycle: 1:1 ; Modulation Type: QPSK

Medium: MSL750 Medium parameters used: $f = 710$ MHz; $\sigma = 0.95$ mho/m; $\epsilon_r = 55.86$; $\rho = 1000$ kg/m³
Phantom section: Flat Section ; Separation Distance : 5 mm (The Vertical-Back side of the EUT to the Phantom)

DASY4 Configuration:

- Probe: ES3DV3 - SN3177; ConvF(6.18, 6.18, 6.18); Calibrated: 2010/8/24
- Sensor-Surface: 3mm (Mechanical Surface Detection)
- Electronics: DAE3 Sn579; Calibrated: 2010/9/20
- Phantom: SAM Twin Phantom V4.0; Type: QD 000 P40 CA; Serial: TP-1202
- Measurement SW: DASY4, V4.7 Build 80; Postprocessing SW: SEMCAD, V1.8 Build 186

Body Position - Mid/Area Scan (7x15x1): Measurement grid: dx=8mm, dy=8mm

Maximum value of SAR (measured) = 0.088 mW/g

Body Position - Mid/Zoom Scan (7x7x7)/Cube 0: Measurement grid: dx=5mm, dy=5mm, dz=5mm

Reference Value = 8.11 V/m; Power Drift = -0.116 dB

Peak SAR (extrapolated) = 0.116 W/kg

SAR(1 g) = 0.075 mW/g; SAR(10 g) = 0.049 mW/g

Body Position - Mid/Zoom Scan (7x7x7)/Cube 1: Measurement grid: dx=5mm, dy=5mm, dz=5mm

Reference Value = 8.11 V/m; Power Drift = -0.116 dB

Peak SAR (extrapolated) = 0.115 W/kg

SAR(1 g) = 0.071 mW/g; SAR(10 g) = 0.044 mW/g

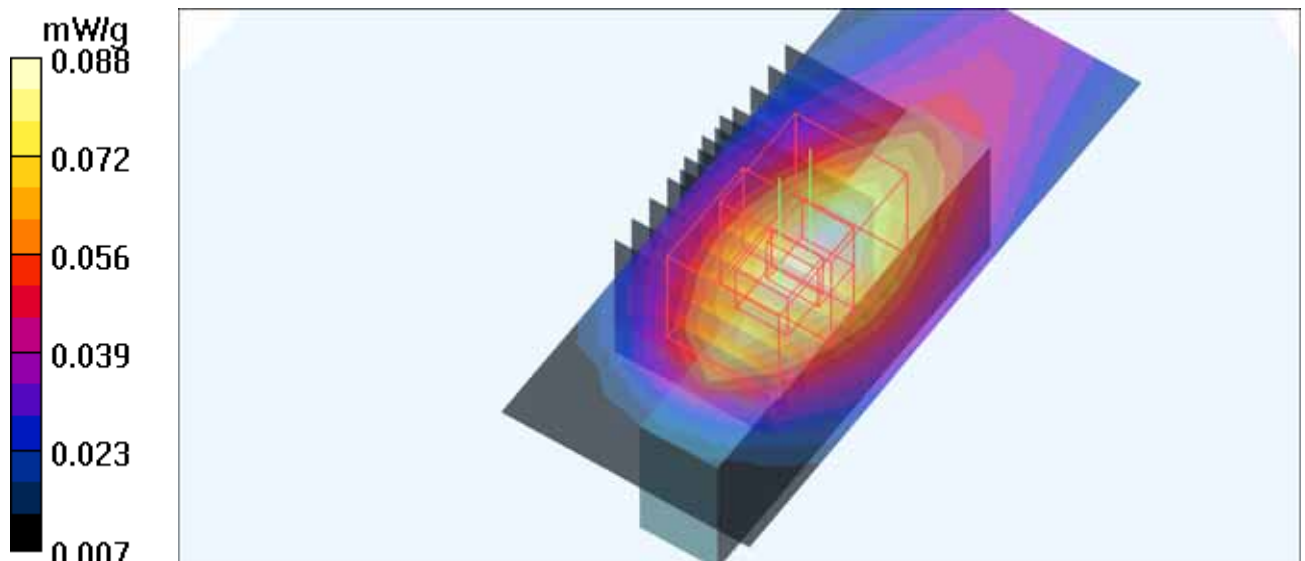

M13-LTE BAND 17-Ch23790 (50% RB centered)

Communication System: LTE band17 (700) ; Frequency: 710 MHz ; Duty Cycle: 1:1 ; Modulation Type: QPSK

Medium: MSL750 Medium parameters used: $f = 710$ MHz; $\sigma = 0.95$ mho/m; $\epsilon_r = 55.86$; $\rho = 1000$ kg/m³

Phantom section: Flat Section ; Separation Distance : 5 mm (The top side of the EUT to the Phantom)

DASY4 Configuration:

- Probe: ES3DV3 - SN3177; ConvF(6.18, 6.18, 6.18); Calibrated: 2010/8/24
- Sensor-Surface: 3mm (Mechanical Surface Detection)
- Electronics: DAE3 Sn579; Calibrated: 2010/9/20
- Phantom: SAM Twin Phantom V4.0; Type: QD 000 P40 CA; Serial: TP-1202
- Measurement SW: DASY4, V4.7 Build 80; Postprocessing SW: SEMCAD, V1.8 Build 186

Body Position - Mid/Area Scan (7x7x1): Measurement grid: dx=8mm, dy=8mm
Maximum value of SAR (measured) = 0.028 mW/g

Body Position - Mid/Zoom Scan (7x7x7)/Cube 0: Measurement grid: dx=5mm, dy=5mm, dz=5mm

Reference Value = 9.01 V/m; Power Drift = 0.115 dB

Peak SAR (extrapolated) = 0.051 W/kg

SAR(1 g) = 0.023 mW/g; SAR(10 g) = 0.013 mW/g

Maximum value of SAR (measured) = 0.029 mW/g

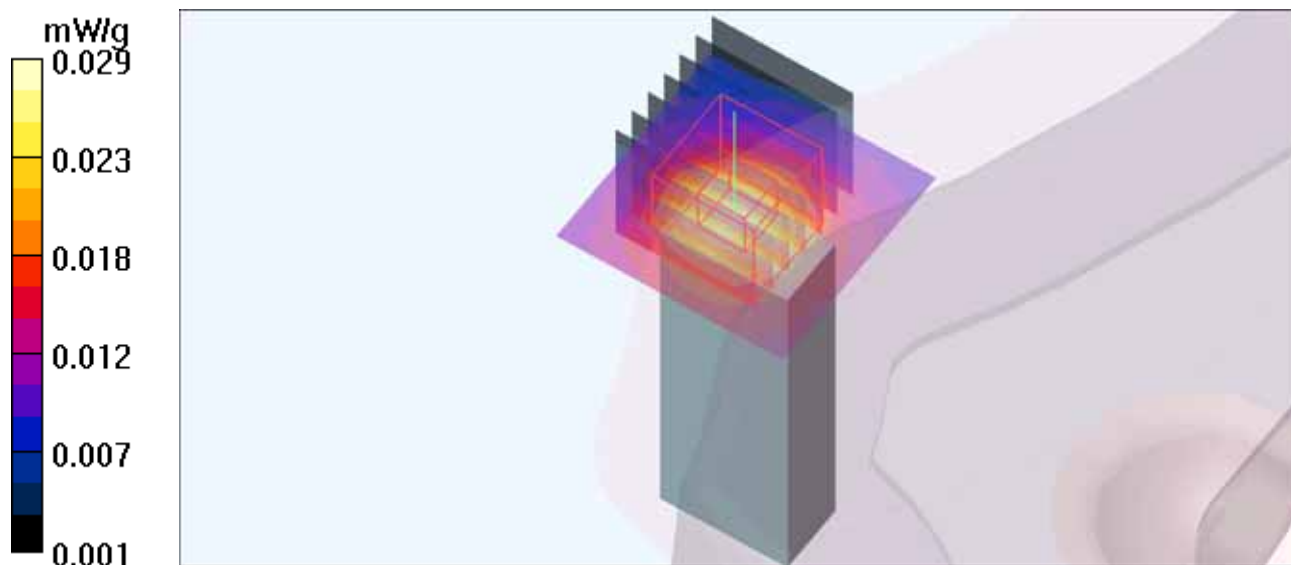

M14-LTE BAND 17-Ch23790 (1RB, Lower edge)

Communication System: LTE band17 (700) ; Frequency: 710 MHz ; Duty Cycle: 1:1; Modulation Type: QPSK

Medium: MSL750 Medium parameters used: $f = 710 \text{ MHz}$; $\sigma = 0.95 \text{ mho/m}$; $\epsilon_r = 55.86$; $\rho = 1000 \text{ kg/m}^3$
Phantom section: Flat Section ; Separation Distance : 5 mm (The top side of the EUT to the Phantom)

DASY4 Configuration:

- Probe: ES3DV3 - SN3177; ConvF(6.18, 6.18, 6.18); Calibrated: 2010/8/24
- Sensor-Surface: 3mm (Mechanical Surface Detection)
- Electronics: DAE3 Sn579; Calibrated: 2010/9/20
- Phantom: SAM Twin Phantom V4.0; Type: QD 000 P40 CA; Serial: TP-1202
- Measurement SW: DASY4, V4.7 Build 80; Postprocessing SW: SEMCAD, V1.8 Build 186

Body Position - Mid/Area Scan (7x7x1): Measurement grid: $dx=8\text{mm}$, $dy=8\text{mm}$
Maximum value of SAR (measured) = 0.022 mW/g

Body Position - Mid/Zoom Scan (7x7x7)/Cube 0: Measurement grid: $dx=5\text{mm}$, $dy=5\text{mm}$, $dz=5\text{mm}$

Reference Value = 7.80 V/m; Power Drift = -0.157 dB

Peak SAR (extrapolated) = 0.042 W/kg

SAR(1 g) = 0.018 mW/g; SAR(10 g) = 0.00997 mW/g

Maximum value of SAR (measured) = 0.023 mW/g

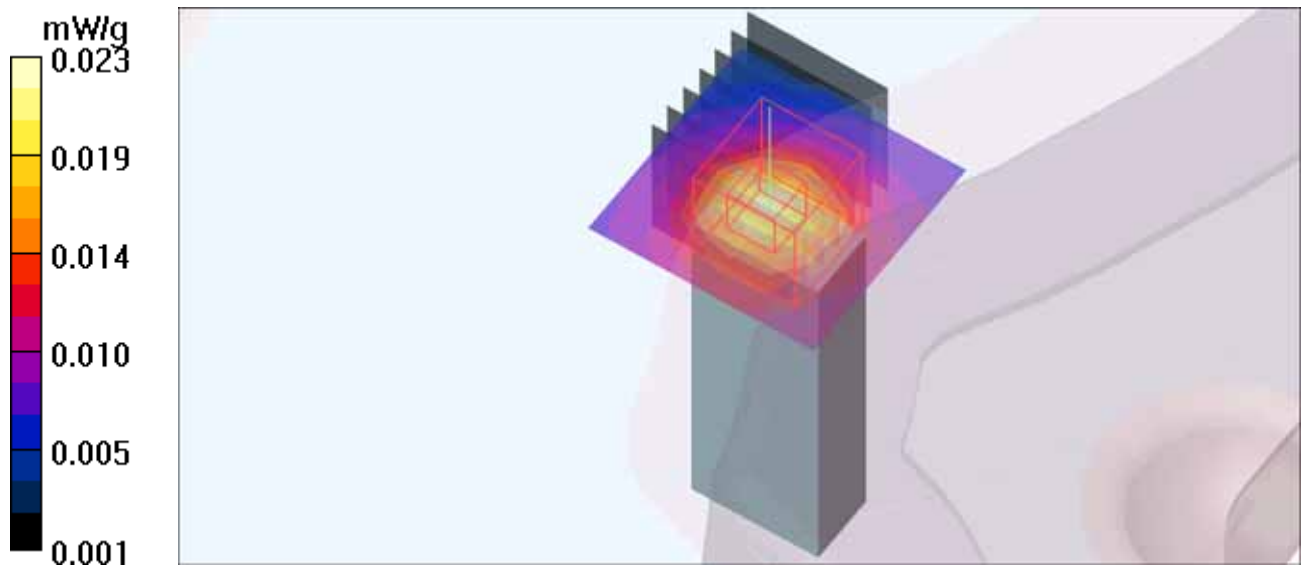

M15-LTE BAND 17-Ch23790 (1RB, Upper edge)

Communication System: LTE band17 (700) ; Frequency: 710 MHz ; Duty Cycle: 1:1; Modulation Type: QPSK

Medium: MSL750 Medium parameters used: $f = 710 \text{ MHz}$; $\sigma = 0.95 \text{ mho/m}$; $\epsilon_r = 55.86$; $\rho = 1000 \text{ kg/m}^3$

Phantom section: Flat Section ; Separation Distance : 5 mm (The top side of the EUT to the Phantom)

DASY4 Configuration:

- Probe: ES3DV3 - SN3177; ConvF(6.18, 6.18, 6.18); Calibrated: 2010/8/24
- Sensor-Surface: 3mm (Mechanical Surface Detection)
- Electronics: DAE3 Sn579; Calibrated: 2010/9/20
- Phantom: SAM Twin Phantom V4.0; Type: QD 000 P40 CA; Serial: TP-1202
- Measurement SW: DASY4, V4.7 Build 80; Postprocessing SW: SEMCAD, V1.8 Build 186

Body Position - Mid/Area Scan (7x7x1): Measurement grid: $dx=8\text{mm}$, $dy=8\text{mm}$
Maximum value of SAR (measured) = 0.023 mW/g

Body Position - Mid/Zoom Scan (7x7x7)/Cube 0: Measurement grid: $dx=5\text{mm}$, $dy=5\text{mm}$, $dz=5\text{mm}$

Reference Value = 8.14 V/m; Power Drift = -0.190 dB

Peak SAR (extrapolated) = 0.039 W/kg

SAR(1 g) = 0.017 mW/g; SAR(10 g) = 0.00977 mW/g

Maximum value of SAR (measured) = 0.022 mW/g

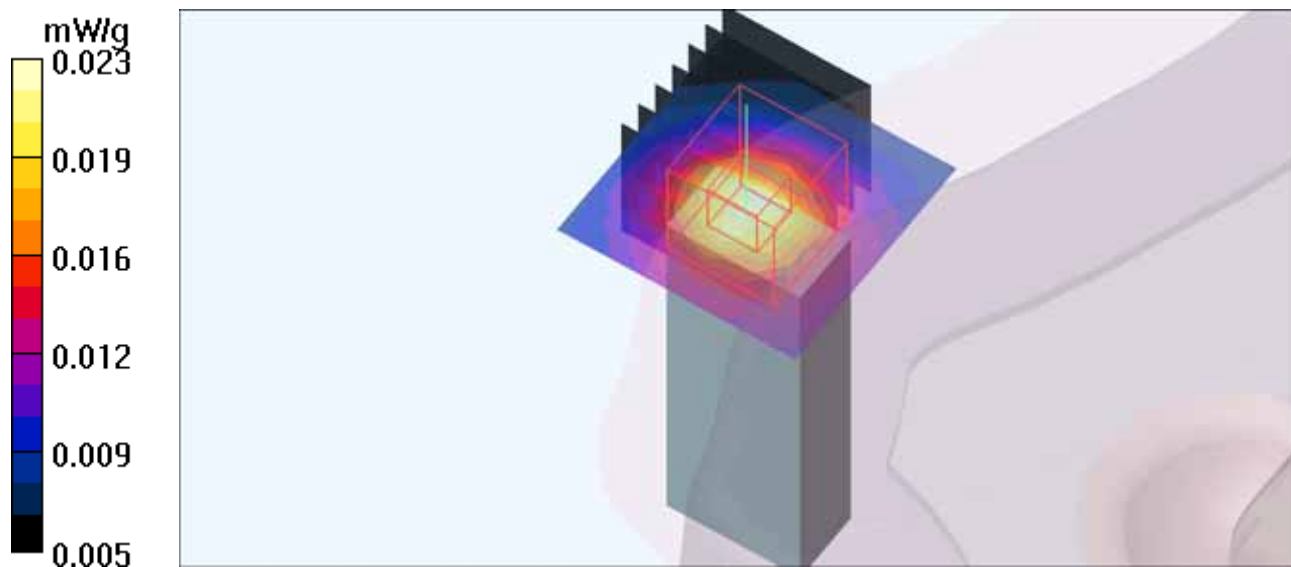

M16-LTE BAND 4-Ch20175 (50% RB centered)

Communication System: LTE band4 (1700) ; Frequency: 1732.5 MHz ; Duty Cycle: 1:1; Modulation Type: QPSK

Medium: MSL1700 Medium parameters used: $f = 1732.5$ MHz; $\sigma = 1.49$ mho/m; $\epsilon_r = 54.38$; $\rho = 1000$ kg/m³

Phantom section: Flat Section ; Separation Distance : 5 mm (The Horizontal-Down side of the EUT to the Phantom)

DASY4 Configuration:

- Probe: EX3DV4 - SN3578; ConvF(6.81, 6.81, 6.81); Calibrated: 2010/6/22
- Sensor-Surface: 2mm (Mechanical Surface Detection)
- Electronics: DAE3 Sn579; Calibrated: 2010/9/20
- Phantom: SAM Twin Phantom V4.0; Type: QD 000 P40 CA; Serial: TP-1202
- Measurement SW: DASY4, V4.7 Build 80; Postprocessing SW: SEMCAD, V1.8 Build 186

Body Position - Mid/Area Scan (7x15x1): Measurement grid: dx=8mm, dy=8mm

Maximum value of SAR (measured) = 0.461 mW/g

Body Position - Mid/Zoom Scan (7x7x7)/Cube 0: Measurement grid: dx=5mm, dy=5mm, dz=5mm

Reference Value = 11.2 V/m; Power Drift = 0.186 dB

Peak SAR (extrapolated) = 0.580 W/kg

SAR(1 g) = 0.336 mW/g; SAR(10 g) = 0.194 mW/g

Maximum value of SAR (measured) = 0.459 mW/g

Body Position - Mid/Zoom Scan (7x7x7)/Cube 1: Measurement grid: dx=5mm, dy=5mm, dz=5mm

Reference Value = 11.2 V/m; Power Drift = 0.186 dB

Peak SAR (extrapolated) = 0.521 W/kg

SAR(1 g) = 0.282 mW/g; SAR(10 g) = 0.151 mW/g

Maximum value of SAR (measured) = 0.396 mW/g

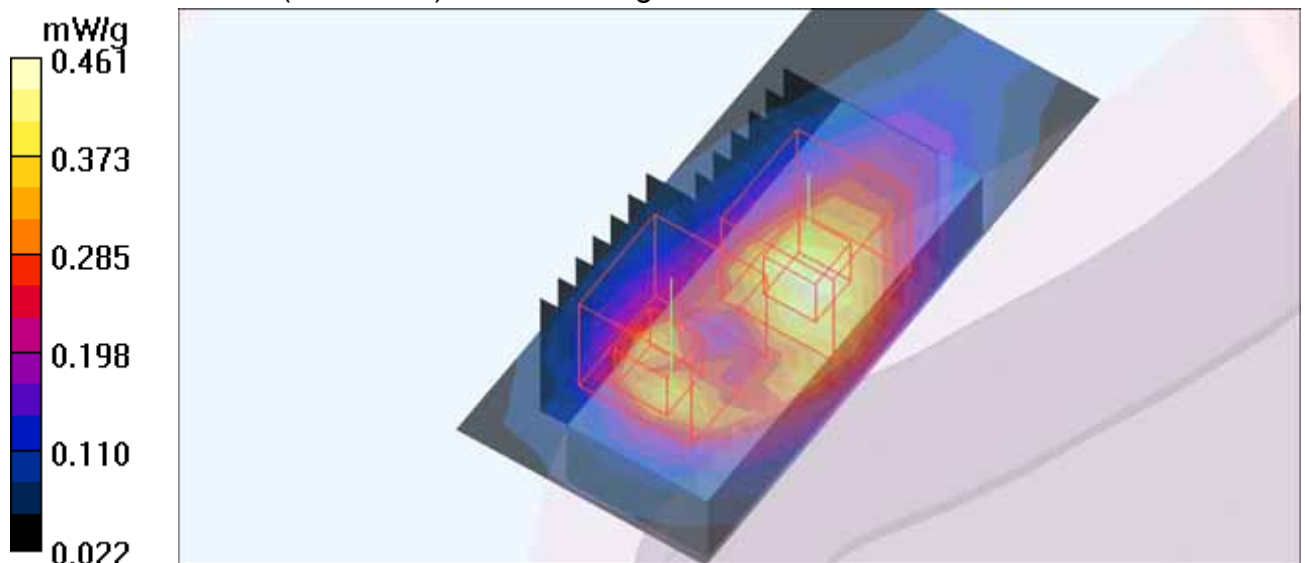

M17-LTE BAND 4-Ch20175 (1RB, Lower edge)

Communication System: LTE band4 (1700) ; Frequency: 1732.5 MHz ; Duty Cycle: 1:1; Modulation Type: QPSK

Medium: MSL1700 Medium parameters used: $f = 1732.5$ MHz; $\sigma = 1.49$ mho/m; $\epsilon_r = 54.38$; $\rho = 1000$ kg/m³

Phantom section: Flat Section ; Separation Distance : 5 mm (The Horizontal-Down side of the EUT to the Phantom)

DASY4 Configuration:

- Probe: EX3DV4 - SN3578; ConvF(6.81, 6.81, 6.81); Calibrated: 2010/6/22
- Sensor-Surface: 2mm (Mechanical Surface Detection)
- Electronics: DAE3 Sn579; Calibrated: 2010/9/20
- Phantom: SAM Twin Phantom V4.0; Type: QD 000 P40 CA; Serial: TP-1202
- Measurement SW: DASY4, V4.7 Build 80; Postprocessing SW: SEMCAD, V1.8 Build 186

Body Position - Mid/Area Scan (7x15x1): Measurement grid: dx=8mm, dy=8mm

Maximum value of SAR (measured) = 0.465 mW/g

Body Position - Mid/Zoom Scan (7x7x7)/Cube 0: Measurement grid: dx=5mm, dy=5mm, dz=5mm

Reference Value = 10.4 V/m; Power Drift = 0.107 dB

Peak SAR (extrapolated) = 0.582 W/kg

SAR(1 g) = 0.340 mW/g; SAR(10 g) = 0.197 mW/g

Maximum value of SAR (measured) = 0.459 mW/g

Body Position - Mid/Zoom Scan (7x7x7)/Cube 1: Measurement grid: dx=5mm, dy=5mm, dz=5mm

Reference Value = 10.4 V/m; Power Drift = 0.107 dB

Peak SAR (extrapolated) = 0.537 W/kg

SAR(1 g) = 0.282 mW/g; SAR(10 g) = 0.153 mW/g

Maximum value of SAR (measured) = 0.399 mW/g

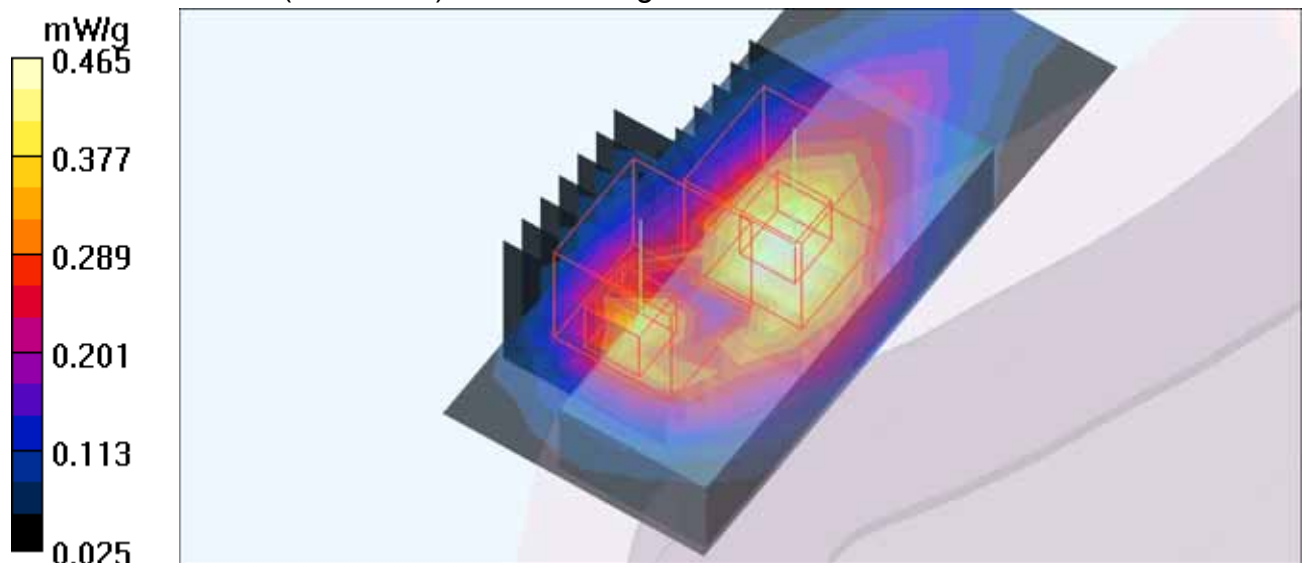

M18-LTE BAND 4-Ch20175 (1RB, Upper edge)

Communication System: LTE band4 (1700) ; Frequency: 1732.5 MHz ; Duty Cycle: 1:1 ; Modulation Type: QPSK

Medium: MSL1700 Medium parameters used: $f = 1732.5$ MHz; $\sigma = 1.49$ mho/m; $\epsilon_r = 54.38$; $\rho = 1000$ kg/m³

Phantom section: Flat Section ; Separation Distance : 5 mm (The Horizontal-Down side of the EUT to the Phantom)

DASY4 Configuration:

- Probe: EX3DV4 - SN3578; ConvF(6.81, 6.81, 6.81); Calibrated: 2010/6/22
- Sensor-Surface: 2mm (Mechanical Surface Detection)
- Electronics: DAE3 Sn579; Calibrated: 2010/9/20
- Phantom: SAM Twin Phantom V4.0; Type: QD 000 P40 CA; Serial: TP-1202
- Measurement SW: DASY4, V4.7 Build 80; Postprocessing SW: SEMCAD, V1.8 Build 186

Body Position - Mid/Area Scan (7x15x1): Measurement grid: dx=8mm, dy=8mm

Maximum value of SAR (measured) = 0.483 mW/g

Body Position - Mid/Zoom Scan (7x7x7)/Cube 0: Measurement grid: dx=5mm, dy=5mm, dz=5mm

Reference Value = 11.0 V/m; Power Drift = 0.159 dB

Peak SAR (extrapolated) = 0.682 W/kg

SAR(1 g) = 0.376 mW/g; SAR(10 g) = 0.216 mW/g

Maximum value of SAR (measured) = 0.530 mW/g

Body Position - Mid/Zoom Scan (7x7x7)/Cube 1: Measurement grid: dx=5mm, dy=5mm, dz=5mm

Reference Value = 11.0 V/m; Power Drift = 0.159 dB

Peak SAR (extrapolated) = 0.669 W/kg

SAR(1 g) = 0.320 mW/g; SAR(10 g) = 0.169 mW/g

Maximum value of SAR (measured) = 0.444 mW/g

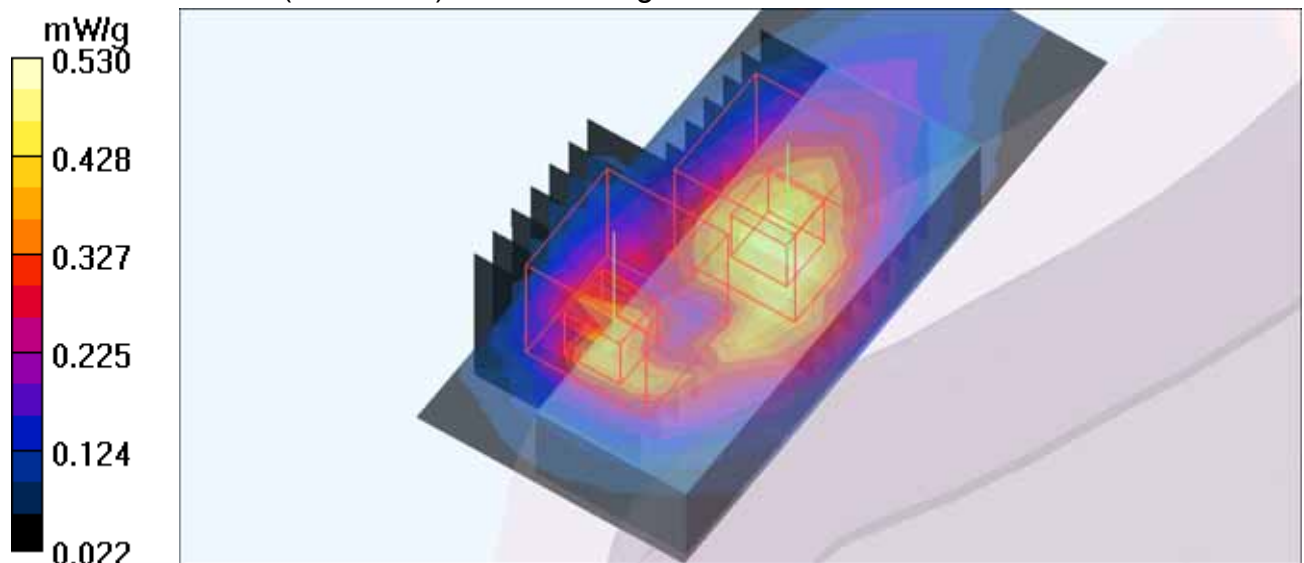

M19-LTE BAND 4-Ch20175 (50% RB centered)

Communication System: LTE band4 (1700) ; Frequency: 1732.5 MHz ; Duty Cycle: 1:1 ; Modulation Type: QPSK

Medium: MSL1700 Medium parameters used: $f = 1732.5$ MHz; $\sigma = 1.49$ mho/m; $\epsilon_r = 54.38$; $\rho = 1000$ kg/m³

Phantom section: Flat Section ; Separation Distance : 5 mm (The Vertical-Front side of the EUT to the Phantom)

DASY4 Configuration:

- Probe: EX3DV4 - SN3578; ConvF(6.81, 6.81, 6.81); Calibrated: 2010/6/22
- Sensor-Surface: 2mm (Mechanical Surface Detection)
- Electronics: DAE3 Sn579; Calibrated: 2010/9/20
- Phantom: SAM Twin Phantom V4.0; Type: QD 000 P40 CA; Serial: TP-1202
- Measurement SW: DASY4, V4.7 Build 80; Postprocessing SW: SEMCAD, V1.8 Build 186

Body Position - Mid/Area Scan (7x15x1): Measurement grid: dx=8mm, dy=8mm

Maximum value of SAR (measured) = 0.601 mW/g

Body Position - Mid/Zoom Scan (7x7x7)/Cube 0: Measurement grid: dx=5mm, dy=5mm, dz=5mm

Reference Value = 7.82 V/m; Power Drift = 0.124 dB

Peak SAR (extrapolated) = 0.793 W/kg

SAR(1 g) = 0.446 mW/g; SAR(10 g) = 0.252 mW/g

Maximum value of SAR (measured) = 0.631 mW/g

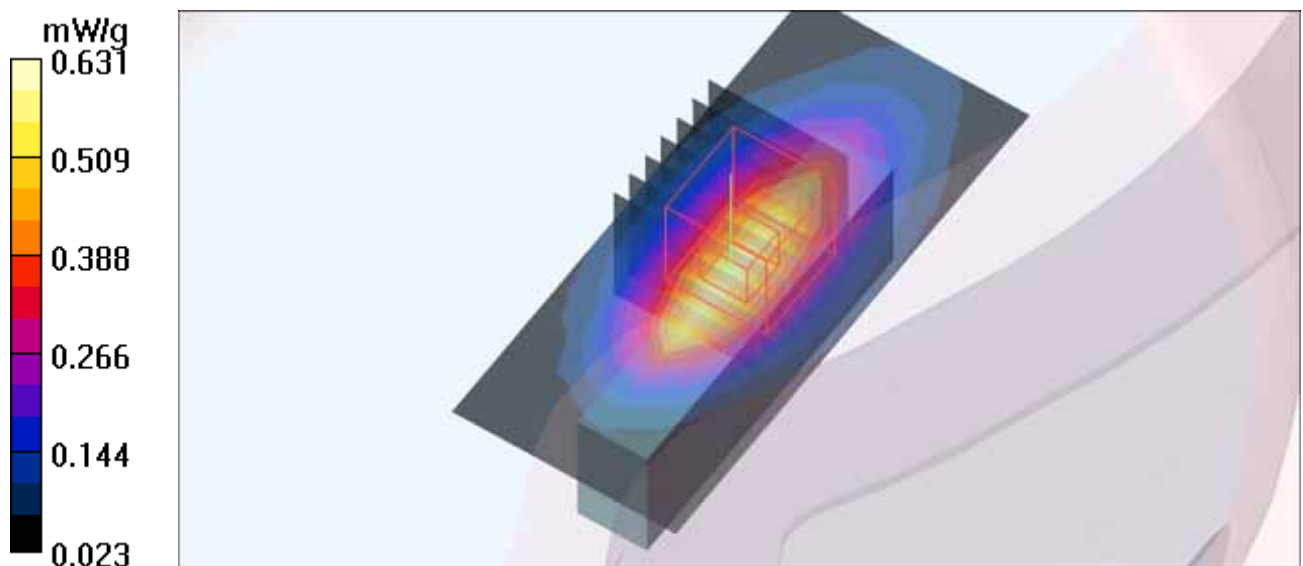

M20-LTE BAND 4-Ch20175 (1RB, Lower edge)

Communication System: LTE band4 (1700) ; Frequency: 1732.5 MHz ; Duty Cycle: 1:1 ; Modulation Type: QPSK

Medium: MSL1700 Medium parameters used: $f = 1732.5$ MHz; $\sigma = 1.49$ mho/m; $\epsilon_r = 54.38$; $\rho = 1000$ kg/m³

Phantom section: Flat Section ; Separation Distance : 5 mm (The Vertical-Front side of the EUT to the Phantom)

DASY4 Configuration:

- Probe: EX3DV4 - SN3578; ConvF(6.81, 6.81, 6.81); Calibrated: 2010/6/22
- Sensor-Surface: 2mm (Mechanical Surface Detection)
- Electronics: DAE3 Sn579; Calibrated: 2010/9/20
- Phantom: SAM Twin Phantom V4.0; Type: QD 000 P40 CA; Serial: TP-1202
- Measurement SW: DASY4, V4.7 Build 80; Postprocessing SW: SEMCAD, V1.8 Build 186

Body Position - Mid/Area Scan (7x15x1): Measurement grid: dx=8mm, dy=8mm

Maximum value of SAR (measured) = 0.569 mW/g

Body Position - Mid/Zoom Scan (7x7x7)/Cube 0: Measurement grid: dx=5mm, dy=5mm, dz=5mm

Reference Value = 9.18 V/m; Power Drift = 0.142 dB

Peak SAR (extrapolated) = 0.851 W/kg

SAR(1 g) = 0.449 mW/g; SAR(10 g) = 0.251 mW/g

Maximum value of SAR (measured) = 0.689 mW/g

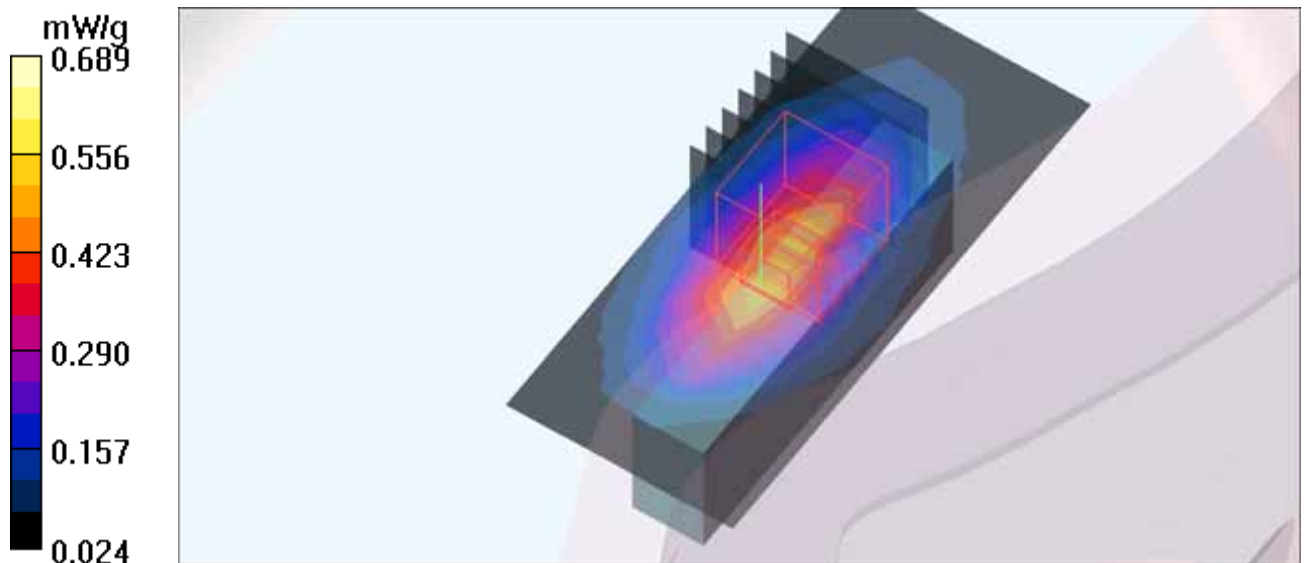

M21-LTE BAND 4-Ch20175 (1RB, Upper edge)

Communication System: LTE band4 (1700) ; Frequency: 1732.5 MHz ; Duty Cycle: 1:1 ; Modulation Type: QPSK

Medium: MSL1700 Medium parameters used: $f = 1732.5$ MHz; $\sigma = 1.49$ mho/m; $\epsilon_r = 54.38$; $\rho = 1000$ kg/m³

Phantom section: Flat Section ; Separation Distance : 5 mm (The Vertical-Front side of the EUT to the Phantom)

DASY4 Configuration:

- Probe: EX3DV4 - SN3578; ConvF(6.81, 6.81, 6.81); Calibrated: 2010/6/22
- Sensor-Surface: 2mm (Mechanical Surface Detection)
- Electronics: DAE3 Sn579; Calibrated: 2010/9/20
- Phantom: SAM Twin Phantom V4.0; Type: QD 000 P40 CA; Serial: TP-1202
- Measurement SW: DASY4, V4.7 Build 80; Postprocessing SW: SEMCAD, V1.8 Build 186

Body Position - Mid/Area Scan (7x15x1): Measurement grid: dx=8mm, dy=8mm

Maximum value of SAR (measured) = 0.740 mW/g

Body Position - Mid/Zoom Scan (7x7x7)/Cube 0: Measurement grid: dx=5mm, dy=5mm, dz=5mm

Reference Value = 11.0 V/m; Power Drift = -0.005 dB

Peak SAR (extrapolated) = 0.926 W/kg

SAR(1 g) = 0.531 mW/g; SAR(10 g) = 0.294 mW/g

Maximum value of SAR (measured) = 0.736 mW/g

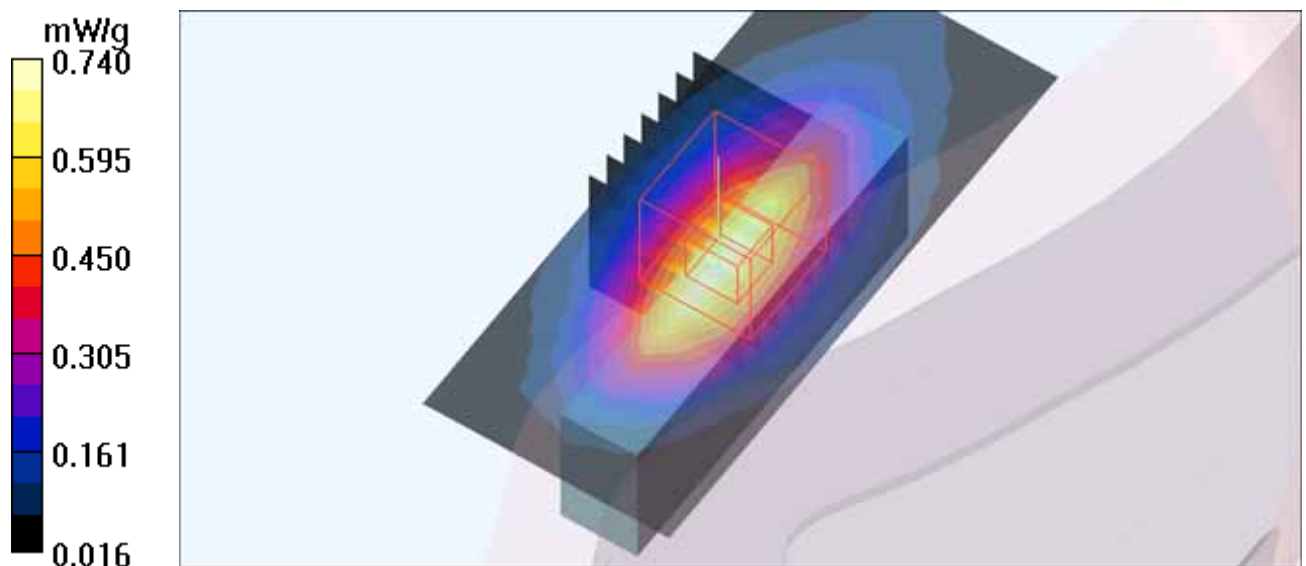

M22-LTE BAND 4-Ch20175 (50% RB centered)

Communication System: LTE band4 (1700) ; Frequency: 1732.5 MHz ; Duty Cycle: 1:1 ; Modulation Type: QPSK

Medium: MSL1700 Medium parameters used: $f = 1732.5$ MHz; $\sigma = 1.49$ mho/m; $\epsilon_r = 54.38$; $\rho = 1000$ kg/m³

Phantom section: Flat Section ; Separation Distance : 5 mm (The Horizontal-Up side of the EUT to the Phantom)

DASY4 Configuration:

- Probe: EX3DV4 - SN3578; ConvF(6.81, 6.81, 6.81); Calibrated: 2010/6/22
- Sensor-Surface: 2mm (Mechanical Surface Detection)
- Electronics: DAE3 Sn579; Calibrated: 2010/9/20
- Phantom: SAM Twin Phantom V4.0; Type: QD 000 P40 CA; Serial: TP-1202
- Measurement SW: DASY4, V4.7 Build 80; Postprocessing SW: SEMCAD, V1.8 Build 186

Body Position - Mid/Area Scan (7x15x1): Measurement grid: dx=8mm, dy=8mm

Maximum value of SAR (measured) = 0.862 mW/g

Body Position - Mid/Zoom Scan (7x7x7)/Cube 0: Measurement grid: dx=5mm, dy=5mm, dz=5mm

Reference Value = 5.69 V/m; Power Drift = 0.015 dB

Peak SAR (extrapolated) = 1.05 W/kg

SAR(1 g) = 0.653 mW/g; SAR(10 g) = 0.383 mW/g

Maximum value of SAR (measured) = 0.869 mW/g

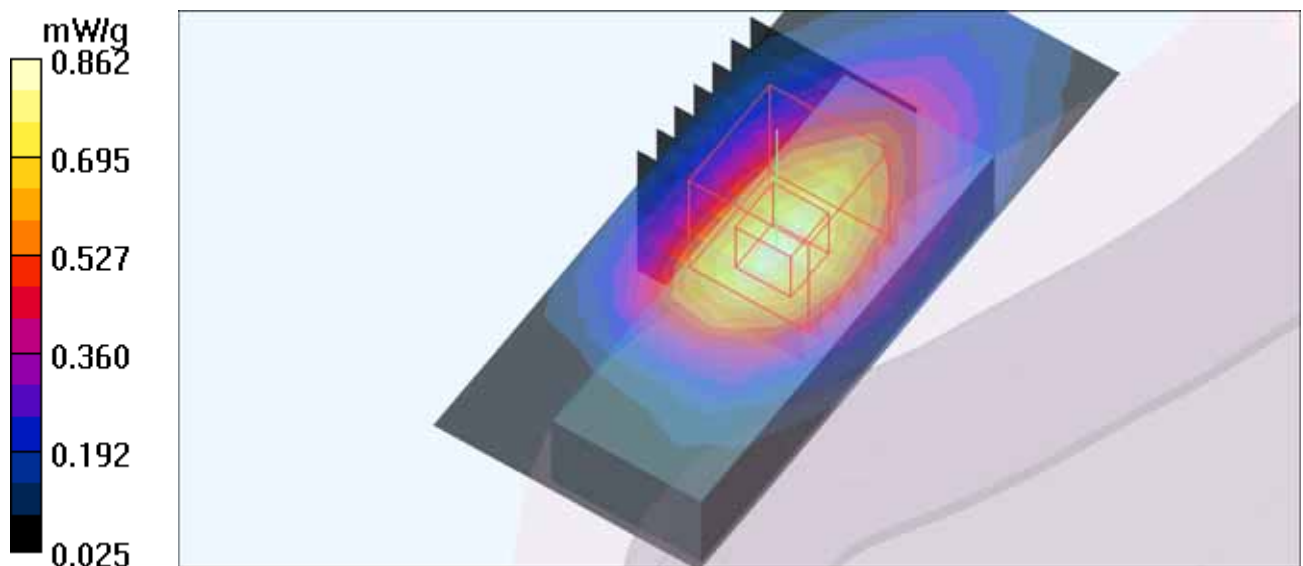

M23-LTE BAND 4-Ch20175 (1RB, Lower edge)

Communication System: LTE band4 (1700) ; Frequency: 1732.5 MHz ; Duty Cycle: 1:1 ; Modulation Type: QPSK

Medium: MSL1700 Medium parameters used: $f = 1732.5$ MHz; $\sigma = 1.49$ mho/m; $\epsilon_r = 54.38$; $\rho = 1000$ kg/m³

Phantom section: Flat Section ; Separation Distance : 5 mm (The Horizontal-Up side of the EUT to the Phantom)

DASY4 Configuration:

- Probe: EX3DV4 - SN3578; ConvF(6.81, 6.81, 6.81); Calibrated: 2010/6/22
- Sensor-Surface: 2mm (Mechanical Surface Detection)
- Electronics: DAE3 Sn579; Calibrated: 2010/9/20
- Phantom: SAM Twin Phantom V4.0; Type: QD 000 P40 CA; Serial: TP-1202
- Measurement SW: DASY4, V4.7 Build 80; Postprocessing SW: SEMCAD, V1.8 Build 186

Body Position - Mid/Area Scan (7x15x1): Measurement grid: dx=8mm, dy=8mm

Maximum value of SAR (measured) = 0.838 mW/g

Body Position - Mid/Zoom Scan (7x7x7)/Cube 0: Measurement grid: dx=5mm, dy=5mm, dz=5mm

Reference Value = 7.35 V/m; Power Drift = 0.169 dB

Peak SAR (extrapolated) = 0.993 W/kg

SAR(1 g) = 0.638 mW/g; SAR(10 g) = 0.383 mW/g

Maximum value of SAR (measured) = 0.818 mW/g

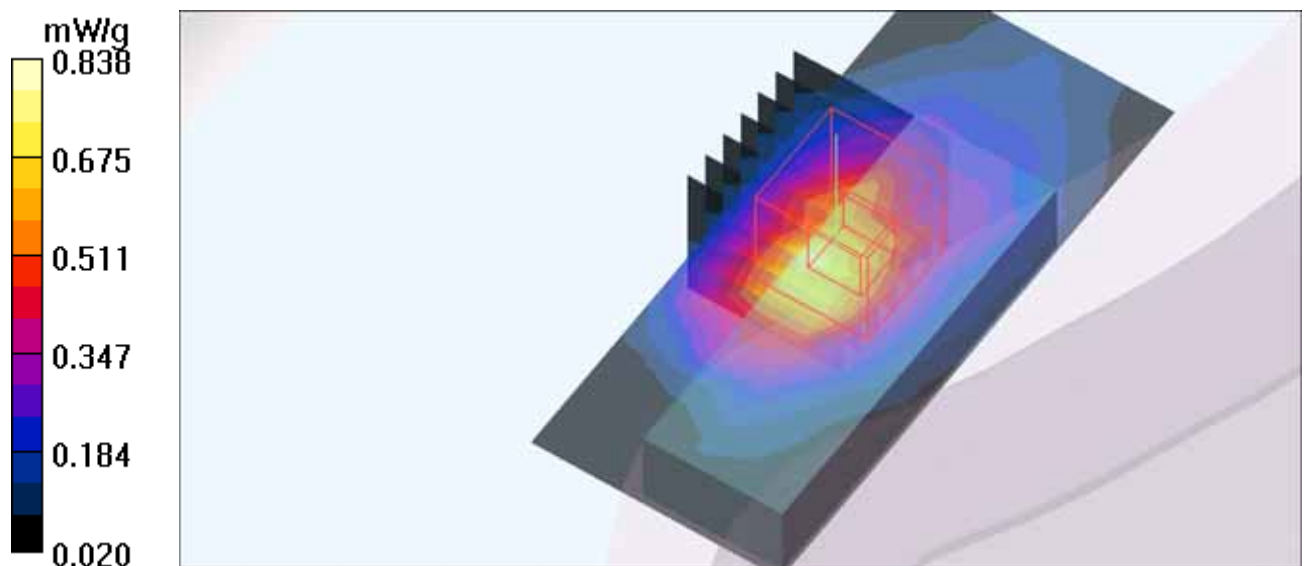

M24-LTE BAND 4-Ch20175 (1RB, Upper edge)

Communication System: LTE band4 (1700) ; Frequency: 1732.5 MHz ; Duty Cycle: 1:1 ; Modulation Type: QPSK

Medium: MSL1700 Medium parameters used: $f = 1732.5$ MHz; $\sigma = 1.49$ mho/m; $\epsilon_r = 54.38$; $\rho = 1000$ kg/m³

Phantom section: Flat Section ; Separation Distance : 5 mm (The Horizontal-Up side of the EUT to the Phantom)

DASY4 Configuration:

- Probe: EX3DV4 - SN3578; ConvF(6.81, 6.81, 6.81); Calibrated: 2010/6/22
- Sensor-Surface: 2mm (Mechanical Surface Detection)
- Electronics: DAE3 Sn579; Calibrated: 2010/9/20
- Phantom: SAM Twin Phantom V4.0; Type: QD 000 P40 CA; Serial: TP-1202
- Measurement SW: DASY4, V4.7 Build 80; Postprocessing SW: SEMCAD, V1.8 Build 186

Body Position - Mid/Area Scan (7x15x1): Measurement grid: dx=8mm, dy=8mm

Maximum value of SAR (measured) = 0.881 mW/g

Body Position - Mid/Zoom Scan (7x7x7)/Cube 0: Measurement grid: dx=5mm, dy=5mm, dz=5mm

Reference Value = 7.88 V/m; Power Drift = 0.152 dB

Peak SAR (extrapolated) = 1.08 W/kg

SAR(1 g) = 0.702 mW/g; SAR(10 g) = 0.422 mW/g

Maximum value of SAR (measured) = 0.902 mW/g

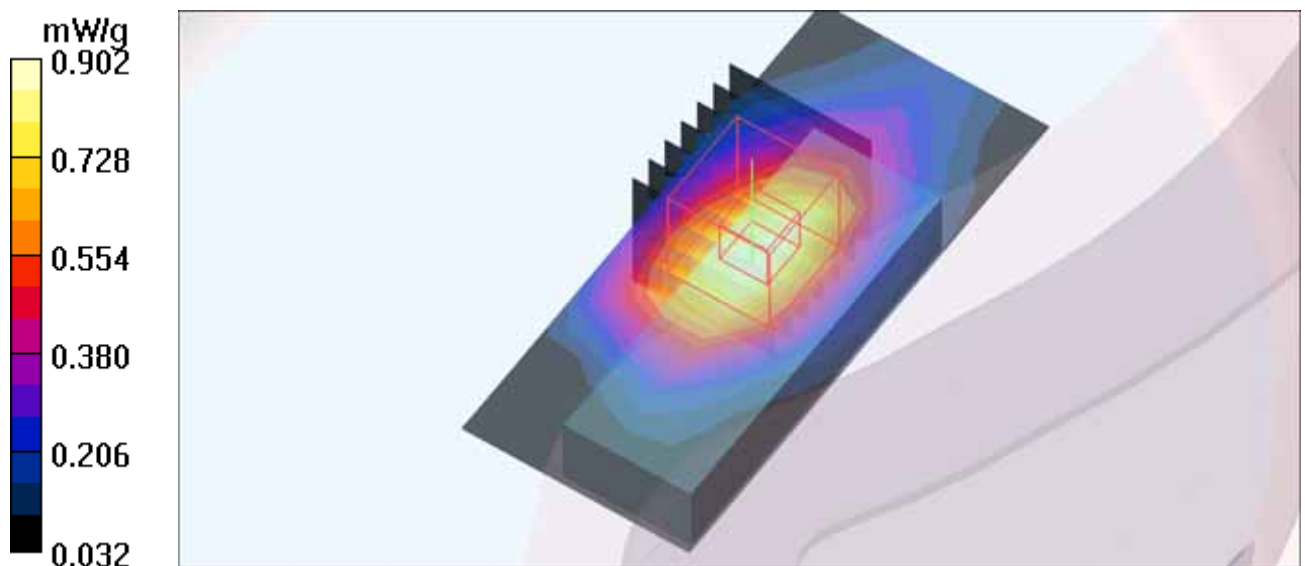

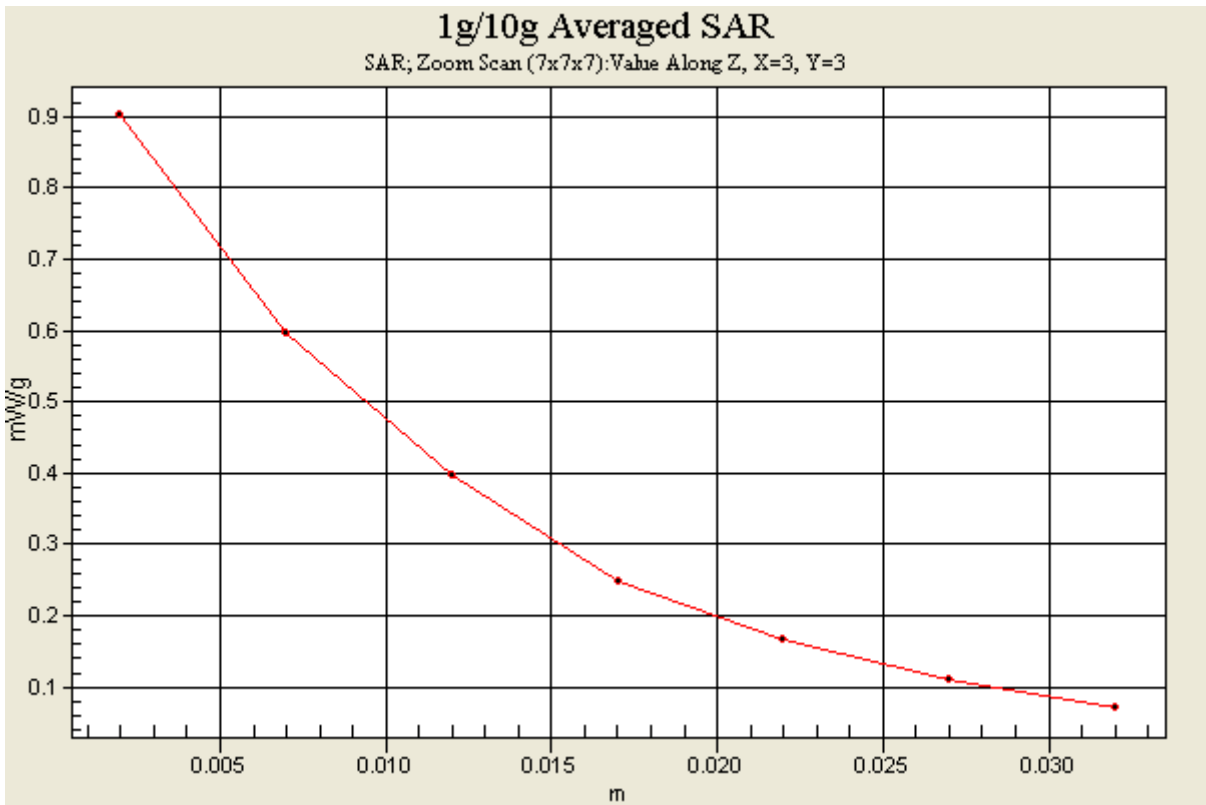

M25-LTE BAND 4-Ch20175 (50% RB centered)

Communication System: LTE band4 (1700) ; Frequency: 1732.5 MHz ; Duty Cycle: 1:1; Modulation Type: QPSK

Medium: MSL1700 Medium parameters used: $f = 1732.5$ MHz; $\sigma = 1.49$ mho/m; $\epsilon_r = 54.38$; $\rho = 1000$ kg/m³

Phantom section: Flat Section ; Separation Distance : 5 mm (The Vertical-Back side of the EUT to the Phantom)

DASY4 Configuration:

- Probe: EX3DV4 - SN3578; ConvF(6.81, 6.81, 6.81); Calibrated: 2010/6/22
- Sensor-Surface: 2mm (Mechanical Surface Detection)
- Electronics: DAE3 Sn579; Calibrated: 2010/9/20
- Phantom: SAM Twin Phantom V4.0; Type: QD 000 P40 CA; Serial: TP-1202
- Measurement SW: DASY4, V4.7 Build 80; Postprocessing SW: SEMCAD, V1.8 Build 186

Body Position - Mid/Area Scan (7x15x1): Measurement grid: dx=8mm, dy=8mm

Maximum value of SAR (measured) = 0.539 mW/g

Body Position - Mid/Zoom Scan (7x7x7) /Cube 0: Measurement grid: dx=5mm, dy=5mm, dz=5mm

Reference Value = 9.01 V/m; Power Drift = 0.092 dB

Peak SAR (extrapolated) = 0.665 W/kg

SAR(1 g) = 0.392 mW/g; SAR(10 g) = 0.227 mW/g

Maximum value of SAR (measured) = 0.529 mW/g

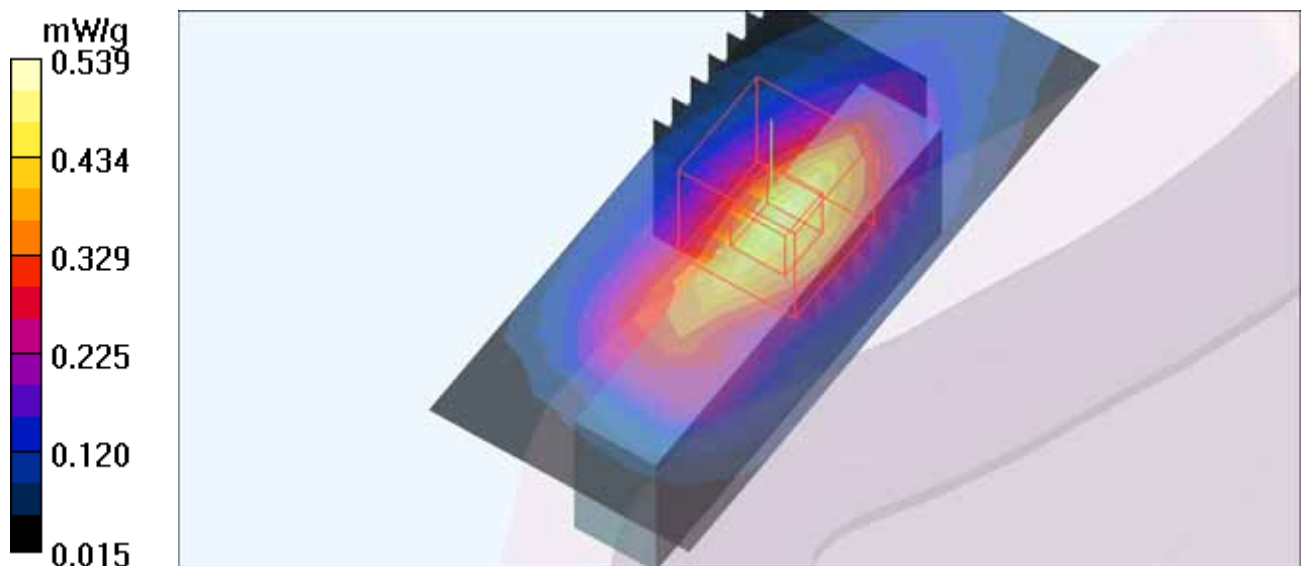

M26-LTE BAND 4-Ch20175 (1RB, Lower edge)

Communication System: LTE band4 (1700) ; Frequency: 1732.5 MHz ; Duty Cycle: 1:1 ; Modulation Type: QPSK

Medium: MSL1700 Medium parameters used: $f = 1732.5$ MHz; $\sigma = 1.49$ mho/m; $\epsilon_r = 54.38$; $\rho = 1000$ kg/m³

Phantom section: Flat Section ; Separation Distance : 5 mm (The Vertical-Back side of the EUT to the Phantom)

DASY4 Configuration:

- Probe: EX3DV4 - SN3578; ConvF(6.81, 6.81, 6.81); Calibrated: 2010/6/22
- Sensor-Surface: 2mm (Mechanical Surface Detection)
- Electronics: DAE3 Sn579; Calibrated: 2010/9/20
- Phantom: SAM Twin Phantom V4.0; Type: QD 000 P40 CA; Serial: TP-1202
- Measurement SW: DASY4, V4.7 Build 80; Postprocessing SW: SEMCAD, V1.8 Build 186

Body Position - Mid/Area Scan (7x15x1): Measurement grid: dx=8mm, dy=8mm

Maximum value of SAR (measured) = 0.508 mW/g

Body Position - Mid/Zoom Scan (7x7x7)/Cube 0: Measurement grid: dx=5mm, dy=5mm, dz=5mm

Reference Value = 10.3 V/m; Power Drift = -0.031 dB

Peak SAR (extrapolated) = 0.596 W/kg

SAR(1 g) = 0.358 mW/g; SAR(10 g) = 0.215 mW/g

Maximum value of SAR (measured) = 0.469 mW/g

Body Position - Mid/Zoom Scan (7x7x7)/Cube 1: Measurement grid: dx=5mm, dy=5mm, dz=5mm

Reference Value = 10.3 V/m; Power Drift = -0.031 dB

Peak SAR (extrapolated) = 0.587 W/kg

SAR(1 g) = 0.349 mW/g; SAR(10 g) = 0.199 mW/g

Maximum value of SAR (measured) = 0.470 mW/g

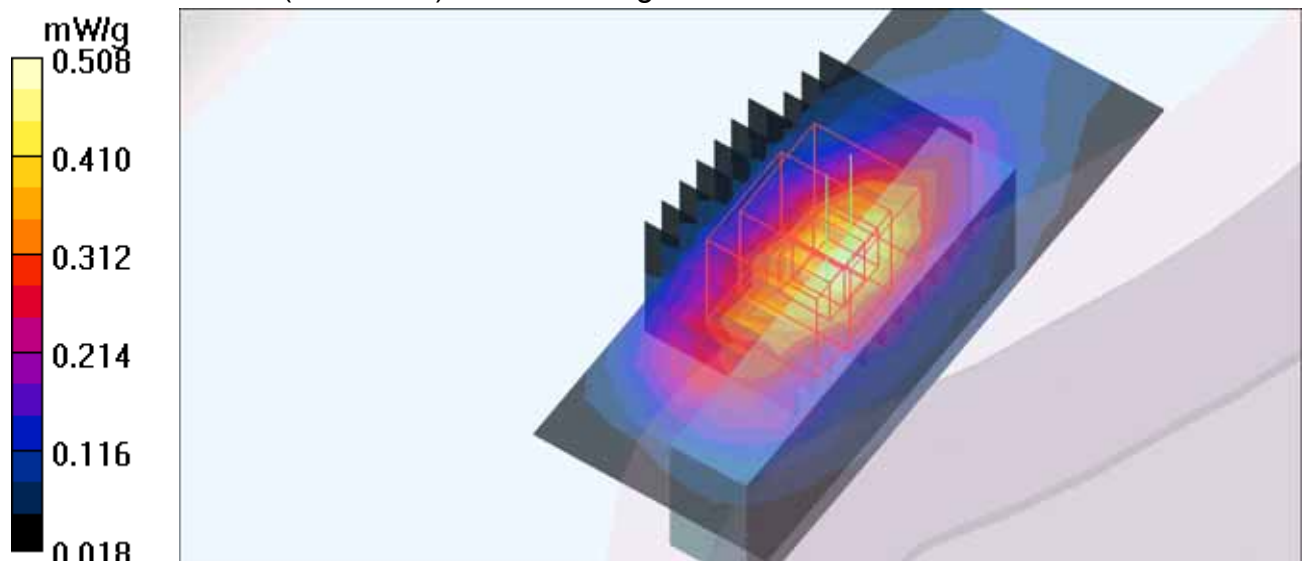

M27-LTE BAND 4-Ch20175 (1RB, Upper edge)

Communication System: LTE band4 (1700) ; Frequency: 1732.5 MHz ; Duty Cycle: 1:1 ; Modulation Type: QPSK

Medium: MSL1700 Medium parameters used: $f = 1732.5$ MHz; $\sigma = 1.49$ mho/m; $\epsilon_r = 54.38$; $\rho = 1000$ kg/m³

Phantom section: Flat Section ; Separation Distance : 5 mm (The Vertical-Back side of the EUT to the Phantom)

DASY4 Configuration:

- Probe: EX3DV4 - SN3578; ConvF(6.81, 6.81, 6.81); Calibrated: 2010/6/22
- Sensor-Surface: 2mm (Mechanical Surface Detection)
- Electronics: DAE3 Sn579; Calibrated: 2010/9/20
- Phantom: SAM Twin Phantom V4.0; Type: QD 000 P40 CA; Serial: TP-1202
- Measurement SW: DASY4, V4.7 Build 80; Postprocessing SW: SEMCAD, V1.8 Build 186

Body Position - Mid/Area Scan (7x15x1): Measurement grid: dx=8mm, dy=8mm

Maximum value of SAR (measured) = 0.520 mW/g

Body Position - Mid/Zoom Scan (7x7x7)/Cube 0: Measurement grid: dx=5mm, dy=5mm, dz=5mm

Reference Value = 10.8 V/m; Power Drift = 0.036 dB

Peak SAR (extrapolated) = 0.624 W/kg

SAR(1 g) = 0.379 mW/g; SAR(10 g) = 0.224 mW/g

Maximum value of SAR (measured) = 0.501 mW/g

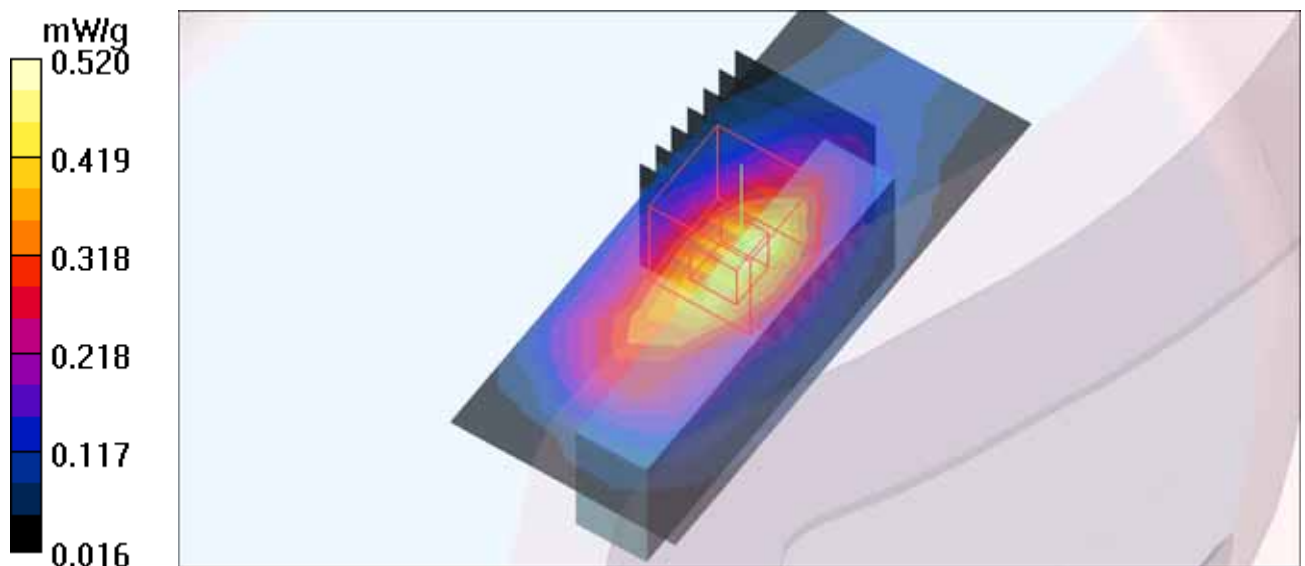

M28-LTE BAND 4-Ch20175 (50% RB centered)

Communication System: LTE band4 (1700) ; Frequency: 1732.5 MHz ; Duty Cycle: 1:1 ; Modulation Type: QPSK

Medium: MSL1700 Medium parameters used: $f = 1732.5$ MHz; $\sigma = 1.49$ mho/m; $\epsilon_r = 54.38$; $\rho = 1000$ kg/m³

Phantom section: Flat Section ; Separation Distance : 5 mm (The top side of the EUT to the Phantom)

DASY4 Configuration:

- Probe: EX3DV4 - SN3578; ConvF(6.81, 6.81, 6.81); Calibrated: 2010/6/22
- Sensor-Surface: 2mm (Mechanical Surface Detection)
- Electronics: DAE3 Sn579; Calibrated: 2010/9/20
- Phantom: SAM Twin Phantom V4.0; Type: QD 000 P40 CA; Serial: TP-1202
- Measurement SW: DASY4, V4.7 Build 80; Postprocessing SW: SEMCAD, V1.8 Build 186

Body Position - Mid/Area Scan (7x7x1): Measurement grid: dx=8mm, dy=8mm

Maximum value of SAR (measured) = 0.166 mW/g

Body Position - Mid/Zoom Scan (7x7x7)/Cube 0: Measurement grid: dx=5mm, dy=5mm, dz=5mm

Reference Value = 8.94 V/m; Power Drift = 0.155 dB

Peak SAR (extrapolated) = 0.218 W/kg

SAR(1 g) = 0.129 mW/g; SAR(10 g) = 0.073 mW/g

Maximum value of SAR (measured) = 0.174 mW/g

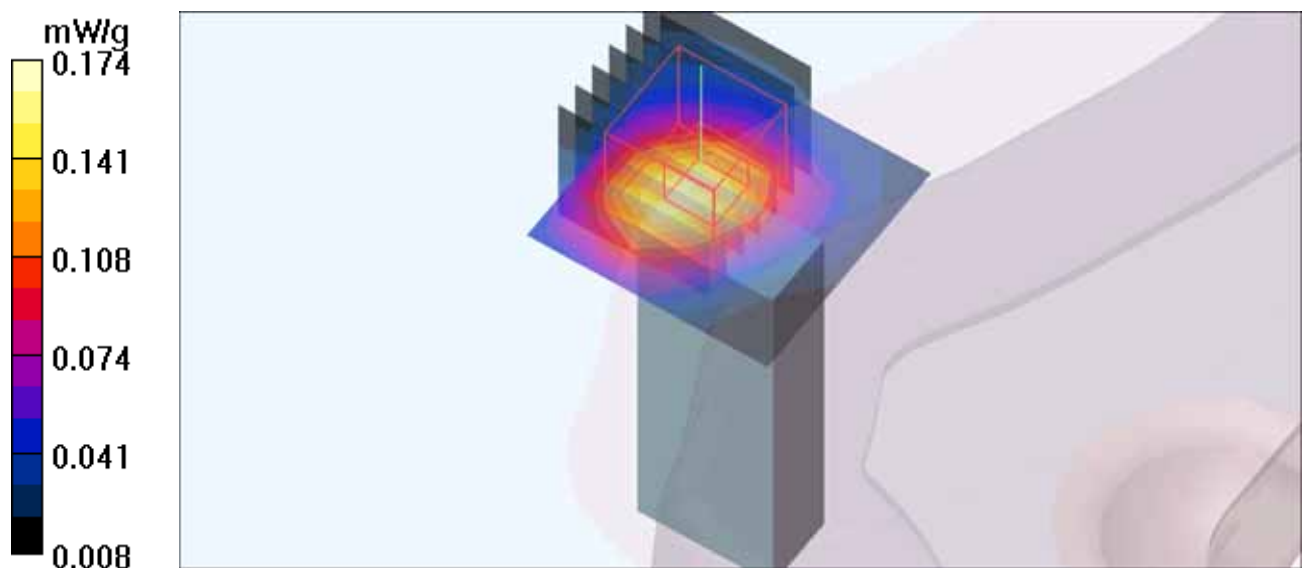

M29-LTE BAND 4-Ch20175 (1RB, Lower edge)

Communication System: LTE band4 (1700) ; Frequency: 1732.5 MHz ; Duty Cycle: 1:1 ; Modulation Type: QPSK

Medium: MSL1700 Medium parameters used: $f = 1732.5$ MHz; $\sigma = 1.49$ mho/m; $\epsilon_r = 54.38$; $\rho = 1000$ kg/m³

Phantom section: Flat Section ; Separation Distance : 5 mm (The top side of the EUT to the Phantom)

DASY4 Configuration:

- Probe: EX3DV4 - SN3578; ConvF(6.81, 6.81, 6.81); Calibrated: 2010/6/22
- Sensor-Surface: 2mm (Mechanical Surface Detection)
- Electronics: DAE3 Sn579; Calibrated: 2010/9/20
- Phantom: SAM Twin Phantom V4.0; Type: QD 000 P40 CA; Serial: TP-1202
- Measurement SW: DASY4, V4.7 Build 80; Postprocessing SW: SEMCAD, V1.8 Build 186

Body Position - Mid channel Low End/Area Scan (7x7x1): Measurement grid: dx=8mm, dy=8mm

Maximum value of SAR (measured) = 0.162 mW/g

Body Position - Mid channel Low End/Zoom Scan (7x7x7)/Cube 0: Measurement grid: dx=5mm, dy=5mm, dz=5mm

Reference Value = 8.72 V/m; Power Drift = 0.18 dB

Peak SAR (extrapolated) = 0.252 W/kg

SAR(1 g) = 0.127 mW/g; SAR(10 g) = 0.072 mW/g

Maximum value of SAR (measured) = 0.185 mW/g

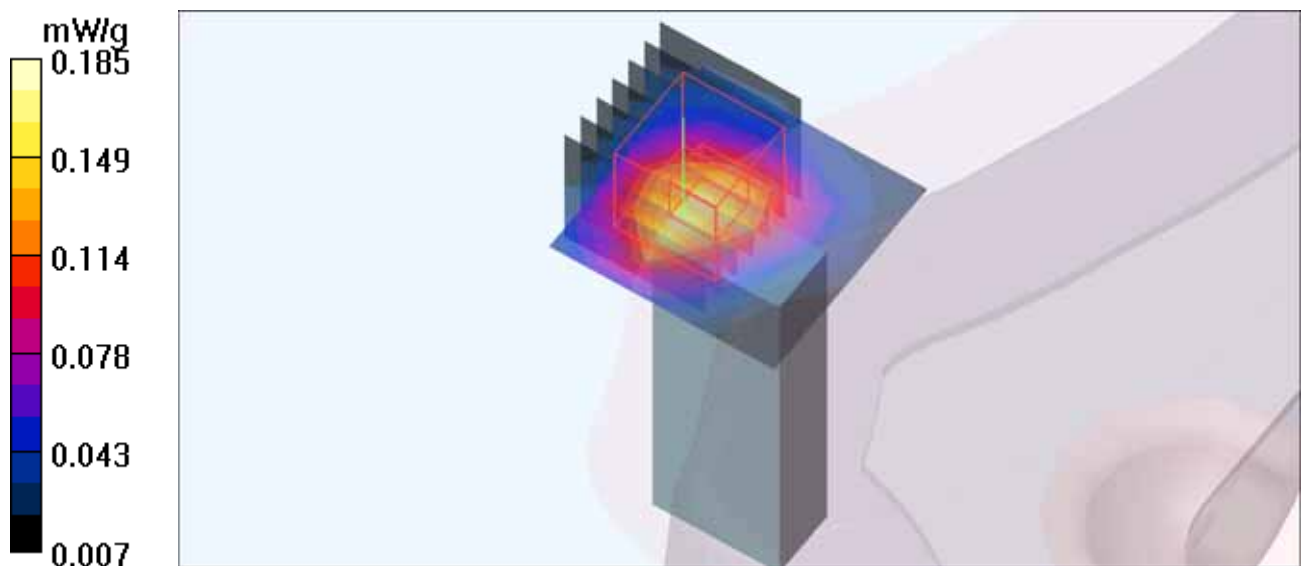

M30-LTE BAND 4-Ch20175 (1RB, Upper edge)

Communication System: LTE band4 (1700) ; Frequency: 1732.5 MHz ; Duty Cycle: 1:1 ; Modulation Type: QPSK

Medium: MSL1700 Medium parameters used: $f = 1732.5$ MHz; $\sigma = 1.49$ mho/m; $\epsilon_r = 54.38$; $\rho = 1000$ kg/m³

Phantom section: Flat Section ; Separation Distance : 5 mm (The top side of the EUT to the Phantom)

DASY4 Configuration:

- Probe: EX3DV4 - SN3578; ConvF(6.81, 6.81, 6.81); Calibrated: 2010/6/22
- Sensor-Surface: 2mm (Mechanical Surface Detection)
- Electronics: DAE3 Sn579; Calibrated: 2010/9/20
- Phantom: SAM Twin Phantom V4.0; Type: QD 000 P40 CA; Serial: TP-1202
- Measurement SW: DASY4, V4.7 Build 80; Postprocessing SW: SEMCAD, V1.8 Build 186

Body Position - Mid/Area Scan (7x7x1): Measurement grid: dx=8mm, dy=8mm

Maximum value of SAR (measured) = 0.196 mW/g

Body Position - Mid/Zoom Scan (7x7x7)/Cube 0: Measurement grid: dx=5mm, dy=5mm, dz=5mm

Reference Value = 9.64 V/m; Power Drift = 0.012 dB

Peak SAR (extrapolated) = 0.240 W/kg

SAR(1 g) = 0.142 mW/g; SAR(10 g) = 0.080 mW/g

Maximum value of SAR (measured) = 0.189 mW/g

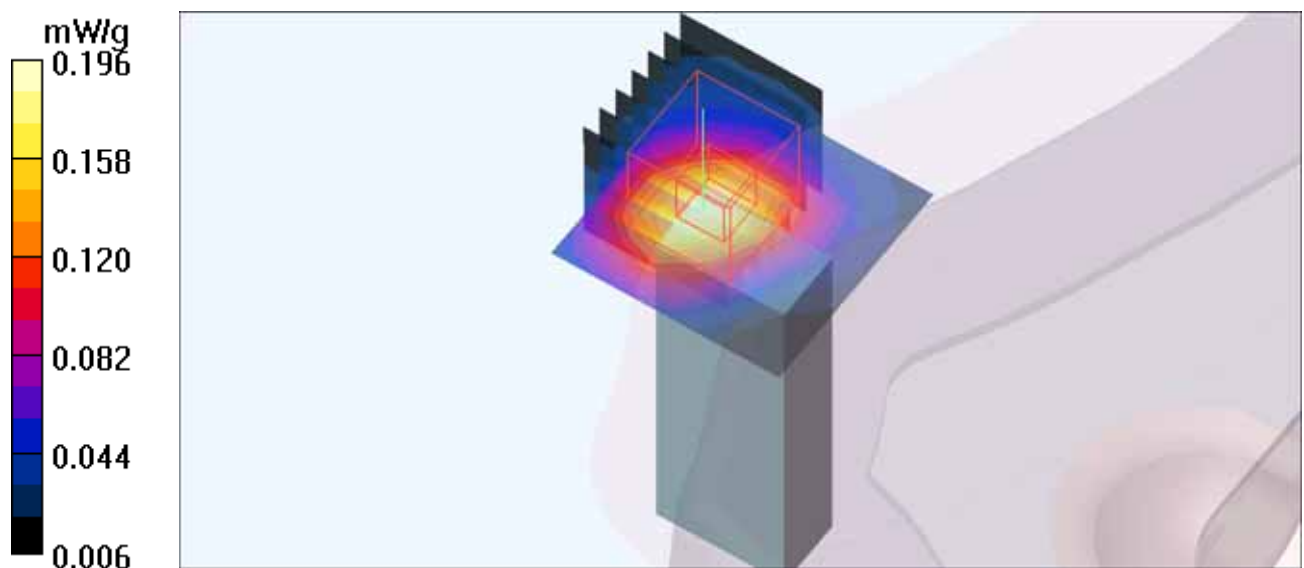

M31-WCDMA AWS BAND-Ch1412

Communication System: WCDMA AWS BAND ; Frequency: 1732.4 MHz ; Duty Cycle: 1:1 ;

Modulation type: BPSK

Medium: MSL1700 Medium parameters used : $f = 1732.4$ MHz; $\sigma = 1.49$ mho/m; $\epsilon_r = 54.38$; $\rho = 1000$ kg/m³

Phantom section: Flat Section ; Separation distance : 5 mm (The Horizontal-Down side of the EUT to the Phantom)

DASY4 Configuration:

- Probe: EX3DV4 - SN3578; ConvF(6.81, 6.81, 6.81); Calibrated: 2010/6/22
- Sensor-Surface: 2mm (Mechanical Surface Detection)
- Electronics: DAE3 Sn579; Calibrated: 2010/9/20
- Phantom: SAM Twin Phantom V4.0; Type: QD 000 P40 CA; Serial: TP-1202
- Measurement SW: DASY4, V4.7 Build 80; Postprocessing SW: SEMCAD, V1.8 Build 186

Body Position - Mid/Area Scan (7x15x1): Measurement grid: dx=8mm, dy=8mm

Maximum value of SAR (measured) = 0.420 mW/g

Body Position - Mid/Zoom Scan (7x7x7)/Cube 0: Measurement grid: dx=5mm, dy=5mm, dz=5mm

Reference Value = 11.5 V/m; Power Drift = 0.136 dB

Peak SAR (extrapolated) = 0.700 W/kg

SAR(1 g) = 0.362 mW/g; SAR(10 g) = 0.187 mW/g

Maximum value of SAR (measured) = 0.519 mW/g

Body Position - Mid/Zoom Scan (7x7x7)/Cube 1: Measurement grid: dx=5mm, dy=5mm, dz=5mm

Reference Value = 11.5 V/m; Power Drift = 0.136 dB

Peak SAR (extrapolated) = 0.618 W/kg

SAR(1 g) = 0.218 mW/g; SAR(10 g) = 0.119 mW/g

Maximum value of SAR (measured) = 0.454 mW/g

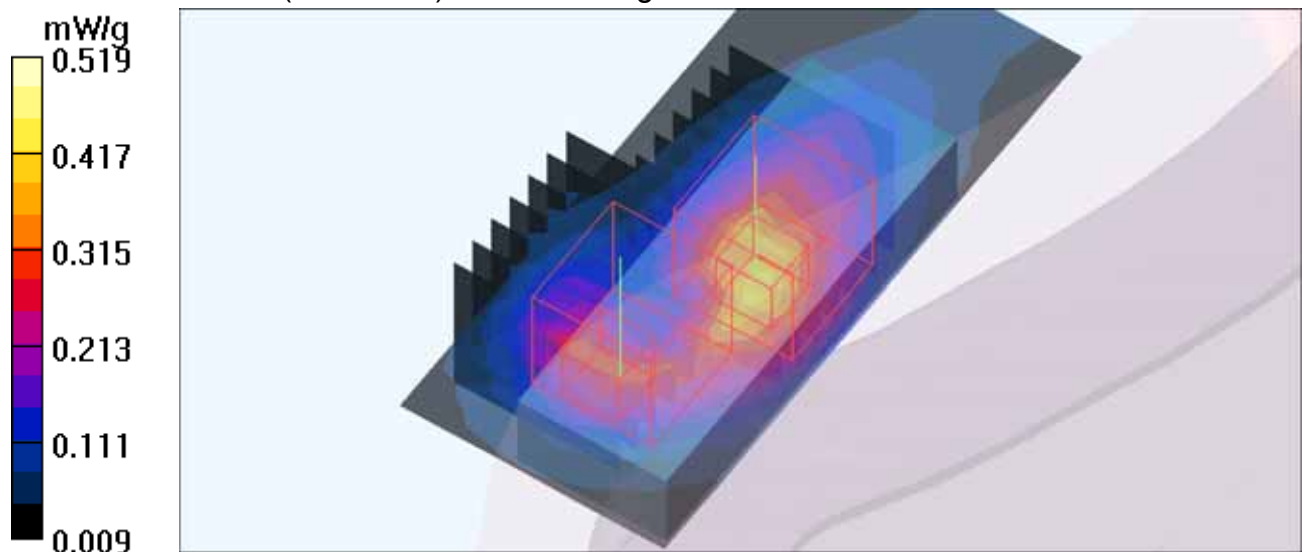

M32-WCDMA AWS BAND-Ch1412

Communication System: WCDMA AWS BAND ; Frequency: 1732.4 MHz ; Duty Cycle: 1:1 ;

Modulation type: BPSK

Medium: MSL1700 Medium parameters used : $f = 1732.4$ MHz; $\sigma = 1.49$ mho/m; $\epsilon_r = 54.38$; $\rho = 1000$ kg/m³

Phantom section: Flat Section ; Separation distance : 5 mm (The Vertical-Front side of the EUT to the Phantom)

DASY4 Configuration:

- Probe: EX3DV4 - SN3578; ConvF(6.81, 6.81, 6.81); Calibrated: 2010/6/22
- Sensor-Surface: 2mm (Mechanical Surface Detection)
- Electronics: DAE3 Sn579; Calibrated: 2010/9/20
- Phantom: SAM Twin Phantom V4.0; Type: QD 000 P40 CA; Serial: TP-1202
- Measurement SW: DASY4, V4.7 Build 80; Postprocessing SW: SEMCAD, V1.8 Build 186

Body Position - Mid/Area Scan (7x15x1): Measurement grid: dx=8mm, dy=8mm

Maximum value of SAR (measured) = 0.561 mW/g

Body Position - Mid/Zoom Scan (7x7x7)/Cube 0: Measurement grid: dx=5mm, dy=5mm, dz=5mm

Reference Value = 7.68 V/m; Power Drift = 0.074 dB

Peak SAR (extrapolated) = 0.699 W/kg

SAR(1 g) = 0.396 mW/g; SAR(10 g) = 0.214 mW/g

Maximum value of SAR (measured) = 0.556 mW/g

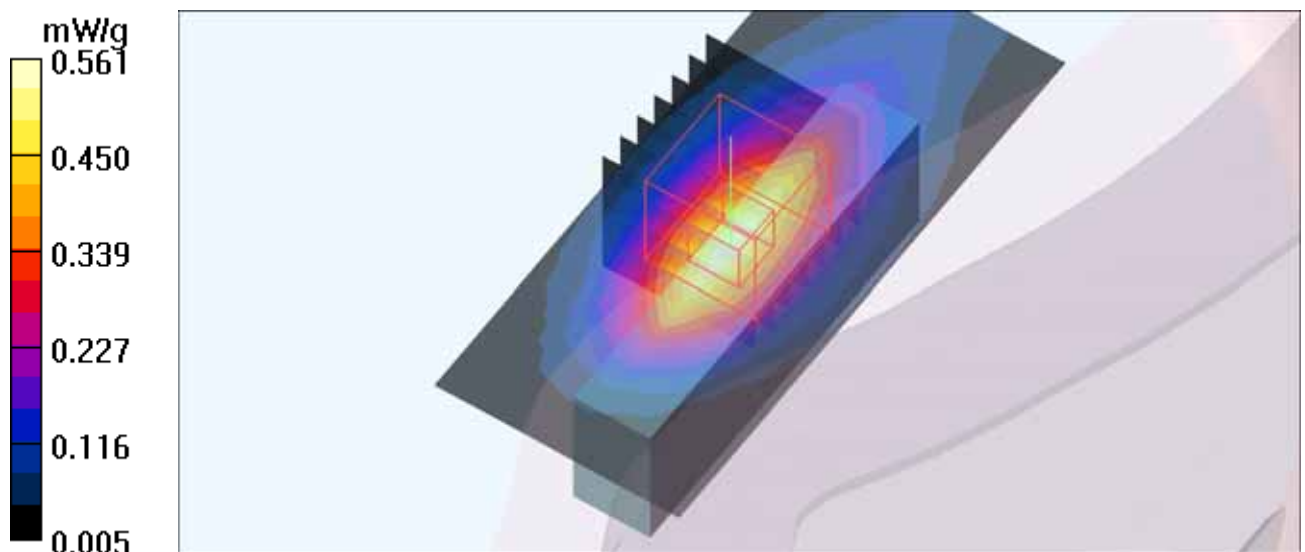

M33-WCDMA AWS BAND-Ch1412

Communication System: WCDMA AWS BAND ; Frequency: 1732.4 MHz ; Duty Cycle: 1:1 ;

Modulation type: BPSK

Medium: MSL1700 Medium parameters used : $f = 1732.4$ MHz; $\sigma = 1.49$ mho/m; $\epsilon_r = 54.38$; $\rho = 1000$ kg/m³

Phantom section: Flat Section ; Separation distance : 5 mm (The Horizontal-Up side of the EUT to the Phantom)

DASY4 Configuration:

- Probe: EX3DV4 - SN3578; ConvF(6.81, 6.81, 6.81); Calibrated: 2010/6/22
- Sensor-Surface: 2mm (Mechanical Surface Detection)
- Electronics: DAE3 Sn579; Calibrated: 2010/9/20
- Phantom: SAM Twin Phantom V4.0; Type: QD 000 P40 CA; Serial: TP-1202
- Measurement SW: DASY4, V4.7 Build 80; Postprocessing SW: SEMCAD, V1.8 Build 186

Body Position - Mid/Area Scan (7x15x1): Measurement grid: dx=8mm, dy=8mm

Maximum value of SAR (measured) = 0.554 mW/g

Body Position - Mid/Zoom Scan (7x7x7)/Cube 0: Measurement grid: dx=5mm, dy=5mm, dz=5mm

Reference Value = 4.60 V/m; Power Drift = -0.156 dB

Peak SAR (extrapolated) = 0.686 W/kg

SAR(1 g) = 0.423 mW/g; SAR(10 g) = 0.247 mW/g

Maximum value of SAR (measured) = 0.564 mW/g

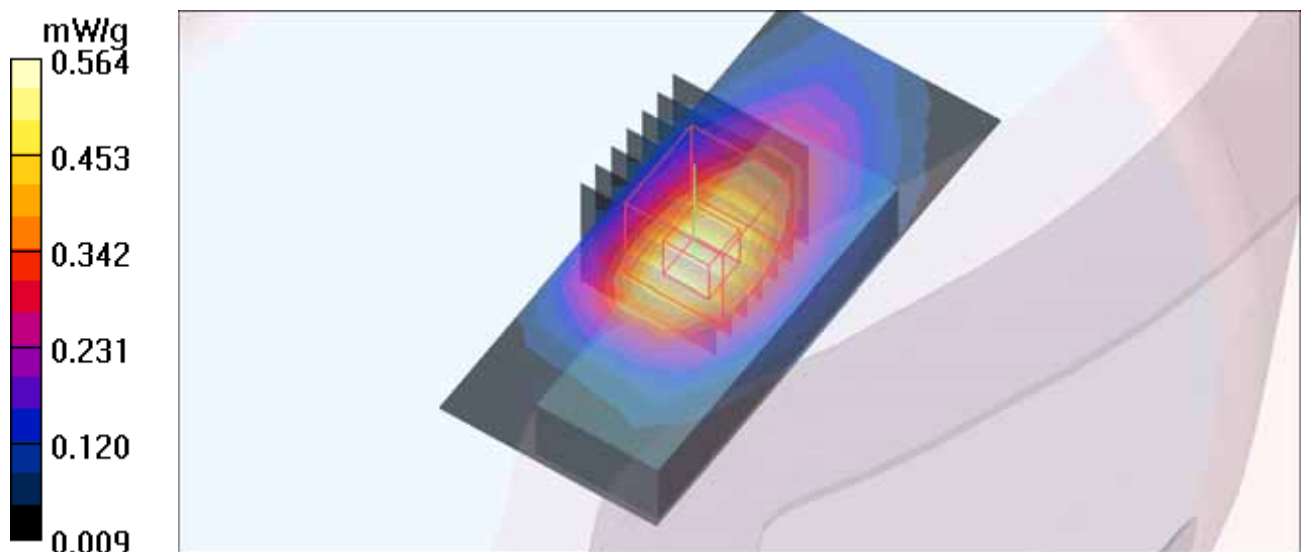

M34-WCDMA AWS BAND-Ch1412

Communication System: WCDMA AWS BAND ; Frequency: 1732.4 MHz ; Duty Cycle: 1:1 ;

Modulation type: BPSK

Medium: MSL1700 Medium parameters used : $f = 1732.4$ MHz; $\sigma = 1.49$ mho/m; $\epsilon_r = 54.38$; $\rho = 1000$ kg/m³

Phantom section: Flat Section ; Separation distance : 5 mm (The Vertical-Back side of the EUT to the Phantom)

DASY4 Configuration:

- Probe: EX3DV4 - SN3578; ConvF(6.81, 6.81, 6.81); Calibrated: 2010/6/22
- Sensor-Surface: 2mm (Mechanical Surface Detection)
- Electronics: DAE3 Sn579; Calibrated: 2010/9/20
- Phantom: SAM Twin Phantom V4.0; Type: QD 000 P40 CA; Serial: TP-1202
- Measurement SW: DASY4, V4.7 Build 80; Postprocessing SW: SEMCAD, V1.8 Build 186

Body Position - Mid/Area Scan (7x15x1): Measurement grid: dx=8mm, dy=8mm

Maximum value of SAR (measured) = 0.273 mW/g

Body Position - Mid/Zoom Scan (7x7x7)/Cube 0: Measurement grid: dx=5mm, dy=5mm, dz=5mm

Reference Value = 6.28 V/m; Power Drift = 0.152 dB

Peak SAR (extrapolated) = 0.336 W/kg

SAR(1 g) = 0.204 mW/g; SAR(10 g) = 0.120 mW/g

Maximum value of SAR (measured) = 0.274 mW/g

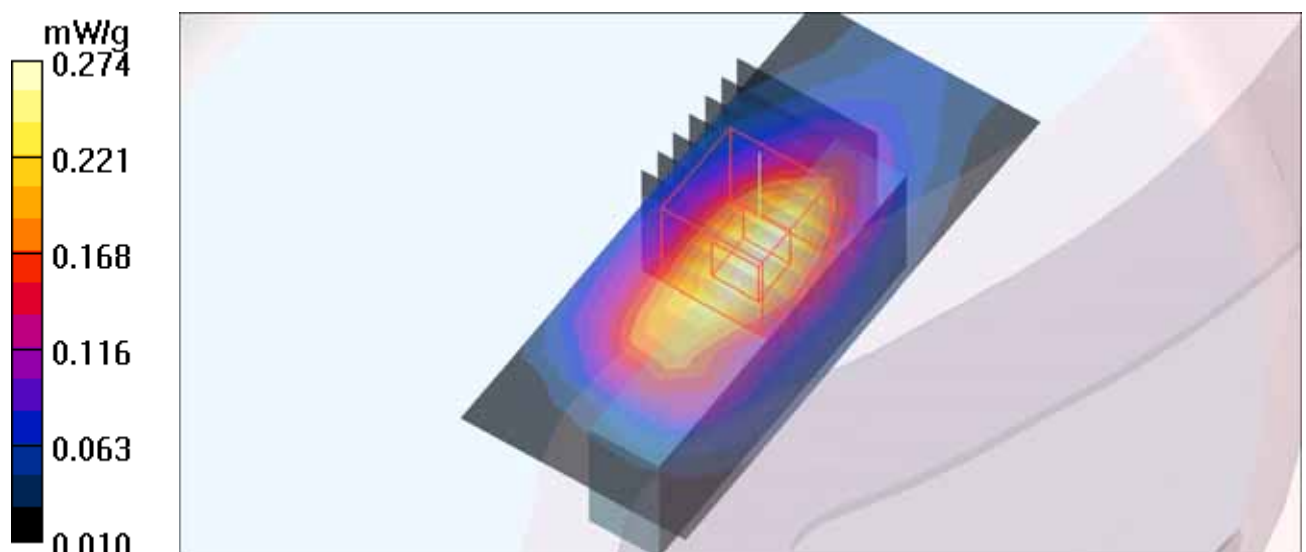

M35-WCDMA AWS BAND-Ch1412

Communication System: WCDMA AWS BAND ; Frequency: 1732.4 MHz ; Duty Cycle: 1:1 ;

Modulation type: BPSK

Medium: MSL1700 Medium parameters used : $f = 1732.4$ MHz; $\sigma = 1.49$ mho/m; $\epsilon_r = 54.38$; $\rho = 1000$ kg/m³

Phantom section: Flat Section ; Separation distance : 5 mm (The top side of the EUT to the Phantom)

DASY4 Configuration:

- Probe: EX3DV4 - SN3578; ConvF(6.81, 6.81, 6.81); Calibrated: 2010/6/22
- Sensor-Surface: 2mm (Mechanical Surface Detection)
- Electronics: DAE3 Sn579; Calibrated: 2010/9/20
- Phantom: SAM Twin Phantom V4.0; Type: QD 000 P40 CA; Serial: TP-1202
- Measurement SW: DASY4, V4.7 Build 80; Postprocessing SW: SEMCAD, V1.8 Build 186

Body Position - Mid/Area Scan (8x10x1): Measurement grid: dx=8mm, dy=8mm

Maximum value of SAR (measured) = 0.093 mW/g

Body Position - Mid/Zoom Scan (7x7x7)/Cube 0: Measurement grid: dx=5mm, dy=5mm, dz=5mm

Reference Value = 6.55 V/m; Power Drift = 0.057 dB

Peak SAR (extrapolated) = 0.120 W/kg

SAR(1 g) = 0.071 mW/g; SAR(10 g) = 0.040 mW/g

Maximum value of SAR (measured) = 0.098 mW/g

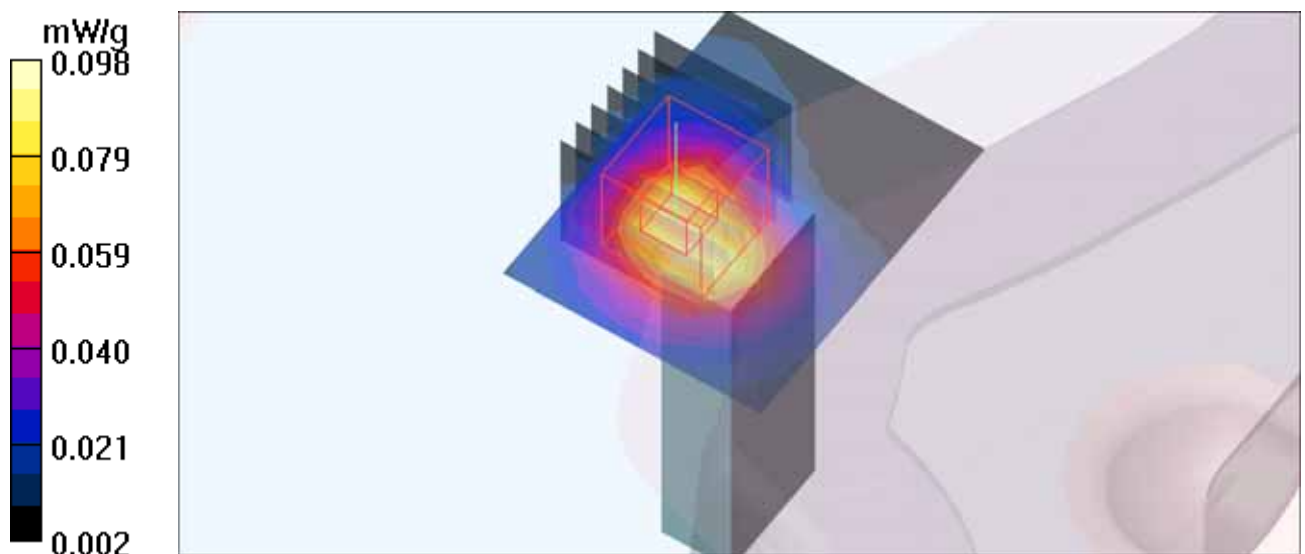

System Validation Check-MSL 750MHz

DUT: Dipole 750 MHz ; Type: D750V3 ; Serial: 1013 ; Test Frequency: 750 MHz

Communication System: CW ; Frequency: 750 MHz; Duty Cycle: 1:1; Modulation type: CW
Medium: MSL750; Medium parameters used: $f = 750 \text{ MHz}$; $\sigma = 0.98 \text{ mho/m}$; $\epsilon_r = 55.84$; $\rho = 1000 \text{ kg/m}^3$; Liquid level : 150 mm
Phantom section: Flat Section ; Separation distance : 15 mm (The feet point of the dipole to the Phantom) Air temp. : 22.3 degrees ; Liquid temp. : 22.1 degrees

DASY4 Configuration:

- Probe: ES3DV3 - SN3177; ConvF(6.18, 6.18, 6.18); Calibrated: 2010/8/24
- Sensor-Surface: 3mm (Mechanical Surface Detection)
- Electronics: DAE3 Sn579; Calibrated: 2010/9/20
- Phantom: SAM Twin Phantom V4.0; Type: QD 000 P40 CA; Serial: TP-1202
- Measurement SW: DASY4, V4.7 Build 80; Postprocessing SW: SEMCAD, V1.8 Build 186

d=15mm, Pin=250mW/Area Scan (7x9x1): Measurement grid: dx=15mm, dy=15mm
Maximum value of SAR (measured) = 2.10 mW/g

d=15mm, Pin=250mW/Zoom Scan (7x7x7)/Cube 0: Measurement grid: dx=5mm, dy=5mm, dz=5mm

Reference Value = 52.5 V/m; Power Drift = -0.023 dB

Peak SAR (extrapolated) = 3.10 W/kg

SAR(1 g) = 2.09 mW/g; SAR(10 g) = 1.38 mW/g

Maximum value of SAR (measured) = 2.41 mW/g

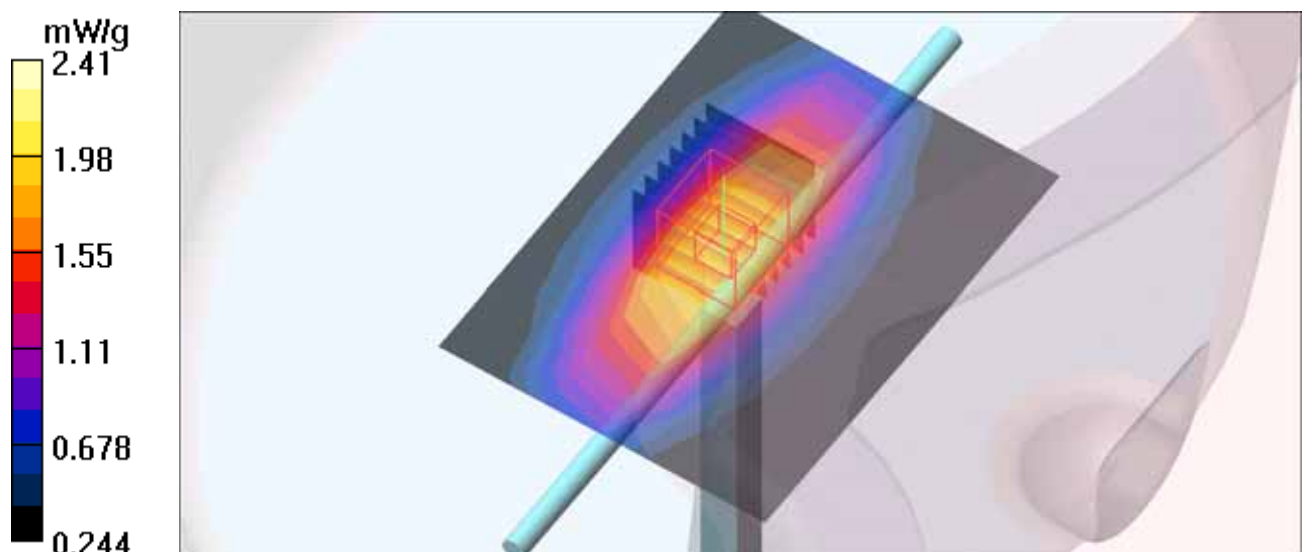

System Performance Check-D1750-MSL1750 MHz

DUT: Dipole 1750 MHz ; Type: D1750V2 ; Serial: D1750V2 - SN:1003 ; Test Frequency: 1750 MHz

Communication System: CW ; Frequency: 1750 MHz; Duty Cycle: 1:1; Modulation type: CW
Medium: MSL1700; Medium parameters used: $f = 1750$ MHz; $\sigma = 1.51$ mho/m; $\epsilon_r = 54.15$; $\rho = 1000$ kg/m³ ; Liquid level : 150 mm
Phantom section: Flat Section ; Separation distance : 10 mm (The feet point of the dipole to the Phantom) Air temp. : 22.1 degrees ; Liquid temp. : 21.3 degrees

DASY4 Configuration:

- Probe: EX3DV4 - SN3578; ConvF(6.81, 6.81, 6.81); Calibrated: 2010/6/22
- Sensor-Surface: 2mm (Mechanical Surface Detection)
- Electronics: DAE3 Sn579; Calibrated: 2010/9/20
- Phantom: SAM Twin Phantom V4.0; Type: QD 000 P40 CA; Serial: TP-1202
- Measurement SW: DASY4, V4.7 Build 80; Postprocessing SW: SEMCAD, V1.8 Build 186

d=10mm, Pin=250mW/Area Scan (7x7x1): Measurement grid: dx=15mm, dy=15mm
Maximum value of SAR (measured) = 13.1 mW/g

d=10mm, Pin=250mW/Zoom Scan (7x7x7)/Cube 0: Measurement grid: dx=5mm, dy=5mm, dz=5mm

Reference Value = 96.4 V/m; Power Drift = 0.050 dB

Peak SAR (extrapolated) = 17.9 W/kg

SAR(1 g) = 9.39 mW/g; SAR(10 g) = 4.97 mW/g

Maximum value of SAR (measured) = 13.7 mW/g

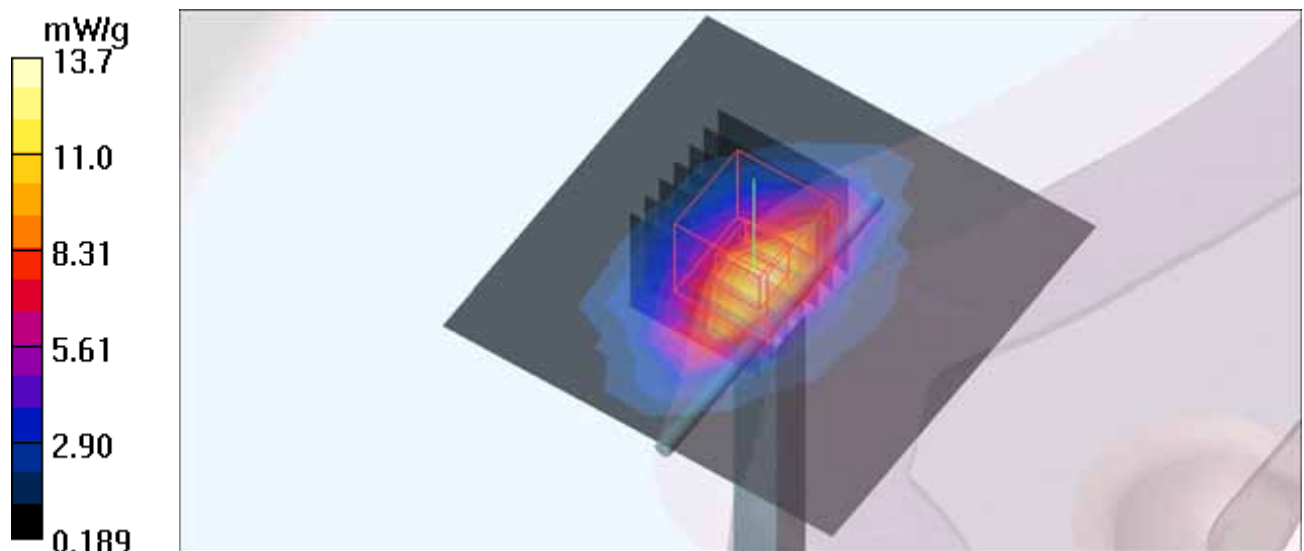

M36-LTE BAND17-Ch23790 (50% RB centered)

Communication System: LTE band17 (700) ; Frequency: 710 MHz ; Duty Cycle: 1:1
Medium: MSL750 Medium parameters used: $f = 710 \text{ MHz}$; $\sigma = 0.96 \text{ mho/m}$; $\epsilon_r = 56.11$; $\rho = 1000 \text{ kg/m}^3$
Phantom section: Flat Section ; DUT test position : Body ; Modulation Type: 16QAM
Separation Distance : 5 mm (The horizontal-down side of the EUT to the Phantom)

DASY4 Configuration:

- Probe: ES3DV3 - SN3177; ConvF(6.18, 6.18, 6.18); Calibrated: 2010/8/24
- Sensor-Surface: 3mm (Mechanical Surface Detection)
- Electronics: DAE3 Sn579; Calibrated: 2010/9/20
- Phantom: SAM Twin Phantom V4.0; Type: QD 000 P40 CA; Serial: TP-1202
- Measurement SW: DASY4, V4.7 Build 80; Postprocessing SW: SEMCAD, V1.8 Build 186

Body Position - Low/Area Scan (7x15x1): Measurement grid: dx=8mm, dy=8mm
Maximum value of SAR (measured) = 0.314 mW/g

Body Position - Low/Zoom Scan (7x7x7)/Cube 0: Measurement grid: dx=5mm, dy=5mm, dz=5mm
Reference Value = 6.78 V/m; Power Drift = 0.027 dB
Peak SAR (extrapolated) = 0.413 W/kg
SAR(1 g) = 0.267 mW/g; SAR(10 g) = 0.168 mW/g
Maximum value of SAR (measured) = 0.317 mW/g

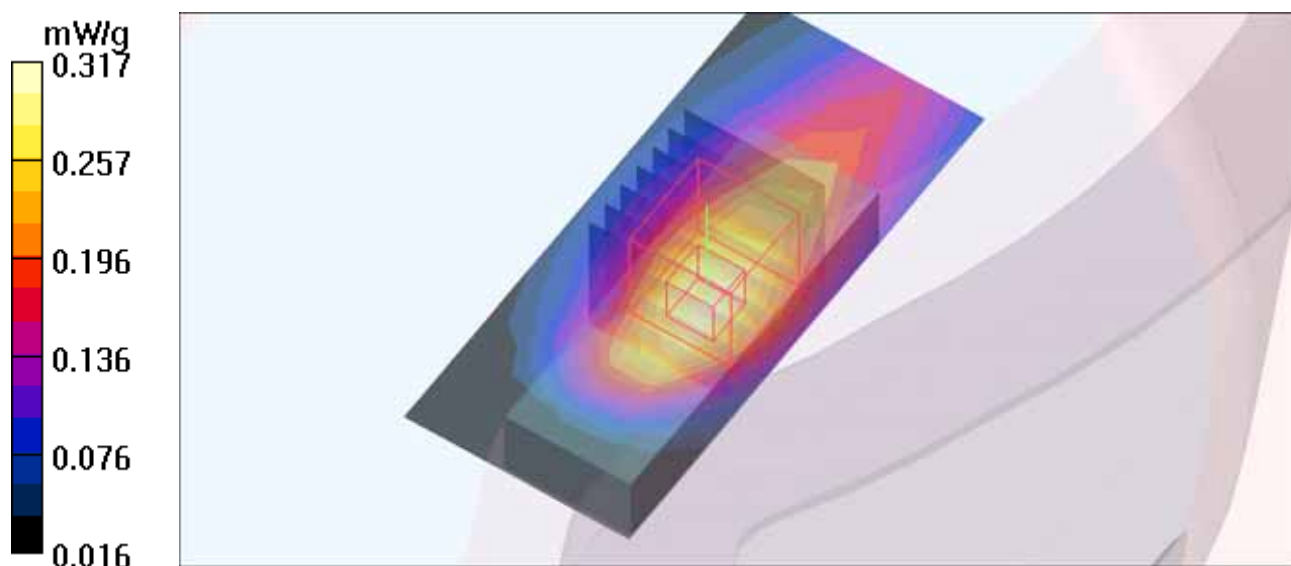

M37-LTE BAND17-Ch23790 (1RB, Lower edge)

Communication System: LTE band17 (700) ; Frequency: 710 MHz ; Duty Cycle: 1:1
Medium: MSL750 Medium parameters used: $f = 710$ MHz; $\sigma = 0.96$ mho/m; $\epsilon_r = 56.11$; $\rho = 1000$ kg/m³
Phantom section: Flat Section ; DUT test position : Body ; Modulation Type: 16QAM
Separation Distance : 5 mm (The horizontal-down side of the EUT to the Phantom)

DASY4 Configuration:

- Probe: ES3DV3 - SN3177; ConvF(6.18, 6.18, 6.18); Calibrated: 2010/8/24
- Sensor-Surface: 3mm (Mechanical Surface Detection)
- Electronics: DAE3 Sn579; Calibrated: 2010/9/20
- Phantom: SAM Twin Phantom V4.0; Type: QD 000 P40 CA; Serial: TP-1202
- Measurement SW: DASY4, V4.7 Build 80; Postprocessing SW: SEMCAD, V1.8 Build 186

Body Position - Low channel/Area Scan (7x15x1): Measurement grid: dx=8mm, dy=8mm
Maximum value of SAR (measured) = 0.296 mW/g

Body Position - Low channel/Zoom Scan (7x7x7)/Cube 0: Measurement grid: dx=5mm, dy=5mm, dz=5mm
Reference Value = 6.69 V/m; Power Drift = -0.046 dB
Peak SAR (extrapolated) = 0.397 W/kg
SAR(1 g) = 0.254 mW/g; SAR(10 g) = 0.160 mW/g
Maximum value of SAR (measured) = 0.301 mW/g

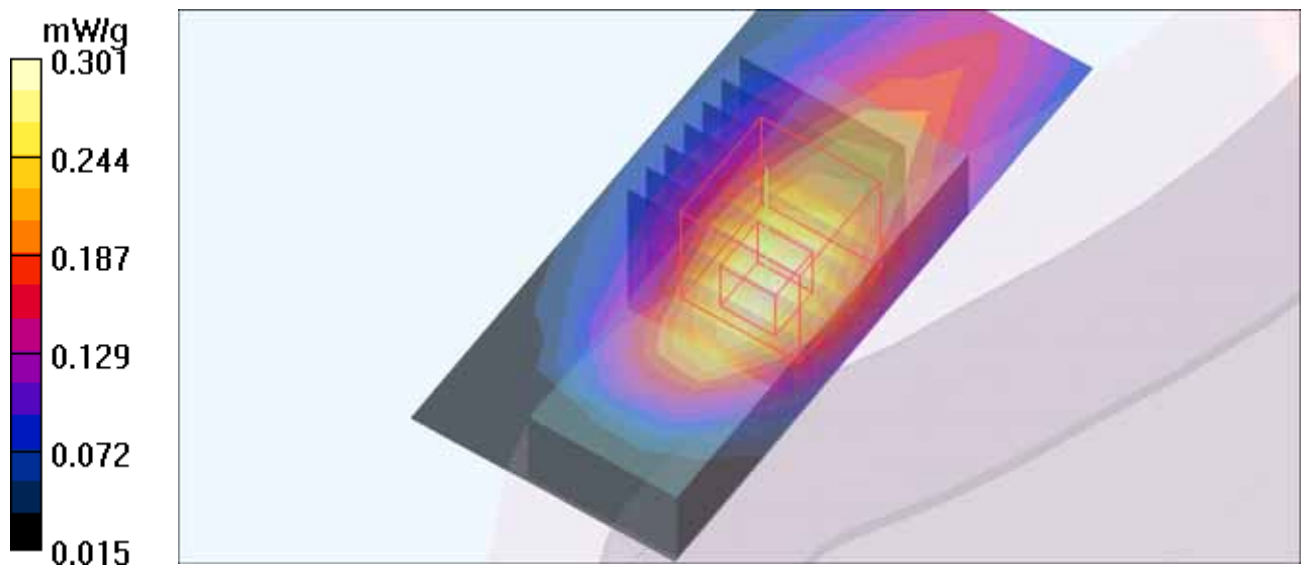

M38-LTE BAND17-Ch23790 (1RB, Upper edge)

Communication System: LTE band17 (700) ; Frequency: 710 MHz ; Duty Cycle: 1:1
Medium: MSL750 Medium parameters used: $f = 710$ MHz; $\sigma = 0.96$ mho/m; $\epsilon_r = 56.11$; $\rho = 1000$ kg/m³
Phantom section: Flat Section ; DUT test position : Body ; Modulation Type: 16QAM
Separation Distance : 5 mm (The horizontal-down side of the EUT to the Phantom)

DASY4 Configuration:

- Probe: ES3DV3 - SN3177; ConvF(6.18, 6.18, 6.18); Calibrated: 2010/8/24
- Sensor-Surface: 3mm (Mechanical Surface Detection)
- Electronics: DAE3 Sn579; Calibrated: 2010/9/20
- Phantom: SAM Twin Phantom V4.0; Type: QD 000 P40 CA; Serial: TP-1202
- Measurement SW: DASY4, V4.7 Build 80; Postprocessing SW: SEMCAD, V1.8 Build 186

Body Position - Low channel/Area Scan (7x15x1): Measurement grid: dx=8mm, dy=8mm
Maximum value of SAR (measured) = 0.260 mW/g

Body Position - Low channel/Zoom Scan (7x7x7)/Cube 0: Measurement grid: dx=5mm, dy=5mm, dz=5mm
Reference Value = 6.37 V/m; Power Drift = -0.027 dB
Peak SAR (extrapolated) = 0.336 W/kg
SAR(1 g) = 0.221 mW/g; SAR(10 g) = 0.140 mW/g
Maximum value of SAR (measured) = 0.261 mW/g

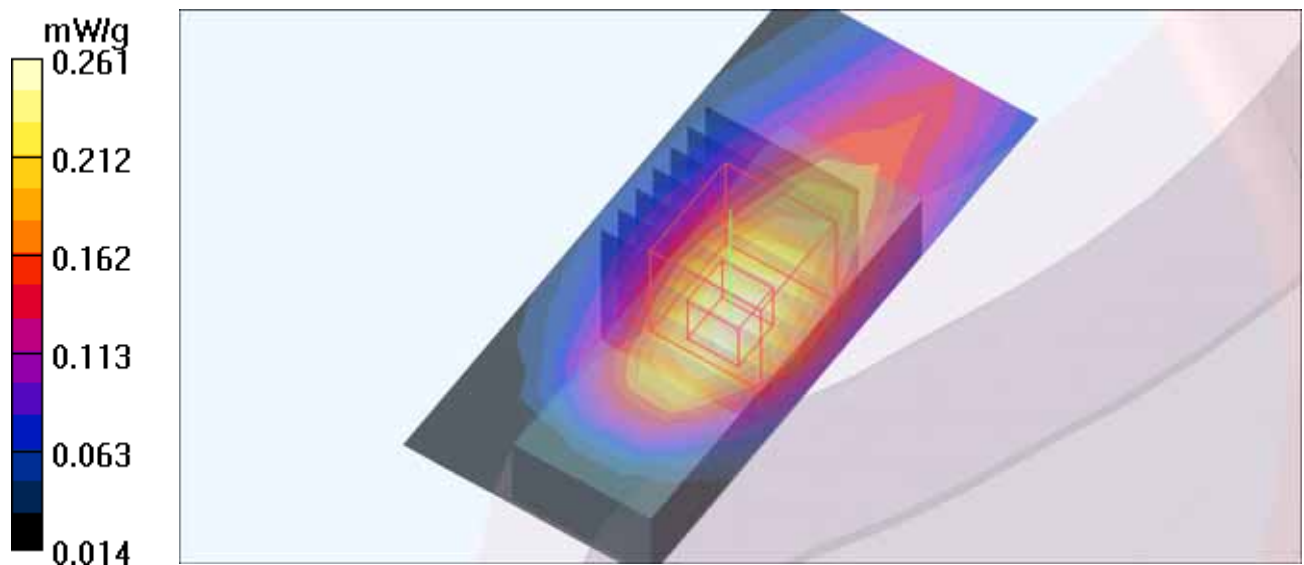

M39-LTE BAND17-Ch23790 (50% RB centered)

Communication System: LTE band17 (700) ; Frequency: 710 MHz ; Duty Cycle: 1:1
Medium: MSL750 Medium parameters used: $f = 710$ MHz; $\sigma = 0.96$ mho/m; $\epsilon_r = 56.11$; $\rho = 1000$ kg/m³
Phantom section: Flat Section ; DUT test position : Body ; Modulation Type: 16QAM
Separation Distance : 5 mm (The vertical-front side of the EUT to the Phantom)

DASY4 Configuration:

- Probe: ES3DV3 - SN3177; ConvF(6.18, 6.18, 6.18); Calibrated: 2010/8/24
- Sensor-Surface: 3mm (Mechanical Surface Detection)
- Electronics: DAE3 Sn579; Calibrated: 2010/9/20
- Phantom: SAM Twin Phantom V4.0; Type: QD 000 P40 CA; Serial: TP-1202
- Measurement SW: DASY4, V4.7 Build 80; Postprocessing SW: SEMCAD, V1.8 Build 186

Body Position - Low/Area Scan (7x15x1): Measurement grid: dx=8mm, dy=8mm
Maximum value of SAR (measured) = 0.163 mW/g

Body Position - Low/Zoom Scan (7x7x7)/Cube 0: Measurement grid: dx=5mm, dy=5mm, dz=5mm
Reference Value = 5.29 V/m; Power Drift = 0.188 dB
Peak SAR (extrapolated) = 0.216 W/kg
SAR(1 g) = 0.135 mW/g; SAR(10 g) = 0.085 mW/g

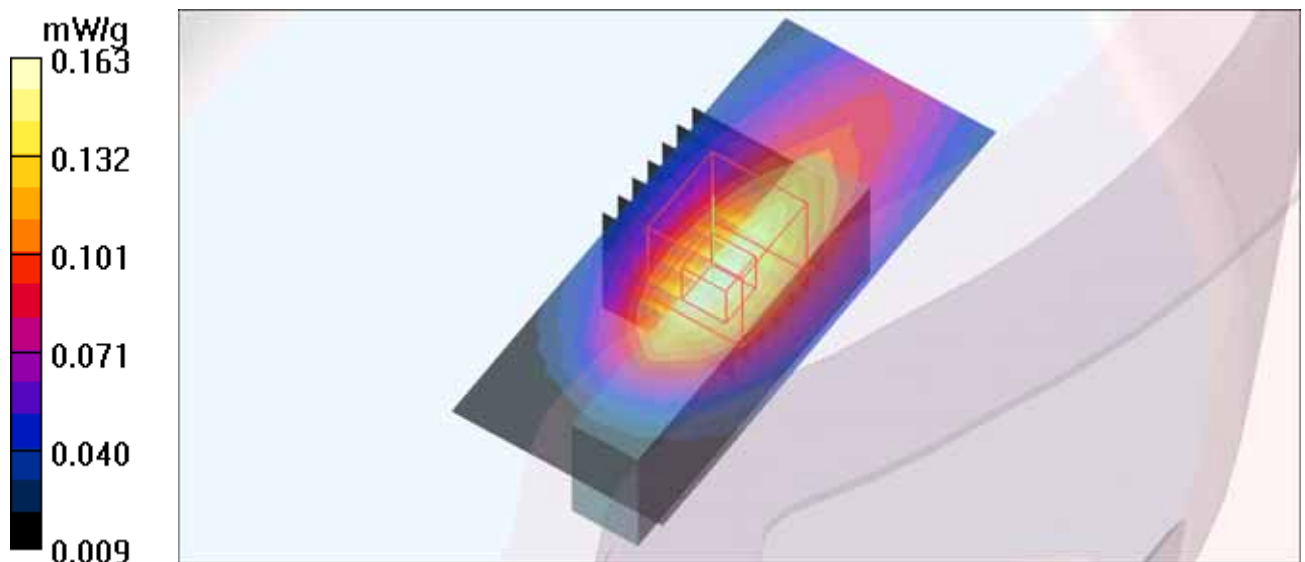

M40-LTE BAND17-Ch23790 (1RB, Lower edge)

Communication System: LTE band17 (700) ; Frequency: 710 MHz ; Duty Cycle: 1:1
Medium: MSL750 Medium parameters used: $f = 710$ MHz; $\sigma = 0.96$ mho/m; $\epsilon_r = 56.11$; $\rho = 1000$ kg/m³
Phantom section: Flat Section ; DUT test position : Body ; Modulation Type: 16QAM
Separation Distance : 5 mm (The vertical-front side of the EUT to the Phantom)

DASY4 Configuration:

- Probe: ES3DV3 - SN3177; ConvF(6.18, 6.18, 6.18); Calibrated: 2010/8/24
- Sensor-Surface: 3mm (Mechanical Surface Detection)
- Electronics: DAE3 Sn579; Calibrated: 2010/9/20
- Phantom: SAM Twin Phantom V4.0; Type: QD 000 P40 CA; Serial: TP-1202
- Measurement SW: DASY4, V4.7 Build 80; Postprocessing SW: SEMCAD, V1.8 Build 186

Body Position - Low channel/Area Scan (7x15x1): Measurement grid: dx=8mm, dy=8mm
Maximum value of SAR (measured) = 0.141 mW/g

Body Position - Low channel/Zoom Scan (7x7x7)/Cube 0: Measurement grid: dx=5mm, dy=5mm, dz=5mm
Reference Value = 5.02 V/m; Power Drift = -0.008 dB
Peak SAR (extrapolated) = 0.187 W/kg
SAR(1 g) = 0.117 mW/g; SAR(10 g) = 0.074 mW/g

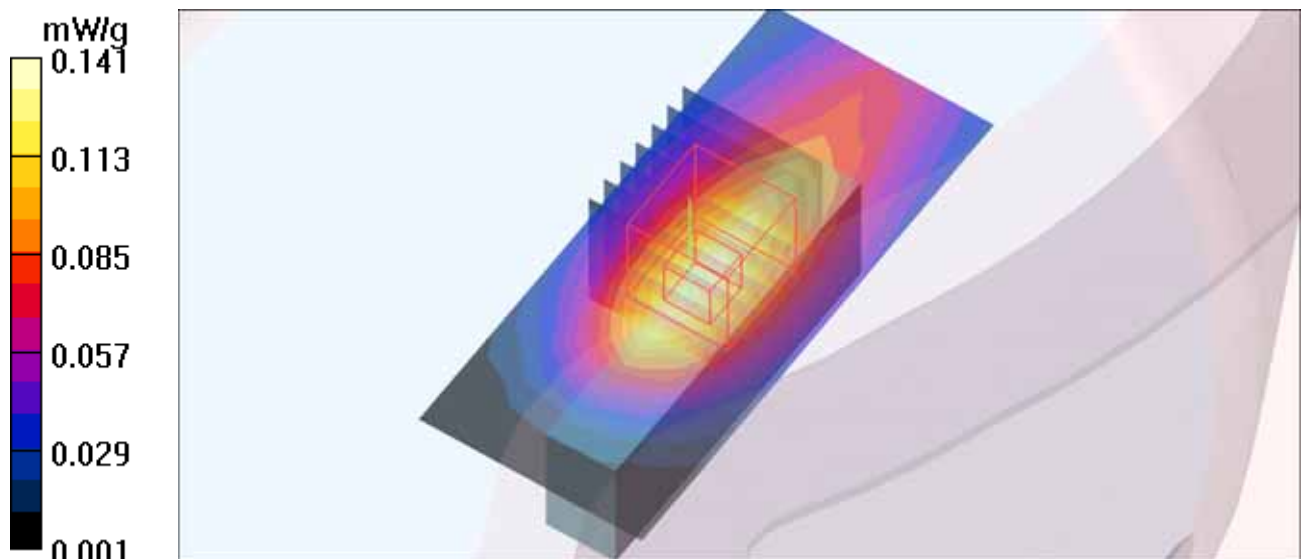

M41-LTE BAND17-Ch23790 (1RB, Upper edge)

Communication System: LTE band17 (700) ; Frequency: 710 MHz ; Duty Cycle: 1:1
Medium: MSL750 Medium parameters used: $f = 710$ MHz; $\sigma = 0.96$ mho/m; $\epsilon_r = 56.11$; $\rho = 1000$ kg/m³
Phantom section: Flat Section ; DUT test position : Body ; Modulation Type: 16QAM
Separation Distance : 5 mm (The vertical-front side of the EUT to the Phantom)

DASY4 Configuration:

- Probe: ES3DV3 - SN3177; ConvF(6.18, 6.18, 6.18); Calibrated: 2010/8/24
- Sensor-Surface: 3mm (Mechanical Surface Detection)
- Electronics: DAE3 Sn579; Calibrated: 2010/9/20
- Phantom: SAM Twin Phantom V4.0; Type: QD 000 P40 CA; Serial: TP-1202
- Measurement SW: DASY4, V4.7 Build 80; Postprocessing SW: SEMCAD, V1.8 Build 186

Body Position - Low channel/Area Scan (7x15x1): Measurement grid: dx=8mm, dy=8mm
Maximum value of SAR (measured) = 0.124 mW/g

Body Position - Low channel/Zoom Scan (7x7x7)/Cube 0: Measurement grid: dx=5mm, dy=5mm, dz=5mm
Reference Value = 4.79 V/m; Power Drift = 0.046 dB
Peak SAR (extrapolated) = 0.166 W/kg
SAR(1 g) = 0.104 mW/g; SAR(10 g) = 0.065 mW/g

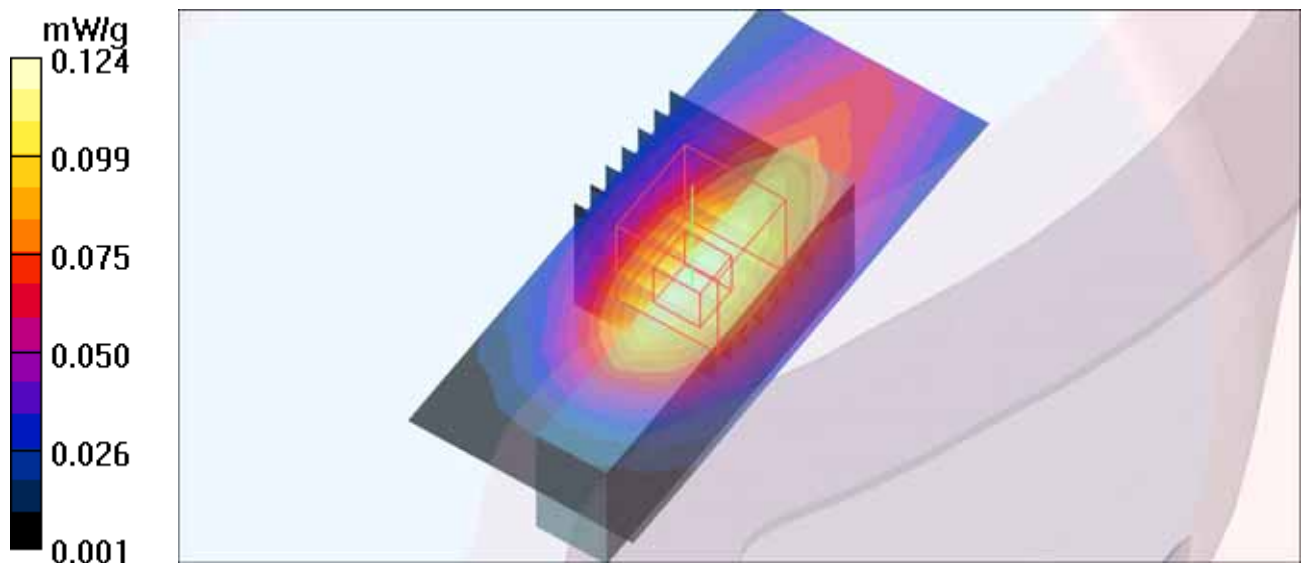

M42-LTE BAND17-Ch23790 (50% RB centered)

Communication System: LTE band17 (700) ; Frequency: 710 MHz ; Duty Cycle: 1:1 ; Modulation type: 16QAM

Medium: MSL750 Medium parameters used: $f = 710$ MHz; $\sigma = 0.96$ mho/m; $\epsilon_r = 56.11$; $\rho = 1000$ kg/m³
Phantom section: Flat Section ; Separation distance : 5 mm (The horizontal-up side of the EUT to the Phantom)

DASY4 Configuration:

- Probe: ES3DV3 - SN3177; ConvF(6.18, 6.18, 6.18); Calibrated: 2010/8/24
- Sensor-Surface: 3mm (Mechanical Surface Detection)
- Electronics: DAE3 Sn579; Calibrated: 2010/9/20
- Phantom: SAM Twin Phantom V4.0; Type: QD 000 P40 CA; Serial: TP-1202
- Measurement SW: DASY4, V4.7 Build 80; Postprocessing SW: SEMCAD, V1.8 Build 186

Body Position - Low/Area Scan (7x15x1): Measurement grid: dx=8mm, dy=8mm

Maximum value of SAR (measured) = 0.249 mW/g

Body Position - Low/Zoom Scan (7x7x7)/Cube 0: Measurement grid: dx=5mm, dy=5mm, dz=5mm

Reference Value = 6.10 V/m; Power Drift = 0.186 dB

Peak SAR (extrapolated) = 0.327 W/kg

SAR(1 g) = 0.213 mW/g; SAR(10 g) = 0.137 mW/g

Maximum value of SAR (measured) = 0.251 mW/g

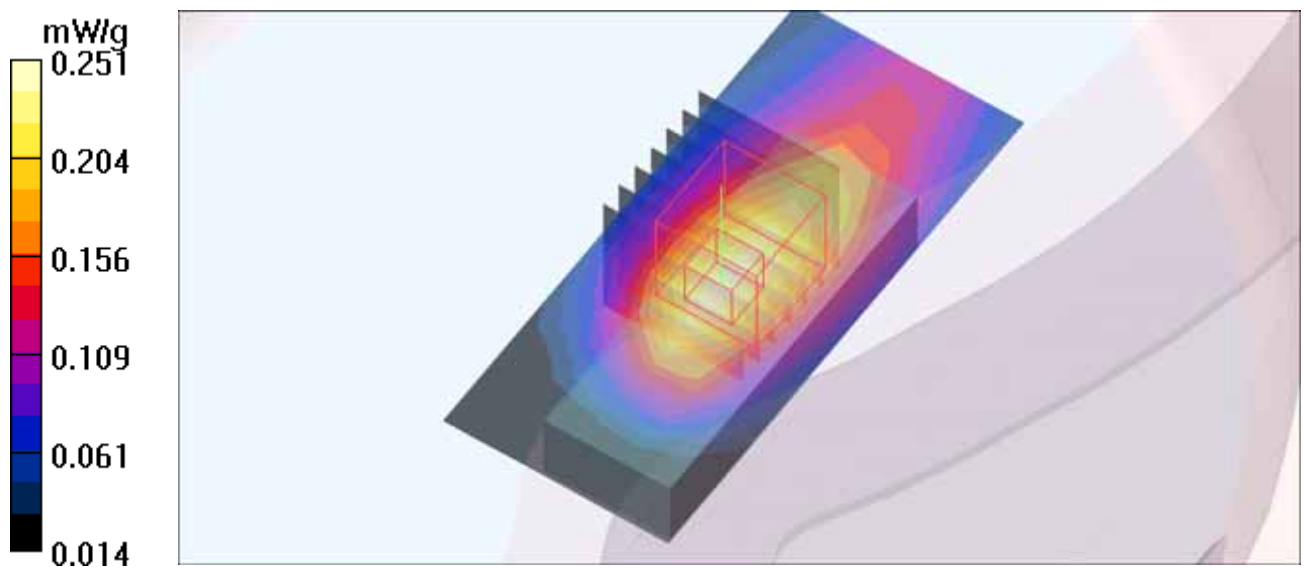

M43- LTE BAND17-Ch23790 (1RB, Lower edge)

Communication System: LTE band17 (700) ; Frequency: 710 MHz ; Duty Cycle: 1:1 ; Modulation type: 16QAM

Medium: MSL750 Medium parameters used: $f = 710$ MHz; $\sigma = 0.96$ mho/m; $\epsilon_r = 56.11$; $\rho = 1000$ kg/m³
Phantom section: Flat Section ; Separation distance : 5 mm (The horizontal-up side of the EUT to the Phantom)

DASY4 Configuration:

- Probe: ES3DV3 - SN3177; ConvF(6.18, 6.18, 6.18); Calibrated: 2010/8/24
- Sensor-Surface: 3mm (Mechanical Surface Detection)
- Electronics: DAE3 Sn579; Calibrated: 2010/9/20
- Phantom: SAM Twin Phantom V4.0; Type: QD 000 P40 CA; Serial: TP-1202
- Measurement SW: DASY4, V4.7 Build 80; Postprocessing SW: SEMCAD, V1.8 Build 186

Body Position - Low channel/Area Scan (7x15x1): Measurement grid: dx=8mm, dy=8mm
Maximum value of SAR (measured) = 0.230 mW/g

Body Position - Low channel/Zoom Scan (7x7x7)/Cube 0: Measurement grid: dx=5mm, dy=5mm, dz=5mm

Reference Value = 5.91 V/m; Power Drift = 0.023 dB

Peak SAR (extrapolated) = 0.296 W/kg

SAR(1 g) = 0.195 mW/g; SAR(10 g) = 0.125 mW/g

Maximum value of SAR (measured) = 0.228 mW/g

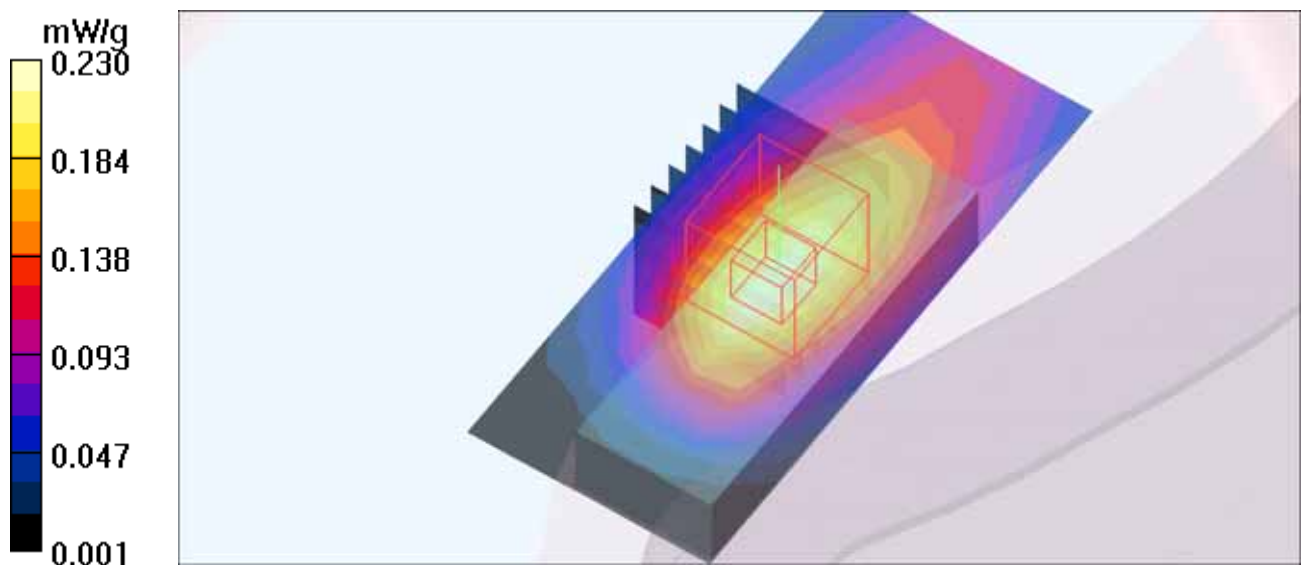

M44- LTE BAND17-Ch23790 (1RB, Upper edge)

Communication System: LTE band17 (700) ; Frequency: 710 MHz ; Duty Cycle: 1:1 ; Modulation type: 16QAM

Medium: MSL750 Medium parameters used: $f = 710$ MHz; $\sigma = 0.96$ mho/m; $\epsilon_r = 56.11$; $\rho = 1000$ kg/m³
Phantom section: Flat Section ; Separation distance : 5 mm (The horizontal-up side of the EUT to the Phantom)

DASY4 Configuration:

- Probe: ES3DV3 - SN3177; ConvF(6.18, 6.18, 6.18); Calibrated: 2010/8/24
- Sensor-Surface: 3mm (Mechanical Surface Detection)
- Electronics: DAE3 Sn579; Calibrated: 2010/9/20
- Phantom: SAM Twin Phantom V4.0; Type: QD 000 P40 CA; Serial: TP-1202
- Measurement SW: DASY4, V4.7 Build 80; Postprocessing SW: SEMCAD, V1.8 Build 186

Body Position - Low channel/Area Scan (7x15x1): Measurement grid: dx=8mm, dy=8mm
Maximum value of SAR (measured) = 0.192 mW/g

Body Position - Low channel/Zoom Scan (7x7x7)/Cube 0: Measurement grid: dx=5mm, dy=5mm, dz=5mm
Reference Value = 5.54 V/m; Power Drift = -0.068 dB
Peak SAR (extrapolated) = 0.248 W/kg
SAR(1 g) = 0.163 mW/g; SAR(10 g) = 0.105 mW/g
Maximum value of SAR (measured) = 0.193 mW/g

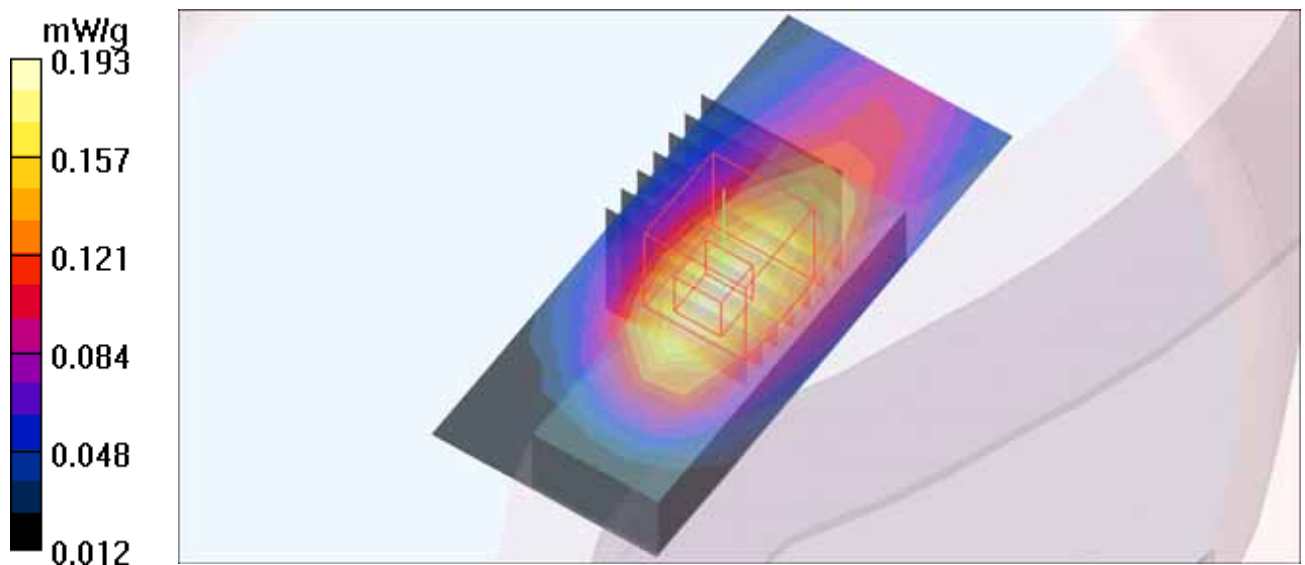

M45- LTE BAND17-Ch23790 (50% RB centered)

Communication System: LTE band17 (700) ; Frequency: 710 MHz ; Duty Cycle: 1:1 ; Modulation type: 16QAM

Medium: MSL750 Medium parameters used: $f = 710$ MHz; $\sigma = 0.96$ mho/m; $\epsilon_r = 56.11$; $\rho = 1000$ kg/m³
Phantom section: Flat Section ; Separation distance : 5 mm (The vertical-back side of the EUT to the Phantom)

DASY4 Configuration:

- Probe: ES3DV3 - SN3177; ConvF(6.18, 6.18, 6.18); Calibrated: 2010/8/24
- Sensor-Surface: 3mm (Mechanical Surface Detection)
- Electronics: DAE3 Sn579; Calibrated: 2010/9/20
- Phantom: SAM Twin Phantom V4.0; Type: QD 000 P40 CA; Serial: TP-1202
- Measurement SW: DASY4, V4.7 Build 80; Postprocessing SW: SEMCAD, V1.8 Build 186

Body Position - Low/Area Scan (7x15x1): Measurement grid: dx=8mm, dy=8mm

Maximum value of SAR (measured) = 0.138 mW/g

Body Position - Low/Zoom Scan (7x7x7)/Cube 0: Measurement grid: dx=5mm, dy=5mm, dz=5mm

Reference Value = 5.06 V/m; Power Drift = 0.198 dB

Peak SAR (extrapolated) = 0.180 W/kg

SAR(1 g) = 0.118 mW/g; SAR(10 g) = 0.077 mW/g

Body Position - Low/Zoom Scan (7x7x7)/Cube 1: Measurement grid: dx=5mm, dy=5mm, dz=5mm

Reference Value = 5.06 V/m; Power Drift = 0.198 dB

Peak SAR (extrapolated) = 0.168 W/kg

SAR(1 g) = 0.102 mW/g; SAR(10 g) = 0.061 mW/g

Maximum value of SAR (measured) = 0.128 mW/g

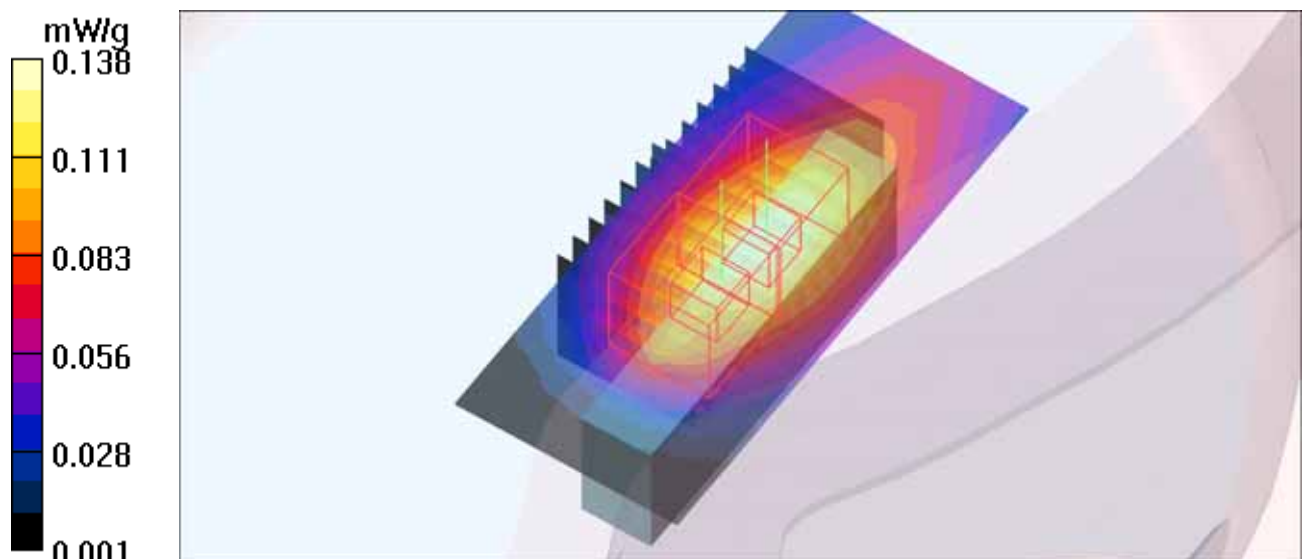

M46- LTE BAND17-Ch23790 (1RB, Lower edge)

Communication System: LTE band17 (700) ; Frequency: 710 MHz ; Duty Cycle: 1:1 ; Modulation type: 16QAM

Medium: MSL750 Medium parameters used: $f = 710$ MHz; $\sigma = 0.96$ mho/m; $\epsilon_r = 56.11$; $\rho = 1000$ kg/m³
Phantom section: Flat Section ; Separation distance : 5 mm (The vertical-back side of the EUT to the Phantom)

DASY4 Configuration:

- Probe: ES3DV3 - SN3177; ConvF(6.18, 6.18, 6.18); Calibrated: 2010/8/24
- Sensor-Surface: 3mm (Mechanical Surface Detection)
- Electronics: DAE3 Sn579; Calibrated: 2010/9/20
- Phantom: SAM Twin Phantom V4.0; Type: QD 000 P40 CA; Serial: TP-1202
- Measurement SW: DASY4, V4.7 Build 80; Postprocessing SW: SEMCAD, V1.8 Build 186

Body Position - Low channel/Area Scan (7x15x1): Measurement grid: dx=8mm, dy=8mm

Maximum value of SAR (measured) = 0.118 mW/g

Body Position - Low channel/Zoom Scan (7x7x7)/Cube 0: Measurement grid: dx=5mm, dy=5mm, dz=5mm

Reference Value = 4.91 V/m; Power Drift = 0.136 dB

Peak SAR (extrapolated) = 0.156 W/kg

SAR(1 g) = 0.102 mW/g; SAR(10 g) = 0.067 mW/g

Maximum value of SAR (measured) = 0.120 mW/g

Body Position - Low channel/Zoom Scan (7x7x7)/Cube 1: Measurement grid: dx=5mm, dy=5mm, dz=5mm

Reference Value = 4.91 V/m; Power Drift = 0.136 dB

Peak SAR (extrapolated) = 0.144 W/kg

SAR(1 g) = 0.088 mW/g; SAR(10 g) = 0.052 mW/g

Maximum value of SAR (measured) = 0.111 mW/g

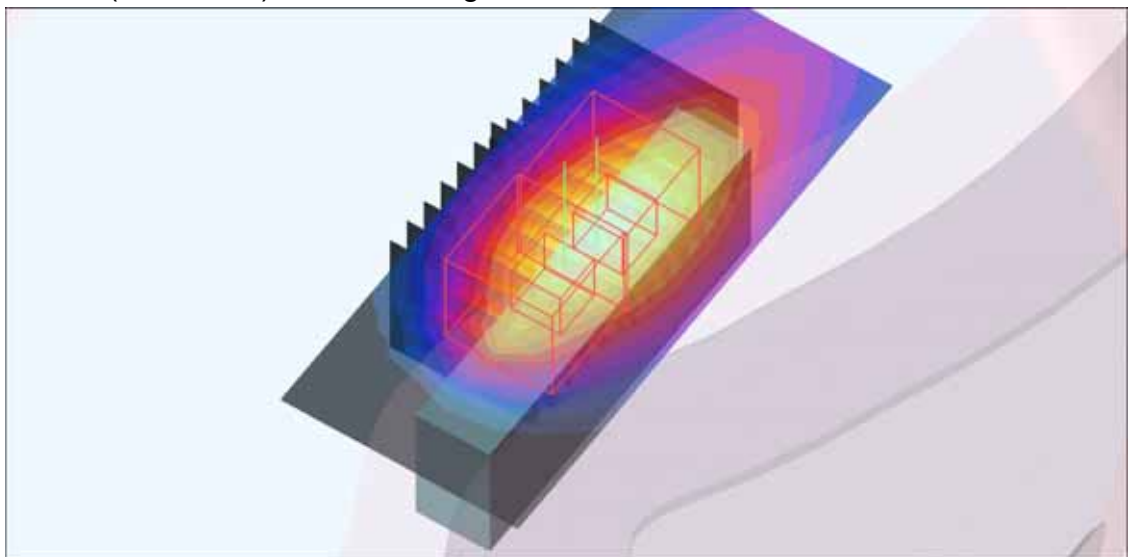
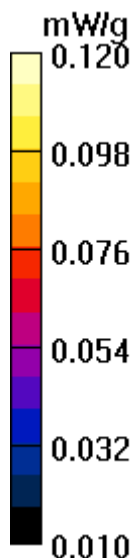

M47- LTE BAND17-Ch23790 (1RB, Upper edge)

Communication System: LTE band17 (700) ; Frequency: 710 MHz ; Duty Cycle: 1:1 ; Modulation type: 16QAM

Medium: MSL750 Medium parameters used: $f = 710$ MHz; $\sigma = 0.96$ mho/m; $\epsilon_r = 56.11$; $\rho = 1000$ kg/m³
Phantom section: Flat Section ; Separation distance : 5 mm (The vertical-back side of the EUT to the Phantom)

DASY4 Configuration:

- Probe: ES3DV3 - SN3177; ConvF(6.18, 6.18, 6.18); Calibrated: 2010/8/24
- Sensor-Surface: 3mm (Mechanical Surface Detection)
- Electronics: DAE3 Sn579; Calibrated: 2010/9/20
- Phantom: SAM Twin Phantom V4.0; Type: QD 000 P40 CA; Serial: TP-1202
- Measurement SW: DASY4, V4.7 Build 80; Postprocessing SW: SEMCAD, V1.8 Build 186

Body Position - Low channel/Area Scan (7x15x1): Measurement grid: dx=8mm, dy=8mm

Maximum value of SAR (measured) = 0.111 mW/g

Body Position - Low channel/Zoom Scan (7x7x7)/Cube 0: Measurement grid: dx=5mm, dy=5mm, dz=5mm

Reference Value = 4.76 V/m; Power Drift = -0.136 dB

Peak SAR (extrapolated) = 0.148 W/kg

SAR(1 g) = 0.096 mW/g; SAR(10 g) = 0.063 mW/g

Maximum value of SAR (measured) = 0.113 mW/g

Body Position - Low channel/Zoom Scan (7x7x7)/Cube 1: Measurement grid: dx=5mm, dy=5mm, dz=5mm

Reference Value = 4.76 V/m; Power Drift = -0.136 dB

Peak SAR (extrapolated) = 0.143 W/kg

SAR(1 g) = 0.085 mW/g; SAR(10 g) = 0.051 mW/g

Maximum value of SAR (measured) = 0.110 mW/g

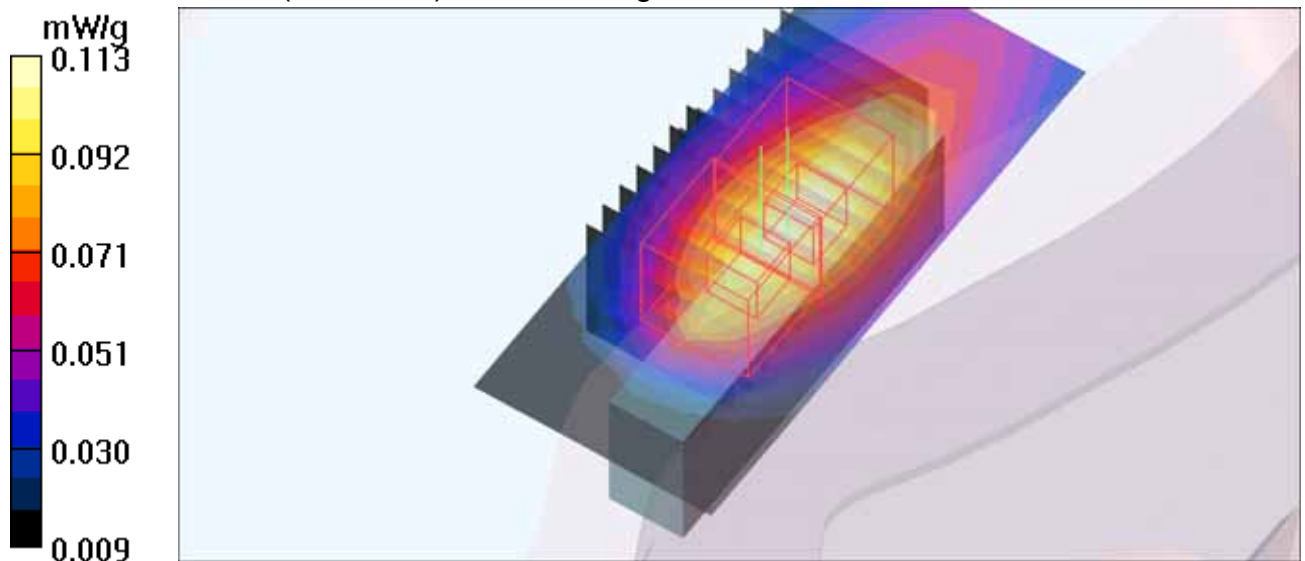

M48-LTE BAND17-Ch23790 (50% RB centered)

Communication System: LTE band17 (700) ; Frequency: 710 MHz ; Duty Cycle: 1:1 ; Modulation type: 16QAM

Medium: MSL750 Medium parameters used: $f = 710$ MHz; $\sigma = 0.96$ mho/m; $\epsilon_r = 56.11$; $\rho = 1000$ kg/m³
Phantom section: Flat Section ; Separation distance : 5 mm (The top side of the EUT to the Phantom)

DASY4 Configuration:

- Probe: ES3DV3 - SN3177; ConvF(6.18, 6.18, 6.18); Calibrated: 2010/8/24
- Sensor-Surface: 3mm (Mechanical Surface Detection)
- Electronics: DAE3 Sn579; Calibrated: 2010/9/20
- Phantom: SAM Twin Phantom V4.0; Type: QD 000 P40 CA; Serial: TP-1202
- Measurement SW: DASY4, V4.7 Build 80; Postprocessing SW: SEMCAD, V1.8 Build 186

Body Position - Low/Area Scan (7x7x1): Measurement grid: dx=8mm, dy=8mm
Maximum value of SAR (measured) = 0.024 mW/g

Body Position - Low/Zoom Scan (7x7x7)/Cube 0: Measurement grid: dx=5mm, dy=5mm, dz=5mm

Reference Value = 5.78 V/m; Power Drift = -0.104 dB

Peak SAR (extrapolated) = 0.042 W/kg

SAR(1 g) = 0.018 mW/g; SAR(10 g) = 0.00998 mW/g

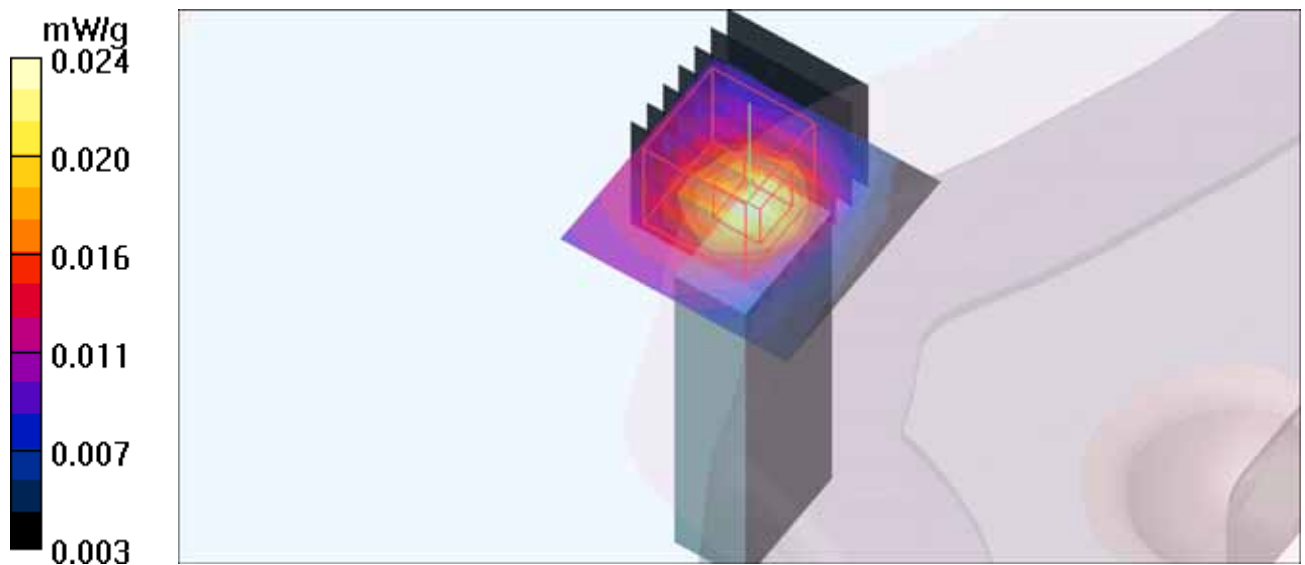

M49-LTE BAND17-Ch23790 (1RB, Lower edge)

Communication System: LTE band17 (700) ; Frequency: 710 MHz ; Duty Cycle: 1:1 ; Modulation type: 16QAM

Medium: MSL750 Medium parameters used: $f = 710$ MHz; $\sigma = 0.96$ mho/m; $\epsilon_r = 56.11$; $\rho = 1000$ kg/m³
Phantom section: Flat Section ; Separation distance : 5 mm (The top side of the EUT to the Phantom)

DASY4 Configuration:

- Probe: ES3DV3 - SN3177; ConvF(6.18, 6.18, 6.18); Calibrated: 2010/8/24
- Sensor-Surface: 3mm (Mechanical Surface Detection)
- Electronics: DAE3 Sn579; Calibrated: 2010/9/20
- Phantom: SAM Twin Phantom V4.0; Type: QD 000 P40 CA; Serial: TP-1202
- Measurement SW: DASY4, V4.7 Build 80; Postprocessing SW: SEMCAD, V1.8 Build 186

Body Position - Low channel/Area Scan (7x7x1): Measurement grid: dx=8mm, dy=8mm
Maximum value of SAR (measured) = 0.015 mW/g

Body Position - Low channel/Zoom Scan (7x7x7)/Cube 0: Measurement grid: dx=5mm, dy=5mm, dz=5mm

Reference Value = 4.13 V/m; Power Drift = -0.181 dB

Peak SAR (extrapolated) = 0.027 W/kg

SAR(1 g) = 0.011 mW/g; SAR(10 g) = 0.00609 mW/g

Maximum value of SAR (measured) = 0.014 mW/g

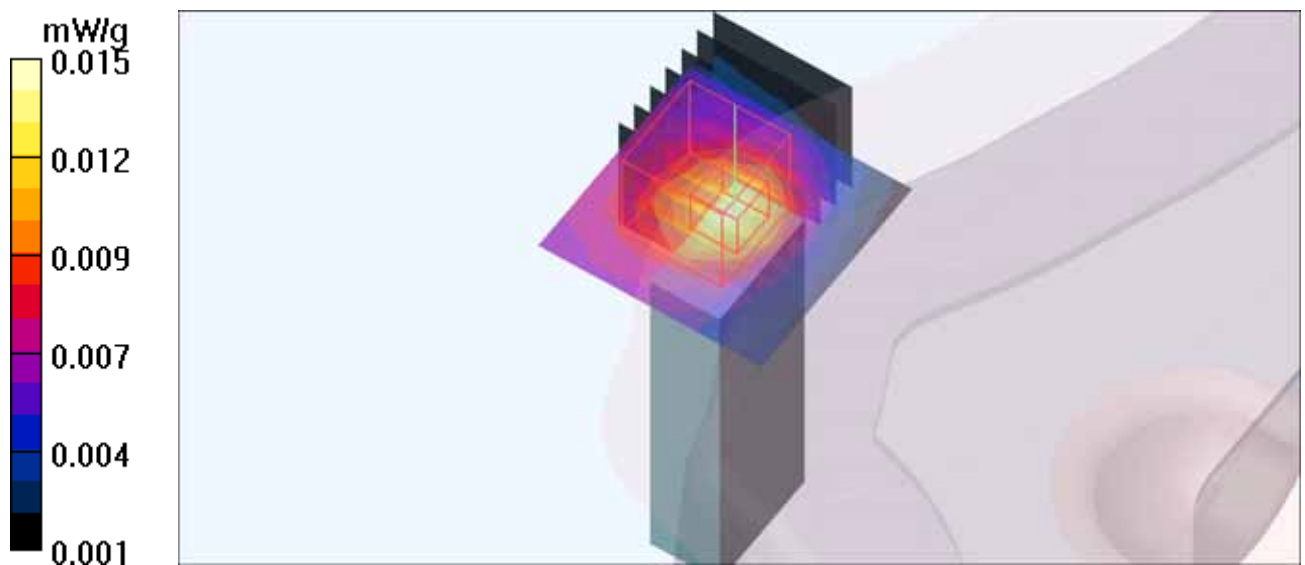

M50-LTE BAND17-Ch23790 (1RB, Upper edge)

Communication System: LTE band17 (700) ; Frequency: 710 MHz ; Duty Cycle: 1:1 ; Modulation type: 16QAM

Medium: MSL750 Medium parameters used: $f = 710$ MHz; $\sigma = 0.96$ mho/m; $\epsilon_r = 56.11$; $\rho = 1000$ kg/m³

Phantom section: Flat Section ; Separation distance : 5 mm (The top side of the EUT to the Phantom)

DASY4 Configuration:

- Probe: ES3DV3 - SN3177; ConvF(6.18, 6.18, 6.18); Calibrated: 2010/8/24
- Sensor-Surface: 3mm (Mechanical Surface Detection)
- Electronics: DAE3 Sn579; Calibrated: 2010/9/20
- Phantom: SAM Twin Phantom V4.0; Type: QD 000 P40 CA; Serial: TP-1202
- Measurement SW: DASY4, V4.7 Build 80; Postprocessing SW: SEMCAD, V1.8 Build 186

Body Position - Low channel/Area Scan (7x7x1): Measurement grid: dx=8mm, dy=8mm
Maximum value of SAR (measured) = 0.017 mW/g

Body Position - Low channel/Zoom Scan (7x7x7)/Cube 0: Measurement grid: dx=5mm, dy=5mm, dz=5mm

Reference Value = 4.28 V/m; Power Drift = 0.119 dB

Peak SAR (extrapolated) = 0.031 W/kg

SAR(1 g) = 0.013 mW/g; SAR(10 g) = 0.0071 mW/g

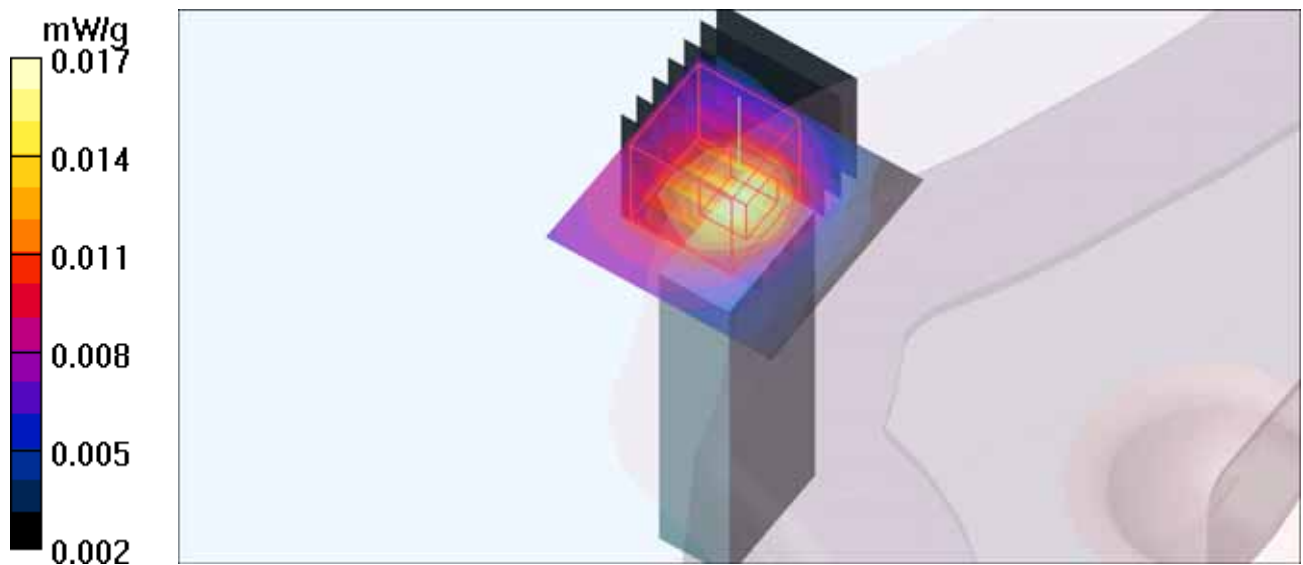

M51-LTE BAND4-Ch20175 (50% RB centered)

Communication System: LTE band4 (1700) ; Frequency: 1732.5 MHz ; Duty Cycle: 1:1

Medium: MSL 1700 Medium parameters used: $f = 1732.5$ MHz; $\sigma = 1.5$ mho/m; $\epsilon_r = 53.65$; $\rho = 1000$ kg/m³

Phantom section: Flat Section ; DUT test position : Body ; Modulation Type: 16QAM

Separation Distance : 5 mm (The horizontal-down side of the EUT to the Phantom)

DASY4 Configuration:

- Probe: EX3DV4 - SN3753; ConvF(7.48, 7.48, 7.48); Calibrated: 2010/12/13
- Sensor-Surface: 2mm (Mechanical Surface Detection)
- Electronics: DAE3 Sn579; Calibrated: 2010/9/20
- Phantom: SAM Twin Phantom V4.0; Type: QD 000 P40 CA; Serial: TP-1202
- Measurement SW: DASY4, V4.7 Build 80; Postprocessing SW: SEMCAD, V1.8 Build 186

Body Position - Low/Area Scan (7x15x1): Measurement grid: dx=8mm, dy=8mm

Maximum value of SAR (measured) = 0.450 mW/g

Body Position - Low/Zoom Scan (7x7x7)/Cube 0: Measurement grid: dx=5mm, dy=5mm, dz=5mm

Reference Value = 11.2 V/m; Power Drift = 0.086 dB

Peak SAR (extrapolated) = 0.598 W/kg

SAR(1 g) = 0.306 mW/g; SAR(10 g) = 0.146 mW/g

Maximum value of SAR (measured) = 0.463 mW/g

Body Position - Low/Zoom Scan (7x7x7)/Cube 1: Measurement grid: dx=5mm, dy=5mm, dz=5mm

Reference Value = 11.2 V/m; Power Drift = 0.086 dB

Peak SAR (extrapolated) = 0.526 W/kg

SAR(1 g) = 0.299 mW/g; SAR(10 g) = 0.163 mW/g

Maximum value of SAR (measured) = 0.414 mW/g

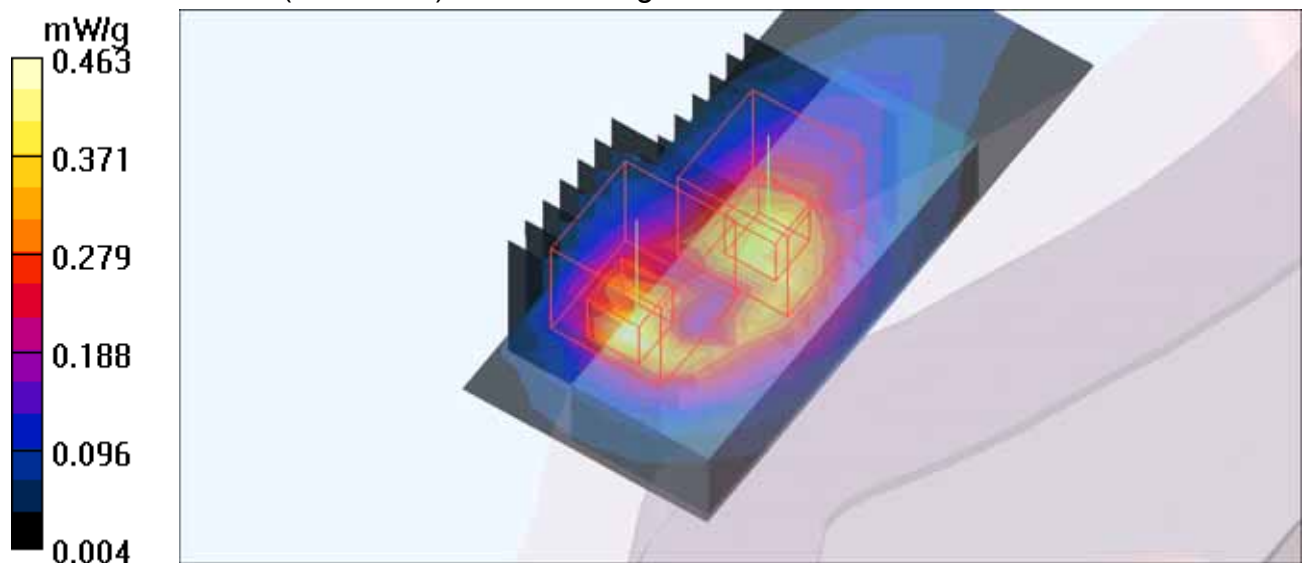

M52-LTE BAND4-Ch20175 (1RB, Lower edge)

Communication System: LTE band4 (1700) ; Frequency: 1732.5 MHz ; Duty Cycle: 1:1

Medium: MSL 1700 Medium parameters used: $f = 1732.5$ MHz; $\sigma = 1.5$ mho/m; $\epsilon_r = 53.65$; $\rho = 1000$ kg/m³

Phantom section: Flat Section ; DUT test position : Body ; Modulation Type: 16QAM

Separation Distance : 5 mm (The horizontal-down side of the EUT to the Phantom)

DASY4 Configuration:

- Probe: EX3DV4 - SN3753; ConvF(7.48, 7.48, 7.48); Calibrated: 2010/12/13
- Sensor-Surface: 2mm (Mechanical Surface Detection)
- Electronics: DAE3 Sn579; Calibrated: 2010/9/20
- Phantom: SAM Twin Phantom V4.0; Type: QD 000 P40 CA; Serial: TP-1202
- Measurement SW: DASY4, V4.7 Build 80; Postprocessing SW: SEMCAD, V1.8 Build 186

Body Position - Low channel/Area Scan (7x15x1): Measurement grid: dx=8mm, dy=8mm
Maximum value of SAR (measured) = 0.538 mW/g

Body Position - Low channel/Zoom Scan (7x7x7)/Cube 0: Measurement grid: dx=5mm, dy=5mm, dz=5mm

Reference Value = 10.7 V/m; Power Drift = 0.12 dB

Peak SAR (extrapolated) = 0.689 W/kg

SAR(1 g) = 0.332 mW/g; SAR(10 g) = 0.161 mW/g

Maximum value of SAR (measured) = 0.506 mW/g

Body Position - Low channel/Zoom Scan (7x7x7)/Cube 1: Measurement grid: dx=5mm, dy=5mm, dz=5mm

Reference Value = 10.7 V/m; Power Drift = 0.12 dB

Peak SAR (extrapolated) = 0.682 W/kg

SAR(1 g) = 0.342 mW/g; SAR(10 g) = 0.188 mW/g

Maximum value of SAR (measured) = 0.499 mW/g

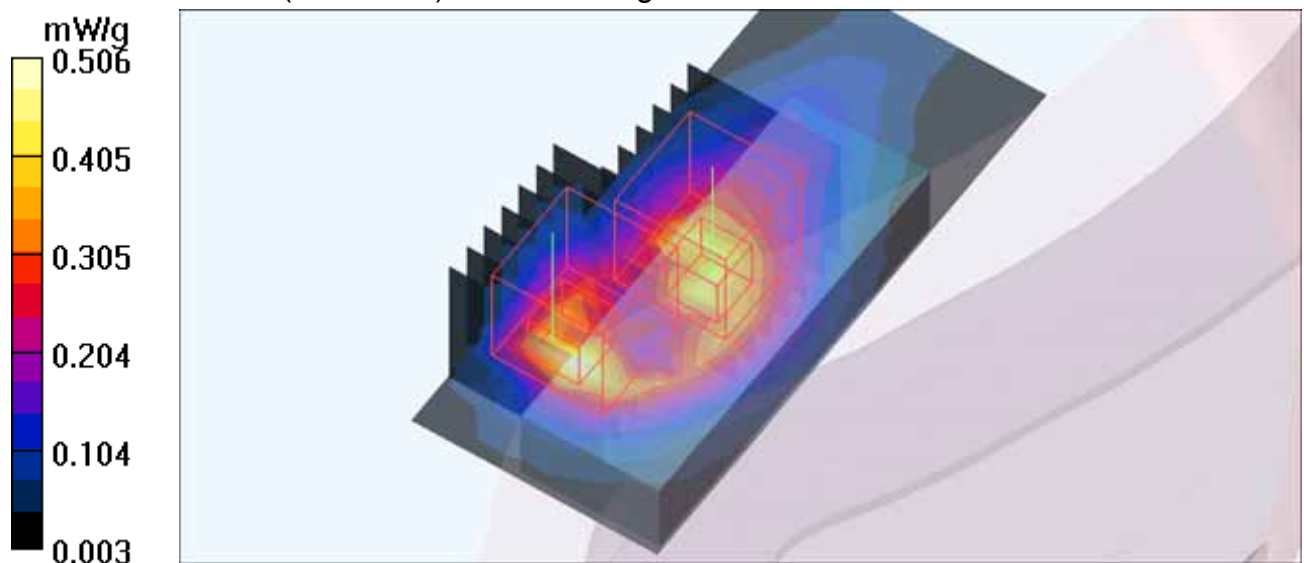

M53-LTE BAND4-Ch20175 (1RB, Upper edge)

Communication System: LTE band4 (1700) ; Frequency: 1732.5 MHz ; Duty Cycle: 1:1

Medium: MSL 1700 Medium parameters used: $f = 1732.5$ MHz; $\sigma = 1.5$ mho/m; $\epsilon_r = 53.65$; $\rho = 1000$ kg/m³

Phantom section: Flat Section ; DUT test position : Body ; Modulation Type: 16QAM
Separation Distance : 5 mm (The horizontal-down side of the EUT to the Phantom)

DASY4 Configuration:

- Probe: EX3DV4 - SN3753; ConvF(7.48, 7.48, 7.48); Calibrated: 2010/12/13
- Sensor-Surface: 2mm (Mechanical Surface Detection)
- Electronics: DAE3 Sn579; Calibrated: 2010/9/20
- Phantom: SAM Twin Phantom V4.0; Type: QD 000 P40 CA; Serial: TP-1202
- Measurement SW: DASY4, V4.7 Build 80; Postprocessing SW: SEMCAD, V1.8 Build 186

Body Position - Low channel/Area Scan (7x15x1): Measurement grid: dx=8mm, dy=8mm
Maximum value of SAR (measured) = 0.543 mW/g

Body Position - Low channel/Zoom Scan (7x7x7)/Cube 0: Measurement grid: dx=5mm, dy=5mm, dz=5mm

Reference Value = 12.4 V/m; Power Drift = 0.032 dB

Peak SAR (extrapolated) = 0.724 W/kg

SAR(1 g) = 0.369 mW/g; SAR(10 g) = 0.175 mW/g

Maximum value of SAR (measured) = 0.567 mW/g

Body Position - Low channel/Zoom Scan (7x7x7)/Cube 1: Measurement grid: dx=5mm, dy=5mm, dz=5mm

Reference Value = 12.4 V/m; Power Drift = 0.032 dB

Peak SAR (extrapolated) = 0.656 W/kg

SAR(1 g) = 0.362 mW/g; SAR(10 g) = 0.197 mW/g

Maximum value of SAR (measured) = 0.510 mW/g

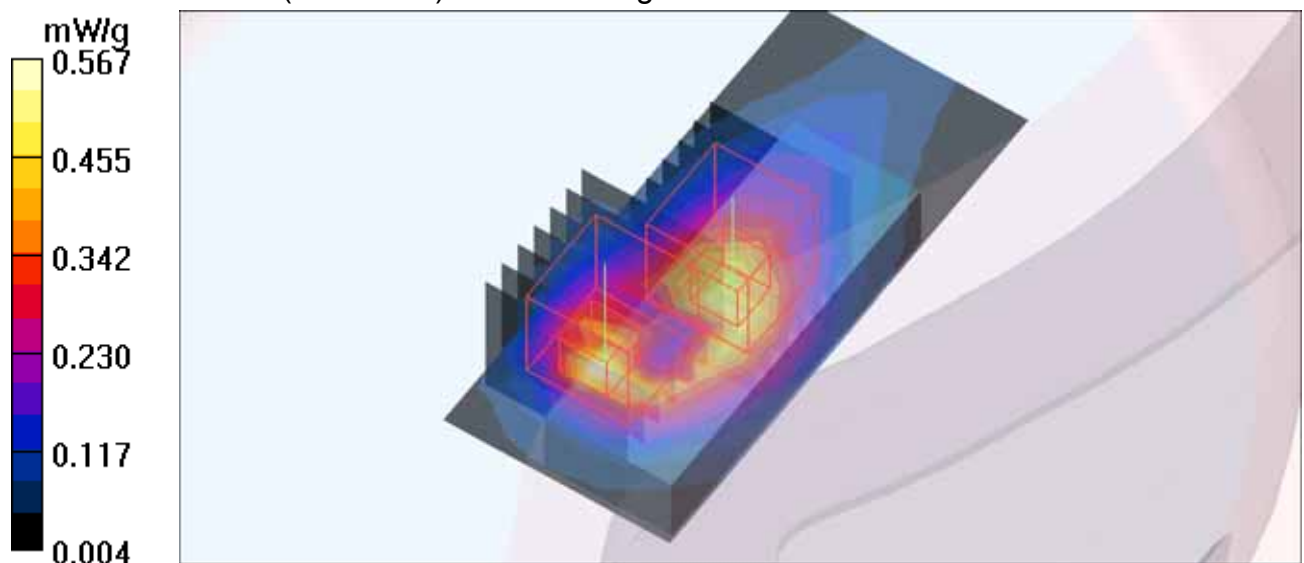

M54-LTE BAND4-Ch20175 (50% RB centered)

Communication System: LTE band4 (1700) ; Frequency: 1732.5 MHz ; Duty Cycle: 1:1

Medium: MSL 1700 Medium parameters used: $f = 1732.5$ MHz; $\sigma = 1.5$ mho/m; $\epsilon_r = 53.65$; $\rho = 1000$ kg/m³

Phantom section: Flat Section ; DUT test position : Body ; Modulation Type: 16QAM

Separation Distance : 5 mm (The vertical-front side of the EUT to the Phantom)

DASY4 Configuration:

- Probe: EX3DV4 - SN3753; ConvF(7.48, 7.48, 7.48); Calibrated: 2010/12/13
- Sensor-Surface: 2mm (Mechanical Surface Detection)
- Electronics: DAE3 Sn579; Calibrated: 2010/9/20
- Phantom: SAM Twin Phantom V4.0; Type: QD 000 P40 CA; Serial: TP-1202
- Measurement SW: DASY4, V4.7 Build 80; Postprocessing SW: SEMCAD, V1.8 Build 186

Body Position - Low/Area Scan (7x15x1): Measurement grid: dx=8mm, dy=8mm

Maximum value of SAR (measured) = 0.524 mW/g

Body Position - Low/Zoom Scan (7x7x7)/Cube 0: Measurement grid: dx=5mm, dy=5mm, dz=5mm

Reference Value = 5.60 V/m; Power Drift = 0.108 dB

Peak SAR (extrapolated) = 0.723 W/kg

SAR(1 g) = 0.397 mW/g; SAR(10 g) = 0.209 mW/g

Maximum value of SAR (measured) = 0.570 mW/g

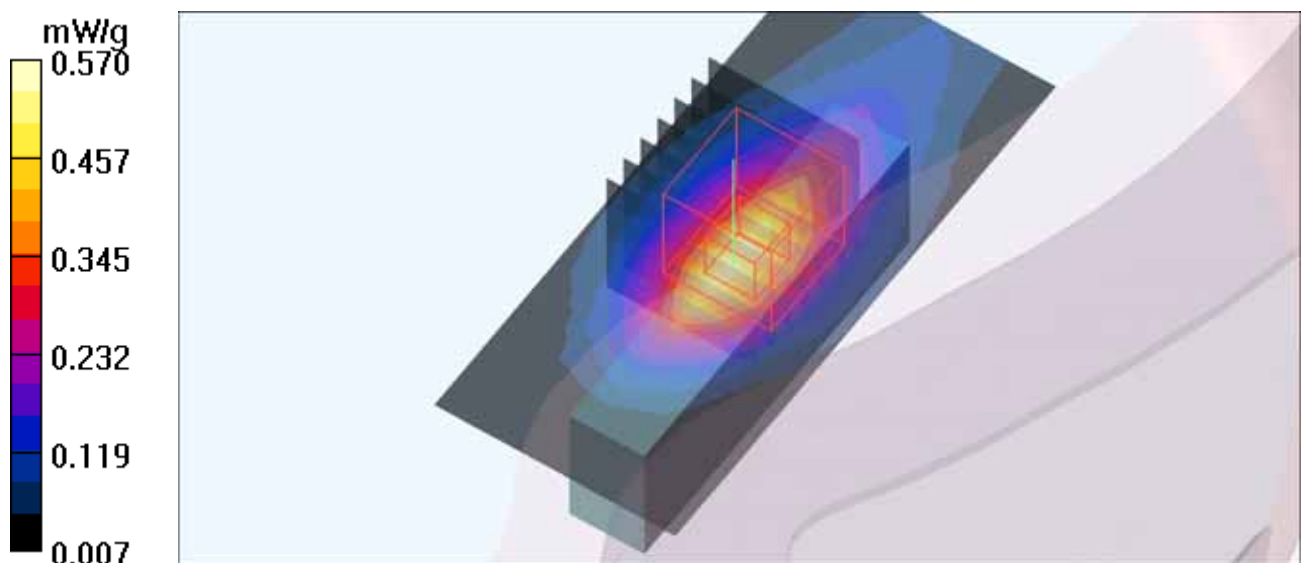

M55-LTE BAND4-Ch20175 (1RB, Lower edge)

Communication System: LTE band4 (1700) ; Frequency: 1732.5 MHz ; Duty Cycle: 1:1

Medium: MSL 1700 Medium parameters used: $f = 1732.5$ MHz; $\sigma = 1.5$ mho/m; $\epsilon_r = 53.65$; $\rho = 1000$ kg/m³

Phantom section: Flat Section ; DUT test position : Body ; Modulation Type: 16QAM

Separation Distance : 5 mm (The vertical-front side of the EUT to the Phantom)

DASY4 Configuration:

- Probe: EX3DV4 - SN3753; ConvF(7.48, 7.48, 7.48); Calibrated: 2010/12/13
- Sensor-Surface: 2mm (Mechanical Surface Detection)
- Electronics: DAE3 Sn579; Calibrated: 2010/9/20
- Phantom: SAM Twin Phantom V4.0; Type: QD 000 P40 CA; Serial: TP-1202
- Measurement SW: DASY4, V4.7 Build 80; Postprocessing SW: SEMCAD, V1.8 Build 186

Body Position - Low channel/Area Scan (7x15x1): Measurement grid: dx=8mm, dy=8mm
Maximum value of SAR (measured) = 0.736 mW/g

Body Position - Low channel/Zoom Scan (7x7x7)/Cube 0: Measurement grid: dx=5mm, dy=5mm, dz=5mm

Reference Value = 5.57 V/m; Power Drift = 0.173 dB

Peak SAR (extrapolated) = 0.923 W/kg

SAR(1 g) = 0.469 mW/g; SAR(10 g) = 0.231 mW/g

Maximum value of SAR (measured) = 0.713 mW/g

Body Position - Low channel/Zoom Scan (7x7x7)/Cube 1: Measurement grid: dx=5mm, dy=5mm, dz=5mm

Reference Value = 5.57 V/m; Power Drift = 0.173 dB

Peak SAR (extrapolated) = 0.876 W/kg

SAR(1 g) = 0.427 mW/g; SAR(10 g) = 0.217 mW/g

Maximum value of SAR (measured) = 0.661 mW/g

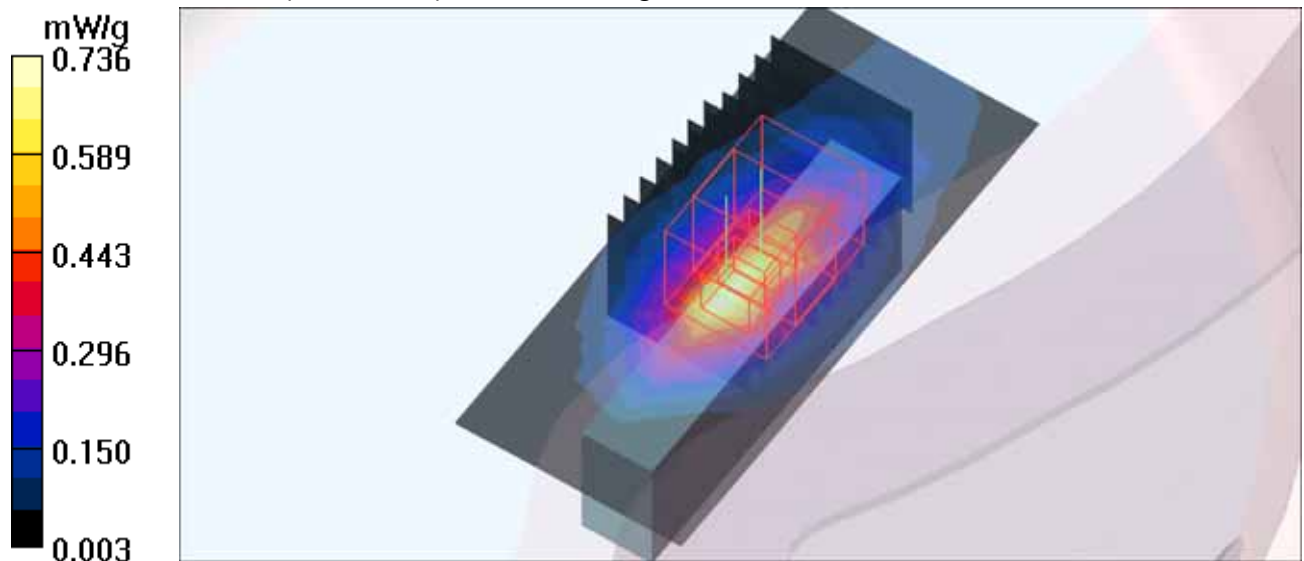

M56-LTE BAND4-Ch20175 (1RB, Upper edge)

Communication System: LTE band4 (1700) ; Frequency: 1732.5 MHz ; Duty Cycle: 1:1

Medium: MSL 1700 Medium parameters used: $f = 1732.5$ MHz; $\sigma = 1.5$ mho/m; $\epsilon_r = 53.65$; $\rho = 1000$ kg/m³

Phantom section: Flat Section ; DUT test position : Body ; Modulation Type: 16QAM

Separation Distance : 5 mm (The vertical-front side of the EUT to the Phantom)

DASY4 Configuration:

- Probe: EX3DV4 - SN3753; ConvF(7.48, 7.48, 7.48); Calibrated: 2010/12/13
- Sensor-Surface: 2mm (Mechanical Surface Detection)
- Electronics: DAE3 Sn579; Calibrated: 2010/9/20
- Phantom: SAM Twin Phantom V4.0; Type: QD 000 P40 CA; Serial: TP-1202
- Measurement SW: DASY4, V4.7 Build 80; Postprocessing SW: SEMCAD, V1.8 Build 186

Body Position - Low channel/Area Scan (7x15x1): Measurement grid: dx=8mm, dy=8mm
Maximum value of SAR (measured) = 0.733 mW/g

Body Position - Low channel/Zoom Scan (7x7x7)/Cube 0: Measurement grid: dx=5mm, dy=5mm, dz=5mm

Reference Value = 6.45 V/m; Power Drift = 0.156 dB

Peak SAR (extrapolated) = 0.961 W/kg

SAR(1 g) = 0.517 mW/g; SAR(10 g) = 0.271 mW/g

Maximum value of SAR (measured) = 0.753 mW/g

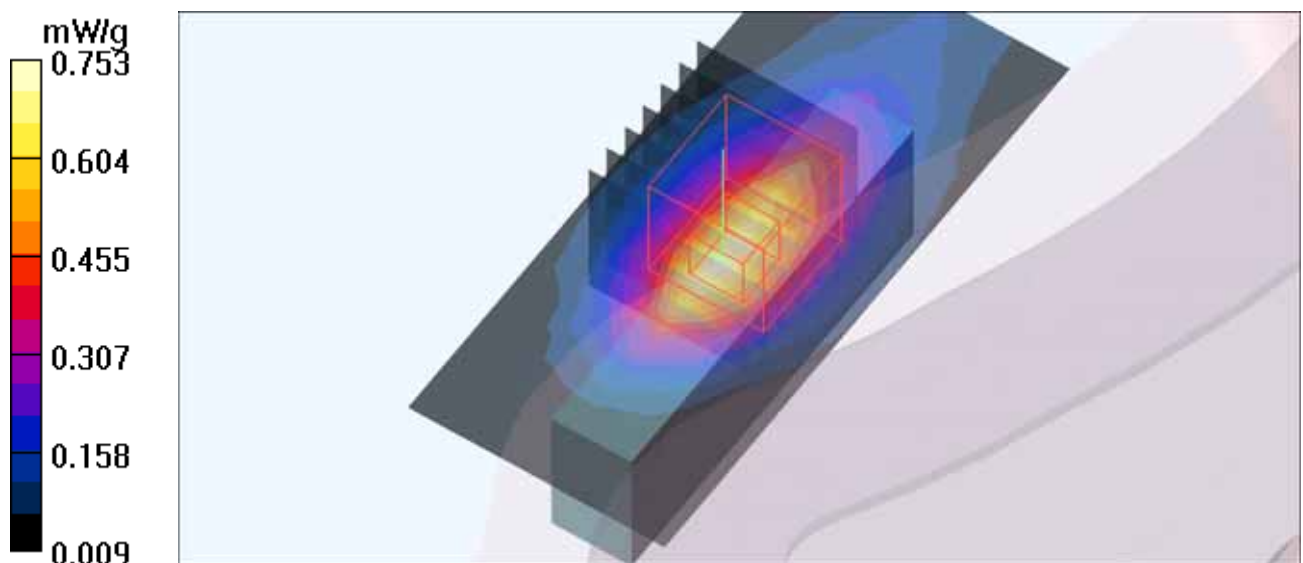

M57-LTE BAND4-Ch20175 (50% RB centered)

Communication System: LTE band4 (1700) ; Frequency: 1732.5 MHz ; Duty Cycle: 1:1

Medium: MSL 1700 Medium parameters used: $f = 1732.5$ MHz; $\sigma = 1.5$ mho/m; $\epsilon_r = 53.65$; $\rho = 1000$ kg/m³

Phantom section: Flat Section ; DUT test position : Body ; Modulation Type: 16QAM

Separation Distance : 5 mm (The horizontal-up side of the EUT to the Phantom)

DASY4 Configuration:

- Probe: EX3DV4 - SN3753; ConvF(7.48, 7.48, 7.48); Calibrated: 2010/12/13
- Sensor-Surface: 2mm (Mechanical Surface Detection)
- Electronics: DAE3 Sn579; Calibrated: 2010/9/20
- Phantom: SAM Twin Phantom V4.0; Type: QD 000 P40 CA; Serial: TP-1202
- Measurement SW: DASY4, V4.7 Build 80; Postprocessing SW: SEMCAD, V1.8 Build 186

Body Position - Low/Area Scan (7x15x1): Measurement grid: dx=8mm, dy=8mm

Maximum value of SAR (measured) = 0.643 mW/g

Body Position - Low/Zoom Scan (7x7x7)/Cube 0: Measurement grid: dx=5mm, dy=5mm, dz=5mm

Reference Value = 4.73 V/m; Power Drift = -0.066 dB

Peak SAR (extrapolated) = 0.805 W/kg

SAR(1 g) = 0.498 mW/g; SAR(10 g) = 0.287 mW/g

Maximum value of SAR (measured) = 0.685 mW/g

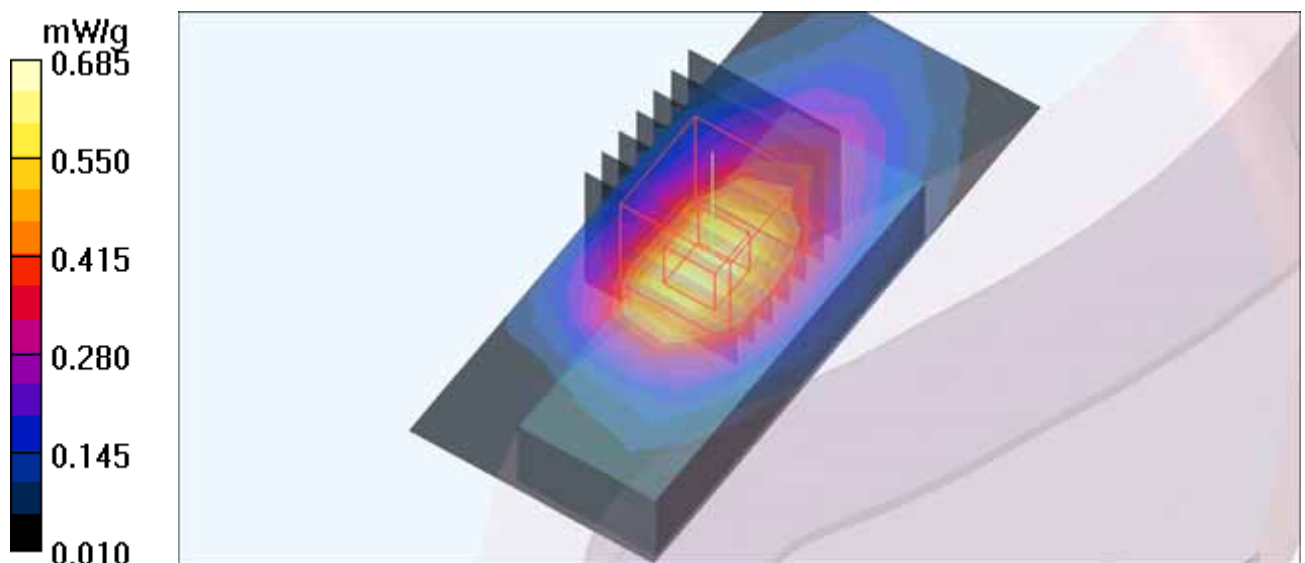

M58-LTE BAND4-Ch20175 (1RB, Lower edge)

Communication System: LTE band4 (1700) ; Frequency: 1732.5 MHz ; Duty Cycle: 1:1

Medium: MSL 1700 Medium parameters used: $f = 1732.5$ MHz; $\sigma = 1.5$ mho/m; $\epsilon_r = 53.65$; $\rho = 1000$ kg/m³

Phantom section: Flat Section ; DUT test position : Body ; Modulation Type: 16QAM

Separation Distance : 5 mm (The horizontal-up side of the EUT to the Phantom)

DASY4 Configuration:

- Probe: EX3DV4 - SN3753; ConvF(7.48, 7.48, 7.48); Calibrated: 2010/12/13
- Sensor-Surface: 2mm (Mechanical Surface Detection)
- Electronics: DAE3 Sn579; Calibrated: 2010/9/20
- Phantom: SAM Twin Phantom V4.0; Type: QD 000 P40 CA; Serial: TP-1202
- Measurement SW: DASY4, V4.7 Build 80; Postprocessing SW: SEMCAD, V1.8 Build 186

Body Position - Low channel/Area Scan (7x15x1): Measurement grid: dx=8mm, dy=8mm
Maximum value of SAR (measured) = 0.769 mW/g

Body Position - Low channel/Zoom Scan (7x7x7)/Cube 0: Measurement grid: dx=5mm, dy=5mm, dz=5mm

Reference Value = 5.73 V/m; Power Drift = -0.157 dB

Peak SAR (extrapolated) = 0.973 W/kg

SAR(1 g) = 0.546 mW/g; SAR(10 g) = 0.303 mW/g

Maximum value of SAR (measured) = 0.772 mW/g

Body Position - Low channel/Zoom Scan (7x7x7)/Cube 1: Measurement grid: dx=5mm, dy=5mm, dz=5mm

Reference Value = 5.73 V/m; Power Drift = -0.157 dB

Peak SAR (extrapolated) = 0.799 W/kg

SAR(1 g) = 0.433 mW/g; SAR(10 g) = 0.234 mW/g

Maximum value of SAR (measured) = 0.706 mW/g

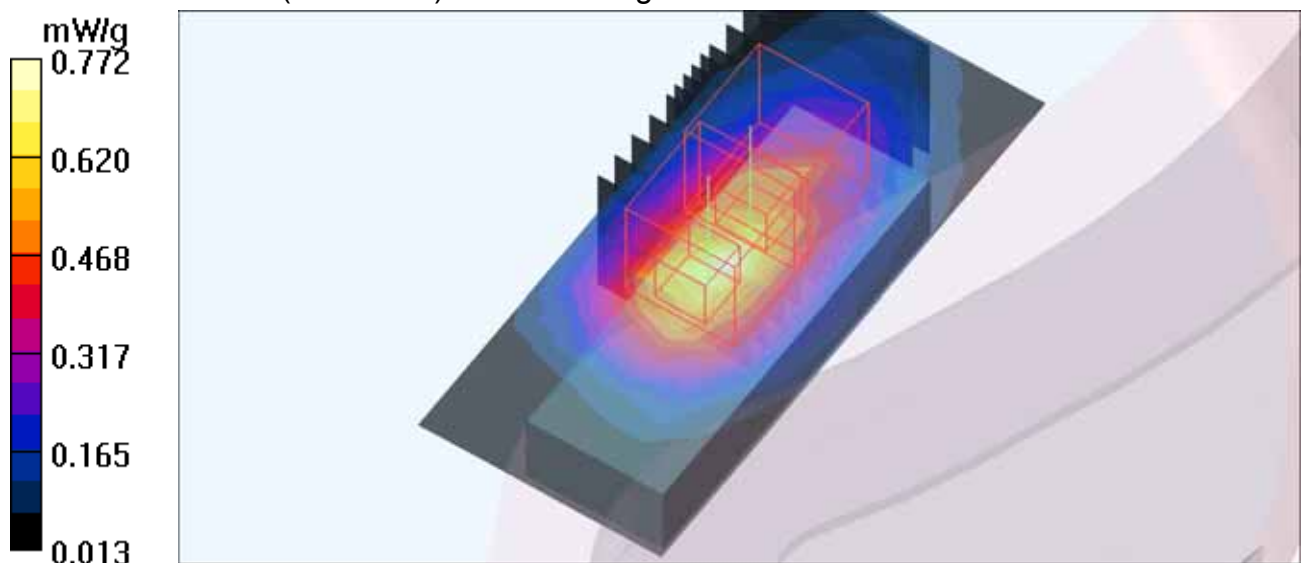

M59-LTE BAND4-Ch20175 (1RB, Upper edge)

Communication System: LTE band4 (1700) ; Frequency: 1732.5 MHz ; Duty Cycle: 1:1

Medium: MSL 1700 Medium parameters used: $f = 1732.5$ MHz; $\sigma = 1.5$ mho/m; $\epsilon_r = 53.65$; $\rho = 1000$ kg/m³

Phantom section: Flat Section ; DUT test position : Body ; Modulation Type: 16QAM

Separation Distance : 5 mm (The horizontal-up side of the EUT to the Phantom)

DASY4 Configuration:

- Probe: EX3DV4 - SN3753; ConvF(7.48, 7.48, 7.48); Calibrated: 2010/12/13
- Sensor-Surface: 2mm (Mechanical Surface Detection)
- Electronics: DAE3 Sn579; Calibrated: 2010/9/20
- Phantom: SAM Twin Phantom V4.0; Type: QD 000 P40 CA; Serial: TP-1202
- Measurement SW: DASY4, V4.7 Build 80; Postprocessing SW: SEMCAD, V1.8 Build 186

Body Position - Low channel/Area Scan (7x15x1): Measurement grid: dx=8mm, dy=8mm
Maximum value of SAR (measured) = 0.830 mW/g

Body Position - Low channel/Zoom Scan (7x7x7)/Cube 0: Measurement grid: dx=5mm, dy=5mm, dz=5mm

Reference Value = 5.01 V/m; Power Drift = -0.112 dB

Peak SAR (extrapolated) = 1.07 W/kg

SAR(1 g) = 0.639 mW/g; SAR(10 g) = 0.330 mW/g

Maximum value of SAR (measured) = 0.842 mW/g

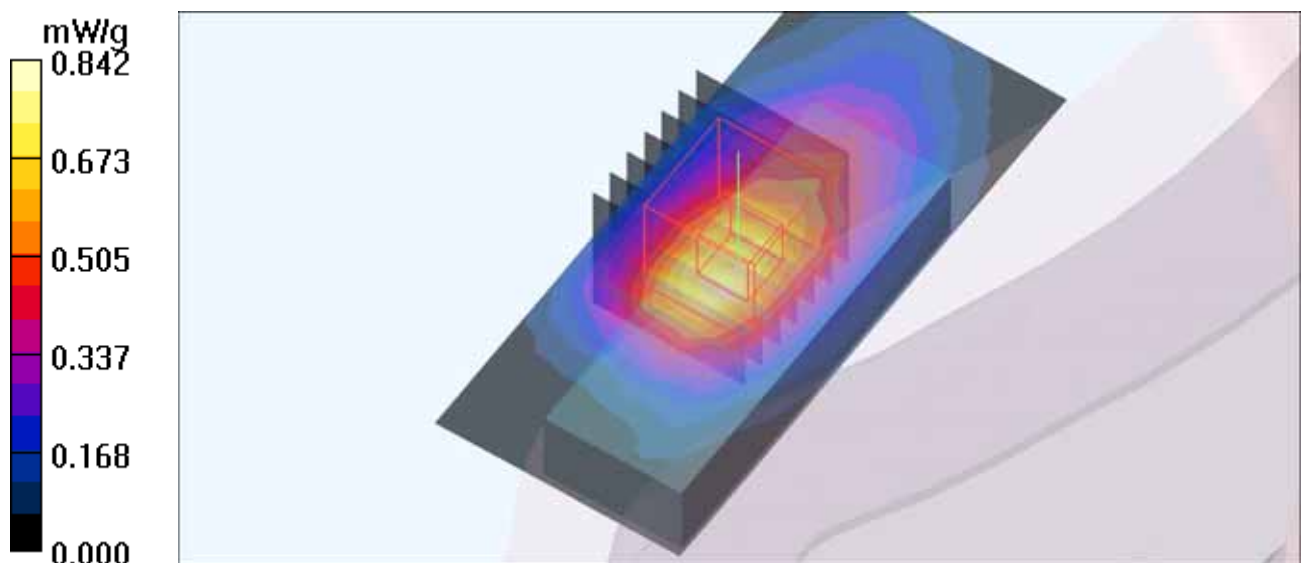

M60-LTE BAND4-Ch20175 (50% RB centered)

Communication System: LTE band4 (1700) ; Frequency: 1732.5 MHz ; Duty Cycle: 1:1

Medium: MSL 1700 Medium parameters used: $f = 1732.5$ MHz; $\sigma = 1.5$ mho/m; $\epsilon_r = 53.65$; $\rho = 1000$ kg/m³

Phantom section: Flat Section ; DUT test position : Body ; Modulation Type: 16QAM

Separation Distance : 5 mm (The vertical-back side of the EUT to the Phantom)

DASY4 Configuration:

- Probe: EX3DV4 - SN3753; ConvF(7.48, 7.48, 7.48); Calibrated: 2010/12/13
- Sensor-Surface: 2mm (Mechanical Surface Detection)
- Electronics: DAE3 Sn579; Calibrated: 2010/9/20
- Phantom: SAM Twin Phantom V4.0; Type: QD 000 P40 CA; Serial: TP-1202
- Measurement SW: DASY4, V4.7 Build 80; Postprocessing SW: SEMCAD, V1.8 Build 186

Body Position - Low/Area Scan (7x15x1): Measurement grid: dx=8mm, dy=8mm

Maximum value of SAR (measured) = 0.269 mW/g

Body Position - Low/Zoom Scan (7x7x7)/Cube 0: Measurement grid: dx=5mm, dy=5mm, dz=5mm

Reference Value = 9.26 V/m; Power Drift = 0.073 dB

Peak SAR (extrapolated) = 0.316 W/kg

SAR(1 g) = 0.198 mW/g; SAR(10 g) = 0.116 mW/g

Maximum value of SAR (measured) = 0.262 mW/g

Body Position - Low/Zoom Scan (7x7x7)/Cube 1: Measurement grid: dx=5mm, dy=5mm, dz=5mm

Reference Value = 9.26 V/m; Power Drift = 0.073 dB

Peak SAR (extrapolated) = 0.304 W/kg

SAR(1 g) = 0.185 mW/g; SAR(10 g) = 0.106 mW/g

Maximum value of SAR (measured) = 0.253 mW/g

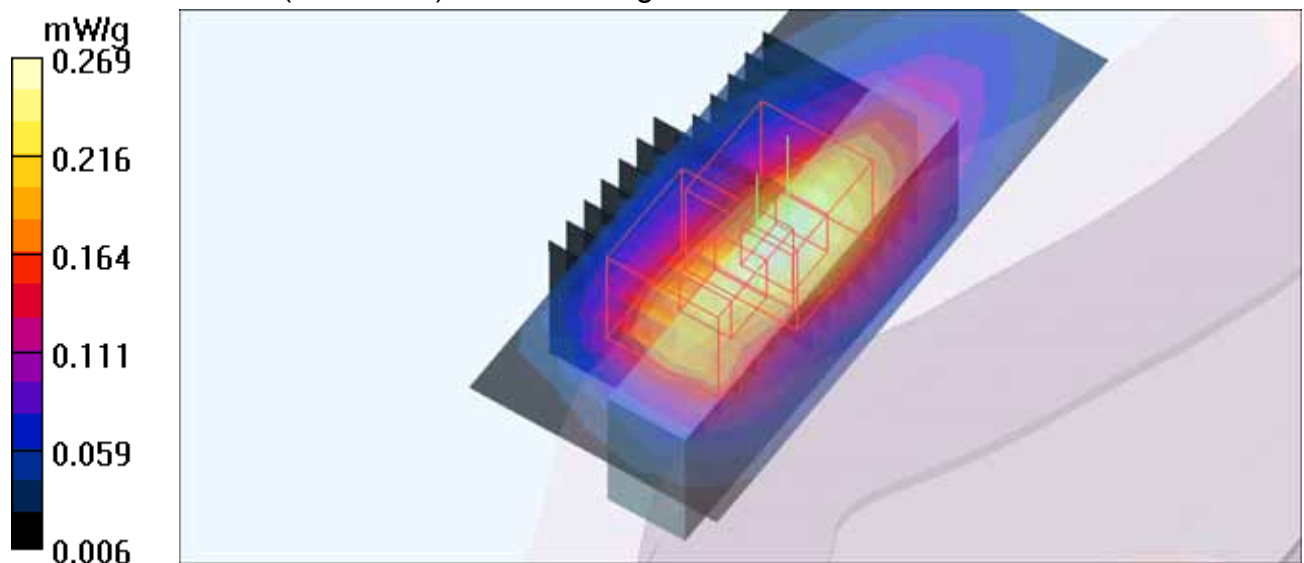

M61-LTE BAND4-Ch20175 (1RB, Lower edge)

Communication System: LTE band4 (1700) ; Frequency: 1732.5 MHz ; Duty Cycle: 1:1

Medium: MSL 1700 Medium parameters used: $f = 1732.5$ MHz; $\sigma = 1.5$ mho/m; $\epsilon_r = 53.65$; $\rho = 1000$ kg/m³

Phantom section: Flat Section ; DUT test position : Body ; Modulation Type: 16QAM

Separation Distance : 5 mm (The vertical-back side of the EUT to the Phantom)

DASY4 Configuration:

- Probe: EX3DV4 - SN3753; ConvF(7.48, 7.48, 7.48); Calibrated: 2010/12/13
- Sensor-Surface: 2mm (Mechanical Surface Detection)
- Electronics: DAE3 Sn579; Calibrated: 2010/9/20
- Phantom: SAM Twin Phantom V4.0; Type: QD 000 P40 CA; Serial: TP-1202
- Measurement SW: DASY4, V4.7 Build 80; Postprocessing SW: SEMCAD, V1.8 Build 186

Body Position - Low channel/Area Scan (7x15x1): Measurement grid: dx=8mm, dy=8mm
Maximum value of SAR (measured) = 0.306 mW/g**Body Position - Low channel/Zoom Scan (7x7x7)/Cube 0:** Measurement grid: dx=5mm, dy=5mm, dz=5mm

Reference Value = 4.74 V/m; Power Drift = 0.161 dB

Peak SAR (extrapolated) = 0.531 W/kg

SAR(1 g) = 0.260 mW/g; SAR(10 g) = 0.147 mW/g

Maximum value of SAR (measured) = 0.369 mW/g

Body Position - Low channel/Zoom Scan (7x7x7)/Cube 1: Measurement grid: dx=5mm, dy=5mm, dz=5mm

Reference Value = 4.74 V/m; Power Drift = 0.161 dB

Peak SAR (extrapolated) = 0.415 W/kg

SAR(1 g) = 0.214 mW/g; SAR(10 g) = 0.109 mW/g

Maximum value of SAR (measured) = 0.313 mW/g

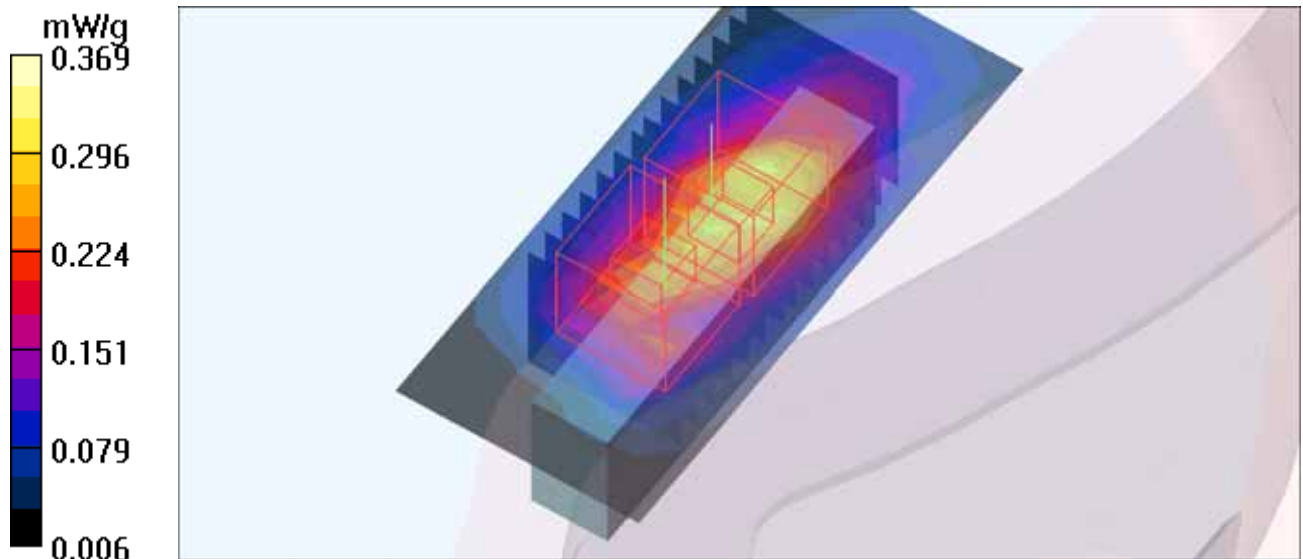

M62-LTE BAND4-Ch20175 (1RB, Upper edge)

Communication System: LTE band4 (1700) ; Frequency: 1732.5 MHz ; Duty Cycle: 1:1

Medium: MSL 1700 Medium parameters used: $f = 1732.5$ MHz; $\sigma = 1.5$ mho/m; $\epsilon_r = 53.65$; $\rho = 1000$ kg/m³

Phantom section: Flat Section ; DUT test position : Body ; Modulation Type: 16QAM

Separation Distance : 5 mm (The vertical-back side of the EUT to the Phantom)

DASY4 Configuration:

- Probe: EX3DV4 - SN3753; ConvF(7.48, 7.48, 7.48); Calibrated: 2010/12/13
- Sensor-Surface: 2mm (Mechanical Surface Detection)
- Electronics: DAE3 Sn579; Calibrated: 2010/9/20
- Phantom: SAM Twin Phantom V4.0; Type: QD 000 P40 CA; Serial: TP-1202
- Measurement SW: DASY4, V4.7 Build 80; Postprocessing SW: SEMCAD, V1.8 Build 186

Body Position - Low channel/Area Scan (7x15x1): Measurement grid: dx=8mm, dy=8mm
Maximum value of SAR (measured) = 0.348 mW/g

Body Position - Low channel/Zoom Scan (7x7x7)/Cube 0: Measurement grid: dx=5mm, dy=5mm, dz=5mm

Reference Value = 6.37 V/m; Power Drift = 0.075 dB

Peak SAR (extrapolated) = 0.458 W/kg

SAR(1 g) = 0.272 mW/g; SAR(10 g) = 0.157 mW/g

Maximum value of SAR (measured) = 0.370 mW/g

Body Position - Low channel/Zoom Scan (7x7x7)/Cube 1: Measurement grid: dx=5mm, dy=5mm, dz=5mm

Reference Value = 6.37 V/m; Power Drift = 0.075 dB

Peak SAR (extrapolated) = 0.395 W/kg

SAR(1 g) = 0.230 mW/g; SAR(10 g) = 0.128 mW/g

Maximum value of SAR (measured) = 0.317 mW/g

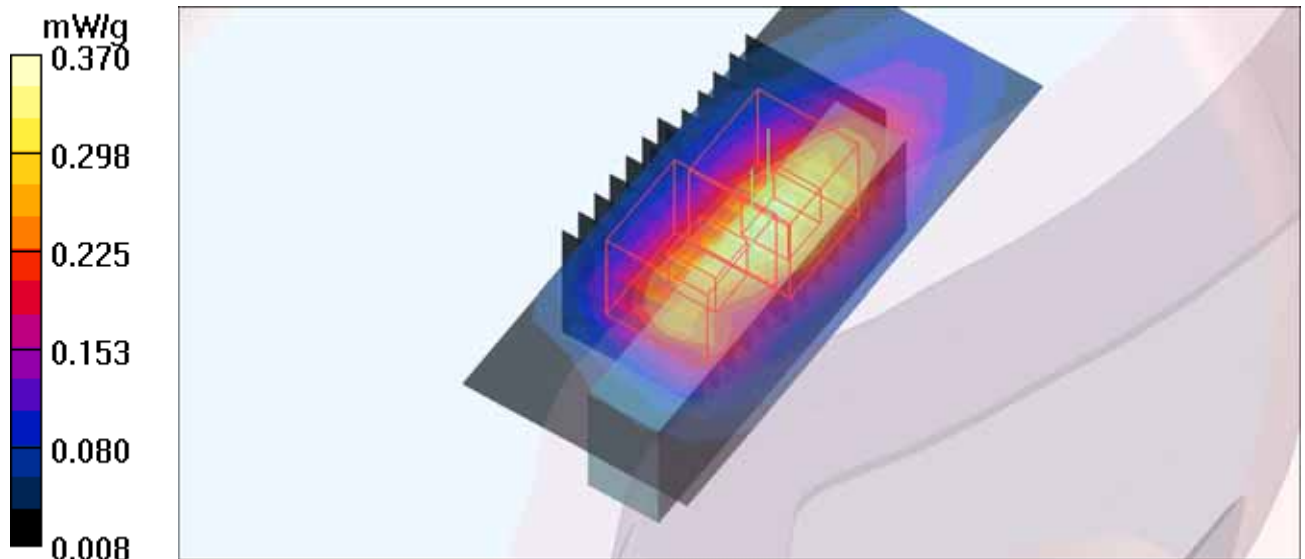

M63-LTE BAND4-Ch20175 (50% RB centered)

Communication System: LTE band4 (1700) ; Frequency: 1732.5 MHz ; Duty Cycle: 1:1

Medium: MSL 1700 Medium parameters used: $f = 1732.5$ MHz; $\sigma = 1.5$ mho/m; $\epsilon_r = 53.65$; $\rho = 1000$ kg/m³

Phantom section: Flat Section ; DUT test position : Body ; Modulation Type: 16QAM

Separation Distance : 5 mm (The top edge side of the EUT to the Phantom)

DASY4 Configuration:

- Probe: EX3DV4 - SN3753; ConvF(7.48, 7.48, 7.48); Calibrated: 2010/12/13
- Sensor-Surface: 2mm (Mechanical Surface Detection)
- Electronics: DAE3 Sn579; Calibrated: 2010/9/20
- Phantom: SAM Twin Phantom V4.0; Type: QD 000 P40 CA; Serial: TP-1202
- Measurement SW: DASY4, V4.7 Build 80; Postprocessing SW: SEMCAD, V1.8 Build 186

Body Position - Low/Area Scan (7x7x1): Measurement grid: dx=8mm, dy=8mm

Maximum value of SAR (measured) = 0.142 mW/g

Body Position - Low/Zoom Scan (7x7x7)/Cube 0: Measurement grid: dx=5mm, dy=5mm, dz=5mm

Reference Value = 9.36 V/m; Power Drift = 0.181 dB

Peak SAR (extrapolated) = 0.189 W/kg

SAR(1 g) = 0.112 mW/g; SAR(10 g) = 0.062 mW/g

Maximum value of SAR (measured) = 0.154 mW/g

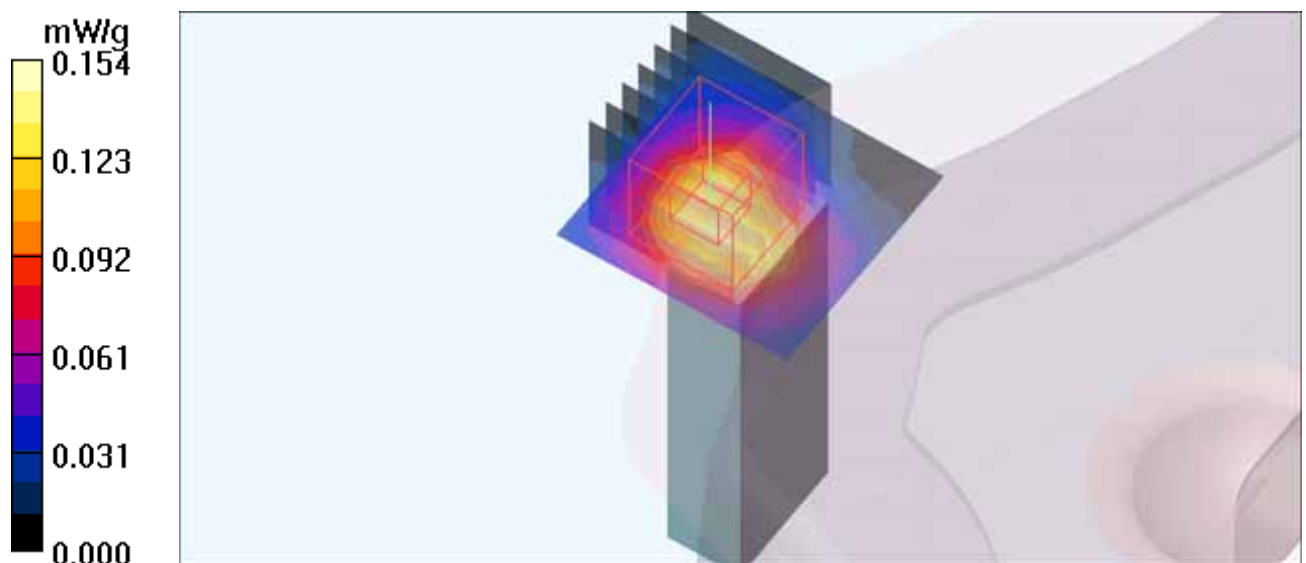

M64-LTE BAND4-Ch20175 (1RB, Lower edge)

Communication System: LTE band4 (1700) ; Frequency: 1732.5 MHz ; Duty Cycle: 1:1

Medium: MSL 1700 Medium parameters used: $f = 1732.5$ MHz; $\sigma = 1.5$ mho/m; $\epsilon_r = 53.65$; $\rho = 1000$ kg/m³

Phantom section: Flat Section ; DUT test position : Body ; Modulation Type: 16QAM

Separation Distance : 5 mm (The top edge side of the EUT to the Phantom)

DASY4 Configuration:

- Probe: EX3DV4 - SN3753; ConvF(7.48, 7.48, 7.48); Calibrated: 2010/12/13
- Sensor-Surface: 2mm (Mechanical Surface Detection)
- Electronics: DAE3 Sn579; Calibrated: 2010/9/20
- Phantom: SAM Twin Phantom V4.0; Type: QD 000 P40 CA; Serial: TP-1202
- Measurement SW: DASY4, V4.7 Build 80; Postprocessing SW: SEMCAD, V1.8 Build 186

Body Position - Low channel/Area Scan (7x7x1): Measurement grid: dx=8mm, dy=8mm
Maximum value of SAR (measured) = 0.169 mW/g

Body Position - Low channel/Zoom Scan (7x7x7)/Cube 0: Measurement grid: dx=5mm, dy=5mm, dz=5mm

Reference Value = 9.88 V/m; Power Drift = 0.043 dB

Peak SAR (extrapolated) = 0.229 W/kg

SAR(1 g) = 0.128 mW/g; SAR(10 g) = 0.069 mW/g

Maximum value of SAR (measured) = 0.184 mW/g

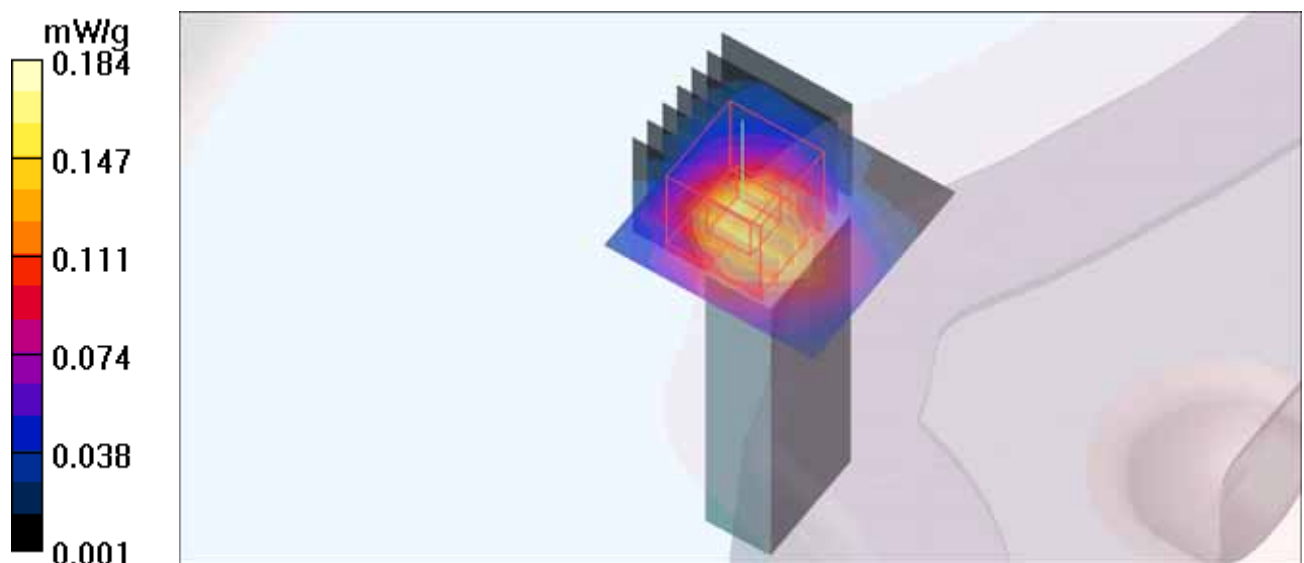

M65-LTE BAND4-Ch20175 (1RB, Upper edge)

Communication System: LTE band4 (1700) ; Frequency: 1732.5 MHz ; Duty Cycle: 1:1

Medium: MSL 1700 Medium parameters used: $f = 1732.5$ MHz; $\sigma = 1.5$ mho/m; $\epsilon_r = 53.65$; $\rho = 1000$ kg/m³

Phantom section: Flat Section ; DUT test position : Body ; Modulation Type: 16QAM

Separation Distance : 5 mm (The top edge side of the EUT to the Phantom)

DASY4 Configuration:

- Probe: EX3DV4 - SN3753; ConvF(7.48, 7.48, 7.48); Calibrated: 2010/12/13
- Sensor-Surface: 2mm (Mechanical Surface Detection)
- Electronics: DAE3 Sn579; Calibrated: 2010/9/20
- Phantom: SAM Twin Phantom V4.0; Type: QD 000 P40 CA; Serial: TP-1202
- Measurement SW: DASY4, V4.7 Build 80; Postprocessing SW: SEMCAD, V1.8 Build 186

Body Position - Low channel/Area Scan (7x7x1): Measurement grid: dx=8mm, dy=8mm
Maximum value of SAR (measured) = 0.164 mW/g

Body Position - Low channel/Zoom Scan (7x7x7)/Cube 0: Measurement grid: dx=5mm, dy=5mm, dz=5mm

Reference Value = 9.87 V/m; Power Drift = 0.141 dB

Peak SAR (extrapolated) = 0.216 W/kg

SAR(1 g) = 0.130 mW/g; SAR(10 g) = 0.071 mW/g

Maximum value of SAR (measured) = 0.177 mW/g

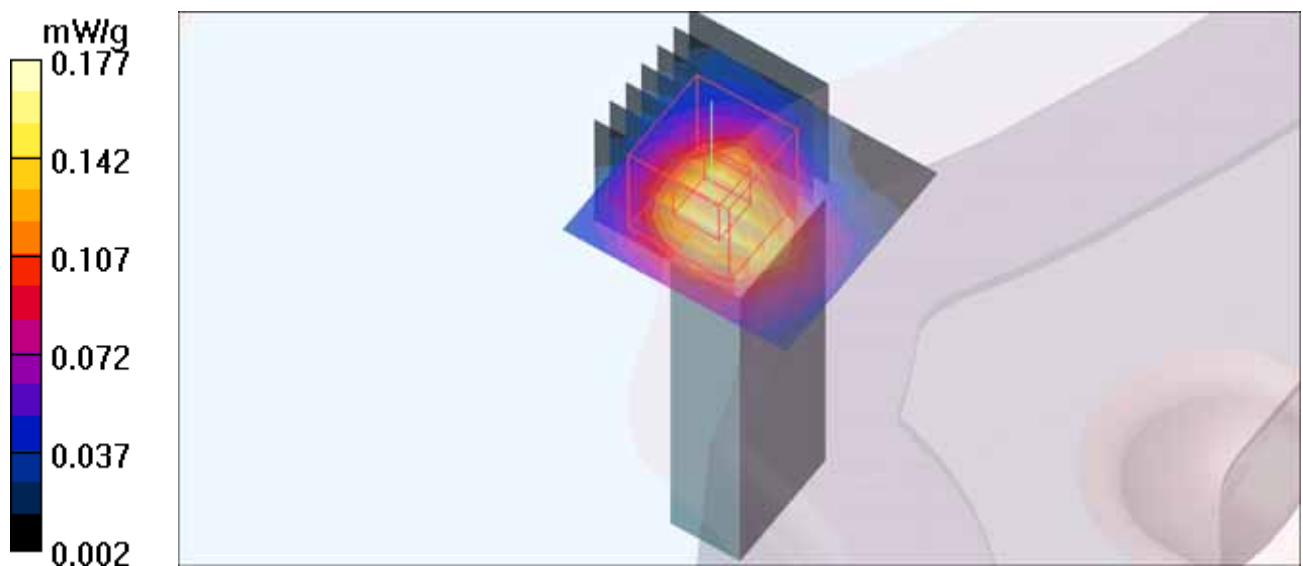

System Validation Check-MSL 750MHz

DUT: Dipole 750 MHz ; Type: D750V3 ; Serial: 1013 ; Test Frequency: 750 MHz

Communication System: CW ; Frequency: 750 MHz; Duty Cycle: 1:1; Modulation type: CW
Medium: MSL750; Medium parameters used: $f = 750$ MHz; $\sigma = 0.99$ mho/m; $\epsilon_r = 56.06$; $\rho = 1000$ kg/m³ ; Liquid level : 150 mm
Phantom section: Flat Section ; Separation distance : 15 mm (The feet point of the dipole to the Phantom) Air temp. : 22.7 degrees ; Liquid temp. : 21.6 degrees

DASY4 Configuration:

- Probe: ES3DV3 - SN3177; ConvF(6.18, 6.18, 6.18); Calibrated: 2010/8/24
- Sensor-Surface: 3mm (Mechanical Surface Detection)
- Electronics: DAE3 Sn579; Calibrated: 2010/9/20
- Phantom: SAM Twin Phantom V4.0; Type: QD 000 P40 CA; Serial: TP-1202
- Measurement SW: DASY4, V4.7 Build 80; Postprocessing SW: SEMCAD, V1.8 Build 186

d=15mm, Pin=250mW/Area Scan (7x9x1): Measurement grid: dx=15mm, dy=15mm
Maximum value of SAR (measured) = 2.11 mW/g

d=15mm, Pin=250mW/Zoom Scan (7x7x7)/Cube 0: Measurement grid: dx=5mm, dy=5mm, dz=5mm

Reference Value = 52.1 V/m; Power Drift = 0.009 dB

Peak SAR (extrapolated) = 3.02 W/kg

SAR(1 g) = 2.06 mW/g; SAR(10 g) = 1.37 mW/g

Maximum value of SAR (measured) = 2.40 mW/g

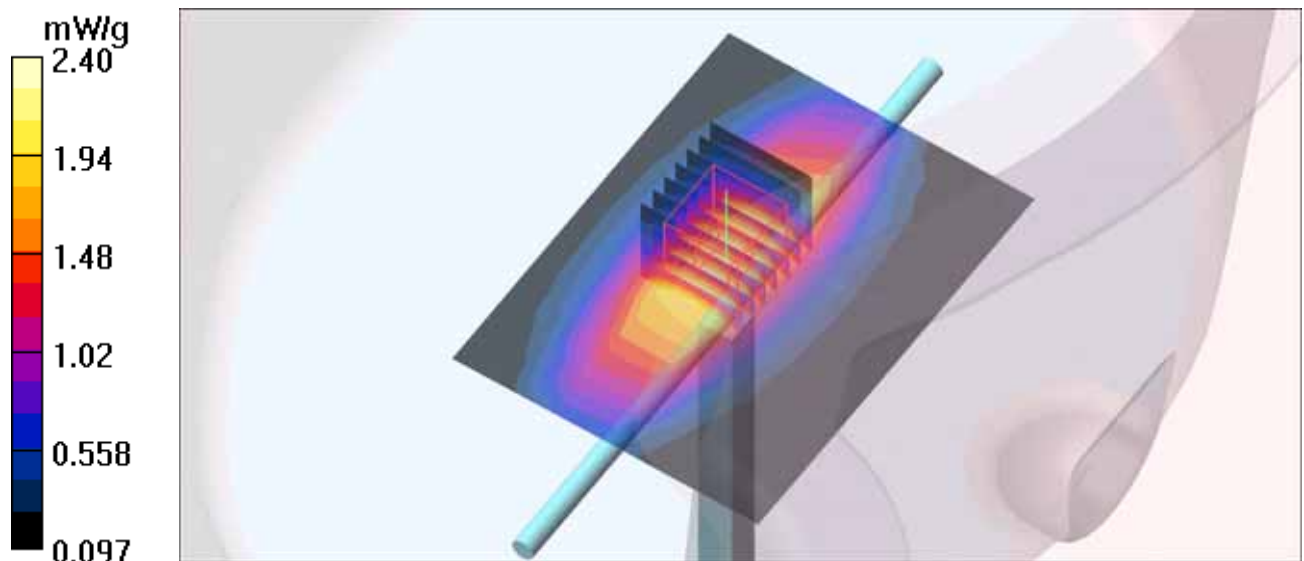

System Performance Check-D1750-MSL1750 MHz

DUT: Dipole 1750 MHz ; Type: D1750V2 ; Serial: D1750V2 - SN:1003 ; Test Frequency: 1750 MHz

Communication System: CW ; Frequency: 1750 MHz; Duty Cycle: 1:1; Modulation type: CW
Medium: MSL1700; Medium parameters used : $f = 1750$ MHz; $\sigma = 1.51$ mho/m; $\epsilon_r = 54.01$; $\rho = 1000$ kg/m³ ; Liquid level : 150 mm
Phantom section: Flat Section ; Separation distance : 10 mm (The feet point of the dipole to the Phantom) Air temp. : 22.4 degrees ; Liquid temp. : 21.2 degrees

DASY4 Configuration:

- Probe: EX3DV4 - SN3753; ConvF(7.48, 7.48, 7.48); Calibrated: 2010/12/13
- Sensor-Surface: 2mm (Mechanical Surface Detection)
- Electronics: DAE3 Sn579; Calibrated: 2010/9/20
- Phantom: SAM Twin Phantom V4.0; Type: QD 000 P40 CA; Serial: TP-1202
- Measurement SW: DASY4, V4.7 Build 80; Postprocessing SW: SEMCAD, V1.8 Build 186

d=10mm, Pin=250mW/Area Scan (7x7x1): Measurement grid: dx=15mm, dy=15mm
Maximum value of SAR (measured) = 13.7 mW/g

d=10mm, Pin=250mW/Zoom Scan (7x7x7)/Cube 0: Measurement grid: dx=5mm, dy=5mm, dz=5mm

Reference Value = 100.0 V/m; Power Drift = 0.014 dB

Peak SAR (extrapolated) = 17.8 W/kg

SAR(1 g) = 9.6 mW/g; SAR(10 g) = 5.07 mW/g

Maximum value of SAR (measured) = 13.6 mW/g

