

SAR TEST REPORT

Equipment Under Test	HSDPA USB Data Modem
Model Number	C152
Brand Name	BandLuxe™
Company Name	BandRich Inc.
Company Address	8F., No. 188, Baociao Rd., Sindian City, Taipei County 23146, Taiwan (R.O.C.)
Date of Receipt	2008.09.10
Date of Test(s)	2008.09.17-2008.09.19,2008.12.05,200812.08
Date of Issue	2008.12.15

Standards:

**FCC OET Bulletin 65 supplement C,
ANSI/IEEE C95.1 , C95.3, IEEE 1528**

In the configuration tested, the EUT complied with the standards specified above.

Remarks:

This report details the results of the testing carried out on one sample, the results contained in this test report do not relate to other samples of the same product. The manufacturer should ensure that all products in series production are in conformity with the product sample detailed in this report.

This report may only be reproduced and distributed in full. If the product in this report is used in any configuration other than that detailed in the report, the manufacturer must ensure the new system complies with all relevant standards. Any mention of SGS Taiwan Electronic & Communication Laboratory or testing done by SGS Taiwan Electronic & Communication Laboratory in connection with distribution or use of the product described in this report must be approved by SGS Taiwan Electronic & Communication Laboratory in writing.

Tested by : Ricky Huang **Date** : 2008.12.18
Asst. Supervisor

Approved by : Robert Chang **Date** : 2008.12.18
Tech. Manager

Contents

1. General Information.....	3
1.1 Testing Laboratory	3
1.2 Details of Applicant	3
1.3 Description of EUT	3
1.4 Test Environment	4
1.5 Operation description	4
1.6 EVALUATION PROCEDURES.....	6
1.7 The SAR Measurement System.....	7
1.8 System Components	9
1.9 SAR System Verification.....	10
1.10 Tissue Simulant Fluid for the Frequency Band.....	12
1.11 Test Standards and Limits	13
2. Summary of Results	15
GSM 850 MHZ.....	15
PCS 1900 MHZ.....	16
WCDMA BAND2	18
WCDMA BAND2_HSDPA mode	19
WCDMA BAND5	21
WCDMA BAND5_HSDPA mode	22
3. Instruments List.....	24
4. Measurements	25
5. System Verification	172
6. DAE & Probe Calibration certificate	178
7. Uncertainty Analysis.....	189
8. Phantom description	190
9. System Validation from Original equipment supplier ...	191

1. General Information

1.1 Testing Laboratory

SGS Taiwan Ltd. Electronics & Communication Laboratory	
134, Wu Kung Road, Wuku industrial zone	
Taipei county, Taiwan, R.O.C.	
Telephone	+886-2-2299-3279
Fax	+886-2-2298-0488
Internet	http://www.tw.sgs.com/

1.2 Details of Applicant

Company Name	BandRich Inc.
Company Address	8F., No. 188, Baociao Rd., Sindian City, Taipei County 23146, Taiwan (R.O.C.)
Contact Person	Sandy Cheng / Deputy Engineer
TEL	(02)8914-6588#317
Fax	(02)7705-1087
E-mail	sandy@bandrich.com
Website	http://www.bandrich.com/

1.3 Description of EUT

EUT Name	HSDPA USB Data Modem			
Brand Name	BandLuxe™			
Model Number	C152			
FCC ID	UZI-C152			
IMEI Code	35588302			
Mode of Operation	GSM /GPRS/EDGE/WCDMA/HSDPA band			
Modulation mode	GMSK/QPSK/8PSK/16QAM			
Duty Cycle	GSM	GPRS/EDGE	WCDMA BAND2	WCDMA BAND5
	1/8	1/2	1	
Maximum RF Conducted Power (Average)	GSM 850	PCS 1900	WCDMA BAND2	WCDMA BAND5
	28	25.2	23.47	22.65

TX Frequency Range (MHz)	GSM 850	PCS 1900	WCDMA BAND2	WCDMA BAND5
	824.2- 848.8	1850.2- 1909.8	1852.4- 1907.6	826.4- 846.6
Channel Number (ARFCN)	GSM 850	PCS 1900	WCDMA BAND2	WCDMA BAND5
	128-251	512-810	9262-9538	4132-4233
Antenna Type	Internal Antenna			
Max. SAR Measured (1 g)	1.1W/kg At WCDMA BAND2_CH9400 _ Configuration 7			

Note:

1. EGPRS mode was not measured because maximum averaged output power is 3 dB lower than in GPRS mode.

1.4 Test Environment

Ambient Temperature: $22.2^{\circ} \pm 2^{\circ}$ C

Tissue Simulating Liquid: $22.2^{\circ} \pm 2^{\circ}$ C

1.5 Operation description

The EUT is a USB Data Modem. When we use it, it will be defined as a portable device since the Notebook will place on the thigh, so SAR measurement is mandatory. The EUT is controlled by using a Communication simulate Tester (R&S CMU200), and the communication between the EUT and the tester is established by air link. Measurements are performed respectively on the lowest, middle and highest channels of the operating band(s). The EUT is set to maximum power level during all tests.

Value of Crest Factors are 2 for GPRS mode (multi-slot=4) and 1 for WCDMA Band 2 & WCDMA Band5 were used for SAR testing according to the nature of the EUT, the category of HSDPA is "6", for HSDPA SAR testing, it is necessary to choose the maximum conducted power with 384 kbps of the following reference channel types to test the low, middle and high frequency channels.

Reference channel type	Conducted power of HSDPA B2		
	CH 9262	CH 9400	CH 9538
12.2 kbps	22.82dbm	22.85dbm	22.49dbm
64 kbps	22.82dbm	22.81dbm	22.52dbm
144 kbps	22.95dbm	22.91dbm	22.61dbm
384 kbps	23.14dbm	23.01dbm	22.62dbm

Reference channel type	Conducted power of HSDPA B5		
	CH 4132	CH 4183	CH 4233
12.2 kbps	22.43dbm	22.01dbm	22.25dbm
64 kbps	22.46dbm	22.06dbm	22.23dbm
144 kbps	22.47dbm	22.08dbm	22.29dbm
384 kbps	22.48dbm	22.16dbm	22.31dbm

By using the program subordinated in the computer, and change into the written channel, and then test of set in highest power. Finally, we will test it by dividing into 8 configurations:

Configuration 1: Front side of the EUT is paralleled with flat phantom, and spacing between EUT and Phantom is 4 mm. (Appendix-Fig.3)

Configuration 2: Rear side of the EUT is paralleled with flat phantom, and spacing between EUT and Phantom is 4 mm. (Appendix-Fig.4)

Configuration 3: Right side of the EUT is paralleled with flat phantom, and spacing between EUT and Phantom is 4 mm. (Appendix-Fig.5)

Configuration 4: Left side of the EUT is paralleled with flat phantom, and spacing between EUT and Phantom is 4 mm. (Appendix-Fig.6)

Configuration 5: Bottom side of the Notebook is paralleled and contacted with flat phantom. (Appendix-Fig.7)

Configuration 6: Top side of the EUT is paralleled with flat phantom, and spacing between EUT and Phantom is 4 mm. (Appendix-Fig.8)

Configuration 7: Bottom side of the Notebook is paralleled and contacted with flat phantom, and front side of the EUT is paralleled with flat phantom. (Appendix-Fig.9)

Configuration 8: Bottom side of the Notebook is paralleled and contacted with flat phantom, and right side of the EUT is paralleled with flat phantom. (Appendix-Fig.10)

1.6 EVALUATION PROCEDURES

The entire evaluation of the spatial peak values is performed within the Post-processing engine (SEMCAD). The system always gives the maximum values for the 1 g and 10 g cubes. The algorithm to find the cube with highest averaged SAR is divided into the following stages:

1. The extraction of the measured data (grid and values) from the Zoom Scan.
2. The calculation of the SAR value at every measurement point based on all stored data (A/D values and measurement parameters)
3. The generation of a high-resolution mesh within the measured volume
4. The interpolation of all measured values from the measurement grid to the high-resolution grid
5. The extrapolation of the entire 3-D field distribution to the phantom surface over the distance from sensor to surface
6. The calculation of the averaged SAR within masses of 1g and 10g.

The probe is calibrated at the center of the dipole sensors that is located 1 to 2.7mm away from the probe tip. During measurements, the probe stops shortly above the phantom surface, depending on the probe and the surface detecting system. Both distances are included as parameters in the probe configuration file. The software always knows exactly how far away the measured point is from the surface. As the probe cannot directly measure at the surface, the values between the deepest measured point and the surface must be extrapolated. The angle between the probe axis and the surface normal line is less than 30 degree.

In the Area Scan, the gradient of the interpolation function is evaluated to find all the extreme of the SAR distribution. The uncertainty on the locations of the extreme is less than 1/20 of the grid size. Only local maximum within -2 dB of the global maximum are searched and passed for the Cube Scan measurement. In the Cube Scan, the interpolation function is used to extrapolate the Peak SAR from the lowest measurement points to the inner phantom surface (the extrapolation distance). The uncertainty increases with the extrapolation distance. To keep the uncertainty within 1% for the 1 g and 10 g cubes, the extrapolation distance should not be larger than 5mm.

The maximum search is automatically performed after each area scan measurement. It is based on splines in two or three dimensions. The procedure can find the maximum for most SAR distributions even with relatively large grid spacing. After the area scanning measurement, the probe is automatically moved to a position at the interpolated maximum.

The following scan can directly use this position for reference, e.g., for a finer resolution grid or the cube evaluations. The 1g and 10g peak evaluations are only available for the predefined cube 7x7x7 scans.

The routines are verified and optimized for the grid dimensions used in these cube measurements. The measured volume of 30x30x30mm contains about 30g of tissue. The first procedure is an extrapolation (incl. Boundary correction) to get the points between the lowest measured plane and the surface. The next step uses 3D interpolation to get all points within the measured volume. In the last step, a 1g cube is placed numerically into the volume and its averaged SAR is calculated. This cube is moved around until the highest averaged SAR is found. If the highest SAR is found at the edge of the measured volume, the system will issue a warning: higher SAR values might be found outside of the measured volume. In that case the cube measurement can be repeated, using the new interpolated maximum as the center.

1.7 The SAR Measurement System

A photograph of the SAR measurement System is given in Fig. a. This SAR Measurement System uses a Computer-controlled 3-D stepper motor system (SPEAG DASY 5 professional system). A Model ES3DV3 field probe is used to determine the internal electric fields.

The SAR can be obtained from the equation $SAR = \sigma (|E_i|^2) / \rho$ where σ and ρ are the conductivity and mass density of the tissue-simulant.

A photograph of the SAR measurement System is given in Fig. a. This SAR Measurement System uses a Computer-controlled 3-D stepper motor system (SPEAG DASY 5 professional system). A Model ES3DV3 3172-field probe is used to determine the internal electric fields. The SAR can be obtained from the equation $SAR = \sigma (|E_i|^2) / \rho$ where σ and ρ are the conductivity and mass density of the tissue-simulant.

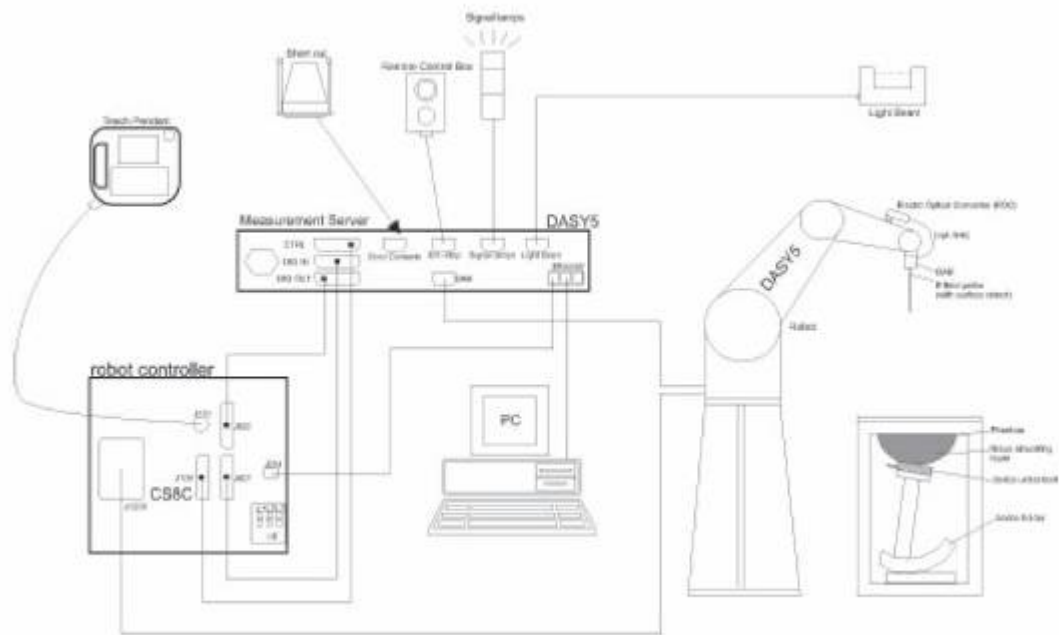

Fig.a The Bloack diagram of SAR system.

The DASY5 system for performing compliance tests consists of the following items:

- A standard high precision 6-axis robot (Staubli RX family) with controller, teach pendant and software. An arm extension is for accommodating the data acquisition electronics (DAE).
- A dosimetric probe, i.e., an isotropic E-field probe optimized and calibrated for usage in tissue simulating liquid. The probe is equipped with an optical surface detector system.
- A data acquisition electronics (DAE) which performs the signal amplification, signal multiplexing, AD-conversion, offset measurements, mechanical surface detection, collision detection, etc. The unit is battery powered with standard or rechargeable batteries. The signal is optically transmitted to the EOC.

- The Electro-optical converter (EOC) performs the conversion between optical and electrical of the signals for the digital communication to the DAE and for the analog signal from the optical surface detection. The EOC is connected to the measurement server.
- The function of the measurement server is to perform the time critical tasks such as signal filtering, control of the robot operation and fast movement interrupts.
- A probe alignment unit which improves the (absolute) accuracy of the probe positioning.
 - A computer operating Windows 2000 or Windows XP.
 - DASY5 software.
- Remote control with teach pendant and additional circuitry for robot safety such as warning lamps, etc.
 - The SAM twin phantom enabling testing left-hand and right-hand usage.
 - The device holder for handheld mobile phones.
 - Tissue simulating liquid mixed according to the given recipes.
 - Validation dipole kits allowing to validate the proper functioning of the system.

1.8 System Components

ES3DV3 E-Field Probe

Construction:	Symmetrical design with triangular core Built-in shielding against static charges PEEK enclosure material (resistant to organic solvents, e.g., DGBE)	
Calibration:	Basic Broad Band Calibration in air Conversion Factors (CF) for HSL835/1900 Additional CF for other liquids and frequencies upon request	
Frequency:	10 MHz to > 3 GHz; Linearity: ± 0.6 dB (30 MHz to 6 GHz)	
Directivity:	± 0.3 dB in HSL (rotation around probe axis) ± 0.5 dB in tissue material (rotation normal to probe axis)	
Dynamic Range:	10 μ W/g to > 100 mW/g; Linearity: ± 0.6 dB (noise: typically < 1 μ W/g)	
Dimensions:	Overall length: 337 mm (Tip: 10 mm) Tip diameter: 4mm (Body: 10 mm) Typical distance from probe tip to dipole centers: 2 mm	
Application:	High precision dosimetric measurements in any exposure scenario (e.g., very strong gradient fields). Only probe which enables compliance testing for frequencies up to 6 GHz with precision of better 30%.	

SAM PHANTOM V4.0C

Construction:	The shell corresponds to the specifications of the Specific Anthropomorphic Mannequin (SAM) phantom defined in IEEE 1528-200X, CENELEC 50361 and IEC 62209. It enables the dosimetric evaluation of left and right hand phone usage as well as body mounted usage at the flat phantom region. A cover prevents evaporation of the liquid. Reference markings on the phantom allow the complete setup of all predefined phantom positions and measurement grids by manually teaching three points with the robot.	
Shell Thickness:	2 ± 0.2 mm	
Filling Volume:	Approx. 25 liters	
Dimensions:	Height: 850 mm; Length: 1000 mm; Width: 500 mm	

DEVICE HOLDER

Construction	In combination with the Twin SAM Phantom V4.0/V4.0C or Twin SAM, the Mounting Device (made from POM) enables the rotation of the mounted transmitter in spherical coordinates, whereby the rotation point is the ear opening. The devices can be easily and accurately positioned according to IEC, IEEE, CENELEC, FCC or other specifications. The device holder can be locked at different phantom locations (left head, right head, flat phantom).	 Device Holder
--------------	---	--

1.9 SAR System Verification

The circuit arrangement for system verification is sketched in Fig. b. The daily system accuracy verification occurs within the flat section of the SAM phantom. A SAR measurement was performed to see if the measured SAR was within +/- 5% from the target SAR values. These tests were done at 850/1900MHz. The tests were conducted on the same days as the measurement of the DUT.

The obtained results from the system accuracy verification are displayed in the table 1. During the tests, the ambient temperature of the laboratory was in the range 22.2°C, the relative humidity was in the range 62% and the liquid depth above the ear reference points was above 15 cm in all the cases. It is seen that the system is operating within its specification, as the results are within acceptable tolerance of the reference values.

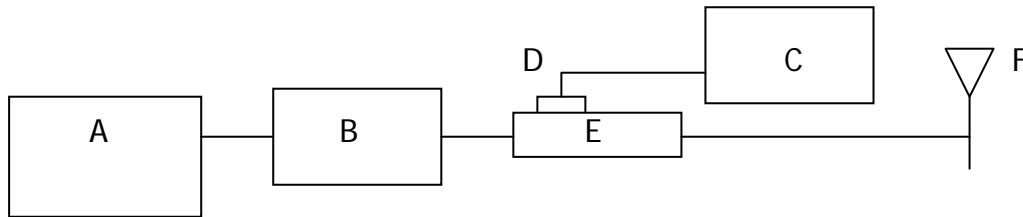
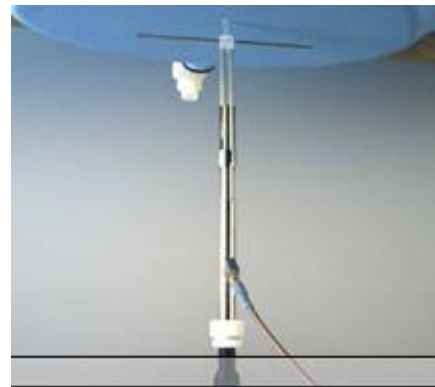

Fig.b The microwave circuit arrangement used for SAR system verification

- A. Agilent Model 8648D Signal Generator
- B. Mini circuits Model ZHL-42 Amplifier
- C. Agilent Model E4416A Power Meter
- D. Agilent Model 8481H Power Sensor
- E. Agilent Model 778D Dual directional coupling
- F. Reference dipole antenna



Photograph of the dipole Antenna

Validation Kit	Frequency (MHz)	Target SAR (1g) (Pin=250mW)	Measured SAR (1g)	Variation	Measured Date
D835V2 S/N: 4d063	835 MHz (Body)	2.44m W/g	2.34mW/g	4%	2008/9/17
D835V2 S/N: 4d063	835 MHz (Body)	2.44m W/g	2.33mW/g	4.5%	2008/9/19
D1900V2 S/N: 5d027	1900 MHz (Body)	9.64m W/g	9.6mW/g	0.4%	2008/9/17

D1900V2 S/N: 5d027	1900 MHz (Body)	9.64m W/g	9.54mW/g	1%	2008/9/18
D835V2 S/N: 4d063	835 MHz (Body)	2.44m W/g	2.5mW/g	2.4%	2008/12/05
D1900V2 S/N: 5d027	1900 MHz (Body)	9.64m W/g	9.51mW/g	1.3%	2008/12/08

Table 1. System validation (follow manufacture target value)

1.10 Tissue Simulant Fluid for the Frequency Band

The dielectric properties for this Head-simulant fluid were measured by using the HP Model 85070D Dielectric Probe (rates frequency band 200 MHz to 20 GHz) in conjunction with HP 8753D Network Analyzer (30 KHz-6000MHz) by using a procedure detailed in Section V.

All dielectric parameters of tissue simulates were measured within 24 hours of SAR measurements. The depth of the tissue simulant in the ear reference point of the phantom was $15\text{cm} \pm 5\text{mm}$ during all tests. (Appendix Fig .2)

Frequency (MHz)	Tissue type	Measurement date/ Limits	Dielectric Parameters		
			ρ	σ (S/m)	Simulated Tissue Temperature($^{\circ}$ C)
850	Body	Measured, 2008.09.17	56.2	0.955	21.7
		Recommended Limits	52.3-57.8	0.92-1.1	20-24
850	Body	Measured, 2008.09.19	56.3	0.955	21.7
		Recommended Limits	52.3-57.8	0.92-1.1	20-24
1900	Body	Measured, 2008.09.17	52.4	1.46	21.7
		Recommended Limits	50.6-56	1.38-1.6	20-24
1900	Body	Measured, 2008.09.18	52.4	1.47	21.7
		Recommended Limits	50.6-56	1.38-1.6	20-24
850	Body	Measured, 2008.12.05	56	0.956	21.7
		Recommended Limits	52.3-57.8	0.92-1.1	20-24
1900	Body	Measured, 2008.12.08	54.5	1.51	21.7
		Recommended Limits	50.6-56	1.38-1.6	20-24

Table 2. Dielectric Parameters of Tissue Simulant Fluid

The composition of the brain tissue simulating liquid for 850 & 1900 band:

Ingredient	850MHz (Body)	1900MHz (Body)
DGMBE	X	300.67g
Water	631.68 g	716.56 g
Salt	11.72 g	4.0 g
Preventol D-7	1.2 g	X
Cellulose	X	X
Sugar	600 g	X
Total amount	1 L 1.0kg)	1 L (1.0kg)

Table 3. Recipes for tissue simulating liquid

1.11 Test Standards and Limits

According to FCC 47CFR §2.1093(d) The limits to be used for evaluation are based generally on criteria published by the American National Standards Institute (ANSI) for localized specific absorption rate ("SAR") in Section 4.2 of "IEEE Standard for Safety Levels with Respect to Human Exposure to Radio Frequency Electromagnetic Fields, 3 kHz to 300 GHz," ANSI/IEEE C95.1-1992, Copyright 1992 by the Institute of Electrical and Electronics Engineers, Inc., New York, New York 10017. These criteria for SAR evaluation are similar to those recommended by the National Council on Radiation Protection and Measurements (NCRP) in "Biological Effects and Exposure Criteria for Radio frequency Electromagnetic Fields," NCRP Report No. 86, Section 17.4.5. Copyright NCRP, 1986, Bethesda, Maryland 20814. SAR is a measure of the rate of energy absorption due to exposure to an RF transmitting source. SAR values have been related to threshold levels for potential biological hazards. The criteria to be used are specified in paragraphs (d)(1) and (d)(2) of this section and shall apply for portable devices transmitting in the frequency range from 100 kHz to 6 GHz. Portable devices that transmit at frequencies above 6 GHz are to be evaluated in terms of the MPE limits specified in § 1.1310 of this chapter. Measurements and calculations to demonstrate compliance with MPE field strength or power density limits for devices operating above 6 GHz should be made at a minimum distance of 5 cm from the radiating source.

(1) Limits for Occupational/Controlled exposure: 0.4 W/kg as averaged over the whole-body and spatial peak SAR not exceeding 8 W/kg as averaged over any 1 gram of tissue (defined as a tissue volume in the shape of a cube). Exceptions are the hands, wrists, feet and ankles where the spatial peak SAR shall not exceed 20 W/kg, as averaged over an 10 grams of tissue (defined as a tissue volume in the shape of a cube). Occupational/Controlled limits apply when persons are exposed as a consequence of their employment provided these persons are fully aware of and exercise control over their exposure. Awareness of exposure can be accomplished by use of warning labels or by specific training or education through appropriate means, such as an RF safety program in a work environment.

(2) Limits for General Population/Uncontrolled exposure: 0.08 W/kg as averaged over the whole-body and spatial peak SAR not exceeding 1.6 W/kg as averaged over any 1 gram of tissue (defined as a tissue volume in the shape of a cube). Exceptions are the hands, wrists, feet and ankles where the spatial peak SAR shall not exceed 4 W/kg, as averaged over any 10 grams of tissue (defined as a tissue volume in the shape of a cube).

General Population/Uncontrolled limits apply when the general public may be exposed, or when persons that are exposed as a consequence of their employment may not be fully aware of the potential for exposure or do not exercise control over their exposure. Warning labels placed on consumer devices such as cellular telephones will not be sufficient reason to allow these devices to be evaluated subject to limits for occupational/controlled exposure in paragraph (d)(1) of this section.(Table .6)

Human Exposure	Uncontrolled Environment General Population	Controlled Environment Occupational
Spatial Peak SAR (Brain)	1.60 m W/g	8.00 m W/g
Spatial Average SAR (Whole Body)	0.08 m W/g	0.40 m W/g
Spatial Peak SAR (Hands/Feet/Ankle/Wrist)	4.00 m W/g	20.00 m W/g

Table .4 RF exposure limits

Notes:

1. Uncontrolled environments are defined as locations where there is potential exposure of individuals who have no knowledge or control of their potential exposure.
2. Controlled environments are defined as locations where there is potential exposure of individuals who have knowledge of their potential exposure and can exercise control over their exposure.

2. Summary of Results

GSM 850 MHZ

Configuration 1 : Front side of the EUT is paralleled with flat phantom, and spacing between EUT and phantom is 4mm.						
Frequency	Channel	MHz	Conducted Output Power (Average)	Measured(W/kg) 1g	Amb. Temp[°C]	Liquid Temp[°C]
850 MHz	128	824.2	27.9dbm	0.162	22.1	21.7
	190	836.6	28 dbm	0.146	22.1	21.7
	251	848.8	28 dbm	0.126	22.1	21.7
Configuration 2 : Back side of the EUT is paralleled with flat phantom, and spacing between EUT and phantom is 4mm.						
Frequency	Channel	MHz	Conducted Output Power (Average)	Measured(W/kg) 1g	Amb. Temp[°C]	Liquid Temp[°C]
850MHz	128	824.2	27.9 dbm	0.123	22.1	21.7
	190	836.6	28 dbm	0.117	22.1	21.7
	251	848.8	28 dbm	0.107	22.1	21.7
Configuration 3: Right side of the EUT is paralleled with flat phantom, and spacing between EUT and phantom is 4mm.						
Frequency	Channel	MHz	Conducted Output Power (Average)	Measured(W/kg) 1g	Amb. Temp[°C]	Liquid Temp[°C]
850 MHz	128	824.2	27.9 dbm	0.117	22.1	21.7
	190	836.6	28 dbm	0.114	22.1	21.7
	251	848.8	28 dbm	0.111	22.1	21.7
Configuration 4: Left side of the EUT is paralleled with flat phantom, and spacing between EUT and phantom is 4mm.						
Frequency	Channel	MHz	Conducted Output Power (Average)	Measured(W/kg) 1g	Amb. Temp[°C]	Liquid Temp[°C]
850 MHz	128	824.2	27.9 dbm	0.111	22.1	21.7
	190	836.6	28 dbm	0.11	22.1	21.7
	251	848.8	28 dbm	0.098	22.1	21.7
Configuration 5 : Bottom side of the Notebook is paralleled and contacted with flat phantom.						
Frequency	Channel	MHz	Conducted Output Power (Average)	Measured(W/kg) 1g	Amb. Temp[°C]	Liquid Temp[°C]
850 MHz	128	824.2	27.9 dbm	0.085	22.1	21.7
	190	836.6	28 dbm	0.089	22.1	21.7
	251	848.8	28 dbm	0.084	22.1	21.7

Configuration 6: Top side of the EUT is paralleled with flat phantom, and spacing between EUT and phantom is 4mm.

Frequency	Channel	MHz	Conducted Output Power (Average)	Measured(W/kg) 1g	Amb. Temp[°C]	Liquid Temp[°C]
850 MHz	128	824.2	27.9 dbm	0.077	22.1	21.7
	190	836.6	28 dbm	0.074	22.1	21.7
	251	848.8	28 dbm	0.07	22.1	21.7

Configuration 7: Bottom side of the Notebook is paralleled and contacted with flat phantom. and front side of the EUT is paralleled with flat phantom.

Frequency	Channel	MHz	Conducted Output Power (Average)	Measured(W/kg) 1g	Amb. Temp[°C]	Liquid Temp[°C]
850 MHz	128	824.2	27.9 dbm	0.12	22.1	21.7
	190	836.6	28 dbm	0.078	22.1	21.7
	251	848.8	28 dbm	0.055	22.1	21.7

Configuration8: Bottom side of the Notebook is paralleled and contacted with flat phantom. and right side of the EUT is paralleled with flat phantom.

Frequency	Channel	MHz	Conducted Output Power (Average)	Measured(W/kg) 1g	Amb. Temp[°C]	Liquid Temp[°C]
850 MHz	128	824.2	27.9 dbm	0.133	22.1	21.7
	190	836.6	28 dbm	0.081	22.1	21.7
	251	848.8	28 dbm	0.053	22.1	21.7

PCS 1900 MHZ

Configuration 1 : Front side of the EUT is paralleled with flat phantom, and spacing between EUT and phantom is 4mm.

Frequency	Channel	MHz	Conducted Output Power (Average)	Measured(W/kg) 1g	Amb. Temp[°C]	Liquid Temp[°C]
1900 MHz	512	1850.2	25.2 dbm	0.744	22.1	21.7
	661	1880	25 dbm	0.533	22.1	21.7
	810	1909.8	24.7 dbm	0.397	22.1	21.7

Configuration 2 : Back side of the EUT is paralleled with flat phantom, and spacing between EUT and phantom is 4mm.

Frequency	Channel	MHz	Conducted Output Power (Average)	Measured(W/kg) 1g	Amb. Temp[°C]	Liquid Temp[°C]
1900 MHz	512	1850.2	25.2 dbm	0.296	22.1	21.7
	661	1880	25 dbm	0.265	22.1	21.7
	810	1909.8	24.7 dbm	0.242	22.1	21.7

Configuration 3: Right side of the EUT is paralleled with flat phantom, and spacing between EUT and phantom is 4mm.						
Frequency	Channel	MHz	Conducted Output Power (Average)	Measured(W/kg) 1g	Amb. Temp[°C]	Liquid Temp[°C]
1900 MHz	512	1850.2	25.2 dbm	0.438	22.1	21.7
	661	1880	25 dbm	0.367	22.1	21.7
	810	1909.8	24.7 dbm	0.327	22.1	21.7
Configuration 4: Left side of the EUT is paralleled with flat phantom, and spacing between EUT and phantom is 4mm.						
Frequency	Channel	MHz	Conducted Output Power (Average)	Measured(W/kg) 1g	Amb. Temp[°C]	Liquid Temp[°C]
1900 MHz	512	1850.2	25.2 dbm	0.34	22.1	21.7
	661	1880	25 dbm	0.299	22.1	21.7
	810	1909.8	24.7 dbm	0.279	22.1	21.7
Configuration 5 : Bottom side of the Notebook is paralleled and contacted with flat phantom.						
Frequency	Channel	MHz	Conducted Output Power (Average)	Measured(W/kg) 1g	Amb. Temp[°C]	Liquid Temp[°C]
1900 MHz	512	1850.2	25.2 dbm	0.16	22.1	21.7
	661	1880	25 dbm	0.151	22.1	21.7
	810	1909.8	24.7 dbm	0.145	22.1	21.7
Configuration 6: Top side of the EUT is paralleled with flat phantom, and spacing between EUT and phantom is 4mm.						
Frequency	Channel	MHz	Conducted Output Power (Average)	Measured(W/kg) 1g	Amb. Temp[°C]	Liquid Temp[°C]
1900 MHz	512	1850.2	25.2 dbm	0.185	22.1	21.7
	661	1880	25 dbm	0.168	22.1	21.7
	810	1909.8	24.7 dbm	0.154	22.1	21.7
Configuration 7: Bottom side of the Notebook is paralleled and contacted with flat phantom. and front side of the EUT is paralleled with flat phantom.						
Frequency	Channel	MHz	Conducted Output Power (Average)	Measured(W/kg) 1g	Amb. Temp[°C]	Liquid Temp[°C]
1900 MHz	512	1850.2	25.2 dbm	0.955	22.1	21.7
	661	1880	25 dbm	0.698	22.1	21.7
	810	1909.8	24.7 dbm	0.519	22.1	21.7
Configuration8: Bottom side of the Notebook is paralleled and contacted with flat phantom. and right side of the EUT is paralleled with flat phantom.						
Frequency	Channel	MHz	Conducted Output Power (Average)	Measured(W/kg) 1g	Amb. Temp[°C]	Liquid Temp[°C]

1900 MHz	512	1850.2	25.2 dbm	0.92	22.1	21.7
	661	1880	25 dbm	0.685	22.1	21.7
	810	1909.8	24.7 dbm	0.509	22.1	21.7

WCDMA BAND2

Configuration 1: Front side of the EUT is paralleled with flat phantom, and spacing between EUT and phantom is 4mm.

Frequency	Channel	MHz	Conducted Output Power (Average)	Measured(W/kg) 1g	Amb. Temp[°C]	Liquid Temp[°C]
WCDMA BAND 2	9262	1852.4	23.47 dbm	0.52	22.1	21.7
	9400	1880	23.19 dbm	0.676	22.1	21.7
	9538	1907.6	22.81 dbm	0.419	22.1	21.7

Configuration 2 : Back side of the EUT is paralleled with flat phantom, and spacing between EUT and phantom is 4mm.

Frequency	Channel	MHz	Conducted Output Power (Average)	Measured(W/kg) 1g	Amb. Temp[°C]	Liquid Temp[°C]
WCDMA BAND 2	9262	1852.4	23.47 dbm	0.173	22.1	21.7
	9400	1880	23.19 dbm	0.239	22.1	21.7
	9538	1907.6	22.81 dbm	0.162	22.1	21.7

Configuration 3: Right side of the EUT is paralleled with flat phantom, and spacing between EUT and phantom is 4mm.

Frequency	Channel	MHz	Conducted Output Power (Average)	Measured(W/kg) 1g	Amb. Temp[°C]	Liquid Temp[°C]
WCDMA BAND 2	9262	1852.4	23.47 dbm	0.326	22.1	21.7
	9400	1880	23.19 dbm	0.488	22.1	21.7
	9538	1907.6	22.81 dbm	0.243	22.1	21.7

Configuration 4: Left side of the EUT is paralleled with flat phantom, and spacing between EUT and phantom is 4mm.

Frequency	Channel	MHz	Conducted Output Power (Average)	Measured(W/kg) 1g	Amb. Temp[°C]	Liquid Temp[°C]
WCDMA BAND 2	9262	1852.4	23.47 dbm	0,199	22.1	21.7
	9400	1880	23.19 dbm	0.271	22.1	21.7
	9538	1907.6	22.81 dbm	0.195	22.1	21.7

Configuration 5 : Bottom side of the Notebook is paralleled and contacted with flat phantom.

Frequency	Channel	MHz	Conducted Output Power (Average)	Measured(W/kg) 1g	Amb. Temp[°C]	Liquid Temp[°C]
WCDMA BAND 2	9262	1852.4	23.47 dbm	0.137	22.1	21.7
	9400	1880	23.19 dbm	0.151	22.1	21.7
	9538	1907.6	22.81 dbm	0.13	22.1	21.7

Configuration 6: Top side of the EUT is paralleled with flat phantom, and spacing between EUT and phantom is 4mm.

Frequency	Channel	MHz	Conducted Output Power (Average)	Measured(W/kg) 1g	Amb. Temp[°C]	Liquid Temp[°C]
WCDMA BAND 2	9262	1852.4	23.47 dbm	0.169	22.1	21.7
	9400	1880	23.19 dbm	0.218	22.1	21.7
	9538	1907.6	22.81 dbm	0.178	22.1	21.7

Configuration 7 : Bottom side of the Notebook is paralleled and contacted with flat phantom. And front side of the EUT is paralleled with flat phantom.

Frequency	Channel	MHz	Conducted Output Power (Average)	Measured(W/kg) 1g	Amb. Temp[°C]	Liquid Temp[°C]
WCDMA BAND 2	9262	1852.4	23.47 dbm	0.731	22.1	21.7
	9400	1880	23.19 dbm	1.1	22.1	21.7
	9538	1907.6	22.81 dbm	0.668	22.1	21.7

Configuration 8: Bottom side of the Notebook is paralleled and contacted with flat phantom. and right side of the EUT is paralleled with flat phantom.

Frequency	Channel	MHz	Conducted Output Power (Average)	Measured(W/kg) 1g	Amb. Temp[°C]	Liquid Temp[°C]
WCDMA BAND 2	9262	1852.4	23.47 dbm	0.619	22.1	21.7
	9400	1880	23.19 dbm	0.941	22.1	21.7
	9538	1907.6	22.81 dbm	0.61	22.1	21.7

WCDMA BAND2_HSDPA mode

Configuration 1: Front side of the EUT is paralleled with flat phantom, and spacing between EUT and phantom is 4mm.

Frequency	Channel	MHz	Conducted Output Power (Average)	Measured(W/kg) 1g	Amb. Temp[°C]	Liquid Temp[°C]
WCDMA BAND 2	9262	1852.4	23.14 dbm	0.651	22.1	21.7
	9400	1880	23.01 dbm	0.866	22.1	21.7
	9538	1907.6	22.62 dbm	0.402	22.1	21.7

Configuration 2 : Back side of the EUT is paralleled with flat phantom, and spacing between EUT and phantom is 4mm.

Frequency	Channel	MHz	Conducted Output Power (Average)	Measured(W/kg) 1g	Amb. Temp[°C]	Liquid Temp[°C]
WCDMA BAND 2	9262	1852.4	23.14 dbm	0.193	22.1	21.7
	9400	1880	23.01 dbm	0.241	22.1	21.7
	9538	1907.6	22.62 dbm	0.153	22.1	21.7

Configuration 3: Right side of the EUT is paralleled with flat phantom, and spacing between EUT and phantom is 4mm.

Frequency	Channel	MHz	Conducted Output Power (Average)	Measured(W/kg) 1g	Amb. Temp[° C]	Liquid Temp[° C]
WCDMA BAND 2	9262	1852.4	23.14 dbm	0.292	22.1	21.7
	9400	1880	23.01 dbm	0.388	22.1	21.7
	9538	1907.6	22.62 dbm	0.237	22.1	21.7
Configuration 4: Left side of the EUT is paralleled with flat phantom, and spacing between EUT and phantom is 4mm.						
Frequency	Channel	MHz	Conducted Output Power (Average)	Measured(W/kg) 1g	Amb. Temp[° C]	Liquid Temp[° C]
WCDMA BAND 2	9262	1852.4	23.14 dbm	0.229	22.1	21.7
	9400	1880	23.01 dbm	0.275	22.1	21.7
	9538	1907.6	22.62 dbm	0.2	22.1	21.7
Configuration 5 : Bottom side of the Notebook is paralleled and contacted with flat phantom.						
Frequency	Channel	MHz	Conducted Output Power (Average)	Measured(W/kg) 1g	Amb. Temp[° C]	Liquid Temp[° C]
WCDMA BAND 2	9262	1852.4	23.14 dbm	0.132	22.1	21.7
	9400	1880	23.01 dbm	0.142	22.1	21.7
	9538	1907.6	22.62 dbm	0.178	22.1	21.7
Configuration 6: Top side of the EUT is paralleled with flat phantom, and spacing between EUT and phantom is 4mm.						
Frequency	Channel	MHz	Conducted Output Power (Average)	Measured(W/kg) 1g	Amb. Temp[° C]	Liquid Temp[° C]
WCDMA BAND 2	9262	1852.4	23.14 dbm	0.184	22.1	21.7
	9400	1880	23.01 dbm	0.237	22.1	21.7
	9538	1907.6	22.62 dbm	0.163	22.1	21.7
Configuration 7 : Bottom side of the Notebook is paralleled and contacted with flat phantom, And front side of the EUT is paralleled with flat phantom.						
Frequency	Channel	MHz	Conducted Output Power (Average)	Measured(W/kg) 1g	Amb. Temp[° C]	Liquid Temp[° C]
WCDMA BAND 2	9262	1852.4	23.47 dbm	0.663	22.1	21.7
	9400	1880	23.19 dbm	0.919	22.1	21.7
	9538	1907.6	22.81 dbm	0.573	22.1	21.7
Configuration 8: Bottom side of the Notebook is paralleled and contacted with flat phantom, and rght side of the EUT is paralleled with flat phantom.						
Frequency	Channel	MHz	Conducted Output Power (Average)	Measured(W/kg) 1g	Amb. Temp[° C]	Liquid Temp[° C]
WCDMA BAND 2	9262	1852.4	23.47 dbm	0.574	22.1	21.7
	9400	1880	23.19 dbm	0.831	22.1	21.7

	9538	1907.6	22.81 dbm	0.502	22.1	21.7
--	------	--------	-----------	-------	------	------

WCDMA BAND5

Configuration 1: Front side of the EUT is paralleled with flat phantom, and spacing between EUT and phantom is 4mm.

Frequency	Channel	MHz	Conducted Output Power (Average)	Measured(W/kg) 1g	Amb. Temp[° C]	Liquid Temp[° C]
WCDMA BAND 5	4132	826.4	22.65 dbm	0.157	22.1	21.7
	4183	836.6	22.42 dbm	0.164	22.1	21.7
	4233	846.6	22.61 dbm	0.176	22.1	21.7

Configuration 2 : Back side of the EUT is paralleled with flat phantom, and spacing between EUT and phantom is 4mm.

Frequency	Channel	MHz	Conducted Output Power (Average)	Measured(W/kg) 1g	Amb. Temp[° C]	Liquid Temp[° C]
WCDMA BAND 5	4132	826.4	22.65 dbm	0.098	22.1	21.7
	4183	836.6	22.42 dbm	0.105	22.1	21.7
	4233	846.6	22.61 dbm	0.102	22.1	21.7

Configuration 3: Right side of the EUT is paralleled with flat phantom, and spacing between EUT and phantom is 4mm.

Frequency	Channel	MHz	Conducted Output Power (Average)	Measured(W/kg) 1g	Amb. Temp[° C]	Liquid Temp[° C]
WCDMA BAND 5	4132	826.4	22.65 dbm	0.114	22.1	21.7
	4183	836.6	22.42 dbm	0.119	22.1	21.7
	4233	846.6	22.61 dbm	0.104	22.1	21.7

Configuration 4: Left side of the EUT is paralleled with flat phantom, and spacing between EUT and phantom is 4mm.

Frequency	Channel	MHz	Conducted Output Power (Average)	Measured(W/kg) 1g	Amb. Temp[° C]	Liquid Temp[° C]
WCDMA BAND 5	4132	826.4	22.65 dbm	0.114	22.1	21.7
	4183	836.6	22.42 dbm	0.128	22.1	21.7
	4233	846.6	22.61 dbm	0.105	22.1	21.7

Configuration 5 : Bottom side of the Notebook is paralleled and contacted with flat phantom.

Frequency	Channel	MHz	Conducted Output Power (Average)	Measured(W/kg) 1g	Amb. Temp[° C]	Liquid Temp[° C]
WCDMA BAND 5	4132	826.4	22.65 dbm	0.082	22.1	21.7
	4183	836.6	22.42 dbm	0.089	22.1	21.7
	4233	846.6	22.61 dbm	0.082	22.1	21.7

Configuration 6: Top side of the EUT is paralleled with flat phantom, and spacing between EUT and phantom is 4mm.

Frequency	Channel	MHz	Conducted Output Power (Average)	Measured(W/kg) 1g	Amb. Temp[°C]	Liquid Temp[°C]
WCDMA BAND 5	4132	826.4	22.65 dbm	0.068	22.1	21.7
	4183	836.6	22.42 dbm	0.072	22.1	21.7
	4233	846.6	22.61 dbm	0.067	22.1	21.7

Configuration 7 : Bottom side of the Notebook is paralleled and contacted with flat phantom, and front side of the EUT is paralleled with flat phantom.

Frequency	Channel	MHz	Conducted Output Power (Average)	Measured(W/kg) 1g	Amb. Temp[°C]	Liquid Temp[°C]
WCDMA BAND 5	4132	826.4	22.65 dbm	0.114	22.1	21.7
	4183	836.6	22.42 dbm	0.109	22.1	21.7
	4233	846.6	22.61 dbm	0.063	22.1	21.7

Configuration 8: Bottom side of the Notebook is paralleled and contacted with flat phantom, and right side of the EUT is paralleled with flat phantom.

Frequency	Channel	MHz	Conducted Output Power (Average)	Measured(W/kg) 1g	Amb. Temp[°C]	Liquid Temp[°C]
WCDMA BAND 5	4132	826.4	22.65 dbm	0.087	22.1	21.7
	4183	836.6	22.42 dbm	0.084	22.1	21.7
	4233	846.6	22.61 dbm	0.049	22.1	21.7

WCDMA BAND5_HSDPA mode

Configuration 1: Front side of the EUT is paralleled with flat phantom, and spacing between EUT and phantom is 4mm.

Frequency	Channel	MHz	Conducted Output Power (Average)	Measured(W/kg) 1g	Amb. Temp[°C]	Liquid Temp[°C]
WCDMA BAND 5	4132	826.4	22.48 dbm	0.129	22.1	21.7
	4183	836.6	22.16 dbm	0.152	22.1	21.7
	4233	846.6	22.31 dbm	0.099	22.1	21.7

Configuration 2 : Back side of the EUT is paralleled with flat phantom, and spacing between EUT and phantom is 4mm.

Frequency	Channel	MHz	Conducted Output Power (Average)	Measured(W/kg) 1g	Amb. Temp[°C]	Liquid Temp[°C]
WCDMA BAND 5	4132	826.4	22.48 dbm	0.105	22.1	21.7
	4183	836.6	22.16 dbm	0.108	22.1	21.7
	4233	846.6	22.31 dbm	0.099	22.1	21.7

Configuration 3: Right side of the EUT is paralleled with flat phantom, and spacing between EUT and phantom is 4mm.

Frequency	Channel	MHz	Conducted Output Power (Average)	Measured(W/kg) 1g	Amb. Temp[°C]	Liquid Temp[°C]
-----------	---------	-----	----------------------------------	-------------------	----------------	------------------

WCDMA BAND 5	4132	826.4	22.48 dbm	0.101	22.1	21.7
	4183	836.6	22.16 dbm	0.108	22.1	21.7
	4233	846.6	22.31 dbm	0.082	22.1	21.7
Configuration 4: Left side of the EUT is paralleled with flat phantom, and spacing between EUT and phantom is 4mm.						
Frequency	Channel	MHz	Conducted Output Power (Average)	Measured(W/kg) 1g	Amb. Temp[°C]	Liquid Temp[°C]
WCDMA BAND 5	4132	826.4	22.48 dbm	0.11	22.1	21.7
	4183	836.6	22.16 dbm	0.121	22.1	21.7
	4233	846.6	22.31 dbm	0.101	22.1	21.7
Configuration 5 : Bottom side of the Notebook is paralleled and contacted with flat phantom.						
Frequency	Channel	MHz	Conducted Output Power (Average)	Measured(W/kg) 1g	Amb. Temp[°C]	Liquid Temp[°C]
WCDMA BAND 5	4132	826.4	22.48 dbm	0.085	22.1	21.7
	4183	836.6	22.16 dbm	0.099	22.1	21.7
	4233	846.6	22.31 dbm	0.097	22.1	21.7
Configuration 6: Top side of the EUT is paralleled with flat phantom, and spacing between EUT and phantom is 4mm.						
Frequency	Channel	MHz	Conducted Output Power (Average)	Measured(W/kg) 1g	Amb. Temp[°C]	Liquid Temp[°C]
WCDMA BAND 5	4132	826.4	22.48 dbm	0.071	22.1	21.7
	4183	836.6	22.16 dbm	0.074	22.1	21.7
	4233	846.6	22.31 dbm	0.066	22.1	21.7
Configuration 7 : Bottom side of the Notebook is paralleled and contacted with flat phantom, And front side of the EUT is paralleled with flat phantom.						
Frequency	Channel	MHz	Conducted Output Power (Average)	Measured(W/kg) 1g	Amb. Temp[°C]	Liquid Temp[°C]
WCDMA BAND 5	4132	826.4	22.48 dbm	0.113	22.1	21.7
	4183	836.6	22.16 dbm	0.111	22.1	21.7
	4233	846.6	22.31 dbm	0.064	22.1	21.7
Configuration 8: Bottom side of the Notebook is paralleled and contacted with flat phantom, and right side of the EUT is paralleled with flat phantom.						
Frequency	Channel	MHz	Conducted Output Power (Average)	Measured(W/kg) 1g	Amb. Temp[°C]	Liquid Temp[°C]
WCDMA BAND 5	4132	826.4	22.48 dbm	0.078	22.1	21.7
	4183	836.6	22.16 dbm	0.075	22.1	21.7
	4233	846.6	22.31 dbm	0.044	22.1	21.7

Note: SAR measurement results for the data card at maximum output power.

3. Instruments List

Manufacturer	Device	Type	Serial number	Date of last calibration
Schmid & Partner Engineering AG	Dosimetric E-FieldProbe	ES3DV3	3172	Jun.23.2008
Schmid & Partner Engineering AG	850/1900MHz System Validation Dipole	D835V2 D1900V2	4d063 5d027	Jun.06.2008 Apr.15.2008
Schmid & Partner Engineering AG	Data acquisition Electronics	DAE4	856	May.07.2008
Schmid & Partner Engineering AG	Software	DASY 5 V5.0 Build 119	N/A	Calibration isn't necessary
Schmid & Partner Engineering AG	Phantom	SAM	N/A	Calibration isn't necessary
Agilent	Network Analyzer	8753D	3410A05547	Nov.14.2007
Agilent	Dielectric Probe Kit	85070D	US01440168	Calibration isn't necessary
Agilent	Dual-directional coupler	778D	50313	Aug.26.2008
Agilent	RF Signal Generator	E4438c	MY45093613	May.21.2008
Agilent	Power Sensor	8481H	MY41091361	May.20.2008
R&S	Radio Communication Test	CMU200	109326	May.11.2008

4. Measurements

Date/Time: 9/17/2008 03:27:15

Configuration 1_CH128

DUT: C152,

Communication System: GSM 850; Frequency: 824.2 MHz; Duty Cycle: 1:2

Medium: GSM 850 Medium parameters used (interpolated): $f = 824.2$ MHz; $\sigma = 0.942$ mho/m; $\epsilon_r = 56.3$; $\rho = 1000$ kg/m³

Phantom section: Flat Section

- Probe: ES3DV3 - SN3172; ConvF(5.61, 5.61, 5.61); Calibrated: 6/23/2008
- Sensor-Surface: 4mm (Mechanical Surface Detection)
- Electronics: DAE4 Sn856; Calibrated: 5/7/2008
- Phantom: SAM1; Type: SAM;
- Measurement SW: DASY5, V5.0 Build 119; SEMCAD X Version 13.2 Build 87

Body/Area Scan: Measurement grid: dx=15mm, dy=15mm

Maximum value of SAR (interpolated) = 0.190 mW/g

Body/Zoom Scan: Measurement grid: dx=8mm, dy=8mm, dz=5mm

Reference Value = 11.6 V/m; Power Drift = 0.012 dB

Peak SAR (extrapolated) = 0.231 W/kg

SAR(1 g) = 0.162 mW/g; SAR(10 g) = 0.123 mW/g

Maximum value of SAR (measured) = 0.171 mW/g

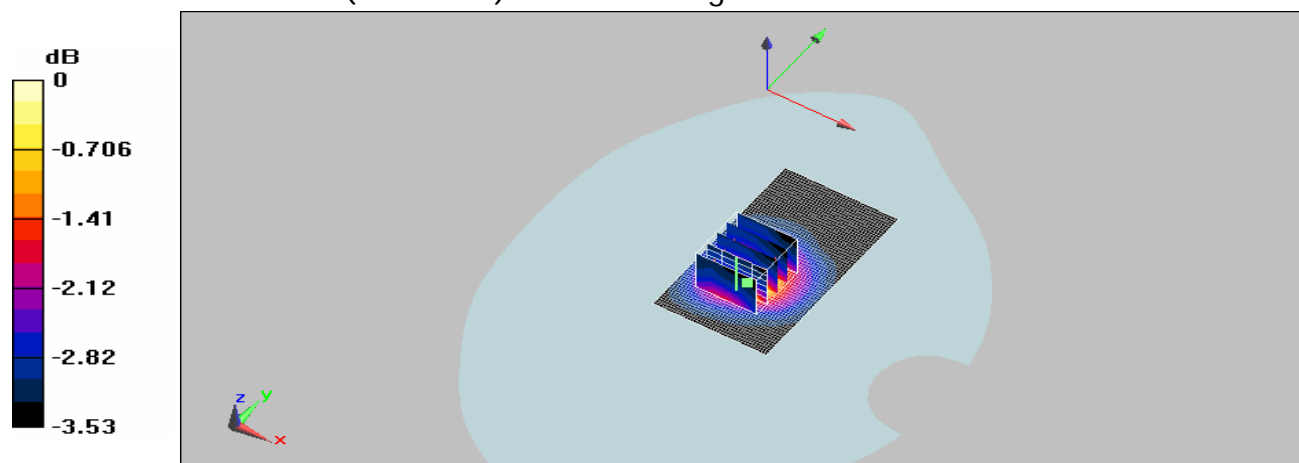

0 dB = 0.171mW/g

Date/Time: 9/17/2008 03:51:37

Configuration 1_CH190

DUT: C152,

Communication System: GSM 850; Frequency: 836.6 MHz; Duty Cycle: 1:2

Medium: GSM 850 Medium parameters used: $f = 837$ MHz; $\sigma = 0.957$ mho/m; $\epsilon_r = 56.2$; $\rho = 1000$ kg/m³

Phantom section: Flat Section

DASY5 Configuration:

- Probe: ES3DV3 - SN3172; ConvF(5.61, 5.61, 5.61); Calibrated: 6/23/2008
- Sensor-Surface: 4mm (Mechanical Surface Detection)
- Electronics: DAE4 Sn856; Calibrated: 5/7/2008
- Phantom: SAM1; Type: SAM;
- Measurement SW: DASY5, V5.0 Build 119; SEMCAD X Version 13.2 Build 87

Body/Area Scan: Measurement grid: dx=15mm, dy=15mm

Maximum value of SAR (interpolated) = 0.162 mW/g

Body/Zoom Scan: Measurement grid: dx=8mm, dy=8mm, dz=5mm

Reference Value = 11 V/m; Power Drift = 0.139 dB

Peak SAR (extrapolated) = 0.191 W/kg

SAR(1 g) = 0.146 mW/g; SAR(10 g) = 0.119 mW/g

Maximum value of SAR (measured) = 0.153 mW/g

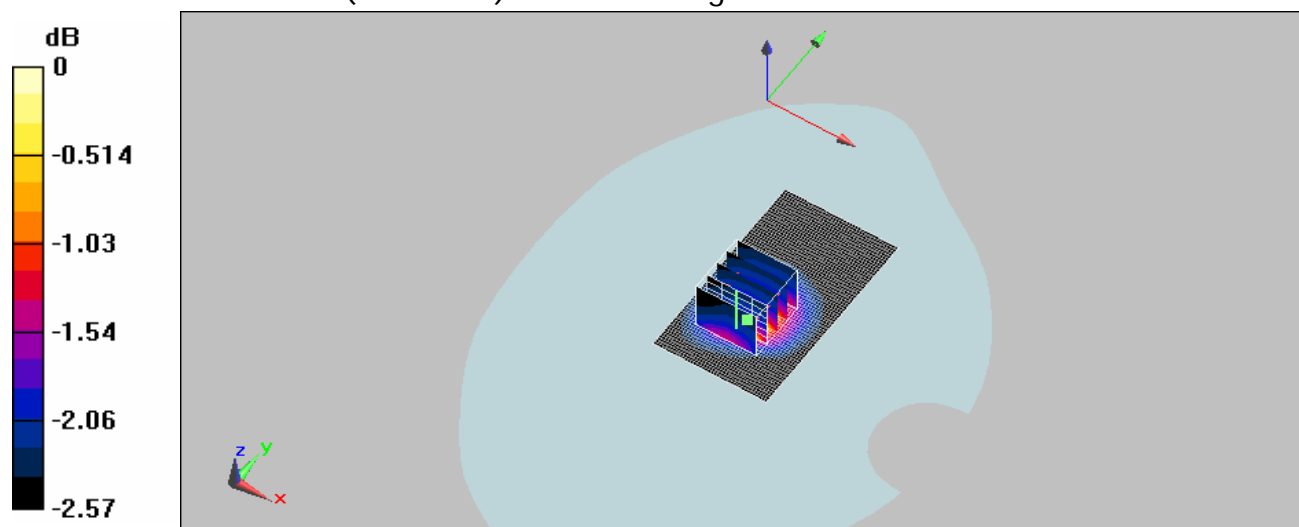

0 dB = 0.153mW/g

Date/Time: 9/17/2008 04:17:28

Configuration 1_CH251

DUT: C152,

Communication System: GSM 850; Frequency: 848.8 MHz; Duty Cycle: 1:2

Medium: GSM 850 Medium parameters used: $f = 849$ MHz; $\sigma = 0.97$ mho/m; $\epsilon_r = 56.1$; $\rho = 1000$ kg/m³

Phantom section: Flat Section

DASY5 Configuration:

- Probe: ES3DV3 - SN3172; ConvF(5.61, 5.61, 5.61); Calibrated: 6/23/2008
- Sensor-Surface: 4mm (Mechanical Surface Detection)
- Electronics: DAE4 Sn856; Calibrated: 5/7/2008
- Phantom: SAM1; Type: SAM;
- Measurement SW: DASY5, V5.0 Build 119; SEMCAD X Version 13.2 Build 87

Body/Area Scan : Measurement grid: dx=15mm, dy=15mm

Maximum value of SAR (interpolated) = 0.137 mW/g

Body/Zoom Scan : Measurement grid: dx=8mm, dy=8mm, dz=5mm

Reference Value = 10.5 V/m; Power Drift = 0.034 dB

Peak SAR (extrapolated) = 0.156 W/kg

SAR(1 g) = 0.126 mW/g; SAR(10 g) = 0.106 mW/g

Maximum value of SAR (measured) = 0.131 mW/g

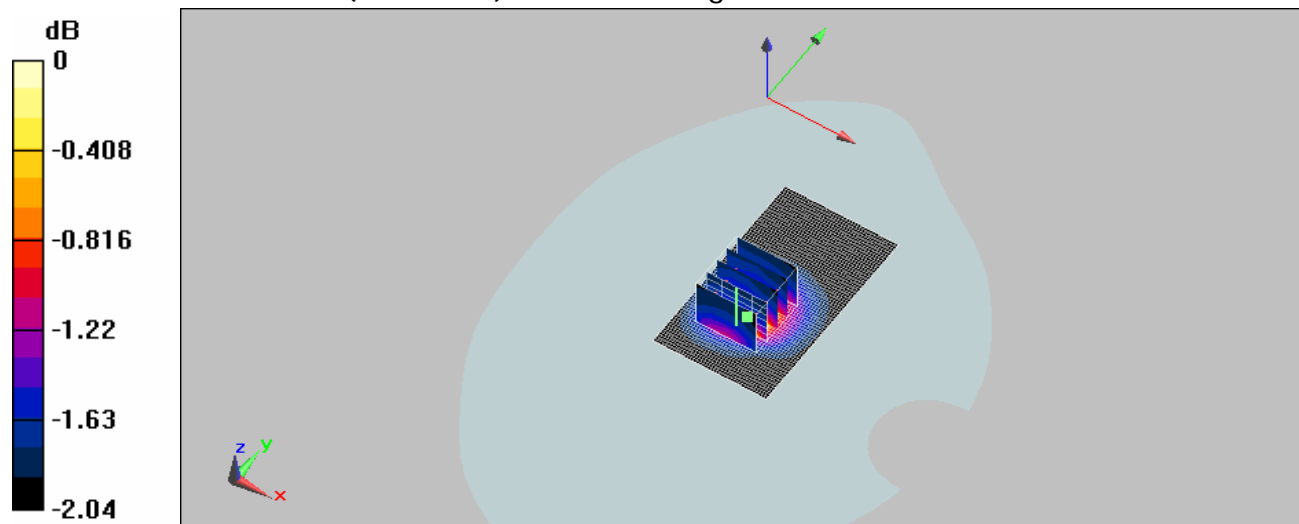

0 dB = 0.131mW/g

Date/Time: 9/17/2008 05:36:30

Configuration 2_CH128

DUT: C152,

Communication System: GSM 850; Frequency: 824.2 MHz; Duty Cycle: 1:2

Medium: GSM 850 Medium parameters used (interpolated): $f = 824.2$ MHz; $\sigma = 0.942$ mho/m; $\epsilon_r = 56.3$; $\rho = 1000$ kg/m³

Phantom section: Flat Section

DASY5 Configuration:

- Probe: ES3DV3 - SN3172; ConvF(5.61, 5.61, 5.61); Calibrated: 6/23/2008
- Sensor-Surface: 4mm (Mechanical Surface Detection)
- Electronics: DAE4 Sn856; Calibrated: 5/7/2008
- Phantom: SAM1; Type: SAM;
- Measurement SW: DASY5, V5.0 Build 119; SEMCAD X Version 13.2 Build 87

Body/Area Scan : Measurement grid: dx=15mm, dy=15mm

Maximum value of SAR (interpolated) = 0.132 mW/g

Body/Zoom Scan : Measurement grid: dx=8mm, dy=8mm, dz=5mm

Reference Value = 10.8 V/m; Power Drift = -0.024 dB

Peak SAR (extrapolated) = 0.142 W/kg

SAR(1 g) = 0.123 mW/g; SAR(10 g) = 0.107 mW/g

Maximum value of SAR (measured) = 0.126 mW/g

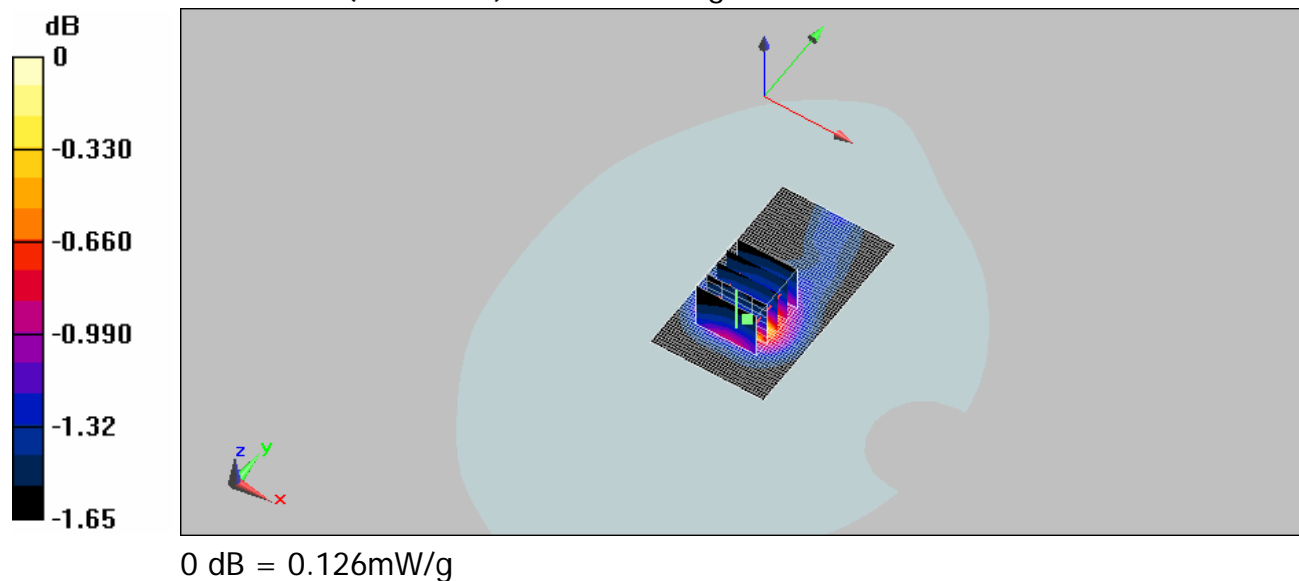

Date/Time: 9/17/2008 05:12:19

Configuration 2_CH190

DUT: C152,

Communication System: GSM 850; Frequency: 836.6 MHz; Duty Cycle: 1:2

Medium: GSM 850 Medium parameters used: $f = 837$ MHz; $\sigma = 0.957$ mho/m; $\epsilon_r = 56.2$; $\rho = 1000$ kg/m³

Phantom section: Flat Section

DASY5 Configuration:

- Probe: ES3DV3 - SN3172; ConvF(5.61, 5.61, 5.61); Calibrated: 6/23/2008
- Sensor-Surface: 4mm (Mechanical Surface Detection)
- Electronics: DAE4 Sn856; Calibrated: 5/7/2008
- Phantom: SAM1; Type: SAM;
- Measurement SW: DASY5, V5.0 Build 119; SEMCAD X Version 13.2 Build 87

Body/Area Scan : Measurement grid: dx=15mm, dy=15mm

Maximum value of SAR (interpolated) = 0.124 mW/g

Body/Zoom Scan : Measurement grid: dx=8mm, dy=8mm, dz=5mm

Reference Value = 10.5 V/m; Power Drift = 0.00935 dB

Peak SAR (extrapolated) = 0.127 W/kg

SAR(1 g) = 0.117 mW/g; SAR(10 g) = 0.106 mW/g

Maximum value of SAR (measured) = 0.118 mW/g

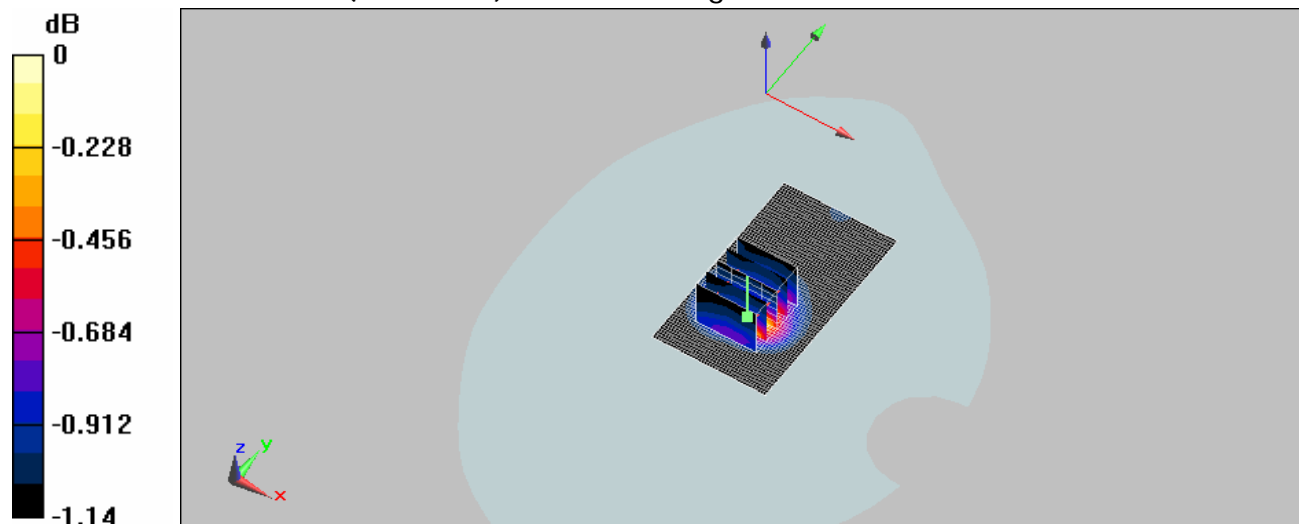

0 dB = 0.118mW/g

Date/Time: 9/17/2008 04:49:41

Configuration 2_CH251

DUT: C152,

Communication System: GSM 850; Frequency: 848.8 MHz; Duty Cycle: 1:2

Medium: GSM 850 Medium parameters used: $f = 849$ MHz; $\sigma = 0.97$ mho/m; $\epsilon_r = 56.1$; $\rho = 1000$ kg/m³

Phantom section: Flat Section

DASY5 Configuration:

- Probe: ES3DV3 - SN3172; ConvF(5.61, 5.61, 5.61); Calibrated: 6/23/2008
- Sensor-Surface: 4mm (Mechanical Surface Detection)
- Electronics: DAE4 Sn856; Calibrated: 5/7/2008
- Phantom: SAM1; Type: SAM;
- Measurement SW: DASY5, V5.0 Build 119; SEMCAD X Version 13.2 Build 87

Body/Area Scan : Measurement grid: dx=15mm, dy=15mm

Maximum value of SAR (interpolated) = 0.109 mW/g

Body/Zoom Scan : Measurement grid: dx=8mm, dy=8mm, dz=5mm

Reference Value = 10.1 V/m; Power Drift = 0.00291 dB

Peak SAR (extrapolated) = 0.111 W/kg

SAR(1 g) = 0.107 mW/g; SAR(10 g) = 0.100 mW/g

Maximum value of SAR (measured) = 0.108 mW/g

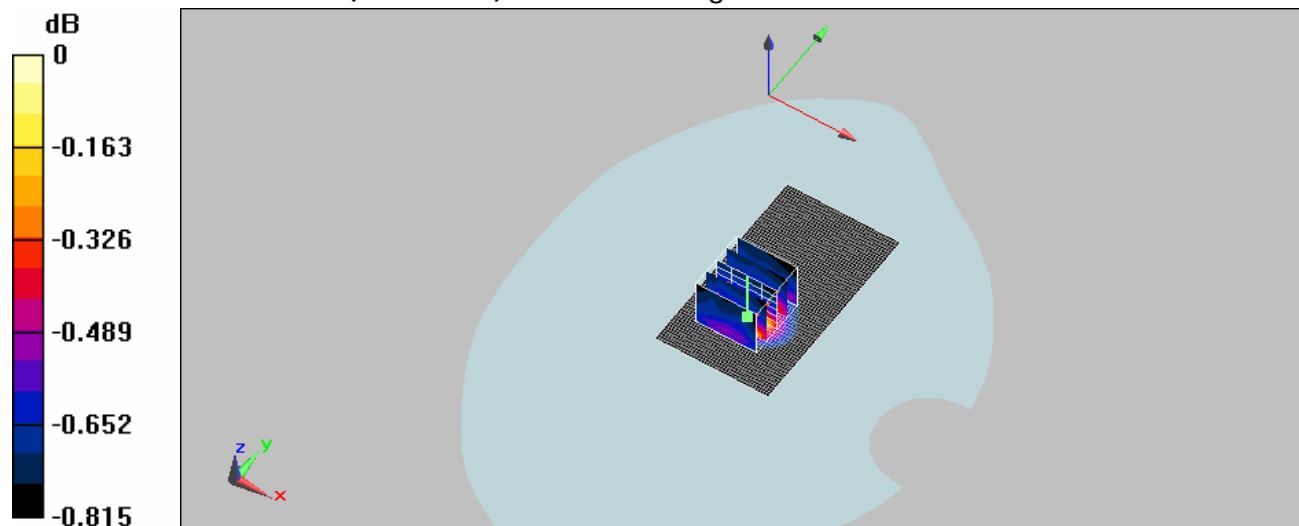

0 dB = 0.108mW/g

Date/Time: 9/17/2008 06:06:02

Configuration 3_CH128

DUT: C152,

Communication System: GSM 850; Frequency: 824.2 MHz; Duty Cycle: 1:2

Medium: GSM 850 Medium parameters used (interpolated): $f = 824.2$ MHz; $\sigma = 0.942$ mho/m; $\epsilon_r = 56.3$; $\rho = 1000$ kg/m³

Phantom section: Flat Section

DASY5 Configuration:

- Probe: ES3DV3 - SN3172; ConvF(5.61, 5.61, 5.61); Calibrated: 6/23/2008
- Sensor-Surface: 4mm (Mechanical Surface Detection)
- Electronics: DAE4 Sn856; Calibrated: 5/7/2008
- Phantom: SAM1; Type: SAM;
- Measurement SW: DASY5, V5.0 Build 119; SEMCAD X Version 13.2 Build 87

Body/Area Scan : Measurement grid: dx=15mm, dy=15mm

Maximum value of SAR (interpolated) = 0.126 mW/g

Body/Zoom Scan : Measurement grid: dx=8mm, dy=8mm, dz=5mm

Reference Value = 11.2 V/m; Power Drift = -0.037 dB

Peak SAR (extrapolated) = 0.132 W/kg

SAR(1 g) = 0.117 mW/g; SAR(10 g) = 0.105 mW/g

Maximum value of SAR (measured) = 0.120 mW/g

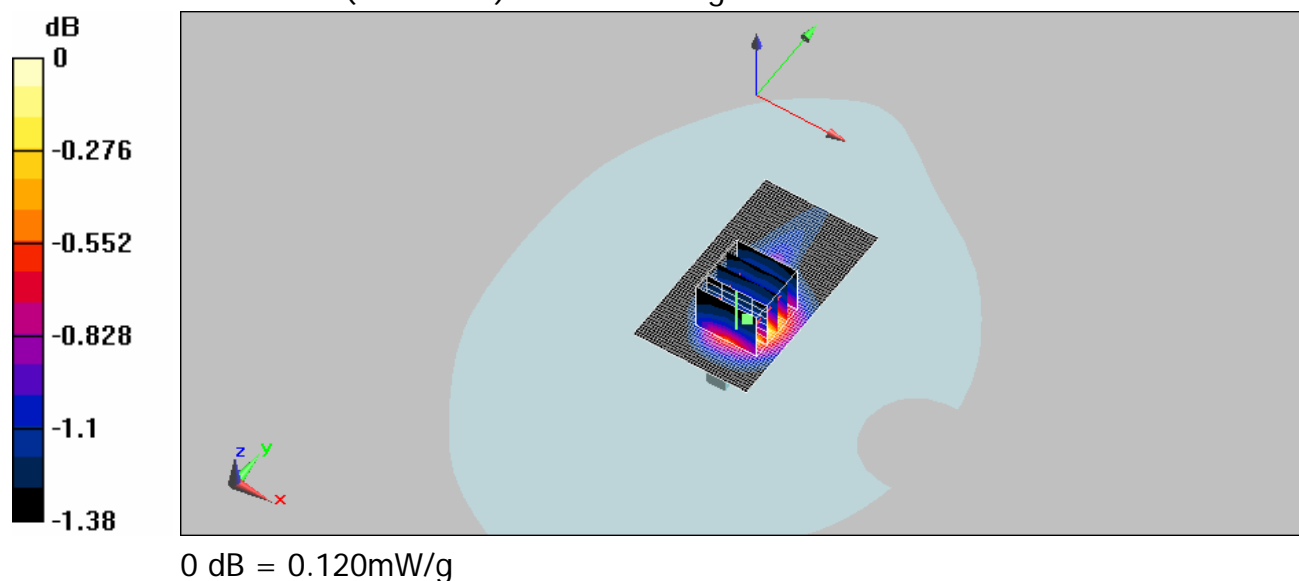

Date/Time: 9/17/2008 06:28:12

Configuration 3_CH190

DUT: C152,

Communication System: GSM 850; Frequency: 836.6 MHz; Duty Cycle: 1:2

Medium: GSM 850 Medium parameters used: $f = 837$ MHz; $\sigma = 0.957$ mho/m; $\epsilon_r = 56.2$; $\rho = 1000$ kg/m³

Phantom section: Flat Section

DASY5 Configuration:

- Probe: ES3DV3 - SN3172; ConvF(5.61, 5.61, 5.61); Calibrated: 6/23/2008
- Sensor-Surface: 4mm (Mechanical Surface Detection)
- Electronics: DAE4 Sn856; Calibrated: 5/7/2008
- Phantom: SAM1; Type: SAM;
- Measurement SW: DASY5, V5.0 Build 119; SEMCAD X Version 13.2 Build 87

Body/Area Scan : Measurement grid: dx=15mm, dy=15mm

Maximum value of SAR (interpolated) = 0.123 mW/g

Body/Zoom Scan : Measurement grid: dx=8mm, dy=8mm, dz=5mm

Reference Value = 10.9 V/m; Power Drift = -0.018 dB

Peak SAR (extrapolated) = 0.127 W/kg

SAR(1 g) = 0.114 mW/g; SAR(10 g) = 0.103 mW/g

Maximum value of SAR (measured) = 0.117 mW/g

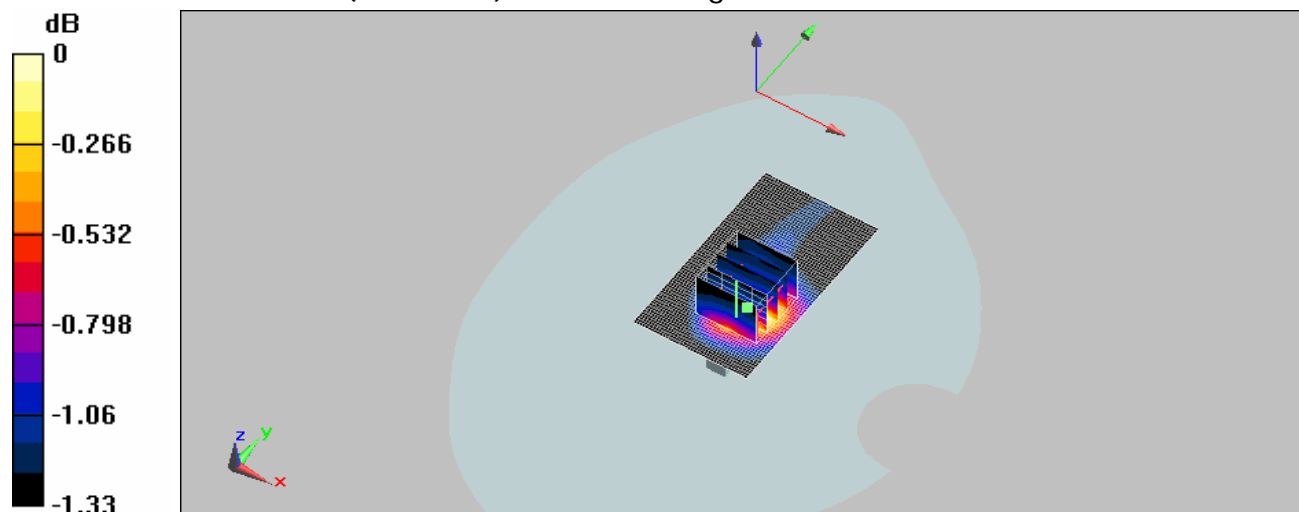

0 dB = 0.117mW/g

Date/Time: 9/17/2008 06:52:29

Configuration 3_CH251

DUT: C152,

Communication System: GSM 850; Frequency: 848.8 MHz; Duty Cycle: 1:2

Medium: GSM 850 Medium parameters used: $f = 849$ MHz; $\sigma = 0.97$ mho/m; $\epsilon_r = 56.1$; $\rho = 1000$ kg/m³

Phantom section: Flat Section

DASY5 Configuration:

- Probe: ES3DV3 - SN3172; ConvF(5.61, 5.61, 5.61); Calibrated: 6/23/2008
- Sensor-Surface: 4mm (Mechanical Surface Detection)
- Electronics: DAE4 Sn856; Calibrated: 5/7/2008
- Phantom: SAM1; Type: SAM;
- Measurement SW: DASY5, V5.0 Build 119; SEMCAD X Version 13.2 Build 87

Body/Area Scan : Measurement grid: dx=15mm, dy=15mm

Maximum value of SAR (interpolated) = 0.117 mW/g

Body/Zoom Scan : Measurement grid: dx=8mm, dy=8mm, dz=5mm

Reference Value = 10.6 V/m; Power Drift = -0.026 dB

Peak SAR (extrapolated) = 0.120 W/kg

SAR(1 g) = 0.111 mW/g; SAR(10 g) = 0.101 mW/g

Maximum value of SAR (measured) = 0.113 mW/g

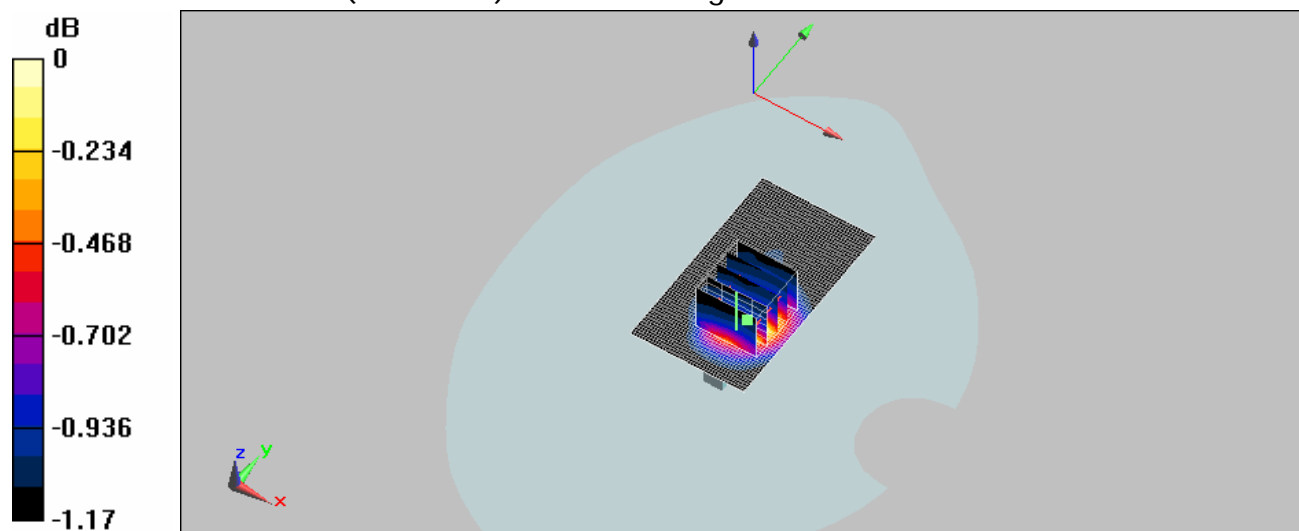

0 dB = 0.113mW/g

Date/Time: 9/17/2008 08:06:32

Configuration 4_CH128**DUT: C152,**

Communication System: GSM 850; Frequency: 824.2 MHz; Duty Cycle: 1:2

Medium: GSM 850 Medium parameters used (interpolated): $f = 824.2$ MHz; $\sigma = 0.942$ mho/m; $\epsilon_r = 56.3$; $\rho = 1000$ kg/m³

Phantom section: Flat Section

DASY5 Configuration:

- Probe: ES3DV3 - SN3172; ConvF(5.61, 5.61, 5.61); Calibrated: 6/23/2008
- Sensor-Surface: 4mm (Mechanical Surface Detection)
- Electronics: DAE4 Sn856; Calibrated: 5/7/2008
- Phantom: SAM1; Type: SAM;
- Measurement SW: DASY5, V5.0 Build 119; SEMCAD X Version 13.2 Build 87

Body/Area Scan : Measurement grid: dx=15mm, dy=15mm

Maximum value of SAR (interpolated) = 0.124 mW/g

Body/Zoom Scan : Measurement grid: dx=8mm, dy=8mm, dz=5mm

Reference Value = 10.1 V/m; Power Drift = -0.104 dB

Peak SAR (extrapolated) = 0.131 W/kg

SAR(1 g) = 0.111 mW/g; SAR(10 g) = 0.095 mW/g

Maximum value of SAR (measured) = 0.114 mW/g

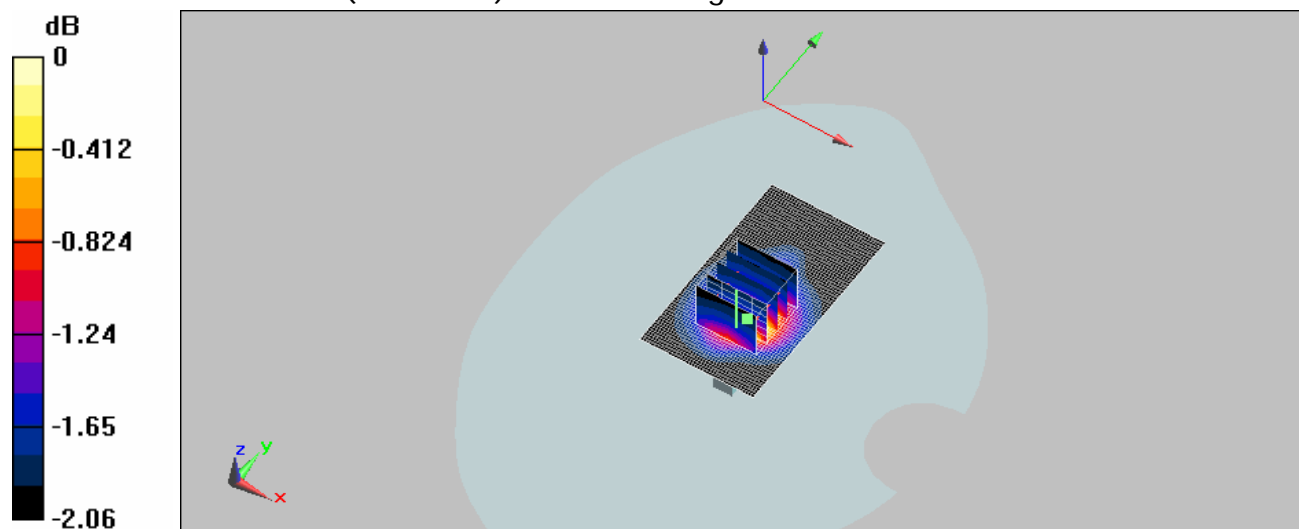

0 dB = 0.114mW/g

Date/Time: 9/17/2008 07:41:47

Configuration 4_CH190

DUT: C152,

Communication System: GSM 850; Frequency: 836.6 MHz; Duty Cycle: 1:2

Medium: GSM 850 Medium parameters used: $f = 837$ MHz; $\sigma = 0.957$ mho/m; $\epsilon_r = 56.2$; $\rho = 1000$ kg/m³

Phantom section: Flat Section

DASY5 Configuration:

- Probe: ES3DV3 - SN3172; ConvF(5.61, 5.61, 5.61); Calibrated: 6/23/2008
- Sensor-Surface: 4mm (Mechanical Surface Detection)
- Electronics: DAE4 Sn856; Calibrated: 5/7/2008
- Phantom: SAM1; Type: SAM;
- Measurement SW: DASY5, V5.0 Build 119; SEMCAD X Version 13.2 Build 87

Body/Area Scan : Measurement grid: dx=15mm, dy=15mm

Maximum value of SAR (interpolated) = 0.120 mW/g

Body/Zoom Scan : Measurement grid: dx=8mm, dy=8mm, dz=5mm

Reference Value = 9.92 V/m; Power Drift = 0.077 dB

Peak SAR (extrapolated) = 0.126 W/kg

SAR(1 g) = 0.110 mW/g; SAR(10 g) = 0.096 mW/g

Maximum value of SAR (measured) = 0.112 mW/g

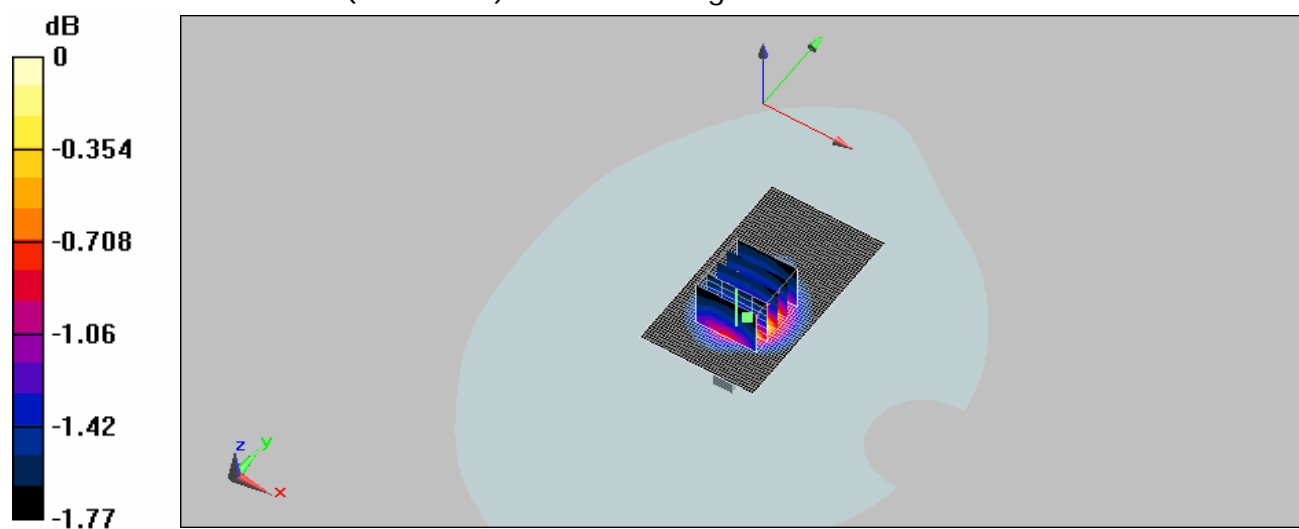

Date/Time: 9/17/2008 07:19:53

Configuration 4_CH251

DUT: C152,

Communication System: GSM 850; Frequency: 848.8 MHz; Duty Cycle: 1:2

Medium: GSM 850 Medium parameters used: $f = 849$ MHz; $\sigma = 0.97$ mho/m; $\epsilon_r = 56.1$; $\rho = 1000$ kg/m³

Phantom section: Flat Section

DASY5 Configuration:

- Probe: ES3DV3 - SN3172; ConvF(5.61, 5.61, 5.61); Calibrated: 6/23/2008
- Sensor-Surface: 4mm (Mechanical Surface Detection)
- Electronics: DAE4 Sn856; Calibrated: 5/7/2008
- Phantom: SAM1; Type: SAM;
- Measurement SW: DASY5, V5.0 Build 119; SEMCAD X Version 13.2 Build 87

Body/Area Scan : Measurement grid: dx=15mm, dy=15mm

Maximum value of SAR (interpolated) = 0.103 mW/g

Body/Zoom Scan : Measurement grid: dx=8mm, dy=8mm, dz=5mm

Reference Value = 9.61 V/m; Power Drift = -0.00412 dB

Peak SAR (extrapolated) = 0.105 W/kg

SAR(1 g) = 0.098 mW/g; SAR(10 g) = 0.089 mW/g

Maximum value of SAR (measured) = 0.099 mW/g

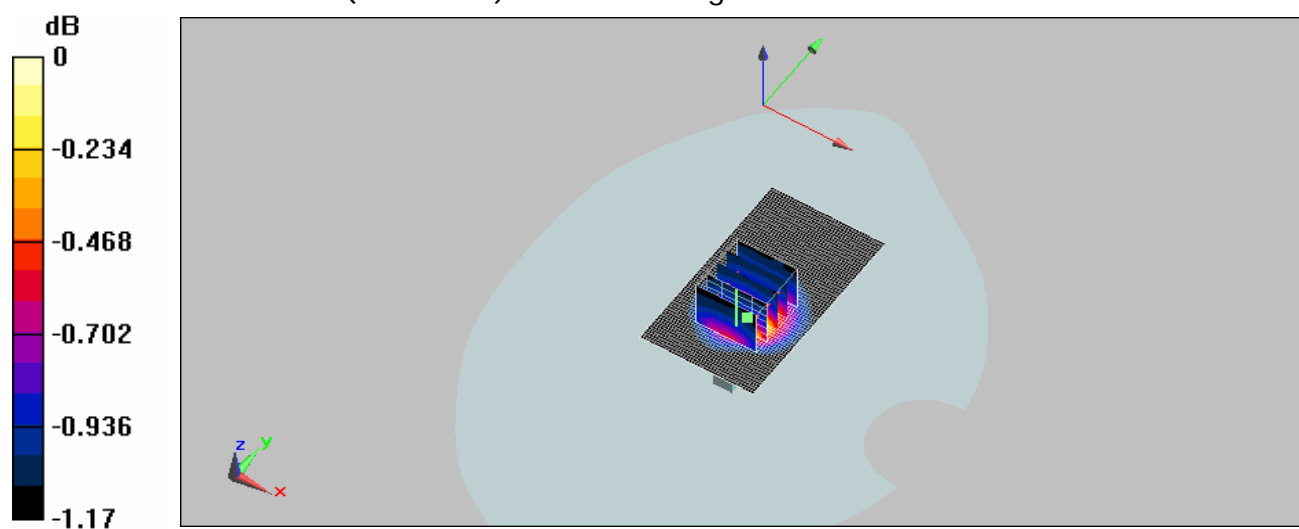

0 dB = 0.099mW/g

Date/Time: 9/17/2008 08:41:55

Configuration 5_CH128

DUT: C152,

Communication System: GSM 850; Frequency: 824.2 MHz; Duty Cycle: 1:2

Medium: GSM850 Medium parameters used (interpolated): $f = 824.2$ MHz; $\sigma = 0.942$ mho/m;

$\epsilon_r = 56.3$; $\rho = 1000$ kg/m³

Phantom section: Flat Section

DASY5 Configuration:

- Probe: ES3DV3 - SN3172; ConvF(5.61, 5.61, 5.61); Calibrated: 6/23/2008
- Sensor-Surface: 4mm (Mechanical Surface Detection)
- Electronics: DAE4 Sn856; Calibrated: 5/7/2008
- Phantom: SAM1; Type: SAM;
- Measurement SW: DASY5, V5.0 Build 119; SEMCAD X Version 13.2 Build 87

Body/Area Scan: Measurement grid: dx=15mm, dy=15mm

Maximum value of SAR (interpolated) = 0.085 mW/g

Body/Zoom Scan : Measurement grid: dx=8mm, dy=8mm, dz=5mm

Reference Value = 9.23 V/m; Power Drift = 0.171 dB

Peak SAR (extrapolated) = 0.086 W/kg

SAR(1 g) = 0.085 mW/g; SAR(10 g) = 0.082 mW/g

Maximum value of SAR (measured) = 0.085 mW/g

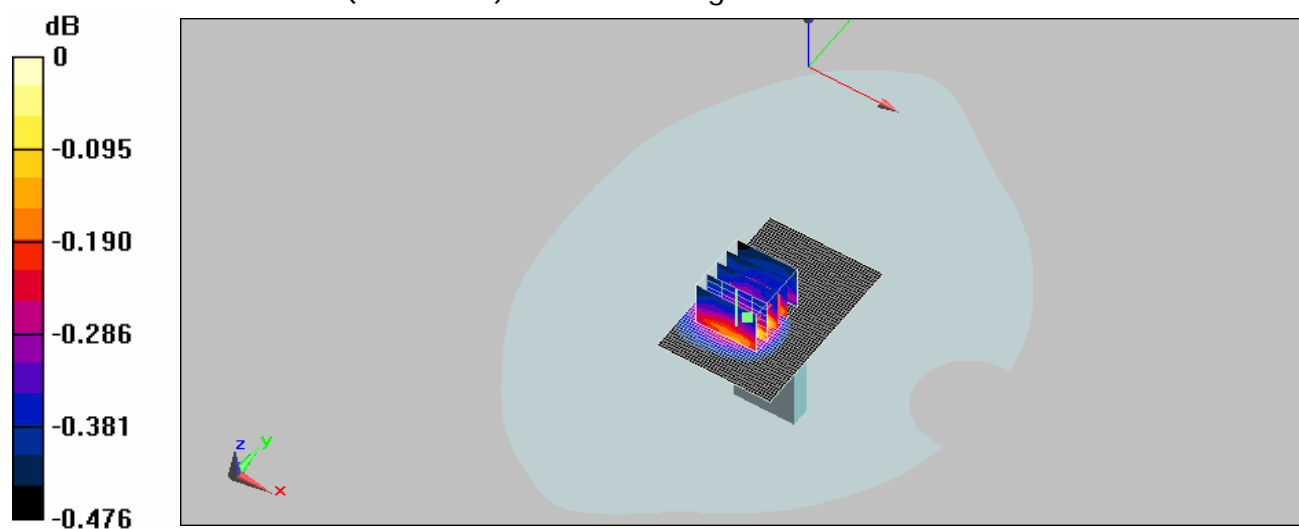

Date/Time: 9/17/2008 09:05:28

Configuration 5_CH190**DUT: C152,**

Communication System: GSM 850; Frequency: 836.6 MHz; Duty Cycle: 1:2

Medium: GSM850 Medium parameters used: $f = 837$ MHz; $\sigma = 0.957$ mho/m; $\epsilon_r = 56.2$; $\rho = 1000$ kg/m³

Phantom section: Flat Section

DASY5 Configuration:

- Probe: ES3DV3 - SN3172; ConvF(5.61, 5.61, 5.61); Calibrated: 6/23/2008
- Sensor-Surface: 4mm (Mechanical Surface Detection)
- Electronics: DAE4 Sn856; Calibrated: 5/7/2008
- Phantom: SAM1; Type: SAM;
- Measurement SW: DASY5, V5.0 Build 119; SEMCAD X Version 13.2 Build 87

Body/Area Scan: Measurement grid: dx=15mm, dy=15mm

Maximum value of SAR (interpolated) = 0.094 mW/g

Body/Zoom Scan : Measurement grid: dx=8mm, dy=8mm, dz=5mm

Reference Value = 9.8 V/m; Power Drift = -0.160 dB

Peak SAR (extrapolated) = 0.091 W/kg

SAR(1 g) = 0.089 mW/g; SAR(10 g) = 0.086 mW/g

Maximum value of SAR (measured) = 0.090 mW/g

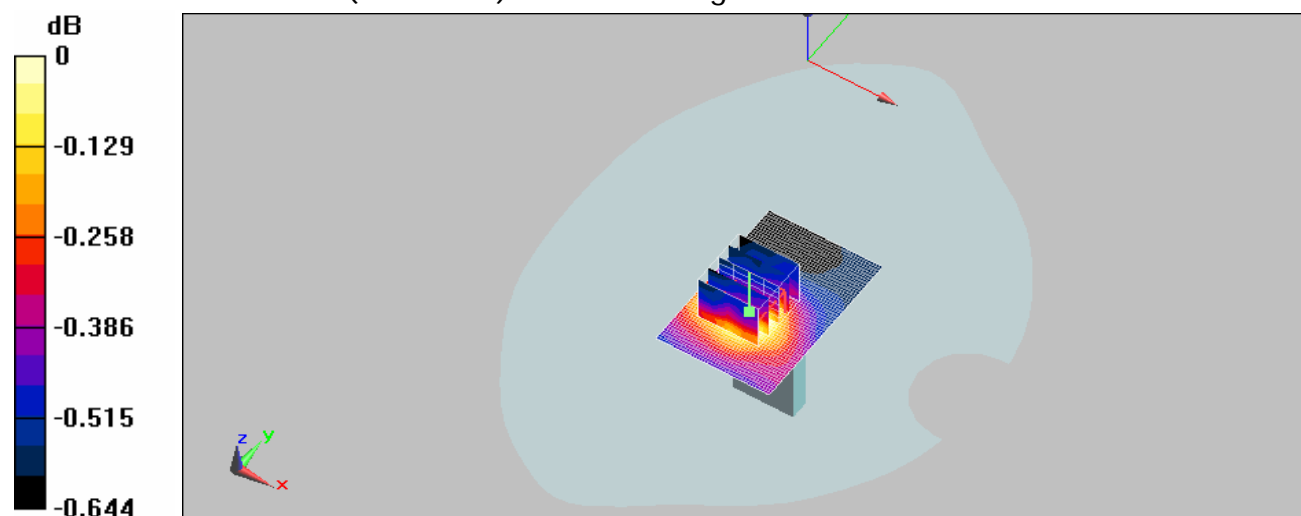

0 dB = 0.090mW/g

Date/Time: 9/17/2008 09:28:18

Configuration 5_CH251

DUT: C152,

Communication System: GSM 850; Frequency: 848.8 MHz; Duty Cycle: 1:2

Medium: GSM850 Medium parameters used: $f = 849$ MHz; $\sigma = 0.97$ mho/m; $\epsilon_r = 56.1$; $\rho = 1000$ kg/m³

Phantom section: Flat Section

DASY5 Configuration:

- Probe: ES3DV3 - SN3172; ConvF(5.61, 5.61, 5.61); Calibrated: 6/23/2008
- Sensor-Surface: 4mm (Mechanical Surface Detection)
- Electronics: DAE4 Sn856; Calibrated: 5/7/2008
- Phantom: SAM1; Type: SAM;
- Measurement SW: DASY5, V5.0 Build 119; SEMCAD X Version 13.2 Build 87

Body/Area Scan : Measurement grid: dx=15mm, dy=15mm

Maximum value of SAR (interpolated) = 0.086 mW/g

Body/Zoom Scan : Measurement grid: dx=8mm, dy=8mm, dz=5mm

Reference Value = 9.33 V/m; Power Drift = -0.098 dB

Peak SAR (extrapolated) = 0.085 W/kg

SAR(1 g) = 0.084 mW/g; SAR(10 g) = 0.082 mW/g

Maximum value of SAR (measured) = 0.085 mW/g

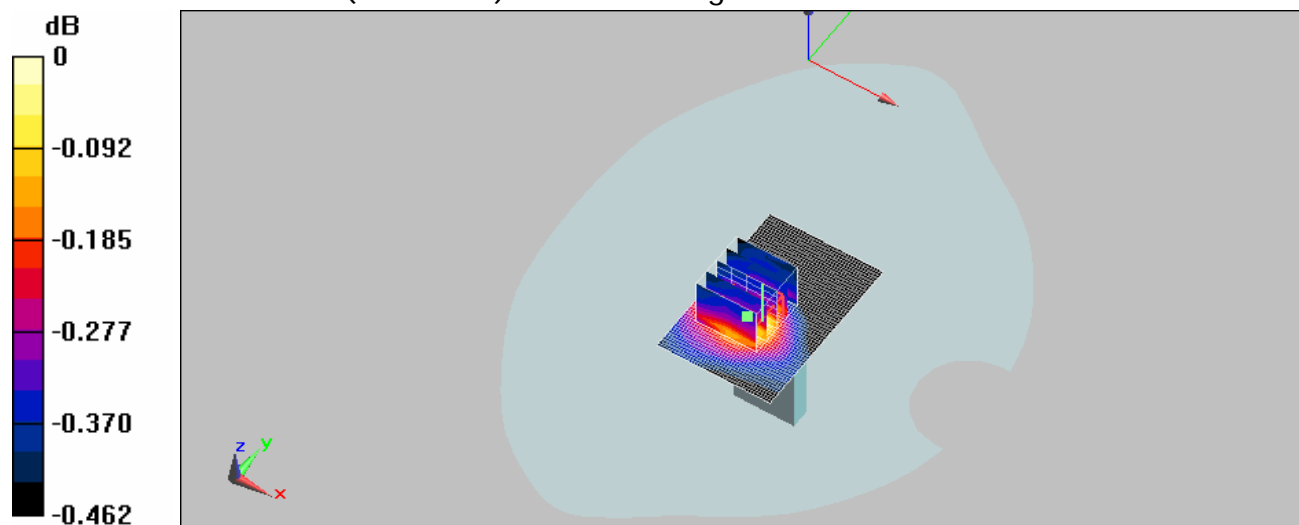

0 dB = 0.085mW/g

Date/Time: 9/17/2008 10:47:52

Configuration 6_CH128**DUT: C152,**

Communication System: GSM 850; Frequency: 824.2 MHz; Duty Cycle: 1:2

Medium: GSM 850 Medium parameters used (interpolated): $f = 824.2$ MHz; $\sigma = 0.942$ mho/m; $\epsilon_r = 56.3$; $\rho = 1000$ kg/m³

Phantom section: Flat Section

DASY5 Configuration:

- Probe: ES3DV3 - SN3172; ConvF(5.61, 5.61, 5.61); Calibrated: 6/23/2008
- Sensor-Surface: 4mm (Mechanical Surface Detection)
- Electronics: DAE4 Sn856; Calibrated: 5/7/2008
- Phantom: SAM1; Type: SAM;
- Measurement SW: DASY5, V5.0 Build 119; SEMCAD X Version 13.2 Build 87

Body/Area Scan: Measurement grid: dx=15mm, dy=15mm

Maximum value of SAR (interpolated) = 0.081 mW/g

Body/Zoom Scan : Measurement grid: dx=8mm, dy=8mm, dz=5mm

Reference Value = 8.33 V/m; Power Drift = 0.026 dB

Peak SAR (extrapolated) = 0.090 W/kg

SAR(1 g) = 0.077 mW/g; SAR(10 g) = 0.070 mW/g

Maximum value of SAR (measured) = 0.078 mW/g

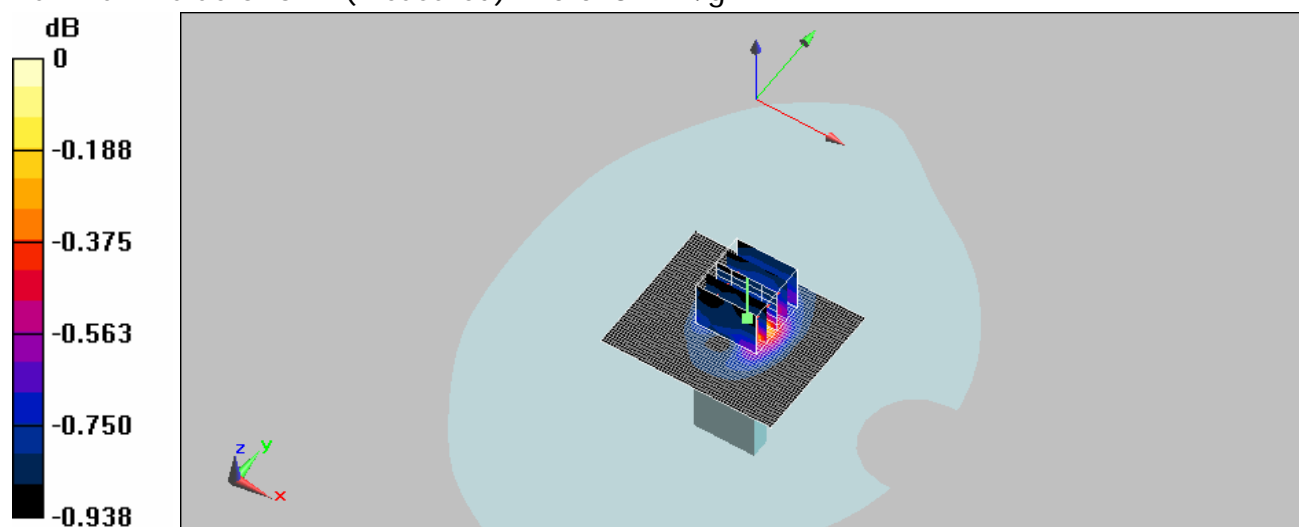

0 dB = 0.078mW/g

Date/Time: 9/17/2008 10:25:50

Configuration 6_CH190

DUT: C152,

Communication System: GSM 850; Frequency: 836.6 MHz; Duty Cycle: 1:2

Medium: GSM 850 Medium parameters used: $f = 837$ MHz; $\sigma = 0.957$ mho/m; $\epsilon_r = 56.2$; $\rho = 1000$ kg/m³

Phantom section: Flat Section

DASY5 Configuration:

- Probe: ES3DV3 - SN3172; ConvF(5.61, 5.61, 5.61); Calibrated: 6/23/2008
- Sensor-Surface: 4mm (Mechanical Surface Detection)
- Electronics: DAE4 Sn856; Calibrated: 5/7/2008
- Phantom: SAM1; Type: SAM;
- Measurement SW: DASY5, V5.0 Build 119; SEMCAD X Version 13.2 Build 87

Body/Area Scan: Measurement grid: dx=15mm, dy=15mm

Maximum value of SAR (interpolated) = 0.078 mW/g

Body/Zoom Scan : Measurement grid: dx=8mm, dy=8mm, dz=5mm

Reference Value = 8.21 V/m; Power Drift = 0.00953 dB

Peak SAR (extrapolated) = 0.084 W/kg

SAR(1 g) = 0.074 mW/g; SAR(10 g) = 0.068 mW/g

Maximum value of SAR (measured) = 0.075 mW/g

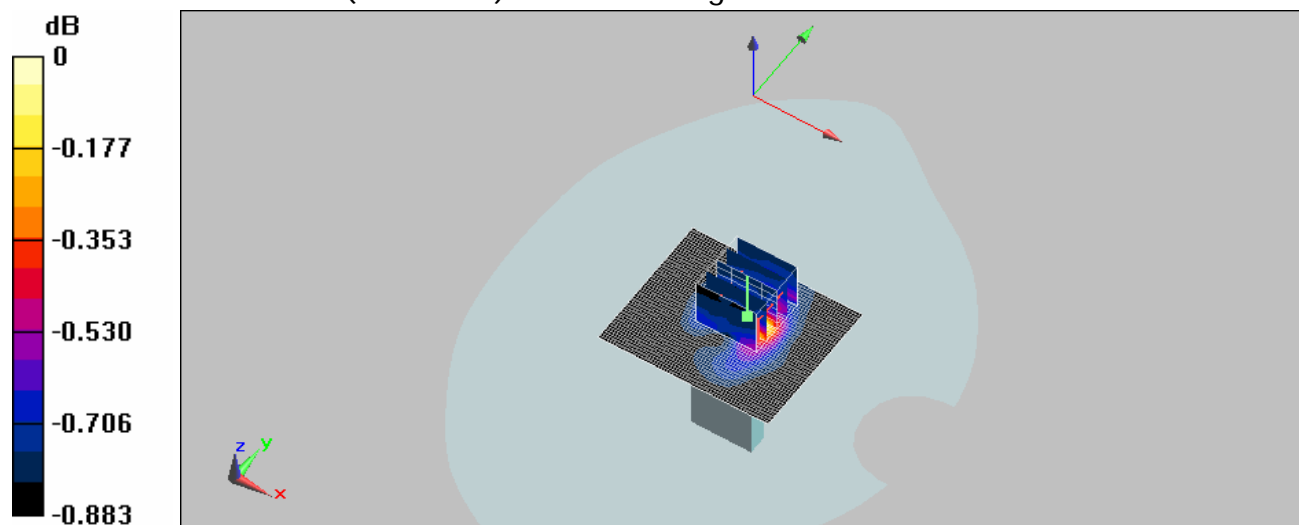

0 dB = 0.075mW/g

Date/Time: 9/17/2008 10:01:32

Configuration 6_CH251

DUT: C152,

Communication System: GSM 850; Frequency: 848.8 MHz; Duty Cycle: 1:2

Medium: GSM 850 Medium parameters used: $f = 849$ MHz; $\sigma = 0.97$ mho/m; $\epsilon_r = 56.1$; $\rho = 1000$ kg/m³

Phantom section: Flat Section

DASY5 Configuration:

- Probe: ES3DV3 - SN3172; ConvF(5.61, 5.61, 5.61); Calibrated: 6/23/2008
- Sensor-Surface: 4mm (Mechanical Surface Detection)
- Electronics: DAE4 Sn856; Calibrated: 5/7/2008
- Phantom: SAM1; Type: SAM;
- Measurement SW: DASY5, V5.0 Build 119; SEMCAD X Version 13.2 Build 87

Body/Area Scan: Measurement grid: dx=15mm, dy=15mm

Maximum value of SAR (interpolated) = 0.073 mW/g

Body/Zoom Scan : Measurement grid: dx=8mm, dy=8mm, dz=5mm

Reference Value = 8.17 V/m; Power Drift = -0.106 dB

Peak SAR (extrapolated) = 0.078 W/kg

SAR(1 g) = 0.070 mW/g; SAR(10 g) = 0.066 mW/g

Maximum value of SAR (measured) = 0.071 mW/g

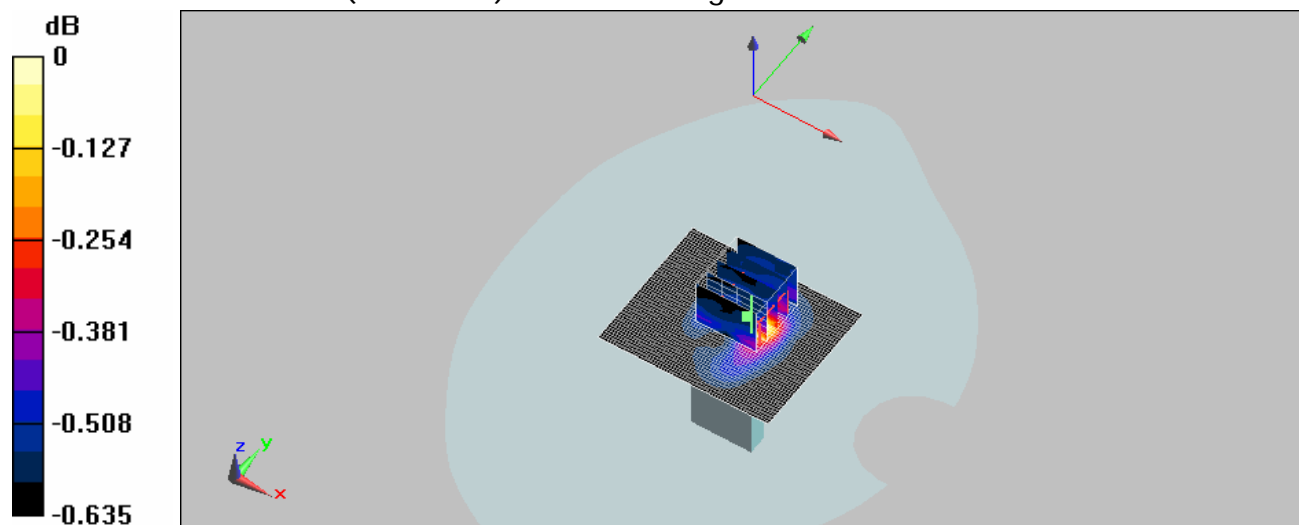

0 dB = 0.071mW/g

Date/Time: 12/5/2008 9:46:07

Configuration 7_CH128

DUT: C152,

Communication System: GSM 850; Frequency: 824.2 MHz; Duty Cycle: 1:2

Medium: Body 900 Medium parameters used: $f = 824.2$ MHz; $\sigma = 0.944$ mho/m; $\epsilon_r = 56.3$; $\rho = 1000$ kg/m³

Phantom section: Flat Section

DASY5 Configuration:

- Probe: ES3DV3 - SN3172; ConvF(5.61, 5.61, 5.61); Calibrated: 6/23/2008
- Sensor-Surface: 4mm (Mechanical Surface Detection)
- Electronics: DAE4 Sn856; Calibrated: 5/7/2008
- Phantom: SAM1; Type: SAM;
- Measurement SW: DASY5, V5.0 Build 119; SEMCAD X Version 13.2 Build 87

Body/Area Scan: Measurement grid: dx=15mm, dy=15mm

Maximum value of SAR (interpolated) = 0.147 mW/g

Body/Zoom Scan: Measurement grid: dx=8mm, dy=8mm, dz=5mm

Reference Value = 7.51 V/m; Power Drift = 0.174 dB

Peak SAR (extrapolated) = 0.175 W/kg

SAR(1 g) = 0.120 mW/g; SAR(10 g) = 0.082 mW/g

Maximum value of SAR (measured) = 0.127 mW/g

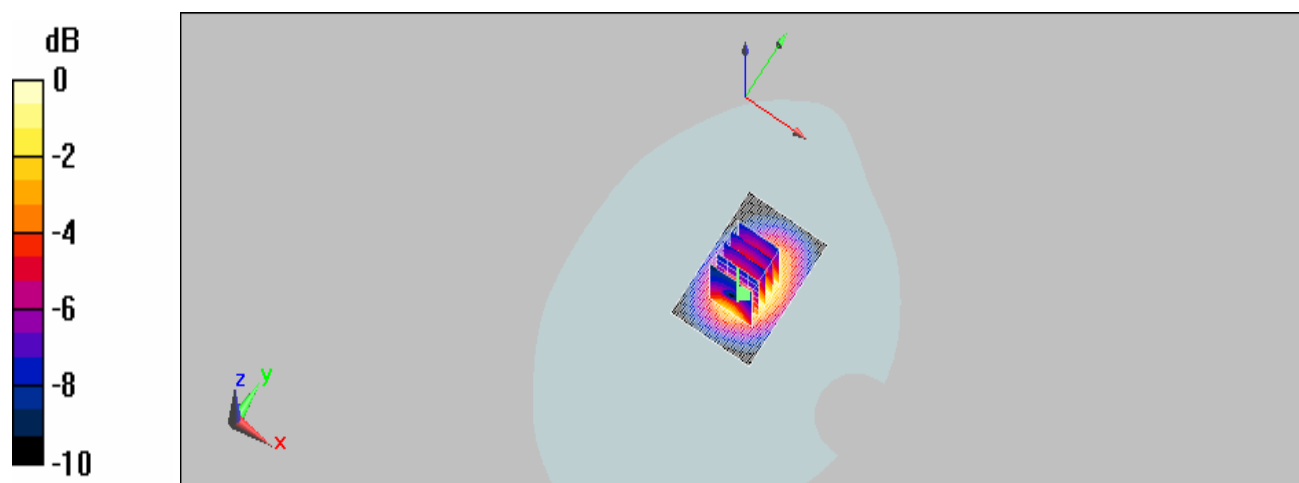

0 dB = 0.127mW/g

Date/Time: 12/5/2008 10:29:23

Configuration 7_CH190

DUT: C152,

Communication System: GSM 850; Frequency: 836.6 MHz; Duty Cycle: 1:2

Medium: Body 900 Medium parameters used: $f = 837$ MHz; $\sigma = 0.957$ mho/m; $\epsilon_r = 56.2$; $\rho = 1000$ kg/m³

Phantom section: Flat Section

DASY5 Configuration:

- Probe: ES3DV3 - SN3172; ConvF(5.61, 5.61, 5.61); Calibrated: 6/23/2008
- Sensor-Surface: 4mm (Mechanical Surface Detection)
- Electronics: DAE4 Sn856; Calibrated: 5/7/2008
- Phantom: SAM1; Type: SAM;
- Measurement SW: DASY5, V5.0 Build 119; SEMCAD X Version 13.2 Build 87

Body/Area Scan: Measurement grid: dx=15mm, dy=15mm

Maximum value of SAR (interpolated) = 0.095 mW/g

Body/Zoom Scan: Measurement grid: dx=8mm, dy=8mm, dz=5mm

Reference Value = 6.16 V/m; Power Drift = 0.050 dB

Peak SAR (extrapolated) = 0.115 W/kg

SAR(1 g) = 0.078 mW/g; SAR(10 g) = 0.054 mW/g

Maximum value of SAR (measured) = 0.083 mW/g

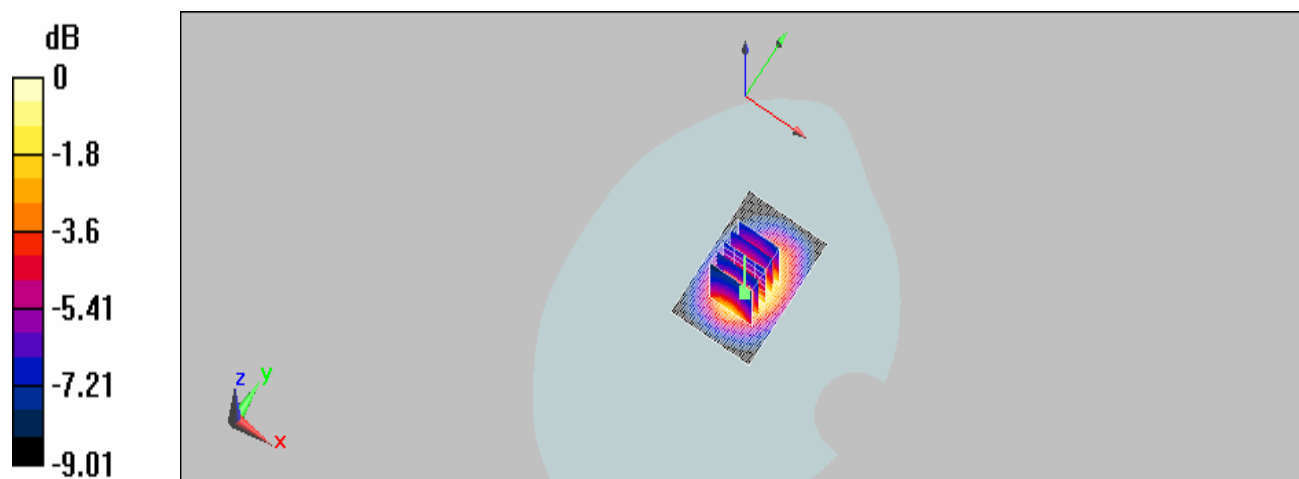

0 dB = 0.083mW/g

Date/Time: 12/5/2008 11:03:27

Configuration 7_CH251

DUT: C152,

Communication System: GSM 850; Frequency: 848.8 MHz; Duty Cycle: 1:2

Medium: Body 900 Medium parameters used: $f = 849$ MHz; $\sigma = 0.971$ mho/m; $\epsilon_r = 56.1$; $\rho = 1000$ kg/m³

Phantom section: Flat Section

DASY5 Configuration:

- Probe: ES3DV3 - SN3172; ConvF(5.61, 5.61, 5.61); Calibrated: 6/23/2008
- Sensor-Surface: 4mm (Mechanical Surface Detection)
- Electronics: DAE4 Sn856; Calibrated: 5/7/2008
- Phantom: SAM1; Type: SAM;
- Measurement SW: DASY5, V5.0 Build 119; SEMCAD X Version 13.2 Build 87

Body/Area Scan: Measurement grid: dx=15mm, dy=15mm

Maximum value of SAR (interpolated) = 0.066 mW/g

Body/Zoom Scan: Measurement grid: dx=8mm, dy=8mm, dz=5mm

Reference Value = 5.22 V/m; Power Drift = 0.050 dB

Peak SAR (extrapolated) = 0.104 W/kg

SAR(1 g) = 0.055 mW/g; SAR(10 g) = 0.038 mW/g

Maximum value of SAR (measured) = 0.056 mW/g

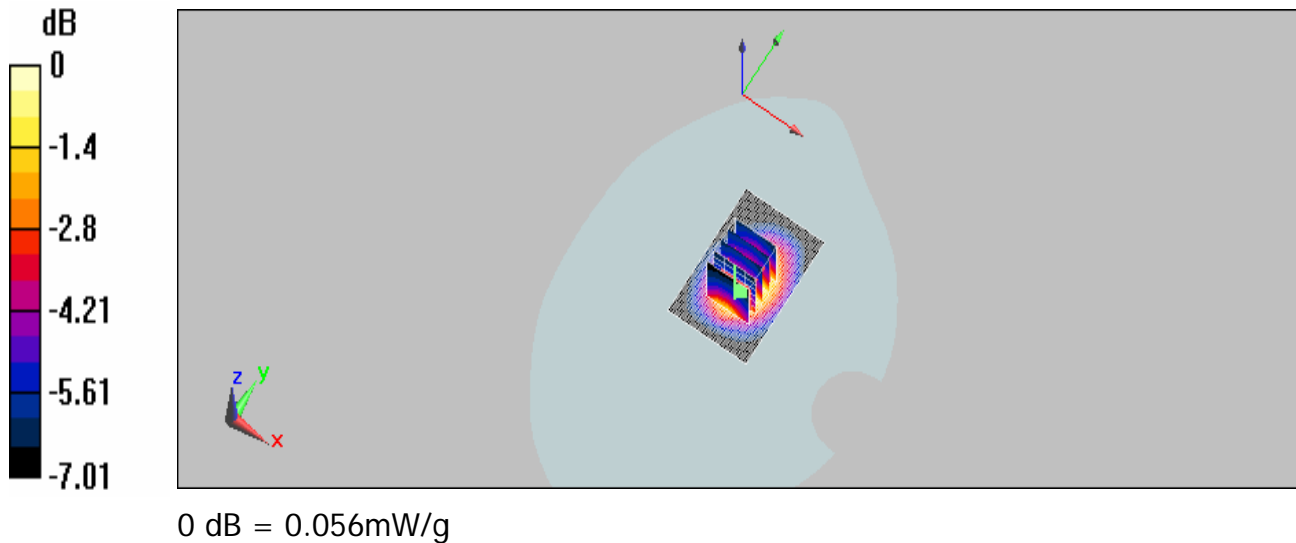

Date/Time: 12/5/2008 12:19:27

Configuration 8_CH 128

DUT: C152,

Communication System: GSM 850; Frequency: 824.2 MHz; Duty Cycle: 1:2

Medium: Body 900 Medium parameters used: $f = 824.2$ MHz; $\sigma = 0.944$ mho/m; $\epsilon_r = 56.3$; $\rho = 1000$ kg/m³

Phantom section: Flat Section

DASY5 Configuration:

- Probe: ES3DV3 - SN3172; ConvF(5.61, 5.61, 5.61); Calibrated: 6/23/2008
- Sensor-Surface: 4mm (Mechanical Surface Detection)
- Electronics: DAE4 Sn856; Calibrated: 5/7/2008
- Phantom: SAM1; Type: SAM;
- Measurement SW: DASY5, V5.0 Build 119; SEMCAD X Version 13.2 Build 87

Body/Area Scan: Measurement grid: dx=15mm, dy=15mm

Maximum value of SAR (interpolated) = 0.160 mW/g

Body/Zoom Scan: Measurement grid: dx=8mm, dy=8mm, dz=5mm

Reference Value = 10.6 V/m; Power Drift = -0.157 dB

Peak SAR (extrapolated) = 0.219 W/kg

SAR(1 g) = 0.133 mW/g; SAR(10 g) = 0.086 mW/g

Maximum value of SAR (measured) = 0.144 mW/g

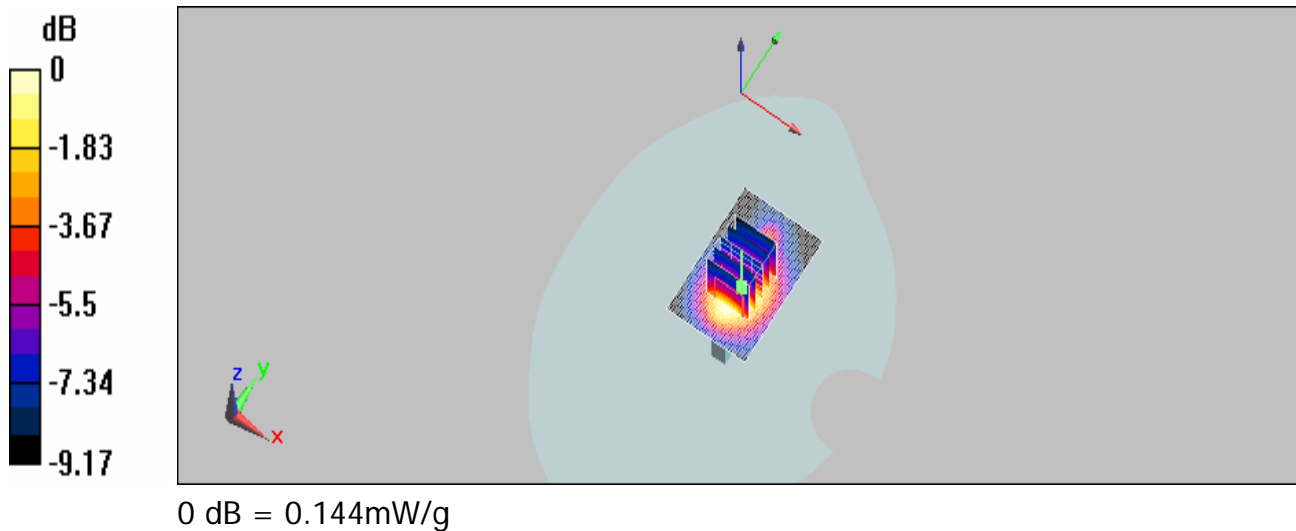

Date/Time: 12/5/2008 12:57:52

Configuration 8_CH 190

DUT: C152,

Communication System: GSM 850; Frequency: 836.6 MHz; Duty Cycle: 1:2

Medium: Body 900 Medium parameters used: $f = 837$ MHz; $\sigma = 0.957$ mho/m; $\epsilon_r = 56.2$; $\rho = 1000$ kg/m³

Phantom section: Flat Section

DASY5 Configuration:

- Probe: ES3DV3 - SN3172; ConvF(5.61, 5.61, 5.61); Calibrated: 6/23/2008
- Sensor-Surface: 4mm (Mechanical Surface Detection)
- Electronics: DAE4 Sn856; Calibrated: 5/7/2008
- Phantom: SAM1; Type: SAM;
- Measurement SW: DASY5, V5.0 Build 119; SEMCAD X Version 13.2 Build 87

Body/Area Scan: Measurement grid: dx=15mm, dy=15mm

Maximum value of SAR (interpolated) = 0.096 mW/g

Body/Zoom Scan: Measurement grid: dx=8mm, dy=8mm, dz=5mm

Reference Value = 8.21 V/m; Power Drift = -0.185 dB

Peak SAR (extrapolated) = 0.134 W/kg

SAR(1 g) = 0.081 mW/g; SAR(10 g) = 0.052 mW/g

Maximum value of SAR (measured) = 0.087 mW/g

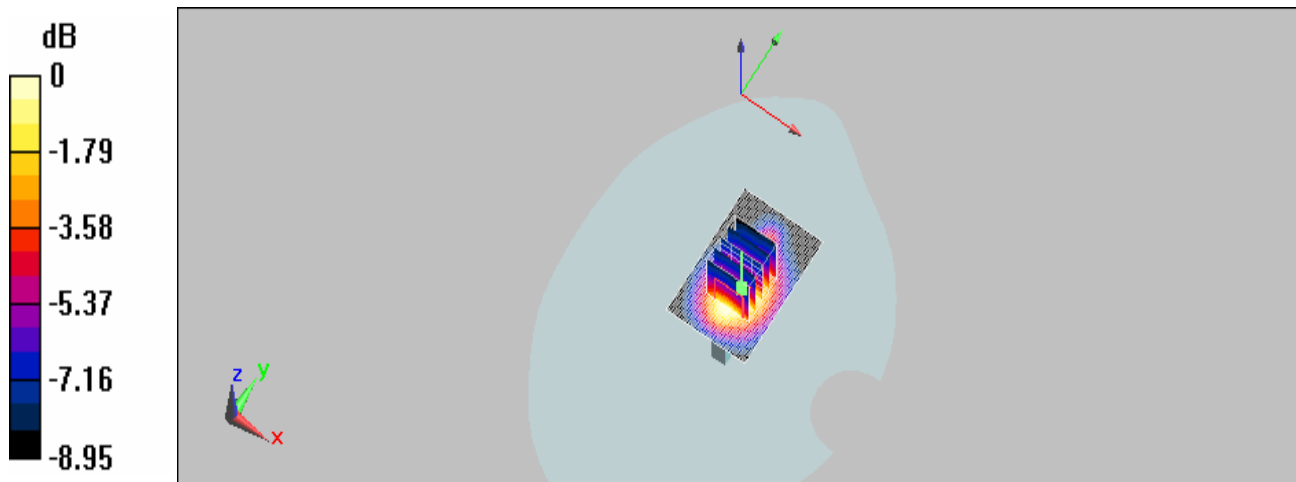

0 dB = 0.087mW/g

Date/Time: 12/5/2008 13:31:36

Configuration 8_CH 251

DUT: C152,

Communication System: GSM 850; Frequency: 848.8 MHz; Duty Cycle: 1:2

Medium: Body 900 Medium parameters used: $f = 849$ MHz; $\sigma = 0.971$ mho/m; $\epsilon_r = 56.1$; $\rho = 1000$ kg/m³

Phantom section: Flat Section

DASY5 Configuration:

- Probe: ES3DV3 - SN3172; ConvF(5.61, 5.61, 5.61); Calibrated: 6/23/2008
- Sensor-Surface: 4mm (Mechanical Surface Detection)
- Electronics: DAE4 Sn856; Calibrated: 5/7/2008
- Phantom: SAM1; Type: SAM;
- Measurement SW: DASY5, V5.0 Build 119; SEMCAD X Version 13.2 Build 87

Body/Area Scan: Measurement grid: dx=15mm, dy=15mm

Maximum value of SAR (interpolated) = 0.063 mW/g

Body/Zoom Scan: Measurement grid: dx=8mm, dy=8mm, dz=5mm

Reference Value = 6.61 V/m; Power Drift = -0.085 dB
Peak SAR (extrapolated) = 0.097 W/kg

SAR(1 g) = 0.053 mW/g; SAR(10 g) = 0.033 mW/g

Maximum value of SAR (measured) = 0.058 mW/g

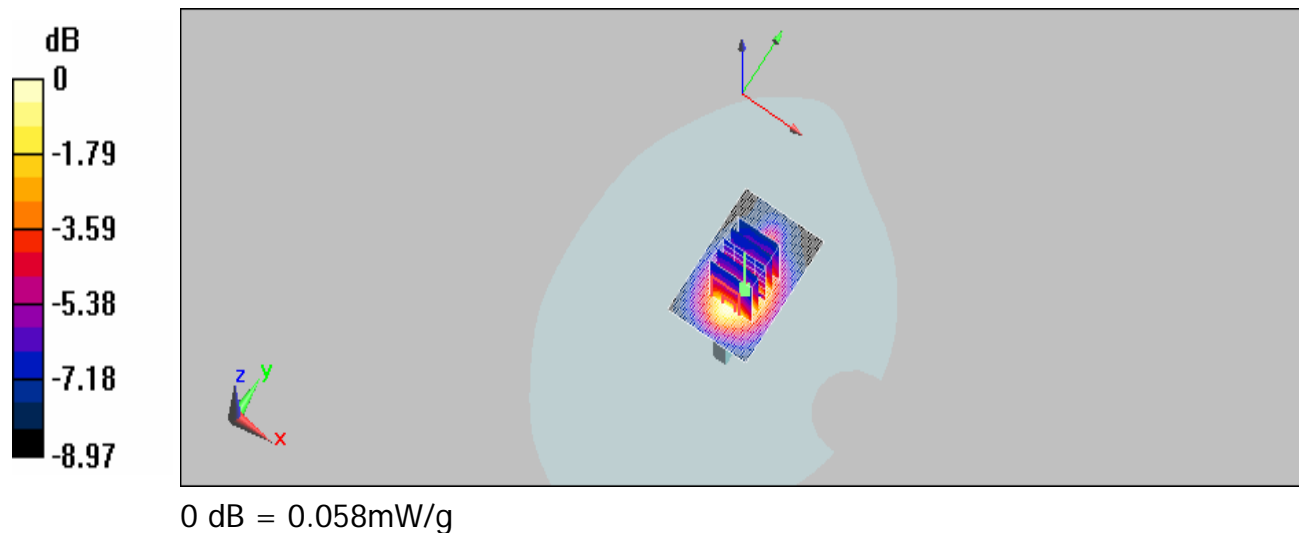

Date/Time: 9/17/2008 12:42:26

Configuration 1_CH512

DUT: C152,

Communication System: GSM1900; Frequency: 1850.2 MHz; Duty Cycle: 1:2

Medium: GSM 1900 Medium parameters used (interpolated): $f = 1850.2$ MHz; $\sigma = 1.43$ mho/m; $\epsilon_r = 52.3$; $\rho = 1000$ kg/m³

Phantom section: Flat Section

DASY5 Configuration:

- Probe: ES3DV3 - SN3172; ConvF(4.73, 4.73, 4.73); Calibrated: 6/23/2008
- Sensor-Surface: 4mm (Mechanical Surface Detection)
- Electronics: DAE4 Sn856; Calibrated: 5/7/2008
- Phantom: SAM1; Type: SAM;
- Measurement SW: DASY5, V5.0 Build 119; SEMCAD X Version 13.2 Build 87

Body/Area Scan : Measurement grid: dx=15mm, dy=15mm

Maximum value of SAR (interpolated) = 0.862 mW/g

Body/Zoom Scan : Measurement grid: dx=8mm, dy=8mm, dz=5mm

Reference Value = 11.8 V/m; Power Drift = -0.110 dB

Peak SAR (extrapolated) = 1.12 W/kg

SAR(1 g) = 0.744 mW/g; SAR(10 g) = 0.468 mW/g

Maximum value of SAR (measured) = 0.788 mW/g

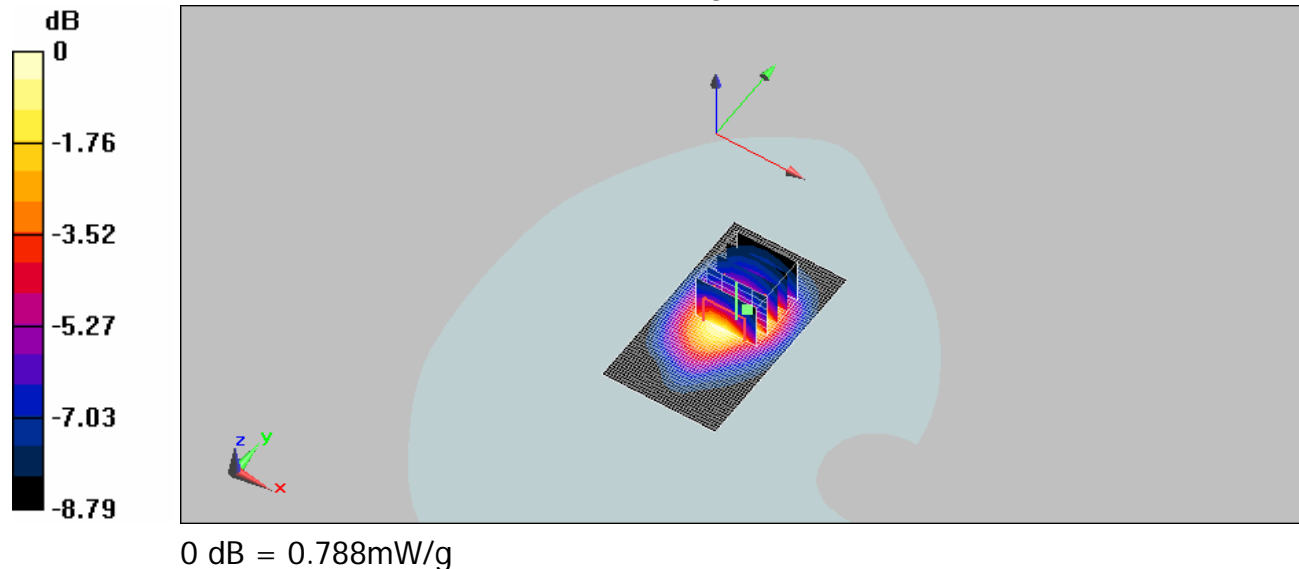

Date/Time: 9/17/2008 13:16:21

Configuration 1_CH661

DUT: C152,

Communication System: GSM1900; Frequency: 1880 MHz; Duty Cycle: 1:2

Medium: GSM 1900 Medium parameters used: $f = 1880$ MHz; $\sigma = 1.44$ mho/m; $\epsilon_r = 52.3$; $\rho = 1000$ kg/m³

Phantom section: Flat Section

DASY5 Configuration:

- Probe: ES3DV3 - SN3172; ConvF(4.73, 4.73, 4.73); Calibrated: 6/23/2008
- Sensor-Surface: 4mm (Mechanical Surface Detection)
- Electronics: DAE4 Sn856; Calibrated: 5/7/2008
- Phantom: SAM1; Type: SAM;
- Measurement SW: DASY5, V5.0 Build 119; SEMCAD X Version 13.2 Build 87

Body/Area Scan : Measurement grid: dx=15mm, dy=15mm
Maximum value of SAR (interpolated) = 0.582 mW/g

Body/Zoom Scan : Measurement grid: dx=8mm, dy=8mm, dz=5mm
Reference Value = 11.2 V/m; Power Drift = 0.023 dB
Peak SAR (extrapolated) = 0.836 W/kg

SAR(1 g) = 0.533 mW/g; SAR(10 g) = 0.351 mW/g

Maximum value of SAR (measured) = 0.559 mW/g

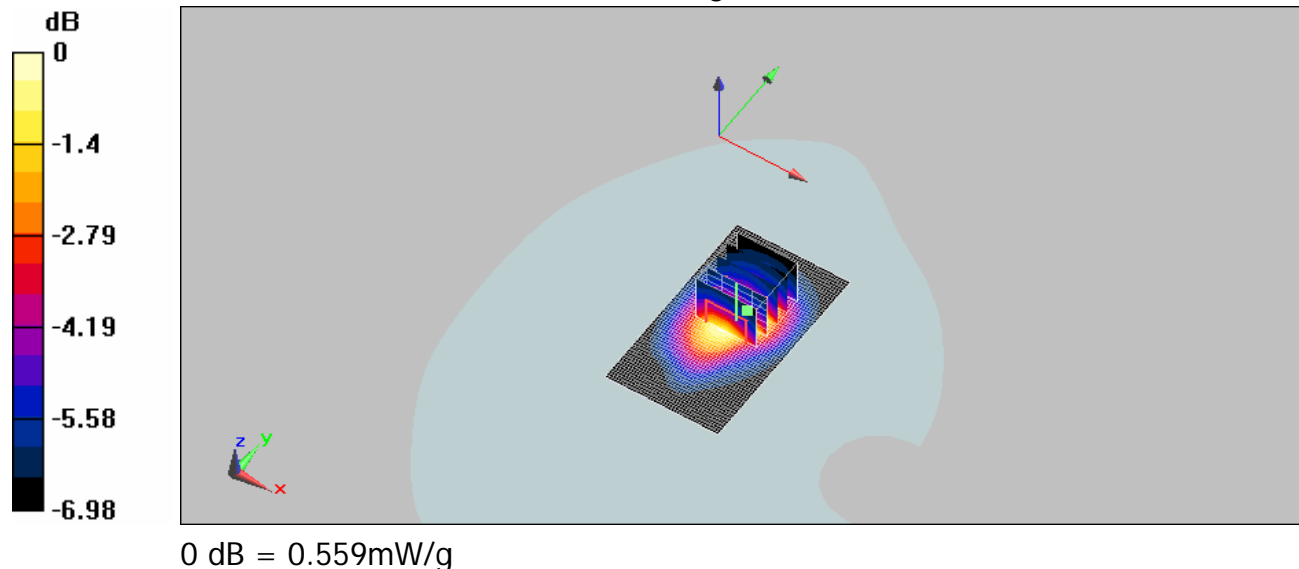

Date/Time: 9/17/2008 13:39:05

Configuration 1_CH810

DUT: C152,

Communication System: GSM1900; Frequency: 1909.8 MHz; Duty Cycle: 1:2

Medium: GSM 1900 Medium parameters used: $f = 1910$ MHz; $\sigma = 1.47$ mho/m; $\epsilon_r = 52.4$; $\rho = 1000$ kg/m³

Phantom section: Flat Section

DASY5 Configuration:

- Probe: ES3DV3 - SN3172; ConvF(4.73, 4.73, 4.73); Calibrated: 6/23/2008
- Sensor-Surface: 4mm (Mechanical Surface Detection)
- Electronics: DAE4 Sn856; Calibrated: 5/7/2008
- Phantom: SAM1; Type: SAM;
- Measurement SW: DASY5, V5.0 Build 119; SEMCAD X Version 13.2 Build 87

Body/Area Scan : Measurement grid: dx=15mm, dy=15mm
Maximum value of SAR (interpolated) = 0.432 mW/g

Body/Zoom Scan : Measurement grid: dx=8mm, dy=8mm, dz=5mm
Reference Value = 10.7 V/m; Power Drift = -0.00468 dB
Peak SAR (extrapolated) = 0.556 W/kg

SAR(1 g) = 0.397 mW/g; SAR(10 g) = 0.279 mW/g

Maximum value of SAR (measured) = 0.418 mW/g

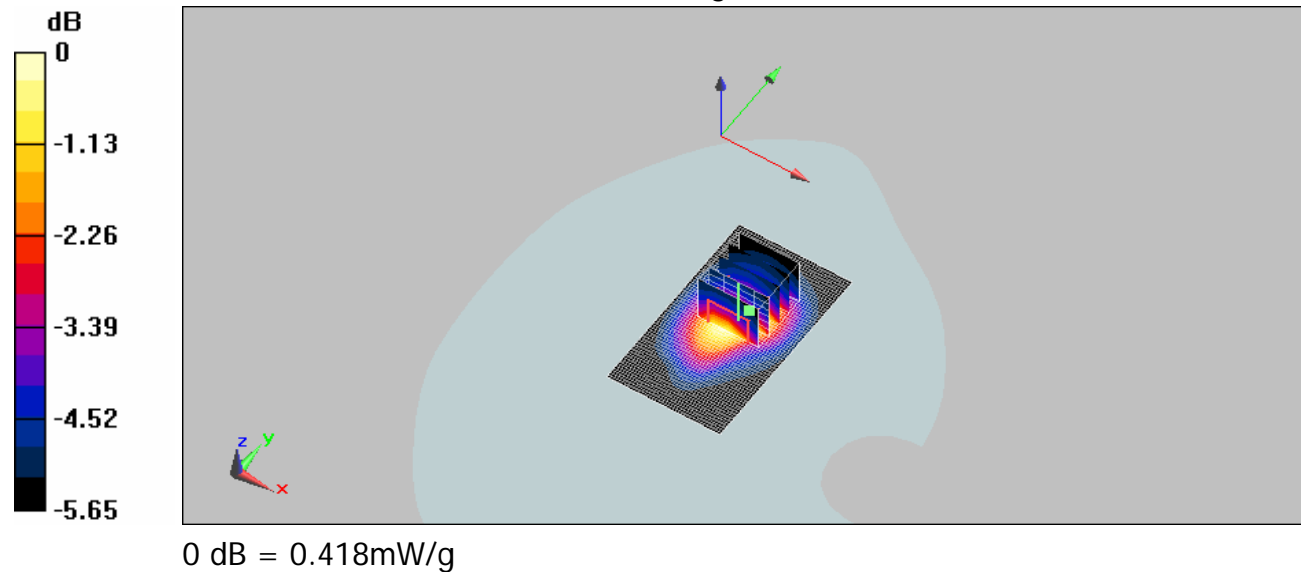

Date/Time: 9/17/2008 14:01:02

Configuration 2_CH512

DUT: C152,

Communication System: GSM1900; Frequency: 1850.2 MHz; Duty Cycle: 1:2

Medium: GSM 1900 Medium parameters used (interpolated): $f = 1850.2$ MHz; $\sigma = 1.43$ mho/m; $\epsilon_r = 52.3$; $\rho = 1000$ kg/m³

Phantom section: Flat Section

DASY5 Configuration:

- Probe: ES3DV3 - SN3172; ConvF(4.73, 4.73, 4.73); Calibrated: 6/23/2008
- Sensor-Surface: 4mm (Mechanical Surface Detection)
- Electronics: DAE4 Sn856; Calibrated: 5/7/2008
- Phantom: SAM1; Type: SAM;
- Measurement SW: DASY5, V5.0 Build 119; SEMCAD X Version 13.2 Build 87

Body/Area Scan : Measurement grid: dx=15mm, dy=15mm
Maximum value of SAR (interpolated) = 0.304 mW/g

Body/Zoom Scan : Measurement grid: dx=8mm, dy=8mm, dz=5mm
Reference Value = 12 V/m; Power Drift = 0.00409 dB
Peak SAR (extrapolated) = 0.328 W/kg

SAR(1 g) = 0.296 mW/g; SAR(10 g) = 0.262 mW/g

Maximum value of SAR (measured) = 0.304 mW/g

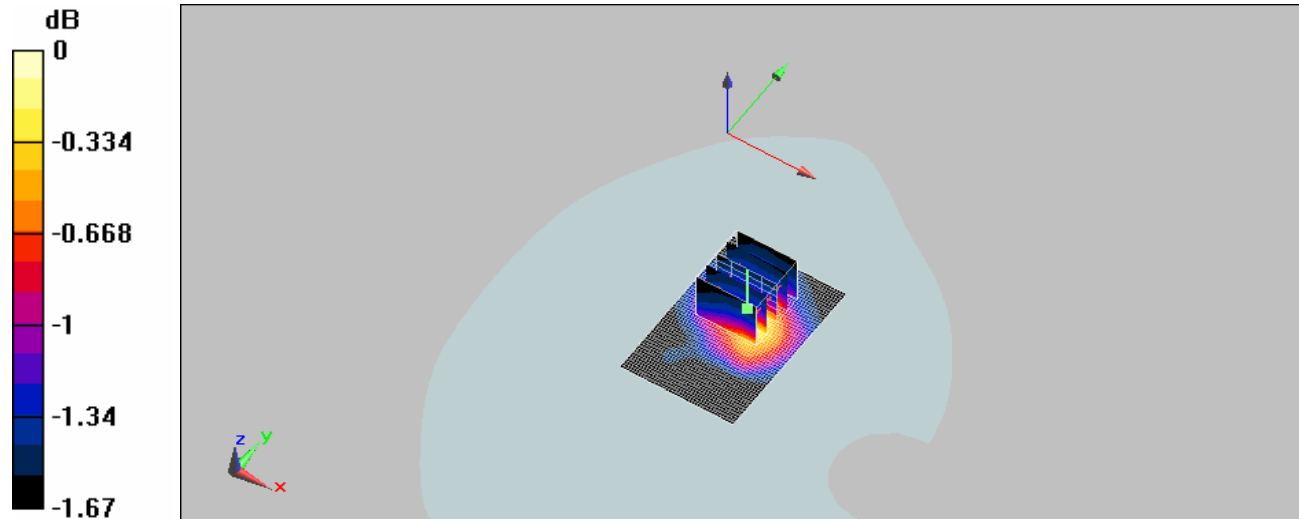

0 dB = 0.304mW/g

Date/Time: 9/17/2008 14:24:04

Configuration 2_CH661

DUT: C152,

Communication System: GSM1900; Frequency: 1880 MHz; Duty Cycle: 1:2

Medium: GSM 1900 Medium parameters used: $f = 1880$ MHz; $\sigma = 1.44$ mho/m; $\epsilon_r = 52.3$; $\rho = 1000$ kg/m³

Phantom section: Flat Section

DASY5 Configuration:

- Probe: ES3DV3 - SN3172; ConvF(4.73, 4.73, 4.73); Calibrated: 6/23/2008
- Sensor-Surface: 4mm (Mechanical Surface Detection)
- Electronics: DAE4 Sn856; Calibrated: 5/7/2008
- Phantom: SAM1; Type: SAM;
- Measurement SW: DASY5, V5.0 Build 119; SEMCAD X Version 13.2 Build 87

Body/Area Scan : Measurement grid: dx=15mm, dy=15mm
Maximum value of SAR (interpolated) = 0.269 mW/g

Body/Zoom Scan : Measurement grid: dx=8mm, dy=8mm, dz=5mm
Reference Value = 12 V/m; Power Drift = -0.00689 dB
Peak SAR (extrapolated) = 0.296 W/kg

SAR(1 g) = 0.265 mW/g; SAR(10 g) = 0.238 mW/g

Maximum value of SAR (measured) = 0.271 mW/g

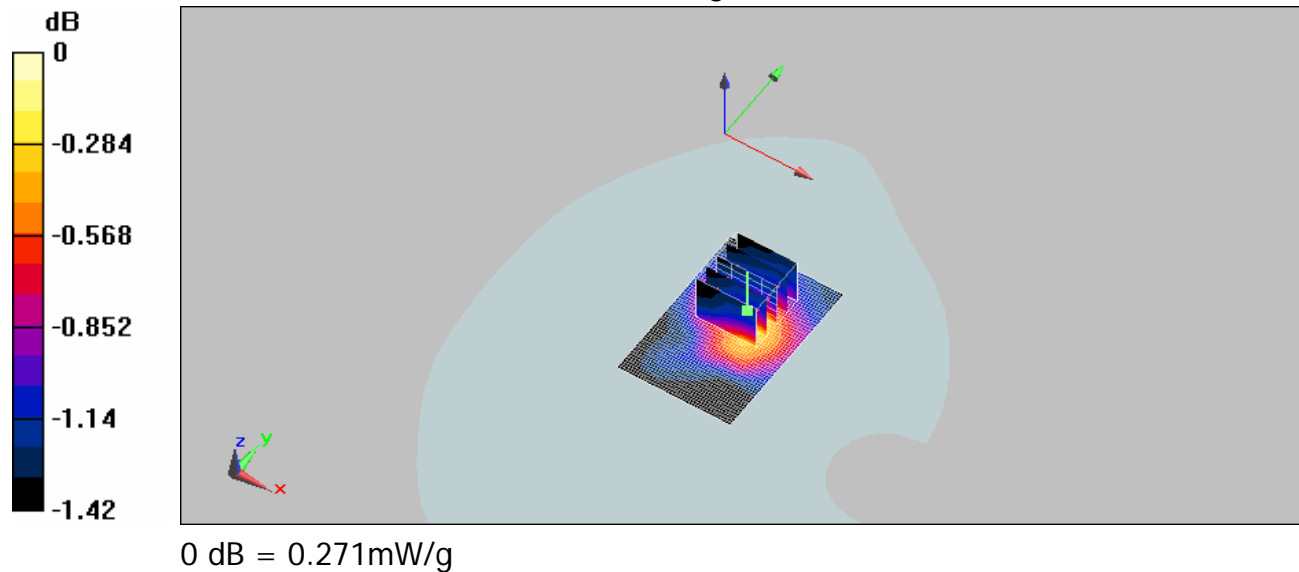

Date/Time: 9/17/2008 14:46:40

Configuration 2_CH810

DUT: C152,

Communication System: GSM1900; Frequency: 1909.8 MHz; Duty Cycle: 1:2

Medium: GSM 1900 Medium parameters used: $f = 1910$ MHz; $\sigma = 1.47$ mho/m; $\epsilon_r = 52.4$; $\rho = 1000$ kg/m³

Phantom section: Flat Section

DASY5 Configuration:

- Probe: ES3DV3 - SN3172; ConvF(4.73, 4.73, 4.73); Calibrated: 6/23/2008
- Sensor-Surface: 4mm (Mechanical Surface Detection)
- Electronics: DAE4 Sn856; Calibrated: 5/7/2008
- Phantom: SAM1; Type: SAM;
- Measurement SW: DASY5, V5.0 Build 119; SEMCAD X Version 13.2 Build 87

Body/Area Scan : Measurement grid: dx=15mm, dy=15mm
Maximum value of SAR (interpolated) = 0.248 mW/g

Body/Zoom Scan : Measurement grid: dx=8mm, dy=8mm, dz=5mm
Reference Value = 11.9 V/m; Power Drift = 0.017 dB
Peak SAR (extrapolated) = 0.256 W/kg

SAR(1 g) = 0.242 mW/g; SAR(10 g) = 0.222 mW/g

Maximum value of SAR (measured) = 0.244 mW/g

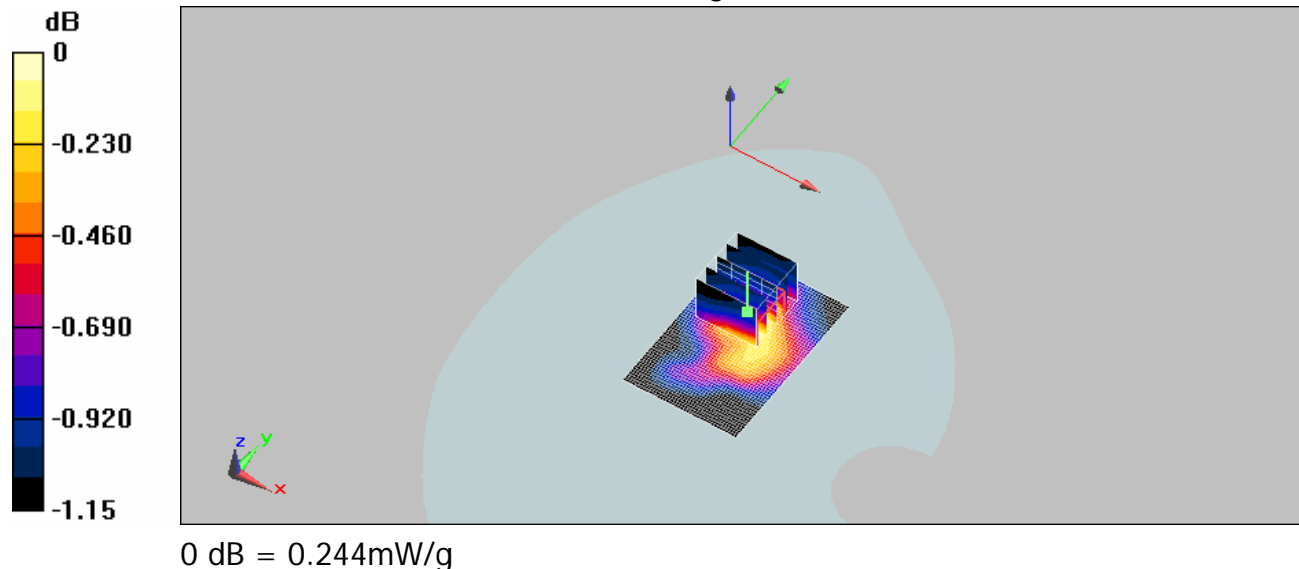

Date/Time: 9/17/2008 16:11:30

Configuration 3_CH512

DUT: C152,

Communication System: GSM1900; Frequency: 1850.2 MHz; Duty Cycle: 1:2

Medium: GSM 1900 Medium parameters used (interpolated): f = 1850.2 MHz; $\sigma = 1.43$ mho/m; $\epsilon_r = 52.3$; $\rho = 1000$ kg/m³

Phantom section: Flat Section

DASY5 Configuration:

- Probe: ES3DV3 - SN3172; ConvF(4.73, 4.73, 4.73); Calibrated: 6/23/2008
- Sensor-Surface: 4mm (Mechanical Surface Detection)
- Electronics: DAE4 Sn856; Calibrated: 5/7/2008
- Phantom: SAM1; Type: SAM;
- Measurement SW: DASY5, V5.0 Build 119; SEMCAD X Version 13.2 Build 87

Body/Area Scan : Measurement grid: dx=15mm, dy=15mm
Maximum value of SAR (interpolated) = 0.482 mW/g

Body/Zoom Scan : Measurement grid: dx=8mm, dy=8mm, dz=5mm
Reference Value = 11.8 V/m; Power Drift = -0.00935 dB
Peak SAR (extrapolated) = 0.633 W/kg

SAR(1 g) = 0.438 mW/g; SAR(10 g) = 0.318 mW/g

Maximum value of SAR (measured) = 0.463 mW/g

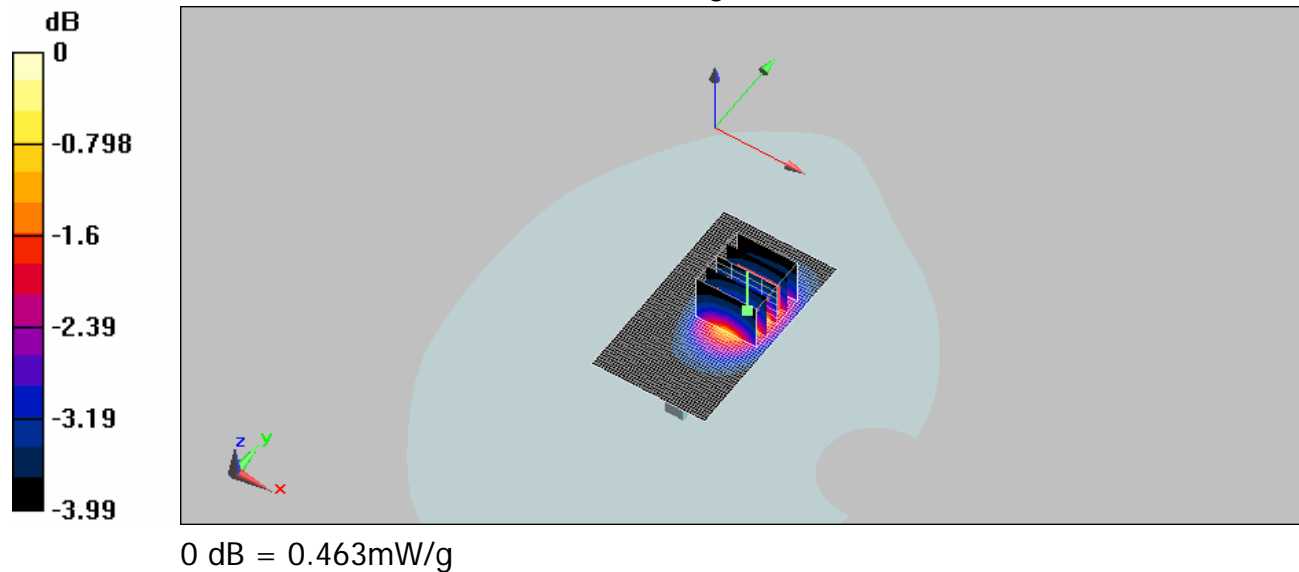

Date/Time: 9/17/2008 15:46:10

Configuration 3_CH661

DUT: C152,

Communication System: GSM1900; Frequency: 1880 MHz; Duty Cycle: 1:2

Medium: GSM 1900 Medium parameters used: f = 1880 MHz; $\sigma = 1.44$ mho/m; $\epsilon_r = 52.3$; $\rho = 1000$ kg/m³

Phantom section: Flat Section

DASY5 Configuration:

- Probe: ES3DV3 - SN3172; ConvF(4.73, 4.73, 4.73); Calibrated: 6/23/2008
- Sensor-Surface: 4mm (Mechanical Surface Detection)
- Electronics: DAE4 Sn856; Calibrated: 5/7/2008
- Phantom: SAM1; Type: SAM;
- Measurement SW: DASY5, V5.0 Build 119; SEMCAD X Version 13.2 Build 87

Body/Area Scan : Measurement grid: dx=15mm, dy=15mm
Maximum value of SAR (interpolated) = 0.391 mW/g

Body/Zoom Scan : Measurement grid: dx=8mm, dy=8mm, dz=5mm
Reference Value = 11.6 V/m; Power Drift = 0.00789 dB
Peak SAR (extrapolated) = 0.506 W/kg

SAR(1 g) = 0.367 mW/g; SAR(10 g) = 0.281 mW/g

Maximum value of SAR (measured) = 0.387 mW/g

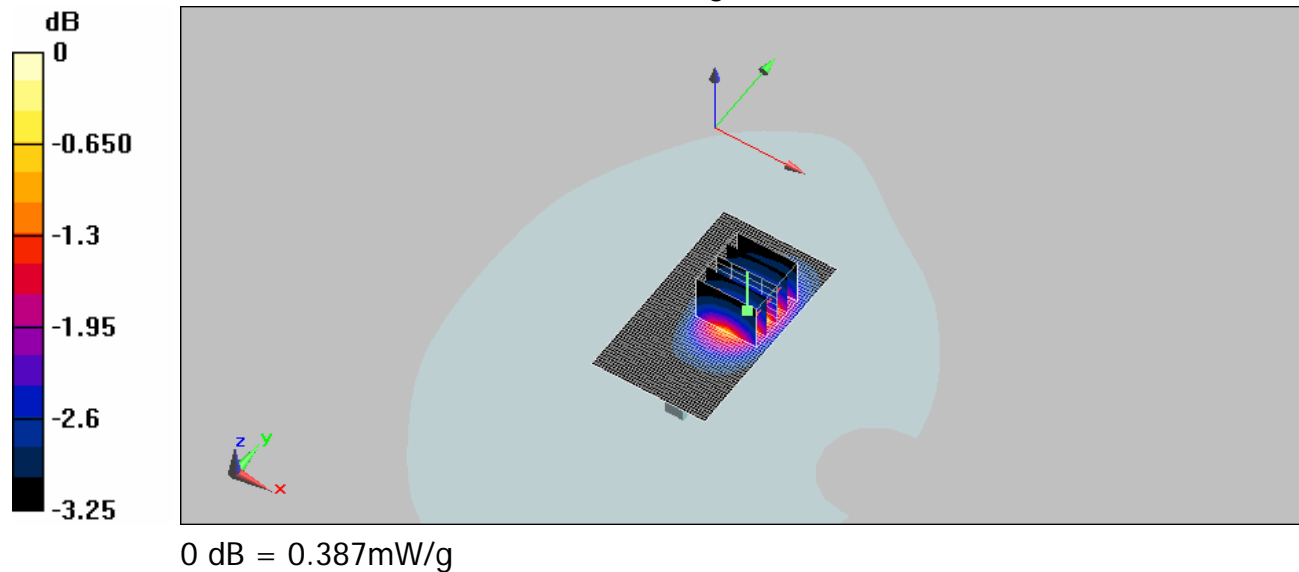

Date/Time: 9/17/2008 15:22:52

Configuration 3_CH810

DUT: C152,

Communication System: GSM1900; Frequency: 1909.8 MHz; Duty Cycle: 1:2

Medium: GSM 1900 Medium parameters used: $f = 1910$ MHz; $\sigma = 1.47$ mho/m; $\epsilon_r = 52.4$; $\rho = 1000$ kg/m³

Phantom section: Flat Section

DASY5 Configuration:

- Probe: ES3DV3 - SN3172; ConvF(4.73, 4.73, 4.73); Calibrated: 6/23/2008
- Sensor-Surface: 4mm (Mechanical Surface Detection)
- Electronics: DAE4 Sn856; Calibrated: 5/7/2008
- Phantom: SAM1; Type: SAM;
- Measurement SW: DASY5, V5.0 Build 119; SEMCAD X Version 13.2 Build 87

Body/Area Scan : Measurement grid: dx=15mm, dy=15mm
Maximum value of SAR (interpolated) = 0.344 mW/g

Body/Zoom Scan : Measurement grid: dx=8mm, dy=8mm, dz=5mm
Reference Value = 11.5 V/m; Power Drift = 0.0084 dB
Peak SAR (extrapolated) = 0.424 W/kg

SAR(1 g) = 0.327 mW/g; SAR(10 g) = 0.261 mW/g

Maximum value of SAR (measured) = 0.343 mW/g

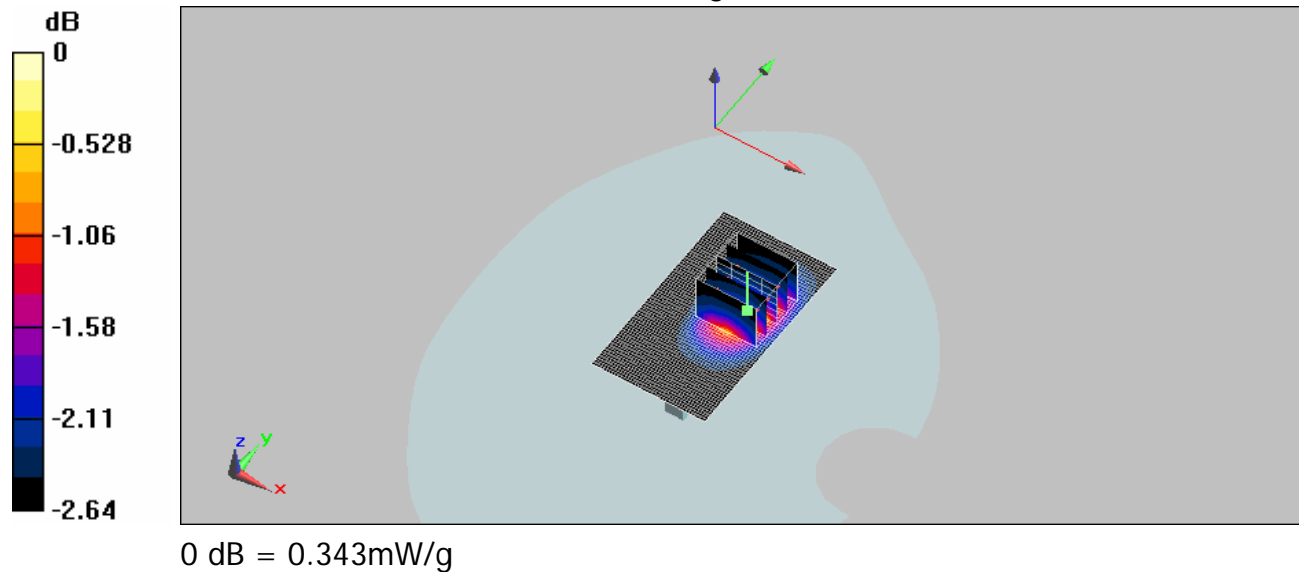

Date/Time: 9/17/2008 16:44:48

Configuration 4_CH512

DUT: C152,

Communication System: GSM1900; Frequency: 1850.2 MHz; Duty Cycle: 1:2

Medium: GSM 1900 Medium parameters used (interpolated): f = 1850.2 MHz; $\sigma = 1.43$ mho/m; $\epsilon_r = 52.3$; $\rho = 1000$ kg/m³

Phantom section: Flat Section

DASY5 Configuration:

- Probe: ES3DV3 - SN3172; ConvF(4.73, 4.73, 4.73); Calibrated: 6/23/2008
- Sensor-Surface: 4mm (Mechanical Surface Detection)
- Electronics: DAE4 Sn856; Calibrated: 5/7/2008
- Phantom: SAM1; Type: SAM;
- Measurement SW: DASY5, V5.0 Build 119; SEMCAD X Version 13.2 Build 87

Body/Area Scan : Measurement grid: dx=15mm, dy=15mm
Maximum value of SAR (interpolated) = 0.371 mW/g

Body/Zoom Scan : Measurement grid: dx=8mm, dy=8mm, dz=5mm
Reference Value = 11.9 V/m; Power Drift = 0.00209 dB
Peak SAR (extrapolated) = 0.463 W/kg

SAR(1 g) = 0.340 mW/g; SAR(10 g) = 0.264 mW/g

Maximum value of SAR (measured) = 0.357 mW/g

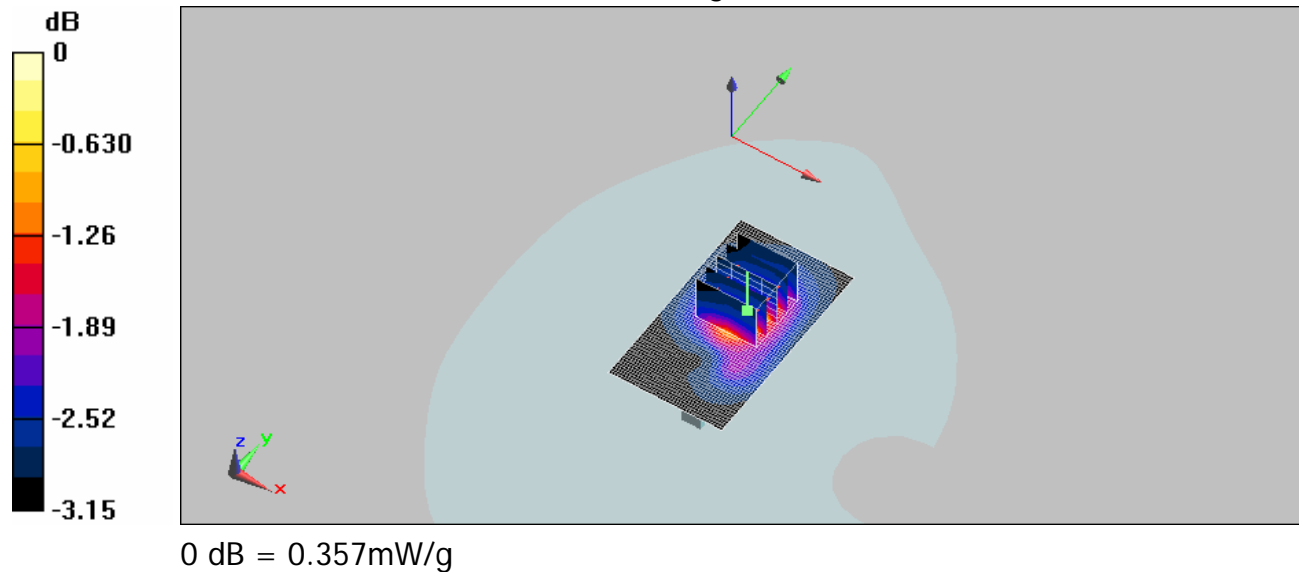

Date/Time: 9/17/2008 17:17:00

Configuration 4_CH661

DUT: C152,

Communication System: GSM1900; Frequency: 1880 MHz; Duty Cycle: 1:2

Medium: GSM 1900 Medium parameters used: $f = 1880$ MHz; $\sigma = 1.44$ mho/m; $\epsilon_r = 52.3$; $\rho = 1000$ kg/m³

Phantom section: Flat Section

DASY5 Configuration:

- Probe: ES3DV3 - SN3172; ConvF(4.73, 4.73, 4.73); Calibrated: 6/23/2008
- Sensor-Surface: 4mm (Mechanical Surface Detection)
- Electronics: DAE4 Sn856; Calibrated: 5/7/2008
- Phantom: SAM1; Type: SAM;
- Measurement SW: DASY5, V5.0 Build 119; SEMCAD X Version 13.2 Build 87

Body/Area Scan : Measurement grid: dx=15mm, dy=15mm
Maximum value of SAR (interpolated) = 0.308 mW/g

Body/Zoom Scan : Measurement grid: dx=8mm, dy=8mm, dz=5mm
Reference Value = 11.3 V/m; Power Drift = -0.015 dB
Peak SAR (extrapolated) = 0.383 W/kg

SAR(1 g) = 0.299 mW/g; SAR(10 g) = 0.244 mW/g

Maximum value of SAR (measured) = 0.307 mW/g

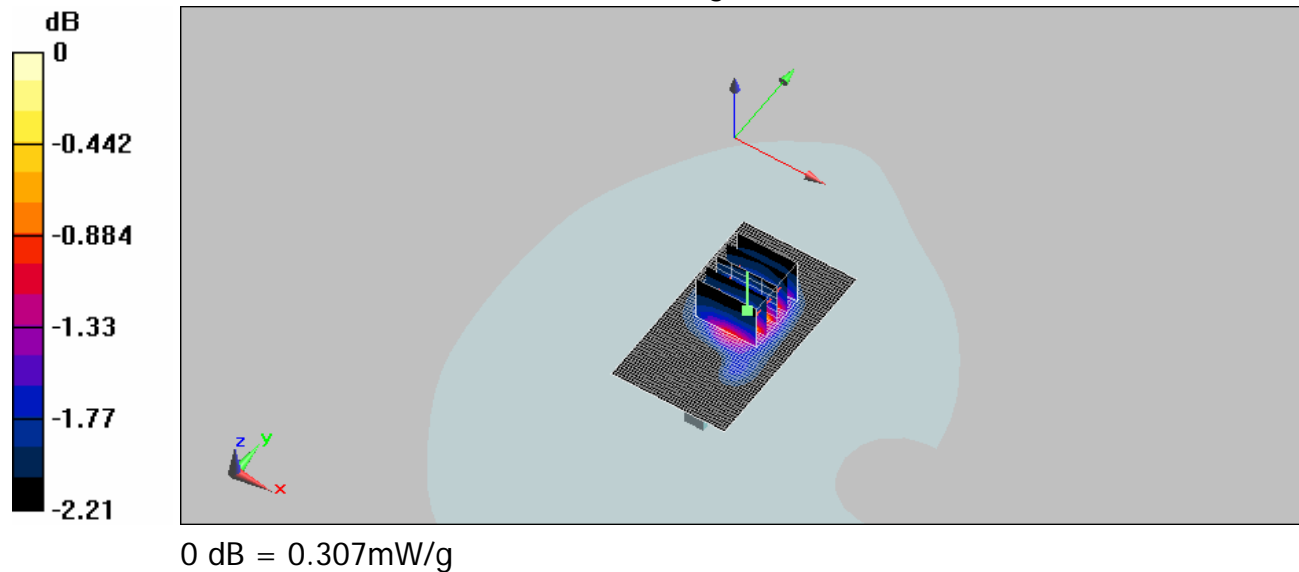

Date/Time: 9/17/2008 17:41:54

Configuration 4_CH810

DUT: C152,

Communication System: GSM1900; Frequency: 1909.8 MHz; Duty Cycle: 1:2

Medium: GSM 1900 Medium parameters used: $f = 1910$ MHz; $\sigma = 1.47$ mho/m; $\epsilon_r = 52.4$; $\rho = 1000$ kg/m³

Phantom section: Flat Section

DASY5 Configuration:

- Probe: ES3DV3 - SN3172; ConvF(4.73, 4.73, 4.73); Calibrated: 6/23/2008
- Sensor-Surface: 4mm (Mechanical Surface Detection)
- Electronics: DAE4 Sn856; Calibrated: 5/7/2008
- Phantom: SAM1; Type: SAM;
- Measurement SW: DASY5, V5.0 Build 119; SEMCAD X Version 13.2 Build 87

Body/Area Scan : Measurement grid: dx=15mm, dy=15mm
Maximum value of SAR (interpolated) = 0.291 mW/g

Body/Zoom Scan : Measurement grid: dx=8mm, dy=8mm, dz=5mm
Reference Value = 11.7 V/m; Power Drift = 0.053 dB
Peak SAR (extrapolated) = 0.332 W/kg

SAR(1 g) = 0.279 mW/g; SAR(10 g) = 0.237 mW/g

Maximum value of SAR (measured) = 0.291 mW/g

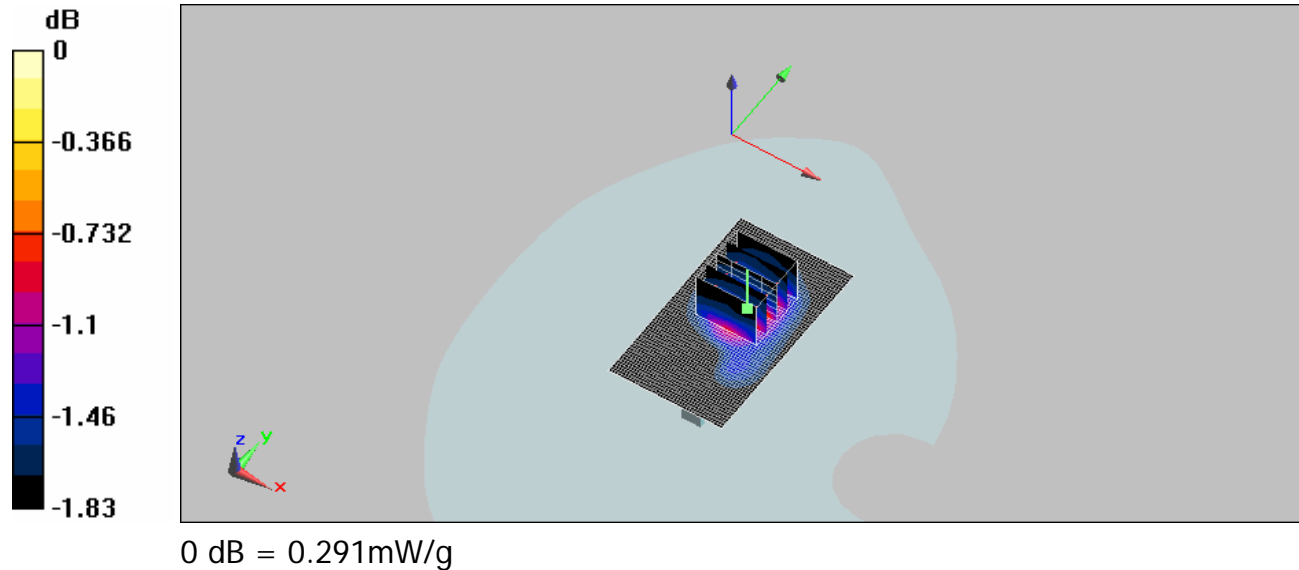

Date/Time: 9/17/2008 18:59:06

Configuration 5_CH512

DUT: C152,

Communication System: GSM 1900; Frequency: 1850.2 MHz; Duty Cycle: 1:2

Medium: GSM 1900 Medium parameters used (interpolated): $f = 1850.2$ MHz; $\sigma = 1.43$ mho/m; $\epsilon_r = 52.3$; $\rho = 1000$ kg/m³

Phantom section: Flat Section

DASY5 Configuration:

- Probe: ES3DV3 - SN3172; ConvF(4.73, 4.73, 4.73); Calibrated: 6/23/2008
- Sensor-Surface: 4mm (Mechanical Surface Detection)
- Electronics: DAE4 Sn856; Calibrated: 5/7/2008
- Phantom: SAM1; Type: SAM;
- Measurement SW: DASY5, V5.0 Build 119; SEMCAD X Version 13.2 Build 87

Body/Area Scan: Measurement grid: dx=15mm, dy=15mm
Maximum value of SAR (interpolated) = 0.162 mW/g

Body/Zoom Scan : Measurement grid: dx=8mm, dy=8mm, dz=5mm
Reference Value = 9.75 V/m; Power Drift = -0.062 dB
Peak SAR (extrapolated) = 0.175 W/kg

SAR(1 g) = 0.160 mW/g; SAR(10 g) = 0.145 mW/g

Maximum value of SAR (measured) = 0.164 mW/g

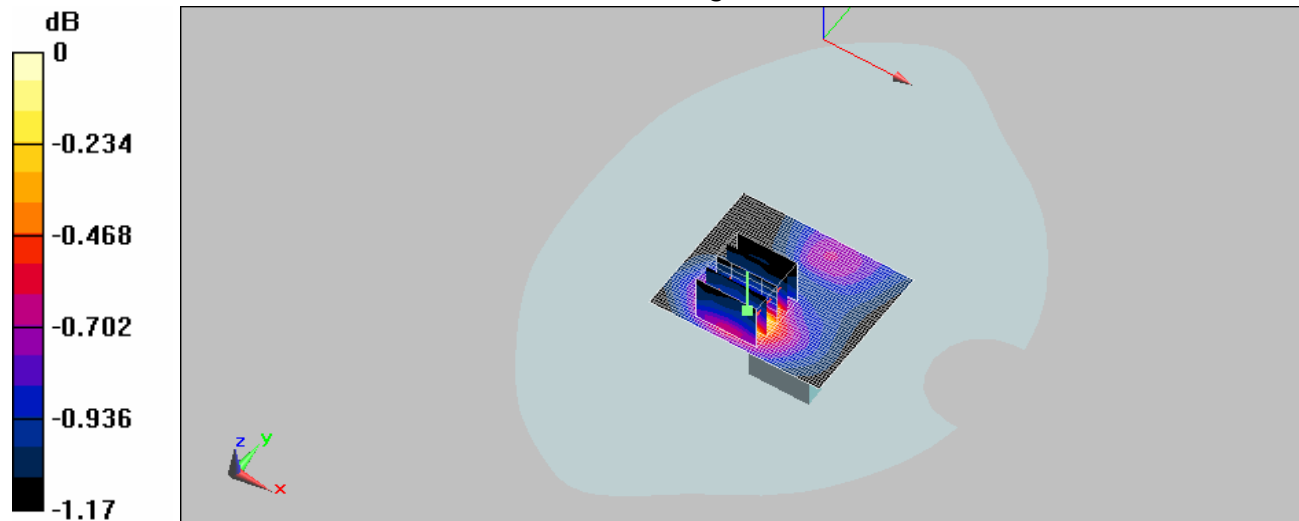

Date/Time: 9/17/2008 18:37:22

Configuration 5_CH661

DUT: C152,

Communication System: GSM 1900; Frequency: 1880 MHz; Duty Cycle: 1:2

Medium: GSM 1900 Medium parameters used: $f = 1880$ MHz; $\sigma = 1.44$ mho/m; $\epsilon_r = 52.3$; $\rho = 1000$ kg/m³

Phantom section: Flat Section

DASY5 Configuration:

- Probe: ES3DV3 - SN3172; ConvF(4.73, 4.73, 4.73); Calibrated: 6/23/2008
- Sensor-Surface: 4mm (Mechanical Surface Detection)
- Electronics: DAE4 Sn856; Calibrated: 5/7/2008
- Phantom: SAM1; Type: SAM;
- Measurement SW: DASY5, V5.0 Build 119; SEMCAD X Version 13.2 Build 87

Body/Area Scan: Measurement grid: dx=15mm, dy=15mm
Maximum value of SAR (interpolated) = 0.154 mW/g

Body/Zoom Scan : Measurement grid: dx=8mm, dy=8mm, dz=5mm
Reference Value = 9.71 V/m; Power Drift = 0.016 dB
Peak SAR (extrapolated) = 0.159 W/kg

SAR(1 g) = 0.151 mW/g; SAR(10 g) = 0.141 mW/g

Maximum value of SAR (measured) = 0.154 mW/g

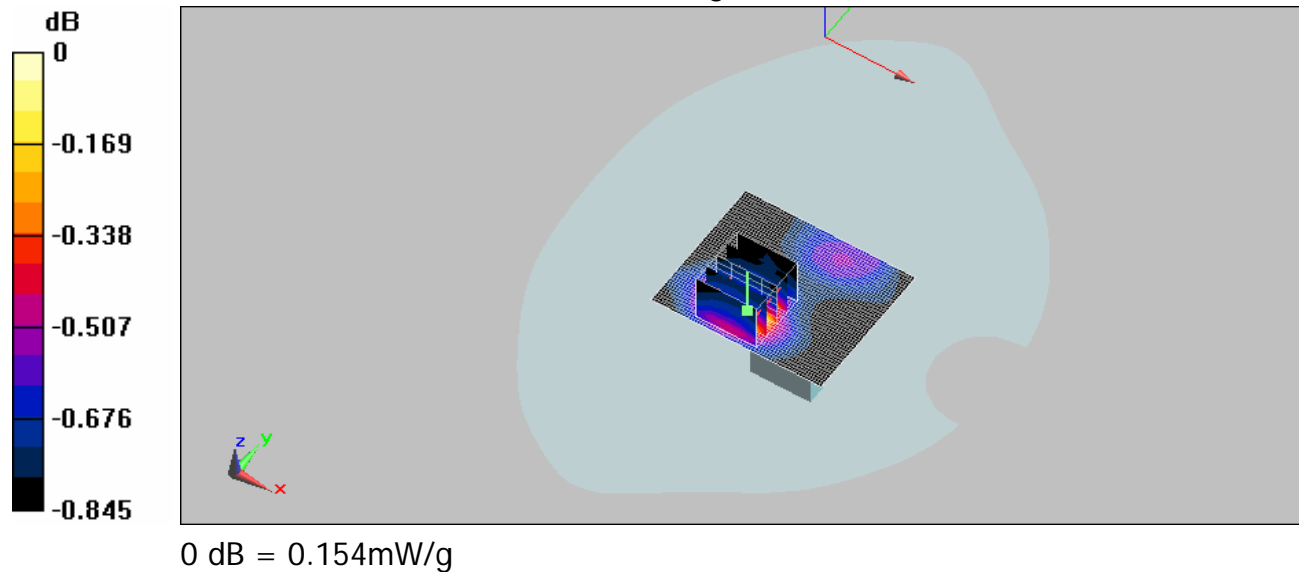

Date/Time: 9/17/2008 18:13:40

Configuration 5_CH810

DUT: C152,

Communication System: GSM 1900; Frequency: 1909.8 MHz; Duty Cycle: 1:2

Medium: GSM 1900 Medium parameters used: $f = 1910$ MHz; $\sigma = 1.47$ mho/m; $\epsilon_r = 52.4$; $\rho = 1000$ kg/m³

Phantom section: Flat Section

DASY5 Configuration:

- Probe: ES3DV3 - SN3172; ConvF(4.73, 4.73, 4.73); Calibrated: 6/23/2008
- Sensor-Surface: 4mm (Mechanical Surface Detection)
- Electronics: DAE4 Sn856; Calibrated: 5/7/2008
- Phantom: SAM1; Type: SAM;
- Measurement SW: DASY5, V5.0 Build 119; SEMCAD X Version 13.2 Build 87

Body/Area Scan: Measurement grid: dx=15mm, dy=15mm
Maximum value of SAR (interpolated) = 0.146 mW/g

Body/Zoom Scan : Measurement grid: dx=8mm, dy=8mm, dz=5mm
Reference Value = 9.67 V/m; Power Drift = 0.013 dB
Peak SAR (extrapolated) = 0.148 W/kg

SAR(1 g) = 0.145 mW/g; SAR(10 g) = 0.139 mW/g

Maximum value of SAR (measured) = 0.148 mW/g

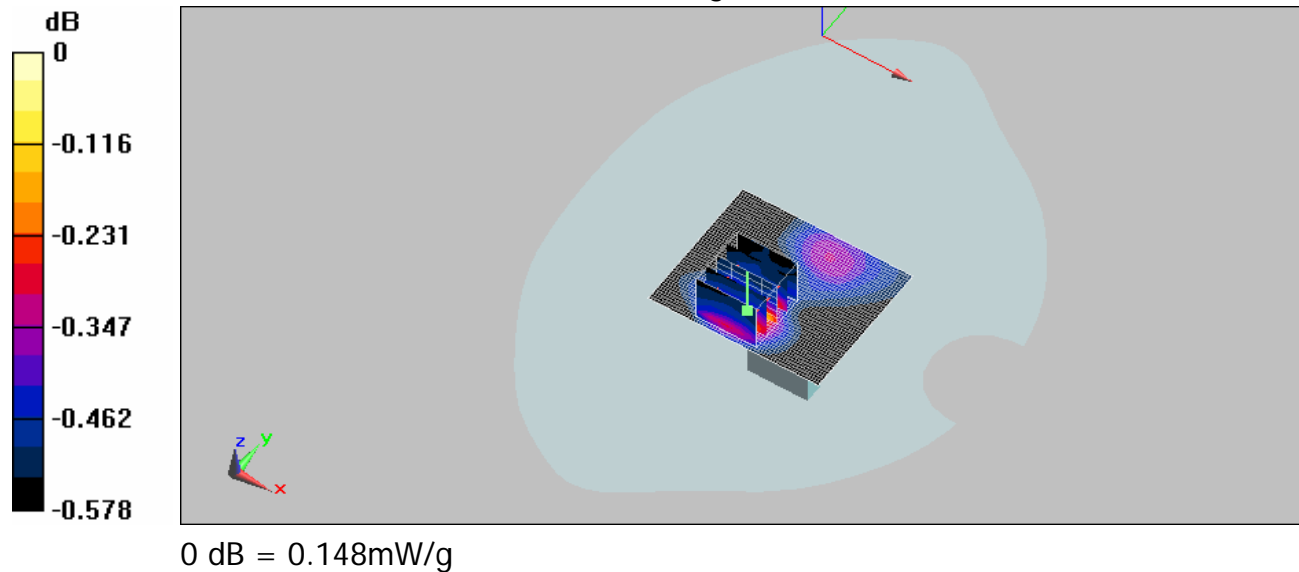

Date/Time: 9/17/2008 19:36:31

Configuration 6_CH512

DUT: C152,

Communication System: GSM1900; Frequency: 1850.2 MHz; Duty Cycle: 1:2

Medium: GPRS 1900 Medium parameters used (interpolated): $f = 1850.2$ MHz; $\sigma = 1.43$ mho/m; $\epsilon_r = 52.3$; $\rho = 1000$ kg/m³

Phantom section: Flat Section

DASY5 Configuration:

- Probe: ES3DV3 - SN3172; ConvF(4.73, 4.73, 4.73); Calibrated: 6/23/2008
- Sensor-Surface: 4mm (Mechanical Surface Detection)
- Electronics: DAE4 Sn856; Calibrated: 5/7/2008
- Phantom: SAM1; Type: SAM;
- Measurement SW: DASY5, V5.0 Build 119; SEMCAD X Version 13.2 Build 87

Body/Area Scan: Measurement grid: dx=15mm, dy=15mm
Maximum value of SAR (interpolated) = 0.232 mW/g

Body/Zoom Scan : Measurement grid: dx=8mm, dy=8mm, dz=5mm
Reference Value = 12 V/m; Power Drift = -0.185 dB
Peak SAR (extrapolated) = 0.364 W/kg

SAR(1 g) = 0.185 mW/g; SAR(10 g) = 0.124 mW/g

Maximum value of SAR (measured) = 0.191 mW/g

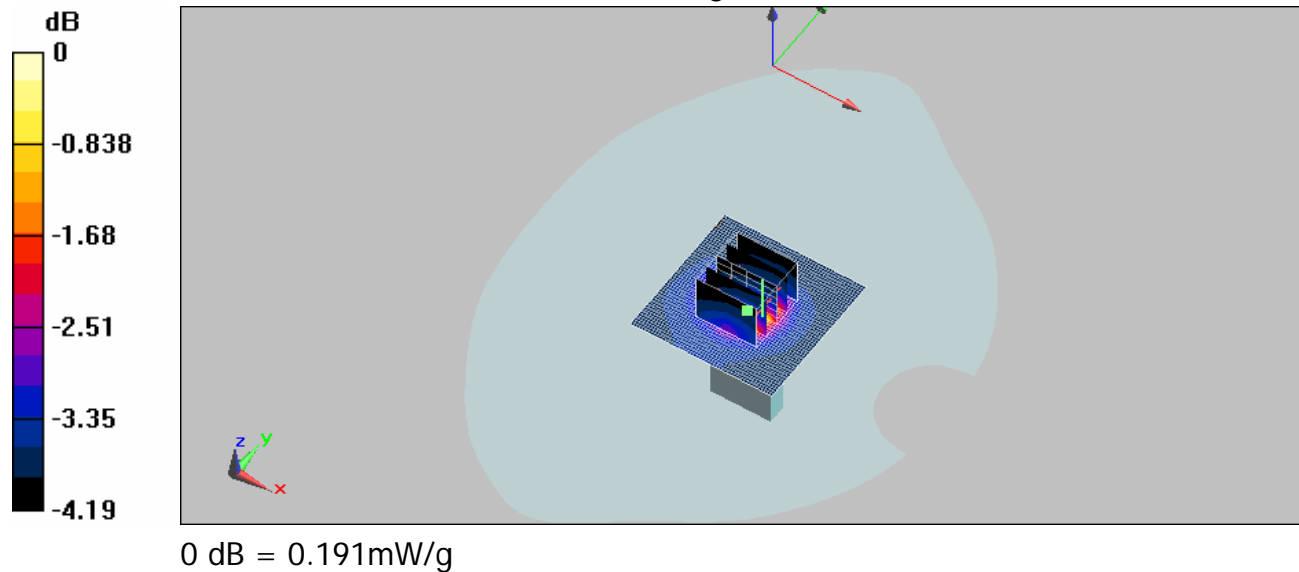

Date/Time: 9/17/2008 20:00:56

Configuration 6_CH661

DUT: C152,

Communication System: GSM1900; Frequency: 1880 MHz; Duty Cycle: 1:2

Medium: GPRS 1900 Medium parameters used: $f = 1880$ MHz; $\sigma = 1.44$ mho/m; $\epsilon_r = 52.3$; $\rho = 1000$ kg/m³

Phantom section: Flat Section

DASY5 Configuration:

- Probe: ES3DV3 - SN3172; ConvF(4.73, 4.73, 4.73); Calibrated: 6/23/2008
- Sensor-Surface: 4mm (Mechanical Surface Detection)
- Electronics: DAE4 Sn856; Calibrated: 5/7/2008
- Phantom: SAM1; Type: SAM;
- Measurement SW: DASY5, V5.0 Build 119; SEMCAD X Version 13.2 Build 87

Body/Area Scan: Measurement grid: dx=15mm, dy=15mm
Maximum value of SAR (interpolated) = 0.191 mW/g

Body/Zoom Scan : Measurement grid: dx=8mm, dy=8mm, dz=5mm
Reference Value = 10.8 V/m; Power Drift = 0.064 dB
Peak SAR (extrapolated) = 0.349 W/kg

SAR(1 g) = 0.168 mW/g; SAR(10 g) = 0.116 mW/g

Maximum value of SAR (measured) = 0.171 mW/g

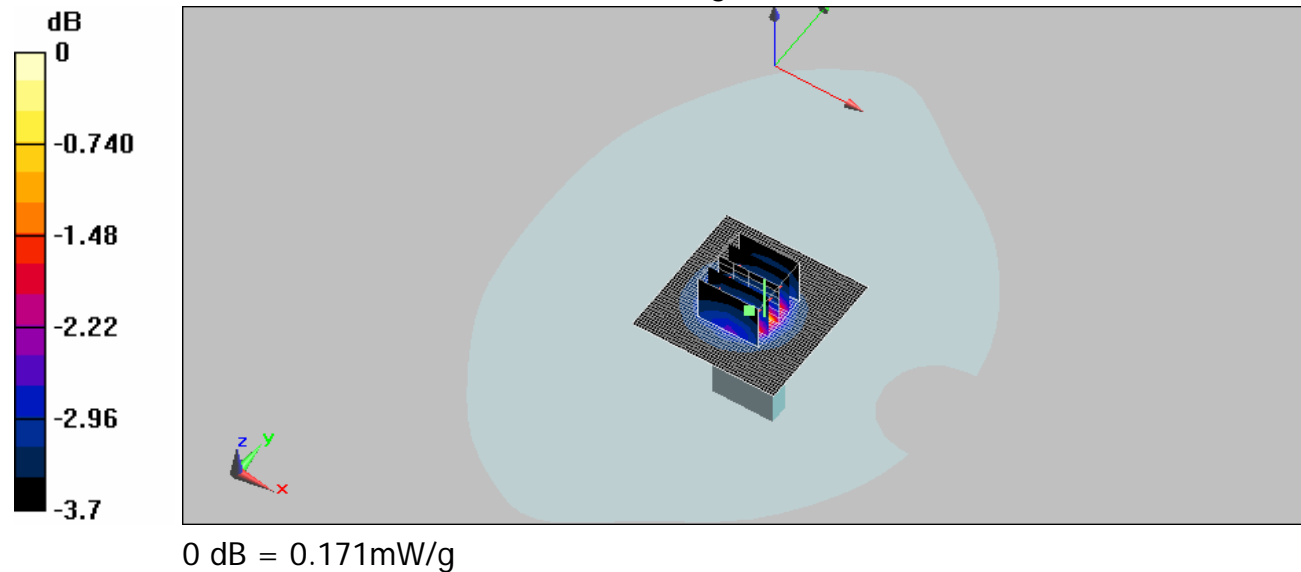

Date/Time: 9/17/2008 20:23:32

Configuration 6_CH810

DUT: C152,

Communication System: GSM1900; Frequency: 1909.8 MHz; Duty Cycle: 1:2

Medium: GPRS 1900 Medium parameters used: $f = 1910$ MHz; $\sigma = 1.47$ mho/m; $\epsilon_r = 52.4$; $\rho = 1000$ kg/m³

Phantom section: Flat Section

DASY5 Configuration:

- Probe: ES3DV3 - SN3172; ConvF(4.73, 4.73, 4.73); Calibrated: 6/23/2008
- Sensor-Surface: 4mm (Mechanical Surface Detection)
- Electronics: DAE4 Sn856; Calibrated: 5/7/2008
- Phantom: SAM1; Type: SAM;
- Measurement SW: DASY5, V5.0 Build 119; SEMCAD X Version 13.2 Build 87

Body/Area Scan: Measurement grid: dx=15mm, dy=15mm
Maximum value of SAR (interpolated) = 0.170 mW/g

Body/Zoom Scan : Measurement grid: dx=8mm, dy=8mm, dz=5mm
Reference Value = 10 V/m; Power Drift = -0.017 dB
Peak SAR (extrapolated) = 0.271 W/kg

SAR(1 g) = 0.154 mW/g; SAR(10 g) = 0.109 mW/g

Maximum value of SAR (measured) = 0.155 mW/g

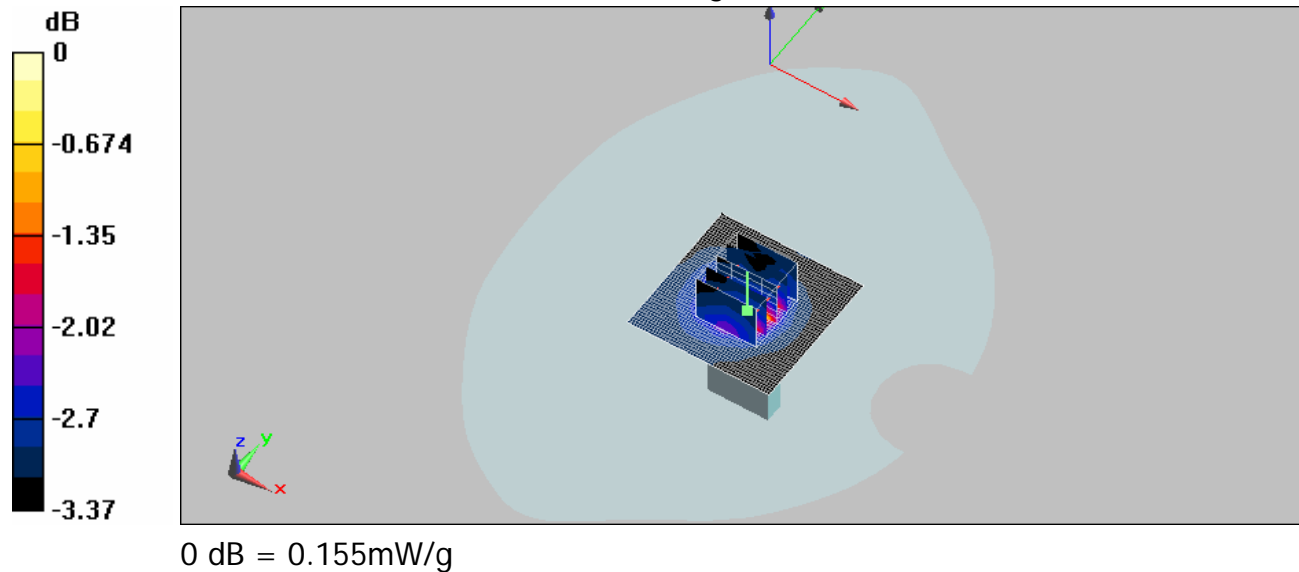

Date/Time: 12/8/2008 6:59:49

Configuration 7_CH512

DUT: C152,

Communication System: GSM 1900; Frequency: 1850.2 MHz; Duty Cycle: 1:2

Medium: GSM 1900 Medium parameters used (interpolated): $f = 1850.2$ MHz; $\sigma = 1.46$ mho/m; $\epsilon_r = 54.7$; $\rho = 1000$ kg/m³

Phantom section: Flat Section

DASY5 Configuration:

- Probe: ES3DV3 - SN3172; ConvF(4.73, 4.73, 4.73); Calibrated: 6/23/2008
- Sensor-Surface: 4mm (Mechanical Surface Detection)
- Electronics: DAE4 Sn856; Calibrated: 5/7/2008
- Phantom: SAM1; Type: SAM;
- Measurement SW: DASY5, V5.0 Build 119; SEMCAD X Version 13.2 Build 87

Body/Area Scan: Measurement grid: dx=15mm, dy=15mm
Maximum value of SAR (interpolated) = 1.2 mW/g

Body/Zoom Scan: Measurement grid: dx=8mm, dy=8mm, dz=5mm
Reference Value = 13.9 V/m; Power Drift = -0.085 dB
Peak SAR (extrapolated) = 1.39 W/kg

SAR(1 g) = 0.955 mW/g; SAR(10 g) = 0.581 mW/g

Maximum value of SAR (measured) = 1.02 mW/g

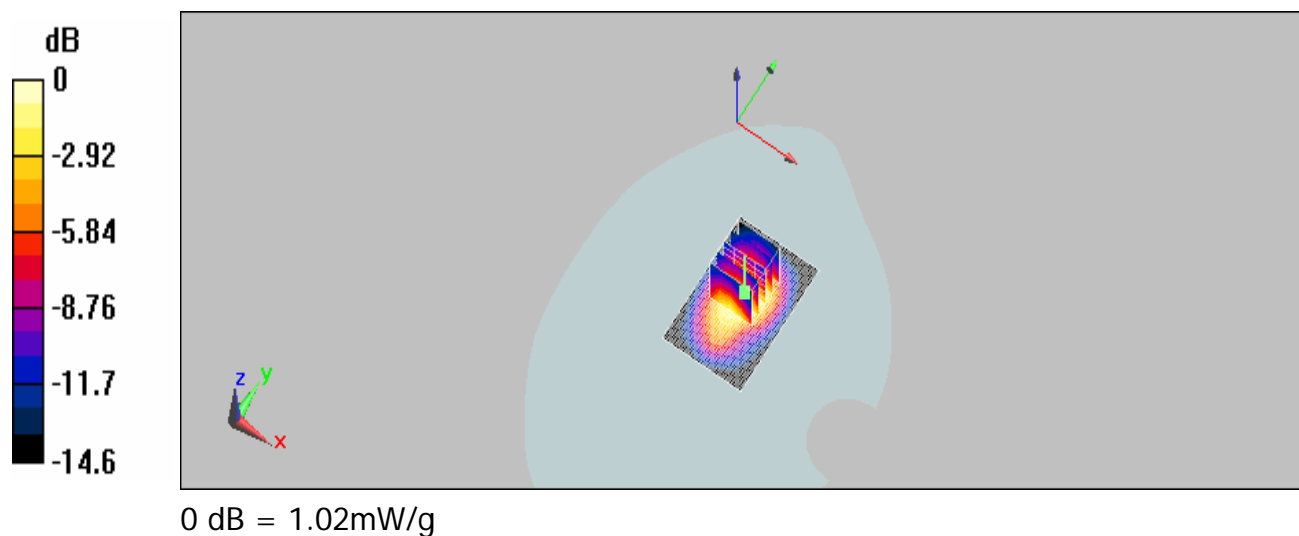

Date/Time: 12/8/2008 7:35:09

Configuration 7_CH661

DUT: C152,

Communication System: GSM 1900; Frequency: 1880 MHz; Duty Cycle: 1:2

Medium: GSM 1900 Medium parameters used: $f = 1880$ MHz; $\sigma = 1.49$ mho/m; $\epsilon_r = 54.6$; $\rho = 1000$ kg/m³

Phantom section: Flat Section

DASY5 Configuration:

- Probe: ES3DV3 - SN3172; ConvF(4.73, 4.73, 4.73); Calibrated: 6/23/2008
- Sensor-Surface: 4mm (Mechanical Surface Detection)
- Electronics: DAE4 Sn856; Calibrated: 5/7/2008
- Phantom: SAM1; Type: SAM;

- Measurement SW: DASY5, V5.0 Build 119; SEMCAD X Version 13.2 Build 87

Body/Area Scan: Measurement grid: dx=15mm, dy=15mm
Maximum value of SAR (interpolated) = 0.886 mW/g

Body/Zoom Scan: Measurement grid: dx=8mm, dy=8mm, dz=5mm
Reference Value = 12.1 V/m; Power Drift = 0.046 dB
Peak SAR (extrapolated) = 0.996 W/kg

SAR(1 g) = 0.698 mW/g; SAR(10 g) = 0.426 mW/g
Maximum value of SAR (measured) = 0.738 mW/g

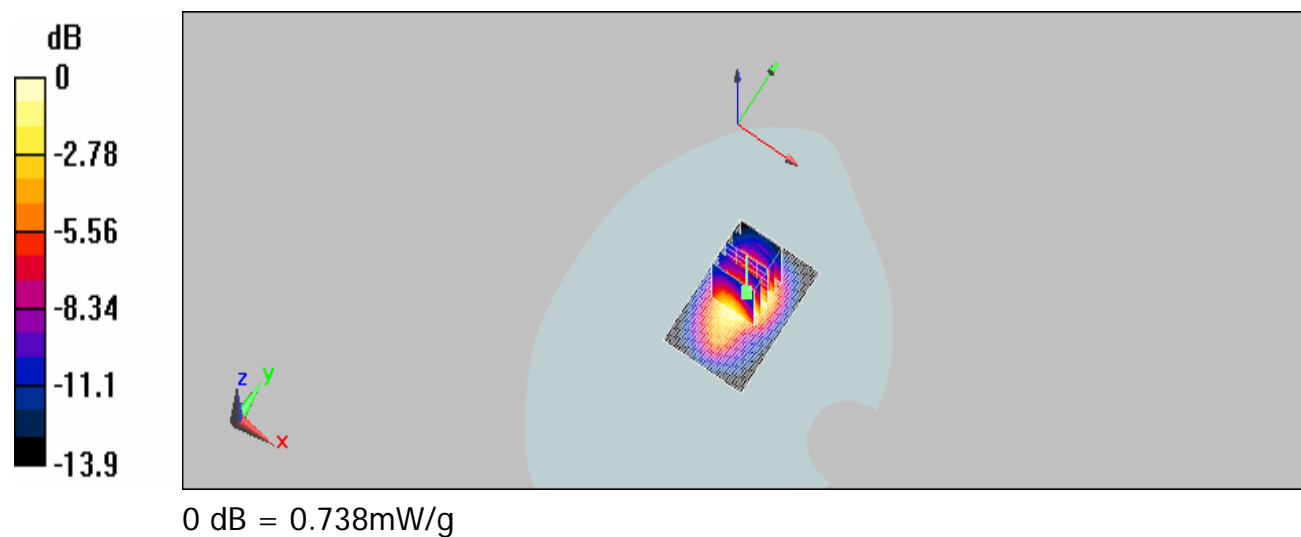

Date/Time: 12/8/2008 8:09:13

Configuration 7_CH810

DUT: C152,

Communication System: GSM 1900; Frequency: 1909.8 MHz; Duty Cycle: 1:2

Medium: GSM 1900 Medium parameters used: $f = 1910$ MHz; $\sigma = 1.52$ mho/m; $\epsilon_r = 54.5$; $\rho = 1000$ kg/m³

Phantom section: Flat Section

DASY5 Configuration:

- Probe: ES3DV3 - SN3172; ConvF(4.73, 4.73, 4.73); Calibrated: 6/23/2008
- Sensor-Surface: 4mm (Mechanical Surface Detection)

- Electronics: DAE4 Sn856; Calibrated: 5/7/2008
- Phantom: SAM1; Type: SAM;
- Measurement SW: DASY5, V5.0 Build 119; SEMCAD X Version 13.2 Build 87

Body/Area Scan: Measurement grid: dx=15mm, dy=15mm
Maximum value of SAR (interpolated) = 0.654 mW/g

Body/Zoom Scan: Measurement grid: dx=8mm, dy=8mm, dz=5mm
Reference Value = 11 V/m; Power Drift = 0.109 dB
Peak SAR (extrapolated) = 0.757 W/kg

SAR(1 g) = 0.519 mW/g; SAR(10 g) = 0.315 mW/g
Maximum value of SAR (measured) = 0.553 mW/g

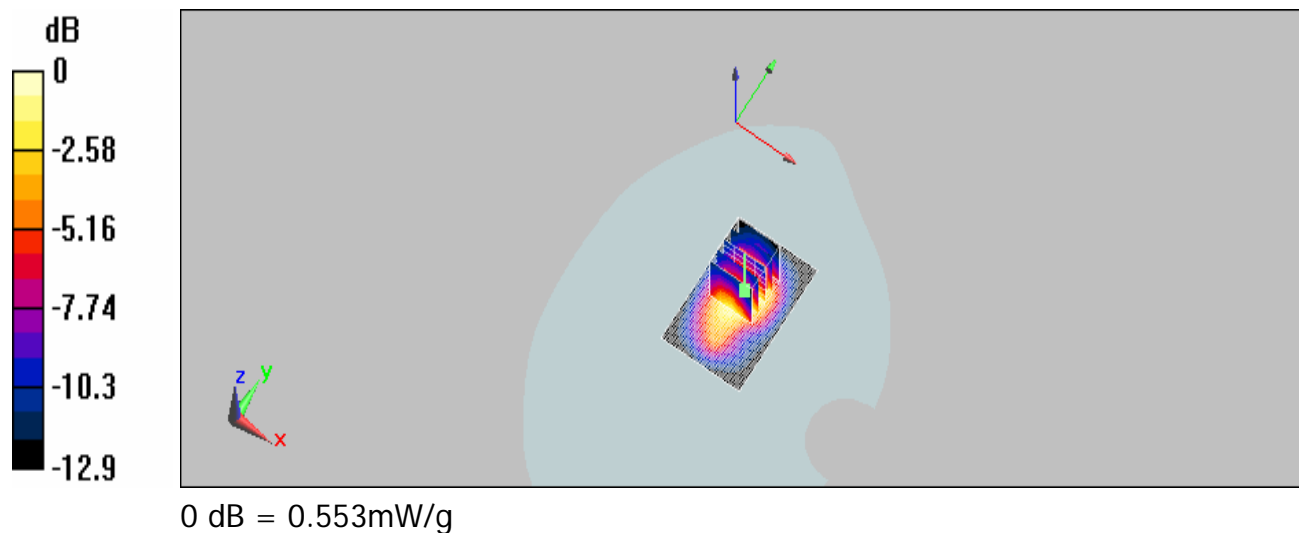

Date/Time: 12/8/2008 9:16:14

Configuration 8_CH 512

DUT: C152,

Communication System: GSM 1900; Frequency: 1850.2 MHz; Duty Cycle: 1:2
Medium: GSM 1900 Medium parameters used (interpolated): $f = 1850.2$ MHz; $\sigma = 1.46$ mho/m; $\epsilon_r = 54.7$; $\rho = 1000$ kg/m³
Phantom section: Flat Section
DASY5 Configuration:

- Probe: ES3DV3 - SN3172; ConvF(4.73, 4.73, 4.73); Calibrated: 6/23/2008

- Sensor-Surface: 4mm (Mechanical Surface Detection)
- Electronics: DAE4 Sn856; Calibrated: 5/7/2008
- Phantom: SAM1; Type: SAM;
- Measurement SW: DASY5, V5.0 Build 119; SEMCAD X Version 13.2 Build 87

Body/Area Scan: Measurement grid: dx=15mm, dy=15mm
Maximum value of SAR (interpolated) = 1.21 mW/g

Body/Zoom Scan: Measurement grid: dx=8mm, dy=8mm, dz=5mm
Reference Value = 5.46 V/m; Power Drift = -0.101 dB
Peak SAR (extrapolated) = 1.67 W/kg

SAR(1 g) = 0.920 mW/g; SAR(10 g) = 0.467 mW/g
Maximum value of SAR (measured) = 1.06 mW/g

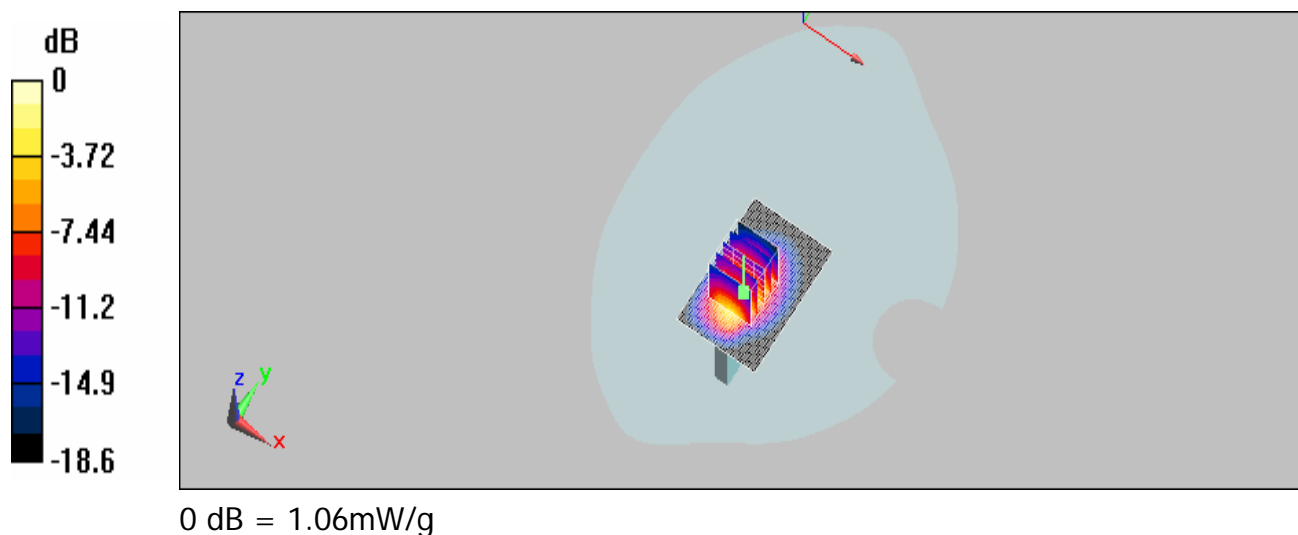

Date/Time: 12/8/2008 9:50:50

Configuration 8_CH 661

DUT: C152,

Communication System: GSM 1900; Frequency: 1880 MHz; Duty Cycle: 1:2

Medium: GSM 1900 Medium parameters used: $f = 1880$ MHz; $\sigma = 1.49$ mho/m; $\epsilon_r = 54.6$; $\rho = 1000$ kg/m³

Phantom section: Flat Section

DASY5 Configuration:

- Probe: ES3DV3 - SN3172; ConvF(4.73, 4.73, 4.73); Calibrated: 6/23/2008
- Sensor-Surface: 4mm (Mechanical Surface Detection)
- Electronics: DAE4 Sn856; Calibrated: 5/7/2008
- Phantom: SAM1; Type: SAM;
- Measurement SW: DASY5, V5.0 Build 119; SEMCAD X Version 13.2 Build 87

Body/Area Scan: Measurement grid: dx=15mm, dy=15mm
Maximum value of SAR (interpolated) = 0.882 mW/g

Body/Zoom Scan: Measurement grid: dx=8mm, dy=8mm, dz=5mm
Reference Value = 4.51 V/m; Power Drift = 0.163 dB
Peak SAR (extrapolated) = 1.29 W/kg

SAR(1 g) = 0.685 mW/g; SAR(10 g) = 0.342 mW/g
Maximum value of SAR (measured) = 0.779 mW/g

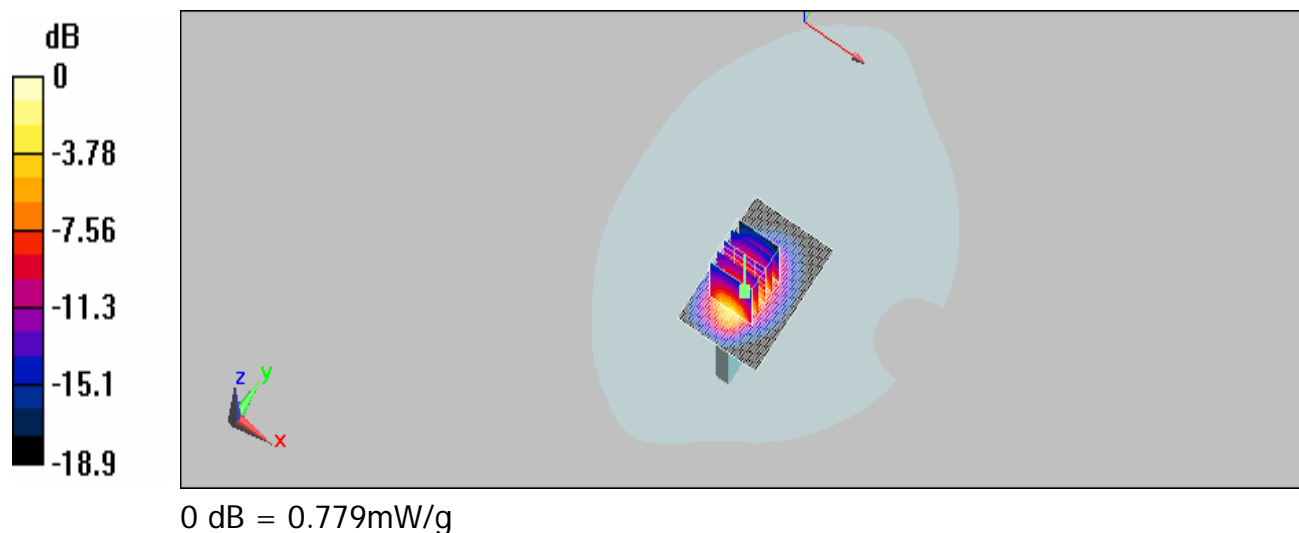

Date/Time: 12/8/2008 10:26:06

Configuration 8_CH 810

DUT: C152,

Communication System: GSM 1900; Frequency: 1909.8 MHz; Duty Cycle: 1:2

Medium: GSM 1900 Medium parameters used: $f = 1910$ MHz; $\sigma = 1.52$ mho/m; $\epsilon_r = 54.5$; $\rho = 1000$ kg/m³

Phantom section: Flat Section

DASY5 Configuration:

- Probe: ES3DV3 - SN3172; ConvF(4.73, 4.73, 4.73); Calibrated: 6/23/2008
- Sensor-Surface: 4mm (Mechanical Surface Detection)
- Electronics: DAE4 Sn856; Calibrated: 5/7/2008
- Phantom: SAM1; Type: SAM;
- Measurement SW: DASY5, V5.0 Build 119; SEMCAD X Version 13.2 Build 87

Body/Area Scan: Measurement grid: dx=15mm, dy=15mm

Maximum value of SAR (interpolated) = 0.674 mW/g

Body/Zoom Scan: Measurement grid: dx=8mm, dy=8mm, dz=5mm

Reference Value = 3.93 V/m; Power Drift = 0.133 dB

Peak SAR (extrapolated) = 0.951 W/kg

SAR(1 g) = 0.509 mW/g; SAR(10 g) = 0.255 mW/g

Maximum value of SAR (measured) = 0.566 mW/g

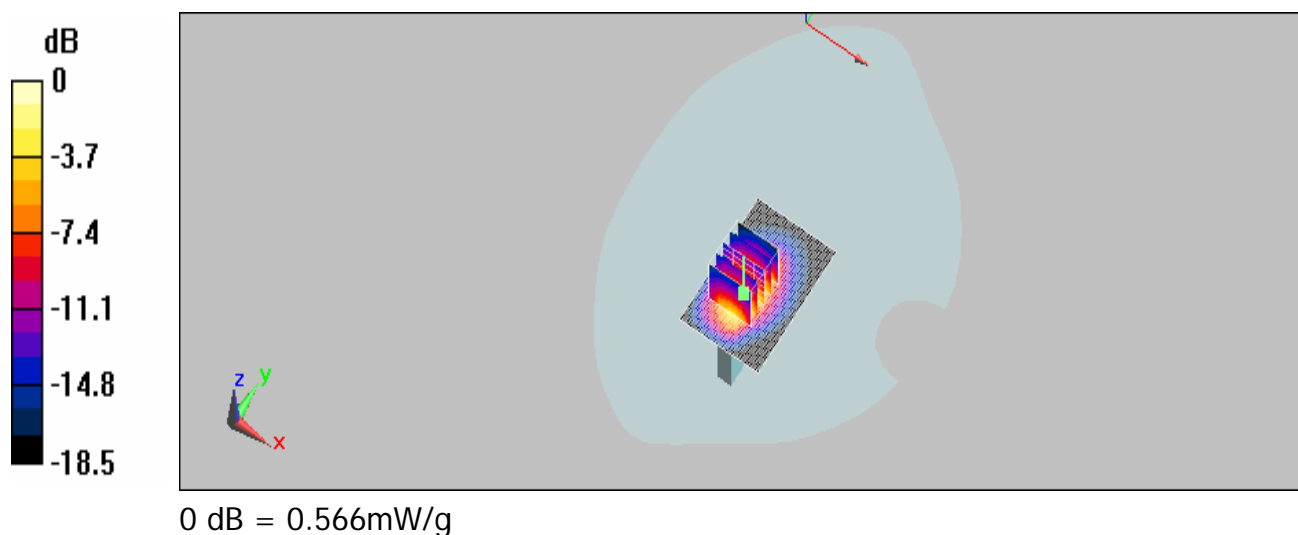

Date/Time: 9/18/2008 02:31:31

Configuration 1_CH9262

DUT: C152,

Communication System: WCDMA BAND2; Frequency: 1852.4 MHz; Duty Cycle: 1:1

Medium: WCDMA Band2 Medium parameters used (interpolated): $f = 1852.4$ MHz; $\sigma = 1.44$

mho/m; $\epsilon_r = 52.3$; $\rho = 1000 \text{ kg/m}^3$

Phantom section: Flat Section

DASY5 Configuration:

- Probe: ES3DV3 - SN3172; ConvF(4.73, 4.73, 4.73); Calibrated: 6/23/2008
- Sensor-Surface: 4mm (Mechanical Surface Detection)
- Electronics: DAE4 Sn856; Calibrated: 5/7/2008
- Phantom: SAM1; Type: SAM;
- Measurement SW: DASY5, V5.0 Build 119; SEMCAD X Version 13.2 Build 87

Body/Area Scan: Measurement grid: dx=15mm, dy=15mm

Maximum value of SAR (interpolated) = 0.656 mW/g

Body/Zoom Scan : Measurement grid: dx=8mm, dy=8mm, dz=5mm

Reference Value = 10.5 V/m; Power Drift = -0.109 dB

Peak SAR (extrapolated) = 0.741 W/kg

SAR(1 g) = 0.520 mW/g; SAR(10 g) = 0.337 mW/g

Maximum value of SAR (measured) = 0.562 mW/g

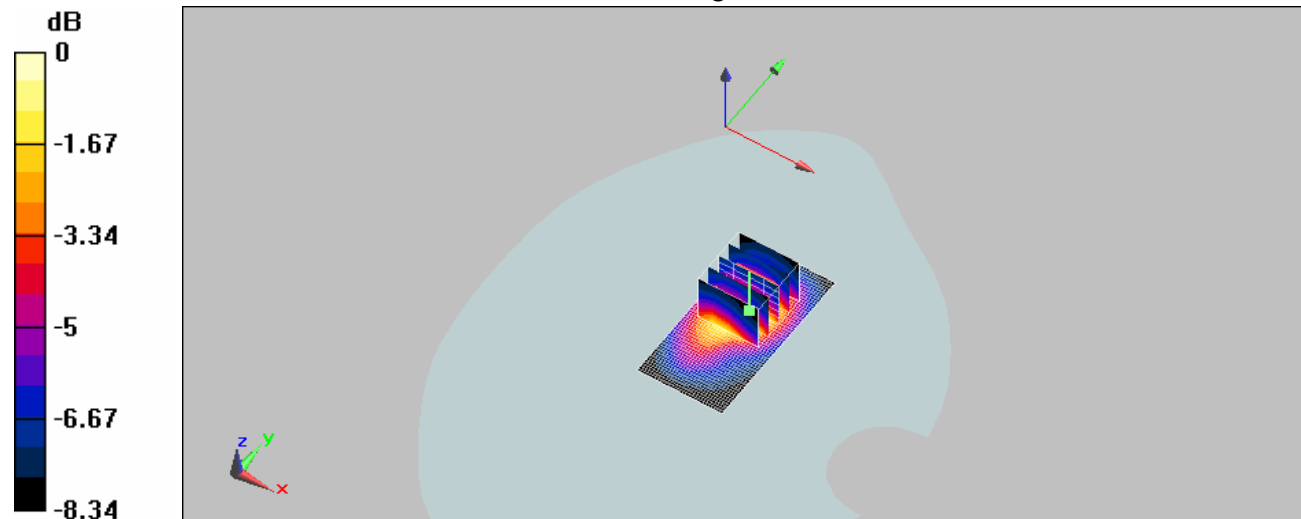

0 dB = 0.562mW/g

Date/Time: 9/18/2008 02:55:42

Configuration 1_CH9400

DUT: C152,

Communication System: WCDMA BAND2; Frequency: 1880 MHz; Duty Cycle: 1:1

Medium: WCDMA Band2 Medium parameters used: $f = 1880$ MHz; $\sigma = 1.46$ mho/m; $\epsilon_r = 52.4$; $\rho = 1000$ kg/m³

Phantom section: Flat Section

DASY5 Configuration:

- Probe: ES3DV3 - SN3172; ConvF(4.73, 4.73, 4.73); Calibrated: 6/23/2008
- Sensor-Surface: 4mm (Mechanical Surface Detection)
- Electronics: DAE4 Sn856; Calibrated: 5/7/2008
- Phantom: SAM1; Type: SAM;
- Measurement SW: DASY5, V5.0 Build 119; SEMCAD X Version 13.2 Build 87

Body/Area Scan: Measurement grid: dx=15mm, dy=15mm

Maximum value of SAR (interpolated) = 0.825 mW/g

Body/Zoom Scan : Measurement grid: dx=8mm, dy=8mm, dz=5mm

Reference Value = 11.7 V/m; Power Drift = -0.068 dB

Peak SAR (extrapolated) = 0.976 W/kg

SAR(1 g) = 0.676 mW/g; SAR(10 g) = 0.434 mW/g

Maximum value of SAR (measured) = 0.725 mW/g

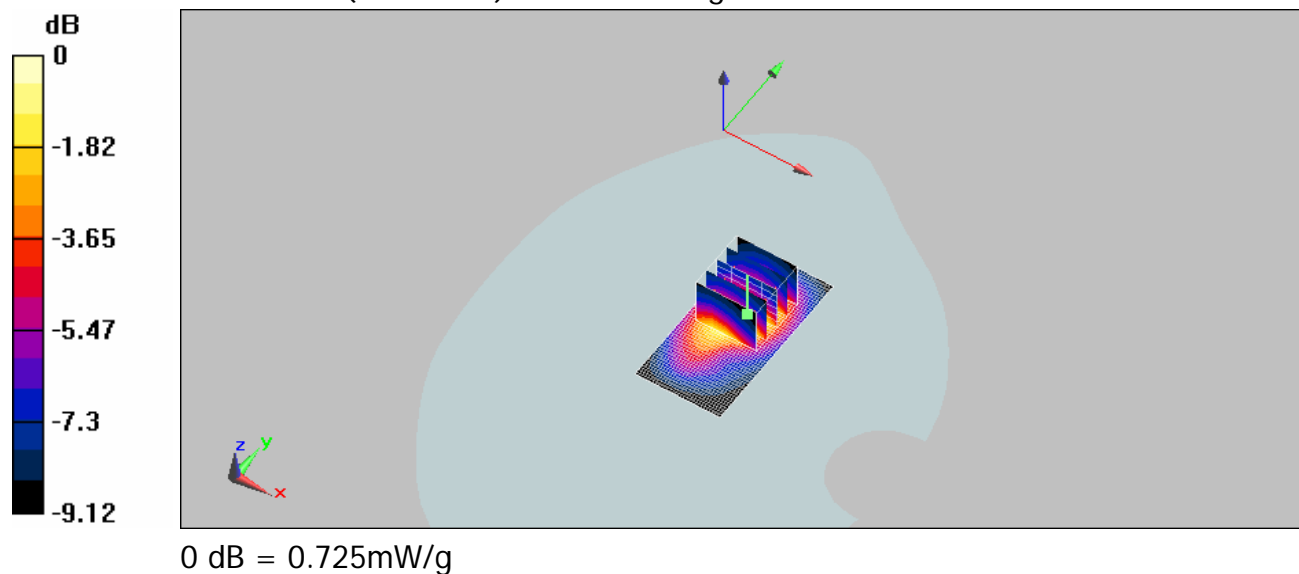

Date/Time: 9/18/2008 03:17:30

Configuration 1_CH9538

DUT: C152,

Communication System: WCDMA BAND2; Frequency: 1907.6 MHz; Duty Cycle: 1:1

Medium: WCDMA Band2 Medium parameters used: $f = 1908$ MHz; $\sigma = 1.48$ mho/m; $\epsilon_r = 52.5$; $\rho = 1000$ kg/m³

Phantom section: Flat Section

DASY5 Configuration:

- Probe: ES3DV3 - SN3172; ConvF(4.73, 4.73, 4.73); Calibrated: 6/23/2008
- Sensor-Surface: 4mm (Mechanical Surface Detection)
- Electronics: DAE4 Sn856; Calibrated: 5/7/2008
- Phantom: SAM1; Type: SAM;
- Measurement SW: DASY5, V5.0 Build 119; SEMCAD X Version 13.2 Build 87

Body/Area Scan : Measurement grid: dx=15mm, dy=15mm

Maximum value of SAR (interpolated) = 0.537 mW/g

Body/Zoom Scan : Measurement grid: dx=8mm, dy=8mm, dz=5mm

Reference Value = 10.5 V/m; Power Drift = -0.144 dB

Peak SAR (extrapolated) = 0.595 W/kg

SAR(1 g) = 0.419 mW/g; SAR(10 g) = 0.284 mW/g

Maximum value of SAR (measured) = 0.443 mW/g

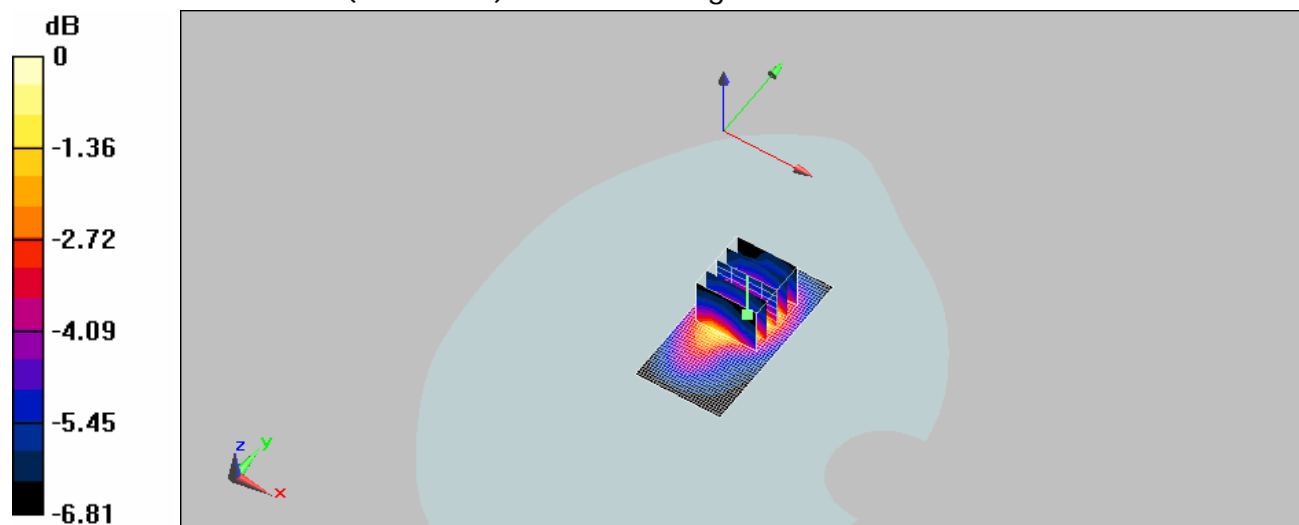

0 dB = 0.443mW/g

Date/Time: 9/18/2008 04:34:59

Configuration 2_CH9262

DUT: C152,

Communication System: WCDMA BAND2; Frequency: 1852.4 MHz; Duty Cycle: 1:1

Medium: WCDMA Band2 Medium parameters used (interpolated): $f = 1852.4$ MHz; $\sigma = 1.44$ mho/m; $\epsilon_r = 52.3$; $\rho = 1000$ kg/m³

Phantom section: Flat Section

DASY5 Configuration:

- Probe: ES3DV3 - SN3172; ConvF(4.73, 4.73, 4.73); Calibrated: 6/23/2008
- Sensor-Surface: 4mm (Mechanical Surface Detection)
- Electronics: DAE4 Sn856; Calibrated: 5/7/2008
- Phantom: SAM1; Type: SAM;
- Measurement SW: DASY5, V5.0 Build 119; SEMCAD X Version 13.2 Build 87

Body/Area Scan : Measurement grid: dx=15mm, dy=15mm

Maximum value of SAR (interpolated) = 0.189 mW/g

Body/Zoom Scan : Measurement grid: dx=8mm, dy=8mm, dz=5mm

Reference Value = 8.18 V/m; Power Drift = -0.110 dB

Peak SAR (extrapolated) = 0.226 W/kg

SAR(1 g) = 0.173 mW/g; SAR(10 g) = 0.133 mW/g

Maximum value of SAR (measured) = 0.181 mW/g

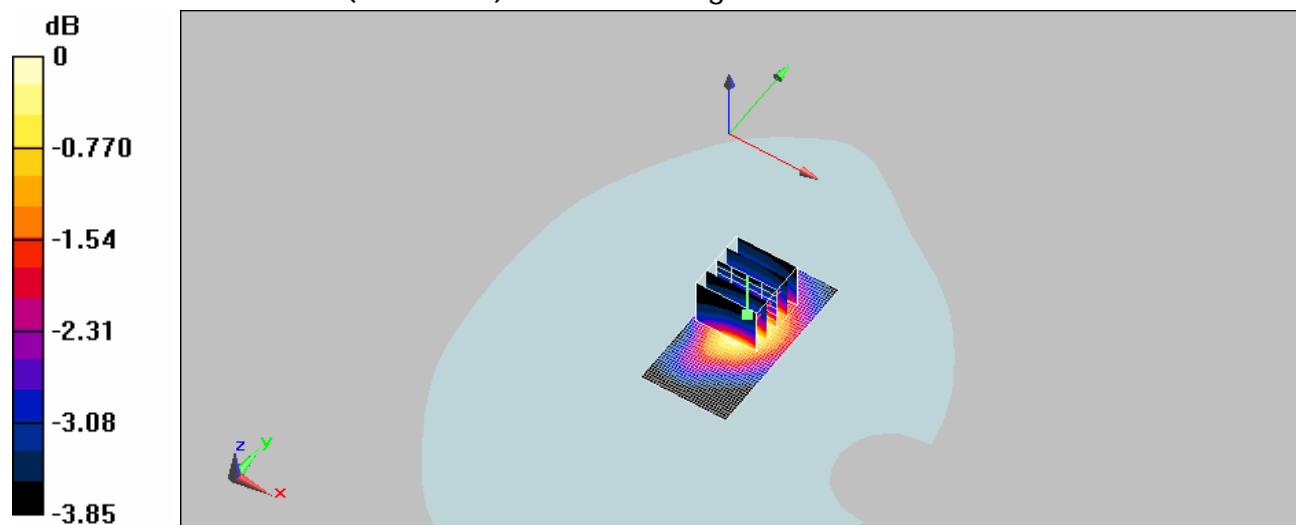

0 dB = 0.181mW/g

Date/Time: 9/18/2008 04:13:52

Configuration 2_CH9400

DUT: C152,

Communication System: WCDMA BAND2; Frequency: 1880 MHz; Duty Cycle: 1:1

Medium: WCDMA Band2 Medium parameters used: $f = 1880$ MHz; $\sigma = 1.46$ mho/m; $\epsilon_r = 52.4$; $\rho = 1000$ kg/m³

Phantom section: Flat Section

DASY5 Configuration:

- Probe: ES3DV3 - SN3172; ConvF(4.73, 4.73, 4.73); Calibrated: 6/23/2008
- Sensor-Surface: 4mm (Mechanical Surface Detection)
- Electronics: DAE4 Sn856; Calibrated: 5/7/2008
- Phantom: SAM1; Type: SAM;
- Measurement SW: DASY5, V5.0 Build 119; SEMCAD X Version 13.2 Build 87

Body/Area Scan : Measurement grid: dx=15mm, dy=15mm

Maximum value of SAR (interpolated) = 0.242 mW/g

Body/Zoom Scan : Measurement grid: dx=8mm, dy=8mm, dz=5mm

Reference Value = 8.74 V/m; Power Drift = 0.123 dB

Peak SAR (extrapolated) = 0.328 W/kg

SAR(1 g) = 0.239 mW/g; SAR(10 g) = 0.173 mW/g

Maximum value of SAR (measured) = 0.246 mW/g

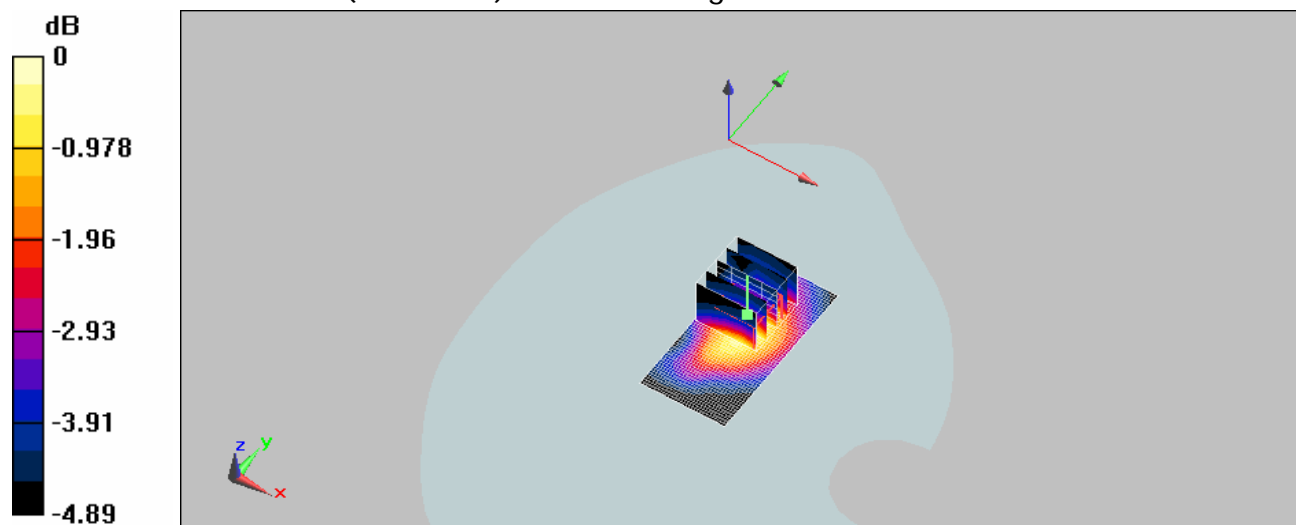

0 dB = 0.246mW/g

Date/Time: 9/18/2008 03:50:05

Configuration 2_CH9538

DUT: C152,

Communication System: WCDMA BAND2; Frequency: 1907.6 MHz; Duty Cycle: 1:1

Medium: WCDMA Band2 Medium parameters used: $f = 1908$ MHz; $\sigma = 1.48$ mho/m; $\epsilon_r = 52.5$; $\rho = 1000$ kg/m³

Phantom section: Flat Section

DASY5 Configuration:

- Probe: ES3DV3 - SN3172; ConvF(4.73, 4.73, 4.73); Calibrated: 6/23/2008
- Sensor-Surface: 4mm (Mechanical Surface Detection)
- Electronics: DAE4 Sn856; Calibrated: 5/7/2008
- Phantom: SAM1; Type: SAM;
- Measurement SW: DASY5, V5.0 Build 119; SEMCAD X Version 13.2 Build 87

Body/Area Scan : Measurement grid: dx=15mm, dy=15mm

Maximum value of SAR (interpolated) = 0.197 mW/g

Body/Zoom Scan : Measurement grid: dx=8mm, dy=8mm, dz=5mm

Reference Value = 8.29 V/m; Power Drift = -0.192 dB

Peak SAR (extrapolated) = 0.226 W/kg

SAR(1 g) = 0.162 mW/g; SAR(10 g) = 0.129 mW/g

Maximum value of SAR (measured) = 0.166 mW/g

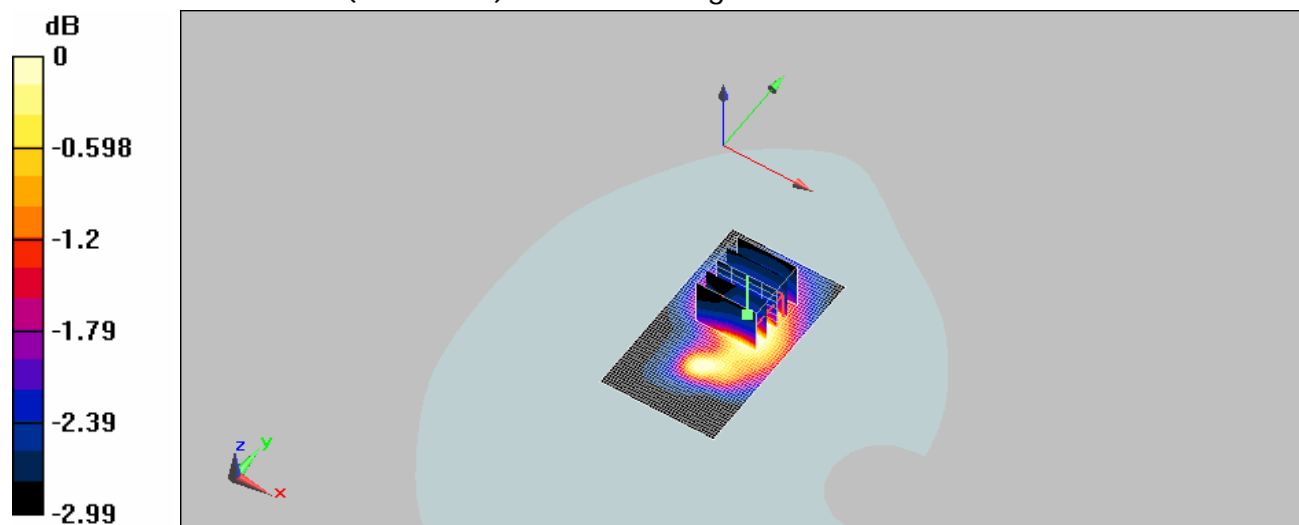

0 dB = 0.166mW/g

Date/Time: 9/18/2008 05:08:43

Configuration 3_CH9262

DUT: C152,

Communication System: WCDMA BAND2; Frequency: 1852.4 MHz; Duty Cycle: 1:1

Medium: WCDMA Band2 Medium parameters used (interpolated): $f = 1852.4$ MHz; $\sigma = 1.44$ mho/m; $\epsilon_r = 52.3$; $\rho = 1000$ kg/m³

Phantom section: Flat Section

DASY5 Configuration:

- Probe: ES3DV3 - SN3172; ConvF(4.73, 4.73, 4.73); Calibrated: 6/23/2008
- Sensor-Surface: 4mm (Mechanical Surface Detection)
- Electronics: DAE4 Sn856; Calibrated: 5/7/2008
- Phantom: SAM1; Type: SAM;
- Measurement SW: DASY5, V5.0 Build 119; SEMCAD X Version 13.2 Build 87

Body/Area Scan : Measurement grid: dx=15mm, dy=15mm

Maximum value of SAR (interpolated) = 0.367 mW/g

Body/Zoom Scan : Measurement grid: dx=8mm, dy=8mm, dz=5mm

Reference Value = 8.21 V/m; Power Drift = 0.115 dB

Peak SAR (extrapolated) = 0.651 W/kg

SAR(1 g) = 0.326 mW/g; SAR(10 g) = 0.199 mW/g

Maximum value of SAR (measured) = 0.346 mW/g

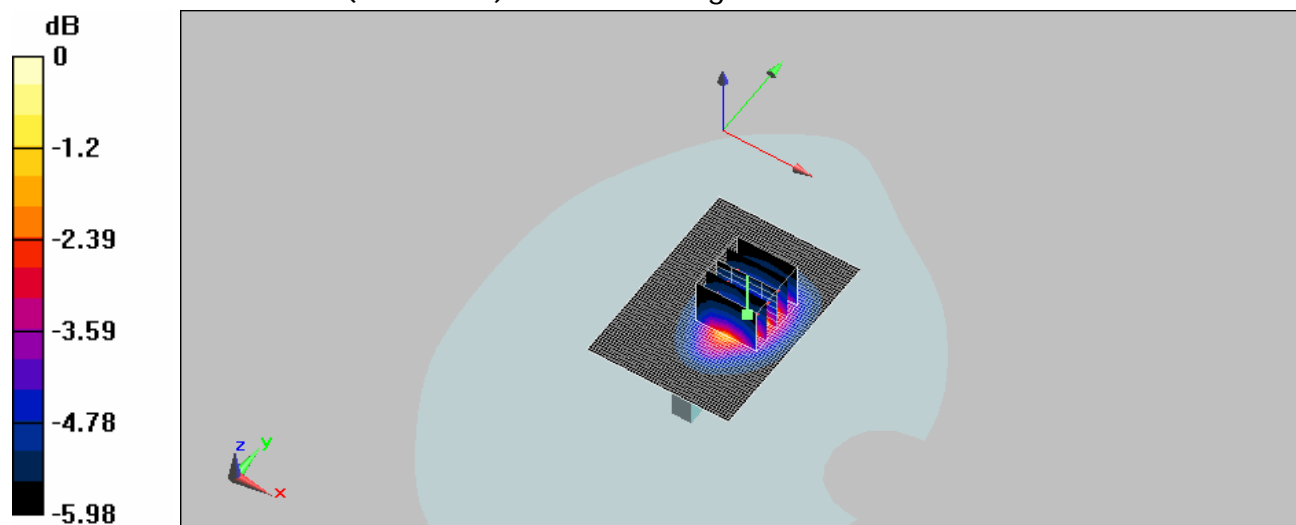

0 dB = 0.346mW/g

Date/Time: 9/18/2008 05:29:54

Configuration 3_CH9400

DUT: C152,

Communication System: WCDMA BAND2; Frequency: 1880 MHz; Duty Cycle: 1:1

Medium: WCDMA Band2 Medium parameters used: $f = 1880$ MHz; $\sigma = 1.46$ mho/m; $\epsilon_r = 52.4$; $\rho = 1000$ kg/m³

Phantom section: Flat Section

DASY5 Configuration:

- Probe: ES3DV3 - SN3172; ConvF(4.73, 4.73, 4.73); Calibrated: 6/23/2008
- Sensor-Surface: 4mm (Mechanical Surface Detection)
- Electronics: DAE4 Sn856; Calibrated: 5/7/2008
- Phantom: SAM1; Type: SAM;
- Measurement SW: DASY5, V5.0 Build 119; SEMCAD X Version 13.2 Build 87

Body/Area Scan : Measurement grid: dx=15mm, dy=15mm

Maximum value of SAR (interpolated) = 0.531 mW/g

Body/Zoom Scan : Measurement grid: dx=8mm, dy=8mm, dz=5mm

Reference Value = 9.23 V/m; Power Drift = -0.120 dB

Peak SAR (extrapolated) = 0.882 W/kg

SAR(1 g) = 0.488 mW/g; SAR(10 g) = 0.287 mW/g

Maximum value of SAR (measured) = 0.523 mW/g

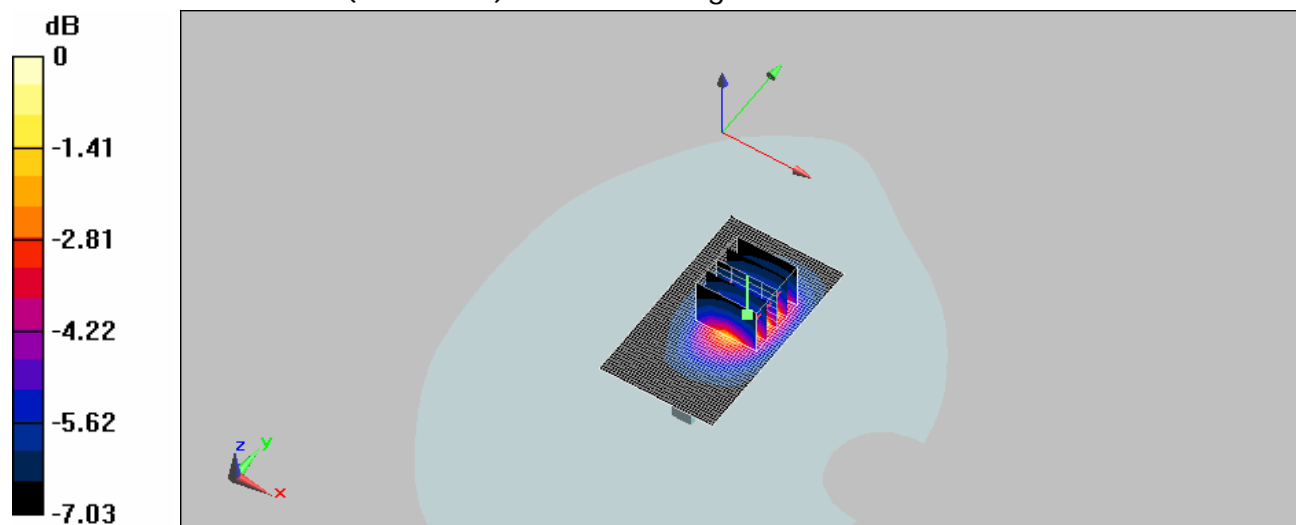

0 dB = 0.523mW/g

Date/Time: 9/18/2008 05:55:12

Configuration 3_CH9538

DUT: C152,

Communication System: WCDMA BAND2; Frequency: 1907.6 MHz; Duty Cycle: 1:1

Medium: WCDMA Band2 Medium parameters used: $f = 1908$ MHz; $\sigma = 1.48$ mho/m; $\epsilon_r = 52.5$; $\rho = 1000$ kg/m³

Phantom section: Flat Section

DASY5 Configuration:

- Probe: ES3DV3 - SN3172; ConvF(4.73, 4.73, 4.73); Calibrated: 6/23/2008
- Sensor-Surface: 4mm (Mechanical Surface Detection)
- Electronics: DAE4 Sn856; Calibrated: 5/7/2008
- Phantom: SAM1; Type: SAM;
- Measurement SW: DASY5, V5.0 Build 119; SEMCAD X Version 13.2 Build 87

Body/Area Scan : Measurement grid: dx=15mm, dy=15mm

Maximum value of SAR (interpolated) = 0.260 mW/g

Body/Zoom Scan : Measurement grid: dx=8mm, dy=8mm, dz=5mm

Reference Value = 8.52 V/m; Power Drift = -0.042 dB

Peak SAR (extrapolated) = 0.407 W/kg

SAR(1 g) = 0.243 mW/g; SAR(10 g) = 0.165 mW/g

Maximum value of SAR (measured) = 0.275 mW/g

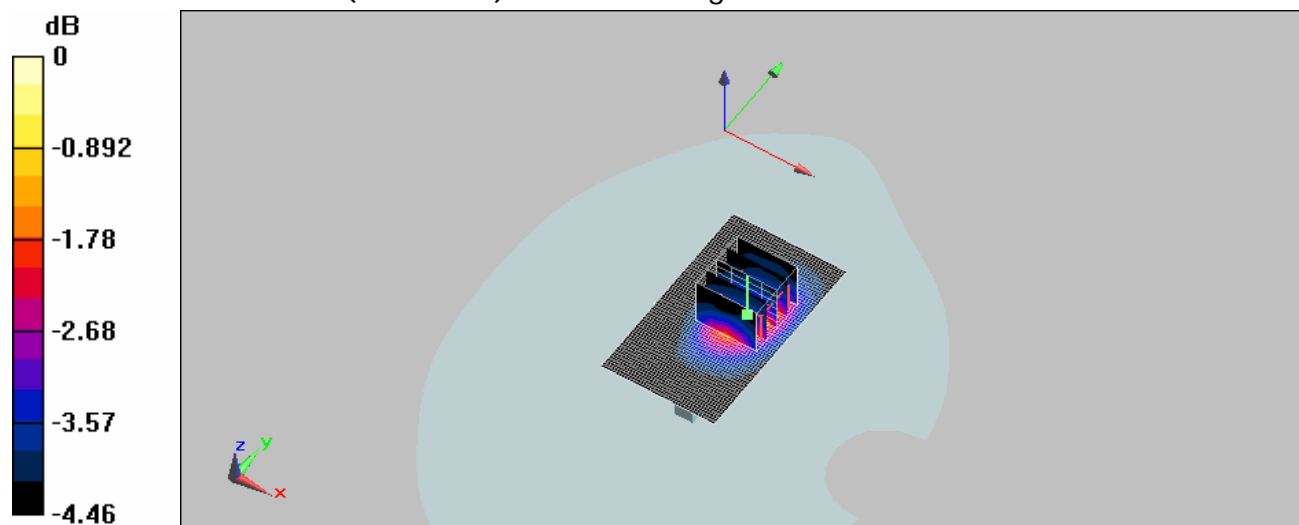

0 dB = 0.275mW/g

Date/Time: 9/18/2008 07:29:19

Configuration 4_CH9262

DUT: C152,

Communication System: WCDMA BAND2; Frequency: 1852.4 MHz; Duty Cycle: 1:1

Medium: WCDMA Band2 Medium parameters used (interpolated): $f = 1852.4$ MHz; $\sigma = 1.44$ mho/m; $\epsilon_r = 52.3$; $\rho = 1000$ kg/m³

Phantom section: Flat Section

DASY5 Configuration:

- Probe: ES3DV3 - SN3172; ConvF(4.73, 4.73, 4.73); Calibrated: 6/23/2008
- Sensor-Surface: 4mm (Mechanical Surface Detection)
- Electronics: DAE4 Sn856; Calibrated: 5/7/2008
- Phantom: SAM1; Type: SAM;
- Measurement SW: DASY5, V5.0 Build 119; SEMCAD X Version 13.2 Build 87

Body/Area Scan : Measurement grid: dx=15mm, dy=15mm

Maximum value of SAR (interpolated) = 0.218 mW/g

Body/Zoom Scan : Measurement grid: dx=8mm, dy=8mm, dz=5mm

Reference Value = 7.88 V/m; Power Drift = -0.059 dB

Peak SAR (extrapolated) = 0.306 W/kg

SAR(1 g) = 0.199 mW/g; SAR(10 g) = 0.139 mW/g

Maximum value of SAR (measured) = 0.207 mW/g

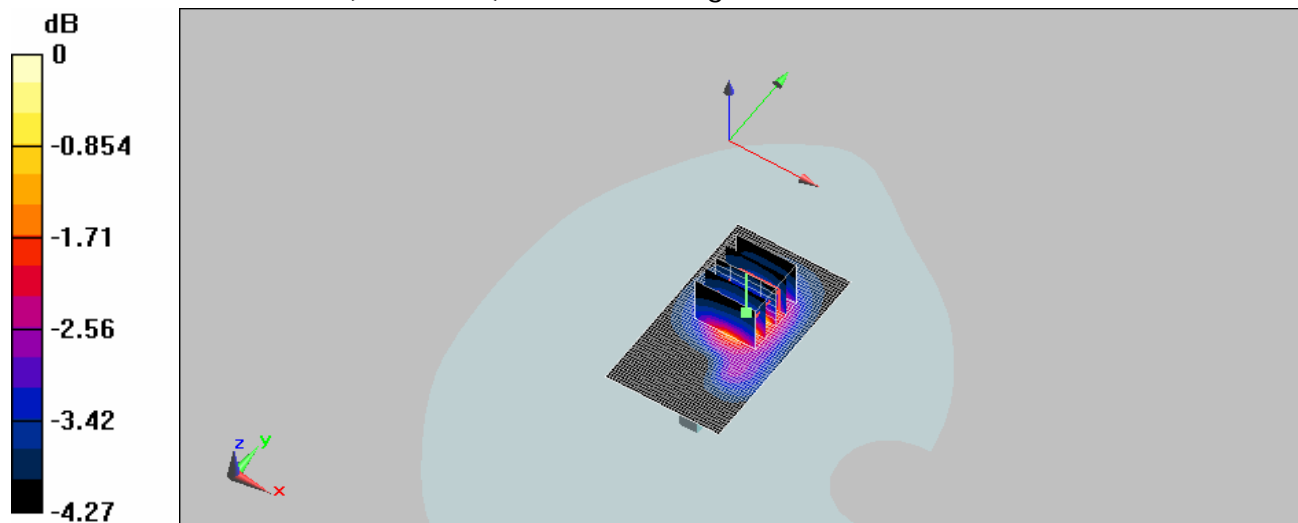

0 dB = 0.207mW/g

Date/Time: 9/18/2008 07:03:41

Configuration 4_CH9400

DUT: C152,

Communication System: WCDMA BAND2; Frequency: 1880 MHz; Duty Cycle: 1:1

Medium: WCDMA Band2 Medium parameters used: $f = 1880$ MHz; $\sigma = 1.46$ mho/m; $\epsilon_r = 52.4$; $\rho = 1000$ kg/m³

Phantom section: Flat Section

DASY5 Configuration:

- Probe: ES3DV3 - SN3172; ConvF(4.73, 4.73, 4.73); Calibrated: 6/23/2008
- Sensor-Surface: 4mm (Mechanical Surface Detection)
- Electronics: DAE4 Sn856; Calibrated: 5/7/2008
- Phantom: SAM1; Type: SAM;
- Measurement SW: DASY5, V5.0 Build 119; SEMCAD X Version 13.2 Build 87

Body/Area Scan : Measurement grid: dx=15mm, dy=15mm

Maximum value of SAR (interpolated) = 0.292 mW/g

Body/Zoom Scan : Measurement grid: dx=8mm, dy=8mm, dz=5mm

Reference Value = 8.16 V/m; Power Drift = 0.010 dB

Peak SAR (extrapolated) = 0.465 W/kg

SAR(1 g) = 0.271 mW/g; SAR(10 g) = 0.174 mW/g

Maximum value of SAR (measured) = 0.283 mW/g

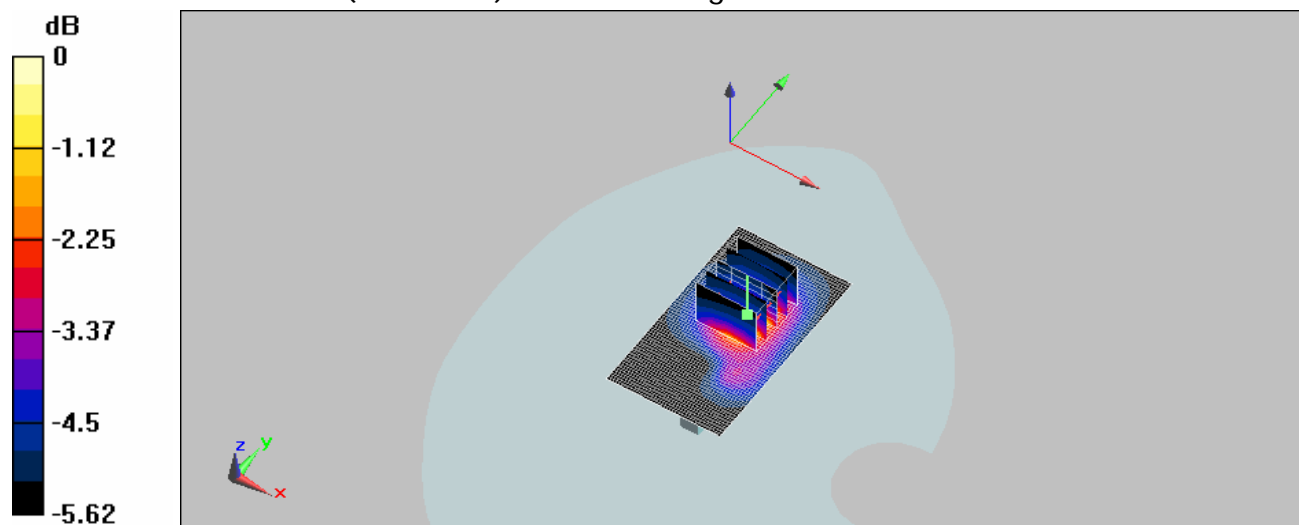

Date/Time: 9/18/2008 06:43:47

Configuration 4_CH9538

DUT: C152,

Communication System: WCDMA BAND2; Frequency: 1907.6 MHz; Duty Cycle: 1:1

Medium: WCDMA Band2 Medium parameters used: $f = 1908$ MHz; $\sigma = 1.48$ mho/m; $\epsilon_r = 52.5$; $\rho = 1000$ kg/m³

Phantom section: Flat Section

DASY5 Configuration:

- Probe: ES3DV3 - SN3172; ConvF(4.73, 4.73, 4.73); Calibrated: 6/23/2008
- Sensor-Surface: 4mm (Mechanical Surface Detection)
- Electronics: DAE4 Sn856; Calibrated: 5/7/2008
- Phantom: SAM1; Type: SAM;
- Measurement SW: DASY5, V5.0 Build 119; SEMCAD X Version 13.2 Build 87

Body/Area Scan : Measurement grid: dx=15mm, dy=15mm

Maximum value of SAR (interpolated) = 0.206 mW/g

Body/Zoom Scan : Measurement grid: dx=8mm, dy=8mm, dz=5mm

Reference Value = 8.91 V/m; Power Drift = 0.136 dB

Peak SAR (extrapolated) = 0.270 W/kg

SAR(1 g) = 0.195 mW/g; SAR(10 g) = 0.154 mW/g

Maximum value of SAR (measured) = 0.203 mW/g

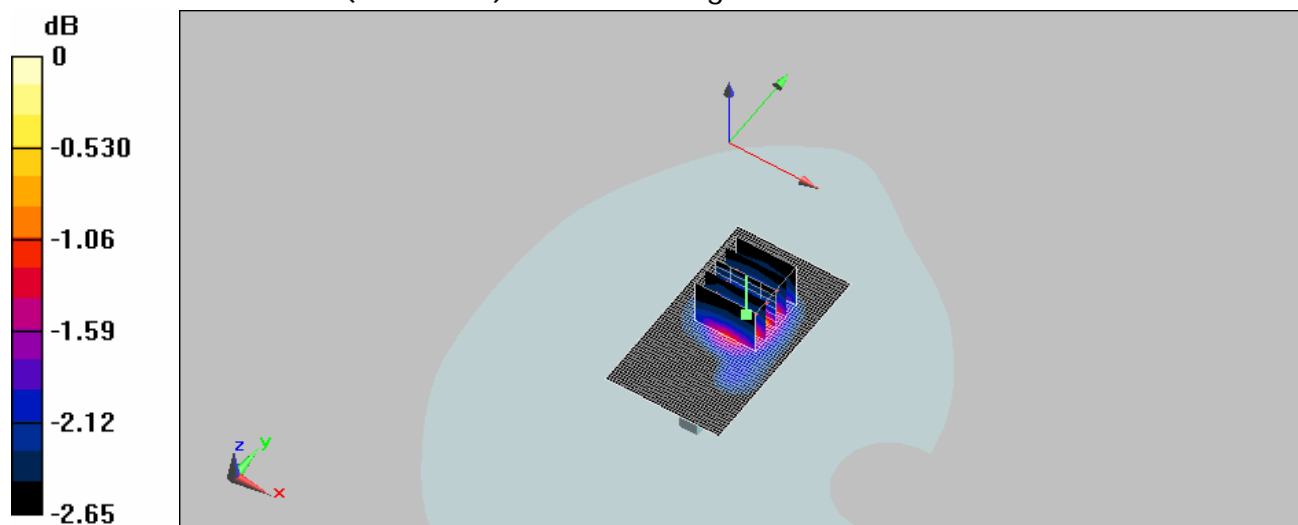

0 dB = 0.203mW/g

Date/Time: 9/18/2008 08:05:06

Configuration 5_CH9262

DUT: C152,

Communication System: WCDMA BAND2; Frequency: 1852.4 MHz; Duty Cycle: 1:1

Medium: WCDMA Band2 Medium parameters used (interpolated): $f = 1852.4$ MHz; $\sigma = 1.44$ mho/m; $\epsilon_r = 52.3$; $\rho = 1000$ kg/m³

Phantom section: Flat Section

DASY5 Configuration:

- Probe: ES3DV3 - SN3172; ConvF(4.73, 4.73, 4.73); Calibrated: 6/23/2008
- Sensor-Surface: 4mm (Mechanical Surface Detection)
- Electronics: DAE4 Sn856; Calibrated: 5/7/2008
- Phantom: SAM1; Type: SAM;
- Measurement SW: DASY5, V5.0 Build 119; SEMCAD X Version 13.2 Build 87

Body/Area Scan : Measurement grid: dx=15mm, dy=15mm

Maximum value of SAR (interpolated) = 0.144 mW/g

Body/Zoom Scan : Measurement grid: dx=8mm, dy=8mm, dz=5mm

Reference Value = 9.04 V/m; Power Drift = -0.111 dB

Peak SAR (extrapolated) = 0.147 W/kg

SAR(1 g) = 0.137 mW/g; SAR(10 g) = 0.125 mW/g

Maximum value of SAR (measured) = 0.141 mW/g

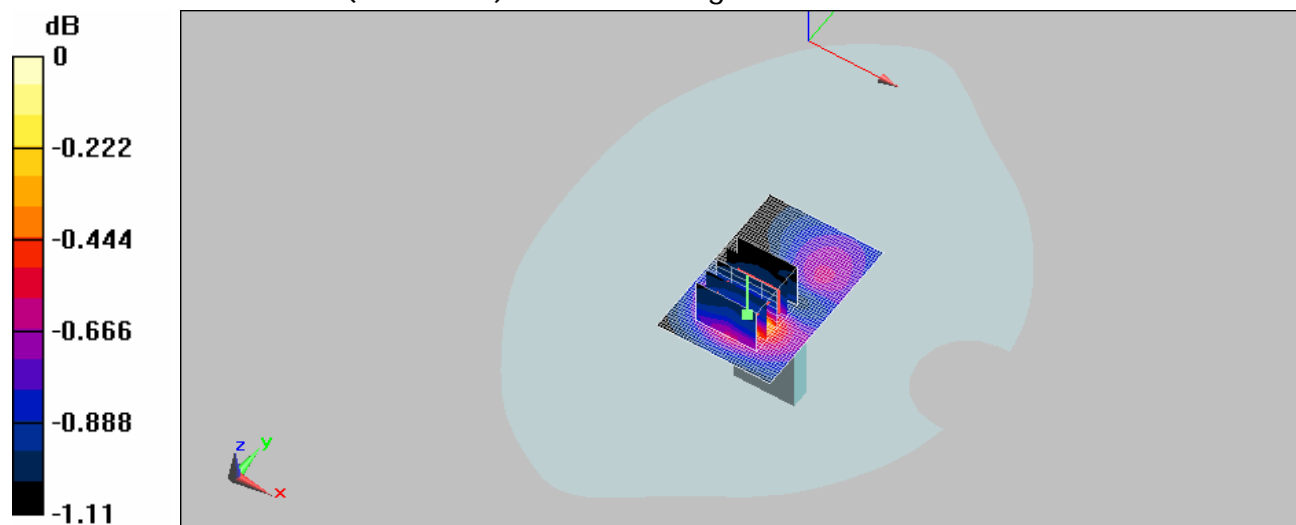

0 dB = 0.141mW/g

Date/Time: 9/18/2008 08:30:36

Configuration 5_CH9400

DUT: C152,

Communication System: WCDMA BAND2; Frequency: 1880 MHz; Duty Cycle: 1:1

Medium: WCDMA Band2 Medium parameters used: $f = 1880$ MHz; $\sigma = 1.46$ mho/m; $\epsilon_r = 52.4$; $\rho = 1000$ kg/m³

Phantom section: Flat Section

DASY5 Configuration:

- Probe: ES3DV3 - SN3172; ConvF(4.73, 4.73, 4.73); Calibrated: 6/23/2008
- Sensor-Surface: 4mm (Mechanical Surface Detection)
- Electronics: DAE4 Sn856; Calibrated: 5/7/2008
- Phantom: SAM1; Type: SAM;
- Measurement SW: DASY5, V5.0 Build 119; SEMCAD X Version 13.2 Build 87

Body/Area Scan : Measurement grid: dx=15mm, dy=15mm

Maximum value of SAR (interpolated) = 0.156 mW/g

Body/Zoom Scan : Measurement grid: dx=8mm, dy=8mm, dz=5mm

Reference Value = 9.11 V/m; Power Drift = 0.00333 dB

Peak SAR (extrapolated) = 0.172 W/kg

SAR(1 g) = 0.151 mW/g; SAR(10 g) = 0.132 mW/g

Maximum value of SAR (measured) = 0.156 mW/g

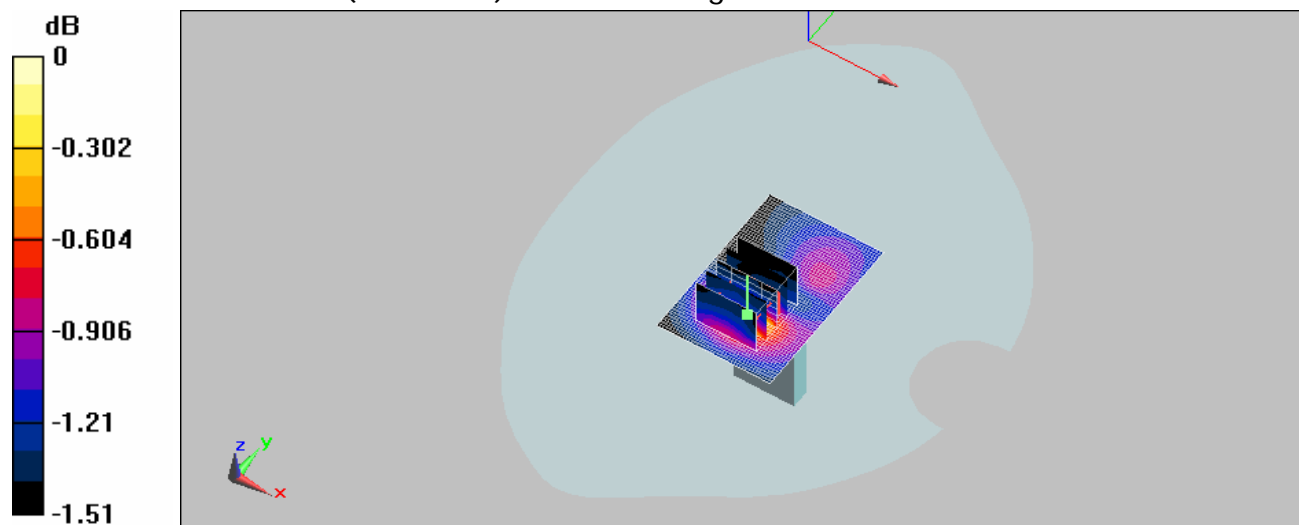

0 dB = 0.156mW/g

Date/Time: 9/18/2008 08:52:16

Configuration 5_CH9538

DUT: C152,

Communication System: WCDMA BAND2; Frequency: 1907.6 MHz; Duty Cycle: 1:1

Medium: WCDMA Band2 Medium parameters used: $f = 1908$ MHz; $\sigma = 1.48$ mho/m; $\epsilon_r = 52.5$; $\rho = 1000$ kg/m³

Phantom section: Flat Section

DASY5 Configuration:

- Probe: ES3DV3 - SN3172; ConvF(4.73, 4.73, 4.73); Calibrated: 6/23/2008
- Sensor-Surface: 4mm (Mechanical Surface Detection)
- Electronics: DAE4 Sn856; Calibrated: 5/7/2008
- Phantom: SAM1; Type: SAM;
- Measurement SW: DASY5, V5.0 Build 119; SEMCAD X Version 13.2 Build 87

Body/Area Scan : Measurement grid: dx=15mm, dy=15mm

Maximum value of SAR (interpolated) = 0.138 mW/g

Body/Zoom Scan : Measurement grid: dx=8mm, dy=8mm, dz=5mm

Reference Value = 9 V/m; Power Drift = 0.024 dB

Peak SAR (extrapolated) = 0.138 W/kg

SAR(1 g) = 0.130 mW/g; SAR(10 g) = 0.122 mW/g

Maximum value of SAR (measured) = 0.136 mW/g

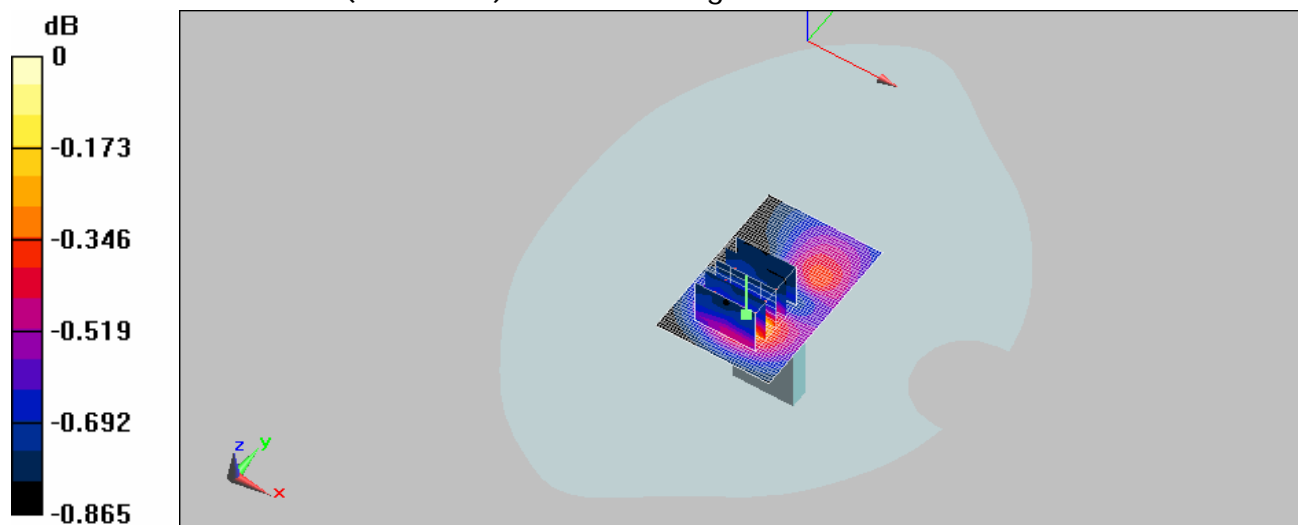

0 dB = 0.136mW/g

Date/Time: 9/18/2008 10:19:26

Configuration 6_CH9262

DUT: C152,

Communication System: WCDMA BAND2; Frequency: 1852.4 MHz; Duty Cycle: 1:1

Medium: WCDMA Band2 Medium parameters used (interpolated): $f = 1852.4$ MHz; $\sigma = 1.44$ mho/m; $\epsilon_r = 52.3$; $\rho = 1000$ kg/m³

Phantom section: Flat Section

DASY5 Configuration:

- Probe: ES3DV3 - SN3172; ConvF(4.73, 4.73, 4.73); Calibrated: 6/23/2008
- Sensor-Surface: 4mm (Mechanical Surface Detection)
- Electronics: DAE4 Sn856; Calibrated: 5/7/2008
- Phantom: SAM1; Type: SAM;
- Measurement SW: DASY5, V5.0 Build 119; SEMCAD X Version 13.2 Build 87

Body/Area Scan: Measurement grid: dx=15mm, dy=15mm

Maximum value of SAR (interpolated) = 0.190 mW/g

Body/Zoom Scan : Measurement grid: dx=8mm, dy=8mm, dz=5mm

Reference Value = 11 V/m; Power Drift = 0.034 dB

Peak SAR (extrapolated) = 0.281 W/kg

SAR(1 g) = 0.169 mW/g; SAR(10 g) = 0.126 mW/g

Maximum value of SAR (measured) = 0.171 mW/g

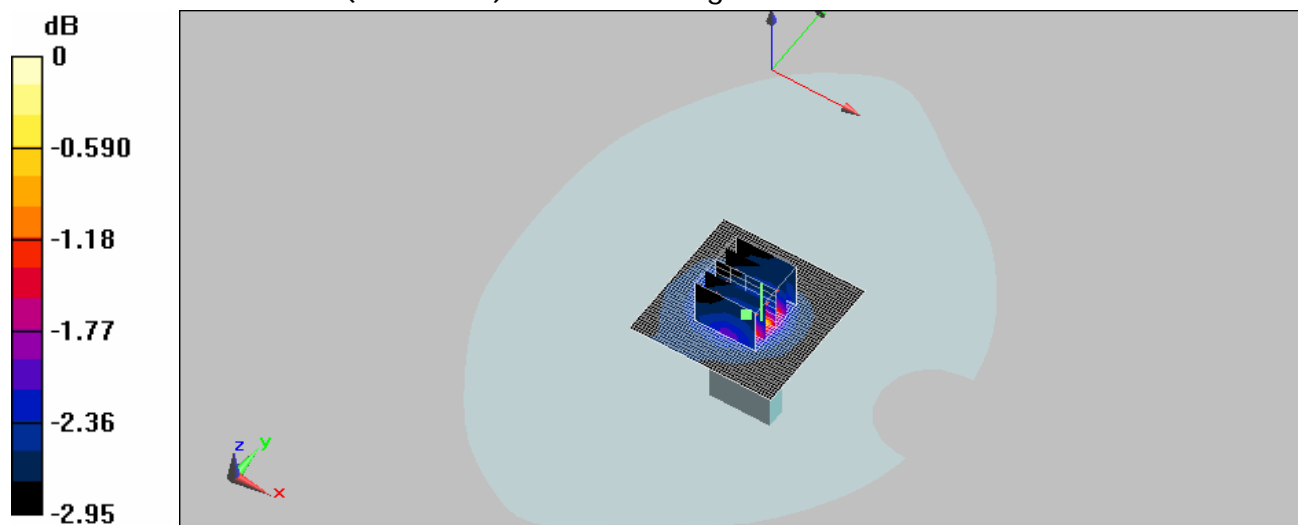

0 dB = 0.171mW/g

Date/Time: 9/18/2008 09:57:46

Configuration 6_CH9400

DUT: C152,

Communication System: WCDMA BAND2; Frequency: 1880 MHz; Duty Cycle: 1:1

Medium: WCDMA Band2 Medium parameters used: $f = 1880$ MHz; $\sigma = 1.46$ mho/m; $\epsilon_r = 52.4$; $\rho = 1000$ kg/m³

Phantom section: Flat Section

DASY5 Configuration:

- Probe: ES3DV3 - SN3172; ConvF(4.73, 4.73, 4.73); Calibrated: 6/23/2008
- Sensor-Surface: 4mm (Mechanical Surface Detection)
- Electronics: DAE4 Sn856; Calibrated: 5/7/2008
- Phantom: SAM1; Type: SAM;
- Measurement SW: DASY5, V5.0 Build 119; SEMCAD X Version 13.2 Build 87

Body/Area Scan: Measurement grid: dx=15mm, dy=15mm

Maximum value of SAR (interpolated) = 0.230 mW/g

Body/Zoom Scan : Measurement grid: dx=8mm, dy=8mm, dz=5mm

Reference Value = 12.3 V/m; Power Drift = -0.078 dB

Peak SAR (extrapolated) = 0.358 W/kg

SAR(1 g) = 0.218 mW/g; SAR(10 g) = 0.157 mW/g

Maximum value of SAR (measured) = 0.225 mW/g

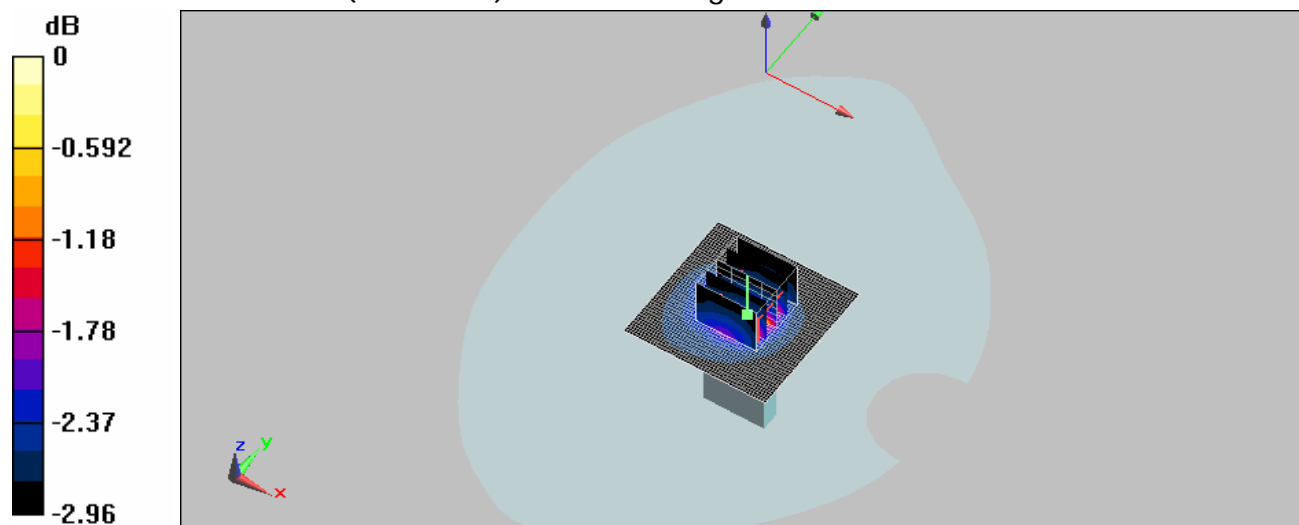

0 dB = 0.225mW/g

Date/Time: 9/18/2008 09:31:29

Configuration 6_CH9538

DUT: C152,

Communication System: WCDMA BAND2; Frequency: 1907.6 MHz; Duty Cycle: 1:1

Medium: WCDMA Band2 Medium parameters used: $f = 1908$ MHz; $\sigma = 1.48$ mho/m; $\epsilon_r = 52.5$; $\rho = 1000$ kg/m³

Phantom section: Flat Section

DASY5 Configuration:

- Probe: ES3DV3 - SN3172; ConvF(4.73, 4.73, 4.73); Calibrated: 6/23/2008
- Sensor-Surface: 4mm (Mechanical Surface Detection)
- Electronics: DAE4 Sn856; Calibrated: 5/7/2008
- Phantom: SAM1; Type: SAM;
- Measurement SW: DASY5, V5.0 Build 119; SEMCAD X Version 13.2 Build 87

Body/Area Scan: Measurement grid: dx=15mm, dy=15mm

Maximum value of SAR (interpolated) = 0.209 mW/g

Body/Zoom Scan : Measurement grid: dx=8mm, dy=8mm, dz=5mm

Reference Value = 11.2 V/m; Power Drift = 0.100 dB

Peak SAR (extrapolated) = 0.228 W/kg

SAR(1 g) = 0.178 mW/g; SAR(10 g) = 0.155 mW/g

Maximum value of SAR (measured) = 0.203 mW/g

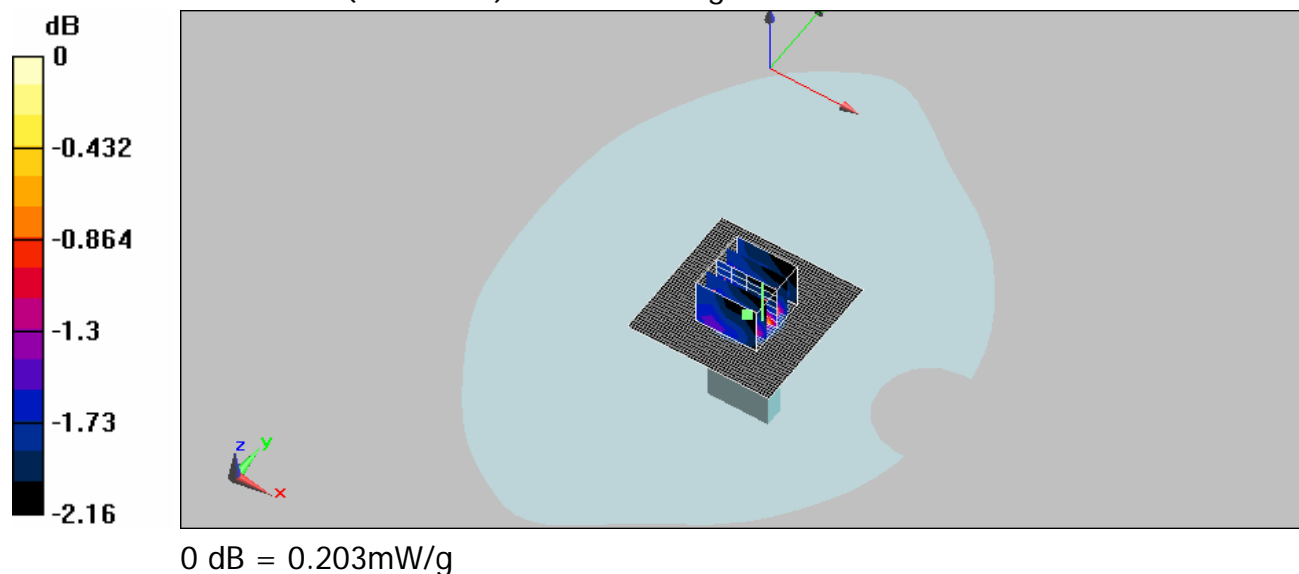

Date/Time: 12/8/2008 11:39:15

Configuration 7_CH9262

DUT: C152,

Communication System: WCDMA B2; Frequency: 1852.4 MHz; Duty Cycle: 1:1

Medium: WCDMA Band2 Medium parameters used: $f = 1852.4$ MHz; $\sigma = 1.46$ mho/m; $\epsilon_r = 54.7$; $\rho = 1000$ kg/m³

Phantom section: Flat Section

DASY5 Configuration:

- Probe: ES3DV3 - SN3172; ConvF(4.73, 4.73, 4.73); Calibrated: 6/23/2008
- Sensor-Surface: 4mm (Mechanical Surface Detection)
- Electronics: DAE4 Sn856; Calibrated: 5/7/2008
- Phantom: SAM1; Type: SAM;
- Measurement SW: DASY5, V5.0 Build 119; SEMCAD X Version 13.2 Build 87

Body/Area Scan: Measurement grid: dx=15mm, dy=15mm

Maximum value of SAR (interpolated) = 0.933 mW/g

Body/Zoom Scan: Measurement grid: dx=8mm, dy=8mm, dz=5mm

Reference Value = 12.4 V/m; Power Drift = 0.015 dB

Peak SAR (extrapolated) = 1.04 W/kg

SAR(1 g) = 0.731 mW/g; SAR(10 g) = 0.447 mW/g

Maximum value of SAR (measured) = 0.767 mW/g

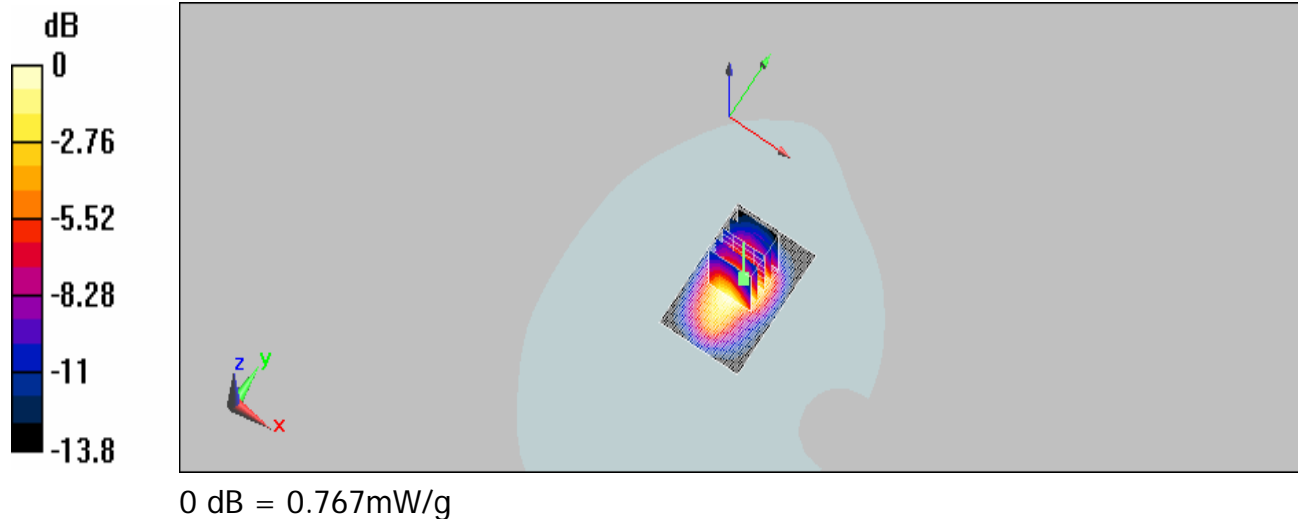

Date/Time: 12/8/2008 12:03:38

Configuration 7_CH9400

DUT: C152,

Communication System: WCDMA B2; Frequency: 1880 MHz; Duty Cycle: 1:1

Medium: WCDMA Band2 Medium parameters used: $f = 1880$ MHz; $\sigma = 1.49$ mho/m; $\epsilon_r = 54.6$; $\rho = 1000$ kg/m³

Phantom section: Flat Section

DASY5 Configuration:

- Probe: ES3DV3 - SN3172; ConvF(4.73, 4.73, 4.73); Calibrated: 6/23/2008
- Sensor-Surface: 4mm (Mechanical Surface Detection)
- Electronics: DAE4 Sn856; Calibrated: 5/7/2008
- Phantom: SAM1; Type: SAM;
- Measurement SW: DASY5, V5.0 Build 119; SEMCAD X Version 13.2 Build 87

Body/Area Scan: Measurement grid: dx=15mm, dy=15mm

Maximum value of SAR (interpolated) = 1.25 mW/g

Body/Zoom Scan: Measurement grid: dx=8mm, dy=8mm, dz=5mm

Reference Value = 14.9 V/m; Power Drift = 0.185 dB

Peak SAR (extrapolated) = 1.59 W/kg

SAR(1 g) = 1.1 mW/g; SAR(10 g) = 0.661 mW/g

Maximum value of SAR (measured) = 1.16 mW/g

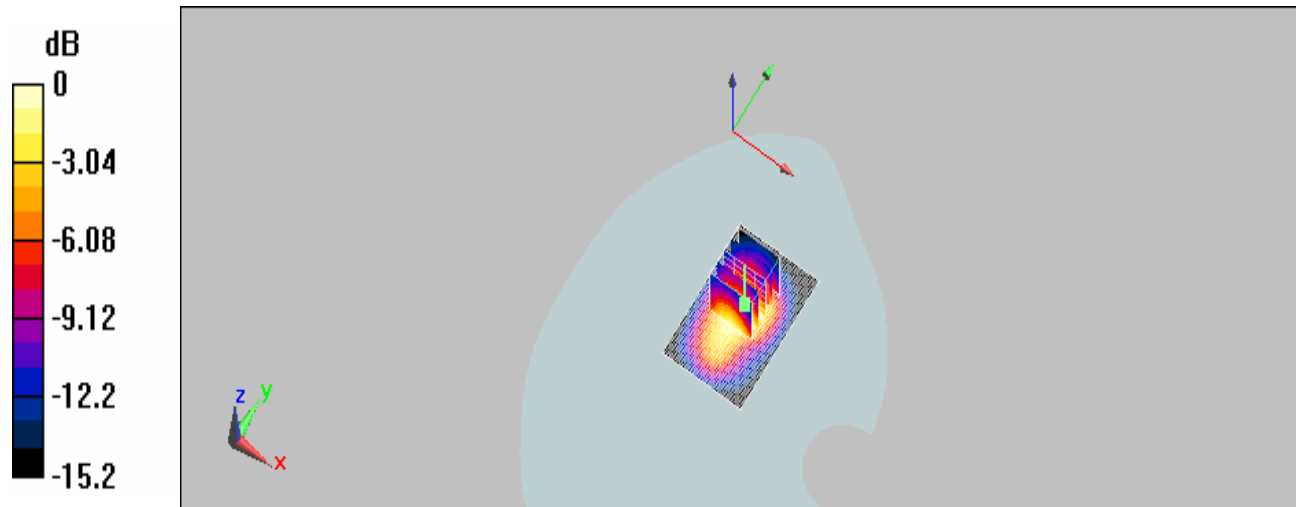

0 dB = 1.16mW/g

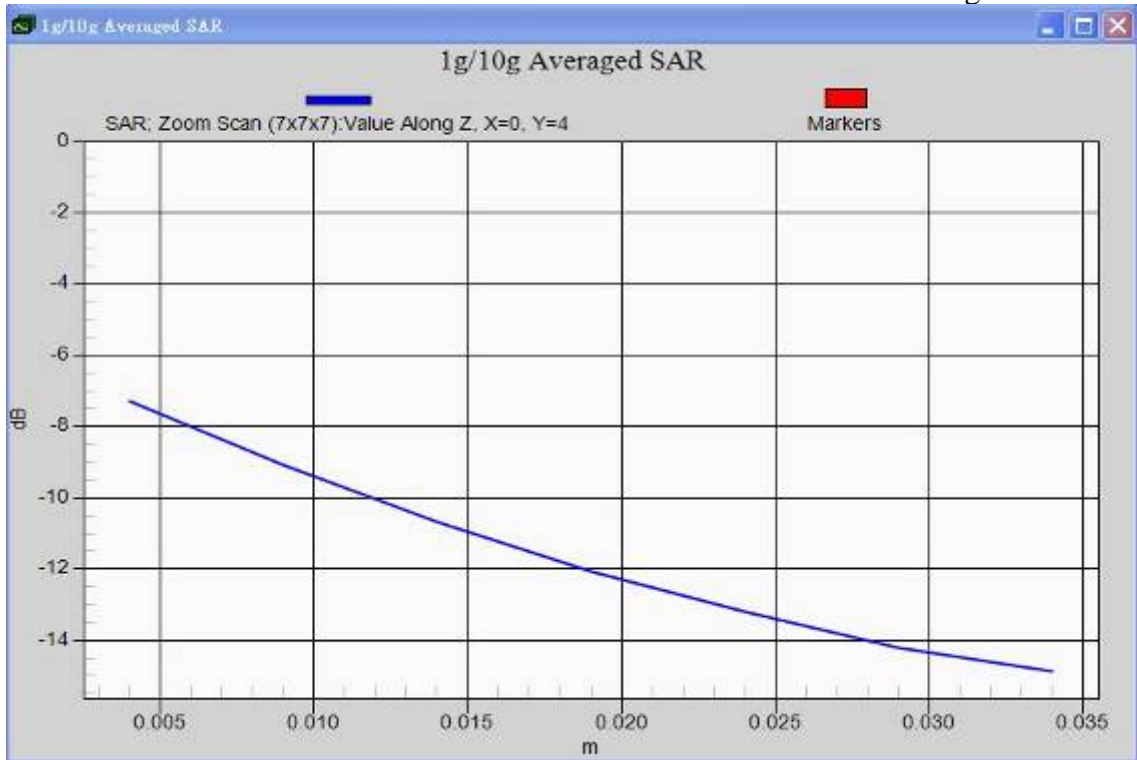

Configuration 7_CH9538

DUT: C152,

Communication System: WCDMA B2; Frequency: 1907.6 MHz; Duty Cycle: 1:1

Medium: WCDMA Band2 Medium parameters used: $f = 1908$ MHz; $\sigma = 1.52$ mho/m; $\epsilon_r = 54.5$; $\rho = 1000$ kg/m³

Phantom section: Flat Section

DASY5 Configuration:

- Probe: ES3DV3 - SN3172; ConvF(4.73, 4.73, 4.73); Calibrated: 6/23/2008
- Sensor-Surface: 4mm (Mechanical Surface Detection)
- Electronics: DAE4 Sn856; Calibrated: 5/7/2008
- Phantom: SAM1; Type: SAM;
- Measurement SW: DASY5, V5.0 Build 119; SEMCAD X Version 13.2 Build 87

Body/Area Scan: Measurement grid: dx=15mm, dy=15mm

Maximum value of SAR (interpolated) = 0.840 mW/g

Body/Zoom Scan: Measurement grid: dx=8mm, dy=8mm, dz=5mm

Reference Value = 12.7 V/m; Power Drift = -0.051 dB

Peak SAR (extrapolated) = 0.981 W/kg

SAR(1 g) = 0.668 mW/g; SAR(10 g) = 0.387 mW/g

Maximum value of SAR (measured) = 0.683 mW/g

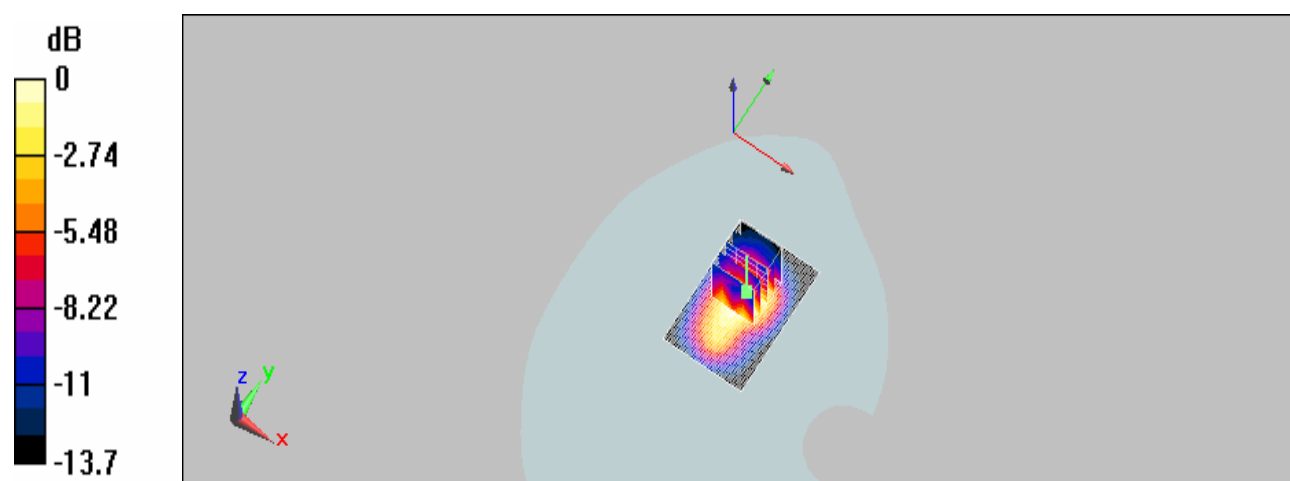

Configuration 8_CH 9262

DUT: C152,

Communication System: WCDMA B2; Frequency: 1852.4 MHz; Duty Cycle: 1:1

Medium: WCDMA Band2 Medium parameters used: $f = 1852.4$ MHz; $\sigma = 1.46$ mho/m; $\epsilon_r = 54.7$; $\rho = 1000$ kg/m³

Phantom section: Flat Section

DASY5 Configuration:

- Probe: ES3DV3 - SN3172; ConvF(4.73, 4.73, 4.73); Calibrated: 6/23/2008
- Sensor-Surface: 4mm (Mechanical Surface Detection)
- Electronics: DAE4 Sn856; Calibrated: 5/7/2008
- Phantom: SAM1; Type: SAM;
- Measurement SW: DASY5, V5.0 Build 119; SEMCAD X Version 13.2 Build 87

Body/Area Scan: Measurement grid: dx=15mm, dy=15mm

Maximum value of SAR (interpolated) = 0.853 mW/g

Body/Zoom Scan: Measurement grid: dx=8mm, dy=8mm, dz=5mm

Reference Value = 4.62 V/m; Power Drift = 0.045 dB

Peak SAR (extrapolated) = 1.15 W/kg

SAR(1 g) = 0.619 mW/g; SAR(10 g) = 0.313 mW/g

Maximum value of SAR (measured) = 0.695 mW/g

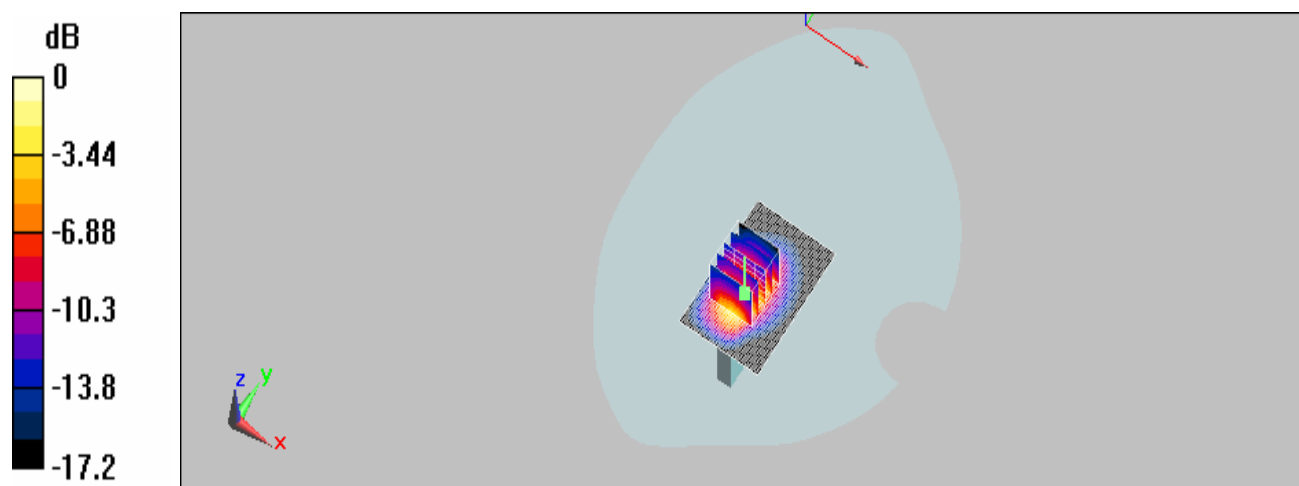

Date/Time: 12/8/2008 14:24:49

Configuration 8_CH 9400

DUT: C152,

Communication System: WCDMA B2; Frequency: 1880 MHz; Duty Cycle: 1:1

Medium: WCDMA Band2 Medium parameters used: $f = 1880$ MHz; $\sigma = 1.49$ mho/m; $\epsilon_r = 54.6$; $\rho = 1000$ kg/m³

Phantom section: Flat Section

DASY5 Configuration:

- Probe: ES3DV3 - SN3172; ConvF(4.73, 4.73, 4.73); Calibrated: 6/23/2008
- Sensor-Surface: 4mm (Mechanical Surface Detection)
- Electronics: DAE4 Sn856; Calibrated: 5/7/2008
- Phantom: SAM1; Type: SAM;
- Measurement SW: DASY5, V5.0 Build 119; SEMCAD X Version 13.2 Build 87

Body/Area Scan: Measurement grid: dx=15mm, dy=15mm

Maximum value of SAR (interpolated) = 1.25 mW/g

Body/Zoom Scan: Measurement grid: dx=8mm, dy=8mm, dz=5mm

Reference Value = 5.27 V/m; Power Drift = 0.103 dB

Peak SAR (extrapolated) = 1.77 W/kg

SAR(1 g) = 0.941 mW/g; SAR(10 g) = 0.471 mW/g

Maximum value of SAR (measured) = 1.05 mW/g

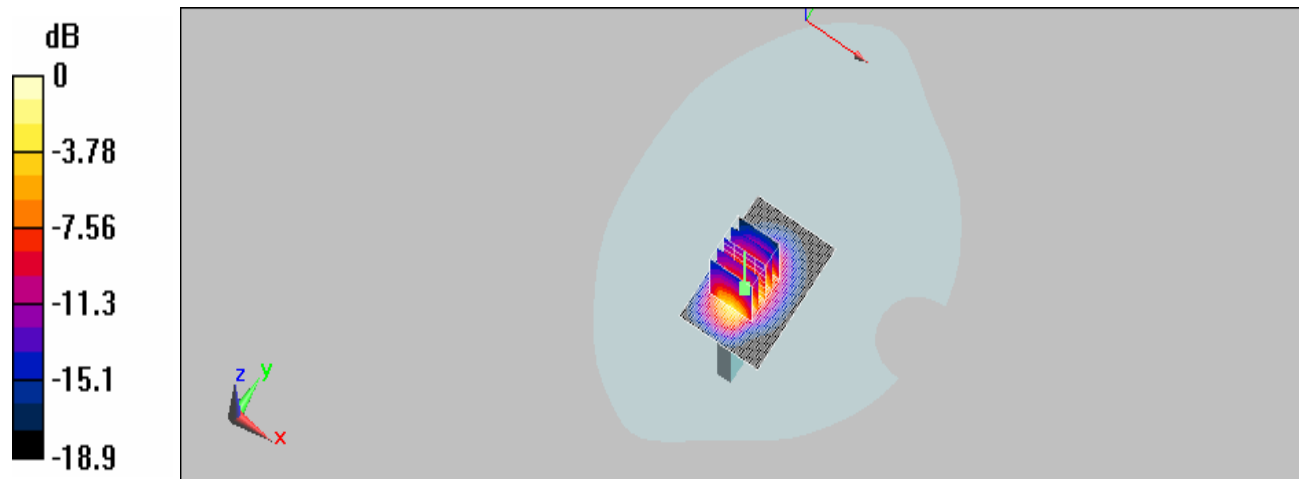

0 dB = 1.05mW/g

Date/Time: 12/8/2008 14:59:24

Configuration 8_CH 9538

DUT: C152,

Communication System: WCDMA B2; Frequency: 1907.6 MHz; Duty Cycle: 1:1

Medium: WCDMA Band2 Medium parameters used: $f = 1908$ MHz; $\sigma = 1.52$ mho/m; $\epsilon_r = 54.5$; $\rho = 1000$ kg/m³

Phantom section: Flat Section

DASY5 Configuration:

- Probe: ES3DV3 - SN3172; ConvF(4.73, 4.73, 4.73); Calibrated: 6/23/2008
- Sensor-Surface: 4mm (Mechanical Surface Detection)
- Electronics: DAE4 Sn856; Calibrated: 5/7/2008
- Phantom: SAM1; Type: SAM;
- Measurement SW: DASY5, V5.0 Build 119; SEMCAD X Version 13.2 Build 87

Body/Area Scan: Measurement grid: dx=15mm, dy=15mm

Maximum value of SAR (interpolated) = 0.798 mW/g

Body/Zoom Scan: Measurement grid: dx=8mm, dy=8mm, dz=5mm

Reference Value = 4.53 V/m; Power Drift = 0.072 dB

Peak SAR (extrapolated) = 1.18 W/kg

SAR(1 g) = 0.610 mW/g; SAR(10 g) = 0.297 mW/g

Maximum value of SAR (measured) = 0.667 mW/g

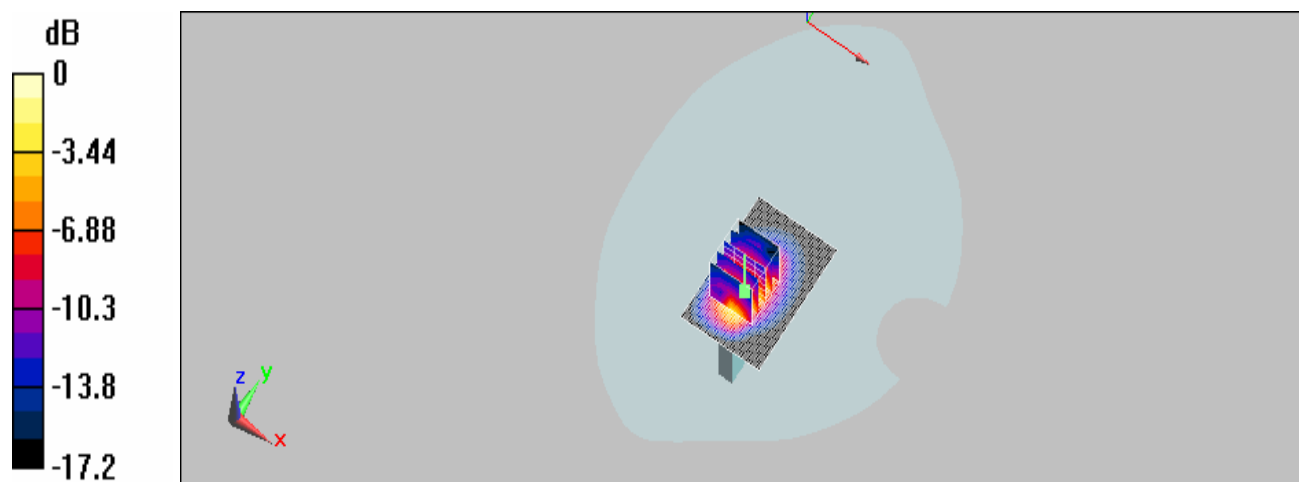

Date/Time: 9/18/2008 12:07:20

Configuration 1_CH9262_HSDPA mode

DUT: C152,

Communication System: WCDMA BAND2; Frequency: 1852.4 MHz; Duty Cycle: 1:1

Medium: WCDMA Band2 Medium parameters used (interpolated): $f = 1852.4$ MHz; $\sigma = 1.44$ mho/m; $\epsilon_r = 52.3$; $\rho = 1000$ kg/m³

Phantom section: Flat Section

DASY5 Configuration:

- Probe: ES3DV3 - SN3172; ConvF(4.73, 4.73, 4.73); Calibrated: 6/23/2008
- Sensor-Surface: 4mm (Mechanical Surface Detection)
- Electronics: DAE4 Sn856; Calibrated: 5/7/2008
- Phantom: SAM1; Type: SAM;
- Measurement SW: DASY5, V5.0 Build 119; SEMCAD X Version 13.2 Build 87

Body/Area Scan : Measurement grid: dx=15mm, dy=15mm

Maximum value of SAR (interpolated) = 0.800 mW/g

Body/Zoom Scan : Measurement grid: dx=8mm, dy=8mm, dz=5mm

Reference Value = 13 V/m; Power Drift = -0.160 dB

Peak SAR (extrapolated) = 0.908 W/kg

SAR(1 g) = 0.651 mW/g; SAR(10 g) = 0.445 mW/g

Maximum value of SAR (measured) = 0.689 mW/g

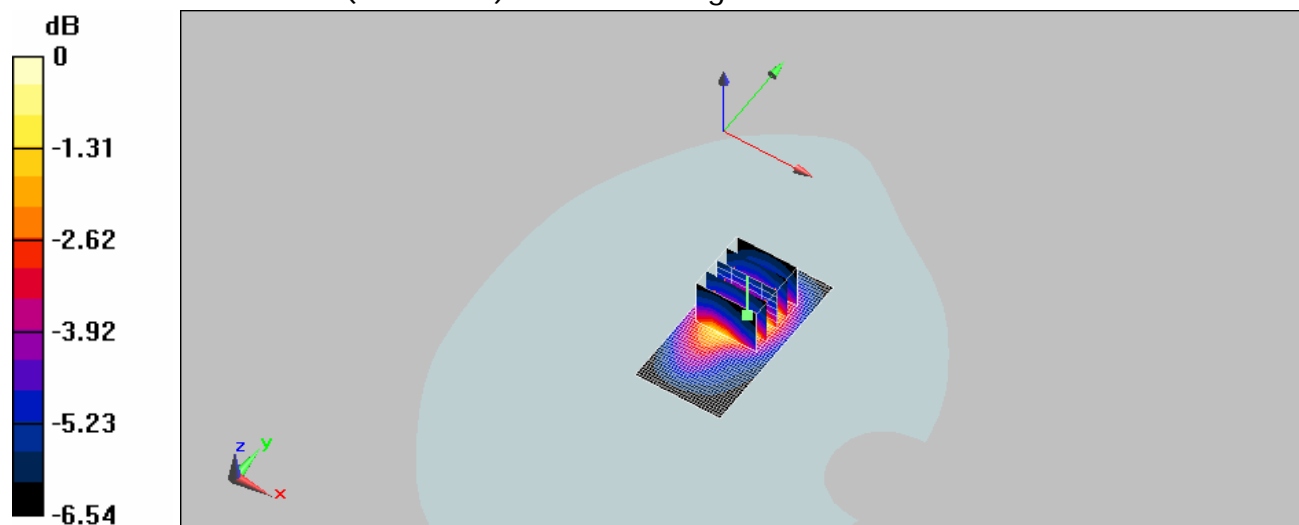

0 dB = 0.689mW/g

Date/Time: 9/18/2008 12:33:43

Configuration 1_CH9400_HSDPA mode

DUT: C152,

Communication System: WCDMA BAND2; Frequency: 1880 MHz; Duty Cycle: 1:1

Medium: WCDMA Band2 Medium parameters used: $f = 1880$ MHz; $\sigma = 1.46$ mho/m; $\epsilon_r = 52.4$; $\rho = 1000$ kg/m³

Phantom section: Flat Section

DASY5 Configuration:

- Probe: ES3DV3 - SN3172; ConvF(4.73, 4.73, 4.73); Calibrated: 6/23/2008
- Sensor-Surface: 4mm (Mechanical Surface Detection)
- Electronics: DAE4 Sn856; Calibrated: 5/7/2008
- Phantom: SAM1; Type: SAM;
- Measurement SW: DASY5, V5.0 Build 119; SEMCAD X Version 13.2 Build 87

Body/Area Scan : Measurement grid: dx=15mm, dy=15mm

Maximum value of SAR (interpolated) = 1.07 mW/g

Body/Zoom Scan : Measurement grid: dx=8mm, dy=8mm, dz=5mm

Reference Value = 14 V/m; Power Drift = -0.025 dB

Peak SAR (extrapolated) = 1.24 W/kg

SAR(1 g) = 0.866 mW/g; SAR(10 g) = 0.568 mW/g

Maximum value of SAR (measured) = 0.926 mW/g

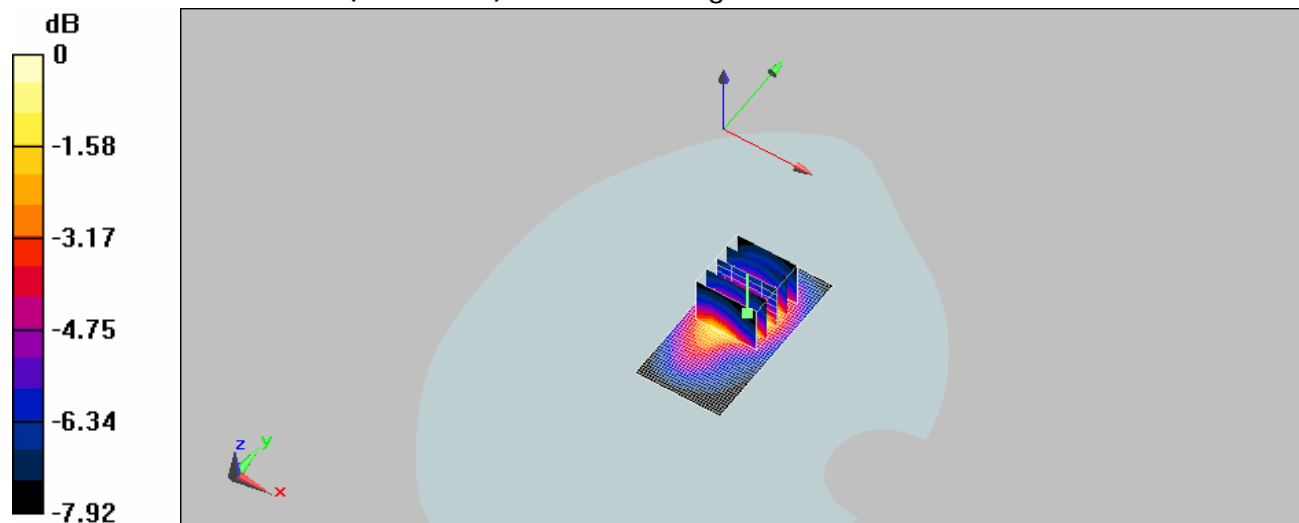

0 dB = 0.926mW/g

Date/Time: 9/18/2008 12:57:57

Configuration 1_CH9538_HSDPA mode

DUT: C152,

Communication System: WCDMA BAND2; Frequency: 1907.6 MHz; Duty Cycle: 1:1

Medium: WCDMA Band2 Medium parameters used: $f = 1908$ MHz; $\sigma = 1.48$ mho/m; $\epsilon_r = 52.5$; $\rho = 1000$ kg/m³

Phantom section: Flat Section

DASY5 Configuration:

- Probe: ES3DV3 - SN3172; ConvF(4.73, 4.73, 4.73); Calibrated: 6/23/2008
- Sensor-Surface: 4mm (Mechanical Surface Detection)
- Electronics: DAE4 Sn856; Calibrated: 5/7/2008
- Phantom: SAM1; Type: SAM;
- Measurement SW: DASY5, V5.0 Build 119; SEMCAD X Version 13.2 Build 87

Body/Area Scan : Measurement grid: dx=15mm, dy=15mm

Maximum value of SAR (interpolated) = 0.462 mW/g

Body/Zoom Scan : Measurement grid: dx=8mm, dy=8mm, dz=5mm

Reference Value = 10.5 V/m; Power Drift = -0.1 dB

Peak SAR (extrapolated) = 0.562 W/kg

SAR(1 g) = 0.402 mW/g; SAR(10 g) = 0.278 mW/g

Maximum value of SAR (measured) = 0.425 mW/g

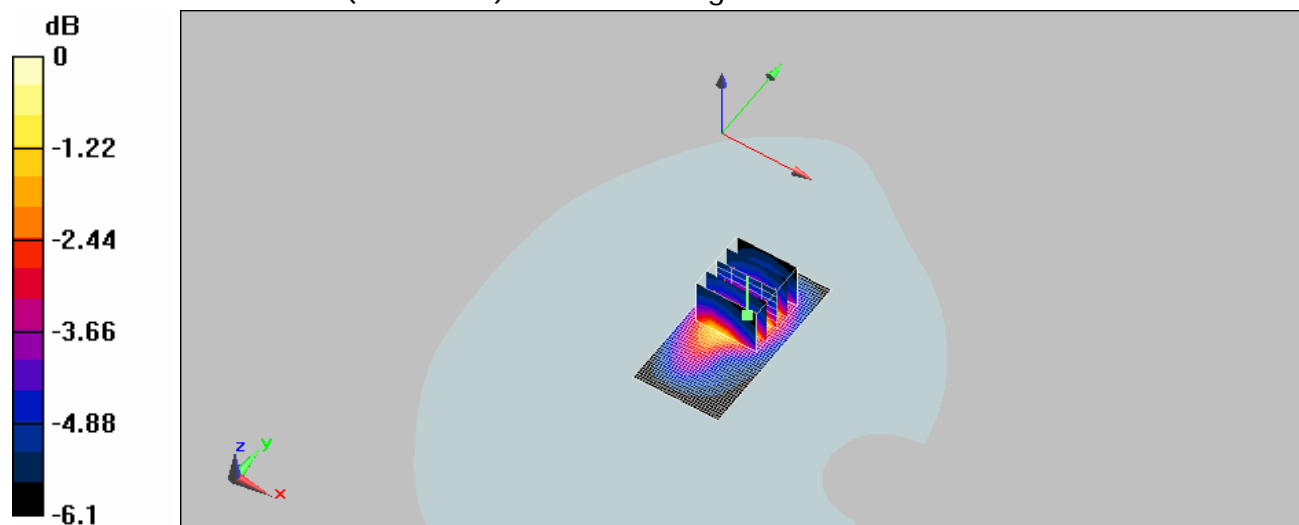

0 dB = 0.425mW/g

Date/Time: 9/18/2008 14:15:13

Configuration 2_CH9262_HSDPA mode

DUT: C152,

Communication System: WCDMA BAND2; Frequency: 1852.4 MHz; Duty Cycle: 1:1

Medium: WCDMA Band2 Medium parameters used (interpolated): $f = 1852.4$ MHz; $\sigma = 1.44$ mho/m; $\epsilon_r = 52.3$; $\rho = 1000$ kg/m³

Phantom section: Flat Section

DASY5 Configuration:

- Probe: ES3DV3 - SN3172; ConvF(4.73, 4.73, 4.73); Calibrated: 6/23/2008
- Sensor-Surface: 4mm (Mechanical Surface Detection)
- Electronics: DAE4 Sn856; Calibrated: 5/7/2008
- Phantom: SAM1; Type: SAM;
- Measurement SW: DASY5, V5.0 Build 119; SEMCAD X Version 13.2 Build 87

Body/Area Scan : Measurement grid: dx=15mm, dy=15mm

Maximum value of SAR (interpolated) = 0.210 mW/g

Body/Zoom Scan : Measurement grid: dx=8mm, dy=8mm, dz=5mm

Reference Value = 8.28 V/m; Power Drift = -0.119 dB

Peak SAR (extrapolated) = 0.255 W/kg

SAR(1 g) = 0.193 mW/g; SAR(10 g) = 0.147 mW/g

Maximum value of SAR (measured) = 0.202 mW/g

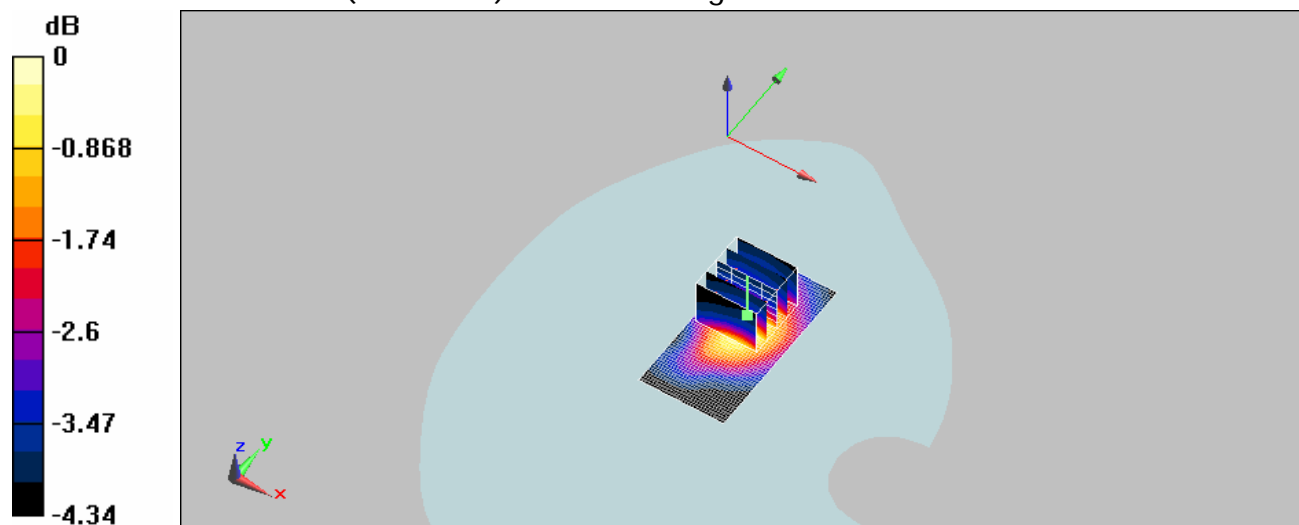

0 dB = 0.202mW/g

Date/Time: 9/18/2008 13:53:15

Configuration 2_CH9400_HSDPA mode

DUT: C152,

Communication System: WCDMA BAND2; Frequency: 1880 MHz; Duty Cycle: 1:1

Medium: WCDMA Band2 Medium parameters used: $f = 1880$ MHz; $\sigma = 1.46$ mho/m; $\epsilon_r = 52.4$; $\rho = 1000$ kg/m³

Phantom section: Flat Section

DASY5 Configuration:

- Probe: ES3DV3 - SN3172; ConvF(4.73, 4.73, 4.73); Calibrated: 6/23/2008
- Sensor-Surface: 4mm (Mechanical Surface Detection)
- Electronics: DAE4 Sn856; Calibrated: 5/7/2008
- Phantom: SAM1; Type: SAM;
- Measurement SW: DASY5, V5.0 Build 119; SEMCAD X Version 13.2 Build 87

Body/Area Scan : Measurement grid: dx=15mm, dy=15mm

Maximum value of SAR (interpolated) = 0.270 mW/g

Body/Zoom Scan : Measurement grid: dx=8mm, dy=8mm, dz=5mm

Reference Value = 9.2 V/m; Power Drift = -0.113 dB

Peak SAR (extrapolated) = 0.364 W/kg

SAR(1 g) = 0.241 mW/g; SAR(10 g) = 0.176 mW/g

Maximum value of SAR (measured) = 0.253 mW/g

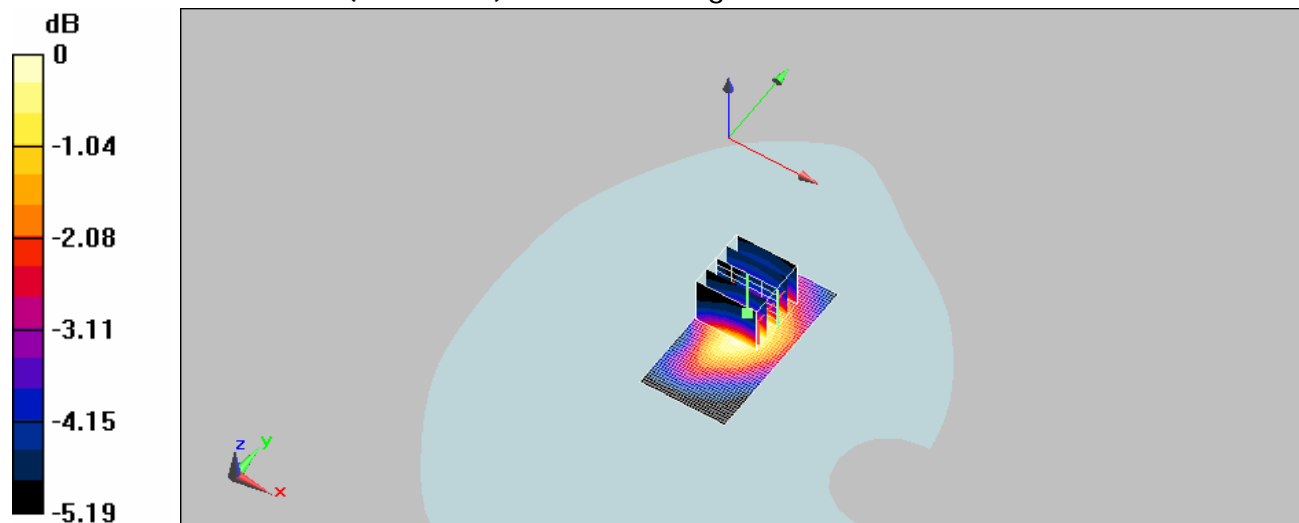

0 dB = 0.253mW/g

Date/Time: 9/18/2008 13:29:43

Configuration 2_CH9538_HSDPA mode

DUT: C152,

Communication System: WCDMA BAND2; Frequency: 1907.6 MHz; Duty Cycle: 1:1

Medium: WCDMA Band2 Medium parameters used: $f = 1908$ MHz; $\sigma = 1.48$ mho/m; $\epsilon_r = 52.5$; $\rho = 1000$ kg/m³

Phantom section: Flat Section

DASY5 Configuration:

- Probe: ES3DV3 - SN3172; ConvF(4.73, 4.73, 4.73); Calibrated: 6/23/2008
- Sensor-Surface: 4mm (Mechanical Surface Detection)
- Electronics: DAE4 Sn856; Calibrated: 5/7/2008
- Phantom: SAM1; Type: SAM;
- Measurement SW: DASY5, V5.0 Build 119; SEMCAD X Version 13.2 Build 87

Body/Area Scan : Measurement grid: dx=15mm, dy=15mm

Maximum value of SAR (interpolated) = 0.163 mW/g

Body/Zoom Scan : Measurement grid: dx=8mm, dy=8mm, dz=5mm

Reference Value = 8.17 V/m; Power Drift = -0.120 dB

Peak SAR (extrapolated) = 0.191 W/kg

SAR(1 g) = 0.153 mW/g; SAR(10 g) = 0.122 mW/g

Maximum value of SAR (measured) = 0.157 mW/g

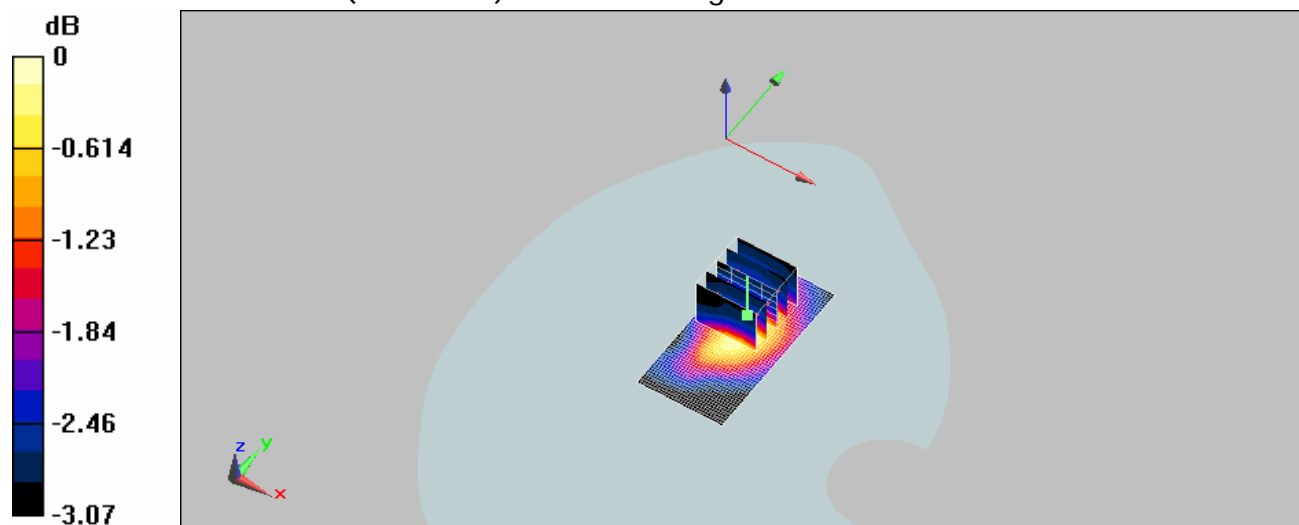

0 dB = 0.157mW/g

Date/Time: 9/18/2008 14:51:26

Configuration 3_CH9262_HSDPA mode

DUT: C152,

Communication System: WCDMA BAND2; Frequency: 1852.4 MHz; Duty Cycle: 1:1

Medium: WCDMA Band2 Medium parameters used (interpolated): $f = 1852.4$ MHz; $\sigma = 1.44$ mho/m; $\epsilon_r = 52.3$; $\rho = 1000$ kg/m³

Phantom section: Flat Section

DASY5 Configuration:

- Probe: ES3DV3 - SN3172; ConvF(4.73, 4.73, 4.73); Calibrated: 6/23/2008
- Sensor-Surface: 4mm (Mechanical Surface Detection)
- Electronics: DAE4 Sn856; Calibrated: 5/7/2008
- Phantom: SAM1; Type: SAM;
- Measurement SW: DASY5, V5.0 Build 119; SEMCAD X Version 13.2 Build 87

Body/Area Scan : Measurement grid: dx=15mm, dy=15mm

Maximum value of SAR (interpolated) = 0.334 mW/g

Body/Zoom Scan : Measurement grid: dx=8mm, dy=8mm, dz=5mm

Reference Value = 8.79 V/m; Power Drift = -0.073 dB

Peak SAR (extrapolated) = 0.573 W/kg

SAR(1 g) = 0.292 mW/g; SAR(10 g) = 0.192 mW/g

Maximum value of SAR (measured) = 0.311 mW/g

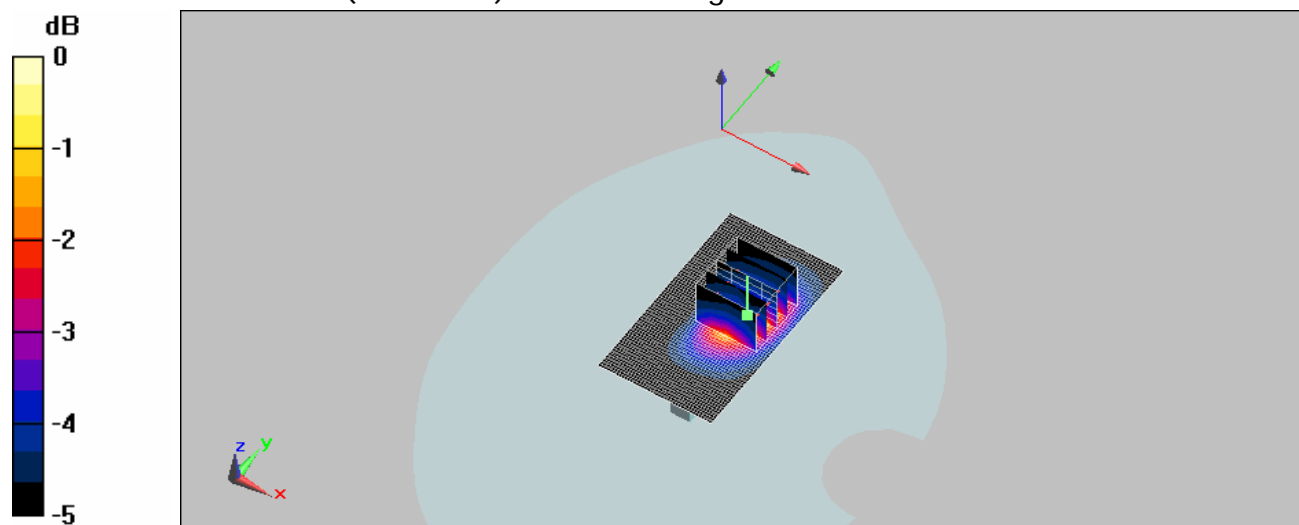

0 dB = 0.311mW/g

Date/Time: 9/18/2008 15:13:08

Configuration 3_CH9400_HSDPA mode

DUT: C152,

Communication System: WCDMA BAND2; Frequency: 1880 MHz; Duty Cycle: 1:1

Medium: WCDMA Band2 Medium parameters used: $f = 1880$ MHz; $\sigma = 1.46$ mho/m; $\epsilon_r = 52.4$; $\rho = 1000$ kg/m³

Phantom section: Flat Section

DASY5 Configuration:

- Probe: ES3DV3 - SN3172; ConvF(4.73, 4.73, 4.73); Calibrated: 6/23/2008
- Sensor-Surface: 4mm (Mechanical Surface Detection)
- Electronics: DAE4 Sn856; Calibrated: 5/7/2008
- Phantom: SAM1; Type: SAM;
- Measurement SW: DASY5, V5.0 Build 119; SEMCAD X Version 13.2 Build 87

Body/Area Scan : Measurement grid: dx=15mm, dy=15mm

Maximum value of SAR (interpolated) = 0.417 mW/g

Body/Zoom Scan : Measurement grid: dx=8mm, dy=8mm, dz=5mm

Reference Value = 8.84 V/m; Power Drift = 0.016 dB

Peak SAR (extrapolated) = 0.727 W/kg

SAR(1 g) = 0.388 mW/g; SAR(10 g) = 0.236 mW/g

Maximum value of SAR (measured) = 0.414 mW/g

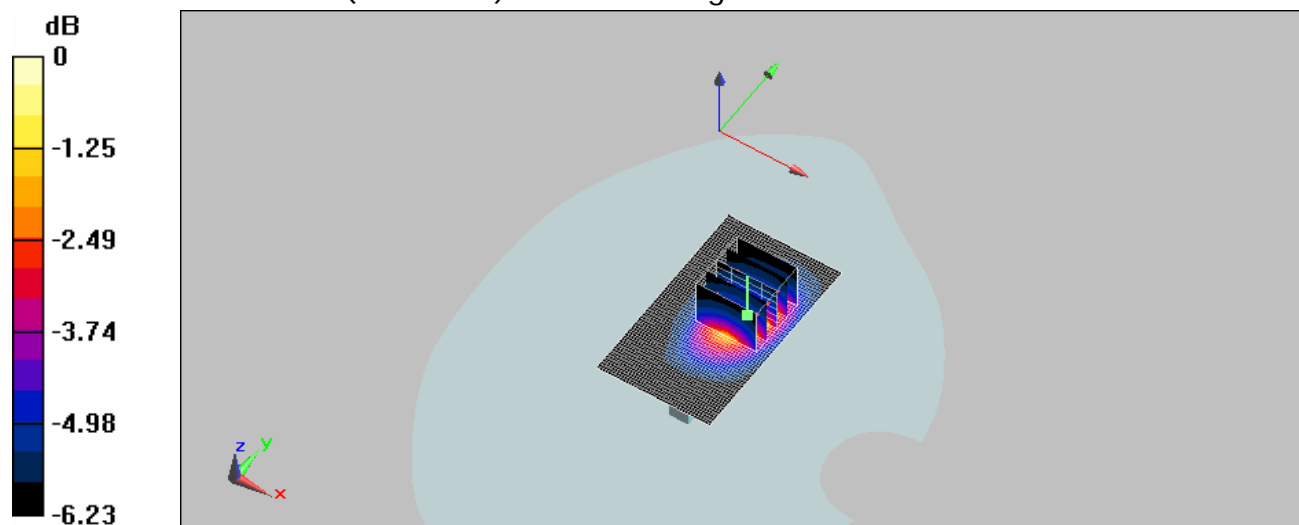

0 dB = 0.414mW/g

Date/Time: 9/18/2008 15:37:12

Configuration 3_CH9538_HSDPA mode

DUT: C152,

Communication System: WCDMA BAND2; Frequency: 1907.6 MHz; Duty Cycle: 1:1

Medium: WCDMA Band2 Medium parameters used: $f = 1908$ MHz; $\sigma = 1.48$ mho/m; $\epsilon_r = 52.5$; $\rho = 1000$ kg/m³

Phantom section: Flat Section

DASY5 Configuration:

- Probe: ES3DV3 - SN3172; ConvF(4.73, 4.73, 4.73); Calibrated: 6/23/2008
- Sensor-Surface: 4mm (Mechanical Surface Detection)
- Electronics: DAE4 Sn856; Calibrated: 5/7/2008
- Phantom: SAM1; Type: SAM;
- Measurement SW: DASY5, V5.0 Build 119; SEMCAD X Version 13.2 Build 87

Body/Area Scan : Measurement grid: dx=15mm, dy=15mm

Maximum value of SAR (interpolated) = 0.270 mW/g

Body/Zoom Scan : Measurement grid: dx=8mm, dy=8mm, dz=5mm

Reference Value = 8.52 V/m; Power Drift = 0.015 dB

Peak SAR (extrapolated) = 0.402 W/kg

SAR(1 g) = 0.237 mW/g; SAR(10 g) = 0.168 mW/g

Maximum value of SAR (measured) = 0.255 mW/g

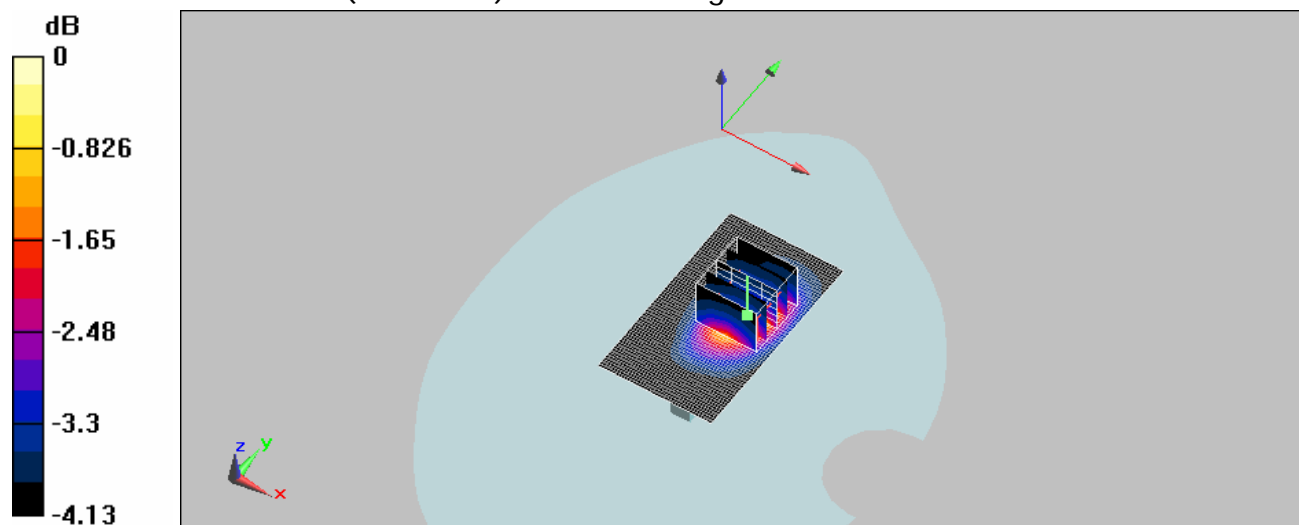

0 dB = 0.255mW/g

Date/Time: 9/18/2008 17:03:55

Configuration 4_CH9262_HSDPA mode

DUT: C152,

Communication System: WCDMA BAND2; Frequency: 1852.4 MHz; Duty Cycle: 1:1

Medium: WCDMA Band2 Medium parameters used (interpolated): $f = 1852.4$ MHz; $\sigma = 1.44$ mho/m; $\epsilon_r = 52.3$; $\rho = 1000$ kg/m³

Phantom section: Flat Section

DASY5 Configuration:

- Probe: ES3DV3 - SN3172; ConvF(4.73, 4.73, 4.73); Calibrated: 6/23/2008
- Sensor-Surface: 4mm (Mechanical Surface Detection)
- Electronics: DAE4 Sn856; Calibrated: 5/7/2008
- Phantom: SAM1; Type: SAM;
- Measurement SW: DASY5, V5.0 Build 119; SEMCAD X Version 13.2 Build 87

Body/Area Scan : Measurement grid: dx=15mm, dy=15mm

Maximum value of SAR (interpolated) = 0.245 mW/g

Body/Zoom Scan : Measurement grid: dx=8mm, dy=8mm, dz=5mm

Reference Value = 8.72 V/m; Power Drift = 0.126 dB

Peak SAR (extrapolated) = 0.337 W/kg

SAR(1 g) = 0.229 mW/g; SAR(10 g) = 0.166 mW/g

Maximum value of SAR (measured) = 0.240 mW/g

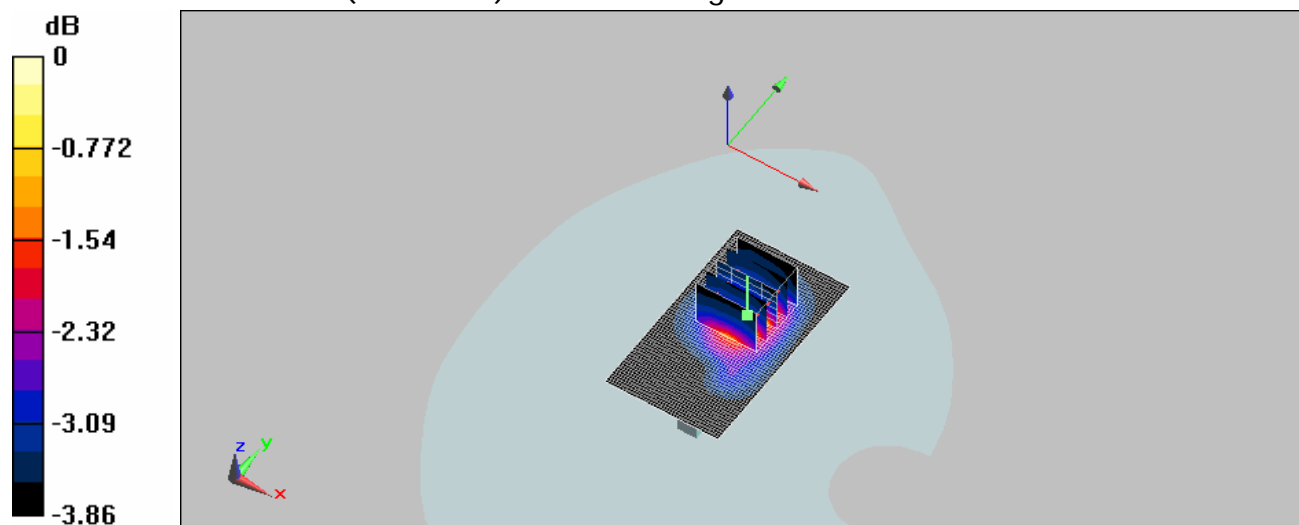

0 dB = 0.240mW/g

Date/Time: 9/18/2008 16:38:34

Configuration 4_CH9400_HSDPA mode

DUT: C152,

Communication System: WCDMA BAND2; Frequency: 1880 MHz; Duty Cycle: 1:1

Medium: WCDMA Band2 Medium parameters used: $f = 1880$ MHz; $\sigma = 1.46$ mho/m; $\epsilon_r = 52.4$; $\rho = 1000$ kg/m³

Phantom section: Flat Section

DASY5 Configuration:

- Probe: ES3DV3 - SN3172; ConvF(4.73, 4.73, 4.73); Calibrated: 6/23/2008
- Sensor-Surface: 4mm (Mechanical Surface Detection)
- Electronics: DAE4 Sn856; Calibrated: 5/7/2008
- Phantom: SAM1; Type: SAM;
- Measurement SW: DASY5, V5.0 Build 119; SEMCAD X Version 13.2 Build 87

Body/Area Scan : Measurement grid: dx=15mm, dy=15mm

Maximum value of SAR (interpolated) = 0.315 mW/g

Body/Zoom Scan : Measurement grid: dx=8mm, dy=8mm, dz=5mm

Reference Value = 9.06 V/m; Power Drift = -0.149 dB

Peak SAR (extrapolated) = 0.457 W/kg

SAR(1 g) = 0.275 mW/g; SAR(10 g) = 0.182 mW/g

Maximum value of SAR (measured) = 0.286 mW/g

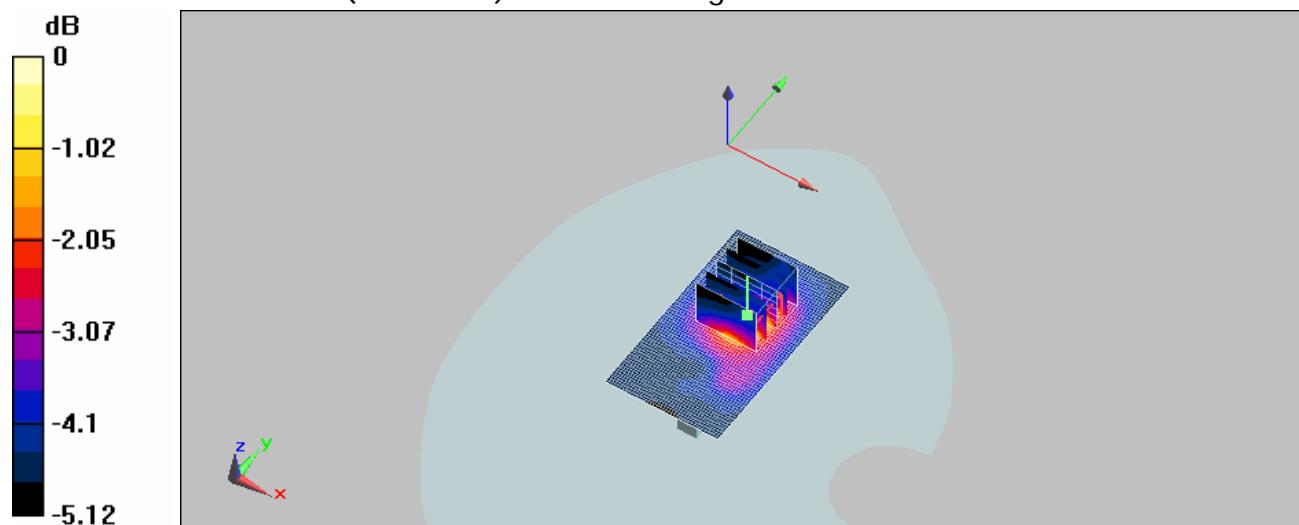

0 dB = 0.286mW/g

Date/Time: 9/18/2008 16:15:28

Configuration 4_CH9538_HSDPA mode

DUT: C152,

Communication System: WCDMA BAND2; Frequency: 1907.6 MHz; Duty Cycle: 1:1

Medium: WCDMA Band2 Medium parameters used: $f = 1908$ MHz; $\sigma = 1.48$ mho/m; $\epsilon_r = 52.5$; $\rho = 1000$ kg/m³

Phantom section: Flat Section

DASY5 Configuration:

- Probe: ES3DV3 - SN3172; ConvF(4.73, 4.73, 4.73); Calibrated: 6/23/2008
- Sensor-Surface: 4mm (Mechanical Surface Detection)
- Electronics: DAE4 Sn856; Calibrated: 5/7/2008
- Phantom: SAM1; Type: SAM;
- Measurement SW: DASY5, V5.0 Build 119; SEMCAD X Version 13.2 Build 87

Body/Area Scan : Measurement grid: dx=15mm, dy=15mm

Maximum value of SAR (interpolated) = 0.210 mW/g

Body/Zoom Scan : Measurement grid: dx=8mm, dy=8mm, dz=5mm

Reference Value = 8.41 V/m; Power Drift = 0.187 dB

Peak SAR (extrapolated) = 0.292 W/kg

SAR(1 g) = 0.200 mW/g; SAR(10 g) = 0.151 mW/g

Maximum value of SAR (measured) = 0.207 mW/g

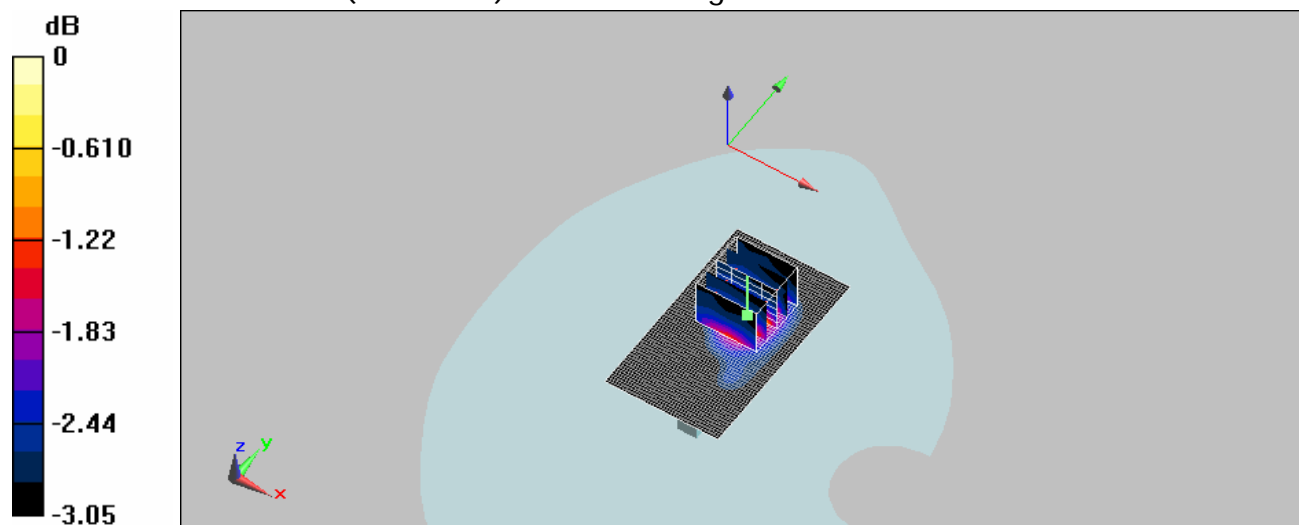

0 dB = 0.207mW/g

Date/Time: 9/18/2008 17:41:45

Configuration 5_CH9262_HSDPA mode

DUT: C152,

Communication System: WCDMA BAND2; Frequency: 1852.4 MHz; Duty Cycle: 1:1

Medium: WCDMA Band2 Medium parameters used (interpolated): $f = 1852.4$ MHz; $\sigma = 1.44$ mho/m; $\epsilon_r = 52.3$; $\rho = 1000$ kg/m³

Phantom section: Flat Section

DASY5 Configuration:

- Probe: ES3DV3 - SN3172; ConvF(4.73, 4.73, 4.73); Calibrated: 6/23/2008
- Sensor-Surface: 4mm (Mechanical Surface Detection)
- Electronics: DAE4 Sn856; Calibrated: 5/7/2008
- Phantom: SAM1; Type: SAM;
- Measurement SW: DASY5, V5.0 Build 119; SEMCAD X Version 13.2 Build 87

Body/Area Scan : Measurement grid: dx=15mm, dy=15mm

Maximum value of SAR (interpolated) = 0.138 mW/g

Body/Zoom Scan : Measurement grid: dx=8mm, dy=8mm, dz=5mm

Reference Value = 8.85 V/m; Power Drift = 0.00773 dB

Peak SAR (extrapolated) = 0.142 W/kg

SAR(1 g) = 0.132 mW/g; SAR(10 g) = 0.121 mW/g

Maximum value of SAR (measured) = 0.135 mW/g

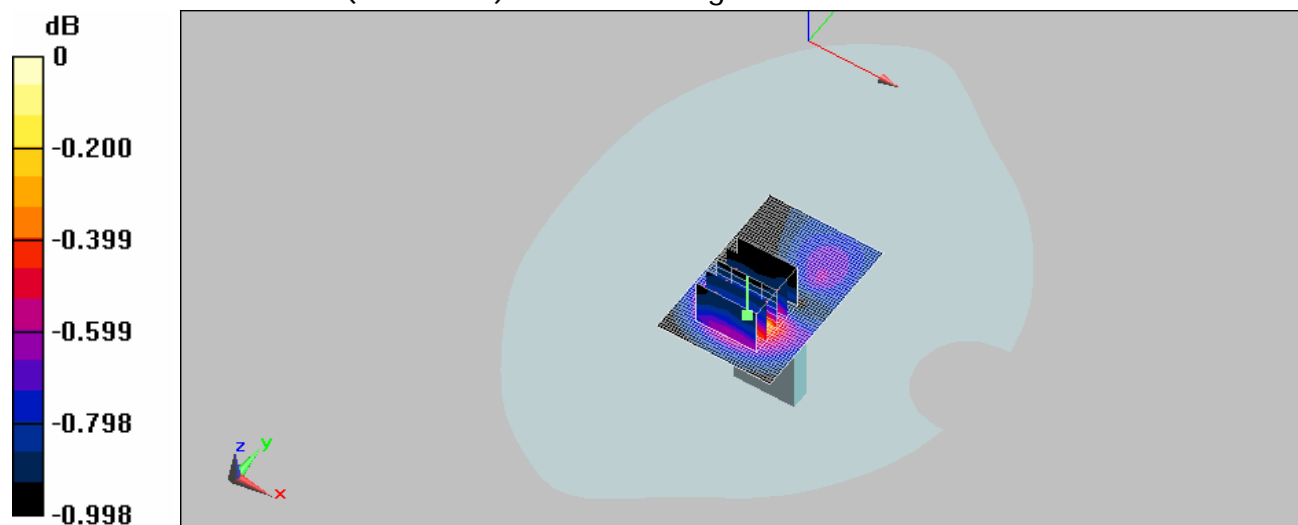

0 dB = 0.135mW/g

Date/Time: 9/18/2008 18:07:04

Configuration 5_CH9400_HSDPA mode

DUT: C152,

Communication System: WCDMA BAND2; Frequency: 1880 MHz; Duty Cycle: 1:1

Medium: WCDMA Band2 Medium parameters used: $f = 1880$ MHz; $\sigma = 1.46$ mho/m; $\epsilon_r = 52.4$; $\rho = 1000$ kg/m³

Phantom section: Flat Section

DASY5 Configuration:

- Probe: ES3DV3 - SN3172; ConvF(4.73, 4.73, 4.73); Calibrated: 6/23/2008
- Sensor-Surface: 4mm (Mechanical Surface Detection)
- Electronics: DAE4 Sn856; Calibrated: 5/7/2008
- Phantom: SAM1; Type: SAM;
- Measurement SW: DASY5, V5.0 Build 119; SEMCAD X Version 13.2 Build 87

Body/Area Scan : Measurement grid: dx=15mm, dy=15mm

Maximum value of SAR (interpolated) = 0.148 mW/g

Body/Zoom Scan : Measurement grid: dx=8mm, dy=8mm, dz=5mm

Reference Value = 8.96 V/m; Power Drift = 0.019 dB

Peak SAR (extrapolated) = 0.159 W/kg

SAR(1 g) = 0.142 mW/g; SAR(10 g) = 0.127 mW/g

Maximum value of SAR (measured) = 0.146 mW/g

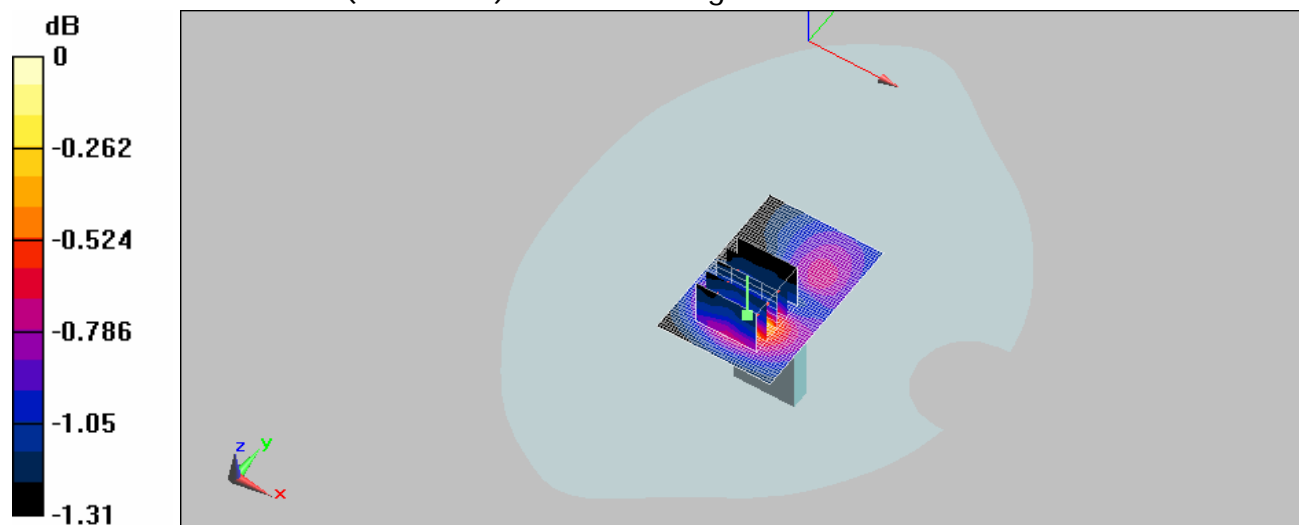

0 dB = 0.146mW/g

Date/Time: 9/18/2008 18:31:07

Configuration 5_CH9538_HSDPA mode

DUT: C152,

Communication System: WCDMA BAND2; Frequency: 1907.6 MHz; Duty Cycle: 1:1

Medium: WCDMA Band2 Medium parameters used: $f = 1908$ MHz; $\sigma = 1.48$ mho/m; $\epsilon_r = 52.5$; $\rho = 1000$ kg/m³

Phantom section: Flat Section

DASY5 Configuration:

- Probe: ES3DV3 - SN3172; ConvF(4.73, 4.73, 4.73); Calibrated: 6/23/2008
- Sensor-Surface: 4mm (Mechanical Surface Detection)
- Electronics: DAE4 Sn856; Calibrated: 5/7/2008
- Phantom: SAM1; Type: SAM;
- Measurement SW: DASY5, V5.0 Build 119; SEMCAD X Version 13.2 Build 87

Body/Area Scan : Measurement grid: dx=15mm, dy=15mm

Maximum value of SAR (interpolated) = 0.179 mW/g

Body/Zoom Scan : Measurement grid: dx=8mm, dy=8mm, dz=5mm

Reference Value = 10.7 V/m; Power Drift = 0.050 dB

Peak SAR (extrapolated) = 0.180 W/kg

SAR(1 g) = 0.178 mW/g; SAR(10 g) = 0.171 mW/g

Maximum value of SAR (measured) = 0.179 mW/g

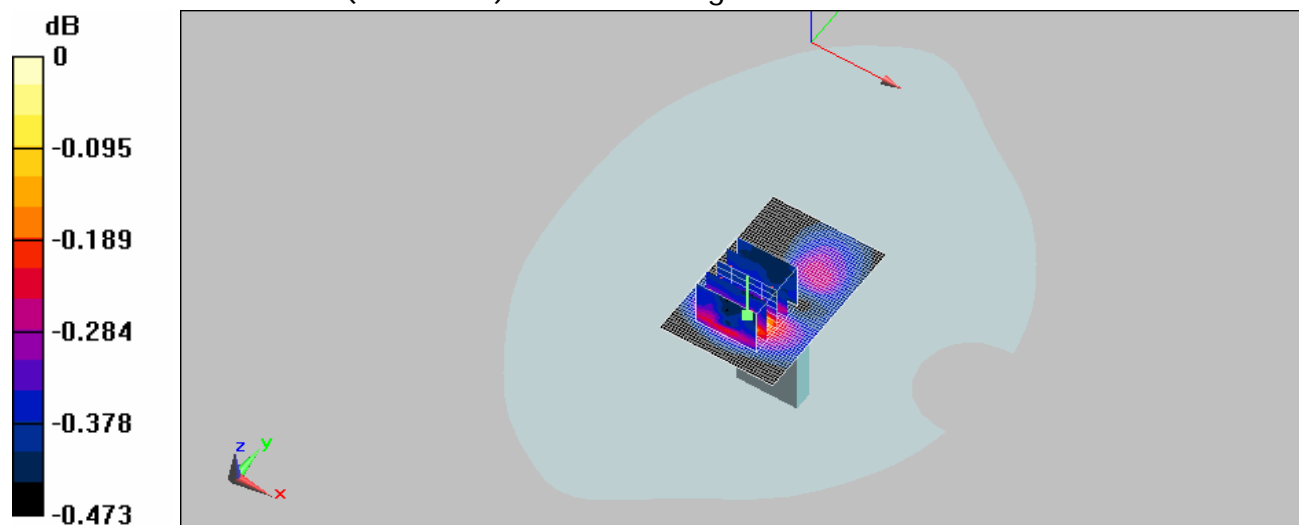

0 dB = 0.179mW/g

Date/Time: 9/18/2008 20:01:28

Configuration 6_CH9262_HSDPA mode

DUT: C152,

Communication System: WCDMA B2; Frequency: 1852.4 MHz; Duty Cycle: 1:1

Medium: WCDMA Band2 Medium parameters used (interpolated): $f = 1852.4$ MHz; $\sigma = 1.44$ mho/m; $\epsilon_r = 52.3$; $\rho = 1000$ kg/m³

Phantom section: Flat Section

DASY5 Configuration:

- Probe: ES3DV3 - SN3172; ConvF(4.73, 4.73, 4.73); Calibrated: 6/23/2008
- Sensor-Surface: 4mm (Mechanical Surface Detection)
- Electronics: DAE4 Sn856; Calibrated: 5/7/2008
- Phantom: SAM1; Type: SAM;
- Measurement SW: DASY5, V5.0 Build 119; SEMCAD X Version 13.2 Build 87

Body/Area Scan: Measurement grid: dx=15mm, dy=15mm

Maximum value of SAR (interpolated) = 0.193 mW/g

Body/Zoom Scan : Measurement grid: dx=8mm, dy=8mm, dz=5mm

Reference Value = 10.2 V/m; Power Drift = -0.00707 dB

Peak SAR (extrapolated) = 0.259 W/kg

SAR(1 g) = 0.184 mW/g; SAR(10 g) = 0.152 mW/g

Maximum value of SAR (measured) = 0.200 mW/g

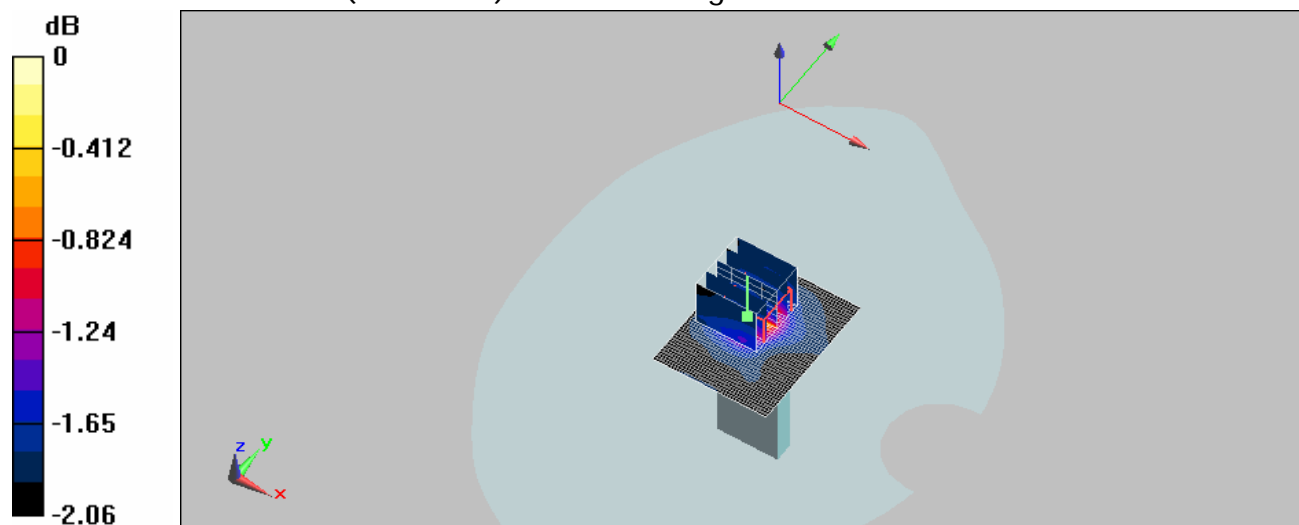

0 dB = 0.200mW/g

Date/Time: 9/18/2008 19:35:32

Configuration 6_CH9400_HSDPA mode

DUT: C152,

Communication System: WCDMA BAND2; Frequency: 1880 MHz; Duty Cycle: 1:1

Medium: WCDMA Band2 Medium parameters used: $f = 1880$ MHz; $\sigma = 1.46$ mho/m; $\epsilon_r = 52.4$; $\rho = 1000$ kg/m³

Phantom section: Flat Section

DASY5 Configuration:

- Probe: ES3DV3 - SN3172; ConvF(4.73, 4.73, 4.73); Calibrated: 6/23/2008
- Sensor-Surface: 4mm (Mechanical Surface Detection)
- Electronics: DAE4 Sn856; Calibrated: 5/7/2008
- Phantom: SAM1; Type: SAM;
- Measurement SW: DASY5, V5.0 Build 119; SEMCAD X Version 13.2 Build 87

Body/Area Scan: Measurement grid: dx=15mm, dy=15mm

Maximum value of SAR (interpolated) = 0.278 mW/g

Body/Zoom Scan : Measurement grid: dx=8mm, dy=8mm, dz=5mm

Reference Value = 10.5 V/m; Power Drift = -0.00442 dB

Peak SAR (extrapolated) = 0.504 W/kg

SAR(1 g) = 0.237 mW/g; SAR(10 g) = 0.175 mW/g

Maximum value of SAR (measured) = 0.250 mW/g

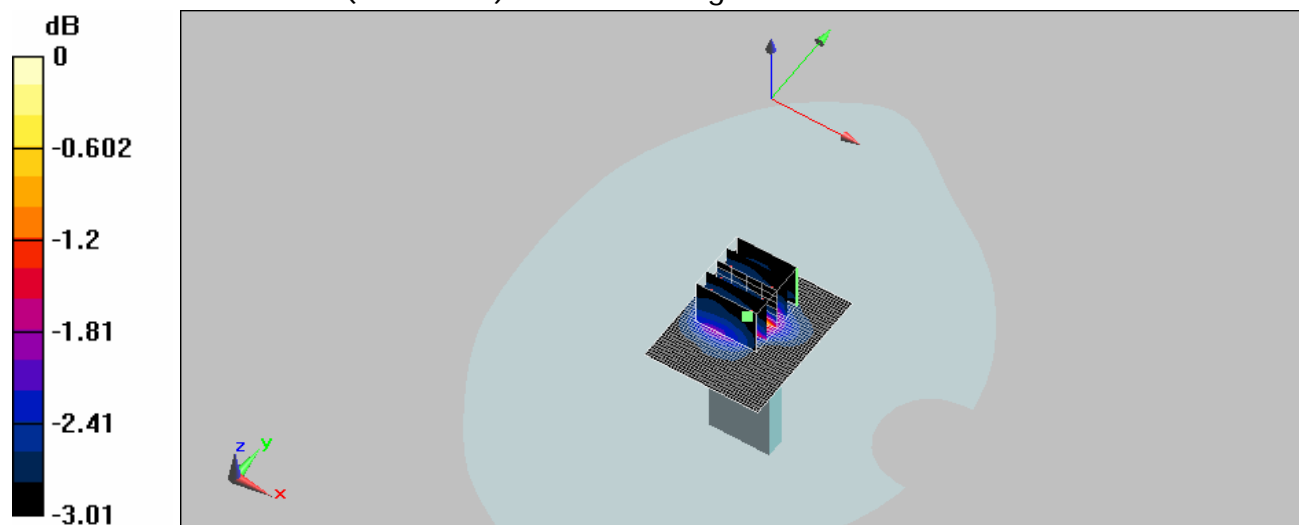

0 dB = 0.250mW/g

Date/Time: 9/18/2008 19:12:03

Configuration 6_CH9538_HSDPA mode**DUT: C152,**

Communication System: WCDMA BAND2; Frequency: 1907.6 MHz; Duty Cycle: 1:1

Medium: WCDMA Band2 Medium parameters used: $f = 1908$ MHz; $\sigma = 1.48$ mho/m; $\epsilon_r = 52.5$; $\rho = 1000$ kg/m³

Phantom section: Flat Section

DASY5 Configuration:

- Probe: ES3DV3 - SN3172; ConvF(4.73, 4.73, 4.73); Calibrated: 6/23/2008
- Sensor-Surface: 4mm (Mechanical Surface Detection)
- Electronics: DAE4 Sn856; Calibrated: 5/7/2008
- Phantom: SAM1; Type: SAM;
- Measurement SW: DASY5, V5.0 Build 119; SEMCAD X Version 13.2 Build 87

Body/Area Scan: Measurement grid: dx=15mm, dy=15mm

Maximum value of SAR (interpolated) = 0.207 mW/g

Body/Zoom Scan : Measurement grid: dx=8mm, dy=8mm, dz=5mm

Reference Value = 9.9 V/m; Power Drift = -0.111 dB

Peak SAR (extrapolated) = 0.264 W/kg

SAR(1 g) = 0.163 mW/g; SAR(10 g) = 0.140 mW/g

Maximum value of SAR (measured) = 0.177 mW/g

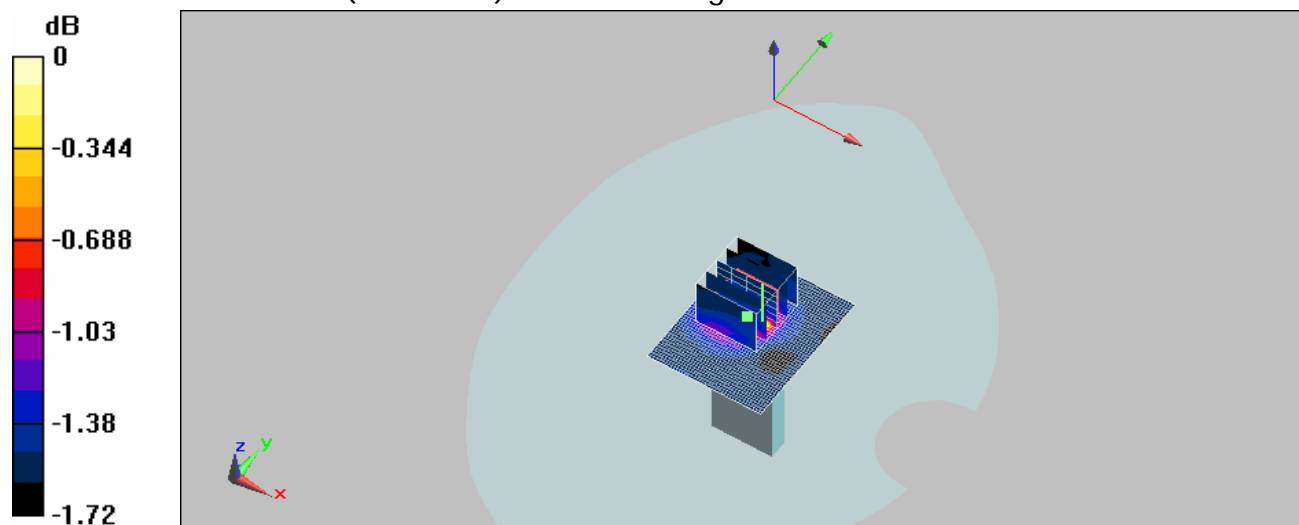

0 dB = 0.177mW/g

Date/Time: 12/8/2008 16:06:51

Configuration 7_CH9262 with HSDPA mode

DUT: C152,

Communication System: WCDMA B2; Frequency: 1852.4 MHz; Duty Cycle: 1:1

Medium: WCDMA Band2 Medium parameters used: $f = 1852.4$ MHz; $\sigma = 1.46$ mho/m; $\epsilon_r = 54.7$; $\rho = 1000$ kg/m³

Phantom section: Flat Section

DASY5 Configuration:

- Probe: ES3DV3 - SN3172; ConvF(4.73, 4.73, 4.73); Calibrated: 6/23/2008
- Sensor-Surface: 4mm (Mechanical Surface Detection)
- Electronics: DAE4 Sn856; Calibrated: 5/7/2008
- Phantom: SAM1; Type: SAM;
- Measurement SW: DASY5, V5.0 Build 119; SEMCAD X Version 13.2 Build 87

Body/Area Scan: Measurement grid: dx=15mm, dy=15mm

Maximum value of SAR (interpolated) = 0.846 mW/g

Body/Zoom Scan: Measurement grid: dx=8mm, dy=8mm, dz=5mm

Reference Value = 11.7 V/m; Power Drift = 0.046 dB

Peak SAR (extrapolated) = 0.942 W/kg

SAR(1 g) = 0.663 mW/g; SAR(10 g) = 0.404 mW/g

Maximum value of SAR (measured) = 0.693 mW/g

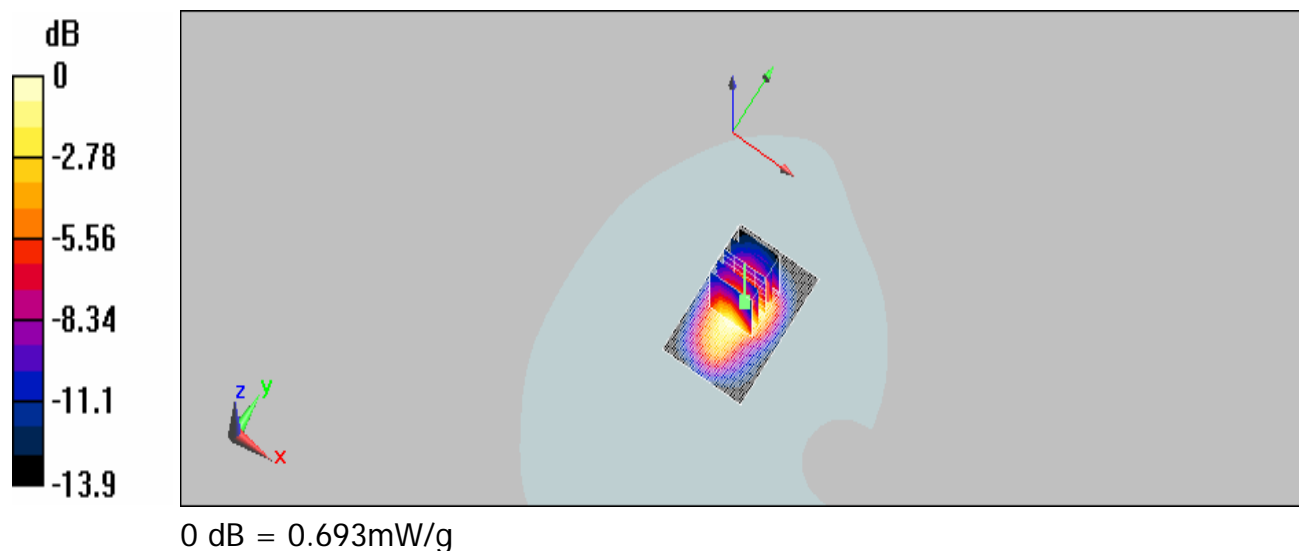

Date/Time: 12/8/2008 16:43:57

Configuration 7_CH9400 with HSDPA mode

DUT: C152,

Communication System: WCDMA B2; Frequency: 1880 MHz; Duty Cycle: 1:1

Medium: WCDMA Band2 Medium parameters used: $f = 1880$ MHz; $\sigma = 1.49$ mho/m; $\epsilon_r = 54.6$; $\rho = 1000$ kg/m³

Phantom section: Flat Section

DASY5 Configuration:

- Probe: ES3DV3 - SN3172; ConvF(4.73, 4.73, 4.73); Calibrated: 6/23/2008
- Sensor-Surface: 4mm (Mechanical Surface Detection)
- Electronics: DAE4 Sn856; Calibrated: 5/7/2008
- Phantom: SAM1; Type: SAM;
- Measurement SW: DASY5, V5.0 Build 119; SEMCAD X Version 13.2 Build 87

Body/Area Scan: Measurement grid: dx=15mm, dy=15mm

Maximum value of SAR (interpolated) = 1.18 mW/g

Body/Zoom Scan: Measurement grid: dx=8mm, dy=8mm, dz=5mm

Reference Value = 14.3 V/m; Power Drift = -0.119 dB

Peak SAR (extrapolated) = 1.39 W/kg

SAR(1 g) = 0.919 mW/g; SAR(10 g) = 0.522 mW/g

Maximum value of SAR (measured) = 0.974 mW/g

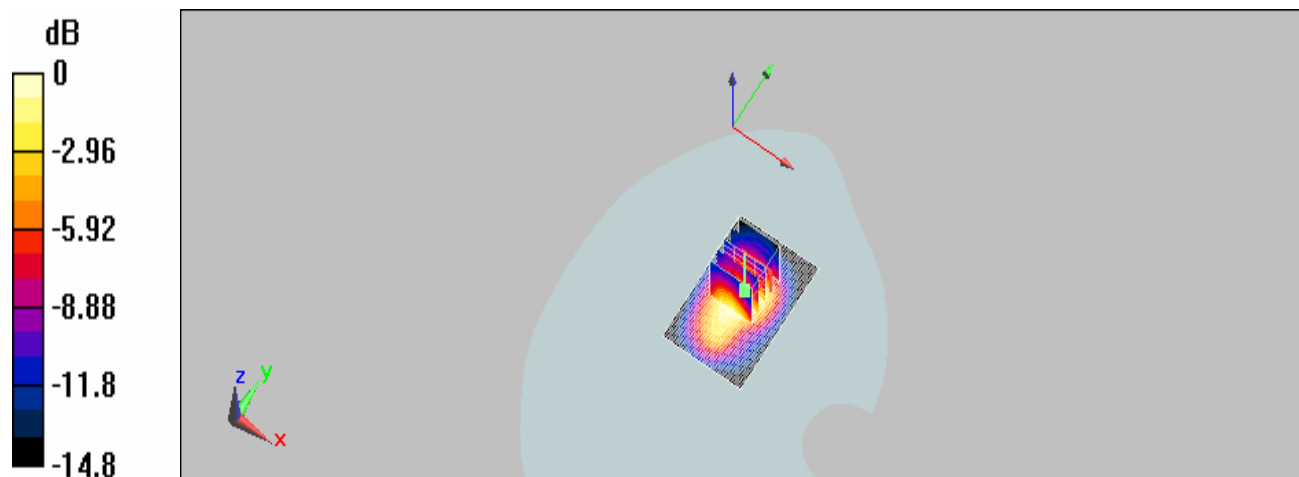

0 dB = 0.974mW/g

Date/Time: 12/8/2008 17:15:06

Configuration 7_CH9538 with HSDPA mode

DUT: C152,

Communication System: WCDMA B2; Frequency: 1907.6 MHz; Duty Cycle: 1:1

Medium: WCDMA Band2 Medium parameters used: $f = 1908$ MHz; $\sigma = 1.52$ mho/m; $\epsilon_r = 54.5$; $\rho = 1000$ kg/m³

Phantom section: Flat Section

DASY5 Configuration:

- Probe: ES3DV3 - SN3172; ConvF(4.73, 4.73, 4.73); Calibrated: 6/23/2008
- Sensor-Surface: 4mm (Mechanical Surface Detection)
- Electronics: DAE4 Sn856; Calibrated: 5/7/2008
- Phantom: SAM1; Type: SAM;
- Measurement SW: DASY5, V5.0 Build 119; SEMCAD X Version 13.2 Build 87

Body/Area Scan: Measurement grid: dx=15mm, dy=15mm

Maximum value of SAR (interpolated) = 0.726 mW/g

Body/Zoom Scan: Measurement grid: dx=8mm, dy=8mm, dz=5mm

Reference Value = 11.6 V/m; Power Drift = 0.010 dB

Peak SAR (extrapolated) = 0.862 W/kg

SAR(1 g) = 0.573 mW/g; SAR(10 g) = 0.338 mW/g

Maximum value of SAR (measured) = 0.584 mW/g

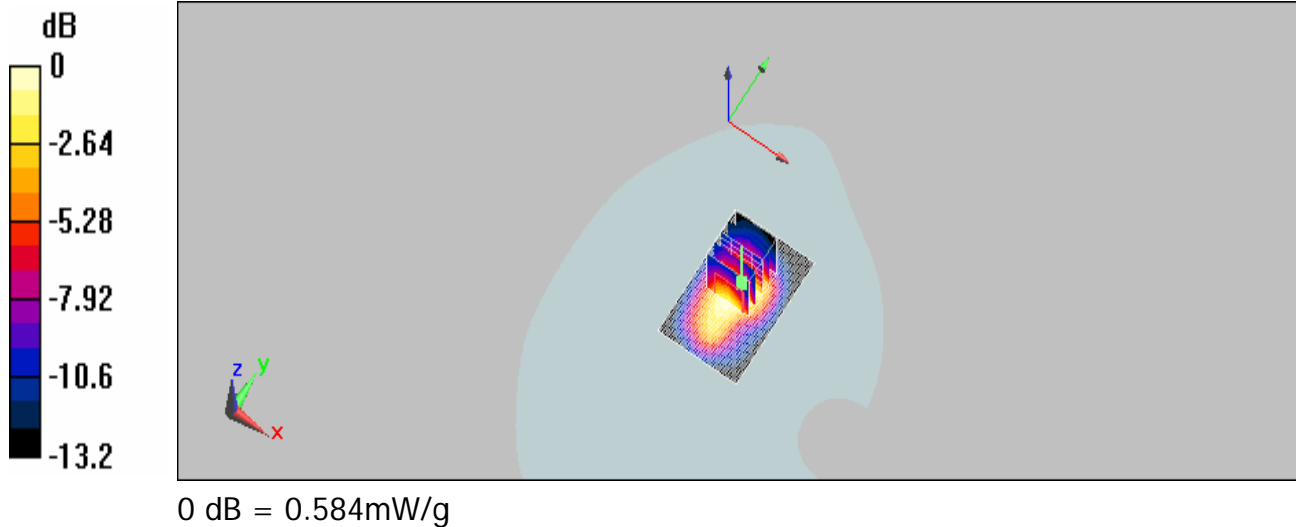

Date/Time: 12/8/2008 18:33:45

Configuration 8_CH 9262 with HSDPA mode

DUT: C152,

Communication System: WCDMA B2; Frequency: 1852.4 MHz; Duty Cycle: 1:1

Medium: WCDMA Band2 Medium parameters used: $f = 1852.4$ MHz; $\sigma = 1.46$ mho/m; $\epsilon_r = 54.7$; $\rho = 1000$ kg/m³

Phantom section: Flat Section

DASY5 Configuration:

- Probe: ES3DV3 - SN3172; ConvF(4.73, 4.73, 4.73); Calibrated: 6/23/2008
- Sensor-Surface: 4mm (Mechanical Surface Detection)
- Electronics: DAE4 Sn856; Calibrated: 5/7/2008
- Phantom: SAM1; Type: SAM;
- Measurement SW: DASY5, V5.0 Build 119; SEMCAD X Version 13.2 Build 87

Body/Area Scan: Measurement grid: dx=15mm, dy=15mm

Maximum value of SAR (interpolated) = 0.795 mW/g

Body/Zoom Scan: Measurement grid: dx=8mm, dy=8mm, dz=5mm

Reference Value = 4.42 V/m; Power Drift = 0.136 dB

Peak SAR (extrapolated) = 1.08 W/kg

SAR(1 g) = 0.574 mW/g; SAR(10 g) = 0.289 mW/g

Maximum value of SAR (measured) = 0.645 mW/g

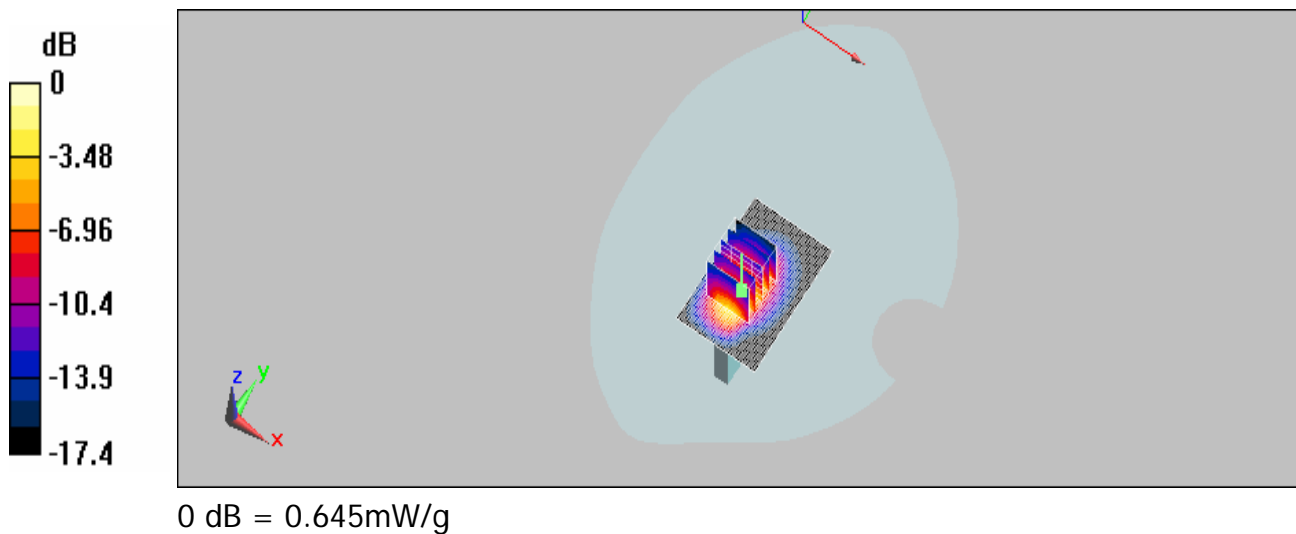

Date/Time: 12/8/2008 19:06:21

Configuration 8_CH 9400 with HSDPA mode

DUT: C152,

Communication System: WCDMA B2; Frequency: 1880 MHz; Duty Cycle: 1:1

Medium: WCDMA Band2 Medium parameters used: $f = 1880$ MHz; $\sigma = 1.49$ mho/m; $\epsilon_r = 54.6$; $\rho = 1000$ kg/m³

Phantom section: Flat Section

DASY5 Configuration:

- Probe: ES3DV3 - SN3172; ConvF(4.73, 4.73, 4.73); Calibrated: 6/23/2008
- Sensor-Surface: 4mm (Mechanical Surface Detection)
- Electronics: DAE4 Sn856; Calibrated: 5/7/2008
- Phantom: SAM1; Type: SAM;
- Measurement SW: DASY5, V5.0 Build 119; SEMCAD X Version 13.2 Build 87

Body/Area Scan: Measurement grid: dx=15mm, dy=15mm

Maximum value of SAR (interpolated) = 1.1 mW/g

Body/Zoom Scan: Measurement grid: dx=8mm, dy=8mm, dz=5mm

Reference Value = 3.79 V/m; Power Drift = 0.177 dB

Peak SAR (extrapolated) = 1.61 W/kg

SAR(1 g) = 0.831 mW/g; SAR(10 g) = 0.409 mW/g

Maximum value of SAR (measured) = 0.915 mW/g

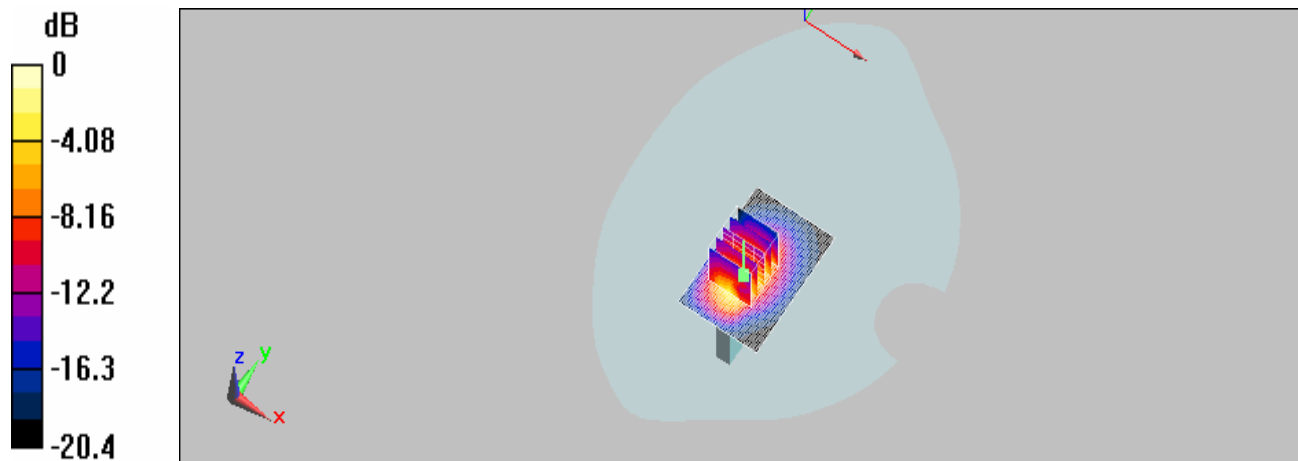

Date/Time: 12/8/2008 19:43:58

Configuration 8_CH 9538 with HSDPA mode

DUT: C152,

Communication System: WCDMA B2; Frequency: 1907.6 MHz; Duty Cycle: 1:1

Medium: WCDMA Band2 Medium parameters used: $f = 1908$ MHz; $\sigma = 1.52$ mho/m; $\epsilon_r = 54.5$; $\rho = 1000$ kg/m³

Phantom section: Flat Section

DASY5 Configuration:

- Probe: ES3DV3 - SN3172; ConvF(4.73, 4.73, 4.73); Calibrated: 6/23/2008
- Sensor-Surface: 4mm (Mechanical Surface Detection)
- Electronics: DAE4 Sn856; Calibrated: 5/7/2008
- Phantom: SAM1; Type: SAM;
- Measurement SW: DASY5, V5.0 Build 119; SEMCAD X Version 13.2 Build 87

Body/Area Scan: Measurement grid: dx=15mm, dy=15mm

Maximum value of SAR (interpolated) = 0.691 mW/g

Body/Zoom Scan: Measurement grid: dx=8mm, dy=8mm, dz=5mm

Reference Value = 4.14 V/m; Power Drift = 0.178 dB
Peak SAR (extrapolated) = 0.943 W/kg

SAR(1 g) = 0.502 mW/g; SAR(10 g) = 0.250 mW/g

Maximum value of SAR (measured) = 0.562 mW/g

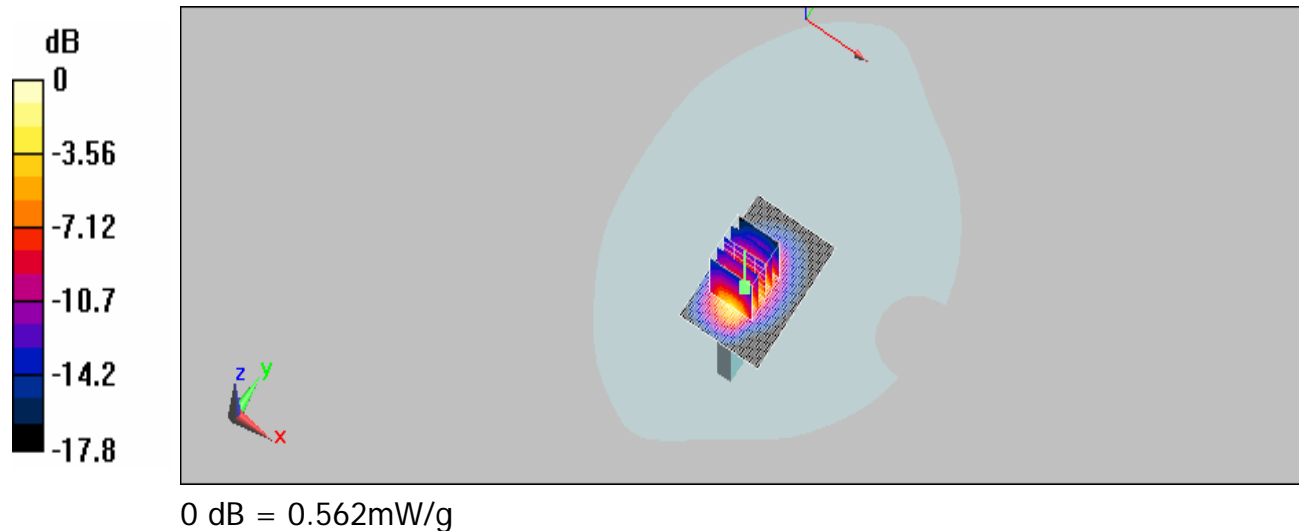

Date/Time: 9/19/2008 01:25:05

Configuration 1_CH4132

DUT: C152,

Communication System: WCDMA BAND5; Frequency: 826.4 MHz; Duty Cycle: 1:1

Medium: WCDMA Band5 Medium parameters used (interpolated): $f = 826.4$ MHz; $\sigma = 0.946$ mho/m; $\epsilon_r = 56.3$; $\rho = 1000$ kg/m³

Phantom section: Flat Section

DASY5 Configuration:

- Probe: ES3DV3 - SN3172; ConvF(5.61, 5.61, 5.61); Calibrated: 6/23/2008
- Sensor-Surface: 4mm (Mechanical Surface Detection)
- Electronics: DAE4 Sn856; Calibrated: 5/7/2008
- Phantom: SAM1; Type: SAM;
- Measurement SW: DASY5, V5.0 Build 119; SEMCAD X Version 13.2 Build 87

Body/Area Scan : Measurement grid: dx=15mm, dy=15mm

Maximum value of SAR (interpolated) = 0.159 mW/g

Body/Zoom Scan : Measurement grid: dx=8mm, dy=8mm, dz=5mm

Reference Value = 11.4 V/m; Power Drift = 0.103 dB

Peak SAR (extrapolated) = 0.205 W/kg

SAR(1 g) = 0.157 mW/g; SAR(10 g) = 0.128 mW/g

Maximum value of SAR (measured) = 0.167 mW/g

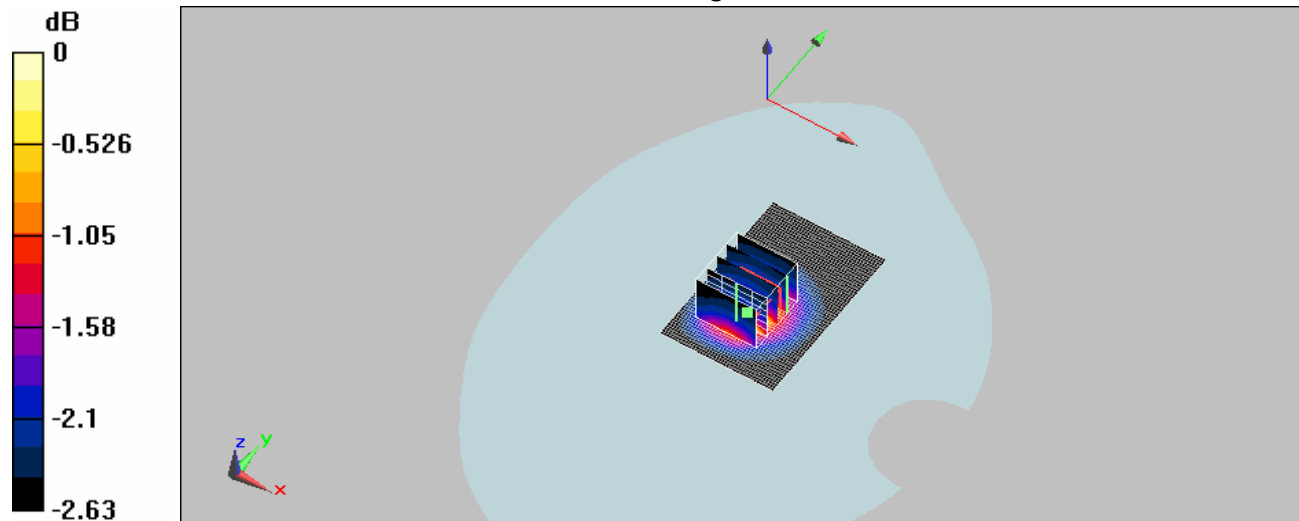

0 dB = 0.167mW/g

Date/Time: 9/19/2008 01:49:20

Configuration 1_CH4183

DUT: C152,

Communication System: WCDMA BAND5; Frequency: 836.6 MHz; Duty Cycle: 1:1

Medium: WCDMA Band5 Medium parameters used: $f = 837$ MHz; $\sigma = 0.958$ mho/m; $\epsilon_r = 56.3$; $\rho = 1000$ kg/m³

Phantom section: Flat Section

DASY5 Configuration:

- Probe: ES3DV3 - SN3172; ConvF(5.61, 5.61, 5.61); Calibrated: 6/23/2008
- Sensor-Surface: 4mm (Mechanical Surface Detection)
- Electronics: DAE4 Sn856; Calibrated: 5/7/2008
- Phantom: SAM1; Type: SAM;
- Measurement SW: DASY5, V5.0 Build 119; SEMCAD X Version 13.2 Build 87

Body/Area Scan : Measurement grid: dx=15mm, dy=15mm

Maximum value of SAR (interpolated) = 0.165 mW/g

Body/Zoom Scan : Measurement grid: dx=8mm, dy=8mm, dz=5mm

Reference Value = 11.7 V/m; Power Drift = 0.016 dB

Peak SAR (extrapolated) = 0.217 W/kg

SAR(1 g) = 0.164 mW/g; SAR(10 g) = 0.132 mW/g

Maximum value of SAR (measured) = 0.175 mW/g

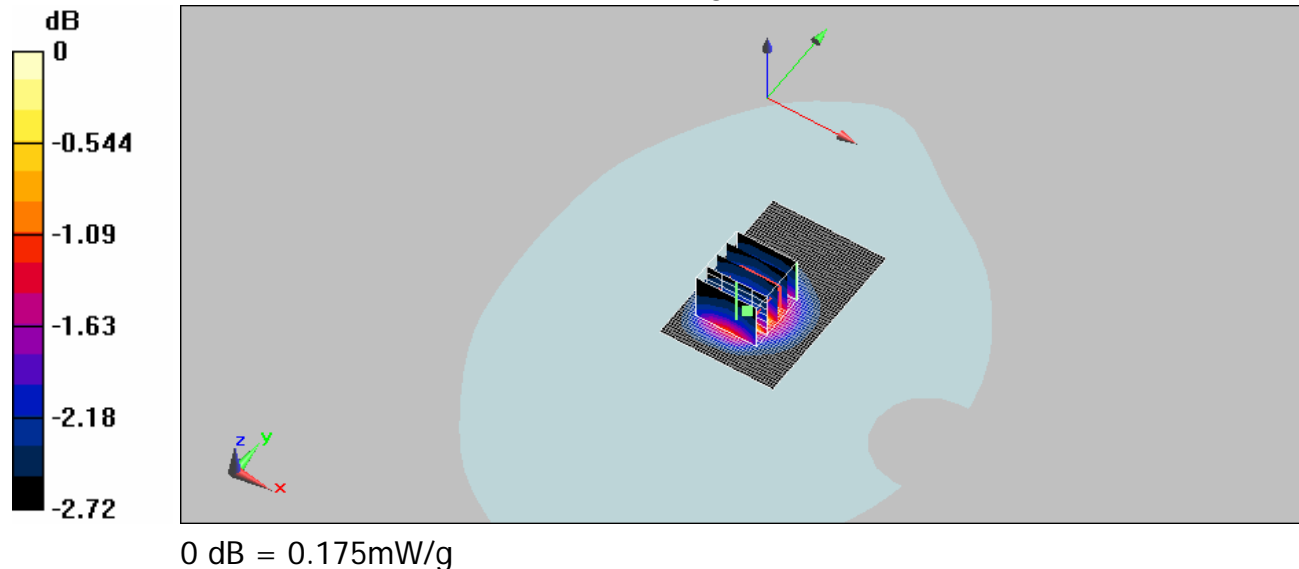

Date/Time: 9/19/2008 02:11:37

Configuration 1_CH4233

DUT: C152,

Communication System: WCDMA B5; Frequency: 846.6 MHz; Duty Cycle: 1:1

Medium: WCDMA Band5 Medium parameters used: $f = 847$ MHz; $\sigma = 0.969$ mho/m; $\epsilon_r = 56.2$; $\rho = 1000$ kg/m³

Phantom section: Flat Section

DASY5 Configuration:

- Probe: ES3DV3 - SN3172; ConvF(5.61, 5.61, 5.61); Calibrated: 6/23/2008
- Sensor-Surface: 4mm (Mechanical Surface Detection)
- Electronics: DAE4 Sn856; Calibrated: 5/7/2008
- Phantom: SAM1; Type: SAM;
- Measurement SW: DASY5, V5.0 Build 119; SEMCAD X Version 13.2 Build 87

Body/Area Scan : Measurement grid: dx=15mm, dy=15mm
Maximum value of SAR (interpolated) = 0.102 mW/g

Body/Zoom Scan : Measurement grid: dx=8mm, dy=8mm, dz=5mm
Reference Value = 9.24 V/m; Power Drift = -0.156 dB
Peak SAR (extrapolated) = 0.273 W/kg

SAR(1 g) = 0.176 mW/g; SAR(10 g) = 0.123 mW/g

Maximum value of SAR (measured) = 0.183 mW/g

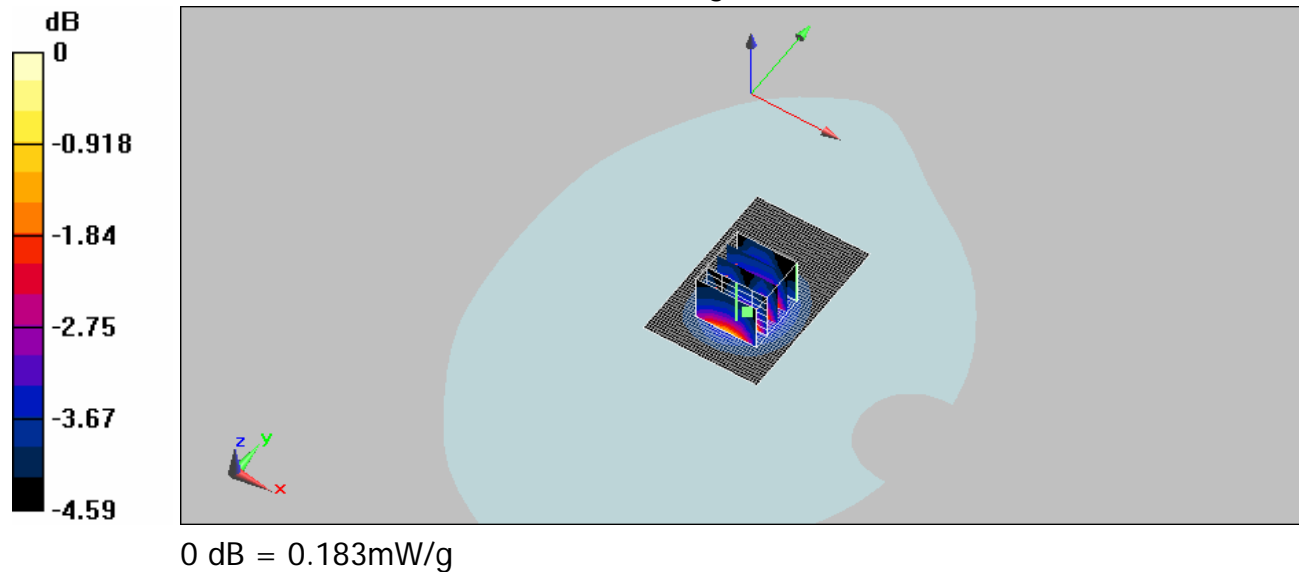

Date/Time: 9/19/2008 03:31:12

Configuration 2_CH4132

DUT: C152,

Communication System: WCDMA BAND5; Frequency: 826.4 MHz; Duty Cycle: 1:1

Medium: WCDMA Band5 Medium parameters used (interpolated): f = 826.4 MHz; $\sigma = 0.946$ mho/m; $\epsilon_r = 56.3$; $\rho = 1000$ kg/m³

Phantom section: Flat Section

DASY5 Configuration:

- Probe: ES3DV3 - SN3172; ConvF(5.61, 5.61, 5.61); Calibrated: 6/23/2008
- Sensor-Surface: 4mm (Mechanical Surface Detection)
- Electronics: DAE4 Sn856; Calibrated: 5/7/2008
- Phantom: SAM1; Type: SAM;
- Measurement SW: DASY5, V5.0 Build 119; SEMCAD X Version 13.2 Build 87

Body/Area Scan : Measurement grid: dx=15mm, dy=15mm
Maximum value of SAR (interpolated) = 0.097 mW/g

Body/Zoom Scan : Measurement grid: dx=8mm, dy=8mm, dz=5mm
Reference Value = 9.07 V/m; Power Drift = 0.099 dB
Peak SAR (extrapolated) = 0.135 W/kg

SAR(1 g) = 0.098 mW/g; SAR(10 g) = 0.084 mW/g

Maximum value of SAR (measured) = 0.102 mW/g

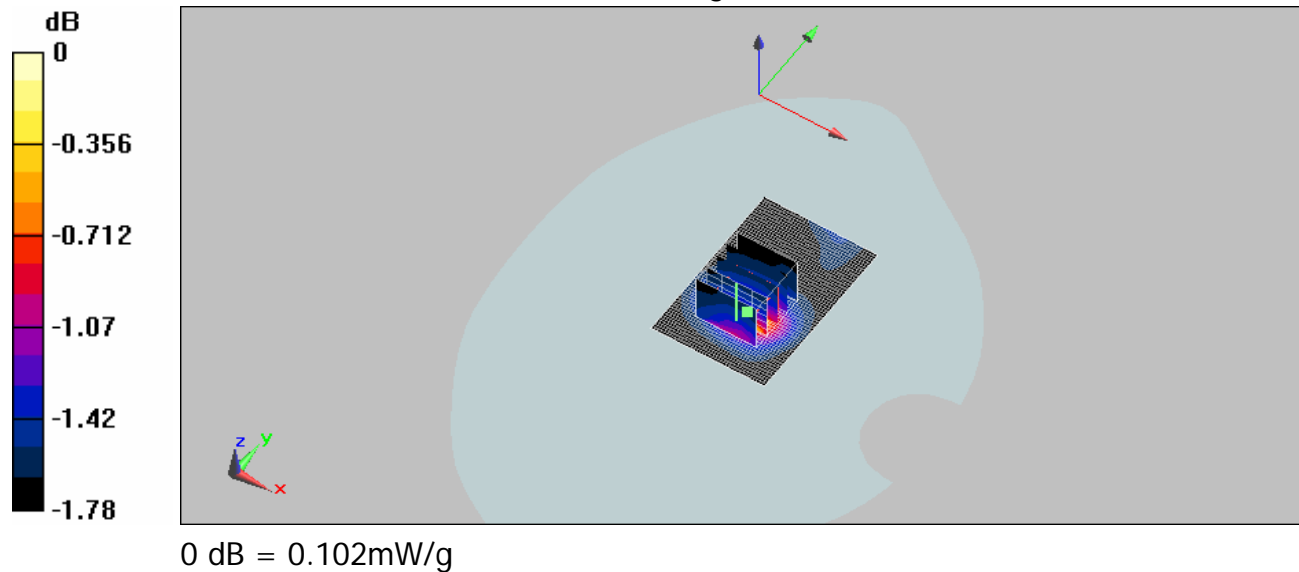

Date/Time: 9/19/2008 03:09:58

Configuration 2_CH4183

DUT: C152,

Communication System: WCDMA BAND5; Frequency: 836.6 MHz; Duty Cycle: 1:1

Medium: WCDMA Band5 Medium parameters used: $f = 837$ MHz; $\sigma = 0.958$ mho/m; $\epsilon_r = 56.3$; $\rho = 1000$ kg/m³

Phantom section: Flat Section

DASY5 Configuration:

- Probe: ES3DV3 - SN3172; ConvF(5.61, 5.61, 5.61); Calibrated: 6/23/2008
- Sensor-Surface: 4mm (Mechanical Surface Detection)
- Electronics: DAE4 Sn856; Calibrated: 5/7/2008
- Phantom: SAM1; Type: SAM;
- Measurement SW: DASY5, V5.0 Build 119; SEMCAD X Version 13.2 Build 87

Body/Area Scan : Measurement grid: dx=15mm, dy=15mm
Maximum value of SAR (interpolated) = 0.107 mW/g

Body/Zoom Scan : Measurement grid: dx=8mm, dy=8mm, dz=5mm
Reference Value = 9.77 V/m; Power Drift = -0.154 dB
Peak SAR (extrapolated) = 0.113 W/kg

SAR(1 g) = 0.105 mW/g; SAR(10 g) = 0.094 mW/g

Maximum value of SAR (measured) = 0.107 mW/g

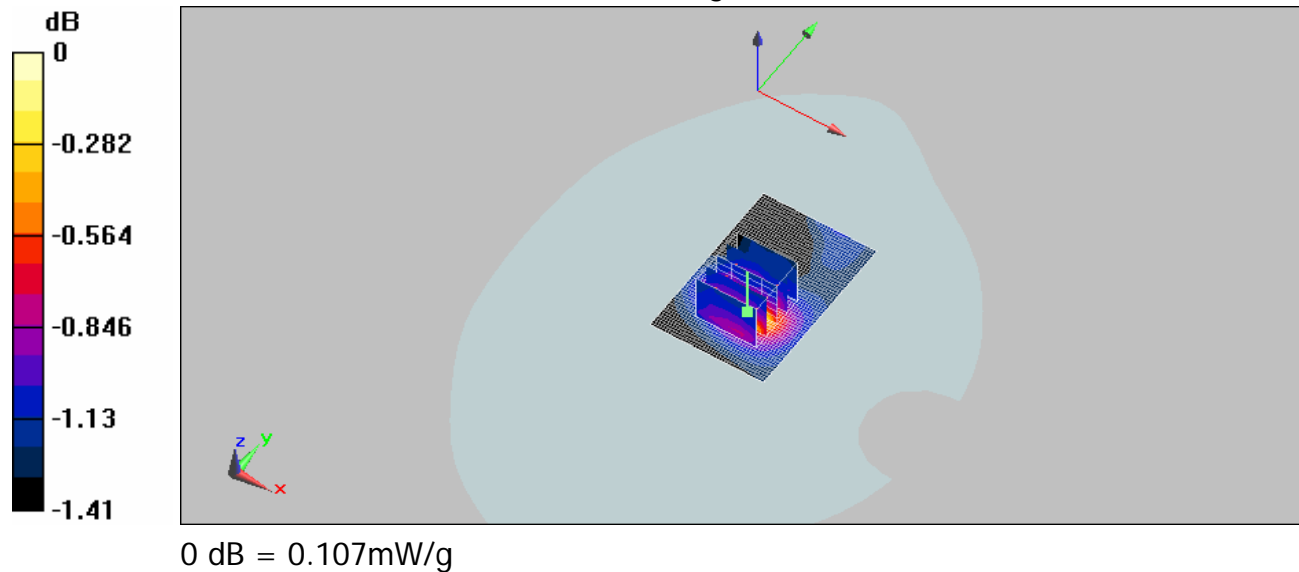

Date/Time: 9/19/2008 02:44:48

Configuration 2_CH4233

DUT: C152,

Communication System: WCDMA BAND5; Frequency: 846.6 MHz; Duty Cycle: 1:1

Medium: WCDMA Band5 Medium parameters used: $f = 847$ MHz; $\sigma = 0.969$ mho/m; $\epsilon_r = 56.2$; $\rho = 1000$ kg/m³

Phantom section: Flat Section

DASY5 Configuration:

- Probe: ES3DV3 - SN3172; ConvF(5.61, 5.61, 5.61); Calibrated: 6/23/2008
- Sensor-Surface: 4mm (Mechanical Surface Detection)
- Electronics: DAE4 Sn856; Calibrated: 5/7/2008
- Phantom: SAM1; Type: SAM;
- Measurement SW: DASY5, V5.0 Build 119; SEMCAD X Version 13.2 Build 87

Body/Area Scan : Measurement grid: dx=15mm, dy=15mm
Maximum value of SAR (interpolated) = 0.104 mW/g

Body/Zoom Scan : Measurement grid: dx=8mm, dy=8mm, dz=5mm
Reference Value = 9.86 V/m; Power Drift = -0.174 dB
Peak SAR (extrapolated) = 0.109 W/kg

SAR(1 g) = 0.102 mW/g; SAR(10 g) = 0.094 mW/g

Maximum value of SAR (measured) = 0.104 mW/g

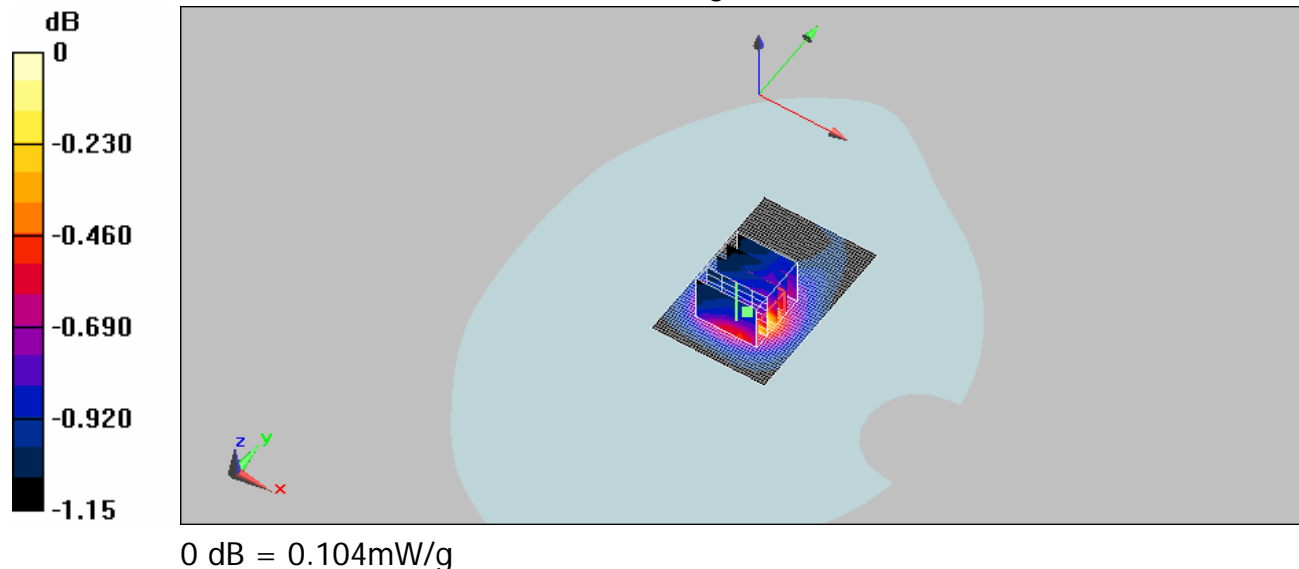

Date/Time: 9/19/2008 04:06:07

Configuration 3_CH4132

DUT: C152,

Communication System: WCDMA BAND5; Frequency: 826.4 MHz; Duty Cycle: 1:1
Medium: GMS 850 Medium parameters used (interpolated): $f = 826.4$ MHz; $\sigma = 0.946$ mho/m; $\epsilon_r = 56.3$; $\rho = 1000$ kg/m³

Phantom section: Flat Section

DASY5 Configuration:

- Probe: ES3DV3 - SN3172; ConvF(5.61, 5.61, 5.61); Calibrated: 6/23/2008
- Sensor-Surface: 4mm (Mechanical Surface Detection)
- Electronics: DAE4 Sn856; Calibrated: 5/7/2008
- Phantom: SAM1; Type: SAM;
- Measurement SW: DASY5, V5.0 Build 119; SEMCAD X Version 13.2 Build 87

Body/Area Scan : Measurement grid: dx=15mm, dy=15mm
Maximum value of SAR (interpolated) = 0.116 mW/g

Body/Zoom Scan : Measurement grid: dx=8mm, dy=8mm, dz=5mm
Reference Value = 10.6 V/m; Power Drift = 0.069 dB
Peak SAR (extrapolated) = 0.129 W/kg

SAR(1 g) = 0.114 mW/g; SAR(10 g) = 0.101 mW/g

Maximum value of SAR (measured) = 0.117 mW/g

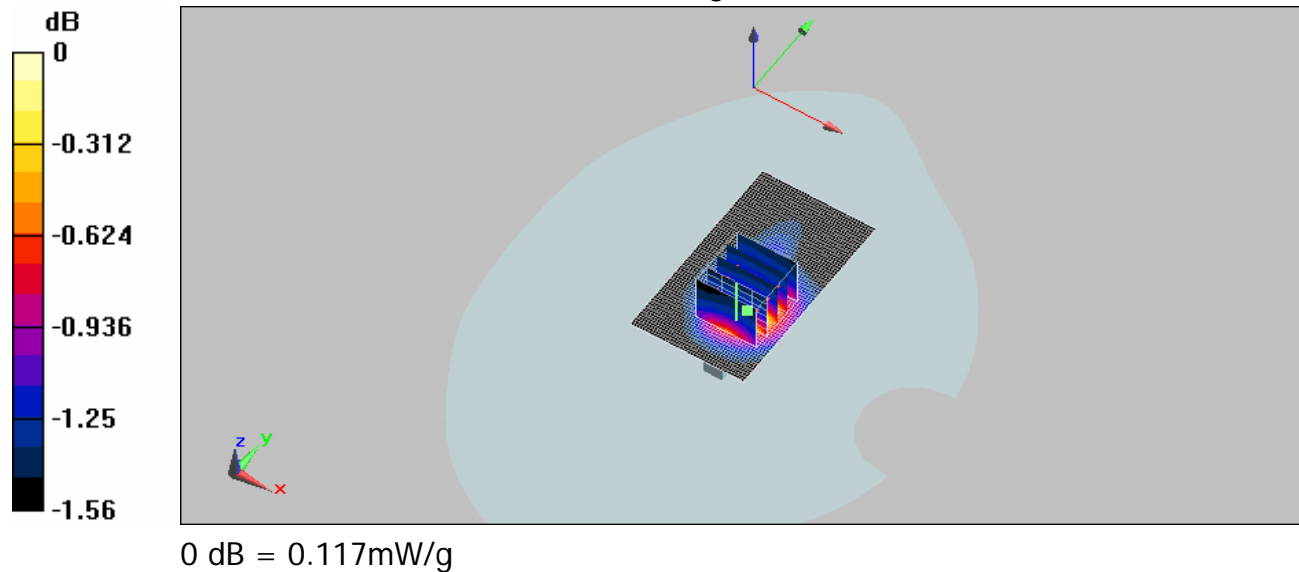

Date/Time: 9/19/2008 04:30:40

Configuration 3_CH4183

DUT: C152,

Communication System: WCDMA BAND5; Frequency: 836.6 MHz; Duty Cycle: 1:1

Medium: GMS 850 Medium parameters used: $f = 837$ MHz; $\sigma = 0.958$ mho/m; $\epsilon_r = 56.3$; $\rho = 1000$ kg/m³

Phantom section: Flat Section

DASY5 Configuration:

- Probe: ES3DV3 - SN3172; ConvF(5.61, 5.61, 5.61); Calibrated: 6/23/2008
- Sensor-Surface: 4mm (Mechanical Surface Detection)
- Electronics: DAE4 Sn856; Calibrated: 5/7/2008
- Phantom: SAM1; Type: SAM;
- Measurement SW: DASY5, V5.0 Build 119; SEMCAD X Version 13.2 Build 87

Body/Area Scan : Measurement grid: dx=15mm, dy=15mm
Maximum value of SAR (interpolated) = 0.129 mW/g

Body/Zoom Scan : Measurement grid: dx=8mm, dy=8mm, dz=5mm
Reference Value = 10.9 V/m; Power Drift = -0.080 dB
Peak SAR (extrapolated) = 0.138 W/kg

SAR(1 g) = 0.119 mW/g; SAR(10 g) = 0.105 mW/g

Maximum value of SAR (measured) = 0.122 mW/g

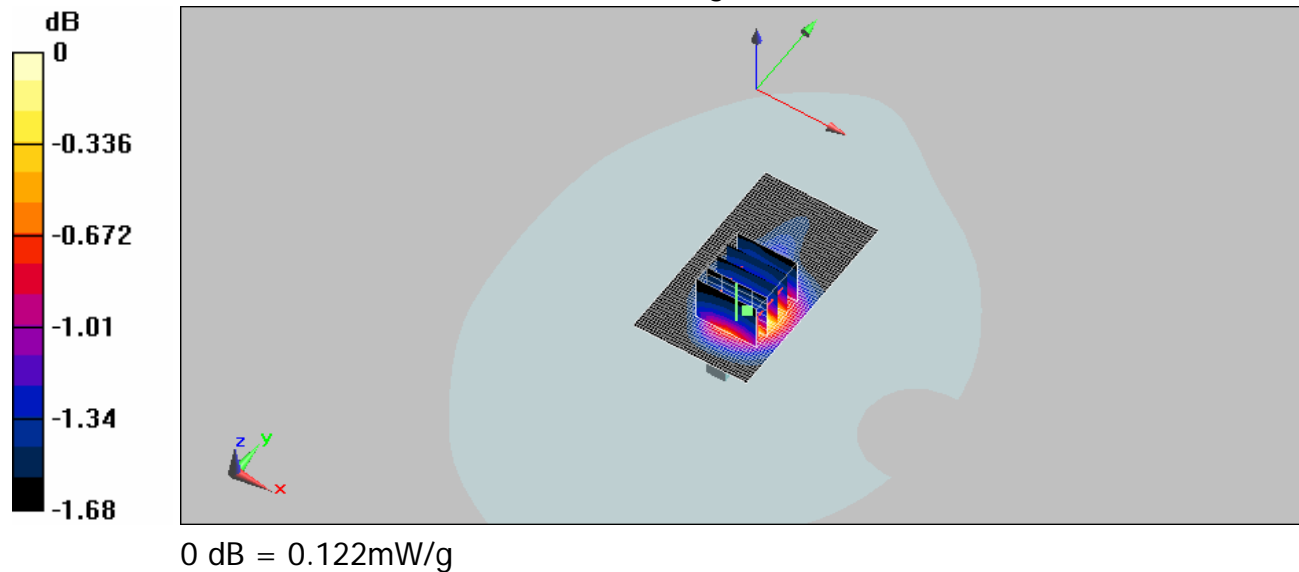

Date/Time: 9/19/2008 05:06:00

Configuration 3_CH4233

DUT: C152,

Communication System: WCDMA BAND5; Frequency: 846.6 MHz; Duty Cycle: 1:1

Medium: GMS 850 Medium parameters used: $f = 847$ MHz; $\sigma = 0.969$ mho/m; $\epsilon_r = 56.2$; $\rho = 1000$ kg/m³

Phantom section: Flat Section

DASY5 Configuration:

- Probe: ES3DV3 - SN3172; ConvF(5.61, 5.61, 5.61); Calibrated: 6/23/2008
- Sensor-Surface: 4mm (Mechanical Surface Detection)
- Electronics: DAE4 Sn856; Calibrated: 5/7/2008
- Phantom: SAM1; Type: SAM;
- Measurement SW: DASY5, V5.0 Build 119; SEMCAD X Version 13.2 Build 87

Body/Area Scan : Measurement grid: dx=15mm, dy=15mm
Maximum value of SAR (interpolated) = 0.111 mW/g

Body/Zoom Scan : Measurement grid: dx=8mm, dy=8mm, dz=5mm
Reference Value = 10.3 V/m; Power Drift = -0.084 dB
Peak SAR (extrapolated) = 0.113 W/kg

SAR(1 g) = 0.104 mW/g; SAR(10 g) = 0.095 mW/g

Maximum value of SAR (measured) = 0.107 mW/g

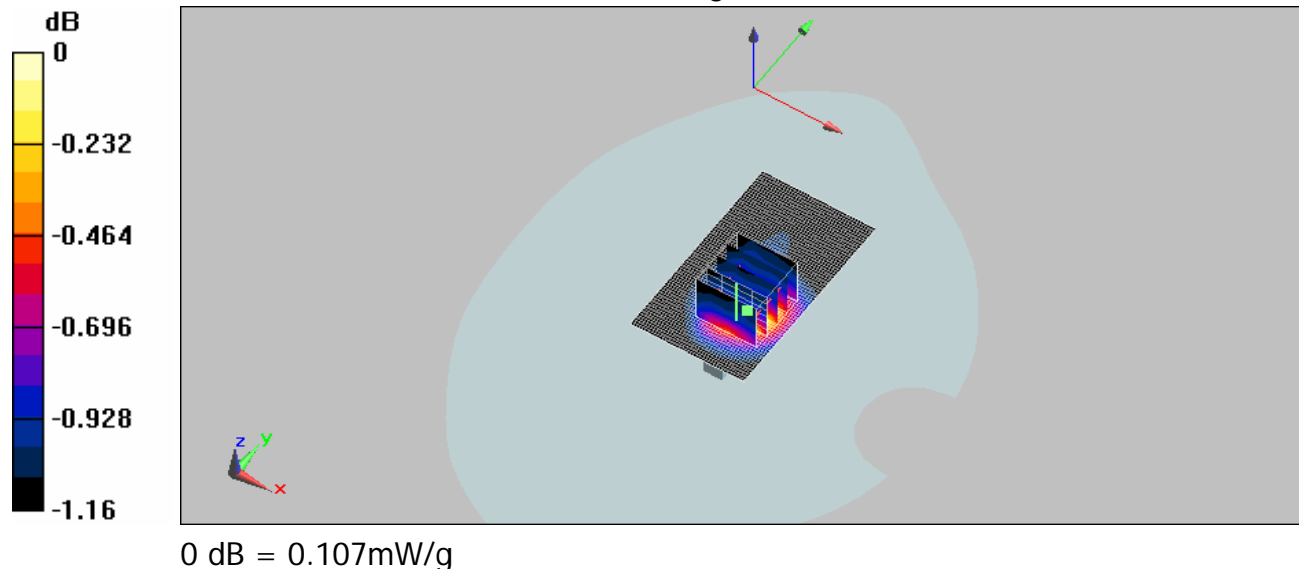

Date/Time: 9/19/2008 06:31:14

Configuration 4_CH4132

DUT: C152,

Communication System: WCDMA BAND5; Frequency: 826.4 MHz; Duty Cycle: 1:1

Medium: WCDMA Band5 Medium parameters used (interpolated): $f = 826.4$ MHz; $\sigma = 0.946$ mho/m; $\epsilon_r = 56.3$; $\rho = 1000$ kg/m³

Phantom section: Flat Section

DASY5 Configuration:

- Probe: ES3DV3 - SN3172; ConvF(5.61, 5.61, 5.61); Calibrated: 6/23/2008
- Sensor-Surface: 4mm (Mechanical Surface Detection)
- Electronics: DAE4 Sn856; Calibrated: 5/7/2008
- Phantom: SAM1; Type: SAM;
- Measurement SW: DASY5, V5.0 Build 119; SEMCAD X Version 13.2 Build 87

Body/Area Scan : Measurement grid: dx=15mm, dy=15mm
Maximum value of SAR (interpolated) = 0.119 mW/g

Body/Zoom Scan : Measurement grid: dx=8mm, dy=8mm, dz=5mm
Reference Value = 10.8 V/m; Power Drift = 0.043 dB
Peak SAR (extrapolated) = 0.133 W/kg

SAR(1 g) = 0.114 mW/g; SAR(10 g) = 0.101 mW/g

Maximum value of SAR (measured) = 0.116 mW/g

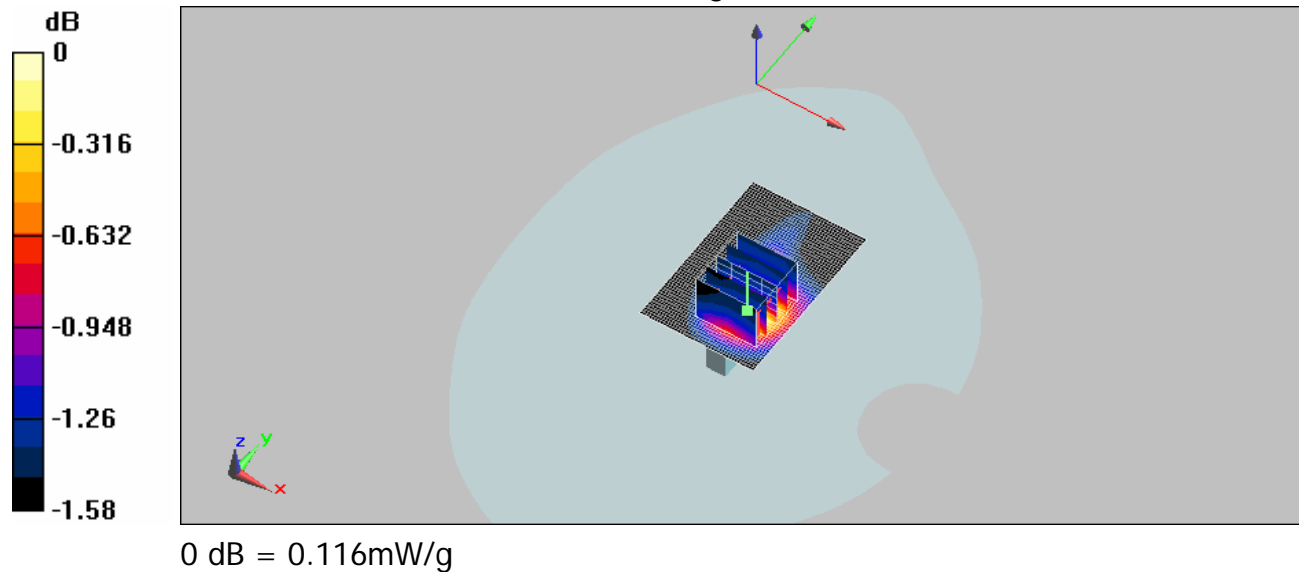

Date/Time: 9/19/2008 06:08:50

Configuration 4_CH4183

DUT: C152,

Communication System: WCDMA BAND5; Frequency: 836.6 MHz; Duty Cycle: 1:1

Medium: WCDMA Band5 Medium parameters used: $f = 837$ MHz; $\sigma = 0.958$ mho/m; $\epsilon_r = 56.3$; $\rho = 1000$ kg/m³

Phantom section: Flat Section

DASY5 Configuration:

- Probe: ES3DV3 - SN3172; ConvF(5.61, 5.61, 5.61); Calibrated: 6/23/2008
- Sensor-Surface: 4mm (Mechanical Surface Detection)
- Electronics: DAE4 Sn856; Calibrated: 5/7/2008
- Phantom: SAM1; Type: SAM;
- Measurement SW: DASY5, V5.0 Build 119; SEMCAD X Version 13.2 Build 87

Body/Area Scan : Measurement grid: dx=15mm, dy=15mm
Maximum value of SAR (interpolated) = 0.135 mW/g

Body/Zoom Scan : Measurement grid: dx=8mm, dy=8mm, dz=5mm
Reference Value = 11.3 V/m; Power Drift = -0.031 dB
Peak SAR (extrapolated) = 0.155 W/kg

SAR(1 g) = 0.128 mW/g; SAR(10 g) = 0.110 mW/g

Maximum value of SAR (measured) = 0.131 mW/g

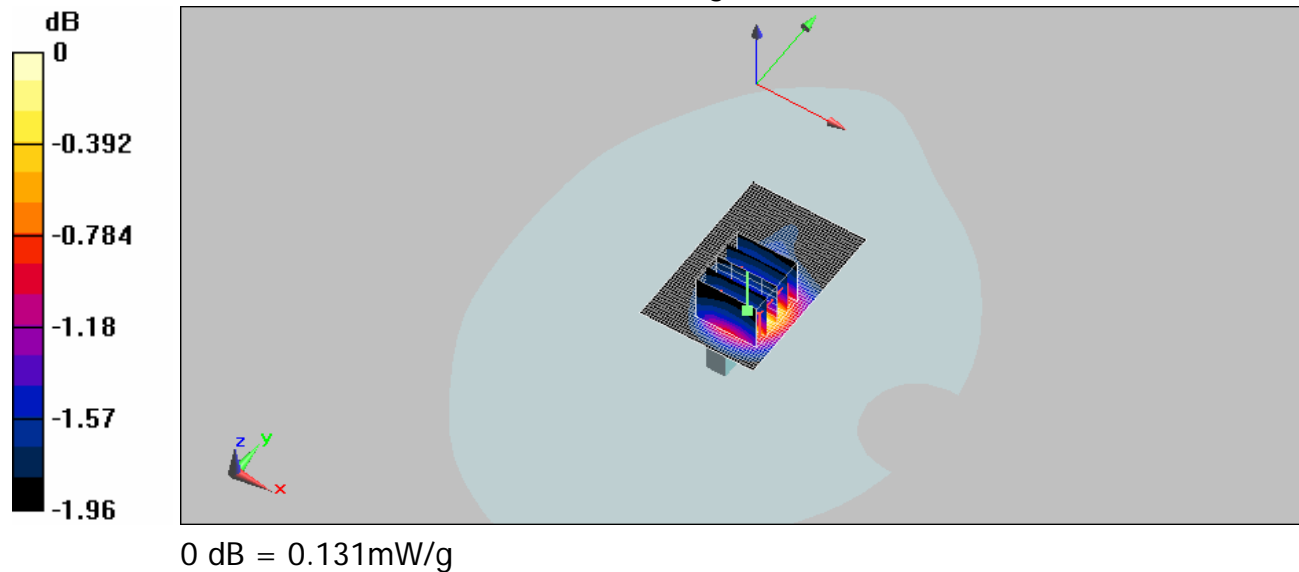

Date/Time: 9/19/2008 05:44:34

Configuration 4_CH4233

DUT: C152,

Communication System: WCDMA BAND5; Frequency: 846.6 MHz; Duty Cycle: 1:1

Medium: WCDMA Band5 Medium parameters used: $f = 847$ MHz; $\sigma = 0.969$ mho/m; $\epsilon_r = 56.2$; $\rho = 1000$ kg/m³

Phantom section: Flat Section

DASY5 Configuration:

- Probe: ES3DV3 - SN3172; ConvF(5.61, 5.61, 5.61); Calibrated: 6/23/2008
- Sensor-Surface: 4mm (Mechanical Surface Detection)
- Electronics: DAE4 Sn856; Calibrated: 5/7/2008
- Phantom: SAM1; Type: SAM;
- Measurement SW: DASY5, V5.0 Build 119; SEMCAD X Version 13.2 Build 87

Body/Area Scan : Measurement grid: dx=15mm, dy=15mm
Maximum value of SAR (interpolated) = 0.107 mW/g

Body/Zoom Scan : Measurement grid: dx=8mm, dy=8mm, dz=5mm
Reference Value = 10.4 V/m; Power Drift = -0.085 dB
Peak SAR (extrapolated) = 0.115 W/kg

SAR(1 g) = 0.105 mW/g; SAR(10 g) = 0.096 mW/g

Maximum value of SAR (measured) = 0.107 mW/g

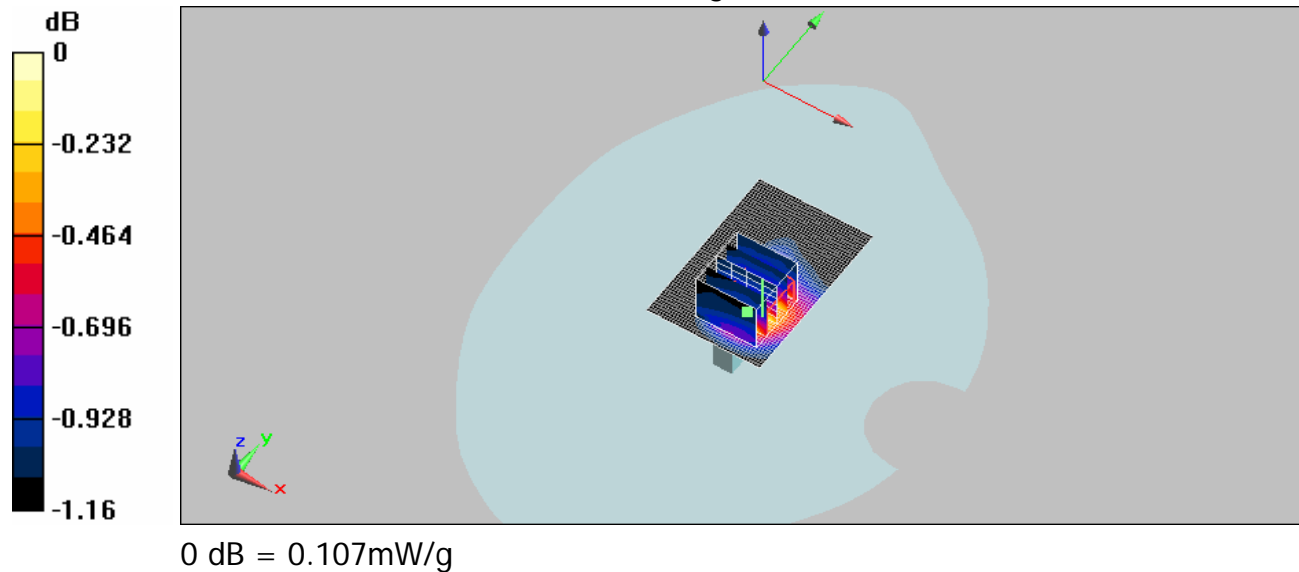

Date/Time: 9/19/2008 07:07:08

Configuration 5_CH4132

DUT: C152,

Communication System: WCDMA B5; Frequency: 826.4 MHz; Duty Cycle: 1:1

Medium: WCDMA Band5 Medium parameters used (interpolated): f = 826.4 MHz; $\sigma = 0.946$ mho/m; $\epsilon_r = 56.3$; $\rho = 1000$ kg/m³

Phantom section: Flat Section

DASY5 Configuration:

- Probe: ES3DV3 - SN3172; ConvF(5.61, 5.61, 5.61); Calibrated: 6/23/2008
- Sensor-Surface: 4mm (Mechanical Surface Detection)
- Electronics: DAE4 Sn856; Calibrated: 5/7/2008
- Phantom: SAM1; Type: SAM;
- Measurement SW: DASY5, V5.0 Build 119; SEMCAD X Version 13.2 Build 87

Body/Area Scan : Measurement grid: dx=15mm, dy=15mm
Maximum value of SAR (interpolated) = 0.084 mW/g

Body/Zoom Scan : Measurement grid: dx=8mm, dy=8mm, dz=5mm
Reference Value = 9.19 V/m; Power Drift = 0.012 dB
Peak SAR (extrapolated) = 0.084 W/kg

SAR(1 g) = 0.082 mW/g; SAR(10 g) = 0.078 mW/g

Maximum value of SAR (measured) = 0.083 mW/g

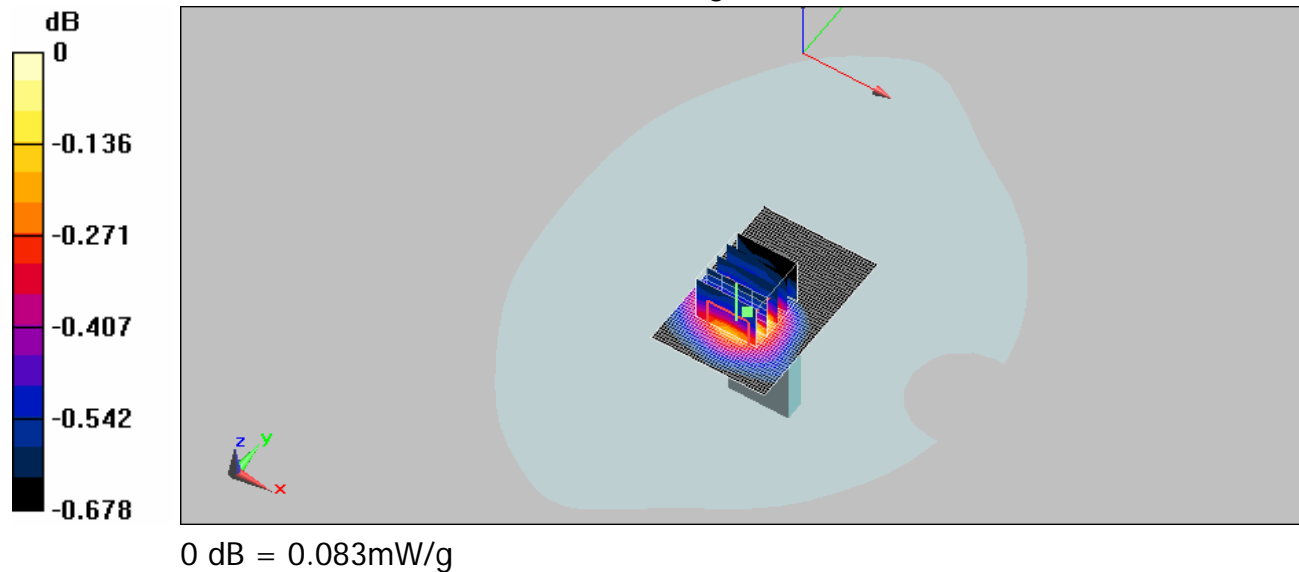

Date/Time: 9/19/2008 07:31:00

Configuration 5_CH4183

DUT: C152,

Communication System: WCDMA B5; Frequency: 836.6 MHz; Duty Cycle: 1:1

Medium: WCDMA Band5 Medium parameters used: $f = 837$ MHz; $\sigma = 0.958$ mho/m; $\epsilon_r = 56.3$; $\rho = 1000$ kg/m³

Phantom section: Flat Section

DASY5 Configuration:

- Probe: ES3DV3 - SN3172; ConvF(5.61, 5.61, 5.61); Calibrated: 6/23/2008
- Sensor-Surface: 4mm (Mechanical Surface Detection)
- Electronics: DAE4 Sn856; Calibrated: 5/7/2008
- Phantom: SAM1; Type: SAM;
- Measurement SW: DASY5, V5.0 Build 119; SEMCAD X Version 13.2 Build 87

Body/Area Scan : Measurement grid: dx=15mm, dy=15mm
Maximum value of SAR (interpolated) = 0.093 mW/g

Body/Zoom Scan : Measurement grid: dx=8mm, dy=8mm, dz=5mm
Reference Value = 9.35 V/m; Power Drift = 0.035 dB
Peak SAR (extrapolated) = 0.094 W/kg

SAR(1 g) = 0.089 mW/g; SAR(10 g) = 0.083 mW/g

Maximum value of SAR (measured) = 0.090 mW/g

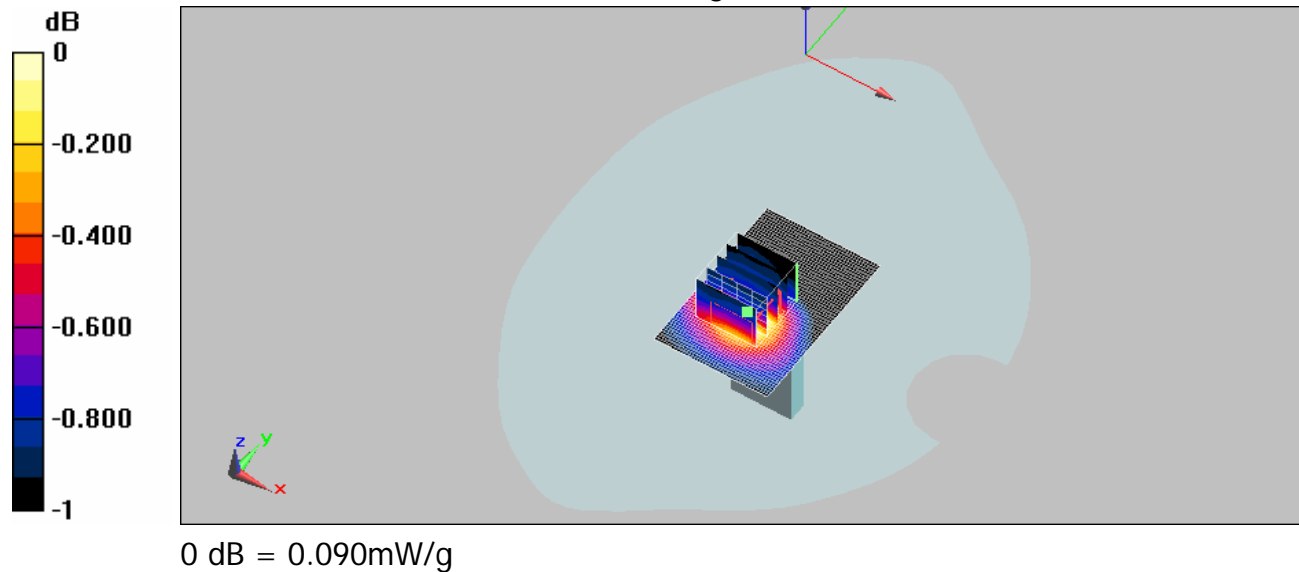

Date/Time: 9/19/2008 07:53:04

Configuration 5_CH4233

DUT: C152,

Communication System: WCDMA B5; Frequency: 846.6 MHz; Duty Cycle: 1:1

Medium: WCDMA Band5 Medium parameters used: $f = 847$ MHz; $\sigma = 0.969$ mho/m; $\epsilon_r = 56.2$; $\rho = 1000$ kg/m³

Phantom section: Flat Section

DASY5 Configuration:

- Probe: ES3DV3 - SN3172; ConvF(5.61, 5.61, 5.61); Calibrated: 6/23/2008
- Sensor-Surface: 4mm (Mechanical Surface Detection)
- Electronics: DAE4 Sn856; Calibrated: 5/7/2008
- Phantom: SAM1; Type: SAM;
- Measurement SW: DASY5, V5.0 Build 119; SEMCAD X Version 13.2 Build 87

Body/Area Scan : Measurement grid: dx=15mm, dy=15mm
Maximum value of SAR (interpolated) = 0.085 mW/g

Body/Zoom Scan : Measurement grid: dx=8mm, dy=8mm, dz=5mm
Reference Value = 9.08 V/m; Power Drift = 0.025 dB
Peak SAR (extrapolated) = 0.084 W/kg

SAR(1 g) = 0.082 mW/g; SAR(10 g) = 0.078 mW/g

Maximum value of SAR (measured) = 0.083 mW/g

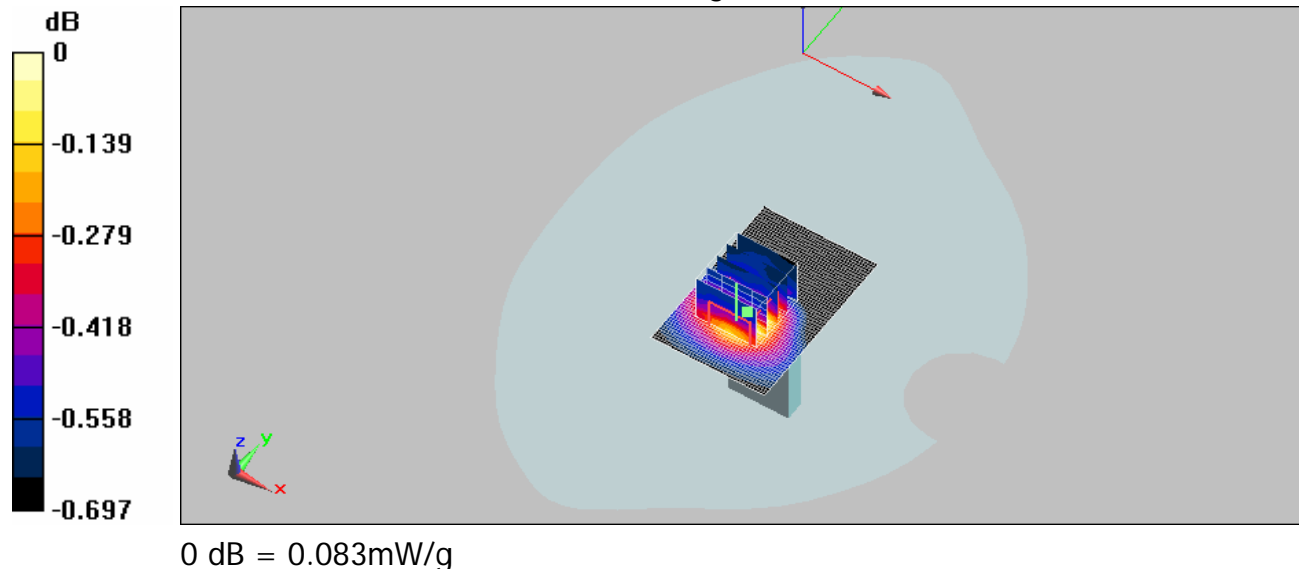

Date/Time: 9/19/2008 09:15:13

Configuration 6_CH4132

DUT: C152,

Communication System: WCDMA B5; Frequency: 826.4 MHz; Duty Cycle: 1:1

Medium: WCDMA BAND5 Medium parameters used (interpolated): f = 826.4 MHz; $\sigma = 0.946$ mho/m; $\epsilon_r = 56.3$; $\rho = 1000$ kg/m³

Phantom section: Flat Section

DASY5 Configuration:

- Probe: ES3DV3 - SN3172; ConvF(5.61, 5.61, 5.61); Calibrated: 6/23/2008
- Sensor-Surface: 4mm (Mechanical Surface Detection)
- Electronics: DAE4 Sn856; Calibrated: 5/7/2008
- Phantom: SAM1; Type: SAM;
- Measurement SW: DASY5, V5.0 Build 119; SEMCAD X Version 13.2 Build 87

Body/Area Scan: Measurement grid: dx=15mm, dy=15mm
Maximum value of SAR (interpolated) = 0.070 mW/g

Body/Zoom Scan : Measurement grid: dx=8mm, dy=8mm, dz=5mm
Reference Value = 7.93 V/m; Power Drift = -0.041 dB
Peak SAR (extrapolated) = 0.078 W/kg

SAR(1 g) = 0.068 mW/g; SAR(10 g) = 0.062 mW/g

Maximum value of SAR (measured) = 0.070 mW/g

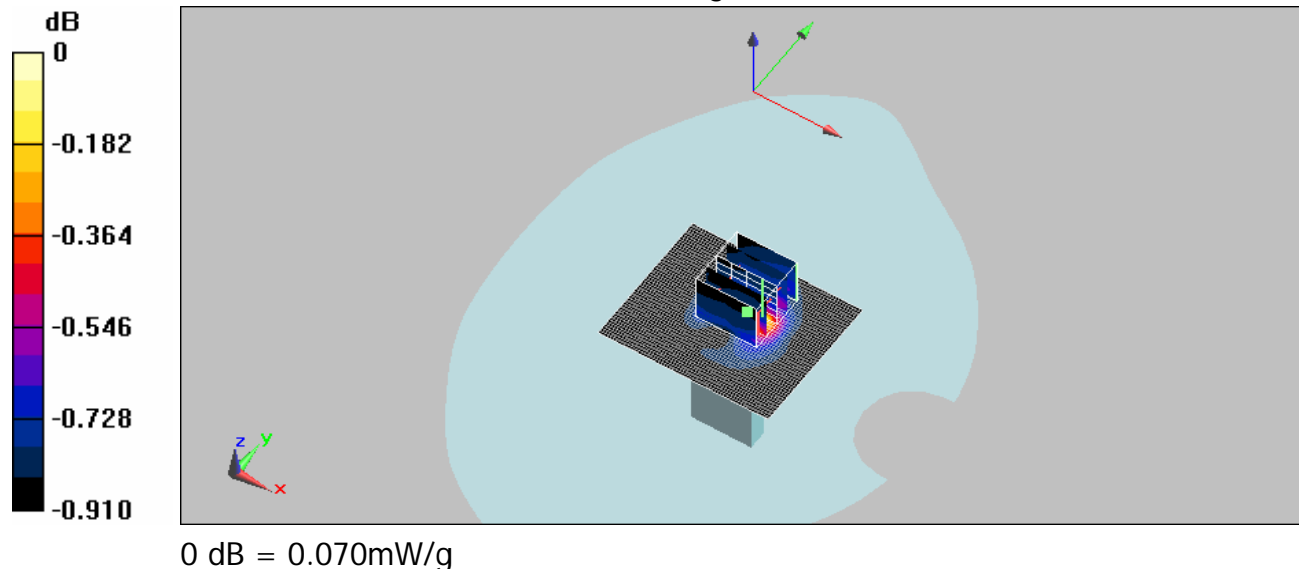

Date/Time: 9/19/2008 08:50:36

Configuration 6_CH4183

DUT: C152,

Communication System: WCDMA B5; Frequency: 836.6 MHz; Duty Cycle: 1:1

Medium: WCDMA BAND5 Medium parameters used: $f = 837$ MHz; $\sigma = 0.958$ mho/m; $\epsilon_r = 56.3$; $\rho = 1000$ kg/m³

Phantom section: Flat Section

DASY5 Configuration:

- Probe: ES3DV3 - SN3172; ConvF(5.61, 5.61, 5.61); Calibrated: 6/23/2008
- Sensor-Surface: 4mm (Mechanical Surface Detection)
- Electronics: DAE4 Sn856; Calibrated: 5/7/2008
- Phantom: SAM1; Type: SAM;
- Measurement SW: DASY5, V5.0 Build 119; SEMCAD X Version 13.2 Build 87

Body/Area Scan: Measurement grid: dx=15mm, dy=15mm
Maximum value of SAR (interpolated) = 0.076 mW/g

Body/Zoom Scan : Measurement grid: dx=8mm, dy=8mm, dz=5mm
Reference Value = 7.96 V/m; Power Drift = -0.070 dB
Peak SAR (extrapolated) = 0.091 W/kg

SAR(1 g) = 0.072 mW/g; SAR(10 g) = 0.064 mW/g

Maximum value of SAR (measured) = 0.075 mW/g

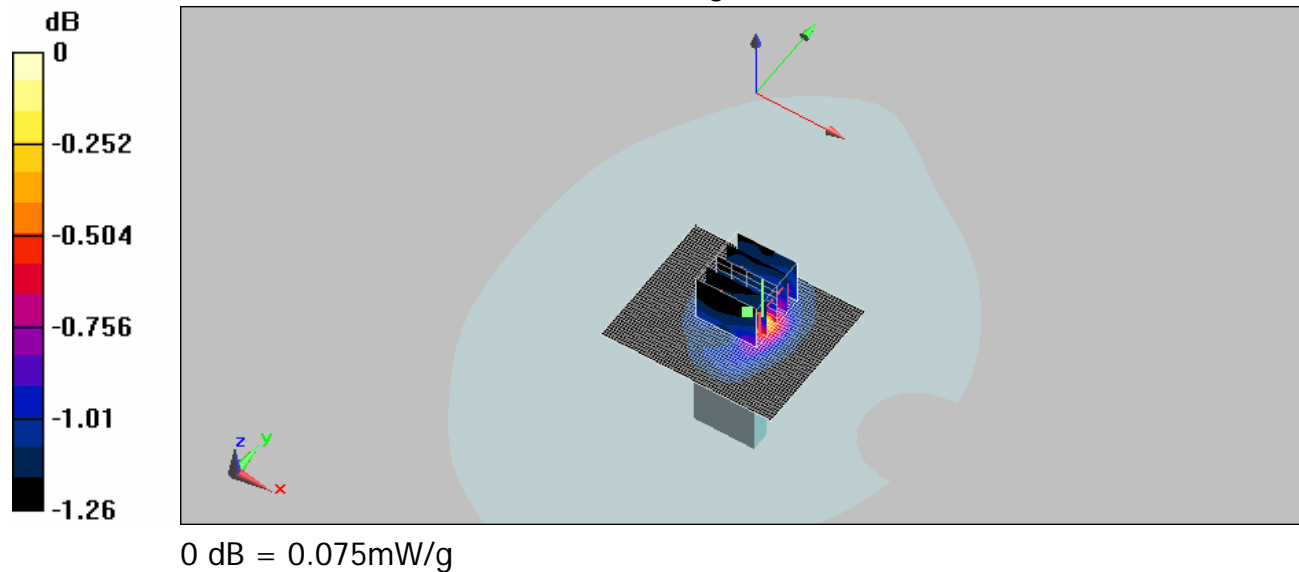

Date/Time: 9/19/2008 08:28:32

Configuration 6_CH4233

DUT: C152,

Communication System: WCDMA B5; Frequency: 846.6 MHz; Duty Cycle: 1:1

Medium: WCDMA BAND5 Medium parameters used: $f = 847$ MHz; $\sigma = 0.969$ mho/m; $\epsilon_r = 56.2$; $\rho = 1000$ kg/m³

Phantom section: Flat Section

DASY5 Configuration:

- Probe: ES3DV3 - SN3172; ConvF(5.61, 5.61, 5.61); Calibrated: 6/23/2008
- Sensor-Surface: 4mm (Mechanical Surface Detection)
- Electronics: DAE4 Sn856; Calibrated: 5/7/2008
- Phantom: SAM1; Type: SAM;
- Measurement SW: DASY5, V5.0 Build 119; SEMCAD X Version 13.2 Build 87

Body/Area Scan: Measurement grid: dx=15mm, dy=15mm
Maximum value of SAR (interpolated) = 0.070 mW/g

Body/Zoom Scan : Measurement grid: dx=8mm, dy=8mm, dz=5mm
Reference Value = 7.81 V/m; Power Drift = 0.197 dB
Peak SAR (extrapolated) = 0.079 W/kg

SAR(1 g) = 0.067 mW/g; SAR(10 g) = 0.061 mW/g

Maximum value of SAR (measured) = 0.069 mW/g

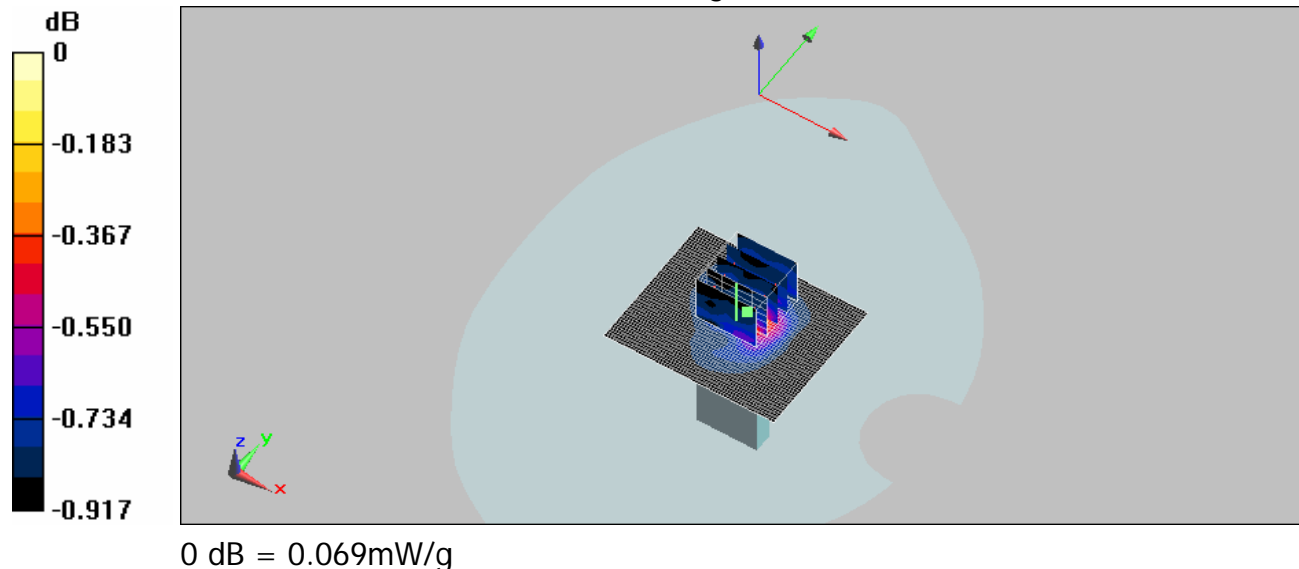

Date/Time: 12/5/2008 14:52:10

Configuration 7_CH4132

DUT: C152,

Communication System: WCDMA B5; Frequency: 826.4 MHz; Duty Cycle: 1:1

Medium: WCDMA Band5 Medium parameters used: $f = 826.4$ MHz; $\sigma = 0.945$ mho/m; $\epsilon_r = 56.3$; $\rho = 1000$ kg/m³

Phantom section: Flat Section

DASY5 Configuration:

- Probe: ES3DV3 - SN3172; ConvF(5.61, 5.61, 5.61); Calibrated: 6/23/2008
- Sensor-Surface: 4mm (Mechanical Surface Detection)
- Electronics: DAE4 Sn856; Calibrated: 5/7/2008
- Phantom: SAM1; Type: SAM;
- Measurement SW: DASY5, V5.0 Build 119; SEMCAD X Version 13.2 Build 87

Body/Area Scan: Measurement grid: dx=15mm, dy=15mm
Maximum value of SAR (interpolated) = 0.129 mW/g

Body/Zoom Scan: Measurement grid: dx=8mm, dy=8mm, dz=5mm
Reference Value = 9.08 V/m; Power Drift = 0.157 dB
Peak SAR (extrapolated) = 0.173 W/kg

SAR(1 g) = 0.114 mW/g; SAR(10 g) = 0.076 mW/g

Maximum value of SAR (measured) = 0.121 mW/g

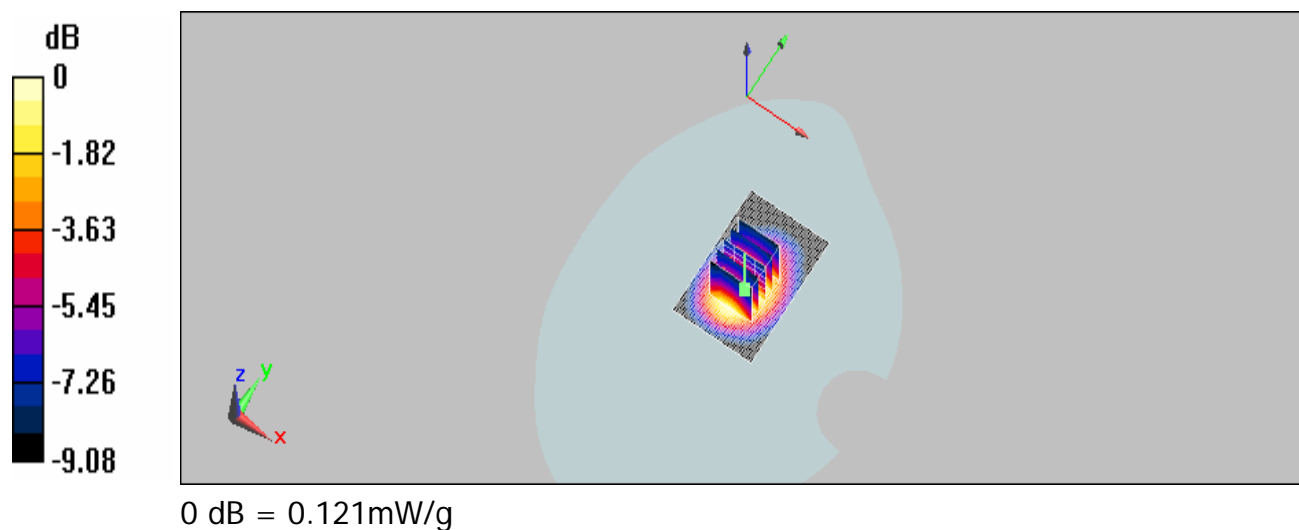

Date/Time: 12/5/2008 15:25:13

Configuration 7_CH4183

DUT: C152,

Communication System: WCDMA B5; Frequency: 836.6 MHz; Duty Cycle: 1:1

Medium: WCDMA Band5 Medium parameters used: $f = 837$ MHz; $\sigma = 0.957$ mho/m; $\epsilon_r = 56.2$; $\rho = 1000$ kg/m³

Phantom section: Flat Section

DASY5 Configuration:

- Probe: ES3DV3 - SN3172; ConvF(5.61, 5.61, 5.61); Calibrated: 6/23/2008
- Sensor-Surface: 4mm (Mechanical Surface Detection)
- Electronics: DAE4 Sn856; Calibrated: 5/7/2008
- Phantom: SAM1; Type: SAM;
- Measurement SW: DASY5, V5.0 Build 119; SEMCAD X Version 13.2 Build 87

Body/Area Scan (41x61x1): Measurement grid: dx=15mm, dy=15mm
Maximum value of SAR (interpolated) = 0.122 mW/g

Body/Zoom Scan (7x7x7) (5x5x7)/Cube 0: Measurement grid: dx=8mm, dy=8mm, dz=5mm
Reference Value = 9.25 V/m; Power Drift = -0.202 dB
Peak SAR (extrapolated) = 0.156 W/kg

SAR(1 g) = 0.109 mW/g; SAR(10 g) = 0.074 mW/g
Maximum value of SAR (measured) = 0.116 mW/g

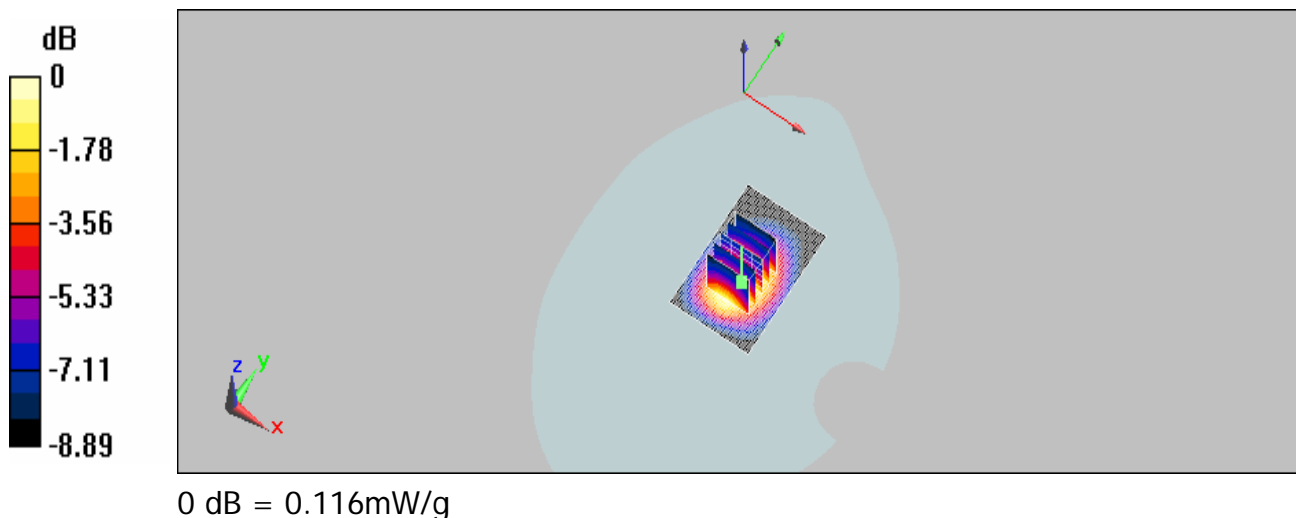

Date/Time: 12/5/2008 16:00:15

Configuration 7_CH4233

DUT: C152,

Communication System: WCDMA B5; Frequency: 846.6 MHz; Duty Cycle: 1:1

Medium: WCDMA Band5 Medium parameters used: $f = 847$ MHz; $\sigma = 0.969$ mho/m; $\epsilon_r = 56.1$; $\rho = 1000$ kg/m³

Phantom section: Flat Section

DASY5 Configuration:

- Probe: ES3DV3 - SN3172; ConvF(5.61, 5.61, 5.61); Calibrated: 6/23/2008
- Sensor-Surface: 4mm (Mechanical Surface Detection)
- Electronics: DAE4 Sn856; Calibrated: 5/7/2008
- Phantom: SAM1; Type: SAM;

- Measurement SW: DASY5, V5.0 Build 119; SEMCAD X Version 13.2 Build 87

Body/Area Scan: Measurement grid: dx=15mm, dy=15mm
Maximum value of SAR (interpolated) = 0.072 mW/g

Body/Zoom Scan: Measurement grid: dx=8mm, dy=8mm, dz=5mm
Reference Value = 6.9 V/m; Power Drift = 0.078 dB
Peak SAR (extrapolated) = 0.091 W/kg

SAR(1 g) = 0.063 mW/g; SAR(10 g) = 0.043 mW/g
Maximum value of SAR (measured) = 0.067 mW/g

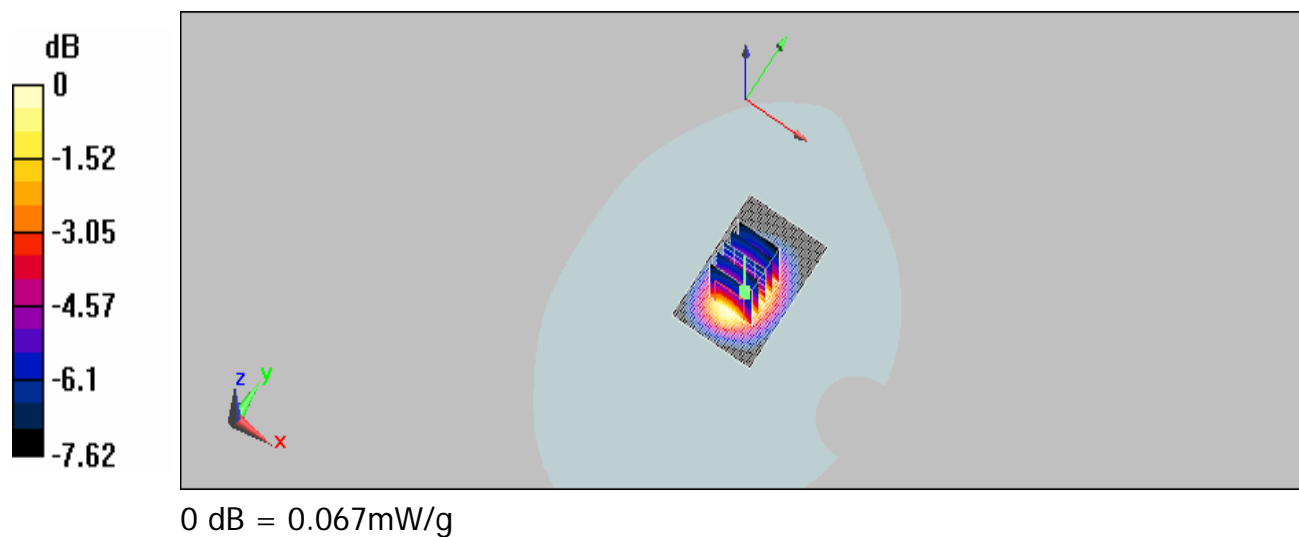

Date/Time: 12/5/2008 17:17:46

Configuration 8_CH 4132

DUT: C152,

Communication System: WCDMA B5; Frequency: 826.4 MHz; Duty Cycle: 1:1

Medium: WCDMA Band5 Medium parameters used: $f = 826.4$ MHz; $\sigma = 0.945$ mho/m; $\epsilon_r = 56.3$; $\rho = 1000$ kg/m³

Phantom section: Flat Section

DASY5 Configuration:

- Probe: ES3DV3 - SN3172; ConvF(5.61, 5.61, 5.61); Calibrated: 6/23/2008
- Sensor-Surface: 4mm (Mechanical Surface Detection)
- Electronics: DAE4 Sn856; Calibrated: 5/7/2008

- Phantom: SAM1; Type: SAM;
- Measurement SW: DASY5, V5.0 Build 119; SEMCAD X Version 13.2 Build 87

Body/Area Scan (41x61x1): Measurement grid: dx=15mm, dy=15mm
Maximum value of SAR (interpolated) = 0.100 mW/g

Body/Zoom Scan (7x7x7) (5x5x7)/Cube 0: Measurement grid: dx=8mm, dy=8mm, dz=5mm
Reference Value = 8.56 V/m; Power Drift = -0.00243 dB
Peak SAR (extrapolated) = 0.158 W/kg

SAR(1 g) = 0.087 mW/g; SAR(10 g) = 0.055 mW/g
Maximum value of SAR (measured) = 0.093 mW/g

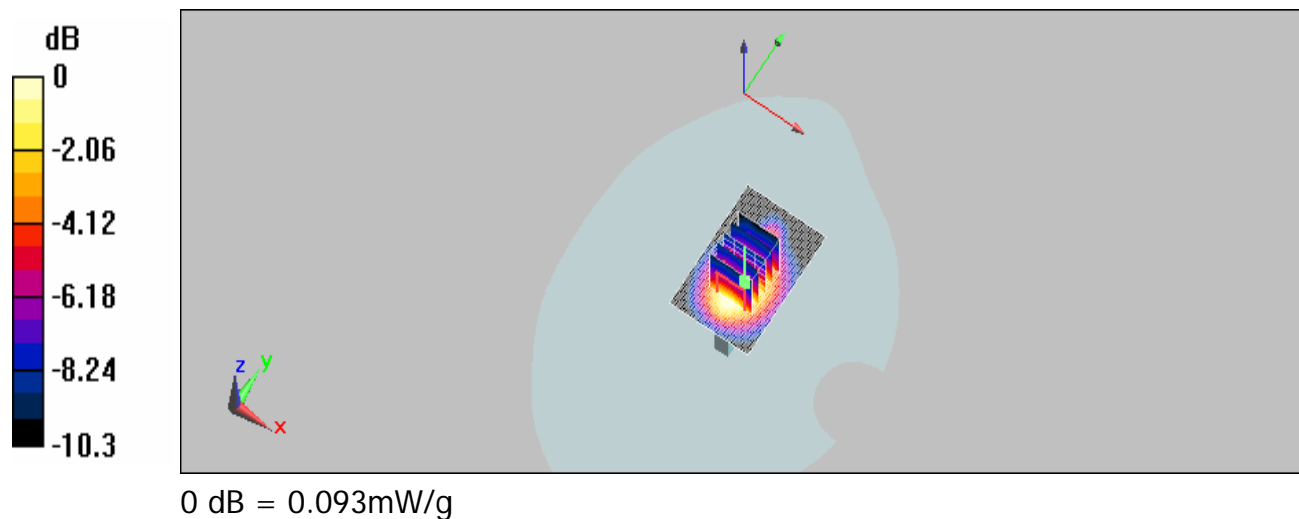

Date/Time: 12/5/2008 17:50:44

Configuration 8_CH 4183

DUT: C152,

Communication System: WCDMA B5; Frequency: 836.6 MHz; Duty Cycle: 1:1

Medium: WCDMA Band5 Medium parameters used: $f = 837$ MHz; $\sigma = 0.957$ mho/m; $\epsilon_r = 56.2$; $\rho = 1000$ kg/m³

Phantom section: Flat Section

DASY5 Configuration:

- Probe: ES3DV3 - SN3172; ConvF(5.61, 5.61, 5.61); Calibrated: 6/23/2008

- Sensor-Surface: 4mm (Mechanical Surface Detection)
- Electronics: DAE4 Sn856; Calibrated: 5/7/2008
- Phantom: SAM1; Type: SAM;
- Measurement SW: DASY5, V5.0 Build 119; SEMCAD X Version 13.2 Build 87

Body/Area Scan: Measurement grid: dx=15mm, dy=15mm
Maximum value of SAR (interpolated) = 0.095 mW/g

Body/Zoom Scan: Measurement grid: dx=8mm, dy=8mm, dz=5mm
Reference Value = 8.24 V/m; Power Drift = 0.040 dB
Peak SAR (extrapolated) = 0.148 W/kg

SAR(1 g) = 0.084 mW/g; SAR(10 g) = 0.052 mW/g
Maximum value of SAR (measured) = 0.089 mW/g

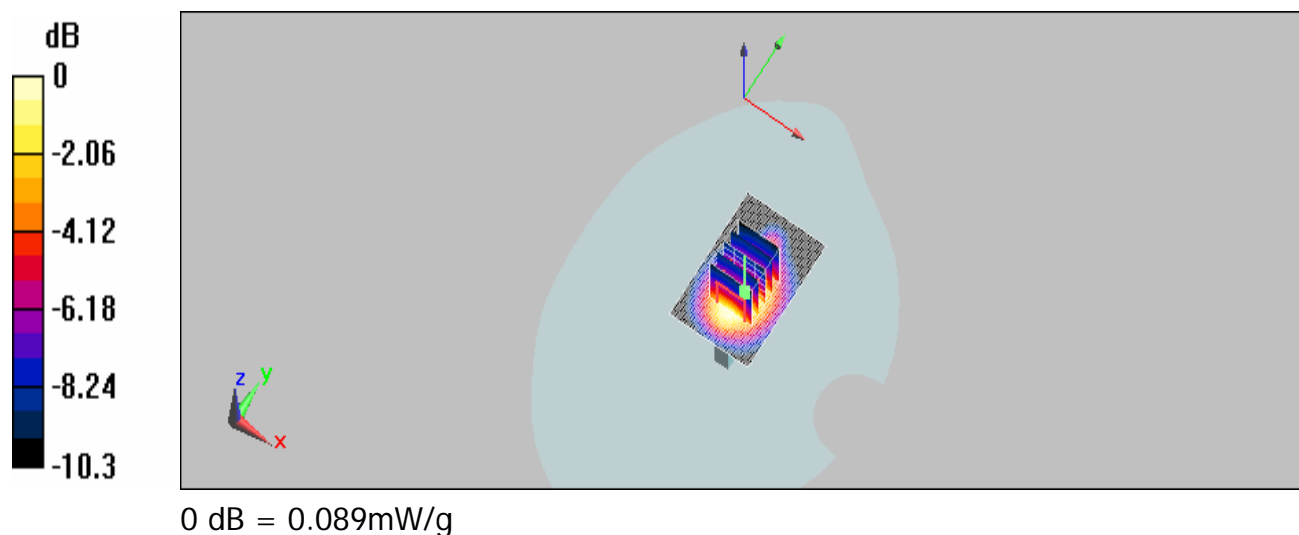

Date/Time: 12/5/2008 18:24:33

Configuration 8_CH 4233

DUT: C152,

Communication System: WCDMA B5; Frequency: 846.6 MHz; Duty Cycle: 1:1

Medium: WCDMA Band5 Medium parameters used: $f = 847$ MHz; $\sigma = 0.969$ mho/m; $\epsilon_r = 56.1$; $\rho = 1000$ kg/m³

Phantom section: Flat Section

DASY5 Configuration:

- Probe: ES3DV3 - SN3172; ConvF(5.61, 5.61, 5.61); Calibrated: 6/23/2008
- Sensor-Surface: 4mm (Mechanical Surface Detection)
- Electronics: DAE4 Sn856; Calibrated: 5/7/2008
- Phantom: SAM1; Type: SAM;
- Measurement SW: DASY5, V5.0 Build 119; SEMCAD X Version 13.2 Build 87

Body/Area Scan: Measurement grid: dx=15mm, dy=15mm
Maximum value of SAR (interpolated) = 0.056 mW/g

Body/Zoom Scan: Measurement grid: dx=8mm, dy=8mm, dz=5mm
Reference Value = 6.32 V/m; Power Drift = 0.089 dB
Peak SAR (extrapolated) = 0.085 W/kg

SAR(1 g) = 0.049 mW/g; SAR(10 g) = 0.031 mW/g
Maximum value of SAR (measured) = 0.051 mW/g

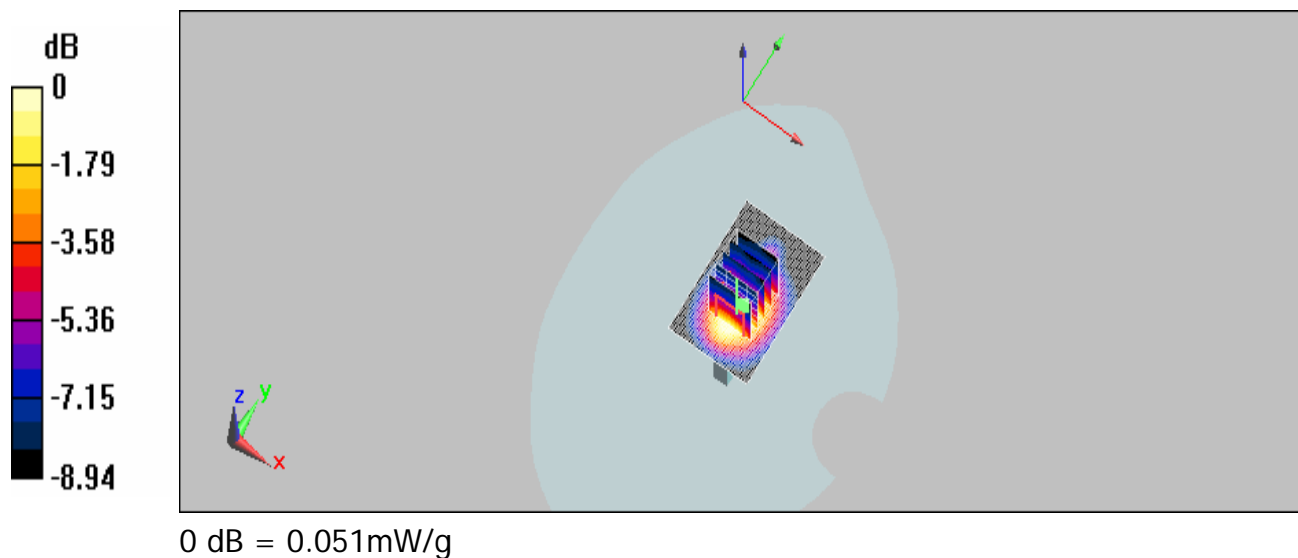

Date/Time: 9/19/2008 11:11:40

Configuration 1_CH4132_HSDPA mode

DUT: C152,

Communication System: WCDMA BAND5; Frequency: 826.4 MHz; Duty Cycle: 1:1

Medium: WCDMA Band5 Medium parameters used (interpolated): $f = 826.4$ MHz; $\sigma = 0.946$ mho/m; $\epsilon_r = 56.3$; $\rho = 1000$ kg/m³

Phantom section: Flat Section

DASY5 Configuration:

- Probe: ES3DV3 - SN3172; ConvF(5.61, 5.61, 5.61); Calibrated: 6/23/2008
- Sensor-Surface: 4mm (Mechanical Surface Detection)
- Electronics: DAE4 Sn856; Calibrated: 5/7/2008
- Phantom: SAM1; Type: SAM;
- Measurement SW: DASYS, V5.0 Build 119; SEMCAD X Version 13.2 Build 87

Body/Area Scan : Measurement grid: dx=15mm, dy=15mm
Maximum value of SAR (interpolated) = 0.145 mW/g

Body/Zoom Scan : Measurement grid: dx=8mm, dy=8mm, dz=5mm
Reference Value = 10.8 V/m; Power Drift = -0.100 dB
Peak SAR (extrapolated) = 0.171 W/kg

SAR(1 g) = 0.129 mW/g; SAR(10 g) = 0.103 mW/g
Maximum value of SAR (measured) = 0.138 mW/g

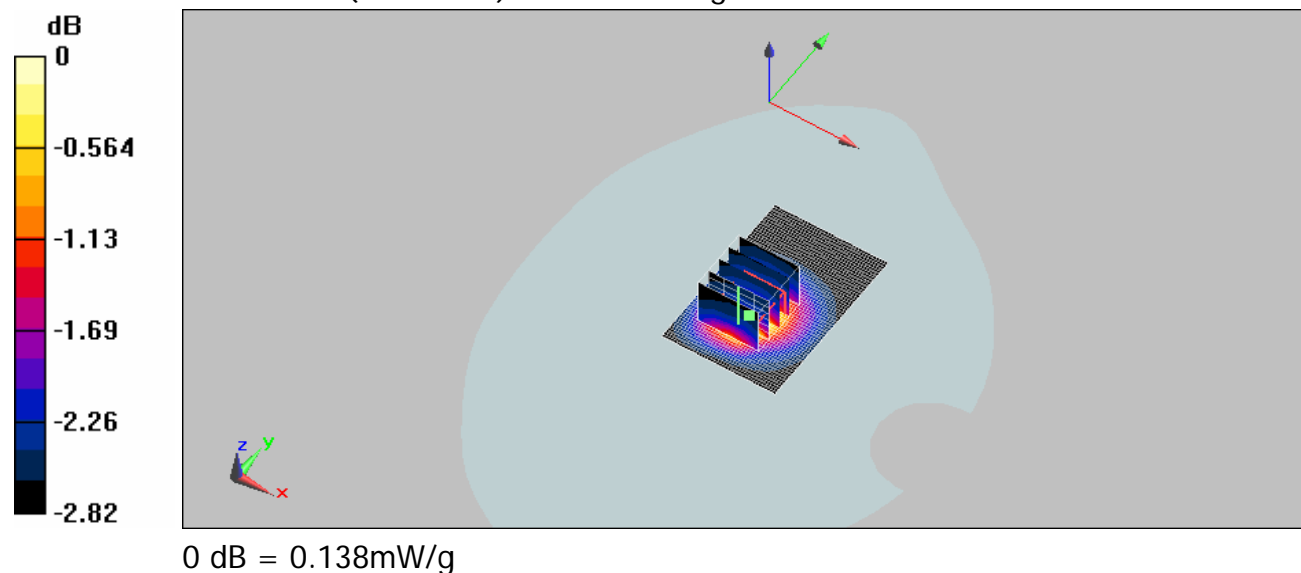

Date/Time: 9/19/2008 11:35:35

Configuration 1_CH4183_HSDPA mode

DUT: C152,

Communication System: WCDMA BAND5; Frequency: 836.6 MHz; Duty Cycle: 1:1

Medium: WCDMA Band5 Medium parameters used: $f = 837$ MHz; $\sigma = 0.958$ mho/m; $\epsilon_r = 56.3$; $\rho = 1000$ kg/m³

Phantom section: Flat Section

DASY5 Configuration:

- Probe: ES3DV3 - SN3172; ConvF(5.61, 5.61, 5.61); Calibrated: 6/23/2008
- Sensor-Surface: 4mm (Mechanical Surface Detection)
- Electronics: DAE4 Sn856; Calibrated: 5/7/2008
- Phantom: SAM1; Type: SAM;
- Measurement SW: DASY5, V5.0 Build 119; SEMCAD X Version 13.2 Build 87

Body/Area Scan : Measurement grid: dx=15mm, dy=15mm
Maximum value of SAR (interpolated) = 0.155 mW/g

Body/Zoom Scan : Measurement grid: dx=8mm, dy=8mm, dz=5mm
Reference Value = 11.3 V/m; Power Drift = 0.027 dB
Peak SAR (extrapolated) = 0.196 W/kg

SAR(1 g) = 0.152 mW/g; SAR(10 g) = 0.123 mW/g
Maximum value of SAR (measured) = 0.161 mW/g

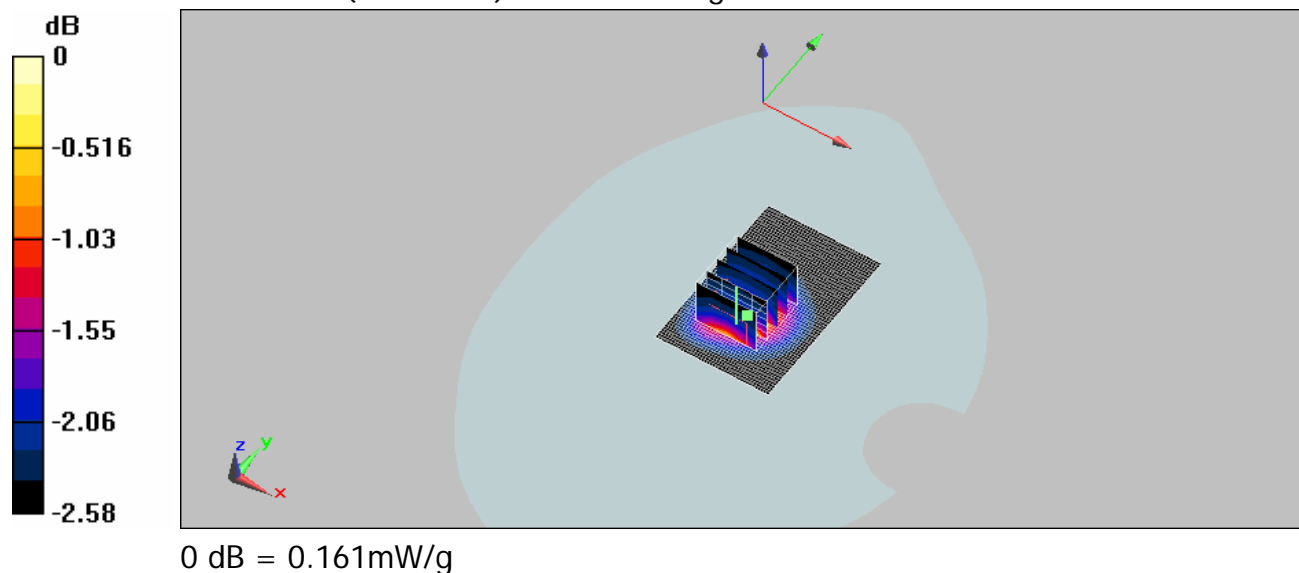

Date/Time: 9/19/2008 12:07:57

Configuration 1_CH4233_HSDPA mode

DUT: C152,

Communication System: WCDMA B5; Frequency: 846.6 MHz; Duty Cycle: 1:1

Medium: WCDMA Band5 Medium parameters used: $f = 847$ MHz; $\sigma = 0.969$ mho/m; $\epsilon_r = 56.2$; $\rho = 1000$ kg/m³

Phantom section: Flat Section

DASY5 Configuration:

- Probe: ES3DV3 - SN3172; ConvF(5.61, 5.61, 5.61); Calibrated: 6/23/2008
- Sensor-Surface: 4mm (Mechanical Surface Detection)
- Electronics: DAE4 Sn856; Calibrated: 5/7/2008
- Phantom: SAM1; Type: SAM;
- Measurement SW: DASY5, V5.0 Build 119; SEMCAD X Version 13.2 Build 87

Body/Area Scan : Measurement grid: dx=15mm, dy=15mm
 Maximum value of SAR (interpolated) = 0.103 mW/g

Body/Zoom Scan : Measurement grid: dx=8mm, dy=8mm, dz=5mm
 Reference Value = 9.18 V/m; Power Drift = 0.050 dB
 Peak SAR (extrapolated) = 0.120 W/kg

SAR(1 g) = 0.099 mW/g; SAR(10 g) = 0.084 mW/g
 Maximum value of SAR (measured) = 0.103 mW/g

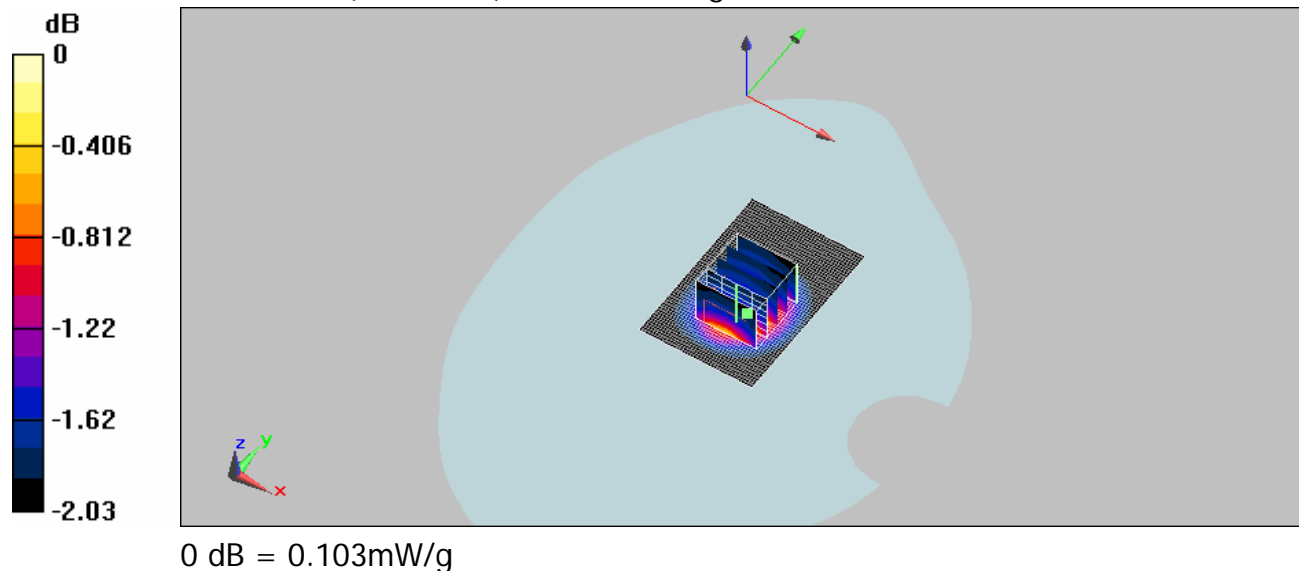

Date/Time: 9/19/2008 13:32:44

Configuration 2_CH4132_HSDPA mode

DUT: C152,

Communication System: WCDMA BAND5; Frequency: 826.4 MHz; Duty Cycle: 1:1
 Medium: WCDMA Band5 Medium parameters used (interpolated): f = 826.4 MHz; $\sigma = 0.946$ mho/m; $\epsilon_r = 56.3$; $\rho = 1000$ kg/m³
 Phantom section: Flat Section
 DASY5 Configuration:

- Probe: ES3DV3 - SN3172; ConvF(5.61, 5.61, 5.61); Calibrated: 6/23/2008
- Sensor-Surface: 4mm (Mechanical Surface Detection)
- Electronics: DAE4 Sn856; Calibrated: 5/7/2008
- Phantom: SAM1; Type: SAM;
- Measurement SW: DASYS, V5.0 Build 119; SEMCAD X Version 13.2 Build 87

Body/Area Scan : Measurement grid: dx=15mm, dy=15mm
 Maximum value of SAR (interpolated) = 0.106 mW/g

Body/Zoom Scan : Measurement grid: dx=8mm, dy=8mm, dz=5mm
 Reference Value = 9.81 V/m; Power Drift = 0.055 dB
 Peak SAR (extrapolated) = 0.117 W/kg

SAR(1 g) = 0.105 mW/g; SAR(10 g) = 0.094 mW/g
 Maximum value of SAR (measured) = 0.107 mW/g

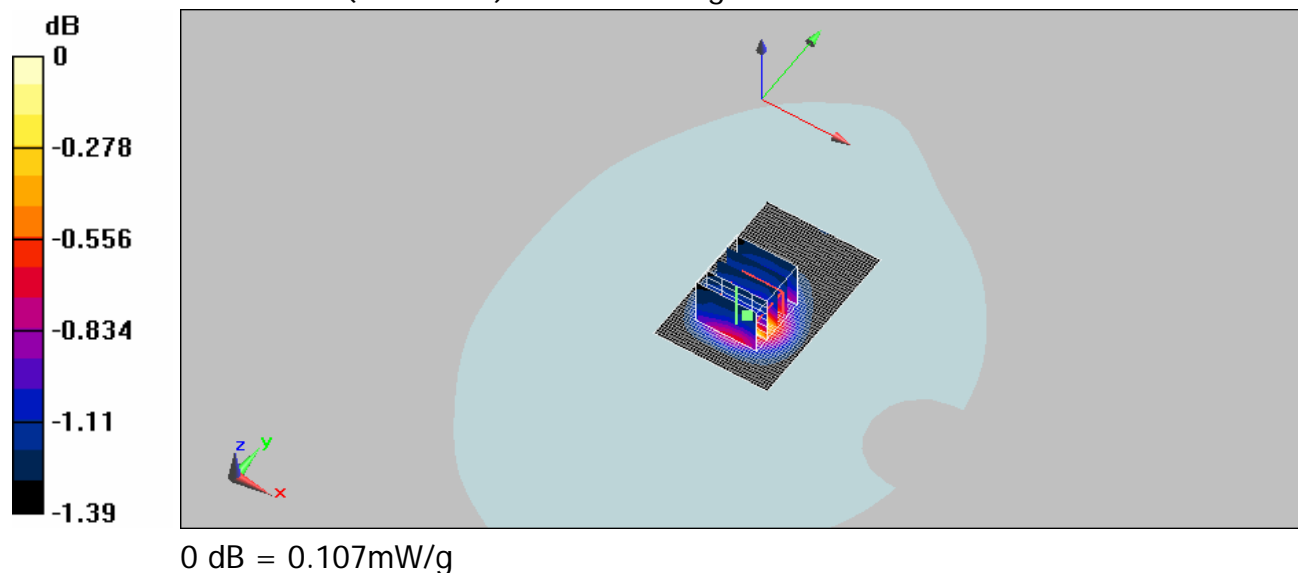

Date/Time: 9/19/2008 13:09:16

Configuration 2_CH4183_HSDPA mode

DUT: C152,

Communication System: WCDMA BAND5; Frequency: 836.6 MHz; Duty Cycle: 1:1

Medium: WCDMA Band5 Medium parameters used: $f = 837$ MHz; $\sigma = 0.958$ mho/m; $\epsilon_r = 56.3$; $\rho = 1000$ kg/m³

Phantom section: Flat Section

DASY5 Configuration:

- Probe: ES3DV3 - SN3172; ConvF(5.61, 5.61, 5.61); Calibrated: 6/23/2008
- Sensor-Surface: 4mm (Mechanical Surface Detection)
- Electronics: DAE4 Sn856; Calibrated: 5/7/2008
- Phantom: SAM1; Type: SAM;
- Measurement SW: DASY5, V5.0 Build 119; SEMCAD X Version 13.2 Build 87

Body/Area Scan : Measurement grid: dx=15mm, dy=15mm
Maximum value of SAR (interpolated) = 0.111 mW/g

Body/Zoom Scan : Measurement grid: dx=8mm, dy=8mm, dz=5mm
Reference Value = 9.89 V/m; Power Drift = -0.087 dB
Peak SAR (extrapolated) = 0.123 W/kg

SAR(1 g) = 0.108 mW/g; SAR(10 g) = 0.095 mW/g
Maximum value of SAR (measured) = 0.111 mW/g

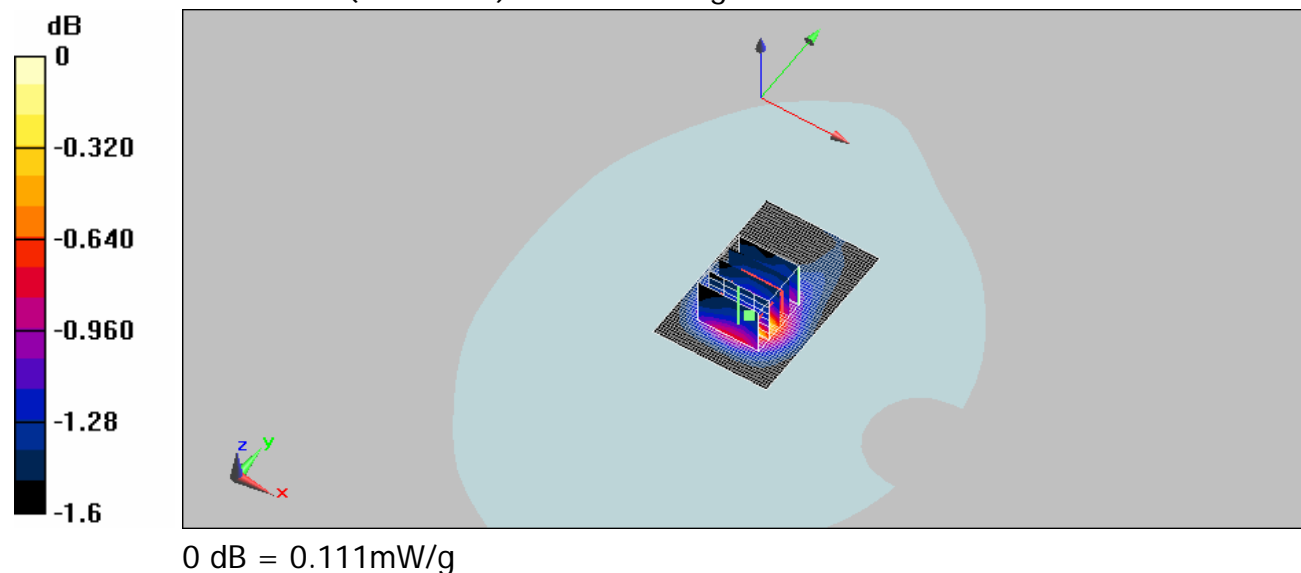

Date/Time: 9/19/2008 12:43:06

Configuration 2_CH4233_HSDPA mode

DUT: C152,

Communication System: WCDMA BAND5; Frequency: 846.6 MHz; Duty Cycle: 1:1

Medium: WCDMA Band5 Medium parameters used: $f = 847$ MHz; $\sigma = 0.969$ mho/m; $\epsilon_r = 56.2$; $\rho = 1000$ kg/m³

Phantom section: Flat Section

DASY5 Configuration:

- Probe: ES3DV3 - SN3172; ConvF(5.61, 5.61, 5.61); Calibrated: 6/23/2008
- Sensor-Surface: 4mm (Mechanical Surface Detection)
- Electronics: DAE4 Sn856; Calibrated: 5/7/2008
- Phantom: SAM1; Type: SAM;
- Measurement SW: DASY5, V5.0 Build 119; SEMCAD X Version 13.2 Build 87

Body/Area Scan : Measurement grid: dx=15mm, dy=15mm
 Maximum value of SAR (interpolated) = 0.101 mW/g

Body/Zoom Scan : Measurement grid: dx=8mm, dy=8mm, dz=5mm
 Reference Value = 9.64 V/m; Power Drift = 0.052 dB
 Peak SAR (extrapolated) = 0.106 W/kg

SAR(1 g) = 0.099 mW/g; SAR(10 g) = 0.091 mW/g
 Maximum value of SAR (measured) = 0.101 mW/g

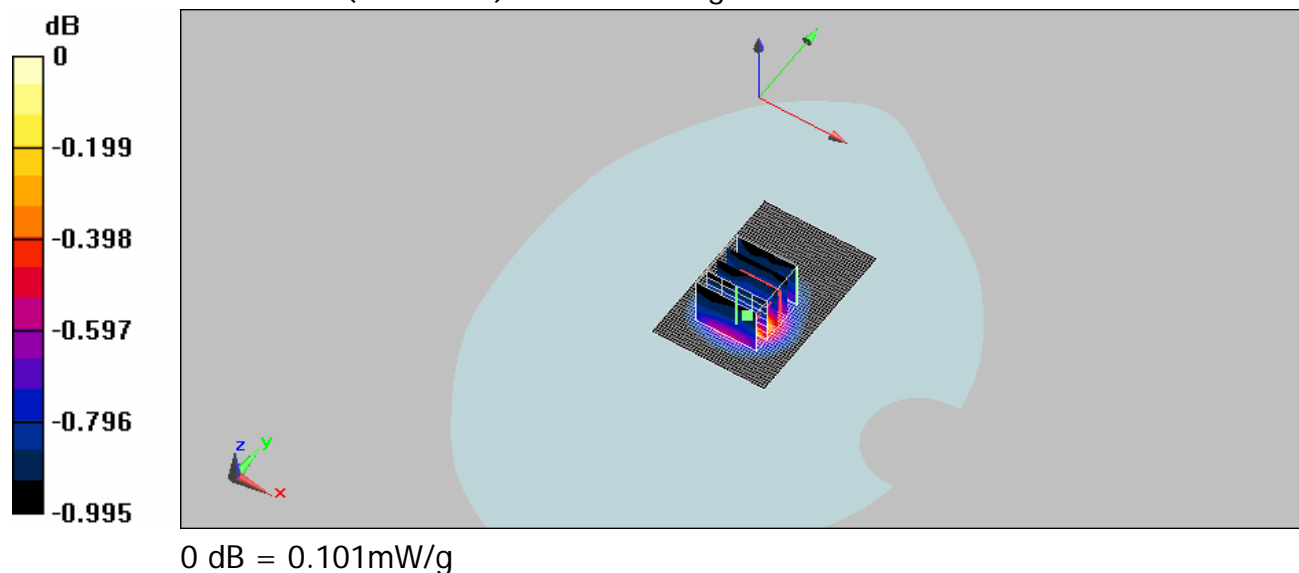

Date/Time: 9/19/2008 14:09:42

Configuration 3_CH4132_HSDPA mode

DUT: C152,

Communication System: WCDMA BAND5; Frequency: 826.4 MHz; Duty Cycle: 1:1

Medium: GMS 850 Medium parameters used (interpolated): $f = 826.4$ MHz; $\sigma = 0.946$ mho/m; $\epsilon_r = 56.3$; $\rho = 1000$ kg/m³

Phantom section: Flat Section

DASY5 Configuration:

- Probe: ES3DV3 - SN3172; ConvF(5.61, 5.61, 5.61); Calibrated: 6/23/2008
- Sensor-Surface: 4mm (Mechanical Surface Detection)
- Electronics: DAE4 Sn856; Calibrated: 5/7/2008
- Phantom: SAM1; Type: SAM;
- Measurement SW: DASY5, V5.0 Build 119; SEMCAD X Version 13.2 Build 87

Body/Area Scan : Measurement grid: dx=15mm, dy=15mm
Maximum value of SAR (interpolated) = 0.111 mW/g

Body/Zoom Scan : Measurement grid: dx=8mm, dy=8mm, dz=5mm
Reference Value = 10.3 V/m; Power Drift = -0.141 dB
Peak SAR (extrapolated) = 0.113 W/kg

SAR(1 g) = 0.101 mW/g; SAR(10 g) = 0.090 mW/g
Maximum value of SAR (measured) = 0.103 mW/g

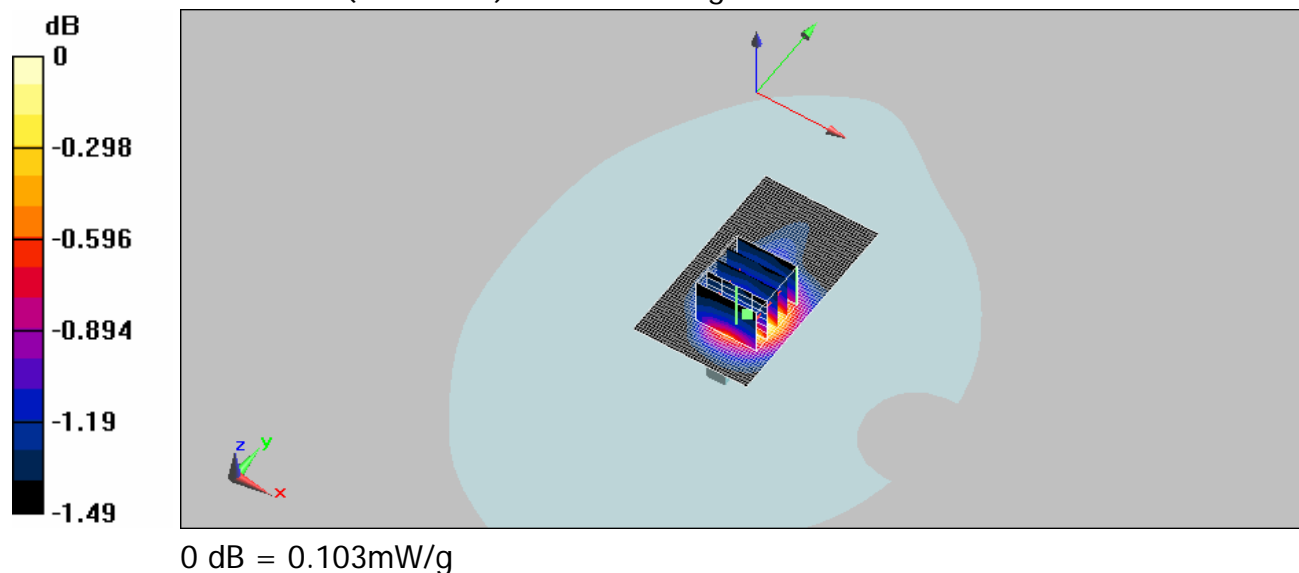

Date/Time: 9/19/2008 14:33:42

Configuration 3_CH4183_HSDPA mode

DUT: C152,

Communication System: WCDMA BAND5; Frequency: 836.6 MHz; Duty Cycle: 1:1

Medium: GMS 850 Medium parameters used: $f = 837$ MHz; $\sigma = 0.958$ mho/m; $\epsilon_r = 56.3$; $\rho = 1000$ kg/m³

Phantom section: Flat Section

DASY5 Configuration:

- Probe: ES3DV3 - SN3172; ConvF(5.61, 5.61, 5.61); Calibrated: 6/23/2008
- Sensor-Surface: 4mm (Mechanical Surface Detection)
- Electronics: DAE4 Sn856; Calibrated: 5/7/2008
- Phantom: SAM1; Type: SAM;
- Measurement SW: DASY5, V5.0 Build 119; SEMCAD X Version 13.2 Build 87

Body/Area Scan : Measurement grid: dx=15mm, dy=15mm
 Maximum value of SAR (interpolated) = 0.120 mW/g

Body/Zoom Scan : Measurement grid: dx=8mm, dy=8mm, dz=5mm
 Reference Value = 10.5 V/m; Power Drift = -0.080 dB
 Peak SAR (extrapolated) = 0.124 W/kg

SAR(1 g) = 0.108 mW/g; SAR(10 g) = 0.095 mW/g
 Maximum value of SAR (measured) = 0.110 mW/g

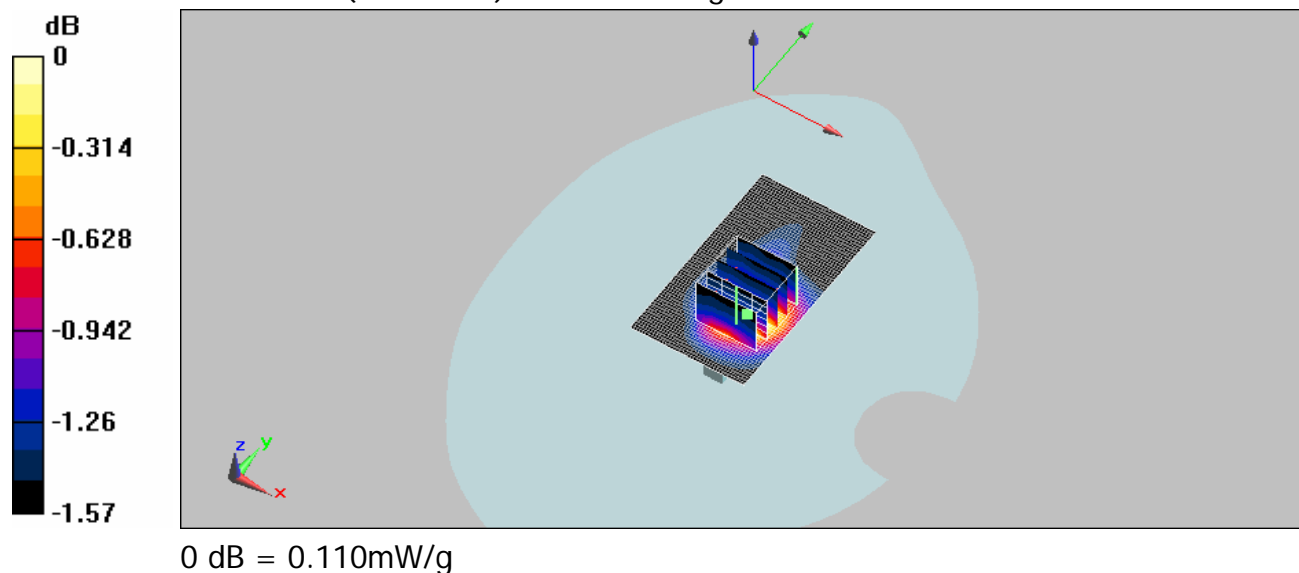

Date/Time: 9/19/2008 14:54:20

Configuration 3_CH4233_HSDPA mode

DUT: C152,

Communication System: WCDMA B5; Frequency: 846.6 MHz; Duty Cycle: 1:1

Medium: WCDMA BAND5 Medium parameters used: $f = 847$ MHz; $\sigma = 0.969$ mho/m; $\epsilon_r = 56.2$; $\rho = 1000$ kg/m³

Phantom section: Flat Section

DASY5 Configuration:

- Probe: ES3DV3 - SN3172; ConvF(5.61, 5.61, 5.61); Calibrated: 6/23/2008
- Sensor-Surface: 4mm (Mechanical Surface Detection)
- Electronics: DAE4 Sn856; Calibrated: 5/7/2008
- Phantom: SAM1; Type: SAM;
- Measurement SW: DASY5, V5.0 Build 119; SEMCAD X Version 13.2 Build 87

Body/Area Scan : Measurement grid: dx=15mm, dy=15mm
Maximum value of SAR (interpolated) = 0.087 mW/g

Body/Zoom Scan : Measurement grid: dx=8mm, dy=8mm, dz=5mm
Reference Value = 8.99 V/m; Power Drift = -0.062 dB
Peak SAR (extrapolated) = 0.094 W/kg

SAR(1 g) = 0.082 mW/g; SAR(10 g) = 0.073 mW/g
Maximum value of SAR (measured) = 0.084 mW/g

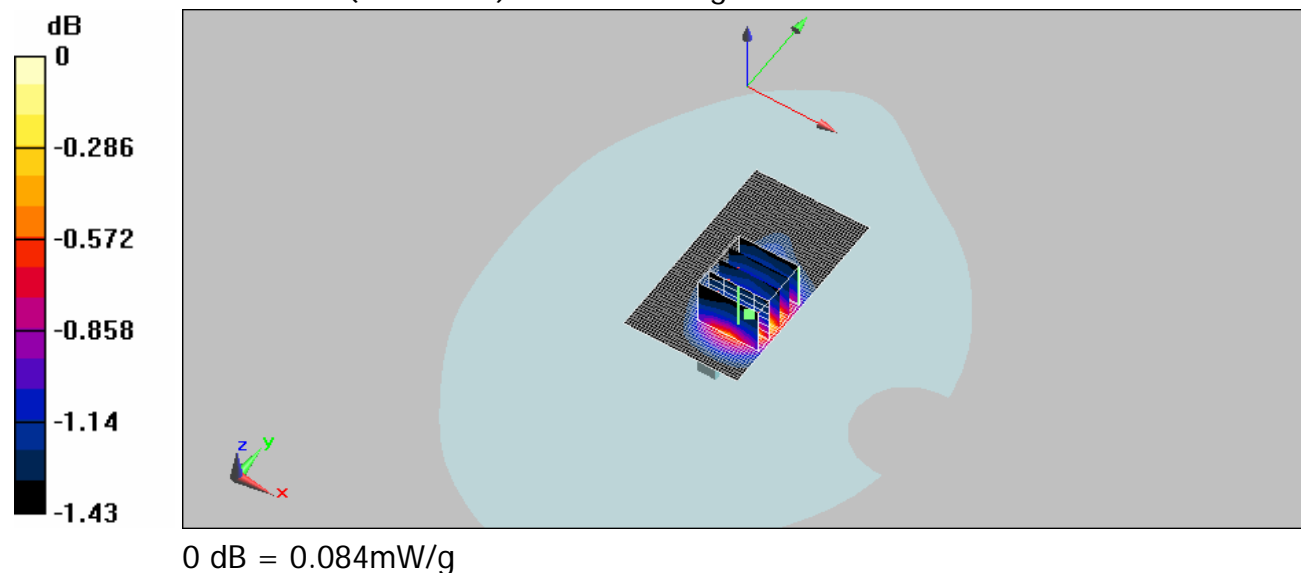

Date/Time: 9/19/2008 16:21:44

Configuration 4_CH4132_HSDPA mode

DUT: C152,

Communication System: WCDMA BAND5; Frequency: 826.4 MHz; Duty Cycle: 1:1

Medium: WCDMA Band5 Medium parameters used (interpolated): $f = 826.4$ MHz; $\sigma = 0.946$ mho/m; $\epsilon_r = 56.3$; $\rho = 1000$ kg/m³

Phantom section: Flat Section

DASY5 Configuration:

- Probe: ES3DV3 - SN3172; ConvF(5.61, 5.61, 5.61); Calibrated: 6/23/2008
- Sensor-Surface: 4mm (Mechanical Surface Detection)
- Electronics: DAE4 Sn856; Calibrated: 5/7/2008
- Phantom: SAM1; Type: SAM;
- Measurement SW: DASY5, V5.0 Build 119; SEMCAD X Version 13.2 Build 87

Body/Area Scan : Measurement grid: dx=15mm, dy=15mm
 Maximum value of SAR (interpolated) = 0.112 mW/g

Body/Zoom Scan : Measurement grid: dx=8mm, dy=8mm, dz=5mm
 Reference Value = 10.5 V/m; Power Drift = 0.057 dB
 Peak SAR (extrapolated) = 0.126 W/kg

SAR(1 g) = 0.110 mW/g; SAR(10 g) = 0.098 mW/g
 Maximum value of SAR (measured) = 0.111 mW/g

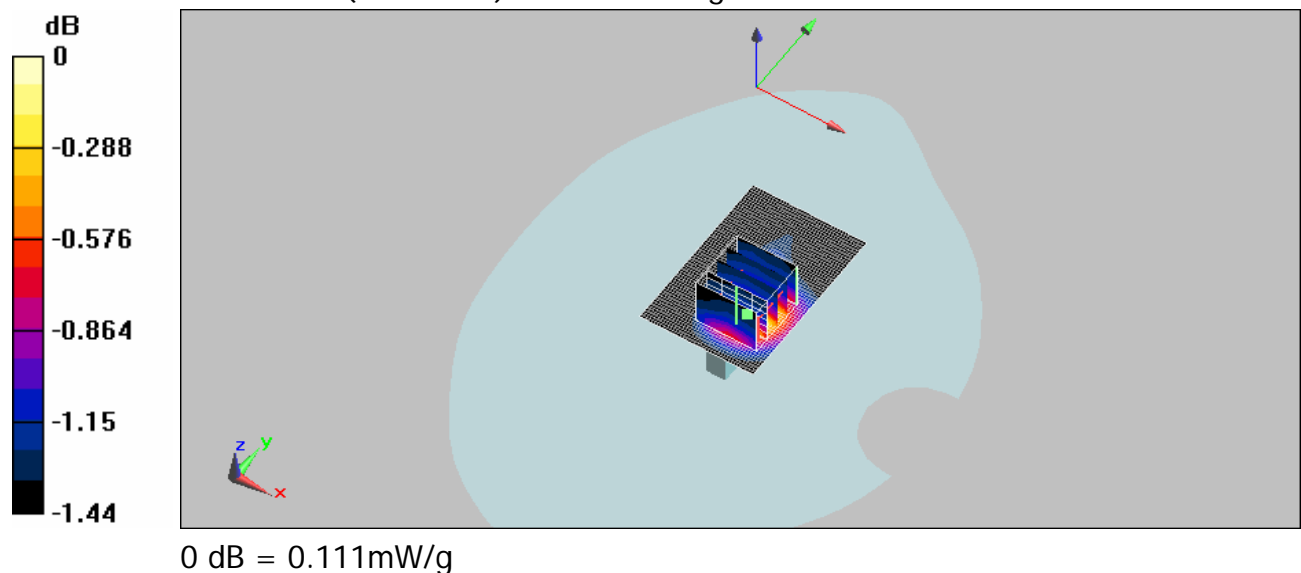

Date/Time: 9/19/2008 15:58:05

Configuration 4_CH4183_HSDPA mode

DUT: C152,

Communication System: WCDMA BAND5; Frequency: 836.6 MHz; Duty Cycle: 1:1

Medium: WCDMA Band5 Medium parameters used: $f = 837$ MHz; $\sigma = 0.958$ mho/m; $\epsilon_r = 56.3$; $\rho = 1000$ kg/m³

Phantom section: Flat Section

DASY5 Configuration:

- Probe: ES3DV3 - SN3172; ConvF(5.61, 5.61, 5.61); Calibrated: 6/23/2008
- Sensor-Surface: 4mm (Mechanical Surface Detection)
- Electronics: DAE4 Sn856; Calibrated: 5/7/2008
- Phantom: SAM1; Type: SAM;
- Measurement SW: DASY5, V5.0 Build 119; SEMCAD X Version 13.2 Build 87

Body/Area Scan : Measurement grid: dx=15mm, dy=15mm
Maximum value of SAR (interpolated) = 0.126 mW/g

Body/Zoom Scan : Measurement grid: dx=8mm, dy=8mm, dz=5mm
Reference Value = 10.9 V/m; Power Drift = -0.072 dB
Peak SAR (extrapolated) = 0.142 W/kg

SAR(1 g) = 0.121 mW/g; SAR(10 g) = 0.104 mW/g
Maximum value of SAR (measured) = 0.122 mW/g

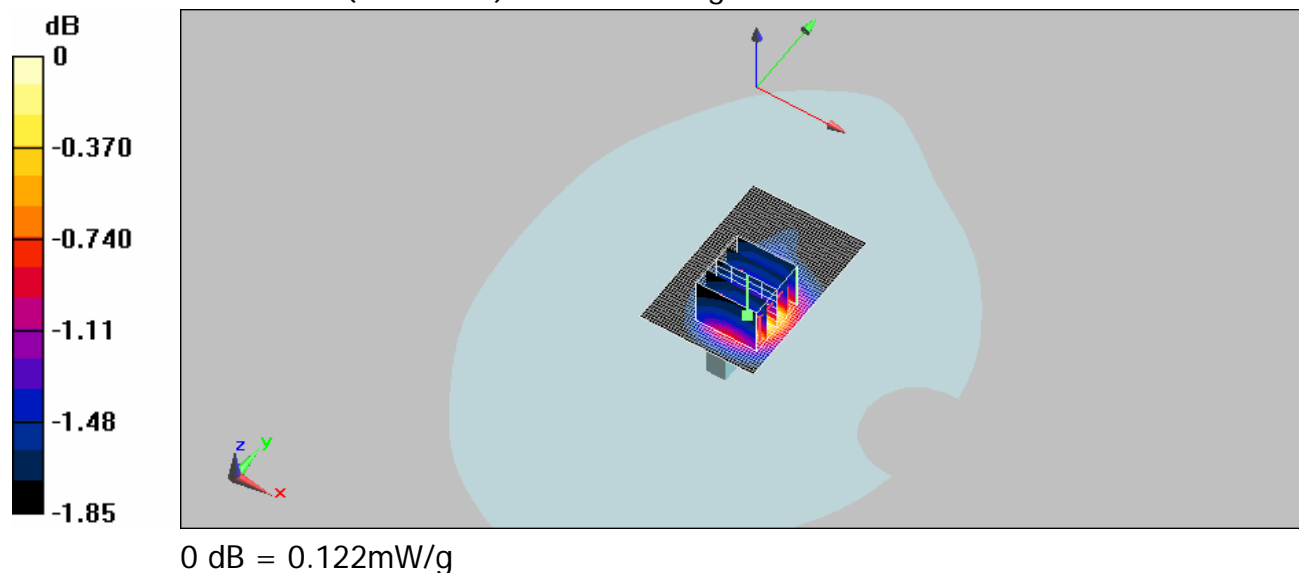

Date/Time: 9/19/2008 15:33:08

Configuration 4_CH4233_HSDPA mode

DUT: C152,

Communication System: WCDMA BAND5; Frequency: 846.6 MHz; Duty Cycle: 1:1

Medium: WCDMA Band5 Medium parameters used: $f = 847$ MHz; $\sigma = 0.969$ mho/m; $\epsilon_r = 56.2$; $\rho = 1000$ kg/m³

Phantom section: Flat Section

DASY5 Configuration:

- Probe: ES3DV3 - SN3172; ConvF(5.61, 5.61, 5.61); Calibrated: 6/23/2008
- Sensor-Surface: 4mm (Mechanical Surface Detection)
- Electronics: DAE4 Sn856; Calibrated: 5/7/2008
- Phantom: SAM1; Type: SAM;
- Measurement SW: DASY5, V5.0 Build 119; SEMCAD X Version 13.2 Build 87

Body/Area Scan : Measurement grid: dx=15mm, dy=15mm
Maximum value of SAR (interpolated) = 0.106 mW/g

Body/Zoom Scan : Measurement grid: dx=8mm, dy=8mm, dz=5mm
Reference Value = 10.2 V/m; Power Drift = -0.070 dB
Peak SAR (extrapolated) = 0.109 W/kg

SAR(1 g) = 0.101 mW/g; SAR(10 g) = 0.093 mW/g
Maximum value of SAR (measured) = 0.102 mW/g

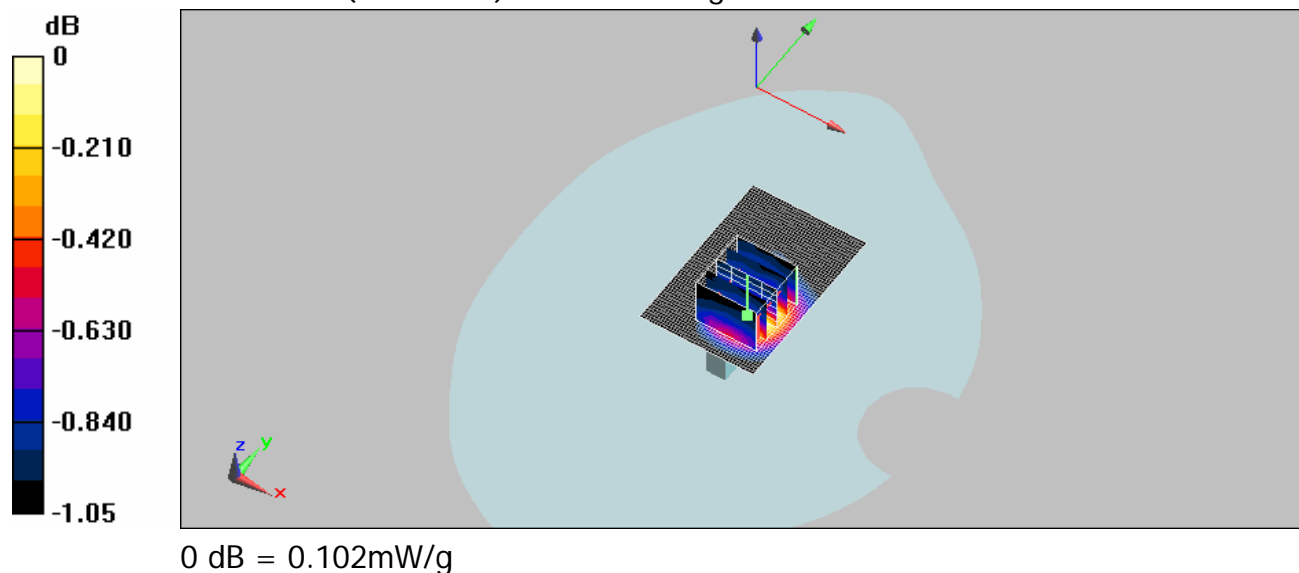

Date/Time: 9/19/2008 16:59:42

Configuration 5_CH4132_HSDPA mode

DUT: C152,

Communication System: WCDMA B5; Frequency: 826.4 MHz; Duty Cycle: 1:1

Medium: WCDMA Band5 Medium parameters used (interpolated): $f = 826.4$ MHz; $\sigma = 0.946$ mho/m; $\epsilon_r = 56.3$; $\rho = 1000$ kg/m³

Phantom section: Flat Section

DASY5 Configuration:

- Probe: ES3DV3 - SN3172; ConvF(5.61, 5.61, 5.61); Calibrated: 6/23/2008
- Sensor-Surface: 4mm (Mechanical Surface Detection)
- Electronics: DAE4 Sn856; Calibrated: 5/7/2008
- Phantom: SAM1; Type: SAM;
- Measurement SW: DASY5, V5.0 Build 119; SEMCAD X Version 13.2 Build 87

Body/Area Scan : Measurement grid: dx=15mm, dy=15mm
Maximum value of SAR (interpolated) = 0.087 mW/g

Body/Zoom Scan : Measurement grid: dx=8mm, dy=8mm, dz=5mm
Reference Value = 9.54 V/m; Power Drift = -0.082 dB
Peak SAR (extrapolated) = 0.086 W/kg

SAR(1 g) = 0.085 mW/g; SAR(10 g) = 0.084 mW/g

Maximum value of SAR (measured) = 0.086 mW/g

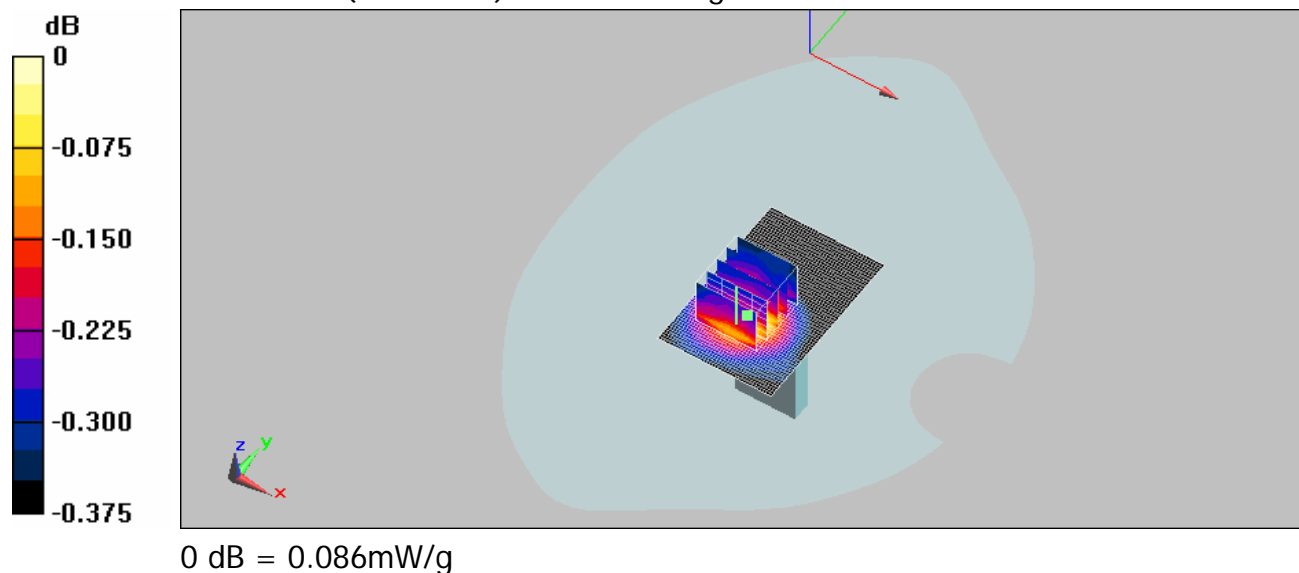

Date/Time: 9/19/2008 17:25:47

Configuration 5_CH4183_HSDPA mode

DUT: C152,

Communication System: WCDMA B5; Frequency: 836.6 MHz; Duty Cycle: 1:1

Medium: WCDMA Band5 Medium parameters used: $f = 837$ MHz; $\sigma = 0.958$ mho/m; $\epsilon_r = 56.3$; $\rho = 1000$ kg/m³

Phantom section: Flat Section

DASY5 Configuration:

- Probe: ES3DV3 - SN3172; ConvF(5.61, 5.61, 5.61); Calibrated: 6/23/2008
- Sensor-Surface: 4mm (Mechanical Surface Detection)
- Electronics: DAE4 Sn856; Calibrated: 5/7/2008
- Phantom: SAM1; Type: SAM;
- Measurement SW: DASYS, V5.0 Build 119; SEMCAD X Version 13.2 Build 87

Body/Area Scan : Measurement grid: dx=15mm, dy=15mm
 Maximum value of SAR (interpolated) = 0.103 mW/g

Body/Zoom Scan : Measurement grid: dx=8mm, dy=8mm, dz=5mm
 Reference Value = 10.2 V/m; Power Drift = -0.108 dB
 Peak SAR (extrapolated) = 0.100 W/kg

SAR(1 g) = 0.099 mW/g; SAR(10 g) = 0.096 mW/g
 Maximum value of SAR (measured) = 0.100 mW/g

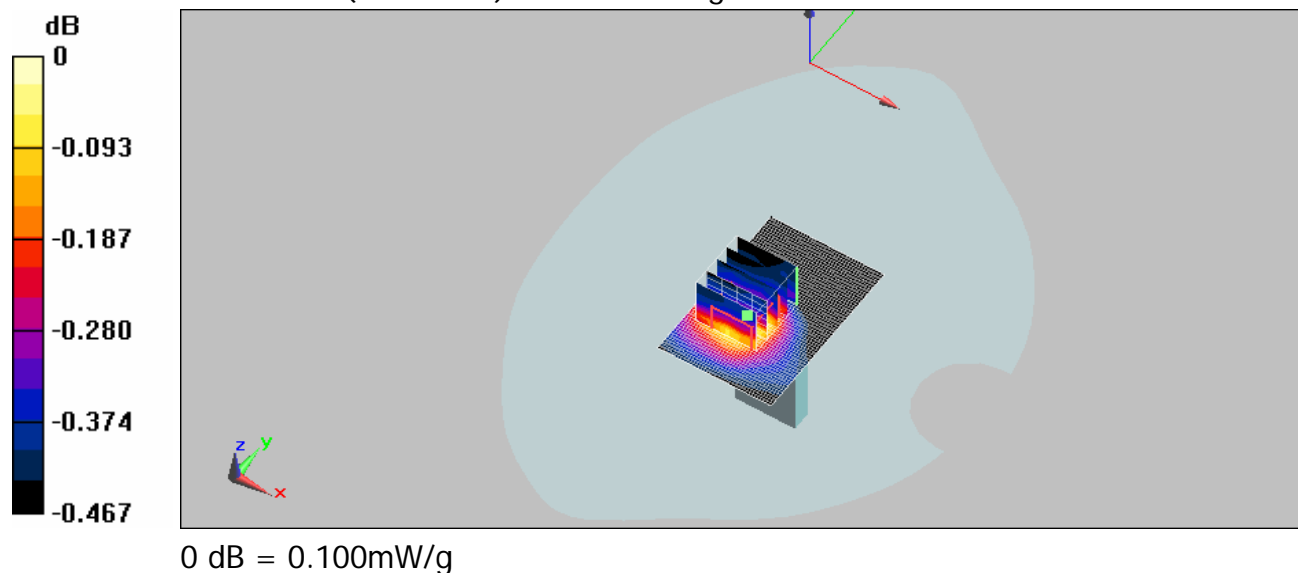

Date/Time: 9/19/2008 17:48:37

Configuration 5_CH4233_HSDPA mode

DUT: C152,

Communication System: WCDMA B5; Frequency: 846.6 MHz; Duty Cycle: 1:1

Medium: WCDMA Band5 Medium parameters used: $f = 847$ MHz; $\sigma = 0.969$ mho/m; $\epsilon_r = 56.2$; $\rho = 1000$ kg/m³

Phantom section: Flat Section

DASY5 Configuration:

- Probe: ES3DV3 - SN3172; ConvF(5.61, 5.61, 5.61); Calibrated: 6/23/2008
- Sensor-Surface: 4mm (Mechanical Surface Detection)
- Electronics: DAE4 Sn856; Calibrated: 5/7/2008
- Phantom: SAM1; Type: SAM;
- Measurement SW: DASY5, V5.0 Build 119; SEMCAD X Version 13.2 Build 87

Body/Area Scan : Measurement grid: dx=15mm, dy=15mm
 Maximum value of SAR (interpolated) = 0.105 mW/g

Body/Zoom Scan : Measurement grid: dx=8mm, dy=8mm, dz=5mm
 Reference Value = 9.52 V/m; Power Drift = 0.082 dB
 Peak SAR (extrapolated) = 0.103 W/kg

SAR(1 g) = 0.097 mW/g; SAR(10 g) = 0.090 mW/g
 Maximum value of SAR (measured) = 0.099 mW/g

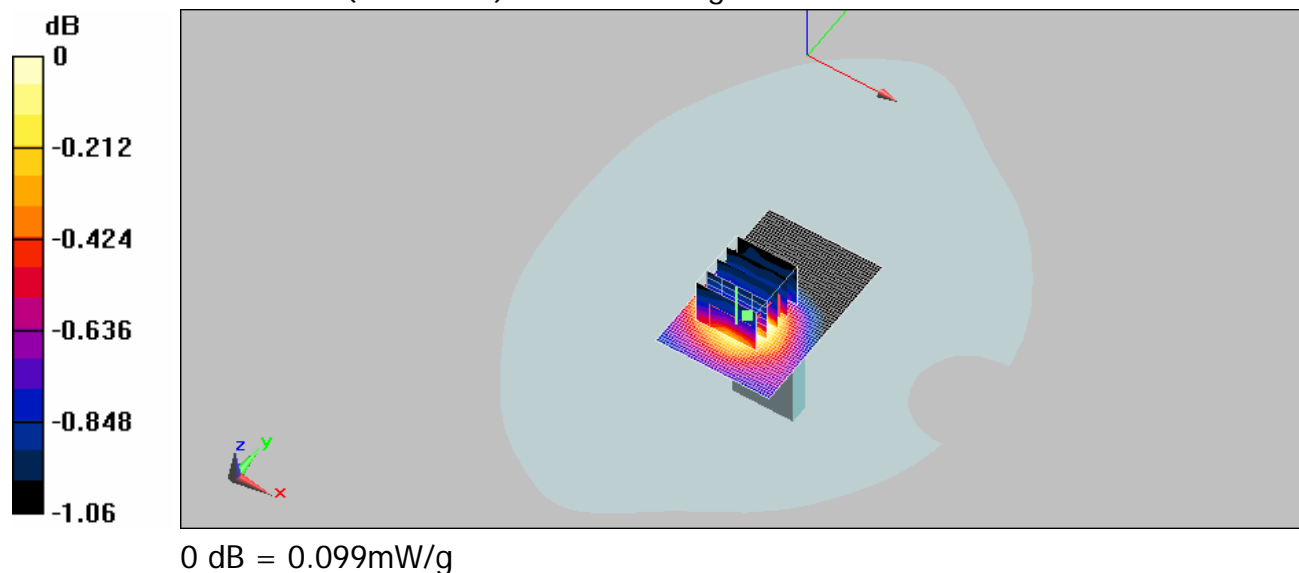

Date/Time: 9/19/2008 18:26:53

Configuration 6_CH4132_HSDPA mode

DUT: C152,

Communication System: WCDMA B5; Frequency: 826.4 MHz; Duty Cycle: 1:1

Medium: WCDMA BAND5 Medium parameters used (interpolated): f = 826.4 MHz; $\sigma = 0.946$ mho/m; $\epsilon_r = 56.3$; $\rho = 1000$ kg/m³

Phantom section: Flat Section

DASY5 Configuration:

- Probe: ES3DV3 - SN3172; ConvF(5.61, 5.61, 5.61); Calibrated: 6/23/2008
- Sensor-Surface: 4mm (Mechanical Surface Detection)
- Electronics: DAE4 Sn856; Calibrated: 5/7/2008
- Phantom: SAM1; Type: SAM;
- Measurement SW: DASY5, V5.0 Build 119; SEMCAD X Version 13.2 Build 87

Body/Area Scan: Measurement grid: dx=15mm, dy=15mm
 Maximum value of SAR (interpolated) = 0.072 mW/g

Body/Zoom Scan : Measurement grid: dx=8mm, dy=8mm, dz=5mm
 Reference Value = 8.05 V/m; Power Drift = 0.031 dB
 Peak SAR (extrapolated) = 0.093 W/kg

SAR(1 g) = 0.071 mW/g; SAR(10 g) = 0.062 mW/g
 Maximum value of SAR (measured) = 0.073 mW/g

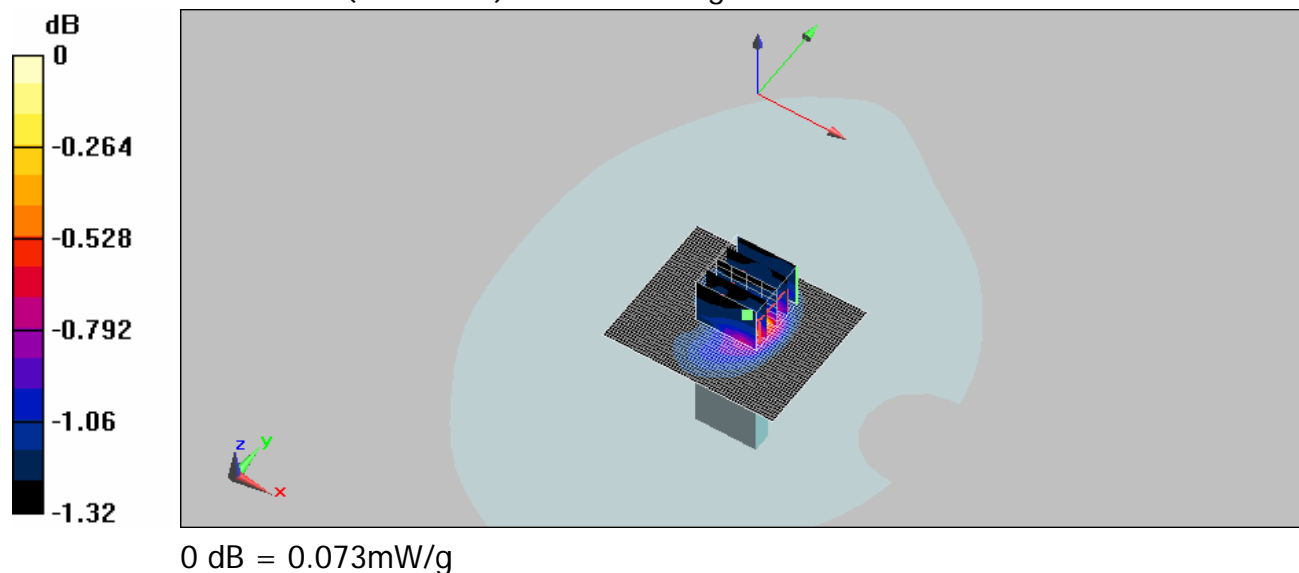

Date/Time: 9/19/2008 18:52:57

Configuration 6_CH4183_HSDPA mode

DUT: C152,

Communication System: WCDMA B5; Frequency: 836.6 MHz; Duty Cycle: 1:1

Medium: WCDMA BAND5 Medium parameters used: $f = 837$ MHz; $\sigma = 0.958$ mho/m; $\epsilon_r = 56.3$; $\rho = 1000$ kg/m³

Phantom section: Flat Section

DASY5 Configuration:

- Probe: ES3DV3 - SN3172; ConvF(5.61, 5.61, 5.61); Calibrated: 6/23/2008
- Sensor-Surface: 4mm (Mechanical Surface Detection)
- Electronics: DAE4 Sn856; Calibrated: 5/7/2008
- Phantom: SAM1; Type: SAM;
- Measurement SW: DASY5, V5.0 Build 119; SEMCAD X Version 13.2 Build 87

Body/Area Scan: Measurement grid: dx=15mm, dy=15mm
 Maximum value of SAR (interpolated) = 0.075 mW/g

Body/Zoom Scan : Measurement grid: dx=8mm, dy=8mm, dz=5mm
 Reference Value = 7.99 V/m; Power Drift = 0.043 dB
 Peak SAR (extrapolated) = 0.092 W/kg

SAR(1 g) = 0.074 mW/g; SAR(10 g) = 0.065 mW/g
 Maximum value of SAR (measured) = 0.077 mW/g

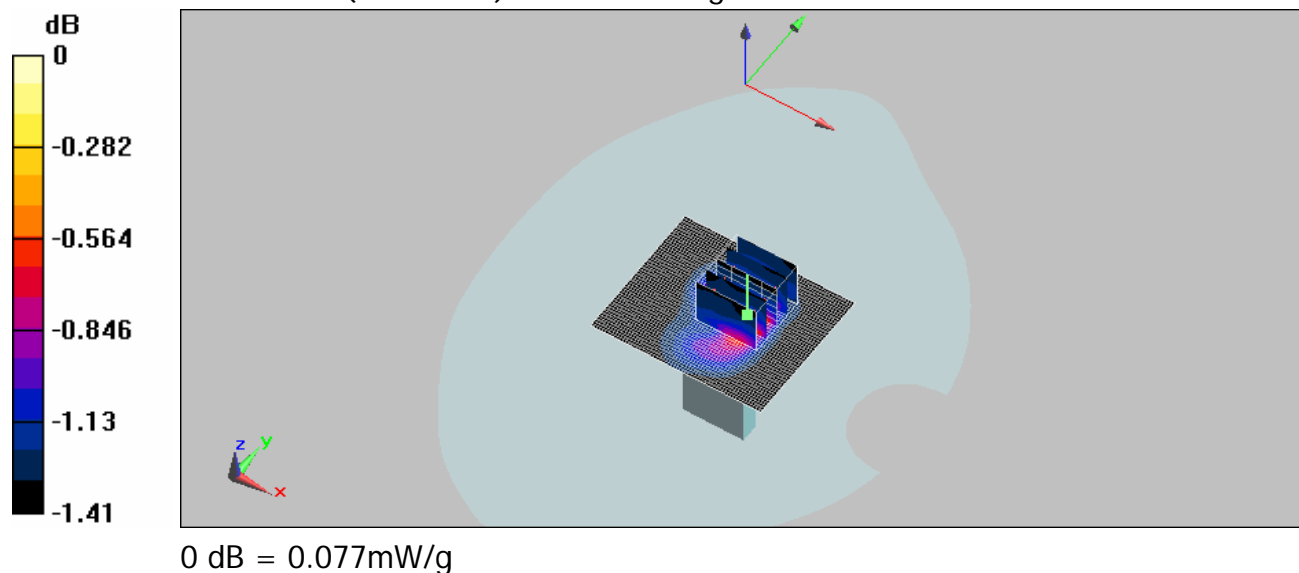

Date/Time: 9/19/2008 19:15:40

Configuration 6_CH4233_HSDPA mode

DUT: C152,

Communication System: WCDMA B5; Frequency: 846.6 MHz; Duty Cycle: 1:1

Medium: WCDMA BAND5 Medium parameters used: $f = 847$ MHz; $\sigma = 0.969$ mho/m; $\epsilon_r = 56.2$; $\rho = 1000$ kg/m³

Phantom section: Flat Section

DASY5 Configuration:

- Probe: ES3DV3 - SN3172; ConvF(5.61, 5.61, 5.61); Calibrated: 6/23/2008
- Sensor-Surface: 4mm (Mechanical Surface Detection)
- Electronics: DAE4 Sn856; Calibrated: 5/7/2008
- Phantom: SAM1; Type: SAM;
- Measurement SW: DASY5, V5.0 Build 119; SEMCAD X Version 13.2 Build 87

Body/Area Scan: Measurement grid: dx=15mm, dy=15mm
 Maximum value of SAR (interpolated) = 0.068 mW/g

Body/Zoom Scan : Measurement grid: dx=8mm, dy=8mm, dz=5mm
 Reference Value = 7.83 V/m; Power Drift = -0.026 dB
 Peak SAR (extrapolated) = 0.075 W/kg

SAR(1 g) = 0.066 mW/g; SAR(10 g) = 0.060 mW/g
 Maximum value of SAR (measured) = 0.069 mW/g

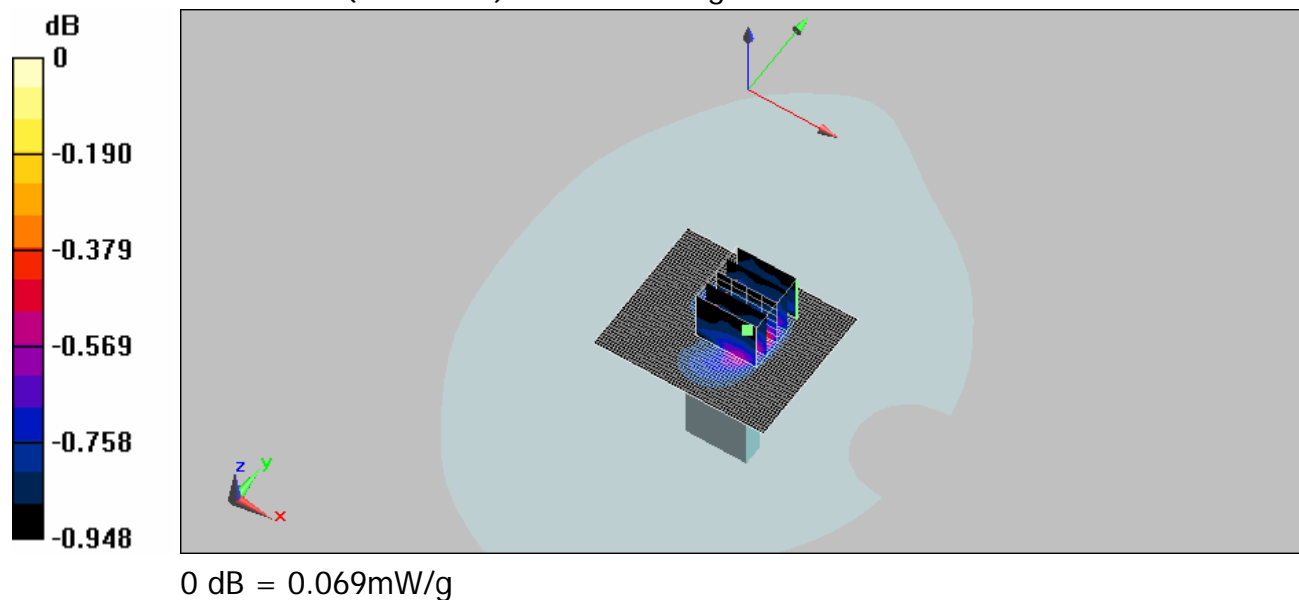

Date/Time: 12/5/2008 19:40:45

Configuration 7_CH4132 with HSDPA mode

DUT: C152,

Communication System: WCDMA B5; Frequency: 826.4 MHz; Duty Cycle: 1:1

Medium: WCDMA Band5 Medium parameters used: $f = 826.4$ MHz; $\sigma = 0.945$ mho/m; $\epsilon_r = 56.3$; $\rho = 1000$ kg/m³

Phantom section: Flat Section

DASY5 Configuration:

- Probe: ES3DV3 - SN3172; ConvF(5.61, 5.61, 5.61); Calibrated: 6/23/2008
- Sensor-Surface: 4mm (Mechanical Surface Detection)
- Electronics: DAE4 Sn856; Calibrated: 5/7/2008
- Phantom: SAM1; Type: SAM;
- Measurement SW: DASY5, V5.0 Build 119; SEMCAD X Version 13.2 Build 87

Body/Area Scan: Measurement grid: dx=15mm, dy=15mm

Maximum value of SAR (interpolated) = 0.131 mW/g

Body/Zoom Scan: Measurement grid: dx=8mm, dy=8mm, dz=5mm

Reference Value = 9.82 V/m; Power Drift = 0.098 dB

Peak SAR (extrapolated) = 0.160 W/kg

SAR(1 g) = 0.113 mW/g; SAR(10 g) = 0.077 mW/g

Maximum value of SAR (measured) = 0.121 mW/g

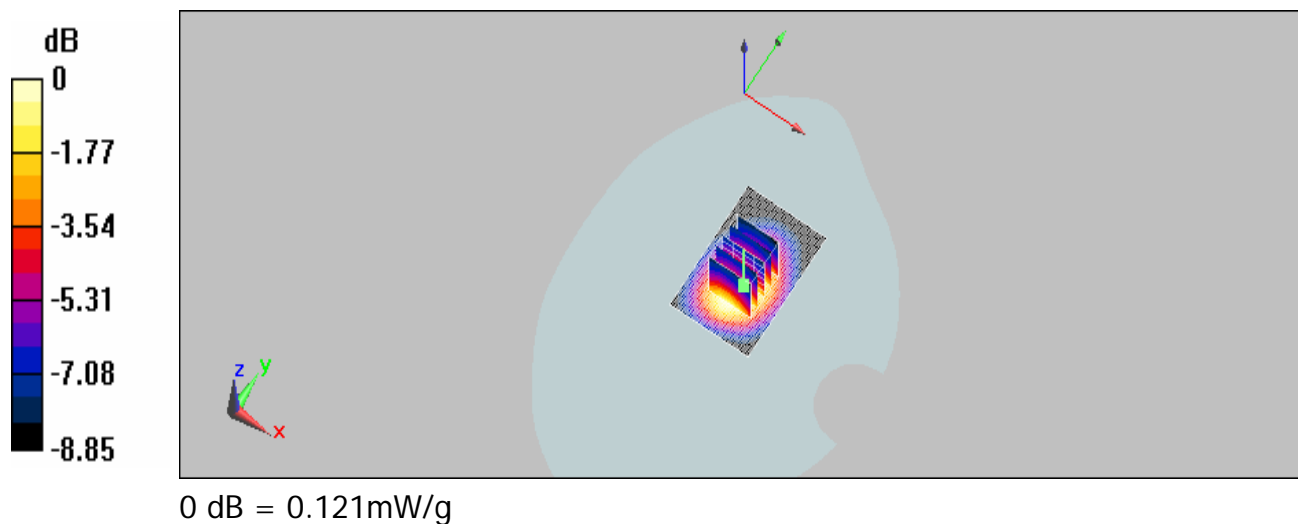

Date/Time: 12/5/2008 20:13:55

Configuration 7_CH4183 with HSDPA mode

DUT: C152,

Communication System: WCDMA B5; Frequency: 836.6 MHz; Duty Cycle: 1:1

Medium: WCDMA Band5 Medium parameters used: $f = 837$ MHz; $\sigma = 0.957$ mho/m; $\epsilon_r =$

56.2; $\rho = 1000 \text{ kg/m}^3$

Phantom section: Flat Section

DASY5Configuration:

- Probe: ES3DV3 - SN3172; ConvF(5.61, 5.61, 5.61); Calibrated: 6/23/2008
- Sensor-Surface: 4mm (Mechanical Surface Detection)
- Electronics: DAE4 Sn856; Calibrated: 5/7/2008
- Phantom: SAM1; Type: SAM;
- Measurement SW: DASY5, V5.0 Build 119; SEMCAD X Version 13.2 Build 87

Body/Area Scan: Measurement grid: dx=15mm, dy=15mm

Maximum value of SAR (interpolated) = 0.126 mW/g

Body/Zoom Scan: Measurement grid: dx=8mm, dy=8mm, dz=5mm

Reference Value = 9.6 V/m; Power Drift = 0.086 dB

Peak SAR (extrapolated) = 0.153 W/kg

SAR(1 g) = 0.111 mW/g; SAR(10 g) = 0.076 mW/g

Maximum value of SAR (measured) = 0.118 mW/g

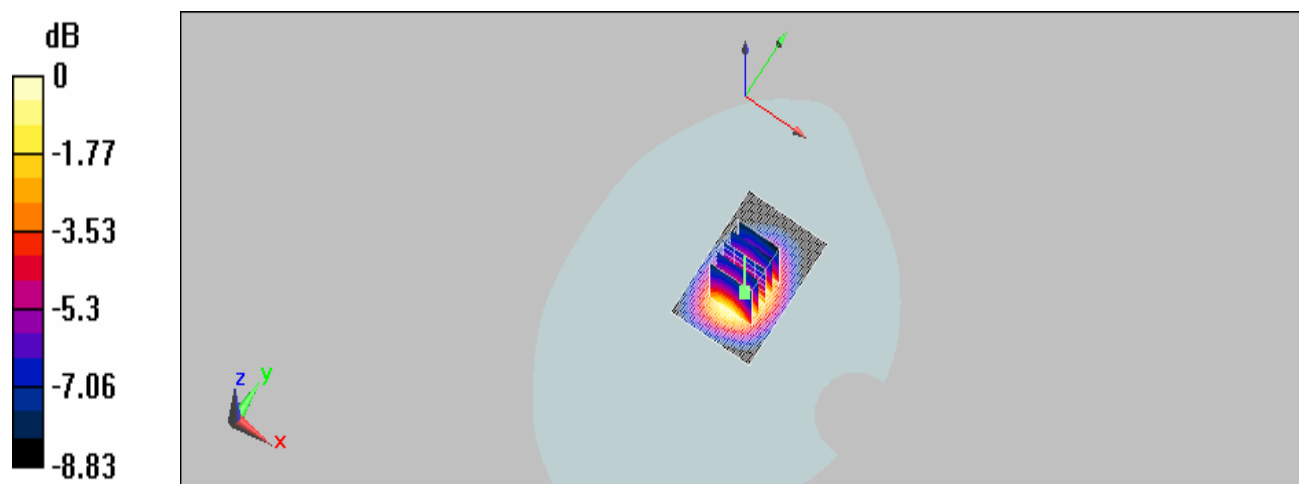

0 dB = 0.118mW/g

Date/Time: 12/5/2008 20:49:23

Configuration 7_CH4233 with HSDPA mode

DUT: C152,

Communication System: WCDMA B5; Frequency: 846.6 MHz; Duty Cycle: 1:1

Medium: WCDMA Band5 Medium parameters used: $f = 847$ MHz; $\sigma = 0.969$ mho/m; $\epsilon_r = 56.1$; $\rho = 1000$ kg/m³

Phantom section: Flat Section

DASY5 Configuration:

- Probe: ES3DV3 - SN3172; ConvF(5.61, 5.61, 5.61); Calibrated: 6/23/2008
- Sensor-Surface: 4mm (Mechanical Surface Detection)
- Electronics: DAE4 Sn856; Calibrated: 5/7/2008
- Phantom: SAM1; Type: SAM;
- Measurement SW: DASY5, V5.0 Build 119; SEMCAD X Version 13.2 Build 87

Body/Area Scan: Measurement grid: dx=15mm, dy=15mm

Maximum value of SAR (interpolated) = 0.071 mW/g

Body/Zoom Scan: Measurement grid: dx=8mm, dy=8mm, dz=5mm

Reference Value = 7.3 V/m; Power Drift = 0.084 dB

Peak SAR (extrapolated) = 0.087 W/kg

SAR(1 g) = 0.064 mW/g; SAR(10 g) = 0.045 mW/g

Maximum value of SAR (measured) = 0.067 mW/g

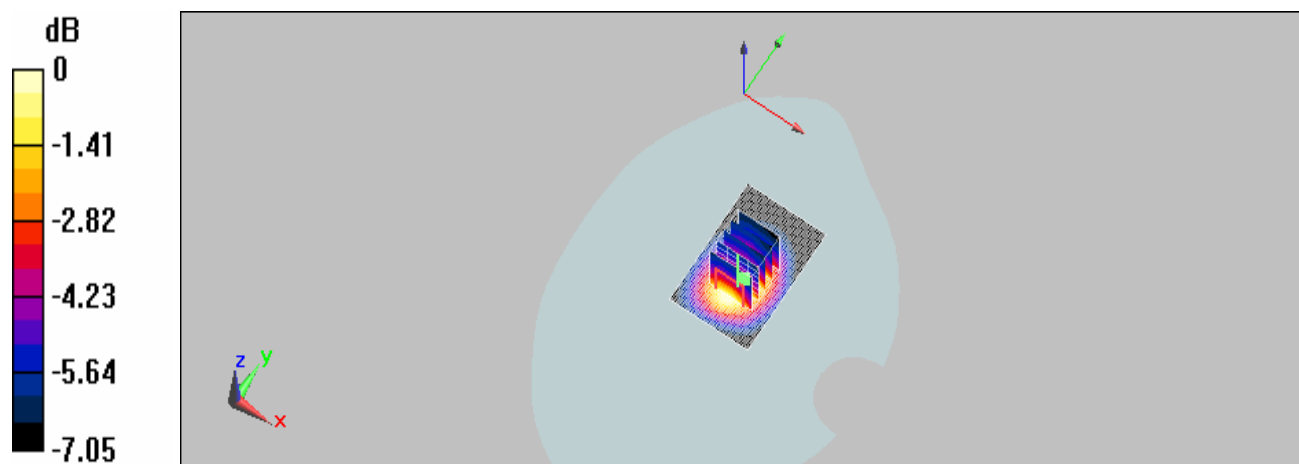

0 dB = 0.067mW/g

Date/Time: 12/5/2008 21:57:44

Configuration 8_CH 4132 with HSDPA mode

DUT: C152,

Communication System: WCDMA B5; Frequency: 826.4 MHz; Duty Cycle: 1:1

Medium: WCDMA Band5 Medium parameters used: $f = 826.4$ MHz; $\sigma = 0.945$ mho/m; $\epsilon_r = 56.3$; $\rho = 1000$ kg/m³

Phantom section: Flat Section

DASY5 Configuration:

- Probe: ES3DV3 - SN3172; ConvF(5.61, 5.61, 5.61); Calibrated: 6/23/2008
- Sensor-Surface: 4mm (Mechanical Surface Detection)
- Electronics: DAE4 Sn856; Calibrated: 5/7/2008
- Phantom: SAM1; Type: SAM;
- Measurement SW: DASY5, V5.0 Build 119; SEMCAD X Version 13.2 Build 87

Body/Area Scan: Measurement grid: dx=15mm, dy=15mm

Maximum value of SAR (interpolated) = 0.088 mW/g

Body/Zoom Scan: Measurement grid: dx=8mm, dy=8mm, dz=5mm

Reference Value = 8.05 V/m; Power Drift = 0.091 dB

Peak SAR (extrapolated) = 0.140 W/kg

SAR(1 g) = 0.078 mW/g; SAR(10 g) = 0.049 mW/g

Maximum value of SAR (measured) = 0.083 mW/g

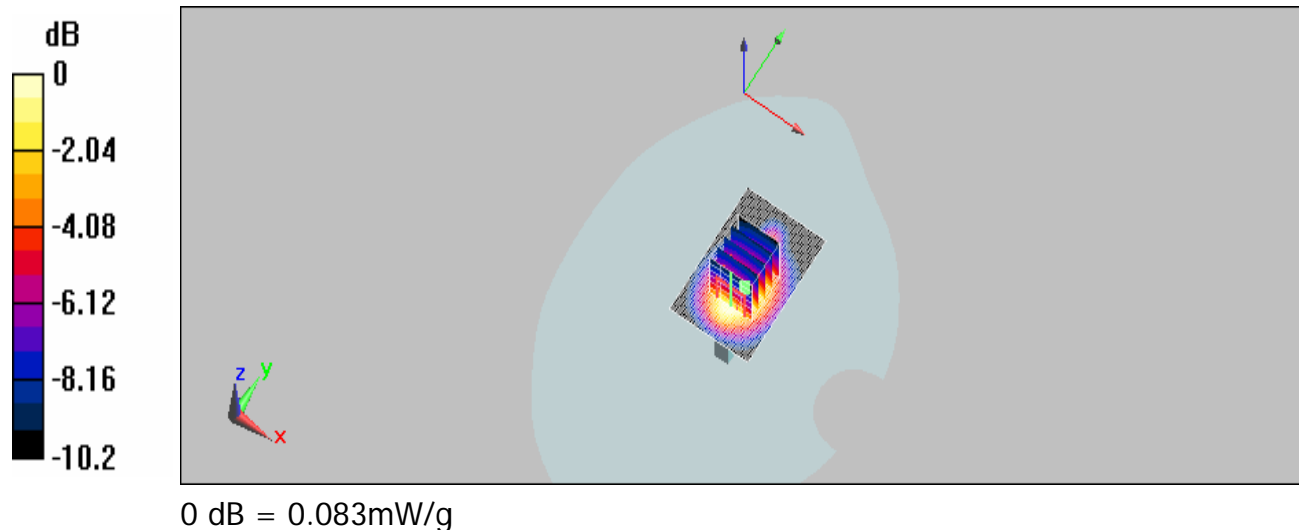

Configuration 8_CH 4183 with HSDPA mode

DUT: C152,

Communication System: WCDMA B5; Frequency: 836.6 MHz; Duty Cycle: 1:1

Medium: WCDMA Band5 Medium parameters used: $f = 837$ MHz; $\sigma = 0.957$ mho/m; $\epsilon_r = 56.2$; $\rho = 1000$ kg/m³

Phantom section: Flat Section

DASY5 Configuration:

- Probe: ES3DV3 - SN3172; ConvF(5.61, 5.61, 5.61); Calibrated: 6/23/2008
- Sensor-Surface: 4mm (Mechanical Surface Detection)
- Electronics: DAE4 Sn856; Calibrated: 5/7/2008
- Phantom: SAM1; Type: SAM;
- Measurement SW: DASY5, V5.0 Build 119; SEMCAD X Version 13.2 Build 87

Body/Area Scan: Measurement grid: dx=15mm, dy=15mm

Maximum value of SAR (interpolated) = 0.087 mW/g

Body/Zoom Scan: Measurement grid: dx=8mm, dy=8mm, dz=5mm

Reference Value = 7.9 V/m; Power Drift = 0.030 dB

Peak SAR (extrapolated) = 0.134 W/kg

SAR(1 g) = 0.075 mW/g; SAR(10 g) = 0.047 mW/g

Maximum value of SAR (measured) = 0.080 mW/g

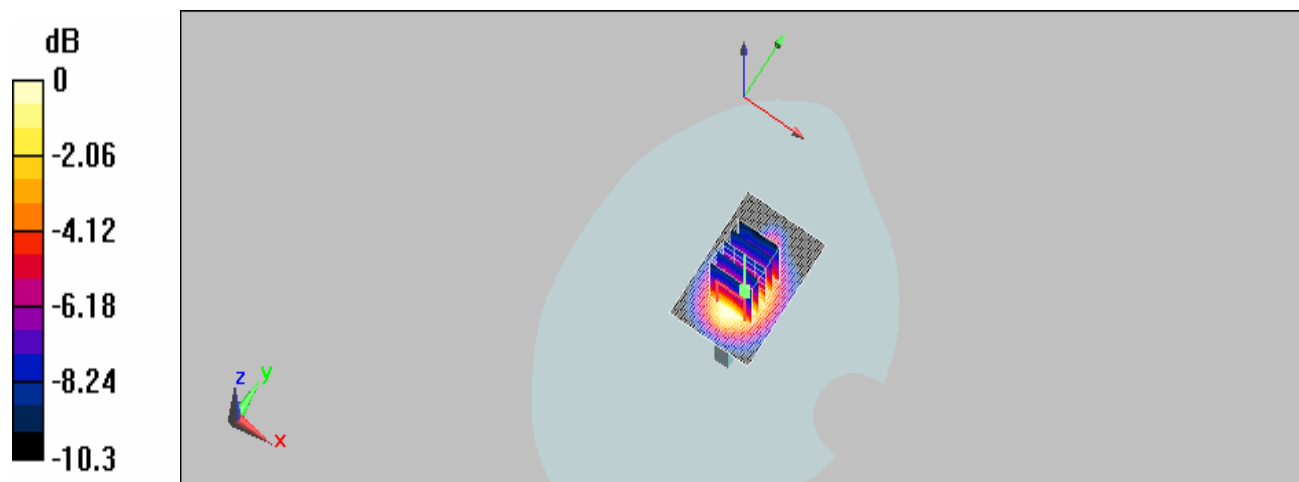

0 dB = 0.080mW/g

Configuration 8_CH 4233 with HSDPA mode

DUT: C152,

Communication System: WCDMA B5; Frequency: 846.6 MHz; Duty Cycle: 1:1

Medium: WCDMA Band5 Medium parameters used: $f = 847$ MHz; $\sigma = 0.969$ mho/m; $\epsilon_r = 56.1$; $\rho = 1000$ kg/m³

Phantom section: Flat Section

DASY5 Configuration:

- Probe: ES3DV3 - SN3172; ConvF(5.61, 5.61, 5.61); Calibrated: 6/23/2008
- Sensor-Surface: 4mm (Mechanical Surface Detection)
- Electronics: DAE4 Sn856; Calibrated: 5/7/2008
- Phantom: SAM1; Type: SAM;
- Measurement SW: DASY5, V5.0 Build 119; SEMCAD X Version 13.2 Build 87

Body/Area Scan: Measurement grid: dx=15mm, dy=15mm

Maximum value of SAR (interpolated) = 0.050 mW/g

Body/Zoom Scan: Measurement grid: dx=8mm, dy=8mm, dz=5mm

Reference Value = 6.1 V/m; Power Drift = -0.001 dB

Peak SAR (extrapolated) = 0.079 W/kg

SAR(1 g) = 0.044 mW/g; SAR(10 g) = 0.028 mW/g

Maximum value of SAR (measured) = 0.047 mW/g

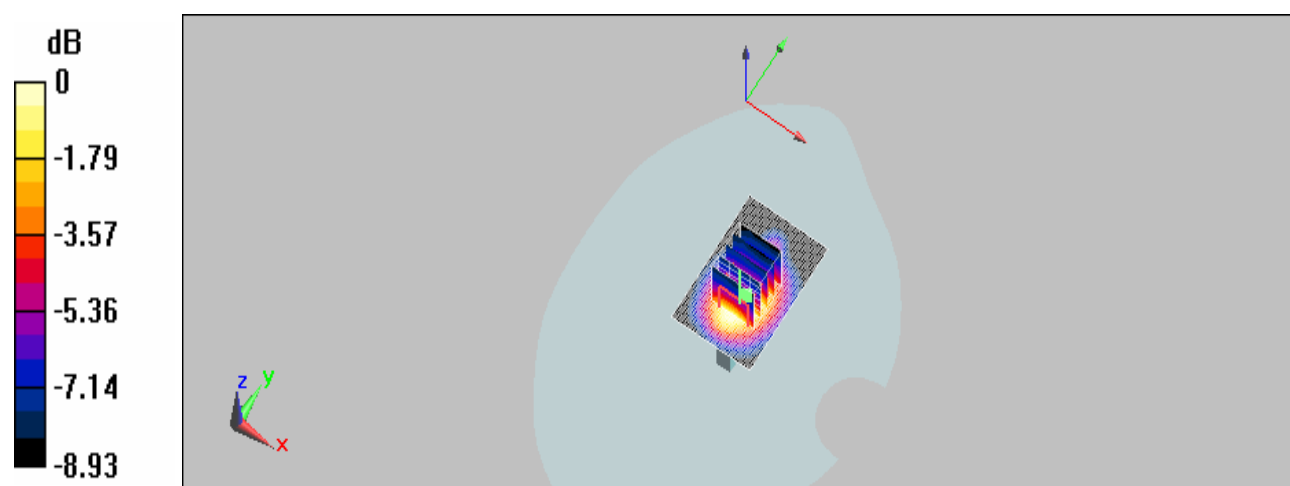

0 dB = 0.047mW/g

5. System Verification

Date/Time: 9/17/2008 02:33

DUT: Dipole 835 MHz; Type: D835V2; Serial:4d063

Communication System: CW; Frequency: 835 MHz; Duty Cycle: 1:1

Medium: HSL900 Medium parameters used: $f = 835 \text{ MHz}$; $\sigma = 0.955 \text{ mho/m}$; $\epsilon_r = 56.2$; $\rho = 1000 \text{ kg/m}^3$

Phantom section: Flat Section

- Probe: ES3DV3 - SN3172; ConvF(5.61, 5.61, 5.61); Calibrated: 6/23/2008
- Sensor-Surface: (Mechanical Surface Detection)
- Electronics: DAE4 Sn856; Calibrated: 5/7/2008
- Phantom: SAM1; Type: SAM;
- Measurement SW: DASY5, V5.0 Build 119; SEMCAD X Version 13.2 Build 87

Pin=250mW, Area Scan: Measurement grid: $dx=15\text{mm}$, $dy=15\text{mm}$

Maximum value of SAR (interpolated) = 2.68 mW/g

Pin=250mW, Zoom Scan: Measurement grid: $dx=5\text{mm}$, $dy=5\text{mm}$, $dz=5\text{mm}$

Reference Value = 54.2 V/m; Power Drift = -0.023 dB

Peak SAR (extrapolated) = 3.4 W/kg

SAR(1 g) = 2.34 mW/g; SAR(10 g) = 1.54 mW/g

Maximum value of SAR (measured) = 2.65 mW/g

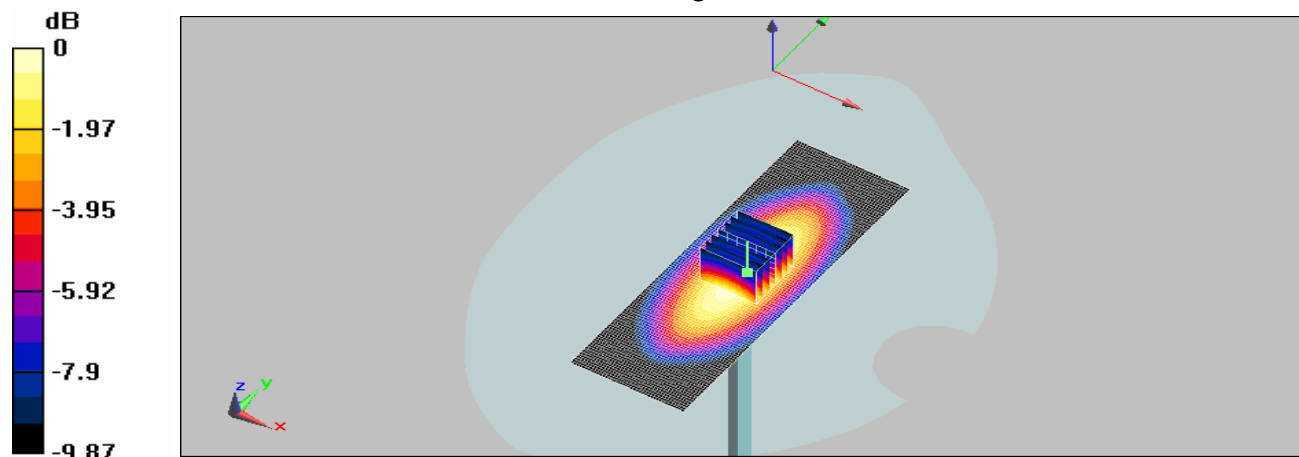

0 dB = 2.65mW/g

DUT: Dipole 835 MHz; Type: D835V2; Serial: 4d063

Communication System: CW; Frequency: 835 MHz; Duty Cycle: 1:1

Medium: HSL900 Medium parameters used: $f = 835$ MHz; $\sigma = 0.955$ mho/m; $\epsilon_r = 56.3$; $\rho = 1000$ kg/m³

Phantom section: Flat Section

- Probe: ES3DV3 - SN3172; ConvF(5.61, 5.61, 5.61); Calibrated: 6/23/2008
- Sensor-Surface: (Mechanical Surface Detection)
- Electronics: DAE4 Sn856; Calibrated: 5/7/2008
- Phantom: SAM1; Type: SAM;
- Measurement SW: DASY5, V5.0 Build 119; SEMCAD X Version 13.2 Build 87

Pin=250mW, Area Scan): Measurement grid: dx=15mm, dy=15mm

Maximum value of SAR (interpolated) = 2.64 mW/g

Pin=250mW, Zoom Scan: Measurement grid: dx=5mm, dy=5mm, dz=5mm

Reference Value = 54 V/m; Power Drift = -0.020 dB

Peak SAR (extrapolated) = 3.38 W/kg

SAR(1 g) = 2.33 mW/g; SAR(10 g) = 1.53 mW/g

Maximum value of SAR (measured) = 2.64 mW/g

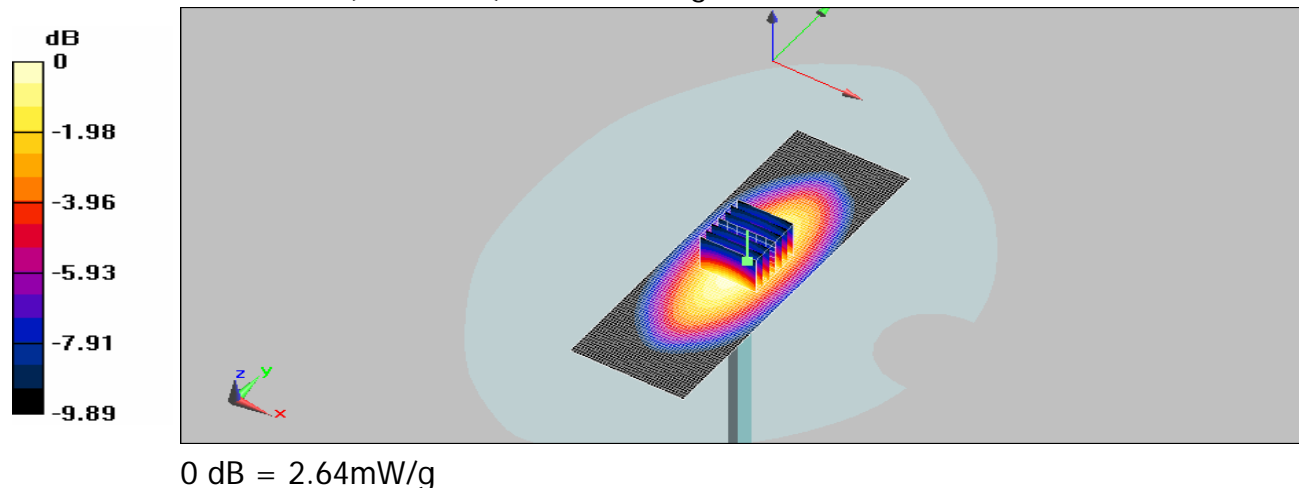

Date/Time: 9/17/2008 12:18

DUT: Dipole 1900 MHz; Type: D1900V2; Serial: 5d027

Communication System: CW; Frequency: 1900 MHz; Duty Cycle: 1:1

Medium: HSL900 Medium parameters used: $f = 1900$ MHz; $\sigma = 1.46$ mho/m; $\epsilon_r = 52.4$; $\rho = 1000$ kg/m³

Phantom section: Flat Section

- Probe: ES3DV3 - SN3172; ConvF(4.73, 4.73, 4.73); Calibrated: 6/23/2008
- Sensor-Surface: (Mechanical Surface Detection)
- Electronics: DAE4 Sn856; Calibrated: 5/7/2008
- Phantom: SAM1; Type: SAM;
- Measurement SW: DASY5, V5.0 Build 119; SEMCAD X Version 13.2 Build 87

Pin=250mW, Area Scan: Measurement grid: dx=15mm, dy=15mm
Maximum value of SAR (interpolated) = 13.4 mW/g**Pin=250mW, Zoom Scan:** Measurement grid: dx=5mm, dy=5mm, dz=5mm
Reference Value = 91.4 V/m; Power Drift = 0.183 dB
Peak SAR (extrapolated) = 17.5 W/kg**SAR(1 g) = 9.6 mW/g; SAR(10 g) = 4.95 mW/g**

Maximum value of SAR (measured) = 11.6 mW/g

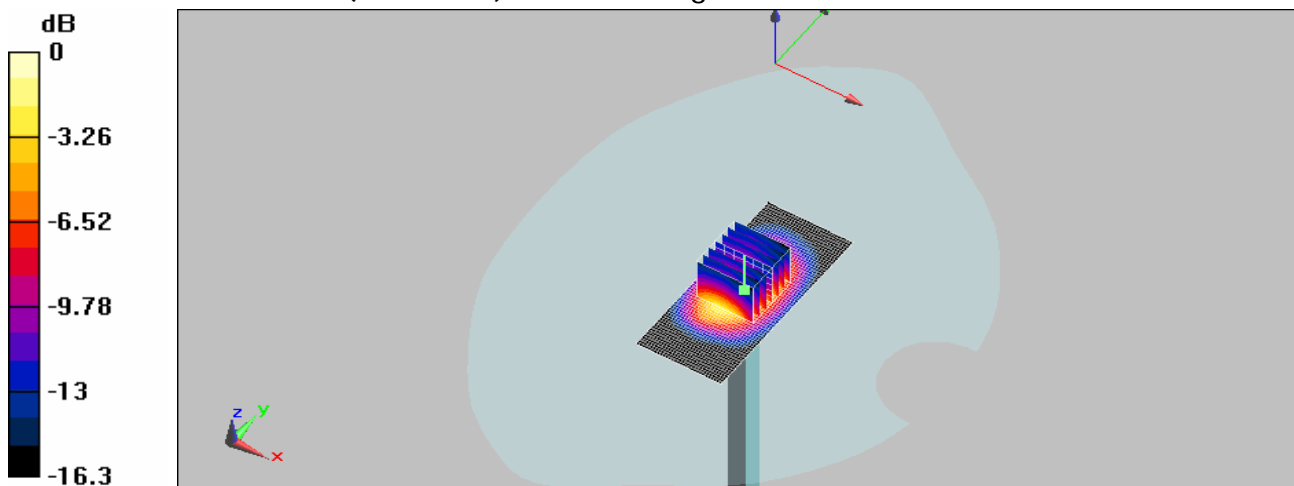

0 dB = 11.6mW/g

Date/Time: 9/18/2008 01:27

DUT: Dipole 1900 MHz; Type: D1900V2; Serial: 5d027

Communication System: CW; Frequency: 1900 MHz; Duty Cycle: 1:1

Medium: HSL900 Medium parameters used: $f = 1900$ MHz; $\sigma = 1.47$ mho/m; $\epsilon_r = 52.4$; $\rho = 1000$ kg/m³

Phantom section: Flat Section

- Probe: ES3DV3 - SN3172; ConvF(4.73, 4.73, 4.73); Calibrated: 6/23/2008
- Sensor-Surface: (Mechanical Surface Detection)
- Electronics: DAE4 Sn856; Calibrated: 5/7/2008
- Phantom: SAM1; Type: SAM;
- Measurement SW: DASY5, V5.0 Build 119; SEMCAD X Version 13.2 Build 87

Pin=250mW, Area Scan: Measurement grid: dx=15mm, dy=15mm
Maximum value of SAR (interpolated) = 14.4 mW/g**Pin=250mW, Zoom Scan:** Measurement grid: dx=5mm, dy=5mm, dz=5mm
Reference Value = 92.2 V/m; Power Drift = -0.047 dB
Peak SAR (extrapolated) = 17.4 W/kg**SAR(1 g) = 9.54 mW/g; SAR(10 g) = 4.92 mW/g**

Maximum value of SAR (measured) = 11.5 mW/g

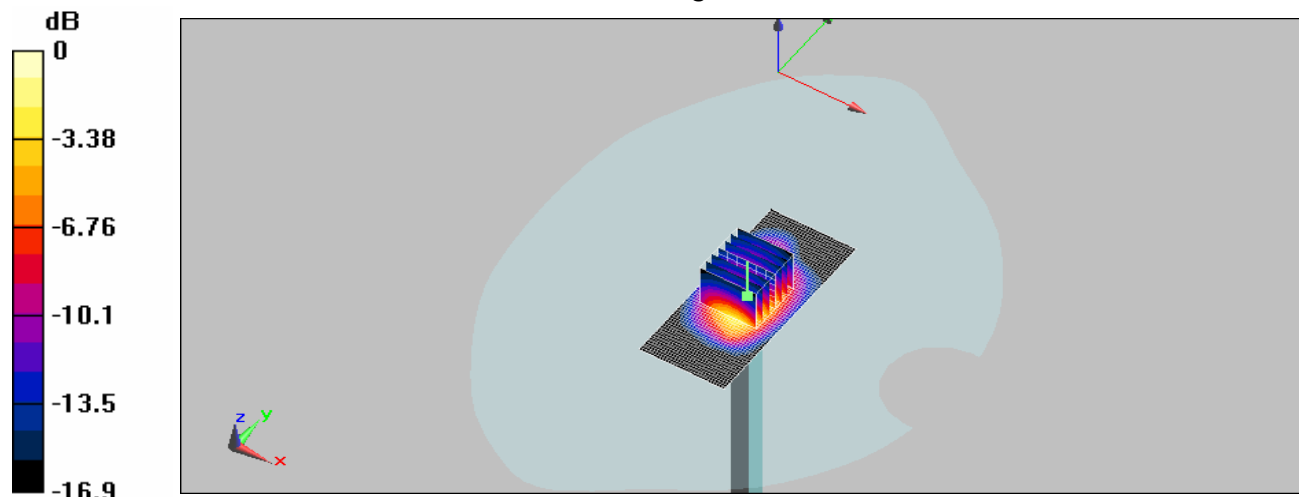

0 dB = 11.5mW/g

Date/Time: 12/5/2008 8:39:31

DUT: Dipole 835 MHz; Type: D835V2; Serial: D835V2 - SN:4d063

Communication System: CW; Frequency: 835 MHz; Duty Cycle: 1:1

Medium: Body 900 Medium parameters used: $f = 835$ MHz; $\sigma = 0.956$ mho/m; $\epsilon_r = 56$; $\rho = 1000$ kg/m³

Phantom section: Flat Section

DASY5 Configuration:

- Probe: ES3DV3 - SN3172; ConvF(5.61, 5.61, 5.61); Calibrated: 6/23/2008
- Sensor-Surface: 3.4mm (Mechanical Surface Detection)
- Electronics: DAE4 Sn856; Calibrated: 5/7/2008
- Phantom: SAM1; Type: SAM;
- Measurement SW: DASY5, V5.0 Build 119; SEMCAD X Version 13.2 Build 87

Pin=250mW, Area Scan : Measurement grid: dx=15mm, dy=15mm

Maximum value of SAR (interpolated) = 2.86 mW/g

Pin=250mW, Zoom Scan: Measurement grid: dx=5mm, dy=5mm, dz=5mm

Reference Value = 55.3 V/m; Power Drift = -0.154 dB

Peak SAR (extrapolated) = 3.59 W/kg

SAR(1 g) = 2.5 mW/g; SAR(10 g) = 1.67 mW/g

Maximum value of SAR (measured) = 2.83 mW/g

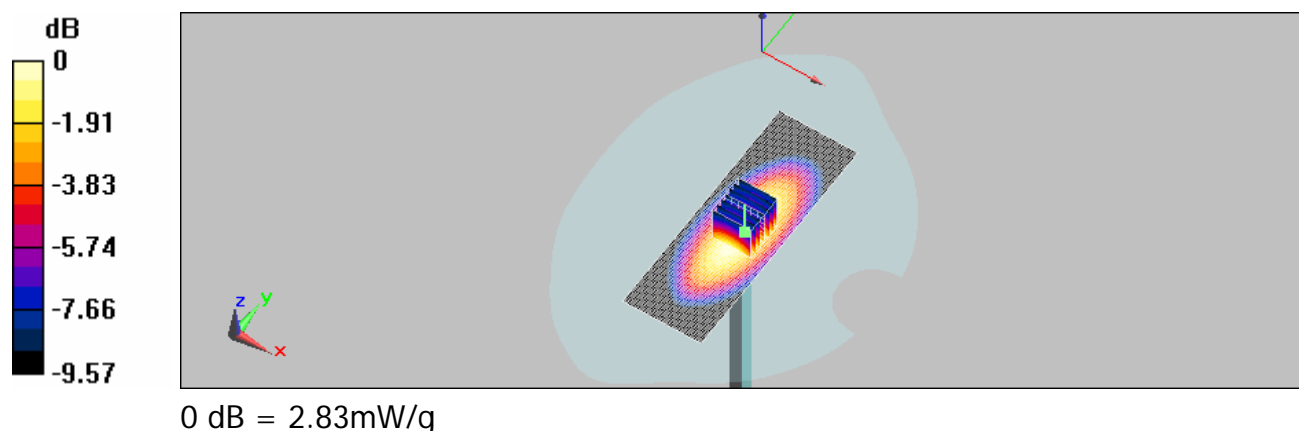

Date/Time: 12/8/2008 5:43:56

DUT: Dipole 1900 MHz; Type: D1900V2; Serial: D1900V2 - SN:5d027

Communication System: CW; Frequency: 1900 MHz; Duty Cycle: 1:1

Medium: HSL1900 Medium parameters used: $f = 1900$ MHz; $\sigma = 1.51$ mho/m; $\epsilon_r = 54.5$; $\rho = 1000$ kg/m³

Phantom section: Flat Section

DASY5 Configuration:

- Probe: ES3DV3 - SN3172; ConvF(4.73, 4.73, 4.73); Calibrated: 6/23/2008
- Sensor-Surface: 3.4mm (Mechanical Surface Detection)
- Electronics: DAE4 Sn856; Calibrated: 5/7/2008
- Phantom: SAM1; Type: SAM;
- Measurement SW: DASY5, V5.0 Build 119; SEMCAD X Version 13.2 Build 87

Pin=250mW, Area Scan : Measurement grid: dx=15mm, dy=15mm

Maximum value of SAR (interpolated) = 12.6 mW/g

Pin=250mW, Zoom Scan : Measurement grid: dx=5mm, dy=5mm, dz=5mm

Reference Value = 89.5 V/m; Power Drift = 0.127 dB

Peak SAR (extrapolated) = 17.7 W/kg

SAR(1 g) = 9.51 mW/g; SAR(10 g) = 4.93 mW/g

Maximum value of SAR (measured) = 11.8 mW/g

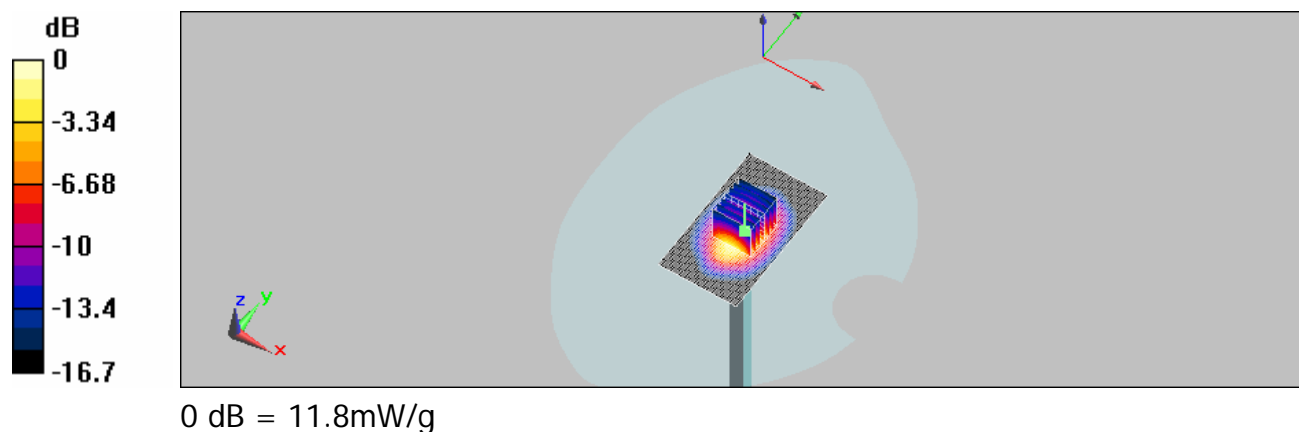

6. DAE & Probe Calibration certificate

**Calibration Laboratory of
Schmid & Partner
Engineering AG**
Zeughausstrasse 43, 8004 Zurich, Switzerland



S Schweizerischer Kalibrierdienst
C Service suisse d'étalonnage
S Servizio svizzero di taratura
S Swiss Calibration Service

Accredited by the Swiss Accreditation Service (SAS)
The Swiss Accreditation Service is one of the signatories to the EA
Multilateral Agreement for the recognition of calibration certificates

Accreditation No.: **SCS 108**

Client

SGS (Aoleu)

Certificate No: **DAE4-856_May08**

CALIBRATION CERTIFICATE

Object: **DAE4 - SD 000 D04 BG - SN: 856**

Calibration procedure(s): **QA CAL-06.v12
Calibration procedure for the data acquisition electronics (DAE)**

Calibration date: **May 7, 2008**

Condition of the calibrated item: **In Tolerance**

This calibration certificate documents the traceability to national standards, which realize the physical units of measurements (SI).
The measurements and the uncertainties with confidence probability are given on the following pages and are part of the certificate.

All calibrations have been conducted in the closed laboratory facility: environment temperature (22 ± 3)°C and humidity < 70%.

Calibration Equipment used (M&TE critical for calibration)

Primary Standards	ID #	Cal Date (Certificate No.)	Scheduled Calibration
Fluke Process Calibrator Type 702	SN: 6295803	04-Oct-07 (No: 6467)	Oct-08
Keithley Multimeter Type 2001	SN: 0610278	03-Oct-07 (No: 6465)	Oct-08
Secondary Standards	ID #	Check Date (in house)	Scheduled Check
Calibrator Box V1.1	SE UMS 006 AB 1004	25-Jun-07 (in house check)	in house check: Jun-08

	Name	Function	Signature
Calibrated by:	Dominique Steffen	Technician	<i>[Signature]</i>
Approved by:	Fin Bornholt	R&D Director	<i>[Signature]</i>

Issued: May 7, 2008

This calibration certificate shall not be reproduced except in full without written approval of the laboratory.

**Calibration Laboratory of
Schmid & Partner
Engineering AG**
Zeughausstrasse 43, 8004 Zurich, Switzerland



S Schweizerischer Kalibrierdienst
C Service suisse d'étalonnage
S Servizio svizzero di taratura
S Swiss Calibration Service

Accredited by the Swiss Accreditation Service (SAS)
The Swiss Accreditation Service is one of the signatories to the EA
Multilateral Agreement for the recognition of calibration certificates

Accreditation No.: **SCS 108**

Client **SGS (Auden)**

Certificate No: **ES3-3172_Jun08**

CALIBRATION CERTIFICATE

Object **ES3DV3 - SN:3172**

Calibration procedure(s) **QA CAL-01.v6 and QA CAL-23.v3
Calibration procedure for dosimetric E-field probes**

Calibration date: **June 23, 2008**

Condition of the calibrated item **In Tolerance**

This calibration certificate documents the traceability to national standards, which realize the physical units of measurements (SI).
The measurements and the uncertainties with confidence probability are given on the following pages and are part of the certificate.

All calibrations have been conducted in the closed laboratory facility: environment temperature (22 ± 3)°C and humidity < 70%.

Calibration Equipment used (M&E critical for calibration)

Primary Standards	ID #	Cal Date (Certificate No.)	Scheduled Calibration
Power meter E4419B	GB41293874	1-Apr-08 (No. 217-00788)	Apr-09
Power sensor E4412A	MY41495277	1-Apr-08 (No. 217-00788)	Apr-09
Power sensor E4412A	MY41498087	1-Apr-08 (No. 217-00788)	Apr-09
Reference 3 dB Attenuator	SN: S5054 (3c)	8-Aug-07 (No. 217-00719)	Aug-08
Reference 20 dB Attenuator	SN: S5086 (20b)	31-Mar-08 (No. 217-00787)	Apr-09
Reference 30 dB Attenuator	SN: S5129 (30b)	8-Aug-07 (No. 217-00720)	Aug-08
Reference Probe ES3DV2	SN: 3013	2-Jan-08 (No. ES3-3013_Jan08)	Jan-09
DAE4	SN: 660	3-Sep-07 (No. DAE4-660_Sep07)	Sep-08
Secondary Standards	ID #	Check Date (in house)	Scheduled Check
RF generator HP 8648C	US3642U01700	4-Aug-99 (in house check Oct-07)	In house check: Oct-09
Network Analyzer HP 8753E	US37390686	18-Oct-01 (in house check Oct-07)	In house check: Oct-08

	Name	Function	Signature
Calibrated by:	Katja Pokovic	Technical Manager	
Approved by:	Niele Kuster	Quality Manager	

Issued: June 24, 2008

This calibration certificate shall not be reproduced except in full without written approval of the laboratory.

Calibration Laboratory of
Schmid & Partner
 Engineering AG
 Zeughausstrasse 43, 8004 Zurich, Switzerland



S Schweizerischer Kalibrierdienst
C Service suisse d'étalonnage
S Servizio svizzero di taratura
S Swiss Calibration Service

Accredited by the Swiss Accreditation Service (SAS)
 The Swiss Accreditation Service is one of the signatories to the EA
 Multilateral Agreement for the recognition of calibration certificates

Accreditation No.: SCS 108

Glossary:

TSL	tissue simulating liquid
NORM _{x,y,z}	sensitivity in free space
ConvF	sensitivity in TSL / NORM _{x,y,z}
DCP	diode compression point
Polarization ϕ	ϕ rotation around probe axis
Polarization ϑ	ϑ rotation around an axis that is in the plane normal to probe axis (at measurement center), i.e., $\vartheta = 0$ is normal to probe axis

Calibration is Performed According to the Following Standards:

- IEEE Std 1528-2003, "IEEE Recommended Practice for Determining the Peak Spatial-Averaged Specific Absorption Rate (SAR) in the Human Head from Wireless Communications Devices: Measurement Techniques", December 2003
- IEC 62209-1, "Procedure to measure the Specific Absorption Rate (SAR) for hand-held devices used in close proximity to the ear (frequency range of 300 MHz to 3 GHz)", February 2005

Methods Applied and Interpretation of Parameters:

- NORM_{x,y,z}:** Assessed for E-field polarization $\vartheta = 0$ ($f \leq 900$ MHz in TEM-cell; $f > 1800$ MHz: R22 waveguide). NORM_{x,y,z} are only intermediate values, i.e., the uncertainties of NORM_{x,y,z} does not effect the E²-field uncertainty inside TSL (see below ConvF).
- NORM(f)_{x,y,z} = NORM_{x,y,z} * frequency_response** (see Frequency Response Chart). This linearization is implemented in DASY4 software versions later than 4.2. The uncertainty of the frequency response is included in the stated uncertainty of ConvF.
- DCP_{x,y,z}:** DCP are numerical linearization parameters assessed based on the data of power sweep (no uncertainty required). DCP does not depend on frequency nor media.
- ConvF and Boundary Effect Parameters:** Assessed in flat phantom using E-field (or Temperature Transfer Standard for $f \leq 800$ MHz) and inside waveguide using analytical field distributions based on power measurements for $f > 800$ MHz. The same setups are used for assessment of the parameters applied for boundary compensation (alpha, depth) of which typical uncertainty values are given. These parameters are used in DASY4 software to improve probe accuracy close to the boundary. The sensitivity in TSL corresponds to NORM_{x,y,z} * ConvF whereby the uncertainty corresponds to that given for ConvF. A frequency dependent ConvF is used in DASY version 4.4 and higher which allows extending the validity from ± 50 MHz to ± 100 MHz.
- Spherical isotropy (3D deviation from isotropy):** in a field of low gradients realized using a flat phantom exposed by a patch antenna.
- Sensor Offset:** The sensor offset corresponds to the offset of virtual measurement center from the probe tip (on probe axis). No tolerance required.

ES3DV3 SN:3172

June 23, 2008

Probe ES3DV3

SN:3172

Manufactured: January 23, 2008

Calibrated: June 23, 2008

Calibrated for DASY Systems

(Note: non-compatible with DASY2 system!)

ES3DV3 SN:3172

June 23, 2008

DASY - Parameters of Probe: ES3DV3 SN:3172

Sensitivity in Free Space ^A			Diode Compression ^B	
NormX	1.38 ± 10.1%	$\mu\text{V}/(\text{V}/\text{m})^2$	DCP X	93 mV
NormY	1.15 ± 10.1%	$\mu\text{V}/(\text{V}/\text{m})^2$	DCP Y	93 mV
NormZ	0.94 ± 10.1%	$\mu\text{V}/(\text{V}/\text{m})^2$	DCP Z	89 mV

Sensitivity in Tissue Simulating Liquid (Conversion Factors)

Please see Page 8.

Boundary Effect

TSL	900 MHz	Typical SAR gradient: 5 % per mm		
	Sensor Center to Phantom Surface Distance		3.0 mm	4.0 mm
	SAR _{be} [%]	Without Correction Algorithm	11.8	6.1
	SAR _{be} [%]	With Correction Algorithm	0.6	0.2
TSL	1810 MHz	Typical SAR gradient: 10 % per mm		
	Sensor Center to Phantom Surface Distance		3.0 mm	4.0 mm
	SAR _{be} [%]	Without Correction Algorithm	10.2	6.5
	SAR _{be} [%]	With Correction Algorithm	0.4	0.4

Sensor Offset

Probe Tip to Sensor Center **2.0 mm**

The reported uncertainty of measurement is stated as the standard uncertainty of measurement multiplied by the coverage factor k=2, which for a normal distribution corresponds to a coverage probability of approximately 95%.

^A The uncertainties of NormX,Y,Z do not affect the E²-field uncertainty inside TSL (see Page 8).

^B Numerical linearization parameter: uncertainty not required.

ES3DV3 SN:3172

June 23, 2008

Frequency Response of E-Field
(TEM-Cell:ifi110 EXX, Waveguide: R22)

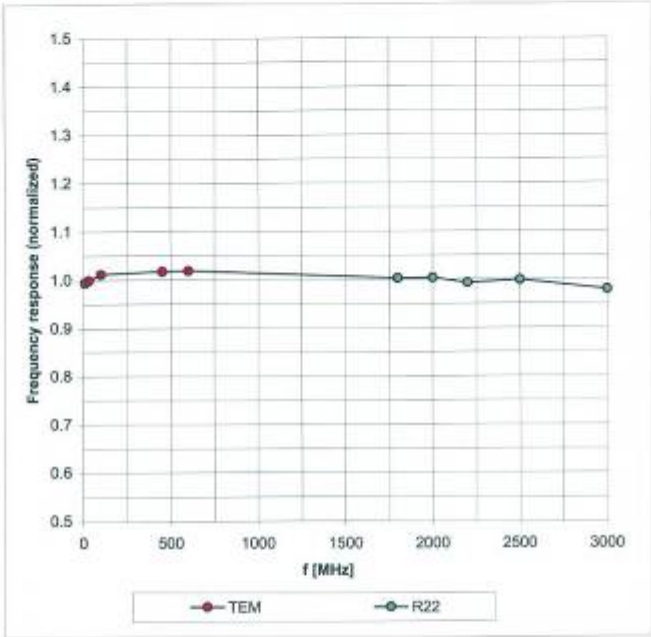

Uncertainty of Frequency Response of E-field: $\pm 6.3\%$ (k=2)

ES3DV3 SN:3172

June 23, 2008

Receiving Pattern (ϕ), $\theta = 0^\circ$

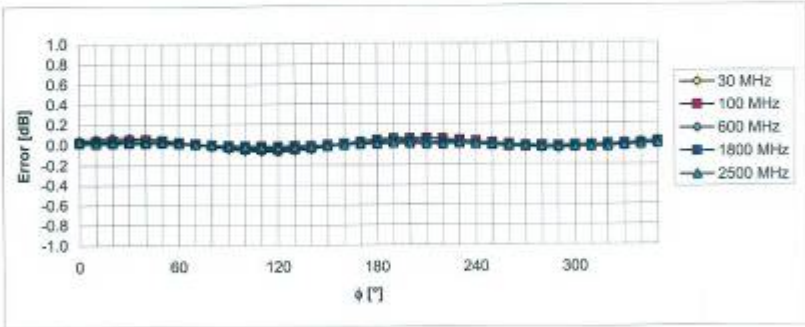
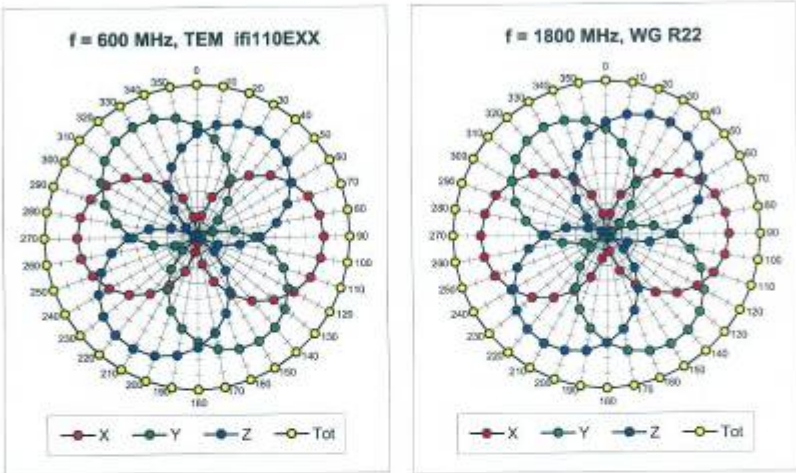

Uncertainty of Axial Isotropy Assessment: $\pm 0.5\%$ (k=2)

ES3DV3 SN:3172

June 23, 2008

Dynamic Range $f(\text{SAR}_{\text{head}})$ (Waveguide R22, $f = 1800$ MHz)

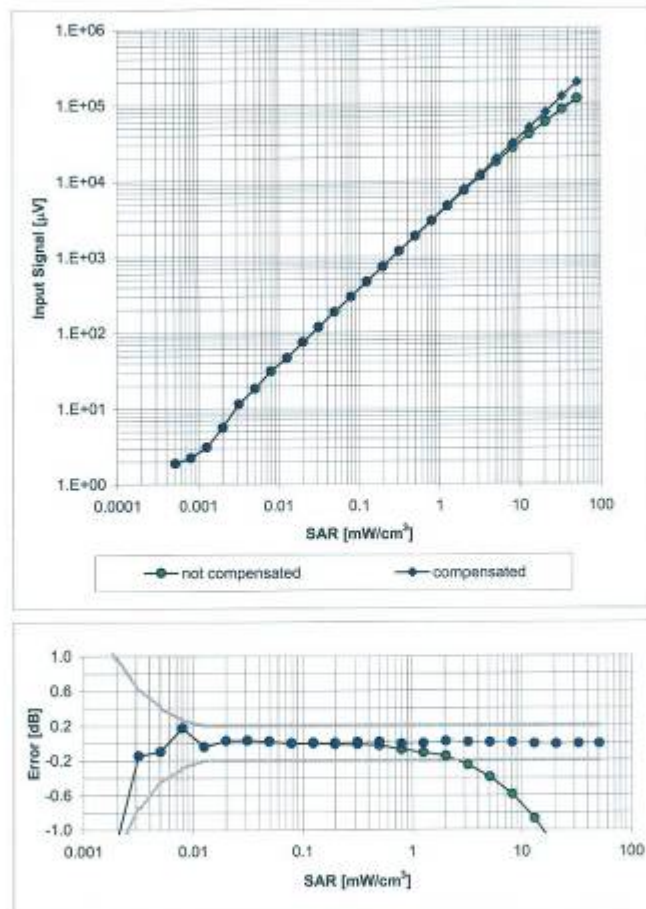

Uncertainty of Linearity Assessment: $\pm 0.6\%$ ($k=2$)

ES3DV3 SN:3172

June 23, 2008

Conversion Factor Assessment

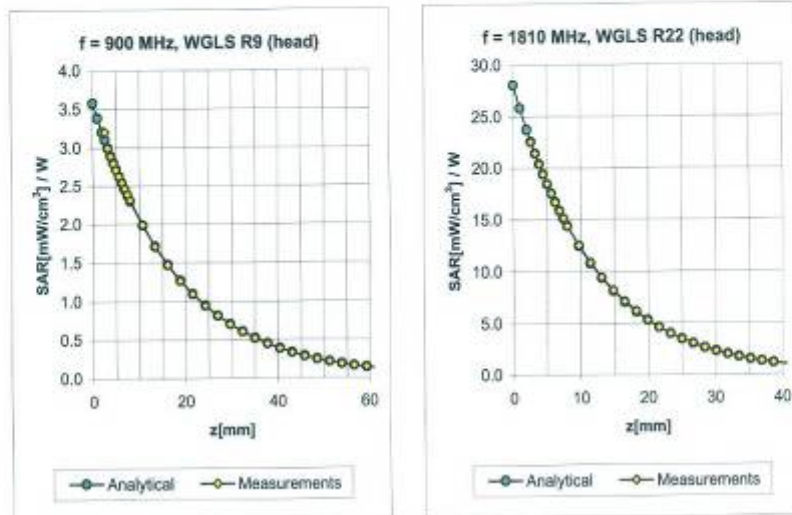

f [MHz]	Validity [MHz] ^c	TSL	Permittivity	Conductivity	Alpha	Depth	ConvF Uncertainty
900	± 50 / ± 100	Head	41.5 ± 5%	0.97 ± 5%	0.23	2.36	5.66 ± 11.0% (k=2)
1810	± 50 / ± 100	Head	40.0 ± 5%	1.40 ± 5%	0.32	2.07	4.97 ± 11.0% (k=2)
1950	± 50 / ± 100	Head	40.0 ± 5%	1.40 ± 5%	0.65	1.40	4.80 ± 11.0% (k=2)
2450	± 50 / ± 100	Head	39.2 ± 5%	1.80 ± 5%	0.72	1.34	4.38 ± 11.0% (k=2)
900	± 50 / ± 100	Body	55.0 ± 5%	1.05 ± 5%	0.35	1.83	5.61 ± 11.0% (k=2)
1810	± 50 / ± 100	Body	53.3 ± 5%	1.52 ± 5%	0.55	1.50	4.73 ± 11.0% (k=2)
1950	± 50 / ± 100	Body	53.3 ± 5%	1.52 ± 5%	0.80	1.35	4.57 ± 11.0% (k=2)
2450	± 50 / ± 100	Body	52.7 ± 5%	1.95 ± 5%	0.75	1.25	3.92 ± 11.0% (k=2)

^c The validity of ± 100 MHz only applies for DASY v4.4 and higher (see Page 2). The uncertainty is the RSS of the ConvF uncertainty at calibration frequency and the uncertainty for the indicated frequency band.

ES3DV3 SN:3172

June 23, 2008

Deviation from Isotropy in HSL
Error (ϕ , θ), $f = 900$ MHz

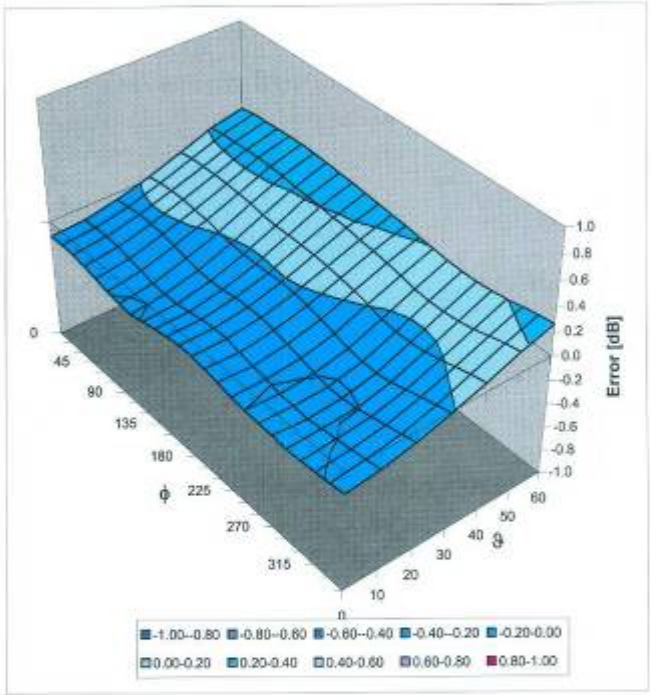

Uncertainty of Spherical Isotropy Assessment: $\pm 2.6\%$ ($k=2$)

7. Uncertainty Analysis

DASY5 Uncertainty Budget According to IEEE 1528 [1]								
Error Description	Uncertainty value	Prob. Dist.	Div.	(c_i) 1g	(c_i) 10g	Std. Unc. (1g)	Std. Unc. (10g)	(v_i) v_{eff}
Measurement System								
Probe Calibration	±5.9%	N	1	1	1	±5.9%	±5.9%	∞
Axial Isotropy	±4.7%	R	$\sqrt{3}$	0.7	0.7	±1.9%	±1.9%	∞
Hemispherical Isotropy	±9.6%	R	$\sqrt{3}$	0.7	0.7	±3.9%	±3.9%	∞
Boundary Effects	±1.0%	R	$\sqrt{3}$	1	1	±0.6%	±0.6%	∞
Linearity	±4.7%	R	$\sqrt{3}$	1	1	±2.7%	±2.7%	∞
System Detection Limits	±1.0%	R	$\sqrt{3}$	1	1	±0.6%	±0.6%	∞
Readout Electronics	±0.3%	N	1	1	1	±0.3%	±0.3%	∞
Response Time	±0.8%	R	$\sqrt{3}$	1	1	±0.5%	±0.5%	∞
Integration Time	±2.6%	R	$\sqrt{3}$	1	1	±1.5%	±1.5%	∞
RF Ambient Noise	±3.0%	R	$\sqrt{3}$	1	1	±1.7%	±1.7%	∞
RF Ambient Reflections	±3.0%	R	$\sqrt{3}$	1	1	±1.7%	±1.7%	∞
Probe Positioner	±0.4%	R	$\sqrt{3}$	1	1	±0.2%	±0.2%	∞
Probe Positioning	±2.9%	R	$\sqrt{3}$	1	1	±1.7%	±1.7%	∞
Max. SAR Eval.	±1.0%	R	$\sqrt{3}$	1	1	±0.6%	±0.6%	∞
Test Sample Related								
Device Positioning	±2.9%	N	1	1	1	±2.9%	±2.9%	145
Device Holder	±3.6%	N	1	1	1	±3.6%	±3.6%	5
Power Drift	±5.0%	R	$\sqrt{3}$	1	1	±2.9%	±2.9%	∞
Phantom and Setup								
Phantom Uncertainty	±4.0%	R	$\sqrt{3}$	1	1	±2.3%	±2.3%	∞
Liquid Conductivity (target)	±5.0%	R	$\sqrt{3}$	0.64	0.43	±1.8%	±1.2%	∞
Liquid Conductivity (meas.)	±2.5%	N	1	0.64	0.43	±1.6%	±1.1%	∞
Liquid Permittivity (target)	±5.0%	R	$\sqrt{3}$	0.6	0.49	±1.7%	±1.4%	∞
Liquid Permittivity (meas.)	±2.5%	N	1	0.6	0.49	±1.5%	±1.2%	∞
Combined Std. Uncertainty						±10.9%	±10.7%	387
Expanded STD Uncertainty						±21.9%	±21.4%	

8. Phantom description

Schmid & Partner Engineering AG

s p e a g

Zeughausstrasse 43, 8004 Zurich, Switzerland
 Phone +41 1 245 9700, Fax +41 1 245 9779
 info@speag.com, http://www.speag.com

Certificate of Conformity / First Article Inspection

Item	SAM Twin Phantom V4.0
Type No	QD 000 P40 C
Series No	TP-1150 and higher
Manufacturer	SPEAG Zeughausstrasse 43 CH-8004 Zurich Switzerland

Tests

The series production process used allows the limitation to test of first articles.
 Complete tests were made on the pre-series Type No. QD 000 P40 AA, Serial No. TP-1001 and on the series first article Type No. QD 000 P40 BA, Serial No. TP-1006. Certain parameters have been retested using further series items (called samples) or are tested at each item.

Test	Requirement	Details	Units tested
Dimensions	Compliant with the geometry according to the CAD model.	IT'IS CAD File (*)	First article, Samples
Material thickness of shell	Compliant with the requirements according to the standards	2mm +/- 0.2mm in flat and specific areas of head section	First article, Samples, TP-1314 ff.
Material thickness at ERP	Compliant with the requirements according to the standards	6mm +/- 0.2mm at ERP	First article, All items
Material parameters	Dielectric parameters for required frequencies	300 MHz – 6 GHz: Relative permittivity < 5, Loss tangent < 0.05	Material samples
Material resistivity	The material has been tested to be compatible with the liquids defined in the standards if handled and cleaned according to the instructions. Observe technical Note for material compatibility.	DEGMBE based simulating liquids	Pre-series, First article, Material samples
Sagging	Compliant with the requirements according to the standards. Sagging of the flat section when filled with tissue simulating liquid.	< 1% typical < 0.8% if filled with 155mm of HSL900 and without DUT below	Prototypes, Sample testing

Standards

- [1] CENELEC EN 50361
 - [2] IEEE Std 1528-2003
 - [3] IEC 62209 Part I
 - [4] FCC OET Bulletin 65, Supplement C, Edition 01-01
- (*) The IT'IS CAD file is derived from [2] and is also within the tolerance requirements of the shapes of the other documents.

Conformity

Based on the sample tests above, we certify that this item is in compliance with the uncertainty requirements of SAR measurements specified in standards [1] to [4].

Date 07.07.2005

s p e a g

Signature / Stamp

Schmid & Partner Engineering AG
 Zeughausstrasse 43, 8004 Zurich, Switzerland
 Phone +41 1 245 9700, Fax +41 1 245 9779
 info@speag.com, http://www.speag.com

9. System Validation from Original equipment supplier

**Calibration Laboratory of
Schmid & Partner
Engineering AG**
Zeughausstrasse 43, 8004 Zurich, Switzerland



S Schweizerischer Kalibrierdienst
C Service suisse d'étalonnage
S Servizio svizzero di taratura
S Swiss Calibration Service

Accredited by the Swiss Accreditation Service (SAS)
The Swiss Accreditation Service is one of the signatories to the EA
Multilateral Agreement for the recognition of calibration certificates

Accreditation No.: **SCS 108**

Client **SGS (Auden)**

Certificate No: **D835V2-4d063_Jun08**

CALIBRATION CERTIFICATE

Object: **D835V2 - SN: 4d063**

Calibration procedure(s): **QA CAL-05.v7
Calibration procedure for dipole validation kits**

Calibration date: **June 06, 2008**

Condition of the calibrated item: **In Tolerance**

This calibration certificate documents the traceability to national standards, which realize the physical units of measurements (SI).
The measurements and the uncertainties with confidence probability are given on the following pages and are part of the certificate.

All calibrations have been conducted in the closed laboratory facility: environment temperature (22 ± 3)°C and humidity < 70%.

Calibration Equipment used (M&TE critical for calibration)

Primary Standards	ID #	Cal Date (Calibrated by, Certificate No.)	Scheduled Calibration
Power meter EPM-442A	GB37480704	04-Oct-07 (METAS, No. 217-00736)	Oct-08
Power sensor HP 8481A	US37292783	04-Oct-07 (METAS, No. 217-00736)	Oct-08
Reference 20 dB Attenuator	SN: 5086 (20g)	07-Aug-07 (METAS, No 217-00718)	Aug-08
Type-N mismatch combination	SN: 5047.2 / 06327	08-Aug-07 (No. 217-00721)	Aug-08
Reference Probe ES3DV2	SN: 3025	28-Apr-08 (No. ES3-3025_Apr08)	Apr-09
DAE4	SN: 601	14-Mar-08 (No. DAE4-601_Mar08)	Mar-09
Secondary Standards	ID #	Check Date (in house)	Scheduled Check
Power sensor HP 8481A	MY41092317	18-Oct-02 (SPEAG, in house check Oct-07)	In house check: Oct-09
RF generator R&S SMT-06	100006	04-Aug-99 (SPEAG, in house check Oct-07)	In house check: Oct-09
Network Analyzer HP 8753E	US37390585 S4206	18-Oct-01 (SPEAG, in house check Oct-07)	In house check: Oct-08

	Name	Function	Signature
Calibrated by:	Jeton Kastrati	Laboratory Technician	
Approved by:	Katja Pokovic	Technical Manager	

Issued: June 13, 2008

This calibration certificate shall not be reproduced except in full without written approval of the laboratory.

DASY4 Validation Report for Body TSL

Date/Time: 06.06.2008 14:01:1

Test Laboratory: SPEAG, Zurich, Switzerland

DUT: Dipole 835 MHz; Type: D835V2; Serial: D835V2 - SN:4d063

Communication System: CW; Frequency: 835 MHz; Duty Cycle: 1:1

Medium: MSL900;

Medium parameters used: $f = 835$ MHz; $\sigma = 0.99$ mho/m; $\epsilon_r = 53.4$; $\rho = 1000$ kg/m³

Phantom section: Flat Section

Measurement Standard: DASY4 (High Precision Assessment)

DASY4 Configuration:

- Probe: ES3DV2 - SN3025; CoevF(5.9, 5.9, 5.9); Calibrated: 28.04.2008
- Sensor-Surface: 3.4mm (Mechanical Surface Detection)
- Electronics: DAE4 Sn601; Calibrated: 14.03.2008
- Phantom: Flat Phantom 4.9L; Type: QD000P49AA; ;
- Measurement SW: DASY4, V4.7 Build 71; Postprocessing SW: SEMCAD, V1.8 Build 184

Pin = 250mW, d = 15mm/Zoom Scan (7x7x7)/Cube 0: Measurement grid: dx=5mm, dy=5mm, dz=5mm

Reference Value = 53.6 V/m; Power Drift = 0.010 dB

Peak SAR (extrapolated) = 3.53 W/kg

SAR(1 g) = 2.44 mW/g; SAR(10 g) = 1.61 mW/g

Maximum value of SAR (measured) = 2.73 mW/g

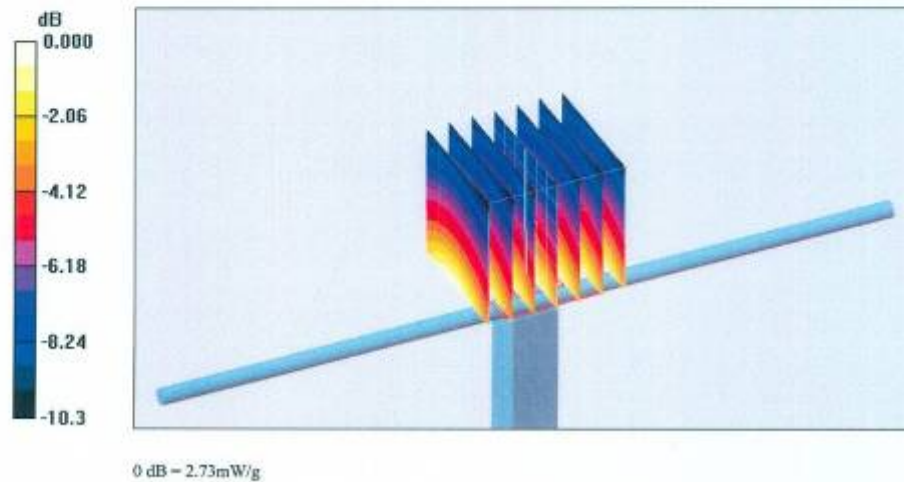

Calibration Laboratory of
Schmid & Partner
Engineering AG
Zaughausstrasse 43, 8004 Zurich, Switzerland



S Schweizerischer Kalibrierdienst
S Service suisse d'étalonnage
S Servizio svizzero di taratura
S Swiss Calibration Service

Accredited by the Swiss Federal Office of Metrology and Accreditation
The Swiss Accreditation Service is one of the signatories to the EA
Multilateral Agreement for the recognition of calibration certificates

Accreditation No.: SCS 108

Client **SGS (Auden)**

Certificate No: D1900V2-5d027_Apr08

CALIBRATION CERTIFICATE

Object: **D1900V2 - SN: 5d027**

Calibration procedure(s): **QA CAL-05.v7
Calibration procedure for dipole validation kits**

Calibration date: **April 15, 2008**

Condition of the calibrated item: **In Tolerance**

This calibration certificate documents the traceability to national standards, which realize the physical units of measurements (SI).
The measurements and the uncertainties with confidence probability are given on the following pages and are part of the certificate.

All calibrations have been conducted in the closed laboratory facility: environment temperature (22 ± 3)°C and humidity < 70%.

Calibration Equipment used (M&TE critical for calibration)

Primary Standards	ID #	Cal Date (Calibrated by, Certificate No.)	Scheduled Calibration
Power meter EPM-442A	GB37480704	04-Oct-07 (No. 217-00736)	Oct-08
Power sensor HP 8481A	US37292783	04-Oct-07 (No. 217-00736)	Oct-08
Reference 20 dB Attenuator	SN: 5086 (20g)	07-Aug-07 (No. 217-00718)	Aug-08
Type-N mismatch combination	SN: 5047.2 / 06327	08-Aug-07 (No. 217-00721)	Aug-08
Reference Probe ES3DV2	SN: 3025	01-Mar-08 (No. ES3-3025_Mar08)	Mar-09
DAE4	SN: 601	14-Mar-08 (No. DAE4-601_Mar08)	Mar-09
Secondary Standards	ID #	Check Date (in house)	Scheduled Check
Power sensor HP 8481A	MY41092317	18-Oct-02 (in house check Oct-07)	In house check: Oct-08
RF generator R&S SMT-06	100005	4-Aug-99 (in house check Oct-07)	In house check: Oct-09
Network Analyzer HP 8753E	US37390585 S4206	18-Oct-01 (in house check Oct-07)	In house check: Oct-08

	Name	Function	Signature
Calibrated by:	Marcel Fehr	Laboratory Technician	
Approved by:	Katja Pokovic	Technical Manager	

Issued: April 17, 2008

This calibration certificate shall not be reproduced except in full without written approval of the laboratory.

DASY4 Validation Report for Body TSL

Date/Time: 15.04.2008 13:51:25

Test Laboratory: SPEAG, Zurich, Switzerland

DUT: Dipole 1900 MHz; Type: D1900V2; Serial: D1900V2 - SN:5d027

Communication System: CW; Frequency: 1900 MHz; Duty Cycle: 1:1

Medium: MSL U10 BB;

Medium parameters used: $f = 1900$ MHz; $\sigma = 1.56$ mho/m; $\epsilon_r = 51.6$; $\rho = 1000$ kg/m³

Phantom section: Flat Section

Measurement Standard: DASY4 (High Precision Assessment)

DASY4 Configuration:

- Probe: ES3DV2 - SN3025; ConvF(4.5, 4.5, 4.5); Calibrated: 01.03.2008
- Sensor-Surface: 3.4mm (Mechanical Surface Detection)
- Electronics: DAE4 Sn801; Calibrated: 14.03.2008
- Phantom: Flat Phantom 5.0 (back); Type: QD000P50AA; ;
- Measurement SW: DASY4, V4.7 Build 55; Postprocessing SW: SEMCAD, V1.8 Build 172

Pin = 250 mW; d = 10 mm/Zoom Scan (7x7x7)/Cube 0:

Measurement grid: dx=5mm, dy=5mm, dz=5mm

Reference Value = 89.3 V/m; Power Drift = -0.022 dB

Peak SAR (extrapolated) = 17.4 W/kg

SAR(1 g) = 9.64 mW/g; SAR(10 g) = 5.07 mW/g

Maximum value of SAR (measured) = 11.7 mW/g

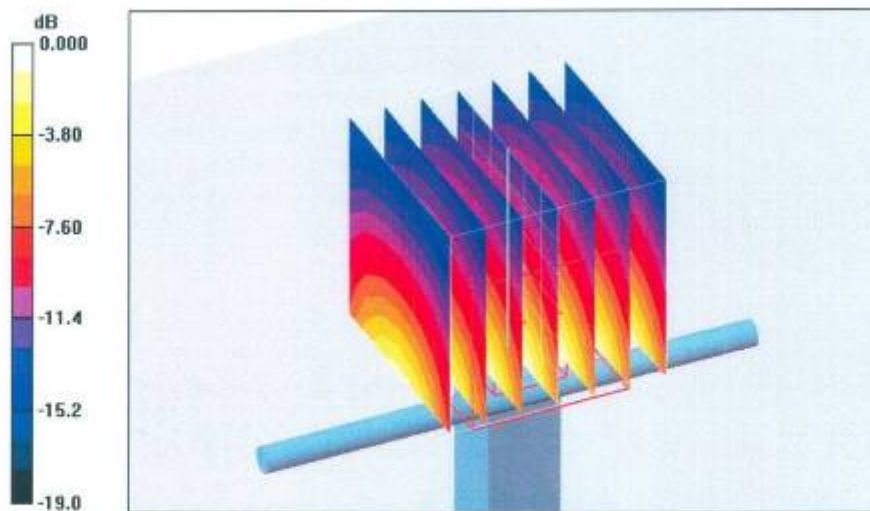
**End of 1st part of report**