



FCC TEST REPORT (PART 24)

REPORT NO.: RF140225C37

MODEL NO.: E580P

FCC ID: UZI-580P

RECEIVED: Feb. 25, 2014

TESTED: Mar. 11 ~ Mar. 18, 2014

ISSUED: Mar. 24, 2014

APPLICANT: BandRich Inc.

ADDRESS: 6F., No. 71, Zhouzi St., Neihu Dist., Taipei City
11493, Taiwan (R.O.C.)

ISSUED BY: Bureau Veritas Consumer Products Services
(H.K.) Ltd., Taoyuan Branch

LAB ADDRESS: No. 47, 14th Ling, Chia Pau Vil., Lin Kou Dist.,
New Taipei City, Taiwan (R.O.C.)

TEST LOCATION: No. 19, Hwa Ya 2nd Rd, Wen Hwa Tsuen, Kwei
Shan Hsiang, Taoyuan Hsien 333, Taiwan, R.O.C.

This report should not be used by the client to claim product certification, approval, or endorsement by TAF or any government agencies.



This report is for your exclusive use. Any copying or replication of this report to or for any other person or entity, or use of our name or trademark, is permitted only with our prior written permission. This report sets forth our findings solely with respect to the test samples identified herein. The results set forth in this report are not indicative or representative of the quality or characteristics of the lot from which a test sample was taken or any similar or identical product unless specifically and expressly noted. Our report includes all of the tests requested by you and the results thereof based upon the information that you provided to us. You have 60 days from date of issuance of this report to notify us of any material error or omission caused by our negligence, provided, however, that such notice shall be in writing and shall specifically address the issue you wish to raise. A failure to raise such issue within the prescribed time shall constitute your unqualified acceptance of the completeness of this report, the tests conducted and the correctness of the report contents. Unless specific mention, the uncertainty of measurement has been explicitly taken into account to declare the compliance or non-compliance to the specification.

TABLE OF CONTENTS

RELEASE CONTROL RECORD	3
1 CERTIFICATION	4
2 SUMMARY OF TEST RESULTS	5
2.1 MEASUREMENT UNCERTAINTY	5
2.2 TEST INSTRUMENTS	6
3 GENERAL INFORMATION	7
3.1 GENERAL DESCRIPTION OF EUT	7
3.2 CONFIGURATION OF SYSTEM UNDER TEST	9
3.3 DESCRIPTION OF SUPPORT UNITS	9
3.4 DESCRIPTION OF TEST MODES	10
3.5 EUT OPERATING CONDITIONS	12
3.6 GENERAL DESCRIPTION OF APPLIED STANDARDS	12
4 TEST TYPES AND RESULTS	13
4.1 OUTPUT POWER MEASUREMENT	13
4.1.1 LIMITS OF OUTPUT POWER MEASUREMENT	13
4.1.2 TEST PROCEDURES	13
4.1.3 TEST SETUP	14
4.1.4 TEST RESULTS	15
4.2 FREQUENCY STABILITY MEASUREMENT	23
4.2.1 LIMITS OF FREQUENCY STABILITY MEASUREMENT	23
4.2.2 TEST PROCEDURE	23
4.2.3 TEST SETUP	23
4.2.4 TEST RESULTS	24
4.3 OCCUPIED BANDWIDTH MEASUREMENT	25
4.3.1 TEST PROCEDURES	25
4.3.2 TEST SETUP	25
4.3.3 TEST RESULTS	26
4.4 PEAK TO AVERAGE RATIO	29
4.4.1 LIMITS OF PEAK TO AVERAGE RATIO MEASUREMENT	29
4.4.2 TEST SETUP	29
4.4.3 TEST PROCEDURES	29
4.4.4 TEST RESULTS	30
4.5 BAND EDGE MEASUREMENT	33
4.5.1 LIMITS OF BAND EDGE MEASUREMENT	33
4.5.2 TEST SETUP	33
4.5.3 TEST PROCEDURES	33
4.5.4 TEST RESULTS	34
4.6 CONDUCTED SPURIOUS EMISSIONS	38
4.6.1 LIMITS OF CONDUCTED SPURIOUS EMISSIONS MEASUREMENT	38
4.6.2 TEST PROCEDURE	38
4.6.3 TEST SETUP	38
4.6.4 TEST RESULTS	39
4.7 RADIATED EMISSION MEASUREMENT	54
4.7.1 LIMITS OF RADIATED EMISSION MEASUREMENT	54
4.7.2 TEST PROCEDURES	54
4.7.3 DEVIATION FROM TEST STANDARD	54
4.7.4 TEST SETUP	55
4.7.5 TEST RESULTS	56
5 PHOTOGRAPHS OF THE TEST CONFIGURATION	68
6 INFORMATION ON THE TESTING LABORATORIES	69
7 APPENDIX A – MODIFICATIONS RECORDERS FOR ENGINEERING CHANGES TO THE EUT BY THE LAB	70



RELEASE CONTROL RECORD

ISSUE NO.	REASON FOR CHANGE	DATE ISSUED
RF140225C37	Original release	Mar. 24, 2014



1 CERTIFICATION

PRODUCT: LTE Outdoor CPE
MODEL NO.: E580P
BRAND: BandLuxe
APPLICANT: BandRich Inc.
TEST SAMPLE: ENGINEERING SAMPLE
TESTED: Mar. 11 ~ Mar. 18, 2014
TEST STANDARDS: **FCC Part 24, Subpart E**
FCC Part 2

The above equipment (model: E580P) has been tested by **Bureau Veritas Consumer Products Services (H.K.) Ltd., Taoyuan Branch**, and found compliance with the requirement of the above standards. The test record, data evaluation & Equipment Under Test (EUT) configurations represented herein are true and accurate accounts of the measurements of the sample's EMC characteristics under the conditions specified in this report.

PREPARED BY :  , **DATE :** Mar. 24, 2014
Pettie Chen / Senior Specialist

APPROVED BY :  , **DATE :** Mar. 24, 2014
Ivan Tsai / Project Engineer

2 SUMMARY OF TEST RESULTS

The EUT has been tested according to the following specifications:

STANDARD SECTION	TEST TYPE AND LIMIT	RESULT	REMARK
2.1046 24.232	Equivalent isotropically radiated power	PASS	Meet the requirement of limit.
2.1055 24.235	Frequency Stability	PASS	Meet the requirement of limit.
2.1049 24.238(b)	Occupied Bandwidth	PASS	Meet the requirement of limit.
24.238(b)	Band Edge Measurements	PASS	Meet the requirement of limit.
2.1051 24.238	Conducted Spurious Emissions	PASS	Meet the requirement of limit.
2.1053 24.238	Radiated Spurious Emissions	PASS	Meet the requirement of limit. Minimum passing margin is -17.20dB at 3703.00MHz.

2.1 MEASUREMENT UNCERTAINTY

Where relevant, the following measurement uncertainty levels have been estimated for tests performed on the EUT as specified in CISPR 16-4-2:

MEASUREMENT	FREQUENCY	UNCERTAINTY
Conducted emissions	9kHz~30MHz	2.44 dB
Radiated emissions	30MHz ~ 200MHz	3.19 dB
	200MHz ~1000MHz	3.21 dB
	1GHz ~ 18GHz	2.26 dB
	18GHz ~ 40GHz	1.94 dB

This uncertainty represents an expanded uncertainty expressed at approximately the 95% confidence level using a coverage factor of k=2.



2.2 TEST INSTRUMENTS

DESCRIPTION & MANUFACTURER	MODEL NO.	SERIAL NO.	DATE OF CALIBRATION	DUE DATE OF CALIBRATION
Test Receiver ROHDE & SCHWARZ	ESCI	100424	Sep. 09, 2013	Sep. 08, 2014
Spectrum Analyzer ROHDE & SCHWARZ	FSU 43	100115	Dec. 18, 2013	Dec. 17, 2014
BILOG Antenna SCHWARZBECK	VULB9168	9168-155	Feb. 26, 2014	Feb. 25, 2015
HORN Antenna SCHWARZBECK	BBHA 9120D	9120D-404	Jan. 05, 2014	Jan. 04, 2015
HORN Antenna SCHWARZBECK	BBHA 9170	148	Jul. 15, 2013	Jul. 14, 2014
Preamplifier Agilent	8449B	3008A01961	Oct. 28, 2013	Oct. 27, 2014
Preamplifier Agilent	8447D	2944A10738	Oct. 18, 2013	Oct. 17, 2014
RF signal cable HUBER+SUHNNER	SUCOFLEX 104	309220/4	Aug. 26, 2013	Aug. 25, 2014
RF signal cable HUBER+SUHNNER	SUCOFLEX 104	250724/4	Aug. 26, 2013	Aug. 25, 2014
RF signal cable HUBER+SUHNNER	SUCOFLEX 104	295012/4	Aug. 26, 2013	Aug. 25, 2014
Software BV ADT	ADT_Radiated_ V7.6.15.9.4	NA	NA	NA
Antenna Tower inn-co GmbH	MA 4000	010303	NA	NA
Antenna Tower Controller inn-co GmbH	CO2000	019303	NA	NA
Turn Table BV ADT	TT100.	TT93021704	NA	NA
Turn Table Controller BV ADT	SC100.	SC93021704	NA	NA
Mini-Circuits Power Splitter	ZN2PD-9G	NA	Sep. 09, 2013	Sep. 08, 2014
JFW 20dB attenuation	50HF-020-SMA	NA	NA	NA

- NOTE:**
1. The calibration interval of the above test instruments is 12 months and the calibrations are traceable to NML/ROC and NIST/USA.
 2. The test was performed in HwaYa Chamber 4.
 3. The horn antenna and HP preamplifier (model: 8449B) are used only for the measurement of emission frequency above 1GHz if tested.
 4. The FCC Site Registration No. is 460141.
 5. The IC Site Registration No. is IC7450F-4.

3 GENERAL INFORMATION

3.1 GENERAL DESCRIPTION OF EUT

EUT	LTE Outdoor CPE	
MODEL NO.	E580P	
POWER SUPPLY	48Vdc (PoE)	
MODULATION TYPE	CDMA	QPSK, OQPSK, HPSK
	LTE	QPSK, 16QAM
FREQUENCY RANGE	CDMA	1851.25MHz ~ 1908.75MHz
	LTE Band 25 (Channel Bandwidth: 3MHz)	1851.5MHz ~ 1913.5MHz
	LTE Band 25 (Channel Bandwidth: 5MHz)	1852.5MHz ~ 1912.5MHz
	LTE Band 25 (Channel Bandwidth: 10MHz)	1855.0MHz ~ 1910.0MHz
MAX. EIRP POWER	CDMA	376.704mW (25.76dBm)
	LTE Band 25 (Channel Bandwidth: 3MHz)	361.410mW (25.58dBm)
	LTE Band 25 (Channel Bandwidth: 5MHz)	299.226mW (24.76dBm)
	LTE Band 25 (Channel Bandwidth: 10MHz)	308.319mW (24.89dBm)
EMISSION DESIGNATOR	CDMA	1M29F9W
	LTE Band 25 (Channel Bandwidth: 3MHz)	QPSK: 2M73G7D
		16QAM: 2M73W7D
	LTE Band 25 (Channel Bandwidth: 5MHz)	QPSK: 4M50G7D
16QAM: 4M50W7D		
LTE Band 25 (Channel Bandwidth: 10MHz)	QPSK: 9M00G7D	
	16QAM: 8M97W7D	
CATEGORY	LTE: 3	
ANTENNA TYPE	Embedded high gain directional antenna with 3dBi gain (TX) Embedded high gain directional antenna with 7dBi gain (RX)	
ANTENNA CONNECTOR	IPEX	
DATA CABLE	NA	
I/O PORTS	Refer to user's manual	
ACCESSORY DEVICES	NA	

NOTE:

1. The EUT uses following PoE.

Brand	ALFA
Model	APOE01(F)
Input Power	48Vdc

Adapter of PoE

Brand	DVE
Model	DSA-42D-48 1 480100 1
Input Power	100-240V~ 50/60Hz 1.2A
Output Power	+48V / 1A
Power Line	AC: 0.6m non-shielded power cord without core DC: 1.5m cable with one core attached on adapter

2. The above EUT information is declared by manufacturer and for more detailed feature description, please refer to the manufacturer's specifications or User's Manual.

3.2 CONFIGURATION OF SYSTEM UNDER TEST

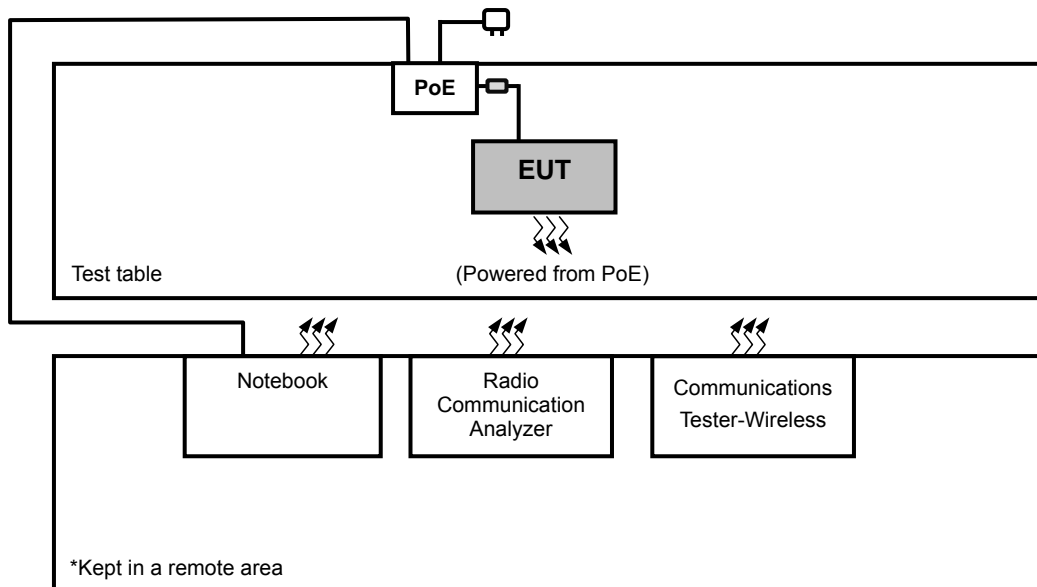

3.3 DESCRIPTION OF SUPPORT UNITS

The EUT has been tested as an independent unit together with other necessary accessories or support units. The following support units or accessories were used to form a representative test configuration during the tests.

NO.	PRODUCT	BRAND	MODEL NO.	SERIAL NO.	FCC ID
1	Notebook	DELL	E5430	FKKCYW1	FCC DoC Approved
2	Communications Tester-Wireless	Agilent	8960 Series 10	MY50260642	NA
3	Radio Communication Analyzer	Anritsu	MT8820C	6201010284	NA

NO.	SIGNAL CABLE DESCRIPTION OF THE ABOVE SUPPORT UNITS
1	NA
2	NA
3	NA

NOTE:

1. All power cords of the above support units are non-shielded (1.8m).
2. Items 2, 3 act as communication partners to transfer data.

3.4 DESCRIPTION OF TEST MODES

Pre-Scan has been conducted to determine the worst-case mode from all possible combinations between available modulations, data rates, XYZ axis and antenna ports. The worst cases were found when positioned on **Y-plane**. Following channel(s) was (were) selected for the final test as listed below:

CDMA

EUT CONFIGURE MODE	TEST ITEM	AVAILABLE CHANNEL	TESTED CHANNEL	MODE
-	EIRP	25 to 1175	25, 600, 1175	CDMA
-	FREQUENCY STABILITY	25 to 1175	600	CDMA
-	OCCUPIED BANDWIDTH	25 to 1175	25, 600, 1175	CDMA , EVDO
-	PEAK TO AVERAGE RATIO	25 to 1175	25, 600, 1175	CDMA , EVDO
-	BAND EDGE	25 to 1175	25, 1175	CDMA , EVDO
-	CONDCUDED EMISSION	25 to 1175	600	CDMA , EVDO
-	RADIATED EMISSION Below 1GHz	25 to 1175	25	CDMA
-	RADIATED EMISSION Above 1GHz	25 to 1175	25, 600, 1175	CDMA



LTE Band 25

TEST ITEM	AVAILABLE CHANNEL	TESTED CHANNEL	CHANNEL BANDWIDTH	MODULATION	MODE
EIRP	26055 to 26675	26055, 26365, 26675	3MHz	QPSK	1 RB / 0 RB Offset
	26065 to 26665	26065, 26365, 26665	5MHz	QPSK	1 RB / 0 RB Offset
	26090 to 26640	26090, 26365, 26640	10MHz	QPSK	1 RB / 0 RB Offset
FREQUENCY STABILITY	26055 to 26675	26365	3MHz	QPSK	1 RB / 0 RB Offset
	26065 to 26665	26365	5MHz	QPSK	1 RB / 0 RB Offset
	26090 to 26640	26365	10MHz	QPSK	1 RB / 0 RB Offset
OCCUPIED BANDWIDTH	26055 to 26675	26055, 26365, 26675	3MHz	QPSK/16QAM	15 RB / 0RB Offset
	26065 to 26665	26065, 26365, 26665	5MHz	QPSK/16QAM	25 RB / 0RB Offset
	26090 to 26640	26090, 26365, 26640	10MHz	QPSK/16QAM	50 RB / 0RB Offset
PEAK TO AVERAGE RATIO	26055 to 26675	26055, 26365, 26675	3MHz	QPSK/16QAM	1 RB / 0 RB Offset
	26065 to 26665	26065, 26365, 26665	5MHz	QPSK/16QAM	1 RB / 0 RB Offset
	26090 to 26640	26090, 26365, 26640	10MHz	QPSK/16QAM	1 RB / 0 RB Offset
BAND EDGE	26055 to 26675	26055, 26675	3MHz	QPSK	15 RB / 0RB Offset
					1 RB / 0RB Offset
					1RB / 14RB Offset
	26065 to 26665	26065, 26665	5MHz	QPSK	25 RB / 0RB Offset
					1 RB / 0RB Offset
					1RB / 24RB Offset
26090 to 26640	26090, 26640	10MHz	QPSK	50 RB / 0RB Offset	
				1 RB / 0RB Offset	
				1RB / 49RB Offset	
CONDCUDETED EMISSION	26055 to 26675	26055, 26365, 26675	3MHz	QPSK	1 RB / 0 RB Offset
	26065 to 26665	26065, 26365, 26665	5MHz	QPSK	1 RB / 0 RB Offset
	26090 to 26640	26090, 26365, 26640	10MHz	QPSK	1 RB / 0 RB Offset
RADIATED EMISSION Below 1GHz	26055 to 26675	26055	3MHz	QPSK	1 RB / 0 RB Offset
	26065 to 26665	26065	5MHz	QPSK	1 RB / 0 RB Offset
	26090 to 26640	26090	10MHz	QPSK	1 RB / 0 RB Offset
RADIATED EMISSION Above 1GHz	26055 to 26675	26055, 26365, 26675	3MHz	QPSK	1 RB / 0 RB Offset
	26065 to 26665	26065, 26365, 26665	5MHz	QPSK	1 RB / 0 RB Offset
	26090 to 26640	26090, 26365, 26640	10MHz	QPSK	1 RB / 0 RB Offset

TEST CONDITION:

TEST ITEM	ENVIRONMENTAL CONDITIONS	INPUT POWER (SYSTEM)	TESTED BY
EIRP	24deg. C, 64%RH	120Vac, 60Hz	Match Tsui
FREQUENCY STABILITY	24deg. C, 64%RH	120Vac, 60Hz	Match Tsui
OCCUPIED BANDWIDTH	24deg. C, 64%RH	120Vac, 60Hz	Match Tsui
PEAK TO AVERAGE RATIO	24deg. C, 64%RH	120Vac, 60Hz	Match Tsui
BAND EDGE	24deg. C, 64%RH	120Vac, 60Hz	Match Tsui
CONDCUDETED EMISSION	24deg. C, 64%RH	120Vac, 60Hz	Match Tsui
RADIATED EMISSION	25deg. C, 65%RH	120Vac, 60Hz	Brad Tung



3.5 EUT OPERATING CONDITIONS

The EUT makes a call to the communication simulator. The communication simulator station system controlled a EUT to export maximum output power under transmission mode and specific channel frequency

3.6 GENERAL DESCRIPTION OF APPLIED STANDARDS

The EUT is a RF product. According to the specifications of the manufacturer, it must comply with the requirements of the following standards:

FCC 47 CFR Part 2

FCC 47 CFR Part 24

ANSI/TIA/EIA-603-C 2004

All test items have been performed and recorded as per the above standards.

4 TEST TYPES AND RESULTS

4.1 OUTPUT POWER MEASUREMENT

4.1.1 LIMITS OF OUTPUT POWER MEASUREMENT

Mobile and portable stations are limited to 2 watts EIRP

4.1.2 TEST PROCEDURES

EIRP MEASUREMENT:

- a. All measurements were done at low, middle and high operational frequency range. RWB and VBW is 5MHz for CDMA mode and 10MHz for LTE mode.
- b. Substitution method is used for E.I.R.P measurement. In the semi-anechoic chamber, EUT placed on the 0.8m height of Turn Table, rotated the table around 360 degrees to search the maximum radiation power and receiver antenna shall be rotated vertical and horizontal polarization and moved height from 1m to 4m to find the maximum polar radiated power. The “Read Value” is the spectrum reading the maximum power value.
- c. The substitution horn antenna is substituted for EUT at the same position and signals generator export the CW signal to the substitution antenna via a tx cable. Rotated the Turn Table and moved receiving antenna to find the maximum radiation power. Adjust output power level of S.G to get a Value of spectrum reading equal to “Read Value” of step c. Record the power level of S.G
- d. $EIRP = \text{Output power level of S.G} - \text{TX cable loss} + \text{Antenna gain of substitution horn.}$

CONDUCTED POWER MEASUREMENT:

The EUT was set up for the maximum power with CDMA / LTE link data modulation and link up with simulator. Set the EUT to transmit under low, middle and high channel and record the power level shown on simulator.

4.1.3 TEST SETUP

EIRP POWER MEASUREMENT:

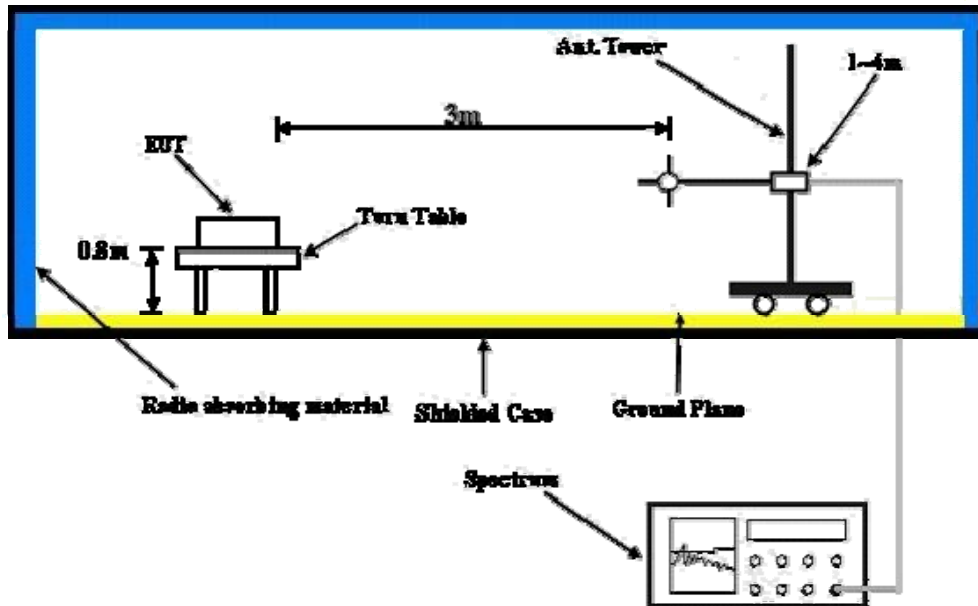

For the actual test configuration, please refer to the attached file (Test Setup Photo).

CONDUCTED POWER MEASUREMENT:

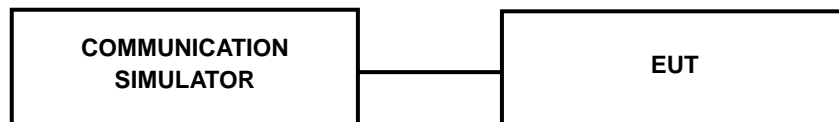

For the actual test configuration, please refer to the attached file (Test Setup Photo).

4.1.4 TEST RESULTS

CONDUCTED OUTPUT POWER (dBm)

Band	CDMA		
	25	600	1175
Channel	1851.25	1880	1908.75
Frequency	1851.25	1880	1908.75
RC1+SO55	25.29	25.28	24.75
RC3+SO55	25.23	25.26	24.72
RC3+SO32(+ F-SCH)	25.30	25.29	24.77
RC3+SO32(+SCH)	25.28	25.25	24.75
RTAP 153.6	24.91	25.03	24.92
RETAP 4096	24.95	24.06	24.97



LTE Band 25								
BW	Modulation	CH	Frequency (MHz)	RB	RB Offset	MPR	Target Power	Measured Power
3 MHz	QPSK	26055	1851.5	1	0	0	23.30	23.01
		26365	1882.5	1	0	0	23.30	23.05
		26675	1913.5	1	0	0	23.30	21.20
		26055	1851.5	1	7	0	23.30	23.03
		26365	1882.5	1	7	0	23.30	23.06
		26675	1913.5	1	7	0	23.30	21.36
		26055	1851.5	1	14	0	23.30	22.87
		26365	1882.5	1	14	0	23.30	22.91
		26675	1913.5	1	14	0	23.30	21.14
		26055	1851.5	8	0	1	23.30	21.90
		26365	1882.5	8	0	1	23.30	21.94
		26675	1913.5	8	0	1	23.30	20.19
		26055	1851.5	8	3	1	23.30	21.99
		26365	1882.5	8	3	1	23.30	22.13
		26675	1913.5	8	3	1	23.30	20.96
		26055	1851.5	8	7	1	23.30	21.90
		26365	1882.5	8	7	1	23.30	21.95
		26675	1913.5	8	7	1	23.30	20.94
	26055	1851.5	15	0	1	23.30	21.98	
	26365	1882.5	15	0	1	23.30	22.04	
	26675	1913.5	15	0	1	23.30	20.98	
	16QAM	26055	1851.5	1	0	1	23.30	22.01
		26365	1882.5	1	0	1	23.30	22.06
		26675	1913.5	1	0	1	23.30	20.31
		26055	1851.5	1	7	1	23.30	22.07
		26365	1882.5	1	7	1	23.30	22.11
		26675	1913.5	1	7	1	23.30	20.35
		26055	1851.5	1	14	1	23.30	22.09
		26365	1882.5	1	14	1	23.30	22.10
		26675	1913.5	1	14	1	23.30	20.38
26055		1851.5	8	0	2	23.30	20.87	
26365		1882.5	8	0	2	23.30	20.90	
26675		1913.5	8	0	2	23.30	19.19	
26055	1851.5	8	3	2	23.30	20.96		
26365	1882.5	8	3	2	23.30	20.99		
26675	1913.5	8	3	2	23.30	19.23		
26055	1851.5	8	7	2	23.30	20.97		
26365	1882.5	8	7	2	23.30	20.10		
26675	1913.5	8	7	2	23.30	19.28		
26055	1851.5	15	0	2	23.30	21.08		
26365	1882.5	15	0	2	23.30	21.13		
26675	1913.5	15	0	2	23.30	19.30		



A D T

LTE Band 25								
BW	Modulation	CH	Frequency (MHz)	RB	RB Offset	MPR	Target Power	Measured Power
5 MHz	QPSK	26065	1852.5	1	0	0	23.30	22.90
		26365	1882.5	1	0	0	23.30	22.91
		26665	1912.5	1	0	0	23.30	21.53
		26065	1852.5	1	12	0	23.30	22.86
		26365	1882.5	1	12	0	23.30	22.94
		26665	1912.5	1	12	0	23.30	21.50
		26065	1852.5	1	24	0	23.30	22.39
		26365	1882.5	1	24	0	23.30	22.44
		26665	1912.5	1	24	0	23.30	21.00
		26065	1852.5	12	0	1	23.30	21.91
		26365	1882.5	12	0	1	23.30	21.95
		26665	1912.5	12	0	1	23.30	20.54
		26065	1852.5	12	6	1	23.30	21.90
		26365	1882.5	12	6	1	23.30	21.91
		26665	1912.5	12	6	1	23.30	20.56
		26065	1852.5	12	13	1	23.30	21.88
		26365	1882.5	12	13	1	23.30	21.91
		26665	1912.5	12	13	1	23.30	20.52
	26065	1852.5	25	0	1	23.30	21.87	
	26365	1882.5	25	0	1	23.30	21.90	
	26665	1912.5	25	0	1	23.30	20.47	
	26065	1852.5	1	0	1	23.30	21.77	
	26365	1882.5	1	0	1	23.30	21.81	
	26665	1912.5	1	0	1	23.30	20.44	
	26065	1852.5	1	12	1	23.30	21.80	
	26365	1882.5	1	12	1	23.30	21.83	
	26665	1912.5	1	12	1	23.30	20.47	
	26065	1852.5	1	24	1	23.30	21.63	
	26365	1882.5	1	24	1	23.30	21.65	
	26665	1912.5	1	24	1	23.30	20.19	
	26065	1852.5	12	0	2	23.30	20.99	
	26365	1882.5	12	0	2	23.30	21.11	
	26665	1912.5	12	0	2	23.30	19.74	
	26065	1852.5	12	6	2	23.30	20.89	
	26365	1882.5	12	6	2	23.30	20.91	
	26665	1912.5	12	6	2	23.30	19.57	
26065	1852.5	12	13	2	23.30	20.90		
26365	1882.5	12	13	2	23.30	20.93		
26665	1912.5	12	13	2	23.30	19.51		
26065	1852.5	25	0	2	23.30	20.91		
26365	1882.5	25	0	2	23.30	20.95		
26665	1912.5	25	0	2	23.30	19.61		



A D T

LTE Band 25								
BW	Modulation	CH	Frequency (MHz)	RB	RB Offset	MPR	Target Power	Measured Power
10 MHz	QPSK	26090	1855	1	0	0	23.30	22.59
		26365	1882.5	1	0	0	23.30	23.07
		26640	1910	1	0	0	23.30	22.94
		26090	1855	1	24	0	23.30	22.70
		26365	1882.5	1	24	0	23.30	23.19
		26640	1910	1	24	0	23.30	23.11
		26090	1855	1	49	0	23.30	22.17
		26365	1882.5	1	49	0	23.30	22.64
		26640	1910	1	49	0	23.30	22.51
		26090	1855	25	0	1	23.30	21.85
		26365	1882.5	25	0	1	23.30	22.39
		26640	1910	25	0	1	23.30	22.24
		26090	1855	25	12	1	23.30	21.85
		26365	1882.5	25	12	1	23.30	22.41
		26640	1910	25	12	1	23.30	22.26
		26090	1855	25	25	1	23.30	21.86
		26365	1882.5	25	25	1	23.30	22.39
		26640	1910	25	25	1	23.30	22.24
	26090	1855	50	0	1	23.30	21.76	
	26365	1882.5	50	0	1	23.30	22.29	
	26640	1910	50	0	1	23.30	22.19	
	26090	1855	1	0	1	23.30	21.97	
	26365	1882.5	1	0	1	23.30	22.46	
	26640	1910	1	0	1	23.30	22.34	
	26090	1855	1	24	1	23.30	22.14	
	26365	1882.5	1	24	1	23.30	22.69	
	26640	1910	1	24	1	23.30	22.55	
	26090	1855	1	49	1	23.30	21.54	
	26365	1882.5	1	49	1	23.30	22.06	
	26640	1910	1	49	1	23.30	21.95	
	26090	1855	25	0	2	23.30	21.72	
	26365	1882.5	25	0	2	23.30	22.28	
	26640	1910	25	0	2	23.30	22.15	
	26090	1855	25	12	2	23.30	20.89	
	26365	1882.5	25	12	2	23.30	20.47	
	26640	1910	25	12	2	23.30	20.35	
26090	1855	25	25	2	23.30	20.88		
26365	1882.5	25	25	2	23.30	20.46		
26640	1910	25	25	2	23.30	20.35		
26090	1855	50	0	2	23.30	20.80		
26365	1882.5	50	0	2	23.30	20.41		
26640	1910	50	0	2	23.30	20.33		



A D T

EIRP POWER

CDMA

MODE		TX channel 25					
ANTENNA POLARITY & TEST DISTANCE: HORIZONTAL AT 3 M							
No.	Freq. (MHz)	Reading (dBm)	S.G Power Value (dBm)	Correction Factor (dB)	EIRP (dBm)	Limit (dBm)	Margin (dB)
1	1851.25	-13.85	24.69	1.07	25.76	33.00	-7.24
ANTENNA POLARITY & TEST DISTANCE: VERTICAL AT 3 M							
No.	Freq. (MHz)	Reading (dBm)	S.G Power Value (dBm)	Correction Factor (dB)	EIRP (dBm)	Limit (dBm)	Margin (dB)
1	1851.25	-17.32	19.30	1.07	20.37	33.00	-12.63

MODE		TX channel 600					
ANTENNA POLARITY & TEST DISTANCE: HORIZONTAL AT 3 M							
No.	Freq. (MHz)	Reading (dBm)	S.G Power Value (dBm)	Correction Factor (dB)	EIRP (dBm)	Limit (dBm)	Margin (dB)
1	1880.00	-15.23	23.49	1.12	24.61	33.00	-8.39
ANTENNA POLARITY & TEST DISTANCE: VERTICAL AT 3 M							
No.	Freq. (MHz)	Reading (dBm)	S.G Power Value (dBm)	Correction Factor (dB)	EIRP (dBm)	Limit (dBm)	Margin (dB)
1	1880.00	-18.12	18.14	1.12	19.26	33.00	-13.74

MODE		TX channel 1175					
ANTENNA POLARITY & TEST DISTANCE: HORIZONTAL AT 3 M							
No.	Freq. (MHz)	Reading (dBm)	S.G Power Value (dBm)	Correction Factor (dB)	EIRP (dBm)	Limit (dBm)	Margin (dB)
1	1908.75	-16.45	22.65	1.11	23.76	33.00	-9.24
ANTENNA POLARITY & TEST DISTANCE: VERTICAL AT 3 M							
No.	Freq. (MHz)	Reading (dBm)	S.G Power Value (dBm)	Correction Factor (dB)	EIRP (dBm)	Limit (dBm)	Margin (dB)
1	1908.75	-17.95	17.95	1.11	19.06	33.00	-13.94

NOTE: Power Value (dBm) = S.G Power Value (dBm) + Correction Factor (dB).

LTE Band 25 (Channel Bandwidth 3MHz)

MODE		TX channel 26055					
ANTENNA POLARITY & TEST DISTANCE: HORIZONTAL AT 3 M							
No.	Freq. (MHz)	Reading (dBm)	S.G Power Value (dBm)	Correction Factor (dB)	EIRP (dBm)	Limit (dBm)	Margin (dB)
1	1851.50	-14.03	24.51	1.07	25.58	33.00	-7.42
ANTENNA POLARITY & TEST DISTANCE: VERTICAL AT 3 M							
No.	Freq. (MHz)	Reading (dBm)	S.G Power Value (dBm)	Correction Factor (dB)	EIRP (dBm)	Limit (dBm)	Margin (dB)
1	1851.50	-16.85	19.77	1.07	20.84	33.00	-12.16

MODE		TX channel 26365					
ANTENNA POLARITY & TEST DISTANCE: HORIZONTAL AT 3 M							
No.	Freq. (MHz)	Reading (dBm)	S.G Power Value (dBm)	Correction Factor (dB)	EIRP (dBm)	Limit (dBm)	Margin (dB)
1	1882.50	-14.33	24.42	1.12	25.54	33.00	-7.46
ANTENNA POLARITY & TEST DISTANCE: VERTICAL AT 3 M							
No.	Freq. (MHz)	Reading (dBm)	S.G Power Value (dBm)	Correction Factor (dB)	EIRP (dBm)	Limit (dBm)	Margin (dB)
1	1882.50	-16.98	19.25	1.12	20.37	33.00	-12.63

MODE		TX channel 26675					
ANTENNA POLARITY & TEST DISTANCE: HORIZONTAL AT 3 M							
No.	Freq. (MHz)	Reading (dBm)	S.G Power Value (dBm)	Correction Factor (dB)	EIRP (dBm)	Limit (dBm)	Margin (dB)
1	1913.50	-15.75	22.85	0.77	23.62	33.00	-9.38
ANTENNA POLARITY & TEST DISTANCE: VERTICAL AT 3 M							
No.	Freq. (MHz)	Reading (dBm)	S.G Power Value (dBm)	Correction Factor (dB)	EIRP (dBm)	Limit (dBm)	Margin (dB)
1	1913.50	-17.75	19.91	0.77	20.68	33.00	-12.32

NOTE: Power Value (dBm) = S.G Power Value (dBm) + Correction Factor (dB).

LTE Band 25 (Channel Bandwidth 5MHz)

MODE		TX channel 26065					
ANTENNA POLARITY & TEST DISTANCE: HORIZONTAL AT 3 M							
No.	Freq. (MHz)	Reading (dBm)	S.G Power Value (dBm)	Correction Factor (dB)	EIRP (dBm)	Limit (dBm)	Margin (dB)
1	1852.50	-14.86	23.69	1.07	24.76	33.00	-8.24
ANTENNA POLARITY & TEST DISTANCE: VERTICAL AT 3 M							
No.	Freq. (MHz)	Reading (dBm)	S.G Power Value (dBm)	Correction Factor (dB)	EIRP (dBm)	Limit (dBm)	Margin (dB)
1	1852.50	-17.18	19.43	1.07	20.50	33.00	-12.50

MODE		TX channel 26365					
ANTENNA POLARITY & TEST DISTANCE: HORIZONTAL AT 3 M							
No.	Freq. (MHz)	Reading (dBm)	S.G Power Value (dBm)	Correction Factor (dB)	EIRP (dBm)	Limit (dBm)	Margin (dB)
1	1882.50	-15.64	23.11	1.12	24.23	33.00	-8.77
ANTENNA POLARITY & TEST DISTANCE: VERTICAL AT 3 M							
No.	Freq. (MHz)	Reading (dBm)	S.G Power Value (dBm)	Correction Factor (dB)	EIRP (dBm)	Limit (dBm)	Margin (dB)
1	1882.50	-17.96	18.27	1.12	19.39	33.00	-13.61

MODE		TX channel 26665					
ANTENNA POLARITY & TEST DISTANCE: HORIZONTAL AT 3 M							
No.	Freq. (MHz)	Reading (dBm)	S.G Power Value (dBm)	Correction Factor (dB)	EIRP (dBm)	Limit (dBm)	Margin (dB)
1	1912.50	-16.56	22.04	0.77	22.81	33.00	-10.19
ANTENNA POLARITY & TEST DISTANCE: VERTICAL AT 3 M							
No.	Freq. (MHz)	Reading (dBm)	S.G Power Value (dBm)	Correction Factor (dB)	EIRP (dBm)	Limit (dBm)	Margin (dB)
1	1912.50	-18.26	19.39	0.77	20.16	33.00	-12.84

NOTE: Power Value (dBm) = S.G Power Value (dBm) + Correction Factor (dB).



A D T

LTE Band 25 (Channel Bandwidth 10MHz)

MODE		TX channel 26090					
ANTENNA POLARITY & TEST DISTANCE: HORIZONTAL AT 3 M							
No.	Freq. (MHz)	Reading (dBm)	S.G Power Value (dBm)	Correction Factor (dB)	EIRP (dBm)	Limit (dBm)	Margin (dB)
1	1855.00	-14.75	23.81	1.08	24.89	33.00	-8.11
ANTENNA POLARITY & TEST DISTANCE: VERTICAL AT 3 M							
No.	Freq. (MHz)	Reading (dBm)	S.G Power Value (dBm)	Correction Factor (dB)	EIRP (dBm)	Limit (dBm)	Margin (dB)
1	1855.00	-17.15	19.42	1.08	20.50	33.00	-12.50

MODE		TX channel 26365					
ANTENNA POLARITY & TEST DISTANCE: HORIZONTAL AT 3 M							
No.	Freq. (MHz)	Reading (dBm)	S.G Power Value (dBm)	Correction Factor (dB)	EIRP (dBm)	Limit (dBm)	Margin (dB)
1	1882.50	-15.42	23.33	1.12	24.45	33.00	-8.55
ANTENNA POLARITY & TEST DISTANCE: VERTICAL AT 3 M							
No.	Freq. (MHz)	Reading (dBm)	S.G Power Value (dBm)	Correction Factor (dB)	EIRP (dBm)	Limit (dBm)	Margin (dB)
1	1882.50	-17.75	18.48	1.12	19.60	33.00	-13.40

MODE		TX channel 26640					
ANTENNA POLARITY & TEST DISTANCE: HORIZONTAL AT 3 M							
No.	Freq. (MHz)	Reading (dBm)	S.G Power Value (dBm)	Correction Factor (dB)	EIRP (dBm)	Limit (dBm)	Margin (dB)
1	1910.00	-16.54	22.07	0.77	22.84	33.00	-10.16
ANTENNA POLARITY & TEST DISTANCE: VERTICAL AT 3 M							
No.	Freq. (MHz)	Reading (dBm)	S.G Power Value (dBm)	Correction Factor (dB)	EIRP (dBm)	Limit (dBm)	Margin (dB)
1	1910.00	-17.96	19.68	0.77	20.45	33.00	-12.55

NOTE: Power Value (dBm) = S.G Power Value (dBm) + Correction Factor (dB).

4.2 FREQUENCY STABILITY MEASUREMENT

4.2.1 LIMITS OF FREQUENCY STABILITY MEASUREMENT

The frequency stability shall be sufficient to ensure that the fundamental emission stays within the authorized frequency block.

4.2.2 TEST PROCEDURE

- a. Device is placed at the oven room. The oven room could control the temperatures and humidity. Power warm up is at least 15 min and power applied should perform before recording frequency error.
- b. EUT is connected the external power supply to control the AC input power. The test voltage range is from minimum to maximum working voltage. Each step shall be record the frequency error rate.
- c. The temperature range step is 10 degrees in this test items. All temperature levels shall be hold the $\pm 0.5^{\circ}\text{C}$ during the measurement testing. The each temperature step shall be at least 0.5 hours, consider the EUT could be test under the stability condition.

NOTE: The frequency error was recorded frequency error from the communication simulator.

4.2.3 TEST SETUP

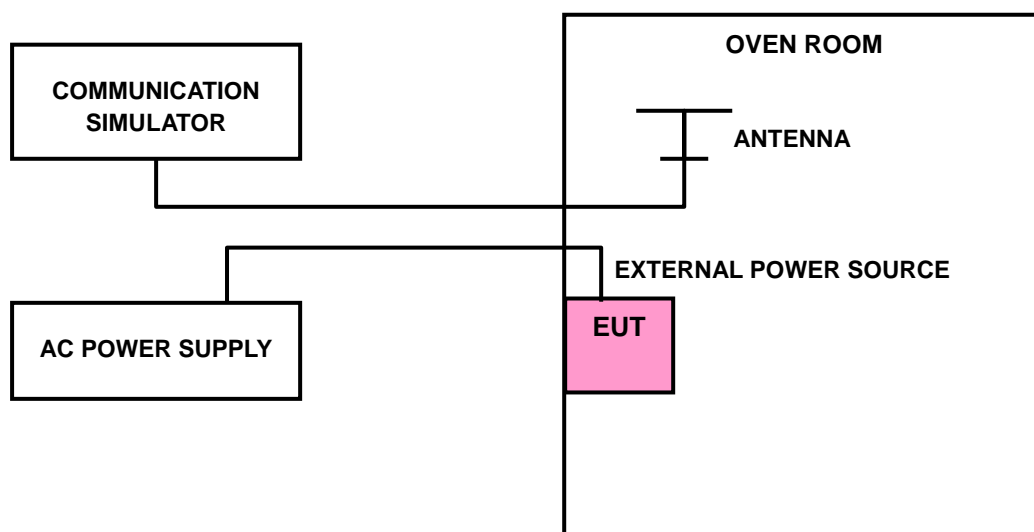

4.2.4 TEST RESULTS

FREQUENCY ERROR VS. VOLTAGE

VOLTAGE (Volts)	FREQUENCY ERROR (ppm)				LIMIT (ppm)
	CDMA	LTE Band 25			
		3MHz	5MHz	10MHz	
132	-0.007	-0.007	-0.007	-0.010	2.5
120	-0.006	-0.007	-0.007	-0.008	2.5
108	-0.006	-0.008	-0.007	-0.009	2.5

NOTE: The applicant defined the normal working voltage of the battery is from 108Vac to 132Vac.

FREQUENCY ERROR vs. TEMPERATURE

TEMP. (°C)	FREQUENCY ERROR (ppm)				LIMIT (ppm)
	CDMA	LTE Band 25			
		3MHz	5MHz	10MHz	
60	-0.013	-0.012	-0.013	-0.016	2.5
50	-0.011	-0.013	-0.012	-0.015	2.5
40	-0.011	-0.012	-0.010	-0.013	2.5
30	-0.010	-0.010	-0.011	-0.009	2.5
20	-0.006	-0.007	-0.007	-0.008	2.5
10	-0.010	-0.008	-0.008	-0.011	2.5
0	-0.012	-0.013	-0.010	-0.013	2.5
-10	-0.014	-0.014	-0.014	-0.019	2.5
-20	-0.016	-0.018	-0.018	-0.022	2.5
-30	-0.016	-0.016	-0.012	-0.024	2.5
-40	-0.019	-0.017	-0.016	-0.023	2.5

4.3 OCCUPIED BANDWIDTH MEASUREMENT

4.3.1 TEST PROCEDURES

The EUT makes a call to the communication simulator. All measurements were done at low, middle and high operational frequency range. The communication simulator station system controlled a EUT to export maximum output power under transmission mode and specific channel frequency. Use OBW measurement function of Spectrum analyzer to measure 99 % occupied bandwidth.

4.3.2 TEST SETUP

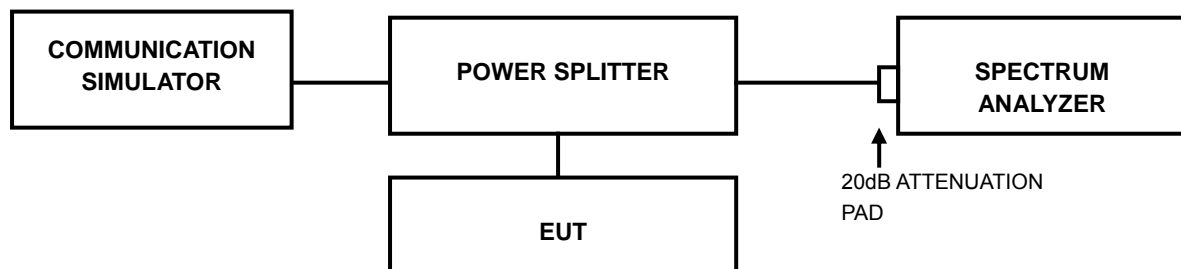

4.3.3 TEST RESULTS

CDMA

CHANNEL	FREQUENCY (MHz)	99% OCCUPIED BANDWIDTH (MHz)	
		CDMA	EVDO
25	1851.25	1.28	1.28
600	1880.00	1.29	1.28
1175	1908.75	1.28	1.29

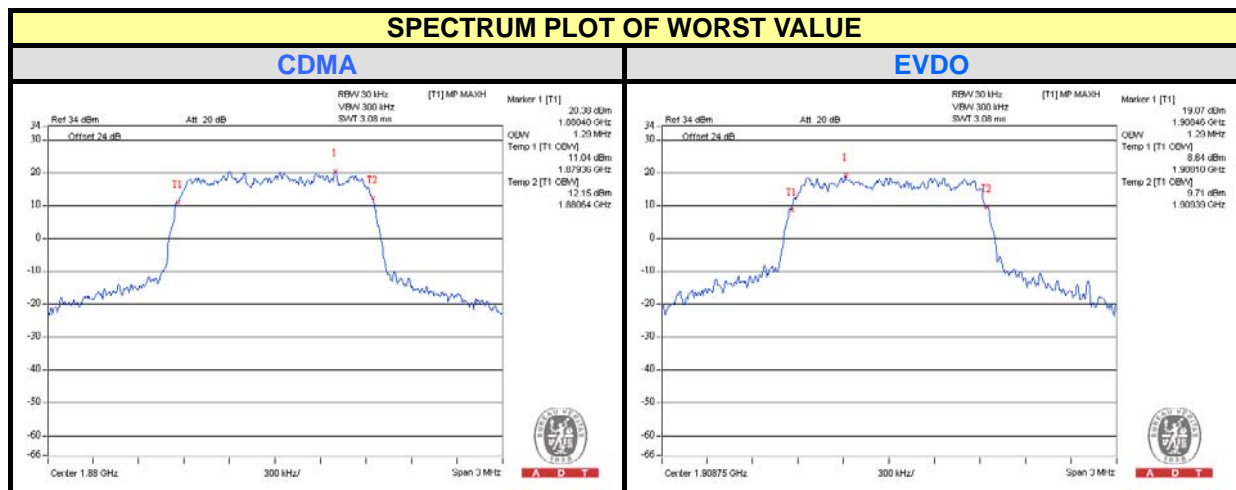



A D T

LTE Band 25

CHANNEL BANDWIDTH 3MHz				CHANNEL BANDWIDTH 5MHz			
CHANNEL	FREQUENCY (MHz)	99% OCCUPIED BANDWIDTH (MHz)		CHANNEL	FREQUENCY (MHz)	99% OCCUPIED BANDWIDTH (MHz)	
		QPSK	16QAM			QPSK	16QAM
26055	1851.5	2.72	2.72	26065	1852.5	4.48	4.48
26365	1882.5	2.73	2.73	26365	1882.5	4.50	4.50
26675	1913.5	2.73	2.72	26665	1912.5	4.48	4.48

CHANNEL BANDWIDTH 10MHz			
CHANNEL	FREQUENCY (MHz)	99% OCCUPIED BANDWIDTH (MHz)	
		QPSK	16QAM
26090	1855.0	9.00	8.93
26365	1882.5	8.93	8.97
26640	1910.0	8.97	8.93

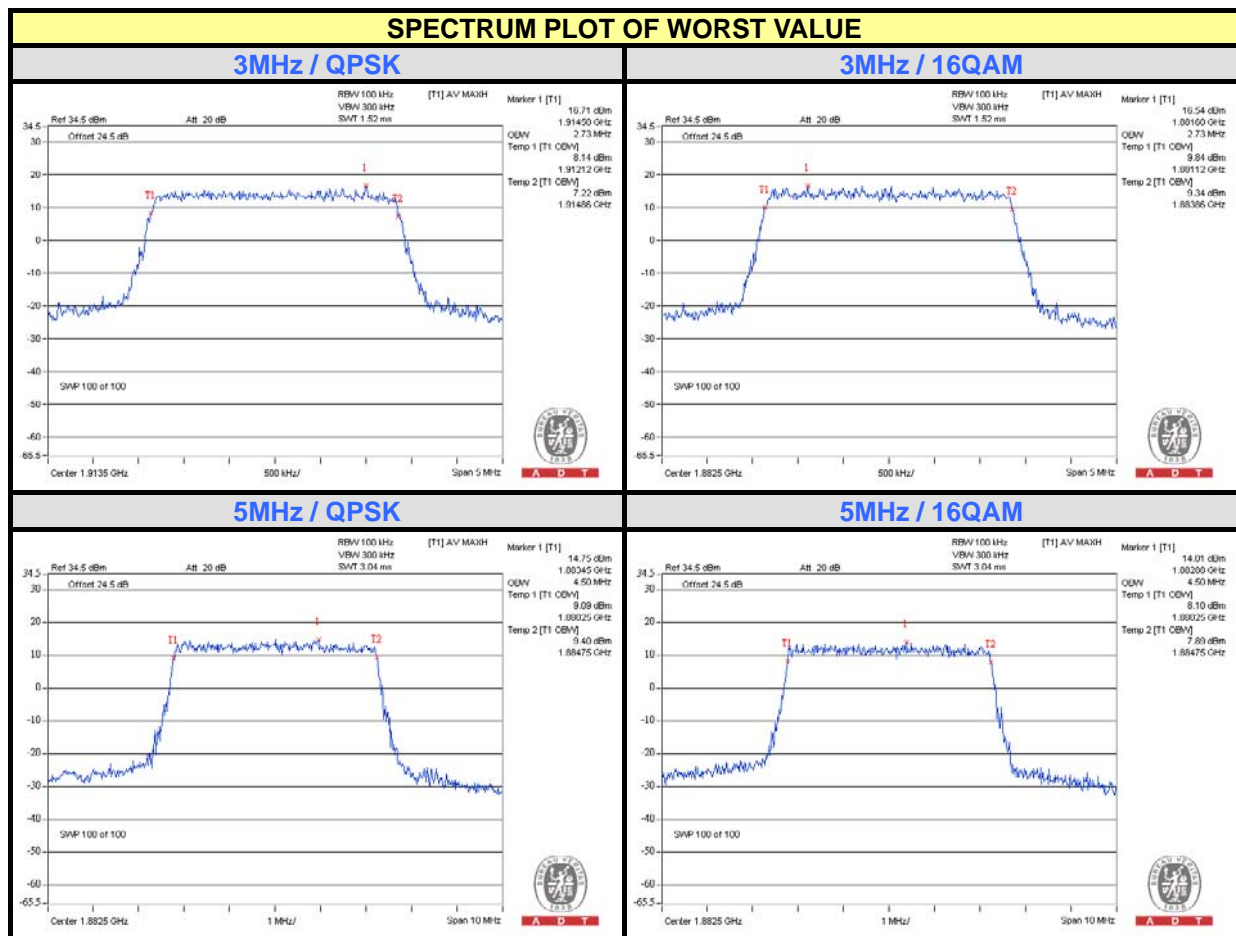



A D T

SPECTRUM PLOT OF WORST VALUE

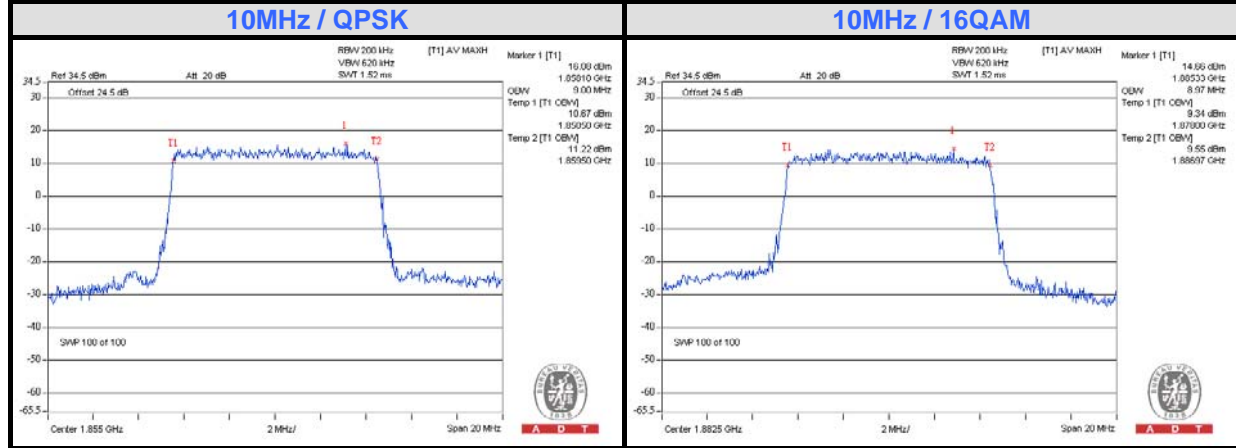

4.4 PEAK TO AVERAGE RATIO

4.4.1 LIMITS OF PEAK TO AVERAGE RATIO MEASUREMENT

In measuring transmissions in this band using an average power technique, the peak to average ratio (PAR) of the transmission may not exceed 13 dB

4.4.2 TEST SETUP

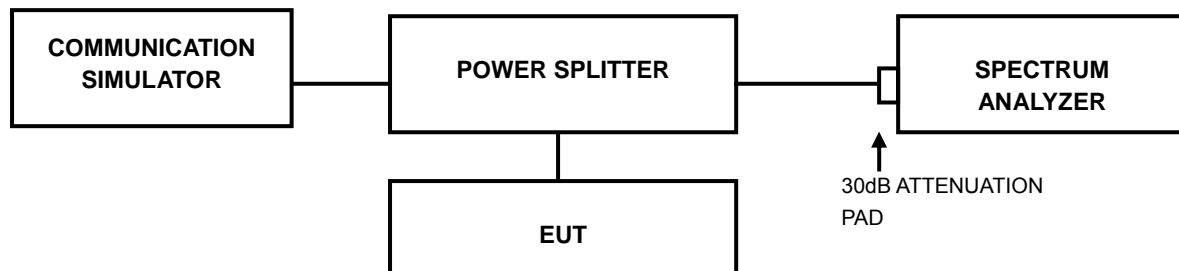

4.4.3 TEST PROCEDURES

1. Set resolution/measurement bandwidth \geq signal's occupied bandwidth;
2. Set the number of counts to a value that stabilizes the measured CCDF curve;
3. Record the maximum PAPR level associated with a probability of 0.1%.

4.4.4 TEST RESULTS

CDMA

CHANNEL	FREQUENCY (MHz)	PEAK TO AVERAGE RATIO (dB)	
		CDMA	EVDO
25	1851.25	2.76	2.73
600	1880.00	2.98	2.97
1175	1908.75	2.94	2.92

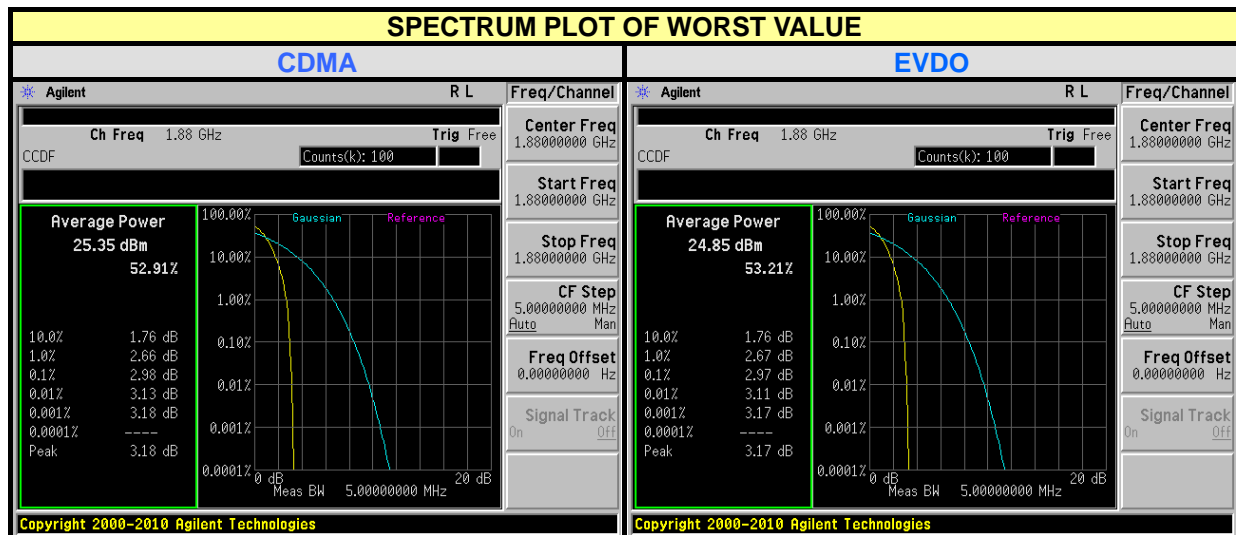



A D T

LTE Band 25

CHANNEL BANDWIDTH 3MHz				CHANNEL BANDWIDTH 5MHz			
CHANNEL	FREQUENCY (MHz)	PEAK TO AVERAGE RATIO (dB)		CHANNEL	FREQUENCY (MHz)	PEAK TO AVERAGE RATIO (dB)	
		QPSK	16QAM			QPSK	16QAM
26055	1851.5	5.28	6.49	26065	1852.5	6.51	6.52
26365	1882.5	5.49	6.67	26365	1882.5	5.48	6.68
26675	1913.5	5.88	7.03	26665	1912.5	5.74	6.87

CHANNEL BANDWIDTH 10MHz			
CHANNEL	FREQUENCY (MHz)	PEAK TO AVERAGE RATIO (dB)	
		QPSK	16QAM
26090	1855.0	5.30	6.23
26365	1882.5	5.36	6.43
26640	1910.0	5.16	6.00

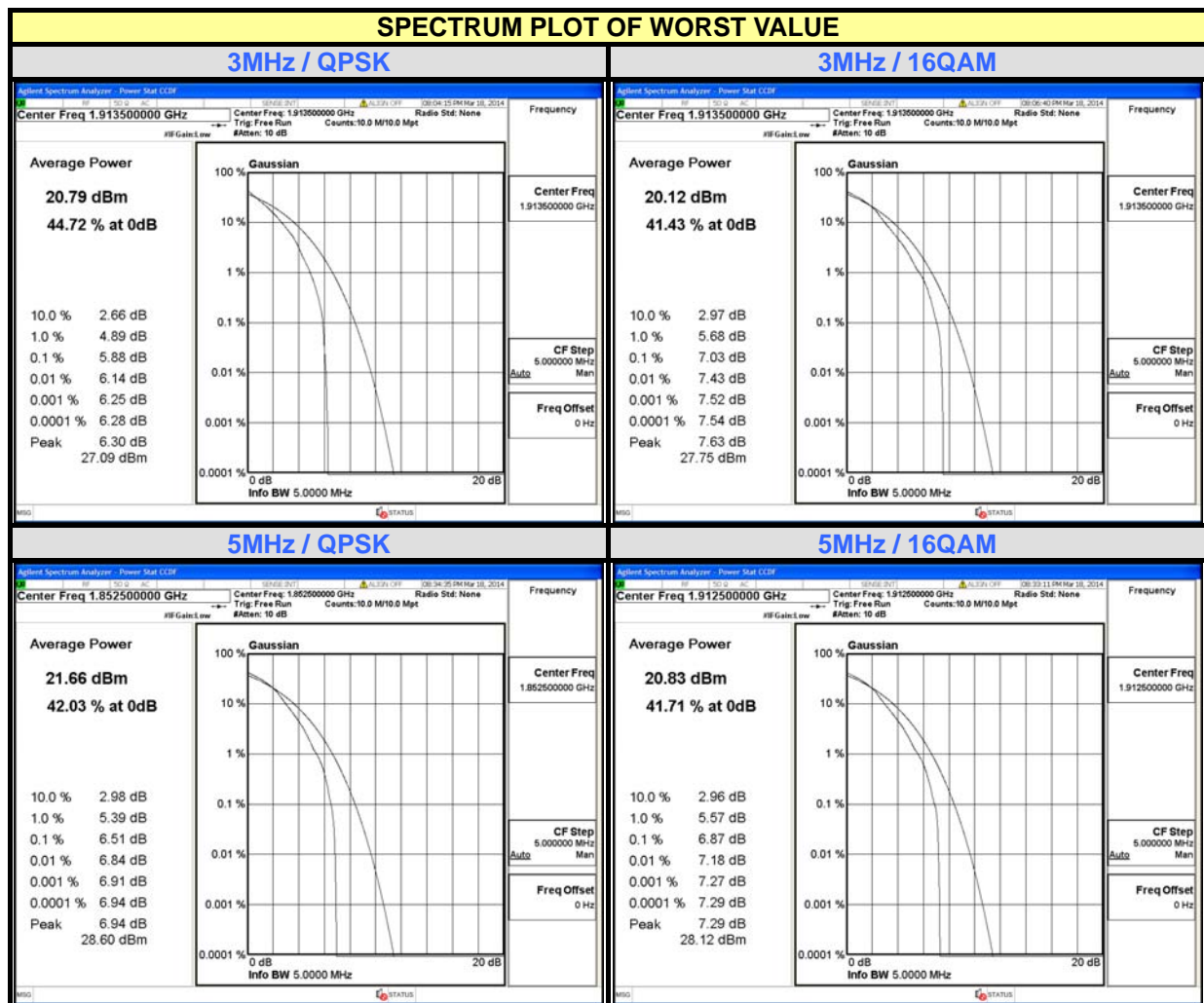



A D T

SPECTRUM PLOT OF WORST VALUE

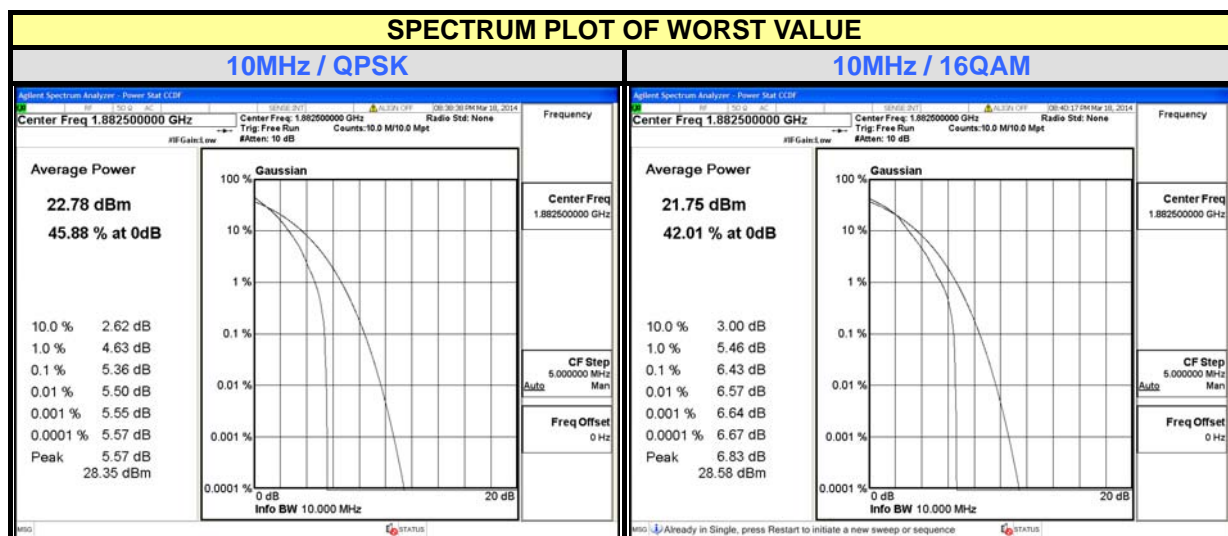

4.5 BAND EDGE MEASUREMENT

4.5.1 LIMITS OF BAND EDGE MEASUREMENT

Power of any emission outside of the authorized operating frequency ranges must be attenuated below the transmitting power (P) by a factor of at least $43 + 10 \log(P)$ dB. In the 1 MHz bands immediately outside and adjacent to the frequency block a resolution bandwidth of at least one percent of the emission bandwidth of the fundamental emission of the transmitter may be employed.

4.5.2 TEST SETUP

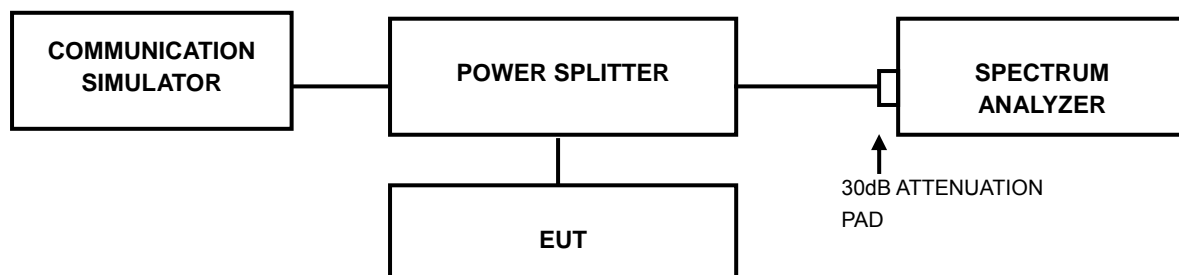

4.5.3 TEST PROCEDURES

- All measurements were done at low and high operational frequency range.
- The center frequency of spectrum is the band edge frequency and span is 3MHz. RB of the spectrum at least 1% of emission bandwidth and $VBW \geq 3RBW$ (CDMA/EVDO).
- The center frequency of spectrum is the band edge frequency and span is 1.5MHz. RB of the spectrum at least 1% of emission bandwidth and $VBW \geq 3RBW$ (LTE).
- Record the max trace plot into the test report.



A D T

4.5.4 TEST RESULTS

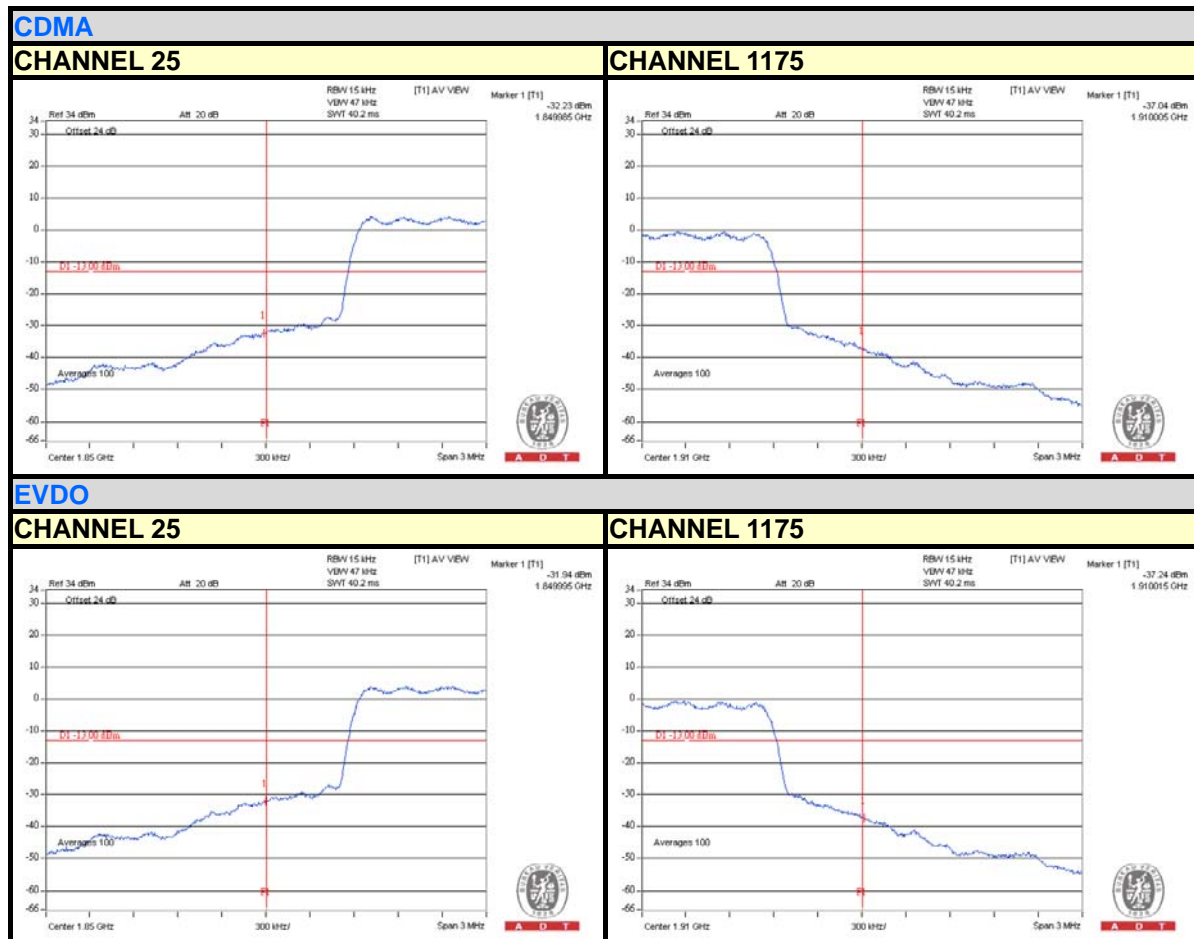



A D T

LTE Band 25 (Channel Bandwidth 3MHz)

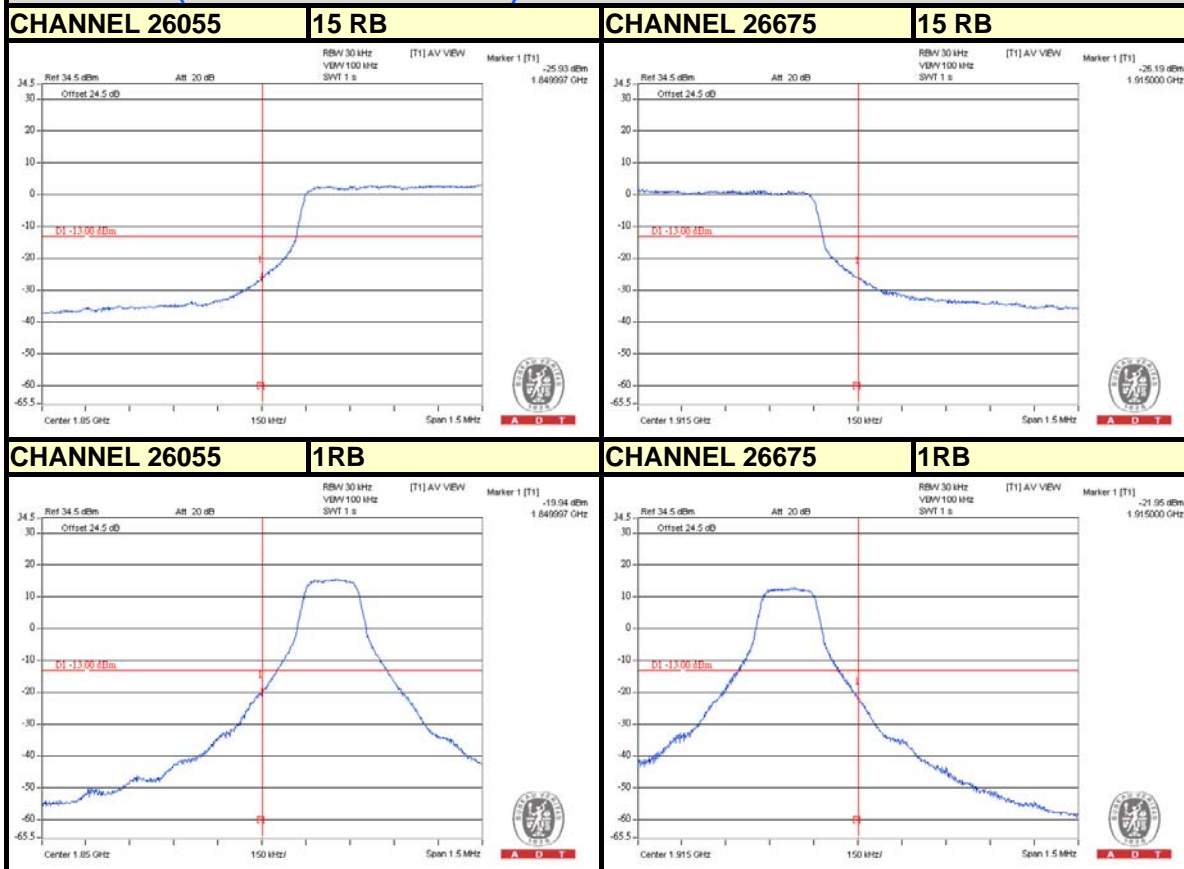



A D T

LTE Band 25 (Channel Bandwidth 5MHz)

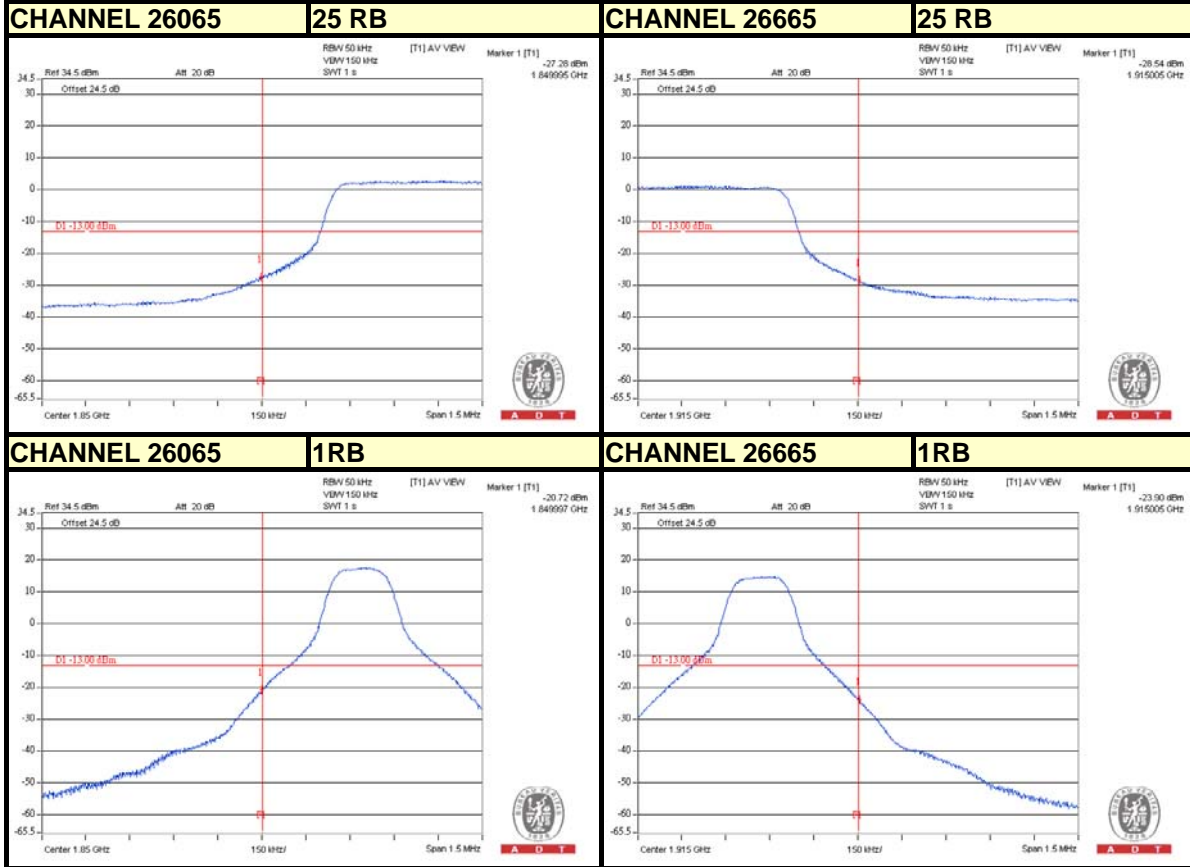



A D T

LTE Band 25 (Channel Bandwidth 10MHz)

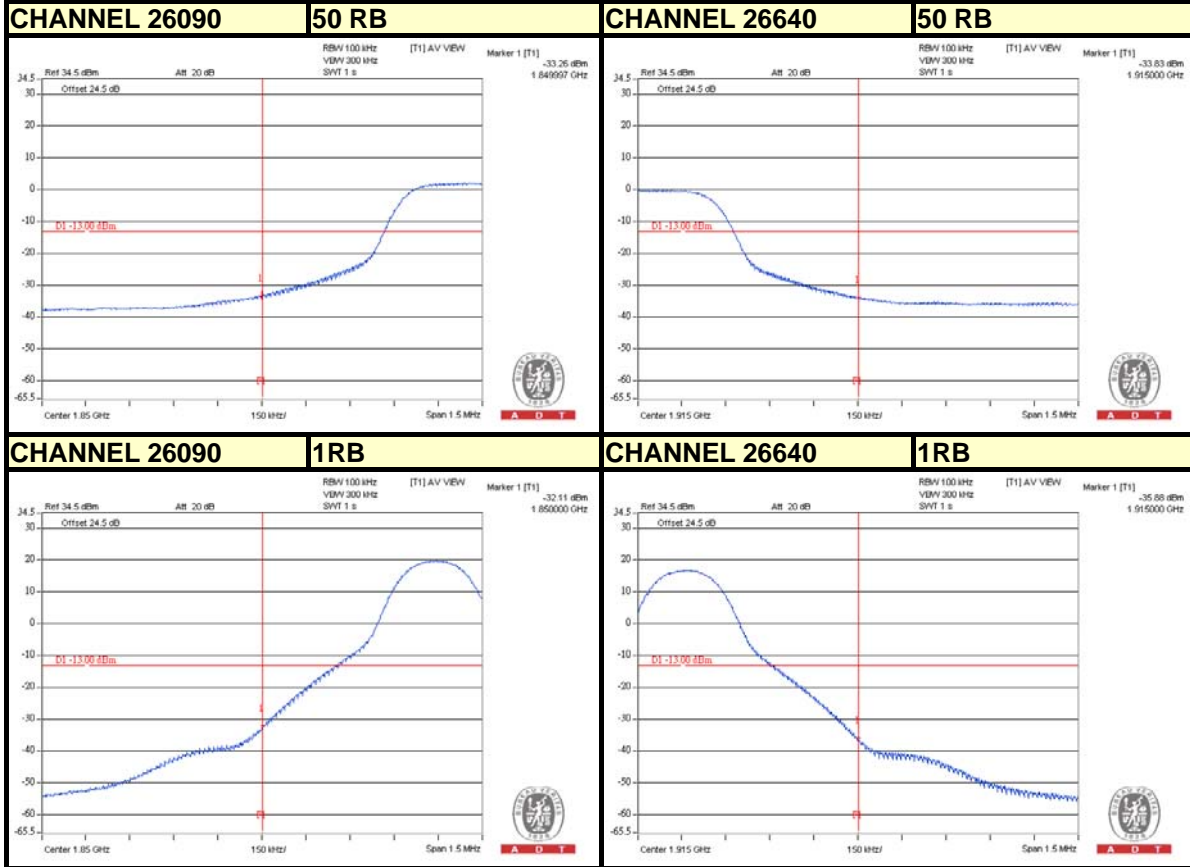

4.6 CONDUCTED SPURIOUS EMISSIONS

4.6.1 LIMITS OF CONDUCTED SPURIOUS EMISSIONS MEASUREMENT

The power of any emission outside of the authorized operating frequency ranges must be attenuated below the transmitting power (P) by a factor of at least $43 + 10 \log(P)$ dB. The emission limit equal to -13dBm .

4.6.2 TEST PROCEDURE

- a. The EUT makes a phone call to the communication simulator. All measurements were done at low, middle and high operational frequency range.
- b. Measuring frequency range is from 9kHz to 20GHz. 20dB attenuation pad is connected with spectrum. RBW=1MHz and VBW=3MHz is used for conducted emission measurement.

4.6.3 TEST SETUP

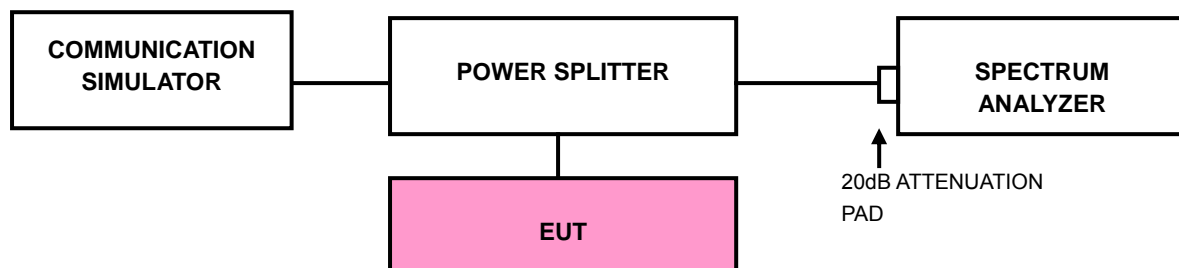



A D T

4.6.4 TEST RESULTS





A D T

CDMA

CHANNEL 600

FREQUENCY RANGE : 9kHz~3GHz

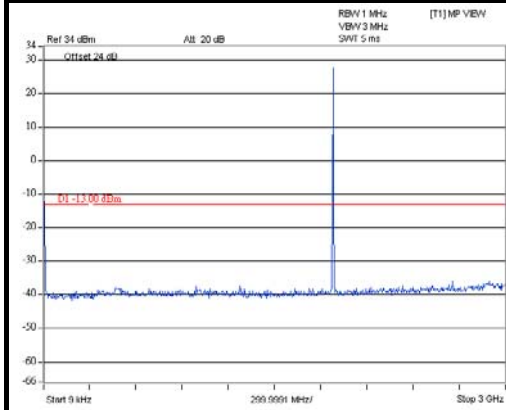

FREQUENCY RANGE : 3GHz~10GHz

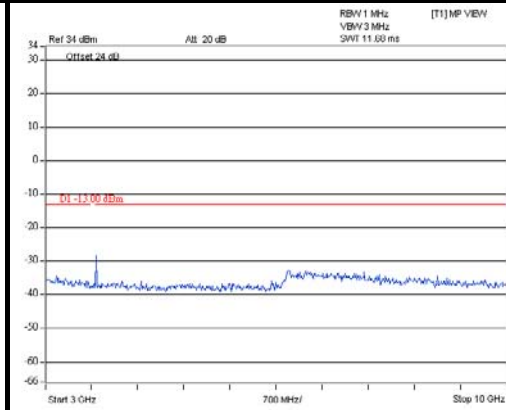

FREQUENCY RANGE : 10GHz~20GHz

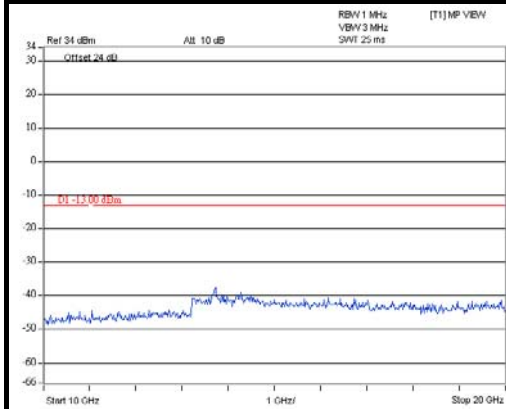



A D T

CDMA

CHANNEL 1175

FREQUENCY RANGE : 9kHz~3GHz

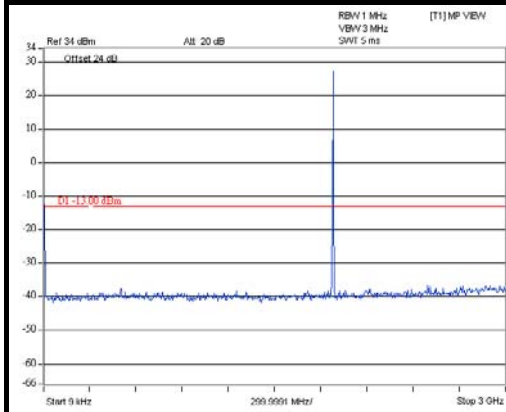

FREQUENCY RANGE : 3GHz~10GHz

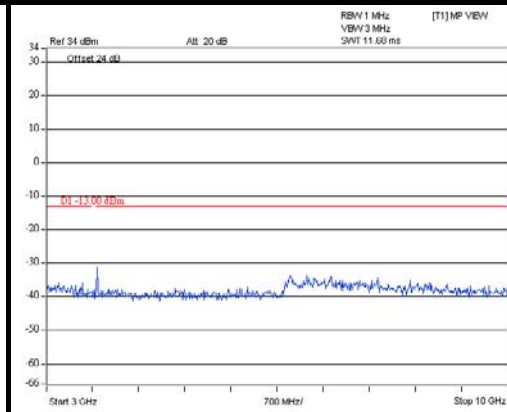

FREQUENCY RANGE : 10GHz~20GHz

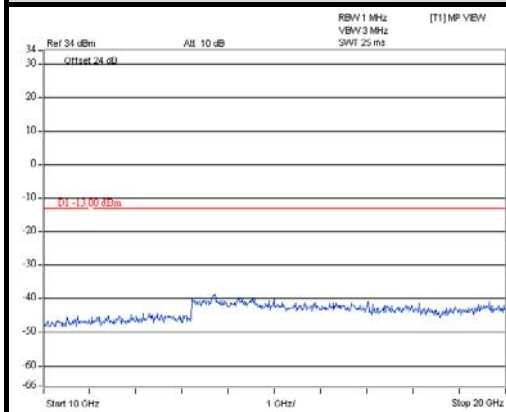



A D T

EVDO

CHANNEL 25

FREQUENCY RANGE : 9kHz~3GHz

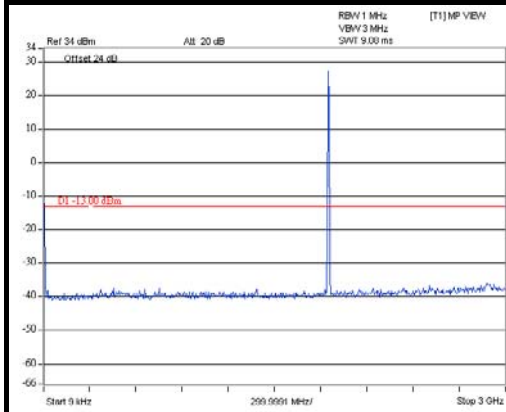

FREQUENCY RANGE : 3GHz~10GHz

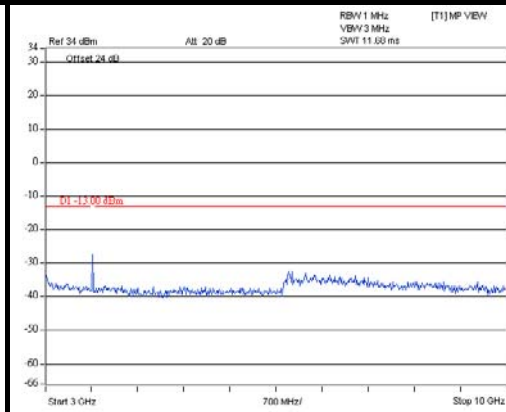

FREQUENCY RANGE : 10GHz~20GHz

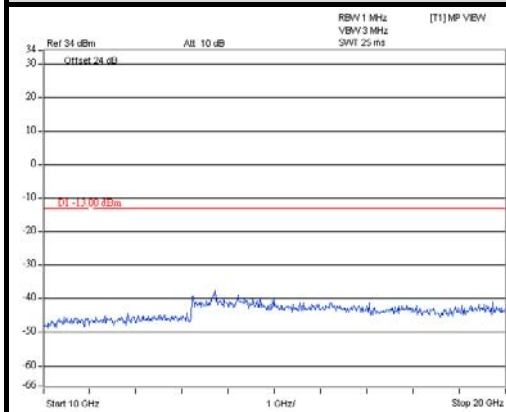



A D T

EVDO

CHANNEL 600

FREQUENCY RANGE : 9kHz~3GHz

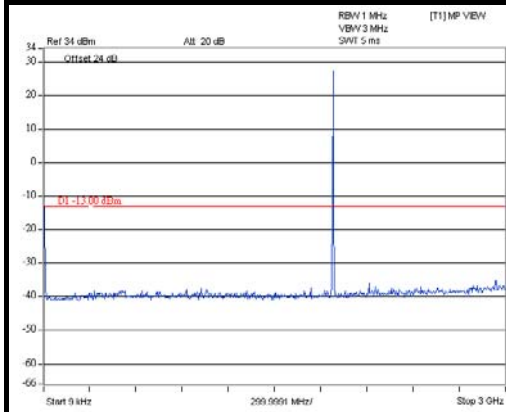

FREQUENCY RANGE : 3GHz~10GHz

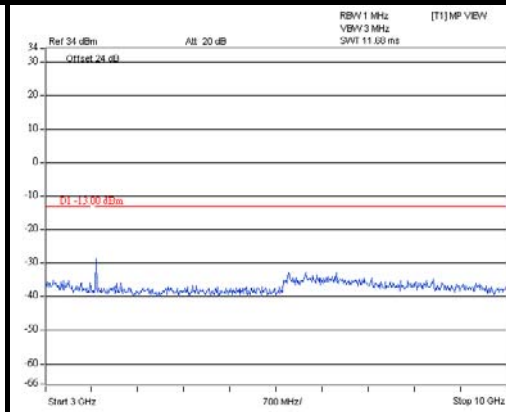

FREQUENCY RANGE : 10GHz~20GHz

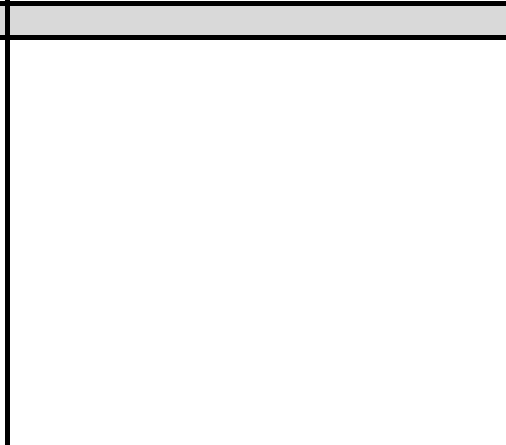
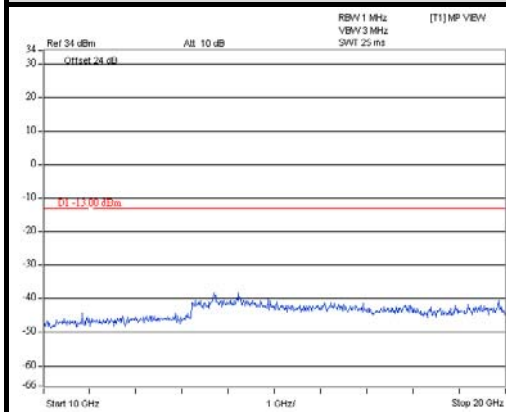



A D T

EVDO

CHANNEL 1175

FREQUENCY RANGE : 9kHz~3GHz

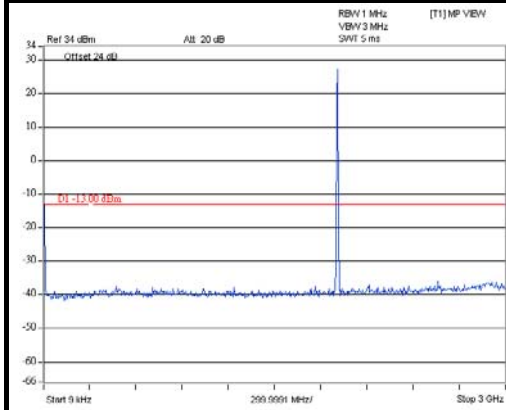

FREQUENCY RANGE : 3GHz~10GHz

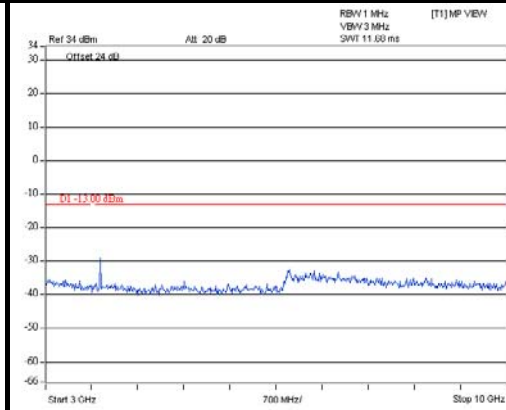

FREQUENCY RANGE : 10GHz~20GHz

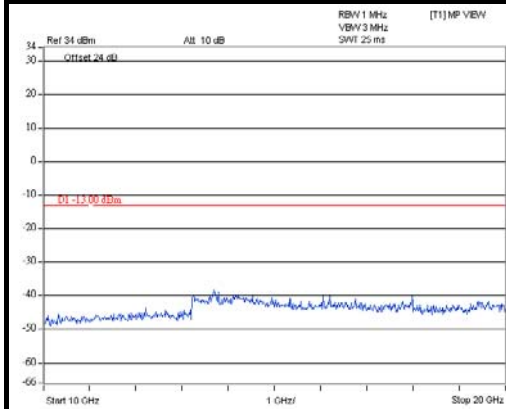



A D T

LTE Band 25 (Channel Bandwidth 3MHz)

CHANNEL 26055

FREQUENCY RANGE : 9kHz~3GHz

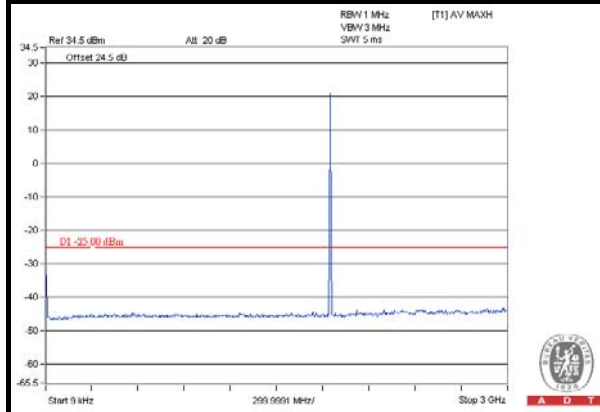

FREQUENCY RANGE : 3GHz~10GHz

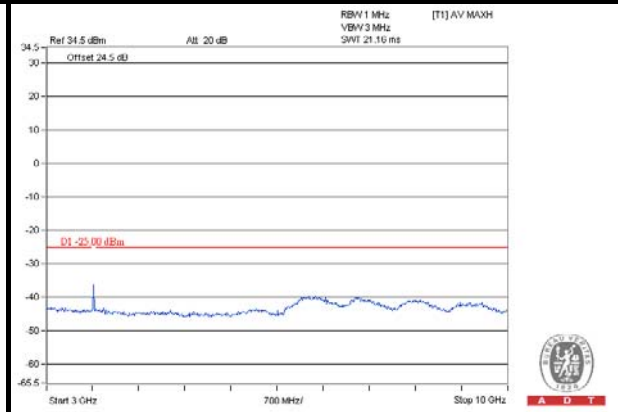

FREQUENCY RANGE : 10GHz~20GHz

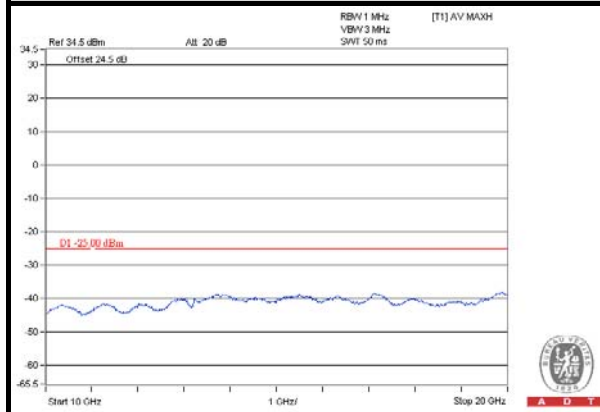



A D T

LTE Band 25 (Channel Bandwidth 3MHz)

CHANNEL 26365

FREQUENCY RANGE : 9kHz~3GHz

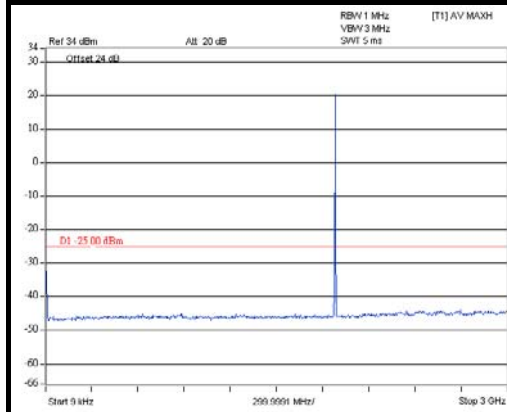

FREQUENCY RANGE : 3GHz~10GHz

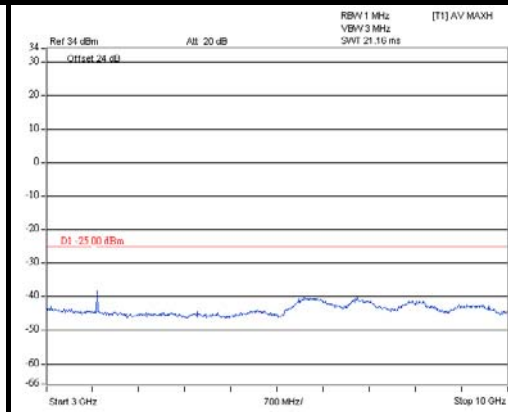

FREQUENCY RANGE : 10GHz~20GHz

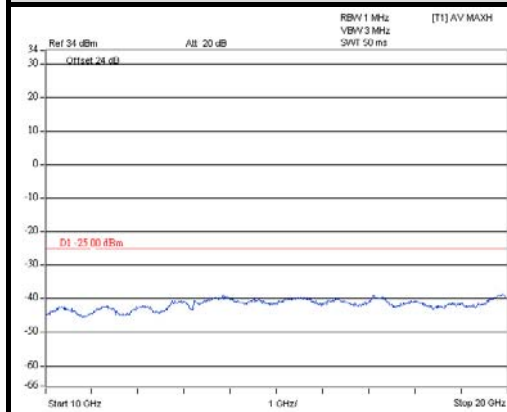



A D T

LTE Band 25 (Channel Bandwidth 3MHz)

CHANNEL 26675

FREQUENCY RANGE : 9kHz~3GHz

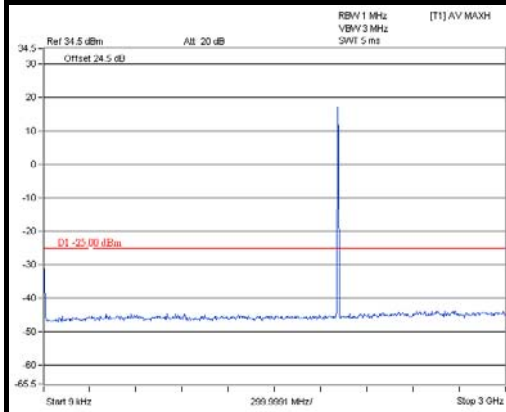

FREQUENCY RANGE : 3GHz~10GHz

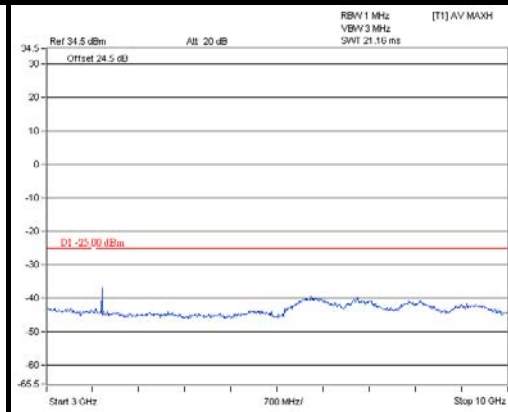

FREQUENCY RANGE : 10GHz~20GHz

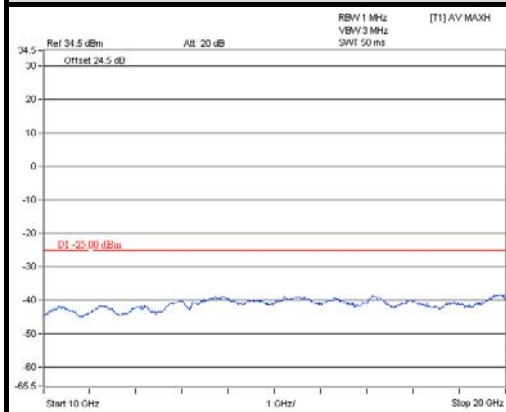



A D T

LTE Band 25 (Channel Bandwidth 5MHz)

CHANNEL 26065

FREQUENCY RANGE : 9kHz~3GHz

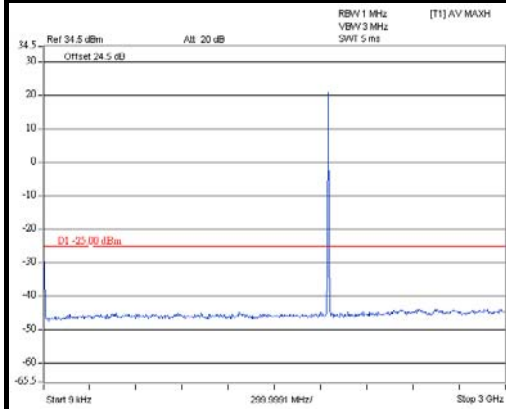

FREQUENCY RANGE : 3GHz~10GHz

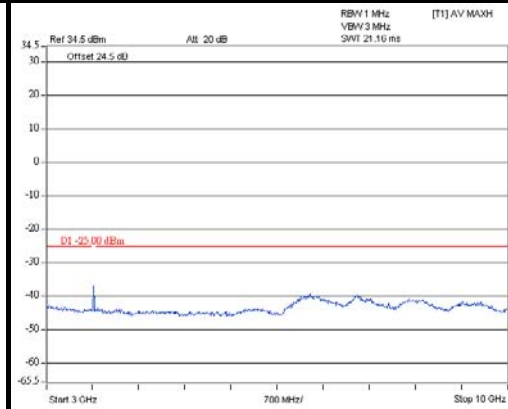

FREQUENCY RANGE : 10GHz~20GHz

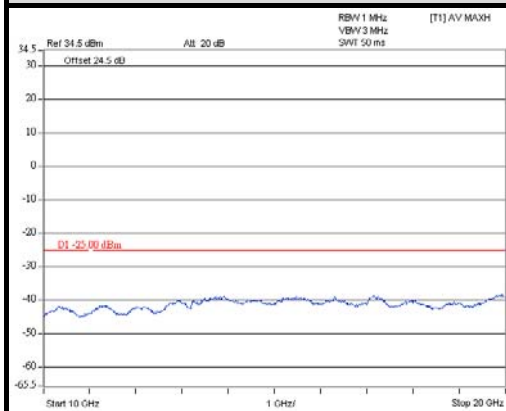



A D T

LTE Band 25 (Channel Bandwidth 5MHz)

CHANNEL 26365

FREQUENCY RANGE : 9kHz~3GHz

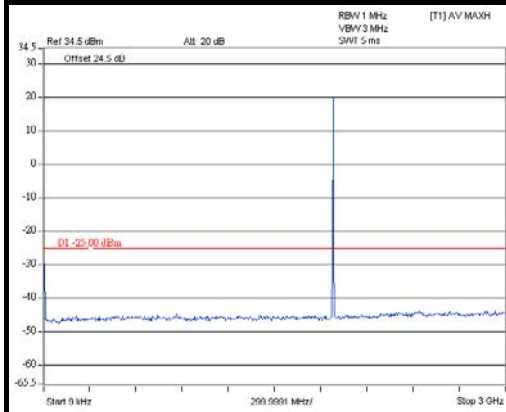

FREQUENCY RANGE : 3GHz~10GHz

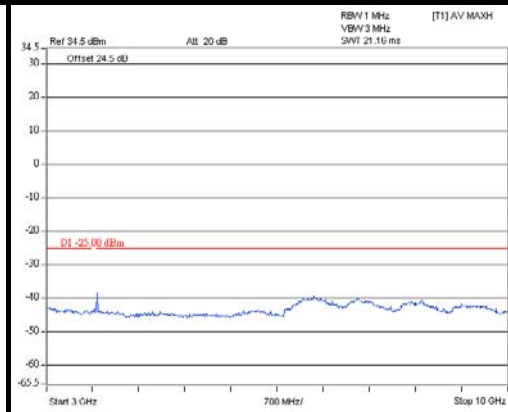

FREQUENCY RANGE : 10GHz~20GHz

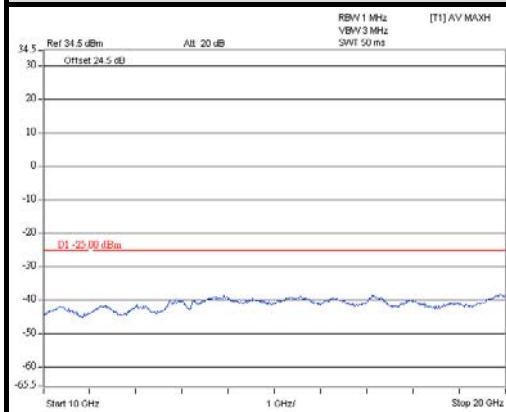



A D T

LTE Band 25 (Channel Bandwidth 5MHz)

CHANNEL 26665

FREQUENCY RANGE : 9kHz~3GHz

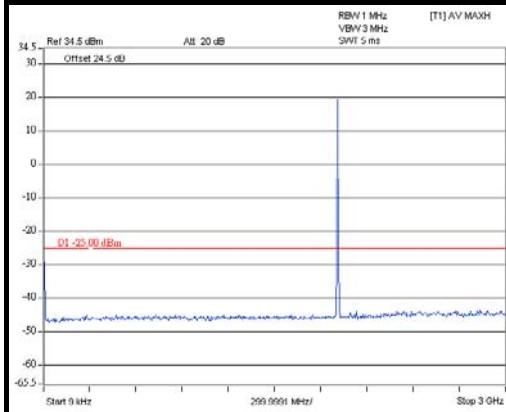

FREQUENCY RANGE : 3GHz~10GHz

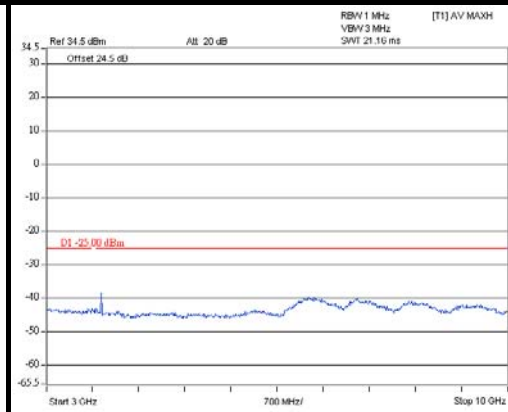

FREQUENCY RANGE : 10GHz~20GHz

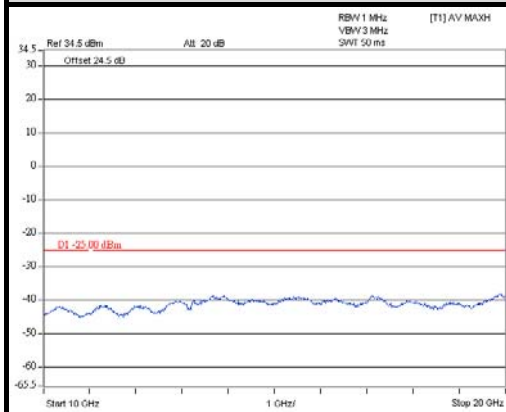



A D T

LTE Band 25 (Channel Bandwidth 10MHz)

CHANNEL 26090

FREQUENCY RANGE : 9kHz~3GHz

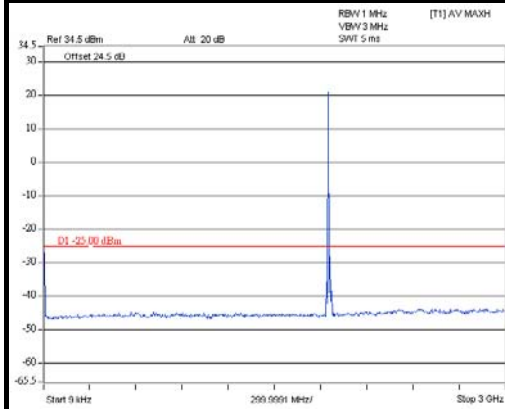

FREQUENCY RANGE : 3GHz~10GHz

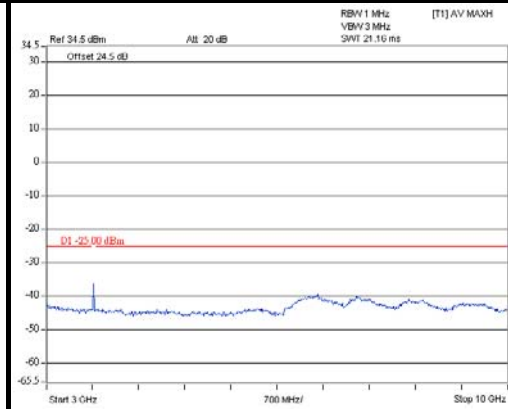

FREQUENCY RANGE : 10GHz~20GHz

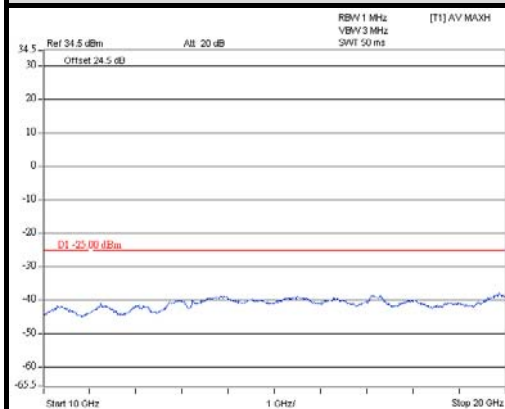



A D T

LTE Band 25 (Channel Bandwidth 10MHz)

CHANNEL 26365

FREQUENCY RANGE : 9kHz~3GHz

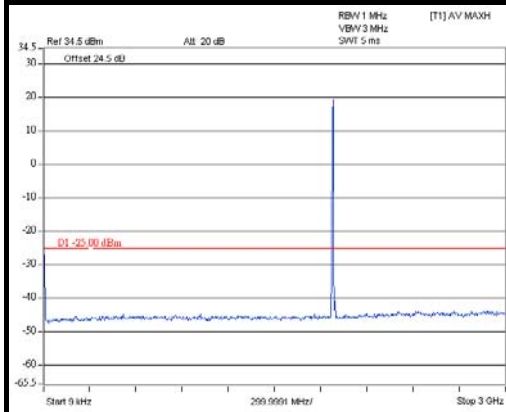

FREQUENCY RANGE : 3GHz~10GHz

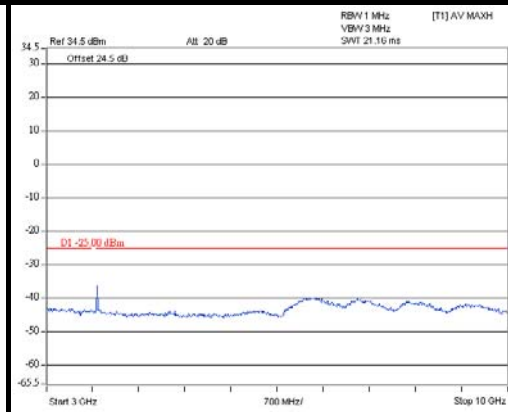

FREQUENCY RANGE : 10GHz~20GHz

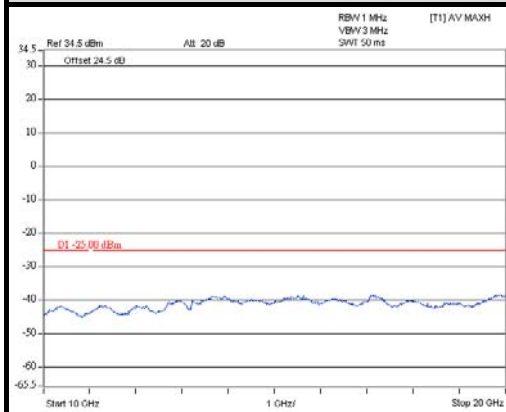



A D T

LTE Band 25 (Channel Bandwidth 10MHz)

CHANNEL 26640

FREQUENCY RANGE : 9kHz~3GHz

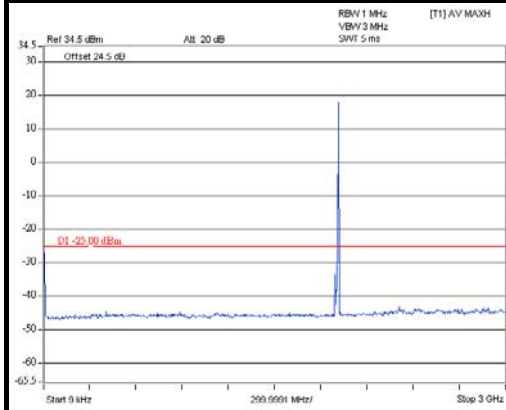

FREQUENCY RANGE : 3GHz~10GHz

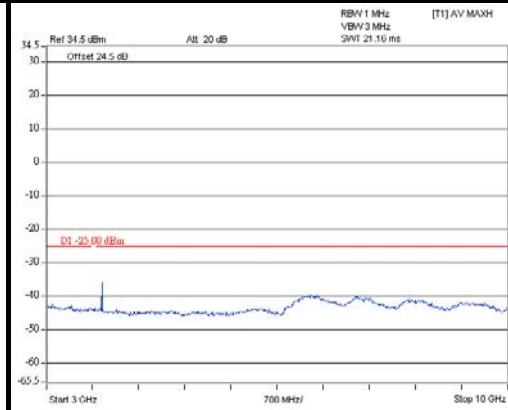

FREQUENCY RANGE : 10GHz~20GHz

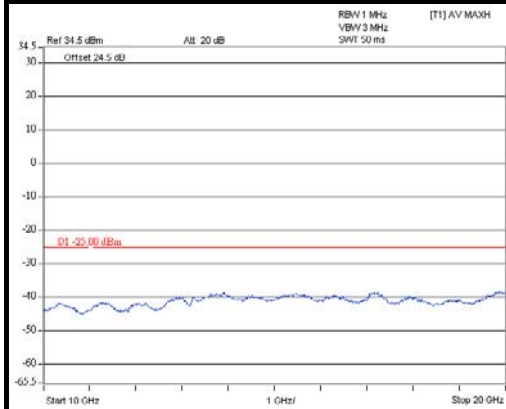

4.7 RADIATED EMISSION MEASUREMENT

4.7.1 LIMITS OF RADIATED EMISSION MEASUREMENT

The power of any emission outside of the authorized operating frequency ranges must be attenuated below the transmitting power (P) by a factor of at least $43 + 10 \log(P)$ dB. The emission limit equal to -13dBm .

4.7.2 TEST PROCEDURES

- a. Substitution method is used for E.I.R.P measurement. In the semi-anechoic chamber, EUT placed on the 0.8m height of Turn Table, rotated the table around 360 degrees to search the maximum radiation power and receiver antenna shall be rotated vertical and horizontal polarization and moved height from 1m to 4m to find the maximum polar radiated power. The "Read Value" is the spectrum reading the maximum power value.
- b. The substitution horn antenna is substituted for EUT at the same position and signals generator export the CW signal to the substitution antenna via a TX cable. Rotated the Turn Table and moved receiving antenna to find the maximum radiation power. Adjust output power level of S.G to get a Value of spectrum reading equal to "Read Value" of step a. Record the power level of S.G
- c. $\text{EIRP} = \text{Output power level of S.G} - \text{TX cable loss} + \text{Antenna gain of substitution horn}$. E.R.P power can be calculated form E.I.R.P power by subtracting the gain of dipole, $\text{E.R.P power} = \text{E.I.R.P power} - 2.15\text{dBi}$.

NOTE: The resolution bandwidth and video bandwidth of test receiver/spectrum analyzer is 1MHz/3MHz.

4.7.3 DEVIATION FROM TEST STANDARD

No deviation

4.7.4 TEST SETUP

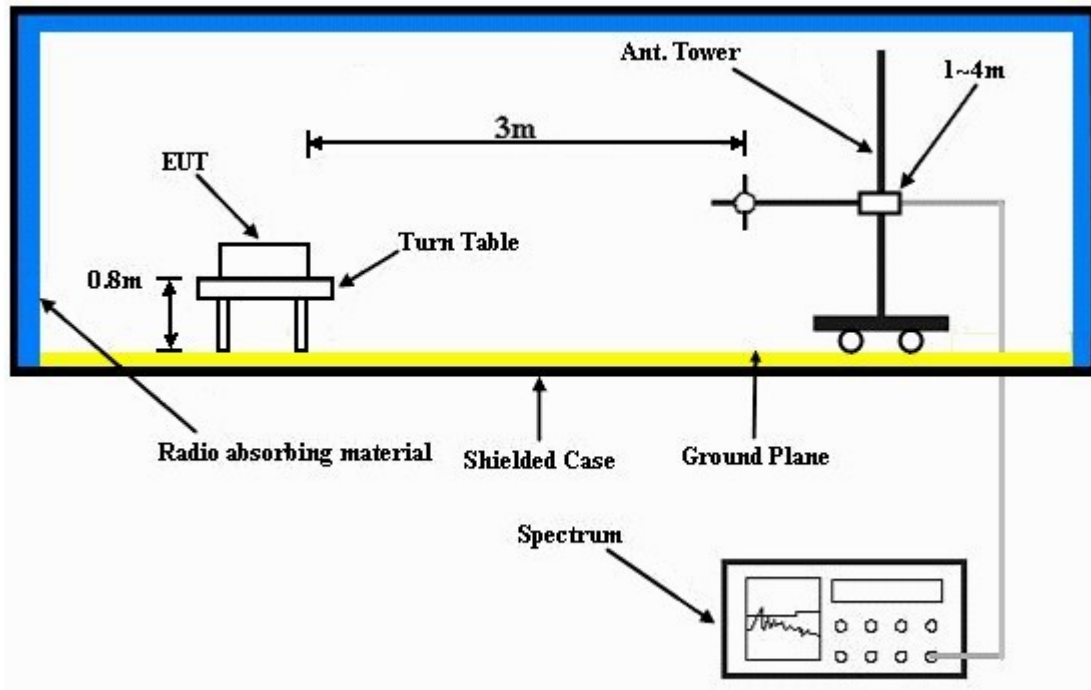

For the actual test configuration, please refer to the attached file (Test Setup Photo).

4.7.5 TEST RESULTS

CDMA

MODE	TX channel 25	FREQUENCY RANGE	Below 1000MHz
ENVIRONMENTAL CONDITIONS	25deg. C, 65%RH	INPUT POWER	120Vac, 60 Hz
TESTED BY	Brad Tung		

ANTENNA POLARITY & TEST DISTANCE: HORIZONTAL AT 3 M							
No.	Freq. (MHz)	Reading (dBm)	S.G Power Value (dBm)	Correction Factor (dB)	EIRP (dBm)	Limit (dBm)	Margin (dB)
1	55.22	-53.96	-45.79	-8.63	-54.42	-13.00	-41.42
2	78.50	-43.49	-48.24	-2.14	-50.38	-13.00	-37.38
3	216.24	-31.88	-43.56	5.46	-38.10	-13.00	-25.10
4	282.20	-48.94	-57.95	5.22	-52.73	-13.00	-39.73
5	375.32	-54.66	-60.46	5.23	-55.23	-13.00	-42.23
6	456.80	-60.54	-65.02	5.06	-59.96	-13.00	-46.96
ANTENNA POLARITY & TEST DISTANCE: VERTICAL AT 3 M							
No.	Freq. (MHz)	Reading (dBm)	S.G Power Value (dBm)	Correction Factor (dB)	EIRP (dBm)	Limit (dBm)	Margin (dB)
1	43.58	-35.75	-30.18	-10.30	-40.48	-13.00	-27.48
2	78.50	-37.22	-39.82	-2.14	-41.96	-13.00	-28.96
3	210.42	-36.69	-44.64	5.46	-39.18	-13.00	-26.18
4	235.64	-44.57	-51.77	5.42	-46.35	-13.00	-33.35
5	336.52	-54.21	-59.45	5.19	-54.26	-13.00	-41.26
6	561.56	-61.46	-62.09	4.61	-57.48	-13.00	-44.48

REMARKS:

1. Power Value (dBm) = S.G Power Value (dBm) + Correction Factor (dB).
2. Correction Factor (dB) = Substitution Antenna Gain (dB) + Cable Loss (dB).



A D T

MODE	TX channel 25	FREQUENCY RANGE	Above 1000MHz
ENVIRONMENTAL CONDITIONS	25deg. C, 65%RH	INPUT POWER	120Vac, 60 Hz
TESTED BY	Brad Tung		

ANTENNA POLARITY & TEST DISTANCE: HORIZONTAL AT 3 M							
No.	Freq. (MHz)	Reading (dBm)	S.G Power Value (dBm)	Correction Factor (dB)	EIRP (dBm)	Limit (dBm)	Margin (dB)
1	3702.50	-45.15	-39.23	7.16	-32.07	-13.00	-19.07

ANTENNA POLARITY & TEST DISTANCE: VERTICAL AT 3 M							
No.	Freq. (MHz)	Reading (dBm)	S.G Power Value (dBm)	Correction Factor (dB)	EIRP (dBm)	Limit (dBm)	Margin (dB)
1	3702.50	-46.75	-41.02	7.16	-33.86	-13.00	-20.86

REMARKS:

1. Power Value (dBm) = S.G Power Value (dBm) + Correction Factor (dB).
2. Correction Factor (dB) = Substitution Antenna Gain (dB) + Cable Loss (dB).

MODE	TX channel 600	FREQUENCY RANGE	Above 1000MHz
ENVIRONMENTAL CONDITIONS	25deg. C, 65%RH	INPUT POWER	120Vac, 60 Hz
TESTED BY	Brad Tung		

ANTENNA POLARITY & TEST DISTANCE: HORIZONTAL AT 3 M							
No.	Freq. (MHz)	Reading (dBm)	S.G Power Value (dBm)	Correction Factor (dB)	EIRP (dBm)	Limit (dBm)	Margin (dB)
1	3760.00	-45.75	-39.69	7.10	-32.59	-13.00	-19.59

ANTENNA POLARITY & TEST DISTANCE: VERTICAL AT 3 M							
No.	Freq. (MHz)	Reading (dBm)	S.G Power Value (dBm)	Correction Factor (dB)	EIRP (dBm)	Limit (dBm)	Margin (dB)
1	3760.00	-47.34	-41.47	7.10	-34.37	-13.00	-21.37

REMARKS:

1. Power Value (dBm) = S.G Power Value (dBm) + Correction Factor (dB).
2. Correction Factor (dB) = Substitution Antenna Gain (dB) + Cable Loss (dB).



A D T

MODE	TX channel 1175	FREQUENCY RANGE	Above 1000MHz
ENVIRONMENTAL CONDITIONS	25deg. C, 65%RH	INPUT POWER	120Vac, 60 Hz
TESTED BY	Brad Tung		

ANTENNA POLARITY & TEST DISTANCE: HORIZONTAL AT 3 M							
No.	Freq. (MHz)	Reading (dBm)	S.G Power Value (dBm)	Correction Factor (dB)	EIRP (dBm)	Limit (dBm)	Margin (dB)
1	3817.50	-46.32	-40.13	7.05	-33.08	-13.00	-20.08

ANTENNA POLARITY & TEST DISTANCE: VERTICAL AT 3 M							
No.	Freq. (MHz)	Reading (dBm)	S.G Power Value (dBm)	Correction Factor (dB)	EIRP (dBm)	Limit (dBm)	Margin (dB)
1	3817.50	-47.96	-41.96	7.05	-34.91	-13.00	-21.91

REMARKS:

1. Power Value (dBm) = S.G Power Value (dBm) + Correction Factor (dB).
2. Correction Factor (dB) = Substitution Antenna Gain (dB) + Cable Loss (dB).



LTE Band 25 (Channel Bandwidth 3MHz)

MODE	TX channel 26055	FREQUENCY RANGE	Below 1000MHz
ENVIRONMENTAL CONDITIONS	25deg. C, 65%RH	INPUT POWER	120Vac, 60 Hz
TESTED BY	Brad Tung		

ANTENNA POLARITY & TEST DISTANCE: HORIZONTAL AT 3 M							
No.	Freq. (MHz)	Reading (dBm)	S.G Power Value (dBm)	Correction Factor (dB)	EIRP (dBm)	Limit (dBm)	Margin (dB)
1	49.40	-59.13	-47.62	-9.85	-57.47	-13.00	-44.47
2	105.66	-52.54	-58.84	0.65	-58.19	-13.00	-45.19
3	214.30	-39.10	-50.78	5.45	-45.33	-13.00	-32.33
4	288.02	-49.67	-58.79	5.19	-53.60	-13.00	-40.60
5	359.80	-54.26	-61.22	5.22	-56.00	-13.00	-43.00
6	602.30	-54.99	-57.73	4.45	-53.28	-13.00	-40.28

ANTENNA POLARITY & TEST DISTANCE: VERTICAL AT 3 M							
No.	Freq. (MHz)	Reading (dBm)	S.G Power Value (dBm)	Correction Factor (dB)	EIRP (dBm)	Limit (dBm)	Margin (dB)
1	49.40	-41.53	-36.73	-9.85	-46.58	-13.00	-33.58
2	119.24	-48.86	-52.50	0.10	-52.40	-13.00	-39.40
3	212.36	-40.17	-48.10	5.46	-42.64	-13.00	-29.64
4	344.28	-54.99	-60.37	5.20	-55.17	-13.00	-42.17
5	532.46	-58.82	-60.23	4.73	-55.50	-13.00	-42.50
6	604.24	-54.89	-54.09	4.46	-49.63	-13.00	-36.63

REMARKS:

1. Power Value (dBm) = S.G Power Value (dBm) + Correction Factor (dB).
2. Correction Factor (dB) = Substitution Antenna Gain (dB) + Cable Loss (dB).



A D T

MODE	Channel 26055	FREQUENCY RANGE	Above 1000MHz
ENVIRONMENTAL CONDITIONS	25deg. C, 65%RH	INPUT POWER	120Vac, 60 Hz
TESTED BY	Brad Tung		

ANTENNA POLARITY & TEST DISTANCE: HORIZONTAL AT 3 M							
No.	Freq. (MHz)	Reading (dBm)	S.G Power Value (dBm)	Correction Factor (dB)	EIRP (dBm)	Limit (dBm)	Margin (dB)
1	3703.00	-43.28	-37.36	7.16	-30.20	-13.00	-17.20

ANTENNA POLARITY & TEST DISTANCE: VERTICAL AT 3 M							
No.	Freq. (MHz)	Reading (dBm)	S.G Power Value (dBm)	Correction Factor (dB)	EIRP (dBm)	Limit (dBm)	Margin (dB)
1	3703.00	-45.90	-40.17	7.16	-33.01	-13.00	-20.01

REMARKS:

1. Power Value (dBm) = S.G Power Value (dBm) + Correction Factor (dB).
2. Correction Factor (dB) = Substitution Antenna Gain (dB) + Cable Loss (dB).

MODE	Channel 26365	FREQUENCY RANGE	Above 1000MHz
ENVIRONMENTAL CONDITIONS	25deg. C, 65%RH	INPUT POWER	120Vac, 60 Hz
TESTED BY	Ted Chang		

ANTENNA POLARITY & TEST DISTANCE: HORIZONTAL AT 3 M							
No.	Freq. (MHz)	Reading (dBm)	S.G Power Value (dBm)	Correction Factor (dB)	EIRP (dBm)	Limit (dBm)	Margin (dB)
1	3765.00	-45.88	-39.80	7.09	-32.71	-13.00	-19.71

ANTENNA POLARITY & TEST DISTANCE: VERTICAL AT 3 M							
No.	Freq. (MHz)	Reading (dBm)	S.G Power Value (dBm)	Correction Factor (dB)	EIRP (dBm)	Limit (dBm)	Margin (dB)
1	3765.00	-49.89	-44.00	7.09	-36.91	-13.00	-23.91

REMARKS:

1. Power Value (dBm) = S.G Power Value (dBm) + Correction Factor (dB).
2. Correction Factor (dB) = Substitution Antenna Gain (dB) + Cable Loss (dB).



A D T

MODE	Channel 26675	FREQUENCY RANGE	Above 1000MHz
ENVIRONMENTAL CONDITIONS	25deg. C, 65%RH	INPUT POWER	120Vac, 60 Hz
TESTED BY	Brad Tung		

ANTENNA POLARITY & TEST DISTANCE: HORIZONTAL AT 3 M							
No.	Freq. (MHz)	Reading (dBm)	S.G Power Value (dBm)	Correction Factor (dB)	EIRP (dBm)	Limit (dBm)	Margin (dB)
1	3827.00	-44.57	-38.38	7.06	-31.32	-13.00	-18.32

ANTENNA POLARITY & TEST DISTANCE: VERTICAL AT 3 M							
No.	Freq. (MHz)	Reading (dBm)	S.G Power Value (dBm)	Correction Factor (dB)	EIRP (dBm)	Limit (dBm)	Margin (dB)
1	3827.00	-47.73	-41.72	7.06	-34.66	-13.00	-21.66

REMARKS:

1. Power Value (dBm) = S.G Power Value (dBm) + Correction Factor (dB).
2. Correction Factor (dB) = Substitution Antenna Gain (dB) + Cable Loss (dB).

LTE Band 25 (Channel Bandwidth 5MHz)

MODE	TX channel 26065	FREQUENCY RANGE	Below 1000MHz
ENVIRONMENTAL CONDITIONS	25deg. C, 65%RH	INPUT POWER	120Vac, 60 Hz
TESTED BY	Brad Tung		

ANTENNA POLARITY & TEST DISTANCE: HORIZONTAL AT 3 M							
No.	Freq. (MHz)	Reading (dBm)	S.G Power Value (dBm)	Correction Factor (dB)	EIRP (dBm)	Limit (dBm)	Margin (dB)
1	39.70	-53.22	-38.31	-10.93	-49.24	-13.00	-36.24
2	214.30	-39.23	-50.91	5.45	-45.46	-13.00	-32.46
3	243.40	-46.07	-56.45	5.40	-51.05	-13.00	-38.05
4	369.50	-55.75	-62.03	5.21	-56.82	-13.00	-43.82
5	532.46	-58.04	-62.15	4.73	-57.42	-13.00	-44.42
6	600.36	-52.84	-55.63	4.44	-51.19	-13.00	-38.19
ANTENNA POLARITY & TEST DISTANCE: VERTICAL AT 3 M							
No.	Freq. (MHz)	Reading (dBm)	S.G Power Value (dBm)	Correction Factor (dB)	EIRP (dBm)	Limit (dBm)	Margin (dB)
1	41.64	-39.25	-33.26	-10.62	-43.88	-13.00	-30.88
2	117.30	-49.67	-53.48	0.18	-53.30	-13.00	-40.30
3	212.36	-39.65	-47.58	5.46	-42.12	-13.00	-29.12
4	272.50	-46.17	-52.89	5.28	-47.61	-13.00	-34.61
5	324.88	-52.45	-57.48	5.17	-52.31	-13.00	-39.31
6	604.24	-55.46	-54.66	4.46	-50.20	-13.00	-37.20

REMARKS:

1. Power Value (dBm) = S.G Power Value (dBm) + Correction Factor (dB).
2. Correction Factor (dB) = Substitution Antenna Gain (dB) + Cable Loss (dB).



A D T

MODE	Channel 26065	FREQUENCY RANGE	Above 1000MHz
ENVIRONMENTAL CONDITIONS	25deg. C, 65%RH	INPUT POWER	120Vac, 60 Hz
TESTED BY	Brad Tung		

ANTENNA POLARITY & TEST DISTANCE: HORIZONTAL AT 3 M							
No.	Freq. (MHz)	Reading (dBm)	S.G Power Value (dBm)	Correction Factor (dB)	EIRP (dBm)	Limit (dBm)	Margin (dB)
1	3705.00	-43.53	-37.60	7.15	-30.45	-13.00	-17.45
ANTENNA POLARITY & TEST DISTANCE: VERTICAL AT 3 M							
No.	Freq. (MHz)	Reading (dBm)	S.G Power Value (dBm)	Correction Factor (dB)	EIRP (dBm)	Limit (dBm)	Margin (dB)
1	3705.00	-46.23	-40.48	7.15	-33.33	-13.00	-20.33

REMARKS:

1. Power Value (dBm) = S.G Power Value (dBm) + Correction Factor (dB).
2. Correction Factor (dB) = Substitution Antenna Gain (dB) + Cable Loss (dB).

MODE	Channel 26365	FREQUENCY RANGE	Above 1000MHz
ENVIRONMENTAL CONDITIONS	25deg. C, 65%RH	INPUT POWER	120Vac, 60 Hz
TESTED BY	Brad Tung		

ANTENNA POLARITY & TEST DISTANCE: HORIZONTAL AT 3 M							
No.	Freq. (MHz)	Reading (dBm)	S.G Power Value (dBm)	Correction Factor (dB)	EIRP (dBm)	Limit (dBm)	Margin (dB)
1	3765.00	-45.24	-39.16	7.09	-32.07	-13.00	-19.07
ANTENNA POLARITY & TEST DISTANCE: VERTICAL AT 3 M							
No.	Freq. (MHz)	Reading (dBm)	S.G Power Value (dBm)	Correction Factor (dB)	EIRP (dBm)	Limit (dBm)	Margin (dB)
1	3765.00	-47.95	-42.06	7.09	-34.97	-13.00	-21.97

REMARKS:

1. Power Value (dBm) = S.G Power Value (dBm) + Correction Factor (dB).
2. Correction Factor (dB) = Substitution Antenna Gain (dB) + Cable Loss (dB).



A D T

MODE	Channel 26665	FREQUENCY RANGE	Above 1000MHz
ENVIRONMENTAL CONDITIONS	25deg. C, 65%RH	INPUT POWER	120Vac, 60 Hz
TESTED BY	Brad Tung		

ANTENNA POLARITY & TEST DISTANCE: HORIZONTAL AT 3 M							
No.	Freq. (MHz)	Reading (dBm)	S.G Power Value (dBm)	Correction Factor (dB)	EIRP (dBm)	Limit (dBm)	Margin (dB)
1	3825.00	-45.96	-39.77	7.06	-32.71	-13.00	-19.71

ANTENNA POLARITY & TEST DISTANCE: VERTICAL AT 3 M							
No.	Freq. (MHz)	Reading (dBm)	S.G Power Value (dBm)	Correction Factor (dB)	EIRP (dBm)	Limit (dBm)	Margin (dB)
1	3825.00	-48.46	-42.46	7.06	-35.40	-13.00	-22.40

REMARKS:

1. Power Value (dBm) = S.G Power Value (dBm) + Correction Factor (dB).
2. Correction Factor (dB) = Substitution Antenna Gain (dB) + Cable Loss (dB).



LTE Band 25 (Channel Bandwidth 10MHz)

MODE	TX channel 26090	FREQUENCY RANGE	Below 1000MHz
ENVIRONMENTAL CONDITIONS	25deg. C, 65%RH	INPUT POWER	120Vac, 60 Hz
TESTED BY	Brad Tung		

ANTENNA POLARITY & TEST DISTANCE: HORIZONTAL AT 3 M							
No.	Freq. (MHz)	Reading (dBm)	S.G Power Value (dBm)	Correction Factor (dB)	EIRP (dBm)	Limit (dBm)	Margin (dB)
1	41.64	-57.73	-43.53	-10.62	-54.15	-13.00	-41.15
2	212.36	-39.11	-50.81	5.46	-45.35	-13.00	-32.35
3	253.10	-41.15	-51.16	5.38	-45.78	-13.00	-32.78
4	303.54	-50.75	-59.64	5.13	-54.51	-13.00	-41.51
5	359.80	-55.38	-62.34	5.22	-57.12	-13.00	-44.12
6	600.36	-53.45	-56.24	4.44	-51.80	-13.00	-38.80
ANTENNA POLARITY & TEST DISTANCE: VERTICAL AT 3 M							
No.	Freq. (MHz)	Reading (dBm)	S.G Power Value (dBm)	Correction Factor (dB)	EIRP (dBm)	Limit (dBm)	Margin (dB)
1	43.58	-39.44	-33.87	-10.30	-44.17	-13.00	-31.17
2	121.18	-48.48	-51.97	0.05	-51.92	-13.00	-38.92
3	214.30	-39.91	-47.82	5.45	-42.37	-13.00	-29.37
4	272.50	-48.25	-54.97	5.28	-49.69	-13.00	-36.69
5	386.96	-53.18	-56.95	5.24	-51.71	-13.00	-38.71
6	600.36	-55.72	-55.02	4.44	-50.58	-13.00	-37.58

REMARKS:

1. Power Value (dBm) = S.G Power Value (dBm) + Correction Factor (dB).
2. Correction Factor (dB) = Substitution Antenna Gain (dB) + Cable Loss (dB).



A D T

MODE	Channel 26090	FREQUENCY RANGE	Above 1000MHz
ENVIRONMENTAL CONDITIONS	25deg. C, 65%RH	INPUT POWER	120Vac, 60 Hz
TESTED BY	Brad Tung		

ANTENNA POLARITY & TEST DISTANCE: HORIZONTAL AT 3 M							
No.	Freq. (MHz)	Reading (dBm)	S.G Power Value (dBm)	Correction Factor (dB)	EIRP (dBm)	Limit (dBm)	Margin (dB)
1	3710.00	-44.28	-38.34	7.15	-31.19	-13.00	-18.19
ANTENNA POLARITY & TEST DISTANCE: VERTICAL AT 3 M							
No.	Freq. (MHz)	Reading (dBm)	S.G Power Value (dBm)	Correction Factor (dB)	EIRP (dBm)	Limit (dBm)	Margin (dB)
1	3710.00	-46.33	-40.58	7.15	-33.43	-13.00	-20.43

REMARKS:

1. Power Value (dBm) = S.G Power Value (dBm) + Correction Factor (dB).
2. Correction Factor (dB) = Substitution Antenna Gain (dB) + Cable Loss (dB).

MODE	Channel 26365	FREQUENCY RANGE	Above 1000MHz
ENVIRONMENTAL CONDITIONS	25deg. C, 65%RH	INPUT POWER	120Vac, 60 Hz
TESTED BY	Brad Tung		

ANTENNA POLARITY & TEST DISTANCE: HORIZONTAL AT 3 M							
No.	Freq. (MHz)	Reading (dBm)	S.G Power Value (dBm)	Correction Factor (dB)	EIRP (dBm)	Limit (dBm)	Margin (dB)
1	3765.00	-44.98	-38.90	7.09	-31.81	-13.00	-18.81
ANTENNA POLARITY & TEST DISTANCE: VERTICAL AT 3 M							
No.	Freq. (MHz)	Reading (dBm)	S.G Power Value (dBm)	Correction Factor (dB)	EIRP (dBm)	Limit (dBm)	Margin (dB)
1	3765.00	-48.26	-42.37	7.09	-35.28	-13.00	-22.28

REMARKS:

1. Power Value (dBm) = S.G Power Value (dBm) + Correction Factor (dB).
2. Correction Factor (dB) = Substitution Antenna Gain (dB) + Cable Loss (dB).



A D T

MODE	Channel 26640	FREQUENCY RANGE	Above 1000MHz
ENVIRONMENTAL CONDITIONS	25deg. C, 65%RH	INPUT POWER	120Vac, 60 Hz
TESTED BY	Brad Tung		

ANTENNA POLARITY & TEST DISTANCE: HORIZONTAL AT 3 M							
No.	Freq. (MHz)	Reading (dBm)	S.G Power Value (dBm)	Correction Factor (dB)	EIRP (dBm)	Limit (dBm)	Margin (dB)
1	3820.00	-45.75	-39.56	7.05	-32.51	-13.00	-19.51

ANTENNA POLARITY & TEST DISTANCE: VERTICAL AT 3 M							
No.	Freq. (MHz)	Reading (dBm)	S.G Power Value (dBm)	Correction Factor (dB)	EIRP (dBm)	Limit (dBm)	Margin (dB)
1	3820.00	-49.03	-43.02	7.05	-35.97	-13.00	-22.97

REMARKS:

1. Power Value (dBm) = S.G Power Value (dBm) + Correction Factor (dB).
2. Correction Factor (dB) = Substitution Antenna Gain (dB) + Cable Loss (dB).



A D T

5 PHOTOGRAPHS OF THE TEST CONFIGURATION

Please refer to the attached file (Test Setup Photo).



6 INFORMATION ON THE TESTING LABORATORIES

We, Bureau Veritas Consumer Products Services (H.K.) Ltd., Taoyuan Branch, were founded in 1988 to provide our best service in EMC, Radio, Telecom and Safety consultation. Our laboratories are accredited and approved according to ISO/IEC 17025.

If you have any comments, please feel free to contact us at the following:

Linko EMC/RF Lab:

Tel: 886-2-26052180

Fax: 886-2-26051924

Hsin Chu EMC/RF Lab:

Tel: 886-3-5935343

Fax: 886-3-5935342

Hwa Ya EMC/RF/Safety/Telecom Lab:

Tel: 886-3-3183232

Fax: 886-3-3270892

Email: service.adt@tw.bureauveritas.com

Web Site: www.bureauveritas-adt.com

The address and road map of all our labs can be found in our web site also.



7 APPENDIX A – MODIFICATIONS RECORDERS FOR ENGINEERING CHANGES TO THE EUT BY THE LAB

No modifications were made to the EUT by the lab during the test.

---END---