



# FCC TEST REPORT (PART 27)

**REPORT NO.:** RF121023C07A-2

**MODEL NO.:** P530

**FCC ID:** UZI-30P58

**RECEIVED:** Oct. 23, 2012

**TESTED:** Nov. 08 ~ Nov. 12, 2012 (LTE mode)  
Jul. 05 ~ Jul. 09, 2013 (EVDO mode)

**ISSUED:** Jul. 17, 2013

**APPLICANT:** BandRich Inc.

**ADDRESS:** 6F., No. 71, Zhouzi St., Neihu Dist., Taipei City  
11493, Taiwan (R.O.C.)

**ISSUED BY:** Bureau Veritas Consumer Products Services  
(H.K.) Ltd., Taoyuan Branch

**LAB ADDRESS:** No. 47, 14th Ling, Chia Pau Vil., Lin Kou Dist.,  
New Taipei City, Taiwan, R.O.C.

**TEST LOCATION:** No. 19, Hwa Ya 2nd Rd, Wen Hwa Tsuen, Kwei  
Shan Hsiang, Taoyuan Hsien 333, Taiwan, R.O.C.

This report should not be used by the client to claim product certification, approval, or endorsement by TAF or any government agencies.



This report is for your exclusive use. Any copying or replication of this report to or for any other person or entity, or use of our name or trademark, is permitted only with our prior written permission. This report sets forth our findings solely with respect to the test samples identified herein. The results set forth in this report are not indicative or representative of the quality or characteristics of the lot from which a test sample was taken or any similar or identical product unless specifically and expressly noted. Our report includes all of the tests requested by you and the results thereof based upon the information that you provided to us. You have 60 days from date of issuance of this report to notify us of any material error or omission caused by our negligence, provided, however, that such notice shall be in writing and shall specifically address the issue you wish to raise. A failure to raise such issue within the prescribed time shall constitute your unqualified acceptance of the completeness of this report, the tests conducted and the correctness of the report contents. Unless specific mention, the uncertainty of measurement has been explicitly taken into account to declare the compliance or non-compliance to the specification



A D T

# TABLE OF CONTENTS

RELEASE CONTROL RECORD.....	4
1 CERTIFICATION .....	5
2 SUMMARY OF TEST RESULTS .....	6
2.1 MEASUREMENT UNCERTAINTY .....	9
2.2 TEST SITE AND INSTRUMENTS .....	10
3 GENERAL INFORMATION.....	12
3.1 GENERAL DESCRIPTION OF EUT.....	12
3.2 CONFIGURATION OF SYSTEM UNDER TEST.....	15
3.3 DESCRIPTION OF TEST MODES.....	17
3.4 GENERAL DESCRIPTION OF APPLIED STANDARDS .....	22
4 TEST TYPES AND RESULTS.....	23
4.1 OUTPUT POWER MEASUREMENT .....	23
4.1.1 LIMITS OF OUTPUT POWER MEASUREMENT.....	23
4.1.2 TEST PROCEDURES.....	23
4.1.3 TEST SETUP .....	24
4.1.4 TEST RESULTS .....	25
4.2 FREQUENCY STABILITY MEASUREMENT .....	39
4.2.1 LIMITS OF FREQUENCY STABILITY MEASUREMENT.....	39
4.2.2 TEST PROCEDURE .....	39
4.2.3 TEST SETUP .....	39
4.2.4 TEST RESULTS .....	40
4.3 OCCUPIED BANDWIDTH MEASUREMENT.....	41
4.3.1 LIMITS OF OCCUPIED BANDWIDTH MEASUREMENT .....	41
4.3.2 TEST SETUP .....	41
4.3.3 TEST PROCEDURES .....	41
4.3.4 TEST RESULTS .....	42
4.4 PEAK TO AVERAGE RATIO .....	48
4.4.1 LIMITS OF PEAK TO AVERAGE RATIO MEASUREMENT .....	48
4.4.2 TEST SETUP .....	48
4.4.3 TEST PROCEDURES.....	48
4.4.4 TEST RESULTS .....	49
4.5 BAND EDGE MEASUREMENT .....	53
4.5.1 LIMITS OF BAND EDGE MEASUREMENT.....	53
4.5.2 TEST SETUP .....	53
4.5.3 TEST PROCEDURES.....	54
4.5.4 TEST RESULTS .....	55
4.6 CONDUCTED SPURIOUS EMISSIONS.....	64
4.6.1 LIMITS OF CONDUCTED SPURIOUS EMISSIONS MEASUREMENT .....	64
4.6.2 TEST PROCEDURE .....	64
4.6.3 TEST SETUP .....	64
4.6.4 TEST RESULTS .....	65
4.7 RADIATED EMISSION MEASUREMENT .....	68
4.7.1 LIMITS OF RADIATED EMISSION MEASUREMENT .....	68



A D T

4.7.2	TEST PROCEDURES .....	68
4.7.3	DEVIATION FROM TEST STANDARD .....	68
4.7.4	TEST SETUP .....	69
4.7.5	TEST RESULTS .....	70
5	INFORMATION ON THE TESTING LABORATORIES .....	104
6	APPENDIX A – MODIFICATIONS RECORDERS FOR ENGINEERING CHANGES TO THE EUT BY THE LAB.....	105



## RELEASE CONTROL RECORD

ISSUE NO.	REASON FOR CHANGE	DATE ISSUED
RF121023C07A-2	Original release.	Jul. 17, 2013



## 1 CERTIFICATION

**PRODUCT:** LTE/EVDO Mobile Router

**MODEL NO.:** P530

**BRAND:** BandLuxe

**APPLICANT:** BandRich Inc.

**TESTED:** Nov. 08 ~ Nov. 12, 2012 (LTE mode)

Jul. 05 ~ Jul. 09, 2013 (EVDO mode)

**TEST SAMPLE:** ENGINEERING SAMPLE

**TEST STANDARDS:** **FCC Part 27, Subpart C, L**

**FCC Part 2**

ANSI C63.4-2003

The above equipment (model: P530) has been tested by **Bureau Veritas Consumer Products Services (H.K.) Ltd., Taoyuan Branch**, and found compliance with the requirement of the above standards. The test record, data evaluation & Equipment Under Test (EUT) configurations represented herein are true and accurate accounts of the measurements of the sample's EMC characteristics under the conditions specified in this report.

**PREPARED BY :** Sun Li , **DATE :** Jul. 17, 2013  
Suntee Liu / Specialist

**APPROVED BY :** Anderson Chiu , **DATE :** Jul. 17, 2013  
Anderson Chiu / Senior Engineer

## 2 SUMMARY OF TEST RESULTS

The EUT has been tested according to the following specifications:

EVDO			
STANDARD SECTION	TEST TYPE	RESULT	REMARK
2.1046 27.50(d)(4)	Equivalent isotropically radiated power	PASS	Meet the requirement of limit.
2.1055 27.54	Frequency Stability	PASS	Meet the requirement of limit.
2.1049 27.53(h)	Occupied Bandwidth	PASS	Meet the requirement of limit.
27.50(d)(5)	Peak to average ratio	PASS	Meet the requirement of limit.
27.53(h)	Band Edge Measurements	PASS	Meet the requirement of limit.
2.1051 27.53(h)	Conducted Spurious Emissions	PASS	Meet the requirement of limit.
2.1053 27.53(h)	Radiated Spurious Emissions	PASS	Meet the requirement of limit. Minimum passing margin is -22.87dB at 3462.50MHz.

<b>LTE BAND 12</b>			
<b>STANDARD SECTION</b>	<b>TEST TYPE AND LIMIT</b>	<b>RESULT</b>	<b>REMARK</b>
2.1046 27.50(C)(10)	Maximum Peak Output Power	PASS	Meet the requirement of limit.
2.1055 27.54	Frequency Stability	PASS	Meet the requirement of limit.
2.1049 27.53(g)	Occupied Bandwidth	PASS	Meet the requirement of limit.
27.50(d)(5)	Peak to average ratio	PASS	Meet the requirement of limit.
27.53(g)	Band Edge Measurements	PASS	Meet the requirement of limit.
2.1051 27.53(g)	Conducted Spurious Emissions	PASS	Meet the requirement of limit.
2.1053 27.53(g)	Radiated Spurious Emissions	PASS	Meet the requirement of limit. Minimum passing margin is -24.07dB at 32.43MHz.



A D T

LTE BAND 17			
STANDARD SECTION	TEST TYPE AND LIMIT	RESULT	REMARK
2.1046 27.50(C)(10)	Maximum Peak Output Power	PASS	Meet the requirement of limit.
2.1055 27.54	Frequency Stability	PASS	Meet the requirement of limit.
2.1049 27.53(g)	Occupied Bandwidth	PASS	Meet the requirement of limit.
27.50(d)(5)	Peak to average ratio	PASS	Meet the requirement of limit.
27.53(g)	Band Edge Measurements	PASS	Meet the requirement of limit.
2.1051 27.53(g)	Conducted Spurious Emissions	PASS	Meet the requirement of limit.
2.1053 27.53(g)	Radiated Spurious Emissions	PASS	Meet the requirement of limit. Minimum passing margin is -24.25dB at 31.89MHz.



LTE BAND 4			
STANDARD SECTION	TEST TYPE AND LIMIT	RESULT	REMARK
2.1046 27.50(d)(4)	Maximum Peak Output Power	PASS	Meet the requirement of limit.
2.1055 27.54	Frequency Stability	PASS	Meet the requirement of limit.
2.1049 27.53(h)	Occupied Bandwidth	PASS	Meet the requirement of limit.
27.50(d)(5)	Peak to average ratio	PASS	Meet the requirement of limit.
27.53(h)	Band Edge Measurements	PASS	Meet the requirement of limit.
2.1051 27.53(h)	Conducted Spurious Emissions	PASS	Meet the requirement of limit.
2.1053 27.53(h)	Radiated Spurious Emissions	PASS	Meet the requirement of limit. Minimum passing margin is -19.98dB at 3465.00MHz.

## 2.1 MEASUREMENT UNCERTAINTY

Where relevant, the following measurement uncertainty levels have been estimated for tests performed on the EUT as specified in CISPR 16-4-2:

MEASUREMENT	FREQUENCY	UNCERTAINTY
Conducted emissions	150kHz~30MHz	2.44 dB
Radiated emissions	30MHz ~ 200MHz	2.93 dB
	200MHz ~1000MHz	2.95 dB
	1GHz ~ 18GHz	2.26 dB
	18GHz ~ 40GHz	1.94 dB

This uncertainty represents an expanded uncertainty expressed at approximately the 95% confidence level using a coverage factor of k=2.



## 2.2 TEST SITE AND INSTRUMENTS

### LTE

DESCRIPTION & MANUFACTURER	MODEL NO.	SERIAL NO.	DATE OF CALIBRATION	DUE DATE OF CALIBRATION
Test Receiver Agilent	N9038A	MY51210203	Dec. 22, 2011	Dec. 21, 2012
Spectrum Analyzer ROHDE & SCHWARZ	FSU43	101261	Dec. 21, 2011	Dec. 20, 2012
BILOG Antenna SCHWARZBECK	VULB9168	9168-472	Dec. 20, 2011	Dec. 19, 2012
HORN Antenna SCHWARZBECK	BBHA 9120 D	9120D-969	Dec. 20, 2011	Dec. 19, 2012
HORN Antenna SCHWARZBECK	BBHA 9170	9170-480	Dec. 20, 2011	Dec. 19, 2012
Preamplifier EMCI	EMC 012645	980115	Dec. 30, 2011	Dec. 29, 2012
Preamplifier EMCI	EMC 330H	980112	Dec. 30, 2011	Dec. 29, 2012
RF signal cable HUBER+SUHNNER	SUCOFLEX 104	309219/4	Oct. 26, 2012	Oct. 25, 2013
RF signal cable HUBER+SUHNNER	SUCOFLEX 104	250130/4	Jan. 02, 2012	Jan. 01, 2013
RF signal cable Worken	RG-213	NA	Jan. 02, 2012	Jan. 01, 2013
Software	E3 6.120103	NA	NA	NA
Antenna Tower MF	MFA-440H	NA	NA	NA
Turn Table MF	MFT-201SS	NA	NA	NA
Antenna Tower & Turn Table Controller MF	MF-7802	NA	NA	NA
Mini-Circuits Power Splitter	ZN2PD-9G	NA	Mar. 23, 2012	Mar. 22, 2013
JFW 20dB attenuation	50HF-020-SMA	NA	NA	NA
Communications Tester-Wireless	8960 Series 10	MY50260642	Nov. 02, 2012	Nov. 01, 2013
Radio Communication Analyzer	MT8820C	6201127458	May 25, 2012	May 24, 2013

**NOTE:** 1. The calibration interval of the above test instruments is 12 months and the calibrations are traceable to NML/ROC and NIST/USA.

2. The test was performed in HwaYa Chamber 9.

3. The horn antenna and HP preamplifier (model: 8449B) are used only for the measurement of emission frequency above 1GHz if tested.

4. The FCC Site Registration No. is 460141.

5. The IC Site Registration No. is IC 7450F-4.

## EVDO

DESCRIPTION & MANUFACTURER	MODEL NO.	SERIAL NO.	DATE OF CALIBRATION	DUE DATE OF CALIBRATION
Test Receiver ROHDE & SCHWARZ	ESCI	100424	Aug. 21, 2012	Aug. 20, 2013
Spectrum Analyzer ROHDE & SCHWARZ	FSU 43	100115	Oct. 25, 2012	Oct. 24, 2013
BILOG Antenna SCHWARZBECK	VULB9168	9168-155	Mar. 25, 2013	Mar. 24, 2014
HORN Antenna SCHWARZBECK	BBHA 9120D	9120D-404	Dec. 22, 2012	Dec. 21, 2013
HORN Antenna SCHWARZBECK	BBHA 9170	148	Jul. 11, 2012	Jul. 10, 2013
Loop Antenna	HFH2-Z2	100070	Jan. 31, 2012	Jan. 30, 2014
Preamplifier Agilent	8449B	3008A01961	Oct. 25, 2012	Oct. 24, 2013
Preamplifier Agilent	8447D	2944A10738	Oct. 23, 2012	Oct. 22, 2013
RF signal cable HUBER+SUHNNER	SUCOFLEX 104	309220/4	Aug. 28, 2012	Aug. 27, 2013
RF signal cable HUBER+SUHNNER	SUCOFLEX 104	250724/4	Aug. 28, 2012	Aug. 27, 2013
RF signal cable HUBER+SUHNNER	SUCOFLEX 104	295012/4	Aug. 28, 2012	Aug. 27, 2013
Software BV ADT	ADT_Radiated_ V7.6.15.9.3	NA	NA	NA
Antenna Tower inn-co GmbH	MA 4000	010303	NA	NA
Antenna Tower Controller inn-co GmbH	CO2000	019303	NA	NA
Turn Table BV ADT	TT100.	TT93021704	NA	NA
Turn Table Controller BV ADT	SC100.	SC93021704	NA	NA
Mini-Circuits Power Splitter	ZN2PD-9G	NA	Mar. 22, 2013	Mar. 21, 2014
JFW 20dB attenuation	50HF-020-SMA	NA	NA	NA
Communications Tester-Wireless	E5515C	MY50266653	Oct. 08, 2012	Oct. 09, 2013

- NOTE:**
1. The calibration interval of the above test instruments is 12 months and the calibrations are traceable to NML/ROC and NIST/USA.
  2. The calibration interval of the loop antenna is 24 months and the calibrations are traceable to NML/ROC and NIST/USA.
  3. The test was performed in HwaYa Chamber 4.
  4. The horn antenna and HP preamplifier (model: 8449B) are used only for the measurement of emission frequency above 1GHz if tested.
  5. The FCC Site Registration No. is 460141.
  6. The IC Site Registration No. is IC7450F-4.

### 3 GENERAL INFORMATION

#### 3.1 GENERAL DESCRIPTION OF EUT

<b>PRODUCT</b>	LTE/EVDO Mobile Router	
<b>MODEL NO.</b>	P530	
<b>POWER SUPPLY</b>	5Vdc (adapter / host equipment) 3.7Vdc (battery)	
<b>HW VERSION</b>	V01	
<b>SW VERSION</b>	QC_2_00012644_2_001_0032	
<b>MODULATION TECHNOLOGY</b>	<b>EVDO</b>	QPSK, OQPSK, HPSK
	<b>LTE</b>	QPSK, 16QAM
<b>FREQUENCY RANGE</b>	<b>EVDO</b>	1711.25MHz ~ 1753.75MHz
	<b>LTE Band 12 (Channel Bandwidth 5MHz)</b>	701.5MHz ~ 713.5MHz
	<b>LTE Band 12 (Channel Bandwidth 10MHz)</b>	704.0MHz ~ 711.0MHz
	<b>LTE Band 17 (Channel Bandwidth 5MHz)</b>	706.5MHz ~ 713.5MHz
	<b>LTE Band 17 (Channel Bandwidth 10MHz)</b>	709MHz ~ 711MHz
	<b>LTE Band 4 (Channel Bandwidth 5MHz)</b>	1712.5MHz ~ 1752.5MHz
	<b>LTE Band 4 (Channel Bandwidth 10MHz)</b>	1715.0MHz ~ 1750.0MHz
	<b>LTE Band 4 (Channel Bandwidth 15MHz)</b>	1717.5MHz ~ 1747.5MHz
	<b>LTE Band 4 (Channel Bandwidth 20MHz)</b>	1720.0MHz ~ 1745.0MHz

<b>MAX. ERP POWER</b>	<b>LTE Band 12 (Channel Bandwidth 5MHz)</b>	QPSK: 79.25mW
	<b>LTE Band 12 (Channel Bandwidth 10MHz)</b>	QPSK: 72.95mW
	<b>LTE Band 17 (Channel Bandwidth 5MHz)</b>	QPSK: 79.25mW
	<b>LTE Band 17 (Channel Bandwidth 10MHz)</b>	QPSK: 60.12mW
<b>MAX. EIRP POWER</b>	<b>EVDO</b>	235.50mW
	<b>LTE Band 4 (Channel Bandwidth 5MHz)</b>	QPSK: 199.07mW
	<b>LTE Band 4 (Channel Bandwidth 10MHz)</b>	QPSK: 225.42mW
	<b>LTE Band 4 (Channel Bandwidth 15MHz)</b>	QPSK: 198.61mW
	<b>LTE Band 4 (Channel Bandwidth 20MHz)</b>	QPSK: 193.64mW
<b>EMISSION DESIGNATOR</b>	<b>EVDO</b>	1M28F9W
	<b>LTE Band 12 (Channel Bandwidth 5MHz)</b>	QPSK: 4M50G7W
		16QAM: 4M50W7W
	<b>LTE Band 12 (Channel Bandwidth 10MHz)</b>	QPSK: 8M93G7W
		16QAM: 8M93W7W
	<b>LTE Band 17 (Channel Bandwidth 5MHz)</b>	QPSK: 4M50G7W
		16QAM: 4M49W7W
	<b>LTE Band 17 (Channel Bandwidth 10MHz)</b>	QPSK: 8M93G7W
		16QAM: 8M93W7W
	<b>LTE Band 4 (Channel Bandwidth 5MHz)</b>	QPSK: 4M49G7W
		16QAM: 4M49W7W
	<b>LTE Band 4 (Channel Bandwidth 10MHz)</b>	QPSK: 8M92G7W
		16QAM: 8M92W7W
<b>LTE Band 4 (Channel Bandwidth 15MHz)</b>	QPSK: 13M4G7W	
	16QAM: 13M4W7W	
<b>LTE Band 4 (Channel Bandwidth 20MHz)</b>	QPSK: 17M9G7W	
	16QAM: 17M9W7W	

<b>CATEGORY</b>	LTE: 3	
<b>ANTENNA TYPE</b>	<b>LTE Band 12/ LTE Band 17</b>	Fixed Internal antenna with -0.5dBi gain
	<b>EVDO/ LTE Band 4</b>	Fixed Internal antenna with -2dBi gain
<b>DATA CABLE</b>	1m non-shielded USB cable without core	
<b>I/O PORTS</b>	Refer to users' manual	
<b>ACCESSORY DEVICES</b>	Adapter, Battery	

**NOTE:**

1. The EUT consumes power from the following battery and adapter.

<b>Battery</b>	
<b>MODEL:</b>	GT-2200
<b>RATING:</b>	3.7Vdc, 8.14WH

<b>ADAPTER</b>	
<b>BRAND:</b>	PHIHONG
<b>MODEL:</b>	PSA05A-050Q
<b>INPUT:</b>	100-240Vac, 0.2A, 50-60Hz
<b>OUTPUT:</b>	5Vdc, 1A

2. The above EUT information is declared by manufacturer and for more detailed features description, please refer to the manufacturer's specifications or User's Manual.

### 3.2 CONFIGURATION OF SYSTEM UNDER TEST

#### FOR RADIATION EMISSION TEST

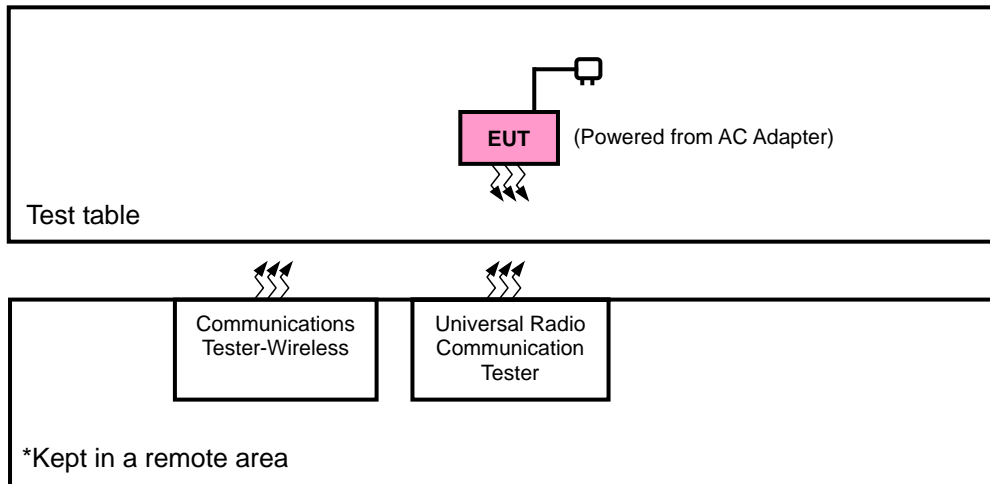

#### FOR E.R.P. TEST

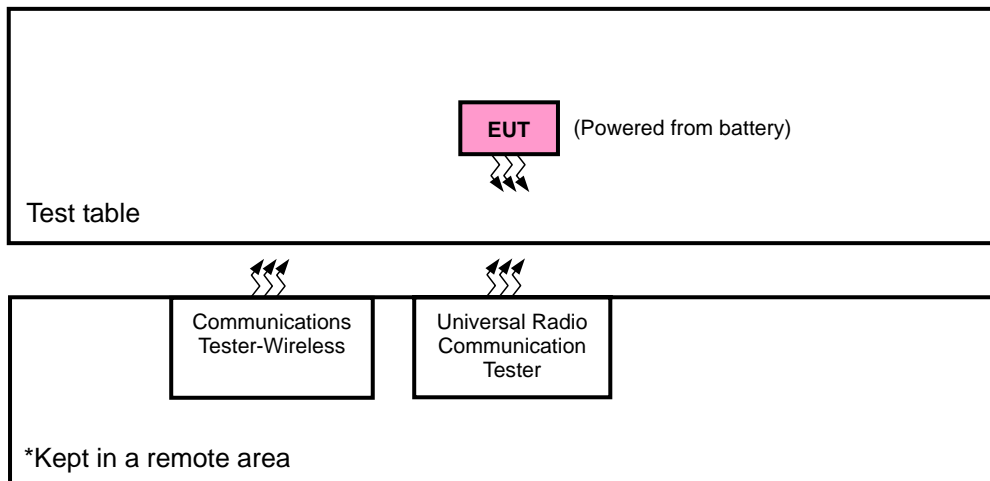



### 3.3 DESCRIPTION OF SUPPORT UNITS

The EUT has been tested as an independent unit together with other necessary accessories or support units. The following support units or accessories were used to form a representative test configuration during the tests.

NO.	PRODUCT	BRAND	MODEL NO.	SERIAL NO.	FCC ID
1	Universal Radio Communication Tester	R&S	CMU200	104958	NA
2	Communications Tester-Wireless	Agilent	8960 Series 10	MY50260642	NA

NO.	SIGNAL CABLE DESCRIPTION OF THE ABOVE SUPPORT UNITS
1	NA
2	NA

**NOTE:**

1. All power cords of the above support units are non-shielded (1.8m).
2. Items 1-2 act as communication partners to transfer data.



### 3.4 DESCRIPTION OF TEST MODES

Pre-Scan has been conducted to determine the worst-case mode from all possible combinations between available modulations, data rates, XYZ axis and antenna ports. The worst cases were found when positioned on **Y-plane** for EVDO mode in EIRP & **X-plane** for LTE Band 12/17 mode in ERP & **Z-plane** for LTE Band 4 mode in EIRP and **X-axis** for LTE Band 12/17/4 mode & **Y-axis** for EVDO mode in radiated emission. Following channel(s) was (were) selected for the final test as listed below:

#### EVDO

EUT CONFIGURE MODE	TEST ITEM	AVAILABLE CHANNEL	TESTED CHANNEL	MODE
-	EIRP	25 to 875	25, 425, 875	EVDO
-	FREQUENCY STABILITY	25 to 875	425	EVDO
-	OCCUPIED BANDWIDTH	25 to 875	25, 425, 875	EVDO
-	PEAK TO AVERAGE RATIO	25 to 875	25, 425, 875	EVDO
-	BAND EDGE	25 to 875	25, 875	EVDO
-	CONDCUDETED EMISSION	25 to 875	425	EVDO
-	RADIATED EMISSION Below 1GHz	25 to 875	425	EVDO
-	RADIATED EMISSION Above 1GHz	25 to 875	425	EVDO



## LTE Band 12

TEST ITEM	AVAILABLE CHANNEL	TESTED CHANNEL	CHANNEL BANDWIDTH	MODULATION	MODE
ERP	23035 to 23155	23035, 23095, 23155	5MHz	QPSK	1 RB / 0 RB Offset
	23060 to 23130	23060, 23095, 23130	10MHz	QPSK	1 RB / 24 RB Offset
FREQUENCY STABILITY	23035 to 23155	23095	5MHz	QPSK	1 RB / 0 RB Offset
	23060 to 23130	23095	10MHz	QPSK	1 RB / 24 RB Offset
OCCUPIED BANDWIDTH	23035 to 23155	23035, 23095, 23155	5MHz	QPSK	25 RB / 0 RB Offset
	23060 to 23130	23060, 23095, 23130	10MHz	QPSK	50 RB / 0 RB Offset
PEAK TO AVERAGE RATIO	23035 to 23155	23035, 23095, 23155	5MHz	QPSK	1 RB / 0 RB Offset
	23060 to 23130	23060, 23095, 23130	10MHz	QPSK	1 RB / 24 RB Offset
BAND EDGE	23035 to 23155	23035	5MHz	QPSK	1 RB / 0 RB Offset
					25 RB / 0 RB Offset
	23060 to 23130	23155	5MHz	QPSK	1 RB / 24 RB Offset
					25 RB / 0 RB Offset
	23060 to 23130	23060	10MHz	QPSK	1 RB / 0 RB Offset
					50 RB / 0 RB Offset
23060 to 23130	23130	10MHz	QPSK	1 RB / 49 RB Offset	
				50 RB / 0 RB Offset	
CONDCUDED EMISSION	23035 to 23155	23095	5MHz	QPSK	1 RB / 0 RB Offset
	23060 to 23130	23095	10MHz	QPSK	1 RB / 24 RB Offset
RADIATED EMISSION	23035 to 23155	23095	5MHz	QPSK	1 RB / 0 RB Offset
					25 RB / 0 RB Offset
	23060 to 23130	23095	10MHz	QPSK	1 RB / 49 RB Offset
					50 RB / 0 RB Offset



### LTE Band 17

TEST ITEM	AVAILABLE CHANNEL	TESTED CHANNEL	CHANNEL BANDWIDTH	MODULATION	MODE
ERP	23755 to 23825	23755, 23790, 23825	5MHz	QPSK	1 RB / 0 RB Offset
	23780 to 23800	23780, 23790, 23800	10MHz	QPSK	1 RB / 0 RB Offset
FREQUENCY STABILITY	23755 to 23825	23790	5MHz	QPSK	1 RB / 0 RB Offset
	23780 to 23800	23790	10MHz	QPSK	1 RB / 0 RB Offset
OCCUPIED BANDWIDTH	23755 to 23825	23755, 23790, 23825	5MHz	QPSK / 16QAM	25 RB / 0 RB Offset
	23780 to 23800	23780, 23790, 23800	10MHz	QPSK / 16QAM	50 RB / 0 RB Offset
PEAK TO AVERAGE RATIO	23755 to 23825	23755, 23790, 23825	5MHz	QPSK	1 RB / 0 RB Offset
	23780 to 23800	23780, 23790, 23800	10MHz	QPSK	1 RB / 0 RB Offset
BAND EDGE	23755 to 23825	23755	5MHz	QPSK	1 RB / 0 RB Offset
					1 RB / 24 RB Offset
	23780 to 23800	23825	5MHz	QPSK	1 RB / 24 RB Offset
					25 RB / 0 RB Offset
		23780	10MHz	QPSK	1 RB / 0 RB Offset
					50 RB / 0 RB Offset
23780 to 23800	23800	10MHz	QPSK	1 RB / 49 RB Offset	
				50 RB / 0 RB Offset	
CONDCUDED EMISSION	23755 to 23825	23790	5MHz	QPSK	1 RB / 0 RB Offset
	23780 to 23800	23790	10MHz	QPSK	1 RB / 0 RB Offset
RADIATED EMISSION	23755 to 23825	23790	5MHz	QPSK	1 RB / 0 RB Offset
					25 RB / 0 RB Offset
	23780 to 23800	23790	10MHz	QPSK	1 RB / 0 RB Offset
					50 RB / 0 RB Offset

### LTE Band 4

TEST ITEM	AVAILABLE CHANNEL	TESTED CHANNEL	CHANNEL BANDWIDTH	MODULATION	MODE	
EIRP	19975 to 20375	19975, 20175, 20375	5MHz	QPSK	1 RB / 0 RB Offset	
	20000 to 20350	20000, 20175, 20350	10MHz	QPSK	1 RB / 24 RB Offset	
	20025 to 20325	20025, 20175, 20325	15MHz	QPSK	1 RB / 0 RB Offset	
	20050 to 20300	20050, 20175, 20300	20MHz	QPSK	1 RB / 0 RB Offset	
FREQUENCY STABILITY	19975 to 20375	20175	5MHz	QPSK	1 RB / 0 RB Offset	
	20000 to 20350	20175	10MHz	QPSK	1 RB / 0 RB Offset	
	20025 to 20325	20175	15MHz	QPSK	1 RB / 0 RB Offset	
	20050 to 20300	20175	20MHz	QPSK	1 RB / 0 RB Offset	
OCCUPIED BANDWIDTH	19975 to 20375	19975, 20175, 20375	5MHz	QPSK / 16QAM	25 RB / 0 RB Offset	
	20000 to 20350	20000, 20175, 20350	10MHz	QPSK / 16QAM	50 RB / 0 RB Offset	
	20025 to 20325	20025, 20175, 20325	15MHz	QPSK / 16QAM	75 RB / 0 RB Offset	
	20050 to 20300	20050, 20175, 20300	20MHz	QPSK / 16QAM	100 RB / 0 RB Offset	
PEAK TO AVERAGE RATIO	19975 to 20375	19975, 20175, 20375	5MHz	QPSK	1 RB / 0 RB Offset	
	20000 to 20350	20000, 20175, 20350	10MHz	QPSK	1 RB / 24 RB Offset	
	20025 to 20325	20025, 20175, 20325	15MHz	QPSK	1 RB / 0 RB Offset	
	20050 to 20300	20050, 20175, 20300	20MHz	QPSK	1 RB / 0 RB Offset	
BAND EDGE	19975 to 20375	19975	5MHz	QPSK	1 RB / 0 RB Offset 25 RB / 0 RB Offset	
		20375	5MHz	QPSK	1 RB / 24 RB Offset 25 RB / 0 RB Offset	
	20000 to 20350	20000	10MHz	QPSK	1 RB / 0 RB Offset 50 RB / 0 RB Offset	
		20350	10MHz	QPSK	1 RB / 49 RB Offset 50 RB / 0 RB Offset	
	20025 to 20325	20025	15MHz	QPSK	1 RB / 0 RB Offset 75 RB / 0 RB Offset	
		20325	15MHz	QPSK	1 RB / 74 RB Offset 75 RB / 0 RB Offset	
	20050 to 20300	20050	20MHz	QPSK	1 RB / 0 RB Offset 100 RB / 0 RB Offset	
		20300	20MHz	QPSK	1 RB / 99 RB Offset 100 RB / 0 RB Offset	
	CONDCUDED EMISSION	19975 to 20375	20175	5MHz	QPSK	1 RB / 0 RB Offset
		20000 to 20350	20175	10MHz	QPSK	1 RB / 0 RB Offset
		20025 to 20325	20175	15MHz	QPSK	1 RB / 0 RB Offset
		20050 to 20300	20175	20MHz	QPSK	1 RB / 0 RB Offset
RADIATED EMISSION	19975 to 20375	20175	5MHz	QPSK	1 RB / 0 RB Offset 25 RB / 0 RB Offset	
					1 RB / 24 RB Offset 50 RB / 0 RB Offset	
	20025 to 20325	20175	15MHz	QPSK	1 RB / 0 RB Offset 75 RB / 0 RB Offset	
					1 RB / 0 RB Offset 100 RB / 0 RB Offset	



**TEST CONDITION:**

**LTE**

TEST ITEM	ENVIRONMENTAL CONDITIONS	INPUT POWER	TESTED BY
EIRP	26deg. C, 58%RH	3.7Vdc	Howard Kao
FREQUENCY STABILITY	26deg. C, 58%RH	3.7Vdc	Howard Kao
OCCUPIED BANDWIDTH	26deg. C, 58%RH	3.7Vdc	Howard Kao
PEAK TO AVERAGE RATIO	26deg. C, 58%RH	3.7Vdc	Howard Kao
BAND EDGE	26deg. C, 58%RH	3.7Vdc	Howard Kao
CONDCUDED EMISSION	26deg. C, 58%RH	3.7Vdc	Howard Kao
RADIATED EMISSION Below 1GHz	25deg. C, 65%RH	120Vac, 60Hz	Kay Wu
RADIATED EMISSION Above 1GHz	25deg. C, 65%RH	120Vac, 60Hz	Kay Wu

**EVDO**

TEST ITEM	ENVIRONMENTAL CONDITIONS	INPUT POWER	TESTED BY
EIRP	25deg. C, 65%RH	3.7Vdc	Chris Lin
FREQUENCY STABILITY	24deg. C, 64%RH	3.7Vdc	Match Tsui
OCCUPIED BANDWIDTH	24deg. C, 64%RH	3.7Vdc	Match Tsui
PEAK TO AVERAGE RATIO	24deg. C, 64%RH	3.7Vdc	Match Tsui
BAND EDGE	24deg. C, 64%RH	3.7Vdc	Match Tsui
CONDCUDED EMISSION	24deg. C, 64%RH	3.7Vdc	Match Tsui
RADIATED EMISSION Below 1GHz	25deg. C, 65%RH	120Vac, 60Hz	Chris Lin
RADIATED EMISSION Above 1GHz	25deg. C, 65%RH	120Vac, 60Hz	Chris Lin

### **3.5 GENERAL DESCRIPTION OF APPLIED STANDARDS**

The EUT is a RF product. According to the specifications of the manufacturer, it must comply with the requirements of the following standards:

**FCC 47 CFR Part 2**

**FCC 47 CFR Part 27**

**ANSI C63.4-2003**

**ANSI/TIA/EIA-603-C 2004**

**NOTE:** All test items have been performed and recorded as per the above standards.

**NOTE:** The EUT is also considered as a kind of computer peripheral, because the connection to computer is necessary for typical use. It has been verified to comply with the requirements of FCC Part 15, Subpart B, Class B. The test report has been issued separately.

## 4 TEST TYPES AND RESULTS

### 4.1 OUTPUT POWER MEASUREMENT

#### 4.1.1 LIMITS OF OUTPUT POWER MEASUREMENT

Fixed, mobile, and portable (hand-held) stations operating in the 1710-1755 MHz band are limited to 1 watt EIRP.

Portable stations (hand-held devices) operating in the 698-746 MHz band are limited to 3 watts ERP

#### 4.1.2 TEST PROCEDURES

##### **EIRP / ERP MEASUREMENT:**

- a. The EUT was set up for the maximum power with LTE link data modulation. The power was measured with R&S Spectrum Analyzer. All measurements were done at 3 channels (low, middle and high operational frequency range). RBW and VBW is 5MHz for EVDO mode and 10MHz for LTE mode.
- b. E.I.R.P power measurement. In the semi-anechoic chamber, EUT placed on the 0.8m height of Turn Table, rotated the table around 360 degrees to search the maximum radiation power and receiver antenna shall be rotated vertical and horizontal polarization and moved height from 1m to 4m to find the maximum polar radiated power. The “Read Value” is the spectrum reading the maximum power value.
- c. The substitution horn antenna is substituted for EUT at the same position and signals generator export the CW signal to the substitution antenna via a TX cable. Rotated the Turn Table and moved receiving antenna to find the maximum radiation power. Adjust output power level of S.G to get a Value of spectrum reading equal to “Read Value” of step a. Record the power level of S.G
- d.  $EIRP = \text{Output power level of S.G} - \text{TX cable loss} + \text{Antenna gain of substitution horn}$
- e.  $E.R.P = E.I.R.P - 2.15 \text{ dB}$

##### **CONDUCTED POWER MEASUREMENT:**

- a. The EUT was set up for the maximum power with EVDO/ LTE link data modulation and link up with simulator.
- b. Set the EUT to transmit under low, middle and high channel and record the power level shown on simulator.

### 4.1.3 TEST SETUP

#### EIRP / ERP MEASUREMENT:

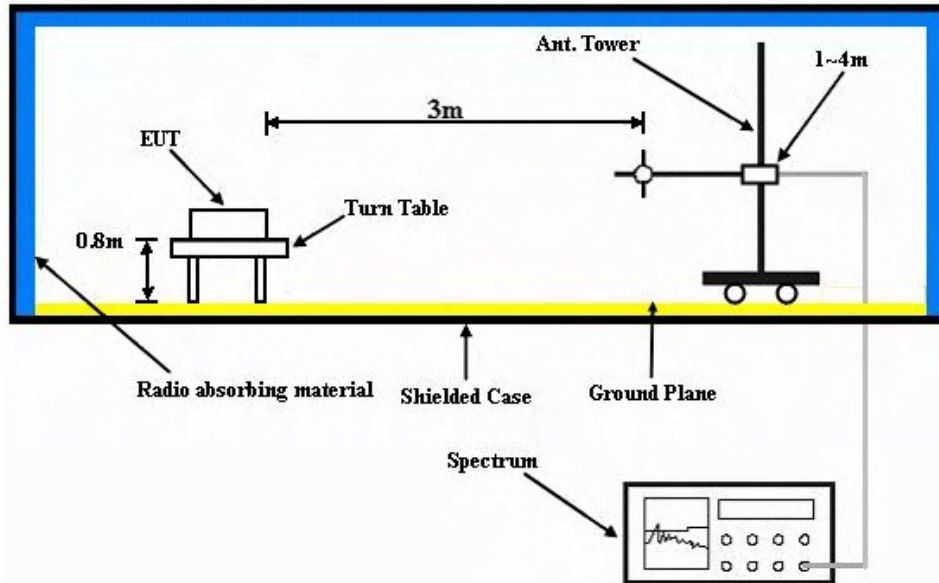

For the actual test configuration, please refer to the attached file (Test Setup Photo).

#### CONDUCTED POWER MEASUREMENT:

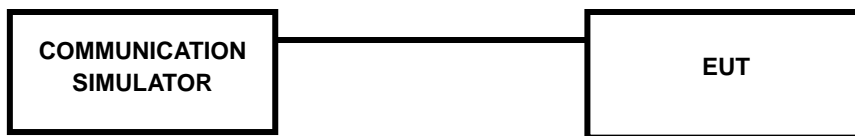

For the actual test configuration, please refer to the attached file (Test Setup Photo).



#### 4.1.4 TEST RESULTS

##### CONDUCTED OUTPUT POWER (dBm)

Band	EVDO BC15		
Channel	25	425	875
Frequency (MHz)	1711.25	1731.25	1753.75
RC1+SO55	22.37	22.30	23.24
RC3+SO55	22.38	22.31	23.25
RC3+SO32(+ F-SCH)	22.34	22.27	23.21
RC3+SO32(+SCH)	22.36	22.29	23.23
RTAP 153.6	22.40	22.33	<b>23.27</b>
RETAP 4096	22.32	22.25	23.19



A D T

LTE Band 12								
BW	Modulation	CH	Frequency	RB	RB Offset	MPR	Target	Measured
			(MHz)				Power	Power
5 MHz	QPSK	23035	701.5	1	0	0	22.5	22.44
		23095	707.5	1	0	0	22.5	22.47
		23155	713.5	1	0	0	22.5	22.39
		23035	701.5	1	12	0	22.5	22.43
		23095	707.5	1	12	0	22.5	22.46
		23155	713.5	1	12	0	22.5	22.38
		23035	701.5	1	24	0	22.5	22.37
		23095	707.5	1	24	0	22.5	22.4
		23155	713.5	1	24	0	22.5	22.32
		23035	701.5	12	0	1	22.5	21.16
		23095	707.5	12	0	1	22.5	21.19
		23155	713.5	12	0	1	22.5	21.11
		23035	701.5	12	6	1	22.5	21.21
		23095	707.5	12	6	1	22.5	21.24
		23155	713.5	12	6	1	22.5	21.16
		23035	701.5	12	13	1	22.5	21.18
		23095	707.5	12	13	1	22.5	21.21
		23155	713.5	12	13	1	22.5	21.13
	23035	701.5	25	0	1	22.5	20.93	
	23095	707.5	25	0	1	22.5	20.96	
	23155	713.5	25	0	1	22.5	20.88	
	23035	701.5	1	0	1	22.5	21.1	
	23095	707.5	1	0	1	22.5	21.13	
	23155	713.5	1	0	1	22.5	21.05	
	23035	701.5	1	12	1	22.5	21.2	
	23095	707.5	1	12	1	22.5	21.23	
	23155	713.5	1	12	1	22.5	21.15	
	23035	701.5	1	24	1	22.5	21.1	
	23095	707.5	1	24	1	22.5	21.13	
	23155	713.5	1	24	1	22.5	21.05	
	23035	701.5	12	0	2	22.5	20.17	
	23095	707.5	12	0	2	22.5	20.2	
	23155	713.5	12	0	2	22.5	20.12	
	23035	701.5	12	6	2	22.5	20.08	
	23095	707.5	12	6	2	22.5	20.11	
	23155	713.5	12	6	2	22.5	20.03	
23035	701.5	12	13	2	22.5	20.06		
23095	707.5	12	13	2	22.5	20.09		
23155	713.5	12	13	2	22.5	20.01		
23035	701.5	25	0	2	22.5	19.9		
23095	707.5	25	0	2	22.5	19.93		
23155	713.5	25	0	2	22.5	19.85		
23035	701.5	1	0	1	22.5	21.1		
23095	707.5	1	0	1	22.5	21.13		
23155	713.5	1	0	1	22.5	21.05		
23035	701.5	1	12	1	22.5	21.2		
23095	707.5	1	12	1	22.5	21.23		
23155	713.5	1	12	1	22.5	21.15		
23035	701.5	1	24	1	22.5	21.1		
23095	707.5	1	24	1	22.5	21.13		
23155	713.5	1	24	1	22.5	21.05		
23035	701.5	12	0	2	22.5	20.17		
23095	707.5	12	0	2	22.5	20.2		
23155	713.5	12	0	2	22.5	20.12		
23035	701.5	12	6	2	22.5	20.08		
23095	707.5	12	6	2	22.5	20.11		
23155	713.5	12	6	2	22.5	20.03		
23035	701.5	12	13	2	22.5	20.06		
23095	707.5	12	13	2	22.5	20.09		
23155	713.5	12	13	2	22.5	20.01		
23035	701.5	25	0	2	22.5	19.9		
23095	707.5	25	0	2	22.5	19.93		
23155	713.5	25	0	2	22.5	19.85		



A D T

LTE Band 12								
BW	Modulation	CH	Frequency	RB	RB Offset	MPR	Target	Measured
			(MHz)				Power	Power
10MHz	QPSK	23060	704	1	0	0	22.5	22.36
		23095	707.5	1	0	0	22.5	22.15
		23130	711	1	0	0	22.5	22.28
		23060	704	1	24	0	22.5	22.5
		23095	707.5	1	24	0	22.5	22.29
		23130	711	1	24	0	22.5	22.42
		23060	704	1	49	0	22.5	22.32
		23095	707.5	1	49	0	22.5	22.11
		23130	711	1	49	0	22.5	22.24
		23060	704	25	0	1	22.5	20.95
		23095	707.5	25	0	1	22.5	20.74
		23130	711	25	0	1	22.5	20.87
		23060	704	25	12	1	22.5	20.93
		23095	707.5	25	12	1	22.5	20.72
		23130	711	25	12	1	22.5	20.85
		23060	704	25	25	1	22.5	20.87
		23095	707.5	25	25	1	22.5	20.66
		23130	711	25	25	1	22.5	20.79
	23060	704	50	0	1	22.5	20.72	
	23095	707.5	50	0	1	22.5	20.51	
	23130	711	50	0	1	22.5	20.64	
	23060	704	1	0	1	22.5	21.11	
	23095	707.5	1	0	1	22.5	20.9	
	23130	711	1	0	1	22.5	21.03	
	23060	704	1	24	1	22.5	21.28	
	23095	707.5	1	24	1	22.5	21.07	
	23130	711	1	24	1	22.5	21.2	
	23060	704	1	49	1	22.5	21.06	
	23095	707.5	1	49	1	22.5	20.85	
	23130	711	1	49	1	22.5	20.98	
	23060	704	25	0	2	22.5	19.87	
	23095	707.5	25	0	2	22.5	19.66	
	23130	711	25	0	2	22.5	19.79	
	23060	704	25	12	2	22.5	19.96	
	23095	707.5	25	12	2	22.5	19.75	
	23130	711	25	12	2	22.5	19.88	
23060	704	25	25	2	22.5	19.9		
23095	707.5	25	25	2	22.5	19.69		
23130	711	25	25	2	22.5	19.82		
23060	704	50	0	2	22.5	19.75		
23095	707.5	50	0	2	22.5	19.54		
23130	711	50	0	2	22.5	19.67		



A D T

LTE Band 17								
BW	Modulation	CH	Frequency	RB	RB Offset	MPR	Target	Measured
			(MHz)				Power	Power
5 MHz	QPSK	23755	706.5	1	0	0	22.5	22.42
		23790	710	1	0	0	22.5	22
		23825	713.5	1	0	0	22.5	22.2
		23755	706.5	1	12	0	22.5	22.26
		23790	710	1	12	0	22.5	21.84
		23825	713.5	1	12	0	22.5	22.04
		23755	706.5	1	24	0	22.5	22.15
		23790	710	1	24	0	22.5	21.73
		23825	713.5	1	24	0	22.5	21.93
		23755	706.5	12	0	1	22.5	20.98
		23790	710	12	0	1	22.5	20.56
		23825	713.5	12	0	1	22.5	20.76
		23755	706.5	12	6	1	22.5	21.01
		23790	710	12	6	1	22.5	20.59
		23825	713.5	12	6	1	22.5	20.79
		23755	706.5	12	13	1	22.5	20.98
		23790	710	12	13	1	22.5	20.56
		23825	713.5	12	13	1	22.5	20.76
		23755	706.5	25	0	1	22.5	20.98
		23790	710	25	0	1	22.5	20.56
	23825	713.5	25	0	1	22.5	20.76	
	23755	706.5	1	0	1	22.5	21.38	
	23790	710	1	0	1	22.5	20.96	
	23825	713.5	1	0	1	22.5	20.74	
	23755	706.5	1	12	1	22.5	21.44	
	23790	710	1	12	1	22.5	21.02	
	23825	713.5	1	12	1	22.5	20.8	
	23755	706.5	1	24	1	22.5	21.29	
	23790	710	1	24	1	22.5	20.87	
	23825	713.5	1	24	1	22.5	20.65	
	23755	706.5	12	0	2	22.5	20.26	
	23790	710	12	0	2	22.5	19.84	
	23825	713.5	12	0	2	22.5	19.62	
	23755	706.5	12	6	2	22.5	20.21	
	23790	710	12	6	2	22.5	19.79	
	23825	713.5	12	6	2	22.5	19.57	
23755	706.5	12	13	2	22.5	20.18		
23790	710	12	13	2	22.5	19.76		
23825	713.5	12	13	2	22.5	19.54		
23755	706.5	25	0	2	22.5	20.08		
23790	710	25	0	2	22.5	19.66		
23825	713.5	25	0	2	22.5	19.54		



LTE Band 17								
BW	Modulation	CH	Frequency	RB	RB Offset	MPR	Target	Measured
			(MHz)				Power	Power
10MHz	QPSK	23780	709	1	0	0	22.5	22.50
		23790	710	1	0	0	22.5	22.37
		23800	711	1	0	0	22.5	22.29
		23780	709	1	24	0	22.5	22.32
		23790	710	1	24	0	22.5	22.24
		23800	711	1	24	0	22.5	22.11
		23780	709	1	49	0	22.5	22.35
		23790	710	1	49	0	22.5	22.11
		23800	711	1	49	0	22.5	22.14
		23780	709	25	0	1	22.5	20.97
		23790	710	25	0	1	22.5	21.47
		23800	711	25	0	1	22.5	20.76
		23780	709	25	12	1	22.5	20.96
		23790	710	25	12	1	22.5	21.36
		23800	711	25	12	1	22.5	20.75
		23780	709	25	25	1	22.5	20.98
		23790	710	25	25	1	22.5	21.23
		23800	711	25	25	1	22.5	20.77
	23780	709	50	0	1	22.5	20.77	
	23790	710	50	0	1	22.5	21.10	
	23800	711	50	0	1	22.5	20.56	
	23780	709	1	0	1	22.5	21.06	
	23790	710	1	0	1	22.5	21.46	
	23800	711	1	0	1	22.5	20.85	
	23780	709	1	24	1	22.5	21.24	
	23790	710	1	24	1	22.5	21.33	
	23800	711	1	24	1	22.5	21.03	
	23780	709	1	49	1	22.5	21.13	
	23790	710	1	49	1	22.5	21.20	
	23800	711	1	49	1	22.5	20.92	
	23780	709	25	0	2	22.5	20.37	
	23790	710	25	0	2	22.5	20.24	
	23800	711	25	0	2	22.5	20.16	
	23780	709	25	12	2	22.5	20.25	
	23790	710	25	12	2	22.5	20.12	
	23800	711	25	12	2	22.5	20.04	
23780	709	25	25	2	22.5	20.26		
23790	710	25	25	2	22.5	20.13		
23800	711	25	25	2	22.5	20.05		
23780	709	50	0	2	22.5	20.05		
23790	710	50	0	2	22.5	19.92		
23800	711	50	0	2	22.5	19.84		



A D T

LTE Band 4								
BW	Modulation	CH	Frequency	RB	RB Offset	MPR	Target	Measured
			(MHz)				Power	Power
5 MHz	QPSK	19975	1712.5	1	0	0	22.6	22.52
		20175	1732.5	1	0	0	22.6	22.23
		20375	1752.5	1	0	0	22.6	22.5
		19975	1712.5	1	12	0	22.6	22.36
		20175	1732.5	1	12	0	22.6	22.07
		20375	1752.5	1	12	0	22.6	22.34
		19975	1712.5	1	24	0	22.6	22.36
		20175	1732.5	1	24	0	22.6	22.07
		20375	1752.5	1	24	0	22.6	22.34
		19975	1712.5	12	0	1	22.6	21.31
		20175	1732.5	12	0	1	22.6	21.02
		20375	1752.5	12	0	1	22.6	21.29
		19975	1712.5	12	6	1	22.6	21.2
		20175	1732.5	12	6	1	22.6	20.91
		20375	1752.5	12	6	1	22.6	21.18
		19975	1712.5	12	13	1	22.6	21.15
		20175	1732.5	12	13	1	22.6	20.86
		20375	1752.5	12	13	1	22.6	21.13
	19975	1712.5	25	0	1	22.6	21.12	
	20175	1732.5	25	0	1	22.6	20.83	
	20375	1752.5	25	0	1	22.6	21.1	
	19975	1712.5	1	0	1	22.6	21.48	
	20175	1732.5	1	0	1	22.6	21.19	
	20375	1752.5	1	0	1	22.6	21.46	
	19975	1712.5	1	12	1	22.6	21.51	
	20175	1732.5	1	12	1	22.6	21.22	
	20375	1752.5	1	12	1	22.6	21.49	
	19975	1712.5	1	24	1	22.6	21.39	
	20175	1732.5	1	24	1	22.6	21.1	
	20375	1752.5	1	24	1	22.6	21.37	
	19975	1712.5	12	0	2	22.6	20.52	
	20175	1732.5	12	0	2	22.6	20.23	
	20375	1752.5	12	0	2	22.6	20.5	
	19975	1712.5	12	6	2	22.6	20.4	
	20175	1732.5	12	6	2	22.6	20.11	
	20375	1752.5	12	6	2	22.6	20.38	
19975	1712.5	12	13	2	22.6	20.34		
20175	1732.5	12	13	2	22.6	20.05		
20375	1752.5	12	13	2	22.6	20.32		
19975	1712.5	25	0	2	22.6	20.35		
20175	1732.5	25	0	2	22.6	20.06		
20375	1752.5	25	0	2	22.6	20.33		



A D T

LTE Band 4								
BW	Modulation	CH	Frequency	RB	RB Offset	MPR	Target	Measured
			(MHz)				Power	Power
10MHz	QPSK	20000	1715	1	0	0	22.6	22.28
		20175	1732.5	1	0	0	22.6	22.02
		20350	1750	1	0	0	22.6	22.43
		20000	1715	1	24	0	22.6	22.39
		20175	1732.5	1	24	0	22.6	22.13
		20350	1750	1	24	0	22.6	22.54
		20000	1715	1	49	0	22.6	22.17
		20175	1732.5	1	49	0	22.6	21.91
		20350	1750	1	49	0	22.6	22.32
		20000	1715	25	0	1	22.6	21.14
		20175	1732.5	25	0	1	22.6	20.88
		20350	1750	25	0	1	22.6	21.29
		20000	1715	25	12	1	22.6	21.17
		20175	1732.5	25	12	1	22.6	20.91
		20350	1750	25	12	1	22.6	21.32
		20000	1715	25	25	1	22.6	21.08
		20175	1732.5	25	25	1	22.6	20.82
		20350	1750	25	25	1	22.6	21.23
	20000	1715	50	0	1	22.6	21.03	
	20175	1732.5	50	0	1	22.6	20.77	
	20350	1750	50	0	1	22.6	21.18	
	20000	1715	1	0	1	22.6	21.14	
	20175	1732.5	1	0	1	22.6	20.88	
	20350	1750	1	0	1	22.6	21.29	
	20000	1715	1	24	1	22.6	21.38	
	20175	1732.5	1	24	1	22.6	21.12	
	20350	1750	1	24	1	22.6	21.53	
	20000	1715	1	49	1	22.6	21.1	
	20175	1732.5	1	49	1	22.6	20.84	
	20350	1750	1	49	1	22.6	21.25	
	20000	1715	25	0	2	22.6	20.11	
	20175	1732.5	25	0	2	22.6	19.85	
	20350	1750	25	0	2	22.6	20.26	
	20000	1715	25	12	2	22.6	20.06	
	20175	1732.5	25	12	2	22.6	19.8	
	20350	1750	25	12	2	22.6	20.21	
20000	1715	25	25	2	22.6	19.98		
20175	1732.5	25	25	2	22.6	19.72		
20350	1750	25	25	2	22.6	20.13		
20000	1715	50	0	2	22.6	19.92		
20175	1732.5	50	0	2	22.6	19.66		
20350	1750	50	0	2	22.6	20.07		



A D T

LTE Band 4								
BW	Modulation	CH	Frequency	RB	RB Offset	MPR	Target	Measured
			(MHz)				Power	Power
15 MHz	QPSK	20025	1717.5	1	0	0	22.6	22.57
		20175	1732.5	1	0	0	22.6	22.18
		20325	1747.5	1	0	0	22.6	22.5
		20025	1717.5	1	37	0	22.6	22.3
		20175	1732.5	1	37	0	22.6	21.91
		20325	1747.5	1	37	0	22.6	22.23
		20025	1717.5	1	74	0	22.6	22.01
		20175	1732.5	1	74	0	22.6	21.62
		20325	1747.5	1	74	0	22.6	21.94
		20025	1717.5	36	0	1	22.6	21.19
		20175	1732.5	36	0	1	22.6	20.8
		20325	1747.5	36	0	1	22.6	21.12
		20025	1717.5	36	19	1	22.6	21.06
		20175	1732.5	36	19	1	22.6	20.67
		20325	1747.5	36	19	1	22.6	20.99
		20025	1717.5	36	39	1	22.6	21
		20175	1732.5	36	39	1	22.6	20.61
		20325	1747.5	36	39	1	22.6	20.93
	20025	1717.5	75	0	1	22.6	21.05	
	20175	1732.5	75	0	1	22.6	20.66	
	20325	1747.5	75	0	1	22.6	20.98	
	20025	1717.5	1	0	1	22.6	21.55	
	20175	1732.5	1	0	1	22.6	21.03	
	20325	1747.5	1	0	1	22.6	21.37	
	20025	1717.5	1	37	1	22.6	21.48	
	20175	1732.5	1	37	1	22.6	20.96	
	20325	1747.5	1	37	1	22.6	21.3	
	20025	1717.5	1	74	1	22.6	21.47	
	20175	1732.5	1	74	1	22.6	20.95	
	20325	1747.5	1	74	1	22.6	21.29	
	20025	1717.5	36	0	2	22.6	20.49	
	20175	1732.5	36	0	2	22.6	19.97	
	20325	1747.5	36	0	2	22.6	20.31	
20025	1717.5	36	19	2	22.6	20.32		
20175	1732.5	36	19	2	22.6	19.8		
20325	1747.5	36	19	2	22.6	20.14		
20025	1717.5	36	39	2	22.6	20.2		
20175	1732.5	36	39	2	22.6	19.68		
20325	1747.5	36	39	2	22.6	20.02		
20025	1717.5	75	0	2	22.6	20.28		
20175	1732.5	75	0	2	22.6	19.76		
20325	1747.5	75	0	2	22.6	20.1		



LTE Band 4								
BW	Modulation	CH	Frequency	RB	RB Offset	MPR	Target	Measured
			(MHz)				Power	Power
20MHz	QPSK	20050	1720	1	0	0	22.6	22.6
		20175	1732.5	1	0	0	22.6	22.45
		20300	1745	1	0	0	22.6	22.41
		20050	1720	1	50	0	22.6	22.46
		20175	1732.5	1	50	0	22.6	22.31
		20300	1745	1	50	0	22.6	22.27
		20050	1720	1	99	0	22.6	22.27
		20175	1732.5	1	99	0	22.6	22.12
		20300	1745	1	99	0	22.6	22.08
		20050	1720	50	0	1	22.6	21.16
		20175	1732.5	50	0	1	22.6	21.01
		20300	1745	50	0	1	22.6	20.97
		20050	1720	50	25	1	22.6	21
		20175	1732.5	50	25	1	22.6	20.85
		20300	1745	50	25	1	22.6	20.81
		20050	1720	50	50	1	22.6	20.88
		20175	1732.5	50	50	1	22.6	20.73
		20300	1745	50	50	1	22.6	20.69
	20050	1720	100	0	1	22.6	21.08	
	20175	1732.5	100	0	1	22.6	20.93	
	20300	1745	100	0	1	22.6	20.89	
	20050	1720	1	0	1	22.6	21.58	
	20175	1732.5	1	0	1	22.6	21.43	
	20300	1745	1	0	1	22.6	21.39	
	20050	1720	1	50	1	22.6	21.53	
	20175	1732.5	1	50	1	22.6	21.38	
	20300	1745	1	50	1	22.6	21.34	
	20050	1720	1	99	1	22.6	21.32	
	20175	1732.5	1	99	1	22.6	21.17	
	20300	1745	1	99	1	22.6	21.13	
	20050	1720	50	0	2	22.6	20.22	
	20175	1732.5	50	0	2	22.6	20.07	
	20300	1745	50	0	2	22.6	20.03	
	20050	1720	50	25	2	22.6	19.91	
	20175	1732.5	50	25	2	22.6	19.76	
	20300	1745	50	25	2	22.6	19.72	
20050	1720	50	50	2	22.6	19.83		
20175	1732.5	50	50	2	22.6	19.68		
20300	1745	50	50	2	22.6	19.64		
20050	1720	100	0	2	22.6	19.96		
20175	1732.5	100	0	2	22.6	19.81		
20300	1745	100	0	2	22.6	19.77		

## EIRP (dBm)

### EVDO

Plane	Channel	Frequency (MHz)	LVL (dBm)	Correction Factor(dB)	EIRP(dBm)	EIRP(mW)	Polarization (H/V)
Y	25	1711.25	-15.48	0.99	23.04	201.37	H
	425	1731.25	-14.95	1.00	23.72	235.50	
	875	1753.75	-15.59	1.02	23.26	211.84	
	25	1711.25	-16.26	0.99	20.66	116.41	V
	425	1731.25	-16.07	1.00	20.96	124.74	
	875	1753.75	-16.54	1.02	20.62	115.35	



A D T

### LTE Band 4 (Channel Bandwidth 5MHz)

Plane	Channel	Frequency (MHz)	LVL (dBm)	Correction Factor(dB)	EIRP(dBm)	EIRP(mW)	Polarization (H/V)
Z	19975	1712.5	-24.33	37.90	13.57	22.75	H
	20175	1732.5	-24.52	37.99	13.47	22.23	
	20375	1752.5	-24.55	38.31	13.76	23.77	
	19975	1712.5	-15.18	37.81	22.63	183.23	V
	20175	1732.5	-15.01	38.00	22.99	199.07	
	20375	1752.5	-15.83	38.22	22.39	173.38	

### LTE Band 4 (Channel Bandwidth 10MHz)

Plane	Channel	Frequency (MHz)	LVL (dBm)	Correction Factor(dB)	EIRP(dBm)	EIRP(mW)	Polarization (H/V)
Z	20000	1715.0	-24.22	37.99	13.77	23.82	H
	20175	1732.5	-24.22	37.99	13.77	23.82	
	20350	1750.0	-24.65	38.36	13.71	23.50	
	20000	1715.0	-14.73	37.91	23.18	207.97	V
	20175	1732.5	-14.98	38.00	23.02	200.45	
	20350	1750.0	-14.75	38.28	23.53	225.42	

**LTE Band 4 (Channel Bandwidth 15MHz)**

Plane	Channel	Frequency (MHz)	LVL (dBm)	Correction Factor(dB)	EIRP(dBm)	EIRP(mW)	Polarization (H/V)
Z	20025	1717.5	-24.44	37.99	13.55	22.65	H
	20175	1732.5	-24.13	37.99	13.86	24.32	
	20325	1747.5	-24.47	38.36	13.89	24.49	
	20025	1717.5	-14.93	37.91	22.98	198.61	V
	20175	1732.5	-15.81	38.00	22.19	165.58	
	20325	1747.5	-15.63	38.28	22.65	184.08	

**LTE Band 4 (Channel Bandwidth 20MHz)**

Plane	Channel	Frequency (MHz)	LVL (dBm)	Correction Factor(dB)	EIRP(dBm)	EIRP(mW)	Polarization (H/V)
Z	20050	1720.0	-24.56	37.99	13.43	22.03	H
	20175	1732.5	-24.16	37.99	13.83	24.15	
	20300	1745.0	-24.38	38.36	13.98	25.00	
	20050	1720.0	-15.11	37.91	22.80	190.55	V
	20175	1732.5	-15.13	38.00	22.87	193.64	
	20300	1745.0	-15.49	38.28	22.79	190.11	

**ERP (dBm)**

**LTE Band 12 (Channel Bandwidth 5MHz)**

Plane	Channel	Frequency (MHz)	LVL (dBm)	Correction Factor(dB)	ERP(dBm)	ERP(mW)	Polarization (H/V)
X	23035	701.5	-9.93	30.36	18.28	67.30	H
	23095	707.5	-9.03	30.17	18.99	79.25	
	23155	713.5	-9.48	30.17	18.54	71.45	
	23035	701.5	-16.78	32.03	13.10	20.42	V
	23095	707.5	-16.14	31.98	13.69	23.39	
	23155	713.5	-16.18	32.06	13.73	23.60	

**LTE Band 12 (Channel Bandwidth 10MHz)**

Plane	Channel	Frequency (MHz)	LVL (dBm)	Correction Factor(dB)	ERP(dBm)	ERP(mW)	Polarization (H/V)
X	23060	704.0	-9.60	30.17	18.42	69.50	H
	23095	707.5	-9.99	30.17	18.03	63.53	
	23130	711.0	-9.40	30.18	18.63	72.95	
	23060	704.0	-16.59	31.96	13.22	20.99	V
	23095	707.5	-16.28	31.98	13.55	22.65	
	23130	711.0	-16.91	32.03	12.97	19.82	



A D T

### LTE Band 17 (Channel Bandwidth 5MHz)

Plane	Channel	Frequency (MHz)	LVL (dBm)	Correction Factor(dB)	ERP(dBm)	ERP(mW)	Polarization (H/V)
X	23755	706.5	-10.07	30.36	18.14	65.16	H
	23790	710.0	-9.10	30.17	18.92	77.98	
	23825	713.5	-9.03	30.17	18.99	79.25	
	23755	706.5	-16.83	32.03	13.05	20.18	V
	23790	710.0	-16.09	31.98	13.74	23.66	
	23825	713.5	-16.31	32.06	13.60	22.91	

### LTE Band 17 (Channel Bandwidth 10MHz)

Plane	Channel	Frequency (MHz)	LVL (dBm)	Correction Factor(dB)	ERP(dBm)	ERP(mW)	Polarization (H/V)
X	23780	709.0	-10.42	30.36	17.79	60.12	H
	23790	710.0	-10.30	30.17	17.72	59.16	
	23800	711.0	-10.27	30.17	17.75	59.57	
	23780	709.0	-16.92	32.03	12.96	19.77	V
	23790	710.0	-17.59	31.98	12.24	16.75	
	23800	711.0	-17.04	32.06	12.87	19.36	

## 4.2 FREQUENCY STABILITY MEASUREMENT

### 4.2.1 LIMITS OF FREQUENCY STABILITY MEASUREMENT

The frequency stability shall be sufficient to ensure that the fundamental emissions stay within the authorized bands of operation.

### 4.2.2 TEST PROCEDURE

- a. Device is placed at the oven room. The oven room could control the temperatures and humidity. Power warm up is at least 15 min and power applied should perform before recording frequency error.
- b. EUT is connected the external power supply to control the DC input power. The test voltage range is from minimum to maximum working voltage. Each step shall be record the frequency error rate.
- c. The temperature range step is 10 degrees in this test items. All temperature levels shall be hold the  $\pm 0.5^{\circ}\text{C}$  during the measurement testing. The each temperature step shall be at least 0.5 hours, consider the EUT could be test under the stability condition.

**NOTE:** The frequency error was recorded frequency error from the communication simulator.

### 4.2.3 TEST SETUP

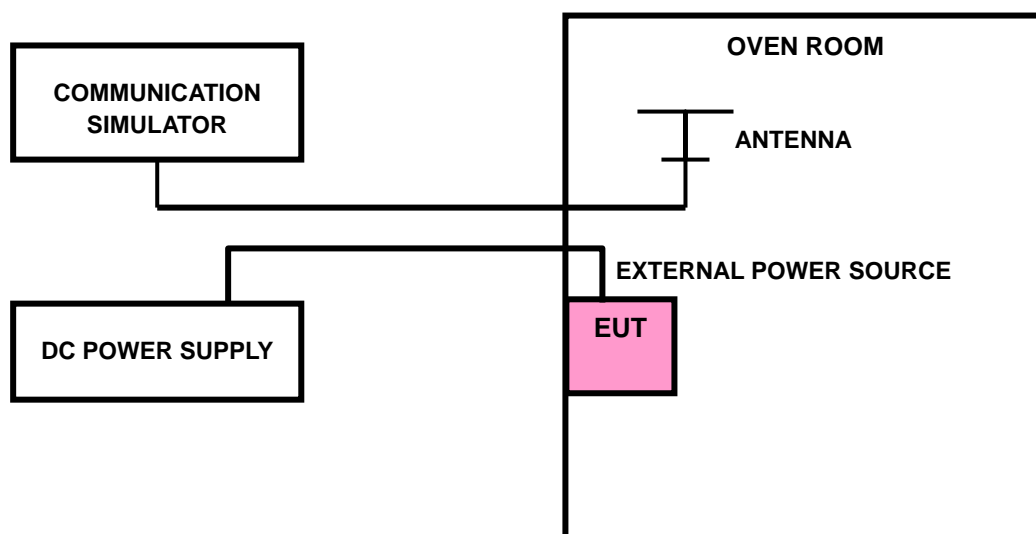

#### 4.2.4 TEST RESULTS

##### FREQUENCY ERROR VS. VOLTAGE

VOLTAGE (Volts)	FREQUENCY ERROR (ppm)									LIMIT (ppm)
	EVDO	LTE Band 12		LTE Band 17		LTE Band 4				
		5MHz	10MHz	5MHz	10MHz	5MHz	10MHz	15MHz	20MHz	
4.26	-0.014	-0.010	-0.003	-0.003	-0.007	-0.003	0.003	0.002	0.001	2.5
3.7	-0.010	-0.004	-0.006	-0.006	-0.003	0.009	0.004	0.002	-0.001	2.5
3.15	-0.011	-0.004	-0.003	-0.004	-0.002	0.004	0.003	-0.004	0.001	2.5

**NOTE:** The applicant defined the normal working voltage of the battery is from 3.15Vdc to 4.26Vdc.

##### FREQUENCY ERROR vs. TEMPERATURE

TEMP. (°C)	FREQUENCY ERROR (ppm)									LIMIT (ppm)
	EVDO	LTE Band 12		LTE Band 17		LTE Band 4				
		5MHz	10MHz	5MHz	10MHz	5MHz	10MHz	15MHz	20MHz	
50	-0.020	-0.001	-0.002	-0.004	-0.003	0.007	0.004	0.002	0.002	2.5
40	-0.018	-0.003	-0.005	-0.009	-0.003	0.003	0.003	0.006	0.001	2.5
30	-0.014	-0.010	-0.007	0.002	-0.003	0.003	-0.002	0.003	-0.001	2.5
20	-0.010	0.006	-0.002	-0.003	-0.011	0.002	0.005	0.003	-0.004	2.5
10	-0.016	-0.008	-0.004	-0.007	-0.005	0.005	-0.002	0.002	0.003	2.5
0	-0.019	-0.004	-0.006	-0.006	-0.004	0.004	0.003	0.004	0.003	2.5
-10	-0.023	-0.003	-0.007	-0.003	-0.005	0.006	0.006	0.004	-0.003	2.5
-20	-0.024	0.007	-0.006	-0.002	-0.005	0.004	0.005	0.002	0.003	2.5
-30	-0.023	-0.010	-0.002	0.003	-0.004	0.006	0.005	-0.003	0.004	2.5



## 4.3 OCCUPIED BANDWIDTH MEASUREMENT

### 4.3.1 LIMITS OF OCCUPIED BANDWIDTH MEASUREMENT

The EUT makes a call to the communication simulator. All measurements were done at low, middle and high operational frequency range. The communication simulator station system controlled a EUT to export maximum output power under transmission mode and specific channel frequency. Use OBW measurement function of Spectrum analyzer to measure 99 % occupied bandwidth.

### 4.3.2 TEST SETUP

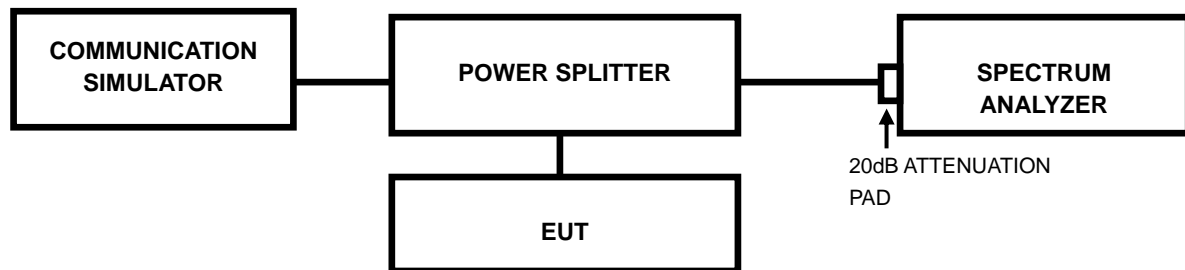

### 4.3.3 TEST PROCEDURES

- The conducted occupied bandwidth used the power splitter via EUT RF power connector between simulation base station and spectrum analyzer.
- Use OBW measurement function of Spectrum analyzer to measure 99 % occupied bandwidth.



A D T

### 4.3.4 TEST RESULTS

CHANNEL	FREQUENCY (MHz)	99% OCCUPIED BANDWIDTH (MHz)
		EVDO
25	1711.25	1.28
425	1731.25	1.28
875	1753.75	1.28

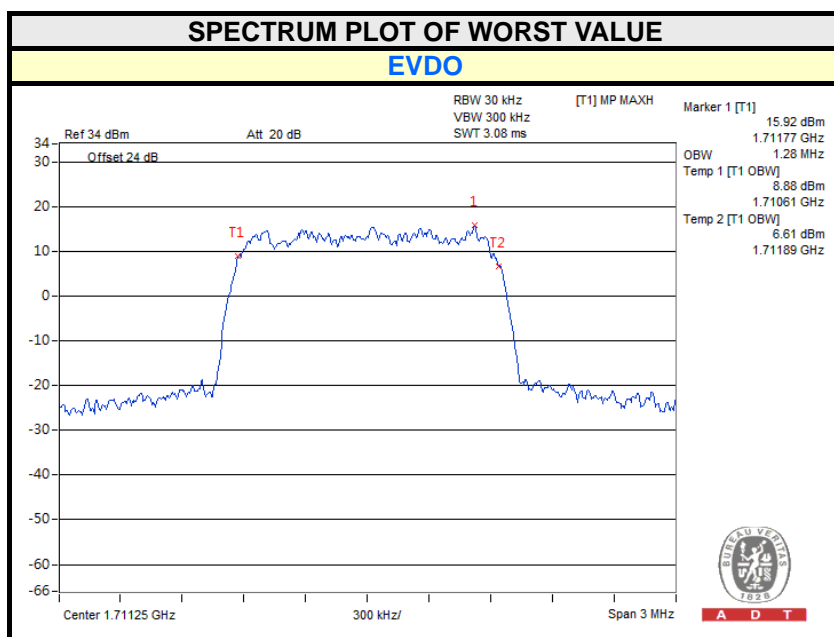



A D T

LTE BAND 12							
CHANNEL BANDWIDTH: 5MHz				CHANNEL BANDWIDTH: 10MHz			
CHANNEL	FREQUENCY (MHz)	99% OCCUPIED BANDWIDTH (MHz)		CHANNEL	FREQUENCY (MHz)	99% OCCUPIED BANDWIDTH (MHz)	
		QPSK	16QAM			QPSK	16QAM
23035	701.5	4.4907	4.4918	23060	704.0	8.9168	8.9123
23095	707.5	4.4979	4.4957	23095	707.5	8.9312	8.9283
23155	713.5	4.4909	4.4916	23130	711.0	8.9277	8.9299

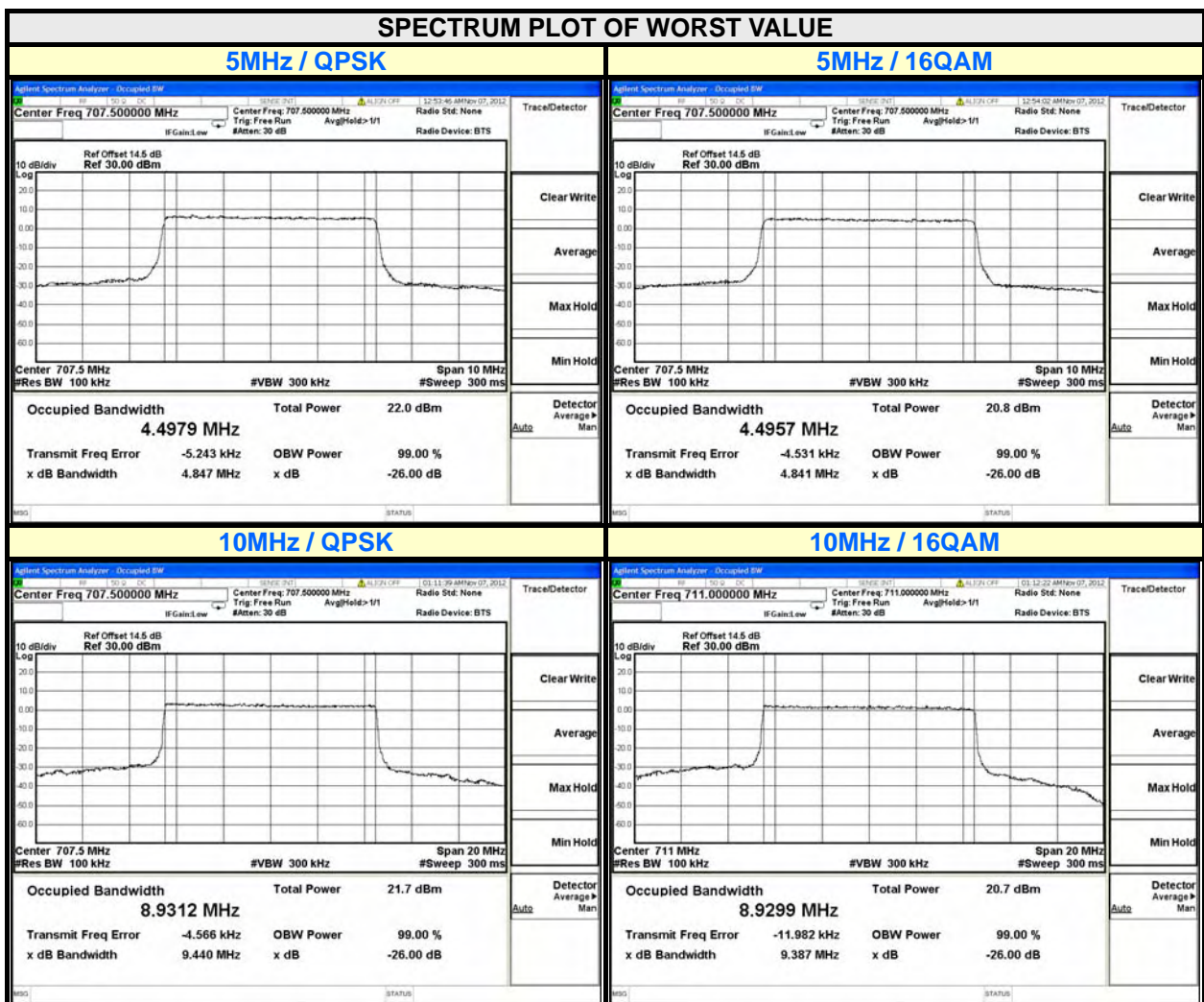



A D T

LTE BAND 17							
CHANNEL BANDWIDTH: 5MHz				CHANNEL BANDWIDTH: 10MHz			
CHANNEL	FREQUENCY (MHz)	99% OCCUPIED BANDWIDTH (MHz)		CHANNEL	FREQUENCY (MHz)	99% OCCUPIED BANDWIDTH (MHz)	
		QPSK	16QAM			QPSK	16QAM
23755	706.5	4.4946	4.4937	23780	709	8.9292	8.9293
23790	710	4.5011	4.4948	23790	710	8.9307	8.9315
23825	713.5	4.4945	4.4892	23800	711	8.9248	8.9194

**SPECTRUM PLOT OF WORST VALUE**

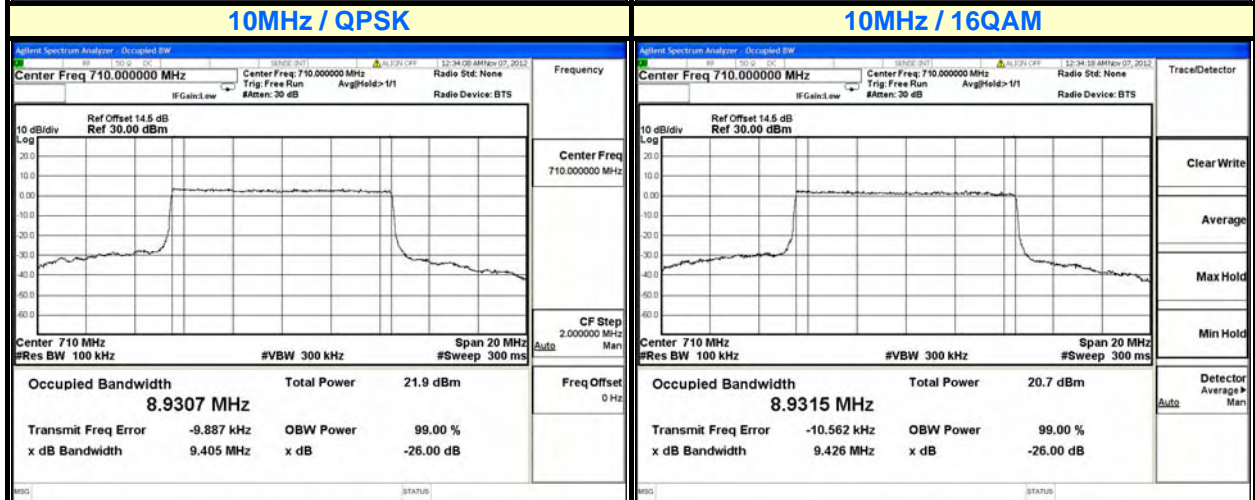
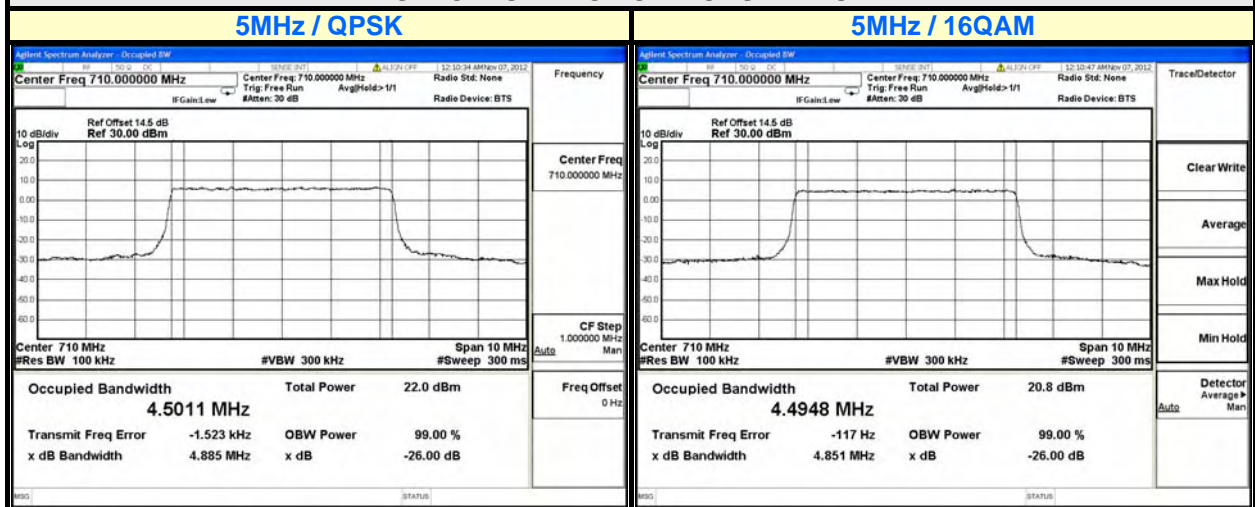

LTE BAND 4							
CHANNEL BANDWIDTH: 5MHz				CHANNEL BANDWIDTH: 10MHz			
CHANNEL	FREQUENCY (MHz)	99% OCCUPIED BANDWIDTH (MHz)		CHANNEL	FREQUENCY (MHz)	99% OCCUPIED BANDWIDTH (MHz)	
		QPSK	16QAM			QPSK	16QAM
19975	1712.5	4.4871	4.4869	20000	1715.0	8.9178	8.9205
20175	1732.5	4.4933	4.4929	20175	1732.5	8.9210	8.9241
20375	1752.5	4.4890	4.4858	20350	1750.0	8.9133	8.9084
CHANNEL BANDWIDTH: 15MHz				CHANNEL BANDWIDTH: 20MHz			
CHANNEL	FREQUENCY (MHz)	99% OCCUPIED BANDWIDTH (MHz)		CHANNEL	FREQUENCY (MHz)	99% OCCUPIED BANDWIDTH (MHz)	
		QPSK	16QAM			QPSK	16QAM
20025	1717.5	13.384	13.370	20050	1720	17.809	17.817
20175	1732.5	13.397	13.389	20175	1732.5	17.848	17.849
20325	1747.5	13.371	13.369	20300	1745	17.819	17.837



A D T

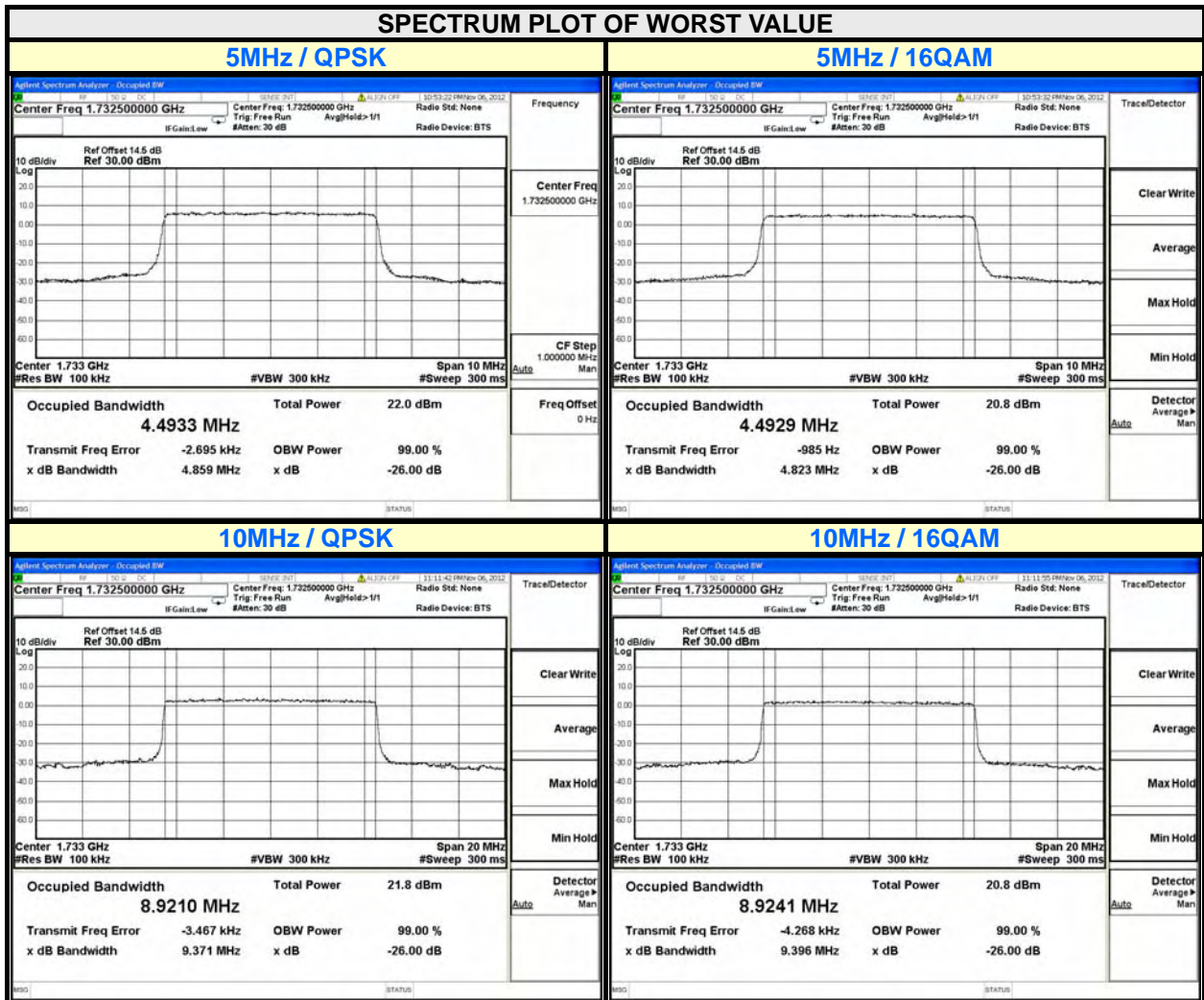





A D T

### SPECTRUM PLOT OF WORST VALUE

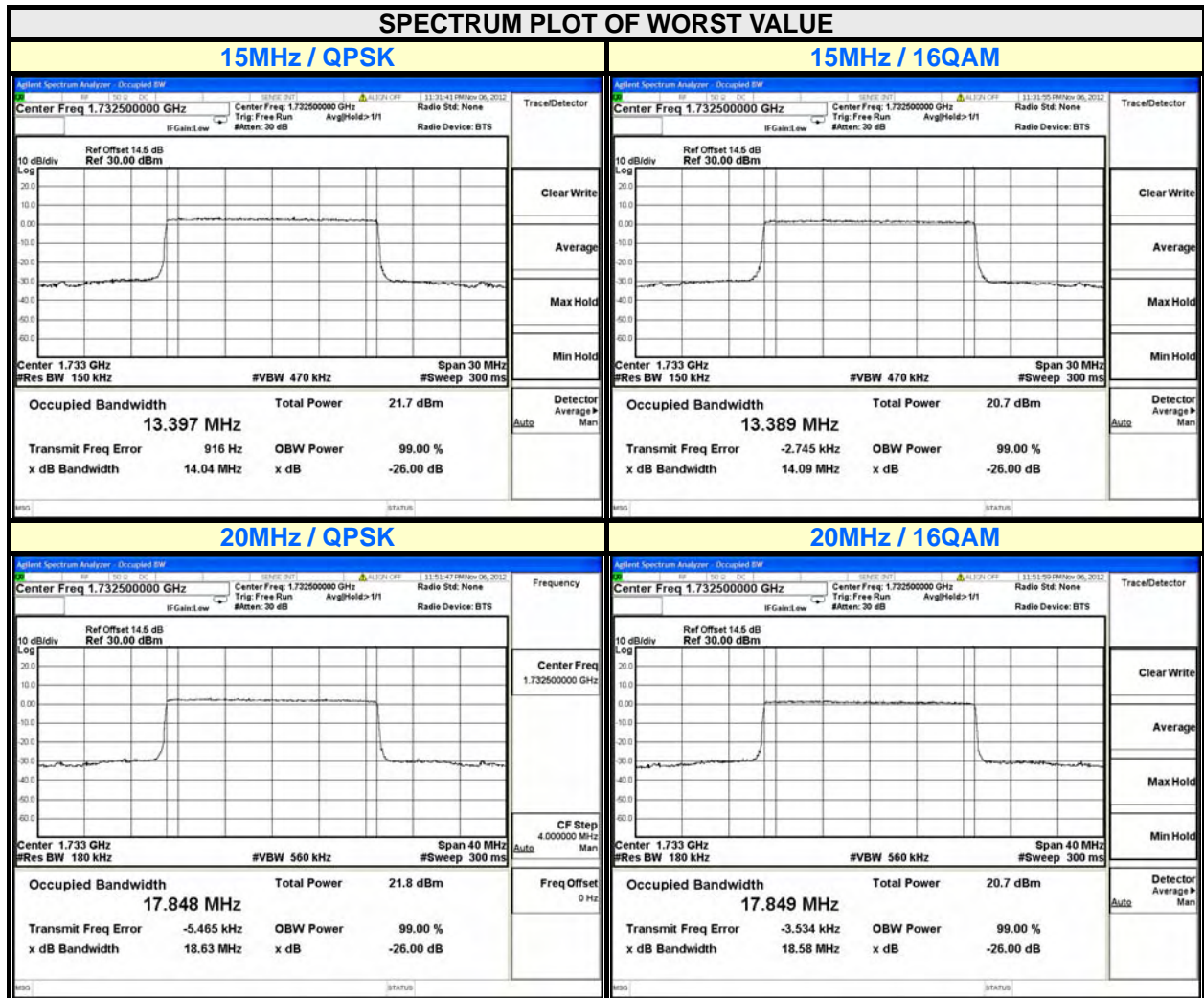

## 4.4 PEAK TO AVERAGE RATIO

### 4.4.1 LIMITS OF PEAK TO AVERAGE RATIO MEASUREMENT

In measuring transmissions in this band using an average power technique, the peak to-average ratio (PAR) of the transmission may not exceed 13 dB

### 4.4.2 TEST SETUP

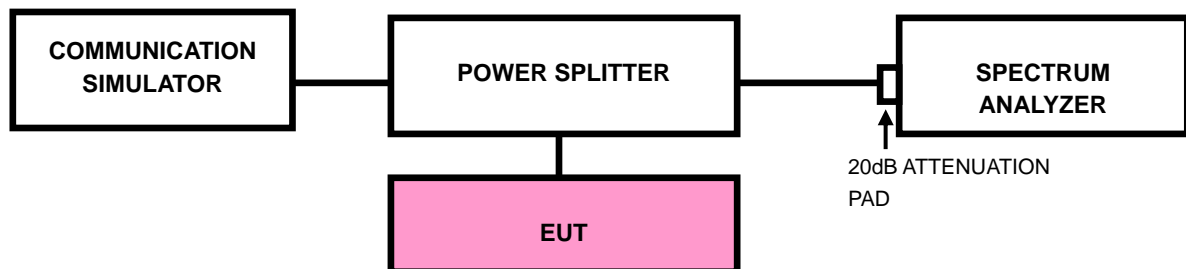

### 4.4.3 TEST PROCEDURES

1. Set resolution/measurement bandwidth  $\geq$  signal's occupied bandwidth;
2. Set the number of counts to a value that stabilizes the measured CCDF curve;
3. Record the maximum PAPR level associated with a probability of 0.1%.



#### 4.4.4 TEST RESULTS

CHANNEL	FREQUENCY (MHz)	PEAK TO AVERAGE RATIO (dB)
		EVDO
25	1711.25	4.26
425	1731.25	3.31
875	1753.75	4.64

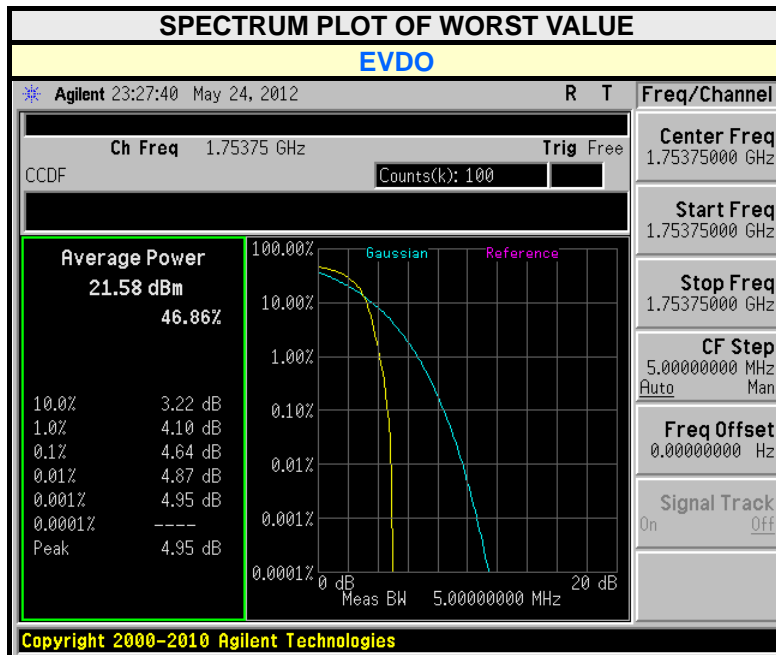



A D T

LTE BAND 12					
CHANNEL BANDWIDTH 5MHz			CHANNEL BANDWIDTH 10MHz		
CHANNEL	FREQUENCY (MHz)	PEAK TO AVERAGE RATIO (dB)	CHANNEL	FREQUENCY (MHz)	PEAK TO AVERAGE RATIO (dB)
23035	701.5	5.73	23060	704.0	5.77
23095	707.5	5.92	23095	707.5	5.91
23155	713.5	5.98	23130	711.0	5.90

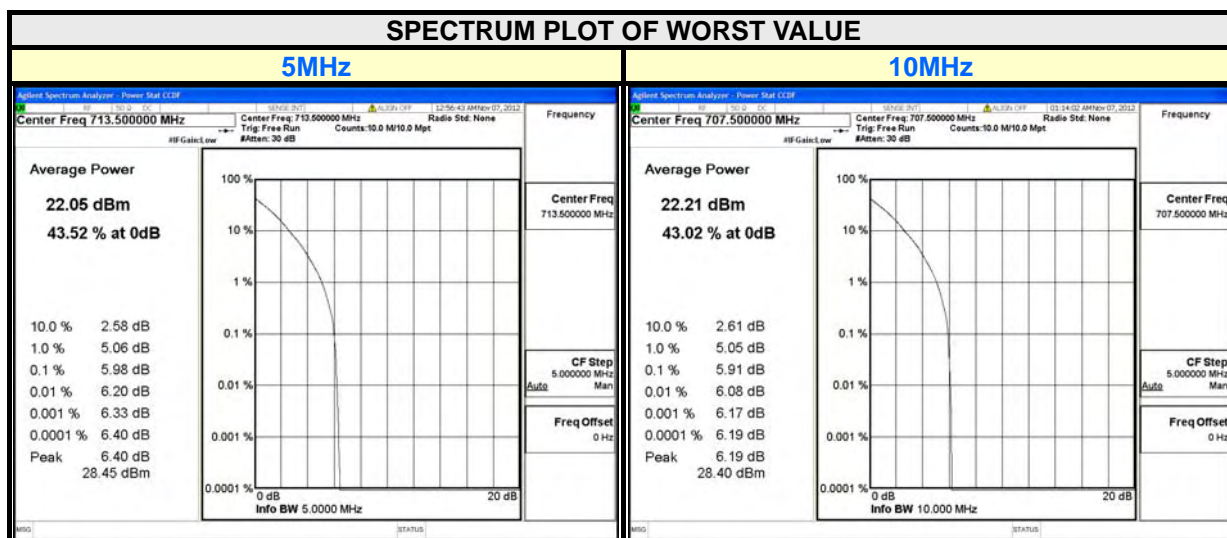



A D T

LTE BAND 17					
CHANNEL BANDWIDTH 5MHz			CHANNEL BANDWIDTH 10MHz		
CHANNEL	FREQUENCY (MHz)	PEAK TO AVERAGE RATIO (dB)	CHANNEL	FREQUENCY (MHz)	PEAK TO AVERAGE RATIO (dB)
23755	706.5	5.94	23780	709	6.19
23790	710	5.99	23790	710	6.17
23825	713.5	6.04	23800	711	6.09

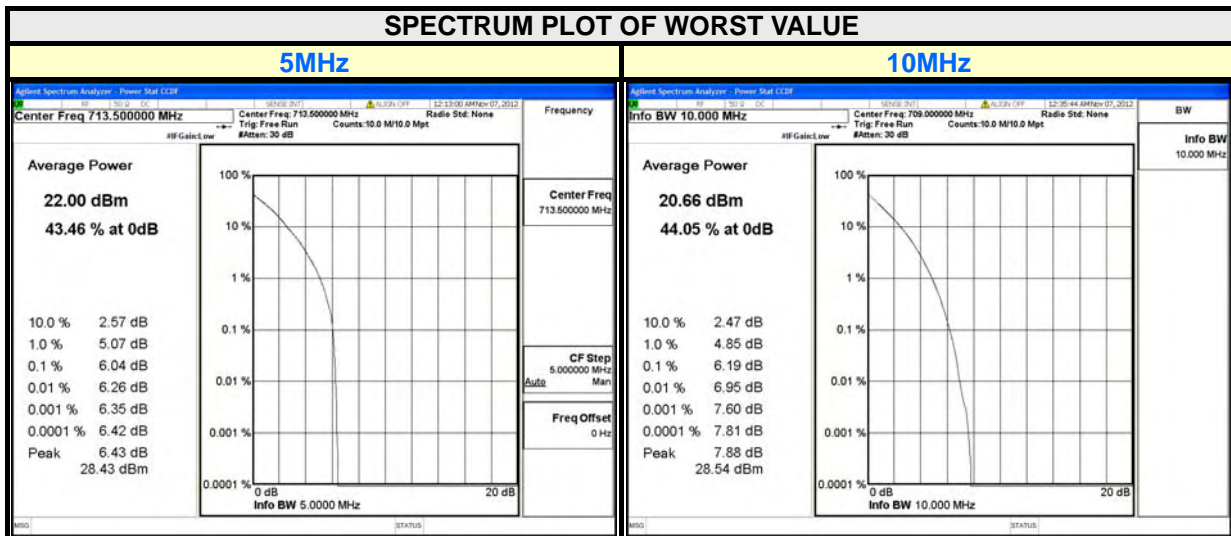



A D T

LTE BAND 4					
CHANNEL BANDWIDTH 5MHz			CHANNEL BANDWIDTH 10MHz		
CHANNEL	FREQUENCY (MHz)	PEAK TO AVERAGE RATIO (dB)	CHANNEL	FREQUENCY (MHz)	PEAK TO AVERAGE RATIO (dB)
19975	1712.5	5.23	20000	1715.0	5.26
20175	1732.5	4.95	20175	1732.5	5.41
20375	1752.5	5.16	20350	1750.0	4.24
CHANNEL BANDWIDTH 15MHz			CHANNEL BANDWIDTH 10MHz		
CHANNEL	FREQUENCY (MHz)	99% OCCUPIED BANDWIDTH (MHz)	CHANNEL	FREQUENCY (MHz)	99% OCCUPIED BANDWIDTH (MHz)
20025	1717.5	5.26	20050	1720	5.45
20175	1732.5	5.51	20175	1732.5	5.47
20325	1747.5	4.02	20300	1745	4.05

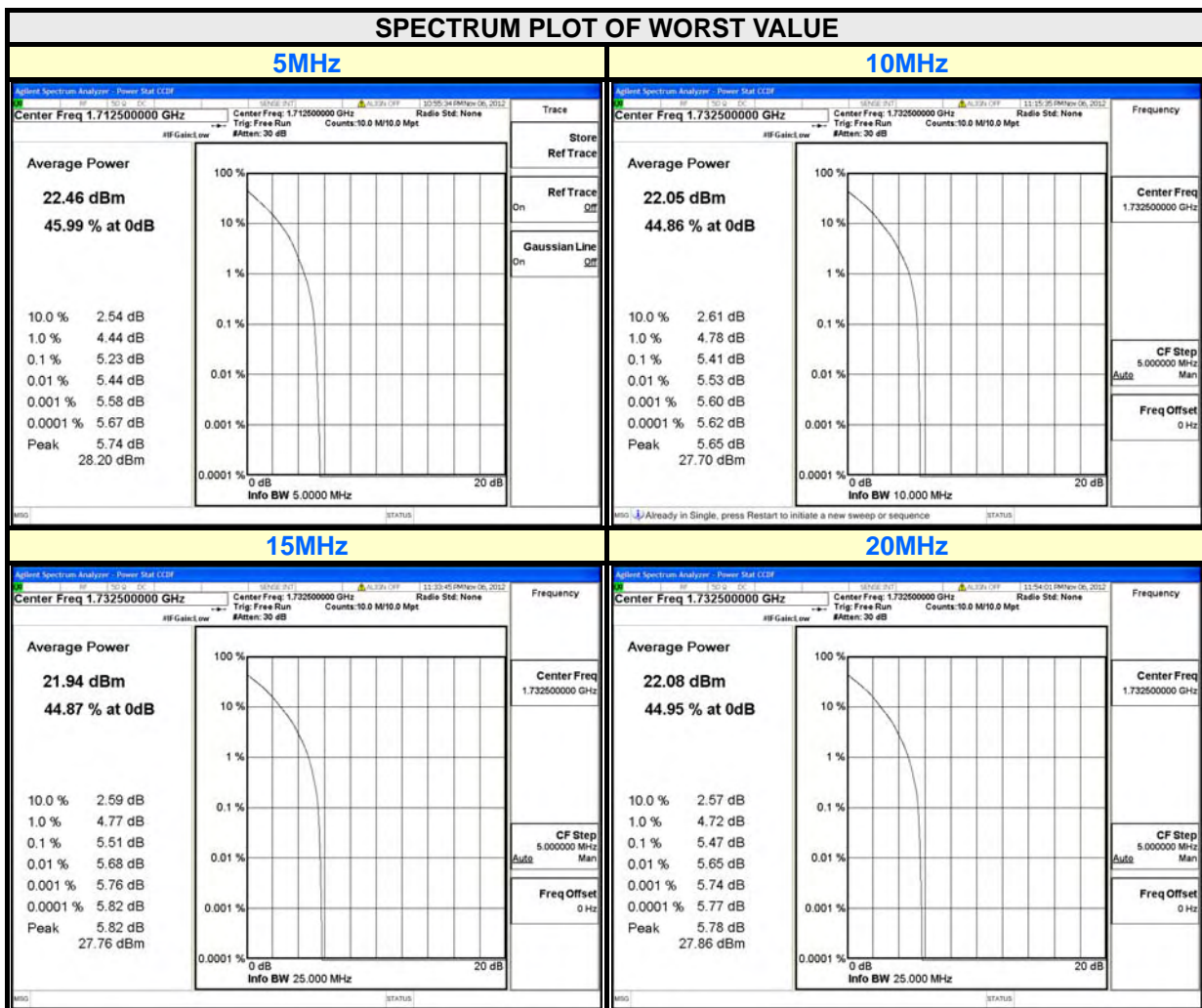

## 4.5 BAND EDGE MEASUREMENT

### 4.5.1 LIMITS OF BAND EDGE MEASUREMENT

Power of any emission outside of the authorized operating frequency ranges must be attenuated below the transmitting power (P) by a factor of at least  $43 + 10 \log(P)$  dB. In the 1 MHz bands immediately outside and adjacent to the frequency block a resolution bandwidth of at least one percent of the emission bandwidth of the fundamental emission of the transmitter may be employed.

### 4.5.2 TEST SETUP

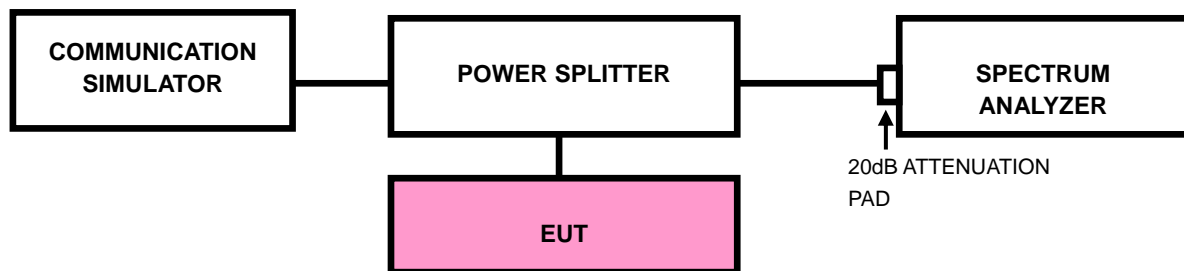

#### 4.5.3 TEST PROCEDURES

- a. All measurements were done at low and high operational frequency range.
- b. The center frequency of spectrum is the band edge frequency and span is 3MHz. RB of the spectrum is 15kHz and VB of the spectrum is 15kHz (EVDO).
- c. The center frequency of spectrum is the band edge frequency and span is 1MHz. RB of the spectrum is 100kHz and VB of the spectrum is 300kHz (LTE Channel Bandwidth 5MHz & 10MHz).
- d. The center frequency of spectrum is the band edge frequency and span is 1MHz. RB of the spectrum is 150kHz and VB of the spectrum is 470kHz (LTE Channel Bandwidth 15MHz).
- e. The center frequency of spectrum is the band edge frequency and span is 1MHz. RB of the spectrum is 180kHz and VB of the spectrum is 560kHz (LTE Channel Bandwidth 20MHz).
- f. Record the max trace plot into the test report.



A D T

### 4.5.4 TEST RESULTS

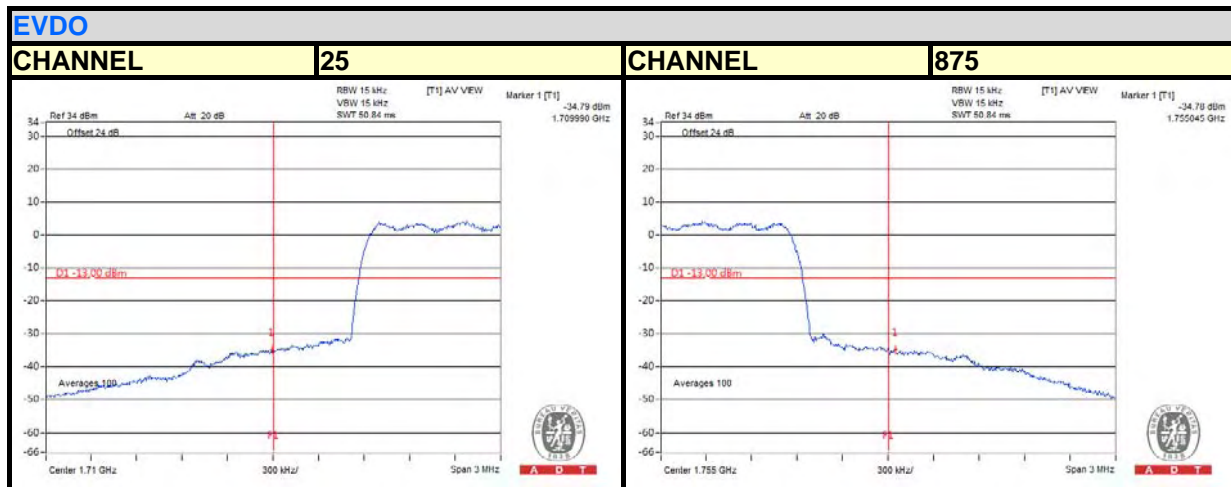



A D T

### LTE Band 12

### Channel Bandwidth 5MHz

#### CHANNEL 23035 1 RB CHANNEL 23155 1 RB

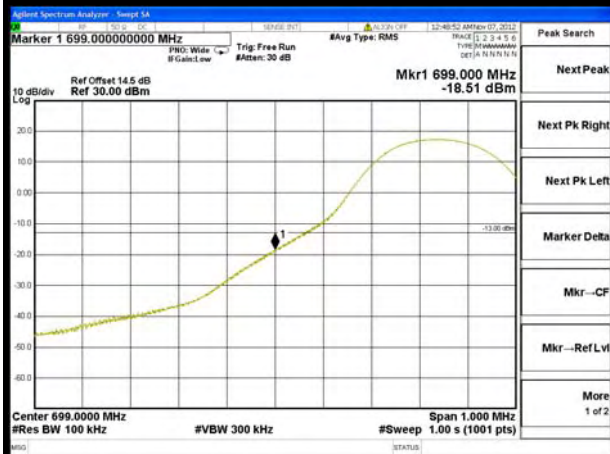

#### CHANNEL 23035 25 RB CHANNEL 23155 25 RB

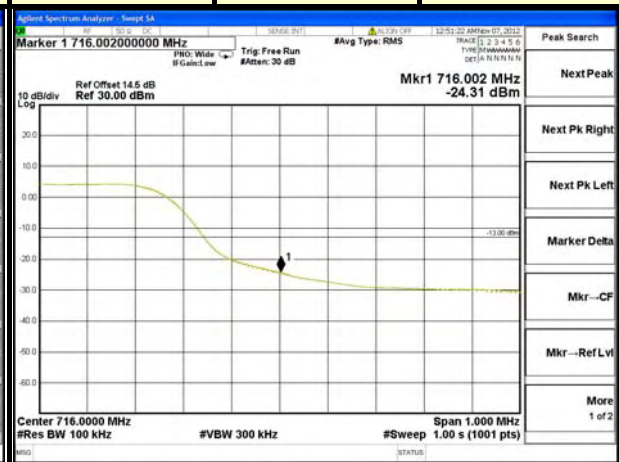
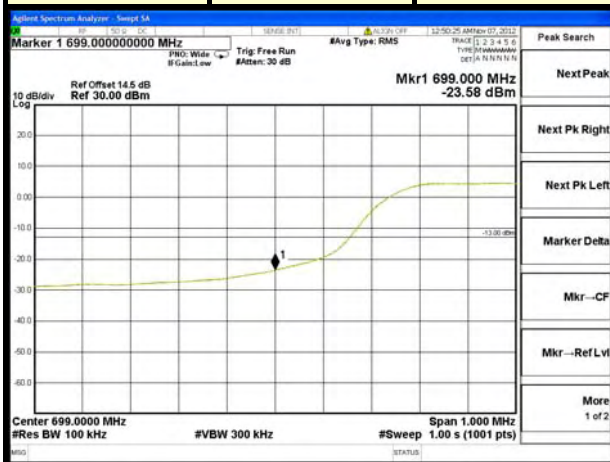





A D T

LTE Band 12

Channel Bandwidth 10MHz

<b>CHANNEL</b>	<b>23060</b>	<b>1 RB</b>	<b>CHANNEL</b>	<b>23130</b>	<b>1 RB</b>
----------------	--------------	-------------	----------------	--------------	-------------

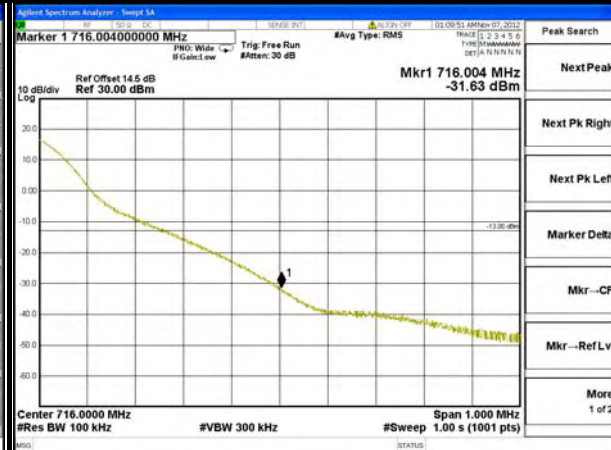
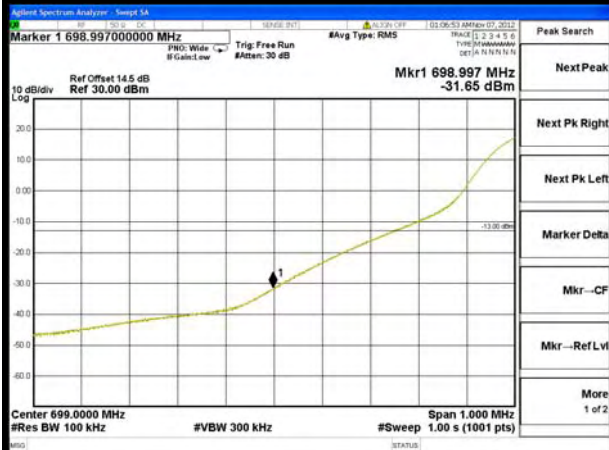

<b>CHANNEL</b>	<b>23060</b>	<b>50 RB</b>	<b>CHANNEL</b>	<b>23130</b>	<b>50 RB</b>
----------------	--------------	--------------	----------------	--------------	--------------

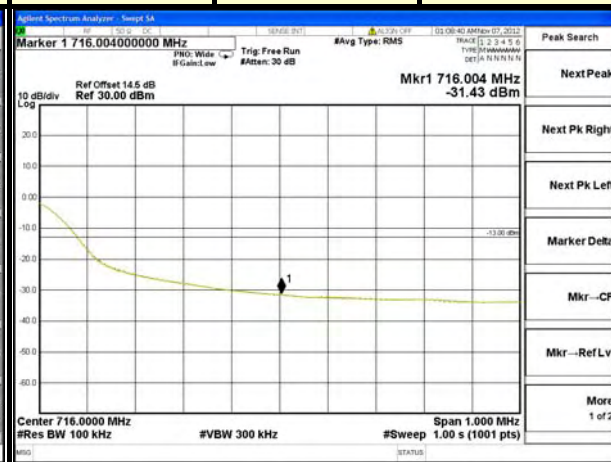
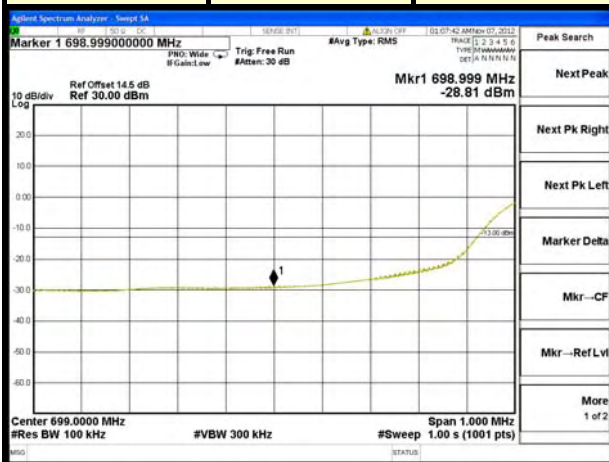



A D T

### LTE Band 17

### Channel Bandwidth 5MHz

<b>CHANNEL</b> 23755	<b>CHANNEL</b> 23825
----------------------	----------------------

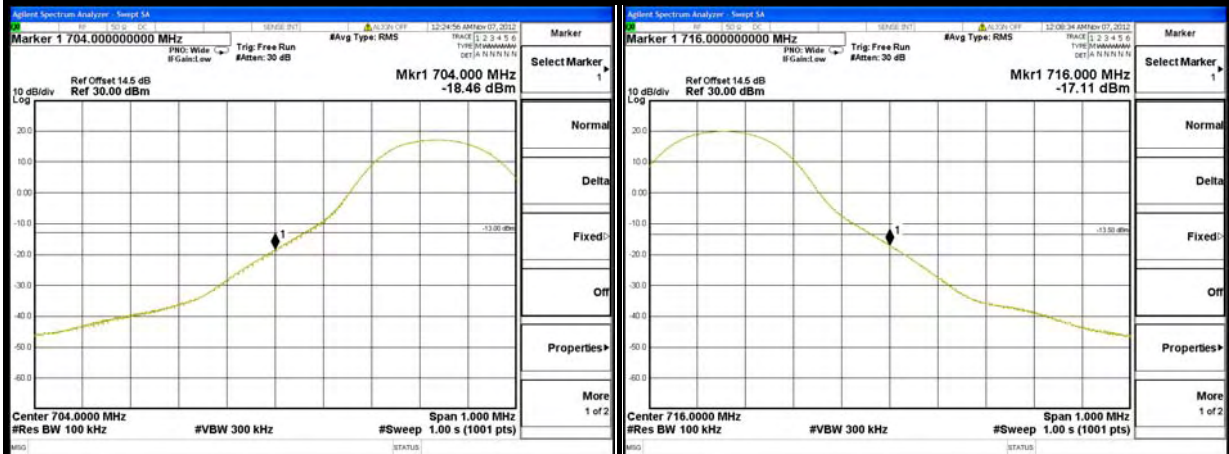

<b>CHANNEL</b> 23755	<b>CHANNEL</b> 23825
----------------------	----------------------

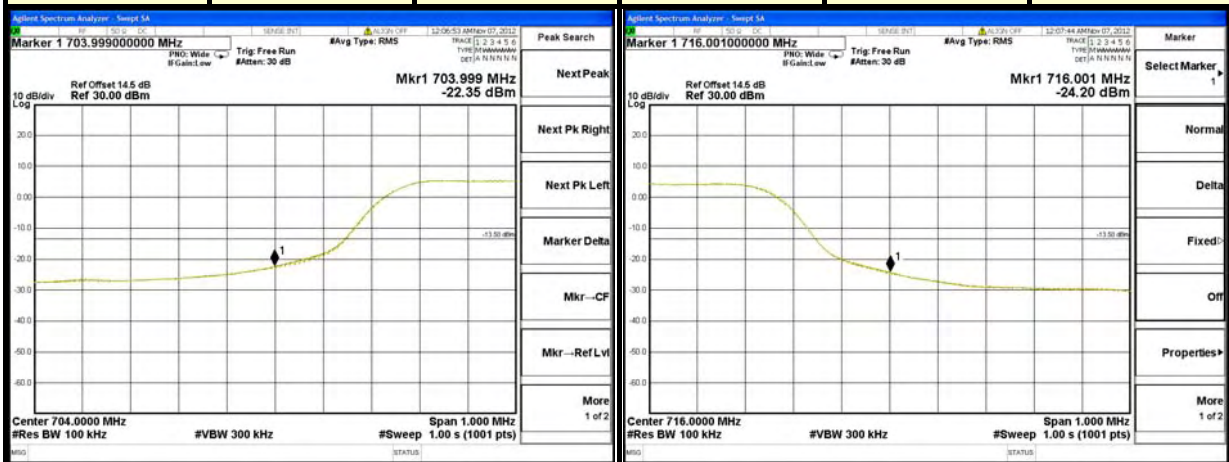



A D T

LTE Band 17

Channel Bandwidth 10MHz

<b>CHANNEL</b>	<b>23780</b>	<b>1 RB</b>	<b>CHANNEL</b>	<b>23800</b>	<b>1 RB</b>
----------------	--------------	-------------	----------------	--------------	-------------

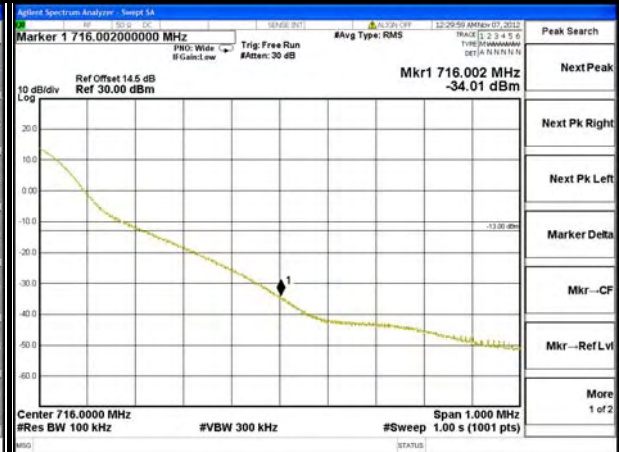

<b>CHANNEL</b>	<b>23780</b>	<b>50 RB</b>	<b>CHANNEL</b>	<b>23800</b>	<b>50 RB</b>
----------------	--------------	--------------	----------------	--------------	--------------

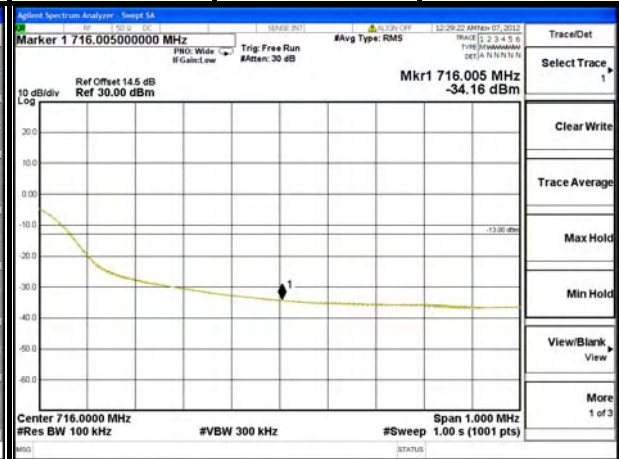
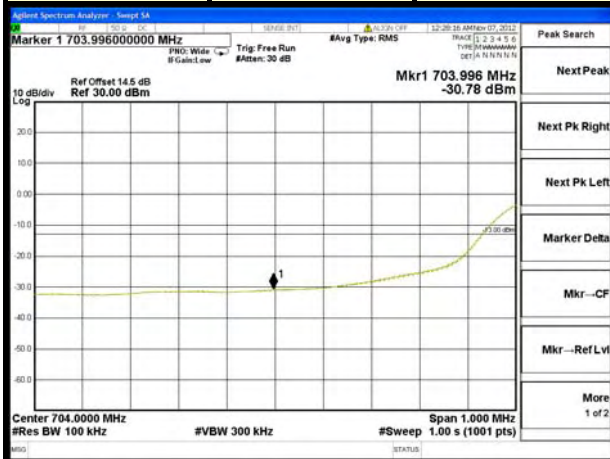



A D T

### LTE Band 4

### Channel Bandwidth 5MHz

#### CHANNEL 19975 1 RB CHANNEL 20375 1 RB



#### CHANNEL 19975 25 RB CHANNEL 20375 25 RB







A D T

### LTE Band 4

### Channel Bandwidth 10MHz

<b>CHANNEL</b>	<b>20000</b>	<b>1 RB</b>	<b>CHANNEL</b>	<b>20350</b>	<b>1 RB</b>
----------------	--------------	-------------	----------------	--------------	-------------

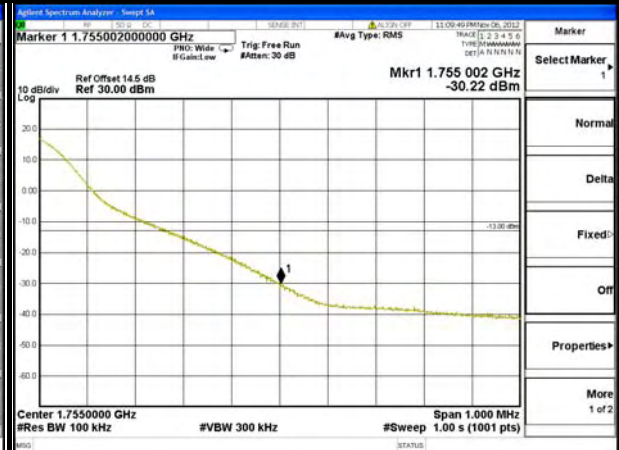

<b>CHANNEL</b>	<b>20000</b>	<b>50 RB</b>	<b>CHANNEL</b>	<b>20350</b>	<b>50 RB</b>
----------------	--------------	--------------	----------------	--------------	--------------

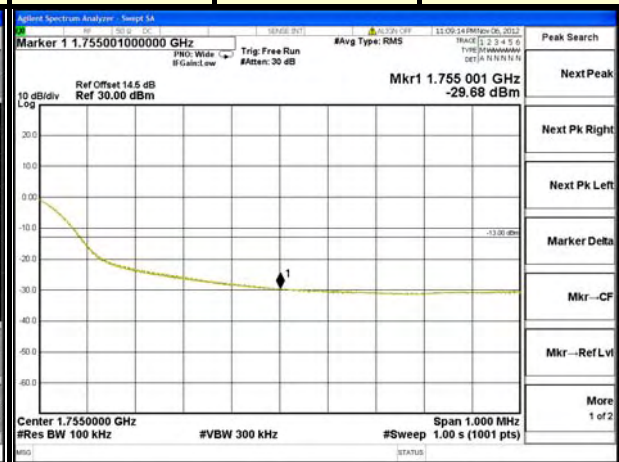
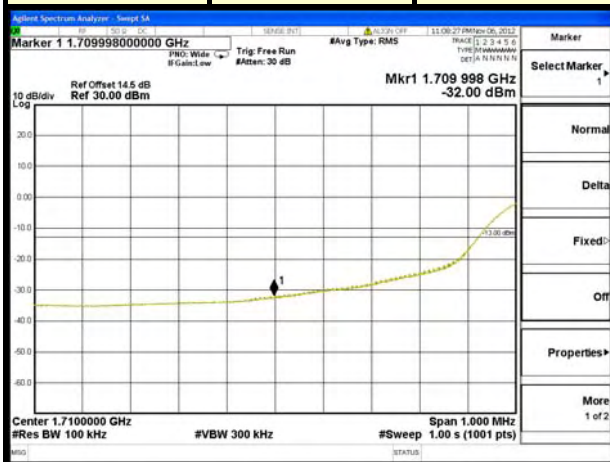



A D T

### LTE Band 4

### Channel Bandwidth 15MHz

<b>CHANNEL</b>	<b>20025</b>	<b>1 RB</b>	<b>CHANNEL</b>	<b>20325</b>	<b>1 RB</b>
----------------	--------------	-------------	----------------	--------------	-------------

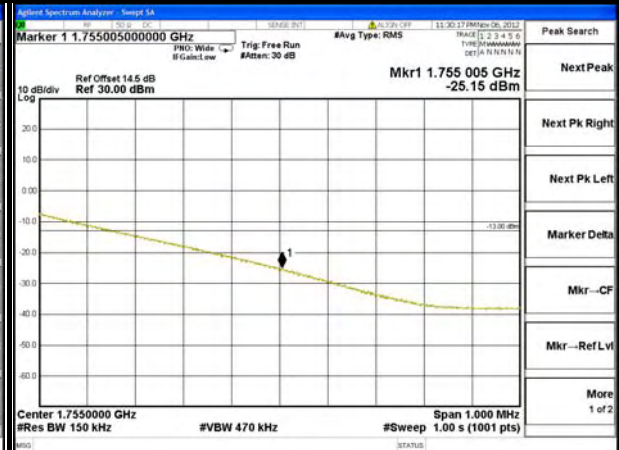
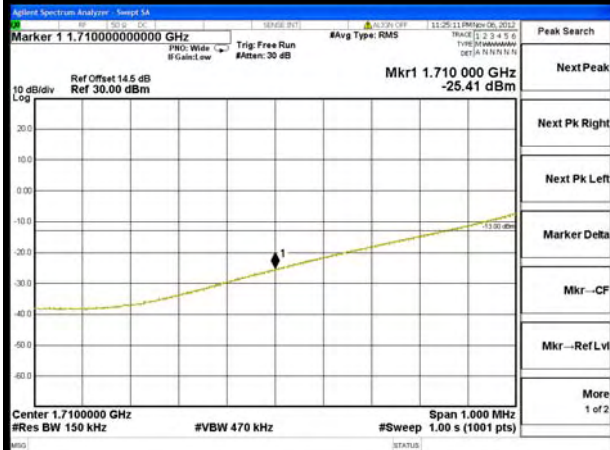

<b>CHANNEL</b>	<b>20025</b>	<b>75 RB</b>	<b>CHANNEL</b>	<b>20325</b>	<b>75 RB</b>
----------------	--------------	--------------	----------------	--------------	--------------

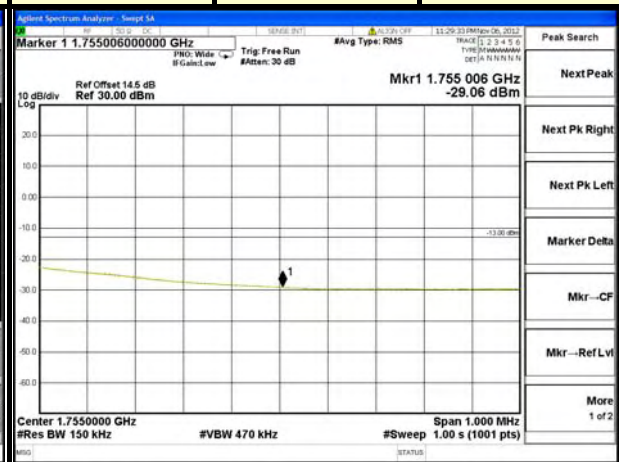
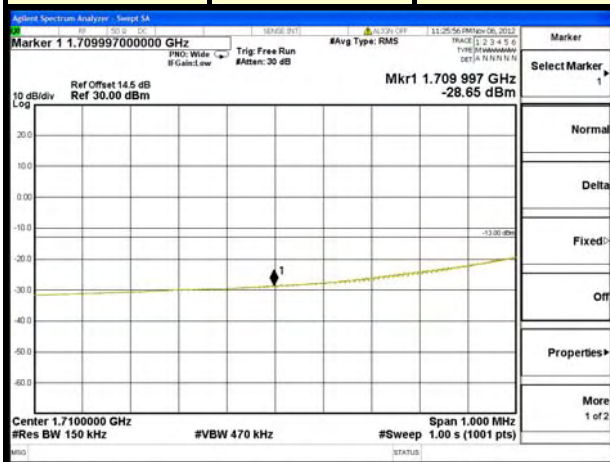



A D T

### LTE Band 4

### Channel Bandwidth 20MHz

<b>CHANNEL</b>	<b>20050</b>	<b>1 RB</b>	<b>CHANNEL</b>	<b>20300</b>	<b>1 RB</b>
----------------	--------------	-------------	----------------	--------------	-------------

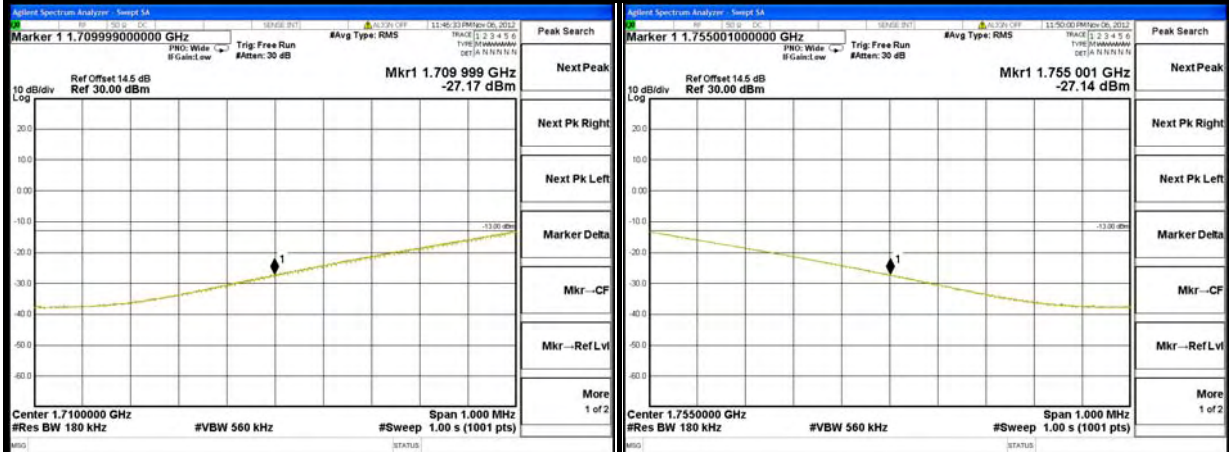

<b>CHANNEL</b>	<b>20050</b>	<b>100 RB</b>	<b>CHANNEL</b>	<b>20300</b>	<b>100 RB</b>
----------------	--------------	---------------	----------------	--------------	---------------

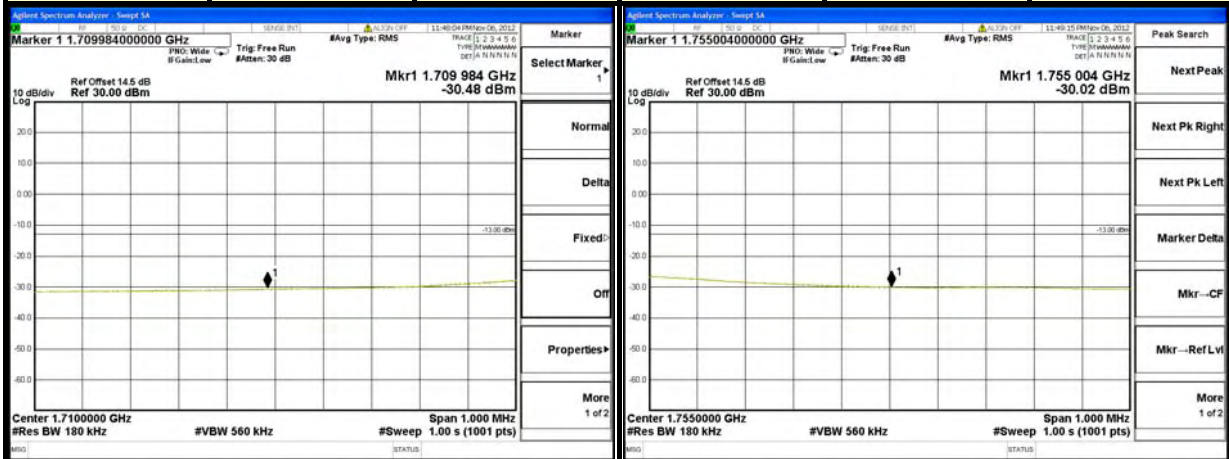

## 4.6 CONDUCTED SPURIOUS EMISSIONS

### 4.6.1 LIMITS OF CONDUCTED SPURIOUS EMISSIONS MEASUREMENT

The power of any emission outside a licensee's frequency block shall be attenuated below the transmitter power (P) by at least  $43 + 10 \log_{10}(P)$  dB. The limit of emission equal to  $-13\text{dBm}$

### 4.6.2 TEST PROCEDURE

- a. The EUT makes a phone call to the communication simulator. All measurements were done at low, middle and high operational frequency range.
- b. Measuring frequency range is from 30MHz to 18GHz (LTE Band 4), from 9kHz to 20GHz (EVDO) and from 30MHz to 8GHz (LTE Band 12/17). 20dB attenuation pad is connected with spectrum. RBW=1MHz and VBW=3MHz are used for conducted emission measurement.

### 4.6.3 TEST SETUP

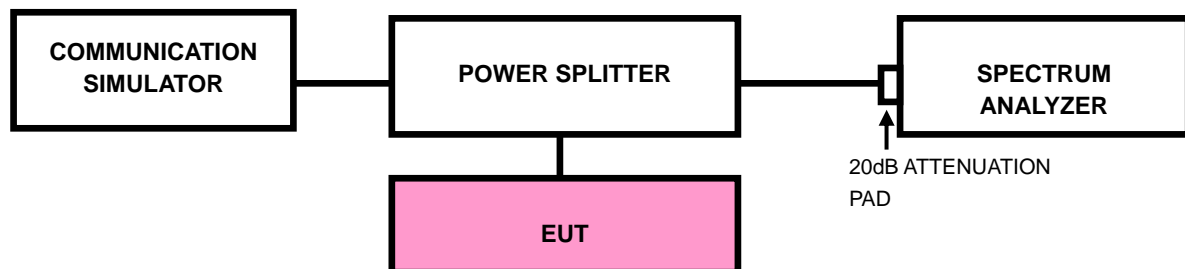





A D T

## 4.6.4 TEST RESULTS





A D T

LTE Band 12 (Channel Bandwidth 5MHz)

CHANNEL 23095

FREQUENCY RANGE : 30MHz~8GHz

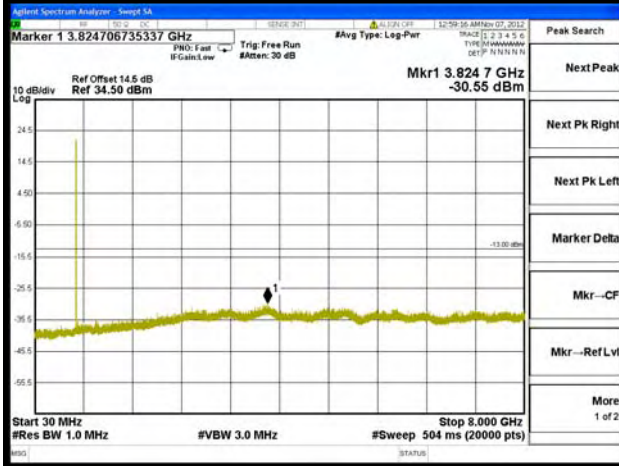

LTE Band 12 (Channel Bandwidth 10MHz)

CHANNEL 23095

FREQUENCY RANGE : 30MHz~8GHz

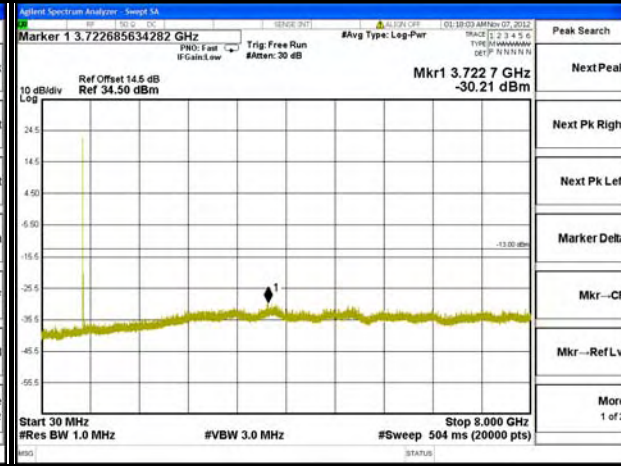

LTE Band 17 (Channel Bandwidth 5MHz)

CHANNEL 23790

FREQUENCY RANGE : 30MHz~8GHz

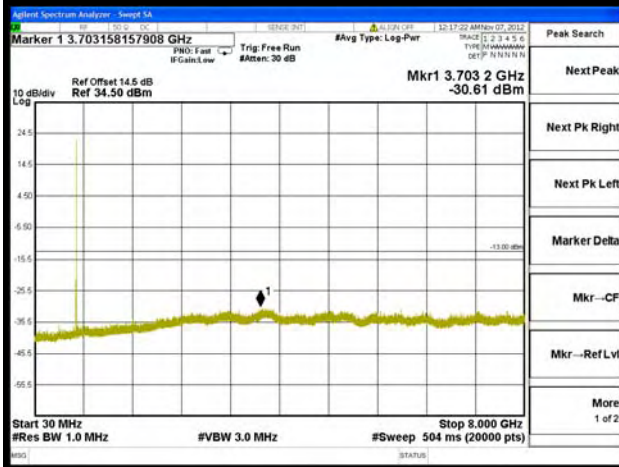

LTE Band 17 (Channel Bandwidth 10MHz)

CHANNEL 23790

FREQUENCY RANGE : 30MHz~8GHz

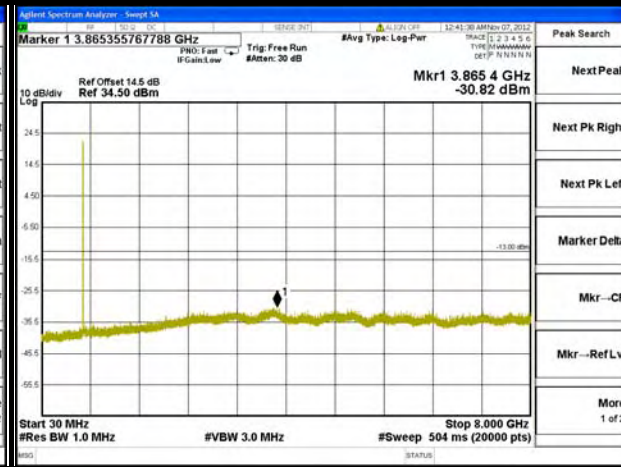



A D T

**LTE Band 4 (Channel Bandwidth 5MHz)**

**CHANNEL 20175**

**FREQUENCY RANGE : 30MHz~18GHz**

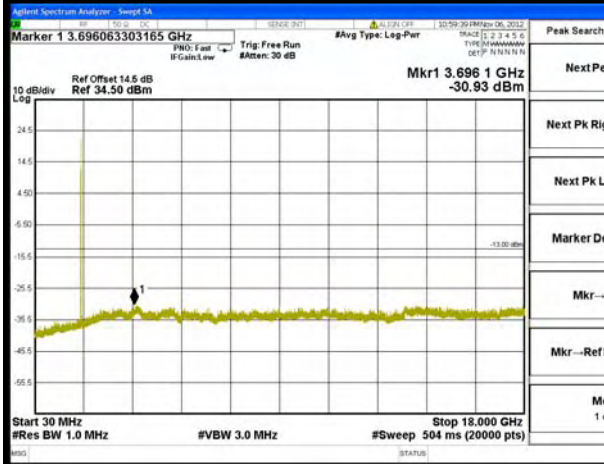

**LTE Band 4 (Channel Bandwidth 10MHz)**

**CHANNEL 20175**

**FREQUENCY RANGE : 30MHz~18GHz**

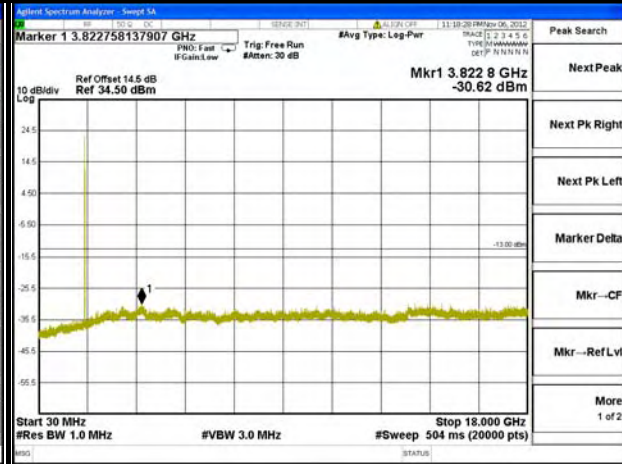

**LTE Band 4 (Channel Bandwidth 15MHz)**

**CHANNEL 20175**

**FREQUENCY RANGE : 30MHz~18GHz**

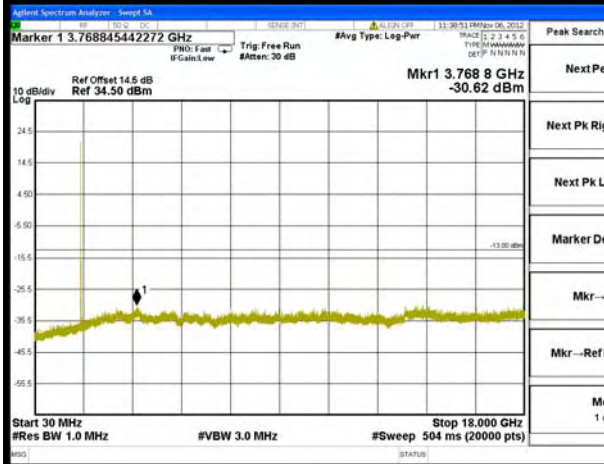

**LTE Band 4 (Channel Bandwidth 20MHz)**

**CHANNEL 20175**

**FREQUENCY RANGE : 30MHz~18GHz**

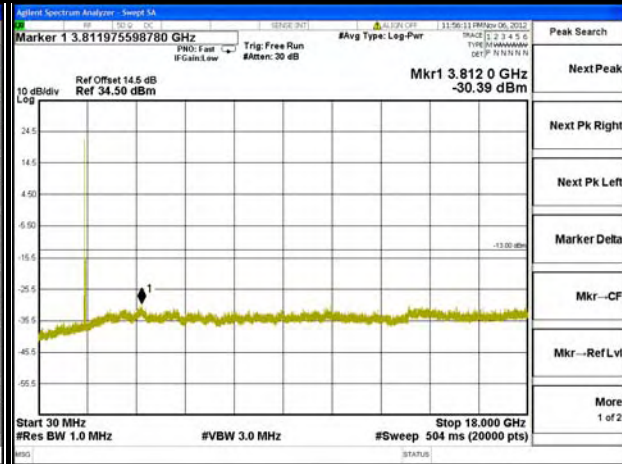

## 4.7 RADIATED EMISSION MEASUREMENT

### 4.7.1 LIMITS OF RADIATED EMISSION MEASUREMENT

The power of any emission outside a licensee's frequency block shall be attenuated below the transmitter power (P) by at least  $43 + 10 \log_{10}(P)$  dB. The limit of emission equal to  $-13\text{dBm}$

### 4.7.2 TEST PROCEDURES

- a. Substitution method is used for E.I.R.P measurement. In the semi-anechoic chamber, EUT placed on the 0.8m height of Turn Table, rotated the table around 360 degrees to search the maximum radiation power and receiver antenna shall be rotated vertical and horizontal polarization and moved height from 1m to 4m to find the maximum polar radiated power. The "Read Value" is the spectrum reading the maximum power value.
- b. The substitution horn antenna is substituted for EUT at the same position and signals generator export the CW signal to the substitution antenna via a TX cable. Rotated the Turn Table and moved receiving antenna to find the maximum radiation power. Adjust output power level of S.G to get a Value of spectrum reading equal to "Read Value" of step a. Record the power level of S.G
- c.  $\text{EIRP} = \text{Output power level of S.G} - \text{TX cable loss} + \text{Antenna gain of substitution horn.}$
- d. E.R.P power can be calculated form E.I.R.P power by subtracting the gain of dipole,  $\text{E.R.P power} = \text{E.I.P.R power} - 2.15\text{dBi.}$

**NOTE:** The resolution bandwidth and video bandwidth of test receiver/spectrum analyzer is 1MHz/3MHz.

### 4.7.3 DEVIATION FROM TEST STANDARD

No deviation

#### 4.7.4 TEST SETUP

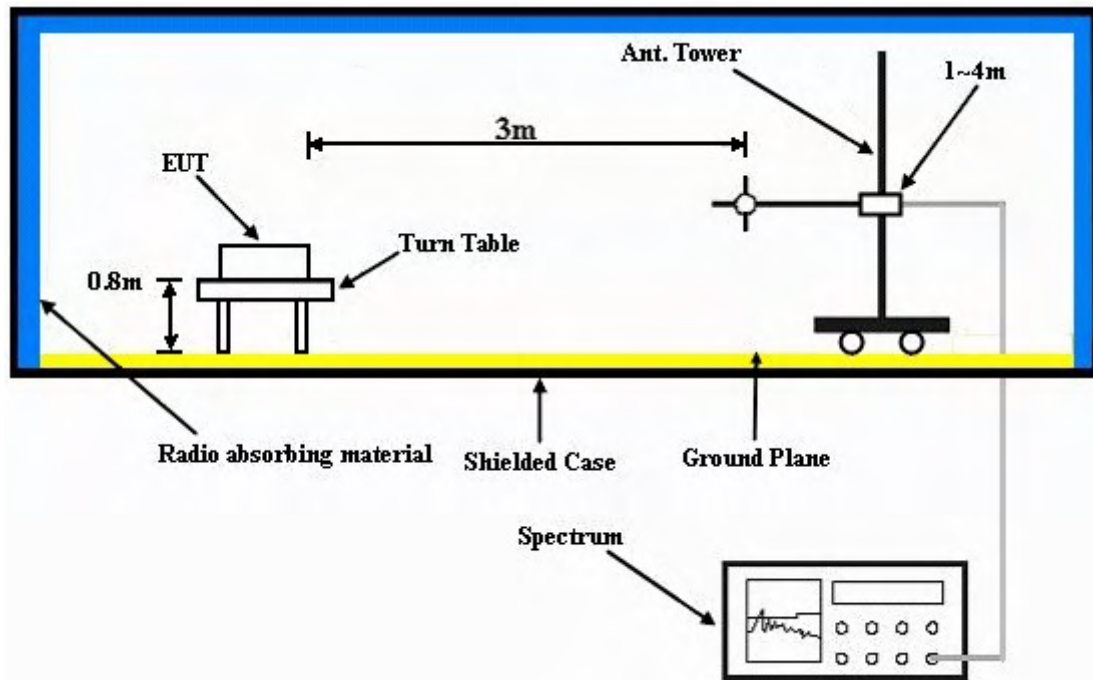

For the actual test configuration, please refer to the attached file (Test Setup Photo).

## 4.7.5 TEST RESULTS

### EVDO

<b>MODE</b>	TX channel 425	<b>FREQUENCY RANGE</b>	Below 1000MHz
<b>ENVIRONMENTAL CONDITIONS</b>	25deg. C, 65%RH	<b>INPUT POWER</b>	120Vac, 60Hz
<b>TESTED BY</b>	Chris Lin		

ANTENNA POLARITY & TEST DISTANCE: HORIZONTAL AT 3 M							
No.	Freq. (MHz)	Reading (dBm)	S.G Power Value (dBm)	Correction Factor (dB)	ERP (dBm)	Limit (dBm)	Margin (dB)
1	107.60	-47.42	-53.66	0.57	-53.09	-13.00	-40.09
2	216.24	-47.77	-59.44	5.45	-53.99	-13.00	-40.99
3	338.46	-50.96	-58.64	5.19	-53.45	-13.00	-40.45
4	474.26	-66.83	-71.36	4.98	-66.38	-13.00	-53.38
5	755.56	-68.62	-67.16	4.57	-62.59	-13.00	-49.59
6	945.68	-68.43	-63.30	3.91	-59.39	-13.00	-46.39
ANTENNA POLARITY & TEST DISTANCE: VERTICAL AT 3 M							
No.	Freq. (MHz)	Reading (dBm)	S.G Power Value (dBm)	Correction Factor (dB)	ERP (dBm)	Limit (dBm)	Margin (dB)
1	55.22	-44.32	-41.22	-8.63	-49.85	-13.00	-36.85
2	78.50	-47.52	-50.11	-2.15	-52.26	-13.00	-39.26
3	210.42	-51.76	-59.71	5.46	-54.25	-13.00	-41.25
4	336.52	-58.23	-63.47	5.19	-58.28	-13.00	-45.28
5	718.70	-67.77	-64.54	5.02	-59.52	-13.00	-46.52
6	920.46	-68.69	-60.99	3.91	-57.08	-13.00	-44.08

### REMARKS:

1.  $ERP(dBm) = S.G \text{ Power Value (dBm)} + \text{Correction Factor (dB)}$ .
2. Correction Factor = gain of substitution antenna + cable loss



A D T

<b>MODE</b>	TX channel 425	<b>FREQUENCY RANGE</b>	Above 1000MHz
<b>ENVIRONMENTAL CONDITIONS</b>	25deg. C, 65%RH	<b>INPUT POWER</b>	120Vac, 60Hz
<b>TESTED BY</b>	Chris Lin		

<b>ANTENNA POLARITY &amp; TEST DISTANCE: HORIZONTAL AT 3 M</b>							
No.	Freq. (MHz)	Reading (dBm)	S.G Power Value (dBm)	Correction Factor (dB)	ERP (dBm)	Limit (dBm)	Margin (dB)
1	3462.50	-48.59	-43.02	7.15	-35.87	-13.00	-22.87
2	5193.75	-58.75	-47.42	6.67	-40.75	-13.00	-27.75
3	6925.00	-63.98	-47.45	4.82	-42.63	-13.00	-29.63
<b>ANTENNA POLARITY &amp; TEST DISTANCE: VERTICAL AT 3 M</b>							
No.	Freq. (MHz)	Reading (dBm)	S.G Power Value (dBm)	Correction Factor (dB)	ERP (dBm)	Limit (dBm)	Margin (dB)
1	3462.50	-48.95	-43.68	7.15	-36.53	-13.00	-23.53
2	5193.75	-54.98	-44.38	6.67	-37.71	-13.00	-24.71
3	6925.00	-60.32	-44.74	4.82	-39.92	-13.00	-26.92

**REMARKS:**

1.  $ERP(dBm) = S.G\ Power\ Value\ (dBm) + Correction\ Factor\ (dB)$ .
2. Correction Factor = gain of substitution antenna + cable loss



LTE Band 12 (Channel Bandwidth 5MHz)



Bureau Veritas Consumer Products Services Ltd., Taoyuan Branch

A D T

Data: 9

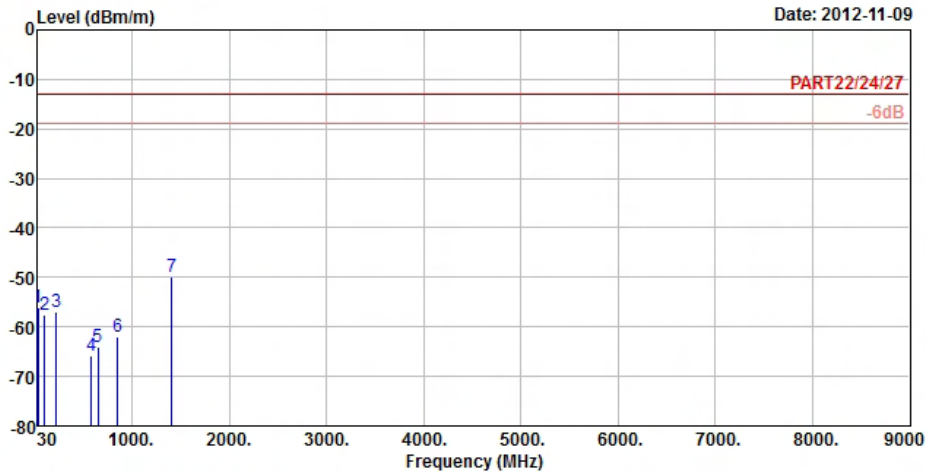

Site : 966 Chamber 5  
 Condition : PART22/24/27 3m EIRP\_RSE\_1G~19G\_3 HORIZONTAL  
 Brand/Model: P530A  
 Remark : Band 12\_5M\_(QPSK 1,0) Link  
 Tested by : Kay Wu  
 Temperature : 25°C  
 Humidity : 65%  
 Plane : X

	Read	Limit	Over			
Freq	Level	Level	Line	Limit	Factor	Remark
MHz	dBm/m	dBm	dBm/m	dB	dB/m	
1	32.70	-56.17	-55.06	-13.00	-43.17	-1.11 Peak
2	99.93	-57.48	-47.08	-13.00	-44.48	-10.40 Peak
3	222.78	-57.09	-50.19	-13.00	-44.09	-6.90 Peak
4	583.50	-65.70	-64.90	-13.00	-52.70	-0.80 Peak
5	647.90	-63.95	-64.46	-13.00	-50.95	0.51 Peak
6	848.10	-61.95	-64.35	-13.00	-48.95	2.40 Peak
7 pp	1410.60	-50.00	-37.49	-13.00	-37.00	-12.51 Peak





A D T



Bureau Veritas Consumer Products Services Ltd., Taoyuan Branch

A D T

Data: 10

Date: 2012-11-09

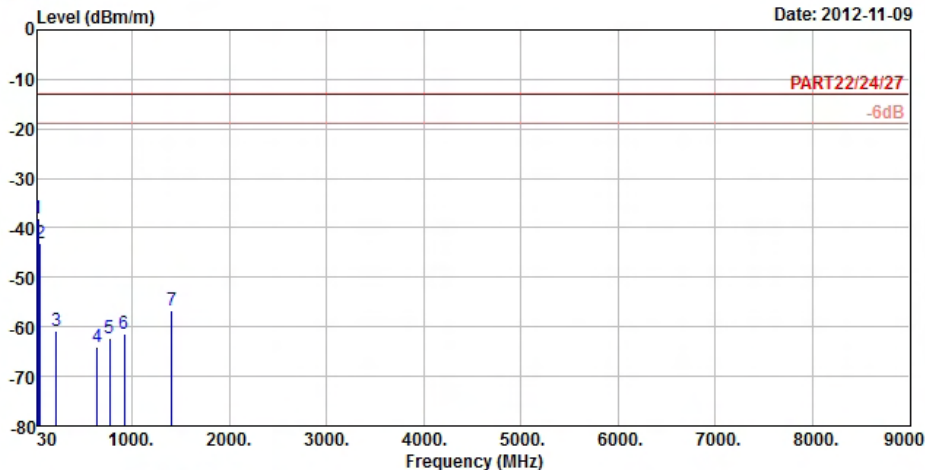

Site : 966 Chamber 5  
 Condition : PART22/24/27 3m EIRP\_RSE\_1G~19G\_3 VERTICAL  
 Brand/Model: P530A  
 Remark : Band 12\_5M\_(QPSK 1,0) Link  
 Tested by : Kay Wu  
 Temperature : 25°C  
 Humidity : 65%  
 Plane : X

	Freq	Level	Read	Limit	Over	
	MHz	dBm/m	Level	Line	Limit	Factor Remark
			dBm	dBm/m	dB	dB/m
1 pp	32.43	-38.07	-36.96	-13.00	-25.07	-1.11 Peak
2	56.46	-42.96	-37.46	-13.00	-29.96	-5.50 Peak
3	221.43	-60.79	-53.80	-13.00	-47.79	-6.99 Peak
4	640.20	-64.05	-64.42	-13.00	-51.05	0.37 Peak
5	771.80	-62.40	-64.34	-13.00	-49.40	1.94 Peak
6	916.00	-61.52	-64.53	-13.00	-48.52	3.01 Peak
7	1410.60	-56.54	-44.03	-13.00	-43.54	-12.51 Peak



A D T



Bureau Veritas Consumer Products Services Ltd., Taoyuan Branch

A D T

Data: 9

Date: 2012-11-09

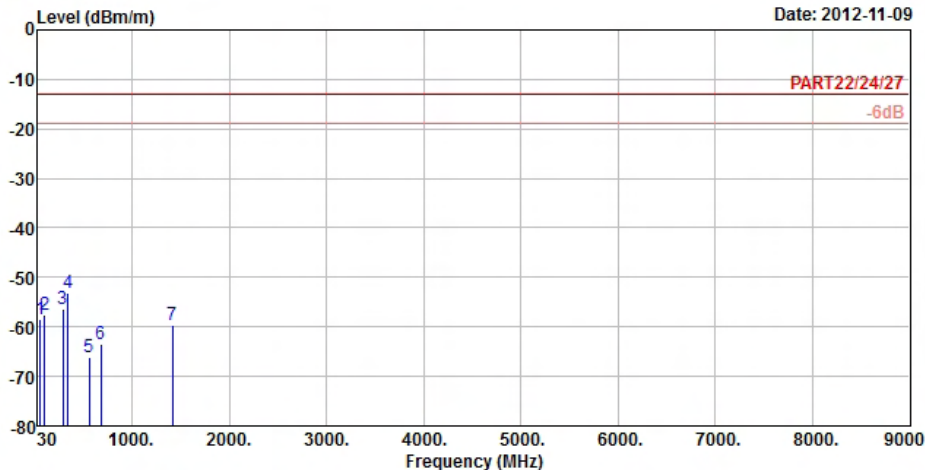

Site : 966 Chamber 5  
 Condition : PART22/24/27 3m EIRP\_RSE\_1G~19G\_3 HORIZONTAL  
 Brand/Model: P530A  
 Remark : Band 12\_5M\_(QPSK 25,0) Link  
 Tested by : Kay Wu  
 Temperature : 25°C  
 Humidity : 65%  
 Plane : X

	Freq	Level	Read	Limit	Over		
	MHz	dBm/m	Level	Line	Limit	Factor	Remark
			dBm	dBm/m	dB	dB/m	
1	55.38	-58.41	-53.06	-13.00	-45.41	-5.35	Peak
2	100.74	-57.64	-47.22	-13.00	-44.64	-10.42	Peak
3	287.85	-56.34	-50.12	-13.00	-43.34	-6.22	Peak
4 pp	342.70	-53.07	-47.01	-13.00	-40.07	-6.06	Peak
5	557.60	-66.22	-64.70	-13.00	-53.22	-1.52	Peak
6	681.50	-63.37	-64.49	-13.00	-50.37	1.12	Peak
7	1415.00	-59.57	-47.06	-13.00	-46.57	-12.51	Peak



A D T



Bureau Veritas Consumer Products Services Ltd., Taoyuan Branch

A D T

Data: 10

Date: 2012-11-09

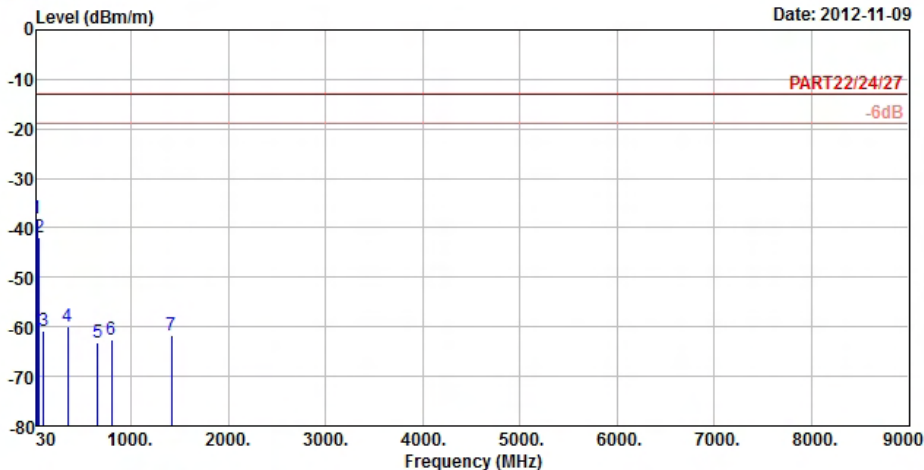

Site : 966 Chamber 5  
 Condition : PART22/24/27 3m EIRP\_RSE\_1G~19G\_3 VERTICAL  
 Brand/Model: P530A  
 Remark : Band 12\_5M\_(QPSK 25,0) Link  
 Tested by : Kay Wu  
 Temperature : 25°C  
 Humidity : 65%  
 Plane : X

	Freq	Level	Read	Limit	Over	
	MHz	dBm/m	Level	Line	Limit	Factor Remark
			dBm	dBm/m	dB	dB/m
1	pp	30.00	-38.16	-39.23	-13.00	-25.16 1.07 Peak
2		55.38	-41.95	-36.60	-13.00	-28.95 -5.35 Peak
3		101.01	-60.77	-50.35	-13.00	-47.77 -10.42 Peak
4		344.80	-60.07	-54.03	-13.00	-47.07 -6.04 Peak
5		659.10	-63.31	-64.03	-13.00	-50.31 0.72 Peak
6		799.10	-62.51	-64.63	-13.00	-49.51 2.12 Peak
7		1415.00	-61.72	-49.21	-13.00	-48.72 -12.51 Peak

LTE Band 12 (Channel Bandwidth 10MHz)



Bureau Veritas Consumer Products Services Ltd., Taoyuan Branch

A D T

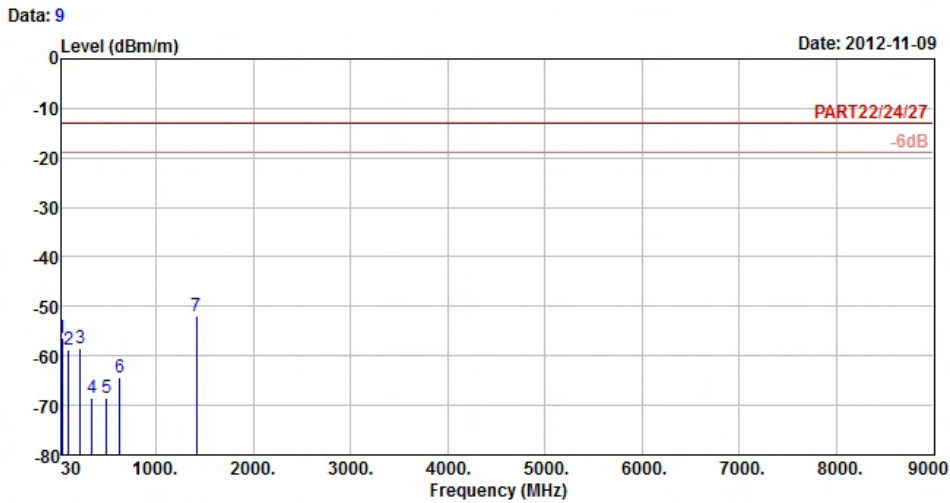

Site : 966 Chamber 5  
 Condition : PART22/24/27 3m EIRP\_RSE\_1G~19G\_3 HORIZONTAL  
 Brand/Model: P530A  
 Remark : Band 12\_10M\_(QPSK 1,24) Link  
 Tested by : Kay Wu  
 Temperature : 25°C  
 Humidity : 65%  
 Plane : X

	Freq	Level	Read Level	Limit	Over Limit	Factor	Remark
	MHz	dBm/m	dBm	dBm/m	dB	dB/m	
1	32.70	-56.51	-55.40	-13.00	-43.51	-1.11	Peak
2	99.12	-58.81	-48.39	-13.00	-45.81	-10.42	Peak
3	220.62	-58.37	-51.38	-13.00	-45.37	-6.99	Peak
4	341.30	-68.39	-62.32	-13.00	-55.39	-6.07	Peak
5	492.50	-68.35	-65.06	-13.00	-55.35	-3.29	Peak
6	627.60	-64.49	-64.63	-13.00	-51.49	0.14	Peak
7 pp	1415.00	-52.10	-39.59	-13.00	-39.10	-12.51	Peak



A D T



Bureau Veritas Consumer Products Services Ltd., Taoyuan Branch

A D T

Data: 10

Date: 2012-11-09

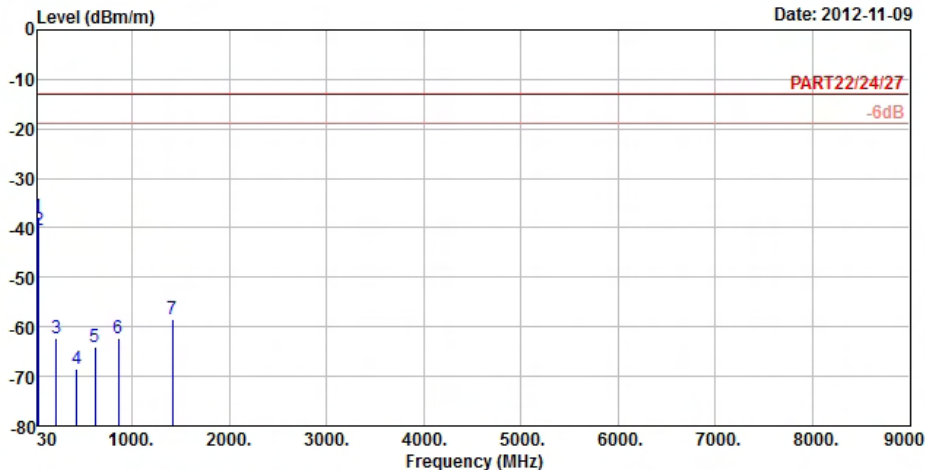

Site : 966 Chamber 5  
 Condition : PART22/24/27 3m EIRP\_RSE\_1G~19G\_3 VERTICAL  
 Brand/Model: P530A  
 Remark : Band 12\_10M\_(QPSK 1,24) Link  
 Tested by : Kay Wu  
 Temperature : 25°C  
 Humidity : 65%  
 Plane : X

	Freq	Level	Read	Limit	Over		
	MHz	dBm/m	Level	Line	Limit	Factor	Remark
			dBm	dBm/m	dB	dB/m	
1	pp	32.16	-37.85	-37.46	-13.00	-24.85	-0.39 Peak
2		39.72	-40.35	-38.82	-13.00	-27.35	-1.53 Peak
3		221.43	-62.39	-55.40	-13.00	-49.39	-6.99 Peak
4		432.30	-68.60	-63.79	-13.00	-55.60	-4.81 Peak
5		615.00	-63.97	-63.88	-13.00	-50.97	-0.09 Peak
6		856.50	-62.43	-64.88	-13.00	-49.43	2.45 Peak
7		1415.00	-58.52	-46.01	-13.00	-45.52	-12.51 Peak



A D T



Bureau Veritas Consumer Products Services Ltd., Taoyuan Branch

A D T

Data: 9

Date: 2012-11-09

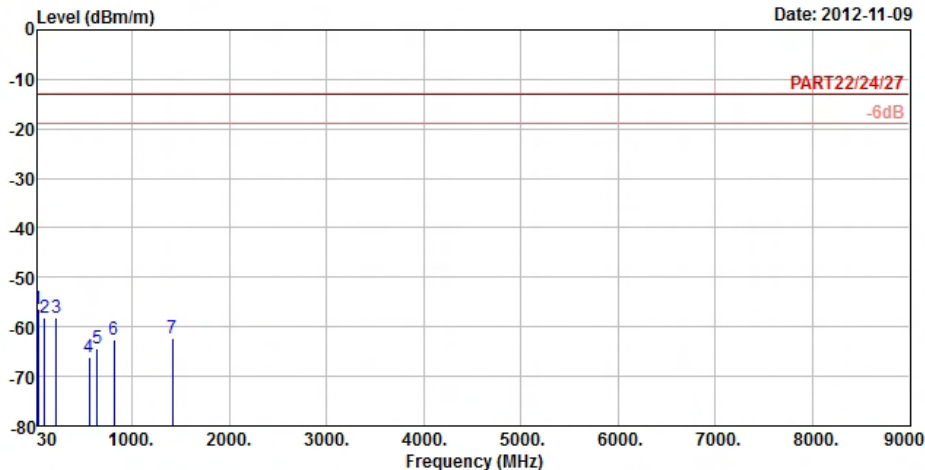

Site : 966 Chamber 5  
 Condition : PART22/24/27 3m EIRP\_RSE\_1G~19G\_3 HORIZONTAL  
 Brand/Model: P530A  
 Remark : Band 12\_10M\_(QPSK 50,0) Link  
 Tested by : Kay Wu  
 Temperature : 25°C  
 Humidity : 65%  
 Plane : X

	Freq	Level	Read	Limit	Over	
	MHz	dBm/m	Level	Line	Limit	Factor Remark
			dBm	dBm/m	dB	dB/m
1	pp	32.16	-56.44	-56.05	-13.00	-43.44 -0.39 Peak
2		101.82	-58.06	-47.62	-13.00	-45.06 -10.44 Peak
3		220.89	-58.07	-51.08	-13.00	-45.07 -6.99 Peak
4		559.00	-66.21	-64.72	-13.00	-53.21 -1.49 Peak
5		643.00	-64.21	-64.63	-13.00	-51.21 0.42 Peak
6		815.90	-62.47	-64.69	-13.00	-49.47 2.22 Peak
7		1415.00	-62.34	-49.83	-13.00	-49.34 -12.51 Peak



A D T



Bureau Veritas Consumer Products Services Ltd., Taoyuan Branch

A D T

Data: 10

Date: 2012-11-09

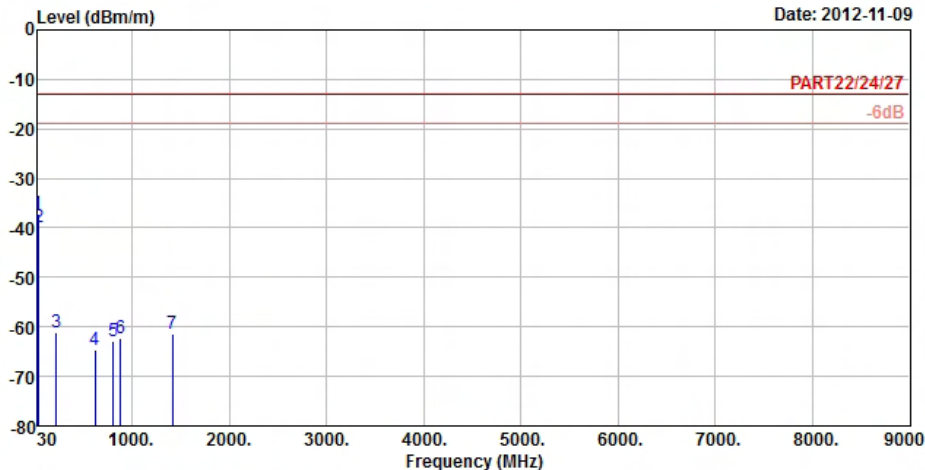

Site : 966 Chamber 5  
 Condition : PART22/24/27 3m EIRP\_RSE\_1G~19G\_3 VERTICAL  
 Brand/Model: P530A  
 Remark : Band 12\_10M\_(QPSK 50,0) Link  
 Tested by : Kay Wu  
 Temperature : 25°C  
 Humidity : 65%  
 Plane : X

	Freq	Level	Read	Limit	Over	
	MHz	dBm/m	Level	Line	Limit	Factor Remark
			dBm	dBm/m	dB	dB/m
1	pp	32.43	-37.07	-35.96	-13.00	-24.07 -1.11 Peak
2		39.18	-39.87	-38.13	-13.00	-26.87 -1.74 Peak
3		221.16	-61.11	-54.12	-13.00	-48.11 -6.99 Peak
4		617.80	-64.60	-64.56	-13.00	-51.60 -0.04 Peak
5		809.60	-62.89	-65.08	-13.00	-49.89 2.19 Peak
6		881.00	-62.27	-64.86	-13.00	-49.27 2.59 Peak
7		1415.00	-61.42	-48.91	-13.00	-48.42 -12.51 Peak





A D T

### LTE Band 17 (Channel Bandwidth 5MHz)



Bureau Veritas Consumer Products Services Ltd., Taoyuan Branch

A D T

Data: 9

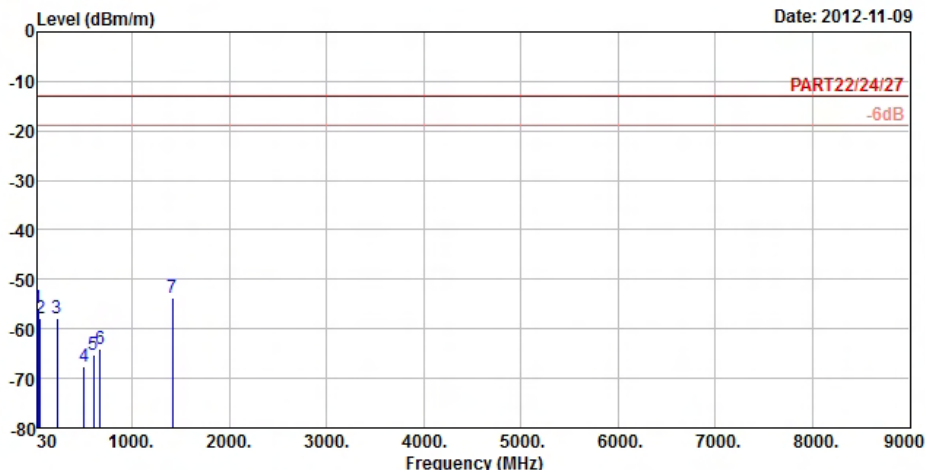

Site : 966 Chamber 5  
 Condition : PART22/24/27 3m EIRP\_RSE\_1G~19G\_3 HORIZONTAL  
 Brand/Model: P530A  
 Remark : Band 17\_5M\_(QPSK 1,0) Link  
 Tested by : Kay Wu  
 Temperature : 25°C  
 Humidity : 65%  
 Plane : X

	Freq	Level	Read Level	Limit Line	Over Limit	Factor	Remark
	MHz	dBm/m	dBm	dBm/m	dB	dB/m	
1	32.43	-55.83	-54.72	-13.00	-42.83	-1.11	Peak
2	56.73	-57.89	-52.24	-13.00	-44.89	-5.65	Peak
3	224.13	-57.96	-51.10	-13.00	-44.96	-6.86	Peak
4	508.60	-67.59	-64.71	-13.00	-54.59	-2.88	Peak
5	601.70	-65.27	-64.94	-13.00	-52.27	-0.33	Peak
6	672.40	-64.04	-64.98	-13.00	-51.04	0.94	Peak
7 pp	1415.60	-53.68	-41.17	-13.00	-40.68	-12.51	Peak





A D T



Bureau Veritas Consumer Products Services Ltd., Taoyuan Branch

A D T

Data: 10

Date: 2012-11-09

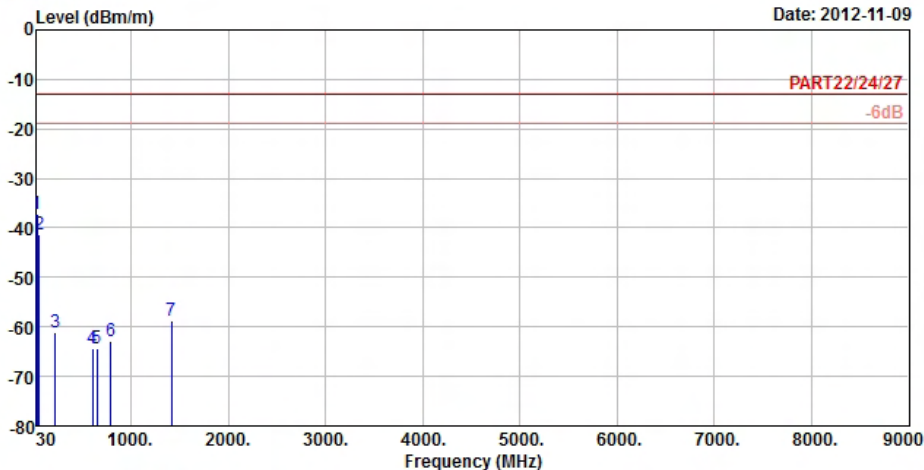

Site : 966 Chamber 5  
 Condition : PART22/24/27 3m EIRP\_RSE\_1G~19G\_3 VERTICAL  
 Brand/Model: P530A  
 Remark : Band 17\_5M\_(QPSK 1,0) Link  
 Tested by : Kay Wu  
 Temperature : 25°C  
 Humidity : 65%  
 Plane : X

	Freq	Level	Read	Limit	Over		
	MHz	dBm/m	Level	Line	Limit	Factor	Remark
			dBm	dBm/m	dB	dB/m	
1	pp	32.70	-37.33	-36.22	-13.00	-24.33	-1.11 Peak
2		55.92	-41.34	-35.84	-13.00	-28.34	-5.50 Peak
3		221.43	-61.18	-54.19	-13.00	-48.18	-6.99 Peak
4		604.50	-64.35	-64.07	-13.00	-51.35	-0.28 Peak
5		648.60	-64.29	-64.81	-13.00	-51.29	0.52 Peak
6		789.30	-62.90	-64.96	-13.00	-49.90	2.06 Peak
7		1415.60	-58.72	-46.21	-13.00	-45.72	-12.51 Peak



A D T



Bureau Veritas Consumer Products Services Ltd., Taoyuan Branch

A D T

Data: 9

Date: 2012-11-09

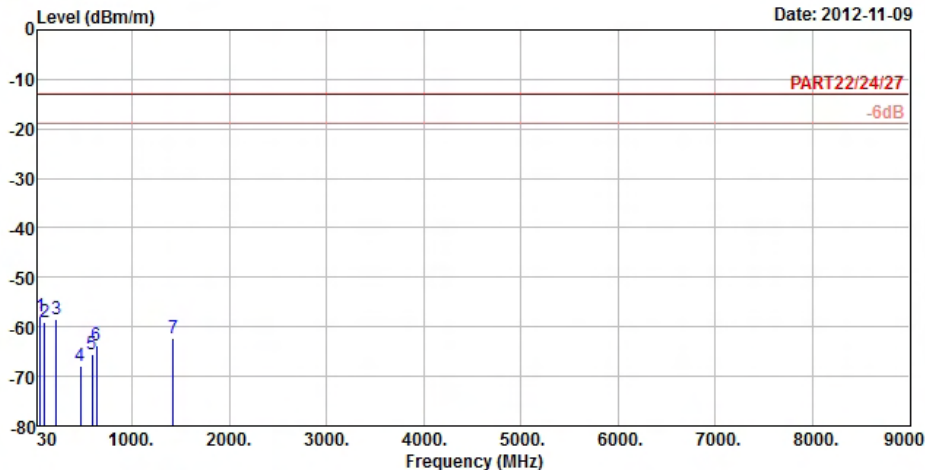

Site : 966 Chamber 5  
 Condition : PART22/24/27 3m EIRP\_RSE\_1G~19G\_3 HORIZONTAL  
 Brand/Model: P530A  
 Remark : Band 17\_5M\_(QPSK 25,0) Link  
 Tested by : Kay Wu  
 Temperature : 25°C  
 Humidity : 65%  
 Plane : X

	Freq	Level	Read	Limit	Over	
	MHz	dBm/m	Level	Line	Limit	Factor Remark
			dBm	dBm/m	dB	dB/m
1	pp	56.46	-57.77	-52.27	-13.00	-44.77 -5.50 Peak
2		101.82	-59.08	-48.64	-13.00	-46.08 -10.44 Peak
3		223.32	-58.38	-51.48	-13.00	-45.38 -6.90 Peak
4		466.60	-68.02	-64.07	-13.00	-55.02 -3.95 Peak
5		589.80	-65.51	-64.87	-13.00	-52.51 -0.64 Peak
6		635.30	-63.85	-64.13	-13.00	-50.85 0.28 Peak
7		1420.00	-62.38	-49.87	-13.00	-49.38 -12.51 Peak



A D T



Bureau Veritas Consumer Products Services Ltd., Taoyuan Branch

A D T

Data: 10

Date: 2012-11-09

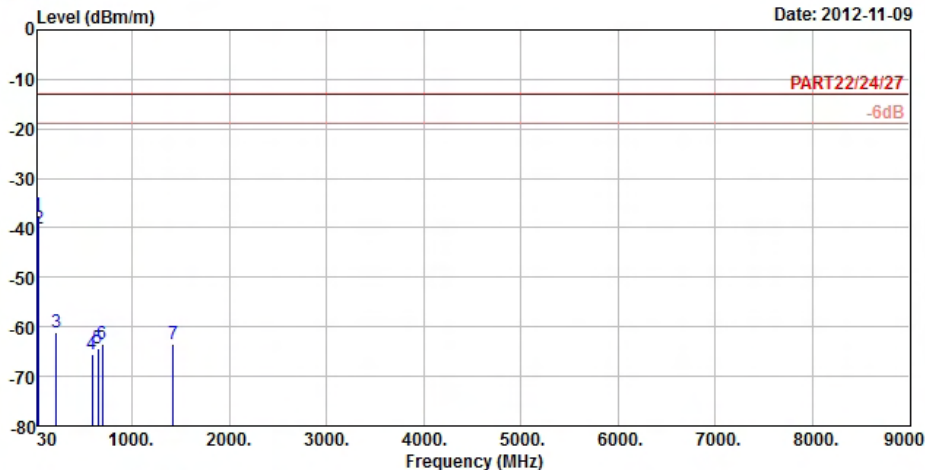

Site : 966 Chamber 5  
 Condition : PART22/24/27 3m EIRP\_RSE\_1G~19G\_3 VERTICAL  
 Brand/Model: P530A  
 Remark : Band 17\_5M\_(QPSK 25,0) Link  
 Tested by : Kay Wu  
 Temperature : 25°C  
 Humidity : 65%  
 Plane : X

	Freq	Level	Read	Limit	Over		
	MHz	dBm/m	Level	Line	Limit	Factor	Remark
			dBm	dBm/m	dB	dB/m	
1 pp	32.43	-37.42	-36.31	-13.00	-24.42	-1.11	Peak
2	39.45	-40.01	-38.48	-13.00	-27.01	-1.53	Peak
3	220.89	-61.21	-54.22	-13.00	-48.21	-6.99	Peak
4	586.30	-65.54	-64.82	-13.00	-52.54	-0.72	Peak
5	650.70	-64.46	-65.02	-13.00	-51.46	0.56	Peak
6	692.00	-63.35	-64.64	-13.00	-50.35	1.29	Peak
7	1420.00	-63.39	-50.88	-13.00	-50.39	-12.51	Peak