



FCC TEST REPORT (PART 24)

REPORT NO.: RF121023C07A-1

MODEL NO.: P530

FCC ID: UZI-30P58

RECEIVED: Oct. 23, 2012

TESTED: Nov. 06 ~ Nov. 08, 2012 (LTE mode)

Jul. 05 ~ Jul. 09, 2013 (EVDO mode)

ISSUED: Jul. 17, 2013

APPLICANT: BandRich Inc.

ADDRESS: 6F., No. 71, Zhouzi St., Neihu Dist., Taipei City
11493, Taiwan (R.O.C.)

ISSUED BY: Bureau Veritas Consumer Products Services
(H.K.) Ltd., Taoyuan Branch

LAB ADDRESS: No. 47, 14th Ling, Chia Pau Vil., Lin Kou Dist., New
Taipei City, Taiwan (R.O.C.)

TEST LOCATION: No. 19, Hwa Ya 2nd Rd, Wen Hwa Tsuen, Kwei
Shan Hsiang, Taoyuan Hsien 333, Taiwan, R.O.C.

This report should not be used by the client to claim
product certification, approval, or endorsement by TAF or
any government agencies.



This report is for your exclusive use. Any copying or replication of this report to or for any other person or entity, or use of our name or trademark, is permitted only with our prior written permission. This report sets forth our findings solely with respect to the test samples identified herein. The results set forth in this report are not indicative or representative of the quality or characteristics of the lot from which a test sample was taken or any similar or identical product unless specifically and expressly noted. Our report includes all of the tests requested by you and the results thereof based upon the information that you provided to us. You have 60 days from date of issuance of this report to notify us of any material error or omission caused by our negligence, provided, however, that such notice shall be in writing and shall specifically address the issue you wish to raise. A failure to raise such issue within the prescribed time shall constitute your unqualified acceptance of the completeness of this report, the tests conducted and the correctness of the report contents. Unless specific mention, the uncertainty of measurement has been explicitly taken into account to declare the compliance or non-compliance to the specification

TABLE OF CONTENTS

RELEASE CONTROL RECORD.....	3
1 CERTIFICATION	4
2 SUMMARY OF TEST RESULTS	5
2.1 MEASUREMENT UNCERTAINTY	5
2.2 TEST SITE AND INSTRUMENTS	6
3 GENERAL INFORMATION.....	8
3.1 GENERAL DESCRIPTION OF EUT.....	8
3.2 CONFIGURATION OF SYSTEM UNDER TEST	11
3.3 DESCRIPTION OF SUPPORT UNITS	11
3.4 TEST ITEM AND TEST CONFIGURATION	13
3.5 EUT OPERATING CONDITIONS.....	17
3.6 GENERAL DESCRIPTION OF APPLIED STANDARDS	17
4 TEST TYPES AND RESULTS.....	18
4.1 OUTPUT POWER MEASUREMENT	18
4.1.1 LIMITS OF OUTPUT POWER MEASUREMENT.....	18
4.1.2 TEST PROCEDURES	18
4.1.3 TEST SETUP	19
4.1.4 TEST RESULTS	20
4.2 FREQUENCY STABILITY MEASUREMENT	34
4.2.1 LIMITS OF FREQUENCY STABILITY MEASUREMENT	34
4.2.2 TEST PROCEDURE	34
4.2.3 TEST SETUP	34
4.2.4 TEST RESULTS	35
4.3 OCCUPIED BANDWIDTH MEASUREMENT.....	36
4.3.1 TEST PROCEDURES.....	36
4.3.2 TEST SETUP	36
4.3.3 TEST RESULTS	37
4.4 BAND EDGE MEASUREMENT	46
4.4.1 LIMITS OF BAND EDGE MEASUREMENT.....	46
4.4.2 TEST SETUP	46
4.4.3 TEST PROCEDURES.....	46
4.4.4 TEST RESULTS	47
4.5 CONDUCTED SPURIOUS EMISSIONS.....	56
4.5.1 LIMITS OF CONDUCTED SPURIOUS EMISSIONS MEASUREMENT	56
4.5.2 TEST PROCEDURE	56
4.5.3 TEST SETUP	56
4.5.4 TEST RESULTS.....	57
4.6 RADIATED EMISSION MEASUREMENT	60
4.6.1 LIMITS OF RADIATED EMISSION MEASUREMENT	60
4.6.2 TEST PROCEDURES.....	60
4.6.3 DEVIATION FROM TEST STANDARD	60
4.6.4 TEST SETUP	61
4.6.5 TEST RESULTS.....	62
5 PHOTOGRAPHS OF THE TEST CONFIGURATION.....	96
6 INFORMATION ON THE TESTING LABORATORIES.....	97
7 APPENDIX A – MODIFICATIONS RECORDERS FOR ENGINEERING CHANGES TO THE EUT BY THE LAB.....	98



RELEASE CONTROL RECORD

ISSUE NO.	REASON FOR CHANGE	DATE ISSUED
RF121023C07A-1	Original release.	Jul. 17, 2013



1 CERTIFICATION

PRODUCT: LTE/EVDO Mobile Router

MODEL: P530

BRAND: BandLuxe

APPLICANT: BandRich Inc.

TESTED: Nov. 06 ~ Nov. 08, 2012 (LTE mode)
Jul. 05 ~ Jul. 09, 2013 (EVDO mode)

TEST SAMPLE: ENGINEERING SAMPLE

STANDARDS: FCC Part 24, Subpart E

The above equipment (model: P530) has been tested by **Bureau Veritas Consumer Products Services (H.K.) Ltd., Taoyuan Branch**, and found compliance with the requirement of the above standards. The test record, data evaluation & Equipment Under Test (EUT) configurations represented herein are true and accurate accounts of the measurements of the sample's EMC characteristics under the conditions specified in this report.

PREPARED BY : Sun Li , **DATE :** Jul. 17, 2013
Suntee Liu / Specialist

APPROVED BY : Anderson Chiu , **DATE :** Jul. 17, 2013
Anderson Chiu / Senior Engineer

2 SUMMARY OF TEST RESULTS

The EUT has been tested according to the following specifications:

APPLIED STANDARD: FCC Part 24 & Part 2			
STANDARD SECTION	TEST TYPE	RESULT	REMARK
2.1046 24.232	Equivalent isotropically radiated power	PASS	Meet the requirement of limit.
2.1055 24.235	Frequency Stability	PASS	Meet the requirement of limit.
2.1049 24.238(b)	Occupied Bandwidth	PASS	Meet the requirement of limit.
24.238(b)	Band Edge Measurements	PASS	Meet the requirement of limit.
2.1051 24.238	Conducted Spurious Emissions	PASS	Meet the requirement of limit.
2.1053 24.238	Radiated Spurious Emissions	PASS	Meet the requirement of limit. Minimum passing margin is -16.43dB at 3755.60MHz.

2.1 MEASUREMENT UNCERTAINTY

Where relevant, the following measurement uncertainty levels have been estimated for tests performed on the EUT as specified in CISPR 16-4-2:

MEASUREMENT	FREQUENCY	UNCERTAINTY
Conducted emissions	150kHz~30MHz	2.44 dB
Radiated emissions	30MHz ~ 200MHz	2.93 dB
	200MHz ~1000MHz	2.95 dB
	1GHz ~ 18GHz	2.26 dB
	18GHz ~ 40GHz	1.94 dB

This uncertainty represents an expanded uncertainty expressed at approximately the 95% confidence level using a coverage factor of k=2.

2.2 TEST SITE AND INSTRUMENTS

LTE

DESCRIPTION & MANUFACTURER	MODEL NO.	SERIAL NO.	DATE OF CALIBRATION	DUE DATE OF CALIBRATION
Test Receiver Agilent	N9038A	MY51210203	Dec. 22, 2011	Dec. 21, 2012
Spectrum Analyzer ROHDE & SCHWARZ	FSU43	101261	Dec. 21, 2011	Dec. 20, 2012
BILOG Antenna SCHWARZBECK	VULB9168	9168-472	Dec. 20, 2011	Dec. 19, 2012
HORN Antenna SCHWARZBECK	BBHA 9120 D	9120D-969	Dec. 20, 2011	Dec. 19, 2012
HORN Antenna SCHWARZBECK	BBHA 9170	9170-480	Dec. 20, 2011	Dec. 19, 2012
Loop Antenna	HFH2-Z2	100070	Jan. 31, 2012	Jan. 30, 2014
Preamplifier EMCI	EMC 012645	980115	Dec. 30, 2011	Dec. 29, 2012
Preamplifier EMCI	EMC 330H	980112	Dec. 30, 2011	Dec. 29, 2012
RF signal cable HUBER+SUHNNER	SUCOFLEX 104	309219/4	Oct. 26, 2012	Oct. 25, 2013
RF signal cable HUBER+SUHNNER	SUCOFLEX 104	250130/4	Jan. 02, 2012	Jan. 01, 2013
RF signal cable Worken	RG-213	NA	Jan. 02, 2012	Jan. 01, 2013
Software	E3 6.120103	NA	NA	NA
Antenna Tower MF	MFA-440H	NA	NA	NA
Turn Table MF	MFT-201SS	NA	NA	NA
Antenna Tower & Turn Table Controller MF	MF-7802	NA	NA	NA
Mini-Circuits Power Splitter	ZN2PD-9G	NA	Mar. 23, 2012	Mar. 22, 2013
JFW 20dB attenuation	50HF-020-SMA	NA	NA	NA
Communications Tester-Wireless	E5515C	MY52102544	Sep. 05, 2012	Sep. 04, 2013
Radio Communication Analyzer	MT8820C	6201127458	May 25, 2012	May 24, 2013

NOTE: 1. The calibration interval of the above test instruments is 12 months and the calibrations are traceable to NML/ROC and NIST/USA.

2. The test was performed in HwaYa Chamber 9.

3. The horn antenna and HP preamplifier (model: 8449B) are used only for the measurement of emission frequency above 1GHz if tested.

4. The FCC Site Registration No. is 460141.

5. The IC Site Registration No. is IC 7450F-4.



A D T

EVDO

DESCRIPTION & MANUFACTURER	MODEL NO.	SERIAL NO.	DATE OF CALIBRATION	DUE DATE OF CALIBRATION
Test Receiver ROHDE & SCHWARZ	ESCI	100424	Aug. 21, 2012	Aug. 20, 2013
Spectrum Analyzer ROHDE & SCHWARZ	FSU 43	100115	Oct. 25, 2012	Oct. 24, 2013
BILOG Antenna SCHWARZBECK	VULB9168	9168-155	Mar. 25, 2013	Mar. 24, 2014
HORN Antenna SCHWARZBECK	BBHA 9120D	9120D-404	Dec. 22, 2012	Dec. 21, 2013
HORN Antenna SCHWARZBECK	BBHA 9170	148	Jul. 11, 2012	Jul. 10, 2013
Loop Antenna	HFH2-Z2	100070	Jan. 31, 2012	Jan. 30, 2014
Preamplifier Agilent	8449B	3008A01961	Oct. 25, 2012	Oct. 24, 2013
Preamplifier Agilent	8447D	2944A10738	Oct. 23, 2012	Oct. 22, 2013
RF signal cable HUBER+SUHNNER	SUCOFLEX 104	309220/4	Aug. 28, 2012	Aug. 27, 2013
RF signal cable HUBER+SUHNNER	SUCOFLEX 104	250724/4	Aug. 28, 2012	Aug. 27, 2013
RF signal cable HUBER+SUHNNER	SUCOFLEX 104	295012/4	Aug. 28, 2012	Aug. 27, 2013
Software BV ADT	ADT_Radiated_ V7.6.15.9.3	NA	NA	NA
Antenna Tower inn-co GmbH	MA 4000	010303	NA	NA
Antenna Tower Controller inn-co GmbH	CO2000	019303	NA	NA
Turn Table BV ADT	TT100.	TT93021704	NA	NA
Turn Table Controller BV ADT	SC100.	SC93021704	NA	NA
Mini-Circuits Power Splitter	ZN2PD-9G	NA	Mar. 22, 2013	Mar. 21, 2014
JFW 20dB attenuation	50HF-020-SMA	NA	NA	NA
Communications Tester-Wireless	E5515C	MY50266653	Oct. 08, 2012	Oct. 09, 2013

- NOTE:**
1. The calibration interval of the above test instruments is 12 months and the calibrations are traceable to NML/ROC and NIST/USA.
 2. The calibration interval of the loop antenna is 24 months and the calibrations are traceable to NML/ROC and NIST/USA.
 3. The test was performed in HwaYa Chamber 4.
 4. The horn antenna and HP preamplifier (model: 8449B) are used only for the measurement of emission frequency above 1GHz if tested.
 5. The FCC Site Registration No. is 460141.
 6. The IC Site Registration No. is IC7450F-4.



3 GENERAL INFORMATION

3.1 GENERAL DESCRIPTION OF EUT

EUT	LTE/EVDO Mobile Router	
MODEL NO.	P530	
POWER SUPPLY	5Vdc (adapter / host equipment) 3.7Vdc (battery)	
HW VERSION	V01	
SW VERSION	QC_2_00012644_2_001_0032	
MODULATION TYPE	EVDO	QPSK, OQPSK, HPSK
	LTE	QPSK, 16QAM
FREQUENCY RANGE	EVDO	1851.25MHz ~ 1908.75MHz
	LTE Band 2 (Channel Bandwidth 5MHz)	1852.5MHz ~ 1907.5MHz
	LTE Band 2 (Channel Bandwidth 10MHz)	1855MHz ~ 1905MHz
	LTE Band 2 (Channel Bandwidth 15MHz)	1857.5MHz ~ 1902.5MHz
	LTE Band 2 (Channel Bandwidth 20MHz)	1860MHz ~ 1900MHz
	LTE Band 25 (Channel Bandwidth 5MHz)	1860MHz ~ 1912.5MHz
	LTE Band 25 (Channel Bandwidth 10MHz)	1855MHz ~ 1910MHz
	LTE Band 25 (Channel Bandwidth 15MHz)	1857.5MHz ~ 1907.5MHz
	LTE Band 25 (Channel Bandwidth 20MHz)	1860MHz ~ 1905MHz



MAX. EIRP POWER	EVDO	466.66mW
	LTE Band 2 (Channel Bandwidth 5MHz)	QPSK: 304.09mW
	LTE Band 2 (Channel Bandwidth 10MHz)	QPSK: 266.69mW
	LTE Band 2 (Channel Bandwidth 15MHz)	QPSK: 310.46mW
	LTE Band 2 (Channel Bandwidth 20MHz)	QPSK: 308.32mW
	LTE Band 25 (Channel Bandwidth 5MHz)	QPSK: 297.17mW
	LTE Band 25 (Channel Bandwidth 10MHz)	QPSK: 289.07mW
	LTE Band 25 (Channel Bandwidth 15MHz)	QPSK: 303.39mW
	LTE Band 25 (Channel Bandwidth 20MHz)	QPSK: 291.07mW
	EMISSION DESIGNATOR	EVDO
LTE Band 2 (Channel Bandwidth 5MHz)		QPSK: 4M49G7D
		16QAM: 4M49W7D
LTE Band 2 (Channel Bandwidth 10MHz)		QPSK: 8M91G7D
		16QAM: 8M92W7D
LTE Band 2 (Channel Bandwidth 15MHz)		QPSK: 13M4G7D
		16QAM: 13M4W7D
LTE Band 2 (Channel Bandwidth 20MHz)		QPSK: 17M8G7D
		16QAM: 17M9W7D
LTE Band 25 (Channel Bandwidth 5MHz)		QPSK: 4M49G7D
		16QAM: 4M49W7D
LTE Band 25 (Channel Bandwidth 10MHz)		QPSK: 8M92G7D
		16QAM: 8M92W7D
LTE Band 25 (Channel Bandwidth 15MHz)		QPSK: 13M4G7D
	16QAM: 13M4W7D	
LTE Band 25 (Channel Bandwidth 20MHz)	QPSK: 17M9G7D	
	16QAM: 17M9W7D	



A D T

CATEGORY	LTE: 3
ANTENNA TYPE	Fixed Internal antenna with 3dBi gain
I/O PORTS	Refer to users' manual
DATA CABLE	1m non-shielded USB cable without core
ACCESSORY DEVICES	Adapter, Battery

NOTE:

1. The EUT consumes power from the following battery and adapter.

Battery	
MODEL:	GT-2200
RATING:	3.7Vdc, 8.14WH

ADAPTER	
BRAND:	PHIHONG
MODEL:	PSA05A-050Q
INPUT:	100-240Vac, 0.2A, 50-60Hz
OUTPUT:	5Vdc, 1A

2. The above EUT information was declared by manufacturer and for more detailed features description, please refer to the manufacturer's specifications or User's Manual.

3.2 CONFIGURATION OF SYSTEM UNDER TEST

FOR RADIATION EMISSION TEST

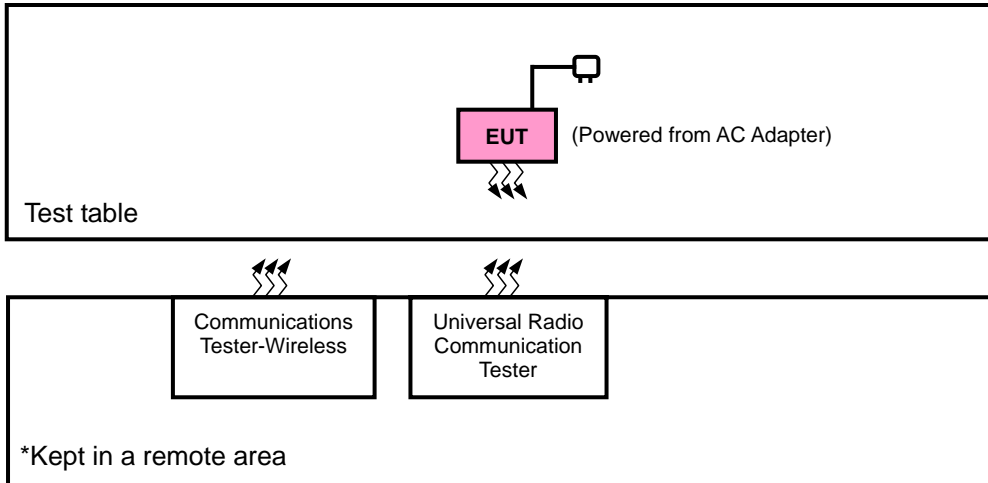

FOR E.I.R.P. TEST

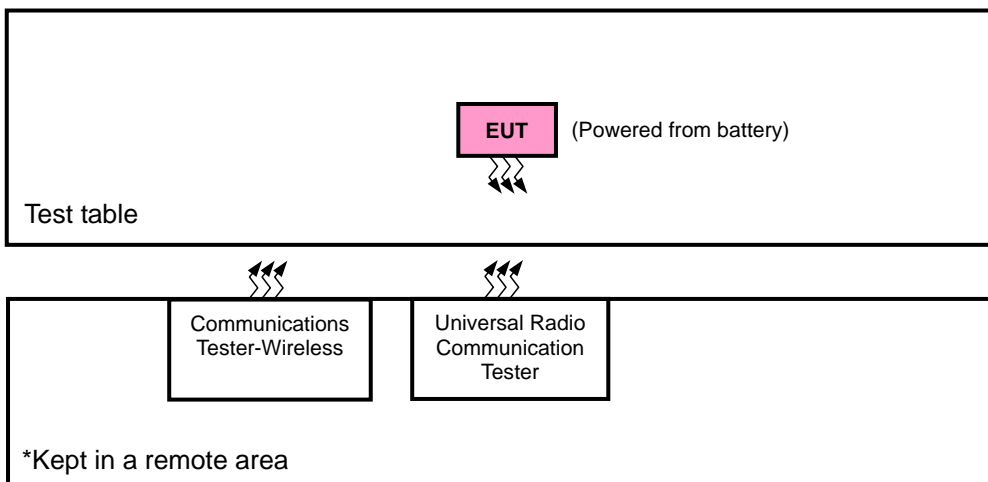



3.3 DESCRIPTION OF SUPPORT UNITS

The EUT has been tested as an independent unit together with other necessary accessories or support units. The following support units or accessories were used to form a representative test configuration during the tests.

NO.	PRODUCT	BRAND	MODEL NO.	SERIAL NO.	FCC ID
1	Universal Radio Communication Tester	R&S	CMU200	104958	NA
2	Communications Tester-Wireless	Agilent	8960 Series 10	MY50260642	NA

NO.	SIGNAL CABLE DESCRIPTION OF THE ABOVE SUPPORT UNITS
1	NA
2	NA

NOTE:

- 1. All power cords of the above support units are non-shielded (1.8m).
- 2. Items 1-2 act as communication partners to transfer data.

3.4 TEST ITEM AND TEST CONFIGURATION

Pre-Scan has been conducted to determine the worst-case mode from all possible combinations between available modulations, data rates, XYZ axis and antenna ports. The worst cases were found when positioned on **Y-plane** in EIRP and **Y-axis** for EVDO/ LTE Band 25 & **X-axis** for LTE Band 2 in radiated emission. Following channel(s) was (were) selected for the final test as listed below:

EVDO

EUT CONFIGURE MODE	TEST ITEM	AVAILABLE CHANNEL	TESTED CHANNEL	MODE
-	EIRP	25 to 1175	25, 600, 1175	EVDO
-	FREQUENCY STABILITY	25 to 1175	600	EVDO
-	OCCUPIED BANDWIDTH	25 to 1175	25, 600, 1175	EVDO
-	PEAK TO AVERAGE RATIO	25 to 1175	25, 600, 1175	EVDO
-	BAND EDGE	25 to 1175	25, 1175	EVDO
-	CONDCUDED EMISSION	25 to 1175	600	EVDO
-	RADIATED EMISSION Below 1GHz	25 to 1175	600	EVDO
-	RADIATED EMISSION Above 1GHz	25 to 1175	600	EVDO

LTE Band 2

TEST ITEM	AVAILABLE CHANNEL	TESTED CHANNEL	CHANNEL BANDWIDTH	MODULATION	MODE	
EIRP	18625 to 19175	18625, 18900, 19175	5MHz	QPSK	1 RB / 0 RB Offset	
	18650 to 19150	18650, 18900, 19150	10MHz	QPSK	1 RB / 24 RB Offset	
	18675 to 19125	18675, 18900, 19125	15MHz	QPSK	1 RB / 37 RB Offset	
	18700 to 19100	18700, 18900, 19100	20MHz	QPSK	1 RB / 50 RB Offset	
FREQUENCY STABILITY	18625 to 19175	18900	5MHz	QPSK	1 RB / 0 RB Offset	
	18650 to 19150	18900	10MHz	QPSK	1 RB / 24 RB Offset	
	18675 to 19125	18900	15MHz	QPSK	1 RB / 37 RB Offset	
	18700 to 19100	18900	20MHz	QPSK	1 RB / 50 RB Offset	
OCCUPIED BANDWIDTH	18625 to 19175	18625, 18900, 19175	5MHz	QPSK / 16QAM	25 RB / 0 RB Offset	
	18650 to 19150	18650, 18900, 19150	10MHz	QPSK / 16QAM	50 RB / 0 RB Offset	
	18675 to 19125	18675, 18900, 19125	15MHz	QPSK / 16QAM	75 RB / 0 RB Offset	
	18700 to 19100	18700, 18900, 19100	20MHz	QPSK / 16QAM	100 RB / 0 RB Offset	
PEAK TO AVERAGE RATIO	18625 to 19175	18625, 18900, 19175	5MHz	QPSK	1 RB / 0 RB Offset	
	18650 to 19150	18650, 18900, 19150	10MHz	QPSK	1 RB / 24 RB Offset	
	18675 to 19125	18675, 18900, 19125	15MHz	QPSK	1 RB / 37 RB Offset	
	18700 to 19100	18700, 18900, 19100	20MHz	QPSK	1 RB / 50 RB Offset	
BAND EDGE	18625 to 19175	18625	5MHz	QPSK	1 RB / 0 RB Offset 25 RB / 0 RB Offset	
		19175	5MHz	QPSK	1 RB / 24 RB Offset 25 RB / 0 RB Offset	
	18650 to 19150	18650	10MHz	QPSK	1 RB / 0 RB Offset 50 RB / 0 RB Offset	
		19150	10MHz	QPSK	1 RB / 49 RB Offset 50 RB / 0 RB Offset	
	18675 to 19125	18675	15MHz	QPSK	1 RB / 0 RB Offset 75 RB / 0 RB Offset	
		19125	15MHz	QPSK	1 RB / 74 RB Offset 75 RB / 0 RB Offset	
	18700 to 19100	18700	20MHz	QPSK	1 RB / 0 RB Offset 100 RB / 0 RB Offset	
		19100	20MHz	QPSK	1 RB / 99 RB Offset 100 RB / 0 RB Offset	
	CONDCUETED EMISSION	18625 to 19175	18900	5MHz	QPSK	1 RB / 0 RB Offset
		18650 to 19150	18900	10MHz	QPSK	1 RB / 24 RB Offset
		18675 to 19125	18900	15MHz	QPSK	1 RB / 37 RB Offset
		18700 to 19100	18900	20MHz	QPSK	1 RB / 50 RB Offset
RADIATED EMISSION	18625 to 19175	18900	5MHz	QPSK	1 RB / 0 RB Offset 25 RB / 0 RB Offset	
					18650 to 19150	18900
	18675 to 19125	18900	15MHz	QPSK	1 RB / 37 RB Offset 75 RB / 0 RB Offset	
					18700 to 19100	18900

LTE Band 25

TEST ITEM	AVAILABLE CHANNEL	TESTED CHANNEL	CHANNEL BANDWIDTH	MODULATION	MODE	
EIRP	26065 to 26665	26065, 26365, 26665	5MHz	QPSK	1 RB / 0 RB Offset	
	26090 to 26640	26090, 26365, 26640	10MHz	QPSK	1 RB / 0 RB Offset	
	26115 to 26615	26115, 26365, 26615	15MHz	QPSK	1 RB / 0 RB Offset	
	26140 to 26590	26140, 26365, 26590	20MHz	QPSK	1 RB / 50 RB Offset	
FREQUENCY STABILITY	26065 to 26665	26365	5MHz	QPSK	1 RB / 0 RB Offset	
	26090 to 26640	26365	10MHz	QPSK	1 RB / 0 RB Offset	
	26115 to 26615	26365	15MHz	QPSK	1 RB / 0 RB Offset	
	26140 to 26590	26365	20MHz	QPSK	1 RB / 50 RB Offset	
OCCUPIED BANDWIDTH	26065 to 26665	26065, 26365, 26665	5MHz	QPSK / 16QAM	25 RB / 0 RB Offset	
	26090 to 26640	26090, 26365, 26640	10MHz	QPSK / 16QAM	50 RB / 0 RB Offset	
	26115 to 26615	26115, 26365, 26615	15MHz	QPSK / 16QAM	75 RB / 0 RB Offset	
	26140 to 26590	26140, 26365, 26590	20MHz	QPSK / 16QAM	100 RB / 0 RB Offset	
PEAK TO AVERAGE RATIO	26065 to 26665	26065, 26365, 26665	5MHz	QPSK / 16QAM	1 RB / 0 RB Offset	
	26090 to 26640	26090, 26365, 26640	10MHz	QPSK / 16QAM	1 RB / 0 RB Offset	
	26115 to 26615	26115, 26365, 26615	15MHz	QPSK / 16QAM	1 RB / 0 RB Offset	
	26140 to 26590	26140, 26365, 26590	20MHz	QPSK / 16QAM	1 RB / 50 RB Offset	
BAND EDGE	26065 to 26665	26065	5MHz	QPSK	1 RB / 0 RB Offset 25 RB / 0 RB Offset	
		26665	5MHz	QPSK	1 RB / 24 RB Offset 25 RB / 0 RB Offset	
	26090 to 26640	26090	10MHz	QPSK	1 RB / 0 RB Offset 50 RB / 0 RB Offset	
		26640	10MHz	QPSK	1 RB / 49 RB Offset 50 RB / 0 RB Offset	
	26115 to 26615	26115	15MHz	QPSK	1 RB / 0 RB Offset 75 RB / 0 RB Offset	
		26615	15MHz	QPSK	1 RB / 74 RB Offset 75 RB / 0 RB Offset	
	26140 to 26590	26140	20MHz	QPSK	1 RB / 0 RB Offset 100 RB / 0 RB Offset	
		26590	20MHz	QPSK	1 RB / 99 RB Offset 100 RB / 0 RB Offset	
	CONDCUETED EMISSION	26065 to 26665	26365	5MHz	QPSK	1 RB / 0 RB Offset
		26090 to 26640	26365	10MHz	QPSK	1 RB / 0 RB Offset
		26115 to 26615	26365	15MHz	QPSK	1 RB / 0 RB Offset
		26140 to 26590	26365	20MHz	QPSK	1 RB / 50 RB Offset
RADIATED EMISSION	26065 to 26665	26365	5MHz	QPSK	1 RB / 0 RB Offset 25 RB / 0 RB Offset	
					26090 to 26640	26365
	26115 to 26615	26365	15MHz	QPSK	1 RB / 0 RB Offset 75 RB / 0 RB Offset	
					26140 to 26590	26365



TEST CONDITION:

LTE

TEST ITEM	ENVIRONMENTAL CONDITIONS	INPUT POWER	TESTED BY
EIRP	26deg. C, 58%RH	3.7Vdc	Howard Kao
FREQUENCY STABILITY	26deg. C, 58%RH	3.7Vdc	Howard Kao
OCCUPIED BANDWIDTH	26deg. C, 58%RH	3.7Vdc	Howard Kao
PEAK TO AVERAGE RATIO	26deg. C, 58%RH	3.7Vdc	Howard Kao
BAND EDGE	26deg. C, 58%RH	3.7Vdc	Howard Kao
CONDCUDED EMISSION	26deg. C, 58%RH	3.7Vdc	Howard Kao
RADIATED EMISSION Below 1GHz	25deg. C, 65%RH	120Vac, 60Hz	Kay Wu
RADIATED EMISSION Above 1GHz	25deg. C, 65%RH	120Vac, 60Hz	Kay Wu

EVDO

TEST ITEM	ENVIRONMENTAL CONDITIONS	INPUT POWER	TESTED BY
EIRP	25deg. C, 65%RH	3.7Vdc	Chris Lin
FREQUENCY STABILITY	24deg. C, 64%RH	3.7Vdc	Match Tsui
OCCUPIED BANDWIDTH	24deg. C, 64%RH	3.7Vdc	Match Tsui
PEAK TO AVERAGE RATIO	24deg. C, 64%RH	3.7Vdc	Match Tsui
BAND EDGE	24deg. C, 64%RH	3.7Vdc	Match Tsui
CONDCUDED EMISSION	24deg. C, 64%RH	3.7Vdc	Match Tsui
RADIATED EMISSION Below 1GHz	25deg. C, 65%RH	120Vac, 60Hz	Chris Lin
RADIATED EMISSION Above 1GHz	25deg. C, 65%RH	120Vac, 60Hz	Chris Lin

3.5 EUT OPERATING CONDITIONS

The EUT makes a call to the communication simulator. The communication simulator station system controlled a EUT to export maximum output power under transmission mode and specific channel frequency

3.6 GENERAL DESCRIPTION OF APPLIED STANDARDS

The EUT is a RF product. According to the specifications of the manufacturer, it must comply with the requirements of the following standards:

FCC 47 CFR Part 2

FCC 47 CFR Part 24

ANSI/TIA/EIA-603-C 2004

NOTE: All test items have been performed and recorded as per the above standards.

4 TEST TYPES AND RESULTS

4.1 OUTPUT POWER MEASUREMENT

4.1.1 LIMITS OF OUTPUT POWER MEASUREMENT

Mobile and portable stations are limited to 2 watts EIRP

4.1.2 TEST PROCEDURES

EIRP MEASUREMENT:

- a. All measurements were done at low, middle and high operational frequency range. RBW and VBW is 5MHz for EVDO mode and 10MHz for LTE mode.
- b. Substitution method is used for E.I.R.P measurement. In the semi-anechoic chamber, EUT placed on the 0.8m height of Turn Table, rotated the table around 360 degrees to search the maximum radiation power and receiver antenna shall be rotated vertical and horizontal polarization and moved height from 1m to 4m to find the maximum polar radiated power. The “Read Value” is the spectrum reading the maximum power value.
- c. The substitution horn antenna is substituted for EUT at the same position and signals generator export the CW signal to the substitution antenna via a tx cable. Rotated the Turn Table and moved receiving antenna to find the maximum radiation power. Adjust output power level of S.G to get a Value of spectrum reading equal to “Read Value” of step b. Record the power level of S.G
- d. $EIRP = \text{Output power level of S.G} - \text{TX cable loss} + \text{Antenna gain of substitution horn.}$

CONDUCTED POWER MEASUREMENT:

The EUT was set up for the maximum power with EVDO/ LTE link data modulation and link up with simulator. Set the EUT to transmit under low, middle and high channel and record the power level shown on simulator.

4.1.3 TEST SETUP

EIRP MEASUREMENT:

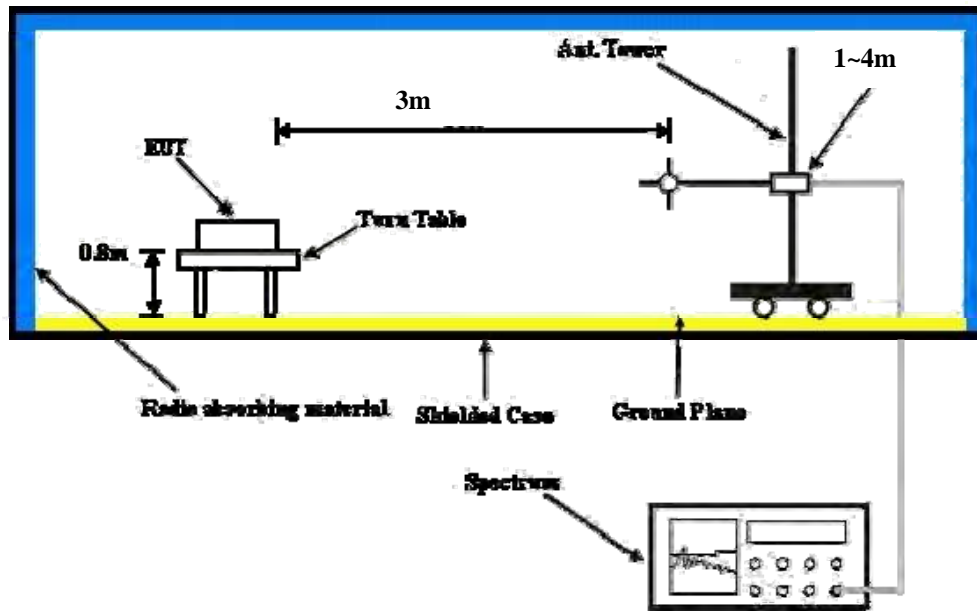

For the actual test configuration, please refer to the attached file (Test Setup Photo).

CONDUCTED POWER MEASUREMENT:

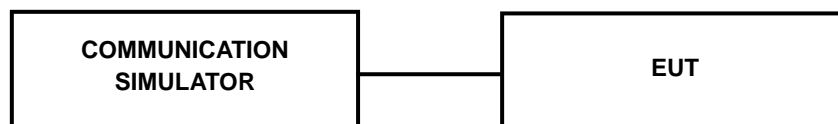

For the actual test configuration, please refer to the attached file (Test Setup Photo).

4.1.4 TEST RESULTS

CONDUCTED OUTPUT POWER (dBm)

Band	EVDO BC1		
Channel	25	600	1175
Frequency (MHz)	1851.25	1880	1908.75
RC1+SO55	22.83	23.07	22.66
RC3+SO55	22.84	23.08	22.67
RC3+SO32(+ F-SCH)	22.85	23.09	22.68
RC3+SO32(+SCH)	22.84	23.08	22.67
RTAP 153.6	23.91	24.15	23.74
RETAP 4096	23.83	24.07	23.66



A D T

LTE Band 2								
BW	Modulation	CH	Frequency	RB	RB Offset	MPR	Target	Measured
			(MHz)				Power	Power
5 MHz	QPSK	18625	1852.5	1	0	0	22.9	22.76
		18900	1880	1	0	0	22.9	22.63
		19175	1907.5	1	0	0	22.9	22.62
		18625	1852.5	1	12	0	22.9	22.76
		18900	1880	1	12	0	22.9	22.63
		19175	1907.5	1	12	0	22.9	22.62
		18625	1852.5	1	24	0	22.9	22.66
		18900	1880	1	24	0	22.9	22.53
		19175	1907.5	1	24	0	22.9	22.52
		18625	1852.5	12	0	1	22.9	21.61
		18900	1880	12	0	1	22.9	21.48
		19175	1907.5	12	0	1	22.9	21.47
		18625	1852.5	12	6	1	22.9	21.61
		18900	1880	12	6	1	22.9	21.48
		19175	1907.5	12	6	1	22.9	21.47
		18625	1852.5	12	13	1	22.9	21.62
		18900	1880	12	13	1	22.9	21.49
		19175	1907.5	12	13	1	22.9	21.48
	18625	1852.5	25	0	1	22.9	21.48	
	18900	1880	25	0	1	22.9	21.35	
	19175	1907.5	25	0	1	22.9	21.34	
	18625	1852.5	1	0	1	22.9	21.55	
	18900	1880	1	0	1	22.9	21.42	
	19175	1907.5	1	0	1	22.9	21.41	
	18625	1852.5	1	12	1	22.9	21.73	
	18900	1880	1	12	1	22.9	21.6	
	19175	1907.5	1	12	1	22.9	21.59	
	18625	1852.5	1	24	1	22.9	21.58	
	18900	1880	1	24	1	22.9	21.45	
	19175	1907.5	1	24	1	22.9	21.44	
	18625	1852.5	12	0	2	22.9	20.6	
	18900	1880	12	0	2	22.9	20.47	
	19175	1907.5	12	0	2	22.9	20.46	
	18625	1852.5	12	6	2	22.9	20.61	
	18900	1880	12	6	2	22.9	20.48	
	19175	1907.5	12	6	2	22.9	20.47	
18625	1852.5	12	13	2	22.9	20.63		
18900	1880	12	13	2	22.9	20.5		
19175	1907.5	12	13	2	22.9	20.49		
18625	1852.5	25	0	2	22.9	20.48		
18900	1880	25	0	2	22.9	20.35		
19175	1907.5	25	0	2	22.9	20.34		



A D T

LTE Band 2								
BW	Modulation	CH	Frequency	RB	RB Offset	MPR	Target	Measured
			(MHz)				Power	Power
10MHz	QPSK	18650	1855	1	0	0	22.9	22.76
		18900	1880	1	0	0	22.9	22.59
		19150	1905	1	0	0	22.9	22.55
		18650	1855	1	24	0	22.9	22.77
		18900	1880	1	24	0	22.9	22.6
		19150	1905	1	24	0	22.9	22.56
		18650	1855	1	49	0	22.9	22.69
		18900	1880	1	49	0	22.9	22.52
		19150	1905	1	49	0	22.9	22.48
		18650	1855	25	0	1	22.9	21.58
		18900	1880	25	0	1	22.9	21.41
		19150	1905	25	0	1	22.9	21.37
		18650	1855	25	12	1	22.9	21.57
		18900	1880	25	12	1	22.9	21.4
		19150	1905	25	12	1	22.9	21.36
		18650	1855	25	25	1	22.9	21.55
		18900	1880	25	25	1	22.9	21.38
		19150	1905	25	25	1	22.9	21.34
	18650	1855	50	0	1	22.9	21.38	
	18900	1880	50	0	1	22.9	21.21	
	19150	1905	50	0	1	22.9	21.17	
	18650	1855	1	0	1	22.9	21.62	
	18900	1880	1	0	1	22.9	21.45	
	19150	1905	1	0	1	22.9	21.41	
	18650	1855	1	24	1	22.9	21.74	
	18900	1880	1	24	1	22.9	21.57	
	19150	1905	1	24	1	22.9	21.53	
	18650	1855	1	49	1	22.9	21.63	
	18900	1880	1	49	1	22.9	21.46	
	19150	1905	1	49	1	22.9	21.42	
	18650	1855	25	0	2	22.9	20.58	
	18900	1880	25	0	2	22.9	20.41	
	19150	1905	25	0	2	22.9	20.37	
	18650	1855	25	12	2	22.9	20.55	
	18900	1880	25	12	2	22.9	20.38	
	19150	1905	25	12	2	22.9	20.34	
18650	1855	25	25	2	22.9	20.4		
18900	1880	25	25	2	22.9	20.23		
19150	1905	25	25	2	22.9	20.19		
18650	1855	50	0	2	22.9	20.38		
18900	1880	50	0	2	22.9	20.21		
19150	1905	50	0	2	22.9	20.17		
18650	1855	1	0	1	22.9	21.62		
18900	1880	1	0	1	22.9	21.45		
19150	1905	1	0	1	22.9	21.41		
18650	1855	1	24	1	22.9	21.74		
18900	1880	1	24	1	22.9	21.57		
19150	1905	1	24	1	22.9	21.53		
18650	1855	1	49	1	22.9	21.63		
18900	1880	1	49	1	22.9	21.46		
19150	1905	1	49	1	22.9	21.42		
18650	1855	25	0	2	22.9	20.58		
18900	1880	25	0	2	22.9	20.41		
19150	1905	25	0	2	22.9	20.37		
18650	1855	25	12	2	22.9	20.55		
18900	1880	25	12	2	22.9	20.38		
19150	1905	25	12	2	22.9	20.34		
18650	1855	25	25	2	22.9	20.4		
18900	1880	25	25	2	22.9	20.23		
19150	1905	25	25	2	22.9	20.19		
18650	1855	50	0	2	22.9	20.38		
18900	1880	50	0	2	22.9	20.21		
19150	1905	50	0	2	22.9	20.17		



A D T

LTE Band 2								
BW	Modulation	CH	Frequency	RB	RB Offset	MPR	Target	Measured
			(MHz)				Power	Power
15MHz	QPSK	18675	1857.5	1	0	0	22.9	22.7
		18900	1880	1	0	0	22.9	22.58
		19125	1902.5	1	0	0	22.9	22.48
		18675	1857.5	1	37	0	22.9	22.83
		18900	1880	1	37	0	22.9	22.71
		19125	1902.5	1	37	0	22.9	22.61
		18675	1857.5	1	74	0	22.9	22.64
		18900	1880	1	74	0	22.9	22.52
		19125	1902.5	1	74	0	22.9	22.42
		18675	1857.5	36	0	1	22.9	21.43
		18900	1880	36	0	1	22.9	21.31
		19125	1902.5	36	0	1	22.9	21.21
		18675	1857.5	36	19	1	22.9	21.42
		18900	1880	36	19	1	22.9	21.3
		19125	1902.5	36	19	1	22.9	21.2
	18675	1857.5	36	39	1	22.9	21.4	
	18900	1880	36	39	1	22.9	21.28	
	19125	1902.5	36	39	1	22.9	21.18	
	18675	1857.5	75	0	1	22.9	21.36	
	18900	1880	75	0	1	22.9	21.24	
	19125	1902.5	75	0	1	22.9	21.14	
	18675	1857.5	1	0	1	22.9	21.51	
	18900	1880	1	0	1	22.9	21.39	
	19125	1902.5	1	0	1	22.9	21.29	
	18675	1857.5	1	37	1	22.9	21.76	
	18900	1880	1	37	1	22.9	21.64	
	19125	1902.5	1	37	1	22.9	21.54	
	18675	1857.5	1	74	1	22.9	21.6	
	18900	1880	1	74	1	22.9	21.48	
	19125	1902.5	1	74	1	22.9	21.38	
18675	1857.5	36	0	2	22.9	20.39		
18900	1880	36	0	2	22.9	20.27		
19125	1902.5	36	0	2	22.9	20.17		
18675	1857.5	36	19	2	22.9	20.24		
18900	1880	36	19	2	22.9	20.12		
19125	1902.5	36	19	2	22.9	20.02		
18675	1857.5	36	39	2	22.9	20.29		
18900	1880	36	39	2	22.9	20.17		
19125	1902.5	36	39	2	22.9	20.07		
18675	1857.5	75	0	2	22.9	20.28		
18900	1880	75	0	2	22.9	20.16		
19125	1902.5	75	0	2	22.9	20.06		



A D T

LTE Band 2								
BW	Modulation	CH	Frequency	RB	RB Offset	MPR	Target	Measured
			(MHz)				Power	Power
20MHz	QPSK	18700	1860	1	0	0	22.9	22.77
		18900	1880	1	0	0	22.9	22.65
		19100	1900	1	0	0	22.9	22.63
		18700	1860	1	50	0	22.9	22.85
		18900	1880	1	50	0	22.9	22.73
		19100	1900	1	50	0	22.9	22.71
		18700	1860	1	99	0	22.9	22.7
		18900	1880	1	99	0	22.9	22.58
		19100	1900	1	99	0	22.9	22.56
		18700	1860	50	0	1	22.9	21.51
		18900	1880	50	0	1	22.9	21.39
		19100	1900	50	0	1	22.9	21.37
		18700	1860	50	25	1	22.9	21.46
		18900	1880	50	25	1	22.9	21.34
		19100	1900	50	25	1	22.9	21.32
		18700	1860	50	50	1	22.9	21.45
		18900	1880	50	50	1	22.9	21.33
		19100	1900	50	50	1	22.9	21.31
	18700	1860	100	0	1	22.9	21.49	
	18900	1880	100	0	1	22.9	21.37	
	19100	1900	100	0	1	22.9	21.35	
	18700	1860	1	0	1	22.9	21.68	
	18900	1880	1	0	1	22.9	21.56	
	19100	1900	1	0	1	22.9	21.54	
	18700	1860	1	50	1	22.9	21.79	
	18900	1880	1	50	1	22.9	21.67	
	19100	1900	1	50	1	22.9	21.65	
	18700	1860	1	99	1	22.9	21.64	
	18900	1880	1	99	1	22.9	21.52	
	19100	1900	1	99	1	22.9	21.5	
	18700	1860	50	0	2	22.9	20.51	
	18900	1880	50	0	2	22.9	20.39	
	19100	1900	50	0	2	22.9	20.37	
	18700	1860	50	25	2	22.9	20.46	
	18900	1880	50	25	2	22.9	20.34	
	19100	1900	50	25	2	22.9	20.32	
18700	1860	50	50	2	22.9	20.47		
18900	1880	50	50	2	22.9	20.35		
19100	1900	50	50	2	22.9	20.33		
18700	1860	100	0	2	22.9	20.46		
18900	1880	100	0	2	22.9	20.34		
19100	1900	100	0	2	22.9	20.32		



A D T

LTE Band 25									
BW	Modulation	CH	Frequency	RB	RB Offset	MPR	Target	Measured	
			(MHz)				Power	Power	
5MHz	QPSK	26065	1860	1	0	0	22.8	22.73	
		26365	1882.5	1	0	0	22.8	22.61	
		26665	1912.5	1	0	0	22.8	22.37	
		26065	1860	1	12	0	22.8	22.66	
		26365	1882.5	1	12	0	22.8	22.54	
		26665	1912.5	1	12	0	22.8	22.3	
		26065	1860	1	24	0	22.8	22.45	
		26365	1882.5	1	24	0	22.8	22.33	
		26665	1912.5	1	24	0	22.8	22.09	
		26065	1860	12	0	1	22.8	21.48	
		26365	1882.5	12	0	1	22.8	21.36	
		26665	1912.5	12	0	1	22.8	21.12	
		26065	1860	12	6	1	22.8	21.47	
		26365	1882.5	12	6	1	22.8	21.35	
		26665	1912.5	12	6	1	22.8	21.11	
		26065	1860	12	13	1	22.8	21.4	
		26365	1882.5	12	13	1	22.8	21.28	
		26665	1912.5	12	13	1	22.8	21.04	
	26065	1860	25	0	1	22.8	21.31		
	26365	1882.5	25	0	1	22.8	21.19		
	26665	1912.5	25	0	1	22.8	20.95		
	26065	16QAM	26065	1860	1	0	1	22.8	21.55
	26365		26365	1882.5	1	0	1	22.8	21.43
	26665		26665	1912.5	1	0	1	22.8	21.19
	26065		26065	1860	1	12	1	22.8	21.5
	26365		26365	1882.5	1	12	1	22.8	21.38
	26665		26665	1912.5	1	12	1	22.8	21.14
	26065		26065	1860	1	24	1	22.8	21.37
	26365		26365	1882.5	1	24	1	22.8	21.25
	26665		26665	1912.5	1	24	1	22.8	21.01
	26065		26065	1860	12	0	2	22.8	20.51
	26365		26365	1882.5	12	0	2	22.8	20.39
	26665		26665	1912.5	12	0	2	22.8	20.15
	26065		26065	1860	12	6	2	22.8	20.54
	26365		26365	1882.5	12	6	2	22.8	20.42
	26665		26665	1912.5	12	6	2	22.8	20.18
26065	26065		1860	12	13	2	22.8	20.44	
26365	26365		1882.5	12	13	2	22.8	20.32	
26665	26665		1912.5	12	13	2	22.8	20.08	
26065	26065	1860	25	0	2	22.8	20.31		
26365	26365	1882.5	25	0	2	22.8	20.19		
26665	26665	1912.5	25	0	2	22.8	19.95		



A D T

LTE Band 25								
BW	Modulation	CH	Frequency	RB	RB Offset	MPR	Target	Measured
			(MHz)				Power	Power
10MHz	QPSK	26090	1855	1	0	0	22.8	22.75
		26365	1882.5	1	0	0	22.8	22.57
		26640	1910	1	0	0	22.8	22.5
		26090	1855	1	24	0	22.8	22.69
		26365	1882.5	1	24	0	22.8	22.51
		26640	1910	1	24	0	22.8	22.44
		26090	1855	1	49	0	22.8	22.6
		26365	1882.5	1	49	0	22.8	22.42
		26640	1910	1	49	0	22.8	22.35
		26090	1855	25	0	1	22.8	21.41
		26365	1882.5	25	0	1	22.8	21.23
		26640	1910	25	0	1	22.8	21.16
		26090	1855	25	12	1	22.8	21.44
		26365	1882.5	25	12	1	22.8	21.26
		26640	1910	25	12	1	22.8	21.19
		26090	1855	25	25	1	22.8	21.38
		26365	1882.5	25	25	1	22.8	21.2
		26640	1910	25	25	1	22.8	21.13
	26090	1855	50	0	1	22.8	21.3	
	26365	1882.5	50	0	1	22.8	21.12	
	26640	1910	50	0	1	22.8	21.05	
	26090	1855	1	0	1	22.8	21.59	
	26365	1882.5	1	0	1	22.8	21.41	
	26640	1910	1	0	1	22.8	21.34	
	26090	1855	1	24	1	22.8	21.49	
	26365	1882.5	1	24	1	22.8	21.31	
	26640	1910	1	24	1	22.8	21.24	
	26090	1855	1	49	1	22.8	21.41	
	26365	1882.5	1	49	1	22.8	21.23	
	26640	1910	1	49	1	22.8	21.16	
	26090	1855	25	0	2	22.8	20.38	
	26365	1882.5	25	0	2	22.8	20.2	
	26640	1910	25	0	2	22.8	20.13	
	26090	1855	25	12	2	22.8	20.42	
	26365	1882.5	25	12	2	22.8	20.24	
	26640	1910	25	12	2	22.8	20.17	
26090	1855	25	25	2	22.8	20.4		
26365	1882.5	25	25	2	22.8	20.22		
26640	1910	25	25	2	22.8	20.15		
26090	1855	50	0	2	22.8	20.32		
26365	1882.5	50	0	2	22.8	20.14		
26640	1910	50	0	2	22.8	20.07		



A D T

LTE Band 25									
BW	Modulation	CH	Frequency	RB	RB Offset	MPR	Target	Measured	
			(MHz)				Power	Power	
15MHz	QPSK	26115	1857.5	1	0	0	22.8	22.76	
		26365	1882.5	1	0	0	22.8	22.6	
		26615	1907.5	1	0	0	22.8	22.45	
		26115	1857.5	1	37	0	22.8	22.76	
		26365	1882.5	1	37	0	22.8	22.6	
		26615	1907.5	1	37	0	22.8	22.45	
		26115	1857.5	1	74	0	22.8	22.72	
		26365	1882.5	1	74	0	22.8	22.56	
		26615	1907.5	1	74	0	22.8	22.41	
		26115	1857.5	36	0	1	22.8	21.48	
		26365	1882.5	36	0	1	22.8	21.32	
		26615	1907.5	36	0	1	22.8	21.17	
		26115	1857.5	36	19	1	22.8	21.56	
		26365	1882.5	36	19	1	22.8	21.4	
		26615	1907.5	36	19	1	22.8	21.25	
		26115	1857.5	36	39	1	22.8	21.44	
		26365	1882.5	36	39	1	22.8	21.28	
		26615	1907.5	36	39	1	22.8	21.13	
	26115	1857.5	75	0	1	22.8	21.33		
	26365	1882.5	75	0	1	22.8	21.17		
	26615	1907.5	75	0	1	22.8	21.02		
	26115	16QAM	26115	1857.5	1	0	1	22.8	21.58
	26365		26365	1882.5	1	0	1	22.8	21.42
	26615		26615	1907.5	1	0	1	22.8	21.27
	26115		26115	1857.5	1	37	1	22.8	21.62
	26365		26365	1882.5	1	37	1	22.8	21.46
	26615		26615	1907.5	1	37	1	22.8	21.31
	26115		26115	1857.5	1	74	1	22.8	21.45
	26365		26365	1882.5	1	74	1	22.8	21.29
	26615		26615	1907.5	1	74	1	22.8	21.14
	26115		26115	1857.5	36	0	2	22.8	20.41
	26365		26365	1882.5	36	0	2	22.8	20.25
	26615		26615	1907.5	36	0	2	22.8	20.1
26115	26115		1857.5	36	19	2	22.8	20.38	
26365	26365		1882.5	36	19	2	22.8	20.22	
26615	26615		1907.5	36	19	2	22.8	20.07	
26115	26115	1857.5	36	39	2	22.8	20.44		
26365	26365	1882.5	36	39	2	22.8	20.28		
26615	26615	1907.5	36	39	2	22.8	20.13		
26115	26115	1857.5	75	0	2	22.8	20.37		
26365	26365	1882.5	75	0	2	22.8	20.21		
26615	26615	1907.5	75	0	2	22.8	20.06		



A D T

LTE Band 25								
BW	Modulation	CH	Frequency	RB	RB Offset	MPR	Target	Measured
			(MHz)				Power	Power
20MHz	QPSK	26140	1860	1	0	0	22.8	22.72
		26365	1882.5	1	0	0	22.8	22.67
		26590	1905	1	0	0	22.8	22.63
		26140	1860	1	50	0	22.8	22.79
		26365	1882.5	1	50	0	22.8	22.74
		26590	1905	1	50	0	22.8	22.7
		26140	1860	1	99	0	22.8	22.64
		26365	1882.5	1	99	0	22.8	22.59
		26590	1905	1	99	0	22.8	22.55
		26140	1860	50	0	1	22.8	21.47
		26365	1882.5	50	0	1	22.8	21.42
		26590	1905	50	0	1	22.8	21.38
		26140	1860	50	25	1	22.8	21.47
		26365	1882.5	50	25	1	22.8	21.42
		26590	1905	50	25	1	22.8	21.38
		26140	1860	50	50	1	22.8	21.51
		26365	1882.5	50	50	1	22.8	21.46
		26590	1905	50	50	1	22.8	21.42
	26140	1860	100	0	1	22.8	21.53	
	26365	1882.5	100	0	1	22.8	21.48	
	26590	1905	100	0	1	22.8	21.44	
	26140	1860	1	0	1	22.8	21.61	
	26365	1882.5	1	0	1	22.8	21.56	
	26590	1905	1	0	1	22.8	21.52	
	26140	1860	1	50	1	22.8	21.74	
	26365	1882.5	1	50	1	22.8	21.69	
	26590	1905	1	50	1	22.8	21.65	
	26140	1860	1	99	1	22.8	21.62	
	26365	1882.5	1	99	1	22.8	21.57	
	26590	1905	1	99	1	22.8	21.53	
	26140	1860	50	0	2	22.8	20.48	
	26365	1882.5	50	0	2	22.8	20.43	
	26590	1905	50	0	2	22.8	20.39	
26140	1860	50	25	2	22.8	20.47		
26365	1882.5	50	25	2	22.8	20.42		
26590	1905	50	25	2	22.8	20.38		
26140	1860	50	50	2	22.8	20.46		
26365	1882.5	50	50	2	22.8	20.41		
26590	1905	50	50	2	22.8	20.37		
26140	1860	100	0	2	22.8	20.44		
26365	1882.5	100	0	2	22.8	20.39		
26590	1905	100	0	2	22.8	20.35		

EIRP POWER (dBm)

EVDO

Plane	Channel	Frequency (MHz)	LVL (dBm)	Correction Factor(dB)	EIRP(dBm)	EIRP(mW)	Polarization (H/V)
Y	25	1851.25	-13.09	1.07	26.52	448.75	H
	600	1880.00	-13.15	1.12	26.69	466.66	H
	1175	1908.75	-13.59	1.11	26.62	459.20	H
	25	1851.25	-15.93	1.07	21.76	149.97	V
	600	1880.00	-16.26	1.12	21.12	129.42	V
	1175	1908.75	-15.88	1.11	21.13	129.72	V

**LTE Band 2 (Channel Bandwidth 5MHz)**

Plane	Channel	Frequency (MHz)	LVL (dBm)	Correction Factor(dB)	EIRP(dBm)	EIRP(mW)	Polarization (H/V)
Y	18625	1852.5	-18.57	38.19	19.62	91.62	H
	18900	1880.0	-18.75	38.70	19.95	98.86	H
	19175	1907.5	-18.69	38.43	19.74	94.19	H
	18625	1852.5	-14.02	38.48	24.46	279.25	V
	18900	1880.0	-14.01	38.59	24.58	287.08	V
	19175	1907.5	-14.04	38.87	24.83	304.09	V

LTE Band 2 (Channel Bandwidth 10MHz)

Plane	Channel	Frequency (MHz)	LVL (dBm)	Correction Factor(dB)	EIRP(dBm)	EIRP(mW)	Polarization (H/V)
Y	18650	1855.0	-18.64	38.19	19.55	90.16	H
	18900	1880.0	-18.64	38.70	20.06	101.39	H
	19150	1905.0	-18.89	38.43	19.54	89.95	H
	18650	1855.0	-14.40	38.48	24.08	255.86	V
	18900	1880.0	-14.33	38.59	24.26	266.69	V
	19150	1905.0	-14.75	38.87	24.12	258.23	V

LTE Band 2 (Channel Bandwidth 15MHz)

Plane	Channel	Frequency (MHz)	LVL (dBm)	Correction Factor(dB)	EIRP(dBm)	EIRP(mW)	Polarization (H/V)
Y	18675	1857.5	-18.89	38.19	19.30	85.11	H
	18900	1880.0	-18.75	38.70	19.95	98.86	H
	19125	1902.5	-18.48	38.43	19.95	98.86	H
	18675	1857.5	-13.56	38.48	24.92	310.46	V
	18900	1880.0	-14.38	38.59	24.21	263.63	V
	19125	1902.5	-14.26	38.87	24.61	289.07	V

LTE Band 2 (Channel Bandwidth 20MHz)

Plane	Channel	Frequency (MHz)	LVL (dBm)	Correction Factor(dB)	EIRP(dBm)	EIRP(mW)	Polarization (H/V)
Y	18700	1860.0	-18.30	38.19	19.89	97.50	H
	18900	1880.0	-19.51	38.70	19.19	82.99	H
	19100	1900.0	-19.12	38.43	19.31	85.31	H
	18700	1860.0	-13.93	38.48	24.55	285.10	V
	18900	1880.0	-13.70	38.59	24.89	308.32	V
	19100	1900.0	-14.01	38.87	24.86	306.20	V

LTE Band 25 (Channel Bandwidth 5MHz)

Plane	Channel	Frequency (MHz)	LVL (dBm)	Correction Factor(dB)	EIRP(dBm)	EIRP(mW)	Polarization (H/V)
Y	26065	1860	-19.65	38.19	18.54	71.45	H
	26365	1882.5	-20.05	38.70	18.65	73.28	H
	26665	1912.5	-19.69	38.43	18.74	74.82	H
	26065	1860	-14.14	38.48	24.34	271.64	V
	26365	1882.5	-13.86	38.59	24.73	297.17	V
	26665	1912.5	-14.88	38.87	23.99	250.61	V

LTE Band 25 (Channel Bandwidth 10MHz)

Plane	Channel	Frequency (MHz)	LVL (dBm)	Correction Factor(dB)	EIRP(dBm)	EIRP(mW)	Polarization (H/V)
Y	26090	1855.0	-19.54	38.19	18.65	73.28	H
	26365	1882.5	-20.29	38.70	18.41	69.34	H
	26640	1910.0	-19.92	38.43	18.51	70.96	H
	26090	1855.0	-14.14	38.48	24.34	271.64	V
	26365	1882.5	-13.98	38.59	24.61	289.07	V
	26640	1910.0	-14.31	38.87	24.56	285.76	V

LTE Band 25 (Channel Bandwidth 15MHz)

Plane	Channel	Frequency (MHz)	LVL (dBm)	Correction Factor(dB)	EIRP(dBm)	EIRP(mW)	Polarization (H/V)
Y	26115	1857.5	-19.48	38.19	18.71	74.30	H
	26365	1882.5	-20.44	38.70	18.26	66.99	H
	26615	1907.5	-19.82	38.43	18.61	72.61	H
	26115	1857.5	-14.05	38.48	24.43	277.33	V
	26365	1882.5	-14.20	38.59	24.39	274.79	V
	26615	1907.5	-14.05	38.87	24.82	303.39	V

LTE Band 25 (Channel Bandwidth 20MHz)

Plane	Channel	Frequency (MHz)	LVL (dBm)	Correction Factor(dB)	EIRP(dBm)	EIRP(mW)	Polarization (H/V)
Y	26140	1860.0	-19.51	38.19	18.68	73.79	H
	26365	1882.5	-19.80	38.70	18.90	77.62	H
	26590	1905.0	-19.96	38.43	18.47	70.31	H
	26140	1860.0	-14.22	38.48	24.26	266.69	V
	26365	1882.5	-14.76	38.59	23.83	241.55	V
	26590	1905.0	-14.23	38.87	24.64	291.07	V

4.2 FREQUENCY STABILITY MEASUREMENT

4.2.1 LIMITS OF FREQUENCY STABILITY MEASUREMENT

The frequency stability shall be sufficient to ensure that the fundamental emission stays within the authorized frequency block.

4.2.2 TEST PROCEDURE

- a. Device is placed at the oven room. The oven room could control the temperatures and humidity. Power warm up is at least 15 min and power applied should perform before recording frequency error.
- b. EUT is connected the external power supply to control the DC input power. The test voltage range is from minimum to maximum working voltage. Each step shall be record the frequency error rate.
- c. The temperature range step is 10 degrees in this test items. All temperature levels shall be hold the $\pm 0.5^{\circ}\text{C}$ during the measurement testing. The each temperature step shall be at least 0.5 hours, consider the EUT could be test under the stability condition.

NOTE: The frequency error was recorded frequency error from the communication simulator.

4.2.3 TEST SETUP

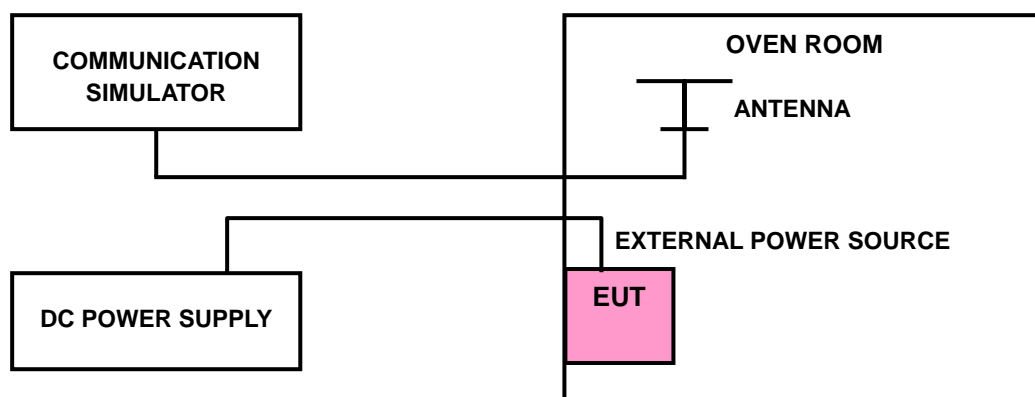

4.2.4 TEST RESULTS

FREQUENCY ERROR VS. VOLTAGE

VOLTAGE (Volts)	FREQUENCY ERROR (ppm)									LIMIT (ppm)
	EVDO	LTE Band 2				LTE Band 25				
		5MHz	10MHz	15MHz	20MHz	5MHz	10MHz	15MHz	20MHz	
4.26	-0.015	0.013	-0.008	-0.013	-0.022	0.006	-0.007	-0.007	-0.007	2.5
3.7	-0.010	0.005	-0.007	-0.008	-0.015	-0.003	0.003	-0.007	-0.009	2.5
3.15	-0.011	-0.008	-0.018	-0.021	-0.011	0.009	-0.009	0.007	0.004	2.5

NOTE: The applicant defined the normal working voltage of the battery is from 3.15Vdc to 4.26Vdc.

FREQUENCY ERROR vs. TEMPERATURE

TEMP. (°C)	FREQUENCY ERROR (ppm)									LIMIT (ppm)
	EVDO	LTE Band 2				LTE Band 25				
		5MHz	10MHz	15MHz	20MHz	5MHz	10MHz	15MHz	20MHz	
50	-0.019	-0.021	-0.005	-0.014	-0.015	0.006	-0.005	-0.006	-0.004	2.5
40	-0.018	0.002	-0.018	0.009	-0.017	0.005	0.004	-0.006	-0.008	2.5
30	-0.014	-0.009	-0.002	-0.008	-0.018	-0.003	0.003	0.005	-0.006	2.5
20	-0.010	-0.002	-0.006	0.011	-0.027	0.004	-0.009	-0.002	-0.010	2.5
10	-0.015	0.003	-0.010	0.008	-0.011	0.002	-0.006	-0.005	0.006	2.5
0	-0.018	0.002	-0.009	0.006	-0.012	-0.001	-0.002	-0.006	0.002	2.5
-10	-0.023	-0.002	-0.017	-0.010	-0.012	0.003	-0.007	-0.006	-0.001	2.5
-20	-0.026	0.011	-0.018	-0.020	-0.015	-0.002	-0.003	-0.005	-0.002	2.5
-30	-0.028	0.013	-0.014	-0.029	-0.020	-0.005	-0.004	-0.008	-0.004	2.5

4.3 OCCUPIED BANDWIDTH MEASUREMENT

4.3.1 TEST PROCEDURES

The EUT makes a call to the communication simulator. All measurements were done at low, middle and high operational frequency range. The communication simulator station system controlled a EUT to export maximum output power under transmission mode and specific channel frequency. Use OBW measurement function of Spectrum analyzer to measure 99 % occupied bandwidth.

4.3.2 TEST SETUP

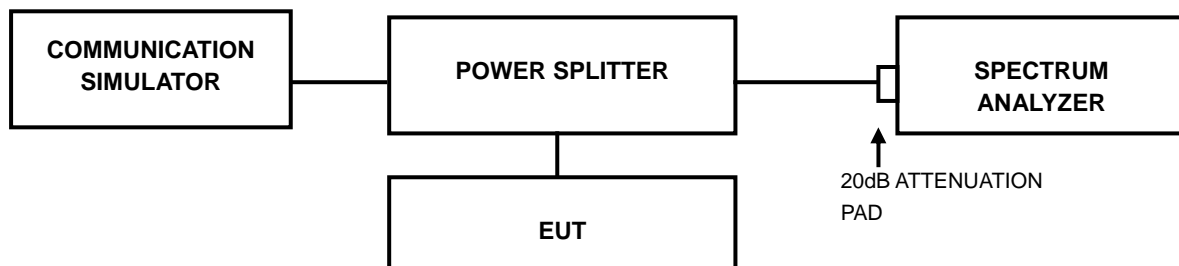

4.3.3 TEST RESULTS

CHANNEL	FREQUENCY (MHz)	99% OCCUPIED BANDWIDTH (MHz)
		EVDO
25	1851.25	1.28
600	1880.00	1.29
1175	1908.75	1.29

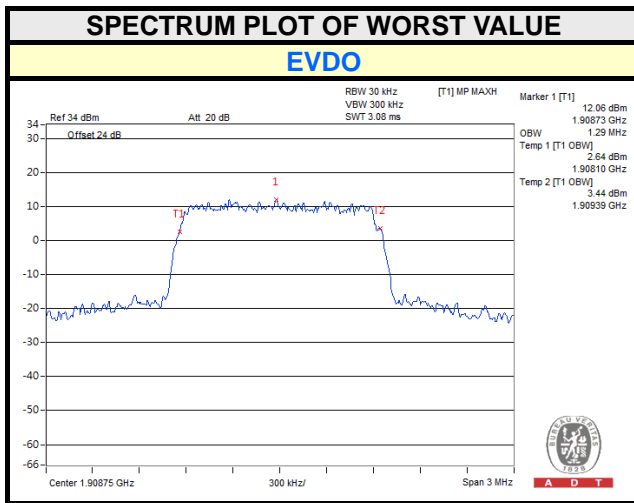



A D T

LTE BAND 2							
CHANNEL BANDWIDTH 5MHz				CHANNEL BANDWIDTH 10MHz			
CHANNEL	FREQUENCY (MHz)	99% OCCUPIED BANDWIDTH (MHz)		CHANNEL	FREQUENCY (MHz)	99% OCCUPIED BANDWIDTH (MHz)	
		QPSK	16QAM			QPSK	16QAM
18625	1852.5	4.4851	4.4863	18650	1855	8.9067	8.9110
18900	1880	4.4896	4.4880	18900	1880	8.9135	8.9173
19175	1907.5	4.4867	4.4827	19150	1905	8.8987	8.8980
CHANNEL BANDWIDTH 15MHz				CHANNEL BANDWIDTH 20MHz			
CHANNEL	FREQUENCY (MHz)	99% OCCUPIED BANDWIDTH (MHz)		CHANNEL	FREQUENCY (MHz)	99% OCCUPIED BANDWIDTH (MHz)	
		QPSK	16QAM			QPSK	16QAM
18675	1857.5	13.357	13.344	18700	1860	17.737	17.748
18900	1880	13.383	13.379	18900	1880	17.844	17.850
19125	1902.5	13.339	13.332	19100	1900	17.742	17.759

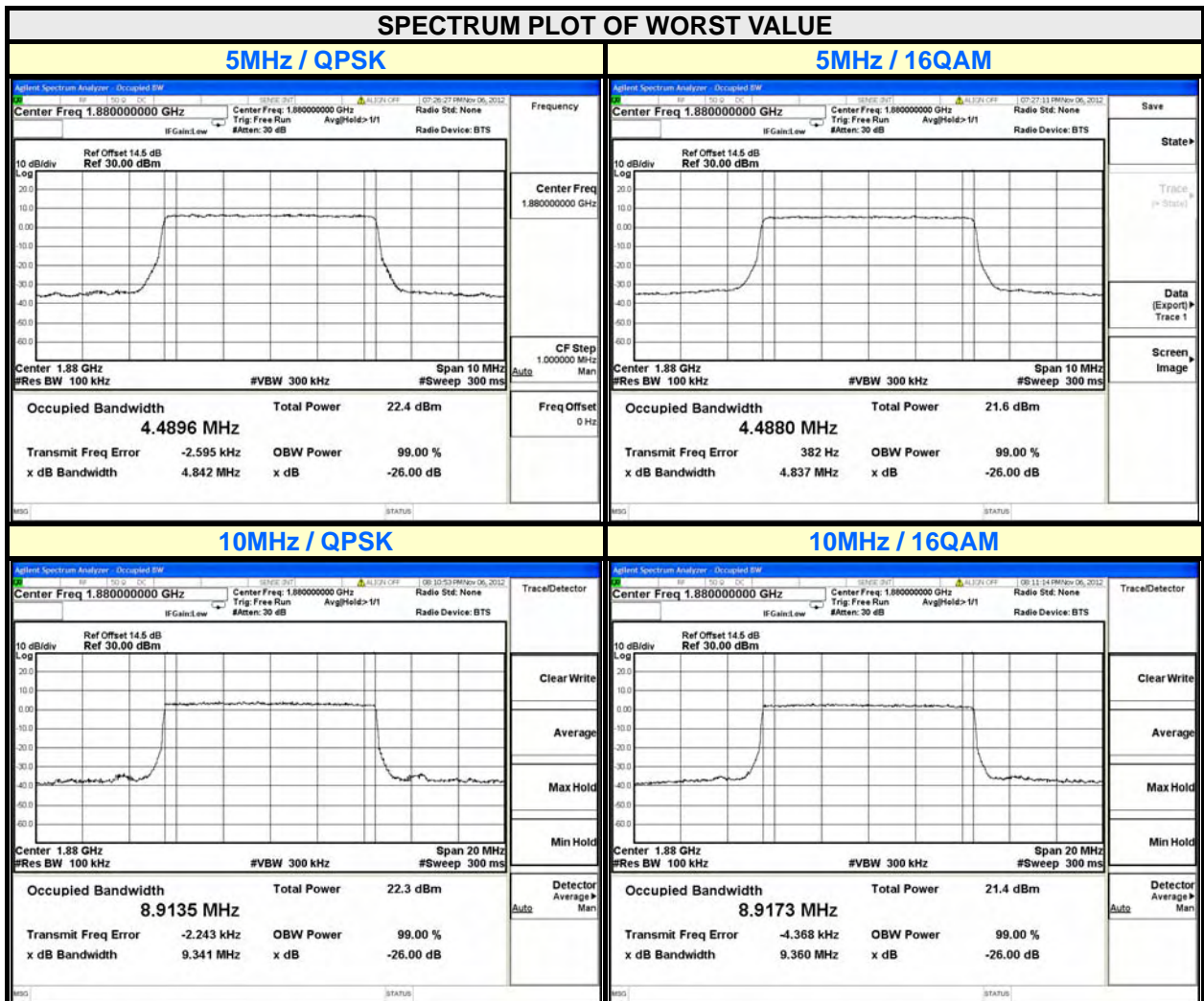



A D T

SPECTRUM PLOT OF WORST VALUE

15MHz / QPSK

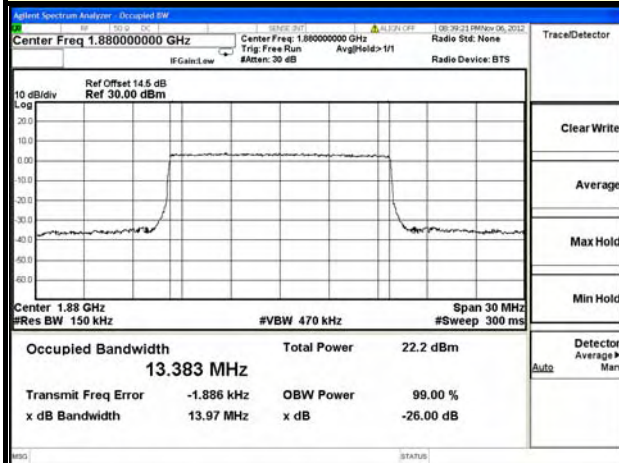

15MHz / 16QAM

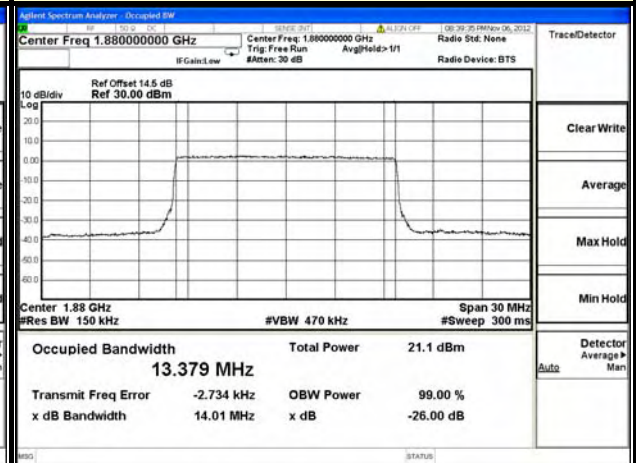

20MHz / QPSK

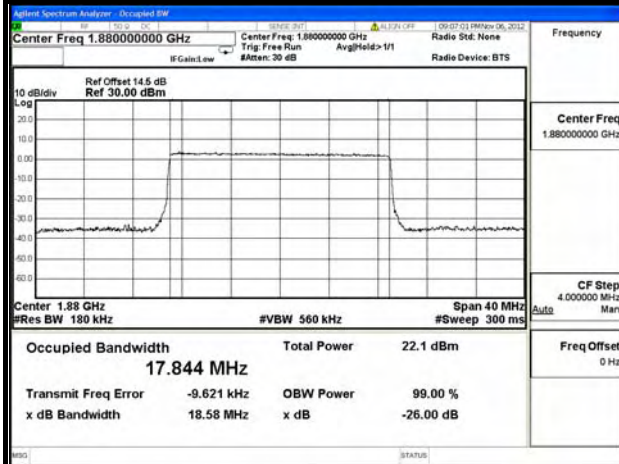

20MHz / 16QAM

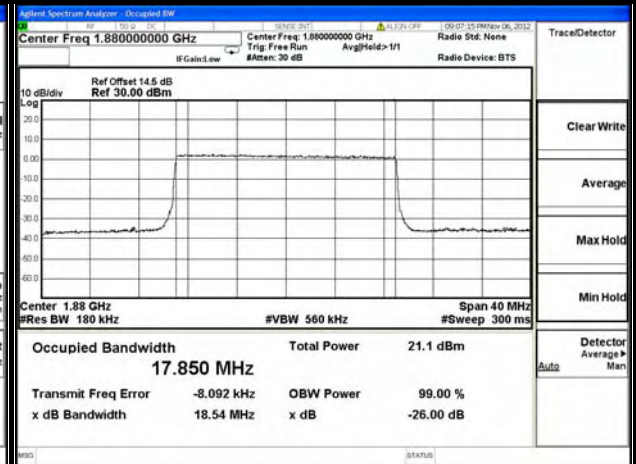



A D T

LTE BAND 25							
CHANNEL BANDWIDTH 5MHz				CHANNEL BANDWIDTH 10MHz			
CHANNEL	FREQUENCY (MHz)	99% OCCUPIED BANDWIDTH (MHz)		CHANNEL	FREQUENCY (MHz)	99% OCCUPIED BANDWIDTH (MHz)	
		QPSK	16QAM			QPSK	16QAM
26065	1860	4.4947	4.4868	26090	1855	8.9064	8.9129
26365	1882.5	4.4869	4.4866	26365	1882.5	8.9188	8.9172
26665	1912.5	4.4932	4.4854	26640	1910	8.9082	8.9067
CHANNEL BANDWIDTH 15MHz				CHANNEL BANDWIDTH 20MHz			
CHANNEL	FREQUENCY (MHz)	99% OCCUPIED BANDWIDTH (MHz)		CHANNEL	FREQUENCY (MHz)	99% OCCUPIED BANDWIDTH (MHz)	
		QPSK	16QAM			QPSK	16QAM
26115	1857.5	13.348	13.334	26140	1860	17.743	17.752
26365	1882.5	13.380	13.377	26365	1882.5	17.855	17.850
26615	1907.5	13.345	13.333	26590	1905	17.736	17.736

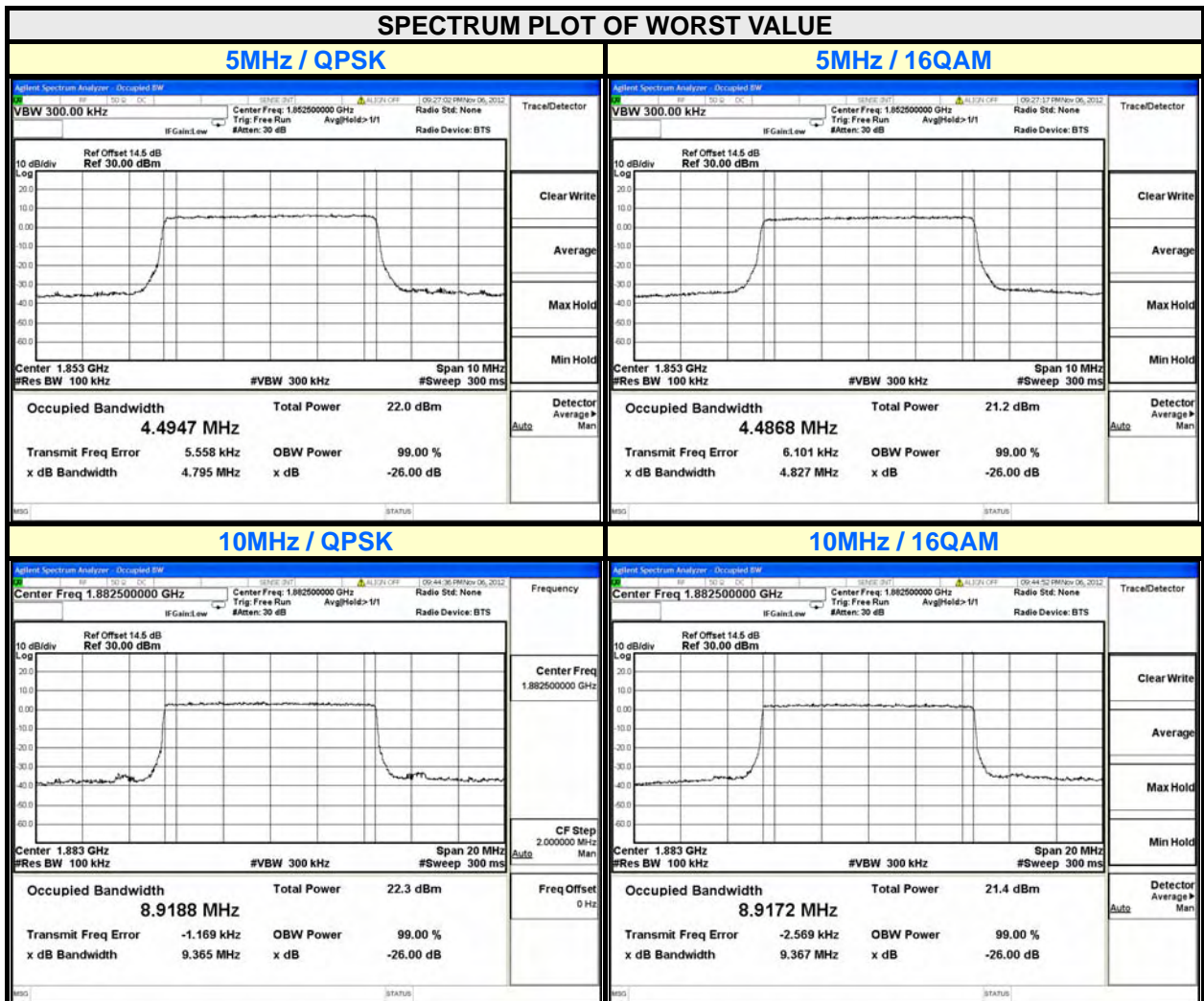



A D T

SPECTRUM PLOT OF WORST VALUE

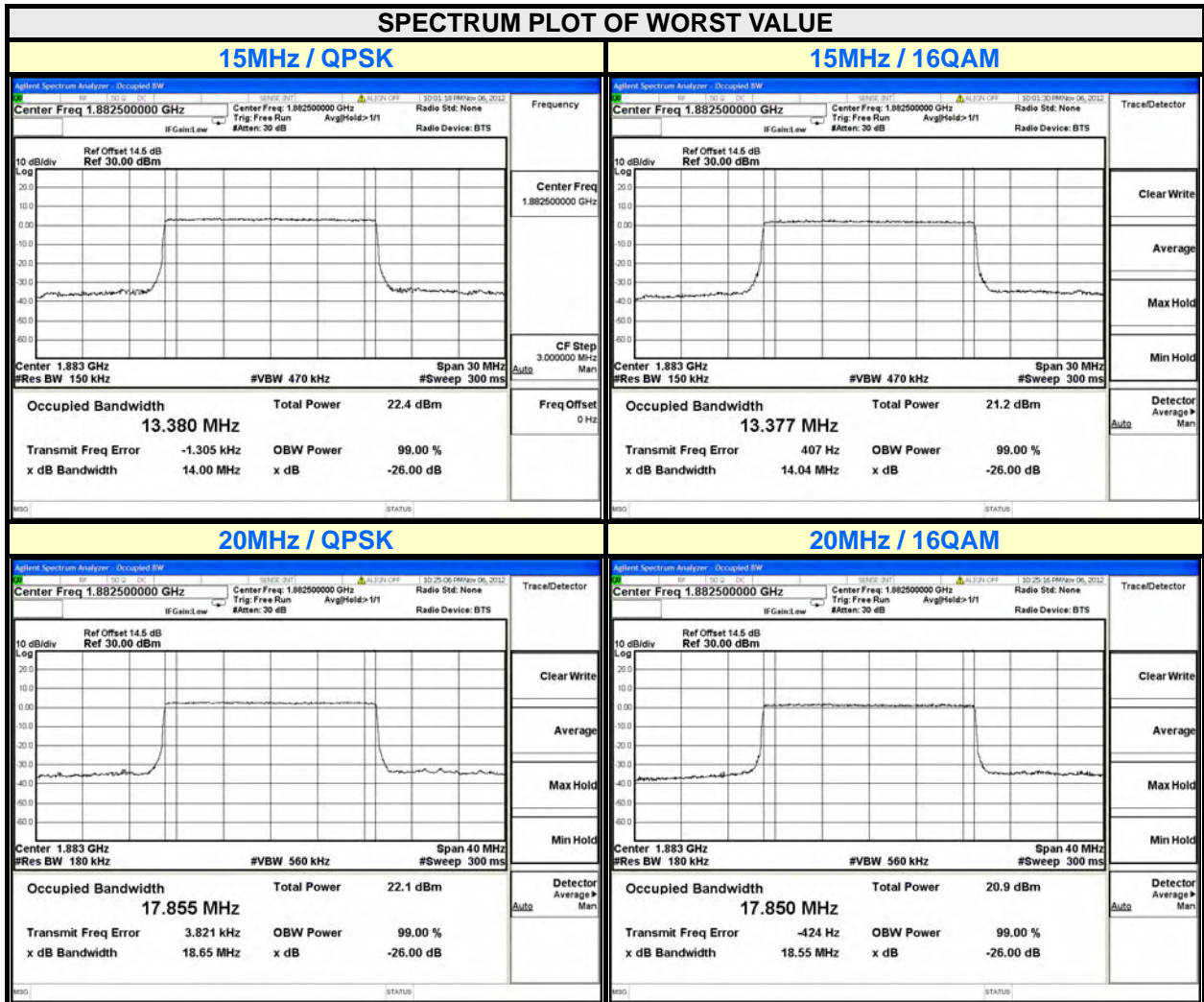

4.4 PEAK TO AVERAGE RATIO

4.4.1 LIMITS OF PEAK TO AVERAGE RATIO MEASUREMENT

In measuring transmissions in this band using an average power technique, the peak to average ratio (PAR) of the transmission may not exceed 13 dB

4.4.2 TEST SETUP

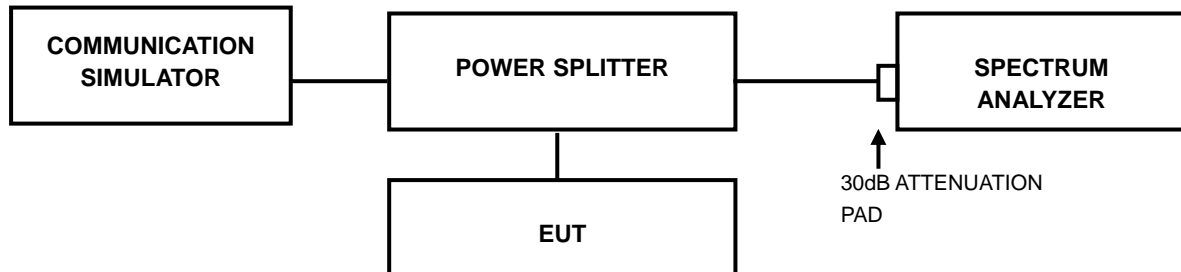

4.4.3 TEST PROCEDURES

1. Set resolution/measurement bandwidth \geq signal's occupied bandwidth;
2. Set the number of counts to a value that stabilizes the measured CCDF curve;
3. Record the maximum PAPR level associated with a probability of 0.1%.

4.4.4 TEST RESULTS

CHANNEL	FREQUENCY (MHz)	PEAK TO AVERAGE RATIO (dB)
		EVDO
25	1851.25	3.89
600	1880.00	3.56
1175	1908.75	3.57

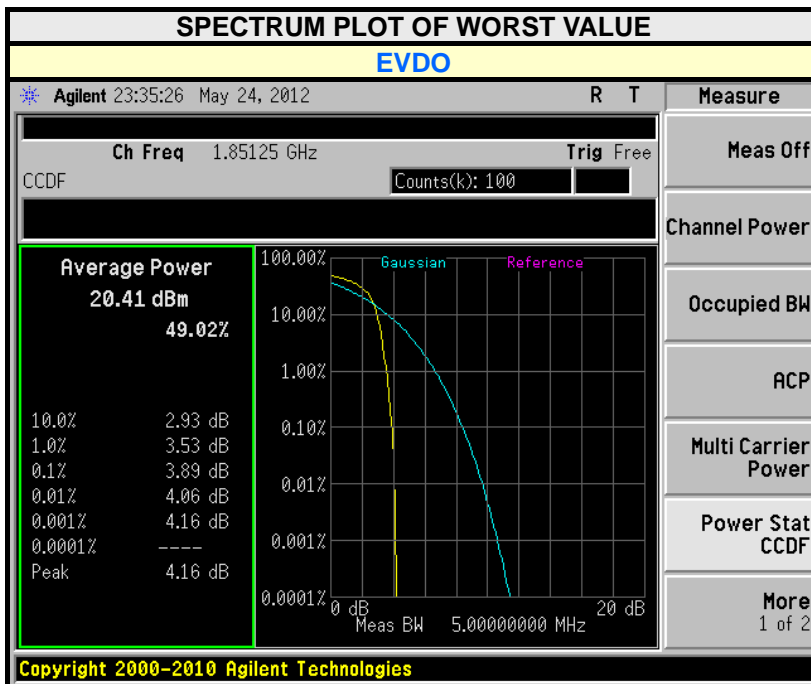



A D T

LTE BAND 2					
CHANNEL BANDWIDTH 5MHz			CHANNEL BANDWIDTH 10MHz		
CHANNEL	FREQUENCY (MHz)	PEAK TO AVERAGE RATIO (dB)	CHANNEL	FREQUENCY (MHz)	PEAK TO AVERAGE RATIO (dB)
18625	1852.5	5.38	18650	1855	5.33
18900	1880	4.98	18900	1880	4.92
19175	1907.5	5.09	19150	1905	4.70
CHANNEL BANDWIDTH 15MHz			CHANNEL BANDWIDTH 20MHz		
CHANNEL	FREQUENCY (MHz)	PEAK TO AVERAGE RATIO (dB)	CHANNEL	FREQUENCY (MHz)	PEAK TO AVERAGE RATIO (dB)
18675	1857.5	5.21	18700	1860	5.18
18900	1880	4.97	18900	1880	4.88
19125	1902.5	4.81	19100	1900	4.56

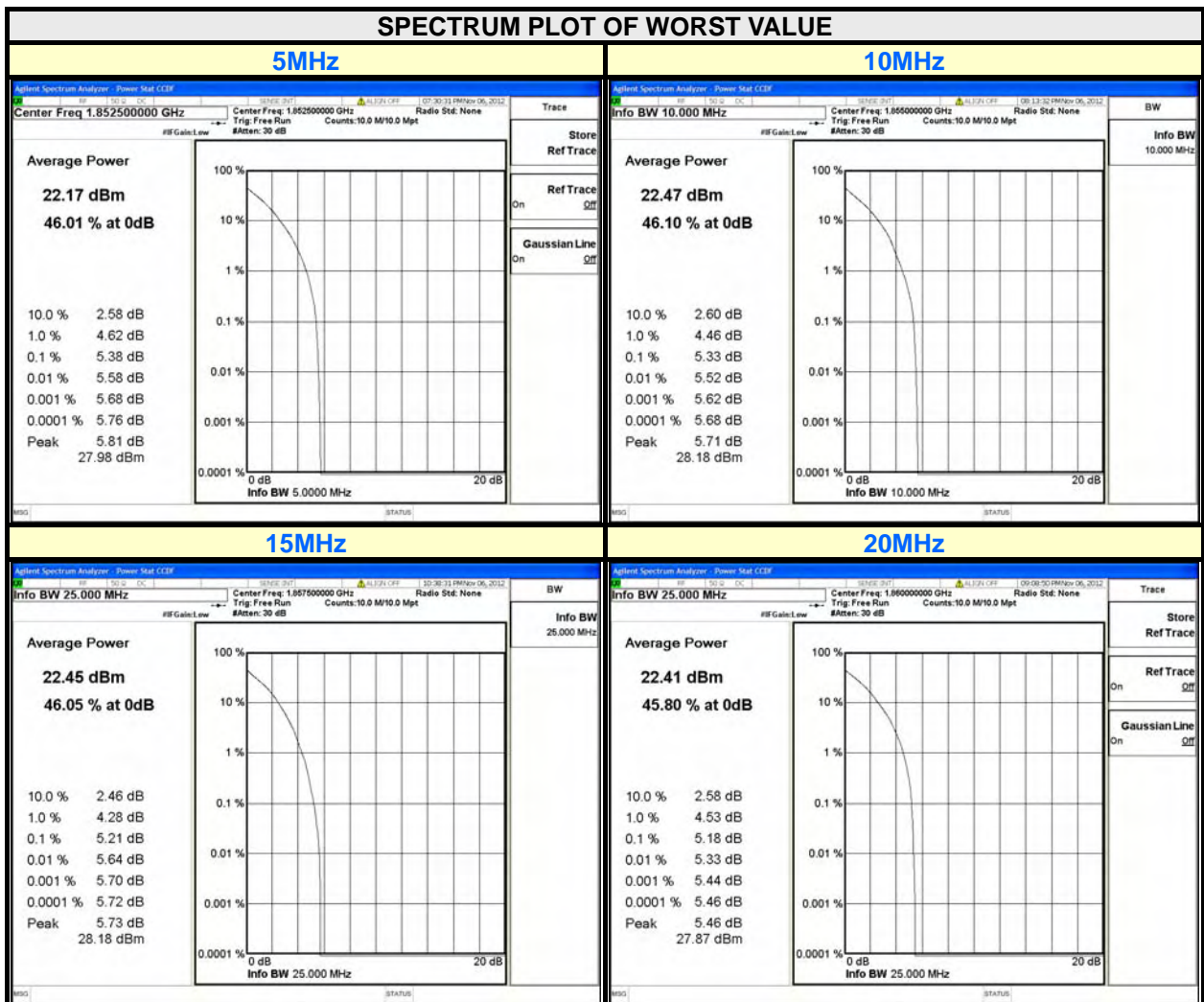



A D T

LTE BAND 25					
CHANNEL BANDWIDTH 5MHz			CHANNEL BANDWIDTH 10MHz		
CHANNEL	FREQUENCY (MHz)	PEAK TO AVERAGE RATIO (dB)	CHANNEL	FREQUENCY (MHz)	PEAK TO AVERAGE RATIO (dB)
26065	1860	5.25	26090	1855	5.32
26365	1882.5	4.90	26365	1882.5	4.94
26665	1912.5	4.83	26640	1910	5.06
CHANNEL BANDWIDTH 15MHz			CHANNEL BANDWIDTH 20MHz		
CHANNEL	FREQUENCY (MHz)	PEAK TO AVERAGE RATIO (dB)	CHANNEL	FREQUENCY (MHz)	PEAK TO AVERAGE RATIO (dB)
26115	1857.5	4.90	26140	1860	5.11
26365	1882.5	4.89	26365	1882.5	5.48
26615	1907.5	4.70	26590	1905	5.27

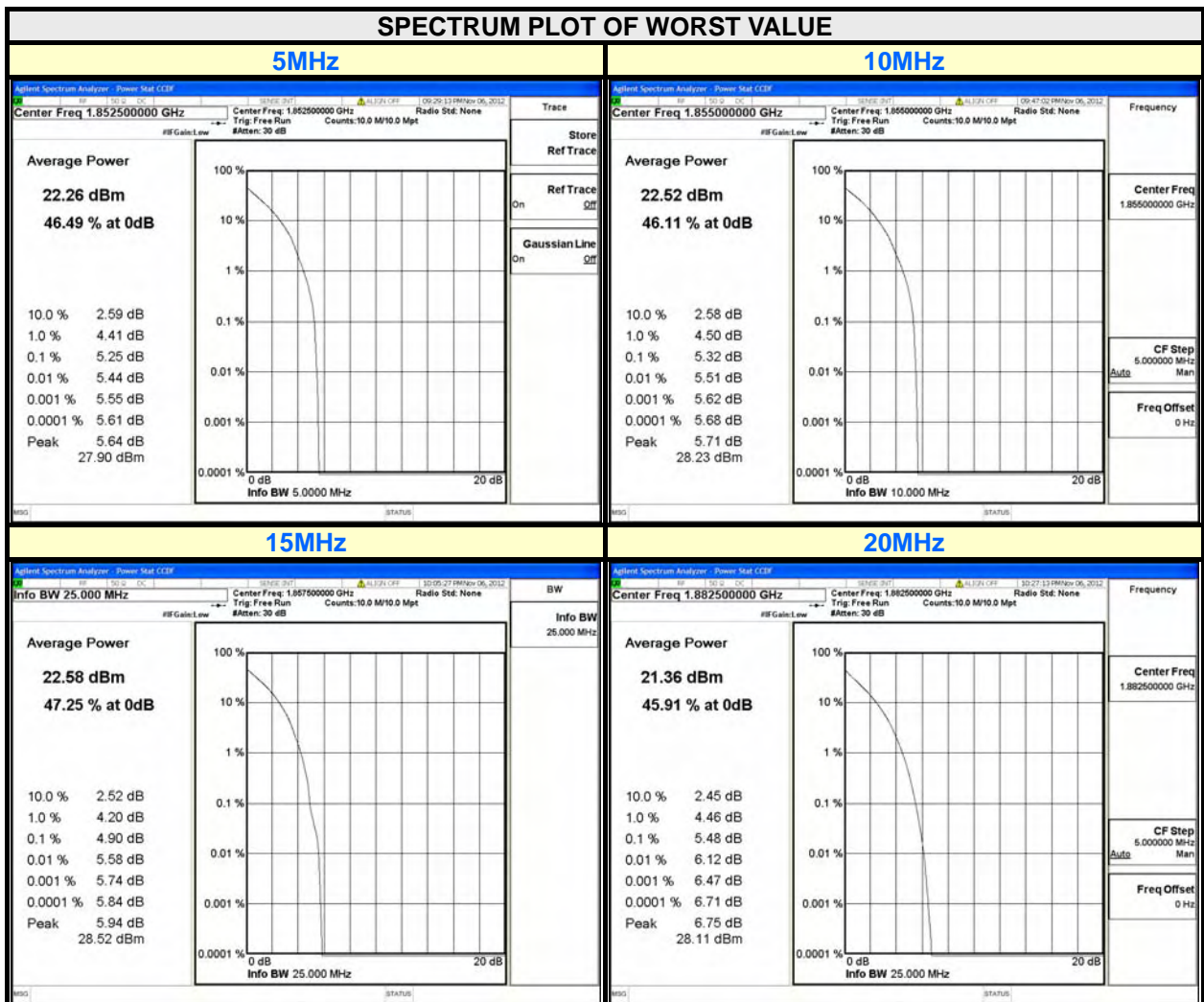

4.5 BAND EDGE MEASUREMENT

4.5.1 LIMITS OF BAND EDGE MEASUREMENT

Power of any emission outside of the authorized operating frequency ranges must be attenuated below the transmitting power (P) by a factor of at least $43 + 10 \log(P)$ dB. In the 1 MHz bands immediately outside and adjacent to the frequency block a resolution bandwidth of at least one percent of the emission bandwidth of the fundamental emission of the transmitter may be employed.

4.5.2 TEST SETUP

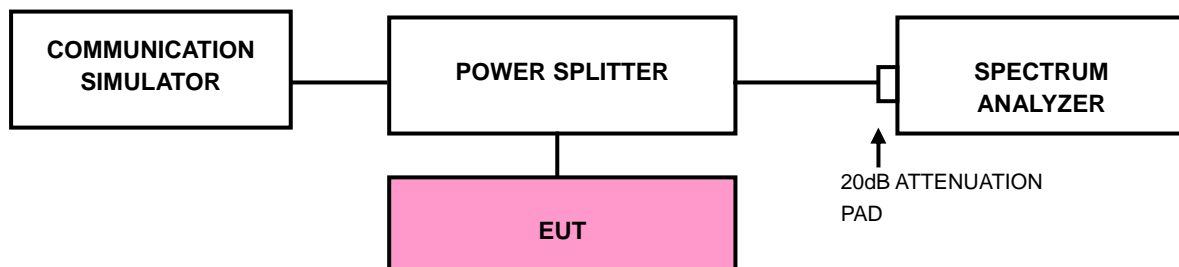

4.5.3 TEST PROCEDURES

- a. All measurements were done at low and high operational frequency range.
- b. The center frequency of spectrum is the band edge frequency and span is 3MHz. RB of the spectrum is 15kHz and VB of the spectrum is 15kHz (EVDO).
- c. The center frequency of spectrum is the band edge frequency and span is 1MHz. RB of the spectrum is 100kHz and VB of the spectrum is 300kHz (LTE Channel Bandwidth 5MHz and 10MHz).
- d. The center frequency of spectrum is the band edge frequency and span is 1MHz. RB of the spectrum is 150kHz and VB of the spectrum is 470kHz (LTE Channel Bandwidth 15MHz).
- e. The center frequency of spectrum is the band edge frequency and span is 1MHz. RB of the spectrum is 180kHz and VB of the spectrum is 560kHz (LTE Channel Bandwidth 20MHz).
- f. Record the max trace plot into the test report.



A D T

4.5.4 TEST RESULTS

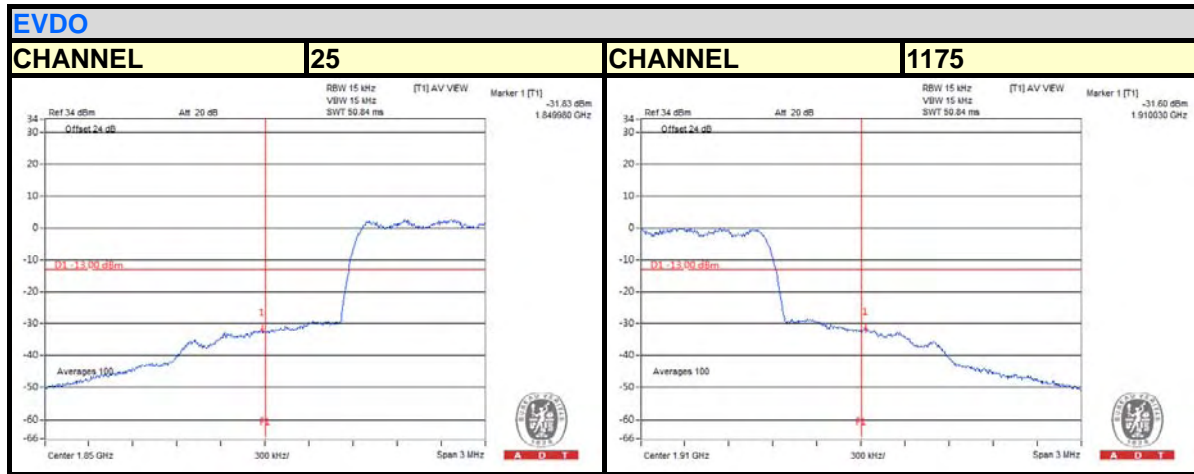



A D T

LTE Band 2

Channel Bandwidth 5MHz

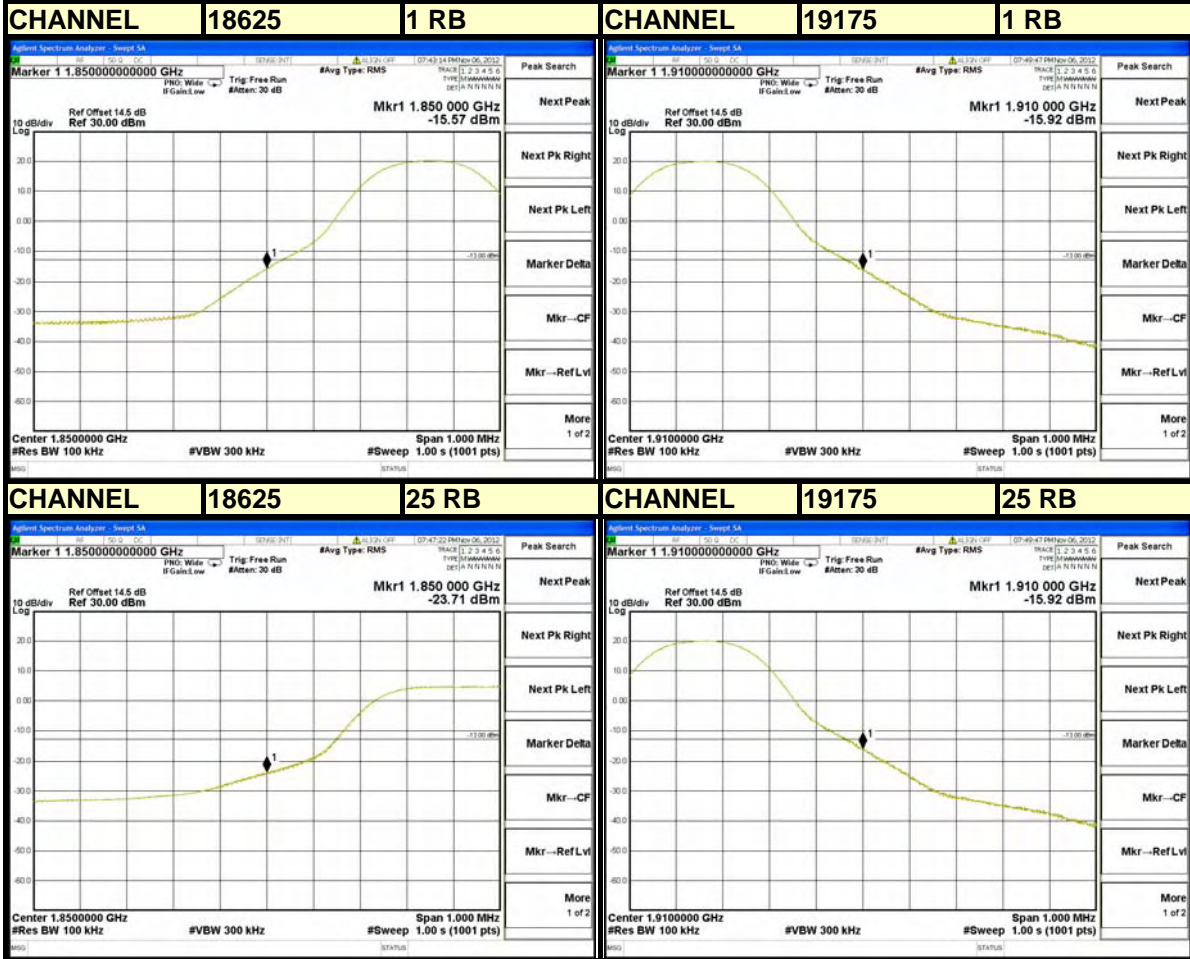



A D T

LTE Band 2

Channel Bandwidth 10MHz

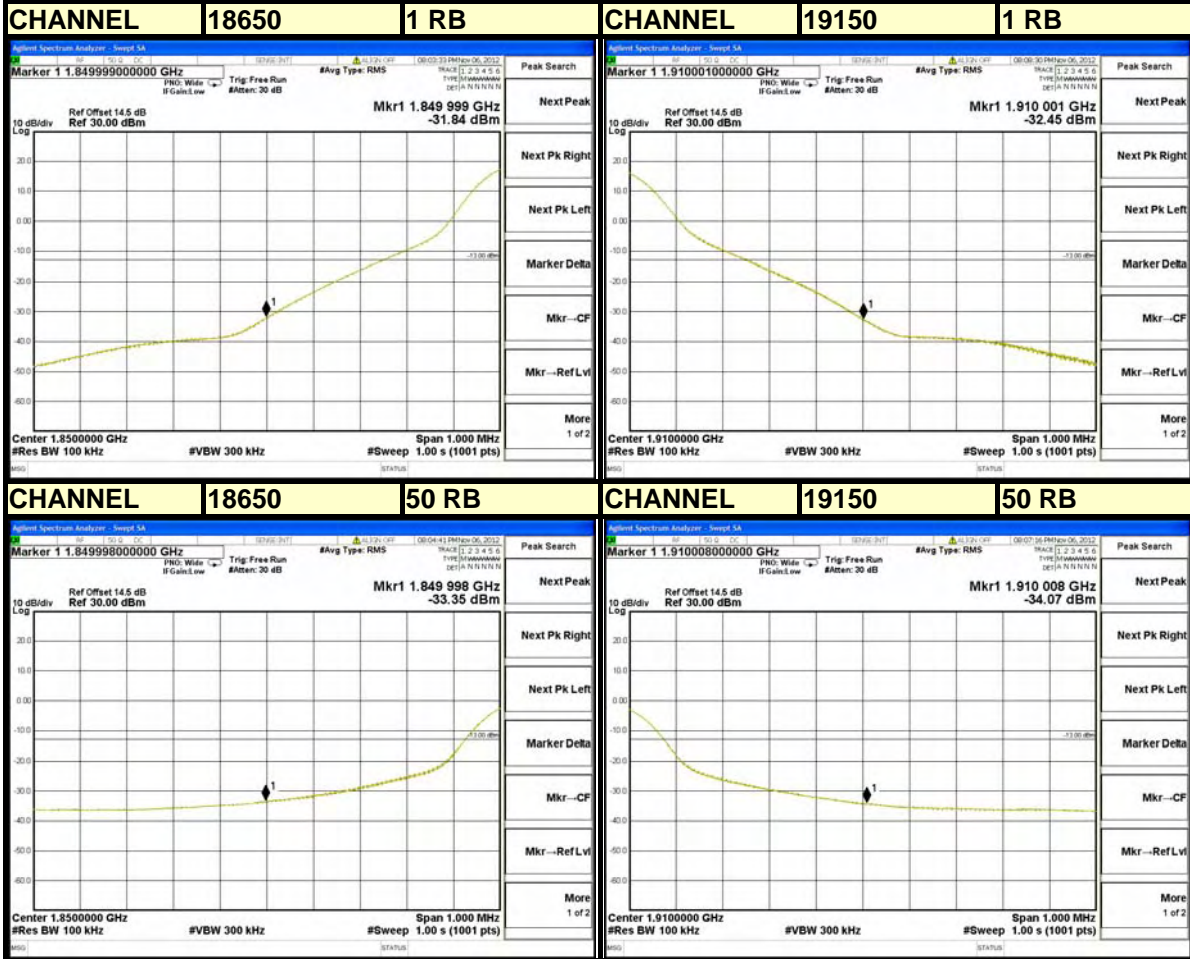



A D T

LTE Band 2

Channel Bandwidth 15MHz

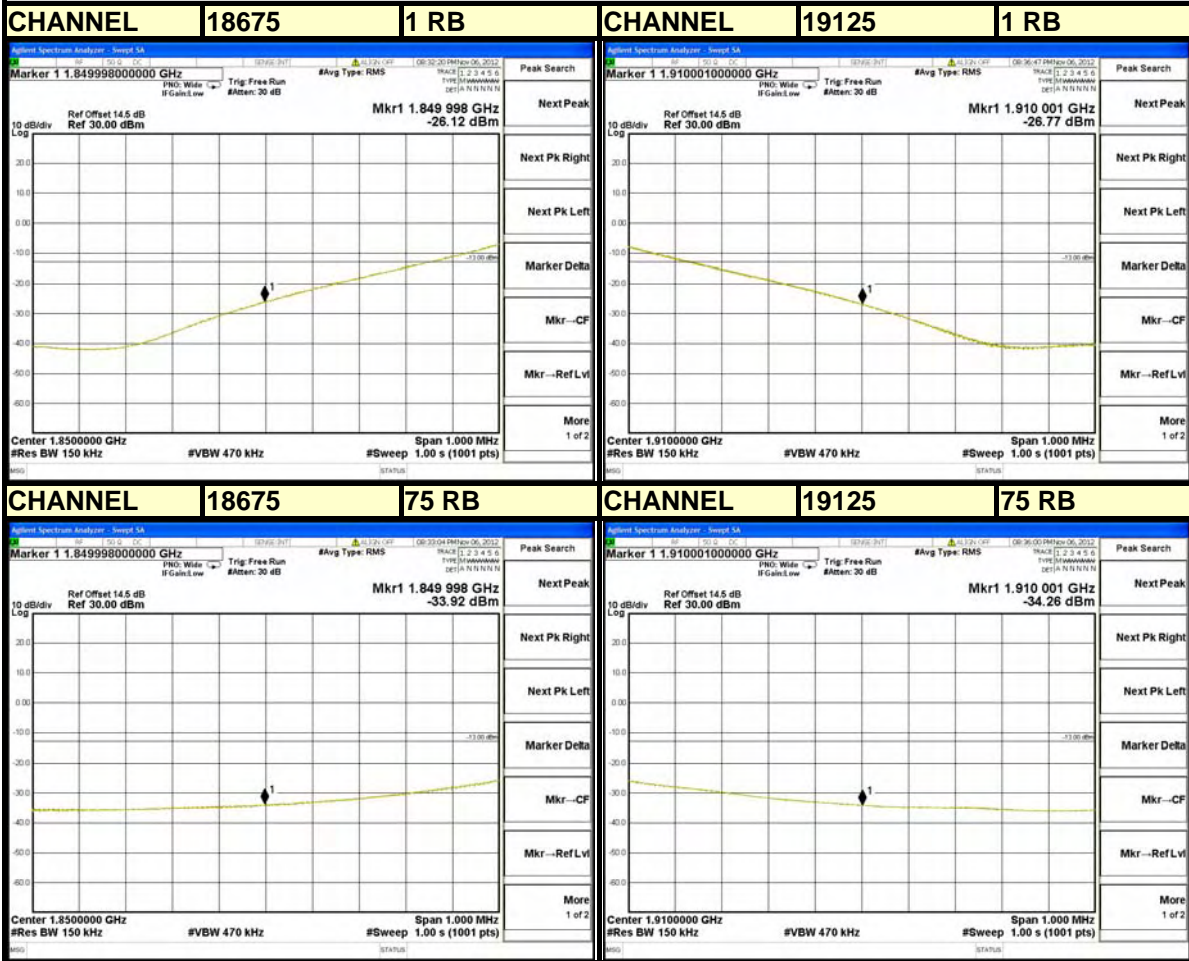



A D T

LTE Band 2

Channel Bandwidth 20MHz

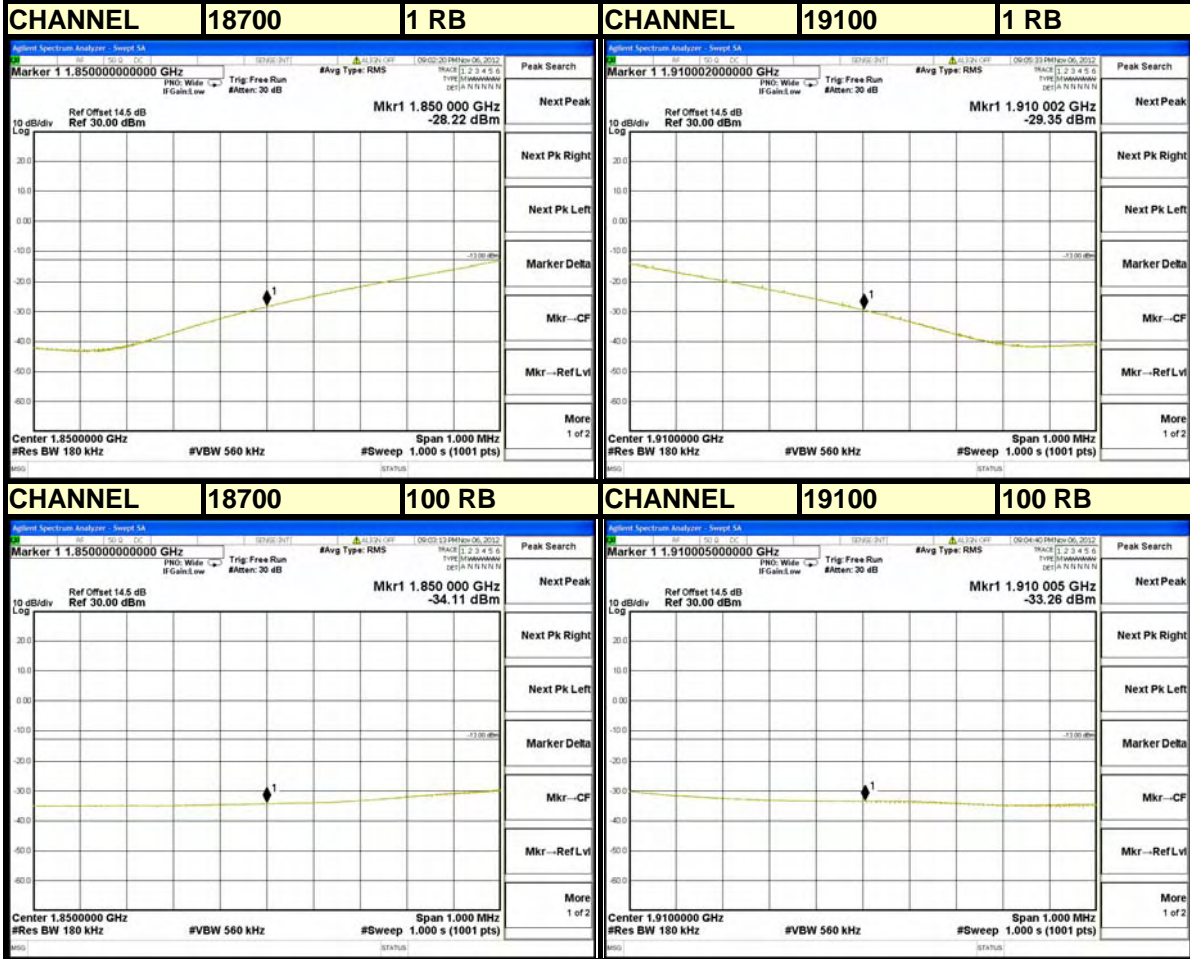



A D T

LTE Band 25

Channel Bandwidth 5MHz

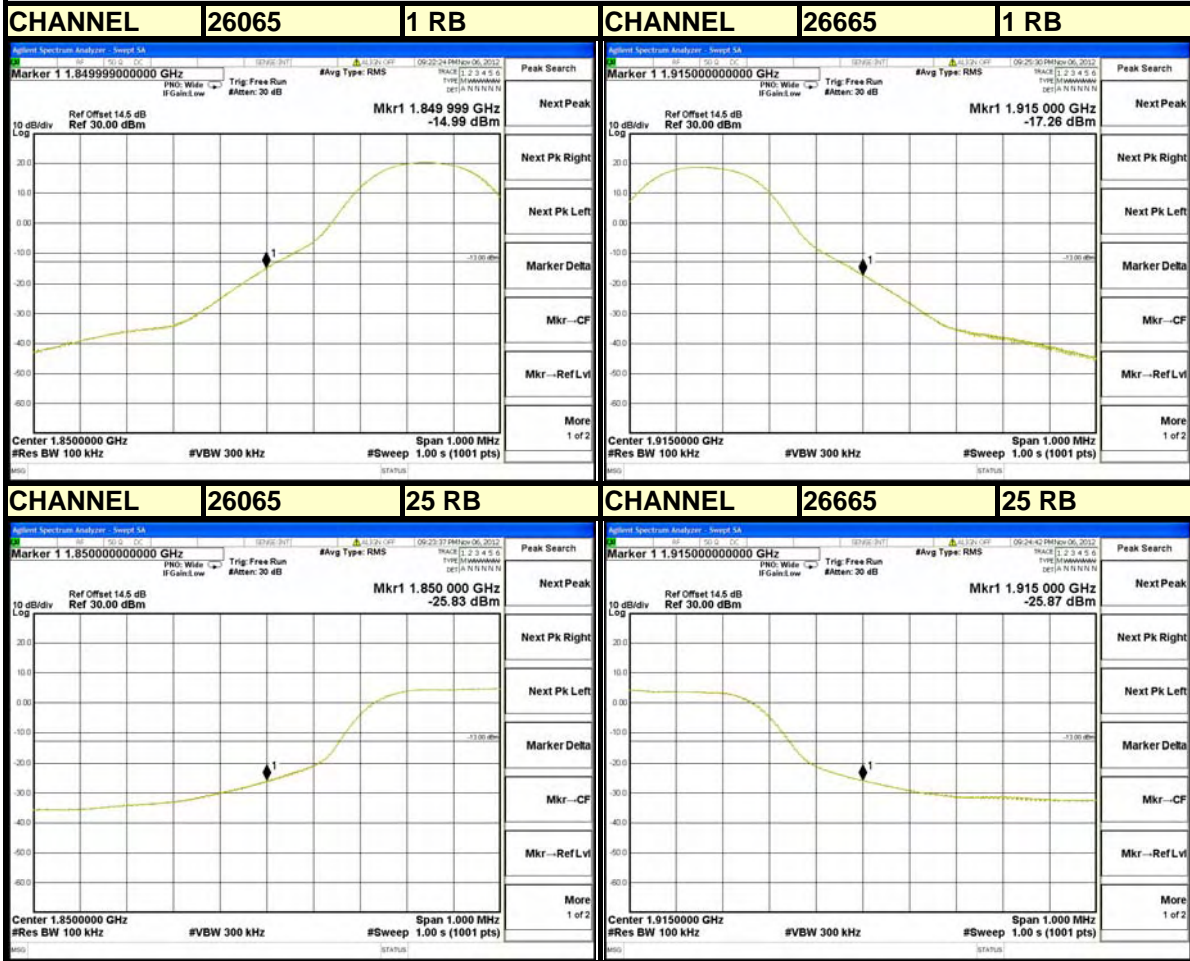



A D T

LTE Band 25

Channel Bandwidth 10MHz

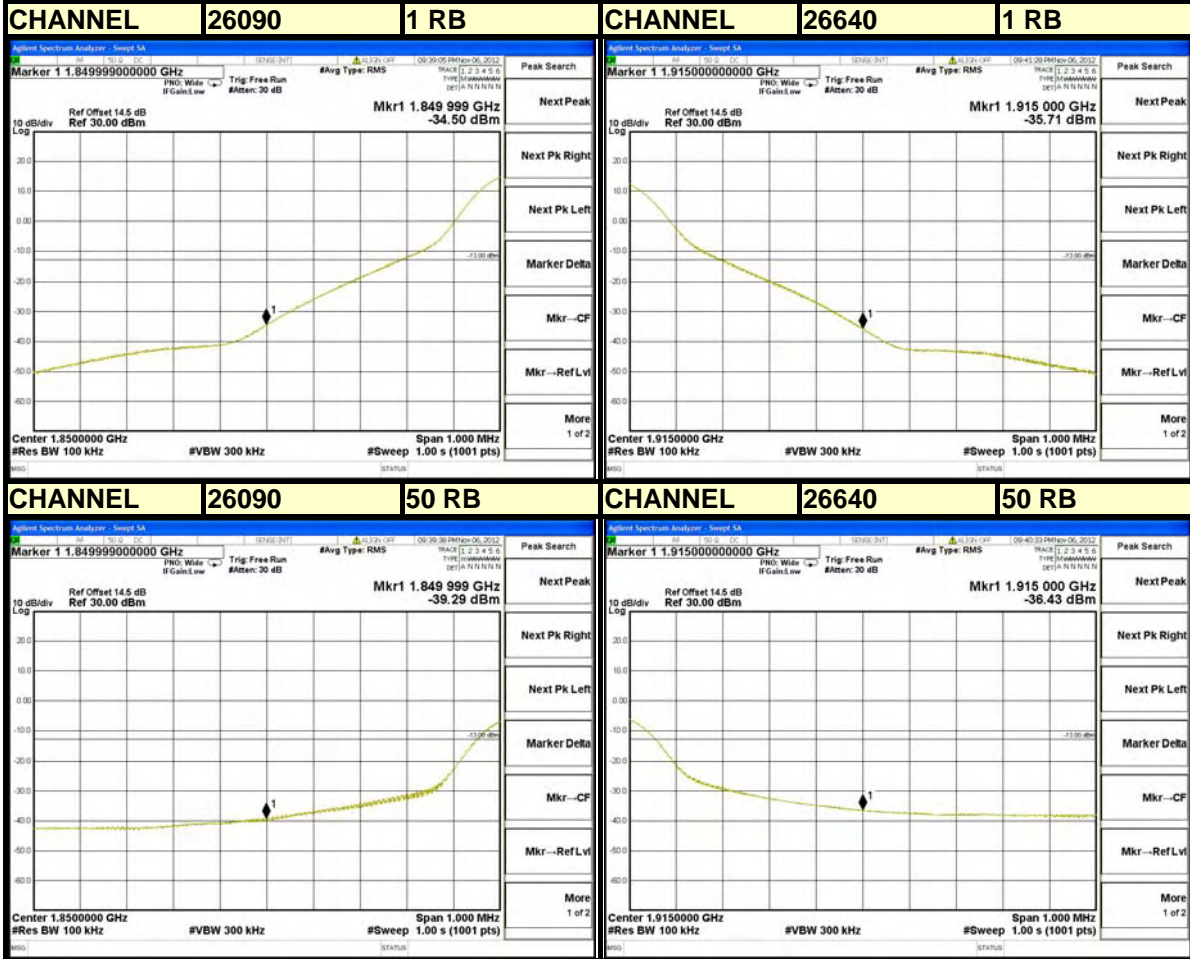



A D T

LTE Band 25

Channel Bandwidth 15MHz

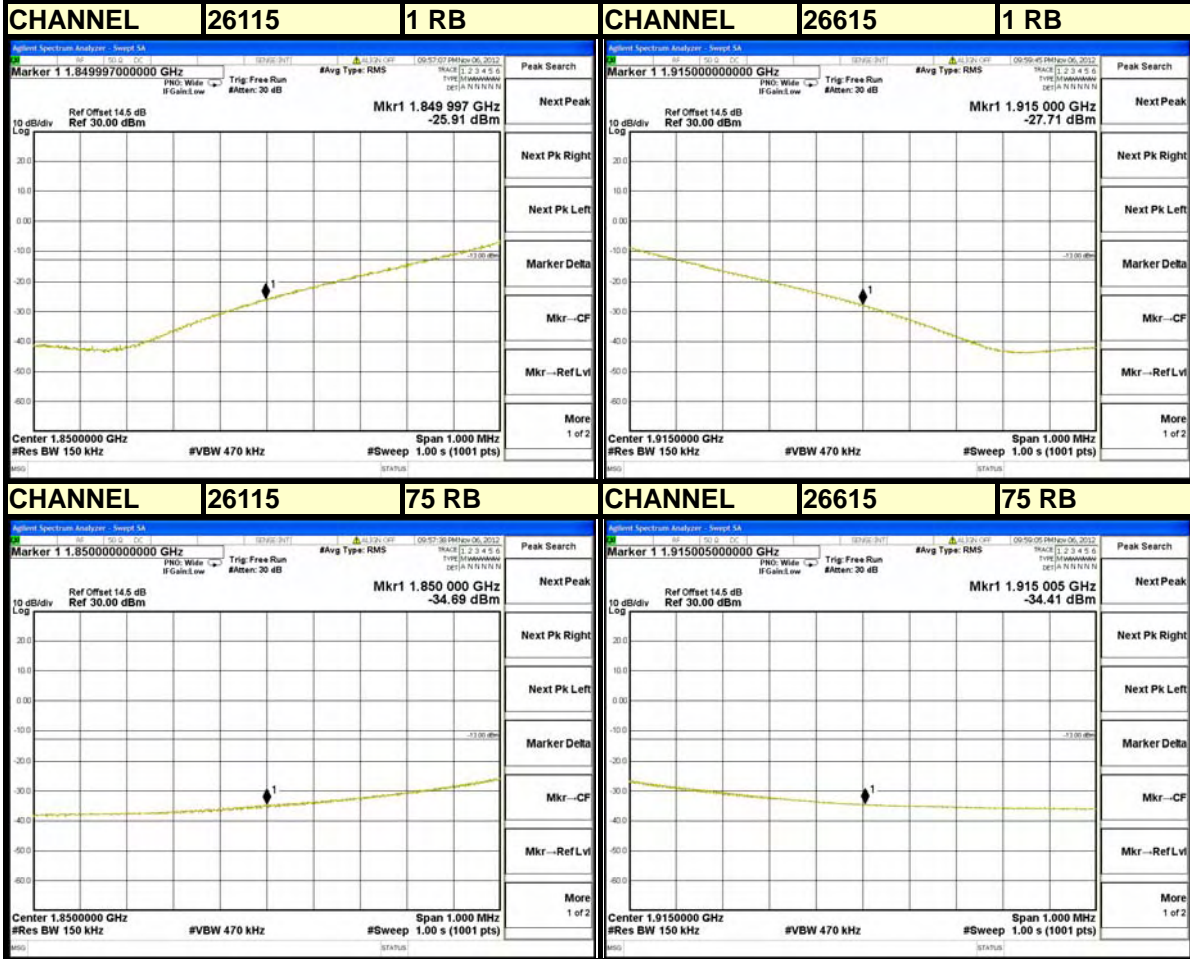



A D T

LTE Band 25

Channel Bandwidth 20MHz

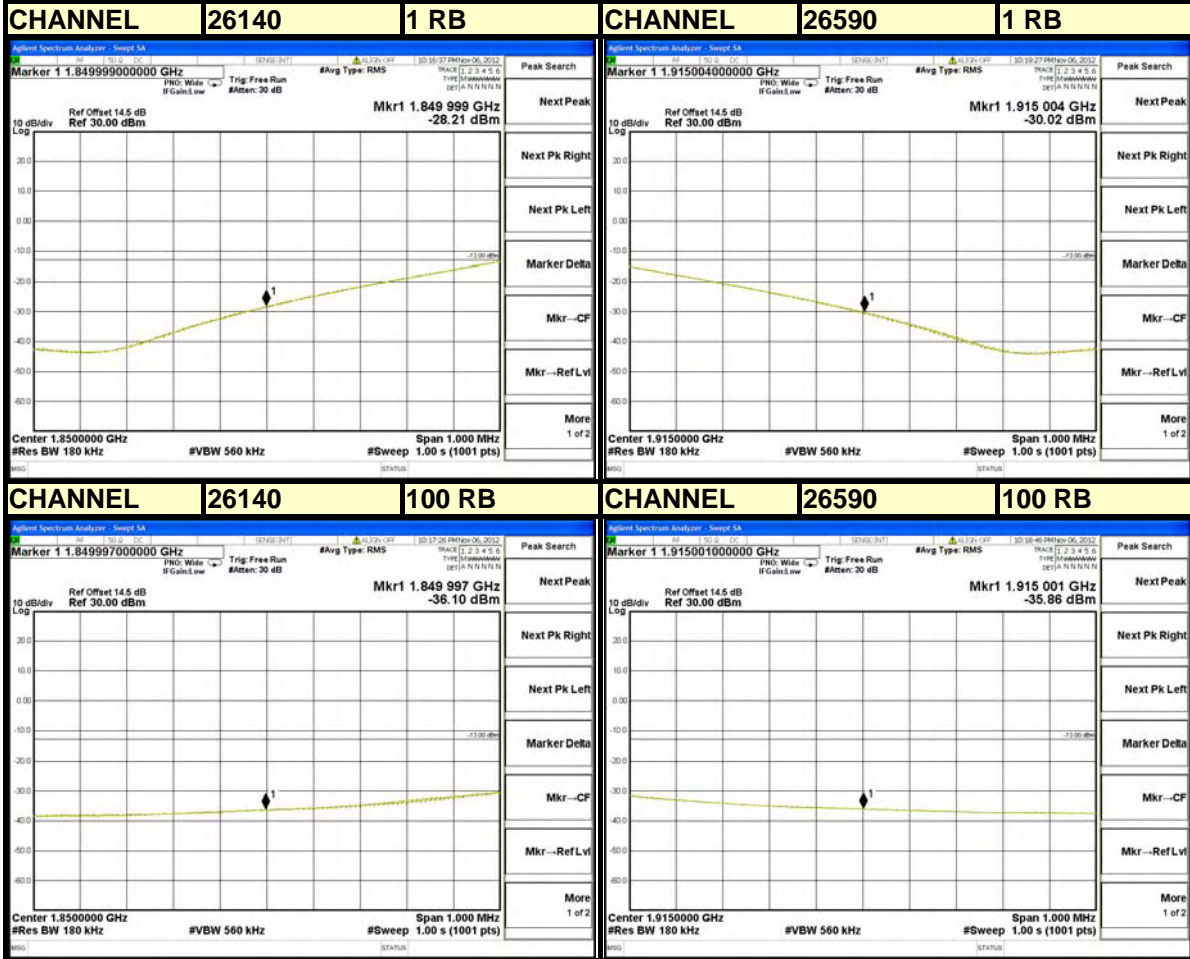

4.6 CONDUCTED SPURIOUS EMISSIONS

4.6.1 LIMITS OF CONDUCTED SPURIOUS EMISSIONS MEASUREMENT

The power of any emission outside of the authorized operating frequency ranges must be attenuated below the transmitting power (P) by a factor of at least $43 + 10 \log(P)$ dB. The emission limit equal to -13dBm .

4.6.2 TEST PROCEDURE

- a. The EUT makes a phone call to the communication simulator. All measurements were done at low, middle and high operational frequency range.
- b. Measuring frequency range is from 30MHz to 19.1GHz (LTE) and from 9kHz to 20GHz (EVDO). 20dB attenuation pad is connected with spectrum. RBW=1MHz and VBW=3MHz is used for conducted emission measurement.

4.6.3 TEST SETUP

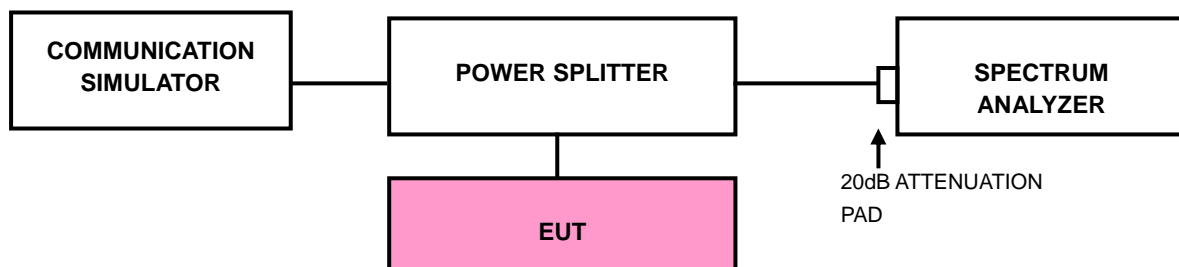



A D T

4.6.4 TEST RESULTS





A D T

LTE Band 2 (Channel Bandwidth 5MHz)

CHANNEL 18900

FREQUENCY RANGE : 30MHz~19.1GHz

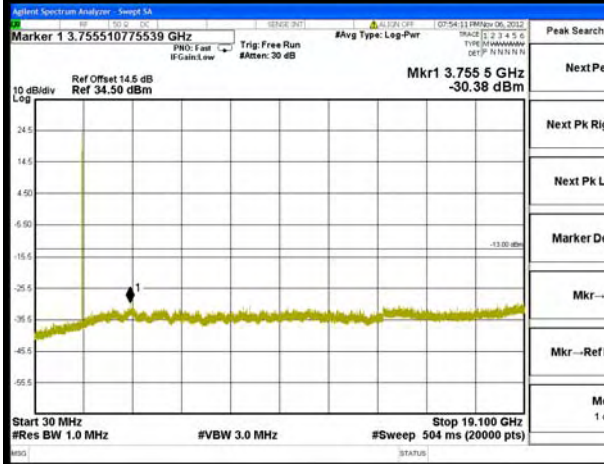

LTE Band 2 (Channel Bandwidth 10MHz)

CHANNEL 18900

FREQUENCY RANGE : 30MHz~19.1GHz

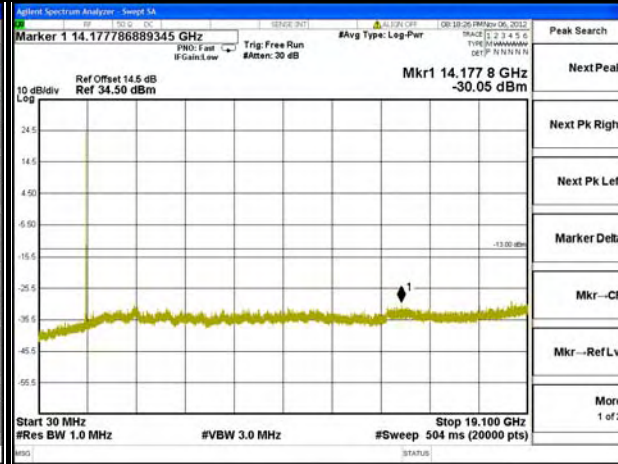

LTE Band 2 (Channel Bandwidth 15MHz)

CHANNEL 18900

FREQUENCY RANGE : 30MHz~19.1GHz

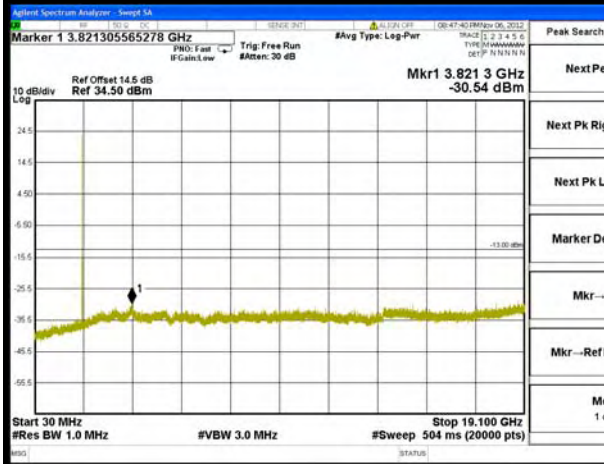

LTE Band 2 (Channel Bandwidth 20MHz)

CHANNEL 18900

FREQUENCY RANGE : 30MHz~19.1GHz

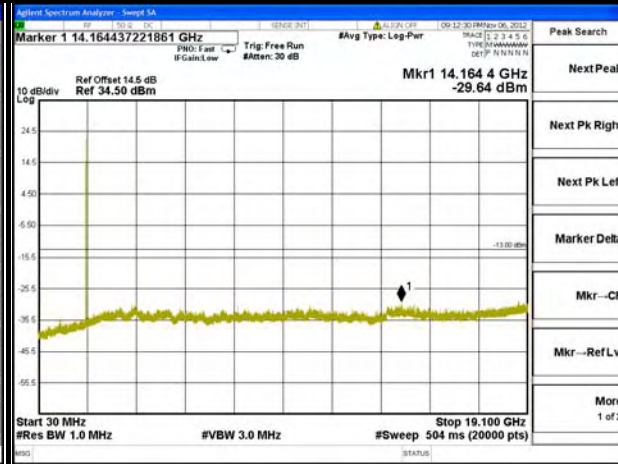



A D T

LTE Band 25 (Channel Bandwidth 5MHz)

CHANNEL 26365

FREQUENCY RANGE : 30MHz~19.1GHz

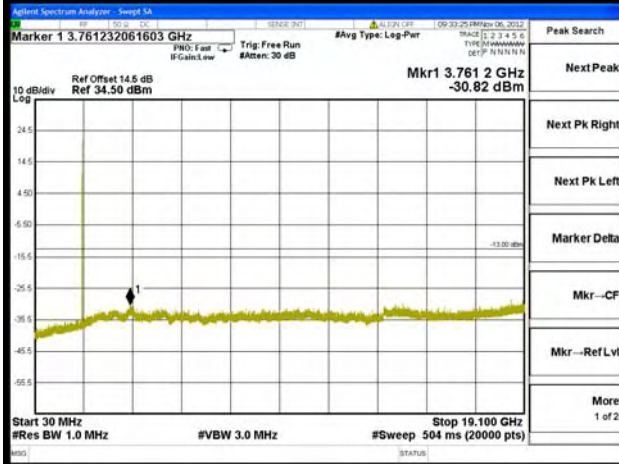

LTE Band 25 (Channel Bandwidth 10MHz)

CHANNEL 26365

FREQUENCY RANGE : 30MHz~19.1GHz

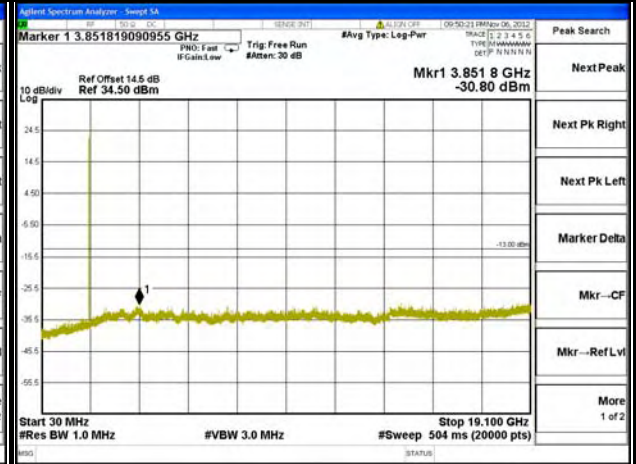

LTE Band 25 (Channel Bandwidth 15MHz)

CHANNEL 26365

FREQUENCY RANGE : 30MHz~19.1GHz

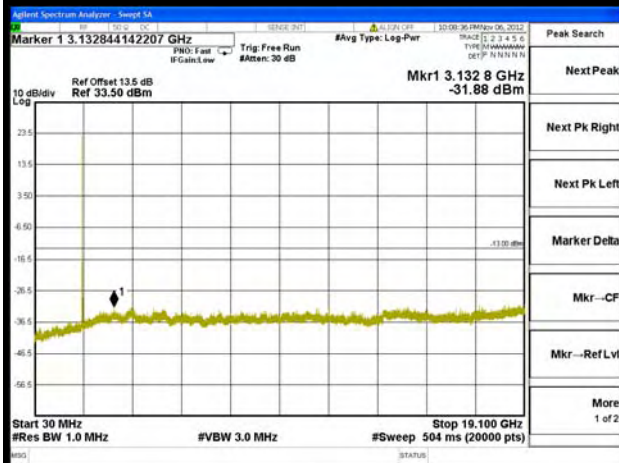

LTE Band 25 (Channel Bandwidth 20MHz)

CHANNEL 26365

FREQUENCY RANGE : 30MHz~19.1GHz

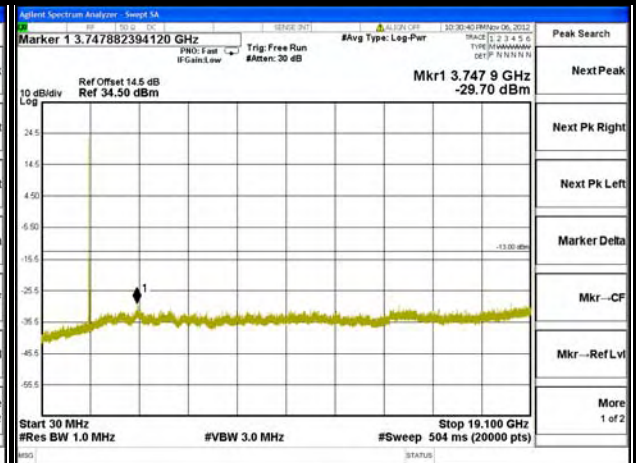

4.7 RADIATED EMISSION MEASUREMENT

4.7.1 LIMITS OF RADIATED EMISSION MEASUREMENT

The power of any emission outside of the authorized operating frequency ranges must be attenuated below the transmitting power (P) by a factor of at least $43 + 10 \log(P)$ dB. The emission limit equal to -13dBm .

4.7.2 TEST PROCEDURES

- a. Substitution method is used for E.I.R.P measurement. In the semi-anechoic chamber, EUT placed on the 0.8m height of Turn Table, rotated the table around 360 degrees to search the maximum radiation power and receiver antenna shall be rotated vertical and horizontal polarization and moved height from 1m to 4m to find the maximum polar radiated power. The “Read Value” is the spectrum reading the maximum power value.
- b. The substitution horn antenna is substituted for EUT at the same position and signals generator export the CW signal to the substitution antenna via a TX cable. Rotated the Turn Table and moved receiving antenna to find the maximum radiation power. Adjust output power level of S.G to get a Value of spectrum reading equal to “Read Value” of step a. Record the power level of S.G
- c. $\text{EIRP} = \text{Output power level of S.G} - \text{TX cable loss} + \text{Antenna gain of substitution horn}$.
- d. E.R.P power can be calculated form E.I.R.P power by subtracting the gain of dipole, $\text{E.R.P power} = \text{E.I.R.P power} - 2.15\text{dBi}$.

NOTE: The resolution bandwidth and video bandwidth of test receiver/spectrum analyzer is 1MHz/3MHz.

4.7.3 DEVIATION FROM TEST STANDARD

No deviation

4.7.4 TEST SETUP

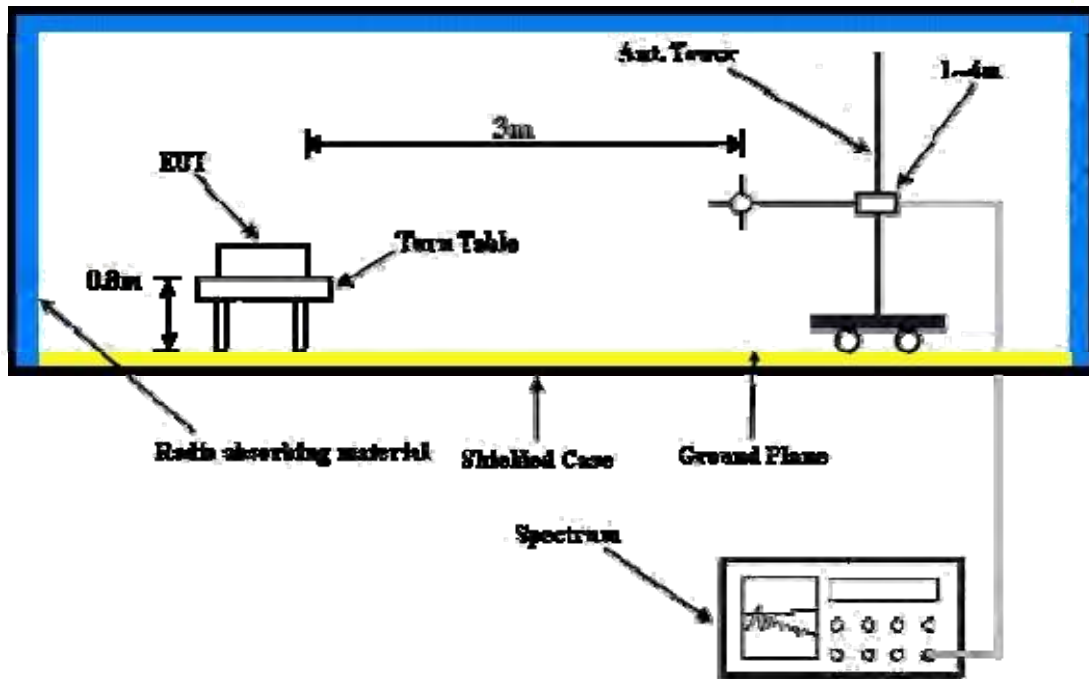

For the actual test configuration, please refer to the attached file (Test Setup Photo).

4.7.5 TEST RESULTS

EVDO

MODE	TX channel 600	FREQUENCY RANGE	Below 1000MHz
ENVIRONMENTAL CONDITIONS	25deg. C, 65%RH	INPUT POWER	120Vac, 60Hz
TESTED BY	Chris Lin		

ANTENNA POLARITY & TEST DISTANCE: HORIZONTAL AT 3 M							
No.	Freq. (MHz)	Reading (dBm)	S.G Power Value (dBm)	Correction Factor (dB)	EIRP (dBm)	Limit (dBm)	Margin (dB)
1	105.66	-47.48	-53.78	0.65	-53.13	-13.00	-40.13
2	210.42	-47.56	-59.28	5.46	-53.82	-13.00	-40.82
3	334.58	-50.87	-58.71	5.18	-53.53	-13.00	-40.53
4	357.86	-52.38	-59.41	5.22	-54.19	-13.00	-41.19
5	714.82	-67.92	-68.36	5.07	-63.29	-13.00	-50.29
6	827.34	-67.08	-64.24	3.98	-60.26	-13.00	-47.26
ANTENNA POLARITY & TEST DISTANCE: VERTICAL AT 3 M							
No.	Freq. (MHz)	Reading (dBm)	S.G Power Value (dBm)	Correction Factor (dB)	EIRP (dBm)	Limit (dBm)	Margin (dB)
1	31.94	-38.64	-33.65	-12.37	-46.02	-13.00	-33.02
2	55.22	-44.54	-41.44	-8.63	-50.07	-13.00	-37.07
3	214.30	-52.96	-60.88	5.46	-55.42	-13.00	-42.42
4	336.52	-58.06	-63.30	5.19	-58.11	-13.00	-45.11
5	712.88	-67.48	-64.47	5.09	-59.38	-13.00	-46.38
6	961.20	-69.24	-60.77	3.91	-56.86	-13.00	-43.86

REMARKS:

1. Power Value (dBm) = S.G Power Value (dBm) + Correction Factor (dB).
2. Correction Factor (dB) = Substitution Antenna Gain (dB) + Cable Loss (dB).



A D T

MODE	TX channel 600	FREQUENCY RANGE	Above 1000MHz
ENVIRONMENTAL CONDITIONS	25deg. C, 65%RH	INPUT POWER	120Vac, 60Hz
TESTED BY	Chris Lin		

ANTENNA POLARITY & TEST DISTANCE: HORIZONTAL AT 3 M							
No.	Freq. (MHz)	Reading (dBm)	S.G Power Value (dBm)	Correction Factor (dB)	EIRP (dBm)	Limit (dBm)	Margin (dB)
1	3760.00	-45.52	-39.46	7.10	-32.36	-13.00	-19.36
2	5640.00	-57.14	-45.12	6.77	-38.35	-13.00	-25.35
3	7520.00	-60.85	-43.07	4.23	-38.84	-13.00	-25.84
ANTENNA POLARITY & TEST DISTANCE: VERTICAL AT 3 M							
No.	Freq. (MHz)	Reading (dBm)	S.G Power Value (dBm)	Correction Factor (dB)	EIRP (dBm)	Limit (dBm)	Margin (dB)
1	3760.00	-46.98	-41.11	7.10	-34.01	-13.00	-21.01
2	5640.00	-58.47	-47.42	6.77	-40.65	-13.00	-27.65
3	7520.00	-61.88	-45.63	4.23	-41.40	-13.00	-28.40

REMARKS:

1. Power Value (dBm) = S.G Power Value (dBm) + Correction Factor (dB).
2. Correction Factor (dB) = Substitution Antenna Gain (dB) + Cable Loss (dB).



A D T

LTE Band 2 (Channel Bandwidth 5MHz)



Bureau Veritas Consumer Products Services Ltd., Taoyuan Branch

A D T

Data: 15

Date: 2012-11-07

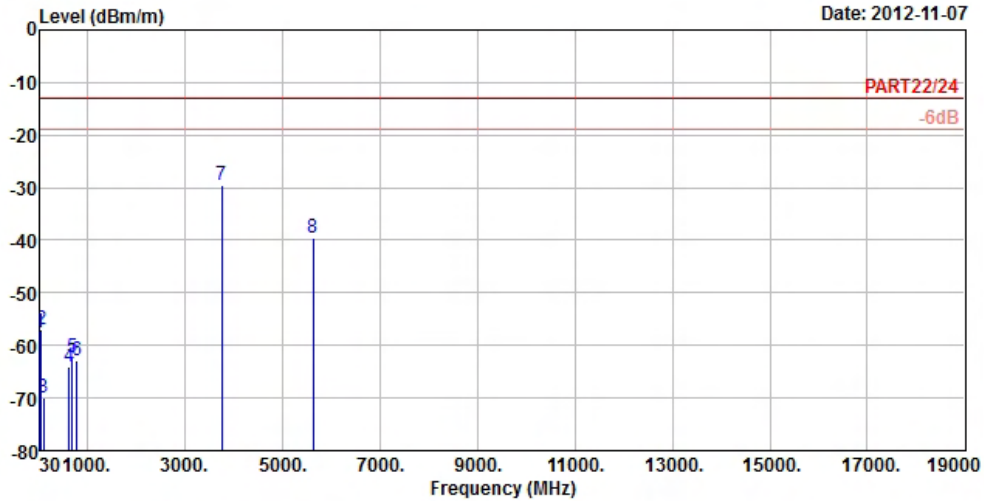

Site : 966 Chamber 5
 Condition : PART22/24 3m EIRP_RSE_1G~19G_3 HORIZONTAL
 Brand/Model: P530A
 Remark : Band 2_5M_(QPSK 1,0) Link
 Tested by : Kay Wu
 Temperature : 25°C
 Humidity : 65%
 Plane : X

	Freq	Level	Read Level	Limit Line	Over Limit	Factor	Remark
	MHz	dBm/m	dBm	dBm/m	dB	dB/m	
1	30.54	-57.50	-57.84	-13.00	-44.50	0.34	Peak
2	43.23	-57.06	-55.80	-13.00	-44.06	-1.26	Peak
3	105.33	-69.92	-59.39	-13.00	-56.92	-10.53	Peak
4	617.80	-64.15	-64.11	-13.00	-51.15	-0.04	Peak
5	680.10	-62.33	-63.41	-13.00	-49.33	1.08	Peak
6	782.30	-62.74	-64.75	-13.00	-49.74	2.01	Peak
7 pp	3755.60	-29.43	-22.70	-13.00	-16.43	-6.73	Peak
8	5633.40	-39.70	-39.88	-13.00	-26.70	0.18	Peak



A D T



Bureau Veritas Consumer Products Services Ltd., Taoyuan Branch

A D T

Data: 16

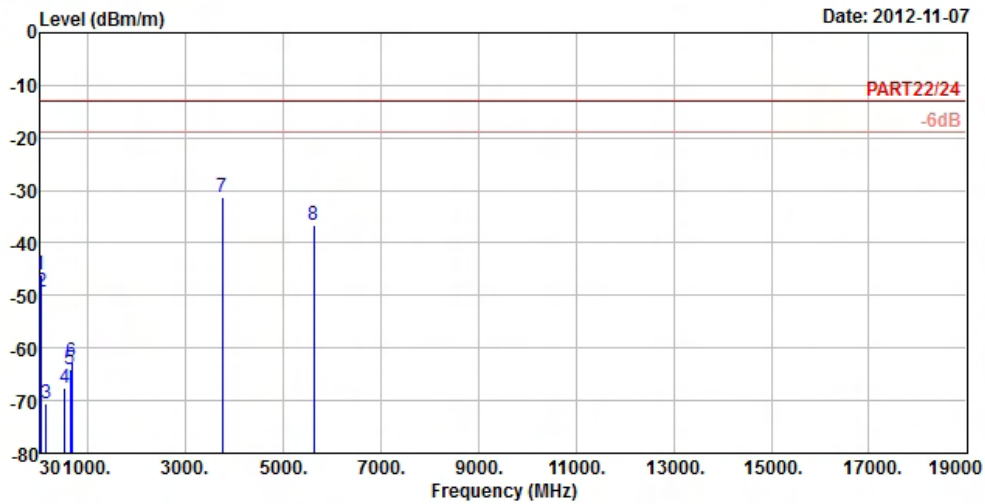

Site : 966 Chamber 5
 Condition : PART22/24 3m EIRP_RSE_1G~19G_3 VERTICAL
 Brand/Model: P530A
 Remark : Band 2_5M_(QPSK 1,0) Link
 Tested by : Kay Wu
 Temperature : 25°C
 Humidity : 65%
 Plane : X

	Freq	Level	Read Level	Limit Line	Over Limit	Factor	Remark
	MHz	dBm/m	dBm	dBm/m	dB	dB/m	
1	30.54	-46.08	-46.42	-13.00	-33.08	0.34	Peak
2	48.63	-49.19	-45.73	-13.00	-36.19	-3.46	Peak
3	140.43	-70.51	-64.78	-13.00	-57.51	-5.73	Peak
4	521.90	-67.49	-64.99	-13.00	-54.49	-2.50	Peak
5	636.00	-64.03	-64.33	-13.00	-51.03	0.30	Peak
6	670.30	-62.71	-63.62	-13.00	-49.71	0.91	Peak
7 pp	3755.60	-31.18	-24.45	-13.00	-18.18	-6.73	Peak
8	5633.40	-36.56	-36.74	-13.00	-23.56	0.18	Peak



A D T



Bureau Veritas Consumer Products Services Ltd., Taoyuan Branch

A D T

Data: 15

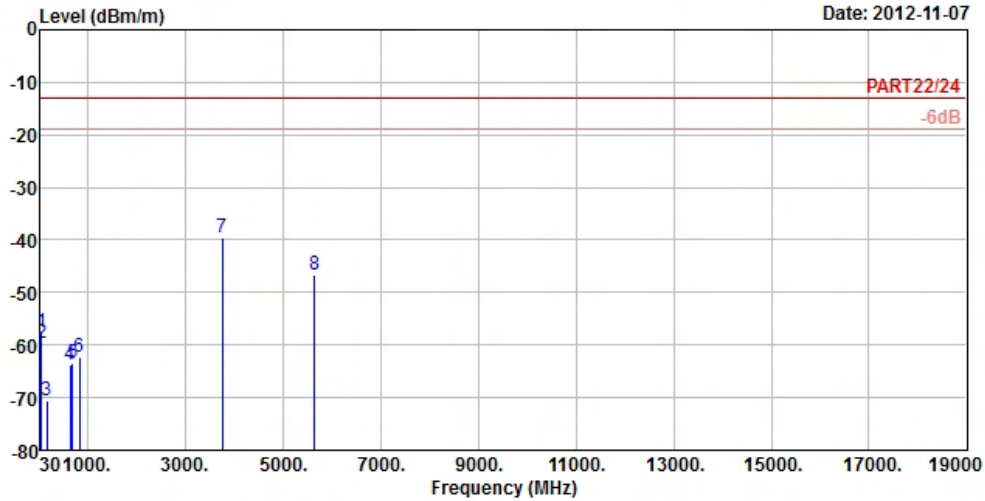

Site : 966 Chamber 5
 Condition : PART22/24 3m EIRP_RSE_1G~19G_3 HORIZONTAL
 Brand/Model: P530A
 Remark : Band 2_5M_(QPSK 25,0) Link
 Tested by : Kay Wu
 Temperature : 25°C
 Humidity : 65%
 Plane : X

	Freq	Level	Read Level	Limit Line	Over Limit	Factor	Remark
	MHz	dBm/m	dBm	dBm/m	dB	dB/m	
1	43.77	-57.66	-56.40	-13.00	-44.66	-1.26	Peak
2	50.52	-59.66	-55.06	-13.00	-46.66	-4.60	Peak
3	162.03	-70.55	-64.00	-13.00	-57.55	-6.55	Peak
4	633.90	-63.89	-64.15	-13.00	-50.89	0.26	Peak
5	691.30	-63.42	-64.71	-13.00	-50.42	1.29	Peak
6	822.90	-62.20	-64.46	-13.00	-49.20	2.26	Peak
7 pp	3760.00	-39.45	-32.72	-13.00	-26.45	-6.73	Peak
8	5640.00	-46.77	-46.98	-13.00	-33.77	0.21	Peak



A D T



Bureau Veritas Consumer Products Services Ltd., Taoyuan Branch

A D T

Data: 16

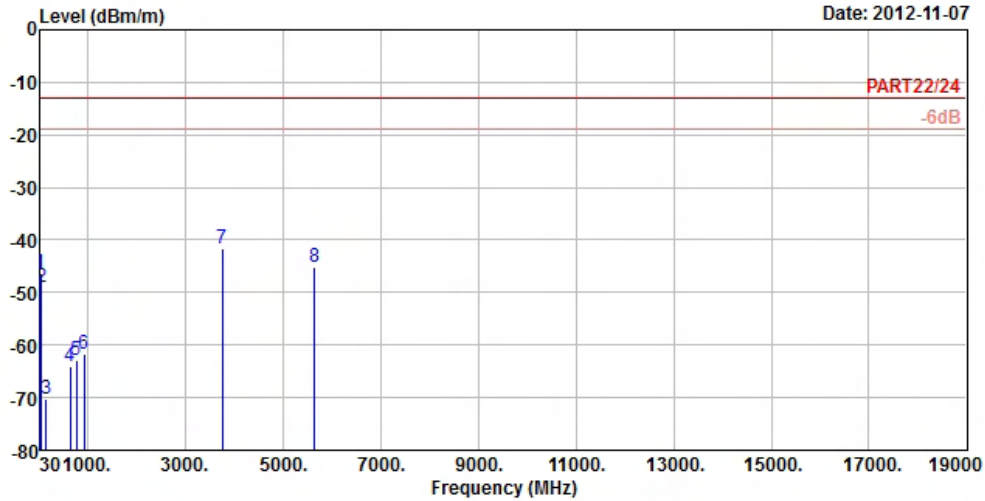

Site : 966 Chamber 5
 Condition : PART22/24 3m EIRP_RSE_1G~19G_3 VERTICAL
 Brand/Model: P530A
 Remark : Band 2_5M_(QPSK 25,0) Link
 Tested by : Kay Wu
 Temperature : 25°C
 Humidity : 65%
 Plane : X

	Freq	Level	Read Level	Limit Line	Over Limit	Factor	Remark
	MHz	dBm/m	dBm	dBm/m	dB	dB/m	
1	30.00	-46.36	-47.43	-13.00	-33.36	1.07	Peak
2	48.90	-49.11	-45.65	-13.00	-36.11	-3.46	Peak
3	142.32	-70.26	-64.40	-13.00	-57.26	-5.86	Peak
4	636.00	-63.92	-64.22	-13.00	-50.92	0.30	Peak
5	764.80	-62.75	-64.64	-13.00	-49.75	1.89	Peak
6	923.70	-61.56	-64.72	-13.00	-48.56	3.16	Peak
7 pp	3760.00	-41.52	-34.79	-13.00	-28.52	-6.73	Peak
8	5640.00	-45.10	-45.31	-13.00	-32.10	0.21	Peak



A D T

LTE Band 2 (Channel Bandwidth 10MHz)



Bureau Veritas Consumer Products Services Ltd., Taoyuan Branch

A D T

Data: 15

Date: 2012-11-07

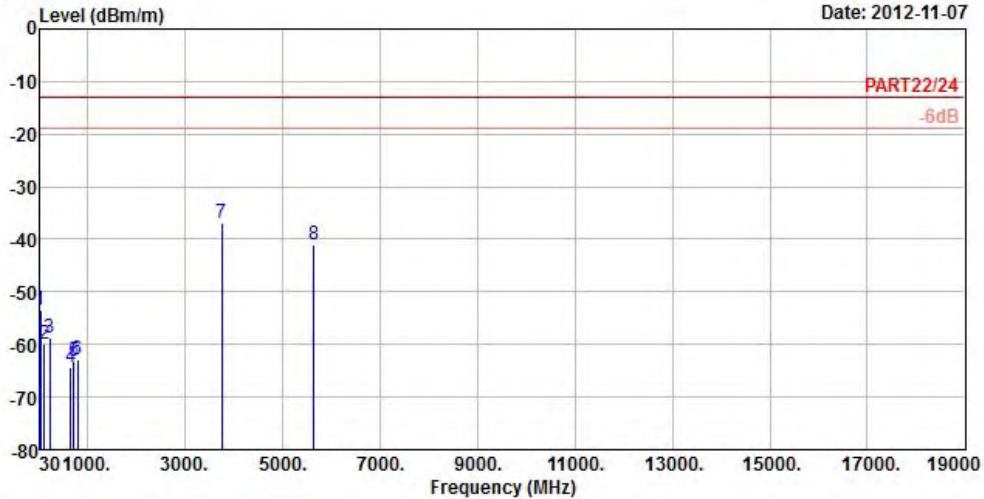

Site : 966 Chamber 5
 Condition : PART22/24 3m EIRP_RSE_1G~19G_3 HORIZONTAL
 Brand/Model: P530A
 Remark : Band 2_10M_(QPSK 1,24) Link
 Tested by : Kay Wu
 Temperature : 25°C
 Humidity : 65%
 Plane : X

	Freq	Level	Read Level	Limit Line	Over Limit	Factor	Remark
	MHz	dBm/m	dBm	dBm/m	dB	dB/m	
1	40.53	-53.39	-51.93	-13.00	-40.39	-1.46	Peak
2	116.13	-59.79	-49.03	-13.00	-46.79	-10.76	Peak
3	226.02	-58.85	-52.08	-13.00	-45.85	-6.77	Peak
4	655.60	-64.26	-64.91	-13.00	-51.26	0.65	Peak
5	725.60	-63.20	-64.82	-13.00	-50.20	1.62	Peak
6	797.00	-62.78	-64.89	-13.00	-49.78	2.11	Peak
7 pp	3760.00	-36.85	-30.12	-13.00	-23.85	-6.73	Peak
8	5640.00	-41.05	-41.26	-13.00	-28.05	0.21	Peak



A D T



Bureau Veritas Consumer Products Services Ltd., Taoyuan Branch

A D T

Data: 16

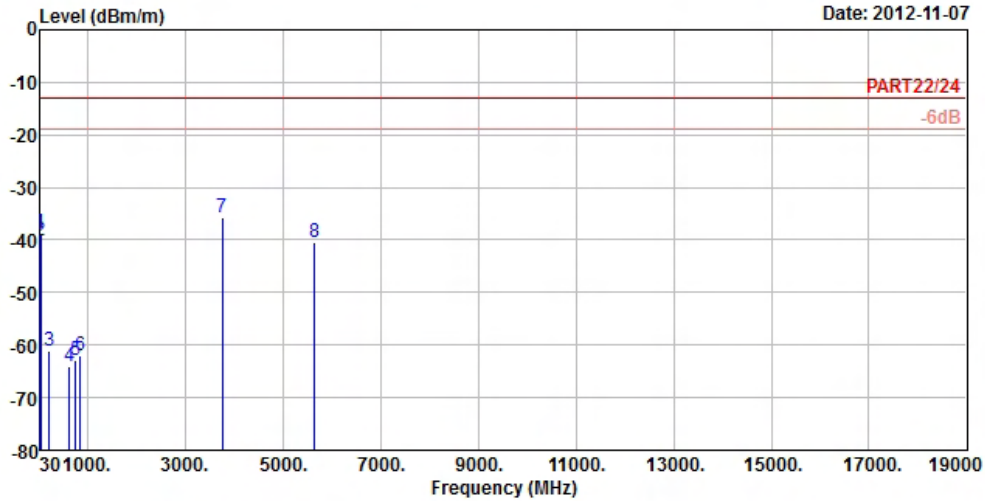

Site : 966 Chamber 5
 Condition : PART22/24 3m EIRP_RSE_1G~19G_3 VERTICAL
 Brand/Model: P530A
 Remark : Band 2_10M_(QPSK 1,24) Link
 Tested by : Kay Wu
 Temperature : 25°C
 Humidity : 65%
 Plane : X

	Freq	Level	Read Level	Limit Line	Over Limit	Factor	Remark
	MHz	dBm/m	dBm	dBm/m	dB	dB/m	
1	32.43	-38.68	-37.57	-13.00	-25.68	-1.11	Peak
2	39.99	-40.11	-38.58	-13.00	-27.11	-1.53	Peak
3	208.47	-60.99	-53.43	-13.00	-47.99	-7.56	Peak
4	616.40	-64.10	-64.05	-13.00	-51.10	-0.05	Peak
5	747.30	-62.87	-64.64	-13.00	-49.87	1.77	Peak
6	847.40	-62.04	-64.44	-13.00	-49.04	2.40	Peak
7 pp	3760.00	-35.64	-28.91	-13.00	-22.64	-6.73	Peak
8	5640.00	-40.34	-40.55	-13.00	-27.34	0.21	Peak



A D T



Bureau Veritas Consumer Products Services Ltd., Taoyuan Branch

A D T

Data: 15

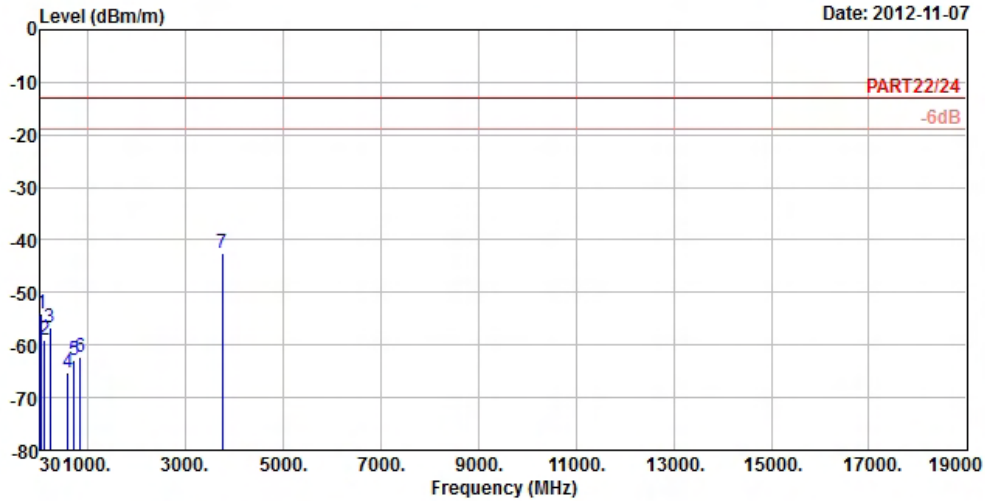

Site : 966 Chamber 5
 Condition : PART22/24 3m EIRP_RSE_1G~19G_3 HORIZONTAL
 Brand/Model: P530A
 Remark : Band 2_10M_(QPSK 50,0) Link
 Tested by : Kay Wu
 Temperature : 25°C
 Humidity : 65%
 Plane : X

	Freq	Level	Read Level	Limit Line	Over Limit	Factor	Remark
	MHz	dBm/m	dBm	dBm/m	dB	dB/m	
1	54.30	-53.90	-48.70	-13.00	-40.90	-5.20	Peak
2	114.51	-59.01	-48.30	-13.00	-46.01	-10.71	Peak
3	228.99	-56.65	-50.01	-13.00	-43.65	-6.64	Peak
4	596.80	-65.32	-64.86	-13.00	-52.32	-0.46	Peak
5	712.30	-62.95	-64.48	-13.00	-49.95	1.53	Peak
6	848.80	-62.23	-64.64	-13.00	-49.23	2.41	Peak
7 pp	3760.00	-42.48	-35.75	-13.00	-29.48	-6.73	Peak



A D T



Bureau Veritas Consumer Products Services Ltd., Taoyuan Branch

A D T

Data: 16

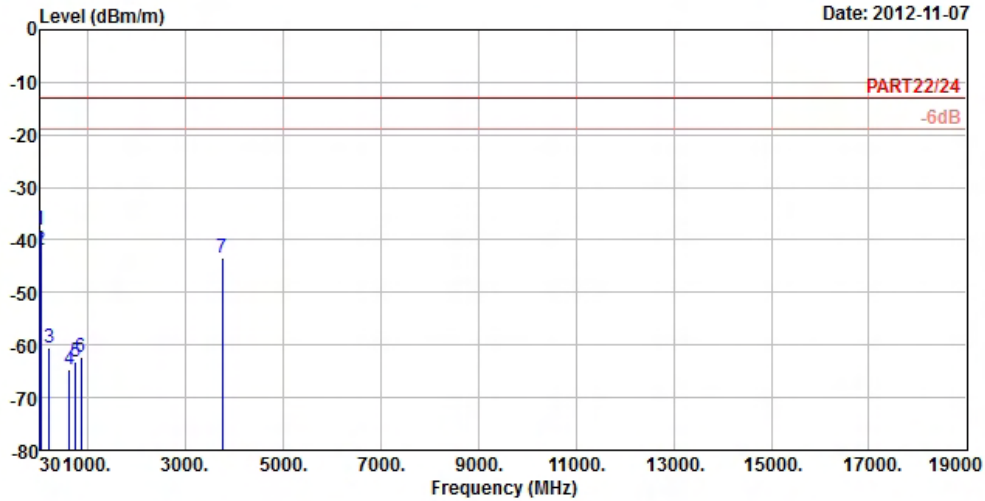

Site : 966 Chamber 5
 Condition : PART22/24 3m EIRP_RSE_1G~19G_3 VERTICAL
 Brand/Model: P530A
 Remark : Band 2_10M_(QPSK 50,0) Link
 Tested by : Kay Wu
 Temperature : 25°C
 Humidity : 65%
 Plane : X

	Freq	Level	Read Level	Limit Line	Over Limit	Factor	Remark
	MHz	dBm/m	dBm	dBm/m	dB	dB/m	
1	pp	30.00	-38.05	-39.12	-13.00	-25.05	1.07 Peak
2		41.34	-41.98	-40.59	-13.00	-28.98	-1.39 Peak
3		212.52	-60.64	-53.26	-13.00	-47.64	-7.38 Peak
4		622.70	-64.67	-64.72	-13.00	-51.67	0.05 Peak
5		745.90	-63.06	-64.82	-13.00	-50.06	1.76 Peak
6		863.50	-62.24	-64.73	-13.00	-49.24	2.49 Peak
7		3760.00	-43.53	-36.80	-13.00	-30.53	-6.73 Peak



A D T

LTE Band 2 (Channel Bandwidth 15MHz)



Bureau Veritas Consumer Products Services Ltd., Taoyuan Branch

A D T

Data: 15

Date: 2012-11-07

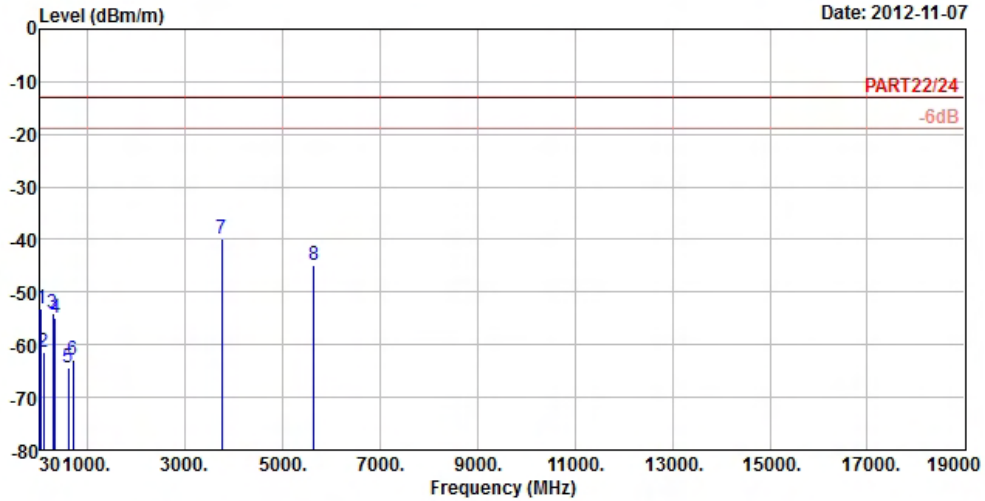

Site : 966 Chamber 5
 Condition : PART22/24 3m EIRP_RSE_1G~19G_3 HORIZONTAL
 Brand/Model: P530A
 Remark : Band 2_15M_(QPSK 1,37) Link
 Tested by : Kay Wu
 Temperature : 25°C
 Humidity : 65%
 Plane : X

	Freq	Level	Read	Limit	Over		
	MHz	dBm/m	Level	Line	Limit	Factor	Remark
			dBm	dBm/m	dB	dB/m	
1	54.57	-53.15	-47.95	-13.00	-40.15	-5.20	Peak
2	103.44	-61.53	-51.05	-13.00	-48.53	-10.48	Peak
3	296.49	-53.91	-47.57	-13.00	-40.91	-6.34	Peak
4	332.90	-54.78	-48.64	-13.00	-41.78	-6.14	Peak
5	605.20	-64.29	-64.03	-13.00	-51.29	-0.26	Peak
6	702.50	-62.99	-64.45	-13.00	-49.99	1.46	Peak
7 pp	3760.00	-39.87	-33.14	-13.00	-26.87	-6.73	Peak
8	5640.00	-44.81	-45.02	-13.00	-31.81	0.21	Peak



A D T



Bureau Veritas Consumer Products Services Ltd., Taoyuan Branch

A D T

Data: 16

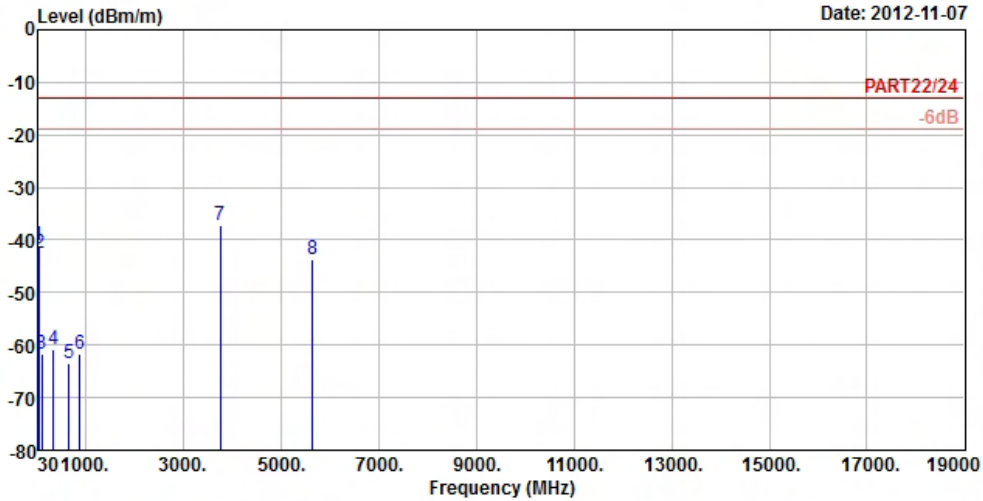

Site : 966 Chamber 5
 Condition : PART22/24 3m EIRP_RSE_1G~19G_3 VERTICAL
 Brand/Model: P530A
 Remark : Band 2_15M_(QPSK 1,37) Link
 Tested by : Kay Wu
 Temperature : 25°C
 Humidity : 65%
 Plane : X

	Freq	Level	Read Level	Limit Line	Over Limit	Factor	Remark
	MHz	dBm/m	dBm	dBm/m	dB	dB/m	
1	30.00	-41.16	-42.23	-13.00	-28.16	1.07	Peak
2	54.57	-42.57	-37.37	-13.00	-29.57	-5.20	Peak
3	102.90	-61.81	-51.35	-13.00	-48.81	-10.46	Peak
4	330.80	-60.81	-54.66	-13.00	-47.81	-6.15	Peak
5	659.80	-63.54	-64.26	-13.00	-50.54	0.72	Peak
6	879.60	-61.82	-64.40	-13.00	-48.82	2.58	Peak
7 pp	3760.00	-37.13	-30.40	-13.00	-24.13	-6.73	Peak
8	5640.00	-43.60	-43.81	-13.00	-30.60	0.21	Peak



A D T



Bureau Veritas Consumer Products Services Ltd., Taoyuan Branch

A D T

Data: 15

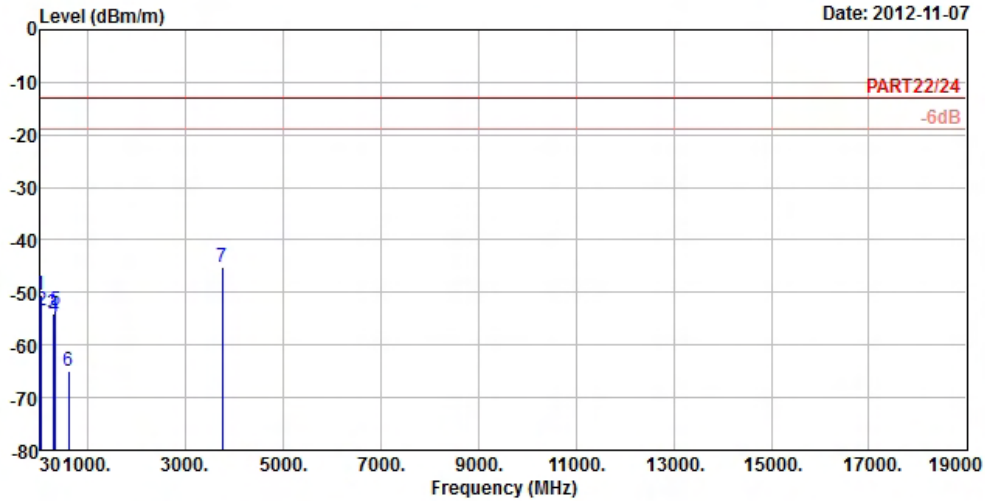

Site : 966 Chamber 5
 Condition : PART22/24 3m EIRP_RSE_1G~19G_3 HORIZONTAL
 Brand/Model: P530A
 Remark : Band 2_15M_(QPSK 75,0) Link
 Tested by : Kay Wu
 Temperature : 25°C
 Humidity : 65%
 Plane : X

	Freq	Level	Read Level	Limit Line	Over Limit	Factor	Remark
	MHz	dBm/m	dBm	dBm/m	dB	dB/m	
1	30.00	-50.38	-51.45	-13.00	-37.38	1.07	Peak
2	55.65	-53.34	-47.99	-13.00	-40.34	-5.35	Peak
3	294.06	-54.08	-47.78	-13.00	-41.08	-6.30	Peak
4	317.50	-54.57	-48.32	-13.00	-41.57	-6.25	Peak
5	344.10	-53.36	-47.31	-13.00	-40.36	-6.05	Peak
6	604.50	-64.96	-64.68	-13.00	-51.96	-0.28	Peak
7 pp	3760.00	-45.10	-38.37	-13.00	-32.10	-6.73	Peak



A D T



Bureau Veritas Consumer Products Services Ltd., Taoyuan Branch

A D T

Data: 16

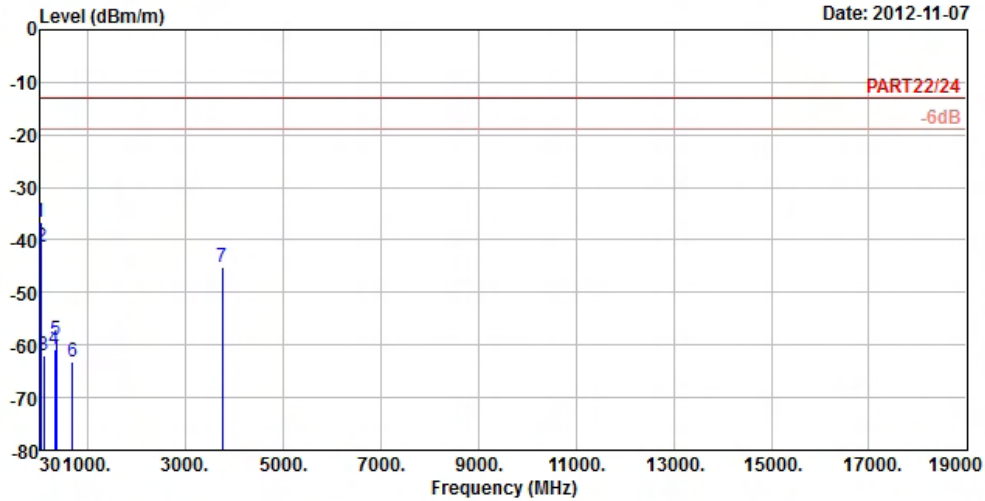

Site : 966 Chamber 5
 Condition : PART22/24 3m EIRP_RSE_1G~19G_3 VERTICAL
 Brand/Model: P530A
 Remark : Band 2_15M_(QPSK 75,0) Link
 Tested by : Kay Wu
 Temperature : 25°C
 Humidity : 65%
 Plane : X

	Freq	Level	Read Level	Limit Line	Over Limit	Factor	Remark
	MHz	dBm/m	dBm	dBm/m	dB	dB/m	
1	pp	30.00	-36.46	-37.53	-13.00	-23.46	1.07 Peak
2		55.65	-41.19	-35.84	-13.00	-28.19	-5.35 Peak
3		104.52	-61.90	-51.40	-13.00	-48.90	-10.50 Peak
4		321.00	-60.68	-54.46	-13.00	-47.68	-6.22 Peak
5		345.50	-59.13	-53.09	-13.00	-46.13	-6.04 Peak
6		685.00	-63.28	-64.45	-13.00	-50.28	1.17 Peak
7		3760.00	-45.19	-38.46	-13.00	-32.19	-6.73 Peak



A D T

LTE Band 2 (Channel Bandwidth 20MHz)



Bureau Veritas Consumer Products Services Ltd., Taoyuan Branch

A D T

Data: 15

Date: 2012-11-07

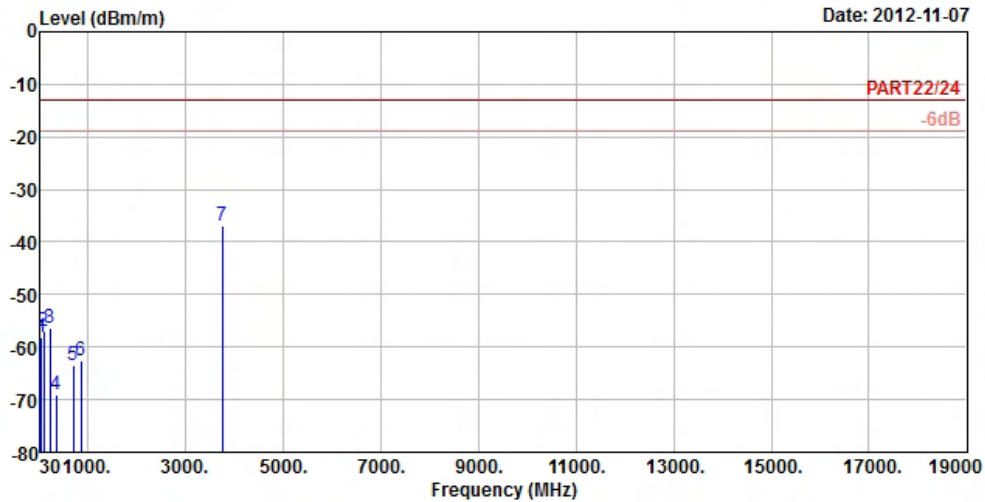

Site : 966 Chamber 5
 Condition : PART22/24 3m EIRP_RSE_1G~19G_3 HORIZONTAL
 Brand/Model: P530A
 Remark : Band 2_20M_(QPSK 1,50) Link
 Tested by : Kay Wu
 Temperature : 25°C
 Humidity : 65%
 Plane : X

	Read	Limit	Over			
Freq	Level	Level	Line	Limit	Factor	Remark
MHz	dBm/m	dBm	dBm/m	dB	dB/m	
1	55.38	-58.02	-52.67	-13.00	-45.02	-5.35 Peak
2	97.77	-56.87	-46.43	-13.00	-43.87	-10.44 Peak
3	223.05	-56.34	-49.44	-13.00	-43.34	-6.90 Peak
4	355.30	-68.98	-63.01	-13.00	-55.98	-5.97 Peak
5	704.60	-63.54	-65.02	-13.00	-50.54	1.48 Peak
6	864.90	-62.53	-65.03	-13.00	-49.53	2.50 Peak
7 pp	3760.00	-36.91	-30.18	-13.00	-23.91	-6.73 Peak



A D T



Bureau Veritas Consumer Products Services Ltd., Taoyuan Branch

A D T

Data: 16

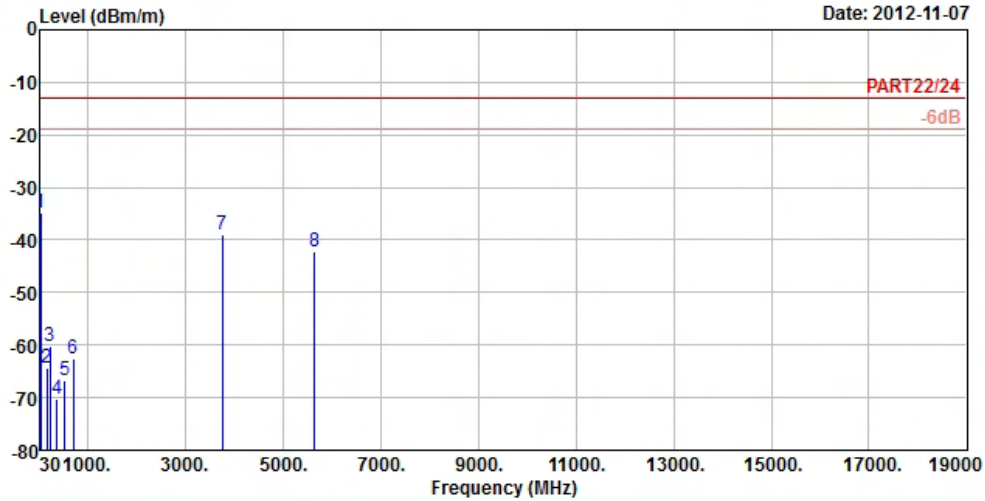

Site : 966 Chamber 5
 Condition : PART22/24 3m EIRP_RSE_1G~19G_3 VERTICAL
 Brand/Model: P530A
 Remark : Band 2_20M_(QPSK 1,50) Link
 Tested by : Kay Wu
 Temperature : 25°C
 Humidity : 65%
 Plane : X

	Freq	Level	Read Level	Limit Line	Over Limit	Factor	Remark
	MHz	dBm/m	dBm	dBm/m	dB	dB/m	
1	pp	30.00	-34.77	-35.84	-13.00	-21.77	1.07 Peak
2		159.06	-64.32	-57.82	-13.00	-51.32	-6.50 Peak
3		225.48	-60.25	-53.48	-13.00	-47.25	-6.77 Peak
4		366.50	-70.35	-64.47	-13.00	-57.35	-5.88 Peak
5		532.40	-66.64	-64.43	-13.00	-53.64	-2.21 Peak
6		703.90	-62.63	-64.11	-13.00	-49.63	1.48 Peak
7		3760.00	-39.06	-32.33	-13.00	-26.06	-6.73 Peak
8		5640.00	-42.35	-42.56	-13.00	-29.35	0.21 Peak



A D T



Bureau Veritas Consumer Products Services Ltd., Taoyuan Branch

A D T

Data: 15

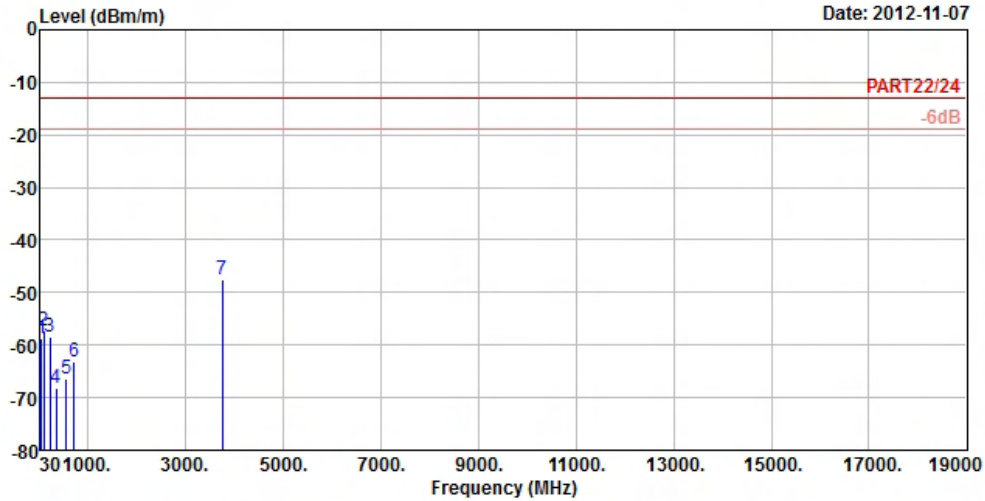

Site : 966 Chamber 5
 Condition : PART22/24 3m EIRP_RSE_1G~19G_3 HORIZONTAL
 Brand/Model: P530A
 Remark : Band 2_20M_(QPSK 100,0) Link
 Tested by : Kay Wu
 Temperature : 25°C
 Humidity : 65%
 Plane : X

	Freq	Level	Read Level	Limit Line	Over Limit	Factor	Remark
	MHz	dBm/m	dBm	dBm/m	dB	dB/m	
1	55.38	-58.74	-53.39	-13.00	-45.74	-5.35	Peak
2	99.39	-57.38	-46.98	-13.00	-44.38	-10.40	Peak
3	222.24	-58.32	-51.37	-13.00	-45.32	-6.95	Peak
4	353.20	-68.07	-62.09	-13.00	-55.07	-5.98	Peak
5	553.40	-66.28	-64.65	-13.00	-53.28	-1.63	Peak
6	713.70	-63.08	-64.62	-13.00	-50.08	1.54	Peak
7 pp	3760.00	-47.55	-40.82	-13.00	-34.55	-6.73	Peak



A D T



Bureau Veritas Consumer Products Services Ltd., Taoyuan Branch

A D T

Data: 16

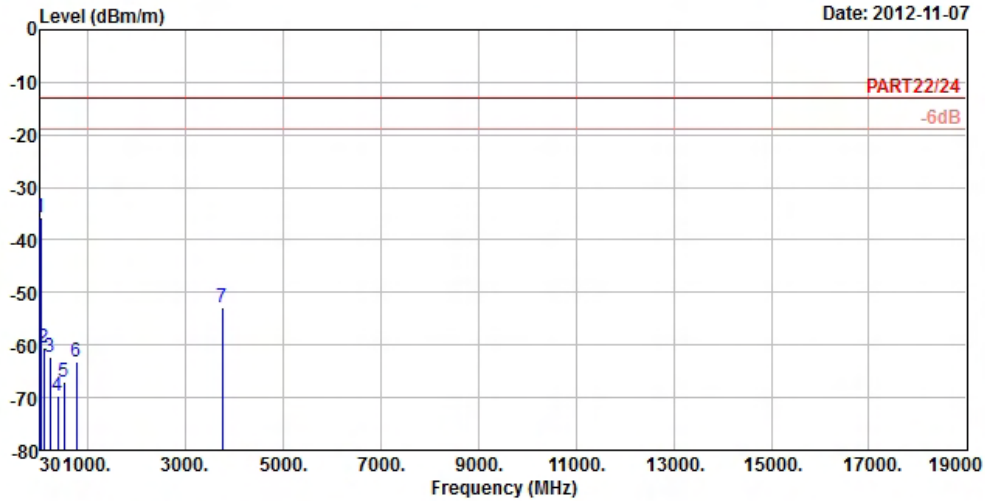

Site : 966 Chamber 5
 Condition : PART22/24 3m EIRP_RSE_1G~19G_3 VERTICAL
 Brand/Model: P530A
 Remark : Band 2_20M_(QPSK 100,0) Link
 Tested by : Kay Wu
 Temperature : 25°C
 Humidity : 65%
 Plane : X

	Freq	Level	Read Level	Limit Line	Over Limit	Factor	Remark
	MHz	dBm/m	dBm	dBm/m	dB	dB/m	
1	pp	30.00	-35.68	-36.75	-13.00	-22.68	1.07 Peak
2		102.90	-60.46	-50.00	-13.00	-47.46	-10.46 Peak
3		220.35	-62.40	-55.37	-13.00	-49.40	-7.03 Peak
4		377.00	-69.55	-63.74	-13.00	-56.55	-5.81 Peak
5		507.90	-66.99	-64.11	-13.00	-53.99	-2.88 Peak
6		767.60	-63.03	-64.94	-13.00	-50.03	1.91 Peak
7		3760.00	-52.81	-46.08	-13.00	-39.81	-6.73 Peak