

## FCC Test Report

**Report No.:** RF160128E09-4

**FCC ID:** UZ7WT6000

**Test Model:** WT6000

**Received Date:** Jan. 28, 2016

**Test Date:** Mar. 02 to Apr. 19, 2016

**Issued Date:** Apr. 26, 2016

**Applicant:** Zebra Technologies Corporation

**Address:** 1 Zebra Plaza, Holtsville, NY 11742

**Manufacturer:** Zebra Technologies Corporation

**Address:** 1 Zebra Plaza, Holtsville, NY 11742

**Issued By:** Bureau Veritas Consumer Products Services (H.K.) Ltd., Taoyuan Branch  
Hsin Chu Laboratory

**Lab Address:** E-2, No.1, Li Hsin 1st Road, Hsinchu Science Park, Hsinchu City 300,  
Taiwan R.O.C.

**Test Location (1):** E-2, No.1, Li Hsin 1st Road, Hsinchu Science Park, Hsinchu City 300,  
Taiwan R.O.C.

**Test Location (2):** No. 49, Ln. 206, Wende Rd., Shangshan Tsuen, Chiung Lin Hsiang, Hsin  
Chu Hsien 307, Taiwan R.O.C.



This report is for your exclusive use. Any copying or replication of this report to or for any other person or entity, or use of our name or trademark, is permitted only with our prior written permission. This report sets forth our findings solely with respect to the test samples identified herein. The results set forth in this report are not indicative or representative of the quality or characteristics of the lot from which a test sample was taken or any similar or identical product unless specifically and expressly noted. Our report includes all of the tests requested by you and the results thereof based upon the information that you provided to us. You have 60 days from date of issuance of this report to notify us of any material error or omission caused by our negligence, provided, however, that such notice shall be in writing and shall specifically address the issue you wish to raise. A failure to raise such issue within the prescribed time shall constitute your unqualified acceptance of the completeness of this report, the tests conducted and the correctness of the report contents. Unless specific mention, the uncertainty of measurement has been explicitly taken into account to declare the compliance or non-compliance to the specification. The report must not be used by the client to claim product certification, approval, or endorsement by TAF or any government agencies.



## Table of Contents

<b>Release Control Record</b> .....	<b>4</b>
<b>1 Certificate of Conformity</b> .....	<b>5</b>
<b>2 Summary of Test Results</b> .....	<b>6</b>
2.1 Measurement Uncertainty.....	6
2.2 Modification Record.....	6
<b>3 General Information</b> .....	<b>7</b>
3.1 General Description of EUT (BT-LE).....	7
3.2 Description of Test Modes.....	10
3.2.1 Test Mode Applicability and Tested Channel Detail.....	11
3.3 Description of Support Units.....	13
3.3.1 Configuration of System under Test.....	14
3.4 Duty Cycle of Test Signal.....	15
3.5 General Description of Applied Standards.....	15
<b>4 Test Types and Results</b> .....	<b>16</b>
4.1 Radiated Emission and Bandedge Measurement.....	16
4.1.1 Limits of Radiated Emission and Bandedge Measurement.....	16
4.1.2 Test Instruments.....	17
4.1.3 Test Procedures.....	19
4.1.4 Deviation from Test Standard.....	19
4.1.5 Test Set Up.....	20
4.1.6 EUT Operating Conditions.....	20
4.1.7 Test Results.....	21
4.2 Conducted Emission Measurement.....	27
4.2.1 Limits of Conducted Emission Measurement.....	27
4.2.2 Test Instruments.....	27
4.2.3 Test Procedures.....	28
4.2.4 Deviation from Test Standard.....	28
4.2.5 Test Setup.....	28
4.2.6 EUT Operating Conditions.....	28
4.2.7 Test Results (Mode 1).....	29
4.2.8 Test Results (Mode 2).....	31
4.3 6dB Bandwidth Measurement.....	33
4.3.1 Limits of 6dB Bandwidth Measurement.....	33
4.3.2 Test Setup.....	33
4.3.3 Test Instruments.....	33
4.3.4 Test Procedure.....	33
4.3.5 Deviation from Test Standard.....	33
4.3.6 EUT Operating Conditions.....	33
4.3.7 Test Result.....	34
4.4 Conducted Output Power Measurement.....	35
4.4.1 Limits OF Conducted Output Power Measurement.....	35
4.4.2 Test Setup.....	35
4.4.3 Test Instruments.....	35
4.4.4 Test Procedures.....	35
4.4.5 Deviation from Test Standard.....	35
4.4.6 EUT Operating Conditions.....	35
4.4.7 Test Results.....	36
4.5 Power Spectral Density Measurement.....	37
4.5.1 Limits of Power Spectral Density Measurement.....	37
4.5.2 Test Setup.....	37
4.5.3 Test Instruments.....	37
4.5.4 Test Procedure.....	37
4.5.5 Deviation from Test Standard.....	37



4.5.6 EUT Operating Condition .....	37
4.5.7 Test Results .....	38
4.6 Conducted Out of Band Emission Measurement.....	39
4.6.1 Limits of Conducted Out of Band Emission Measurement .....	39
4.6.2 Test Setup.....	39
4.6.3 Test Instruments .....	39
4.6.4 Test Procedure .....	39
4.6.5 Deviation from Test Standard .....	39
4.6.6 EUT Operating Condition .....	39
4.6.7 Test Results .....	40
<b>5 Pictures of Test Arrangements.....</b>	<b>41</b>
<b>Appendix – Information on the Testing Laboratories .....</b>	<b>42</b>



A D T

### Release Control Record

Issue No.	Description	Date Issued
RF160128E09-4	Original release.	Apr. 26, 2016



1 Certificate of Conformity

**Product:** Wearable Terminal  
**Brand:** Zebra  
**Test Model:** WT6000  
**Sample Status:** ENGINEERING SAMPLE  
**Applicant:** Zebra Technologies Corporation  
**Test Date:** Mar. 02 to Apr. 19, 2016  
**Standards:** 47 CFR FCC Part 15, Subpart C (Section 15.247)  
ANSI C63.10: 2013

The above equipment has been tested by **Bureau Veritas Consumer Products Services (H.K.) Ltd., Taoyuan Branch**, and found compliance with the requirement of the above standards. The test record, data evaluation & Equipment Under Test (EUT) configurations represented herein are true and accurate accounts of the measurements of the sample's EMC characteristics under the conditions specified in this report.

**Prepared by :** Wendy Wu , **Date:** Apr. 26, 2016  
Wendy Wu / Specialist

**Approved by :** May Chen , **Date:** Apr. 26, 2016  
May Chen / Manager

## 2 Summary of Test Results

47 CFR FCC Part 15, Subpart C (SECTION 15.247)			
FCC Clause	Test Item	Result	Remarks
15.207	AC Power Conducted Emission	PASS	Meet the requirement of limit. Minimum passing margin is -12.35dB at 0.42312MHz.
15.205 & 209 & 15.247(d)	Radiated Emissions & Band Edge Measurement	PASS	Meet the requirement of limit. Minimum passing margin is -3.6dB at 323.42MHz and 323.64MHz.
15.247(d)	Antenna Port Emission	PASS	Meet the requirement of limit.
15.247(a)(2)	6dB bandwidth	PASS	Meet the requirement of limit.
15.247(b)	Conducted power	PASS	Meet the requirement of limit.
15.247(e)	Power Spectral Density	PASS	Meet the requirement of limit.
15.203	Antenna Requirement	PASS	Antenna connector is i-pex (MHF) not a standard connector.

### 2.1 Measurement Uncertainty

Where relevant, the following measurement uncertainty levels have been estimated for tests performed on the EUT as specified in CISPR 16-4-2:

Measurement	Frequency	Expanded Uncertainty (k=2) ( $\pm$ )
Conducted Emissions at mains ports	150kHz ~ 30MHz	2.86 dB
Radiated Emissions up to 1 GHz	30MHz ~ 1GHz	5.31 dB
Radiated Emissions above 1 GHz	1GHz ~ 6GHz	3.43 dB
	6GHz ~ 18GHz	3.49 dB
	18GHz ~ 40GHz	4.11 dB

### 2.2 Modification Record

There were no modifications required for compliance.

### 3 General Information

#### 3.1 General Description of EUT (BT-LE)

Product	Wearable Terminal
Brand	Zebra
Test Model	WT6000
Status of EUT	ENGINEERING SAMPLE
SW Version	3.14.52
Power Supply Rating	DC 3.6V from Battery or DC 5.4V from Cradle or DC 5.4V from Adapter
Modulation Type	GFSK
Modulation Technology	DTS
Transfer Rate	Up to 1Mbps
Operating Frequency	2402MHz ~ 2480MHz
Number of Channel	40
Output Power	4.721mW
Antenna Type	Refer to Note
Antenna Connector	Refer to Note
Accessory Device	Battery x1
Data Cable Supplied	NA

**Note:**

1. There are WLAN, BT, NFC technology used for the EUT.
2. For WLAN: 2.4GHz and 5GHz technology cannot transmit at same time.
3. WLAN <2.4GHz (1x2) or 5GHz (1x2)> + BT + NFC technology can transmit at same time.
4. The EUT could be supplied with a cradle, adapter or battery as below table:

<b>Battery</b>	
Brand:	ZEBRA TECHNOLOGIES CORPORATION
Part No.:	BT000262A01
Rating:	TYP: 3350mAh, 12.06WH Min: 3200mAh, 11.52WH Rechargeable, normal voltage: 3.6V, limit 4.2V
<b>Cradles- 1slot (not for sale together)</b>	
Brand:	Zebra
Model No.:	SHARECRADLE-01
Part No.:	SAC-TC8X-4SCHG-01
Input Power	+12V ----- 4.16A
Output Power:	DC 5.4V(for EUT used) DC 4.2V(for Battery used)
I/O Port	DC Port x 1 USB Port x 2
Associated Devices:	Adapter x 1 (Adapter: Part No.: PWRS-14000-148R)
Cradle adapter (for Cradle- 1slot used, not for sale together)	
Brand:	HIPRO
Model No.:	HP-A0502R3D
Part No.:	PWRS-14000-148R
Input power :	100-240Vac, 2.4A, 50-60Hz
Output power :	+12Vdc ----- 4.16A DC output cable (unshielded, 1.8m with one core)
<b>Adapter (not for sale together)</b>	
Brand:	Zebra
Model No.:	PWRS-14000-249R
Input Power	100-240Vac, 50-60Hz, 0.6A
Output Power:	+5.4Vdc ----- 3A 1. DC output cable (unshielded, 1.8m) 2. USB charging cable (Brand: SINBON, Model: A9304774-005, shielded, 0.95m with one core)



5. The EUT antennas information:

WLAN / BT antenna				
Transmitter Circuit	Antenna Gain(dBi) <Including cable loss>	Frequency range	Antenna Type	Connector Type
Chain (0)	3.37	2.4~2.4835GHz	Patch	i-pex(MHF)
	3.3	5.15~5.25GHz	Patch	i-pex(MHF)
	3.3	5.25~5.35GHz	Patch	i-pex(MHF)
	3.2	5.47~5.725GHz	Patch	i-pex(MHF)
	0.61	5.725~5.85GHz	Patch	i-pex(MHF)
Chain (1)	3.86	2.4~2.4835GHz	Patch	i-pex(MHF)
	3.66	5.15~5.25GHz	Patch	i-pex(MHF)
	3.66	5.25~5.35GHz	Patch	i-pex(MHF)
	3.99	5.47~5.725GHz	Patch	i-pex(MHF)
	3.99	5.725~5.85GHz	Patch	i-pex(MHF)

NFC antenna		
Frequency range	Antenna Type	Connector Type
13.56MHz	Loop	NA

**Note:** In this report, it will fix transmission on Chain (0).

6. The EUT was pre-tested under following test modes:

Mode	Terminal	Cradle	I/O (left)	I/O (right)	Polarity
Mode A	WT6000	-----	USB charge cable	wired RS419 coil	X-Y
Mode B	WT6000	-----	USB charge cable	wired RS419 coil	X-Z
Mode C	WT6000	-----	USB charge cable	wired RS419 coil	Y-Z
Mode D	WT6000	1-slot	1-slot cradle	wired RS419 coil	NA

From the above modes, the spurious emission below 1GHz worst case was found in **Mode D** and the spurious emission above 1GHz worst case was found in **Mode B**. Therefore only the test data of the modes were recorded in this report individually.

7. The above EUT information is declared by manufacturer and for more detailed features description, please refer to the manufacturer's specifications or user's manual.

### 3.2 Description of Test Modes

40 channels are provided to this EUT:

CHANNEL	FREQ. (MHz)	CHANNEL	FREQ. (MHz)	CHANNEL	FREQ. (MHz)	CHANNEL	FREQ. (MHz)
0	2402	10	2422	20	2442	30	2462
1	2404	11	2424	21	2444	31	2464
2	2406	12	2426	22	2446	32	2466
3	2408	13	2428	23	2448	33	2468
4	2410	14	2430	24	2450	34	2470
5	2412	15	2432	25	2452	35	2472
6	2414	16	2434	26	2454	36	2474
7	2416	17	2436	27	2456	37	2476
8	2418	18	2438	28	2458	38	2478
9	2420	19	2440	29	2460	39	2480

### 3.2.1 Test Mode Applicability and Tested Channel Detail

EUT CONFIGURE MODE	APPLICABLE TO				DESCRIPTION
	RE $\geq$ 1G	RE $<$ 1G	PLC	APCM	
1	√	√	√	√	With Adapter
2			√		With Cradles

Where **RE $\geq$ 1G:** Radiated Emission above 1GHz      **RE $<$ 1G:** Radiated Emission below 1GHz  
**PLC:** Power Line Conducted Emission      **APCM:** Antenna Port Conducted Measurement

**NOTE:** The EUT had been pre-tested on the positioned of each 3 axis. The worst case was found when positioned on **Z-plane**.

**NOTE:** "-" means no effect.

#### **Radiated Emission Test (Above 1GHz):**

- Pre-Scan has been conducted to determine the worst-case mode from all possible combinations between available modulations, data rates and antenna ports (if EUT with antenna diversity architecture).
- Following channel(s) was (were) selected for the final test as listed below.

AVAILABLE CHANNEL	TESTED CHANNEL	MODULATION TYPE	DATA RATE (Mbps)
0 to 39	0, 19, 39	GFSK	1

#### **Radiated Emission Test (Below 1GHz):**

- Pre-Scan has been conducted to determine the worst-case mode from all possible combinations between available modulations, data rates and antenna ports (if EUT with antenna diversity architecture).
- Following channel(s) was (were) selected for the final test as listed below.

AVAILABLE CHANNEL	TESTED CHANNEL	MODULATION TYPE	DATA RATE (Mbps)
0 to 39	0, 19, 39	GFSK	1

#### **Power Line Conducted Emission Test:**

- Pre-Scan has been conducted to determine the worst-case mode from all possible combinations between available modulations, data rates and antenna ports (if EUT with antenna diversity architecture).
- Following channel(s) was (were) selected for the final test as listed below.

AVAILABLE CHANNEL	TESTED CHANNEL	MODULATION TYPE	DATA RATE (Mbps)
0 to 39	0	GFSK	1

**Antenna Port Conducted Measurement:**

- This item includes all test value of each mode, but only includes spectrum plot of worst value of each mode.
- Pre-Scan has been conducted to determine the worst-case mode from all possible combinations between available modulations, data rates and antenna ports (if EUT with antenna diversity architecture).
- Following channel(s) was (were) selected for the final test as listed below.

AVAILABLE CHANNEL	TESTED CHANNEL	MODULATION TYPE	DATA RATE (Mbps)
0 to 39	0, 19, 39	GFSK	1

**Test Condition:**

APPLICABLE TO	ENVIRONMENTAL CONDITIONS	INPUT POWER	TESTED BY	TEST LOCATION
<b>RE<math>\geq</math>1G</b>	25deg. C, 68%RH	120Vac, 60Hz	Tim Ho	1
<b>RE<math>&lt;</math>1G</b>	20deg. C, 71%RH	120Vac, 60Hz	Tim Ho	1
<b>PLC</b>	24deg. C, 82%RH	120Vac, 60Hz	Wythe Lin	2
<b>APCM</b>	16deg. C, 64%RH	120Vac, 60Hz	Anderson Chen	1

### 3.3 Description of Support Units

The EUT has been tested as an independent unit together with other necessary accessories or support units. The following support units or accessories were used to form a representative test configuration during the tests.

ID	Product	Brand	Model No.	Serial No.	FCC ID	Remarks
A.	Cradle Adapter	HIPRO	HP-A0502R3D	NA	NA	Supplied by client
B.	Cradles-1slot	ZEBRA	SHARECRADLE-01	NA	NA	Supplied by client
C.	Notebook Computer	HP	Pavilion 14-ab023TU	5CD5340WXZ	NA	Provided by Lab
D.	iPod shuffle	Apple	MC749TA/A	CC4DMFJUDFDM	NA	Provided by Lab
E.	Wired Scanner	ZEBRA	RS419	NA	NA	Supplied by client
F.	Adapter	Motorola	PWRS-14000-249R	NA	NA	Supplied by client

Note:

1. All power cords of the above support units are non-shielded (1.8m).

ID	Descriptions	Qty.	Length (m)	Shielding (Yes/No)	Cores (Qty.)	Remarks
1.	AC cable	1	1.8	No	0	Supplied by client
2.	DC cable	1	1.8	No	1	Supplied by client
3.	USB cable	1	1.4	Yes	0	Supplied by client
4.	Wired Scanner cable	1	0.5	No	0	Supplied by client
5.	USB cable	1	0.1	Yes	0	Provided by Lab
6.	USB cable	1	0.95	Yes	1	Supplied by client
7.	DC cable	1	1.8	No	0	Supplied by client

Note: The core(s) is(are) originally attached to the cable(s).

### 3.3.1 Configuration of System under Test

#### For Radiated Emissions (below 1GHz) & Cradle mode test:

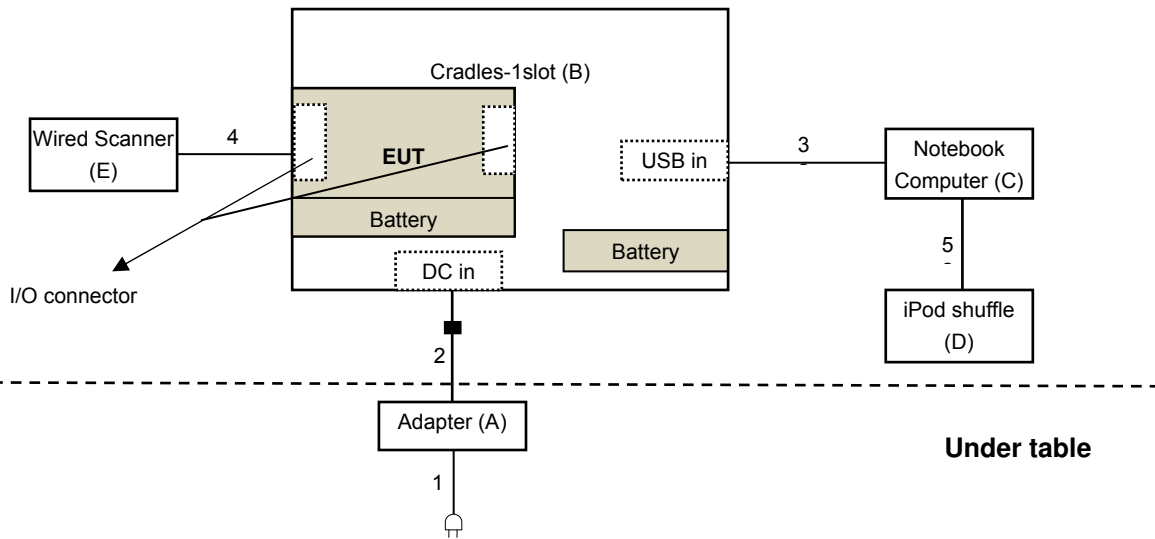

#### For Radiated Emissions (Above 1GHz) & Adapter mode test:

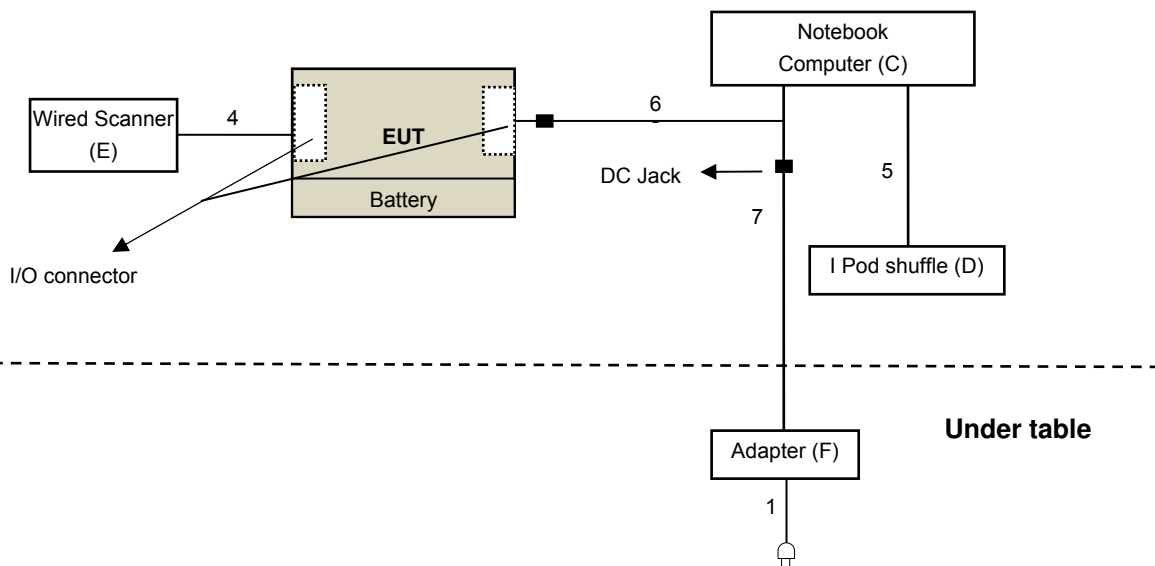

### 3.4 Duty Cycle of Test Signal

Duty cycle of test signal is < 98 %, duty factor shall be considered.

Duty cycle =  $0.382 \text{ ms} / 0.63 \text{ ms} = 0.606$ , Duty factor =  $10 * \log(1/0.606) = 2.2$

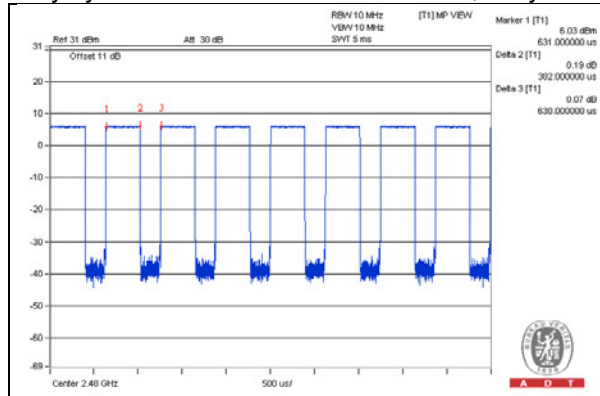

### 3.5 General Description of Applied Standards

The EUT is a RF Product. According to the specifications of the manufacturer, it must comply with the requirements of the following standards:

- FCC Part 15, Subpart C (15.247)**
- KDB 558074 D01 DTS Meas Guidance v03r05**
- ANSI C63.10-2013

All test items have been performed and recorded as per the above standards.

**NOTE:** The EUT has been verified to comply with the requirements of FCC Part 15, Subpart B, Class B (DoC). The test report has been issued separately.

## 4 Test Types and Results

### 4.1 Radiated Emission and Bandedge Measurement

#### 4.1.1 Limits of Radiated Emission and Bandedge Measurement

Radiated emissions which fall in the restricted bands must comply with the radiated emission limits specified as below table. Other emissions shall be at least 20dB below the highest level of the desired power:

Frequencies (MHz)	Field Strength (microvolts/meter)	Measurement Distance (meters)
0.009 ~ 0.490	2400/F(kHz)	300
0.490 ~ 1.705	24000/F(kHz)	30
1.705 ~ 30.0	30	30
30 ~ 88	100	3
88 ~ 216	150	3
216 ~ 960	200	3
Above 960	500	3

#### NOTE:

1. The lower limit shall apply at the transition frequencies.
2. Emission level (dBuV/m) = 20 log Emission level (uV/m).
3. For frequencies above 1000MHz, the field strength limits are based on average detector, however, the peak field strength of any emission shall not exceed the maximum permitted average limits, specified above by more than 20dB under any condition of modulation.



#### 4.1.2 Test Instruments

##### For Radiated Emissions (below 1GHz) test:

DESCRIPTION & MANUFACTURER	MODEL NO.	SERIAL NO.	CALIBRATED DATE	CALIBRATED UNTIL
Test Receiver Agilent	N9038A	MY50010156	Aug. 12, 2015	Aug. 11, 2016
Pre-Amplifier <sup>(*)</sup> EMCI	EMC001340	980142	Jan. 20, 2016	Jan. 19, 2018
Loop Antenna <sup>(*)</sup> Electro-Metrics	EM-6879	264	Dec. 16, 2014	Dec. 15, 2016
RF Cable	NA	LOOPCAB-001 LOOPCAB-002	Jan. 18, 2016	Jan. 17, 2017
Pre-Amplifier Mini-Circuits	ZFL-1000VH2 B	AMP-ZFL-07	May 08, 2015	May 07, 2016
Trilog Broadband Antenna SCHWARZBECK	VULB 9168	9168-156	Jan. 04, 2016	Jan. 03, 2017
RF Cable	8D	966-3-1 966-3-2 966-3-3	Apr. 02, 2016	Apr. 01, 2017
Software	ADT_Radiated _V8.7.07	NA	NA	NA
Antenna Tower & Turn Table CT	NA	NA	NA	NA

##### Note:

1. The calibration interval of the above test instruments is 12 months and the calibrations are traceable to NML/ROC and NIST/USA.
2. \*The calibration interval of the above test instruments is 24 months and the calibrations are traceable to NML/ROC and NIST/USA.
3. The test was performed in 966 Chamber No. 3.
4. The FCC Site Registration No. is 147459
6. The CANADA Site Registration No. is 20331-1
7. Loop antenna was used for all emissions below 30 MHz.
8. Tested Date: Apr. 19, 2016

**For Radiated Emissions (Above 1GHz) test:**

DESCRIPTION & MANUFACTURER	MODEL NO.	SERIAL NO.	CALIBRATED DATE	CALIBRATED UNTIL
Test Receiver Agilent	N9038A	MY54450088	July 24, 2015	July 23, 2016
Horn_Antenna SCHWARZBECK	BBHA 9120D	9120D-783	Jan. 19, 2016	Jan. 18, 2017
Pre-Amplifier Agilent	8449B	3008A01922	Sep. 19, 2015	Sep. 18, 2016
RF Cable	EMC104-SM-S M-2000 EMC104-SM-S M-5000 EMC104-SM-S M-5000	150318 150323 150324	Mar. 30, 2016	Mar. 29, 2017
Boresight Antenna Fixture	NA	NA	NA	NA
Pre-Amplifier EMCI	EMC184045	980143	Jan. 15, 2016	Jan. 14, 2017
Horn_Antenna SCHWARZBECK	BBHA 9170	BBHA9170608	Jan. 08, 2016	Jan. 07, 2017
RF Cable	SUCOFLEX 102	36432/2 36441/2	Jan. 16, 2016	Jan. 15, 2017
Software	ADT_Radiated _V8.7.07	NA	NA	NA
Antenna Tower & Turn Table CT	NA	NA	NA	NA
Spectrum Analyzer R&S	FSP 40	100060	May 08, 2015	May 07, 2016
Power meter Anritsu	ML2495A	1014008	Apr. 28, 2015	Apr. 27, 2016
Power sensor Anritsu	MA2411B	0917122	Apr. 28, 2015	Apr. 27, 2016

**Note:**

1. The calibration interval of the above test instruments is 12 months and the calibrations are traceable to NML/ROC and NIST/USA.
2. The horn antenna, preamplifier (model: 8449B) are used only for the measurement of emission frequency above 1GHz if tested.
3. The test was performed in 966 Chamber No. 4.
4. The FCC Site Registration No. is 292998
5. The CANADA Site Registration No. is 20331-2
6. Tested Date: Apr. 14, 2016

#### 4.1.3 Test Procedures

- a. The EUT was placed on the top of a rotating table 0.8 meters (for below 1GHz) / 1.5 meters (for above 1GHz) above the ground at 3 meter chamber room for test. The table was rotated 360 degrees to determine the position of the highest radiation.
- b. The EUT was set 3 meters away from the interference-receiving antenna, which was mounted on the top of a variable-height antenna tower.
- c. The height of antenna is varied from one meter to four meters above the ground to determine the maximum value of the field strength. Both horizontal and vertical polarizations of the antenna are set to make the measurement.
- d. For each suspected emission, the EUT was arranged to its worst case and then the antenna was tuned to heights from 1 meter to 4 meters and the rotatable table was turned from 0 degrees to 360 degrees to find the maximum reading.
- e. The test-receiver system was set to quasi-peak detect function and specified bandwidth with maximum hold mode when the test frequency is below 1 GHz.
- f. The test-receiver system was set to peak and average detect function and specified bandwidth with maximum hold mode when the test frequency is above 1 GHz. If the peak reading value also meets average limit, measurement with the average detector is unnecessary.

#### Note:

1. The resolution bandwidth and video bandwidth of test receiver/spectrum analyzer is 120kHz for Quasi-peak detection (QP) at frequency below 1GHz.
2. The resolution bandwidth of test receiver/spectrum analyzer is 1 MHz and the video bandwidth is 3 MHz for Peak detection (PK) at frequency above 1GHz.
3. The resolution bandwidth of test receiver/spectrum analyzer is 1MHz and the video bandwidth is  $\geq 1/T$  (Duty cycle < 98%) or 10Hz (Duty cycle  $\geq 98\%$ ) for Average detection (AV) at frequency above 1GHz.
4. All modes of operation were investigated and the worst-case emissions are reported.

#### 4.1.4 Deviation from Test Standard

No deviation.

#### 4.1.5 Test Set Up

##### <Frequency Range below 1GHz>

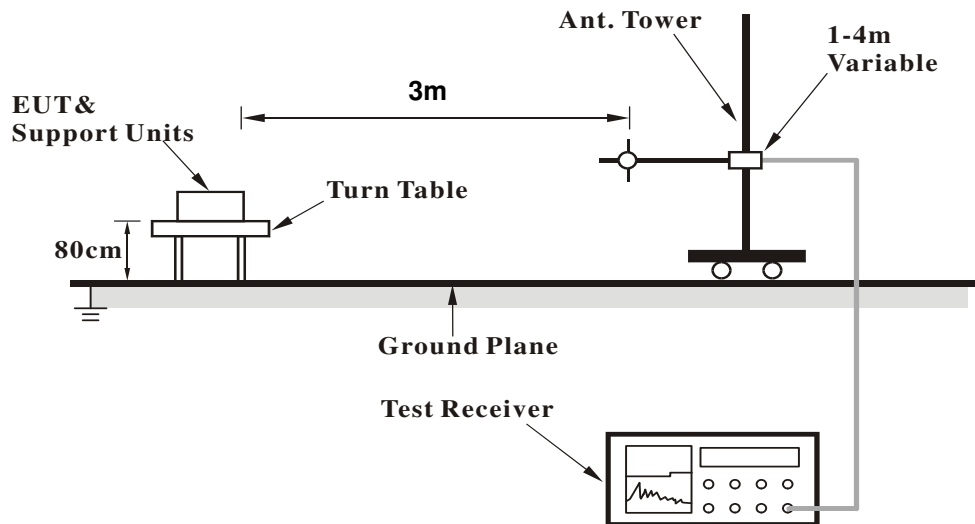

##### <Frequency Range above 1GHz>

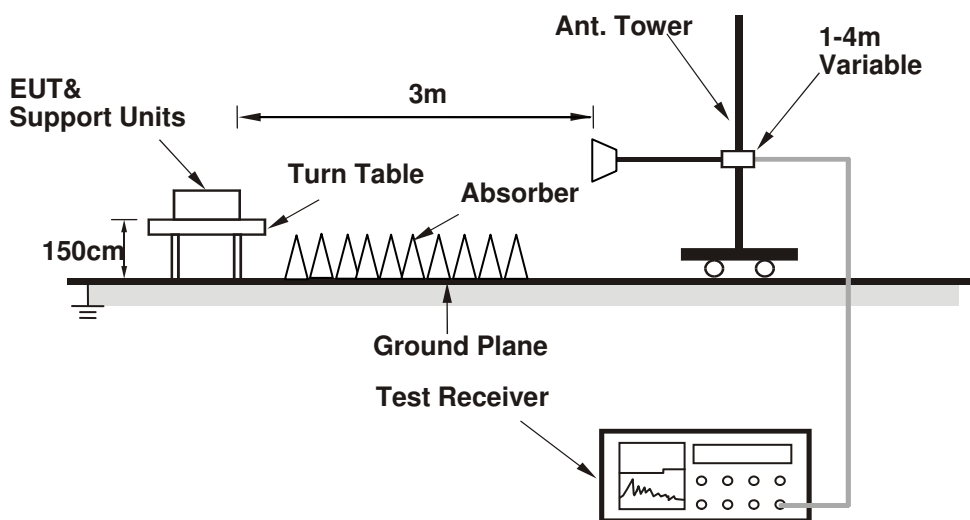

For the actual test configuration, please refer to the attached file (Test Setup Photo).

#### 4.1.6 EUT Operating Conditions

1. Connect the EUT with the support unit C (Notebook Computer) which is placed on remote site.
2. The communication partner run test program "adb push cmd.txt" to enable EUT under transmission/receiving condition continuously at specific channel frequency.

**4.1.7 Test Results**
**Above 1GHz Data:**
**BT\_LE-GFSK**

<b>CHANNEL</b>	TX Channel 0	<b>DETECTOR FUNCTION</b>	Peak (PK)
<b>FREQUENCY RANGE</b>	1GHz ~ 25GHz		Average (AV)

**ANTENNA POLARITY & TEST DISTANCE: HORIZONTAL AT 3 M**

NO.	FREQ. (MHz)	EMISSION LEVEL (dBuV/m)	LIMIT (dBuV/m)	MARGIN (dB)	ANTENNA HEIGHT (m)	TABLE ANGLE (Degree)	RAW VALUE (dBuV)	CORRECTION FACTOR (dB/m)
1	2390.00	46.1 PK	74.0	-27.9	2.03 H	126	51.71	-5.61
2	2390.00	34.5 AV	54.0	-19.5	2.03 H	126	40.11	-5.61
3	*2402.00	89.5 PK			2.03 H	126	95.07	-5.57
4	*2402.00	88.3 AV			2.03 H	126	93.87	-5.57
5	4804.00	41.3 PK	74.0	-32.7	2.17 H	289	40.45	0.85
6	4804.00	30.6 AV	54.0	-23.4	2.17 H	289	29.75	0.85

**ANTENNA POLARITY & TEST DISTANCE: VERTICAL AT 3 M**

NO.	FREQ. (MHz)	EMISSION LEVEL (dBuV/m)	LIMIT (dBuV/m)	MARGIN (dB)	ANTENNA HEIGHT (m)	TABLE ANGLE (Degree)	RAW VALUE (dBuV)	CORRECTION FACTOR (dB/m)
1	2390.00	47.3 PK	74.0	-26.7	1.48 V	127	52.91	-5.61
2	2390.00	35.6 AV	54.0	-18.4	1.48 V	127	41.21	-5.61
3	*2402.00	101.6 PK			1.48 V	127	107.17	-5.57
4	*2402.00	100.2 AV			1.48 V	127	105.77	-5.57
5	4804.00	41.0 PK	74.0	-33.0	2.13 V	36	40.15	0.85
6	4804.00	30.5 AV	54.0	-23.5	2.13 V	36	29.65	0.85

**REMARKS:**

1. Emission Level(dBuV/m) = Raw Value(dBuV) + Correction Factor(dB/m)
2. Correction Factor(dB/m) = Antenna Factor(dB/m) + Cable Factor(dB) – Pre-Amplifier Factor(dB)
3. The other emission levels were very low against the limit.
4. Margin value = Emission Level – Limit value
5. " \* ": Fundamental frequency.

<b>CHANNEL</b>	TX Channel 19	<b>DETECTOR FUNCTION</b>	Peak (PK)
<b>FREQUENCY RANGE</b>	1GHz ~ 25GHz		Average (AV)

**ANTENNA POLARITY & TEST DISTANCE: HORIZONTAL AT 3 M**

NO.	FREQ. (MHz)	EMISSION LEVEL (dBuV/m)	LIMIT (dBuV/m)	MARGIN (dB)	ANTENNA HEIGHT (m)	TABLE ANGLE (Degree)	RAW VALUE (dBuV)	CORRECTION FACTOR (dB/m)
1	*2440.00	91.0 PK			2.03 H	132	96.44	-5.44
2	*2440.00	89.5 AV			2.03 H	132	94.94	-5.44
3	4880.00	41.3 PK	74.0	-32.7	2.14 H	298	40.21	1.09
4	4880.00	30.7 AV	54.0	-23.3	2.14 H	298	29.61	1.09
5	7320.00	46.5 PK	74.0	-27.5	2.16 H	70	38.83	7.67
6	7320.00	34.6 AV	54.0	-19.4	2.16 H	70	26.93	7.67

**ANTENNA POLARITY & TEST DISTANCE: VERTICAL AT 3 M**

NO.	FREQ. (MHz)	EMISSION LEVEL (dBuV/m)	LIMIT (dBuV/m)	MARGIN (dB)	ANTENNA HEIGHT (m)	TABLE ANGLE (Degree)	RAW VALUE (dBuV)	CORRECTION FACTOR (dB/m)
1	*2440.00	103.2 PK			1.36 V	106	108.64	-5.44
2	*2440.00	102.0 AV			1.36 V	106	107.44	-5.44
3	4880.00	41.1 PK	74.0	-32.9	2.13 V	47	40.01	1.09
4	4880.00	30.5 AV	54.0	-23.5	2.13 V	47	29.41	1.09
5	7320.00	45.3 PK	74.0	-28.7	2.13 V	292	37.63	7.67
6	7320.00	33.6 AV	54.0	-20.4	2.13 V	292	25.93	7.67

**REMARKS:**

1. Emission Level(dBuV/m) = Raw Value(dBuV) + Correction Factor(dB/m)
2. Correction Factor(dB/m) = Antenna Factor(dB/m) + Cable Factor(dB) – Pre-Amplifier Factor(dB)
3. The other emission levels were very low against the limit.
4. Margin value = Emission Level – Limit value
5. " \* ": Fundamental frequency.

<b>CHANNEL</b>	TX Channel 39	<b>DETECTOR FUNCTION</b>	Peak (PK)
<b>FREQUENCY RANGE</b>	1GHz ~ 25GHz		Average (AV)

**ANTENNA POLARITY & TEST DISTANCE: HORIZONTAL AT 3 M**

NO.	FREQ. (MHz)	EMISSION LEVEL (dBuV/m)	LIMIT (dBuV/m)	MARGIN (dB)	ANTENNA HEIGHT (m)	TABLE ANGLE (Degree)	RAW VALUE (dBuV)	CORRECTION FACTOR (dB/m)
1	*2480.00	91.9 PK			2.02 H	133	97.18	-5.28
2	*2480.00	90.9 AV			2.02 H	133	96.18	-5.28
3	2483.50	49.2 PK	74.0	-24.8	2.01 H	137	54.47	-5.27
4	2483.50	36.9 AV	54.0	-17.1	2.01 H	137	42.17	-5.27
5	4960.00	41.2 PK	74.0	-32.8	2.18 H	288	39.88	1.32
6	4960.00	30.7 AV	54.0	-23.3	2.18 H	288	29.38	1.32
7	7440.00	46.0 PK	74.0	-28.0	2.16 H	61	38.10	7.90
8	7440.00	34.2 AV	54.0	-19.8	2.16 H	61	26.30	7.90

**ANTENNA POLARITY & TEST DISTANCE: VERTICAL AT 3 M**

NO.	FREQ. (MHz)	EMISSION LEVEL (dBuV/m)	LIMIT (dBuV/m)	MARGIN (dB)	ANTENNA HEIGHT (m)	TABLE ANGLE (Degree)	RAW VALUE (dBuV)	CORRECTION FACTOR (dB/m)
1	*2480.00	104.4 PK			1.37 V	103	109.68	-5.28
2	*2480.00	103.2 AV			1.37 V	103	108.48	-5.28
3	2483.50	49.5 PK	74.0	-24.5	1.37 V	100	54.77	-5.27
4	2483.50	37.6 AV	54.0	-16.4	1.37 V	100	42.87	-5.27
5	4960.00	40.9 PK	74.0	-33.1	2.11 V	44	39.58	1.32
6	4960.00	30.5 AV	54.0	-23.5	2.11 V	44	29.18	1.32
7	7440.00	45.5 PK	74.0	-28.5	2.19 V	291	37.60	7.90
8	7440.00	33.9 AV	54.0	-20.1	2.19 V	291	26.00	7.90

**REMARKS:**

1. Emission Level(dBuV/m) = Raw Value(dBuV) + Correction Factor(dB/m)
2. Correction Factor(dB/m) = Antenna Factor(dB/m) + Cable Factor(dB) – Pre-Amplifier Factor(dB)
3. The other emission levels were very low against the limit.
4. Margin value = Emission Level – Limit value
5. " \* ": Fundamental frequency.

**Below 1GHz Data:**
**BT\_LE-GFSK**

<b>CHANNEL</b>	TX Channel 0	<b>DETECTOR FUNCTION</b>	Quasi-Peak (QP)
<b>FREQUENCY RANGE</b>	30MHz ~ 1GHz		

**ANTENNA POLARITY & TEST DISTANCE: HORIZONTAL AT 3 M**

NO.	FREQ. (MHz)	EMISSION LEVEL (dBuV/m)	LIMIT (dBuV/m)	MARGIN (dB)	ANTENNA HEIGHT (m)	TABLE ANGLE (Degree)	RAW VALUE (dBuV)	CORRECTION FACTOR (dB/m)
1	42.49	31.4 QP	40.0	-8.6	1.55 H	271	35.74	-4.34
2	201.46	33.6 QP	43.5	-9.9	1.02 H	38	40.70	-7.10
3	314.80	41.3 QP	46.0	-4.7	1.00 H	282	44.18	-2.88
4	323.58	42.0 QP	46.0	-4.0	1.05 H	58	44.63	-2.63
5	498.19	35.9 QP	46.0	-10.1	1.45 H	162	34.53	1.37
6	931.01	38.8 QP	46.0	-7.2	1.56 H	56	30.03	8.77

**ANTENNA POLARITY & TEST DISTANCE: VERTICAL AT 3 M**

NO.	FREQ. (MHz)	EMISSION LEVEL (dBuV/m)	LIMIT (dBuV/m)	MARGIN (dB)	ANTENNA HEIGHT (m)	TABLE ANGLE (Degree)	RAW VALUE (dBuV)	CORRECTION FACTOR (dB/m)
1	37.53	34.9 QP	40.0	-5.1	1.04 V	128	39.84	-4.94
2	58.47	29.6 QP	40.0	-10.4	1.58 V	48	33.87	-4.27
3	218.86	32.3 QP	46.0	-13.7	2.01 V	194	39.17	-6.87
4	267.95	32.1 QP	46.0	-13.9	1.96 V	301	36.46	-4.36
5	320.18	38.8 QP	46.0	-7.2	1.00 V	128	41.55	-2.75
6	797.49	38.2 QP	46.0	-7.8	1.60 V	115	31.55	6.65

**REMARKS:**

1. Emission Level(dBuV/m) = Raw Value(dBuV) + Correction Factor(dB/m)
2. Correction Factor(dB/m) = Antenna Factor(dB/m) + Cable Factor(dB) – Pre-Amplifier Factor(dB)
3. The other emission levels were very low against the limit.
4. Margin value = Emission Level – Limit value



<b>CHANNEL</b>	TX Channel 19	<b>DETECTOR FUNCTION</b>	Quasi-Peak (QP)
<b>FREQUENCY RANGE</b>	30MHz ~ 1GHz		

**ANTENNA POLARITY & TEST DISTANCE: HORIZONTAL AT 3 M**

NO.	FREQ. (MHz)	EMISSION LEVEL (dBuV/m)	LIMIT (dBuV/m)	MARGIN (dB)	ANTENNA HEIGHT (m)	TABLE ANGLE (Degree)	RAW VALUE (dBuV)	CORRECTION FACTOR (dB/m)
1	42.36	31.8 QP	40.0	-8.2	1.61 H	260	36.17	-4.37
2	201.17	33.4 QP	43.5	-10.1	1.06 H	51	40.49	-7.09
3	315.06	41.3 QP	46.0	-4.7	1.05 H	277	44.17	-2.87
4	<b>323.42</b>	<b>42.4 QP</b>	<b>46.0</b>	<b>-3.6</b>	<b>1.01 H</b>	<b>38</b>	<b>45.03</b>	<b>-2.63</b>
5	497.72	36.3 QP	46.0	-9.7	1.51 H	138	34.95	1.35
6	931.01	38.5 QP	46.0	-7.5	1.52 H	69	29.73	8.77

**ANTENNA POLARITY & TEST DISTANCE: VERTICAL AT 3 M**

NO.	FREQ. (MHz)	EMISSION LEVEL (dBuV/m)	LIMIT (dBuV/m)	MARGIN (dB)	ANTENNA HEIGHT (m)	TABLE ANGLE (Degree)	RAW VALUE (dBuV)	CORRECTION FACTOR (dB/m)
1	37.13	35.2 QP	40.0	-4.8	1.00 V	120	40.23	-5.03
2	58.93	29.4 QP	40.0	-10.6	1.52 V	47	33.68	-4.28
3	218.88	32.6 QP	46.0	-13.4	2.01 V	181	39.47	-6.87
4	267.57	31.8 QP	46.0	-14.2	1.95 V	301	36.18	-4.38
5	320.25	38.4 QP	46.0	-7.6	1.00 V	120	41.15	-2.75
6	797.49	37.8 QP	46.0	-8.2	1.60 V	122	31.15	6.65

**REMARKS:**

1. Emission Level(dBuV/m) = Raw Value(dBuV) + Correction Factor(dB/m)
2. Correction Factor(dB/m) = Antenna Factor(dB/m) + Cable Factor(dB) – Pre-Amplifier Factor(dB)
3. The other emission levels were very low against the limit.
4. Margin value = Emission Level – Limit value

<b>CHANNEL</b>	TX Channel 39	<b>DETECTOR FUNCTION</b>	Quasi-Peak (QP)
<b>FREQUENCY RANGE</b>	30MHz ~ 1GHz		

**ANTENNA POLARITY & TEST DISTANCE: HORIZONTAL AT 3 M**

NO.	FREQ. (MHz)	EMISSION LEVEL (dBuV/m)	LIMIT (dBuV/m)	MARGIN (dB)	ANTENNA HEIGHT (m)	TABLE ANGLE (Degree)	RAW VALUE (dBuV)	CORRECTION FACTOR (dB/m)
1	42.35	31.4 QP	40.0	-8.6	1.62 H	262	35.77	-4.37
2	200.96	33.5 QP	43.5	-10.0	1.00 H	61	40.58	-7.08
3	314.77	41.5 QP	46.0	-4.5	1.00 H	282	44.38	-2.88
4	<b>323.64</b>	<b>42.4 QP</b>	<b>46.0</b>	<b>-3.6</b>	<b>1.00 H</b>	<b>47</b>	<b>45.02</b>	<b>-2.62</b>
5	497.83	35.8 QP	46.0	-10.2	1.49 H	163	34.44	1.36
6	931.01	38.8 QP	46.0	-7.2	1.54 H	71	30.03	8.77

**ANTENNA POLARITY & TEST DISTANCE: VERTICAL AT 3 M**

NO.	FREQ. (MHz)	EMISSION LEVEL (dBuV/m)	LIMIT (dBuV/m)	MARGIN (dB)	ANTENNA HEIGHT (m)	TABLE ANGLE (Degree)	RAW VALUE (dBuV)	CORRECTION FACTOR (dB/m)
1	37.56	34.9 QP	40.0	-5.1	1.00 V	128	39.83	-4.93
2	59.03	30.0 QP	40.0	-10.0	1.51 V	38	34.28	-4.28
3	218.81	32.4 QP	46.0	-13.6	2.00 V	195	39.27	-6.87
4	267.87	32.3 QP	46.0	-13.7	2.01 V	285	36.67	-4.37
5	319.95	38.4 QP	46.0	-7.6	1.00 V	144	41.16	-2.76
6	797.49	37.7 QP	46.0	-8.3	1.61 V	113	31.05	6.65

**REMARKS:**

1. Emission Level(dBuV/m) = Raw Value(dBuV) + Correction Factor(dB/m)
2. Correction Factor(dB/m) = Antenna Factor(dB/m) + Cable Factor(dB) – Pre-Amplifier Factor(dB)
3. The other emission levels were very low against the limit.
4. Margin value = Emission Level – Limit value

## 4.2 Conducted Emission Measurement

### 4.2.1 Limits of Conducted Emission Measurement

Frequency (MHz)	Conducted Limit (dBuV)	
	Quasi-peak	Average
0.15 - 0.5	66 - 56	56 - 46
0.50 - 5.0	56	46
5.0 - 30.0	60	50

Note: 1. The lower limit shall apply at the transition frequencies.

2. The limit decreases in line with the logarithm of the frequency in the range of 0.15 to 0.50MHz.

### 4.2.2 Test Instruments

DESCRIPTION & MANUFACTURER	MODEL NO.	SERIAL NO.	CALIBRATED DATE	CALIBRATED UNTIL
Test Receiver R&S	ESCS 30	100375	May 06, 2015	May 05, 2016
Line-Impedance Stabilization Network (for EUT) SCHWARZBECK	NSLK-8127	8127-522	Sep. 01, 2015	Aug. 31, 2016
Line-Impedance Stabilization Network (for Peripheral ) R&S	ENV216	100072	June 11, 2015	June 10, 2016
RF Cable	5D-FB	COCCAB-001	Mar. 08, 2016	Mar. 07, 2017
50 ohms Terminator	N/A	EMC-03	Sep. 23, 2015	Sep. 22, 2016
50 ohms Terminator	N/A	EMC-02	Oct. 01, 2015	Sep. 30, 2016
50 ohms Terminator	E1-011315	13	Dec. 11, 2015	Dec. 10, 2016
Software BVADT	BVADT_Cond_ V7.3.7.3	NA	NA	NA

**Note:**

1. The calibration interval of the above test instruments are 12 months and the calibrations are traceable to NML/ROC and NIST/USA.
2. The test was performed in Shielded Room No. C.
3. The VCCI Con C Registration No. is C-3611.
4. Tested Date: Apr. 11, 2016

#### 4.2.3 Test Procedures

- The EUT was placed 0.4 meters from the conducting wall of the shielded room with EUT being connected to the power mains through a line impedance stabilization network (LISN). Other support units were connected to the power mains through another LISN. The two LISNs provide 50 ohm/ 50uH of coupling impedance for the measuring instrument.
- Both lines of the power mains connected to the EUT were checked for maximum conducted interference.
- The frequency range from 150kHz to 30MHz was searched. Emission levels under (Limit - 20dB) was not recorded.

**NOTE:** The resolution bandwidth and video bandwidth of test receiver is 9kHz for quasi-peak detection (QP) and average detection (AV) at frequency 0.15MHz-30MHz.

#### 4.2.4 Deviation from Test Standard

No deviation.

#### 4.2.5 Test Setup

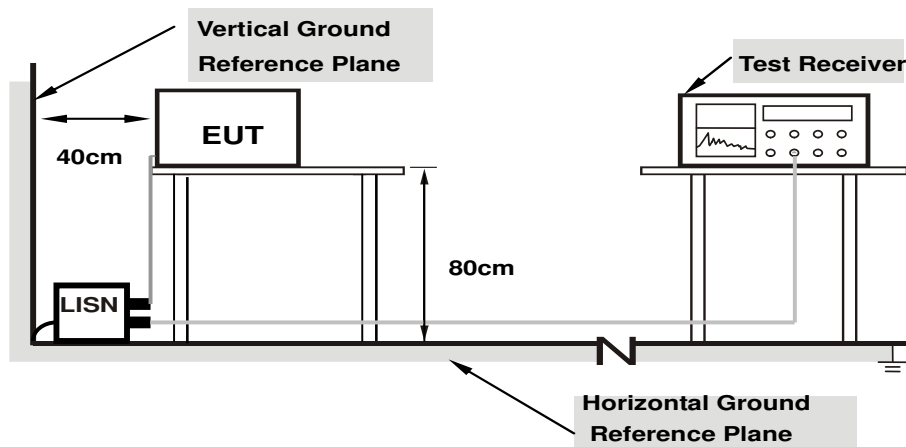

**Note: 1.Support units were connected to second LISN.**

For the actual test configuration, please refer to the attached file (Test Setup Photo).

#### 4.2.6 EUT Operating Conditions

Same as 4.1.6.

4.2.7 Test Results (Mode 1)

Phase	Line (L)	Detector Function	Quasi-Peak (QP) / Average (AV)
-------	----------	-------------------	--------------------------------

Phase Of Power : Line (L)										
No	Frequency (MHz)	Correction Factor (dB)	Reading Value (dBuV)		Emission Level (dBuV)		Limit (dBuV)		Margin (dB)	
			Q.P.	AV.	Q.P.	AV.	Q.P.	AV.	Q.P.	AV.
1	0.15391	10.32	40.62	22.97	50.94	33.29	65.79	55.79	-14.84	-22.49
2	0.16172	10.31	37.24	21.12	47.55	31.43	65.38	55.38	-17.82	-23.94
3	0.21641	10.28	34.11	15.89	44.39	26.17	62.96	52.96	-18.56	-26.78
4	0.24766	10.28	30.80	13.95	41.08	24.23	61.84	51.84	-20.75	-27.60
5	0.54106	10.28	23.84	20.12	34.12	30.40	56.00	46.00	-21.88	-15.60
6	20.32031	10.95	22.72	16.53	33.67	27.48	60.00	50.00	-26.33	-22.52

Remarks:

1. Q.P. and AV. are abbreviations of quasi-peak and average individually.
2. The emission levels of other frequencies were very low against the limit.
3. Margin value = Emission level – Limit value
4. Correction factor = Insertion loss + Cable loss
5. Emission Level = Correction Factor + Reading Value

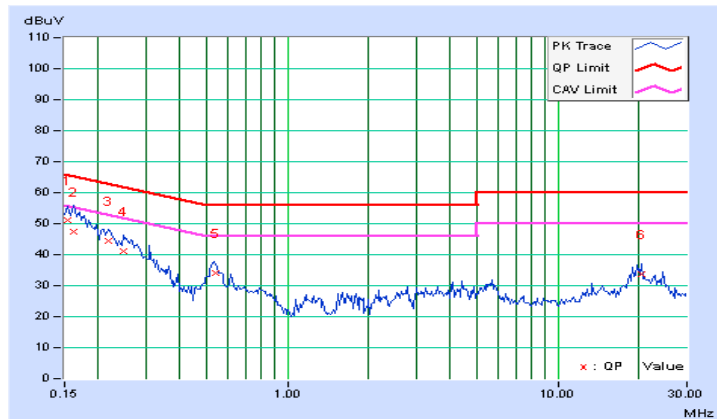

Phase	Neutral (N)	Detector Function	Quasi-Peak (QP) / Average (AV)
-------	-------------	-------------------	--------------------------------

Phase Of Power : Neutral (N)										
No	Frequency (MHz)	Correction Factor (dB)	Reading Value (dBuV)		Emission Level (dBuV)		Limit (dBuV)		Margin (dB)	
			Q.P.	AV.	Q.P.	AV.	Q.P.	AV.	Q.P.	AV.
1	0.15000	10.30	40.14	23.08	50.44	33.38	66.00	56.00	-15.56	-22.62
2	0.16953	10.29	37.45	22.57	47.74	32.86	64.98	54.98	-17.25	-22.13
3	0.18906	10.27	35.42	19.99	45.69	30.26	64.08	54.08	-18.39	-23.82
4	0.25547	10.27	27.66	15.44	37.93	25.71	61.58	51.58	-23.65	-25.87
5	0.54063	10.27	23.88	20.16	34.15	30.43	56.00	46.00	-21.85	-15.57
6	20.03516	10.98	17.77	12.27	28.75	23.25	60.00	50.00	-31.25	-26.75

**Remarks:**

1. Q.P. and AV. are abbreviations of quasi-peak and average individually.
2. The emission levels of other frequencies were very low against the limit.
3. Margin value = Emission level – Limit value
4. Correction factor = Insertion loss + Cable loss
5. Emission Level = Correction Factor + Reading Value

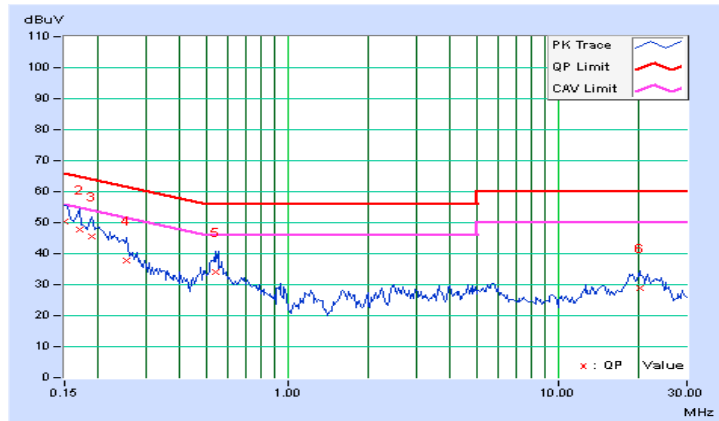

4.2.8 Test Results (Mode 2)

Phase	Line (L)	Detector Function	Quasi-Peak (QP) / Average (AV)
-------	----------	-------------------	--------------------------------

Phase Of Power : Line (L)										
No	Frequency (MHz)	Correction Factor (dB)	Reading Value (dBuV)		Emission Level (dBuV)		Limit (dBuV)		Margin (dB)	
			Q.P.	AV.	Q.P.	AV.	Q.P.	AV.	Q.P.	AV.
1	0.15000	10.32	32.06	21.48	42.38	31.80	66.00	56.00	-23.62	-24.20
2	0.16562	10.31	29.30	17.30	39.61	27.61	65.18	55.18	-25.57	-27.57
3	0.18516	10.29	25.72	13.86	36.01	24.15	64.25	54.25	-28.24	-30.10
4	0.21250	10.28	22.46	10.17	32.74	20.45	63.11	53.11	-30.37	-32.66
<b>5</b>	<b>0.42312</b>	<b>10.30</b>	<b>29.81</b>	<b>24.74</b>	<b>40.11</b>	<b>35.04</b>	<b>57.39</b>	<b>47.39</b>	<b>-17.28</b>	<b>-12.35</b>
6	0.51719	10.29	16.60	10.84	26.89	21.13	56.00	46.00	-29.11	-24.87

**Remarks:**

1. Q.P. and AV. are abbreviations of quasi-peak and average individually.
2. The emission levels of other frequencies were very low against the limit.
3. Margin value = Emission level – Limit value
4. Correction factor = Insertion loss + Cable loss
5. Emission Level = Correction Factor + Reading Value

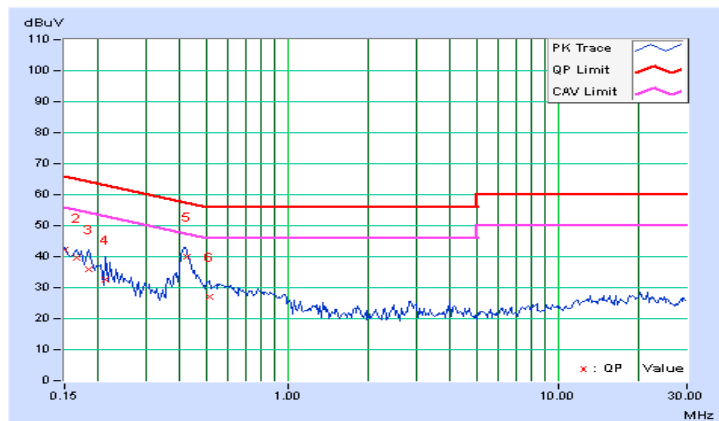

Phase	Neutral (N)	Detector Function	Quasi-Peak (QP) / Average (AV)
-------	-------------	-------------------	--------------------------------

Phase Of Power : Neutral (N)										
No	Frequency (MHz)	Correction Factor (dB)	Reading Value (dBuV)		Emission Level (dBuV)		Limit (dBuV)		Margin (dB)	
			Q.P.	AV.	Q.P.	AV.	Q.P.	AV.	Q.P.	AV.
1	0.15391	10.30	31.77	20.46	42.07	30.76	65.79	55.79	-23.71	-25.02
2	0.17734	10.28	29.68	15.69	39.96	25.97	64.61	54.61	-24.65	-28.64
3	0.18906	10.27	28.04	12.85	38.31	23.12	64.08	54.08	-25.77	-30.96
4	0.21641	10.26	23.30	11.85	33.56	22.11	62.96	52.96	-29.39	-30.84
5	0.24766	10.26	21.30	10.39	31.56	20.65	61.84	51.84	-30.27	-31.18
6	0.41563	10.28	30.04	24.54	40.32	34.82	57.54	47.54	-17.22	-12.72

**Remarks:**

1. Q.P. and AV. are abbreviations of quasi-peak and average individually.
2. The emission levels of other frequencies were very low against the limit.
3. Margin value = Emission level – Limit value
4. Correction factor = Insertion loss + Cable loss
5. Emission Level = Correction Factor + Reading Value

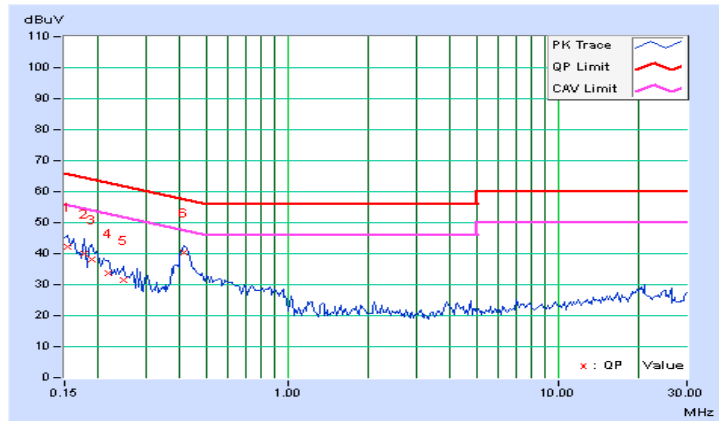



### 4.3 6dB Bandwidth Measurement

#### 4.3.1 Limits of 6dB Bandwidth Measurement

The minimum of 6dB Bandwidth Measurement is 0.5 MHz.

#### 4.3.2 Test Setup

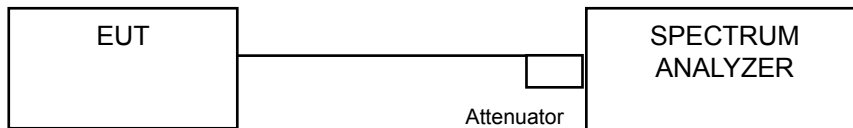

#### 4.3.3 Test Instruments

Refer to section 4.1.2 to get information of above instrument.

#### 4.3.4 Test Procedure

- a. Set resolution bandwidth (RBW) = 100kHz
- b. Set the video bandwidth (VBW)  $\geq 3 \times$  RBW, Detector = Peak.
- c. Trace mode = max hold.
- d. Sweep = auto couple.
- e. Measure the maximum width of the emission that is constrained by the frequencies associated with the two amplitude points (upper and lower) that are attenuated by 6 dB relative to the maximum level measured in the fundamental emission

#### 4.3.5 Deviation from Test Standard

No deviation.

#### 4.3.6 EUT Operating Conditions

The software provided by client to enable the EUT under transmission condition continuously at lowest, middle and highest channel frequencies individually.

4.3.7 Test Result

Channel	Frequency (MHz)	6dB Bandwidth (MHz)	Minimum Limit (MHz)	Pass / Fail
0	2402	0.69	0.5	PASS
19	2440	0.71	0.5	PASS
39	2480	0.69	0.5	PASS

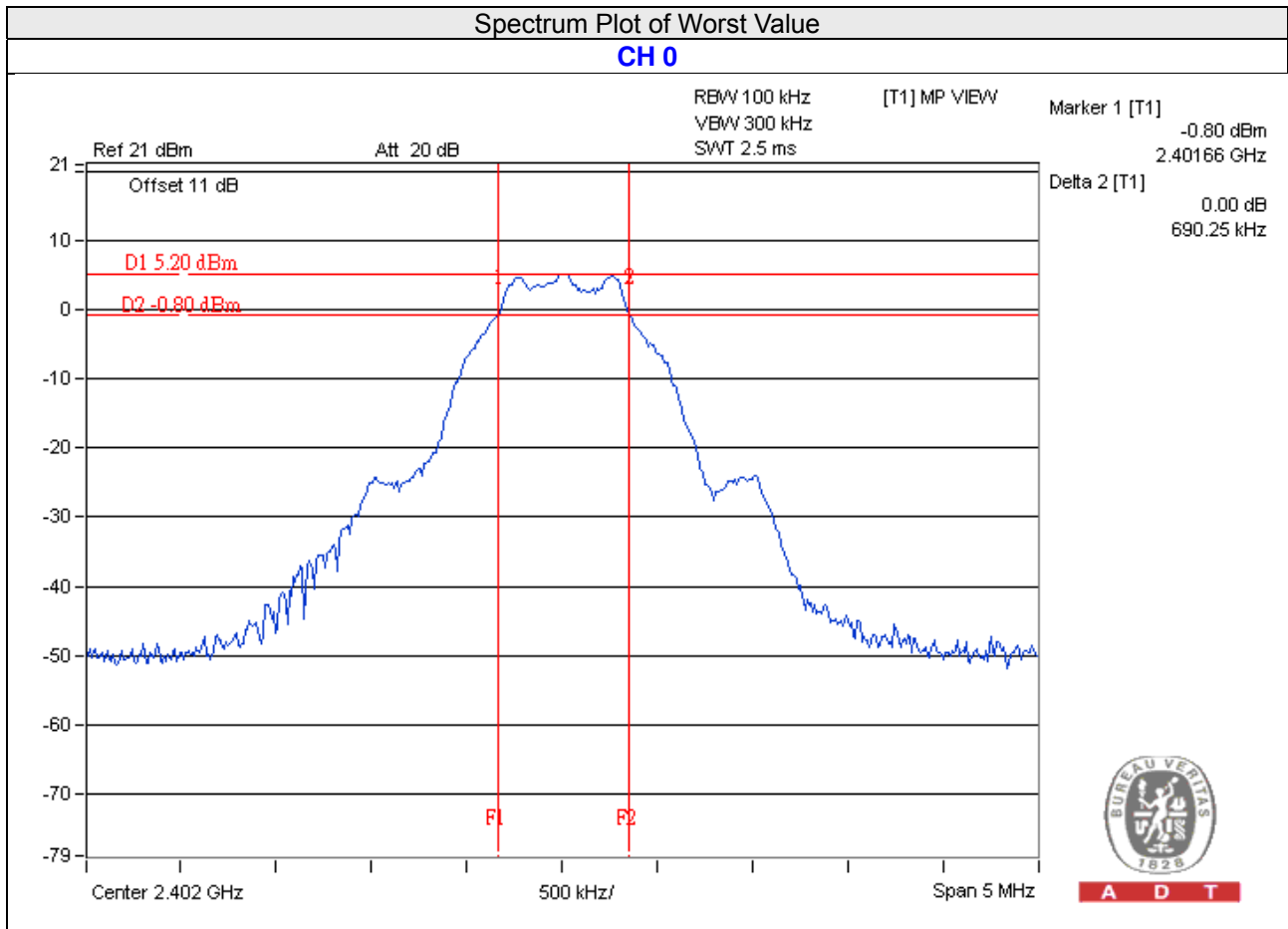

#### 4.4 Conducted Output Power Measurement

##### 4.4.1 Limits OF Conducted Output Power Measurement

For systems using digital modulation in the 2400–2483.5 MHz bands: 1 Watt (30dBm)

##### 4.4.2 Test Setup

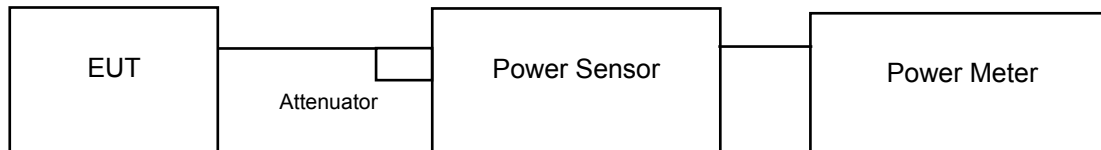

##### 4.4.3 Test Instruments

Refer to section 4.1.2 to get information of above instrument.

##### 4.4.4 Test Procedures

A peak / average power sensor was used on the output port of the EUT. A power meter was used to read the response of the peak / average power sensor. Record the power level.

##### 4.4.5 Deviation from Test Standard

No deviation.

##### 4.4.6 EUT Operating Conditions

Same as Item 4.3.6.

#### 4.4.7 Test Results

##### FOR PEAK POWER

Channel	Frequency (MHz)	Peak Power (mW)	Peak Power (dBm)	Limit (dBm)	Pass/Fail
0	2402	3.999	6.02	30	Pass
19	2440	4.083	6.11	30	Pass
39	2480	4.721	6.74	30	Pass

##### FOR AVERAGE POWER

Channel	Frequency (MHz)	Average Power (mW)	Average Power (dBm)
0	2402	3.724	5.71
19	2440	3.99	6.01
39	2480	4.667	6.69

## 4.5 Power Spectral Density Measurement

### 4.5.1 Limits of Power Spectral Density Measurement

The Maximum of Power Spectral Density Measurement is 8dBm.

### 4.5.2 Test Setup

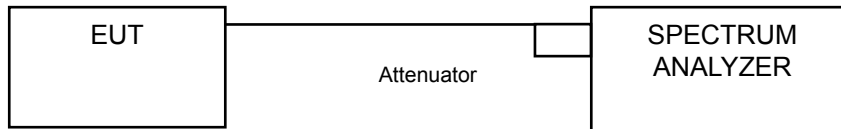

### 4.5.3 Test Instruments

Refer to section 4.1.2 to get information of above instrument.

### 4.5.4 Test Procedure

- a. Set analyzer center frequency to DTS channel center frequency.
- b. Set the span to 1.5 times the DTS bandwidth.
- c. Set the RBW to:  $3 \text{ kHz} \leq \text{RBW} \leq 100 \text{ kHz}$ .
- d. Set the VBW  $\geq 3 \times \text{RBW}$ .
- e. Detector = peak.
- f. Sweep time = auto couple.
- g. Trace mode = max hold.
- h. Allow trace to fully stabilize.
- i. Use the peak marker function to determine the maximum amplitude level within the RBW.

### 4.5.5 Deviation from Test Standard

No deviation.

### 4.5.6 EUT Operating Condition

Same as Item 4.3.6

4.5.7 Test Results

Channel	Freq. (MHz)	PSD (dBm/3kHz)	Limit (dBm/3kHz)	Pass /Fail
0	2402	-8.77	8	Pass
19	2440	-8.50	8	Pass
39	2480	-8.04	8	Pass

**Spectrum Plot of Worst Value**  
**CH 39**

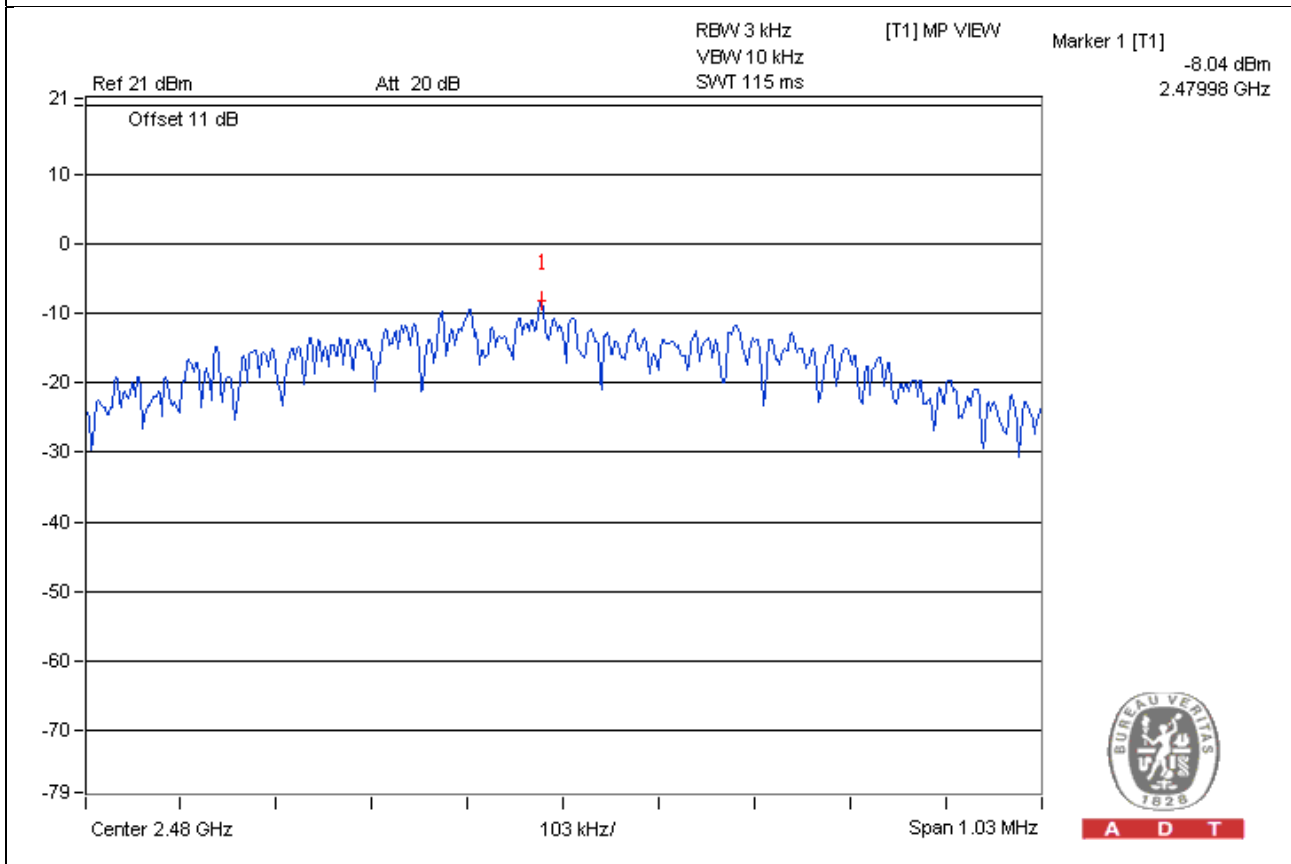

## 4.6 Conducted Out of Band Emission Measurement

### 4.6.1 Limits of Conducted Out of Band Emission Measurement

Below  $-20\text{dB}$  of the highest emission level of operating band (in 100kHz Resolution Bandwidth).

### 4.6.2 Test Setup

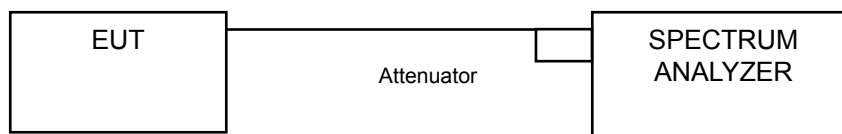

### 4.6.3 Test Instruments

Refer to section 4.1.2 to get information of above instrument.

### 4.6.4 Test Procedure

#### MEASUREMENT PROCEDURE REF

1. Set the RBW = 100 kHz.
2. Set the VBW  $\geq$  300 kHz.
3. Detector = peak.
4. Sweep time = auto couple.
5. Trace mode = max hold.
6. Allow trace to fully stabilize.
7. Use the peak marker function to determine the maximum power level in any 100 kHz band segment within the fundamental EBW.

#### MEASUREMENT PROCEDURE OOB

1. Set RBW = 100 kHz.
2. Set VBW  $\geq$  300 kHz.
3. Detector = peak.
4. Sweep = auto couple.
5. Trace Mode = max hold.
6. Allow trace to fully stabilize.
7. Use the peak marker function to determine the maximum amplitude level.

### 4.6.5 Deviation from Test Standard

No deviation.

### 4.6.6 EUT Operating Condition

Same as Item 4.3.6

### 4.6.7 Test Results

#### CH 0

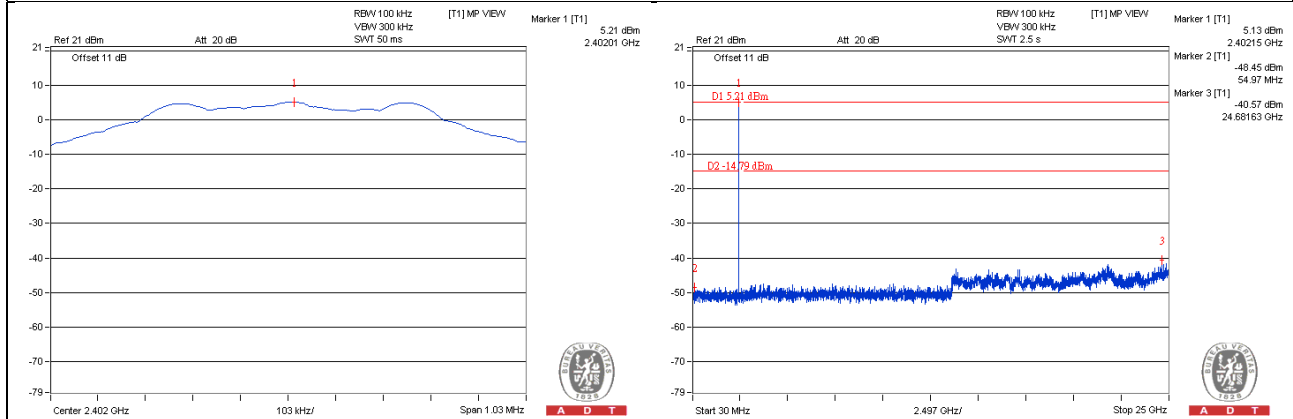

#### CH 19

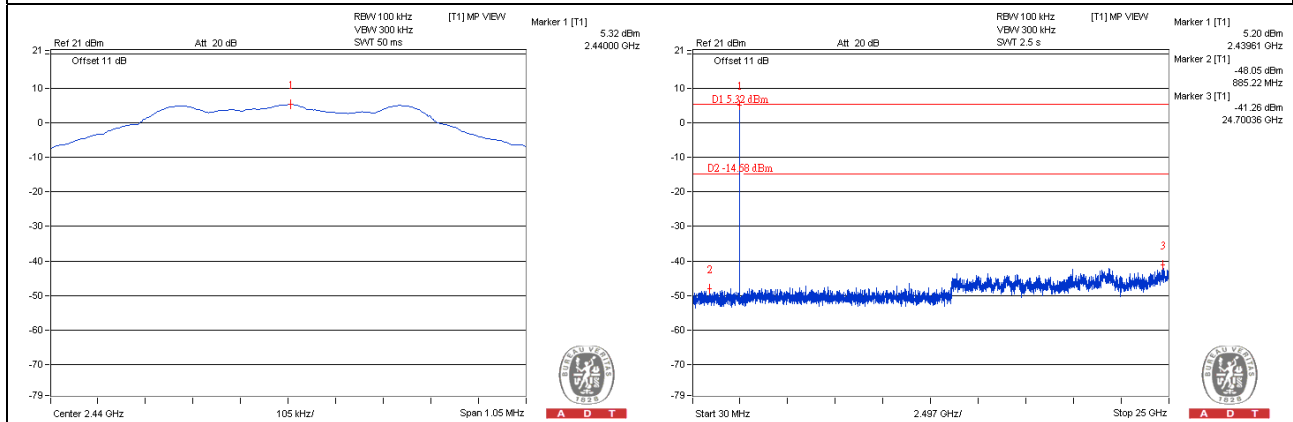

#### CH 39

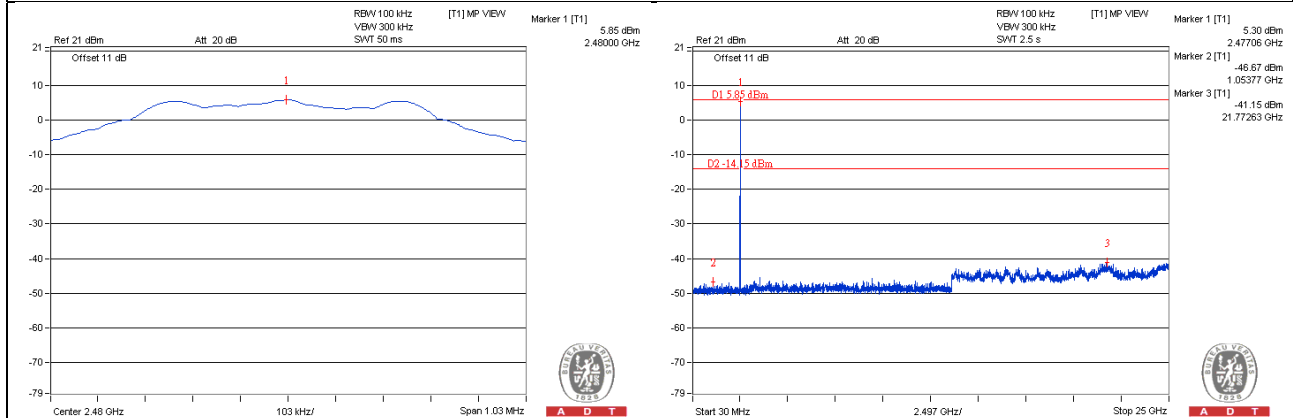

#### CH 0 Band edge

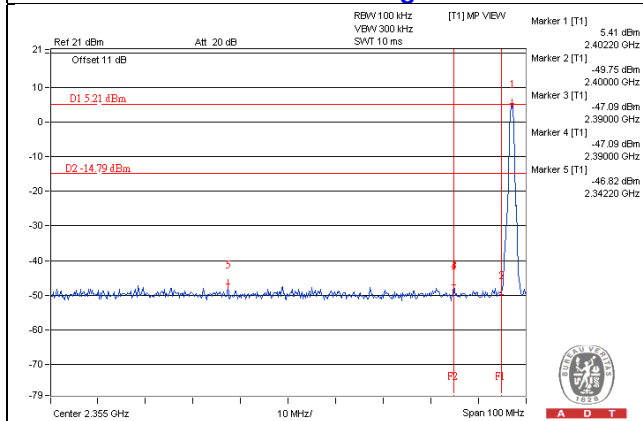

#### CH 39 Band edge

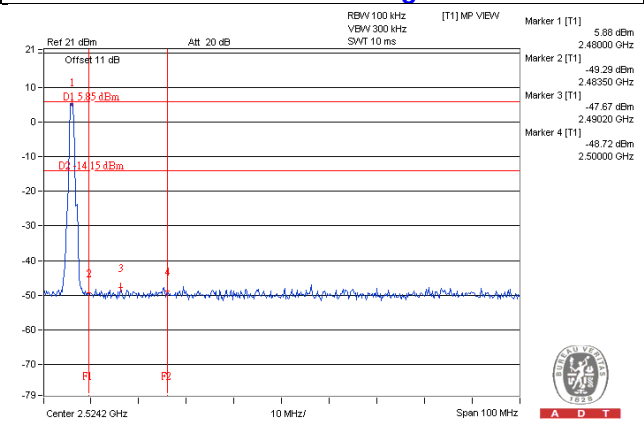



## 5 Pictures of Test Arrangements

Please refer to the attached file (Test Setup Photo).



## Appendix – Information on the Testing Laboratories

We, Bureau Veritas Consumer Products Services (H.K.) Ltd., Taoyuan Branch, were founded in 1988 to provide our best service in EMC, Radio, Telecom and Safety consultation. Our laboratories are accredited and approved according to ISO/IEC 17025.

If you have any comments, please feel free to contact us at the following:

**Linko EMC/RF Lab**

Tel: 886-2-26052180

Fax: 886-2-26051924

**Hsin Chu EMC/RF/Telecom Lab**

Tel: 886-3-6668565

Fax: 886-3-6668323

**Hwa Ya EMC/RF/Safety Lab**

Tel: 886-3-3183232

Fax: 886-3-3270892

**Email:** [service.adt@tw.bureauveritas.com](mailto:service.adt@tw.bureauveritas.com)

**Web Site:** [www.bureauveritas-adt.com](http://www.bureauveritas-adt.com)

The address and road map of all our labs can be found in our web site also.

--- END ---