

FCC Test Report

Report No.: RF160128E09-1

FCC ID: UZ7WT6000

Test Model: WT6000

Received Date: Jan. 28, 2016

Test Date: Mar. 02 to Apr. 18, 2016

Issued Date: Apr. 26, 2016

Applicant: Zebra Technologies Corporation

Address: 1 Zebra Plaza, Holtsville, NY 11742

Manufacturer: Zebra Technologies Corporation

Address: 1 Zebra Plaza, Holtsville, NY 11742

Issued By: Bureau Veritas Consumer Products Services (H.K.) Ltd., Taoyuan Branch
Hsin Chu Laboratory

Lab Address: E-2, No.1, Li Hsin 1st Road, Hsinchu Science Park, Hsinchu City 300,
Taiwan R.O.C.

Test Location (1): E-2, No.1, Li Hsin 1st Road, Hsinchu Science Park, Hsinchu City 300,
Taiwan R.O.C.

Test Location (2): No. 49, Ln. 206, Wende Rd., Shangshan Tsuen, Chiung Lin Hsiang, Hsin
Chu Hsien 307, Taiwan R.O.C.



This report is for your exclusive use. Any copying or replication of this report to or for any other person or entity, or use of our name or trademark, is permitted only with our prior written permission. This report sets forth our findings solely with respect to the test samples identified herein. The results set forth in this report are not indicative or representative of the quality or characteristics of the lot from which a test sample was taken or any similar or identical product unless specifically and expressly noted. Our report includes all of the tests requested by you and the results thereof based upon the information that you provided to us. You have 60 days from date of issuance of this report to notify us of any material error or omission caused by our negligence, provided, however, that such notice shall be in writing and shall specifically address the issue you wish to raise. A failure to raise such issue within the prescribed time shall constitute your unqualified acceptance of the completeness of this report, the tests conducted and the correctness of the report contents. Unless specific mention, the uncertainty of measurement has been explicitly taken into account to declare the compliance or non-compliance to the specification. The report must not be used by the client to claim product certification, approval, or endorsement by TAF or any government agencies.

Table of Contents

Release Control Record	4
1 Certificate of Conformity	5
2 Summary of Test Results	6
2.1 Measurement Uncertainty	6
2.2 Modification Record	6
3 General Information	7
3.1 General Description of EUT (WLAN 5GHz).....	7
3.2 Description of Test Modes.....	12
3.2.1 Test Mode Applicability and Tested Channel Detail.....	14
3.3 Duty Cycle of Test Signal	18
3.4 Description of Support Units	19
3.4.1 Configuration of System under Test	20
3.5 General Description of Applied Standard.....	21
4 Test Types and Results	22
4.1 Radiated Emission and Bandedge Measurement.....	22
4.1.1 Limits of Radiated Emission and Bandedge Measurement	22
4.1.2 Test Instruments	23
4.1.3 Test Procedure	26
4.1.4 Deviation from Test Standard	26
4.1.5 Test Setup.....	27
4.1.6 EUT Operating Condition	27
4.1.7 Test Results	28
4.2 Conducted Emission Measurement	138
4.2.1 Limits of Conducted Emission Measurement	138
4.2.2 Test Instruments	138
4.2.3 Test Procedure	139
4.2.4 Deviation from Test Standard	139
4.2.5 Test Setup.....	139
4.2.6 EUT Operating Condition	139
4.2.7 Test Results (Mode 1).....	140
4.2.8 Test Results (Mode 2).....	142
4.3 Transmit Power Measurement	144
4.3.1 Limits of Transmit Power Measurement	144
4.3.2 Test Setup.....	145
4.3.3 Test Instruments	146
4.3.4 Test Procedure	146
4.3.5 Deviation from Test Standard	146
4.3.6 EUT Operating Condition	146
4.3.7 Test Result.....	147
4.4 Peak Power Spectral Density Measurement	168
4.4.1 Limits of Peak Power Spectral Density Measurement	168
4.4.2 Test Setup.....	168
4.4.3 Test Instruments	168
4.4.4 Test Procedure	169
4.4.5 Deviation from Test Standard	169
4.4.6 EUT Operating Condition	169
4.4.7 Test Results	170
4.5 Frequency Stability Measurement	179
4.5.1 Limits of Frequency Stability Measurement	179
4.5.2 Test Setup.....	179
4.5.3 Test Instruments	179
4.5.4 Test Procedure	179
4.5.5 Deviation from Test Standard	179

4.5.6 EUT Operating Condition	179
4.5.7 Test Results	180
4.6 6dB Bandwidth Measurement	181
4.6.1 Limits of 6dB Bandwidth Measurement	181
4.6.2 Test Setup	181
4.6.3 Test Instruments	181
4.6.4 Test Procedure	181
4.6.5 Deviation from Test Standard	181
4.6.6 EUT Operating Condition	181
4.6.7 Test Results	182
5 Pictures of Test Arrangements	185
Appendix – Information on the Testing Laboratories	186



A D T

Release Control Record

Issue No.	Description	Date Issued
RF160128E09-1	Original release.	Apr. 26, 2016



1 Certificate of Conformity

Product: Wearable Terminal
Brand: Zebra
Test Model: WT6000
Sample Status: ENGINEERING SAMPLE
Applicant: Zebra Technologies Corporation
Test Date: Mar. 02 to Apr. 18, 2016
Standard: 47 CFR FCC Part 15, Subpart E (Section 15.407)
ANSI C63.10: 2013

The above equipment has been tested by **Bureau Veritas Consumer Products Services (H.K.) Ltd., Taoyuan Branch**, and found compliance with the requirement of the above standards. The test record, data evaluation & Equipment Under Test (EUT) configurations represented herein are true and accurate accounts of the measurements of the sample's EMC characteristics under the conditions specified in this report.

Prepared by : Wendy Wu , **Date:** Apr. 26, 2016
Wendy Wu-Specialist

Approved by : May Chen , **Date:** Apr. 26, 2016
May Chen / Manager

2 Summary of Test Results

47 CFR FCC Part 15, Subpart E (SECTION 15.407)			
FCC Clause	Test Item	Result	Remarks
15.407(b)(6)	AC Power Conducted Emissions	PASS	Meet the requirement of limit. Minimum passing margin is -12.29dB at 0.42087MHz.
15.407(b)(1/2/3/4/6)	Radiated Emissions & Band Edge Measurement	PASS	Meet the requirement of limit. Minimum passing margin is -1.3dB at 5725.00MHz and 5150.00MHz.
15.407(a)(1/2/3)	Max Average Transmit Power	PASS	Meet the requirement of limit.
15.407(a)(1/2/3)	Peak Power Spectral Density	PASS	Meet the requirement of limit.
15.407(e)	6dB bandwidth	PASS	Meet the requirement of limit. (U-NII-3 Band only)
15.407(g)	Frequency Stability	PASS	Meet the requirement of limit.
15.203	Antenna Requirement	PASS	Antenna connector is i-pex (MHF) not a standard connector.

NOTE: 1. For WLAN: The EUT was operating in 2.412 ~ 2.472GHz, 5.18~5.24 GHz, 5.26~5.32 GHz, 5.50~5.72GHz and 5.745~5.825GHz frequency bands. This report was recorded the RF parameters including 5.18~5.24 GHz, 5.26~5.32 GHz, 5.50~5.72GHz and 5.745~5.825GHz. For the 2.412 ~ 2.472GHz RF parameters was recorded in another test report.

2.1 Measurement Uncertainty

Where relevant, the following measurement uncertainty levels have been estimated for tests performed on the EUT as specified in CISPR 16-4-2:

Measurement	Frequency	Expanded Uncertainty (k=2) (±)
Conducted Emissions at mains ports	150kHz ~ 30MHz	2.86 dB
Radiated Emissions up to 1 GHz	30MHz ~ 1GHz	5.31 dB
Radiated Emissions above 1 GHz	1GHz ~ 6GHz	3.43 dB
	6GHz ~ 18GHz	3.49 dB
	18GHz ~ 40GHz	4.11 dB

2.2 Modification Record

There were no modifications required for compliance.

3 General Information

3.1 General Description of EUT (WLAN 5GHz)

Product	Wearable Terminal
Brand	Zebra
Test Model	WT6000
Status of EUT	ENGINEERING SAMPLE
SW Version	3.14.52
Power Supply Rating	DC 3.6V from Battery or DC 5.4V from Cradle or DC 5.4V from Adapter
Modulation Type	CCK, DQPSK, DBPSK for DSSS 64QAM, 16QAM, QPSK, BPSK for OFDM 256QAM for OFDM in 11ac mode only
Modulation Technology	DSSS, OFDM
Transfer Rate	802.11b: up to 11Mbps 802.11a/g: up to 54Mbps 802.11n: up to 300Mbps 802.11ac: up to 866.7Mbps
Operating Frequency	For 15.407: 5.18GHz ~ 5.24GHz, 5.26GHz ~ 5.32GHz, 5.50GHz ~ 5.70GHz, 5.745GHz ~ 5.825GHz
	For 15.247: 2.412 ~ 2.472GHz
Number of Channel	For 15.407: 802.11a, 802.11n (HT20), 802.11ac (VHT20): 22 802.11n (HT40), 802.11ac (VHT40): 10 802.11ac (VHT80): 6
	For 15.247: 802.11b, 802.11g, 802.11n (HT20): 13

Output Power	For 15.407: 5.18GHz ~ 5.24GHz 1TX 77.446mW 2TX CDD Mode 136.602mW Beamforming Mode 138.179mW SDM Mode 136.962mW 5.26GHz ~ 5.32GHz 1TX 77.983mW 2TX CDD Mode 140.356mW Beamforming Mode 153.864mW SDM Mode 142.056mW 5.50GHz ~ 5.70GHz 1TX 58.749mW 2TX CDD Mode 137.273mW Beamforming Mode 156.203mW SDM Mode 148.91mW 5.745GHz ~ 5.825GHz 1TX 56.754mW 2TX CDD Mode 114.166mW Beamforming Mode 102.756mW SDM Mode 101.187mW
	For 15.247: 1TX 245.471mW 2TX CDD Mode 461.663mW Beamforming Mode 492.679mW SDM Mode 481.452mW
Antenna Type	Refer to Note
Antenna Connector	Refer to Note
Accessory Device	Battery x1
Data Cable Supplied	NA

Note:

1. There are WLAN, BT, NFC technology used for the EUT.
2. For WLAN: 2.4GHz and 5GHz technology cannot transmit at same time.
3. WLAN <2.4GHz (1x2) or 5GHz (1x2)> + BT + NFC technology can transmit at same time.
4. The EUT could be supplied with a cradle, adapter or battery as below table:

Battery	
Brand:	ZEBRA TECHNOLOGIES CORPORATION
Part No.:	BT000262A01
Rating:	TYP: 3350mAh, 12.06WH Min: 3200mAh, 11.52WH Rechargeable, normal voltage: 3.6V, limit 4.2V
Cradles- 1slot (not for sale together)	
Brand:	Zebra
Model No.:	SHARECRADLE-01
Part No.:	SAC-TC8X-4SCHG-01
Input Power	+12V ----- 4.16A
Output Power:	DC 5.4V(for EUT used) DC 4.2V(for Battery used)
I/O Port	DC Port x 1 USB Port x 2
Associated Devices:	Adapter x 1 (Adapter: Part No.: PWRS-14000-148R)
Cradle adapter (for Cradle- 1slot used, not for sale together)	
Brand:	HIPRO
Model No.:	HP-A0502R3D
Part No.:	PWRS-14000-148R
Input power :	100-240Vac, 2.4A, 50-60Hz
Output power :	+12Vdc ----- 4.16A DC output cable (unshielded, 1.8m with one core)
Adapter (not for sale together)	
Brand:	Zebra
Model No.:	PWRS-14000-249R
Input Power	100-240Vac, 50-60Hz, 0.6A
Output Power:	+5.4Vdc ----- 3A 1. DC output cable (unshielded, 1.8m) 2. USB charging cable (Brand: SINBON, Model: A9304774-005, shielded, 0.95m with one core)

5. The EUT antennas information:

WLAN / BT antenna				
Transmitter Circuit	Antenna Gain(dBi) <Including cable loss>	Frequency range	Antenna Type	Connector Type
Chain (0)	3.37	2.4~2.4835GHz	Patch	i-pex(MHF)
	3.3	5.15~5.25GHz	Patch	i-pex(MHF)
	3.3	5.25~5.35GHz	Patch	i-pex(MHF)
	3.2	5.47~5.725GHz	Patch	i-pex(MHF)
	0.61	5.725~5.85GHz	Patch	i-pex(MHF)
Chain (1)	3.86	2.4~2.4835GHz	Patch	i-pex(MHF)
	3.66	5.15~5.25GHz	Patch	i-pex(MHF)
	3.66	5.25~5.35GHz	Patch	i-pex(MHF)
	3.99	5.47~5.725GHz	Patch	i-pex(MHF)
	3.99	5.725~5.85GHz	Patch	i-pex(MHF)
NFC antenna				
Frequency range	Antenna Type		Connector Type	
13.56MHz	Loop		NA	
Note: From the above antennas, Chain (1) was selected as representative antenna for 1TX configuration and its data was recorded in this report.				

6. The EUT incorporates a MIMO function.

2.4GHz Band			
MODULATION MODE	DATA RATE (MCS)	TX & RX CONFIGURATION	
802.11b	1 ~ 11Mbps	2TX / 1TX (diversity)	2RX
802.11g	6 ~ 54Mbps	2TX / 1TX (diversity)	2RX
802.11n (HT20)	MCS 0~7	2TX / 1TX (diversity)	2RX
	MCS 8~15	2TX	2RX
5GHz Band			
MODULATION MODE	DATA RATE (MCS)	TX & RX CONFIGURATION	
802.11a	6 ~ 54Mbps	2TX / 1TX (diversity)	2RX
802.11n (HT20)	MCS 0~7	2TX / 1TX (diversity)	2RX
	MCS 8~15	2TX	2RX
802.11n (HT40)	MCS 0~7	2TX / 1TX (diversity)	2RX
	MCS 8~15	2TX	2RX
802.11ac (VHT20)	MCS 0~8, NSS=1	2TX / 1TX (diversity)	2RX
	MCS 0~8, NSS=2	2TX	2RX
802.11ac (VHT40)	MCS 0~9, NSS=1	2TX / 1TX (diversity)	2RX
	MCS 0~9, NSS=2	2TX	2RX
802.11ac (VHT80)	MCS 0~9, NSS=1	2TX / 1TX (diversity)	2RX
	MCS 0~9, NSS=2	2TX	2RX
Note:			
1. All of modulation mode support beamforming function except 802.11a/b/g modulation mode.			
2. The modulation and bandwidth are similar for 802.11n mode for 20MHz (40MHz) and 802.11ac mode for 20MHz (40MHz), therefore investigated worst case to representative mode in test report.			

7. The EUT was pre-tested under following test modes:

Mode	Terminal	Cradle	I/O (left)	I/O (right)	Polarity
Mode A	WT6000	-----	USB charge cable	wired RS419 coil	X-Y
Mode B	WT6000	-----	USB charge cable	wired RS419 coil	X-Z
Mode C	WT6000	-----	USB charge cable	wired RS419 coil	Y-Z
Mode D	WT6000	1-slot	1-slot cradle	wired RS419 coil	NA

From the above modes, the spurious emission below 1GHz worst case was found in **Mode D** and the spurious emission above 1GHz worst case was found in **Mode B** .Therefore only the test data of the modes were recorded in this report individually.

8. The above EUT information is declared by manufacturer and for more detailed features description, please refer to the manufacturer's specifications or user's manual.

3.2 Description of Test Modes

FOR 5180 ~ 5240MHz

4 channels are provided for 802.11a, 802.11n (HT20), 802.11ac (VHT20):

Channel	Frequency	Channel	Frequency
36	5180 MHz	44	5220 MHz
40	5200 MHz	48	5240 MHz

2 channels are provided for 802.11n (HT40), 802.11ac (VHT40):

Channel	Frequency	Channel	Frequency
38	5190 MHz	46	5230 MHz

1 channel is provided for 802.11ac (VHT80):

Channel	Frequency
42	5210MHz

FOR 5260 ~ 5320MHz

4 channels are provided for 802.11a (HT20), 802.11ac (VHT20):

Channel	Frequency	Channel	Frequency
52	5260 MHz	60	5300 MHz
56	5280 MHz	64	5320 MHz

2 channels are provided for 802.11n (HT40), 802.11ac (VHT40):

Channel	Frequency	Channel	Frequency
54	5270 MHz	62	5310 MHz

1 channel is provided for 802.11ac (VHT80):

Channel	Frequency
58	5290MHz

FOR 5500 ~ 5720MHz

9 channels are provided for 802.11a, 802.11n (HT20), 802.11ac (VHT20):

Channel	Frequency	Channel	Frequency
100	5500 MHz	132	5660 MHz
104	5520 MHz	136	5680 MHz
108	5540 MHz	140	5700 MHz
112	5560 MHz	144	5720 MHz
116	5580 MHz		

4 channels are provided for 802.11n (HT40), 802.11ac (VHT40):

Channel	Frequency	Channel	Frequency
102	5510 MHz	134	5670 MHz
110	5550 MHz	142	5710 MHz

3 channels are provided for 802.11ac (VHT80):

Channel	Frequency	Channel	Frequency
106	5530MHz	138	5690 MHz
122	5610 MHz		

FOR 5745 ~ 5825MHz:

5 channels are provided for 802.11a, 802.11n (HT20), 802.11ac (VHT20):

Channel	Frequency	Channel	Frequency
149	5745MHz	161	5805MHz
153	5765MHz	165	5825MHz
157	5785MHz		

2 channels are provided for 802.11n (HT40), 802.11ac (VHT40):

Channel	Frequency	Channel	Frequency
151	5755MHz	159	5795MHz

1 channel is provided for 802.11ac (VHT80):

Channel	Frequency
155	5775MHz

3.2.1 Test Mode Applicability and Tested Channel Detail

EUT CONFIGURE MODE	APPLICABLE TO				DESCRIPTION
	RE≥1G	RE<1G	PLC	APCM	
1	√	√	√	√	With Adapter
2	-	-	√	-	With Cradles

Where **RE≥1G**: Radiated Emission above 1GHz **RE<1G**: Radiated Emission below 1GHz
PLC: Power Line Conducted Emission **APCM**: Antenna Port Conducted Measurement

NOTE:

1. The EUT had been pre-tested on the positioned of each 3 axis. The worst case was found when positioned on **Z-plane**.
2. “-” means no effect.

Radiated Emission Test (Above 1GHz):

- Pre-Scan has been conducted to determine the worst-case mode from all possible combinations between available modulations, data rates and antenna ports (if EUT with antenna diversity architecture).
- Following channel(s) was (were) selected for the final test as listed below.

1TX Configuration					
MODE	FREQ. BAND (MHz)	AVAILABLE CHANNEL	TESTED CHANNEL	MODULATION TECHNOLOGY	DATA RATE (Mbps)
802.11a	5180-5240	36 to 48	36, 40, 48	OFDM	6
802.11a	5260-5320	52 to 64	52, 60, 64	OFDM	6
802.11a	5500-5720	100 to 140	100, 116, 140, 144	OFDM	6
802.11a	5745-5825	149 to 165	149, 157, 165	OFDM	6
2TX Configuration					
CDD Mode					
MODE	FREQ. BAND (MHz)	AVAILABLE CHANNEL	TESTED CHANNEL	MODULATION TECHNOLOGY	DATA RATE (Mbps)
802.11a	5180-5240	36 to 48	36, 40, 48	OFDM	6
802.11a	5260-5320	52 to 64	52, 60, 64	OFDM	6
802.11a	5500-5720	100 to 140	100, 116, 140, 144	OFDM	6
802.11a	5745-5825	149 to 165	149, 157, 165	OFDM	6
Beamforming Mode					
MODE	FREQ. BAND (MHz)	AVAILABLE CHANNEL	TESTED CHANNEL	MODULATION TECHNOLOGY	DATA RATE (Mbps)
802.11ac (VHT20)	5180-5240	36 to 48	36, 40, 48	OFDM	6.5
802.11ac (VHT40)		38 to 46	38, 46	OFDM	13.5
802.11ac (VHT80)		42	42	OFDM	29.3
802.11ac (VHT20)	5260-5320	52 to 64	52, 60, 64	OFDM	6.5
802.11ac (VHT40)		54 to 62	54, 62	OFDM	13.5
802.11ac (VHT80)		58	58	OFDM	29.3
802.11ac (VHT20)	5500-5720	100 to 140	100, 116, 140, 144	OFDM	6.5
802.11ac (VHT40)		102 to 134	102, 110, 134, 142	OFDM	13.5
802.11ac (VHT80)		106, 122, 138	106, 122, 138	OFDM	29.3
802.11ac (VHT20)	5745-5825	149 to 165	149, 157, 165	OFDM	6.5
802.11ac (VHT40)		151 to 159	151, 159	OFDM	13.5
802.11ac (VHT80)		155	155	OFDM	29.3

Radiated Emission Test (Below 1GHz):

- Pre-Scan has been conducted to determine the worst-case mode from all possible combinations between available modulations, data rates and antenna ports (if EUT with antenna diversity architecture).
- Following channel(s) was (were) selected for the final test as listed below.

1TX Configuration					
MODE	FREQ. BAND (MHz)	AVAILABLE CHANNEL	TESTED CHANNEL	MODULATION TECHNOLOGY	DATA RATE (Mbps)
802.11a	5180-5240	36 to 48	36, 40, 48	OFDM	6
802.11a	5260-5320	52 to 64	52, 60, 64	OFDM	6
802.11a	5500-5720	100 to 140	100, 116, 140, 144	OFDM	6
802.11a	5745-5825	149 to 165	149, 157, 165	OFDM	6
2TX Configuration					
CDD Mode					
MODE	FREQ. BAND (MHz)	AVAILABLE CHANNEL	TESTED CHANNEL	MODULATION TECHNOLOGY	DATA RATE (Mbps)
802.11a	5180-5240	36 to 48	36, 40, 48	OFDM	6
802.11a	5260-5320	52 to 64	52, 60, 64	OFDM	6
802.11a	5500-5720	100 to 140	100, 116, 140, 144	OFDM	6
802.11a	5745-5825	149 to 165	149, 157, 165	OFDM	6
Beamforming Mode					
MODE	FREQ. BAND (MHz)	AVAILABLE CHANNEL	TESTED CHANNEL	MODULATION TECHNOLOGY	DATA RATE (Mbps)
802.11ac (VHT20)	5180-5240	36 to 48	36, 40, 48	OFDM	6.5
802.11ac (VHT40)		38 to 46	38, 46	OFDM	13.5
802.11ac (VHT80)		42	42	OFDM	29.3
802.11ac (VHT20)	5260-5320	52 to 64	52, 60, 64	OFDM	6.5
802.11ac (VHT40)		54 to 62	54, 62	OFDM	13.5
802.11ac (VHT80)		58	58	OFDM	29.3
802.11ac (VHT20)	5500-5720	100 to 140	100, 116, 140, 144	OFDM	6.5
802.11ac (VHT40)		102 to 134	102, 110, 134, 142	OFDM	13.5
802.11ac (VHT80)		106, 122, 138	106, 122, 138	OFDM	29.3
802.11ac (VHT20)	5745-5825	149 to 165	149, 157, 165	OFDM	6.5
802.11ac (VHT40)		151 to 159	151, 159	OFDM	13.5
802.11ac (VHT80)		155	155	OFDM	29.3

Power Line Conducted Emission Test:

- Pre-Scan has been conducted to determine the worst-case mode from all possible combinations between available modulations, data rates and antenna ports (if EUT with antenna diversity architecture).
- Following channel(s) was (were) selected for the final test as listed below.

2TX Configuration					
MODE	FREQ. BAND (MHz)	AVAILABLE CHANNEL	TESTED CHANNEL	MODULATION TECHNOLOGY	DATA RATE (Mbps)
802.11ac (VHT40)	5180-5320, 5500-5720, 5745-5825	38 to 46 52 to 64 102 to 134 151 to 159	110	OFDM	13.5

Antenna Port Conducted Measurement:

- This item includes all test value of each mode, but only includes spectrum plot of worst value of each mode.
- Pre-Scan has been conducted to determine the worst-case mode from all possible combinations between available modulations, data rates and antenna ports (if EUT with antenna diversity architecture).
- Following channel(s) was (were) selected for the final test as listed below.

1TX Configuration					
MODE	FREQ. BAND (MHz)	AVAILABLE CHANNEL	TESTED CHANNEL	MODULATION TECHNOLOGY	DATA RATE (Mbps)
802.11a	5180-5240	36 to 48	36, 40, 48	OFDM	6
802.11a	5260-5320	52 to 64	52, 60, 64	OFDM	6
802.11a	5500-5720	100 to 140	100, 116, 140, 144	OFDM	6
802.11a	5745-5825	149 to 165	149, 157, 165	OFDM	6
2TX Configuration					
CDD Mode					
MODE	FREQ. BAND (MHz)	AVAILABLE CHANNEL	TESTED CHANNEL	MODULATION TECHNOLOGY	DATA RATE (Mbps)
802.11a	5180-5240	36 to 48	36, 40, 48	OFDM	6
802.11a	5260-5320	52 to 64	52, 60, 64	OFDM	6
802.11a	5500-5720	100 to 140	100, 116, 140, 144	OFDM	6
802.11a	5745-5825	149 to 165	149, 157, 165	OFDM	6
Beamforming Mode					
MODE	FREQ. BAND (MHz)	AVAILABLE CHANNEL	TESTED CHANNEL	MODULATION TECHNOLOGY	DATA RATE (Mbps)
802.11ac (VHT20)	5180-5240	36 to 48	36, 40, 48	OFDM	6.5
802.11ac (VHT40)		38 to 46	38, 46	OFDM	13.5
802.11ac (VHT80)		42	42	OFDM	29.3
802.11ac (VHT20)	5260-5320	52 to 64	52, 60, 64	OFDM	6.5
802.11ac (VHT40)		54 to 62	54, 62	OFDM	13.5
802.11ac (VHT80)		58	58	OFDM	29.3
802.11ac (VHT20)	5500-5720	100 to 140	100, 116, 140, 144	OFDM	6.5
802.11ac (VHT40)		102 to 134	102, 110, 134, 142	OFDM	13.5
802.11ac (VHT80)		106, 122, 138	106, 122, 138	OFDM	29.3
802.11ac (VHT20)	5745-5825	149 to 165	149, 157, 165	OFDM	6.5
802.11ac (VHT40)		151 to 159	151, 159	OFDM	13.5
802.11ac (VHT80)		155	155	OFDM	29.3

SDM Mode (Output power only)					
MODE	FREQ. BAND (MHz)	AVAILABLE CHANNEL	TESTED CHANNEL	MODULATION TECHNOLOGY	DATA RATE (Mbps)
802.11ac (VHT20)	5180-5240	36 to 48	36, 40, 48	OFDM	13
802.11ac (VHT40)		38 to 46	38, 46	OFDM	27
802.11ac (VHT80)		42	42	OFDM	58.5
802.11ac (VHT20)	5260-5320	52 to 64	52, 60, 64	OFDM	13
802.11ac (VHT40)		54 to 62	54, 62	OFDM	27
802.11ac (VHT80)		58	58	OFDM	58.5
802.11ac (VHT20)	5500--5720	100 to 140	100, 116, 140, 144	OFDM	13
802.11ac (VHT40)		102 to 134	102, 110, 134, 142	OFDM	27
802.11ac (VHT80)		106, 122, 138	106, 122, 138	OFDM	58.5
802.11ac (VHT20)	5745-5825	149 to 165	149, 157, 165	OFDM	13
802.11ac (VHT40)		151 to 159	151, 159	OFDM	27
802.11ac (VHT80)		155	155	OFDM	58.5

Test Condition:

APPLICABLE TO	ENVIRONMENTAL CONDITIONS	INPUT POWER	TESTED BY	TEST LOCATION
RE\geq1G	25deg. C, 68%RH	120Vac, 60Hz	Gary Cheng	1
RE$<$1G	20deg. C, 71%RH	120Vac, 60Hz	Weiwei Lo	1
PLC	24deg. C, 82%RH	120Vac, 60Hz	Wythe Lin	2
APCM	16deg. C, 64%RH	120Vac, 60Hz	Anderson Chen	1

3.3 Duty Cycle of Test Signal

If duty cycle of test signal is $\geq 98\%$, duty factor is not required.

If duty cycle of test signal is $< 98\%$, duty factor shall be considered.

802.11a: Duty cycle = $2.08 \text{ ms} / 2.018 \text{ ms} = 0.987$

802.11ac (VHT20): Duty cycle = $1.298 \text{ ms} / 1.319 \text{ ms} = 0.984$

802.11ac (VHT40): Duty cycle = $0.646 \text{ ms} / 0.668 \text{ ms} = 0.967$, Duty factor = $10 * \log(1/0.967) = 0.15$

802.11ac (VHT80): Duty cycle = $0.322 \text{ ms} / 0.344 \text{ ms} = 0.936$, Duty factor = $10 * \log(1/0.936) = 0.29$

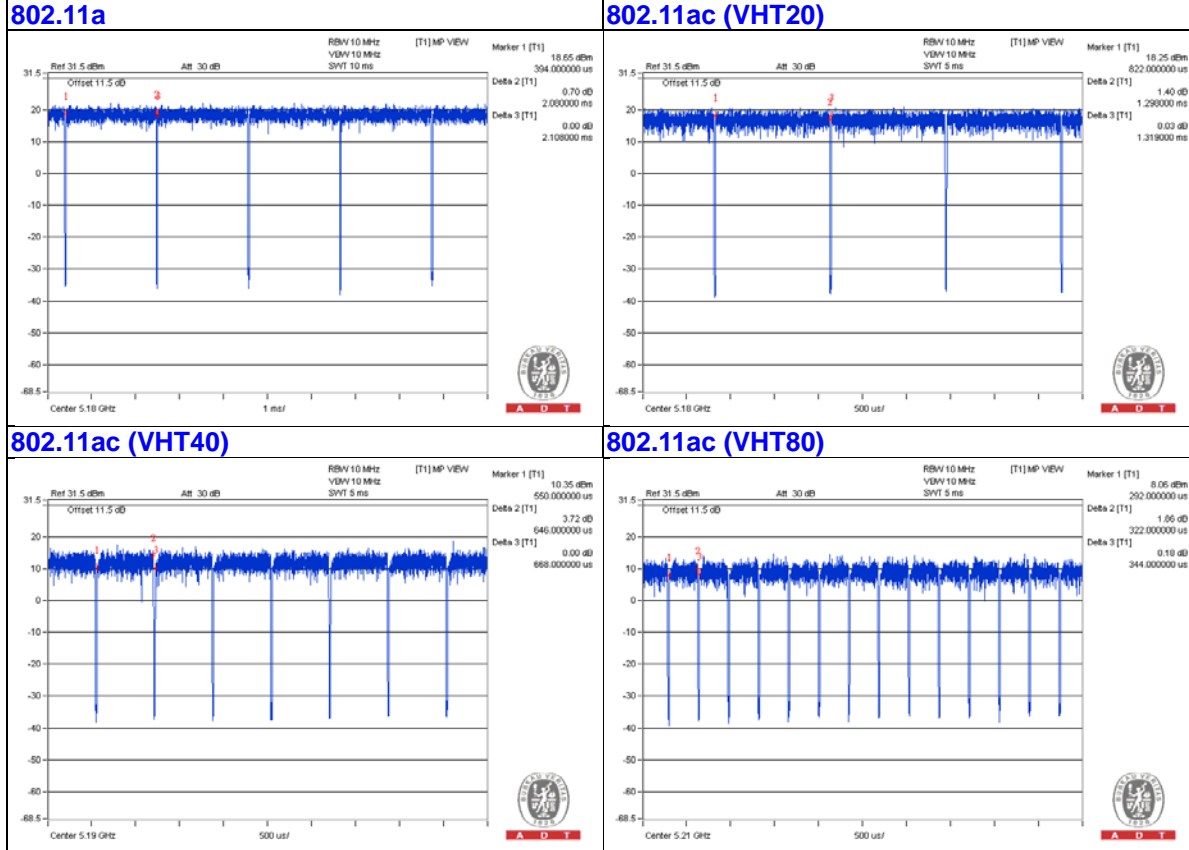

3.4 Description of Support Units

The EUT has been tested as an independent unit together with other necessary accessories or support units. The following support units or accessories were used to form a representative test configuration during the tests.

ID	Product	Brand	Model No.	Serial No.	FCC ID	Remarks
A.	Cradle Adapter	HIPRO	HP-A0502R3D	NA	NA	Supplied by client
B.	Cradles-1slot	ZEBRA	SHARECRADLE-01	NA	NA	Supplied by client
C.	Notebook Computer	HP	Pavilion 14-ab023TU	5CD5340WXZ	NA	Provided by Lab
D.	iPod shuffle	Apple	MC749TA/A	CC4DMFJUDFDM	NA	Provided by Lab
E.	Wired Scanner	ZEBRA	RS419	NA	NA	Supplied by client
F.	Adapter	Motorola	PWRS-14000-249R	NA	NA	Supplied by client

Note:

1. All power cords of the above support units are non-shielded (1.8m).

ID	Descriptions	Qty.	Length (m)	Shielding (Yes/No)	Cores (Qty.)	Remarks
1.	AC cable	1	1.8	No	0	Supplied by client
2.	DC cable	1	1.8	No	1	Supplied by client
3.	USB cable	1	1.4	Yes	0	Supplied by client
4.	Wired Scanner cable	1	0.5	No	0	Supplied by client
5.	USB cable	1	0.1	Yes	0	Provided by Lab
6.	USB cable	1	0.95	Yes	1	Supplied by client
7.	DC cable	1	1.8	No	0	Supplied by client

Note: The core(s) is(are) originally attached to the cable(s).

3.4.1 Configuration of System under Test

For Radiated Emissions (below 1GHz) & Cradel mode test:

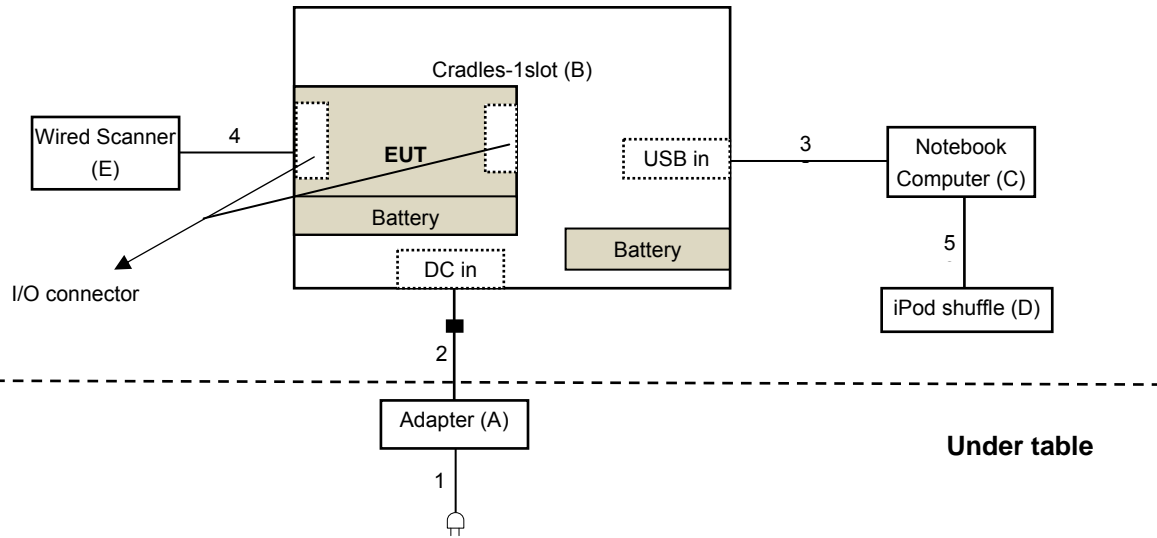

For Radiated Emissions (Above 1GHz) & Adapter mode test:

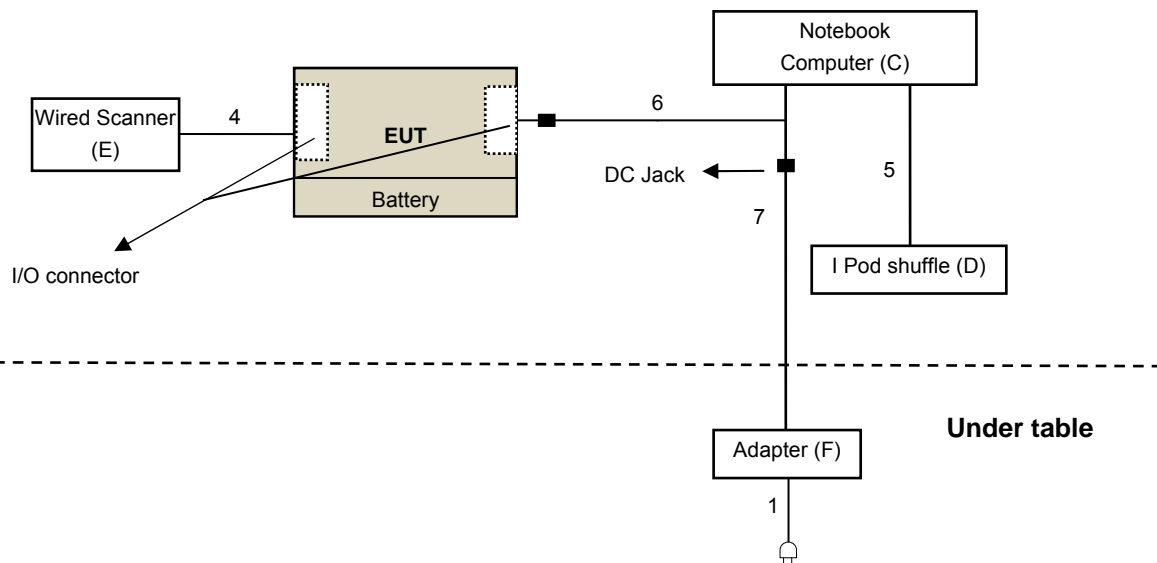

3.5 General Description of Applied Standard

The EUT is a RF Product. According to the specifications of the manufacturer, it must comply with the requirements of the following standards:

FCC Part 15, Subpart E (15.407)

KDB 789033 D02 General UNII Test Procedure New Rules v01r02

KDB 662911 D01 Multiple Transmitter Output v02r01

ANSI C63.10-2013 2009

All test items have been performed and recorded as per the above standards.

NOTE: The EUT has been verified to comply with the requirements of FCC Part 15, Subpart B, Class B (DoC). The test report has been issued separately.

4 Test Types and Results

4.1 Radiated Emission and Bandedge Measurement

4.1.1 Limits of Radiated Emission and Bandedge Measurement

Radiated emissions which fall in the restricted bands must comply with the radiated emission limits specified as below table.

Frequencies (MHz)	Field Strength (microvolts/meter)	Measurement Distance (meters)
0.009 ~ 0.490	2400/F(kHz)	300
0.490 ~ 1.705	24000/F(kHz)	30
1.705 ~ 30.0	30	30
30 ~ 88	100	3
88 ~ 216	150	3
216 ~ 960	200	3
Above 960	500	3

NOTE:

1. The lower limit shall apply at the transition frequencies.
2. Emission level (dBuV/m) = 20 log Emission level (uV/m).
3. For frequencies above 1000MHz, the field strength limits are based on average detector, however, the peak field strength of any emission shall not exceed the maximum permitted average limits, specified above by more than 20dB under any condition of modulation.

LIMITS OF UNWANTED EMISSION OUT OF THE RESTRICTED BANDS

APPLICABLE TO	LIMIT	
789033 D02 General UNII Test Procedure New Rules v01r02	FIELD STRENGTH AT 3m	
	PK:74 (dBµV/m)	AV:54 (dBµV/m)
APPLICABLE TO	EIRP LIMIT	EQUIVALENT FIELD STRENGTH AT 3m
15.407(b)(1)	PK:-27 (dBm/MHz)	PK:68.2(dBµV/m)
15.407(b)(2)		
15.407(b)(3)		
15.407(b)(4)	PK:-27 (dBm/MHz) ^{*1} PK:-17 (dBm/MHz) ^{*2}	PK: 68.2(dBµV/m) ^{*1} PK:78.2 (dBµV/m) ^{*2}

NOTE: ^{*1} beyond 10MHz of the band edge ^{*2} within 10 MHz of band edge

The following formula is used to convert the equipment isotropic radiated power (eirp) to field strength:

$$E = \frac{1000000\sqrt{30P}}{3} \mu\text{V/m, where P is the eirp (Watts).$$

4.1.2 Test Instruments

For Radiated Emissions (below 1GHz) test:

DESCRIPTION & MANUFACTURER	MODEL NO.	SERIAL NO.	CALIBRATED DATE	CALIBRATED UNTIL
Test Receiver Agilent	N9038A	MY50010156	Aug. 12, 2015	Aug. 11, 2016
Pre-Amplifier ^(*) EMCI	EMC001340	980142	Jan. 20, 2016	Jan. 19, 2018
Loop Antenna ^(*) Electro-Metrics	EM-6879	264	Dec. 16, 2014	Dec. 15, 2016
RF Cable	NA	LOOPCAB-001 LOOPCAB-002	Jan. 18, 2016	Jan. 17, 2017
Pre-Amplifier Mini-Circuits	ZFL-1000VH2 B	AMP-ZFL-07	May 08, 2015	May 07, 2016
Trilog Broadband Antenna SCHWARZBECK	VULB 9168	9168-156	Jan. 04, 2016	Jan. 03, 2017
RF Cable	8D	966-3-1 966-3-2 966-3-3	Apr. 02, 2016	Apr. 01, 2017
Software	ADT_Radiated _V8.7.07	NA	NA	NA
Antenna Tower & Turn Table CT	NA	NA	NA	NA

Note:

1. The calibration interval of the above test instruments is 12 months and the calibrations are traceable to NML/ROC and NIST/USA.
2. *The calibration interval of the above test instruments is 24 months and the calibrations are traceable to NML/ROC and NIST/USA.
3. The test was performed in 966 Chamber No. 3.
4. The FCC Site Registration No. is 147459
6. The CANADA Site Registration No. is 20331-1
7. Loop antenna was used for all emissions below 30 MHz.
8. Tested Date: Apr. 07 to 18, 2016

For Radiated Emissions (Above 1GHz 1TX mode) test:

DESCRIPTION & MANUFACTURER	MODEL NO.	SERIAL NO.	CALIBRATED DATE	CALIBRATED UNTIL
Test Receiver Agilent	N9038A	MY54450088	July 24, 2015	July 23, 2016
Horn_Antenna SCHWARZBECK	BBHA 9120D	9120D-783	Jan. 19, 2016	Jan. 18, 2017
Pre-Amplifier Agilent	8449B	3008A01922	Sep. 19, 2015	Sep. 18, 2016
RF Cable	EMC104-SM-S M-2000 EMC104-SM-S M-5000 EMC104-SM-S M-5000	150318 150323 150324	Mar. 30, 2016	Mar. 29, 2017
Boresight Antenna Fixture	NA	NA	NA	NA
Pre-Amplifier EMCI	EMC184045	980143	Jan. 15, 2016	Jan. 14, 2017
Horn_Antenna SCHWARZBECK	BBHA 9170	BBHA9170608	Jan. 08, 2016	Jan. 07, 2017
RF Cable	SUCOFLEX 102	36432/2 36441/2	Jan. 16, 2016	Jan. 15, 2017
Software	ADT_Radiated _V8.7.07	NA	NA	NA
Antenna Tower & Turn Table CT	NA	NA	NA	NA
Spectrum Analyzer R&S	FSP 40	100060	May 08, 2015	May 07, 2016
Power meter Anritsu	ML2495A	1014008	Apr. 28, 2015	Apr. 27, 2016
Power sensor Anritsu	MA2411B	0917122	Apr. 28, 2015	Apr. 27, 2016
Temperature & Humidity Chamber GIANTFORCE	GTH-150-40-S P-AR	MAA0812-008	Jan. 15, 2016	Jan. 14, 2017

Note:

1. The calibration interval of the above test instruments is 12 months and the calibrations are traceable to NML/ROC and NIST/USA.
2. The horn antenna, preamplifier (model: 8449B) are used only for the measurement of emission frequency above 1GHz if tested.
3. The test was performed in 966 Chamber No. 4.
4. The FCC Site Registration No. is 292998
5. The CANADA Site Registration No. is 20331-2
6. Tested Date: Apr. 14, 2016

For Radiated Emissions (Above 1GHz 2TX mode) test:

DESCRIPTION & MANUFACTURER	MODEL NO.	SERIAL NO.	CALIBRATED DATE	CALIBRATED UNTIL
Test Receiver Agilent	N9038A	MY54450088	July 24, 2015	July 23, 2016
Horn_Antenna SCHWARZBECK	BBHA 9120D	9120D-783	Jan. 19, 2016	Jan. 18, 2017
Pre-Amplifier Agilent	8449B	3008A01922	Sep. 19, 2015	Sep. 18, 2016
RF Cable	EMC104-SM-S M-2000 EMC104-SM-S M-5000 EMC104-SM-S M-5000	150318 150323 150324	Mar. 31, 2015	Mar. 30, 2016
Pre-Amplifier EMCI	EMC184045	980143	Jan. 15, 2016	Jan. 14, 2017
Horn_Antenna SCHWARZBECK	BBHA 9170	BBHA9170608	Jan. 08, 2016	Jan. 07, 2017
RF Cable	SUCOFLEX 102	36432/2 36441/2	Jan. 16, 2016	Jan. 15, 2017
Software	ADT_Radiated _V8.7.07	NA	NA	NA
Antenna Tower & Turn Table CT	NA	NA	NA	NA
Boresight Antenna Fixture	NA	NA	NA	NA

Note:

1. The calibration interval of the above test instruments is 12 months and the calibrations are traceable to NML/ROC and NIST/USA.
2. The horn antenna, preamplifier (model: 8449B) are used only for the measurement of emission frequency above 1GHz if tested.
3. The test was performed in 966 Chamber No. 4.
4. The FCC Site Registration No. is 292998
5. The CANADA Site Registration No. is 20331-2
6. Tested Date: Mar. 05, 2016

4.1.3 Test Procedure

- a. The EUT was placed on the top of a rotating table 0.8 meters (for below 1GHz) / 1.5 meters (for above 1GHz) above the ground at 3 meter chamber room for test. The table was rotated 360 degrees to determine the position of the highest radiation.
- b. The EUT was set 3 meters away from the interference-receiving antenna, which was mounted on the top of a variable-height antenna tower.
- c. The height of antenna is varied from one meter to four meters above the ground to determine the maximum value of the field strength. Both horizontal and vertical polarizations of the antenna are set to make the measurement.
- d. For each suspected emission, the EUT was arranged to its worst case and then the antenna was tuned to heights from 1 meter to 4 meters and the rotatable table was turned from 0 degrees to 360 degrees to find the maximum reading.
- e. The test-receiver system was set to quasi-peak detect function and specified bandwidth with maximum hold mode when the test frequency is below 1 GHz.
- f. The test-receiver system was set to peak and average detect function and specified bandwidth with maximum hold mode when the test frequency is above 1 GHz. If the peak reading value also meets average limit, measurement with the average detector is unnecessary.

Note:

1. The resolution bandwidth and video bandwidth of test receiver/spectrum analyzer is 120kHz for Quasi-peak detection (QP) at frequency below 1GHz.
2. The resolution bandwidth of test receiver/spectrum analyzer is 1 MHz and the video bandwidth is 3 MHz for Peak detection (PK) at frequency above 1GHz.
3. The resolution bandwidth of test receiver/spectrum analyzer is 1MHz and the video bandwidth is 3MHz for RMS Average (Duty cycle < 98%) for Average detection (AV) at frequency above 1GHz, then the measurement results was added to a correction factor ($10 \log(1/\text{duty cycle})$).
4. The resolution bandwidth of test receiver/spectrum analyzer is 1MHz and the video bandwidth is 10Hz (Duty cycle \geq 98%) for Average detection (AV) at frequency above 1GHz.
5. All modes of operation were investigated and the worst-case emissions are reported.

4.1.4 Deviation from Test Standard

No deviation.

4.1.5 Test Setup

<Frequency Range below 1GHz>

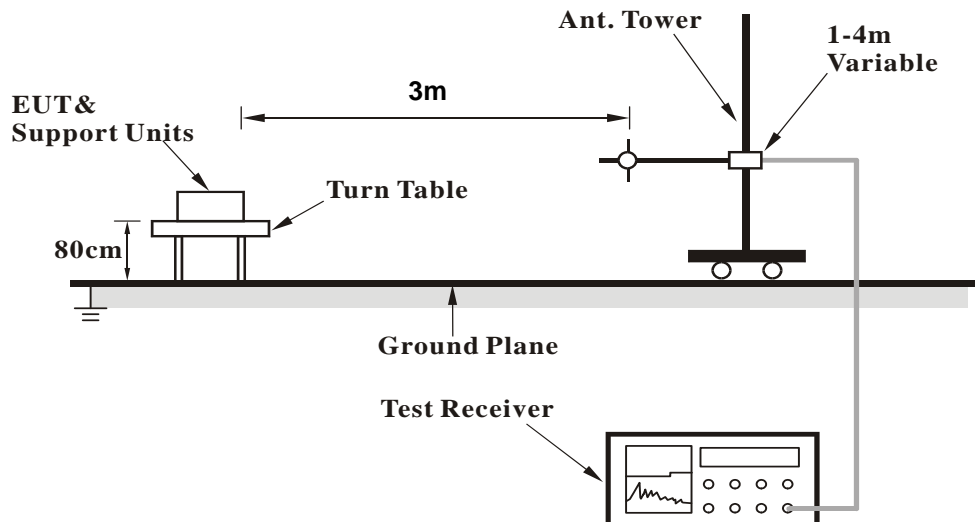

<Frequency Range above 1GHz>

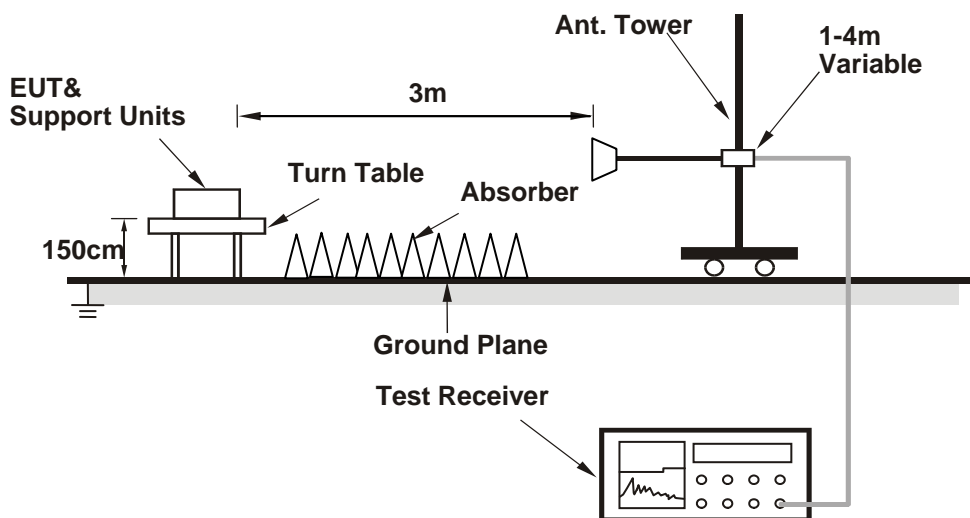

For the actual test configuration, please refer to the attached file (Test Setup Photo).

4.1.6 EUT Operating Condition

1. Connect the EUT with the support unit C (Notebook Computer) which is placed on test table.
2. The communication partner run test program "abd wl command" to enable EUT under transmission/receiving condition continuously at specific channel frequency.

4.1.7 Test Results

1TX

Above 1GHz Data:

802.11a

CHANNEL	TX Channel 36	DETECTOR FUNCTION	Peak (PK)
FREQUENCY RANGE	1GHz ~ 40GHz		Average (AV)

ANTENNA POLARITY & TEST DISTANCE: HORIZONTAL AT 3 M

NO.	FREQ. (MHz)	EMISSION LEVEL (dBuV/m)	LIMIT (dBuV/m)	MARGIN (dB)	ANTENNA HEIGHT (m)	TABLE ANGLE (Degree)	RAW VALUE (dBuV)	CORRECTION FACTOR (dB/m)
1	5150.00	68.0 PK	74.0	-6.0	1.03 H	216	67.20	0.80
2	5150.00	52.7 AV	54.0	-1.3	1.03 H	216	51.90	0.80
3	*5180.00	109.1 PK			1.03 H	216	108.21	0.89
4	*5180.00	97.4 AV			1.03 H	216	96.51	0.89
5	#10360.00	60.2 PK	74.0	-13.8	2.36 H	102	49.22	10.98
6	#10360.00	41.4 AV	54.0	-12.6	2.36 H	102	30.42	10.98
7	15540.00	58.5 PK	74.0	-15.5	1.48 H	202	45.77	12.73
8	15540.00	46.4 AV	54.0	-7.6	1.48 H	202	33.67	12.73

ANTENNA POLARITY & TEST DISTANCE: VERTICAL AT 3 M

NO.	FREQ. (MHz)	EMISSION LEVEL (dBuV/m)	LIMIT (dBuV/m)	MARGIN (dB)	ANTENNA HEIGHT (m)	TABLE ANGLE (Degree)	RAW VALUE (dBuV)	CORRECTION FACTOR (dB/m)
1	5150.00	52.5 PK	74.0	-21.5	1.00 V	252	51.70	0.80
2	5150.00	42.2 AV	54.0	-11.8	1.00 V	252	41.40	0.80
3	*5180.00	104.3 PK			1.00 V	252	103.41	0.89
4	*5180.00	92.8 AV			1.00 V	252	91.91	0.89
5	#10360.00	53.4 PK	74.0	-20.6	1.48 V	215	42.42	10.98
6	#10360.00	40.4 AV	54.0	-13.6	1.48 V	215	29.42	10.98
7	15540.00	56.6 PK	74.0	-17.4	1.52 V	202	43.87	12.73
8	15540.00	43.8 AV	54.0	-10.2	1.52 V	202	31.07	12.73

REMARKS:

1. Emission Level(dBuV/m) = Raw Value(dBuV) + Correction Factor(dB/m)
2. Correction Factor(dB/m) = Antenna Factor(dB/m) + Cable Factor(dB) – Pre-Amplifier Factor(dB)
3. The other emission levels were very low against the limit.
4. Margin value = Emission Level – Limit value
5. " * ": Fundamental frequency.
6. " # ": The radiated frequency is out of the restricted band.

CHANNEL	TX Channel 40	DETECTOR FUNCTION	Peak (PK)
FREQUENCY RANGE	1GHz ~ 40GHz		Average (AV)

ANTENNA POLARITY & TEST DISTANCE: HORIZONTAL AT 3 M

NO.	FREQ. (MHz)	EMISSION LEVEL (dBuV/m)	LIMIT (dBuV/m)	MARGIN (dB)	ANTENNA HEIGHT (m)	TABLE ANGLE (Degree)	RAW VALUE (dBuV)	CORRECTION FACTOR (dB/m)
1	5150.00	60.4 PK	74.0	-13.6	1.02 H	220	59.60	0.80
2	5150.00	48.0 AV	54.0	-6.0	1.02 H	220	47.20	0.80
3	*5200.00	111.5 PK			1.02 H	220	110.56	0.94
4	*5200.00	99.4 AV			1.02 H	220	98.46	0.94
5	#10400.00	60.6 PK	74.0	-13.4	2.36 H	107	49.27	11.33
6	#10400.00	41.6 AV	54.0	-12.4	2.36 H	107	30.27	11.33
7	15600.00	58.6 PK	74.0	-15.4	1.52 H	193	45.73	12.87
8	15600.00	46.2 AV	54.0	-7.8	1.52 H	193	33.33	12.87

ANTENNA POLARITY & TEST DISTANCE: VERTICAL AT 3 M

NO.	FREQ. (MHz)	EMISSION LEVEL (dBuV/m)	LIMIT (dBuV/m)	MARGIN (dB)	ANTENNA HEIGHT (m)	TABLE ANGLE (Degree)	RAW VALUE (dBuV)	CORRECTION FACTOR (dB/m)
1	5150.00	45.4 PK	74.0	-28.6	1.02 V	255	44.60	0.80
2	5150.00	40.2 AV	54.0	-13.8	1.02 V	255	39.40	0.80
3	*5200.00	106.7 PK			1.02 V	255	105.76	0.94
4	*5200.00	94.8 AV			1.02 V	255	93.86	0.94
5	#10400.00	53.3 PK	74.0	-20.7	1.43 V	220	41.97	11.33
6	#10400.00	40.1 AV	54.0	-13.9	1.43 V	220	28.77	11.33
7	15600.00	57.0 PK	74.0	-17.0	1.55 V	212	44.13	12.87
8	15600.00	44.1 AV	54.0	-9.9	1.55 V	212	31.23	12.87

REMARKS:

1. Emission Level(dBuV/m) = Raw Value(dBuV) + Correction Factor(dB/m)
2. Correction Factor(dB/m) = Antenna Factor(dB/m) + Cable Factor(dB) – Pre-Amplifier Factor(dB)
3. The other emission levels were very low against the limit.
4. Margin value = Emission Level – Limit value
5. " * ": Fundamental frequency.
6. " # ": The radiated frequency is out of the restricted band.

CHANNEL	TX Channel 48	DETECTOR FUNCTION	Peak (PK)
FREQUENCY RANGE	1GHz ~ 40GHz		Average (AV)

ANTENNA POLARITY & TEST DISTANCE: HORIZONTAL AT 3 M

NO.	FREQ. (MHz)	EMISSION LEVEL (dBuV/m)	LIMIT (dBuV/m)	MARGIN (dB)	ANTENNA HEIGHT (m)	TABLE ANGLE (Degree)	RAW VALUE (dBuV)	CORRECTION FACTOR (dB/m)
1	5150.00	53.3 PK	74.0	-20.7	1.05 H	220	52.50	0.80
2	5150.00	40.0 AV	54.0	-14.0	1.05 H	220	39.20	0.80
3	*5240.00	111.6 PK			1.05 H	220	110.54	1.06
4	*5240.00	99.2 AV			1.05 H	220	98.14	1.06
5	#5320.00	53.7 PK	74.0	-20.3	1.05 H	220	52.42	1.28
6	#5320.00	40.0 AV	54.0	-14.0	1.05 H	220	38.72	1.28
7	#10480.00	60.6 PK	74.0	-13.4	2.32 H	100	49.41	11.19
8	#10480.00	41.8 AV	54.0	-12.2	2.32 H	100	30.61	11.19
9	15720.00	59.1 PK	74.0	-14.9	1.47 H	200	46.79	12.31
10	15720.00	46.7 AV	54.0	-7.3	1.47 H	200	34.39	12.31

ANTENNA POLARITY & TEST DISTANCE: VERTICAL AT 3 M

NO.	FREQ. (MHz)	EMISSION LEVEL (dBuV/m)	LIMIT (dBuV/m)	MARGIN (dB)	ANTENNA HEIGHT (m)	TABLE ANGLE (Degree)	RAW VALUE (dBuV)	CORRECTION FACTOR (dB/m)
1	5150.00	45.9 PK	74.0	-28.1	1.07 V	267	45.10	0.80
2	5150.00	40.4 AV	54.0	-13.6	1.07 V	267	39.60	0.80
3	*5240.00	107.2 PK			1.00 V	267	106.14	1.06
4	*5240.00	95.1 AV			1.00 V	267	94.04	1.06
5	#5320.00	46.1 PK	74.0	-27.9	1.07 V	267	44.82	1.28
6	#5320.00	40.6 AV	54.0	-13.4	1.07 V	267	39.32	1.28
7	#10480.00	53.3 PK	74.0	-20.7	1.46 V	227	42.11	11.19
8	#10480.00	40.4 AV	54.0	-13.6	1.46 V	227	29.21	11.19
9	15720.00	57.6 PK	74.0	-16.4	1.59 V	200	45.29	12.31
10	15720.00	44.4 AV	54.0	-9.6	1.59 V	200	32.09	12.31

REMARKS:

1. Emission Level(dBuV/m) = Raw Value(dBuV) + Correction Factor(dB/m)
2. Correction Factor(dB/m) = Antenna Factor(dB/m) + Cable Factor(dB) – Pre-Amplifier Factor(dB)
3. The other emission levels were very low against the limit.
4. Margin value = Emission Level – Limit value
5. " * ": Fundamental frequency.
6. " # ": The radiated frequency is out of the restricted band.

CHANNEL	TX Channel 52	DETECTOR FUNCTION	Peak (PK)
FREQUENCY RANGE	1GHz ~ 40GHz		Average (AV)

ANTENNA POLARITY & TEST DISTANCE: HORIZONTAL AT 3 M

NO.	FREQ. (MHz)	EMISSION LEVEL (dBuV/m)	LIMIT (dBuV/m)	MARGIN (dB)	ANTENNA HEIGHT (m)	TABLE ANGLE (Degree)	RAW VALUE (dBuV)	CORRECTION FACTOR (dB/m)
1	*5260.00	112.1 PK			1.03 H	222	110.95	1.15
2	*5260.00	99.8 AV			1.03 H	222	98.65	1.15
3	5350.00	52.2 PK	74.0	-21.8	1.03 H	222	50.90	1.30
4	5350.00	40.8 AV	54.0	-13.2	1.03 H	222	39.50	1.30
5	#10520.00	60.3 PK	74.0	-13.7	2.31 H	98	49.05	11.25
6	#10520.00	41.8 AV	54.0	-12.2	2.31 H	98	30.55	11.25
7	15780.00	58.5 PK	74.0	-15.5	1.46 H	202	46.25	12.25
8	15780.00	46.3 AV	54.0	-7.7	1.46 H	202	34.05	12.25

ANTENNA POLARITY & TEST DISTANCE: VERTICAL AT 3 M

NO.	FREQ. (MHz)	EMISSION LEVEL (dBuV/m)	LIMIT (dBuV/m)	MARGIN (dB)	ANTENNA HEIGHT (m)	TABLE ANGLE (Degree)	RAW VALUE (dBuV)	CORRECTION FACTOR (dB/m)
1	*5260.00	106.3 PK			1.04 V	269	105.15	1.15
2	*5260.00	94.4 AV			1.04 V	269	93.25	1.15
3	5350.00	45.4 PK	74.0	-28.6	1.04 V	269	44.10	1.30
4	5350.00	40.4 AV	54.0	-13.6	1.04 V	269	39.10	1.30
5	#10520.00	53.2 PK	74.0	-20.8	1.46 V	226	41.95	11.25
6	#10520.00	39.8 AV	54.0	-14.2	1.46 V	226	28.55	11.25
7	15780.00	57.2 PK	74.0	-16.8	1.57 V	199	44.95	12.25
8	15780.00	44.1 AV	54.0	-9.9	1.57 V	199	31.85	12.25

REMARKS:

1. Emission Level(dBuV/m) = Raw Value(dBuV) + Correction Factor(dB/m)
2. Correction Factor(dB/m) = Antenna Factor(dB/m) + Cable Factor(dB) – Pre-Amplifier Factor(dB)
3. The other emission levels were very low against the limit.
4. Margin value = Emission Level – Limit value
5. " * ": Fundamental frequency.
6. " # ": The radiated frequency is out of the restricted band.

CHANNEL	TX Channel 60	DETECTOR FUNCTION	Peak (PK)
FREQUENCY RANGE	1GHz ~ 40GHz		Average (AV)

ANTENNA POLARITY & TEST DISTANCE: HORIZONTAL AT 3 M

NO.	FREQ. (MHz)	EMISSION LEVEL (dBuV/m)	LIMIT (dBuV/m)	MARGIN (dB)	ANTENNA HEIGHT (m)	TABLE ANGLE (Degree)	RAW VALUE (dBuV)	CORRECTION FACTOR (dB/m)
1	*5300.00	111.8 PK			1.03 H	224	110.53	1.27
2	*5300.00	99.6 AV			1.03 H	224	98.33	1.27
3	5350.00	64.5 PK	74.0	-9.5	1.03 H	224	63.20	1.30
4	5350.00	48.6 AV	54.0	-5.4	1.03 H	224	47.30	1.30
5	10600.00	60.3 PK	74.0	-13.7	2.31 H	95	48.66	11.64
6	10600.00	41.5 AV	54.0	-12.5	2.31 H	95	29.86	11.64
7	15900.00	58.8 PK	74.0	-15.2	1.46 H	187	46.33	12.47
8	15900.00	46.9 AV	54.0	-7.1	1.46 H	187	34.43	12.47

ANTENNA POLARITY & TEST DISTANCE: VERTICAL AT 3 M

NO.	FREQ. (MHz)	EMISSION LEVEL (dBuV/m)	LIMIT (dBuV/m)	MARGIN (dB)	ANTENNA HEIGHT (m)	TABLE ANGLE (Degree)	RAW VALUE (dBuV)	CORRECTION FACTOR (dB/m)
1	*5300.00	105.6 PK			1.03 V	279	104.33	1.27
2	*5300.00	93.9 AV			1.03 V	279	92.63	1.27
3	5350.00	45.1 PK	74.0	-28.9	1.03 V	279	43.80	1.30
4	5350.00	40.1 AV	54.0	-13.9	1.03 V	279	38.80	1.30
5	10600.00	53.3 PK	74.0	-20.7	1.46 V	226	41.66	11.64
6	10600.00	39.6 AV	54.0	-14.4	1.46 V	226	27.96	11.64
7	15900.00	57.3 PK	74.0	-16.7	1.54 V	211	44.83	12.47
8	15900.00	44.0 AV	54.0	-10.0	1.54 V	211	31.53	12.47

REMARKS:

1. Emission Level(dBuV/m) = Raw Value(dBuV) + Correction Factor(dB/m)
2. Correction Factor(dB/m) = Antenna Factor(dB/m) + Cable Factor(dB) – Pre-Amplifier Factor(dB)
3. The other emission levels were very low against the limit.
4. Margin value = Emission Level – Limit value
5. " * ": Fundamental frequency.

CHANNEL	TX Channel 64	DETECTOR FUNCTION	Peak (PK)
FREQUENCY RANGE	1GHz ~ 40GHz		Average (AV)

ANTENNA POLARITY & TEST DISTANCE: HORIZONTAL AT 3 M

NO.	FREQ. (MHz)	EMISSION LEVEL (dBuV/m)	LIMIT (dBuV/m)	MARGIN (dB)	ANTENNA HEIGHT (m)	TABLE ANGLE (Degree)	RAW VALUE (dBuV)	CORRECTION FACTOR (dB/m)
1	*5320.00	110.1 PK			1.06 H	221	108.82	1.28
2	*5320.00	98.1 AV			1.06 H	221	96.82	1.28
3	5350.00	66.8 PK	74.0	-7.2	1.06 H	221	65.50	1.30
4	5350.00	52.5 AV	54.0	-1.5	1.06 H	221	51.20	1.30
5	10640.00	59.6 PK	74.0	-14.4	2.41 H	91	47.92	11.68
6	10640.00	40.9 AV	54.0	-13.1	2.41 H	91	29.22	11.68
7	15960.00	58.1 PK	74.0	-15.9	1.42 H	203	45.65	12.45
8	15960.00	46.1 AV	54.0	-7.9	1.42 H	203	33.65	12.45

ANTENNA POLARITY & TEST DISTANCE: VERTICAL AT 3 M

NO.	FREQ. (MHz)	EMISSION LEVEL (dBuV/m)	LIMIT (dBuV/m)	MARGIN (dB)	ANTENNA HEIGHT (m)	TABLE ANGLE (Degree)	RAW VALUE (dBuV)	CORRECTION FACTOR (dB/m)
1	*5320.00	104.4 PK			1.01 V	290	103.12	1.28
2	*5320.00	93.0 AV			1.01 V	290	91.72	1.28
3	5350.00	51.2 PK	74.0	-22.8	1.01 V	290	49.90	1.30
4	5350.00	42.1 AV	54.0	-11.9	1.01 V	290	40.80	1.30
5	10640.00	53.6 PK	74.0	-20.4	1.44 V	225	41.92	11.68
6	10640.00	40.9 AV	54.0	-13.1	1.44 V	225	29.22	11.68
7	15960.00	56.7 PK	74.0	-17.3	1.58 V	207	44.25	12.45
8	15960.00	44.0 AV	54.0	-10.0	1.58 V	207	31.55	12.45

REMARKS:

1. Emission Level(dBuV/m) = Raw Value(dBuV) + Correction Factor(dB/m)
2. Correction Factor(dB/m) = Antenna Factor(dB/m) + Cable Factor(dB) – Pre-Amplifier Factor(dB)
3. The other emission levels were very low against the limit.
4. Margin value = Emission Level – Limit value
5. " * ": Fundamental frequency.

CHANNEL	TX Channel 100	DETECTOR FUNCTION	Peak (PK)
FREQUENCY RANGE	1GHz ~ 40GHz		Average (AV)

ANTENNA POLARITY & TEST DISTANCE: HORIZONTAL AT 3 M

NO.	FREQ. (MHz)	EMISSION LEVEL (dBuV/m)	LIMIT (dBuV/m)	MARGIN (dB)	ANTENNA HEIGHT (m)	TABLE ANGLE (Degree)	RAW VALUE (dBuV)	CORRECTION FACTOR (dB/m)
1	#5470.00	67.6 PK	74.0	-6.4	1.03 H	222	66.15	1.45
2	#5470.00	52.5 AV	54.0	-1.5	1.03 H	222	51.05	1.45
3	*5500.00	109.0 PK			1.03 H	222	107.49	1.51
4	*5500.00	96.8 AV			1.03 H	222	95.29	1.51
5	11000.00	60.8 PK	74.0	-13.2	2.38 H	89	47.76	13.04
6	11000.00	41.8 AV	54.0	-12.2	2.38 H	89	28.76	13.04
7	#16500.00	58.0 PK	74.0	-16.0	1.47 H	217	42.73	15.27
8	#16500.00	46.0 AV	54.0	-8.0	1.47 H	217	30.73	15.27

ANTENNA POLARITY & TEST DISTANCE: VERTICAL AT 3 M

NO.	FREQ. (MHz)	EMISSION LEVEL (dBuV/m)	LIMIT (dBuV/m)	MARGIN (dB)	ANTENNA HEIGHT (m)	TABLE ANGLE (Degree)	RAW VALUE (dBuV)	CORRECTION FACTOR (dB/m)
1	#5470.00	53.1 PK	74.0	-20.9	1.08 V	264	51.65	1.45
2	#5470.00	42.1 AV	54.0	-11.9	1.08 V	264	40.65	1.45
3	*5500.00	103.9 PK			1.08 V	264	102.39	1.51
4	*5500.00	91.8 AV			1.08 V	264	90.29	1.51
5	11000.00	53.0 PK	74.0	-21.0	1.49 V	222	39.96	13.04
6	11000.00	40.8 AV	54.0	-13.2	1.49 V	222	27.76	13.04
7	#16500.00	55.7 PK	74.0	-18.3	1.48 V	217	40.43	15.27
8	#16500.00	42.9 AV	54.0	-11.1	1.48 V	217	27.63	15.27

REMARKS:

1. Emission Level(dBuV/m) = Raw Value(dBuV) + Correction Factor(dB/m)
2. Correction Factor(dB/m) = Antenna Factor(dB/m) + Cable Factor(dB) – Pre-Amplifier Factor(dB)
3. The other emission levels were very low against the limit.
4. Margin value = Emission Level – Limit value
5. " * ": Fundamental frequency.
6. " # ": The radiated frequency is out of the restricted band.

CHANNEL	TX Channel 116	DETECTOR FUNCTION	Peak (PK)
FREQUENCY RANGE	1GHz ~ 40GHz		Average (AV)

ANTENNA POLARITY & TEST DISTANCE: HORIZONTAL AT 3 M

NO.	FREQ. (MHz)	EMISSION LEVEL (dBuV/m)	LIMIT (dBuV/m)	MARGIN (dB)	ANTENNA HEIGHT (m)	TABLE ANGLE (Degree)	RAW VALUE (dBuV)	CORRECTION FACTOR (dB/m)
1	#5470.00	52.6 PK	74.0	-21.4	1.19 H	226	51.15	1.45
2	#5470.00	40.0 AV	54.0	-14.0	1.19 H	226	38.55	1.45
3	*5580.00	110.4 PK			1.19 H	226	108.74	1.66
4	*5580.00	99.3 AV			1.19 H	226	97.64	1.66
5	#5725.00	52.1 PK	74.0	-21.9	1.19 H	226	50.17	1.93
6	#5725.00	40.0 AV	54.0	-14.0	1.19 H	226	38.07	1.93
7	11160.00	60.1 PK	74.0	-13.9	2.30 H	88	47.28	12.82
8	11160.00	41.2 AV	54.0	-12.8	2.30 H	88	28.38	12.82
9	#16740.00	57.7 PK	74.0	-16.3	1.50 H	200	41.71	15.99
10	#16740.00	45.9 AV	54.0	-8.1	1.50 H	200	29.91	15.99

ANTENNA POLARITY & TEST DISTANCE: VERTICAL AT 3 M

NO.	FREQ. (MHz)	EMISSION LEVEL (dBuV/m)	LIMIT (dBuV/m)	MARGIN (dB)	ANTENNA HEIGHT (m)	TABLE ANGLE (Degree)	RAW VALUE (dBuV)	CORRECTION FACTOR (dB/m)
1	#5470.00	44.8 PK	74.0	-29.2	1.05 V	269	43.35	1.45
2	#5470.00	39.6 AV	54.0	-14.4	1.05 V	269	38.15	1.45
3	*5580.00	104.9 PK			1.05 V	269	103.24	1.66
4	*5580.00	93.5 AV			1.05 V	269	91.84	1.66
5	#5725.00	44.6 PK	74.0	-29.4	1.05 V	269	42.67	1.93
6	#5725.00	39.4 AV	54.0	-14.6	1.05 V	269	37.47	1.93
7	11160.00	53.5 PK	74.0	-20.5	1.48 V	223	40.68	12.82
8	11160.00	39.7 AV	54.0	-14.3	1.48 V	223	26.88	12.82
9	#16740.00	57.8 PK	74.0	-16.2	1.57 V	198	41.81	15.99
10	#16740.00	44.4 AV	54.0	-9.6	1.57 V	198	28.41	15.99

REMARKS:

1. Emission Level(dBuV/m) = Raw Value(dBuV) + Correction Factor(dB/m)
2. Correction Factor(dB/m) = Antenna Factor(dB/m) + Cable Factor(dB) – Pre-Amplifier Factor(dB)
3. The other emission levels were very low against the limit.
4. Margin value = Emission Level – Limit value
5. " * ": Fundamental frequency.
6. " # ": The radiated frequency is out of the restricted band.

CHANNEL	TX Channel 140	DETECTOR FUNCTION	Peak (PK)
FREQUENCY RANGE	1GHz ~ 40GHz		Average (AV)

ANTENNA POLARITY & TEST DISTANCE: HORIZONTAL AT 3 M

NO.	FREQ. (MHz)	EMISSION LEVEL (dBuV/m)	LIMIT (dBuV/m)	MARGIN (dB)	ANTENNA HEIGHT (m)	TABLE ANGLE (Degree)	RAW VALUE (dBuV)	CORRECTION FACTOR (dB/m)
1	*5700.00	108.1 PK			1.17 H	223	106.21	1.89
2	*5700.00	97.8 AV			1.17 H	223	95.91	1.89
3	#5725.00	66.8 PK	74.0	-7.2	1.17 H	223	64.87	1.93
4	#5725.00	52.7 AV	54.0	-1.3	1.17 H	223	50.77	1.93
5	11400.00	60.4 PK	74.0	-13.6	2.41 H	114	47.52	12.88
6	11400.00	41.9 AV	54.0	-12.1	2.41 H	114	29.02	12.88
7	#17100.00	58.2 PK	74.0	-15.8	1.48 H	195	40.89	17.31
8	#17100.00	46.0 AV	54.0	-8.0	1.48 H	195	28.69	17.31

ANTENNA POLARITY & TEST DISTANCE: VERTICAL AT 3 M

NO.	FREQ. (MHz)	EMISSION LEVEL (dBuV/m)	LIMIT (dBuV/m)	MARGIN (dB)	ANTENNA HEIGHT (m)	TABLE ANGLE (Degree)	RAW VALUE (dBuV)	CORRECTION FACTOR (dB/m)
1	*5700.00	103.8 PK			1.03 V	250	101.91	1.89
2	*5700.00	91.7 AV			1.03 V	250	89.81	1.89
3	#5725.00	53.3 PK	74.0	-20.7	1.03 V	250	51.37	1.93
4	#5725.00	42.5 AV	54.0	-11.5	1.03 V	250	40.57	1.93
5	11400.00	53.0 PK	74.0	-21.0	1.49 V	221	40.12	12.88
6	11400.00	40.6 AV	54.0	-13.4	1.49 V	221	27.72	12.88
7	#17100.00	55.6 PK	74.0	-18.4	1.03 V	250	38.29	17.31
8	#17100.00	42.8 AV	54.0	-11.2	1.03 V	250	25.49	17.31

REMARKS:

1. Emission Level(dBuV/m) = Raw Value(dBuV) + Correction Factor(dB/m)
2. Correction Factor(dB/m) = Antenna Factor(dB/m) + Cable Factor(dB) – Pre-Amplifier Factor(dB)
3. The other emission levels were very low against the limit.
4. Margin value = Emission Level – Limit value
5. " * ": Fundamental frequency.
6. " # ": The radiated frequency is out of the restricted band.

CHANNEL	TX Channel 144	DETECTOR FUNCTION	Peak (PK)
FREQUENCY RANGE	1GHz ~ 40GHz		Average (AV)

ANTENNA POLARITY & TEST DISTANCE: HORIZONTAL AT 3 M

NO.	FREQ. (MHz)	EMISSION LEVEL (dBuV/m)	LIMIT (dBuV/m)	MARGIN (dB)	ANTENNA HEIGHT (m)	TABLE ANGLE (Degree)	RAW VALUE (dBuV)	CORRECTION FACTOR (dB/m)
1	#5470.00	52.2 PK	74.0	-21.8	1.17 H	213	50.75	1.45
2	#5470.00	39.7 AV	54.0	-14.3	1.17 H	213	38.25	1.45
3	*5720.00	110.7 PK			1.17 H	213	108.78	1.92
4	*5720.00	99.5 AV			1.17 H	213	97.58	1.92
5	#5850.00	52.2 PK	74.0	-21.8	1.17 H	213	50.07	2.13
6	#5850.00	40.3 AV	54.0	-13.7	1.17 H	213	38.17	2.13
7	11440.00	60.4 PK	74.0	-13.6	2.33 H	95	47.53	12.87
8	11440.00	41.6 AV	54.0	-12.4	2.33 H	95	28.73	12.87
9	#17160.00	59.1 PK	74.0	-14.9	1.54 H	187	41.71	17.39
10	#17160.00	46.9 AV	54.0	-7.1	1.54 H	187	29.51	17.39

ANTENNA POLARITY & TEST DISTANCE: VERTICAL AT 3 M

NO.	FREQ. (MHz)	EMISSION LEVEL (dBuV/m)	LIMIT (dBuV/m)	MARGIN (dB)	ANTENNA HEIGHT (m)	TABLE ANGLE (Degree)	RAW VALUE (dBuV)	CORRECTION FACTOR (dB/m)
1	#5470.00	45.2 PK	74.0	-28.8	1.10 V	260	43.75	1.45
2	#5470.00	40.0 AV	54.0	-14.0	1.10 V	260	38.55	1.45
3	*5720.00	105.3 PK			1.10 V	260	103.38	1.92
4	*5720.00	93.7 AV			1.10 V	260	91.78	1.92
5	#5850.00	44.7 PK	74.0	-29.3	1.10 V	260	42.57	2.13
6	#5850.00	39.6 AV	54.0	-14.4	1.10 V	260	37.47	2.13
7	11440.00	52.9 PK	74.0	-21.1	1.45 V	223	40.03	12.87
8	11440.00	39.3 AV	54.0	-14.7	1.45 V	223	26.43	12.87
9	#17160.00	57.9 PK	74.0	-16.1	1.59 V	187	40.51	17.39
10	#17160.00	44.6 AV	54.0	-9.4	1.59 V	187	27.21	17.39

REMARKS:

1. Emission Level(dBuV/m) = Raw Value(dBuV) + Correction Factor(dB/m)
2. Correction Factor(dB/m) = Antenna Factor(dB/m) + Cable Factor(dB) – Pre-Amplifier Factor(dB)
3. The other emission levels were very low against the limit.
4. Margin value = Emission Level – Limit value
5. " * ": Fundamental frequency.
6. " # ": The radiated frequency is out of the restricted band.

CHANNEL	TX Channel 149	DETECTOR FUNCTION	Peak (PK)
FREQUENCY RANGE	1GHz ~ 40GHz		Average (AV)

ANTENNA POLARITY & TEST DISTANCE: HORIZONTAL AT 3 M

NO.	FREQ. (MHz)	EMISSION LEVEL (dBuV/m)	LIMIT (dBuV/m)	MARGIN (dB)	ANTENNA HEIGHT (m)	TABLE ANGLE (Degree)	RAW VALUE (dBuV)	CORRECTION FACTOR (dB/m)
1	#5715.00	65.7 PK	74.0	-8.3	1.02 H	222	63.78	1.92
2	#5715.00	51.2 AV	54.0	-2.8	1.02 H	222	49.28	1.92
3	#5725.00	76.6 PK	78.2	-1.6	1.02 H	222	74.67	1.93
4	*5745.00	106.1 PK			1.02 H	222	104.12	1.98
5	*5745.00	97.6 AV			1.02 H	222	95.62	1.98
6	11490.00	59.7 PK	74.0	-14.3	2.39 H	103	46.83	12.87
7	11490.00	41.2 AV	54.0	-12.8	2.39 H	103	28.33	12.87
8	#17235.00	58.0 PK	74.0	-16.0	1.45 H	198	40.44	17.56
9	#17235.00	46.0 AV	54.0	-8.0	1.45 H	198	28.44	17.56

ANTENNA POLARITY & TEST DISTANCE: VERTICAL AT 3 M

NO.	FREQ. (MHz)	EMISSION LEVEL (dBuV/m)	LIMIT (dBuV/m)	MARGIN (dB)	ANTENNA HEIGHT (m)	TABLE ANGLE (Degree)	RAW VALUE (dBuV)	CORRECTION FACTOR (dB/m)
1	#5715.00	57.8 PK	74.0	-16.2	1.06 V	253	55.88	1.92
2	#5715.00	40.7 AV	54.0	-13.3	1.06 V	253	38.78	1.92
3	#5725.00	61.0 PK	78.2	-17.2	1.06 V	253	59.07	1.93
4	*5745.00	101.6 PK			1.06 V	253	99.62	1.98
5	*5745.00	93.5 AV			1.06 V	253	91.52	1.98
6	11490.00	53.1 PK	74.0	-20.9	1.49 V	204	40.23	12.87
7	11490.00	40.4 AV	54.0	-13.6	1.49 V	204	27.53	12.87
8	#17235.00	56.2 PK	74.0	-17.8	1.52 V	193	38.64	17.56
9	#17235.00	43.3 AV	54.0	-10.7	1.52 V	193	25.74	17.56

REMARKS:

1. Emission Level(dBuV/m) = Raw Value(dBuV) + Correction Factor(dB/m)
2. Correction Factor(dB/m) = Antenna Factor(dB/m) + Cable Factor(dB) – Pre-Amplifier Factor(dB)
3. The other emission levels were very low against the limit.
4. Margin value = Emission Level – Limit value
5. " * ": Fundamental frequency.
6. " # ": The radiated frequency is out of the restricted band.

CHANNEL	TX Channel 157	DETECTOR FUNCTION	Peak (PK)
FREQUENCY RANGE	1GHz ~ 40GHz		Average (AV)

ANTENNA POLARITY & TEST DISTANCE: HORIZONTAL AT 3 M

NO.	FREQ. (MHz)	EMISSION LEVEL (dBuV/m)	LIMIT (dBuV/m)	MARGIN (dB)	ANTENNA HEIGHT (m)	TABLE ANGLE (Degree)	RAW VALUE (dBuV)	CORRECTION FACTOR (dB/m)
1	#5715.00	56.1 PK	74.0	-17.9	1.04 H	223	54.18	1.92
2	#5715.00	42.4 AV	54.0	-11.6	1.04 H	223	40.48	1.92
3	#5725.00	61.1 PK	78.2	-17.1	1.04 H	223	59.17	1.93
4	*5785.00	110.4 PK			1.04 H	223	108.34	2.06
5	*5785.00	98.8 AV			1.04 H	223	96.74	2.06
6	#5850.00	57.6 PK	78.2	-20.6	1.04 H	223	55.47	2.13
7	#5860.00	53.3 PK	74.0	-20.7	1.04 H	223	51.17	2.13
8	#5860.00	41.2 AV	54.0	-12.8	1.04 H	223	39.07	2.13
9	11570.00	60.0 PK	74.0	-14.0	2.37 H	90	47.38	12.62
10	11570.00	41.0 AV	54.0	-13.0	2.37 H	90	28.38	12.62
11	#17355.00	58.3 PK	74.0	-15.7	1.50 H	202	40.12	18.18
12	#17355.00	46.1 AV	54.0	-7.9	1.50 H	202	27.92	18.18

ANTENNA POLARITY & TEST DISTANCE: VERTICAL AT 3 M

NO.	FREQ. (MHz)	EMISSION LEVEL (dBuV/m)	LIMIT (dBuV/m)	MARGIN (dB)	ANTENNA HEIGHT (m)	TABLE ANGLE (Degree)	RAW VALUE (dBuV)	CORRECTION FACTOR (dB/m)
1	#5715.00	49.2 PK	74.0	-24.8	1.15 V	270	47.28	1.92
2	#5715.00	36.5 AV	54.0	-17.5	1.15 V	270	34.58	1.92
3	#5725.00	58.4 PK	78.2	-19.8	1.15 V	270	56.47	1.93
4	*5785.00	105.6 PK			1.15 V	270	103.54	2.06
5	*5785.00	94.0 AV			1.15 V	270	91.94	2.06
6	#5850.00	50.5 PK	78.2	-27.7	1.15 V	270	48.37	2.13
7	#5860.00	48.8 PK	74.0	-25.2	1.15 V	270	46.67	2.13
8	#5860.00	36.4 AV	54.0	-17.6	1.15 V	270	34.27	2.13
9	11570.00	53.0 PK	74.0	-21.0	1.50 V	217	40.38	12.62
10	11570.00	40.4 AV	54.0	-13.6	1.50 V	217	27.78	12.62
11	#17355.00	56.0 PK	74.0	-18.0	1.50 V	193	37.82	18.18
12	#17355.00	43.6 AV	54.0	-10.4	1.50 V	193	25.42	18.18

REMARKS:

1. Emission Level(dBuV/m) = Raw Value(dBuV) + Correction Factor(dB/m)
2. Correction Factor(dB/m) = Antenna Factor(dB/m) + Cable Factor(dB) – Pre-Amplifier Factor(dB)
3. The other emission levels were very low against the limit.
4. Margin value = Emission Level – Limit value
5. " * ": Fundamental frequency.
6. " # ": The radiated frequency is out of the restricted band.

CHANNEL	TX Channel 165	DETECTOR FUNCTION	Peak (PK)
FREQUENCY RANGE	1GHz ~ 40GHz		Average (AV)

ANTENNA POLARITY & TEST DISTANCE: HORIZONTAL AT 3 M

NO.	FREQ. (MHz)	EMISSION LEVEL (dBuV/m)	LIMIT (dBuV/m)	MARGIN (dB)	ANTENNA HEIGHT (m)	TABLE ANGLE (Degree)	RAW VALUE (dBuV)	CORRECTION FACTOR (dB/m)
1	*5825.00	108.7 PK			1.05 H	222	106.58	2.12
2	*5825.00	98.4 AV			1.05 H	222	96.28	2.12
3	#5850.00	71.6 PK	78.2	-6.6	1.05 H	222	69.47	2.13
4	#5860.00	64.4 PK	74.0	-9.6	1.05 H	222	62.27	2.13
5	#5860.00	52.5 AV	54.0	-1.5	1.05 H	222	50.37	2.13
6	11650.00	60.8 PK	74.0	-13.2	2.35 H	115	48.35	12.45
7	11650.00	41.7 AV	54.0	-12.3	2.35 H	115	29.25	12.45
8	#17475.00	58.3 PK	74.0	-15.7	1.44 H	210	39.55	18.75
9	#17475.00	46.4 AV	54.0	-7.6	1.44 H	210	27.65	18.75

ANTENNA POLARITY & TEST DISTANCE: VERTICAL AT 3 M

NO.	FREQ. (MHz)	EMISSION LEVEL (dBuV/m)	LIMIT (dBuV/m)	MARGIN (dB)	ANTENNA HEIGHT (m)	TABLE ANGLE (Degree)	RAW VALUE (dBuV)	CORRECTION FACTOR (dB/m)
1	*5825.00	103.8 PK			1.11 V	275	101.68	2.12
2	*5825.00	93.7 AV			1.11 V	275	91.58	2.12
3	#5850.00	55.5 PK	78.2	-22.7	1.11 V	275	53.37	2.13
4	#5860.00	55.6 PK	74.0	-18.4	1.11 V	275	53.47	2.13
5	#5860.00	42.3 AV	54.0	-11.7	1.11 V	275	40.17	2.13
6	11650.00	52.9 PK	74.0	-21.1	1.53 V	216	40.45	12.45
7	11650.00	39.8 AV	54.0	-14.2	1.53 V	216	27.35	12.45
8	#17475.00	57.3 PK	74.0	-16.7	1.47 V	205	38.55	18.75
9	#17475.00	44.4 AV	54.0	-9.6	1.47 V	205	25.65	18.75

REMARKS:

1. Emission Level(dBuV/m) = Raw Value(dBuV) + Correction Factor(dB/m)
2. Correction Factor(dB/m) = Antenna Factor(dB/m) + Cable Factor(dB) – Pre-Amplifier Factor(dB)
3. The other emission levels were very low against the limit.
4. Margin value = Emission Level – Limit value
5. " * ": Fundamental frequency.
6. " # ": The radiated frequency is out of the restricted band.

2TX Mode

Above 1GHz Data:

802.11a

CHANNEL	TX Channel 36	DETECTOR FUNCTION	Peak (PK)
FREQUENCY RANGE	1GHz ~ 40GHz		Average (AV)

ANTENNA POLARITY & TEST DISTANCE: HORIZONTAL AT 3 M

NO.	FREQ. (MHz)	EMISSION LEVEL (dBuV/m)	LIMIT (dBuV/m)	MARGIN (dB)	ANTENNA HEIGHT (m)	TABLE ANGLE (Degree)	RAW VALUE (dBuV)	CORRECTION FACTOR (dB/m)
1	5150.00	67.7 PK	74.0	-6.3	2.14 H	232	66.13	1.57
2	5150.00	52.0 AV	54.0	-2.0	2.14 H	232	50.43	1.57
3	*5180.00	111.1 PK			2.14 H	232	109.42	1.68
4	*5180.00	100.4 AV			2.14 H	232	98.72	1.68
5	#10360.00	59.5 PK	74.0	-14.5	2.36 H	99	47.78	11.72
6	#10360.00	40.6 AV	54.0	-13.4	2.36 H	99	28.88	11.72
7	15540.00	58.0 PK	74.0	-16.0	1.51 H	224	44.70	13.30
8	15540.00	45.5 AV	54.0	-8.5	1.51 H	224	32.20	13.30

ANTENNA POLARITY & TEST DISTANCE: VERTICAL AT 3 M

NO.	FREQ. (MHz)	EMISSION LEVEL (dBuV/m)	LIMIT (dBuV/m)	MARGIN (dB)	ANTENNA HEIGHT (m)	TABLE ANGLE (Degree)	RAW VALUE (dBuV)	CORRECTION FACTOR (dB/m)
1	5150.00	64.4 PK	74.0	-9.6	2.78 V	285	62.83	1.57
2	5150.00	50.0 AV	54.0	-4.0	2.78 V	285	48.43	1.57
3	*5180.00	108.6 PK			2.78 V	285	106.92	1.68
4	*5180.00	96.9 AV			2.78 V	285	95.22	1.68
5	#10360.00	53.1 PK	74.0	-20.9	1.46 V	218	41.38	11.72
6	#10360.00	39.6 AV	54.0	-14.4	1.46 V	218	27.88	11.72
7	15540.00	56.7 PK	74.0	-17.3	1.47 V	170	43.40	13.30
8	15540.00	43.8 AV	54.0	-10.2	1.47 V	170	30.50	13.30

REMARKS:

1. Emission Level(dBuV/m) = Raw Value(dBuV) + Correction Factor(dB/m)
2. Correction Factor(dB/m) = Antenna Factor(dB/m) + Cable Factor(dB) – Pre-Amplifier Factor(dB)
3. The other emission levels were very low against the limit.
4. Margin value = Emission Level – Limit value
5. " * ": Fundamental frequency.
6. " # ": The radiated frequency is out of the restricted band.

CHANNEL	TX Channel 40	DETECTOR FUNCTION	Peak (PK)
FREQUENCY RANGE	1GHz ~ 40GHz		Average (AV)

ANTENNA POLARITY & TEST DISTANCE: HORIZONTAL AT 3 M

NO.	FREQ. (MHz)	EMISSION LEVEL (dBuV/m)	LIMIT (dBuV/m)	MARGIN (dB)	ANTENNA HEIGHT (m)	TABLE ANGLE (Degree)	RAW VALUE (dBuV)	CORRECTION FACTOR (dB/m)
1	5150.00	61.0 PK	74.0	-13.0	1.00 H	246	59.43	1.57
2	5150.00	48.4 AV	54.0	-5.6	1.00 H	246	46.83	1.57
3	*5200.00	113.0 PK			1.00 H	246	111.26	1.74
4	*5200.00	100.8 AV			1.00 H	246	99.06	1.74
5	#10400.00	60.6 PK	74.0	-13.4	2.31 H	86	48.68	11.92
6	#10400.00	41.8 AV	54.0	-12.2	2.31 H	86	29.88	11.92
7	15600.00	58.7 PK	74.0	-15.3	1.51 H	215	45.40	13.30
8	15600.00	46.4 AV	54.0	-7.6	1.51 H	215	33.10	13.30

ANTENNA POLARITY & TEST DISTANCE: VERTICAL AT 3 M

NO.	FREQ. (MHz)	EMISSION LEVEL (dBuV/m)	LIMIT (dBuV/m)	MARGIN (dB)	ANTENNA HEIGHT (m)	TABLE ANGLE (Degree)	RAW VALUE (dBuV)	CORRECTION FACTOR (dB/m)
1	5150.00	54.2 PK	74.0	-19.8	2.74 V	287	52.63	1.57
2	5150.00	42.4 AV	54.0	-11.6	2.74 V	287	40.83	1.57
3	*5200.00	108.8 PK			2.74 V	287	107.06	1.74
4	*5200.00	97.3 AV			2.74 V	287	95.56	1.74
5	#10400.00	53.5 PK	74.0	-20.5	1.50 V	205	41.58	11.92
6	#10400.00	40.0 AV	54.0	-14.0	1.50 V	205	28.08	11.92
7	15600.00	57.1 PK	74.0	-16.9	1.49 V	179	43.80	13.30
8	15600.00	44.2 AV	54.0	-9.8	1.49 V	179	30.90	13.30

REMARKS:

1. Emission Level(dBuV/m) = Raw Value(dBuV) + Correction Factor(dB/m)
2. Correction Factor(dB/m) = Antenna Factor(dB/m) + Cable Factor(dB) – Pre-Amplifier Factor(dB)
3. The other emission levels were very low against the limit.
4. Margin value = Emission Level – Limit value
5. " * ": Fundamental frequency.
6. " # ": The radiated frequency is out of the restricted band.

CHANNEL	TX Channel 48	DETECTOR FUNCTION	Peak (PK)
FREQUENCY RANGE	1GHz ~ 40GHz		Average (AV)

ANTENNA POLARITY & TEST DISTANCE: HORIZONTAL AT 3 M

NO.	FREQ. (MHz)	EMISSION LEVEL (dBuV/m)	LIMIT (dBuV/m)	MARGIN (dB)	ANTENNA HEIGHT (m)	TABLE ANGLE (Degree)	RAW VALUE (dBuV)	CORRECTION FACTOR (dB/m)
1	5150.00	53.3 PK	74.0	-20.7	1.12 H	225	51.73	1.57
2	5150.00	40.3 AV	54.0	-13.7	1.12 H	225	38.73	1.57
3	*5240.00	114.3 PK			1.12 H	225	112.45	1.85
4	*5240.00	101.8 AV			1.12 H	225	99.95	1.85
5	5350.00	54.7 PK	74.0	-19.3	1.12 H	225	52.59	2.11
6	5350.00	41.1 AV	54.0	-12.9	1.12 H	225	38.99	2.11
7	#10480.00	60.0 PK	74.0	-14.0	2.32 H	102	47.74	12.26
8	#10480.00	41.3 AV	54.0	-12.7	2.32 H	102	29.04	12.26
9	15720.00	59.0 PK	74.0	-15.0	1.56 H	202	45.82	13.18
10	15720.00	46.7 AV	54.0	-7.3	1.56 H	202	33.52	13.18

ANTENNA POLARITY & TEST DISTANCE: VERTICAL AT 3 M

NO.	FREQ. (MHz)	EMISSION LEVEL (dBuV/m)	LIMIT (dBuV/m)	MARGIN (dB)	ANTENNA HEIGHT (m)	TABLE ANGLE (Degree)	RAW VALUE (dBuV)	CORRECTION FACTOR (dB/m)
1	5150.00	46.5 PK	74.0	-27.5	2.75 V	316	44.93	1.57
2	5150.00	34.2 AV	54.0	-19.8	2.75 V	316	32.63	1.57
3	*5240.00	109.6 PK			2.75 V	316	107.75	1.85
4	*5240.00	98.1 AV			2.75 V	316	96.25	1.85
5	5350.00	48.2 PK	74.0	-25.8	2.75 V	316	46.09	2.11
6	5350.00	35.6 AV	54.0	-18.4	2.75 V	316	33.49	2.11
7	#10480.00	53.9 PK	74.0	-20.1	1.49 V	212	41.64	12.26
8	#10480.00	40.7 AV	54.0	-13.3	1.49 V	212	28.44	12.26
9	15720.00	56.2 PK	74.0	-17.8	1.58 V	182	43.02	13.18
10	15720.00	43.6 AV	54.0	-10.4	1.58 V	182	30.42	13.18

REMARKS:

1. Emission Level(dBuV/m) = Raw Value(dBuV) + Correction Factor(dB/m)
2. Correction Factor(dB/m) = Antenna Factor(dB/m) + Cable Factor(dB) – Pre-Amplifier Factor(dB)
3. The other emission levels were very low against the limit.
4. Margin value = Emission Level – Limit value
5. " * ": Fundamental frequency.
6. " # ": The radiated frequency is out of the restricted band.

CHANNEL	TX Channel 52	DETECTOR FUNCTION	Peak (PK)
FREQUENCY RANGE	1GHz ~ 40GHz		Average (AV)

ANTENNA POLARITY & TEST DISTANCE: HORIZONTAL AT 3 M

NO.	FREQ. (MHz)	EMISSION LEVEL (dBuV/m)	LIMIT (dBuV/m)	MARGIN (dB)	ANTENNA HEIGHT (m)	TABLE ANGLE (Degree)	RAW VALUE (dBuV)	CORRECTION FACTOR (dB/m)
1	5150.00	52.1 PK	74.0	-21.9	1.00 H	246	50.53	1.57
2	5150.00	40.5 AV	54.0	-13.5	1.00 H	246	38.93	1.57
3	*5260.00	114.3 PK			1.00 H	246	112.37	1.93
4	*5260.00	103.0 AV			1.00 H	246	101.07	1.93
5	5350.00	54.6 PK	74.0	-19.4	1.00 H	246	52.49	2.11
6	5350.00	41.1 AV	54.0	-12.9	1.00 H	246	38.99	2.11
7	#10520.00	60.5 PK	74.0	-13.5	2.34 H	109	48.08	12.42
8	#10520.00	41.7 AV	54.0	-12.3	2.34 H	109	29.28	12.42
9	15780.00	58.0 PK	74.0	-16.0	1.52 H	208	44.88	13.12
10	15780.00	46.0 AV	54.0	-8.0	1.52 H	208	32.88	13.12

ANTENNA POLARITY & TEST DISTANCE: VERTICAL AT 3 M

NO.	FREQ. (MHz)	EMISSION LEVEL (dBuV/m)	LIMIT (dBuV/m)	MARGIN (dB)	ANTENNA HEIGHT (m)	TABLE ANGLE (Degree)	RAW VALUE (dBuV)	CORRECTION FACTOR (dB/m)
1	5150.00	45.3 PK	74.0	-28.7	2.78 V	289	43.73	1.57
2	5150.00	35.4 AV	54.0	-18.6	2.78 V	289	33.83	1.57
3	*5260.00	109.9 PK			2.78 V	289	107.97	1.93
4	*5260.00	99.3 AV			2.78 V	289	97.37	1.93
5	5350.00	48.4 PK	74.0	-25.6	2.78 V	289	46.29	2.11
6	5350.00	34.3 AV	54.0	-19.7	2.78 V	289	32.19	2.11
7	#10520.00	53.7 PK	74.0	-20.3	1.56 V	215	41.28	12.42
8	#10520.00	40.8 AV	54.0	-13.2	1.56 V	215	28.38	12.42
9	15780.00	56.9 PK	74.0	-17.1	1.53 V	188	43.78	13.12
10	15780.00	44.4 AV	54.0	-9.6	1.53 V	188	31.28	13.12

REMARKS:

1. Emission Level(dBuV/m) = Raw Value(dBuV) + Correction Factor(dB/m)
2. Correction Factor(dB/m) = Antenna Factor(dB/m) + Cable Factor(dB) – Pre-Amplifier Factor(dB)
3. The other emission levels were very low against the limit.
4. Margin value = Emission Level – Limit value
5. " * ": Fundamental frequency.
6. " # ": The radiated frequency is out of the restricted band.

CHANNEL	TX Channel 60	DETECTOR FUNCTION	Peak (PK)
FREQUENCY RANGE	1GHz ~ 40GHz		Average (AV)

ANTENNA POLARITY & TEST DISTANCE: HORIZONTAL AT 3 M

NO.	FREQ. (MHz)	EMISSION LEVEL (dBuV/m)	LIMIT (dBuV/m)	MARGIN (dB)	ANTENNA HEIGHT (m)	TABLE ANGLE (Degree)	RAW VALUE (dBuV)	CORRECTION FACTOR (dB/m)
1	*5300.00	113.6 PK			1.02 H	248	111.56	2.04
2	*5300.00	102.6 AV			1.02 H	248	100.56	2.04
3	5350.00	64.1 PK	74.0	-9.9	1.02 H	248	61.99	2.11
4	5350.00	49.0 AV	54.0	-5.0	1.02 H	248	46.89	2.11
5	10600.00	60.5 PK	74.0	-13.5	2.33 H	112	47.81	12.69
6	10600.00	41.5 AV	54.0	-12.5	2.33 H	112	28.81	12.69
7	15900.00	58.6 PK	74.0	-15.4	1.57 H	223	45.21	13.39
8	15900.00	46.3 AV	54.0	-7.7	1.57 H	223	32.91	13.39

ANTENNA POLARITY & TEST DISTANCE: VERTICAL AT 3 M

NO.	FREQ. (MHz)	EMISSION LEVEL (dBuV/m)	LIMIT (dBuV/m)	MARGIN (dB)	ANTENNA HEIGHT (m)	TABLE ANGLE (Degree)	RAW VALUE (dBuV)	CORRECTION FACTOR (dB/m)
1	*5300.00	108.8 PK			2.72 V	302	106.76	2.04
2	*5300.00	98.5 AV			2.72 V	302	96.46	2.04
3	5350.00	57.1 PK	74.0	-16.9	2.72 V	302	54.99	2.11
4	5350.00	42.6 AV	54.0	-11.4	2.72 V	302	40.49	2.11
5	10600.00	53.3 PK	74.0	-20.7	1.58 V	211	40.61	12.69
6	10600.00	40.2 AV	54.0	-13.8	1.58 V	211	27.51	12.69
7	15900.00	56.7 PK	74.0	-17.3	1.51 V	181	43.31	13.39
8	15900.00	44.2 AV	54.0	-9.8	1.51 V	181	30.81	13.39

REMARKS:

1. Emission Level(dBuV/m) = Raw Value(dBuV) + Correction Factor(dB/m)
2. Correction Factor(dB/m) = Antenna Factor(dB/m) + Cable Factor(dB) – Pre-Amplifier Factor(dB)
3. The other emission levels were very low against the limit.
4. Margin value = Emission Level – Limit value
5. " * ": Fundamental frequency.

CHANNEL	TX Channel 64	DETECTOR FUNCTION	Peak (PK)
FREQUENCY RANGE	1GHz ~ 40GHz		Average (AV)

ANTENNA POLARITY & TEST DISTANCE: HORIZONTAL AT 3 M

NO.	FREQ. (MHz)	EMISSION LEVEL (dBuV/m)	LIMIT (dBuV/m)	MARGIN (dB)	ANTENNA HEIGHT (m)	TABLE ANGLE (Degree)	RAW VALUE (dBuV)	CORRECTION FACTOR (dB/m)
1	*5320.00	111.7 PK			2.17 H	235	109.63	2.07
2	*5320.00	99.6 AV			2.17 H	235	97.53	2.07
3	5350.00	67.0 PK	74.0	-7.0	2.17 H	235	64.89	2.11
4	5350.00	52.0 AV	54.0	-2.0	2.17 H	235	49.89	2.11
5	10640.00	60.1 PK	74.0	-13.9	2.46 H	100	47.44	12.66
6	10640.00	41.0 AV	54.0	-13.0	2.46 H	100	28.34	12.66
7	15960.00	58.8 PK	74.0	-15.2	1.58 H	221	45.63	13.17
8	15960.00	46.1 AV	54.0	-7.9	1.58 H	221	32.93	13.17

ANTENNA POLARITY & TEST DISTANCE: VERTICAL AT 3 M

NO.	FREQ. (MHz)	EMISSION LEVEL (dBuV/m)	LIMIT (dBuV/m)	MARGIN (dB)	ANTENNA HEIGHT (m)	TABLE ANGLE (Degree)	RAW VALUE (dBuV)	CORRECTION FACTOR (dB/m)
1	*5320.00	107.8 PK			2.65 V	300	105.73	2.07
2	*5320.00	95.2 AV			2.65 V	300	93.13	2.07
3	5350.00	62.4 PK	74.0	-11.6	2.65 V	300	60.29	2.11
4	5350.00	47.4 AV	54.0	-6.6	2.65 V	300	45.29	2.11
5	10640.00	53.8 PK	74.0	-20.2	1.57 V	196	41.14	12.66
6	10640.00	41.0 AV	54.0	-13.0	1.57 V	196	28.34	12.66
7	15960.00	57.0 PK	74.0	-17.0	1.46 V	200	43.83	13.17
8	15960.00	43.7 AV	54.0	-10.3	1.46 V	200	30.53	13.17

REMARKS:

1. Emission Level(dBuV/m) = Raw Value(dBuV) + Correction Factor(dB/m)
2. Correction Factor(dB/m) = Antenna Factor(dB/m) + Cable Factor(dB) – Pre-Amplifier Factor(dB)
3. The other emission levels were very low against the limit.
4. Margin value = Emission Level – Limit value
5. " * ": Fundamental frequency.

CHANNEL	TX Channel 100	DETECTOR FUNCTION	Peak (PK)
FREQUENCY RANGE	1GHz ~ 40GHz		Average (AV)

ANTENNA POLARITY & TEST DISTANCE: HORIZONTAL AT 3 M

NO.	FREQ. (MHz)	EMISSION LEVEL (dBuV/m)	LIMIT (dBuV/m)	MARGIN (dB)	ANTENNA HEIGHT (m)	TABLE ANGLE (Degree)	RAW VALUE (dBuV)	CORRECTION FACTOR (dB/m)
1	#5470.00	69.4 PK	74.0	-4.6	1.04 H	227	67.14	2.26
2	#5470.00	52.4 AV	54.0	-1.6	1.04 H	227	50.14	2.26
3	*5500.00	110.3 PK			1.04 H	227	108.00	2.30
4	*5500.00	97.8 AV			1.04 H	227	95.50	2.30
5	11000.00	60.4 PK	74.0	-13.6	2.40 H	109	46.94	13.46
6	11000.00	41.4 AV	54.0	-12.6	2.40 H	109	27.94	13.46
7	#16500.00	58.6 PK	74.0	-15.4	1.60 H	216	42.94	15.66
8	#16500.00	46.1 AV	54.0	-7.9	1.60 H	216	30.44	15.66

ANTENNA POLARITY & TEST DISTANCE: VERTICAL AT 3 M

NO.	FREQ. (MHz)	EMISSION LEVEL (dBuV/m)	LIMIT (dBuV/m)	MARGIN (dB)	ANTENNA HEIGHT (m)	TABLE ANGLE (Degree)	RAW VALUE (dBuV)	CORRECTION FACTOR (dB/m)
1	#5470.00	62.4 PK	74.0	-11.6	2.81 V	286	60.14	2.26
2	#5470.00	46.2 AV	54.0	-7.8	2.81 V	286	43.94	2.26
3	*5500.00	105.3 PK			2.81 V	286	103.00	2.30
4	*5500.00	93.7 AV			2.81 V	286	91.40	2.30
5	11000.00	54.2 PK	74.0	-19.8	1.56 V	209	40.74	13.46
6	11000.00	41.2 AV	54.0	-12.8	1.56 V	209	27.74	13.46
7	#16500.00	57.2 PK	74.0	-16.8	1.48 V	199	41.54	15.66
8	#16500.00	43.8 AV	54.0	-10.2	1.48 V	199	28.14	15.66

REMARKS:

1. Emission Level(dBuV/m) = Raw Value(dBuV) + Correction Factor(dB/m)
2. Correction Factor(dB/m) = Antenna Factor(dB/m) + Cable Factor(dB) – Pre-Amplifier Factor(dB)
3. The other emission levels were very low against the limit.
4. Margin value = Emission Level – Limit value
5. " * ": Fundamental frequency.
6. " # ": The radiated frequency is out of the restricted band.

CHANNEL	TX Channel 116	DETECTOR FUNCTION	Peak (PK)
FREQUENCY RANGE	1GHz ~ 40GHz		Average (AV)

ANTENNA POLARITY & TEST DISTANCE: HORIZONTAL AT 3 M

NO.	FREQ. (MHz)	EMISSION LEVEL (dBuV/m)	LIMIT (dBuV/m)	MARGIN (dB)	ANTENNA HEIGHT (m)	TABLE ANGLE (Degree)	RAW VALUE (dBuV)	CORRECTION FACTOR (dB/m)
1	#5470.00	53.1 PK	74.0	-20.9	1.19 H	229	50.84	2.26
2	#5470.00	40.1 AV	54.0	-13.9	1.19 H	229	37.84	2.26
3	*5580.00	111.2 PK			1.19 H	229	108.70	2.50
4	*5580.00	100.0 AV			1.19 H	229	97.50	2.50
5	#5725.00	51.9 PK	74.0	-22.1	1.19 H	229	49.12	2.78
6	#5725.00	40.2 AV	54.0	-13.8	1.19 H	229	37.42	2.78
7	11160.00	59.9 PK	74.0	-14.1	2.29 H	97	46.59	13.31
8	11160.00	41.2 AV	54.0	-12.8	2.29 H	97	27.89	13.31
9	#16740.00	58.4 PK	74.0	-15.6	1.56 H	198	42.05	16.35
10	#16740.00	45.8 AV	54.0	-8.2	1.56 H	198	29.45	16.35

ANTENNA POLARITY & TEST DISTANCE: VERTICAL AT 3 M

NO.	FREQ. (MHz)	EMISSION LEVEL (dBuV/m)	LIMIT (dBuV/m)	MARGIN (dB)	ANTENNA HEIGHT (m)	TABLE ANGLE (Degree)	RAW VALUE (dBuV)	CORRECTION FACTOR (dB/m)
1	#5470.00	48.3 PK	74.0	-25.7	2.76 V	314	46.04	2.26
2	#5470.00	34.0 AV	54.0	-20.0	2.76 V	314	31.74	2.26
3	*5580.00	106.6 PK			2.76 V	314	104.10	2.50
4	*5580.00	96.0 AV			2.76 V	314	93.50	2.50
5	#5725.00	44.9 PK	74.0	-29.1	2.76 V	314	42.12	2.78
6	#5725.00	34.1 AV	54.0	-19.9	2.76 V	314	31.32	2.78
7	11160.00	53.4 PK	74.0	-20.6	1.51 V	221	40.09	13.31
8	11160.00	40.8 AV	54.0	-13.2	1.51 V	221	27.49	13.31
9	#16740.00	57.7 PK	74.0	-16.3	1.57 V	187	41.35	16.35
10	#16740.00	44.8 AV	54.0	-9.2	1.57 V	187	28.45	16.35

REMARKS:

1. Emission Level(dBuV/m) = Raw Value(dBuV) + Correction Factor(dB/m)
2. Correction Factor(dB/m) = Antenna Factor(dB/m) + Cable Factor(dB) – Pre-Amplifier Factor(dB)
3. The other emission levels were very low against the limit.
4. Margin value = Emission Level – Limit value
5. " * ": Fundamental frequency.
6. " # ": The radiated frequency is out of the restricted band.

CHANNEL	TX Channel 140	DETECTOR FUNCTION	Peak (PK)
FREQUENCY RANGE	1GHz ~ 40GHz		Average (AV)

ANTENNA POLARITY & TEST DISTANCE: HORIZONTAL AT 3 M

NO.	FREQ. (MHz)	EMISSION LEVEL (dBuV/m)	LIMIT (dBuV/m)	MARGIN (dB)	ANTENNA HEIGHT (m)	TABLE ANGLE (Degree)	RAW VALUE (dBuV)	CORRECTION FACTOR (dB/m)
1	*5700.00	108.2 PK			1.06 H	222	105.46	2.74
2	*5700.00	96.1 AV			1.06 H	222	93.36	2.74
3	#5725.00	67.8 PK	74.0	-6.2	1.06 H	222	65.02	2.78
4	#5725.00	52.7 AV	54.0	-1.3	1.06 H	222	49.92	2.78
5	11400.00	59.7 PK	74.0	-14.3	2.33 H	105	46.34	13.36
6	11400.00	41.1 AV	54.0	-12.9	2.33 H	105	27.74	13.36
7	#17100.00	58.1 PK	74.0	-15.9	1.49 H	202	40.13	17.97
8	#17100.00	46.1 AV	54.0	-7.9	1.49 H	202	28.13	17.97

ANTENNA POLARITY & TEST DISTANCE: VERTICAL AT 3 M

NO.	FREQ. (MHz)	EMISSION LEVEL (dBuV/m)	LIMIT (dBuV/m)	MARGIN (dB)	ANTENNA HEIGHT (m)	TABLE ANGLE (Degree)	RAW VALUE (dBuV)	CORRECTION FACTOR (dB/m)
1	*5700.00	103.4 PK			2.82 V	308	100.66	2.74
2	*5700.00	92.1 AV			2.82 V	308	89.36	2.74
3	#5725.00	60.7 PK	74.0	-13.3	2.82 V	308	57.92	2.78
4	#5725.00	46.6 AV	54.0	-7.4	2.82 V	308	43.82	2.78
5	11400.00	52.8 PK	74.0	-21.2	1.54 V	233	39.44	13.36
6	11400.00	40.1 AV	54.0	-13.9	1.54 V	233	26.74	13.36
7	#17100.00	55.9 PK	74.0	-18.1	1.50 V	187	37.93	17.97
8	#17100.00	43.3 AV	54.0	-10.7	1.50 V	187	25.33	17.97

REMARKS:

1. Emission Level(dBuV/m) = Raw Value(dBuV) + Correction Factor(dB/m)
2. Correction Factor(dB/m) = Antenna Factor(dB/m) + Cable Factor(dB) – Pre-Amplifier Factor(dB)
3. The other emission levels were very low against the limit.
4. Margin value = Emission Level – Limit value
5. " * ": Fundamental frequency.
6. " # ": The radiated frequency is out of the restricted band.

CHANNEL	TX Channel 144	DETECTOR FUNCTION	Peak (PK)
FREQUENCY RANGE	1GHz ~ 40GHz		Average (AV)

ANTENNA POLARITY & TEST DISTANCE: HORIZONTAL AT 3 M

NO.	FREQ. (MHz)	EMISSION LEVEL (dBuV/m)	LIMIT (dBuV/m)	MARGIN (dB)	ANTENNA HEIGHT (m)	TABLE ANGLE (Degree)	RAW VALUE (dBuV)	CORRECTION FACTOR (dB/m)
1	#5470.00	52.8 PK	74.0	-21.2	1.16 H	215	50.54	2.26
2	#5470.00	40.0 AV	54.0	-14.0	1.16 H	215	37.74	2.26
3	*5720.00	111.6 PK			1.16 H	215	108.83	2.77
4	*5720.00	100.3 AV			1.16 H	215	97.53	2.77
5	#5850.00	52.2 PK	74.0	-21.8	1.16 H	215	49.26	2.94
6	#5850.00	40.6 AV	54.0	-13.4	1.16 H	215	37.66	2.94
7	11440.00	60.6 PK	74.0	-13.4	2.34 H	105	47.20	13.40
8	11440.00	41.6 AV	54.0	-12.4	2.34 H	105	28.20	13.40
9	#17160.00	58.8 PK	74.0	-15.2	1.50 H	212	40.63	18.17
10	#17160.00	46.5 AV	54.0	-7.5	1.50 H	212	28.33	18.17

ANTENNA POLARITY & TEST DISTANCE: VERTICAL AT 3 M

NO.	FREQ. (MHz)	EMISSION LEVEL (dBuV/m)	LIMIT (dBuV/m)	MARGIN (dB)	ANTENNA HEIGHT (m)	TABLE ANGLE (Degree)	RAW VALUE (dBuV)	CORRECTION FACTOR (dB/m)
1	#5470.00	45.6 PK	74.0	-28.4	2.81 V	312	43.34	2.26
2	#5470.00	33.8 AV	54.0	-20.2	2.81 V	312	31.54	2.26
3	*5720.00	107.3 PK			2.81 V	312	104.53	2.77
4	*5720.00	97.1 AV			2.81 V	312	94.33	2.77
5	#5850.00	45.2 PK	74.0	-28.8	2.81 V	312	42.26	2.94
6	#5850.00	34.2 AV	54.0	-19.8	2.81 V	312	31.26	2.94
7	11440.00	53.4 PK	74.0	-20.6	1.56 V	203	40.00	13.40
8	11440.00	40.5 AV	54.0	-13.5	1.56 V	203	27.10	13.40
9	#17160.00	55.7 PK	74.0	-18.3	1.51 V	194	37.53	18.17
10	#17160.00	43.3 AV	54.0	-10.7	1.51 V	194	25.13	18.17

REMARKS:

1. Emission Level(dBuV/m) = Raw Value(dBuV) + Correction Factor(dB/m)
2. Correction Factor(dB/m) = Antenna Factor(dB/m) + Cable Factor(dB) – Pre-Amplifier Factor(dB)
3. The other emission levels were very low against the limit.
4. Margin value = Emission Level – Limit value
5. " * ": Fundamental frequency.
6. " # ": The radiated frequency is out of the restricted band.

CHANNEL	TX Channel 149	DETECTOR FUNCTION	Peak (PK)
FREQUENCY RANGE	1GHz ~ 40GHz		Average (AV)

ANTENNA POLARITY & TEST DISTANCE: HORIZONTAL AT 3 M

NO.	FREQ. (MHz)	EMISSION LEVEL (dBuV/m)	LIMIT (dBuV/m)	MARGIN (dB)	ANTENNA HEIGHT (m)	TABLE ANGLE (Degree)	RAW VALUE (dBuV)	CORRECTION FACTOR (dB/m)
1	#5715.00	65.7 PK	74.0	-8.3	1.09 H	226	63.78	1.92
2	#5715.00	50.4 AV	54.0	-3.6	1.09 H	226	48.48	1.92
3	#5725.00	76.9 PK	78.2	-1.3	1.09 H	226	74.97	1.93
4	*5745.00	108.5 PK			1.09 H	226	106.52	1.98
5	*5745.00	96.5 AV			1.09 H	226	94.52	1.98
6	11490.00	60.2 PK	74.0	-13.8	2.32 H	89	47.33	12.87
7	11490.00	41.5 AV	54.0	-12.5	2.32 H	89	28.63	12.87
8	#17235.00	58.5 PK	74.0	-15.5	1.48 H	201	40.94	17.56
9	#17235.00	46.4 AV	54.0	-7.6	1.48 H	201	28.84	17.56

ANTENNA POLARITY & TEST DISTANCE: VERTICAL AT 3 M

NO.	FREQ. (MHz)	EMISSION LEVEL (dBuV/m)	LIMIT (dBuV/m)	MARGIN (dB)	ANTENNA HEIGHT (m)	TABLE ANGLE (Degree)	RAW VALUE (dBuV)	CORRECTION FACTOR (dB/m)
1	#5715.00	59.1 PK	74.0	-14.9	2.75 V	296	57.18	1.92
2	#5715.00	44.4 AV	54.0	-9.6	2.75 V	296	42.48	1.92
3	#5725.00	69.8 PK	78.2	-8.4	2.75 V	296	67.87	1.93
4	*5745.00	103.4 PK			2.75 V	296	101.42	1.98
5	*5745.00	92.3 AV			2.75 V	296	90.32	1.98
6	11490.00	53.4 PK	74.0	-20.6	1.58 V	221	40.53	12.87
7	11490.00	40.7 AV	54.0	-13.3	1.58 V	221	27.83	12.87
8	#17235.00	57.6 PK	74.0	-16.4	1.55 V	182	40.04	17.56
9	#17235.00	44.4 AV	54.0	-9.6	1.55 V	182	26.84	17.56

REMARKS:

1. Emission Level(dBuV/m) = Raw Value(dBuV) + Correction Factor(dB/m)
2. Correction Factor(dB/m) = Antenna Factor(dB/m) + Cable Factor(dB) – Pre-Amplifier Factor(dB)
3. The other emission levels were very low against the limit.
4. Margin value = Emission Level – Limit value
5. " * ": Fundamental frequency.
6. " # ": The radiated frequency is out of the restricted band.

CHANNEL	TX Channel 157	DETECTOR FUNCTION	Peak (PK)
FREQUENCY RANGE	1GHz ~ 40GHz		Average (AV)

ANTENNA POLARITY & TEST DISTANCE: HORIZONTAL AT 3 M

NO.	FREQ. (MHz)	EMISSION LEVEL (dBuV/m)	LIMIT (dBuV/m)	MARGIN (dB)	ANTENNA HEIGHT (m)	TABLE ANGLE (Degree)	RAW VALUE (dBuV)	CORRECTION FACTOR (dB/m)
1	#5715.00	57.6 PK	74.0	-16.4	1.00 H	226	55.68	1.92
2	#5715.00	42.3 AV	54.0	-11.7	1.00 H	226	40.38	1.92
3	#5725.00	60.6 PK	78.2	-17.6	1.00 H	226	58.67	1.93
4	*5785.00	109.4 PK			1.00 H	226	107.34	2.06
5	*5785.00	98.4 AV			1.00 H	226	96.34	2.06
6	#5850.00	57.0 PK	78.2	-21.2	1.00 H	226	54.87	2.13
7	#5860.00	54.3 PK	74.0	-19.7	1.00 H	226	52.17	2.13
8	#5860.00	40.5 AV	54.0	-13.5	1.00 H	226	38.37	2.13
9	11570.00	60.1 PK	74.0	-13.9	2.38 H	105	47.48	12.62
10	11570.00	41.1 AV	54.0	-12.9	2.38 H	105	28.48	12.62
11	#17355.00	58.8 PK	74.0	-15.2	1.50 H	209	40.62	18.18
12	#17355.00	46.4 AV	54.0	-7.6	1.50 H	209	28.22	18.18

ANTENNA POLARITY & TEST DISTANCE: VERTICAL AT 3 M

NO.	FREQ. (MHz)	EMISSION LEVEL (dBuV/m)	LIMIT (dBuV/m)	MARGIN (dB)	ANTENNA HEIGHT (m)	TABLE ANGLE (Degree)	RAW VALUE (dBuV)	CORRECTION FACTOR (dB/m)
1	#5715.00	51.0 PK	74.0	-23.0	2.75 V	310	49.08	1.92
2	#5715.00	36.7 AV	54.0	-17.3	2.75 V	310	34.78	1.92
3	#5725.00	53.8 PK	78.2	-24.4	2.75 V	310	51.87	1.93
4	*5785.00	104.3 PK			2.75 V	310	102.24	2.06
5	*5785.00	94.3 AV			2.75 V	310	92.24	2.06
6	#5850.00	50.3 PK	78.2	-27.9	2.75 V	310	48.17	2.13
7	#5860.00	47.9 PK	74.0	-26.1	2.75 V	310	45.77	2.13
8	#5860.00	34.9 AV	54.0	-19.1	2.75 V	310	32.77	2.13
9	11570.00	53.4 PK	74.0	-20.6	1.53 V	215	40.78	12.62
10	11570.00	40.6 AV	54.0	-13.4	1.53 V	215	27.98	12.62
11	#17355.00	56.5 PK	74.0	-17.5	1.52 V	206	38.32	18.18
12	#17355.00	43.7 AV	54.0	-10.3	1.52 V	206	25.52	18.18

REMARKS:

1. Emission Level(dBuV/m) = Raw Value(dBuV) + Correction Factor(dB/m)
2. Correction Factor(dB/m) = Antenna Factor(dB/m) + Cable Factor(dB) – Pre-Amplifier Factor(dB)
3. The other emission levels were very low against the limit.
4. Margin value = Emission Level – Limit value
5. " * ": Fundamental frequency.
6. " # ": The radiated frequency is out of the restricted band.

CHANNEL	TX Channel 165	DETECTOR FUNCTION	Peak (PK)
FREQUENCY RANGE	1GHz ~ 40GHz		Average (AV)

ANTENNA POLARITY & TEST DISTANCE: HORIZONTAL AT 3 M

NO.	FREQ. (MHz)	EMISSION LEVEL (dBuV/m)	LIMIT (dBuV/m)	MARGIN (dB)	ANTENNA HEIGHT (m)	TABLE ANGLE (Degree)	RAW VALUE (dBuV)	CORRECTION FACTOR (dB/m)
1	*5825.00	108.7 PK			1.04 H	220	106.58	2.12
2	*5825.00	96.0 AV			1.04 H	220	93.88	2.12
3	#5850.00	71.3 PK	78.2	-6.9	1.04 H	220	69.17	2.13
4	#5860.00	67.5 PK	74.0	-6.5	1.04 H	220	65.37	2.13
5	#5860.00	52.6 AV	54.0	-1.4	1.04 H	220	50.47	2.13
6	11650.00	60.1 PK	74.0	-13.9	2.39 H	90	47.65	12.45
7	11650.00	41.6 AV	54.0	-12.4	2.39 H	90	29.15	12.45
8	#17475.00	57.9 PK	74.0	-16.1	1.56 H	216	39.15	18.75
9	#17475.00	45.9 AV	54.0	-8.1	1.56 H	216	27.15	18.75

ANTENNA POLARITY & TEST DISTANCE: VERTICAL AT 3 M

NO.	FREQ. (MHz)	EMISSION LEVEL (dBuV/m)	LIMIT (dBuV/m)	MARGIN (dB)	ANTENNA HEIGHT (m)	TABLE ANGLE (Degree)	RAW VALUE (dBuV)	CORRECTION FACTOR (dB/m)
1	*5825.00	104.5 PK			2.75 V	287	102.38	2.12
2	*5825.00	92.5 AV			2.75 V	287	90.38	2.12
3	#5850.00	64.3 PK	78.2	-13.9	2.75 V	287	62.17	2.13
4	#5860.00	60.9 PK	74.0	-13.1	2.75 V	287	58.77	2.13
5	#5860.00	46.6 AV	54.0	-7.4	2.75 V	287	44.47	2.13
6	11650.00	53.6 PK	74.0	-20.4	1.50 V	207	41.15	12.45
7	11650.00	40.9 AV	54.0	-13.1	1.50 V	207	28.45	12.45
8	#17475.00	55.9 PK	74.0	-18.1	1.51 V	186	37.15	18.75
9	#17475.00	43.4 AV	54.0	-10.6	1.51 V	186	24.65	18.75

REMARKS:

1. Emission Level(dBuV/m) = Raw Value(dBuV) + Correction Factor(dB/m)
2. Correction Factor(dB/m) = Antenna Factor(dB/m) + Cable Factor(dB) – Pre-Amplifier Factor(dB)
3. The other emission levels were very low against the limit.
4. Margin value = Emission Level – Limit value
5. " * ": Fundamental frequency.
6. " # ": The radiated frequency is out of the restricted band.

802.11ac VHT20

CHANNEL	TX Channel 36	DETECTOR FUNCTION	Peak (PK)
FREQUENCY RANGE	1GHz ~ 40GHz		Average (AV)

ANTENNA POLARITY & TEST DISTANCE: HORIZONTAL AT 3 M								
NO.	FREQ. (MHz)	EMISSION LEVEL (dBuV/m)	LIMIT (dBuV/m)	MARGIN (dB)	ANTENNA HEIGHT (m)	TABLE ANGLE (Degree)	RAW VALUE (dBuV)	CORRECTION FACTOR (dB/m)
1	5150.00	66.6 PK	74.0	-7.4	1.00 H	223	65.03	1.57
2	5150.00	52.3 AV	54.0	-1.7	1.00 H	223	50.73	1.57
3	*5180.00	111.5 PK			1.00 H	223	109.82	1.68
4	*5180.00	98.5 AV			1.00 H	223	96.82	1.68
5	#10360.00	60.3 PK	74.0	-13.7	2.34 H	95	48.58	11.72
6	#10360.00	41.7 AV	54.0	-12.3	2.34 H	95	29.98	11.72
7	15540.00	58.0 PK	74.0	-16.0	1.51 H	196	44.70	13.30
8	15540.00	45.9 AV	54.0	-8.1	1.51 H	196	32.60	13.30

ANTENNA POLARITY & TEST DISTANCE: VERTICAL AT 3 M								
NO.	FREQ. (MHz)	EMISSION LEVEL (dBuV/m)	LIMIT (dBuV/m)	MARGIN (dB)	ANTENNA HEIGHT (m)	TABLE ANGLE (Degree)	RAW VALUE (dBuV)	CORRECTION FACTOR (dB/m)
1	5150.00	60.4 PK	74.0	-13.6	2.78 V	287	58.83	1.57
2	5150.00	46.8 AV	54.0	-7.2	2.78 V	287	45.23	1.57
3	*5180.00	107.4 PK			2.78 V	287	105.72	1.68
4	*5180.00	94.9 AV			2.78 V	287	93.22	1.68
5	#10360.00	53.3 PK	74.0	-20.7	1.59 V	229	41.58	11.72
6	#10360.00	40.4 AV	54.0	-13.6	1.59 V	229	28.68	11.72
7	15540.00	56.8 PK	74.0	-17.2	1.50 V	188	43.50	13.30
8	15540.00	44.0 AV	54.0	-10.0	1.50 V	188	30.70	13.30

REMARKS:

- Emission Level(dBuV/m) = Raw Value(dBuV) + Correction Factor(dB/m)
- Correction Factor(dB/m) = Antenna Factor(dB/m) + Cable Factor(dB) – Pre-Amplifier Factor(dB)
- The other emission levels were very low against the limit.
- Margin value = Emission Level – Limit value
- " * ": Fundamental frequency.
- " # ": The radiated frequency is out of the restricted band.



CHANNEL	TX Channel 40	DETECTOR FUNCTION	Peak (PK)
FREQUENCY RANGE	1GHz ~ 40GHz		Average (AV)

ANTENNA POLARITY & TEST DISTANCE: HORIZONTAL AT 3 M

NO.	FREQ. (MHz)	EMISSION LEVEL (dBuV/m)	LIMIT (dBuV/m)	MARGIN (dB)	ANTENNA HEIGHT (m)	TABLE ANGLE (Degree)	RAW VALUE (dBuV)	CORRECTION FACTOR (dB/m)
1	5150.00	62.1 PK	74.0	-11.9	1.06 H	222	60.53	1.57
2	5150.00	48.0 AV	54.0	-6.0	1.06 H	222	46.43	1.57
3	*5200.00	112.9 PK			1.06 H	222	111.16	1.74
4	*5200.00	100.2 AV			1.06 H	222	98.46	1.74
5	#10400.00	60.3 PK	74.0	-13.7	2.32 H	104	48.38	11.92
6	#10400.00	41.7 AV	54.0	-12.3	2.32 H	104	29.78	11.92
7	15600.00	58.7 PK	74.0	-15.3	1.56 H	193	45.40	13.30
8	15600.00	46.4 AV	54.0	-7.6	1.56 H	193	33.10	13.30

ANTENNA POLARITY & TEST DISTANCE: VERTICAL AT 3 M

NO.	FREQ. (MHz)	EMISSION LEVEL (dBuV/m)	LIMIT (dBuV/m)	MARGIN (dB)	ANTENNA HEIGHT (m)	TABLE ANGLE (Degree)	RAW VALUE (dBuV)	CORRECTION FACTOR (dB/m)
1	5150.00	54.6 PK	74.0	-19.4	2.73 V	291	53.03	1.57
2	5150.00	42.9 AV	54.0	-11.1	2.73 V	291	41.33	1.57
3	*5200.00	108.7 PK			2.73 V	291	106.96	1.74
4	*5200.00	96.7 AV			2.73 V	291	94.96	1.74
5	#10400.00	53.2 PK	74.0	-20.8	1.60 V	207	41.28	11.92
6	#10400.00	40.1 AV	54.0	-13.9	1.60 V	207	28.18	11.92
7	15600.00	56.5 PK	74.0	-17.5	1.54 V	200	43.20	13.30
8	15600.00	43.7 AV	54.0	-10.3	1.54 V	200	30.40	13.30

REMARKS:

1. Emission Level(dBuV/m) = Raw Value(dBuV) + Correction Factor(dB/m)
2. Correction Factor(dB/m) = Antenna Factor(dB/m) + Cable Factor(dB) – Pre-Amplifier Factor(dB)
3. The other emission levels were very low against the limit.
4. Margin value = Emission Level – Limit value
5. " * ": Fundamental frequency.
6. " # ": The radiated frequency is out of the restricted band.

CHANNEL	TX Channel 48	DETECTOR FUNCTION	Peak (PK)
FREQUENCY RANGE	1GHz ~ 40GHz		Average (AV)

ANTENNA POLARITY & TEST DISTANCE: HORIZONTAL AT 3 M

NO.	FREQ. (MHz)	EMISSION LEVEL (dBuV/m)	LIMIT (dBuV/m)	MARGIN (dB)	ANTENNA HEIGHT (m)	TABLE ANGLE (Degree)	RAW VALUE (dBuV)	CORRECTION FACTOR (dB/m)
1	*5240.00	113.7 PK			1.09 H	230	111.85	1.85
2	*5240.00	100.0 AV			1.09 H	230	98.15	1.85
3	5350.00	54.6 PK	74.0	-19.4	1.09 H	230	52.49	2.11
4	5350.00	41.3 AV	54.0	-12.7	1.09 H	230	39.19	2.11
5	#10480.00	60.0 PK	74.0	-14.0	2.34 H	88	47.74	12.26
6	#10480.00	41.2 AV	54.0	-12.8	2.34 H	88	28.94	12.26
7	15720.00	58.8 PK	74.0	-15.2	1.58 H	195	45.62	13.18
8	15720.00	46.6 AV	54.0	-7.4	1.58 H	195	33.42	13.18

ANTENNA POLARITY & TEST DISTANCE: VERTICAL AT 3 M

NO.	FREQ. (MHz)	EMISSION LEVEL (dBuV/m)	LIMIT (dBuV/m)	MARGIN (dB)	ANTENNA HEIGHT (m)	TABLE ANGLE (Degree)	RAW VALUE (dBuV)	CORRECTION FACTOR (dB/m)
1	*5240.00	109.4 PK			2.69 V	302	107.55	1.85
2	*5240.00	97.1 AV			2.69 V	302	95.25	1.85
3	5350.00	54.3 PK	74.0	-19.7	2.69 V	302	52.19	2.11
4	5350.00	42.5 AV	54.0	-11.5	2.69 V	302	40.39	2.11
5	#10480.00	53.1 PK	74.0	-20.9	1.60 V	202	40.84	12.26
6	#10480.00	39.9 AV	54.0	-14.1	1.60 V	202	27.64	12.26
7	15720.00	56.9 PK	74.0	-17.1	1.54 V	198	43.72	13.18
8	15720.00	44.1 AV	54.0	-9.9	1.54 V	198	30.92	13.18

REMARKS:

1. Emission Level(dBuV/m) = Raw Value(dBuV) + Correction Factor(dB/m)
2. Correction Factor(dB/m) = Antenna Factor(dB/m) + Cable Factor(dB) – Pre-Amplifier Factor(dB)
3. The other emission levels were very low against the limit.
4. Margin value = Emission Level – Limit value
5. " * ": Fundamental frequency.
6. " # ": The radiated frequency is out of the restricted band.

CHANNEL	TX Channel 52	DETECTOR FUNCTION	Peak (PK)
FREQUENCY RANGE	1GHz ~ 40GHz		Average (AV)

ANTENNA POLARITY & TEST DISTANCE: HORIZONTAL AT 3 M

NO.	FREQ. (MHz)	EMISSION LEVEL (dBuV/m)	LIMIT (dBuV/m)	MARGIN (dB)	ANTENNA HEIGHT (m)	TABLE ANGLE (Degree)	RAW VALUE (dBuV)	CORRECTION FACTOR (dB/m)
1	*5260.00	113.2 PK			1.02 H	246	111.27	1.93
2	*5260.00	100.4 AV			1.02 H	246	98.47	1.93
3	5350.00	53.7 PK	74.0	-20.3	1.02 H	246	51.59	2.11
4	5350.00	41.0 AV	54.0	-13.0	1.02 H	246	38.89	2.11
5	#10520.00	60.2 PK	74.0	-13.8	2.31 H	98	47.78	12.42
6	#10520.00	41.7 AV	54.0	-12.3	2.31 H	98	29.28	12.42
7	15780.00	58.7 PK	74.0	-15.3	1.57 H	204	45.58	13.12
8	15780.00	46.3 AV	54.0	-7.7	1.57 H	204	33.18	13.12

ANTENNA POLARITY & TEST DISTANCE: VERTICAL AT 3 M

NO.	FREQ. (MHz)	EMISSION LEVEL (dBuV/m)	LIMIT (dBuV/m)	MARGIN (dB)	ANTENNA HEIGHT (m)	TABLE ANGLE (Degree)	RAW VALUE (dBuV)	CORRECTION FACTOR (dB/m)
1	*5260.00	109.0 PK			2.79 V	280	107.07	1.93
2	*5260.00	96.7 AV			2.79 V	280	94.77	1.93
3	5350.00	54.3 PK	74.0	-19.7	2.79 V	280	52.19	2.11
4	5350.00	42.9 AV	54.0	-11.1	2.79 V	280	40.79	2.11
5	#10520.00	53.1 PK	74.0	-20.9	1.54 V	202	40.68	12.42
6	#10520.00	39.7 AV	54.0	-14.3	1.54 V	202	27.28	12.42
7	15780.00	56.3 PK	74.0	-17.7	1.53 V	186	43.18	13.12
8	15780.00	43.8 AV	54.0	-10.2	1.53 V	186	30.68	13.12

REMARKS:

1. Emission Level(dBuV/m) = Raw Value(dBuV) + Correction Factor(dB/m)
2. Correction Factor(dB/m) = Antenna Factor(dB/m) + Cable Factor(dB) – Pre-Amplifier Factor(dB)
3. The other emission levels were very low against the limit.
4. Margin value = Emission Level – Limit value
5. " * ": Fundamental frequency.
6. " # ": The radiated frequency is out of the restricted band.

CHANNEL	TX Channel 60	DETECTOR FUNCTION	Peak (PK)
FREQUENCY RANGE	1GHz ~ 40GHz		Average (AV)

ANTENNA POLARITY & TEST DISTANCE: HORIZONTAL AT 3 M

NO.	FREQ. (MHz)	EMISSION LEVEL (dBuV/m)	LIMIT (dBuV/m)	MARGIN (dB)	ANTENNA HEIGHT (m)	TABLE ANGLE (Degree)	RAW VALUE (dBuV)	CORRECTION FACTOR (dB/m)
1	*5300.00	113.3 PK			1.00 H	250	111.26	2.04
2	*5300.00	100.4 AV			1.00 H	250	98.36	2.04
3	5350.00	60.1 PK	74.0	-13.9	1.00 H	250	57.99	2.11
4	5350.00	47.4 AV	54.0	-6.6	1.00 H	250	45.29	2.11
5	10600.00	60.3 PK	74.0	-13.7	2.30 H	111	47.61	12.69
6	10600.00	41.4 AV	54.0	-12.6	2.30 H	111	28.71	12.69
7	15900.00	58.5 PK	74.0	-15.5	1.49 H	196	45.11	13.39
8	15900.00	46.4 AV	54.0	-7.6	1.49 H	196	33.01	13.39

ANTENNA POLARITY & TEST DISTANCE: VERTICAL AT 3 M

NO.	FREQ. (MHz)	EMISSION LEVEL (dBuV/m)	LIMIT (dBuV/m)	MARGIN (dB)	ANTENNA HEIGHT (m)	TABLE ANGLE (Degree)	RAW VALUE (dBuV)	CORRECTION FACTOR (dB/m)
1	*5300.00	109.1 PK			2.77 V	279	107.06	2.04
2	*5300.00	97.0 AV			2.77 V	279	94.96	2.04
3	5350.00	54.5 PK	74.0	-19.5	2.77 V	279	52.39	2.11
4	5350.00	42.8 AV	54.0	-11.2	2.77 V	279	40.69	2.11
5	10600.00	53.6 PK	74.0	-20.4	1.60 V	232	40.91	12.69
6	10600.00	40.4 AV	54.0	-13.6	1.60 V	232	27.71	12.69
7	15900.00	56.0 PK	74.0	-18.0	1.47 V	192	42.61	13.39
8	15900.00	43.3 AV	54.0	-10.7	1.47 V	192	29.91	13.39

REMARKS:

1. Emission Level(dBuV/m) = Raw Value(dBuV) + Correction Factor(dB/m)
2. Correction Factor(dB/m) = Antenna Factor(dB/m) + Cable Factor(dB) – Pre-Amplifier Factor(dB)
3. The other emission levels were very low against the limit.
4. Margin value = Emission Level – Limit value
5. " * ": Fundamental frequency.

CHANNEL	TX Channel 64	DETECTOR FUNCTION	Peak (PK)
FREQUENCY RANGE	1GHz ~ 40GHz		Average (AV)

ANTENNA POLARITY & TEST DISTANCE: HORIZONTAL AT 3 M

NO.	FREQ. (MHz)	EMISSION LEVEL (dBuV/m)	LIMIT (dBuV/m)	MARGIN (dB)	ANTENNA HEIGHT (m)	TABLE ANGLE (Degree)	RAW VALUE (dBuV)	CORRECTION FACTOR (dB/m)
1	*5320.00	111.4 PK			1.02 H	243	109.33	2.07
2	*5320.00	98.8 AV			1.02 H	243	96.73	2.07
3	5350.00	65.2 PK	74.0	-8.8	1.02 H	243	63.09	2.11
4	5350.00	52.3 AV	54.0	-1.7	1.02 H	243	50.19	2.11
5	10640.00	60.1 PK	74.0	-13.9	2.33 H	107	47.44	12.66
6	10640.00	41.3 AV	54.0	-12.7	2.33 H	107	28.64	12.66
7	15960.00	59.1 PK	74.0	-14.9	1.52 H	214	45.93	13.17
8	15960.00	46.7 AV	54.0	-7.3	1.52 H	214	33.53	13.17

ANTENNA POLARITY & TEST DISTANCE: VERTICAL AT 3 M

NO.	FREQ. (MHz)	EMISSION LEVEL (dBuV/m)	LIMIT (dBuV/m)	MARGIN (dB)	ANTENNA HEIGHT (m)	TABLE ANGLE (Degree)	RAW VALUE (dBuV)	CORRECTION FACTOR (dB/m)
1	*5320.00	107.8 PK			2.78 V	279	105.73	2.07
2	*5320.00	95.9 AV			2.78 V	279	93.83	2.07
3	5350.00	62.3 PK	74.0	-11.7	2.78 V	279	60.19	2.11
4	5350.00	47.0 AV	54.0	-7.0	2.78 V	279	44.89	2.11
5	10640.00	52.7 PK	74.0	-21.3	1.50 V	224	40.04	12.66
6	10640.00	40.3 AV	54.0	-13.7	1.50 V	224	27.64	12.66
7	15960.00	58.0 PK	74.0	-16.0	1.50 V	185	44.83	13.17
8	15960.00	44.6 AV	54.0	-9.4	1.50 V	185	31.43	13.17

REMARKS:

1. Emission Level(dBuV/m) = Raw Value(dBuV) + Correction Factor(dB/m)
2. Correction Factor(dB/m) = Antenna Factor(dB/m) + Cable Factor(dB) – Pre-Amplifier Factor(dB)
3. The other emission levels were very low against the limit.
4. Margin value = Emission Level – Limit value
5. " * ": Fundamental frequency.

CHANNEL	TX Channel 100	DETECTOR FUNCTION	Peak (PK)
FREQUENCY RANGE	1GHz ~ 40GHz		Average (AV)

ANTENNA POLARITY & TEST DISTANCE: HORIZONTAL AT 3 M

NO.	FREQ. (MHz)	EMISSION LEVEL (dBuV/m)	LIMIT (dBuV/m)	MARGIN (dB)	ANTENNA HEIGHT (m)	TABLE ANGLE (Degree)	RAW VALUE (dBuV)	CORRECTION FACTOR (dB/m)
1	#5470.00	69.6 PK	74.0	-4.4	1.04 H	224	67.34	2.26
2	#5470.00	52.6 AV	54.0	-1.4	1.04 H	224	50.34	2.26
3	*5500.00	110.2 PK			1.04 H	224	107.90	2.30
4	*5500.00	97.6 AV			1.04 H	224	95.30	2.30
5	11000.00	59.4 PK	74.0	-14.6	2.29 H	106	45.94	13.46
6	11000.00	40.9 AV	54.0	-13.1	2.29 H	106	27.44	13.46
7	#16500.00	58.8 PK	74.0	-15.2	1.54 H	220	43.14	15.66
8	#16500.00	46.3 AV	54.0	-7.7	1.54 H	220	30.64	15.66

ANTENNA POLARITY & TEST DISTANCE: VERTICAL AT 3 M

NO.	FREQ. (MHz)	EMISSION LEVEL (dBuV/m)	LIMIT (dBuV/m)	MARGIN (dB)	ANTENNA HEIGHT (m)	TABLE ANGLE (Degree)	RAW VALUE (dBuV)	CORRECTION FACTOR (dB/m)
1	#5470.00	61.7 PK	74.0	-12.3	2.78 V	292	59.44	2.26
2	#5470.00	47.0 AV	54.0	-7.0	2.78 V	292	44.74	2.26
3	*5500.00	107.3 PK			2.78 V	292	105.00	2.30
4	*5500.00	95.5 AV			2.78 V	292	93.20	2.30
5	11000.00	52.5 PK	74.0	-21.5	1.54 V	210	39.04	13.46
6	11000.00	40.2 AV	54.0	-13.8	1.54 V	210	26.74	13.46
7	#16500.00	57.4 PK	74.0	-16.6	1.50 V	182	41.74	15.66
8	#16500.00	44.5 AV	54.0	-9.5	1.50 V	182	28.84	15.66

REMARKS:

1. Emission Level(dBuV/m) = Raw Value(dBuV) + Correction Factor(dB/m)
2. Correction Factor(dB/m) = Antenna Factor(dB/m) + Cable Factor(dB) – Pre-Amplifier Factor(dB)
3. The other emission levels were very low against the limit.
4. Margin value = Emission Level – Limit value
5. " * ": Fundamental frequency.
6. " # ": The radiated frequency is out of the restricted band.

CHANNEL	TX Channel 116	DETECTOR FUNCTION	Peak (PK)
FREQUENCY RANGE	1GHz ~ 40GHz		Average (AV)

ANTENNA POLARITY & TEST DISTANCE: HORIZONTAL AT 3 M

NO.	FREQ. (MHz)	EMISSION LEVEL (dBuV/m)	LIMIT (dBuV/m)	MARGIN (dB)	ANTENNA HEIGHT (m)	TABLE ANGLE (Degree)	RAW VALUE (dBuV)	CORRECTION FACTOR (dB/m)
1	*5580.00	109.1 PK			1.01 H	227	106.60	2.50
2	*5580.00	96.4 AV			1.01 H	227	93.90	2.50
3	#5725.00	52.5 PK	74.0	-21.5	1.01 H	227	49.72	2.78
4	#5725.00	40.2 AV	54.0	-13.8	1.01 H	227	37.42	2.78
5	11160.00	59.8 PK	74.0	-14.2	2.32 H	90	46.49	13.31
6	11160.00	41.0 AV	54.0	-13.0	2.32 H	90	27.69	13.31
7	#16740.00	59.2 PK	74.0	-14.8	1.51 H	219	42.85	16.35
8	#16740.00	46.7 AV	54.0	-7.3	1.51 H	219	30.35	16.35

ANTENNA POLARITY & TEST DISTANCE: VERTICAL AT 3 M

NO.	FREQ. (MHz)	EMISSION LEVEL (dBuV/m)	LIMIT (dBuV/m)	MARGIN (dB)	ANTENNA HEIGHT (m)	TABLE ANGLE (Degree)	RAW VALUE (dBuV)	CORRECTION FACTOR (dB/m)
1	*5580.00	106.6 PK			2.73 V	296	104.10	2.50
2	*5580.00	96.2 AV			2.73 V	296	93.70	2.50
3	#5725.00	48.5 PK	74.0	-25.5	2.73 V	296	45.72	2.78
4	#5725.00	34.5 AV	54.0	-19.5	2.73 V	296	31.72	2.78
5	11160.00	53.1 PK	74.0	-20.9	1.54 V	214	39.79	13.31
6	11160.00	40.4 AV	54.0	-13.6	1.54 V	214	27.09	13.31
7	#16740.00	57.7 PK	74.0	-16.3	1.49 V	188	41.35	16.35
8	#16740.00	45.0 AV	54.0	-9.0	1.49 V	188	28.65	16.35

REMARKS:

1. Emission Level(dBuV/m) = Raw Value(dBuV) + Correction Factor(dB/m)
2. Correction Factor(dB/m) = Antenna Factor(dB/m) + Cable Factor(dB) – Pre-Amplifier Factor(dB)
3. The other emission levels were very low against the limit.
4. Margin value = Emission Level – Limit value
5. " * ": Fundamental frequency.
6. " # ": The radiated frequency is out of the restricted band.

CHANNEL	TX Channel 140	DETECTOR FUNCTION	Peak (PK)
FREQUENCY RANGE	1GHz ~ 40GHz		Average (AV)

ANTENNA POLARITY & TEST DISTANCE: HORIZONTAL AT 3 M

NO.	FREQ. (MHz)	EMISSION LEVEL (dBuV/m)	LIMIT (dBuV/m)	MARGIN (dB)	ANTENNA HEIGHT (m)	TABLE ANGLE (Degree)	RAW VALUE (dBuV)	CORRECTION FACTOR (dB/m)
1	*5700.00	106.5 PK			1.00 H	226	103.76	2.74
2	*5700.00	94.3 AV			1.00 H	226	91.56	2.74
3	#5725.00	67.9 PK	74.0	-6.1	1.00 H	226	65.12	2.78
4	#5725.00	52.7 AV	54.0	-1.3	1.00 H	226	49.92	2.78
5	11400.00	60.0 PK	74.0	-14.0	2.32 H	103	46.64	13.36
6	11400.00	41.1 AV	54.0	-12.9	2.32 H	103	27.74	13.36
7	#17100.00	58.3 PK	74.0	-15.7	1.59 H	209	40.33	17.97
8	#17100.00	45.8 AV	54.0	-8.2	1.59 H	209	27.83	17.97

ANTENNA POLARITY & TEST DISTANCE: VERTICAL AT 3 M

NO.	FREQ. (MHz)	EMISSION LEVEL (dBuV/m)	LIMIT (dBuV/m)	MARGIN (dB)	ANTENNA HEIGHT (m)	TABLE ANGLE (Degree)	RAW VALUE (dBuV)	CORRECTION FACTOR (dB/m)
1	*5700.00	102.3 PK			2.71 V	273	99.56	2.74
2	*5700.00	91.1 AV			2.71 V	273	88.36	2.74
3	#5725.00	61.3 PK	74.0	-12.7	2.71 V	273	58.52	2.78
4	#5725.00	46.5 AV	54.0	-7.5	2.71 V	273	43.72	2.78
5	11400.00	53.9 PK	74.0	-20.1	1.57 V	212	40.54	13.36
6	11400.00	40.5 AV	54.0	-13.5	1.57 V	212	27.14	13.36
7	#17100.00	56.1 PK	74.0	-17.9	1.49 V	195	38.13	17.97
8	#17100.00	43.5 AV	54.0	-10.5	1.49 V	195	25.53	17.97

REMARKS:

1. Emission Level(dBuV/m) = Raw Value(dBuV) + Correction Factor(dB/m)
2. Correction Factor(dB/m) = Antenna Factor(dB/m) + Cable Factor(dB) – Pre-Amplifier Factor(dB)
3. The other emission levels were very low against the limit.
4. Margin value = Emission Level – Limit value
5. " * ": Fundamental frequency.
6. " # ": The radiated frequency is out of the restricted band.

CHANNEL	TX Channel 144	DETECTOR FUNCTION	Peak (PK)
FREQUENCY RANGE	1GHz ~ 40GHz		Average (AV)

ANTENNA POLARITY & TEST DISTANCE: HORIZONTAL AT 3 M

NO.	FREQ. (MHz)	EMISSION LEVEL (dBuV/m)	LIMIT (dBuV/m)	MARGIN (dB)	ANTENNA HEIGHT (m)	TABLE ANGLE (Degree)	RAW VALUE (dBuV)	CORRECTION FACTOR (dB/m)
1	#5470.00	53.1 PK	74.0	-20.9	1.01 H	221	50.84	2.26
2	#5470.00	40.5 AV	54.0	-13.5	1.01 H	221	38.24	2.26
3	*5720.00	109.1 PK			1.01 H	221	106.33	2.77
4	*5720.00	96.5 AV			1.01 H	221	93.73	2.77
5	#5850.00	52.8 PK	74.0	-21.2	1.01 H	221	49.86	2.94
6	#5850.00	40.1 AV	54.0	-13.9	1.01 H	221	37.16	2.94
7	11440.00	60.2 PK	74.0	-13.8	2.38 H	104	46.80	13.40
8	11440.00	41.6 AV	54.0	-12.4	2.38 H	104	28.20	13.40
9	#17160.00	58.9 PK	74.0	-15.1	1.59 H	204	40.73	18.17
10	#17160.00	46.5 AV	54.0	-7.5	1.59 H	204	28.33	18.17

ANTENNA POLARITY & TEST DISTANCE: VERTICAL AT 3 M

NO.	FREQ. (MHz)	EMISSION LEVEL (dBuV/m)	LIMIT (dBuV/m)	MARGIN (dB)	ANTENNA HEIGHT (m)	TABLE ANGLE (Degree)	RAW VALUE (dBuV)	CORRECTION FACTOR (dB/m)
1	#5470.00	45.7 PK	74.0	-28.3	2.73 V	271	43.44	2.26
2	#5470.00	34.0 AV	54.0	-20.0	2.73 V	271	31.74	2.26
3	*5720.00	107.1 PK			2.73 V	271	104.33	2.77
4	*5720.00	97.2 AV			2.73 V	271	94.43	2.77
5	#5850.00	45.2 PK	74.0	-28.8	1.00 V	0	42.26	2.94
6	#5850.00	34.2 AV	54.0	-19.8	1.00 V	0	31.26	2.94
7	11440.00	53.3 PK	74.0	-20.7	1.58 V	205	39.90	13.40
8	11440.00	40.5 AV	54.0	-13.5	1.58 V	205	27.10	13.40
9	#17160.00	56.0 PK	74.0	-18.0	1.47 V	198	37.83	18.17
10	#17160.00	43.6 AV	54.0	-10.4	1.47 V	198	25.43	18.17

REMARKS:

1. Emission Level(dBuV/m) = Raw Value(dBuV) + Correction Factor(dB/m)
2. Correction Factor(dB/m) = Antenna Factor(dB/m) + Cable Factor(dB) – Pre-Amplifier Factor(dB)
3. The other emission levels were very low against the limit.
4. Margin value = Emission Level – Limit value
5. " * ": Fundamental frequency.
6. " # ": The radiated frequency is out of the restricted band.

CHANNEL	TX Channel 149	DETECTOR FUNCTION	Peak (PK)
FREQUENCY RANGE	1GHz ~ 40GHz		Average (AV)

ANTENNA POLARITY & TEST DISTANCE: HORIZONTAL AT 3 M

NO.	FREQ. (MHz)	EMISSION LEVEL (dBuV/m)	LIMIT (dBuV/m)	MARGIN (dB)	ANTENNA HEIGHT (m)	TABLE ANGLE (Degree)	RAW VALUE (dBuV)	CORRECTION FACTOR (dB/m)
1	#5715.00	63.9 PK	74.0	-10.1	1.00 H	225	61.98	1.92
2	#5715.00	48.9 AV	54.0	-5.1	1.00 H	225	46.98	1.92
3	#5725.00	76.8 PK	78.2	-1.4	1.00 H	225	74.87	1.93
4	*5745.00	106.4 PK			1.00 H	225	104.42	1.98
5	*5745.00	94.3 AV			1.00 H	225	92.32	1.98
6	11490.00	60.0 PK	74.0	-14.0	2.29 H	113	47.13	12.87
7	11490.00	41.0 AV	54.0	-13.0	2.29 H	113	28.13	12.87
8	#17235.00	58.2 PK	74.0	-15.8	1.55 H	197	40.64	17.56
9	#17235.00	46.1 AV	54.0	-7.9	1.55 H	197	28.54	17.56

ANTENNA POLARITY & TEST DISTANCE: VERTICAL AT 3 M

NO.	FREQ. (MHz)	EMISSION LEVEL (dBuV/m)	LIMIT (dBuV/m)	MARGIN (dB)	ANTENNA HEIGHT (m)	TABLE ANGLE (Degree)	RAW VALUE (dBuV)	CORRECTION FACTOR (dB/m)
1	#5715.00	59.7 PK	74.0	-14.3	2.78 V	284	57.78	1.92
2	#5715.00	44.7 AV	54.0	-9.3	2.78 V	284	42.78	1.92
3	#5725.00	69.8 PK	78.2	-8.4	2.78 V	284	67.87	1.93
4	*5745.00	104.1 PK			2.78 V	284	102.12	1.98
5	*5745.00	92.7 AV			2.78 V	284	90.72	1.98
6	11490.00	53.2 PK	74.0	-20.8	1.58 V	219	40.33	12.87
7	11490.00	40.7 AV	54.0	-13.3	1.58 V	219	27.83	12.87
8	#17235.00	57.5 PK	74.0	-16.5	1.48 V	205	39.94	17.56
9	#17235.00	44.0 AV	54.0	-10.0	1.48 V	205	26.44	17.56

REMARKS:

1. Emission Level(dBuV/m) = Raw Value(dBuV) + Correction Factor(dB/m)
2. Correction Factor(dB/m) = Antenna Factor(dB/m) + Cable Factor(dB) – Pre-Amplifier Factor(dB)
3. The other emission levels were very low against the limit.
4. Margin value = Emission Level – Limit value
5. " * ": Fundamental frequency.
6. " # ": The radiated frequency is out of the restricted band.

CHANNEL	TX Channel 157	DETECTOR FUNCTION	Peak (PK)
FREQUENCY RANGE	1GHz ~ 40GHz		Average (AV)

ANTENNA POLARITY & TEST DISTANCE: HORIZONTAL AT 3 M

NO.	FREQ. (MHz)	EMISSION LEVEL (dBuV/m)	LIMIT (dBuV/m)	MARGIN (dB)	ANTENNA HEIGHT (m)	TABLE ANGLE (Degree)	RAW VALUE (dBuV)	CORRECTION FACTOR (dB/m)
1	#5715.00	62.6 PK	74.0	-11.4	1.00 H	223	60.68	1.92
2	#5715.00	42.8 AV	54.0	-11.2	1.00 H	223	40.88	1.92
3	#5725.00	63.8 PK	78.2	-14.4	1.00 H	223	61.87	1.93
4	*5785.00	109.7 PK			1.00 H	223	107.64	2.06
5	*5785.00	96.1 AV			1.00 H	223	94.04	2.06
6	#5850.00	58.1 PK	78.2	-20.1	1.00 H	223	55.97	2.13
7	#5860.00	53.3 PK	74.0	-20.7	1.00 H	223	51.17	2.13
8	#5860.00	41.7 AV	54.0	-12.3	1.00 H	223	39.57	2.13
9	11570.00	60.2 PK	74.0	-13.8	2.35 H	114	47.58	12.62
10	11570.00	41.3 AV	54.0	-12.7	2.35 H	114	28.68	12.62
11	#17355.00	58.5 PK	74.0	-15.5	1.59 H	210	40.32	18.18
12	#17355.00	46.0 AV	54.0	-8.0	1.59 H	210	27.82	18.18

ANTENNA POLARITY & TEST DISTANCE: VERTICAL AT 3 M

NO.	FREQ. (MHz)	EMISSION LEVEL (dBuV/m)	LIMIT (dBuV/m)	MARGIN (dB)	ANTENNA HEIGHT (m)	TABLE ANGLE (Degree)	RAW VALUE (dBuV)	CORRECTION FACTOR (dB/m)
1	#5715.00	50.7 PK	74.0	-23.3	2.79 V	290	48.78	1.92
2	#5715.00	36.5 AV	54.0	-17.5	2.79 V	290	34.58	1.92
3	#5725.00	54.2 PK	78.2	-24.0	2.79 V	290	52.27	1.93
4	*5785.00	104.7 PK			2.79 V	290	102.64	2.06
5	*5785.00	94.8 AV			2.79 V	290	92.74	2.06
6	#5850.00	50.6 PK	78.2	-27.6	2.79 V	290	48.47	2.13
7	#5860.00	47.5 PK	74.0	-26.5	2.79 V	290	45.37	2.13
8	#5860.00	34.8 AV	54.0	-19.2	2.79 V	290	32.67	2.13
9	11570.00	53.2 PK	74.0	-20.8	1.52 V	223	40.58	12.62
10	11570.00	40.7 AV	54.0	-13.3	1.52 V	223	28.08	12.62
11	#17355.00	56.3 PK	74.0	-17.7	1.59 V	182	38.12	18.18
12	#17355.00	43.5 AV	54.0	-10.5	1.59 V	182	25.32	18.18

REMARKS:

1. Emission Level(dBuV/m) = Raw Value(dBuV) + Correction Factor(dB/m)
2. Correction Factor(dB/m) = Antenna Factor(dB/m) + Cable Factor(dB) – Pre-Amplifier Factor(dB)
3. The other emission levels were very low against the limit.
4. Margin value = Emission Level – Limit value
5. " * ": Fundamental frequency.
6. " # ": The radiated frequency is out of the restricted band.

CHANNEL	TX Channel 165	DETECTOR FUNCTION	Peak (PK)
FREQUENCY RANGE	1GHz ~ 40GHz		Average (AV)

ANTENNA POLARITY & TEST DISTANCE: HORIZONTAL AT 3 M

NO.	FREQ. (MHz)	EMISSION LEVEL (dBuV/m)	LIMIT (dBuV/m)	MARGIN (dB)	ANTENNA HEIGHT (m)	TABLE ANGLE (Degree)	RAW VALUE (dBuV)	CORRECTION FACTOR (dB/m)
1	*5825.00	107.2 PK			1.00 H	225	105.08	2.12
2	*5825.00	95.1 AV			1.00 H	225	92.98	2.12
3	#5850.00	76.6 PK	78.2	-1.6	1.00 H	225	74.47	2.13
4	#5860.00	61.5 PK	74.0	-12.5	1.00 H	225	59.37	2.13
5	#5860.00	48.8 AV	54.0	-5.2	1.00 H	225	46.67	2.13
6	11650.00	60.5 PK	74.0	-13.5	2.31 H	92	48.05	12.45
7	11650.00	41.6 AV	54.0	-12.4	2.31 H	92	29.15	12.45
8	#17475.00	59.0 PK	74.0	-15.0	1.59 H	191	40.25	18.75
9	#17475.00	46.8 AV	54.0	-7.2	1.59 H	191	28.05	18.75

ANTENNA POLARITY & TEST DISTANCE: VERTICAL AT 3 M

NO.	FREQ. (MHz)	EMISSION LEVEL (dBuV/m)	LIMIT (dBuV/m)	MARGIN (dB)	ANTENNA HEIGHT (m)	TABLE ANGLE (Degree)	RAW VALUE (dBuV)	CORRECTION FACTOR (dB/m)
1	*5825.00	102.4 PK			2.79 V	289	100.28	2.12
2	*5825.00	91.4 AV			2.79 V	289	89.28	2.12
3	#5850.00	69.4 PK	78.2	-8.8	2.79 V	289	67.27	2.13
4	#5860.00	55.8 PK	74.0	-18.2	2.79 V	289	53.67	2.13
5	#5860.00	43.2 AV	54.0	-10.8	2.79 V	289	41.07	2.13
6	11650.00	53.2 PK	74.0	-20.8	1.60 V	210	40.75	12.45
7	11650.00	40.1 AV	54.0	-13.9	1.60 V	210	27.65	12.45
8	#17475.00	57.3 PK	74.0	-16.7	1.48 V	200	38.55	18.75
9	#17475.00	44.6 AV	54.0	-9.4	1.48 V	200	25.85	18.75

REMARKS:

1. Emission Level(dBuV/m) = Raw Value(dBuV) + Correction Factor(dB/m)
2. Correction Factor(dB/m) = Antenna Factor(dB/m) + Cable Factor(dB) – Pre-Amplifier Factor(dB)
3. The other emission levels were very low against the limit.
4. Margin value = Emission Level – Limit value
5. " * ": Fundamental frequency.
6. " # ": The radiated frequency is out of the restricted band.

802.11ac VHT40

CHANNEL	TX Channel 38	DETECTOR FUNCTION	Peak (PK)
FREQUENCY RANGE	1GHz ~ 40GHz		Average (AV)

ANTENNA POLARITY & TEST DISTANCE: HORIZONTAL AT 3 M

NO.	FREQ. (MHz)	EMISSION LEVEL (dBuV/m)	LIMIT (dBuV/m)	MARGIN (dB)	ANTENNA HEIGHT (m)	TABLE ANGLE (Degree)	RAW VALUE (dBuV)	CORRECTION FACTOR (dB/m)
1	5150.00	67.6 PK	74.0	-6.4	1.04 H	221	66.03	1.57
2	5150.00	52.4 AV	54.0	-1.6	1.04 H	221	50.83	1.57
3	*5190.00	106.3 PK			1.04 H	221	104.59	1.71
4	*5190.00	89.5 AV			1.04 H	221	87.79	1.71
5	5350.00	52.1 PK	74.0	-21.9	1.04 H	221	49.99	2.11
6	5350.00	40.2 AV	54.0	-13.8	1.04 H	221	38.09	2.11
7	#10380.00	59.8 PK	74.0	-14.2	2.29 H	117	47.98	11.82
8	#10380.00	40.9 AV	54.0	-13.1	2.29 H	117	29.08	11.82
9	15570.00	59.0 PK	74.0	-15.0	1.58 H	200	45.70	13.30
10	15570.00	46.7 AV	54.0	-7.3	1.58 H	200	33.40	13.30

ANTENNA POLARITY & TEST DISTANCE: VERTICAL AT 3 M

NO.	FREQ. (MHz)	EMISSION LEVEL (dBuV/m)	LIMIT (dBuV/m)	MARGIN (dB)	ANTENNA HEIGHT (m)	TABLE ANGLE (Degree)	RAW VALUE (dBuV)	CORRECTION FACTOR (dB/m)
1	5150.00	62.0 PK	74.0	-12.0	2.76 V	290	60.43	1.57
2	5150.00	47.7 AV	54.0	-6.3	2.76 V	290	46.13	1.57
3	*5190.00	103.0 PK			2.76 V	290	101.29	1.71
4	*5190.00	87.2 AV			2.76 V	290	85.49	1.71
5	5350.00	45.9 PK	74.0	-28.1	2.76 V	290	43.79	2.11
6	5350.00	35.0 AV	54.0	-19.0	2.76 V	290	32.89	2.11
7	#10380.00	52.6 PK	74.0	-21.4	1.51 V	221	40.78	11.82
8	#10380.00	40.0 AV	54.0	-14.0	1.51 V	221	28.18	11.82
9	15570.00	56.1 PK	74.0	-17.9	1.50 V	209	42.80	13.30
10	15570.00	43.3 AV	54.0	-10.7	1.50 V	209	30.00	13.30

REMARKS:

- Emission Level(dBuV/m) = Raw Value(dBuV) + Correction Factor(dB/m)
- Correction Factor(dB/m) = Antenna Factor(dB/m) + Cable Factor(dB) – Pre-Amplifier Factor(dB)
- The other emission levels were very low against the limit.
- Margin value = Emission Level – Limit value
- " * ": Fundamental frequency.
- " # ": The radiated frequency is out of the restricted band.

CHANNEL	TX Channel 46	DETECTOR FUNCTION	Peak (PK)
FREQUENCY RANGE	1GHz ~ 40GHz		Average (AV)

ANTENNA POLARITY & TEST DISTANCE: HORIZONTAL AT 3 M

NO.	FREQ. (MHz)	EMISSION LEVEL (dBuV/m)	LIMIT (dBuV/m)	MARGIN (dB)	ANTENNA HEIGHT (m)	TABLE ANGLE (Degree)	RAW VALUE (dBuV)	CORRECTION FACTOR (dB/m)
1	5150.00	62.0 PK	74.0	-12.0	1.04 H	221	60.43	1.57
2	5150.00	49.3 AV	54.0	-4.7	1.04 H	221	47.73	1.57
3	*5230.00	110.1 PK			1.04 H	221	108.27	1.83
4	*5230.00	95.8 AV			1.04 H	221	93.97	1.83
5	5350.00	56.5 PK	74.0	-17.5	1.04 H	221	54.39	2.11
6	5350.00	43.2 AV	54.0	-10.8	1.04 H	221	41.09	2.11
7	#10460.00	59.7 PK	74.0	-14.3	2.40 H	107	47.52	12.18
8	#10460.00	41.1 AV	54.0	-12.9	2.40 H	107	28.92	12.18
9	15690.00	58.2 PK	74.0	-15.8	1.58 H	196	44.98	13.22
10	15690.00	46.1 AV	54.0	-7.9	1.58 H	196	32.88	13.22

ANTENNA POLARITY & TEST DISTANCE: VERTICAL AT 3 M

NO.	FREQ. (MHz)	EMISSION LEVEL (dBuV/m)	LIMIT (dBuV/m)	MARGIN (dB)	ANTENNA HEIGHT (m)	TABLE ANGLE (Degree)	RAW VALUE (dBuV)	CORRECTION FACTOR (dB/m)
1	5150.00	56.0 PK	74.0	-18.0	2.77 V	284	54.43	1.57
2	5150.00	44.3 AV	54.0	-9.7	2.77 V	284	42.73	1.57
3	*5230.00	106.4 PK			2.77 V	284	104.57	1.83
4	*5230.00	92.9 AV			2.77 V	284	91.07	1.83
5	5350.00	50.9 PK	74.0	-23.1	2.77 V	284	48.79	2.11
6	5350.00	38.3 AV	54.0	-15.7	2.77 V	284	36.19	2.11
7	#10460.00	53.9 PK	74.0	-20.1	1.49 V	219	41.72	12.18
8	#10460.00	40.4 AV	54.0	-13.6	1.49 V	219	28.22	12.18
9	15690.00	57.2 PK	74.0	-16.8	1.57 V	204	43.98	13.22
10	15690.00	44.1 AV	54.0	-9.9	1.57 V	204	30.88	13.22

REMARKS:

1. Emission Level(dBuV/m) = Raw Value(dBuV) + Correction Factor(dB/m)
2. Correction Factor(dB/m) = Antenna Factor(dB/m) + Cable Factor(dB) – Pre-Amplifier Factor(dB)
3. The other emission levels were very low against the limit.
4. Margin value = Emission Level – Limit value
5. " * ": Fundamental frequency.
6. " # ": The radiated frequency is out of the restricted band.

CHANNEL	TX Channel 54	DETECTOR FUNCTION	Peak (PK)
FREQUENCY RANGE	1GHz ~ 40GHz		Average (AV)

ANTENNA POLARITY & TEST DISTANCE: HORIZONTAL AT 3 M

NO.	FREQ. (MHz)	EMISSION LEVEL (dBuV/m)	LIMIT (dBuV/m)	MARGIN (dB)	ANTENNA HEIGHT (m)	TABLE ANGLE (Degree)	RAW VALUE (dBuV)	CORRECTION FACTOR (dB/m)
1	*5270.00	110.7 PK			1.04 H	222	108.75	1.95
2	*5270.00	96.1 AV			1.04 H	222	94.15	1.95
3	5350.00	64.9 PK	74.0	-9.1	1.04 H	222	62.79	2.11
4	5350.00	51.8 AV	54.0	-2.2	1.04 H	222	49.69	2.11
5	#10540.00	60.6 PK	74.0	-13.4	2.36 H	97	48.11	12.49
6	#10540.00	41.7 AV	54.0	-12.3	2.36 H	97	29.21	12.49
7	15810.00	58.0 PK	74.0	-16.0	1.56 H	222	44.88	13.12
8	15810.00	45.8 AV	54.0	-8.2	1.56 H	222	32.68	13.12

ANTENNA POLARITY & TEST DISTANCE: VERTICAL AT 3 M

NO.	FREQ. (MHz)	EMISSION LEVEL (dBuV/m)	LIMIT (dBuV/m)	MARGIN (dB)	ANTENNA HEIGHT (m)	TABLE ANGLE (Degree)	RAW VALUE (dBuV)	CORRECTION FACTOR (dB/m)
1	*5270.00	106.8 PK			2.80 V	281	104.85	1.95
2	*5270.00	93.1 AV			2.80 V	281	91.15	1.95
3	5350.00	59.2 PK	74.0	-14.8	1.00 V	0	57.09	2.11
4	5350.00	47.1 AV	54.0	-6.9	1.00 V	0	44.99	2.11
5	#10540.00	53.7 PK	74.0	-20.3	1.52 V	225	41.21	12.49
6	#10540.00	41.1 AV	54.0	-12.9	1.52 V	225	28.61	12.49
7	15810.00	56.8 PK	74.0	-17.2	1.50 V	211	43.68	13.12
8	15810.00	43.9 AV	54.0	-10.1	1.50 V	211	30.78	13.12

REMARKS:

1. Emission Level(dBuV/m) = Raw Value(dBuV) + Correction Factor(dB/m)
2. Correction Factor(dB/m) = Antenna Factor(dB/m) + Cable Factor(dB) – Pre-Amplifier Factor(dB)
3. The other emission levels were very low against the limit.
4. Margin value = Emission Level – Limit value
5. " * ": Fundamental frequency.
6. " # ": The radiated frequency is out of the restricted band.

CHANNEL	TX Channel 62	DETECTOR FUNCTION	Peak (PK)
FREQUENCY RANGE	1GHz ~ 40GHz		Average (AV)

ANTENNA POLARITY & TEST DISTANCE: HORIZONTAL AT 3 M

NO.	FREQ. (MHz)	EMISSION LEVEL (dBuV/m)	LIMIT (dBuV/m)	MARGIN (dB)	ANTENNA HEIGHT (m)	TABLE ANGLE (Degree)	RAW VALUE (dBuV)	CORRECTION FACTOR (dB/m)
1	*5310.00	105.4 PK			1.02 H	223	103.35	2.05
2	*5310.00	91.9 AV			1.02 H	223	89.85	2.05
3	5350.00	68.2 PK	74.0	-5.8	1.02 H	223	66.09	2.11
4	5350.00	52.4 AV	54.0	-1.6	1.02 H	223	50.29	2.11
5	10620.00	60.2 PK	74.0	-13.8	2.34 H	108	47.53	12.67
6	10620.00	41.5 AV	54.0	-12.5	2.34 H	108	28.83	12.67
7	15930.00	58.4 PK	74.0	-15.6	1.53 H	198	45.13	13.27
8	15930.00	46.3 AV	54.0	-7.7	1.53 H	198	33.03	13.27

ANTENNA POLARITY & TEST DISTANCE: VERTICAL AT 3 M

NO.	FREQ. (MHz)	EMISSION LEVEL (dBuV/m)	LIMIT (dBuV/m)	MARGIN (dB)	ANTENNA HEIGHT (m)	TABLE ANGLE (Degree)	RAW VALUE (dBuV)	CORRECTION FACTOR (dB/m)
1	*5310.00	102.2 PK			2.81 V	289	100.15	2.05
2	*5310.00	89.5 AV			2.81 V	289	87.45	2.05
3	5350.00	62.1 PK	74.0	-11.9	2.81 V	289	59.99	2.11
4	5350.00	46.9 AV	54.0	-7.1	2.81 V	289	44.79	2.11
5	10620.00	53.2 PK	74.0	-20.8	1.58 V	233	40.53	12.67
6	10620.00	40.3 AV	54.0	-13.7	1.58 V	233	27.63	12.67
7	15930.00	57.7 PK	74.0	-16.3	1.55 V	183	44.43	13.27
8	15930.00	44.6 AV	54.0	-9.4	1.55 V	183	31.33	13.27

REMARKS:

1. Emission Level(dBuV/m) = Raw Value(dBuV) + Correction Factor(dB/m)
2. Correction Factor(dB/m) = Antenna Factor(dB/m) + Cable Factor(dB) – Pre-Amplifier Factor(dB)
3. The other emission levels were very low against the limit.
4. Margin value = Emission Level – Limit value
5. " * ": Fundamental frequency.

CHANNEL	TX Channel 102	DETECTOR FUNCTION	Peak (PK)
FREQUENCY RANGE	1GHz ~ 40GHz		Average (AV)

ANTENNA POLARITY & TEST DISTANCE: HORIZONTAL AT 3 M

NO.	FREQ. (MHz)	EMISSION LEVEL (dBuV/m)	LIMIT (dBuV/m)	MARGIN (dB)	ANTENNA HEIGHT (m)	TABLE ANGLE (Degree)	RAW VALUE (dBuV)	CORRECTION FACTOR (dB/m)
1	#5470.00	68.2 PK	74.0	-5.8	1.03 H	225	65.94	2.26
2	#5470.00	52.4 AV	54.0	-1.6	1.03 H	225	50.14	2.26
3	*5510.00	104.8 PK			1.03 H	225	102.48	2.32
4	*5510.00	90.9 AV			1.03 H	225	88.58	2.32
5	11020.00	60.6 PK	74.0	-13.4	2.39 H	99	47.19	13.41
6	11020.00	41.7 AV	54.0	-12.3	2.39 H	99	28.29	13.41
7	#16530.00	59.2 PK	74.0	-14.8	1.53 H	209	43.35	15.85
8	#16530.00	46.7 AV	54.0	-7.3	1.53 H	209	30.85	15.85

ANTENNA POLARITY & TEST DISTANCE: VERTICAL AT 3 M

NO.	FREQ. (MHz)	EMISSION LEVEL (dBuV/m)	LIMIT (dBuV/m)	MARGIN (dB)	ANTENNA HEIGHT (m)	TABLE ANGLE (Degree)	RAW VALUE (dBuV)	CORRECTION FACTOR (dB/m)
1	#5470.00	62.2 PK	74.0	-11.8	2.78 V	292	59.94	2.26
2	#5470.00	47.1 AV	54.0	-6.9	2.78 V	292	44.84	2.26
3	*5510.00	100.8 PK			2.78 V	292	98.48	2.32
4	*5510.00	87.7 AV			2.78 V	292	85.38	2.32
5	11020.00	53.1 PK	74.0	-20.9	1.50 V	233	39.69	13.41
6	11020.00	40.5 AV	54.0	-13.5	1.50 V	233	27.09	13.41
7	#16530.00	56.9 PK	74.0	-17.1	1.52 V	208	41.05	15.85
8	#16530.00	43.9 AV	54.0	-10.1	1.52 V	208	28.05	15.85

REMARKS:

1. Emission Level(dBuV/m) = Raw Value(dBuV) + Correction Factor(dB/m)
2. Correction Factor(dB/m) = Antenna Factor(dB/m) + Cable Factor(dB) – Pre-Amplifier Factor(dB)
3. The other emission levels were very low against the limit.
4. Margin value = Emission Level – Limit value
5. " * ": Fundamental frequency.
6. " # ": The radiated frequency is out of the restricted band.

CHANNEL	TX Channel 110	DETECTOR FUNCTION	Peak (PK)
FREQUENCY RANGE	1GHz ~ 40GHz		Average (AV)

ANTENNA POLARITY & TEST DISTANCE: HORIZONTAL AT 3 M

NO.	FREQ. (MHz)	EMISSION LEVEL (dBuV/m)	LIMIT (dBuV/m)	MARGIN (dB)	ANTENNA HEIGHT (m)	TABLE ANGLE (Degree)	RAW VALUE (dBuV)	CORRECTION FACTOR (dB/m)
1	#5470.00	71.1 PK	74.0	-2.9	1.03 H	224	68.84	2.26
2	#5470.00	52.2 AV	54.0	-1.8	1.03 H	224	49.94	2.26
3	*5550.00	108.4 PK			1.03 H	224	105.98	2.42
4	*5550.00	94.4 AV			1.03 H	224	91.98	2.42
5	11100.00	60.0 PK	74.0	-14.0	2.31 H	90	46.77	13.23
6	11100.00	41.4 AV	54.0	-12.6	2.31 H	90	28.17	13.23
7	#16650.00	58.4 PK	74.0	-15.6	1.50 H	207	42.26	16.14
8	#16650.00	46.4 AV	54.0	-7.6	1.50 H	207	30.26	16.14

ANTENNA POLARITY & TEST DISTANCE: VERTICAL AT 3 M

NO.	FREQ. (MHz)	EMISSION LEVEL (dBuV/m)	LIMIT (dBuV/m)	MARGIN (dB)	ANTENNA HEIGHT (m)	TABLE ANGLE (Degree)	RAW VALUE (dBuV)	CORRECTION FACTOR (dB/m)
1	#5470.00	65.8 PK	74.0	-8.2	2.72 V	276	63.54	2.26
2	#5470.00	47.1 AV	54.0	-6.9	2.72 V	276	44.84	2.26
3	*5550.00	104.6 PK			2.72 V	276	102.18	2.42
4	*5550.00	91.7 AV			2.72 V	276	89.28	2.42
5	11100.00	53.3 PK	74.0	-20.7	1.51 V	229	40.07	13.23
6	11100.00	40.8 AV	54.0	-13.2	1.51 V	229	27.57	13.23
7	#16650.00	56.7 PK	74.0	-17.3	1.56 V	210	40.56	16.14
8	#16650.00	43.7 AV	54.0	-10.3	1.56 V	210	27.56	16.14

REMARKS:

1. Emission Level(dBuV/m) = Raw Value(dBuV) + Correction Factor(dB/m)
2. Correction Factor(dB/m) = Antenna Factor(dB/m) + Cable Factor(dB) – Pre-Amplifier Factor(dB)
3. The other emission levels were very low against the limit.
4. Margin value = Emission Level – Limit value
5. " * ": Fundamental frequency.
6. " # ": The radiated frequency is out of the restricted band.

CHANNEL	TX Channel 134	DETECTOR FUNCTION	Peak (PK)
FREQUENCY RANGE	1GHz ~ 40GHz		Average (AV)

ANTENNA POLARITY & TEST DISTANCE: HORIZONTAL AT 3 M

NO.	FREQ. (MHz)	EMISSION LEVEL (dBuV/m)	LIMIT (dBuV/m)	MARGIN (dB)	ANTENNA HEIGHT (m)	TABLE ANGLE (Degree)	RAW VALUE (dBuV)	CORRECTION FACTOR (dB/m)
1	*5670.00	106.1 PK			1.01 H	220	103.42	2.68
2	*5670.00	92.2 AV			1.01 H	220	89.52	2.68
3	#5725.00	65.8 PK	74.0	-8.2	1.01 H	220	63.02	2.78
4	#5725.00	52.4 AV	54.0	-1.6	1.01 H	220	49.62	2.78
5	11340.00	60.3 PK	74.0	-13.7	2.39 H	110	46.54	13.76
6	11340.00	41.8 AV	54.0	-12.2	2.39 H	110	28.04	13.76
7	#17010.00	58.7 PK	74.0	-15.3	1.50 H	197	40.93	17.77
8	#17010.00	46.6 AV	54.0	-7.4	1.50 H	197	28.83	17.77

ANTENNA POLARITY & TEST DISTANCE: VERTICAL AT 3 M

NO.	FREQ. (MHz)	EMISSION LEVEL (dBuV/m)	LIMIT (dBuV/m)	MARGIN (dB)	ANTENNA HEIGHT (m)	TABLE ANGLE (Degree)	RAW VALUE (dBuV)	CORRECTION FACTOR (dB/m)
1	*5670.00	103.0 PK			2.78 V	289	100.32	2.68
2	*5670.00	89.8 AV			2.78 V	289	87.12	2.68
3	#5725.00	60.2 PK	74.0	-13.8	2.78 V	289	57.42	2.78
4	#5725.00	47.7 AV	54.0	-6.3	2.78 V	289	44.92	2.78
5	11340.00	53.1 PK	74.0	-20.9	1.50 V	232	39.34	13.76
6	11340.00	40.3 AV	54.0	-13.7	1.50 V	232	26.54	13.76
7	#17010.00	56.3 PK	74.0	-17.7	1.53 V	187	38.53	17.77
8	#17010.00	43.7 AV	54.0	-10.3	1.53 V	187	25.93	17.77

REMARKS:

1. Emission Level(dBuV/m) = Raw Value(dBuV) + Correction Factor(dB/m)
2. Correction Factor(dB/m) = Antenna Factor(dB/m) + Cable Factor(dB) – Pre-Amplifier Factor(dB)
3. The other emission levels were very low against the limit.
4. Margin value = Emission Level – Limit value
5. " * ": Fundamental frequency.
6. " # ": The radiated frequency is out of the restricted band.

CHANNEL	TX Channel 142	DETECTOR FUNCTION	Peak (PK)
FREQUENCY RANGE	1GHz ~ 40GHz		Average (AV)

ANTENNA POLARITY & TEST DISTANCE: HORIZONTAL AT 3 M

NO.	FREQ. (MHz)	EMISSION LEVEL (dBuV/m)	LIMIT (dBuV/m)	MARGIN (dB)	ANTENNA HEIGHT (m)	TABLE ANGLE (Degree)	RAW VALUE (dBuV)	CORRECTION FACTOR (dB/m)
1	#5470.00	55.4 PK	74.0	-18.6	1.01 H	236	53.14	2.26
2	#5470.00	43.7 AV	54.0	-10.3	1.01 H	236	41.44	2.26
3	*5710.00	108.5 PK			1.01 H	236	105.75	2.75
4	*5710.00	94.4 AV			1.01 H	236	91.65	2.75
5	#5850.00	55.3 PK	74.0	-18.7	1.01 H	236	52.36	2.94
6	#5850.00	43.3 AV	54.0	-10.7	1.01 H	236	40.36	2.94
7	11420.00	60.7 PK	74.0	-13.3	2.40 H	105	47.31	13.39
8	11420.00	41.6 AV	54.0	-12.4	2.40 H	105	28.21	13.39
9	#17130.00	58.7 PK	74.0	-15.3	1.57 H	208	40.64	18.06
10	#17130.00	46.1 AV	54.0	-7.9	1.57 H	208	28.04	18.06

ANTENNA POLARITY & TEST DISTANCE: VERTICAL AT 3 M

NO.	FREQ. (MHz)	EMISSION LEVEL (dBuV/m)	LIMIT (dBuV/m)	MARGIN (dB)	ANTENNA HEIGHT (m)	TABLE ANGLE (Degree)	RAW VALUE (dBuV)	CORRECTION FACTOR (dB/m)
1	#5470.00	49.9 PK	74.0	-24.1	2.82 V	276	47.64	2.26
2	#5470.00	39.2 AV	54.0	-14.8	2.82 V	276	36.94	2.26
3	*5710.00	104.8 PK			2.82 V	276	102.05	2.75
4	*5710.00	91.9 AV			2.82 V	276	89.15	2.75
5	#5850.00	49.6 PK	74.0	-24.4	2.82 V	276	46.66	2.94
6	#5850.00	38.3 AV	54.0	-15.7	2.82 V	276	35.36	2.94
7	11420.00	53.7 PK	74.0	-20.3	1.53 V	218	40.31	13.39
8	11420.00	40.9 AV	54.0	-13.1	1.53 V	218	27.51	13.39
9	#17130.00	56.6 PK	74.0	-17.4	1.50 V	188	38.54	18.06
10	#17130.00	43.9 AV	54.0	-10.1	1.50 V	188	25.84	18.06

REMARKS:

1. Emission Level(dBuV/m) = Raw Value(dBuV) + Correction Factor(dB/m)
2. Correction Factor(dB/m) = Antenna Factor(dB/m) + Cable Factor(dB) – Pre-Amplifier Factor(dB)
3. The other emission levels were very low against the limit.
4. Margin value = Emission Level – Limit value
5. " * ": Fundamental frequency.
6. " # ": The radiated frequency is out of the restricted band.

CHANNEL	TX Channel 151	DETECTOR FUNCTION	Peak (PK)
FREQUENCY RANGE	1GHz ~ 40GHz		Average (AV)

ANTENNA POLARITY & TEST DISTANCE: HORIZONTAL AT 3 M

NO.	FREQ. (MHz)	EMISSION LEVEL (dBuV/m)	LIMIT (dBuV/m)	MARGIN (dB)	ANTENNA HEIGHT (m)	TABLE ANGLE (Degree)	RAW VALUE (dBuV)	CORRECTION FACTOR (dB/m)
1	#5715.00	67.6 PK	74.0	-6.4	1.02 H	221	65.68	1.92
2	#5715.00	52.5 AV	54.0	-1.5	1.02 H	221	50.58	1.92
3	#5725.00	69.5 PK	78.2	-8.7	1.02 H	221	67.57	1.93
4	*5755.00	102.0 PK			1.02 H	221	100.00	2.00
5	*5755.00	88.3 AV			1.02 H	221	86.30	2.00
6	11510.00	60.5 PK	74.0	-13.5	2.39 H	91	47.67	12.83
7	11510.00	41.5 AV	54.0	-12.5	2.39 H	91	28.67	12.83
8	#17265.00	58.4 PK	74.0	-15.6	1.52 H	206	40.75	17.65
9	#17265.00	46.1 AV	54.0	-7.9	1.52 H	206	28.45	17.65

ANTENNA POLARITY & TEST DISTANCE: VERTICAL AT 3 M

NO.	FREQ. (MHz)	EMISSION LEVEL (dBuV/m)	LIMIT (dBuV/m)	MARGIN (dB)	ANTENNA HEIGHT (m)	TABLE ANGLE (Degree)	RAW VALUE (dBuV)	CORRECTION FACTOR (dB/m)
1	#5715.00	61.7 PK	74.0	-12.3	2.76 V	293	59.78	1.92
2	#5715.00	47.0 AV	54.0	-7.0	2.76 V	293	45.08	1.92
3	#5725.00	64.2 PK	78.2	-14.0	2.76 V	293	62.27	1.93
4	*5755.00	98.6 PK			2.76 V	293	96.60	2.00
5	*5755.00	86.1 AV			2.76 V	293	84.10	2.00
6	11510.00	54.4 PK	74.0	-19.6	1.49 V	217	41.57	12.83
7	11510.00	41.4 AV	54.0	-12.6	1.49 V	217	28.57	12.83
8	#17265.00	57.2 PK	74.0	-16.8	1.54 V	206	39.55	17.65
9	#17265.00	44.1 AV	54.0	-9.9	1.54 V	206	26.45	17.65

REMARKS:

1. Emission Level(dBuV/m) = Raw Value(dBuV) + Correction Factor(dB/m)
2. Correction Factor(dB/m) = Antenna Factor(dB/m) + Cable Factor(dB) – Pre-Amplifier Factor(dB)
3. The other emission levels were very low against the limit.
4. Margin value = Emission Level – Limit value
5. " * ": Fundamental frequency.
6. " # ": The radiated frequency is out of the restricted band.

CHANNEL	TX Channel 159	DETECTOR FUNCTION	Peak (PK)
FREQUENCY RANGE	1GHz ~ 40GHz		Average (AV)

ANTENNA POLARITY & TEST DISTANCE: HORIZONTAL AT 3 M

NO.	FREQ. (MHz)	EMISSION LEVEL (dBuV/m)	LIMIT (dBuV/m)	MARGIN (dB)	ANTENNA HEIGHT (m)	TABLE ANGLE (Degree)	RAW VALUE (dBuV)	CORRECTION FACTOR (dB/m)
1	*5795.00	106.1 PK			1.02 H	223	104.01	2.09
2	*5795.00	91.7 AV			1.02 H	223	89.61	2.09
3	#5850.00	71.8 PK	78.2	-6.4	1.02 H	223	69.67	2.13
4	#5860.00	67.7 PK	74.0	-6.3	1.02 H	223	65.57	2.13
5	#5860.00	52.3 AV	54.0	-1.7	1.02 H	223	50.17	2.13
6	11590.00	59.9 PK	74.0	-14.1	2.32 H	95	47.35	12.55
7	11590.00	41.2 AV	54.0	-12.8	2.32 H	95	28.65	12.55
8	#17385.00	58.3 PK	74.0	-15.7	1.51 H	215	39.91	18.39
9	#17385.00	46.0 AV	54.0	-8.0	1.51 H	215	27.61	18.39

ANTENNA POLARITY & TEST DISTANCE: VERTICAL AT 3 M

NO.	FREQ. (MHz)	EMISSION LEVEL (dBuV/m)	LIMIT (dBuV/m)	MARGIN (dB)	ANTENNA HEIGHT (m)	TABLE ANGLE (Degree)	RAW VALUE (dBuV)	CORRECTION FACTOR (dB/m)
1	*5795.00	102.4 PK			2.76 V	274	100.31	2.09
2	*5795.00	88.9 AV			2.76 V	274	86.81	2.09
3	#5850.00	65.8 PK	78.2	-12.4	2.76 V	274	63.67	2.13
4	#5860.00	62.0 PK	74.0	-12.0	2.76 V	274	59.87	2.13
5	#5860.00	47.3 AV	54.0	-6.7	2.76 V	274	45.17	2.13
6	11590.00	53.6 PK	74.0	-20.4	1.59 V	213	41.05	12.55
7	11590.00	40.6 AV	54.0	-13.4	1.59 V	213	28.05	12.55
8	#17385.00	55.7 PK	74.0	-18.3	1.56 V	201	37.31	18.39
9	#17385.00	43.0 AV	54.0	-11.0	1.56 V	201	24.61	18.39

REMARKS:

1. Emission Level(dBuV/m) = Raw Value(dBuV) + Correction Factor(dB/m)
2. Correction Factor(dB/m) = Antenna Factor(dB/m) + Cable Factor(dB) – Pre-Amplifier Factor(dB)
3. The other emission levels were very low against the limit.
4. Margin value = Emission Level – Limit value
5. " * ": Fundamental frequency.
6. " # ": The radiated frequency is out of the restricted band.

802.11ac VHT80

CHANNEL	TX Channel 42	DETECTOR FUNCTION	Peak (PK)
FREQUENCY RANGE	1GHz ~ 40GHz		Average (AV)

ANTENNA POLARITY & TEST DISTANCE: HORIZONTAL AT 3 M

NO.	FREQ. (MHz)	EMISSION LEVEL (dBuV/m)	LIMIT (dBuV/m)	MARGIN (dB)	ANTENNA HEIGHT (m)	TABLE ANGLE (Degree)	RAW VALUE (dBuV)	CORRECTION FACTOR (dB/m)
1	5150.00	68.2 PK	74.0	-5.8	1.02 H	220	66.63	1.57
2	5150.00	52.7 AV	54.0	-1.3	1.02 H	220	51.13	1.57
3	*5210.00	103.8 PK			1.02 H	220	102.03	1.77
4	*5210.00	88.3 AV			1.02 H	220	86.53	1.77
5	5350.00	54.7 PK	74.0	-19.3	1.02 H	220	52.59	2.11
6	5350.00	42.9 AV	54.0	-11.1	1.02 H	220	40.79	2.11
7	#10420.00	60.1 PK	74.0	-13.9	2.30 H	101	48.09	12.01
8	#10420.00	41.3 AV	54.0	-12.7	2.30 H	101	29.29	12.01
9	15630.00	58.3 PK	74.0	-15.7	1.51 H	203	45.03	13.27
10	15630.00	46.1 AV	54.0	-7.9	1.51 H	203	32.83	13.27

ANTENNA POLARITY & TEST DISTANCE: VERTICAL AT 3 M

NO.	FREQ. (MHz)	EMISSION LEVEL (dBuV/m)	LIMIT (dBuV/m)	MARGIN (dB)	ANTENNA HEIGHT (m)	TABLE ANGLE (Degree)	RAW VALUE (dBuV)	CORRECTION FACTOR (dB/m)
1	5150.00	65.4 PK	74.0	-8.6	2.72 V	266	63.83	1.57
2	5150.00	48.4 AV	54.0	-5.6	2.72 V	266	46.83	1.57
3	*5210.00	101.6 PK			2.72 V	266	99.83	1.77
4	*5210.00	87.1 AV			2.72 V	266	85.33	1.77
5	5350.00	49.8 PK	74.0	-24.2	2.72 V	266	47.69	2.11
6	5350.00	38.9 AV	54.0	-15.1	2.72 V	266	36.79	2.11
7	#10420.00	53.1 PK	74.0	-20.9	1.54 V	204	41.09	12.01
8	#10420.00	40.3 AV	54.0	-13.7	1.54 V	204	28.29	12.01
9	15630.00	56.8 PK	74.0	-17.2	1.48 V	185	43.53	13.27
10	15630.00	44.2 AV	54.0	-9.8	1.48 V	185	30.93	13.27

REMARKS:

- Emission Level(dBuV/m) = Raw Value(dBuV) + Correction Factor(dB/m)
- Correction Factor(dB/m) = Antenna Factor(dB/m) + Cable Factor(dB) – Pre-Amplifier Factor(dB)
- The other emission levels were very low against the limit.
- Margin value = Emission Level – Limit value
- " * ": Fundamental frequency.
- " # ": The radiated frequency is out of the restricted band.

CHANNEL	TX Channel 58	DETECTOR FUNCTION	Peak (PK)
FREQUENCY RANGE	1GHz ~ 40GHz		Average (AV)

ANTENNA POLARITY & TEST DISTANCE: HORIZONTAL AT 3 M

NO.	FREQ. (MHz)	EMISSION LEVEL (dBuV/m)	LIMIT (dBuV/m)	MARGIN (dB)	ANTENNA HEIGHT (m)	TABLE ANGLE (Degree)	RAW VALUE (dBuV)	CORRECTION FACTOR (dB/m)
1	5150.00	57.7 PK	74.0	-16.3	1.02 H	218	56.13	1.57
2	5150.00	44.6 AV	54.0	-9.4	1.02 H	218	43.03	1.57
3	*5290.00	102.3 PK			1.02 H	218	100.29	2.01
4	*5290.00	86.9 AV			1.02 H	218	84.89	2.01
5	5350.00	68.6 PK	74.0	-5.4	1.02 H	218	66.49	2.11
6	5350.00	52.5 AV	54.0	-1.5	1.02 H	218	50.39	2.11
7	#10580.00	59.8 PK	74.0	-14.2	2.38 H	109	47.17	12.63
8	#10580.00	41.1 AV	54.0	-12.9	2.38 H	109	28.47	12.63
9	15870.00	58.5 PK	74.0	-15.5	1.51 H	208	45.20	13.30
10	15870.00	46.2 AV	54.0	-7.8	1.51 H	208	32.90	13.30

ANTENNA POLARITY & TEST DISTANCE: VERTICAL AT 3 M

NO.	FREQ. (MHz)	EMISSION LEVEL (dBuV/m)	LIMIT (dBuV/m)	MARGIN (dB)	ANTENNA HEIGHT (m)	TABLE ANGLE (Degree)	RAW VALUE (dBuV)	CORRECTION FACTOR (dB/m)
1	5150.00	53.1 PK	74.0	-20.9	2.81 V	288	51.53	1.57
2	5150.00	41.0 AV	54.0	-13.0	2.81 V	288	39.43	1.57
3	*5290.00	99.5 PK			2.81 V	288	97.49	2.01
4	*5290.00	85.0 AV			2.81 V	288	82.99	2.01
5	5350.00	64.1 PK	74.0	-9.9	2.81 V	288	61.99	2.11
6	5350.00	48.5 AV	54.0	-5.5	2.81 V	288	46.39	2.11
7	#10580.00	53.4 PK	74.0	-20.6	1.49 V	217	40.77	12.63
8	#10580.00	40.8 AV	54.0	-13.2	1.49 V	217	28.17	12.63
9	15870.00	57.1 PK	74.0	-16.9	1.55 V	189	43.80	13.30
10	15870.00	43.9 AV	54.0	-10.1	1.55 V	189	30.60	13.30

REMARKS:

1. Emission Level(dBuV/m) = Raw Value(dBuV) + Correction Factor(dB/m)
2. Correction Factor(dB/m) = Antenna Factor(dB/m) + Cable Factor(dB) – Pre-Amplifier Factor(dB)
3. The other emission levels were very low against the limit.
4. Margin value = Emission Level – Limit value
5. " * ": Fundamental frequency.
6. " # ": The radiated frequency is out of the restricted band.

CHANNEL	TX Channel 106	DETECTOR FUNCTION	Peak (PK)
FREQUENCY RANGE	1GHz ~ 40GHz		Average (AV)

ANTENNA POLARITY & TEST DISTANCE: HORIZONTAL AT 3 M

NO.	FREQ. (MHz)	EMISSION LEVEL (dBuV/m)	LIMIT (dBuV/m)	MARGIN (dB)	ANTENNA HEIGHT (m)	TABLE ANGLE (Degree)	RAW VALUE (dBuV)	CORRECTION FACTOR (dB/m)
1	#5470.00	68.0 PK	74.0	-6.0	1.02 H	222	65.74	2.26
2	#5470.00	52.4 AV	54.0	-1.6	1.02 H	222	50.14	2.26
3	*5530.00	102.0 PK			1.02 H	222	99.63	2.37
4	*5530.00	86.6 AV			1.02 H	222	84.23	2.37
5	#5725.00	52.1 PK	74.0	-21.9	1.02 H	222	49.32	2.78
6	#5725.00	40.2 AV	54.0	-13.8	1.02 H	222	37.42	2.78
7	11060.00	59.8 PK	74.0	-14.2	2.39 H	104	46.48	13.32
8	11060.00	40.9 AV	54.0	-13.1	2.39 H	104	27.58	13.32
9	#16590.00	58.8 PK	74.0	-15.2	1.60 H	193	42.58	16.22
10	#16590.00	46.6 AV	54.0	-7.4	1.60 H	193	30.38	16.22

ANTENNA POLARITY & TEST DISTANCE: VERTICAL AT 3 M

NO.	FREQ. (MHz)	EMISSION LEVEL (dBuV/m)	LIMIT (dBuV/m)	MARGIN (dB)	ANTENNA HEIGHT (m)	TABLE ANGLE (Degree)	RAW VALUE (dBuV)	CORRECTION FACTOR (dB/m)
1	#5470.00	63.0 PK	74.0	-11.0	2.75 V	264	60.74	2.26
2	#5470.00	48.2 AV	54.0	-5.8	2.75 V	264	45.94	2.26
3	*5530.00	98.9 PK			2.75 V	264	96.53	2.37
4	*5530.00	84.5 AV			2.75 V	264	82.13	2.37
5	#5725.00	47.5 PK	74.0	-26.5	2.75 V	264	44.72	2.78
6	#5725.00	36.7 AV	54.0	-17.3	2.75 V	264	33.92	2.78
7	11060.00	53.0 PK	74.0	-21.0	1.59 V	229	39.68	13.32
8	11060.00	40.1 AV	54.0	-13.9	1.59 V	229	26.78	13.32
9	#16590.00	57.4 PK	74.0	-16.6	1.55 V	211	41.18	16.22
10	#16590.00	44.1 AV	54.0	-9.9	1.55 V	211	27.88	16.22

REMARKS:

1. Emission Level(dBuV/m) = Raw Value(dBuV) + Correction Factor(dB/m)
2. Correction Factor(dB/m) = Antenna Factor(dB/m) + Cable Factor(dB) – Pre-Amplifier Factor(dB)
3. The other emission levels were very low against the limit.
4. Margin value = Emission Level – Limit value
5. " * ": Fundamental frequency.
6. " # ": The radiated frequency is out of the restricted band.

CHANNEL	TX Channel 122	DETECTOR FUNCTION	Peak (PK)
FREQUENCY RANGE	1GHz ~ 40GHz		Average (AV)

ANTENNA POLARITY & TEST DISTANCE: HORIZONTAL AT 3 M

NO.	FREQ. (MHz)	EMISSION LEVEL (dBuV/m)	LIMIT (dBuV/m)	MARGIN (dB)	ANTENNA HEIGHT (m)	TABLE ANGLE (Degree)	RAW VALUE (dBuV)	CORRECTION FACTOR (dB/m)
1	*5610.00	104.3 PK			1.05 H	218	101.74	2.56
2	*5610.00	88.5 AV			1.05 H	218	85.94	2.56
3	#5725.00	64.7 PK	74.0	-9.3	1.05 H	218	61.92	2.78
4	#5725.00	52.5 AV	54.0	-1.5	1.05 H	218	49.72	2.78
5	11220.00	59.8 PK	74.0	-14.2	2.32 H	109	46.30	13.50
6	11220.00	41.0 AV	54.0	-13.0	2.32 H	109	27.50	13.50
7	#16830.00	59.2 PK	74.0	-14.8	1.60 H	223	42.17	17.03
8	#16830.00	46.7 AV	54.0	-7.3	1.60 H	223	29.67	17.03

ANTENNA POLARITY & TEST DISTANCE: VERTICAL AT 3 M

NO.	FREQ. (MHz)	EMISSION LEVEL (dBuV/m)	LIMIT (dBuV/m)	MARGIN (dB)	ANTENNA HEIGHT (m)	TABLE ANGLE (Degree)	RAW VALUE (dBuV)	CORRECTION FACTOR (dB/m)
1	*5610.00	101.9 PK			2.73 V	261	99.34	2.56
2	*5610.00	87.0 AV			2.73 V	261	84.44	2.56
3	#5725.00	59.8 PK	74.0	-14.2	2.73 V	261	57.02	2.78
4	#5725.00	48.7 AV	54.0	-5.3	2.73 V	261	45.92	2.78
5	11220.00	53.7 PK	74.0	-20.3	1.52 V	205	40.20	13.50
6	11220.00	40.8 AV	54.0	-13.2	1.52 V	205	27.30	13.50
7	#16830.00	56.5 PK	74.0	-17.5	1.48 V	210	39.47	17.03
8	#16830.00	43.3 AV	54.0	-10.7	1.48 V	210	26.27	17.03

REMARKS:

1. Emission Level(dBuV/m) = Raw Value(dBuV) + Correction Factor(dB/m)
2. Correction Factor(dB/m) = Antenna Factor(dB/m) + Cable Factor(dB) – Pre-Amplifier Factor(dB)
3. The other emission levels were very low against the limit.
4. Margin value = Emission Level – Limit value
5. " * ": Fundamental frequency.
6. " # ": The radiated frequency is out of the restricted band.

CHANNEL	TX Channel 138	DETECTOR FUNCTION	Peak (PK)
FREQUENCY RANGE	1GHz ~ 40GHz		Average (AV)

ANTENNA POLARITY & TEST DISTANCE: HORIZONTAL AT 3 M

NO.	FREQ. (MHz)	EMISSION LEVEL (dBuV/m)	LIMIT (dBuV/m)	MARGIN (dB)	ANTENNA HEIGHT (m)	TABLE ANGLE (Degree)	RAW VALUE (dBuV)	CORRECTION FACTOR (dB/m)
1	#5470.00	58.3 PK	74.0	-15.7	1.01 H	214	56.04	2.26
2	#5470.00	45.0 AV	54.0	-9.0	1.01 H	214	42.74	2.26
3	*5690.00	105.0 PK			1.01 H	214	102.28	2.72
4	*5690.00	89.1 AV			1.01 H	214	86.38	2.72
5	#5850.00	58.2 PK	74.0	-15.8	1.01 H	214	55.26	2.94
6	#5850.00	44.8 AV	54.0	-9.2	1.01 H	214	41.86	2.94
7	11380.00	59.7 PK	74.0	-14.3	2.36 H	110	46.21	13.49
8	11380.00	41.2 AV	54.0	-12.8	2.36 H	110	27.71	13.49
9	#17070.00	58.2 PK	74.0	-15.8	1.59 H	205	40.29	17.91
10	#17070.00	45.9 AV	54.0	-8.1	1.59 H	205	27.99	17.91

ANTENNA POLARITY & TEST DISTANCE: VERTICAL AT 3 M

NO.	FREQ. (MHz)	EMISSION LEVEL (dBuV/m)	LIMIT (dBuV/m)	MARGIN (dB)	ANTENNA HEIGHT (m)	TABLE ANGLE (Degree)	RAW VALUE (dBuV)	CORRECTION FACTOR (dB/m)
1	#5470.00	53.9 PK	74.0	-20.1	2.70 V	268	51.64	2.26
2	#5470.00	41.5 AV	54.0	-12.5	2.70 V	268	39.24	2.26
3	*5690.00	102.4 PK			2.70 V	268	99.68	2.72
4	*5690.00	87.2 AV			2.70 V	268	84.48	2.72
5	#5850.00	53.7 PK	74.0	-20.3	2.70 V	268	50.76	2.94
6	#5850.00	41.1 AV	54.0	-12.9	2.70 V	268	38.16	2.94
7	11380.00	53.5 PK	74.0	-20.5	1.50 V	224	40.01	13.49
8	11380.00	40.3 AV	54.0	-13.7	1.50 V	224	26.81	13.49
9	#17070.00	56.8 PK	74.0	-17.2	1.58 V	184	38.89	17.91
10	#17070.00	43.9 AV	54.0	-10.1	1.58 V	184	25.99	17.91

REMARKS:

1. Emission Level(dBuV/m) = Raw Value(dBuV) + Correction Factor(dB/m)
2. Correction Factor(dB/m) = Antenna Factor(dB/m) + Cable Factor(dB) – Pre-Amplifier Factor(dB)
3. The other emission levels were very low against the limit.
4. Margin value = Emission Level – Limit value
5. " * ": Fundamental frequency.
6. " # ": The radiated frequency is out of the restricted band.



CHANNEL	TX Channel 155	DETECTOR FUNCTION	Peak (PK)
FREQUENCY RANGE	1GHz ~ 40GHz		Average (AV)

ANTENNA POLARITY & TEST DISTANCE: HORIZONTAL AT 3 M

NO.	FREQ. (MHz)	EMISSION LEVEL (dBuV/m)	LIMIT (dBuV/m)	MARGIN (dB)	ANTENNA HEIGHT (m)	TABLE ANGLE (Degree)	RAW VALUE (dBuV)	CORRECTION FACTOR (dB/m)
1	#5715.00	68.2 PK	74.0	-5.8	1.16 H	222	66.28	1.92
2	#5715.00	52.6 AV	54.0	-1.4	1.16 H	222	50.68	1.92
3	#5725.00	69.0 PK	78.2	-9.2	1.16 H	222	67.07	1.93
4	*5775.00	99.1 PK			1.16 H	222	97.05	2.05
5	*5775.00	84.2 AV			1.16 H	222	82.15	2.05
6	#5850.00	65.1 PK	78.2	-13.1	1.16 H	222	62.97	2.13
7	#5860.00	62.7 PK	74.0	-11.3	1.16 H	222	60.57	2.13
8	#5860.00	48.7 AV	54.0	-5.3	1.16 H	222	46.57	2.13
9	11550.00	59.7 PK	74.0	-14.3	2.36 H	111	47.02	12.68
10	11550.00	41.0 AV	54.0	-13.0	2.36 H	111	28.32	12.68
11	#17325.00	57.8 PK	74.0	-16.2	1.50 H	213	39.86	17.94
12	#17325.00	45.8 AV	54.0	-8.2	1.50 H	213	27.86	17.94

ANTENNA POLARITY & TEST DISTANCE: VERTICAL AT 3 M

NO.	FREQ. (MHz)	EMISSION LEVEL (dBuV/m)	LIMIT (dBuV/m)	MARGIN (dB)	ANTENNA HEIGHT (m)	TABLE ANGLE (Degree)	RAW VALUE (dBuV)	CORRECTION FACTOR (dB/m)
1	#5715.00	65.3 PK	74.0	-8.7	1.02 V	116	63.38	1.92
2	#5715.00	50.2 AV	54.0	-3.8	1.02 V	116	48.28	1.92
3	#5725.00	66.8 PK	78.2	-11.4	1.02 V	116	64.87	1.93
4	*5775.00	97.2 PK			1.02 V	116	95.15	2.05
5	*5775.00	82.5 AV			1.02 V	116	80.45	2.05
6	#5850.00	64.7 PK	78.2	-13.5	1.02 V	116	62.57	2.13
7	#5860.00	62.5 PK	74.0	-11.5	1.02 V	116	60.37	2.13
8	#5860.00	48.1 AV	54.0	-5.9	1.02 V	116	45.97	2.13
9	11550.00	53.6 PK	74.0	-20.4	1.50 V	209	40.92	12.68
10	11550.00	40.7 AV	54.0	-13.3	1.50 V	209	28.02	12.68
11	#17325.00	56.6 PK	74.0	-17.4	1.59 V	187	38.66	17.94
12	#17325.00	43.5 AV	54.0	-10.5	1.59 V	187	25.56	17.94

REMARKS:

1. Emission Level(dBuV/m) = Raw Value(dBuV) + Correction Factor(dB/m)
2. Correction Factor(dB/m) = Antenna Factor(dB/m) + Cable Factor(dB) – Pre-Amplifier Factor(dB)
3. The other emission levels were very low against the limit.
4. Margin value = Emission Level – Limit value
5. " * ": Fundamental frequency.
6. " # ": The radiated frequency is out of the restricted band.

Below 1GHz Data:
1TX
802.11a

CHANNEL	TX Channel 36	DETECTOR FUNCTION	Quasi-Peak (QP)
FREQUENCY RANGE	30MHz ~ 1GHz		

ANTENNA POLARITY & TEST DISTANCE: HORIZONTAL AT 3 M

NO.	FREQ. (MHz)	EMISSION LEVEL (dBuV/m)	LIMIT (dBuV/m)	MARGIN (dB)	ANTENNA HEIGHT (m)	TABLE ANGLE (Degree)	RAW VALUE (dBuV)	CORRECTION FACTOR (dB/m)
1	42.36	31.8 QP	40.0	-8.2	1.56 H	260	36.17	-4.37
2	201.06	33.5 QP	43.5	-10.0	1.00 H	51	40.58	-7.08
3	314.65	41.6 QP	46.0	-4.4	1.00 H	277	44.49	-2.89
4	323.36	41.8 QP	46.0	-4.2	1.00 H	60	44.44	-2.64
5	498.17	35.9 QP	46.0	-10.1	1.46 H	139	34.53	1.37
6	931.01	38.6 QP	46.0	-7.4	1.61 H	67	29.83	8.77

ANTENNA POLARITY & TEST DISTANCE: VERTICAL AT 3 M

NO.	FREQ. (MHz)	EMISSION LEVEL (dBuV/m)	LIMIT (dBuV/m)	MARGIN (dB)	ANTENNA HEIGHT (m)	TABLE ANGLE (Degree)	RAW VALUE (dBuV)	CORRECTION FACTOR (dB/m)
1	37.32	34.5 QP	40.0	-5.5	1.01 V	126	39.49	-4.99
2	58.63	29.8 QP	40.0	-10.2	1.52 V	44	34.07	-4.27
3	218.98	32.8 QP	46.0	-13.2	1.99 V	201	39.67	-6.87
4	267.87	32.0 QP	46.0	-14.0	1.95 V	307	36.37	-4.37
5	319.82	38.6 QP	46.0	-7.4	1.05 V	124	41.36	-2.76
6	797.49	37.5 QP	46.0	-8.5	1.59 V	112	30.85	6.65

REMARKS:

1. Emission Level(dBuV/m) = Raw Value(dBuV) + Correction Factor(dB/m)
2. Correction Factor(dB/m) = Antenna Factor(dB/m) + Cable Factor(dB) – Pre-Amplifier Factor(dB)
3. The other emission levels were very low against the limit.
4. Margin value = Emission Level – Limit value

CHANNEL	TX Channel 40	DETECTOR FUNCTION	Quasi-Peak (QP)
FREQUENCY RANGE	30MHz ~ 1GHz		

ANTENNA POLARITY & TEST DISTANCE: HORIZONTAL AT 3 M

NO.	FREQ. (MHz)	EMISSION LEVEL (dBuV/m)	LIMIT (dBuV/m)	MARGIN (dB)	ANTENNA HEIGHT (m)	TABLE ANGLE (Degree)	RAW VALUE (dBuV)	CORRECTION FACTOR (dB/m)
1	42.59	31.9 QP	40.0	-8.1	1.56 H	271	36.22	-4.32
2	201.42	33.3 QP	43.5	-10.2	1.00 H	45	40.40	-7.10
3	315.08	41.5 QP	46.0	-4.5	1.05 H	277	44.37	-2.87
4	323.94	41.9 QP	46.0	-4.1	1.00 H	54	44.51	-2.61
5	498.16	36.1 QP	46.0	-9.9	1.50 H	150	34.73	1.37
6	931.01	38.6 QP	46.0	-7.4	1.55 H	57	29.83	8.77

ANTENNA POLARITY & TEST DISTANCE: VERTICAL AT 3 M

NO.	FREQ. (MHz)	EMISSION LEVEL (dBuV/m)	LIMIT (dBuV/m)	MARGIN (dB)	ANTENNA HEIGHT (m)	TABLE ANGLE (Degree)	RAW VALUE (dBuV)	CORRECTION FACTOR (dB/m)
1	36.77	34.4 QP	40.0	-5.6	1.00 V	130	39.53	-5.13
2	58.83	29.8 QP	40.0	-10.2	1.54 V	38	34.08	-4.28
3	219.39	32.6 QP	46.0	-13.4	2.00 V	185	39.48	-6.88
4	268.17	32.1 QP	46.0	-13.9	1.96 V	280	36.45	-4.35
5	319.70	38.6 QP	46.0	-7.4	1.07 V	134	41.37	-2.77
6	797.49	37.7 QP	46.0	-8.3	1.53 V	110	31.05	6.65

REMARKS:

1. Emission Level(dBuV/m) = Raw Value(dBuV) + Correction Factor(dB/m)
2. Correction Factor(dB/m) = Antenna Factor(dB/m) + Cable Factor(dB) – Pre-Amplifier Factor(dB)
3. The other emission levels were very low against the limit.
4. Margin value = Emission Level – Limit value

CHANNEL	TX Channel 48	DETECTOR FUNCTION	Quasi-Peak (QP)
FREQUENCY RANGE	30MHz ~ 1GHz		

ANTENNA POLARITY & TEST DISTANCE: HORIZONTAL AT 3 M

NO.	FREQ. (MHz)	EMISSION LEVEL (dBuV/m)	LIMIT (dBuV/m)	MARGIN (dB)	ANTENNA HEIGHT (m)	TABLE ANGLE (Degree)	RAW VALUE (dBuV)	CORRECTION FACTOR (dB/m)
1	42.75	31.9 QP	40.0	-8.1	1.61 H	271	36.19	-4.29
2	201.44	33.4 QP	43.5	-10.1	1.00 H	67	40.50	-7.10
3	314.60	41.7 QP	46.0	-4.3	1.05 H	278	44.59	-2.89
4	323.89	42.0 QP	46.0	-4.0	1.03 H	54	44.61	-2.61
5	498.01	36.1 QP	46.0	-9.9	1.51 H	137	34.74	1.36
6	931.01	39.1 QP	46.0	-6.9	1.56 H	51	30.33	8.77

ANTENNA POLARITY & TEST DISTANCE: VERTICAL AT 3 M

NO.	FREQ. (MHz)	EMISSION LEVEL (dBuV/m)	LIMIT (dBuV/m)	MARGIN (dB)	ANTENNA HEIGHT (m)	TABLE ANGLE (Degree)	RAW VALUE (dBuV)	CORRECTION FACTOR (dB/m)
1	37.33	34.6 QP	40.0	-5.4	1.00 V	122	39.58	-4.98
2	58.39	29.4 QP	40.0	-10.6	1.53 V	23	33.67	-4.27
3	219.38	32.8 QP	46.0	-13.2	2.02 V	182	39.68	-6.88
4	267.80	31.9 QP	46.0	-14.1	2.00 V	286	36.27	-4.37
5	319.84	38.6 QP	46.0	-7.4	1.06 V	127	41.36	-2.76
6	797.49	37.9 QP	46.0	-8.1	1.55 V	110	31.25	6.65

REMARKS:

1. Emission Level(dBuV/m) = Raw Value(dBuV) + Correction Factor(dB/m)
2. Correction Factor(dB/m) = Antenna Factor(dB/m) + Cable Factor(dB) – Pre-Amplifier Factor(dB)
3. The other emission levels were very low against the limit.
4. Margin value = Emission Level – Limit value

CHANNEL	TX Channel 52	DETECTOR FUNCTION	Quasi-Peak (QP)
FREQUENCY RANGE	30MHz ~ 1GHz		

ANTENNA POLARITY & TEST DISTANCE: HORIZONTAL AT 3 M

NO.	FREQ. (MHz)	EMISSION LEVEL (dBuV/m)	LIMIT (dBuV/m)	MARGIN (dB)	ANTENNA HEIGHT (m)	TABLE ANGLE (Degree)	RAW VALUE (dBuV)	CORRECTION FACTOR (dB/m)
1	42.20	31.6 QP	40.0	-8.4	1.61 H	260	35.99	-4.39
2	201.06	33.2 QP	43.5	-10.3	1.04 H	49	40.28	-7.08
3	314.81	41.2 QP	46.0	-4.8	1.00 H	274	44.08	-2.88
4	323.47	42.1 QP	46.0	-3.9	1.00 H	48	44.73	-2.63
5	497.93	36.0 QP	46.0	-10.0	1.45 H	161	34.64	1.36
6	931.01	38.7 QP	46.0	-7.3	1.51 H	51	29.93	8.77

ANTENNA POLARITY & TEST DISTANCE: VERTICAL AT 3 M

NO.	FREQ. (MHz)	EMISSION LEVEL (dBuV/m)	LIMIT (dBuV/m)	MARGIN (dB)	ANTENNA HEIGHT (m)	TABLE ANGLE (Degree)	RAW VALUE (dBuV)	CORRECTION FACTOR (dB/m)
1	37.26	34.8 QP	40.0	-5.2	1.01 V	129	39.80	-5.00
2	58.33	29.5 QP	40.0	-10.5	1.54 V	24	33.77	-4.27
3	218.95	32.4 QP	46.0	-13.6	2.05 V	196	39.27	-6.87
4	267.74	31.6 QP	46.0	-14.4	1.96 V	291	35.97	-4.37
5	319.73	38.9 QP	46.0	-7.1	1.00 V	134	41.67	-2.77
6	797.49	37.8 QP	46.0	-8.2	1.59 V	119	31.15	6.65

REMARKS:

1. Emission Level(dBuV/m) = Raw Value(dBuV) + Correction Factor(dB/m)
2. Correction Factor(dB/m) = Antenna Factor(dB/m) + Cable Factor(dB) – Pre-Amplifier Factor(dB)
3. The other emission levels were very low against the limit.
4. Margin value = Emission Level – Limit value

CHANNEL	TX Channel 60	DETECTOR FUNCTION	Quasi-Peak (QP)
FREQUENCY RANGE	30MHz ~ 1GHz		

ANTENNA POLARITY & TEST DISTANCE: HORIZONTAL AT 3 M

NO.	FREQ. (MHz)	EMISSION LEVEL (dBuV/m)	LIMIT (dBuV/m)	MARGIN (dB)	ANTENNA HEIGHT (m)	TABLE ANGLE (Degree)	RAW VALUE (dBuV)	CORRECTION FACTOR (dB/m)
1	42.42	31.4 QP	40.0	-8.6	1.58 H	283	35.75	-4.35
2	201.34	33.7 QP	43.5	-9.8	1.01 H	66	40.79	-7.09
3	314.97	41.3 QP	46.0	-4.7	1.05 H	288	44.18	-2.88
4	323.62	41.8 QP	46.0	-4.2	1.03 H	36	44.43	-2.63
5	498.33	36.0 QP	46.0	-10.0	1.43 H	134	34.63	1.37
6	931.01	38.9 QP	46.0	-7.1	1.60 H	56	30.13	8.77

ANTENNA POLARITY & TEST DISTANCE: VERTICAL AT 3 M

NO.	FREQ. (MHz)	EMISSION LEVEL (dBuV/m)	LIMIT (dBuV/m)	MARGIN (dB)	ANTENNA HEIGHT (m)	TABLE ANGLE (Degree)	RAW VALUE (dBuV)	CORRECTION FACTOR (dB/m)
1	37.22	34.4 QP	40.0	-5.6	1.07 V	114	39.41	-5.01
2	58.65	29.5 QP	40.0	-10.5	1.59 V	17	33.77	-4.27
3	218.93	32.9 QP	46.0	-13.1	2.08 V	178	39.77	-6.87
4	267.76	32.0 QP	46.0	-14.0	1.96 V	290	36.37	-4.37
5	319.82	38.6 QP	46.0	-7.4	1.03 V	127	41.36	-2.76
6	797.49	37.6 QP	46.0	-8.4	1.58 V	121	30.95	6.65

REMARKS:

1. Emission Level(dBuV/m) = Raw Value(dBuV) + Correction Factor(dB/m)
2. Correction Factor(dB/m) = Antenna Factor(dB/m) + Cable Factor(dB) – Pre-Amplifier Factor(dB)
3. The other emission levels were very low against the limit.
4. Margin value = Emission Level – Limit value

CHANNEL	TX Channel 64	DETECTOR FUNCTION	Quasi-Peak (QP)
FREQUENCY RANGE	30MHz ~ 1GHz		

ANTENNA POLARITY & TEST DISTANCE: HORIZONTAL AT 3 M

NO.	FREQ. (MHz)	EMISSION LEVEL (dBuV/m)	LIMIT (dBuV/m)	MARGIN (dB)	ANTENNA HEIGHT (m)	TABLE ANGLE (Degree)	RAW VALUE (dBuV)	CORRECTION FACTOR (dB/m)
1	42.62	31.7 QP	40.0	-8.3	1.57 H	270	36.02	-4.32
2	201.23	33.7 QP	43.5	-9.8	1.00 H	59	40.79	-7.09
3	314.62	41.2 QP	46.0	-4.8	1.00 H	283	44.09	-2.89
4	323.44	41.9 QP	46.0	-4.1	1.00 H	56	44.53	-2.63
5	498.41	36.1 QP	46.0	-9.9	1.46 H	145	34.73	1.37
6	931.01	38.7 QP	46.0	-7.3	1.62 H	71	29.93	8.77

ANTENNA POLARITY & TEST DISTANCE: VERTICAL AT 3 M

NO.	FREQ. (MHz)	EMISSION LEVEL (dBuV/m)	LIMIT (dBuV/m)	MARGIN (dB)	ANTENNA HEIGHT (m)	TABLE ANGLE (Degree)	RAW VALUE (dBuV)	CORRECTION FACTOR (dB/m)
1	36.92	34.7 QP	40.0	-5.3	1.05 V	126	39.78	-5.08
2	58.27	29.7 QP	40.0	-10.3	1.51 V	33	33.97	-4.27
3	218.85	32.7 QP	46.0	-13.3	2.09 V	194	39.57	-6.87
4	268.07	31.8 QP	46.0	-14.2	2.04 V	305	36.16	-4.36
5	319.77	38.8 QP	46.0	-7.2	1.01 V	146	41.56	-2.76
6	797.49	38.0 QP	46.0	-8.0	1.56 V	113	31.35	6.65

REMARKS:

1. Emission Level(dBuV/m) = Raw Value(dBuV) + Correction Factor(dB/m)
2. Correction Factor(dB/m) = Antenna Factor(dB/m) + Cable Factor(dB) – Pre-Amplifier Factor(dB)
3. The other emission levels were very low against the limit.
4. Margin value = Emission Level – Limit value

CHANNEL	TX Channel 100	DETECTOR FUNCTION	Quasi-Peak (QP)
FREQUENCY RANGE	30MHz ~ 1GHz		

ANTENNA POLARITY & TEST DISTANCE: HORIZONTAL AT 3 M

NO.	FREQ. (MHz)	EMISSION LEVEL (dBuV/m)	LIMIT (dBuV/m)	MARGIN (dB)	ANTENNA HEIGHT (m)	TABLE ANGLE (Degree)	RAW VALUE (dBuV)	CORRECTION FACTOR (dB/m)
1	42.54	32.0 QP	40.0	-8.0	1.62 H	267	36.33	-4.33
2	201.19	33.2 QP	43.5	-10.3	1.01 H	57	40.29	-7.09
3	314.58	41.6 QP	46.0	-4.4	1.01 H	279	44.49	-2.89
4	323.45	41.7 QP	46.0	-4.3	1.05 H	63	44.33	-2.63
5	497.90	36.2 QP	46.0	-9.8	1.43 H	149	34.84	1.36
6	931.01	38.6 QP	46.0	-7.4	1.50 H	80	29.83	8.77

ANTENNA POLARITY & TEST DISTANCE: VERTICAL AT 3 M

NO.	FREQ. (MHz)	EMISSION LEVEL (dBuV/m)	LIMIT (dBuV/m)	MARGIN (dB)	ANTENNA HEIGHT (m)	TABLE ANGLE (Degree)	RAW VALUE (dBuV)	CORRECTION FACTOR (dB/m)
1	37.29	34.7 QP	40.0	-5.3	1.05 V	129	39.69	-4.99
2	58.80	29.8 QP	40.0	-10.2	1.58 V	39	34.08	-4.28
3	219.31	32.6 QP	46.0	-13.4	2.02 V	195	39.48	-6.88
4	268.00	31.8 QP	46.0	-14.2	1.99 V	300	36.16	-4.36
5	320.03	38.8 QP	46.0	-7.2	1.00 V	138	41.56	-2.76
6	797.49	37.5 QP	46.0	-8.5	1.57 V	108	30.85	6.65

REMARKS:

1. Emission Level(dBuV/m) = Raw Value(dBuV) + Correction Factor(dB/m)
2. Correction Factor(dB/m) = Antenna Factor(dB/m) + Cable Factor(dB) – Pre-Amplifier Factor(dB)
3. The other emission levels were very low against the limit.
4. Margin value = Emission Level – Limit value

CHANNEL	TX Channel 116	DETECTOR FUNCTION	Quasi-Peak (QP)
FREQUENCY RANGE	30MHz ~ 1GHz		

ANTENNA POLARITY & TEST DISTANCE: HORIZONTAL AT 3 M

NO.	FREQ. (MHz)	EMISSION LEVEL (dBuV/m)	LIMIT (dBuV/m)	MARGIN (dB)	ANTENNA HEIGHT (m)	TABLE ANGLE (Degree)	RAW VALUE (dBuV)	CORRECTION FACTOR (dB/m)
1	42.22	31.9 QP	40.0	-8.1	1.62 H	286	36.29	-4.39
2	201.08	33.3 QP	43.5	-10.2	1.01 H	65	40.38	-7.08
3	315.00	41.7 QP	46.0	-4.3	1.00 H	300	44.57	-2.87
4	323.75	41.9 QP	46.0	-4.1	1.00 H	47	44.52	-2.62
5	498.15	36.2 QP	46.0	-9.8	1.43 H	136	34.83	1.37
6	931.01	39.2 QP	46.0	-6.8	1.57 H	62	30.43	8.77

ANTENNA POLARITY & TEST DISTANCE: VERTICAL AT 3 M

NO.	FREQ. (MHz)	EMISSION LEVEL (dBuV/m)	LIMIT (dBuV/m)	MARGIN (dB)	ANTENNA HEIGHT (m)	TABLE ANGLE (Degree)	RAW VALUE (dBuV)	CORRECTION FACTOR (dB/m)
1	37.01	34.6 QP	40.0	-5.4	1.01 V	120	39.66	-5.06
2	58.28	29.6 QP	40.0	-10.4	1.56 V	24	33.87	-4.27
3	218.88	33.0 QP	46.0	-13.0	2.04 V	197	39.87	-6.87
4	268.16	31.9 QP	46.0	-14.1	2.00 V	309	36.25	-4.35
5	319.74	38.6 QP	46.0	-7.4	1.07 V	127	41.37	-2.77
6	797.49	37.6 QP	46.0	-8.4	1.58 V	107	30.95	6.65

REMARKS:

1. Emission Level(dBuV/m) = Raw Value(dBuV) + Correction Factor(dB/m)
2. Correction Factor(dB/m) = Antenna Factor(dB/m) + Cable Factor(dB) – Pre-Amplifier Factor(dB)
3. The other emission levels were very low against the limit.
4. Margin value = Emission Level – Limit value

CHANNEL	TX Channel 140	DETECTOR FUNCTION	Quasi-Peak (QP)
FREQUENCY RANGE	30MHz ~ 1GHz		

ANTENNA POLARITY & TEST DISTANCE: HORIZONTAL AT 3 M

NO.	FREQ. (MHz)	EMISSION LEVEL (dBuV/m)	LIMIT (dBuV/m)	MARGIN (dB)	ANTENNA HEIGHT (m)	TABLE ANGLE (Degree)	RAW VALUE (dBuV)	CORRECTION FACTOR (dB/m)
1	42.42	31.6 QP	40.0	-8.4	1.56 H	264	35.95	-4.35
2	201.31	33.8 QP	43.5	-9.7	1.00 H	51	40.89	-7.09
3	314.63	41.3 QP	46.0	-4.7	1.05 H	280	44.19	-2.89
4	323.68	41.8 QP	46.0	-4.2	1.06 H	65	44.42	-2.62
5	497.81	36.1 QP	46.0	-9.9	1.43 H	154	34.74	1.36
6	931.01	39.2 QP	46.0	-6.8	1.55 H	60	30.43	8.77

ANTENNA POLARITY & TEST DISTANCE: VERTICAL AT 3 M

NO.	FREQ. (MHz)	EMISSION LEVEL (dBuV/m)	LIMIT (dBuV/m)	MARGIN (dB)	ANTENNA HEIGHT (m)	TABLE ANGLE (Degree)	RAW VALUE (dBuV)	CORRECTION FACTOR (dB/m)
1	36.85	34.5 QP	40.0	-5.5	1.06 V	129	39.61	-5.11
2	58.66	29.5 QP	40.0	-10.5	1.59 V	27	33.77	-4.27
3	219.41	32.5 QP	46.0	-13.5	2.00 V	184	39.38	-6.88
4	267.98	31.7 QP	46.0	-14.3	2.06 V	292	36.06	-4.36
5	319.81	38.6 QP	46.0	-7.4	1.00 V	130	41.36	-2.76
6	797.49	37.5 QP	46.0	-8.5	1.50 V	97	30.85	6.65

REMARKS:

1. Emission Level(dBuV/m) = Raw Value(dBuV) + Correction Factor(dB/m)
2. Correction Factor(dB/m) = Antenna Factor(dB/m) + Cable Factor(dB) – Pre-Amplifier Factor(dB)
3. The other emission levels were very low against the limit.
4. Margin value = Emission Level – Limit value

CHANNEL	TX Channel 144	DETECTOR FUNCTION	Quasi-Peak (QP)
FREQUENCY RANGE	30MHz ~ 1GHz		

ANTENNA POLARITY & TEST DISTANCE: HORIZONTAL AT 3 M

NO.	FREQ. (MHz)	EMISSION LEVEL (dBuV/m)	LIMIT (dBuV/m)	MARGIN (dB)	ANTENNA HEIGHT (m)	TABLE ANGLE (Degree)	RAW VALUE (dBuV)	CORRECTION FACTOR (dB/m)
1	42.36	31.7 QP	40.0	-8.3	1.59 H	284	36.07	-4.37
2	201.32	33.7 QP	43.5	-9.8	1.03 H	59	40.79	-7.09
3	314.66	41.6 QP	46.0	-4.4	1.00 H	274	44.49	-2.89
4	323.55	41.8 QP	46.0	-4.2	1.05 H	56	44.43	-2.63
5	498.32	36.2 QP	46.0	-9.8	1.52 H	137	34.83	1.37
6	931.01	39.1 QP	46.0	-6.9	1.59 H	68	30.33	8.77

ANTENNA POLARITY & TEST DISTANCE: VERTICAL AT 3 M

NO.	FREQ. (MHz)	EMISSION LEVEL (dBuV/m)	LIMIT (dBuV/m)	MARGIN (dB)	ANTENNA HEIGHT (m)	TABLE ANGLE (Degree)	RAW VALUE (dBuV)	CORRECTION FACTOR (dB/m)
1	37.15	34.6 QP	40.0	-5.4	1.06 V	137	39.63	-5.03
2	58.32	29.8 QP	40.0	-10.2	1.60 V	14	34.07	-4.27
3	218.85	32.7 QP	46.0	-13.3	2.02 V	188	39.57	-6.87
4	267.64	32.1 QP	46.0	-13.9	2.04 V	293	36.48	-4.38
5	319.69	38.9 QP	46.0	-7.1	1.00 V	151	41.67	-2.77
6	797.49	38.1 QP	46.0	-7.9	1.59 V	117	31.45	6.65

REMARKS:

1. Emission Level(dBuV/m) = Raw Value(dBuV) + Correction Factor(dB/m)
2. Correction Factor(dB/m) = Antenna Factor(dB/m) + Cable Factor(dB) – Pre-Amplifier Factor(dB)
3. The other emission levels were very low against the limit.
4. Margin value = Emission Level – Limit value

CHANNEL	TX Channel 149	DETECTOR FUNCTION	Quasi-Peak (QP)
FREQUENCY RANGE	30MHz ~ 1GHz		

ANTENNA POLARITY & TEST DISTANCE: HORIZONTAL AT 3 M

NO.	FREQ. (MHz)	EMISSION LEVEL (dBuV/m)	LIMIT (dBuV/m)	MARGIN (dB)	ANTENNA HEIGHT (m)	TABLE ANGLE (Degree)	RAW VALUE (dBuV)	CORRECTION FACTOR (dB/m)
1	42.76	31.7 QP	40.0	-8.3	1.62 H	266	35.99	-4.29
2	200.87	33.3 QP	43.5	-10.2	1.01 H	64	40.37	-7.07
3	314.97	41.6 QP	46.0	-4.4	1.00 H	277	44.48	-2.88
4	323.66	42.0 QP	46.0	-4.0	1.04 H	56	44.62	-2.62
5	498.34	36.0 QP	46.0	-10.0	1.47 H	159	34.63	1.37
6	931.01	39.0 QP	46.0	-7.0	1.60 H	56	30.23	8.77

ANTENNA POLARITY & TEST DISTANCE: VERTICAL AT 3 M

NO.	FREQ. (MHz)	EMISSION LEVEL (dBuV/m)	LIMIT (dBuV/m)	MARGIN (dB)	ANTENNA HEIGHT (m)	TABLE ANGLE (Degree)	RAW VALUE (dBuV)	CORRECTION FACTOR (dB/m)
1	36.84	34.9 QP	40.0	-5.1	1.00 V	140	40.01	-5.11
2	58.65	29.4 QP	40.0	-10.6	1.59 V	27	33.67	-4.27
3	219.37	32.8 QP	46.0	-13.2	2.00 V	197	39.68	-6.88
4	267.67	31.7 QP	46.0	-14.3	1.97 V	286	36.07	-4.37
5	319.95	38.5 QP	46.0	-7.5	1.04 V	137	41.26	-2.76
6	797.49	37.8 QP	46.0	-8.2	1.60 V	101	31.15	6.65

REMARKS:

1. Emission Level(dBuV/m) = Raw Value(dBuV) + Correction Factor(dB/m)
2. Correction Factor(dB/m) = Antenna Factor(dB/m) + Cable Factor(dB) – Pre-Amplifier Factor(dB)
3. The other emission levels were very low against the limit.
4. Margin value = Emission Level – Limit value

CHANNEL	TX Channel 157	DETECTOR FUNCTION	Quasi-Peak (QP)
FREQUENCY RANGE	30MHz ~ 1GHz		

ANTENNA POLARITY & TEST DISTANCE: HORIZONTAL AT 3 M

NO.	FREQ. (MHz)	EMISSION LEVEL (dBuV/m)	LIMIT (dBuV/m)	MARGIN (dB)	ANTENNA HEIGHT (m)	TABLE ANGLE (Degree)	RAW VALUE (dBuV)	CORRECTION FACTOR (dB/m)
1	42.70	31.5 QP	40.0	-8.5	1.60 H	287	35.80	-4.30
2	201.31	33.7 QP	43.5	-9.8	1.00 H	63	40.79	-7.09
3	314.86	41.6 QP	46.0	-4.4	1.00 H	296	44.48	-2.88
4	323.56	42.0 QP	46.0	-4.0	1.00 H	53	44.63	-2.63
5	498.04	36.1 QP	46.0	-9.9	1.52 H	158	34.74	1.36
6	931.01	39.1 QP	46.0	-6.9	1.55 H	56	30.33	8.77

ANTENNA POLARITY & TEST DISTANCE: VERTICAL AT 3 M

NO.	FREQ. (MHz)	EMISSION LEVEL (dBuV/m)	LIMIT (dBuV/m)	MARGIN (dB)	ANTENNA HEIGHT (m)	TABLE ANGLE (Degree)	RAW VALUE (dBuV)	CORRECTION FACTOR (dB/m)
1	37.32	34.8 QP	40.0	-5.2	1.00 V	119	39.79	-4.99
2	58.52	29.7 QP	40.0	-10.3	1.62 V	43	33.97	-4.27
3	219.15	32.9 QP	46.0	-13.1	2.01 V	198	39.78	-6.88
4	267.99	32.1 QP	46.0	-13.9	2.04 V	281	36.46	-4.36
5	319.75	39.1 QP	46.0	-6.9	1.03 V	136	41.87	-2.77
6	797.49	38.0 QP	46.0	-8.0	1.61 V	115	31.35	6.65

REMARKS:

1. Emission Level(dBuV/m) = Raw Value(dBuV) + Correction Factor(dB/m)
2. Correction Factor(dB/m) = Antenna Factor(dB/m) + Cable Factor(dB) – Pre-Amplifier Factor(dB)
3. The other emission levels were very low against the limit.
4. Margin value = Emission Level – Limit value

CHANNEL	TX Channel 165	DETECTOR FUNCTION	Quasi-Peak (QP)
FREQUENCY RANGE	30MHz ~ 1GHz		

ANTENNA POLARITY & TEST DISTANCE: HORIZONTAL AT 3 M

NO.	FREQ. (MHz)	EMISSION LEVEL (dBuV/m)	LIMIT (dBuV/m)	MARGIN (dB)	ANTENNA HEIGHT (m)	TABLE ANGLE (Degree)	RAW VALUE (dBuV)	CORRECTION FACTOR (dB/m)
1	42.20	31.9 QP	40.0	-8.1	1.57 H	284	36.29	-4.39
2	201.05	33.7 QP	43.5	-9.8	1.01 H	68	40.78	-7.08
3	314.69	41.4 QP	46.0	-4.6	1.00 H	277	44.29	-2.89
4	323.47	42.0 QP	46.0	-4.0	1.03 H	46	44.63	-2.63
5	498.05	35.7 QP	46.0	-10.3	1.43 H	157	34.34	1.36
6	931.01	38.8 QP	46.0	-7.2	1.61 H	56	30.03	8.77

ANTENNA POLARITY & TEST DISTANCE: VERTICAL AT 3 M

NO.	FREQ. (MHz)	EMISSION LEVEL (dBuV/m)	LIMIT (dBuV/m)	MARGIN (dB)	ANTENNA HEIGHT (m)	TABLE ANGLE (Degree)	RAW VALUE (dBuV)	CORRECTION FACTOR (dB/m)
1	37.24	34.5 QP	40.0	-5.5	1.00 V	135	39.51	-5.01
2	58.54	29.9 QP	40.0	-10.1	1.55 V	14	34.17	-4.27
3	218.88	32.4 QP	46.0	-13.6	1.99 V	185	39.27	-6.87
4	267.93	31.6 QP	46.0	-14.4	2.00 V	279	35.96	-4.36
5	320.05	39.1 QP	46.0	-6.9	1.00 V	121	41.86	-2.76
6	797.49	37.8 QP	46.0	-8.2	1.54 V	99	31.15	6.65

REMARKS:

1. Emission Level(dBuV/m) = Raw Value(dBuV) + Correction Factor(dB/m)
2. Correction Factor(dB/m) = Antenna Factor(dB/m) + Cable Factor(dB) – Pre-Amplifier Factor(dB)
3. The other emission levels were very low against the limit.
4. Margin value = Emission Level – Limit value

2TX

CDD Mode

802.11a

CHANNEL	TX Channel 36	DETECTOR FUNCTION	Quasi-Peak (QP)
FREQUENCY RANGE	30MHz ~ 1GHz		

ANTENNA POLARITY & TEST DISTANCE: HORIZONTAL AT 3 M

NO.	FREQ. (MHz)	EMISSION LEVEL (dBuV/m)	LIMIT (dBuV/m)	MARGIN (dB)	ANTENNA HEIGHT (m)	TABLE ANGLE (Degree)	RAW VALUE (dBuV)	CORRECTION FACTOR (dB/m)
1	42.48	31.7 QP	40.0	-8.3	1.56 H	289	36.04	-4.34
2	201.19	33.6 QP	43.5	-9.9	1.00 H	48	40.69	-7.09
3	314.90	41.4 QP	46.0	-4.6	1.00 H	298	44.28	-2.88
4	323.41	42.2 QP	46.0	-3.8	1.05 H	44	44.83	-2.63
5	498.25	35.6 QP	46.0	-10.4	1.51 H	150	34.23	1.37
6	931.01	38.6 QP	46.0	-7.4	1.55 H	68	29.83	8.77

ANTENNA POLARITY & TEST DISTANCE: VERTICAL AT 3 M

NO.	FREQ. (MHz)	EMISSION LEVEL (dBuV/m)	LIMIT (dBuV/m)	MARGIN (dB)	ANTENNA HEIGHT (m)	TABLE ANGLE (Degree)	RAW VALUE (dBuV)	CORRECTION FACTOR (dB/m)
1	36.98	34.8 QP	40.0	-5.2	1.07 V	116	39.87	-5.07
2	58.29	29.5 QP	40.0	-10.5	1.54 V	37	33.77	-4.27
3	219.38	32.9 QP	46.0	-13.1	2.00 V	194	39.78	-6.88
4	267.87	31.8 QP	46.0	-14.2	1.97 V	282	36.17	-4.37
5	319.49	38.9 QP	46.0	-7.1	1.02 V	136	41.67	-2.77
6	797.49	37.6 QP	46.0	-8.4	1.60 V	109	30.95	6.65

REMARKS:

1. Emission Level(dBuV/m) = Raw Value(dBuV) + Correction Factor(dB/m)
2. Correction Factor(dB/m) = Antenna Factor(dB/m) + Cable Factor(dB) – Pre-Amplifier Factor(dB)
3. The other emission levels were very low against the limit.
4. Margin value = Emission Level – Limit value

CHANNEL	TX Channel 40	DETECTOR FUNCTION	Quasi-Peak (QP)
FREQUENCY RANGE	30MHz ~ 1GHz		

ANTENNA POLARITY & TEST DISTANCE: HORIZONTAL AT 3 M

NO.	FREQ. (MHz)	EMISSION LEVEL (dBuV/m)	LIMIT (dBuV/m)	MARGIN (dB)	ANTENNA HEIGHT (m)	TABLE ANGLE (Degree)	RAW VALUE (dBuV)	CORRECTION FACTOR (dB/m)
1	42.25	31.6 QP	40.0	-8.4	1.53 H	277	35.98	-4.38
2	200.99	33.4 QP	43.5	-10.1	1.00 H	51	40.48	-7.08
3	314.73	41.2 QP	46.0	-4.8	1.00 H	303	44.09	-2.89
4	323.89	41.9 QP	46.0	-4.1	1.04 H	45	44.51	-2.61
5	498.01	35.6 QP	46.0	-10.4	1.47 H	150	34.24	1.36
6	931.01	39.0 QP	46.0	-7.0	1.58 H	64	30.23	8.77

ANTENNA POLARITY & TEST DISTANCE: VERTICAL AT 3 M

NO.	FREQ. (MHz)	EMISSION LEVEL (dBuV/m)	LIMIT (dBuV/m)	MARGIN (dB)	ANTENNA HEIGHT (m)	TABLE ANGLE (Degree)	RAW VALUE (dBuV)	CORRECTION FACTOR (dB/m)
1	37.31	34.8 QP	40.0	-5.2	1.00 V	128	39.79	-4.99
2	58.71	29.8 QP	40.0	-10.2	1.56 V	32	34.07	-4.27
3	219.22	33.0 QP	46.0	-13.0	1.99 V	173	39.88	-6.88
4	268.06	31.6 QP	46.0	-14.4	2.05 V	288	35.96	-4.36
5	319.49	38.6 QP	46.0	-7.4	1.06 V	134	41.37	-2.77
6	797.49	37.7 QP	46.0	-8.3	1.60 V	119	31.05	6.65

REMARKS:

1. Emission Level(dBuV/m) = Raw Value(dBuV) + Correction Factor(dB/m)
2. Correction Factor(dB/m) = Antenna Factor(dB/m) + Cable Factor(dB) – Pre-Amplifier Factor(dB)
3. The other emission levels were very low against the limit.
4. Margin value = Emission Level – Limit value

CHANNEL	TX Channel 48	DETECTOR FUNCTION	Quasi-Peak (QP)
FREQUENCY RANGE	30MHz ~ 1GHz		

ANTENNA POLARITY & TEST DISTANCE: HORIZONTAL AT 3 M

NO.	FREQ. (MHz)	EMISSION LEVEL (dBuV/m)	LIMIT (dBuV/m)	MARGIN (dB)	ANTENNA HEIGHT (m)	TABLE ANGLE (Degree)	RAW VALUE (dBuV)	CORRECTION FACTOR (dB/m)
1	42.49	31.9 QP	40.0	-8.1	1.58 H	261	36.24	-4.34
2	201.39	33.8 QP	43.5	-9.7	1.04 H	55	40.90	-7.10
3	314.93	41.8 QP	46.0	-4.2	1.00 H	273	44.68	-2.88
4	323.58	42.1 QP	46.0	-3.9	1.00 H	56	44.73	-2.63
5	498.16	35.7 QP	46.0	-10.3	1.52 H	141	34.33	1.37
6	931.01	38.7 QP	46.0	-7.3	1.53 H	78	29.93	8.77

ANTENNA POLARITY & TEST DISTANCE: VERTICAL AT 3 M

NO.	FREQ. (MHz)	EMISSION LEVEL (dBuV/m)	LIMIT (dBuV/m)	MARGIN (dB)	ANTENNA HEIGHT (m)	TABLE ANGLE (Degree)	RAW VALUE (dBuV)	CORRECTION FACTOR (dB/m)
1	37.09	34.7 QP	40.0	-5.3	1.00 V	127	39.74	-5.04
2	58.47	29.6 QP	40.0	-10.4	1.56 V	25	33.87	-4.27
3	219.41	32.8 QP	46.0	-13.2	2.03 V	180	39.68	-6.88
4	268.21	31.9 QP	46.0	-14.1	1.98 V	307	36.25	-4.35
5	319.54	38.6 QP	46.0	-7.4	1.02 V	144	41.37	-2.77
6	797.49	37.6 QP	46.0	-8.4	1.59 V	108	30.95	6.65

REMARKS:

1. Emission Level(dBuV/m) = Raw Value(dBuV) + Correction Factor(dB/m)
2. Correction Factor(dB/m) = Antenna Factor(dB/m) + Cable Factor(dB) – Pre-Amplifier Factor(dB)
3. The other emission levels were very low against the limit.
4. Margin value = Emission Level – Limit value

CHANNEL	TX Channel 52	DETECTOR FUNCTION	Quasi-Peak (QP)
FREQUENCY RANGE	30MHz ~ 1GHz		

ANTENNA POLARITY & TEST DISTANCE: HORIZONTAL AT 3 M

NO.	FREQ. (MHz)	EMISSION LEVEL (dBuV/m)	LIMIT (dBuV/m)	MARGIN (dB)	ANTENNA HEIGHT (m)	TABLE ANGLE (Degree)	RAW VALUE (dBuV)	CORRECTION FACTOR (dB/m)
1	42.73	31.7 QP	40.0	-8.3	1.64 H	263	36.00	-4.30
2	201.33	33.5 QP	43.5	-10.0	1.01 H	62	40.59	-7.09
3	315.12	41.7 QP	46.0	-4.3	1.00 H	282	44.57	-2.87
4	323.90	41.9 QP	46.0	-4.1	1.03 H	53	44.51	-2.61
5	498.29	35.7 QP	46.0	-10.3	1.43 H	152	34.33	1.37
6	931.01	38.8 QP	46.0	-7.2	1.52 H	52	30.03	8.77

ANTENNA POLARITY & TEST DISTANCE: VERTICAL AT 3 M

NO.	FREQ. (MHz)	EMISSION LEVEL (dBuV/m)	LIMIT (dBuV/m)	MARGIN (dB)	ANTENNA HEIGHT (m)	TABLE ANGLE (Degree)	RAW VALUE (dBuV)	CORRECTION FACTOR (dB/m)
1	37.24	34.8 QP	40.0	-5.2	1.03 V	129	39.81	-5.01
2	58.80	29.6 QP	40.0	-10.4	1.63 V	25	33.88	-4.28
3	219.39	32.5 QP	46.0	-13.5	2.00 V	186	39.38	-6.88
4	267.73	32.0 QP	46.0	-14.0	1.98 V	284	36.37	-4.37
5	319.93	38.8 QP	46.0	-7.2	1.02 V	132	41.56	-2.76
6	797.49	37.8 QP	46.0	-8.2	1.49 V	96	31.15	6.65

REMARKS:

1. Emission Level(dBuV/m) = Raw Value(dBuV) + Correction Factor(dB/m)
2. Correction Factor(dB/m) = Antenna Factor(dB/m) + Cable Factor(dB) – Pre-Amplifier Factor(dB)
3. The other emission levels were very low against the limit.
4. Margin value = Emission Level – Limit value

CHANNEL	TX Channel 60	DETECTOR FUNCTION	Quasi-Peak (QP)
FREQUENCY RANGE	30MHz ~ 1GHz		

ANTENNA POLARITY & TEST DISTANCE: HORIZONTAL AT 3 M

NO.	FREQ. (MHz)	EMISSION LEVEL (dBuV/m)	LIMIT (dBuV/m)	MARGIN (dB)	ANTENNA HEIGHT (m)	TABLE ANGLE (Degree)	RAW VALUE (dBuV)	CORRECTION FACTOR (dB/m)
1	42.68	32.0 QP	40.0	-8.0	1.65 H	276	36.31	-4.31
2	201.36	33.6 QP	43.5	-9.9	1.00 H	70	40.69	-7.09
3	314.62	41.4 QP	46.0	-4.6	1.00 H	298	44.29	-2.89
4	323.69	42.0 QP	46.0	-4.0	1.05 H	37	44.62	-2.62
5	498.03	36.1 QP	46.0	-9.9	1.43 H	142	34.74	1.36
6	931.01	39.0 QP	46.0	-7.0	1.58 H	55	30.23	8.77

ANTENNA POLARITY & TEST DISTANCE: VERTICAL AT 3 M

NO.	FREQ. (MHz)	EMISSION LEVEL (dBuV/m)	LIMIT (dBuV/m)	MARGIN (dB)	ANTENNA HEIGHT (m)	TABLE ANGLE (Degree)	RAW VALUE (dBuV)	CORRECTION FACTOR (dB/m)
1	36.92	35.0 QP	40.0	-5.0	1.06 V	109	40.08	-5.08
2	58.62	29.8 QP	40.0	-10.2	1.62 V	35	34.07	-4.27
3	219.12	32.4 QP	46.0	-13.6	2.00 V	174	39.28	-6.88
4	267.91	31.8 QP	46.0	-14.2	2.04 V	307	36.16	-4.36
5	319.75	38.5 QP	46.0	-7.5	1.07 V	131	41.27	-2.77
6	797.49	37.6 QP	46.0	-8.4	1.54 V	90	30.95	6.65

REMARKS:

1. Emission Level(dBuV/m) = Raw Value(dBuV) + Correction Factor(dB/m)
2. Correction Factor(dB/m) = Antenna Factor(dB/m) + Cable Factor(dB) – Pre-Amplifier Factor(dB)
3. The other emission levels were very low against the limit.
4. Margin value = Emission Level – Limit value

CHANNEL	TX Channel 64	DETECTOR FUNCTION	Quasi-Peak (QP)
FREQUENCY RANGE	30MHz ~ 1GHz		

ANTENNA POLARITY & TEST DISTANCE: HORIZONTAL AT 3 M

NO.	FREQ. (MHz)	EMISSION LEVEL (dBUV/m)	LIMIT (dBUV/m)	MARGIN (dB)	ANTENNA HEIGHT (m)	TABLE ANGLE (Degree)	RAW VALUE (dBUV)	CORRECTION FACTOR (dB/m)
1	42.34	31.7 QP	40.0	-8.3	1.60 H	278	36.07	-4.37
2	201.01	33.3 QP	43.5	-10.2	1.00 H	69	40.38	-7.08
3	314.89	41.8 QP	46.0	-4.2	1.01 H	303	44.68	-2.88
4	323.67	42.0 QP	46.0	-4.0	1.00 H	41	44.62	-2.62
5	498.29	35.7 QP	46.0	-10.3	1.46 H	131	34.33	1.37
6	931.01	39.1 QP	46.0	-6.9	1.56 H	60	30.33	8.77

ANTENNA POLARITY & TEST DISTANCE: VERTICAL AT 3 M

NO.	FREQ. (MHz)	EMISSION LEVEL (dBUV/m)	LIMIT (dBUV/m)	MARGIN (dB)	ANTENNA HEIGHT (m)	TABLE ANGLE (Degree)	RAW VALUE (dBUV)	CORRECTION FACTOR (dB/m)
1	36.91	34.9 QP	40.0	-5.1	1.00 V	121	39.99	-5.09
2	58.79	29.6 QP	40.0	-10.4	1.59 V	43	33.88	-4.28
3	219.20	32.8 QP	46.0	-13.2	2.06 V	179	39.68	-6.88
4	267.66	31.9 QP	46.0	-14.1	2.02 V	288	36.28	-4.38
5	319.71	39.1 QP	46.0	-6.9	1.00 V	132	41.87	-2.77
6	797.49	37.8 QP	46.0	-8.2	1.51 V	109	31.15	6.65

REMARKS:

1. Emission Level(dBUV/m) = Raw Value(dBUV) + Correction Factor(dB/m)
2. Correction Factor(dB/m) = Antenna Factor(dB/m) + Cable Factor(dB) – Pre-Amplifier Factor(dB)
3. The other emission levels were very low against the limit.
4. Margin value = Emission Level – Limit value

CHANNEL	TX Channel 100	DETECTOR FUNCTION	Quasi-Peak (QP)
FREQUENCY RANGE	30MHz ~ 1GHz		

ANTENNA POLARITY & TEST DISTANCE: HORIZONTAL AT 3 M

NO.	FREQ. (MHz)	EMISSION LEVEL (dBuV/m)	LIMIT (dBuV/m)	MARGIN (dB)	ANTENNA HEIGHT (m)	TABLE ANGLE (Degree)	RAW VALUE (dBuV)	CORRECTION FACTOR (dB/m)
1	42.71	31.8 QP	40.0	-8.2	1.56 H	276	36.10	-4.30
2	200.86	33.3 QP	43.5	-10.2	1.00 H	52	40.37	-7.07
3	315.05	41.4 QP	46.0	-4.6	1.05 H	297	44.27	-2.87
4	323.74	41.6 QP	46.0	-4.4	1.00 H	43	44.22	-2.62
5	498.41	35.9 QP	46.0	-10.1	1.44 H	131	34.53	1.37
6	931.01	39.0 QP	46.0	-7.0	1.61 H	60	30.23	8.77

ANTENNA POLARITY & TEST DISTANCE: VERTICAL AT 3 M

NO.	FREQ. (MHz)	EMISSION LEVEL (dBuV/m)	LIMIT (dBuV/m)	MARGIN (dB)	ANTENNA HEIGHT (m)	TABLE ANGLE (Degree)	RAW VALUE (dBuV)	CORRECTION FACTOR (dB/m)
1	36.90	34.5 QP	40.0	-5.5	1.00 V	125	39.59	-5.09
2	58.70	29.7 QP	40.0	-10.3	1.54 V	39	33.97	-4.27
3	218.91	32.5 QP	46.0	-13.5	2.07 V	193	39.37	-6.87
4	267.92	31.8 QP	46.0	-14.2	2.06 V	279	36.16	-4.36
5	320.01	38.6 QP	46.0	-7.4	1.08 V	148	41.36	-2.76
6	797.49	37.5 QP	46.0	-8.5	1.56 V	91	30.85	6.65

REMARKS:

1. Emission Level(dBuV/m) = Raw Value(dBuV) + Correction Factor(dB/m)
2. Correction Factor(dB/m) = Antenna Factor(dB/m) + Cable Factor(dB) – Pre-Amplifier Factor(dB)
3. The other emission levels were very low against the limit.
4. Margin value = Emission Level – Limit value

CHANNEL	TX Channel 116	DETECTOR FUNCTION	Quasi-Peak (QP)
FREQUENCY RANGE	30MHz ~ 1GHz		

ANTENNA POLARITY & TEST DISTANCE: HORIZONTAL AT 3 M

NO.	FREQ. (MHz)	EMISSION LEVEL (dBuV/m)	LIMIT (dBuV/m)	MARGIN (dB)	ANTENNA HEIGHT (m)	TABLE ANGLE (Degree)	RAW VALUE (dBuV)	CORRECTION FACTOR (dB/m)
1	42.29	31.9 QP	40.0	-8.1	1.60 H	285	36.28	-4.38
2	201.12	33.4 QP	43.5	-10.1	1.00 H	65	40.48	-7.08
3	314.64	41.4 QP	46.0	-4.6	1.00 H	292	44.29	-2.89
4	323.93	41.9 QP	46.0	-4.1	1.00 H	44	44.51	-2.61
5	498.00	35.8 QP	46.0	-10.2	1.52 H	152	34.44	1.36
6	931.01	38.6 QP	46.0	-7.4	1.54 H	81	29.83	8.77

ANTENNA POLARITY & TEST DISTANCE: VERTICAL AT 3 M

NO.	FREQ. (MHz)	EMISSION LEVEL (dBuV/m)	LIMIT (dBuV/m)	MARGIN (dB)	ANTENNA HEIGHT (m)	TABLE ANGLE (Degree)	RAW VALUE (dBuV)	CORRECTION FACTOR (dB/m)
1	36.98	35.0 QP	40.0	-5.0	1.03 V	113	40.07	-5.07
2	58.69	29.9 QP	40.0	-10.1	1.55 V	33	34.17	-4.27
3	219.10	32.8 QP	46.0	-13.2	2.05 V	189	39.68	-6.88
4	268.02	31.7 QP	46.0	-14.3	2.02 V	301	36.06	-4.36
5	319.52	39.0 QP	46.0	-7.0	1.00 V	137	41.77	-2.77
6	797.49	37.9 QP	46.0	-8.1	1.50 V	111	31.25	6.65

REMARKS:

1. Emission Level(dBuV/m) = Raw Value(dBuV) + Correction Factor(dB/m)
2. Correction Factor(dB/m) = Antenna Factor(dB/m) + Cable Factor(dB) – Pre-Amplifier Factor(dB)
3. The other emission levels were very low against the limit.
4. Margin value = Emission Level – Limit value

CHANNEL	TX Channel 140	DETECTOR FUNCTION	Quasi-Peak (QP)
FREQUENCY RANGE	30MHz ~ 1GHz		

ANTENNA POLARITY & TEST DISTANCE: HORIZONTAL AT 3 M

NO.	FREQ. (MHz)	EMISSION LEVEL (dBuV/m)	LIMIT (dBuV/m)	MARGIN (dB)	ANTENNA HEIGHT (m)	TABLE ANGLE (Degree)	RAW VALUE (dBuV)	CORRECTION FACTOR (dB/m)
1	42.31	31.6 QP	40.0	-8.4	1.53 H	272	35.97	-4.37
2	201.06	33.7 QP	43.5	-9.8	1.00 H	43	40.78	-7.08
3	314.83	41.4 QP	46.0	-4.6	1.03 H	293	44.28	-2.88
4	323.53	41.9 QP	46.0	-4.1	1.02 H	50	44.53	-2.63
5	498.07	36.1 QP	46.0	-9.9	1.45 H	151	34.74	1.36
6	931.01	38.7 QP	46.0	-7.3	1.52 H	81	29.93	8.77

ANTENNA POLARITY & TEST DISTANCE: VERTICAL AT 3 M

NO.	FREQ. (MHz)	EMISSION LEVEL (dBuV/m)	LIMIT (dBuV/m)	MARGIN (dB)	ANTENNA HEIGHT (m)	TABLE ANGLE (Degree)	RAW VALUE (dBuV)	CORRECTION FACTOR (dB/m)
1	37.10	34.6 QP	40.0	-5.4	1.03 V	125	39.64	-5.04
2	58.81	29.4 QP	40.0	-10.6	1.59 V	37	33.68	-4.28
3	219.04	32.8 QP	46.0	-13.2	2.08 V	195	39.68	-6.88
4	267.68	32.1 QP	46.0	-13.9	2.06 V	283	36.47	-4.37
5	319.78	38.6 QP	46.0	-7.4	1.00 V	126	41.36	-2.76
6	797.49	38.0 QP	46.0	-8.0	1.60 V	98	31.35	6.65

REMARKS:

1. Emission Level(dBuV/m) = Raw Value(dBuV) + Correction Factor(dB/m)
2. Correction Factor(dB/m) = Antenna Factor(dB/m) + Cable Factor(dB) – Pre-Amplifier Factor(dB)
3. The other emission levels were very low against the limit.
4. Margin value = Emission Level – Limit value

CHANNEL	TX Channel 144	DETECTOR FUNCTION	Quasi-Peak (QP)
FREQUENCY RANGE	30MHz ~ 1GHz		

ANTENNA POLARITY & TEST DISTANCE: HORIZONTAL AT 3 M

NO.	FREQ. (MHz)	EMISSION LEVEL (dBuV/m)	LIMIT (dBuV/m)	MARGIN (dB)	ANTENNA HEIGHT (m)	TABLE ANGLE (Degree)	RAW VALUE (dBuV)	CORRECTION FACTOR (dB/m)
1	42.63	31.5 QP	40.0	-8.5	1.58 H	273	35.82	-4.32
2	201.24	33.3 QP	43.5	-10.2	1.00 H	52	40.39	-7.09
3	315.14	41.5 QP	46.0	-4.5	1.05 H	289	44.37	-2.87
4	323.55	41.7 QP	46.0	-4.3	1.02 H	59	44.33	-2.63
5	498.36	35.6 QP	46.0	-10.4	1.44 H	145	34.23	1.37
6	931.01	38.6 QP	46.0	-7.4	1.53 H	57	29.83	8.77

ANTENNA POLARITY & TEST DISTANCE: VERTICAL AT 3 M

NO.	FREQ. (MHz)	EMISSION LEVEL (dBuV/m)	LIMIT (dBuV/m)	MARGIN (dB)	ANTENNA HEIGHT (m)	TABLE ANGLE (Degree)	RAW VALUE (dBuV)	CORRECTION FACTOR (dB/m)
1	37.06	35.0 QP	40.0	-5.0	1.00 V	129	40.05	-5.05
2	58.80	29.8 QP	40.0	-10.2	1.55 V	36	34.08	-4.28
3	219.05	32.5 QP	46.0	-13.5	2.07 V	191	39.38	-6.88
4	267.71	31.5 QP	46.0	-14.5	2.02 V	292	35.87	-4.37
5	319.86	38.6 QP	46.0	-7.4	1.01 V	150	41.36	-2.76
6	797.49	37.6 QP	46.0	-8.4	1.61 V	92	30.95	6.65

REMARKS:

1. Emission Level(dBuV/m) = Raw Value(dBuV) + Correction Factor(dB/m)
2. Correction Factor(dB/m) = Antenna Factor(dB/m) + Cable Factor(dB) – Pre-Amplifier Factor(dB)
3. The other emission levels were very low against the limit.
4. Margin value = Emission Level – Limit value

CHANNEL	TX Channel 149	DETECTOR FUNCTION	Quasi-Peak (QP)
FREQUENCY RANGE	30MHz ~ 1GHz		

ANTENNA POLARITY & TEST DISTANCE: HORIZONTAL AT 3 M

NO.	FREQ. (MHz)	EMISSION LEVEL (dBuV/m)	LIMIT (dBuV/m)	MARGIN (dB)	ANTENNA HEIGHT (m)	TABLE ANGLE (Degree)	RAW VALUE (dBuV)	CORRECTION FACTOR (dB/m)
1	42.45	31.8 QP	40.0	-8.2	1.63 H	288	36.15	-4.35
2	201.10	33.6 QP	43.5	-9.9	1.03 H	62	40.68	-7.08
3	315.02	41.4 QP	46.0	-4.6	1.00 H	296	44.27	-2.87
4	323.77	41.8 QP	46.0	-4.2	1.04 H	52	44.42	-2.62
5	497.89	36.2 QP	46.0	-9.8	1.47 H	137	34.84	1.36
6	931.01	39.1 QP	46.0	-6.9	1.56 H	80	30.33	8.77

ANTENNA POLARITY & TEST DISTANCE: VERTICAL AT 3 M

NO.	FREQ. (MHz)	EMISSION LEVEL (dBuV/m)	LIMIT (dBuV/m)	MARGIN (dB)	ANTENNA HEIGHT (m)	TABLE ANGLE (Degree)	RAW VALUE (dBuV)	CORRECTION FACTOR (dB/m)
1	37.25	34.9 QP	40.0	-5.1	1.00 V	132	39.90	-5.00
2	58.83	29.9 QP	40.0	-10.1	1.59 V	14	34.18	-4.28
3	219.18	32.7 QP	46.0	-13.3	2.00 V	186	39.58	-6.88
4	267.80	31.6 QP	46.0	-14.4	2.03 V	293	35.97	-4.37
5	319.56	38.8 QP	46.0	-7.2	1.06 V	138	41.57	-2.77
6	797.49	37.9 QP	46.0	-8.1	1.58 V	108	31.25	6.65

REMARKS:

1. Emission Level(dBuV/m) = Raw Value(dBuV) + Correction Factor(dB/m)
2. Correction Factor(dB/m) = Antenna Factor(dB/m) + Cable Factor(dB) – Pre-Amplifier Factor(dB)
3. The other emission levels were very low against the limit.
4. Margin value = Emission Level – Limit value

CHANNEL	TX Channel 157	DETECTOR FUNCTION	Quasi-Peak (QP)
FREQUENCY RANGE	30MHz ~ 1GHz		

ANTENNA POLARITY & TEST DISTANCE: HORIZONTAL AT 3 M

NO.	FREQ. (MHz)	EMISSION LEVEL (dBuV/m)	LIMIT (dBuV/m)	MARGIN (dB)	ANTENNA HEIGHT (m)	TABLE ANGLE (Degree)	RAW VALUE (dBuV)	CORRECTION FACTOR (dB/m)
1	42.42	31.8 QP	40.0	-8.2	1.57 H	269	36.15	-4.35
2	201.24	33.8 QP	43.5	-9.7	1.05 H	69	40.89	-7.09
3	314.74	41.5 QP	46.0	-4.5	1.00 H	276	44.39	-2.89
4	323.61	42.2 QP	46.0	-3.8	1.04 H	36	44.83	-2.63
5	498.23	35.8 QP	46.0	-10.2	1.48 H	135	34.43	1.37
6	931.01	39.1 QP	46.0	-6.9	1.62 H	56	30.33	8.77

ANTENNA POLARITY & TEST DISTANCE: VERTICAL AT 3 M

NO.	FREQ. (MHz)	EMISSION LEVEL (dBuV/m)	LIMIT (dBuV/m)	MARGIN (dB)	ANTENNA HEIGHT (m)	TABLE ANGLE (Degree)	RAW VALUE (dBuV)	CORRECTION FACTOR (dB/m)
1	37.14	34.6 QP	40.0	-5.4	1.00 V	117	39.63	-5.03
2	58.28	29.9 QP	40.0	-10.1	1.57 V	41	34.17	-4.27
3	219.10	32.5 QP	46.0	-13.5	2.07 V	179	39.38	-6.88
4	267.88	31.8 QP	46.0	-14.2	2.02 V	290	36.17	-4.37
5	319.95	39.0 QP	46.0	-7.0	1.08 V	131	41.76	-2.76
6	797.49	38.1 QP	46.0	-7.9	1.58 V	92	31.45	6.65

REMARKS:

1. Emission Level(dBuV/m) = Raw Value(dBuV) + Correction Factor(dB/m)
2. Correction Factor(dB/m) = Antenna Factor(dB/m) + Cable Factor(dB) – Pre-Amplifier Factor(dB)
3. The other emission levels were very low against the limit.
4. Margin value = Emission Level – Limit value

CHANNEL	TX Channel 165	DETECTOR FUNCTION	Quasi-Peak (QP)
FREQUENCY RANGE	30MHz ~ 1GHz		

ANTENNA POLARITY & TEST DISTANCE: HORIZONTAL AT 3 M

NO.	FREQ. (MHz)	EMISSION LEVEL (dBuV/m)	LIMIT (dBuV/m)	MARGIN (dB)	ANTENNA HEIGHT (m)	TABLE ANGLE (Degree)	RAW VALUE (dBuV)	CORRECTION FACTOR (dB/m)
1	42.42	32.0 QP	40.0	-8.0	1.56 H	273	36.35	-4.35
2	201.28	33.7 QP	43.5	-9.8	1.02 H	63	40.79	-7.09
3	315.08	41.8 QP	46.0	-4.2	1.02 H	283	44.67	-2.87
4	323.68	41.9 QP	46.0	-4.1	1.01 H	44	44.52	-2.62
5	497.93	35.7 QP	46.0	-10.3	1.52 H	145	34.34	1.36
6	931.01	39.0 QP	46.0	-7.0	1.58 H	73	30.23	8.77

ANTENNA POLARITY & TEST DISTANCE: VERTICAL AT 3 M

NO.	FREQ. (MHz)	EMISSION LEVEL (dBuV/m)	LIMIT (dBuV/m)	MARGIN (dB)	ANTENNA HEIGHT (m)	TABLE ANGLE (Degree)	RAW VALUE (dBuV)	CORRECTION FACTOR (dB/m)
1	37.19	34.5 QP	40.0	-5.5	1.00 V	129	39.52	-5.02
2	58.41	29.8 QP	40.0	-10.2	1.56 V	26	34.07	-4.27
3	218.83	32.9 QP	46.0	-13.1	2.04 V	189	39.77	-6.87
4	267.79	31.6 QP	46.0	-14.4	2.03 V	292	35.97	-4.37
5	319.54	39.0 QP	46.0	-7.0	1.03 V	124	41.77	-2.77
6	797.49	37.8 QP	46.0	-8.2	1.56 V	104	31.15	6.65

REMARKS:

1. Emission Level(dBuV/m) = Raw Value(dBuV) + Correction Factor(dB/m)
2. Correction Factor(dB/m) = Antenna Factor(dB/m) + Cable Factor(dB) – Pre-Amplifier Factor(dB)
3. The other emission levels were very low against the limit.
4. Margin value = Emission Level – Limit value

Beamforming Mode

802.11ac VHT20

CHANNEL	TX Channel 36	DETECTOR FUNCTION	Quasi-Peak (QP)
FREQUENCY RANGE	30MHz ~ 1GHz		

ANTENNA POLARITY & TEST DISTANCE: HORIZONTAL AT 3 M

NO.	FREQ. (MHz)	EMISSION LEVEL (dBuV/m)	LIMIT (dBuV/m)	MARGIN (dB)	ANTENNA HEIGHT (m)	TABLE ANGLE (Degree)	RAW VALUE (dBuV)	CORRECTION FACTOR (dB/m)
1	42.50	31.8 QP	40.0	-8.2	1.56 H	287	36.14	-4.34
2	200.97	33.3 QP	43.5	-10.2	1.00 H	66	40.38	-7.08
3	314.79	41.2 QP	46.0	-4.8	1.00 H	285	44.08	-2.88
4	323.48	42.2 QP	46.0	-3.8	1.00 H	37	44.83	-2.63
5	497.97	35.7 QP	46.0	-10.3	1.47 H	130	34.34	1.36
6	931.01	39.1 QP	46.0	-6.9	1.59 H	62	30.33	8.77

ANTENNA POLARITY & TEST DISTANCE: VERTICAL AT 3 M

NO.	FREQ. (MHz)	EMISSION LEVEL (dBuV/m)	LIMIT (dBuV/m)	MARGIN (dB)	ANTENNA HEIGHT (m)	TABLE ANGLE (Degree)	RAW VALUE (dBuV)	CORRECTION FACTOR (dB/m)
1	36.96	34.6 QP	40.0	-5.4	1.04 V	126	39.67	-5.07
2	58.46	29.9 QP	40.0	-10.1	1.61 V	37	34.17	-4.27
3	219.40	32.6 QP	46.0	-13.4	2.00 V	202	39.48	-6.88
4	267.87	31.7 QP	46.0	-14.3	1.98 V	308	36.07	-4.37
5	319.85	38.9 QP	46.0	-7.1	1.02 V	130	41.66	-2.76
6	797.49	37.7 QP	46.0	-8.3	1.54 V	100	31.05	6.65

REMARKS:

1. Emission Level(dBuV/m) = Raw Value(dBuV) + Correction Factor(dB/m)
2. Correction Factor(dB/m) = Antenna Factor(dB/m) + Cable Factor(dB) – Pre-Amplifier Factor(dB)
3. The other emission levels were very low against the limit.
4. Margin value = Emission Level – Limit value

CHANNEL	TX Channel 40	DETECTOR FUNCTION	Quasi-Peak (QP)
FREQUENCY RANGE	30MHz ~ 1GHz		

ANTENNA POLARITY & TEST DISTANCE: HORIZONTAL AT 3 M

NO.	FREQ. (MHz)	EMISSION LEVEL (dBuV/m)	LIMIT (dBuV/m)	MARGIN (dB)	ANTENNA HEIGHT (m)	TABLE ANGLE (Degree)	RAW VALUE (dBuV)	CORRECTION FACTOR (dB/m)
1	42.69	31.7 QP	40.0	-8.3	1.58 H	259	36.01	-4.31
2	201.10	33.8 QP	43.5	-9.7	1.00 H	65	40.88	-7.08
3	314.82	41.3 QP	46.0	-4.7	1.03 H	289	44.18	-2.88
4	323.76	41.7 QP	46.0	-4.3	1.00 H	55	44.32	-2.62
5	498.33	35.6 QP	46.0	-10.4	1.49 H	149	34.23	1.37
6	931.01	38.8 QP	46.0	-7.2	1.58 H	79	30.03	8.77

ANTENNA POLARITY & TEST DISTANCE: VERTICAL AT 3 M

NO.	FREQ. (MHz)	EMISSION LEVEL (dBuV/m)	LIMIT (dBuV/m)	MARGIN (dB)	ANTENNA HEIGHT (m)	TABLE ANGLE (Degree)	RAW VALUE (dBuV)	CORRECTION FACTOR (dB/m)
1	37.31	34.8 QP	40.0	-5.2	1.00 V	119	39.79	-4.99
2	58.67	29.7 QP	40.0	-10.3	1.55 V	29	33.97	-4.27
3	219.15	32.5 QP	46.0	-13.5	1.99 V	176	39.38	-6.88
4	267.70	31.7 QP	46.0	-14.3	1.96 V	300	36.07	-4.37
5	319.99	38.8 QP	46.0	-7.2	1.00 V	150	41.56	-2.76
6	797.49	37.6 QP	46.0	-8.4	1.54 V	112	30.95	6.65

REMARKS:

1. Emission Level(dBuV/m) = Raw Value(dBuV) + Correction Factor(dB/m)
2. Correction Factor(dB/m) = Antenna Factor(dB/m) + Cable Factor(dB) – Pre-Amplifier Factor(dB)
3. The other emission levels were very low against the limit.
4. Margin value = Emission Level – Limit value

CHANNEL	TX Channel 48	DETECTOR FUNCTION	Quasi-Peak (QP)
FREQUENCY RANGE	30MHz ~ 1GHz		

ANTENNA POLARITY & TEST DISTANCE: HORIZONTAL AT 3 M

NO.	FREQ. (MHz)	EMISSION LEVEL (dBuV/m)	LIMIT (dBuV/m)	MARGIN (dB)	ANTENNA HEIGHT (m)	TABLE ANGLE (Degree)	RAW VALUE (dBuV)	CORRECTION FACTOR (dB/m)
1	42.32	32.0 QP	40.0	-8.0	1.54 H	261	36.37	-4.37
2	201.23	33.3 QP	43.5	-10.2	1.00 H	58	40.39	-7.09
3	314.70	41.8 QP	46.0	-4.2	1.00 H	291	44.69	-2.89
4	323.88	41.9 QP	46.0	-4.1	1.05 H	42	44.51	-2.61
5	497.99	35.9 QP	46.0	-10.1	1.47 H	131	34.54	1.36
6	931.01	38.9 QP	46.0	-7.1	1.51 H	66	30.13	8.77

ANTENNA POLARITY & TEST DISTANCE: VERTICAL AT 3 M

NO.	FREQ. (MHz)	EMISSION LEVEL (dBuV/m)	LIMIT (dBuV/m)	MARGIN (dB)	ANTENNA HEIGHT (m)	TABLE ANGLE (Degree)	RAW VALUE (dBuV)	CORRECTION FACTOR (dB/m)
1	37.16	34.6 QP	40.0	-5.4	1.01 V	110	39.63	-5.03
2	58.60	29.5 QP	40.0	-10.5	1.51 V	28	33.77	-4.27
3	219.08	32.9 QP	46.0	-13.1	1.98 V	189	39.78	-6.88
4	267.70	32.0 QP	46.0	-14.0	2.04 V	280	36.37	-4.37
5	319.97	38.7 QP	46.0	-7.3	1.00 V	137	41.46	-2.76
6	797.49	38.0 QP	46.0	-8.0	1.51 V	103	31.35	6.65

REMARKS:

1. Emission Level(dBuV/m) = Raw Value(dBuV) + Correction Factor(dB/m)
2. Correction Factor(dB/m) = Antenna Factor(dB/m) + Cable Factor(dB) – Pre-Amplifier Factor(dB)
3. The other emission levels were very low against the limit.
4. Margin value = Emission Level – Limit value

CHANNEL	TX Channel 52	DETECTOR FUNCTION	Quasi-Peak (QP)
FREQUENCY RANGE	30MHz ~ 1GHz		

ANTENNA POLARITY & TEST DISTANCE: HORIZONTAL AT 3 M

NO.	FREQ. (MHz)	EMISSION LEVEL (dBuV/m)	LIMIT (dBuV/m)	MARGIN (dB)	ANTENNA HEIGHT (m)	TABLE ANGLE (Degree)	RAW VALUE (dBuV)	CORRECTION FACTOR (dB/m)
1	42.54	31.6 QP	40.0	-8.4	1.62 H	287	35.93	-4.33
2	201.03	33.5 QP	43.5	-10.0	1.01 H	59	40.58	-7.08
3	314.71	41.4 QP	46.0	-4.6	1.00 H	290	44.29	-2.89
4	323.52	41.9 QP	46.0	-4.1	1.01 H	34	44.53	-2.63
5	498.38	36.1 QP	46.0	-9.9	1.46 H	130	34.73	1.37
6	931.01	38.9 QP	46.0	-7.1	1.58 H	72	30.13	8.77

ANTENNA POLARITY & TEST DISTANCE: VERTICAL AT 3 M

NO.	FREQ. (MHz)	EMISSION LEVEL (dBuV/m)	LIMIT (dBuV/m)	MARGIN (dB)	ANTENNA HEIGHT (m)	TABLE ANGLE (Degree)	RAW VALUE (dBuV)	CORRECTION FACTOR (dB/m)
1	37.35	34.6 QP	40.0	-5.4	1.00 V	129	39.58	-4.98
2	58.33	29.7 QP	40.0	-10.3	1.60 V	22	33.97	-4.27
3	219.03	32.8 QP	46.0	-13.2	2.05 V	196	39.68	-6.88
4	267.88	31.7 QP	46.0	-14.3	2.06 V	284	36.07	-4.37
5	319.84	39.0 QP	46.0	-7.0	1.01 V	132	41.76	-2.76
6	797.49	37.9 QP	46.0	-8.1	1.57 V	104	31.25	6.65

REMARKS:

1. Emission Level(dBuV/m) = Raw Value(dBuV) + Correction Factor(dB/m)
2. Correction Factor(dB/m) = Antenna Factor(dB/m) + Cable Factor(dB) – Pre-Amplifier Factor(dB)
3. The other emission levels were very low against the limit.
4. Margin value = Emission Level – Limit value

CHANNEL	TX Channel 60	DETECTOR FUNCTION	Quasi-Peak (QP)
FREQUENCY RANGE	30MHz ~ 1GHz		

ANTENNA POLARITY & TEST DISTANCE: HORIZONTAL AT 3 M

NO.	FREQ. (MHz)	EMISSION LEVEL (dBuV/m)	LIMIT (dBuV/m)	MARGIN (dB)	ANTENNA HEIGHT (m)	TABLE ANGLE (Degree)	RAW VALUE (dBuV)	CORRECTION FACTOR (dB/m)
1	42.38	31.8 QP	40.0	-8.2	1.57 H	289	36.16	-4.36
2	201.27	33.6 QP	43.5	-9.9	1.06 H	42	40.69	-7.09
3	314.84	41.7 QP	46.0	-4.3	1.00 H	299	44.58	-2.88
4	323.67	41.8 QP	46.0	-4.2	1.01 H	50	44.42	-2.62
5	498.25	36.1 QP	46.0	-9.9	1.52 H	154	34.73	1.37
6	931.01	38.8 QP	46.0	-7.2	1.58 H	81	30.03	8.77

ANTENNA POLARITY & TEST DISTANCE: VERTICAL AT 3 M

NO.	FREQ. (MHz)	EMISSION LEVEL (dBuV/m)	LIMIT (dBuV/m)	MARGIN (dB)	ANTENNA HEIGHT (m)	TABLE ANGLE (Degree)	RAW VALUE (dBuV)	CORRECTION FACTOR (dB/m)
1	37.28	34.8 QP	40.0	-5.2	1.05 V	110	39.80	-5.00
2	58.40	29.4 QP	40.0	-10.6	1.57 V	44	33.67	-4.27
3	219.00	32.9 QP	46.0	-13.1	1.97 V	191	39.77	-6.87
4	268.05	32.0 QP	46.0	-14.0	1.98 V	295	36.36	-4.36
5	319.76	38.8 QP	46.0	-7.2	1.00 V	151	41.56	-2.76
6	797.49	37.5 QP	46.0	-8.5	1.60 V	89	30.85	6.65

REMARKS:

1. Emission Level(dBuV/m) = Raw Value(dBuV) + Correction Factor(dB/m)
2. Correction Factor(dB/m) = Antenna Factor(dB/m) + Cable Factor(dB) – Pre-Amplifier Factor(dB)
3. The other emission levels were very low against the limit.
4. Margin value = Emission Level – Limit value

CHANNEL	TX Channel 64	DETECTOR FUNCTION	Quasi-Peak (QP)
FREQUENCY RANGE	30MHz ~ 1GHz		

ANTENNA POLARITY & TEST DISTANCE: HORIZONTAL AT 3 M

NO.	FREQ. (MHz)	EMISSION LEVEL (dBuV/m)	LIMIT (dBuV/m)	MARGIN (dB)	ANTENNA HEIGHT (m)	TABLE ANGLE (Degree)	RAW VALUE (dBuV)	CORRECTION FACTOR (dB/m)
1	42.48	31.4 QP	40.0	-8.6	1.60 H	261	35.74	-4.34
2	201.38	33.6 QP	43.5	-9.9	1.04 H	61	40.70	-7.10
3	314.70	41.4 QP	46.0	-4.6	1.02 H	289	44.29	-2.89
4	323.70	41.7 QP	46.0	-4.3	1.02 H	50	44.32	-2.62
5	498.36	35.8 QP	46.0	-10.2	1.41 H	144	34.43	1.37
6	931.01	38.7 QP	46.0	-7.3	1.53 H	69	29.93	8.77

ANTENNA POLARITY & TEST DISTANCE: VERTICAL AT 3 M

NO.	FREQ. (MHz)	EMISSION LEVEL (dBuV/m)	LIMIT (dBuV/m)	MARGIN (dB)	ANTENNA HEIGHT (m)	TABLE ANGLE (Degree)	RAW VALUE (dBuV)	CORRECTION FACTOR (dB/m)
1	37.06	34.6 QP	40.0	-5.4	1.03 V	118	39.65	-5.05
2	58.42	29.7 QP	40.0	-10.3	1.52 V	14	33.97	-4.27
3	218.92	32.8 QP	46.0	-13.2	1.99 V	176	39.67	-6.87
4	267.73	31.7 QP	46.0	-14.3	1.97 V	308	36.07	-4.37
5	319.55	38.5 QP	46.0	-7.5	1.06 V	143	41.27	-2.77
6	797.49	37.9 QP	46.0	-8.1	1.59 V	111	31.25	6.65

REMARKS:

1. Emission Level(dBuV/m) = Raw Value(dBuV) + Correction Factor(dB/m)
2. Correction Factor(dB/m) = Antenna Factor(dB/m) + Cable Factor(dB) – Pre-Amplifier Factor(dB)
3. The other emission levels were very low against the limit.
4. Margin value = Emission Level – Limit value

CHANNEL	TX Channel 100	DETECTOR FUNCTION	Quasi-Peak (QP)
FREQUENCY RANGE	30MHz ~ 1GHz		

ANTENNA POLARITY & TEST DISTANCE: HORIZONTAL AT 3 M

NO.	FREQ. (MHz)	EMISSION LEVEL (dBuV/m)	LIMIT (dBuV/m)	MARGIN (dB)	ANTENNA HEIGHT (m)	TABLE ANGLE (Degree)	RAW VALUE (dBuV)	CORRECTION FACTOR (dB/m)
1	42.60	31.8 QP	40.0	-8.2	1.55 H	265	36.12	-4.32
2	200.88	33.7 QP	43.5	-9.8	1.00 H	63	40.78	-7.08
3	314.66	41.6 QP	46.0	-4.4	1.00 H	281	44.49	-2.89
4	323.78	41.7 QP	46.0	-4.3	1.03 H	64	44.32	-2.62
5	498.23	35.9 QP	46.0	-10.1	1.51 H	140	34.53	1.37
6	931.01	38.9 QP	46.0	-7.1	1.59 H	66	30.13	8.77

ANTENNA POLARITY & TEST DISTANCE: VERTICAL AT 3 M

NO.	FREQ. (MHz)	EMISSION LEVEL (dBuV/m)	LIMIT (dBuV/m)	MARGIN (dB)	ANTENNA HEIGHT (m)	TABLE ANGLE (Degree)	RAW VALUE (dBuV)	CORRECTION FACTOR (dB/m)
1	36.82	34.6 QP	40.0	-5.4	1.01 V	133	39.72	-5.12
2	58.53	29.3 QP	40.0	-10.7	1.58 V	29	33.57	-4.27
3	218.98	32.7 QP	46.0	-13.3	1.98 V	174	39.57	-6.87
4	267.98	32.0 QP	46.0	-14.0	2.01 V	289	36.36	-4.36
5	320.04	39.0 QP	46.0	-7.0	1.06 V	148	41.76	-2.76
6	797.49	37.5 QP	46.0	-8.5	1.60 V	116	30.85	6.65

REMARKS:

1. Emission Level(dBuV/m) = Raw Value(dBuV) + Correction Factor(dB/m)
2. Correction Factor(dB/m) = Antenna Factor(dB/m) + Cable Factor(dB) – Pre-Amplifier Factor(dB)
3. The other emission levels were very low against the limit.
4. Margin value = Emission Level – Limit value

CHANNEL	TX Channel 116	DETECTOR FUNCTION	Quasi-Peak (QP)
FREQUENCY RANGE	30MHz ~ 1GHz		

ANTENNA POLARITY & TEST DISTANCE: HORIZONTAL AT 3 M

NO.	FREQ. (MHz)	EMISSION LEVEL (dBuV/m)	LIMIT (dBuV/m)	MARGIN (dB)	ANTENNA HEIGHT (m)	TABLE ANGLE (Degree)	RAW VALUE (dBuV)	CORRECTION FACTOR (dB/m)
1	42.46	31.6 QP	40.0	-8.4	1.57 H	261	35.95	-4.35
2	201.05	33.7 QP	43.5	-9.8	1.00 H	67	40.78	-7.08
3	314.76	41.3 QP	46.0	-4.7	1.04 H	272	44.18	-2.88
4	323.86	42.0 QP	46.0	-4.0	1.04 H	59	44.62	-2.62
5	498.15	35.8 QP	46.0	-10.2	1.49 H	136	34.43	1.37
6	931.01	38.7 QP	46.0	-7.3	1.52 H	62	29.93	8.77

ANTENNA POLARITY & TEST DISTANCE: VERTICAL AT 3 M

NO.	FREQ. (MHz)	EMISSION LEVEL (dBuV/m)	LIMIT (dBuV/m)	MARGIN (dB)	ANTENNA HEIGHT (m)	TABLE ANGLE (Degree)	RAW VALUE (dBuV)	CORRECTION FACTOR (dB/m)
1	36.98	34.9 QP	40.0	-5.1	1.00 V	139	39.97	-5.07
2	58.28	29.4 QP	40.0	-10.6	1.53 V	29	33.67	-4.27
3	218.90	32.9 QP	46.0	-13.1	2.00 V	193	39.77	-6.87
4	267.67	31.6 QP	46.0	-14.4	2.01 V	288	35.97	-4.37
5	319.62	38.6 QP	46.0	-7.4	1.01 V	141	41.37	-2.77
6	797.49	37.6 QP	46.0	-8.4	1.60 V	93	30.95	6.65

REMARKS:

1. Emission Level(dBuV/m) = Raw Value(dBuV) + Correction Factor(dB/m)
2. Correction Factor(dB/m) = Antenna Factor(dB/m) + Cable Factor(dB) – Pre-Amplifier Factor(dB)
3. The other emission levels were very low against the limit.
4. Margin value = Emission Level – Limit value

CHANNEL	TX Channel 140	DETECTOR FUNCTION	Quasi-Peak (QP)
FREQUENCY RANGE	30MHz ~ 1GHz		

ANTENNA POLARITY & TEST DISTANCE: HORIZONTAL AT 3 M

NO.	FREQ. (MHz)	EMISSION LEVEL (dBuV/m)	LIMIT (dBuV/m)	MARGIN (dB)	ANTENNA HEIGHT (m)	TABLE ANGLE (Degree)	RAW VALUE (dBuV)	CORRECTION FACTOR (dB/m)
1	42.58	32.0 QP	40.0	-8.0	1.62 H	259	36.33	-4.33
2	201.15	33.5 QP	43.5	-10.0	1.05 H	51	40.59	-7.09
3	314.74	41.3 QP	46.0	-4.7	1.01 H	297	44.19	-2.89
4	323.45	42.0 QP	46.0	-4.0	1.00 H	41	44.63	-2.63
5	497.83	35.7 QP	46.0	-10.3	1.47 H	129	34.34	1.36
6	931.01	39.0 QP	46.0	-7.0	1.57 H	52	30.23	8.77

ANTENNA POLARITY & TEST DISTANCE: VERTICAL AT 3 M

NO.	FREQ. (MHz)	EMISSION LEVEL (dBuV/m)	LIMIT (dBuV/m)	MARGIN (dB)	ANTENNA HEIGHT (m)	TABLE ANGLE (Degree)	RAW VALUE (dBuV)	CORRECTION FACTOR (dB/m)
1	36.87	34.7 QP	40.0	-5.3	1.05 V	126	39.81	-5.11
2	58.70	29.9 QP	40.0	-10.1	1.58 V	40	34.17	-4.27
3	218.91	32.6 QP	46.0	-13.4	1.97 V	181	39.47	-6.87
4	267.87	31.6 QP	46.0	-14.4	1.96 V	287	35.97	-4.37
5	319.69	39.1 QP	46.0	-6.9	1.08 V	147	41.87	-2.77
6	797.49	38.1 QP	46.0	-7.9	1.52 V	92	31.45	6.65

REMARKS:

1. Emission Level(dBuV/m) = Raw Value(dBuV) + Correction Factor(dB/m)
2. Correction Factor(dB/m) = Antenna Factor(dB/m) + Cable Factor(dB) – Pre-Amplifier Factor(dB)
3. The other emission levels were very low against the limit.
4. Margin value = Emission Level – Limit value

CHANNEL	TX Channel 144	DETECTOR FUNCTION	Quasi-Peak (QP)
FREQUENCY RANGE	30MHz ~ 1GHz		

ANTENNA POLARITY & TEST DISTANCE: HORIZONTAL AT 3 M

NO.	FREQ. (MHz)	EMISSION LEVEL (dBuV/m)	LIMIT (dBuV/m)	MARGIN (dB)	ANTENNA HEIGHT (m)	TABLE ANGLE (Degree)	RAW VALUE (dBuV)	CORRECTION FACTOR (dB/m)
1	42.18	31.8 QP	40.0	-8.2	1.56 H	275	36.20	-4.40
2	201.30	33.3 QP	43.5	-10.2	1.00 H	53	40.39	-7.09
3	315.11	41.7 QP	46.0	-4.3	1.00 H	274	44.57	-2.87
4	323.72	42.2 QP	46.0	-3.8	1.00 H	52	44.82	-2.62
5	498.14	35.8 QP	46.0	-10.2	1.44 H	130	34.44	1.36
6	931.01	39.2 QP	46.0	-6.8	1.59 H	75	30.43	8.77

ANTENNA POLARITY & TEST DISTANCE: VERTICAL AT 3 M

NO.	FREQ. (MHz)	EMISSION LEVEL (dBuV/m)	LIMIT (dBuV/m)	MARGIN (dB)	ANTENNA HEIGHT (m)	TABLE ANGLE (Degree)	RAW VALUE (dBuV)	CORRECTION FACTOR (dB/m)
1	37.23	35.0 QP	40.0	-5.0	1.00 V	119	40.01	-5.01
2	58.78	29.7 QP	40.0	-10.3	1.51 V	18	33.98	-4.28
3	218.84	32.6 QP	46.0	-13.4	2.00 V	201	39.47	-6.87
4	268.01	31.8 QP	46.0	-14.2	1.96 V	282	36.16	-4.36
5	319.71	38.8 QP	46.0	-7.2	1.00 V	125	41.57	-2.77
6	797.49	38.1 QP	46.0	-7.9	1.55 V	101	31.45	6.65

REMARKS:

1. Emission Level(dBuV/m) = Raw Value(dBuV) + Correction Factor(dB/m)
2. Correction Factor(dB/m) = Antenna Factor(dB/m) + Cable Factor(dB) – Pre-Amplifier Factor(dB)
3. The other emission levels were very low against the limit.
4. Margin value = Emission Level – Limit value

CHANNEL	TX Channel 149	DETECTOR FUNCTION	Quasi-Peak (QP)
FREQUENCY RANGE	30MHz ~ 1GHz		

ANTENNA POLARITY & TEST DISTANCE: HORIZONTAL AT 3 M

NO.	FREQ. (MHz)	EMISSION LEVEL (dBuV/m)	LIMIT (dBuV/m)	MARGIN (dB)	ANTENNA HEIGHT (m)	TABLE ANGLE (Degree)	RAW VALUE (dBuV)	CORRECTION FACTOR (dB/m)
1	42.67	31.5 QP	40.0	-8.5	1.57 H	276	35.81	-4.31
2	201.12	33.2 QP	43.5	-10.3	1.00 H	49	40.28	-7.08
3	314.90	41.3 QP	46.0	-4.7	1.04 H	296	44.18	-2.88
4	323.59	42.2 QP	46.0	-3.8	1.03 H	51	44.83	-2.63
5	498.24	36.0 QP	46.0	-10.0	1.42 H	134	34.63	1.37
6	931.01	38.7 QP	46.0	-7.3	1.56 H	80	29.93	8.77

ANTENNA POLARITY & TEST DISTANCE: VERTICAL AT 3 M

NO.	FREQ. (MHz)	EMISSION LEVEL (dBuV/m)	LIMIT (dBuV/m)	MARGIN (dB)	ANTENNA HEIGHT (m)	TABLE ANGLE (Degree)	RAW VALUE (dBuV)	CORRECTION FACTOR (dB/m)
1	36.83	34.9 QP	40.0	-5.1	1.00 V	129	40.02	-5.12
2	58.50	29.7 QP	40.0	-10.3	1.54 V	42	33.97	-4.27
3	218.87	32.8 QP	46.0	-13.2	2.06 V	203	39.67	-6.87
4	267.82	31.6 QP	46.0	-14.4	1.98 V	290	35.97	-4.37
5	320.00	38.8 QP	46.0	-7.2	1.06 V	136	41.56	-2.76
6	797.49	37.5 QP	46.0	-8.5	1.50 V	90	30.85	6.65

REMARKS:

1. Emission Level(dBuV/m) = Raw Value(dBuV) + Correction Factor(dB/m)
2. Correction Factor(dB/m) = Antenna Factor(dB/m) + Cable Factor(dB) – Pre-Amplifier Factor(dB)
3. The other emission levels were very low against the limit.
4. Margin value = Emission Level – Limit value

CHANNEL	TX Channel 157	DETECTOR FUNCTION	Quasi-Peak (QP)
FREQUENCY RANGE	30MHz ~ 1GHz		

ANTENNA POLARITY & TEST DISTANCE: HORIZONTAL AT 3 M

NO.	FREQ. (MHz)	EMISSION LEVEL (dBuV/m)	LIMIT (dBuV/m)	MARGIN (dB)	ANTENNA HEIGHT (m)	TABLE ANGLE (Degree)	RAW VALUE (dBuV)	CORRECTION FACTOR (dB/m)
1	42.35	31.8 QP	40.0	-8.2	1.64 H	273	36.17	-4.37
2	201.11	33.4 QP	43.5	-10.1	1.04 H	54	40.48	-7.08
3	314.85	41.2 QP	46.0	-4.8	1.02 H	295	44.08	-2.88
4	323.41	42.0 QP	46.0	-4.0	1.04 H	45	44.63	-2.63
5	498.08	36.0 QP	46.0	-10.0	1.41 H	154	34.64	1.36
6	931.01	39.1 QP	46.0	-6.9	1.52 H	78	30.33	8.77

ANTENNA POLARITY & TEST DISTANCE: VERTICAL AT 3 M

NO.	FREQ. (MHz)	EMISSION LEVEL (dBuV/m)	LIMIT (dBuV/m)	MARGIN (dB)	ANTENNA HEIGHT (m)	TABLE ANGLE (Degree)	RAW VALUE (dBuV)	CORRECTION FACTOR (dB/m)
1	37.28	34.7 QP	40.0	-5.3	1.01 V	140	39.70	-5.00
2	58.74	29.5 QP	40.0	-10.5	1.55 V	27	33.77	-4.27
3	218.85	33.0 QP	46.0	-13.0	2.06 V	184	39.87	-6.87
4	268.15	31.6 QP	46.0	-14.4	2.05 V	291	35.95	-4.35
5	319.58	38.9 QP	46.0	-7.1	1.01 V	150	41.67	-2.77
6	797.49	37.9 QP	46.0	-8.1	1.50 V	120	31.25	6.65

REMARKS:

1. Emission Level(dBuV/m) = Raw Value(dBuV) + Correction Factor(dB/m)
2. Correction Factor(dB/m) = Antenna Factor(dB/m) + Cable Factor(dB) – Pre-Amplifier Factor(dB)
3. The other emission levels were very low against the limit.
4. Margin value = Emission Level – Limit value

CHANNEL	TX Channel 165	DETECTOR FUNCTION	Quasi-Peak (QP)
FREQUENCY RANGE	30MHz ~ 1GHz		

ANTENNA POLARITY & TEST DISTANCE: HORIZONTAL AT 3 M

NO.	FREQ. (MHz)	EMISSION LEVEL (dBuV/m)	LIMIT (dBuV/m)	MARGIN (dB)	ANTENNA HEIGHT (m)	TABLE ANGLE (Degree)	RAW VALUE (dBuV)	CORRECTION FACTOR (dB/m)
1	42.28	31.9 QP	40.0	-8.1	1.54 H	273	36.28	-4.38
2	201.04	33.8 QP	43.5	-9.7	1.06 H	52	40.88	-7.08
3	314.63	41.7 QP	46.0	-4.3	1.00 H	303	44.59	-2.89
4	323.75	41.8 QP	46.0	-4.2	1.00 H	35	44.42	-2.62
5	498.32	36.2 QP	46.0	-9.8	1.47 H	153	34.83	1.37
6	931.01	38.8 QP	46.0	-7.2	1.56 H	73	30.03	8.77

ANTENNA POLARITY & TEST DISTANCE: VERTICAL AT 3 M

NO.	FREQ. (MHz)	EMISSION LEVEL (dBuV/m)	LIMIT (dBuV/m)	MARGIN (dB)	ANTENNA HEIGHT (m)	TABLE ANGLE (Degree)	RAW VALUE (dBuV)	CORRECTION FACTOR (dB/m)
1	37.04	34.7 QP	40.0	-5.3	1.00 V	111	39.76	-5.06
2	58.85	29.9 QP	40.0	-10.1	1.51 V	13	34.18	-4.28
3	219.16	32.5 QP	46.0	-13.5	1.98 V	188	39.38	-6.88
4	267.74	31.8 QP	46.0	-14.2	2.02 V	299	36.17	-4.37
5	319.54	38.6 QP	46.0	-7.4	1.01 V	134	41.37	-2.77
6	797.49	37.8 QP	46.0	-8.2	1.57 V	111	31.15	6.65

REMARKS:

1. Emission Level(dBuV/m) = Raw Value(dBuV) + Correction Factor(dB/m)
2. Correction Factor(dB/m) = Antenna Factor(dB/m) + Cable Factor(dB) – Pre-Amplifier Factor(dB)
3. The other emission levels were very low against the limit.
4. Margin value = Emission Level – Limit value

802.11ac VHT40

CHANNEL	TX Channel 38	DETECTOR FUNCTION	Quasi-Peak (QP)
FREQUENCY RANGE	30MHz ~ 1GHz		

ANTENNA POLARITY & TEST DISTANCE: HORIZONTAL AT 3 M								
NO.	FREQ. (MHz)	EMISSION LEVEL (dBuV/m)	LIMIT (dBuV/m)	MARGIN (dB)	ANTENNA HEIGHT (m)	TABLE ANGLE (Degree)	RAW VALUE (dBuV)	CORRECTION FACTOR (dB/m)
1	42.73	31.6 QP	40.0	-8.4	1.53 H	290	35.90	-4.30
2	201.04	33.2 QP	43.5	-10.3	1.00 H	52	40.28	-7.08
3	314.96	41.7 QP	46.0	-4.3	1.00 H	276	44.58	-2.88
4	323.36	41.7 QP	46.0	-4.3	1.00 H	41	44.34	-2.64
5	497.89	36.2 QP	46.0	-9.8	1.46 H	148	34.84	1.36
6	931.01	38.7 QP	46.0	-7.3	1.59 H	58	29.93	8.77

ANTENNA POLARITY & TEST DISTANCE: VERTICAL AT 3 M								
NO.	FREQ. (MHz)	EMISSION LEVEL (dBuV/m)	LIMIT (dBuV/m)	MARGIN (dB)	ANTENNA HEIGHT (m)	TABLE ANGLE (Degree)	RAW VALUE (dBuV)	CORRECTION FACTOR (dB/m)
1	36.89	35.0 QP	40.0	-5.0	1.00 V	117	40.09	-5.09
2	58.80	29.4 QP	40.0	-10.6	1.61 V	39	33.68	-4.28
3	219.23	32.8 QP	46.0	-13.2	2.08 V	182	39.68	-6.88
4	267.77	31.6 QP	46.0	-14.4	2.04 V	289	35.97	-4.37
5	319.74	38.9 QP	46.0	-7.1	1.07 V	147	41.67	-2.77
6	797.49	37.7 QP	46.0	-8.3	1.58 V	96	31.05	6.65

REMARKS:

1. Emission Level(dBuV/m) = Raw Value(dBuV) + Correction Factor(dB/m)
2. Correction Factor(dB/m) = Antenna Factor(dB/m) + Cable Factor(dB) – Pre-Amplifier Factor(dB)
3. The other emission levels were very low against the limit.
4. Margin value = Emission Level – Limit value

CHANNEL	TX Channel 46	DETECTOR FUNCTION	Quasi-Peak (QP)
FREQUENCY RANGE	30MHz ~ 1GHz		

ANTENNA POLARITY & TEST DISTANCE: HORIZONTAL AT 3 M

NO.	FREQ. (MHz)	EMISSION LEVEL (dBuV/m)	LIMIT (dBuV/m)	MARGIN (dB)	ANTENNA HEIGHT (m)	TABLE ANGLE (Degree)	RAW VALUE (dBuV)	CORRECTION FACTOR (dB/m)
1	42.25	31.6 QP	40.0	-8.4	1.62 H	267	35.98	-4.38
2	201.03	33.8 QP	43.5	-9.7	1.01 H	72	40.88	-7.08
3	315.09	41.4 QP	46.0	-4.6	1.00 H	298	44.27	-2.87
4	323.76	42.0 QP	46.0	-4.0	1.00 H	47	44.62	-2.62
5	498.13	35.8 QP	46.0	-10.2	1.51 H	142	34.44	1.36
6	931.01	38.7 QP	46.0	-7.3	1.61 H	76	29.93	8.77

ANTENNA POLARITY & TEST DISTANCE: VERTICAL AT 3 M

NO.	FREQ. (MHz)	EMISSION LEVEL (dBuV/m)	LIMIT (dBuV/m)	MARGIN (dB)	ANTENNA HEIGHT (m)	TABLE ANGLE (Degree)	RAW VALUE (dBuV)	CORRECTION FACTOR (dB/m)
1	37.25	34.9 QP	40.0	-5.1	1.06 V	118	39.90	-5.00
2	58.84	29.4 QP	40.0	-10.6	1.51 V	24	33.68	-4.28
3	219.04	32.5 QP	46.0	-13.5	1.98 V	176	39.38	-6.88
4	268.15	31.8 QP	46.0	-14.2	2.02 V	291	36.15	-4.35
5	320.08	38.7 QP	46.0	-7.3	1.00 V	127	41.46	-2.76
6	797.49	37.7 QP	46.0	-8.3	1.58 V	120	31.05	6.65

REMARKS:

1. Emission Level(dBuV/m) = Raw Value(dBuV) + Correction Factor(dB/m)
2. Correction Factor(dB/m) = Antenna Factor(dB/m) + Cable Factor(dB) – Pre-Amplifier Factor(dB)
3. The other emission levels were very low against the limit.
4. Margin value = Emission Level – Limit value

CHANNEL	TX Channel 54	DETECTOR FUNCTION	Quasi-Peak (QP)
FREQUENCY RANGE	30MHz ~ 1GHz		

ANTENNA POLARITY & TEST DISTANCE: HORIZONTAL AT 3 M

NO.	FREQ. (MHz)	EMISSION LEVEL (dBuV/m)	LIMIT (dBuV/m)	MARGIN (dB)	ANTENNA HEIGHT (m)	TABLE ANGLE (Degree)	RAW VALUE (dBuV)	CORRECTION FACTOR (dB/m)
1	42.56	31.4 QP	40.0	-8.6	1.58 H	279	35.73	-4.33
2	201.18	33.4 QP	43.5	-10.1	1.00 H	63	40.49	-7.09
3	314.64	41.6 QP	46.0	-4.4	1.00 H	284	44.49	-2.89
4	323.48	42.2 QP	46.0	-3.8	1.00 H	61	44.83	-2.63
5	498.05	35.7 QP	46.0	-10.3	1.43 H	160	34.34	1.36
6	931.01	38.7 QP	46.0	-7.3	1.58 H	74	29.93	8.77

ANTENNA POLARITY & TEST DISTANCE: VERTICAL AT 3 M

NO.	FREQ. (MHz)	EMISSION LEVEL (dBuV/m)	LIMIT (dBuV/m)	MARGIN (dB)	ANTENNA HEIGHT (m)	TABLE ANGLE (Degree)	RAW VALUE (dBuV)	CORRECTION FACTOR (dB/m)
1	37.17	34.6 QP	40.0	-5.4	1.02 V	129	39.62	-5.02
2	58.81	29.4 QP	40.0	-10.6	1.55 V	24	33.68	-4.28
3	219.36	32.6 QP	46.0	-13.4	2.01 V	173	39.48	-6.88
4	267.83	32.0 QP	46.0	-14.0	1.97 V	299	36.37	-4.37
5	319.55	38.9 QP	46.0	-7.1	1.01 V	145	41.67	-2.77
6	797.49	37.9 QP	46.0	-8.1	1.59 V	119	31.25	6.65

REMARKS:

1. Emission Level(dBuV/m) = Raw Value(dBuV) + Correction Factor(dB/m)
2. Correction Factor(dB/m) = Antenna Factor(dB/m) + Cable Factor(dB) – Pre-Amplifier Factor(dB)
3. The other emission levels were very low against the limit.
4. Margin value = Emission Level – Limit value

CHANNEL	TX Channel 62	DETECTOR FUNCTION	Quasi-Peak (QP)
FREQUENCY RANGE	30MHz ~ 1GHz		

ANTENNA POLARITY & TEST DISTANCE: HORIZONTAL AT 3 M

NO.	FREQ. (MHz)	EMISSION LEVEL (dBUV/m)	LIMIT (dBUV/m)	MARGIN (dB)	ANTENNA HEIGHT (m)	TABLE ANGLE (Degree)	RAW VALUE (dBUV)	CORRECTION FACTOR (dB/m)
1	42.21	31.5 QP	40.0	-8.5	1.57 H	286	35.89	-4.39
2	200.90	33.4 QP	43.5	-10.1	1.00 H	61	40.48	-7.08
3	314.80	41.7 QP	46.0	-4.3	1.05 H	289	44.58	-2.88
4	323.51	42.0 QP	46.0	-4.0	1.00 H	39	44.63	-2.63
5	497.82	35.7 QP	46.0	-10.3	1.41 H	148	34.34	1.36
6	931.01	39.1 QP	46.0	-6.9	1.60 H	77	30.33	8.77

ANTENNA POLARITY & TEST DISTANCE: VERTICAL AT 3 M

NO.	FREQ. (MHz)	EMISSION LEVEL (dBUV/m)	LIMIT (dBUV/m)	MARGIN (dB)	ANTENNA HEIGHT (m)	TABLE ANGLE (Degree)	RAW VALUE (dBUV)	CORRECTION FACTOR (dB/m)
1	36.79	34.5 QP	40.0	-5.5	1.01 V	125	39.63	-5.13
2	58.41	29.3 QP	40.0	-10.7	1.53 V	41	33.57	-4.27
3	219.41	32.8 QP	46.0	-13.2	2.04 V	183	39.68	-6.88
4	267.92	31.6 QP	46.0	-14.4	1.99 V	293	35.96	-4.36
5	319.97	39.1 QP	46.0	-6.9	1.07 V	149	41.86	-2.76
6	797.49	38.0 QP	46.0	-8.0	1.60 V	98	31.35	6.65

REMARKS:

1. Emission Level(dBUV/m) = Raw Value(dBUV) + Correction Factor(dB/m)
2. Correction Factor(dB/m) = Antenna Factor(dB/m) + Cable Factor(dB) – Pre-Amplifier Factor(dB)
3. The other emission levels were very low against the limit.
4. Margin value = Emission Level – Limit value

CHANNEL	TX Channel 102	DETECTOR FUNCTION	Quasi-Peak (QP)
FREQUENCY RANGE	30MHz ~ 1GHz		

ANTENNA POLARITY & TEST DISTANCE: HORIZONTAL AT 3 M

NO.	FREQ. (MHz)	EMISSION LEVEL (dBuV/m)	LIMIT (dBuV/m)	MARGIN (dB)	ANTENNA HEIGHT (m)	TABLE ANGLE (Degree)	RAW VALUE (dBuV)	CORRECTION FACTOR (dB/m)
1	42.54	31.7 QP	40.0	-8.3	1.60 H	281	36.03	-4.33
2	201.34	33.5 QP	43.5	-10.0	1.03 H	69	40.59	-7.09
3	314.67	41.6 QP	46.0	-4.4	1.05 H	278	44.49	-2.89
4	323.40	41.7 QP	46.0	-4.3	1.02 H	41	44.33	-2.63
5	498.13	36.2 QP	46.0	-9.8	1.46 H	160	34.84	1.36
6	931.01	39.2 QP	46.0	-6.8	1.57 H	75	30.43	8.77

ANTENNA POLARITY & TEST DISTANCE: VERTICAL AT 3 M

NO.	FREQ. (MHz)	EMISSION LEVEL (dBuV/m)	LIMIT (dBuV/m)	MARGIN (dB)	ANTENNA HEIGHT (m)	TABLE ANGLE (Degree)	RAW VALUE (dBuV)	CORRECTION FACTOR (dB/m)
1	37.30	34.5 QP	40.0	-5.5	1.00 V	125	39.49	-4.99
2	58.60	29.7 QP	40.0	-10.3	1.57 V	17	33.97	-4.27
3	219.03	33.0 QP	46.0	-13.0	2.01 V	180	39.88	-6.88
4	267.70	31.9 QP	46.0	-14.1	2.02 V	293	36.27	-4.37
5	319.76	38.8 QP	46.0	-7.2	1.00 V	143	41.56	-2.76
6	797.49	37.8 QP	46.0	-8.2	1.51 V	113	31.15	6.65

REMARKS:

1. Emission Level(dBuV/m) = Raw Value(dBuV) + Correction Factor(dB/m)
2. Correction Factor(dB/m) = Antenna Factor(dB/m) + Cable Factor(dB) – Pre-Amplifier Factor(dB)
3. The other emission levels were very low against the limit.
4. Margin value = Emission Level – Limit value

CHANNEL	TX Channel 110	DETECTOR FUNCTION	Quasi-Peak (QP)
FREQUENCY RANGE	30MHz ~ 1GHz		

ANTENNA POLARITY & TEST DISTANCE: HORIZONTAL AT 3 M

NO.	FREQ. (MHz)	EMISSION LEVEL (dBuV/m)	LIMIT (dBuV/m)	MARGIN (dB)	ANTENNA HEIGHT (m)	TABLE ANGLE (Degree)	RAW VALUE (dBuV)	CORRECTION FACTOR (dB/m)
1	42.61	31.6 QP	40.0	-8.4	1.55 H	275	35.92	-4.32
2	201.45	33.3 QP	43.5	-10.2	1.03 H	72	40.40	-7.10
3	315.10	41.5 QP	46.0	-4.5	1.00 H	274	44.37	-2.87
4	323.38	41.8 QP	46.0	-4.2	1.02 H	38	44.43	-2.63
5	498.21	35.9 QP	46.0	-10.1	1.47 H	156	34.53	1.37
6	931.01	38.8 QP	46.0	-7.2	1.61 H	68	30.03	8.77

ANTENNA POLARITY & TEST DISTANCE: VERTICAL AT 3 M

NO.	FREQ. (MHz)	EMISSION LEVEL (dBuV/m)	LIMIT (dBuV/m)	MARGIN (dB)	ANTENNA HEIGHT (m)	TABLE ANGLE (Degree)	RAW VALUE (dBuV)	CORRECTION FACTOR (dB/m)
1	36.81	34.6 QP	40.0	-5.4	1.00 V	123	39.72	-5.12
2	58.66	29.6 QP	40.0	-10.4	1.55 V	31	33.87	-4.27
3	218.85	32.7 QP	46.0	-13.3	2.09 V	199	39.57	-6.87
4	267.88	32.0 QP	46.0	-14.0	2.02 V	293	36.37	-4.37
5	319.75	38.8 QP	46.0	-7.2	1.08 V	149	41.57	-2.77
6	797.49	37.5 QP	46.0	-8.5	1.57 V	111	30.85	6.65

REMARKS:

1. Emission Level(dBuV/m) = Raw Value(dBuV) + Correction Factor(dB/m)
2. Correction Factor(dB/m) = Antenna Factor(dB/m) + Cable Factor(dB) – Pre-Amplifier Factor(dB)
3. The other emission levels were very low against the limit.
4. Margin value = Emission Level – Limit value

CHANNEL	TX Channel 134	DETECTOR FUNCTION	Quasi-Peak (QP)
FREQUENCY RANGE	30MHz ~ 1GHz		

ANTENNA POLARITY & TEST DISTANCE: HORIZONTAL AT 3 M

NO.	FREQ. (MHz)	EMISSION LEVEL (dBuV/m)	LIMIT (dBuV/m)	MARGIN (dB)	ANTENNA HEIGHT (m)	TABLE ANGLE (Degree)	RAW VALUE (dBuV)	CORRECTION FACTOR (dB/m)
1	42.62	31.7 QP	40.0	-8.3	1.57 H	267	36.02	-4.32
2	201.41	33.7 QP	43.5	-9.8	1.04 H	44	40.80	-7.10
3	314.83	41.5 QP	46.0	-4.5	1.02 H	280	44.38	-2.88
4	323.47	42.2 QP	46.0	-3.8	1.00 H	36	44.83	-2.63
5	498.34	36.2 QP	46.0	-9.8	1.52 H	152	34.83	1.37
6	931.01	38.9 QP	46.0	-7.1	1.56 H	63	30.13	8.77

ANTENNA POLARITY & TEST DISTANCE: VERTICAL AT 3 M

NO.	FREQ. (MHz)	EMISSION LEVEL (dBuV/m)	LIMIT (dBuV/m)	MARGIN (dB)	ANTENNA HEIGHT (m)	TABLE ANGLE (Degree)	RAW VALUE (dBuV)	CORRECTION FACTOR (dB/m)
1	37.01	34.9 QP	40.0	-5.1	1.03 V	126	39.96	-5.06
2	58.29	29.5 QP	40.0	-10.5	1.52 V	16	33.77	-4.27
3	219.28	32.7 QP	46.0	-13.3	2.04 V	183	39.58	-6.88
4	267.62	31.5 QP	46.0	-14.5	2.06 V	304	35.88	-4.38
5	319.71	38.7 QP	46.0	-7.3	1.07 V	146	41.47	-2.77
6	797.49	37.6 QP	46.0	-8.4	1.60 V	115	30.95	6.65

REMARKS:

1. Emission Level(dBuV/m) = Raw Value(dBuV) + Correction Factor(dB/m)
2. Correction Factor(dB/m) = Antenna Factor(dB/m) + Cable Factor(dB) – Pre-Amplifier Factor(dB)
3. The other emission levels were very low against the limit.
4. Margin value = Emission Level – Limit value

CHANNEL	TX Channel 142	DETECTOR FUNCTION	Quasi-Peak (QP)
FREQUENCY RANGE	30MHz ~ 1GHz		

ANTENNA POLARITY & TEST DISTANCE: HORIZONTAL AT 3 M

NO.	FREQ. (MHz)	EMISSION LEVEL (dBuV/m)	LIMIT (dBuV/m)	MARGIN (dB)	ANTENNA HEIGHT (m)	TABLE ANGLE (Degree)	RAW VALUE (dBuV)	CORRECTION FACTOR (dB/m)
1	42.62	31.9 QP	40.0	-8.1	1.60 H	269	36.22	-4.32
2	201.15	33.6 QP	43.5	-9.9	1.01 H	69	40.69	-7.09
3	315.11	41.5 QP	46.0	-4.5	1.03 H	274	44.37	-2.87
4	323.91	41.6 QP	46.0	-4.4	1.00 H	55	44.21	-2.61
5	497.83	35.9 QP	46.0	-10.1	1.47 H	131	34.54	1.36
6	931.01	38.7 QP	46.0	-7.3	1.59 H	68	29.93	8.77

ANTENNA POLARITY & TEST DISTANCE: VERTICAL AT 3 M

NO.	FREQ. (MHz)	EMISSION LEVEL (dBuV/m)	LIMIT (dBuV/m)	MARGIN (dB)	ANTENNA HEIGHT (m)	TABLE ANGLE (Degree)	RAW VALUE (dBuV)	CORRECTION FACTOR (dB/m)
1	36.90	34.4 QP	40.0	-5.6	1.00 V	111	39.49	-5.09
2	58.70	29.3 QP	40.0	-10.7	1.56 V	22	33.57	-4.27
3	219.19	32.5 QP	46.0	-13.5	2.07 V	175	39.38	-6.88
4	267.93	31.7 QP	46.0	-14.3	2.02 V	282	36.06	-4.36
5	319.68	39.0 QP	46.0	-7.0	1.07 V	130	41.77	-2.77
6	797.49	37.5 QP	46.0	-8.5	1.51 V	106	30.85	6.65

REMARKS:

1. Emission Level(dBuV/m) = Raw Value(dBuV) + Correction Factor(dB/m)
2. Correction Factor(dB/m) = Antenna Factor(dB/m) + Cable Factor(dB) – Pre-Amplifier Factor(dB)
3. The other emission levels were very low against the limit.
4. Margin value = Emission Level – Limit value

CHANNEL	TX Channel 151	DETECTOR FUNCTION	Quasi-Peak (QP)
FREQUENCY RANGE	30MHz ~ 1GHz		

ANTENNA POLARITY & TEST DISTANCE: HORIZONTAL AT 3 M

NO.	FREQ. (MHz)	EMISSION LEVEL (dBUV/m)	LIMIT (dBUV/m)	MARGIN (dB)	ANTENNA HEIGHT (m)	TABLE ANGLE (Degree)	RAW VALUE (dBUV)	CORRECTION FACTOR (dB/m)
1	42.48	31.6 QP	40.0	-8.4	1.55 H	273	35.94	-4.34
2	201.45	33.6 QP	43.5	-9.9	1.01 H	44	40.70	-7.10
3	314.89	41.8 QP	46.0	-4.2	1.02 H	281	44.68	-2.88
4	323.90	42.1 QP	46.0	-3.9	1.00 H	37	44.71	-2.61
5	498.12	35.8 QP	46.0	-10.2	1.50 H	137	34.44	1.36
6	931.01	38.7 QP	46.0	-7.3	1.56 H	66	29.93	8.77

ANTENNA POLARITY & TEST DISTANCE: VERTICAL AT 3 M

NO.	FREQ. (MHz)	EMISSION LEVEL (dBUV/m)	LIMIT (dBUV/m)	MARGIN (dB)	ANTENNA HEIGHT (m)	TABLE ANGLE (Degree)	RAW VALUE (dBUV)	CORRECTION FACTOR (dB/m)
1	36.91	34.8 QP	40.0	-5.2	1.06 V	119	39.89	-5.09
2	58.53	29.7 QP	40.0	-10.3	1.57 V	17	33.97	-4.27
3	219.18	32.4 QP	46.0	-13.6	1.98 V	175	39.28	-6.88
4	267.79	32.1 QP	46.0	-13.9	1.99 V	302	36.47	-4.37
5	320.09	39.1 QP	46.0	-6.9	1.07 V	123	41.86	-2.76
6	797.49	37.9 QP	46.0	-8.1	1.59 V	108	31.25	6.65

REMARKS:

1. Emission Level(dBUV/m) = Raw Value(dBUV) + Correction Factor(dB/m)
2. Correction Factor(dB/m) = Antenna Factor(dB/m) + Cable Factor(dB) – Pre-Amplifier Factor(dB)
3. The other emission levels were very low against the limit.
4. Margin value = Emission Level – Limit value

CHANNEL	TX Channel 159	DETECTOR FUNCTION	Quasi-Peak (QP)
FREQUENCY RANGE	30MHz ~ 1GHz		

ANTENNA POLARITY & TEST DISTANCE: HORIZONTAL AT 3 M

NO.	FREQ. (MHz)	EMISSION LEVEL (dBUV/m)	LIMIT (dBUV/m)	MARGIN (dB)	ANTENNA HEIGHT (m)	TABLE ANGLE (Degree)	RAW VALUE (dBUV)	CORRECTION FACTOR (dB/m)
1	42.43	32.0 QP	40.0	-8.0	1.56 H	285	36.35	-4.35
2	201.32	33.6 QP	43.5	-9.9	1.00 H	62	40.69	-7.09
3	314.88	41.3 QP	46.0	-4.7	1.03 H	299	44.18	-2.88
4	323.71	42.2 QP	46.0	-3.8	1.00 H	43	44.82	-2.62
5	498.19	35.9 QP	46.0	-10.1	1.41 H	147	34.53	1.37
6	931.01	39.1 QP	46.0	-6.9	1.62 H	69	30.33	8.77

ANTENNA POLARITY & TEST DISTANCE: VERTICAL AT 3 M

NO.	FREQ. (MHz)	EMISSION LEVEL (dBUV/m)	LIMIT (dBUV/m)	MARGIN (dB)	ANTENNA HEIGHT (m)	TABLE ANGLE (Degree)	RAW VALUE (dBUV)	CORRECTION FACTOR (dB/m)
1	37.03	34.7 QP	40.0	-5.3	1.00 V	121	39.76	-5.06
2	58.62	29.6 QP	40.0	-10.4	1.62 V	27	33.87	-4.27
3	218.86	32.5 QP	46.0	-13.5	2.01 V	181	39.37	-6.87
4	267.65	31.6 QP	46.0	-14.4	2.00 V	297	35.98	-4.38
5	319.58	38.9 QP	46.0	-7.1	1.00 V	152	41.67	-2.77
6	797.49	37.6 QP	46.0	-8.4	1.52 V	114	30.95	6.65

REMARKS:

1. Emission Level(dBUV/m) = Raw Value(dBUV) + Correction Factor(dB/m)
2. Correction Factor(dB/m) = Antenna Factor(dB/m) + Cable Factor(dB) – Pre-Amplifier Factor(dB)
3. The other emission levels were very low against the limit.
4. Margin value = Emission Level – Limit value

802.11ac VHT80

CHANNEL	TX Channel 42	DETECTOR FUNCTION	Quasi-Peak (QP)
FREQUENCY RANGE	30MHz ~ 1GHz		

ANTENNA POLARITY & TEST DISTANCE: HORIZONTAL AT 3 M

NO.	FREQ. (MHz)	EMISSION LEVEL (dBuV/m)	LIMIT (dBuV/m)	MARGIN (dB)	ANTENNA HEIGHT (m)	TABLE ANGLE (Degree)	RAW VALUE (dBuV)	CORRECTION FACTOR (dB/m)
1	42.70	31.6 QP	40.0	-8.4	1.63 H	277	35.90	-4.30
2	200.95	33.8 QP	43.5	-9.7	1.03 H	71	40.88	-7.08
3	314.92	41.4 QP	46.0	-4.6	1.00 H	285	44.28	-2.88
4	323.76	41.6 QP	46.0	-4.4	1.05 H	48	44.22	-2.62
5	498.39	35.9 QP	46.0	-10.1	1.41 H	152	34.53	1.37
6	931.01	38.9 QP	46.0	-7.1	1.50 H	69	30.13	8.77

ANTENNA POLARITY & TEST DISTANCE: VERTICAL AT 3 M

NO.	FREQ. (MHz)	EMISSION LEVEL (dBuV/m)	LIMIT (dBuV/m)	MARGIN (dB)	ANTENNA HEIGHT (m)	TABLE ANGLE (Degree)	RAW VALUE (dBuV)	CORRECTION FACTOR (dB/m)
1	37.04	34.9 QP	40.0	-5.1	1.01 V	115	39.96	-5.06
2	58.40	29.3 QP	40.0	-10.7	1.57 V	22	33.57	-4.27
3	219.26	32.9 QP	46.0	-13.1	2.02 V	188	39.78	-6.88
4	267.97	31.6 QP	46.0	-14.4	2.03 V	299	35.96	-4.36
5	319.84	39.0 QP	46.0	-7.0	1.00 V	140	41.76	-2.76
6	797.49	37.7 QP	46.0	-8.3	1.55 V	113	31.05	6.65

REMARKS:

1. Emission Level(dBuV/m) = Raw Value(dBuV) + Correction Factor(dB/m)
2. Correction Factor(dB/m) = Antenna Factor(dB/m) + Cable Factor(dB) – Pre-Amplifier Factor(dB)
3. The other emission levels were very low against the limit.
4. Margin value = Emission Level – Limit value

CHANNEL	TX Channel 58	DETECTOR FUNCTION	Quasi-Peak (QP)
FREQUENCY RANGE	30MHz ~ 1GHz		

ANTENNA POLARITY & TEST DISTANCE: HORIZONTAL AT 3 M

NO.	FREQ. (MHz)	EMISSION LEVEL (dBuV/m)	LIMIT (dBuV/m)	MARGIN (dB)	ANTENNA HEIGHT (m)	TABLE ANGLE (Degree)	RAW VALUE (dBuV)	CORRECTION FACTOR (dB/m)
1	42.51	31.6 QP	40.0	-8.4	1.54 H	279	35.94	-4.34
2	201.45	33.7 QP	43.5	-9.8	1.00 H	52	40.80	-7.10
3	314.59	41.3 QP	46.0	-4.7	1.05 H	283	44.19	-2.89
4	323.41	41.8 QP	46.0	-4.2	1.00 H	59	44.43	-2.63
5	498.14	35.7 QP	46.0	-10.3	1.45 H	153	34.34	1.36
6	931.01	38.7 QP	46.0	-7.3	1.51 H	78	29.93	8.77

ANTENNA POLARITY & TEST DISTANCE: VERTICAL AT 3 M

NO.	FREQ. (MHz)	EMISSION LEVEL (dBuV/m)	LIMIT (dBuV/m)	MARGIN (dB)	ANTENNA HEIGHT (m)	TABLE ANGLE (Degree)	RAW VALUE (dBuV)	CORRECTION FACTOR (dB/m)
1	37.16	34.7 QP	40.0	-5.3	1.05 V	139	39.73	-5.03
2	58.80	29.4 QP	40.0	-10.6	1.61 V	23	33.68	-4.28
3	219.40	32.7 QP	46.0	-13.3	2.00 V	179	39.58	-6.88
4	267.74	31.5 QP	46.0	-14.5	1.96 V	306	35.87	-4.37
5	319.84	38.7 QP	46.0	-7.3	1.00 V	149	41.46	-2.76
6	797.49	37.5 QP	46.0	-8.5	1.54 V	97	30.85	6.65

REMARKS:

1. Emission Level(dBuV/m) = Raw Value(dBuV) + Correction Factor(dB/m)
2. Correction Factor(dB/m) = Antenna Factor(dB/m) + Cable Factor(dB) – Pre-Amplifier Factor(dB)
3. The other emission levels were very low against the limit.
4. Margin value = Emission Level – Limit value

CHANNEL	TX Channel 106	DETECTOR FUNCTION	Quasi-Peak (QP)
FREQUENCY RANGE	30MHz ~ 1GHz		

ANTENNA POLARITY & TEST DISTANCE: HORIZONTAL AT 3 M

NO.	FREQ. (MHz)	EMISSION LEVEL (dBuV/m)	LIMIT (dBuV/m)	MARGIN (dB)	ANTENNA HEIGHT (m)	TABLE ANGLE (Degree)	RAW VALUE (dBuV)	CORRECTION FACTOR (dB/m)
1	42.70	31.8 QP	40.0	-8.2	1.56 H	277	36.10	-4.30
2	201.11	33.7 QP	43.5	-9.8	1.00 H	50	40.78	-7.08
3	314.63	41.8 QP	46.0	-4.2	1.00 H	298	44.69	-2.89
4	323.49	41.8 QP	46.0	-4.2	1.00 H	52	44.43	-2.63
5	498.13	36.2 QP	46.0	-9.8	1.48 H	160	34.84	1.36
6	931.01	39.0 QP	46.0	-7.0	1.59 H	64	30.23	8.77

ANTENNA POLARITY & TEST DISTANCE: VERTICAL AT 3 M

NO.	FREQ. (MHz)	EMISSION LEVEL (dBuV/m)	LIMIT (dBuV/m)	MARGIN (dB)	ANTENNA HEIGHT (m)	TABLE ANGLE (Degree)	RAW VALUE (dBuV)	CORRECTION FACTOR (dB/m)
1	37.17	34.4 QP	40.0	-5.6	1.00 V	109	39.42	-5.02
2	58.44	29.5 QP	40.0	-10.5	1.57 V	41	33.77	-4.27
3	219.14	32.6 QP	46.0	-13.4	2.02 V	186	39.48	-6.88
4	267.87	31.8 QP	46.0	-14.2	2.06 V	306	36.17	-4.37
5	319.51	38.9 QP	46.0	-7.1	1.00 V	133	41.67	-2.77
6	797.49	37.6 QP	46.0	-8.4	1.53 V	111	30.95	6.65

REMARKS:

1. Emission Level(dBuV/m) = Raw Value(dBuV) + Correction Factor(dB/m)
2. Correction Factor(dB/m) = Antenna Factor(dB/m) + Cable Factor(dB) – Pre-Amplifier Factor(dB)
3. The other emission levels were very low against the limit.
4. Margin value = Emission Level – Limit value

CHANNEL	TX Channel 122	DETECTOR FUNCTION	Quasi-Peak (QP)
FREQUENCY RANGE	30MHz ~ 1GHz		

ANTENNA POLARITY & TEST DISTANCE: HORIZONTAL AT 3 M

NO.	FREQ. (MHz)	EMISSION LEVEL (dBuV/m)	LIMIT (dBuV/m)	MARGIN (dB)	ANTENNA HEIGHT (m)	TABLE ANGLE (Degree)	RAW VALUE (dBuV)	CORRECTION FACTOR (dB/m)
1	42.37	31.8 QP	40.0	-8.2	1.65 H	261	36.16	-4.36
2	200.88	33.3 QP	43.5	-10.2	1.02 H	46	40.38	-7.08
3	314.58	41.7 QP	46.0	-4.3	1.03 H	298	44.59	-2.89
4	323.46	42.1 QP	46.0	-3.9	1.01 H	39	44.73	-2.63
5	498.38	35.6 QP	46.0	-10.4	1.44 H	154	34.23	1.37
6	931.01	38.8 QP	46.0	-7.2	1.51 H	75	30.03	8.77

ANTENNA POLARITY & TEST DISTANCE: VERTICAL AT 3 M

NO.	FREQ. (MHz)	EMISSION LEVEL (dBuV/m)	LIMIT (dBuV/m)	MARGIN (dB)	ANTENNA HEIGHT (m)	TABLE ANGLE (Degree)	RAW VALUE (dBuV)	CORRECTION FACTOR (dB/m)
1	37.29	34.7 QP	40.0	-5.3	1.06 V	126	39.69	-4.99
2	58.83	29.7 QP	40.0	-10.3	1.55 V	17	33.98	-4.28
3	219.25	33.0 QP	46.0	-13.0	2.07 V	184	39.88	-6.88
4	267.83	31.5 QP	46.0	-14.5	2.07 V	294	35.87	-4.37
5	319.80	39.0 QP	46.0	-7.0	1.01 V	135	41.76	-2.76
6	797.49	37.7 QP	46.0	-8.3	1.52 V	102	31.05	6.65

REMARKS:

1. Emission Level(dBuV/m) = Raw Value(dBuV) + Correction Factor(dB/m)
2. Correction Factor(dB/m) = Antenna Factor(dB/m) + Cable Factor(dB) – Pre-Amplifier Factor(dB)
3. The other emission levels were very low against the limit.
4. Margin value = Emission Level – Limit value

CHANNEL	TX Channel 138	DETECTOR FUNCTION	Quasi-Peak (QP)
FREQUENCY RANGE	30MHz ~ 1GHz		

ANTENNA POLARITY & TEST DISTANCE: HORIZONTAL AT 3 M

NO.	FREQ. (MHz)	EMISSION LEVEL (dBuV/m)	LIMIT (dBuV/m)	MARGIN (dB)	ANTENNA HEIGHT (m)	TABLE ANGLE (Degree)	RAW VALUE (dBuV)	CORRECTION FACTOR (dB/m)
1	42.18	31.8 QP	40.0	-8.2	1.61 H	260	36.20	-4.40
2	201.12	33.5 QP	43.5	-10.0	1.06 H	71	40.58	-7.08
3	314.70	41.3 QP	46.0	-4.7	1.00 H	285	44.19	-2.89
4	323.57	42.1 QP	46.0	-3.9	1.00 H	49	44.73	-2.63
5	498.05	35.9 QP	46.0	-10.1	1.44 H	153	34.54	1.36
6	931.01	39.0 QP	46.0	-7.0	1.59 H	70	30.23	8.77

ANTENNA POLARITY & TEST DISTANCE: VERTICAL AT 3 M

NO.	FREQ. (MHz)	EMISSION LEVEL (dBuV/m)	LIMIT (dBuV/m)	MARGIN (dB)	ANTENNA HEIGHT (m)	TABLE ANGLE (Degree)	RAW VALUE (dBuV)	CORRECTION FACTOR (dB/m)
1	37.10	34.6 QP	40.0	-5.4	1.00 V	120	39.64	-5.04
2	58.56	29.8 QP	40.0	-10.2	1.59 V	26	34.07	-4.27
3	219.09	32.7 QP	46.0	-13.3	1.99 V	181	39.58	-6.88
4	267.83	31.7 QP	46.0	-14.3	2.07 V	286	36.07	-4.37
5	319.80	38.9 QP	46.0	-7.1	1.06 V	151	41.66	-2.76
6	797.49	37.5 QP	46.0	-8.5	1.57 V	120	30.85	6.65

REMARKS:

1. Emission Level(dBuV/m) = Raw Value(dBuV) + Correction Factor(dB/m)
2. Correction Factor(dB/m) = Antenna Factor(dB/m) + Cable Factor(dB) – Pre-Amplifier Factor(dB)
3. The other emission levels were very low against the limit.
4. Margin value = Emission Level – Limit value

CHANNEL	TX Channel 155	DETECTOR FUNCTION	Quasi-Peak (QP)
FREQUENCY RANGE	30MHz ~ 1GHz		

ANTENNA POLARITY & TEST DISTANCE: HORIZONTAL AT 3 M

NO.	FREQ. (MHz)	EMISSION LEVEL (dBuV/m)	LIMIT (dBuV/m)	MARGIN (dB)	ANTENNA HEIGHT (m)	TABLE ANGLE (Degree)	RAW VALUE (dBuV)	CORRECTION FACTOR (dB/m)
1	42.71	31.4 QP	40.0	-8.6	1.60 H	269	35.70	-4.30
2	200.92	33.4 QP	43.5	-10.1	1.00 H	41	40.48	-7.08
3	315.05	41.3 QP	46.0	-4.7	1.05 H	301	44.17	-2.87
4	323.96	41.9 QP	46.0	-4.1	1.06 H	43	44.51	-2.61
5	498.38	36.1 QP	46.0	-9.9	1.42 H	138	34.73	1.37
6	931.01	39.2 QP	46.0	-6.8	1.50 H	58	30.43	8.77

ANTENNA POLARITY & TEST DISTANCE: VERTICAL AT 3 M

NO.	FREQ. (MHz)	EMISSION LEVEL (dBuV/m)	LIMIT (dBuV/m)	MARGIN (dB)	ANTENNA HEIGHT (m)	TABLE ANGLE (Degree)	RAW VALUE (dBuV)	CORRECTION FACTOR (dB/m)
1	36.99	34.8 QP	40.0	-5.2	1.00 V	130	39.87	-5.07
2	58.81	29.7 QP	40.0	-10.3	1.62 V	20	33.98	-4.28
3	219.09	32.8 QP	46.0	-13.2	1.99 V	194	39.68	-6.88
4	267.67	31.7 QP	46.0	-14.3	1.98 V	287	36.07	-4.37
5	319.99	38.6 QP	46.0	-7.4	1.04 V	135	41.36	-2.76
6	797.49	37.8 QP	46.0	-8.2	1.50 V	120	31.15	6.65

REMARKS:

1. Emission Level(dBuV/m) = Raw Value(dBuV) + Correction Factor(dB/m)
2. Correction Factor(dB/m) = Antenna Factor(dB/m) + Cable Factor(dB) – Pre-Amplifier Factor(dB)
3. The other emission levels were very low against the limit.
4. Margin value = Emission Level – Limit value

4.2 Conducted Emission Measurement

4.2.1 Limits of Conducted Emission Measurement

Frequency (MHz)	Conducted Limit (dBuV)	
	Quasi-peak	Average
0.15 - 0.5	66 - 56	56 - 46
0.50 - 5.0	56	46
5.0 - 30.0	60	50

Note: 1. The lower limit shall apply at the transition frequencies.

2. The limit decreases in line with the logarithm of the frequency in the range of 0.15 to 0.50MHz.

4.2.2 Test Instruments

DESCRIPTION & MANUFACTURER	MODEL NO.	SERIAL NO.	CALIBRATED DATE	CALIBRATED UNTIL
Test Receiver R&S	ESCS 30	100375	May 06, 2015	May 05, 2016
Line-Impedance Stabilization Network (for EUT) SCHWARZBECK	NSLK-8127	8127-522	Sep. 01, 2015	Aug. 31, 2016
Line-Impedance Stabilization Network (for Peripheral) R&S	ENV216	100072	June 11, 2015	June 10, 2016
RF Cable	5D-FB	COCCAB-001	Mar. 08, 2016	Mar. 07, 2017
50 ohms Terminator	N/A	EMC-03	Sep. 23, 2015	Sep. 22, 2016
50 ohms Terminator	N/A	EMC-02	Oct. 01, 2015	Sep. 30, 2016
50 ohms Terminator	E1-011315	13	Dec. 11 2015	Dec. 10 2016
Software BVADT	BVADT_Cond_ V7.3.7.3	NA	NA	NA

Note:

1. The calibration interval of the above test instruments are 12 months and the calibrations are traceable to NML/ROC and NIST/USA.
2. The test was performed in Shielded Room No. C.
3. The VCCI Con C Registration No. is C-3611.
4. Tested Date: Apr. 11, 2016

4.2.3 Test Procedure

- The EUT was placed 0.4 meters from the conducting wall of the shielded room with EUT being connected to the power mains through a line impedance stabilization network (LISN). Other support units were connected to the power mains through another LISN. The two LISNs provide 50 ohm/ 50uH of coupling impedance for the measuring instrument.
- Both lines of the power mains connected to the EUT were checked for maximum conducted interference.
- The frequency range from 150kHz to 30MHz was searched. Emission levels under (Limit - 20dB) was not recorded.

NOTE: All modes of operation were investigated and the worst-case emissions are reported.

4.2.4 Deviation from Test Standard

No deviation.

4.2.5 Test Setup

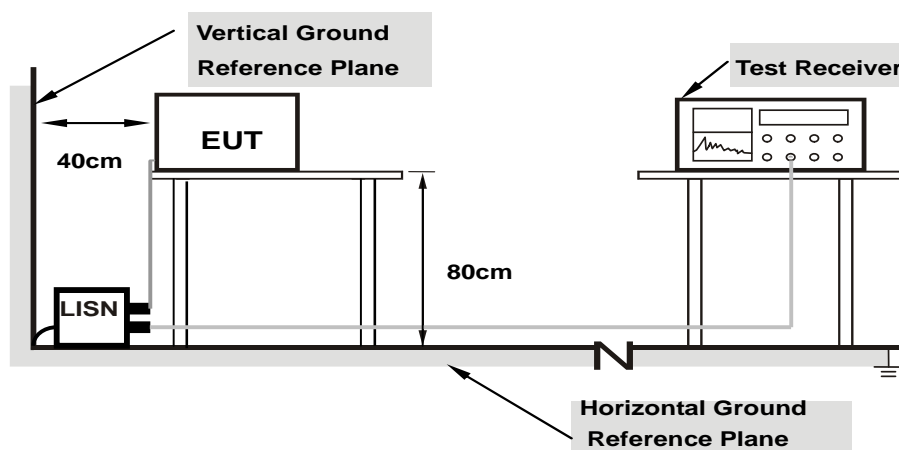

Note: 1.Support units were connected to second LISN.

For the actual test configuration, please refer to the attached file (Test Setup Photo).

4.2.6 EUT Operating Condition

Same as 4.1.6.

4.2.7 Test Results (Mode 1)

Phase	Line (L)	Detector Function	Quasi-Peak (QP) / Average (AV)
-------	----------	-------------------	--------------------------------

No	Freq. [MHz]	Corr.	Reading Value		Emission Level		Limit		Margin	
		Factor (dB)	[dB (uV)]		[dB (uV)]		[dB (uV)]		(dB)	
	Q.P.	AV.	Q.P.	AV.	Q.P.	AV.	Q.P.	AV.	Q.P.	AV.
1	0.15000	10.32	41.78	22.90	52.10	33.22	66.00	56.00	-13.90	-22.78
2	0.16562	10.31	39.77	20.08	50.08	30.39	65.18	55.18	-15.10	-24.79
3	0.18906	10.29	36.80	19.11	47.09	29.40	64.08	54.08	-16.99	-24.68
4	0.21641	10.28	31.66	16.15	41.94	26.43	62.96	52.96	-21.01	-26.52
5	0.54453	10.28	23.44	19.49	33.72	29.77	56.00	46.00	-22.28	-16.23
6	20.31641	10.95	23.14	15.66	34.09	26.61	60.00	50.00	-25.91	-23.39

REMARKS:

1. Q.P. and AV. are abbreviations of quasi-peak and average individually.
2. The emission levels of other frequencies were very low against the limit.
3. Margin value = Emission level - Limit value
4. Correction factor = Insertion loss + Cable loss
5. Emission Level = Correction Factor + Reading Value

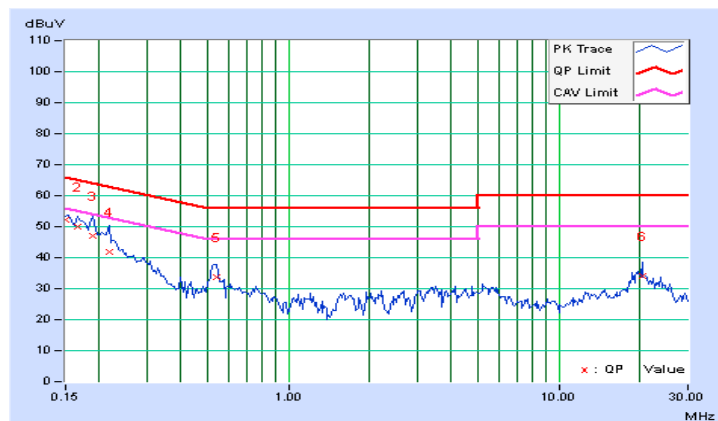

Phase	Neutral (N)	Detector Function	Quasi-Peak (QP) / Average (AV)
-------	-------------	-------------------	--------------------------------

No	Freq. [MHz]	Corr.	Reading Value		Emission Level		Limit		Margin	
		Factor (dB)	[dB (uV)]		[dB (uV)]		[dB (uV)]		(dB)	
	Q.P.	AV.	Q.P.	AV.	Q.P.	AV.	Q.P.	AV.	Q.P.	AV.
1	0.16172	10.29	39.08	22.69	49.37	32.98	65.38	55.38	-16.00	-22.39
2	0.18125	10.28	36.25	19.21	46.53	29.49	64.43	54.43	-17.90	-24.94
3	0.20469	10.26	33.26	18.55	43.52	28.81	63.42	53.42	-19.90	-24.61
4	0.25938	10.27	28.85	15.22	39.12	25.49	61.45	51.45	-22.34	-25.97
5	0.55625	10.26	21.96	15.49	32.22	25.75	56.00	46.00	-23.78	-20.25
6	19.71094	10.97	22.36	18.75	33.33	29.72	60.00	50.00	-26.67	-20.28

REMARKS:

1. Q.P. and AV. are abbreviations of quasi-peak and average individually.
2. The emission levels of other frequencies were very low against the limit.
3. Margin value = Emission level - Limit value
4. Correction factor = Insertion loss + Cable loss
5. Emission Level = Correction Factor + Reading Value

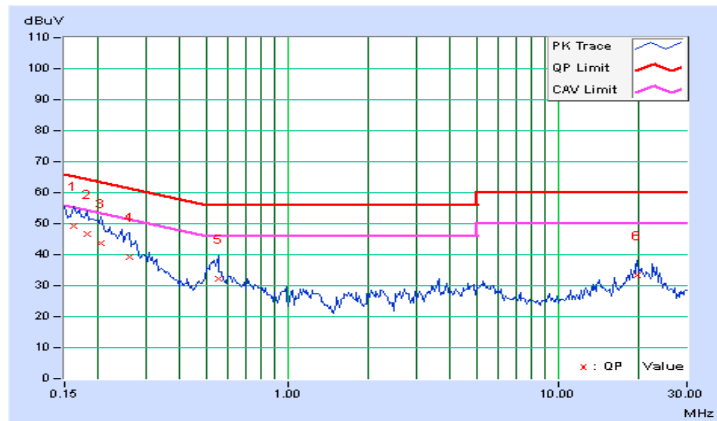

4.2.8 Test Results (Mode 2)

Phase	Line (L)	Detector Function	Quasi-Peak (QP) / Average (AV)
-------	----------	-------------------	--------------------------------

No	Freq. [MHz]	Corr.	Reading Value		Emission Level		Limit		Margin	
		Factor	[dB (uV)]		[dB (uV)]		[dB (uV)]		(dB)	
	(dB)	Q.P.	AV.	Q.P.	AV.	Q.P.	AV.	Q.P.	AV.	
1	0.15000	10.32	31.73	21.40	42.05	31.72	66.00	56.00	-23.95	-24.28
2	0.16562	10.31	30.27	17.26	40.58	27.57	65.18	55.18	-24.60	-27.61
3	0.18125	10.30	26.57	14.20	36.87	24.50	64.43	54.43	-27.56	-29.93
4	0.19687	10.28	24.52	12.19	34.80	22.47	63.74	53.74	-28.94	-31.27
5	0.21641	10.28	22.87	9.07	33.15	19.35	62.96	52.96	-29.80	-33.60
6	0.42087	10.30	30.14	24.84	40.44	35.14	57.43	47.43	-16.99	-12.29

REMARKS:

1. Q.P. and AV. are abbreviations of quasi-peak and average individually.
2. The emission levels of other frequencies were very low against the limit.
3. Margin value = Emission level - Limit value
4. Correction factor = Insertion loss + Cable loss
5. Emission Level = Correction Factor + Reading Value

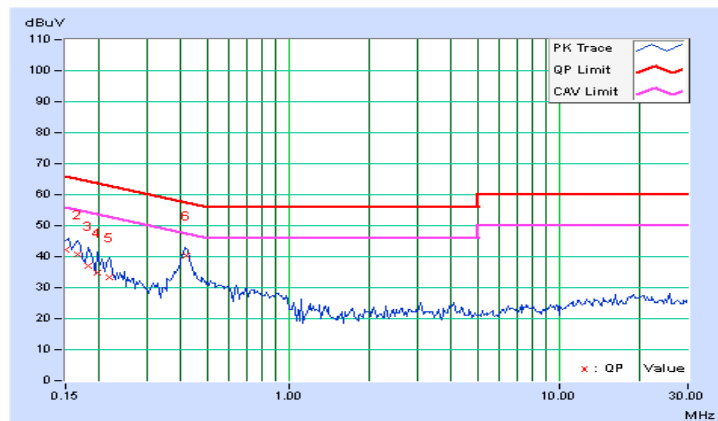

Phase	Neutral (N)	Detector Function	Quasi-Peak (QP) / Average (AV)
-------	-------------	-------------------	--------------------------------

No	Freq. [MHz]	Corr.	Reading Value		Emission Level		Limit		Margin	
		Factor	[dB (uV)]		[dB (uV)]		[dB (uV)]		(dB)	
		(dB)	Q.P.	AV.	Q.P.	AV.	Q.P.	AV.	Q.P.	AV.
1	0.15000	10.30	33.60	21.58	43.90	31.88	66.00	56.00	-22.10	-24.12
2	0.16172	10.29	30.35	18.47	40.64	28.76	65.38	55.38	-24.73	-26.61
3	0.17734	10.28	29.51	15.35	39.79	25.63	64.61	54.61	-24.82	-28.98
4	0.20469	10.26	25.84	12.71	36.10	22.97	63.42	53.42	-27.32	-30.45
5	0.41863	10.28	30.34	24.80	40.62	35.08	57.48	47.48	-16.86	-12.40
6	0.54453	10.27	17.37	10.66	27.64	20.93	56.00	46.00	-28.36	-25.07

REMARKS:

1. Q.P. and AV. are abbreviations of quasi-peak and average individually.
2. The emission levels of other frequencies were very low against the limit.
3. Margin value = Emission level - Limit value
4. Correction factor = Insertion loss + Cable loss
5. Emission Level = Correction Factor + Reading Value

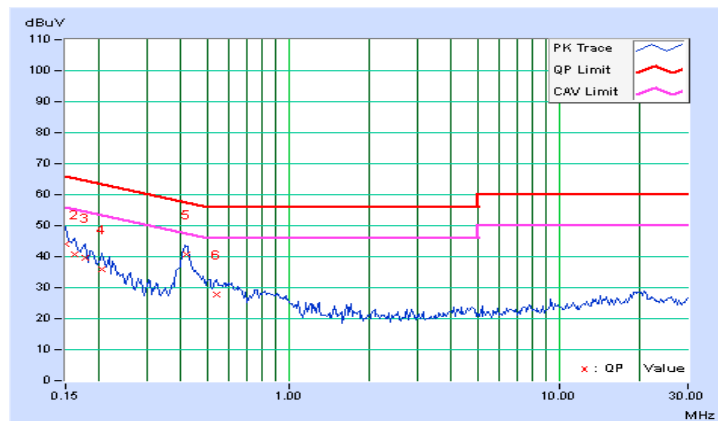

4.3 Transmit Power Measurement

4.3.1 Limits of Transmit Power Measurement

Operation Band	EUT Category		LIMIT
U-NII-1		Outdoor Access Point	1 Watt (30 dBm) (Max. e.i.r.p \leq 125mW(21 dBm) at any elevation angle above 30 degrees as measured from the horizon)
		Fixed point-to-point Access Point	1 Watt (30 dBm)
		Indoor Access Point	1 Watt (30 dBm)
	√	Mobile and Portable client device	250mW (24 dBm)
U-NII-2A		√	250mW (24 dBm) or 11 dBm+10 log B*
U-NII-2C		√	250mW (24 dBm) or 11 dBm+10 log B*
U-NII-3		√	1 Watt (30 dBm)

*B is the 26 dB emission bandwidth in megahertz

Per KDB 662911 Method of conducted output power measurement on IEEE 802.11 devices,

Array Gain = 0 dB (i.e., no array gain) for $N_{ANT} \leq 4$;

Array Gain = 0 dB (i.e., no array gain) for channel widths ≥ 40 MHz for any N_{ANT} ;

Array Gain = $5 \log(N_{ANT}/N_{SS})$ dB or 3 dB, whichever is less for 20-MHz channel widths with $N_{ANT} \geq 5$.

For power measurements on all other devices: Array Gain = $10 \log(N_{ANT}/N_{SS})$ dB.

4.3.2 Test Setup

FOR POWER OUTPUT MEASUREMENT

For channel straddling 5725MHz:

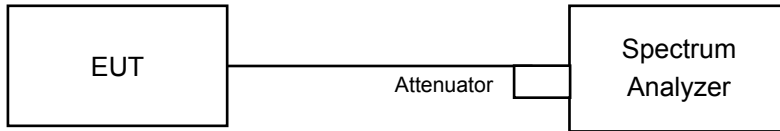

For other channels:

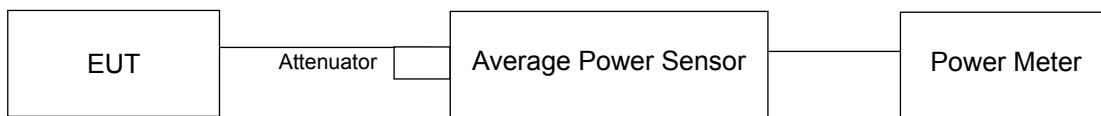

FOR 26dB OCCUPIED BANDWIDTH

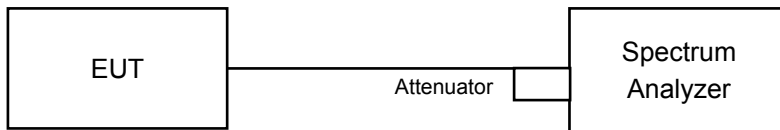

4.3.3 Test Instruments

Refer to section 4.1.2 to get information of above instrument.

4.3.4 Test Procedure

FOR AVERAGE POWER MEASUREMENT

For channel straddling 5725MHz:

802.11ac (VHT80)

Method SA-2

1. Set span to encompass the emission bandwidth (EBW) of the signal.
2. Set RBW =1MHz.
3. Set the VBW $\geq 3 \times$ RBW.
4. Number of points in sweep ≥ 2 Span / RBW.
5. Sweep time = auto.
6. Detector = RMS.
7. Trace average at least 100 traces in power averaging mode
8. Compute power by integrating the spectrum across the 26 dB EBW of the signal.
9. Duty factor need added to measured value (duty cycle < 98 percent).

Other Modulation mode

Method SA-1

1. Set span to encompass the entire emission bandwidth (EBW) of the signal.
2. Set RBW =1MHz.
3. Set the VBW $\geq 3 \times$ RBW.
4. Number of points in sweep ≥ 2 Span / RBW.
5. Sweep time = auto.
6. Set trigger to free run (duty cycle ≥ 98 percent)
7. Detector = RMS.
8. Trace average at least 100 traces in power averaging mode
9. Compute power by integrating the spectrum across the 26 dB EBW of the signal.

For other channels:

Method PM is used to perform output power measurement, trigger and gating function of wide band power meter is enabled to measure max output power of TX on burst. Duty factor is not added to measured value.

FOR 26dB OCCUPIED BANDWIDTH

1. Set RBW = approximately 1% of the emission bandwidth.
2. Set the VBW > RBW.
3. Detector = Peak.
4. Trace mode = max hold.
5. Measure the maximum width of the emission that is 26 dB down from the peak of the emission. Compare this with the RBW setting of the analyzer. Readjust RBW and repeat measurement as needed until the RBW/EBW ratio is approximately 1%.

4.3.5 Deviation from Test Standard

No deviation.

4.3.6 EUT Operating Condition

The software provided by client to enable the EUT under transmission condition continuously at lowest, middle and highest channel frequencies individually.

4.3.7 Test Result
POWER OUTPUT:
1TX
802.11a

Chan.	Chan. Freq. (MHz)	Average Power (mW)	Average Power (dBm)	Limit (dBm)	Pass / Fail
36	5180	61.518	17.89	24	Pass
40	5200	76.736	18.85	24	Pass
48	5240	77.446	18.89	24	Pass
52	5260	77.983	18.92	24	Pass
60	5300	74.302	18.71	24	Pass
64	5320	57.016	17.56	24	Pass
100	5500	42.756	16.31	24	Pass
116	5580	58.749	17.69	24	Pass
140	5700	31.333	14.96	24	Pass
*144 (UNII-2c Band)	5720	24.099	13.82	24	Pass
*144 (UNII-3 Band)	5720	5.768	7.61	30	Pass
149	5745	33.963	15.31	30	Pass
157	5785	56.754	17.54	30	Pass
165	5825	50.35	17.02	30	Pass

Note: * Test was performed in accordance with Measurement follow FCC KDB 789033 UNII test procedure Method SA-1 and use spectrum analyzer test.

The Total Power for the straddle channel:

Chan.	Chan. Freq. (MHz)	Average Power (mW)	Average Power (dBm)
*144	5720	29.867	14.75

Note: The total power was calculated through formula and record the value for reference only.

26dB OCCUPIED BANDWIDTH

Channel	Frequency (MHz)	26dBc Bandwidth (MHz)
36	5180	21.84
40	5200	33.89
48	5240	32.96
52	5260	35.42
60	5300	31.11
64	5320	21.75
100	5500	21.85
116	5580	36.51
140	5700	21.77
144 (UNII-2c Band)	5720	22.07

Note: For U-NII-2A, U-NII-2C Band output power limitation is determined based on 26dBc bandwidth

Power Limit = 11dBm + 10logB < U-NII-2A, U-NII-2C >			
Channel Number	Freq.(MHz)	Min. B(MHz)	Determined Conducted Limit (dBm)
52	5260	35.42	26.49 > 24
60	5300	31.11	25.92 > 24
64	5320	21.75	24.37 > 24
100	5500	21.85	24.39 > 24
116	5580	36.51	26.62 > 24
140	5700	21.77	24.37 > 24
144 (UNII-2c Band)	5720	22.07	24.43 > 24

Spectrum Plot of Worst Value

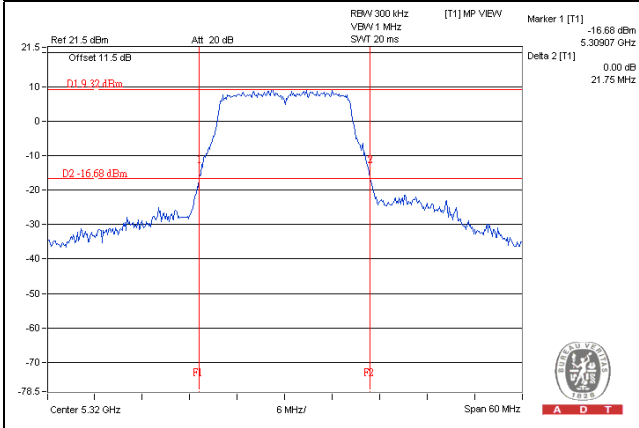
802.11a / CH64

2TX
CDD Mode
802.11a

Chan.	Chan. Freq. (MHz)	Average Power (dBm)		Total Power (mW)	Total Power (dBm)	Limit (dBm)	Pass / Fail
		Chain 0	Chain 1				
36	5180	15.28	16.84	82.035	19.14	24	Pass
40	5200	17.33	18.85	130.811	21.17	24	Pass
48	5240	17.72	18.89	136.602	21.35	24	Pass
52	5260	17.95	18.92	140.356	21.47	24	Pass
60	5300	18.10	18.71	138.867	21.43	24	Pass
64	5320	15.77	16.74	84.963	19.29	24	Pass
100	5500	16.85	15.93	87.591	19.42	24	Pass
116	5580	18.95	17.69	137.273	21.38	24	Pass
140	5700	16.50	14.76	74.591	18.73	24	Pass
*144 (UNII-2c Band)	5720	14.90	14.05	56.313	17.51	24	Pass
*144 (UNII-3 Band)	5720	9.17	8.14	14.776	11.70	30	Pass
149	5745	15.86	15.31	72.511	18.60	30	Pass
157	5785	17.59	17.54	114.166	20.58	30	Pass
165	5825	15.67	16.85	85.315	19.31	30	Pass

Note: * Test was performed in accordance with Measurement follow FCC KDB 789033 UNII test procedure Method SA-1 and use spectrum analyzer test.

The Total Power for the straddle channel:

Chan.	Chan. Freq. (MHz)	Average Power (mW)	Average Power (dBm)
*144	5720	71.089	18.52

Note: The total power was calculated through formula and record the value for reference only.

26dB OCCUPIED BANDWIDTH

Channel	Frequency (MHz)	26dBc Bandwidth (MHz)	
		Chain 0	Chain 1
36	5180	21.85	21.77
40	5200	34.17	34.39
48	5240	35.82	33.91
52	5260	34.16	33.21
60	5300	33.72	30.65
64	5320	21.86	21.56
100	5500	21.73	21.76
116	5580	28.65	29.06
140	5700	21.75	21.50
144 (UNII-2c Band)	5720	24.63	23.14

Note: For U-NII-2A, U-NII-2C Band output power limitation is determined based on 26dBc bandwidth

Power Limit = 11dBm + 10logB < U-NII-2A, U-NII-2C >			
Channel Number	Freq.(MHz)	Min. B(MHz)	Determined Conducted Limit (dBm)
52	5260	33.21	26.21 > 24
60	5300	30.65	25.86 > 24
64	5320	21.56	24.33 > 24
100	5500	21.73	24.37 > 24
116	5580	28.65	25.57 > 24
140	5700	21.50	24.32 > 24
144 (UNII-2c Band)	5720	23.14	24.64 > 24

Beamforming Mode
802.11ac (VHT20)

Chan.	Chan. Freq. (MHz)	Average Power (dBm)		Total Power (mW)	Total Power (dBm)	Limit (dBm)	Pass / Fail
		Chain 0	Chain 1				
36	5180	15.83	17.47	94.129	19.74	23.51	Pass
40	5200	17.45	18.45	125.574	20.99	23.51	Pass
48	5240	17.86	18.69	135.055	21.31	23.51	Pass
52	5260	17.91	19.35	147.901	21.70	23.51	Pass
60	5300	18.25	18.71	141.136	21.50	23.51	Pass
64	5320	16.85	17.11	99.821	19.99	23.51	Pass
100	5500	17.55	16.47	101.246	20.05	23.39	Pass
116	5580	19.28	17.39	139.551	21.45	23.39	Pass
140	5700	16.41	14.47	71.742	18.56	23.39	Pass
*144 (UNII-2c Band)	5720	14.85	14.07	56.076	17.49	23.39	Pass
*144 (UNII-3 Band)	5720	9.49	8.61	16.153	12.08	30	Pass
149	5745	15.40	14.49	62.793	17.98	30	Pass
157	5785	16.95	17.26	102.756	20.12	30	Pass
165	5825	15.57	16.27	78.422	18.94	30	Pass

Note: 1. * Test was performed in accordance with Measurement follow FCC KDB 789033 UNII test procedure Method SA-1 and use spectrum analyzer test.

2. For UNII-1 and UNII-2a: Directional gain = $10 \log[(10^{G1/20} + 10^{G2/20})^2 / 2] = 6.49\text{dBi} > 6\text{dBi}$, so the power limit shall be reduced to $24-(6.49-6) = 23.51\text{dBm}$.

3. For UNII-2c: Directional gain = $10 \log[(10^{G1/20} + 10^{G2/20})^2 / 2] = 6.61\text{dBi} > 6\text{dBi}$, so the power limit shall be reduced to $24-(6.61-6) = 23.39\text{dBm}$.

4. For UNII-3: Directional gain = $10 \log[(10^{G1/20} + 10^{G2/20})^2 / 2] = 5.47\text{dBi} < 6\text{dBi}$, so the power limit shall not be reduced.

The Total Power for the straddle channel:

Chan.	Chan. Freq. (MHz)	Average Power (mW)	Average Power (dBm)
*144	5720	72.229	18.59

Note: The total power was calculated through formula and record the value for reference only.

26dB OCCUPIED BANDWIDTH

Channel	Frequency (MHz)	26dBc Bandwidth (MHz)	
		Chain 0	Chain 1
36	5180	23.95	21.86
40	5200	36.01	31.17
48	5240	35.68	25.86
52	5260	37.84	31.47
60	5300	39.62	28.15
64	5320	22.05	21.86
100	5500	22.08	21.80
116	5580	25.26	29.35
140	5700	22.11	21.87
144 (UNII-2c Band)	5720	26.42	23.64

Note: For U-NII-2A, U-NII-2C Band output power limitation is determined based on 26dBc bandwidth

Power Limit = 11dBm + 10logB < U-NII-2A, U-NII-2C >			
Channel Number	Freq.(MHz)	Min. B(MHz)	Determined Conducted Limit (dBm)
52	5260	31.47	25.97 > 24
60	5300	28.15	25.49 > 24
64	5320	21.86	24.39 > 24
100	5500	21.80	24.38 > 24
116	5580	25.26	25.02 > 24
140	5700	21.87	24.39 > 24
144 (UNII-2c Band)	5720	23.64	24.73 > 24

802.11ac (VHT40)

Chan.	Chan. Freq. (MHz)	Average Power (dBm)		Total Power (mW)	Total Power (dBm)	Limit (dBm)	Pass / Fail
		Chain 0	Chain 1				
38	5190	14.24	15.52	62.191	17.94	23.51	Pass
46	5230	17.73	18.97	138.179	21.40	23.51	Pass
54	5270	18.07	19.53	153.864	21.87	23.51	Pass
62	5310	13.60	14.16	48.971	16.90	23.51	Pass
102	5510	14.99	14.00	56.669	17.53	23.39	Pass
110	5550	19.29	18.53	156.203	21.94	23.39	Pass
134	5670	17.91	16.35	104.954	20.21	23.39	Pass
*142 (UNII-2c Band)	5710	15.61	15.72	76.227	18.82	23.39	Pass
*142 (UNII-3 Band)	5710	5.86	5.92	8.027	9.05	30	Pass
151	5755	13.05	12.87	39.548	15.97	30	Pass
159	5795	15.93	16.42	83.027	19.19	30	Pass

Note: 1. * Test was performed in accordance with Measurement follow FCC KDB 789033 UNII test procedure Method SA-1 and use spectrum analyzer test.

2. For UNII-1 and UNII-2a: Directional gain = $10 \log[(10^{G1/20} + 10^{G2/20})^2 / 2] = 6.49\text{dBi} > 6\text{dBi}$, so the power limit shall be reduced to $24 - (6.49 - 6) = 23.51\text{dBm}$.

3. For UNII-2c: Directional gain = $10 \log[(10^{G1/20} + 10^{G2/20})^2 / 2] = 6.61\text{dBi} > 6\text{dBi}$, so the power limit shall be reduced to $24 - (6.61 - 6) = 23.39\text{dBm}$.

4. For UNII-3: Directional gain = $10 \log[(10^{G1/20} + 10^{G2/20})^2 / 2] = 5.47\text{dBi} < 6\text{dBi}$, so the power limit shall not be reduced.

The Total Power for the straddle channel:

Chan.	Chan. Freq. (MHz)	Average Power (mW)	Average Power (dBm)
*142	5710	84.254	19.26

Note: The total power was calculated through formula and record the value for reference only.

26dB OCCUPIED BANDWIDTH

Channel	Frequency (MHz)	26dBc Bandwidth (MHz)	
		Chain 0	Chain 1
38	5190	41.75	41.67
46	5230	95.05	80.89
54	5270	94.77	96.85
62	5310	41.52	41.37
102	5510	41.72	41.53
110	5550	88.41	92.49
134	5670	88.91	92.89
142 (UNII-2c Band)	5710	64.57	64.78

Note: For U-NII-2A, U-NII-2C Band output power limitation is determined based on 26dBc bandwidth

Power Limit = 11dBm + 10logB < U-NII-2A, U-NII-2C >			
Channel Number	Freq.(MHz)	Min. B(MHz)	Determined Conducted Limit (dBm)
54	5270	96.85	30.76 > 24
62	5310	41.37	27.16 > 24
102	5510	41.53	27.18 > 24
110	5550	88.41	30.46 > 24
134	5670	88.91	30.48 > 24
142 (UNII-2c Band)	5710	64.57	29.10 > 24

802.11ac (VHT80)

Chan.	Chan. Freq. (MHz)	Average Power (dBm)		Total Power (mW)	Total Power (dBm)	Limit (dBm)	Pass / Fail
		Chain 0	Chain 1				
42	5210	14.47	15.79	65.921	18.19	23.51	Pass
58	5290	13.85	14.64	53.373	17.27	23.51	Pass
106	5530	15.14	14.13	58.541	17.67	23.39	Pass
122	5610	18.19	17.15	117.797	20.71	23.39	Pass
*138 (UNII-2c Band)	5690	15.26	14.23	64.162	18.07	23.39	Pass
*138 (UNII-3 Band)	5690	1.39	0.36	2.631	4.20	30	Pass
155	5775	13.16	13.17	41.45	16.18	30	Pass

Note: 1. * Test was performed in accordance with Measurement follow FCC KDB 789033 UNII test procedure Method SA-2 and use spectrum analyzer test.

2. For UNII-1 and UNII-2a: Directional gain = $10 \log[(10^{G1/20} + 10^{G2/20})^2 / 2] = 6.49\text{dBi} > 6\text{dBi}$, so the power limit shall be reduced to $24-(6.49-6) = 23.51\text{dBm}$.

3. For UNII-2c: Directional gain = $10 \log[(10^{G1/20} + 10^{G2/20})^2 / 2] = 6.61\text{dBi} > 6\text{dBi}$, so the power limit shall be reduced to $24-(6.61-6) = 23.39\text{dBm}$.

4. For UNII-3: Directional gain = $10 \log[(10^{G1/20} + 10^{G2/20})^2 / 2] = 5.47\text{dBi} < 6\text{dBi}$, so the power limit shall not be reduced.

The Total Power for the straddle channel:

Chan.	Chan. Freq. (MHz)	Average Power (mW)	Average Power (dBm)
*138	5690	66.793	18.25

Note: The total power was calculated through formula and record the value for reference only.

26dB OCCUPIED BANDWIDTH

Channel	Frequency (MHz)	26dBc Bandwidth (MHz)	
		Chain 0	Chain 1
42	5210	82.91	82.07
58	5290	82.57	82.30
106	5530	82.56	82.52
122	5610	129.07	143.60
138 (UNII-2c Band)	5690	115.00	115.00

Note: For U-NII-2A, U-NII-2C Band output power limitation is determined based on 26dBc bandwidth

Power Limit = 11dBm + 10logB < U-NII-2A, U-NII-2C >			
Channel Number	Freq.(MHz)	Min. B(MHz)	Determined Conducted Limit (dBm)
58	5290	82.30	30.15 > 24
106	5530	82.52	30.16 > 24
122	5610	129.07	32.10 > 24
138 (UNII-2c Band)	5690	115.00	31.60 > 24

SDM Mode
802.11ac (VHT20)

Chan.	Chan. Freq. (MHz)	Average Power (dBm)		Total Power (mW)	Total Power (dBm)	Limit (dBm)	Pass / Fail
		Chain 0	Chain 1				
36	5180	15.73	17.46	93.13	19.69	24	Pass
40	5200	17.32	18.38	122.816	20.89	24	Pass
48	5240	17.80	18.56	132.035	21.21	24	Pass
52	5260	17.89	18.95	140.042	21.46	24	Pass
60	5300	18.12	18.64	137.977	21.40	24	Pass
64	5320	16.71	16.97	96.655	19.85	24	Pass
100	5500	17.47	16.37	99.198	19.97	24	Pass
116	5580	18.96	17.32	132.656	21.23	24	Pass
140	5700	16.34	14.39	70.532	18.48	24	Pass
*144 (UNII-2c Band)	5720	14.85	14.07	56.076	17.49	24	Pass
*144 (UNII-3 Band)	5720	9.49	8.61	16.153	12.08	30	Pass
149	5745	15.35	14.43	62.01	17.92	30	Pass
157	5785	16.95	17.13	101.187	20.05	30	Pass
165	5825	15.46	16.20	76.843	18.86	30	Pass

Note: * Test was performed in accordance with Measurement follow FCC KDB 789033 UNII test procedure Method SA-1 and use spectrum analyzer test.

The Total Power for the straddle channel:

Chan.	Chan. Freq. (MHz)	Average Power (mW)	Average Power (dBm)
*144	5720	72.229	18.59

Note: The total power was calculated through formula and record the value for reference only.

802.11ac (VHT40)

Chan.	Chan. Freq. (MHz)	Average Power (dBm)		Total Power (mW)	Total Power (dBm)	Limit (dBm)	Pass / Fail
		Chain 0	Chain 1				
38	5190	14.12	15.52	61.468	17.89	30	Pass
46	5230	17.64	18.97	136.962	21.37	30	Pass
54	5270	17.98	18.99	142.056	21.52	24	Pass
62	5310	13.50	14.16	48.449	16.85	24	Pass
102	5510	14.88	14.00	55.88	17.47	24	Pass
110	5550	18.90	18.53	148.91	21.73	24	Pass
134	5670	17.77	16.35	102.993	20.13	24	Pass
*142 (UNII-2c Band)	5710	15.61	15.72	76.227	18.82	24	Pass
*142 (UNII-3 Band)	5710	5.86	5.92	8.027	9.05	30	Pass
151	5755	12.96	12.87	39.134	15.93	30	Pass
159	5795	15.87	16.42	82.49	19.16	30	Pass

Note: * Test was performed in accordance with Measurement follow FCC KDB 789033 UNII test procedure Method SA-1 and use spectrum analyzer test.

The Total Power for the straddle channel:

Chan.	Chan. Freq. (MHz)	Average Power (mW)	Average Power (dBm)
*142	5710	84.254	19.26

Note: The total power was calculated through formula and record the value for reference only.

802.11ac (VHT80)

Chan.	Chan. Freq. (MHz)	Average Power (dBm)		Total Power (mW)	Total Power (dBm)	Limit (dBm)	Pass / Fail
		Chain 0	Chain 1				
42	5210	14.38	15.77	65.173	18.14	24	Pass
58	5290	13.70	14.63	52.482	17.20	24	Pass
106	5530	15.05	14.11	57.752	17.62	24	Pass
122	5610	18.19	17.10	117.203	20.69	24	Pass
*138 (UNII-2c Band)	5690	15.26	14.23	64.162	18.07	24	Pass
*138 (UNII-3 Band)	5690	1.39	0.36	2.631	4.20	30	Pass
155	5775	13.12	13.06	40.742	16.10	30	Pass

Note: * Test was performed in accordance with Measurement follow FCC KDB 789033 UNII test procedure Method SA-2 and use spectrum analyzer test.

The Total Power for the straddle channel:

Chan.	Chan. Freq. (MHz)	Average Power (mW)	Average Power (dBm)
*138	5690	66.793	18.25

Note: The total power was calculated through formula and record the value for reference only.

Spectrum Plot of Worst Value

802.11a_Chain 1 / CH140

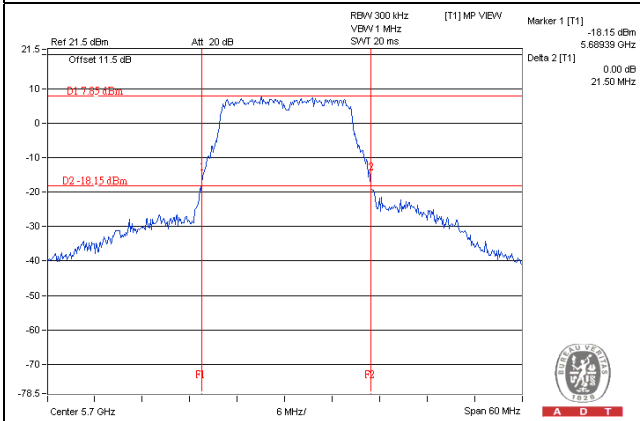

802.11ac (VHT20)_Chain 1 / CH100

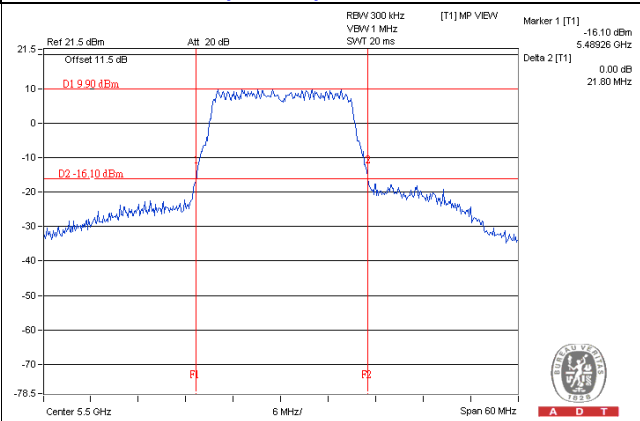

802.11ac (VHT40)_Chain 1 / CH62

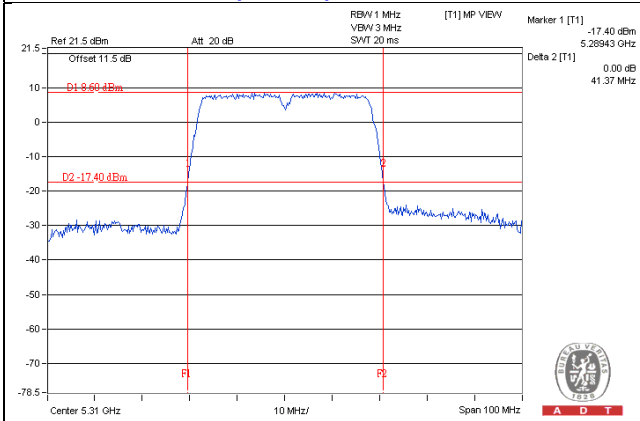

802.11ac (VHT80)_Chain 1 / CH42

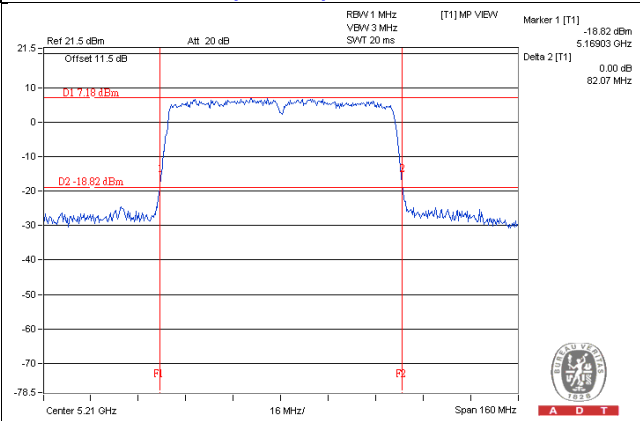

1TX
For Reference only – Power meter value

The power value was measured by power meter with average sensor.

Chan.	Chan. Freq. (MHz)	Average Power (mW)	Average Power (dBm)
802.11a			
144	5720	57.81	17.62

2TX
CDD Mode
For Reference only – Power meter value

The power value was measured by power meter with average sensor.

Chan.	Chan. Freq. (MHz)	Average Power (dBm)		Total Power (mW)	Total Power (dBm)
		Chain 0	Chain 1		
802.11a					
144	5720	18.89	17.62	135.256	21.31

Beamforming Mode
For Reference only – Power meter value

The power value was measured by power meter with average sensor.

Chan.	Chan. Freq. (MHz)	Average Power (dBm)		Total Power (mW)	Total Power (dBm)
		Chain 0	Chain 1		
802.11ac (VHT20)					
144	5720	18.92	17.41	133.064	21.24
802.11ac (VHT40)					
142	5710	18.82	18.45	146.192	21.65
802.11ac (VHT80)					
138	5690	18.98	18.56	150.847	21.79

Note: The total power was calculated through formula and record the value for reference only.

SDM Mode
For Reference only – Power meter value

The power value was measured by power meter with average sensor.

Chan.	Chan. Freq. (MHz)	Average Power (dBm)		Total Power (mW)	Total Power (dBm)
		Chain 0	Chain 1		
802.11ac (VHT20)					
144	5720	18.89	17.27	130.779	21.17
802.11ac (VHT40)					
142	5710	18.78	18.45	145.493	21.63
802.11ac (VHT80)					
138	5690	18.88	18.46	147.414	21.69

Note: The total power was calculated through formula and record the value for reference only.

※Add test for each data rate output power (require by manufacturer):

1TX

802.11a

CHANNEL	FREQUENCY (MHz)	AVERAGE POWER (dBm)							
		Data rate							
		6Mbps	9Mbps	12Mbps	18Mbps	24Mbps	36Mbps	48Mbps	54Mbps
36	5180	17.89	17.84	17.63	17.67	17.66	17.57	17.72	17.87
40	5200	18.85	18.82	18.75	18.70	18.68	18.53	18.75	18.75
48	5240	18.89	18.76	18.87	18.76	18.58	18.66	18.69	18.69
52	5260	18.92	18.76	18.59	18.54	18.61	18.63	18.77	18.85
60	5300	18.71	18.57	18.48	18.28	18.27	18.2	18.28	18.31
64	5320	17.56	17.41	17.54	17.38	17.16	17.24	17.03	16.97
100	5500	16.31	16.16	16.03	16.10	16.21	16.23	16.28	16.06
116	5580	17.69	17.68	17.63	17.63	17.63	17.55	17.61	17.5
140	5700	14.96	14.81	14.82	14.85	14.71	14.72	14.79	14.79
144	5720	17.62	17.46	17.36	17.44	17.35	17.29	17.08	17.04
149	5745	15.31	15.18	15.27	15.15	15.06	14.84	14.78	14.64
157	5785	17.54	17.48	17.30	17.29	17.22	17.14	17.2	17.06
165	5825	17.02	16.96	16.78	16.58	16.75	16.89	16.91	16.97

2TX
CDD Mode
802.11a

CHANNEL	FREQUENCY (MHz)	AVERAGE POWER (dBm)							
		Data rate							
		6Mbps	9Mbps	12Mbps	18Mbps	24Mbps	36Mbps	48Mbps	54Mbps
36	5180	19.14	18.96	18.94	18.98	18.80	18.90	18.76	18.62
40	5200	21.17	21.16	21.08	21.11	21.12	21.08	20.94	20.79
48	5240	21.35	21.30	21.23	21.30	21.25	21.28	21.15	21
52	5260	21.47	21.35	21.23	21.22	21.15	21.22	21.37	21.2
60	5300	21.43	21.35	21.28	21.23	21.02	20.85	20.84	20.81
64	5320	19.29	19.23	19.17	19.16	19.03	19.06	18.95	18.99
100	5500	19.42	19.39	19.41	19.33	19.34	19.21	19.28	19.17
116	5580	21.38	21.29	21.33	21.35	21.25	21.28	21.06	21.26
140	5700	18.73	18.62	18.47	18.37	18.35	18.14	18.3	18.51
144	5720	21.31	21.19	21.15	21.19	21.17	21.3	21.19	21.21
149	5745	18.60	18.50	18.34	18.28	18.15	18.09	17.99	17.82
157	5785	20.58	20.42	20.37	20.40	20.29	20.43	20.57	20.54
165	5825	19.31	19.11	18.97	18.85	18.94	19.03	19.2	19.19

Beamforming Mode
802.11ac (VHT20)

CHANNEL	FREQUENCY (MHz)	AVERAGE POWER (dBm)								
		Data rate								
		MCS0	MCS1	MCS2	MCS3	MCS4	MCS5	MCS6	MCS7	MCS8
36	5180	19.74	19.66	19.64	19.64	19.68	19.61	19.67	19.63	19.53
40	5200	20.99	20.82	20.80	20.67	20.61	20.63	20.52	20.66	20.74
48	5240	21.31	21.26	21.18	21.20	20.98	20.97	21.11	20.97	21.16
52	5260	21.70	21.64	21.61	21.43	21.47	21.57	21.5	21.5	21.5
60	5300	21.50	21.37	21.36	21.32	21.23	21.11	21.27	21.08	21.25
64	5320	19.99	19.79	19.97	19.83	19.79	19.86	19.69	19.9	19.8
100	5500	20.05	20.01	19.83	19.94	19.94	19.86	19.98	20.04	20.04
116	5580	21.45	21.24	21.21	21.34	21.3	21.1	21.16	21.18	21.08
140	5700	18.56	18.52	18.39	18.30	18.44	18.32	18.4	18.3	18.46
144	5720	21.24	21.22	21.14	21.03	21.09	21.19	21.19	21.01	20.85
149	5745	17.98	17.95	17.77	17.81	17.61	17.82	17.68	17.78	17.74
157	5785	20.12	19.99	20.08	19.96	19.82	20.03	19.82	19.72	19.66
165	5825	18.94	18.79	18.86	18.74	18.9	18.78	18.89	18.67	18.63

**802.11ac (VHT40)**

CHANNEL	FREQUENCY (MHz)	AVERAGE POWER (dBm)									
		Data rate									
		MCS0	MCS1	MCS2	MCS3	MCS4	MCS5	MCS6	MCS7	MCS8	MCS9
38	5190	17.94	17.78	17.72	17.84	17.92	17.77	17.57	17.62	17.70	17.86
46	5230	21.40	21.26	21.38	21.39	21.25	21.09	21.28	21.17	21.39	21.37
54	5270	21.87	21.79	21.80	21.78	21.76	21.56	21.54	21.39	21.56	21.43
62	5310	16.90	16.79	16.85	16.63	16.68	16.54	16.74	16.55	16.61	16.67
102	5510	17.53	17.42	17.39	17.19	17.05	17.01	17.12	17.27	17.39	17.25
110	5550	21.94	21.77	21.75	21.89	21.84	21.82	21.82	21.81	21.77	21.75
134	5670	20.21	19.99	20.15	20.10	19.96	20.09	19.96	20.01	19.82	19.88
142	5710	21.65	21.57	21.64	21.50	21.56	21.6	21.46	21.39	21.5	21.54
151	5755	15.97	15.81	15.67	15.75	15.93	15.75	15.57	15.73	15.94	15.85
159	5795	19.19	19.15	19.15	19.12	19.05	18.83	18.87	18.71	18.7	18.81

802.11ac (VHT80)

CHANNEL	FREQUENCY (MHz)	AVERAGE POWER (dBm)									
		Data rate									
		MCS0	MCS1	MCS2	MCS3	MCS4	MCS5	MCS6	MCS7	MCS8	MCS9
42	5210	18.19	18.05	17.91	17.99	18.05	17.97	18.08	18.09	17.91	17.70
58	5290	17.27	17.10	17.19	17.10	17.19	17.15	17.04	17.13	17.18	17.19
106	5530	17.67	17.55	17.34	17.38	17.46	17.66	17.52	17.63	17.66	17.48
122	5610	20.71	20.62	20.69	20.57	20.46	20.62	20.48	20.32	20.18	20.10
138	5690	21.79	21.70	21.76	21.77	21.6	21.68	21.63	21.75	21.55	21.33
155	5775	16.18	16.14	16.01	16.08	16	15.91	16.02	16.09	16.08	15.90

SDM Mode
802.11ac (VHT20)

CHANNEL	FREQUENCY (MHz)	AVERAGE POWER (dBm)								
		Data rate								
		MCS0	MCS1	MCS2	MCS3	MCS4	MCS5	MCS6	MCS7	MCS8
36	5180	19.69	19.64	19.61	19.41	19.38	19.21	19.24	19.04	19.04
40	5200	20.89	20.73	20.60	20.46	20.27	20.34	20.18	20.06	20.15
48	5240	21.21	21.08	20.93	20.87	20.84	20.82	20.71	20.5	20.31
52	5260	21.46	21.42	21.31	21.35	21.42	21.3	21.12	20.9	20.73
60	5300	21.40	21.21	21.13	21.05	21.05	20.9	20.83	20.85	20.71
64	5320	19.85	19.70	19.73	19.74	19.77	19.66	19.73	19.64	19.55
100	5500	19.97	19.85	19.93	19.87	19.89	19.86	19.93	19.77	19.66
116	5580	21.23	21.03	20.96	20.76	20.85	20.66	20.88	20.76	20.55
140	5700	18.48	18.45	18.30	18.24	18.41	18.36	18.29	18.39	18.43
144	5720	21.17	21.14	20.98	20.86	20.82	21	20.82	20.82	20.84
149	5745	17.92	17.83	17.72	17.54	17.6	17.46	17.53	17.67	17.83
157	5785	20.05	19.93	19.96	19.94	19.94	20	19.92	19.94	19.93
165	5825	18.86	18.74	18.65	18.45	18.62	18.56	18.54	18.47	18.27

802.11ac (VHT40)

CHANNEL	FREQUENCY (MHz)	AVERAGE POWER (dBm)									
		Data rate									
		MCS0	MCS1	MCS2	MCS3	MCS4	MCS5	MCS6	MCS7	MCS8	MCS9
38	5190	17.89	17.79	17.64	17.45	17.40	17.24	17.03	17.04	16.93	16.84
46	5230	21.37	21.19	21.09	21.10	21.22	21.28	21.13	21.11	21.06	21.23
54	5270	21.52	21.44	21.44	21.24	21.38	21.22	21.18	21.09	21	20.93
62	5310	16.85	16.72	16.63	16.53	16.7	16.84	16.79	16.8	16.77	16.65
102	5510	17.47	17.41	17.39	17.42	17.31	17.37	17.29	17.21	17.36	17.31
110	5550	21.73	21.65	21.51	21.57	21.37	21.16	21.04	20.87	20.74	20.58
134	5670	20.13	20.09	19.99	19.86	19.92	19.9	19.69	19.77	19.66	19.84
142	5710	21.63	21.43	21.49	21.46	21.4	21.54	21.41	21.39	21.33	21.42
151	5755	15.93	15.74	15.78	15.70	15.49	15.34	15.21	15.03	14.85	15.07
159	5795	19.16	19.15	19.10	18.88	18.86	18.69	18.59	18.73	18.91	18.94

802.11ac (VHT80)

CHANNEL	FREQUENCY (MHz)	AVERAGE POWER (dBm)									
		Data rate									
		MCS0	MCS1	MCS2	MCS3	MCS4	MCS5	MCS6	MCS7	MCS8	MCS9
42	5210	18.14	18.06	18.11	18.13	18.08	17.94	17.88	17.96	18.12	18.03
58	5290	17.20	17.09	17.18	17.14	17.07	17.04	17	16.82	16.84	16.77
106	5530	17.62	17.58	17.51	17.46	17.51	17.58	17.59	17.61	17.54	17.36
122	5610	20.69	20.53	20.49	20.68	20.53	20.48	20.56	20.62	20.53	20.59
138	5690	21.69	21.59	21.38	21.18	21.21	21.36	21.35	21.35	21.16	21.00
155	5775	16.10	16.05	15.86	15.74	15.73	15.64	15.45	15.35	15.33	15.24

4.4 Peak Power Spectral Density Measurement

4.4.1 Limits of Peak Power Spectral Density Measurement

Operation Band	EUT Category		LIMIT
U-NII-1		Outdoor Access Point	17dBm/ MHz
		Fixed point-to-point Access Point	
		Indoor Access Point	
	√	Mobile and Portable client device	11dBm/ MHz
U-NII-2A		√	11dBm/ MHz
U-NII-2C		√	11dBm/ MHz
U-NII-3		√	30dBm/ 500kHz

4.4.2 Test Setup

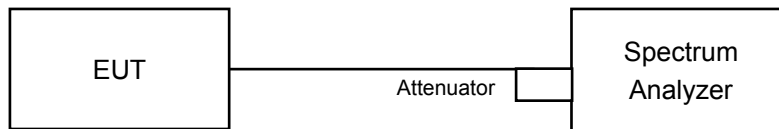

4.4.3 Test Instruments

Refer to section 4.1.2 to get information of above instrument.

4.4.4 Test Procedure

802.11a, 802.11ac (VHT20), 802.11ac (VHT40)

For U-NII-1, U-NII-2A, U-NII-2C band:

Using method SA-1

1. Set span to encompass the entire emission bandwidth (EBW) of the signal.
2. Set RBW = 1 MHz, Set VBW \geq 3 MHz, Detector = RMS
3. Sweep time = auto, trigger set to "free run".
4. Trace average at least 100 traces in power averaging mode.
5. Record the max value

802.11ac (VHT80)

Using method SA-2

1. Set span to encompass the entire emission bandwidth (EBW) of the signal.
2. Set RBW = 1 MHz, Set VBW \geq 3 MHz, Detector = RMS
3. Sweep time = auto, trigger set to "free run".
4. Trace average at least 100 traces in power averaging mode.
5. Record the max value and add $10 \log (1/\text{duty cycle})$

For U-NII-3:

1. Set span to encompass the entire emission bandwidth (EBW) of the signal.
2. Set RBW = 300 kHz, Set VBW \geq 1 MHz, Detector = RMS
3. Use the peak marker function to determine the maximum power level in any 300 kHz band segment within the fundamental EBW.
4. Scale the observed power level to an equivalent value in 500 kHz by adjusting (reducing) the measured power by a bandwidth correction factor (BWCF) where $BWCF = 10 \log(500 \text{ kHz}/300 \text{ kHz})$
5. Sweep time = auto, trigger set to "free run".
6. Trace average at least 100 traces in power averaging mode.
7. Record the max value and add $10 \log (1/\text{duty cycle})$

4.4.5 Deviation from Test Standard

No deviation.

4.4.6 EUT Operating Condition

Same as Item 4.3.6.

4.4.7 Test Results

1TX Mode**802.11a**

Chan.	Chan. Freq. (MHz)	PSD (dBm/MHz)	MAX. Limit (dBm/MHz)	Pass / Fail
36	5180	3.15	11	Pass
40	5200	4.46	11	Pass
48	5240	4.93	11	Pass
52	5260	5.33	11	Pass
60	5300	5.21	11	Pass
64	5320	3.72	11	Pass
100	5500	4.28	11	Pass
116	5580	5.80	11	Pass
140	5700	1.33	11	Pass
144 (UNII-2c Band)	5720	3.58	11	Pass

2TX Mode
CDD Mode
802.11a

Chan.	Chan. Freq. (MHz)	PSD (dBm/MHz)		Total Power Density (dBm/MHz)	MAX. Limit (dBm/MHz)	Pass / Fail
		Chain 0	Chain 1			
36	5180	2.22	2.23	5.24	10.51	Pass
40	5200	4.11	4.24	7.19	10.51	Pass
48	5240	4.15	4.30	7.24	10.51	Pass
52	5260	4.15	4.43	7.30	10.51	Pass
60	5300	4.28	4.21	7.26	10.51	Pass
64	5320	2.72	2.67	5.71	10.51	Pass
100	5500	3.21	2.93	6.08	10.39	Pass
116	5580	5.14	4.99	8.08	10.39	Pass
140	5700	2.62	1.98	5.32	10.39	Pass
144 (UNII-2c Band)	5720	4.75	3.95	7.38	10.39	Pass

- Note:**
- Method a) of power density measurement of KDB 662911 is using for calculating total power density. Total power density is summing entire spectra across corresponding frequency bins on the various outputs by computer.
 - For UNII-1 & UNII-2a: Directional gain = $10 \log[(10^{G1/20} + 10^{G2/20})^2 / 2] = 6.49\text{dBi} > 6\text{dBi}$, so the power density limit shall be reduced to $11-(6.49-6) = 10.51\text{dBm}$.
 - For UNII-2c: Directional gain = $10 \log[(10^{G1/20} + 10^{G2/20})^2 / 2] = 6.61\text{dBi} > 6\text{dBi}$, so the power density limit shall be reduced to $11-(6.61-6) = 10.39\text{dBm}$.

Beamforming Mode

802.11ac (VHT20)

Chan.	Chan. Freq. (MHz)	PSD (dBm/MHz)		Total Power Density (dBm/MHz)	MAX. Limit (dBm/MHz)	Pass / Fail
		Chain 0	Chain 1			
36	5180	2.72	3.09	5.92	10.51	Pass
40	5200	3.76	4.12	6.95	10.51	Pass
48	5240	3.85	3.97	6.92	10.51	Pass
52	5260	3.95	4.24	7.11	10.51	Pass
60	5300	4.07	3.90	7.00	10.51	Pass
64	5320	2.70	2.49	5.61	10.51	Pass
100	5500	3.61	3.62	6.63	10.39	Pass
116	5580	4.79	4.87	7.84	10.39	Pass
140	5700	2.49	1.96	5.24	10.39	Pass
144 (UNII-2c Band)	5720	4.34	3.73	7.06	10.39	Pass

- Note:**
- Method a) of power density measurement of KDB 662911 is using for calculating total power density. Total power density is summing entire spectra across corresponding frequency bins on the various outputs by computer.
 - For UNII-1 & UNII-2a: Directional gain = $10 \log[(10^{G1/20} + 10^{G2/20})^2 / 2] = 6.49 \text{dBi} > 6 \text{dBi}$, so the power density limit shall be reduced to $11 - (6.49 - 6) = 10.51 \text{dBm}$.
 - For UNII-2c: Directional gain = $10 \log[(10^{G1/20} + 10^{G2/20})^2 / 2] = 6.61 \text{dBi} > 6 \text{dBi}$, so the power density limit shall be reduced to $11 - (6.61 - 6) = 10.39 \text{dBm}$.

802.11ac (VHT40)

Chan.	Chan. Freq. (MHz)	PSD (dBm/MHz)		Total Power Density (dBm/MHz)	MAX. Limit (dBm/MHz)	Pass / Fail
		Chain 0	Chain 1			
38	5190	-2.23	-1.64	1.23	10.51	Pass
46	5230	0.91	1.06	4.14	10.51	Pass
54	5270	1.27	1.54	4.56	10.51	Pass
62	5310	-3.23	-3.21	-0.06	10.51	Pass
102	5510	-1.84	-2.04	1.22	10.39	Pass
110	5550	1.88	1.89	5.04	10.39	Pass
134	5670	0.66	0.52	3.75	10.39	Pass
142 (UNII-2c Band)	5710	1.64	1.83	4.89	10.39	Pass

- Note:** 1. Method a) of power density measurement of KDB 662911 is using for calculating total power density. Total power density is summing entire spectra across corresponding frequency bins on the various outputs by computer.
2. For UNII-1 & UNII-2a: Directional gain = $10 \log[(10^{G1/20} + 10^{G2/20})^2 / 2] = 6.49\text{dBi} > 6\text{dBi}$, so the power density limit shall be reduced to $11-(6.49-6) = 10.51\text{dBm}$.
3. For UNII-2c: Directional gain = $10 \log[(10^{G1/20} + 10^{G2/20})^2 / 2] = 6.61\text{dBi} > 6\text{dBi}$, so the power density limit shall be reduced to $11-(6.61-6) = 10.39\text{dBm}$.

802.11ac (VHT80)

Chan.	Chan. Freq. (MHz)	PSD (dBm/MHz)		Total Power Density (dBm/MHz)	MAX. Limit (dBm/MHz)	Pass / Fail
		Chain 0	Chain 1			
42	5210	-5.09	-4.74	-1.61	10.51	Pass
58	5290	-5.89	-5.49	-2.39	10.51	Pass
106	5530	-3.36	-3.89	-0.32	10.39	Pass
122	5610	-1.06	-1.53	2.01	10.39	Pass
138 (UNII-2c Band)	5690	-1.64	-2.65	1.18	10.39	Pass

- Note:** 1. Method a) of power density measurement of KDB 662911 is using for calculating total power density. Total power density is summing entire spectra across corresponding frequency bins on the various outputs by computer.
2. For UNII-1 & UNII-2a: Directional gain = $10 \log[(10^{G1/20} + 10^{G2/20})^2 / 2] = 6.49\text{dBi} > 6\text{dBi}$, so the power density limit shall be reduced to $11-(6.49-6) = 10.51\text{dBm}$.
3. For UNII-2c: Directional gain = $10 \log[(10^{G1/20} + 10^{G2/20})^2 / 2] = 6.61\text{dBi} > 6\text{dBi}$, so the power density limit shall be reduced to $11-(6.61-6) = 10.39\text{dBm}$.

Spectrum Plot of Worst Value

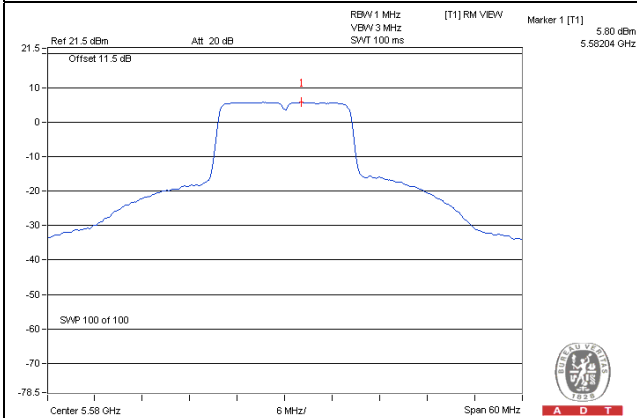
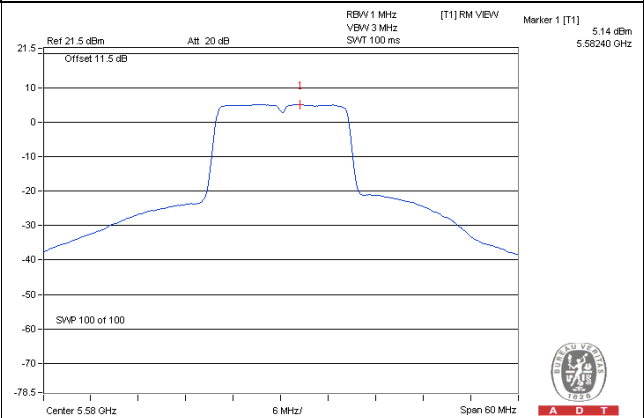
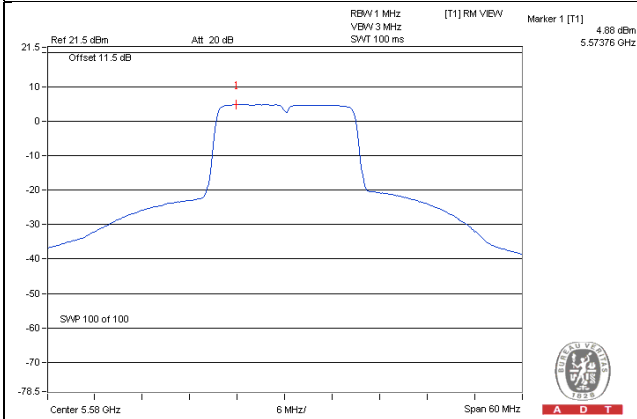
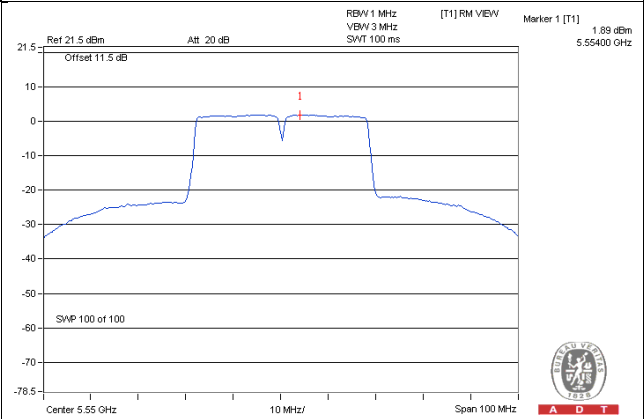
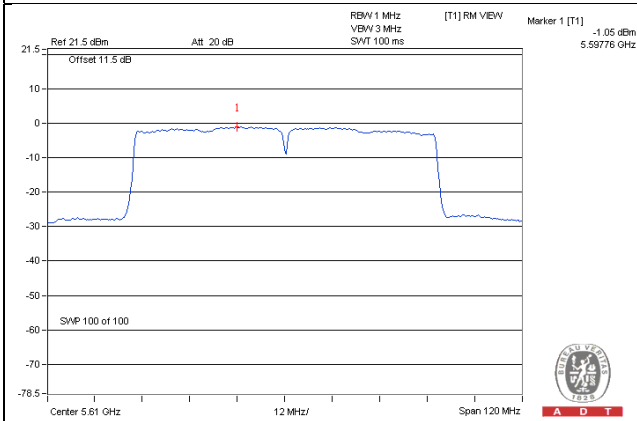
802.11a_Chain 1 / CH116 (1TX)

802.11a_Chain 0 / CH116 (2TX)

802.11ac (VHT20)_Chain 1 / CH116

802.11ac (VHT40)_Chain 1 / CH110

802.11ac (VHT80)_Chain 0 / CH122

For U-NII-3:
1TX Mode
802.11a

Chan.	Chan. Freq. (MHz)	PSD (dBm/300kHz)	PSD (dBm/500kHz)	Limit (dBm/500kHz)	Pass /Fail
144 (UNII-3 Band)	5720	-4.65	-2.43	30	Pass
149	5745	-6.02	-3.80	30	Pass
157	5785	-4.11	-1.89	30	Pass
165	5825	-4.48	-2.26	30	Pass

2TX Mode
CDD Mode
802.11a

TX chain	Channel	Freq. (MHz)	PSD (dBm/300k Hz)	PSD (dBm/500k Hz)	10 log (N=2) dB	Total PSD (dBm/500k Hz)	Limit (dBm/500k Hz)	Pass /Fail
0	144 (UNII-3 Band)	5720	-3.17	-0.95	3.01	2.06	30	Pass
	149	5745	-5.23	-3.01	3.01	0.00	30	Pass
	157	5785	-3.71	-1.49	3.01	1.52	30	Pass
	165	5825	-5.16	-2.94	3.01	0.07	30	Pass
1	144 (UNII-3 Band)	5720	-4.19	-1.97	3.01	1.04	30	Pass
	149	5745	-5.75	-3.53	3.01	-0.52	30	Pass
	157	5785	-4.23	-2.01	3.01	1.00	30	Pass
	165	5825	-5.48	-3.26	3.01	-0.25	30	Pass

Note: 1. Directional gain = $10 \log[(10^{G1/20} + 10^{G2/20})^2 / 2] = 5.47\text{dBi} < 6\text{dBi}$, so the power density limit shall not be reduced.

Beamforming Mode

802.11ac (VHT20)

TX chain	Channel	Freq. (MHz)	PSD (dBm/300k Hz)	PSD (dBm/500k Hz)	10 log (N=2) dB	Total PSD (dBm/500k Hz)	Limit (dBm/500k Hz)	Pass /Fail
0	144 (UNII-3 Band)	5720	-3.73	-1.51	3.01	1.50	30	Pass
	149	5745	-5.69	-3.47	3.01	-0.46	30	Pass
	157	5785	-4.71	-2.49	3.01	0.52	30	Pass
	165	5825	-5.97	-3.75	3.01	-0.74	30	Pass
1	144 (UNII-3 Band)	5720	-4.35	-2.13	3.01	0.88	30	Pass
	149	5745	-6.18	-3.96	3.01	-0.95	30	Pass
	157	5785	-4.85	-2.63	3.01	0.38	30	Pass
	165	5825	-6.32	-4.10	3.01	-1.09	30	Pass

Note: 1. Directional gain = $10 \log[(10^{G1/20} + 10^{G2/20})^2 / 2]$ = 5.47dBi < 6dBi , so the power density limit shall not be reduced.

802.11ac (VHT40)

TX chain	Chan.	Chan. Freq. (MHz)	PSD W/O Duty Factor		10 log (N=2) dB	Duty Factor (dB)	Total PSD With Duty Factor (dBm/500kHz)	Limit (dBm/500kHz)	Pass /Fail
			(dBm/300kHz)	(dBm/500kHz)					
0	142 (UNII-3 Band)	5710	-7.00	-4.78	3.01	0.15	-1.62	30	Pass
	151	5755	-11.50	-9.28	3.01	0.15	-6.12	30	Pass
	159	5795	-8.97	-6.75	3.01	0.15	-3.59	30	Pass
1	142 (UNII-3 Band)	5710	-6.97	-4.75	3.01	0.15	-1.59	30	Pass
	151	5755	-11.91	-9.69	3.01	0.15	-6.53	30	Pass
	159	5795	-9.45	-7.23	3.01	0.15	-4.07	30	Pass

Note: 1. Directional gain = $10 \log[(10^{G1/20} + 10^{G2/20})^2 / 2]$ = 5.47dBi < 6dBi , so the power density limit shall not be reduced.

2. Refer to section 3.3 for duty cycle spectrum plot.

802.11ac (VHT80)

TX chain	Chan.	Chan. Freq. (MHz)	PSD W/O Duty Factor		10 log (N=2) dB	Duty Factor (dB)	Total PSD With Duty Factor (dBm/500kHz)	Limit (dBm/500kHz)	Pass /Fail
			(dBm/300kHz)	(dBm/500kHz)					
0	138 (UNII-3 Band)	5690	-11.40	-9.18	3.01	0.29	-5.88	30	Pass
	155	5775	-13.97	-11.75	3.01	0.29	-8.45	30	Pass
1	138 (UNII-3 Band)	5690	-12.40	-10.18	3.01	0.29	-6.88	30	Pass
	155	5775	-14.32	-12.10	3.01	0.29	-8.80	30	Pass

Note: 1. Directional gain = $10 \log[(10^{G1/20} + 10^{G2/20})^2 / 2] = 5.47\text{dBi} < 6\text{dBi}$, so the power density limit shall not be reduced.

2. Refer to section 3.3 for duty cycle spectrum plot.

Spectrum Plot of Worst Value

802.11a_Chain 1 / CH157 (1TX)

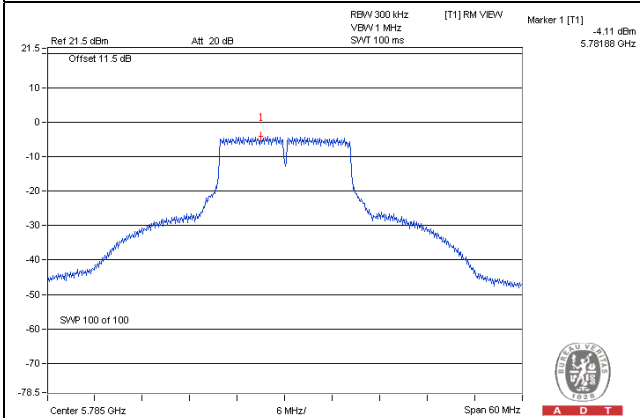

802.11a_Chain 0 / CH144 (2TX/UNII-3 Band)

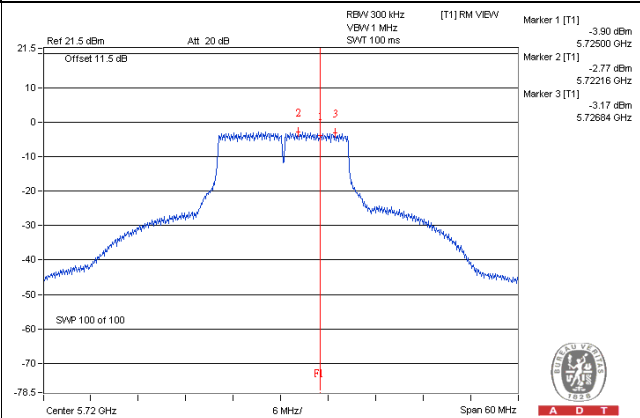

802.11ac (VHT20)_Chain 0 / CH144 (UNII-3 Band)

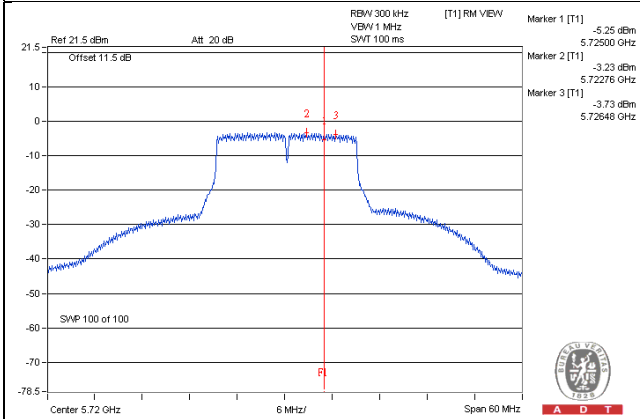

802.11ac (VHT40)_Chain 1 / CH142(UNII-3 Band)

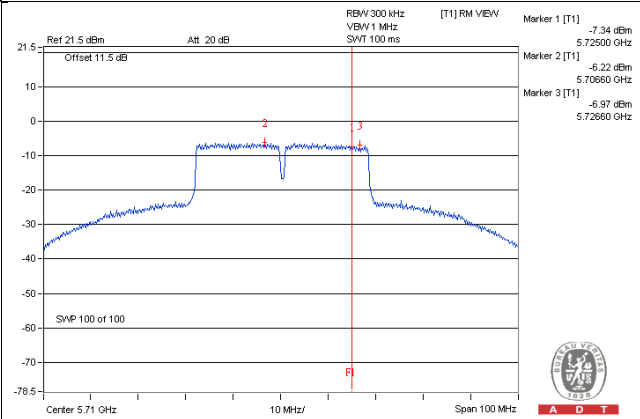

802.11ac (VHT80)_Chain 0 / CH138 (UNII-3 Band)

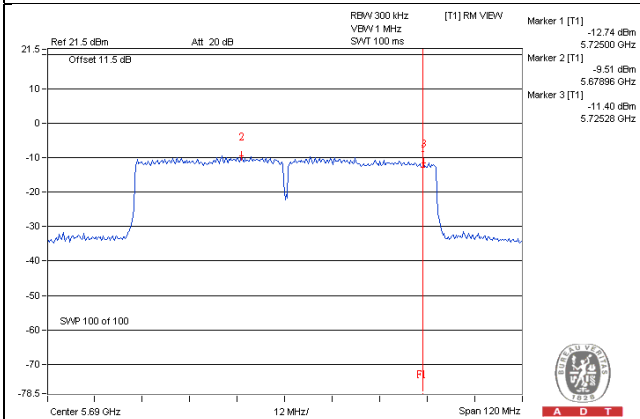

4.5 Frequency Stability Measurement

4.5.1 Limits of Frequency Stability Measurement

The frequency of the carrier signal shall be maintained within band of operation

4.5.2 Test Setup

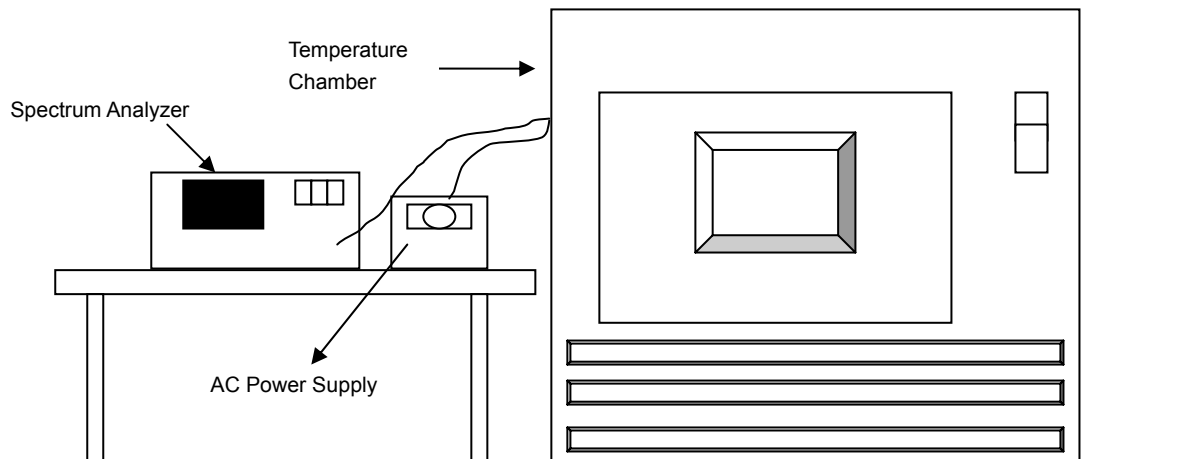

4.5.3 Test Instruments

Refer to section 4.1.2 to get information of above instrument.

4.5.4 Test Procedure

- The EUT was placed inside the environmental test chamber and powered by nominal AC voltage.
- Turn the EUT on and couple its output to a spectrum analyzer.
- Turn the EUT off and set the chamber to the highest temperature specified.
- Allow sufficient time (approximately 30 min) for the temperature of the chamber to stabilize, turn the EUT on and measure the operating frequency after 2, 5, and 10 minutes.
- Repeat step 2 and 3 with the temperature chamber set to the lowest temperature.
- The test chamber was allowed to stabilize at +20 degree C for a minimum of 30 minutes. The supply voltage was then adjusted on the EUT from 85% to 115% and the frequency record.

4.5.5 Deviation from Test Standard

No deviation.

4.5.6 EUT Operating Condition

Set the EUT transmit at un-modulation mode to test frequency stability.

4.5.7 Test Results

FREQUENCY STABILITY VERSUS TEMP.									
OPERATING FREQUENCY: 5180MHz									
TEMP. (°C)	POWER SUPPLY (Vac)	0 MINUTE		2 MINUTE		5 MINUTE		10 MINUTE	
		Measured Frequency (MHz)	Frequency Drift (%)	Measured Frequency (MHz)	Frequency Drift (%)	Measured Frequency (MHz)	Frequency Drift (%)	Measured Frequency (MHz)	Frequency Drift (%)
50	120	5179.9743	-0.00050	5179.9769	-0.00045	5179.9769	-0.00045	5179.9775	-0.00043
40	120	5179.9809	-0.00037	5179.9815	-0.00036	5179.9809	-0.00037	5179.9839	-0.00031
30	120	5179.998	-0.00004	5179.9964	-0.00007	5179.9985	-0.00003	5179.9964	-0.00007
20	120	5179.989	-0.00021	5179.9899	-0.00019	5179.9917	-0.00016	5179.9902	-0.00019
10	120	5180.0154	0.00030	5180.0141	0.00027	5180.0133	0.00026	5180.0126	0.00024
0	120	5180.0007	0.00001	5179.998	-0.00004	5179.999	-0.00002	5180.0014	0.00003
-10	120	5179.9936	-0.00012	5179.9903	-0.00019	5179.9944	-0.00011	5179.99	-0.00019
-20	120	5179.9989	-0.00002	5179.9996	-0.00001	5180.0004	0.00001	5179.9968	-0.00006
-30	120	5180.0118	0.00023	5180.0146	0.00028	5180.0117	0.00023	5180.0129	0.00025

FREQUENCY STABILITY VERSUS VOLTAGE									
OPERATING FREQUENCY: 5180MHz									
TEMP. (°C)	POWER SUPPLY (Vac)	0 MINUTE		2 MINUTE		5 MINUTE		10 MINUTE	
		Measured Frequency (MHz)	Frequency Drift (%)	Measured Frequency (MHz)	Frequency Drift (%)	Measured Frequency (MHz)	Frequency Drift (%)	Measured Frequency (MHz)	Frequency Drift (%)
20	138	5179.9881	-0.00023	5179.9903	-0.00019	5179.9915	-0.00016	5179.9912	-0.00017
	120	5179.989	-0.00021	5179.9899	-0.00019	5179.9917	-0.00016	5179.9902	-0.00019
	102	5179.99	-0.00019	5179.989	-0.00021	5179.9914	-0.00017	5179.9895	-0.00020

4.6 6dB Bandwidth Measurement

4.6.1 Limits of 6dB Bandwidth Measurement

The minimum of 6dB Bandwidth Measurement is 0.5MHz.

4.6.2 Test Setup

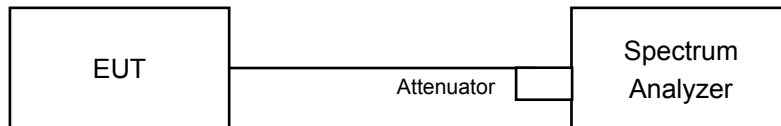

4.6.3 Test Instruments

Refer to section 4.1.2 to get information of above instrument.

4.6.4 Test Procedure

MEASUREMENT PROCEDURE REF

- a. Set resolution bandwidth (RBW) = 100kHz
- b. Set the video bandwidth (VBW) $\geq 3 \times$ RBW, Detector = Peak.
- c. Trace mode = max hold.
- d. Sweep = auto couple.
- e. Measure the maximum width of the emission that is constrained by the frequencies associated with the two amplitude points (upper and lower) that are attenuated by 6 dB relative to the maximum level measured in the fundamental emission

4.6.5 Deviation from Test Standard

No deviation.

4.6.6 EUT Operating Condition

The software provided by client to enable the EUT under transmission condition continuously at lowest, middle and highest channel frequencies individually.

4.6.7 Test Results

1TX Mode

802.11a

Channel	Frequency (MHz)	6dB Bandwidth (MHz)	Minimum Limit (MHz)	Pass / Fail
*144 (UNII-3 Band)	5720	3.21	0.5	Pass
149	5745	16.40	0.5	Pass
157	5785	16.40	0.5	Pass
165	5825	16.39	0.5	Pass

Note: *The 6dB bandwidth above 5725MHz = Marker 1 + Delta 2 - 5725MHz

2TX Mode

CDD Mode

802.11a

Channel	Frequency (MHz)	6dB Bandwidth (MHz)		Minimum Limit (MHz)	Pass / Fail
		Chain 0	Chain 1		
*144 (UNII-3 Band)	5720	3.46	3.38	0.5	Pass
149	5745	16.40	16.40	0.5	Pass
157	5785	16.39	16.42	0.5	Pass
165	5825	16.39	16.41	0.5	Pass

Note: *The 6dB bandwidth above 5725MHz = Marker 1 + Delta 2 - 5725MHz

Beamforming Mode

802.11ac (VHT20)

Channel	Frequency (MHz)	6dB Bandwidth (MHz)		Minimum Limit (MHz)	Pass / Fail
		Chain 0	Chain 1		
*144 (UNII-3 Band)	5720	4.04	4.01	0.5	Pass
149	5745	17.60	17.64	0.5	Pass
157	5785	17.63	17.66	0.5	Pass
165	5825	17.63	17.67	0.5	Pass

Note: *The 6dB bandwidth above 5725MHz = Marker 1 + Delta 2 - 5725MHz

802.11ac (VHT40)

Channel	Frequency (MHz)	6dB Bandwidth (MHz)		Minimum Limit (MHz)	Pass / Fail
		Chain 0	Chain 1		
*142 (UNII-3 Band)	5710	3.51	3.53	0.5	Pass
151	5755	36.46	36.41	0.5	Pass
159	5795	36.43	36.47	0.5	Pass

Note: *The 6dB bandwidth above 5725MHz = Marker 1 + Delta 2 - 5725MHz

802.11ac (VHT80)

Channel	Frequency (MHz)	6dB Bandwidth (MHz)		Minimum Limit (MHz)	Pass / Fail
		Chain 0	Chain 1		
*138 (UNII-3 Band)	5690	2.98	3.15	0.5	Pass
155	5775	75.91	75.98	0.5	Pass

Note: *The 6dB bandwidth above 5725MHz = Marker 1 + Delta 2 - 5725MHz

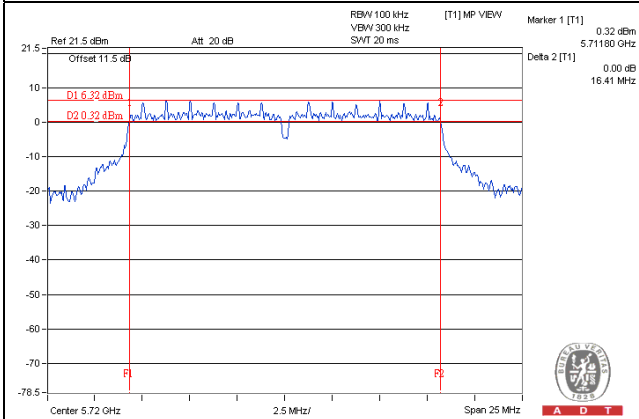
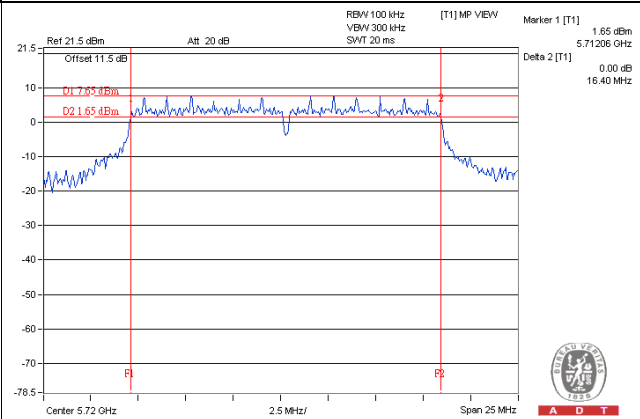
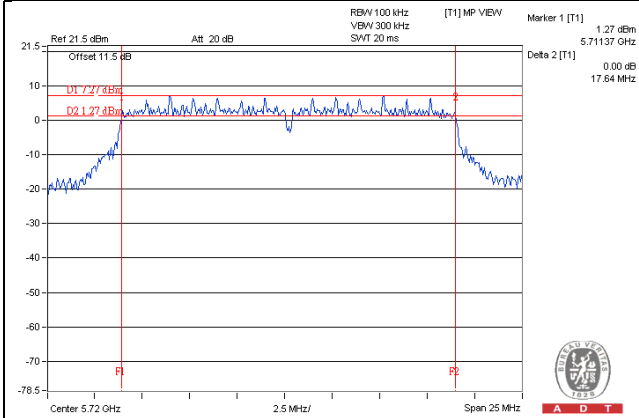
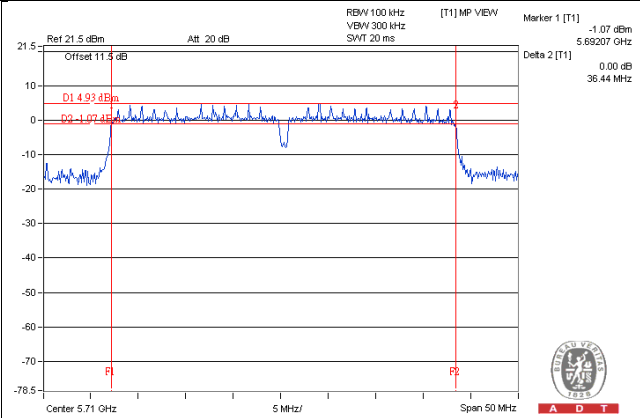
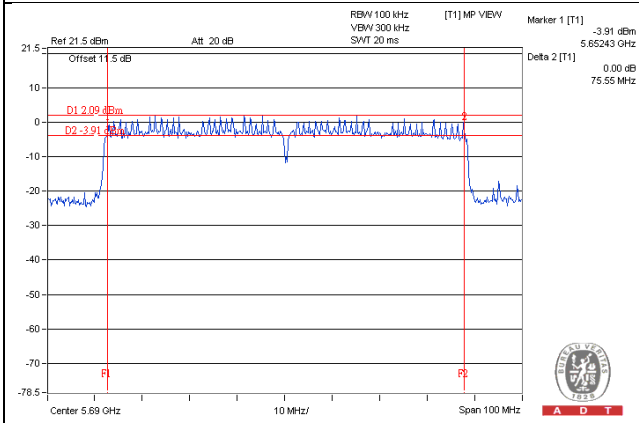
Spectrum Plot of Worst Value**802.11a_Chain 1 / CH144 (1TX/UNII-3 Band)****802.11a_Chain 0 / CH144 (2TX/UNII-3 Band)****802.11ac (VHT20)_Chain 1 / CH144 (UNII-3 Band)****802.11ac (VHT40)_Chain 0 / CH142(UNII-3 Band)****802.11ac (VHT80)_Chain 0 / CH138 (UNII-3 Band)**

5 Pictures of Test Arrangements

Please refer to the attached file (Test Setup Photo).

Appendix – Information on the Testing Laboratories

We, Bureau Veritas Consumer Products Services (H.K.) Ltd., Taoyuan Branch, were founded in 1988 to provide our best service in EMC, Radio, Telecom and Safety consultation. Our laboratories are accredited and approved according to ISO/IEC 17025.

If you have any comments, please feel free to contact us at the following:

Linko EMC/RF Lab

Tel: 886-2-26052180

Fax: 886-2-26051924

Hsin Chu EMC/RF/Telecom Lab

Tel: 886-3-6668565

Fax: 886-3-6668323

Hwa Ya EMC/RF/Safety Lab

Tel: 886-3-3183232

Fax: 886-3-3270892

Email: service.adt@tw.bureauveritas.com

Web Site: www.bureauveritas-adt.com

The address and road map of all our labs can be found in our web site also.

--- END ---