

Supplementary FCC Test Report

Report No.: RF120210E04L-1

FCC ID: UZ7WT41N0

Test Model: WT41N0

Received Date: Mar. 20, 2015

Test Date: Mar. 25 to May 16 , 2015

Issued Date: July 01, 2015

Applicant: Zebra Technologies Corporation

Address: 1 Zebra Plaza, Holtsville, NY 11742

Manufacturer: Symbol Technologies, Inc.

Address: 1 Zebra Plaza, Holtsville, NY 11742

Issued By: Bureau Veritas Consumer Products Services (H.K.) Ltd., Taoyuan Branch
Hsin Chu Laboratory

Lab Address: No. 81-1, Lu Liao Keng, 9th Ling,Wu Lung Tsuen, Chiung Lin Hsiang, Hsin
Chu Hsien 307, Taiwan R.O.C.

Test Location (1): No. 81-1, Lu Liao Keng, 9th Ling,Wu Lung Tsuen, Chiung Lin Hsiang, Hsin
Chu Hsien 307, Taiwan R.O.C.

Test Location (2): No. 49, Ln. 206, Wende Rd., Shangshan Tsuen, Chiung Lin Hsiang, Hsin
Chu Hsien 307, Taiwan R.O.C.



This report is for your exclusive use. Any copying or replication of this report to or for any other person or entity, or use of our name or trademark, is permitted only with our prior written permission. This report sets forth our findings solely with respect to the test samples identified herein. The results set forth in this report are not indicative or representative of the quality or characteristics of the lot from which a test sample was taken or any similar or identical product unless specifically and expressly noted. Our report includes all of the tests requested by you and the results thereof based upon the information that you provided to us. You have 60 days from date of issuance of this report to notify us of any material error or omission caused by our negligence, provided, however, that such notice shall be in writing and shall specifically address the issue you wish to raise. A failure to raise such issue within the prescribed time shall constitute your unqualified acceptance of the completeness of this report, the tests conducted and the correctness of the report contents. Unless specific mention, the uncertainty of measurement has been explicitly taken into account to declare the compliance or non-compliance to the specification. The report must not be used by the client to claim product certification, approval, or endorsement by TAF or any government agencies.

Table of Contents

Report Issue History Record of EUT (WT41N0)..... 4

Release Control Record..... 4

1 Certificate of Conformity..... 5

2 Summary of Test Results 6

 2.1 Measurement Uncertainty 6

 2.2 Modification Record 6

3 General Information..... 7

 3.1 General Description of EUT 7

 3.2 Description of Test Modes 11

 3.2.1 Test Mode Applicability and Tested Channel Detail 12

 3.3 Duty Cycle of Test Signal 14

 3.4 Description of Support Units 15

 3.4.1 Configuration of System under Test 16

 3.5 General Description of Applied Standard 18

4 Test Types and Results 19

 4.1 Radiated Emission and Bandedge Measurement..... 19

 4.1.1 Limits of Radiated Emission and Bandedge Measurement 19

 4.1.2 Test Instruments 20

 4.1.3 Test Procedure 22

 4.1.4 Deviation from Test Standard 22

 4.1.5 Test Setup..... 23

 4.1.6 EUT Operating Condition 23

 4.1.7 Test Results 24

 4.2 Conducted Emission Measurement 48

 4.2.1 Limits of Conducted Emission Measurement 48

 4.2.2 Test Instruments 48

 4.2.3 Test Procedure 49

 4.2.4 Deviation from Test Standard 49

 4.2.5 Test Setup..... 49

 4.2.6 EUT Operating Condition 49

 4.2.7 Test Results (Mode 1)..... 50

 4.2.8 Test Results (Mode 2)..... 52

 4.3 Transmit Power Measurement 54

 4.3.1 Limits of Transmit Power Measurement 54

 4.3.2 Test Setup..... 54

 4.3.3 Test Instruments 54

 4.3.4 Test Procedure 54

 4.3.5 Deviation from Test Standard 54

 4.3.6 EUT Operating Condition 55

 4.3.7 Test Result..... 56

 4.4 Peak Power Spectral Density Measurement 58

 4.4.1 Limits of Peak Power Spectral Density Measurement 58

 4.4.2 Test Setup..... 58

 4.4.3 Test Instruments 58

 4.4.4 Test Procedure 58

 4.4.5 Deviation from Test Standard 59

 4.4.6 EUT Operating Condition 59

 4.4.7 Test Results 60

 4.5 Frequency Stability Measurement 62

 4.5.1 Limits of Frequency Stability Measurement 62

 4.5.2 Test Setup..... 62

 4.5.3 Test Instruments 62

4.5.4	Test Procedure	62
4.5.5	Deviation from Test Standard	62
4.5.6	EUT Operating Condition	62
4.5.7	Test Results	63
4.6	6dB Bandwidth Measurement	64
4.6.1	Limits of 6dB Bandwidth Measurement	64
4.6.2	Test Setup	64
4.6.3	Test Instruments	64
4.6.4	Test Procedure	64
4.6.5	Deviation from Test Standard	64
4.6.6	EUT Operating Condition	64
4.6.7	Test Results	65
5	Pictures of Test Arrangements	66
	Appendix – Information on the Testing Laboratories	67



Report Issue History Record of EUT (WT41N0)

Attachment No.	Issue Date	Description
120210E04	Nov. 09, 2012	Original
120210E04L	July 01, 2015	Upgrade the versions of the standard to section 15.407 under new rule

Release Control Record

Issue No.	Description	Date Issued
RF120210E04L-1	Original release.	July 01, 2015

2 Summary of Test Results

47 CFR FCC Part 15, Subpart E (SECTION 15.407 Under New Rule)			
FCC Clause	Test Item	Result	Remarks
15.407(b)(6)	AC Power Conducted Emissions	PASS	Meet the requirement of limit. Minimum passing margin is -4.69dB at 0.71250MHz.
15.407(b)(1/2/3/4/6)	Radiated Emissions & Band Edge Measurement	PASS	Meet the requirement of limit. Minimum passing margin is -1.0dB at 5725.00MHz.
15.407(a)(1/2/3)	Max Average Transmit Power	PASS	Meet the requirement of limit.
15.407(a)(1/2/3)	Peak Power Spectral Density	PASS	Meet the requirement of limit.
15.407(e)	6dB bandwidth	PASS	Meet the requirement of limit. (U-NII-3 Band only)
15.407(g)	Frequency Stability	PASS	Meet the requirement of limit.
15.203	Antenna Requirement	PASS	No antenna connector is used.

- NOTE:**
1. For WLAN: The EUT was operating in 2400 ~ 2483.5MHz, 5.15~5.35GHz, 5.47~5.725GHz and 5.725~5.850GHz frequencies band. This report was recorded the RF parameters including 5.15~5.25GHz and 5.725~5.850GHz.
 2. The DFS report was recorded in another test report.
 3. This report is prepared for FCC Class II change. (Upgrade the versions of the standard to section 15.407 under new rule).

2.1 Measurement Uncertainty

Where relevant, the following measurement uncertainty levels have been estimated for tests performed on the EUT as specified in CISPR 16-4-2:

Measurement	Frequency	Expanded Uncertainty (k=2) (±)
Conducted Emissions at mains ports	150kHz ~ 30MHz	2.86 dB
Radiated Emissions up to 1 GHz	30MHz ~ 1GHz	5.37 dB
Radiated Emissions above 1 GHz	1GHz ~ 6GHz	3.72 dB
	6GHz ~ 18GHz	4.00 dB
	18GHz ~ 40GHz	4.11 dB

2.2 Modification Record

There were no modifications required for compliance.

3 General Information

3.1 General Description of EUT

Product	Wearable Terminal
Brand	Symbol
Test Model	WT41N0
Status of EUT	MASS-PRODUCTION
Power Supply Rating	DC 3.7V
Modulation Type	CCK, DQPSK, DBPSK for DSSS 64QAM, 16QAM, QPSK, BPSK for OFDM
Modulation Technology	DSSS, OFDM
Transfer Rate	802.11b: up to 11Mbps 802.11g / a: up to 54Mbps 802.11n (HT20, 800ns GI): up to 65Mbps 802.11n (HT20, 400ns GI): up to 72.2Mbps
Operating Frequency	For 15.407 5GHz: 5.18 ~ 5.24GHz, 5.26 ~ 5.32GHz, 5.47~5.6GHz, 5.65~5.725GHz, 5.745 ~ 5.825GHz For 15.247 2.4GHz: 2.412 ~ 2.472GHz
Number of Channel	For 15.407 24 for 802.11a, 802.11n (HT20) For 15.247 11 for 802.11b, 802.11g, 802.11n (HT20)
Output Power	For 15.407 5180 ~ 5240MHz 802.11a: 70.146mW 802.11n (HT20): 73.451mW 5745 ~ 5825MHz 802.11a: 66.222mW 802.11n (HT20): 58.345mW
Antenna Type	Please see NOTE
Antenna Connector	Please see NOTE
Accessory Device	Battery × 1
Data Cable Supplied	NA

Note:

1. This report is prepared for FCC Class II change. The difference compared with the Report No.: RF120210E04L-1 design is as the following:

◆ Upgrade the versions of the standard to section 15.407 under new rule.

2. According to above conditions, all test items of U-NII band 1 and U-NII band 3 and Dynamic Frequency Selection test item need to be performed. And all data was verified to meet the requirements.
3. There are Bluetooth technology and WLAN 802.11 a/b/g/n technology.
4. WLAN & BT technology can transmit at same time.
5. The EUT has different versions, the relationship of testing sample versions are listed as below:

Sample No.	Brand	Model	Description
1	MOTOROLA	WT41N0	VOW version
2			Touch version
3			Non-Touch version

6. The EUT hardware/software information are as below:

Brand	Model	Description
Wearable Terminal	OS Version	07.00.2806
	OEM Name	MOTOROLA WT41N0
	OEM Version	00.17.0001
	HW Version	WT41N0_MB V3.0
Wireless (Fusion)	Part Number	31-FUSION-X2.00
	Version	X_2.00.0.0.93
XWingCon	XappVersion	X_2.00.0.0.24
BTRegTestVer4.1	Version	4.1

7. The EUT could be supplied from a cradle, power adapter and battery, the information are listed as below:

Cradle 1 (1-slot, option)	
Brand:	MOTOROLA
Model No.:	CRD4000-1000UR
Part No.:	CRD4000-1000UR
Input power :	+12V ----- 3.33A
I/O Ports:	USB Port x 1
Associated Devices:	USB cable (Part No.:25-64396-01R) Adapter x 1 (Adapter 1: Part No.: 50-14000-148R)
Adapter 1 (option)	
Brand:	HIPRO
Model No.:	HP-O2040D43
Part No.:	50-14000-148R
Input power :	100-240V, 50-60Hz, 1.5A
Output power :	+12V ----- 3.33A DC output cable (unshielded, 1.8m with one core)
Battery 1	
Brand:	SYMBOL
Part No.:	82-90005-05 Rev. A (1X LiION)
Rating:	3.7V, 2400mAh, 8.88Wh
Battery 2	
Brand:	SYMBOL
Part No.:	82-90005-04 Rev. D (2X LiION)
Rating:	3.7V, 4800mAh, 17.76Wh

8. The EUT could be supplied with one laser scanner (optional). There are four options as below:

Laser scanner 1 (option)	
Brand:	MOTOROLA
Model No.:	RS409 1D Laser scanner
Laser scanner 2 (option)	
Brand:	MOTOROLA
Model No.:	RS309 1D Laser scanner
Laser scanner 3 (option)	
Brand:	MOTOROLA
Model No.:	RS507 2D Imager scanner
Description :	Wireless link (no direct wire-link to EUT)
Laser scanner 4 (option)	
Brand:	MOTOROLA
Model No.:	RS419 scanner
Description :	Type 1: Long USB cable (Length: 2.3m) Type 2: Short USB cable (Length: 0.4m)

9. The EUT antennas information:

Bluetooth Antenna Spec			
Antenna Type	Gain (dBi)	Connecter Type	Frequency range (MHz)
PIFA	1.47	NA	2400~2500
WLAN Antenna Spec.			
Antenna Type	Gain (dBi)	Connecter Type	Frequency range (MHz)
PIFA	1.48 (2.4G)	NA	2400~2500
	5.7 (5G)		4900~5850

10. The EUT incorporates a SISO function.

MODULATION MODE	DATA RATE (MCS)	TX & RX CONFIGURATION	
802.11b	1 ~ 11Mbps	1TX	1RX
802.11g	6 ~ 54Mbps	1TX	1RX
802.11a	6 ~ 54Mbps	1TX	1RX
802.11n (HT20)	MCS 0~7	1TX	1RX

11. Radiated and Conducted emission of the simultaneous operation (Bluetooth and WLAN technology) has been evaluated and no non-compliance was found.

12. The above EUT information was declared by the manufacturer and for more detailed features description, please refer to the manufacturer's specifications or User's Manual.

3.2 Description of Test Modes

FOR 5180 ~ 5240MHz

4 channels are provided for 802.11a, 802.11n (HT20):

Channel	Frequency	Channel	Frequency
36	5180 MHz	44	5220 MHz
40	5200 MHz	48	5240 MHz

FOR 5745 ~ 5825MHz:

5 channels are provided for 802.11a, 802.11n (HT20):

Channel	Frequency	Channel	Frequency
149	5745MHz	161	5805MHz
153	5765MHz	165	5825MHz
157	5785MHz		

3.2.1 Test Mode Applicability and Tested Channel Detail

EUT CONFIGURE MODE	APPLICABLE TO				DESCRIPTION
	RE \geq 1G	RE $<$ 1G	PLC	APCM	
1	-	√	√	√	Cradle 1 + Battery 2
	√	-	-	-	Battery 2
2	-	-	√	-	Cradle 1 + Battery 1

Where **RE \geq 1G**: Radiated Emission above 1GHz **RE $<$ 1G**: Radiated Emission below 1GHz
PLC: Power Line Conducted Emission **APCM**: Antenna Port Conducted Measurement

NOTE:

1. The test mode was reference to the worst case in the original test report.
2. “-” means no effect.

Radiated Emission Test (Above 1GHz):

- Pre-Scan has been conducted to determine the worst-case mode from all possible combinations between available modulations, data rates and antenna ports (if EUT with antenna diversity architecture).
- Following channel(s) was (were) selected for the final test as listed below.

MODE	FREQ. BAND (MHz)	AVAILABLE CHANNEL	TESTED CHANNEL	MODULATION TECHNOLOGY	MODULATION TYPE	DATA RATE (Mbps)
802.11a	5180-5240	36 to 48	36, 40, 48	OFDM	BPSK	6
802.11n (HT20)		36 to 48	36, 40, 48	OFDM	BPSK	6.5
802.11a	5745-5825	149 to 165	149, 157, 165	OFDM	BPSK	6
802.11n (HT20)		149 to 165	149, 157, 165	OFDM	BPSK	6.5

Radiated Emission Test (Below 1GHz):

- Pre-Scan has been conducted to determine the worst-case mode from all possible combinations between available modulations, data rates and antenna ports (if EUT with antenna diversity architecture).
- Following channel(s) was (were) selected for the final test as listed below.

MODE	FREQ. BAND (MHz)	AVAILABLE CHANNEL	TESTED CHANNEL	MODULATION TECHNOLOGY	MODULATION TYPE	DATA RATE (Mbps)
802.11a	5180-5240	36 to 48	36, 40, 48	OFDM	BPSK	6
802.11n (HT20)		36 to 48	36, 40, 48	OFDM	BPSK	6.5
802.11a	5745-5825	149 to 165	149, 157, 165	OFDM	BPSK	6
802.11n (HT20)		149 to 165	149, 157, 165	OFDM	BPSK	6.5

Power Line Conducted Emission Test:

- Pre-Scan has been conducted to determine the worst-case mode from all possible combinations between available modulations, data rates and antenna ports (if EUT with antenna diversity architecture).
- Following channel(s) was (were) selected for the final test as listed below.

MODE	FREQ. BAND (MHz)	AVAILABLE CHANNEL	TESTED CHANNEL	MODULATION TECHNOLOGY	MODULATION TYPE	DATA RATE (Mbps)
802.11a	5180-5240	36 to 48	40	OFDM	BPSK	6
	5745-5825	149 to 165				

Antenna Port Conducted Measurement:

- This item includes all test value of each mode, but only includes spectrum plot of worst value of each mode.
- Pre-Scan has been conducted to determine the worst-case mode from all possible combinations between available modulations, data rates and antenna ports (if EUT with antenna diversity architecture).
- Following channel(s) was (were) selected for the final test as listed below.

MODE	FREQ. BAND (MHz)	AVAILABLE CHANNEL	TESTED CHANNEL	MODULATION TECHNOLOGY	MODULATION TYPE	DATA RATE (Mbps)
802.11a	5180-5240	36 to 48	36, 40, 48	OFDM	BPSK	6
802.11n (HT20)		36 to 48	36, 40, 48	OFDM	BPSK	6.5
802.11a	5745-5825	149 to 165	149, 157, 165	OFDM	BPSK	6
802.11n (HT20)		149 to 165	149, 157, 165	OFDM	BPSK	6.5

Test Condition:

APPLICABLE TO	ENVIRONMENTAL CONDITIONS	INPUT POWER	TESTED BY
RE \geq 1G	21deg. C, 65%RH	120Vac, 60Hz	Weiwei lo
RE<1G	29deg. C, 70%RH	120Vac, 60Hz	Gary Cheng
PLC	23deg. C, 65%RH	120Vac, 60Hz	Wythe Lin
APCM	25deg. C, 60%RH	120Vac, 60Hz	Anderson Chen

3.3 Duty Cycle of Test Signal

Duty cycle of test signal is $\geq 98\%$, duty factor is not required.

802.11a: Duty cycle = $1.426 \text{ ms} / 1.45 \text{ ms} = 0.983$

802.11n (HT20): Duty cycle = $1.205 \text{ ms} / 1.228 \text{ ms} = 0.981$

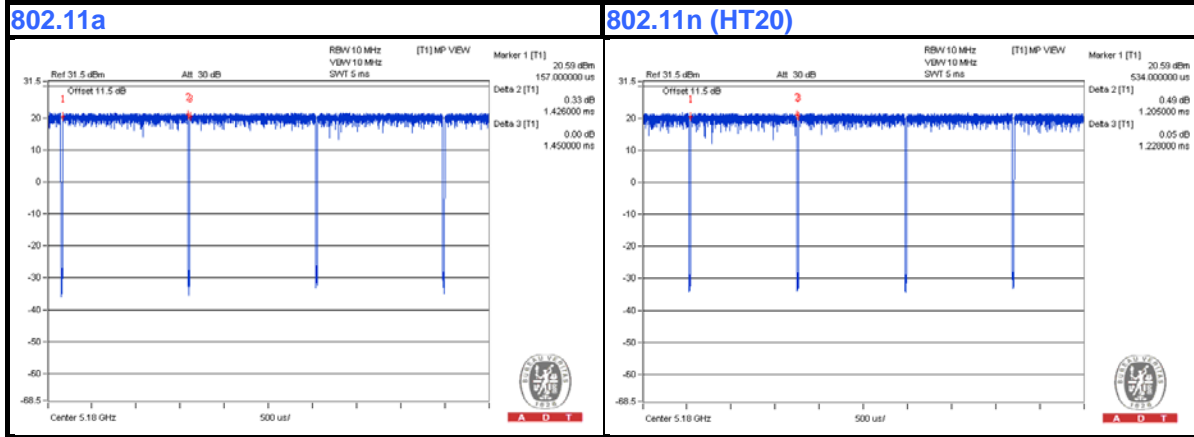

3.4 Description of Support Units

The EUT has been tested as an independent unit together with other necessary accessories or support units. The following support units or accessories were used to form a representative test configuration during the tests.

ID	Product	Brand	Model No.	Serial No.	FCC ID	Remarks
A.	NOTEBOOK COMPUTER	DELL	E5430	4YV4VY1	FCC DoC	Provided by Lab
B.	iPod shuffle	Apple	MC749TA/A	CC4DMFJUDFDM	NA	Provided by Lab
C.	Ear phone	Motorola	Vix	NA	NA	Supplied by client
D.	Single Slot Cradle	Motorola	NA	NA	NA	Supplied by client
E.	Laser scanner	Motorola	RS419 scanner	NA	NA	Supplied by client

Note:

1. All power cords of the above support units are non-shielded (1.8m).

ID	Descriptions	Qty.	Length (m)	Shielding (Yes/No)	Cores (Qty.)	Remarks
1.	USB	1	1.6	Yes	0	Supplied by client
2.	Audio	1	1.2	No	0	Supplied by client
3.	USB	1	0.1	Yes	0	Provided by Lab
4.	DC	1	1.8	Yes	1	Supplied by client
5.	AC	1	1.8	Yes	0	Provided by Lab
6.	Scanner	1	0.4	Yes	0	Supplied by client

Note: The core(s) is(are) originally attached to the cable(s).

3.4.1 Configuration of System under Test

For Conducted emission / Radiated emission (below 1GHz) test:

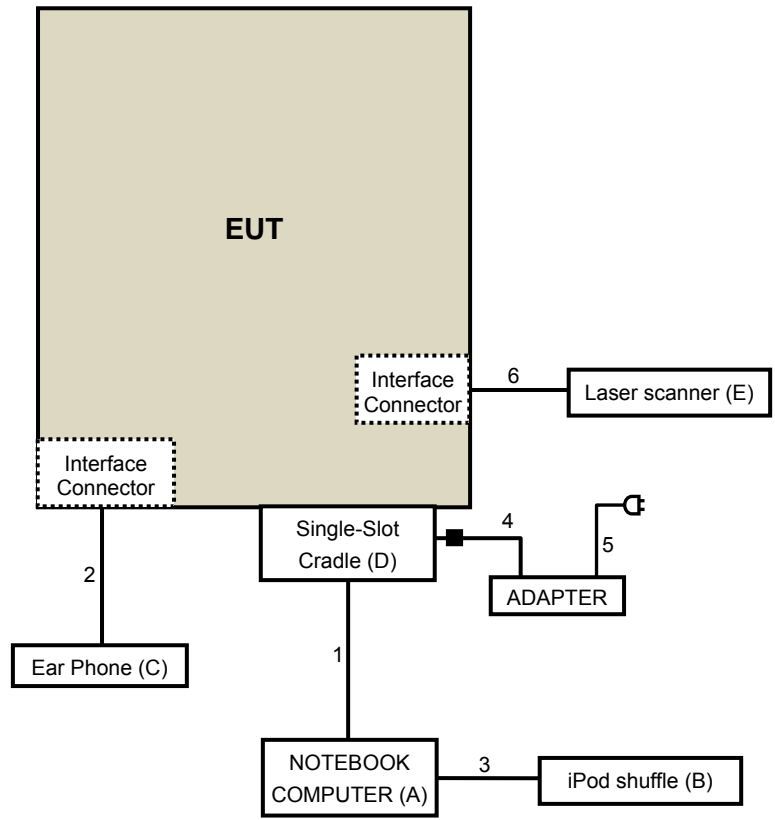

For Radiated emission (above 1GHz) test:

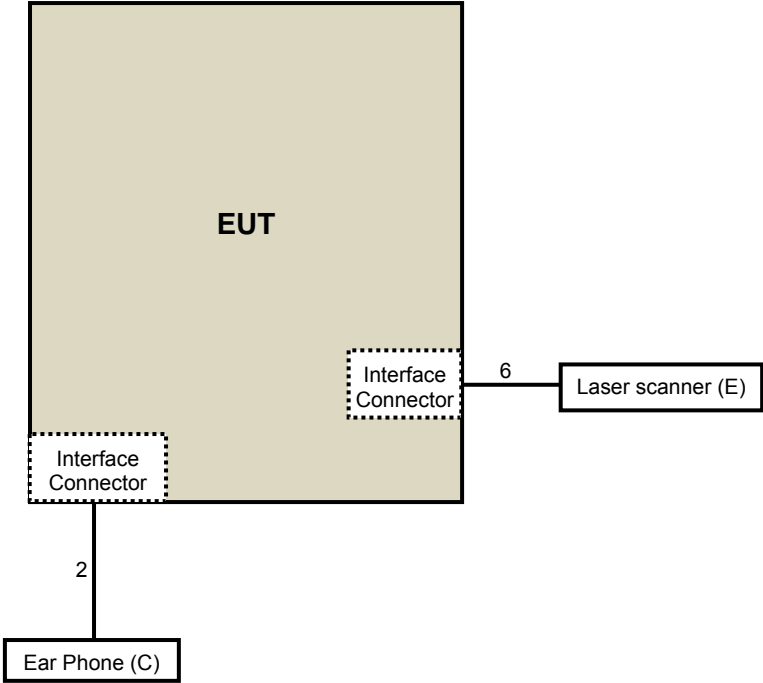

3.5 General Description of Applied Standard

The EUT is a RF Product. According to the specifications of the manufacturer, it must comply with the requirements of the following standards:

FCC Part 15, Subpart E (15.407)
789033 D02 General UNII Test Procedure New Rules v01
ANSI C63.10-2009

All test items have been performed and recorded as per the above standards.

Note: The EUT has been verified to comply with the requirements of FCC Part 15, Subpart B, Class B (DoC). The test report has been issued separately.

4 Test Types and Results

4.1 Radiated Emission and Bandedge Measurement

4.1.1 Limits of Radiated Emission and Bandedge Measurement

Radiated emissions which fall in the restricted bands must comply with the radiated emission limits specified as below table.

Frequencies (MHz)	Field Strength (microvolts/meter)	Measurement Distance (meters)
0.009 ~ 0.490	2400/F(kHz)	300
0.490 ~ 1.705	24000/F(kHz)	30
1.705 ~ 30.0	30	30
30 ~ 88	100	3
88 ~ 216	150	3
216 ~ 960	200	3
Above 960	500	3

NOTE:

1. The lower limit shall apply at the transition frequencies.
2. Emission level (dBuV/m) = 20 log Emission level (uV/m).
3. For frequencies above 1000MHz, the field strength limits are based on average detector, however, the peak field strength of any emission shall not exceed the maximum permitted average limits, specified above by more than 20dB under any condition of modulation.

LIMITS OF UNWANTED EMISSION OUT OF THE RESTRICTED BANDS

APPLICABLE TO	LIMIT	
789033 D02 General UNII Test Procedure New Rules v01	FIELD STRENGTH AT 3m	
	PK:74 (dBuV/m)	AV:54 (dBuV/m)
APPLICABLE TO	EIRP LIMIT	EQUIVALENT FIELD STRENGTH AT 3m
15.407(b)(1)	PK:-27 (dBm/MHz)	PK:68.2(dBuV/m)
15.407(b)(2)		
15.407(b)(3)		
15.407(b)(4)	PK:-27 (dBm/MHz) ^{*1} PK:-17 (dBm/MHz) ^{*2}	PK: 68.2(dBuV/m) ^{*1} PK:78.2 (dBuV/m) ^{*2}

NOTE: ^{*1} beyond 10MHz of the band edge ^{*2} within 10 MHz of band edge

The following formula is used to convert the equipment isotropic radiated power (eirp) to field strength:

$$E = \frac{1000000\sqrt{30P}}{3} \mu\text{V/m, where P is the eirp (Watts).$$

4.1.2 Test Instruments

For below 1GHz

DESCRIPTION & MANUFACTURER	MODEL NO.	SERIAL NO.	CALIBRATED DATE	CALIBRATED UNTIL
Test Receiver Agilent	N9038A	MY51210105	July 21,2014	July 20,2015
Pre-Amplifier Mini-Circuits	ZFL-1000VH2 B	AMP-ZFL-03	Nov. 12, 2014	Nov. 11, 2015
Trilog Broadband Antenna SCHWARZBECK	VULB 9168	9168-360	Feb. 06, 2015	Feb. 05, 2016
RF Cable	NA	CHGCAB_001	Oct. 04, 2014	Oct. 03, 2015
Horn_Antenna AISI	AIH.8018	0000320091110	Feb. 09, 2015	Feb. 08, 2016
Pre-Amplifier Agilent	8449B	3008A02578	June 24, 2014	June 23, 2015
RF Cable	NA	131205 131216 131217 SNMY23684/4	Jan. 16, 2015	Jan. 15, 2016
Spectrum Analyzer R&S	FSV40	100964	July 05, 2014	July 04, 2015
Pre-Amplifier SPACEK LABS	SLKKa-48-6	9K16	Dec. 12, 2014	Dec. 11, 2015
Horn_Antenna SCHWARZBECK	BBHA 9170	9170-424	Feb. 05, 2015	Feb. 04, 2016
RF Cable	NA	329751/4 RF104-204	Dec. 11, 2014	Dec. 10, 2015
Antenna Tower & Turn Table CT	NA	NA	NA	NA

Note:

1. The calibration interval of the above test instruments is 12 months and the calibrations are traceable to NML/ROC and NIST/USA.
2. The horn antenna, preamplifier (model: 8449B) are used only for the measurement of emission frequency above 1GHz if tested.
3. The test was performed in 966 Chamber No. G.
4. The FCC Site Registration No. is 966073.
5. The VCCI Site Registration No. is G-137.
6. The CANADA Site Registration No. is IC 7450H-2.
7. Tested Date: Apr. 21, 2015

For above 1GHz

DESCRIPTION & MANUFACTURER	MODEL NO.	SERIAL NO.	CALIBRATED DATE	CALIBRATED UNTIL
Test Receiver Agilent	N9038A	MY50010156	Aug. 11, 2014	Aug. 10, 2015
Pre-Amplifier Mini-Circuits	ZFL-1000VH2 B	AMP-ZFL-04	Nov. 12, 2014	Nov. 11, 2015
Trilog Broadband Antenna SCHWARZBECK	VULB 9168	9168-361	Feb. 09, 2015	Feb. 08, 2016
RF Cable	NA	CHHCAB_001	Oct. 05, 2014	Oct. 04, 2015
Horn_Antenna AISI	AIH.8018	0000220091110	Feb. 06, 2015	Feb. 05, 2016
Pre-Amplifier Agilent	8449B	300801923	Oct. 28, 2014	Oct. 27, 2015
RF Cable	NA	131206 131213 131215 SNMY23685/4	Jan. 16, 2015	Jan. 15, 2016
Spectrum Analyzer R&S	FSV40	100964	July 05, 2014	July 04, 2015
Pre-Amplifier SPACEK LABS	SLKKa-48-6	9K16	Dec. 12, 2014	Dec. 11, 2015
Horn_Antenna SCHWARZBECK	BBHA 9170	9170-424	Feb. 05, 2015	Feb. 04, 2016
RF Cable	NA	329751/4 RF104-204	Dec. 11, 2014	Dec. 10, 2015
Software	ADT_Radiated _V8.7.07	NA	NA	NA
Antenna Tower & Turn Table CT	NA	NA	NA	NA
Spectrum Analyzer R&S	FSP 40	100060	May 08, 2015	May 07, 2016
Power meter Anritsu	ML2495A	0824006	May 22, 2014	May 21, 2015
Power sensor Anritsu	MA2411B	0738172	May 22, 2014	May 21, 2015

Note:

1. The calibration interval of the above test instruments is 12 months and the calibrations are traceable to NML/ROC and NIST/USA.
2. The horn antenna, preamplifier (model: 8449B) are used only for the measurement of emission frequency above 1GHz if tested.
3. The test was performed in 966 Chamber No. H.
4. The FCC Site Registration No. is 797305.
5. The CANADA Site Registration No. is IC 7450H-3.
6. Tested Date: May 15, 2015

4.1.3 Test Procedure

- a. The EUT was placed on the top of a rotating table 0.8 meters above the ground at 3 meter chamber room for test. The table was rotated 360 degrees to determine the position of the highest radiation.
- b. The EUT was set 3 meters away from the interference-receiving antenna, which was mounted on the top of a variable-height antenna tower.
- c. The height of antenna is varied from one meter to four meters above the ground to determine the maximum value of the field strength. Both horizontal and vertical polarizations of the antenna are set to make the measurement.
- d. For each suspected emission, the EUT was arranged to its worst case and then the antenna was tuned to heights from 1 meter to 4 meters and the rotatable table was turned from 0 degrees to 360 degrees to find the maximum reading.
- e. The test-receiver system was set to quasi-peak detect function and specified bandwidth with maximum hold mode when the test frequency is below 1 GHz.
- f. The test-receiver system was set to peak and average detect function and specified bandwidth with maximum hold mode when the test frequency is above 1 GHz. If the peak reading value also meets average limit, measurement with the average detector is unnecessary.

Note:

1. For emission measurements above 1 GHz, the EUT shall be placed at a height of 1.5 m above the ground at 3 meter chamber room for test
2. The resolution bandwidth and video bandwidth of test receiver/spectrum analyzer is 120kHz for Quasi-peak detection (QP) at frequency below 1GHz.
3. The resolution bandwidth of test receiver/spectrum analyzer is 1 MHz and the video bandwidth is 3 MHz for Peak detection (PK) at frequency above 1GHz.
4. The resolution bandwidth of test receiver/spectrum analyzer is 1MHz and the video bandwidth is 3MHz for RMS Average (Duty cycle < 98%) for Average detection (AV) at frequency above 1GHz, then the measurement results was added to a correction factor ($10 \log(1/\text{duty cycle})$).
5. The resolution bandwidth of test receiver/spectrum analyzer is 1MHz and the video bandwidth is 10Hz (Duty cycle $\geq 98\%$) for Average detection (AV) at frequency above 1GHz.
6. All modes of operation were investigated and the worst-case emissions are reported.

4.1.4 Deviation from Test Standard

No deviation.

4.1.5 Test Setup

<Frequency Range below 1GHz>

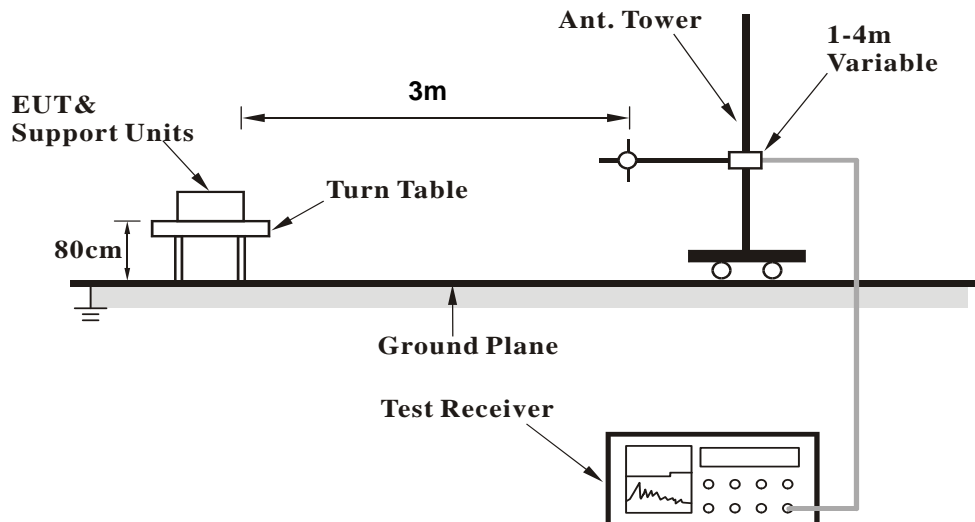

<Frequency Range above 1GHz>

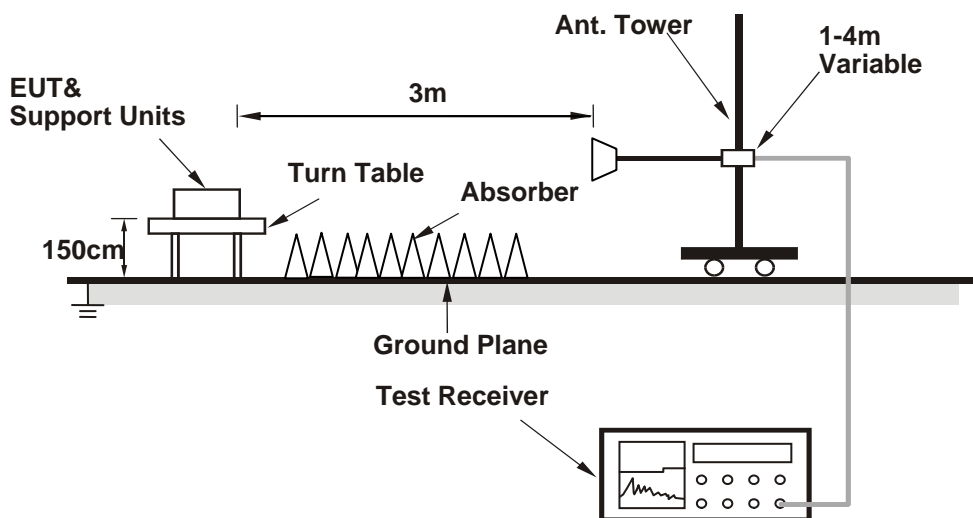

For the actual test configuration, please refer to the attached file (Test Setup Photo).

4.1.6 EUT Operating Condition

1. Connect the EUT with the support unit A (NOTEBOOK COMPUTER) which is placed on remote site.
2. Controlling software (XW2DMT[Ver X_2.00.0.0.28]) has been activated to set the EUT on specific status.

4.1.7 Test Results

ABOVE 1GHz WORST-CASE DATA

802.11a

CHANNEL	TX Channel 36	DETECTOR FUNCTION	Peak (PK)
FREQUENCY RANGE	1GHz ~ 40GHz		Average (AV)

ANTENNA POLARITY & TEST DISTANCE: HORIZONTAL AT 3 M

NO.	FREQ. (MHz)	EMISSION LEVEL (dBuV/m)	LIMIT (dBuV/m)	MARGIN (dB)	ANTENNA HEIGHT (m)	TABLE ANGLE (Degree)	RAW VALUE (dBuV)	CORRECTION FACTOR (dB/m)
1	5150.00	61.5 PK	74.0	-12.5	1.32 H	213	55.03	6.47
2	5150.00	52.1 AV	54.0	-1.9	1.32 H	213	45.63	6.47
3	*5180.00	112.1 PK			1.32 H	213	105.45	6.65
4	*5180.00	103.2 AV			1.32 H	213	96.55	6.65
5	#10360.00	56.7 PK	74.0	-17.3	1.31 H	146	42.49	14.21
6	#10360.00	43.7 AV	54.0	-10.3	1.31 H	146	29.49	14.21
7	15540.00	64.7 PK	74.0	-9.3	1.20 H	237	45.94	18.76
8	15540.00	50.9 AV	54.0	-3.1	1.20 H	237	32.14	18.76

ANTENNA POLARITY & TEST DISTANCE: VERTICAL AT 3 M

NO.	FREQ. (MHz)	EMISSION LEVEL (dBuV/m)	LIMIT (dBuV/m)	MARGIN (dB)	ANTENNA HEIGHT (m)	TABLE ANGLE (Degree)	RAW VALUE (dBuV)	CORRECTION FACTOR (dB/m)
1	5150.00	56.7 PK	74.0	-17.3	1.59 V	289	50.23	6.47
2	5150.00	45.3 AV	54.0	-8.7	1.59 V	289	38.83	6.47
3	*5180.00	105.6 PK			1.59 V	289	98.95	6.65
4	*5180.00	95.8 AV			1.59 V	289	89.15	6.65
5	#10360.00	55.7 PK	74.0	-18.3	1.07 V	163	41.49	14.21
6	#10360.00	42.6 AV	54.0	-11.4	1.07 V	163	28.39	14.21
7	15540.00	61.1 PK	74.0	-12.9	1.19 V	109	42.34	18.76
8	15540.00	49.1 AV	54.0	-4.9	1.19 V	109	30.34	18.76

REMARKS:

1. Emission Level(dBuV/m) = Raw Value(dBuV) + Correction Factor(dB/m)
2. Correction Factor(dB/m) = Antenna Factor(dB/m) + Cable Factor(dB) – Pre-Amplifier Factor(dB)
3. The other emission levels were very low against the limit.
4. Margin value = Emission Level – Limit value
5. " * ": Fundamental frequency.
6. " # ": The radiated frequency is out of the restricted band.

CHANNEL	TX Channel 40	DETECTOR FUNCTION	Peak (PK)
FREQUENCY RANGE	1GHz ~ 40GHz		Average (AV)

ANTENNA POLARITY & TEST DISTANCE: HORIZONTAL AT 3 M

NO.	FREQ. (MHz)	EMISSION LEVEL (dBuV/m)	LIMIT (dBuV/m)	MARGIN (dB)	ANTENNA HEIGHT (m)	TABLE ANGLE (Degree)	RAW VALUE (dBuV)	CORRECTION FACTOR (dB/m)
1	*5200.00	112.3 PK			1.35 H	219	105.53	6.77
2	*5200.00	103.7 AV			1.35 H	219	96.93	6.77
3	#10400.00	56.9 PK	74.0	-17.1	1.29 H	158	42.68	14.22
4	#10400.00	43.8 AV	54.0	-10.2	1.29 H	158	29.58	14.22
5	15600.00	64.7 PK	74.0	-9.3	1.17 H	252	46.36	18.34
6	15600.00	50.3 AV	54.0	-3.7	1.17 H	252	31.96	18.34

ANTENNA POLARITY & TEST DISTANCE: VERTICAL AT 3 M

NO.	FREQ. (MHz)	EMISSION LEVEL (dBuV/m)	LIMIT (dBuV/m)	MARGIN (dB)	ANTENNA HEIGHT (m)	TABLE ANGLE (Degree)	RAW VALUE (dBuV)	CORRECTION FACTOR (dB/m)
1	*5200.00	106.2 PK			1.55 V	278	99.43	6.77
2	*5200.00	96.0 AV			1.55 V	278	89.23	6.77
3	#10400.00	55.6 PK	74.0	-18.4	1.01 V	140	41.38	14.22
4	#10400.00	42.3 AV	54.0	-11.7	1.01 V	140	28.08	14.22
5	15600.00	61.3 PK	74.0	-12.7	1.21 V	121	42.96	18.34
6	15600.00	49.2 AV	54.0	-4.8	1.21 V	121	30.86	18.34

REMARKS:

1. Emission Level(dBuV/m) = Raw Value(dBuV) + Correction Factor(dB/m)
2. Correction Factor(dB/m) = Antenna Factor(dB/m) + Cable Factor(dB) – Pre-Amplifier Factor(dB)
3. The other emission levels were very low against the limit.
4. Margin value = Emission Level – Limit value
5. " * ": Fundamental frequency.
6. " # ": The radiated frequency is out of the restricted band.

CHANNEL	TX Channel 48	DETECTOR FUNCTION	Peak (PK)
FREQUENCY RANGE	1GHz ~ 40GHz		Average (AV)

ANTENNA POLARITY & TEST DISTANCE: HORIZONTAL AT 3 M

NO.	FREQ. (MHz)	EMISSION LEVEL (dBuV/m)	LIMIT (dBuV/m)	MARGIN (dB)	ANTENNA HEIGHT (m)	TABLE ANGLE (Degree)	RAW VALUE (dBuV)	CORRECTION FACTOR (dB/m)
1	*5240.00	112.0 PK			1.33 H	227	105.18	6.82
2	*5240.00	103.3 AV			1.33 H	227	96.48	6.82
3	5350.00	55.9 PK	74.0	-18.1	1.60 H	212	48.86	7.04
4	5350.00	45.3 AV	54.0	-8.7	1.60 H	212	38.26	7.04
5	#10480.00	57.2 PK	74.0	-16.8	1.29 H	157	43.21	13.99
6	#10480.00	43.9 AV	54.0	-10.1	1.29 H	157	29.91	13.99
7	15720.00	64.1 PK	74.0	-9.9	1.22 H	242	45.07	19.03
8	15720.00	50.6 AV	54.0	-3.4	1.22 H	242	31.57	19.03

ANTENNA POLARITY & TEST DISTANCE: VERTICAL AT 3 M

NO.	FREQ. (MHz)	EMISSION LEVEL (dBuV/m)	LIMIT (dBuV/m)	MARGIN (dB)	ANTENNA HEIGHT (m)	TABLE ANGLE (Degree)	RAW VALUE (dBuV)	CORRECTION FACTOR (dB/m)
1	*5240.00	105.5 PK			1.60 V	299	98.68	6.82
2	*5240.00	95.6 AV			1.60 V	299	88.78	6.82
3	5350.00	54.3 PK	74.0	-19.7	1.55 V	286	47.26	7.04
4	5350.00	40.6 AV	54.0	-13.4	1.55 V	286	33.56	7.04
5	#10480.00	56.2 PK	74.0	-17.8	1.02 V	145	42.21	13.99
6	#10480.00	42.4 AV	54.0	-11.6	1.02 V	145	28.41	13.99
7	15720.00	61.5 PK	74.0	-12.5	1.11 V	143	42.47	19.03
8	15720.00	49.2 AV	54.0	-4.8	1.11 V	143	30.17	19.03

REMARKS:

1. Emission Level(dBuV/m) = Raw Value(dBuV) + Correction Factor(dB/m)
2. Correction Factor(dB/m) = Antenna Factor(dB/m) + Cable Factor(dB) – Pre-Amplifier Factor(dB)
3. The other emission levels were very low against the limit.
4. Margin value = Emission Level – Limit value
5. " * ": Fundamental frequency.
6. " # ": The radiated frequency is out of the restricted band.

CHANNEL	TX Channel 149	DETECTOR FUNCTION	Peak (PK)
FREQUENCY RANGE	1GHz ~ 40GHz		Average (AV)

ANTENNA POLARITY & TEST DISTANCE: HORIZONTAL AT 3 M

NO.	FREQ. (MHz)	EMISSION LEVEL (dBuV/m)	LIMIT (dBuV/m)	MARGIN (dB)	ANTENNA HEIGHT (m)	TABLE ANGLE (Degree)	RAW VALUE (dBuV)	CORRECTION FACTOR (dB/m)
1	#5715.00	66.3 PK	74.0	-7.7	1.42 H	191	58.92	7.38
2	#5715.00	48.9 AV	54.0	-5.1	1.42 H	191	41.52	7.38
3	#5725.00	77.2 PK	78.2	-1.0	1.42 H	191	69.82	7.38
4	*5745.00	112.3 PK			1.42 H	191	104.92	7.38
5	*5745.00	101.7 AV			1.42 H	191	94.32	7.38
6	11490.00	59.2 PK	74.0	-14.8	1.48 H	193	44.68	14.52
7	11490.00	46.2 AV	54.0	-7.8	1.48 H	193	31.68	14.52
8	#17235.00	63.8 PK	74.0	-10.2	1.22 H	261	40.04	23.76
9	#17235.00	49.7 AV	54.0	-4.3	1.22 H	261	25.94	23.76

ANTENNA POLARITY & TEST DISTANCE: VERTICAL AT 3 M

NO.	FREQ. (MHz)	EMISSION LEVEL (dBuV/m)	LIMIT (dBuV/m)	MARGIN (dB)	ANTENNA HEIGHT (m)	TABLE ANGLE (Degree)	RAW VALUE (dBuV)	CORRECTION FACTOR (dB/m)
1	#5715.00	61.3 PK	74.0	-12.7	1.42 V	205	53.92	7.38
2	#5715.00	47.3 AV	54.0	-6.7	1.42 V	205	39.92	7.38
3	#5725.00	72.1 PK	78.2	-6.1	1.42 V	205	64.72	7.38
4	*5745.00	104.8 PK			1.42 V	205	97.42	7.38
5	*5745.00	93.3 AV			1.42 V	205	85.92	7.38
6	11490.00	58.7 PK	74.0	-15.3	1.09 V	174	44.18	14.52
7	11490.00	45.4 AV	54.0	-8.6	1.09 V	174	30.88	14.52
8	#17235.00	61.1 PK	74.0	-12.9	1.17 V	115	37.34	23.76
9	#17235.00	48.2 AV	54.0	-5.8	1.17 V	115	24.44	23.76

REMARKS:

1. Emission Level(dBuV/m) = Raw Value(dBuV) + Correction Factor(dB/m)
2. Correction Factor(dB/m) = Antenna Factor(dB/m) + Cable Factor(dB) – Pre-Amplifier Factor(dB)
3. The other emission levels were very low against the limit.
4. Margin value = Emission Level – Limit value
5. " * ": Fundamental frequency.
6. " # ": The radiated frequency is out of the restricted band.

CHANNEL	TX Channel 157	DETECTOR FUNCTION	Peak (PK)
FREQUENCY RANGE	1GHz ~ 40GHz		Average (AV)

ANTENNA POLARITY & TEST DISTANCE: HORIZONTAL AT 3 M

NO.	FREQ. (MHz)	EMISSION LEVEL (dBuV/m)	LIMIT (dBuV/m)	MARGIN (dB)	ANTENNA HEIGHT (m)	TABLE ANGLE (Degree)	RAW VALUE (dBuV)	CORRECTION FACTOR (dB/m)
1	*5785.00	114.6 PK			1.39 H	192	107.22	7.38
2	*5785.00	102.4 AV			1.39 H	192	95.02	7.38
3	11570.00	59.4 PK	74.0	-14.6	1.42 H	186	44.83	14.57
4	11570.00	47.6 AV	54.0	-6.4	1.42 H	186	33.03	14.57
5	#17355.00	64.7 PK	74.0	-9.3	1.17 H	269	40.64	24.06
6	#17355.00	50.2 AV	54.0	-3.8	1.17 H	269	26.14	24.06

ANTENNA POLARITY & TEST DISTANCE: VERTICAL AT 3 M

NO.	FREQ. (MHz)	EMISSION LEVEL (dBuV/m)	LIMIT (dBuV/m)	MARGIN (dB)	ANTENNA HEIGHT (m)	TABLE ANGLE (Degree)	RAW VALUE (dBuV)	CORRECTION FACTOR (dB/m)
1	*5785.00	107.1 PK			1.38 V	185	99.72	7.38
2	*5785.00	94.1 AV			1.38 V	185	86.72	7.38
3	11570.00	58.1 PK	74.0	-15.9	1.12 V	159	43.53	14.57
4	11570.00	46.5 AV	54.0	-7.5	1.12 V	159	31.93	14.57
5	#17355.00	60.3 PK	74.0	-13.7	1.12 V	102	36.24	24.06
6	#17355.00	49.4 AV	54.0	-4.6	1.12 V	102	25.34	24.06

REMARKS:

1. Emission Level(dBuV/m) = Raw Value(dBuV) + Correction Factor(dB/m)
2. Correction Factor(dB/m) = Antenna Factor(dB/m) + Cable Factor(dB) – Pre-Amplifier Factor(dB)
3. The other emission levels were very low against the limit.
4. Margin value = Emission Level – Limit value
5. " * ": Fundamental frequency.
6. " # ": The radiated frequency is out of the restricted band.

CHANNEL	TX Channel 165	DETECTOR FUNCTION	Peak (PK)
FREQUENCY RANGE	1GHz ~ 40GHz		Average (AV)

ANTENNA POLARITY & TEST DISTANCE: HORIZONTAL AT 3 M

NO.	FREQ. (MHz)	EMISSION LEVEL (dBuV/m)	LIMIT (dBuV/m)	MARGIN (dB)	ANTENNA HEIGHT (m)	TABLE ANGLE (Degree)	RAW VALUE (dBuV)	CORRECTION FACTOR (dB/m)
1	*5825.00	114.5 PK			1.40 H	200	107.19	7.31
2	*5825.00	102.3 AV			1.40 H	200	94.99	7.31
3	#5850.00	73.7 PK	78.2	-4.5	1.41 H	188	66.45	7.25
4	#5860.00	62.2 PK	74.0	-11.8	1.41 H	188	54.98	7.22
5	#5860.00	48.7 AV	54.0	-5.3	1.41 H	188	41.48	7.22
6	11650.00	59.3 PK	74.0	-14.7	1.48 H	190	44.63	14.67
7	11650.00	47.5 AV	54.0	-6.5	1.48 H	190	32.83	14.67
8	#17475.00	64.0 PK	74.0	-10.0	1.15 H	262	39.98	24.02
9	#17475.00	50.1 AV	54.0	-3.9	1.15 H	262	26.08	24.02

ANTENNA POLARITY & TEST DISTANCE: VERTICAL AT 3 M

NO.	FREQ. (MHz)	EMISSION LEVEL (dBuV/m)	LIMIT (dBuV/m)	MARGIN (dB)	ANTENNA HEIGHT (m)	TABLE ANGLE (Degree)	RAW VALUE (dBuV)	CORRECTION FACTOR (dB/m)
1	*5825.00	106.9 PK			1.44 V	183	99.59	7.31
2	*5825.00	93.9 AV			1.44 V	183	86.59	7.31
3	#5850.00	69.9 PK	78.2	-8.3	1.44 V	183	62.65	7.25
4	#5860.00	59.6 PK	74.0	-14.4	1.44 V	183	52.38	7.22
5	#5860.00	47.6 AV	54.0	-6.4	1.44 V	183	40.38	7.22
6	11650.00	57.6 PK	74.0	-16.4	1.13 V	170	42.93	14.67
7	11650.00	45.3 AV	54.0	-8.7	1.13 V	170	30.63	14.67
8	#17475.00	59.4 PK	74.0	-14.6	1.09 V	111	35.38	24.02
9	#17475.00	48.8 AV	54.0	-5.2	1.09 V	111	24.78	24.02

REMARKS:

1. Emission Level(dBuV/m) = Raw Value(dBuV) + Correction Factor(dB/m)
2. Correction Factor(dB/m) = Antenna Factor(dB/m) + Cable Factor(dB) – Pre-Amplifier Factor(dB)
3. The other emission levels were very low against the limit.
4. Margin value = Emission Level – Limit value
5. " * ": Fundamental frequency.
6. " # ": The radiated frequency is out of the restricted band.

802.11n (HT20)

CHANNEL	TX Channel 36	DETECTOR FUNCTION	Peak (PK)
FREQUENCY RANGE	1GHz ~ 40GHz		Average (AV)

ANTENNA POLARITY & TEST DISTANCE: HORIZONTAL AT 3 M

NO.	FREQ. (MHz)	EMISSION LEVEL (dBuV/m)	LIMIT (dBuV/m)	MARGIN (dB)	ANTENNA HEIGHT (m)	TABLE ANGLE (Degree)	RAW VALUE (dBuV)	CORRECTION FACTOR (dB/m)
1	5150.00	65.9 PK	74.0	-8.1	1.60 H	217	59.43	6.47
2	5150.00	50.3 AV	54.0	-3.7	1.60 H	217	43.83	6.47
3	*5180.00	111.7 PK			1.63 H	217	105.05	6.65
4	*5180.00	101.8 AV			1.63 H	217	95.15	6.65
5	#10360.00	56.8 PK	74.0	-17.2	1.65 H	218	42.59	14.21
6	#10360.00	46.2 AV	54.0	-7.8	1.65 H	218	31.99	14.21
7	15540.00	65.0 PK	74.0	-9.0	1.65 H	218	46.24	18.76
8	15540.00	50.9 AV	54.0	-3.1	1.65 H	218	32.14	18.76

ANTENNA POLARITY & TEST DISTANCE: VERTICAL AT 3 M

NO.	FREQ. (MHz)	EMISSION LEVEL (dBuV/m)	LIMIT (dBuV/m)	MARGIN (dB)	ANTENNA HEIGHT (m)	TABLE ANGLE (Degree)	RAW VALUE (dBuV)	CORRECTION FACTOR (dB/m)
1	5150.00	59.1 PK	74.0	-14.9	1.62 V	280	52.63	6.47
2	5150.00	43.6 AV	54.0	-10.4	1.62 V	280	37.13	6.47
3	*5180.00	104.5 PK			1.64 V	280	97.85	6.65
4	*5180.00	94.0 AV			1.64 V	280	87.35	6.65
5	#10360.00	54.6 PK	74.0	-19.4	1.12 V	151	40.39	14.21
6	#10360.00	41.0 AV	54.0	-13.0	1.12 V	151	26.79	14.21
7	15540.00	59.9 PK	74.0	-14.1	1.22 V	120	41.14	18.76
8	15540.00	48.4 AV	54.0	-5.6	1.22 V	120	29.64	18.76

REMARKS:

1. Emission Level(dBuV/m) = Raw Value(dBuV) + Correction Factor(dB/m)
2. Correction Factor(dB/m) = Antenna Factor(dB/m) + Cable Factor(dB) – Pre-Amplifier Factor(dB)
3. The other emission levels were very low against the limit.
4. Margin value = Emission Level – Limit value
5. " * ": Fundamental frequency.
6. " # ": The radiated frequency is out of the restricted band.

CHANNEL	TX Channel 40	DETECTOR FUNCTION	Peak (PK)
FREQUENCY RANGE	1GHz ~ 40GHz		Average (AV)

ANTENNA POLARITY & TEST DISTANCE: HORIZONTAL AT 3 M

NO.	FREQ. (MHz)	EMISSION LEVEL (dBuV/m)	LIMIT (dBuV/m)	MARGIN (dB)	ANTENNA HEIGHT (m)	TABLE ANGLE (Degree)	RAW VALUE (dBuV)	CORRECTION FACTOR (dB/m)
1	*5200.00	111.3 PK			1.56 H	220	104.53	6.77
2	*5200.00	101.9 AV			1.56 H	220	95.13	6.77
3	#10400.00	57.1 PK	74.0	-16.9	1.69 H	210	42.88	14.22
4	#10400.00	46.3 AV	54.0	-7.7	1.69 H	210	32.08	14.22
5	15600.00	64.8 PK	74.0	-9.2	1.71 H	221	46.46	18.34
6	15600.00	50.7 AV	54.0	-3.3	1.71 H	221	32.36	18.34

ANTENNA POLARITY & TEST DISTANCE: VERTICAL AT 3 M

NO.	FREQ. (MHz)	EMISSION LEVEL (dBuV/m)	LIMIT (dBuV/m)	MARGIN (dB)	ANTENNA HEIGHT (m)	TABLE ANGLE (Degree)	RAW VALUE (dBuV)	CORRECTION FACTOR (dB/m)
1	*5200.00	104.4 PK			1.65 V	283	97.63	6.77
2	*5200.00	93.9 AV			1.65 V	283	87.13	6.77
3	#10400.00	54.9 PK	74.0	-19.1	1.14 V	140	40.68	14.22
4	#10400.00	41.2 AV	54.0	-12.8	1.14 V	140	26.98	14.22
5	15600.00	60.0 PK	74.0	-14.0	1.27 V	115	41.66	18.34
6	15600.00	48.6 AV	54.0	-5.4	1.27 V	115	30.26	18.34

REMARKS:

1. Emission Level(dBuV/m) = Raw Value(dBuV) + Correction Factor(dB/m)
2. Correction Factor(dB/m) = Antenna Factor(dB/m) + Cable Factor(dB) – Pre-Amplifier Factor(dB)
3. The other emission levels were very low against the limit.
4. Margin value = Emission Level – Limit value
5. " * ": Fundamental frequency.
6. " # ": The radiated frequency is out of the restricted band.

CHANNEL	TX Channel 48	DETECTOR FUNCTION	Peak (PK)
FREQUENCY RANGE	1GHz ~ 40GHz		Average (AV)

ANTENNA POLARITY & TEST DISTANCE: HORIZONTAL AT 3 M

NO.	FREQ. (MHz)	EMISSION LEVEL (dBuV/m)	LIMIT (dBuV/m)	MARGIN (dB)	ANTENNA HEIGHT (m)	TABLE ANGLE (Degree)	RAW VALUE (dBuV)	CORRECTION FACTOR (dB/m)
1	*5240.00	111.5 PK			1.59 H	208	104.68	6.82
2	*5240.00	101.6 AV			1.59 H	208	94.78	6.82
3	5350.00	54.2 PK	74.0	-19.8	1.59 H	220	47.16	7.04
4	5350.00	42.3 AV	54.0	-11.7	1.59 H	220	35.26	7.04
5	#10480.00	57.7 PK	74.0	-16.3	1.69 H	201	43.71	13.99
6	#10480.00	46.6 AV	54.0	-7.4	1.69 H	201	32.61	13.99
7	15720.00	64.9 PK	74.0	-9.1	1.68 H	233	45.87	19.03
8	15720.00	50.7 AV	54.0	-3.3	1.68 H	233	31.67	19.03

ANTENNA POLARITY & TEST DISTANCE: VERTICAL AT 3 M

NO.	FREQ. (MHz)	EMISSION LEVEL (dBuV/m)	LIMIT (dBuV/m)	MARGIN (dB)	ANTENNA HEIGHT (m)	TABLE ANGLE (Degree)	RAW VALUE (dBuV)	CORRECTION FACTOR (dB/m)
1	*5240.00	104.6 PK			1.66 V	267	97.78	6.82
2	*5240.00	94.1 AV			1.66 V	267	87.28	6.82
3	5350.00	54.9 PK	74.0	-19.1	1.59 V	284	47.86	7.04
4	5350.00	41.0 AV	54.0	-13.0	1.59 V	284	33.96	7.04
5	#10480.00	54.1 PK	74.0	-19.9	1.11 V	165	40.11	13.99
6	#10480.00	40.6 AV	54.0	-13.4	1.11 V	165	26.61	13.99
7	15720.00	59.3 PK	74.0	-14.7	1.31 V	102	40.27	19.03
8	15720.00	47.8 AV	54.0	-6.2	1.31 V	102	28.77	19.03

REMARKS:

1. Emission Level(dBuV/m) = Raw Value(dBuV) + Correction Factor(dB/m)
2. Correction Factor(dB/m) = Antenna Factor(dB/m) + Cable Factor(dB) – Pre-Amplifier Factor(dB)
3. The other emission levels were very low against the limit.
4. Margin value = Emission Level – Limit value
5. " * ": Fundamental frequency.
6. " # ": The radiated frequency is out of the restricted band.

CHANNEL	TX Channel 149	DETECTOR FUNCTION	Peak (PK)
FREQUENCY RANGE	1GHz ~ 40GHz		Average (AV)

ANTENNA POLARITY & TEST DISTANCE: HORIZONTAL AT 3 M

NO.	FREQ. (MHz)	EMISSION LEVEL (dBuV/m)	LIMIT (dBuV/m)	MARGIN (dB)	ANTENNA HEIGHT (m)	TABLE ANGLE (Degree)	RAW VALUE (dBuV)	CORRECTION FACTOR (dB/m)
1	#5715.00	66.4 PK	74.0	-7.6	1.42 H	193	59.02	7.38
2	#5715.00	49.1 AV	54.0	-4.9	1.42 H	193	41.72	7.38
3	#5725.00	76.9 PK	78.2	-1.3	1.42 H	193	69.52	7.38
4	*5745.00	112.7 PK			1.42 H	193	105.32	7.38
5	*5745.00	100.9 AV			1.42 H	193	93.52	7.38
6	11490.00	59.5 PK	74.0	-14.5	1.48 H	207	44.98	14.52
7	11490.00	47.5 AV	54.0	-6.5	1.48 H	207	32.98	14.52
8	#17235.00	63.6 PK	74.0	-10.4	1.22 H	245	39.84	23.76
9	#17235.00	49.7 AV	54.0	-4.3	1.22 H	245	25.94	23.76

ANTENNA POLARITY & TEST DISTANCE: VERTICAL AT 3 M

NO.	FREQ. (MHz)	EMISSION LEVEL (dBuV/m)	LIMIT (dBuV/m)	MARGIN (dB)	ANTENNA HEIGHT (m)	TABLE ANGLE (Degree)	RAW VALUE (dBuV)	CORRECTION FACTOR (dB/m)
1	#5715.00	63.5 PK	74.0	-10.5	1.38 V	200	56.12	7.38
2	#5715.00	48.7 AV	54.0	-5.3	1.38 V	200	41.32	7.38
3	#5725.00	73.1 PK	78.2	-5.1	1.38 V	200	65.72	7.38
4	*5745.00	104.2 PK			1.38 V	200	96.82	7.38
5	*5745.00	91.5 AV			1.38 V	200	84.12	7.38
6	11490.00	58.4 PK	74.0	-15.6	1.18 V	166	43.88	14.52
7	11490.00	46.6 AV	54.0	-7.4	1.18 V	166	32.08	14.52
8	#17235.00	60.2 PK	74.0	-13.8	1.09 V	101	36.44	23.76
9	#17235.00	48.5 AV	54.0	-5.5	1.09 V	101	24.74	23.76

REMARKS:

1. Emission Level(dBuV/m) = Raw Value(dBuV) + Correction Factor(dB/m)
2. Correction Factor(dB/m) = Antenna Factor(dB/m) + Cable Factor(dB) – Pre-Amplifier Factor(dB)
3. The other emission levels were very low against the limit.
4. Margin value = Emission Level – Limit value
5. " * ": Fundamental frequency.
6. " # ": The radiated frequency is out of the restricted band.

CHANNEL	TX Channel 157	DETECTOR FUNCTION	Peak (PK)
FREQUENCY RANGE	1GHz ~ 40GHz		Average (AV)

ANTENNA POLARITY & TEST DISTANCE: HORIZONTAL AT 3 M

NO.	FREQ. (MHz)	EMISSION LEVEL (dBuV/m)	LIMIT (dBuV/m)	MARGIN (dB)	ANTENNA HEIGHT (m)	TABLE ANGLE (Degree)	RAW VALUE (dBuV)	CORRECTION FACTOR (dB/m)
1	*5785.00	113.1 PK			1.43 H	188	105.72	7.38
2	*5785.00	101.3 AV			1.43 H	188	93.92	7.38
3	11570.00	59.5 PK	74.0	-14.5	1.44 H	187	44.93	14.57
4	11570.00	48.0 AV	54.0	-6.0	1.44 H	187	33.43	14.57
5	#17355.00	64.1 PK	74.0	-9.9	1.18 H	256	40.04	24.06
6	#17355.00	50.4 AV	54.0	-3.6	1.18 H	256	26.34	24.06

ANTENNA POLARITY & TEST DISTANCE: VERTICAL AT 3 M

NO.	FREQ. (MHz)	EMISSION LEVEL (dBuV/m)	LIMIT (dBuV/m)	MARGIN (dB)	ANTENNA HEIGHT (m)	TABLE ANGLE (Degree)	RAW VALUE (dBuV)	CORRECTION FACTOR (dB/m)
1	*5785.00	104.6 PK			1.42 V	193	97.22	7.38
2	*5785.00	91.9 AV			1.42 V	193	84.52	7.38
3	11570.00	56.3 PK	74.0	-17.7	1.18 V	156	41.73	14.57
4	11570.00	47.4 AV	54.0	-6.6	1.18 V	156	32.83	14.57
5	#17355.00	61.8 PK	74.0	-12.2	1.12 V	108	37.74	24.06
6	#17355.00	49.3 AV	54.0	-4.7	1.12 V	108	25.24	24.06

REMARKS:

1. Emission Level(dBuV/m) = Raw Value(dBuV) + Correction Factor(dB/m)
2. Correction Factor(dB/m) = Antenna Factor(dB/m) + Cable Factor(dB) – Pre-Amplifier Factor(dB)
3. The other emission levels were very low against the limit.
4. Margin value = Emission Level – Limit value
5. " * ": Fundamental frequency.
6. " # ": The radiated frequency is out of the restricted band.

CHANNEL	TX Channel 165	DETECTOR FUNCTION	Peak (PK)
FREQUENCY RANGE	1GHz ~ 40GHz		Average (AV)

ANTENNA POLARITY & TEST DISTANCE: HORIZONTAL AT 3 M

NO.	FREQ. (MHz)	EMISSION LEVEL (dBuV/m)	LIMIT (dBuV/m)	MARGIN (dB)	ANTENNA HEIGHT (m)	TABLE ANGLE (Degree)	RAW VALUE (dBuV)	CORRECTION FACTOR (dB/m)
1	*5825.00	113.4 PK			1.39 H	192	106.09	7.31
2	*5825.00	101.6 AV			1.39 H	192	94.29	7.31
3	#5850.00	75.1 PK	78.2	-3.1	1.39 H	192	67.85	7.25
4	#5860.00	65.2 PK	74.0	-8.8	1.39 H	192	57.98	7.22
5	#5860.00	50.1 AV	54.0	-3.9	1.39 H	192	42.88	7.22
6	11650.00	58.2 PK	74.0	-15.8	1.66 H	193	43.53	14.67
7	11650.00	46.9 AV	54.0	-7.1	1.66 H	193	32.23	14.67
8	#17475.00	64.9 PK	74.0	-9.1	1.72 H	233	40.88	24.02
9	#17475.00	50.0 AV	54.0	-4.0	1.72 H	233	25.98	24.02

ANTENNA POLARITY & TEST DISTANCE: VERTICAL AT 3 M

NO.	FREQ. (MHz)	EMISSION LEVEL (dBuV/m)	LIMIT (dBuV/m)	MARGIN (dB)	ANTENNA HEIGHT (m)	TABLE ANGLE (Degree)	RAW VALUE (dBuV)	CORRECTION FACTOR (dB/m)
1	*5825.00	104.8 PK			1.44 V	179	97.49	7.31
2	*5825.00	92.2 AV			1.44 V	179	84.89	7.31
3	#5850.00	71.5 PK	78.2	-6.7	1.44 V	179	64.25	7.25
4	#5860.00	61.6 PK	74.0	-12.4	1.44 V	179	54.38	7.22
5	#5860.00	49.8 AV	54.0	-4.2	1.44 V	179	42.58	7.22
6	11650.00	56.4 PK	74.0	-17.6	1.19 V	140	41.73	14.67
7	11650.00	45.6 AV	54.0	-8.4	1.19 V	140	30.93	14.67
8	#17475.00	61.7 PK	74.0	-12.3	1.11 V	118	37.68	24.02
9	#17475.00	49.8 AV	54.0	-4.2	1.11 V	118	25.78	24.02

REMARKS:

1. Emission Level(dBuV/m) = Raw Value(dBuV) + Correction Factor(dB/m)
2. Correction Factor(dB/m) = Antenna Factor(dB/m) + Cable Factor(dB) – Pre-Amplifier Factor(dB)
3. The other emission levels were very low against the limit.
4. Margin value = Emission Level – Limit value
5. " * ": Fundamental frequency.
6. " # ": The radiated frequency is out of the restricted band.

BELOW 1GHz WORST-CASE DATA
802.11a

CHANNEL	TX Channel 36	DETECTOR FUNCTION	Quasi-Peak (QP)
FREQUENCY RANGE	30MHz ~ 1GHz		

ANTENNA POLARITY & TEST DISTANCE: HORIZONTAL AT 3 M

NO.	FREQ. (MHz)	EMISSION LEVEL (dBuV/m)	LIMIT (dBuV/m)	MARGIN (dB)	ANTENNA HEIGHT (m)	TABLE ANGLE (Degree)	RAW VALUE (dBuV)	CORRECTION FACTOR (dB/m)
1	87.81	31.0 QP	40.0	-9.0	2.00 H	116	49.72	-18.76
2	94.65	33.9 QP	43.5	-9.6	2.00 H	116	52.23	-18.34
3	166.29	35.2 QP	43.5	-8.4	2.00 H	204	48.48	-13.33
4	232.83	38.4 QP	46.0	-7.6	1.00 H	70	53.60	-15.17
5	240.01	38.9 QP	46.0	-7.1	1.00 H	85	53.36	-14.44
6	798.24	39.5 QP	46.0	-6.5	1.00 H	241	40.08	-0.61

ANTENNA POLARITY & TEST DISTANCE: VERTICAL AT 3 M

NO.	FREQ. (MHz)	EMISSION LEVEL (dBuV/m)	LIMIT (dBuV/m)	MARGIN (dB)	ANTENNA HEIGHT (m)	TABLE ANGLE (Degree)	RAW VALUE (dBuV)	CORRECTION FACTOR (dB/m)
1	39.51	29.9 QP	40.0	-10.1	1.00 V	314	43.45	-13.54
2	94.84	33.5 QP	43.5	-10.0	2.00 V	67	51.82	-18.34
3	165.99	36.2 QP	43.5	-7.4	1.00 V	279	49.47	-13.32
4	240.01	32.9 QP	46.0	-13.1	1.50 V	122	47.35	-14.44
5	796.59	41.3 QP	46.0	-4.7	1.50 V	360	41.93	-0.66
6	960.04	35.8 QP	54.0	-18.3	1.00 V	360	34.06	1.69

REMARKS:

1. Emission Level(dBuV/m) = Raw Value(dBuV) + Correction Factor(dB/m)
2. Correction Factor(dB/m) = Antenna Factor(dB/m) + Cable Factor(dB) – Pre-Amplifier Factor(dB)
3. The other emission levels were very low against the limit.
4. Margin value = Emission Level – Limit value

CHANNEL	TX Channel 40	DETECTOR FUNCTION	Quasi-Peak (QP)
FREQUENCY RANGE	30MHz ~ 1GHz		

ANTENNA POLARITY & TEST DISTANCE: HORIZONTAL AT 3 M

NO.	FREQ. (MHz)	EMISSION LEVEL (dBuV/m)	LIMIT (dBuV/m)	MARGIN (dB)	ANTENNA HEIGHT (m)	TABLE ANGLE (Degree)	RAW VALUE (dBuV)	CORRECTION FACTOR (dB/m)
1	91.79	35.7 QP	43.5	-7.8	2.00 H	127	54.54	-18.82
2	99.50	35.2 QP	43.5	-8.3	2.00 H	147	52.82	-17.61
3	165.99	34.6 QP	43.5	-8.9	2.00 H	211	47.93	-13.32
4	232.78	38.1 QP	46.0	-7.9	1.00 H	71	53.24	-15.18
5	240.01	37.4 QP	46.0	-8.6	1.00 H	83	51.87	-14.44
6	796.54	39.0 QP	46.0	-7.0	1.00 H	241	39.65	-0.66

ANTENNA POLARITY & TEST DISTANCE: VERTICAL AT 3 M

NO.	FREQ. (MHz)	EMISSION LEVEL (dBuV/m)	LIMIT (dBuV/m)	MARGIN (dB)	ANTENNA HEIGHT (m)	TABLE ANGLE (Degree)	RAW VALUE (dBuV)	CORRECTION FACTOR (dB/m)
1	94.55	33.4 QP	43.5	-10.1	2.00 V	46	51.76	-18.34
2	166.29	35.8 QP	43.5	-7.8	1.00 V	267	49.08	-13.33
3	232.34	32.9 QP	46.0	-13.1	1.00 V	305	48.16	-15.24
4	240.01	32.8 QP	46.0	-13.2	1.50 V	140	47.28	-14.44
5	798.19	39.6 QP	46.0	-6.4	1.50 V	13	40.17	-0.61
6	959.99	34.6 QP	46.0	-11.4	1.00 V	16	32.89	1.69

REMARKS:

1. Emission Level(dBuV/m) = Raw Value(dBuV) + Correction Factor(dB/m)
2. Correction Factor(dB/m) = Antenna Factor(dB/m) + Cable Factor(dB) – Pre-Amplifier Factor(dB)
3. The other emission levels were very low against the limit.
4. Margin value = Emission Level – Limit value

CHANNEL	TX Channel 48	DETECTOR FUNCTION	Quasi-Peak (QP)
FREQUENCY RANGE	30MHz ~ 1GHz		

ANTENNA POLARITY & TEST DISTANCE: HORIZONTAL AT 3 M

NO.	FREQ. (MHz)	EMISSION LEVEL (dBuV/m)	LIMIT (dBuV/m)	MARGIN (dB)	ANTENNA HEIGHT (m)	TABLE ANGLE (Degree)	RAW VALUE (dBuV)	CORRECTION FACTOR (dB/m)
1	87.80	30.9 QP	40.0	-9.1	1.90 H	120	49.66	-18.76
2	94.60	33.8 QP	43.5	-9.7	1.90 H	120	52.13	-18.34
3	166.32	35.2 QP	43.5	-8.3	2.00 H	200	48.54	-13.33
4	232.80	38.4 QP	46.0	-7.6	1.00 H	170	53.58	-15.18
5	240.00	38.9 QP	46.0	-7.1	1.10 H	78	53.34	-14.44
6	798.20	39.5 QP	46.0	-6.5	1.01 H	240	40.13	-0.61

ANTENNA POLARITY & TEST DISTANCE: VERTICAL AT 3 M

NO.	FREQ. (MHz)	EMISSION LEVEL (dBuV/m)	LIMIT (dBuV/m)	MARGIN (dB)	ANTENNA HEIGHT (m)	TABLE ANGLE (Degree)	RAW VALUE (dBuV)	CORRECTION FACTOR (dB/m)
1	94.50	33.4 QP	43.5	-10.1	1.92 V	146	51.74	-18.34
2	166.20	35.8 QP	43.5	-7.7	1.10 V	260	49.12	-13.33
3	232.30	32.9 QP	46.0	-13.1	1.10 V	300	48.14	-15.24
4	240.00	32.8 QP	46.0	-13.2	1.54 V	110	47.24	-14.44
5	798.19	39.5 QP	46.0	-6.5	1.53 V	130	40.11	-0.61
6	959.98	34.6 QP	46.0	-11.4	1.10 V	116	32.93	1.69

REMARKS:

1. Emission Level(dBuV/m) = Raw Value(dBuV) + Correction Factor(dB/m)
2. Correction Factor(dB/m) = Antenna Factor(dB/m) + Cable Factor(dB) – Pre-Amplifier Factor(dB)
3. The other emission levels were very low against the limit.
4. Margin value = Emission Level – Limit value

CHANNEL	TX Channel 149	DETECTOR FUNCTION	Quasi-Peak (QP)
FREQUENCY RANGE	30MHz ~ 1GHz		

ANTENNA POLARITY & TEST DISTANCE: HORIZONTAL AT 3 M

NO.	FREQ. (MHz)	EMISSION LEVEL (dBuV/m)	LIMIT (dBuV/m)	MARGIN (dB)	ANTENNA HEIGHT (m)	TABLE ANGLE (Degree)	RAW VALUE (dBuV)	CORRECTION FACTOR (dB/m)
1	91.82	35.7 QP	43.5	-7.8	1.86 H	130	54.53	-18.83
2	99.50	35.2 QP	43.5	-8.3	1.80 H	140	52.79	-17.61
3	165.99	34.6 QP	43.5	-8.9	1.92 H	201	47.92	-13.32
4	232.70	38.0 QP	46.0	-8.0	1.10 H	69	53.19	-15.19
5	240.01	37.4 QP	46.0	-8.6	1.13 H	80	51.84	-14.44
6	796.50	38.9 QP	46.0	-7.1	1.12 H	268	39.56	-0.66

ANTENNA POLARITY & TEST DISTANCE: VERTICAL AT 3 M

NO.	FREQ. (MHz)	EMISSION LEVEL (dBuV/m)	LIMIT (dBuV/m)	MARGIN (dB)	ANTENNA HEIGHT (m)	TABLE ANGLE (Degree)	RAW VALUE (dBuV)	CORRECTION FACTOR (dB/m)
1	94.52	33.5 QP	43.5	-10.0	1.90 V	152	51.82	-18.34
2	166.21	35.8 QP	43.5	-7.7	1.00 V	180	49.13	-13.33
3	232.31	32.9 QP	46.0	-13.1	1.00 V	276	48.10	-15.24
4	240.29	32.8 QP	46.0	-13.2	1.50 V	100	47.19	-14.42
5	798.19	39.5 QP	46.0	-6.5	1.50 V	110	40.13	-0.61
6	959.97	34.7 QP	46.0	-11.3	1.00 V	106	33.01	1.69

REMARKS:

1. Emission Level(dBuV/m) = Raw Value(dBuV) + Correction Factor(dB/m)
2. Correction Factor(dB/m) = Antenna Factor(dB/m) + Cable Factor(dB) – Pre-Amplifier Factor(dB)
3. The other emission levels were very low against the limit.
4. Margin value = Emission Level – Limit value

CHANNEL	TX Channel 157	DETECTOR FUNCTION	Quasi-Peak (QP)
FREQUENCY RANGE	30MHz ~ 1GHz		

ANTENNA POLARITY & TEST DISTANCE: HORIZONTAL AT 3 M

NO.	FREQ. (MHz)	EMISSION LEVEL (dBuV/m)	LIMIT (dBuV/m)	MARGIN (dB)	ANTENNA HEIGHT (m)	TABLE ANGLE (Degree)	RAW VALUE (dBuV)	CORRECTION FACTOR (dB/m)
1	91.80	35.8 QP	43.5	-7.7	1.80 H	128	54.61	-18.82
2	99.52	35.1 QP	43.5	-8.4	1.72 H	115	52.73	-17.60
3	165.90	34.6 QP	43.5	-8.9	1.90 H	200	47.93	-13.30
4	232.71	38.2 QP	46.0	-7.8	1.00 H	70	53.39	-15.19
5	240.00	37.3 QP	46.0	-8.7	1.03 H	120	51.76	-14.44
6	796.50	38.9 QP	46.0	-7.1	1.02 H	268	39.56	-0.66

ANTENNA POLARITY & TEST DISTANCE: VERTICAL AT 3 M

NO.	FREQ. (MHz)	EMISSION LEVEL (dBuV/m)	LIMIT (dBuV/m)	MARGIN (dB)	ANTENNA HEIGHT (m)	TABLE ANGLE (Degree)	RAW VALUE (dBuV)	CORRECTION FACTOR (dB/m)
1	94.50	33.4 QP	43.5	-10.1	1.86 V	146	51.74	-18.34
2	166.32	35.7 QP	43.5	-7.8	1.10 V	260	49.03	-13.33
3	232.34	32.9 QP	46.0	-13.1	1.00 V	300	48.14	-15.24
4	240.00	32.8 QP	46.0	-13.2	1.10 V	120	47.24	-14.44
5	798.19	39.5 QP	46.0	-6.5	1.10 V	113	40.11	-0.61
6	959.92	34.5 QP	46.0	-11.5	1.20 V	116	32.81	1.69

REMARKS:

1. Emission Level(dBuV/m) = Raw Value(dBuV) + Correction Factor(dB/m)
2. Correction Factor(dB/m) = Antenna Factor(dB/m) + Cable Factor(dB) – Pre-Amplifier Factor(dB)
3. The other emission levels were very low against the limit.
4. Margin value = Emission Level – Limit value

CHANNEL	TX Channel 165	DETECTOR FUNCTION	Quasi-Peak (QP)
FREQUENCY RANGE	30MHz ~ 1GHz		

ANTENNA POLARITY & TEST DISTANCE: HORIZONTAL AT 3 M

NO.	FREQ. (MHz)	EMISSION LEVEL (dBuV/m)	LIMIT (dBuV/m)	MARGIN (dB)	ANTENNA HEIGHT (m)	TABLE ANGLE (Degree)	RAW VALUE (dBuV)	CORRECTION FACTOR (dB/m)
1	87.77	30.8 QP	40.0	-9.2	1.50 H	112	49.60	-18.76
2	94.58	33.8 QP	43.5	-9.7	1.50 H	122	52.15	-18.34
3	166.32	35.1 QP	43.5	-8.4	1.50 H	212	48.44	-13.33
4	232.78	38.4 QP	46.0	-7.6	1.50 H	75	53.56	-15.18
5	240.00	38.9 QP	46.0	-7.2	1.50 H	93	53.29	-14.44
6	798.20	39.4 QP	46.0	-6.6	1.50 H	235	39.98	-0.61

ANTENNA POLARITY & TEST DISTANCE: VERTICAL AT 3 M

NO.	FREQ. (MHz)	EMISSION LEVEL (dBuV/m)	LIMIT (dBuV/m)	MARGIN (dB)	ANTENNA HEIGHT (m)	TABLE ANGLE (Degree)	RAW VALUE (dBuV)	CORRECTION FACTOR (dB/m)
1	39.46	29.8 QP	40.0	-10.2	1.00 V	308	43.38	-13.55
2	94.78	33.4 QP	43.5	-10.1	2.00 V	61	51.76	-18.34
3	165.90	36.1 QP	43.5	-7.4	1.00 V	273	49.41	-13.30
4	240.00	32.9 QP	46.0	-13.2	1.50 V	117	47.29	-14.44
5	796.52	41.2 QP	46.0	-4.8	1.50 V	355	41.86	-0.66
6	960.02	35.7 QP	54.0	-18.3	1.00 V	356	34.02	1.69

REMARKS:

1. Emission Level(dBuV/m) = Raw Value(dBuV) + Correction Factor(dB/m)
2. Correction Factor(dB/m) = Antenna Factor(dB/m) + Cable Factor(dB) – Pre-Amplifier Factor(dB)
3. The other emission levels were very low against the limit.
4. Margin value = Emission Level – Limit value

802.11n (HT20)

CHANNEL	TX Channel 36	DETECTOR FUNCTION	Quasi-Peak (QP)
FREQUENCY RANGE	30MHz ~ 1GHz		

ANTENNA POLARITY & TEST DISTANCE: HORIZONTAL AT 3 M

NO.	FREQ. (MHz)	EMISSION LEVEL (dBuV/m)	LIMIT (dBuV/m)	MARGIN (dB)	ANTENNA HEIGHT (m)	TABLE ANGLE (Degree)	RAW VALUE (dBuV)	CORRECTION FACTOR (dB/m)
1	91.71	35.7 QP	43.5	-7.8	1.90 H	132	54.52	-18.82
2	99.50	35.4 QP	43.5	-8.1	1.80 H	168	52.99	-17.61
3	165.99	34.6 QP	43.5	-8.9	1.90 H	201	47.92	-13.32
4	232.70	38.0 QP	46.0	-8.0	1.00 H	70	53.19	-15.19
5	240.12	37.4 QP	46.0	-8.6	1.00 H	80	51.83	-14.43
6	796.50	38.9 QP	46.0	-7.1	1.10 H	211	39.53	-0.66

ANTENNA POLARITY & TEST DISTANCE: VERTICAL AT 3 M

NO.	FREQ. (MHz)	EMISSION LEVEL (dBuV/m)	LIMIT (dBuV/m)	MARGIN (dB)	ANTENNA HEIGHT (m)	TABLE ANGLE (Degree)	RAW VALUE (dBuV)	CORRECTION FACTOR (dB/m)
1	94.51	33.3 QP	43.5	-10.2	1.80 V	118	51.66	-18.34
2	166.30	35.7 QP	43.5	-7.8	1.00 V	240	49.01	-13.33
3	232.30	32.8 QP	46.0	-13.2	1.10 V	286	48.02	-15.24
4	240.19	32.8 QP	46.0	-13.2	1.00 V	100	47.21	-14.43
5	798.21	39.7 QP	46.0	-6.3	1.00 V	103	40.29	-0.61
6	959.90	34.7 QP	46.0	-11.3	1.10 V	108	32.99	1.69

REMARKS:

1. Emission Level(dBuV/m) = Raw Value(dBuV) + Correction Factor(dB/m)
2. Correction Factor(dB/m) = Antenna Factor(dB/m) + Cable Factor(dB) – Pre-Amplifier Factor(dB)
3. The other emission levels were very low against the limit.
4. Margin value = Emission Level – Limit value

CHANNEL	TX Channel 40	DETECTOR FUNCTION	Quasi-Peak (QP)
FREQUENCY RANGE	30MHz ~ 1GHz		

ANTENNA POLARITY & TEST DISTANCE: HORIZONTAL AT 3 M

NO.	FREQ. (MHz)	EMISSION LEVEL (dBuV/m)	LIMIT (dBuV/m)	MARGIN (dB)	ANTENNA HEIGHT (m)	TABLE ANGLE (Degree)	RAW VALUE (dBuV)	CORRECTION FACTOR (dB/m)
1	91.70	35.7 QP	43.5	-7.8	1.72 H	136	54.50	-18.82
2	99.52	35.4 QP	43.5	-8.1	1.90 H	172	53.02	-17.60
3	165.91	34.7 QP	43.5	-8.8	1.80 H	200	48.03	-13.31
4	232.72	38.2 QP	46.0	-7.8	1.10 H	170	53.42	-15.19
5	240.11	37.5 QP	46.0	-8.5	1.20 H	180	51.95	-14.43
6	796.52	38.8 QP	46.0	-7.2	1.00 H	201	39.46	-0.66

ANTENNA POLARITY & TEST DISTANCE: VERTICAL AT 3 M

NO.	FREQ. (MHz)	EMISSION LEVEL (dBuV/m)	LIMIT (dBuV/m)	MARGIN (dB)	ANTENNA HEIGHT (m)	TABLE ANGLE (Degree)	RAW VALUE (dBuV)	CORRECTION FACTOR (dB/m)
1	94.50	33.4 QP	43.5	-10.1	1.80 V	146	51.74	-18.34
2	166.32	35.7 QP	43.5	-7.8	1.10 V	222	49.03	-13.33
3	232.31	32.9 QP	46.0	-13.1	1.10 V	300	48.14	-15.24
4	240.00	32.8 QP	46.0	-13.2	1.10 V	110	47.24	-14.44
5	798.19	39.6 QP	46.0	-6.5	1.10 V	113	40.16	-0.61
6	959.90	34.6 QP	46.0	-11.4	1.10 V	116	32.93	1.69

REMARKS:

1. Emission Level(dBuV/m) = Raw Value(dBuV) + Correction Factor(dB/m)
2. Correction Factor(dB/m) = Antenna Factor(dB/m) + Cable Factor(dB) – Pre-Amplifier Factor(dB)
3. The other emission levels were very low against the limit.
4. Margin value = Emission Level – Limit value

CHANNEL	TX Channel 48	DETECTOR FUNCTION	Quasi-Peak (QP)
FREQUENCY RANGE	30MHz ~ 1GHz		

ANTENNA POLARITY & TEST DISTANCE: HORIZONTAL AT 3 M

NO.	FREQ. (MHz)	EMISSION LEVEL (dBuV/m)	LIMIT (dBuV/m)	MARGIN (dB)	ANTENNA HEIGHT (m)	TABLE ANGLE (Degree)	RAW VALUE (dBuV)	CORRECTION FACTOR (dB/m)
1	91.82	35.7 QP	43.5	-7.8	1.86 H	123	54.53	-18.83
2	99.50	35.2 QP	43.5	-8.3	1.92 H	140	52.81	-17.61
3	165.90	34.8 QP	43.5	-8.7	1.92 H	202	48.08	-13.30
4	232.70	38.0 QP	46.0	-8.0	1.10 H	68	53.19	-15.19
5	240.00	37.4 QP	46.0	-8.6	1.10 H	80	51.84	-14.44
6	796.50	38.8 QP	46.0	-7.2	1.12 H	221	39.44	-0.66

ANTENNA POLARITY & TEST DISTANCE: VERTICAL AT 3 M

NO.	FREQ. (MHz)	EMISSION LEVEL (dBuV/m)	LIMIT (dBuV/m)	MARGIN (dB)	ANTENNA HEIGHT (m)	TABLE ANGLE (Degree)	RAW VALUE (dBuV)	CORRECTION FACTOR (dB/m)
1	94.52	33.5 QP	43.5	-10.0	1.77 V	152	51.82	-18.34
2	166.32	35.7 QP	43.5	-7.8	1.00 V	202	49.01	-13.33
3	232.30	32.8 QP	46.0	-13.2	1.00 V	280	48.03	-15.24
4	240.15	32.7 QP	46.0	-13.3	1.00 V	100	47.11	-14.43
5	798.11	39.5 QP	46.0	-6.5	1.10 V	103	40.11	-0.61
6	959.91	34.6 QP	46.0	-11.4	1.10 V	112	32.91	1.69

REMARKS:

1. Emission Level(dBuV/m) = Raw Value(dBuV) + Correction Factor(dB/m)
2. Correction Factor(dB/m) = Antenna Factor(dB/m) + Cable Factor(dB) – Pre-Amplifier Factor(dB)
3. The other emission levels were very low against the limit.
4. Margin value = Emission Level – Limit value

CHANNEL	TX Channel 149	DETECTOR FUNCTION	Quasi-Peak (QP)
FREQUENCY RANGE	30MHz ~ 1GHz		

ANTENNA POLARITY & TEST DISTANCE: HORIZONTAL AT 3 M

NO.	FREQ. (MHz)	EMISSION LEVEL (dBuV/m)	LIMIT (dBuV/m)	MARGIN (dB)	ANTENNA HEIGHT (m)	TABLE ANGLE (Degree)	RAW VALUE (dBuV)	CORRECTION FACTOR (dB/m)
1	91.78	35.7 QP	43.5	-7.8	1.78 H	120	54.50	-18.82
2	99.51	35.2 QP	43.5	-8.3	1.90 H	132	52.83	-17.61
3	165.82	34.8 QP	43.5	-8.7	1.72 H	186	48.07	-13.29
4	232.72	38.2 QP	46.0	-7.8	1.00 H	72	53.38	-15.19
5	240.15	37.3 QP	46.0	-8.7	1.00 H	78	51.75	-14.43
6	796.51	38.7 QP	46.0	-7.3	1.02 H	201	39.34	-0.66

ANTENNA POLARITY & TEST DISTANCE: VERTICAL AT 3 M

NO.	FREQ. (MHz)	EMISSION LEVEL (dBuV/m)	LIMIT (dBuV/m)	MARGIN (dB)	ANTENNA HEIGHT (m)	TABLE ANGLE (Degree)	RAW VALUE (dBuV)	CORRECTION FACTOR (dB/m)
1	93.80	33.3 QP	43.5	-10.2	1.20 V	132	51.71	-18.39
2	166.30	35.7 QP	43.5	-7.8	1.01 V	20	49.06	-13.33
3	232.38	32.9 QP	46.0	-13.1	1.00 V	300	48.13	-15.23
4	240.17	32.7 QP	46.0	-13.3	1.04 V	112	47.13	-14.43
5	798.10	39.5 QP	46.0	-6.5	1.10 V	102	40.10	-0.61
6	959.02	34.2 QP	46.0	-11.8	1.10 V	160	32.50	1.66

REMARKS:

1. Emission Level(dBuV/m) = Raw Value(dBuV) + Correction Factor(dB/m)
2. Correction Factor(dB/m) = Antenna Factor(dB/m) + Cable Factor(dB) – Pre-Amplifier Factor(dB)
3. The other emission levels were very low against the limit.
4. Margin value = Emission Level – Limit value

CHANNEL	TX Channel 157	DETECTOR FUNCTION	Quasi-Peak (QP)
FREQUENCY RANGE	30MHz ~ 1GHz		

ANTENNA POLARITY & TEST DISTANCE: HORIZONTAL AT 3 M

NO.	FREQ. (MHz)	EMISSION LEVEL (dBuV/m)	LIMIT (dBuV/m)	MARGIN (dB)	ANTENNA HEIGHT (m)	TABLE ANGLE (Degree)	RAW VALUE (dBuV)	CORRECTION FACTOR (dB/m)
1	91.70	35.6 QP	43.5	-7.9	1.70 H	117	54.42	-18.82
2	99.50	35.2 QP	43.5	-8.3	1.80 H	130	52.81	-17.61
3	165.80	34.7 QP	43.5	-8.8	1.62 H	176	48.00	-13.29
4	232.70	38.3 QP	46.0	-7.7	1.19 H	100	53.47	-15.19
5	240.11	37.4 QP	46.0	-8.6	1.15 H	108	51.85	-14.43
6	796.50	38.7 QP	46.0	-7.3	1.00 H	200	39.38	-0.66

ANTENNA POLARITY & TEST DISTANCE: VERTICAL AT 3 M

NO.	FREQ. (MHz)	EMISSION LEVEL (dBuV/m)	LIMIT (dBuV/m)	MARGIN (dB)	ANTENNA HEIGHT (m)	TABLE ANGLE (Degree)	RAW VALUE (dBuV)	CORRECTION FACTOR (dB/m)
1	93.86	33.3 QP	43.5	-10.2	1.60 V	119	51.65	-18.37
2	166.31	35.7 QP	43.5	-7.8	1.00 V	207	49.01	-13.33
3	232.32	32.9 QP	46.0	-13.1	1.10 V	310	48.16	-15.24
4	240.20	32.7 QP	46.0	-13.3	1.14 V	142	47.15	-14.43
5	798.02	39.7 QP	46.0	-6.3	1.40 V	32	40.31	-0.61
6	959.28	34.6 QP	46.0	-11.4	1.00 V	158	32.93	1.67

REMARKS:

1. Emission Level(dBuV/m) = Raw Value(dBuV) + Correction Factor(dB/m)
2. Correction Factor(dB/m) = Antenna Factor(dB/m) + Cable Factor(dB) – Pre-Amplifier Factor(dB)
3. The other emission levels were very low against the limit.
4. Margin value = Emission Level – Limit value

CHANNEL	TX Channel 165	DETECTOR FUNCTION	Quasi-Peak (QP)
FREQUENCY RANGE	30MHz ~ 1GHz		

ANTENNA POLARITY & TEST DISTANCE: HORIZONTAL AT 3 M

NO.	FREQ. (MHz)	EMISSION LEVEL (dBuV/m)	LIMIT (dBuV/m)	MARGIN (dB)	ANTENNA HEIGHT (m)	TABLE ANGLE (Degree)	RAW VALUE (dBuV)	CORRECTION FACTOR (dB/m)
1	91.68	35.6 QP	43.5	-7.9	1.40 H	102	54.44	-18.82
2	99.52	35.3 QP	43.5	-8.2	1.72 H	110	52.92	-17.60
3	165.72	34.6 QP	43.5	-8.9	1.00 H	170	47.90	-13.28
4	232.71	38.3 QP	46.0	-7.7	1.09 H	110	53.51	-15.19
5	240.10	37.3 QP	46.0	-8.7	1.11 H	100	51.73	-14.43
6	796.54	38.7 QP	46.0	-7.3	1.10 H	190	39.34	-0.66

ANTENNA POLARITY & TEST DISTANCE: VERTICAL AT 3 M

NO.	FREQ. (MHz)	EMISSION LEVEL (dBuV/m)	LIMIT (dBuV/m)	MARGIN (dB)	ANTENNA HEIGHT (m)	TABLE ANGLE (Degree)	RAW VALUE (dBuV)	CORRECTION FACTOR (dB/m)
1	94.50	33.4 QP	43.5	-10.1	1.70 V	19	51.74	-18.34
2	166.32	35.7 QP	43.5	-7.8	1.10 V	217	49.03	-13.33
3	232.30	32.9 QP	46.0	-13.1	1.40 V	300	48.14	-15.24
4	240.00	32.8 QP	46.0	-13.2	1.44 V	138	47.24	-14.44
5	798.19	39.7 QP	46.0	-6.3	1.40 V	28	40.33	-0.61
6	959.90	34.6 QP	46.0	-11.4	1.10 V	58	32.93	1.69

REMARKS:

1. Emission Level(dBuV/m) = Raw Value(dBuV) + Correction Factor(dB/m)
2. Correction Factor(dB/m) = Antenna Factor(dB/m) + Cable Factor(dB) – Pre-Amplifier Factor(dB)
3. The other emission levels were very low against the limit.
4. Margin value = Emission Level – Limit value

4.2 Conducted Emission Measurement

4.2.1 Limits of Conducted Emission Measurement

Frequency (MHz)	Conducted Limit (dBuV)	
	Quasi-peak	Average
0.15 - 0.5	66 - 56	56 - 46
0.50 - 5.0	56	46
5.0 - 30.0	60	50

Note: 1. The lower limit shall apply at the transition frequencies.

2. The limit decreases in line with the logarithm of the frequency in the range of 0.15 to 0.50MHz.

4.2.2 Test Instruments

DESCRIPTION & MANUFACTURER	MODEL NO.	SERIAL NO.	CALIBRATED DATE	CALIBRATED UNTIL
Test Receiver ROHDE & SCHWARZ	ESCS 30	847124/029	Oct. 22, 2014	Oct. 21, 2015
Line-Impedance Stabilization Network (for EUT) SCHWARZBECK	NSLK-8127	8127-522	Sep. 15, 2014	Sep. 14, 2015
Line-Impedance Stabilization Network (for Peripheral) ROHDE & SCHWARZ	ENV216	100071	Nov. 10, 2014	Nov. 09, 2015
RF Cable (JYEBAO)	5D-FB	COCCAB-001	Mar. 09, 2015	Mar. 08, 2016
50 ohms Terminator	N/A	EMC-03	Sep. 22, 2014	Sep. 21, 2015
50 ohms Terminator	N/A	EMC-02	Sep. 30, 2014	Sep. 29, 2015
Software ADT	BV ADT_Cond_V7.3.7.3	NA	NA	NA

Note:

1. The calibration interval of the above test instruments is 12 months and the calibrations are traceable to NML/ROC and NIST/USA.
2. The test was performed in Shielded Room No. C.
3. The VCCI Con C Registration No. is C-3611.
4. Tested Date: Mar. 25, 2015

4.2.3 Test Procedure

- a. The EUT was placed 0.4 meters from the conducting wall of the shielded room with EUT being connected to the power mains through a line impedance stabilization network (LISN). Other support units were connected to the power mains through another LISN. The two LISNs provide 50 ohm/ 50uH of coupling impedance for the measuring instrument.
- b. Both lines of the power mains connected to the EUT were checked for maximum conducted interference.
- c. The frequency range from 150kHz to 30MHz was searched. Emission levels under (Limit - 20dB) was not recorded.

NOTE: All modes of operation were investigated and the worst-case emissions are reported.

4.2.4 Deviation from Test Standard

No deviation.

4.2.5 Test Setup

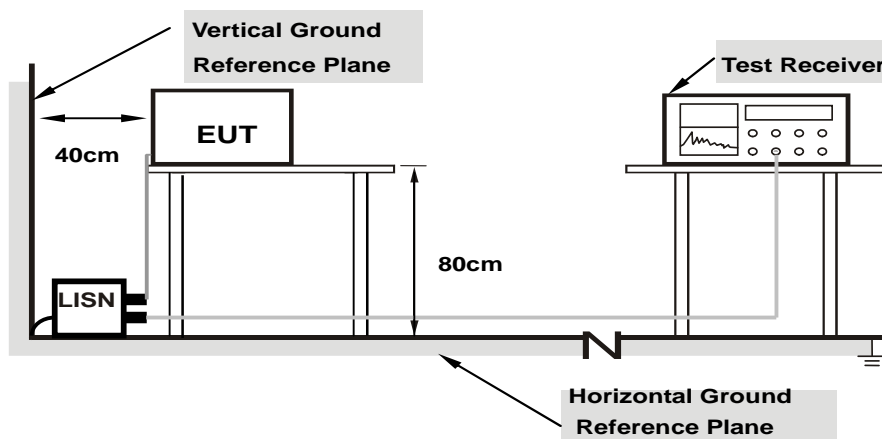

Note: 1.Support units were connected to second LISN.

For the actual test configuration, please refer to the attached file (Test Setup Photo).

4.2.6 EUT Operating Condition

Same as 4.1.6.

4.2.7 Test Results (Mode 1)

Phase	Line (L)	Detector Function	Quasi-Peak (QP) / Average (AV)
-------	----------	-------------------	--------------------------------

No	Freq. [MHz]	Corr.	Reading Value		Emission Level		Limit		Margin	
		Factor	[dB (uV)]		[dB (uV)]		[dB (uV)]		(dB)	
	(dB)	Q.P.	AV.	Q.P.	AV.	Q.P.	AV.	Q.P.	AV.	
1	0.20469	0.09	46.25	40.33	46.34	40.42	63.42	53.42	-17.08	-13.00
2	0.30625	0.10	41.98	38.99	42.08	39.09	60.07	50.07	-18.00	-10.99
3	0.71250	0.12	43.26	38.51	43.38	38.63	56.00	46.00	-12.62	-7.37
4	2.24219	0.18	38.55	33.69	38.73	33.87	56.00	46.00	-17.27	-12.13
5	2.85938	0.19	40.29	32.74	40.48	32.93	56.00	46.00	-15.52	-13.07
6	16.82031	0.62	34.52	31.21	35.14	31.83	60.00	50.00	-24.86	-18.17

REMARKS:

1. Q.P. and AV. are abbreviations of quasi-peak and average individually.
2. The emission levels of other frequencies were very low against the limit.
3. Margin value = Emission level - Limit value
4. Correction factor = Insertion loss + Cable loss
5. Emission Level = Correction Factor + Reading Value.

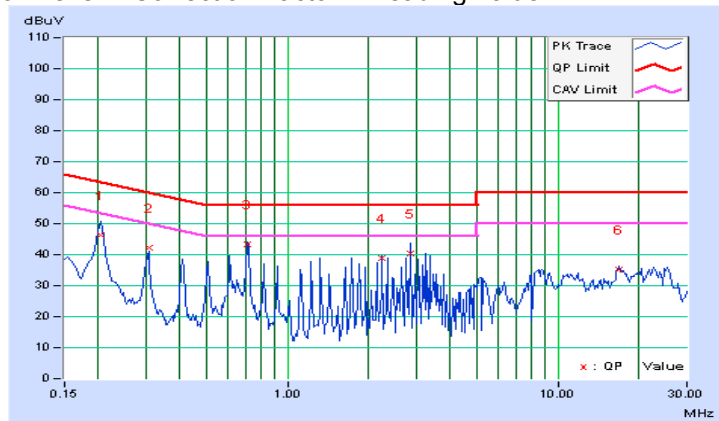

Phase	Neutral (N)	Detector Function	Quasi-Peak (QP) / Average (AV)
-------	-------------	-------------------	--------------------------------

No	Freq. [MHz]	Corr.	Reading Value		Emission Level		Limit		Margin	
		Factor	[dB (uV)]		[dB (uV)]		[dB (uV)]		(dB)	
		(dB)	Q.P.	AV.	Q.P.	AV.	Q.P.	AV.	Q.P.	AV.
1	0.20469	0.08	48.52	40.39	48.60	40.47	63.42	53.42	-14.82	-12.95
2	0.30625	0.09	40.78	35.49	40.87	35.58	60.07	50.07	-19.20	-14.49
3	0.71250	0.12	40.66	38.28	40.78	38.40	56.00	46.00	-15.22	-7.60
4	2.85547	0.20	40.37	30.85	40.57	31.05	56.00	46.00	-15.43	-14.95
5	3.16016	0.20	39.26	31.27	39.46	31.47	56.00	46.00	-16.54	-14.53
6	22.73297	0.81	35.22	30.46	36.03	31.27	60.00	50.00	-23.97	-18.73

REMARKS:

1. Q.P. and AV. are abbreviations of quasi-peak and average individually.
2. The emission levels of other frequencies were very low against the limit.
3. Margin value = Emission level - Limit value
4. Correction factor = Insertion loss + Cable loss
5. Emission Level = Correction Factor + Reading Value.

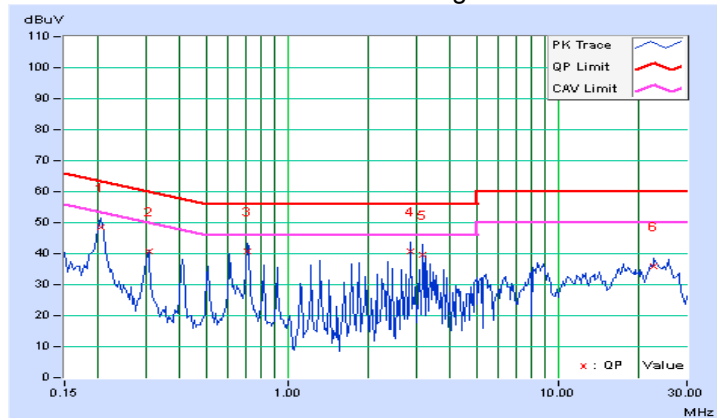

4.2.8 Test Results (Mode 2)

Phase	Line (L)	Detector Function	Quasi-Peak (QP) / Average (AV)
-------	----------	-------------------	--------------------------------

No	Freq. [MHz]	Corr.	Reading Value		Emission Level		Limit		Margin	
		Factor	[dB (uV)]		[dB (uV)]		[dB (uV)]		(dB)	
	(dB)	Q.P.	AV.	Q.P.	AV.	Q.P.	AV.	Q.P.	AV.	
1	0.20469	0.09	48.40	41.82	48.49	41.91	63.42	53.42	-14.93	-11.51
2	0.71250	0.12	42.33	41.19	42.45	41.31	56.00	46.00	-13.55	-4.69
3	1.32422	0.14	37.35	35.94	37.49	36.08	56.00	46.00	-18.51	-9.92
4	1.73438	0.16	37.39	35.50	37.55	35.66	56.00	46.00	-18.45	-10.34
5	2.24219	0.18	37.36	34.78	37.54	34.96	56.00	46.00	-18.46	-11.04
6	2.85462	0.19	38.46	31.38	38.65	31.57	56.00	46.00	-17.35	-14.43

REMARKS:

1. Q.P. and AV. are abbreviations of quasi-peak and average individually.
2. The emission levels of other frequencies were very low against the limit.
3. Margin value = Emission level - Limit value
4. Correction factor = Insertion loss + Cable loss
5. Emission Level = Correction Factor + Reading Value.

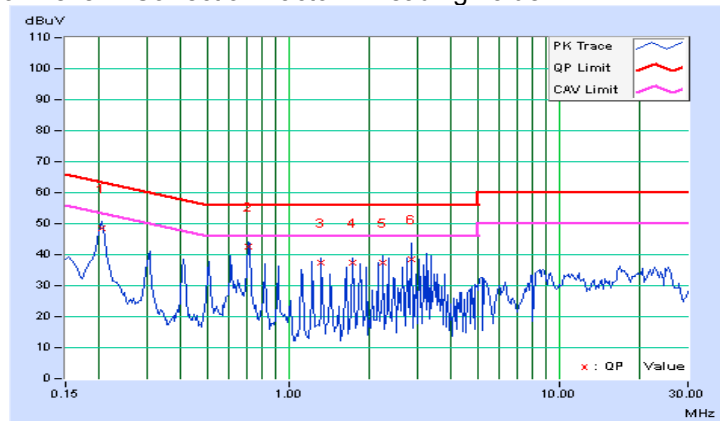

Phase	Neutral (N)	Detector Function	Quasi-Peak (QP) / Average (AV)
-------	-------------	-------------------	--------------------------------

No	Freq. [MHz]	Corr. Factor (dB)	Reading Value		Emission Level		Limit		Margin	
			[dB (uV)]		[dB (uV)]		[dB (uV)]		(dB)	
			Q.P.	AV.	Q.P.	AV.	Q.P.	AV.	Q.P.	AV.
1	0.20469	0.08	49.38	41.86	49.46	41.94	63.42	53.42	-13.96	-11.48
2	0.61094	0.11	37.71	36.34	37.82	36.45	56.00	46.00	-18.18	-9.55
3	0.71250	0.12	41.46	40.68	41.58	40.80	56.00	46.00	-14.42	-5.20
4	2.85547	0.20	38.24	29.91	38.44	30.11	56.00	46.00	-17.56	-15.89
5	3.16016	0.20	37.81	30.23	38.01	30.43	56.00	46.00	-17.99	-15.57
6	22.73297	0.81	34.39	29.51	35.20	30.32	60.00	50.00	-24.80	-19.68

REMARKS:

1. Q.P. and AV. are abbreviations of quasi-peak and average individually.
2. The emission levels of other frequencies were very low against the limit.
3. Margin value = Emission level - Limit value
4. Correction factor = Insertion loss + Cable loss
5. Emission Level = Correction Factor + Reading Value.

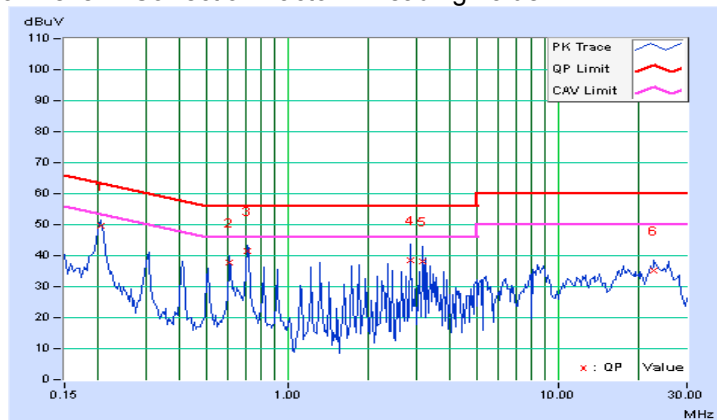

4.3 Transmit Power Measurement

4.3.1 Limits of Transmit Power Measurement

Operation Band	EUT Category		LIMIT
U-NII-1		Outdoor Access Point	1 Watt (30 dBm) (Max. e.i.r.p \leq 125mW(21 dBm) at any elevation angle above 30 degrees as measured from the horizon)
		Fixed point-to-point Access Point	1 Watt (30 dBm)
		Indoor Access Point	1 Watt (30 dBm)
	√	Mobile and Portable client device	250mW (24 dBm)
U-NII-2A	---		250mW (24 dBm) or 11 dBm+10 log B*
U-NII-2C	---		250mW (24 dBm) or 11 dBm+10 log B*
U-NII-3	√		1 Watt (30 dBm)

*B is the 26 dB emission bandwidth in megahertz

4.3.2 Test Setup

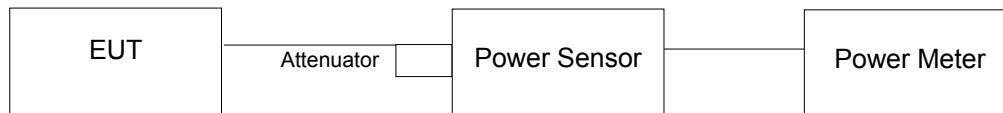

4.3.3 Test Instruments

Refer to section 4.1.2 to get information of above instrument.

4.3.4 Test Procedure

Method PM is used to perform output power measurement, trigger and gating function of wide band power meter is enabled to measure max output power of TX on burst. Duty factor is not added to measured value.

4.3.5 Deviation from Test Standard

No deviation.

4.3.6 EUT Operating Condition

The software provided by client to enable the EUT under transmission condition continuously at lowest, middle and highest channel frequencies individually.

4.3.7 Test Result

POWER OUTPUT:

802.11a

CHANNEL	CHANNEL FREQUENCY (MHz)	MAXIMUM CONDUCTED POWER (mW)	MAXIMUM CONDUCTED POWER (dBm)	POWER LIMIT (dBm)	PASS/FAIL
36	5180	65.917	18.19	24	PASS
40	5200	70.146	18.46	24	PASS
48	5240	64.565	18.10	24	PASS
149	5745	15.959	12.03	30	PASS
157	5785	65.464	18.16	30	PASS
165	5825	66.222	18.21	30	PASS

※Add test for each data rate output power (require by manufacturer):

802.11a

CHANNEL	FREQUENCY (MHz)	AVERAGE POWER (dBm)							
		Data rate							
		6Mbps	9Mbps	12Mbps	18Mbps	24Mbps	36Mbps	48Mbps	54Mbps
36	5180	18.19	18.05	18.11	18.07	18.02	18.04	18.00	18.16
40	5200	18.46	18.32	18.35	18.36	18.33	18.45	18.37	18.41
48	5240	18.10	18.06	17.99	18.07	17.97	17.91	17.95	18.07
149	5745	12.03	11.97	11.86	11.94	11.92	11.92	11.95	11.93
157	5785	18.16	17.98	18.00	18.15	17.99	17.96	18.03	18.14
165	5825	18.21	18.14	18.02	18.05	18.08	18.12	18.18	18.11

802.11n (HT20)

CHANNEL	CHANNEL FREQUENCY (MHz)	MAXIMUM CONDUCTED POWER (mW)	MAXIMUM CONDUCTED POWER (dBm)	POWER LIMIT (dBm)	PASS/FAIL
36	5180	66.069	18.20	24	PASS
40	5200	73.451	18.66	24	PASS
48	5240	65.615	18.17	24	PASS
149	5745	13.677	11.36	30	PASS
157	5785	58.345	17.66	30	PASS
165	5825	56.885	17.55	30	PASS

※Add test for each data rate output power (require by manufacturer):

802.11a

CHANNEL	FREQUENCY (MHz)	AVERAGE POWER (dBm)							
		Data rate							
		MCS0	MCS1	MCS2	MCS3	MCS4	MCS5	MCS6	MCS7
36	5180	18.20	18.12	18.02	18.06	18.04	18.12	18.09	18.05
40	5200	18.66	18.60	18.47	18.63	18.59	18.57	18.54	18.52
48	5240	18.17	18.06	18.11	18.00	18.02	18.02	18.01	18.05
149	5745	11.36	11.24	11.25	11.22	11.32	11.25	11.31	11.17
157	5785	17.66	17.65	17.61	17.60	17.62	17.53	17.61	17.49
165	5825	17.55	17.47	17.43	17.38	17.44	17.48	17.48	17.52

4.4 Peak Power Spectral Density Measurement

4.4.1 Limits of Peak Power Spectral Density Measurement

Operation Band	EUT Category		LIMIT
U-NII-1		Outdoor Access Point	17dBm/ MHz
		Fixed point-to-point Access Point	
		Indoor Access Point	
	√	Mobile and Portable client device	11dBm/ MHz
U-NII-2A	---		11dBm/ MHz
U-NII-2C	---		11dBm/ MHz
U-NII-3	√		30dBm/ 500kHz

4.4.2 Test Setup

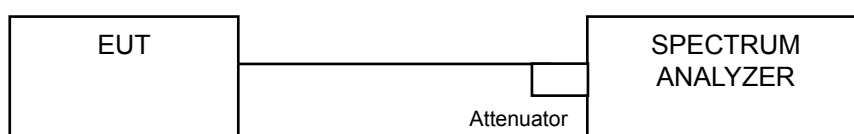

4.4.3 Test Instruments

Refer to section 4.1.2 to get information of above instrument.

4.4.4 Test Procedure

Using method SA-1

※For U-NII-1:

1. Set span to encompass the entire emission bandwidth (EBW) of the signal.
2. Set RBW = 1 MHz, Set VBW ≥ 3 MHz, Detector = RMS
3. Sweep time = auto, trigger set to "free run".
4. Trace average at least 100 traces in power averaging mode.
5. Record the max value

※For U-NII-3:

1. Set span to encompass the entire emission bandwidth (EBW) of the signal.
2. Set RBW = 300 kHz, Set VBW ≥ 1 MHz, Detector = RMS
3. Use the peak marker function to determine the maximum power level in any 300 kHz band segment within the fundamental EBW.
4. Scale the observed power level to an equivalent value in 500 kHz by adjusting (reducing) the measured power by a bandwidth correction factor (BWCF) where $BWCF = 10\log(500\text{ kHz}/300\text{ kHz})$
5. Sweep time = auto, trigger set to "free run".
6. Trace average at least 100 traces in power averaging mode.
7. Record the max value

4.4.5 Deviation from Test Standard

No deviation.

4.4.6 EUT Operating Condition

Same as Item 4.3.6.

4.4.7 Test Results

For U-NII-1
802.11a

CHANNEL	FREQUENCY (MHz)	PSD (dBm)	MAXIMUM LIMIT (dBm)	PASS/FAIL
36	5180	6.29	11	PASS
40	5200	6.54	11	PASS
48	5240	6.53	11	PASS

802.11n (HT20)

CHANNEL	FREQUENCY (MHz)	PSD (dBm)	MAXIMUM LIMIT (dBm)	PASS/FAIL
36	5180	5.79	11	PASS
40	5200	5.84	11	PASS
48	5240	5.94	11	PASS

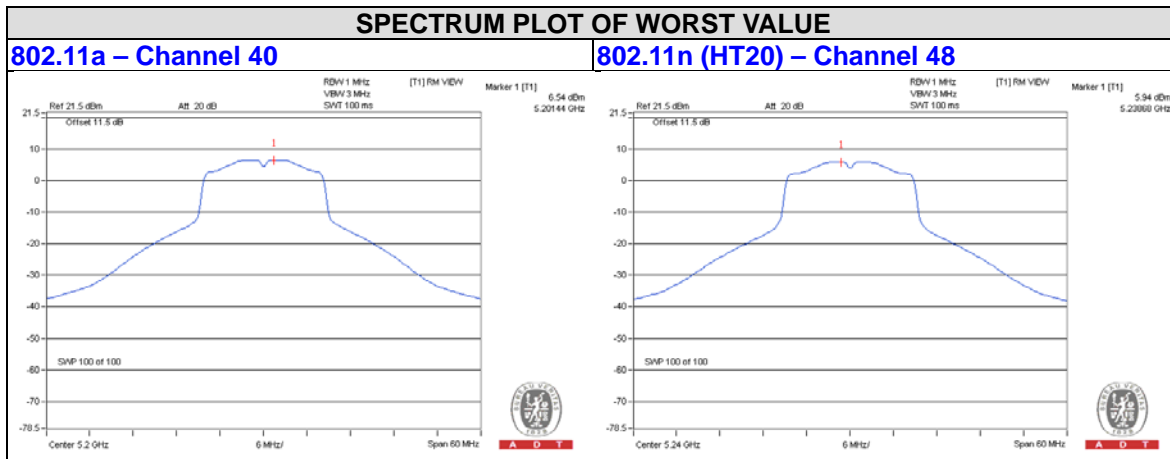

For U-NII-3 Band

802.11a

Chan.	Chan. Freq. (MHz)	PSD (dBm/300kHz)	PSD (dBm/500kHz)	Limit (dBm/500kHz)	Pass /Fail
149	5745	-9.51	-7.29	30	Pass
157	5785	-3.35	-1.13	30	Pass
165	5825	-3.51	-1.29	30	Pass

802.11n (HT20)

Chan.	Chan. Freq. (MHz)	PSD (dBm/300kHz)	PSD (dBm/500kHz)	Limit (dBm/500kHz)	Pass /Fail
149	5745	-10.57	-8.35	30	Pass
157	5785	-4.45	-2.23	30	Pass
165	5825	-4.43	-2.21	30	Pass

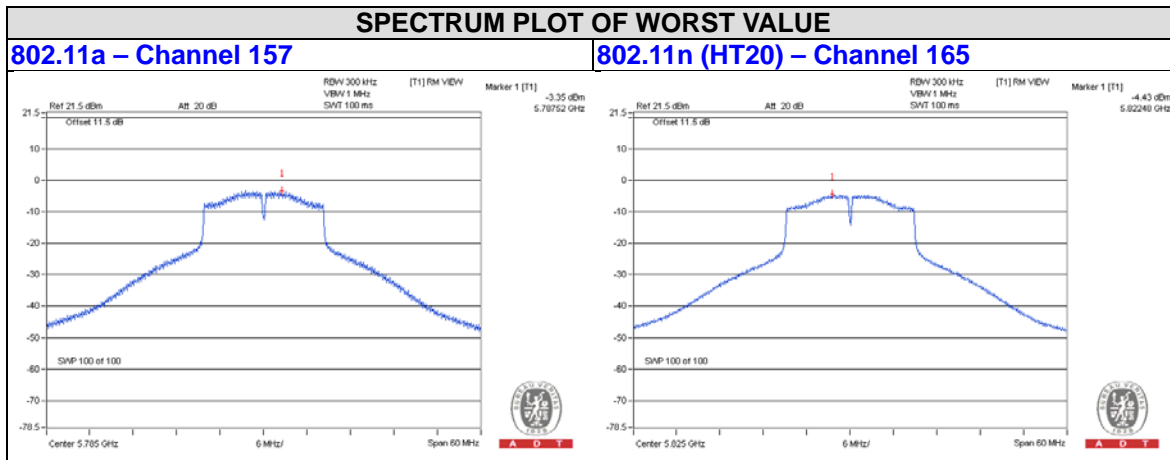

4.5 Frequency Stability Measurement

4.5.1 Limits of Frequency Stability Measurement

The frequency of the carrier signal shall be maintained within band of operation

4.5.2 Test Setup

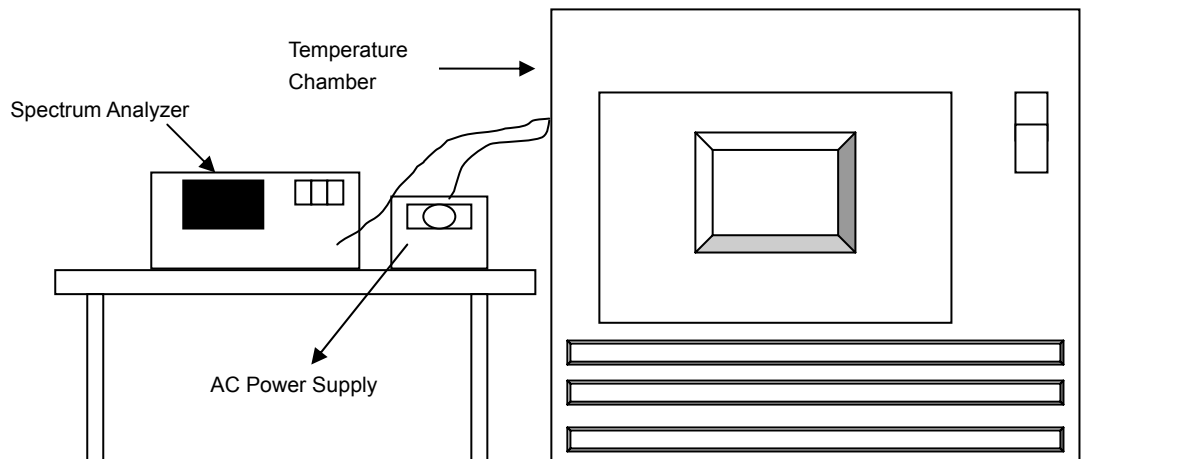

4.5.3 Test Instruments

Refer to section 4.1.2 to get information of above instrument.

4.5.4 Test Procedure

- The EUT was placed inside the environmental test chamber and powered by nominal AC voltage.
- Turn the EUT on and couple its output to a spectrum analyzer.
- Turn the EUT off and set the chamber to the highest temperature specified.
- Allow sufficient time (approximately 30 min) for the temperature of the chamber to stabilize, turn the EUT on and measure the operating frequency after 2, 5, and 10 minutes.
- Repeat step 2 and 3 with the temperature chamber set to the lowest temperature.
- The test chamber was allowed to stabilize at +20 degree C for a minimum of 30 minutes. The supply voltage was then adjusted on the EUT from 85% to 115% and the frequency record.

4.5.5 Deviation from Test Standard

No deviation.

4.5.6 EUT Operating Condition

Set the EUT transmit at un-modulation mode to test frequency stability.

4.5.7 Test Results

FREQUENCY STABILITY VERSUS TEMP.									
OPERATING FREQUENCY: 5180MHz									
TEMP. (°C)	POWER SUPPLY (Vac)	0 MINUTE		2 MINUTE		5 MINUTE		10 MINUTE	
		Measured Frequency (MHz)	Frequency Drift (%)	Measured Frequency (MHz)	Frequency Drift (%)	Measured Frequency (MHz)	Frequency Drift (%)	Measured Frequency (MHz)	Frequency Drift (%)
50	120	5180.003	0.00006	5180.0023	0.00004	5180	0.00000	5180.0028	0.00005
40	120	5179.9884	-0.00022	5179.9906	-0.00018	5179.991	-0.00017	5179.9891	-0.00021
30	120	5179.9886	-0.00022	5179.9889	-0.00021	5179.9885	-0.00022	5179.9894	-0.00020
20	120	5179.9756	-0.00047	5179.9779	-0.00043	5179.9761	-0.00046	5179.9732	-0.00052
10	120	5179.981	-0.00037	5179.9832	-0.00032	5179.9804	-0.00038	5179.9814	-0.00036
0	120	5180.0234	0.00045	5180.0259	0.00050	5180.0224	0.00043	5180.0261	0.00050
-10	120	5180.0161	0.00031	5180.0171	0.00033	5180.0167	0.00032	5180.0161	0.00031
-20	120	5179.9971	-0.00006	5179.9968	-0.00006	5179.9962	-0.00007	5179.9947	-0.00010
-30	120	5180.0047	0.00009	5180.0018	0.00003	5180.0036	0.00007	5180.0016	0.00003

FREQUENCY STABILITY VERSUS VOLTAGE									
OPERATING FREQUENCY: 5180MHz									
TEMP. (°C)	POWER SUPPLY (Vac)	0 MINUTE		2 MINUTE		5 MINUTE		10 MINUTE	
		Measured Frequency (MHz)	Frequency Drift (%)	Measured Frequency (MHz)	Frequency Drift (%)	Measured Frequency (MHz)	Frequency Drift (%)	Measured Frequency (MHz)	Frequency Drift (%)
20	138	5179.9752	-0.00048	5179.9771	-0.00044	5179.9771	-0.00044	5179.9739	-0.00050
	120	5179.9756	-0.00047	5179.9779	-0.00043	5179.9761	-0.00046	5179.9732	-0.00052
	102	5179.9765	-0.00045	5179.9772	-0.00044	5179.9764	-0.00046	5179.9731	-0.00052

4.6 6dB Bandwidth Measurement

4.6.1 Limits of 6dB Bandwidth Measurement

The minimum of 6dB Bandwidth Measurement is 0.5MHz.

4.6.2 Test Setup



4.6.3 Test Instruments

Refer to section 4.1.2 to get information of above instrument.

4.6.4 Test Procedure

MEASUREMENT PROCEDURE REF

- a. Set resolution bandwidth (RBW) = 100kHz
- b. Set the video bandwidth (VBW) $\geq 3 \times$ RBW, Detector = Peak.
- c. Trace mode = max hold.
- d. Sweep = auto couple.
- e. Measure the maximum width of the emission that is constrained by the frequencies associated with the two amplitude points (upper and lower) that are attenuated by 6 dB relative to the maximum level measured in the fundamental emission

4.6.5 Deviation from Test Standard

No deviation.

4.6.6 EUT Operating Condition

The software provided by client to enable the EUT under transmission condition continuously at lowest, middle and highest channel frequencies individually.

4.6.7 Test Results

802.11a

CHANNEL	FREQUENCY (MHZ)	6dB BANDWIDTH (MHZ)	MINIMUM LIMIT (MHZ)	PASS / FAIL
149	5745	15.15	0.5	PASS
157	5785	15.20	0.5	PASS
165	5825	15.19	0.5	PASS

802.11n (HT20)

CHANNEL	FREQUENCY (MHZ)	6dB BANDWIDTH (MHZ)	MINIMUM LIMIT (MHZ)	PASS / FAIL
149	5745	15.18	0.5	PASS
157	5785	15.19	0.5	PASS
165	5825	15.19	0.5	PASS

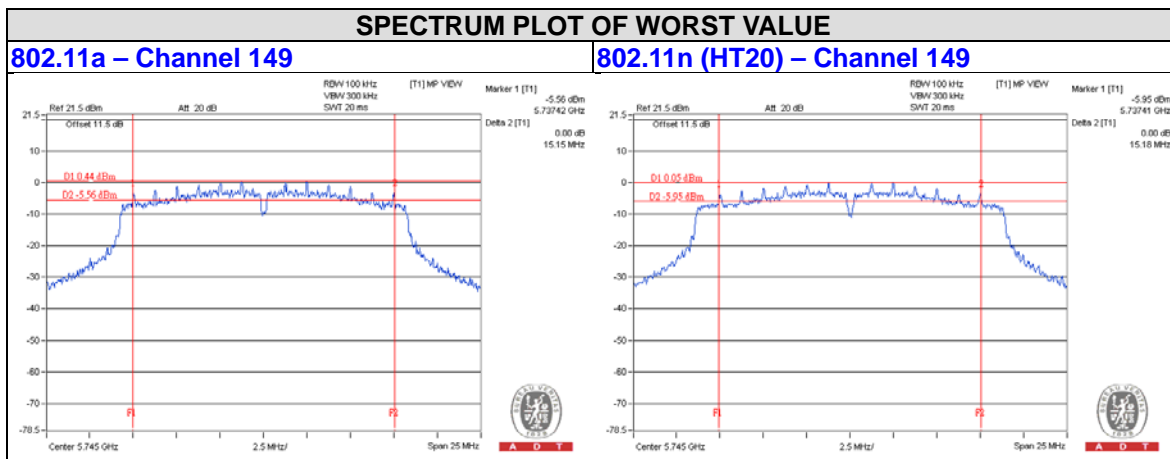

5 Pictures of Test Arrangements

Please refer to the attached file (Test Setup Photo).



Appendix – Information on the Testing Laboratories

We, Bureau Veritas Consumer Products Services (H.K.) Ltd., Taoyuan Branch, were founded in 1988 to provide our best service in EMC, Radio, Telecom and Safety consultation. Our laboratories are accredited and approved according to ISO/IEC 17025.

If you have any comments, please feel free to contact us at the following:

Linko EMC/RF Lab

Tel: 886-2-26052180

Fax: 886-2-26051924

Hsin Chu EMC/RF Lab/Telecom Lab

Tel: 886-3-5935343

Fax: 886-3-5935342

Hwa Ya EMC/RF/Safety

Tel: 886-3-3183232

Fax: 886-3-3270892

Email: service.adt@tw.bureauveritas.com

Web Site: www.bureauveritas-adt.com

The address and road map of all our labs can be found in our web site also.

--- END ---