



TABLE OF CONTENTS

REVISION HISTORY... 3
SUMMARY OF TEST RESULT ... 4
1 GENERAL DESCRIPTION ... 5
1.1 Feature of Equipment Under Test ... 5
1.3 Maximum ERP Power, and Emission Designator ... 6
1.4 Testing Site ... 6
1.5 Test Software ... 7
1.6 Applied Standards ... 7
2 TEST CONFIGURATION OF EQUIPMENT UNDER TEST ... 8
2.1 Test Mode ... 8
2.2 Connection Diagram of Test System ... 9
2.3 Support Unit used in test configuration and system ... 9
2.4 Measurement Results Explanation Example ... 9
2.5 Frequency List of Low/Middle/High Channels ... 10
3 CONDUCTED TEST ITEMS ... 11
3.1 Measuring Instruments ... 11
3.2 Conducted Output Power and ERP ... 12
3.3 Peak-to-Average Ratio ... 13
3.4 Occupied Bandwidth ... 14
3.5 Conducted Band Edge Measurement ... 15
3.6 Emission Mask ... 16
3.7 Conducted Spurious Emission Measurement ... 17
3.8 Frequency Stability Measurement ... 18
4 RADIATED TEST ITEMS ... 19
4.1 Measuring Instruments ... 19
4.2 Test Setup ... 19
4.3 Test Result of Radiated Test ... 20
4.4 Radiated Spurious Emission Measurement ... 21
5 LIST OF MEASURING EQUIPMENT ... 22
6 UNCERTAINTY OF EVALUATION ... 23
APPENDIX A. TEST RESULTS OF CONDUCTED TEST
APPENDIX B. TEST RESULTS OF RADIATED TEST
APPENDIX C. TEST SETUP PHOTOGRAPHS

SUMMARY OF TEST RESULT

Report Section	FCC Rule	Description	Limit	Result	Remark
3.2	§2.1046	Conducted Output Power	—	Reporting only	-
	§90.542 (a)(7)	Effective Radiated Power	ERP < 3Watt	PASS	-
3.3	-	Peak-to-Average Ratio	—	Reporting only	-
3.4	§2.1049	Occupied Bandwidth	—	Reporting only	-
3.5	§2.1053	Conducted Band Edge Measurement	Refer standard	PASS	-
	§90.543 (e)(2)(3)				
3.6	§2.1051	Emission Mask	Mask B	PASS	-
	§90.210(n)				
3.7	§2.1053	Conducted Spurious Emission	< 43+10log ₁₀ (P[Watts])	PASS	-
	§90.543 (e)(3)				
3.8	§2.1055	Frequency Stability Temperature & Voltage	< ±1.25 ppm	PASS	-
	§90.539 (e)				
4.4	§2.1053 §90.543 (e)(3) §90.543 (f)	Radiated Spurious Emission	< 43+10log ₁₀ (P[Watts])	PASS	Under limit 24.13 dB at 1584.000 MHz

Declaration of Conformity:

The test results with all measurement uncertainty excluded are presented in accordance with the regulation limits or requirements declared by manufacturers.

Comments and Explanations:

The declared of product specification for EUT presented in the report are provided by the manufacturer, and the manufacturer takes all the responsibilities for the accuracy of product specification.

1 General Description

1.1 Feature of Equipment Under Test

Product Feature	
Equipment	Touch Computer
Brand Name	Zebra
Model Name	WCMTA
FCC ID	UZ7WCMTA
Sample 1	Scanner(SE4710)
Sample 2	Scanner(SE5500)
HW Version	DV
SW Version	13-09-09.00-TG-U00-PRD-ATH-04
MFD	09MAR23
EUT Stage	Identical Prototype

Remark:

1. The above EUT's information was declared by manufacturer. Please refer to the specifications or user's manual for more detailed description.
2. There are two types of EUT: the main differences between them are the scanner and memory. According to the difference, we choose the Sample 1 to perform full test, and verify the worst RSE for Sample 2.

Specification of Accessory				
Battery 1	Brand Name	Zebra	Model Number	BT-000473

Supported Unit used in test configuration and system				
Battery 2	Brand Name	Zebra	Model Number	BT-000473B
Battery 3	Brand Name	Zebra	Model Number	BT-000473E
AC Adapter	Brand Name	Zebra	Part Number	PWR-WUA5V12W0US
Earphone 1	Brand Name	Zebra	Part Number	HDST-35MM-PTT1-01
Earphone 2	Brand Name	Zebra	Part Number	HDST-USBC-PTT1-01
USB Cable (Type C to Type A)	Brand Name	Zebra	Part Number	CBL-TC5X-USBC2A-01
Type C-Audio Cable (Type C to 3.5mm)	Brand Name	Zebra	Part Number	ADP-USBC-35MM1-01
Trigger Handle	Brand Name	Zebra	Part Number	TRG-TC2L-SNP1-01
Hand Strap	Brand Name	Zebra	Part Number	SG-TC2L-HSTRP1-01
Soft Holster	Brand Name	Zebra	Part Number	SG-TC2L-HLSTR1-01

1.2 Product Specification of Equipment Under Test

Product Feature	
Tx Frequency	5G NR n14 : 788 MHz ~ 798 MHz
Rx Frequency	5G NR n14 : 758 MHz ~ 768 MHz
Bandwidth	5MHz / 10MHz
SCS	15kHz
Antenna Gain	Ant.0: -2.5 dBi
Type of Modulation	DFT-s-OFDM (PI/2 BPSK / QPSK / 16QAM / 64QAM / 256QAM) CP-OFDM (QPSK / 16QAM / 64QAM / 256QAM)

Remark: 5G NR n14 only support SA mode.

1.3 Maximum ERP Power, and Emission Designator

5G NR n14		PI/2 BPSK/QPSK		16QAM/64QAM/256QAM	
BW (MHz)	Frequency Range (MHz)	Maximum ERP(W)	Emission Designator (99%OBW)	Maximum ERP(W)	Emission Designator (99%OBW)
5	790.5~795.5	0.0679	4M47G7D	0.0579	4M49W7D
10	793	0.0703	9M26G7D	0.0703	9M27W7D

1.4 Testing Site

Sporton International Inc. (Kunshan) is accredited to ISO/IEC 17025:2017 by American Association for Laboratory Accreditation with Certificate Number 5145.02.

Test Firm	Sporton International Inc. (Kunshan)		
Test Site Location	No. 1098, Pengxi North Road, Kunshan Economic Development Zone Jiangsu Province 215300 People's Republic of China TEL : +86-512-57900158		
Test Site No.	Sporton Site No.	FCC Designation No.	FCC Test Firm Registration No.
	03CH04-KS TH01-KS	CN1257	314309

1.5 Test Software

Item	Site	Manufacturer	Name	Version
1.	03CH04-KS	AUDIX	E3	6.2009-8-24al

1.6 Applied Standards

According to the specifications of the manufacturer, the EUT must comply with the requirements of the following standards:

- ♦ 47 CFR Part 2, Part 90(R)
- ♦ ANSI C63.26
- ♦ KDB 971168 D01 Power Meas License Digital Systems v03r01
- ♦ KDB 412172 D01 Determining ERP and EIRP v01r01

Remark:

1. All test items were verified and recorded according to the standards and without any deviation during the test.
2. This EUT has also been tested and complied with the requirements of FCC Part 15, Subpart B, recorded in a separate test report.

2 Test Configuration of Equipment Under Test

2.1 Test Mode

Antenna port conducted and radiated test items listed below are performed according to KDB 971168 D01 Power Meas License Digital Systems v03r01 with maximum output power.

Radiated measurements are performed by rotating the EUT in three different orthogonal test planes to find the maximum emission.

Conducted Test Cases	Band	Bandwidth (MHz)						Modulation					RB #			Test Channel		
		1.4	3	5	10	15	20	PI/2 BPSK	QPSK	16QAM	64QAM	256QAM	1	Half	Full	L	M	H
Max. Output Power	n14	-	-	V		-	-	V	V	V	V	V	V		V	V	V	V
	n14	-	-		V	-	-	V	V	V	V	V		V			V	
Peak-to-Average Ratio	n14	-	-		V	-	-	V	V				V		V		V	
26dB and 99% Bandwidth	n14	-	-	V	V	-	-	V	V	V	V	V			V		V	
Conducted Band Edge	n14	-	-	V		-	-	V	V				V		V	V		V
	n14	-	-		V	-	-	V	V				V		V		V	
Emission Mask	n14	-	-	V		-	-	V	V				V		V	V	V	V
	n14	-	-		V	-	-	V	V				V		V		V	
Conducted Spurious Emission	n14	-	-	V		-	-	V	V				V			V	V	V
	n14	-	-		V	-	-	V	V				V				V	
Frequency Stability	n14	-	-	V	V	-	-		V						V		V	
E.R.P	n14	-	-	V		-	-	V	V	V	V	V	V		V	V	V	V
	n14	-	-		V	-	-	V	V	V	V	V	V		V		V	
Radiated Spurious Emission	n14	Worst Case													V	V	V	
Note	<ol style="list-style-type: none"> The mark "v" means that this configuration is chosen for testing The mark "-" means that this bandwidth is not supported. The device is investigated from 30MHz to 10 times of fundamental signal for radiated spurious emission test under different RB size/offset and modulations in exploratory test. Subsequently, only the worst case emissions are reported. Frequency Stability : Normal Voltage = 3.85V ; Low Voltage =3.45V. ; High Voltage =4.41V 																	

2.2 Connection Diagram of Test System

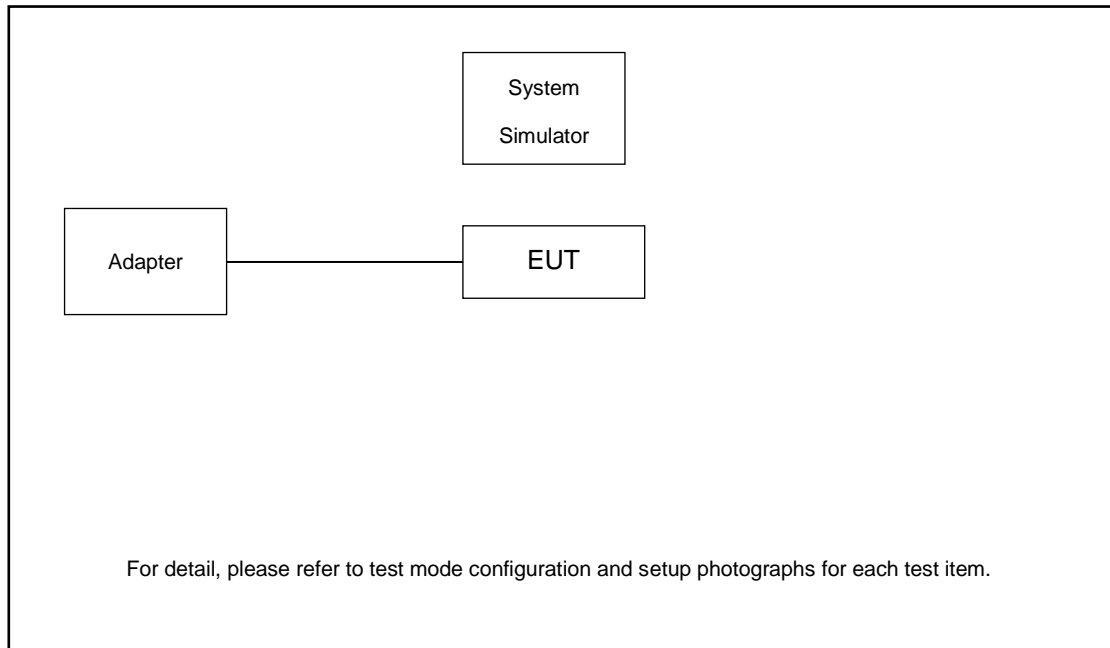

2.3 Support Unit used in test configuration and system

Item	Equipment	Trade Name	Model No.	FCC ID	Data Cable	Power Cord
1.	DC Power Supply	GW	GPS-3030D	N/A	N/A	Unshielded, 1.8 m
2.	Base Station	Anritsu	MT8000A	N/A	N/A	Unshielded, 1.8m
3.	Base Station	Anritsu	MT8821C	N/A	N/A	Unshielded, 1.8m

2.4 Measurement Results Explanation Example

For all conducted test items:

The offset level is set in the spectrum analyzer to compensate the RF cable loss and attenuator factor between EUT conducted output port and spectrum analyzer. With the offset compensation, the spectrum analyzer reading level is exactly the EUT RF output level.

The spectrum analyzer offset is derived from RF cable loss and attenuator factor.

$$\text{Offset} = \text{RF cable loss} + \text{attenuator factor}.$$

Following shows an offset computation example with cable loss 6.5 dB and 20dB attenuator.

Example :

$$\text{Offset(dB)} = \text{RF cable loss(dB)} + \text{attenuator factor(dB)}.$$

$$= 6.5 + 20 = 26.5 \text{ (dB)}$$

2.5 Frequency List of Low/Middle/High Channels

5G NR n14 Channel and Frequency List				
BW [MHz]	Channel/Frequency(MHz)	Lowest	Middle	Highest
10	Channel	-	158600	-
	Frequency	-	793	-
5	Channel	158100	158600	159100
	Frequency	790.5	793	795.5

3 Conducted Test Items

3.1 Measuring Instruments

See list of measuring instruments of this test report.

3.1.1 Test Setup

3.1.2 Conducted Output Power

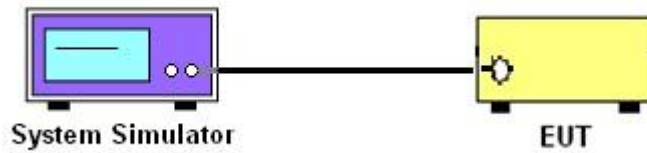

3.1.3 Peak-to-Average Ratio, Occupied Bandwidth, Conducted Band-Edge, Emission Mask, and Conducted Spurious Emission

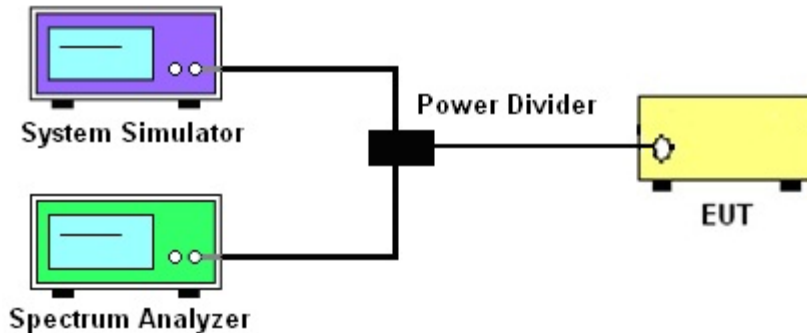

3.1.4 Frequency Stability

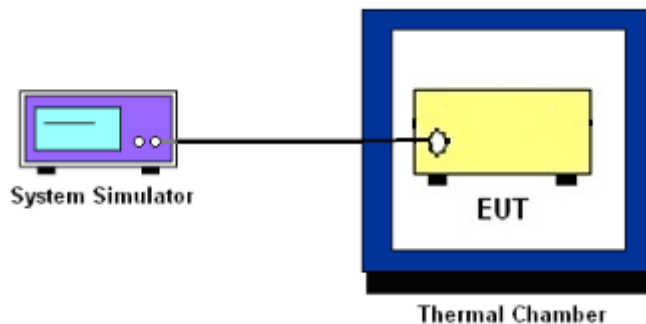

3.1.5 Test Result of Conducted Test

Please refer to Appendix A.

3.2 Conducted Output Power and ERP

3.2.1 Description of the Conducted Output Power Measurement and ERP

A base station simulator was used to establish communication with the EUT. Its parameters were set to transmit the maximum power on the EUT. The measured power in the radio frequency on the transmitter output terminals shall be reported.

The ERP of mobile transmitters must not exceed 3 Watts.

According to KDB 412172 D01 Power Approach,

$EIRP = P_T + G_T - L_C$, $ERP = EIRP - 2.15$, where

P_T = transmitter output power in dBm

G_T = gain of the transmitting antenna in dBi

L_C = signal attenuation in the connecting cable between the transmitter and antenna in dB

3.2.2 Test Procedures

1. The testing follows ANSI C63.26 Section 5.2
2. The transmitter output port was connected to the system simulator.
3. Set EUT at maximum power through the system simulator.
4. Select lowest, middle, and highest channels for each band and different modulation.
5. Measure and record the power level from the system simulator.

3.3 Peak-to-Average Ratio

3.3.1 Description of the PAR Measurement

Power Complementary Cumulative Distribution Function (CCDF) curves provide a means for characterizing the power peaks of a digitally modulated signal on a statistical basis. A CCDF curve depicts the probability of the peak signal amplitude exceeding the average power level. Most contemporary measurement instrumentation include the capability to produce CCDF curves for an input signal provided that the instrument's resolution bandwidth can be set wide enough to accommodate the entire input signal bandwidth. In measuring transmissions in this band using an average power technique, the peak-to-average ratio (PAR) of the transmission may not exceed 13 dB.

3.3.2 Test Procedures

1. The EUT was connected to spectrum and system simulator via a power divider.
2. Set the CCDF (Complementary Cumulative Distribution Function) option in spectrum analyzer.
3. The highest RF powers were measured and recorded the maximum PAPR level associated with a probability of 0.1 %.
4. Record the deviation as Peak to Average Ratio.

3.4 Occupied Bandwidth

3.4.1 Description of Occupied Bandwidth Measurement

The occupied bandwidth is the width of a frequency band such that, below the lower and above the upper frequency limits, the mean powers emitted are each equal to a specified percentage 0.5% of the total mean transmitted power.

The 26 dB emission bandwidth is defined as the frequency range between two points, one above and one below the carrier frequency, at which the spectral density of the emission is attenuated 26 dB below the maximum in-band spectral density of the modulated signal. Spectral density (power per unit bandwidth) is to be measured with a detector of resolution bandwidth equal to approximately 1.0% of the emission bandwidth.

3.4.2 Test Procedures

1. The testing follows ANSI C63.26 Section 5.4
2. The EUT was connected to spectrum analyzer and system simulator via a power divider.
3. The spectrum analyzer center frequency is set to the nominal EUT channel center frequency. The span range for the spectrum analyzer shall be between two and five times the anticipated OBW.
4. The nominal resolution bandwidth (RBW) shall be in the range of 1 to 5 % of the anticipated OBW, and the VBW shall be at least 3 times the RBW.
5. Set the detection mode to peak, and the trace mode to max hold.
6. Determine the reference value: Set the EUT to transmit a modulated signal. Allow the trace to stabilize. Set the spectrum analyzer marker to the highest level of the displayed trace.
(this is the reference value)
7. Determine the “-26 dB down amplitude” as equal to (Reference Value – X).
8. Place two markers, one at the lowest and the other at the highest frequency of the envelope of the spectral display such that each marker is at or slightly below the “-X dB down amplitude” determined in step 6. If a marker is below this “-X dB down amplitude” value it shall be placed as close as possible to this value. The OBW is the positive frequency difference between the two markers.
9. Use the 99 % power bandwidth function of the spectrum analyzer and report the measured bandwidth.

3.5 Conducted Band Edge Measurement

3.5.1 Description of Conducted Band Edge Measurement

For operations in the 758-768 MHz and the 788-798 MHz bands

- (1) On all frequencies between 769-775 MHz and 799-805 MHz, by a factor not less than $76 + 10 \log (P)$ dB in a 6.25 kHz band segment, for base and fixed stations.
- (2) On all frequencies between 769-775 MHz and 799-805 MHz, by a factor not less than $65 + 10 \log (P)$ dB in a 6.25 kHz band segment, for mobile and portable stations.
- (3) On any frequency between 775-788 MHz, above 805 MHz, and below 758 MHz, by at least $43 + 10 \log (P)$ dB.

3.5.2 Test Procedures

1. The testing follows ANSI C63.26 section 5.7
2. The EUT was connected to spectrum analyzer and system simulator via a power divider.
3. The band edges of low and high channels for the highest RF powers were measured.
4. Set spectrum analyzer with RMS detector.
5. The RF fundamental frequency should be excluded against the limit line in the operating frequency band.
6. Checked that all the results comply with the emission limit line.

Example:

$$\begin{aligned} & \text{The limit line is derived from } 43 + 10\log(P)\text{dB below the transmitter power } P(\text{Watts}) \\ & = P(\text{W}) - [43 + 10\log(P)] \text{ (dB)} \\ & = [30 + 10\log(P)] \text{ (dBm)} - [43 + 10\log(P)] \text{ (dB)} = -13\text{dBm}. \end{aligned}$$

3.6 Emission Mask

3.6.1 Description of Emission Mask

<Emission Mask B>.

For transmitters that are equipped with an audio low-pass filter, the power of any emission must be attenuated below the unmodulated carrier power (P) as follows:

- (1) On any frequency removed from the assigned frequency by more than 50 percent, but not more than 100 percent of the authorized bandwidth: At least 25 dB.
- (2) On any frequency removed from the assigned frequency by more than 100 percent, but not more than 250 percent of the authorized bandwidth: At least 35 dB.
- (3) On any frequency removed from the assigned frequency by more than 250 percent of the authorized bandwidth: At least $43 + 10 \log (P)$ dB.

3.6.2 Test Procedures

1. The testing follows ANSI C63.26 section 5.7
2. The EUT was connected to spectrum analyzer and system simulator via a power divider.
3. The RF output of EUT was connected to the spectrum analyzer by RF cable and attenuator. The path loss was compensated to the results for each measurement.
4. Make the measurement with the spectrum analyzer's RBW = 1MHz, VBW = 3MHz.
5. Set spectrum analyzer with RMS detector.
6. Taking the record of maximum spurious emission.
7. The RF fundamental frequency should be excluded against the limit line in the operating frequency band.
8. The limit line is derived from $43 + 10\log(P)$ dB below the transmitter power P(Watts)
= $P(W) - [43 + 10\log(P)]$ (dB)
= $[30 + 10\log(P)]$ (dBm) - $[43 + 10\log(P)]$ (dB)
= -13dBm.

3.7 Conducted Spurious Emission Measurement

3.7.1 Description of Conducted Spurious Emission Measurement

The power of any emission outside of the authorized operating frequency ranges must be lower than the transmitter power (P) by a factor of at least $43 + 10 \log (P)$ dB.

It is measured by means of a calibrated spectrum analyzer and scanned from 30MHz up to a frequency including its 10th harmonic.

3.7.2 Test Procedures

1. The testing follows ANSI C63.26 section 5.7
2. The EUT was connected to spectrum analyzer and base station via power divider.
3. The RF output of EUT was connected to the spectrum analyzer by RF cable and attenuator. The path loss was compensated to the results for each measurement.
4. The middle channel for the highest RF power within the transmitting frequency was measured.
5. The conducted spurious emission for the whole frequency range was taken.
6. Make the measurement with the spectrum analyzer's, for under 1GHz RBW = 100kHz, VBW = 300kHz and for above 1GHz RBW = 1MHz, VBW = 3MHz, taking the record of maximum spurious emission.
7. Set spectrum analyzer with RMS detector.
8. The RF fundamental frequency should be excluded against the limit line in the operating frequency band.
9. The limit line is derived from $43 + 10\log(P)$ dB below the transmitter power P(Watts)
= P(W)- [43 + 10log(P)] (dB)
= [30 + 10log(P)] (dBm) - [43 + 10log(P)] (dB)
= -13dBm.

3.8 Frequency Stability Measurement

3.8.1 Description of Frequency Stability Measurement

The frequency stability shall be measured by variation of ambient temperature and variation of primary supply voltage to ensure that the fundamental emission stays within the authorized frequency block. The frequency stability of the transmitter shall be maintained within ± 1.25 ppm of the center frequency.

3.8.2 Test Procedures for Temperature Variation

1. The testing follows ANSI C63.26 section 5.6.4
2. The EUT was set up in the thermal chamber and connected with the system simulator.
3. With power OFF, the temperature was decreased to -30°C and the EUT was stabilized before testing. Power was applied and the maximum change in frequency was recorded within one minute.
4. With power OFF, the temperature was raised in 10°C step up to 50°C . The EUT was stabilized at each step for at least half an hour. Power was applied and the maximum frequency change was recorded within one minute.

3.8.3 Test Procedures for Voltage Variation

1. The testing follows ANSI C63.26 section 5.6.5.
2. The EUT was placed in a temperature chamber at $20\pm 5^{\circ}\text{C}$ and connected with the system simulator.
3. The power supply voltage to the EUT was varied from 85% to 115% of the nominal value for other than hand carried battery equipment.
4. For hand carried, battery powered equipment, reduce the primary ac or dc supply voltage to the battery operating end point, which shall be specified by the manufacturer.
5. The variation in frequency was measured for the worst case.

4 Radiated Test Items

4.1 Measuring Instruments

See list of measuring instruments of this test report.

4.2 Test Setup

4.2.1 For radiated test below 30MHz



4.2.2 For radiated test from 30MHz to 1GHz

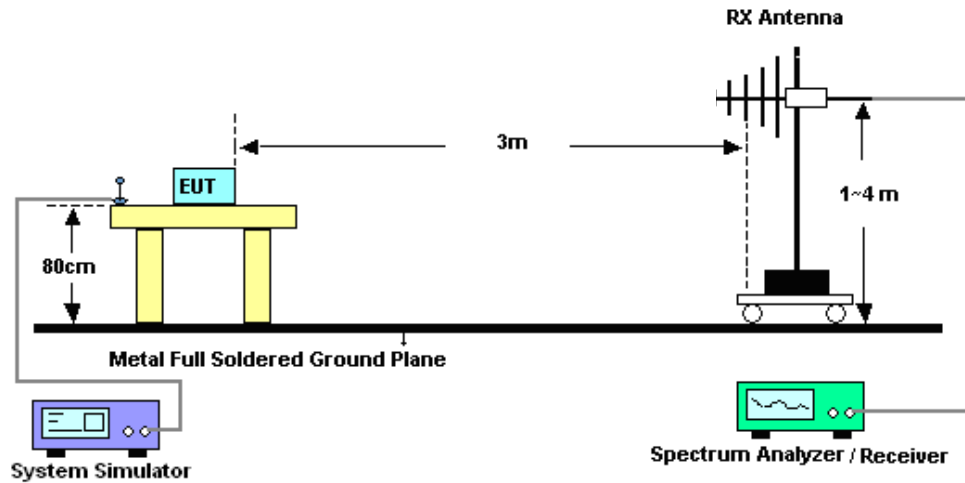

4.2.3 For radiated test above 1GHz



4.3 Test Result of Radiated Test

The low frequency, which started from 9 kHz to 30MHz, was pre-scanned and the result which was 20dB lower than the limit line was not reported.

Please refer to Appendix B.

4.4 Radiated Spurious Emission Measurement

4.4.1 Description of Radiated Spurious Emission

The radiated spurious emission was measured by substitution method according to ANSI C63.26.

The power of any emission outside of the authorized operating frequency ranges must be attenuated below the transmitter power (P) by a factor of at least $43 + 10 \log (P)$ dB.

For operations in the 758-775 MHz and 788-805 MHz bands, all emissions including harmonics in the band 1559–1610 MHz shall be limited to -70 dBW/MHz equivalent isotropically radiated power (EIRP) for wideband signals, and -80 dBW EIRP for discrete emissions of less than 700 Hz bandwidth. For the purpose of equipment authorization, a transmitter shall be tested with an antenna that is representative of the type that will be used with the equipment in normal operation.

4.4.2 Test Procedures

1. The testing follows ANSI C63.26 Section 5.5
2. The EUT was placed on a turntable with 0.8 meter height for frequency below 1GHz and 1.5 meter height for frequency above 1GHz respectively above ground.
3. The EUT was set 3 meters from the receiving antenna mounted on the antenna tower.
4. The table was rotated 360 degrees to determine the position of the highest spurious emission.
5. The height of the receiving antenna is varied between 1m to 4m to search the maximum spurious emission for both horizontal and vertical polarizations.
6. During the measurement, the system simulator parameters were set to force the EUT transmitting at maximum output power.
7. Make the measurement with the spectrum analyzer's RBW = 1MHz, VBW = 3MHz, taking the record of maximum spurious emission.
8. A horn antenna was substituted in place of the EUT and was driven by a signal generator.
9. Tune the output power of signal generator to the same emission level with EUT maximum spurious emission.
10. $EIRP \text{ (dBm)} = S.G. \text{ Power} - Tx \text{ Cable Loss} + Tx \text{ Antenna Gain}$
11. $ERP \text{ (dBm)} = EIRP - 2.15$
12. The RF fundamental frequency should be excluded against the limit line in the operating frequency band.

The limit line is derived from $43 + 10\log(P)$ dB below the transmitter power P(Watts)
 $= P(W) - [43 + 10\log(P)] \text{ (dB)}$
 $= [30 + 10\log(P)] \text{ (dBm)} - [43 + 10\log(P)] \text{ (dB)}$
 $= -13\text{dBm}.$



5 List of Measuring Equipment

Instrument	Manufacturer	Model No.	Serial No.	Characteristics	Calibration Date	Test Date	Due Date	Remark
Spectrum Analyzer	R&S	FSV40	101040	10Hz~40GHz	Oct. 12, 2022	Feb. 22, 2023~ Mar. 15, 2023	Oct. 11, 2023	Conducted (TH01-KS)
Power divider	STI	STI08-0055	-	0.5~40GHz	NCR	Feb. 22, 2023~ Mar. 15, 2023	NCR	Conducted (TH01-KS)
Temperature & humidity chamber	Hongzhan	LP-150U	H2014011440	-40~+150°C 20%~95%RH	Jul. 15, 2022	Feb. 22, 2023~ Mar. 15, 2023	Jul. 14, 2023	Conducted (TH01-KS)
EXA Spectrum Analyzer	Keysight	N9010B	MY57471079	10Hz-44G,MAX 30dB	Oct. 12, 2022	Mar. 01, 2023	Oct. 11, 2023	Radiation (03CH04-KS)
Loop Antenna	R&S	HFH2-Z2	100321	9kHz~30MHz	Oct. 16, 2022	Mar. 01, 2023	Oct. 15, 2023	Radiation (03CH04-KS)
Bilog Antenna	TeseQ	CBL6111D	49922	30MHz-1GHz	May 24, 2022	Mar. 01, 2023	May 23, 2023	Radiation (03CH04-KS)
Horn Antenna	Schwarzbeck	BBHA9120D	1284	1GHz~18GHz	Oct. 16, 2022	Mar. 01, 2023	Oct. 15, 2023	Radiation (03CH04-KS)
SHF-EHF Horn	Com-power	AH-840	101070	18GHz~40GHz	Jan. 08, 2023	Mar. 01, 2023	Jan. 07, 2024	Radiation (03CH04-KS)
Amplifier	SONOMA	310N	187289	9KHz-1GHz	May 24, 2022	Mar. 01, 2023	May 23, 2023	Radiation (03CH04-KS)
Amplifier	MITEQ	EM18G40G GA	060728	18~40GHz	Jan. 05, 2023	Mar. 01, 2023	Jan. 04, 2024	Radiation (03CH04-KS)
high gain Amplifier	EM	EM01G18G A	060840	1Ghz-18Ghz	Oct. 12, 2022	Mar. 01, 2023	Oct. 11, 2023	Radiation (03CH04-KS)
Amplifier	Agilent	8449B	3008A02370	1Ghz-18Ghz	Oct. 12, 2022	Mar. 01, 2023	Oct. 11, 2023	Radiation (03CH04-KS)
AC Power Source	Chroma	61601	F104090004	N/A	NCR	Mar. 01, 2023	NCR	Radiation (03CH04-KS)
Turn Table	ChamPro	EM 1000-T	060762-T	0~360 degree	NCR	Mar. 01, 2023	NCR	Radiation (03CH04-KS)
Antenna Mast	ChamPro	EM 1000-A	060762-A	1 m~4 m	NCR	Mar. 01, 2023	NCR	Radiation (03CH04-KS)

NCR: No Calibration Required

6 Uncertainty of Evaluation

The measurement uncertainties shown below were calculated in accordance with the requirements of ANSI 63.26-2015. All the measurement uncertainty value were shown with a coverage K=2 to indicate 95% level of confidence. The measurement data show herein meets or exceeds the CISPR measurement uncertainty values specified in CISPR 16-4-2 and can be compared directly to specified limit to determine compliance.

Uncertainty of Conducted Measurement

Test Item	Uncertainty
Conducted Power	±0.46 dB
Conducted Emissions	±0.48 dB
Occupied Channel Bandwidth	±0.1 %

Uncertainty of Radiated Emission Measurement (30 MHz ~ 1000 MHz)

Measuring Uncertainty for a Level of Confidence of 95% (U = 2Uc(y))	3.3dB
---	-------

Uncertainty of Radiated Emission Measurement (1GHz ~ 40GHz)

Measuring Uncertainty for a Level of Confidence of 95% (U = 2Uc(y))	2.8dB
---	-------

----- THE END -----



Appendix A. Test Results of Conducted Test

Conducted Output Power (Average power) and ERP,

Ant.0 (GT-LC=-2.5dBi)

NR Band	SCS	BandWidth	Arfcn	Freq(MHz)	Modulation	RB	Conducted Power(dBm)	ERP(dBm)	ERP(W)
14	15	10	158600	793	DFT-s-OFDM PI/2 BPSK	25@12	23.05	18.4	0.0692
14	15	10	158600	793	DFT-s-OFDM PI/2 BPSK	1@1	23.12	18.47	0.0703
14	15	10	158600	793	DFT-s-OFDM PI/2 BPSK	1@50	22.94	18.29	0.0675
14	15	10	158600	793	DFT-s-OFDM QPSK	25@12	22.97	18.32	0.0679
14	15	10	158600	793	DFT-s-OFDM QPSK	1@1	22.98	18.33	0.0681
14	15	10	158600	793	DFT-s-OFDM QPSK	1@50	23.03	18.38	0.0689
14	15	10	158600	793	DFT-s-OFDM 16 QAM	25@12	22.99	18.34	0.0682
14	15	10	158600	793	DFT-s-OFDM 16 QAM	1@1	23.12	18.47	0.0703
14	15	10	158600	793	DFT-s-OFDM 16 QAM	1@50	23.05	18.4	0.0692
14	15	10	158600	793	DFT-s-OFDM 64 QAM	25@12	21.69	17.04	0.0506
14	15	10	158600	793	DFT-s-OFDM 64 QAM	1@1	21.71	17.06	0.0508
14	15	10	158600	793	DFT-s-OFDM 64 QAM	1@50	21.63	16.98	0.0499
14	15	10	158600	793	DFT-s-OFDM 256 QAM	25@12	19.44	14.79	0.0301
14	15	10	158600	793	DFT-s-OFDM 256 QAM	1@1	19.18	14.53	0.0284
14	15	10	158600	793	DFT-s-OFDM 256 QAM	1@50	19.32	14.67	0.0293
14	15	10	158600	793	CP-OFDM QPSK	26@13	22.48	17.83	0.0607
14	15	10	158600	793	CP-OFDM QPSK	1@1	22.62	17.97	0.0627
14	15	10	158600	793	CP-OFDM QPSK	1@50	22.67	18.02	0.0634
14	15	5	158100	790.5	DFT-s-OFDM PI/2 BPSK	12@6	22.89	18.24	0.0667
14	15	5	158100	790.5	DFT-s-OFDM PI/2 BPSK	1@1	22.94	18.29	0.0675
14	15	5	158100	790.5	DFT-s-OFDM PI/2 BPSK	1@23	22.92	18.27	0.0671
14	15	5	158100	790.5	DFT-s-OFDM QPSK	12@6	22.96	18.31	0.0678
14	15	5	158100	790.5	DFT-s-OFDM QPSK	1@1	22.97	18.32	0.0679
14	15	5	158100	790.5	DFT-s-OFDM QPSK	1@23	22.93	18.28	0.0673
14	15	5	158100	790.5	DFT-s-OFDM 16 QAM	12@6	22.07	17.42	0.0552
14	15	5	158100	790.5	DFT-s-OFDM 16 QAM	1@1	22.28	17.63	0.0579
14	15	5	158100	790.5	DFT-s-OFDM 16 QAM	1@23	22.19	17.54	0.0568
14	15	5	158100	790.5	DFT-s-OFDM 64 QAM	12@6	20.69	16.04	0.0402
14	15	5	158100	790.5	DFT-s-OFDM 64 QAM	1@1	20.87	16.22	0.0419
14	15	5	158100	790.5	DFT-s-OFDM 64 QAM	1@23	20.7	16.05	0.0403
14	15	5	158100	790.5	DFT-s-OFDM 256 QAM	12@6	18.6	13.95	0.0248
14	15	5	158100	790.5	DFT-s-OFDM 256 QAM	1@1	18.38	13.73	0.0236
14	15	5	158100	790.5	DFT-s-OFDM 256 QAM	1@23	18.34	13.69	0.0234
14	15	5	158100	790.5	CP-OFDM QPSK	1@1	21.76	17.11	0.0514
14	15	5	158600	793	DFT-s-OFDM PI/2 BPSK	12@6	22.9	18.25	0.0668
14	15	5	158600	793	DFT-s-OFDM PI/2 BPSK	1@1	22.89	18.24	0.0667
14	15	5	158600	793	DFT-s-OFDM PI/2 BPSK	1@23	22.95	18.3	0.0676
14	15	5	158600	793	DFT-s-OFDM QPSK	12@6	22.96	18.31	0.0678
14	15	5	158600	793	DFT-s-OFDM QPSK	1@1	22.95	18.3	0.0676
14	15	5	158600	793	DFT-s-OFDM QPSK	1@23	22.97	18.32	0.0679
14	15	5	158600	793	DFT-s-OFDM 16 QAM	12@6	22.04	17.39	0.0548



14	15	5	158600	793	DFT-s-OFDM 16 QAM	1@1	22.22	17.57	0.0571
14	15	5	158600	793	DFT-s-OFDM 16 QAM	1@23	22.19	17.54	0.0568
14	15	5	158600	793	DFT-s-OFDM 64 QAM	12@6	20.77	16.12	0.0409
14	15	5	158600	793	DFT-s-OFDM 64 QAM	1@1	20.84	16.19	0.0416
14	15	5	158600	793	DFT-s-OFDM 64 QAM	1@23	20.68	16.03	0.0401
14	15	5	158600	793	DFT-s-OFDM 256 QAM	12@6	18.56	13.91	0.0246
14	15	5	158600	793	DFT-s-OFDM 256 QAM	1@1	18.41	13.76	0.0238
14	15	5	158600	793	DFT-s-OFDM 256 QAM	1@23	18.36	13.71	0.0235
14	15	5	158600	793	CP-OFDM QPSK	1@1	21.75	17.1	0.0513
14	15	5	159100	795.5	DFT-s-OFDM PI/2 BPSK	12@6	22.88	18.23	0.0665
14	15	5	159100	795.5	DFT-s-OFDM PI/2 BPSK	1@1	22.92	18.27	0.0671
14	15	5	159100	795.5	DFT-s-OFDM PI/2 BPSK	1@23	22.96	18.31	0.0678
14	15	5	159100	795.5	DFT-s-OFDM QPSK	12@6	22.85	18.2	0.0661
14	15	5	159100	795.5	DFT-s-OFDM QPSK	1@1	22.86	18.21	0.0662
14	15	5	159100	795.5	DFT-s-OFDM QPSK	1@23	22.90	18.25	0.0668
14	15	5	159100	795.5	DFT-s-OFDM 16 QAM	12@6	22.08	17.43	0.0553
14	15	5	159100	795.5	DFT-s-OFDM 16 QAM	1@1	22.26	17.61	0.0577
14	15	5	159100	795.5	DFT-s-OFDM 16 QAM	1@23	22.25	17.6	0.0575
14	15	5	159100	795.5	DFT-s-OFDM 64 QAM	12@6	20.68	16.03	0.0401
14	15	5	159100	795.5	DFT-s-OFDM 64 QAM	1@1	20.79	16.14	0.0411
14	15	5	159100	795.5	DFT-s-OFDM 64 QAM	1@23	20.79	16.14	0.0411
14	15	5	159100	795.5	DFT-s-OFDM 256 QAM	12@6	18.57	13.92	0.0247
14	15	5	159100	795.5	DFT-s-OFDM 256 QAM	1@1	18.32	13.67	0.0233
14	15	5	159100	795.5	DFT-s-OFDM 256 QAM	1@23	18.43	13.78	0.0239
14	15	5	159100	795.5	CP-OFDM QPSK	1@1	21.78	17.13	0.0516



Frequency Stability

NR	SCS	Bandwidth	Arfcn	Freq	Modulation	RB	Deviation	Verdict	Environment
Band	(kHz)	(MHz)		(MHz)			(ppm)		
14	15	10	158600	793.0	DFT-s-OFDM QPSK	50@0	0.0022	PASS	NV
14	15	10	158600	793.0	DFT-s-OFDM QPSK	50@0	0.0013	PASS	LV
14	15	10	158600	793.0	DFT-s-OFDM QPSK	50@0	0.0009	PASS	HV
14	15	10	158600	793.0	DFT-s-OFDM QPSK	50@0	-0.0011	PASS	-30°C
14	15	10	158600	793.0	DFT-s-OFDM QPSK	50@0	0.0021	PASS	-20°C
14	15	10	158600	793.0	DFT-s-OFDM QPSK	50@0	0.0025	PASS	-10°C
14	15	10	158600	793.0	DFT-s-OFDM QPSK	50@0	0.0032	PASS	0°C
14	15	10	158600	793.0	DFT-s-OFDM QPSK	50@0	0.0026	PASS	10°C
14	15	10	158600	793.0	DFT-s-OFDM QPSK	50@0	-0.0017	PASS	20°C
14	15	10	158600	793.0	DFT-s-OFDM QPSK	50@0	0.0025	PASS	30°C
14	15	10	158600	793.0	DFT-s-OFDM QPSK	50@0	0.0016	PASS	40°C
14	15	10	158600	793.0	DFT-s-OFDM QPSK	50@0	0.0014	PASS	50°C



NR	SCS	Bandwidth	Arfcn	Freq	Modulation	RB	Deviation	Verdict	Environment
Band	(kHz)	(MHz)		(MHz)			(ppm)		
14	15	5	158600	793.0	DFT-s-OFDM QPSK	25@0	0.0010	PASS	NV
14	15	5	158600	793.0	DFT-s-OFDM QPSK	25@0	0.0004	PASS	LV
14	15	5	158600	793.0	DFT-s-OFDM QPSK	25@0	0.0023	PASS	HV
14	15	5	158600	793.0	DFT-s-OFDM QPSK	25@0	0.0008	PASS	-30°C
14	15	5	158600	793.0	DFT-s-OFDM QPSK	25@0	0.0007	PASS	-20°C
14	15	5	158600	793.0	DFT-s-OFDM QPSK	25@0	0.0046	PASS	-10°C
14	15	5	158600	793.0	DFT-s-OFDM QPSK	25@0	0.0007	PASS	0°C
14	15	5	158600	793.0	DFT-s-OFDM QPSK	25@0	0.0035	PASS	10°C
14	15	5	158600	793.0	DFT-s-OFDM QPSK	25@0	0.0035	PASS	20°C
14	15	5	158600	793.0	DFT-s-OFDM QPSK	25@0	0.00011	PASS	30°C
14	15	5	158600	793.0	DFT-s-OFDM QPSK	25@0	0.00018	PASS	40°C
14	15	5	158600	793.0	DFT-s-OFDM QPSK	25@0	0.0042	PASS	50°C



Peak to Average Ratio

NR	SCS	Bandwidth	Arfcn	Freq	Modulation	RB	Result	Limit	Verdict
Band	(kHz)	(MHz)		(MHz)			(dB)	(dB)	
14	15	10	158600	793.0	DFT-s-OFDM PI/2 BPSK	50@0	4.15	13	PASS
14	15	10	158600	793.0	DFT-s-OFDM PI/2 BPSK	1@0	4.47	13	PASS
14	15	10	158600	793.0	DFT-s-OFDM QPSK	50@0	5.82	13	PASS
14	15	10	158600	793.0	DFT-s-OFDM QPSK	1@0	6.36	13	PASS



N14(10M)_DFT-s-OFDM_PI_2-BPSK_Outer_ Full_Mid_CH



N14(10M)_DFT-s-OFDM_PI_2-BPSK_Edge_1RB _Left_Mid_CH



N14(10M)_DFT-s-OFDM_QPSK_Outer_Full_ Mid_CH

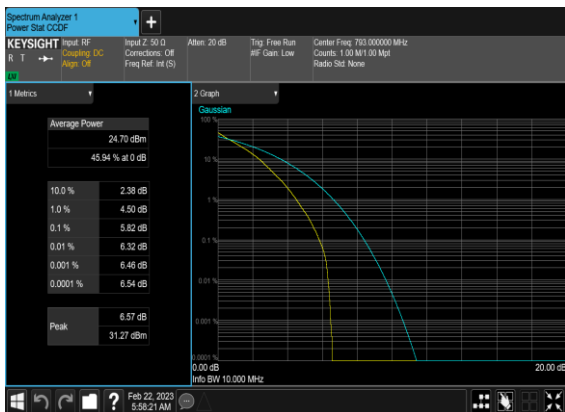

N14(10M)_DFT-s-OFDM_QPSK_Edge_1RB_Left_ _Mid_CH

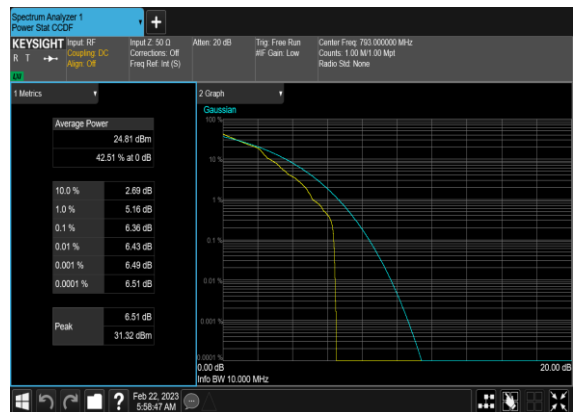



Occupied Bandwidth

NR	SCS	Bandwidth	Arfcn	Freq	Modulation	RB	OBW	26dB BW
Band	(kHz)	(MHz)		(MHz)			(MHz)	(MHz)
14	15	5	158600	793.0	CP-OFDM QPSK	25@0	4.4683	4.902
14	15	5	158600	793.0	CP-OFDM 16 QAM	25@0	4.4878	4.92
14	15	5	158600	793.0	CP-OFDM 64 QAM	25@0	4.4573	4.844
14	15	5	158600	793.0	CP-OFDM 256 QAM	25@0	4.4761	4.871
14	15	10	158600	793.0	CP-OFDM QPSK	52@0	9.2573	9.84
14	15	10	158600	793.0	CP-OFDM 16 QAM	52@0	9.2593	9.874
14	15	10	158600	793.0	CP-OFDM 64 QAM	52@0	9.2474	9.772
14	15	10	158600	793.0	CP-OFDM 256 QAM	52@0	9.2734	9.827



N14(5M)_CP-OFDM_QPSK_Outer_Full_Mid_CH

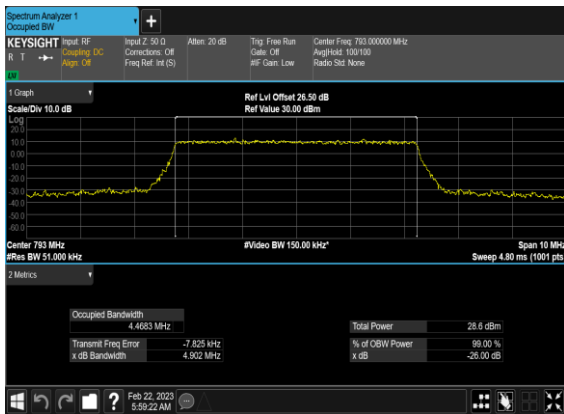

N14(5M)_CP-OFDM_64 QAM_Outer_Full_Mid_CH

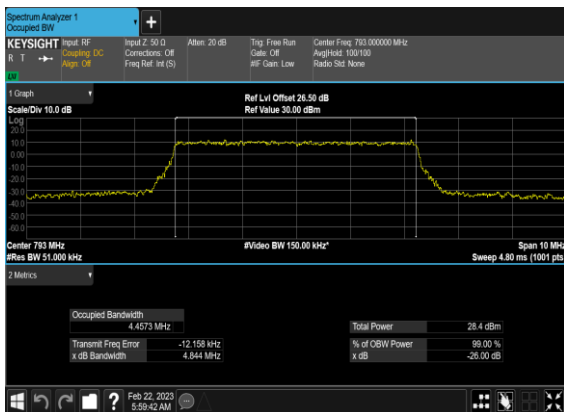

N14(5M)_CP-OFDM_16 QAM_Outer_Full_Mid_CH

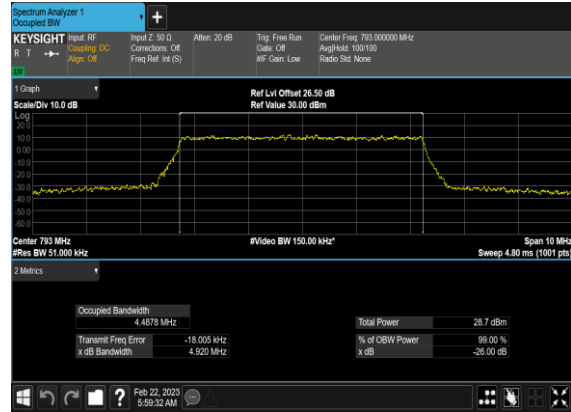

N14(5M)_CP-OFDM_256 QAM_Outer_Full_Mid_CH

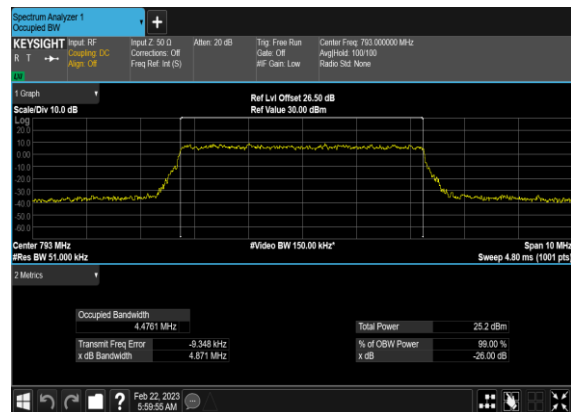

N14(10M)_CP-OFDM_QPSK_Outer_Full_Mid_CH

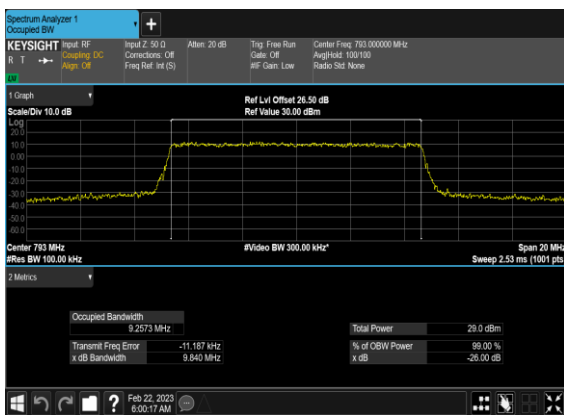

N14(10M)_CP-OFDM_16 QAM_Outer_Full_Mid_CH

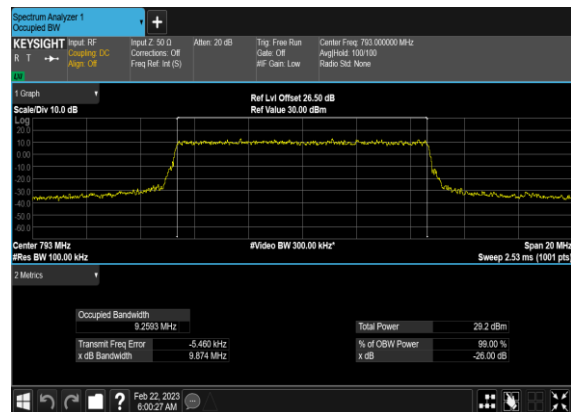



N14(10M)_CP-OFDM_64
QAM_Outer_Full_Mid_CH



N14(10M)_CP-OFDM_256
QAM_Outer_Full_Mid_CH

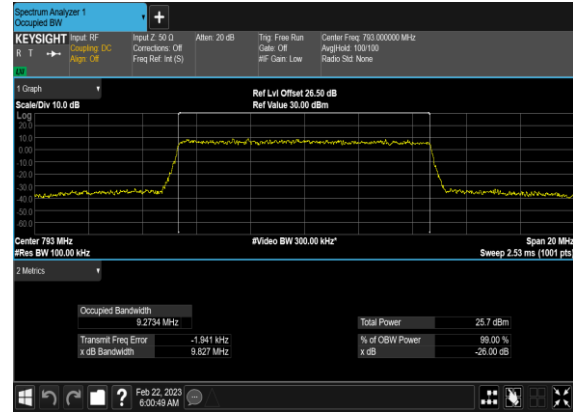



Emission Mask

NR Band	SCS (kHz)	Bandwidth (MHz)	Arfcn	Freq (MHz)	Modulation	RB	Limit (dBm/MHz)	Verdict
14	15	5	158100	790.5	DFT-s-OFDM BPSK	1@0	see graph	PASS
14	15	5	158100	790.5	DFT-s-OFDM QPSK	1@0	see graph	PASS
14	15	5	158100	790.5	DFT-s-OFDM BPSK	1@24	see graph	PASS
14	15	5	158100	790.5	DFT-s-OFDM QPSK	1@24	see graph	PASS
14	15	5	158100	790.5	DFT-s-OFDM BPSK	25@0	see graph	PASS
14	15	5	158100	790.5	DFT-s-OFDM QPSK	25@0	see graph	PASS
14	15	5	158600	793.0	DFT-s-OFDM BPSK	1@0	see graph	PASS
14	15	5	158600	793.0	DFT-s-OFDM QPSK	1@0	see graph	PASS
14	15	5	158600	793.0	DFT-s-OFDM BPSK	1@24	see graph	PASS
14	15	5	158600	793.0	DFT-s-OFDM QPSK	1@24	see graph	PASS
14	15	5	158600	793.0	DFT-s-OFDM BPSK	25@0	see graph	PASS
14	15	5	158600	793.0	DFT-s-OFDM QPSK	25@0	see graph	PASS
14	15	5	159100	795.5	DFT-s-OFDM BPSK	1@0	see graph	PASS
14	15	5	159100	795.5	DFT-s-OFDM QPSK	1@0	see graph	PASS
14	15	5	159100	795.5	DFT-s-OFDM BPSK	1@24	see graph	PASS
14	15	5	159100	795.5	DFT-s-OFDM QPSK	1@24	see graph	PASS
14	15	5	159100	795.5	DFT-s-OFDM BPSK	25@0	see graph	PASS
14	15	5	159100	795.5	DFT-s-OFDM QPSK	25@0	see graph	PASS
14	15	10	158600	793.0	DFT-s-OFDM BPSK	1@0	see graph	PASS
14	15	10	158600	793.0	DFT-s-OFDM QPSK	1@0	see graph	PASS
14	15	10	158600	793.0	DFT-s-OFDM BPSK	1@51	see graph	PASS
14	15	10	158600	793.0	DFT-s-OFDM QPSK	1@51	see graph	PASS
14	15	10	158600	793.0	DFT-s-OFDM BPSK	50@0	see graph	PASS
14	15	10	158600	793.0	DFT-s-OFDM QPSK	50@0	see graph	PASS

N14(5M)_DFT-s-OFDM_BPSK_Edge_1RB_Left_Lo

w_CH

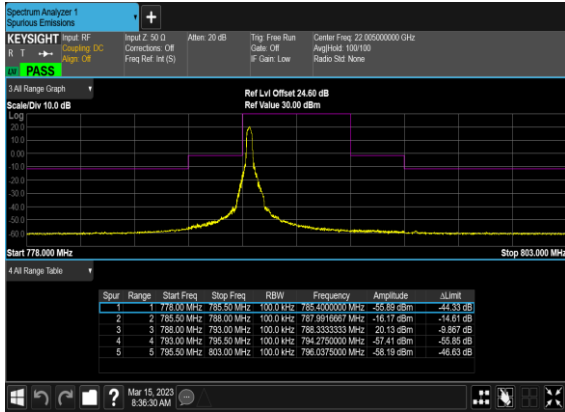

N14(5M)_DFT-s-OFDM_QPSK_Edge_1RB_Left_Lo

w_CH

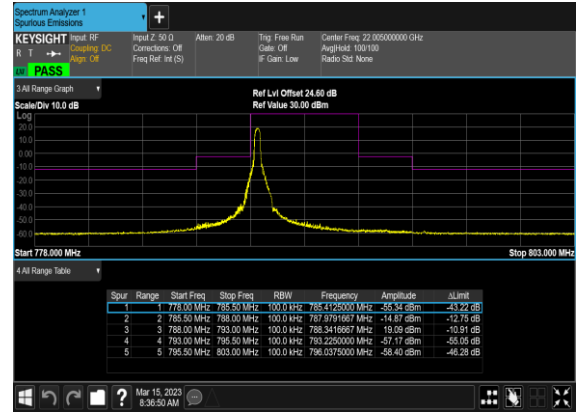

N14(5M)_DFT-s-OFDM_BPSK_Edge_1RB_Right_L

ow_CH

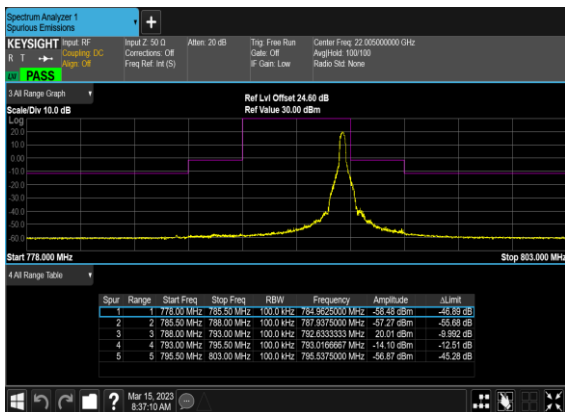

N14(5M)_DFT-s-OFDM_QPSK_Edge_1RB_Right_L

ow_CH

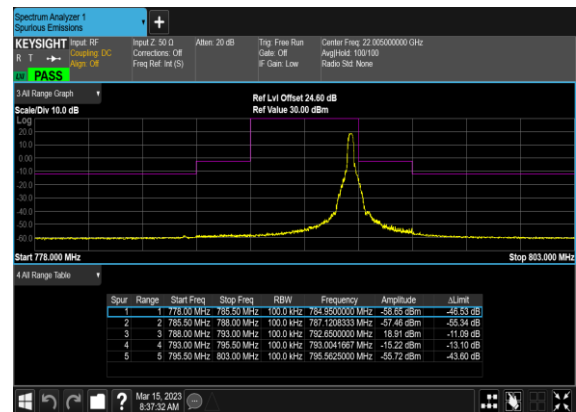

N14(5M)_DFT-s-OFDM_BPSK_Outer_Full_Low_CH

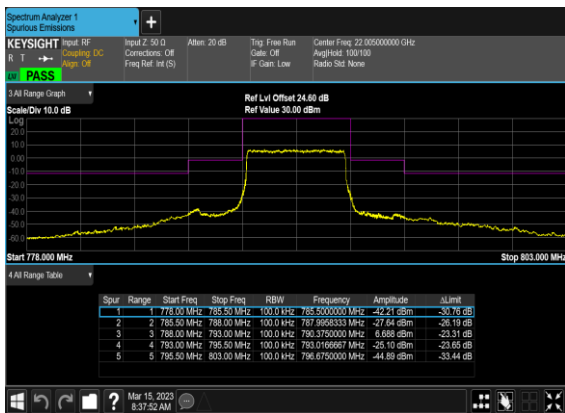

N14(5M)_DFT-s-OFDM_QPSK_Outer_Full_Low_CH

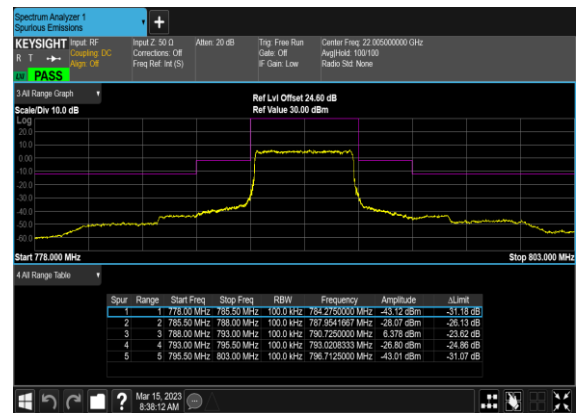

N14(5M)_DFT-s-OFDM_BPSK_Edge_1RB_Left_Mi
d_CH

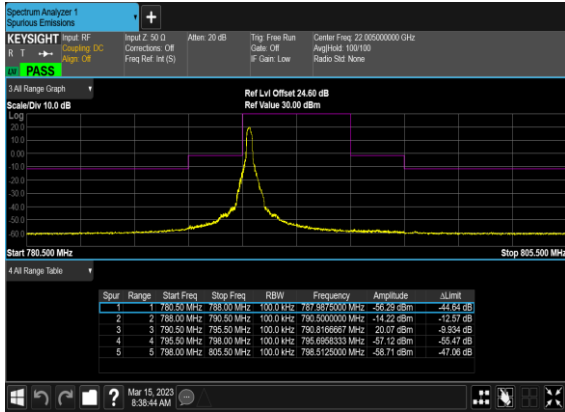

N14(5M)_DFT-s-OFDM_QPSK_Edge_1RB_Left_Mi
d_CH

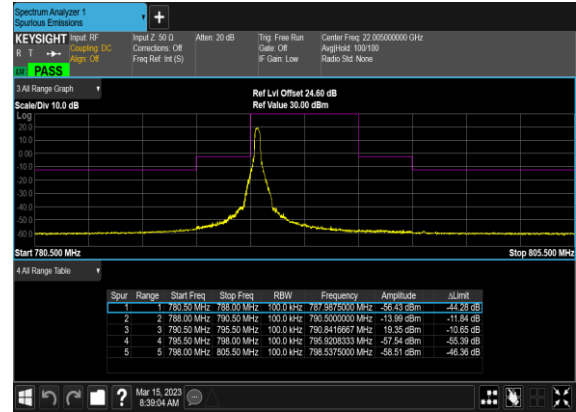

N14(5M)_DFT-s-OFDM_BPSK_Edge_1RB_Right_M
id_CH

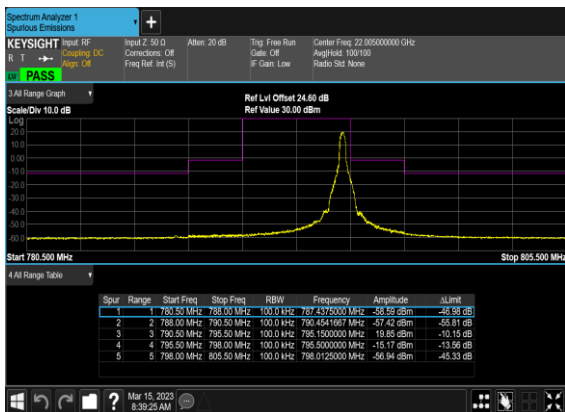

N14(5M)_DFT-s-OFDM_QPSK_Edge_1RB_Right_M
id_CH

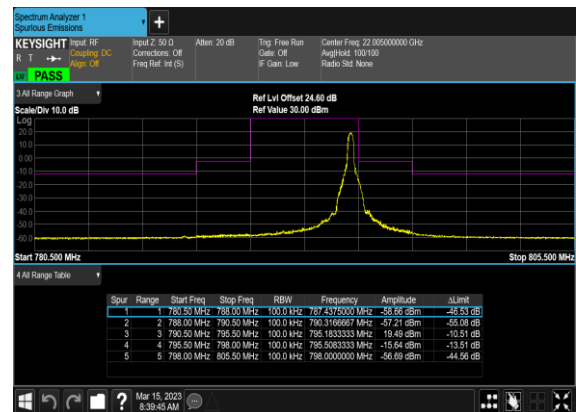

N14(5M)_DFT-s-OFDM_BPSK_Outer_Full_Mid_CH

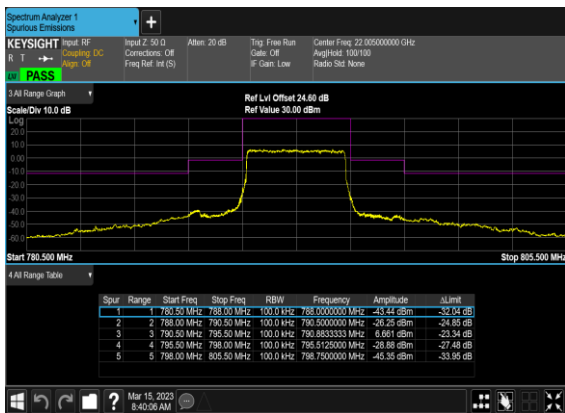

N14(5M)_DFT-s-OFDM_QPSK_Outer_Full_Mid_CH

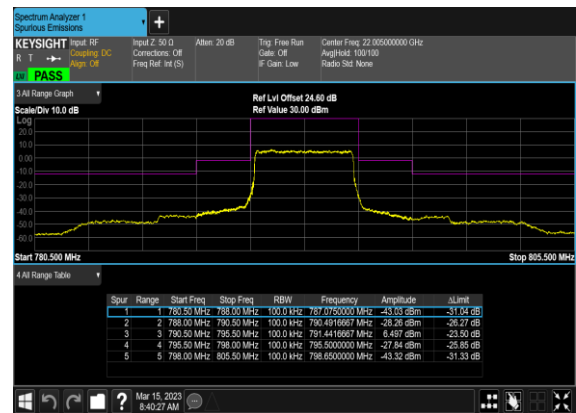

N14(5M)_DFT-s-OFDM_BPSK_Edge_1RB_Left_Hig

h_CH

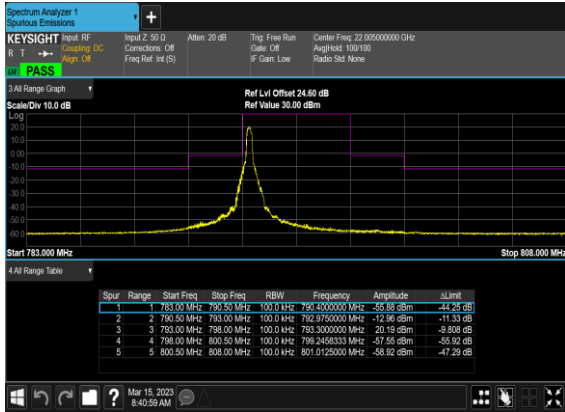

N14(5M)_DFT-s-OFDM_QPSK_Edge_1RB_Left_Hig

h_CH

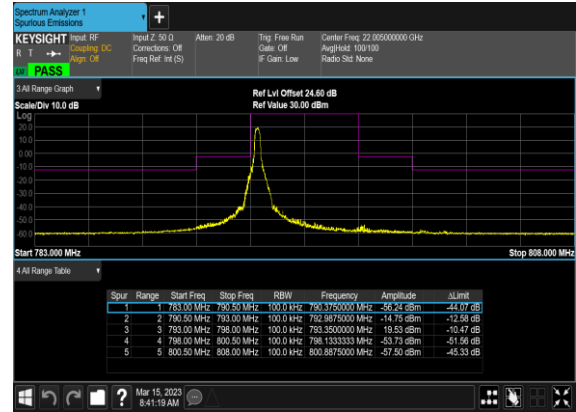

N14(5M)_DFT-s-OFDM_BPSK_Edge_1RB_Right_H

igh_CH

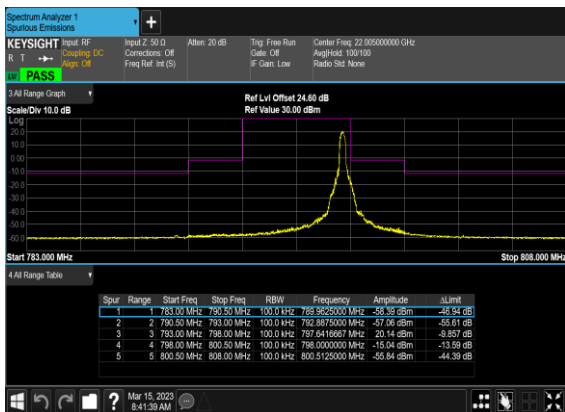

N14(5M)_DFT-s-OFDM_QPSK_Edge_1RB_Right_H

igh_CH

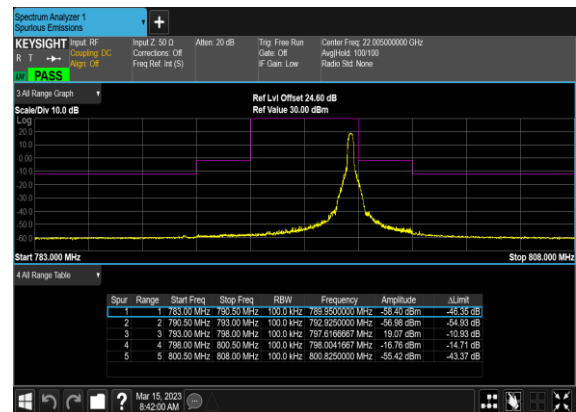

N14(5M)_DFT-s-OFDM_BPSK_Outer_Full_High_C

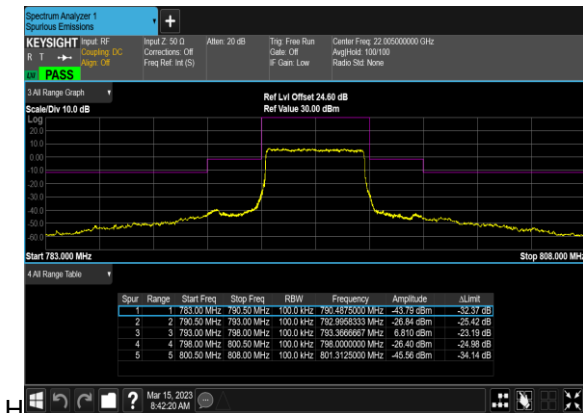

N14(5M)_DFT-s-OFDM_QPSK_Outer_Full_High_C

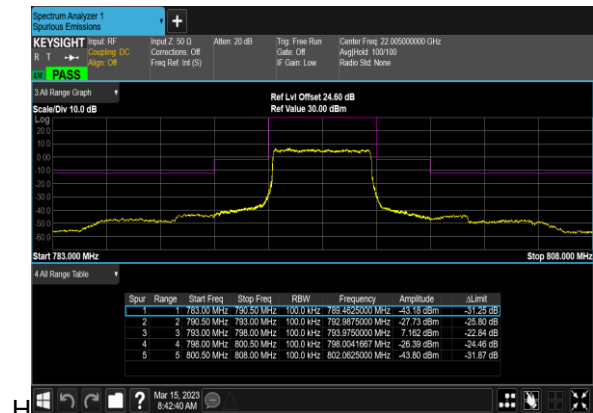

N14(10M)_DFT-s-OFDM_BPSK_Edge_1RB_Left_M

id_CH

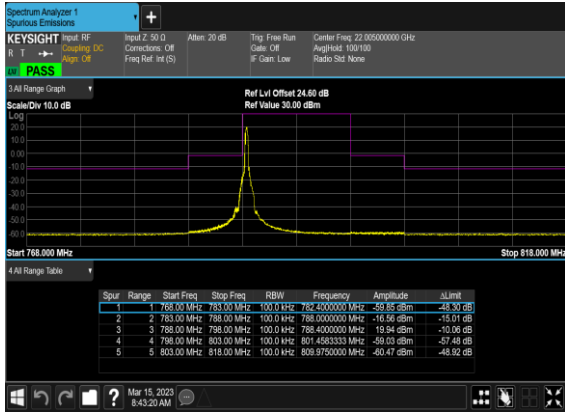

N14(10M)_DFT-s-OFDM_QPSK_Edge_1RB_Left_M

id_CH

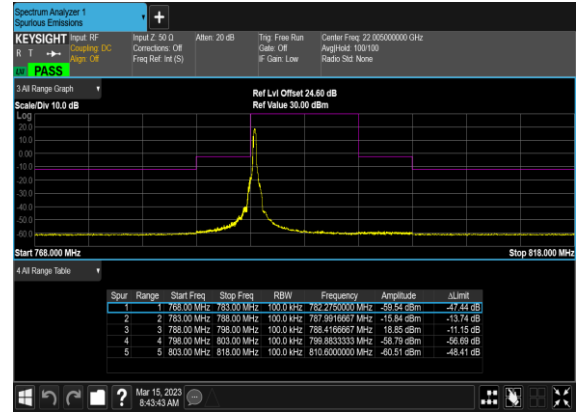

N14(10M)_DFT-s-OFDM_BPSK_Edge_1RB_Right_M

Mid_CH

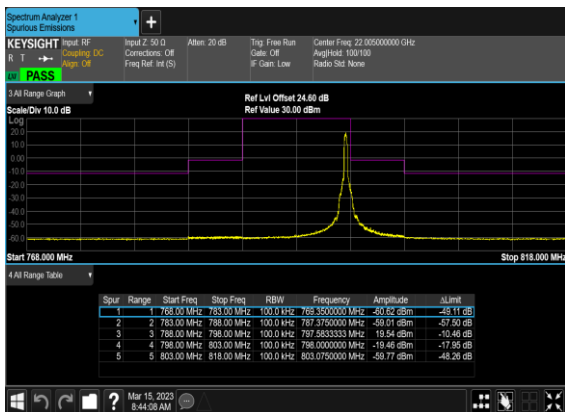

N14(10M)_DFT-s-OFDM_QPSK_Edge_1RB_Right_M

Mid_CH

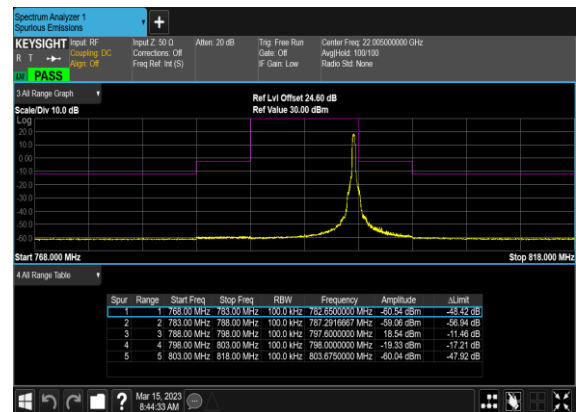

N14(10M)_DFT-s-OFDM_BPSK_Outer_Full_Mid_C

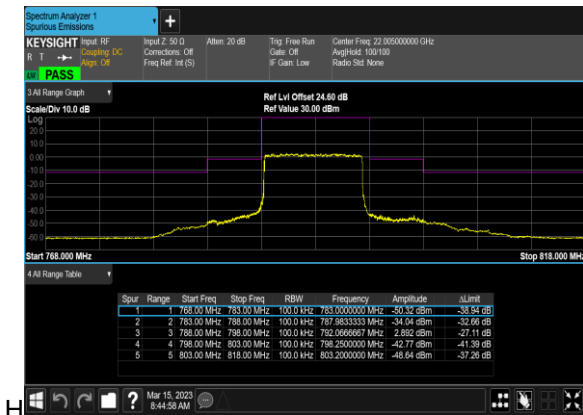

N14(10M)_DFT-s-OFDM_QPSK_Outer_Full_Mid_C

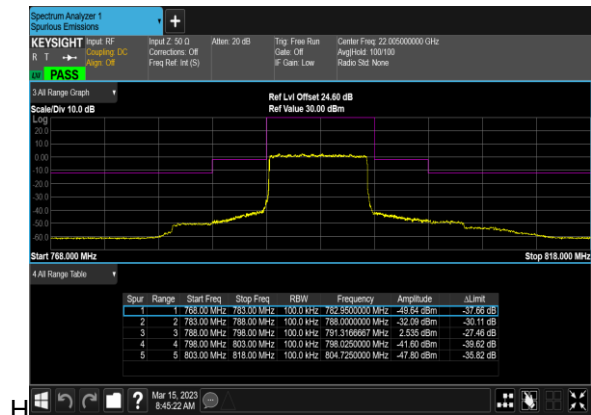



Conducted Spurious Emissions

NR Band	SCS (kHz)	Bandwidth (MHz)	Arfcn	Freq (MHz)	Modulation	RB	Result	Verdict
14	15	5	158100	790.5	DFT-s-OFDM BPSK	1@0	see graph	---
14	15	5	158100	790.5	DFT-s-OFDM BPSK	1@0	see graph	PASS
14	15	5	158100	790.5	DFT-s-OFDM QPSK	1@0	see graph	---
14	15	5	158100	790.5	DFT-s-OFDM QPSK	1@0	see graph	PASS
14	15	5	158600	793.0	DFT-s-OFDM BPSK	1@0	see graph	---
14	15	5	158600	793.0	DFT-s-OFDM BPSK	1@0	see graph	PASS
14	15	5	158600	793.0	DFT-s-OFDM QPSK	1@0	see graph	---
14	15	5	158600	793.0	DFT-s-OFDM QPSK	1@0	see graph	PASS
14	15	5	159100	795.5	DFT-s-OFDM BPSK	1@0	see graph	---
14	15	5	159100	795.5	DFT-s-OFDM BPSK	1@0	see graph	PASS
14	15	5	159100	795.5	DFT-s-OFDM QPSK	1@0	see graph	---
14	15	5	159100	795.5	DFT-s-OFDM QPSK	1@0	see graph	PASS
14	15	10	158600	793.0	DFT-s-OFDM BPSK	1@0	see graph	---
14	15	10	158600	793.0	DFT-s-OFDM BPSK	1@0	see graph	PASS
14	15	10	158600	793.0	DFT-s-OFDM QPSK	1@0	see graph	---
14	15	10	158600	793.0	DFT-s-OFDM QPSK	1@0	see graph	PASS



N14(5M)_DFT-s-OFDM_BPSK_Edge_1RB_Left
_Low_CH

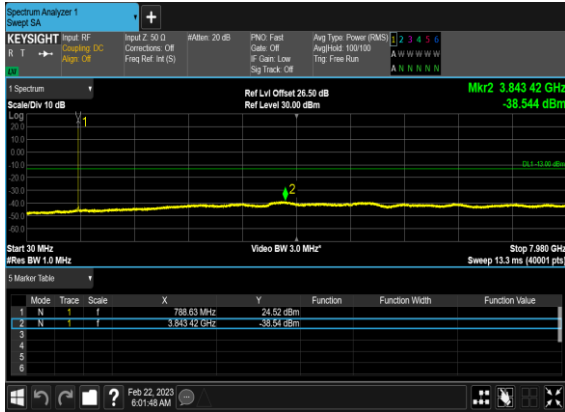

N14(5M)_DFT-s-OFDM_QPSK_Edge_1RB_Left
_Low_CH

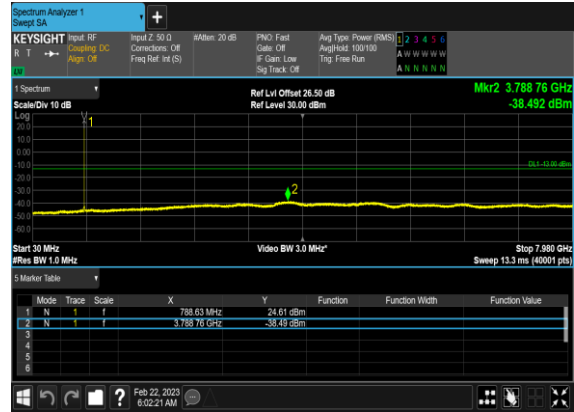

N14(5M)_DFT-s-OFDM_BPSK_Edge_1RB_Left
_Mid_CH

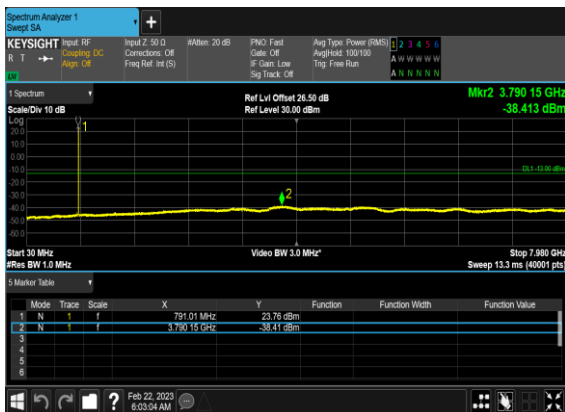

N14(5M)_DFT-s-OFDM_QPSK_Edge_1RB_Left
_Mid_CH

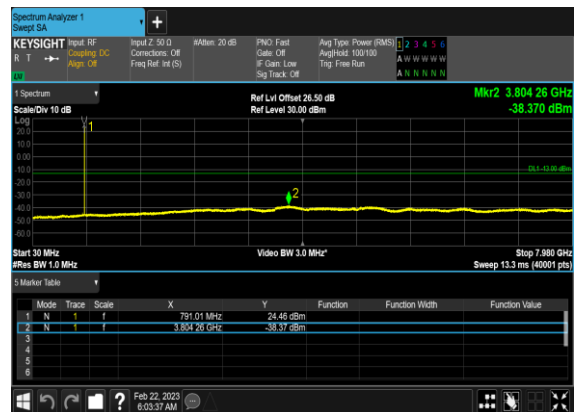

N14(5M)_DFT-s-OFDM_BPSK_Edge_1RB_Left
_High_CH

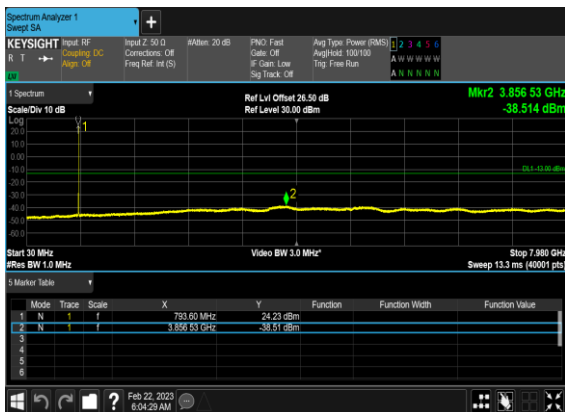

N14(5M)_DFT-s-OFDM_QPSK_Edge_1RB_Left
_High_CH

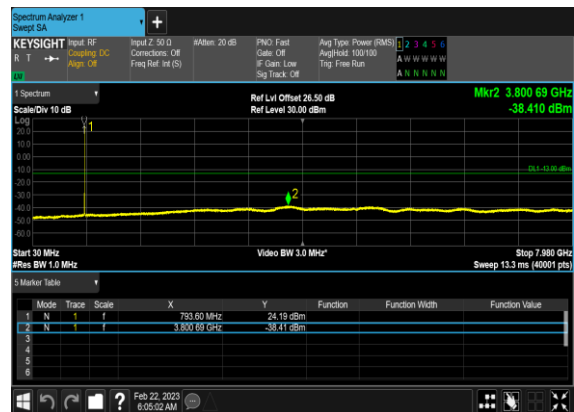



N14(10M)_DFT-s-OFDM_BPSK_Edge_1RB_Le ft_Mid_CH N14(10M)_DFT-s-OFDM_QPSK_Edge_1RB_Le ft_Mid_CH

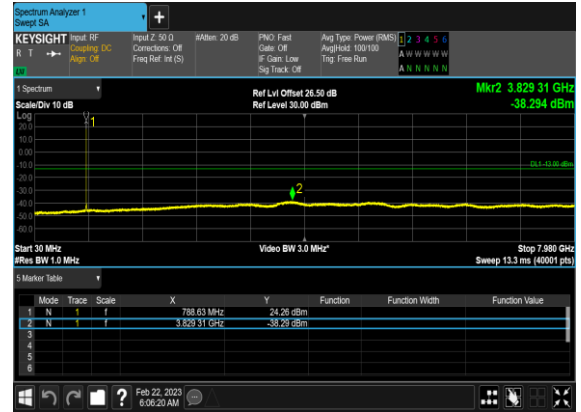
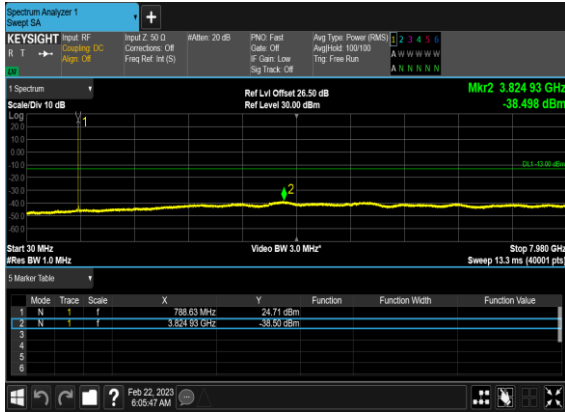



Conducted Band Edge

NR Band	SCS (kHz)	Bandwidth (MHz)	Arfcn	Freq (MHz)	Modulation	RB	Result	Verdict
14	15	5	158100	790.5	DFT-s-OFDM BPSK	1@0	see graph	PASS
14	15	5	158100	790.5	DFT-s-OFDM QPSK	1@0	see graph	PASS
14	15	5	158100	790.5	DFT-s-OFDM BPSK	25@0	see graph	PASS
14	15	5	158100	790.5	DFT-s-OFDM QPSK	25@0	see graph	PASS
14	15	5	159100	795.5	DFT-s-OFDM BPSK	1@24	see graph	PASS
14	15	5	159100	795.5	DFT-s-OFDM QPSK	1@24	see graph	PASS
14	15	5	159100	795.5	DFT-s-OFDM BPSK	25@0	see graph	PASS
14	15	5	159100	795.5	DFT-s-OFDM QPSK	25@0	see graph	PASS
14	15	10	158600	793.0	DFT-s-OFDM BPSK	1@0	see graph	PASS
14	15	10	158600	793.0	DFT-s-OFDM QPSK	1@0	see graph	PASS
14	15	10	158600	793.0	DFT-s-OFDM BPSK	1@51	see graph	PASS
14	15	10	158600	793.0	DFT-s-OFDM QPSK	1@51	see graph	PASS
14	15	10	158600	793.0	DFT-s-OFDM BPSK	50@0	see graph	PASS
14	15	10	158600	793.0	DFT-s-OFDM QPSK	50@0	see graph	PASS



N14(5M)_DFT-s-OFDM_BPSK_Edge_1RB_Left_Lo
w_CH

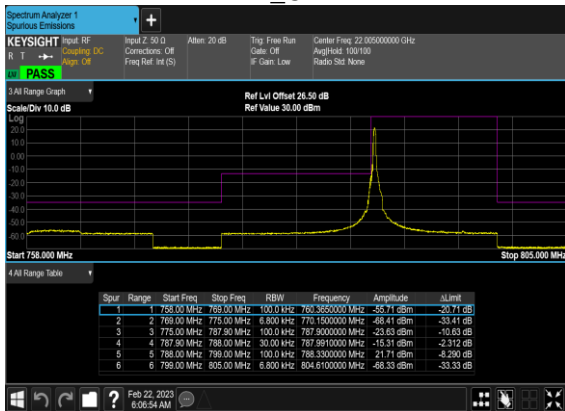

N14(5M)_DFT-s-OFDM_QPSK_Edge_1RB_Left_Lo
w_CH

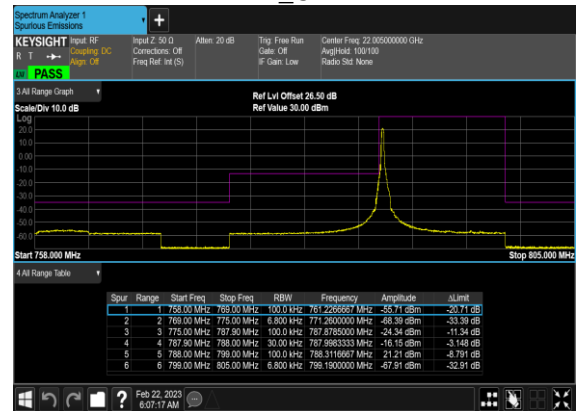

N14(5M)_DFT-s-OFDM_BPSK_Outer_Full_Low_CH

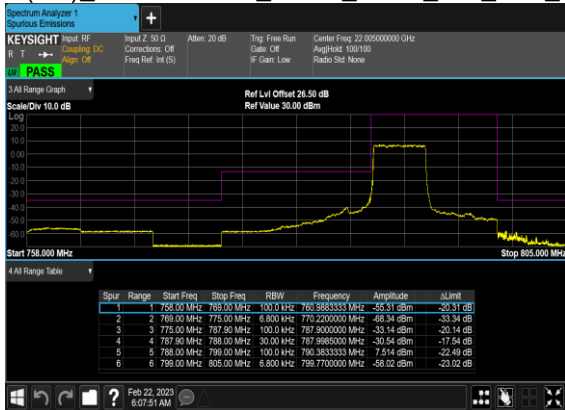

N14(5M)_DFT-s-OFDM_QPSK_Outer_Full_Low_CH

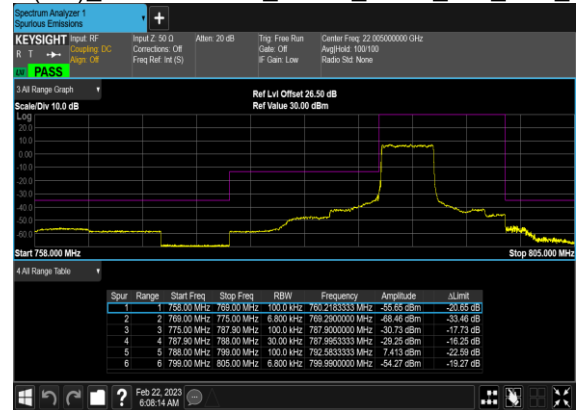

N14(5M)_DFT-s-OFDM_BPSK_Edge_1RB_Right_H
igh_CH

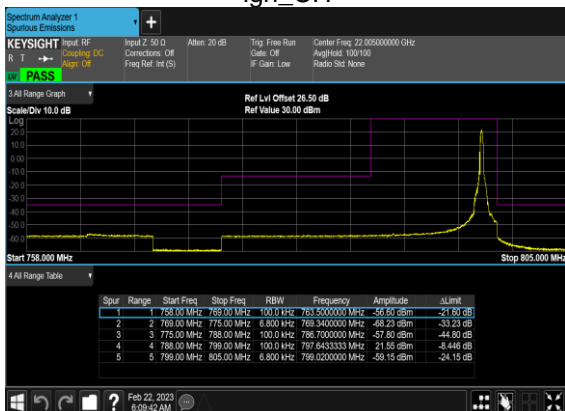

N14(5M)_DFT-s-OFDM_QPSK_Edge_1RB_Right_H
igh_CH

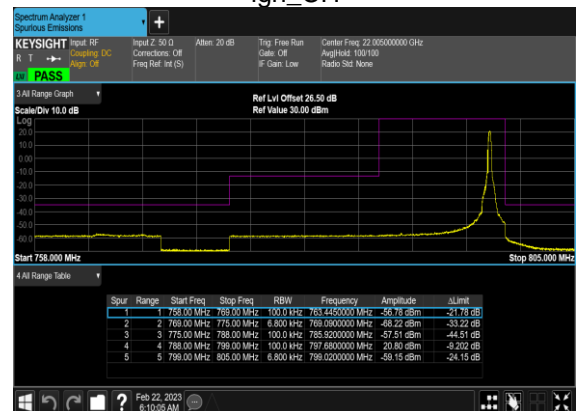

N14(5M)_DFT-s-OFDM_BPSK_Outer_Full_High_C

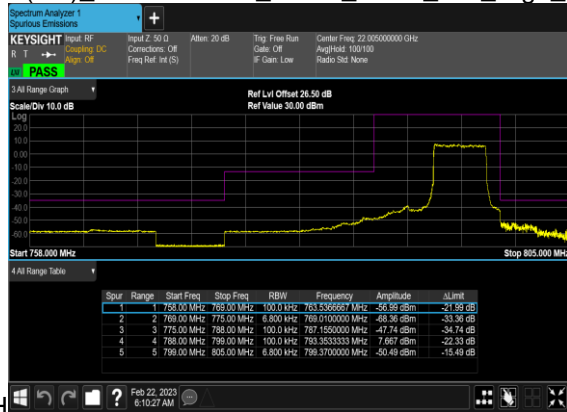

N14(5M)_DFT-s-OFDM_QPSK_Outer_Full_High_C

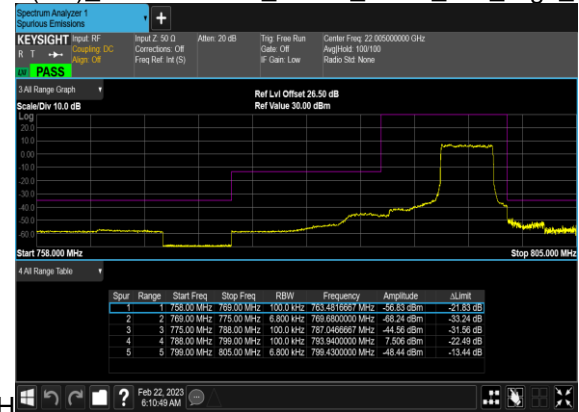

N14(10M)_DFT-s-OFDM_BPSK_Edge_1RB_Left_M id_CH

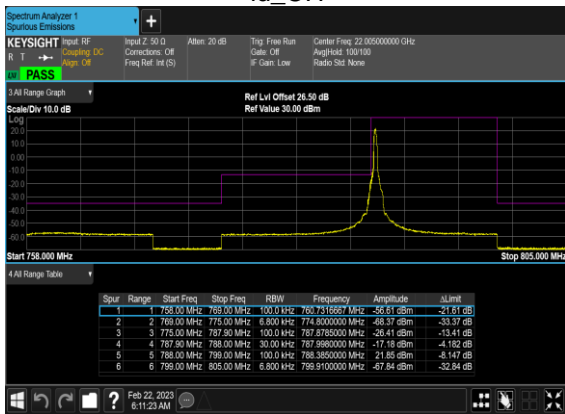

N14(10M)_DFT-s-OFDM_QPSK_Edge_1RB_Left_M id_CH

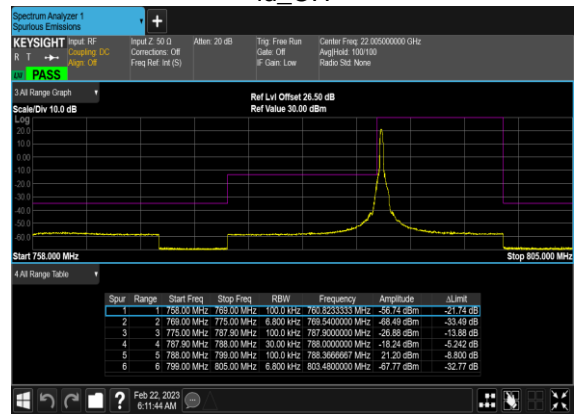

N14(10M)_DFT-s-OFDM_BPSK_Edge_1RB_Right_Mid_CH

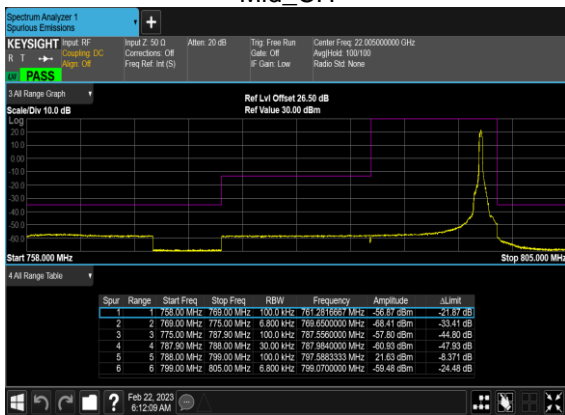

N14(10M)_DFT-s-OFDM_QPSK_Edge_1RB_Right_Mid_CH

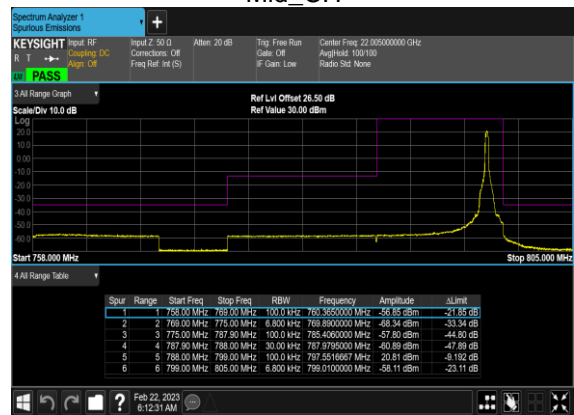



N14(10M)_DFT-s-OFDM_BPSK_Outer_Full_Mid_C

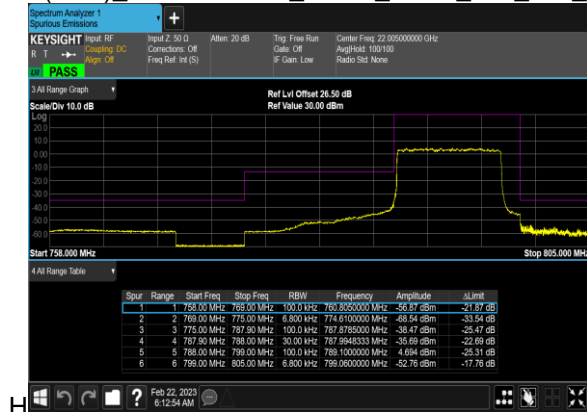

N14(10M)_DFT-s-OFDM_QPSK_Outer_Full_Mid_C

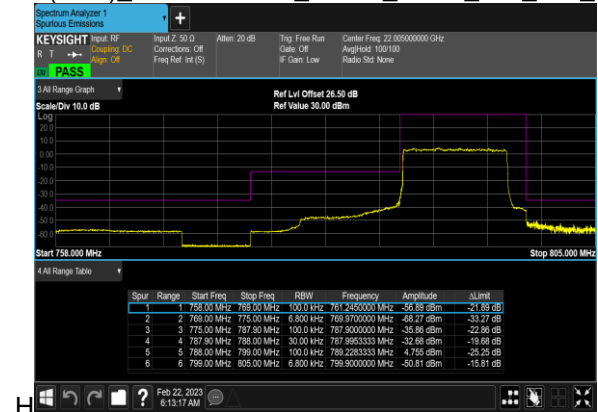

Appendix B. Test Results of Radiated Test

Field Strength of Spurious Radiated

Test Engineer :	Carry Xu	Temperature :	23~25°C
		Relative Humidity :	41~42%

SA 5G NR n14 / 10MHz / QPSK								
Channel	Frequency (MHz)	ERP (dBm)	Limit (dBm)	Over Limit (dB)	S.G. Power (dBm)	TX Cable loss (dB)	TX Antenna Gain (dBi)	Polarization (H/V)
Low	1576	-67.19	-42.15	-25.04	-69.82	1.09	5.87	H
	2365	-61.74	-13	-48.74	-64.14	1.37	5.92	H
	3153	-60.71	-13	-47.71	-64.60	1.64	7.68	H
	1576	-66.60	-42.15	-24.45	-69.23	1.09	5.87	V
	2365	-60.18	-13	-47.18	-62.58	1.37	5.92	V
	3153	-61.10	-13	-48.10	-64.99	1.64	7.68	V
Middle	1584	-67.13	-42.15	-24.98	-69.76	1.09	5.87	H
	2376	-62.16	-13	-49.16	-64.56	1.37	5.92	H
	3160	-60.72	-13	-47.72	-64.61	1.64	7.68	H
	1584	-66.28	-42.15	-24.13	-68.91	1.09	5.87	V
	2376	-60.50	-13	-47.50	-62.90	1.37	5.92	V
	3160	-60.67	-13	-47.67	-64.56	1.64	7.68	V
High	1584	-67.13	-42.15	-24.98	-69.76	1.09	5.87	H
	2384	-61.93	-13	-48.93	-64.33	1.37	5.92	H
	3176	-60.83	-13	-47.83	-64.72	1.64	7.68	H
	1584	-66.28	-42.15	-24.13	-68.91	1.09	5.87	V
	2384	-60.66	-13	-47.66	-63.06	1.37	5.92	V
	3176	-60.73	-13	-47.73	-64.62	1.64	7.68	V

Remark: Spurious emissions within 30-1000MHz were found more than 20dB below limit line.

SA 5G NR n14 / 10MHz / QPSK								
Channel	Frequency (MHz)	ERP (dBm)	Limit (dBm)	Over Limit (dB)	S.G. Power (dBm)	TX Cable loss (dB)	TX Antenna Gain (dBi)	Polarization (H/V)
Middle	1576	-67.28	-42.15	-25.13	-69.91	1.09	5.87	H
	2368	-61.89	-13	-48.89	-64.29	1.37	5.92	H
	3152	-60.83	-13	-47.83	-64.72	1.64	7.68	H
	1576	-66.67	-42.15	-24.52	-69.30	1.09	5.87	V
	2368	-60.37	-13	-47.37	-62.77	1.37	5.92	V
	3152	-61.01	-13	-48.01	-64.90	1.64	7.68	V

Remark: Spurious emissions within 30-1000MHz were found more than 20dB below limit line.