

## FCC Test Report (WLAN)

**Report No.:** RF151104E03-1

**FCC ID:** UZ7VC80

**Test Model:** VC80

**Received Date:** Nov. 04, 2015

**Test Date:** Nov. 18 to 27, 2015

**Issued Date:** Dec. 16, 2015

**Applicant:** Zebra Technologies Corporation

**Address:** 1 Zebra Plaza, Holtsville, NY 11742

**Manufacturer:** Zebra Technologies Corporation

**Address:** 1 Zebra Plaza, Holtsville, NY 11742

**Issued By:** Bureau Veritas Consumer Products Services (H.K.) Ltd., Taoyuan Branch  
Hsin Chu Laboratory

**Lab Address:** E-2, No.1, Li Hsin 1st Road, Hsinchu Science Park, Hsinchu City 300,  
Taiwan R.O.C.

**Test Location (1):** E-2, No.1, Li Hsin 1st Road, Hsinchu Science Park, Hsinchu City 300,  
Taiwan R.O.C.

**Test Location (2):** No. 49, Ln. 206, Wende Rd., Shangshan Tsuen, Chiung Lin Hsiang, Hsin  
Chu Hsien 307, Taiwan R.O.C.



This report is for your exclusive use. Any copying or replication of this report to or for any other person or entity, or use of our name or trademark, is permitted only with our prior written permission. This report sets forth our findings solely with respect to the test samples identified herein. The results set forth in this report are not indicative or representative of the quality or characteristics of the lot from which a test sample was taken or any similar or identical product unless specifically and expressly noted. Our report includes all of the tests requested by you and the results thereof based upon the information that you provided to us. You have 60 days from date of issuance of this report to notify us of any material error or omission caused by our negligence, provided, however, that such notice shall be in writing and shall specifically address the issue you wish to raise. A failure to raise such issue within the prescribed time shall constitute your unqualified acceptance of the completeness of this report, the tests conducted and the correctness of the report contents. Unless specific mention, the uncertainty of measurement has been explicitly taken into account to declare the compliance or non-compliance to the specification. The report must not be used by the client to claim product certification, approval, or endorsement by TAF or any government agencies.

## Table of Contents

<b>Release Control Record</b> .....	<b>4</b>
<b>1 Certificate of Conformity</b> .....	<b>5</b>
<b>2 Summary of Test Results</b> .....	<b>6</b>
2.1 Measurement Uncertainty .....	6
2.2 Modification Record .....	6
<b>3 General Information</b> .....	<b>7</b>
3.1 General Description of EUT (WLAN) .....	7
3.2 Description of Test Modes .....	11
3.2.1 Test Mode Applicability and Tested Channel Detail.....	13
3.3 Duty Cycle of Test Signal .....	16
3.4 Description of Support Units .....	17
3.4.1 Configuration of System under Test .....	18
3.5 General Description of Applied Standard.....	20
<b>4 Test Types and Results</b> .....	<b>21</b>
4.1 Radiated Emission and Bandedge Measurement.....	21
4.1.1 Limits of Radiated Emission and Bandedge Measurement .....	21
4.1.2 Test Instruments .....	22
4.1.3 Test Procedure .....	24
4.1.4 Deviation from Test Standard .....	24
4.1.5 Test Setup.....	25
4.1.6 EUT Operating Condition .....	25
4.1.7 Test Results (Mode 1).....	26
4.1.8 Test Results (Mode 2).....	114
4.1.9 Test Results (Mode 3).....	202
4.2 Conducted Emission Measurement .....	290
4.2.1 Limits of Conducted Emission Measurement .....	290
4.2.2 Test Instruments .....	290
4.2.3 Test Procedure .....	291
4.2.4 Deviation from Test Standard .....	291
4.2.5 Test Setup.....	291
4.2.6 EUT Operating Condition .....	291
4.2.7 Test Results (Mode 2).....	292
4.2.8 Test Results (Mode 4).....	294
4.2.9 Test Results (Mode 5).....	296
4.3 Transmit Power Measurement .....	298
4.3.1 Limits of Transmit Power Measurement .....	298
4.3.2 Test Setup.....	298
4.3.3 Test Instruments .....	299
4.3.4 Test Procedure .....	299
4.3.5 Deviation from Test Standard .....	299
4.3.6 EUT Operating Condition .....	299
4.3.7 Test Result.....	300
4.4 Peak Power Spectral Density Measurement .....	313
4.4.1 Limits of Peak Power Spectral Density Measurement .....	313
4.4.2 Test Setup.....	313
4.4.3 Test Instruments .....	313
4.4.4 Test Procedure .....	314
4.4.5 Deviation from Test Standard .....	314
4.4.6 EUT Operating Condition .....	314
4.4.7 Test Results .....	315
4.5 Frequency Stability Measurement .....	320
4.5.1 Limits of Frequency Stability Measurement .....	320
4.5.2 Test Setup.....	320

4.5.3	Test Instruments .....	320
4.5.4	Test Procedure .....	320
4.5.5	Deviation from Test Standard .....	320
4.5.6	EUT Operating Condition .....	320
4.5.7	Test Results .....	321
4.6	6dB Bandwidth Measurement .....	322
4.6.1	Limits of 6dB Bandwidth Measurement .....	322
4.6.2	Test Setup .....	322
4.6.3	Test Instruments .....	322
4.6.4	Test Procedure .....	322
4.6.5	Deviation from Test Standard .....	322
4.6.6	EUT Operating Condition .....	322
4.6.7	Test Results .....	323
<b>5</b>	<b>Pictures of Test Arrangements .....</b>	<b>325</b>
	<b>Appendix – Information on the Testing Laboratories .....</b>	<b>326</b>



### Release Control Record

Issue No.	Description	Date Issued
RF151104E03-1	Original release.	Dec. 16, 2015



## 2 Summary of Test Results

47 CFR FCC Part 15, Subpart E (SECTION 15.407)			
FCC Clause	Test Item	Result	Remarks
15.407(b)(6)	AC Power Conducted Emissions	Pass	Meet the requirement of limit. Minimum passing margin is -3.23dB at 0.58356MHz.
15.407(b) (1/2/3/4/6)	Radiated Emissions & Band Edge Measurement	Pass	Meet the requirement of limit. Minimum passing margin is -1dB at 5150.00MHz, 5715.00MHz, 5350.00MHz.
15.407(a)(1/2 /3)	Max Average Transmit Power	PASS	Meet the requirement of limit.
15.407(a)(1/2 /3)	Peak Power Spectral Density	PASS	Meet the requirement of limit.
15.407(e)	6dB bandwidth	PASS	Meet the requirement of limit. (U-NII-3 Band only)
15.407(g)	Frequency Stability	PASS	Meet the requirement of limit.
15.203	Antenna Requirement	PASS	Antenna connector is i-pex(MHFL4) or RPSMA not a standard connector.

**NOTE:** 1. For WLAN: The EUT was operating in 2400 ~ 2483.5MHz, 5.15~5.35 GHz, 5.47~5.725GHz and 5.725~5.85GHz frequencies band. This report was recorded the RF parameters including 5.15~5.35GHz, 5.47~5.725GHz and 5.725~5.85GHz. For the 2400 ~ 2483.5MHz RF parameters was recorded in another test report.

### 2.1 Measurement Uncertainty

Where relevant, the following measurement uncertainty levels have been estimated for tests performed on the EUT as specified in CISPR 16-4-2:

Measurement	Frequency	Expanded Uncertainty (k=2) (±)
Conducted Emissions at mains ports	150kHz ~ 30MHz	2.86 dB
Radiated Emissions up to 1 GHz	30MHz ~ 1000MHz	5.31 dB
Radiated Emissions above 1 GHz	1GHz ~ 6GHz	3.40 dB
	6GHz ~ 18GHz	3.73 dB
	18GHz ~ 40GHz	4.11 dB

### 2.2 Modification Record

There were no modifications required for compliance.

### 3 General Information

#### 3.1 General Description of EUT (WLAN)

Product	Vehicle Computer
Brand	Zebra
Test Model	VC80
Status of EUT	ENGINEERING SAMPLE
Power Supply Rating	DC 9-24V from Adapter DC 12-60V from Vehicle Battery DC 12.6V from PSU Battery
Modulation Type	CCK, DQPSK, DBPSK for DSSS 64QAM, 16QAM, QPSK, BPSK for OFDM 256QAM for OFDM in 11ac mode
Modulation Technology	DSSS, OFDM
Transfer Rate	802.11a: up to 54Mbps 802.11n : up to 300Mbps 802.11ac: up to 866.7Mbps
Operating Frequency	<b>For 15.407</b> 5.18 ~ 5.24GHz, 5.26 ~ 5.32GHz, 5.5 ~ 5.72GHz, 5.745 ~ 5.825GHz
	<b>For 15.247</b> 2.412 ~ 2.462GHz
Number of Channel	<b>For 15.407</b> 24 for 802.11a, 802.11n (HT20), 802.11ac (VHT20) 11 for 802.11n (HT40), 802.11ac (VHT40) 7 for 802.11ac (VHT80)
	<b>For 15.247</b> 13 for 802.11b, 802.11g, 802.11n (HT20) 9 for 802.11n (HT40)

Output Power	<b>For 15.407 (Average Power)</b> <b>5.18 ~ 5.24GHz:</b> 802.11a: 102.329mW 802.11ac (VHT20): 196.066mW 802.11ac (VHT40): 199.739mW 802.11ac (VHT80): 64.536mW <b>5.26 ~ 5.32GHz:</b> 802.11a: 100.462mW 802.11ac (VHT20): 193.688mW 802.11ac (VHT40): 191.865mW 802.11ac (VHT80): 59.459mW <b>5.5 ~ 5.72MHz:</b> 802.11a: 100.462mW 802.11ac (VHT20): 154.143mW 802.11ac (VHT40): 182.681mW 802.11ac (VHT80): 166.495mW <b>5.745 ~ 5.825MHz:</b> 802.11a: 112.98mW 802.11ac (VHT20): 201.444mW 802.11ac (VHT40): 187.408mW 802.11ac (VHT80): 48.718mW
	<b>For 15.247 (Peak Power)</b> 802.11b: 275.423mW 802.11g: 390.841mW 802.11n (HT20): 764.224mW 802.11n (HT40): 534.652mW
Antenna Type	Refer to Note
Antenna Connector	Refer to Note
Accessory Device	NA
Data Cable Supplied	NA

Note:

- The EUT has two different types could be chosen and please refer the below table:

Type	Difference
1	With External antenna
2	With Internal antenna

- There are WLAN and BT technology used for the EUT.
- For WLAN: 2.4GHz and 5GHz technology cannot transmit at same time.
- 2.4GHz/5GHz WLAN + BT will timely shared at same antenna port
- The EUT could be supplied with a power adaper as below table (only for test, not for sale):

Brand	FSP GROUP INC.
Model No.	FSP150-AAAN2
Input power	100-240V, 50-60Hz, 2A
Output power	+24V, 6.25A
	DC output cable (Unshielded, 1.8m with 2 cores)



**6. The EUT antennas information:**

Antenna No	PCB Chain No.	Model	Antenna Type	Antenna Connector	Antenna Gain (dBi) Exclude cable loss	Internal cable loss (dB)	External cable loss (dB)	Antenna Gain (dBi) Include cable loss	Internal cable length (mm)	External cable length (mm)	Frequency (GHz to GHz)
1	Int.Chain0	AN000097A01	Patch	i-pex (MHFL4)	5	NA	NA	5	NA	NA	2.4~2.4835
					5	NA	NA	5	NA	NA	5.15~5.85
	Int.Chain1				5	NA	NA	5	NA	NA	2.4~2.4835
					5	NA	NA	5	NA	NA	5.15~5.85
2	ext.Chain0	AN2010	Monopole	RPSMA	2	0.6	1.8	-0.4	147	2850	2.4~2.4835
					2	0.9	2.6	-1.5	147	2850	5.15~5.85
	ext.Chain1				2	0.6	1.8	-0.4	147	2850	2.4~2.4835
					2	0.9	2.6	-1.5	147	2850	5.15~5.85
3	ext.Chain0	AN2020	Monopole	RPSMA	5	0.6	1.8	2.6	147	2850	2.4~2.4835
	ext.Chain1				5	0.6	1.8	2.6	147	2850	2.4~2.4835
4	ext.Chain0	AN2030	Dipole	RPSMA	2	0.6	NA	1.4	147	NA	2.4~2.4835
					3.7	0.9	NA	2.8	147	NA	5.15~5.85
	ext.Chain1				2	0.6	NA	1.4	147	NA	2.4~2.4835
					3.7	0.9	NA	2.8	147	NA	5.15~5.85
5	ext.Chain0	AN2040	Dipole	RPSMA	2	0.6	NA	1.4	147	NA	2.4~2.4835
	ext.Chain1				2	0.6	NA	1.4	147	NA	2.4~2.4835

**Note:**

1. For 1TX configuration mode: max gain was selected as representative antenna.

**7. The Version of EUT information are as below:**

HW Version	MLB	EVT
	IO Board	EVT
	Battery Heater	EVT
	DTB	EVT
	DB9	EVT
	PSU	2
	Keypad	EVT
	Screen	Mitsubishi
SW Version	Operating System	WIN 7 professional
		WIN 7 Embedded
	Broadcom-WLAN	6.30.223.249 for Embedde
		6.30.223.262 for professional

**8. The HW spec. are as below:**

Detail HW spec.	Basic Warehouse int. Antenna	Basic Warehouse ext. Antenna
Intel E3825 Dual Core, 1.33GHz, 1MB Cache, 2GB RAM	v	v
16 GB SSD	v	v
Internal Antenna	v	
External Antenna (mag mount)		v
400 NITs Display	v	v
CAN Bus I/O	v	v

9. The EUT incorporates a MIMO function.

2.4GHz Band			
MODULATION MODE	DATA RATE (MCS)	TX & RX CONFIGURATION	
802.11b	1 ~ 11Mbps	1TX (diversity)	2RX
802.11g	6 ~ 54Mbps	1TX (diversity)	2RX
802.11n (HT20)	MCS 0~7	1TX (diversity)	2RX
	MCS 8~15	2TX	2RX
802.11n (HT40)	MCS 0~7	1TX (diversity)	2RX
	MCS 8~15	2TX	2RX
5GHz Band			
MODULATION MODE	DATA RATE (MCS)	TX & RX CONFIGURATION	
802.11a	6 ~ 54Mbps	1TX (diversity)	2RX
802.11n (HT20)	MCS 0~7	1TX (diversity)	2RX
	MCS 8~15	2TX	2RX
802.11n (HT40)	MCS 0~7	1TX (diversity)	2RX
	MCS 8~15	2TX	2RX
802.11ac (VHT20)	MCS 0~8, NSS=1	1TX (diversity)	2RX
	MCS 0~8, NSS=2	2TX	2RX
802.11ac (VHT40)	MCS 0~9, NSS=1	1TX (diversity)	2RX
	MCS 0~9, NSS=2	2TX	2RX
802.11ac (VHT80)	MCS 0~9, NSS=1	1TX (diversity)	2RX
	MCS 0~9, NSS=2	2TX	2RX

The modulation and bandwidth are similar for 802.11n mode for 20MHz (40MHz) and 802.11ac mode for 20MHz (40MHz), therefore investigated worst case to representative mode in test report. (Final test mode refer section 3.2.1)

10. The EUT was pre-tested under following test modes:

Pre-test Mode	Description
Mode A	Power from Adapter
Mode B	DC 12V from DC Power Supply
Mode C	DC 24V from DC Power Supply

From the above modes, the worst case was found in **Mode A**. Therefore only the test data of the modes were recorded in this report individually.

11. The above EUT information is declared by manufacturer and for more detailed features description, please refer to the manufacturer's specifications or user's manual.

### 3.2 Description of Test Modes

#### FOR 5180 ~ 5240MHz

4 channels are provided for 802.11a, 802.11n (HT20), 802.11ac (VHT20):

Channel	Frequency	Channel	Frequency
36	5180 MHz	44	5220 MHz
40	5200 MHz	48	5240 MHz

2 channels are provided for 802.11n (HT40), 802.11ac (VHT40):

Channel	Frequency	Channel	Frequency
38	5190 MHz	46	5230 MHz

1 channel is provided for 802.11ac (VHT80):

Channel	Frequency
42	5210MHz

#### FOR 5260 ~ 5320MHz

4 channels are provided for 802.11a, 802.11n (HT20), 802.11ac (VHT20):

Channel	Frequency	Channel	Frequency
52	5260 MHz	60	5300 MHz
56	5280 MHz	64	5320 MHz

2 channels are provided for 802.11n (HT40), 802.11ac (VHT40):

Channel	Frequency	Channel	Frequency
54	5270 MHz	62	5310 MHz

1 channel is provided for 802.11ac (VHT80):

Channel	Frequency
58	5290MHz

**FOR 5500 ~ 5720MHz**

11 channels are provided for 802.11a, 802.11n (HT20), 802.11ac (VHT20):

Channel	Frequency	Channel	Frequency
100	5500 MHz	124	5620 MHz
104	5520 MHz	128	5640 MHz
108	5540 MHz	132	5660 MHz
112	5560 MHz	136	5680 MHz
116	5580 MHz	140	5700 MHz
120	5600 MHz		

5 channels are provided for 802.11n (HT40), 802.11ac (VHT40):

Channel	Frequency	Channel	Frequency
102	5510 MHz	126	5630 MHz
110	5550 MHz	134	5670 MHz
118	5590 MHz		

3 channels are provided for 802.11ac (VHT80):

Channel	Frequency	Channel	Frequency
106	5530MHz	138	5690 MHz
122	5610 MHz		

**FOR 5745 ~ 5825MHz:**

5 channels are provided for 802.11a, 802.11n (HT20), 802.11ac (VHT20):

Channel	Frequency	Channel	Frequency
149	5745MHz	161	5805MHz
153	5765MHz	165	5825MHz
157	5785MHz		

2 channels are provided for 802.11n (HT40), 802.11ac (VHT40):

Channel	Frequency	Channel	Frequency
151	5755MHz	159	5795MHz

1 channel is provided for 802.11ac (VHT80):

Channel	Frequency
155	5775MHz

### 3.2.1 Test Mode Applicability and Tested Channel Detail

EUT CONFIGURE MODE	APPLICABLE TO				DESCRIPTION
	RE≥1G	RE<1G	PLC	APCM	
1	√	√	-	√	With Antenna 1 (Power from adapter)
2	√	√	√	-	With Antenna 2 (Power from adapter)
3	√	√	-	-	With Antenna 4 (Power from adapter)
4	-	-	√	-	With Antenna 2 (DC 24V from DC power supply)
5	-	-	√	-	With Antenna 2 (DC 12V from DC power supply)

Where **RE≥1G**: Radiated Emission above 1GHz      **RE<1G**: Radiated Emission below 1GHz  
**PLC**: Power Line Conducted Emission      **APCM**: Antenna Port Conducted Measurement  
 2. "-" means no effect.

#### Radiated Emission Test (Above 1GHz):

- Pre-Scan has been conducted to determine the worst-case mode from all possible combinations between available modulations, data rates and antenna ports (if EUT with antenna diversity architecture).
- Following channel(s) was (were) selected for the final test as listed below.

1TX Configuration					
MODE	FREQ. BAND (MHz)	AVAILABLE CHANNEL	TESTED CHANNEL	MODULATION TECHNOLOGY	DATA RATE (Mbps)
802.11a	5180-5240	36 to 48	36, 40, 48	OFDM	6
802.11a	5260-5320	52 to 64	52, 60, 64	OFDM	6
802.11a	5500-5720	100 to 140	100, 116, 120, 132, 140	OFDM	6
802.11a	5745-5825	149 to 165	149, 157, 165	OFDM	6
2TX Configuration					
MODE	FREQ. BAND (MHz)	AVAILABLE CHANNEL	TESTED CHANNEL	MODULATION TECHNOLOGY	DATA RATE (Mbps)
802.11ac (VHT20)	5180-5240	36 to 48	36, 40, 48	OFDM	13
802.11ac (VHT40)		38 to 46	38, 46	OFDM	27
802.11ac (VHT80)		42	42	OFDM	58.5
802.11ac (VHT20)	5260-5320	52 to 64	52, 60, 64	OFDM	13
802.11ac (VHT40)		54 to 62	54, 62	OFDM	27
802.11ac (VHT80)		58	58	OFDM	58.5
802.11ac (VHT20)	5500--5720	100 to 140	100, 116, 120, 132, 140	OFDM	13
802.11ac (VHT40)		102 to 134	102, 110, 118, 134	OFDM	27
802.11ac (VHT80)		106, 122, 138	106, 122, 138	OFDM	58.5
802.11ac (VHT20)	5745-5825	149 to 165	149, 157, 165	OFDM	13
802.11ac (VHT40)		151 to 159	151, 159	OFDM	27
802.11ac (VHT80)		155	155	OFDM	58.5

**Radiated Emission Test (Below 1GHz):**

- Pre-Scan has been conducted to determine the worst-case mode from all possible combinations between available modulations, data rates and antenna ports (if EUT with antenna diversity architecture).
- Following channel(s) was (were) selected for the final test as listed below.

1TX Configuration					
MODE	FREQ. BAND (MHz)	AVAILABLE CHANNEL	TESTED CHANNEL	MODULATION TECHNOLOGY	DATA RATE (Mbps)
802.11a	5180-5240	36 to 48	36, 40, 48	OFDM	6
802.11a	5260-5320	52 to 64	52, 60, 64	OFDM	6
802.11a	5500-5720	100 to 140	100, 116, 120, 132, 140	OFDM	6
802.11a	5745-5825	149 to 165	149, 157, 165	OFDM	6
2TX Configuration					
MODE	FREQ. BAND (MHz)	AVAILABLE CHANNEL	TESTED CHANNEL	MODULATION TECHNOLOGY	DATA RATE (Mbps)
802.11ac (VHT20)	5180-5240	36 to 48	36, 40, 48	OFDM	13
802.11ac (VHT40)		38 to 46	38, 46	OFDM	27
802.11ac (VHT80)		42	42	OFDM	58.5
802.11ac (VHT20)	5260-5320	52 to 64	52, 60, 64	OFDM	13
802.11ac (VHT40)		54 to 62	54, 62	OFDM	27
802.11ac (VHT80)		58	58	OFDM	58.5
802.11ac (VHT20)	5500--5720	100 to 140	100, 116, 120, 132, 140	OFDM	13
802.11ac (VHT40)		102 to 134	102, 110, 118, 134	OFDM	27
802.11ac (VHT80)		106, 122, 138	106, 122, 138	OFDM	58.5
802.11ac (VHT20)	5745-5825	149 to 165	149, 157, 165	OFDM	13
802.11ac (VHT40)		151 to 159	151, 159	OFDM	27
802.11ac (VHT80)		155	155	OFDM	58.5

**Power Line Conducted Emission Test:**

- Pre-Scan has been conducted to determine the worst-case mode from all possible combinations between available modulations, data rates and antenna ports (if EUT with antenna diversity architecture).
- Following channel(s) was (were) selected for the final test as listed below.

2TX Configuration					
MODE	FREQ. BAND (MHz)	AVAILABLE CHANNEL	TESTED CHANNEL	MODULATION TECHNOLOGY	DATA RATE (Mbps)
802.11ac (VHT20)	5180-5320, 5500-5720, 5745-5825	36 to 64, 102 to 140, 149 to 165	157	OFDM	13

**Antenna Port Conducted Measurement:**

- This item includes all test value of each mode, but only includes spectrum plot of worst value of each mode.
- Pre-Scan has been conducted to determine the worst-case mode from all possible combinations between available modulations, data rates and antenna ports (if EUT with antenna diversity architecture).
- Following channel(s) was (were) selected for the final test as listed below.

1TX Configuration					
MODE	FREQ. BAND (MHz)	AVAILABLE CHANNEL	TESTED CHANNEL	MODULATION TECHNOLOGY	DATA RATE (Mbps)
802.11a	5180-5240	36 to 48	36, 40, 48	OFDM	6
802.11a	5260-5320	52 to 64	52, 60, 64	OFDM	6
802.11a	5500-5720	100 to 140	100, 116, 120, 132, 140	OFDM	6
802.11a	5745-5825	149 to 165	149, 157, 165	OFDM	6
2TX Configuration					
MODE	FREQ. BAND (MHz)	AVAILABLE CHANNEL	TESTED CHANNEL	MODULATION TECHNOLOGY	DATA RATE (Mbps)
802.11ac (VHT20)	5180-5240	36 to 48	36, 40, 48	OFDM	13
802.11ac (VHT40)		38 to 46	38, 46	OFDM	27
802.11ac (VHT80)		42	42	OFDM	58.5
802.11ac (VHT20)	5260-5320	52 to 64	52, 60, 64	OFDM	13
802.11ac (VHT40)		54 to 62	54, 62	OFDM	27
802.11ac (VHT80)		58	58	OFDM	58.5
802.11ac (VHT20)	5500-5720	100 to 140	100, 116, 120, 132, 140	OFDM	13
802.11ac (VHT40)		102 to 118, 134	102, 110, 118, 134	OFDM	27
802.11ac (VHT80)		106, 122, 138	106, 122, 138	OFDM	58.5
802.11ac (VHT20)	5745-5825	149 to 165	149, 157, 165	OFDM	13
802.11ac (VHT40)		151 to 159	151, 159	OFDM	27
802.11ac (VHT80)		155	155	OFDM	58.5

**Test Condition:**

APPLICABLE TO	ENVIRONMENTAL CONDITIONS	INPUT POWER (SYSTEM)	TESTED BY
RE $\geq$ 1G	24deg. C, 68%RH 25deg. C, 73%RH 23deg. C, 63%RH	120Vac, 60Hz	Andy Ho Jyunchun Lin
RE $<$ 1G	26deg. C, 71%RH	120Vac, 60Hz	Tim Ho
PLC	25deg. C, 63%RH 22deg. C, 63%RH 24deg. C, 62%RH	120Vac, 60Hz DC 24V DC 12V	Andy Ho
APCM	25deg. C, 60%RH	120Vac, 60Hz	Anderson Chen

### 3.3 Duty Cycle of Test Signal

If duty cycle of test signal is  $\geq 98\%$ , duty factor is not required.  
 If duty cycle of test signal is  $< 98\%$ , duty factor shall be considered.

**802.11a:** Duty cycle =  $2.066 \text{ ms} / 2.084 \text{ ms} = 0.991$

**802.11ac (VHT20):** Duty cycle =  $1.919 \text{ ms} / 1.939 \text{ ms} = 0.99$

**802.11ac (VHT40):** Duty cycle =  $0.948 \text{ ms} / 0.965 \text{ ms} = 0.982$

**802.11ac (VHT80):** Duty cycle =  $0.459 \text{ ms} / 0.48 \text{ ms} = 0.956$ , Duty factor =  $10 * \log(1/0.956) = 0.19$

**802.11a** **802.11ac (VHT20)**

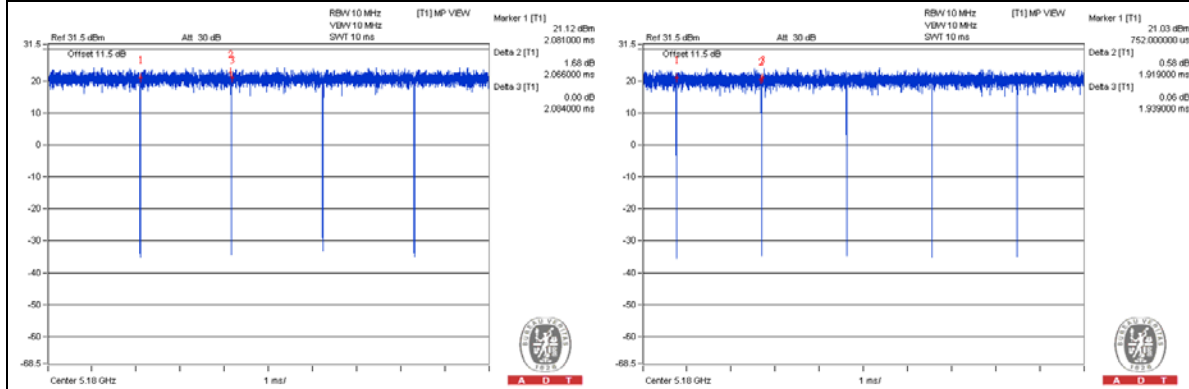

**802.11ac (VHT40)** **802.11ac (VHT80)**

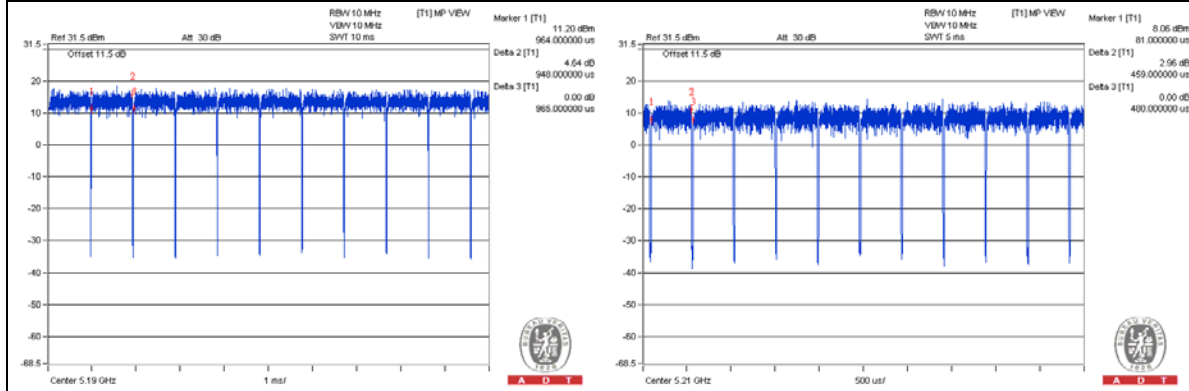



### 3.4 Description of Support Units

The EUT has been tested as an independent unit together with other necessary accessories or support units. The following support units or accessories were used to form a representative test configuration during the tests.

ID	Product	Brand	Model No.	Serial No.	FCC ID	Remarks
A.	Modem	ACEEX	1414	0206026778	IFAXDM1414	Provided by Lab
B.	Modem	ACEEX	1414	0206026779	IFAXDM1414	Provided by Lab
C.	Notebook Computer	DELL	PP27L	7YLB32S	FCC DoC	Provided by Lab
D.	Keyboard	MOTOROLA	KYBD-NU-VC70	NA	NA	Supplied by Client
E.	Scanner	Symbol	DS3508	NA	NA	Supplied by Client
F.	Speaker/ mic	OTTO	V2-10332 1250	NA	NA	Supplied by Client
G.	Adapter	FSP GROUP INC.	FSP150-AAAN2	H00000231	NA	Supplied by Client
H.	DC Power Supply	Topward	6603D	795551	NA	Provided by Lab

Note:

1. All power cords of the above support units are non-shielded (1.8m).

ID	Descriptions	Qty.	Length (m)	Shielding (Yes/No)	Cores (Qty.)	Remarks
1.	RS232	1	0.9	No	0	Provided by Lab
2.	RS232	1	0.9	No	0	Provided by Lab
3.	RJ45	1	10	No	0	Provided by Lab
4.	DC	1	0.6	No	0	Supplied by Client
5.	DC	1	1.8	No	2	Supplied by Client
6.	AC	1	1.8	No	0	Provided by Lab
7.	USB	1	0.9	No	0	Supplied by Client
8.	USB	1	2	No	0	Supplied by Client
9.	Audio	1	0.6	No	1	Supplied by Client
10.	DC	1	1.8	No	0	Supplied by Client

Note: The core(s) is(are) originally attached to the cable(s).

### 3.4.1 Configuration of System under Test

#### For Conducted emission test mode 4 & 5:

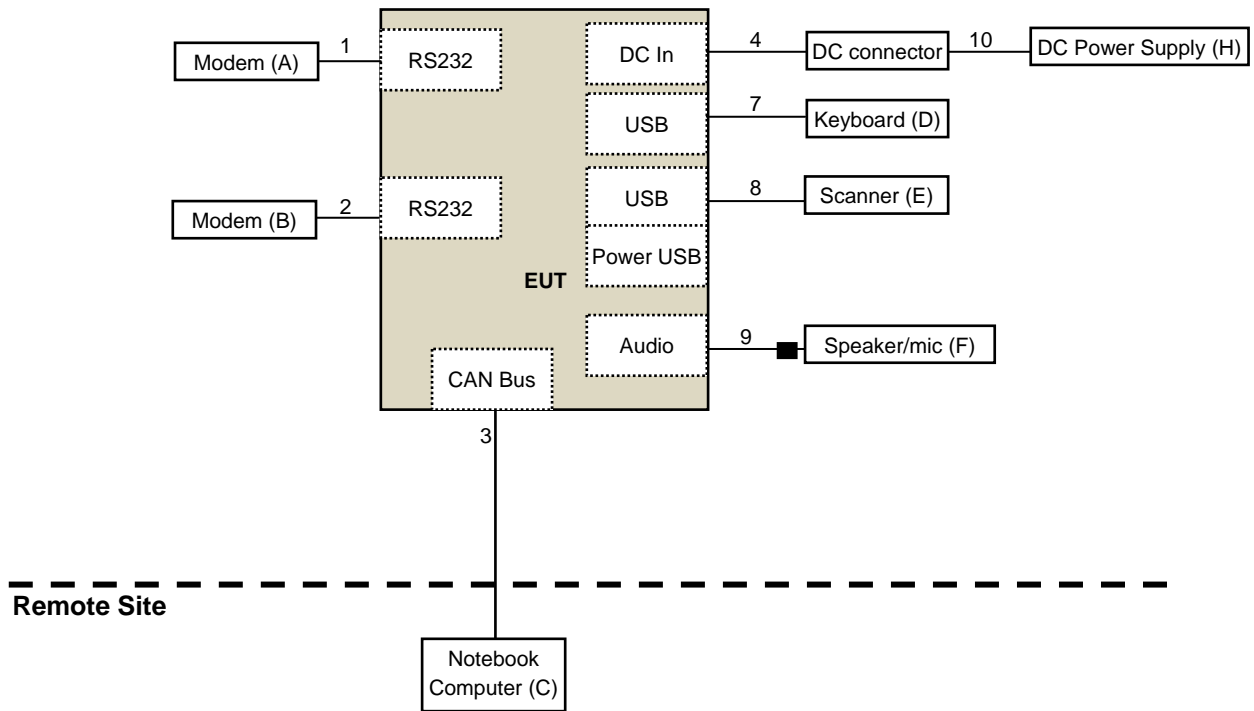

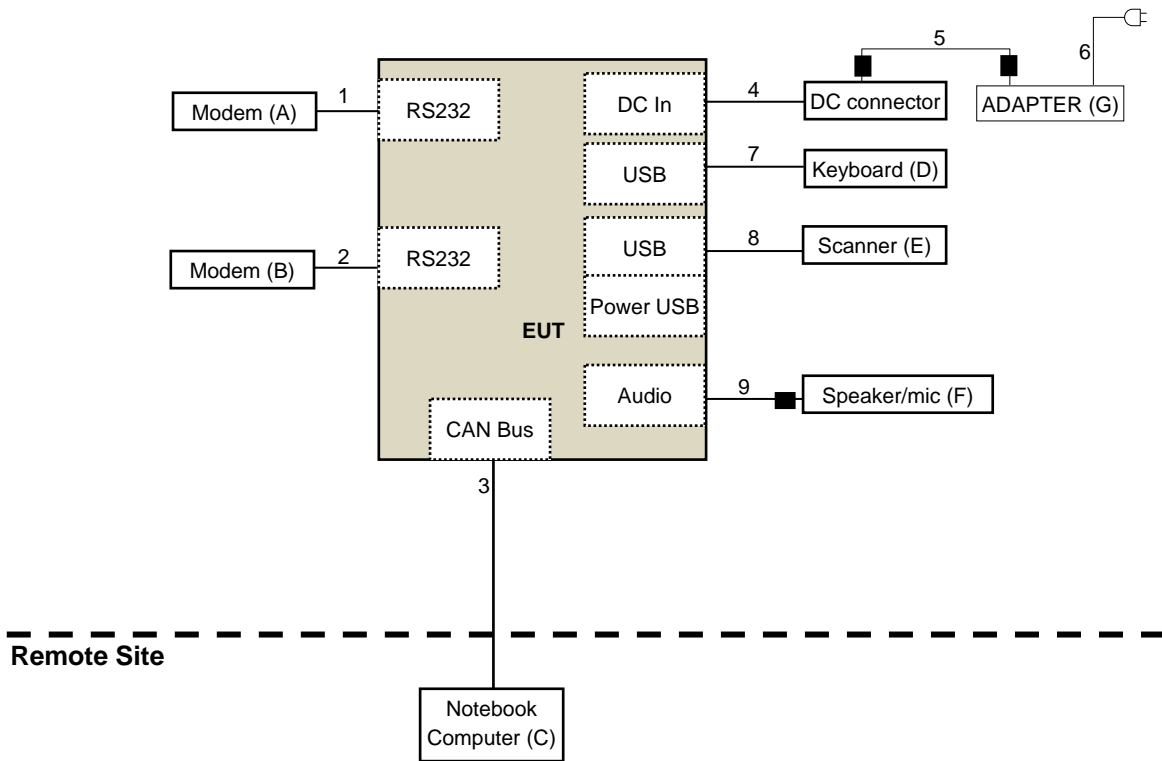
**For Other test items:**

### 3.5 General Description of Applied Standard

The EUT is a RF Product. According to the specifications of the manufacturer, it must comply with the requirements of the following standards:

**FCC Part 15, Subpart E (15.407)**

**789033 D02 General UNII Test Procedure New Rules v01**

ANSI C63.10-2013

All test items have been performed and recorded as per the above standards.

## 4 Test Types and Results

### 4.1 Radiated Emission and Bandedge Measurement

#### 4.1.1 Limits of Radiated Emission and Bandedge Measurement

Radiated emissions which fall in the restricted bands must comply with the radiated emission limits specified as below table.

Frequencies (MHz)	Field Strength (microvolts/meter)	Measurement Distance (meters)
0.009 ~ 0.490	2400/F(kHz)	300
0.490 ~ 1.705	24000/F(kHz)	30
1.705 ~ 30.0	30	30
30 ~ 88	100	3
88 ~ 216	150	3
216 ~ 960	200	3
Above 960	500	3

**NOTE:**

1. The lower limit shall apply at the transition frequencies.
2. Emission level (dBuV/m) = 20 log Emission level (uV/m).
3. For frequencies above 1000MHz, the field strength limits are based on average detector, however, the peak field strength of any emission shall not exceed the maximum permitted average limits, specified above by more than 20dB under any condition of modulation.

**LIMITS OF UNWANTED EMISSION OUT OF THE RESTRICTED BANDS**

APPLICABLE TO	LIMIT	
789033 D02 General UNII Test Procedure New Rules v01	FIELD STRENGTH AT 3m	
	PK:74 (dBuV/m)	AV:54 (dBuV/m)
APPLICABLE TO	EIRP LIMIT	EQUIVALENT FIELD STRENGTH AT 3m
15.407(b)(1)	PK:-27 (dBm/MHz)	PK:68.2(dBuV/m)
15.407(b)(2)		
15.407(b)(3)		
15.407(b)(4)	PK:-27 (dBm/MHz) <sup>*1</sup> PK:-17 (dBm/MHz) <sup>*2</sup>	PK: 68.2(dBuV/m) <sup>*1</sup> PK:78.2 (dBuV/m) <sup>*2</sup>

**NOTE:** <sup>\*1</sup> beyond 10MHz of the band edge <sup>\*2</sup> within 10 MHz of band edge

The following formula is used to convert the equipment isotropic radiated power (eirp) to field strength:

$$E = \frac{1000000\sqrt{30P}}{3} \mu\text{V/m, where P is the eirp (Watts).$$

**4.1.2 Test Instruments**

<b>DESCRIPTION &amp; MANUFACTURER</b>	<b>MODEL NO.</b>	<b>SERIAL NO.</b>	<b>CALIBRATED DATE</b>	<b>CALIBRATED UNTIL</b>
Test Receiver Agilent	N9038A	MY50010156	Aug. 12, 2015	Aug. 11, 2016
Pre-Amplifier(*) EMCI	EMC001340	980142	Jan. 13, 2014	Jan. 12, 2016
Loop Antenna(*) Electro-Metrics	EM-6879	264	Dec. 16, 2014	Dec. 15, 2016
RF Cable	NA	LOOPCAB-00 1 LOOPCAB-00 2	Jan. 18, 2015	Jan. 17, 2016
Pre-Amplifier Mini-Circuits	ZFL-1000VH2 B	AMP-ZFL-07	May 08, 2015	May 07, 2016
Trilog Broadband Antenna SCHWARZBECK	VULB 9168	138	Feb. 03, 2015	Feb. 02, 2016
RF Cable	8D	966-3-1 966-3-2 966-3-3	Apr. 03, 2015	Apr. 02, 2016
Horn_Antenna SCHWARZBECK	BBHA9120-D	9120D-406	Feb. 05, 2015	Feb. 04, 2016
Pre-Amplifier Agilent	8449B	3008A02465	Apr. 06, 2015	Apr. 05, 2016
RF Cable	EMC104-SM- SM-2000 EMC104-SM- SM-5000 EMC104-SM- SM-5000	150317 150321 150322	Mar. 31, 2015	Mar. 30, 2016
Spectrum Analyzer Keysight	N9030A	MY54490520	July 26, 2015	July 25, 2016
Pre-Amplifier EMCI	EMC184045	980143	Jan. 16, 2015	Jan. 15, 2016
Horn_Antenna SCHWARZBECK	BBHA 9170	BBHA9170608	Feb. 05, 2015	Feb. 04, 2016
RF Cable	SUCOFLEX10 4	329751/4 RF104-204	Dec. 11, 2014	Dec. 10, 2015
Software	ADT_Radiated _V8.7.07	NA	NA	NA
Antenna Tower & Turn Table CT	NA	NA	NA	NA
Power Meter Anritsu	ML2495A	1014008	Apr. 28, 2015	Apr. 27, 2016
Power Sensor Anritsu	MA2411B	0917122	Apr. 28, 2015	Apr. 27, 2016
Spectrum Analyzer R&S	FSP40	100060	May 08, 2015	May 07, 2016

**Note:**

1. The calibration interval of the above test instruments is 12 months and the calibrations are traceable to NML/ROC and NIST/USA.
2. \*The calibration interval of the above test instruments is 24 months and the calibrations are traceable to NML/ROC and NIST/USA.
3. Loop antenna was used for all emissions below 30 MHz.
4. The horn antenna, preamplifier (model: 8449B) are used only for the measurement of emission frequency above 1GHz if tested.
5. The test was performed in 966 Chamber No. 3.
- 6 The FCC Site Registration No. is 147459
- 7 The CANADA Site Registration No. is 20331-1
- 8 Tested Date: Nov. 18 to 27, 2015

#### 4.1.3 Test Procedure

- a. The EUT was placed on the top of a rotating table 0.8 meters (for below 1GHz) / 1.5 meters (for above 1GHz) above the ground at 3 meter chamber room for test. The table was rotated 360 degrees to determine the position of the highest radiation.
- b. The EUT was set 3 meters away from the interference-receiving antenna, which was mounted on the top of a variable-height antenna tower.
- c. The height of antenna is varied from one meter to four meters above the ground to determine the maximum value of the field strength. Both horizontal and vertical polarizations of the antenna are set to make the measurement.
- d. For each suspected emission, the EUT was arranged to its worst case and then the antenna was tuned to heights from 1 meter to 4 meters and the rotatable table was turned from 0 degrees to 360 degrees to find the maximum reading.
- e. The test-receiver system was set to quasi-peak detect function and specified bandwidth with maximum hold mode when the test frequency is below 1 GHz.
- f. The test-receiver system was set to peak and average detect function and specified bandwidth with maximum hold mode when the test frequency is above 1 GHz. If the peak reading value also meets average limit, measurement with the average detector is unnecessary.

**Note:**

1. The resolution bandwidth and video bandwidth of test receiver/spectrum analyzer is 120kHz for Quasi-peak detection (QP) at frequency below 1GHz.
2. The resolution bandwidth of test receiver/spectrum analyzer is 1 MHz and the video bandwidth is 3 MHz for Peak detection (PK) at frequency above 1GHz.
3. The resolution bandwidth of test receiver/spectrum analyzer is 1MHz and the video bandwidth is 3MHz for RMS Average (Duty cycle < 98%) for Average detection (AV) at frequency above 1GHz, then the measurement results was added to a correction factor ( $10 \log(1/\text{duty cycle})$ ).
4. The resolution bandwidth of test receiver/spectrum analyzer is 1MHz and the video bandwidth is 10Hz (Duty cycle  $\geq 98\%$ ) for Average detection (AV) at frequency above 1GHz.
5. All modes of operation were investigated and the worst-case emissions are reported.

#### 4.1.4 Deviation from Test Standard

No deviation.



#### 4.1.5 Test Setup

##### <Frequency Range below 1GHz>

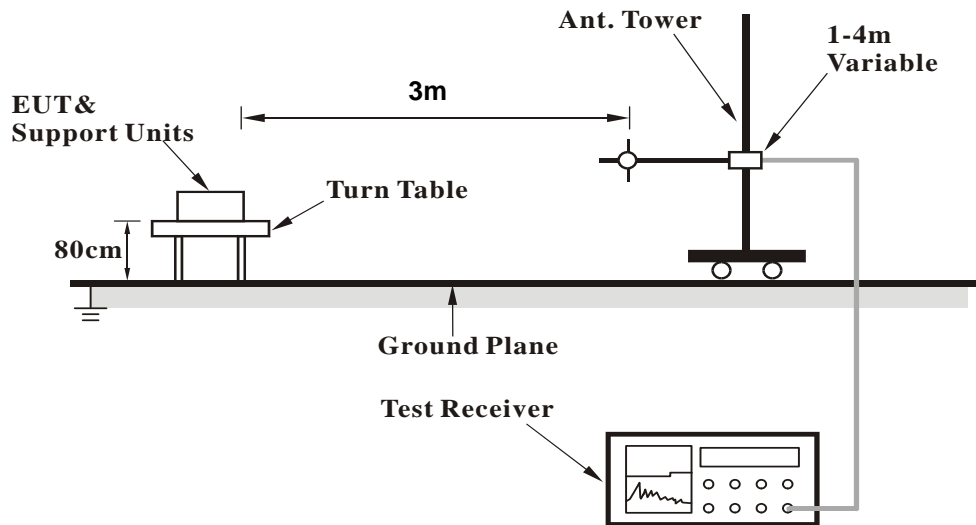

##### <Frequency Range above 1GHz>

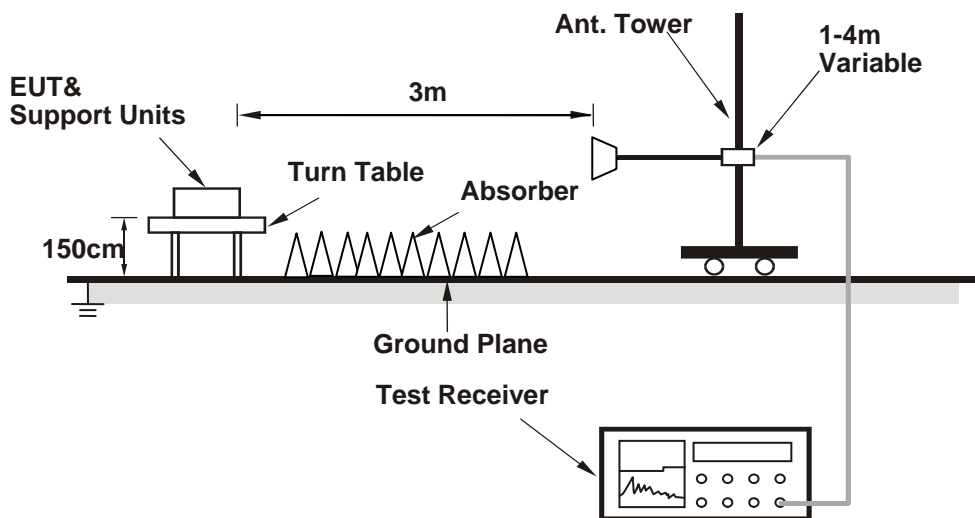

For the actual test configuration, please refer to the attached file (Test Setup Photo).

#### 4.1.6 EUT Operating Condition

1. Connect the EUT with the support unit C (Notebook Computer) which is placed on remote site.
2. The communication partner run test program "Mtool 2.0.0.72" to enable EUT under transmission/receiving condition continuously at specific channel frequency.

4.1.7 Test Results (Mode 1)

Above 1GHz Data

802.11a

<b>CHANNEL</b>	TX Channel 36	<b>DETECTOR FUNCTION</b>	Peak (PK)
<b>FREQUENCY RANGE</b>	1GHz ~ 40GHz		Average (AV)

**ANTENNA POLARITY & TEST DISTANCE: HORIZONTAL AT 3 M**

NO.	FREQ. (MHz)	EMISSION LEVEL (dBuV/m)	LIMIT (dBuV/m)	MARGIN (dB)	ANTENNA HEIGHT (m)	TABLE ANGLE (Degree)	RAW VALUE (dBuV)	CORRECTION FACTOR (dB/m)
1	5150.00	67.1 PK	74.0	-6.9	2.15 H	325	60.63	6.47
2	5150.00	52.9 AV	54.0	-1.1	2.15 H	325	46.43	6.47
3	*5180.00	110.1 PK			2.15 H	325	103.45	6.65
4	*5180.00	100.1 AV			2.15 H	325	93.45	6.65
5	#10360.00	49.6 PK	74.0	-24.4	1.53 H	271	35.39	14.21
6	#10360.00	37.6 AV	54.0	-16.4	1.53 H	271	23.39	14.21
7	15540.00	51.7 PK	74.0	-22.3	1.46 H	215	32.94	18.76
8	15540.00	39.7 AV	54.0	-14.3	1.46 H	215	20.94	18.76

**ANTENNA POLARITY & TEST DISTANCE: VERTICAL AT 3 M**

NO.	FREQ. (MHz)	EMISSION LEVEL (dBuV/m)	LIMIT (dBuV/m)	MARGIN (dB)	ANTENNA HEIGHT (m)	TABLE ANGLE (Degree)	RAW VALUE (dBuV)	CORRECTION FACTOR (dB/m)
1	5150.00	64.7 PK	74.0	-9.3	1.73 V	290	58.23	6.47
2	5150.00	52.7 AV	54.0	-1.3	1.73 V	290	46.23	6.47
3	*5180.00	108.1 PK			1.73 V	290	101.45	6.65
4	*5180.00	99.0 AV			1.73 V	290	92.35	6.65
5	#10360.00	51.8 PK	74.0	-22.2	1.63 V	236	37.59	14.21
6	#10360.00	39.4 AV	54.0	-14.6	1.63 V	236	25.19	14.21
7	15540.00	58.7 PK	74.0	-15.3	1.64 V	28	39.94	18.76
8	15540.00	47.4 AV	54.0	-6.6	1.64 V	28	28.64	18.76

**REMARKS:**

1. Emission Level(dBuV/m) = Raw Value(dBuV) + Correction Factor(dB/m)
2. Correction Factor(dB/m) = Antenna Factor(dB/m) + Cable Factor(dB) – Pre-Amplifier Factor(dB)
3. The other emission levels were very low against the limit.
4. Margin value = Emission Level – Limit value
5. " \* ": Fundamental frequency.
6. " # ": The radiated frequency is out of the restricted band.

<b>CHANNEL</b>	TX Channel 40	<b>DETECTOR FUNCTION</b>	Peak (PK)
<b>FREQUENCY RANGE</b>	1GHz ~ 40GHz		Average (AV)

**ANTENNA POLARITY & TEST DISTANCE: HORIZONTAL AT 3 M**

NO.	FREQ. (MHz)	EMISSION LEVEL (dBuV/m)	LIMIT (dBuV/m)	MARGIN (dB)	ANTENNA HEIGHT (m)	TABLE ANGLE (Degree)	RAW VALUE (dBuV)	CORRECTION FACTOR (dB/m)
1	5150.00	61.0 PK	74.0	-13.0	2.15 H	316	54.53	6.47
2	5150.00	46.3 AV	54.0	-7.7	2.15 H	316	39.83	6.47
3	*5200.00	111.4 PK			2.15 H	316	104.63	6.77
4	*5200.00	101.2 AV			2.15 H	316	94.43	6.77
5	5350.00	58.5 PK	74.0	-15.5	2.15 H	53	51.46	7.04
6	5350.00	45.6 AV	54.0	-8.4	2.15 H	53	38.56	7.04
7	#10400.00	52.3 PK	74.0	-21.7	1.44 H	202	38.08	14.22
8	#10400.00	39.8 AV	54.0	-14.2	1.44 H	202	25.58	14.22
9	15600.00	56.9 PK	74.0	-17.1	1.54 H	48	38.56	18.34
10	15600.00	45.8 AV	54.0	-8.2	1.54 H	48	27.46	18.34

**ANTENNA POLARITY & TEST DISTANCE: VERTICAL AT 3 M**

NO.	FREQ. (MHz)	EMISSION LEVEL (dBuV/m)	LIMIT (dBuV/m)	MARGIN (dB)	ANTENNA HEIGHT (m)	TABLE ANGLE (Degree)	RAW VALUE (dBuV)	CORRECTION FACTOR (dB/m)
1	5150.00	58.6 PK	74.0	-15.4	1.72 V	296	52.13	6.47
2	5150.00	45.0 AV	54.0	-9.0	1.72 V	296	38.53	6.47
3	*5200.00	109.5 PK			1.72 V	296	102.73	6.77
4	*5200.00	100.1 AV			1.72 V	296	93.33	6.77
5	5350.00	56.9 PK	74.0	-17.1	2.06 V	301	49.86	7.04
6	5350.00	45.5 AV	54.0	-8.5	2.06 V	301	38.46	7.04
7	#10400.00	52.9 PK	74.0	-21.1	1.69 V	225	38.68	14.22
8	#10400.00	40.2 AV	54.0	-13.8	1.69 V	225	25.98	14.22
9	15600.00	58.5 PK	74.0	-15.5	1.68 V	16	40.16	18.34
10	15600.00	47.4 AV	54.0	-6.6	1.68 V	16	29.06	18.34

**REMARKS:**

1. Emission Level(dBuV/m) = Raw Value(dBuV) + Correction Factor(dB/m)
2. Correction Factor(dB/m) = Antenna Factor(dB/m) + Cable Factor(dB) – Pre-Amplifier Factor(dB)
3. The other emission levels were very low against the limit.
4. Margin value = Emission Level – Limit value
5. " \* ": Fundamental frequency.
6. " # ": The radiated frequency is out of the restricted band.

<b>CHANNEL</b>	TX Channel 48	<b>DETECTOR FUNCTION</b>	Peak (PK)
<b>FREQUENCY RANGE</b>	1GHz ~ 40GHz		Average (AV)

**ANTENNA POLARITY & TEST DISTANCE: HORIZONTAL AT 3 M**

NO.	FREQ. (MHz)	EMISSION LEVEL (dBuV/m)	LIMIT (dBuV/m)	MARGIN (dB)	ANTENNA HEIGHT (m)	TABLE ANGLE (Degree)	RAW VALUE (dBuV)	CORRECTION FACTOR (dB/m)
1	5122.00	54.2 PK	74.0	-19.8	2.17 H	320	47.89	6.31
2	5122.00	43.6 AV	54.0	-10.4	2.17 H	320	37.29	6.31
3	*5240.00	110.8 PK			2.46 H	54	103.98	6.82
4	*5240.00	100.9 AV			2.46 H	54	94.08	6.82
5	5401.00	55.6 PK	74.0	-18.4	2.46 H	54	48.41	7.19
6	5401.00	45.0 AV	54.0	-9.0	2.46 H	54	37.81	7.19
7	#10480.00	52.1 PK	74.0	-21.9	1.36 H	206	38.11	13.99
8	#10480.00	39.5 AV	54.0	-14.5	1.36 H	206	25.51	13.99
9	15720.00	57.1 PK	74.0	-16.9	1.48 H	49	38.07	19.03
10	15720.00	45.7 AV	54.0	-8.3	1.48 H	49	26.67	19.03

**ANTENNA POLARITY & TEST DISTANCE: VERTICAL AT 3 M**

NO.	FREQ. (MHz)	EMISSION LEVEL (dBuV/m)	LIMIT (dBuV/m)	MARGIN (dB)	ANTENNA HEIGHT (m)	TABLE ANGLE (Degree)	RAW VALUE (dBuV)	CORRECTION FACTOR (dB/m)
1	5122.00	52.6 PK	74.0	-21.4	1.70 V	301	46.29	6.31
2	5122.00	42.5 AV	54.0	-11.5	1.70 V	301	36.19	6.31
3	*5240.00	109.6 PK			1.77 V	310	102.78	6.82
4	*5240.00	100.2 AV			1.77 V	310	93.38	6.82
5	5401.00	53.2 PK	74.0	-20.8	1.77 V	310	46.01	7.19
6	5401.00	43.8 AV	54.0	-10.2	1.77 V	310	36.61	7.19
7	#10480.00	52.6 PK	74.0	-21.4	1.64 V	218	38.61	13.99
8	#10480.00	39.9 AV	54.0	-14.1	1.64 V	218	25.91	13.99
9	15720.00	58.2 PK	74.0	-15.8	1.67 V	29	39.17	19.03
10	15720.00	47.2 AV	54.0	-6.8	1.67 V	29	28.17	19.03

**REMARKS:**

1. Emission Level(dBuV/m) = Raw Value(dBuV) + Correction Factor(dB/m)
2. Correction Factor(dB/m) = Antenna Factor(dB/m) + Cable Factor(dB) – Pre-Amplifier Factor(dB)
3. The other emission levels were very low against the limit.
4. Margin value = Emission Level – Limit value
5. " \* ": Fundamental frequency.
6. " # ": The radiated frequency is out of the restricted band.

<b>CHANNEL</b>	TX Channel 52	<b>DETECTOR FUNCTION</b>	Peak (PK)
<b>FREQUENCY RANGE</b>	1GHz ~ 40GHz		Average (AV)

**ANTENNA POLARITY & TEST DISTANCE: HORIZONTAL AT 3 M**

NO.	FREQ. (MHz)	EMISSION LEVEL (dBuV/m)	LIMIT (dBuV/m)	MARGIN (dB)	ANTENNA HEIGHT (m)	TABLE ANGLE (Degree)	RAW VALUE (dBuV)	CORRECTION FACTOR (dB/m)
1	5150.00	55.8 PK	74.0	-18.2	1.99 H	322	49.33	6.47
2	5150.00	44.1 AV	54.0	-9.9	1.99 H	322	37.63	6.47
3	*5260.00	110.8 PK			2.19 H	54	103.95	6.85
4	*5260.00	100.6 AV			2.19 H	54	93.75	6.85
5	5421.00	57.8 PK	74.0	-16.2	2.19 H	54	50.57	7.23
6	5421.00	46.1 AV	54.0	-7.9	2.19 H	54	38.87	7.23
7	#10520.00	51.7 PK	74.0	-22.3	1.33 H	198	37.87	13.83
8	#10520.00	39.6 AV	54.0	-14.4	1.33 H	198	25.77	13.83
9	15780.00	58.0 PK	74.0	-16.0	1.55 H	28	38.64	19.36
10	15780.00	46.5 AV	54.0	-7.5	1.55 H	28	27.14	19.36

**ANTENNA POLARITY & TEST DISTANCE: VERTICAL AT 3 M**

NO.	FREQ. (MHz)	EMISSION LEVEL (dBuV/m)	LIMIT (dBuV/m)	MARGIN (dB)	ANTENNA HEIGHT (m)	TABLE ANGLE (Degree)	RAW VALUE (dBuV)	CORRECTION FACTOR (dB/m)
1	5150.00	53.2 PK	74.0	-20.8	1.70 V	283	46.73	6.47
2	5150.00	42.8 AV	54.0	-11.2	1.70 V	283	36.33	6.47
3	*5260.00	109.2 PK			1.70 V	283	102.35	6.85
4	*5260.00	99.8 AV			1.70 V	283	92.95	6.85
5	5421.00	56.3 PK	74.0	-17.7	1.70 V	283	49.07	7.23
6	5421.00	45.0 AV	54.0	-9.0	1.70 V	283	37.77	7.23
7	#10520.00	52.6 PK	74.0	-21.4	1.65 V	250	38.77	13.83
8	#10520.00	40.0 AV	54.0	-14.0	1.65 V	250	26.17	13.83
9	15780.00	58.5 PK	74.0	-15.5	1.74 V	27	39.14	19.36
10	15780.00	47.2 AV	54.0	-6.8	1.74 V	27	27.84	19.36

**REMARKS:**

1. Emission Level(dBuV/m) = Raw Value(dBuV) + Correction Factor(dB/m)
2. Correction Factor(dB/m) = Antenna Factor(dB/m) + Cable Factor(dB) – Pre-Amplifier Factor(dB)
3. The other emission levels were very low against the limit.
4. Margin value = Emission Level – Limit value
5. " \* ": Fundamental frequency.
6. " # ": The radiated frequency is out of the restricted band.

<b>CHANNEL</b>	TX Channel 60	<b>DETECTOR FUNCTION</b>	Peak (PK)
<b>FREQUENCY RANGE</b>	1GHz ~ 40GHz		Average (AV)

**ANTENNA POLARITY & TEST DISTANCE: HORIZONTAL AT 3 M**

NO.	FREQ. (MHz)	EMISSION LEVEL (dBuV/m)	LIMIT (dBuV/m)	MARGIN (dB)	ANTENNA HEIGHT (m)	TABLE ANGLE (Degree)	RAW VALUE (dBuV)	CORRECTION FACTOR (dB/m)
1	*5300.00	111.2 PK			2.17 H	53	104.30	6.90
2	*5300.00	101.4 AV			2.17 H	53	94.50	6.90
3	5350.00	60.5 PK	74.0	-13.5	2.17 H	53	53.46	7.04
4	5350.00	46.8 AV	54.0	-7.2	2.17 H	53	39.76	7.04
5	10600.00	51.9 PK	74.0	-22.1	1.43 H	195	38.46	13.44
6	10600.00	39.7 AV	54.0	-14.3	1.43 H	195	26.26	13.44
7	15900.00	57.2 PK	74.0	-16.8	1.47 H	35	38.19	19.01
8	15900.00	45.2 AV	54.0	-8.8	1.47 H	35	26.19	19.01

**ANTENNA POLARITY & TEST DISTANCE: VERTICAL AT 3 M**

NO.	FREQ. (MHz)	EMISSION LEVEL (dBuV/m)	LIMIT (dBuV/m)	MARGIN (dB)	ANTENNA HEIGHT (m)	TABLE ANGLE (Degree)	RAW VALUE (dBuV)	CORRECTION FACTOR (dB/m)
1	*5300.00	109.8 PK			1.66 V	310	102.90	6.90
2	*5300.00	100.2 AV			1.66 V	310	93.30	6.90
3	5350.00	57.9 PK	74.0	-16.1	1.66 V	310	50.86	7.04
4	5350.00	45.6 AV	54.0	-8.4	1.66 V	310	38.56	7.04
5	10600.00	52.4 PK	74.0	-21.6	1.66 V	234	38.96	13.44
6	10600.00	39.8 AV	54.0	-14.2	1.66 V	234	26.36	13.44
7	15900.00	58.8 PK	74.0	-15.2	1.69 V	14	39.79	19.01
8	15900.00	47.5 AV	54.0	-6.5	1.69 V	14	28.49	19.01

**REMARKS:**

1. Emission Level(dBuV/m) = Raw Value(dBuV) + Correction Factor(dB/m)
2. Correction Factor(dB/m) = Antenna Factor(dB/m) + Cable Factor(dB) – Pre-Amplifier Factor(dB)
3. The other emission levels were very low against the limit.
4. Margin value = Emission Level – Limit value
5. " \* ": Fundamental frequency.

<b>CHANNEL</b>	TX Channel 64	<b>DETECTOR FUNCTION</b>	Peak (PK)
<b>FREQUENCY RANGE</b>	1GHz ~ 40GHz		Average (AV)

**ANTENNA POLARITY & TEST DISTANCE: HORIZONTAL AT 3 M**

NO.	FREQ. (MHz)	EMISSION LEVEL (dBuV/m)	LIMIT (dBuV/m)	MARGIN (dB)	ANTENNA HEIGHT (m)	TABLE ANGLE (Degree)	RAW VALUE (dBuV)	CORRECTION FACTOR (dB/m)
1	*5320.00	110.1 PK			1.84 H	315	103.13	6.97
2	*5320.00	100.7 AV			1.84 H	315	93.73	6.97
3	5350.00	68.8 PK	74.0	-5.2	1.84 H	315	61.76	7.04
4	5350.00	52.9 AV	54.0	-1.1	1.84 H	315	45.86	7.04
5	10640.00	51.5 PK	74.0	-22.5	1.41 H	191	37.83	13.67
6	10640.00	39.1 AV	54.0	-14.9	1.41 H	191	25.43	13.67
7	15960.00	57.4 PK	74.0	-16.6	1.55 H	33	38.56	18.84
8	15960.00	46.3 AV	54.0	-7.7	1.55 H	33	27.46	18.84

**ANTENNA POLARITY & TEST DISTANCE: VERTICAL AT 3 M**

NO.	FREQ. (MHz)	EMISSION LEVEL (dBuV/m)	LIMIT (dBuV/m)	MARGIN (dB)	ANTENNA HEIGHT (m)	TABLE ANGLE (Degree)	RAW VALUE (dBuV)	CORRECTION FACTOR (dB/m)
1	*5320.00	109.8 PK			1.70 V	293	102.83	6.97
2	*5320.00	100.3 AV			1.70 V	293	93.33	6.97
3	5350.00	66.6 PK	74.0	-7.4	1.70 V	293	59.56	7.04
4	5350.00	51.6 AV	54.0	-2.4	1.70 V	293	44.56	7.04
5	10640.00	52.9 PK	74.0	-21.1	1.63 V	247	39.23	13.67
6	10640.00	40.3 AV	54.0	-13.7	1.63 V	247	26.63	13.67
7	15960.00	58.9 PK	74.0	-15.1	1.72 V	12	40.06	18.84
8	15960.00	47.8 AV	54.0	-6.2	1.72 V	12	28.96	18.84

**REMARKS:**

1. Emission Level(dBuV/m) = Raw Value(dBuV) + Correction Factor(dB/m)
2. Correction Factor(dB/m) = Antenna Factor(dB/m) + Cable Factor(dB) – Pre-Amplifier Factor(dB)
3. The other emission levels were very low against the limit.
4. Margin value = Emission Level – Limit value
5. " \* ": Fundamental frequency.

<b>CHANNEL</b>	TX Channel 100	<b>DETECTOR FUNCTION</b>	Peak (PK)
<b>FREQUENCY RANGE</b>	1GHz ~ 40GHz		Average (AV)

**ANTENNA POLARITY & TEST DISTANCE: HORIZONTAL AT 3 M**

NO.	FREQ. (MHz)	EMISSION LEVEL (dBuV/m)	LIMIT (dBuV/m)	MARGIN (dB)	ANTENNA HEIGHT (m)	TABLE ANGLE (Degree)	RAW VALUE (dBuV)	CORRECTION FACTOR (dB/m)
1	#5470.00	66.9 PK	74.0	-7.1	1.84 H	315	59.70	7.20
2	#5470.00	52.7 AV	54.0	-1.3	1.84 H	315	45.50	7.20
3	*5500.00	110.6 PK			1.84 H	315	103.20	7.40
4	*5500.00	100.4 AV			1.84 H	315	93.00	7.40
5	11000.00	51.5 PK	74.0	-22.5	1.40 H	176	37.30	14.20
6	11000.00	39.3 AV	54.0	-14.7	1.40 H	176	25.10	14.20
7	#16500.00	57.2 PK	74.0	-16.8	1.55 H	56	36.20	21.00
8	#16500.00	45.9 AV	54.0	-8.1	1.55 H	56	24.90	21.00

**ANTENNA POLARITY & TEST DISTANCE: VERTICAL AT 3 M**

NO.	FREQ. (MHz)	EMISSION LEVEL (dBuV/m)	LIMIT (dBuV/m)	MARGIN (dB)	ANTENNA HEIGHT (m)	TABLE ANGLE (Degree)	RAW VALUE (dBuV)	CORRECTION FACTOR (dB/m)
1	#5470.00	64.3 PK	74.0	-9.7	1.77 V	305	57.10	7.20
2	#5470.00	50.4 AV	54.0	-3.6	1.77 V	305	43.20	7.20
3	*5500.00	109.2 PK			1.77 V	305	101.80	7.40
4	*5500.00	100.0 AV			1.77 V	305	92.60	7.40
5	11000.00	52.8 PK	74.0	-21.2	1.68 V	222	38.60	14.20
6	11000.00	40.0 AV	54.0	-14.0	1.68 V	222	25.80	14.20
7	#16500.00	59.0 PK	74.0	-15.0	1.71 V	11	38.00	21.00
8	#16500.00	47.5 AV	54.0	-6.5	1.71 V	11	26.50	21.00

**REMARKS:**

1. Emission Level(dBuV/m) = Raw Value(dBuV) + Correction Factor(dB/m)
2. Correction Factor(dB/m) = Antenna Factor(dB/m) + Cable Factor(dB) – Pre-Amplifier Factor(dB)
3. The other emission levels were very low against the limit.
4. Margin value = Emission Level – Limit value
5. " \* ": Fundamental frequency.
6. " # ": The radiated frequency is out of the restricted band.



<b>CHANNEL</b>	TX Channel 116	<b>DETECTOR FUNCTION</b>	Peak (PK)
<b>FREQUENCY RANGE</b>	1GHz ~ 40GHz		Average (AV)

**ANTENNA POLARITY & TEST DISTANCE: HORIZONTAL AT 3 M**

NO.	FREQ. (MHz)	EMISSION LEVEL (dBuV/m)	LIMIT (dBuV/m)	MARGIN (dB)	ANTENNA HEIGHT (m)	TABLE ANGLE (Degree)	RAW VALUE (dBuV)	CORRECTION FACTOR (dB/m)
1	5421.00	58.3 PK	74.0	-15.7	1.76 H	317	51.07	7.23
2	5421.00	46.3 AV	54.0	-7.7	1.76 H	317	39.07	7.23
3	*5580.00	112.1 PK			1.78 H	320	104.92	7.18
4	*5580.00	102.0 AV			1.78 H	320	94.82	7.18
5	#5738.00	57.4 PK	74.0	-16.6	1.68 H	317	50.02	7.38
6	#5738.00	45.9 AV	54.0	-8.1	1.68 H	317	38.52	7.38
7	11160.00	51.9 PK	74.0	-22.1	1.36 H	207	37.44	14.46
8	11160.00	39.6 AV	54.0	-14.4	1.36 H	207	25.14	14.46
9	#16740.00	57.0 PK	74.0	-17.0	1.54 H	35	35.04	21.96
10	#16740.00	45.7 AV	54.0	-8.3	1.54 H	35	23.74	21.96

**ANTENNA POLARITY & TEST DISTANCE: VERTICAL AT 3 M**

NO.	FREQ. (MHz)	EMISSION LEVEL (dBuV/m)	LIMIT (dBuV/m)	MARGIN (dB)	ANTENNA HEIGHT (m)	TABLE ANGLE (Degree)	RAW VALUE (dBuV)	CORRECTION FACTOR (dB/m)
1	5421.00	56.1 PK	74.0	-17.9	1.71 V	308	48.87	7.23
2	5421.00	44.9 AV	54.0	-9.1	1.71 V	308	37.67	7.23
3	*5580.00	109.8 PK			1.71 V	308	102.62	7.18
4	*5580.00	100.3 AV			1.71 V	308	93.12	7.18
5	#5738.00	55.8 PK	74.0	-18.2	1.71 V	308	48.42	7.38
6	#5738.00	44.6 AV	54.0	-9.4	1.71 V	308	37.22	7.38
7	11160.00	52.2 PK	74.0	-21.8	1.71 V	239	37.74	14.46
8	11160.00	39.9 AV	54.0	-14.1	1.71 V	239	25.44	14.46
9	#16740.00	59.0 PK	74.0	-15.0	1.72 V	6	37.04	21.96
10	#16740.00	47.5 AV	54.0	-6.5	1.72 V	6	25.54	21.96

**REMARKS:**

1. Emission Level(dBuV/m) = Raw Value(dBuV) + Correction Factor(dB/m)
2. Correction Factor(dB/m) = Antenna Factor(dB/m) + Cable Factor(dB) – Pre-Amplifier Factor(dB)
3. The other emission levels were very low against the limit.
4. Margin value = Emission Level – Limit value
5. " \* ": Fundamental frequency.
6. " # ": The radiated frequency is out of the restricted band.

<b>CHANNEL</b>	TX Channel 120	<b>DETECTOR FUNCTION</b>	Peak (PK)
<b>FREQUENCY RANGE</b>	1GHz ~ 40GHz		Average (AV)

**ANTENNA POLARITY & TEST DISTANCE: HORIZONTAL AT 3 M**

NO.	FREQ. (MHz)	EMISSION LEVEL (dBuV/m)	LIMIT (dBuV/m)	MARGIN (dB)	ANTENNA HEIGHT (m)	TABLE ANGLE (Degree)	RAW VALUE (dBuV)	CORRECTION FACTOR (dB/m)
1	5439.00	58.4 PK	74.0	-15.6	1.83 H	315	51.14	7.26
2	5439.00	46.8 AV	54.0	-7.2	1.83 H	315	39.54	7.26
3	*5600.00	111.4 PK			1.77 H	320	104.27	7.13
4	*5600.00	101.4 AV			1.77 H	320	94.27	7.13
5	11200.00	52.2 PK	74.0	-21.8	1.39 H	200	37.73	14.47
6	11200.00	39.7 AV	54.0	-14.3	1.39 H	200	25.23	14.47
7	#16800.00	57.5 PK	74.0	-16.5	1.56 H	46	35.40	22.10
8	#16800.00	46.3 AV	54.0	-7.7	1.56 H	46	24.20	22.10

**ANTENNA POLARITY & TEST DISTANCE: VERTICAL AT 3 M**

NO.	FREQ. (MHz)	EMISSION LEVEL (dBuV/m)	LIMIT (dBuV/m)	MARGIN (dB)	ANTENNA HEIGHT (m)	TABLE ANGLE (Degree)	RAW VALUE (dBuV)	CORRECTION FACTOR (dB/m)
1	5439.00	55.7 PK	74.0	-18.3	1.71 V	302	48.44	7.26
2	5439.00	45.5 AV	54.0	-8.5	1.71 V	302	38.24	7.26
3	*5600.00	109.7 PK			1.71 V	302	102.57	7.13
4	*5600.00	100.5 AV			1.71 V	302	93.37	7.13
5	11200.00	52.4 PK	74.0	-21.6	1.61 V	222	37.93	14.47
6	11200.00	39.7 AV	54.0	-14.3	1.61 V	222	25.23	14.47
7	#16800.00	58.4 PK	74.0	-15.6	1.70 V	11	36.30	22.10
8	#16800.00	47.3 AV	54.0	-6.7	1.70 V	11	25.20	22.10

**REMARKS:**

1. Emission Level(dBuV/m) = Raw Value(dBuV) + Correction Factor(dB/m)
2. Correction Factor(dB/m) = Antenna Factor(dB/m) + Cable Factor(dB) – Pre-Amplifier Factor(dB)
3. The other emission levels were very low against the limit.
4. Margin value = Emission Level – Limit value
5. " \* ": Fundamental frequency.
6. " # ": The radiated frequency is out of the restricted band.

<b>CHANNEL</b>	TX Channel 132	<b>DETECTOR FUNCTION</b>	Peak (PK)
<b>FREQUENCY RANGE</b>	1GHz ~ 40GHz		Average (AV)

**ANTENNA POLARITY & TEST DISTANCE: HORIZONTAL AT 3 M**

NO.	FREQ. (MHz)	EMISSION LEVEL (dBuV/m)	LIMIT (dBuV/m)	MARGIN (dB)	ANTENNA HEIGHT (m)	TABLE ANGLE (Degree)	RAW VALUE (dBuV)	CORRECTION FACTOR (dB/m)
1	*5660.00	113.1 PK			2.43 H	318	105.82	7.28
2	*5660.00	103.6 AV			2.43 H	318	96.32	7.28
3	#5821.00	60.0 PK	74.0	-14.0	2.38 H	317	52.68	7.32
4	#5821.00	48.1 AV	54.0	-5.9	2.38 H	317	40.78	7.32
5	11320.00	51.8 PK	74.0	-22.2	1.38 H	192	37.34	14.46
6	11320.00	39.5 AV	54.0	-14.5	1.38 H	192	25.04	14.46
7	#16980.00	57.3 PK	74.0	-16.7	1.50 H	41	34.07	23.23
8	#16980.00	46.0 AV	54.0	-8.0	1.50 H	41	22.77	23.23

**ANTENNA POLARITY & TEST DISTANCE: VERTICAL AT 3 M**

NO.	FREQ. (MHz)	EMISSION LEVEL (dBuV/m)	LIMIT (dBuV/m)	MARGIN (dB)	ANTENNA HEIGHT (m)	TABLE ANGLE (Degree)	RAW VALUE (dBuV)	CORRECTION FACTOR (dB/m)
1	*5660.00	111.2 PK			2.15 V	307	103.92	7.28
2	*5660.00	101.1 AV			2.15 V	307	93.82	7.28
3	#5821.00	56.1 PK	74.0	-17.9	2.25 V	283	48.78	7.32
4	#5821.00	44.9 AV	54.0	-9.1	2.25 V	283	37.58	7.32
5	11320.00	52.3 PK	74.0	-21.7	1.64 V	218	37.84	14.46
6	11320.00	39.9 AV	54.0	-14.1	1.64 V	218	25.44	14.46
7	#16980.00	58.1 PK	74.0	-15.9	1.67 V	25	34.87	23.23
8	#16980.00	47.0 AV	54.0	-7.0	1.67 V	25	23.77	23.23

**REMARKS:**

1. Emission Level(dBuV/m) = Raw Value(dBuV) + Correction Factor(dB/m)
2. Correction Factor(dB/m) = Antenna Factor(dB/m) + Cable Factor(dB) – Pre-Amplifier Factor(dB)
3. The other emission levels were very low against the limit.
4. Margin value = Emission Level – Limit value
5. " \* ": Fundamental frequency.
6. " # ": The radiated frequency is out of the restricted band.

<b>CHANNEL</b>	TX Channel 140	<b>DETECTOR FUNCTION</b>	Peak (PK)
<b>FREQUENCY RANGE</b>	1GHz ~ 40GHz		Average (AV)

**ANTENNA POLARITY & TEST DISTANCE: HORIZONTAL AT 3 M**

NO.	FREQ. (MHz)	EMISSION LEVEL (dBuV/m)	LIMIT (dBuV/m)	MARGIN (dB)	ANTENNA HEIGHT (m)	TABLE ANGLE (Degree)	RAW VALUE (dBuV)	CORRECTION FACTOR (dB/m)
1	*5700.00	108.9 PK			1.97 H	314	101.51	7.39
2	*5700.00	99.6 AV			1.97 H	314	92.21	7.39
3	#5725.00	68.1 PK	74.0	-5.9	1.97 H	314	60.72	7.38
4	#5725.00	52.9 AV	54.0	-1.1	1.97 H	314	45.52	7.38
5	11400.00	51.7 PK	74.0	-22.3	1.42 H	203	36.84	14.86
6	11400.00	39.1 AV	54.0	-14.9	1.42 H	203	24.24	14.86
7	#17100.00	57.5 PK	74.0	-16.5	1.55 H	37	34.51	22.99
8	#17100.00	46.0 AV	54.0	-8.0	1.55 H	37	23.01	22.99

**ANTENNA POLARITY & TEST DISTANCE: VERTICAL AT 3 M**

NO.	FREQ. (MHz)	EMISSION LEVEL (dBuV/m)	LIMIT (dBuV/m)	MARGIN (dB)	ANTENNA HEIGHT (m)	TABLE ANGLE (Degree)	RAW VALUE (dBuV)	CORRECTION FACTOR (dB/m)
1	*5700.00	107.7 PK			2.00 V	301	100.31	7.39
2	*5700.00	98.5 AV			2.00 V	301	91.11	7.39
3	#5725.00	66.2 PK	74.0	-7.8	2.00 V	301	58.82	7.38
4	#5725.00	51.0 AV	54.0	-3.0	2.00 V	301	43.62	7.38
5	11400.00	53.0 PK	74.0	-21.0	1.71 V	247	38.14	14.86
6	11400.00	40.1 AV	54.0	-13.9	1.71 V	247	25.24	14.86
7	#17100.00	58.9 PK	74.0	-15.1	1.72 V	52	35.91	22.99
8	#17100.00	47.8 AV	54.0	-6.2	1.72 V	52	24.81	22.99

**REMARKS:**

1. Emission Level(dBuV/m) = Raw Value(dBuV) + Correction Factor(dB/m)
2. Correction Factor(dB/m) = Antenna Factor(dB/m) + Cable Factor(dB) – Pre-Amplifier Factor(dB)
3. The other emission levels were very low against the limit.
4. Margin value = Emission Level – Limit value
5. " \* ": Fundamental frequency.
6. " # ": The radiated frequency is out of the restricted band.

<b>CHANNEL</b>	TX Channel 149	<b>DETECTOR FUNCTION</b>	Peak (PK)
<b>FREQUENCY RANGE</b>	1GHz ~ 40GHz		Average (AV)

**ANTENNA POLARITY & TEST DISTANCE: HORIZONTAL AT 3 M**

NO.	FREQ. (MHz)	EMISSION LEVEL (dBuV/m)	LIMIT (dBuV/m)	MARGIN (dB)	ANTENNA HEIGHT (m)	TABLE ANGLE (Degree)	RAW VALUE (dBuV)	CORRECTION FACTOR (dB/m)
1	#5715.00	62.3 PK	74.0	-11.7	1.94 H	309	54.92	7.38
2	#5715.00	49.5 AV	54.0	-4.5	1.94 H	309	42.12	7.38
3	#5725.00	77.0 PK	78.2	-1.2	1.94 H	309	69.62	7.38
4	*5745.00	108.1 PK			1.94 H	309	100.72	7.38
5	*5745.00	98.5 AV			1.94 H	309	91.12	7.38
6	#5984.00	55.8 PK	74.0	-18.2	1.94 H	304	48.65	7.15
7	#5984.00	46.4 AV	54.0	-7.6	1.94 H	304	39.25	7.15
8	11490.00	51.4 PK	74.0	-22.6	1.39 H	202	36.88	14.52
9	11490.00	38.9 AV	54.0	-15.1	1.39 H	202	24.38	14.52
10	#17235.00	56.7 PK	74.0	-17.3	1.49 H	23	32.94	23.76
11	#17235.00	45.5 AV	54.0	-8.5	1.49 H	23	21.74	23.76

**ANTENNA POLARITY & TEST DISTANCE: VERTICAL AT 3 M**

NO.	FREQ. (MHz)	EMISSION LEVEL (dBuV/m)	LIMIT (dBuV/m)	MARGIN (dB)	ANTENNA HEIGHT (m)	TABLE ANGLE (Degree)	RAW VALUE (dBuV)	CORRECTION FACTOR (dB/m)
1	#5715.00	59.9 PK	74.0	-14.1	2.11 V	325	52.52	7.38
2	#5715.00	47.9 AV	54.0	-6.1	2.11 V	325	40.52	7.38
3	#5725.00	74.5 PK	78.2	-3.7	2.11 V	325	67.12	7.38
4	*5745.00	107.0 PK			2.11 V	325	99.62	7.38
5	*5745.00	97.3 AV			2.11 V	325	89.92	7.38
6	#5984.00	53.5 PK	74.0	-20.5	2.12 V	300	46.35	7.15
7	#5984.00	44.8 AV	54.0	-9.2	2.12 V	300	37.65	7.15
8	11490.00	51.8 PK	74.0	-22.2	1.63 V	207	37.28	14.52
9	11490.00	39.8 AV	54.0	-14.2	1.63 V	207	25.28	14.52
10	#17235.00	57.9 PK	74.0	-16.1	1.64 V	27	34.14	23.76
11	#17235.00	46.8 AV	54.0	-7.2	1.64 V	27	23.04	23.76

**REMARKS:**

1. Emission Level(dBuV/m) = Raw Value(dBuV) + Correction Factor(dB/m)
2. Correction Factor(dB/m) = Antenna Factor(dB/m) + Cable Factor(dB) – Pre-Amplifier Factor(dB)
3. The other emission levels were very low against the limit.
4. Margin value = Emission Level – Limit value
5. " \* ": Fundamental frequency.
6. " # ": The radiated frequency is out of the restricted band.

<b>CHANNEL</b>	TX Channel 157	<b>DETECTOR FUNCTION</b>	Peak (PK)
<b>FREQUENCY RANGE</b>	1GHz ~ 40GHz		Average (AV)

**ANTENNA POLARITY & TEST DISTANCE: HORIZONTAL AT 3 M**

NO.	FREQ. (MHz)	EMISSION LEVEL (dBuV/m)	LIMIT (dBuV/m)	MARGIN (dB)	ANTENNA HEIGHT (m)	TABLE ANGLE (Degree)	RAW VALUE (dBuV)	CORRECTION FACTOR (dB/m)
1	#5622.00	59.4 PK	74.0	-14.6	1.94 H	317	52.21	7.19
2	#5622.00	47.4 AV	54.0	-6.6	1.94 H	317	40.21	7.19
3	#5725.00	60.4 PK	78.2	-17.8	2.44 H	313	53.02	7.38
4	*5785.00	113.2 PK			2.44 H	313	105.82	7.38
5	*5785.00	102.8 AV			2.44 H	313	95.42	7.38
6	#5850.00	58.9 PK	78.2	-19.3	2.44 H	313	51.65	7.25
7	11570.00	51.6 PK	74.0	-22.4	1.34 H	187	37.03	14.57
8	11570.00	39.3 AV	54.0	-14.7	1.34 H	187	24.73	14.57
9	#17355.00	57.3 PK	74.0	-16.7	1.54 H	33	33.24	24.06
10	#17355.00	45.9 AV	54.0	-8.1	1.54 H	33	21.84	24.06

**ANTENNA POLARITY & TEST DISTANCE: VERTICAL AT 3 M**

NO.	FREQ. (MHz)	EMISSION LEVEL (dBuV/m)	LIMIT (dBuV/m)	MARGIN (dB)	ANTENNA HEIGHT (m)	TABLE ANGLE (Degree)	RAW VALUE (dBuV)	CORRECTION FACTOR (dB/m)
1	#5622.00	56.8 PK	74.0	-17.2	1.66 V	302	49.61	7.19
2	#5622.00	45.9 AV	54.0	-8.1	1.66 V	302	38.71	7.19
3	#5725.00	58.1 PK	78.2	-20.1	1.66 V	302	50.72	7.38
4	*5785.00	109.7 PK			1.66 V	302	102.32	7.38
5	*5785.00	100.1 AV			1.66 V	302	92.72	7.38
6	#5850.00	56.3 PK	78.2	-21.9	1.66 V	302	49.05	7.25
7	11570.00	52.5 PK	74.0	-21.5	1.61 V	212	37.93	14.57
8	11570.00	40.3 AV	54.0	-13.7	1.61 V	212	25.73	14.57
9	#17355.00	57.6 PK	74.0	-16.4	1.64 V	32	33.54	24.06
10	#17355.00	46.7 AV	54.0	-7.3	1.64 V	32	22.64	24.06

**REMARKS:**

- Emission Level(dBuV/m) = Raw Value(dBuV) + Correction Factor(dB/m)
- Correction Factor(dB/m) = Antenna Factor(dB/m) + Cable Factor(dB) – Pre-Amplifier Factor(dB)
- The other emission levels were very low against the limit.
- Margin value = Emission Level – Limit value
- " \* ": Fundamental frequency.
- " # ": The radiated frequency is out of the restricted band.

<b>CHANNEL</b>	TX Channel 165	<b>DETECTOR FUNCTION</b>	Peak (PK)
<b>FREQUENCY RANGE</b>	1GHz ~ 40GHz		Average (AV)

**ANTENNA POLARITY & TEST DISTANCE: HORIZONTAL AT 3 M**

NO.	FREQ. (MHz)	EMISSION LEVEL (dBuV/m)	LIMIT (dBuV/m)	MARGIN (dB)	ANTENNA HEIGHT (m)	TABLE ANGLE (Degree)	RAW VALUE (dBuV)	CORRECTION FACTOR (dB/m)
1	*5825.00	110.9 PK			1.96 H	314	103.59	7.31
2	*5825.00	101.2 AV			1.96 H	314	93.89	7.31
3	#5850.00	77.1 PK	78.2	-1.1	1.96 H	314	69.85	7.25
4	#5860.00	63.8 PK	74.0	-10.2	1.96 H	314	56.58	7.22
5	#5860.00	51.0 AV	54.0	-3.0	1.96 H	314	43.78	7.22
6	11650.00	51.7 PK	74.0	-22.3	1.38 H	188	37.03	14.67
7	11650.00	39.2 AV	54.0	-14.8	1.38 H	188	24.53	14.67
8	#17475.00	57.9 PK	74.0	-16.1	1.60 H	47	33.88	24.02
9	#17475.00	46.4 AV	54.0	-7.6	1.60 H	47	22.38	24.02

**ANTENNA POLARITY & TEST DISTANCE: VERTICAL AT 3 M**

NO.	FREQ. (MHz)	EMISSION LEVEL (dBuV/m)	LIMIT (dBuV/m)	MARGIN (dB)	ANTENNA HEIGHT (m)	TABLE ANGLE (Degree)	RAW VALUE (dBuV)	CORRECTION FACTOR (dB/m)
1	*5825.00	109.3 PK			1.69 V	285	101.99	7.31
2	*5825.00	99.9 AV			1.69 V	285	92.59	7.31
3	#5850.00	74.6 PK	78.2	-3.6	1.68 V	285	67.35	7.25
4	#5860.00	61.5 PK	74.0	-12.5	1.68 V	285	54.28	7.22
5	#5860.00	49.4 AV	54.0	-4.6	1.68 V	285	42.18	7.22
6	11650.00	52.4 PK	74.0	-21.6	1.66 V	228	37.73	14.67
7	11650.00	40.2 AV	54.0	-13.8	1.66 V	228	25.53	14.67
8	#17475.00	57.9 PK	74.0	-16.1	1.58 V	23	33.88	24.02
9	#17475.00	46.9 AV	54.0	-7.1	1.58 V	23	22.88	24.02

**REMARKS:**

1. Emission Level(dBuV/m) = Raw Value(dBuV) + Correction Factor(dB/m)
2. Correction Factor(dB/m) = Antenna Factor(dB/m) + Cable Factor(dB) – Pre-Amplifier Factor(dB)
3. The other emission levels were very low against the limit.
4. Margin value = Emission Level – Limit value
5. " \* ": Fundamental frequency.
6. " # ": The radiated frequency is out of the restricted band.

802.11ac (VHT20)

<b>CHANNEL</b>	TX Channel 36	<b>DETECTOR FUNCTION</b>	Peak (PK)
<b>FREQUENCY RANGE</b>	1GHz ~ 40GHz		Average (AV)

ANTENNA POLARITY & TEST DISTANCE: HORIZONTAL AT 3 M								
NO.	FREQ. (MHz)	EMISSION LEVEL (dBuV/m)	LIMIT (dBuV/m)	MARGIN (dB)	ANTENNA HEIGHT (m)	TABLE ANGLE (Degree)	RAW VALUE (dBuV)	CORRECTION FACTOR (dB/m)
1	5150.00	66.6 PK	74.0	-7.4	2.03 H	320	60.13	6.47
2	5150.00	52.7 AV	54.0	-1.3	2.03 H	320	46.23	6.47
3	*5180.00	111.1 PK			2.03 H	320	104.45	6.65
4	*5180.00	100.2 AV			2.03 H	320	93.55	6.65
5	#10360.00	52.1 PK	74.0	-21.9	1.36 H	191	37.89	14.21
6	#10360.00	39.4 AV	54.0	-14.6	1.36 H	191	25.19	14.21
7	15540.00	56.9 PK	74.0	-17.1	1.45 H	47	38.14	18.76
8	15540.00	45.5 AV	54.0	-8.5	1.45 H	47	26.74	18.76

ANTENNA POLARITY & TEST DISTANCE: VERTICAL AT 3 M								
NO.	FREQ. (MHz)	EMISSION LEVEL (dBuV/m)	LIMIT (dBuV/m)	MARGIN (dB)	ANTENNA HEIGHT (m)	TABLE ANGLE (Degree)	RAW VALUE (dBuV)	CORRECTION FACTOR (dB/m)
1	5150.00	65.7 PK	74.0	-8.3	2.29 V	84	59.23	6.47
2	5150.00	50.5 AV	54.0	-3.5	2.29 V	84	44.03	6.47
3	*5180.00	109.4 PK			2.29 V	84	102.75	6.65
4	*5180.00	99.1 AV			2.29 V	84	92.45	6.65
5	#10360.00	52.5 PK	74.0	-21.5	1.70 V	223	38.29	14.21
6	#10360.00	39.8 AV	54.0	-14.2	1.70 V	223	25.59	14.21
7	15540.00	58.4 PK	74.0	-15.6	1.74 V	17	39.64	18.76
8	15540.00	47.6 AV	54.0	-6.4	1.74 V	17	28.84	18.76

**REMARKS:**

1. Emission Level(dBuV/m) = Raw Value(dBuV) + Correction Factor(dB/m)
2. Correction Factor(dB/m) = Antenna Factor(dB/m) + Cable Factor(dB) – Pre-Amplifier Factor(dB)
3. The other emission levels were very low against the limit.
4. Margin value = Emission Level – Limit value
5. " \* ": Fundamental frequency.
6. " # ": The radiated frequency is out of the restricted band.



<b>CHANNEL</b>	TX Channel 40	<b>DETECTOR FUNCTION</b>	Peak (PK)
<b>FREQUENCY RANGE</b>	1GHz ~ 40GHz		Average (AV)

**ANTENNA POLARITY & TEST DISTANCE: HORIZONTAL AT 3 M**

NO.	FREQ. (MHz)	EMISSION LEVEL (dBuV/m)	LIMIT (dBuV/m)	MARGIN (dB)	ANTENNA HEIGHT (m)	TABLE ANGLE (Degree)	RAW VALUE (dBuV)	CORRECTION FACTOR (dB/m)
1	5150.00	58.7 PK	74.0	-15.3	2.12 H	321	52.23	6.47
2	5150.00	44.9 AV	54.0	-9.1	2.12 H	321	38.43	6.47
3	*5200.00	111.8 PK			2.12 H	321	105.03	6.77
4	*5200.00	100.5 AV			2.12 H	321	93.73	6.77
5	5362.00	58.0 PK	74.0	-16.0	1.80 H	321	50.91	7.09
6	5362.00	47.2 AV	54.0	-6.8	1.80 H	321	40.11	7.09
7	#10400.00	52.2 PK	74.0	-21.8	1.37 H	190	37.98	14.22
8	#10400.00	39.8 AV	54.0	-14.2	1.37 H	190	25.58	14.22
9	15600.00	57.2 PK	74.0	-16.8	1.49 H	36	38.86	18.34
10	15600.00	45.9 AV	54.0	-8.1	1.49 H	36	27.56	18.34

**ANTENNA POLARITY & TEST DISTANCE: VERTICAL AT 3 M**

NO.	FREQ. (MHz)	EMISSION LEVEL (dBuV/m)	LIMIT (dBuV/m)	MARGIN (dB)	ANTENNA HEIGHT (m)	TABLE ANGLE (Degree)	RAW VALUE (dBuV)	CORRECTION FACTOR (dB/m)
1	5150.00	57.6 PK	74.0	-16.4	2.00 V	285	51.13	6.47
2	5150.00	42.7 AV	54.0	-11.3	2.00 V	285	36.23	6.47
3	*5200.00	110.3 PK			2.00 V	285	103.53	6.77
4	*5200.00	99.2 AV			2.00 V	285	92.43	6.77
5	5362.00	56.8 PK	74.0	-17.2	2.00 V	290	49.71	7.09
6	5362.00	45.8 AV	54.0	-8.2	2.00 V	290	38.71	7.09
7	#10400.00	52.7 PK	74.0	-21.3	1.72 V	229	38.48	14.22
8	#10400.00	39.9 AV	54.0	-14.1	1.72 V	229	25.68	14.22
9	15600.00	58.6 PK	74.0	-15.4	1.70 V	33	40.26	18.34
10	15600.00	47.5 AV	54.0	-6.5	1.70 V	33	29.16	18.34

**REMARKS:**

1. Emission Level(dBuV/m) = Raw Value(dBuV) + Correction Factor(dB/m)
2. Correction Factor(dB/m) = Antenna Factor(dB/m) + Cable Factor(dB) – Pre-Amplifier Factor(dB)
3. The other emission levels were very low against the limit.
4. Margin value = Emission Level – Limit value
5. " \* ": Fundamental frequency.
6. " # ": The radiated frequency is out of the restricted band.

<b>CHANNEL</b>	TX Channel 48	<b>DETECTOR FUNCTION</b>	Peak (PK)
<b>FREQUENCY RANGE</b>	1GHz ~ 40GHz		Average (AV)

**ANTENNA POLARITY & TEST DISTANCE: HORIZONTAL AT 3 M**

NO.	FREQ. (MHz)	EMISSION LEVEL (dBuV/m)	LIMIT (dBuV/m)	MARGIN (dB)	ANTENNA HEIGHT (m)	TABLE ANGLE (Degree)	RAW VALUE (dBuV)	CORRECTION FACTOR (dB/m)
1	*5240.00	112.6 PK			2.12 H	324	105.78	6.82
2	*5240.00	101.2 AV			2.12 H	324	94.38	6.82
3	5402.00	59.7 PK	74.0	-14.3	1.84 H	324	52.51	7.19
4	5402.00	48.2 AV	54.0	-5.8	1.84 H	324	41.01	7.19
5	#10480.00	52.2 PK	74.0	-21.8	1.35 H	206	38.21	13.99
6	#10480.00	39.9 AV	54.0	-14.1	1.35 H	206	25.91	13.99
7	15720.00	57.5 PK	74.0	-16.5	1.51 H	25	38.47	19.03
8	15720.00	46.1 AV	54.0	-7.9	1.51 H	25	27.07	19.03

**ANTENNA POLARITY & TEST DISTANCE: VERTICAL AT 3 M**

NO.	FREQ. (MHz)	EMISSION LEVEL (dBuV/m)	LIMIT (dBuV/m)	MARGIN (dB)	ANTENNA HEIGHT (m)	TABLE ANGLE (Degree)	RAW VALUE (dBuV)	CORRECTION FACTOR (dB/m)
1	*5240.00	111.7 PK			2.16 V	300	104.88	6.82
2	*5240.00	99.9 AV			2.16 V	300	93.08	6.82
3	5402.00	58.4 PK	74.0	-15.6	2.06 V	288	51.21	7.19
4	5402.00	46.9 AV	54.0	-7.1	2.06 V	288	39.71	7.19
5	#10480.00	52.7 PK	74.0	-21.3	1.69 V	236	38.71	13.99
6	#10480.00	39.8 AV	54.0	-14.2	1.69 V	236	25.81	13.99
7	15720.00	58.9 PK	74.0	-15.1	1.66 V	24	39.87	19.03
8	15720.00	47.7 AV	54.0	-6.3	1.66 V	24	28.67	19.03

**REMARKS:**

1. Emission Level(dBuV/m) = Raw Value(dBuV) + Correction Factor(dB/m)
2. Correction Factor(dB/m) = Antenna Factor(dB/m) + Cable Factor(dB) – Pre-Amplifier Factor(dB)
3. The other emission levels were very low against the limit.
4. Margin value = Emission Level – Limit value
5. " \* ": Fundamental frequency.
6. " # ": The radiated frequency is out of the restricted band.

<b>CHANNEL</b>	TX Channel 52	<b>DETECTOR FUNCTION</b>	Peak (PK)
<b>FREQUENCY RANGE</b>	1GHz ~ 40GHz		Average (AV)

**ANTENNA POLARITY & TEST DISTANCE: HORIZONTAL AT 3 M**

NO.	FREQ. (MHz)	EMISSION LEVEL (dBuV/m)	LIMIT (dBuV/m)	MARGIN (dB)	ANTENNA HEIGHT (m)	TABLE ANGLE (Degree)	RAW VALUE (dBuV)	CORRECTION FACTOR (dB/m)
1	5097.00	57.0 PK	74.0	-17.0	1.97 H	321	50.82	6.18
2	5097.00	44.0 AV	54.0	-10.0	1.97 H	321	37.82	6.18
3	*5260.00	113.1 PK			1.97 H	321	106.25	6.85
4	*5260.00	101.8 AV			1.97 H	321	94.95	6.85
5	5422.00	60.8 PK	74.0	-13.2	1.97 H	321	53.57	7.23
6	5422.00	49.1 AV	54.0	-4.9	1.97 H	321	41.87	7.23
7	#10520.00	51.9 PK	74.0	-22.1	1.42 H	186	38.07	13.83
8	#10520.00	39.3 AV	54.0	-14.7	1.42 H	186	25.47	13.83
9	15780.00	57.1 PK	74.0	-16.9	1.45 H	32	37.74	19.36
10	15780.00	45.8 AV	54.0	-8.2	1.45 H	32	26.44	19.36

**ANTENNA POLARITY & TEST DISTANCE: VERTICAL AT 3 M**

NO.	FREQ. (MHz)	EMISSION LEVEL (dBuV/m)	LIMIT (dBuV/m)	MARGIN (dB)	ANTENNA HEIGHT (m)	TABLE ANGLE (Degree)	RAW VALUE (dBuV)	CORRECTION FACTOR (dB/m)
1	5097.00	55.6 PK	74.0	-18.4	2.08 V	278	49.42	6.18
2	5097.00	42.7 AV	54.0	-11.3	2.08 V	278	36.52	6.18
3	*5260.00	111.8 PK			2.13 V	299	104.95	6.85
4	*5260.00	100.2 AV			2.13 V	299	93.35	6.85
5	5422.00	59.4 PK	74.0	-14.6	2.12 V	306	52.17	7.23
6	5422.00	47.8 AV	54.0	-6.2	2.12 V	306	40.57	7.23
7	#10520.00	52.6 PK	74.0	-21.4	1.73 V	245	38.77	13.83
8	#10520.00	40.0 AV	54.0	-14.0	1.73 V	245	26.17	13.83
9	15780.00	59.0 PK	74.0	-15.0	1.74 V	41	39.64	19.36
10	15780.00	47.9 AV	54.0	-6.1	1.74 V	41	28.54	19.36

**REMARKS:**

1. Emission Level(dBuV/m) = Raw Value(dBuV) + Correction Factor(dB/m)
2. Correction Factor(dB/m) = Antenna Factor(dB/m) + Cable Factor(dB) – Pre-Amplifier Factor(dB)
3. The other emission levels were very low against the limit.
4. Margin value = Emission Level – Limit value
5. " \* ": Fundamental frequency.
6. " # ": The radiated frequency is out of the restricted band.

<b>CHANNEL</b>	TX Channel 60	<b>DETECTOR FUNCTION</b>	Peak (PK)
<b>FREQUENCY RANGE</b>	1GHz ~ 40GHz		Average (AV)

**ANTENNA POLARITY & TEST DISTANCE: HORIZONTAL AT 3 M**

NO.	FREQ. (MHz)	EMISSION LEVEL (dBuV/m)	LIMIT (dBuV/m)	MARGIN (dB)	ANTENNA HEIGHT (m)	TABLE ANGLE (Degree)	RAW VALUE (dBuV)	CORRECTION FACTOR (dB/m)
1	*5300.00	114.2 PK			1.86 H	319	107.30	6.90
2	*5300.00	102.6 AV			1.86 H	319	95.70	6.90
3	#5462.00	61.3 PK	74.0	-12.7	1.95 H	315	54.03	7.27
4	#5462.00	49.0 AV	54.0	-5.0	1.95 H	315	41.73	7.27
5	10600.00	52.2 PK	74.0	-21.8	1.40 H	177	38.76	13.44
6	10600.00	40.1 AV	54.0	-13.9	1.40 H	177	26.66	13.44
7	15900.00	57.1 PK	74.0	-16.9	1.52 H	37	38.09	19.01
8	15900.00	45.6 AV	54.0	-8.4	1.52 H	37	26.59	19.01

**ANTENNA POLARITY & TEST DISTANCE: VERTICAL AT 3 M**

NO.	FREQ. (MHz)	EMISSION LEVEL (dBuV/m)	LIMIT (dBuV/m)	MARGIN (dB)	ANTENNA HEIGHT (m)	TABLE ANGLE (Degree)	RAW VALUE (dBuV)	CORRECTION FACTOR (dB/m)
1	*5300.00	112.7 PK			2.16 V	291	105.80	6.90
2	*5300.00	101.7 AV			2.16 V	291	94.80	6.90
3	#5462.00	59.6 PK	74.0	-14.4	2.03 V	292	52.33	7.27
4	#5462.00	47.9 AV	54.0	-6.1	2.03 V	292	40.63	7.27
5	10600.00	53.4 PK	74.0	-20.6	1.78 V	232	39.96	13.44
6	10600.00	40.3 AV	54.0	-13.7	1.78 V	232	26.86	13.44
7	15900.00	59.0 PK	74.0	-15.0	1.75 V	33	39.99	19.01
8	15900.00	47.7 AV	54.0	-6.3	1.75 V	33	28.69	19.01

**REMARKS:**

1. Emission Level(dBuV/m) = Raw Value(dBuV) + Correction Factor(dB/m)
2. Correction Factor(dB/m) = Antenna Factor(dB/m) + Cable Factor(dB) – Pre-Amplifier Factor(dB)
3. The other emission levels were very low against the limit.
4. Margin value = Emission Level – Limit value
5. " \* ": Fundamental frequency.
6. " # ": The radiated frequency is out of the restricted band.

<b>CHANNEL</b>	TX Channel 64	<b>DETECTOR FUNCTION</b>	Peak (PK)
<b>FREQUENCY RANGE</b>	1GHz ~ 40GHz		Average (AV)

**ANTENNA POLARITY & TEST DISTANCE: HORIZONTAL AT 3 M**

NO.	FREQ. (MHz)	EMISSION LEVEL (dBuV/m)	LIMIT (dBuV/m)	MARGIN (dB)	ANTENNA HEIGHT (m)	TABLE ANGLE (Degree)	RAW VALUE (dBuV)	CORRECTION FACTOR (dB/m)
1	*5320.00	113.4 PK			2.04 H	318	106.43	6.97
2	*5320.00	102.2 AV			2.04 H	318	95.23	6.97
3	5350.00	69.3 PK	74.0	-4.7	2.04 H	318	62.26	7.04
4	5350.00	52.7 AV	54.0	-1.3	2.04 H	318	45.66	7.04
5	#5619.00	60.1 PK	74.0	-13.9	1.84 H	316	52.92	7.18
6	#5619.00	49.5 AV	54.0	-4.5	1.84 H	316	42.32	7.18
7	10640.00	51.7 PK	74.0	-22.3	1.42 H	194	38.03	13.67
8	10640.00	39.6 AV	54.0	-14.4	1.42 H	194	25.93	13.67
9	15960.00	57.8 PK	74.0	-16.2	1.46 H	28	38.96	18.84
10	15960.00	46.4 AV	54.0	-7.6	1.46 H	28	27.56	18.84

**ANTENNA POLARITY & TEST DISTANCE: VERTICAL AT 3 M**

NO.	FREQ. (MHz)	EMISSION LEVEL (dBuV/m)	LIMIT (dBuV/m)	MARGIN (dB)	ANTENNA HEIGHT (m)	TABLE ANGLE (Degree)	RAW VALUE (dBuV)	CORRECTION FACTOR (dB/m)
1	*5320.00	112.6 PK			2.12 V	295	105.63	6.97
2	*5320.00	101.6 AV			2.12 V	295	94.63	6.97
3	5350.00	68.1 PK	74.0	-5.9	2.12 V	295	61.06	7.04
4	5350.00	52.5 AV	54.0	-1.5	2.12 V	295	45.46	7.04
5	#5619.00	58.2 PK	74.0	-15.8	2.03 V	283	51.02	7.18
6	#5619.00	47.0 AV	54.0	-7.0	2.03 V	283	39.82	7.18
7	10640.00	52.3 PK	74.0	-21.7	1.70 V	222	38.63	13.67
8	10640.00	39.4 AV	54.0	-14.6	1.70 V	222	25.73	13.67
9	15960.00	58.0 PK	74.0	-16.0	1.65 V	22	39.16	18.84
10	15960.00	47.2 AV	54.0	-6.8	1.65 V	22	28.36	18.84

**REMARKS:**

1. Emission Level(dBuV/m) = Raw Value(dBuV) + Correction Factor(dB/m)
2. Correction Factor(dB/m) = Antenna Factor(dB/m) + Cable Factor(dB) – Pre-Amplifier Factor(dB)
3. The other emission levels were very low against the limit.
4. Margin value = Emission Level – Limit value
5. " \* ": Fundamental frequency.
6. " # ": The radiated frequency is out of the restricted band.

<b>CHANNEL</b>	TX Channel 100	<b>DETECTOR FUNCTION</b>	Peak (PK)
<b>FREQUENCY RANGE</b>	1GHz ~ 40GHz		Average (AV)

**ANTENNA POLARITY & TEST DISTANCE: HORIZONTAL AT 3 M**

NO.	FREQ. (MHz)	EMISSION LEVEL (dBuV/m)	LIMIT (dBuV/m)	MARGIN (dB)	ANTENNA HEIGHT (m)	TABLE ANGLE (Degree)	RAW VALUE (dBuV)	CORRECTION FACTOR (dB/m)
1	#5470.00	67.4 PK	74.0	-6.6	2.10 H	315	60.11	7.29
2	#5470.00	52.9 AV	54.0	-1.1	2.10 H	315	45.61	7.29
3	*5500.00	113.9 PK			2.10 H	315	106.57	7.33
4	*5500.00	102.9 AV			2.10 H	315	95.57	7.33
5	#5731.00	58.3 PK	74.0	-15.7	2.26 H	316	50.91	7.39
6	#5731.00	47.4 AV	54.0	-6.6	2.26 H	316	40.01	7.39
7	11000.00	52.6 PK	74.0	-21.4	1.39 H	183	38.37	14.23
8	11000.00	40.0 AV	54.0	-14.0	1.39 H	183	25.77	14.23
9	#16500.00	57.2 PK	74.0	-16.8	1.55 H	48	36.23	20.97
10	#16500.00	46.0 AV	54.0	-8.0	1.55 H	48	25.03	20.97

**ANTENNA POLARITY & TEST DISTANCE: VERTICAL AT 3 M**

NO.	FREQ. (MHz)	EMISSION LEVEL (dBuV/m)	LIMIT (dBuV/m)	MARGIN (dB)	ANTENNA HEIGHT (m)	TABLE ANGLE (Degree)	RAW VALUE (dBuV)	CORRECTION FACTOR (dB/m)
1	#5470.00	65.3 PK	74.0	-8.7	1.98 V	292	58.01	7.29
2	#5470.00	52.0 AV	54.0	-2.0	1.98 V	292	44.71	7.29
3	*5500.00	112.9 PK			1.98 V	292	105.57	7.33
4	*5500.00	101.8 AV			1.98 V	292	94.47	7.33
5	#5731.00	56.5 PK	74.0	-17.5	1.98 V	292	49.11	7.39
6	#5731.00	45.3 AV	54.0	-8.7	1.98 V	292	37.91	7.39
7	11000.00	52.3 PK	74.0	-21.7	1.73 V	243	38.07	14.23
8	11000.00	39.6 AV	54.0	-14.4	1.73 V	243	25.37	14.23
9	#16500.00	58.4 PK	74.0	-15.6	1.71 V	19	37.43	20.97
10	#16500.00	47.2 AV	54.0	-6.8	1.71 V	19	26.23	20.97

**REMARKS:**

1. Emission Level(dBuV/m) = Raw Value(dBuV) + Correction Factor(dB/m)
2. Correction Factor(dB/m) = Antenna Factor(dB/m) + Cable Factor(dB) – Pre-Amplifier Factor(dB)
3. The other emission levels were very low against the limit.
4. Margin value = Emission Level – Limit value
5. " \* ": Fundamental frequency.
6. " # ": The radiated frequency is out of the restricted band.

<b>CHANNEL</b>	TX Channel 116	<b>DETECTOR FUNCTION</b>	Peak (PK)
<b>FREQUENCY RANGE</b>	1GHz ~ 40GHz		Average (AV)

**ANTENNA POLARITY & TEST DISTANCE: HORIZONTAL AT 3 M**

NO.	FREQ. (MHz)	EMISSION LEVEL (dBuV/m)	LIMIT (dBuV/m)	MARGIN (dB)	ANTENNA HEIGHT (m)	TABLE ANGLE (Degree)	RAW VALUE (dBuV)	CORRECTION FACTOR (dB/m)
1	5422.00	60.2 PK	74.0	-13.8	1.98 H	318	52.97	7.23
2	5422.00	48.9 AV	54.0	-5.1	1.98 H	318	41.67	7.23
3	*5580.00	114.5 PK			1.97 H	316	107.32	7.18
4	*5580.00	103.9 AV			1.97 H	316	96.72	7.18
5	#5742.00	62.9 PK	74.0	-11.1	2.02 H	318	55.52	7.38
6	#5742.00	49.2 AV	54.0	-4.8	2.02 H	318	41.82	7.38
7	11160.00	52.1 PK	74.0	-21.9	1.31 H	192	37.64	14.46
8	11160.00	39.6 AV	54.0	-14.4	1.31 H	192	25.14	14.46
9	#16740.00	57.2 PK	74.0	-16.8	1.49 H	19	35.24	21.96
10	#16740.00	46.1 AV	54.0	-7.9	1.49 H	19	24.14	21.96

**ANTENNA POLARITY & TEST DISTANCE: VERTICAL AT 3 M**

NO.	FREQ. (MHz)	EMISSION LEVEL (dBuV/m)	LIMIT (dBuV/m)	MARGIN (dB)	ANTENNA HEIGHT (m)	TABLE ANGLE (Degree)	RAW VALUE (dBuV)	CORRECTION FACTOR (dB/m)
1	5422.00	57.6 PK	74.0	-16.4	1.96 V	290	50.37	7.23
2	5422.00	47.3 AV	54.0	-6.7	1.96 V	290	40.07	7.23
3	*5580.00	112.9 PK			1.96 V	290	105.72	7.18
4	*5580.00	102.2 AV			1.96 V	290	95.02	7.18
5	#5742.00	61.1 PK	74.0	-12.9	1.99 V	299	53.72	7.38
6	#5742.00	47.6 AV	54.0	-6.4	1.99 V	299	40.22	7.38
7	11160.00	52.7 PK	74.0	-21.3	1.56 V	209	38.24	14.46
8	11160.00	40.8 AV	54.0	-13.2	1.56 V	209	26.34	14.46
9	#16740.00	57.1 PK	74.0	-16.9	1.58 V	19	35.14	21.96
10	#16740.00	46.2 AV	54.0	-7.8	1.58 V	19	24.24	21.96

**REMARKS:**

1. Emission Level(dBuV/m) = Raw Value(dBuV) + Correction Factor(dB/m)
2. Correction Factor(dB/m) = Antenna Factor(dB/m) + Cable Factor(dB) – Pre-Amplifier Factor(dB)
3. The other emission levels were very low against the limit.
4. Margin value = Emission Level – Limit value
5. " \* ": Fundamental frequency.
6. " # ": The radiated frequency is out of the restricted band.

<b>CHANNEL</b>	TX Channel 120	<b>DETECTOR FUNCTION</b>	Peak (PK)
<b>FREQUENCY RANGE</b>	1GHz ~ 40GHz		Average (AV)

**ANTENNA POLARITY & TEST DISTANCE: HORIZONTAL AT 3 M**

NO.	FREQ. (MHz)	EMISSION LEVEL (dBuV/m)	LIMIT (dBuV/m)	MARGIN (dB)	ANTENNA HEIGHT (m)	TABLE ANGLE (Degree)	RAW VALUE (dBuV)	CORRECTION FACTOR (dB/m)
1	5442.00	60.2 PK	74.0	-13.8	2.04 H	317	52.95	7.25
2	5442.00	48.6 AV	54.0	-5.4	2.04 H	317	41.35	7.25
3	*5600.00	114.8 PK			1.92 H	316	107.67	7.13
4	*5600.00	103.8 AV			1.92 H	316	96.67	7.13
5	#5762.00	61.0 PK	74.0	-13.0	2.16 H	323	53.62	7.38
6	#5762.00	49.3 AV	54.0	-4.7	2.16 H	323	41.92	7.38
7	11200.00	51.9 PK	74.0	-22.1	1.33 H	195	37.43	14.47
8	11200.00	39.6 AV	54.0	-14.4	1.33 H	195	25.13	14.47
9	#16800.00	57.6 PK	74.0	-16.4	1.43 H	36	35.50	22.10
10	#16800.00	46.1 AV	54.0	-7.9	1.43 H	36	24.00	22.10

**ANTENNA POLARITY & TEST DISTANCE: VERTICAL AT 3 M**

NO.	FREQ. (MHz)	EMISSION LEVEL (dBuV/m)	LIMIT (dBuV/m)	MARGIN (dB)	ANTENNA HEIGHT (m)	TABLE ANGLE (Degree)	RAW VALUE (dBuV)	CORRECTION FACTOR (dB/m)
1	5442.00	58.6 PK	74.0	-15.4	1.92 V	287	51.35	7.25
2	5442.00	47.2 AV	54.0	-6.8	1.92 V	287	39.95	7.25
3	*5600.00	113.3 PK			1.92 V	287	106.17	7.13
4	*5600.00	102.3 AV			1.92 V	287	95.17	7.13
5	#5762.00	59.4 PK	74.0	-14.6	1.90 V	292	52.02	7.38
6	#5762.00	47.8 AV	54.0	-6.2	1.90 V	292	40.42	7.38
7	11200.00	52.2 PK	74.0	-21.8	1.71 V	193	37.73	14.47
8	11200.00	39.9 AV	54.0	-14.1	1.71 V	193	25.43	14.47
9	#16800.00	57.2 PK	74.0	-16.8	1.66 V	45	35.10	22.10
10	#16800.00	46.2 AV	54.0	-7.8	1.66 V	45	24.10	22.10

**REMARKS:**

1. Emission Level(dBuV/m) = Raw Value(dBuV) + Correction Factor(dB/m)
2. Correction Factor(dB/m) = Antenna Factor(dB/m) + Cable Factor(dB) – Pre-Amplifier Factor(dB)
3. The other emission levels were very low against the limit.
4. Margin value = Emission Level – Limit value
5. " \* ": Fundamental frequency.
6. " # ": The radiated frequency is out of the restricted band.



<b>CHANNEL</b>	TX Channel 132	<b>DETECTOR FUNCTION</b>	Peak (PK)
<b>FREQUENCY RANGE</b>	1GHz ~ 40GHz		Average (AV)

**ANTENNA POLARITY & TEST DISTANCE: HORIZONTAL AT 3 M**

NO.	FREQ. (MHz)	EMISSION LEVEL (dBuV/m)	LIMIT (dBuV/m)	MARGIN (dB)	ANTENNA HEIGHT (m)	TABLE ANGLE (Degree)	RAW VALUE (dBuV)	CORRECTION FACTOR (dB/m)
1	5421.00	61.0 PK	74.0	-13.0	2.01 H	323	53.77	7.23
2	5421.00	49.0 AV	54.0	-5.0	2.01 H	323	41.77	7.23
3	*5660.00	115.0 PK			1.98 H	322	107.72	7.28
4	*5660.00	104.4 AV			1.98 H	322	97.12	7.28
5	#5822.00	61.4 PK	74.0	-12.6	2.34 H	318	54.08	7.32
6	#5822.00	50.5 AV	54.0	-3.5	2.34 H	318	43.18	7.32
7	11320.00	51.8 PK	74.0	-22.2	1.34 H	175	37.34	14.46
8	11320.00	39.4 AV	54.0	-14.6	1.34 H	175	24.94	14.46
9	#16980.00	57.6 PK	74.0	-16.4	1.51 H	41	34.37	23.23
10	#16980.00	46.1 AV	54.0	-7.9	1.51 H	41	22.87	23.23

**ANTENNA POLARITY & TEST DISTANCE: VERTICAL AT 3 M**

NO.	FREQ. (MHz)	EMISSION LEVEL (dBuV/m)	LIMIT (dBuV/m)	MARGIN (dB)	ANTENNA HEIGHT (m)	TABLE ANGLE (Degree)	RAW VALUE (dBuV)	CORRECTION FACTOR (dB/m)
1	5421.00	58.6 PK	74.0	-15.4	2.00 V	291	51.37	7.23
2	5421.00	47.2 AV	54.0	-6.8	2.00 V	291	39.97	7.23
3	*5660.00	112.7 PK			2.10 V	286	105.42	7.28
4	*5660.00	102.2 AV			2.10 V	286	94.92	7.28
5	#5822.00	57.7 PK	74.0	-16.3	2.21 V	282	50.38	7.32
6	#5822.00	47.0 AV	54.0	-7.0	2.21 V	282	39.68	7.32
7	11320.00	52.3 PK	74.0	-21.7	1.63 V	187	37.84	14.46
8	11320.00	40.0 AV	54.0	-14.0	1.63 V	187	25.54	14.46
9	#16980.00	56.8 PK	74.0	-17.2	1.69 V	49	33.57	23.23
10	#16980.00	46.0 AV	54.0	-8.0	1.69 V	49	22.77	23.23

**REMARKS:**

1. Emission Level(dBuV/m) = Raw Value(dBuV) + Correction Factor(dB/m)
2. Correction Factor(dB/m) = Antenna Factor(dB/m) + Cable Factor(dB) – Pre-Amplifier Factor(dB)
3. The other emission levels were very low against the limit.
4. Margin value = Emission Level – Limit value
5. " \* ": Fundamental frequency.
6. " # ": The radiated frequency is out of the restricted band.

<b>CHANNEL</b>	TX Channel 140	<b>DETECTOR FUNCTION</b>	Peak (PK)
<b>FREQUENCY RANGE</b>	1GHz ~ 40GHz		Average (AV)

**ANTENNA POLARITY & TEST DISTANCE: HORIZONTAL AT 3 M**

NO.	FREQ. (MHz)	EMISSION LEVEL (dBuV/m)	LIMIT (dBuV/m)	MARGIN (dB)	ANTENNA HEIGHT (m)	TABLE ANGLE (Degree)	RAW VALUE (dBuV)	CORRECTION FACTOR (dB/m)
1	5456.00	62.1 PK	74.0	-11.9	1.71 H	326	54.83	7.27
2	5456.00	50.4 AV	54.0	-3.6	1.71 H	326	43.13	7.27
3	*5700.00	111.4 PK			2.26 H	316	104.01	7.39
4	*5700.00	100.4 AV			2.26 H	316	93.01	7.39
5	#5725.00	68.5 PK	74.0	-5.5	2.26 H	316	61.12	7.38
6	#5725.00	52.8 AV	54.0	-1.2	2.26 H	316	45.42	7.38
7	11400.00	52.6 PK	74.0	-21.4	1.37 H	179	37.74	14.86
8	11400.00	40.3 AV	54.0	-13.7	1.37 H	179	25.44	14.86
9	#17100.00	56.9 PK	74.0	-17.1	1.46 H	49	33.91	22.99
10	#17100.00	45.7 AV	54.0	-8.3	1.46 H	49	22.71	22.99

**ANTENNA POLARITY & TEST DISTANCE: VERTICAL AT 3 M**

NO.	FREQ. (MHz)	EMISSION LEVEL (dBuV/m)	LIMIT (dBuV/m)	MARGIN (dB)	ANTENNA HEIGHT (m)	TABLE ANGLE (Degree)	RAW VALUE (dBuV)	CORRECTION FACTOR (dB/m)
1	5456.00	57.9 PK	74.0	-16.1	1.92 V	91	50.63	7.27
2	5456.00	47.4 AV	54.0	-6.6	1.92 V	91	40.13	7.27
3	*5700.00	107.6 PK			2.12 V	290	100.21	7.39
4	*5700.00	98.7 AV			2.12 V	290	91.31	7.39
5	#5725.00	64.4 PK	74.0	-9.6	2.12 V	290	57.02	7.38
6	#5725.00	48.4 AV	54.0	-5.6	2.12 V	290	41.02	7.38
7	11400.00	51.7 PK	74.0	-22.3	1.61 V	202	36.84	14.86
8	11400.00	39.8 AV	54.0	-14.2	1.61 V	202	24.94	14.86
9	#17100.00	57.4 PK	74.0	-16.6	1.71 V	37	34.41	22.99
10	#17100.00	46.6 AV	54.0	-7.4	1.71 V	37	23.61	22.99

**REMARKS:**

1. Emission Level(dBuV/m) = Raw Value(dBuV) + Correction Factor(dB/m)
2. Correction Factor(dB/m) = Antenna Factor(dB/m) + Cable Factor(dB) – Pre-Amplifier Factor(dB)
3. The other emission levels were very low against the limit.
4. Margin value = Emission Level – Limit value
5. " \* ": Fundamental frequency.
6. " # ": The radiated frequency is out of the restricted band.

<b>CHANNEL</b>	TX Channel 149	<b>DETECTOR FUNCTION</b>	Peak (PK)
<b>FREQUENCY RANGE</b>	1GHz ~ 40GHz		Average (AV)

**ANTENNA POLARITY & TEST DISTANCE: HORIZONTAL AT 3 M**

NO.	FREQ. (MHz)	EMISSION LEVEL (dBuV/m)	LIMIT (dBuV/m)	MARGIN (dB)	ANTENNA HEIGHT (m)	TABLE ANGLE (Degree)	RAW VALUE (dBuV)	CORRECTION FACTOR (dB/m)
1	#5715.00	58.7 PK	74.0	-15.3	2.49 H	316	51.32	7.38
2	#5715.00	47.8 AV	54.0	-6.2	2.49 H	316	40.42	7.38
3	#5725.00	77.0 PK	78.2	-1.2	2.49 H	316	69.62	7.38
4	*5745.00	112.5 PK			2.49 H	316	105.12	7.38
5	*5745.00	100.5 AV			2.49 H	316	93.12	7.38
6	#5984.00	57.0 PK	74.0	-17.0	1.88 H	322	49.85	7.15
7	#5984.00	48.6 AV	54.0	-5.4	1.88 H	322	41.45	7.15
8	11490.00	51.3 PK	74.0	-22.7	1.34 H	183	36.78	14.52
9	11490.00	38.9 AV	54.0	-15.1	1.34 H	183	24.38	14.52
10	#17235.00	57.2 PK	74.0	-16.8	2.02 H	27	33.44	23.76
11	#17235.00	45.4 AV	54.0	-8.6	2.02 H	27	21.64	23.76

**ANTENNA POLARITY & TEST DISTANCE: VERTICAL AT 3 M**

NO.	FREQ. (MHz)	EMISSION LEVEL (dBuV/m)	LIMIT (dBuV/m)	MARGIN (dB)	ANTENNA HEIGHT (m)	TABLE ANGLE (Degree)	RAW VALUE (dBuV)	CORRECTION FACTOR (dB/m)
1	#5715.00	50.4 PK	74.0	-23.6	2.17 V	293	43.02	7.38
2	#5715.00	43.5 AV	54.0	-10.5	2.17 V	293	36.12	7.38
3	#5725.00	73.2 PK	78.2	-5.0	2.17 V	293	65.82	7.38
4	*5745.00	108.2 PK			2.17 V	293	100.82	7.38
5	*5745.00	99.1 AV			2.17 V	293	91.72	7.38
6	#5984.00	52.9 PK	74.0	-21.1	2.20 V	295	45.75	7.15
7	#5984.00	45.8 AV	54.0	-8.2	2.20 V	295	38.65	7.15
8	11490.00	52.6 PK	74.0	-21.4	1.71 V	192	38.08	14.52
9	11490.00	40.3 AV	54.0	-13.7	1.71 V	192	25.78	14.52
10	#17235.00	56.7 PK	74.0	-17.3	1.67 V	27	32.94	23.76
11	#17235.00	45.9 AV	54.0	-8.1	1.67 V	27	22.14	23.76

**REMARKS:**

1. Emission Level(dBuV/m) = Raw Value(dBuV) + Correction Factor(dB/m)
2. Correction Factor(dB/m) = Antenna Factor(dB/m) + Cable Factor(dB) – Pre-Amplifier Factor(dB)
3. The other emission levels were very low against the limit.
4. Margin value = Emission Level – Limit value
5. " \* ": Fundamental frequency.
6. " # ": The radiated frequency is out of the restricted band.

<b>CHANNEL</b>	TX Channel 157	<b>DETECTOR FUNCTION</b>	Peak (PK)
<b>FREQUENCY RANGE</b>	1GHz ~ 40GHz		Average (AV)

**ANTENNA POLARITY & TEST DISTANCE: HORIZONTAL AT 3 M**

NO.	FREQ. (MHz)	EMISSION LEVEL (dBuV/m)	LIMIT (dBuV/m)	MARGIN (dB)	ANTENNA HEIGHT (m)	TABLE ANGLE (Degree)	RAW VALUE (dBuV)	CORRECTION FACTOR (dB/m)
1	#5627.00	60.3 PK	74.0	-13.7	1.79 H	318	53.10	7.20
2	#5627.00	49.7 AV	54.0	-4.3	1.79 H	318	42.50	7.20
3	*5785.00	116.4 PK			2.35 H	320	109.02	7.38
4	*5785.00	105.0 AV			2.35 H	320	97.62	7.38
5	#5947.00	60.4 PK	74.0	-13.6	1.94 H	322	53.26	7.14
6	#5947.00	49.5 AV	54.0	-4.5	1.94 H	322	42.36	7.14
7	11570.00	51.4 PK	74.0	-22.6	1.34 H	183	36.83	14.57
8	11570.00	39.0 AV	54.0	-15.0	1.34 H	183	24.43	14.57
9	#17355.00	56.7 PK	74.0	-17.3	2.02 H	25	32.64	24.06
10	#17355.00	45.0 AV	54.0	-9.0	2.02 H	25	20.94	24.06

**ANTENNA POLARITY & TEST DISTANCE: VERTICAL AT 3 M**

NO.	FREQ. (MHz)	EMISSION LEVEL (dBuV/m)	LIMIT (dBuV/m)	MARGIN (dB)	ANTENNA HEIGHT (m)	TABLE ANGLE (Degree)	RAW VALUE (dBuV)	CORRECTION FACTOR (dB/m)
1	#5627.00	56.1 PK	74.0	-17.9	2.15 V	290	48.90	7.20
2	#5627.00	46.5 AV	54.0	-7.5	2.15 V	290	39.30	7.20
3	*5785.00	115.1 PK			2.15 V	290	107.72	7.38
4	*5785.00	103.6 AV			2.15 V	290	96.22	7.38
5	#5947.00	56.3 PK	74.0	-17.7	2.10 V	288	49.16	7.14
6	#5947.00	46.2 AV	54.0	-7.8	2.10 V	288	39.06	7.14
7	11570.00	52.4 PK	74.0	-21.6	1.66 V	198	37.83	14.57
8	11570.00	40.2 AV	54.0	-13.8	1.66 V	198	25.63	14.57
9	#17355.00	57.2 PK	74.0	-16.8	1.69 V	37	33.14	24.06
10	#17355.00	46.3 AV	54.0	-7.7	1.69 V	37	22.24	24.06

**REMARKS:**

1. Emission Level(dBuV/m) = Raw Value(dBuV) + Correction Factor(dB/m)
2. Correction Factor(dB/m) = Antenna Factor(dB/m) + Cable Factor(dB) – Pre-Amplifier Factor(dB)
3. The other emission levels were very low against the limit.
4. Margin value = Emission Level – Limit value
5. " \* ": Fundamental frequency.
6. " # ": The radiated frequency is out of the restricted band.

<b>CHANNEL</b>	TX Channel 165	<b>DETECTOR FUNCTION</b>	Peak (PK)
<b>FREQUENCY RANGE</b>	1GHz ~ 40GHz		Average (AV)

**ANTENNA POLARITY & TEST DISTANCE: HORIZONTAL AT 3 M**

NO.	FREQ. (MHz)	EMISSION LEVEL (dBuV/m)	LIMIT (dBuV/m)	MARGIN (dB)	ANTENNA HEIGHT (m)	TABLE ANGLE (Degree)	RAW VALUE (dBuV)	CORRECTION FACTOR (dB/m)
1	#5580.00	59.1 PK	74.0	-14.9	1.80 H	318	51.92	7.18
2	#5580.00	49.1 AV	54.0	-4.9	1.80 H	318	41.92	7.18
3	*5825.00	115.0 PK			2.43 H	319	107.69	7.31
4	*5825.00	104.1 AV			2.43 H	319	96.79	7.31
5	#5850.00	76.9 PK	78.2	-1.3	2.43 H	319	69.65	7.25
6	#5860.00	66.8 PK	74.0	-7.2	2.43 H	319	59.58	7.22
7	#5860.00	50.7 AV	54.0	-3.3	2.43 H	319	43.48	7.22
8	11650.00	52.1 PK	74.0	-21.9	1.70 H	208	37.43	14.67
9	11650.00	39.9 AV	54.0	-14.1	1.70 H	208	25.23	14.67
10	#17475.00	56.7 PK	74.0	-17.3	1.74 H	50	32.68	24.02
11	#17475.00	45.8 AV	54.0	-8.2	1.74 H	50	21.78	24.02

**ANTENNA POLARITY & TEST DISTANCE: VERTICAL AT 3 M**

NO.	FREQ. (MHz)	EMISSION LEVEL (dBuV/m)	LIMIT (dBuV/m)	MARGIN (dB)	ANTENNA HEIGHT (m)	TABLE ANGLE (Degree)	RAW VALUE (dBuV)	CORRECTION FACTOR (dB/m)
1	#5580.00	56.2 PK	74.0	-17.8	2.22 V	304	49.02	7.18
2	#5580.00	46.8 AV	54.0	-7.2	2.22 V	304	39.62	7.18
3	*5825.00	113.4 PK			2.20 V	296	106.09	7.31
4	*5825.00	102.6 AV			2.20 V	296	95.29	7.31
5	#5850.00	74.6 PK	78.2	-3.6	2.20 V	296	67.35	7.25
6	#5860.00	64.9 PK	74.0	-9.1	2.20 V	296	57.68	7.22
7	#5860.00	47.4 AV	54.0	-6.6	2.20 V	296	40.18	7.22
8	11650.00	52.5 PK	74.0	-21.5	1.64 V	201	37.83	14.67
9	11650.00	40.2 AV	54.0	-13.8	1.64 V	201	25.53	14.67
10	#17475.00	57.6 PK	74.0	-16.4	1.63 V	21	33.58	24.02
11	#17475.00	46.4 AV	54.0	-7.6	1.63 V	21	22.38	24.02

**REMARKS:**

1. Emission Level(dBuV/m) = Raw Value(dBuV) + Correction Factor(dB/m)
2. Correction Factor(dB/m) = Antenna Factor(dB/m) + Cable Factor(dB) – Pre-Amplifier Factor(dB)
3. The other emission levels were very low against the limit.
4. Margin value = Emission Level – Limit value
5. " \* ": Fundamental frequency.
6. " # ": The radiated frequency is out of the restricted band.

**802.11ac (VHT40)**

<b>CHANNEL</b>	TX Channel 38	<b>DETECTOR FUNCTION</b>	Peak (PK)
<b>FREQUENCY RANGE</b>	1GHz ~ 40GHz		Average (AV)

**ANTENNA POLARITY & TEST DISTANCE: HORIZONTAL AT 3 M**

NO.	FREQ. (MHz)	EMISSION LEVEL (dBuV/m)	LIMIT (dBuV/m)	MARGIN (dB)	ANTENNA HEIGHT (m)	TABLE ANGLE (Degree)	RAW VALUE (dBuV)	CORRECTION FACTOR (dB/m)
1	5150.00	65.5 PK	74.0	-8.5	2.33 H	319	59.03	6.47
2	5150.00	52.6 AV	54.0	-1.4	2.33 H	319	46.13	6.47
3	*5190.00	104.5 PK			2.33 H	319	97.80	6.70
4	*5190.00	91.9 AV			2.33 H	319	85.20	6.70
5	5350.00	53.0 PK	74.0	-21.0	2.33 H	319	45.96	7.04
6	5350.00	41.5 AV	54.0	-12.5	2.33 H	319	34.46	7.04
7	#10380.00	52.3 PK	74.0	-21.7	1.69 H	218	38.09	14.21
8	#10380.00	40.0 AV	54.0	-14.0	1.69 H	218	25.79	14.21
9	15570.00	56.5 PK	74.0	-17.5	1.77 H	41	37.95	18.55
10	15570.00	45.6 AV	54.0	-8.4	1.77 H	41	27.05	18.55

**ANTENNA POLARITY & TEST DISTANCE: VERTICAL AT 3 M**

NO.	FREQ. (MHz)	EMISSION LEVEL (dBuV/m)	LIMIT (dBuV/m)	MARGIN (dB)	ANTENNA HEIGHT (m)	TABLE ANGLE (Degree)	RAW VALUE (dBuV)	CORRECTION FACTOR (dB/m)
1	5150.00	64.1 PK	74.0	-9.9	2.16 V	291	57.63	6.47
2	5150.00	51.2 AV	54.0	-2.8	2.16 V	291	44.73	6.47
3	*5190.00	103.1 PK			2.16 V	291	96.40	6.70
4	*5190.00	90.4 AV			2.16 V	291	83.70	6.70
5	5350.00	51.8 PK	74.0	-22.2	2.16 V	291	44.76	7.04
6	5350.00	40.1 AV	54.0	-13.9	2.16 V	291	33.06	7.04
7	#10380.00	52.8 PK	74.0	-21.2	1.70 V	198	38.59	14.21
8	#10380.00	40.3 AV	54.0	-13.7	1.70 V	198	26.09	14.21
9	15570.00	58.0 PK	74.0	-16.0	1.58 V	21	39.45	18.55
10	15570.00	46.8 AV	54.0	-7.2	1.58 V	21	28.25	18.55

**REMARKS:**

1. Emission Level(dBuV/m) = Raw Value(dBuV) + Correction Factor(dB/m)
2. Correction Factor(dB/m) = Antenna Factor(dB/m) + Cable Factor(dB) – Pre-Amplifier Factor(dB)
3. The other emission levels were very low against the limit.
4. Margin value = Emission Level – Limit value
5. " \* ": Fundamental frequency.
6. " # ": The radiated frequency is out of the restricted band.

<b>CHANNEL</b>	TX Channel 46	<b>DETECTOR FUNCTION</b>	Peak (PK)
<b>FREQUENCY RANGE</b>	1GHz ~ 40GHz		Average (AV)

**ANTENNA POLARITY & TEST DISTANCE: HORIZONTAL AT 3 M**

NO.	FREQ. (MHz)	EMISSION LEVEL (dBuV/m)	LIMIT (dBuV/m)	MARGIN (dB)	ANTENNA HEIGHT (m)	TABLE ANGLE (Degree)	RAW VALUE (dBuV)	CORRECTION FACTOR (dB/m)
1	5150.00	56.4 PK	74.0	-17.6	2.33 H	326	49.93	6.47
2	5150.00	41.0 AV	54.0	-13.0	2.33 H	326	34.53	6.47
3	*5230.00	109.1 PK			2.33 H	326	102.29	6.81
4	*5230.00	96.7 AV			2.33 H	326	89.89	6.81
5	5350.00	58.4 PK	74.0	-15.6	1.89 H	310	51.36	7.04
6	5350.00	45.1 AV	54.0	-8.9	1.89 H	310	38.06	7.04
7	#10460.00	52.4 PK	74.0	-21.6	1.72 H	206	38.35	14.05
8	#10460.00	40.3 AV	54.0	-13.7	1.72 H	206	26.25	14.05
9	15690.00	57.0 PK	74.0	-17.0	1.70 H	45	38.13	18.87
10	15690.00	46.2 AV	54.0	-7.8	1.70 H	45	27.33	18.87

**ANTENNA POLARITY & TEST DISTANCE: VERTICAL AT 3 M**

NO.	FREQ. (MHz)	EMISSION LEVEL (dBuV/m)	LIMIT (dBuV/m)	MARGIN (dB)	ANTENNA HEIGHT (m)	TABLE ANGLE (Degree)	RAW VALUE (dBuV)	CORRECTION FACTOR (dB/m)
1	5150.00	54.9 PK	74.0	-19.1	2.20 V	301	48.43	6.47
2	5150.00	39.8 AV	54.0	-14.2	2.20 V	301	33.33	6.47
3	*5230.00	107.3 PK			2.20 V	301	100.49	6.81
4	*5230.00	95.2 AV			2.20 V	301	88.39	6.81
5	5350.00	56.8 PK	74.0	-17.2	2.20 V	301	49.76	7.04
6	5350.00	43.9 AV	54.0	-10.1	2.20 V	301	36.86	7.04
7	#10460.00	52.3 PK	74.0	-21.7	1.66 V	187	38.25	14.05
8	#10460.00	40.3 AV	54.0	-13.7	1.66 V	187	26.25	14.05
9	15690.00	57.4 PK	74.0	-16.6	1.62 V	34	38.53	18.87
10	15690.00	46.3 AV	54.0	-7.7	1.62 V	34	27.43	18.87

**REMARKS:**

1. Emission Level(dBuV/m) = Raw Value(dBuV) + Correction Factor(dB/m)
2. Correction Factor(dB/m) = Antenna Factor(dB/m) + Cable Factor(dB) – Pre-Amplifier Factor(dB)
3. The other emission levels were very low against the limit.
4. Margin value = Emission Level – Limit value
5. " \* ": Fundamental frequency.
6. " # ": The radiated frequency is out of the restricted band.

<b>CHANNEL</b>	TX Channel 54	<b>DETECTOR FUNCTION</b>	Peak (PK)
<b>FREQUENCY RANGE</b>	1GHz ~ 40GHz		Average (AV)

**ANTENNA POLARITY & TEST DISTANCE: HORIZONTAL AT 3 M**

NO.	FREQ. (MHz)	EMISSION LEVEL (dBuV/m)	LIMIT (dBuV/m)	MARGIN (dB)	ANTENNA HEIGHT (m)	TABLE ANGLE (Degree)	RAW VALUE (dBuV)	CORRECTION FACTOR (dB/m)
1	5150.00	57.3 PK	74.0	-16.7	1.99 H	320	50.83	6.47
2	5150.00	42.0 AV	54.0	-12.0	1.99 H	320	35.53	6.47
3	*5270.00	110.1 PK			1.99 H	320	103.24	6.86
4	*5270.00	97.3 AV			1.99 H	320	90.44	6.86
5	5350.00	62.0 PK	74.0	-12.0	1.99 H	320	54.96	7.04
6	5350.00	47.0 AV	54.0	-7.0	1.99 H	320	39.96	7.04
7	#10540.00	52.8 PK	74.0	-21.2	1.64 H	215	39.07	13.73
8	#10540.00	40.3 AV	54.0	-13.7	1.64 H	215	26.57	13.73
9	15810.00	56.5 PK	74.0	-17.5	1.76 H	64	37.08	19.42
10	15810.00	45.6 AV	54.0	-8.4	1.76 H	64	26.18	19.42

**ANTENNA POLARITY & TEST DISTANCE: VERTICAL AT 3 M**

NO.	FREQ. (MHz)	EMISSION LEVEL (dBuV/m)	LIMIT (dBuV/m)	MARGIN (dB)	ANTENNA HEIGHT (m)	TABLE ANGLE (Degree)	RAW VALUE (dBuV)	CORRECTION FACTOR (dB/m)
1	5150.00	55.2 PK	74.0	-18.8	2.19 V	307	48.73	6.47
2	5150.00	39.7 AV	54.0	-14.3	2.19 V	307	33.23	6.47
3	*5270.00	108.3 PK			2.19 V	307	101.44	6.86
4	*5270.00	95.8 AV			2.19 V	307	88.94	6.86
5	5350.00	60.2 PK	74.0	-13.8	2.19 V	307	53.16	7.04
6	5350.00	45.1 AV	54.0	-8.9	2.19 V	307	38.06	7.04
7	#10540.00	52.8 PK	74.0	-21.2	1.60 V	192	39.07	13.73
8	#10540.00	40.5 AV	54.0	-13.5	1.60 V	192	26.77	13.73
9	15810.00	57.4 PK	74.0	-16.6	1.62 V	21	37.98	19.42
10	15810.00	46.0 AV	54.0	-8.0	1.62 V	21	26.58	19.42

**REMARKS:**

1. Emission Level(dBuV/m) = Raw Value(dBuV) + Correction Factor(dB/m)
2. Correction Factor(dB/m) = Antenna Factor(dB/m) + Cable Factor(dB) – Pre-Amplifier Factor(dB)
3. The other emission levels were very low against the limit.
4. Margin value = Emission Level – Limit value
5. " \* ": Fundamental frequency.
6. " # ": The radiated frequency is out of the restricted band.



<b>CHANNEL</b>	TX Channel 62	<b>DETECTOR FUNCTION</b>	Peak (PK)
<b>FREQUENCY RANGE</b>	1GHz ~ 40GHz		Average (AV)

**ANTENNA POLARITY & TEST DISTANCE: HORIZONTAL AT 3 M**

NO.	FREQ. (MHz)	EMISSION LEVEL (dBuV/m)	LIMIT (dBuV/m)	MARGIN (dB)	ANTENNA HEIGHT (m)	TABLE ANGLE (Degree)	RAW VALUE (dBuV)	CORRECTION FACTOR (dB/m)
1	*5310.00	105.9 PK			1.96 H	322	98.96	6.94
2	*5310.00	93.4 AV			1.96 H	322	86.46	6.94
3	5350.00	71.2 PK	74.0	-2.8	1.96 H	322	64.16	7.04
4	5350.00	52.9 AV	54.0	-1.1	1.96 H	322	45.86	7.04
5	10620.00	52.2 PK	74.0	-21.8	1.65 H	192	38.66	13.54
6	10620.00	39.7 AV	54.0	-14.3	1.65 H	192	26.16	13.54
7	15930.00	57.3 PK	74.0	-16.7	1.68 H	35	38.38	18.92
8	15930.00	46.2 AV	54.0	-7.8	1.68 H	35	27.28	18.92

**ANTENNA POLARITY & TEST DISTANCE: VERTICAL AT 3 M**

NO.	FREQ. (MHz)	EMISSION LEVEL (dBuV/m)	LIMIT (dBuV/m)	MARGIN (dB)	ANTENNA HEIGHT (m)	TABLE ANGLE (Degree)	RAW VALUE (dBuV)	CORRECTION FACTOR (dB/m)
1	*5310.00	104.1 PK			2.10 V	305	97.16	6.94
2	*5310.00	91.6 AV			2.10 V	305	84.66	6.94
3	5350.00	69.2 PK	74.0	-4.8	2.10 V	305	62.16	7.04
4	5350.00	51.1 AV	54.0	-2.9	2.10 V	305	44.06	7.04
5	10620.00	52.5 PK	74.0	-21.5	1.64 V	211	38.96	13.54
6	10620.00	40.5 AV	54.0	-13.5	1.64 V	211	26.96	13.54
7	15930.00	57.1 PK	74.0	-16.9	1.58 V	15	38.18	18.92
8	15930.00	46.0 AV	54.0	-8.0	1.58 V	15	27.08	18.92

**REMARKS:**

1. Emission Level(dBuV/m) = Raw Value(dBuV) + Correction Factor(dB/m)
2. Correction Factor(dB/m) = Antenna Factor(dB/m) + Cable Factor(dB) – Pre-Amplifier Factor(dB)
3. The other emission levels were very low against the limit.
4. Margin value = Emission Level – Limit value
5. " \* ": Fundamental frequency.

<b>CHANNEL</b>	TX Channel 102	<b>DETECTOR FUNCTION</b>	Peak (PK)
<b>FREQUENCY RANGE</b>	1GHz ~ 40GHz		Average (AV)

**ANTENNA POLARITY & TEST DISTANCE: HORIZONTAL AT 3 M**

NO.	FREQ. (MHz)	EMISSION LEVEL (dBuV/m)	LIMIT (dBuV/m)	MARGIN (dB)	ANTENNA HEIGHT (m)	TABLE ANGLE (Degree)	RAW VALUE (dBuV)	CORRECTION FACTOR (dB/m)
1	#5470.00	67.4 PK	74.0	-6.6	1.96 H	316	60.11	7.29
2	#5470.00	52.9 AV	54.0	-1.1	1.96 H	316	45.61	7.29
3	*5510.00	107.4 PK			1.96 H	316	100.09	7.31
4	*5510.00	94.8 AV			1.96 H	316	87.49	7.31
5	11020.00	51.8 PK	74.0	-22.2	1.75 H	203	37.52	14.28
6	11020.00	39.4 AV	54.0	-14.6	1.75 H	203	25.12	14.28
7	#16530.00	56.7 PK	74.0	-17.3	1.74 H	52	35.47	21.23
8	#16530.00	45.6 AV	54.0	-8.4	1.74 H	52	24.37	21.23

**ANTENNA POLARITY & TEST DISTANCE: VERTICAL AT 3 M**

NO.	FREQ. (MHz)	EMISSION LEVEL (dBuV/m)	LIMIT (dBuV/m)	MARGIN (dB)	ANTENNA HEIGHT (m)	TABLE ANGLE (Degree)	RAW VALUE (dBuV)	CORRECTION FACTOR (dB/m)
1	#5470.00	65.3 PK	74.0	-8.7	2.05 V	288	58.01	7.29
2	#5470.00	50.7 AV	54.0	-3.3	2.05 V	288	43.41	7.29
3	*5510.00	105.5 PK			2.05 V	288	98.19	7.31
4	*5510.00	92.7 AV			2.05 V	288	85.39	7.31
5	11020.00	52.5 PK	74.0	-21.5	1.68 V	192	38.22	14.28
6	11020.00	40.3 AV	54.0	-13.7	1.68 V	192	26.02	14.28
7	#16530.00	57.6 PK	74.0	-16.4	1.60 V	47	36.37	21.23
8	#16530.00	46.2 AV	54.0	-7.8	1.60 V	47	24.97	21.23

**REMARKS:**

1. Emission Level(dBuV/m) = Raw Value(dBuV) + Correction Factor(dB/m)
2. Correction Factor(dB/m) = Antenna Factor(dB/m) + Cable Factor(dB) – Pre-Amplifier Factor(dB)
3. The other emission levels were very low against the limit.
4. Margin value = Emission Level – Limit value
5. " \* ": Fundamental frequency.
6. " # ": The radiated frequency is out of the restricted band.

<b>CHANNEL</b>	TX Channel 110	<b>DETECTOR FUNCTION</b>	Peak (PK)
<b>FREQUENCY RANGE</b>	1GHz ~ 40GHz		Average (AV)

**ANTENNA POLARITY & TEST DISTANCE: HORIZONTAL AT 3 M**

NO.	FREQ. (MHz)	EMISSION LEVEL (dBuV/m)	LIMIT (dBuV/m)	MARGIN (dB)	ANTENNA HEIGHT (m)	TABLE ANGLE (Degree)	RAW VALUE (dBuV)	CORRECTION FACTOR (dB/m)
1	#5470.00	65.8 PK	74.0	-8.2	1.92 H	314	58.51	7.29
2	#5470.00	51.0 AV	54.0	-3.0	1.92 H	314	43.71	7.29
3	*5550.00	111.3 PK			1.92 H	314	104.06	7.24
4	*5550.00	99.5 AV			1.92 H	314	92.26	7.24
5	11100.00	52.5 PK	74.0	-21.5	1.68 H	201	38.06	14.44
6	11100.00	40.1 AV	54.0	-13.9	1.68 H	201	25.66	14.44
7	#16650.00	56.7 PK	74.0	-17.3	1.68 H	39	34.85	21.85
8	#16650.00	45.7 AV	54.0	-8.3	1.68 H	39	23.85	21.85

**ANTENNA POLARITY & TEST DISTANCE: VERTICAL AT 3 M**

NO.	FREQ. (MHz)	EMISSION LEVEL (dBuV/m)	LIMIT (dBuV/m)	MARGIN (dB)	ANTENNA HEIGHT (m)	TABLE ANGLE (Degree)	RAW VALUE (dBuV)	CORRECTION FACTOR (dB/m)
1	#5470.00	64.1 PK	74.0	-9.9	2.18 V	310	56.81	7.29
2	#5470.00	49.2 AV	54.0	-4.8	2.18 V	310	41.91	7.29
3	*5550.00	109.8 PK			2.18 V	310	102.56	7.24
4	*5550.00	98.2 AV			2.18 V	310	90.96	7.24
5	11100.00	52.5 PK	74.0	-21.5	1.67 V	209	38.06	14.44
6	11100.00	40.1 AV	54.0	-13.9	1.67 V	209	25.66	14.44
7	#16650.00	57.5 PK	74.0	-16.5	1.64 V	30	35.65	21.85
8	#16650.00	46.2 AV	54.0	-7.8	1.64 V	30	24.35	21.85

**REMARKS:**

1. Emission Level(dBuV/m) = Raw Value(dBuV) + Correction Factor(dB/m)
2. Correction Factor(dB/m) = Antenna Factor(dB/m) + Cable Factor(dB) – Pre-Amplifier Factor(dB)
3. The other emission levels were very low against the limit.
4. Margin value = Emission Level – Limit value
5. " \* ": Fundamental frequency.
6. " # ": The radiated frequency is out of the restricted band.

<b>CHANNEL</b>	TX Channel 118	<b>DETECTOR FUNCTION</b>	Peak (PK)
<b>FREQUENCY RANGE</b>	1GHz ~ 40GHz		Average (AV)

**ANTENNA POLARITY & TEST DISTANCE: HORIZONTAL AT 3 M**

NO.	FREQ. (MHz)	EMISSION LEVEL (dBuV/m)	LIMIT (dBuV/m)	MARGIN (dB)	ANTENNA HEIGHT (m)	TABLE ANGLE (Degree)	RAW VALUE (dBuV)	CORRECTION FACTOR (dB/m)
1	#5466.00	59.4 PK	74.0	-14.6	2.25 H	318	52.11	7.29
2	#5466.00	45.7 AV	54.0	-8.3	2.25 H	318	38.41	7.29
3	*5590.00	112.5 PK			1.92 H	316	105.35	7.15
4	*5590.00	99.5 AV			1.92 H	316	92.35	7.15
5	#5746.00	61.2 PK	74.0	-12.8	2.25 H	317	53.82	7.38
6	#5746.00	47.1 AV	54.0	-6.9	2.25 H	317	39.72	7.38
7	11180.00	51.8 PK	74.0	-22.2	1.65 H	205	37.33	14.47
8	11180.00	39.4 AV	54.0	-14.6	1.65 H	205	24.93	14.47
9	#16770.00	57.2 PK	74.0	-16.8	1.70 H	40	35.17	22.03
10	#16770.00	46.2 AV	54.0	-7.8	1.70 H	40	24.17	22.03

**ANTENNA POLARITY & TEST DISTANCE: VERTICAL AT 3 M**

NO.	FREQ. (MHz)	EMISSION LEVEL (dBuV/m)	LIMIT (dBuV/m)	MARGIN (dB)	ANTENNA HEIGHT (m)	TABLE ANGLE (Degree)	RAW VALUE (dBuV)	CORRECTION FACTOR (dB/m)
1	#5466.00	57.8 PK	74.0	-16.2	2.20 V	289	50.51	7.29
2	#5466.00	44.0 AV	54.0	-10.0	2.20 V	289	36.71	7.29
3	*5590.00	111.0 PK			2.19 V	308	103.85	7.15
4	*5590.00	98.2 AV			2.19 V	308	91.05	7.15
5	#5746.00	59.5 PK	74.0	-14.5	2.10 V	300	52.12	7.38
6	#5746.00	45.3 AV	54.0	-8.7	2.10 V	300	37.92	7.38
7	11180.00	53.2 PK	74.0	-20.8	1.64 V	186	38.73	14.47
8	11180.00	40.6 AV	54.0	-13.4	1.64 V	186	26.13	14.47
9	#16770.00	57.4 PK	74.0	-16.6	1.63 V	31	35.37	22.03
10	#16770.00	46.1 AV	54.0	-7.9	1.63 V	31	24.07	22.03

**REMARKS:**

1. Emission Level(dBuV/m) = Raw Value(dBuV) + Correction Factor(dB/m)
2. Correction Factor(dB/m) = Antenna Factor(dB/m) + Cable Factor(dB) – Pre-Amplifier Factor(dB)
3. The other emission levels were very low against the limit.
4. Margin value = Emission Level – Limit value
5. " \* ": Fundamental frequency.
6. " # ": The radiated frequency is out of the restricted band.

<b>CHANNEL</b>	TX Channel 134	<b>DETECTOR FUNCTION</b>	Peak (PK)
<b>FREQUENCY RANGE</b>	1GHz ~ 40GHz		Average (AV)

**ANTENNA POLARITY & TEST DISTANCE: HORIZONTAL AT 3 M**

NO.	FREQ. (MHz)	EMISSION LEVEL (dBuV/m)	LIMIT (dBuV/m)	MARGIN (dB)	ANTENNA HEIGHT (m)	TABLE ANGLE (Degree)	RAW VALUE (dBuV)	CORRECTION FACTOR (dB/m)
1	*5670.00	111.6 PK			2.09 H	319	104.29	7.31
2	*5670.00	98.6 AV			2.09 H	319	91.29	7.31
3	#5725.00	68.4 PK	74.0	-5.6	2.09 H	319	61.02	7.38
4	#5725.00	52.7 AV	54.0	-1.3	2.09 H	319	45.32	7.38
5	11340.00	52.3 PK	74.0	-21.7	1.66 H	198	37.74	14.56
6	11340.00	40.0 AV	54.0	-14.0	1.66 H	198	25.44	14.56
7	#17010.00	57.1 PK	74.0	-16.9	1.70 H	36	33.71	23.39
8	#17010.00	46.0 AV	54.0	-8.0	1.70 H	36	22.61	23.39

**ANTENNA POLARITY & TEST DISTANCE: VERTICAL AT 3 M**

NO.	FREQ. (MHz)	EMISSION LEVEL (dBuV/m)	LIMIT (dBuV/m)	MARGIN (dB)	ANTENNA HEIGHT (m)	TABLE ANGLE (Degree)	RAW VALUE (dBuV)	CORRECTION FACTOR (dB/m)
1	*5670.00	109.7 PK			2.11 V	305	102.39	7.31
2	*5670.00	96.5 AV			2.11 V	305	89.19	7.31
3	#5725.00	66.4 PK	74.0	-7.6	2.11 V	305	59.02	7.38
4	#5725.00	50.8 AV	54.0	-3.2	2.11 V	305	43.42	7.38
5	11340.00	52.2 PK	74.0	-21.8	1.65 V	209	37.64	14.56
6	11340.00	40.0 AV	54.0	-14.0	1.65 V	209	25.44	14.56
7	#17010.00	58.0 PK	74.0	-16.0	1.57 V	7	34.61	23.39
8	#17010.00	46.9 AV	54.0	-7.1	1.57 V	7	23.51	23.39

**REMARKS:**

1. Emission Level(dBuV/m) = Raw Value(dBuV) + Correction Factor(dB/m)
2. Correction Factor(dB/m) = Antenna Factor(dB/m) + Cable Factor(dB) – Pre-Amplifier Factor(dB)
3. The other emission levels were very low against the limit.
4. Margin value = Emission Level – Limit value
5. " \* ": Fundamental frequency.
6. " # ": The radiated frequency is out of the restricted band.

<b>CHANNEL</b>	TX Channel 151	<b>DETECTOR FUNCTION</b>	Peak (PK)
<b>FREQUENCY RANGE</b>	1GHz ~ 40GHz		Average (AV)

**ANTENNA POLARITY & TEST DISTANCE: HORIZONTAL AT 3 M**

NO.	FREQ. (MHz)	EMISSION LEVEL (dBuV/m)	LIMIT (dBuV/m)	MARGIN (dB)	ANTENNA HEIGHT (m)	TABLE ANGLE (Degree)	RAW VALUE (dBuV)	CORRECTION FACTOR (dB/m)
1	#5715.00	67.1 PK	74.0	-6.9	2.00 H	316	61.30	5.80
2	#5715.00	52.9 AV	54.0	-1.1	2.00 H	316	47.10	5.80
3	#5725.00	75.5 PK	78.2	-2.7	2.00 H	316	69.60	5.90
4	*5755.00	107.8 PK			2.00 H	316	101.90	5.90
5	*5755.00	95.5 AV			2.00 H	316	89.60	5.90
6	#5911.00	56.2 PK	74.0	-17.8	2.07 H	321	50.60	5.60
7	#5911.00	44.1 AV	54.0	-9.9	2.07 H	321	38.50	5.60
8	11510.00	52.3 PK	74.0	-21.7	1.73 H	194	39.90	12.40
9	11510.00	40.1 AV	54.0	-13.9	1.73 H	194	27.70	12.40
10	#17265.00	56.8 PK	74.0	-17.2	1.78 H	53	36.10	20.70
11	#17265.00	46.0 AV	54.0	-8.0	1.78 H	53	25.30	20.70

**ANTENNA POLARITY & TEST DISTANCE: VERTICAL AT 3 M**

NO.	FREQ. (MHz)	EMISSION LEVEL (dBuV/m)	LIMIT (dBuV/m)	MARGIN (dB)	ANTENNA HEIGHT (m)	TABLE ANGLE (Degree)	RAW VALUE (dBuV)	CORRECTION FACTOR (dB/m)
1	#5715.00	65.2 PK	74.0	-8.8	2.07 V	307	59.40	5.80
2	#5715.00	51.3 AV	54.0	-2.7	2.07 V	307	45.50	5.80
3	#5725.00	73.5 PK	78.2	-4.7	2.07 V	307	67.60	5.90
4	*5755.00	105.7 PK			2.07 V	307	99.80	5.90
5	*5755.00	93.6 AV			2.07 V	307	87.70	5.90
6	#5911.00	54.5 PK	74.0	-19.5	4.00 V	289	48.90	5.60
7	#5911.00	42.2 AV	54.0	-11.8	4.00 V	289	36.60	5.60
8	11510.00	52.3 PK	74.0	-21.7	1.58 V	204	39.90	12.40
9	11510.00	40.2 AV	54.0	-13.8	1.58 V	204	27.80	12.40
10	#17265.00	57.9 PK	74.0	-16.1	1.59 V	20	37.20	20.70
11	#17265.00	46.6 AV	54.0	-7.4	1.59 V	20	25.90	20.70

**REMARKS:**

1. Emission Level(dBuV/m) = Raw Value(dBuV) + Correction Factor(dB/m)
2. Correction Factor(dB/m) = Antenna Factor(dB/m) + Cable Factor(dB) – Pre-Amplifier Factor(dB)
3. The other emission levels were very low against the limit.
4. Margin value = Emission Level – Limit value
5. " \* ": Fundamental frequency.
6. " # ": The radiated frequency is out of the restricted band.

<b>CHANNEL</b>	TX Channel 159	<b>DETECTOR FUNCTION</b>	Peak (PK)
<b>FREQUENCY RANGE</b>	1GHz ~ 40GHz		Average (AV)

**ANTENNA POLARITY & TEST DISTANCE: HORIZONTAL AT 3 M**

NO.	FREQ. (MHz)	EMISSION LEVEL (dBuV/m)	LIMIT (dBuV/m)	MARGIN (dB)	ANTENNA HEIGHT (m)	TABLE ANGLE (Degree)	RAW VALUE (dBuV)	CORRECTION FACTOR (dB/m)
1	*5795.00	113.2 PK			2.05 H	316	105.82	7.38
2	*5795.00	100.1 AV			2.05 H	316	92.72	7.38
3	#5850.00	73.3 PK	78.2	-4.9	2.05 H	316	66.05	7.25
4	#5860.00	70.1 PK	74.0	-3.9	2.05 H	316	62.88	7.22
5	#5860.00	52.8 AV	54.0	-1.2	2.05 H	316	45.58	7.22
6	11590.00	52.1 PK	74.0	-21.9	1.70 H	198	37.49	14.61
7	11590.00	40.1 AV	54.0	-13.9	1.70 H	198	25.49	14.61
8	#17385.00	56.6 PK	74.0	-17.4	1.74 H	48	32.11	24.49
9	#17385.00	45.4 AV	54.0	-8.6	1.74 H	48	20.91	24.49

**ANTENNA POLARITY & TEST DISTANCE: VERTICAL AT 3 M**

NO.	FREQ. (MHz)	EMISSION LEVEL (dBuV/m)	LIMIT (dBuV/m)	MARGIN (dB)	ANTENNA HEIGHT (m)	TABLE ANGLE (Degree)	RAW VALUE (dBuV)	CORRECTION FACTOR (dB/m)
1	*5795.00	112.3 PK			2.18 V	322	104.92	7.38
2	*5795.00	98.7 AV			2.18 V	322	91.32	7.38
3	#5850.00	71.4 PK	78.2	-6.8	2.18 V	322	64.15	7.25
4	#5860.00	68.0 PK	74.0	-6.0	2.18 V	322	60.78	7.22
5	#5860.00	50.9 AV	54.0	-3.1	2.18 V	322	43.68	7.22
6	11590.00	52.4 PK	74.0	-21.6	1.57 V	208	37.79	14.61
7	11590.00	40.1 AV	54.0	-13.9	1.57 V	208	25.49	14.61
8	#17385.00	58.1 PK	74.0	-15.9	1.53 V	25	33.61	24.49
9	#17385.00	46.9 AV	54.0	-7.1	1.53 V	25	22.41	24.49

**REMARKS:**

1. Emission Level(dBuV/m) = Raw Value(dBuV) + Correction Factor(dB/m)
2. Correction Factor(dB/m) = Antenna Factor(dB/m) + Cable Factor(dB) – Pre-Amplifier Factor(dB)
3. The other emission levels were very low against the limit.
4. Margin value = Emission Level – Limit value
5. " \* ": Fundamental frequency.
6. " # ": The radiated frequency is out of the restricted band.

**802.11ac (VHT80)**

<b>CHANNEL</b>	TX Channel 42	<b>DETECTOR FUNCTION</b>	Peak (PK)
<b>FREQUENCY RANGE</b>	1GHz ~ 40GHz		Average (AV)

**ANTENNA POLARITY & TEST DISTANCE: HORIZONTAL AT 3 M**

NO.	FREQ. (MHz)	EMISSION LEVEL (dBuV/m)	LIMIT (dBuV/m)	MARGIN (dB)	ANTENNA HEIGHT (m)	TABLE ANGLE (Degree)	RAW VALUE (dBuV)	CORRECTION FACTOR (dB/m)
1	5150.00	68.5 PK	74.0	-5.5	2.26 H	326	62.00	6.50
2	5150.00	52.9 AV	54.0	-1.1	2.26 H	326	46.40	6.50
3	*5210.00	101.0 PK			2.26 H	326	94.20	6.80
4	*5210.00	88.2 AV			2.26 H	326	81.40	6.80
5	#5788.90	56.7 PK	74.0	-17.3	2.28 H	314	49.30	7.40
6	#5788.90	51.0 AV	54.0	-3.0	2.28 H	314	43.60	7.40
7	#10420.00	52.3 PK	74.0	-21.7	1.66 H	213	38.10	14.20
8	#10420.00	40.1 AV	54.0	-13.9	1.66 H	213	25.90	14.20
9	15630.00	57.3 PK	74.0	-16.7	1.78 H	60	38.80	18.50
10	15630.00	46.1 AV	54.0	-7.9	1.78 H	60	27.60	18.50

**ANTENNA POLARITY & TEST DISTANCE: VERTICAL AT 3 M**

NO.	FREQ. (MHz)	EMISSION LEVEL (dBuV/m)	LIMIT (dBuV/m)	MARGIN (dB)	ANTENNA HEIGHT (m)	TABLE ANGLE (Degree)	RAW VALUE (dBuV)	CORRECTION FACTOR (dB/m)
1	5150.00	66.7 PK	74.0	-7.3	2.17 V	325	60.23	6.47
2	5150.00	50.9 AV	54.0	-3.1	2.17 V	325	44.43	6.47
3	*5210.00	99.2 PK			2.17 V	325	92.42	6.78
4	*5210.00	86.3 AV			2.17 V	325	79.52	6.78
5	#5788.90	54.8 PK	74.0	-19.2	2.20 V	308	47.43	7.37
6	#5788.90	49.4 AV	54.0	-4.6	2.20 V	308	42.03	7.37
7	#10420.00	52.2 PK	74.0	-21.8	1.62 V	205	38.05	14.15
8	#10420.00	40.3 AV	54.0	-13.7	1.62 V	205	26.15	14.15
9	15630.00	58.3 PK	74.0	-15.7	1.55 V	28	39.78	18.52
10	15630.00	46.7 AV	54.0	-7.3	1.55 V	28	28.18	18.52

**REMARKS:**

- Emission Level(dBuV/m) = Raw Value(dBuV) + Correction Factor(dB/m)
- Correction Factor(dB/m) = Antenna Factor(dB/m) + Cable Factor(dB) – Pre-Amplifier Factor(dB)
- The other emission levels were very low against the limit.
- Margin value = Emission Level – Limit value
- " \* ": Fundamental frequency.
- " # ": The radiated frequency is out of the restricted band.



<b>CHANNEL</b>	TX Channel 58	<b>DETECTOR FUNCTION</b>	Peak (PK)
<b>FREQUENCY RANGE</b>	1GHz ~ 40GHz		Average (AV)

**ANTENNA POLARITY & TEST DISTANCE: HORIZONTAL AT 3 M**

NO.	FREQ. (MHz)	EMISSION LEVEL (dBuV/m)	LIMIT (dBuV/m)	MARGIN (dB)	ANTENNA HEIGHT (m)	TABLE ANGLE (Degree)	RAW VALUE (dBuV)	CORRECTION FACTOR (dB/m)
1	*5290.00	102.7 PK			1.86 H	317	95.81	6.89
2	*5290.00	88.9 AV			1.86 H	317	82.01	6.89
3	5350.00	69.9 PK	74.0	-4.1	1.86 H	317	62.86	7.04
4	5350.00	52.7 AV	54.0	-1.3	1.86 H	317	45.66	7.04
5	#10580.00	52.9 PK	74.0	-21.1	1.69 H	215	39.37	13.53
6	#10580.00	40.4 AV	54.0	-13.6	1.69 H	215	26.87	13.53
7	15870.00	57.1 PK	74.0	-16.9	1.69 H	37	37.95	19.15
8	15870.00	46.2 AV	54.0	-7.8	1.69 H	37	27.05	19.15

**ANTENNA POLARITY & TEST DISTANCE: VERTICAL AT 3 M**

NO.	FREQ. (MHz)	EMISSION LEVEL (dBuV/m)	LIMIT (dBuV/m)	MARGIN (dB)	ANTENNA HEIGHT (m)	TABLE ANGLE (Degree)	RAW VALUE (dBuV)	CORRECTION FACTOR (dB/m)
1	*5290.00	100.6 PK			2.11 V	341	93.71	6.89
2	*5290.00	86.8 AV			2.11 V	341	79.91	6.89
3	5350.00	67.8 PK	74.0	-6.2	2.11 V	341	60.76	7.04
4	5350.00	50.5 AV	54.0	-3.5	2.11 V	341	43.46	7.04
5	#10580.00	52.1 PK	74.0	-21.9	1.53 V	191	38.57	13.53
6	#10580.00	39.8 AV	54.0	-14.2	1.53 V	191	26.27	13.53
7	15870.00	57.5 PK	74.0	-16.5	1.62 V	31	38.35	19.15
8	15870.00	46.3 AV	54.0	-7.7	1.62 V	31	27.15	19.15

**REMARKS:**

1. Emission Level(dBuV/m) = Raw Value(dBuV) + Correction Factor(dB/m)
2. Correction Factor(dB/m) = Antenna Factor(dB/m) + Cable Factor(dB) – Pre-Amplifier Factor(dB)
3. The other emission levels were very low against the limit.
4. Margin value = Emission Level – Limit value
5. " \* ": Fundamental frequency.
6. " # ": The radiated frequency is out of the restricted band.

<b>CHANNEL</b>	TX Channel 106	<b>DETECTOR FUNCTION</b>	Peak (PK)
<b>FREQUENCY RANGE</b>	1GHz ~ 40GHz		Average (AV)

**ANTENNA POLARITY & TEST DISTANCE: HORIZONTAL AT 3 M**

NO.	FREQ. (MHz)	EMISSION LEVEL (dBuV/m)	LIMIT (dBuV/m)	MARGIN (dB)	ANTENNA HEIGHT (m)	TABLE ANGLE (Degree)	RAW VALUE (dBuV)	CORRECTION FACTOR (dB/m)
1	#5470.00	68.5 PK	74.0	-5.5	1.82 H	314	61.21	7.29
2	#5470.00	52.9 AV	54.0	-1.1	1.82 H	314	45.61	7.29
3	*5530.00	104.3 PK			1.82 H	314	97.03	7.27
4	*5530.00	90.7 AV			1.82 H	314	83.43	7.27
5	#5725.00	52.4 PK	74.0	-21.6	1.82 H	314	45.02	7.38
6	#5725.00	40.6 AV	54.0	-13.4	1.82 H	314	33.22	7.38
7	11060.00	52.5 PK	74.0	-21.5	1.64 H	194	38.15	14.35
8	11060.00	40.2 AV	54.0	-13.8	1.64 H	194	25.85	14.35
9	#16590.00	56.8 PK	74.0	-17.2	1.74 H	45	35.06	21.74
10	#16590.00	46.2 AV	54.0	-7.8	1.74 H	45	24.46	21.74

**ANTENNA POLARITY & TEST DISTANCE: VERTICAL AT 3 M**

NO.	FREQ. (MHz)	EMISSION LEVEL (dBuV/m)	LIMIT (dBuV/m)	MARGIN (dB)	ANTENNA HEIGHT (m)	TABLE ANGLE (Degree)	RAW VALUE (dBuV)	CORRECTION FACTOR (dB/m)
1	#5470.00	66.6 PK	74.0	-7.4	2.07 V	335	59.31	7.29
2	#5470.00	51.1 AV	54.0	-2.9	2.07 V	335	43.81	7.29
3	*5530.00	102.4 PK			2.07 V	335	95.13	7.27
4	*5530.00	88.5 AV			2.07 V	335	81.23	7.27
5	#5725.00	50.3 PK	74.0	-23.7	2.07 V	335	42.92	7.38
6	#5725.00	38.7 AV	54.0	-15.3	2.07 V	335	31.32	7.38
7	11060.00	52.9 PK	74.0	-21.1	1.61 V	196	38.55	14.35
8	11060.00	40.6 AV	54.0	-13.4	1.61 V	196	26.25	14.35
9	#16590.00	58.5 PK	74.0	-15.5	1.64 V	27	36.76	21.74
10	#16590.00	47.0 AV	54.0	-7.0	1.64 V	27	25.26	21.74

**REMARKS:**

1. Emission Level(dBuV/m) = Raw Value(dBuV) + Correction Factor(dB/m)
2. Correction Factor(dB/m) = Antenna Factor(dB/m) + Cable Factor(dB) – Pre-Amplifier Factor(dB)
3. The other emission levels were very low against the limit.
4. Margin value = Emission Level – Limit value
5. " \* ": Fundamental frequency.
6. " # ": The radiated frequency is out of the restricted band.

<b>CHANNEL</b>	TX Channel 122	<b>DETECTOR FUNCTION</b>	Peak (PK)
<b>FREQUENCY RANGE</b>	1GHz ~ 40GHz		Average (AV)

**ANTENNA POLARITY & TEST DISTANCE: HORIZONTAL AT 3 M**

NO.	FREQ. (MHz)	EMISSION LEVEL (dBuV/m)	LIMIT (dBuV/m)	MARGIN (dB)	ANTENNA HEIGHT (m)	TABLE ANGLE (Degree)	RAW VALUE (dBuV)	CORRECTION FACTOR (dB/m)
1	*5610.00	110.2 PK			1.71 H	314	103.05	7.15
2	*5610.00	95.4 AV			1.71 H	314	88.25	7.15
3	#5725.00	67.9 PK	74.0	-6.1	1.71 H	314	60.52	7.38
4	#5725.00	52.8 AV	54.0	-1.2	1.71 H	314	45.42	7.38
5	11220.00	52.1 PK	74.0	-21.9	1.69 H	199	37.66	14.44
6	11220.00	39.9 AV	54.0	-14.1	1.69 H	199	25.46	14.44
7	#16830.00	56.5 PK	74.0	-17.5	1.75 H	65	34.32	22.18
8	#16830.00	45.6 AV	54.0	-8.4	1.75 H	65	23.42	22.18

**ANTENNA POLARITY & TEST DISTANCE: VERTICAL AT 3 M**

NO.	FREQ. (MHz)	EMISSION LEVEL (dBuV/m)	LIMIT (dBuV/m)	MARGIN (dB)	ANTENNA HEIGHT (m)	TABLE ANGLE (Degree)	RAW VALUE (dBuV)	CORRECTION FACTOR (dB/m)
1	*5610.00	107.9 PK			2.03 V	349	100.75	7.15
2	*5610.00	93.5 AV			2.03 V	349	86.35	7.15
3	#5725.00	65.8 PK	74.0	-8.2	2.03 V	349	58.42	7.38
4	#5725.00	50.7 AV	54.0	-3.3	2.03 V	349	43.32	7.38
5	11220.00	52.0 PK	74.0	-22.0	1.62 V	211	37.56	14.44
6	11220.00	40.0 AV	54.0	-14.0	1.62 V	211	25.56	14.44
7	#16830.00	58.5 PK	74.0	-15.5	1.58 V	27	36.32	22.18
8	#16830.00	47.0 AV	54.0	-7.0	1.58 V	27	24.82	22.18

**REMARKS:**

1. Emission Level(dBuV/m) = Raw Value(dBuV) + Correction Factor(dB/m)
2. Correction Factor(dB/m) = Antenna Factor(dB/m) + Cable Factor(dB) – Pre-Amplifier Factor(dB)
3. The other emission levels were very low against the limit.
4. Margin value = Emission Level – Limit value
5. " \* ": Fundamental frequency.
6. " # ": The radiated frequency is out of the restricted band.

<b>CHANNEL</b>	TX Channel 138	<b>DETECTOR FUNCTION</b>	Peak (PK)
<b>FREQUENCY RANGE</b>	1GHz ~ 40GHz		Average (AV)

**ANTENNA POLARITY & TEST DISTANCE: HORIZONTAL AT 3 M**

NO.	FREQ. (MHz)	EMISSION LEVEL (dBuV/m)	LIMIT (dBuV/m)	MARGIN (dB)	ANTENNA HEIGHT (m)	TABLE ANGLE (Degree)	RAW VALUE (dBuV)	CORRECTION FACTOR (dB/m)
1	#5470.00	54.7 PK	74.0	-19.3	2.04 H	320	47.41	7.29
2	#5470.00	43.0 AV	54.0	-11.0	2.04 H	320	35.71	7.29
3	*5690.00	111.1 PK			2.04 H	320	103.73	7.37
4	*5690.00	96.3 AV			2.04 H	320	88.93	7.37
5	#5850.00	64.1 PK	74.0	-9.9	2.04 H	320	56.85	7.25
6	#5850.00	48.2 AV	54.0	-5.8	2.04 H	320	40.95	7.25
7	11380.00	52.2 PK	74.0	-21.8	1.66 H	213	37.44	14.76
8	11380.00	39.9 AV	54.0	-14.1	1.66 H	213	25.14	14.76
9	#17070.00	57.2 PK	74.0	-16.8	1.68 H	64	34.07	23.13
10	#17070.00	46.1 AV	54.0	-7.9	1.68 H	64	22.97	23.13

**ANTENNA POLARITY & TEST DISTANCE: VERTICAL AT 3 M**

NO.	FREQ. (MHz)	EMISSION LEVEL (dBuV/m)	LIMIT (dBuV/m)	MARGIN (dB)	ANTENNA HEIGHT (m)	TABLE ANGLE (Degree)	RAW VALUE (dBuV)	CORRECTION FACTOR (dB/m)
1	#5470.00	52.5 PK	74.0	-21.5	2.00 V	334	45.21	7.29
2	#5470.00	41.2 AV	54.0	-12.8	2.00 V	334	33.91	7.29
3	*5690.00	109.1 PK			2.00 V	334	101.73	7.37
4	*5690.00	94.4 AV			2.00 V	334	87.03	7.37
5	#5850.00	62.0 PK	74.0	-12.0	2.00 V	334	54.75	7.25
6	#5850.00	46.3 AV	54.0	-7.7	2.00 V	334	39.05	7.25
7	11380.00	52.0 PK	74.0	-22.0	1.53 V	191	37.24	14.76
8	11380.00	39.8 AV	54.0	-14.2	1.53 V	191	25.04	14.76
9	#17070.00	58.3 PK	74.0	-15.7	1.60 V	20	35.17	23.13
10	#17070.00	46.8 AV	54.0	-7.2	1.60 V	20	23.67	23.13

**REMARKS:**

1. Emission Level(dBuV/m) = Raw Value(dBuV) + Correction Factor(dB/m)
2. Correction Factor(dB/m) = Antenna Factor(dB/m) + Cable Factor(dB) – Pre-Amplifier Factor(dB)
3. The other emission levels were very low against the limit.
4. Margin value = Emission Level – Limit value
5. " \* ": Fundamental frequency.
6. " # ": The radiated frequency is out of the restricted band.

<b>CHANNEL</b>	TX Channel 155	<b>DETECTOR FUNCTION</b>	Peak (PK)
<b>FREQUENCY RANGE</b>	1GHz ~ 40GHz		Average (AV)

**ANTENNA POLARITY & TEST DISTANCE: HORIZONTAL AT 3 M**

NO.	FREQ. (MHz)	EMISSION LEVEL (dBuV/m)	LIMIT (dBuV/m)	MARGIN (dB)	ANTENNA HEIGHT (m)	TABLE ANGLE (Degree)	RAW VALUE (dBuV)	CORRECTION FACTOR (dB/m)
1	#5715.00	67.8 PK	74.0	-6.2	2.33 H	318	60.42	7.38
2	#5715.00	52.7 AV	54.0	-1.3	2.33 H	318	45.32	7.38
3	#5725.00	72.8 PK	78.2	-5.4	2.33 H	318	65.42	7.38
4	*5775.00	104.8 PK			2.33 H	318	97.42	7.38
5	*5775.00	91.3 AV			2.33 H	318	83.92	7.38
6	#5850.00	69.8 PK	78.2	-8.4	2.33 H	318	62.55	7.25
7	#5860.00	65.2 PK	74.0	-8.8	2.33 H	318	57.98	7.22
8	#5860.00	48.9 AV	54.0	-5.1	2.33 H	318	41.68	7.22
9	11550.00	52.1 PK	74.0	-21.9	1.66 H	210	37.55	14.55
10	11550.00	40.0 AV	54.0	-14.0	1.66 H	210	25.45	14.55
11	#17325.00	56.5 PK	74.0	-17.5	1.76 H	35	32.88	23.62
12	#17325.00	45.6 AV	54.0	-8.4	1.76 H	35	21.98	23.62

**ANTENNA POLARITY & TEST DISTANCE: VERTICAL AT 3 M**

NO.	FREQ. (MHz)	EMISSION LEVEL (dBuV/m)	LIMIT (dBuV/m)	MARGIN (dB)	ANTENNA HEIGHT (m)	TABLE ANGLE (Degree)	RAW VALUE (dBuV)	CORRECTION FACTOR (dB/m)
1	#5715.00	65.5 PK	74.0	-8.5	2.01 V	344	58.12	7.38
2	#5715.00	50.8 AV	54.0	-3.2	2.01 V	344	43.42	7.38
3	#5725.00	70.9 PK	78.2	-7.3	2.01 V	344	63.52	7.38
4	*5775.00	102.9 PK			2.01 V	344	95.52	7.38
5	*5775.00	89.4 AV			2.01 V	344	82.02	7.38
6	#5850.00	68.0 PK	78.2	-10.2	2.01 V	344	60.75	7.25
7	#5860.00	63.3 PK	74.0	-10.7	2.01 V	344	56.08	7.22
8	#5860.00	47.0 AV	54.0	-7.0	2.01 V	344	39.78	7.22
9	11550.00	51.9 PK	74.0	-22.1	1.55 V	213	37.35	14.55
10	11550.00	39.8 AV	54.0	-14.2	1.55 V	213	25.25	14.55
11	#17325.00	58.1 PK	74.0	-15.9	1.64 V	23	34.48	23.62
12	#17325.00	46.8 AV	54.0	-7.2	1.64 V	23	23.18	23.62

**REMARKS:**

1. Emission Level(dBuV/m) = Raw Value(dBuV) + Correction Factor(dB/m)
2. Correction Factor(dB/m) = Antenna Factor(dB/m) + Cable Factor(dB) – Pre-Amplifier Factor(dB)
3. The other emission levels were very low against the limit.
4. Margin value = Emission Level – Limit value
5. " \* " : Fundamental frequency.
6. " # " : The radiated frequency is out of the restricted band.

**Below 1GHz Data:**

**802.11a**

<b>CHANNEL</b>	TX Channel 36	<b>DETECTOR FUNCTION</b>	Quasi-Peak (QP)
<b>FREQUENCY RANGE</b>	Below 1GHz		

**ANTENNA POLARITY & TEST DISTANCE: HORIZONTAL AT 3 M**

NO.	FREQ. (MHz)	EMISSION LEVEL (dBuV/m)	LIMIT (dBuV/m)	MARGIN (dB)	ANTENNA HEIGHT (m)	TABLE ANGLE (Degree)	RAW VALUE (dBuV)	CORRECTION FACTOR (dB/m)
1	33.57	24.2 QP	40.0	-15.8	1.51 H	162	33.80	-9.60
2	195.11	40.1 QP	43.5	-3.4	1.42 H	33	51.40	-11.30
3	260.06	42.8 QP	46.0	-3.2	1.45 H	77	51.70	-8.90
4	380.14	32.9 QP	46.0	-13.1	1.13 H	343	38.20	-5.30
5	696.03	37.5 QP	46.0	-8.5	1.02 H	325	36.10	1.40
6	1000.00	41.2 QP	54.0	-12.8	1.95 H	281	35.50	5.70

**ANTENNA POLARITY & TEST DISTANCE: VERTICAL AT 3 M**

NO.	FREQ. (MHz)	EMISSION LEVEL (dBuV/m)	LIMIT (dBuV/m)	MARGIN (dB)	ANTENNA HEIGHT (m)	TABLE ANGLE (Degree)	RAW VALUE (dBuV)	CORRECTION FACTOR (dB/m)
1	98.10	25.2 QP	43.5	-18.3	1.93 V	309	38.60	-13.40
2	195.51	33.7 QP	43.5	-9.8	1.62 V	214	45.10	-11.40
3	260.02	38.6 QP	46.0	-7.4	2.02 V	146	47.50	-8.90
4	325.77	32.0 QP	46.0	-14.0	1.05 V	46	38.40	-6.40
5	749.83	36.5 QP	46.0	-9.5	1.64 V	333	34.10	2.40
6	1000.00	38.8 QP	54.0	-15.2	1.00 V	291	33.10	5.70

**REMARKS:**

1. Emission Level(dBuV/m) = Raw Value(dBuV) + Correction Factor(dB/m)
2. Correction Factor(dB/m) = Antenna Factor(dB/m) + Cable Factor(dB) – Pre-Amplifier Factor(dB)
3. The other emission levels were very low against the limit.
4. Margin value = Emission Level – Limit value

<b>CHANNEL</b>	TX Channel 40	<b>DETECTOR FUNCTION</b>	Quasi-Peak (QP)
<b>FREQUENCY RANGE</b>	Below 1GHz		

**ANTENNA POLARITY & TEST DISTANCE: HORIZONTAL AT 3 M**

NO.	FREQ. (MHz)	EMISSION LEVEL (dBuV/m)	LIMIT (dBuV/m)	MARGIN (dB)	ANTENNA HEIGHT (m)	TABLE ANGLE (Degree)	RAW VALUE (dBuV)	CORRECTION FACTOR (dB/m)
1	34.07	23.9 QP	40.0	-16.1	1.47 H	154	33.40	-9.50
2	194.96	40.1 QP	43.5	-3.4	1.48 H	34	51.40	-11.30
3	260.60	42.5 QP	46.0	-3.5	1.46 H	78	51.40	-8.90
4	380.13	32.9 QP	46.0	-13.1	1.17 H	336	38.20	-5.30
5	695.79	37.7 QP	46.0	-8.3	1.00 H	315	36.30	1.40
6	1000.00	41.3 QP	54.0	-12.7	1.97 H	261	35.60	5.70

**ANTENNA POLARITY & TEST DISTANCE: VERTICAL AT 3 M**

NO.	FREQ. (MHz)	EMISSION LEVEL (dBuV/m)	LIMIT (dBuV/m)	MARGIN (dB)	ANTENNA HEIGHT (m)	TABLE ANGLE (Degree)	RAW VALUE (dBuV)	CORRECTION FACTOR (dB/m)
1	98.27	25.6 QP	43.5	-17.9	1.96 V	303	39.00	-13.40
2	195.86	33.5 QP	43.5	-10.0	1.60 V	223	44.90	-11.40
3	259.71	39.0 QP	46.0	-7.0	1.99 V	132	48.10	-9.10
4	326.02	32.4 QP	46.0	-13.6	1.00 V	35	38.80	-6.40
5	749.60	36.5 QP	46.0	-9.5	1.64 V	329	34.10	2.40
6	1000.00	38.5 QP	54.0	-15.5	1.00 V	292	32.80	5.70

**REMARKS:**

1. Emission Level(dBuV/m) = Raw Value(dBuV) + Correction Factor(dB/m)
2. Correction Factor(dB/m) = Antenna Factor(dB/m) + Cable Factor(dB) – Pre-Amplifier Factor(dB)
3. The other emission levels were very low against the limit.
4. Margin value = Emission Level – Limit value

<b>CHANNEL</b>	TX Channel 48	<b>DETECTOR FUNCTION</b>	Quasi-Peak (QP)
<b>FREQUENCY RANGE</b>	Below 1GHz		

**ANTENNA POLARITY & TEST DISTANCE: HORIZONTAL AT 3 M**

NO.	FREQ. (MHz)	EMISSION LEVEL (dBuV/m)	LIMIT (dBuV/m)	MARGIN (dB)	ANTENNA HEIGHT (m)	TABLE ANGLE (Degree)	RAW VALUE (dBuV)	CORRECTION FACTOR (dB/m)
1	33.52	24.0 QP	40.0	-16.0	1.54 H	160	33.60	-9.60
2	194.85	40.2 QP	43.5	-3.3	1.47 H	42	51.50	-11.30
3	260.50	42.4 QP	46.0	-3.6	1.43 H	70	51.30	-8.90
4	380.21	32.9 QP	46.0	-13.1	1.11 H	337	38.20	-5.30
5	695.56	37.8 QP	46.0	-8.2	1.00 H	328	36.40	1.40
6	1000.00	41.3 QP	54.0	-12.7	1.88 H	274	35.60	5.70

**ANTENNA POLARITY & TEST DISTANCE: VERTICAL AT 3 M**

NO.	FREQ. (MHz)	EMISSION LEVEL (dBuV/m)	LIMIT (dBuV/m)	MARGIN (dB)	ANTENNA HEIGHT (m)	TABLE ANGLE (Degree)	RAW VALUE (dBuV)	CORRECTION FACTOR (dB/m)
1	98.08	25.6 QP	43.5	-17.9	1.98 V	313	39.10	-13.50
2	196.02	33.6 QP	43.5	-9.9	1.60 V	227	45.00	-11.40
3	259.62	38.7 QP	46.0	-7.3	1.96 V	137	47.80	-9.10
4	325.99	32.5 QP	46.0	-13.5	1.00 V	35	38.90	-6.40
5	749.70	37.1 QP	46.0	-8.9	1.63 V	349	34.70	2.40
6	1000.00	38.6 QP	54.0	-15.4	1.00 V	303	32.90	5.70

**REMARKS:**

1. Emission Level(dBuV/m) = Raw Value(dBuV) + Correction Factor(dB/m)
2. Correction Factor(dB/m) = Antenna Factor(dB/m) + Cable Factor(dB) – Pre-Amplifier Factor(dB)
3. The other emission levels were very low against the limit.
4. Margin value = Emission Level – Limit value



<b>CHANNEL</b>	TX Channel 52	<b>DETECTOR FUNCTION</b>	Quasi-Peak (QP)
<b>FREQUENCY RANGE</b>	Below 1GHz		

**ANTENNA POLARITY & TEST DISTANCE: HORIZONTAL AT 3 M**

NO.	FREQ. (MHz)	EMISSION LEVEL (dBuV/m)	LIMIT (dBuV/m)	MARGIN (dB)	ANTENNA HEIGHT (m)	TABLE ANGLE (Degree)	RAW VALUE (dBuV)	CORRECTION FACTOR (dB/m)
1	33.60	24.0 QP	40.0	-16.0	1.54 H	162	33.60	-9.60
2	194.99	40.2 QP	43.5	-3.3	1.43 H	43	51.50	-11.30
3	260.05	42.9 QP	46.0	-3.1	1.38 H	56	51.80	-8.90
4	380.20	32.4 QP	46.0	-13.6	1.10 H	330	37.70	-5.30
5	695.76	37.5 QP	46.0	-8.5	1.01 H	338	36.10	1.40
6	1000.00	41.4 QP	54.0	-12.6	1.96 H	271	35.70	5.70

**ANTENNA POLARITY & TEST DISTANCE: VERTICAL AT 3 M**

NO.	FREQ. (MHz)	EMISSION LEVEL (dBuV/m)	LIMIT (dBuV/m)	MARGIN (dB)	ANTENNA HEIGHT (m)	TABLE ANGLE (Degree)	RAW VALUE (dBuV)	CORRECTION FACTOR (dB/m)
1	97.86	25.5 QP	43.5	-18.0	2.00 V	318	39.00	-13.50
2	195.77	33.6 QP	43.5	-9.9	1.58 V	223	45.00	-11.40
3	259.76	39.0 QP	46.0	-7.0	2.03 V	158	48.10	-9.10
4	326.02	32.6 QP	46.0	-13.4	1.06 V	46	39.00	-6.40
5	749.59	37.0 QP	46.0	-9.0	1.56 V	337	34.60	2.40
6	1000.00	39.1 QP	54.0	-14.9	1.00 V	276	33.40	5.70

**REMARKS:**

1. Emission Level(dBuV/m) = Raw Value(dBuV) + Correction Factor(dB/m)
2. Correction Factor(dB/m) = Antenna Factor(dB/m) + Cable Factor(dB) – Pre-Amplifier Factor(dB)
3. The other emission levels were very low against the limit.
4. Margin value = Emission Level – Limit value

<b>CHANNEL</b>	TX Channel 60	<b>DETECTOR FUNCTION</b>	Quasi-Peak (QP)
<b>FREQUENCY RANGE</b>	Below 1GHz		

**ANTENNA POLARITY & TEST DISTANCE: HORIZONTAL AT 3 M**

NO.	FREQ. (MHz)	EMISSION LEVEL (dBuV/m)	LIMIT (dBuV/m)	MARGIN (dB)	ANTENNA HEIGHT (m)	TABLE ANGLE (Degree)	RAW VALUE (dBuV)	CORRECTION FACTOR (dB/m)
1	33.67	23.9 QP	40.0	-16.1	1.49 H	156	33.50	-9.60
2	194.78	40.4 QP	43.5	-3.1	1.47 H	27	51.70	-11.30
3	260.56	42.7 QP	46.0	-3.3	1.35 H	77	51.60	-8.90
4	379.75	32.8 QP	46.0	-13.2	1.20 H	351	38.10	-5.30
5	695.93	37.8 QP	46.0	-8.2	1.00 H	321	36.40	1.40
6	1000.00	41.1 QP	54.0	-12.9	1.94 H	256	35.40	5.70

**ANTENNA POLARITY & TEST DISTANCE: VERTICAL AT 3 M**

NO.	FREQ. (MHz)	EMISSION LEVEL (dBuV/m)	LIMIT (dBuV/m)	MARGIN (dB)	ANTENNA HEIGHT (m)	TABLE ANGLE (Degree)	RAW VALUE (dBuV)	CORRECTION FACTOR (dB/m)
1	97.69	25.5 QP	43.5	-18.0	1.97 V	294	39.00	-13.50
2	195.98	33.7 QP	43.5	-9.8	1.67 V	231	45.10	-11.40
3	259.58	38.7 QP	46.0	-7.3	2.02 V	145	47.80	-9.10
4	326.00	32.1 QP	46.0	-13.9	1.06 V	38	38.50	-6.40
5	749.72	37.0 QP	46.0	-9.0	1.58 V	344	34.60	2.40
6	1000.00	38.9 QP	54.0	-15.1	1.00 V	300	33.20	5.70

**REMARKS:**

1. Emission Level(dBuV/m) = Raw Value(dBuV) + Correction Factor(dB/m)
2. Correction Factor(dB/m) = Antenna Factor(dB/m) + Cable Factor(dB) – Pre-Amplifier Factor(dB)
3. The other emission levels were very low against the limit.
4. Margin value = Emission Level – Limit value

<b>CHANNEL</b>	TX Channel 64	<b>DETECTOR FUNCTION</b>	Quasi-Peak (QP)
<b>FREQUENCY RANGE</b>	Below 1GHz		

**ANTENNA POLARITY & TEST DISTANCE: HORIZONTAL AT 3 M**

NO.	FREQ. (MHz)	EMISSION LEVEL (dBuV/m)	LIMIT (dBuV/m)	MARGIN (dB)	ANTENNA HEIGHT (m)	TABLE ANGLE (Degree)	RAW VALUE (dBuV)	CORRECTION FACTOR (dB/m)
1	33.99	24.1 QP	40.0	-15.9	1.49 H	180	33.60	-9.50
2	195.11	40.4 QP	43.5	-3.1	1.48 H	35	51.70	-11.30
3	260.05	43.0 QP	46.0	-3.0	1.40 H	71	51.90	-8.90
4	380.12	32.5 QP	46.0	-13.5	1.13 H	339	37.80	-5.30
5	695.81	37.7 QP	46.0	-8.3	1.00 H	332	36.30	1.40
6	1000.00	41.2 QP	54.0	-12.8	1.90 H	274	35.50	5.70

**ANTENNA POLARITY & TEST DISTANCE: VERTICAL AT 3 M**

NO.	FREQ. (MHz)	EMISSION LEVEL (dBuV/m)	LIMIT (dBuV/m)	MARGIN (dB)	ANTENNA HEIGHT (m)	TABLE ANGLE (Degree)	RAW VALUE (dBuV)	CORRECTION FACTOR (dB/m)
1	97.78	25.2 QP	43.5	-18.3	1.93 V	296	38.70	-13.50
2	195.98	34.1 QP	43.5	-9.4	1.57 V	209	45.50	-11.40
3	259.68	38.6 QP	46.0	-7.4	2.01 V	159	47.70	-9.10
4	325.51	32.5 QP	46.0	-13.5	1.04 V	39	38.90	-6.40
5	749.65	36.9 QP	46.0	-9.1	1.62 V	341	34.50	2.40
6	1000.00	39.1 QP	54.0	-14.9	1.00 V	291	33.40	5.70

**REMARKS:**

1. Emission Level(dBuV/m) = Raw Value(dBuV) + Correction Factor(dB/m)
2. Correction Factor(dB/m) = Antenna Factor(dB/m) + Cable Factor(dB) – Pre-Amplifier Factor(dB)
3. The other emission levels were very low against the limit.
4. Margin value = Emission Level – Limit value

<b>CHANNEL</b>	TX Channel 100	<b>DETECTOR FUNCTION</b>	Quasi-Peak (QP)
<b>FREQUENCY RANGE</b>	Below 1GHz		

**ANTENNA POLARITY & TEST DISTANCE: HORIZONTAL AT 3 M**

NO.	FREQ. (MHz)	EMISSION LEVEL (dBuV/m)	LIMIT (dBuV/m)	MARGIN (dB)	ANTENNA HEIGHT (m)	TABLE ANGLE (Degree)	RAW VALUE (dBuV)	CORRECTION FACTOR (dB/m)
1	34.07	24.0 QP	40.0	-16.0	1.52 H	179	33.50	-9.50
2	194.68	40.3 QP	43.5	-3.2	1.46 H	30	51.60	-11.30
3	260.14	42.6 QP	46.0	-3.4	1.38 H	75	51.50	-8.90
4	379.94	32.6 QP	46.0	-13.4	1.12 H	342	37.90	-5.30
5	695.56	37.8 QP	46.0	-8.2	1.04 H	312	36.40	1.40
6	1000.00	41.2 QP	54.0	-12.8	1.91 H	258	35.50	5.70

**ANTENNA POLARITY & TEST DISTANCE: VERTICAL AT 3 M**

NO.	FREQ. (MHz)	EMISSION LEVEL (dBuV/m)	LIMIT (dBuV/m)	MARGIN (dB)	ANTENNA HEIGHT (m)	TABLE ANGLE (Degree)	RAW VALUE (dBuV)	CORRECTION FACTOR (dB/m)
1	98.10	25.3 QP	43.5	-18.2	1.99 V	308	38.70	-13.40
2	195.58	33.6 QP	43.5	-9.9	1.66 V	224	45.00	-11.40
3	259.89	38.7 QP	46.0	-7.3	2.04 V	129	47.70	-9.00
4	325.57	32.4 QP	46.0	-13.6	1.00 V	39	38.80	-6.40
5	749.48	36.5 QP	46.0	-9.5	1.59 V	356	34.10	2.40
6	1000.00	39.0 QP	54.0	-15.0	1.00 V	289	33.30	5.70

**REMARKS:**

1. Emission Level(dBuV/m) = Raw Value(dBuV) + Correction Factor(dB/m)
2. Correction Factor(dB/m) = Antenna Factor(dB/m) + Cable Factor(dB) – Pre-Amplifier Factor(dB)
3. The other emission levels were very low against the limit.
4. Margin value = Emission Level – Limit value

<b>CHANNEL</b>	TX Channel 116	<b>DETECTOR FUNCTION</b>	Quasi-Peak (QP)
<b>FREQUENCY RANGE</b>	Below 1GHz		

**ANTENNA POLARITY & TEST DISTANCE: HORIZONTAL AT 3 M**

NO.	FREQ. (MHz)	EMISSION LEVEL (dBuV/m)	LIMIT (dBuV/m)	MARGIN (dB)	ANTENNA HEIGHT (m)	TABLE ANGLE (Degree)	RAW VALUE (dBuV)	CORRECTION FACTOR (dB/m)
1	33.96	24.0 QP	40.0	-16.0	1.47 H	151	33.50	-9.50
2	195.10	40.0 QP	43.5	-3.5	1.43 H	30	51.30	-11.30
3	260.10	42.6 QP	46.0	-3.4	1.35 H	65	51.50	-8.90
4	379.89	32.8 QP	46.0	-13.2	1.21 H	329	38.10	-5.30
5	695.50	37.8 QP	46.0	-8.2	1.08 H	332	36.40	1.40
6	1000.00	41.1 QP	54.0	-12.9	1.94 H	260	35.40	5.70

**ANTENNA POLARITY & TEST DISTANCE: VERTICAL AT 3 M**

NO.	FREQ. (MHz)	EMISSION LEVEL (dBuV/m)	LIMIT (dBuV/m)	MARGIN (dB)	ANTENNA HEIGHT (m)	TABLE ANGLE (Degree)	RAW VALUE (dBuV)	CORRECTION FACTOR (dB/m)
1	98.14	25.7 QP	43.5	-17.8	1.92 V	312	39.10	-13.40
2	196.02	33.5 QP	43.5	-10.0	1.69 V	232	44.90	-11.40
3	259.82	38.6 QP	46.0	-7.4	2.05 V	149	47.60	-9.00
4	325.59	32.2 QP	46.0	-13.8	1.00 V	42	38.60	-6.40
5	749.46	36.8 QP	46.0	-9.2	1.55 V	352	34.40	2.40
6	1000.00	38.8 QP	54.0	-15.2	1.00 V	282	33.10	5.70

**REMARKS:**

1. Emission Level(dBuV/m) = Raw Value(dBuV) + Correction Factor(dB/m)
2. Correction Factor(dB/m) = Antenna Factor(dB/m) + Cable Factor(dB) – Pre-Amplifier Factor(dB)
3. The other emission levels were very low against the limit.
4. Margin value = Emission Level – Limit value

<b>CHANNEL</b>	TX Channel 120	<b>DETECTOR FUNCTION</b>	Quasi-Peak (QP)
<b>FREQUENCY RANGE</b>	Below 1GHz		

**ANTENNA POLARITY & TEST DISTANCE: HORIZONTAL AT 3 M**

NO.	FREQ. (MHz)	EMISSION LEVEL (dBuV/m)	LIMIT (dBuV/m)	MARGIN (dB)	ANTENNA HEIGHT (m)	TABLE ANGLE (Degree)	RAW VALUE (dBuV)	CORRECTION FACTOR (dB/m)
1	33.60	24.3 QP	40.0	-15.7	1.46 H	166	33.90	-9.60
2	194.62	39.9 QP	43.5	-3.6	1.46 H	32	51.20	-11.30
3	260.03	43.0 QP	46.0	-3.0	1.37 H	82	51.90	-8.90
4	380.06	32.8 QP	46.0	-13.2	1.12 H	328	38.10	-5.30
5	695.90	37.6 QP	46.0	-8.4	1.01 H	336	36.20	1.40
6	1000.00	40.8 QP	54.0	-13.2	1.92 H	270	35.10	5.70

**ANTENNA POLARITY & TEST DISTANCE: VERTICAL AT 3 M**

NO.	FREQ. (MHz)	EMISSION LEVEL (dBuV/m)	LIMIT (dBuV/m)	MARGIN (dB)	ANTENNA HEIGHT (m)	TABLE ANGLE (Degree)	RAW VALUE (dBuV)	CORRECTION FACTOR (dB/m)
1	98.09	25.3 QP	43.5	-18.2	2.01 V	310	38.70	-13.40
2	195.69	34.1 QP	43.5	-9.4	1.66 V	229	45.50	-11.40
3	259.84	38.6 QP	46.0	-7.4	1.96 V	155	47.60	-9.00
4	325.97	32.1 QP	46.0	-13.9	1.03 V	41	38.50	-6.40
5	749.99	36.8 QP	46.0	-9.2	1.60 V	327	34.40	2.40
6	1000.00	38.9 QP	54.0	-15.1	1.00 V	284	33.20	5.70

**REMARKS:**

1. Emission Level(dBuV/m) = Raw Value(dBuV) + Correction Factor(dB/m)
2. Correction Factor(dB/m) = Antenna Factor(dB/m) + Cable Factor(dB) – Pre-Amplifier Factor(dB)
3. The other emission levels were very low against the limit.
4. Margin value = Emission Level – Limit value

<b>CHANNEL</b>	TX Channel 132	<b>DETECTOR FUNCTION</b>	Quasi-Peak (QP)
<b>FREQUENCY RANGE</b>	Below 1GHz		

**ANTENNA POLARITY & TEST DISTANCE: HORIZONTAL AT 3 M**

NO.	FREQ. (MHz)	EMISSION LEVEL (dBuV/m)	LIMIT (dBuV/m)	MARGIN (dB)	ANTENNA HEIGHT (m)	TABLE ANGLE (Degree)	RAW VALUE (dBuV)	CORRECTION FACTOR (dB/m)
1	33.70	23.9 QP	40.0	-16.1	1.52 H	163	33.50	-9.60
2	195.21	39.9 QP	43.5	-3.6	1.47 H	41	51.20	-11.30
3	260.20	42.9 QP	46.0	-3.1	1.41 H	63	51.80	-8.90
4	379.93	32.6 QP	46.0	-13.4	1.17 H	331	37.90	-5.30
5	695.76	37.4 QP	46.0	-8.6	1.00 H	340	36.00	1.40
6	1000.00	41.2 QP	54.0	-12.8	1.99 H	273	35.50	5.70

**ANTENNA POLARITY & TEST DISTANCE: VERTICAL AT 3 M**

NO.	FREQ. (MHz)	EMISSION LEVEL (dBuV/m)	LIMIT (dBuV/m)	MARGIN (dB)	ANTENNA HEIGHT (m)	TABLE ANGLE (Degree)	RAW VALUE (dBuV)	CORRECTION FACTOR (dB/m)
1	97.86	25.7 QP	43.5	-17.8	1.95 V	303	39.20	-13.50
2	195.68	34.1 QP	43.5	-9.4	1.66 V	230	45.50	-11.40
3	259.88	38.7 QP	46.0	-7.3	2.01 V	145	47.70	-9.00
4	325.97	32.5 QP	46.0	-13.5	1.04 V	58	38.90	-6.40
5	749.87	36.8 QP	46.0	-9.2	1.58 V	329	34.40	2.40
6	1000.00	38.9 QP	54.0	-15.1	1.00 V	285	33.20	5.70

**REMARKS:**

1. Emission Level(dBuV/m) = Raw Value(dBuV) + Correction Factor(dB/m)
2. Correction Factor(dB/m) = Antenna Factor(dB/m) + Cable Factor(dB) – Pre-Amplifier Factor(dB)
3. The other emission levels were very low against the limit.
4. Margin value = Emission Level – Limit value

<b>CHANNEL</b>	TX Channel 140	<b>DETECTOR FUNCTION</b>	Quasi-Peak (QP)
<b>FREQUENCY RANGE</b>	Below 1GHz		

**ANTENNA POLARITY & TEST DISTANCE: HORIZONTAL AT 3 M**

NO.	FREQ. (MHz)	EMISSION LEVEL (dBuV/m)	LIMIT (dBuV/m)	MARGIN (dB)	ANTENNA HEIGHT (m)	TABLE ANGLE (Degree)	RAW VALUE (dBuV)	CORRECTION FACTOR (dB/m)
1	33.66	23.8 QP	40.0	-16.2	1.55 H	177	33.40	-9.60
2	194.88	40.2 QP	43.5	-3.3	1.49 H	45	51.50	-11.30
3	260.59	42.5 QP	46.0	-3.5	1.42 H	69	51.40	-8.90
4	379.63	32.6 QP	46.0	-13.4	1.10 H	331	37.90	-5.30
5	695.61	37.9 QP	46.0	-8.1	1.03 H	315	36.50	1.40
6	1000.00	41.0 QP	54.0	-13.0	1.88 H	268	35.30	5.70

**ANTENNA POLARITY & TEST DISTANCE: VERTICAL AT 3 M**

NO.	FREQ. (MHz)	EMISSION LEVEL (dBuV/m)	LIMIT (dBuV/m)	MARGIN (dB)	ANTENNA HEIGHT (m)	TABLE ANGLE (Degree)	RAW VALUE (dBuV)	CORRECTION FACTOR (dB/m)
1	98.15	25.5 QP	43.5	-18.0	1.98 V	323	38.90	-13.40
2	195.65	34.1 QP	43.5	-9.4	1.68 V	225	45.50	-11.40
3	259.83	38.7 QP	46.0	-7.3	1.94 V	137	47.70	-9.00
4	325.70	32.0 QP	46.0	-14.0	1.00 V	39	38.40	-6.40
5	749.47	37.1 QP	46.0	-8.9	1.63 V	342	34.70	2.40
6	1000.00	38.5 QP	54.0	-15.5	1.00 V	289	32.80	5.70

**REMARKS:**

1. Emission Level(dBuV/m) = Raw Value(dBuV) + Correction Factor(dB/m)
2. Correction Factor(dB/m) = Antenna Factor(dB/m) + Cable Factor(dB) – Pre-Amplifier Factor(dB)
3. The other emission levels were very low against the limit.
4. Margin value = Emission Level – Limit value



<b>CHANNEL</b>	TX Channel 149	<b>DETECTOR FUNCTION</b>	Quasi-Peak (QP)
<b>FREQUENCY RANGE</b>	Below 1GHz		

**ANTENNA POLARITY & TEST DISTANCE: HORIZONTAL AT 3 M**

NO.	FREQ. (MHz)	EMISSION LEVEL (dBuV/m)	LIMIT (dBuV/m)	MARGIN (dB)	ANTENNA HEIGHT (m)	TABLE ANGLE (Degree)	RAW VALUE (dBuV)	CORRECTION FACTOR (dB/m)
1	33.81	24.0 QP	40.0	-16.0	1.52 H	172	33.60	-9.60
2	195.05	40.0 QP	43.5	-3.5	1.51 H	22	51.30	-11.30
3	260.05	42.9 QP	46.0	-3.1	1.37 H	61	51.80	-8.90
4	380.12	32.8 QP	46.0	-13.2	1.19 H	337	38.10	-5.30
5	695.48	37.9 QP	46.0	-8.1	1.02 H	324	36.50	1.40
6	1000.00	41.0 QP	54.0	-13.0	1.93 H	283	35.30	5.70

**ANTENNA POLARITY & TEST DISTANCE: VERTICAL AT 3 M**

NO.	FREQ. (MHz)	EMISSION LEVEL (dBuV/m)	LIMIT (dBuV/m)	MARGIN (dB)	ANTENNA HEIGHT (m)	TABLE ANGLE (Degree)	RAW VALUE (dBuV)	CORRECTION FACTOR (dB/m)
1	97.74	25.5 QP	43.5	-18.0	2.00 V	314	39.00	-13.50
2	195.65	33.7 QP	43.5	-9.8	1.57 V	222	45.10	-11.40
3	259.71	38.6 QP	46.0	-7.4	1.94 V	140	47.70	-9.10
4	326.03	32.3 QP	46.0	-13.7	1.06 V	39	38.70	-6.40
5	749.53	36.6 QP	46.0	-9.4	1.61 V	337	34.20	2.40
6	1000.00	38.7 QP	54.0	-15.3	1.00 V	297	33.00	5.70

**REMARKS:**

1. Emission Level(dBuV/m) = Raw Value(dBuV) + Correction Factor(dB/m)
2. Correction Factor(dB/m) = Antenna Factor(dB/m) + Cable Factor(dB) – Pre-Amplifier Factor(dB)
3. The other emission levels were very low against the limit.
4. Margin value = Emission Level – Limit value

<b>CHANNEL</b>	TX Channel 157	<b>DETECTOR FUNCTION</b>	Quasi-Peak (QP)
<b>FREQUENCY RANGE</b>	Below 1GHz		

**ANTENNA POLARITY & TEST DISTANCE: HORIZONTAL AT 3 M**

NO.	FREQ. (MHz)	EMISSION LEVEL (dBuV/m)	LIMIT (dBuV/m)	MARGIN (dB)	ANTENNA HEIGHT (m)	TABLE ANGLE (Degree)	RAW VALUE (dBuV)	CORRECTION FACTOR (dB/m)
1	34.00	24.4 QP	40.0	-15.6	1.48 H	178	33.90	-9.50
2	195.00	40.1 QP	43.5	-3.4	1.50 H	44	51.40	-11.30
3	260.17	42.4 QP	46.0	-3.6	1.46 H	81	51.30	-8.90
4	380.00	32.5 QP	46.0	-13.5	1.12 H	340	37.80	-5.30
5	695.69	37.7 QP	46.0	-8.3	1.02 H	318	36.30	1.40
6	1000.00	41.3 QP	54.0	-12.7	1.93 H	273	35.60	5.70

**ANTENNA POLARITY & TEST DISTANCE: VERTICAL AT 3 M**

NO.	FREQ. (MHz)	EMISSION LEVEL (dBuV/m)	LIMIT (dBuV/m)	MARGIN (dB)	ANTENNA HEIGHT (m)	TABLE ANGLE (Degree)	RAW VALUE (dBuV)	CORRECTION FACTOR (dB/m)
1	98.07	25.4 QP	43.5	-18.1	1.98 V	319	38.90	-13.50
2	195.99	33.6 QP	43.5	-9.9	1.69 V	220	45.00	-11.40
3	259.86	38.8 QP	46.0	-7.2	1.93 V	150	47.80	-9.00
4	325.59	32.3 QP	46.0	-13.7	1.03 V	53	38.70	-6.40
5	749.91	36.8 QP	46.0	-9.2	1.65 V	337	34.40	2.40
6	1000.00	38.8 QP	54.0	-15.2	1.00 V	296	33.10	5.70

**REMARKS:**

1. Emission Level(dBuV/m) = Raw Value(dBuV) + Correction Factor(dB/m)
2. Correction Factor(dB/m) = Antenna Factor(dB/m) + Cable Factor(dB) – Pre-Amplifier Factor(dB)
3. The other emission levels were very low against the limit.
4. Margin value = Emission Level – Limit value

<b>CHANNEL</b>	TX Channel 165	<b>DETECTOR FUNCTION</b>	Quasi-Peak (QP)
<b>FREQUENCY RANGE</b>	Below 1GHz		

**ANTENNA POLARITY & TEST DISTANCE: HORIZONTAL AT 3 M**

NO.	FREQ. (MHz)	EMISSION LEVEL (dBuV/m)	LIMIT (dBuV/m)	MARGIN (dB)	ANTENNA HEIGHT (m)	TABLE ANGLE (Degree)	RAW VALUE (dBuV)	CORRECTION FACTOR (dB/m)
1	33.59	24.0 QP	40.0	-16.0	1.45 H	170	33.60	-9.60
2	194.63	39.9 QP	43.5	-3.6	1.46 H	44	51.20	-11.30
3	260.56	43.0 QP	46.0	-3.0	1.45 H	69	51.90	-8.90
4	379.92	32.4 QP	46.0	-13.6	1.13 H	340	37.70	-5.30
5	695.99	37.5 QP	46.0	-8.5	1.07 H	323	36.10	1.40
6	1000.00	40.8 QP	54.0	-13.2	1.87 H	258	35.10	5.70

**ANTENNA POLARITY & TEST DISTANCE: VERTICAL AT 3 M**

NO.	FREQ. (MHz)	EMISSION LEVEL (dBuV/m)	LIMIT (dBuV/m)	MARGIN (dB)	ANTENNA HEIGHT (m)	TABLE ANGLE (Degree)	RAW VALUE (dBuV)	CORRECTION FACTOR (dB/m)
1	97.76	25.5 QP	43.5	-18.0	1.96 V	324	39.00	-13.50
2	195.61	34.1 QP	43.5	-9.4	1.64 V	233	45.50	-11.40
3	259.91	38.6 QP	46.0	-7.4	1.94 V	128	47.60	-9.00
4	326.04	32.0 QP	46.0	-14.0	1.02 V	34	38.40	-6.40
5	749.90	36.7 QP	46.0	-9.3	1.55 V	332	34.30	2.40
6	1000.00	39.1 QP	54.0	-14.9	1.00 V	274	33.40	5.70

**REMARKS:**

1. Emission Level(dBuV/m) = Raw Value(dBuV) + Correction Factor(dB/m)
2. Correction Factor(dB/m) = Antenna Factor(dB/m) + Cable Factor(dB) – Pre-Amplifier Factor(dB)
3. The other emission levels were very low against the limit.
4. Margin value = Emission Level – Limit value

802.11ac (VHT20)

<b>CHANNEL</b>	TX Channel 36	<b>DETECTOR FUNCTION</b>	Quasi-Peak (QP)
<b>FREQUENCY RANGE</b>	Below 1GHz		

ANTENNA POLARITY & TEST DISTANCE: HORIZONTAL AT 3 M								
NO.	FREQ. (MHz)	EMISSION LEVEL (dBuV/m)	LIMIT (dBuV/m)	MARGIN (dB)	ANTENNA HEIGHT (m)	TABLE ANGLE (Degree)	RAW VALUE (dBuV)	CORRECTION FACTOR (dB/m)
1	33.77	24.3 QP	40.0	-15.7	1.47 H	174	33.90	-9.60
2	195.04	39.9 QP	43.5	-3.6	1.42 H	23	51.20	-11.30
3	260.01	42.9 QP	46.0	-3.1	1.42 H	85	51.80	-8.90
4	380.11	32.8 QP	46.0	-13.2	1.11 H	340	38.10	-5.30
5	695.96	37.5 QP	46.0	-8.5	1.03 H	314	36.10	1.40
6	1000.00	41.1 QP	54.0	-12.9	1.96 H	280	35.40	5.70

ANTENNA POLARITY & TEST DISTANCE: VERTICAL AT 3 M								
NO.	FREQ. (MHz)	EMISSION LEVEL (dBuV/m)	LIMIT (dBuV/m)	MARGIN (dB)	ANTENNA HEIGHT (m)	TABLE ANGLE (Degree)	RAW VALUE (dBuV)	CORRECTION FACTOR (dB/m)
1	98.24	25.3 QP	43.5	-18.2	1.93 V	323	38.70	-13.40
2	195.81	33.8 QP	43.5	-9.7	1.64 V	218	45.20	-11.40
3	259.80	38.7 QP	46.0	-7.3	2.03 V	130	47.70	-9.00
4	325.86	32.4 QP	46.0	-13.6	1.00 V	41	38.80	-6.40
5	749.88	36.9 QP	46.0	-9.1	1.57 V	329	34.50	2.40
6	1000.00	38.8 QP	54.0	-15.2	1.00 V	303	33.10	5.70

**REMARKS:**

1. Emission Level(dBuV/m) = Raw Value(dBuV) + Correction Factor(dB/m)
2. Correction Factor(dB/m) = Antenna Factor(dB/m) + Cable Factor(dB) – Pre-Amplifier Factor(dB)
3. The other emission levels were very low against the limit.
4. Margin value = Emission Level – Limit value

<b>CHANNEL</b>	TX Channel 40	<b>DETECTOR FUNCTION</b>	Quasi-Peak (QP)
<b>FREQUENCY RANGE</b>	Below 1GHz		

**ANTENNA POLARITY & TEST DISTANCE: HORIZONTAL AT 3 M**

NO.	FREQ. (MHz)	EMISSION LEVEL (dBuV/m)	LIMIT (dBuV/m)	MARGIN (dB)	ANTENNA HEIGHT (m)	TABLE ANGLE (Degree)	RAW VALUE (dBuV)	CORRECTION FACTOR (dB/m)
1	33.61	24.0 QP	40.0	-16.0	1.45 H	159	33.60	-9.60
2	195.16	40.5 QP	43.5	-3.0	1.47 H	35	51.80	-11.30
3	260.21	42.5 QP	46.0	-3.5	1.40 H	79	51.40	-8.90
4	379.82	32.9 QP	46.0	-13.1	1.19 H	353	38.20	-5.30
5	695.86	37.8 QP	46.0	-8.2	1.03 H	338	36.40	1.40
6	1000.00	40.9 QP	54.0	-13.1	1.96 H	276	35.20	5.70

**ANTENNA POLARITY & TEST DISTANCE: VERTICAL AT 3 M**

NO.	FREQ. (MHz)	EMISSION LEVEL (dBuV/m)	LIMIT (dBuV/m)	MARGIN (dB)	ANTENNA HEIGHT (m)	TABLE ANGLE (Degree)	RAW VALUE (dBuV)	CORRECTION FACTOR (dB/m)
1	97.68	25.7 QP	43.5	-17.8	1.99 V	313	39.20	-13.50
2	195.50	34.1 QP	43.5	-9.4	1.68 V	211	45.50	-11.40
3	259.50	39.0 QP	46.0	-7.0	1.99 V	132	48.10	-9.10
4	325.62	32.4 QP	46.0	-13.6	1.00 V	39	38.80	-6.40
5	749.90	36.6 QP	46.0	-9.4	1.58 V	332	34.20	2.40
6	1000.00	38.8 QP	54.0	-15.2	1.02 V	301	33.10	5.70

**REMARKS:**

1. Emission Level(dBuV/m) = Raw Value(dBuV) + Correction Factor(dB/m)
2. Correction Factor(dB/m) = Antenna Factor(dB/m) + Cable Factor(dB) – Pre-Amplifier Factor(dB)
3. The other emission levels were very low against the limit.
4. Margin value = Emission Level – Limit value

<b>CHANNEL</b>	TX Channel 48	<b>DETECTOR FUNCTION</b>	Quasi-Peak (QP)
<b>FREQUENCY RANGE</b>	Below 1GHz		

**ANTENNA POLARITY & TEST DISTANCE: HORIZONTAL AT 3 M**

NO.	FREQ. (MHz)	EMISSION LEVEL (dBuV/m)	LIMIT (dBuV/m)	MARGIN (dB)	ANTENNA HEIGHT (m)	TABLE ANGLE (Degree)	RAW VALUE (dBuV)	CORRECTION FACTOR (dB/m)
1	33.90	24.0 QP	40.0	-16.0	1.46 H	176	33.50	-9.50
2	195.03	40.0 QP	43.5	-3.5	1.48 H	20	51.30	-11.30
3	260.16	42.8 QP	46.0	-3.2	1.46 H	80	51.70	-8.90
4	380.11	32.5 QP	46.0	-13.5	1.11 H	344	37.80	-5.30
5	695.92	37.8 QP	46.0	-8.2	1.08 H	312	36.40	1.40
6	1000.00	40.9 QP	54.0	-13.1	1.95 H	260	35.20	5.70

**ANTENNA POLARITY & TEST DISTANCE: VERTICAL AT 3 M**

NO.	FREQ. (MHz)	EMISSION LEVEL (dBuV/m)	LIMIT (dBuV/m)	MARGIN (dB)	ANTENNA HEIGHT (m)	TABLE ANGLE (Degree)	RAW VALUE (dBuV)	CORRECTION FACTOR (dB/m)
1	98.08	25.6 QP	43.5	-17.9	1.97 V	322	39.10	-13.50
2	195.97	34.0 QP	43.5	-9.5	1.67 V	217	45.40	-11.40
3	259.49	39.0 QP	46.0	-7.0	1.95 V	157	48.10	-9.10
4	325.76	32.2 QP	46.0	-13.8	1.00 V	62	38.60	-6.40
5	749.73	36.6 QP	46.0	-9.4	1.62 V	327	34.20	2.40
6	1000.00	38.7 QP	54.0	-15.3	1.02 V	304	33.00	5.70

**REMARKS:**

1. Emission Level(dBuV/m) = Raw Value(dBuV) + Correction Factor(dB/m)
2. Correction Factor(dB/m) = Antenna Factor(dB/m) + Cable Factor(dB) – Pre-Amplifier Factor(dB)
3. The other emission levels were very low against the limit.
4. Margin value = Emission Level – Limit value

<b>CHANNEL</b>	TX Channel 52	<b>DETECTOR FUNCTION</b>	Quasi-Peak (QP)
<b>FREQUENCY RANGE</b>	Below 1GHz		

**ANTENNA POLARITY & TEST DISTANCE: HORIZONTAL AT 3 M**

NO.	FREQ. (MHz)	EMISSION LEVEL (dBuV/m)	LIMIT (dBuV/m)	MARGIN (dB)	ANTENNA HEIGHT (m)	TABLE ANGLE (Degree)	RAW VALUE (dBuV)	CORRECTION FACTOR (dB/m)
1	33.79	24.2 QP	40.0	-15.8	1.55 H	156	33.80	-9.60
2	194.73	40.2 QP	43.5	-3.3	1.51 H	39	51.50	-11.30
3	260.33	42.9 QP	46.0	-3.1	1.36 H	67	51.80	-8.90
4	379.72	32.9 QP	46.0	-13.1	1.18 H	349	38.20	-5.30
5	695.59	37.5 QP	46.0	-8.5	1.02 H	314	36.10	1.40
6	1000.00	41.0 QP	54.0	-13.0	1.94 H	278	35.30	5.70

**ANTENNA POLARITY & TEST DISTANCE: VERTICAL AT 3 M**

NO.	FREQ. (MHz)	EMISSION LEVEL (dBuV/m)	LIMIT (dBuV/m)	MARGIN (dB)	ANTENNA HEIGHT (m)	TABLE ANGLE (Degree)	RAW VALUE (dBuV)	CORRECTION FACTOR (dB/m)
1	97.87	25.7 QP	43.5	-17.8	2.00 V	315	39.20	-13.50
2	196.04	33.9 QP	43.5	-9.6	1.69 V	210	45.30	-11.40
3	260.05	38.7 QP	46.0	-7.3	2.05 V	153	47.60	-8.90
4	325.82	32.0 QP	46.0	-14.0	1.06 V	59	38.40	-6.40
5	749.67	36.7 QP	46.0	-9.3	1.60 V	330	34.30	2.40
6	1000.00	38.7 QP	54.0	-15.3	1.00 V	282	33.00	5.70

**REMARKS:**

1. Emission Level(dBuV/m) = Raw Value(dBuV) + Correction Factor(dB/m)
2. Correction Factor(dB/m) = Antenna Factor(dB/m) + Cable Factor(dB) – Pre-Amplifier Factor(dB)
3. The other emission levels were very low against the limit.
4. Margin value = Emission Level – Limit value

<b>CHANNEL</b>	TX Channel 60	<b>DETECTOR FUNCTION</b>	Quasi-Peak (QP)
<b>FREQUENCY RANGE</b>	Below 1GHz		

**ANTENNA POLARITY & TEST DISTANCE: HORIZONTAL AT 3 M**

NO.	FREQ. (MHz)	EMISSION LEVEL (dBuV/m)	LIMIT (dBuV/m)	MARGIN (dB)	ANTENNA HEIGHT (m)	TABLE ANGLE (Degree)	RAW VALUE (dBuV)	CORRECTION FACTOR (dB/m)
1	33.62	24.3 QP	40.0	-15.7	1.55 H	167	33.90	-9.60
2	195.14	40.1 QP	43.5	-3.4	1.52 H	42	51.40	-11.30
3	260.19	42.8 QP	46.0	-3.2	1.42 H	57	51.70	-8.90
4	379.67	32.5 QP	46.0	-13.5	1.19 H	358	37.80	-5.30
5	695.67	37.7 QP	46.0	-8.3	1.00 H	333	36.30	1.40
6	1000.00	40.9 QP	54.0	-13.1	1.88 H	259	35.20	5.70

**ANTENNA POLARITY & TEST DISTANCE: VERTICAL AT 3 M**

NO.	FREQ. (MHz)	EMISSION LEVEL (dBuV/m)	LIMIT (dBuV/m)	MARGIN (dB)	ANTENNA HEIGHT (m)	TABLE ANGLE (Degree)	RAW VALUE (dBuV)	CORRECTION FACTOR (dB/m)
1	97.97	25.3 QP	43.5	-18.2	2.00 V	314	38.80	-13.50
2	196.05	33.5 QP	43.5	-10.0	1.61 V	222	44.90	-11.40
3	259.87	39.0 QP	46.0	-7.0	1.95 V	133	48.00	-9.00
4	325.96	32.4 QP	46.0	-13.6	1.00 V	42	38.80	-6.40
5	749.61	36.6 QP	46.0	-9.4	1.56 V	339	34.20	2.40
6	1000.00	38.6 QP	54.0	-15.4	1.02 V	280	32.90	5.70

**REMARKS:**

1. Emission Level(dBuV/m) = Raw Value(dBuV) + Correction Factor(dB/m)
2. Correction Factor(dB/m) = Antenna Factor(dB/m) + Cable Factor(dB) – Pre-Amplifier Factor(dB)
3. The other emission levels were very low against the limit.
4. Margin value = Emission Level – Limit value



<b>CHANNEL</b>	TX Channel 64	<b>DETECTOR FUNCTION</b>	Quasi-Peak (QP)
<b>FREQUENCY RANGE</b>	Below 1GHz		

**ANTENNA POLARITY & TEST DISTANCE: HORIZONTAL AT 3 M**

NO.	FREQ. (MHz)	EMISSION LEVEL (dBuV/m)	LIMIT (dBuV/m)	MARGIN (dB)	ANTENNA HEIGHT (m)	TABLE ANGLE (Degree)	RAW VALUE (dBuV)	CORRECTION FACTOR (dB/m)
1	33.78	23.9 QP	40.0	-16.1	1.47 H	168	33.50	-9.60
2	194.66	39.9 QP	43.5	-3.6	1.46 H	44	51.20	-11.30
3	260.30	42.7 QP	46.0	-3.3	1.41 H	67	51.60	-8.90
4	379.86	32.8 QP	46.0	-13.2	1.12 H	342	38.10	-5.30
5	695.56	37.7 QP	46.0	-8.3	1.00 H	323	36.30	1.40
6	1000.00	41.2 QP	54.0	-12.8	1.88 H	280	35.50	5.70

**ANTENNA POLARITY & TEST DISTANCE: VERTICAL AT 3 M**

NO.	FREQ. (MHz)	EMISSION LEVEL (dBuV/m)	LIMIT (dBuV/m)	MARGIN (dB)	ANTENNA HEIGHT (m)	TABLE ANGLE (Degree)	RAW VALUE (dBuV)	CORRECTION FACTOR (dB/m)
1	98.11	25.7 QP	43.5	-17.8	1.96 V	323	39.10	-13.40
2	195.93	33.8 QP	43.5	-9.7	1.59 V	231	45.20	-11.40
3	259.71	39.0 QP	46.0	-7.0	2.01 V	132	48.10	-9.10
4	325.83	32.0 QP	46.0	-14.0	1.00 V	36	38.40	-6.40
5	749.52	36.9 QP	46.0	-9.1	1.64 V	341	34.50	2.40
6	1000.00	38.8 QP	54.0	-15.2	1.00 V	284	33.10	5.70

**REMARKS:**

1. Emission Level(dBuV/m) = Raw Value(dBuV) + Correction Factor(dB/m)
2. Correction Factor(dB/m) = Antenna Factor(dB/m) + Cable Factor(dB) – Pre-Amplifier Factor(dB)
3. The other emission levels were very low against the limit.
4. Margin value = Emission Level – Limit value

<b>CHANNEL</b>	TX Channel 100	<b>DETECTOR FUNCTION</b>	Quasi-Peak (QP)
<b>FREQUENCY RANGE</b>	Below 1GHz		

**ANTENNA POLARITY & TEST DISTANCE: HORIZONTAL AT 3 M**

NO.	FREQ. (MHz)	EMISSION LEVEL (dBuV/m)	LIMIT (dBuV/m)	MARGIN (dB)	ANTENNA HEIGHT (m)	TABLE ANGLE (Degree)	RAW VALUE (dBuV)	CORRECTION FACTOR (dB/m)
1	33.58	24.0 QP	40.0	-16.0	1.44 H	154	33.60	-9.60
2	194.68	40.1 QP	43.5	-3.4	1.51 H	43	51.40	-11.30
3	260.04	42.8 QP	46.0	-3.2	1.44 H	78	51.70	-8.90
4	380.18	32.6 QP	46.0	-13.4	1.18 H	346	37.90	-5.30
5	695.91	37.6 QP	46.0	-8.4	1.04 H	312	36.20	1.40
6	1000.00	41.1 QP	54.0	-12.9	1.93 H	277	35.40	5.70

**ANTENNA POLARITY & TEST DISTANCE: VERTICAL AT 3 M**

NO.	FREQ. (MHz)	EMISSION LEVEL (dBuV/m)	LIMIT (dBuV/m)	MARGIN (dB)	ANTENNA HEIGHT (m)	TABLE ANGLE (Degree)	RAW VALUE (dBuV)	CORRECTION FACTOR (dB/m)
1	98.21	25.2 QP	43.5	-18.3	1.94 V	299	38.60	-13.40
2	196.03	33.6 QP	43.5	-9.9	1.62 V	215	45.00	-11.40
3	259.56	38.8 QP	46.0	-7.2	1.97 V	139	47.90	-9.10
4	325.99	32.5 QP	46.0	-13.5	1.04 V	58	38.90	-6.40
5	749.42	36.8 QP	46.0	-9.2	1.56 V	351	34.40	2.40
6	1000.00	38.8 QP	54.0	-15.2	1.00 V	281	33.10	5.70

**REMARKS:**

1. Emission Level(dBuV/m) = Raw Value(dBuV) + Correction Factor(dB/m)
2. Correction Factor(dB/m) = Antenna Factor(dB/m) + Cable Factor(dB) – Pre-Amplifier Factor(dB)
3. The other emission levels were very low against the limit.
4. Margin value = Emission Level – Limit value

<b>CHANNEL</b>	TX Channel 116	<b>DETECTOR FUNCTION</b>	Quasi-Peak (QP)
<b>FREQUENCY RANGE</b>	Below 1GHz		

**ANTENNA POLARITY & TEST DISTANCE: HORIZONTAL AT 3 M**

NO.	FREQ. (MHz)	EMISSION LEVEL (dBuV/m)	LIMIT (dBuV/m)	MARGIN (dB)	ANTENNA HEIGHT (m)	TABLE ANGLE (Degree)	RAW VALUE (dBuV)	CORRECTION FACTOR (dB/m)
1	34.04	24.1 QP	40.0	-15.9	1.44 H	168	33.60	-9.50
2	194.90	40.0 QP	43.5	-3.5	1.51 H	47	51.30	-11.30
3	260.60	42.9 QP	46.0	-3.1	1.36 H	78	51.80	-8.90
4	379.98	32.7 QP	46.0	-13.3	1.19 H	328	38.00	-5.30
5	696.01	37.6 QP	46.0	-8.4	1.07 H	316	36.20	1.40
6	1000.00	40.8 QP	54.0	-13.2	1.91 H	273	35.10	5.70

**ANTENNA POLARITY & TEST DISTANCE: VERTICAL AT 3 M**

NO.	FREQ. (MHz)	EMISSION LEVEL (dBuV/m)	LIMIT (dBuV/m)	MARGIN (dB)	ANTENNA HEIGHT (m)	TABLE ANGLE (Degree)	RAW VALUE (dBuV)	CORRECTION FACTOR (dB/m)
1	97.76	25.6 QP	43.5	-17.9	1.94 V	297	39.10	-13.50
2	195.54	34.0 QP	43.5	-9.5	1.65 V	218	45.40	-11.40
3	259.64	38.7 QP	46.0	-7.3	2.00 V	149	47.80	-9.10
4	325.57	32.3 QP	46.0	-13.7	1.00 V	35	38.70	-6.40
5	749.95	37.0 QP	46.0	-9.0	1.60 V	340	34.60	2.40
6	1000.00	39.1 QP	54.0	-14.9	1.00 V	273	33.40	5.70

**REMARKS:**

1. Emission Level(dBuV/m) = Raw Value(dBuV) + Correction Factor(dB/m)
2. Correction Factor(dB/m) = Antenna Factor(dB/m) + Cable Factor(dB) – Pre-Amplifier Factor(dB)
3. The other emission levels were very low against the limit.
4. Margin value = Emission Level – Limit value

<b>CHANNEL</b>	TX Channel 120	<b>DETECTOR FUNCTION</b>	Quasi-Peak (QP)
<b>FREQUENCY RANGE</b>	Below 1GHz		

**ANTENNA POLARITY & TEST DISTANCE: HORIZONTAL AT 3 M**

NO.	FREQ. (MHz)	EMISSION LEVEL (dBuV/m)	LIMIT (dBuV/m)	MARGIN (dB)	ANTENNA HEIGHT (m)	TABLE ANGLE (Degree)	RAW VALUE (dBuV)	CORRECTION FACTOR (dB/m)
1	33.59	24.2 QP	40.0	-15.8	1.45 H	181	33.80	-9.60
2	194.73	40.0 QP	43.5	-3.5	1.48 H	18	51.30	-11.30
3	260.24	42.7 QP	46.0	-3.3	1.45 H	62	51.60	-8.90
4	379.95	32.5 QP	46.0	-13.5	1.16 H	330	37.80	-5.30
5	696.01	37.8 QP	46.0	-8.2	1.04 H	314	36.40	1.40
6	1000.00	41.2 QP	54.0	-12.8	1.95 H	266	35.50	5.70

**ANTENNA POLARITY & TEST DISTANCE: VERTICAL AT 3 M**

NO.	FREQ. (MHz)	EMISSION LEVEL (dBuV/m)	LIMIT (dBuV/m)	MARGIN (dB)	ANTENNA HEIGHT (m)	TABLE ANGLE (Degree)	RAW VALUE (dBuV)	CORRECTION FACTOR (dB/m)
1	97.73	25.8 QP	43.5	-17.7	1.94 V	301	39.30	-13.50
2	195.51	33.5 QP	43.5	-10.0	1.58 V	216	44.90	-11.40
3	260.07	38.8 QP	46.0	-7.2	2.02 V	148	47.70	-8.90
4	325.78	32.2 QP	46.0	-13.8	1.00 V	57	38.60	-6.40
5	749.67	36.5 QP	46.0	-9.5	1.58 V	355	34.10	2.40
6	1000.00	38.6 QP	54.0	-15.4	1.03 V	283	32.90	5.70

**REMARKS:**

1. Emission Level(dBuV/m) = Raw Value(dBuV) + Correction Factor(dB/m)
2. Correction Factor(dB/m) = Antenna Factor(dB/m) + Cable Factor(dB) – Pre-Amplifier Factor(dB)
3. The other emission levels were very low against the limit.
4. Margin value = Emission Level – Limit value

<b>CHANNEL</b>	TX Channel 132	<b>DETECTOR FUNCTION</b>	Quasi-Peak (QP)
<b>FREQUENCY RANGE</b>	Below 1GHz		

**ANTENNA POLARITY & TEST DISTANCE: HORIZONTAL AT 3 M**

NO.	FREQ. (MHz)	EMISSION LEVEL (dBuV/m)	LIMIT (dBuV/m)	MARGIN (dB)	ANTENNA HEIGHT (m)	TABLE ANGLE (Degree)	RAW VALUE (dBuV)	CORRECTION FACTOR (dB/m)
1	33.92	24.3 QP	40.0	-15.7	1.52 H	162	33.80	-9.50
2	194.98	40.5 QP	43.5	-3.0	1.42 H	28	51.80	-11.30
3	260.42	42.6 QP	46.0	-3.4	1.37 H	74	51.50	-8.90
4	380.11	32.8 QP	46.0	-13.2	1.17 H	359	38.10	-5.30
5	695.82	37.9 QP	46.0	-8.1	1.00 H	336	36.50	1.40
6	1000.00	41.4 QP	54.0	-12.6	1.96 H	284	35.70	5.70

**ANTENNA POLARITY & TEST DISTANCE: VERTICAL AT 3 M**

NO.	FREQ. (MHz)	EMISSION LEVEL (dBuV/m)	LIMIT (dBuV/m)	MARGIN (dB)	ANTENNA HEIGHT (m)	TABLE ANGLE (Degree)	RAW VALUE (dBuV)	CORRECTION FACTOR (dB/m)
1	97.72	25.3 QP	43.5	-18.2	1.93 V	316	38.80	-13.50
2	195.54	34.0 QP	43.5	-9.5	1.62 V	214	45.40	-11.40
3	259.60	39.1 QP	46.0	-6.9	2.02 V	136	48.20	-9.10
4	325.76	32.4 QP	46.0	-13.6	1.00 V	57	38.80	-6.40
5	749.98	36.9 QP	46.0	-9.1	1.63 V	334	34.50	2.40
6	1000.00	38.6 QP	54.0	-15.4	1.00 V	304	32.90	5.70

**REMARKS:**

1. Emission Level(dBuV/m) = Raw Value(dBuV) + Correction Factor(dB/m)
2. Correction Factor(dB/m) = Antenna Factor(dB/m) + Cable Factor(dB) – Pre-Amplifier Factor(dB)
3. The other emission levels were very low against the limit.
4. Margin value = Emission Level – Limit value

<b>CHANNEL</b>	TX Channel 140	<b>DETECTOR FUNCTION</b>	Quasi-Peak (QP)
<b>FREQUENCY RANGE</b>	Below 1GHz		

**ANTENNA POLARITY & TEST DISTANCE: HORIZONTAL AT 3 M**

NO.	FREQ. (MHz)	EMISSION LEVEL (dBuV/m)	LIMIT (dBuV/m)	MARGIN (dB)	ANTENNA HEIGHT (m)	TABLE ANGLE (Degree)	RAW VALUE (dBuV)	CORRECTION FACTOR (dB/m)
1	33.99	23.9 QP	40.0	-16.1	1.51 H	153	33.40	-9.50
2	195.15	40.5 QP	43.5	-3.0	1.43 H	34	51.80	-11.30
3	260.14	43.0 QP	46.0	-3.0	1.46 H	77	51.90	-8.90
4	379.97	32.9 QP	46.0	-13.1	1.16 H	349	38.20	-5.30
5	695.65	37.4 QP	46.0	-8.6	1.05 H	332	36.00	1.40
6	1000.00	41.2 QP	54.0	-12.8	1.96 H	282	35.50	5.70

**ANTENNA POLARITY & TEST DISTANCE: VERTICAL AT 3 M**

NO.	FREQ. (MHz)	EMISSION LEVEL (dBuV/m)	LIMIT (dBuV/m)	MARGIN (dB)	ANTENNA HEIGHT (m)	TABLE ANGLE (Degree)	RAW VALUE (dBuV)	CORRECTION FACTOR (dB/m)
1	97.76	25.6 QP	43.5	-17.9	2.01 V	303	39.10	-13.50
2	195.68	33.9 QP	43.5	-9.6	1.59 V	208	45.30	-11.40
3	259.79	38.9 QP	46.0	-7.1	2.02 V	157	47.90	-9.00
4	325.90	32.0 QP	46.0	-14.0	1.04 V	33	38.40	-6.40
5	749.61	36.9 QP	46.0	-9.1	1.57 V	345	34.50	2.40
6	1000.00	39.0 QP	54.0	-15.0	1.00 V	282	33.30	5.70

**REMARKS:**

1. Emission Level(dBuV/m) = Raw Value(dBuV) + Correction Factor(dB/m)
2. Correction Factor(dB/m) = Antenna Factor(dB/m) + Cable Factor(dB) – Pre-Amplifier Factor(dB)
3. The other emission levels were very low against the limit.
4. Margin value = Emission Level – Limit value

<b>CHANNEL</b>	TX Channel 149	<b>DETECTOR FUNCTION</b>	Quasi-Peak (QP)
<b>FREQUENCY RANGE</b>	Below 1GHz		

**ANTENNA POLARITY & TEST DISTANCE: HORIZONTAL AT 3 M**

NO.	FREQ. (MHz)	EMISSION LEVEL (dBuV/m)	LIMIT (dBuV/m)	MARGIN (dB)	ANTENNA HEIGHT (m)	TABLE ANGLE (Degree)	RAW VALUE (dBuV)	CORRECTION FACTOR (dB/m)
1	33.56	24.3 QP	40.0	-15.7	1.50 H	162	33.90	-9.60
2	194.68	40.1 QP	43.5	-3.4	1.53 H	23	51.40	-11.30
3	260.36	42.5 QP	46.0	-3.5	1.44 H	71	51.40	-8.90
4	379.90	32.5 QP	46.0	-13.5	1.19 H	349	37.80	-5.30
5	695.86	37.8 QP	46.0	-8.2	1.03 H	319	36.40	1.40
6	1000.00	41.3 QP	54.0	-12.7	1.95 H	265	35.60	5.70

**ANTENNA POLARITY & TEST DISTANCE: VERTICAL AT 3 M**

NO.	FREQ. (MHz)	EMISSION LEVEL (dBuV/m)	LIMIT (dBuV/m)	MARGIN (dB)	ANTENNA HEIGHT (m)	TABLE ANGLE (Degree)	RAW VALUE (dBuV)	CORRECTION FACTOR (dB/m)
1	97.95	25.6 QP	43.5	-17.9	1.94 V	306	39.10	-13.50
2	195.76	33.8 QP	43.5	-9.7	1.65 V	235	45.20	-11.40
3	259.72	38.6 QP	46.0	-7.4	1.97 V	146	47.70	-9.10
4	325.55	32.4 QP	46.0	-13.6	1.00 V	49	38.80	-6.40
5	749.76	37.0 QP	46.0	-9.0	1.60 V	330	34.60	2.40
6	1000.00	38.7 QP	54.0	-15.3	1.00 V	285	33.00	5.70

**REMARKS:**

1. Emission Level(dBuV/m) = Raw Value(dBuV) + Correction Factor(dB/m)
2. Correction Factor(dB/m) = Antenna Factor(dB/m) + Cable Factor(dB) – Pre-Amplifier Factor(dB)
3. The other emission levels were very low against the limit.
4. Margin value = Emission Level – Limit value

<b>CHANNEL</b>	TX Channel 157	<b>DETECTOR FUNCTION</b>	Quasi-Peak (QP)
<b>FREQUENCY RANGE</b>	Below 1GHz		

**ANTENNA POLARITY & TEST DISTANCE: HORIZONTAL AT 3 M**

NO.	FREQ. (MHz)	EMISSION LEVEL (dBuV/m)	LIMIT (dBuV/m)	MARGIN (dB)	ANTENNA HEIGHT (m)	TABLE ANGLE (Degree)	RAW VALUE (dBuV)	CORRECTION FACTOR (dB/m)
1	33.79	23.9 QP	40.0	-16.1	1.46 H	182	33.50	-9.60
2	194.83	40.0 QP	43.5	-3.5	1.46 H	22	51.30	-11.30
3	260.34	42.5 QP	46.0	-3.5	1.45 H	77	51.40	-8.90
4	379.75	32.9 QP	46.0	-13.1	1.20 H	351	38.20	-5.30
5	695.84	37.5 QP	46.0	-8.5	1.04 H	334	36.10	1.40
6	1000.00	40.8 QP	54.0	-13.2	1.91 H	280	35.10	5.70

**ANTENNA POLARITY & TEST DISTANCE: VERTICAL AT 3 M**

NO.	FREQ. (MHz)	EMISSION LEVEL (dBuV/m)	LIMIT (dBuV/m)	MARGIN (dB)	ANTENNA HEIGHT (m)	TABLE ANGLE (Degree)	RAW VALUE (dBuV)	CORRECTION FACTOR (dB/m)
1	97.69	25.4 QP	43.5	-18.1	1.98 V	305	38.90	-13.50
2	195.60	34.0 QP	43.5	-9.5	1.58 V	221	45.40	-11.40
3	259.64	38.7 QP	46.0	-7.3	1.97 V	159	47.80	-9.10
4	326.04	32.3 QP	46.0	-13.7	1.05 V	39	38.70	-6.40
5	749.55	36.9 QP	46.0	-9.1	1.65 V	337	34.50	2.40
6	1000.00	39.0 QP	54.0	-15.0	1.00 V	276	33.30	5.70

**REMARKS:**

1. Emission Level(dBuV/m) = Raw Value(dBuV) + Correction Factor(dB/m)
2. Correction Factor(dB/m) = Antenna Factor(dB/m) + Cable Factor(dB) – Pre-Amplifier Factor(dB)
3. The other emission levels were very low against the limit.
4. Margin value = Emission Level – Limit value



<b>CHANNEL</b>	TX Channel 165	<b>DETECTOR FUNCTION</b>	Quasi-Peak (QP)
<b>FREQUENCY RANGE</b>	Below 1GHz		

**ANTENNA POLARITY & TEST DISTANCE: HORIZONTAL AT 3 M**

NO.	FREQ. (MHz)	EMISSION LEVEL (dBuV/m)	LIMIT (dBuV/m)	MARGIN (dB)	ANTENNA HEIGHT (m)	TABLE ANGLE (Degree)	RAW VALUE (dBuV)	CORRECTION FACTOR (dB/m)
1	33.56	23.8 QP	40.0	-16.2	1.52 H	163	33.40	-9.60
2	194.81	40.0 QP	43.5	-3.5	1.50 H	28	51.30	-11.30
3	260.01	42.8 QP	46.0	-3.2	1.47 H	56	51.70	-8.90
4	380.13	32.4 QP	46.0	-13.6	1.18 H	352	37.70	-5.30
5	695.54	37.6 QP	46.0	-8.4	1.06 H	335	36.20	1.40
6	1000.00	40.9 QP	54.0	-13.1	1.97 H	259	35.20	5.70

**ANTENNA POLARITY & TEST DISTANCE: VERTICAL AT 3 M**

NO.	FREQ. (MHz)	EMISSION LEVEL (dBuV/m)	LIMIT (dBuV/m)	MARGIN (dB)	ANTENNA HEIGHT (m)	TABLE ANGLE (Degree)	RAW VALUE (dBuV)	CORRECTION FACTOR (dB/m)
1	98.12	25.4 QP	43.5	-18.1	2.01 V	308	38.80	-13.40
2	195.91	34.1 QP	43.5	-9.4	1.68 V	224	45.50	-11.40
3	259.60	38.8 QP	46.0	-7.2	2.02 V	133	47.90	-9.10
4	325.89	32.0 QP	46.0	-14.0	1.00 V	36	38.40	-6.40
5	749.46	36.5 QP	46.0	-9.5	1.59 V	347	34.10	2.40
6	1000.00	38.8 QP	54.0	-15.2	1.00 V	279	33.10	5.70

**REMARKS:**

1. Emission Level(dBuV/m) = Raw Value(dBuV) + Correction Factor(dB/m)
2. Correction Factor(dB/m) = Antenna Factor(dB/m) + Cable Factor(dB) – Pre-Amplifier Factor(dB)
3. The other emission levels were very low against the limit.
4. Margin value = Emission Level – Limit value

**802.11ac (VHT40)**

<b>CHANNEL</b>	TX Channel 38	<b>DETECTOR FUNCTION</b>	Quasi-Peak (QP)
<b>FREQUENCY RANGE</b>	Below 1GHz		

<b>ANTENNA POLARITY &amp; TEST DISTANCE: HORIZONTAL AT 3 M</b>								
<b>NO.</b>	<b>FREQ. (MHz)</b>	<b>EMISSION LEVEL (dBuV/m)</b>	<b>LIMIT (dBuV/m)</b>	<b>MARGIN (dB)</b>	<b>ANTENNA HEIGHT (m)</b>	<b>TABLE ANGLE (Degree)</b>	<b>RAW VALUE (dBuV)</b>	<b>CORRECTION FACTOR (dB/m)</b>
1	33.49	23.9 QP	40.0	-16.1	1.49 H	153	33.50	-9.60
2	194.70	40.4 QP	43.5	-3.1	1.51 H	48	51.70	-11.30
3	260.28	42.5 QP	46.0	-3.5	1.45 H	55	51.40	-8.90
4	380.17	32.7 QP	46.0	-13.3	1.21 H	346	38.00	-5.30
5	695.83	37.7 QP	46.0	-8.3	1.08 H	334	36.30	1.40
6	1000.00	41.0 QP	54.0	-13.0	1.92 H	262	35.30	5.70

<b>ANTENNA POLARITY &amp; TEST DISTANCE: VERTICAL AT 3 M</b>								
<b>NO.</b>	<b>FREQ. (MHz)</b>	<b>EMISSION LEVEL (dBuV/m)</b>	<b>LIMIT (dBuV/m)</b>	<b>MARGIN (dB)</b>	<b>ANTENNA HEIGHT (m)</b>	<b>TABLE ANGLE (Degree)</b>	<b>RAW VALUE (dBuV)</b>	<b>CORRECTION FACTOR (dB/m)</b>
1	97.96	25.4 QP	43.5	-18.1	1.98 V	297	38.90	-13.50
2	195.61	33.9 QP	43.5	-9.6	1.64 V	220	45.30	-11.40
3	259.89	39.0 QP	46.0	-7.0	2.03 V	136	48.00	-9.00
4	325.78	32.3 QP	46.0	-13.7	1.00 V	42	38.70	-6.40
5	749.92	36.7 QP	46.0	-9.3	1.63 V	336	34.30	2.40
6	1000.00	38.9 QP	54.0	-15.1	1.01 V	293	33.20	5.70

**REMARKS:**

1. Emission Level(dBuV/m) = Raw Value(dBuV) + Correction Factor(dB/m)
2. Correction Factor(dB/m) = Antenna Factor(dB/m) + Cable Factor(dB) – Pre-Amplifier Factor(dB)
3. The other emission levels were very low against the limit.
4. Margin value = Emission Level – Limit value

<b>CHANNEL</b>	TX Channel 46	<b>DETECTOR FUNCTION</b>	Quasi-Peak (QP)
<b>FREQUENCY RANGE</b>	Below 1GHz		

**ANTENNA POLARITY & TEST DISTANCE: HORIZONTAL AT 3 M**

NO.	FREQ. (MHz)	EMISSION LEVEL (dBuV/m)	LIMIT (dBuV/m)	MARGIN (dB)	ANTENNA HEIGHT (m)	TABLE ANGLE (Degree)	RAW VALUE (dBuV)	CORRECTION FACTOR (dB/m)
1	34.06	24.1 QP	40.0	-15.9	1.52 H	163	33.60	-9.50
2	194.64	40.1 QP	43.5	-3.4	1.52 H	41	51.40	-11.30
3	260.45	42.7 QP	46.0	-3.3	1.45 H	55	51.60	-8.90
4	379.97	32.9 QP	46.0	-13.1	1.19 H	359	38.20	-5.30
5	695.96	37.8 QP	46.0	-8.2	1.00 H	323	36.40	1.40
6	1000.00	41.0 QP	54.0	-13.0	1.97 H	257	35.30	5.70

**ANTENNA POLARITY & TEST DISTANCE: VERTICAL AT 3 M**

NO.	FREQ. (MHz)	EMISSION LEVEL (dBuV/m)	LIMIT (dBuV/m)	MARGIN (dB)	ANTENNA HEIGHT (m)	TABLE ANGLE (Degree)	RAW VALUE (dBuV)	CORRECTION FACTOR (dB/m)
1	97.91	25.5 QP	43.5	-18.0	1.97 V	315	39.00	-13.50
2	195.80	33.7 QP	43.5	-9.8	1.65 V	208	45.10	-11.40
3	259.92	38.6 QP	46.0	-7.4	1.96 V	152	47.60	-9.00
4	325.72	32.2 QP	46.0	-13.8	1.01 V	44	38.60	-6.40
5	749.83	37.0 QP	46.0	-9.0	1.63 V	351	34.60	2.40
6	1000.00	38.8 QP	54.0	-15.2	1.00 V	301	33.10	5.70

**REMARKS:**

1. Emission Level(dBuV/m) = Raw Value(dBuV) + Correction Factor(dB/m)
2. Correction Factor(dB/m) = Antenna Factor(dB/m) + Cable Factor(dB) – Pre-Amplifier Factor(dB)
3. The other emission levels were very low against the limit.
4. Margin value = Emission Level – Limit value

<b>CHANNEL</b>	TX Channel 54	<b>DETECTOR FUNCTION</b>	Quasi-Peak (QP)
<b>FREQUENCY RANGE</b>	Below 1GHz		

**ANTENNA POLARITY & TEST DISTANCE: HORIZONTAL AT 3 M**

NO.	FREQ. (MHz)	EMISSION LEVEL (dBuV/m)	LIMIT (dBuV/m)	MARGIN (dB)	ANTENNA HEIGHT (m)	TABLE ANGLE (Degree)	RAW VALUE (dBuV)	CORRECTION FACTOR (dB/m)
1	33.71	24.3 QP	40.0	-15.7	1.53 H	180	33.90	-9.60
2	194.98	40.2 QP	43.5	-3.3	1.49 H	21	51.50	-11.30
3	260.25	42.5 QP	46.0	-3.5	1.41 H	74	51.40	-8.90
4	379.76	32.9 QP	46.0	-13.1	1.21 H	350	38.20	-5.30
5	695.69	37.8 QP	46.0	-8.2	1.02 H	318	36.40	1.40
6	1000.00	41.1 QP	54.0	-12.9	1.95 H	265	35.40	5.70

**ANTENNA POLARITY & TEST DISTANCE: VERTICAL AT 3 M**

NO.	FREQ. (MHz)	EMISSION LEVEL (dBuV/m)	LIMIT (dBuV/m)	MARGIN (dB)	ANTENNA HEIGHT (m)	TABLE ANGLE (Degree)	RAW VALUE (dBuV)	CORRECTION FACTOR (dB/m)
1	97.70	25.4 QP	43.5	-18.1	1.94 V	322	38.90	-13.50
2	195.81	33.9 QP	43.5	-9.6	1.64 V	219	45.30	-11.40
3	259.92	39.1 QP	46.0	-6.9	1.95 V	145	48.10	-9.00
4	326.08	32.3 QP	46.0	-13.7	1.02 V	44	38.70	-6.40
5	749.89	36.9 QP	46.0	-9.1	1.60 V	352	34.50	2.40
6	1000.00	38.5 QP	54.0	-15.5	1.03 V	281	32.80	5.70

**REMARKS:**

1. Emission Level(dBuV/m) = Raw Value(dBuV) + Correction Factor(dB/m)
2. Correction Factor(dB/m) = Antenna Factor(dB/m) + Cable Factor(dB) – Pre-Amplifier Factor(dB)
3. The other emission levels were very low against the limit.
4. Margin value = Emission Level – Limit value

<b>CHANNEL</b>	TX Channel 62	<b>DETECTOR FUNCTION</b>	Quasi-Peak (QP)
<b>FREQUENCY RANGE</b>	Below 1GHz		

**ANTENNA POLARITY & TEST DISTANCE: HORIZONTAL AT 3 M**

NO.	FREQ. (MHz)	EMISSION LEVEL (dBuV/m)	LIMIT (dBuV/m)	MARGIN (dB)	ANTENNA HEIGHT (m)	TABLE ANGLE (Degree)	RAW VALUE (dBuV)	CORRECTION FACTOR (dB/m)
1	33.67	24.3 QP	40.0	-15.7	1.53 H	171	33.90	-9.60
2	194.87	40.5 QP	43.5	-3.0	1.44 H	25	51.80	-11.30
3	260.59	42.6 QP	46.0	-3.4	1.44 H	69	51.50	-8.90
4	379.73	32.7 QP	46.0	-13.3	1.14 H	340	38.00	-5.30
5	695.63	37.8 QP	46.0	-8.2	1.06 H	316	36.40	1.40
6	1000.00	41.2 QP	54.0	-12.8	1.90 H	262	35.50	5.70

**ANTENNA POLARITY & TEST DISTANCE: VERTICAL AT 3 M**

NO.	FREQ. (MHz)	EMISSION LEVEL (dBuV/m)	LIMIT (dBuV/m)	MARGIN (dB)	ANTENNA HEIGHT (m)	TABLE ANGLE (Degree)	RAW VALUE (dBuV)	CORRECTION FACTOR (dB/m)
1	97.87	25.3 QP	43.5	-18.2	1.97 V	295	38.80	-13.50
2	195.53	34.0 QP	43.5	-9.5	1.58 V	212	45.40	-11.40
3	259.60	38.5 QP	46.0	-7.5	2.05 V	134	47.60	-9.10
4	325.65	32.3 QP	46.0	-13.7	1.03 V	47	38.70	-6.40
5	749.68	36.7 QP	46.0	-9.3	1.53 V	339	34.30	2.40
6	1000.00	38.8 QP	54.0	-15.2	1.03 V	290	33.10	5.70

**REMARKS:**

1. Emission Level(dBuV/m) = Raw Value(dBuV) + Correction Factor(dB/m)
2. Correction Factor(dB/m) = Antenna Factor(dB/m) + Cable Factor(dB) – Pre-Amplifier Factor(dB)
3. The other emission levels were very low against the limit.
4. Margin value = Emission Level – Limit value

<b>CHANNEL</b>	TX Channel 102	<b>DETECTOR FUNCTION</b>	Quasi-Peak (QP)
<b>FREQUENCY RANGE</b>	Below 1GHz		

**ANTENNA POLARITY & TEST DISTANCE: HORIZONTAL AT 3 M**

NO.	FREQ. (MHz)	EMISSION LEVEL (dBuV/m)	LIMIT (dBuV/m)	MARGIN (dB)	ANTENNA HEIGHT (m)	TABLE ANGLE (Degree)	RAW VALUE (dBuV)	CORRECTION FACTOR (dB/m)
1	33.75	24.2 QP	40.0	-15.8	1.48 H	152	33.80	-9.60
2	195.07	40.2 QP	43.5	-3.3	1.48 H	38	51.50	-11.30
3	260.06	42.4 QP	46.0	-3.6	1.39 H	81	51.30	-8.90
4	379.83	32.7 QP	46.0	-13.3	1.12 H	350	38.00	-5.30
5	695.87	37.5 QP	46.0	-8.5	1.08 H	343	36.10	1.40
6	1000.00	41.0 QP	54.0	-13.0	1.96 H	268	35.30	5.70

**ANTENNA POLARITY & TEST DISTANCE: VERTICAL AT 3 M**

NO.	FREQ. (MHz)	EMISSION LEVEL (dBuV/m)	LIMIT (dBuV/m)	MARGIN (dB)	ANTENNA HEIGHT (m)	TABLE ANGLE (Degree)	RAW VALUE (dBuV)	CORRECTION FACTOR (dB/m)
1	98.15	25.2 QP	43.5	-18.3	1.95 V	295	38.60	-13.40
2	195.94	33.5 QP	43.5	-10.0	1.59 V	210	44.90	-11.40
3	259.98	38.8 QP	46.0	-7.2	1.98 V	150	47.80	-9.00
4	325.62	32.0 QP	46.0	-14.0	1.00 V	37	38.40	-6.40
5	749.97	37.0 QP	46.0	-9.0	1.64 V	327	34.60	2.40
6	1000.00	38.5 QP	54.0	-15.5	1.00 V	297	32.80	5.70

**REMARKS:**

1. Emission Level(dBuV/m) = Raw Value(dBuV) + Correction Factor(dB/m)
2. Correction Factor(dB/m) = Antenna Factor(dB/m) + Cable Factor(dB) – Pre-Amplifier Factor(dB)
3. The other emission levels were very low against the limit.
4. Margin value = Emission Level – Limit value

<b>CHANNEL</b>	TX Channel 110	<b>DETECTOR FUNCTION</b>	Quasi-Peak (QP)
<b>FREQUENCY RANGE</b>	Below 1GHz		

**ANTENNA POLARITY & TEST DISTANCE: HORIZONTAL AT 3 M**

NO.	FREQ. (MHz)	EMISSION LEVEL (dBuV/m)	LIMIT (dBuV/m)	MARGIN (dB)	ANTENNA HEIGHT (m)	TABLE ANGLE (Degree)	RAW VALUE (dBuV)	CORRECTION FACTOR (dB/m)
1	33.83	24.1 QP	40.0	-15.9	1.53 H	183	33.70	-9.60
2	195.20	40.4 QP	43.5	-3.1	1.46 H	33	51.70	-11.30
3	260.02	42.9 QP	46.0	-3.1	1.45 H	77	51.80	-8.90
4	379.80	32.4 QP	46.0	-13.6	1.13 H	348	37.70	-5.30
5	696.04	37.5 QP	46.0	-8.5	1.06 H	325	36.10	1.40
6	1000.00	40.9 QP	54.0	-13.1	1.97 H	274	35.20	5.70

**ANTENNA POLARITY & TEST DISTANCE: VERTICAL AT 3 M**

NO.	FREQ. (MHz)	EMISSION LEVEL (dBuV/m)	LIMIT (dBuV/m)	MARGIN (dB)	ANTENNA HEIGHT (m)	TABLE ANGLE (Degree)	RAW VALUE (dBuV)	CORRECTION FACTOR (dB/m)
1	98.21	25.4 QP	43.5	-18.1	1.92 V	325	38.80	-13.40
2	195.75	33.5 QP	43.5	-10.0	1.59 V	225	44.90	-11.40
3	259.78	38.8 QP	46.0	-7.2	1.97 V	156	47.80	-9.00
4	325.91	32.1 QP	46.0	-13.9	1.00 V	40	38.50	-6.40
5	749.78	36.7 QP	46.0	-9.3	1.61 V	334	34.30	2.40
6	1000.00	38.5 QP	54.0	-15.5	1.00 V	296	32.80	5.70

**REMARKS:**

1. Emission Level(dBuV/m) = Raw Value(dBuV) + Correction Factor(dB/m)
2. Correction Factor(dB/m) = Antenna Factor(dB/m) + Cable Factor(dB) – Pre-Amplifier Factor(dB)
3. The other emission levels were very low against the limit.
4. Margin value = Emission Level – Limit value

<b>CHANNEL</b>	TX Channel 118	<b>DETECTOR FUNCTION</b>	Quasi-Peak (QP)
<b>FREQUENCY RANGE</b>	Below 1GHz		

**ANTENNA POLARITY & TEST DISTANCE: HORIZONTAL AT 3 M**

NO.	FREQ. (MHz)	EMISSION LEVEL (dBuV/m)	LIMIT (dBuV/m)	MARGIN (dB)	ANTENNA HEIGHT (m)	TABLE ANGLE (Degree)	RAW VALUE (dBuV)	CORRECTION FACTOR (dB/m)
1	33.63	24.3 QP	40.0	-15.7	1.55 H	158	33.90	-9.60
2	195.05	40.5 QP	43.5	-3.0	1.46 H	42	51.80	-11.30
3	260.16	42.9 QP	46.0	-3.1	1.43 H	83	51.80	-8.90
4	379.74	32.8 QP	46.0	-13.2	N/A H	N/A	38.10	-5.30
5	695.57	37.5 QP	46.0	-8.5	1.08 H	338	36.10	1.40
6	1000.00	40.9 QP	54.0	-13.1	1.89 H	260	35.20	5.70

**ANTENNA POLARITY & TEST DISTANCE: VERTICAL AT 3 M**

NO.	FREQ. (MHz)	EMISSION LEVEL (dBuV/m)	LIMIT (dBuV/m)	MARGIN (dB)	ANTENNA HEIGHT (m)	TABLE ANGLE (Degree)	RAW VALUE (dBuV)	CORRECTION FACTOR (dB/m)
1	98.21	25.6 QP	43.5	-17.9	1.96 V	315	39.00	-13.40
2	195.79	33.7 QP	43.5	-9.8	1.61 V	225	45.10	-11.40
3	259.91	38.9 QP	46.0	-7.1	2.03 V	144	47.90	-9.00
4	325.94	32.1 QP	46.0	-13.9	1.00 V	50	38.50	-6.40
5	749.41	36.5 QP	46.0	-9.5	1.61 V	351	34.10	2.40
6	1000.00	38.9 QP	54.0	-15.1	1.00 V	281	33.20	5.70

**REMARKS:**

1. Emission Level(dBuV/m) = Raw Value(dBuV) + Correction Factor(dB/m)
2. Correction Factor(dB/m) = Antenna Factor(dB/m) + Cable Factor(dB) – Pre-Amplifier Factor(dB)
3. The other emission levels were very low against the limit.
4. Margin value = Emission Level – Limit value



<b>CHANNEL</b>	TX Channel 134	<b>DETECTOR FUNCTION</b>	Quasi-Peak (QP)
<b>FREQUENCY RANGE</b>	Below 1GHz		

**ANTENNA POLARITY & TEST DISTANCE: HORIZONTAL AT 3 M**

NO.	FREQ. (MHz)	EMISSION LEVEL (dBuV/m)	LIMIT (dBuV/m)	MARGIN (dB)	ANTENNA HEIGHT (m)	TABLE ANGLE (Degree)	RAW VALUE (dBuV)	CORRECTION FACTOR (dB/m)
1	33.70	24.0 QP	40.0	-16.0	1.50 H	154	33.60	-9.60
2	194.97	40.0 QP	43.5	-3.5	1.48 H	41	51.30	-11.30
3	260.21	43.0 QP	46.0	-3.0	1.43 H	54	51.90	-8.90
4	380.09	32.9 QP	46.0	-13.1	1.10 H	338	38.20	-5.30
5	695.60	37.8 QP	46.0	-8.2	1.00 H	333	36.40	1.40
6	1000.00	41.0 QP	54.0	-13.0	1.99 H	265	35.30	5.70

**ANTENNA POLARITY & TEST DISTANCE: VERTICAL AT 3 M**

NO.	FREQ. (MHz)	EMISSION LEVEL (dBuV/m)	LIMIT (dBuV/m)	MARGIN (dB)	ANTENNA HEIGHT (m)	TABLE ANGLE (Degree)	RAW VALUE (dBuV)	CORRECTION FACTOR (dB/m)
1	98.22	25.6 QP	43.5	-17.9	1.94 V	323	39.00	-13.40
2	195.96	34.0 QP	43.5	-9.5	1.62 V	209	45.40	-11.40
3	259.93	38.5 QP	46.0	-7.5	2.04 V	138	47.50	-9.00
4	325.63	32.0 QP	46.0	-14.0	1.04 V	45	38.40	-6.40
5	749.82	37.0 QP	46.0	-9.0	1.57 V	332	34.60	2.40
6	1000.00	39.0 QP	54.0	-15.0	1.02 V	302	33.30	5.70

**REMARKS:**

1. Emission Level(dBuV/m) = Raw Value(dBuV) + Correction Factor(dB/m)
2. Correction Factor(dB/m) = Antenna Factor(dB/m) + Cable Factor(dB) – Pre-Amplifier Factor(dB)
3. The other emission levels were very low against the limit.
4. Margin value = Emission Level – Limit value

<b>CHANNEL</b>	TX Channel 151	<b>DETECTOR FUNCTION</b>	Quasi-Peak (QP)
<b>FREQUENCY RANGE</b>	Below 1GHz		

**ANTENNA POLARITY & TEST DISTANCE: HORIZONTAL AT 3 M**

NO.	FREQ. (MHz)	EMISSION LEVEL (dBuV/m)	LIMIT (dBuV/m)	MARGIN (dB)	ANTENNA HEIGHT (m)	TABLE ANGLE (Degree)	RAW VALUE (dBuV)	CORRECTION FACTOR (dB/m)
1	34.06	24.4 QP	40.0	-15.6	1.52 H	152	33.90	-9.50
2	194.83	40.4 QP	43.5	-3.1	1.48 H	36	51.70	-11.30
3	260.19	42.8 QP	46.0	-3.2	1.44 H	63	51.70	-8.90
4	380.01	32.6 QP	46.0	-13.4	1.18 H	341	37.90	-5.30
5	696.05	37.8 QP	46.0	-8.2	1.01 H	329	36.40	1.40
6	1000.00	40.8 QP	54.0	-13.2	1.94 H	281	35.10	5.70

**ANTENNA POLARITY & TEST DISTANCE: VERTICAL AT 3 M**

NO.	FREQ. (MHz)	EMISSION LEVEL (dBuV/m)	LIMIT (dBuV/m)	MARGIN (dB)	ANTENNA HEIGHT (m)	TABLE ANGLE (Degree)	RAW VALUE (dBuV)	CORRECTION FACTOR (dB/m)
1	97.83	25.3 QP	43.5	-18.2	2.00 V	323	38.80	-13.50
2	195.99	34.0 QP	43.5	-9.5	1.68 V	212	45.40	-11.40
3	259.70	38.6 QP	46.0	-7.4	1.95 V	158	47.70	-9.10
4	325.92	32.2 QP	46.0	-13.8	1.00 V	42	38.60	-6.40
5	749.67	37.0 QP	46.0	-9.0	1.54 V	339	34.60	2.40
6	1000.00	38.8 QP	54.0	-15.2	1.00 V	289	33.10	5.70

**REMARKS:**

1. Emission Level(dBuV/m) = Raw Value(dBuV) + Correction Factor(dB/m)
2. Correction Factor(dB/m) = Antenna Factor(dB/m) + Cable Factor(dB) – Pre-Amplifier Factor(dB)
3. The other emission levels were very low against the limit.
4. Margin value = Emission Level – Limit value

<b>CHANNEL</b>	TX Channel 159	<b>DETECTOR FUNCTION</b>	Quasi-Peak (QP)
<b>FREQUENCY RANGE</b>	Below 1GHz		

**ANTENNA POLARITY & TEST DISTANCE: HORIZONTAL AT 3 M**

NO.	FREQ. (MHz)	EMISSION LEVEL (dBuV/m)	LIMIT (dBuV/m)	MARGIN (dB)	ANTENNA HEIGHT (m)	TABLE ANGLE (Degree)	RAW VALUE (dBuV)	CORRECTION FACTOR (dB/m)
1	33.96	23.9 QP	40.0	-16.1	1.53 H	174	33.40	-9.50
2	194.71	40.1 QP	43.5	-3.4	1.52 H	32	51.40	-11.30
3	260.28	42.8 QP	46.0	-3.2	1.42 H	76	51.70	-8.90
4	379.88	32.6 QP	46.0	-13.4	1.13 H	359	37.90	-5.30
5	695.51	37.8 QP	46.0	-8.2	1.02 H	340	36.40	1.40
6	1000.00	41.1 QP	54.0	-12.9	1.96 H	279	35.40	5.70

**ANTENNA POLARITY & TEST DISTANCE: VERTICAL AT 3 M**

NO.	FREQ. (MHz)	EMISSION LEVEL (dBuV/m)	LIMIT (dBuV/m)	MARGIN (dB)	ANTENNA HEIGHT (m)	TABLE ANGLE (Degree)	RAW VALUE (dBuV)	CORRECTION FACTOR (dB/m)
1	98.18	25.4 QP	43.5	-18.1	1.96 V	301	38.80	-13.40
2	195.60	33.9 QP	43.5	-9.6	1.62 V	236	45.30	-11.40
3	259.64	38.8 QP	46.0	-7.2	2.02 V	151	47.90	-9.10
4	325.48	32.2 QP	46.0	-13.8	1.04 V	35	38.60	-6.40
5	749.92	36.5 QP	46.0	-9.5	1.58 V	328	34.10	2.40
6	1000.00	39.0 QP	54.0	-15.0	1.03 V	300	33.30	5.70

**REMARKS:**

1. Emission Level(dBuV/m) = Raw Value(dBuV) + Correction Factor(dB/m)
2. Correction Factor(dB/m) = Antenna Factor(dB/m) + Cable Factor(dB) – Pre-Amplifier Factor(dB)
3. The other emission levels were very low against the limit.
4. Margin value = Emission Level – Limit value

**802.11ac (VHT80)**

<b>CHANNEL</b>	TX Channel 42	<b>DETECTOR FUNCTION</b>	Quasi-Peak (QP)
<b>FREQUENCY RANGE</b>	Below 1GHz		

**ANTENNA POLARITY & TEST DISTANCE: HORIZONTAL AT 3 M**

NO.	FREQ. (MHz)	EMISSION LEVEL (dBuV/m)	LIMIT (dBuV/m)	MARGIN (dB)	ANTENNA HEIGHT (m)	TABLE ANGLE (Degree)	RAW VALUE (dBuV)	CORRECTION FACTOR (dB/m)
1	33.51	24.2 QP	40.0	-15.8	1.52 H	156	33.80	-9.60
2	195.10	40.2 QP	43.5	-3.3	1.48 H	37	51.50	-11.30
3	260.51	42.9 QP	46.0	-3.1	1.38 H	78	51.80	-8.90
4	380.03	32.6 QP	46.0	-13.4	1.17 H	333	37.90	-5.30
5	695.49	37.9 QP	46.0	-8.1	1.07 H	332	36.50	1.40
6	1000.00	41.4 QP	54.0	-12.6	1.88 H	258	35.70	5.70

**ANTENNA POLARITY & TEST DISTANCE: VERTICAL AT 3 M**

NO.	FREQ. (MHz)	EMISSION LEVEL (dBuV/m)	LIMIT (dBuV/m)	MARGIN (dB)	ANTENNA HEIGHT (m)	TABLE ANGLE (Degree)	RAW VALUE (dBuV)	CORRECTION FACTOR (dB/m)
1	97.75	25.4 QP	43.5	-18.1	1.93 V	296	38.90	-13.50
2	195.96	33.6 QP	43.5	-9.9	1.65 V	218	45.00	-11.40
3	259.54	39.0 QP	46.0	-7.0	1.99 V	130	48.10	-9.10
4	325.86	32.4 QP	46.0	-13.6	1.03 V	42	38.80	-6.40
5	749.99	36.6 QP	46.0	-9.4	1.56 V	341	34.20	2.40
6	1000.00	38.6 QP	54.0	-15.4	1.00 V	302	32.90	5.70

**REMARKS:**

1. Emission Level(dBuV/m) = Raw Value(dBuV) + Correction Factor(dB/m)
2. Correction Factor(dB/m) = Antenna Factor(dB/m) + Cable Factor(dB) – Pre-Amplifier Factor(dB)
3. The other emission levels were very low against the limit.
4. Margin value = Emission Level – Limit value

<b>CHANNEL</b>	TX Channel 58	<b>DETECTOR FUNCTION</b>	Quasi-Peak (QP)
<b>FREQUENCY RANGE</b>	Below 1GHz		

**ANTENNA POLARITY & TEST DISTANCE: HORIZONTAL AT 3 M**

NO.	FREQ. (MHz)	EMISSION LEVEL (dBuV/m)	LIMIT (dBuV/m)	MARGIN (dB)	ANTENNA HEIGHT (m)	TABLE ANGLE (Degree)	RAW VALUE (dBuV)	CORRECTION FACTOR (dB/m)
1	33.69	23.8 QP	40.0	-16.2	1.49 H	178	33.40	-9.60
2	195.11	40.1 QP	43.5	-3.4	1.47 H	42	51.40	-11.30
3	260.20	42.8 QP	46.0	-3.2	1.44 H	67	51.70	-8.90
4	379.71	32.5 QP	46.0	-13.5	1.17 H	357	37.80	-5.30
5	695.97	37.5 QP	46.0	-8.5	1.08 H	326	36.10	1.40
6	1000.00	41.2 QP	54.0	-12.8	1.89 H	258	35.50	5.70

**ANTENNA POLARITY & TEST DISTANCE: VERTICAL AT 3 M**

NO.	FREQ. (MHz)	EMISSION LEVEL (dBuV/m)	LIMIT (dBuV/m)	MARGIN (dB)	ANTENNA HEIGHT (m)	TABLE ANGLE (Degree)	RAW VALUE (dBuV)	CORRECTION FACTOR (dB/m)
1	98.01	25.6 QP	43.5	-17.9	1.96 V	311	39.10	-13.50
2	195.61	33.7 QP	43.5	-9.8	1.62 V	232	45.10	-11.40
3	259.80	39.0 QP	46.0	-7.0	1.95 V	130	48.00	-9.00
4	326.01	32.1 QP	46.0	-13.9	1.02 V	61	38.50	-6.40
5	749.87	36.7 QP	46.0	-9.3	1.54 V	339	34.30	2.40
6	1000.00	38.8 QP	54.0	-15.2	1.00 V	281	33.10	5.70

**REMARKS:**

1. Emission Level(dBuV/m) = Raw Value(dBuV) + Correction Factor(dB/m)
2. Correction Factor(dB/m) = Antenna Factor(dB/m) + Cable Factor(dB) – Pre-Amplifier Factor(dB)
3. The other emission levels were very low against the limit.
4. Margin value = Emission Level – Limit value

<b>CHANNEL</b>	TX Channel 106	<b>DETECTOR FUNCTION</b>	Quasi-Peak (QP)
<b>FREQUENCY RANGE</b>	Below 1GHz		

**ANTENNA POLARITY & TEST DISTANCE: HORIZONTAL AT 3 M**

NO.	FREQ. (MHz)	EMISSION LEVEL (dBuV/m)	LIMIT (dBuV/m)	MARGIN (dB)	ANTENNA HEIGHT (m)	TABLE ANGLE (Degree)	RAW VALUE (dBuV)	CORRECTION FACTOR (dB/m)
1	34.05	24.2 QP	40.0	-15.8	1.56 H	156	33.70	-9.50
2	194.88	40.2 QP	43.5	-3.3	1.42 H	27	51.50	-11.30
3	260.41	42.7 QP	46.0	-3.3	1.35 H	68	51.60	-8.90
4	379.68	32.8 QP	46.0	-13.2	1.11 H	342	38.10	-5.30
5	695.79	37.7 QP	46.0	-8.3	1.02 H	330	36.30	1.40
6	1000.00	40.8 QP	54.0	-13.2	1.93 H	281	35.10	5.70

**ANTENNA POLARITY & TEST DISTANCE: VERTICAL AT 3 M**

NO.	FREQ. (MHz)	EMISSION LEVEL (dBuV/m)	LIMIT (dBuV/m)	MARGIN (dB)	ANTENNA HEIGHT (m)	TABLE ANGLE (Degree)	RAW VALUE (dBuV)	CORRECTION FACTOR (dB/m)
1	98.07	25.3 QP	43.5	-18.2	1.91 V	309	38.80	-13.50
2	195.50	34.0 QP	43.5	-9.5	1.64 V	213	45.40	-11.40
3	259.53	38.6 QP	46.0	-7.4	2.01 V	156	47.70	-9.10
4	325.98	32.4 QP	46.0	-13.6	1.01 V	47	38.80	-6.40
5	749.78	36.7 QP	46.0	-9.3	1.65 V	348	34.30	2.40
6	1000.00	38.5 QP	54.0	-15.5	1.00 V	289	32.80	5.70

**REMARKS:**

1. Emission Level(dBuV/m) = Raw Value(dBuV) + Correction Factor(dB/m)
2. Correction Factor(dB/m) = Antenna Factor(dB/m) + Cable Factor(dB) – Pre-Amplifier Factor(dB)
3. The other emission levels were very low against the limit.
4. Margin value = Emission Level – Limit value

<b>CHANNEL</b>	TX Channel 122	<b>DETECTOR FUNCTION</b>	Quasi-Peak (QP)
<b>FREQUENCY RANGE</b>	Below 1GHz		

**ANTENNA POLARITY & TEST DISTANCE: HORIZONTAL AT 3 M**

NO.	FREQ. (MHz)	EMISSION LEVEL (dBuV/m)	LIMIT (dBuV/m)	MARGIN (dB)	ANTENNA HEIGHT (m)	TABLE ANGLE (Degree)	RAW VALUE (dBuV)	CORRECTION FACTOR (dB/m)
1	33.83	24.1 QP	40.0	-15.9	1.48 H	154	33.70	-9.60
2	195.19	40.2 QP	43.5	-3.3	1.52 H	18	51.50	-11.30
3	260.07	42.7 QP	46.0	-3.3	1.42 H	70	51.60	-8.90
4	379.77	32.7 QP	46.0	-13.3	1.17 H	342	38.00	-5.30
5	695.47	37.5 QP	46.0	-8.5	1.01 H	330	36.10	1.40
6	1000.00	41.2 QP	54.0	-12.8	1.91 H	282	35.50	5.70

**ANTENNA POLARITY & TEST DISTANCE: VERTICAL AT 3 M**

NO.	FREQ. (MHz)	EMISSION LEVEL (dBuV/m)	LIMIT (dBuV/m)	MARGIN (dB)	ANTENNA HEIGHT (m)	TABLE ANGLE (Degree)	RAW VALUE (dBuV)	CORRECTION FACTOR (dB/m)
1	97.82	25.4 QP	43.5	-18.1	1.97 V	323	38.90	-13.50
2	196.08	33.9 QP	43.5	-9.6	1.63 V	230	45.30	-11.40
3	260.05	39.1 QP	46.0	-6.9	2.05 V	153	48.00	-8.90
4	325.71	32.4 QP	46.0	-13.6	1.00 V	57	38.80	-6.40
5	749.41	36.7 QP	46.0	-9.3	1.61 V	352	34.30	2.40
6	1000.00	39.0 QP	54.0	-15.0	1.00 V	303	33.30	5.70

**REMARKS:**

1. Emission Level(dBuV/m) = Raw Value(dBuV) + Correction Factor(dB/m)
2. Correction Factor(dB/m) = Antenna Factor(dB/m) + Cable Factor(dB) – Pre-Amplifier Factor(dB)
3. The other emission levels were very low against the limit.
4. Margin value = Emission Level – Limit value

<b>CHANNEL</b>	TX Channel 138	<b>DETECTOR FUNCTION</b>	Quasi-Peak (QP)
<b>FREQUENCY RANGE</b>	Below 1GHz		

**ANTENNA POLARITY & TEST DISTANCE: HORIZONTAL AT 3 M**

NO.	FREQ. (MHz)	EMISSION LEVEL (dBuV/m)	LIMIT (dBuV/m)	MARGIN (dB)	ANTENNA HEIGHT (m)	TABLE ANGLE (Degree)	RAW VALUE (dBuV)	CORRECTION FACTOR (dB/m)
1	33.95	24.1 QP	40.0	-15.9	1.55 H	153	33.60	-9.50
2	194.68	39.9 QP	43.5	-3.6	1.51 H	34	51.20	-11.30
3	260.09	42.8 QP	46.0	-3.2	1.35 H	60	51.70	-8.90
4	380.00	32.8 QP	46.0	-13.2	1.18 H	329	38.10	-5.30
5	695.57	37.9 QP	46.0	-8.1	1.00 H	329	36.50	1.40
6	1000.00	41.1 QP	54.0	-12.9	1.94 H	255	35.40	5.70

**ANTENNA POLARITY & TEST DISTANCE: VERTICAL AT 3 M**

NO.	FREQ. (MHz)	EMISSION LEVEL (dBuV/m)	LIMIT (dBuV/m)	MARGIN (dB)	ANTENNA HEIGHT (m)	TABLE ANGLE (Degree)	RAW VALUE (dBuV)	CORRECTION FACTOR (dB/m)
1	97.70	25.7 QP	43.5	-17.8	1.98 V	322	39.20	-13.50
2	195.64	33.8 QP	43.5	-9.7	1.59 V	208	45.20	-11.40
3	259.88	38.8 QP	46.0	-7.2	1.95 V	151	47.80	-9.00
4	325.62	32.1 QP	46.0	-13.9	1.00 V	45	38.50	-6.40
5	749.80	36.9 QP	46.0	-9.1	1.53 V	352	34.50	2.40
6	1000.00	39.1 QP	54.0	-14.9	1.00 V	285	33.40	5.70

**REMARKS:**

1. Emission Level(dBuV/m) = Raw Value(dBuV) + Correction Factor(dB/m)
2. Correction Factor(dB/m) = Antenna Factor(dB/m) + Cable Factor(dB) – Pre-Amplifier Factor(dB)
3. The other emission levels were very low against the limit.
4. Margin value = Emission Level – Limit value



<b>CHANNEL</b>	TX Channel 155	<b>DETECTOR FUNCTION</b>	Quasi-Peak (QP)
<b>FREQUENCY RANGE</b>	Below 1GHz		

**ANTENNA POLARITY & TEST DISTANCE: HORIZONTAL AT 3 M**

NO.	FREQ. (MHz)	EMISSION LEVEL (dBuV/m)	LIMIT (dBuV/m)	MARGIN (dB)	ANTENNA HEIGHT (m)	TABLE ANGLE (Degree)	RAW VALUE (dBuV)	CORRECTION FACTOR (dB/m)
1	33.53	23.8 QP	40.0	-16.2	1.55 H	159	33.40	-9.60
2	194.75	40.3 QP	43.5	-3.2	1.47 H	49	51.60	-11.30
3	260.46	42.8 QP	46.0	-3.2	1.36 H	82	51.70	-8.90
4	379.78	32.9 QP	46.0	-13.1	1.16 H	337	38.20	-5.30
5	695.95	37.8 QP	46.0	-8.2	1.05 H	340	36.40	1.40
6	1000.00	41.0 QP	54.0	-13.0	1.90 H	262	35.30	5.70

**ANTENNA POLARITY & TEST DISTANCE: VERTICAL AT 3 M**

NO.	FREQ. (MHz)	EMISSION LEVEL (dBuV/m)	LIMIT (dBuV/m)	MARGIN (dB)	ANTENNA HEIGHT (m)	TABLE ANGLE (Degree)	RAW VALUE (dBuV)	CORRECTION FACTOR (dB/m)
1	97.81	25.6 QP	43.5	-17.9	1.91 V	325	39.10	-13.50
2	195.77	34.0 QP	43.5	-9.5	1.65 V	212	45.40	-11.40
3	259.99	39.0 QP	46.0	-7.0	1.96 V	148	48.00	-9.00
4	325.69	32.0 QP	46.0	-14.0	1.05 V	48	38.40	-6.40
5	749.75	37.1 QP	46.0	-8.9	1.65 V	333	34.70	2.40
6	1000.00	38.9 QP	54.0	-15.1	1.00 V	272	33.20	5.70

**REMARKS:**

1. Emission Level(dBuV/m) = Raw Value(dBuV) + Correction Factor(dB/m)
2. Correction Factor(dB/m) = Antenna Factor(dB/m) + Cable Factor(dB) – Pre-Amplifier Factor(dB)
3. The other emission levels were very low against the limit.
4. Margin value = Emission Level – Limit value

4.1.8 Test Results (Mode 2)

Above 1GHz Data

802.11a

<b>CHANNEL</b>	TX Channel 36	<b>DETECTOR FUNCTION</b>	Peak (PK)
<b>FREQUENCY RANGE</b>	1GHz ~ 40GHz		Average (AV)

**ANTENNA POLARITY & TEST DISTANCE: HORIZONTAL AT 3 M**

NO.	FREQ. (MHz)	EMISSION LEVEL (dBuV/m)	LIMIT (dBuV/m)	MARGIN (dB)	ANTENNA HEIGHT (m)	TABLE ANGLE (Degree)	RAW VALUE (dBuV)	CORRECTION FACTOR (dB/m)
1	5150.00	56.6 PK	74.0	-17.4	1.50 H	241	51.63	4.97
2	5150.00	41.6 AV	54.0	-12.4	1.50 H	241	36.63	4.97
3	*5180.00	92.9 PK			2.39 H	260	87.90	5.00
4	*5180.00	83.1 AV			2.39 H	260	78.10	5.00
5	#10360.00	51.4 PK	74.0	-22.6	1.74 H	289	35.73	15.67
6	#10360.00	38.0 AV	54.0	-16.0	1.74 H	289	22.33	15.67
7	15540.00	53.4 PK	74.0	-20.6	1.71 H	208	36.16	17.24
8	15540.00	38.9 AV	54.0	-15.1	1.71 H	208	21.66	17.24

**ANTENNA POLARITY & TEST DISTANCE: VERTICAL AT 3 M**

NO.	FREQ. (MHz)	EMISSION LEVEL (dBuV/m)	LIMIT (dBuV/m)	MARGIN (dB)	ANTENNA HEIGHT (m)	TABLE ANGLE (Degree)	RAW VALUE (dBuV)	CORRECTION FACTOR (dB/m)
1	5150.00	60.1 PK	74.0	-13.9	1.37 V	47	55.13	4.97
2	<b>5150.00</b>	<b>53.0 AV</b>	<b>54.0</b>	<b>-1.0</b>	<b>1.37 V</b>	<b>47</b>	<b>48.03</b>	<b>4.97</b>
3	*5180.00	105.4 PK			1.37 V	47	100.40	5.00
4	*5180.00	95.4 AV			1.37 V	47	90.40	5.00
5	#10360.00	50.7 PK	74.0	-23.3	2.08 V	332	35.03	15.67
6	#10360.00	37.7 AV	54.0	-16.3	2.08 V	332	22.03	15.67
7	15540.00	54.6 PK	74.0	-19.4	1.89 V	17	37.36	17.24
8	15540.00	39.3 AV	54.0	-14.7	1.89 V	17	22.06	17.24

**REMARKS:**

1. Emission Level(dBuV/m) = Raw Value(dBuV) + Correction Factor(dB/m)
2. Correction Factor(dB/m) = Antenna Factor(dB/m) + Cable Factor(dB) – Pre-Amplifier Factor(dB)
3. The other emission levels were very low against the limit.
4. Margin value = Emission Level – Limit value
5. " \* ": Fundamental frequency.
6. " # ": The radiated frequency is out of the restricted band.

<b>CHANNEL</b>	TX Channel 40	<b>DETECTOR FUNCTION</b>	Peak (PK)
<b>FREQUENCY RANGE</b>	1GHz ~ 40GHz		Average (AV)

**ANTENNA POLARITY & TEST DISTANCE: HORIZONTAL AT 3 M**

NO.	FREQ. (MHz)	EMISSION LEVEL (dBuV/m)	LIMIT (dBuV/m)	MARGIN (dB)	ANTENNA HEIGHT (m)	TABLE ANGLE (Degree)	RAW VALUE (dBuV)	CORRECTION FACTOR (dB/m)
1	*5200.00	96.1 PK			2.30 H	255	91.07	5.03
2	*5200.00	86.2 AV			2.30 H	255	81.17	5.03
3	#10400.00	51.5 PK	74.0	-22.5	1.70 H	275	35.39	16.11
4	#10400.00	38.1 AV	54.0	-15.9	1.70 H	275	21.99	16.11
5	15600.00	52.7 PK	74.0	-21.3	1.69 H	199	35.17	17.53
6	15600.00	38.5 AV	54.0	-15.5	1.69 H	199	20.97	17.53

**ANTENNA POLARITY & TEST DISTANCE: VERTICAL AT 3 M**

NO.	FREQ. (MHz)	EMISSION LEVEL (dBuV/m)	LIMIT (dBuV/m)	MARGIN (dB)	ANTENNA HEIGHT (m)	TABLE ANGLE (Degree)	RAW VALUE (dBuV)	CORRECTION FACTOR (dB/m)
1	*5200.00	108.5 PK			1.18 V	47	103.47	5.03
2	*5200.00	98.3 AV			1.18 V	47	93.27	5.03
3	#10400.00	50.8 PK	74.0	-23.2	2.12 V	336	34.69	16.11
4	#10400.00	37.9 AV	54.0	-16.1	2.12 V	336	21.79	16.11
5	15600.00	54.5 PK	74.0	-19.5	1.84 V	31	36.97	17.53
6	15600.00	39.3 AV	54.0	-14.7	1.84 V	31	21.77	17.53

**REMARKS:**

1. Emission Level(dBuV/m) = Raw Value(dBuV) + Correction Factor(dB/m)
2. Correction Factor(dB/m) = Antenna Factor(dB/m) + Cable Factor(dB) – Pre-Amplifier Factor(dB)
3. The other emission levels were very low against the limit.
4. Margin value = Emission Level – Limit value
5. " \* ": Fundamental frequency.
6. " # ": The radiated frequency is out of the restricted band.

<b>CHANNEL</b>	TX Channel 48	<b>DETECTOR FUNCTION</b>	Peak (PK)
<b>FREQUENCY RANGE</b>	1GHz ~ 40GHz		Average (AV)

**ANTENNA POLARITY & TEST DISTANCE: HORIZONTAL AT 3 M**

NO.	FREQ. (MHz)	EMISSION LEVEL (dBuV/m)	LIMIT (dBuV/m)	MARGIN (dB)	ANTENNA HEIGHT (m)	TABLE ANGLE (Degree)	RAW VALUE (dBuV)	CORRECTION FACTOR (dB/m)
1	*5240.00	95.6 PK			2.31 H	246	90.50	5.10
2	*5240.00	85.9 AV			2.31 H	246	80.80	5.10
3	#10480.00	51.2 PK	74.0	-22.8	1.72 H	286	34.95	16.25
4	#10480.00	37.9 AV	54.0	-16.1	1.72 H	286	21.65	16.25
5	15720.00	53.0 PK	74.0	-21.0	1.71 H	219	35.43	17.57
6	15720.00	38.6 AV	54.0	-15.4	1.71 H	219	21.03	17.57

**ANTENNA POLARITY & TEST DISTANCE: VERTICAL AT 3 M**

NO.	FREQ. (MHz)	EMISSION LEVEL (dBuV/m)	LIMIT (dBuV/m)	MARGIN (dB)	ANTENNA HEIGHT (m)	TABLE ANGLE (Degree)	RAW VALUE (dBuV)	CORRECTION FACTOR (dB/m)
1	*5240.00	108.5 PK			1.22 V	40	103.40	5.10
2	*5240.00	98.2 AV			1.22 V	40	93.10	5.10
3	#10480.00	51.0 PK	74.0	-23.0	2.03 V	326	34.75	16.25
4	#10480.00	37.7 AV	54.0	-16.3	2.03 V	326	21.45	16.25
5	15720.00	54.7 PK	74.0	-19.3	1.89 V	17	37.13	17.57
6	15720.00	39.3 AV	54.0	-14.7	1.89 V	17	21.73	17.57

**REMARKS:**

1. Emission Level(dBuV/m) = Raw Value(dBuV) + Correction Factor(dB/m)
2. Correction Factor(dB/m) = Antenna Factor(dB/m) + Cable Factor(dB) – Pre-Amplifier Factor(dB)
3. The other emission levels were very low against the limit.
4. Margin value = Emission Level – Limit value
5. " \* ": Fundamental frequency.
6. " # ": The radiated frequency is out of the restricted band.

<b>CHANNEL</b>	TX Channel 52	<b>DETECTOR FUNCTION</b>	Peak (PK)
<b>FREQUENCY RANGE</b>	1GHz ~ 40GHz		Average (AV)

**ANTENNA POLARITY & TEST DISTANCE: HORIZONTAL AT 3 M**

NO.	FREQ. (MHz)	EMISSION LEVEL (dBuV/m)	LIMIT (dBuV/m)	MARGIN (dB)	ANTENNA HEIGHT (m)	TABLE ANGLE (Degree)	RAW VALUE (dBuV)	CORRECTION FACTOR (dB/m)
1	*5260.00	95.9 PK			2.25 H	244	90.75	5.15
2	*5260.00	86.1 AV			2.25 H	244	80.95	5.15
3	#10520.00	51.3 PK	74.0	-22.7	1.72 H	278	34.98	16.32
4	#10520.00	37.9 AV	54.0	-16.1	1.72 H	278	21.58	16.32
5	15780.00	53.1 PK	74.0	-20.9	1.65 H	208	36.00	17.10
6	15780.00	38.7 AV	54.0	-15.3	1.65 H	208	21.60	17.10

**ANTENNA POLARITY & TEST DISTANCE: VERTICAL AT 3 M**

NO.	FREQ. (MHz)	EMISSION LEVEL (dBuV/m)	LIMIT (dBuV/m)	MARGIN (dB)	ANTENNA HEIGHT (m)	TABLE ANGLE (Degree)	RAW VALUE (dBuV)	CORRECTION FACTOR (dB/m)
1	*5260.00	108.7 PK			1.20 V	27	103.55	5.15
2	*5260.00	98.4 AV			1.20 V	27	93.25	5.15
3	#10520.00	50.9 PK	74.0	-23.1	2.06 V	317	34.58	16.32
4	#10520.00	37.8 AV	54.0	-16.2	2.06 V	317	21.48	16.32
5	15780.00	54.8 PK	74.0	-19.2	1.91 V	13	37.70	17.10
6	15780.00	39.5 AV	54.0	-14.5	1.91 V	13	22.40	17.10

**REMARKS:**

1. Emission Level(dBuV/m) = Raw Value(dBuV) + Correction Factor(dB/m)
2. Correction Factor(dB/m) = Antenna Factor(dB/m) + Cable Factor(dB) – Pre-Amplifier Factor(dB)
3. The other emission levels were very low against the limit.
4. Margin value = Emission Level – Limit value
5. " \* ": Fundamental frequency.
6. " # ": The radiated frequency is out of the restricted band.

<b>CHANNEL</b>	TX Channel 60	<b>DETECTOR FUNCTION</b>	Peak (PK)
<b>FREQUENCY RANGE</b>	1GHz ~ 40GHz		Average (AV)

**ANTENNA POLARITY & TEST DISTANCE: HORIZONTAL AT 3 M**

NO.	FREQ. (MHz)	EMISSION LEVEL (dBuV/m)	LIMIT (dBuV/m)	MARGIN (dB)	ANTENNA HEIGHT (m)	TABLE ANGLE (Degree)	RAW VALUE (dBuV)	CORRECTION FACTOR (dB/m)
1	*5300.00	98.0 PK			2.23 H	239	92.78	5.22
2	*5300.00	87.6 AV			2.23 H	239	82.38	5.22
3	5350.00	52.1 PK	74.0	-21.9	2.23 H	239	46.74	5.36
4	5350.00	39.6 AV	54.0	-14.4	2.23 H	239	34.24	5.36
5	10600.00	50.6 PK	74.0	-23.4	2.05 H	331	34.15	16.45
6	10600.00	37.4 AV	54.0	-16.6	2.05 H	331	20.95	16.45
7	15900.00	54.5 PK	74.0	-19.5	1.90 H	6	37.94	16.56
8	15900.00	39.1 AV	54.0	-14.9	1.90 H	6	22.54	16.56

**ANTENNA POLARITY & TEST DISTANCE: VERTICAL AT 3 M**

NO.	FREQ. (MHz)	EMISSION LEVEL (dBuV/m)	LIMIT (dBuV/m)	MARGIN (dB)	ANTENNA HEIGHT (m)	TABLE ANGLE (Degree)	RAW VALUE (dBuV)	CORRECTION FACTOR (dB/m)
1	*5300.00	109.8 PK			1.59 V	47	104.58	5.22
2	*5300.00	98.9 AV			1.59 V	47	93.68	5.22
3	5350.00	66.5 PK	74.0	-7.5	1.59 V	47	61.14	5.36
4	5350.00	45.4 AV	54.0	-8.6	1.59 V	47	40.04	5.36
5	10600.00	51.2 PK	74.0	-22.8	2.05 V	309	34.75	16.45
6	10600.00	37.8 AV	54.0	-16.2	2.05 V	309	21.35	16.45
7	15900.00	54.5 PK	74.0	-19.5	1.95 V	10	37.94	16.56
8	15900.00	39.2 AV	54.0	-14.8	1.95 V	10	22.64	16.56

**REMARKS:**

1. Emission Level(dBuV/m) = Raw Value(dBuV) + Correction Factor(dB/m)
2. Correction Factor(dB/m) = Antenna Factor(dB/m) + Cable Factor(dB) – Pre-Amplifier Factor(dB)
3. The other emission levels were very low against the limit.
4. Margin value = Emission Level – Limit value
5. " \* ": Fundamental frequency.

<b>CHANNEL</b>	TX Channel 64	<b>DETECTOR FUNCTION</b>	Peak (PK)
<b>FREQUENCY RANGE</b>	1GHz ~ 40GHz		Average (AV)

**ANTENNA POLARITY & TEST DISTANCE: HORIZONTAL AT 3 M**

NO.	FREQ. (MHz)	EMISSION LEVEL (dBuV/m)	LIMIT (dBuV/m)	MARGIN (dB)	ANTENNA HEIGHT (m)	TABLE ANGLE (Degree)	RAW VALUE (dBuV)	CORRECTION FACTOR (dB/m)
1	*5320.00	95.1 PK			2.21 H	232	89.82	5.28
2	*5320.00	85.2 AV			2.21 H	232	79.92	5.28
3	5350.00	62.3 PK	74.0	-11.7	2.21 H	232	56.94	5.36
4	5350.00	41.1 AV	54.0	-12.9	2.21 H	232	35.74	5.36
5	10640.00	51.2 PK	74.0	-22.8	2.06 H	296	34.87	16.33
6	10640.00	37.6 AV	54.0	-16.4	2.06 H	296	21.27	16.33
7	15960.00	54.8 PK	74.0	-19.2	2.00 H	19	38.10	16.70
8	15960.00	39.6 AV	54.0	-14.4	2.00 H	19	22.90	16.70

**ANTENNA POLARITY & TEST DISTANCE: VERTICAL AT 3 M**

NO.	FREQ. (MHz)	EMISSION LEVEL (dBuV/m)	LIMIT (dBuV/m)	MARGIN (dB)	ANTENNA HEIGHT (m)	TABLE ANGLE (Degree)	RAW VALUE (dBuV)	CORRECTION FACTOR (dB/m)
1	*5320.00	107.3 PK			2.06 V	46	102.02	5.28
2	*5320.00	97.4 AV			2.06 V	46	92.12	5.28
3	5350.00	66.8 PK	74.0	-7.2	2.06 V	46	61.44	5.36
4	5350.00	52.9 AV	54.0	-1.1	2.06 V	46	47.54	5.36
5	10640.00	50.9 PK	74.0	-23.1	2.04 V	294	34.57	16.33
6	10640.00	37.7 AV	54.0	-16.3	2.04 V	294	21.37	16.33
7	15960.00	54.2 PK	74.0	-19.8	1.90 V	22	37.50	16.70
8	15960.00	39.1 AV	54.0	-14.9	1.90 V	22	22.40	16.70

**REMARKS:**

1. Emission Level(dBuV/m) = Raw Value(dBuV) + Correction Factor(dB/m)
2. Correction Factor(dB/m) = Antenna Factor(dB/m) + Cable Factor(dB) – Pre-Amplifier Factor(dB)
3. The other emission levels were very low against the limit.
4. Margin value = Emission Level – Limit value
5. " \* ": Fundamental frequency.

<b>CHANNEL</b>	TX Channel 100	<b>DETECTOR FUNCTION</b>	Peak (PK)
<b>FREQUENCY RANGE</b>	1GHz ~ 40GHz		Average (AV)

**ANTENNA POLARITY & TEST DISTANCE: HORIZONTAL AT 3 M**

NO.	FREQ. (MHz)	EMISSION LEVEL (dBuV/m)	LIMIT (dBuV/m)	MARGIN (dB)	ANTENNA HEIGHT (m)	TABLE ANGLE (Degree)	RAW VALUE (dBuV)	CORRECTION FACTOR (dB/m)
1	#5470.00	62.7 PK	74.0	-11.3	2.21 H	236	57.06	5.64
2	#5470.00	41.3 AV	54.0	-12.7	2.21 H	236	35.66	5.64
3	*5500.00	95.0 PK			2.21 H	236	89.30	5.70
4	*5500.00	85.2 AV			2.21 H	236	79.50	5.70
5	10640.00	50.7 PK	74.0	-23.3	2.11 H	306	34.37	16.33
6	10640.00	37.4 AV	54.0	-16.6	2.11 H	306	21.07	16.33
7	15960.00	54.7 PK	74.0	-19.3	1.96 H	35	38.00	16.70
8	15960.00	39.5 AV	54.0	-14.5	1.96 H	35	22.80	16.70

**ANTENNA POLARITY & TEST DISTANCE: VERTICAL AT 3 M**

NO.	FREQ. (MHz)	EMISSION LEVEL (dBuV/m)	LIMIT (dBuV/m)	MARGIN (dB)	ANTENNA HEIGHT (m)	TABLE ANGLE (Degree)	RAW VALUE (dBuV)	CORRECTION FACTOR (dB/m)
1	#5470.00	65.9 PK	74.0	-8.1	2.06 V	47	60.26	5.64
2	#5470.00	52.9 AV	54.0	-1.1	2.06 V	47	47.26	5.64
3	*5500.00	107.0 PK			2.06 V	47	101.30	5.70
4	*5500.00	97.1 AV			2.06 V	47	91.40	5.70
5	11000.00	50.7 PK	74.0	-23.3	2.05 V	288	33.52	17.18
6	11000.00	37.6 AV	54.0	-16.4	2.05 V	288	20.42	17.18
7	#16500.00	54.4 PK	74.0	-19.6	1.91 V	18	34.86	19.54
8	#16500.00	39.3 AV	54.0	-14.7	1.91 V	18	19.76	19.54

**REMARKS:**

1. Emission Level(dBuV/m) = Raw Value(dBuV) + Correction Factor(dB/m)
2. Correction Factor(dB/m) = Antenna Factor(dB/m) + Cable Factor(dB) – Pre-Amplifier Factor(dB)
3. The other emission levels were very low against the limit.
4. Margin value = Emission Level – Limit value
5. " \* ": Fundamental frequency.
6. " # ": The radiated frequency is out of the restricted band.



<b>CHANNEL</b>	TX Channel 116	<b>DETECTOR FUNCTION</b>	Peak (PK)
<b>FREQUENCY RANGE</b>	1GHz ~ 40GHz		Average (AV)

**ANTENNA POLARITY & TEST DISTANCE: HORIZONTAL AT 3 M**

NO.	FREQ. (MHz)	EMISSION LEVEL (dBuV/m)	LIMIT (dBuV/m)	MARGIN (dB)	ANTENNA HEIGHT (m)	TABLE ANGLE (Degree)	RAW VALUE (dBuV)	CORRECTION FACTOR (dB/m)
1	*5580.00	95.2 PK			2.18 H	246	89.43	5.77
2	*5580.00	85.4 AV			2.18 H	246	79.63	5.77
3	11160.00	50.7 PK	74.0	-23.3	2.02 H	347	33.53	17.17
4	11160.00	37.6 AV	54.0	-16.4	2.02 H	347	20.43	17.17
5	#16740.00	54.7 PK	74.0	-19.3	1.94 H	21	35.02	19.68
6	#16740.00	39.4 AV	54.0	-14.6	1.94 H	21	19.72	19.68

**ANTENNA POLARITY & TEST DISTANCE: VERTICAL AT 3 M**

NO.	FREQ. (MHz)	EMISSION LEVEL (dBuV/m)	LIMIT (dBuV/m)	MARGIN (dB)	ANTENNA HEIGHT (m)	TABLE ANGLE (Degree)	RAW VALUE (dBuV)	CORRECTION FACTOR (dB/m)
1	*5580.00	109.3 PK			1.57 V	34	103.53	5.77
2	*5580.00	98.5 AV			1.57 V	34	92.73	5.77
3	11160.00	50.9 PK	74.0	-23.1	2.01 V	299	33.73	17.17
4	11160.00	37.5 AV	54.0	-16.5	2.01 V	299	20.33	17.17
5	#16740.00	54.7 PK	74.0	-19.3	1.99 V	13	35.02	19.68
6	#16740.00	39.6 AV	54.0	-14.4	1.99 V	13	19.92	19.68

**REMARKS:**

1. Emission Level(dBuV/m) = Raw Value(dBuV) + Correction Factor(dB/m)
2. Correction Factor(dB/m) = Antenna Factor(dB/m) + Cable Factor(dB) – Pre-Amplifier Factor(dB)
3. The other emission levels were very low against the limit.
4. Margin value = Emission Level – Limit value
5. " \* ": Fundamental frequency.
6. " # ": The radiated frequency is out of the restricted band.

<b>CHANNEL</b>	TX Channel 120	<b>DETECTOR FUNCTION</b>	Peak (PK)
<b>FREQUENCY RANGE</b>	1GHz ~ 40GHz		Average (AV)

**ANTENNA POLARITY & TEST DISTANCE: HORIZONTAL AT 3 M**

NO.	FREQ. (MHz)	EMISSION LEVEL (dBuV/m)	LIMIT (dBuV/m)	MARGIN (dB)	ANTENNA HEIGHT (m)	TABLE ANGLE (Degree)	RAW VALUE (dBuV)	CORRECTION FACTOR (dB/m)
1	*5600.00	94.9 PK			2.18 H	230	89.12	5.78
2	*5600.00	85.1 AV			2.18 H	230	79.32	5.78
3	11200.00	50.8 PK	74.0	-23.2	2.07 H	345	33.95	16.85
4	11200.00	37.8 AV	54.0	-16.2	2.07 H	345	20.95	16.85
5	#16800.00	54.7 PK	74.0	-19.3	1.90 H	14	34.90	19.80
6	#16800.00	39.6 AV	54.0	-14.4	1.90 H	14	19.80	19.80

**ANTENNA POLARITY & TEST DISTANCE: VERTICAL AT 3 M**

NO.	FREQ. (MHz)	EMISSION LEVEL (dBuV/m)	LIMIT (dBuV/m)	MARGIN (dB)	ANTENNA HEIGHT (m)	TABLE ANGLE (Degree)	RAW VALUE (dBuV)	CORRECTION FACTOR (dB/m)
1	*5600.00	109.9 PK			1.64 V	51	104.12	5.78
2	*5600.00	99.3 AV			1.64 V	51	93.52	5.78
3	11200.00	51.5 PK	74.0	-22.5	2.05 V	295	34.65	16.85
4	11200.00	38.3 AV	54.0	-15.7	2.05 V	295	21.45	16.85
5	#16800.00	55.2 PK	74.0	-18.8	1.92 V	22	35.40	19.80
6	#16800.00	39.6 AV	54.0	-14.4	1.92 V	22	19.80	19.80

**REMARKS:**

1. Emission Level(dBuV/m) = Raw Value(dBuV) + Correction Factor(dB/m)
2. Correction Factor(dB/m) = Antenna Factor(dB/m) + Cable Factor(dB) – Pre-Amplifier Factor(dB)
3. The other emission levels were very low against the limit.
4. Margin value = Emission Level – Limit value
5. " \* ": Fundamental frequency.
6. " # ": The radiated frequency is out of the restricted band.

<b>CHANNEL</b>	TX Channel 132	<b>DETECTOR FUNCTION</b>	Peak (PK)
<b>FREQUENCY RANGE</b>	1GHz ~ 40GHz		Average (AV)

**ANTENNA POLARITY & TEST DISTANCE: HORIZONTAL AT 3 M**

NO.	FREQ. (MHz)	EMISSION LEVEL (dBuV/m)	LIMIT (dBuV/m)	MARGIN (dB)	ANTENNA HEIGHT (m)	TABLE ANGLE (Degree)	RAW VALUE (dBuV)	CORRECTION FACTOR (dB/m)
1	*5660.00	94.7 PK			2.17 H	237	88.75	5.95
2	*5660.00	85.1 AV			2.17 H	237	79.15	5.95
3	11320.00	50.8 PK	74.0	-23.2	2.08 H	333	33.55	17.25
4	11320.00	37.5 AV	54.0	-16.5	2.08 H	333	20.25	17.25
5	#16980.00	53.8 PK	74.0	-20.2	1.91 H	19	32.39	21.41
6	#16980.00	38.7 AV	54.0	-15.3	1.91 H	19	17.29	21.41

**ANTENNA POLARITY & TEST DISTANCE: VERTICAL AT 3 M**

NO.	FREQ. (MHz)	EMISSION LEVEL (dBuV/m)	LIMIT (dBuV/m)	MARGIN (dB)	ANTENNA HEIGHT (m)	TABLE ANGLE (Degree)	RAW VALUE (dBuV)	CORRECTION FACTOR (dB/m)
1	*5660.00	109.6 PK			1.64 V	37	103.65	5.95
2	*5660.00	98.8 AV			1.64 V	37	92.85	5.95
3	11320.00	50.8 PK	74.0	-23.2	2.08 V	325	33.55	17.25
4	11320.00	37.6 AV	54.0	-16.4	2.08 V	325	20.35	17.25
5	#16980.00	54.7 PK	74.0	-19.3	1.92 V	11	33.29	21.41
6	#16980.00	39.6 AV	54.0	-14.4	1.92 V	11	18.19	21.41

**REMARKS:**

1. Emission Level(dBuV/m) = Raw Value(dBuV) + Correction Factor(dB/m)
2. Correction Factor(dB/m) = Antenna Factor(dB/m) + Cable Factor(dB) – Pre-Amplifier Factor(dB)
3. The other emission levels were very low against the limit.
4. Margin value = Emission Level – Limit value
5. " \* ": Fundamental frequency.
6. " # ": The radiated frequency is out of the restricted band.

<b>CHANNEL</b>	TX Channel 140	<b>DETECTOR FUNCTION</b>	Peak (PK)
<b>FREQUENCY RANGE</b>	1GHz ~ 40GHz		Average (AV)

**ANTENNA POLARITY & TEST DISTANCE: HORIZONTAL AT 3 M**

NO.	FREQ. (MHz)	EMISSION LEVEL (dBuV/m)	LIMIT (dBuV/m)	MARGIN (dB)	ANTENNA HEIGHT (m)	TABLE ANGLE (Degree)	RAW VALUE (dBuV)	CORRECTION FACTOR (dB/m)
1	*5700.00	89.9 PK			2.10 H	222	83.83	6.07
2	*5700.00	81.2 AV			2.10 H	222	75.13	6.07
3	11400.00	51.3 PK	74.0	-22.7	2.04 H	319	34.13	17.17
4	11400.00	37.9 AV	54.0	-16.1	2.04 H	319	20.73	17.17
5	#17100.00	53.1 PK	74.0	-20.9	1.96 H	64	31.29	21.81
6	#17100.00	38.3 AV	54.0	-15.7	1.96 H	64	16.49	21.81

**ANTENNA POLARITY & TEST DISTANCE: VERTICAL AT 3 M**

NO.	FREQ. (MHz)	EMISSION LEVEL (dBuV/m)	LIMIT (dBuV/m)	MARGIN (dB)	ANTENNA HEIGHT (m)	TABLE ANGLE (Degree)	RAW VALUE (dBuV)	CORRECTION FACTOR (dB/m)
1	*5700.00	104.6 PK			2.37 V	53	98.53	6.07
2	*5700.00	94.9 AV			2.37 V	53	88.83	6.07
3	11400.00	50.5 PK	74.0	-23.5	2.10 V	321	33.33	17.17
4	11400.00	37.2 AV	54.0	-16.8	2.10 V	321	20.03	17.17
5	#17100.00	55.2 PK	74.0	-18.8	1.95 V	11	33.39	21.81
6	#17100.00	40.0 AV	54.0	-14.0	1.95 V	11	18.19	21.81

**REMARKS:**

1. Emission Level(dBuV/m) = Raw Value(dBuV) + Correction Factor(dB/m)
2. Correction Factor(dB/m) = Antenna Factor(dB/m) + Cable Factor(dB) – Pre-Amplifier Factor(dB)
3. The other emission levels were very low against the limit.
4. Margin value = Emission Level – Limit value
5. " \* ": Fundamental frequency.
6. " # ": The radiated frequency is out of the restricted band.

<b>CHANNEL</b>	TX Channel 149	<b>DETECTOR FUNCTION</b>	Peak (PK)
<b>FREQUENCY RANGE</b>	1GHz ~ 40GHz		Average (AV)

**ANTENNA POLARITY & TEST DISTANCE: HORIZONTAL AT 3 M**

NO.	FREQ. (MHz)	EMISSION LEVEL (dBuV/m)	LIMIT (dBuV/m)	MARGIN (dB)	ANTENNA HEIGHT (m)	TABLE ANGLE (Degree)	RAW VALUE (dBuV)	CORRECTION FACTOR (dB/m)
1	#5715.00	58.7 PK	74.0	-15.3	2.00 H	182	52.59	6.11
2	#5715.00	43.3 AV	54.0	-10.7	2.00 H	182	37.19	6.11
3	#5725.00	69.9 PK	78.2	-8.3	2.00 H	182	63.76	6.14
4	*5745.00	89.0 PK			2.00 H	182	82.81	6.19
5	*5745.00	80.3 AV			2.00 H	182	74.11	6.19
6	11490.00	50.7 PK	74.0	-23.3	2.09 H	319	33.82	16.88
7	11490.00	37.6 AV	54.0	-16.4	2.09 H	319	20.72	16.88
8	#17235.00	54.3 PK	74.0	-19.7	1.90 H	26	32.18	22.12
9	#17235.00	39.1 AV	54.0	-14.9	1.90 H	26	16.98	22.12

**ANTENNA POLARITY & TEST DISTANCE: VERTICAL AT 3 M**

NO.	FREQ. (MHz)	EMISSION LEVEL (dBuV/m)	LIMIT (dBuV/m)	MARGIN (dB)	ANTENNA HEIGHT (m)	TABLE ANGLE (Degree)	RAW VALUE (dBuV)	CORRECTION FACTOR (dB/m)
1	#5715.00	62.2 PK	74.0	-11.8	2.50 V	34	56.09	6.11
2	#5715.00	46.6 AV	54.0	-7.4	2.50 V	34	40.49	6.11
3	#5725.00	74.8 PK	78.2	-3.4	2.50 V	34	68.66	6.14
4	*5745.00	104.0 PK			2.50 V	34	97.81	6.19
5	*5745.00	94.3 AV			2.50 V	34	88.11	6.19
6	11490.00	50.7 PK	74.0	-23.3	2.13 V	313	33.82	16.88
7	11490.00	37.6 AV	54.0	-16.4	2.13 V	313	20.72	16.88
8	#17235.00	55.2 PK	74.0	-18.8	1.93 V	23	33.08	22.12
9	#17235.00	40.0 AV	54.0	-14.0	1.93 V	23	17.88	22.12

**REMARKS:**

1. Emission Level(dBuV/m) = Raw Value(dBuV) + Correction Factor(dB/m)
2. Correction Factor(dB/m) = Antenna Factor(dB/m) + Cable Factor(dB) – Pre-Amplifier Factor(dB)
3. The other emission levels were very low against the limit.
4. Margin value = Emission Level – Limit value
5. " \* ": Fundamental frequency.
6. " # ": The radiated frequency is out of the restricted band.

<b>CHANNEL</b>	TX Channel 157	<b>DETECTOR FUNCTION</b>	Peak (PK)
<b>FREQUENCY RANGE</b>	1GHz ~ 40GHz		Average (AV)

**ANTENNA POLARITY & TEST DISTANCE: HORIZONTAL AT 3 M**

NO.	FREQ. (MHz)	EMISSION LEVEL (dBuV/m)	LIMIT (dBuV/m)	MARGIN (dB)	ANTENNA HEIGHT (m)	TABLE ANGLE (Degree)	RAW VALUE (dBuV)	CORRECTION FACTOR (dB/m)
1	#5542.00	52.4 PK	74.0	-21.6	2.29 H	244	46.67	5.73
2	#5542.00	39.9 AV	54.0	-14.1	2.29 H	244	34.17	5.73
3	#5725.00	52.3 PK	78.2	-25.9	2.29 H	244	46.16	6.14
4	*5785.00	95.6 PK			2.29 H	244	89.28	6.32
5	*5785.00	85.8 AV			2.29 H	244	79.48	6.32
6	#5850.00	51.9 PK	78.2	-26.3	2.29 H	244	45.51	6.39
7	11570.00	50.9 PK	74.0	-23.1	2.08 H	335	34.23	16.67
8	11570.00	37.3 AV	54.0	-16.7	2.08 H	335	20.63	16.67
9	#17355.00	54.3 PK	74.0	-19.7	1.92 H	9	31.65	22.65
10	#17355.00	39.2 AV	54.0	-14.8	1.92 H	9	16.55	22.65

**ANTENNA POLARITY & TEST DISTANCE: VERTICAL AT 3 M**

NO.	FREQ. (MHz)	EMISSION LEVEL (dBuV/m)	LIMIT (dBuV/m)	MARGIN (dB)	ANTENNA HEIGHT (m)	TABLE ANGLE (Degree)	RAW VALUE (dBuV)	CORRECTION FACTOR (dB/m)
1	#5542.00	56.0 PK	74.0	-18.0	1.18 V	41	50.27	5.73
2	#5542.00	42.9 AV	54.0	-11.1	1.18 V	41	37.17	5.73
3	#5725.00	55.8 PK	78.2	-22.4	1.18 V	41	49.66	6.14
4	*5785.00	109.0 PK			1.18 V	41	102.68	6.32
5	*5785.00	98.5 AV			1.18 V	41	92.18	6.32
6	#5850.00	55.5 PK	78.2	-22.7	1.18 V	41	49.11	6.39
7	11570.00	51.2 PK	74.0	-22.8	2.08 V	324	34.53	16.67
8	11570.00	37.9 AV	54.0	-16.1	2.08 V	324	21.23	16.67
9	#17355.00	54.5 PK	74.0	-19.5	1.96 V	11	31.85	22.65
10	#17355.00	39.4 AV	54.0	-14.6	1.96 V	11	16.75	22.65

**REMARKS:**

1. Emission Level(dBuV/m) = Raw Value(dBuV) + Correction Factor(dB/m)
2. Correction Factor(dB/m) = Antenna Factor(dB/m) + Cable Factor(dB) – Pre-Amplifier Factor(dB)
3. The other emission levels were very low against the limit.
4. Margin value = Emission Level – Limit value
5. " \* ": Fundamental frequency.
6. " # ": The radiated frequency is out of the restricted band.

<b>CHANNEL</b>	TX Channel 165	<b>DETECTOR FUNCTION</b>	Peak (PK)
<b>FREQUENCY RANGE</b>	1GHz ~ 40GHz		Average (AV)

**ANTENNA POLARITY & TEST DISTANCE: HORIZONTAL AT 3 M**

NO.	FREQ. (MHz)	EMISSION LEVEL (dBuV/m)	LIMIT (dBuV/m)	MARGIN (dB)	ANTENNA HEIGHT (m)	TABLE ANGLE (Degree)	RAW VALUE (dBuV)	CORRECTION FACTOR (dB/m)
1	*5825.00	95.7 PK			2.36 H	254	89.32	6.38
2	*5825.00	85.7 AV			2.36 H	254	79.32	6.38
3	#5850.00	67.8 PK	78.2	-10.4	2.36 H	254	61.41	6.39
4	#5860.00	58.2 PK	74.0	-15.8	2.36 H	254	51.79	6.41
5	#5860.00	45.1 AV	54.0	-8.9	2.36 H	254	38.69	6.41
6	11650.00	50.5 PK	74.0	-23.5	2.06 H	325	34.05	16.45
7	11650.00	37.3 AV	54.0	-16.7	2.06 H	325	20.85	16.45
8	#17475.00	54.1 PK	74.0	-19.9	1.85 H	23	30.95	23.15
9	#17475.00	39.0 AV	54.0	-15.0	1.85 H	23	15.85	23.15

**ANTENNA POLARITY & TEST DISTANCE: VERTICAL AT 3 M**

NO.	FREQ. (MHz)	EMISSION LEVEL (dBuV/m)	LIMIT (dBuV/m)	MARGIN (dB)	ANTENNA HEIGHT (m)	TABLE ANGLE (Degree)	RAW VALUE (dBuV)	CORRECTION FACTOR (dB/m)
1	*5825.00	109.4 PK			2.76 V	33	103.02	6.38
2	*5825.00	98.7 AV			2.76 V	33	92.32	6.38
3	#5850.00	72.5 PK	78.2	-5.7	2.76 V	33	66.11	6.39
4	#5860.00	63.5 PK	74.0	-10.5	2.76 V	33	57.09	6.41
5	#5860.00	48.7 AV	54.0	-5.3	2.76 V	33	42.29	6.41
6	11650.00	50.7 PK	74.0	-23.3	2.07 V	328	34.25	16.45
7	11650.00	37.3 AV	54.0	-16.7	2.07 V	328	20.85	16.45
8	#17475.00	55.3 PK	74.0	-18.7	1.95 V	9	32.15	23.15
9	#17475.00	40.0 AV	54.0	-14.0	1.95 V	9	16.85	23.15

**REMARKS:**

1. Emission Level(dBuV/m) = Raw Value(dBuV) + Correction Factor(dB/m)
2. Correction Factor(dB/m) = Antenna Factor(dB/m) + Cable Factor(dB) – Pre-Amplifier Factor(dB)
3. The other emission levels were very low against the limit.
4. Margin value = Emission Level – Limit value
5. " \* ": Fundamental frequency.
6. " # ": The radiated frequency is out of the restricted band.

802.11ac (VHT20)

<b>CHANNEL</b>	TX Channel 36	<b>DETECTOR FUNCTION</b>	Peak (PK)
<b>FREQUENCY RANGE</b>	1GHz ~ 40GHz		Average (AV)

ANTENNA POLARITY & TEST DISTANCE: HORIZONTAL AT 3 M								
NO.	FREQ. (MHz)	EMISSION LEVEL (dBuV/m)	LIMIT (dBuV/m)	MARGIN (dB)	ANTENNA HEIGHT (m)	TABLE ANGLE (Degree)	RAW VALUE (dBuV)	CORRECTION FACTOR (dB/m)
1	5150.00	55.4 PK	74.0	-18.6	1.63 H	38	50.43	4.97
2	5150.00	41.2 AV	54.0	-12.8	1.63 H	38	36.23	4.97
3	*5180.00	98.2 PK			1.63 H	38	93.20	5.00
4	*5180.00	87.8 AV			1.63 H	38	82.80	5.00
5	#10360.00	50.6 PK	74.0	-23.4	2.06 H	318	34.93	15.67
6	#10360.00	37.2 AV	54.0	-16.8	2.06 H	318	21.53	15.67
7	15540.00	54.0 PK	74.0	-20.0	1.83 H	15	36.76	17.24
8	15540.00	38.7 AV	54.0	-15.3	1.83 H	15	21.46	17.24

ANTENNA POLARITY & TEST DISTANCE: VERTICAL AT 3 M								
NO.	FREQ. (MHz)	EMISSION LEVEL (dBuV/m)	LIMIT (dBuV/m)	MARGIN (dB)	ANTENNA HEIGHT (m)	TABLE ANGLE (Degree)	RAW VALUE (dBuV)	CORRECTION FACTOR (dB/m)
1	5150.00	72.3 PK	74.0	-1.7	1.55 V	330	67.33	4.97
2	5150.00	53.0 AV	54.0	-1.0	1.55 V	330	48.03	4.97
3	*5180.00	109.4 PK			1.55 V	330	104.40	5.00
4	*5180.00	98.7 AV			1.55 V	330	93.70	5.00
5	#10360.00	50.7 PK	74.0	-23.3	2.08 V	333	35.03	15.67
6	#10360.00	37.2 AV	54.0	-16.8	2.08 V	333	21.53	15.67
7	15540.00	55.0 PK	74.0	-19.0	1.91 V	11	37.76	17.24
8	15540.00	39.7 AV	54.0	-14.3	1.91 V	11	22.46	17.24

**REMARKS:**

1. Emission Level(dBuV/m) = Raw Value(dBuV) + Correction Factor(dB/m)
2. Correction Factor(dB/m) = Antenna Factor(dB/m) + Cable Factor(dB) – Pre-Amplifier Factor(dB)
3. The other emission levels were very low against the limit.
4. Margin value = Emission Level – Limit value
5. " \* ": Fundamental frequency.
6. " # ": The radiated frequency is out of the restricted band.



<b>CHANNEL</b>	TX Channel 40	<b>DETECTOR FUNCTION</b>	Peak (PK)
<b>FREQUENCY RANGE</b>	1GHz ~ 40GHz		Average (AV)

**ANTENNA POLARITY & TEST DISTANCE: HORIZONTAL AT 3 M**

NO.	FREQ. (MHz)	EMISSION LEVEL (dBuV/m)	LIMIT (dBuV/m)	MARGIN (dB)	ANTENNA HEIGHT (m)	TABLE ANGLE (Degree)	RAW VALUE (dBuV)	CORRECTION FACTOR (dB/m)
1	*5200.00	100.5 PK			1.46 H	38	95.47	5.03
2	*5200.00	89.8 AV			1.46 H	38	84.77	5.03
3	#10400.00	51.1 PK	74.0	-22.9	2.11 H	323	34.99	16.11
4	#10400.00	37.8 AV	54.0	-16.2	2.11 H	323	21.69	16.11
5	15600.00	53.7 PK	74.0	-20.3	1.84 H	11	36.17	17.53
6	15600.00	38.6 AV	54.0	-15.4	1.84 H	11	21.07	17.53

**ANTENNA POLARITY & TEST DISTANCE: VERTICAL AT 3 M**

NO.	FREQ. (MHz)	EMISSION LEVEL (dBuV/m)	LIMIT (dBuV/m)	MARGIN (dB)	ANTENNA HEIGHT (m)	TABLE ANGLE (Degree)	RAW VALUE (dBuV)	CORRECTION FACTOR (dB/m)
1	*5200.00	111.8 PK			1.55 V	330	106.77	5.03
2	*5200.00	101.2 AV			1.55 V	330	96.17	5.03
3	#10400.00	50.6 PK	74.0	-23.4	2.02 V	316	34.49	16.11
4	#10400.00	37.4 AV	54.0	-16.6	2.02 V	316	21.29	16.11
5	15600.00	55.4 PK	74.0	-18.6	1.93 V	45	37.87	17.53
6	15600.00	40.2 AV	54.0	-13.8	1.93 V	45	22.67	17.53

**REMARKS:**

1. Emission Level(dBuV/m) = Raw Value(dBuV) + Correction Factor(dB/m)
2. Correction Factor(dB/m) = Antenna Factor(dB/m) + Cable Factor(dB) – Pre-Amplifier Factor(dB)
3. The other emission levels were very low against the limit.
4. Margin value = Emission Level – Limit value
5. " \* ": Fundamental frequency.
6. " # ": The radiated frequency is out of the restricted band.

<b>CHANNEL</b>	TX Channel 48	<b>DETECTOR FUNCTION</b>	Peak (PK)
<b>FREQUENCY RANGE</b>	1GHz ~ 40GHz		Average (AV)

**ANTENNA POLARITY & TEST DISTANCE: HORIZONTAL AT 3 M**

NO.	FREQ. (MHz)	EMISSION LEVEL (dBuV/m)	LIMIT (dBuV/m)	MARGIN (dB)	ANTENNA HEIGHT (m)	TABLE ANGLE (Degree)	RAW VALUE (dBuV)	CORRECTION FACTOR (dB/m)
1	*5240.00	99.8 PK			1.60 H	40	94.70	5.10
2	*5240.00	89.9 AV			1.60 H	40	84.80	5.10
3	#10480.00	50.7 PK	74.0	-23.3	2.06 H	333	34.45	16.25
4	#10480.00	37.8 AV	54.0	-16.2	2.06 H	333	21.55	16.25
5	15720.00	54.3 PK	74.0	-19.7	1.81 H	30	36.73	17.57
6	15720.00	39.1 AV	54.0	-14.9	1.81 H	30	21.53	17.57

**ANTENNA POLARITY & TEST DISTANCE: VERTICAL AT 3 M**

NO.	FREQ. (MHz)	EMISSION LEVEL (dBuV/m)	LIMIT (dBuV/m)	MARGIN (dB)	ANTENNA HEIGHT (m)	TABLE ANGLE (Degree)	RAW VALUE (dBuV)	CORRECTION FACTOR (dB/m)
1	*5240.00	111.2 PK			1.60 V	343	106.10	5.10
2	*5240.00	100.8 AV			1.60 V	343	95.70	5.10
3	#10480.00	50.6 PK	74.0	-23.4	2.01 V	338	34.35	16.25
4	#10480.00	37.4 AV	54.0	-16.6	2.01 V	338	21.15	16.25
5	15720.00	55.8 PK	74.0	-18.2	1.91 V	16	38.23	17.57
6	15720.00	40.5 AV	54.0	-13.5	1.91 V	16	22.93	17.57

**REMARKS:**

1. Emission Level(dBuV/m) = Raw Value(dBuV) + Correction Factor(dB/m)
2. Correction Factor(dB/m) = Antenna Factor(dB/m) + Cable Factor(dB) – Pre-Amplifier Factor(dB)
3. The other emission levels were very low against the limit.
4. Margin value = Emission Level – Limit value
5. " \* ": Fundamental frequency.
6. " # ": The radiated frequency is out of the restricted band.

<b>CHANNEL</b>	TX Channel 52	<b>DETECTOR FUNCTION</b>	Peak (PK)
<b>FREQUENCY RANGE</b>	1GHz ~ 40GHz		Average (AV)

**ANTENNA POLARITY & TEST DISTANCE: HORIZONTAL AT 3 M**

NO.	FREQ. (MHz)	EMISSION LEVEL (dBuV/m)	LIMIT (dBuV/m)	MARGIN (dB)	ANTENNA HEIGHT (m)	TABLE ANGLE (Degree)	RAW VALUE (dBuV)	CORRECTION FACTOR (dB/m)
1	*5260.00	100.2 PK			1.57 H	41	95.05	5.15
2	*5260.00	90.2 AV			1.57 H	41	85.05	5.15
3	#10520.00	50.8 PK	74.0	-23.2	2.12 H	322	34.48	16.32
4	#10520.00	37.5 AV	54.0	-16.5	2.12 H	322	21.18	16.32
5	15780.00	54.3 PK	74.0	-19.7	1.88 H	22	37.20	17.10
6	15780.00	38.9 AV	54.0	-15.1	1.88 H	22	21.80	17.10

**ANTENNA POLARITY & TEST DISTANCE: VERTICAL AT 3 M**

NO.	FREQ. (MHz)	EMISSION LEVEL (dBuV/m)	LIMIT (dBuV/m)	MARGIN (dB)	ANTENNA HEIGHT (m)	TABLE ANGLE (Degree)	RAW VALUE (dBuV)	CORRECTION FACTOR (dB/m)
1	*5260.00	111.4 PK			1.58 V	343	106.25	5.15
2	*5260.00	101.0 AV			1.58 V	343	95.85	5.15
3	#10520.00	50.6 PK	74.0	-23.4	2.01 V	322	34.28	16.32
4	#10520.00	37.1 AV	54.0	-16.9	2.01 V	322	20.78	16.32
5	15780.00	55.3 PK	74.0	-18.7	1.98 V	5	38.20	17.10
6	15780.00	40.2 AV	54.0	-13.8	1.98 V	5	23.10	17.10

**REMARKS:**

1. Emission Level(dBuV/m) = Raw Value(dBuV) + Correction Factor(dB/m)
2. Correction Factor(dB/m) = Antenna Factor(dB/m) + Cable Factor(dB) – Pre-Amplifier Factor(dB)
3. The other emission levels were very low against the limit.
4. Margin value = Emission Level – Limit value
5. " \* ": Fundamental frequency.
6. " # ": The radiated frequency is out of the restricted band.

<b>CHANNEL</b>	TX Channel 60	<b>DETECTOR FUNCTION</b>	Peak (PK)
<b>FREQUENCY RANGE</b>	1GHz ~ 40GHz		Average (AV)

**ANTENNA POLARITY & TEST DISTANCE: HORIZONTAL AT 3 M**

NO.	FREQ. (MHz)	EMISSION LEVEL (dBuV/m)	LIMIT (dBuV/m)	MARGIN (dB)	ANTENNA HEIGHT (m)	TABLE ANGLE (Degree)	RAW VALUE (dBuV)	CORRECTION FACTOR (dB/m)
1	*5300.00	99.4 PK			1.62 H	28	94.18	5.22
2	*5300.00	89.7 AV			1.62 H	28	84.48	5.22
3	#10520.00	50.4 PK	74.0	-23.6	2.01 H	323	34.08	16.32
4	#10520.00	37.1 AV	54.0	-16.9	2.01 H	323	20.78	16.32
5	15780.00	53.8 PK	74.0	-20.2	1.80 H	13	36.70	17.10
6	15780.00	38.7 AV	54.0	-15.3	1.80 H	13	21.60	17.10

**ANTENNA POLARITY & TEST DISTANCE: VERTICAL AT 3 M**

NO.	FREQ. (MHz)	EMISSION LEVEL (dBuV/m)	LIMIT (dBuV/m)	MARGIN (dB)	ANTENNA HEIGHT (m)	TABLE ANGLE (Degree)	RAW VALUE (dBuV)	CORRECTION FACTOR (dB/m)
1	*5300.00	111.1 PK			1.54 V	336	105.88	5.22
2	*5300.00	100.7 AV			1.54 V	336	95.48	5.22
3	#10520.00	50.7 PK	74.0	-23.3	2.05 V	343	34.38	16.32
4	#10520.00	37.4 AV	54.0	-16.6	2.05 V	343	21.08	16.32
5	15780.00	55.3 PK	74.0	-18.7	2.00 V	9	38.20	17.10
6	15780.00	40.0 AV	54.0	-14.0	2.00 V	9	22.90	17.10

**REMARKS:**

1. Emission Level(dBuV/m) = Raw Value(dBuV) + Correction Factor(dB/m)
2. Correction Factor(dB/m) = Antenna Factor(dB/m) + Cable Factor(dB) – Pre-Amplifier Factor(dB)
3. The other emission levels were very low against the limit.
4. Margin value = Emission Level – Limit value
5. " \* ": Fundamental frequency.
6. " # ": The radiated frequency is out of the restricted band.

<b>CHANNEL</b>	TX Channel 64	<b>DETECTOR FUNCTION</b>	Peak (PK)
<b>FREQUENCY RANGE</b>	1GHz ~ 40GHz		Average (AV)

**ANTENNA POLARITY & TEST DISTANCE: HORIZONTAL AT 3 M**

NO.	FREQ. (MHz)	EMISSION LEVEL (dBuV/m)	LIMIT (dBuV/m)	MARGIN (dB)	ANTENNA HEIGHT (m)	TABLE ANGLE (Degree)	RAW VALUE (dBuV)	CORRECTION FACTOR (dB/m)
1	*5320.00	101.5 PK			1.53 H	70	96.22	5.28
2	*5320.00	90.0 AV			1.53 H	70	84.72	5.28
3	5350.00	55.1 PK	74.0	-18.9	1.53 H	70	49.74	5.36
4	5350.00	41.2 AV	54.0	-12.8	1.53 H	70	35.84	5.36
5	10640.00	50.6 PK	74.0	-23.4	1.96 H	322	34.27	16.33
6	10640.00	37.2 AV	54.0	-16.8	1.96 H	322	20.87	16.33
7	15960.00	53.6 PK	74.0	-20.4	1.79 H	0	36.90	16.70
8	15960.00	38.9 AV	54.0	-15.1	1.79 H	0	22.20	16.70

**ANTENNA POLARITY & TEST DISTANCE: VERTICAL AT 3 M**

NO.	FREQ. (MHz)	EMISSION LEVEL (dBuV/m)	LIMIT (dBuV/m)	MARGIN (dB)	ANTENNA HEIGHT (m)	TABLE ANGLE (Degree)	RAW VALUE (dBuV)	CORRECTION FACTOR (dB/m)
1	*5320.00	110.9 PK			2.18 V	331	105.62	5.28
2	*5320.00	100.7 AV			2.18 V	331	95.42	5.28
3	5350.00	71.4 PK	74.0	-2.6	2.18 V	331	66.04	5.36
4	5350.00	52.9 AV	54.0	-1.1	2.18 V	331	47.54	5.36
5	10640.00	50.6 PK	74.0	-23.4	2.08 V	335	34.27	16.33
6	10640.00	37.1 AV	54.0	-16.9	2.08 V	335	20.77	16.33
7	15960.00	54.9 PK	74.0	-19.1	2.04 V	23	38.20	16.70
8	15960.00	39.8 AV	54.0	-14.2	2.04 V	23	23.10	16.70

**REMARKS:**

1. Emission Level(dBuV/m) = Raw Value(dBuV) + Correction Factor(dB/m)
2. Correction Factor(dB/m) = Antenna Factor(dB/m) + Cable Factor(dB) – Pre-Amplifier Factor(dB)
3. The other emission levels were very low against the limit.
4. Margin value = Emission Level – Limit value
5. " \* ": Fundamental frequency.

<b>CHANNEL</b>	TX Channel 100	<b>DETECTOR FUNCTION</b>	Peak (PK)
<b>FREQUENCY RANGE</b>	1GHz ~ 40GHz		Average (AV)

**ANTENNA POLARITY & TEST DISTANCE: HORIZONTAL AT 3 M**

NO.	FREQ. (MHz)	EMISSION LEVEL (dBuV/m)	LIMIT (dBuV/m)	MARGIN (dB)	ANTENNA HEIGHT (m)	TABLE ANGLE (Degree)	RAW VALUE (dBuV)	CORRECTION FACTOR (dB/m)
1	#5470.00	58.7 PK	74.0	-15.3	1.55 H	82	53.06	5.64
2	#5470.00	45.7 AV	54.0	-8.3	1.55 H	82	40.06	5.64
3	*5500.00	99.3 PK			1.55 H	82	93.60	5.70
4	*5500.00	89.1 AV			1.55 H	82	83.40	5.70
5	#5735.00	49.5 PK	74.0	-24.5	1.55 H	82	43.33	6.17
6	#5735.00	38.7 AV	54.0	-15.3	1.55 H	82	32.53	6.17
7	11000.00	50.1 PK	74.0	-23.9	1.97 H	330	32.92	17.18
8	11000.00	36.4 AV	54.0	-17.6	1.97 H	330	19.22	17.18
9	#16500.00	53.0 PK	74.0	-21.0	1.78 H	10	33.46	19.54
10	#16500.00	37.9 AV	54.0	-16.1	1.78 H	10	18.36	19.54

**ANTENNA POLARITY & TEST DISTANCE: VERTICAL AT 3 M**

NO.	FREQ. (MHz)	EMISSION LEVEL (dBuV/m)	LIMIT (dBuV/m)	MARGIN (dB)	ANTENNA HEIGHT (m)	TABLE ANGLE (Degree)	RAW VALUE (dBuV)	CORRECTION FACTOR (dB/m)
1	#5470.00	62.8 PK	74.0	-11.2	2.00 V	311	57.16	5.64
2	#5470.00	49.7 AV	54.0	-4.3	2.00 V	311	44.06	5.64
3	*5500.00	109.8 PK			2.00 V	311	104.10	5.70
4	*5500.00	99.7 AV			2.00 V	311	94.00	5.70
5	#5735.00	53.6 PK	74.0	-20.4	2.00 V	311	47.43	6.17
6	#5735.00	42.0 AV	54.0	-12.0	2.00 V	311	35.83	6.17
7	11000.00	50.3 PK	74.0	-23.7	2.01 V	336	33.12	17.18
8	11000.00	37.1 AV	54.0	-16.9	2.01 V	336	19.92	17.18
9	#16500.00	55.3 PK	74.0	-18.7	2.02 V	44	35.76	19.54
10	#16500.00	40.2 AV	54.0	-13.8	2.02 V	44	20.66	19.54

**REMARKS:**

1. Emission Level(dBuV/m) = Raw Value(dBuV) + Correction Factor(dB/m)
2. Correction Factor(dB/m) = Antenna Factor(dB/m) + Cable Factor(dB) – Pre-Amplifier Factor(dB)
3. The other emission levels were very low against the limit.
4. Margin value = Emission Level – Limit value
5. " \* ": Fundamental frequency.
6. " # ": The radiated frequency is out of the restricted band.

<b>CHANNEL</b>	TX Channel 116	<b>DETECTOR FUNCTION</b>	Peak (PK)
<b>FREQUENCY RANGE</b>	1GHz ~ 40GHz		Average (AV)

**ANTENNA POLARITY & TEST DISTANCE: HORIZONTAL AT 3 M**

NO.	FREQ. (MHz)	EMISSION LEVEL (dBuV/m)	LIMIT (dBuV/m)	MARGIN (dB)	ANTENNA HEIGHT (m)	TABLE ANGLE (Degree)	RAW VALUE (dBuV)	CORRECTION FACTOR (dB/m)
1	*5580.00	98.9 PK			1.57 H	23	93.13	5.77
2	*5580.00	89.2 AV			1.57 H	23	83.43	5.77
3	11160.00	50.2 PK	74.0	-23.8	2.04 H	332	33.03	17.17
4	11160.00	36.7 AV	54.0	-17.3	2.04 H	332	19.53	17.17
5	#16740.00	53.3 PK	74.0	-20.7	1.85 H	15	33.62	19.68
6	#16740.00	38.3 AV	54.0	-15.7	1.85 H	15	18.62	19.68

**ANTENNA POLARITY & TEST DISTANCE: VERTICAL AT 3 M**

NO.	FREQ. (MHz)	EMISSION LEVEL (dBuV/m)	LIMIT (dBuV/m)	MARGIN (dB)	ANTENNA HEIGHT (m)	TABLE ANGLE (Degree)	RAW VALUE (dBuV)	CORRECTION FACTOR (dB/m)
1	*5580.00	111.6 PK			1.57 V	338	105.83	5.77
2	*5580.00	101.2 AV			1.57 V	338	95.43	5.77
3	11160.00	50.3 PK	74.0	-23.7	2.03 V	339	33.13	17.17
4	11160.00	37.0 AV	54.0	-17.0	2.03 V	339	19.83	17.17
5	#16740.00	55.9 PK	74.0	-18.1	2.04 V	60	36.22	19.68
6	#16740.00	40.4 AV	54.0	-13.6	2.04 V	60	20.72	19.68

**REMARKS:**

1. Emission Level(dBuV/m) = Raw Value(dBuV) + Correction Factor(dB/m)
2. Correction Factor(dB/m) = Antenna Factor(dB/m) + Cable Factor(dB) – Pre-Amplifier Factor(dB)
3. The other emission levels were very low against the limit.
4. Margin value = Emission Level – Limit value
5. " \* ": Fundamental frequency.
6. " # ": The radiated frequency is out of the restricted band.

<b>CHANNEL</b>	TX Channel 120	<b>DETECTOR FUNCTION</b>	Peak (PK)
<b>FREQUENCY RANGE</b>	1GHz ~ 40GHz		Average (AV)

**ANTENNA POLARITY & TEST DISTANCE: HORIZONTAL AT 3 M**

NO.	FREQ. (MHz)	EMISSION LEVEL (dBuV/m)	LIMIT (dBuV/m)	MARGIN (dB)	ANTENNA HEIGHT (m)	TABLE ANGLE (Degree)	RAW VALUE (dBuV)	CORRECTION FACTOR (dB/m)
1	*5600.00	99.2 PK			1.64 H	25	93.42	5.78
2	*5600.00	89.6 AV			1.64 H	25	83.82	5.78
3	11200.00	51.0 PK	74.0	-23.0	2.07 H	333	34.15	16.85
4	11200.00	37.5 AV	54.0	-16.5	2.07 H	333	20.65	16.85
5	#16800.00	54.1 PK	74.0	-19.9	1.83 H	21	34.30	19.80
6	#16800.00	38.7 AV	54.0	-15.3	1.83 H	21	18.90	19.80

**ANTENNA POLARITY & TEST DISTANCE: VERTICAL AT 3 M**

NO.	FREQ. (MHz)	EMISSION LEVEL (dBuV/m)	LIMIT (dBuV/m)	MARGIN (dB)	ANTENNA HEIGHT (m)	TABLE ANGLE (Degree)	RAW VALUE (dBuV)	CORRECTION FACTOR (dB/m)
1	*5600.00	111.0 PK			1.60 V	333	105.22	5.78
2	*5600.00	100.5 AV			1.60 V	333	94.72	5.78
3	11200.00	50.3 PK	74.0	-23.7	2.00 V	356	33.45	16.85
4	11200.00	37.0 AV	54.0	-17.0	2.00 V	356	20.15	16.85
5	#16800.00	55.4 PK	74.0	-18.6	1.96 V	20	35.60	19.80
6	#16800.00	40.2 AV	54.0	-13.8	1.96 V	20	20.40	19.80

**REMARKS:**

1. Emission Level(dBuV/m) = Raw Value(dBuV) + Correction Factor(dB/m)
2. Correction Factor(dB/m) = Antenna Factor(dB/m) + Cable Factor(dB) – Pre-Amplifier Factor(dB)
3. The other emission levels were very low against the limit.
4. Margin value = Emission Level – Limit value
5. " \* ": Fundamental frequency.
6. " # ": The radiated frequency is out of the restricted band.



<b>CHANNEL</b>	TX Channel 132	<b>DETECTOR FUNCTION</b>	Peak (PK)
<b>FREQUENCY RANGE</b>	1GHz ~ 40GHz		Average (AV)

**ANTENNA POLARITY & TEST DISTANCE: HORIZONTAL AT 3 M**

NO.	FREQ. (MHz)	EMISSION LEVEL (dBuV/m)	LIMIT (dBuV/m)	MARGIN (dB)	ANTENNA HEIGHT (m)	TABLE ANGLE (Degree)	RAW VALUE (dBuV)	CORRECTION FACTOR (dB/m)
1	*5660.00	100.0 PK			1.57 H	17	94.05	5.95
2	*5660.00	90.0 AV			1.57 H	17	84.05	5.95
3	11320.00	50.7 PK	74.0	-23.3	2.04 H	323	33.45	17.25
4	11320.00	37.3 AV	54.0	-16.7	2.04 H	323	20.05	17.25
5	#16980.00	53.4 PK	74.0	-20.6	1.85 H	22	31.99	21.41
6	#16980.00	38.4 AV	54.0	-15.6	1.85 H	22	16.99	21.41

**ANTENNA POLARITY & TEST DISTANCE: VERTICAL AT 3 M**

NO.	FREQ. (MHz)	EMISSION LEVEL (dBuV/m)	LIMIT (dBuV/m)	MARGIN (dB)	ANTENNA HEIGHT (m)	TABLE ANGLE (Degree)	RAW VALUE (dBuV)	CORRECTION FACTOR (dB/m)
1	*5660.00	111.2 PK			1.49 V	326	105.25	5.95
2	*5660.00	100.8 AV			1.49 V	326	94.85	5.95
3	11320.00	50.7 PK	74.0	-23.3	2.08 V	343	33.45	17.25
4	11320.00	37.3 AV	54.0	-16.7	2.08 V	343	20.05	17.25
5	#16980.00	55.3 PK	74.0	-18.7	2.03 V	7	33.89	21.41
6	#16980.00	40.1 AV	54.0	-13.9	2.03 V	7	18.69	21.41

**REMARKS:**

1. Emission Level(dBuV/m) = Raw Value(dBuV) + Correction Factor(dB/m)
2. Correction Factor(dB/m) = Antenna Factor(dB/m) + Cable Factor(dB) – Pre-Amplifier Factor(dB)
3. The other emission levels were very low against the limit.
4. Margin value = Emission Level – Limit value
5. " \* ": Fundamental frequency.
6. " # ": The radiated frequency is out of the restricted band.

<b>CHANNEL</b>	TX Channel 140	<b>DETECTOR FUNCTION</b>	Peak (PK)
<b>FREQUENCY RANGE</b>	1GHz ~ 40GHz		Average (AV)

**ANTENNA POLARITY & TEST DISTANCE: HORIZONTAL AT 3 M**

NO.	FREQ. (MHz)	EMISSION LEVEL (dBuV/m)	LIMIT (dBuV/m)	MARGIN (dB)	ANTENNA HEIGHT (m)	TABLE ANGLE (Degree)	RAW VALUE (dBuV)	CORRECTION FACTOR (dB/m)
1	*5700.00	94.8 PK			1.55 H	22	88.73	6.07
2	*5700.00	85.9 AV			1.55 H	22	79.83	6.07
3	#5725.00	57.4 PK	74.0	-16.6	1.55 H	22	51.26	6.14
4	#5725.00	42.1 AV	54.0	-11.9	1.55 H	22	35.96	6.14
5	11400.00	50.0 PK	74.0	-24.0	1.96 H	321	32.83	17.17
6	11400.00	36.7 AV	54.0	-17.3	1.96 H	321	19.53	17.17
7	#17100.00	53.1 PK	74.0	-20.9	1.78 H	8	31.29	21.81
8	#17100.00	38.0 AV	54.0	-16.0	1.78 H	8	16.19	21.81

**ANTENNA POLARITY & TEST DISTANCE: VERTICAL AT 3 M**

NO.	FREQ. (MHz)	EMISSION LEVEL (dBuV/m)	LIMIT (dBuV/m)	MARGIN (dB)	ANTENNA HEIGHT (m)	TABLE ANGLE (Degree)	RAW VALUE (dBuV)	CORRECTION FACTOR (dB/m)
1	*5700.00	105.9 PK			1.55 V	308	99.83	6.07
2	*5700.00	96.9 AV			1.55 V	308	90.83	6.07
3	#5725.00	61.3 PK	74.0	-12.7	1.55 V	308	55.16	6.14
4	#5725.00	46.0 AV	54.0	-8.0	1.55 V	308	39.86	6.14
5	11400.00	50.5 PK	74.0	-23.5	2.06 V	357	33.33	17.17
6	11400.00	37.5 AV	54.0	-16.5	2.06 V	357	20.33	17.17
7	#17100.00	55.4 PK	74.0	-18.6	2.02 V	0	33.59	21.81
8	#17100.00	40.2 AV	54.0	-13.8	2.02 V	0	18.39	21.81

**REMARKS:**

1. Emission Level(dBuV/m) = Raw Value(dBuV) + Correction Factor(dB/m)
2. Correction Factor(dB/m) = Antenna Factor(dB/m) + Cable Factor(dB) – Pre-Amplifier Factor(dB)
3. The other emission levels were very low against the limit.
4. Margin value = Emission Level – Limit value
5. " \* ": Fundamental frequency.
6. " # ": The radiated frequency is out of the restricted band.

<b>CHANNEL</b>	TX Channel 149	<b>DETECTOR FUNCTION</b>	Peak (PK)
<b>FREQUENCY RANGE</b>	1GHz ~ 40GHz		Average (AV)

**ANTENNA POLARITY & TEST DISTANCE: HORIZONTAL AT 3 M**

NO.	FREQ. (MHz)	EMISSION LEVEL (dBuV/m)	LIMIT (dBuV/m)	MARGIN (dB)	ANTENNA HEIGHT (m)	TABLE ANGLE (Degree)	RAW VALUE (dBuV)	CORRECTION FACTOR (dB/m)
1	#5715.00	52.2 PK	74.0	-21.8	1.58 H	21	46.09	6.11
2	#5715.00	38.6 AV	54.0	-15.4	1.58 H	21	32.49	6.11
3	#5725.00	68.8 PK	78.2	-9.4	1.58 H	21	62.66	6.14
4	*5745.00	94.7 PK			1.58 H	21	88.51	6.19
5	*5745.00	86.0 AV			1.58 H	21	79.81	6.19
6	11490.00	50.0 PK	74.0	-24.0	1.98 H	333	33.12	16.88
7	11490.00	36.7 AV	54.0	-17.3	1.98 H	333	19.82	16.88
8	#17235.00	52.6 PK	74.0	-21.4	1.76 H	13	30.48	22.12
9	#17235.00	38.0 AV	54.0	-16.0	1.76 H	13	15.88	22.12

**ANTENNA POLARITY & TEST DISTANCE: VERTICAL AT 3 M**

NO.	FREQ. (MHz)	EMISSION LEVEL (dBuV/m)	LIMIT (dBuV/m)	MARGIN (dB)	ANTENNA HEIGHT (m)	TABLE ANGLE (Degree)	RAW VALUE (dBuV)	CORRECTION FACTOR (dB/m)
1	#5715.00	56.1 PK	74.0	-17.9	1.51 V	303	49.99	6.11
2	#5715.00	42.4 AV	54.0	-11.6	1.51 V	303	36.29	6.11
3	#5725.00	72.6 PK	78.2	-5.6	1.51 V	303	66.46	6.14
4	*5745.00	105.3 PK			1.51 V	303	99.11	6.19
5	*5745.00	96.5 AV			1.51 V	303	90.31	6.19
6	11490.00	51.2 PK	74.0	-22.8	2.07 V	343	34.32	16.88
7	11490.00	37.8 AV	54.0	-16.2	2.07 V	343	20.92	16.88
8	#17235.00	55.7 PK	74.0	-18.3	1.96 V	23	33.58	22.12
9	#17235.00	40.2 AV	54.0	-13.8	1.96 V	23	18.08	22.12

**REMARKS:**

1. Emission Level(dBuV/m) = Raw Value(dBuV) + Correction Factor(dB/m)
2. Correction Factor(dB/m) = Antenna Factor(dB/m) + Cable Factor(dB) – Pre-Amplifier Factor(dB)
3. The other emission levels were very low against the limit.
4. Margin value = Emission Level – Limit value
5. " \* ": Fundamental frequency.
6. " # ": The radiated frequency is out of the restricted band.

<b>CHANNEL</b>	TX Channel 157	<b>DETECTOR FUNCTION</b>	Peak (PK)
<b>FREQUENCY RANGE</b>	1GHz ~ 40GHz		Average (AV)

**ANTENNA POLARITY & TEST DISTANCE: HORIZONTAL AT 3 M**

NO.	FREQ. (MHz)	EMISSION LEVEL (dBuV/m)	LIMIT (dBuV/m)	MARGIN (dB)	ANTENNA HEIGHT (m)	TABLE ANGLE (Degree)	RAW VALUE (dBuV)	CORRECTION FACTOR (dB/m)
1	*5785.00	99.3 PK			1.57 H	15	92.98	6.32
2	*5785.00	89.3 AV			1.57 H	15	82.98	6.32
3	11570.00	50.3 PK	74.0	-23.7	2.01 H	318	33.63	16.67
4	11570.00	36.8 AV	54.0	-17.2	2.01 H	318	20.13	16.67
5	#17355.00	53.3 PK	74.0	-20.7	1.76 H	10	30.65	22.65
6	#17355.00	38.4 AV	54.0	-15.6	1.76 H	10	15.75	22.65

**ANTENNA POLARITY & TEST DISTANCE: VERTICAL AT 3 M**

NO.	FREQ. (MHz)	EMISSION LEVEL (dBuV/m)	LIMIT (dBuV/m)	MARGIN (dB)	ANTENNA HEIGHT (m)	TABLE ANGLE (Degree)	RAW VALUE (dBuV)	CORRECTION FACTOR (dB/m)
1	*5785.00	110.7 PK			1.51 V	328	104.38	6.32
2	*5785.00	100.3 AV			1.51 V	328	93.98	6.32
3	11570.00	50.4 PK	74.0	-23.6	2.01 V	343	33.73	16.67
4	11570.00	37.2 AV	54.0	-16.8	2.01 V	343	20.53	16.67
5	#17355.00	55.6 PK	74.0	-18.4	2.00 V	23	32.95	22.65
6	#17355.00	40.3 AV	54.0	-13.7	2.00 V	23	17.65	22.65

**REMARKS:**

1. Emission Level(dBuV/m) = Raw Value(dBuV) + Correction Factor(dB/m)
2. Correction Factor(dB/m) = Antenna Factor(dB/m) + Cable Factor(dB) – Pre-Amplifier Factor(dB)
3. The other emission levels were very low against the limit.
4. Margin value = Emission Level – Limit value
5. " \* ": Fundamental frequency.
6. " # ": The radiated frequency is out of the restricted band.

<b>CHANNEL</b>	TX Channel 165	<b>DETECTOR FUNCTION</b>	Peak (PK)
<b>FREQUENCY RANGE</b>	1GHz ~ 40GHz		Average (AV)

**ANTENNA POLARITY & TEST DISTANCE: HORIZONTAL AT 3 M**

NO.	FREQ. (MHz)	EMISSION LEVEL (dBuV/m)	LIMIT (dBuV/m)	MARGIN (dB)	ANTENNA HEIGHT (m)	TABLE ANGLE (Degree)	RAW VALUE (dBuV)	CORRECTION FACTOR (dB/m)
1	*5825.00	98.4 PK			1.55 H	28	92.02	6.38
2	*5825.00	88.3 AV			1.55 H	28	81.92	6.38
3	#5850.00	65.5 PK	78.2	-12.7	1.55 H	28	59.11	6.39
4	#5860.00	59.7 PK	74.0	-14.3	1.55 H	28	53.29	6.41
5	#5860.00	40.1 AV	54.0	-13.9	1.55 H	28	33.69	6.41
6	11650.00	51.0 PK	74.0	-23.0	2.06 H	322	34.55	16.45
7	11650.00	37.2 AV	54.0	-16.8	2.06 H	322	20.75	16.45
8	#17475.00	52.8 PK	74.0	-21.2	1.80 H	6	29.65	23.15
9	#17475.00	38.0 AV	54.0	-16.0	1.80 H	6	14.85	23.15

**ANTENNA POLARITY & TEST DISTANCE: VERTICAL AT 3 M**

NO.	FREQ. (MHz)	EMISSION LEVEL (dBuV/m)	LIMIT (dBuV/m)	MARGIN (dB)	ANTENNA HEIGHT (m)	TABLE ANGLE (Degree)	RAW VALUE (dBuV)	CORRECTION FACTOR (dB/m)
1	*5825.00	109.5 PK			1.55 V	320	103.12	6.38
2	*5825.00	99.2 AV			1.55 V	320	92.82	6.38
3	#5860.00	64.1 PK	74.0	-9.9	1.55 V	320	57.69	6.41
4	#5860.00	45.5 AV	54.0	-8.5	1.55 V	320	39.09	6.41
5	11650.00	50.7 PK	74.0	-23.3	2.04 V	334	34.25	16.45
6	11650.00	37.6 AV	54.0	-16.4	2.04 V	334	21.15	16.45
7	#17475.00	54.8 PK	74.0	-19.2	1.96 V	36	31.65	23.15
8	#17475.00	39.5 AV	54.0	-14.5	1.96 V	36	16.35	23.15

**REMARKS:**

1. Emission Level(dBuV/m) = Raw Value(dBuV) + Correction Factor(dB/m)
2. Correction Factor(dB/m) = Antenna Factor(dB/m) + Cable Factor(dB) – Pre-Amplifier Factor(dB)
3. The other emission levels were very low against the limit.
4. Margin value = Emission Level – Limit value
5. " \* ": Fundamental frequency.
6. " # ": The radiated frequency is out of the restricted band.

**802.11ac (VHT40)**

<b>CHANNEL</b>	TX Channel 38	<b>DETECTOR FUNCTION</b>	Peak (PK)
<b>FREQUENCY RANGE</b>	1GHz ~ 40GHz		Average (AV)

**ANTENNA POLARITY & TEST DISTANCE: HORIZONTAL AT 3 M**

NO.	FREQ. (MHz)	EMISSION LEVEL (dBuV/m)	LIMIT (dBuV/m)	MARGIN (dB)	ANTENNA HEIGHT (m)	TABLE ANGLE (Degree)	RAW VALUE (dBuV)	CORRECTION FACTOR (dB/m)
1	5150.00	66.3 PK	74.0	-7.7	1.62 H	48	61.33	4.97
2	5150.00	48.8 AV	54.0	-5.2	1.62 H	48	43.83	4.97
3	*5190.00	94.7 PK			1.62 H	48	89.68	5.02
4	*5190.00	85.4 AV			1.62 H	48	80.38	5.02
5	#10380.00	50.3 PK	74.0	-23.7	2.07 H	307	34.42	15.88
6	#10380.00	36.8 AV	54.0	-17.2	2.07 H	307	20.92	15.88
7	15570.00	52.7 PK	74.0	-21.3	1.77 H	12	35.33	17.37
8	15570.00	37.6 AV	54.0	-16.4	1.77 H	12	20.23	17.37

**ANTENNA POLARITY & TEST DISTANCE: VERTICAL AT 3 M**

NO.	FREQ. (MHz)	EMISSION LEVEL (dBuV/m)	LIMIT (dBuV/m)	MARGIN (dB)	ANTENNA HEIGHT (m)	TABLE ANGLE (Degree)	RAW VALUE (dBuV)	CORRECTION FACTOR (dB/m)
1	5150.00	70.2 PK	74.0	-3.8	2.20 V	300	65.20	5.00
2	<b>5150.00</b>	<b>53.0 AV</b>	<b>54.0</b>	<b>-1.0</b>	<b>2.20 V</b>	<b>300</b>	<b>48.00</b>	<b>5.00</b>
3	*5190.00	105.1 PK			2.20 V	300	100.10	5.00
4	*5190.00	95.5 AV			2.20 V	300	90.50	5.00
5	#10380.00	50.8 PK	74.0	-23.2	2.07 V	323	34.90	15.90
6	#10380.00	37.3 AV	54.0	-16.7	2.07 V	323	21.40	15.90
7	15570.00	56.1 PK	74.0	-17.9	1.98 V	69	38.70	17.40
8	15570.00	40.4 AV	54.0	-13.6	1.98 V	69	23.00	17.40

**REMARKS:**

- Emission Level(dBuV/m) = Raw Value(dBuV) + Correction Factor(dB/m)
- Correction Factor(dB/m) = Antenna Factor(dB/m) + Cable Factor(dB) – Pre-Amplifier Factor(dB)
- The other emission levels were very low against the limit.
- Margin value = Emission Level – Limit value
- " \* ": Fundamental frequency.
- " # ": The radiated frequency is out of the restricted band.

<b>CHANNEL</b>	TX Channel 46	<b>DETECTOR FUNCTION</b>	Peak (PK)
<b>FREQUENCY RANGE</b>	1GHz ~ 40GHz		Average (AV)

**ANTENNA POLARITY & TEST DISTANCE: HORIZONTAL AT 3 M**

NO.	FREQ. (MHz)	EMISSION LEVEL (dBuV/m)	LIMIT (dBuV/m)	MARGIN (dB)	ANTENNA HEIGHT (m)	TABLE ANGLE (Degree)	RAW VALUE (dBuV)	CORRECTION FACTOR (dB/m)
1	5150.00	64.9 PK	74.0	-9.1	1.60 H	36	59.93	4.97
2	5150.00	46.3 AV	54.0	-7.7	1.60 H	36	41.33	4.97
3	*5230.00	99.8 PK			1.60 H	36	94.71	5.09
4	*5230.00	89.5 AV			1.60 H	36	84.41	5.09
5	#10460.00	50.6 PK	74.0	-23.4	2.02 H	315	34.38	16.22
6	#10460.00	37.0 AV	54.0	-17.0	2.02 H	315	20.78	16.22
7	15690.00	52.6 PK	74.0	-21.4	1.80 H	7	34.89	17.71
8	15690.00	37.9 AV	54.0	-16.1	1.80 H	7	20.19	17.71

**ANTENNA POLARITY & TEST DISTANCE: VERTICAL AT 3 M**

NO.	FREQ. (MHz)	EMISSION LEVEL (dBuV/m)	LIMIT (dBuV/m)	MARGIN (dB)	ANTENNA HEIGHT (m)	TABLE ANGLE (Degree)	RAW VALUE (dBuV)	CORRECTION FACTOR (dB/m)
1	5150.00	68.6 PK	74.0	-5.4	2.45 V	312	63.63	4.97
2	5150.00	50.0 AV	54.0	-4.0	2.45 V	312	45.03	4.97
3	*5230.00	110.3 PK			2.45 V	312	105.21	5.09
4	*5230.00	99.4 AV			2.45 V	312	94.31	5.09
5	#10460.00	49.8 PK	74.0	-24.2	2.04 V	353	33.58	16.22
6	#10460.00	36.5 AV	54.0	-17.5	2.04 V	353	20.28	16.22
7	15690.00	55.6 PK	74.0	-18.4	2.09 V	74	37.89	17.71
8	15690.00	40.2 AV	54.0	-13.8	2.09 V	74	22.49	17.71

**REMARKS:**

1. Emission Level(dBuV/m) = Raw Value(dBuV) + Correction Factor(dB/m)
2. Correction Factor(dB/m) = Antenna Factor(dB/m) + Cable Factor(dB) – Pre-Amplifier Factor(dB)
3. The other emission levels were very low against the limit.
4. Margin value = Emission Level – Limit value
5. " \* ": Fundamental frequency.
6. " # ": The radiated frequency is out of the restricted band.

<b>CHANNEL</b>	TX Channel 54	<b>DETECTOR FUNCTION</b>	Peak (PK)
<b>FREQUENCY RANGE</b>	1GHz ~ 40GHz		Average (AV)

**ANTENNA POLARITY & TEST DISTANCE: HORIZONTAL AT 3 M**

NO.	FREQ. (MHz)	EMISSION LEVEL (dBuV/m)	LIMIT (dBuV/m)	MARGIN (dB)	ANTENNA HEIGHT (m)	TABLE ANGLE (Degree)	RAW VALUE (dBuV)	CORRECTION FACTOR (dB/m)
1	*5270.00	99.8 PK			1.54 H	43	94.64	5.16
2	*5270.00	89.7 AV			1.54 H	43	84.54	5.16
3	5350.00	65.3 PK	74.0	-8.7	1.54 H	43	59.94	5.36
4	5350.00	47.4 AV	54.0	-6.6	1.54 H	43	42.04	5.36
5	#10540.00	51.4 PK	74.0	-22.6	2.01 H	336	35.05	16.35
6	#10540.00	37.6 AV	54.0	-16.4	2.01 H	336	21.25	16.35
7	15810.00	52.3 PK	74.0	-21.7	1.81 H	6	35.39	16.91
8	15810.00	37.8 AV	54.0	-16.2	1.81 H	6	20.89	16.91

**ANTENNA POLARITY & TEST DISTANCE: VERTICAL AT 3 M**

NO.	FREQ. (MHz)	EMISSION LEVEL (dBuV/m)	LIMIT (dBuV/m)	MARGIN (dB)	ANTENNA HEIGHT (m)	TABLE ANGLE (Degree)	RAW VALUE (dBuV)	CORRECTION FACTOR (dB/m)
1	*5270.00	110.5 PK			2.45 V	317	105.34	5.16
2	*5270.00	99.4 AV			2.45 V	317	94.24	5.16
3	5350.00	69.6 PK	74.0	-4.4	2.45 V	317	64.24	5.36
4	5350.00	51.7 AV	54.0	-2.3	2.45 V	317	46.34	5.36
5	#10540.00	50.0 PK	74.0	-24.0	2.03 V	333	33.65	16.35
6	#10540.00	36.6 AV	54.0	-17.4	2.03 V	333	20.25	16.35
7	15810.00	55.9 PK	74.0	-18.1	2.01 V	72	38.99	16.91
8	15810.00	40.1 AV	54.0	-13.9	2.01 V	72	23.19	16.91

**REMARKS:**

1. Emission Level(dBuV/m) = Raw Value(dBuV) + Correction Factor(dB/m)
2. Correction Factor(dB/m) = Antenna Factor(dB/m) + Cable Factor(dB) – Pre-Amplifier Factor(dB)
3. The other emission levels were very low against the limit.
4. Margin value = Emission Level – Limit value
5. " \* ": Fundamental frequency.
6. " # ": The radiated frequency is out of the restricted band.



<b>CHANNEL</b>	TX Channel 62	<b>DETECTOR FUNCTION</b>	Peak (PK)
<b>FREQUENCY RANGE</b>	1GHz ~ 40GHz		Average (AV)

**ANTENNA POLARITY & TEST DISTANCE: HORIZONTAL AT 3 M**

NO.	FREQ. (MHz)	EMISSION LEVEL (dBuV/m)	LIMIT (dBuV/m)	MARGIN (dB)	ANTENNA HEIGHT (m)	TABLE ANGLE (Degree)	RAW VALUE (dBuV)	CORRECTION FACTOR (dB/m)
1	*5310.00	93.7 PK			1.62 H	65	88.45	5.25
2	*5310.00	82.6 AV			1.62 H	65	77.35	5.25
3	5350.00	65.6 PK	74.0	-8.4	1.62 H	65	60.24	5.36
4	5350.00	48.9 AV	54.0	-5.1	1.62 H	65	43.54	5.36
5	10620.00	51.2 PK	74.0	-22.8	2.07 H	310	34.81	16.39
6	10620.00	37.5 AV	54.0	-16.5	2.07 H	310	21.11	16.39
7	15930.00	52.2 PK	74.0	-21.8	1.85 H	21	35.56	16.64
8	15930.00	37.5 AV	54.0	-16.5	1.85 H	21	20.86	16.64

**ANTENNA POLARITY & TEST DISTANCE: VERTICAL AT 3 M**

NO.	FREQ. (MHz)	EMISSION LEVEL (dBuV/m)	LIMIT (dBuV/m)	MARGIN (dB)	ANTENNA HEIGHT (m)	TABLE ANGLE (Degree)	RAW VALUE (dBuV)	CORRECTION FACTOR (dB/m)
1	*5310.00	104.2 PK			2.40 V	310	98.95	5.25
2	*5310.00	93.7 AV			2.40 V	310	88.45	5.25
3	5350.00	69.8 PK	74.0	-4.2	2.40 V	310	64.44	5.36
4	5350.00	52.6 AV	54.0	-1.4	2.40 V	310	47.24	5.36
5	10620.00	50.1 PK	74.0	-23.9	1.97 V	349	33.71	16.39
6	10620.00	36.9 AV	54.0	-17.1	1.97 V	349	20.51	16.39
7	15930.00	56.2 PK	74.0	-17.8	2.01 V	65	39.56	16.64
8	15930.00	40.8 AV	54.0	-13.2	2.01 V	65	24.16	16.64

**REMARKS:**

1. Emission Level(dBuV/m) = Raw Value(dBuV) + Correction Factor(dB/m)
2. Correction Factor(dB/m) = Antenna Factor(dB/m) + Cable Factor(dB) – Pre-Amplifier Factor(dB)
3. The other emission levels were very low against the limit.
4. Margin value = Emission Level – Limit value
5. " \* ": Fundamental frequency.

<b>CHANNEL</b>	TX Channel 102	<b>DETECTOR FUNCTION</b>	Peak (PK)
<b>FREQUENCY RANGE</b>	1GHz ~ 40GHz		Average (AV)

**ANTENNA POLARITY & TEST DISTANCE: HORIZONTAL AT 3 M**

NO.	FREQ. (MHz)	EMISSION LEVEL (dBuV/m)	LIMIT (dBuV/m)	MARGIN (dB)	ANTENNA HEIGHT (m)	TABLE ANGLE (Degree)	RAW VALUE (dBuV)	CORRECTION FACTOR (dB/m)
1	#5470.00	63.6 PK	74.0	-10.4	1.66 H	52	57.96	5.64
2	#5470.00	44.9 AV	54.0	-9.1	1.66 H	52	39.26	5.64
3	*5510.00	93.4 PK			1.66 H	52	87.69	5.71
4	*5510.00	82.3 AV			1.66 H	52	76.59	5.71
5	11020.00	51.4 PK	74.0	-22.6	2.04 H	333	34.13	17.27
6	11020.00	37.4 AV	54.0	-16.6	2.04 H	333	20.13	17.27
7	#16530.00	53.0 PK	74.0	-21.0	1.82 H	20	33.45	19.55
8	#16530.00	38.0 AV	54.0	-16.0	1.82 H	20	18.45	19.55

**ANTENNA POLARITY & TEST DISTANCE: VERTICAL AT 3 M**

NO.	FREQ. (MHz)	EMISSION LEVEL (dBuV/m)	LIMIT (dBuV/m)	MARGIN (dB)	ANTENNA HEIGHT (m)	TABLE ANGLE (Degree)	RAW VALUE (dBuV)	CORRECTION FACTOR (dB/m)
1	#5470.00	67.9 PK	74.0	-6.1	2.42 V	331	62.26	5.64
2	#5470.00	50.6 AV	54.0	-3.4	2.42 V	331	44.96	5.64
3	*5510.00	104.2 PK			2.42 V	331	98.49	5.71
4	*5510.00	93.2 AV			2.42 V	331	87.49	5.71
5	11020.00	50.6 PK	74.0	-23.4	2.00 V	351	33.33	17.27
6	11020.00	37.3 AV	54.0	-16.7	2.00 V	351	20.03	17.27
7	#16530.00	55.3 PK	74.0	-18.7	2.03 V	71	35.75	19.55
8	#16530.00	40.1 AV	54.0	-13.9	2.03 V	71	20.55	19.55

**REMARKS:**

1. Emission Level(dBuV/m) = Raw Value(dBuV) + Correction Factor(dB/m)
2. Correction Factor(dB/m) = Antenna Factor(dB/m) + Cable Factor(dB) – Pre-Amplifier Factor(dB)
3. The other emission levels were very low against the limit.
4. Margin value = Emission Level – Limit value
5. " \* ": Fundamental frequency.
6. " # ": The radiated frequency is out of the restricted band.

<b>CHANNEL</b>	TX Channel 110	<b>DETECTOR FUNCTION</b>	Peak (PK)
<b>FREQUENCY RANGE</b>	1GHz ~ 40GHz		Average (AV)

**ANTENNA POLARITY & TEST DISTANCE: HORIZONTAL AT 3 M**

NO.	FREQ. (MHz)	EMISSION LEVEL (dBuV/m)	LIMIT (dBuV/m)	MARGIN (dB)	ANTENNA HEIGHT (m)	TABLE ANGLE (Degree)	RAW VALUE (dBuV)	CORRECTION FACTOR (dB/m)
1	#5470.00	59.8 PK	74.0	-14.2	1.57 H	11	54.16	5.64
2	#5470.00	46.7 AV	54.0	-7.3	1.57 H	11	41.06	5.64
3	*5550.00	99.7 PK			1.57 H	11	93.96	5.74
4	*5550.00	89.6 AV			1.57 H	11	83.86	5.74
5	11100.00	50.9 PK	74.0	-23.1	2.05 H	326	33.25	17.65
6	11100.00	37.1 AV	54.0	-16.9	2.05 H	326	19.45	17.65
7	#16650.00	52.7 PK	74.0	-21.3	1.77 H	13	33.13	19.57
8	#16650.00	38.0 AV	54.0	-16.0	1.77 H	13	18.43	19.57

**ANTENNA POLARITY & TEST DISTANCE: VERTICAL AT 3 M**

NO.	FREQ. (MHz)	EMISSION LEVEL (dBuV/m)	LIMIT (dBuV/m)	MARGIN (dB)	ANTENNA HEIGHT (m)	TABLE ANGLE (Degree)	RAW VALUE (dBuV)	CORRECTION FACTOR (dB/m)
1	#5470.00	64.0 PK	74.0	-10.0	2.51 V	327	58.36	5.64
2	#5470.00	50.1 AV	54.0	-3.9	2.51 V	327	44.46	5.64
3	*5550.00	109.8 PK			2.51 V	327	104.06	5.74
4	*5550.00	99.0 AV			2.51 V	327	93.26	5.74
5	11100.00	50.6 PK	74.0	-23.4	2.00 V	326	32.95	17.65
6	11100.00	37.3 AV	54.0	-16.7	2.00 V	326	19.65	17.65
7	#16650.00	55.6 PK	74.0	-18.4	2.06 V	75	36.03	19.57
8	#16650.00	40.3 AV	54.0	-13.7	2.06 V	75	20.73	19.57

**REMARKS:**

1. Emission Level(dBuV/m) = Raw Value(dBuV) + Correction Factor(dB/m)
2. Correction Factor(dB/m) = Antenna Factor(dB/m) + Cable Factor(dB) – Pre-Amplifier Factor(dB)
3. The other emission levels were very low against the limit.
4. Margin value = Emission Level – Limit value
5. " \* ": Fundamental frequency.
6. " # ": The radiated frequency is out of the restricted band.

<b>CHANNEL</b>	TX Channel 118	<b>DETECTOR FUNCTION</b>	Peak (PK)
<b>FREQUENCY RANGE</b>	1GHz ~ 40GHz		Average (AV)

**ANTENNA POLARITY & TEST DISTANCE: HORIZONTAL AT 3 M**

NO.	FREQ. (MHz)	EMISSION LEVEL (dBuV/m)	LIMIT (dBuV/m)	MARGIN (dB)	ANTENNA HEIGHT (m)	TABLE ANGLE (Degree)	RAW VALUE (dBuV)	CORRECTION FACTOR (dB/m)
1	*5590.00	100.0 PK			1.54 H	6	94.23	5.77
2	*5590.00	89.7 AV			1.54 H	6	83.93	5.77
3	11180.00	50.9 PK	74.0	-23.1	2.12 H	318	33.89	17.01
4	11180.00	37.1 AV	54.0	-16.9	2.12 H	318	20.09	17.01
5	#16770.00	52.5 PK	74.0	-21.5	1.76 H	6	32.76	19.74
6	#16770.00	37.8 AV	54.0	-16.2	1.76 H	6	18.06	19.74

**ANTENNA POLARITY & TEST DISTANCE: VERTICAL AT 3 M**

NO.	FREQ. (MHz)	EMISSION LEVEL (dBuV/m)	LIMIT (dBuV/m)	MARGIN (dB)	ANTENNA HEIGHT (m)	TABLE ANGLE (Degree)	RAW VALUE (dBuV)	CORRECTION FACTOR (dB/m)
1	*5590.00	110.5 PK			2.48 V	300	104.73	5.77
2	*5590.00	99.7 AV			2.48 V	300	93.93	5.77
3	11180.00	50.3 PK	74.0	-23.7	1.98 V	330	33.29	17.01
4	11180.00	36.8 AV	54.0	-17.2	1.98 V	330	19.79	17.01
5	#16770.00	55.8 PK	74.0	-18.2	2.07 V	59	36.06	19.74
6	#16770.00	40.4 AV	54.0	-13.6	2.07 V	59	20.66	19.74

**REMARKS:**

1. Emission Level(dBuV/m) = Raw Value(dBuV) + Correction Factor(dB/m)
2. Correction Factor(dB/m) = Antenna Factor(dB/m) + Cable Factor(dB) – Pre-Amplifier Factor(dB)
3. The other emission levels were very low against the limit.
4. Margin value = Emission Level – Limit value
5. " \* ": Fundamental frequency.
6. " # ": The radiated frequency is out of the restricted band.

<b>CHANNEL</b>	TX Channel 134	<b>DETECTOR FUNCTION</b>	Peak (PK)
<b>FREQUENCY RANGE</b>	1GHz ~ 40GHz		Average (AV)

**ANTENNA POLARITY & TEST DISTANCE: HORIZONTAL AT 3 M**

NO.	FREQ. (MHz)	EMISSION LEVEL (dBuV/m)	LIMIT (dBuV/m)	MARGIN (dB)	ANTENNA HEIGHT (m)	TABLE ANGLE (Degree)	RAW VALUE (dBuV)	CORRECTION FACTOR (dB/m)
1	*5670.00	100.1 PK			1.62 H	38	94.13	5.97
2	*5670.00	89.9 AV			1.62 H	38	83.93	5.97
3	#5725.00	68.6 PK	74.0	-5.4	1.62 H	38	62.46	6.14
4	#5725.00	48.8 AV	54.0	-5.2	1.62 H	38	42.66	6.14
5	11340.00	50.8 PK	74.0	-23.2	2.00 H	319	33.57	17.23
6	11340.00	37.1 AV	54.0	-16.9	2.00 H	319	19.87	17.23
7	#17010.00	53.1 PK	74.0	-20.9	1.79 H	5	31.46	21.64
8	#17010.00	38.1 AV	54.0	-15.9	1.79 H	5	16.46	21.64

**ANTENNA POLARITY & TEST DISTANCE: VERTICAL AT 3 M**

NO.	FREQ. (MHz)	EMISSION LEVEL (dBuV/m)	LIMIT (dBuV/m)	MARGIN (dB)	ANTENNA HEIGHT (m)	TABLE ANGLE (Degree)	RAW VALUE (dBuV)	CORRECTION FACTOR (dB/m)
1	*5670.00	110.7 PK			2.40 V	360	104.73	5.97
2	*5670.00	99.8 AV			2.40 V	360	93.83	5.97
3	#5725.00	72.6 PK	74.0	-1.4	2.40 V	360	66.46	6.14
4	#5725.00	52.9 AV	54.0	-1.1	2.40 V	360	46.76	6.14
5	11340.00	50.1 PK	74.0	-23.9	2.08 V	324	32.87	17.23
6	11340.00	36.6 AV	54.0	-17.4	2.08 V	324	19.37	17.23
7	#17010.00	56.2 PK	74.0	-17.8	2.06 V	49	34.56	21.64
8	#17010.00	40.6 AV	54.0	-13.4	2.06 V	49	18.96	21.64

**REMARKS:**

1. Emission Level(dBuV/m) = Raw Value(dBuV) + Correction Factor(dB/m)
2. Correction Factor(dB/m) = Antenna Factor(dB/m) + Cable Factor(dB) – Pre-Amplifier Factor(dB)
3. The other emission levels were very low against the limit.
4. Margin value = Emission Level – Limit value
5. " \* ": Fundamental frequency.
6. " # ": The radiated frequency is out of the restricted band.

<b>CHANNEL</b>	TX Channel 151	<b>DETECTOR FUNCTION</b>	Peak (PK)
<b>FREQUENCY RANGE</b>	1GHz ~ 40GHz		Average (AV)

**ANTENNA POLARITY & TEST DISTANCE: HORIZONTAL AT 3 M**

NO.	FREQ. (MHz)	EMISSION LEVEL (dBuV/m)	LIMIT (dBuV/m)	MARGIN (dB)	ANTENNA HEIGHT (m)	TABLE ANGLE (Degree)	RAW VALUE (dBuV)	CORRECTION FACTOR (dB/m)
1	#5715.00	65.4 PK	74.0	-8.6	1.55 H	48	59.29	6.11
2	#5715.00	49.1 AV	54.0	-4.9	1.55 H	48	42.99	6.11
3	#5725.00	68.9 PK	78.2	-9.3	1.55 H	48	62.76	6.14
4	*5755.00	96.5 PK			1.55 H	48	90.26	6.24
5	*5755.00	86.2 AV			1.55 H	48	79.96	6.24
6	11510.00	50.9 PK	74.0	-23.1	2.09 H	318	34.09	16.81
7	11510.00	36.8 AV	54.0	-17.2	2.09 H	318	19.99	16.81
8	#17265.00	52.4 PK	74.0	-21.6	1.80 H	21	30.25	22.15
9	#17265.00	37.7 AV	54.0	-16.3	1.80 H	21	15.55	22.15

**ANTENNA POLARITY & TEST DISTANCE: VERTICAL AT 3 M**

NO.	FREQ. (MHz)	EMISSION LEVEL (dBuV/m)	LIMIT (dBuV/m)	MARGIN (dB)	ANTENNA HEIGHT (m)	TABLE ANGLE (Degree)	RAW VALUE (dBuV)	CORRECTION FACTOR (dB/m)
1	#5715.00	69.3 PK	74.0	-4.7	2.48 V	342	63.19	6.11
2	#5715.00	53.0 AV	54.0	-1.0	2.48 V	342	46.89	6.11
3	#5725.00	72.8 PK	78.2	-5.4	2.48 V	342	66.66	6.14
4	*5755.00	107.4 PK			2.48 V	342	101.16	6.24
5	*5755.00	96.1 AV			2.48 V	342	89.86	6.24
6	11510.00	50.8 PK	74.0	-23.2	2.09 V	344	33.99	16.81
7	11510.00	37.2 AV	54.0	-16.8	2.09 V	344	20.39	16.81
8	#17265.00	55.8 PK	74.0	-18.2	2.00 V	48	33.65	22.15
9	#17265.00	40.1 AV	54.0	-13.9	2.00 V	48	17.95	22.15

**REMARKS:**

1. Emission Level(dBuV/m) = Raw Value(dBuV) + Correction Factor(dB/m)
2. Correction Factor(dB/m) = Antenna Factor(dB/m) + Cable Factor(dB) – Pre-Amplifier Factor(dB)
3. The other emission levels were very low against the limit.
4. Margin value = Emission Level – Limit value
5. " \* ": Fundamental frequency.
6. " # ": The radiated frequency is out of the restricted band.

<b>CHANNEL</b>	TX Channel 159	<b>DETECTOR FUNCTION</b>	Peak (PK)
<b>FREQUENCY RANGE</b>	1GHz ~ 40GHz		Average (AV)

**ANTENNA POLARITY & TEST DISTANCE: HORIZONTAL AT 3 M**

NO.	FREQ. (MHz)	EMISSION LEVEL (dBuV/m)	LIMIT (dBuV/m)	MARGIN (dB)	ANTENNA HEIGHT (m)	TABLE ANGLE (Degree)	RAW VALUE (dBuV)	CORRECTION FACTOR (dB/m)
1	*5795.00	100.8 PK			1.55 H	40	94.46	6.34
2	*5795.00	90.1 AV			1.55 H	40	83.76	6.34
3	#5850.00	69.1 PK	78.2	-9.1	1.55 H	40	62.71	6.39
4	#5860.00	66.2 PK	74.0	-7.8	1.55 H	40	59.79	6.41
5	#5860.00	49.0 AV	54.0	-5.0	1.55 H	40	42.59	6.41
6	11590.00	50.8 PK	74.0	-23.2	2.06 H	323	34.19	16.61
7	11590.00	36.7 AV	54.0	-17.3	2.06 H	323	20.09	16.61
8	#17385.00	52.5 PK	74.0	-21.5	1.76 H	19	29.59	22.91
9	#17385.00	37.9 AV	54.0	-16.1	1.76 H	19	14.99	22.91

**ANTENNA POLARITY & TEST DISTANCE: VERTICAL AT 3 M**

NO.	FREQ. (MHz)	EMISSION LEVEL (dBuV/m)	LIMIT (dBuV/m)	MARGIN (dB)	ANTENNA HEIGHT (m)	TABLE ANGLE (Degree)	RAW VALUE (dBuV)	CORRECTION FACTOR (dB/m)
1	*5795.00	111.5 PK			2.52 V	293	105.16	6.34
2	*5795.00	100.6 AV			2.52 V	293	94.26	6.34
3	#5850.00	73.0 PK	78.2	-5.2	2.52 V	293	66.61	6.39
4	#5860.00	70.4 PK	74.0	-3.6	2.52 V	293	63.99	6.41
5	#5860.00	52.9 AV	54.0	-1.1	2.52 V	293	46.49	6.41
6	11590.00	50.5 PK	74.0	-23.5	2.08 V	336	33.89	16.61
7	11590.00	37.1 AV	54.0	-16.9	2.08 V	336	20.49	16.61
8	#17385.00	55.6 PK	74.0	-18.4	2.00 V	72	32.69	22.91
9	#17385.00	40.1 AV	54.0	-13.9	2.00 V	72	17.19	22.91

**REMARKS:**

1. Emission Level(dBuV/m) = Raw Value(dBuV) + Correction Factor(dB/m)
2. Correction Factor(dB/m) = Antenna Factor(dB/m) + Cable Factor(dB) – Pre-Amplifier Factor(dB)
3. The other emission levels were very low against the limit.
4. Margin value = Emission Level – Limit value
5. " \* ": Fundamental frequency.
6. " # ": The radiated frequency is out of the restricted band.

**802.11ac (VHT80)**

<b>CHANNEL</b>	TX Channel 42	<b>DETECTOR FUNCTION</b>	Peak (PK)
<b>FREQUENCY RANGE</b>	1GHz ~ 40GHz		Average (AV)

<b>ANTENNA POLARITY &amp; TEST DISTANCE: HORIZONTAL AT 3 M</b>								
<b>NO.</b>	<b>FREQ. (MHz)</b>	<b>EMISSION LEVEL (dBuV/m)</b>	<b>LIMIT (dBuV/m)</b>	<b>MARGIN (dB)</b>	<b>ANTENNA HEIGHT (m)</b>	<b>TABLE ANGLE (Degree)</b>	<b>RAW VALUE (dBuV)</b>	<b>CORRECTION FACTOR (dB/m)</b>
1	5150.00	63.3 PK	74.0	-10.7	1.55 H	42	58.33	4.97
2	5150.00	49.6 AV	54.0	-4.4	1.55 H	42	44.63	4.97
3	*5210.00	92.8 PK			1.55 H	42	87.75	5.05
4	*5210.00	78.9 AV			1.55 H	42	73.85	5.05
5	#10420.00	50.2 PK	74.0	-23.8	2.10 H	321	34.06	16.14
6	#10420.00	36.5 AV	54.0	-17.5	2.10 H	321	20.36	16.14
7	15630.00	51.2 PK	74.0	-22.8	1.79 H	19	33.61	17.59
8	15630.00	36.2 AV	54.0	-17.8	1.79 H	19	18.61	17.59

<b>ANTENNA POLARITY &amp; TEST DISTANCE: VERTICAL AT 3 M</b>								
<b>NO.</b>	<b>FREQ. (MHz)</b>	<b>EMISSION LEVEL (dBuV/m)</b>	<b>LIMIT (dBuV/m)</b>	<b>MARGIN (dB)</b>	<b>ANTENNA HEIGHT (m)</b>	<b>TABLE ANGLE (Degree)</b>	<b>RAW VALUE (dBuV)</b>	<b>CORRECTION FACTOR (dB/m)</b>
1	5150.00	67.8 PK	74.0	-6.2	2.77 V	343	62.83	4.97
2	<b>5150.00</b>	<b>53.0 AV</b>	<b>54.0</b>	<b>-1.0</b>	<b>2.77 V</b>	<b>343</b>	<b>48.03</b>	<b>4.97</b>
3	*5210.00	103.1 PK			2.77 V	343	98.05	5.05
4	*5210.00	89.9 AV			2.77 V	343	84.85	5.05
5	#10420.00	49.6 PK	74.0	-24.4	2.09 V	346	33.46	16.14
6	#10420.00	36.4 AV	54.0	-17.6	2.09 V	346	20.26	16.14
7	15630.00	54.3 PK	74.0	-19.7	1.98 V	65	36.71	17.59
8	15630.00	38.6 AV	54.0	-15.4	1.98 V	65	21.01	17.59

**REMARKS:**

- Emission Level(dBuV/m) = Raw Value(dBuV) + Correction Factor(dB/m)
- Correction Factor(dB/m) = Antenna Factor(dB/m) + Cable Factor(dB) – Pre-Amplifier Factor(dB)
- The other emission levels were very low against the limit.
- Margin value = Emission Level – Limit value
- " \* ": Fundamental frequency.
- " # ": The radiated frequency is out of the restricted band.



<b>CHANNEL</b>	TX Channel 58	<b>DETECTOR FUNCTION</b>	Peak (PK)
<b>FREQUENCY RANGE</b>	1GHz ~ 40GHz		Average (AV)

**ANTENNA POLARITY & TEST DISTANCE: HORIZONTAL AT 3 M**

NO.	FREQ. (MHz)	EMISSION LEVEL (dBuV/m)	LIMIT (dBuV/m)	MARGIN (dB)	ANTENNA HEIGHT (m)	TABLE ANGLE (Degree)	RAW VALUE (dBuV)	CORRECTION FACTOR (dB/m)
1	*5290.00	92.4 PK			1.55 H	57	87.20	5.20
2	*5290.00	78.4 AV			1.55 H	57	73.20	5.20
3	5350.00	63.8 PK	74.0	-10.2	1.55 H	57	58.44	5.36
4	5350.00	50.1 AV	54.0	-3.9	1.55 H	57	44.74	5.36
5	#10580.00	50.2 PK	74.0	-23.8	2.16 H	328	33.79	16.41
6	#10580.00	36.6 AV	54.0	-17.4	2.16 H	328	20.19	16.41
7	15870.00	50.8 PK	74.0	-23.2	1.80 H	33	34.12	16.68
8	15870.00	36.1 AV	54.0	-17.9	1.80 H	33	19.42	16.68

**ANTENNA POLARITY & TEST DISTANCE: VERTICAL AT 3 M**

NO.	FREQ. (MHz)	EMISSION LEVEL (dBuV/m)	LIMIT (dBuV/m)	MARGIN (dB)	ANTENNA HEIGHT (m)	TABLE ANGLE (Degree)	RAW VALUE (dBuV)	CORRECTION FACTOR (dB/m)
1	*5290.00	103.3 PK			2.98 V	342	98.10	5.20
2	*5290.00	90.0 AV			2.98 V	342	84.80	5.20
3	5350.00	69.7 PK	74.0	-4.3	2.98 V	342	64.34	5.36
<b>4</b>	<b>5350.00</b>	<b>53.0 AV</b>	<b>54.0</b>	<b>-1.0</b>	<b>2.98 V</b>	<b>342</b>	<b>47.64</b>	<b>5.36</b>
5	#10580.00	49.3 PK	74.0	-24.7	2.03 V	339	32.89	16.41
6	#10580.00	36.3 AV	54.0	-17.7	2.03 V	339	19.89	16.41
7	15870.00	54.3 PK	74.0	-19.7	2.03 V	74	37.62	16.68
8	15870.00	38.4 AV	54.0	-15.6	2.03 V	74	21.72	16.68

**REMARKS:**

1. Emission Level(dBuV/m) = Raw Value(dBuV) + Correction Factor(dB/m)
2. Correction Factor(dB/m) = Antenna Factor(dB/m) + Cable Factor(dB) – Pre-Amplifier Factor(dB)
3. The other emission levels were very low against the limit.
4. Margin value = Emission Level – Limit value
5. " \* ": Fundamental frequency.
6. " # ": The radiated frequency is out of the restricted band.

<b>CHANNEL</b>	TX Channel 106	<b>DETECTOR FUNCTION</b>	Peak (PK)
<b>FREQUENCY RANGE</b>	1GHz ~ 40GHz		Average (AV)

**ANTENNA POLARITY & TEST DISTANCE: HORIZONTAL AT 3 M**

NO.	FREQ. (MHz)	EMISSION LEVEL (dBuV/m)	LIMIT (dBuV/m)	MARGIN (dB)	ANTENNA HEIGHT (m)	TABLE ANGLE (Degree)	RAW VALUE (dBuV)	CORRECTION FACTOR (dB/m)
1	#5470.00	65.6 PK	74.0	-8.4	1.52 H	49	59.90	5.70
2	#5470.00	48.6 AV	54.0	-5.4	1.52 H	49	42.90	5.70
3	*5530.00	93.2 PK			1.52 H	49	87.40	5.80
4	*5530.00	79.2 AV			1.52 H	49	73.40	5.80
5	11060.00	49.6 PK	74.0	-24.4	2.16 H	315	32.20	17.40
6	11060.00	36.1 AV	54.0	-17.9	2.16 H	315	18.70	17.40
7	#16590.00	51.5 PK	74.0	-22.5	1.76 H	22	31.90	19.60
8	#16590.00	36.5 AV	54.0	-17.5	1.76 H	22	16.90	19.60

**ANTENNA POLARITY & TEST DISTANCE: VERTICAL AT 3 M**

NO.	FREQ. (MHz)	EMISSION LEVEL (dBuV/m)	LIMIT (dBuV/m)	MARGIN (dB)	ANTENNA HEIGHT (m)	TABLE ANGLE (Degree)	RAW VALUE (dBuV)	CORRECTION FACTOR (dB/m)
1	#5470.00	69.8 PK	74.0	-4.2	2.97 V	338	64.10	5.70
2	#5470.00	52.0 AV	54.0	-2.0	2.97 V	338	46.30	5.70
3	*5530.00	101.5 PK			2.97 V	338	95.70	5.80
4	*5530.00	89.2 AV			2.97 V	338	83.40	5.80
5	11060.00	49.3 PK	74.0	-24.7	2.08 V	347	31.90	17.40
6	11060.00	36.2 AV	54.0	-17.8	2.08 V	347	18.80	17.40
7	#16590.00	53.9 PK	74.0	-20.1	2.01 V	75	34.30	19.60
8	#16590.00	38.2 AV	54.0	-15.8	2.01 V	75	18.60	19.60

**REMARKS:**

1. Emission Level(dBuV/m) = Raw Value(dBuV) + Correction Factor(dB/m)
2. Correction Factor(dB/m) = Antenna Factor(dB/m) + Cable Factor(dB) – Pre-Amplifier Factor(dB)
3. The other emission levels were very low against the limit.
4. Margin value = Emission Level – Limit value
5. " \* ": Fundamental frequency.
6. " # ": The radiated frequency is out of the restricted band.

<b>CHANNEL</b>	TX Channel 122	<b>DETECTOR FUNCTION</b>	Peak (PK)
<b>FREQUENCY RANGE</b>	1GHz ~ 40GHz		Average (AV)

**ANTENNA POLARITY & TEST DISTANCE: HORIZONTAL AT 3 M**

NO.	FREQ. (MHz)	EMISSION LEVEL (dBuV/m)	LIMIT (dBuV/m)	MARGIN (dB)	ANTENNA HEIGHT (m)	TABLE ANGLE (Degree)	RAW VALUE (dBuV)	CORRECTION FACTOR (dB/m)
1	*5610.00	96.8 PK			1.53 H	45	90.99	5.81
2	*5610.00	83.2 AV			1.53 H	45	77.39	5.81
3	#5725.00	56.2 PK	74.0	-17.8	1.53 H	45	50.06	6.14
4	#5725.00	46.2 AV	54.0	-7.8	1.53 H	45	40.06	6.14
5	11220.00	50.5 PK	74.0	-23.5	2.10 H	323	33.57	16.93
6	11220.00	37.0 AV	54.0	-17.0	2.10 H	323	20.07	16.93
7	#16830.00	50.8 PK	74.0	-23.2	1.78 H	38	30.78	20.02
8	#16830.00	36.1 AV	54.0	-17.9	1.78 H	38	16.08	20.02

**ANTENNA POLARITY & TEST DISTANCE: VERTICAL AT 3 M**

NO.	FREQ. (MHz)	EMISSION LEVEL (dBuV/m)	LIMIT (dBuV/m)	MARGIN (dB)	ANTENNA HEIGHT (m)	TABLE ANGLE (Degree)	RAW VALUE (dBuV)	CORRECTION FACTOR (dB/m)
1	*5610.00	107.1 PK			3.19 V	339	101.29	5.81
2	*5610.00	94.4 AV			3.19 V	339	88.59	5.81
3	#5725.00	61.4 PK	74.0	-12.6	3.19 V	339	55.26	6.14
4	#5725.00	50.5 AV	54.0	-3.5	3.19 V	339	44.36	6.14
5	11220.00	49.1 PK	74.0	-24.9	2.05 V	336	32.17	16.93
6	11220.00	36.1 AV	54.0	-17.9	2.05 V	336	19.17	16.93
7	#16830.00	54.7 PK	74.0	-19.3	1.94 V	56	34.68	20.02
8	#16830.00	39.0 AV	54.0	-15.0	1.94 V	56	18.98	20.02

**REMARKS:**

1. Emission Level(dBuV/m) = Raw Value(dBuV) + Correction Factor(dB/m)
2. Correction Factor(dB/m) = Antenna Factor(dB/m) + Cable Factor(dB) – Pre-Amplifier Factor(dB)
3. The other emission levels were very low against the limit.
4. Margin value = Emission Level – Limit value
5. " \* ": Fundamental frequency.
6. " # ": The radiated frequency is out of the restricted band.

<b>CHANNEL</b>	TX Channel 138	<b>DETECTOR FUNCTION</b>	Peak (PK)
<b>FREQUENCY RANGE</b>	1GHz ~ 40GHz		Average (AV)

**ANTENNA POLARITY & TEST DISTANCE: HORIZONTAL AT 3 M**

NO.	FREQ. (MHz)	EMISSION LEVEL (dBuV/m)	LIMIT (dBuV/m)	MARGIN (dB)	ANTENNA HEIGHT (m)	TABLE ANGLE (Degree)	RAW VALUE (dBuV)	CORRECTION FACTOR (dB/m)
1	#5470.00	55.4 PK	74.0	-18.6	1.55 H	27	49.76	5.64
2	#5470.00	42.6 AV	54.0	-11.4	1.55 H	27	36.96	5.64
3	*5690.00	98.3 PK			1.55 H	27	92.26	6.04
4	*5690.00	83.6 AV			1.55 H	27	77.56	6.04
5	#5850.00	63.4 PK	74.0	-10.6	1.55 H	27	57.01	6.39
6	#5850.00	46.0 AV	54.0	-8.0	1.55 H	27	39.61	6.39
7	11380.00	50.2 PK	74.0	-23.8	2.15 H	334	33.01	17.19
8	11380.00	36.6 AV	54.0	-17.4	2.15 H	334	19.41	17.19
9	#17070.00	51.2 PK	74.0	-22.8	1.76 H	47	29.45	21.75
10	#17070.00	36.4 AV	54.0	-17.6	1.76 H	47	14.65	21.75

**ANTENNA POLARITY & TEST DISTANCE: VERTICAL AT 3 M**

NO.	FREQ. (MHz)	EMISSION LEVEL (dBuV/m)	LIMIT (dBuV/m)	MARGIN (dB)	ANTENNA HEIGHT (m)	TABLE ANGLE (Degree)	RAW VALUE (dBuV)	CORRECTION FACTOR (dB/m)
1	#5470.00	57.3 PK	74.0	-16.7	3.32 V	340	51.66	5.64
2	#5470.00	44.7 AV	54.0	-9.3	3.32 V	340	39.06	5.64
3	*5690.00	108.4 PK			3.32 V	340	102.36	6.04
4	*5690.00	94.6 AV			3.32 V	340	88.56	6.04
5	#5850.00	67.1 PK	74.0	-6.9	3.32 V	340	60.71	6.39
6	#5850.00	50.2 AV	54.0	-3.8	3.32 V	340	43.81	6.39
7	11380.00	50.0 PK	74.0	-24.0	2.09 V	359	32.81	17.19
8	11380.00	36.7 AV	54.0	-17.3	2.09 V	359	19.51	17.19
9	#17070.00	53.7 PK	74.0	-20.3	2.02 V	57	31.95	21.75
10	#17070.00	38.3 AV	54.0	-15.7	2.02 V	57	16.55	21.75

**REMARKS:**

1. Emission Level(dBuV/m) = Raw Value(dBuV) + Correction Factor(dB/m)
2. Correction Factor(dB/m) = Antenna Factor(dB/m) + Cable Factor(dB) – Pre-Amplifier Factor(dB)
3. The other emission levels were very low against the limit.
4. Margin value = Emission Level – Limit value
5. " \* ": Fundamental frequency.
6. " # ": The radiated frequency is out of the restricted band.

<b>CHANNEL</b>	TX Channel 155	<b>DETECTOR FUNCTION</b>	Peak (PK)
<b>FREQUENCY RANGE</b>	1GHz ~ 40GHz		Average (AV)

**ANTENNA POLARITY & TEST DISTANCE: HORIZONTAL AT 3 M**

NO.	FREQ. (MHz)	EMISSION LEVEL (dBuV/m)	LIMIT (dBuV/m)	MARGIN (dB)	ANTENNA HEIGHT (m)	TABLE ANGLE (Degree)	RAW VALUE (dBuV)	CORRECTION FACTOR (dB/m)
1	#5715.00	63.2 PK	74.0	-10.8	1.54 H	30	57.09	6.11
2	#5715.00	47.6 AV	54.0	-6.4	1.54 H	30	41.49	6.11
3	#5725.00	67.4 PK	78.2	-10.8	1.54 H	30	61.26	6.14
4	*5775.00	90.3 PK			1.54 H	30	84.01	6.29
5	*5775.00	78.4 AV			1.54 H	30	72.11	6.29
6	#5850.00	61.3 PK	78.2	-16.9	1.54 H	30	54.91	6.39
7	#5860.00	58.9 PK	74.0	-15.1	1.54 H	30	52.49	6.41
8	#5860.00	42.2 AV	54.0	-11.8	1.54 H	30	35.79	6.41
9	11550.00	50.0 PK	74.0	-24.0	2.11 H	323	33.29	16.71
10	11550.00	36.3 AV	54.0	-17.7	2.11 H	323	19.59	16.71
11	#17325.00	50.6 PK	74.0	-23.4	1.78 H	31	28.20	22.40
12	#17325.00	35.9 AV	54.0	-18.1	1.78 H	31	13.50	22.40

**ANTENNA POLARITY & TEST DISTANCE: VERTICAL AT 3 M**

NO.	FREQ. (MHz)	EMISSION LEVEL (dBuV/m)	LIMIT (dBuV/m)	MARGIN (dB)	ANTENNA HEIGHT (m)	TABLE ANGLE (Degree)	RAW VALUE (dBuV)	CORRECTION FACTOR (dB/m)
1	#5715.00	67.3 PK	74.0	-6.7	3.35 V	339	61.19	6.11
2	#5715.00	50.5 AV	54.0	-3.5	3.35 V	339	44.39	6.11
3	#5725.00	70.9 PK	78.2	-7.3	3.35 V	339	64.76	6.14
4	*5775.00	100.4 PK			3.35 V	339	94.11	6.29
5	*5775.00	87.6 AV			3.35 V	339	81.31	6.29
6	#5850.00	65.6 PK	78.2	-12.6	3.35 V	339	59.21	6.39
7	#5860.00	61.3 PK	74.0	-12.7	3.35 V	339	54.89	6.41
8	#5860.00	46.7 AV	54.0	-7.3	3.35 V	339	40.29	6.41
9	11550.00	49.4 PK	74.0	-24.6	2.04 V	341	32.69	16.71
10	11550.00	36.4 AV	54.0	-17.6	2.04 V	341	19.69	16.71
11	#17325.00	54.4 PK	74.0	-19.6	1.92 V	65	32.00	22.40
12	#17325.00	38.6 AV	54.0	-15.4	1.92 V	65	16.20	22.40

**REMARKS:**

1. Emission Level(dBuV/m) = Raw Value(dBuV) + Correction Factor(dB/m)
2. Correction Factor(dB/m) = Antenna Factor(dB/m) + Cable Factor(dB) – Pre-Amplifier Factor(dB)
3. The other emission levels were very low against the limit.
4. Margin value = Emission Level – Limit value
5. " \* ": Fundamental frequency.
6. " # ": The radiated frequency is out of the restricted band.

**Below 1GHz Data:**
**802.11a**

<b>CHANNEL</b>	TX Channel 36	<b>DETECTOR FUNCTION</b>	Quasi-Peak (QP)
<b>FREQUENCY RANGE</b>	Below 1GHz		

**ANTENNA POLARITY & TEST DISTANCE: HORIZONTAL AT 3 M**

NO.	FREQ. (MHz)	EMISSION LEVEL (dBuV/m)	LIMIT (dBuV/m)	MARGIN (dB)	ANTENNA HEIGHT (m)	TABLE ANGLE (Degree)	RAW VALUE (dBuV)	CORRECTION FACTOR (dB/m)
1	33.95	24.4 QP	40.0	-15.6	1.51 H	173	33.90	-9.50
2	194.82	40.2 QP	43.5	-3.3	1.45 H	28	51.50	-11.30
3	260.57	42.4 QP	46.0	-3.6	1.46 H	57	51.30	-8.90
4	379.89	32.9 QP	46.0	-13.1	1.11 H	330	38.20	-5.30
5	695.72	37.6 QP	46.0	-8.4	1.05 H	333	36.20	1.40
6	1000.00	41.2 QP	54.0	-12.8	1.95 H	285	35.50	5.70

**ANTENNA POLARITY & TEST DISTANCE: VERTICAL AT 3 M**

NO.	FREQ. (MHz)	EMISSION LEVEL (dBuV/m)	LIMIT (dBuV/m)	MARGIN (dB)	ANTENNA HEIGHT (m)	TABLE ANGLE (Degree)	RAW VALUE (dBuV)	CORRECTION FACTOR (dB/m)
1	98.14	25.4 QP	43.5	-18.1	1.95 V	317	38.80	-13.40
2	195.82	34.1 QP	43.5	-9.4	1.59 V	208	45.50	-11.40
3	259.64	38.7 QP	46.0	-7.3	1.96 V	128	47.80	-9.10
4	326.07	32.0 QP	46.0	-14.0	1.03 V	32	38.40	-6.40
5	749.92	36.7 QP	46.0	-9.3	1.58 V	333	34.30	2.40
6	1000.00	38.9 QP	54.0	-15.1	1.00 V	294	33.20	5.70

**REMARKS:**

1. Emission Level(dBuV/m) = Raw Value(dBuV) + Correction Factor(dB/m)
2. Correction Factor(dB/m) = Antenna Factor(dB/m) + Cable Factor(dB) – Pre-Amplifier Factor(dB)
3. The other emission levels were very low against the limit.
4. Margin value = Emission Level – Limit value

<b>CHANNEL</b>	TX Channel 40	<b>DETECTOR FUNCTION</b>	Quasi-Peak (QP)
<b>FREQUENCY RANGE</b>	Below 1GHz		

**ANTENNA POLARITY & TEST DISTANCE: HORIZONTAL AT 3 M**

NO.	FREQ. (MHz)	EMISSION LEVEL (dBuV/m)	LIMIT (dBuV/m)	MARGIN (dB)	ANTENNA HEIGHT (m)	TABLE ANGLE (Degree)	RAW VALUE (dBuV)	CORRECTION FACTOR (dB/m)
1	33.97	24.3 QP	40.0	-15.7	1.55 H	156	33.80	-9.50
2	194.82	40.1 QP	43.5	-3.4	1.47 H	40	51.40	-11.30
3	260.35	42.9 QP	46.0	-3.1	1.38 H	80	51.80	-8.90
4	380.15	32.9 QP	46.0	-13.1	1.19 H	341	38.20	-5.30
5	695.65	38.0 QP	46.0	-8.0	1.00 H	320	36.60	1.40
6	1000.00	40.8 QP	54.0	-13.2	1.96 H	270	35.10	5.70

**ANTENNA POLARITY & TEST DISTANCE: VERTICAL AT 3 M**

NO.	FREQ. (MHz)	EMISSION LEVEL (dBuV/m)	LIMIT (dBuV/m)	MARGIN (dB)	ANTENNA HEIGHT (m)	TABLE ANGLE (Degree)	RAW VALUE (dBuV)	CORRECTION FACTOR (dB/m)
1	97.92	25.5 QP	43.5	-18.0	1.94 V	313	39.00	-13.50
2	195.73	33.9 QP	43.5	-9.6	1.58 V	211	45.30	-11.40
3	259.83	38.6 QP	46.0	-7.4	1.99 V	128	47.60	-9.00
4	325.93	32.1 QP	46.0	-13.9	1.00 V	48	38.50	-6.40
5	749.73	36.9 QP	46.0	-9.1	1.57 V	355	34.50	2.40
6	1000.00	38.7 QP	54.0	-15.3	1.00 V	277	33.00	5.70

**REMARKS:**

1. Emission Level(dBuV/m) = Raw Value(dBuV) + Correction Factor(dB/m)
2. Correction Factor(dB/m) = Antenna Factor(dB/m) + Cable Factor(dB) – Pre-Amplifier Factor(dB)
3. The other emission levels were very low against the limit.
4. Margin value = Emission Level – Limit value

<b>CHANNEL</b>	TX Channel 48	<b>DETECTOR FUNCTION</b>	Quasi-Peak (QP)
<b>FREQUENCY RANGE</b>	Below 1GHz		

**ANTENNA POLARITY & TEST DISTANCE: HORIZONTAL AT 3 M**

NO.	FREQ. (MHz)	EMISSION LEVEL (dBuV/m)	LIMIT (dBuV/m)	MARGIN (dB)	ANTENNA HEIGHT (m)	TABLE ANGLE (Degree)	RAW VALUE (dBuV)	CORRECTION FACTOR (dB/m)
1	33.62	24.3 QP	40.0	-15.7	1.53 H	181	33.90	-9.60
2	194.78	40.2 QP	43.5	-3.3	1.53 H	48	51.50	-11.30
3	260.56	42.6 QP	46.0	-3.4	1.46 H	57	51.50	-8.90
4	380.22	32.6 QP	46.0	-13.4	1.11 H	356	37.90	-5.30
5	695.92	37.7 QP	46.0	-8.3	1.04 H	335	36.30	1.40
6	1000.00	40.8 QP	54.0	-13.2	1.88 H	263	35.10	5.70

**ANTENNA POLARITY & TEST DISTANCE: VERTICAL AT 3 M**

NO.	FREQ. (MHz)	EMISSION LEVEL (dBuV/m)	LIMIT (dBuV/m)	MARGIN (dB)	ANTENNA HEIGHT (m)	TABLE ANGLE (Degree)	RAW VALUE (dBuV)	CORRECTION FACTOR (dB/m)
1	97.79	25.7 QP	43.5	-17.8	2.02 V	307	39.20	-13.50
2	195.58	33.6 QP	43.5	-9.9	1.66 V	221	45.00	-11.40
3	259.93	38.6 QP	46.0	-7.4	1.97 V	155	47.60	-9.00
4	325.56	32.2 QP	46.0	-13.8	1.00 V	50	38.60	-6.40
5	749.85	36.8 QP	46.0	-9.2	1.55 V	328	34.40	2.40
6	1000.00	38.8 QP	54.0	-15.2	1.00 V	280	33.10	5.70

**REMARKS:**

1. Emission Level(dBuV/m) = Raw Value(dBuV) + Correction Factor(dB/m)
2. Correction Factor(dB/m) = Antenna Factor(dB/m) + Cable Factor(dB) – Pre-Amplifier Factor(dB)
3. The other emission levels were very low against the limit.
4. Margin value = Emission Level – Limit value



<b>CHANNEL</b>	TX Channel 52	<b>DETECTOR FUNCTION</b>	Quasi-Peak (QP)
<b>FREQUENCY RANGE</b>	Below 1GHz		

**ANTENNA POLARITY & TEST DISTANCE: HORIZONTAL AT 3 M**

NO.	FREQ. (MHz)	EMISSION LEVEL (dBuV/m)	LIMIT (dBuV/m)	MARGIN (dB)	ANTENNA HEIGHT (m)	TABLE ANGLE (Degree)	RAW VALUE (dBuV)	CORRECTION FACTOR (dB/m)
1	33.57	24.0 QP	40.0	-16.0	1.54 H	157	33.60	-9.60
2	195.06	40.4 QP	43.5	-3.1	1.47 H	46	51.70	-11.30
3	260.29	42.8 QP	46.0	-3.2	1.38 H	83	51.70	-8.90
4	380.12	32.8 QP	46.0	-13.2	1.13 H	329	38.10	-5.30
5	695.61	37.4 QP	46.0	-8.6	1.00 H	330	36.00	1.40
6	1000.00	41.3 QP	54.0	-12.7	1.89 H	270	35.60	5.70

**ANTENNA POLARITY & TEST DISTANCE: VERTICAL AT 3 M**

NO.	FREQ. (MHz)	EMISSION LEVEL (dBuV/m)	LIMIT (dBuV/m)	MARGIN (dB)	ANTENNA HEIGHT (m)	TABLE ANGLE (Degree)	RAW VALUE (dBuV)	CORRECTION FACTOR (dB/m)
1	97.73	25.2 QP	43.5	-18.3	1.93 V	315	38.70	-13.50
2	195.64	33.7 QP	43.5	-9.8	1.60 V	217	45.10	-11.40
3	259.80	38.7 QP	46.0	-7.3	1.93 V	136	47.70	-9.00
4	326.05	32.1 QP	46.0	-13.9	1.00 V	55	38.50	-6.40
5	749.64	36.8 QP	46.0	-9.2	1.61 V	334	34.40	2.40
6	1000.00	38.9 QP	54.0	-15.1	1.00 V	294	33.20	5.70

**REMARKS:**

1. Emission Level(dBuV/m) = Raw Value(dBuV) + Correction Factor(dB/m)
2. Correction Factor(dB/m) = Antenna Factor(dB/m) + Cable Factor(dB) – Pre-Amplifier Factor(dB)
3. The other emission levels were very low against the limit.
4. Margin value = Emission Level – Limit value

<b>CHANNEL</b>	TX Channel 60	<b>DETECTOR FUNCTION</b>	Quasi-Peak (QP)
<b>FREQUENCY RANGE</b>	Below 1GHz		

**ANTENNA POLARITY & TEST DISTANCE: HORIZONTAL AT 3 M**

NO.	FREQ. (MHz)	EMISSION LEVEL (dBuV/m)	LIMIT (dBuV/m)	MARGIN (dB)	ANTENNA HEIGHT (m)	TABLE ANGLE (Degree)	RAW VALUE (dBuV)	CORRECTION FACTOR (dB/m)
1	33.59	24.0 QP	40.0	-16.0	1.47 H	158	33.60	-9.60
2	194.81	40.3 QP	43.5	-3.2	1.52 H	45	51.60	-11.30
3	260.34	42.6 QP	46.0	-3.4	1.43 H	58	51.50	-8.90
4	380.00	32.7 QP	46.0	-13.3	1.15 H	349	38.00	-5.30
5	695.75	37.4 QP	46.0	-8.6	1.06 H	315	36.00	1.40
6	1000.00	41.0 QP	54.0	-13.0	1.97 H	274	35.30	5.70

**ANTENNA POLARITY & TEST DISTANCE: VERTICAL AT 3 M**

NO.	FREQ. (MHz)	EMISSION LEVEL (dBuV/m)	LIMIT (dBuV/m)	MARGIN (dB)	ANTENNA HEIGHT (m)	TABLE ANGLE (Degree)	RAW VALUE (dBuV)	CORRECTION FACTOR (dB/m)
1	98.01	25.8 QP	43.5	-17.7	1.95 V	305	39.30	-13.50
2	196.00	34.0 QP	43.5	-9.5	1.59 V	233	45.40	-11.40
3	260.06	39.0 QP	46.0	-7.0	2.02 V	158	47.90	-8.90
4	325.60	32.4 QP	46.0	-13.6	1.00 V	42	38.80	-6.40
5	749.60	36.6 QP	46.0	-9.4	1.61 V	343	34.20	2.40
6	1000.00	38.8 QP	54.0	-15.2	1.00 V	295	33.10	5.70

**REMARKS:**

1. Emission Level(dBuV/m) = Raw Value(dBuV) + Correction Factor(dB/m)
2. Correction Factor(dB/m) = Antenna Factor(dB/m) + Cable Factor(dB) – Pre-Amplifier Factor(dB)
3. The other emission levels were very low against the limit.
4. Margin value = Emission Level – Limit value

<b>CHANNEL</b>	TX Channel 64	<b>DETECTOR FUNCTION</b>	Quasi-Peak (QP)
<b>FREQUENCY RANGE</b>	Below 1GHz		

**ANTENNA POLARITY & TEST DISTANCE: HORIZONTAL AT 3 M**

NO.	FREQ. (MHz)	EMISSION LEVEL (dBuV/m)	LIMIT (dBuV/m)	MARGIN (dB)	ANTENNA HEIGHT (m)	TABLE ANGLE (Degree)	RAW VALUE (dBuV)	CORRECTION FACTOR (dB/m)
1	33.93	23.9 QP	40.0	-16.1	1.46 H	172	33.40	-9.50
2	194.64	40.3 QP	43.5	-3.2	1.46 H	23	51.60	-11.30
3	260.25	42.5 QP	46.0	-3.5	1.36 H	63	51.40	-8.90
4	380.11	32.6 QP	46.0	-13.4	1.09 H	332	37.90	-5.30
5	695.69	37.6 QP	46.0	-8.4	1.02 H	334	36.20	1.40
6	1000.00	41.3 QP	54.0	-12.7	1.89 H	282	35.60	5.70

**ANTENNA POLARITY & TEST DISTANCE: VERTICAL AT 3 M**

NO.	FREQ. (MHz)	EMISSION LEVEL (dBuV/m)	LIMIT (dBuV/m)	MARGIN (dB)	ANTENNA HEIGHT (m)	TABLE ANGLE (Degree)	RAW VALUE (dBuV)	CORRECTION FACTOR (dB/m)
1	98.24	25.5 QP	43.5	-18.0	1.91 V	319	38.90	-13.40
2	195.49	33.9 QP	43.5	-9.6	1.57 V	228	45.30	-11.40
3	260.05	39.0 QP	46.0	-7.0	2.03 V	136	47.90	-8.90
4	326.03	32.2 QP	46.0	-13.8	1.02 V	55	38.60	-6.40
5	749.54	37.0 QP	46.0	-9.0	1.57 V	352	34.60	2.40
6	1000.00	38.9 QP	54.0	-15.1	1.00 V	301	33.20	5.70

**REMARKS:**

1. Emission Level(dBuV/m) = Raw Value(dBuV) + Correction Factor(dB/m)
2. Correction Factor(dB/m) = Antenna Factor(dB/m) + Cable Factor(dB) – Pre-Amplifier Factor(dB)
3. The other emission levels were very low against the limit.
4. Margin value = Emission Level – Limit value

<b>CHANNEL</b>	TX Channel 100	<b>DETECTOR FUNCTION</b>	Quasi-Peak (QP)
<b>FREQUENCY RANGE</b>	Below 1GHz		

**ANTENNA POLARITY & TEST DISTANCE: HORIZONTAL AT 3 M**

NO.	FREQ. (MHz)	EMISSION LEVEL (dBuV/m)	LIMIT (dBuV/m)	MARGIN (dB)	ANTENNA HEIGHT (m)	TABLE ANGLE (Degree)	RAW VALUE (dBuV)	CORRECTION FACTOR (dB/m)
1	33.88	24.1 QP	40.0	-15.9	1.47 H	182	33.70	-9.60
2	195.06	40.3 QP	43.5	-3.2	1.43 H	46	51.60	-11.30
3	260.12	42.8 QP	46.0	-3.2	1.45 H	54	51.70	-8.90
4	380.13	32.6 QP	46.0	-13.4	1.20 H	340	37.90	-5.30
5	695.77	37.7 QP	46.0	-8.3	1.04 H	334	36.30	1.40
6	1000.00	41.2 QP	54.0	-12.8	1.95 H	266	35.50	5.70

**ANTENNA POLARITY & TEST DISTANCE: VERTICAL AT 3 M**

NO.	FREQ. (MHz)	EMISSION LEVEL (dBuV/m)	LIMIT (dBuV/m)	MARGIN (dB)	ANTENNA HEIGHT (m)	TABLE ANGLE (Degree)	RAW VALUE (dBuV)	CORRECTION FACTOR (dB/m)
1	97.90	25.5 QP	43.5	-18.0	1.97 V	311	39.00	-13.50
2	195.69	33.9 QP	43.5	-9.6	1.67 V	207	45.30	-11.40
3	259.55	38.5 QP	46.0	-7.5	1.93 V	151	47.60	-9.10
4	325.66	32.4 QP	46.0	-13.6	1.01 V	37	38.80	-6.40
5	749.51	36.6 QP	46.0	-9.4	1.55 V	341	34.20	2.40
6	1000.00	39.0 QP	54.0	-15.0	1.00 V	290	33.30	5.70

**REMARKS:**

1. Emission Level(dBuV/m) = Raw Value(dBuV) + Correction Factor(dB/m)
2. Correction Factor(dB/m) = Antenna Factor(dB/m) + Cable Factor(dB) – Pre-Amplifier Factor(dB)
3. The other emission levels were very low against the limit.
4. Margin value = Emission Level – Limit value

<b>CHANNEL</b>	TX Channel 116	<b>DETECTOR FUNCTION</b>	Quasi-Peak (QP)
<b>FREQUENCY RANGE</b>	Below 1GHz		

**ANTENNA POLARITY & TEST DISTANCE: HORIZONTAL AT 3 M**

NO.	FREQ. (MHz)	EMISSION LEVEL (dBuV/m)	LIMIT (dBuV/m)	MARGIN (dB)	ANTENNA HEIGHT (m)	TABLE ANGLE (Degree)	RAW VALUE (dBuV)	CORRECTION FACTOR (dB/m)
1	34.04	24.2 QP	40.0	-15.8	1.46 H	154	33.70	-9.50
2	195.22	40.1 QP	43.5	-3.4	1.46 H	27	51.40	-11.30
3	260.56	43.0 QP	46.0	-3.0	1.44 H	71	51.90	-8.90
4	380.06	32.8 QP	46.0	-13.2	1.21 H	347	38.10	-5.30
5	696.05	37.7 QP	46.0	-8.3	1.00 H	313	36.30	1.40
6	1000.00	40.9 QP	54.0	-13.1	1.93 H	280	35.20	5.70

**ANTENNA POLARITY & TEST DISTANCE: VERTICAL AT 3 M**

NO.	FREQ. (MHz)	EMISSION LEVEL (dBuV/m)	LIMIT (dBuV/m)	MARGIN (dB)	ANTENNA HEIGHT (m)	TABLE ANGLE (Degree)	RAW VALUE (dBuV)	CORRECTION FACTOR (dB/m)
1	97.92	25.3 QP	43.5	-18.2	1.91 V	295	38.80	-13.50
2	195.93	33.9 QP	43.5	-9.6	1.58 V	217	45.30	-11.40
3	259.51	38.9 QP	46.0	-7.1	1.93 V	128	48.00	-9.10
4	325.73	32.1 QP	46.0	-13.9	1.04 V	61	38.50	-6.40
5	749.86	37.0 QP	46.0	-9.0	1.59 V	344	34.60	2.40
6	1000.00	38.5 QP	54.0	-15.5	1.01 V	282	32.80	5.70

**REMARKS:**

1. Emission Level(dBuV/m) = Raw Value(dBuV) + Correction Factor(dB/m)
2. Correction Factor(dB/m) = Antenna Factor(dB/m) + Cable Factor(dB) – Pre-Amplifier Factor(dB)
3. The other emission levels were very low against the limit.
4. Margin value = Emission Level – Limit value

<b>CHANNEL</b>	TX Channel 120	<b>DETECTOR FUNCTION</b>	Quasi-Peak (QP)
<b>FREQUENCY RANGE</b>	Below 1GHz		

**ANTENNA POLARITY & TEST DISTANCE: HORIZONTAL AT 3 M**

NO.	FREQ. (MHz)	EMISSION LEVEL (dBuV/m)	LIMIT (dBuV/m)	MARGIN (dB)	ANTENNA HEIGHT (m)	TABLE ANGLE (Degree)	RAW VALUE (dBuV)	CORRECTION FACTOR (dB/m)
1	33.87	23.9 QP	40.0	-16.1	1.54 H	160	33.50	-9.60
2	194.81	40.2 QP	43.5	-3.3	1.48 H	24	51.50	-11.30
3	260.36	42.8 QP	46.0	-3.2	1.43 H	78	51.70	-8.90
4	380.07	32.9 QP	46.0	-13.1	1.13 H	338	38.20	-5.30
5	695.81	37.8 QP	46.0	-8.2	1.00 H	331	36.40	1.40
6	1000.00	41.0 QP	54.0	-13.0	1.99 H	258	35.30	5.70

**ANTENNA POLARITY & TEST DISTANCE: VERTICAL AT 3 M**

NO.	FREQ. (MHz)	EMISSION LEVEL (dBuV/m)	LIMIT (dBuV/m)	MARGIN (dB)	ANTENNA HEIGHT (m)	TABLE ANGLE (Degree)	RAW VALUE (dBuV)	CORRECTION FACTOR (dB/m)
1	98.27	25.5 QP	43.5	-18.0	2.02 V	311	38.90	-13.40
2	195.86	33.8 QP	43.5	-9.7	1.67 V	209	45.20	-11.40
3	259.61	39.1 QP	46.0	-6.9	1.93 V	138	48.20	-9.10
4	325.83	32.4 QP	46.0	-13.6	1.04 V	54	38.80	-6.40
5	749.75	36.6 QP	46.0	-9.4	1.58 V	328	34.20	2.40
6	1000.00	39.0 QP	54.0	-15.0	1.00 V	286	33.30	5.70

**REMARKS:**

1. Emission Level(dBuV/m) = Raw Value(dBuV) + Correction Factor(dB/m)
2. Correction Factor(dB/m) = Antenna Factor(dB/m) + Cable Factor(dB) – Pre-Amplifier Factor(dB)
3. The other emission levels were very low against the limit.
4. Margin value = Emission Level – Limit value

<b>CHANNEL</b>	TX Channel 132	<b>DETECTOR FUNCTION</b>	Quasi-Peak (QP)
<b>FREQUENCY RANGE</b>	Below 1GHz		

**ANTENNA POLARITY & TEST DISTANCE: HORIZONTAL AT 3 M**

NO.	FREQ. (MHz)	EMISSION LEVEL (dBuV/m)	LIMIT (dBuV/m)	MARGIN (dB)	ANTENNA HEIGHT (m)	TABLE ANGLE (Degree)	RAW VALUE (dBuV)	CORRECTION FACTOR (dB/m)
1	33.68	24.2 QP	40.0	-15.8	1.54 H	151	33.80	-9.60
2	195.12	40.4 QP	43.5	-3.1	1.47 H	35	51.70	-11.30
3	260.10	42.8 QP	46.0	-3.2	1.38 H	78	51.70	-8.90
4	379.71	32.9 QP	46.0	-13.1	1.10 H	334	38.20	-5.30
5	696.03	37.4 QP	46.0	-8.6	1.00 H	321	36.00	1.40
6	1000.00	41.4 QP	54.0	-12.6	1.97 H	265	35.70	5.70

**ANTENNA POLARITY & TEST DISTANCE: VERTICAL AT 3 M**

NO.	FREQ. (MHz)	EMISSION LEVEL (dBuV/m)	LIMIT (dBuV/m)	MARGIN (dB)	ANTENNA HEIGHT (m)	TABLE ANGLE (Degree)	RAW VALUE (dBuV)	CORRECTION FACTOR (dB/m)
1	97.98	25.8 QP	43.5	-17.7	2.01 V	320	39.30	-13.50
2	195.71	33.8 QP	43.5	-9.7	1.66 V	226	45.20	-11.40
3	259.75	39.0 QP	46.0	-7.0	1.97 V	137	48.10	-9.10
4	326.08	32.2 QP	46.0	-13.8	1.00 V	61	38.60	-6.40
5	749.44	36.9 QP	46.0	-9.1	1.56 V	337	34.50	2.40
6	1000.00	38.9 QP	54.0	-15.1	1.00 V	293	33.20	5.70

**REMARKS:**

1. Emission Level(dBuV/m) = Raw Value(dBuV) + Correction Factor(dB/m)
2. Correction Factor(dB/m) = Antenna Factor(dB/m) + Cable Factor(dB) – Pre-Amplifier Factor(dB)
3. The other emission levels were very low against the limit.
4. Margin value = Emission Level – Limit value

<b>CHANNEL</b>	TX Channel 140	<b>DETECTOR FUNCTION</b>	Quasi-Peak (QP)
<b>FREQUENCY RANGE</b>	Below 1GHz		

**ANTENNA POLARITY & TEST DISTANCE: HORIZONTAL AT 3 M**

NO.	FREQ. (MHz)	EMISSION LEVEL (dBuV/m)	LIMIT (dBuV/m)	MARGIN (dB)	ANTENNA HEIGHT (m)	TABLE ANGLE (Degree)	RAW VALUE (dBuV)	CORRECTION FACTOR (dB/m)
1	33.81	24.2 QP	40.0	-15.8	1.49 H	154	33.80	-9.60
2	194.76	39.9 QP	43.5	-3.6	1.51 H	44	51.20	-11.30
3	260.43	42.6 QP	46.0	-3.4	1.41 H	62	51.50	-8.90
4	379.77	33.0 QP	46.0	-13.0	1.16 H	352	38.30	-5.30
5	695.93	38.0 QP	46.0	-8.0	1.02 H	317	36.60	1.40
6	1000.00	40.9 QP	54.0	-13.1	1.94 H	277	35.20	5.70

**ANTENNA POLARITY & TEST DISTANCE: VERTICAL AT 3 M**

NO.	FREQ. (MHz)	EMISSION LEVEL (dBuV/m)	LIMIT (dBuV/m)	MARGIN (dB)	ANTENNA HEIGHT (m)	TABLE ANGLE (Degree)	RAW VALUE (dBuV)	CORRECTION FACTOR (dB/m)
1	98.24	25.7 QP	43.5	-17.8	1.98 V	320	39.10	-13.40
2	196.06	34.0 QP	43.5	-9.5	1.69 V	223	45.40	-11.40
3	259.49	38.6 QP	46.0	-7.4	1.99 V	144	47.70	-9.10
4	325.94	32.5 QP	46.0	-13.5	1.02 V	46	38.90	-6.40
5	749.63	36.9 QP	46.0	-9.1	1.53 V	325	34.50	2.40
6	1000.00	38.6 QP	54.0	-15.4	1.01 V	288	32.90	5.70

**REMARKS:**

1. Emission Level(dBuV/m) = Raw Value(dBuV) + Correction Factor(dB/m)
2. Correction Factor(dB/m) = Antenna Factor(dB/m) + Cable Factor(dB) – Pre-Amplifier Factor(dB)
3. The other emission levels were very low against the limit.
4. Margin value = Emission Level – Limit value



<b>CHANNEL</b>	TX Channel 149	<b>DETECTOR FUNCTION</b>	Quasi-Peak (QP)
<b>FREQUENCY RANGE</b>	Below 1GHz		

**ANTENNA POLARITY & TEST DISTANCE: HORIZONTAL AT 3 M**

NO.	FREQ. (MHz)	EMISSION LEVEL (dBuV/m)	LIMIT (dBuV/m)	MARGIN (dB)	ANTENNA HEIGHT (m)	TABLE ANGLE (Degree)	RAW VALUE (dBuV)	CORRECTION FACTOR (dB/m)
1	34.05	24.2 QP	40.0	-15.8	1.48 H	178	33.70	-9.50
2	194.84	40.1 QP	43.5	-3.4	1.45 H	48	51.40	-11.30
3	260.29	42.5 QP	46.0	-3.5	1.46 H	80	51.40	-8.90
4	379.77	32.9 QP	46.0	-13.1	1.18 H	355	38.20	-5.30
5	695.81	37.9 QP	46.0	-8.1	1.02 H	329	36.50	1.40
6	1000.00	41.4 QP	54.0	-12.6	1.89 H	271	35.70	5.70

**ANTENNA POLARITY & TEST DISTANCE: VERTICAL AT 3 M**

NO.	FREQ. (MHz)	EMISSION LEVEL (dBuV/m)	LIMIT (dBuV/m)	MARGIN (dB)	ANTENNA HEIGHT (m)	TABLE ANGLE (Degree)	RAW VALUE (dBuV)	CORRECTION FACTOR (dB/m)
1	97.95	25.7 QP	43.5	-17.8	2.02 V	319	39.20	-13.50
2	195.93	33.9 QP	43.5	-9.6	1.69 V	217	45.30	-11.40
3	259.70	39.0 QP	46.0	-7.0	2.03 V	155	48.10	-9.10
4	325.58	32.1 QP	46.0	-13.9	1.00 V	49	38.50	-6.40
5	749.89	36.6 QP	46.0	-9.4	1.63 V	354	34.20	2.40
6	1000.00	38.6 QP	54.0	-15.4	1.02 V	275	32.90	5.70

**REMARKS:**

1. Emission Level(dBuV/m) = Raw Value(dBuV) + Correction Factor(dB/m)
2. Correction Factor(dB/m) = Antenna Factor(dB/m) + Cable Factor(dB) – Pre-Amplifier Factor(dB)
3. The other emission levels were very low against the limit.
4. Margin value = Emission Level – Limit value

<b>CHANNEL</b>	TX Channel 157	<b>DETECTOR FUNCTION</b>	Quasi-Peak (QP)
<b>FREQUENCY RANGE</b>	Below 1GHz		

**ANTENNA POLARITY & TEST DISTANCE: HORIZONTAL AT 3 M**

NO.	FREQ. (MHz)	EMISSION LEVEL (dBuV/m)	LIMIT (dBuV/m)	MARGIN (dB)	ANTENNA HEIGHT (m)	TABLE ANGLE (Degree)	RAW VALUE (dBuV)	CORRECTION FACTOR (dB/m)
1	33.67	23.9 QP	40.0	-16.1	1.46 H	167	33.50	-9.60
2	194.88	40.1 QP	43.5	-3.4	1.48 H	38	51.40	-11.30
3	260.14	42.8 QP	46.0	-3.2	1.44 H	85	51.70	-8.90
4	379.82	32.4 QP	46.0	-13.6	1.11 H	331	37.70	-5.30
5	695.59	38.0 QP	46.0	-8.0	1.00 H	315	36.60	1.40
6	1000.00	41.3 QP	54.0	-12.7	1.88 H	263	35.60	5.70

**ANTENNA POLARITY & TEST DISTANCE: VERTICAL AT 3 M**

NO.	FREQ. (MHz)	EMISSION LEVEL (dBuV/m)	LIMIT (dBuV/m)	MARGIN (dB)	ANTENNA HEIGHT (m)	TABLE ANGLE (Degree)	RAW VALUE (dBuV)	CORRECTION FACTOR (dB/m)
1	97.83	25.7 QP	43.5	-17.8	1.96 V	310	39.20	-13.50
2	195.71	34.0 QP	43.5	-9.5	1.66 V	226	45.40	-11.40
3	259.88	39.0 QP	46.0	-7.0	2.04 V	150	48.00	-9.00
4	325.97	32.2 QP	46.0	-13.8	1.00 V	57	38.60	-6.40
5	749.71	37.1 QP	46.0	-8.9	1.61 V	329	34.70	2.40
6	1000.00	39.1 QP	54.0	-14.9	1.00 V	300	33.40	5.70

**REMARKS:**

1. Emission Level(dBuV/m) = Raw Value(dBuV) + Correction Factor(dB/m)
2. Correction Factor(dB/m) = Antenna Factor(dB/m) + Cable Factor(dB) – Pre-Amplifier Factor(dB)
3. The other emission levels were very low against the limit.
4. Margin value = Emission Level – Limit value

<b>CHANNEL</b>	TX Channel 165	<b>DETECTOR FUNCTION</b>	Quasi-Peak (QP)
<b>FREQUENCY RANGE</b>	Below 1GHz		

**ANTENNA POLARITY & TEST DISTANCE: HORIZONTAL AT 3 M**

NO.	FREQ. (MHz)	EMISSION LEVEL (dBuV/m)	LIMIT (dBuV/m)	MARGIN (dB)	ANTENNA HEIGHT (m)	TABLE ANGLE (Degree)	RAW VALUE (dBuV)	CORRECTION FACTOR (dB/m)
1	33.59	24.3 QP	40.0	-15.7	1.53 H	166	33.90	-9.60
2	194.82	40.1 QP	43.5	-3.4	1.42 H	23	51.40	-11.30
3	260.51	42.8 QP	46.0	-3.2	1.47 H	68	51.70	-8.90
4	380.11	32.9 QP	46.0	-13.1	1.11 H	336	38.20	-5.30
5	695.70	37.8 QP	46.0	-8.2	1.03 H	325	36.40	1.40
6	1000.00	41.1 QP	54.0	-12.9	1.95 H	269	35.40	5.70

**ANTENNA POLARITY & TEST DISTANCE: VERTICAL AT 3 M**

NO.	FREQ. (MHz)	EMISSION LEVEL (dBuV/m)	LIMIT (dBuV/m)	MARGIN (dB)	ANTENNA HEIGHT (m)	TABLE ANGLE (Degree)	RAW VALUE (dBuV)	CORRECTION FACTOR (dB/m)
1	97.93	25.4 QP	43.5	-18.1	1.93 V	314	38.90	-13.50
2	195.97	34.1 QP	43.5	-9.4	1.60 V	234	45.50	-11.40
3	259.95	38.8 QP	46.0	-7.2	1.98 V	143	47.80	-9.00
4	325.80	32.0 QP	46.0	-14.0	1.00 V	50	38.40	-6.40
5	749.43	37.0 QP	46.0	-9.0	1.62 V	347	34.60	2.40
6	1000.00	39.1 QP	54.0	-14.9	1.00 V	292	33.40	5.70

**REMARKS:**

1. Emission Level(dBuV/m) = Raw Value(dBuV) + Correction Factor(dB/m)
2. Correction Factor(dB/m) = Antenna Factor(dB/m) + Cable Factor(dB) – Pre-Amplifier Factor(dB)
3. The other emission levels were very low against the limit.
4. Margin value = Emission Level – Limit value

802.11ac (VHT20)

<b>CHANNEL</b>	TX Channel 36	<b>DETECTOR FUNCTION</b>	Quasi-Peak (QP)
<b>FREQUENCY RANGE</b>	Below 1GHz		

**ANTENNA POLARITY & TEST DISTANCE: HORIZONTAL AT 3 M**

NO.	FREQ. (MHz)	EMISSION LEVEL (dBuV/m)	LIMIT (dBuV/m)	MARGIN (dB)	ANTENNA HEIGHT (m)	TABLE ANGLE (Degree)	RAW VALUE (dBuV)	CORRECTION FACTOR (dB/m)
1	33.71	24.3 QP	40.0	-15.7	1.55 H	173	33.90	-9.60
2	194.93	40.0 QP	43.5	-3.5	1.50 H	39	51.30	-11.30
3	260.48	42.6 QP	46.0	-3.4	1.36 H	83	51.50	-8.90
4	380.00	32.7 QP	46.0	-13.3	1.14 H	336	38.00	-5.30
5	695.58	37.7 QP	46.0	-8.3	1.08 H	322	36.30	1.40
6	1000.00	41.3 QP	54.0	-12.7	1.91 H	260	35.60	5.70

**ANTENNA POLARITY & TEST DISTANCE: VERTICAL AT 3 M**

NO.	FREQ. (MHz)	EMISSION LEVEL (dBuV/m)	LIMIT (dBuV/m)	MARGIN (dB)	ANTENNA HEIGHT (m)	TABLE ANGLE (Degree)	RAW VALUE (dBuV)	CORRECTION FACTOR (dB/m)
1	98.05	25.4 QP	43.5	-18.1	1.98 V	297	38.90	-13.50
2	195.60	33.6 QP	43.5	-9.9	1.65 V	210	45.00	-11.40
3	259.84	38.8 QP	46.0	-7.2	1.94 V	140	47.80	-9.00
4	326.01	32.2 QP	46.0	-13.8	1.05 V	32	38.60	-6.40
5	749.58	36.6 QP	46.0	-9.4	1.55 V	333	34.20	2.40
6	1000.00	38.7 QP	54.0	-15.3	1.00 V	276	33.00	5.70

**REMARKS:**

1. Emission Level(dBuV/m) = Raw Value(dBuV) + Correction Factor(dB/m)
2. Correction Factor(dB/m) = Antenna Factor(dB/m) + Cable Factor(dB) – Pre-Amplifier Factor(dB)
3. The other emission levels were very low against the limit.
4. Margin value = Emission Level – Limit value

<b>CHANNEL</b>	TX Channel 40	<b>DETECTOR FUNCTION</b>	Quasi-Peak (QP)
<b>FREQUENCY RANGE</b>	Below 1GHz		

**ANTENNA POLARITY & TEST DISTANCE: HORIZONTAL AT 3 M**

NO.	FREQ. (MHz)	EMISSION LEVEL (dBuV/m)	LIMIT (dBuV/m)	MARGIN (dB)	ANTENNA HEIGHT (m)	TABLE ANGLE (Degree)	RAW VALUE (dBuV)	CORRECTION FACTOR (dB/m)
1	33.65	23.9 QP	40.0	-16.1	1.51 H	178	33.50	-9.60
2	194.95	40.2 QP	43.5	-3.3	1.49 H	48	51.50	-11.30
3	260.51	42.7 QP	46.0	-3.3	1.36 H	69	51.60	-8.90
4	379.69	32.4 QP	46.0	-13.6	1.16 H	339	37.70	-5.30
5	695.87	37.9 QP	46.0	-8.1	1.06 H	331	36.50	1.40
6	1000.00	41.2 QP	54.0	-12.8	1.93 H	257	35.50	5.70

**ANTENNA POLARITY & TEST DISTANCE: VERTICAL AT 3 M**

NO.	FREQ. (MHz)	EMISSION LEVEL (dBuV/m)	LIMIT (dBuV/m)	MARGIN (dB)	ANTENNA HEIGHT (m)	TABLE ANGLE (Degree)	RAW VALUE (dBuV)	CORRECTION FACTOR (dB/m)
1	97.71	25.7 QP	43.5	-17.8	1.92 V	312	39.20	-13.50
2	195.53	33.9 QP	43.5	-9.6	1.64 V	237	45.30	-11.40
3	259.56	38.9 QP	46.0	-7.1	1.98 V	135	48.00	-9.10
4	325.94	32.2 QP	46.0	-13.8	1.01 V	61	38.60	-6.40
5	749.73	36.9 QP	46.0	-9.1	1.59 V	330	34.50	2.40
6	1000.00	38.6 QP	54.0	-15.4	1.02 V	294	32.90	5.70

**REMARKS:**

1. Emission Level(dBuV/m) = Raw Value(dBuV) + Correction Factor(dB/m)
2. Correction Factor(dB/m) = Antenna Factor(dB/m) + Cable Factor(dB) – Pre-Amplifier Factor(dB)
3. The other emission levels were very low against the limit.
4. Margin value = Emission Level – Limit value

<b>CHANNEL</b>	TX Channel 48	<b>DETECTOR FUNCTION</b>	Quasi-Peak (QP)
<b>FREQUENCY RANGE</b>	Below 1GHz		

**ANTENNA POLARITY & TEST DISTANCE: HORIZONTAL AT 3 M**

NO.	FREQ. (MHz)	EMISSION LEVEL (dBuV/m)	LIMIT (dBuV/m)	MARGIN (dB)	ANTENNA HEIGHT (m)	TABLE ANGLE (Degree)	RAW VALUE (dBuV)	CORRECTION FACTOR (dB/m)
1	34.02	24.2 QP	40.0	-15.8	1.48 H	162	33.70	-9.50
2	195.05	40.1 QP	43.5	-3.4	1.46 H	20	51.40	-11.30
3	260.10	42.4 QP	46.0	-3.6	1.37 H	76	51.30	-8.90
4	379.84	32.5 QP	46.0	-13.5	1.15 H	360	37.80	-5.30
5	696.07	37.4 QP	46.0	-8.6	1.01 H	338	36.00	1.40
6	1000.00	41.0 QP	54.0	-13.0	1.94 H	284	35.30	5.70

**ANTENNA POLARITY & TEST DISTANCE: VERTICAL AT 3 M**

NO.	FREQ. (MHz)	EMISSION LEVEL (dBuV/m)	LIMIT (dBuV/m)	MARGIN (dB)	ANTENNA HEIGHT (m)	TABLE ANGLE (Degree)	RAW VALUE (dBuV)	CORRECTION FACTOR (dB/m)
1	97.85	25.6 QP	43.5	-17.9	1.90 V	319	39.10	-13.50
2	195.77	33.7 QP	43.5	-9.8	1.62 V	211	45.10	-11.40
3	259.90	38.6 QP	46.0	-7.4	1.95 V	159	47.60	-9.00
4	325.74	32.5 QP	46.0	-13.5	1.00 V	56	38.90	-6.40
5	749.79	36.9 QP	46.0	-9.1	1.61 V	326	34.50	2.40
6	1000.00	38.6 QP	54.0	-15.4	1.00 V	297	32.90	5.70

**REMARKS:**

1. Emission Level(dBuV/m) = Raw Value(dBuV) + Correction Factor(dB/m)
2. Correction Factor(dB/m) = Antenna Factor(dB/m) + Cable Factor(dB) – Pre-Amplifier Factor(dB)
3. The other emission levels were very low against the limit.
4. Margin value = Emission Level – Limit value

<b>CHANNEL</b>	TX Channel 52	<b>DETECTOR FUNCTION</b>	Quasi-Peak (QP)
<b>FREQUENCY RANGE</b>	Below 1GHz		

**ANTENNA POLARITY & TEST DISTANCE: HORIZONTAL AT 3 M**

NO.	FREQ. (MHz)	EMISSION LEVEL (dBuV/m)	LIMIT (dBuV/m)	MARGIN (dB)	ANTENNA HEIGHT (m)	TABLE ANGLE (Degree)	RAW VALUE (dBuV)	CORRECTION FACTOR (dB/m)
1	33.48	24.0 QP	40.0	-16.0	1.50 H	163	33.60	-9.60
2	194.93	40.4 QP	43.5	-3.1	1.43 H	32	51.70	-11.30
3	260.12	42.9 QP	46.0	-3.1	1.40 H	81	51.80	-8.90
4	379.66	33.0 QP	46.0	-13.0	1.10 H	349	38.30	-5.30
5	695.76	38.0 QP	46.0	-8.0	1.07 H	322	36.60	1.40
6	1000.00	41.3 QP	54.0	-12.7	1.90 H	285	35.60	5.70

**ANTENNA POLARITY & TEST DISTANCE: VERTICAL AT 3 M**

NO.	FREQ. (MHz)	EMISSION LEVEL (dBuV/m)	LIMIT (dBuV/m)	MARGIN (dB)	ANTENNA HEIGHT (m)	TABLE ANGLE (Degree)	RAW VALUE (dBuV)	CORRECTION FACTOR (dB/m)
1	98.00	25.3 QP	43.5	-18.2	1.93 V	306	38.80	-13.50
2	195.70	33.8 QP	43.5	-9.7	1.63 V	214	45.20	-11.40
3	259.58	38.8 QP	46.0	-7.2	2.04 V	146	47.90	-9.10
4	325.56	32.2 QP	46.0	-13.8	1.00 V	61	38.60	-6.40
5	749.66	37.0 QP	46.0	-9.0	1.57 V	329	34.60	2.40
6	1000.00	38.5 QP	54.0	-15.5	1.00 V	277	32.80	5.70

**REMARKS:**

1. Emission Level(dBuV/m) = Raw Value(dBuV) + Correction Factor(dB/m)
2. Correction Factor(dB/m) = Antenna Factor(dB/m) + Cable Factor(dB) – Pre-Amplifier Factor(dB)
3. The other emission levels were very low against the limit.
4. Margin value = Emission Level – Limit value

<b>CHANNEL</b>	TX Channel 60	<b>DETECTOR FUNCTION</b>	Quasi-Peak (QP)
<b>FREQUENCY RANGE</b>	Below 1GHz		

**ANTENNA POLARITY & TEST DISTANCE: HORIZONTAL AT 3 M**

NO.	FREQ. (MHz)	EMISSION LEVEL (dBuV/m)	LIMIT (dBuV/m)	MARGIN (dB)	ANTENNA HEIGHT (m)	TABLE ANGLE (Degree)	RAW VALUE (dBuV)	CORRECTION FACTOR (dB/m)
1	33.80	24.1 QP	40.0	-15.9	1.55 H	175	33.70	-9.60
2	194.68	40.2 QP	43.5	-3.3	1.48 H	21	51.50	-11.30
3	260.24	42.5 QP	46.0	-3.5	1.35 H	55	51.40	-8.90
4	379.76	32.6 QP	46.0	-13.4	1.19 H	336	37.90	-5.30
5	695.66	37.5 QP	46.0	-8.5	1.05 H	329	36.10	1.40
6	1000.00	41.3 QP	54.0	-12.7	1.89 H	271	35.60	5.70

**ANTENNA POLARITY & TEST DISTANCE: VERTICAL AT 3 M**

NO.	FREQ. (MHz)	EMISSION LEVEL (dBuV/m)	LIMIT (dBuV/m)	MARGIN (dB)	ANTENNA HEIGHT (m)	TABLE ANGLE (Degree)	RAW VALUE (dBuV)	CORRECTION FACTOR (dB/m)
1	98.21	25.7 QP	43.5	-17.8	1.96 V	316	39.10	-13.40
2	195.80	33.9 QP	43.5	-9.6	1.64 V	232	45.30	-11.40
3	260.07	38.9 QP	46.0	-7.1	1.99 V	134	47.80	-8.90
4	325.91	32.4 QP	46.0	-13.6	1.01 V	40	38.80	-6.40
5	749.97	36.7 QP	46.0	-9.3	1.56 V	357	34.30	2.40
6	1000.00	38.8 QP	54.0	-15.2	1.00 V	296	33.10	5.70

**REMARKS:**

1. Emission Level(dBuV/m) = Raw Value(dBuV) + Correction Factor(dB/m)
2. Correction Factor(dB/m) = Antenna Factor(dB/m) + Cable Factor(dB) – Pre-Amplifier Factor(dB)
3. The other emission levels were very low against the limit.
4. Margin value = Emission Level – Limit value



<b>CHANNEL</b>	TX Channel 64	<b>DETECTOR FUNCTION</b>	Quasi-Peak (QP)
<b>FREQUENCY RANGE</b>	Below 1GHz		

**ANTENNA POLARITY & TEST DISTANCE: HORIZONTAL AT 3 M**

NO.	FREQ. (MHz)	EMISSION LEVEL (dBuV/m)	LIMIT (dBuV/m)	MARGIN (dB)	ANTENNA HEIGHT (m)	TABLE ANGLE (Degree)	RAW VALUE (dBuV)	CORRECTION FACTOR (dB/m)
1	33.79	23.8 QP	40.0	-16.2	1.44 H	174	33.40	-9.60
2	195.00	40.0 QP	43.5	-3.5	1.49 H	29	51.30	-11.30
3	260.15	42.9 QP	46.0	-3.1	1.45 H	81	51.80	-8.90
4	380.13	32.9 QP	46.0	-13.1	1.20 H	343	38.20	-5.30
5	695.84	37.9 QP	46.0	-8.1	1.00 H	340	36.50	1.40
6	1000.00	40.8 QP	54.0	-13.2	1.92 H	263	35.10	5.70

**ANTENNA POLARITY & TEST DISTANCE: VERTICAL AT 3 M**

NO.	FREQ. (MHz)	EMISSION LEVEL (dBuV/m)	LIMIT (dBuV/m)	MARGIN (dB)	ANTENNA HEIGHT (m)	TABLE ANGLE (Degree)	RAW VALUE (dBuV)	CORRECTION FACTOR (dB/m)
1	97.93	25.3 QP	43.5	-18.2	2.00 V	306	38.80	-13.50
2	195.87	33.7 QP	43.5	-9.8	1.65 V	216	45.10	-11.40
3	259.72	38.7 QP	46.0	-7.3	1.98 V	143	47.80	-9.10
4	325.79	32.4 QP	46.0	-13.6	1.00 V	61	38.80	-6.40
5	749.65	36.7 QP	46.0	-9.3	1.55 V	336	34.30	2.40
6	1000.00	39.0 QP	54.0	-15.0	1.00 V	297	33.30	5.70

**REMARKS:**

1. Emission Level(dBuV/m) = Raw Value(dBuV) + Correction Factor(dB/m)
2. Correction Factor(dB/m) = Antenna Factor(dB/m) + Cable Factor(dB) – Pre-Amplifier Factor(dB)
3. The other emission levels were very low against the limit.
4. Margin value = Emission Level – Limit value

<b>CHANNEL</b>	TX Channel 100	<b>DETECTOR FUNCTION</b>	Quasi-Peak (QP)
<b>FREQUENCY RANGE</b>	Below 1GHz		

**ANTENNA POLARITY & TEST DISTANCE: HORIZONTAL AT 3 M**

NO.	FREQ. (MHz)	EMISSION LEVEL (dBuV/m)	LIMIT (dBuV/m)	MARGIN (dB)	ANTENNA HEIGHT (m)	TABLE ANGLE (Degree)	RAW VALUE (dBuV)	CORRECTION FACTOR (dB/m)
1	33.68	24.1 QP	40.0	-15.9	1.52 H	160	33.70	-9.60
2	194.64	40.0 QP	43.5	-3.5	1.42 H	41	51.30	-11.30
3	260.38	42.6 QP	46.0	-3.4	1.45 H	67	51.50	-8.90
4	380.03	32.6 QP	46.0	-13.4	1.20 H	354	37.90	-5.30
5	695.60	37.5 QP	46.0	-8.5	1.06 H	321	36.10	1.40
6	1000.00	41.3 QP	54.0	-12.7	1.99 H	269	35.60	5.70

**ANTENNA POLARITY & TEST DISTANCE: VERTICAL AT 3 M**

NO.	FREQ. (MHz)	EMISSION LEVEL (dBuV/m)	LIMIT (dBuV/m)	MARGIN (dB)	ANTENNA HEIGHT (m)	TABLE ANGLE (Degree)	RAW VALUE (dBuV)	CORRECTION FACTOR (dB/m)
1	97.81	25.6 QP	43.5	-17.9	1.95 V	309	39.10	-13.50
2	195.94	34.0 QP	43.5	-9.5	1.62 V	223	45.40	-11.40
3	259.90	39.0 QP	46.0	-7.0	1.95 V	130	48.00	-9.00
4	325.60	32.5 QP	46.0	-13.5	1.01 V	56	38.90	-6.40
5	749.61	37.0 QP	46.0	-9.0	1.58 V	348	34.60	2.40
6	1000.00	38.5 QP	54.0	-15.5	1.00 V	290	32.80	5.70

**REMARKS:**

1. Emission Level(dBuV/m) = Raw Value(dBuV) + Correction Factor(dB/m)
2. Correction Factor(dB/m) = Antenna Factor(dB/m) + Cable Factor(dB) – Pre-Amplifier Factor(dB)
3. The other emission levels were very low against the limit.
4. Margin value = Emission Level – Limit value

<b>CHANNEL</b>	TX Channel 116	<b>DETECTOR FUNCTION</b>	Quasi-Peak (QP)
<b>FREQUENCY RANGE</b>	Below 1GHz		

**ANTENNA POLARITY & TEST DISTANCE: HORIZONTAL AT 3 M**

NO.	FREQ. (MHz)	EMISSION LEVEL (dBuV/m)	LIMIT (dBuV/m)	MARGIN (dB)	ANTENNA HEIGHT (m)	TABLE ANGLE (Degree)	RAW VALUE (dBuV)	CORRECTION FACTOR (dB/m)
1	33.56	24.0 QP	40.0	-16.0	1.51 H	159	33.60	-9.60
2	194.93	40.3 QP	43.5	-3.2	1.52 H	31	51.60	-11.30
3	260.40	42.9 QP	46.0	-3.1	1.41 H	59	51.80	-8.90
4	380.09	32.9 QP	46.0	-13.1	1.18 H	336	38.20	-5.30
5	695.80	37.9 QP	46.0	-8.1	1.00 H	320	36.50	1.40
6	1000.00	41.3 QP	54.0	-12.7	1.90 H	264	35.60	5.70

**ANTENNA POLARITY & TEST DISTANCE: VERTICAL AT 3 M**

NO.	FREQ. (MHz)	EMISSION LEVEL (dBuV/m)	LIMIT (dBuV/m)	MARGIN (dB)	ANTENNA HEIGHT (m)	TABLE ANGLE (Degree)	RAW VALUE (dBuV)	CORRECTION FACTOR (dB/m)
1	98.22	25.5 QP	43.5	-18.0	2.02 V	309	38.90	-13.40
2	195.69	33.7 QP	43.5	-9.8	1.66 V	232	45.10	-11.40
3	259.60	38.9 QP	46.0	-7.1	1.97 V	135	48.00	-9.10
4	325.57	32.5 QP	46.0	-13.5	1.05 V	34	38.90	-6.40
5	749.70	37.0 QP	46.0	-9.0	1.64 V	348	34.60	2.40
6	1000.00	38.7 QP	54.0	-15.3	1.00 V	281	33.00	5.70

**REMARKS:**

1. Emission Level(dBuV/m) = Raw Value(dBuV) + Correction Factor(dB/m)
2. Correction Factor(dB/m) = Antenna Factor(dB/m) + Cable Factor(dB) – Pre-Amplifier Factor(dB)
3. The other emission levels were very low against the limit.
4. Margin value = Emission Level – Limit value

<b>CHANNEL</b>	TX Channel 120	<b>DETECTOR FUNCTION</b>	Quasi-Peak (QP)
<b>FREQUENCY RANGE</b>	Below 1GHz		

**ANTENNA POLARITY & TEST DISTANCE: HORIZONTAL AT 3 M**

NO.	FREQ. (MHz)	EMISSION LEVEL (dBuV/m)	LIMIT (dBuV/m)	MARGIN (dB)	ANTENNA HEIGHT (m)	TABLE ANGLE (Degree)	RAW VALUE (dBuV)	CORRECTION FACTOR (dB/m)
1	33.77	24.1 QP	40.0	-15.9	1.49 H	162	33.70	-9.60
2	194.89	40.1 QP	43.5	-3.4	1.53 H	26	51.40	-11.30
3	260.15	42.4 QP	46.0	-3.6	1.41 H	55	51.30	-8.90
4	379.90	32.9 QP	46.0	-13.1	1.14 H	342	38.20	-5.30
5	695.64	37.9 QP	46.0	-8.1	1.00 H	329	36.50	1.40
6	1000.00	40.9 QP	54.0	-13.1	1.88 H	281	35.20	5.70

**ANTENNA POLARITY & TEST DISTANCE: VERTICAL AT 3 M**

NO.	FREQ. (MHz)	EMISSION LEVEL (dBuV/m)	LIMIT (dBuV/m)	MARGIN (dB)	ANTENNA HEIGHT (m)	TABLE ANGLE (Degree)	RAW VALUE (dBuV)	CORRECTION FACTOR (dB/m)
1	97.93	25.6 QP	43.5	-17.9	1.99 V	311	39.10	-13.50
2	195.66	33.9 QP	43.5	-9.6	1.64 V	230	45.30	-11.40
3	259.70	39.0 QP	46.0	-7.0	2.03 V	135	48.10	-9.10
4	325.86	32.3 QP	46.0	-13.7	1.02 V	40	38.70	-6.40
5	749.50	36.9 QP	46.0	-9.1	1.56 V	326	34.50	2.40
6	1000.00	38.9 QP	54.0	-15.1	1.00 V	276	33.20	5.70

**REMARKS:**

1. Emission Level(dBuV/m) = Raw Value(dBuV) + Correction Factor(dB/m)
2. Correction Factor(dB/m) = Antenna Factor(dB/m) + Cable Factor(dB) – Pre-Amplifier Factor(dB)
3. The other emission levels were very low against the limit.
4. Margin value = Emission Level – Limit value

<b>CHANNEL</b>	TX Channel 132	<b>DETECTOR FUNCTION</b>	Quasi-Peak (QP)
<b>FREQUENCY RANGE</b>	Below 1GHz		

**ANTENNA POLARITY & TEST DISTANCE: HORIZONTAL AT 3 M**

NO.	FREQ. (MHz)	EMISSION LEVEL (dBuV/m)	LIMIT (dBuV/m)	MARGIN (dB)	ANTENNA HEIGHT (m)	TABLE ANGLE (Degree)	RAW VALUE (dBuV)	CORRECTION FACTOR (dB/m)
1	33.81	24.0 QP	40.0	-16.0	1.50 H	176	33.60	-9.60
2	195.09	40.4 QP	43.5	-3.1	1.42 H	35	51.70	-11.30
3	260.59	42.7 QP	46.0	-3.3	1.46 H	80	51.60	-8.90
4	379.62	32.9 QP	46.0	-13.1	1.12 H	342	38.20	-5.30
5	695.51	37.6 QP	46.0	-8.4	1.06 H	337	36.20	1.40
6	1000.00	40.8 QP	54.0	-13.2	1.90 H	275	35.10	5.70

**ANTENNA POLARITY & TEST DISTANCE: VERTICAL AT 3 M**

NO.	FREQ. (MHz)	EMISSION LEVEL (dBuV/m)	LIMIT (dBuV/m)	MARGIN (dB)	ANTENNA HEIGHT (m)	TABLE ANGLE (Degree)	RAW VALUE (dBuV)	CORRECTION FACTOR (dB/m)
1	97.73	25.3 QP	43.5	-18.2	1.98 V	304	38.80	-13.50
2	195.74	33.9 QP	43.5	-9.6	1.62 V	226	45.30	-11.40
3	259.84	38.6 QP	46.0	-7.4	1.94 V	128	47.60	-9.00
4	325.68	32.0 QP	46.0	-14.0	1.00 V	35	38.40	-6.40
5	749.81	36.7 QP	46.0	-9.3	1.56 V	344	34.30	2.40
6	1000.00	38.8 QP	54.0	-15.2	1.00 V	274	33.10	5.70

**REMARKS:**

1. Emission Level(dBuV/m) = Raw Value(dBuV) + Correction Factor(dB/m)
2. Correction Factor(dB/m) = Antenna Factor(dB/m) + Cable Factor(dB) – Pre-Amplifier Factor(dB)
3. The other emission levels were very low against the limit.
4. Margin value = Emission Level – Limit value

<b>CHANNEL</b>	TX Channel 140	<b>DETECTOR FUNCTION</b>	Quasi-Peak (QP)
<b>FREQUENCY RANGE</b>	Below 1GHz		

**ANTENNA POLARITY & TEST DISTANCE: HORIZONTAL AT 3 M**

NO.	FREQ. (MHz)	EMISSION LEVEL (dBuV/m)	LIMIT (dBuV/m)	MARGIN (dB)	ANTENNA HEIGHT (m)	TABLE ANGLE (Degree)	RAW VALUE (dBuV)	CORRECTION FACTOR (dB/m)
1	33.52	24.1 QP	40.0	-15.9	1.54 H	158	33.70	-9.60
2	194.82	40.4 QP	43.5	-3.1	1.45 H	28	51.70	-11.30
3	260.31	42.5 QP	46.0	-3.5	1.41 H	86	51.40	-8.90
4	379.83	32.6 QP	46.0	-13.4	1.12 H	328	37.90	-5.30
5	695.73	37.6 QP	46.0	-8.4	1.08 H	323	36.20	1.40
6	1000.00	41.1 QP	54.0	-12.9	1.96 H	272	35.40	5.70

**ANTENNA POLARITY & TEST DISTANCE: VERTICAL AT 3 M**

NO.	FREQ. (MHz)	EMISSION LEVEL (dBuV/m)	LIMIT (dBuV/m)	MARGIN (dB)	ANTENNA HEIGHT (m)	TABLE ANGLE (Degree)	RAW VALUE (dBuV)	CORRECTION FACTOR (dB/m)
1	98.15	25.4 QP	43.5	-18.1	1.99 V	303	38.80	-13.40
2	195.60	34.0 QP	43.5	-9.5	1.64 V	225	45.40	-11.40
3	259.92	38.9 QP	46.0	-7.1	1.97 V	150	47.90	-9.00
4	325.99	32.4 QP	46.0	-13.6	1.00 V	59	38.80	-6.40
5	749.91	36.9 QP	46.0	-9.1	1.62 V	330	34.50	2.40
6	1000.00	39.1 QP	54.0	-14.9	1.00 V	283	33.40	5.70

**REMARKS:**

1. Emission Level(dBuV/m) = Raw Value(dBuV) + Correction Factor(dB/m)
2. Correction Factor(dB/m) = Antenna Factor(dB/m) + Cable Factor(dB) – Pre-Amplifier Factor(dB)
3. The other emission levels were very low against the limit.
4. Margin value = Emission Level – Limit value

<b>CHANNEL</b>	TX Channel 149	<b>DETECTOR FUNCTION</b>	Quasi-Peak (QP)
<b>FREQUENCY RANGE</b>	Below 1GHz		

**ANTENNA POLARITY & TEST DISTANCE: HORIZONTAL AT 3 M**

NO.	FREQ. (MHz)	EMISSION LEVEL (dBuV/m)	LIMIT (dBuV/m)	MARGIN (dB)	ANTENNA HEIGHT (m)	TABLE ANGLE (Degree)	RAW VALUE (dBuV)	CORRECTION FACTOR (dB/m)
1	33.57	24.0 QP	40.0	-16.0	1.45 H	168	33.60	-9.60
2	194.73	40.1 QP	43.5	-3.4	1.42 H	43	51.40	-11.30
3	260.06	42.9 QP	46.0	-3.1	1.38 H	58	51.80	-8.90
4	379.82	32.4 QP	46.0	-13.6	1.20 H	333	37.70	-5.30
5	695.51	37.7 QP	46.0	-8.3	1.06 H	341	36.30	1.40
6	1000.00	40.9 QP	54.0	-13.1	1.93 H	255	35.20	5.70

**ANTENNA POLARITY & TEST DISTANCE: VERTICAL AT 3 M**

NO.	FREQ. (MHz)	EMISSION LEVEL (dBuV/m)	LIMIT (dBuV/m)	MARGIN (dB)	ANTENNA HEIGHT (m)	TABLE ANGLE (Degree)	RAW VALUE (dBuV)	CORRECTION FACTOR (dB/m)
1	97.69	25.7 QP	43.5	-17.8	2.00 V	311	39.20	-13.50
2	195.88	33.8 QP	43.5	-9.7	1.67 V	213	45.20	-11.40
3	259.54	39.0 QP	46.0	-7.0	2.02 V	150	48.10	-9.10
4	325.72	32.3 QP	46.0	-13.7	1.01 V	31	38.70	-6.40
5	749.95	37.0 QP	46.0	-9.0	1.60 V	336	34.60	2.40
6	1000.00	39.1 QP	54.0	-14.9	1.02 V	272	33.40	5.70

**REMARKS:**

1. Emission Level(dBuV/m) = Raw Value(dBuV) + Correction Factor(dB/m)
2. Correction Factor(dB/m) = Antenna Factor(dB/m) + Cable Factor(dB) – Pre-Amplifier Factor(dB)
3. The other emission levels were very low against the limit.
4. Margin value = Emission Level – Limit value

<b>CHANNEL</b>	TX Channel 157	<b>DETECTOR FUNCTION</b>	Quasi-Peak (QP)
<b>FREQUENCY RANGE</b>	Below 1GHz		

**ANTENNA POLARITY & TEST DISTANCE: HORIZONTAL AT 3 M**

NO.	FREQ. (MHz)	EMISSION LEVEL (dBuV/m)	LIMIT (dBuV/m)	MARGIN (dB)	ANTENNA HEIGHT (m)	TABLE ANGLE (Degree)	RAW VALUE (dBuV)	CORRECTION FACTOR (dB/m)
1	33.85	23.9 QP	40.0	-16.1	1.47 H	157	33.50	-9.60
2	194.72	40.3 QP	43.5	-3.2	1.43 H	48	51.60	-11.30
3	260.01	42.6 QP	46.0	-3.4	1.43 H	64	51.50	-8.90
4	379.66	32.7 QP	46.0	-13.3	1.13 H	339	38.00	-5.30
5	695.54	37.9 QP	46.0	-8.1	1.03 H	322	36.50	1.40
6	1000.00	40.9 QP	54.0	-13.1	1.97 H	273	35.20	5.70

**ANTENNA POLARITY & TEST DISTANCE: VERTICAL AT 3 M**

NO.	FREQ. (MHz)	EMISSION LEVEL (dBuV/m)	LIMIT (dBuV/m)	MARGIN (dB)	ANTENNA HEIGHT (m)	TABLE ANGLE (Degree)	RAW VALUE (dBuV)	CORRECTION FACTOR (dB/m)
1	98.03	25.7 QP	43.5	-17.8	1.92 V	303	39.20	-13.50
2	195.77	33.6 QP	43.5	-9.9	1.60 V	219	45.00	-11.40
3	259.94	38.9 QP	46.0	-7.1	2.04 V	152	47.90	-9.00
4	325.57	32.0 QP	46.0	-14.0	1.05 V	53	38.40	-6.40
5	749.62	36.6 QP	46.0	-9.4	1.64 V	342	34.20	2.40
6	1000.00	38.9 QP	54.0	-15.1	1.00 V	276	33.20	5.70

**REMARKS:**

1. Emission Level(dBuV/m) = Raw Value(dBuV) + Correction Factor(dB/m)
2. Correction Factor(dB/m) = Antenna Factor(dB/m) + Cable Factor(dB) – Pre-Amplifier Factor(dB)
3. The other emission levels were very low against the limit.
4. Margin value = Emission Level – Limit value



<b>CHANNEL</b>	TX Channel 165	<b>DETECTOR FUNCTION</b>	Quasi-Peak (QP)
<b>FREQUENCY RANGE</b>	Below 1GHz		

**ANTENNA POLARITY & TEST DISTANCE: HORIZONTAL AT 3 M**

NO.	FREQ. (MHz)	EMISSION LEVEL (dBuV/m)	LIMIT (dBuV/m)	MARGIN (dB)	ANTENNA HEIGHT (m)	TABLE ANGLE (Degree)	RAW VALUE (dBuV)	CORRECTION FACTOR (dB/m)
1	34.04	24.3 QP	40.0	-15.7	1.52 H	152	33.80	-9.50
2	194.99	40.5 QP	43.5	-3.0	1.52 H	18	51.80	-11.30
3	260.45	42.7 QP	46.0	-3.3	1.35 H	67	51.60	-8.90
4	380.14	32.8 QP	46.0	-13.2	1.14 H	329	38.10	-5.30
5	695.77	37.7 QP	46.0	-8.3	1.03 H	343	36.30	1.40
6	1000.00	41.3 QP	54.0	-12.7	1.87 H	282	35.60	5.70

**ANTENNA POLARITY & TEST DISTANCE: VERTICAL AT 3 M**

NO.	FREQ. (MHz)	EMISSION LEVEL (dBuV/m)	LIMIT (dBuV/m)	MARGIN (dB)	ANTENNA HEIGHT (m)	TABLE ANGLE (Degree)	RAW VALUE (dBuV)	CORRECTION FACTOR (dB/m)
1	98.07	25.6 QP	43.5	-17.9	2.02 V	301	39.10	-13.50
2	196.04	34.0 QP	43.5	-9.5	1.58 V	236	45.40	-11.40
3	259.62	38.9 QP	46.0	-7.1	2.02 V	149	48.00	-9.10
4	325.88	32.4 QP	46.0	-13.6	1.00 V	33	38.80	-6.40
5	749.74	36.5 QP	46.0	-9.5	1.65 V	338	34.10	2.40
6	1000.00	38.8 QP	54.0	-15.2	1.00 V	282	33.10	5.70

**REMARKS:**

1. Emission Level(dBuV/m) = Raw Value(dBuV) + Correction Factor(dB/m)
2. Correction Factor(dB/m) = Antenna Factor(dB/m) + Cable Factor(dB) – Pre-Amplifier Factor(dB)
3. The other emission levels were very low against the limit.
4. Margin value = Emission Level – Limit value

802.11ac (VHT40)

<b>CHANNEL</b>	TX Channel 38	<b>DETECTOR FUNCTION</b>	Quasi-Peak (QP)
<b>FREQUENCY RANGE</b>	Below 1GHz		

ANTENNA POLARITY & TEST DISTANCE: HORIZONTAL AT 3 M								
NO.	FREQ. (MHz)	EMISSION LEVEL (dBuV/m)	LIMIT (dBuV/m)	MARGIN (dB)	ANTENNA HEIGHT (m)	TABLE ANGLE (Degree)	RAW VALUE (dBuV)	CORRECTION FACTOR (dB/m)
1	33.66	23.9 QP	40.0	-16.1	1.50 H	167	33.50	-9.60
2	194.79	40.3 QP	43.5	-3.2	1.50 H	20	51.60	-11.30
3	260.51	42.4 QP	46.0	-3.6	1.40 H	60	51.30	-8.90
4	380.08	32.4 QP	46.0	-13.6	1.20 H	347	37.70	-5.30
5	695.58	37.6 QP	46.0	-8.4	1.01 H	331	36.20	1.40
6	1000.00	41.4 QP	54.0	-12.6	1.99 H	272	35.70	5.70

ANTENNA POLARITY & TEST DISTANCE: VERTICAL AT 3 M								
NO.	FREQ. (MHz)	EMISSION LEVEL (dBuV/m)	LIMIT (dBuV/m)	MARGIN (dB)	ANTENNA HEIGHT (m)	TABLE ANGLE (Degree)	RAW VALUE (dBuV)	CORRECTION FACTOR (dB/m)
1	97.82	25.4 QP	43.5	-18.1	1.93 V	311	38.90	-13.50
2	195.97	33.6 QP	43.5	-9.9	1.67 V	213	45.00	-11.40
3	259.62	38.6 QP	46.0	-7.4	2.04 V	128	47.70	-9.10
4	325.66	32.5 QP	46.0	-13.5	1.01 V	42	38.90	-6.40
5	749.96	36.7 QP	46.0	-9.3	1.62 V	351	34.30	2.40
6	1000.00	39.0 QP	54.0	-15.0	1.00 V	283	33.30	5.70

**REMARKS:**

1. Emission Level(dBuV/m) = Raw Value(dBuV) + Correction Factor(dB/m)
2. Correction Factor(dB/m) = Antenna Factor(dB/m) + Cable Factor(dB) – Pre-Amplifier Factor(dB)
3. The other emission levels were very low against the limit.
4. Margin value = Emission Level – Limit value

<b>CHANNEL</b>	TX Channel 46	<b>DETECTOR FUNCTION</b>	Quasi-Peak (QP)
<b>FREQUENCY RANGE</b>	Below 1GHz		

**ANTENNA POLARITY & TEST DISTANCE: HORIZONTAL AT 3 M**

NO.	FREQ. (MHz)	EMISSION LEVEL (dBuV/m)	LIMIT (dBuV/m)	MARGIN (dB)	ANTENNA HEIGHT (m)	TABLE ANGLE (Degree)	RAW VALUE (dBuV)	CORRECTION FACTOR (dB/m)
1	33.88	24.3 QP	40.0	-15.7	1.52 H	170	33.90	-9.60
2	195.14	40.1 QP	43.5	-3.4	1.44 H	38	51.40	-11.30
3	260.38	42.8 QP	46.0	-3.2	1.39 H	67	51.70	-8.90
4	379.94	33.0 QP	46.0	-13.0	1.10 H	343	38.30	-5.30
5	695.94	38.0 QP	46.0	-8.0	1.01 H	316	36.60	1.40
6	1000.00	40.9 QP	54.0	-13.1	1.94 H	256	35.20	5.70

**ANTENNA POLARITY & TEST DISTANCE: VERTICAL AT 3 M**

NO.	FREQ. (MHz)	EMISSION LEVEL (dBuV/m)	LIMIT (dBuV/m)	MARGIN (dB)	ANTENNA HEIGHT (m)	TABLE ANGLE (Degree)	RAW VALUE (dBuV)	CORRECTION FACTOR (dB/m)
1	98.03	25.3 QP	43.5	-18.2	2.01 V	304	38.80	-13.50
2	195.52	33.5 QP	43.5	-10.0	1.69 V	213	44.90	-11.40
3	259.70	39.1 QP	46.0	-6.9	2.01 V	138	48.20	-9.10
4	325.95	32.0 QP	46.0	-14.0	1.01 V	62	38.40	-6.40
5	749.63	36.9 QP	46.0	-9.1	1.55 V	342	34.50	2.40
6	1000.00	38.7 QP	54.0	-15.3	1.00 V	288	33.00	5.70

**REMARKS:**

1. Emission Level(dBuV/m) = Raw Value(dBuV) + Correction Factor(dB/m)
2. Correction Factor(dB/m) = Antenna Factor(dB/m) + Cable Factor(dB) – Pre-Amplifier Factor(dB)
3. The other emission levels were very low against the limit.
4. Margin value = Emission Level – Limit value

<b>CHANNEL</b>	TX Channel 54	<b>DETECTOR FUNCTION</b>	Quasi-Peak (QP)
<b>FREQUENCY RANGE</b>	Below 1GHz		

**ANTENNA POLARITY & TEST DISTANCE: HORIZONTAL AT 3 M**

NO.	FREQ. (MHz)	EMISSION LEVEL (dBuV/m)	LIMIT (dBuV/m)	MARGIN (dB)	ANTENNA HEIGHT (m)	TABLE ANGLE (Degree)	RAW VALUE (dBuV)	CORRECTION FACTOR (dB/m)
1	33.92	23.9 QP	40.0	-16.1	1.47 H	159	33.40	-9.50
2	195.10	40.0 QP	43.5	-3.5	1.43 H	29	51.30	-11.30
3	260.05	42.8 QP	46.0	-3.2	1.42 H	55	51.70	-8.90
4	380.15	32.6 QP	46.0	-13.4	1.14 H	353	37.90	-5.30
5	695.48	37.6 QP	46.0	-8.4	1.07 H	329	36.20	1.40
6	1000.00	41.3 QP	54.0	-12.7	1.97 H	264	35.60	5.70

**ANTENNA POLARITY & TEST DISTANCE: VERTICAL AT 3 M**

NO.	FREQ. (MHz)	EMISSION LEVEL (dBuV/m)	LIMIT (dBuV/m)	MARGIN (dB)	ANTENNA HEIGHT (m)	TABLE ANGLE (Degree)	RAW VALUE (dBuV)	CORRECTION FACTOR (dB/m)
1	98.19	25.7 QP	43.5	-17.8	2.01 V	312	39.10	-13.40
2	195.96	33.8 QP	43.5	-9.7	1.57 V	237	45.20	-11.40
3	259.91	38.7 QP	46.0	-7.3	1.97 V	146	47.70	-9.00
4	325.88	32.3 QP	46.0	-13.7	1.00 V	39	38.70	-6.40
5	749.93	36.7 QP	46.0	-9.3	1.64 V	328	34.30	2.40
6	1000.00	38.7 QP	54.0	-15.3	1.00 V	285	33.00	5.70

**REMARKS:**

1. Emission Level(dBuV/m) = Raw Value(dBuV) + Correction Factor(dB/m)
2. Correction Factor(dB/m) = Antenna Factor(dB/m) + Cable Factor(dB) – Pre-Amplifier Factor(dB)
3. The other emission levels were very low against the limit.
4. Margin value = Emission Level – Limit value

<b>CHANNEL</b>	TX Channel 62	<b>DETECTOR FUNCTION</b>	Quasi-Peak (QP)
<b>FREQUENCY RANGE</b>	Below 1GHz		

**ANTENNA POLARITY & TEST DISTANCE: HORIZONTAL AT 3 M**

NO.	FREQ. (MHz)	EMISSION LEVEL (dBuV/m)	LIMIT (dBuV/m)	MARGIN (dB)	ANTENNA HEIGHT (m)	TABLE ANGLE (Degree)	RAW VALUE (dBuV)	CORRECTION FACTOR (dB/m)
1	33.63	24.4 QP	40.0	-15.6	1.49 H	156	34.00	-9.60
2	194.62	40.2 QP	43.5	-3.3	1.50 H	22	51.50	-11.30
3	260.18	42.6 QP	46.0	-3.4	1.43 H	57	51.50	-8.90
4	380.20	32.8 QP	46.0	-13.2	1.19 H	330	38.10	-5.30
5	695.50	37.7 QP	46.0	-8.3	1.00 H	327	36.30	1.40
6	1000.00	41.2 QP	54.0	-12.8	1.98 H	257	35.50	5.70

**ANTENNA POLARITY & TEST DISTANCE: VERTICAL AT 3 M**

NO.	FREQ. (MHz)	EMISSION LEVEL (dBuV/m)	LIMIT (dBuV/m)	MARGIN (dB)	ANTENNA HEIGHT (m)	TABLE ANGLE (Degree)	RAW VALUE (dBuV)	CORRECTION FACTOR (dB/m)
1	97.88	25.2 QP	43.5	-18.3	1.97 V	320	38.70	-13.50
2	195.91	34.0 QP	43.5	-9.5	1.59 V	210	45.40	-11.40
3	259.70	38.9 QP	46.0	-7.1	1.96 V	159	48.00	-9.10
4	325.57	32.3 QP	46.0	-13.7	1.00 V	56	38.70	-6.40
5	749.95	36.9 QP	46.0	-9.1	1.64 V	345	34.50	2.40
6	1000.00	38.9 QP	54.0	-15.1	1.00 V	297	33.20	5.70

**REMARKS:**

1. Emission Level(dBuV/m) = Raw Value(dBuV) + Correction Factor(dB/m)
2. Correction Factor(dB/m) = Antenna Factor(dB/m) + Cable Factor(dB) – Pre-Amplifier Factor(dB)
3. The other emission levels were very low against the limit.
4. Margin value = Emission Level – Limit value

<b>CHANNEL</b>	TX Channel 102	<b>DETECTOR FUNCTION</b>	Quasi-Peak (QP)
<b>FREQUENCY RANGE</b>	Below 1GHz		

**ANTENNA POLARITY & TEST DISTANCE: HORIZONTAL AT 3 M**

NO.	FREQ. (MHz)	EMISSION LEVEL (dBuV/m)	LIMIT (dBuV/m)	MARGIN (dB)	ANTENNA HEIGHT (m)	TABLE ANGLE (Degree)	RAW VALUE (dBuV)	CORRECTION FACTOR (dB/m)
1	33.66	23.9 QP	40.0	-16.1	1.55 H	169	33.50	-9.60
2	194.95	40.1 QP	43.5	-3.4	1.42 H	31	51.40	-11.30
3	260.59	42.9 QP	46.0	-3.1	1.43 H	82	51.80	-8.90
4	379.68	32.8 QP	46.0	-13.2	1.14 H	345	38.10	-5.30
5	695.91	37.6 QP	46.0	-8.4	1.06 H	315	36.20	1.40
6	1000.00	41.2 QP	54.0	-12.8	1.88 H	286	35.50	5.70

**ANTENNA POLARITY & TEST DISTANCE: VERTICAL AT 3 M**

NO.	FREQ. (MHz)	EMISSION LEVEL (dBuV/m)	LIMIT (dBuV/m)	MARGIN (dB)	ANTENNA HEIGHT (m)	TABLE ANGLE (Degree)	RAW VALUE (dBuV)	CORRECTION FACTOR (dB/m)
1	97.86	25.4 QP	43.5	-18.1	2.02 V	298	38.90	-13.50
2	195.66	33.6 QP	43.5	-9.9	1.61 V	214	45.00	-11.40
3	259.86	38.7 QP	46.0	-7.3	2.03 V	131	47.70	-9.00
4	325.85	32.4 QP	46.0	-13.6	1.01 V	60	38.80	-6.40
5	749.44	36.6 QP	46.0	-9.4	1.58 V	354	34.20	2.40
6	1000.00	38.9 QP	54.0	-15.1	1.02 V	283	33.20	5.70

**REMARKS:**

1. Emission Level(dBuV/m) = Raw Value(dBuV) + Correction Factor(dB/m)
2. Correction Factor(dB/m) = Antenna Factor(dB/m) + Cable Factor(dB) – Pre-Amplifier Factor(dB)
3. The other emission levels were very low against the limit.
4. Margin value = Emission Level – Limit value

<b>CHANNEL</b>	TX Channel 110	<b>DETECTOR FUNCTION</b>	Quasi-Peak (QP)
<b>FREQUENCY RANGE</b>	Below 1GHz		

**ANTENNA POLARITY & TEST DISTANCE: HORIZONTAL AT 3 M**

NO.	FREQ. (MHz)	EMISSION LEVEL (dBuV/m)	LIMIT (dBuV/m)	MARGIN (dB)	ANTENNA HEIGHT (m)	TABLE ANGLE (Degree)	RAW VALUE (dBuV)	CORRECTION FACTOR (dB/m)
1	33.99	23.9 QP	40.0	-16.1	1.52 H	179	33.40	-9.50
2	194.69	40.2 QP	43.5	-3.3	1.44 H	40	51.50	-11.30
3	260.27	42.5 QP	46.0	-3.5	1.44 H	61	51.40	-8.90
4	380.18	32.7 QP	46.0	-13.3	1.16 H	352	38.00	-5.30
5	695.62	37.9 QP	46.0	-8.1	1.02 H	340	36.50	1.40
6	1000.00	41.2 QP	54.0	-12.8	1.91 H	268	35.50	5.70

**ANTENNA POLARITY & TEST DISTANCE: VERTICAL AT 3 M**

NO.	FREQ. (MHz)	EMISSION LEVEL (dBuV/m)	LIMIT (dBuV/m)	MARGIN (dB)	ANTENNA HEIGHT (m)	TABLE ANGLE (Degree)	RAW VALUE (dBuV)	CORRECTION FACTOR (dB/m)
1	97.84	25.5 QP	43.5	-18.0	1.97 V	302	39.00	-13.50
2	195.54	33.6 QP	43.5	-9.9	1.60 V	222	45.00	-11.40
3	259.67	39.0 QP	46.0	-7.0	2.03 V	153	48.10	-9.10
4	325.67	32.2 QP	46.0	-13.8	1.00 V	56	38.60	-6.40
5	749.80	36.5 QP	46.0	-9.5	1.56 V	338	34.10	2.40
6	1000.00	38.8 QP	54.0	-15.2	1.04 V	303	33.10	5.70

**REMARKS:**

1. Emission Level(dBuV/m) = Raw Value(dBuV) + Correction Factor(dB/m)
2. Correction Factor(dB/m) = Antenna Factor(dB/m) + Cable Factor(dB) – Pre-Amplifier Factor(dB)
3. The other emission levels were very low against the limit.
4. Margin value = Emission Level – Limit value

<b>CHANNEL</b>	TX Channel 118	<b>DETECTOR FUNCTION</b>	Quasi-Peak (QP)
<b>FREQUENCY RANGE</b>	Below 1GHz		

**ANTENNA POLARITY & TEST DISTANCE: HORIZONTAL AT 3 M**

NO.	FREQ. (MHz)	EMISSION LEVEL (dBuV/m)	LIMIT (dBuV/m)	MARGIN (dB)	ANTENNA HEIGHT (m)	TABLE ANGLE (Degree)	RAW VALUE (dBuV)	CORRECTION FACTOR (dB/m)
1	33.72	24.2 QP	40.0	-15.8	1.47 H	182	33.80	-9.60
2	195.13	40.3 QP	43.5	-3.2	1.44 H	48	51.60	-11.30
3	260.20	42.7 QP	46.0	-3.3	1.46 H	72	51.60	-8.90
4	379.67	32.5 QP	46.0	-13.5	1.09 H	338	37.80	-5.30
5	695.60	37.7 QP	46.0	-8.3	1.07 H	339	36.30	1.40
6	1000.00	41.3 QP	54.0	-12.7	1.94 H	254	35.60	5.70

**ANTENNA POLARITY & TEST DISTANCE: VERTICAL AT 3 M**

NO.	FREQ. (MHz)	EMISSION LEVEL (dBuV/m)	LIMIT (dBuV/m)	MARGIN (dB)	ANTENNA HEIGHT (m)	TABLE ANGLE (Degree)	RAW VALUE (dBuV)	CORRECTION FACTOR (dB/m)
1	97.99	25.6 QP	43.5	-17.9	1.94 V	306	39.10	-13.50
2	195.78	34.0 QP	43.5	-9.5	1.67 V	223	45.40	-11.40
3	259.52	38.7 QP	46.0	-7.3	1.98 V	157	47.80	-9.10
4	325.99	32.2 QP	46.0	-13.8	1.00 V	59	38.60	-6.40
5	749.99	36.7 QP	46.0	-9.3	1.56 V	331	34.30	2.40
6	1000.00	38.5 QP	54.0	-15.5	1.04 V	287	32.80	5.70

**REMARKS:**

1. Emission Level(dBuV/m) = Raw Value(dBuV) + Correction Factor(dB/m)
2. Correction Factor(dB/m) = Antenna Factor(dB/m) + Cable Factor(dB) – Pre-Amplifier Factor(dB)
3. The other emission levels were very low against the limit.
4. Margin value = Emission Level – Limit value



<b>CHANNEL</b>	TX Channel 134	<b>DETECTOR FUNCTION</b>	Quasi-Peak (QP)
<b>FREQUENCY RANGE</b>	Below 1GHz		

**ANTENNA POLARITY & TEST DISTANCE: HORIZONTAL AT 3 M**

NO.	FREQ. (MHz)	EMISSION LEVEL (dBuV/m)	LIMIT (dBuV/m)	MARGIN (dB)	ANTENNA HEIGHT (m)	TABLE ANGLE (Degree)	RAW VALUE (dBuV)	CORRECTION FACTOR (dB/m)
1	33.66	23.9 QP	40.0	-16.1	1.54 H	178	33.50	-9.60
2	194.97	40.3 QP	43.5	-3.2	1.45 H	22	51.60	-11.30
3	260.36	43.0 QP	46.0	-3.0	1.43 H	63	51.90	-8.90
4	379.94	32.5 QP	46.0	-13.5	1.12 H	336	37.80	-5.30
5	695.78	37.6 QP	46.0	-8.4	1.07 H	332	36.20	1.40
6	1000.00	41.0 QP	54.0	-13.0	1.94 H	273	35.30	5.70

**ANTENNA POLARITY & TEST DISTANCE: VERTICAL AT 3 M**

NO.	FREQ. (MHz)	EMISSION LEVEL (dBuV/m)	LIMIT (dBuV/m)	MARGIN (dB)	ANTENNA HEIGHT (m)	TABLE ANGLE (Degree)	RAW VALUE (dBuV)	CORRECTION FACTOR (dB/m)
1	98.22	25.7 QP	43.5	-17.8	2.01 V	306	39.10	-13.40
2	196.05	33.7 QP	43.5	-9.8	1.69 V	207	45.10	-11.40
3	259.87	39.0 QP	46.0	-7.0	1.97 V	154	48.00	-9.00
4	325.95	32.1 QP	46.0	-13.9	1.04 V	55	38.50	-6.40
5	749.69	37.0 QP	46.0	-9.0	1.65 V	352	34.60	2.40
6	1000.00	38.8 QP	54.0	-15.2	1.01 V	276	33.10	5.70

**REMARKS:**

1. Emission Level(dBuV/m) = Raw Value(dBuV) + Correction Factor(dB/m)
2. Correction Factor(dB/m) = Antenna Factor(dB/m) + Cable Factor(dB) – Pre-Amplifier Factor(dB)
3. The other emission levels were very low against the limit.
4. Margin value = Emission Level – Limit value

<b>CHANNEL</b>	TX Channel 151	<b>DETECTOR FUNCTION</b>	Quasi-Peak (QP)
<b>FREQUENCY RANGE</b>	Below 1GHz		

**ANTENNA POLARITY & TEST DISTANCE: HORIZONTAL AT 3 M**

NO.	FREQ. (MHz)	EMISSION LEVEL (dBuV/m)	LIMIT (dBuV/m)	MARGIN (dB)	ANTENNA HEIGHT (m)	TABLE ANGLE (Degree)	RAW VALUE (dBuV)	CORRECTION FACTOR (dB/m)
1	33.61	24.3 QP	40.0	-15.7	1.47 H	172	33.90	-9.60
2	194.65	40.2 QP	43.5	-3.3	1.52 H	36	51.50	-11.30
3	260.16	42.6 QP	46.0	-3.4	1.37 H	86	51.50	-8.90
4	380.07	32.8 QP	46.0	-13.2	1.19 H	352	38.10	-5.30
5	695.70	38.0 QP	46.0	-8.0	1.08 H	336	36.60	1.40
6	1000.00	40.9 QP	54.0	-13.1	1.93 H	260	35.20	5.70

**ANTENNA POLARITY & TEST DISTANCE: VERTICAL AT 3 M**

NO.	FREQ. (MHz)	EMISSION LEVEL (dBuV/m)	LIMIT (dBuV/m)	MARGIN (dB)	ANTENNA HEIGHT (m)	TABLE ANGLE (Degree)	RAW VALUE (dBuV)	CORRECTION FACTOR (dB/m)
1	97.68	25.5 QP	43.5	-18.0	1.96 V	314	39.00	-13.50
2	195.93	34.0 QP	43.5	-9.5	1.61 V	216	45.40	-11.40
3	259.61	38.8 QP	46.0	-7.2	2.00 V	152	47.90	-9.10
4	326.01	32.6 QP	46.0	-13.4	1.04 V	58	39.00	-6.40
5	749.88	36.6 QP	46.0	-9.4	1.53 V	327	34.20	2.40
6	1000.00	38.9 QP	54.0	-15.1	1.02 V	287	33.20	5.70

**REMARKS:**

1. Emission Level(dBuV/m) = Raw Value(dBuV) + Correction Factor(dB/m)
2. Correction Factor(dB/m) = Antenna Factor(dB/m) + Cable Factor(dB) – Pre-Amplifier Factor(dB)
3. The other emission levels were very low against the limit.
4. Margin value = Emission Level – Limit value

<b>CHANNEL</b>	TX Channel 159	<b>DETECTOR FUNCTION</b>	Quasi-Peak (QP)
<b>FREQUENCY RANGE</b>	Below 1GHz		

**ANTENNA POLARITY & TEST DISTANCE: HORIZONTAL AT 3 M**

NO.	FREQ. (MHz)	EMISSION LEVEL (dBuV/m)	LIMIT (dBuV/m)	MARGIN (dB)	ANTENNA HEIGHT (m)	TABLE ANGLE (Degree)	RAW VALUE (dBuV)	CORRECTION FACTOR (dB/m)
1	33.90	24.3 QP	40.0	-15.7	1.51 H	173	33.80	-9.50
2	194.84	40.2 QP	43.5	-3.3	1.50 H	31	51.50	-11.30
3	260.49	42.8 QP	46.0	-3.2	1.40 H	85	51.70	-8.90
4	380.05	32.7 QP	46.0	-13.3	1.16 H	340	38.00	-5.30
5	695.96	37.6 QP	46.0	-8.4	1.06 H	313	36.20	1.40
6	1000.00	41.3 QP	54.0	-12.7	1.89 H	282	35.60	5.70

**ANTENNA POLARITY & TEST DISTANCE: VERTICAL AT 3 M**

NO.	FREQ. (MHz)	EMISSION LEVEL (dBuV/m)	LIMIT (dBuV/m)	MARGIN (dB)	ANTENNA HEIGHT (m)	TABLE ANGLE (Degree)	RAW VALUE (dBuV)	CORRECTION FACTOR (dB/m)
1	97.93	25.4 QP	43.5	-18.1	1.90 V	319	38.90	-13.50
2	195.95	33.8 QP	43.5	-9.7	1.67 V	217	45.20	-11.40
3	259.82	39.0 QP	46.0	-7.0	2.04 V	152	48.00	-9.00
4	325.61	32.6 QP	46.0	-13.4	1.04 V	32	39.00	-6.40
5	749.77	37.1 QP	46.0	-8.9	1.60 V	332	34.70	2.40
6	1000.00	38.9 QP	54.0	-15.1	1.00 V	294	33.20	5.70

**REMARKS:**

1. Emission Level(dBuV/m) = Raw Value(dBuV) + Correction Factor(dB/m)
2. Correction Factor(dB/m) = Antenna Factor(dB/m) + Cable Factor(dB) – Pre-Amplifier Factor(dB)
3. The other emission levels were very low against the limit.
4. Margin value = Emission Level – Limit value

802.11ac (VHT80)

<b>CHANNEL</b>	TX Channel 42	<b>DETECTOR FUNCTION</b>	Quasi-Peak (QP)
<b>FREQUENCY RANGE</b>	Below 1GHz		

**ANTENNA POLARITY & TEST DISTANCE: HORIZONTAL AT 3 M**

NO.	FREQ. (MHz)	EMISSION LEVEL (dBuV/m)	LIMIT (dBuV/m)	MARGIN (dB)	ANTENNA HEIGHT (m)	TABLE ANGLE (Degree)	RAW VALUE (dBuV)	CORRECTION FACTOR (dB/m)
1	34.03	23.9 QP	40.0	-16.1	1.51 H	180	33.40	-9.50
2	194.86	40.4 QP	43.5	-3.1	1.45 H	30	51.70	-11.30
3	260.47	42.6 QP	46.0	-3.4	1.39 H	77	51.50	-8.90
4	379.68	33.0 QP	46.0	-13.0	1.14 H	340	38.30	-5.30
5	695.72	37.4 QP	46.0	-8.6	1.05 H	319	36.00	1.40
6	1000.00	41.2 QP	54.0	-12.8	1.89 H	263	35.50	5.70

**ANTENNA POLARITY & TEST DISTANCE: VERTICAL AT 3 M**

NO.	FREQ. (MHz)	EMISSION LEVEL (dBuV/m)	LIMIT (dBuV/m)	MARGIN (dB)	ANTENNA HEIGHT (m)	TABLE ANGLE (Degree)	RAW VALUE (dBuV)	CORRECTION FACTOR (dB/m)
1	98.08	25.8 QP	43.5	-17.7	2.00 V	324	39.30	-13.50
2	195.93	33.9 QP	43.5	-9.6	1.62 V	210	45.30	-11.40
3	259.98	38.7 QP	46.0	-7.3	2.02 V	146	47.70	-9.00
4	325.58	32.5 QP	46.0	-13.5	1.00 V	56	38.90	-6.40
5	749.41	37.0 QP	46.0	-9.0	1.60 V	347	34.60	2.40
6	1000.00	39.0 QP	54.0	-15.0	1.02 V	291	33.30	5.70

**REMARKS:**

1. Emission Level(dBuV/m) = Raw Value(dBuV) + Correction Factor(dB/m)
2. Correction Factor(dB/m) = Antenna Factor(dB/m) + Cable Factor(dB) – Pre-Amplifier Factor(dB)
3. The other emission levels were very low against the limit.
4. Margin value = Emission Level – Limit value

<b>CHANNEL</b>	TX Channel 58	<b>DETECTOR FUNCTION</b>	Quasi-Peak (QP)
<b>FREQUENCY RANGE</b>	Below 1GHz		

**ANTENNA POLARITY & TEST DISTANCE: HORIZONTAL AT 3 M**

NO.	FREQ. (MHz)	EMISSION LEVEL (dBuV/m)	LIMIT (dBuV/m)	MARGIN (dB)	ANTENNA HEIGHT (m)	TABLE ANGLE (Degree)	RAW VALUE (dBuV)	CORRECTION FACTOR (dB/m)
1	33.69	24.0 QP	40.0	-16.0	1.46 H	155	33.60	-9.60
2	194.96	40.1 QP	43.5	-3.4	1.42 H	33	51.40	-11.30
3	260.45	42.7 QP	46.0	-3.3	1.36 H	56	51.60	-8.90
4	379.67	32.8 QP	46.0	-13.2	1.21 H	335	38.10	-5.30
5	695.81	37.5 QP	46.0	-8.5	1.00 H	342	36.10	1.40
6	1000.00	41.3 QP	54.0	-12.7	1.87 H	257	35.60	5.70

**ANTENNA POLARITY & TEST DISTANCE: VERTICAL AT 3 M**

NO.	FREQ. (MHz)	EMISSION LEVEL (dBuV/m)	LIMIT (dBuV/m)	MARGIN (dB)	ANTENNA HEIGHT (m)	TABLE ANGLE (Degree)	RAW VALUE (dBuV)	CORRECTION FACTOR (dB/m)
1	97.75	25.4 QP	43.5	-18.1	1.90 V	319	38.90	-13.50
2	195.53	33.9 QP	43.5	-9.6	1.65 V	223	45.30	-11.40
3	259.90	39.1 QP	46.0	-6.9	2.02 V	131	48.10	-9.00
4	325.73	32.3 QP	46.0	-13.7	1.06 V	48	38.70	-6.40
5	749.57	36.6 QP	46.0	-9.4	1.56 V	355	34.20	2.40
6	1000.00	38.9 QP	54.0	-15.1	1.03 V	301	33.20	5.70

**REMARKS:**

1. Emission Level(dBuV/m) = Raw Value(dBuV) + Correction Factor(dB/m)
2. Correction Factor(dB/m) = Antenna Factor(dB/m) + Cable Factor(dB) – Pre-Amplifier Factor(dB)
3. The other emission levels were very low against the limit.
4. Margin value = Emission Level – Limit value

<b>CHANNEL</b>	TX Channel 106	<b>DETECTOR FUNCTION</b>	Quasi-Peak (QP)
<b>FREQUENCY RANGE</b>	Below 1GHz		

**ANTENNA POLARITY & TEST DISTANCE: HORIZONTAL AT 3 M**

NO.	FREQ. (MHz)	EMISSION LEVEL (dBuV/m)	LIMIT (dBuV/m)	MARGIN (dB)	ANTENNA HEIGHT (m)	TABLE ANGLE (Degree)	RAW VALUE (dBuV)	CORRECTION FACTOR (dB/m)
1	33.48	24.4 QP	40.0	-15.6	1.51 H	174	34.00	-9.60
2	194.89	40.2 QP	43.5	-3.3	1.51 H	49	51.50	-11.30
3	260.06	42.5 QP	46.0	-3.5	1.45 H	69	51.40	-8.90
4	379.84	32.6 QP	46.0	-13.4	1.20 H	337	37.90	-5.30
5	696.07	37.9 QP	46.0	-8.1	1.08 H	330	36.50	1.40
6	1000.00	40.9 QP	54.0	-13.1	1.98 H	261	35.20	5.70

**ANTENNA POLARITY & TEST DISTANCE: VERTICAL AT 3 M**

NO.	FREQ. (MHz)	EMISSION LEVEL (dBuV/m)	LIMIT (dBuV/m)	MARGIN (dB)	ANTENNA HEIGHT (m)	TABLE ANGLE (Degree)	RAW VALUE (dBuV)	CORRECTION FACTOR (dB/m)
1	97.91	25.4 QP	43.5	-18.1	1.91 V	294	38.90	-13.50
2	196.08	34.1 QP	43.5	-9.4	1.63 V	223	45.50	-11.40
3	259.73	38.5 QP	46.0	-7.5	2.04 V	151	47.60	-9.10
4	325.65	32.0 QP	46.0	-14.0	1.02 V	57	38.40	-6.40
5	749.94	36.6 QP	46.0	-9.4	1.57 V	349	34.20	2.40
6	1000.00	38.7 QP	54.0	-15.3	1.00 V	288	33.00	5.70

**REMARKS:**

1. Emission Level(dBuV/m) = Raw Value(dBuV) + Correction Factor(dB/m)
2. Correction Factor(dB/m) = Antenna Factor(dB/m) + Cable Factor(dB) – Pre-Amplifier Factor(dB)
3. The other emission levels were very low against the limit.
4. Margin value = Emission Level – Limit value

<b>CHANNEL</b>	TX Channel 122	<b>DETECTOR FUNCTION</b>	Quasi-Peak (QP)
<b>FREQUENCY RANGE</b>	Below 1GHz		

**ANTENNA POLARITY & TEST DISTANCE: HORIZONTAL AT 3 M**

NO.	FREQ. (MHz)	EMISSION LEVEL (dBuV/m)	LIMIT (dBuV/m)	MARGIN (dB)	ANTENNA HEIGHT (m)	TABLE ANGLE (Degree)	RAW VALUE (dBuV)	CORRECTION FACTOR (dB/m)
1	33.78	24.3 QP	40.0	-15.7	1.52 H	154	33.90	-9.60
2	194.64	40.2 QP	43.5	-3.3	1.43 H	44	51.50	-11.30
3	260.59	42.5 QP	46.0	-3.5	1.43 H	57	51.40	-8.90
4	379.87	32.4 QP	46.0	-13.6	1.17 H	331	37.70	-5.30
5	696.00	37.8 QP	46.0	-8.2	1.06 H	337	36.40	1.40
6	1000.00	41.2 QP	54.0	-12.8	1.95 H	263	35.50	5.70

**ANTENNA POLARITY & TEST DISTANCE: VERTICAL AT 3 M**

NO.	FREQ. (MHz)	EMISSION LEVEL (dBuV/m)	LIMIT (dBuV/m)	MARGIN (dB)	ANTENNA HEIGHT (m)	TABLE ANGLE (Degree)	RAW VALUE (dBuV)	CORRECTION FACTOR (dB/m)
1	97.70	25.4 QP	43.5	-18.1	1.93 V	313	38.90	-13.50
2	195.78	33.7 QP	43.5	-9.8	1.67 V	218	45.10	-11.40
3	259.67	38.9 QP	46.0	-7.1	1.99 V	147	48.00	-9.10
4	325.95	32.3 QP	46.0	-13.7	1.06 V	57	38.70	-6.40
5	749.90	36.7 QP	46.0	-9.3	1.55 V	339	34.30	2.40
6	1000.00	38.6 QP	54.0	-15.4	1.00 V	303	32.90	5.70

**REMARKS:**

1. Emission Level(dBuV/m) = Raw Value(dBuV) + Correction Factor(dB/m)
2. Correction Factor(dB/m) = Antenna Factor(dB/m) + Cable Factor(dB) – Pre-Amplifier Factor(dB)
3. The other emission levels were very low against the limit.
4. Margin value = Emission Level – Limit value

<b>CHANNEL</b>	TX Channel 138	<b>DETECTOR FUNCTION</b>	Quasi-Peak (QP)
<b>FREQUENCY RANGE</b>	Below 1GHz		

**ANTENNA POLARITY & TEST DISTANCE: HORIZONTAL AT 3 M**

NO.	FREQ. (MHz)	EMISSION LEVEL (dBuV/m)	LIMIT (dBuV/m)	MARGIN (dB)	ANTENNA HEIGHT (m)	TABLE ANGLE (Degree)	RAW VALUE (dBuV)	CORRECTION FACTOR (dB/m)
1	33.48	24.0 QP	40.0	-16.0	1.49 H	175	33.60	-9.60
2	194.71	39.9 QP	43.5	-3.6	1.53 H	49	51.20	-11.30
3	260.48	42.8 QP	46.0	-3.2	1.46 H	70	51.70	-8.90
4	379.94	32.4 QP	46.0	-13.6	1.11 H	350	37.70	-5.30
5	695.97	37.4 QP	46.0	-8.6	1.00 H	339	36.00	1.40
6	1000.00	41.3 QP	54.0	-12.7	1.93 H	271	35.60	5.70

**ANTENNA POLARITY & TEST DISTANCE: VERTICAL AT 3 M**

NO.	FREQ. (MHz)	EMISSION LEVEL (dBuV/m)	LIMIT (dBuV/m)	MARGIN (dB)	ANTENNA HEIGHT (m)	TABLE ANGLE (Degree)	RAW VALUE (dBuV)	CORRECTION FACTOR (dB/m)
1	97.90	25.8 QP	43.5	-17.7	1.94 V	320	39.30	-13.50
2	195.57	33.6 QP	43.5	-9.9	1.62 V	228	45.00	-11.40
3	260.07	39.0 QP	46.0	-7.0	1.95 V	145	47.90	-8.90
4	325.55	32.4 QP	46.0	-13.6	1.04 V	42	38.80	-6.40
5	749.69	36.5 QP	46.0	-9.5	1.60 V	354	34.10	2.40
6	1000.00	39.1 QP	54.0	-14.9	1.00 V	290	33.40	5.70

**REMARKS:**

1. Emission Level(dBuV/m) = Raw Value(dBuV) + Correction Factor(dB/m)
2. Correction Factor(dB/m) = Antenna Factor(dB/m) + Cable Factor(dB) – Pre-Amplifier Factor(dB)
3. The other emission levels were very low against the limit.
4. Margin value = Emission Level – Limit value



<b>CHANNEL</b>	TX Channel 155	<b>DETECTOR FUNCTION</b>	Quasi-Peak (QP)
<b>FREQUENCY RANGE</b>	Below 1GHz		

**ANTENNA POLARITY & TEST DISTANCE: HORIZONTAL AT 3 M**

NO.	FREQ. (MHz)	EMISSION LEVEL (dBuV/m)	LIMIT (dBuV/m)	MARGIN (dB)	ANTENNA HEIGHT (m)	TABLE ANGLE (Degree)	RAW VALUE (dBuV)	CORRECTION FACTOR (dB/m)
1	34.00	24.3 QP	40.0	-15.7	1.44 H	151	33.80	-9.50
2	194.99	40.0 QP	43.5	-3.5	1.42 H	23	51.30	-11.30
3	260.39	42.9 QP	46.0	-3.1	1.40 H	59	51.80	-8.90
4	379.87	32.9 QP	46.0	-13.1	1.10 H	328	38.20	-5.30
5	695.84	37.4 QP	46.0	-8.6	1.07 H	335	36.00	1.40
6	1000.00	40.8 QP	54.0	-13.2	1.95 H	280	35.10	5.70

**ANTENNA POLARITY & TEST DISTANCE: VERTICAL AT 3 M**

NO.	FREQ. (MHz)	EMISSION LEVEL (dBuV/m)	LIMIT (dBuV/m)	MARGIN (dB)	ANTENNA HEIGHT (m)	TABLE ANGLE (Degree)	RAW VALUE (dBuV)	CORRECTION FACTOR (dB/m)
1	98.22	25.5 QP	43.5	-18.0	1.99 V	303	38.90	-13.40
2	195.49	33.9 QP	43.5	-9.6	1.64 V	218	45.30	-11.40
3	259.77	38.7 QP	46.0	-7.3	2.00 V	153	47.80	-9.10
4	326.01	32.1 QP	46.0	-13.9	1.00 V	41	38.50	-6.40
5	749.86	36.9 QP	46.0	-9.1	1.63 V	327	34.50	2.40
6	1000.00	39.0 QP	54.0	-15.0	1.00 V	291	33.30	5.70

**REMARKS:**

1. Emission Level(dBuV/m) = Raw Value(dBuV) + Correction Factor(dB/m)
2. Correction Factor(dB/m) = Antenna Factor(dB/m) + Cable Factor(dB) – Pre-Amplifier Factor(dB)
3. The other emission levels were very low against the limit.
4. Margin value = Emission Level – Limit value

4.1.9 Test Results (Mode 3)

Above 1GHz Data

802.11a

<b>CHANNEL</b>	TX Channel 36	<b>DETECTOR FUNCTION</b>	Peak (PK)
<b>FREQUENCY RANGE</b>	1GHz ~ 40GHz		Average (AV)

**ANTENNA POLARITY & TEST DISTANCE: HORIZONTAL AT 3 M**

NO.	FREQ. (MHz)	EMISSION LEVEL (dBuV/m)	LIMIT (dBuV/m)	MARGIN (dB)	ANTENNA HEIGHT (m)	TABLE ANGLE (Degree)	RAW VALUE (dBuV)	CORRECTION FACTOR (dB/m)
1	5150.00	64.3 PK	74.0	-9.7	1.50 H	241	57.83	6.47
2	5150.00	49.4 AV	54.0	-4.6	1.50 H	241	42.93	6.47
3	*5180.00	104.6 PK			1.50 H	241	97.95	6.65
4	*5180.00	94.5 AV			1.50 H	241	87.85	6.65
5	#10360.00	51.1 PK	74.0	-22.9	1.72 H	282	36.89	14.21
6	#10360.00	37.8 AV	54.0	-16.2	1.72 H	282	23.59	14.21
7	15540.00	53.3 PK	74.0	-20.7	1.76 H	214	34.54	18.76
8	15540.00	38.9 AV	54.0	-15.1	1.76 H	214	20.14	18.76

**ANTENNA POLARITY & TEST DISTANCE: VERTICAL AT 3 M**

NO.	FREQ. (MHz)	EMISSION LEVEL (dBuV/m)	LIMIT (dBuV/m)	MARGIN (dB)	ANTENNA HEIGHT (m)	TABLE ANGLE (Degree)	RAW VALUE (dBuV)	CORRECTION FACTOR (dB/m)
1	5150.00	67.5 PK	74.0	-6.5	1.48 V	60	61.03	6.47
2	<b>5150.00</b>	<b>53.0 AV</b>	<b>54.0</b>	<b>-1.0</b>	<b>1.48 V</b>	<b>60</b>	<b>46.53</b>	<b>6.47</b>
3	*5180.00	108.4 PK			1.48 V	60	101.75	6.65
4	*5180.00	98.5 AV			1.48 V	60	91.85	6.65
5	#10360.00	51.2 PK	74.0	-22.8	2.11 V	326	36.99	14.21
6	#10360.00	37.9 AV	54.0	-16.1	2.11 V	326	23.69	14.21
7	15540.00	55.2 PK	74.0	-18.8	1.83 V	34	36.44	18.76
8	15540.00	39.7 AV	54.0	-14.3	1.83 V	34	20.94	18.76

**REMARKS:**

1. Emission Level(dBuV/m) = Raw Value(dBuV) + Correction Factor(dB/m)
2. Correction Factor(dB/m) = Antenna Factor(dB/m) + Cable Factor(dB) – Pre-Amplifier Factor(dB)
3. The other emission levels were very low against the limit.
4. Margin value = Emission Level – Limit value
5. " \* ": Fundamental frequency.
6. " # ": The radiated frequency is out of the restricted band.

<b>CHANNEL</b>	TX Channel 40	<b>DETECTOR FUNCTION</b>	Peak (PK)
<b>FREQUENCY RANGE</b>	1GHz ~ 40GHz		Average (AV)

**ANTENNA POLARITY & TEST DISTANCE: HORIZONTAL AT 3 M**

NO.	FREQ. (MHz)	EMISSION LEVEL (dBuV/m)	LIMIT (dBuV/m)	MARGIN (dB)	ANTENNA HEIGHT (m)	TABLE ANGLE (Degree)	RAW VALUE (dBuV)	CORRECTION FACTOR (dB/m)
1	*5200.00	107.8 PK			1.55 H	253	101.03	6.77
2	*5200.00	97.8 AV			1.55 H	253	91.03	6.77
3	#10400.00	50.7 PK	74.0	-23.3	1.72 H	288	36.48	14.22
4	#10400.00	37.5 AV	54.0	-16.5	1.72 H	288	23.28	14.22
5	15600.00	53.6 PK	74.0	-20.4	1.75 H	218	35.26	18.34
6	15600.00	39.1 AV	54.0	-14.9	1.75 H	218	20.76	18.34

**ANTENNA POLARITY & TEST DISTANCE: VERTICAL AT 3 M**

NO.	FREQ. (MHz)	EMISSION LEVEL (dBuV/m)	LIMIT (dBuV/m)	MARGIN (dB)	ANTENNA HEIGHT (m)	TABLE ANGLE (Degree)	RAW VALUE (dBuV)	CORRECTION FACTOR (dB/m)
1	*5200.00	112.4 PK			1.51 V	284	105.63	6.77
2	*5200.00	102.0 AV			1.51 V	284	95.23	6.77
3	#10400.00	51.5 PK	74.0	-22.5	2.10 V	322	37.28	14.22
4	#10400.00	38.0 AV	54.0	-16.0	2.10 V	322	23.78	14.22
5	15600.00	55.1 PK	74.0	-18.9	1.80 V	48	36.76	18.34
6	15600.00	39.7 AV	54.0	-14.3	1.80 V	48	21.36	18.34

**REMARKS:**

1. Emission Level(dBuV/m) = Raw Value(dBuV) + Correction Factor(dB/m)
2. Correction Factor(dB/m) = Antenna Factor(dB/m) + Cable Factor(dB) – Pre-Amplifier Factor(dB)
3. The other emission levels were very low against the limit.
4. Margin value = Emission Level – Limit value
5. " \* ": Fundamental frequency.
6. " # ": The radiated frequency is out of the restricted band.

<b>CHANNEL</b>	TX Channel 48	<b>DETECTOR FUNCTION</b>	Peak (PK)
<b>FREQUENCY RANGE</b>	1GHz ~ 40GHz		Average (AV)

**ANTENNA POLARITY & TEST DISTANCE: HORIZONTAL AT 3 M**

NO.	FREQ. (MHz)	EMISSION LEVEL (dBuV/m)	LIMIT (dBuV/m)	MARGIN (dB)	ANTENNA HEIGHT (m)	TABLE ANGLE (Degree)	RAW VALUE (dBuV)	CORRECTION FACTOR (dB/m)
1	*5240.00	107.5 PK			1.47 H	245	100.68	6.82
2	*5240.00	97.5 AV			1.47 H	245	90.68	6.82
3	#10480.00	50.8 PK	74.0	-23.2	1.69 H	273	36.81	13.99
4	#10480.00	37.5 AV	54.0	-16.5	1.69 H	273	23.51	13.99
5	15720.00	53.0 PK	74.0	-21.0	1.76 H	234	33.97	19.03
6	15720.00	38.6 AV	54.0	-15.4	1.76 H	234	19.57	19.03

**ANTENNA POLARITY & TEST DISTANCE: VERTICAL AT 3 M**

NO.	FREQ. (MHz)	EMISSION LEVEL (dBuV/m)	LIMIT (dBuV/m)	MARGIN (dB)	ANTENNA HEIGHT (m)	TABLE ANGLE (Degree)	RAW VALUE (dBuV)	CORRECTION FACTOR (dB/m)
1	*5240.00	112.2 PK			1.52 V	283	105.38	6.82
2	*5240.00	102.1 AV			1.52 V	283	95.28	6.82
3	#10480.00	51.1 PK	74.0	-22.9	2.06 V	323	37.11	13.99
4	#10480.00	37.8 AV	54.0	-16.2	2.06 V	323	23.81	13.99
5	15720.00	55.1 PK	74.0	-18.9	1.84 V	58	36.07	19.03
6	15720.00	39.6 AV	54.0	-14.4	1.84 V	58	20.57	19.03

**REMARKS:**

1. Emission Level(dBuV/m) = Raw Value(dBuV) + Correction Factor(dB/m)
2. Correction Factor(dB/m) = Antenna Factor(dB/m) + Cable Factor(dB) – Pre-Amplifier Factor(dB)
3. The other emission levels were very low against the limit.
4. Margin value = Emission Level – Limit value
5. " \* ": Fundamental frequency.
6. " # ": The radiated frequency is out of the restricted band.

<b>CHANNEL</b>	TX Channel 52	<b>DETECTOR FUNCTION</b>	Peak (PK)
<b>FREQUENCY RANGE</b>	1GHz ~ 40GHz		Average (AV)

**ANTENNA POLARITY & TEST DISTANCE: HORIZONTAL AT 3 M**

NO.	FREQ. (MHz)	EMISSION LEVEL (dBuV/m)	LIMIT (dBuV/m)	MARGIN (dB)	ANTENNA HEIGHT (m)	TABLE ANGLE (Degree)	RAW VALUE (dBuV)	CORRECTION FACTOR (dB/m)
1	*5260.00	108.0 PK			1.45 H	246	101.15	6.85
2	*5260.00	97.7 AV			1.45 H	246	90.85	6.85
3	#10520.00	51.0 PK	74.0	-23.0	1.68 H	297	37.17	13.83
4	#10520.00	37.6 AV	54.0	-16.4	1.68 H	297	23.77	13.83
5	15780.00	53.4 PK	74.0	-20.6	1.74 H	215	34.04	19.36
6	15780.00	38.7 AV	54.0	-15.3	1.74 H	215	19.34	19.36

**ANTENNA POLARITY & TEST DISTANCE: VERTICAL AT 3 M**

NO.	FREQ. (MHz)	EMISSION LEVEL (dBuV/m)	LIMIT (dBuV/m)	MARGIN (dB)	ANTENNA HEIGHT (m)	TABLE ANGLE (Degree)	RAW VALUE (dBuV)	CORRECTION FACTOR (dB/m)
1	*5260.00	113.5 PK			1.50 V	287	106.65	6.85
2	*5260.00	103.1 AV			1.50 V	287	96.25	6.85
3	#10520.00	52.1 PK	74.0	-21.9	2.10 V	307	38.27	13.83
4	#10520.00	38.5 AV	54.0	-15.5	2.10 V	307	24.67	13.83
5	15780.00	55.2 PK	74.0	-18.8	1.79 V	59	35.84	19.36
6	15780.00	39.9 AV	54.0	-14.1	1.79 V	59	20.54	19.36

**REMARKS:**

1. Emission Level(dBuV/m) = Raw Value(dBuV) + Correction Factor(dB/m)
2. Correction Factor(dB/m) = Antenna Factor(dB/m) + Cable Factor(dB) – Pre-Amplifier Factor(dB)
3. The other emission levels were very low against the limit.
4. Margin value = Emission Level – Limit value
5. " \* ": Fundamental frequency.
6. " # ": The radiated frequency is out of the restricted band.

<b>CHANNEL</b>	TX Channel 60	<b>DETECTOR FUNCTION</b>	Peak (PK)
<b>FREQUENCY RANGE</b>	1GHz ~ 40GHz		Average (AV)

**ANTENNA POLARITY & TEST DISTANCE: HORIZONTAL AT 3 M**

NO.	FREQ. (MHz)	EMISSION LEVEL (dBuV/m)	LIMIT (dBuV/m)	MARGIN (dB)	ANTENNA HEIGHT (m)	TABLE ANGLE (Degree)	RAW VALUE (dBuV)	CORRECTION FACTOR (dB/m)
1	*5300.00	107.7 PK			1.49 H	243	100.80	6.90
2	*5300.00	97.6 AV			1.49 H	243	90.70	6.90
3	5350.00	59.1 PK	74.0	-14.9	1.49 H	243	52.06	7.04
4	5350.00	45.6 AV	54.0	-8.4	1.49 H	243	38.56	7.04
5	10600.00	50.4 PK	74.0	-23.6	1.75 H	273	36.96	13.44
6	10600.00	37.1 AV	54.0	-16.9	1.75 H	273	23.66	13.44
7	15900.00	53.5 PK	74.0	-20.5	1.76 H	221	34.49	19.01
8	15900.00	38.9 AV	54.0	-15.1	1.76 H	221	19.89	19.01

**ANTENNA POLARITY & TEST DISTANCE: VERTICAL AT 3 M**

NO.	FREQ. (MHz)	EMISSION LEVEL (dBuV/m)	LIMIT (dBuV/m)	MARGIN (dB)	ANTENNA HEIGHT (m)	TABLE ANGLE (Degree)	RAW VALUE (dBuV)	CORRECTION FACTOR (dB/m)
1	*5300.00	113.4 PK			1.50 V	288	106.50	6.90
2	*5300.00	103.1 AV			1.50 V	288	96.20	6.90
3	5350.00	67.7 PK	74.0	-6.3	1.50 V	288	60.66	7.04
4	5350.00	50.0 AV	54.0	-4.0	1.50 V	288	42.96	7.04
5	10600.00	51.0 PK	74.0	-23.0	2.05 V	330	37.56	13.44
6	10600.00	37.6 AV	54.0	-16.4	2.05 V	330	24.16	13.44
7	15900.00	55.1 PK	74.0	-18.9	1.75 V	64	36.09	19.01
8	15900.00	39.4 AV	54.0	-14.6	1.75 V	64	20.39	19.01

**REMARKS:**

1. Emission Level(dBuV/m) = Raw Value(dBuV) + Correction Factor(dB/m)
2. Correction Factor(dB/m) = Antenna Factor(dB/m) + Cable Factor(dB) – Pre-Amplifier Factor(dB)
3. The other emission levels were very low against the limit.
4. Margin value = Emission Level – Limit value
5. " \* ": Fundamental frequency.

<b>CHANNEL</b>	TX Channel 64	<b>DETECTOR FUNCTION</b>	Peak (PK)
<b>FREQUENCY RANGE</b>	1GHz ~ 40GHz		Average (AV)

**ANTENNA POLARITY & TEST DISTANCE: HORIZONTAL AT 3 M**

NO.	FREQ. (MHz)	EMISSION LEVEL (dBuV/m)	LIMIT (dBuV/m)	MARGIN (dB)	ANTENNA HEIGHT (m)	TABLE ANGLE (Degree)	RAW VALUE (dBuV)	CORRECTION FACTOR (dB/m)
1	*5320.00	107.2 PK			1.49 H	226	100.23	6.97
2	*5320.00	96.0 AV			1.49 H	226	89.03	6.97
3	5350.00	64.0 PK	74.0	-10.0	1.49 H	226	56.96	7.04
4	5350.00	49.3 AV	54.0	-4.7	1.49 H	226	42.26	7.04
5	10640.00	51.0 PK	74.0	-23.0	1.67 H	275	37.33	13.67
6	10640.00	37.9 AV	54.0	-16.1	1.67 H	275	24.23	13.67
7	15960.00	54.1 PK	74.0	-19.9	1.78 H	232	35.26	18.84
8	15960.00	39.3 AV	54.0	-14.7	1.78 H	232	20.46	18.84

**ANTENNA POLARITY & TEST DISTANCE: VERTICAL AT 3 M**

NO.	FREQ. (MHz)	EMISSION LEVEL (dBuV/m)	LIMIT (dBuV/m)	MARGIN (dB)	ANTENNA HEIGHT (m)	TABLE ANGLE (Degree)	RAW VALUE (dBuV)	CORRECTION FACTOR (dB/m)
1	*5320.00	111.1 PK			1.47 V	285	104.13	6.97
2	*5320.00	100.9 AV			1.47 V	285	93.93	6.97
3	5350.00	70.2 PK	74.0	-3.8	1.47 V	285	63.16	7.04
4	5350.00	52.9 AV	54.0	-1.1	1.47 V	285	45.86	7.04
5	10640.00	51.3 PK	74.0	-22.7	2.08 V	315	37.63	13.67
6	10640.00	37.7 AV	54.0	-16.3	2.08 V	315	24.03	13.67
7	15960.00	55.2 PK	74.0	-18.8	1.83 V	56	36.36	18.84
8	15960.00	39.6 AV	54.0	-14.4	1.83 V	56	20.76	18.84

**REMARKS:**

1. Emission Level(dBuV/m) = Raw Value(dBuV) + Correction Factor(dB/m)
2. Correction Factor(dB/m) = Antenna Factor(dB/m) + Cable Factor(dB) – Pre-Amplifier Factor(dB)
3. The other emission levels were very low against the limit.
4. Margin value = Emission Level – Limit value
5. " \* ": Fundamental frequency.

<b>CHANNEL</b>	TX Channel 100	<b>DETECTOR FUNCTION</b>	Peak (PK)
<b>FREQUENCY RANGE</b>	1GHz ~ 40GHz		Average (AV)

**ANTENNA POLARITY & TEST DISTANCE: HORIZONTAL AT 3 M**

NO.	FREQ. (MHz)	EMISSION LEVEL (dBuV/m)	LIMIT (dBuV/m)	MARGIN (dB)	ANTENNA HEIGHT (m)	TABLE ANGLE (Degree)	RAW VALUE (dBuV)	CORRECTION FACTOR (dB/m)
1	#5470.00	62.3 PK	74.0	-11.7	1.47 H	254	55.01	7.29
2	#5470.00	49.5 AV	54.0	-4.5	1.47 H	254	42.21	7.29
3	*5500.00	107.0 PK			1.47 H	254	99.67	7.33
4	*5500.00	95.7 AV			1.47 H	254	88.37	7.33
5	11000.00	50.8 PK	74.0	-23.2	1.68 H	297	36.57	14.23
6	11000.00	37.4 AV	54.0	-16.6	1.68 H	297	23.17	14.23
7	#16500.00	53.7 PK	74.0	-20.3	1.70 H	231	32.73	20.97
8	#16500.00	39.2 AV	54.0	-14.8	1.70 H	231	18.23	20.97

**ANTENNA POLARITY & TEST DISTANCE: VERTICAL AT 3 M**

NO.	FREQ. (MHz)	EMISSION LEVEL (dBuV/m)	LIMIT (dBuV/m)	MARGIN (dB)	ANTENNA HEIGHT (m)	TABLE ANGLE (Degree)	RAW VALUE (dBuV)	CORRECTION FACTOR (dB/m)
1	#5470.00	67.1 PK	74.0	-6.9	1.47 V	221	59.81	7.29
2	#5470.00	52.9 AV	54.0	-1.1	1.47 V	221	45.61	7.29
3	*5500.00	110.2 PK			1.47 V	221	102.87	7.33
4	*5500.00	100.2 AV			1.47 V	221	92.87	7.33
5	11000.00	51.2 PK	74.0	-22.8	2.12 V	332	36.97	14.23
6	11000.00	37.7 AV	54.0	-16.3	2.12 V	332	23.47	14.23
7	#16500.00	55.5 PK	74.0	-18.5	1.84 V	59	34.53	20.97
8	#16500.00	40.2 AV	54.0	-13.8	1.84 V	59	19.23	20.97

**REMARKS:**

1. Emission Level(dBuV/m) = Raw Value(dBuV) + Correction Factor(dB/m)
2. Correction Factor(dB/m) = Antenna Factor(dB/m) + Cable Factor(dB) – Pre-Amplifier Factor(dB)
3. The other emission levels were very low against the limit.
4. Margin value = Emission Level – Limit value
5. " \* ": Fundamental frequency.
6. " # ": The radiated frequency is out of the restricted band.



<b>CHANNEL</b>	TX Channel 116	<b>DETECTOR FUNCTION</b>	Peak (PK)
<b>FREQUENCY RANGE</b>	1GHz ~ 40GHz		Average (AV)

**ANTENNA POLARITY & TEST DISTANCE: HORIZONTAL AT 3 M**

NO.	FREQ. (MHz)	EMISSION LEVEL (dBuV/m)	LIMIT (dBuV/m)	MARGIN (dB)	ANTENNA HEIGHT (m)	TABLE ANGLE (Degree)	RAW VALUE (dBuV)	CORRECTION FACTOR (dB/m)
1	*5580.00	108.1 PK			1.48 H	243	100.92	7.18
2	*5580.00	98.2 AV			1.48 H	243	91.02	7.18
3	11160.00	50.3 PK	74.0	-23.7	1.74 H	282	35.84	14.46
4	11160.00	37.4 AV	54.0	-16.6	1.74 H	282	22.94	14.46
5	#16740.00	53.2 PK	74.0	-20.8	1.69 H	228	31.24	21.96
6	#16740.00	39.0 AV	54.0	-15.0	1.69 H	228	17.04	21.96

**ANTENNA POLARITY & TEST DISTANCE: VERTICAL AT 3 M**

NO.	FREQ. (MHz)	EMISSION LEVEL (dBuV/m)	LIMIT (dBuV/m)	MARGIN (dB)	ANTENNA HEIGHT (m)	TABLE ANGLE (Degree)	RAW VALUE (dBuV)	CORRECTION FACTOR (dB/m)
1	*5580.00	112.6 PK			1.54 V	223	105.42	7.18
2	*5580.00	102.3 AV			1.54 V	223	95.12	7.18
3	11160.00	51.9 PK	74.0	-22.1	2.10 V	332	37.44	14.46
4	11160.00	38.3 AV	54.0	-15.7	2.10 V	332	23.84	14.46
5	#16740.00	55.5 PK	74.0	-18.5	1.78 V	32	33.54	21.96
6	#16740.00	40.1 AV	54.0	-13.9	1.78 V	32	18.14	21.96

**REMARKS:**

1. Emission Level(dBuV/m) = Raw Value(dBuV) + Correction Factor(dB/m)
2. Correction Factor(dB/m) = Antenna Factor(dB/m) + Cable Factor(dB) – Pre-Amplifier Factor(dB)
3. The other emission levels were very low against the limit.
4. Margin value = Emission Level – Limit value
5. " \* ": Fundamental frequency.
6. " # ": The radiated frequency is out of the restricted band.

<b>CHANNEL</b>	TX Channel 120	<b>DETECTOR FUNCTION</b>	Peak (PK)
<b>FREQUENCY RANGE</b>	1GHz ~ 40GHz		Average (AV)

**ANTENNA POLARITY & TEST DISTANCE: HORIZONTAL AT 3 M**

NO.	FREQ. (MHz)	EMISSION LEVEL (dBuV/m)	LIMIT (dBuV/m)	MARGIN (dB)	ANTENNA HEIGHT (m)	TABLE ANGLE (Degree)	RAW VALUE (dBuV)	CORRECTION FACTOR (dB/m)
1	*5600.00	108.1 PK			1.45 H	236	100.97	7.13
2	*5600.00	98.3 AV			1.45 H	236	91.17	7.13
3	11200.00	50.7 PK	74.0	-23.3	1.77 H	281	36.23	14.47
4	11200.00	37.8 AV	54.0	-16.2	1.77 H	281	23.33	14.47
5	#16800.00	53.8 PK	74.0	-20.2	1.76 H	206	31.70	22.10
6	#16800.00	39.5 AV	54.0	-14.5	1.76 H	206	17.40	22.10

**ANTENNA POLARITY & TEST DISTANCE: VERTICAL AT 3 M**

NO.	FREQ. (MHz)	EMISSION LEVEL (dBuV/m)	LIMIT (dBuV/m)	MARGIN (dB)	ANTENNA HEIGHT (m)	TABLE ANGLE (Degree)	RAW VALUE (dBuV)	CORRECTION FACTOR (dB/m)
1	*5600.00	113.0 PK			1.53 V	237	105.87	7.13
2	*5600.00	102.3 AV			1.53 V	237	95.17	7.13
3	11200.00	51.6 PK	74.0	-22.4	2.14 V	316	37.13	14.47
4	11200.00	38.2 AV	54.0	-15.8	2.14 V	316	23.73	14.47
5	#16800.00	54.8 PK	74.0	-19.2	1.75 V	48	32.70	22.10
6	#16800.00	39.4 AV	54.0	-14.6	1.75 V	48	17.30	22.10

**REMARKS:**

1. Emission Level(dBuV/m) = Raw Value(dBuV) + Correction Factor(dB/m)
2. Correction Factor(dB/m) = Antenna Factor(dB/m) + Cable Factor(dB) – Pre-Amplifier Factor(dB)
3. The other emission levels were very low against the limit.
4. Margin value = Emission Level – Limit value
5. " \* ": Fundamental frequency.
6. " # ": The radiated frequency is out of the restricted band.

<b>CHANNEL</b>	TX Channel 132	<b>DETECTOR FUNCTION</b>	Peak (PK)
<b>FREQUENCY RANGE</b>	1GHz ~ 40GHz		Average (AV)

**ANTENNA POLARITY & TEST DISTANCE: HORIZONTAL AT 3 M**

NO.	FREQ. (MHz)	EMISSION LEVEL (dBuV/m)	LIMIT (dBuV/m)	MARGIN (dB)	ANTENNA HEIGHT (m)	TABLE ANGLE (Degree)	RAW VALUE (dBuV)	CORRECTION FACTOR (dB/m)
1	*5660.00	108.1 PK			1.48 H	226	100.82	7.28
2	*5660.00	98.2 AV			1.48 H	226	90.92	7.28
3	11320.00	50.9 PK	74.0	-23.1	1.68 H	273	36.44	14.46
4	11320.00	37.9 AV	54.0	-16.1	1.68 H	273	23.44	14.46
5	#16980.00	53.4 PK	74.0	-20.6	1.72 H	203	30.17	23.23
6	#16980.00	38.8 AV	54.0	-15.2	1.72 H	203	15.57	23.23

**ANTENNA POLARITY & TEST DISTANCE: VERTICAL AT 3 M**

NO.	FREQ. (MHz)	EMISSION LEVEL (dBuV/m)	LIMIT (dBuV/m)	MARGIN (dB)	ANTENNA HEIGHT (m)	TABLE ANGLE (Degree)	RAW VALUE (dBuV)	CORRECTION FACTOR (dB/m)
1	*5660.00	112.5 PK			1.50 V	223	105.22	7.28
2	*5660.00	102.1 AV			1.50 V	223	94.82	7.28
3	11320.00	51.5 PK	74.0	-22.5	2.08 V	320	37.04	14.46
4	11320.00	37.9 AV	54.0	-16.1	2.08 V	320	23.44	14.46
5	#16980.00	54.4 PK	74.0	-19.6	1.80 V	51	31.17	23.23
6	#16980.00	39.3 AV	54.0	-14.7	1.80 V	51	16.07	23.23

**REMARKS:**

1. Emission Level(dBuV/m) = Raw Value(dBuV) + Correction Factor(dB/m)
2. Correction Factor(dB/m) = Antenna Factor(dB/m) + Cable Factor(dB) – Pre-Amplifier Factor(dB)
3. The other emission levels were very low against the limit.
4. Margin value = Emission Level – Limit value
5. " \* ": Fundamental frequency.
6. " # ": The radiated frequency is out of the restricted band.

<b>CHANNEL</b>	TX Channel 140	<b>DETECTOR FUNCTION</b>	Peak (PK)
<b>FREQUENCY RANGE</b>	1GHz ~ 40GHz		Average (AV)

**ANTENNA POLARITY & TEST DISTANCE: HORIZONTAL AT 3 M**

NO.	FREQ. (MHz)	EMISSION LEVEL (dBuV/m)	LIMIT (dBuV/m)	MARGIN (dB)	ANTENNA HEIGHT (m)	TABLE ANGLE (Degree)	RAW VALUE (dBuV)	CORRECTION FACTOR (dB/m)
1	*5700.00	103.8 PK			1.55 H	230	96.41	7.39
2	*5700.00	92.9 AV			1.55 H	230	85.51	7.39
3	#5725.00	61.6 PK	74.0	-12.4	1.55 H	230	54.22	7.38
4	#5725.00	48.6 AV	54.0	-5.4	1.55 H	230	41.22	7.38
5	11400.00	50.3 PK	74.0	-23.7	1.71 H	284	35.44	14.86
6	11400.00	37.1 AV	54.0	-16.9	1.71 H	284	22.24	14.86
7	#17100.00	53.3 PK	74.0	-20.7	1.80 H	228	30.31	22.99
8	#17100.00	39.0 AV	54.0	-15.0	1.80 H	228	16.01	22.99

**ANTENNA POLARITY & TEST DISTANCE: VERTICAL AT 3 M**

NO.	FREQ. (MHz)	EMISSION LEVEL (dBuV/m)	LIMIT (dBuV/m)	MARGIN (dB)	ANTENNA HEIGHT (m)	TABLE ANGLE (Degree)	RAW VALUE (dBuV)	CORRECTION FACTOR (dB/m)
1	*5700.00	107.1 PK			1.47 V	280	99.71	7.39
2	*5700.00	97.9 AV			1.47 V	280	90.51	7.39
3	#5725.00	65.9 PK	74.0	-8.1	1.47 V	280	58.52	7.38
4	#5725.00	51.7 AV	54.0	-2.3	1.47 V	280	44.32	7.38
5	11400.00	51.5 PK	74.0	-22.5	2.09 V	335	36.64	14.86
6	11400.00	38.1 AV	54.0	-15.9	2.09 V	335	23.24	14.86
7	#17100.00	54.6 PK	74.0	-19.4	1.78 V	58	31.61	22.99
8	#17100.00	39.5 AV	54.0	-14.5	1.78 V	58	16.51	22.99

**REMARKS:**

1. Emission Level(dBuV/m) = Raw Value(dBuV) + Correction Factor(dB/m)
2. Correction Factor(dB/m) = Antenna Factor(dB/m) + Cable Factor(dB) – Pre-Amplifier Factor(dB)
3. The other emission levels were very low against the limit.
4. Margin value = Emission Level – Limit value
5. " \* ": Fundamental frequency.
6. " # ": The radiated frequency is out of the restricted band.

<b>CHANNEL</b>	TX Channel 149	<b>DETECTOR FUNCTION</b>	Peak (PK)
<b>FREQUENCY RANGE</b>	1GHz ~ 40GHz		Average (AV)

**ANTENNA POLARITY & TEST DISTANCE: HORIZONTAL AT 3 M**

NO.	FREQ. (MHz)	EMISSION LEVEL (dBuV/m)	LIMIT (dBuV/m)	MARGIN (dB)	ANTENNA HEIGHT (m)	TABLE ANGLE (Degree)	RAW VALUE (dBuV)	CORRECTION FACTOR (dB/m)
1	#5715.00	61.6 PK	74.0	-12.4	1.45 H	232	55.49	6.11
2	#5715.00	48.6 AV	54.0	-5.4	1.45 H	232	42.49	6.11
3	#5725.00	71.6 PK	78.2	-6.6	1.45 H	232	65.46	6.14
4	*5745.00	102.3 PK			1.45 H	232	96.11	6.19
5	*5745.00	92.1 AV			1.45 H	232	85.91	6.19
6	11490.00	50.5 PK	74.0	-23.5	1.69 H	296	33.62	16.88
7	11490.00	37.1 AV	54.0	-16.9	1.69 H	296	20.22	16.88
8	#17235.00	54.0 PK	74.0	-20.0	1.70 H	231	31.88	22.12
9	#17235.00	39.2 AV	54.0	-14.8	1.70 H	231	17.08	22.12

**ANTENNA POLARITY & TEST DISTANCE: VERTICAL AT 3 M**

NO.	FREQ. (MHz)	EMISSION LEVEL (dBuV/m)	LIMIT (dBuV/m)	MARGIN (dB)	ANTENNA HEIGHT (m)	TABLE ANGLE (Degree)	RAW VALUE (dBuV)	CORRECTION FACTOR (dB/m)
1	#5715.00	65.0 PK	74.0	-9.0	1.48 V	66	58.89	6.11
2	#5715.00	51.8 AV	54.0	-2.2	1.48 V	66	45.69	6.11
3	#5725.00	76.6 PK	78.2	-1.6	1.48 V	66	70.46	6.14
4	*5745.00	106.6 PK			1.48 V	66	100.41	6.19
5	*5745.00	96.5 AV			1.48 V	66	90.31	6.19
6	11490.00	52.3 PK	74.0	-21.7	2.09 V	321	35.42	16.88
7	11490.00	38.6 AV	54.0	-15.4	2.09 V	321	21.72	16.88
8	#17235.00	57.4 PK	74.0	-16.6	1.77 V	61	35.28	22.12
9	#17235.00	43.2 AV	54.0	-10.8	1.77 V	61	21.08	22.12

**REMARKS:**

1. Emission Level(dBuV/m) = Raw Value(dBuV) + Correction Factor(dB/m)
2. Correction Factor(dB/m) = Antenna Factor(dB/m) + Cable Factor(dB) – Pre-Amplifier Factor(dB)
3. The other emission levels were very low against the limit.
4. Margin value = Emission Level – Limit value
5. " \* ": Fundamental frequency.
6. " # ": The radiated frequency is out of the restricted band.

<b>CHANNEL</b>	TX Channel 157	<b>DETECTOR FUNCTION</b>	Peak (PK)
<b>FREQUENCY RANGE</b>	1GHz ~ 40GHz		Average (AV)

**ANTENNA POLARITY & TEST DISTANCE: HORIZONTAL AT 3 M**

NO.	FREQ. (MHz)	EMISSION LEVEL (dBuV/m)	LIMIT (dBuV/m)	MARGIN (dB)	ANTENNA HEIGHT (m)	TABLE ANGLE (Degree)	RAW VALUE (dBuV)	CORRECTION FACTOR (dB/m)
1	#5542.00	55.2 PK	74.0	-18.8	1.47 H	234	49.47	5.73
2	#5542.00	40.1 AV	54.0	-13.9	1.47 H	234	34.37	5.73
3	#5725.00	54.6 PK	78.2	-23.6	1.47 H	234	48.46	6.14
4	*5785.00	104.3 PK			1.47 H	234	97.98	6.32
5	*5785.00	95.0 AV			1.47 H	234	88.68	6.32
6	#5850.00	53.2 PK	78.2	-25.0	1.47 H	234	46.81	6.39
7	11570.00	51.9 PK	74.0	-22.1	1.61 H	92	35.23	16.67
8	11570.00	38.0 AV	54.0	-16.0	1.61 H	92	21.33	16.67
9	#17355.00	58.8 PK	74.0	-15.2	1.55 H	81	36.15	22.65
10	#17355.00	43.3 AV	54.0	-10.7	1.55 H	81	20.65	22.65

**ANTENNA POLARITY & TEST DISTANCE: VERTICAL AT 3 M**

NO.	FREQ. (MHz)	EMISSION LEVEL (dBuV/m)	LIMIT (dBuV/m)	MARGIN (dB)	ANTENNA HEIGHT (m)	TABLE ANGLE (Degree)	RAW VALUE (dBuV)	CORRECTION FACTOR (dB/m)
1	#5542.00	60.2 PK	74.0	-13.8	1.47 V	276	54.47	5.73
2	#5542.00	45.1 AV	54.0	-8.9	1.47 V	276	39.37	5.73
3	#5725.00	59.6 PK	78.2	-18.6	1.47 V	276	53.46	6.14
4	*5785.00	109.3 PK			1.47 V	276	102.98	6.32
5	*5785.00	99.4 AV			1.47 V	276	93.08	6.32
6	#5850.00	58.0 PK	78.2	-20.2	1.47 V	276	51.61	6.39
7	11570.00	52.4 PK	74.0	-21.6	1.63 V	220	35.73	16.67
8	11570.00	38.6 AV	54.0	-15.4	1.63 V	220	21.93	16.67
9	#17355.00	59.5 PK	74.0	-14.5	1.70 V	200	36.85	22.65
10	#17355.00	44.1 AV	54.0	-9.9	1.70 V	200	21.45	22.65

**REMARKS:**

1. Emission Level(dBuV/m) = Raw Value(dBuV) + Correction Factor(dB/m)
2. Correction Factor(dB/m) = Antenna Factor(dB/m) + Cable Factor(dB) – Pre-Amplifier Factor(dB)
3. The other emission levels were very low against the limit.
4. Margin value = Emission Level – Limit value
5. " \* ": Fundamental frequency.
6. " # ": The radiated frequency is out of the restricted band.

<b>CHANNEL</b>	TX Channel 165	<b>DETECTOR FUNCTION</b>	Peak (PK)
<b>FREQUENCY RANGE</b>	1GHz ~ 40GHz		Average (AV)

**ANTENNA POLARITY & TEST DISTANCE: HORIZONTAL AT 3 M**

NO.	FREQ. (MHz)	EMISSION LEVEL (dBuV/m)	LIMIT (dBuV/m)	MARGIN (dB)	ANTENNA HEIGHT (m)	TABLE ANGLE (Degree)	RAW VALUE (dBuV)	CORRECTION FACTOR (dB/m)
1	*5825.00	104.3 PK			1.56 H	228	97.92	6.38
2	*5825.00	94.7 AV			1.56 H	228	88.32	6.38
3	#5850.00	69.2 PK	78.2	-9.0	1.56 H	228	62.81	6.39
4	#5860.00	58.8 PK	74.0	-15.2	1.56 H	228	52.39	6.41
5	#5860.00	45.4 AV	54.0	-8.6	1.56 H	228	38.99	6.41
6	11650.00	52.0 PK	74.0	-22.0	1.67 H	97	35.55	16.45
7	11650.00	38.1 AV	54.0	-15.9	1.67 H	97	21.65	16.45
8	#17475.00	58.7 PK	74.0	-15.3	1.56 H	88	35.55	23.15
9	#17475.00	43.1 AV	54.0	-10.9	1.56 H	88	19.95	23.15

**ANTENNA POLARITY & TEST DISTANCE: VERTICAL AT 3 M**

NO.	FREQ. (MHz)	EMISSION LEVEL (dBuV/m)	LIMIT (dBuV/m)	MARGIN (dB)	ANTENNA HEIGHT (m)	TABLE ANGLE (Degree)	RAW VALUE (dBuV)	CORRECTION FACTOR (dB/m)
1	*5825.00	109.2 PK			1.47 V	235	102.82	6.38
2	*5825.00	99.2 AV			1.47 V	235	92.82	6.38
3	#5850.00	74.0 PK	78.2	-4.2	1.47 V	235	67.61	6.39
4	#5860.00	64.3 PK	74.0	-9.7	1.47 V	235	57.89	6.41
5	#5860.00	49.1 AV	54.0	-4.9	1.47 V	235	42.69	6.41
6	11650.00	52.5 PK	74.0	-21.5	1.63 V	218	36.05	16.45
7	11650.00	38.6 AV	54.0	-15.4	1.63 V	218	22.15	16.45
8	#17475.00	59.9 PK	74.0	-14.1	1.69 V	208	36.75	23.15
9	#17475.00	44.6 AV	54.0	-9.4	1.69 V	208	21.45	23.15

**REMARKS:**

1. Emission Level(dBuV/m) = Raw Value(dBuV) + Correction Factor(dB/m)
2. Correction Factor(dB/m) = Antenna Factor(dB/m) + Cable Factor(dB) – Pre-Amplifier Factor(dB)
3. The other emission levels were very low against the limit.
4. Margin value = Emission Level – Limit value
5. " \* ": Fundamental frequency.
6. " # ": The radiated frequency is out of the restricted band.

**802.11ac (VHT20)**

<b>CHANNEL</b>	TX Channel 36	<b>DETECTOR FUNCTION</b>	Peak (PK)
<b>FREQUENCY RANGE</b>	1GHz ~ 40GHz		Average (AV)

<b>ANTENNA POLARITY &amp; TEST DISTANCE: HORIZONTAL AT 3 M</b>								
NO.	FREQ. (MHz)	EMISSION LEVEL (dBuV/m)	LIMIT (dBuV/m)	MARGIN (dB)	ANTENNA HEIGHT (m)	TABLE ANGLE (Degree)	RAW VALUE (dBuV)	CORRECTION FACTOR (dB/m)
1	5150.00	63.9 PK	74.0	-10.1	1.49 H	232	57.43	6.47
2	5150.00	49.0 AV	54.0	-5.0	1.49 H	232	42.53	6.47
3	*5180.00	108.2 PK			1.49 H	232	101.55	6.65
4	*5180.00	96.3 AV			1.49 H	232	89.65	6.65
5	#10360.00	50.9 PK	74.0	-23.1	1.81 H	266	36.69	14.21
6	#10360.00	38.0 AV	54.0	-16.0	1.81 H	266	23.79	14.21
7	15540.00	53.8 PK	74.0	-20.2	1.75 H	191	35.04	18.76
8	15540.00	39.3 AV	54.0	-14.7	1.75 H	191	20.54	18.76

<b>ANTENNA POLARITY &amp; TEST DISTANCE: VERTICAL AT 3 M</b>								
NO.	FREQ. (MHz)	EMISSION LEVEL (dBuV/m)	LIMIT (dBuV/m)	MARGIN (dB)	ANTENNA HEIGHT (m)	TABLE ANGLE (Degree)	RAW VALUE (dBuV)	CORRECTION FACTOR (dB/m)
1	5150.00	69.5 PK	74.0	-4.5	1.50 V	285	63.03	6.47
2	5150.00	52.7 AV	54.0	-1.3	1.50 V	285	46.23	6.47
3	*5180.00	112.6 PK			1.50 V	285	105.95	6.65
4	*5180.00	101.1 AV			1.50 V	285	94.45	6.65
5	#10360.00	51.6 PK	74.0	-22.4	2.14 V	310	37.39	14.21
6	#10360.00	37.8 AV	54.0	-16.2	2.14 V	310	23.59	14.21
7	15540.00	55.7 PK	74.0	-18.3	1.83 V	52	36.94	18.76
8	15540.00	40.1 AV	54.0	-13.9	1.83 V	52	21.34	18.76

**REMARKS:**

- Emission Level(dBuV/m) = Raw Value(dBuV) + Correction Factor(dB/m)
- Correction Factor(dB/m) = Antenna Factor(dB/m) + Cable Factor(dB) – Pre-Amplifier Factor(dB)
- The other emission levels were very low against the limit.
- Margin value = Emission Level – Limit value
- " \* ": Fundamental frequency.
- " # ": The radiated frequency is out of the restricted band.



<b>CHANNEL</b>	TX Channel 40	<b>DETECTOR FUNCTION</b>	Peak (PK)
<b>FREQUENCY RANGE</b>	1GHz ~ 40GHz		Average (AV)

**ANTENNA POLARITY & TEST DISTANCE: HORIZONTAL AT 3 M**

NO.	FREQ. (MHz)	EMISSION LEVEL (dBuV/m)	LIMIT (dBuV/m)	MARGIN (dB)	ANTENNA HEIGHT (m)	TABLE ANGLE (Degree)	RAW VALUE (dBuV)	CORRECTION FACTOR (dB/m)
1	*5200.00	110.1 PK			1.54 H	253	103.33	6.77
2	*5200.00	99.3 AV			1.54 H	253	92.53	6.77
3	#10400.00	50.6 PK	74.0	-23.4	1.74 H	288	36.38	14.22
4	#10400.00	37.7 AV	54.0	-16.3	1.74 H	288	23.48	14.22
5	15600.00	54.4 PK	74.0	-19.6	1.74 H	201	36.06	18.34
6	15600.00	39.9 AV	54.0	-14.1	1.74 H	201	21.56	18.34

**ANTENNA POLARITY & TEST DISTANCE: VERTICAL AT 3 M**

NO.	FREQ. (MHz)	EMISSION LEVEL (dBuV/m)	LIMIT (dBuV/m)	MARGIN (dB)	ANTENNA HEIGHT (m)	TABLE ANGLE (Degree)	RAW VALUE (dBuV)	CORRECTION FACTOR (dB/m)
1	*5200.00	115.2 PK			1.58 V	288	108.43	6.77
2	*5200.00	104.0 AV			1.58 V	288	97.23	6.77
3	#10400.00	50.9 PK	74.0	-23.1	2.05 V	332	36.68	14.22
4	#10400.00	37.6 AV	54.0	-16.4	2.05 V	332	23.38	14.22
5	15600.00	54.6 PK	74.0	-19.4	1.77 V	53	36.26	18.34
6	15600.00	39.5 AV	54.0	-14.5	1.77 V	53	21.16	18.34

**REMARKS:**

1. Emission Level(dBuV/m) = Raw Value(dBuV) + Correction Factor(dB/m)
2. Correction Factor(dB/m) = Antenna Factor(dB/m) + Cable Factor(dB) – Pre-Amplifier Factor(dB)
3. The other emission levels were very low against the limit.
4. Margin value = Emission Level – Limit value
5. " \* ": Fundamental frequency.
6. " # ": The radiated frequency is out of the restricted band.

<b>CHANNEL</b>	TX Channel 48	<b>DETECTOR FUNCTION</b>	Peak (PK)
<b>FREQUENCY RANGE</b>	1GHz ~ 40GHz		Average (AV)

**ANTENNA POLARITY & TEST DISTANCE: HORIZONTAL AT 3 M**

NO.	FREQ. (MHz)	EMISSION LEVEL (dBuV/m)	LIMIT (dBuV/m)	MARGIN (dB)	ANTENNA HEIGHT (m)	TABLE ANGLE (Degree)	RAW VALUE (dBuV)	CORRECTION FACTOR (dB/m)
1	*5240.00	109.7 PK			1.47 H	247	102.88	6.82
2	*5240.00	98.9 AV			1.47 H	247	92.08	6.82
3	#10480.00	50.9 PK	74.0	-23.1	1.72 H	290	36.91	13.99
4	#10480.00	38.0 AV	54.0	-16.0	1.72 H	290	24.01	13.99
5	15720.00	53.2 PK	74.0	-20.8	1.76 H	202	34.17	19.03
6	15720.00	39.0 AV	54.0	-15.0	1.76 H	202	19.97	19.03

**ANTENNA POLARITY & TEST DISTANCE: VERTICAL AT 3 M**

NO.	FREQ. (MHz)	EMISSION LEVEL (dBuV/m)	LIMIT (dBuV/m)	MARGIN (dB)	ANTENNA HEIGHT (m)	TABLE ANGLE (Degree)	RAW VALUE (dBuV)	CORRECTION FACTOR (dB/m)
1	*5240.00	115.9 PK			1.55 V	288	109.08	6.82
2	*5240.00	104.1 AV			1.55 V	288	97.28	6.82
3	#10480.00	51.5 PK	74.0	-22.5	2.08 V	309	37.51	13.99
4	#10480.00	38.2 AV	54.0	-15.8	2.08 V	309	24.21	13.99
5	15720.00	54.5 PK	74.0	-19.5	1.78 V	35	35.47	19.03
6	15720.00	39.2 AV	54.0	-14.8	1.78 V	35	20.17	19.03

**REMARKS:**

1. Emission Level(dBuV/m) = Raw Value(dBuV) + Correction Factor(dB/m)
2. Correction Factor(dB/m) = Antenna Factor(dB/m) + Cable Factor(dB) – Pre-Amplifier Factor(dB)
3. The other emission levels were very low against the limit.
4. Margin value = Emission Level – Limit value
5. " \* ": Fundamental frequency.
6. " # ": The radiated frequency is out of the restricted band.

<b>CHANNEL</b>	TX Channel 52	<b>DETECTOR FUNCTION</b>	Peak (PK)
<b>FREQUENCY RANGE</b>	1GHz ~ 40GHz		Average (AV)

**ANTENNA POLARITY & TEST DISTANCE: HORIZONTAL AT 3 M**

NO.	FREQ. (MHz)	EMISSION LEVEL (dBuV/m)	LIMIT (dBuV/m)	MARGIN (dB)	ANTENNA HEIGHT (m)	TABLE ANGLE (Degree)	RAW VALUE (dBuV)	CORRECTION FACTOR (dB/m)
1	*5260.00	110.0 PK			1.52 H	256	103.15	6.85
2	*5260.00	99.4 AV			1.52 H	256	92.55	6.85
3	#10520.00	50.5 PK	74.0	-23.5	1.73 H	276	36.67	13.83
4	#10520.00	37.8 AV	54.0	-16.2	1.73 H	276	23.97	13.83
5	15780.00	53.7 PK	74.0	-20.3	1.71 H	217	34.34	19.36
6	15780.00	39.4 AV	54.0	-14.6	1.71 H	217	20.04	19.36

**ANTENNA POLARITY & TEST DISTANCE: VERTICAL AT 3 M**

NO.	FREQ. (MHz)	EMISSION LEVEL (dBuV/m)	LIMIT (dBuV/m)	MARGIN (dB)	ANTENNA HEIGHT (m)	TABLE ANGLE (Degree)	RAW VALUE (dBuV)	CORRECTION FACTOR (dB/m)
1	*5260.00	115.1 PK			1.60 V	168	108.25	6.85
2	*5260.00	104.4 AV			1.60 V	168	97.55	6.85
3	#10520.00	51.9 PK	74.0	-22.1	2.11 V	319	38.07	13.83
4	#10520.00	38.1 AV	54.0	-15.9	2.11 V	319	24.27	13.83
5	15780.00	54.9 PK	74.0	-19.1	1.80 V	53	35.54	19.36
6	15780.00	39.3 AV	54.0	-14.7	1.80 V	53	19.94	19.36

**REMARKS:**

1. Emission Level(dBuV/m) = Raw Value(dBuV) + Correction Factor(dB/m)
2. Correction Factor(dB/m) = Antenna Factor(dB/m) + Cable Factor(dB) – Pre-Amplifier Factor(dB)
3. The other emission levels were very low against the limit.
4. Margin value = Emission Level – Limit value
5. " \* ": Fundamental frequency.
6. " # ": The radiated frequency is out of the restricted band.

<b>CHANNEL</b>	TX Channel 60	<b>DETECTOR FUNCTION</b>	Peak (PK)
<b>FREQUENCY RANGE</b>	1GHz ~ 40GHz		Average (AV)

**ANTENNA POLARITY & TEST DISTANCE: HORIZONTAL AT 3 M**

NO.	FREQ. (MHz)	EMISSION LEVEL (dBuV/m)	LIMIT (dBuV/m)	MARGIN (dB)	ANTENNA HEIGHT (m)	TABLE ANGLE (Degree)	RAW VALUE (dBuV)	CORRECTION FACTOR (dB/m)
1	*5300.00	109.7 PK			1.45 H	243	102.80	6.90
2	*5300.00	98.8 AV			1.45 H	243	91.90	6.90
3	10600.00	50.9 PK	74.0	-23.1	1.80 H	282	37.46	13.44
4	10600.00	37.8 AV	54.0	-16.2	1.80 H	282	24.36	13.44
5	15900.00	53.1 PK	74.0	-20.9	1.78 H	194	34.09	19.01
6	15900.00	39.0 AV	54.0	-15.0	1.78 H	194	19.99	19.01

**ANTENNA POLARITY & TEST DISTANCE: VERTICAL AT 3 M**

NO.	FREQ. (MHz)	EMISSION LEVEL (dBuV/m)	LIMIT (dBuV/m)	MARGIN (dB)	ANTENNA HEIGHT (m)	TABLE ANGLE (Degree)	RAW VALUE (dBuV)	CORRECTION FACTOR (dB/m)
1	*5300.00	115.0 PK			1.60 V	131	108.10	6.90
2	*5300.00	103.8 AV			1.60 V	131	96.90	6.90
3	10600.00	51.0 PK	74.0	-23.0	2.05 V	323	37.56	13.44
4	10600.00	37.6 AV	54.0	-16.4	2.05 V	323	24.16	13.44
5	15900.00	54.6 PK	74.0	-19.4	1.85 V	36	35.59	19.01
6	15900.00	39.3 AV	54.0	-14.7	1.85 V	36	20.29	19.01

**REMARKS:**

1. Emission Level(dBuV/m) = Raw Value(dBuV) + Correction Factor(dB/m)
2. Correction Factor(dB/m) = Antenna Factor(dB/m) + Cable Factor(dB) – Pre-Amplifier Factor(dB)
3. The other emission levels were very low against the limit.
4. Margin value = Emission Level – Limit value
5. " \* ": Fundamental frequency.

<b>CHANNEL</b>	TX Channel 64	<b>DETECTOR FUNCTION</b>	Peak (PK)
<b>FREQUENCY RANGE</b>	1GHz ~ 40GHz		Average (AV)

**ANTENNA POLARITY & TEST DISTANCE: HORIZONTAL AT 3 M**

NO.	FREQ. (MHz)	EMISSION LEVEL (dBuV/m)	LIMIT (dBuV/m)	MARGIN (dB)	ANTENNA HEIGHT (m)	TABLE ANGLE (Degree)	RAW VALUE (dBuV)	CORRECTION FACTOR (dB/m)
1	*5320.00	108.2 PK			1.44 H	227	101.23	6.97
2	*5320.00	98.2 AV			1.44 H	227	91.23	6.97
3	5350.00	64.1 PK	74.0	-9.9	1.44 H	227	57.06	7.04
4	5350.00	49.1 AV	54.0	-4.9	1.44 H	227	42.06	7.04
5	10640.00	50.9 PK	74.0	-23.1	1.82 H	282	37.23	13.67
6	10640.00	37.9 AV	54.0	-16.1	1.82 H	282	24.23	13.67
7	15960.00	53.8 PK	74.0	-20.2	1.78 H	210	34.96	18.84
8	15960.00	39.2 AV	54.0	-14.8	1.78 H	210	20.36	18.84

**ANTENNA POLARITY & TEST DISTANCE: VERTICAL AT 3 M**

NO.	FREQ. (MHz)	EMISSION LEVEL (dBuV/m)	LIMIT (dBuV/m)	MARGIN (dB)	ANTENNA HEIGHT (m)	TABLE ANGLE (Degree)	RAW VALUE (dBuV)	CORRECTION FACTOR (dB/m)
1	*5320.00	113.8 PK			1.60 V	200	106.83	6.97
2	*5320.00	103.0 AV			1.60 V	200	96.03	6.97
3	5350.00	70.4 PK	74.0	-3.6	1.60 V	200	63.36	7.04
4	5350.00	52.3 AV	54.0	-1.7	1.60 V	200	45.26	7.04
5	10640.00	51.9 PK	74.0	-22.1	2.15 V	314	38.23	13.67
6	10640.00	38.5 AV	54.0	-15.5	2.15 V	314	24.83	13.67
7	15960.00	54.9 PK	74.0	-19.1	1.79 V	53	36.06	18.84
8	15960.00	39.6 AV	54.0	-14.4	1.79 V	53	20.76	18.84

**REMARKS:**

1. Emission Level(dBuV/m) = Raw Value(dBuV) + Correction Factor(dB/m)
2. Correction Factor(dB/m) = Antenna Factor(dB/m) + Cable Factor(dB) – Pre-Amplifier Factor(dB)
3. The other emission levels were very low against the limit.
4. Margin value = Emission Level – Limit value
5. " \* ": Fundamental frequency.

<b>CHANNEL</b>	TX Channel 100	<b>DETECTOR FUNCTION</b>	Peak (PK)
<b>FREQUENCY RANGE</b>	1GHz ~ 40GHz		Average (AV)

**ANTENNA POLARITY & TEST DISTANCE: HORIZONTAL AT 3 M**

NO.	FREQ. (MHz)	EMISSION LEVEL (dBuV/m)	LIMIT (dBuV/m)	MARGIN (dB)	ANTENNA HEIGHT (m)	TABLE ANGLE (Degree)	RAW VALUE (dBuV)	CORRECTION FACTOR (dB/m)
1	#5470.00	59.0 PK	74.0	-15.0	1.52 H	247	51.71	7.29
2	#5470.00	45.7 AV	54.0	-8.3	1.52 H	247	38.41	7.29
3	*5500.00	106.7 PK			1.52 H	247	99.37	7.33
4	*5500.00	96.1 AV			1.52 H	247	88.77	7.33
5	#5735.00	51.4 PK	74.0	-22.6	1.52 H	247	44.02	7.38
6	#5735.00	39.1 AV	54.0	-14.9	1.52 H	247	31.72	7.38
7	11000.00	50.5 PK	74.0	-23.5	1.72 H	266	36.27	14.23
8	11000.00	37.5 AV	54.0	-16.5	1.72 H	266	23.27	14.23
9	#16500.00	53.5 PK	74.0	-20.5	1.76 H	197	32.53	20.97
10	#16500.00	39.3 AV	54.0	-14.7	1.76 H	197	18.33	20.97

**ANTENNA POLARITY & TEST DISTANCE: VERTICAL AT 3 M**

NO.	FREQ. (MHz)	EMISSION LEVEL (dBuV/m)	LIMIT (dBuV/m)	MARGIN (dB)	ANTENNA HEIGHT (m)	TABLE ANGLE (Degree)	RAW VALUE (dBuV)	CORRECTION FACTOR (dB/m)
1	#5470.00	64.3 PK	74.0	-9.7	1.70 V	196	57.01	7.29
2	#5470.00	49.9 AV	54.0	-4.1	1.70 V	196	42.61	7.29
3	*5500.00	111.2 PK			1.70 V	196	103.87	7.33
4	*5500.00	100.5 AV			1.70 V	196	93.17	7.33
5	#5735.00	56.2 PK	74.0	-17.8	1.70 V	196	48.82	7.38
6	#5735.00	43.1 AV	54.0	-10.9	1.70 V	196	35.72	7.38
7	11000.00	51.6 PK	74.0	-22.4	2.07 V	328	37.37	14.23
8	11000.00	37.8 AV	54.0	-16.2	2.07 V	328	23.57	14.23
9	#16500.00	54.1 PK	74.0	-19.9	1.76 V	54	33.13	20.97
10	#16500.00	39.1 AV	54.0	-14.9	1.76 V	54	18.13	20.97

**REMARKS:**

1. Emission Level(dBuV/m) = Raw Value(dBuV) + Correction Factor(dB/m)
2. Correction Factor(dB/m) = Antenna Factor(dB/m) + Cable Factor(dB) – Pre-Amplifier Factor(dB)
3. The other emission levels were very low against the limit.
4. Margin value = Emission Level – Limit value
5. " \* ": Fundamental frequency.
6. " # ": The radiated frequency is out of the restricted band.

<b>CHANNEL</b>	TX Channel 116	<b>DETECTOR FUNCTION</b>	Peak (PK)
<b>FREQUENCY RANGE</b>	1GHz ~ 40GHz		Average (AV)

**ANTENNA POLARITY & TEST DISTANCE: HORIZONTAL AT 3 M**

NO.	FREQ. (MHz)	EMISSION LEVEL (dBuV/m)	LIMIT (dBuV/m)	MARGIN (dB)	ANTENNA HEIGHT (m)	TABLE ANGLE (Degree)	RAW VALUE (dBuV)	CORRECTION FACTOR (dB/m)
1	*5580.00	108.0 PK			1.49 H	255	100.82	7.18
2	*5580.00	98.1 AV			1.49 H	255	90.92	7.18
3	11160.00	50.5 PK	74.0	-23.5	1.73 H	265	36.04	14.46
4	11160.00	37.7 AV	54.0	-16.3	1.73 H	265	23.24	14.46
5	#16740.00	52.9 PK	74.0	-21.1	1.75 H	195	30.94	21.96
6	#16740.00	38.9 AV	54.0	-15.1	1.75 H	195	16.94	21.96

**ANTENNA POLARITY & TEST DISTANCE: VERTICAL AT 3 M**

NO.	FREQ. (MHz)	EMISSION LEVEL (dBuV/m)	LIMIT (dBuV/m)	MARGIN (dB)	ANTENNA HEIGHT (m)	TABLE ANGLE (Degree)	RAW VALUE (dBuV)	CORRECTION FACTOR (dB/m)
1	*5580.00	114.0 PK			1.70 V	197	106.82	7.18
2	*5580.00	103.0 AV			1.70 V	197	95.82	7.18
3	11160.00	51.9 PK	74.0	-22.1	2.11 V	332	37.44	14.46
4	11160.00	38.5 AV	54.0	-15.5	2.11 V	332	24.04	14.46
5	#16740.00	54.9 PK	74.0	-19.1	1.81 V	58	32.94	21.96
6	#16740.00	39.4 AV	54.0	-14.6	1.81 V	58	17.44	21.96

**REMARKS:**

1. Emission Level(dBuV/m) = Raw Value(dBuV) + Correction Factor(dB/m)
2. Correction Factor(dB/m) = Antenna Factor(dB/m) + Cable Factor(dB) – Pre-Amplifier Factor(dB)
3. The other emission levels were very low against the limit.
4. Margin value = Emission Level – Limit value
5. " \* " : Fundamental frequency.
6. " # " : The radiated frequency is out of the restricted band.

<b>CHANNEL</b>	TX Channel 120	<b>DETECTOR FUNCTION</b>	Peak (PK)
<b>FREQUENCY RANGE</b>	1GHz ~ 40GHz		Average (AV)

**ANTENNA POLARITY & TEST DISTANCE: HORIZONTAL AT 3 M**

NO.	FREQ. (MHz)	EMISSION LEVEL (dBuV/m)	LIMIT (dBuV/m)	MARGIN (dB)	ANTENNA HEIGHT (m)	TABLE ANGLE (Degree)	RAW VALUE (dBuV)	CORRECTION FACTOR (dB/m)
1	*5600.00	108.2 PK			1.53 H	241	101.07	7.13
2	*5600.00	98.0 AV			1.53 H	241	90.87	7.13
3	11200.00	50.8 PK	74.0	-23.2	1.70 H	269	36.33	14.47
4	11200.00	37.8 AV	54.0	-16.2	1.70 H	269	23.33	14.47
5	#16800.00	54.0 PK	74.0	-20.0	1.73 H	195	31.90	22.10
6	#16800.00	39.6 AV	54.0	-14.4	1.73 H	195	17.50	22.10

**ANTENNA POLARITY & TEST DISTANCE: VERTICAL AT 3 M**

NO.	FREQ. (MHz)	EMISSION LEVEL (dBuV/m)	LIMIT (dBuV/m)	MARGIN (dB)	ANTENNA HEIGHT (m)	TABLE ANGLE (Degree)	RAW VALUE (dBuV)	CORRECTION FACTOR (dB/m)
1	*5600.00	114.1 PK			1.70 V	172	106.97	7.13
2	*5600.00	103.1 AV			1.70 V	172	95.97	7.13
3	11200.00	51.4 PK	74.0	-22.6	2.16 V	315	36.93	14.47
4	11200.00	37.7 AV	54.0	-16.3	2.16 V	315	23.23	14.47
5	#16800.00	54.7 PK	74.0	-19.3	1.79 V	54	32.60	22.10
6	#16800.00	39.2 AV	54.0	-14.8	1.79 V	54	17.10	22.10

**REMARKS:**

1. Emission Level(dBuV/m) = Raw Value(dBuV) + Correction Factor(dB/m)
2. Correction Factor(dB/m) = Antenna Factor(dB/m) + Cable Factor(dB) – Pre-Amplifier Factor(dB)
3. The other emission levels were very low against the limit.
4. Margin value = Emission Level – Limit value
5. " \* ": Fundamental frequency.
6. " # ": The radiated frequency is out of the restricted band.



<b>CHANNEL</b>	TX Channel 132	<b>DETECTOR FUNCTION</b>	Peak (PK)
<b>FREQUENCY RANGE</b>	1GHz ~ 40GHz		Average (AV)

**ANTENNA POLARITY & TEST DISTANCE: HORIZONTAL AT 3 M**

NO.	FREQ. (MHz)	EMISSION LEVEL (dBuV/m)	LIMIT (dBuV/m)	MARGIN (dB)	ANTENNA HEIGHT (m)	TABLE ANGLE (Degree)	RAW VALUE (dBuV)	CORRECTION FACTOR (dB/m)
1	*5660.00	107.3 PK			1.54 H	237	100.02	7.28
2	*5660.00	97.4 AV			1.54 H	237	90.12	7.28
3	11320.00	50.9 PK	74.0	-23.1	1.70 H	272	36.44	14.46
4	11320.00	37.6 AV	54.0	-16.4	1.70 H	272	23.14	14.46
5	#16980.00	53.2 PK	74.0	-20.8	1.76 H	186	29.97	23.23
6	#16980.00	39.0 AV	54.0	-15.0	1.76 H	186	15.77	23.23

**ANTENNA POLARITY & TEST DISTANCE: VERTICAL AT 3 M**

NO.	FREQ. (MHz)	EMISSION LEVEL (dBuV/m)	LIMIT (dBuV/m)	MARGIN (dB)	ANTENNA HEIGHT (m)	TABLE ANGLE (Degree)	RAW VALUE (dBuV)	CORRECTION FACTOR (dB/m)
1	*5660.00	114.4 PK			1.70 V	217	107.12	7.28
2	*5660.00	102.4 AV			1.70 V	217	95.12	7.28
3	11320.00	51.5 PK	74.0	-22.5	2.14 V	319	37.04	14.46
4	11320.00	38.1 AV	54.0	-15.9	2.14 V	319	23.64	14.46
5	#16980.00	54.5 PK	74.0	-19.5	1.81 V	33	31.27	23.23
6	#16980.00	39.4 AV	54.0	-14.6	1.81 V	33	16.17	23.23

**REMARKS:**

1. Emission Level(dBuV/m) = Raw Value(dBuV) + Correction Factor(dB/m)
2. Correction Factor(dB/m) = Antenna Factor(dB/m) + Cable Factor(dB) – Pre-Amplifier Factor(dB)
3. The other emission levels were very low against the limit.
4. Margin value = Emission Level – Limit value
5. " \* ": Fundamental frequency.
6. " # ": The radiated frequency is out of the restricted band.

<b>CHANNEL</b>	TX Channel 140	<b>DETECTOR FUNCTION</b>	Peak (PK)
<b>FREQUENCY RANGE</b>	1GHz ~ 40GHz		Average (AV)

**ANTENNA POLARITY & TEST DISTANCE: HORIZONTAL AT 3 M**

NO.	FREQ. (MHz)	EMISSION LEVEL (dBuV/m)	LIMIT (dBuV/m)	MARGIN (dB)	ANTENNA HEIGHT (m)	TABLE ANGLE (Degree)	RAW VALUE (dBuV)	CORRECTION FACTOR (dB/m)
1	*5700.00	104.9 PK			1.55 H	227	97.51	7.39
2	*5700.00	93.4 AV			1.55 H	227	86.01	7.39
3	#5725.00	58.4 PK	74.0	-15.6	1.55 H	227	51.02	7.38
4	#5725.00	44.9 AV	54.0	-9.1	1.55 H	227	37.52	7.38
5	11400.00	50.8 PK	74.0	-23.2	1.67 H	267	35.94	14.86
6	11400.00	37.5 AV	54.0	-16.5	1.67 H	267	22.64	14.86
7	#17100.00	54.1 PK	74.0	-19.9	1.70 H	209	31.11	22.99
8	#17100.00	39.8 AV	54.0	-14.2	1.70 H	209	16.81	22.99

**ANTENNA POLARITY & TEST DISTANCE: VERTICAL AT 3 M**

NO.	FREQ. (MHz)	EMISSION LEVEL (dBuV/m)	LIMIT (dBuV/m)	MARGIN (dB)	ANTENNA HEIGHT (m)	TABLE ANGLE (Degree)	RAW VALUE (dBuV)	CORRECTION FACTOR (dB/m)
1	*5700.00	109.1 PK			1.70 V	217	101.71	7.39
2	*5700.00	98.4 AV			1.70 V	217	91.01	7.39
3	#5725.00	65.1 PK	74.0	-8.9	1.70 V	217	57.72	7.38
4	#5725.00	49.5 AV	54.0	-4.5	1.70 V	217	42.12	7.38
5	11400.00	51.3 PK	74.0	-22.7	2.19 V	314	36.44	14.86
6	11400.00	38.0 AV	54.0	-16.0	2.19 V	314	23.14	14.86
7	#17100.00	54.4 PK	74.0	-19.6	1.85 V	28	31.41	22.99
8	#17100.00	39.3 AV	54.0	-14.7	1.85 V	28	16.31	22.99

**REMARKS:**

1. Emission Level(dBuV/m) = Raw Value(dBuV) + Correction Factor(dB/m)
2. Correction Factor(dB/m) = Antenna Factor(dB/m) + Cable Factor(dB) – Pre-Amplifier Factor(dB)
3. The other emission levels were very low against the limit.
4. Margin value = Emission Level – Limit value
5. " \* ": Fundamental frequency.
6. " # ": The radiated frequency is out of the restricted band.

<b>CHANNEL</b>	TX Channel 149	<b>DETECTOR FUNCTION</b>	Peak (PK)
<b>FREQUENCY RANGE</b>	1GHz ~ 40GHz		Average (AV)

**ANTENNA POLARITY & TEST DISTANCE: HORIZONTAL AT 3 M**

NO.	FREQ. (MHz)	EMISSION LEVEL (dBUV/m)	LIMIT (dBUV/m)	MARGIN (dB)	ANTENNA HEIGHT (m)	TABLE ANGLE (Degree)	RAW VALUE (dBUV)	CORRECTION FACTOR (dB/m)
1	#5715.00	58.1 PK	74.0	-15.9	1.46 H	252	51.99	6.11
2	#5715.00	42.1 AV	54.0	-11.9	1.46 H	252	35.99	6.11
3	#5725.00	69.5 PK	78.2	-8.7	1.46 H	252	63.36	6.14
4	*5745.00	104.3 PK			1.46 H	252	98.11	6.19
5	*5745.00	93.1 AV			1.46 H	252	86.91	6.19
6	11490.00	51.2 PK	74.0	-22.8	1.72 H	282	34.32	16.88
7	11490.00	37.9 AV	54.0	-16.1	1.72 H	282	21.02	16.88
8	#17235.00	54.0 PK	74.0	-20.0	1.73 H	189	31.88	22.12
9	#17235.00	39.7 AV	54.0	-14.3	1.73 H	189	17.58	22.12

**ANTENNA POLARITY & TEST DISTANCE: VERTICAL AT 3 M**

NO.	FREQ. (MHz)	EMISSION LEVEL (dBUV/m)	LIMIT (dBUV/m)	MARGIN (dB)	ANTENNA HEIGHT (m)	TABLE ANGLE (Degree)	RAW VALUE (dBUV)	CORRECTION FACTOR (dB/m)
1	#5715.00	62.8 PK	74.0	-11.2	1.70 V	191	56.69	6.11
2	#5715.00	46.3 AV	54.0	-7.7	1.70 V	191	40.19	6.11
3	#5725.00	74.6 PK	78.2	-3.6	1.70 V	191	68.46	6.14
4	*5745.00	108.9 PK			1.70 V	191	102.71	6.19
5	*5745.00	97.5 AV			1.70 V	191	91.31	6.19
6	11490.00	51.1 PK	74.0	-22.9	2.11 V	324	34.22	16.88
7	11490.00	37.9 AV	54.0	-16.1	2.11 V	324	21.02	16.88
8	#17235.00	52.1 PK	74.0	-21.9	1.86 V	42	29.98	22.12
9	#17235.00	40.4 AV	54.0	-13.6	1.86 V	42	18.28	22.12

**REMARKS:**

1. Emission Level(dBUV/m) = Raw Value(dBuV) + Correction Factor(dB/m)
2. Correction Factor(dB/m) = Antenna Factor(dB/m) + Cable Factor(dB) – Pre-Amplifier Factor(dB)
3. The other emission levels were very low against the limit.
4. Margin value = Emission Level – Limit value
5. " \* ": Fundamental frequency.
6. " # ": The radiated frequency is out of the restricted band.

<b>CHANNEL</b>	TX Channel 157	<b>DETECTOR FUNCTION</b>	Peak (PK)
<b>FREQUENCY RANGE</b>	1GHz ~ 40GHz		Average (AV)

**ANTENNA POLARITY & TEST DISTANCE: HORIZONTAL AT 3 M**

NO.	FREQ. (MHz)	EMISSION LEVEL (dBuV/m)	LIMIT (dBuV/m)	MARGIN (dB)	ANTENNA HEIGHT (m)	TABLE ANGLE (Degree)	RAW VALUE (dBuV)	CORRECTION FACTOR (dB/m)
1	*5785.00	106.5 PK			1.47 H	250	100.18	6.32
2	*5785.00	95.7 AV			1.47 H	250	89.38	6.32
3	11570.00	52.6 PK	74.0	-21.4	1.55 H	104	35.93	16.67
4	11570.00	38.5 AV	54.0	-15.5	1.55 H	104	21.83	16.67
5	#17355.00	58.9 PK	74.0	-15.1	1.57 H	75	36.25	22.65
6	#17355.00	43.3 AV	54.0	-10.7	1.57 H	75	20.65	22.65

**ANTENNA POLARITY & TEST DISTANCE: VERTICAL AT 3 M**

NO.	FREQ. (MHz)	EMISSION LEVEL (dBuV/m)	LIMIT (dBuV/m)	MARGIN (dB)	ANTENNA HEIGHT (m)	TABLE ANGLE (Degree)	RAW VALUE (dBuV)	CORRECTION FACTOR (dB/m)
1	*5785.00	112.7 PK			1.68 V	0	106.38	6.32
2	*5785.00	100.8 AV			1.68 V	0	94.48	6.32
3	11570.00	52.8 PK	74.0	-21.2	1.67 V	216	36.13	16.67
4	11570.00	38.7 AV	54.0	-15.3	1.67 V	216	22.03	16.67
5	#17355.00	59.8 PK	74.0	-14.2	1.67 V	210	37.15	22.65
6	#17355.00	44.3 AV	54.0	-9.7	1.67 V	210	21.65	22.65

**REMARKS:**

1. Emission Level(dBuV/m) = Raw Value(dBuV) + Correction Factor(dB/m)
2. Correction Factor(dB/m) = Antenna Factor(dB/m) + Cable Factor(dB) – Pre-Amplifier Factor(dB)
3. The other emission levels were very low against the limit.
4. Margin value = Emission Level – Limit value
5. " \* ": Fundamental frequency.
6. " # ": The radiated frequency is out of the restricted band.

<b>CHANNEL</b>	TX Channel 165	<b>DETECTOR FUNCTION</b>	Peak (PK)
<b>FREQUENCY RANGE</b>	1GHz ~ 40GHz		Average (AV)

**ANTENNA POLARITY & TEST DISTANCE: HORIZONTAL AT 3 M**

NO.	FREQ. (MHz)	EMISSION LEVEL (dBuV/m)	LIMIT (dBuV/m)	MARGIN (dB)	ANTENNA HEIGHT (m)	TABLE ANGLE (Degree)	RAW VALUE (dBuV)	CORRECTION FACTOR (dB/m)
1	*5825.00	107.2 PK			1.48 H	234	100.82	6.38
2	*5825.00	95.9 AV			1.48 H	234	89.52	6.38
3	#5850.00	66.4 PK	78.2	-11.8	1.48 H	234	60.01	6.39
4	#5860.00	61.4 PK	74.0	-12.6	1.48 H	234	54.99	6.41
5	#5860.00	43.1 AV	54.0	-10.9	1.48 H	234	36.69	6.41
6	11650.00	51.7 PK	74.0	-22.3	1.67 H	84	35.25	16.45
7	11650.00	37.8 AV	54.0	-16.2	1.67 H	84	21.35	16.45
8	#17475.00	58.0 PK	74.0	-16.0	1.57 H	78	34.85	23.15
9	#17475.00	42.8 AV	54.0	-11.2	1.57 H	78	19.65	23.15

**ANTENNA POLARITY & TEST DISTANCE: VERTICAL AT 3 M**

NO.	FREQ. (MHz)	EMISSION LEVEL (dBuV/m)	LIMIT (dBuV/m)	MARGIN (dB)	ANTENNA HEIGHT (m)	TABLE ANGLE (Degree)	RAW VALUE (dBuV)	CORRECTION FACTOR (dB/m)
1	*5825.00	111.5 PK			1.68 V	318	105.12	6.38
2	*5825.00	99.8 AV			1.68 V	318	93.42	6.38
3	#5860.00	66.2 PK	74.0	-7.8	1.68 V	318	59.79	6.41
4	#5860.00	47.7 AV	54.0	-6.3	1.68 V	318	41.29	6.41
5	11650.00	52.1 PK	74.0	-21.9	1.59 V	225	35.65	16.45
6	11650.00	38.2 AV	54.0	-15.8	1.59 V	225	21.75	16.45
7	#17475.00	59.6 PK	74.0	-14.4	1.74 V	200	36.45	23.15
8	#17475.00	44.1 AV	54.0	-9.9	1.74 V	200	20.95	23.15

**REMARKS:**

1. Emission Level(dBuV/m) = Raw Value(dBuV) + Correction Factor(dB/m)
2. Correction Factor(dB/m) = Antenna Factor(dB/m) + Cable Factor(dB) – Pre-Amplifier Factor(dB)
3. The other emission levels were very low against the limit.
4. Margin value = Emission Level – Limit value
5. " \* ": Fundamental frequency.
6. " # ": The radiated frequency is out of the restricted band.

802.11ac (VHT40)

<b>CHANNEL</b>	TX Channel 38	<b>DETECTOR FUNCTION</b>	Peak (PK)
<b>FREQUENCY RANGE</b>	1GHz ~ 40GHz		Average (AV)

ANTENNA POLARITY & TEST DISTANCE: HORIZONTAL AT 3 M								
NO.	FREQ. (MHz)	EMISSION LEVEL (dBuV/m)	LIMIT (dBuV/m)	MARGIN (dB)	ANTENNA HEIGHT (m)	TABLE ANGLE (Degree)	RAW VALUE (dBuV)	CORRECTION FACTOR (dB/m)
1	5150.00	64.1 PK	74.0	-9.9	1.48 H	253	57.63	6.47
2	5150.00	49.2 AV	54.0	-4.8	1.48 H	253	42.73	6.47
3	*5190.00	101.6 PK			1.48 H	253	94.90	6.70
4	*5190.00	89.9 AV			1.48 H	253	83.20	6.70
5	#10380.00	50.4 PK	74.0	-23.6	1.78 H	257	36.19	14.21
6	#10380.00	37.6 AV	54.0	-16.4	1.78 H	257	23.39	14.21
7	15570.00	54.0 PK	74.0	-20.0	1.70 H	182	35.45	18.55
8	15570.00	39.6 AV	54.0	-14.4	1.70 H	182	21.05	18.55

ANTENNA POLARITY & TEST DISTANCE: VERTICAL AT 3 M								
NO.	FREQ. (MHz)	EMISSION LEVEL (dBuV/m)	LIMIT (dBuV/m)	MARGIN (dB)	ANTENNA HEIGHT (m)	TABLE ANGLE (Degree)	RAW VALUE (dBuV)	CORRECTION FACTOR (dB/m)
1	5150.00	71.7 PK	74.0	-2.3	1.68 V	183	65.20	6.50
2	5150.00	53.0 AV	54.0	-1.0	1.68 V	183	46.50	6.50
3	*5190.00	106.7 PK			1.68 V	163	100.00	6.70
4	*5190.00	95.8 AV			1.68 V	163	89.10	6.70
5	#10380.00	50.8 PK	74.0	-23.2	2.18 V	300	36.70	14.10
6	#10380.00	37.3 AV	54.0	-16.7	2.18 V	300	23.20	14.10
7	15570.00	54.8 PK	74.0	-19.2	1.81 V	59	36.40	18.40
8	15570.00	39.1 AV	54.0	-14.9	1.81 V	59	20.70	18.40

**REMARKS:**

1. Emission Level(dBuV/m) = Raw Value(dBuV) + Correction Factor(dB/m)
2. Correction Factor(dB/m) = Antenna Factor(dB/m) + Cable Factor(dB) – Pre-Amplifier Factor(dB)
3. The other emission levels were very low against the limit.
4. Margin value = Emission Level – Limit value
5. " \* ": Fundamental frequency.
6. " # ": The radiated frequency is out of the restricted band.

<b>CHANNEL</b>	TX Channel 46	<b>DETECTOR FUNCTION</b>	Peak (PK)
<b>FREQUENCY RANGE</b>	1GHz ~ 40GHz		Average (AV)

**ANTENNA POLARITY & TEST DISTANCE: HORIZONTAL AT 3 M**

NO.	FREQ. (MHz)	EMISSION LEVEL (dBuV/m)	LIMIT (dBuV/m)	MARGIN (dB)	ANTENNA HEIGHT (m)	TABLE ANGLE (Degree)	RAW VALUE (dBuV)	CORRECTION FACTOR (dB/m)
1	5150.00	58.1 PK	74.0	-15.9	1.53 H	225	51.63	6.47
2	5150.00	44.8 AV	54.0	-9.2	1.53 H	225	38.33	6.47
3	*5230.00	107.2 PK			1.53 H	225	100.39	6.81
4	*5230.00	96.1 AV			1.53 H	225	89.29	6.81
5	#10460.00	50.6 PK	74.0	-23.4	1.81 H	255	36.55	14.05
6	#10460.00	37.5 AV	54.0	-16.5	1.81 H	255	23.45	14.05
7	15690.00	53.5 PK	74.0	-20.5	1.64 H	193	34.63	18.87
8	15690.00	39.2 AV	54.0	-14.8	1.64 H	193	20.33	18.87

**ANTENNA POLARITY & TEST DISTANCE: VERTICAL AT 3 M**

NO.	FREQ. (MHz)	EMISSION LEVEL (dBuV/m)	LIMIT (dBuV/m)	MARGIN (dB)	ANTENNA HEIGHT (m)	TABLE ANGLE (Degree)	RAW VALUE (dBuV)	CORRECTION FACTOR (dB/m)
1	5150.00	65.0 PK	74.0	-9.0	1.45 V	231	58.53	6.47
2	5150.00	49.4 AV	54.0	-4.6	1.45 V	231	42.93	6.47
3	*5230.00	111.9 PK			1.45 V	231	105.09	6.81
4	*5230.00	100.7 AV			1.45 V	231	93.89	6.81
5	#10460.00	51.6 PK	74.0	-22.4	2.12 V	311	37.55	14.05
6	#10460.00	37.6 AV	54.0	-16.4	2.12 V	311	23.55	14.05
7	15690.00	55.2 PK	74.0	-18.8	1.84 V	68	36.33	18.87
8	15690.00	39.6 AV	54.0	-14.4	1.84 V	68	20.73	18.87

**REMARKS:**

1. Emission Level(dBuV/m) = Raw Value(dBuV) + Correction Factor(dB/m)
2. Correction Factor(dB/m) = Antenna Factor(dB/m) + Cable Factor(dB) – Pre-Amplifier Factor(dB)
3. The other emission levels were very low against the limit.
4. Margin value = Emission Level – Limit value
5. " \* ": Fundamental frequency.
6. " # ": The radiated frequency is out of the restricted band.

<b>CHANNEL</b>	TX Channel 54	<b>DETECTOR FUNCTION</b>	Peak (PK)
<b>FREQUENCY RANGE</b>	1GHz ~ 40GHz		Average (AV)

**ANTENNA POLARITY & TEST DISTANCE: HORIZONTAL AT 3 M**

NO.	FREQ. (MHz)	EMISSION LEVEL (dBuV/m)	LIMIT (dBuV/m)	MARGIN (dB)	ANTENNA HEIGHT (m)	TABLE ANGLE (Degree)	RAW VALUE (dBuV)	CORRECTION FACTOR (dB/m)
1	*5270.00	107.4 PK			1.46 H	240	100.54	6.86
2	*5270.00	96.5 AV			1.46 H	240	89.64	6.86
3	5350.00	64.1 PK	74.0	-9.9	1.46 H	240	57.06	7.04
4	5350.00	49.2 AV	54.0	-4.8	1.46 H	240	42.16	7.04
5	#10540.00	50.3 PK	74.0	-23.7	1.77 H	251	36.57	13.73
6	#10540.00	37.3 AV	54.0	-16.7	1.77 H	251	23.57	13.73
7	15810.00	54.0 PK	74.0	-20.0	1.74 H	191	34.58	19.42
8	15810.00	39.6 AV	54.0	-14.4	1.74 H	191	20.18	19.42

**ANTENNA POLARITY & TEST DISTANCE: VERTICAL AT 3 M**

NO.	FREQ. (MHz)	EMISSION LEVEL (dBuV/m)	LIMIT (dBuV/m)	MARGIN (dB)	ANTENNA HEIGHT (m)	TABLE ANGLE (Degree)	RAW VALUE (dBuV)	CORRECTION FACTOR (dB/m)
1	*5270.00	112.5 PK			1.46 V	230	105.64	6.86
2	*5270.00	101.4 AV			1.46 V	230	94.54	6.86
3	5350.00	68.6 PK	74.0	-5.4	1.46 V	230	61.56	7.04
4	5350.00	52.9 AV	54.0	-1.1	1.46 V	230	45.86	7.04
5	#10540.00	51.0 PK	74.0	-23.0	2.16 V	311	37.27	13.73
6	#10540.00	37.3 AV	54.0	-16.7	2.16 V	311	23.57	13.73
7	15810.00	54.8 PK	74.0	-19.2	1.79 V	49	35.38	19.42
8	15810.00	39.4 AV	54.0	-14.6	1.79 V	49	19.98	19.42

**REMARKS:**

1. Emission Level(dBuV/m) = Raw Value(dBuV) + Correction Factor(dB/m)
2. Correction Factor(dB/m) = Antenna Factor(dB/m) + Cable Factor(dB) – Pre-Amplifier Factor(dB)
3. The other emission levels were very low against the limit.
4. Margin value = Emission Level – Limit value
5. " \* ": Fundamental frequency.
6. " # ": The radiated frequency is out of the restricted band.



<b>CHANNEL</b>	TX Channel 62	<b>DETECTOR FUNCTION</b>	Peak (PK)
<b>FREQUENCY RANGE</b>	1GHz ~ 40GHz		Average (AV)

**ANTENNA POLARITY & TEST DISTANCE: HORIZONTAL AT 3 M**

NO.	FREQ. (MHz)	EMISSION LEVEL (dBuV/m)	LIMIT (dBuV/m)	MARGIN (dB)	ANTENNA HEIGHT (m)	TABLE ANGLE (Degree)	RAW VALUE (dBuV)	CORRECTION FACTOR (dB/m)
1	*5310.00	101.9 PK			1.45 H	237	94.96	6.94
2	*5310.00	90.1 AV			1.45 H	237	83.16	6.94
3	5350.00	64.7 PK	74.0	-9.3	1.45 H	237	57.66	7.04
4	5350.00	49.8 AV	54.0	-4.2	1.45 H	237	42.76	7.04
5	10620.00	49.9 PK	74.0	-24.1	1.75 H	254	36.36	13.54
6	10620.00	37.2 AV	54.0	-16.8	1.75 H	254	23.66	13.54
7	15930.00	53.3 PK	74.0	-20.7	1.74 H	190	34.38	18.92
8	15930.00	39.1 AV	54.0	-14.9	1.74 H	190	20.18	18.92

**ANTENNA POLARITY & TEST DISTANCE: VERTICAL AT 3 M**

NO.	FREQ. (MHz)	EMISSION LEVEL (dBuV/m)	LIMIT (dBuV/m)	MARGIN (dB)	ANTENNA HEIGHT (m)	TABLE ANGLE (Degree)	RAW VALUE (dBuV)	CORRECTION FACTOR (dB/m)
1	*5310.00	106.3 PK			1.46 V	228	99.36	6.94
2	*5310.00	95.2 AV			1.46 V	228	88.26	6.94
3	5350.00	70.4 PK	74.0	-3.6	1.46 V	228	63.36	7.04
<b>4</b>	<b>5350.00</b>	<b>53.0 AV</b>	<b>54.0</b>	<b>-1.0</b>	<b>1.46 V</b>	<b>228</b>	<b>45.96</b>	<b>7.04</b>
5	10620.00	51.2 PK	74.0	-22.8	2.14 V	331	37.66	13.54
6	10620.00	37.6 AV	54.0	-16.4	2.14 V	331	24.06	13.54
7	15930.00	54.1 PK	74.0	-19.9	1.78 V	56	35.18	18.92
8	15930.00	38.9 AV	54.0	-15.1	1.78 V	56	19.98	18.92

**REMARKS:**

1. Emission Level(dBuV/m) = Raw Value(dBuV) + Correction Factor(dB/m)
2. Correction Factor(dB/m) = Antenna Factor(dB/m) + Cable Factor(dB) – Pre-Amplifier Factor(dB)
3. The other emission levels were very low against the limit.
4. Margin value = Emission Level – Limit value
5. " \* ": Fundamental frequency.

<b>CHANNEL</b>	TX Channel 102	<b>DETECTOR FUNCTION</b>	Peak (PK)
<b>FREQUENCY RANGE</b>	1GHz ~ 40GHz		Average (AV)

**ANTENNA POLARITY & TEST DISTANCE: HORIZONTAL AT 3 M**

NO.	FREQ. (MHz)	EMISSION LEVEL (dBuV/m)	LIMIT (dBuV/m)	MARGIN (dB)	ANTENNA HEIGHT (m)	TABLE ANGLE (Degree)	RAW VALUE (dBuV)	CORRECTION FACTOR (dB/m)
1	#5470.00	66.7 PK	74.0	-7.3	1.55 H	226	59.41	7.29
2	#5470.00	48.7 AV	54.0	-5.3	1.55 H	226	41.41	7.29
3	*5510.00	101.4 PK			1.55 H	226	94.09	7.31
4	*5510.00	89.9 AV			1.55 H	226	82.59	7.31
5	11020.00	50.6 PK	74.0	-23.4	1.83 H	263	36.32	14.28
6	11020.00	37.6 AV	54.0	-16.4	1.83 H	263	23.32	14.28
7	#16530.00	54.5 PK	74.0	-19.5	1.65 H	195	33.27	21.23
8	#16530.00	39.9 AV	54.0	-14.1	1.65 H	195	18.67	21.23

**ANTENNA POLARITY & TEST DISTANCE: VERTICAL AT 3 M**

NO.	FREQ. (MHz)	EMISSION LEVEL (dBuV/m)	LIMIT (dBuV/m)	MARGIN (dB)	ANTENNA HEIGHT (m)	TABLE ANGLE (Degree)	RAW VALUE (dBuV)	CORRECTION FACTOR (dB/m)
1	#5470.00	68.3 PK	74.0	-5.7	1.46 V	165	61.01	7.29
2	#5470.00	51.6 AV	54.0	-2.4	1.46 V	165	44.31	7.29
3	*5510.00	106.6 PK			1.46 V	165	99.29	7.31
4	*5510.00	94.4 AV			1.46 V	165	87.09	7.31
5	11020.00	51.0 PK	74.0	-23.0	2.10 V	322	36.72	14.28
6	11020.00	37.5 AV	54.0	-16.5	2.10 V	322	23.22	14.28
7	#16530.00	54.5 PK	74.0	-19.5	1.83 V	56	33.27	21.23
8	#16530.00	38.8 AV	54.0	-15.2	1.83 V	56	17.57	21.23

**REMARKS:**

1. Emission Level(dBuV/m) = Raw Value(dBuV) + Correction Factor(dB/m)
2. Correction Factor(dB/m) = Antenna Factor(dB/m) + Cable Factor(dB) – Pre-Amplifier Factor(dB)
3. The other emission levels were very low against the limit.
4. Margin value = Emission Level – Limit value
5. " \* ": Fundamental frequency.
6. " # ": The radiated frequency is out of the restricted band.

<b>CHANNEL</b>	TX Channel 110	<b>DETECTOR FUNCTION</b>	Peak (PK)
<b>FREQUENCY RANGE</b>	1GHz ~ 40GHz		Average (AV)

**ANTENNA POLARITY & TEST DISTANCE: HORIZONTAL AT 3 M**

NO.	FREQ. (MHz)	EMISSION LEVEL (dBuV/m)	LIMIT (dBuV/m)	MARGIN (dB)	ANTENNA HEIGHT (m)	TABLE ANGLE (Degree)	RAW VALUE (dBuV)	CORRECTION FACTOR (dB/m)
1	#5470.00	59.0 PK	74.0	-15.0	1.48 H	251	51.71	7.29
2	#5470.00	45.4 AV	54.0	-8.6	1.48 H	251	38.11	7.29
3	*5550.00	105.5 PK			1.48 H	251	98.26	7.24
4	*5550.00	94.1 AV			1.48 H	251	86.86	7.24
5	11100.00	50.3 PK	74.0	-23.7	1.80 H	256	35.86	14.44
6	11100.00	37.4 AV	54.0	-16.6	1.80 H	256	22.96	14.44
7	#16650.00	54.0 PK	74.0	-20.0	1.60 H	199	32.15	21.85
8	#16650.00	39.4 AV	54.0	-14.6	1.60 H	199	17.55	21.85

**ANTENNA POLARITY & TEST DISTANCE: VERTICAL AT 3 M**

NO.	FREQ. (MHz)	EMISSION LEVEL (dBuV/m)	LIMIT (dBuV/m)	MARGIN (dB)	ANTENNA HEIGHT (m)	TABLE ANGLE (Degree)	RAW VALUE (dBuV)	CORRECTION FACTOR (dB/m)
1	#5470.00	61.3 PK	74.0	-12.7	1.48 V	163	54.01	7.29
2	#5470.00	48.1 AV	54.0	-5.9	1.48 V	163	40.81	7.29
3	*5550.00	111.0 PK			1.48 V	163	103.76	7.24
4	*5550.00	99.0 AV			1.48 V	163	91.76	7.24
5	11100.00	51.2 PK	74.0	-22.8	2.21 V	324	36.76	14.44
6	11100.00	37.5 AV	54.0	-16.5	2.21 V	324	23.06	14.44
7	#16650.00	54.8 PK	74.0	-19.2	1.83 V	69	32.95	21.85
8	#16650.00	39.5 AV	54.0	-14.5	1.83 V	69	17.65	21.85

**REMARKS:**

1. Emission Level(dBuV/m) = Raw Value(dBuV) + Correction Factor(dB/m)
2. Correction Factor(dB/m) = Antenna Factor(dB/m) + Cable Factor(dB) – Pre-Amplifier Factor(dB)
3. The other emission levels were very low against the limit.
4. Margin value = Emission Level – Limit value
5. " \* ": Fundamental frequency.
6. " # ": The radiated frequency is out of the restricted band.

<b>CHANNEL</b>	TX Channel 118	<b>DETECTOR FUNCTION</b>	Peak (PK)
<b>FREQUENCY RANGE</b>	1GHz ~ 40GHz		Average (AV)

**ANTENNA POLARITY & TEST DISTANCE: HORIZONTAL AT 3 M**

NO.	FREQ. (MHz)	EMISSION LEVEL (dBuV/m)	LIMIT (dBuV/m)	MARGIN (dB)	ANTENNA HEIGHT (m)	TABLE ANGLE (Degree)	RAW VALUE (dBuV)	CORRECTION FACTOR (dB/m)
1	*5590.00	105.7 PK			1.53 H	257	98.55	7.15
2	*5590.00	94.3 AV			1.53 H	257	87.15	7.15
3	11180.00	50.4 PK	74.0	-23.6	1.77 H	249	35.93	14.47
4	11180.00	37.4 AV	54.0	-16.6	1.77 H	249	22.93	14.47
5	#16770.00	54.0 PK	74.0	-20.0	1.64 H	210	31.97	22.03
6	#16770.00	39.7 AV	54.0	-14.3	1.64 H	210	17.67	22.03

**ANTENNA POLARITY & TEST DISTANCE: VERTICAL AT 3 M**

NO.	FREQ. (MHz)	EMISSION LEVEL (dBuV/m)	LIMIT (dBuV/m)	MARGIN (dB)	ANTENNA HEIGHT (m)	TABLE ANGLE (Degree)	RAW VALUE (dBuV)	CORRECTION FACTOR (dB/m)
1	*5590.00	110.6 PK			1.49 V	163	103.45	7.15
2	*5590.00	99.0 AV			1.49 V	163	91.85	7.15
3	11180.00	51.3 PK	74.0	-22.7	2.13 V	299	36.83	14.47
4	11180.00	37.4 AV	54.0	-16.6	2.13 V	299	22.93	14.47
5	#16770.00	55.1 PK	74.0	-18.9	1.81 V	67	33.07	22.03
6	#16770.00	39.4 AV	54.0	-14.6	1.81 V	67	17.37	22.03

**REMARKS:**

1. Emission Level(dBuV/m) = Raw Value(dBuV) + Correction Factor(dB/m)
2. Correction Factor(dB/m) = Antenna Factor(dB/m) + Cable Factor(dB) – Pre-Amplifier Factor(dB)
3. The other emission levels were very low against the limit.
4. Margin value = Emission Level – Limit value
5. " \* ": Fundamental frequency.
6. " # ": The radiated frequency is out of the restricted band.

<b>CHANNEL</b>	TX Channel 134	<b>DETECTOR FUNCTION</b>	Peak (PK)
<b>FREQUENCY RANGE</b>	1GHz ~ 40GHz		Average (AV)

**ANTENNA POLARITY & TEST DISTANCE: HORIZONTAL AT 3 M**

NO.	FREQ. (MHz)	EMISSION LEVEL (dBuV/m)	LIMIT (dBuV/m)	MARGIN (dB)	ANTENNA HEIGHT (m)	TABLE ANGLE (Degree)	RAW VALUE (dBuV)	CORRECTION FACTOR (dB/m)
1	*5670.00	104.0 PK			1.46 H	234	96.69	7.31
2	*5670.00	93.0 AV			1.46 H	234	85.69	7.31
3	#5725.00	66.1 PK	74.0	-7.9	1.46 H	234	58.72	7.38
4	#5725.00	48.3 AV	54.0	-5.7	1.46 H	234	40.92	7.38
5	11340.00	50.4 PK	74.0	-23.6	1.78 H	249	35.84	14.56
6	11340.00	37.5 AV	54.0	-16.5	1.78 H	249	22.94	14.56
7	#17010.00	54.5 PK	74.0	-19.5	1.67 H	193	31.11	23.39
8	#17010.00	40.1 AV	54.0	-13.9	1.67 H	193	16.71	23.39

**ANTENNA POLARITY & TEST DISTANCE: VERTICAL AT 3 M**

NO.	FREQ. (MHz)	EMISSION LEVEL (dBuV/m)	LIMIT (dBuV/m)	MARGIN (dB)	ANTENNA HEIGHT (m)	TABLE ANGLE (Degree)	RAW VALUE (dBuV)	CORRECTION FACTOR (dB/m)
1	*5670.00	110.3 PK			1.40 V	222	102.99	7.31
2	*5670.00	97.4 AV			1.40 V	222	90.09	7.31
3	#5725.00	70.3 PK	74.0	-3.7	1.40 V	222	62.92	7.38
4	#5725.00	51.7 AV	54.0	-2.3	1.40 V	222	44.32	7.38
5	11340.00	52.1 PK	74.0	-21.9	2.18 V	307	37.54	14.56
6	11340.00	38.2 AV	54.0	-15.8	2.18 V	307	23.64	14.56
7	#17010.00	54.9 PK	74.0	-19.1	1.73 V	58	31.51	23.39
8	#17010.00	39.4 AV	54.0	-14.6	1.73 V	58	16.01	23.39

**REMARKS:**

1. Emission Level(dBuV/m) = Raw Value(dBuV) + Correction Factor(dB/m)
2. Correction Factor(dB/m) = Antenna Factor(dB/m) + Cable Factor(dB) – Pre-Amplifier Factor(dB)
3. The other emission levels were very low against the limit.
4. Margin value = Emission Level – Limit value
5. " \* ": Fundamental frequency.
6. " # ": The radiated frequency is out of the restricted band.

<b>CHANNEL</b>	TX Channel 151	<b>DETECTOR FUNCTION</b>	Peak (PK)
<b>FREQUENCY RANGE</b>	1GHz ~ 40GHz		Average (AV)

**ANTENNA POLARITY & TEST DISTANCE: HORIZONTAL AT 3 M**

NO.	FREQ. (MHz)	EMISSION LEVEL (dBuV/m)	LIMIT (dBuV/m)	MARGIN (dB)	ANTENNA HEIGHT (m)	TABLE ANGLE (Degree)	RAW VALUE (dBuV)	CORRECTION FACTOR (dB/m)
1	#5715.00	60.3 PK	74.0	-13.7	1.47 H	234	54.19	6.11
2	#5715.00	45.2 AV	54.0	-8.8	1.47 H	234	39.09	6.11
3	#5725.00	67.3 PK	78.2	-10.9	1.47 H	234	61.16	6.14
4	*5755.00	100.2 PK			1.47 H	234	93.96	6.24
5	*5755.00	87.4 AV			1.47 H	234	81.16	6.24
6	11510.00	50.2 PK	74.0	-23.8	1.84 H	266	33.39	16.81
7	11510.00	37.1 AV	54.0	-16.9	1.84 H	266	20.29	16.81
8	#17265.00	54.7 PK	74.0	-19.3	1.70 H	197	32.55	22.15
9	#17265.00	40.3 AV	54.0	-13.7	1.70 H	197	18.15	22.15

**ANTENNA POLARITY & TEST DISTANCE: VERTICAL AT 3 M**

NO.	FREQ. (MHz)	EMISSION LEVEL (dBuV/m)	LIMIT (dBuV/m)	MARGIN (dB)	ANTENNA HEIGHT (m)	TABLE ANGLE (Degree)	RAW VALUE (dBuV)	CORRECTION FACTOR (dB/m)
1	#5715.00	65.8 PK	74.0	-8.2	1.60 V	356	59.69	6.11
2	#5715.00	50.2 AV	54.0	-3.8	1.60 V	356	44.09	6.11
3	#5725.00	72.4 PK	78.2	-5.8	1.60 V	356	66.26	6.14
4	*5755.00	104.8 PK			1.60 V	356	98.56	6.24
5	*5755.00	92.4 AV			1.60 V	356	86.16	6.24
6	11510.00	51.1 PK	74.0	-22.9	2.14 V	310	34.29	16.81
7	11510.00	37.3 AV	54.0	-16.7	2.14 V	310	20.49	16.81
8	#17265.00	55.2 PK	74.0	-18.8	1.80 V	57	33.05	22.15
9	#17265.00	39.6 AV	54.0	-14.4	1.80 V	57	17.45	22.15

**REMARKS:**

1. Emission Level(dBuV/m) = Raw Value(dBuV) + Correction Factor(dB/m)
2. Correction Factor(dB/m) = Antenna Factor(dB/m) + Cable Factor(dB) – Pre-Amplifier Factor(dB)
3. The other emission levels were very low against the limit.
4. Margin value = Emission Level – Limit value
5. " \* ": Fundamental frequency.
6. " # ": The radiated frequency is out of the restricted band.

<b>CHANNEL</b>	TX Channel 159	<b>DETECTOR FUNCTION</b>	Peak (PK)
<b>FREQUENCY RANGE</b>	1GHz ~ 40GHz		Average (AV)

**ANTENNA POLARITY & TEST DISTANCE: HORIZONTAL AT 3 M**

NO.	FREQ. (MHz)	EMISSION LEVEL (dBuV/m)	LIMIT (dBuV/m)	MARGIN (dB)	ANTENNA HEIGHT (m)	TABLE ANGLE (Degree)	RAW VALUE (dBuV)	CORRECTION FACTOR (dB/m)
1	*5795.00	104.6 PK			1.47 H	244	98.26	6.34
2	*5795.00	93.2 AV			1.47 H	244	86.86	6.34
3	#5850.00	67.1 PK	78.2	-11.1	1.47 H	244	60.71	6.39
4	#5860.00	60.2 PK	74.0	-13.8	1.47 H	244	53.79	6.41
5	#5860.00	45.2 AV	54.0	-8.8	1.47 H	244	38.79	6.41
6	11590.00	50.8 PK	74.0	-23.2	1.80 H	267	34.19	16.61
7	11590.00	38.0 AV	54.0	-16.0	1.80 H	267	21.39	16.61
8	#17385.00	54.7 PK	74.0	-19.3	1.67 H	195	31.79	22.91
9	#17385.00	40.0 AV	54.0	-14.0	1.67 H	195	17.09	22.91

**ANTENNA POLARITY & TEST DISTANCE: VERTICAL AT 3 M**

NO.	FREQ. (MHz)	EMISSION LEVEL (dBuV/m)	LIMIT (dBuV/m)	MARGIN (dB)	ANTENNA HEIGHT (m)	TABLE ANGLE (Degree)	RAW VALUE (dBuV)	CORRECTION FACTOR (dB/m)
1	*5795.00	110.1 PK			1.60 V	360	103.76	6.34
2	*5795.00	98.1 AV			1.60 V	360	91.76	6.34
3	#5850.00	73.0 PK	78.2	-5.2	1.60 V	360	66.61	6.39
4	#5860.00	69.4 PK	74.0	-4.6	1.60 V	360	62.99	6.41
5	#5860.00	50.2 AV	54.0	-3.8	1.60 V	360	43.79	6.41
6	11590.00	51.9 PK	74.0	-22.1	2.10 V	317	35.29	16.61
7	11590.00	38.0 AV	54.0	-16.0	2.10 V	317	21.39	16.61
8	#17385.00	54.4 PK	74.0	-19.6	1.76 V	64	31.49	22.91
9	#17385.00	39.1 AV	54.0	-14.9	1.76 V	64	16.19	22.91

**REMARKS:**

1. Emission Level(dBuV/m) = Raw Value(dBuV) + Correction Factor(dB/m)
2. Correction Factor(dB/m) = Antenna Factor(dB/m) + Cable Factor(dB) – Pre-Amplifier Factor(dB)
3. The other emission levels were very low against the limit.
4. Margin value = Emission Level – Limit value
5. " \* ": Fundamental frequency.
6. " # ": The radiated frequency is out of the restricted band.

**802.11ac (VHT80)**

<b>CHANNEL</b>	TX Channel 42	<b>DETECTOR FUNCTION</b>	Peak (PK)
<b>FREQUENCY RANGE</b>	1GHz ~ 40GHz		Average (AV)

<b>ANTENNA POLARITY &amp; TEST DISTANCE: HORIZONTAL AT 3 M</b>								
NO.	FREQ. (MHz)	EMISSION LEVEL (dBuV/m)	LIMIT (dBuV/m)	MARGIN (dB)	ANTENNA HEIGHT (m)	TABLE ANGLE (Degree)	RAW VALUE (dBuV)	CORRECTION FACTOR (dB/m)
1	5150.00	66.0 PK	74.0	-8.0	1.48 H	228	59.53	6.47
2	5150.00	49.5 AV	54.0	-4.5	1.48 H	228	43.03	6.47
3	*5210.00	100.4 PK			1.48 H	228	93.62	6.78
4	*5210.00	87.8 AV			1.48 H	228	81.02	6.78
5	#10420.00	51.3 PK	74.0	-22.7	1.77 H	258	37.15	14.15
6	#10420.00	38.0 AV	54.0	-16.0	1.77 H	258	23.85	14.15
7	15630.00	55.2 PK	74.0	-18.8	1.69 H	193	36.68	18.52
8	15630.00	40.4 AV	54.0	-13.6	1.69 H	193	21.88	18.52

<b>ANTENNA POLARITY &amp; TEST DISTANCE: VERTICAL AT 3 M</b>								
NO.	FREQ. (MHz)	EMISSION LEVEL (dBuV/m)	LIMIT (dBuV/m)	MARGIN (dB)	ANTENNA HEIGHT (m)	TABLE ANGLE (Degree)	RAW VALUE (dBuV)	CORRECTION FACTOR (dB/m)
1	5150.00	69.5 PK	74.0	-4.5	1.46 V	136	63.03	6.47
2	5150.00	52.9 AV	54.0	-1.1	1.46 V	136	46.43	6.47
3	*5210.00	104.2 PK			1.46 V	136	97.42	6.78
4	*5210.00	91.2 AV			1.46 V	136	84.42	6.78
5	#10420.00	50.7 PK	74.0	-23.3	2.20 V	314	36.55	14.15
6	#10420.00	37.3 AV	54.0	-16.7	2.20 V	314	23.15	14.15
7	15630.00	54.6 PK	74.0	-19.4	1.81 V	63	36.08	18.52
8	15630.00	39.3 AV	54.0	-14.7	1.81 V	63	20.78	18.52

**REMARKS:**

- Emission Level(dBuV/m) = Raw Value(dBuV) + Correction Factor(dB/m)
- Correction Factor(dB/m) = Antenna Factor(dB/m) + Cable Factor(dB) – Pre-Amplifier Factor(dB)
- The other emission levels were very low against the limit.
- Margin value = Emission Level – Limit value
- " \* ": Fundamental frequency.
- " # ": The radiated frequency is out of the restricted band.



<b>CHANNEL</b>	TX Channel 58	<b>DETECTOR FUNCTION</b>	Peak (PK)
<b>FREQUENCY RANGE</b>	1GHz ~ 40GHz		Average (AV)

**ANTENNA POLARITY & TEST DISTANCE: HORIZONTAL AT 3 M**

NO.	FREQ. (MHz)	EMISSION LEVEL (dBuV/m)	LIMIT (dBuV/m)	MARGIN (dB)	ANTENNA HEIGHT (m)	TABLE ANGLE (Degree)	RAW VALUE (dBuV)	CORRECTION FACTOR (dB/m)
1	*5290.00	98.4 PK			1.45 H	228	91.51	6.89
2	*5290.00	88.4 AV			1.45 H	228	81.51	6.89
3	5350.00	66.3 PK	74.0	-7.7	1.45 H	228	59.26	7.04
4	5350.00	49.6 AV	54.0	-4.4	1.45 H	228	42.56	7.04
5	#10580.00	50.4 PK	74.0	-23.6	1.82 H	248	36.87	13.53
6	#10580.00	37.5 AV	54.0	-16.5	1.82 H	248	23.97	13.53
7	15870.00	54.1 PK	74.0	-19.9	1.62 H	184	34.95	19.15
8	15870.00	39.7 AV	54.0	-14.3	1.62 H	184	20.55	19.15

**ANTENNA POLARITY & TEST DISTANCE: VERTICAL AT 3 M**

NO.	FREQ. (MHz)	EMISSION LEVEL (dBuV/m)	LIMIT (dBuV/m)	MARGIN (dB)	ANTENNA HEIGHT (m)	TABLE ANGLE (Degree)	RAW VALUE (dBuV)	CORRECTION FACTOR (dB/m)
1	*5290.00	102.6 PK			1.46 V	233	95.71	6.89
2	*5290.00	92.7 AV			1.46 V	233	85.81	6.89
3	5350.00	71.2 PK	74.0	-2.8	1.46 V	233	64.16	7.04
4	5350.00	52.9 AV	54.0	-1.1	1.46 V	233	45.86	7.04
5	#10580.00	51.7 PK	74.0	-22.3	2.17 V	326	38.17	13.53
6	#10580.00	37.7 AV	54.0	-16.3	2.17 V	326	24.17	13.53
7	15870.00	55.4 PK	74.0	-18.6	1.80 V	52	36.25	19.15
8	15870.00	39.6 AV	54.0	-14.4	1.80 V	52	20.45	19.15

**REMARKS:**

1. Emission Level(dBuV/m) = Raw Value(dBuV) + Correction Factor(dB/m)
2. Correction Factor(dB/m) = Antenna Factor(dB/m) + Cable Factor(dB) – Pre-Amplifier Factor(dB)
3. The other emission levels were very low against the limit.
4. Margin value = Emission Level – Limit value
5. " \* ": Fundamental frequency.
6. " # ": The radiated frequency is out of the restricted band.

<b>CHANNEL</b>	TX Channel 106	<b>DETECTOR FUNCTION</b>	Peak (PK)
<b>FREQUENCY RANGE</b>	1GHz ~ 40GHz		Average (AV)

**ANTENNA POLARITY & TEST DISTANCE: HORIZONTAL AT 3 M**

NO.	FREQ. (MHz)	EMISSION LEVEL (dBuV/m)	LIMIT (dBuV/m)	MARGIN (dB)	ANTENNA HEIGHT (m)	TABLE ANGLE (Degree)	RAW VALUE (dBuV)	CORRECTION FACTOR (dB/m)
1	#5470.00	66.1 PK	74.0	-7.9	1.46 H	237	58.81	7.29
2	#5470.00	49.6 AV	54.0	-4.4	1.46 H	237	42.31	7.29
3	*5530.00	97.9 PK			1.46 H	237	90.63	7.27
4	*5530.00	85.0 AV			1.46 H	237	77.73	7.27
5	11060.00	50.2 PK	74.0	-23.8	1.81 H	266	35.85	14.35
6	11060.00	37.4 AV	54.0	-16.6	1.81 H	266	23.05	14.35
7	#16590.00	55.0 PK	74.0	-19.0	1.62 H	186	33.26	21.74
8	#16590.00	40.4 AV	54.0	-13.6	1.62 H	186	18.66	21.74

**ANTENNA POLARITY & TEST DISTANCE: VERTICAL AT 3 M**

NO.	FREQ. (MHz)	EMISSION LEVEL (dBuV/m)	LIMIT (dBuV/m)	MARGIN (dB)	ANTENNA HEIGHT (m)	TABLE ANGLE (Degree)	RAW VALUE (dBuV)	CORRECTION FACTOR (dB/m)
1	#5470.00	69.6 PK	74.0	-4.4	1.46 V	196	62.31	7.29
2	#5470.00	52.0 AV	54.0	-2.0	1.46 V	196	44.71	7.29
3	*5530.00	102.8 PK			1.46 V	196	95.53	7.27
4	*5530.00	89.5 AV			1.46 V	196	82.23	7.27
5	11060.00	51.7 PK	74.0	-22.3	2.15 V	321	37.35	14.35
6	11060.00	37.9 AV	54.0	-16.1	2.15 V	321	23.55	14.35
7	#16590.00	54.4 PK	74.0	-19.6	1.78 V	51	32.66	21.74
8	#16590.00	38.8 AV	54.0	-15.2	1.78 V	51	17.06	21.74

**REMARKS:**

1. Emission Level(dBuV/m) = Raw Value(dBuV) + Correction Factor(dB/m)
2. Correction Factor(dB/m) = Antenna Factor(dB/m) + Cable Factor(dB) – Pre-Amplifier Factor(dB)
3. The other emission levels were very low against the limit.
4. Margin value = Emission Level – Limit value
5. " \* ": Fundamental frequency.
6. " # ": The radiated frequency is out of the restricted band.

<b>CHANNEL</b>	TX Channel 122	<b>DETECTOR FUNCTION</b>	Peak (PK)
<b>FREQUENCY RANGE</b>	1GHz ~ 40GHz		Average (AV)

**ANTENNA POLARITY & TEST DISTANCE: HORIZONTAL AT 3 M**

NO.	FREQ. (MHz)	EMISSION LEVEL (dBuV/m)	LIMIT (dBuV/m)	MARGIN (dB)	ANTENNA HEIGHT (m)	TABLE ANGLE (Degree)	RAW VALUE (dBuV)	CORRECTION FACTOR (dB/m)
1	*5610.00	102.1 PK			1.46 H	245	94.95	7.15
2	*5610.00	90.1 AV			1.46 H	245	82.95	7.15
3	#5725.00	64.4 PK	74.0	-9.6	1.46 H	245	57.02	7.38
4	#5725.00	47.9 AV	54.0	-6.1	1.46 H	245	40.52	7.38
5	11220.00	50.6 PK	74.0	-23.4	1.82 H	263	36.16	14.44
6	11220.00	37.7 AV	54.0	-16.3	1.82 H	263	23.26	14.44
7	#16830.00	54.3 PK	74.0	-19.7	1.63 H	200	32.12	22.18
8	#16830.00	39.6 AV	54.0	-14.4	1.63 H	200	17.42	22.18

**ANTENNA POLARITY & TEST DISTANCE: VERTICAL AT 3 M**

NO.	FREQ. (MHz)	EMISSION LEVEL (dBuV/m)	LIMIT (dBuV/m)	MARGIN (dB)	ANTENNA HEIGHT (m)	TABLE ANGLE (Degree)	RAW VALUE (dBuV)	CORRECTION FACTOR (dB/m)
1	*5610.00	108.6 PK			1.46 V	223	101.45	7.15
2	*5610.00	94.6 AV			1.46 V	223	87.45	7.15
3	#5725.00	68.4 PK	74.0	-5.6	1.46 V	223	61.02	7.38
4	#5725.00	51.8 AV	54.0	-2.2	1.46 V	223	44.42	7.38
5	11220.00	51.3 PK	74.0	-22.7	2.21 V	329	36.86	14.44
6	11220.00	37.4 AV	54.0	-16.6	2.21 V	329	22.96	14.44
7	#16830.00	54.4 PK	74.0	-19.6	1.73 V	45	32.22	22.18
8	#16830.00	39.0 AV	54.0	-15.0	1.73 V	45	16.82	22.18

**REMARKS:**

1. Emission Level(dBuV/m) = Raw Value(dBuV) + Correction Factor(dB/m)
2. Correction Factor(dB/m) = Antenna Factor(dB/m) + Cable Factor(dB) – Pre-Amplifier Factor(dB)
3. The other emission levels were very low against the limit.
4. Margin value = Emission Level – Limit value
5. " \* ": Fundamental frequency.
6. " # ": The radiated frequency is out of the restricted band.

<b>CHANNEL</b>	TX Channel 138	<b>DETECTOR FUNCTION</b>	Peak (PK)
<b>FREQUENCY RANGE</b>	1GHz ~ 40GHz		Average (AV)

**ANTENNA POLARITY & TEST DISTANCE: HORIZONTAL AT 3 M**

NO.	FREQ. (MHz)	EMISSION LEVEL (dBuV/m)	LIMIT (dBuV/m)	MARGIN (dB)	ANTENNA HEIGHT (m)	TABLE ANGLE (Degree)	RAW VALUE (dBuV)	CORRECTION FACTOR (dB/m)
1	#5470.00	58.7 PK	74.0	-15.3	1.53 H	244	51.41	7.29
2	#5470.00	45.2 AV	54.0	-8.8	1.53 H	244	37.91	7.29
3	*5690.00	103.6 PK			1.53 H	244	96.23	7.37
4	*5690.00	90.1 AV			1.53 H	244	82.73	7.37
5	#5850.00	64.0 PK	74.0	-10.0	1.53 H	244	56.75	7.25
6	#5850.00	49.1 AV	54.0	-4.9	1.53 H	244	41.85	7.25
7	11380.00	50.7 PK	74.0	-23.3	1.78 H	275	35.94	14.76
8	11380.00	37.9 AV	54.0	-16.1	1.78 H	275	23.14	14.76
9	#17070.00	53.9 PK	74.0	-20.1	1.71 H	188	30.77	23.13
10	#17070.00	39.5 AV	54.0	-14.5	1.71 H	188	16.37	23.13

**ANTENNA POLARITY & TEST DISTANCE: VERTICAL AT 3 M**

NO.	FREQ. (MHz)	EMISSION LEVEL (dBuV/m)	LIMIT (dBuV/m)	MARGIN (dB)	ANTENNA HEIGHT (m)	TABLE ANGLE (Degree)	RAW VALUE (dBuV)	CORRECTION FACTOR (dB/m)
1	#5470.00	62.1 PK	74.0	-11.9	1.41 V	223	54.81	7.29
2	#5470.00	48.4 AV	54.0	-5.6	1.41 V	223	41.11	7.29
3	*5690.00	110.6 PK			1.41 V	223	103.23	7.37
4	*5690.00	95.6 AV			1.41 V	223	88.23	7.37
5	#5850.00	68.1 PK	74.0	-5.9	1.41 V	223	60.85	7.25
6	#5850.00	52.9 AV	54.0	-1.1	1.41 V	223	45.65	7.25
7	11380.00	50.8 PK	74.0	-23.2	2.20 V	323	36.04	14.76
8	11380.00	37.3 AV	54.0	-16.7	2.20 V	323	22.54	14.76
9	#17070.00	54.2 PK	74.0	-19.8	1.76 V	62	31.07	23.13
10	#17070.00	38.7 AV	54.0	-15.3	1.76 V	62	15.57	23.13

**REMARKS:**

1. Emission Level(dBuV/m) = Raw Value(dBuV) + Correction Factor(dB/m)
2. Correction Factor(dB/m) = Antenna Factor(dB/m) + Cable Factor(dB) – Pre-Amplifier Factor(dB)
3. The other emission levels were very low against the limit.
4. Margin value = Emission Level – Limit value
5. " \* ": Fundamental frequency.
6. " # ": The radiated frequency is out of the restricted band.

<b>CHANNEL</b>	TX Channel 155	<b>DETECTOR FUNCTION</b>	Peak (PK)
<b>FREQUENCY RANGE</b>	1GHz ~ 40GHz		Average (AV)

**ANTENNA POLARITY & TEST DISTANCE: HORIZONTAL AT 3 M**

NO.	FREQ. (MHz)	EMISSION LEVEL (dBuV/m)	LIMIT (dBuV/m)	MARGIN (dB)	ANTENNA HEIGHT (m)	TABLE ANGLE (Degree)	RAW VALUE (dBuV)	CORRECTION FACTOR (dB/m)
1	#5715.00	58.0 PK	74.0	-16.0	1.52 H	240	51.89	6.11
2	#5715.00	44.8 AV	54.0	-9.2	1.52 H	240	38.69	6.11
3	#5725.00	65.2 PK	78.2	-13.0	1.52 H	240	59.06	6.14
4	*5775.00	97.6 PK			1.52 H	240	91.31	6.29
5	*5775.00	84.7 AV			1.52 H	240	78.41	6.29
6	#5850.00	61.5 PK	78.2	-16.7	1.52 H	240	55.11	6.39
7	#5860.00	58.7 PK	74.0	-15.3	1.52 H	240	52.29	6.41
8	#5860.00	44.9 AV	54.0	-9.1	1.52 H	240	38.49	6.41
9	11550.00	50.9 PK	74.0	-23.1	1.77 H	276	34.19	16.71
10	11550.00	37.8 AV	54.0	-16.2	1.77 H	276	21.09	16.71
11	#17325.00	54.0 PK	74.0	-20.0	1.60 H	209	31.60	22.40
12	#17325.00	39.4 AV	54.0	-14.6	1.60 H	209	17.00	22.40

**ANTENNA POLARITY & TEST DISTANCE: VERTICAL AT 3 M**

NO.	FREQ. (MHz)	EMISSION LEVEL (dBuV/m)	LIMIT (dBuV/m)	MARGIN (dB)	ANTENNA HEIGHT (m)	TABLE ANGLE (Degree)	RAW VALUE (dBuV)	CORRECTION FACTOR (dB/m)
1	#5715.00	66.3 PK	74.0	-7.7	1.29 V	223	60.19	6.11
2	#5715.00	49.1 AV	54.0	-4.9	1.29 V	223	42.99	6.11
3	#5725.00	70.0 PK	78.2	-8.2	1.29 V	223	63.86	6.14
4	*5775.00	102.1 PK			1.29 V	223	95.81	6.29
5	*5775.00	89.2 AV			1.29 V	223	82.91	6.29
6	#5850.00	66.2 PK	78.2	-12.0	1.29 V	223	59.81	6.39
7	#5860.00	63.9 PK	74.0	-10.1	1.29 V	223	57.49	6.41
8	#5860.00	48.7 AV	54.0	-5.3	1.29 V	223	42.29	6.41
9	11550.00	52.0 PK	74.0	-22.0	2.11 V	315	35.29	16.71
10	11550.00	38.0 AV	54.0	-16.0	2.11 V	315	21.29	16.71
11	#17325.00	54.6 PK	74.0	-19.4	1.83 V	45	32.20	22.40
12	#17325.00	38.9 AV	54.0	-15.1	1.83 V	45	16.50	22.40

**REMARKS:**

1. Emission Level(dBuV/m) = Raw Value(dBuV) + Correction Factor(dB/m)
2. Correction Factor(dB/m) = Antenna Factor(dB/m) + Cable Factor(dB) – Pre-Amplifier Factor(dB)
3. The other emission levels were very low against the limit.
4. Margin value = Emission Level – Limit value
5. " \* ": Fundamental frequency.
6. " # ": The radiated frequency is out of the restricted band.

**Below 1GHz Data:**

**802.11a**

<b>CHANNEL</b>	TX Channel 36	<b>DETECTOR FUNCTION</b>	Quasi-Peak (QP)
<b>FREQUENCY RANGE</b>	Below 1GHz		

**ANTENNA POLARITY & TEST DISTANCE: HORIZONTAL AT 3 M**

NO.	FREQ. (MHz)	EMISSION LEVEL (dBuV/m)	LIMIT (dBuV/m)	MARGIN (dB)	ANTENNA HEIGHT (m)	TABLE ANGLE (Degree)	RAW VALUE (dBuV)	CORRECTION FACTOR (dB/m)
1	33.88	24.2 QP	40.0	-15.8	1.48 H	179	33.80	-9.60
2	194.98	40.3 QP	43.5	-3.2	1.43 H	48	51.60	-11.30
3	260.29	42.7 QP	46.0	-3.3	1.44 H	67	51.60	-8.90
4	379.97	32.8 QP	46.0	-13.2	1.15 H	359	38.10	-5.30
5	695.81	37.9 QP	46.0	-8.1	1.00 H	323	36.50	1.40
6	1000.00	41.0 QP	54.0	-13.0	1.93 H	279	35.30	5.70

**ANTENNA POLARITY & TEST DISTANCE: VERTICAL AT 3 M**

NO.	FREQ. (MHz)	EMISSION LEVEL (dBuV/m)	LIMIT (dBuV/m)	MARGIN (dB)	ANTENNA HEIGHT (m)	TABLE ANGLE (Degree)	RAW VALUE (dBuV)	CORRECTION FACTOR (dB/m)
1	98.21	25.5 QP	43.5	-18.0	1.97 V	296	38.90	-13.40
2	195.72	33.9 QP	43.5	-9.6	1.66 V	206	45.30	-11.40
3	260.03	38.6 QP	46.0	-7.4	1.93 V	140	47.50	-8.90
4	326.06	32.2 QP	46.0	-13.8	1.04 V	47	38.60	-6.40
5	749.60	36.6 QP	46.0	-9.4	1.56 V	333	34.20	2.40
6	1000.00	38.7 QP	54.0	-15.3	1.02 V	282	33.00	5.70

**REMARKS:**

1. Emission Level(dBuV/m) = Raw Value(dBuV) + Correction Factor(dB/m)
2. Correction Factor(dB/m) = Antenna Factor(dB/m) + Cable Factor(dB) – Pre-Amplifier Factor(dB)
3. The other emission levels were very low against the limit.
4. Margin value = Emission Level – Limit value

<b>CHANNEL</b>	TX Channel 40	<b>DETECTOR FUNCTION</b>	Quasi-Peak (QP)
<b>FREQUENCY RANGE</b>	Below 1GHz		

**ANTENNA POLARITY & TEST DISTANCE: HORIZONTAL AT 3 M**

NO.	FREQ. (MHz)	EMISSION LEVEL (dBuV/m)	LIMIT (dBuV/m)	MARGIN (dB)	ANTENNA HEIGHT (m)	TABLE ANGLE (Degree)	RAW VALUE (dBuV)	CORRECTION FACTOR (dB/m)
1	33.84	23.9 QP	40.0	-16.1	1.52 H	162	33.50	-9.60
2	194.66	40.2 QP	43.5	-3.3	1.43 H	41	51.50	-11.30
3	260.60	42.4 QP	46.0	-3.6	1.36 H	66	51.30	-8.90
4	380.04	32.7 QP	46.0	-13.3	1.17 H	349	38.00	-5.30
5	695.84	37.5 QP	46.0	-8.5	1.04 H	337	36.10	1.40
6	1000.00	40.9 QP	54.0	-13.1	1.93 H	281	35.20	5.70

**ANTENNA POLARITY & TEST DISTANCE: VERTICAL AT 3 M**

NO.	FREQ. (MHz)	EMISSION LEVEL (dBuV/m)	LIMIT (dBuV/m)	MARGIN (dB)	ANTENNA HEIGHT (m)	TABLE ANGLE (Degree)	RAW VALUE (dBuV)	CORRECTION FACTOR (dB/m)
1	97.82	25.6 QP	43.5	-17.9	2.01 V	325	39.10	-13.50
2	195.66	33.7 QP	43.5	-9.8	1.67 V	230	45.10	-11.40
3	260.02	38.8 QP	46.0	-7.2	2.00 V	134	47.70	-8.90
4	326.04	32.4 QP	46.0	-13.6	1.02 V	53	38.80	-6.40
5	749.97	36.9 QP	46.0	-9.1	1.56 V	333	34.50	2.40
6	1000.00	38.9 QP	54.0	-15.1	1.03 V	297	33.20	5.70

**REMARKS:**

1. Emission Level(dBuV/m) = Raw Value(dBuV) + Correction Factor(dB/m)
2. Correction Factor(dB/m) = Antenna Factor(dB/m) + Cable Factor(dB) – Pre-Amplifier Factor(dB)
3. The other emission levels were very low against the limit.
4. Margin value = Emission Level – Limit value

<b>CHANNEL</b>	TX Channel 48	<b>DETECTOR FUNCTION</b>	Quasi-Peak (QP)
<b>FREQUENCY RANGE</b>	Below 1GHz		

**ANTENNA POLARITY & TEST DISTANCE: HORIZONTAL AT 3 M**

NO.	FREQ. (MHz)	EMISSION LEVEL (dBuV/m)	LIMIT (dBuV/m)	MARGIN (dB)	ANTENNA HEIGHT (m)	TABLE ANGLE (Degree)	RAW VALUE (dBuV)	CORRECTION FACTOR (dB/m)
1	33.67	24.3 QP	40.0	-15.7	1.56 H	171	33.90	-9.60
2	194.95	40.3 QP	43.5	-3.2	1.50 H	44	51.60	-11.30
3	260.52	42.9 QP	46.0	-3.1	1.38 H	68	51.80	-8.90
4	379.70	32.5 QP	46.0	-13.5	1.18 H	333	37.80	-5.30
5	695.76	38.0 QP	46.0	-8.0	1.06 H	340	36.60	1.40
6	1000.00	41.4 QP	54.0	-12.6	1.94 H	282	35.70	5.70

**ANTENNA POLARITY & TEST DISTANCE: VERTICAL AT 3 M**

NO.	FREQ. (MHz)	EMISSION LEVEL (dBuV/m)	LIMIT (dBuV/m)	MARGIN (dB)	ANTENNA HEIGHT (m)	TABLE ANGLE (Degree)	RAW VALUE (dBuV)	CORRECTION FACTOR (dB/m)
1	97.96	25.8 QP	43.5	-17.7	1.99 V	319	39.30	-13.50
2	195.51	33.8 QP	43.5	-9.7	1.69 V	223	45.20	-11.40
3	260.04	38.5 QP	46.0	-7.5	2.01 V	128	47.40	-8.90
4	325.50	32.2 QP	46.0	-13.8	1.00 V	44	38.60	-6.40
5	749.48	36.9 QP	46.0	-9.1	1.62 V	345	34.50	2.40
6	1000.00	38.6 QP	54.0	-15.4	1.00 V	276	32.90	5.70

**REMARKS:**

1. Emission Level(dBuV/m) = Raw Value(dBuV) + Correction Factor(dB/m)
2. Correction Factor(dB/m) = Antenna Factor(dB/m) + Cable Factor(dB) – Pre-Amplifier Factor(dB)
3. The other emission levels were very low against the limit.
4. Margin value = Emission Level – Limit value



<b>CHANNEL</b>	TX Channel 52	<b>DETECTOR FUNCTION</b>	Quasi-Peak (QP)
<b>FREQUENCY RANGE</b>	Below 1GHz		

**ANTENNA POLARITY & TEST DISTANCE: HORIZONTAL AT 3 M**

NO.	FREQ. (MHz)	EMISSION LEVEL (dBuV/m)	LIMIT (dBuV/m)	MARGIN (dB)	ANTENNA HEIGHT (m)	TABLE ANGLE (Degree)	RAW VALUE (dBuV)	CORRECTION FACTOR (dB/m)
1	33.84	24.0 QP	40.0	-16.0	1.48 H	167	33.60	-9.60
2	195.13	40.2 QP	43.5	-3.3	1.43 H	41	51.50	-11.30
3	260.50	42.5 QP	46.0	-3.5	1.44 H	83	51.40	-8.90
4	379.98	32.5 QP	46.0	-13.5	1.21 H	331	37.80	-5.30
5	695.55	37.9 QP	46.0	-8.1	1.06 H	329	36.50	1.40
6	1000.00	41.3 QP	54.0	-12.7	1.88 H	283	35.60	5.70

**ANTENNA POLARITY & TEST DISTANCE: VERTICAL AT 3 M**

NO.	FREQ. (MHz)	EMISSION LEVEL (dBuV/m)	LIMIT (dBuV/m)	MARGIN (dB)	ANTENNA HEIGHT (m)	TABLE ANGLE (Degree)	RAW VALUE (dBuV)	CORRECTION FACTOR (dB/m)
1	98.06	25.3 QP	43.5	-18.2	1.99 V	305	38.80	-13.50
2	196.03	33.7 QP	43.5	-9.8	1.67 V	229	45.10	-11.40
3	259.70	38.6 QP	46.0	-7.4	2.04 V	132	47.70	-9.10
4	325.63	32.4 QP	46.0	-13.6	1.01 V	57	38.80	-6.40
5	749.59	36.8 QP	46.0	-9.2	1.59 V	339	34.40	2.40
6	1000.00	39.0 QP	54.0	-15.0	1.00 V	292	33.30	5.70

**REMARKS:**

1. Emission Level(dBuV/m) = Raw Value(dBuV) + Correction Factor(dB/m)
2. Correction Factor(dB/m) = Antenna Factor(dB/m) + Cable Factor(dB) – Pre-Amplifier Factor(dB)
3. The other emission levels were very low against the limit.
4. Margin value = Emission Level – Limit value

<b>CHANNEL</b>	TX Channel 60	<b>DETECTOR FUNCTION</b>	Quasi-Peak (QP)
<b>FREQUENCY RANGE</b>	Below 1GHz		

**ANTENNA POLARITY & TEST DISTANCE: HORIZONTAL AT 3 M**

NO.	FREQ. (MHz)	EMISSION LEVEL (dBuV/m)	LIMIT (dBuV/m)	MARGIN (dB)	ANTENNA HEIGHT (m)	TABLE ANGLE (Degree)	RAW VALUE (dBuV)	CORRECTION FACTOR (dB/m)
1	33.97	24.2 QP	40.0	-15.8	1.46 H	182	33.70	-9.50
2	194.69	40.4 QP	43.5	-3.1	1.45 H	35	51.70	-11.30
3	260.10	42.5 QP	46.0	-3.5	1.39 H	66	51.40	-8.90
4	379.98	32.5 QP	46.0	-13.5	1.17 H	359	37.80	-5.30
5	695.50	37.5 QP	46.0	-8.5	1.00 H	343	36.10	1.40
6	1000.00	41.3 QP	54.0	-12.7	1.92 H	261	35.60	5.70

**ANTENNA POLARITY & TEST DISTANCE: VERTICAL AT 3 M**

NO.	FREQ. (MHz)	EMISSION LEVEL (dBuV/m)	LIMIT (dBuV/m)	MARGIN (dB)	ANTENNA HEIGHT (m)	TABLE ANGLE (Degree)	RAW VALUE (dBuV)	CORRECTION FACTOR (dB/m)
1	98.19	25.4 QP	43.5	-18.1	1.94 V	314	38.80	-13.40
2	195.64	33.9 QP	43.5	-9.6	1.64 V	216	45.30	-11.40
3	259.93	38.6 QP	46.0	-7.4	1.94 V	135	47.60	-9.00
4	325.78	32.0 QP	46.0	-14.0	1.00 V	53	38.40	-6.40
5	749.89	36.7 QP	46.0	-9.3	1.60 V	327	34.30	2.40
6	1000.00	38.9 QP	54.0	-15.1	1.00 V	304	33.20	5.70

**REMARKS:**

1. Emission Level(dBuV/m) = Raw Value(dBuV) + Correction Factor(dB/m)
2. Correction Factor(dB/m) = Antenna Factor(dB/m) + Cable Factor(dB) – Pre-Amplifier Factor(dB)
3. The other emission levels were very low against the limit.
4. Margin value = Emission Level – Limit value

<b>CHANNEL</b>	TX Channel 64	<b>DETECTOR FUNCTION</b>	Quasi-Peak (QP)
<b>FREQUENCY RANGE</b>	Below 1GHz		

**ANTENNA POLARITY & TEST DISTANCE: HORIZONTAL AT 3 M**

NO.	FREQ. (MHz)	EMISSION LEVEL (dBuV/m)	LIMIT (dBuV/m)	MARGIN (dB)	ANTENNA HEIGHT (m)	TABLE ANGLE (Degree)	RAW VALUE (dBuV)	CORRECTION FACTOR (dB/m)
1	33.93	23.8 QP	40.0	-16.2	1.54 H	165	33.30	-9.50
2	194.69	40.3 QP	43.5	-3.2	1.48 H	35	51.60	-11.30
3	260.14	42.9 QP	46.0	-3.1	1.38 H	65	51.80	-8.90
4	379.77	32.7 QP	46.0	-13.3	1.20 H	342	38.00	-5.30
5	695.62	37.7 QP	46.0	-8.3	1.05 H	318	36.30	1.40
6	1000.00	41.3 QP	54.0	-12.7	1.94 H	263	35.60	5.70

**ANTENNA POLARITY & TEST DISTANCE: VERTICAL AT 3 M**

NO.	FREQ. (MHz)	EMISSION LEVEL (dBuV/m)	LIMIT (dBuV/m)	MARGIN (dB)	ANTENNA HEIGHT (m)	TABLE ANGLE (Degree)	RAW VALUE (dBuV)	CORRECTION FACTOR (dB/m)
1	98.04	25.5 QP	43.5	-18.0	1.94 V	317	39.00	-13.50
2	195.64	34.0 QP	43.5	-9.5	1.69 V	223	45.40	-11.40
3	259.61	38.8 QP	46.0	-7.2	1.94 V	138	47.90	-9.10
4	326.06	32.6 QP	46.0	-13.4	1.04 V	54	39.00	-6.40
5	749.89	36.9 QP	46.0	-9.1	1.56 V	332	34.50	2.40
6	1000.00	38.5 QP	54.0	-15.5	1.00 V	283	32.80	5.70

**REMARKS:**

1. Emission Level(dBuV/m) = Raw Value(dBuV) + Correction Factor(dB/m)
2. Correction Factor(dB/m) = Antenna Factor(dB/m) + Cable Factor(dB) – Pre-Amplifier Factor(dB)
3. The other emission levels were very low against the limit.
4. Margin value = Emission Level – Limit value

<b>CHANNEL</b>	TX Channel 100	<b>DETECTOR FUNCTION</b>	Quasi-Peak (QP)
<b>FREQUENCY RANGE</b>	Below 1GHz		

**ANTENNA POLARITY & TEST DISTANCE: HORIZONTAL AT 3 M**

NO.	FREQ. (MHz)	EMISSION LEVEL (dBuV/m)	LIMIT (dBuV/m)	MARGIN (dB)	ANTENNA HEIGHT (m)	TABLE ANGLE (Degree)	RAW VALUE (dBuV)	CORRECTION FACTOR (dB/m)
1	33.56	24.4 QP	40.0	-15.6	1.46 H	178	34.00	-9.60
2	194.90	40.1 QP	43.5	-3.4	1.42 H	46	51.40	-11.30
3	260.47	42.8 QP	46.0	-3.2	1.37 H	71	51.70	-8.90
4	379.80	32.8 QP	46.0	-13.2	1.19 H	328	38.10	-5.30
5	695.64	37.9 QP	46.0	-8.1	1.00 H	323	36.50	1.40
6	1000.00	41.2 QP	54.0	-12.8	1.97 H	284	35.50	5.70

**ANTENNA POLARITY & TEST DISTANCE: VERTICAL AT 3 M**

NO.	FREQ. (MHz)	EMISSION LEVEL (dBuV/m)	LIMIT (dBuV/m)	MARGIN (dB)	ANTENNA HEIGHT (m)	TABLE ANGLE (Degree)	RAW VALUE (dBuV)	CORRECTION FACTOR (dB/m)
1	98.18	25.4 QP	43.5	-18.1	2.01 V	321	38.80	-13.40
2	195.87	33.5 QP	43.5	-10.0	1.61 V	232	44.90	-11.40
3	259.67	38.7 QP	46.0	-7.3	1.93 V	140	47.80	-9.10
4	325.56	32.1 QP	46.0	-13.9	1.06 V	50	38.50	-6.40
5	749.43	36.6 QP	46.0	-9.4	1.54 V	355	34.20	2.40
6	1000.00	38.8 QP	54.0	-15.2	1.00 V	301	33.10	5.70

**REMARKS:**

1. Emission Level(dBuV/m) = Raw Value(dBuV) + Correction Factor(dB/m)
2. Correction Factor(dB/m) = Antenna Factor(dB/m) + Cable Factor(dB) – Pre-Amplifier Factor(dB)
3. The other emission levels were very low against the limit.
4. Margin value = Emission Level – Limit value

<b>CHANNEL</b>	TX Channel 116	<b>DETECTOR FUNCTION</b>	Quasi-Peak (QP)
<b>FREQUENCY RANGE</b>	Below 1GHz		

**ANTENNA POLARITY & TEST DISTANCE: HORIZONTAL AT 3 M**

NO.	FREQ. (MHz)	EMISSION LEVEL (dBuV/m)	LIMIT (dBuV/m)	MARGIN (dB)	ANTENNA HEIGHT (m)	TABLE ANGLE (Degree)	RAW VALUE (dBuV)	CORRECTION FACTOR (dB/m)
1	33.90	23.9 QP	40.0	-16.1	1.53 H	156	33.40	-9.50
2	194.63	40.0 QP	43.5	-3.5	1.47 H	49	51.30	-11.30
3	260.16	42.7 QP	46.0	-3.3	1.41 H	64	51.60	-8.90
4	380.04	33.0 QP	46.0	-13.0	1.19 H	333	38.30	-5.30
5	695.62	37.5 QP	46.0	-8.5	1.06 H	331	36.10	1.40
6	1000.00	41.2 QP	54.0	-12.8	1.94 H	283	35.50	5.70

**ANTENNA POLARITY & TEST DISTANCE: VERTICAL AT 3 M**

NO.	FREQ. (MHz)	EMISSION LEVEL (dBuV/m)	LIMIT (dBuV/m)	MARGIN (dB)	ANTENNA HEIGHT (m)	TABLE ANGLE (Degree)	RAW VALUE (dBuV)	CORRECTION FACTOR (dB/m)
1	98.02	25.7 QP	43.5	-17.8	2.00 V	307	39.20	-13.50
2	196.00	34.0 QP	43.5	-9.5	1.63 V	221	45.40	-11.40
3	259.84	39.0 QP	46.0	-7.0	1.97 V	147	48.00	-9.00
4	325.97	32.6 QP	46.0	-13.4	1.01 V	40	39.00	-6.40
5	749.55	36.5 QP	46.0	-9.5	1.64 V	327	34.10	2.40
6	1000.00	38.9 QP	54.0	-15.1	1.00 V	287	33.20	5.70

**REMARKS:**

1. Emission Level(dBuV/m) = Raw Value(dBuV) + Correction Factor(dB/m)
2. Correction Factor(dB/m) = Antenna Factor(dB/m) + Cable Factor(dB) – Pre-Amplifier Factor(dB)
3. The other emission levels were very low against the limit.
4. Margin value = Emission Level – Limit value

<b>CHANNEL</b>	TX Channel 120	<b>DETECTOR FUNCTION</b>	Quasi-Peak (QP)
<b>FREQUENCY RANGE</b>	Below 1GHz		

**ANTENNA POLARITY & TEST DISTANCE: HORIZONTAL AT 3 M**

NO.	FREQ. (MHz)	EMISSION LEVEL (dBuV/m)	LIMIT (dBuV/m)	MARGIN (dB)	ANTENNA HEIGHT (m)	TABLE ANGLE (Degree)	RAW VALUE (dBuV)	CORRECTION FACTOR (dB/m)
1	34.02	24.0 QP	40.0	-16.0	1.46 H	179	33.50	-9.50
2	194.95	40.2 QP	43.5	-3.3	1.43 H	28	51.50	-11.30
3	260.31	42.6 QP	46.0	-3.4	1.38 H	73	51.50	-8.90
4	379.71	32.6 QP	46.0	-13.4	1.15 H	330	37.90	-5.30
5	695.61	37.9 QP	46.0	-8.1	1.00 H	340	36.50	1.40
6	1000.00	41.2 QP	54.0	-12.8	1.90 H	266	35.50	5.70

**ANTENNA POLARITY & TEST DISTANCE: VERTICAL AT 3 M**

NO.	FREQ. (MHz)	EMISSION LEVEL (dBuV/m)	LIMIT (dBuV/m)	MARGIN (dB)	ANTENNA HEIGHT (m)	TABLE ANGLE (Degree)	RAW VALUE (dBuV)	CORRECTION FACTOR (dB/m)
1	97.88	25.4 QP	43.5	-18.1	1.98 V	313	38.90	-13.50
2	196.08	33.9 QP	43.5	-9.6	1.64 V	226	45.30	-11.40
3	259.96	38.6 QP	46.0	-7.4	1.95 V	131	47.60	-9.00
4	325.81	32.3 QP	46.0	-13.7	1.01 V	37	38.70	-6.40
5	749.58	36.9 QP	46.0	-9.1	1.55 V	350	34.50	2.40
6	1000.00	38.9 QP	54.0	-15.1	1.00 V	296	33.20	5.70

**REMARKS:**

1. Emission Level(dBuV/m) = Raw Value(dBuV) + Correction Factor(dB/m)
2. Correction Factor(dB/m) = Antenna Factor(dB/m) + Cable Factor(dB) – Pre-Amplifier Factor(dB)
3. The other emission levels were very low against the limit.
4. Margin value = Emission Level – Limit value

<b>CHANNEL</b>	TX Channel 132	<b>DETECTOR FUNCTION</b>	Quasi-Peak (QP)
<b>FREQUENCY RANGE</b>	Below 1GHz		

**ANTENNA POLARITY & TEST DISTANCE: HORIZONTAL AT 3 M**

NO.	FREQ. (MHz)	EMISSION LEVEL (dBuV/m)	LIMIT (dBuV/m)	MARGIN (dB)	ANTENNA HEIGHT (m)	TABLE ANGLE (Degree)	RAW VALUE (dBuV)	CORRECTION FACTOR (dB/m)
1	33.50	24.3 QP	40.0	-15.7	1.52 H	170	33.90	-9.60
2	195.21	40.4 QP	43.5	-3.1	1.42 H	32	51.70	-11.30
3	260.48	42.9 QP	46.0	-3.1	1.46 H	62	51.80	-8.90
4	380.07	32.7 QP	46.0	-13.3	1.14 H	330	38.00	-5.30
5	695.79	37.8 QP	46.0	-8.2	1.04 H	339	36.40	1.40
6	1000.00	41.1 QP	54.0	-12.9	1.98 H	284	35.40	5.70

**ANTENNA POLARITY & TEST DISTANCE: VERTICAL AT 3 M**

NO.	FREQ. (MHz)	EMISSION LEVEL (dBuV/m)	LIMIT (dBuV/m)	MARGIN (dB)	ANTENNA HEIGHT (m)	TABLE ANGLE (Degree)	RAW VALUE (dBuV)	CORRECTION FACTOR (dB/m)
1	98.19	25.4 QP	43.5	-18.1	1.92 V	310	38.80	-13.40
2	195.96	33.9 QP	43.5	-9.6	1.68 V	217	45.30	-11.40
3	260.05	39.1 QP	46.0	-6.9	2.00 V	134	48.00	-8.90
4	325.70	32.0 QP	46.0	-14.0	1.00 V	57	38.40	-6.40
5	749.96	36.5 QP	46.0	-9.5	1.63 V	350	34.10	2.40
6	1000.00	38.5 QP	54.0	-15.5	1.00 V	288	32.80	5.70

**REMARKS:**

1. Emission Level(dBuV/m) = Raw Value(dBuV) + Correction Factor(dB/m)
2. Correction Factor(dB/m) = Antenna Factor(dB/m) + Cable Factor(dB) – Pre-Amplifier Factor(dB)
3. The other emission levels were very low against the limit.
4. Margin value = Emission Level – Limit value

<b>CHANNEL</b>	TX Channel 140	<b>DETECTOR FUNCTION</b>	Quasi-Peak (QP)
<b>FREQUENCY RANGE</b>	Below 1GHz		

**ANTENNA POLARITY & TEST DISTANCE: HORIZONTAL AT 3 M**

NO.	FREQ. (MHz)	EMISSION LEVEL (dBuV/m)	LIMIT (dBuV/m)	MARGIN (dB)	ANTENNA HEIGHT (m)	TABLE ANGLE (Degree)	RAW VALUE (dBuV)	CORRECTION FACTOR (dB/m)
1	33.83	23.9 QP	40.0	-16.1	1.53 H	152	33.50	-9.60
2	194.99	40.3 QP	43.5	-3.2	1.43 H	37	51.60	-11.30
3	260.58	42.5 QP	46.0	-3.5	1.41 H	59	51.40	-8.90
4	379.78	32.5 QP	46.0	-13.5	1.14 H	352	37.80	-5.30
5	695.69	37.6 QP	46.0	-8.4	1.04 H	332	36.20	1.40
6	1000.00	41.3 QP	54.0	-12.7	1.95 H	255	35.60	5.70

**ANTENNA POLARITY & TEST DISTANCE: VERTICAL AT 3 M**

NO.	FREQ. (MHz)	EMISSION LEVEL (dBuV/m)	LIMIT (dBuV/m)	MARGIN (dB)	ANTENNA HEIGHT (m)	TABLE ANGLE (Degree)	RAW VALUE (dBuV)	CORRECTION FACTOR (dB/m)
1	97.71	25.3 QP	43.5	-18.2	2.01 V	298	38.80	-13.50
2	195.57	34.1 QP	43.5	-9.4	1.57 V	206	45.50	-11.40
3	259.62	39.0 QP	46.0	-7.0	2.04 V	146	48.10	-9.10
4	325.94	32.1 QP	46.0	-13.9	1.00 V	60	38.50	-6.40
5	749.74	36.6 QP	46.0	-9.4	1.65 V	328	34.20	2.40
6	1000.00	39.0 QP	54.0	-15.0	1.00 V	275	33.30	5.70

**REMARKS:**

1. Emission Level(dBuV/m) = Raw Value(dBuV) + Correction Factor(dB/m)
2. Correction Factor(dB/m) = Antenna Factor(dB/m) + Cable Factor(dB) – Pre-Amplifier Factor(dB)
3. The other emission levels were very low against the limit.
4. Margin value = Emission Level – Limit value



<b>CHANNEL</b>	TX Channel 149	<b>DETECTOR FUNCTION</b>	Quasi-Peak (QP)
<b>FREQUENCY RANGE</b>	Below 1GHz		

**ANTENNA POLARITY & TEST DISTANCE: HORIZONTAL AT 3 M**

NO.	FREQ. (MHz)	EMISSION LEVEL (dBuV/m)	LIMIT (dBuV/m)	MARGIN (dB)	ANTENNA HEIGHT (m)	TABLE ANGLE (Degree)	RAW VALUE (dBuV)	CORRECTION FACTOR (dB/m)
1	33.67	24.0 QP	40.0	-16.0	1.46 H	153	33.60	-9.60
2	194.72	40.1 QP	43.5	-3.4	1.42 H	25	51.40	-11.30
3	260.39	42.8 QP	46.0	-3.2	1.40 H	84	51.70	-8.90
4	379.85	33.0 QP	46.0	-13.0	1.17 H	353	38.30	-5.30
5	695.79	37.7 QP	46.0	-8.3	1.01 H	316	36.30	1.40
6	1000.00	41.1 QP	54.0	-12.9	1.92 H	260	35.40	5.70

**ANTENNA POLARITY & TEST DISTANCE: VERTICAL AT 3 M**

NO.	FREQ. (MHz)	EMISSION LEVEL (dBuV/m)	LIMIT (dBuV/m)	MARGIN (dB)	ANTENNA HEIGHT (m)	TABLE ANGLE (Degree)	RAW VALUE (dBuV)	CORRECTION FACTOR (dB/m)
1	97.85	25.3 QP	43.5	-18.2	1.94 V	319	38.80	-13.50
2	195.94	33.5 QP	43.5	-10.0	1.65 V	228	44.90	-11.40
3	260.04	38.6 QP	46.0	-7.4	1.97 V	144	47.50	-8.90
4	325.98	32.2 QP	46.0	-13.8	1.00 V	40	38.60	-6.40
5	749.84	36.9 QP	46.0	-9.1	1.56 V	351	34.50	2.40
6	1000.00	38.9 QP	54.0	-15.1	1.02 V	277	33.20	5.70

**REMARKS:**

1. Emission Level(dBuV/m) = Raw Value(dBuV) + Correction Factor(dB/m)
2. Correction Factor(dB/m) = Antenna Factor(dB/m) + Cable Factor(dB) – Pre-Amplifier Factor(dB)
3. The other emission levels were very low against the limit.
4. Margin value = Emission Level – Limit value

<b>CHANNEL</b>	TX Channel 157	<b>DETECTOR FUNCTION</b>	Quasi-Peak (QP)
<b>FREQUENCY RANGE</b>	Below 1GHz		

**ANTENNA POLARITY & TEST DISTANCE: HORIZONTAL AT 3 M**

NO.	FREQ. (MHz)	EMISSION LEVEL (dBuV/m)	LIMIT (dBuV/m)	MARGIN (dB)	ANTENNA HEIGHT (m)	TABLE ANGLE (Degree)	RAW VALUE (dBuV)	CORRECTION FACTOR (dB/m)
1	33.63	24.1 QP	40.0	-15.9	1.55 H	167	33.70	-9.60
2	195.01	40.4 QP	43.5	-3.1	1.49 H	40	51.70	-11.30
3	260.17	42.4 QP	46.0	-3.6	1.41 H	61	51.30	-8.90
4	380.08	32.6 QP	46.0	-13.4	1.14 H	333	37.90	-5.30
5	695.59	37.9 QP	46.0	-8.1	1.00 H	317	36.50	1.40
6	1000.00	41.3 QP	54.0	-12.7	1.95 H	264	35.60	5.70

**ANTENNA POLARITY & TEST DISTANCE: VERTICAL AT 3 M**

NO.	FREQ. (MHz)	EMISSION LEVEL (dBuV/m)	LIMIT (dBuV/m)	MARGIN (dB)	ANTENNA HEIGHT (m)	TABLE ANGLE (Degree)	RAW VALUE (dBuV)	CORRECTION FACTOR (dB/m)
1	98.17	25.8 QP	43.5	-17.7	1.95 V	298	39.20	-13.40
2	195.68	33.5 QP	43.5	-10.0	1.60 V	228	44.90	-11.40
3	259.99	39.0 QP	46.0	-7.0	1.93 V	131	48.00	-9.00
4	325.89	32.3 QP	46.0	-13.7	1.00 V	42	38.70	-6.40
5	749.65	36.8 QP	46.0	-9.2	1.59 V	337	34.40	2.40
6	1000.00	39.1 QP	54.0	-14.9	1.02 V	288	33.40	5.70

**REMARKS:**

1. Emission Level(dBuV/m) = Raw Value(dBuV) + Correction Factor(dB/m)
2. Correction Factor(dB/m) = Antenna Factor(dB/m) + Cable Factor(dB) – Pre-Amplifier Factor(dB)
3. The other emission levels were very low against the limit.
4. Margin value = Emission Level – Limit value

<b>CHANNEL</b>	TX Channel 165	<b>DETECTOR FUNCTION</b>	Quasi-Peak (QP)
<b>FREQUENCY RANGE</b>	Below 1GHz		

**ANTENNA POLARITY & TEST DISTANCE: HORIZONTAL AT 3 M**

NO.	FREQ. (MHz)	EMISSION LEVEL (dBuV/m)	LIMIT (dBuV/m)	MARGIN (dB)	ANTENNA HEIGHT (m)	TABLE ANGLE (Degree)	RAW VALUE (dBuV)	CORRECTION FACTOR (dB/m)
1	33.61	24.1 QP	40.0	-15.9	1.47 H	166	33.70	-9.60
2	195.07	40.3 QP	43.5	-3.2	1.43 H	34	51.60	-11.30
3	260.45	42.8 QP	46.0	-3.2	1.36 H	55	51.70	-8.90
4	379.75	32.4 QP	46.0	-13.6	1.16 H	349	37.70	-5.30
5	695.60	37.8 QP	46.0	-8.2	1.05 H	320	36.40	1.40
6	1000.00	41.0 QP	54.0	-13.0	1.91 H	277	35.30	5.70

**ANTENNA POLARITY & TEST DISTANCE: VERTICAL AT 3 M**

NO.	FREQ. (MHz)	EMISSION LEVEL (dBuV/m)	LIMIT (dBuV/m)	MARGIN (dB)	ANTENNA HEIGHT (m)	TABLE ANGLE (Degree)	RAW VALUE (dBuV)	CORRECTION FACTOR (dB/m)
1	98.07	25.5 QP	43.5	-18.0	1.95 V	317	39.00	-13.50
2	195.78	33.8 QP	43.5	-9.7	1.59 V	231	45.20	-11.40
3	259.67	39.0 QP	46.0	-7.0	1.96 V	152	48.10	-9.10
4	325.97	32.3 QP	46.0	-13.7	1.05 V	33	38.70	-6.40
5	749.79	37.0 QP	46.0	-9.0	1.57 V	346	34.60	2.40
6	1000.00	39.1 QP	54.0	-14.9	1.00 V	301	33.40	5.70

**REMARKS:**

1. Emission Level(dBuV/m) = Raw Value(dBuV) + Correction Factor(dB/m)
2. Correction Factor(dB/m) = Antenna Factor(dB/m) + Cable Factor(dB) – Pre-Amplifier Factor(dB)
3. The other emission levels were very low against the limit.
4. Margin value = Emission Level – Limit value

**802.11ac (VHT20)**

<b>CHANNEL</b>	TX Channel 36	<b>DETECTOR FUNCTION</b>	Quasi-Peak (QP)
<b>FREQUENCY RANGE</b>	Below 1GHz		

<b>ANTENNA POLARITY &amp; TEST DISTANCE: HORIZONTAL AT 3 M</b>								
<b>NO.</b>	<b>FREQ. (MHz)</b>	<b>EMISSION LEVEL (dBuV/m)</b>	<b>LIMIT (dBuV/m)</b>	<b>MARGIN (dB)</b>	<b>ANTENNA HEIGHT (m)</b>	<b>TABLE ANGLE (Degree)</b>	<b>RAW VALUE (dBuV)</b>	<b>CORRECTION FACTOR (dB/m)</b>
1	33.66	24.2 QP	40.0	-15.8	1.47 H	169	33.80	-9.60
2	194.68	40.5 QP	43.5	-3.0	1.48 H	39	51.80	-11.30
3	260.32	42.7 QP	46.0	-3.3	1.37 H	82	51.60	-8.90
4	379.96	32.9 QP	46.0	-13.1	1.18 H	333	38.20	-5.30
5	695.64	37.6 QP	46.0	-8.4	1.03 H	333	36.20	1.40
6	1000.00	41.3 QP	54.0	-12.7	1.93 H	278	35.60	5.70

<b>ANTENNA POLARITY &amp; TEST DISTANCE: VERTICAL AT 3 M</b>								
<b>NO.</b>	<b>FREQ. (MHz)</b>	<b>EMISSION LEVEL (dBuV/m)</b>	<b>LIMIT (dBuV/m)</b>	<b>MARGIN (dB)</b>	<b>ANTENNA HEIGHT (m)</b>	<b>TABLE ANGLE (Degree)</b>	<b>RAW VALUE (dBuV)</b>	<b>CORRECTION FACTOR (dB/m)</b>
1	97.91	25.5 QP	43.5	-18.0	1.91 V	295	39.00	-13.50
2	195.72	33.6 QP	43.5	-9.9	1.65 V	219	45.00	-11.40
3	259.70	38.7 QP	46.0	-7.3	1.98 V	153	47.80	-9.10
4	326.00	32.4 QP	46.0	-13.6	1.04 V	35	38.80	-6.40
5	749.73	36.6 QP	46.0	-9.4	1.62 V	328	34.20	2.40
6	1000.00	38.6 QP	54.0	-15.4	1.00 V	286	32.90	5.70

**REMARKS:**

1. Emission Level(dBuV/m) = Raw Value(dBuV) + Correction Factor(dB/m)
2. Correction Factor(dB/m) = Antenna Factor(dB/m) + Cable Factor(dB) – Pre-Amplifier Factor(dB)
3. The other emission levels were very low against the limit.
4. Margin value = Emission Level – Limit value

<b>CHANNEL</b>	TX Channel 40	<b>DETECTOR FUNCTION</b>	Quasi-Peak (QP)
<b>FREQUENCY RANGE</b>	Below 1GHz		

**ANTENNA POLARITY & TEST DISTANCE: HORIZONTAL AT 3 M**

NO.	FREQ. (MHz)	EMISSION LEVEL (dBuV/m)	LIMIT (dBuV/m)	MARGIN (dB)	ANTENNA HEIGHT (m)	TABLE ANGLE (Degree)	RAW VALUE (dBuV)	CORRECTION FACTOR (dB/m)
1	33.95	23.9 QP	40.0	-16.1	1.50 H	162	33.40	-9.50
2	194.89	40.2 QP	43.5	-3.3	1.43 H	37	51.50	-11.30
3	260.20	42.9 QP	46.0	-3.1	1.46 H	84	51.80	-8.90
4	379.74	32.8 QP	46.0	-13.2	1.16 H	334	38.10	-5.30
5	695.92	37.4 QP	46.0	-8.6	1.02 H	336	36.00	1.40
6	1000.00	41.3 QP	54.0	-12.7	1.99 H	280	35.60	5.70

**ANTENNA POLARITY & TEST DISTANCE: VERTICAL AT 3 M**

NO.	FREQ. (MHz)	EMISSION LEVEL (dBuV/m)	LIMIT (dBuV/m)	MARGIN (dB)	ANTENNA HEIGHT (m)	TABLE ANGLE (Degree)	RAW VALUE (dBuV)	CORRECTION FACTOR (dB/m)
1	97.93	25.3 QP	43.5	-18.2	1.93 V	305	38.80	-13.50
2	195.94	34.0 QP	43.5	-9.5	1.64 V	238	45.40	-11.40
3	259.52	38.8 QP	46.0	-7.2	2.03 V	149	47.90	-9.10
4	325.87	32.2 QP	46.0	-13.8	1.00 V	34	38.60	-6.40
5	749.71	36.6 QP	46.0	-9.4	1.63 V	356	34.20	2.40
6	1000.00	38.7 QP	54.0	-15.3	1.01 V	275	33.00	5.70

**REMARKS:**

1. Emission Level(dBuV/m) = Raw Value(dBuV) + Correction Factor(dB/m)
2. Correction Factor(dB/m) = Antenna Factor(dB/m) + Cable Factor(dB) – Pre-Amplifier Factor(dB)
3. The other emission levels were very low against the limit.
4. Margin value = Emission Level – Limit value

<b>CHANNEL</b>	TX Channel 48	<b>DETECTOR FUNCTION</b>	Quasi-Peak (QP)
<b>FREQUENCY RANGE</b>	Below 1GHz		

**ANTENNA POLARITY & TEST DISTANCE: HORIZONTAL AT 3 M**

NO.	FREQ. (MHz)	EMISSION LEVEL (dBuV/m)	LIMIT (dBuV/m)	MARGIN (dB)	ANTENNA HEIGHT (m)	TABLE ANGLE (Degree)	RAW VALUE (dBuV)	CORRECTION FACTOR (dB/m)
1	33.54	23.9 QP	40.0	-16.1	1.47 H	153	33.50	-9.60
2	194.70	40.1 QP	43.5	-3.4	1.44 H	49	51.40	-11.30
3	260.31	42.9 QP	46.0	-3.1	1.46 H	75	51.80	-8.90
4	379.70	32.4 QP	46.0	-13.6	1.17 H	356	37.70	-5.30
5	695.68	37.8 QP	46.0	-8.2	1.01 H	319	36.40	1.40
6	1000.00	41.0 QP	54.0	-13.0	1.97 H	277	35.30	5.70

**ANTENNA POLARITY & TEST DISTANCE: VERTICAL AT 3 M**

NO.	FREQ. (MHz)	EMISSION LEVEL (dBuV/m)	LIMIT (dBuV/m)	MARGIN (dB)	ANTENNA HEIGHT (m)	TABLE ANGLE (Degree)	RAW VALUE (dBuV)	CORRECTION FACTOR (dB/m)
1	98.21	25.3 QP	43.5	-18.2	1.92 V	298	38.70	-13.40
2	195.76	34.1 QP	43.5	-9.4	1.58 V	223	45.50	-11.40
3	259.60	38.5 QP	46.0	-7.5	1.99 V	134	47.60	-9.10
4	325.73	32.5 QP	46.0	-13.5	1.00 V	52	38.90	-6.40
5	750.00	36.9 QP	46.0	-9.1	1.61 V	354	34.50	2.40
6	1000.00	38.8 QP	54.0	-15.2	1.00 V	293	33.10	5.70

**REMARKS:**

1. Emission Level(dBuV/m) = Raw Value(dBuV) + Correction Factor(dB/m)
2. Correction Factor(dB/m) = Antenna Factor(dB/m) + Cable Factor(dB) – Pre-Amplifier Factor(dB)
3. The other emission levels were very low against the limit.
4. Margin value = Emission Level – Limit value

<b>CHANNEL</b>	TX Channel 52	<b>DETECTOR FUNCTION</b>	Quasi-Peak (QP)
<b>FREQUENCY RANGE</b>	Below 1GHz		

**ANTENNA POLARITY & TEST DISTANCE: HORIZONTAL AT 3 M**

NO.	FREQ. (MHz)	EMISSION LEVEL (dBuV/m)	LIMIT (dBuV/m)	MARGIN (dB)	ANTENNA HEIGHT (m)	TABLE ANGLE (Degree)	RAW VALUE (dBuV)	CORRECTION FACTOR (dB/m)
1	33.59	24.0 QP	40.0	-16.0	1.45 H	166	33.60	-9.60
2	195.01	39.9 QP	43.5	-3.6	1.41 H	38	51.20	-11.30
3	260.54	42.9 QP	46.0	-3.1	1.41 H	76	51.80	-8.90
4	380.16	33.0 QP	46.0	-13.0	1.10 H	339	38.30	-5.30
5	695.89	37.6 QP	46.0	-8.4	1.00 H	316	36.20	1.40
6	1000.00	41.0 QP	54.0	-13.0	1.91 H	282	35.30	5.70

**ANTENNA POLARITY & TEST DISTANCE: VERTICAL AT 3 M**

NO.	FREQ. (MHz)	EMISSION LEVEL (dBuV/m)	LIMIT (dBuV/m)	MARGIN (dB)	ANTENNA HEIGHT (m)	TABLE ANGLE (Degree)	RAW VALUE (dBuV)	CORRECTION FACTOR (dB/m)
1	97.76	25.5 QP	43.5	-18.0	1.96 V	297	39.00	-13.50
2	195.66	33.7 QP	43.5	-9.8	1.59 V	209	45.10	-11.40
3	259.57	39.1 QP	46.0	-6.9	2.01 V	155	48.20	-9.10
4	325.70	32.2 QP	46.0	-13.8	1.04 V	49	38.60	-6.40
5	749.52	36.9 QP	46.0	-9.1	1.60 V	329	34.50	2.40
6	1000.00	38.6 QP	54.0	-15.4	1.00 V	277	32.90	5.70

**REMARKS:**

1. Emission Level(dBuV/m) = Raw Value(dBuV) + Correction Factor(dB/m)
2. Correction Factor(dB/m) = Antenna Factor(dB/m) + Cable Factor(dB) – Pre-Amplifier Factor(dB)
3. The other emission levels were very low against the limit.
4. Margin value = Emission Level – Limit value

<b>CHANNEL</b>	TX Channel 60	<b>DETECTOR FUNCTION</b>	Quasi-Peak (QP)
<b>FREQUENCY RANGE</b>	Below 1GHz		

**ANTENNA POLARITY & TEST DISTANCE: HORIZONTAL AT 3 M**

NO.	FREQ. (MHz)	EMISSION LEVEL (dBuV/m)	LIMIT (dBuV/m)	MARGIN (dB)	ANTENNA HEIGHT (m)	TABLE ANGLE (Degree)	RAW VALUE (dBuV)	CORRECTION FACTOR (dB/m)
1	33.60	24.0 QP	40.0	-16.0	1.56 H	178	33.60	-9.60
2	195.18	40.5 QP	43.5	-3.0	1.48 H	35	51.80	-11.30
3	260.29	42.7 QP	46.0	-3.3	1.36 H	68	51.60	-8.90
4	380.12	33.0 QP	46.0	-13.0	1.13 H	348	38.30	-5.30
5	695.89	37.6 QP	46.0	-8.4	1.05 H	320	36.20	1.40
6	1000.00	40.9 QP	54.0	-13.1	1.90 H	271	35.20	5.70

**ANTENNA POLARITY & TEST DISTANCE: VERTICAL AT 3 M**

NO.	FREQ. (MHz)	EMISSION LEVEL (dBuV/m)	LIMIT (dBuV/m)	MARGIN (dB)	ANTENNA HEIGHT (m)	TABLE ANGLE (Degree)	RAW VALUE (dBuV)	CORRECTION FACTOR (dB/m)
1	97.70	25.3 QP	43.5	-18.2	1.97 V	320	38.80	-13.50
2	195.51	33.5 QP	43.5	-10.0	1.65 V	208	44.90	-11.40
3	259.89	39.1 QP	46.0	-6.9	2.01 V	157	48.10	-9.00
4	325.75	32.4 QP	46.0	-13.6	1.03 V	43	38.80	-6.40
5	749.72	36.8 QP	46.0	-9.2	1.64 V	347	34.40	2.40
6	1000.00	38.9 QP	54.0	-15.1	1.00 V	290	33.20	5.70

**REMARKS:**

1. Emission Level(dBuV/m) = Raw Value(dBuV) + Correction Factor(dB/m)
2. Correction Factor(dB/m) = Antenna Factor(dB/m) + Cable Factor(dB) – Pre-Amplifier Factor(dB)
3. The other emission levels were very low against the limit.
4. Margin value = Emission Level – Limit value



<b>CHANNEL</b>	TX Channel 64	<b>DETECTOR FUNCTION</b>	Quasi-Peak (QP)
<b>FREQUENCY RANGE</b>	Below 1GHz		

**ANTENNA POLARITY & TEST DISTANCE: HORIZONTAL AT 3 M**

NO.	FREQ. (MHz)	EMISSION LEVEL (dBuV/m)	LIMIT (dBuV/m)	MARGIN (dB)	ANTENNA HEIGHT (m)	TABLE ANGLE (Degree)	RAW VALUE (dBuV)	CORRECTION FACTOR (dB/m)
1	33.97	23.9 QP	40.0	-16.1	1.49 H	172	33.40	-9.50
2	195.05	40.0 QP	43.5	-3.5	1.47 H	32	51.30	-11.30
3	260.38	42.5 QP	46.0	-3.5	1.39 H	80	51.40	-8.90
4	379.90	32.7 QP	46.0	-13.3	1.10 H	336	38.00	-5.30
5	695.50	37.7 QP	46.0	-8.3	1.02 H	320	36.30	1.40
6	1000.00	40.8 QP	54.0	-13.2	1.88 H	262	35.10	5.70

**ANTENNA POLARITY & TEST DISTANCE: VERTICAL AT 3 M**

NO.	FREQ. (MHz)	EMISSION LEVEL (dBuV/m)	LIMIT (dBuV/m)	MARGIN (dB)	ANTENNA HEIGHT (m)	TABLE ANGLE (Degree)	RAW VALUE (dBuV)	CORRECTION FACTOR (dB/m)
1	97.83	25.4 QP	43.5	-18.1	1.95 V	304	38.90	-13.50
2	195.49	34.1 QP	43.5	-9.4	1.58 V	233	45.50	-11.40
3	259.83	38.9 QP	46.0	-7.1	2.04 V	134	47.90	-9.00
4	326.00	32.3 QP	46.0	-13.7	1.00 V	50	38.70	-6.40
5	749.95	36.8 QP	46.0	-9.2	1.59 V	354	34.40	2.40
6	1000.00	39.0 QP	54.0	-15.0	1.00 V	285	33.30	5.70

**REMARKS:**

1. Emission Level(dBuV/m) = Raw Value(dBuV) + Correction Factor(dB/m)
2. Correction Factor(dB/m) = Antenna Factor(dB/m) + Cable Factor(dB) – Pre-Amplifier Factor(dB)
3. The other emission levels were very low against the limit.
4. Margin value = Emission Level – Limit value

<b>CHANNEL</b>	TX Channel 100	<b>DETECTOR FUNCTION</b>	Quasi-Peak (QP)
<b>FREQUENCY RANGE</b>	Below 1GHz		

**ANTENNA POLARITY & TEST DISTANCE: HORIZONTAL AT 3 M**

NO.	FREQ. (MHz)	EMISSION LEVEL (dBuV/m)	LIMIT (dBuV/m)	MARGIN (dB)	ANTENNA HEIGHT (m)	TABLE ANGLE (Degree)	RAW VALUE (dBuV)	CORRECTION FACTOR (dB/m)
1	33.96	23.9 QP	40.0	-16.1	1.50 H	173	33.40	-9.50
2	195.08	40.4 QP	43.5	-3.1	1.51 H	43	51.70	-11.30
3	260.22	42.7 QP	46.0	-3.3	1.46 H	79	51.60	-8.90
4	380.15	32.9 QP	46.0	-13.1	1.20 H	334	38.20	-5.30
5	695.90	37.8 QP	46.0	-8.2	1.00 H	334	36.40	1.40
6	1000.00	41.3 QP	54.0	-12.7	1.96 H	264	35.60	5.70

**ANTENNA POLARITY & TEST DISTANCE: VERTICAL AT 3 M**

NO.	FREQ. (MHz)	EMISSION LEVEL (dBuV/m)	LIMIT (dBuV/m)	MARGIN (dB)	ANTENNA HEIGHT (m)	TABLE ANGLE (Degree)	RAW VALUE (dBuV)	CORRECTION FACTOR (dB/m)
1	97.98	25.8 QP	43.5	-17.7	1.93 V	316	39.30	-13.50
2	195.80	34.1 QP	43.5	-9.4	1.63 V	222	45.50	-11.40
3	259.83	38.7 QP	46.0	-7.3	1.98 V	150	47.70	-9.00
4	325.82	32.6 QP	46.0	-13.4	1.00 V	58	39.00	-6.40
5	749.77	37.0 QP	46.0	-9.0	1.63 V	329	34.60	2.40
6	1000.00	39.0 QP	54.0	-15.0	1.02 V	302	33.30	5.70

**REMARKS:**

1. Emission Level(dBuV/m) = Raw Value(dBuV) + Correction Factor(dB/m)
2. Correction Factor(dB/m) = Antenna Factor(dB/m) + Cable Factor(dB) – Pre-Amplifier Factor(dB)
3. The other emission levels were very low against the limit.
4. Margin value = Emission Level – Limit value

<b>CHANNEL</b>	TX Channel 116	<b>DETECTOR FUNCTION</b>	Quasi-Peak (QP)
<b>FREQUENCY RANGE</b>	Below 1GHz		

**ANTENNA POLARITY & TEST DISTANCE: HORIZONTAL AT 3 M**

NO.	FREQ. (MHz)	EMISSION LEVEL (dBuV/m)	LIMIT (dBuV/m)	MARGIN (dB)	ANTENNA HEIGHT (m)	TABLE ANGLE (Degree)	RAW VALUE (dBuV)	CORRECTION FACTOR (dB/m)
1	33.61	24.1 QP	40.0	-15.9	1.50 H	152	33.70	-9.60
2	194.87	40.1 QP	43.5	-3.4	1.41 H	24	51.40	-11.30
3	260.03	42.6 QP	46.0	-3.4	1.40 H	55	51.50	-8.90
4	380.16	32.6 QP	46.0	-13.4	1.13 H	355	37.90	-5.30
5	695.74	37.9 QP	46.0	-8.1	1.06 H	328	36.50	1.40
6	1000.00	41.4 QP	54.0	-12.6	1.95 H	268	35.70	5.70

**ANTENNA POLARITY & TEST DISTANCE: VERTICAL AT 3 M**

NO.	FREQ. (MHz)	EMISSION LEVEL (dBuV/m)	LIMIT (dBuV/m)	MARGIN (dB)	ANTENNA HEIGHT (m)	TABLE ANGLE (Degree)	RAW VALUE (dBuV)	CORRECTION FACTOR (dB/m)
1	97.98	25.7 QP	43.5	-17.8	1.97 V	295	39.20	-13.50
2	195.59	33.7 QP	43.5	-9.8	1.58 V	237	45.10	-11.40
3	259.84	39.0 QP	46.0	-7.0	2.05 V	140	48.00	-9.00
4	325.59	32.5 QP	46.0	-13.5	1.00 V	44	38.90	-6.40
5	749.79	36.9 QP	46.0	-9.1	1.56 V	335	34.50	2.40
6	1000.00	38.9 QP	54.0	-15.1	1.02 V	275	33.20	5.70

**REMARKS:**

1. Emission Level(dBuV/m) = Raw Value(dBuV) + Correction Factor(dB/m)
2. Correction Factor(dB/m) = Antenna Factor(dB/m) + Cable Factor(dB) – Pre-Amplifier Factor(dB)
3. The other emission levels were very low against the limit.
4. Margin value = Emission Level – Limit value

<b>CHANNEL</b>	TX Channel 120	<b>DETECTOR FUNCTION</b>	Quasi-Peak (QP)
<b>FREQUENCY RANGE</b>	Below 1GHz		

**ANTENNA POLARITY & TEST DISTANCE: HORIZONTAL AT 3 M**

NO.	FREQ. (MHz)	EMISSION LEVEL (dBuV/m)	LIMIT (dBuV/m)	MARGIN (dB)	ANTENNA HEIGHT (m)	TABLE ANGLE (Degree)	RAW VALUE (dBuV)	CORRECTION FACTOR (dB/m)
1	33.53	24.2 QP	40.0	-15.8	1.52 H	170	33.80	-9.60
2	194.68	40.3 QP	43.5	-3.2	1.52 H	24	51.60	-11.30
3	260.36	42.5 QP	46.0	-3.5	1.36 H	58	51.40	-8.90
4	379.93	32.8 QP	46.0	-13.2	1.12 H	331	38.10	-5.30
5	696.07	38.0 QP	46.0	-8.0	1.03 H	340	36.60	1.40
6	1000.00	41.1 QP	54.0	-12.9	1.88 H	258	35.40	5.70

**ANTENNA POLARITY & TEST DISTANCE: VERTICAL AT 3 M**

NO.	FREQ. (MHz)	EMISSION LEVEL (dBuV/m)	LIMIT (dBuV/m)	MARGIN (dB)	ANTENNA HEIGHT (m)	TABLE ANGLE (Degree)	RAW VALUE (dBuV)	CORRECTION FACTOR (dB/m)
1	97.71	25.2 QP	43.5	-18.3	1.94 V	322	38.70	-13.50
2	195.93	33.7 QP	43.5	-9.8	1.62 V	224	45.10	-11.40
3	259.57	38.6 QP	46.0	-7.4	1.96 V	154	47.70	-9.10
4	325.99	32.5 QP	46.0	-13.5	1.00 V	51	38.90	-6.40
5	749.88	37.0 QP	46.0	-9.0	1.58 V	354	34.60	2.40
6	1000.00	39.0 QP	54.0	-15.0	1.01 V	274	33.30	5.70

**REMARKS:**

1. Emission Level(dBuV/m) = Raw Value(dBuV) + Correction Factor(dB/m)
2. Correction Factor(dB/m) = Antenna Factor(dB/m) + Cable Factor(dB) – Pre-Amplifier Factor(dB)
3. The other emission levels were very low against the limit.
4. Margin value = Emission Level – Limit value

<b>CHANNEL</b>	TX Channel 132	<b>DETECTOR FUNCTION</b>	Quasi-Peak (QP)
<b>FREQUENCY RANGE</b>	Below 1GHz		

**ANTENNA POLARITY & TEST DISTANCE: HORIZONTAL AT 3 M**

NO.	FREQ. (MHz)	EMISSION LEVEL (dBuV/m)	LIMIT (dBuV/m)	MARGIN (dB)	ANTENNA HEIGHT (m)	TABLE ANGLE (Degree)	RAW VALUE (dBuV)	CORRECTION FACTOR (dB/m)
1	34.03	23.9 QP	40.0	-16.1	1.52 H	156	33.40	-9.50
2	194.90	40.4 QP	43.5	-3.1	1.49 H	44	51.70	-11.30
3	260.17	42.4 QP	46.0	-3.6	1.44 H	60	51.30	-8.90
4	380.16	32.8 QP	46.0	-13.2	1.16 H	354	38.10	-5.30
5	696.04	37.6 QP	46.0	-8.4	1.07 H	330	36.20	1.40
6	1000.00	41.2 QP	54.0	-12.8	1.95 H	261	35.50	5.70

**ANTENNA POLARITY & TEST DISTANCE: VERTICAL AT 3 M**

NO.	FREQ. (MHz)	EMISSION LEVEL (dBuV/m)	LIMIT (dBuV/m)	MARGIN (dB)	ANTENNA HEIGHT (m)	TABLE ANGLE (Degree)	RAW VALUE (dBuV)	CORRECTION FACTOR (dB/m)
1	97.98	25.6 QP	43.5	-17.9	1.95 V	311	39.10	-13.50
2	195.76	33.9 QP	43.5	-9.6	1.57 V	217	45.30	-11.40
3	260.07	38.6 QP	46.0	-7.4	1.94 V	138	47.50	-8.90
4	325.49	32.2 QP	46.0	-13.8	1.02 V	35	38.60	-6.40
5	749.63	36.8 QP	46.0	-9.2	1.60 V	354	34.40	2.40
6	1000.00	38.6 QP	54.0	-15.4	1.00 V	288	32.90	5.70

**REMARKS:**

1. Emission Level(dBuV/m) = Raw Value(dBuV) + Correction Factor(dB/m)
2. Correction Factor(dB/m) = Antenna Factor(dB/m) + Cable Factor(dB) – Pre-Amplifier Factor(dB)
3. The other emission levels were very low against the limit.
4. Margin value = Emission Level – Limit value

<b>CHANNEL</b>	TX Channel 140	<b>DETECTOR FUNCTION</b>	Quasi-Peak (QP)
<b>FREQUENCY RANGE</b>	Below 1GHz		

**ANTENNA POLARITY & TEST DISTANCE: HORIZONTAL AT 3 M**

NO.	FREQ. (MHz)	EMISSION LEVEL (dBuV/m)	LIMIT (dBuV/m)	MARGIN (dB)	ANTENNA HEIGHT (m)	TABLE ANGLE (Degree)	RAW VALUE (dBuV)	CORRECTION FACTOR (dB/m)
1	33.90	24.4 QP	40.0	-15.6	1.51 H	179	33.90	-9.50
2	194.91	40.0 QP	43.5	-3.5	1.51 H	48	51.30	-11.30
3	260.19	43.0 QP	46.0	-3.0	1.40 H	61	51.90	-8.90
4	380.18	32.7 QP	46.0	-13.3	1.12 H	360	38.00	-5.30
5	695.47	37.5 QP	46.0	-8.5	1.06 H	327	36.10	1.40
6	1000.00	41.3 QP	54.0	-12.7	1.95 H	286	35.60	5.70

**ANTENNA POLARITY & TEST DISTANCE: VERTICAL AT 3 M**

NO.	FREQ. (MHz)	EMISSION LEVEL (dBuV/m)	LIMIT (dBuV/m)	MARGIN (dB)	ANTENNA HEIGHT (m)	TABLE ANGLE (Degree)	RAW VALUE (dBuV)	CORRECTION FACTOR (dB/m)
1	98.17	25.5 QP	43.5	-18.0	1.96 V	326	38.90	-13.40
2	195.50	33.6 QP	43.5	-9.9	1.62 V	224	45.00	-11.40
3	259.71	38.7 QP	46.0	-7.3	2.04 V	152	47.80	-9.10
4	325.87	32.5 QP	46.0	-13.5	1.00 V	59	38.90	-6.40
5	749.64	37.0 QP	46.0	-9.0	1.56 V	351	34.60	2.40
6	1000.00	39.0 QP	54.0	-15.0	1.00 V	283	33.30	5.70

**REMARKS:**

1. Emission Level(dBuV/m) = Raw Value(dBuV) + Correction Factor(dB/m)
2. Correction Factor(dB/m) = Antenna Factor(dB/m) + Cable Factor(dB) – Pre-Amplifier Factor(dB)
3. The other emission levels were very low against the limit.
4. Margin value = Emission Level – Limit value

<b>CHANNEL</b>	TX Channel 149	<b>DETECTOR FUNCTION</b>	Quasi-Peak (QP)
<b>FREQUENCY RANGE</b>	Below 1GHz		

**ANTENNA POLARITY & TEST DISTANCE: HORIZONTAL AT 3 M**

NO.	FREQ. (MHz)	EMISSION LEVEL (dBuV/m)	LIMIT (dBuV/m)	MARGIN (dB)	ANTENNA HEIGHT (m)	TABLE ANGLE (Degree)	RAW VALUE (dBuV)	CORRECTION FACTOR (dB/m)
1	33.54	24.3 QP	40.0	-15.7	1.45 H	163	33.90	-9.60
2	194.90	40.3 QP	43.5	-3.2	1.46 H	22	51.60	-11.30
3	260.02	42.8 QP	46.0	-3.2	1.43 H	71	51.70	-8.90
4	379.86	32.7 QP	46.0	-13.3	1.10 H	334	38.00	-5.30
5	696.03	37.9 QP	46.0	-8.1	1.03 H	314	36.50	1.40
6	1000.00	41.4 QP	54.0	-12.6	1.96 H	263	35.70	5.70

**ANTENNA POLARITY & TEST DISTANCE: VERTICAL AT 3 M**

NO.	FREQ. (MHz)	EMISSION LEVEL (dBuV/m)	LIMIT (dBuV/m)	MARGIN (dB)	ANTENNA HEIGHT (m)	TABLE ANGLE (Degree)	RAW VALUE (dBuV)	CORRECTION FACTOR (dB/m)
1	97.76	25.6 QP	43.5	-17.9	1.96 V	309	39.10	-13.50
2	195.49	33.6 QP	43.5	-9.9	1.65 V	211	45.00	-11.40
3	259.79	39.0 QP	46.0	-7.0	1.98 V	152	48.00	-9.00
4	325.60	32.4 QP	46.0	-13.6	1.00 V	46	38.80	-6.40
5	749.69	36.9 QP	46.0	-9.1	1.65 V	333	34.50	2.40
6	1000.00	38.7 QP	54.0	-15.3	1.00 V	294	33.00	5.70

**REMARKS:**

1. Emission Level(dBuV/m) = Raw Value(dBuV) + Correction Factor(dB/m)
2. Correction Factor(dB/m) = Antenna Factor(dB/m) + Cable Factor(dB) – Pre-Amplifier Factor(dB)
3. The other emission levels were very low against the limit.
4. Margin value = Emission Level – Limit value

<b>CHANNEL</b>	TX Channel 157	<b>DETECTOR FUNCTION</b>	Quasi-Peak (QP)
<b>FREQUENCY RANGE</b>	Below 1GHz		

**ANTENNA POLARITY & TEST DISTANCE: HORIZONTAL AT 3 M**

NO.	FREQ. (MHz)	EMISSION LEVEL (dBuV/m)	LIMIT (dBuV/m)	MARGIN (dB)	ANTENNA HEIGHT (m)	TABLE ANGLE (Degree)	RAW VALUE (dBuV)	CORRECTION FACTOR (dB/m)
1	33.53	23.9 QP	40.0	-16.1	1.45 H	171	33.50	-9.60
2	194.91	40.3 QP	43.5	-3.2	1.50 H	47	51.60	-11.30
3	260.51	42.9 QP	46.0	-3.1	1.45 H	77	51.80	-8.90
4	379.62	32.7 QP	46.0	-13.3	1.10 H	337	38.00	-5.30
5	695.90	37.5 QP	46.0	-8.5	1.06 H	313	36.10	1.40
6	1000.00	41.2 QP	54.0	-12.8	1.99 H	281	35.50	5.70

**ANTENNA POLARITY & TEST DISTANCE: VERTICAL AT 3 M**

NO.	FREQ. (MHz)	EMISSION LEVEL (dBuV/m)	LIMIT (dBuV/m)	MARGIN (dB)	ANTENNA HEIGHT (m)	TABLE ANGLE (Degree)	RAW VALUE (dBuV)	CORRECTION FACTOR (dB/m)
1	97.76	25.2 QP	43.5	-18.3	1.91 V	299	38.70	-13.50
2	195.85	33.8 QP	43.5	-9.7	1.64 V	220	45.20	-11.40
3	259.84	38.9 QP	46.0	-7.1	1.96 V	153	47.90	-9.00
4	325.98	32.5 QP	46.0	-13.5	1.00 V	31	38.90	-6.40
5	749.88	36.8 QP	46.0	-9.2	1.63 V	326	34.40	2.40
6	1000.00	38.9 QP	54.0	-15.1	1.02 V	285	33.20	5.70

**REMARKS:**

1. Emission Level(dBuV/m) = Raw Value(dBuV) + Correction Factor(dB/m)
2. Correction Factor(dB/m) = Antenna Factor(dB/m) + Cable Factor(dB) – Pre-Amplifier Factor(dB)
3. The other emission levels were very low against the limit.
4. Margin value = Emission Level – Limit value



<b>CHANNEL</b>	TX Channel 165	<b>DETECTOR FUNCTION</b>	Quasi-Peak (QP)
<b>FREQUENCY RANGE</b>	Below 1GHz		

**ANTENNA POLARITY & TEST DISTANCE: HORIZONTAL AT 3 M**

NO.	FREQ. (MHz)	EMISSION LEVEL (dBuV/m)	LIMIT (dBuV/m)	MARGIN (dB)	ANTENNA HEIGHT (m)	TABLE ANGLE (Degree)	RAW VALUE (dBuV)	CORRECTION FACTOR (dB/m)
1	33.96	24.3 QP	40.0	-15.7	1.51 H	182	33.80	-9.50
2	195.18	40.3 QP	43.5	-3.2	1.50 H	20	51.60	-11.30
3	260.41	42.9 QP	46.0	-3.1	1.44 H	60	51.80	-8.90
4	379.82	32.9 QP	46.0	-13.1	1.17 H	356	38.20	-5.30
5	695.73	37.9 QP	46.0	-8.1	1.02 H	315	36.50	1.40
6	1000.00	40.8 QP	54.0	-13.2	1.92 H	266	35.10	5.70

**ANTENNA POLARITY & TEST DISTANCE: VERTICAL AT 3 M**

NO.	FREQ. (MHz)	EMISSION LEVEL (dBuV/m)	LIMIT (dBuV/m)	MARGIN (dB)	ANTENNA HEIGHT (m)	TABLE ANGLE (Degree)	RAW VALUE (dBuV)	CORRECTION FACTOR (dB/m)
1	97.73	25.3 QP	43.5	-18.2	1.93 V	311	38.80	-13.50
2	195.84	33.6 QP	43.5	-9.9	1.60 V	236	45.00	-11.40
3	260.09	38.5 QP	46.0	-7.5	1.96 V	158	47.40	-8.90
4	326.01	32.2 QP	46.0	-13.8	1.01 V	49	38.60	-6.40
5	749.67	36.7 QP	46.0	-9.3	1.60 V	346	34.30	2.40
6	1000.00	38.9 QP	54.0	-15.1	1.00 V	292	33.20	5.70

**REMARKS:**

1. Emission Level(dBuV/m) = Raw Value(dBuV) + Correction Factor(dB/m)
2. Correction Factor(dB/m) = Antenna Factor(dB/m) + Cable Factor(dB) – Pre-Amplifier Factor(dB)
3. The other emission levels were very low against the limit.
4. Margin value = Emission Level – Limit value

**802.11ac (VHT40)**

<b>CHANNEL</b>	TX Channel 38	<b>DETECTOR FUNCTION</b>	Quasi-Peak (QP)
<b>FREQUENCY RANGE</b>	Below 1GHz		

<b>ANTENNA POLARITY &amp; TEST DISTANCE: HORIZONTAL AT 3 M</b>								
<b>NO.</b>	<b>FREQ. (MHz)</b>	<b>EMISSION LEVEL (dBuV/m)</b>	<b>LIMIT (dBuV/m)</b>	<b>MARGIN (dB)</b>	<b>ANTENNA HEIGHT (m)</b>	<b>TABLE ANGLE (Degree)</b>	<b>RAW VALUE (dBuV)</b>	<b>CORRECTION FACTOR (dB/m)</b>
1	34.04	24.0 QP	40.0	-16.0	1.49 H	151	33.50	-9.50
2	195.06	40.0 QP	43.5	-3.5	1.47 H	28	51.30	-11.30
3	260.26	42.8 QP	46.0	-3.2	1.38 H	86	51.70	-8.90
4	380.02	32.7 QP	46.0	-13.3	1.10 H	346	38.00	-5.30
5	696.06	37.9 QP	46.0	-8.1	1.03 H	320	36.50	1.40
6	1000.00	40.9 QP	54.0	-13.1	1.99 H	258	35.20	5.70

<b>ANTENNA POLARITY &amp; TEST DISTANCE: VERTICAL AT 3 M</b>								
<b>NO.</b>	<b>FREQ. (MHz)</b>	<b>EMISSION LEVEL (dBuV/m)</b>	<b>LIMIT (dBuV/m)</b>	<b>MARGIN (dB)</b>	<b>ANTENNA HEIGHT (m)</b>	<b>TABLE ANGLE (Degree)</b>	<b>RAW VALUE (dBuV)</b>	<b>CORRECTION FACTOR (dB/m)</b>
1	97.98	25.5 QP	43.5	-18.0	2.00 V	320	39.00	-13.50
2	195.48	33.8 QP	43.5	-9.7	1.57 V	217	45.20	-11.40
3	259.61	38.7 QP	46.0	-7.3	2.01 V	136	47.80	-9.10
4	325.91	32.6 QP	46.0	-13.4	1.00 V	40	39.00	-6.40
5	749.85	36.7 QP	46.0	-9.3	1.55 V	344	34.30	2.40
6	1000.00	38.7 QP	54.0	-15.3	1.01 V	291	33.00	5.70

**REMARKS:**

1. Emission Level(dBuV/m) = Raw Value(dBuV) + Correction Factor(dB/m)
2. Correction Factor(dB/m) = Antenna Factor(dB/m) + Cable Factor(dB) – Pre-Amplifier Factor(dB)
3. The other emission levels were very low against the limit.
4. Margin value = Emission Level – Limit value

<b>CHANNEL</b>	TX Channel 46	<b>DETECTOR FUNCTION</b>	Quasi-Peak (QP)
<b>FREQUENCY RANGE</b>	Below 1GHz		

**ANTENNA POLARITY & TEST DISTANCE: HORIZONTAL AT 3 M**

NO.	FREQ. (MHz)	EMISSION LEVEL (dBuV/m)	LIMIT (dBuV/m)	MARGIN (dB)	ANTENNA HEIGHT (m)	TABLE ANGLE (Degree)	RAW VALUE (dBuV)	CORRECTION FACTOR (dB/m)
1	33.87	23.8 QP	40.0	-16.2	1.49 H	174	33.40	-9.60
2	194.76	40.5 QP	43.5	-3.0	1.52 H	40	51.80	-11.30
3	260.18	42.6 QP	46.0	-3.4	1.43 H	82	51.50	-8.90
4	380.00	32.4 QP	46.0	-13.6	1.14 H	331	37.70	-5.30
5	695.82	37.8 QP	46.0	-8.2	1.03 H	338	36.40	1.40
6	1000.00	40.9 QP	54.0	-13.1	1.97 H	281	35.20	5.70

**ANTENNA POLARITY & TEST DISTANCE: VERTICAL AT 3 M**

NO.	FREQ. (MHz)	EMISSION LEVEL (dBuV/m)	LIMIT (dBuV/m)	MARGIN (dB)	ANTENNA HEIGHT (m)	TABLE ANGLE (Degree)	RAW VALUE (dBuV)	CORRECTION FACTOR (dB/m)
1	98.04	25.6 QP	43.5	-17.9	1.92 V	308	39.10	-13.50
2	196.01	33.7 QP	43.5	-9.8	1.65 V	207	45.10	-11.40
3	259.66	38.5 QP	46.0	-7.5	2.00 V	145	47.60	-9.10
4	325.53	32.3 QP	46.0	-13.7	1.00 V	40	38.70	-6.40
5	749.81	36.9 QP	46.0	-9.1	1.62 V	351	34.50	2.40
6	1000.00	38.8 QP	54.0	-15.2	1.00 V	296	33.10	5.70

**REMARKS:**

1. Emission Level(dBuV/m) = Raw Value(dBuV) + Correction Factor(dB/m)
2. Correction Factor(dB/m) = Antenna Factor(dB/m) + Cable Factor(dB) – Pre-Amplifier Factor(dB)
3. The other emission levels were very low against the limit.
4. Margin value = Emission Level – Limit value

<b>CHANNEL</b>	TX Channel 54	<b>DETECTOR FUNCTION</b>	Quasi-Peak (QP)
<b>FREQUENCY RANGE</b>	Below 1GHz		

**ANTENNA POLARITY & TEST DISTANCE: HORIZONTAL AT 3 M**

NO.	FREQ. (MHz)	EMISSION LEVEL (dBuV/m)	LIMIT (dBuV/m)	MARGIN (dB)	ANTENNA HEIGHT (m)	TABLE ANGLE (Degree)	RAW VALUE (dBuV)	CORRECTION FACTOR (dB/m)
1	34.06	24.2 QP	40.0	-15.8	1.55 H	161	33.70	-9.50
2	194.93	40.2 QP	43.5	-3.3	1.47 H	19	51.50	-11.30
3	260.46	42.5 QP	46.0	-3.5	1.40 H	86	51.40	-8.90
4	380.05	32.6 QP	46.0	-13.4	1.17 H	339	37.90	-5.30
5	695.93	37.6 QP	46.0	-8.4	1.06 H	313	36.20	1.40
6	1000.00	40.9 QP	54.0	-13.1	1.96 H	279	35.20	5.70

**ANTENNA POLARITY & TEST DISTANCE: VERTICAL AT 3 M**

NO.	FREQ. (MHz)	EMISSION LEVEL (dBuV/m)	LIMIT (dBuV/m)	MARGIN (dB)	ANTENNA HEIGHT (m)	TABLE ANGLE (Degree)	RAW VALUE (dBuV)	CORRECTION FACTOR (dB/m)
1	98.25	25.4 QP	43.5	-18.1	1.91 V	309	38.80	-13.40
2	195.83	34.0 QP	43.5	-9.5	1.69 V	210	45.40	-11.40
3	259.73	38.8 QP	46.0	-7.2	1.98 V	154	47.90	-9.10
4	325.83	32.2 QP	46.0	-13.8	1.00 V	48	38.60	-6.40
5	749.73	36.8 QP	46.0	-9.2	1.57 V	327	34.40	2.40
6	1000.00	39.0 QP	54.0	-15.0	1.00 V	284	33.30	5.70

**REMARKS:**

1. Emission Level(dBuV/m) = Raw Value(dBuV) + Correction Factor(dB/m)
2. Correction Factor(dB/m) = Antenna Factor(dB/m) + Cable Factor(dB) – Pre-Amplifier Factor(dB)
3. The other emission levels were very low against the limit.
4. Margin value = Emission Level – Limit value

<b>CHANNEL</b>	TX Channel 62	<b>DETECTOR FUNCTION</b>	Quasi-Peak (QP)
<b>FREQUENCY RANGE</b>	Below 1GHz		

**ANTENNA POLARITY & TEST DISTANCE: HORIZONTAL AT 3 M**

NO.	FREQ. (MHz)	EMISSION LEVEL (dBuV/m)	LIMIT (dBuV/m)	MARGIN (dB)	ANTENNA HEIGHT (m)	TABLE ANGLE (Degree)	RAW VALUE (dBuV)	CORRECTION FACTOR (dB/m)
1	33.47	24.2 QP	40.0	-15.8	1.45 H	172	33.80	-9.60
2	194.94	40.2 QP	43.5	-3.3	1.52 H	42	51.50	-11.30
3	260.60	42.9 QP	46.0	-3.1	1.45 H	57	51.80	-8.90
4	379.98	32.5 QP	46.0	-13.5	1.15 H	336	37.80	-5.30
5	695.52	37.5 QP	46.0	-8.5	1.08 H	312	36.10	1.40
6	1000.00	40.8 QP	54.0	-13.2	1.98 H	262	35.10	5.70

**ANTENNA POLARITY & TEST DISTANCE: VERTICAL AT 3 M**

NO.	FREQ. (MHz)	EMISSION LEVEL (dBuV/m)	LIMIT (dBuV/m)	MARGIN (dB)	ANTENNA HEIGHT (m)	TABLE ANGLE (Degree)	RAW VALUE (dBuV)	CORRECTION FACTOR (dB/m)
1	98.25	25.5 QP	43.5	-18.0	1.97 V	296	38.90	-13.40
2	195.97	33.8 QP	43.5	-9.7	1.61 V	215	45.20	-11.40
3	259.58	38.7 QP	46.0	-7.3	2.03 V	142	47.80	-9.10
4	325.86	32.3 QP	46.0	-13.7	1.00 V	44	38.70	-6.40
5	749.68	36.6 QP	46.0	-9.4	1.58 V	356	34.20	2.40
6	1000.00	38.6 QP	54.0	-15.4	1.00 V	295	32.90	5.70

**REMARKS:**

1. Emission Level(dBuV/m) = Raw Value(dBuV) + Correction Factor(dB/m)
2. Correction Factor(dB/m) = Antenna Factor(dB/m) + Cable Factor(dB) – Pre-Amplifier Factor(dB)
3. The other emission levels were very low against the limit.
4. Margin value = Emission Level – Limit value

<b>CHANNEL</b>	TX Channel 102	<b>DETECTOR FUNCTION</b>	Quasi-Peak (QP)
<b>FREQUENCY RANGE</b>	Below 1GHz		

**ANTENNA POLARITY & TEST DISTANCE: HORIZONTAL AT 3 M**

NO.	FREQ. (MHz)	EMISSION LEVEL (dBuV/m)	LIMIT (dBuV/m)	MARGIN (dB)	ANTENNA HEIGHT (m)	TABLE ANGLE (Degree)	RAW VALUE (dBuV)	CORRECTION FACTOR (dB/m)
1	33.78	23.9 QP	40.0	-16.1	1.47 H	163	33.50	-9.60
2	194.84	40.0 QP	43.5	-3.5	1.50 H	31	51.30	-11.30
3	260.26	42.4 QP	46.0	-3.6	1.39 H	79	51.30	-8.90
4	380.09	32.5 QP	46.0	-13.5	1.10 H	352	37.80	-5.30
5	695.51	37.8 QP	46.0	-8.2	1.06 H	338	36.40	1.40
6	1000.00	41.3 QP	54.0	-12.7	1.96 H	271	35.60	5.70

**ANTENNA POLARITY & TEST DISTANCE: VERTICAL AT 3 M**

NO.	FREQ. (MHz)	EMISSION LEVEL (dBuV/m)	LIMIT (dBuV/m)	MARGIN (dB)	ANTENNA HEIGHT (m)	TABLE ANGLE (Degree)	RAW VALUE (dBuV)	CORRECTION FACTOR (dB/m)
1	97.78	25.7 QP	43.5	-17.8	1.91 V	319	39.20	-13.50
2	195.73	33.7 QP	43.5	-9.8	1.63 V	227	45.10	-11.40
3	259.85	38.7 QP	46.0	-7.3	2.04 V	158	47.70	-9.00
4	325.76	32.3 QP	46.0	-13.7	1.00 V	45	38.70	-6.40
5	749.52	36.9 QP	46.0	-9.1	1.53 V	346	34.50	2.40
6	1000.00	38.8 QP	54.0	-15.2	1.01 V	296	33.10	5.70

**REMARKS:**

1. Emission Level(dBuV/m) = Raw Value(dBuV) + Correction Factor(dB/m)
2. Correction Factor(dB/m) = Antenna Factor(dB/m) + Cable Factor(dB) – Pre-Amplifier Factor(dB)
3. The other emission levels were very low against the limit.
4. Margin value = Emission Level – Limit value

<b>CHANNEL</b>	TX Channel 110	<b>DETECTOR FUNCTION</b>	Quasi-Peak (QP)
<b>FREQUENCY RANGE</b>	Below 1GHz		

**ANTENNA POLARITY & TEST DISTANCE: HORIZONTAL AT 3 M**

NO.	FREQ. (MHz)	EMISSION LEVEL (dBuV/m)	LIMIT (dBuV/m)	MARGIN (dB)	ANTENNA HEIGHT (m)	TABLE ANGLE (Degree)	RAW VALUE (dBuV)	CORRECTION FACTOR (dB/m)
1	33.81	24.0 QP	40.0	-16.0	1.56 H	175	33.60	-9.60
2	195.01	40.0 QP	43.5	-3.5	1.49 H	47	51.30	-11.30
3	260.00	42.7 QP	46.0	-3.3	1.41 H	56	51.70	-9.00
4	380.12	32.5 QP	46.0	-13.5	1.16 H	344	37.80	-5.30
5	695.89	37.6 QP	46.0	-8.4	1.00 H	337	36.20	1.40
6	1000.00	41.0 QP	54.0	-13.0	1.97 H	260	35.30	5.70

**ANTENNA POLARITY & TEST DISTANCE: VERTICAL AT 3 M**

NO.	FREQ. (MHz)	EMISSION LEVEL (dBuV/m)	LIMIT (dBuV/m)	MARGIN (dB)	ANTENNA HEIGHT (m)	TABLE ANGLE (Degree)	RAW VALUE (dBuV)	CORRECTION FACTOR (dB/m)
1	98.21	25.6 QP	43.5	-17.9	2.01 V	313	39.00	-13.40
2	195.57	33.9 QP	43.5	-9.6	1.60 V	219	45.30	-11.40
3	260.00	38.8 QP	46.0	-7.2	2.05 V	138	47.80	-9.00
4	325.88	32.1 QP	46.0	-13.9	1.06 V	60	38.50	-6.40
5	749.51	36.6 QP	46.0	-9.4	1.55 V	353	34.20	2.40
6	1000.00	38.9 QP	54.0	-15.1	1.00 V	281	33.20	5.70

**REMARKS:**

1. Emission Level(dBuV/m) = Raw Value(dBuV) + Correction Factor(dB/m)
2. Correction Factor(dB/m) = Antenna Factor(dB/m) + Cable Factor(dB) – Pre-Amplifier Factor(dB)
3. The other emission levels were very low against the limit.
4. Margin value = Emission Level – Limit value

<b>CHANNEL</b>	TX Channel 118	<b>DETECTOR FUNCTION</b>	Quasi-Peak (QP)
<b>FREQUENCY RANGE</b>	Below 1GHz		

**ANTENNA POLARITY & TEST DISTANCE: HORIZONTAL AT 3 M**

NO.	FREQ. (MHz)	EMISSION LEVEL (dBuV/m)	LIMIT (dBuV/m)	MARGIN (dB)	ANTENNA HEIGHT (m)	TABLE ANGLE (Degree)	RAW VALUE (dBuV)	CORRECTION FACTOR (dB/m)
1	33.88	24.2 QP	40.0	-15.8	1.45 H	158	33.80	-9.60
2	194.71	40.4 QP	43.5	-3.1	1.46 H	35	51.70	-11.30
3	260.39	42.5 QP	46.0	-3.5	1.46 H	57	51.40	-8.90
4	380.10	32.9 QP	46.0	-13.1	1.12 H	336	38.20	-5.30
5	695.95	37.7 QP	46.0	-8.3	1.00 H	341	36.30	1.40
6	1000.00	41.3 QP	54.0	-12.7	1.93 H	272	35.60	5.70

**ANTENNA POLARITY & TEST DISTANCE: VERTICAL AT 3 M**

NO.	FREQ. (MHz)	EMISSION LEVEL (dBuV/m)	LIMIT (dBuV/m)	MARGIN (dB)	ANTENNA HEIGHT (m)	TABLE ANGLE (Degree)	RAW VALUE (dBuV)	CORRECTION FACTOR (dB/m)
1	97.74	25.4 QP	43.5	-18.1	2.00 V	324	38.90	-13.50
2	195.97	33.8 QP	43.5	-9.7	1.67 V	207	45.20	-11.40
3	259.71	39.1 QP	46.0	-6.9	1.95 V	158	48.20	-9.10
4	326.00	32.4 QP	46.0	-13.6	1.02 V	31	38.80	-6.40
5	749.67	37.0 QP	46.0	-9.0	1.57 V	331	34.60	2.40
6	1000.00	39.1 QP	54.0	-14.9	1.00 V	276	33.40	5.70

**REMARKS:**

1. Emission Level(dBuV/m) = Raw Value(dBuV) + Correction Factor(dB/m)
2. Correction Factor(dB/m) = Antenna Factor(dB/m) + Cable Factor(dB) – Pre-Amplifier Factor(dB)
3. The other emission levels were very low against the limit.
4. Margin value = Emission Level – Limit value



<b>CHANNEL</b>	TX Channel 134	<b>DETECTOR FUNCTION</b>	Quasi-Peak (QP)
<b>FREQUENCY RANGE</b>	Below 1GHz		

**ANTENNA POLARITY & TEST DISTANCE: HORIZONTAL AT 3 M**

NO.	FREQ. (MHz)	EMISSION LEVEL (dBuV/m)	LIMIT (dBuV/m)	MARGIN (dB)	ANTENNA HEIGHT (m)	TABLE ANGLE (Degree)	RAW VALUE (dBuV)	CORRECTION FACTOR (dB/m)
1	33.89	24.2 QP	40.0	-15.8	1.51 H	161	33.80	-9.60
2	194.94	40.4 QP	43.5	-3.1	1.49 H	24	51.70	-11.30
3	260.51	42.8 QP	46.0	-3.2	1.37 H	73	51.70	-8.90
4	379.99	32.8 QP	46.0	-13.2	1.10 H	356	38.10	-5.30
5	695.92	37.9 QP	46.0	-8.1	1.02 H	313	36.50	1.40
6	1000.00	41.0 QP	54.0	-13.0	1.89 H	264	35.30	5.70

**ANTENNA POLARITY & TEST DISTANCE: VERTICAL AT 3 M**

NO.	FREQ. (MHz)	EMISSION LEVEL (dBuV/m)	LIMIT (dBuV/m)	MARGIN (dB)	ANTENNA HEIGHT (m)	TABLE ANGLE (Degree)	RAW VALUE (dBuV)	CORRECTION FACTOR (dB/m)
1	97.95	25.3 QP	43.5	-18.2	2.00 V	326	38.80	-13.50
2	195.89	33.7 QP	43.5	-9.8	1.67 V	206	45.10	-11.40
3	259.49	38.7 QP	46.0	-7.3	2.01 V	145	47.80	-9.10
4	326.01	32.2 QP	46.0	-13.8	1.04 V	39	38.60	-6.40
5	749.81	36.7 QP	46.0	-9.3	1.56 V	341	34.30	2.40
6	1000.00	38.8 QP	54.0	-15.2	1.01 V	284	33.10	5.70

**REMARKS:**

1. Emission Level(dBuV/m) = Raw Value(dBuV) + Correction Factor(dB/m)
2. Correction Factor(dB/m) = Antenna Factor(dB/m) + Cable Factor(dB) – Pre-Amplifier Factor(dB)
3. The other emission levels were very low against the limit.
4. Margin value = Emission Level – Limit value

<b>CHANNEL</b>	TX Channel 151	<b>DETECTOR FUNCTION</b>	Quasi-Peak (QP)
<b>FREQUENCY RANGE</b>	Below 1GHz		

**ANTENNA POLARITY & TEST DISTANCE: HORIZONTAL AT 3 M**

NO.	FREQ. (MHz)	EMISSION LEVEL (dBuV/m)	LIMIT (dBuV/m)	MARGIN (dB)	ANTENNA HEIGHT (m)	TABLE ANGLE (Degree)	RAW VALUE (dBuV)	CORRECTION FACTOR (dB/m)
1	33.75	24.2 QP	40.0	-15.8	1.44 H	171	33.80	-9.60
2	194.79	40.4 QP	43.5	-3.1	1.43 H	31	51.70	-11.30
3	260.04	42.7 QP	46.0	-3.3	1.45 H	59	51.60	-8.90
4	380.08	32.6 QP	46.0	-13.4	1.14 H	332	37.90	-5.30
5	695.74	37.7 QP	46.0	-8.3	1.02 H	328	36.30	1.40
6	1000.00	41.3 QP	54.0	-12.7	1.88 H	279	35.60	5.70

**ANTENNA POLARITY & TEST DISTANCE: VERTICAL AT 3 M**

NO.	FREQ. (MHz)	EMISSION LEVEL (dBuV/m)	LIMIT (dBuV/m)	MARGIN (dB)	ANTENNA HEIGHT (m)	TABLE ANGLE (Degree)	RAW VALUE (dBuV)	CORRECTION FACTOR (dB/m)
1	97.88	25.7 QP	43.5	-17.8	1.95 V	320	39.20	-13.50
2	195.51	34.0 QP	43.5	-9.5	1.66 V	216	45.40	-11.40
3	259.58	38.6 QP	46.0	-7.4	1.97 V	139	47.70	-9.10
4	325.80	32.3 QP	46.0	-13.7	1.00 V	53	38.70	-6.40
5	749.99	36.8 QP	46.0	-9.2	1.55 V	339	34.40	2.40
6	1000.00	38.6 QP	54.0	-15.4	1.00 V	292	32.90	5.70

**REMARKS:**

1. Emission Level(dBuV/m) = Raw Value(dBuV) + Correction Factor(dB/m)
2. Correction Factor(dB/m) = Antenna Factor(dB/m) + Cable Factor(dB) – Pre-Amplifier Factor(dB)
3. The other emission levels were very low against the limit.
4. Margin value = Emission Level – Limit value

<b>CHANNEL</b>	TX Channel 159	<b>DETECTOR FUNCTION</b>	Quasi-Peak (QP)
<b>FREQUENCY RANGE</b>	Below 1GHz		

**ANTENNA POLARITY & TEST DISTANCE: HORIZONTAL AT 3 M**

NO.	FREQ. (MHz)	EMISSION LEVEL (dBuV/m)	LIMIT (dBuV/m)	MARGIN (dB)	ANTENNA HEIGHT (m)	TABLE ANGLE (Degree)	RAW VALUE (dBuV)	CORRECTION FACTOR (dB/m)
1	33.99	24.3 QP	40.0	-15.7	1.50 H	166	33.80	-9.50
2	194.79	40.2 QP	43.5	-3.3	1.45 H	25	51.50	-11.30
3	260.39	42.5 QP	46.0	-3.5	1.40 H	79	51.40	-8.90
4	380.20	32.7 QP	46.0	-13.3	1.20 H	353	38.00	-5.30
5	695.73	37.5 QP	46.0	-8.5	1.07 H	312	36.10	1.40
6	1000.00	41.4 QP	54.0	-12.6	1.91 H	265	35.70	5.70

**ANTENNA POLARITY & TEST DISTANCE: VERTICAL AT 3 M**

NO.	FREQ. (MHz)	EMISSION LEVEL (dBuV/m)	LIMIT (dBuV/m)	MARGIN (dB)	ANTENNA HEIGHT (m)	TABLE ANGLE (Degree)	RAW VALUE (dBuV)	CORRECTION FACTOR (dB/m)
1	98.27	25.6 QP	43.5	-17.9	1.92 V	306	39.00	-13.40
2	195.70	33.9 QP	43.5	-9.6	1.63 V	233	45.30	-11.40
3	259.73	38.7 QP	46.0	-7.3	2.02 V	128	47.80	-9.10
4	325.77	32.4 QP	46.0	-13.6	1.05 V	49	38.80	-6.40
5	749.79	36.9 QP	46.0	-9.1	1.56 V	346	34.50	2.40
6	1000.00	38.9 QP	54.0	-15.1	1.02 V	280	33.20	5.70

**REMARKS:**

1. Emission Level(dBuV/m) = Raw Value(dBuV) + Correction Factor(dB/m)
2. Correction Factor(dB/m) = Antenna Factor(dB/m) + Cable Factor(dB) – Pre-Amplifier Factor(dB)
3. The other emission levels were very low against the limit.
4. Margin value = Emission Level – Limit value

**802.11ac (VHT80)**

<b>CHANNEL</b>	TX Channel 42	<b>DETECTOR FUNCTION</b>	Quasi-Peak (QP)
<b>FREQUENCY RANGE</b>	Below 1GHz		

**ANTENNA POLARITY & TEST DISTANCE: HORIZONTAL AT 3 M**

NO.	FREQ. (MHz)	EMISSION LEVEL (dBuV/m)	LIMIT (dBuV/m)	MARGIN (dB)	ANTENNA HEIGHT (m)	TABLE ANGLE (Degree)	RAW VALUE (dBuV)	CORRECTION FACTOR (dB/m)
1	33.96	24.1 QP	40.0	-15.9	1.46 H	180	33.60	-9.50
2	195.20	40.2 QP	43.5	-3.3	1.45 H	21	51.50	-11.30
3	260.27	42.7 QP	46.0	-3.3	1.42 H	69	51.60	-8.90
4	379.65	32.5 QP	46.0	-13.5	1.17 H	354	37.80	-5.30
5	695.71	37.7 QP	46.0	-8.3	1.00 H	314	36.30	1.40
6	1000.00	41.2 QP	54.0	-12.8	1.97 H	266	35.50	5.70

**ANTENNA POLARITY & TEST DISTANCE: VERTICAL AT 3 M**

NO.	FREQ. (MHz)	EMISSION LEVEL (dBuV/m)	LIMIT (dBuV/m)	MARGIN (dB)	ANTENNA HEIGHT (m)	TABLE ANGLE (Degree)	RAW VALUE (dBuV)	CORRECTION FACTOR (dB/m)
1	97.96	25.7 QP	43.5	-17.8	1.95 V	314	39.20	-13.50
2	196.03	33.5 QP	43.5	-10.0	1.58 V	225	44.90	-11.40
3	259.53	39.0 QP	46.0	-7.0	1.95 V	144	48.10	-9.10
4	326.02	32.5 QP	46.0	-13.5	1.05 V	32	38.90	-6.40
5	749.82	36.7 QP	46.0	-9.3	1.64 V	327	34.30	2.40
6	1000.00	39.1 QP	54.0	-14.9	1.02 V	300	33.40	5.70

**REMARKS:**

1. Emission Level(dBuV/m) = Raw Value(dBuV) + Correction Factor(dB/m)
2. Correction Factor(dB/m) = Antenna Factor(dB/m) + Cable Factor(dB) – Pre-Amplifier Factor(dB)
3. The other emission levels were very low against the limit.
4. Margin value = Emission Level – Limit value

<b>CHANNEL</b>	TX Channel 58	<b>DETECTOR FUNCTION</b>	Quasi-Peak (QP)
<b>FREQUENCY RANGE</b>	Below 1GHz		

**ANTENNA POLARITY & TEST DISTANCE: HORIZONTAL AT 3 M**

NO.	FREQ. (MHz)	EMISSION LEVEL (dBuV/m)	LIMIT (dBuV/m)	MARGIN (dB)	ANTENNA HEIGHT (m)	TABLE ANGLE (Degree)	RAW VALUE (dBuV)	CORRECTION FACTOR (dB/m)
1	33.79	24.3 QP	40.0	-15.7	1.55 H	155	33.90	-9.60
2	195.01	39.9 QP	43.5	-3.6	1.45 H	44	51.20	-11.30
3	260.55	42.7 QP	46.0	-3.3	1.35 H	84	51.60	-8.90
4	380.04	32.4 QP	46.0	-13.6	1.09 H	353	37.70	-5.30
5	695.49	37.5 QP	46.0	-8.5	1.06 H	331	36.10	1.40
6	1000.00	41.4 QP	54.0	-12.6	1.95 H	255	35.70	5.70

**ANTENNA POLARITY & TEST DISTANCE: VERTICAL AT 3 M**

NO.	FREQ. (MHz)	EMISSION LEVEL (dBuV/m)	LIMIT (dBuV/m)	MARGIN (dB)	ANTENNA HEIGHT (m)	TABLE ANGLE (Degree)	RAW VALUE (dBuV)	CORRECTION FACTOR (dB/m)
1	97.98	25.8 QP	43.5	-17.7	1.92 V	301	39.30	-13.50
2	195.89	33.5 QP	43.5	-10.0	1.57 V	233	44.90	-11.40
3	260.07	38.7 QP	46.0	-7.3	1.98 V	130	47.60	-8.90
4	325.76	32.6 QP	46.0	-13.4	1.02 V	42	39.00	-6.40
5	749.94	36.9 QP	46.0	-9.1	1.58 V	339	34.50	2.40
6	1000.00	39.1 QP	54.0	-14.9	1.00 V	275	33.40	5.70

**REMARKS:**

1. Emission Level(dBuV/m) = Raw Value(dBuV) + Correction Factor(dB/m)
2. Correction Factor(dB/m) = Antenna Factor(dB/m) + Cable Factor(dB) – Pre-Amplifier Factor(dB)
3. The other emission levels were very low against the limit.
4. Margin value = Emission Level – Limit value

<b>CHANNEL</b>	TX Channel 106	<b>DETECTOR FUNCTION</b>	Quasi-Peak (QP)
<b>FREQUENCY RANGE</b>	Below 1GHz		

**ANTENNA POLARITY & TEST DISTANCE: HORIZONTAL AT 3 M**

NO.	FREQ. (MHz)	EMISSION LEVEL (dBuV/m)	LIMIT (dBuV/m)	MARGIN (dB)	ANTENNA HEIGHT (m)	TABLE ANGLE (Degree)	RAW VALUE (dBuV)	CORRECTION FACTOR (dB/m)
1	33.57	24.1 QP	40.0	-15.9	1.53 H	151	33.70	-9.60
2	194.71	40.1 QP	43.5	-3.4	1.46 H	26	51.40	-11.30
3	260.53	42.9 QP	46.0	-3.1	1.40 H	54	51.80	-8.90
4	379.72	32.8 QP	46.0	-13.2	1.11 H	333	38.10	-5.30
5	695.69	37.4 QP	46.0	-8.6	1.01 H	330	36.00	1.40
6	1000.00	41.1 QP	54.0	-12.9	1.95 H	260	35.40	5.70

**ANTENNA POLARITY & TEST DISTANCE: VERTICAL AT 3 M**

NO.	FREQ. (MHz)	EMISSION LEVEL (dBuV/m)	LIMIT (dBuV/m)	MARGIN (dB)	ANTENNA HEIGHT (m)	TABLE ANGLE (Degree)	RAW VALUE (dBuV)	CORRECTION FACTOR (dB/m)
1	97.71	25.6 QP	43.5	-17.9	1.99 V	307	39.10	-13.50
2	195.95	33.9 QP	43.5	-9.6	1.64 V	226	45.30	-11.40
3	259.56	38.6 QP	46.0	-7.4	1.96 V	144	47.70	-9.10
4	325.91	32.6 QP	46.0	-13.4	1.03 V	47	39.00	-6.40
5	749.80	36.9 QP	46.0	-9.1	1.56 V	336	34.50	2.40
6	1000.00	38.5 QP	54.0	-15.5	1.04 V	272	32.80	5.70

**REMARKS:**

1. Emission Level(dBuV/m) = Raw Value(dBuV) + Correction Factor(dB/m)
2. Correction Factor(dB/m) = Antenna Factor(dB/m) + Cable Factor(dB) – Pre-Amplifier Factor(dB)
3. The other emission levels were very low against the limit.
4. Margin value = Emission Level – Limit value

<b>CHANNEL</b>	TX Channel 122	<b>DETECTOR FUNCTION</b>	Quasi-Peak (QP)
<b>FREQUENCY RANGE</b>	Below 1GHz		

**ANTENNA POLARITY & TEST DISTANCE: HORIZONTAL AT 3 M**

NO.	FREQ. (MHz)	EMISSION LEVEL (dBuV/m)	LIMIT (dBuV/m)	MARGIN (dB)	ANTENNA HEIGHT (m)	TABLE ANGLE (Degree)	RAW VALUE (dBuV)	CORRECTION FACTOR (dB/m)
1	33.95	23.9 QP	40.0	-16.1	1.46 H	170	33.40	-9.50
2	195.08	40.2 QP	43.5	-3.3	1.52 H	32	51.50	-11.30
3	260.48	42.5 QP	46.0	-3.5	1.42 H	73	51.40	-8.90
4	380.06	32.8 QP	46.0	-13.2	1.16 H	344	38.10	-5.30
5	695.88	37.9 QP	46.0	-8.1	1.00 H	343	36.50	1.40
6	1000.00	40.9 QP	54.0	-13.1	1.96 H	260	35.20	5.70

**ANTENNA POLARITY & TEST DISTANCE: VERTICAL AT 3 M**

NO.	FREQ. (MHz)	EMISSION LEVEL (dBuV/m)	LIMIT (dBuV/m)	MARGIN (dB)	ANTENNA HEIGHT (m)	TABLE ANGLE (Degree)	RAW VALUE (dBuV)	CORRECTION FACTOR (dB/m)
1	97.93	25.2 QP	43.5	-18.3	1.96 V	317	38.70	-13.50
2	196.06	33.9 QP	43.5	-9.6	1.68 V	226	45.30	-11.40
3	259.55	39.0 QP	46.0	-7.0	1.94 V	132	48.10	-9.10
4	325.82	32.0 QP	46.0	-14.0	1.03 V	57	38.40	-6.40
5	749.64	36.8 QP	46.0	-9.2	1.64 V	335	34.40	2.40
6	1000.00	39.1 QP	54.0	-14.9	1.03 V	283	33.40	5.70

**REMARKS:**

1. Emission Level(dBuV/m) = Raw Value(dBuV) + Correction Factor(dB/m)
2. Correction Factor(dB/m) = Antenna Factor(dB/m) + Cable Factor(dB) – Pre-Amplifier Factor(dB)
3. The other emission levels were very low against the limit.
4. Margin value = Emission Level – Limit value

<b>CHANNEL</b>	TX Channel 138	<b>DETECTOR FUNCTION</b>	Quasi-Peak (QP)
<b>FREQUENCY RANGE</b>	Below 1GHz		

**ANTENNA POLARITY & TEST DISTANCE: HORIZONTAL AT 3 M**

NO.	FREQ. (MHz)	EMISSION LEVEL (dBuV/m)	LIMIT (dBuV/m)	MARGIN (dB)	ANTENNA HEIGHT (m)	TABLE ANGLE (Degree)	RAW VALUE (dBuV)	CORRECTION FACTOR (dB/m)
1	33.77	23.9 QP	40.0	-16.1	1.44 H	166	33.50	-9.60
2	195.07	39.9 QP	43.5	-3.6	1.53 H	25	51.20	-11.30
3	260.26	42.8 QP	46.0	-3.2	1.37 H	59	51.70	-8.90
4	379.67	32.8 QP	46.0	-13.2	1.21 H	358	38.10	-5.30
5	695.53	37.7 QP	46.0	-8.3	1.04 H	332	36.30	1.40
6	1000.00	40.8 QP	54.0	-13.2	1.87 H	266	35.10	5.70

**ANTENNA POLARITY & TEST DISTANCE: VERTICAL AT 3 M**

NO.	FREQ. (MHz)	EMISSION LEVEL (dBuV/m)	LIMIT (dBuV/m)	MARGIN (dB)	ANTENNA HEIGHT (m)	TABLE ANGLE (Degree)	RAW VALUE (dBuV)	CORRECTION FACTOR (dB/m)
1	98.18	25.5 QP	43.5	-18.0	1.93 V	314	38.90	-13.40
2	195.76	33.6 QP	43.5	-9.9	1.59 V	230	45.00	-11.40
3	259.75	39.0 QP	46.0	-7.0	1.97 V	127	48.10	-9.10
4	325.92	32.2 QP	46.0	-13.8	1.04 V	38	38.60	-6.40
5	749.80	36.9 QP	46.0	-9.1	1.60 V	326	34.50	2.40
6	1000.00	38.9 QP	54.0	-15.1	1.00 V	283	33.20	5.70

**REMARKS:**

1. Emission Level(dBuV/m) = Raw Value(dBuV) + Correction Factor(dB/m)
2. Correction Factor(dB/m) = Antenna Factor(dB/m) + Cable Factor(dB) – Pre-Amplifier Factor(dB)
3. The other emission levels were very low against the limit.
4. Margin value = Emission Level – Limit value



<b>CHANNEL</b>	TX Channel 155	<b>DETECTOR FUNCTION</b>	Quasi-Peak (QP)
<b>FREQUENCY RANGE</b>	Below 1GHz		

**ANTENNA POLARITY & TEST DISTANCE: HORIZONTAL AT 3 M**

NO.	FREQ. (MHz)	EMISSION LEVEL (dBuV/m)	LIMIT (dBuV/m)	MARGIN (dB)	ANTENNA HEIGHT (m)	TABLE ANGLE (Degree)	RAW VALUE (dBuV)	CORRECTION FACTOR (dB/m)
1	33.65	24.2 QP	40.0	-15.8	1.51 H	167	33.80	-9.60
2	194.68	40.1 QP	43.5	-3.4	1.44 H	21	51.40	-11.30
3	260.41	42.6 QP	46.0	-3.4	1.39 H	59	51.50	-8.90
4	379.64	32.9 QP	46.0	-13.1	1.18 H	333	38.20	-5.30
5	695.55	37.8 QP	46.0	-8.2	1.01 H	321	36.40	1.40
6	1000.00	40.9 QP	54.0	-13.1	1.91 H	263	35.20	5.70

**ANTENNA POLARITY & TEST DISTANCE: VERTICAL AT 3 M**

NO.	FREQ. (MHz)	EMISSION LEVEL (dBuV/m)	LIMIT (dBuV/m)	MARGIN (dB)	ANTENNA HEIGHT (m)	TABLE ANGLE (Degree)	RAW VALUE (dBuV)	CORRECTION FACTOR (dB/m)
1	97.94	25.6 QP	43.5	-17.9	1.92 V	305	39.10	-13.50
2	196.02	33.5 QP	43.5	-10.0	1.61 V	212	44.90	-11.40
3	259.92	38.9 QP	46.0	-7.1	2.04 V	148	47.90	-9.00
4	325.76	32.3 QP	46.0	-13.7	1.03 V	55	38.70	-6.40
5	749.56	36.6 QP	46.0	-9.4	1.60 V	325	34.20	2.40
6	1000.00	39.0 QP	54.0	-15.0	1.00 V	293	33.30	5.70

**REMARKS:**

1. Emission Level(dBuV/m) = Raw Value(dBuV) + Correction Factor(dB/m)
2. Correction Factor(dB/m) = Antenna Factor(dB/m) + Cable Factor(dB) – Pre-Amplifier Factor(dB)
3. The other emission levels were very low against the limit.
4. Margin value = Emission Level – Limit value

## 4.2 Conducted Emission Measurement

### 4.2.1 Limits of Conducted Emission Measurement

Frequency (MHz)	Conducted Limit (dBuV)	
	Quasi-peak	Average
0.15 - 0.5	66 - 56	56 - 46
0.50 - 5.0	56	46
5.0 - 30.0	60	50

Note: 1. The lower limit shall apply at the transition frequencies.

2. The limit decreases in line with the logarithm of the frequency in the range of 0.15 to 0.50MHz.

### 4.2.2 Test Instruments

DESCRIPTION & MANUFACTURER	MODEL NO.	SERIAL NO.	CALIBRATED DATE	CALIBRATED UNTIL
Test Receiver R&S	ESCS 30	100375	May 06, 2015	May 05, 2016
Line-Impedance Stabilization Network (for EUT) SCHWARZBECK	NSLK-8127	8127-522	Sep. 01, 2015	Aug. 31, 2016
Line-Impedance Stabilization Network (for Peripheral ) R&S	ENV216	100072	June 11, 2015	June 10, 2016
RF Cable	5D-FB	COCCAB-001	Mar. 09, 2015	Mar. 08, 2016
50 ohms Terminator	N/A	EMC-03	Sep. 23, 2015	Sep. 22, 2016
50 ohms Terminator	N/A	EMC-02	Oct. 01, 2015	Sep. 30, 2016
Software BVADT	BVADT_Cond_ V7.3.7.3	NA	NA	NA

**Note:**

1. The calibration interval of the above test instruments are 12 months and the calibrations are traceable to NML/ROC and NIST/USA.
2. The test was performed in Shielded Room No. C.
- 3 The VCCI Con C Registration No. is C-3611.
- 4 Tested Date: Nov. 20 to 28, 2015

#### 4.2.3 Test Procedure

- a. The EUT was placed 0.4 meters from the conducting wall of the shielded room with EUT being connected to the power mains through a line impedance stabilization network (LISN). Other support units were connected to the power mains through another LISN. The two LISNs provide 50 ohm/ 50uH of coupling impedance for the measuring instrument.
- b. Both lines of the power mains connected to the EUT were checked for maximum conducted interference.
- c. The frequency range from 150kHz to 30MHz was searched. Emission levels under (Limit - 20dB) was not recorded.

**NOTE:** All modes of operation were investigated and the worst-case emissions are reported.

#### 4.2.4 Deviation from Test Standard

No deviation.

#### 4.2.5 Test Setup

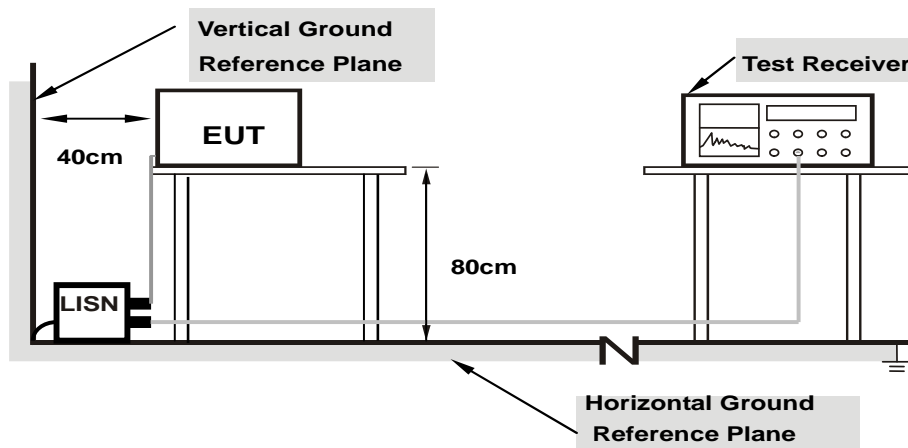

**Note: 1.Support units were connected to second LISN.**

For the actual test configuration, please refer to the attached file (Test Setup Photo).

#### 4.2.6 EUT Operating Condition

Same as 4.1.6.

#### 4.2.7 Test Results (Mode 2)

Phase	Line (L)	Detector Function	Quasi-Peak (QP) / Average (AV)
-------	----------	-------------------	--------------------------------

Phase Of Power : Line (L)										
No	Frequency (MHz)	Correction Factor (dB)	Reading Value (dBuV)		Emission Level (dBuV)		Limit (dBuV)		Margin (dB)	
			Q.P.	AV.	Q.P.	AV.	Q.P.	AV.	Q.P.	AV.
1	0.23589	10.22	41.76	36.32	51.98	46.54	62.24	52.24	-10.26	-5.70
2	0.35310	10.24	38.84	35.18	49.08	45.42	58.89	48.89	-9.81	-3.47
3	0.43512	10.24	34.86	25.67	45.10	35.91	57.15	47.15	-12.06	-11.25
<b>4</b>	<b>0.58356</b>	<b>10.22</b>	<b>40.03</b>	<b>32.55</b>	<b>50.25</b>	<b>42.77</b>	<b>56.00</b>	<b>46.00</b>	<b>-5.75</b>	<b>-3.23</b>
5	1.05074	10.17	34.32	29.21	44.49	39.38	56.00	46.00	-11.51	-6.62
6	7.62886	10.46	28.41	27.08	38.87	37.54	60.00	50.00	-21.13	-12.46

**Remarks:**

1. Q.P. and AV. are abbreviations of quasi-peak and average individually.
2. The emission levels of other frequencies were very low against the limit.
3. Margin value = Emission level – Limit value
4. Correction factor = Insertion loss + Cable loss
5. Emission Level = Correction Factor + Reading Value

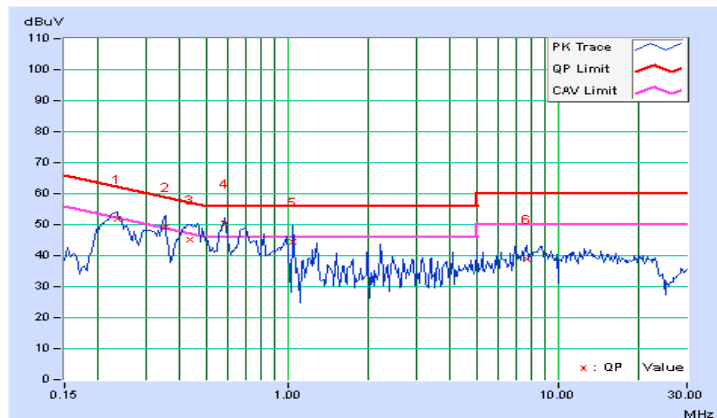

Phase	Neutral (N)	Detector Function	Quasi-Peak (QP) / Average (AV)
-------	-------------	-------------------	--------------------------------

Phase Of Power : Neutral (N)										
No	Frequency (MHz)	Correction Factor (dB)	Reading Value (dBuV)		Emission Level (dBuV)		Limit (dBuV)		Margin (dB)	
			Q.P.	AV.	Q.P.	AV.	Q.P.	AV.	Q.P.	AV.
1	0.15000	10.24	42.68	23.79	52.92	34.03	66.00	56.00	-13.08	-21.97
2	0.18516	10.21	39.33	22.93	49.54	33.14	64.25	54.25	-14.71	-21.11
3	0.23984	10.20	37.12	25.14	47.32	35.34	62.10	52.10	-14.78	-16.76
4	0.57969	10.20	29.63	20.52	39.83	30.72	56.00	46.00	-16.17	-15.28
5	0.75156	10.18	29.20	18.86	39.38	29.04	56.00	46.00	-16.62	-16.96
6	22.09766	10.97	29.21	14.16	40.18	25.13	60.00	50.00	-19.82	-24.87

**Remarks:**

1. Q.P. and AV. are abbreviations of quasi-peak and average individually.
2. The emission levels of other frequencies were very low against the limit.
3. Margin value = Emission level – Limit value
4. Correction factor = Insertion loss + Cable loss
5. Emission Level = Correction Factor + Reading Value

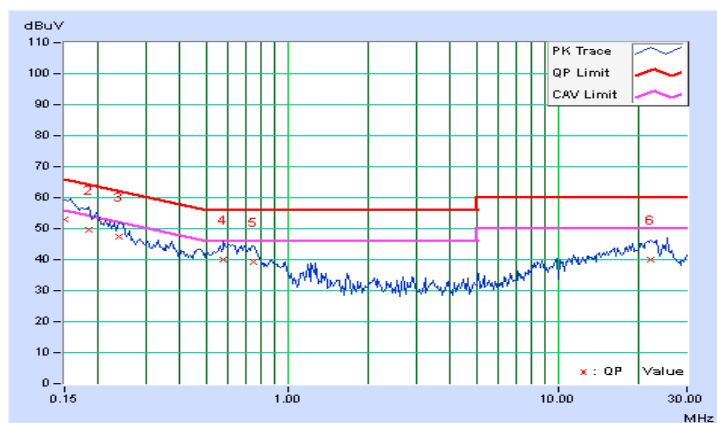

4.2.8 Test Results (Mode 4)

Phase	Line (L)	Detector Function	Quasi-Peak (QP) / Average (AV)
-------	----------	-------------------	--------------------------------

Phase Of Power : Line (L)										
No	Frequency (MHz)	Correction Factor (dB)	Reading Value (dBuV)		Emission Level (dBuV)		Limit (dBuV)		Margin (dB)	
			Q.P.	AV.	Q.P.	AV.	Q.P.	AV.	Q.P.	AV.
1	0.15000	10.26	42.49	14.02	52.75	24.28	66.00	56.00	-13.25	-31.72
2	0.17736	10.24	39.51	10.12	49.75	20.36	64.61	54.61	-14.86	-34.25
3	0.20860	10.22	34.49	6.03	44.71	16.25	63.26	53.26	-18.55	-37.01
4	10.65624	10.55	24.53	24.56	35.08	35.11	60.00	50.00	-24.92	-14.89
5	20.22268	10.92	26.36	25.94	37.28	36.86	60.00	50.00	-22.72	-13.14
6	23.23048	10.96	35.12	33.38	46.08	44.34	60.00	50.00	-13.92	-5.66

Remarks:

1. Q.P. and AV. are abbreviations of quasi-peak and average individually.
2. The emission levels of other frequencies were very low against the limit.
3. Margin value = Emission level – Limit value
4. Correction factor = Insertion loss + Cable loss
5. Emission Level = Correction Factor + Reading Value

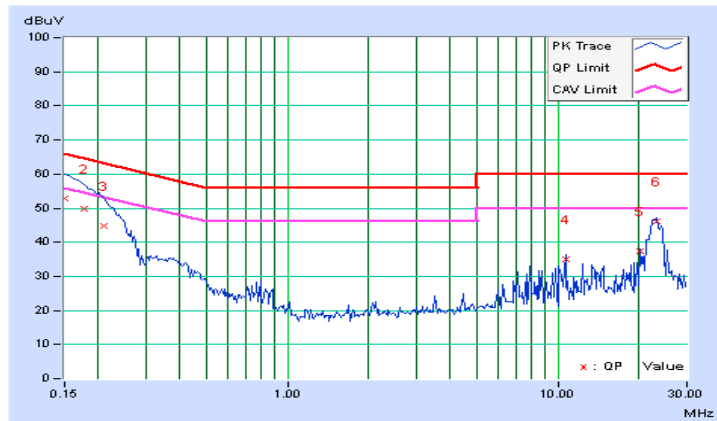

Phase	Neutral (N)	Detector Function	Quasi-Peak (QP) / Average (AV)
-------	-------------	-------------------	--------------------------------

Phase Of Power : Neutral (N)										
No	Frequency (MHz)	Correction Factor (dB)	Reading Value (dBuV)		Emission Level (dBuV)		Limit (dBuV)		Margin (dB)	
			Q.P.	AV.	Q.P.	AV.	Q.P.	AV.	Q.P.	AV.
1	0.15000	10.24	43.91	14.41	54.15	24.65	66.00	56.00	-11.85	-31.35
2	0.18126	10.21	40.36	11.26	50.57	21.47	64.43	54.43	-13.85	-32.95
3	0.23206	10.20	35.21	8.61	45.41	18.81	62.38	52.38	-16.96	-33.56
4	8.74610	10.50	23.36	22.78	33.86	33.28	60.00	50.00	-26.14	-16.72
5	23.23049	10.98	32.51	32.03	43.49	43.01	60.00	50.00	-16.51	-6.99
6	24.32426	10.99	30.41	30.11	41.40	41.10	60.00	50.00	-18.60	-8.90

**Remarks:**

1. Q.P. and AV. are abbreviations of quasi-peak and average individually.
2. The emission levels of other frequencies were very low against the limit.
3. Margin value = Emission level – Limit value
4. Correction factor = Insertion loss + Cable loss
5. Emission Level = Correction Factor + Reading Value

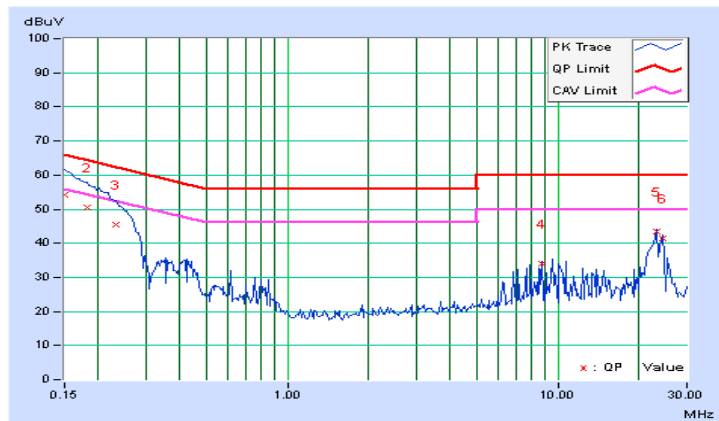

4.2.9 Test Results (Mode 5)

Phase	Line (L)	Detector Function	Quasi-Peak (QP) / Average (AV)
-------	----------	-------------------	--------------------------------

Phase Of Power : Line (L)										
No	Frequency (MHz)	Correction Factor (dB)	Reading Value (dBuV)		Emission Level (dBuV)		Limit (dBuV)		Margin (dB)	
			Q.P.	AV.	Q.P.	AV.	Q.P.	AV.	Q.P.	AV.
1	0.15000	10.26	47.21	17.45	57.47	27.71	66.00	56.00	-8.53	-28.29
2	0.18124	10.24	42.34	13.36	52.58	23.60	64.43	54.43	-11.85	-30.83
3	10.66018	10.55	23.25	22.64	33.80	33.19	60.00	50.00	-26.20	-16.81
4	22.14062	10.95	33.06	32.53	44.01	43.48	60.00	50.00	-15.99	-6.52
5	23.23440	10.96	35.22	33.49	46.18	44.45	60.00	50.00	-13.82	-5.55
6	24.32815	10.97	31.84	31.63	42.81	42.60	60.00	50.00	-17.19	-7.40

Remarks:

1. Q.P. and AV. are abbreviations of quasi-peak and average individually.
2. The emission levels of other frequencies were very low against the limit.
3. Margin value = Emission level – Limit value
4. Correction factor = Insertion loss + Cable loss
5. Emission Level = Correction Factor + Reading Value

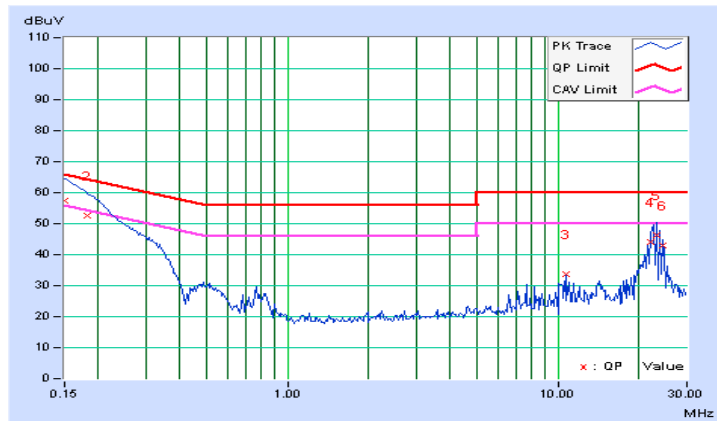



Phase	Neutral (N)	Detector Function	Quasi-Peak (QP) / Average (AV)
-------	-------------	-------------------	--------------------------------

Phase Of Power : Neutral (N)										
No	Frequency (MHz)	Correction Factor (dB)	Reading Value (dBuV)		Emission Level (dBuV)		Limit (dBuV)		Margin (dB)	
			Q.P.	AV.	Q.P.	AV.	Q.P.	AV.	Q.P.	AV.
1	0.15000	10.24	46.86	17.78	57.10	28.02	66.00	56.00	-8.90	-27.98
2	0.18126	10.21	42.36	13.45	52.57	23.66	64.43	54.43	-11.85	-30.76
3	0.30624	10.21	28.53	6.65	38.74	16.86	60.07	50.07	-21.33	-33.21
4	10.11326	10.54	21.64	20.38	32.18	30.92	60.00	50.00	-27.82	-19.08
5	22.68752	10.97	30.82	30.12	41.79	41.09	60.00	50.00	-18.21	-8.91
6	23.23440	10.98	31.23	30.13	42.21	41.11	60.00	50.00	-17.79	-8.89

**Remarks:**

1. Q.P. and AV. are abbreviations of quasi-peak and average individually.
2. The emission levels of other frequencies were very low against the limit.
3. Margin value = Emission level – Limit value
4. Correction factor = Insertion loss + Cable loss
5. Emission Level = Correction Factor + Reading Value

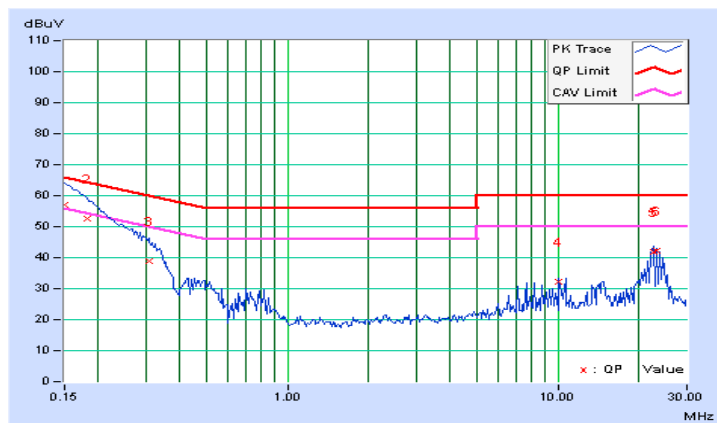

### 4.3 Transmit Power Measurement

#### 4.3.1 Limits of Transmit Power Measurement

Operation Band	EUT Category		LIMIT
U-NII-1		Outdoor Access Point	1 Watt (30 dBm) (Max. e.i.r.p $\leq$ 125mW(21 dBm) at any elevation angle above 30 degrees as measured from the horizon)
		Fixed point-to-point Access Point	1 Watt (30 dBm)
		Indoor Access Point	1 Watt (30 dBm)
	√	Mobile and Portable client device	250mW (24 dBm)
U-NII-2A		√	250mW (24 dBm) or 11 dBm+10 log B*
U-NII-2C		√	250mW (24 dBm) or 11 dBm+10 log B*
U-NII-3		√	1 Watt (30 dBm)

\*B is the 26 dB emission bandwidth in megahertz

#### 4.3.2 Test Setup

##### FOR POWER OUTPUT MEASUREMENT

For channel straddling 5725MHz:

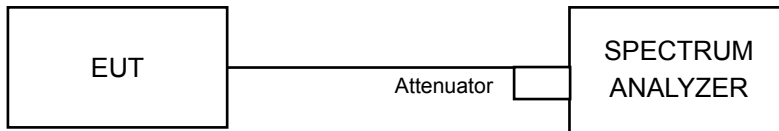

For other channels:

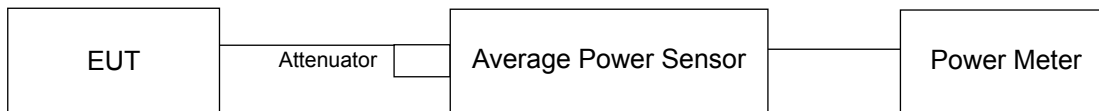

##### FOR 26dB OCCUPIED BANDWIDTH

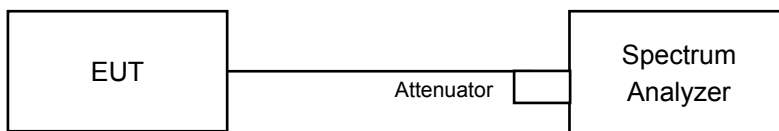

#### 4.3.3 Test Instruments

Refer to section 4.1.2 to get information of above instrument.

#### 4.3.4 Test Procedure

##### FOR AVERAGE POWER MEASUREMENT

##### For channel straddling 5725MHz:

Follow FCC KDB 789033 UNII test procedure:

##### 802.11ac (VHT80)

Method SA-2

1. Set span to encompass the entire 99% occupied bandwidth of the signal.
2. Set RBW = 1MHz.
3. Set the VBW  $\geq 3 \times$  RBW.
4. Number of points in sweep  $\geq 2$  Span / RBW.
5. Sweep time = auto.
6. Detector = RMS.
7. Trace average at least 100 traces in power averaging mode
8. Compute power by integrating the spectrum across the entire 99% occupied bandwidth of the signal.
9. Duty factor need added to measured value (duty cycle < 98 percent).

##### For other channels:

Method PM is used to perform output power measurement, trigger and gating function of wide band power meter is enabled to measure max output power of TX on burst and set the detector to AVERAGE. Duty factor is not added to measured value.

##### FOR 26dB OCCUPIED BANDWIDTH

1. Set RBW = approximately 1% of the emission bandwidth.
2. Set the VBW > RBW.
3. Detector = Peak.
4. Trace mode = max hold.
5. Measure the maximum width of the emission that is 26 dB down from the peak of the emission. Compare this with the RBW setting of the analyzer. Readjust RBW and repeat measurement as needed until the RBW/EBW ratio is approximately 1%.

#### 4.3.5 Deviation from Test Standard

No deviation.

#### 4.3.6 EUT Operating Condition

The software provided by client to enable the EUT under transmission condition continuously at lowest, middle and highest channel frequencies individually.

#### 4.3.7 Test Result

##### 802.11a

##### POWER OUTPUT

Channel	Frequency (MHz)	Average Power (mW)	Average Power (dBm)	Limit (dBm)	Pass / Fail
36	5180	95.499	19.80	24	Pass
40	5200	101.158	20.05	24	Pass
48	5240	102.329	20.10	24	Pass
52	5260	100.462	20.02	24	Pass
60	5300	100.231	20.01	24	Pass
64	5320	95.28	19.79	24	Pass
100	5500	89.536	19.52	24	Pass
116	5580	92.045	19.64	24	Pass
120	5600	95.06	19.78	24	Pass
132	5660	100.462	20.02	24	Pass
140	5700	66.834	18.25	24	Pass
149	5745	62.661	17.97	30	Pass
157	5785	110.917	20.45	30	Pass
165	5825	112.98	20.53	30	Pass

**26dB OCCUPIED BANDWIDTH**

Channel	Frequency (MHz)	26dBc Bandwidth (MHz)
36	5180	33.21
40	5200	33.36
48	5240	33.13
52	5260	32.56
60	5300	32.04
64	5320	29.34
100	5500	24.66
116	5580	30.53
120	5600	29.36
132	5660	33.07
140	5700	26.66

**Note: For U-NII-2A, U-NII-2C Band output power limitation is determined based on 26dBc bandwidth**

Power Limit = 11dBm + 10logB < U-NII-2A, U-NII-2C >			
Channel	Frequency (MHz)	Min. B(MHz)	Determined Conducted Limit (dBm)
52	5260	32.56	26.12 > 24
60	5300	32.04	26.05 > 24
64	5320	29.34	25.67 > 24
100	5500	24.66	24.91 > 24
116	5580	30.53	25.84 > 24
120	5600	29.36	25.67 > 24
132	5660	33.07	26.19 > 24
140	5700	26.66	25.25 > 24

**802.11ac (VHT20)**
**POWER OUTPUT**

Chan.	Chan. Freq. (MHz)	Average Power (dBm)		Total Power (mW)	Total Power (dBm)	Limit (dBm)	Pass / Fail
		Chain 0	Chain 1				
36	5180	18.95	19.64	170.569	22.32	24	Pass
40	5200	19.51	19.95	188.186	22.75	24	Pass
48	5240	19.73	20.09	196.066	22.92	24	Pass
52	5260	19.72	19.97	193.068	22.86	24	Pass
60	5300	19.78	19.94	193.688	22.87	24	Pass
64	5320	19.51	19.75	183.737	22.64	24	Pass
100	5500	17.80	17.66	118.601	20.74	24	Pass
116	5580	18.65	18.75	148.271	21.71	24	Pass
120	5600	18.56	18.79	147.462	21.69	24	Pass
132	5660	18.68	19.05	154.143	21.88	24	Pass
140	5700	16.10	16.63	86.764	19.38	24	Pass
149	5745	15.68	16.82	85.067	19.30	30	Pass
157	5785	19.58	20.44	201.444	23.04	30	Pass
165	5825	18.62	19.37	159.275	22.02	30	Pass

**26dB OCCUPIED BANDWIDTH**

Channel	Frequency (MHz)	26dBc Bandwidth (MHz)	
		Chain 0	Chain 1
36	5180	34.98	35.20
40	5200	35.19	31.43
48	5240	33.62	35.85
52	5260	33.34	31.61
60	5300	34.72	30.17
64	5320	36.26	29.38
100	5500	25.08	22.79
116	5580	27.17	27.76
120	5600	28.86	30.27
132	5660	30.18	37.93
140	5700	20.91	20.89

**Note: For U-NII-2A, U-NII-2C Band output power limitation is determined based on 26dBc bandwidth**

Power Limit = 11dBm + 10logB < U-NII-2A, U-NII-2C >			
Channel	Frequency (MHz)	Min. B(MHz)	Determined Conducted Limit (dBm)
52	5260	31.61	25.99 > 24
60	5300	30.17	25.79 > 24
64	5320	29.38	25.68 > 24
100	5500	22.79	24.57 > 24
116	5580	27.17	25.34 > 24
120	5600	28.86	25.6 > 24
132	5660	30.18	25.79 > 24
140	5700	20.89	24.19 > 24

**802.11ac (VHT40)**
**POWER OUTPUT**

Chan.	Chan. Freq. (MHz)	Average Power (dBm)		Total Power (mW)	Total Power (dBm)	Limit (dBm)	Pass / Fail
		Chain 0	Chain 1				
38	5190	14.85	15.66	67.362	18.28	24	Pass
46	5230	19.70	20.27	199.739	23.00	24	Pass
54	5270	19.52	20.10	191.865	22.83	24	Pass
62	5310	15.28	15.98	73.357	18.65	24	Pass
102	5510	14.66	14.91	60.216	17.80	24	Pass
110	5550	19.38	19.75	181.102	22.58	24	Pass
118	5590	19.36	19.84	182.681	22.62	24	Pass
134	5670	18.23	18.98	145.595	21.63	24	Pass
151	5755	14.64	15.48	64.425	18.09	30	Pass
159	5795	19.20	20.18	187.408	22.73	30	Pass



**26dB OCCUPIED BANDWIDTH**

Channel	Frequency (MHz)	26dBc Bandwidth (MHz)	
		Chain 0	Chain 1
38	5190	41.69	42.22
46	5230	73.88	81.52
54	5270	72.07	71.09
62	5310	41.67	41.52
102	5510	41.49	41.51
110	5550	73.91	76.47
118	5590	77.10	74.87
134	5670	68.30	70.22

**Note: For U-NII-2A, U-NII-2C Band output power limitation is determined based on 26dBc bandwidth**

Power Limit = 11dBm + 10logB < U-NII-2A, U-NII-2C >			
Channel	Frequency (MHz)	Min. B(MHz)	Determined Conducted Limit (dBm)
54	5270	71.09	29.51 > 24
62	5310	41.52	27.18 > 24
102	5510	41.49	27.17 > 24
110	5550	73.91	29.68 > 24
118	5590	74.87	29.74 > 24
134	5670	68.30	29.34 > 24

**802.11ac (VHT80)**

**POWER OUTPUT**

Chan.	Chan. Freq. (MHz)	Average Power (dBm)		Total Power (mW)	Total Power (dBm)	Limit (dBm)	Pass / Fail
		Chain 0	Chain 1				
42	5210	14.62	15.51	64.536	18.10	24	Pass
58	5290	14.48	14.97	59.459	17.74	24	Pass
106	5530	14.21	14.07	51.89	17.15	24	Pass
122	5610	19.02	19.38	166.495	22.21	24	Pass
138 (UNII-2c Band)	5690	15.53	15.70	76.235	18.82	24	Pass
138 (UNII-3 Band)	5690	1.77	1.94	3.207	5.06	30	Pass
155	5775	13.62	14.10	48.718	16.88	30	Pass

**Note:** \* Test was performed in accordance with Measurement follow FCC KDB 789033 UNII test procedure Method SA-2 and use spectrum analyzer test.

The Total Power for the straddle channel:

Chan.	Chan. Freq. (MHz)	Average Power (mW)	Average Power (dBm)
*138	5690	79.442	19

Note: The total power was calculated through formula and record the value for reference only.

**26dB OCCUPIED BANDWIDTH**

Channel	Frequency (MHz)	26dBc Bandwidth (MHz)	
		Chain 0	Chain 1
42	5210	82.96	83.25
58	5290	83.10	82.87
106	5530	83.85	83.13
122	5610	123.60	129.02
138 (UNII-2c Band)	5690	114.73	114.54

**Note: For U-NII-2A, U-NII-2C Band output power limitation is determined based on 26dBc bandwidth**

Power Limit = 11dBm + 10logB < U-NII-2A, U-NII-2C >			
Channel	Frequency (MHz)	Min. B(MHz)	Determined Conducted Limit (dBm)
58	5290	82.87	30.18 > 24
106	5530	83.13	30.19 > 24
122	5610	123.60	31.92 > 24
138 (UNII-2c Band)	5690	114.54	31.58 > 24

Spectrum Plot of Worst Value

802.11a: CH100

802.11ac (VHT20) -Chain (1): CH140

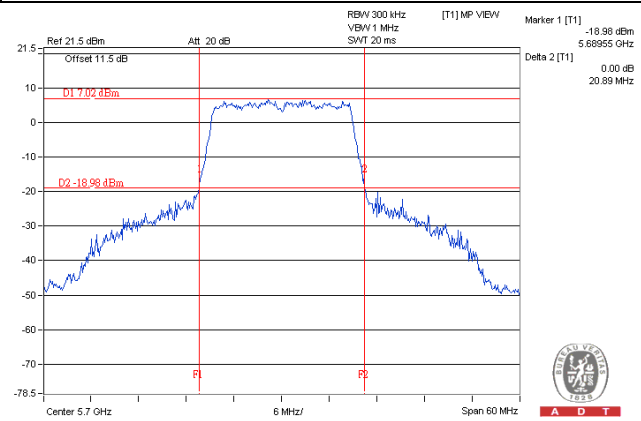
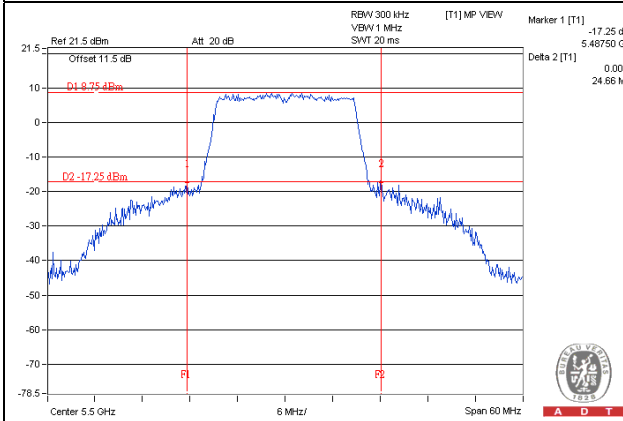

802.11ac (VHT40) -Chain (0): CH102

802.11ac (VHT80)-Chain (0): CH138 (UNII-3 Band)

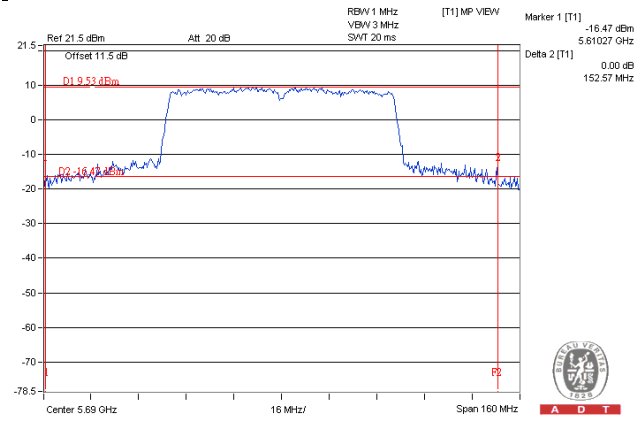
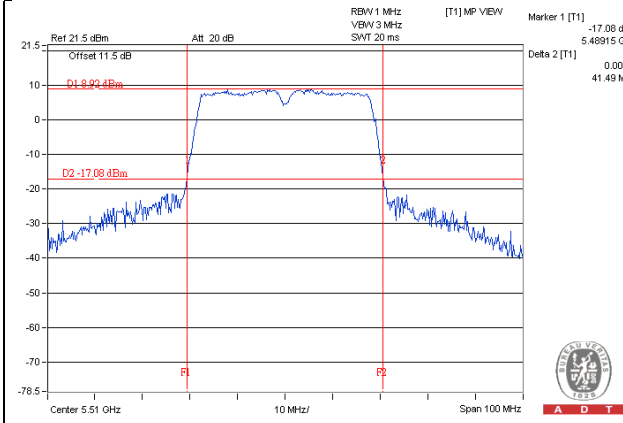

**NOTE:**

For CH138 (UNII-2c Band) = 5725MHz - Marker 1

※Add test for each data rate output power (require by manufacturer):

802.11a

CHANNEL	FREQUENCY (MHz)	AVERAGE POWER (dBm)							
		Data rate							
		6Mbps	9Mbps	12Mbps	18Mbps	24Mbps	36Mbps	48Mbps	54Mbps
36	5180	19.80	19.61	19.63	19.53	19.74	19.65	19.54	19.44
40	5200	20.05	20.03	19.87	19.94	20.01	20.02	19.81	19.68
48	5240	20.10	19.99	19.77	19.90	19.96	19.75	19.85	20
52	5260	20.02	19.89	19.95	19.80	19.91	19.74	19.74	19.58
60	5300	20.01	19.92	19.76	19.80	19.81	19.73	19.86	19.98
64	5320	19.79	19.70	19.77	19.69	19.72	19.55	19.47	19.52
100	5500	19.52	19.30	19.23	19.26	19.23	19.45	19.41	19.5
116	5580	19.64	19.45	19.38	19.57	19.53	19.38	19.23	19.06
120	5600	19.78	19.66	19.55	19.57	19.42	19.53	19.73	19.76
132	5660	20.02	19.91	19.80	19.76	19.58	19.46	19.33	19.27
140	5700	18.25	18.12	17.97	17.85	17.66	17.66	17.82	17.88
149	5745	17.97	17.92	17.89	17.95	17.9	17.77	17.86	17.73
157	5785	20.45	20.43	20.36	20.16	20.05	19.96	19.83	19.84
165	5825	20.53	20.40	20.18	20.01	20.21	20.38	20.4	20.23

**802.11ac (VHT20)**
**NSS=1**

CHANNEL	FREQUENCY (MHz)	AVERAGE POWER (dBm)								
		Data rate								
		MCS0	MCS1	MCS2	MCS3	MCS4	MCS5	MCS6	MCS7	MCS8
36	5180	22.31	22.22	22.03	22.10	22.19	22.02	21.84	22.05	22.06
40	5200	22.70	22.65	22.62	22.43	22.28	22.47	22.27	22.15	22.33
48	5240	22.91	22.81	22.82	22.79	22.86	22.83	22.69	22.61	22.67
52	5260	22.84	22.74	22.59	22.56	22.46	22.45	22.49	22.42	22.28
60	5300	22.83	22.64	22.47	22.28	22.2	21.99	21.99	21.97	22.16
64	5320	22.60	22.43	22.54	22.50	22.34	22.34	22.41	22.49	22.48
100	5500	20.71	20.60	20.54	20.32	20.35	20.14	19.99	19.94	19.8
116	5580	21.69	21.48	21.63	21.66	21.51	21.66	21.67	21.51	21.35
120	5600	21.68	21.62	21.45	21.37	21.51	21.35	21.23	21.2	21.13
132	5660	21.85	21.72	21.59	21.42	21.41	21.34	21.29	21.1	21.12
140	5700	19.37	19.28	19.11	19.04	19.12	18.93	18.9	18.97	18.88
149	5745	19.27	19.07	19.16	19.16	19.02	18.86	18.92	19.05	18.99
157	5785	23.03	22.94	23.00	22.99	22.95	22.86	23.02	22.86	22.71
165	5825	22.01	21.96	21.84	21.62	21.61	21.54	21.62	21.75	21.68

**NSS=2**

CHANNEL	FREQUENCY (MHz)	AVERAGE POWER (dBm)								
		Data rate								
		MCS0	MCS1	MCS2	MCS3	MCS4	MCS5	MCS6	MCS7	MCS8
36	5180	22.32	22.22	22.11	22.03	21.81	21.79	22.01	22.02	21.95
40	5200	22.75	22.62	22.58	22.55	22.61	22.71	22.49	22.45	22.47
48	5240	22.92	22.88	22.67	22.70	22.82	22.62	22.83	22.79	22.83
52	5260	22.86	22.68	22.54	22.76	22.77	22.73	22.53	22.41	22.48
60	5300	22.87	22.86	22.80	22.79	22.66	22.64	22.57	22.38	22.21
64	5320	22.64	22.48	22.52	22.35	22.36	22.23	22.31	22.15	22.3
100	5500	20.74	20.71	20.71	20.71	20.67	20.55	20.55	20.44	20.31
116	5580	21.71	21.52	21.65	21.49	21.55	21.59	21.38	21.34	21.42
120	5600	21.69	21.58	21.55	21.49	21.51	21.64	21.63	21.52	21.55
132	5660	21.88	21.77	21.84	21.63	21.64	21.81	21.7	21.5	21.42
140	5700	19.38	19.23	19.32	19.26	19.34	19.32	19.13	19.32	19.11
149	5745	19.30	19.08	18.91	19.04	19.24	19.16	19.09	19.23	19.03
157	5785	23.04	22.89	22.93	22.95	23	23.02	22.83	22.71	22.68
165	5825	22.02	21.82	22.01	21.88	21.93	21.95	21.82	21.99	21.91

**802.11ac (VHT40)**

**NSS=1**

CHANNEL	FREQUENCY (MHz)	AVERAGE POWER (dBm)									
		Data rate									
		MCS0	MCS1	MCS2	MCS3	MCS4	MCS5	MCS6	MCS7	MCS8	MCS9
38	5190	18.27	18.10	18.08	17.96	17.92	17.96	17.87	17.77	17.96	17.90
46	5230	22.97	22.91	22.74	22.73	22.79	22.8	22.62	22.61	22.61	22.65
54	5270	22.81	22.73	22.57	22.55	22.44	22.27	22.27	22.23	22.32	22.18
62	5310	18.60	18.53	18.58	18.38	18.18	18.13	18.26	18.04	17.88	17.92
102	5510	17.76	17.60	17.55	17.71	17.5	17.39	17.22	17.36	17.58	17.36
110	5550	22.55	22.33	22.46	22.32	22.19	22.11	22.09	22.2	22.09	22.02
118	5590	22.60	22.45	22.48	22.35	22.32	22.18	22.36	22.18	22.03	21.84
134	5670	21.60	21.50	21.42	21.57	21.45	21.39	21.39	21.24	21.44	21.45
151	5755	18.07	18.06	17.91	17.85	17.73	17.77	17.73	17.53	17.74	17.58
159	5795	22.70	22.64	22.52	22.31	22.25	22.33	22.29	22.08	22.27	22.24

**NSS=2**

CHANNEL	FREQUENCY (MHz)	AVERAGE POWER (dBm)									
		Data rate									
		MCS0	MCS1	MCS2	MCS3	MCS4	MCS5	MCS6	MCS7	MCS8	MCS9
38	5190	18.28	18.18	18.02	18.05	18.09	18.03	17.99	17.96	17.90	17.75
46	5230	23.00	22.91	22.95	22.89	22.95	22.99	22.85	22.88	22.71	22.77
54	5270	22.83	22.70	22.61	22.42	22.37	22.37	22.24	22.19	22.24	22.27
62	5310	18.65	18.45	18.60	18.48	18.42	18.56	18.41	18.43	18.55	18.35
102	5510	17.80	17.71	17.64	17.71	17.5	17.66	17.75	17.73	17.55	17.55
110	5550	22.58	22.38	22.28	22.15	22.28	22.2	22.22	22.21	22.06	21.89
118	5590	22.62	22.55	22.47	22.25	22.4	22.4	22.39	22.36	22.48	22.44
134	5670	21.63	21.54	21.61	21.61	21.61	21.49	21.29	21.2	21.36	21.57
151	5755	18.09	17.92	17.86	18.08	17.89	17.8	17.94	17.88	17.88	17.73
159	5795	22.73	22.58	22.61	22.68	22.71	22.5	22.63	22.43	22.57	22.46

802.11ac (VHT80)

NSS=1

CHANNEL	FREQUENCY (MHz)	AVERAGE POWER (dBm)									
		Data rate									
		MCS0	MCS1	MCS2	MCS3	MCS4	MCS5	MCS6	MCS7	MCS8	MCS9
42	5210	18.08	18.03	17.93	17.94	17.88	17.88	17.97	17.80	17.61	17.45
58	5290	17.71	17.55	17.47	17.49	17.42	17.43	17.41	17.41	17.42	17.61
106	5530	17.13	17.01	16.84	16.75	16.84	16.77	16.87	17.05	17.07	16.85
122	5610	22.20	22.08	21.89	21.84	21.82	21.94	21.79	21.67	21.77	21.93
138	5690	22.97	22.96	22.88	22.92	22.74	22.66	22.68	22.9	22.78	22.59
155	5775	16.87	16.71	16.71	16.85	16.85	16.8	16.78	16.81	16.6	16.51

NSS=2

CHANNEL	FREQUENCY (MHz)	AVERAGE POWER (dBm)									
		Data rate									
		MCS0	MCS1	MCS2	MCS3	MCS4	MCS5	MCS6	MCS7	MCS8	MCS9
42	5210	18.10	18.09	17.98	17.95	17.93	18.09	18.05	18.02	17.96	18.08
58	5290	17.74	17.68	17.68	17.62	17.4	17.5	17.47	17.43	17.28	17.08
106	5530	17.15	17.07	16.98	16.90	16.89	16.81	16.9	16.69	16.53	16.43
122	5610	22.21	22.10	22.02	22.08	22.19	22.09	22.03	21.99	22.19	22.07
138	5690	23.00	22.88	22.73	22.87	22.98	22.99	22.9	22.68	22.74	22.86
155	5775	16.88	16.78	16.78	16.57	16.71	16.7	16.85	16.83	16.81	16.63



#### 4.4 Peak Power Spectral Density Measurement

##### 4.4.1 Limits of Peak Power Spectral Density Measurement

Operation Band	EUT Category		LIMIT
U-NII-1		Outdoor Access Point	17dBm/ MHz
		Fixed point-to-point Access Point	
		Indoor Access Point	
	√	Mobile and Portable client device	11dBm/ MHz
U-NII-2A	√		11dBm/ MHz
U-NII-2C	√		11dBm/ MHz
U-NII-3	√		30dBm/ 500kHz

##### 4.4.2 Test Setup

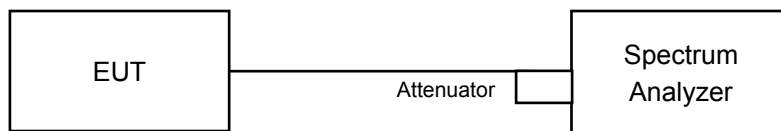

##### 4.4.3 Test Instruments

Refer to section 4.1.2 to get information of above instrument.

#### 4.4.4 Test Procedure

**For 802.11a, 802.11ac (VHT20) & 802.11ac (VHT40):**

**For U-NII-1, U-NII-2A & U-NII-2C:**

Using method SA-1

1. Set span to encompass the entire emission bandwidth (EBW) of the signal.
2. Set RBW = 1 MHz, Set VBW  $\geq$  3 MHz, Detector = RMS
3. Sweep time = auto, trigger set to "free run".
4. Trace average at least 100 traces in power averaging mode.
5. Record the max value

**For U-NII-3:**

1. Set span to encompass the entire emission bandwidth (EBW) of the signal.
2. Set RBW = 300 kHz, Set VBW  $\geq$  1 MHz, Detector = RMS
3. Use the peak marker function to determine the maximum power level in any 300 kHz band segment within the fundamental EBW.
4. Scale the observed power level to an equivalent value in 500 kHz by adjusting (reducing) the measured power by a bandwidth correction factor (BWCF) where  $BWCF = 10\log(500 \text{ kHz}/300\text{kHz})$
5. Sweep time = auto, trigger set to "free run".
6. Trace average at least 100 traces in power averaging mode.
7. Record the max value

**For 802.11ac (VHT80):**

**For U-NII-1, U-NII-2A & U-NII-2C:**

Using method SA-2

1. Set span to encompass the entire emission bandwidth (EBW) of the signal.
2. Set RBW = 1 MHz, Set VBW  $\geq$  3 MHz, Detector = RMS
3. Sweep time = auto, trigger set to "free run".
4. Trace average at least 100 traces in power averaging mode.
5. Record the max value and add  $10 \log (1/\text{duty cycle})$

**For U-NII-3:**

1. Set span to encompass the entire emission bandwidth (EBW) of the signal.
2. Set RBW = 300 kHz, Set VBW  $\geq$  1 MHz, Detector = RMS
3. Use the peak marker function to determine the maximum power level in any 300 kHz band segment within the fundamental EBW.
4. Scale the observed power level to an equivalent value in 500 kHz by adjusting (reducing) the measured power by a bandwidth correction factor (BWCF) where  $BWCF = 10\log(500 \text{ kHz}/300\text{kHz})$
5. Sweep time = auto, trigger set to "free run".
6. Trace average at least 100 traces in power averaging mode.
7. Record the max value and add  $10 \log (1/\text{duty cycle})$

#### 4.4.5 Deviation from Test Standard

No deviation.

#### 4.4.6 EUT Operating Condition

Same as Item 4.3.6.

**4.4.7 Test Results**
**For U-NII-1, U-NII-2A & U-NII-2C:**
**802.11a**

Channel	Frequency (MHz)	Power Density (dBm/MHz)	MAX. Limit (dBm/MHz)	Pass / Fail
36	5180	5.93	11	Pass
40	5200	6.11	11	Pass
48	5240	5.97	11	Pass
52	5260	6.01	11	Pass
60	5300	6.37	11	Pass
64	5320	5.96	11	Pass
100	5500	3.53	11	Pass
116	5580	5.05	11	Pass
120	5600	6.24	11	Pass
132	5660	5.66	11	Pass
140	5700	4.19	11	Pass

**802.11ac (VHT20)**

Channel	Frequency (MHz)	PSD (dBm/MHz)		Total Power Density (dBm/MHz)	MAX. Limit (dBm/MHz)	Pass / Fail
		Chain 0	Chain 1			
36	5180	5.43	5.32	8.39	11	PASS
40	5200	5.37	5.30	8.35	11	PASS
48	5240	5.46	5.25	8.37	11	PASS
52	5260	5.45	5.14	8.31	11	PASS
60	5300	5.61	5.52	8.58	11	PASS
64	5320	5.59	5.64	8.63	11	PASS
100	5500	4.09	3.53	6.83	11	PASS
116	5580	5.42	4.85	8.15	11	PASS
120	5600	4.91	4.55	7.74	11	PASS
132	5660	3.98	4.82	7.43	11	PASS
140	5700	1.85	1.53	4.70	11	PASS

**NOTE:** 1. Method a) of power density measurement of KDB 662911 is using for calculating total power density. Total power density is summing entire spectra across corresponding frequency bins on the various outputs by computer.

**802.11ac (VHT40)**

Channel	Frequency (MHz)	PSD (dBm/MHz)		Total Power Density (dBm/MHz)	MAX. Limit (dBm/MHz)	Pass / Fail
		Chain 0	Chain 1			
38	5190	-1.45	-1.71	1.43	11	PASS
46	5230	2.84	2.95	5.91	11	PASS
54	5270	2.49	2.35	5.43	11	PASS
62	5310	-1.23	-1.26	1.77	11	PASS
102	5510	-1.94	-1.36	1.37	11	PASS
110	5550	3.12	2.91	6.03	11	PASS
118	5590	2.79	2.76	5.79	11	PASS
134	5670	1.05	1.16	4.12	11	PASS

**NOTE:** 1. Method a) of power density measurement of KDB 662911 is using for calculating total power density. Total power density is summing entire spectra across corresponding frequency bins on the various outputs by computer.

**802.11ac (VHT80)**

Chan.	Chan. Freq. (MHz)	PSD W/O Duty Factor (dBm/MHz)		Duty Factor (dB)	Total PSD With Duty Factor (dBm/MHz)	MAX. Limit (dBm/MHz)	Pass / Fail
		Chain 0	Chain 1				
42	5210	-5.00	-4.38	0.19	-1.47	11	Pass
58	5290	-5.84	-4.93	0.19	-2.16	11	Pass
106	5530	-5.54	-4.70	0.19	-1.89	11	Pass
122	5610	-0.85	-0.13	0.19	2.73	11	Pass
138 (UNII-2c Band)	5690	-1.20	-1.05	0.19	2.08	11	Pass

**NOTE:** 1. Method a) of power density measurement of KDB 662911 is using for calculating total power density. Total power density is summing entire spectra across corresponding frequency bins on the various outputs by computer.

2. Refer to section 3.3 for duty cycle spectrum plot.

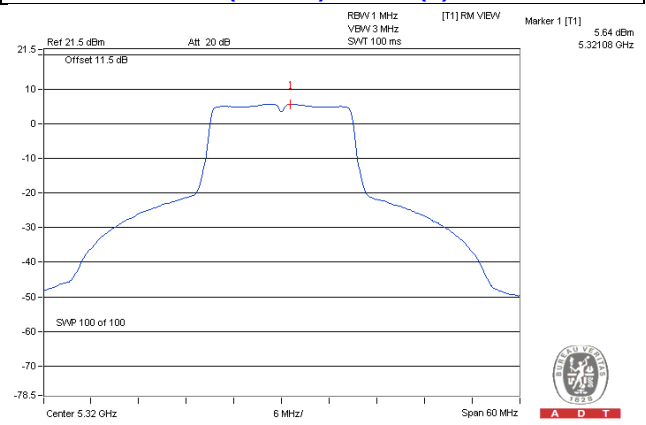
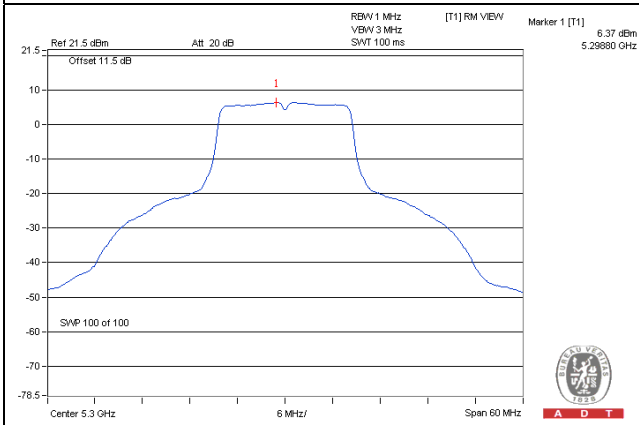
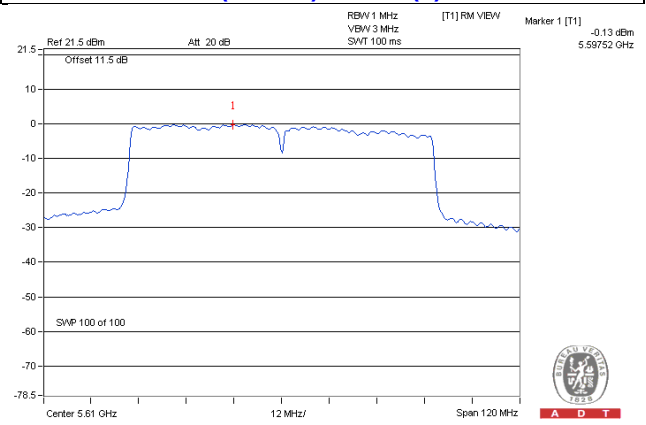
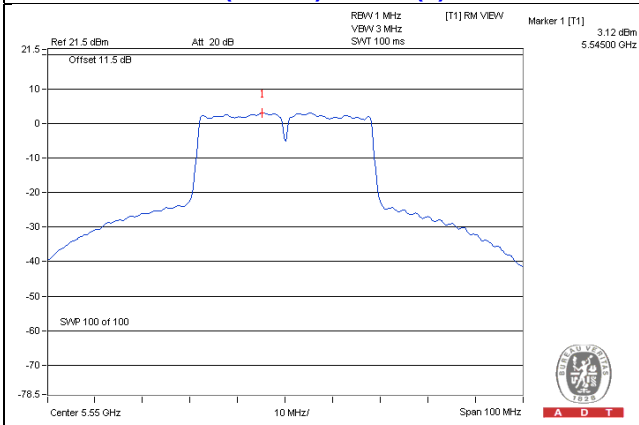
**Spectrum Plot of Worst Value****802.11a: CH60****802.11ac (VHT20)-Chain (1): CH64****802.11ac (VHT40)-Chain (0): CH110****802.11ac (VHT80)-Chain (1): CH122**

**For U-NII-3:**
**802.11a**

Channel	Frequency (MHz)	PSD (dBm/300kHz)	PSD (dBm/500kHz)	Limit (dBm/500kHz)	Pass /Fail
149	5745	-4.66	-2.44	30.00	Pass
157	5785	-1.75	0.47	30.00	Pass
165	5825	-2.03	0.19	30.00	Pass

**802.11ac (VHT20)**

TX chain	Channel	Freq. (MHz)	PSD (dBm/300kHz)	PSD (dBm/500kHz)	10 log (N=2) dB	Total PSD (dBm/500kHz)	Limit (dBm/500kHz)	Pass /Fail
0	149	5745	-6.02	-3.80	3.01	-0.79	30	Pass
	157	5785	-2.13	0.09	3.01	3.10	30	Pass
	165	5825	-3.44	-1.22	3.01	1.79	30	Pass
1	149	5745	-6.06	-3.84	3.01	-0.83	30	Pass
	157	5785	-2.56	-0.34	3.01	2.67	30	Pass
	165	5825	-3.14	-0.92	3.01	2.09	30	Pass

**802.11ac (VHT40)**

TX chain	Channel	Freq. (MHz)	PSD (dBm/300kHz)	PSD (dBm/500kHz)	10 log (N=2) dB	Total PSD (dBm/500kHz)	Limit (dBm/500kHz)	Pass /Fail
0	151	5755	-9.67	-7.45	3.01	-4.44	30	Pass
	159	5795	-5.62	-3.40	3.01	-0.39	30	Pass
1	151	5755	-9.82	-7.60	3.01	-4.59	30	Pass
	159	5795	-5.71	-3.49	3.01	-0.48	30	Pass

**802.11ac (VHT80)**

TX chain	Chan.	Chan. Freq. (MHz)	PSD W/O Duty Factor		10 log (N=2) dB	Duty Factor (dB)	Total PSD With Duty Factor (dBm/500kHz)	Limit (dBm/500kHz)	Pass /Fail
			(dBm/300kHz)	(dBm/500kHz)					
0	138 (UNII-3 Band)	5690	-10.82	-8.60	3.01	0.19	-5.40	30	Pass
	155	5775	-14.51	-12.29	3.01	0.19	-9.09	30	Pass
1	138 (UNII-3 Band)	5690	-10.55	-8.33	3.01	0.19	-5.13	30	Pass
	155	5775	-13.84	-11.62	3.01	0.19	-8.42	30	Pass

**Note:** 1. Refer to section 3.3 for duty cycle spectrum plot.

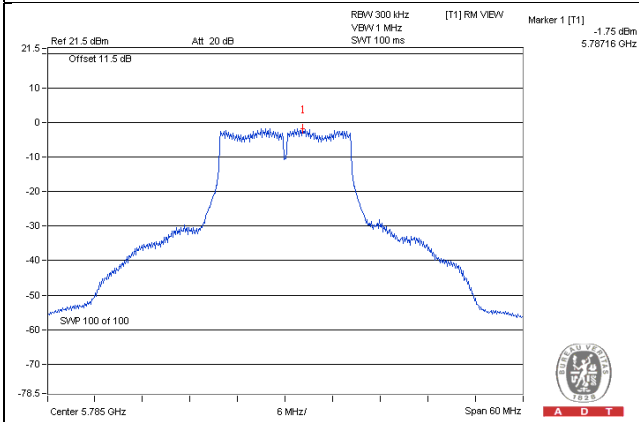
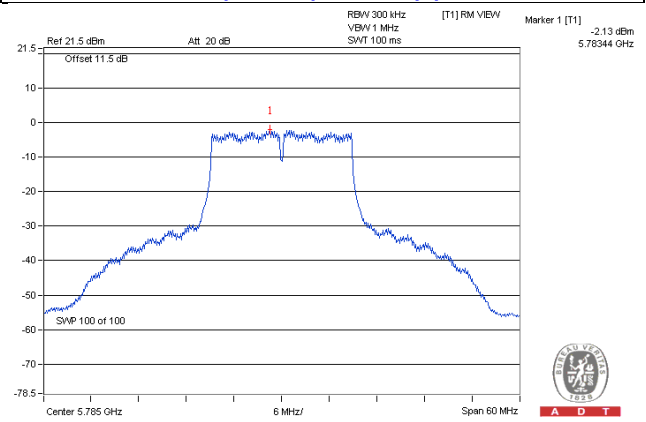
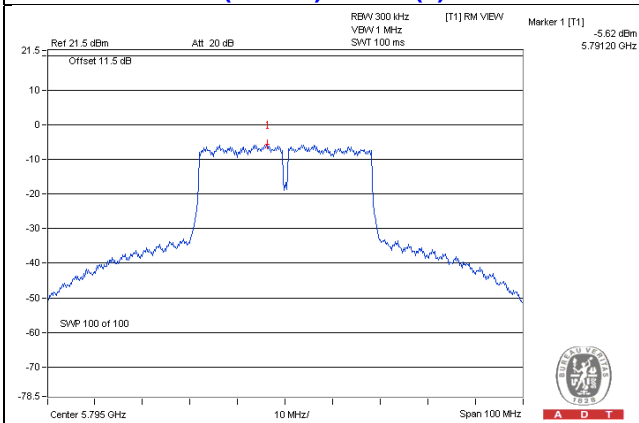
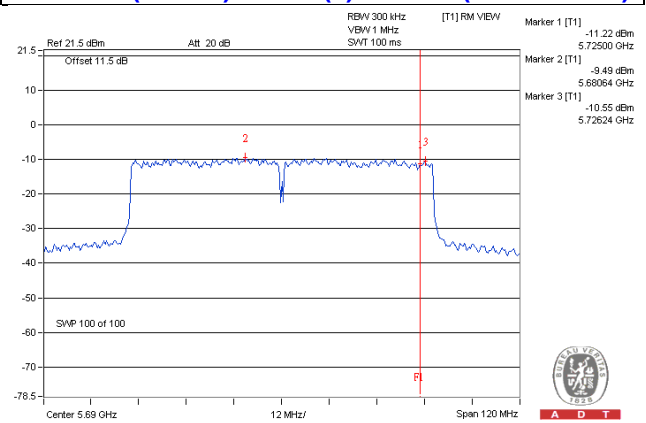
**Spectrum Plot of Worst Value****802.11a: CH157****802.11a (VHT20)-Chain (0): CH157****802.11ac (VHT40)-Chain (0): CH159****802.11ac (VHT80)-Chain (1): CH138 (UNII-3 Band)**

## 4.5 Frequency Stability Measurement

### 4.5.1 Limits of Frequency Stability Measurement

The frequency of the carrier signal shall be maintained within band of operation

### 4.5.2 Test Setup

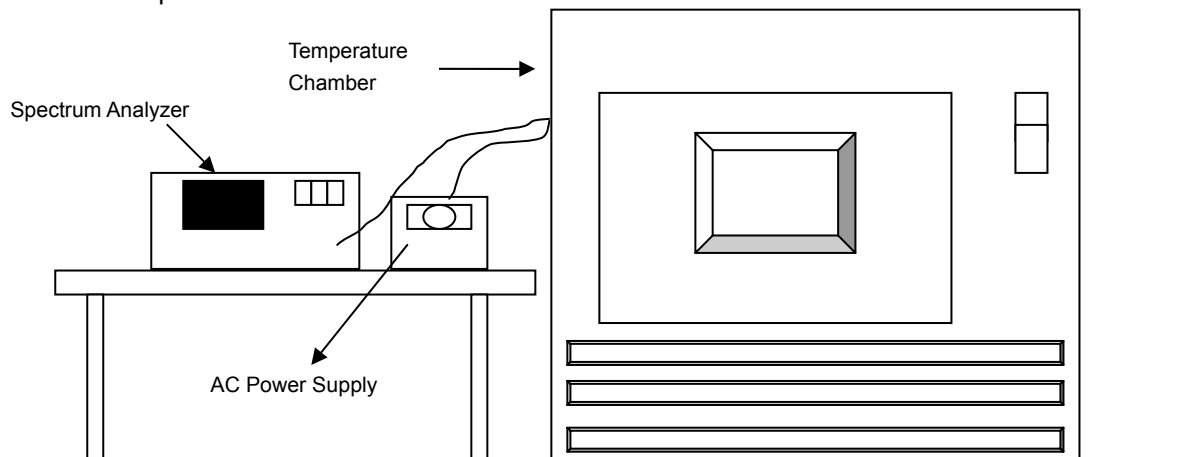

### 4.5.3 Test Instruments

Refer to section 4.1.2 to get information of above instrument.

### 4.5.4 Test Procedure

- a. The EUT was placed inside the environmental test chamber and powered by nominal AC voltage.
- b. Turn the EUT on and couple its output to a spectrum analyzer.
- c. Turn the EUT off and set the chamber to the highest temperature specified.
- d. Allow sufficient time (approximately 30 min) for the temperature of the chamber to stabilize, turn the EUT on and measure the operating frequency after 2, 5, and 10 minutes.
- e. Repeat step 2 and 3 with the temperature chamber set to the lowest temperature.
- f. The test chamber was allowed to stabilize at +20 degree C for a minimum of 30 minutes. The supply voltage was then adjusted on the EUT from 85% to 115% and the frequency record.

### 4.5.5 Deviation from Test Standard

No deviation.

### 4.5.6 EUT Operating Condition

Set the EUT transmit at un-modulation mode to test frequency stability.



#### 4.5.7 Test Results

FREQUENCY STABILITY VERSUS TEMP.									
OPERATING FREQUENCY: 5180MHz									
TEMP. (°C)	POWER SUPPLY (Vac)	0 MINUTE		2 MINUTE		5 MINUTE		10 MINUTE	
		Measured Frequency (MHz)	Frequency Drift (%)	Measured Frequency (MHz)	Frequency Drift (%)	Measured Frequency (MHz)	Frequency Drift (%)	Measured Frequency (MHz)	Frequency Drift (%)
50	120	5180.0017	0.00003	5180.0029	0.00006	5179.9993	-0.00001	5180.0011	0.00002
40	120	5179.9853	-0.00028	5179.9838	-0.00031	5179.9848	-0.00029	5179.9837	-0.00031
30	120	5180.0151	0.00029	5180.0127	0.00025	5180.0143	0.00028	5180.0148	0.00029
20	120	5179.9851	-0.00029	5179.9827	-0.00033	5179.984	-0.00031	5179.9823	-0.00034
10	120	5179.9975	-0.00005	5179.9976	-0.00005	5179.9949	-0.00010	5179.9956	-0.00008
0	120	5180.0049	0.00009	5180.0037	0.00007	5180.0067	0.00013	5180.0074	0.00014
-10	120	5179.9992	-0.00002	5179.9972	-0.00005	5180.0015	0.00003	5179.9979	-0.00004
-20	120	5180.0181	0.00035	5180.0154	0.00030	5180.0167	0.00032	5180.0172	0.00033
-30	120	5180.0093	0.00018	5180.0066	0.00013	5180.0077	0.00015	5180.0109	0.00021

FREQUENCY STABILITY VERSUS VOLTAGE									
OPERATING FREQUENCY: 5180MHz									
TEMP. (°C)	POWER SUPPLY (Vac)	0 MINUTE		2 MINUTE		5 MINUTE		10 MINUTE	
		Measured Frequency (MHz)	Frequency Drift (%)	Measured Frequency (MHz)	Frequency Drift (%)	Measured Frequency (MHz)	Frequency Drift (%)	Measured Frequency (MHz)	Frequency Drift (%)
20	138	5179.9856	-0.00028	5179.9825	-0.00034	5179.9844	-0.00030	5179.9829	-0.00033
	120	5179.9851	-0.00029	5179.9827	-0.00033	5179.984	-0.00031	5179.9823	-0.00034
	102	5179.9845	-0.00030	5179.9822	-0.00034	5179.9848	-0.00029	5179.9832	-0.00032

## 4.6 6dB Bandwidth Measurement

### 4.6.1 Limits of 6dB Bandwidth Measurement

The minimum of 6dB Bandwidth Measurement is 0.5MHz.

### 4.6.2 Test Setup

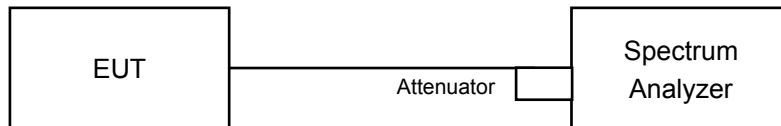

### 4.6.3 Test Instruments

Refer to section 4.1.2 to get information of above instrument.

### 4.6.4 Test Procedure

#### MEASUREMENT PROCEDURE REF

- Set resolution bandwidth (RBW) = 100kHz
- Set the video bandwidth (VBW)  $\geq 3 \times$  RBW, Detector = Peak.
- Trace mode = max hold.
- Sweep = auto couple.
- Measure the maximum width of the emission that is constrained by the frequencies associated with the two amplitude points (upper and lower) that are attenuated by 6 dB relative to the maximum level measured in the fundamental emission

### 4.6.5 Deviation from Test Standard

No deviation.

### 4.6.6 EUT Operating Condition

The software provided by client to enable the EUT under transmission condition continuously at lowest, middle and highest channel frequencies individually.

#### 4.6.7 Test Results

##### 802.11a

Channel	Frequency (MHz)	6dB Bandwidth (MHz)	Minimum Limit (MHz)	Pass / Fail
149	5745	16.40	0.5	Pass
157	5785	16.40	0.5	Pass
165	5825	16.40	0.5	Pass

##### 802.11ac (VHT20)

Channel	Frequency (MHz)	6dB Bandwidth (MHz)		Minimum Limit (MHz)	Pass / Fail
		Chain 0	Chain 1		
149	5745	17.65	17.64	0.5	Pass
157	5785	17.63	17.67	0.5	Pass
165	5825	17.63	17.63	0.5	Pass

##### 802.11ac (VHT40)

Channel	Frequency (MHz)	6dB Bandwidth (MHz)		Minimum Limit (MHz)	Pass / Fail
		Chain 0	Chain 1		
151	5755	36.15	36.19	0.5	Pass
159	5795	36.41	36.44	0.5	Pass

##### 802.11ac (VHT80)

Channel	Frequency (MHz)	6dB Bandwidth (MHz)		Minimum Limit (MHz)	Pass / Fail
		Chain 0	Chain 1		
138 (UNII-3 Band)	5690	2.94	2.78	0.5	Pass
155	5775	75.66	75.69	0.5	Pass

Spectrum Plot of Worst Value

802.11a: CH149

802.11a (VHT20)-Chain (0): CH165

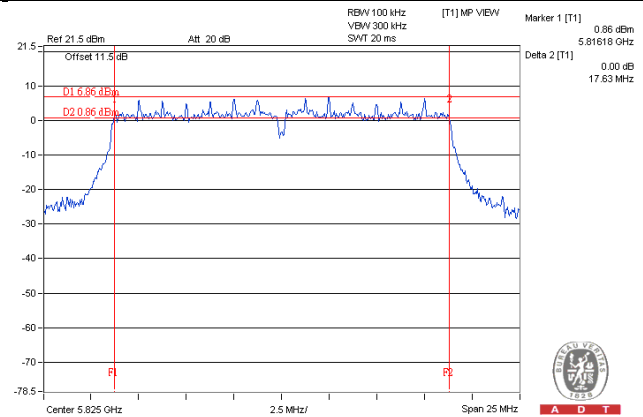
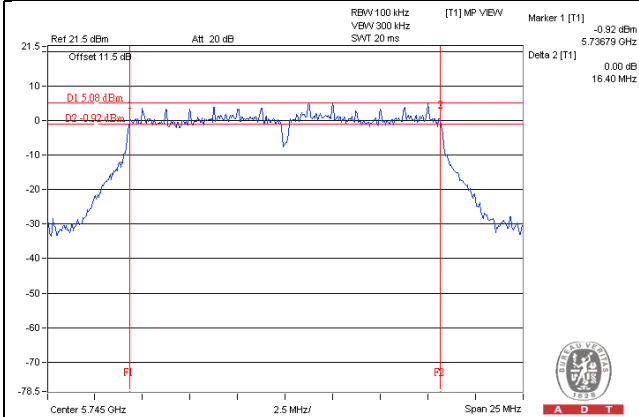

802.11ac (VHT40)-Chain (0): CH151

802.11ac (VHT80)-Chain (1): CH138 (UNII-3 Band)

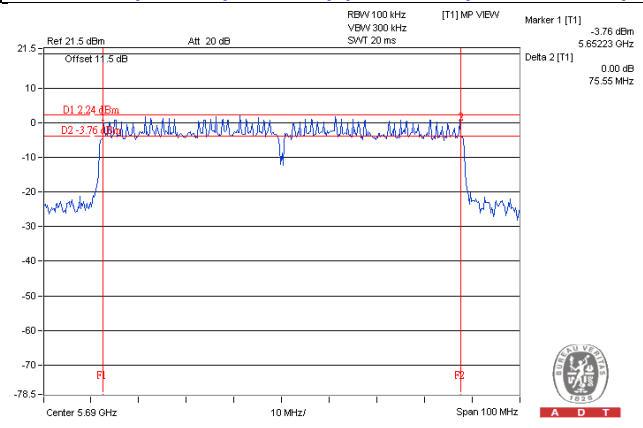
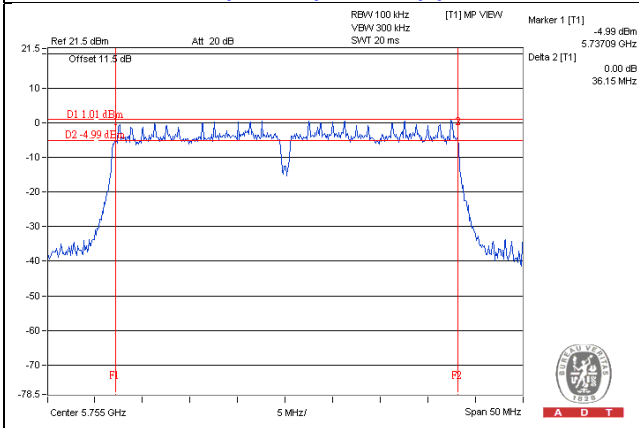

**Note:** For CH138 (UNII-3 Band): The 6dB bandwidth above 5725MHz = Marker 1 + Delta 2 - 5725MHz

## 5 Pictures of Test Arrangements

Please refer to the attached file (Test Setup Photo).



## Appendix – Information on the Testing Laboratories

We, Bureau Veritas Consumer Products Services (H.K.) Ltd., Taoyuan Branch, were founded in 1988 to provide our best service in EMC, Radio, Telecom and Safety consultation. Our laboratories are accredited and approved according to ISO/IEC 17025.

If you have any comments, please feel free to contact us at the following:

**Linko EMC/RF Lab**

Tel: 886-2-26052180

Fax: 886-2-26051924

**Hsin Chu EMC/RF/Telecom Lab**

Tel: 886-3-6668565

Fax: 886-3-6668323

**Hwa Ya EMC/RF/Safety Lab**

Tel: 886-3-3183232

Fax: 886-3-3270892

**Email:** [service.adt@tw.bureauveritas.com](mailto:service.adt@tw.bureauveritas.com)

**Web Site:** [www.bureauveritas-adt.com](http://www.bureauveritas-adt.com)

The address and road map of all our labs can be found in our web site also.

--- END ---