

FCC Test Report (WLAN)

Report No.: RF151104E03

FCC ID: UZ7VC80

Test Model: VC80

Received Date: Nov. 04, 2015

Test Date: Nov. 18 to 28, 2015

Issued Date: Dec. 16, 2015

Applicant: Zebra Technologies Corporation

Address: 1 Zebra Plaza, Holtsville, NY 11742

Manufacturer: Zebra Technologies Corporation

Address: 1 Zebra Plaza, Holtsville, NY 11742

Issued By: Bureau Veritas Consumer Products Services (H.K.) Ltd., Taoyuan Branch
Hsin Chu Laboratory

Lab Address: E-2, No.1, Li Hsin 1st Road, Hsinchu Science Park, Hsinchu City 300,
Taiwan R.O.C.

Test Location (1): E-2, No.1, Li Hsin 1st Road, Hsinchu Science Park, Hsinchu City 300,
Taiwan R.O.C.

Test Location (2): No. 49, Ln. 206, Wende Rd., Shangshan Tsuen, Chiung Lin Hsiang, Hsin
Chu Hsien 307, Taiwan R.O.C.



This report is for your exclusive use. Any copying or replication of this report to or for any other person or entity, or use of our name or trademark, is permitted only with our prior written permission. This report sets forth our findings solely with respect to the test samples identified herein. The results set forth in this report are not indicative or representative of the quality or characteristics of the lot from which a test sample was taken or any similar or identical product unless specifically and expressly noted. Our report includes all of the tests requested by you and the results thereof based upon the information that you provided to us. You have 60 days from date of issuance of this report to notify us of any material error or omission caused by our negligence, provided, however, that such notice shall be in writing and shall specifically address the issue you wish to raise. A failure to raise such issue within the prescribed time shall constitute your unqualified acceptance of the completeness of this report, the tests conducted and the correctness of the report contents. Unless specifically mentioned, the uncertainty of measurement has been explicitly taken into account to declare the compliance or non-compliance to the specification. The report must not be used by the client to claim product certification, approval, or endorsement by TAF or any government agencies.

Table of Contents

Release Control Record	4
1 Certificate of Conformity	5
2 Summary of Test Results	6
2.1 Measurement Uncertainty	6
2.2 Modification Record	6
3 General Information	7
3.1 General Description of EUT (WLAN)	7
3.2 Description of Test Modes	11
3.2.1 Test Mode Applicability and Tested Channel Detail	12
3.3 Duty Cycle of Test Signal	14
3.4 Description of Support Units	15
3.4.1 Configuration of System under Test	16
3.5 General Description of Applied Standards	18
4 Test Types and Results	19
4.1 Radiated Emission and Bandedge Measurement.....	19
4.1.1 Limits of Radiated Emission and Bandedge Measurement	19
4.1.2 Test Instruments	20
4.1.3 Test Procedures.....	22
4.1.4 Deviation from Test Standard	22
4.1.5 Test Setup.....	23
4.1.6 EUT Operating Conditions.....	23
4.1.7 Test Results (Mode 1).....	24
4.1.8 Test Results (Mode 2).....	64
4.1.9 Test Results (Mode 3).....	104
4.2 Conducted Emission Measurement	144
4.2.1 Limits of Conducted Emission Measurement	144
4.2.2 Test Instruments	144
4.2.3 Test Procedures.....	145
4.2.4 Deviation from Test Standard	145
4.2.5 Test Setup.....	145
4.2.6 EUT Operating Conditions.....	145
4.2.7 Test Results (Mode 2).....	146
4.2.8 Test Results (Mode 4).....	148
4.2.9 Test Results (Mode 5).....	150
4.3 6dB Bandwidth Measurement	152
4.3.1 Limits of 6dB Bandwidth Measurement	152
4.3.2 Test Setup.....	152
4.3.3 Test Instruments	152
4.3.4 Test Procedure	152
4.3.5 Deviation from Test Standard	152
4.3.6 EUT Operating Conditions.....	152
4.3.7 Test Result	153
4.4 Conducted Output Power Measurement.....	155
4.4.1 Limits of Conducted Output Power Measurement	155
4.4.2 Test Setup.....	155
4.4.3 Test Instruments	155
4.4.4 Test Procedures.....	155
4.4.5 Deviation from Test Standard	155
4.4.6 EUT Operating Conditions.....	155
4.4.7 Test Results	156
4.5 Power Spectral Density Measurement.....	161
4.5.1 Limits of Power Spectral Density Measurement	161
4.5.2 Test Setup.....	161

4.5.3	Test Instruments	161
4.5.4	Test Procedure	161
4.5.5	Deviation from Test Standard	161
4.5.6	EUT Operating Condition	161
4.5.7	Test Results	162
4.6	Conducted Out of Band Emission Measurement.....	164
4.6.1	Limits of Conducted Out of Band Emission Measurement	164
4.6.2	Test Setup.....	164
4.6.3	Test Instruments	164
4.6.4	Test Procedure	164
4.6.5	Deviation from Test Standard	164
4.6.6	EUT Operating Condition	164
4.6.7	Test Results	164
5	Pictures of Test Arrangements.....	177
	Appendix – Information on the Testing Laboratories	178



A D T

Release Control Record

Issue No.	Description	Date Issued
RF151104E03	Original release.	Dec. 16, 2015



1 Certificate of Conformity

Product: Vehicle Computer
Brand: Zebra
Test Model: VC80
Sample Status: ENGINEERING SAMPLE
Applicant: Zebra Technologies Corporation
Test Date: Nov. 18 to 28, 2015
Standards: 47 CFR FCC Part 15, Subpart C (Section 15.247)
ANSI C63.10: 2013

The above equipment has been tested by **Bureau Veritas Consumer Products Services (H.K.) Ltd., Taoyuan Branch**, and found compliance with the requirement of the above standards. The test record, data evaluation & Equipment Under Test (EUT) configurations represented herein are true and accurate accounts of the measurements of the sample's EMC characteristics under the conditions specified in this report.

Prepared by :  , **Date:** Dec. 16, 2015
Elsie Hsu / Specialist

Approved by :  , **Date:** Dec. 16, 2015
May Chen / Manager

2 Summary of Test Results

47 CFR FCC Part 15, Subpart C (SECTION 15.247)			
FCC Clause	Test Item	Result	Remarks
15.207	AC Power Conducted Emission	PASS	Meet the requirement of limit. Minimum passing margin is -3.12dB at 0.58361MHz.
15.205 / 15.209 / 15.247(d)	Radiated Emissions and Band Edge Measurement	PASS	Meet the requirement of limit. Minimum passing margin is -1.0dB at 2483.50MHz.
15.247(d)	Antenna Port Emission	PASS	Meet the requirement of limit.
15.247(a)(2)	6dB bandwidth	PASS	Meet the requirement of limit.
15.247(b)	Conducted power	PASS	Meet the requirement of limit.
15.247(e)	Power Spectral Density	PASS	Meet the requirement of limit.
15.203	Antenna Requirement	PASS	No antenna connector is used.

NOTE: 1. For WLAN: The EUT was operating in 2400 ~ 2483.5MHz, 5.15~5.35 GHz, 5.47~5.725GHz and 5.725~5.85GHz frequencies band. This report was recorded the RF parameters including 2400 ~ 2483.5MHz. For the 5.15~5.35GHz, 5.47~5.725GHz and 5.725~5.85GHz RF parameters was recorded in another test report.

2.1 Measurement Uncertainty

Where relevant, the following measurement uncertainty levels have been estimated for tests performed on the EUT as specified in CISPR 16-4-2:

Measurement	Frequency	Expanded Uncertainty (k=2) (±)
Conducted Emissions at mains ports	150kHz ~ 30MHz	2.86 dB
Radiated Emissions up to 1 GHz	30MHz ~ 1GHz	5.31 dB
Radiated Emissions above 1 GHz	1GHz ~6GHz	3.40 dB
	6GHz ~ 18GHz	3.73 dB
	18GHz ~ 40GHz	4.11 dB

2.2 Modification Record

There were no modifications required for compliance.

3 General Information

3.1 General Description of EUT (WLAN)

Product	Vehicle Computer
Brand	Zebra
Test Model	VC80
Status of EUT	ENGINEERING SAMPLE
Power Supply Rating	DC 9-24V from Adapter DC 12-60V from Vehicle Battery DC 12.6V from PSU Battery
Modulation Type	CCK, DQPSK, DBPSK for DSSS 64QAM, 16QAM, QPSK, BPSK for OFDM 256QAM for OFDM in 11ac mode
Modulation Technology	DSSS, OFDM
Transfer Rate	802.11a: up to 54Mbps 802.11n : up to 300Mbps 802.11ac: up to 866.7Mbps
Operating Frequency	For 15.407 5.18 ~ 5.24GHz, 5.26 ~ 5.32GHz, 5.5 ~ 5.7GHz, 5.745 ~ 5.825GHz
	For 15.247 2.412 ~ 2.462GHz
Number of Channel	For 15.407 24 for 802.11a, 802.11n (HT20), 802.11ac (VHT20) 11 for 802.11n (HT40), 802.11ac (VHT40) 6 for 802.11ac (VHT80)
	For 15.247 11 for 802.11b, 802.11g, 802.11n (HT20) 7 for 802.11n (HT40)

Output Power	For 15.407 (Average Power) 5.18 ~ 5.24GHz: 802.11a: 102.329mW 802.11ac (VHT20): 196.066mW 802.11ac (VHT40): 199.739mW 802.11ac (VHT80): 64.536mW 5.26 ~ 5.32GHz: 802.11a: 100.462mW 802.11ac (VHT20): 193.688mW 802.11ac (VHT40): 191.865mW 802.11ac (VHT80): 59.459mW 5.5 ~ 5.72MHz: 802.11a: 100.462mW 802.11ac (VHT20): 154.143mW 802.11ac (VHT40): 182.681mW 802.11ac (VHT80): 166.495mW 5.745 ~ 5.825MHz: 802.11a: 112.98mW 802.11ac (VHT20): 201.444mW 802.11ac (VHT40): 187.408mW 802.11ac (VHT80): 48.718mW
	For 15.247 (Peak Power) 802.11b: 275.423mW 802.11g: 390.841mW 802.11n (HT20): 764.224mW 802.11n (HT40): 534.652mW
Antenna Type	Refer to Note
Antenna Connector	Refer to Note
Accessory Device	NA
Data Cable Supplied	NA

Note:

- The EUT has two different types could be chosen and please refer the below table:

Type	Difference
1	With External antenna
2	With Internal antenna

- There are WLAN and BT technology used for the EUT.
- For WLAN: 2.4GHz and 5GHz technology cannot transmit at same time.
- 2.4GHz/5GHz WLAN + BT will timely shared at same antenna port
- The EUT could be supplied with a power adaper as below table (only for test, not for sale):

Brand	FSP GROUP INC.
Model No.	FSP150-AAAN2
Input power	100-240V, 50-60Hz, 2A
Output power	+24V, 6.25A DC output cable (Unshielded, 1.8m with 2 cores)

6. The EUT antennas information:

Antenna No	PCB Chain No.	Model	Antenna Type	Antenna Connector	Antenna Gain (dBi) Exclude cable loss	Internal cable loss (dB)	External cable loss (dB)	Antenna Gain (dBi) Include cable loss	Internal cable length (mm)	External cable length (mm)	Frequency (GHz to GHz)
1	Int.Chain0	AN000097A01	Patch	i-pex (MHFL4)	5	NA	NA	5	NA	NA	2.4~2.4835
					5	NA	NA	5	NA	NA	5.15~5.85
	Int.Chain1				5	NA	NA	5	NA	NA	2.4~2.4835
					5	NA	NA	5	NA	NA	5.15~5.85
2	ext.Chain0	AN2010	Monopole	RPSMA	2	0.6	1.8	-0.4	147	2850	2.4~2.4835
					2	0.9	2.6	-1.5	147	2850	5.15~5.85
	ext.Chain1				2	0.6	1.8	-0.4	147	2850	2.4~2.4835
					2	0.9	2.6	-1.5	147	2850	5.15~5.85
3	ext.Chain0	AN2020	Monopole	RPSMA	5	0.6	1.8	2.6	147	2850	2.4~2.4835
	ext.Chain1				5	0.6	1.8	2.6	147	2850	2.4~2.4835
4	ext.Chain0	AN2030	Dipole	RPSMA	2	0.6	NA	1.4	147	NA	2.4~2.4835
					3.7	0.9	NA	2.8	147	NA	5.15~5.85
	ext.Chain1				2	0.6	NA	1.4	147	NA	2.4~2.4835
					3.7	0.9	NA	2.8	147	NA	5.15~5.85
5	ext.Chain0	AN2040	Dipole	RPSMA	2	0.6	NA	1.4	147	NA	2.4~2.4835
	ext.Chain1				2	0.6	NA	1.4	147	NA	2.4~2.4835

Note:

1. For 1TX configuration mode: max gain was selected as representative antenna.

7. The Version of EUT information are as below:

HW Version	MLB	EVT
	IO Board	EVT
	Battery Heater	EVT
	DTB	EVT
	DB9	EVT
	PSU	2
	Keypad	EVT
	Screen	Mitsubishi
SW Version	Operating System	WIN 7 professional
		WIN 7 Embedded
	Broadcom-WLAN	6.30.223.249 for Embedde
		6.30.223.262 for professional

8. The HW spec. are as below:

Detail HW spec.	Basic Warehouse int. Antenna	Basic Warehouse ext. Antenna
Intel E3825 Dual Core, 1.33GHz, 1MB Cache, 2GB RAM	v	v
16 GB SSD	v	v
Internal Antenna	v	
External Antenna (mag mount)		v
400 NITs Display	v	v
CAN Bus I/O	v	v

9. The EUT incorporates a MIMO function.

2.4GHz Band			
MODULATION MODE	DATA RATE (MCS)	TX & RX CONFIGURATION	
802.11b	1 ~ 11Mbps	1TX (diversity)	2RX
802.11g	6 ~ 54Mbps	1TX (diversity)	2RX
802.11n (HT20)	MCS 0~7	1TX (diversity)	2RX
	MCS 8~15	2TX	2RX
802.11n (HT40)	MCS 0~7	1TX (diversity)	2RX
	MCS 8~15	2TX	2RX
5GHz Band			
MODULATION MODE	DATA RATE (MCS)	TX & RX CONFIGURATION	
802.11a	6 ~ 54Mbps	1TX (diversity)	2RX
802.11n (HT20)	MCS 0~7	1TX (diversity)	2RX
	MCS 8~15	2TX	2RX
802.11n (HT40)	MCS 0~7	1TX (diversity)	2RX
	MCS 8~15	2TX	2RX
802.11ac (VHT20)	MCS 0~8, NSS=1	1TX (diversity)	2RX
	MCS 0~8, NSS=2	2TX	2RX
802.11ac (VHT40)	MCS 0~9, NSS=1	1TX (diversity)	2RX
	MCS 0~9, NSS=2	2TX	2RX
802.11ac (VHT80)	MCS 0~9, NSS=1	1TX (diversity)	2RX
	MCS 0~9, NSS=2	2TX	2RX

The modulation and bandwidth are similar for 802.11n mode for 20MHz (40MHz) and 802.11ac mode for 20MHz (40MHz), therefore investigated worst case to representative mode in test report. (Final test mode refer section 3.2.1)

10. The EUT was pre-tested under following test modes:

Pre-test Mode	Description
Mode A	Power from Adapter
Mode B	DC 12V from DC Power Supply
Mode C	DC 24V from DC Power Supply

From the above modes, the worst case was found in **Mode A**. Therefore only the test data of the modes were recorded in this report individually.

11. The above EUT information is declared by manufacturer and for more detailed features description, please refer to the manufacturer's specifications or user's manual.

3.2 Description of Test Modes

11 channels are provided for 802.11b, 802.11g and 802.11n (HT20):

Channel	Frequency	Channel	Frequency
1	2412MHz	7	2442MHz
2	2417MHz	8	2447MHz
3	2422MHz	9	2452MHz
4	2427MHz	10	2457MHz
5	2432MHz	11	2462MHz
6	2437MHz		

9 channels are provided for 802.11n (HT40):

Channel	Frequency	Channel	Frequency
3	2422MHz	7	2442MHz
4	2427MHz	8	2447MHz
5	2432MHz	9	2452MHz
6	2437MHz		

3.2.1 Test Mode Applicability and Tested Channel Detail

EUT CONFIGURE MODE	APPLICABLE TO				DESCRIPTION
	RE \geq 1G	RE $<$ 1G	PLC	APCM	
1	√	√	-	√	With Antenna 1 (Power from adapter)
2	√	√	√	-	With Antenna 3 (Power from adapter)
3	√	√	-	-	With Antenna 4 (Power from adapter)
4	-	-	√	-	With Antenna 3 (DC 24V from DC power supply)
5	-	-	√	-	With Antenna 3 (DC 12V from DC power supply)

Where **RE \geq 1G**: Radiated Emission above 1GHz & Bandedge Measurement

RE $<$ 1G: Radiated Emission below 1GHz

PLC: Power Line Conducted Emission

APCM: Antenna Port Conducted Measurement

NOTE: "-" means no effect.

Radiated Emission Test (Above 1GHz):

- Pre-Scan has been conducted to determine the worst-case mode from all possible combinations between available modulations, data rates and antenna ports (if EUT with antenna diversity architecture).
- Following channel(s) was (were) selected for the final test as listed below.

1TX Configuration					
MODE	AVAILABLE CHANNEL	TESTED CHANNEL	MODULATION TECHNOLOGY	MODULATION TYPE	DATA RATE (Mbps)
802.11b	1 to 11	1,2, 6, 10, 11	DSSS	DBPSK	1
802.11g	1 to 11	1,2, 6, 10, 11	OFDM	BPSK	6
2TX Configuration					
MODE	AVAILABLE CHANNEL	TESTED CHANNEL	MODULATION TECHNOLOGY	MODULATION TYPE	DATA RATE (Mbps)
802.11n (HT20)	1 to 11	1,2, 6, 10, 11	OFDM	BPSK	13
802.11n (HT40)	3 to 9	3, 4, 6, 8, 9	OFDM	BPSK	27

Radiated Emission Test (Below 1GHz):

- Pre-Scan has been conducted to determine the worst-case mode from all possible combinations between available modulations, data rates and antenna ports (if EUT with antenna diversity architecture).
- Following channel(s) was (were) selected for the final test as listed below.

1TX Configuration					
MODE	AVAILABLE CHANNEL	TESTED CHANNEL	MODULATION TECHNOLOGY	MODULATION TYPE	DATA RATE (Mbps)
802.11b	1 to 11	1,2, 6, 10, 11	DSSS	DBPSK	1
802.11g	1 to 11	1,2, 6, 10, 11	OFDM	BPSK	6
2TX Configuration					
MODE	AVAILABLE CHANNEL	TESTED CHANNEL	MODULATION TECHNOLOGY	MODULATION TYPE	DATA RATE (Mbps)
802.11n (HT20)	1 to 11	1,2, 6, 10, 11	OFDM	BPSK	13
802.11n (HT40)	3 to 9	3, 4, 6, 8, 9	OFDM	BPSK	27

Power Line Conducted Emission Test:

- Pre-Scan has been conducted to determine the worst-case mode from all possible combinations between available modulations, data rates and antenna ports (if EUT with antenna diversity architecture).
- Following channel(s) was (were) selected for the final test as listed below.

2TX Configuration					
MODE	AVAILABLE CHANNEL	TESTED CHANNEL	MODULATION TECHNOLOGY	MODULATION TYPE	DATA RATE (Mbps)
802.11n (HT20)	1 to 11	6	OFDM	BPSK	13

Antenna Port Conducted Measurement:

- This item includes all test value of each mode, but only includes spectrum plot of worst value of each mode.
- Pre-Scan has been conducted to determine the worst-case mode from all possible combinations between available modulations, data rates and antenna ports (if EUT with antenna diversity architecture).
- Following channel(s) was (were) selected for the final test as listed below.

1TX Configuration					
MODE	AVAILABLE CHANNEL	TESTED CHANNEL	MODULATION TECHNOLOGY	MODULATION TYPE	DATA RATE (Mbps)
802.11b	1 to 11	1,2, 6, 10, 11	DSSS	DBPSK	1
802.11g	1 to 11	1,2, 6, 10, 11	OFDM	BPSK	6

2TX Configuration					
MODE	AVAILABLE CHANNEL	TESTED CHANNEL	MODULATION TECHNOLOGY	MODULATION TYPE	DATA RATE (Mbps)
802.11n (HT20)	1 to 11	1,2, 6, 10, 11	OFDM	BPSK	13
802.11n (HT40)	3 to 9	3, 4, 6, 8, 9	OFDM	BPSK	27

Test Condition:

APPLICABLE TO	ENVIRONMENTAL CONDITIONS	INPUT POWER	TESTED BY
RE≥1G	25deg. C, 73%RH 26deg. C, 63%RH	120Vac, 60Hz	Tim Ho Jyunchun Lin
RE<1G	26deg. C, 71%RH	120Vac, 60Hz	Tim Ho
PLC	25deg. C, 63%RH 22deg. C, 63%RH 24deg. C, 62%RH	120Vac, 60Hz DC 24V DC 12V	Andy Ho
APCM	25deg. C, 60%RH	120Vac, 60Hz	Anderson Chen

3.3 Duty Cycle of Test Signal

Duty cycle of test signal is $\geq 98\%$, duty factor is not required.

802.11b: Duty cycle = $12.405 \text{ ms} / 12.428 \text{ ms} = 0.998$

802.11g: Duty cycle = $2.08 \text{ ms} / 2.102 \text{ ms} = 0.99$

802.11n (HT20): Duty cycle = $1.92 \text{ ms} / 1.94 \text{ ms} = 0.99$

802.11n (HT40): Duty cycle = $0.945 \text{ ms} / 0.962 \text{ ms} = 0.982$

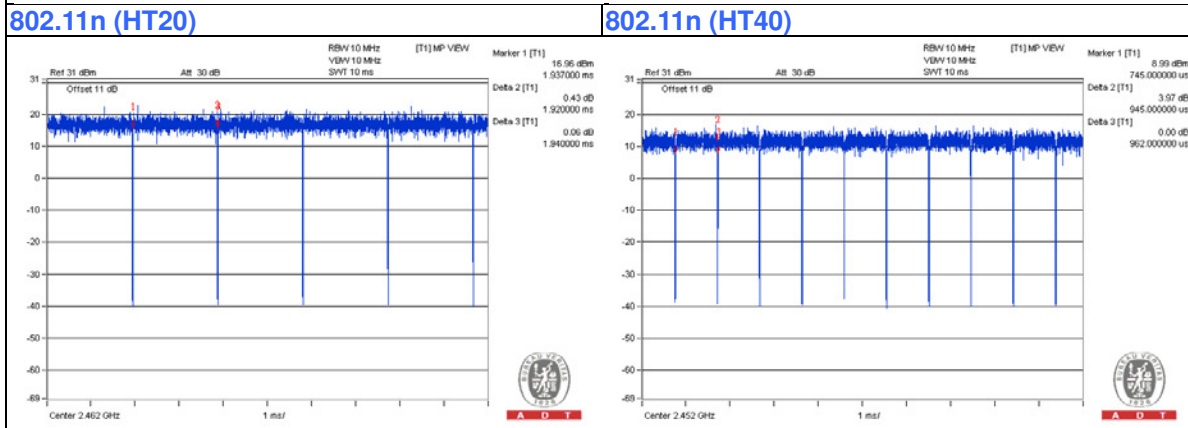
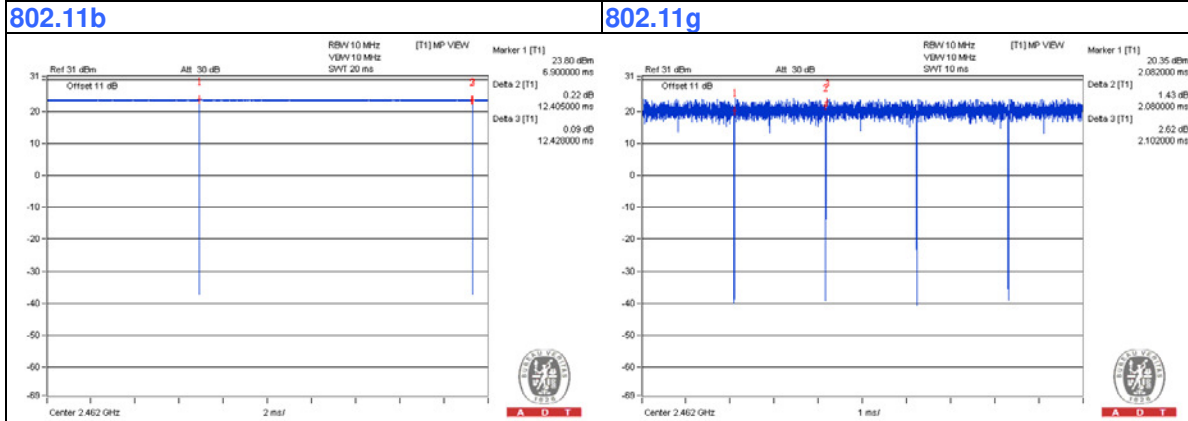

3.4 Description of Support Units

The EUT has been tested as an independent unit together with other necessary accessories or support units. The following support units or accessories were used to form a representative test configuration during the tests.

ID	Product	Brand	Model No.	Serial No.	FCC ID	Remarks
A.	Modem	ACEEX	1414	0206026778	IFAXDM1414	Provided by Lab
B.	Modem	ACEEX	1414	0206026779	IFAXDM1414	Provided by Lab
C.	Notebook Computer	DELL	PP27L	7YLB32S	FCC DoC	Provided by Lab
D.	Keyboard	MOTOROLA	KYBD-NU-VC70	NA	NA	Supplied by Client
E.	Scanner	Symbol	DS3508	NA	NA	Supplied by Client
F.	Speaker/ mic	OTTO	V2-10332 1250	NA	NA	Supplied by Client
G.	Adapter	FSP GROUP INC.	FSP150-AAAN2	H00000231	NA	Supplied by Client
H.	DC Power Supply	Topward	6603D	795551	NA	Provided by Lab

Note:

1. All power cords of the above support units are non-shielded (1.8m).

ID	Descriptions	Qty.	Length (m)	Shielding (Yes/No)	Cores (Qty.)	Remarks
1.	RS232	1	0.9	No	0	Provided by Lab
2.	RS232	1	0.9	No	0	Provided by Lab
3.	RJ45	1	10	No	0	Provided by Lab
4.	DC	1	0.6	No	0	Supplied by Client
5.	DC	1	1.8	No	2	Supplied by Client
6.	AC	1	1.8	No	0	Provided by Lab
7.	USB	1	0.9	No	0	Supplied by Client
8.	USB	1	2	No	0	Supplied by Client
9.	Audio	1	0.6	No	1	Supplied by Client
10.	DC	1	1.8	No	0	Supplied by Client

Note: The core(s) is(are) originally attached to the cable(s).

3.4.1 Configuration of System under Test

For Conducted emission test mode 4 & 5:

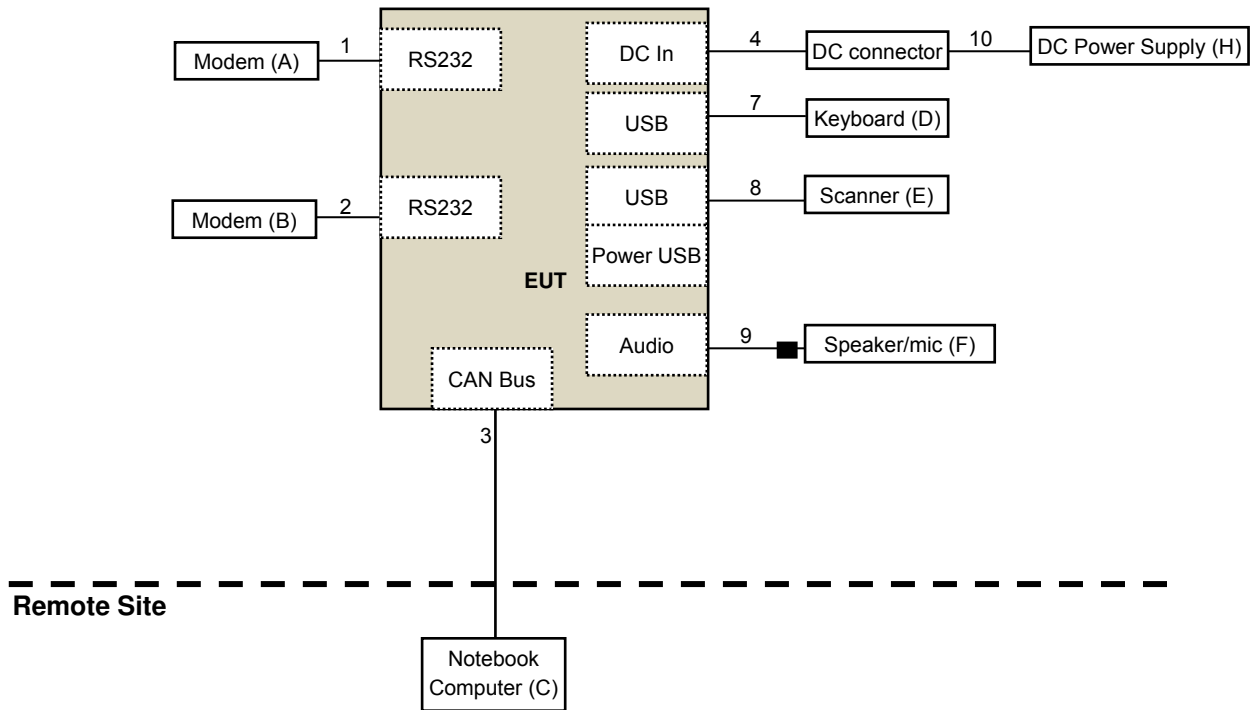

For Other test items:

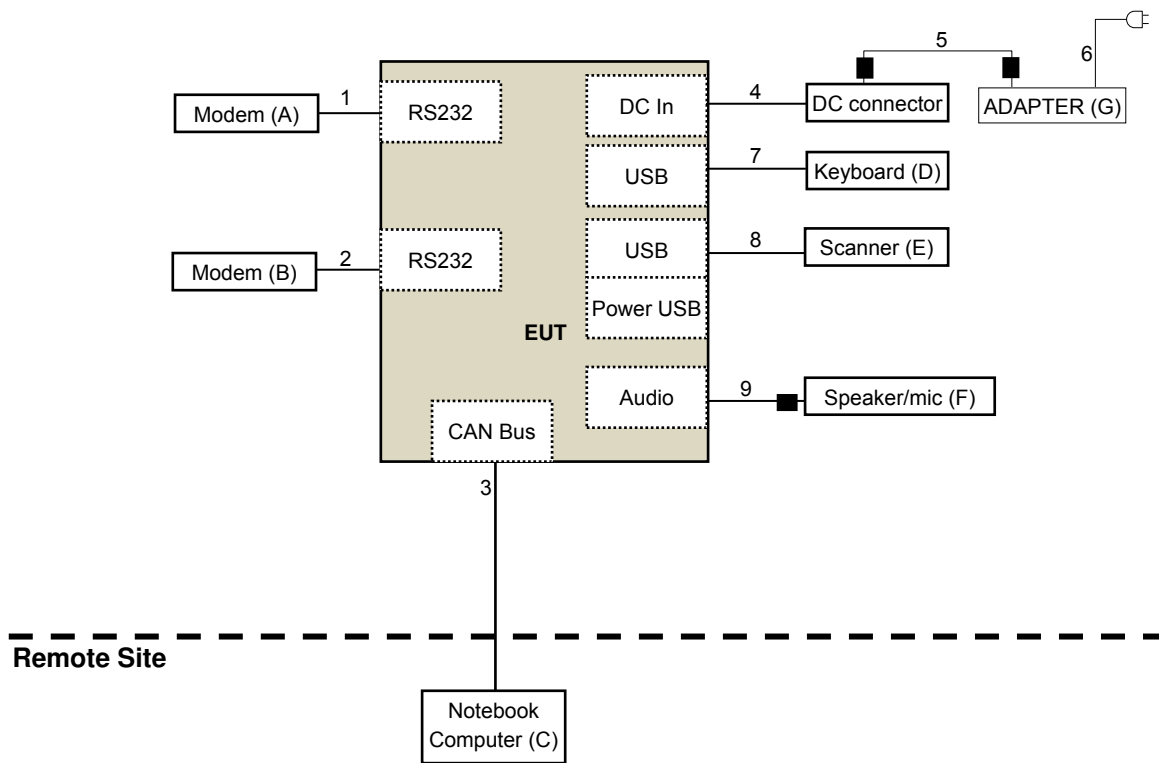

3.5 General Description of Applied Standards

The EUT is a RF Product. According to the specifications of the manufacturer, it must comply with the requirements of the following standards:

FCC Part 15, Subpart C (15.247)
KDB 558074 D01 DTS Meas Guidance v03r04
KDB 662911 D01 Multiple Transmitter Output v02r01
ANSI C63.10-2013

All test items have been performed and recorded as per the above standards.

4 Test Types and Results

4.1 Radiated Emission and Bandedge Measurement

4.1.1 Limits of Radiated Emission and Bandedge Measurement

Radiated emissions which fall in the restricted bands must comply with the radiated emission limits specified as below table. Other emissions shall be at least 20dB below the highest level of the desired power:

Frequencies (MHz)	Field Strength (microvolts/meter)	Measurement Distance (meters)
0.009 ~ 0.490	2400/F(kHz)	300
0.490 ~ 1.705	24000/F(kHz)	30
1.705 ~ 30.0	30	30
30 ~ 88	100	3
88 ~ 216	150	3
216 ~ 960	200	3
Above 960	500	3

NOTE:

1. The lower limit shall apply at the transition frequencies.
2. Emission level (dBuV/m) = 20 log Emission level (uV/m).
3. For frequencies above 1000MHz, the field strength limits are based on average detector, however, the peak field strength of any emission shall not exceed the maximum permitted average limits, specified above by more than 20dB under any condition of modulation.

4.1.2 Test Instruments

DESCRIPTION & MANUFACTURER	MODEL NO.	SERIAL NO.	CALIBRATED DATE	CALIBRATED UNTIL
Test Receiver Agilent	N9038A	MY50010156	Aug. 12, 2015	Aug. 11, 2016
Pre-Amplifier(*) EMCI	EMC001340	980142	Jan. 13, 2014	Jan. 12, 2016
Loop Antenna(*) Electro-Metrics	EM-6879	264	Dec. 16, 2014	Dec. 15, 2016
RF Cable	NA	LOOPCAB-00 1 LOOPCAB-00 2	Jan. 18, 2015	Jan. 17, 2016
Pre-Amplifier Mini-Circuits	ZFL-1000VH2 B	AMP-ZFL-07	May 08, 2015	May 07, 2016
Trilog Broadband Antenna SCHWARZBECK	VULB 9168	138	Feb. 03, 2015	Feb. 02, 2016
RF Cable	8D	966-3-1 966-3-2 966-3-3	Apr. 03, 2015	Apr. 02, 2016
Horn_Antenna SCHWARZBECK	BBHA9120-D	9120D-406	Feb. 05, 2015	Feb. 04, 2016
Pre-Amplifier Agilent	8449B	3008A02465	Apr. 06, 2015	Apr. 05, 2016
RF Cable	EMC104-SM- SM-2000 EMC104-SM- SM-5000 EMC104-SM- SM-5000	150317 150321 150322	Mar. 31, 2015	Mar. 30, 2016
Spectrum Analyzer Keysight	N9030A	MY54490520	July 26, 2015	July 25, 2016
Pre-Amplifier EMCI	EMC184045	980143	Jan. 16, 2015	Jan. 15, 2016
Horn_Antenna SCHWARZBECK	BBHA 9170	BBHA9170608	Feb. 05, 2015	Feb. 04, 2016
RF Cable	SUCOFLEX10 4	329751/4 RF104-204	Dec. 11, 2014	Dec. 10, 2015
Software	ADT_Radiated _V8.7.07	NA	NA	NA
Antenna Tower & Turn Table CT	NA	NA	NA	NA
Power Meter Anritsu	ML2495A	1014008	Apr. 28, 2015	Apr. 27, 2016
Power Sensor Anritsu	MA2411B	0917122	Apr. 28, 2015	Apr. 27, 2016
Spectrum Analyzer R&S	FSP40	100060	May 08, 2015	May 07, 2016



Note:

1. The calibration interval of the above test instruments is 12 months and the calibrations are traceable to NML/ROC and NIST/USA.
2. *The calibration interval of the above test instruments is 24 months and the calibrations are traceable to NML/ROC and NIST/USA.
3. Loop antenna was used for all emissions below 30 MHz.
4. The horn antenna, preamplifier (model: 8449B) are used only for the measurement of emission frequency above 1GHz if tested.
5. The test was performed in 966 Chamber No. 3.
- 6 The FCC Site Registration No. is 147459
- 7 The CANADA Site Registration No. is 20331-1
- 8 Tested Date: Nov. 18 to 27, 2015

4.1.3 Test Procedures

- a. The EUT was placed on the top of a rotating table 0.8 meters (for below 1GHz) / 1.5 meters (for above 1GHz) above the ground at 3 meter chamber room for test. The table was rotated 360 degrees to determine the position of the highest radiation.
- b. The EUT was set 3 meters away from the interference-receiving antenna, which was mounted on the top of a variable-height antenna tower.
- c. The height of antenna is varied from one meter to four meters above the ground to determine the maximum value of the field strength. Both horizontal and vertical polarizations of the antenna are set to make the measurement.
- d. For each suspected emission, the EUT was arranged to its worst case and then the antenna was tuned to heights from 1 meter to 4 meters and the rotatable table was turned from 0 degrees to 360 degrees to find the maximum reading.
- e. The test-receiver system was set to quasi-peak detect function and specified bandwidth with maximum hold mode when the test frequency is below 1 GHz.
- f. The test-receiver system was set to peak and average detect function and specified bandwidth with maximum hold mode when the test frequency is above 1 GHz. If the peak reading value also meets average limit, measurement with the average detector is unnecessary.

Note:

1. The resolution bandwidth and video bandwidth of test receiver/spectrum analyzer is 120kHz for Quasi-peak detection (QP) at frequency below 1GHz.
2. The resolution bandwidth of test receiver/spectrum analyzer is 1 MHz and the video bandwidth is 3 MHz for Peak detection (PK) at frequency above 1GHz.
3. The resolution bandwidth of test receiver/spectrum analyzer is 1MHz and the video bandwidth is 3MHz for RMS Average (Duty cycle < 98%) for Average detection (AV) at frequency above 1GHz, then the measurement results was added to a correction factor ($10 \log(1/\text{duty cycle})$).
4. The resolution bandwidth of test receiver/spectrum analyzer is 1MHz and the video bandwidth is 10Hz (Duty cycle $\geq 98\%$) for Average detection (AV) at frequency above 1GHz.
5. All modes of operation were investigated and the worst-case emissions are reported.

4.1.4 Deviation from Test Standard

No deviation.

4.1.5 Test Setup

<Frequency Range below 1GHz>

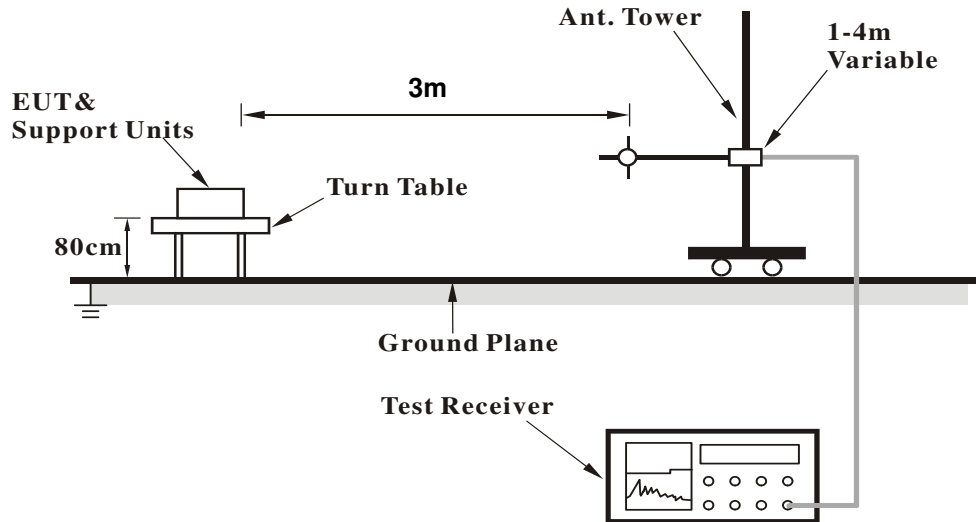

<Frequency Range above 1GHz>

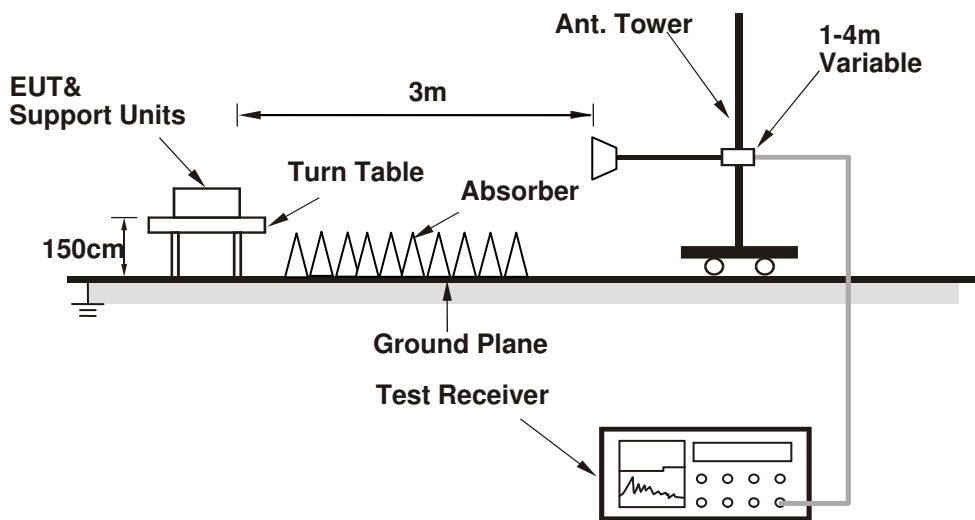

For the actual test configuration, please refer to the attached file (Test Setup Photo).

4.1.6 EUT Operating Conditions

1. Connect the EUT with the support unit C (Notebook Computer) which is placed on remote site.
2. The communication partner run test program "Mtool 2.0.0.72" to enable EUT under transmission/receiving condition continuously at specific channel frequency.

4.1.7 Test Results (Mode 1)

Above 1GHz Data:

802.11b

CHANNEL	TX Channel 1	DETECTOR FUNCTION	Peak (PK)
FREQUENCY RANGE	1GHz ~ 25GHz		Average (AV)

ANTENNA POLARITY & TEST DISTANCE: HORIZONTAL AT 3 M

NO.	FREQ. (MHz)	EMISSION LEVEL (dBuV/m)	LIMIT (dBuV/m)	MARGIN (dB)	ANTENNA HEIGHT (m)	TABLE ANGLE (Degree)	RAW VALUE (dBuV)	CORRECTION FACTOR (dB/m)
1	2390.00	58.6 PK	74.0	-15.4	2.93 H	205	61.27	-2.67
2	2390.00	52.6 AV	54.0	-1.4	2.93 H	205	55.27	-2.67
3	*2412.00	110.7 PK			2.93 H	205	113.27	-2.57
4	*2412.00	108.3 AV			2.93 H	205	110.87	-2.57
5	4824.00	44.8 PK	74.0	-29.2	1.94 H	225	40.65	4.15
6	4824.00	40.0 AV	54.0	-14.0	1.94 H	225	35.85	4.15

ANTENNA POLARITY & TEST DISTANCE: VERTICAL AT 3 M

NO.	FREQ. (MHz)	EMISSION LEVEL (dBuV/m)	LIMIT (dBuV/m)	MARGIN (dB)	ANTENNA HEIGHT (m)	TABLE ANGLE (Degree)	RAW VALUE (dBuV)	CORRECTION FACTOR (dB/m)
1	2390.00	55.0 PK	74.0	-19.0	2.21 V	253	57.67	-2.67
2	2390.00	47.6 AV	54.0	-6.4	2.21 V	253	50.27	-2.67
3	*2412.00	107.2 PK			2.21 V	253	109.77	-2.57
4	*2412.00	104.6 AV			2.21 V	253	107.17	-2.57
5	4824.00	45.9 PK	74.0	-28.1	2.06 V	118	41.75	4.15
6	4824.00	42.8 AV	54.0	-11.2	2.06 V	118	38.65	4.15

REMARKS:

1. Emission Level(dBuV/m) = Raw Value(dBuV) + Correction Factor(dB/m)
2. Correction Factor(dB/m) = Antenna Factor(dB/m) + Cable Factor(dB) – Pre-Amplifier Factor(dB)
3. The other emission levels were very low against the limit.
4. Margin value = Emission Level – Limit value
5. " * ": Fundamental frequency.

CHANNEL	TX Channel 2	DETECTOR FUNCTION	Peak (PK)
FREQUENCY RANGE	1GHz ~ 25GHz		Average (AV)

ANTENNA POLARITY & TEST DISTANCE: HORIZONTAL AT 3 M

NO.	FREQ. (MHz)	EMISSION LEVEL (dBuV/m)	LIMIT (dBuV/m)	MARGIN (dB)	ANTENNA HEIGHT (m)	TABLE ANGLE (Degree)	RAW VALUE (dBuV)	CORRECTION FACTOR (dB/m)
1	2390.00	56.6 PK	74.0	-17.4	2.92 H	215	59.27	-2.67
2	2390.00	51.4 AV	54.0	-2.6	2.92 H	215	54.07	-2.67
3	*2417.00	111.3 PK			2.92 H	215	113.86	-2.56
4	*2417.00	108.6 AV			2.92 H	215	111.16	-2.56
5	4834.00	44.4 PK	74.0	-29.6	1.85 H	223	40.23	4.17
6	4834.00	39.4 AV	54.0	-14.6	1.85 H	223	35.23	4.17
7	7251.00	53.4 PK	74.0	-20.6	2.15 H	132	42.99	10.41
8	7251.00	48.4 AV	54.0	-5.6	2.15 H	132	37.99	10.41

ANTENNA POLARITY & TEST DISTANCE: VERTICAL AT 3 M

NO.	FREQ. (MHz)	EMISSION LEVEL (dBuV/m)	LIMIT (dBuV/m)	MARGIN (dB)	ANTENNA HEIGHT (m)	TABLE ANGLE (Degree)	RAW VALUE (dBuV)	CORRECTION FACTOR (dB/m)
1	2390.00	54.3 PK	74.0	-19.7	2.20 V	267	56.97	-2.67
2	2390.00	46.8 AV	54.0	-7.2	2.20 V	267	49.47	-2.67
3	*2417.00	107.1 PK			2.20 V	267	109.66	-2.56
4	*2417.00	104.6 AV			2.20 V	267	107.16	-2.56
5	4834.00	45.3 PK	74.0	-28.7	2.08 V	114	41.13	4.17
6	4834.00	42.1 AV	54.0	-11.9	2.08 V	114	37.93	4.17
7	7251.00	51.3 PK	74.0	-22.7	2.70 V	132	40.89	10.41
8	7251.00	45.4 AV	54.0	-8.6	2.70 V	132	34.99	10.41

REMARKS:

1. Emission Level(dBuV/m) = Raw Value(dBuV) + Correction Factor(dB/m)
2. Correction Factor(dB/m) = Antenna Factor(dB/m) + Cable Factor(dB) – Pre-Amplifier Factor(dB)
3. The other emission levels were very low against the limit.
4. Margin value = Emission Level – Limit value
5. " * ": Fundamental frequency.

CHANNEL	TX Channel 6	DETECTOR FUNCTION	Peak (PK)
FREQUENCY RANGE	1GHz ~ 25GHz		Average (AV)

ANTENNA POLARITY & TEST DISTANCE: HORIZONTAL AT 3 M

NO.	FREQ. (MHz)	EMISSION LEVEL (dBuV/m)	LIMIT (dBuV/m)	MARGIN (dB)	ANTENNA HEIGHT (m)	TABLE ANGLE (Degree)	RAW VALUE (dBuV)	CORRECTION FACTOR (dB/m)
1	*2437.00	111.4 PK			2.88 H	221	113.88	-2.48
2	*2437.00	109.0 AV			2.88 H	221	111.48	-2.48
3	4874.00	44.3 PK	74.0	-29.7	1.86 H	212	40.02	4.28
4	4874.00	39.1 AV	54.0	-14.9	1.86 H	212	34.82	4.28
5	7311.00	53.6 PK	74.0	-20.4	2.13 H	121	42.98	10.62
6	7311.00	48.3 AV	54.0	-5.7	2.13 H	121	37.68	10.62

ANTENNA POLARITY & TEST DISTANCE: VERTICAL AT 3 M

NO.	FREQ. (MHz)	EMISSION LEVEL (dBuV/m)	LIMIT (dBuV/m)	MARGIN (dB)	ANTENNA HEIGHT (m)	TABLE ANGLE (Degree)	RAW VALUE (dBuV)	CORRECTION FACTOR (dB/m)
1	*2437.00	106.9 PK			2.20 V	257	109.38	-2.48
2	*2437.00	104.3 AV			2.20 V	257	106.78	-2.48
3	4874.00	44.7 PK	74.0	-29.3	2.04 V	121	40.42	4.28
4	4874.00	41.7 AV	54.0	-12.3	2.04 V	121	37.42	4.28
5	7311.00	51.7 PK	74.0	-22.3	2.73 V	130	41.08	10.62
6	7311.00	45.8 AV	54.0	-8.2	2.73 V	130	35.18	10.62

REMARKS:

1. Emission Level(dBuV/m) = Raw Value(dBuV) + Correction Factor(dB/m)
2. Correction Factor(dB/m) = Antenna Factor(dB/m) + Cable Factor(dB) – Pre-Amplifier Factor(dB)
3. The other emission levels were very low against the limit.
4. Margin value = Emission Level – Limit value
5. " * ": Fundamental frequency.

CHANNEL	TX Channel 10	DETECTOR FUNCTION	Peak (PK)
FREQUENCY RANGE	1GHz ~ 25GHz		Average (AV)

ANTENNA POLARITY & TEST DISTANCE: HORIZONTAL AT 3 M

NO.	FREQ. (MHz)	EMISSION LEVEL (dBuV/m)	LIMIT (dBuV/m)	MARGIN (dB)	ANTENNA HEIGHT (m)	TABLE ANGLE (Degree)	RAW VALUE (dBuV)	CORRECTION FACTOR (dB/m)
1	*2457.00	111.4 PK			2.89 H	225	113.80	-2.40
2	*2457.00	109.1 AV			2.89 H	225	111.50	-2.40
3	4914.00	43.7 PK	74.0	-30.3	1.85 H	218	39.29	4.41
4	4914.00	38.7 AV	54.0	-15.3	1.85 H	218	34.29	4.41
5	7371.00	53.3 PK	74.0	-20.7	2.14 H	133	42.50	10.80
6	7371.00	48.0 AV	54.0	-6.0	2.14 H	133	37.20	10.80

ANTENNA POLARITY & TEST DISTANCE: VERTICAL AT 3 M

NO.	FREQ. (MHz)	EMISSION LEVEL (dBuV/m)	LIMIT (dBuV/m)	MARGIN (dB)	ANTENNA HEIGHT (m)	TABLE ANGLE (Degree)	RAW VALUE (dBuV)	CORRECTION FACTOR (dB/m)
1	*2457.00	107.4 PK			2.23 V	268	109.80	-2.40
2	*2457.00	104.9 AV			2.23 V	268	107.30	-2.40
3	4914.00	45.2 PK	74.0	-28.8	2.12 V	124	40.79	4.41
4	4914.00	42.0 AV	54.0	-12.0	2.12 V	124	37.59	4.41
5	7371.00	51.2 PK	74.0	-22.8	2.66 V	136	40.40	10.80
6	7371.00	45.4 AV	54.0	-8.6	2.66 V	136	34.60	10.80

REMARKS:

1. Emission Level(dBuV/m) = Raw Value(dBuV) + Correction Factor(dB/m)
2. Correction Factor(dB/m) = Antenna Factor(dB/m) + Cable Factor(dB) – Pre-Amplifier Factor(dB)
3. The other emission levels were very low against the limit.
4. Margin value = Emission Level – Limit value
5. " * ": Fundamental frequency.

CHANNEL	TX Channel 11	DETECTOR FUNCTION	Peak (PK)
FREQUENCY RANGE	1GHz ~ 25GHz		Average (AV)

ANTENNA POLARITY & TEST DISTANCE: HORIZONTAL AT 3 M

NO.	FREQ. (MHz)	EMISSION LEVEL (dBuV/m)	LIMIT (dBuV/m)	MARGIN (dB)	ANTENNA HEIGHT (m)	TABLE ANGLE (Degree)	RAW VALUE (dBuV)	CORRECTION FACTOR (dB/m)
1	*2462.00	111.2 PK			2.57 H	200	113.58	-2.38
2	*2462.00	108.8 AV			2.57 H	200	111.18	-2.38
3	2483.50	59.5 PK	74.0	-14.5	2.57 H	200	61.80	-2.30
4	2483.50	52.4 AV	54.0	-1.6	2.57 H	200	54.70	-2.30
5	4924.00	43.6 PK	74.0	-30.4	1.86 H	207	39.13	4.47
6	4924.00	38.3 AV	54.0	-15.7	1.86 H	207	33.83	4.47
7	7386.00	52.9 PK	74.0	-21.1	2.12 H	134	42.05	10.85
8	7386.00	47.5 AV	54.0	-6.5	2.12 H	134	36.65	10.85

ANTENNA POLARITY & TEST DISTANCE: VERTICAL AT 3 M

NO.	FREQ. (MHz)	EMISSION LEVEL (dBuV/m)	LIMIT (dBuV/m)	MARGIN (dB)	ANTENNA HEIGHT (m)	TABLE ANGLE (Degree)	RAW VALUE (dBuV)	CORRECTION FACTOR (dB/m)
1	*2462.00	107.5 PK			2.26 V	268	109.88	-2.38
2	*2462.00	104.9 AV			2.26 V	268	107.28	-2.38
3	2483.50	51.8 PK	74.0	-22.2	2.26 V	268	54.10	-2.30
4	2483.50	45.6 AV	54.0	-8.4	2.26 V	268	47.90	-2.30
5	4924.00	44.8 PK	74.0	-29.2	2.11 V	126	40.33	4.47
6	4924.00	41.7 AV	54.0	-12.3	2.11 V	126	37.23	4.47
7	7386.00	51.5 PK	74.0	-22.5	2.64 V	152	40.65	10.85
8	7386.00	45.6 AV	54.0	-8.4	2.64 V	152	34.75	10.85

REMARKS:

1. Emission Level(dBuV/m) = Raw Value(dBuV) + Correction Factor(dB/m)
2. Correction Factor(dB/m) = Antenna Factor(dB/m) + Cable Factor(dB) – Pre-Amplifier Factor(dB)
3. The other emission levels were very low against the limit.
4. Margin value = Emission Level – Limit value
5. " * ": Fundamental frequency.

802.11g

CHANNEL	TX Channel 1	DETECTOR FUNCTION	Peak (PK)
FREQUENCY RANGE	1GHz ~ 25GHz		Average (AV)

ANTENNA POLARITY & TEST DISTANCE: HORIZONTAL AT 3 M

NO.	FREQ. (MHz)	EMISSION LEVEL (dBuV/m)	LIMIT (dBuV/m)	MARGIN (dB)	ANTENNA HEIGHT (m)	TABLE ANGLE (Degree)	RAW VALUE (dBuV)	CORRECTION FACTOR (dB/m)
1	2390.00	72.6 PK	74.0	-1.4	2.81 H	205	75.27	-2.67
2	2390.00	51.4 AV	54.0	-2.6	2.81 H	205	54.07	-2.67
3	*2412.00	109.1 PK			2.81 H	205	111.67	-2.57
4	*2412.00	99.2 AV			2.81 H	205	101.77	-2.57
5	4824.00	44.5 PK	74.0	-29.5	2.03 H	216	40.35	4.15
6	4824.00	31.3 AV	54.0	-22.7	2.03 H	216	27.15	4.15

ANTENNA POLARITY & TEST DISTANCE: VERTICAL AT 3 M

NO.	FREQ. (MHz)	EMISSION LEVEL (dBuV/m)	LIMIT (dBuV/m)	MARGIN (dB)	ANTENNA HEIGHT (m)	TABLE ANGLE (Degree)	RAW VALUE (dBuV)	CORRECTION FACTOR (dB/m)
1	2390.00	67.5 PK	74.0	-6.5	2.16 V	271	70.17	-2.67
2	2390.00	47.3 AV	54.0	-6.7	2.16 V	271	49.97	-2.67
3	*2412.00	106.5 PK			2.16 V	271	109.07	-2.57
4	*2412.00	94.2 AV			2.16 V	271	96.77	-2.57
5	4824.00	46.6 PK	74.0	-27.4	2.03 V	145	42.45	4.15
6	4824.00	32.1 AV	54.0	-21.9	2.03 V	145	27.95	4.15

REMARKS:

1. Emission Level(dBuV/m) = Raw Value(dBuV) + Correction Factor(dB/m)
2. Correction Factor(dB/m) = Antenna Factor(dB/m) + Cable Factor(dB) – Pre-Amplifier Factor(dB)
3. The other emission levels were very low against the limit.
4. Margin value = Emission Level – Limit value
5. " * ": Fundamental frequency.

CHANNEL	TX Channel 2	DETECTOR FUNCTION	Peak (PK)
FREQUENCY RANGE	1GHz ~ 25GHz		Average (AV)

ANTENNA POLARITY & TEST DISTANCE: HORIZONTAL AT 3 M

NO.	FREQ. (MHz)	EMISSION LEVEL (dBuV/m)	LIMIT (dBuV/m)	MARGIN (dB)	ANTENNA HEIGHT (m)	TABLE ANGLE (Degree)	RAW VALUE (dBuV)	CORRECTION FACTOR (dB/m)
1	2390.00	68.1 PK	74.0	-5.9	2.81 H	197	70.77	-2.67
2	2390.00	52.6 AV	54.0	-1.4	2.81 H	197	55.27	-2.67
3	*2417.00	111.9 PK			2.81 H	197	114.46	-2.56
4	*2417.00	101.8 AV			2.81 H	197	104.36	-2.56
5	4834.00	44.4 PK	74.0	-29.6	2.01 H	231	40.23	4.17
6	4834.00	31.3 AV	54.0	-22.7	2.01 H	231	27.13	4.17
7	7251.00	51.2 PK	74.0	-22.8	1.76 H	141	40.79	10.41
8	7251.00	39.0 AV	54.0	-15.0	1.76 H	141	28.59	10.41

ANTENNA POLARITY & TEST DISTANCE: VERTICAL AT 3 M

NO.	FREQ. (MHz)	EMISSION LEVEL (dBuV/m)	LIMIT (dBuV/m)	MARGIN (dB)	ANTENNA HEIGHT (m)	TABLE ANGLE (Degree)	RAW VALUE (dBuV)	CORRECTION FACTOR (dB/m)
1	2390.00	64.4 PK	74.0	-9.6	2.15 V	280	67.07	-2.67
2	2390.00	48.6 AV	54.0	-5.4	2.15 V	280	51.27	-2.67
3	*2417.00	108.0 PK			2.15 V	280	110.56	-2.56
4	*2417.00	97.9 AV			2.15 V	280	100.46	-2.56
5	4834.00	46.2 PK	74.0	-27.8	2.01 V	136	42.03	4.17
6	4834.00	31.9 AV	54.0	-22.1	2.01 V	136	27.73	4.17
7	7251.00	50.2 PK	74.0	-23.8	2.60 V	157	39.79	10.41
8	7251.00	37.8 AV	54.0	-16.2	2.60 V	157	27.39	10.41

REMARKS:

1. Emission Level(dBuV/m) = Raw Value(dBuV) + Correction Factor(dB/m)
2. Correction Factor(dB/m) = Antenna Factor(dB/m) + Cable Factor(dB) – Pre-Amplifier Factor(dB)
3. The other emission levels were very low against the limit.
4. Margin value = Emission Level – Limit value
5. " * ": Fundamental frequency.

CHANNEL	TX Channel 6	DETECTOR FUNCTION	Peak (PK)
FREQUENCY RANGE	1GHz ~ 25GHz		Average (AV)

ANTENNA POLARITY & TEST DISTANCE: HORIZONTAL AT 3 M

NO.	FREQ. (MHz)	EMISSION LEVEL (dBuV/m)	LIMIT (dBuV/m)	MARGIN (dB)	ANTENNA HEIGHT (m)	TABLE ANGLE (Degree)	RAW VALUE (dBuV)	CORRECTION FACTOR (dB/m)
1	*2437.00	112.3 PK			2.79 H	190	114.78	-2.48
2	*2437.00	102.2 AV			2.79 H	190	104.68	-2.48
3	4874.00	44.2 PK	74.0	-29.8	2.01 H	229	39.92	4.28
4	4874.00	30.9 AV	54.0	-23.1	2.01 H	229	26.62	4.28
5	7311.00	51.0 PK	74.0	-23.0	1.81 H	135	40.38	10.62
6	7311.00	38.7 AV	54.0	-15.3	1.81 H	135	28.08	10.62

ANTENNA POLARITY & TEST DISTANCE: VERTICAL AT 3 M

NO.	FREQ. (MHz)	EMISSION LEVEL (dBuV/m)	LIMIT (dBuV/m)	MARGIN (dB)	ANTENNA HEIGHT (m)	TABLE ANGLE (Degree)	RAW VALUE (dBuV)	CORRECTION FACTOR (dB/m)
1	*2437.00	107.9 PK			2.15 V	296	110.38	-2.48
2	*2437.00	98.1 AV			2.15 V	296	100.58	-2.48
3	4874.00	46.3 PK	74.0	-27.7	2.05 V	126	42.02	4.28
4	4874.00	32.2 AV	54.0	-21.8	2.05 V	126	27.92	4.28
5	7311.00	50.5 PK	74.0	-23.5	2.63 V	141	39.88	10.62
6	7311.00	38.1 AV	54.0	-15.9	2.63 V	141	27.48	10.62

REMARKS:

1. Emission Level(dBuV/m) = Raw Value(dBuV) + Correction Factor(dB/m)
2. Correction Factor(dB/m) = Antenna Factor(dB/m) + Cable Factor(dB) – Pre-Amplifier Factor(dB)
3. The other emission levels were very low against the limit.
4. Margin value = Emission Level – Limit value
5. " * ": Fundamental frequency.

CHANNEL	TX Channel 10	DETECTOR FUNCTION	Peak (PK)
FREQUENCY RANGE	1GHz ~ 25GHz		Average (AV)

ANTENNA POLARITY & TEST DISTANCE: HORIZONTAL AT 3 M

NO.	FREQ. (MHz)	EMISSION LEVEL (dBuV/m)	LIMIT (dBuV/m)	MARGIN (dB)	ANTENNA HEIGHT (m)	TABLE ANGLE (Degree)	RAW VALUE (dBuV)	CORRECTION FACTOR (dB/m)
1	*2457.00	112.3 PK			2.80 H	183	114.70	-2.40
2	*2457.00	102.4 AV			2.80 H	183	104.80	-2.40
3	4914.00	44.6 PK	74.0	-29.4	2.06 H	221	40.19	4.41
4	4914.00	31.3 AV	54.0	-22.7	2.06 H	221	26.89	4.41
5	7371.00	50.9 PK	74.0	-23.1	1.77 H	141	40.10	10.80
6	7371.00	38.4 AV	54.0	-15.6	1.77 H	141	27.60	10.80

ANTENNA POLARITY & TEST DISTANCE: VERTICAL AT 3 M

NO.	FREQ. (MHz)	EMISSION LEVEL (dBuV/m)	LIMIT (dBuV/m)	MARGIN (dB)	ANTENNA HEIGHT (m)	TABLE ANGLE (Degree)	RAW VALUE (dBuV)	CORRECTION FACTOR (dB/m)
1	*2457.00	108.1 PK			2.12 V	271	110.50	-2.40
2	*2457.00	98.3 AV			2.12 V	271	100.70	-2.40
3	4914.00	46.4 PK	74.0	-27.6	2.05 V	127	41.99	4.41
4	4914.00	32.4 AV	54.0	-21.6	2.05 V	127	27.99	4.41
5	7371.00	50.6 PK	74.0	-23.4	2.66 V	145	39.80	10.80
6	7371.00	37.9 AV	54.0	-16.1	2.66 V	145	27.10	10.80

REMARKS:

1. Emission Level(dBuV/m) = Raw Value(dBuV) + Correction Factor(dB/m)
2. Correction Factor(dB/m) = Antenna Factor(dB/m) + Cable Factor(dB) – Pre-Amplifier Factor(dB)
3. The other emission levels were very low against the limit.
4. Margin value = Emission Level – Limit value
5. " * ": Fundamental frequency.

CHANNEL	TX Channel 11	DETECTOR FUNCTION	Peak (PK)
FREQUENCY RANGE	1GHz ~ 25GHz		Average (AV)

ANTENNA POLARITY & TEST DISTANCE: HORIZONTAL AT 3 M

NO.	FREQ. (MHz)	EMISSION LEVEL (dBuV/m)	LIMIT (dBuV/m)	MARGIN (dB)	ANTENNA HEIGHT (m)	TABLE ANGLE (Degree)	RAW VALUE (dBuV)	CORRECTION FACTOR (dB/m)
1	*2462.00	109.5 PK			2.60 H	205	111.88	-2.38
2	*2462.00	99.6 AV			2.60 H	205	101.98	-2.38
3	2483.50	73.0 PK	74.0	-1.0	2.60 H	205	75.30	-2.30
4	2483.50	52.5 AV	54.0	-1.5	2.60 H	205	54.80	-2.30
5	4924.00	44.8 PK	74.0	-29.2	1.97 H	226	40.33	4.47
6	4924.00	31.3 AV	54.0	-22.7	1.97 H	226	26.83	4.47
7	7386.00	50.4 PK	74.0	-23.6	1.76 H	131	39.55	10.85
8	7386.00	38.3 AV	54.0	-15.7	1.76 H	131	27.45	10.85

ANTENNA POLARITY & TEST DISTANCE: VERTICAL AT 3 M

NO.	FREQ. (MHz)	EMISSION LEVEL (dBuV/m)	LIMIT (dBuV/m)	MARGIN (dB)	ANTENNA HEIGHT (m)	TABLE ANGLE (Degree)	RAW VALUE (dBuV)	CORRECTION FACTOR (dB/m)
1	*2462.00	105.4 PK			2.18 V	269	107.78	-2.38
2	*2462.00	95.5 AV			2.18 V	269	97.88	-2.38
3	2483.50	69.2 PK	74.0	-4.8	2.18 V	269	71.50	-2.30
4	2483.50	48.9 AV	54.0	-5.1	2.18 V	269	51.20	-2.30
5	4924.00	46.6 PK	74.0	-27.4	2.00 V	124	42.13	4.47
6	4924.00	32.3 AV	54.0	-21.7	2.00 V	124	27.83	4.47
7	7386.00	50.9 PK	74.0	-23.1	2.68 V	132	40.05	10.85
8	7386.00	38.5 AV	54.0	-15.5	2.68 V	132	27.65	10.85

REMARKS:

1. Emission Level(dBuV/m) = Raw Value(dBuV) + Correction Factor(dB/m)
2. Correction Factor(dB/m) = Antenna Factor(dB/m) + Cable Factor(dB) – Pre-Amplifier Factor(dB)
3. The other emission levels were very low against the limit.
4. Margin value = Emission Level – Limit value
5. " * ": Fundamental frequency.

802.11n (HT20)

CHANNEL	TX Channel 1	DETECTOR FUNCTION	Peak (PK)
FREQUENCY RANGE	1GHz ~ 25GHz		Average (AV)

ANTENNA POLARITY & TEST DISTANCE: HORIZONTAL AT 3 M								
NO.	FREQ. (MHz)	EMISSION LEVEL (dBuV/m)	LIMIT (dBuV/m)	MARGIN (dB)	ANTENNA HEIGHT (m)	TABLE ANGLE (Degree)	RAW VALUE (dBuV)	CORRECTION FACTOR (dB/m)
1	2390.00	72.9 PK	74.0	-1.1	2.23 H	194	75.57	-2.67
2	2390.00	52.0 AV	54.0	-2.0	2.23 H	194	54.67	-2.67
3	*2412.00	110.2 PK			2.27 H	199	112.77	-2.57
4	*2412.00	97.9 AV			2.27 H	199	100.47	-2.57
5	4824.00	44.3 PK	74.0	-29.7	2.08 H	213	40.15	4.15
6	4824.00	31.0 AV	54.0	-23.0	2.08 H	213	26.85	4.15

ANTENNA POLARITY & TEST DISTANCE: VERTICAL AT 3 M								
NO.	FREQ. (MHz)	EMISSION LEVEL (dBuV/m)	LIMIT (dBuV/m)	MARGIN (dB)	ANTENNA HEIGHT (m)	TABLE ANGLE (Degree)	RAW VALUE (dBuV)	CORRECTION FACTOR (dB/m)
1	2390.00	68.6 PK	74.0	-5.4	2.12 V	271	71.27	-2.67
2	2390.00	48.6 AV	54.0	-5.4	2.12 V	271	51.27	-2.67
3	*2412.00	106.8 PK			2.12 V	271	109.37	-2.57
4	*2412.00	94.2 AV			2.12 V	271	96.77	-2.57
5	4824.00	47.0 PK	74.0	-27.0	2.01 V	146	42.85	4.15
6	4824.00	32.5 AV	54.0	-21.5	2.01 V	146	28.35	4.15

REMARKS:

1. Emission Level(dBuV/m) = Raw Value(dBuV) + Correction Factor(dB/m)
2. Correction Factor(dB/m) = Antenna Factor(dB/m) + Cable Factor(dB) – Pre-Amplifier Factor(dB)
3. The other emission levels were very low against the limit.
4. Margin value = Emission Level – Limit value
5. " * ": Fundamental frequency.

CHANNEL	TX Channel 2	DETECTOR FUNCTION	Peak (PK)
FREQUENCY RANGE	1GHz ~ 25GHz		Average (AV)

ANTENNA POLARITY & TEST DISTANCE: HORIZONTAL AT 3 M

NO.	FREQ. (MHz)	EMISSION LEVEL (dBuV/m)	LIMIT (dBuV/m)	MARGIN (dB)	ANTENNA HEIGHT (m)	TABLE ANGLE (Degree)	RAW VALUE (dBuV)	CORRECTION FACTOR (dB/m)
1	2390.00	67.4 PK	74.0	-6.6	2.53 H	203	70.07	-2.67
2	2390.00	52.2 AV	54.0	-1.8	2.53 H	203	54.87	-2.67
3	*2417.00	113.5 PK			2.29 H	204	116.06	-2.56
4	*2417.00	101.1 AV			2.29 H	204	103.66	-2.56
5	4834.00	44.2 PK	74.0	-29.8	2.03 H	217	40.03	4.17
6	4834.00	30.8 AV	54.0	-23.2	2.03 H	217	26.63	4.17
7	7251.00	51.2 PK	74.0	-22.8	1.79 H	150	40.79	10.41
8	7251.00	38.7 AV	54.0	-15.3	1.79 H	150	28.29	10.41

ANTENNA POLARITY & TEST DISTANCE: VERTICAL AT 3 M

NO.	FREQ. (MHz)	EMISSION LEVEL (dBuV/m)	LIMIT (dBuV/m)	MARGIN (dB)	ANTENNA HEIGHT (m)	TABLE ANGLE (Degree)	RAW VALUE (dBuV)	CORRECTION FACTOR (dB/m)
1	2390.00	63.6 PK	74.0	-10.4	2.14 V	275	66.27	-2.67
2	2390.00	48.6 AV	54.0	-5.4	2.14 V	275	51.27	-2.67
3	*2417.00	109.3 PK			2.14 V	275	111.86	-2.56
4	*2417.00	96.9 AV			2.14 V	275	99.46	-2.56
5	4834.00	46.0 PK	74.0	-28.0	2.09 V	139	41.83	4.17
6	4834.00	31.9 AV	54.0	-22.1	2.09 V	139	27.73	4.17
7	7251.00	50.1 PK	74.0	-23.9	2.60 V	137	39.69	10.41
8	7251.00	38.0 AV	54.0	-16.0	2.60 V	137	27.59	10.41

REMARKS:

1. Emission Level(dBuV/m) = Raw Value(dBuV) + Correction Factor(dB/m)
2. Correction Factor(dB/m) = Antenna Factor(dB/m) + Cable Factor(dB) – Pre-Amplifier Factor(dB)
3. The other emission levels were very low against the limit.
4. Margin value = Emission Level – Limit value
5. " * ": Fundamental frequency.

CHANNEL	TX Channel 6	DETECTOR FUNCTION	Peak (PK)
FREQUENCY RANGE	1GHz ~ 25GHz		Average (AV)

ANTENNA POLARITY & TEST DISTANCE: HORIZONTAL AT 3 M

NO.	FREQ. (MHz)	EMISSION LEVEL (dBuV/m)	LIMIT (dBuV/m)	MARGIN (dB)	ANTENNA HEIGHT (m)	TABLE ANGLE (Degree)	RAW VALUE (dBuV)	CORRECTION FACTOR (dB/m)
1	2390.00	62.6 PK	74.0	-11.4	2.47 H	203	65.27	-2.67
2	2390.00	48.1 AV	54.0	-5.9	2.47 H	203	50.77	-2.67
3	*2437.00	117.4 PK			2.47 H	203	119.88	-2.48
4	*2437.00	105.0 AV			2.47 H	203	107.48	-2.48
5	2483.50	64.8 PK	74.0	-9.2	2.47 H	203	67.10	-2.30
6	2483.50	50.1 AV	54.0	-3.9	2.47 H	203	52.40	-2.30
7	4874.00	44.1 PK	74.0	-29.9	1.99 H	235	39.82	4.28
8	4874.00	30.9 AV	54.0	-23.1	1.99 H	235	26.62	4.28
9	7311.00	51.0 PK	74.0	-23.0	1.86 H	140	40.38	10.62
10	7311.00	38.4 AV	54.0	-15.6	1.86 H	140	27.78	10.62

ANTENNA POLARITY & TEST DISTANCE: VERTICAL AT 3 M

NO.	FREQ. (MHz)	EMISSION LEVEL (dBuV/m)	LIMIT (dBuV/m)	MARGIN (dB)	ANTENNA HEIGHT (m)	TABLE ANGLE (Degree)	RAW VALUE (dBuV)	CORRECTION FACTOR (dB/m)
1	2390.00	60.4 PK	74.0	-13.6	2.17 V	262	63.07	-2.67
2	2390.00	46.6 AV	54.0	-7.4	2.17 V	262	49.27	-2.67
3	*2437.00	115.3 PK			2.17 V	262	117.78	-2.48
4	*2437.00	101.4 AV			2.17 V	262	103.88	-2.48
5	2483.50	60.5 PK	74.0	-13.5	2.17 V	262	62.80	-2.30
6	2483.50	46.1 AV	54.0	-7.9	2.17 V	262	48.40	-2.30
7	4874.00	45.9 PK	74.0	-28.1	2.10 V	124	41.62	4.28
8	4874.00	32.0 AV	54.0	-22.0	2.10 V	124	27.72	4.28
9	7311.00	51.0 PK	74.0	-23.0	2.59 V	156	40.38	10.62
10	7311.00	38.5 AV	54.0	-15.5	2.59 V	156	27.88	10.62

REMARKS:

1. Emission Level(dBuV/m) = Raw Value(dBuV) + Correction Factor(dB/m)
2. Correction Factor(dB/m) = Antenna Factor(dB/m) + Cable Factor(dB) – Pre-Amplifier Factor(dB)
3. The other emission levels were very low against the limit.
4. Margin value = Emission Level – Limit value
5. " * ": Fundamental frequency.

CHANNEL	TX Channel 10	DETECTOR FUNCTION	Peak (PK)
FREQUENCY RANGE	1GHz ~ 25GHz		Average (AV)

ANTENNA POLARITY & TEST DISTANCE: HORIZONTAL AT 3 M

NO.	FREQ. (MHz)	EMISSION LEVEL (dBuV/m)	LIMIT (dBuV/m)	MARGIN (dB)	ANTENNA HEIGHT (m)	TABLE ANGLE (Degree)	RAW VALUE (dBuV)	CORRECTION FACTOR (dB/m)
1	*2457.00	114.4 PK			2.28 H	196	116.80	-2.40
2	*2457.00	101.8 AV			2.28 H	196	104.20	-2.40
3	2483.50	70.3 PK	74.0	-3.7	2.47 H	192	72.60	-2.30
4	2483.50	52.7 AV	54.0	-1.3	2.47 H	192	55.00	-2.30
5	4914.00	44.0 PK	74.0	-30.0	2.03 H	237	39.59	4.41
6	4914.00	30.8 AV	54.0	-23.2	2.03 H	237	26.39	4.41
7	7371.00	51.3 PK	74.0	-22.7	1.77 H	128	40.50	10.80
8	7371.00	38.9 AV	54.0	-15.1	1.77 H	128	28.10	10.80

ANTENNA POLARITY & TEST DISTANCE: VERTICAL AT 3 M

NO.	FREQ. (MHz)	EMISSION LEVEL (dBuV/m)	LIMIT (dBuV/m)	MARGIN (dB)	ANTENNA HEIGHT (m)	TABLE ANGLE (Degree)	RAW VALUE (dBuV)	CORRECTION FACTOR (dB/m)
1	*2457.00	109.1 PK			2.11 V	265	111.50	-2.40
2	*2457.00	96.7 AV			2.11 V	265	99.10	-2.40
3	2483.50	63.6 PK	74.0	-10.4	2.11 V	265	65.90	-2.30
4	2483.50	48.8 AV	54.0	-5.2	2.11 V	265	51.10	-2.30
5	4914.00	46.0 PK	74.0	-28.0	2.06 V	124	41.59	4.41
6	4914.00	32.2 AV	54.0	-21.8	2.06 V	124	27.79	4.41
7	7371.00	50.1 PK	74.0	-23.9	2.66 V	126	39.30	10.80
8	7371.00	37.7 AV	54.0	-16.3	2.66 V	126	26.90	10.80

REMARKS:

1. Emission Level(dBuV/m) = Raw Value(dBuV) + Correction Factor(dB/m)
2. Correction Factor(dB/m) = Antenna Factor(dB/m) + Cable Factor(dB) – Pre-Amplifier Factor(dB)
3. The other emission levels were very low against the limit.
4. Margin value = Emission Level – Limit value
5. " * ": Fundamental frequency.

CHANNEL	TX Channel 11	DETECTOR FUNCTION	Peak (PK)
FREQUENCY RANGE	1GHz ~ 25GHz		Average (AV)

ANTENNA POLARITY & TEST DISTANCE: HORIZONTAL AT 3 M

NO.	FREQ. (MHz)	EMISSION LEVEL (dBuV/m)	LIMIT (dBuV/m)	MARGIN (dB)	ANTENNA HEIGHT (m)	TABLE ANGLE (Degree)	RAW VALUE (dBuV)	CORRECTION FACTOR (dB/m)
1	*2462.00	111.1 PK			2.43 H	197	113.48	-2.38
2	*2462.00	98.6 AV			2.43 H	197	100.98	-2.38
3	2483.50	72.9 PK	74.0	-1.1	2.56 H	197	75.20	-2.30
4	2483.50	50.4 AV	54.0	-3.6	2.56 H	197	52.70	-2.30
5	4924.00	44.2 PK	74.0	-29.8	2.03 H	228	39.73	4.47
6	4924.00	30.7 AV	54.0	-23.3	2.03 H	228	26.23	4.47
7	7386.00	50.9 PK	74.0	-23.1	1.81 H	131	40.05	10.85
8	7386.00	38.6 AV	54.0	-15.4	1.81 H	131	27.75	10.85

ANTENNA POLARITY & TEST DISTANCE: VERTICAL AT 3 M

NO.	FREQ. (MHz)	EMISSION LEVEL (dBuV/m)	LIMIT (dBuV/m)	MARGIN (dB)	ANTENNA HEIGHT (m)	TABLE ANGLE (Degree)	RAW VALUE (dBuV)	CORRECTION FACTOR (dB/m)
1	*2462.00	106.9 PK			2.10 V	272	109.28	-2.38
2	*2462.00	94.4 AV			2.10 V	272	96.78	-2.38
3	2483.50	68.8 PK	74.0	-5.2	2.10 V	272	71.10	-2.30
4	2483.50	46.1 AV	54.0	-7.9	2.10 V	272	48.40	-2.30
5	4924.00	47.0 PK	74.0	-27.0	2.09 V	121	42.53	4.47
6	4924.00	32.6 AV	54.0	-21.4	2.09 V	121	28.13	4.47
7	7386.00	51.1 PK	74.0	-22.9	2.64 V	143	40.25	10.85
8	7386.00	38.5 AV	54.0	-15.5	2.64 V	143	27.65	10.85

REMARKS:

1. Emission Level(dBuV/m) = Raw Value(dBuV) + Correction Factor(dB/m)
2. Correction Factor(dB/m) = Antenna Factor(dB/m) + Cable Factor(dB) – Pre-Amplifier Factor(dB)
3. The other emission levels were very low against the limit.
4. Margin value = Emission Level – Limit value
5. " * ": Fundamental frequency.

802.11n (HT40)

CHANNEL	TX Channel 3	DETECTOR FUNCTION	Peak (PK)
FREQUENCY RANGE	1GHz ~ 25GHz		Average (AV)

ANTENNA POLARITY & TEST DISTANCE: HORIZONTAL AT 3 M								
NO.	FREQ. (MHz)	EMISSION LEVEL (dBuV/m)	LIMIT (dBuV/m)	MARGIN (dB)	ANTENNA HEIGHT (m)	TABLE ANGLE (Degree)	RAW VALUE (dBuV)	CORRECTION FACTOR (dB/m)
1	2390.00	68.4 PK	74.0	-5.6	1.70 H	193	71.07	-2.67
2	2390.00	52.8 AV	54.0	-1.2	1.70 H	193	55.47	-2.67
3	*2422.00	108.7 PK			1.78 H	196	111.24	-2.54
4	*2422.00	95.7 AV			1.78 H	196	98.24	-2.54
5	4844.00	43.8 PK	74.0	-30.2	1.97 H	222	39.60	4.20
6	4844.00	30.7 AV	54.0	-23.3	1.97 H	222	26.50	4.20
7	7266.00	51.1 PK	74.0	-22.9	1.79 H	122	40.63	10.47
8	7266.00	38.9 AV	54.0	-15.1	1.79 H	122	28.43	10.47

ANTENNA POLARITY & TEST DISTANCE: VERTICAL AT 3 M								
NO.	FREQ. (MHz)	EMISSION LEVEL (dBuV/m)	LIMIT (dBuV/m)	MARGIN (dB)	ANTENNA HEIGHT (m)	TABLE ANGLE (Degree)	RAW VALUE (dBuV)	CORRECTION FACTOR (dB/m)
1	2390.00	64.4 PK	74.0	-9.6	1.87 V	207	67.07	-2.67
2	2390.00	48.6 AV	54.0	-5.4	1.87 V	207	51.27	-2.67
3	*2422.00	101.5 PK			1.87 V	207	104.04	-2.54
4	*2422.00	87.8 AV			1.87 V	207	90.34	-2.54
5	4844.00	44.3 PK	74.0	-29.7	2.05 V	135	40.10	4.20
6	4844.00	30.2 AV	54.0	-23.8	2.05 V	135	26.00	4.20
7	7266.00	48.4 PK	74.0	-25.6	2.69 V	149	37.93	10.47
8	7266.00	36.3 AV	54.0	-17.7	2.69 V	149	25.83	10.47

REMARKS:

1. Emission Level(dBuV/m) = Raw Value(dBuV) + Correction Factor(dB/m)
2. Correction Factor(dB/m) = Antenna Factor(dB/m) + Cable Factor(dB) – Pre-Amplifier Factor(dB)
3. The other emission levels were very low against the limit.
4. Margin value = Emission Level – Limit value
5. " * ": Fundamental frequency.

CHANNEL	TX Channel 4	DETECTOR FUNCTION	Peak (PK)
FREQUENCY RANGE	1GHz ~ 25GHz		Average (AV)

ANTENNA POLARITY & TEST DISTANCE: HORIZONTAL AT 3 M

NO.	FREQ. (MHz)	EMISSION LEVEL (dBuV/m)	LIMIT (dBuV/m)	MARGIN (dB)	ANTENNA HEIGHT (m)	TABLE ANGLE (Degree)	RAW VALUE (dBuV)	CORRECTION FACTOR (dB/m)
1	2390.00	68.1 PK	74.0	-5.9	2.26 H	216	70.77	-2.67
2	2390.00	52.9 AV	54.0	-1.1	2.26 H	216	55.57	-2.67
3	*2427.00	110.1 PK			2.05 H	194	112.62	-2.52
4	*2427.00	97.4 AV			2.05 H	194	99.92	-2.52
5	4854.00	43.6 PK	74.0	-30.4	2.01 H	214	39.38	4.22
6	4854.00	30.5 AV	54.0	-23.5	2.01 H	214	26.28	4.22
7	7281.00	51.2 PK	74.0	-22.8	1.78 H	143	40.68	10.52
8	7281.00	38.9 AV	54.0	-15.1	1.78 H	143	28.38	10.52

ANTENNA POLARITY & TEST DISTANCE: VERTICAL AT 3 M

NO.	FREQ. (MHz)	EMISSION LEVEL (dBuV/m)	LIMIT (dBuV/m)	MARGIN (dB)	ANTENNA HEIGHT (m)	TABLE ANGLE (Degree)	RAW VALUE (dBuV)	CORRECTION FACTOR (dB/m)
1	2390.00	64.6 PK	74.0	-9.4	1.89 V	192	67.27	-2.67
2	2390.00	48.3 AV	54.0	-5.7	1.89 V	192	50.97	-2.67
3	*2427.00	103.5 PK			1.89 V	192	106.02	-2.52
4	*2427.00	93.3 AV			1.89 V	192	95.82	-2.52
5	4854.00	44.0 PK	74.0	-30.0	2.03 V	128	39.78	4.22
6	4854.00	29.8 AV	54.0	-24.2	2.03 V	128	25.58	4.22
7	7281.00	48.0 PK	74.0	-26.0	2.66 V	144	37.48	10.52
8	7281.00	36.0 AV	54.0	-18.0	2.66 V	144	25.48	10.52

REMARKS:

1. Emission Level(dBuV/m) = Raw Value(dBuV) + Correction Factor(dB/m)
2. Correction Factor(dB/m) = Antenna Factor(dB/m) + Cable Factor(dB) – Pre-Amplifier Factor(dB)
3. The other emission levels were very low against the limit.
4. Margin value = Emission Level – Limit value
5. " * ": Fundamental frequency.

CHANNEL	TX Channel 6	DETECTOR FUNCTION	Peak (PK)
FREQUENCY RANGE	1GHz ~ 25GHz		Average (AV)

ANTENNA POLARITY & TEST DISTANCE: HORIZONTAL AT 3 M

NO.	FREQ. (MHz)	EMISSION LEVEL (dBuV/m)	LIMIT (dBuV/m)	MARGIN (dB)	ANTENNA HEIGHT (m)	TABLE ANGLE (Degree)	RAW VALUE (dBuV)	CORRECTION FACTOR (dB/m)
1	2390.00	64.9 PK	74.0	-9.1	2.31 H	195	67.57	-2.67
2	2390.00	48.9 AV	54.0	-5.1	2.31 H	195	51.57	-2.67
3	*2437.00	111.1 PK			2.19 H	196	113.58	-2.48
4	*2437.00	98.0 AV			2.19 H	196	100.48	-2.48
5	2483.50	70.6 PK	74.0	-3.4	2.31 H	195	72.90	-2.30
6	2483.50	52.9 AV	54.0	-1.1	2.31 H	195	55.20	-2.30
7	4874.00	44.3 PK	74.0	-29.7	1.99 H	237	40.02	4.28
8	4874.00	31.1 AV	54.0	-22.9	1.99 H	237	26.82	4.28
9	7311.00	50.5 PK	74.0	-23.5	1.82 H	148	39.88	10.62
10	7311.00	38.2 AV	54.0	-15.8	1.82 H	148	27.58	10.62

ANTENNA POLARITY & TEST DISTANCE: VERTICAL AT 3 M

NO.	FREQ. (MHz)	EMISSION LEVEL (dBuV/m)	LIMIT (dBuV/m)	MARGIN (dB)	ANTENNA HEIGHT (m)	TABLE ANGLE (Degree)	RAW VALUE (dBuV)	CORRECTION FACTOR (dB/m)
1	2390.00	62.2 PK	74.0	-11.8	1.90 V	199	64.87	-2.67
2	2390.00	46.6 AV	54.0	-7.4	1.90 V	199	49.27	-2.67
3	*2437.00	104.6 PK			1.90 V	199	107.08	-2.48
4	*2437.00	94.4 AV			1.90 V	199	96.88	-2.48
5	2483.50	65.6 PK	74.0	-8.4	1.90 V	199	67.90	-2.30
6	2483.50	48.6 AV	54.0	-5.4	1.90 V	199	50.90	-2.30
7	4874.00	44.1 PK	74.0	-29.9	2.05 V	150	39.82	4.28
8	4874.00	30.0 AV	54.0	-24.0	2.05 V	150	25.72	4.28
9	7311.00	48.0 PK	74.0	-26.0	2.64 V	158	37.38	10.62
10	7311.00	36.2 AV	54.0	-17.8	2.64 V	158	25.58	10.62

REMARKS:

1. Emission Level(dBuV/m) = Raw Value(dBuV) + Correction Factor(dB/m)
2. Correction Factor(dB/m) = Antenna Factor(dB/m) + Cable Factor(dB) – Pre-Amplifier Factor(dB)
3. The other emission levels were very low against the limit.
4. Margin value = Emission Level – Limit value
5. " * ": Fundamental frequency.

CHANNEL	TX Channel 8	DETECTOR FUNCTION	Peak (PK)
FREQUENCY RANGE	1GHz ~ 25GHz		Average (AV)

ANTENNA POLARITY & TEST DISTANCE: HORIZONTAL AT 3 M

NO.	FREQ. (MHz)	EMISSION LEVEL (dBuV/m)	LIMIT (dBuV/m)	MARGIN (dB)	ANTENNA HEIGHT (m)	TABLE ANGLE (Degree)	RAW VALUE (dBuV)	CORRECTION FACTOR (dB/m)
1	*2447.00	109.5 PK			2.11 H	195	111.94	-2.44
2	*2447.00	96.3 AV			2.11 H	195	98.74	-2.44
3	2483.50	70.7 PK	74.0	-3.3	2.19 H	195	73.00	-2.30
4	2483.50	52.9 AV	54.0	-1.1	2.19 H	195	55.20	-2.30
5	4894.00	44.5 PK	74.0	-29.5	2.05 H	218	40.17	4.33
6	4894.00	31.0 AV	54.0	-23.0	2.05 H	218	26.67	4.33
7	7341.00	51.2 PK	74.0	-22.8	1.77 H	144	40.49	10.71
8	7341.00	39.1 AV	54.0	-14.9	1.77 H	144	28.39	10.71

ANTENNA POLARITY & TEST DISTANCE: VERTICAL AT 3 M

NO.	FREQ. (MHz)	EMISSION LEVEL (dBuV/m)	LIMIT (dBuV/m)	MARGIN (dB)	ANTENNA HEIGHT (m)	TABLE ANGLE (Degree)	RAW VALUE (dBuV)	CORRECTION FACTOR (dB/m)
1	*2447.00	104.4 PK			1.86 V	200	106.84	-2.44
2	*2447.00	92.1 AV			1.86 V	200	94.54	-2.44
3	2483.50	66.5 PK	74.0	-7.5	1.86 V	200	68.80	-2.30
4	2483.50	48.8 AV	54.0	-5.2	1.86 V	200	51.10	-2.30
5	4894.00	43.7 PK	74.0	-30.3	2.03 V	128	39.37	4.33
6	4894.00	29.9 AV	54.0	-24.1	2.03 V	128	25.57	4.33
7	7341.00	48.4 PK	74.0	-25.6	2.72 V	142	37.69	10.71
8	7341.00	36.4 AV	54.0	-17.6	2.72 V	142	25.69	10.71

REMARKS:

1. Emission Level(dBuV/m) = Raw Value(dBuV) + Correction Factor(dB/m)
2. Correction Factor(dB/m) = Antenna Factor(dB/m) + Cable Factor(dB) – Pre-Amplifier Factor(dB)
3. The other emission levels were very low against the limit.
4. Margin value = Emission Level – Limit value
5. " * ": Fundamental frequency.

CHANNEL	TX Channel 9	DETECTOR FUNCTION	Peak (PK)
FREQUENCY RANGE	1GHz ~ 25GHz		Average (AV)

ANTENNA POLARITY & TEST DISTANCE: HORIZONTAL AT 3 M

NO.	FREQ. (MHz)	EMISSION LEVEL (dBuV/m)	LIMIT (dBuV/m)	MARGIN (dB)	ANTENNA HEIGHT (m)	TABLE ANGLE (Degree)	RAW VALUE (dBuV)	CORRECTION FACTOR (dB/m)
1	*2452.00	108.9 PK			1.94 H	196	111.32	-2.42
2	*2452.00	95.6 AV			1.94 H	196	98.02	-2.42
3	2483.50	70.3 PK	74.0	-3.7	1.94 H	193	72.60	-2.30
4	2483.50	52.9 AV	54.0	-1.1	1.94 H	193	55.20	-2.30
5	4904.00	44.2 PK	74.0	-29.8	2.00 H	223	39.84	4.36
6	4904.00	30.9 AV	54.0	-23.1	2.00 H	223	26.54	4.36
7	7356.00	50.7 PK	74.0	-23.3	1.80 H	132	39.94	10.76
8	7356.00	38.2 AV	54.0	-15.8	1.80 H	132	27.44	10.76

ANTENNA POLARITY & TEST DISTANCE: VERTICAL AT 3 M

NO.	FREQ. (MHz)	EMISSION LEVEL (dBuV/m)	LIMIT (dBuV/m)	MARGIN (dB)	ANTENNA HEIGHT (m)	TABLE ANGLE (Degree)	RAW VALUE (dBuV)	CORRECTION FACTOR (dB/m)
1	*2452.00	103.6 PK			1.90 V	192	106.02	-2.42
2	*2452.00	91.4 AV			1.90 V	192	93.82	-2.42
3	2483.50	66.2 PK	74.0	-7.8	1.90 V	192	68.50	-2.30
4	2483.50	48.3 AV	54.0	-5.7	1.90 V	192	50.60	-2.30
5	4904.00	43.8 PK	74.0	-30.2	2.09 V	147	39.44	4.36
6	4904.00	29.9 AV	54.0	-24.1	2.09 V	147	25.54	4.36
7	7356.00	48.0 PK	74.0	-26.0	2.66 V	142	37.24	10.76
8	7356.00	36.2 AV	54.0	-17.8	2.66 V	142	25.44	10.76

REMARKS:

1. Emission Level(dBuV/m) = Raw Value(dBuV) + Correction Factor(dB/m)
2. Correction Factor(dB/m) = Antenna Factor(dB/m) + Cable Factor(dB) – Pre-Amplifier Factor(dB)
3. The other emission levels were very low against the limit.
4. Margin value = Emission Level – Limit value
5. " * ": Fundamental frequency.

Below 1GHz Data:

802.11b

CHANNEL	TX Channel 1	DETECTOR FUNCTION	Quasi-Peak (QP)
FREQUENCY RANGE	Below 1GHz		

ANTENNA POLARITY & TEST DISTANCE: HORIZONTAL AT 3 M

NO.	FREQ. (MHz)	EMISSION LEVEL (dBuV/m)	LIMIT (dBuV/m)	MARGIN (dB)	ANTENNA HEIGHT (m)	TABLE ANGLE (Degree)	RAW VALUE (dBuV)	CORRECTION FACTOR (dB/m)
1	33.87	24.6 QP	40.0	-15.4	1.44 H	155	34.20	-9.60
2	195.19	40.4 QP	43.5	-3.1	1.51 H	36	51.70	-11.30
3	260.22	42.6 QP	46.0	-3.4	1.49 H	43	51.50	-8.90
4	379.58	33.0 QP	46.0	-13.0	1.14 H	341	38.30	-5.30
5	695.86	37.4 QP	46.0	-8.6	1.04 H	329	36.00	1.40
6	1000.00	41.1 QP	54.0	-12.9	1.94 H	262	35.40	5.70

ANTENNA POLARITY & TEST DISTANCE: VERTICAL AT 3 M

NO.	FREQ. (MHz)	EMISSION LEVEL (dBuV/m)	LIMIT (dBuV/m)	MARGIN (dB)	ANTENNA HEIGHT (m)	TABLE ANGLE (Degree)	RAW VALUE (dBuV)	CORRECTION FACTOR (dB/m)
1	97.99	25.3 QP	43.5	-18.2	1.94 V	312	38.80	-13.50
2	195.82	33.4 QP	43.5	-10.1	1.59 V	237	44.80	-11.40
3	259.63	38.5 QP	46.0	-7.5	1.96 V	123	47.60	-9.10
4	325.51	32.4 QP	46.0	-13.6	1.08 V	39	38.80	-6.40
5	749.66	36.8 QP	46.0	-9.2	1.58 V	325	34.40	2.40
6	1000.00	39.2 QP	54.0	-14.8	1.00 V	287	33.50	5.70

REMARKS:

1. Emission Level(dBuV/m) = Raw Value(dBuV) + Correction Factor(dB/m)
2. Correction Factor(dB/m) = Antenna Factor(dB/m) + Cable Factor(dB) – Pre-Amplifier Factor(dB)
3. The other emission levels were very low against the limit.
4. Margin value = Emission Level – Limit value

CHANNEL	TX Channel 2	DETECTOR FUNCTION	Quasi-Peak (QP)
FREQUENCY RANGE	Below 1GHz		

ANTENNA POLARITY & TEST DISTANCE: HORIZONTAL AT 3 M

NO.	FREQ. (MHz)	EMISSION LEVEL (dBuV/m)	LIMIT (dBuV/m)	MARGIN (dB)	ANTENNA HEIGHT (m)	TABLE ANGLE (Degree)	RAW VALUE (dBuV)	CORRECTION FACTOR (dB/m)
1	33.59	24.0 QP	40.0	-16.0	1.45 H	180	33.60	-9.60
2	194.70	40.3 QP	43.5	-3.2	1.50 H	61	51.60	-11.30
3	260.27	42.4 QP	46.0	-3.6	1.49 H	44	51.30	-8.90
4	379.93	33.1 QP	46.0	-12.9	1.14 H	346	38.40	-5.30
5	696.01	37.4 QP	46.0	-8.6	1.01 H	327	36.00	1.40
6	1000.00	41.3 QP	54.0	-12.7	2.01 H	268	35.60	5.70

ANTENNA POLARITY & TEST DISTANCE: VERTICAL AT 3 M

NO.	FREQ. (MHz)	EMISSION LEVEL (dBuV/m)	LIMIT (dBuV/m)	MARGIN (dB)	ANTENNA HEIGHT (m)	TABLE ANGLE (Degree)	RAW VALUE (dBuV)	CORRECTION FACTOR (dB/m)
1	98.07	25.5 QP	43.5	-18.0	1.88 V	316	39.00	-13.50
2	195.70	33.6 QP	43.5	-9.9	1.61 V	220	45.00	-11.40
3	260.06	38.7 QP	46.0	-7.3	2.03 V	147	47.60	-8.90
4	325.83	32.3 QP	46.0	-13.7	1.08 V	52	38.70	-6.40
5	749.49	36.6 QP	46.0	-9.4	1.64 V	347	34.20	2.40
6	1000.00	39.2 QP	54.0	-14.8	1.00 V	273	33.50	5.70

REMARKS:

1. Emission Level(dBuV/m) = Raw Value(dBuV) + Correction Factor(dB/m)
2. Correction Factor(dB/m) = Antenna Factor(dB/m) + Cable Factor(dB) – Pre-Amplifier Factor(dB)
3. The other emission levels were very low against the limit.
4. Margin value = Emission Level – Limit value

CHANNEL	TX Channel 6	DETECTOR FUNCTION	Quasi-Peak (QP)
FREQUENCY RANGE	Below 1GHz		

ANTENNA POLARITY & TEST DISTANCE: HORIZONTAL AT 3 M

NO.	FREQ. (MHz)	EMISSION LEVEL (dBuV/m)	LIMIT (dBuV/m)	MARGIN (dB)	ANTENNA HEIGHT (m)	TABLE ANGLE (Degree)	RAW VALUE (dBuV)	CORRECTION FACTOR (dB/m)
1	33.61	24.5 QP	40.0	-15.5	1.44 H	182	34.10	-9.60
2	194.73	40.4 QP	43.5	-3.1	1.48 H	61	51.70	-11.30
3	259.96	42.2 QP	46.0	-3.8	1.49 H	64	51.20	-9.00
4	379.85	33.0 QP	46.0	-13.0	1.13 H	346	38.30	-5.30
5	695.73	37.1 QP	46.0	-8.9	1.00 H	319	35.70	1.40
6	1000.00	41.6 QP	54.0	-12.4	2.00 H	248	35.90	5.70

ANTENNA POLARITY & TEST DISTANCE: VERTICAL AT 3 M

NO.	FREQ. (MHz)	EMISSION LEVEL (dBuV/m)	LIMIT (dBuV/m)	MARGIN (dB)	ANTENNA HEIGHT (m)	TABLE ANGLE (Degree)	RAW VALUE (dBuV)	CORRECTION FACTOR (dB/m)
1	98.27	25.6 QP	43.5	-17.9	1.99 V	307	39.00	-13.40
2	195.89	33.8 QP	43.5	-9.7	1.56 V	225	45.20	-11.40
3	259.87	38.6 QP	46.0	-7.4	2.06 V	143	47.60	-9.00
4	325.85	32.0 QP	46.0	-14.0	1.00 V	37	38.40	-6.40
5	749.86	37.1 QP	46.0	-8.9	1.62 V	337	34.70	2.40
6	1000.00	39.1 QP	54.0	-14.9	1.03 V	298	33.40	5.70

REMARKS:

1. Emission Level(dBuV/m) = Raw Value(dBuV) + Correction Factor(dB/m)
2. Correction Factor(dB/m) = Antenna Factor(dB/m) + Cable Factor(dB) – Pre-Amplifier Factor(dB)
3. The other emission levels were very low against the limit.
4. Margin value = Emission Level – Limit value

CHANNEL	TX Channel 10	DETECTOR FUNCTION	Quasi-Peak (QP)
FREQUENCY RANGE	Below 1GHz		

ANTENNA POLARITY & TEST DISTANCE: HORIZONTAL AT 3 M

NO.	FREQ. (MHz)	EMISSION LEVEL (dBuV/m)	LIMIT (dBuV/m)	MARGIN (dB)	ANTENNA HEIGHT (m)	TABLE ANGLE (Degree)	RAW VALUE (dBuV)	CORRECTION FACTOR (dB/m)
1	33.68	24.4 QP	40.0	-15.6	1.54 H	170	34.00	-9.60
2	195.17	40.4 QP	43.5	-3.1	1.50 H	40	51.70	-11.30
3	260.28	42.3 QP	46.0	-3.7	1.45 H	42	51.20	-8.90
4	379.63	33.2 QP	46.0	-12.8	1.08 H	346	38.50	-5.30
5	695.60	37.5 QP	46.0	-8.5	1.00 H	341	36.10	1.40
6	1000.00	41.4 QP	54.0	-12.6	1.99 H	261	35.70	5.70

ANTENNA POLARITY & TEST DISTANCE: VERTICAL AT 3 M

NO.	FREQ. (MHz)	EMISSION LEVEL (dBuV/m)	LIMIT (dBuV/m)	MARGIN (dB)	ANTENNA HEIGHT (m)	TABLE ANGLE (Degree)	RAW VALUE (dBuV)	CORRECTION FACTOR (dB/m)
1	98.49	25.3 QP	43.5	-18.2	2.00 V	318	38.60	-13.30
2	195.96	33.8 QP	43.5	-9.7	1.57 V	242	45.20	-11.40
3	259.96	38.8 QP	46.0	-7.2	2.02 V	143	47.80	-9.00
4	325.62	32.0 QP	46.0	-14.0	1.04 V	34	38.40	-6.40
5	749.71	36.9 QP	46.0	-9.1	1.58 V	326	34.50	2.40
6	1000.00	39.3 QP	54.0	-14.7	1.01 V	280	33.60	5.70

REMARKS:

1. Emission Level(dBuV/m) = Raw Value(dBuV) + Correction Factor(dB/m)
2. Correction Factor(dB/m) = Antenna Factor(dB/m) + Cable Factor(dB) – Pre-Amplifier Factor(dB)
3. The other emission levels were very low against the limit.
4. Margin value = Emission Level – Limit value

CHANNEL	TX Channel 11	DETECTOR FUNCTION	Quasi-Peak (QP)
FREQUENCY RANGE	Below 1GHz		

ANTENNA POLARITY & TEST DISTANCE: HORIZONTAL AT 3 M

NO.	FREQ. (MHz)	EMISSION LEVEL (dBuV/m)	LIMIT (dBuV/m)	MARGIN (dB)	ANTENNA HEIGHT (m)	TABLE ANGLE (Degree)	RAW VALUE (dBuV)	CORRECTION FACTOR (dB/m)
1	33.96	24.1 QP	40.0	-15.9	1.51 H	153	33.60	-9.50
2	194.74	40.2 QP	43.5	-3.3	1.46 H	58	51.50	-11.30
3	260.34	42.2 QP	46.0	-3.8	1.45 H	53	51.10	-8.90
4	379.59	32.9 QP	46.0	-13.1	1.12 H	325	38.20	-5.30
5	695.74	37.7 QP	46.0	-8.3	1.00 H	341	36.30	1.40
6	1000.00	41.1 QP	54.0	-12.9	1.99 H	258	35.40	5.70

ANTENNA POLARITY & TEST DISTANCE: VERTICAL AT 3 M

NO.	FREQ. (MHz)	EMISSION LEVEL (dBuV/m)	LIMIT (dBuV/m)	MARGIN (dB)	ANTENNA HEIGHT (m)	TABLE ANGLE (Degree)	RAW VALUE (dBuV)	CORRECTION FACTOR (dB/m)
1	98.30	25.7 QP	43.5	-17.8	1.91 V	308	39.10	-13.40
2	196.10	33.4 QP	43.5	-10.1	1.56 V	236	44.80	-11.40
3	259.60	38.7 QP	46.0	-7.3	2.04 V	129	47.80	-9.10
4	325.56	32.1 QP	46.0	-13.9	1.09 V	27	38.50	-6.40
5	749.49	36.5 QP	46.0	-9.5	1.62 V	319	34.10	2.40
6	1000.00	38.8 QP	54.0	-15.2	1.03 V	298	33.10	5.70

REMARKS:

1. Emission Level(dBuV/m) = Raw Value(dBuV) + Correction Factor(dB/m)
2. Correction Factor(dB/m) = Antenna Factor(dB/m) + Cable Factor(dB) – Pre-Amplifier Factor(dB)
3. The other emission levels were very low against the limit.
4. Margin value = Emission Level – Limit value

802.11g

CHANNEL	TX Channel 1	DETECTOR FUNCTION	Quasi-Peak (QP)
FREQUENCY RANGE	Below 1GHz		

ANTENNA POLARITY & TEST DISTANCE: HORIZONTAL AT 3 M

NO.	FREQ. (MHz)	EMISSION LEVEL (dBuV/m)	LIMIT (dBuV/m)	MARGIN (dB)	ANTENNA HEIGHT (m)	TABLE ANGLE (Degree)	RAW VALUE (dBuV)	CORRECTION FACTOR (dB/m)
1	33.98	24.3 QP	40.0	-15.7	1.55 H	155	33.80	-9.50
2	195.13	39.9 QP	43.5	-3.6	1.46 H	49	51.20	-11.30
3	259.96	42.2 QP	46.0	-3.8	1.48 H	52	51.20	-9.00
4	379.52	32.8 QP	46.0	-13.2	1.06 H	333	38.10	-5.30
5	695.63	37.4 QP	46.0	-8.6	1.03 H	322	36.00	1.40
6	1000.00	41.6 QP	54.0	-12.4	1.99 H	256	35.90	5.70

ANTENNA POLARITY & TEST DISTANCE: VERTICAL AT 3 M

NO.	FREQ. (MHz)	EMISSION LEVEL (dBuV/m)	LIMIT (dBuV/m)	MARGIN (dB)	ANTENNA HEIGHT (m)	TABLE ANGLE (Degree)	RAW VALUE (dBuV)	CORRECTION FACTOR (dB/m)
1	98.41	25.3 QP	43.5	-18.2	1.96 V	335	38.60	-13.30
2	195.63	33.8 QP	43.5	-9.7	1.59 V	228	45.20	-11.40
3	259.63	38.9 QP	46.0	-7.1	2.03 V	140	48.00	-9.10
4	325.56	32.5 QP	46.0	-13.5	1.01 V	44	38.90	-6.40
5	749.87	36.7 QP	46.0	-9.3	1.57 V	342	34.30	2.40
6	1000.00	39.2 QP	54.0	-14.8	1.00 V	276	33.50	5.70

REMARKS:

1. Emission Level(dBuV/m) = Raw Value(dBuV) + Correction Factor(dB/m)
2. Correction Factor(dB/m) = Antenna Factor(dB/m) + Cable Factor(dB) – Pre-Amplifier Factor(dB)
3. The other emission levels were very low against the limit.
4. Margin value = Emission Level – Limit value

CHANNEL	TX Channel 2	DETECTOR FUNCTION	Quasi-Peak (QP)
FREQUENCY RANGE	Below 1GHz		

ANTENNA POLARITY & TEST DISTANCE: HORIZONTAL AT 3 M

NO.	FREQ. (MHz)	EMISSION LEVEL (dBuV/m)	LIMIT (dBuV/m)	MARGIN (dB)	ANTENNA HEIGHT (m)	TABLE ANGLE (Degree)	RAW VALUE (dBuV)	CORRECTION FACTOR (dB/m)
1	33.53	24.6 QP	40.0	-15.4	1.53 H	155	34.20	-9.60
2	195.03	40.3 QP	43.5	-3.2	1.50 H	54	51.60	-11.30
3	259.90	42.3 QP	46.0	-3.7	1.51 H	45	51.30	-9.00
4	379.85	33.3 QP	46.0	-12.7	1.08 H	326	38.60	-5.30
5	695.84	37.6 QP	46.0	-8.4	1.02 H	342	36.20	1.40
6	1000.00	41.3 QP	54.0	-12.7	2.03 H	259	35.60	5.70

ANTENNA POLARITY & TEST DISTANCE: VERTICAL AT 3 M

NO.	FREQ. (MHz)	EMISSION LEVEL (dBuV/m)	LIMIT (dBuV/m)	MARGIN (dB)	ANTENNA HEIGHT (m)	TABLE ANGLE (Degree)	RAW VALUE (dBuV)	CORRECTION FACTOR (dB/m)
1	98.51	25.4 QP	43.5	-18.1	1.93 V	332	38.70	-13.30
2	195.75	33.7 QP	43.5	-9.8	1.62 V	218	45.10	-11.40
3	260.02	38.9 QP	46.0	-7.1	2.00 V	140	47.80	-8.90
4	325.59	32.5 QP	46.0	-13.5	1.07 V	49	38.90	-6.40
5	749.79	36.7 QP	46.0	-9.3	1.57 V	338	34.30	2.40
6	1000.00	39.0 QP	54.0	-15.0	1.00 V	292	33.30	5.70

REMARKS:

1. Emission Level(dBuV/m) = Raw Value(dBuV) + Correction Factor(dB/m)
2. Correction Factor(dB/m) = Antenna Factor(dB/m) + Cable Factor(dB) – Pre-Amplifier Factor(dB)
3. The other emission levels were very low against the limit.
4. Margin value = Emission Level – Limit value

CHANNEL	TX Channel 6	DETECTOR FUNCTION	Quasi-Peak (QP)
FREQUENCY RANGE	Below 1GHz		

ANTENNA POLARITY & TEST DISTANCE: HORIZONTAL AT 3 M

NO.	FREQ. (MHz)	EMISSION LEVEL (dBuV/m)	LIMIT (dBuV/m)	MARGIN (dB)	ANTENNA HEIGHT (m)	TABLE ANGLE (Degree)	RAW VALUE (dBuV)	CORRECTION FACTOR (dB/m)
1	33.41	24.1 QP	40.0	-15.9	1.44 H	171	33.70	-9.60
2	194.77	40.2 QP	43.5	-3.3	1.52 H	49	51.50	-11.30
3	259.91	42.2 QP	46.0	-3.8	1.46 H	65	51.20	-9.00
4	379.97	33.1 QP	46.0	-12.9	1.07 H	349	38.40	-5.30
5	696.01	37.6 QP	46.0	-8.4	1.02 H	330	36.20	1.40
6	1000.00	41.2 QP	54.0	-12.8	2.01 H	267	35.50	5.70

ANTENNA POLARITY & TEST DISTANCE: VERTICAL AT 3 M

NO.	FREQ. (MHz)	EMISSION LEVEL (dBuV/m)	LIMIT (dBuV/m)	MARGIN (dB)	ANTENNA HEIGHT (m)	TABLE ANGLE (Degree)	RAW VALUE (dBuV)	CORRECTION FACTOR (dB/m)
1	98.31	25.4 QP	43.5	-18.1	1.88 V	315	38.80	-13.40
2	196.08	33.9 QP	43.5	-9.6	1.62 V	241	45.30	-11.40
3	259.87	39.0 QP	46.0	-7.0	1.98 V	129	48.00	-9.00
4	325.39	32.4 QP	46.0	-13.6	1.00 V	47	38.80	-6.40
5	749.46	36.5 QP	46.0	-9.5	1.57 V	324	34.10	2.40
6	1000.00	39.2 QP	54.0	-14.8	1.02 V	273	33.50	5.70

REMARKS:

1. Emission Level(dBuV/m) = Raw Value(dBuV) + Correction Factor(dB/m)
2. Correction Factor(dB/m) = Antenna Factor(dB/m) + Cable Factor(dB) – Pre-Amplifier Factor(dB)
3. The other emission levels were very low against the limit.
4. Margin value = Emission Level – Limit value

CHANNEL	TX Channel 10	DETECTOR FUNCTION	Quasi-Peak (QP)
FREQUENCY RANGE	Below 1GHz		

ANTENNA POLARITY & TEST DISTANCE: HORIZONTAL AT 3 M

NO.	FREQ. (MHz)	EMISSION LEVEL (dBuV/m)	LIMIT (dBuV/m)	MARGIN (dB)	ANTENNA HEIGHT (m)	TABLE ANGLE (Degree)	RAW VALUE (dBuV)	CORRECTION FACTOR (dB/m)
1	33.48	24.3 QP	40.0	-15.7	1.49 H	174	33.90	-9.60
2	194.70	40.0 QP	43.5	-3.5	1.48 H	49	51.30	-11.30
3	260.06	42.5 QP	46.0	-3.5	1.41 H	49	51.40	-8.90
4	379.80	32.8 QP	46.0	-13.2	1.15 H	337	38.10	-5.30
5	695.78	37.3 QP	46.0	-8.7	1.04 H	329	35.90	1.40
6	1000.00	41.4 QP	54.0	-12.6	1.96 H	256	35.70	5.70

ANTENNA POLARITY & TEST DISTANCE: VERTICAL AT 3 M

NO.	FREQ. (MHz)	EMISSION LEVEL (dBuV/m)	LIMIT (dBuV/m)	MARGIN (dB)	ANTENNA HEIGHT (m)	TABLE ANGLE (Degree)	RAW VALUE (dBuV)	CORRECTION FACTOR (dB/m)
1	98.39	25.3 QP	43.5	-18.2	1.96 V	313	38.60	-13.30
2	195.66	33.7 QP	43.5	-9.8	1.63 V	236	45.10	-11.40
3	260.02	38.6 QP	46.0	-7.4	1.98 V	126	47.50	-8.90
4	325.90	32.1 QP	46.0	-13.9	1.10 V	33	38.50	-6.40
5	749.44	36.9 QP	46.0	-9.1	1.57 V	330	34.50	2.40
6	1000.00	38.9 QP	54.0	-15.1	1.00 V	293	33.20	5.70

REMARKS:

1. Emission Level(dBuV/m) = Raw Value(dBuV) + Correction Factor(dB/m)
2. Correction Factor(dB/m) = Antenna Factor(dB/m) + Cable Factor(dB) – Pre-Amplifier Factor(dB)
3. The other emission levels were very low against the limit.
4. Margin value = Emission Level – Limit value

CHANNEL	TX Channel 11	DETECTOR FUNCTION	Quasi-Peak (QP)
FREQUENCY RANGE	Below 1GHz		

ANTENNA POLARITY & TEST DISTANCE: HORIZONTAL AT 3 M

NO.	FREQ. (MHz)	EMISSION LEVEL (dBuV/m)	LIMIT (dBuV/m)	MARGIN (dB)	ANTENNA HEIGHT (m)	TABLE ANGLE (Degree)	RAW VALUE (dBuV)	CORRECTION FACTOR (dB/m)
1	33.54	24.1 QP	40.0	-15.9	1.47 H	183	33.70	-9.60
2	195.01	40.5 QP	43.5	-3.0	1.46 H	58	51.80	-11.30
3	260.14	42.3 QP	46.0	-3.7	1.49 H	58	51.20	-8.90
4	379.63	32.8 QP	46.0	-13.2	1.16 H	333	38.10	-5.30
5	695.82	37.1 QP	46.0	-8.9	1.02 H	326	35.70	1.40
6	1000.00	41.2 QP	54.0	-12.8	1.99 H	263	35.50	5.70

ANTENNA POLARITY & TEST DISTANCE: VERTICAL AT 3 M

NO.	FREQ. (MHz)	EMISSION LEVEL (dBuV/m)	LIMIT (dBuV/m)	MARGIN (dB)	ANTENNA HEIGHT (m)	TABLE ANGLE (Degree)	RAW VALUE (dBuV)	CORRECTION FACTOR (dB/m)
1	98.04	25.7 QP	43.5	-17.8	2.00 V	307	39.20	-13.50
2	196.16	33.7 QP	43.5	-9.8	1.59 V	241	45.10	-11.40
3	259.63	39.0 QP	46.0	-7.0	1.98 V	142	48.10	-9.10
4	325.74	32.1 QP	46.0	-13.9	1.09 V	47	38.50	-6.40
5	749.41	36.7 QP	46.0	-9.3	1.58 V	325	34.30	2.40
6	1000.00	38.9 QP	54.0	-15.1	1.02 V	300	33.20	5.70

REMARKS:

1. Emission Level(dBuV/m) = Raw Value(dBuV) + Correction Factor(dB/m)
2. Correction Factor(dB/m) = Antenna Factor(dB/m) + Cable Factor(dB) – Pre-Amplifier Factor(dB)
3. The other emission levels were very low against the limit.
4. Margin value = Emission Level – Limit value

802.11n (HT20)

CHANNEL	TX Channel 1	DETECTOR FUNCTION	Quasi-Peak (QP)
FREQUENCY RANGE	Below 1GHz		

ANTENNA POLARITY & TEST DISTANCE: HORIZONTAL AT 3 M

NO.	FREQ. (MHz)	EMISSION LEVEL (dBuV/m)	LIMIT (dBuV/m)	MARGIN (dB)	ANTENNA HEIGHT (m)	TABLE ANGLE (Degree)	RAW VALUE (dBuV)	CORRECTION FACTOR (dB/m)
1	33.40	24.0 QP	40.0	-16.0	1.52 H	180	33.60	-9.60
2	194.68	40.0 QP	43.5	-3.5	1.49 H	35	51.30	-11.30
3	259.86	42.4 QP	46.0	-3.6	1.48 H	49	51.40	-9.00
4	379.91	33.0 QP	46.0	-13.0	1.16 H	341	38.30	-5.30
5	695.90	37.5 QP	46.0	-8.5	1.02 H	319	36.10	1.40
6	1000.00	41.2 QP	54.0	-12.8	1.96 H	270	35.50	5.70

ANTENNA POLARITY & TEST DISTANCE: VERTICAL AT 3 M

NO.	FREQ. (MHz)	EMISSION LEVEL (dBuV/m)	LIMIT (dBuV/m)	MARGIN (dB)	ANTENNA HEIGHT (m)	TABLE ANGLE (Degree)	RAW VALUE (dBuV)	CORRECTION FACTOR (dB/m)
1	98.06	25.3 QP	43.5	-18.2	1.98 V	307	38.80	-13.50
2	196.15	33.5 QP	43.5	-10.0	1.63 V	230	44.90	-11.40
3	259.96	38.7 QP	46.0	-7.3	1.99 V	131	47.70	-9.00
4	325.59	32.2 QP	46.0	-13.8	1.00 V	34	38.60	-6.40
5	749.65	37.1 QP	46.0	-8.9	1.65 V	330	34.70	2.40
6	1000.00	38.8 QP	54.0	-15.2	1.00 V	271	33.10	5.70

REMARKS:

1. Emission Level(dBuV/m) = Raw Value(dBuV) + Correction Factor(dB/m)
2. Correction Factor(dB/m) = Antenna Factor(dB/m) + Cable Factor(dB) – Pre-Amplifier Factor(dB)
3. The other emission levels were very low against the limit.
4. Margin value = Emission Level – Limit value

CHANNEL	TX Channel 2	DETECTOR FUNCTION	Quasi-Peak (QP)
FREQUENCY RANGE	Below 1GHz		

ANTENNA POLARITY & TEST DISTANCE: HORIZONTAL AT 3 M

NO.	FREQ. (MHz)	EMISSION LEVEL (dBuV/m)	LIMIT (dBuV/m)	MARGIN (dB)	ANTENNA HEIGHT (m)	TABLE ANGLE (Degree)	RAW VALUE (dBuV)	CORRECTION FACTOR (dB/m)
1	33.52	24.5 QP	40.0	-15.5	1.53 H	179	34.10	-9.60
2	194.70	40.4 QP	43.5	-3.1	1.45 H	51	51.70	-11.30
3	260.06	42.5 QP	46.0	-3.5	1.49 H	51	51.40	-8.90
4	379.64	32.8 QP	46.0	-13.2	1.13 H	339	38.10	-5.30
5	695.95	37.2 QP	46.0	-8.8	1.00 H	322	35.80	1.40
6	1000.00	41.5 QP	54.0	-12.5	1.95 H	259	35.80	5.70

ANTENNA POLARITY & TEST DISTANCE: VERTICAL AT 3 M

NO.	FREQ. (MHz)	EMISSION LEVEL (dBuV/m)	LIMIT (dBuV/m)	MARGIN (dB)	ANTENNA HEIGHT (m)	TABLE ANGLE (Degree)	RAW VALUE (dBuV)	CORRECTION FACTOR (dB/m)
1	98.52	25.5 QP	43.5	-18.0	1.95 V	321	38.80	-13.30
2	195.97	34.0 QP	43.5	-9.5	1.57 V	244	45.40	-11.40
3	259.76	39.0 QP	46.0	-7.0	2.03 V	135	48.10	-9.10
4	325.50	32.4 QP	46.0	-13.6	1.02 V	36	38.80	-6.40
5	749.75	36.6 QP	46.0	-9.4	1.63 V	321	34.20	2.40
6	1000.00	39.3 QP	54.0	-14.7	1.00 V	278	33.60	5.70

REMARKS:

1. Emission Level(dBuV/m) = Raw Value(dBuV) + Correction Factor(dB/m)
2. Correction Factor(dB/m) = Antenna Factor(dB/m) + Cable Factor(dB) – Pre-Amplifier Factor(dB)
3. The other emission levels were very low against the limit.
4. Margin value = Emission Level – Limit value

CHANNEL	TX Channel 6	DETECTOR FUNCTION	Quasi-Peak (QP)
FREQUENCY RANGE	Below 1GHz		

ANTENNA POLARITY & TEST DISTANCE: HORIZONTAL AT 3 M

NO.	FREQ. (MHz)	EMISSION LEVEL (dBuV/m)	LIMIT (dBuV/m)	MARGIN (dB)	ANTENNA HEIGHT (m)	TABLE ANGLE (Degree)	RAW VALUE (dBuV)	CORRECTION FACTOR (dB/m)
1	33.46	24.4 QP	40.0	-15.6	1.51 H	162	34.00	-9.60
2	194.87	39.9 QP	43.5	-3.6	1.44 H	31	51.20	-11.30
3	260.15	42.3 QP	46.0	-3.7	1.50 H	42	51.20	-8.90
4	379.63	33.0 QP	46.0	-13.0	1.11 H	335	38.30	-5.30
5	696.07	37.2 QP	46.0	-8.8	1.00 H	331	35.80	1.40
6	1000.00	41.3 QP	54.0	-12.7	2.00 H	266	35.60	5.70

ANTENNA POLARITY & TEST DISTANCE: VERTICAL AT 3 M

NO.	FREQ. (MHz)	EMISSION LEVEL (dBuV/m)	LIMIT (dBuV/m)	MARGIN (dB)	ANTENNA HEIGHT (m)	TABLE ANGLE (Degree)	RAW VALUE (dBuV)	CORRECTION FACTOR (dB/m)
1	97.97	25.8 QP	43.5	-17.7	1.90 V	311	39.30	-13.50
2	195.90	33.9 QP	43.5	-9.6	1.56 V	225	45.30	-11.40
3	259.75	39.0 QP	46.0	-7.0	2.05 V	150	48.10	-9.10
4	325.46	31.9 QP	46.0	-14.1	1.06 V	38	38.30	-6.40
5	749.73	36.6 QP	46.0	-9.4	1.57 V	342	34.20	2.40
6	1000.00	39.1 QP	54.0	-14.9	1.01 V	274	33.40	5.70

REMARKS:

1. Emission Level(dBuV/m) = Raw Value(dBuV) + Correction Factor(dB/m)
2. Correction Factor(dB/m) = Antenna Factor(dB/m) + Cable Factor(dB) – Pre-Amplifier Factor(dB)
3. The other emission levels were very low against the limit.
4. Margin value = Emission Level – Limit value

CHANNEL	TX Channel 10	DETECTOR FUNCTION	Quasi-Peak (QP)
FREQUENCY RANGE	Below 1GHz		

ANTENNA POLARITY & TEST DISTANCE: HORIZONTAL AT 3 M

NO.	FREQ. (MHz)	EMISSION LEVEL (dBuV/m)	LIMIT (dBuV/m)	MARGIN (dB)	ANTENNA HEIGHT (m)	TABLE ANGLE (Degree)	RAW VALUE (dBuV)	CORRECTION FACTOR (dB/m)
1	33.55	24.2 QP	40.0	-15.8	1.48 H	182	33.80	-9.60
2	194.76	40.1 QP	43.5	-3.4	1.44 H	32	51.40	-11.30
3	260.17	42.2 QP	46.0	-3.8	1.47 H	44	51.10	-8.90
4	379.81	32.7 QP	46.0	-13.3	1.12 H	352	38.00	-5.30
5	695.73	37.3 QP	46.0	-8.7	1.03 H	314	35.90	1.40
6	1000.00	41.2 QP	54.0	-12.8	1.95 H	278	35.50	5.70

ANTENNA POLARITY & TEST DISTANCE: VERTICAL AT 3 M

NO.	FREQ. (MHz)	EMISSION LEVEL (dBuV/m)	LIMIT (dBuV/m)	MARGIN (dB)	ANTENNA HEIGHT (m)	TABLE ANGLE (Degree)	RAW VALUE (dBuV)	CORRECTION FACTOR (dB/m)
1	98.26	25.4 QP	43.5	-18.1	1.96 V	314	38.80	-13.40
2	195.69	33.9 QP	43.5	-9.6	1.54 V	220	45.30	-11.40
3	259.55	38.6 QP	46.0	-7.4	2.07 V	150	47.70	-9.10
4	325.91	32.5 QP	46.0	-13.5	1.01 V	36	38.90	-6.40
5	749.52	36.9 QP	46.0	-9.1	1.59 V	347	34.50	2.40
6	1000.00	39.2 QP	54.0	-14.8	1.00 V	276	33.50	5.70

REMARKS:

1. Emission Level(dBuV/m) = Raw Value(dBuV) + Correction Factor(dB/m)
2. Correction Factor(dB/m) = Antenna Factor(dB/m) + Cable Factor(dB) – Pre-Amplifier Factor(dB)
3. The other emission levels were very low against the limit.
4. Margin value = Emission Level – Limit value

CHANNEL	TX Channel 11	DETECTOR FUNCTION	Quasi-Peak (QP)
FREQUENCY RANGE	Below 1GHz		

ANTENNA POLARITY & TEST DISTANCE: HORIZONTAL AT 3 M

NO.	FREQ. (MHz)	EMISSION LEVEL (dBuV/m)	LIMIT (dBuV/m)	MARGIN (dB)	ANTENNA HEIGHT (m)	TABLE ANGLE (Degree)	RAW VALUE (dBuV)	CORRECTION FACTOR (dB/m)
1	33.51	24.1 QP	40.0	-15.9	1.49 H	172	33.70	-9.60
2	194.99	40.5 QP	43.5	-3.0	1.50 H	51	51.80	-11.30
3	259.93	42.3 QP	46.0	-3.7	1.42 H	71	51.30	-9.00
4	379.66	32.8 QP	46.0	-13.2	1.11 H	353	38.10	-5.30
5	695.58	37.5 QP	46.0	-8.5	1.00 H	342	36.10	1.40
6	1000.00	41.3 QP	54.0	-12.7	1.99 H	257	35.60	5.70

ANTENNA POLARITY & TEST DISTANCE: VERTICAL AT 3 M

NO.	FREQ. (MHz)	EMISSION LEVEL (dBuV/m)	LIMIT (dBuV/m)	MARGIN (dB)	ANTENNA HEIGHT (m)	TABLE ANGLE (Degree)	RAW VALUE (dBuV)	CORRECTION FACTOR (dB/m)
1	98.17	25.4 QP	43.5	-18.1	1.88 V	306	38.80	-13.40
2	196.05	33.7 QP	43.5	-9.8	1.62 V	216	45.10	-11.40
3	259.84	38.6 QP	46.0	-7.4	2.04 V	140	47.60	-9.00
4	325.76	32.0 QP	46.0	-14.0	1.03 V	40	38.40	-6.40
5	749.63	37.0 QP	46.0	-9.0	1.62 V	334	34.60	2.40
6	1000.00	39.0 QP	54.0	-15.0	1.00 V	298	33.30	5.70

REMARKS:

1. Emission Level(dBuV/m) = Raw Value(dBuV) + Correction Factor(dB/m)
2. Correction Factor(dB/m) = Antenna Factor(dB/m) + Cable Factor(dB) – Pre-Amplifier Factor(dB)
3. The other emission levels were very low against the limit.
4. Margin value = Emission Level – Limit value

802.11n (HT40)

CHANNEL	TX Channel 3	DETECTOR FUNCTION	Quasi-Peak (QP)
FREQUENCY RANGE	Below 1GHz		

ANTENNA POLARITY & TEST DISTANCE: HORIZONTAL AT 3 M

NO.	FREQ. (MHz)	EMISSION LEVEL (dBuV/m)	LIMIT (dBuV/m)	MARGIN (dB)	ANTENNA HEIGHT (m)	TABLE ANGLE (Degree)	RAW VALUE (dBuV)	CORRECTION FACTOR (dB/m)
1	33.86	24.2 QP	40.0	-15.8	1.45 H	174	33.80	-9.60
2	194.65	40.2 QP	43.5	-3.3	1.50 H	52	51.50	-11.30
3	259.87	42.2 QP	46.0	-3.8	1.42 H	69	51.20	-9.00
4	380.09	33.0 QP	46.0	-13.0	1.13 H	330	38.30	-5.30
5	695.72	37.6 QP	46.0	-8.4	1.00 H	326	36.20	1.40
6	1000.00	41.5 QP	54.0	-12.5	1.94 H	258	35.80	5.70

ANTENNA POLARITY & TEST DISTANCE: VERTICAL AT 3 M

NO.	FREQ. (MHz)	EMISSION LEVEL (dBuV/m)	LIMIT (dBuV/m)	MARGIN (dB)	ANTENNA HEIGHT (m)	TABLE ANGLE (Degree)	RAW VALUE (dBuV)	CORRECTION FACTOR (dB/m)
1	98.17	25.5 QP	43.5	-18.0	2.00 V	321	38.90	-13.40
2	195.91	33.9 QP	43.5	-9.6	1.55 V	238	45.30	-11.40
3	259.89	39.0 QP	46.0	-7.0	2.02 V	143	48.00	-9.00
4	325.41	32.3 QP	46.0	-13.7	1.00 V	27	38.70	-6.40
5	749.68	37.1 QP	46.0	-8.9	1.67 V	342	34.70	2.40
6	1000.00	38.8 QP	54.0	-15.2	1.00 V	296	33.10	5.70

REMARKS:

1. Emission Level(dBuV/m) = Raw Value(dBuV) + Correction Factor(dB/m)
2. Correction Factor(dB/m) = Antenna Factor(dB/m) + Cable Factor(dB) – Pre-Amplifier Factor(dB)
3. The other emission levels were very low against the limit.
4. Margin value = Emission Level – Limit value

CHANNEL	TX Channel 4	DETECTOR FUNCTION	Quasi-Peak (QP)
FREQUENCY RANGE	Below 1GHz		

ANTENNA POLARITY & TEST DISTANCE: HORIZONTAL AT 3 M

NO.	FREQ. (MHz)	EMISSION LEVEL (dBuV/m)	LIMIT (dBuV/m)	MARGIN (dB)	ANTENNA HEIGHT (m)	TABLE ANGLE (Degree)	RAW VALUE (dBuV)	CORRECTION FACTOR (dB/m)
1	33.48	24.1 QP	40.0	-15.9	1.53 H	181	33.70	-9.60
2	195.03	40.3 QP	43.5	-3.2	1.52 H	45	51.60	-11.30
3	260.37	42.7 QP	46.0	-3.3	1.42 H	64	51.60	-8.90
4	380.09	32.7 QP	46.0	-13.3	1.12 H	332	38.00	-5.30
5	695.65	37.4 QP	46.0	-8.6	1.00 H	339	36.00	1.40
6	1000.00	41.2 QP	54.0	-12.8	1.94 H	266	35.50	5.70

ANTENNA POLARITY & TEST DISTANCE: VERTICAL AT 3 M

NO.	FREQ. (MHz)	EMISSION LEVEL (dBuV/m)	LIMIT (dBuV/m)	MARGIN (dB)	ANTENNA HEIGHT (m)	TABLE ANGLE (Degree)	RAW VALUE (dBuV)	CORRECTION FACTOR (dB/m)
1	98.12	25.4 QP	43.5	-18.1	1.96 V	319	38.80	-13.40
2	196.01	34.0 QP	43.5	-9.5	1.63 V	242	45.40	-11.40
3	259.57	38.6 QP	46.0	-7.4	2.03 V	143	47.70	-9.10
4	325.45	32.0 QP	46.0	-14.0	1.09 V	23	38.40	-6.40
5	749.37	36.8 QP	46.0	-9.2	1.64 V	328	34.40	2.40
6	1000.00	38.9 QP	54.0	-15.1	1.05 V	283	33.20	5.70

REMARKS:

1. Emission Level(dBuV/m) = Raw Value(dBuV) + Correction Factor(dB/m)
2. Correction Factor(dB/m) = Antenna Factor(dB/m) + Cable Factor(dB) – Pre-Amplifier Factor(dB)
3. The other emission levels were very low against the limit.
4. Margin value = Emission Level – Limit value

CHANNEL	TX Channel 6	DETECTOR FUNCTION	Quasi-Peak (QP)
FREQUENCY RANGE	Below 1GHz		

ANTENNA POLARITY & TEST DISTANCE: HORIZONTAL AT 3 M

NO.	FREQ. (MHz)	EMISSION LEVEL (dBuV/m)	LIMIT (dBuV/m)	MARGIN (dB)	ANTENNA HEIGHT (m)	TABLE ANGLE (Degree)	RAW VALUE (dBuV)	CORRECTION FACTOR (dB/m)
1	33.63	24.4 QP	40.0	-15.6	1.46 H	168	34.00	-9.60
2	195.10	40.0 QP	43.5	-3.5	1.54 H	41	51.30	-11.30
3	259.98	42.2 QP	46.0	-3.8	1.43 H	52	51.20	-9.00
4	380.09	33.1 QP	46.0	-12.9	1.13 H	346	38.40	-5.30
5	695.84	37.1 QP	46.0	-8.9	1.00 H	318	35.70	1.40
6	1000.00	41.2 QP	54.0	-12.8	1.96 H	271	35.50	5.70

ANTENNA POLARITY & TEST DISTANCE: VERTICAL AT 3 M

NO.	FREQ. (MHz)	EMISSION LEVEL (dBuV/m)	LIMIT (dBuV/m)	MARGIN (dB)	ANTENNA HEIGHT (m)	TABLE ANGLE (Degree)	RAW VALUE (dBuV)	CORRECTION FACTOR (dB/m)
1	98.17	25.5 QP	43.5	-18.0	1.96 V	309	38.90	-13.40
2	196.13	34.0 QP	43.5	-9.5	1.53 V	234	45.40	-11.40
3	259.60	38.6 QP	46.0	-7.4	2.06 V	138	47.70	-9.10
4	325.81	32.3 QP	46.0	-13.7	1.10 V	28	38.70	-6.40
5	749.65	36.5 QP	46.0	-9.5	1.56 V	343	34.10	2.40
6	1000.00	39.2 QP	54.0	-14.8	1.00 V	299	33.50	5.70

REMARKS:

1. Emission Level(dBuV/m) = Raw Value(dBuV) + Correction Factor(dB/m)
2. Correction Factor(dB/m) = Antenna Factor(dB/m) + Cable Factor(dB) – Pre-Amplifier Factor(dB)
3. The other emission levels were very low against the limit.
4. Margin value = Emission Level – Limit value

CHANNEL	TX Channel 8	DETECTOR FUNCTION	Quasi-Peak (QP)
FREQUENCY RANGE	Below 1GHz		

ANTENNA POLARITY & TEST DISTANCE: HORIZONTAL AT 3 M

NO.	FREQ. (MHz)	EMISSION LEVEL (dBuV/m)	LIMIT (dBuV/m)	MARGIN (dB)	ANTENNA HEIGHT (m)	TABLE ANGLE (Degree)	RAW VALUE (dBuV)	CORRECTION FACTOR (dB/m)
1	33.51	24.1 QP	40.0	-15.9	1.49 H	182	33.70	-9.60
2	194.99	40.3 QP	43.5	-3.2	1.52 H	50	51.60	-11.30
3	259.81	42.3 QP	46.0	-3.7	1.45 H	41	51.30	-9.00
4	379.99	33.2 QP	46.0	-12.8	1.07 H	335	38.50	-5.30
5	695.67	37.5 QP	46.0	-8.5	1.05 H	343	36.10	1.40
6	1000.00	41.4 QP	54.0	-12.6	2.05 H	257	35.70	5.70

ANTENNA POLARITY & TEST DISTANCE: VERTICAL AT 3 M

NO.	FREQ. (MHz)	EMISSION LEVEL (dBuV/m)	LIMIT (dBuV/m)	MARGIN (dB)	ANTENNA HEIGHT (m)	TABLE ANGLE (Degree)	RAW VALUE (dBuV)	CORRECTION FACTOR (dB/m)
1	98.38	25.8 QP	43.5	-17.7	1.89 V	317	39.10	-13.30
2	195.79	33.5 QP	43.5	-10.0	1.59 V	214	44.90	-11.40
3	259.87	38.9 QP	46.0	-7.1	2.02 V	135	47.90	-9.00
4	325.82	32.4 QP	46.0	-13.6	1.00 V	52	38.80	-6.40
5	749.65	36.9 QP	46.0	-9.1	1.67 V	342	34.50	2.40
6	1000.00	38.8 QP	54.0	-15.2	1.00 V	299	33.10	5.70

REMARKS:

1. Emission Level(dBuV/m) = Raw Value(dBuV) + Correction Factor(dB/m)
2. Correction Factor(dB/m) = Antenna Factor(dB/m) + Cable Factor(dB) – Pre-Amplifier Factor(dB)
3. The other emission levels were very low against the limit.
4. Margin value = Emission Level – Limit value

CHANNEL	TX Channel 9	DETECTOR FUNCTION	Quasi-Peak (QP)
FREQUENCY RANGE	Below 1GHz		

ANTENNA POLARITY & TEST DISTANCE: HORIZONTAL AT 3 M

NO.	FREQ. (MHz)	EMISSION LEVEL (dBuV/m)	LIMIT (dBuV/m)	MARGIN (dB)	ANTENNA HEIGHT (m)	TABLE ANGLE (Degree)	RAW VALUE (dBuV)	CORRECTION FACTOR (dB/m)
1	33.52	24.1 QP	40.0	-15.9	1.44 H	172	33.70	-9.60
2	195.11	40.2 QP	43.5	-3.3	1.44 H	42	51.50	-11.30
3	260.24	42.4 QP	46.0	-3.6	1.50 H	55	51.30	-8.90
4	380.08	32.8 QP	46.0	-13.2	1.16 H	346	38.10	-5.30
5	695.75	37.6 QP	46.0	-8.4	1.05 H	339	36.20	1.40
6	1000.00	41.3 QP	54.0	-12.7	1.94 H	268	35.60	5.70

ANTENNA POLARITY & TEST DISTANCE: VERTICAL AT 3 M

NO.	FREQ. (MHz)	EMISSION LEVEL (dBuV/m)	LIMIT (dBuV/m)	MARGIN (dB)	ANTENNA HEIGHT (m)	TABLE ANGLE (Degree)	RAW VALUE (dBuV)	CORRECTION FACTOR (dB/m)
1	98.41	25.4 QP	43.5	-18.1	1.95 V	334	38.70	-13.30
2	196.13	34.0 QP	43.5	-9.5	1.62 V	224	45.40	-11.40
3	259.67	39.0 QP	46.0	-7.0	1.97 V	139	48.10	-9.10
4	325.52	32.4 QP	46.0	-13.6	1.01 V	34	38.80	-6.40
5	749.63	37.1 QP	46.0	-8.9	1.59 V	323	34.70	2.40
6	1000.00	38.7 QP	54.0	-15.3	1.02 V	286	33.00	5.70

REMARKS:

1. Emission Level(dBuV/m) = Raw Value(dBuV) + Correction Factor(dB/m)
2. Correction Factor(dB/m) = Antenna Factor(dB/m) + Cable Factor(dB) – Pre-Amplifier Factor(dB)
3. The other emission levels were very low against the limit.
4. Margin value = Emission Level – Limit value

4.1.8 Test Results (Mode 2)

Above 1GHz Data:

802.11b

CHANNEL	TX Channel 1	DETECTOR FUNCTION	Peak (PK)
FREQUENCY RANGE	1GHz ~ 25GHz		Average (AV)

ANTENNA POLARITY & TEST DISTANCE: HORIZONTAL AT 3 M

NO.	FREQ. (MHz)	EMISSION LEVEL (dBuV/m)	LIMIT (dBuV/m)	MARGIN (dB)	ANTENNA HEIGHT (m)	TABLE ANGLE (Degree)	RAW VALUE (dBuV)	CORRECTION FACTOR (dB/m)
1	2390.00	52.5 PK	74.0	-21.5	2.22 H	187	55.69	-3.19
2	2390.00	43.8 AV	54.0	-10.2	2.22 H	187	46.99	-3.19
3	*2412.00	104.8 PK			2.22 H	187	107.93	-3.13
4	*2412.00	102.3 AV			2.22 H	187	105.43	-3.13
5	4824.00	40.4 PK	74.0	-33.6	1.28 H	121	34.43	5.97
6	4824.00	35.3 AV	54.0	-18.7	1.28 H	121	29.33	5.97

ANTENNA POLARITY & TEST DISTANCE: VERTICAL AT 3 M

NO.	FREQ. (MHz)	EMISSION LEVEL (dBuV/m)	LIMIT (dBuV/m)	MARGIN (dB)	ANTENNA HEIGHT (m)	TABLE ANGLE (Degree)	RAW VALUE (dBuV)	CORRECTION FACTOR (dB/m)
1	2390.00	57.0 PK	74.0	-17.0	1.52 V	182	60.19	-3.19
2	2390.00	49.4 AV	54.0	-4.6	1.52 V	182	52.59	-3.19
3	*2412.00	110.6 PK			1.52 V	182	113.73	-3.13
4	*2412.00	108.0 AV			1.52 V	182	111.13	-3.13
5	4824.00	45.5 PK	74.0	-28.5	1.04 V	269	39.53	5.97
6	4824.00	40.8 AV	54.0	-13.2	1.04 V	269	34.83	5.97

REMARKS:

1. Emission Level(dBuV/m) = Raw Value(dBuV) + Correction Factor(dB/m)
2. Correction Factor(dB/m) = Antenna Factor(dB/m) + Cable Factor(dB) – Pre-Amplifier Factor(dB)
3. The other emission levels were very low against the limit.
4. Margin value = Emission Level – Limit value
5. " * ": Fundamental frequency.

CHANNEL	TX Channel 2	DETECTOR FUNCTION	Peak (PK)
FREQUENCY RANGE	1GHz ~ 25GHz		Average (AV)

ANTENNA POLARITY & TEST DISTANCE: HORIZONTAL AT 3 M

NO.	FREQ. (MHz)	EMISSION LEVEL (dBuV/m)	LIMIT (dBuV/m)	MARGIN (dB)	ANTENNA HEIGHT (m)	TABLE ANGLE (Degree)	RAW VALUE (dBuV)	CORRECTION FACTOR (dB/m)
1	2390.00	49.0 PK	74.0	-25.0	2.20 H	190	52.19	-3.19
2	2390.00	39.1 AV	54.0	-14.9	2.20 H	190	42.29	-3.19
3	*2417.00	104.6 PK			2.20 H	190	107.71	-3.11
4	*2417.00	102.2 AV			2.20 H	190	105.31	-3.11
5	4834.00	41.6 PK	74.0	-32.4	1.31 H	122	35.61	5.99
6	4834.00	35.9 AV	54.0	-18.1	1.31 H	122	29.91	5.99
7	7251.00	46.1 PK	74.0	-27.9	1.27 H	125	35.22	10.88
8	7251.00	40.6 AV	54.0	-13.4	1.27 H	125	29.72	10.88

ANTENNA POLARITY & TEST DISTANCE: VERTICAL AT 3 M

NO.	FREQ. (MHz)	EMISSION LEVEL (dBuV/m)	LIMIT (dBuV/m)	MARGIN (dB)	ANTENNA HEIGHT (m)	TABLE ANGLE (Degree)	RAW VALUE (dBuV)	CORRECTION FACTOR (dB/m)
1	2390.00	52.9 PK	74.0	-21.1	1.50 V	184	56.09	-3.19
2	2390.00	41.3 AV	54.0	-12.7	1.50 V	184	44.49	-3.19
3	*2417.00	110.2 PK			1.50 V	184	113.31	-3.11
4	*2417.00	107.7 AV			1.50 V	184	110.81	-3.11
5	4834.00	46.0 PK	74.0	-28.0	1.00 V	273	40.01	5.99
6	4834.00	41.1 AV	54.0	-12.9	1.00 V	273	35.11	5.99
7	7251.00	50.4 PK	74.0	-23.6	1.00 V	260	39.52	10.88
8	7251.00	46.5 AV	54.0	-7.5	1.00 V	260	35.62	10.88

REMARKS:

1. Emission Level(dBuV/m) = Raw Value(dBuV) + Correction Factor(dB/m)
2. Correction Factor(dB/m) = Antenna Factor(dB/m) + Cable Factor(dB) – Pre-Amplifier Factor(dB)
3. The other emission levels were very low against the limit.
4. Margin value = Emission Level – Limit value
5. " * ": Fundamental frequency.

CHANNEL	TX Channel 6	DETECTOR FUNCTION	Peak (PK)
FREQUENCY RANGE	1GHz ~ 25GHz		Average (AV)

ANTENNA POLARITY & TEST DISTANCE: HORIZONTAL AT 3 M

NO.	FREQ. (MHz)	EMISSION LEVEL (dBuV/m)	LIMIT (dBuV/m)	MARGIN (dB)	ANTENNA HEIGHT (m)	TABLE ANGLE (Degree)	RAW VALUE (dBuV)	CORRECTION FACTOR (dB/m)
1	*2437.00	104.3 PK			2.15 H	188	107.34	-3.04
2	*2437.00	101.8 AV			2.15 H	188	104.84	-3.04
3	4874.00	43.3 PK	74.0	-30.7	1.36 H	130	37.25	6.05
4	4874.00	36.6 AV	54.0	-17.4	1.36 H	130	30.55	6.05
5	7311.00	45.7 PK	74.0	-28.3	1.28 H	111	34.76	10.94
6	7311.00	41.8 AV	54.0	-12.2	1.28 H	111	30.86	10.94

ANTENNA POLARITY & TEST DISTANCE: VERTICAL AT 3 M

NO.	FREQ. (MHz)	EMISSION LEVEL (dBuV/m)	LIMIT (dBuV/m)	MARGIN (dB)	ANTENNA HEIGHT (m)	TABLE ANGLE (Degree)	RAW VALUE (dBuV)	CORRECTION FACTOR (dB/m)
1	*2437.00	110.0 PK			1.67 V	180	113.04	-3.04
2	*2437.00	107.3 AV			1.67 V	180	110.34	-3.04
3	4874.00	48.1 PK	74.0	-25.9	1.48 V	133	42.05	6.05
4	4874.00	42.4 AV	54.0	-11.6	1.48 V	133	36.35	6.05
5	7311.00	50.3 PK	74.0	-23.7	1.00 V	58	39.36	10.94
6	7311.00	46.5 AV	54.0	-7.5	1.00 V	58	35.56	10.94

REMARKS:

1. Emission Level(dBuV/m) = Raw Value(dBuV) + Correction Factor(dB/m)
2. Correction Factor(dB/m) = Antenna Factor(dB/m) + Cable Factor(dB) – Pre-Amplifier Factor(dB)
3. The other emission levels were very low against the limit.
4. Margin value = Emission Level – Limit value
5. " * ": Fundamental frequency.

CHANNEL	TX Channel 10	DETECTOR FUNCTION	Peak (PK)
FREQUENCY RANGE	1GHz ~ 25GHz		Average (AV)

ANTENNA POLARITY & TEST DISTANCE: HORIZONTAL AT 3 M

NO.	FREQ. (MHz)	EMISSION LEVEL (dBuV/m)	LIMIT (dBuV/m)	MARGIN (dB)	ANTENNA HEIGHT (m)	TABLE ANGLE (Degree)	RAW VALUE (dBuV)	CORRECTION FACTOR (dB/m)
1	*2457.00	104.0 PK			2.14 H	190	106.97	-2.97
2	*2457.00	101.1 AV			2.14 H	190	104.07	-2.97
3	2483.50	51.2 PK	74.0	-22.8	2.14 H	190	54.07	-2.87
4	2483.50	41.0 AV	54.0	-13.0	2.14 H	190	43.87	-2.87
5	4914.00	43.8 PK	74.0	-30.2	1.32 H	121	37.73	6.07
6	4914.00	36.9 AV	54.0	-17.1	1.32 H	121	30.83	6.07
7	7371.00	46.2 PK	74.0	-27.8	1.30 H	110	34.88	11.32
8	7371.00	42.2 AV	54.0	-11.8	1.30 H	110	30.88	11.32

ANTENNA POLARITY & TEST DISTANCE: VERTICAL AT 3 M

NO.	FREQ. (MHz)	EMISSION LEVEL (dBuV/m)	LIMIT (dBuV/m)	MARGIN (dB)	ANTENNA HEIGHT (m)	TABLE ANGLE (Degree)	RAW VALUE (dBuV)	CORRECTION FACTOR (dB/m)
1	*2457.00	109.5 PK			1.83 V	182	112.47	-2.97
2	*2457.00	106.8 AV			1.83 V	182	109.77	-2.97
3	2483.50	55.4 PK	74.0	-18.6	1.83 V	182	58.27	-2.87
4	2483.50	45.3 AV	54.0	-8.7	1.83 V	182	48.17	-2.87
5	4914.00	48.4 PK	74.0	-25.6	1.00 V	250	42.33	6.07
6	4914.00	42.9 AV	54.0	-11.1	1.00 V	250	36.83	6.07
7	7371.00	50.3 PK	74.0	-23.7	1.00 V	301	38.98	11.32
8	7371.00	46.5 AV	54.0	-7.5	1.00 V	301	35.18	11.32

REMARKS:

1. Emission Level(dBuV/m) = Raw Value(dBuV) + Correction Factor(dB/m)
2. Correction Factor(dB/m) = Antenna Factor(dB/m) + Cable Factor(dB) – Pre-Amplifier Factor(dB)
3. The other emission levels were very low against the limit.
4. Margin value = Emission Level – Limit value
5. " * ": Fundamental frequency.

CHANNEL	TX Channel 11	DETECTOR FUNCTION	Peak (PK)
FREQUENCY RANGE	1GHz ~ 25GHz		Average (AV)

ANTENNA POLARITY & TEST DISTANCE: HORIZONTAL AT 3 M

NO.	FREQ. (MHz)	EMISSION LEVEL (dBuV/m)	LIMIT (dBuV/m)	MARGIN (dB)	ANTENNA HEIGHT (m)	TABLE ANGLE (Degree)	RAW VALUE (dBuV)	CORRECTION FACTOR (dB/m)
1	*2462.00	103.4 PK			2.13 H	181	106.34	-2.94
2	*2462.00	100.9 AV			2.13 H	181	103.84	-2.94
3	2483.50	52.5 PK	74.0	-21.5	2.13 H	181	55.37	-2.87
4	2483.50	43.5 AV	54.0	-10.5	2.13 H	181	46.37	-2.87
5	4924.00	43.6 PK	74.0	-30.4	1.36 H	129	37.53	6.07
6	4924.00	36.7 AV	54.0	-17.3	1.36 H	129	30.63	6.07
7	7386.00	45.8 PK	74.0	-28.2	1.25 H	124	34.38	11.42
8	7386.00	42.1 AV	54.0	-11.9	1.25 H	124	30.68	11.42

ANTENNA POLARITY & TEST DISTANCE: VERTICAL AT 3 M

NO.	FREQ. (MHz)	EMISSION LEVEL (dBuV/m)	LIMIT (dBuV/m)	MARGIN (dB)	ANTENNA HEIGHT (m)	TABLE ANGLE (Degree)	RAW VALUE (dBuV)	CORRECTION FACTOR (dB/m)
1	*2462.00	109.1 PK			1.80 V	183	112.04	-2.94
2	*2462.00	106.5 AV			1.80 V	183	109.44	-2.94
3	2483.50	58.1 PK	74.0	-15.9	1.80 V	183	60.97	-2.87
4	2483.50	49.1 AV	54.0	-4.9	1.80 V	183	51.97	-2.87
5	4924.00	47.9 PK	74.0	-26.1	1.05 V	247	41.83	6.07
6	4924.00	42.7 AV	54.0	-11.3	1.05 V	247	36.63	6.07
7	7386.00	49.9 PK	74.0	-24.1	1.04 V	285	38.48	11.42
8	7386.00	46.3 AV	54.0	-7.7	1.04 V	285	34.88	11.42

REMARKS:

1. Emission Level(dBuV/m) = Raw Value(dBuV) + Correction Factor(dB/m)
2. Correction Factor(dB/m) = Antenna Factor(dB/m) + Cable Factor(dB) – Pre-Amplifier Factor(dB)
3. The other emission levels were very low against the limit.
4. Margin value = Emission Level – Limit value
5. " * ": Fundamental frequency.

802.11g

CHANNEL	TX Channel 1	DETECTOR FUNCTION	Peak (PK)
FREQUENCY RANGE	1GHz ~ 25GHz		Average (AV)

ANTENNA POLARITY & TEST DISTANCE: HORIZONTAL AT 3 M

NO.	FREQ. (MHz)	EMISSION LEVEL (dBuV/m)	LIMIT (dBuV/m)	MARGIN (dB)	ANTENNA HEIGHT (m)	TABLE ANGLE (Degree)	RAW VALUE (dBuV)	CORRECTION FACTOR (dB/m)
1	2390.00	61.3 PK	74.0	-12.7	2.12 H	199	64.49	-3.19
2	2390.00	45.1 AV	54.0	-8.9	2.12 H	199	48.29	-3.19
3	*2412.00	104.3 PK			2.12 H	199	107.43	-3.13
4	*2412.00	93.2 AV			2.12 H	199	96.33	-3.13
5	4824.00	45.4 PK	74.0	-28.6	1.37 H	93	39.43	5.97
6	4824.00	31.5 AV	54.0	-22.5	1.37 H	93	25.53	5.97

ANTENNA POLARITY & TEST DISTANCE: VERTICAL AT 3 M

NO.	FREQ. (MHz)	EMISSION LEVEL (dBuV/m)	LIMIT (dBuV/m)	MARGIN (dB)	ANTENNA HEIGHT (m)	TABLE ANGLE (Degree)	RAW VALUE (dBuV)	CORRECTION FACTOR (dB/m)
1	2390.00	72.0 PK	74.0	-2.0	1.46 V	112	75.19	-3.19
2	2390.00	51.1 AV	54.0	-2.9	1.46 V	112	54.29	-3.19
3	*2412.00	109.0 PK			1.46 V	112	112.13	-3.13
4	*2412.00	98.7 AV			1.46 V	112	101.83	-3.13
5	4824.00	46.4 PK	74.0	-27.6	1.00 V	114	40.43	5.97
6	4824.00	32.8 AV	54.0	-21.2	1.00 V	114	26.83	5.97

REMARKS:

1. Emission Level(dBuV/m) = Raw Value(dBuV) + Correction Factor(dB/m)
2. Correction Factor(dB/m) = Antenna Factor(dB/m) + Cable Factor(dB) – Pre-Amplifier Factor(dB)
3. The other emission levels were very low against the limit.
4. Margin value = Emission Level – Limit value
5. " * ": Fundamental frequency.

CHANNEL	TX Channel 2	DETECTOR FUNCTION	Peak (PK)
FREQUENCY RANGE	1GHz ~ 25GHz		Average (AV)

ANTENNA POLARITY & TEST DISTANCE: HORIZONTAL AT 3 M

NO.	FREQ. (MHz)	EMISSION LEVEL (dBuV/m)	LIMIT (dBuV/m)	MARGIN (dB)	ANTENNA HEIGHT (m)	TABLE ANGLE (Degree)	RAW VALUE (dBuV)	CORRECTION FACTOR (dB/m)
1	2390.00	63.4 PK	74.0	-10.6	2.10 H	184	66.59	-3.19
2	2390.00	47.6 AV	54.0	-6.4	2.10 H	184	50.79	-3.19
3	*2417.00	105.5 PK			2.10 H	184	108.61	-3.11
4	*2417.00	95.2 AV			2.10 H	184	98.31	-3.11
5	4834.00	45.5 PK	74.0	-28.5	1.33 H	95	39.51	5.99
6	4834.00	31.6 AV	54.0	-22.4	1.33 H	95	25.61	5.99
7	7251.00	45.7 PK	74.0	-28.3	1.27 H	116	34.82	10.88
8	7251.00	35.4 AV	54.0	-18.6	1.27 H	116	24.52	10.88

ANTENNA POLARITY & TEST DISTANCE: VERTICAL AT 3 M

NO.	FREQ. (MHz)	EMISSION LEVEL (dBuV/m)	LIMIT (dBuV/m)	MARGIN (dB)	ANTENNA HEIGHT (m)	TABLE ANGLE (Degree)	RAW VALUE (dBuV)	CORRECTION FACTOR (dB/m)
1	2390.00	68.4 PK	74.0	-5.6	1.44 V	112	71.59	-3.19
2	2390.00	52.5 AV	54.0	-1.5	1.44 V	112	55.69	-3.19
3	*2417.00	111.3 PK			1.44 V	112	114.41	-3.11
4	*2417.00	100.9 AV			1.44 V	112	104.01	-3.11
5	4834.00	46.4 PK	74.0	-27.6	1.00 V	128	40.41	5.99
6	4834.00	32.6 AV	54.0	-21.4	1.00 V	128	26.61	5.99
7	7251.00	47.2 PK	74.0	-26.8	1.00 V	97	36.32	10.88
8	7251.00	36.7 AV	54.0	-17.3	1.00 V	97	25.82	10.88

REMARKS:

1. Emission Level(dBuV/m) = Raw Value(dBuV) + Correction Factor(dB/m)
2. Correction Factor(dB/m) = Antenna Factor(dB/m) + Cable Factor(dB) – Pre-Amplifier Factor(dB)
3. The other emission levels were very low against the limit.
4. Margin value = Emission Level – Limit value
5. " * ": Fundamental frequency.

CHANNEL	TX Channel 6	DETECTOR FUNCTION	Peak (PK)
FREQUENCY RANGE	1GHz ~ 25GHz		Average (AV)

ANTENNA POLARITY & TEST DISTANCE: HORIZONTAL AT 3 M

NO.	FREQ. (MHz)	EMISSION LEVEL (dBuV/m)	LIMIT (dBuV/m)	MARGIN (dB)	ANTENNA HEIGHT (m)	TABLE ANGLE (Degree)	RAW VALUE (dBuV)	CORRECTION FACTOR (dB/m)
1	*2437.00	106.1 PK			2.16 H	186	109.14	-3.04
2	*2437.00	95.7 AV			2.16 H	186	98.74	-3.04
3	4874.00	45.4 PK	74.0	-28.6	1.37 H	104	39.35	6.05
4	4874.00	31.5 AV	54.0	-22.5	1.37 H	104	25.45	6.05
5	7311.00	45.5 PK	74.0	-28.5	1.34 H	110	34.56	10.94
6	7311.00	35.6 AV	54.0	-18.4	1.34 H	110	24.66	10.94

ANTENNA POLARITY & TEST DISTANCE: VERTICAL AT 3 M

NO.	FREQ. (MHz)	EMISSION LEVEL (dBuV/m)	LIMIT (dBuV/m)	MARGIN (dB)	ANTENNA HEIGHT (m)	TABLE ANGLE (Degree)	RAW VALUE (dBuV)	CORRECTION FACTOR (dB/m)
1	*2437.00	111.7 PK			1.61 V	113	114.74	-3.04
2	*2437.00	101.5 AV			1.61 V	113	104.54	-3.04
3	4874.00	46.9 PK	74.0	-27.1	1.00 V	124	40.85	6.05
4	4874.00	33.2 AV	54.0	-20.8	1.00 V	124	27.15	6.05
5	7311.00	47.0 PK	74.0	-27.0	1.00 V	100	36.06	10.94
6	7311.00	36.3 AV	54.0	-17.7	1.00 V	100	25.36	10.94

REMARKS:

1. Emission Level(dBuV/m) = Raw Value(dBuV) + Correction Factor(dB/m)
2. Correction Factor(dB/m) = Antenna Factor(dB/m) + Cable Factor(dB) – Pre-Amplifier Factor(dB)
3. The other emission levels were very low against the limit.
4. Margin value = Emission Level – Limit value
5. " * ": Fundamental frequency.

CHANNEL	TX Channel 10	DETECTOR FUNCTION	Peak (PK)
FREQUENCY RANGE	1GHz ~ 25GHz		Average (AV)

ANTENNA POLARITY & TEST DISTANCE: HORIZONTAL AT 3 M

NO.	FREQ. (MHz)	EMISSION LEVEL (dBuV/m)	LIMIT (dBuV/m)	MARGIN (dB)	ANTENNA HEIGHT (m)	TABLE ANGLE (Degree)	RAW VALUE (dBuV)	CORRECTION FACTOR (dB/m)
1	*2457.00	106.2 PK			2.17 H	189	109.17	-2.97
2	*2457.00	95.5 AV			2.17 H	189	98.47	-2.97
3	2483.50	66.5 PK	74.0	-7.5	2.17 H	189	69.37	-2.87
4	2483.50	48.2 AV	54.0	-5.8	2.17 H	189	51.07	-2.87
5	4914.00	45.8 PK	74.0	-28.2	1.34 H	108	39.73	6.07
6	4914.00	32.3 AV	54.0	-21.7	1.34 H	108	26.23	6.07
7	7371.00	45.5 PK	74.0	-28.5	1.27 H	116	34.18	11.32
8	7371.00	35.5 AV	54.0	-18.5	1.27 H	116	24.18	11.32

ANTENNA POLARITY & TEST DISTANCE: VERTICAL AT 3 M

NO.	FREQ. (MHz)	EMISSION LEVEL (dBuV/m)	LIMIT (dBuV/m)	MARGIN (dB)	ANTENNA HEIGHT (m)	TABLE ANGLE (Degree)	RAW VALUE (dBuV)	CORRECTION FACTOR (dB/m)
1	*2457.00	111.8 PK			1.40 V	114	114.77	-2.97
2	*2457.00	101.3 AV			1.40 V	114	104.27	-2.97
3	2483.50	71.7 PK	74.0	-2.3	1.40 V	114	74.57	-2.87
4	2483.50	53.0 AV	54.0	-1.0	1.40 V	114	55.87	-2.87
5	4914.00	46.1 PK	74.0	-27.9	1.00 V	101	40.03	6.07
6	4914.00	32.8 AV	54.0	-21.2	1.00 V	101	26.73	6.07
7	7371.00	47.0 PK	74.0	-27.0	1.00 V	89	35.68	11.32
8	7371.00	36.6 AV	54.0	-17.4	1.00 V	89	25.28	11.32

REMARKS:

1. Emission Level(dBuV/m) = Raw Value(dBuV) + Correction Factor(dB/m)
2. Correction Factor(dB/m) = Antenna Factor(dB/m) + Cable Factor(dB) – Pre-Amplifier Factor(dB)
3. The other emission levels were very low against the limit.
4. Margin value = Emission Level – Limit value
5. " * ": Fundamental frequency.

CHANNEL	TX Channel 11	DETECTOR FUNCTION	Peak (PK)
FREQUENCY RANGE	1GHz ~ 25GHz		Average (AV)

ANTENNA POLARITY & TEST DISTANCE: HORIZONTAL AT 3 M

NO.	FREQ. (MHz)	EMISSION LEVEL (dBuV/m)	LIMIT (dBuV/m)	MARGIN (dB)	ANTENNA HEIGHT (m)	TABLE ANGLE (Degree)	RAW VALUE (dBuV)	CORRECTION FACTOR (dB/m)
1	*2462.00	102.7 PK			2.20 H	184	105.64	-2.94
2	*2462.00	92.2 AV			2.20 H	184	95.14	-2.94
3	2483.50	68.1 PK	74.0	-5.9	2.20 H	184	70.97	-2.87
4	2483.50	48.1 AV	54.0	-5.9	2.20 H	184	50.97	-2.87
5	4924.00	46.2 PK	74.0	-27.8	1.39 H	86	40.13	6.07
6	4924.00	32.4 AV	54.0	-21.6	1.39 H	86	26.33	6.07
7	7386.00	46.8 PK	74.0	-27.2	1.33 H	109	35.38	11.42
8	7386.00	36.3 AV	54.0	-17.7	1.33 H	109	24.88	11.42

ANTENNA POLARITY & TEST DISTANCE: VERTICAL AT 3 M

NO.	FREQ. (MHz)	EMISSION LEVEL (dBuV/m)	LIMIT (dBuV/m)	MARGIN (dB)	ANTENNA HEIGHT (m)	TABLE ANGLE (Degree)	RAW VALUE (dBuV)	CORRECTION FACTOR (dB/m)
1	*2462.00	108.4 PK			1.33 V	112	111.34	-2.94
2	*2462.00	97.7 AV			1.33 V	112	100.64	-2.94
3	2483.50	73.0 PK	74.0	-1.0	1.33 V	112	75.87	-2.87
4	2483.50	52.7 AV	54.0	-1.3	1.33 V	112	55.57	-2.87
5	4924.00	46.7 PK	74.0	-27.3	1.00 V	106	40.63	6.07
6	4924.00	33.1 AV	54.0	-20.9	1.00 V	106	27.03	6.07
7	7386.00	46.8 PK	74.0	-27.2	1.00 V	92	35.38	11.42
8	7386.00	36.6 AV	54.0	-17.4	1.00 V	92	25.18	11.42

REMARKS:

1. Emission Level(dBuV/m) = Raw Value(dBuV) + Correction Factor(dB/m)
2. Correction Factor(dB/m) = Antenna Factor(dB/m) + Cable Factor(dB) – Pre-Amplifier Factor(dB)
3. The other emission levels were very low against the limit.
4. Margin value = Emission Level – Limit value
5. " * ": Fundamental frequency.

802.11n (HT20)

CHANNEL	TX Channel 1	DETECTOR FUNCTION	Peak (PK)
FREQUENCY RANGE	1GHz ~ 25GHz		Average (AV)

ANTENNA POLARITY & TEST DISTANCE: HORIZONTAL AT 3 M

NO.	FREQ. (MHz)	EMISSION LEVEL (dBuV/m)	LIMIT (dBuV/m)	MARGIN (dB)	ANTENNA HEIGHT (m)	TABLE ANGLE (Degree)	RAW VALUE (dBuV)	CORRECTION FACTOR (dB/m)
1	2390.00	61.8 PK	74.0	-12.2	2.20 H	183	64.99	-3.19
2	2390.00	45.5 AV	54.0	-8.5	2.20 H	183	48.69	-3.19
3	*2412.00	106.2 PK			2.20 H	183	109.33	-3.13
4	*2412.00	93.1 AV			2.20 H	183	96.23	-3.13
5	4824.00	45.2 PK	74.0	-28.8	1.34 H	107	39.23	5.97
6	4824.00	31.8 AV	54.0	-22.2	1.34 H	107	25.83	5.97

ANTENNA POLARITY & TEST DISTANCE: VERTICAL AT 3 M

NO.	FREQ. (MHz)	EMISSION LEVEL (dBuV/m)	LIMIT (dBuV/m)	MARGIN (dB)	ANTENNA HEIGHT (m)	TABLE ANGLE (Degree)	RAW VALUE (dBuV)	CORRECTION FACTOR (dB/m)
1	2390.00	72.5 PK	74.0	-1.5	1.50 V	144	75.69	-3.19
2	2390.00	51.6 AV	54.0	-2.4	1.50 V	144	54.79	-3.19
3	*2412.00	112.0 PK			1.50 V	144	115.13	-3.13
4	*2412.00	98.6 AV			1.50 V	144	101.73	-3.13
5	4824.00	46.0 PK	74.0	-28.0	1.00 V	122	40.03	5.97
6	4824.00	32.6 AV	54.0	-21.4	1.00 V	122	26.63	5.97

REMARKS:

1. Emission Level(dBuV/m) = Raw Value(dBuV) + Correction Factor(dB/m)
2. Correction Factor(dB/m) = Antenna Factor(dB/m) + Cable Factor(dB) – Pre-Amplifier Factor(dB)
3. The other emission levels were very low against the limit.
4. Margin value = Emission Level – Limit value
5. " * ": Fundamental frequency.

CHANNEL	TX Channel 2	DETECTOR FUNCTION	Peak (PK)
FREQUENCY RANGE	1GHz ~ 25GHz		Average (AV)

ANTENNA POLARITY & TEST DISTANCE: HORIZONTAL AT 3 M

NO.	FREQ. (MHz)	EMISSION LEVEL (dBuV/m)	LIMIT (dBuV/m)	MARGIN (dB)	ANTENNA HEIGHT (m)	TABLE ANGLE (Degree)	RAW VALUE (dBuV)	CORRECTION FACTOR (dB/m)
1	2390.00	61.9 PK	74.0	-12.1	2.15 H	195	65.09	-3.19
2	2390.00	45.6 AV	54.0	-8.4	2.15 H	195	48.79	-3.19
3	*2417.00	108.9 PK			2.15 H	195	112.01	-3.11
4	*2417.00	96.7 AV			2.15 H	195	99.81	-3.11
5	4834.00	45.6 PK	74.0	-28.4	1.37 H	95	39.61	5.99
6	4834.00	31.9 AV	54.0	-22.1	1.37 H	95	25.91	5.99
7	7251.00	46.0 PK	74.0	-28.0	1.29 H	103	35.12	10.88
8	7251.00	35.8 AV	54.0	-18.2	1.29 H	103	24.92	10.88

ANTENNA POLARITY & TEST DISTANCE: VERTICAL AT 3 M

NO.	FREQ. (MHz)	EMISSION LEVEL (dBuV/m)	LIMIT (dBuV/m)	MARGIN (dB)	ANTENNA HEIGHT (m)	TABLE ANGLE (Degree)	RAW VALUE (dBuV)	CORRECTION FACTOR (dB/m)
1	2390.00	67.0 PK	74.0	-7.0	1.48 V	162	70.19	-3.19
2	2390.00	50.3 AV	54.0	-3.7	1.48 V	162	53.49	-3.19
3	*2417.00	114.5 PK			1.48 V	162	117.61	-3.11
4	*2417.00	102.1 AV			1.48 V	162	105.21	-3.11
5	4834.00	46.8 PK	74.0	-27.2	1.00 V	101	40.81	5.99
6	4834.00	33.2 AV	54.0	-20.8	1.00 V	101	27.21	5.99
7	7251.00	46.7 PK	74.0	-27.3	1.00 V	110	35.82	10.88
8	7251.00	36.1 AV	54.0	-17.9	1.00 V	110	25.22	10.88

REMARKS:

1. Emission Level(dBuV/m) = Raw Value(dBuV) + Correction Factor(dB/m)
2. Correction Factor(dB/m) = Antenna Factor(dB/m) + Cable Factor(dB) – Pre-Amplifier Factor(dB)
3. The other emission levels were very low against the limit.
4. Margin value = Emission Level – Limit value
5. " * ": Fundamental frequency.

CHANNEL	TX Channel 6	DETECTOR FUNCTION	Peak (PK)
FREQUENCY RANGE	1GHz ~ 25GHz		Average (AV)

ANTENNA POLARITY & TEST DISTANCE: HORIZONTAL AT 3 M

NO.	FREQ. (MHz)	EMISSION LEVEL (dBuV/m)	LIMIT (dBuV/m)	MARGIN (dB)	ANTENNA HEIGHT (m)	TABLE ANGLE (Degree)	RAW VALUE (dBuV)	CORRECTION FACTOR (dB/m)
1	2390.00	56.4 PK	74.0	-17.6	2.22 H	182	59.59	-3.19
2	2390.00	38.7 AV	54.0	-15.3	2.22 H	182	41.89	-3.19
3	*2437.00	111.9 PK			2.22 H	182	114.94	-3.04
4	*2437.00	99.3 AV			2.22 H	182	102.34	-3.04
5	2483.50	56.7 PK	74.0	-17.3	2.22 H	182	59.57	-2.87
6	2483.50	38.9 AV	54.0	-15.1	2.22 H	182	41.77	-2.87
7	4874.00	45.4 PK	74.0	-28.6	1.39 H	103	39.35	6.05
8	4874.00	32.2 AV	54.0	-21.8	1.39 H	103	26.15	6.05
9	7311.00	46.0 PK	74.0	-28.0	1.23 H	95	35.06	10.94
10	7311.00	36.0 AV	54.0	-18.0	1.23 H	95	25.06	10.94

ANTENNA POLARITY & TEST DISTANCE: VERTICAL AT 3 M

NO.	FREQ. (MHz)	EMISSION LEVEL (dBuV/m)	LIMIT (dBuV/m)	MARGIN (dB)	ANTENNA HEIGHT (m)	TABLE ANGLE (Degree)	RAW VALUE (dBuV)	CORRECTION FACTOR (dB/m)
1	2390.00	62.0 PK	74.0	-12.0	1.55 V	186	65.19	-3.19
2	2390.00	44.4 AV	54.0	-9.6	1.55 V	186	47.59	-3.19
3	*2437.00	117.5 PK			1.55 V	186	120.54	-3.04
4	*2437.00	104.8 AV			1.55 V	186	107.84	-3.04
5	2483.50	60.1 PK	74.0	-13.9	1.55 V	186	62.97	-2.87
6	2483.50	44.8 AV	54.0	-9.2	1.55 V	186	47.67	-2.87
7	4874.00	47.1 PK	74.0	-26.9	1.00 V	127	41.05	6.05
8	4874.00	33.3 AV	54.0	-20.7	1.00 V	127	27.25	6.05
9	7311.00	46.6 PK	74.0	-27.4	1.00 V	90	35.66	10.94
10	7311.00	36.1 AV	54.0	-17.9	1.00 V	90	25.16	10.94

REMARKS:

1. Emission Level(dBuV/m) = Raw Value(dBuV) + Correction Factor(dB/m)
2. Correction Factor(dB/m) = Antenna Factor(dB/m) + Cable Factor(dB) – Pre-Amplifier Factor(dB)
3. The other emission levels were very low against the limit.
4. Margin value = Emission Level – Limit value
5. " * ": Fundamental frequency.

CHANNEL	TX Channel 10	DETECTOR FUNCTION	Peak (PK)
FREQUENCY RANGE	1GHz ~ 25GHz		Average (AV)

ANTENNA POLARITY & TEST DISTANCE: HORIZONTAL AT 3 M

NO.	FREQ. (MHz)	EMISSION LEVEL (dBuV/m)	LIMIT (dBuV/m)	MARGIN (dB)	ANTENNA HEIGHT (m)	TABLE ANGLE (Degree)	RAW VALUE (dBuV)	CORRECTION FACTOR (dB/m)
1	*2457.00	109.2 PK			2.24 H	168	112.17	-2.97
2	*2457.00	97.2 AV			2.24 H	168	100.17	-2.97
3	2483.50	61.4 PK	74.0	-12.6	2.24 H	168	64.27	-2.87
4	2483.50	42.6 AV	54.0	-11.4	2.24 H	168	45.47	-2.87
5	4914.00	45.2 PK	74.0	-28.8	1.34 H	93	39.13	6.07
6	4914.00	32.1 AV	54.0	-21.9	1.34 H	93	26.03	6.07
7	7371.00	46.6 PK	74.0	-27.4	1.23 H	90	35.28	11.32
8	7371.00	36.3 AV	54.0	-17.7	1.23 H	90	24.98	11.32

ANTENNA POLARITY & TEST DISTANCE: VERTICAL AT 3 M

NO.	FREQ. (MHz)	EMISSION LEVEL (dBuV/m)	LIMIT (dBuV/m)	MARGIN (dB)	ANTENNA HEIGHT (m)	TABLE ANGLE (Degree)	RAW VALUE (dBuV)	CORRECTION FACTOR (dB/m)
1	*2457.00	114.8 PK			1.50 V	148	117.77	-2.97
2	*2457.00	102.6 AV			1.50 V	148	105.57	-2.97
3	2483.50	66.1 PK	74.0	-7.9	1.50 V	148	68.97	-2.87
4	2483.50	48.1 AV	54.0	-5.9	1.50 V	148	50.97	-2.87
5	4914.00	46.3 PK	74.0	-27.7	1.00 V	108	40.23	6.07
6	4914.00	32.4 AV	54.0	-21.6	1.00 V	108	26.33	6.07
7	7371.00	46.6 PK	74.0	-27.4	1.00 V	85	35.28	11.32
8	7371.00	36.4 AV	54.0	-17.6	1.00 V	85	25.08	11.32

REMARKS:

1. Emission Level(dBuV/m) = Raw Value(dBuV) + Correction Factor(dB/m)
2. Correction Factor(dB/m) = Antenna Factor(dB/m) + Cable Factor(dB) – Pre-Amplifier Factor(dB)
3. The other emission levels were very low against the limit.
4. Margin value = Emission Level – Limit value
5. " * ": Fundamental frequency.

CHANNEL	TX Channel 11	DETECTOR FUNCTION	Peak (PK)
FREQUENCY RANGE	1GHz ~ 25GHz		Average (AV)

ANTENNA POLARITY & TEST DISTANCE: HORIZONTAL AT 3 M

NO.	FREQ. (MHz)	EMISSION LEVEL (dBuV/m)	LIMIT (dBuV/m)	MARGIN (dB)	ANTENNA HEIGHT (m)	TABLE ANGLE (Degree)	RAW VALUE (dBuV)	CORRECTION FACTOR (dB/m)
1	*2462.00	105.6 PK			2.17 H	186	108.54	-2.94
2	*2462.00	93.4 AV			2.17 H	186	96.34	-2.94
3	2483.50	63.2 PK	74.0	-10.8	2.17 H	186	66.07	-2.87
4	2483.50	43.7 AV	54.0	-10.3	2.17 H	186	46.57	-2.87
5	4924.00	44.9 PK	74.0	-29.1	1.29 H	102	38.83	6.07
6	4924.00	31.6 AV	54.0	-22.4	1.29 H	102	25.53	6.07
7	7386.00	46.9 PK	74.0	-27.1	1.21 H	107	35.48	11.42
8	7386.00	36.4 AV	54.0	-17.6	1.21 H	107	24.98	11.42

ANTENNA POLARITY & TEST DISTANCE: VERTICAL AT 3 M

NO.	FREQ. (MHz)	EMISSION LEVEL (dBuV/m)	LIMIT (dBuV/m)	MARGIN (dB)	ANTENNA HEIGHT (m)	TABLE ANGLE (Degree)	RAW VALUE (dBuV)	CORRECTION FACTOR (dB/m)
1	*2462.00	111.4 PK			1.74 V	213	114.34	-2.94
2	*2462.00	99.3 AV			1.74 V	213	102.24	-2.94
3	2483.50	69.8 PK	74.0	-4.2	1.74 V	213	72.67	-2.87
4	2483.50	49.3 AV	54.0	-4.7	1.74 V	213	52.17	-2.87
5	4924.00	46.4 PK	74.0	-27.6	1.00 V	115	40.33	6.07
6	4924.00	32.6 AV	54.0	-21.4	1.00 V	115	26.53	6.07
7	7386.00	46.8 PK	74.0	-27.2	1.00 V	85	35.38	11.42
8	7386.00	36.6 AV	54.0	-17.4	1.00 V	85	25.18	11.42

REMARKS:

1. Emission Level(dBuV/m) = Raw Value(dBuV) + Correction Factor(dB/m)
2. Correction Factor(dB/m) = Antenna Factor(dB/m) + Cable Factor(dB) – Pre-Amplifier Factor(dB)
3. The other emission levels were very low against the limit.
4. Margin value = Emission Level – Limit value
5. " * ": Fundamental frequency.

802.11n (HT40)

CHANNEL	TX Channel 3	DETECTOR FUNCTION	Peak (PK)
FREQUENCY RANGE	1GHz ~ 25GHz		Average (AV)

ANTENNA POLARITY & TEST DISTANCE: HORIZONTAL AT 3 M

NO.	FREQ. (MHz)	EMISSION LEVEL (dBuV/m)	LIMIT (dBuV/m)	MARGIN (dB)	ANTENNA HEIGHT (m)	TABLE ANGLE (Degree)	RAW VALUE (dBuV)	CORRECTION FACTOR (dB/m)
1	2390.00	61.2 PK	74.0	-12.8	2.15 H	184	64.39	-3.19
2	2390.00	45.1 AV	54.0	-8.9	2.15 H	184	48.29	-3.19
3	*2422.00	103.1 PK			2.15 H	184	106.19	-3.09
4	*2422.00	91.2 AV			2.15 H	184	94.29	-3.09
5	4844.00	44.7 PK	74.0	-29.3	1.29 H	101	38.71	5.99
6	4844.00	31.6 AV	54.0	-22.4	1.29 H	101	25.61	5.99
7	7266.00	46.4 PK	74.0	-27.6	1.22 H	109	35.51	10.89
8	7266.00	35.8 AV	54.0	-18.2	1.22 H	109	24.91	10.89

ANTENNA POLARITY & TEST DISTANCE: VERTICAL AT 3 M

NO.	FREQ. (MHz)	EMISSION LEVEL (dBuV/m)	LIMIT (dBuV/m)	MARGIN (dB)	ANTENNA HEIGHT (m)	TABLE ANGLE (Degree)	RAW VALUE (dBuV)	CORRECTION FACTOR (dB/m)
1	2390.00	67.8 PK	74.0	-6.2	1.78 V	334	70.99	-3.19
2	2390.00	51.0 AV	54.0	-3.0	1.78 V	334	54.19	-3.19
3	*2422.00	108.9 PK			1.78 V	334	111.99	-3.09
4	*2422.00	96.6 AV			1.78 V	334	99.69	-3.09
5	4844.00	45.7 PK	74.0	-28.3	1.00 V	106	39.71	5.99
6	4844.00	32.4 AV	54.0	-21.6	1.00 V	106	26.41	5.99
7	7266.00	47.0 PK	74.0	-27.0	1.00 V	97	36.11	10.89
8	7266.00	36.2 AV	54.0	-17.8	1.00 V	97	25.31	10.89

REMARKS:

1. Emission Level(dBuV/m) = Raw Value(dBuV) + Correction Factor(dB/m)
2. Correction Factor(dB/m) = Antenna Factor(dB/m) + Cable Factor(dB) – Pre-Amplifier Factor(dB)
3. The other emission levels were very low against the limit.
4. Margin value = Emission Level – Limit value
5. " * ": Fundamental frequency.

CHANNEL	TX Channel 4	DETECTOR FUNCTION	Peak (PK)
FREQUENCY RANGE	1GHz ~ 25GHz		Average (AV)

ANTENNA POLARITY & TEST DISTANCE: HORIZONTAL AT 3 M

NO.	FREQ. (MHz)	EMISSION LEVEL (dBuV/m)	LIMIT (dBuV/m)	MARGIN (dB)	ANTENNA HEIGHT (m)	TABLE ANGLE (Degree)	RAW VALUE (dBuV)	CORRECTION FACTOR (dB/m)
1	2390.00	61.8 PK	74.0	-12.2	2.16 H	168	64.99	-3.19
2	2390.00	45.7 AV	54.0	-8.3	2.16 H	168	48.89	-3.19
3	*2427.00	104.7 PK			2.16 H	168	107.77	-3.07
4	*2427.00	92.2 AV			2.16 H	168	95.27	-3.07
5	4854.00	44.9 PK	74.0	-29.1	1.34 H	105	38.88	6.02
6	4854.00	31.4 AV	54.0	-22.6	1.34 H	105	25.38	6.02
7	7281.00	46.6 PK	74.0	-27.4	1.29 H	111	35.72	10.88
8	7281.00	36.6 AV	54.0	-17.4	1.29 H	111	25.72	10.88

ANTENNA POLARITY & TEST DISTANCE: VERTICAL AT 3 M

NO.	FREQ. (MHz)	EMISSION LEVEL (dBuV/m)	LIMIT (dBuV/m)	MARGIN (dB)	ANTENNA HEIGHT (m)	TABLE ANGLE (Degree)	RAW VALUE (dBuV)	CORRECTION FACTOR (dB/m)
1	2390.00	66.9 PK	74.0	-7.1	1.80 V	342	70.09	-3.19
2	2390.00	51.8 AV	54.0	-2.2	1.80 V	342	54.99	-3.19
3	*2427.00	110.2 PK			1.80 V	342	113.27	-3.07
4	*2427.00	97.6 AV			1.80 V	342	100.67	-3.07
5	4854.00	45.9 PK	74.0	-28.1	1.00 V	101	39.88	6.02
6	4854.00	32.6 AV	54.0	-21.4	1.00 V	101	26.58	6.02
7	7281.00	47.0 PK	74.0	-27.0	1.00 V	112	36.12	10.88
8	7281.00	36.6 AV	54.0	-17.4	1.00 V	112	25.72	10.88

REMARKS:

1. Emission Level(dBuV/m) = Raw Value(dBuV) + Correction Factor(dB/m)
2. Correction Factor(dB/m) = Antenna Factor(dB/m) + Cable Factor(dB) – Pre-Amplifier Factor(dB)
3. The other emission levels were very low against the limit.
4. Margin value = Emission Level – Limit value
5. " * ": Fundamental frequency.

CHANNEL	TX Channel 6	DETECTOR FUNCTION	Peak (PK)
FREQUENCY RANGE	1GHz ~ 25GHz		Average (AV)

ANTENNA POLARITY & TEST DISTANCE: HORIZONTAL AT 3 M

NO.	FREQ. (MHz)	EMISSION LEVEL (dBuV/m)	LIMIT (dBuV/m)	MARGIN (dB)	ANTENNA HEIGHT (m)	TABLE ANGLE (Degree)	RAW VALUE (dBuV)	CORRECTION FACTOR (dB/m)
1	2390.00	60.1 PK	74.0	-13.9	2.17 H	182	63.29	-3.19
2	2390.00	41.6 AV	54.0	-12.4	2.17 H	182	44.79	-3.19
3	*2437.00	105.5 PK			2.17 H	182	108.54	-3.04
4	*2437.00	92.7 AV			2.17 H	182	95.74	-3.04
5	2483.50	60.7 PK	74.0	-13.3	2.17 H	182	63.57	-2.87
6	2483.50	42.2 AV	54.0	-11.8	2.17 H	182	45.07	-2.87
7	4874.00	45.0 PK	74.0	-29.0	1.29 H	105	38.95	6.05
8	4874.00	31.8 AV	54.0	-22.2	1.29 H	105	25.75	6.05
9	7311.00	46.0 PK	74.0	-28.0	1.21 H	112	35.06	10.94
10	7311.00	35.9 AV	54.0	-18.1	1.21 H	112	24.96	10.94

ANTENNA POLARITY & TEST DISTANCE: VERTICAL AT 3 M

NO.	FREQ. (MHz)	EMISSION LEVEL (dBuV/m)	LIMIT (dBuV/m)	MARGIN (dB)	ANTENNA HEIGHT (m)	TABLE ANGLE (Degree)	RAW VALUE (dBuV)	CORRECTION FACTOR (dB/m)
1	2390.00	64.5 PK	74.0	-9.5	1.66 V	346	67.69	-3.19
2	2390.00	47.8 AV	54.0	-6.2	1.66 V	346	50.99	-3.19
3	*2437.00	111.1 PK			1.66 V	346	114.14	-3.04
4	*2437.00	98.2 AV			1.66 V	346	101.24	-3.04
5	2483.50	68.6 PK	74.0	-5.4	1.66 V	346	71.47	-2.87
6	2483.50	48.0 AV	54.0	-6.0	1.66 V	346	50.87	-2.87
7	4874.00	46.5 PK	74.0	-27.5	1.00 V	120	40.45	6.05
8	4874.00	32.9 AV	54.0	-21.1	1.00 V	120	26.85	6.05
9	7311.00	46.8 PK	74.0	-27.2	1.00 V	95	35.86	10.94
10	7311.00	36.0 AV	54.0	-18.0	1.00 V	95	25.06	10.94

REMARKS:

1. Emission Level(dBuV/m) = Raw Value(dBuV) + Correction Factor(dB/m)
2. Correction Factor(dB/m) = Antenna Factor(dB/m) + Cable Factor(dB) – Pre-Amplifier Factor(dB)
3. The other emission levels were very low against the limit.
4. Margin value = Emission Level – Limit value
5. " * ": Fundamental frequency.

CHANNEL	TX Channel 8	DETECTOR FUNCTION	Peak (PK)
FREQUENCY RANGE	1GHz ~ 25GHz		Average (AV)

ANTENNA POLARITY & TEST DISTANCE: HORIZONTAL AT 3 M

NO.	FREQ. (MHz)	EMISSION LEVEL (dBuV/m)	LIMIT (dBuV/m)	MARGIN (dB)	ANTENNA HEIGHT (m)	TABLE ANGLE (Degree)	RAW VALUE (dBuV)	CORRECTION FACTOR (dB/m)
1	*2447.00	103.2 PK			2.23 H	175	106.20	-3.00
2	*2447.00	90.4 AV			2.23 H	175	93.40	-3.00
3	2483.50	62.2 PK	74.0	-11.8	2.23 H	175	65.07	-2.87
4	2483.50	45.8 AV	54.0	-8.2	2.23 H	175	48.67	-2.87
5	4894.00	45.5 PK	74.0	-28.5	1.35 H	100	39.43	6.07
6	4894.00	32.2 AV	54.0	-21.8	1.35 H	100	26.13	6.07
7	7341.00	46.8 PK	74.0	-27.2	1.25 H	113	35.67	11.13
8	7341.00	36.5 AV	54.0	-17.5	1.25 H	113	25.37	11.13

ANTENNA POLARITY & TEST DISTANCE: VERTICAL AT 3 M

NO.	FREQ. (MHz)	EMISSION LEVEL (dBuV/m)	LIMIT (dBuV/m)	MARGIN (dB)	ANTENNA HEIGHT (m)	TABLE ANGLE (Degree)	RAW VALUE (dBuV)	CORRECTION FACTOR (dB/m)
1	*2447.00	108.9 PK			1.80 V	350	111.90	-3.00
2	*2447.00	95.9 AV			1.80 V	350	98.90	-3.00
3	2483.50	69.2 PK	74.0	-4.8	1.80 V	350	72.07	-2.87
4	2483.50	50.0 AV	54.0	-4.0	1.80 V	350	52.87	-2.87
5	4894.00	46.4 PK	74.0	-27.6	1.00 V	115	40.33	6.07
6	4894.00	32.7 AV	54.0	-21.3	1.00 V	115	26.63	6.07
7	7341.00	47.4 PK	74.0	-26.6	1.00 V	96	36.27	11.13
8	7341.00	36.8 AV	54.0	-17.2	1.00 V	96	25.67	11.13

REMARKS:

1. Emission Level(dBuV/m) = Raw Value(dBuV) + Correction Factor(dB/m)
2. Correction Factor(dB/m) = Antenna Factor(dB/m) + Cable Factor(dB) – Pre-Amplifier Factor(dB)
3. The other emission levels were very low against the limit.
4. Margin value = Emission Level – Limit value
5. " * ": Fundamental frequency.

CHANNEL	TX Channel 9	DETECTOR FUNCTION	Peak (PK)
FREQUENCY RANGE	1GHz ~ 25GHz		Average (AV)

ANTENNA POLARITY & TEST DISTANCE: HORIZONTAL AT 3 M

NO.	FREQ. (MHz)	EMISSION LEVEL (dBuV/m)	LIMIT (dBuV/m)	MARGIN (dB)	ANTENNA HEIGHT (m)	TABLE ANGLE (Degree)	RAW VALUE (dBuV)	CORRECTION FACTOR (dB/m)
1	*2452.00	102.9 PK			2.17 H	184	105.88	-2.98
2	*2452.00	90.3 AV			2.17 H	184	93.28	-2.98
3	2483.50	61.6 PK	74.0	-12.4	2.17 H	184	64.47	-2.87
4	2483.50	45.4 AV	54.0	-8.6	2.17 H	184	48.27	-2.87
5	4904.00	44.8 PK	74.0	-29.2	1.31 H	109	38.72	6.08
6	4904.00	31.6 AV	54.0	-22.4	1.31 H	109	25.52	6.08
7	7356.00	46.4 PK	74.0	-27.6	1.25 H	111	35.18	11.22
8	7356.00	36.1 AV	54.0	-17.9	1.25 H	111	24.88	11.22

ANTENNA POLARITY & TEST DISTANCE: VERTICAL AT 3 M

NO.	FREQ. (MHz)	EMISSION LEVEL (dBuV/m)	LIMIT (dBuV/m)	MARGIN (dB)	ANTENNA HEIGHT (m)	TABLE ANGLE (Degree)	RAW VALUE (dBuV)	CORRECTION FACTOR (dB/m)
1	*2452.00	108.5 PK			1.89 V	335	111.48	-2.98
2	*2452.00	95.8 AV			1.89 V	335	98.78	-2.98
3	2483.50	69.0 PK	74.0	-5.0	1.89 V	335	71.87	-2.87
4	2483.50	50.0 AV	54.0	-4.0	1.89 V	335	52.87	-2.87
5	4904.00	46.4 PK	74.0	-27.6	1.00 V	104	40.32	6.08
6	4904.00	32.5 AV	54.0	-21.5	1.00 V	104	26.42	6.08
7	7356.00	46.7 PK	74.0	-27.3	1.00 V	100	35.48	11.22
8	7356.00	36.2 AV	54.0	-17.8	1.00 V	100	24.98	11.22

REMARKS:

1. Emission Level(dBuV/m) = Raw Value(dBuV) + Correction Factor(dB/m)
2. Correction Factor(dB/m) = Antenna Factor(dB/m) + Cable Factor(dB) – Pre-Amplifier Factor(dB)
3. The other emission levels were very low against the limit.
4. Margin value = Emission Level – Limit value
5. " * ": Fundamental frequency.

Below 1GHz Data:

802.11b

CHANNEL	TX Channel 1	DETECTOR FUNCTION	Quasi-Peak (QP)
FREQUENCY RANGE	Below 1GHz		

ANTENNA POLARITY & TEST DISTANCE: HORIZONTAL AT 3 M

NO.	FREQ. (MHz)	EMISSION LEVEL (dBuV/m)	LIMIT (dBuV/m)	MARGIN (dB)	ANTENNA HEIGHT (m)	TABLE ANGLE (Degree)	RAW VALUE (dBuV)	CORRECTION FACTOR (dB/m)
1	33.56	24.0 QP	40.0	-16.0	1.50 H	155	33.60	-9.60
2	195.19	40.0 QP	43.5	-3.5	1.41 H	40	51.30	-11.30
3	260.41	42.8 QP	46.0	-3.2	1.40 H	85	51.70	-8.90
4	379.68	33.0 QP	46.0	-13.0	1.13 H	328	38.30	-5.30
5	695.48	37.7 QP	46.0	-8.3	1.05 H	323	36.30	1.40
6	1000.00	41.2 QP	54.0	-12.8	1.91 H	280	35.50	5.70

ANTENNA POLARITY & TEST DISTANCE: VERTICAL AT 3 M

NO.	FREQ. (MHz)	EMISSION LEVEL (dBuV/m)	LIMIT (dBuV/m)	MARGIN (dB)	ANTENNA HEIGHT (m)	TABLE ANGLE (Degree)	RAW VALUE (dBuV)	CORRECTION FACTOR (dB/m)
1	97.71	25.2 QP	43.5	-18.3	1.91 V	297	38.70	-13.50
2	196.01	33.5 QP	43.5	-10.0	1.62 V	225	44.90	-11.40
3	259.73	38.8 QP	46.0	-7.2	1.94 V	151	47.90	-9.10
4	325.63	32.6 QP	46.0	-13.4	1.03 V	39	39.00	-6.40
5	749.63	36.8 QP	46.0	-9.2	1.64 V	340	34.40	2.40
6	1000.00	39.0 QP	54.0	-15.0	1.00 V	300	33.30	5.70

REMARKS:

1. Emission Level(dBuV/m) = Raw Value(dBuV) + Correction Factor(dB/m)
2. Correction Factor(dB/m) = Antenna Factor(dB/m) + Cable Factor(dB) – Pre-Amplifier Factor(dB)
3. The other emission levels were very low against the limit.
4. Margin value = Emission Level – Limit value

CHANNEL	TX Channel 2	DETECTOR FUNCTION	Quasi-Peak (QP)
FREQUENCY RANGE	Below 1GHz		

ANTENNA POLARITY & TEST DISTANCE: HORIZONTAL AT 3 M

NO.	FREQ. (MHz)	EMISSION LEVEL (dBuV/m)	LIMIT (dBuV/m)	MARGIN (dB)	ANTENNA HEIGHT (m)	TABLE ANGLE (Degree)	RAW VALUE (dBuV)	CORRECTION FACTOR (dB/m)
1	33.79	24.1 QP	40.0	-15.9	1.55 H	166	33.70	-9.60
2	194.81	40.0 QP	43.5	-3.5	1.49 H	23	51.30	-11.30
3	260.19	42.8 QP	46.0	-3.2	1.43 H	65	51.70	-8.90
4	380.22	32.7 QP	46.0	-13.3	1.19 H	335	38.00	-5.30
5	695.78	37.8 QP	46.0	-8.2	1.04 H	327	36.40	1.40
6	1000.00	41.3 QP	54.0	-12.7	1.99 H	284	35.60	5.70

ANTENNA POLARITY & TEST DISTANCE: VERTICAL AT 3 M

NO.	FREQ. (MHz)	EMISSION LEVEL (dBuV/m)	LIMIT (dBuV/m)	MARGIN (dB)	ANTENNA HEIGHT (m)	TABLE ANGLE (Degree)	RAW VALUE (dBuV)	CORRECTION FACTOR (dB/m)
1	97.96	25.8 QP	43.5	-17.7	1.98 V	314	39.30	-13.50
2	195.57	33.5 QP	43.5	-10.0	1.63 V	233	44.90	-11.40
3	259.84	38.5 QP	46.0	-7.5	2.02 V	136	47.50	-9.00
4	325.57	32.1 QP	46.0	-13.9	1.05 V	58	38.50	-6.40
5	749.90	36.6 QP	46.0	-9.4	1.54 V	343	34.20	2.40
6	1000.00	39.0 QP	54.0	-15.0	1.03 V	283	33.30	5.70

REMARKS:

1. Emission Level(dBuV/m) = Raw Value(dBuV) + Correction Factor(dB/m)
2. Correction Factor(dB/m) = Antenna Factor(dB/m) + Cable Factor(dB) – Pre-Amplifier Factor(dB)
3. The other emission levels were very low against the limit.
4. Margin value = Emission Level – Limit value

CHANNEL	TX Channel 6	DETECTOR FUNCTION	Quasi-Peak (QP)
FREQUENCY RANGE	Below 1GHz		

ANTENNA POLARITY & TEST DISTANCE: HORIZONTAL AT 3 M

NO.	FREQ. (MHz)	EMISSION LEVEL (dBuV/m)	LIMIT (dBuV/m)	MARGIN (dB)	ANTENNA HEIGHT (m)	TABLE ANGLE (Degree)	RAW VALUE (dBuV)	CORRECTION FACTOR (dB/m)
1	33.92	24.0 QP	40.0	-16.0	1.49 H	171	33.50	-9.50
2	194.83	40.4 QP	43.5	-3.1	1.45 H	37	51.70	-11.30
3	260.42	42.7 QP	46.0	-3.3	1.44 H	66	51.60	-8.90
4	380.17	32.8 QP	46.0	-13.2	1.13 H	330	38.10	-5.30
5	695.77	37.6 QP	46.0	-8.4	1.04 H	312	36.20	1.40
6	1000.00	40.8 QP	54.0	-13.2	1.91 H	267	35.10	5.70

ANTENNA POLARITY & TEST DISTANCE: VERTICAL AT 3 M

NO.	FREQ. (MHz)	EMISSION LEVEL (dBuV/m)	LIMIT (dBuV/m)	MARGIN (dB)	ANTENNA HEIGHT (m)	TABLE ANGLE (Degree)	RAW VALUE (dBuV)	CORRECTION FACTOR (dB/m)
1	98.13	25.7 QP	43.5	-17.8	1.96 V	305	39.10	-13.40
2	195.60	33.7 QP	43.5	-9.8	1.64 V	235	45.10	-11.40
3	260.04	38.5 QP	46.0	-7.5	1.99 V	152	47.40	-8.90
4	325.54	32.2 QP	46.0	-13.8	1.00 V	52	38.60	-6.40
5	749.81	36.7 QP	46.0	-9.3	1.61 V	326	34.30	2.40
6	1000.00	38.6 QP	54.0	-15.4	1.01 V	279	32.90	5.70

REMARKS:

1. Emission Level(dBuV/m) = Raw Value(dBuV) + Correction Factor(dB/m)
2. Correction Factor(dB/m) = Antenna Factor(dB/m) + Cable Factor(dB) – Pre-Amplifier Factor(dB)
3. The other emission levels were very low against the limit.
4. Margin value = Emission Level – Limit value

CHANNEL	TX Channel 10	DETECTOR FUNCTION	Quasi-Peak (QP)
FREQUENCY RANGE	Below 1GHz		

ANTENNA POLARITY & TEST DISTANCE: HORIZONTAL AT 3 M

NO.	FREQ. (MHz)	EMISSION LEVEL (dBuV/m)	LIMIT (dBuV/m)	MARGIN (dB)	ANTENNA HEIGHT (m)	TABLE ANGLE (Degree)	RAW VALUE (dBuV)	CORRECTION FACTOR (dB/m)
1	33.89	23.8 QP	40.0	-16.2	1.54 H	169	33.40	-9.60
2	194.74	40.1 QP	43.5	-3.4	1.41 H	49	51.40	-11.30
3	260.38	42.4 QP	46.0	-3.6	1.45 H	80	51.30	-8.90
4	380.18	32.9 QP	46.0	-13.1	1.10 H	353	38.20	-5.30
5	695.81	37.8 QP	46.0	-8.2	1.00 H	318	36.40	1.40
6	1000.00	41.1 QP	54.0	-12.9	1.92 H	270	35.40	5.70

ANTENNA POLARITY & TEST DISTANCE: VERTICAL AT 3 M

NO.	FREQ. (MHz)	EMISSION LEVEL (dBuV/m)	LIMIT (dBuV/m)	MARGIN (dB)	ANTENNA HEIGHT (m)	TABLE ANGLE (Degree)	RAW VALUE (dBuV)	CORRECTION FACTOR (dB/m)
1	98.21	25.3 QP	43.5	-18.2	1.93 V	300	38.70	-13.40
2	195.93	33.9 QP	43.5	-9.6	1.64 V	208	45.30	-11.40
3	259.54	38.6 QP	46.0	-7.4	1.98 V	146	47.70	-9.10
4	326.01	32.4 QP	46.0	-13.6	1.04 V	58	38.80	-6.40
5	749.64	36.9 QP	46.0	-9.1	1.58 V	347	34.50	2.40
6	1000.00	38.8 QP	54.0	-15.2	1.00 V	272	33.10	5.70

REMARKS:

1. Emission Level(dBuV/m) = Raw Value(dBuV) + Correction Factor(dB/m)
2. Correction Factor(dB/m) = Antenna Factor(dB/m) + Cable Factor(dB) – Pre-Amplifier Factor(dB)
3. The other emission levels were very low against the limit.
4. Margin value = Emission Level – Limit value

CHANNEL	TX Channel 11	DETECTOR FUNCTION	Quasi-Peak (QP)
FREQUENCY RANGE	Below 1GHz		

ANTENNA POLARITY & TEST DISTANCE: HORIZONTAL AT 3 M

NO.	FREQ. (MHz)	EMISSION LEVEL (dBuV/m)	LIMIT (dBuV/m)	MARGIN (dB)	ANTENNA HEIGHT (m)	TABLE ANGLE (Degree)	RAW VALUE (dBuV)	CORRECTION FACTOR (dB/m)
1	33.79	24.2 QP	40.0	-15.8	1.53 H	179	33.80	-9.60
2	195.06	40.5 QP	43.5	-3.0	1.51 H	36	51.80	-11.30
3	260.22	42.6 QP	46.0	-3.4	1.43 H	69	51.50	-8.90
4	380.20	32.9 QP	46.0	-13.1	1.16 H	352	38.20	-5.30
5	695.82	38.0 QP	46.0	-8.0	1.08 H	313	36.60	1.40
6	1000.00	40.9 QP	54.0	-13.1	1.93 H	256	35.20	5.70

ANTENNA POLARITY & TEST DISTANCE: VERTICAL AT 3 M

NO.	FREQ. (MHz)	EMISSION LEVEL (dBuV/m)	LIMIT (dBuV/m)	MARGIN (dB)	ANTENNA HEIGHT (m)	TABLE ANGLE (Degree)	RAW VALUE (dBuV)	CORRECTION FACTOR (dB/m)
1	98.26	25.3 QP	43.5	-18.2	1.94 V	315	38.70	-13.40
2	195.83	33.6 QP	43.5	-9.9	1.60 V	234	45.00	-11.40
3	259.57	38.6 QP	46.0	-7.4	2.04 V	142	47.70	-9.10
4	325.92	32.4 QP	46.0	-13.6	1.00 V	38	38.80	-6.40
5	749.48	37.1 QP	46.0	-8.9	1.60 V	335	34.70	2.40
6	1000.00	39.0 QP	54.0	-15.0	1.00 V	300	33.30	5.70

REMARKS:

1. Emission Level(dBuV/m) = Raw Value(dBuV) + Correction Factor(dB/m)
2. Correction Factor(dB/m) = Antenna Factor(dB/m) + Cable Factor(dB) – Pre-Amplifier Factor(dB)
3. The other emission levels were very low against the limit.
4. Margin value = Emission Level – Limit value

802.11g

CHANNEL	TX Channel 1	DETECTOR FUNCTION	Quasi-Peak (QP)
FREQUENCY RANGE	Below 1GHz		

ANTENNA POLARITY & TEST DISTANCE: HORIZONTAL AT 3 M

NO.	FREQ. (MHz)	EMISSION LEVEL (dBuV/m)	LIMIT (dBuV/m)	MARGIN (dB)	ANTENNA HEIGHT (m)	TABLE ANGLE (Degree)	RAW VALUE (dBuV)	CORRECTION FACTOR (dB/m)
1	33.56	24.1 QP	40.0	-15.9	1.47 H	156	33.70	-9.60
2	194.78	40.4 QP	43.5	-3.1	1.45 H	19	51.70	-11.30
3	260.57	42.8 QP	46.0	-3.2	1.42 H	65	51.70	-8.90
4	379.84	32.5 QP	46.0	-13.5	1.11 H	349	37.80	-5.30
5	696.05	37.5 QP	46.0	-8.5	1.01 H	328	36.10	1.40
6	1000.00	40.8 QP	54.0	-13.2	1.99 H	265	35.10	5.70

ANTENNA POLARITY & TEST DISTANCE: VERTICAL AT 3 M

NO.	FREQ. (MHz)	EMISSION LEVEL (dBuV/m)	LIMIT (dBuV/m)	MARGIN (dB)	ANTENNA HEIGHT (m)	TABLE ANGLE (Degree)	RAW VALUE (dBuV)	CORRECTION FACTOR (dB/m)
1	98.24	25.5 QP	43.5	-18.0	1.92 V	304	38.90	-13.40
2	195.97	34.0 QP	43.5	-9.5	1.66 V	223	45.40	-11.40
3	259.77	38.7 QP	46.0	-7.3	1.98 V	152	47.80	-9.10
4	325.83	32.3 QP	46.0	-13.7	1.00 V	57	38.70	-6.40
5	749.84	36.5 QP	46.0	-9.5	1.58 V	327	34.10	2.40
6	1000.00	38.9 QP	54.0	-15.1	1.00 V	286	33.20	5.70

REMARKS:

1. Emission Level(dBuV/m) = Raw Value(dBuV) + Correction Factor(dB/m)
2. Correction Factor(dB/m) = Antenna Factor(dB/m) + Cable Factor(dB) – Pre-Amplifier Factor(dB)
3. The other emission levels were very low against the limit.
4. Margin value = Emission Level – Limit value

CHANNEL	TX Channel 2	DETECTOR FUNCTION	Quasi-Peak (QP)
FREQUENCY RANGE	Below 1GHz		

ANTENNA POLARITY & TEST DISTANCE: HORIZONTAL AT 3 M

NO.	FREQ. (MHz)	EMISSION LEVEL (dBuV/m)	LIMIT (dBuV/m)	MARGIN (dB)	ANTENNA HEIGHT (m)	TABLE ANGLE (Degree)	RAW VALUE (dBuV)	CORRECTION FACTOR (dB/m)
1	33.73	23.8 QP	40.0	-16.2	1.55 H	164	33.40	-9.60
2	194.95	39.9 QP	43.5	-3.6	1.52 H	37	51.20	-11.30
3	260.44	42.7 QP	46.0	-3.3	1.44 H	84	51.60	-8.90
4	379.67	32.9 QP	46.0	-13.1	1.11 H	345	38.20	-5.30
5	696.00	38.0 QP	46.0	-8.0	1.02 H	321	36.60	1.40
6	1000.00	41.4 QP	54.0	-12.6	1.99 H	259	35.70	5.70

ANTENNA POLARITY & TEST DISTANCE: VERTICAL AT 3 M

NO.	FREQ. (MHz)	EMISSION LEVEL (dBuV/m)	LIMIT (dBuV/m)	MARGIN (dB)	ANTENNA HEIGHT (m)	TABLE ANGLE (Degree)	RAW VALUE (dBuV)	CORRECTION FACTOR (dB/m)
1	98.05	25.8 QP	43.5	-17.7	1.98 V	319	39.30	-13.50
2	195.81	33.8 QP	43.5	-9.7	1.65 V	226	45.20	-11.40
3	259.56	38.6 QP	46.0	-7.4	2.04 V	131	47.70	-9.10
4	325.58	32.1 QP	46.0	-13.9	1.00 V	36	38.50	-6.40
5	749.71	36.7 QP	46.0	-9.3	1.61 V	325	34.30	2.40
6	1000.00	38.6 QP	54.0	-15.4	1.00 V	292	32.90	5.70

REMARKS:

1. Emission Level(dBuV/m) = Raw Value(dBuV) + Correction Factor(dB/m)
2. Correction Factor(dB/m) = Antenna Factor(dB/m) + Cable Factor(dB) – Pre-Amplifier Factor(dB)
3. The other emission levels were very low against the limit.
4. Margin value = Emission Level – Limit value

CHANNEL	TX Channel 6	DETECTOR FUNCTION	Quasi-Peak (QP)
FREQUENCY RANGE	Below 1GHz		

ANTENNA POLARITY & TEST DISTANCE: HORIZONTAL AT 3 M

NO.	FREQ. (MHz)	EMISSION LEVEL (dBuV/m)	LIMIT (dBuV/m)	MARGIN (dB)	ANTENNA HEIGHT (m)	TABLE ANGLE (Degree)	RAW VALUE (dBuV)	CORRECTION FACTOR (dB/m)
1	33.48	24.3 QP	40.0	-15.7	1.46 H	177	33.90	-9.60
2	195.06	40.2 QP	43.5	-3.3	1.50 H	38	51.50	-11.30
3	260.10	42.6 QP	46.0	-3.4	1.38 H	75	51.50	-8.90
4	380.22	32.7 QP	46.0	-13.3	1.11 H	352	38.00	-5.30
5	696.01	37.9 QP	46.0	-8.1	1.03 H	342	36.50	1.40
6	1000.00	41.4 QP	54.0	-12.6	1.98 H	275	35.70	5.70

ANTENNA POLARITY & TEST DISTANCE: VERTICAL AT 3 M

NO.	FREQ. (MHz)	EMISSION LEVEL (dBuV/m)	LIMIT (dBuV/m)	MARGIN (dB)	ANTENNA HEIGHT (m)	TABLE ANGLE (Degree)	RAW VALUE (dBuV)	CORRECTION FACTOR (dB/m)
1	97.75	25.2 QP	43.5	-18.3	1.91 V	305	38.70	-13.50
2	196.03	33.9 QP	43.5	-9.6	1.62 V	213	45.30	-11.40
3	259.62	38.8 QP	46.0	-7.2	1.95 V	137	47.90	-9.10
4	325.87	32.1 QP	46.0	-13.9	1.00 V	45	38.50	-6.40
5	749.76	36.6 QP	46.0	-9.4	1.55 V	325	34.20	2.40
6	1000.00	38.9 QP	54.0	-15.1	1.00 V	285	33.20	5.70

REMARKS:

1. Emission Level(dBuV/m) = Raw Value(dBuV) + Correction Factor(dB/m)
2. Correction Factor(dB/m) = Antenna Factor(dB/m) + Cable Factor(dB) – Pre-Amplifier Factor(dB)
3. The other emission levels were very low against the limit.
4. Margin value = Emission Level – Limit value

CHANNEL	TX Channel 10	DETECTOR FUNCTION	Quasi-Peak (QP)
FREQUENCY RANGE	Below 1GHz		

ANTENNA POLARITY & TEST DISTANCE: HORIZONTAL AT 3 M

NO.	FREQ. (MHz)	EMISSION LEVEL (dBuV/m)	LIMIT (dBuV/m)	MARGIN (dB)	ANTENNA HEIGHT (m)	TABLE ANGLE (Degree)	RAW VALUE (dBuV)	CORRECTION FACTOR (dB/m)
1	34.00	24.3 QP	40.0	-15.7	1.53 H	177	33.80	-9.50
2	195.02	40.1 QP	43.5	-3.4	1.46 H	28	51.40	-11.30
3	260.44	42.4 QP	46.0	-3.6	1.36 H	56	51.30	-8.90
4	379.90	32.5 QP	46.0	-13.5	1.18 H	332	37.80	-5.30
5	695.49	37.9 QP	46.0	-8.1	1.07 H	314	36.50	1.40
6	1000.00	41.2 QP	54.0	-12.8	1.98 H	256	35.50	5.70

ANTENNA POLARITY & TEST DISTANCE: VERTICAL AT 3 M

NO.	FREQ. (MHz)	EMISSION LEVEL (dBuV/m)	LIMIT (dBuV/m)	MARGIN (dB)	ANTENNA HEIGHT (m)	TABLE ANGLE (Degree)	RAW VALUE (dBuV)	CORRECTION FACTOR (dB/m)
1	98.07	25.2 QP	43.5	-18.3	2.02 V	315	38.70	-13.50
2	195.86	33.7 QP	43.5	-9.8	1.65 V	230	45.10	-11.40
3	259.80	38.5 QP	46.0	-7.5	2.03 V	144	47.50	-9.00
4	325.72	32.4 QP	46.0	-13.6	1.00 V	47	38.80	-6.40
5	749.99	36.8 QP	46.0	-9.2	1.61 V	337	34.40	2.40
6	1000.00	38.9 QP	54.0	-15.1	1.03 V	303	33.20	5.70

REMARKS:

1. Emission Level(dBuV/m) = Raw Value(dBuV) + Correction Factor(dB/m)
2. Correction Factor(dB/m) = Antenna Factor(dB/m) + Cable Factor(dB) – Pre-Amplifier Factor(dB)
3. The other emission levels were very low against the limit.
4. Margin value = Emission Level – Limit value

CHANNEL	TX Channel 11	DETECTOR FUNCTION	Quasi-Peak (QP)
FREQUENCY RANGE	Below 1GHz		

ANTENNA POLARITY & TEST DISTANCE: HORIZONTAL AT 3 M

NO.	FREQ. (MHz)	EMISSION LEVEL (dBuV/m)	LIMIT (dBuV/m)	MARGIN (dB)	ANTENNA HEIGHT (m)	TABLE ANGLE (Degree)	RAW VALUE (dBuV)	CORRECTION FACTOR (dB/m)
1	33.89	23.9 QP	40.0	-16.1	1.44 H	153	33.50	-9.60
2	194.95	40.2 QP	43.5	-3.3	1.45 H	40	51.50	-11.30
3	260.28	42.9 QP	46.0	-3.1	1.45 H	74	51.80	-8.90
4	379.79	32.6 QP	46.0	-13.4	1.09 H	353	37.90	-5.30
5	695.86	37.7 QP	46.0	-8.3	1.00 H	318	36.30	1.40
6	1000.00	41.3 QP	54.0	-12.7	1.95 H	262	35.60	5.70

ANTENNA POLARITY & TEST DISTANCE: VERTICAL AT 3 M

NO.	FREQ. (MHz)	EMISSION LEVEL (dBuV/m)	LIMIT (dBuV/m)	MARGIN (dB)	ANTENNA HEIGHT (m)	TABLE ANGLE (Degree)	RAW VALUE (dBuV)	CORRECTION FACTOR (dB/m)
1	98.14	25.8 QP	43.5	-17.7	1.99 V	317	39.20	-13.40
2	196.05	34.0 QP	43.5	-9.5	1.58 V	223	45.40	-11.40
3	259.76	38.5 QP	46.0	-7.5	1.98 V	134	47.60	-9.10
4	325.50	32.4 QP	46.0	-13.6	1.04 V	54	38.80	-6.40
5	749.47	36.9 QP	46.0	-9.1	1.63 V	345	34.50	2.40
6	1000.00	38.7 QP	54.0	-15.3	1.00 V	275	33.00	5.70

REMARKS:

1. Emission Level(dBuV/m) = Raw Value(dBuV) + Correction Factor(dB/m)
2. Correction Factor(dB/m) = Antenna Factor(dB/m) + Cable Factor(dB) – Pre-Amplifier Factor(dB)
3. The other emission levels were very low against the limit.
4. Margin value = Emission Level – Limit value

802.11n (HT20)

CHANNEL	TX Channel 1	DETECTOR FUNCTION	Quasi-Peak (QP)
FREQUENCY RANGE	Below 1GHz		

ANTENNA POLARITY & TEST DISTANCE: HORIZONTAL AT 3 M

NO.	FREQ. (MHz)	EMISSION LEVEL (dBuV/m)	LIMIT (dBuV/m)	MARGIN (dB)	ANTENNA HEIGHT (m)	TABLE ANGLE (Degree)	RAW VALUE (dBuV)	CORRECTION FACTOR (dB/m)
1	33.64	24.2 QP	40.0	-15.8	1.50 H	167	33.80	-9.60
2	194.98	40.2 QP	43.5	-3.3	1.46 H	45	51.50	-11.30
3	260.49	42.6 QP	46.0	-3.4	1.42 H	83	51.50	-8.90
4	379.74	32.9 QP	46.0	-13.1	1.20 H	355	38.20	-5.30
5	695.81	37.6 QP	46.0	-8.4	1.03 H	312	36.20	1.40
6	1000.00	41.1 QP	54.0	-12.9	1.88 H	278	35.40	5.70

ANTENNA POLARITY & TEST DISTANCE: VERTICAL AT 3 M

NO.	FREQ. (MHz)	EMISSION LEVEL (dBuV/m)	LIMIT (dBuV/m)	MARGIN (dB)	ANTENNA HEIGHT (m)	TABLE ANGLE (Degree)	RAW VALUE (dBuV)	CORRECTION FACTOR (dB/m)
1	97.88	25.3 QP	43.5	-18.2	2.00 V	317	38.80	-13.50
2	195.79	34.0 QP	43.5	-9.5	1.67 V	223	45.40	-11.40
3	259.56	38.8 QP	46.0	-7.2	1.99 V	150	47.90	-9.10
4	325.63	32.2 QP	46.0	-13.8	1.00 V	37	38.60	-6.40
5	749.90	36.6 QP	46.0	-9.4	1.63 V	334	34.20	2.40
6	1000.00	38.9 QP	54.0	-15.1	1.00 V	279	33.20	5.70

REMARKS:

1. Emission Level(dBuV/m) = Raw Value(dBuV) + Correction Factor(dB/m)
2. Correction Factor(dB/m) = Antenna Factor(dB/m) + Cable Factor(dB) – Pre-Amplifier Factor(dB)
3. The other emission levels were very low against the limit.
4. Margin value = Emission Level – Limit value

CHANNEL	TX Channel 2	DETECTOR FUNCTION	Quasi-Peak (QP)
FREQUENCY RANGE	Below 1GHz		

ANTENNA POLARITY & TEST DISTANCE: HORIZONTAL AT 3 M

NO.	FREQ. (MHz)	EMISSION LEVEL (dBuV/m)	LIMIT (dBuV/m)	MARGIN (dB)	ANTENNA HEIGHT (m)	TABLE ANGLE (Degree)	RAW VALUE (dBuV)	CORRECTION FACTOR (dB/m)
1	33.69	24.2 QP	40.0	-15.8	1.51 H	178	33.80	-9.60
2	194.73	40.0 QP	43.5	-3.5	1.52 H	28	51.30	-11.30
3	260.13	42.8 QP	46.0	-3.2	1.43 H	61	51.70	-8.90
4	380.14	32.9 QP	46.0	-13.1	1.10 H	337	38.20	-5.30
5	695.48	37.8 QP	46.0	-8.2	1.01 H	333	36.40	1.40
6	1000.00	41.2 QP	54.0	-12.8	1.98 H	275	35.50	5.70

ANTENNA POLARITY & TEST DISTANCE: VERTICAL AT 3 M

NO.	FREQ. (MHz)	EMISSION LEVEL (dBuV/m)	LIMIT (dBuV/m)	MARGIN (dB)	ANTENNA HEIGHT (m)	TABLE ANGLE (Degree)	RAW VALUE (dBuV)	CORRECTION FACTOR (dB/m)
1	97.77	25.7 QP	43.5	-17.8	1.97 V	313	39.20	-13.50
2	195.74	34.0 QP	43.5	-9.5	1.68 V	229	45.40	-11.40
3	260.03	38.8 QP	46.0	-7.2	2.02 V	155	47.70	-8.90
4	325.84	32.3 QP	46.0	-13.7	1.00 V	62	38.70	-6.40
5	749.86	36.9 QP	46.0	-9.1	1.62 V	344	34.50	2.40
6	1000.00	38.7 QP	54.0	-15.3	1.03 V	296	33.00	5.70

REMARKS:

1. Emission Level(dBuV/m) = Raw Value(dBuV) + Correction Factor(dB/m)
2. Correction Factor(dB/m) = Antenna Factor(dB/m) + Cable Factor(dB) – Pre-Amplifier Factor(dB)
3. The other emission levels were very low against the limit.
4. Margin value = Emission Level – Limit value

CHANNEL	TX Channel 6	DETECTOR FUNCTION	Quasi-Peak (QP)
FREQUENCY RANGE	Below 1GHz		

ANTENNA POLARITY & TEST DISTANCE: HORIZONTAL AT 3 M

NO.	FREQ. (MHz)	EMISSION LEVEL (dBuV/m)	LIMIT (dBuV/m)	MARGIN (dB)	ANTENNA HEIGHT (m)	TABLE ANGLE (Degree)	RAW VALUE (dBuV)	CORRECTION FACTOR (dB/m)
1	34.07	23.9 QP	40.0	-16.1	1.56 H	169	33.40	-9.50
2	194.90	40.1 QP	43.5	-3.4	1.51 H	48	51.40	-11.30
3	260.20	42.6 QP	46.0	-3.4	1.45 H	72	51.50	-8.90
4	379.77	32.9 QP	46.0	-13.1	1.17 H	338	38.20	-5.30
5	695.93	38.0 QP	46.0	-8.0	1.02 H	314	36.60	1.40
6	1000.00	41.2 QP	54.0	-12.8	1.94 H	262	35.50	5.70

ANTENNA POLARITY & TEST DISTANCE: VERTICAL AT 3 M

NO.	FREQ. (MHz)	EMISSION LEVEL (dBuV/m)	LIMIT (dBuV/m)	MARGIN (dB)	ANTENNA HEIGHT (m)	TABLE ANGLE (Degree)	RAW VALUE (dBuV)	CORRECTION FACTOR (dB/m)
1	98.24	25.4 QP	43.5	-18.1	1.90 V	309	38.80	-13.40
2	195.86	34.1 QP	43.5	-9.4	1.65 V	236	45.50	-11.40
3	259.89	39.1 QP	46.0	-6.9	1.93 V	152	48.10	-9.00
4	325.62	32.6 QP	46.0	-13.4	1.01 V	51	39.00	-6.40
5	749.92	36.9 QP	46.0	-9.1	1.53 V	334	34.50	2.40
6	1000.00	38.7 QP	54.0	-15.3	1.00 V	303	33.00	5.70

REMARKS:

1. Emission Level(dBuV/m) = Raw Value(dBuV) + Correction Factor(dB/m)
2. Correction Factor(dB/m) = Antenna Factor(dB/m) + Cable Factor(dB) – Pre-Amplifier Factor(dB)
3. The other emission levels were very low against the limit.
4. Margin value = Emission Level – Limit value

CHANNEL	TX Channel 10	DETECTOR FUNCTION	Quasi-Peak (QP)
FREQUENCY RANGE	Below 1GHz		

ANTENNA POLARITY & TEST DISTANCE: HORIZONTAL AT 3 M

NO.	FREQ. (MHz)	EMISSION LEVEL (dBuV/m)	LIMIT (dBuV/m)	MARGIN (dB)	ANTENNA HEIGHT (m)	TABLE ANGLE (Degree)	RAW VALUE (dBuV)	CORRECTION FACTOR (dB/m)
1	33.93	24.3 QP	40.0	-15.7	1.50 H	161	33.80	-9.50
2	194.79	40.1 QP	43.5	-3.4	1.46 H	39	51.40	-11.30
3	260.51	42.7 QP	46.0	-3.3	1.47 H	68	51.60	-8.90
4	379.98	32.5 QP	46.0	-13.5	1.15 H	342	37.80	-5.30
5	695.47	37.5 QP	46.0	-8.5	1.03 H	340	36.10	1.40
6	1000.00	40.9 QP	54.0	-13.1	1.90 H	269	35.20	5.70

ANTENNA POLARITY & TEST DISTANCE: VERTICAL AT 3 M

NO.	FREQ. (MHz)	EMISSION LEVEL (dBuV/m)	LIMIT (dBuV/m)	MARGIN (dB)	ANTENNA HEIGHT (m)	TABLE ANGLE (Degree)	RAW VALUE (dBuV)	CORRECTION FACTOR (dB/m)
1	98.26	25.4 QP	43.5	-18.1	2.00 V	324	38.80	-13.40
2	196.00	33.5 QP	43.5	-10.0	1.67 V	218	44.90	-11.40
3	259.79	38.8 QP	46.0	-7.2	2.02 V	128	47.80	-9.00
4	326.05	32.3 QP	46.0	-13.7	1.01 V	33	38.70	-6.40
5	749.87	36.7 QP	46.0	-9.3	1.57 V	333	34.30	2.40
6	1000.00	39.0 QP	54.0	-15.0	1.00 V	287	33.30	5.70

REMARKS:

1. Emission Level(dBuV/m) = Raw Value(dBuV) + Correction Factor(dB/m)
2. Correction Factor(dB/m) = Antenna Factor(dB/m) + Cable Factor(dB) – Pre-Amplifier Factor(dB)
3. The other emission levels were very low against the limit.
4. Margin value = Emission Level – Limit value

CHANNEL	TX Channel 11	DETECTOR FUNCTION	Quasi-Peak (QP)
FREQUENCY RANGE	Below 1GHz		

ANTENNA POLARITY & TEST DISTANCE: HORIZONTAL AT 3 M

NO.	FREQ. (MHz)	EMISSION LEVEL (dBuV/m)	LIMIT (dBuV/m)	MARGIN (dB)	ANTENNA HEIGHT (m)	TABLE ANGLE (Degree)	RAW VALUE (dBuV)	CORRECTION FACTOR (dB/m)
1	33.52	24.2 QP	40.0	-15.8	1.55 H	168	33.80	-9.60
2	195.19	40.4 QP	43.5	-3.1	1.45 H	37	51.70	-11.30
3	260.43	42.8 QP	46.0	-3.2	1.37 H	86	51.70	-8.90
4	379.66	32.8 QP	46.0	-13.2	1.20 H	334	38.10	-5.30
5	695.80	37.7 QP	46.0	-8.3	1.09 H	316	36.30	1.40
6	1000.00	41.1 QP	54.0	-12.9	1.90 H	282	35.40	5.70

ANTENNA POLARITY & TEST DISTANCE: VERTICAL AT 3 M

NO.	FREQ. (MHz)	EMISSION LEVEL (dBuV/m)	LIMIT (dBuV/m)	MARGIN (dB)	ANTENNA HEIGHT (m)	TABLE ANGLE (Degree)	RAW VALUE (dBuV)	CORRECTION FACTOR (dB/m)
1	97.86	25.8 QP	43.5	-17.7	2.01 V	324	39.30	-13.50
2	195.86	33.9 QP	43.5	-9.6	1.67 V	237	45.30	-11.40
3	259.51	38.8 QP	46.0	-7.2	1.93 V	140	47.90	-9.10
4	325.52	32.0 QP	46.0	-14.0	1.00 V	43	38.40	-6.40
5	749.63	36.8 QP	46.0	-9.2	1.63 V	343	34.40	2.40
6	1000.00	39.0 QP	54.0	-15.0	1.00 V	295	33.30	5.70

REMARKS:

1. Emission Level(dBuV/m) = Raw Value(dBuV) + Correction Factor(dB/m)
2. Correction Factor(dB/m) = Antenna Factor(dB/m) + Cable Factor(dB) – Pre-Amplifier Factor(dB)
3. The other emission levels were very low against the limit.
4. Margin value = Emission Level – Limit value

802.11n (HT40)

CHANNEL	TX Channel 3	DETECTOR FUNCTION	Quasi-Peak (QP)
FREQUENCY RANGE	Below 1GHz		

ANTENNA POLARITY & TEST DISTANCE: HORIZONTAL AT 3 M

NO.	FREQ. (MHz)	EMISSION LEVEL (dBuV/m)	LIMIT (dBuV/m)	MARGIN (dB)	ANTENNA HEIGHT (m)	TABLE ANGLE (Degree)	RAW VALUE (dBuV)	CORRECTION FACTOR (dB/m)
1	33.78	24.2 QP	40.0	-15.8	1.51 H	162	33.80	-9.60
2	194.99	40.3 QP	43.5	-3.2	1.48 H	20	51.60	-11.30
3	260.32	42.4 QP	46.0	-3.6	1.40 H	64	51.30	-8.90
4	380.10	32.5 QP	46.0	-13.5	1.16 H	336	37.80	-5.30
5	695.60	37.8 QP	46.0	-8.2	1.00 H	341	36.40	1.40
6	1000.00	41.4 QP	54.0	-12.6	1.98 H	262	35.70	5.70

ANTENNA POLARITY & TEST DISTANCE: VERTICAL AT 3 M

NO.	FREQ. (MHz)	EMISSION LEVEL (dBuV/m)	LIMIT (dBuV/m)	MARGIN (dB)	ANTENNA HEIGHT (m)	TABLE ANGLE (Degree)	RAW VALUE (dBuV)	CORRECTION FACTOR (dB/m)
1	97.94	25.5 QP	43.5	-18.0	1.95 V	304	39.00	-13.50
2	195.85	34.0 QP	43.5	-9.5	1.62 V	210	45.40	-11.40
3	259.67	38.9 QP	46.0	-7.1	2.00 V	143	48.00	-9.10
4	325.91	32.4 QP	46.0	-13.6	1.02 V	45	38.80	-6.40
5	749.71	36.6 QP	46.0	-9.4	1.57 V	350	34.20	2.40
6	1000.00	38.9 QP	54.0	-15.1	1.00 V	284	33.20	5.70

REMARKS:

1. Emission Level(dBuV/m) = Raw Value(dBuV) + Correction Factor(dB/m)
2. Correction Factor(dB/m) = Antenna Factor(dB/m) + Cable Factor(dB) – Pre-Amplifier Factor(dB)
3. The other emission levels were very low against the limit.
4. Margin value = Emission Level – Limit value

CHANNEL	TX Channel 4	DETECTOR FUNCTION	Quasi-Peak (QP)
FREQUENCY RANGE	Below 1GHz		

ANTENNA POLARITY & TEST DISTANCE: HORIZONTAL AT 3 M

NO.	FREQ. (MHz)	EMISSION LEVEL (dBuV/m)	LIMIT (dBuV/m)	MARGIN (dB)	ANTENNA HEIGHT (m)	TABLE ANGLE (Degree)	RAW VALUE (dBuV)	CORRECTION FACTOR (dB/m)
1	33.64	24.2 QP	40.0	-15.8	1.53 H	163	33.80	-9.60
2	195.14	40.1 QP	43.5	-3.4	1.47 H	30	51.40	-11.30
3	260.19	43.0 QP	46.0	-3.0	1.43 H	71	51.90	-8.90
4	379.93	32.6 QP	46.0	-13.4	1.16 H	350	37.90	-5.30
5	695.83	37.6 QP	46.0	-8.4	1.00 H	337	36.20	1.40
6	1000.00	41.1 QP	54.0	-12.9	1.92 H	282	35.40	5.70

ANTENNA POLARITY & TEST DISTANCE: VERTICAL AT 3 M

NO.	FREQ. (MHz)	EMISSION LEVEL (dBuV/m)	LIMIT (dBuV/m)	MARGIN (dB)	ANTENNA HEIGHT (m)	TABLE ANGLE (Degree)	RAW VALUE (dBuV)	CORRECTION FACTOR (dB/m)
1	98.06	25.5 QP	43.5	-18.0	1.91 V	309	39.00	-13.50
2	195.80	34.1 QP	43.5	-9.4	1.64 V	211	45.50	-11.40
3	260.09	39.1 QP	46.0	-6.9	1.94 V	128	48.00	-8.90
4	325.53	32.1 QP	46.0	-13.9	1.00 V	42	38.50	-6.40
5	749.80	36.9 QP	46.0	-9.1	1.57 V	345	34.50	2.40
6	1000.00	38.7 QP	54.0	-15.3	1.03 V	273	33.00	5.70

REMARKS:

1. Emission Level(dBuV/m) = Raw Value(dBuV) + Correction Factor(dB/m)
2. Correction Factor(dB/m) = Antenna Factor(dB/m) + Cable Factor(dB) – Pre-Amplifier Factor(dB)
3. The other emission levels were very low against the limit.
4. Margin value = Emission Level – Limit value

CHANNEL	TX Channel 6	DETECTOR FUNCTION	Quasi-Peak (QP)
FREQUENCY RANGE	Below 1GHz		

ANTENNA POLARITY & TEST DISTANCE: HORIZONTAL AT 3 M

NO.	FREQ. (MHz)	EMISSION LEVEL (dBuV/m)	LIMIT (dBuV/m)	MARGIN (dB)	ANTENNA HEIGHT (m)	TABLE ANGLE (Degree)	RAW VALUE (dBuV)	CORRECTION FACTOR (dB/m)
1	33.85	24.0 QP	40.0	-16.0	1.44 H	164	33.60	-9.60
2	195.10	40.0 QP	43.5	-3.5	1.49 H	43	51.30	-11.30
3	260.23	42.7 QP	46.0	-3.3	1.45 H	81	51.60	-8.90
4	380.18	32.9 QP	46.0	-13.1	1.10 H	349	38.20	-5.30
5	696.02	37.6 QP	46.0	-8.4	1.00 H	342	36.20	1.40
6	1000.00	40.8 QP	54.0	-13.2	1.88 H	275	35.10	5.70

ANTENNA POLARITY & TEST DISTANCE: VERTICAL AT 3 M

NO.	FREQ. (MHz)	EMISSION LEVEL (dBuV/m)	LIMIT (dBuV/m)	MARGIN (dB)	ANTENNA HEIGHT (m)	TABLE ANGLE (Degree)	RAW VALUE (dBuV)	CORRECTION FACTOR (dB/m)
1	97.80	25.4 QP	43.5	-18.1	1.96 V	310	38.90	-13.50
2	195.91	33.5 QP	43.5	-10.0	1.58 V	206	44.90	-11.40
3	260.07	38.9 QP	46.0	-7.1	2.00 V	152	47.80	-8.90
4	325.68	32.2 QP	46.0	-13.8	1.00 V	50	38.60	-6.40
5	749.62	36.7 QP	46.0	-9.3	1.63 V	350	34.30	2.40
6	1000.00	38.7 QP	54.0	-15.3	1.00 V	299	33.00	5.70

REMARKS:

1. Emission Level(dBuV/m) = Raw Value(dBuV) + Correction Factor(dB/m)
2. Correction Factor(dB/m) = Antenna Factor(dB/m) + Cable Factor(dB) – Pre-Amplifier Factor(dB)
3. The other emission levels were very low against the limit.
4. Margin value = Emission Level – Limit value

CHANNEL	TX Channel 8	DETECTOR FUNCTION	Quasi-Peak (QP)
FREQUENCY RANGE	Below 1GHz		

ANTENNA POLARITY & TEST DISTANCE: HORIZONTAL AT 3 M

NO.	FREQ. (MHz)	EMISSION LEVEL (dBuV/m)	LIMIT (dBuV/m)	MARGIN (dB)	ANTENNA HEIGHT (m)	TABLE ANGLE (Degree)	RAW VALUE (dBuV)	CORRECTION FACTOR (dB/m)
1	34.04	24.3 QP	40.0	-15.7	1.54 H	168	33.80	-9.50
2	195.11	40.3 QP	43.5	-3.2	1.48 H	50	51.60	-11.30
3	260.44	42.7 QP	46.0	-3.3	1.45 H	83	51.60	-8.90
4	379.67	32.9 QP	46.0	-13.1	1.16 H	351	38.20	-5.30
5	695.48	37.4 QP	46.0	-8.6	1.00 H	334	36.00	1.40
6	1000.00	41.1 QP	54.0	-12.9	1.90 H	282	35.40	5.70

ANTENNA POLARITY & TEST DISTANCE: VERTICAL AT 3 M

NO.	FREQ. (MHz)	EMISSION LEVEL (dBuV/m)	LIMIT (dBuV/m)	MARGIN (dB)	ANTENNA HEIGHT (m)	TABLE ANGLE (Degree)	RAW VALUE (dBuV)	CORRECTION FACTOR (dB/m)
1	97.67	25.6 QP	43.5	-17.9	1.95 V	314	39.10	-13.50
2	196.00	33.6 QP	43.5	-9.9	1.68 V	231	45.00	-11.40
3	259.60	38.8 QP	46.0	-7.2	2.02 V	156	47.90	-9.10
4	326.01	32.1 QP	46.0	-13.9	1.05 V	59	38.50	-6.40
5	749.46	36.8 QP	46.0	-9.2	1.54 V	334	34.40	2.40
6	1000.00	39.1 QP	54.0	-14.9	1.00 V	292	33.40	5.70

REMARKS:

1. Emission Level(dBuV/m) = Raw Value(dBuV) + Correction Factor(dB/m)
2. Correction Factor(dB/m) = Antenna Factor(dB/m) + Cable Factor(dB) – Pre-Amplifier Factor(dB)
3. The other emission levels were very low against the limit.
4. Margin value = Emission Level – Limit value

CHANNEL	TX Channel 9	DETECTOR FUNCTION	Quasi-Peak (QP)
FREQUENCY RANGE	Below 1GHz		

ANTENNA POLARITY & TEST DISTANCE: HORIZONTAL AT 3 M

NO.	FREQ. (MHz)	EMISSION LEVEL (dBuV/m)	LIMIT (dBuV/m)	MARGIN (dB)	ANTENNA HEIGHT (m)	TABLE ANGLE (Degree)	RAW VALUE (dBuV)	CORRECTION FACTOR (dB/m)
1	33.52	24.3 QP	40.0	-15.7	1.44 H	160	33.90	-9.60
2	194.93	40.1 QP	43.5	-3.4	1.52 H	47	51.40	-11.30
3	260.11	42.6 QP	46.0	-3.4	1.41 H	84	51.50	-8.90
4	379.87	32.6 QP	46.0	-13.4	1.20 H	348	37.90	-5.30
5	695.86	37.9 QP	46.0	-8.1	1.02 H	322	36.50	1.40
6	1000.00	41.3 QP	54.0	-12.7	1.97 H	275	35.60	5.70

ANTENNA POLARITY & TEST DISTANCE: VERTICAL AT 3 M

NO.	FREQ. (MHz)	EMISSION LEVEL (dBuV/m)	LIMIT (dBuV/m)	MARGIN (dB)	ANTENNA HEIGHT (m)	TABLE ANGLE (Degree)	RAW VALUE (dBuV)	CORRECTION FACTOR (dB/m)
1	98.26	25.5 QP	43.5	-18.0	2.00 V	307	38.90	-13.40
2	195.67	33.7 QP	43.5	-9.8	1.64 V	206	45.10	-11.40
3	259.53	38.6 QP	46.0	-7.4	2.00 V	156	47.70	-9.10
4	326.02	32.4 QP	46.0	-13.6	1.05 V	34	38.80	-6.40
5	749.46	37.0 QP	46.0	-9.0	1.64 V	353	34.60	2.40
6	1000.00	38.9 QP	54.0	-15.1	1.00 V	287	33.20	5.70

REMARKS:

1. Emission Level(dBuV/m) = Raw Value(dBuV) + Correction Factor(dB/m)
2. Correction Factor(dB/m) = Antenna Factor(dB/m) + Cable Factor(dB) – Pre-Amplifier Factor(dB)
3. The other emission levels were very low against the limit.
4. Margin value = Emission Level – Limit value

4.1.9 Test Results (Mode 3)

Above 1GHz Data:

802.11b

CHANNEL	TX Channel 1	DETECTOR FUNCTION	Peak (PK)
FREQUENCY RANGE	1GHz ~ 25GHz		Average (AV)

ANTENNA POLARITY & TEST DISTANCE: HORIZONTAL AT 3 M

NO.	FREQ. (MHz)	EMISSION LEVEL (dBuV/m)	LIMIT (dBuV/m)	MARGIN (dB)	ANTENNA HEIGHT (m)	TABLE ANGLE (Degree)	RAW VALUE (dBuV)	CORRECTION FACTOR (dB/m)
1	2390.00	58.7 PK	74.0	-15.3	2.36 H	321	61.89	-3.19
2	2390.00	41.4 AV	54.0	-12.6	2.36 H	321	44.59	-3.19
3	*2412.00	104.5 PK			2.36 H	321	107.63	-3.13
4	*2412.00	100.8 AV			2.36 H	321	103.93	-3.13
5	4824.00	49.5 PK	74.0	-24.5	1.77 H	360	43.53	5.97
6	4824.00	45.6 AV	54.0	-8.4	1.77 H	360	39.63	5.97

ANTENNA POLARITY & TEST DISTANCE: VERTICAL AT 3 M

NO.	FREQ. (MHz)	EMISSION LEVEL (dBuV/m)	LIMIT (dBuV/m)	MARGIN (dB)	ANTENNA HEIGHT (m)	TABLE ANGLE (Degree)	RAW VALUE (dBuV)	CORRECTION FACTOR (dB/m)
1	2390.00	56.7 PK	74.0	-17.3	2.13 V	79	59.89	-3.19
2	2390.00	47.8 AV	54.0	-6.2	2.13 V	79	50.99	-3.19
3	*2412.00	108.7 PK			2.13 V	79	111.83	-3.13
4	*2412.00	105.6 AV			2.13 V	79	108.73	-3.13
5	4824.00	51.2 PK	74.0	-22.8	1.46 V	117	45.23	5.97
6	4824.00	48.6 AV	54.0	-5.4	1.46 V	117	42.63	5.97

REMARKS:

1. Emission Level(dBuV/m) = Raw Value(dBuV) + Correction Factor(dB/m)
2. Correction Factor(dB/m) = Antenna Factor(dB/m) + Cable Factor(dB) – Pre-Amplifier Factor(dB)
3. The other emission levels were very low against the limit.
4. Margin value = Emission Level – Limit value
5. " * ": Fundamental frequency.

CHANNEL	TX Channel 2	DETECTOR FUNCTION	Peak (PK)
FREQUENCY RANGE	1GHz ~ 25GHz		Average (AV)

ANTENNA POLARITY & TEST DISTANCE: HORIZONTAL AT 3 M

NO.	FREQ. (MHz)	EMISSION LEVEL (dBuV/m)	LIMIT (dBuV/m)	MARGIN (dB)	ANTENNA HEIGHT (m)	TABLE ANGLE (Degree)	RAW VALUE (dBuV)	CORRECTION FACTOR (dB/m)
1	2390.00	51.6 PK	74.0	-22.4	2.27 H	322	54.79	-3.19
2	2390.00	39.0 AV	54.0	-15.0	2.27 H	322	42.19	-3.19
3	*2417.00	104.5 PK			2.27 H	322	107.61	-3.11
4	*2417.00	101.2 AV			2.27 H	322	104.31	-3.11
5	4834.00	49.5 PK	74.0	-24.5	1.76 H	360	43.51	5.99
6	4834.00	45.5 AV	54.0	-8.5	1.76 H	360	39.51	5.99
7	7251.00	47.6 PK	74.0	-26.4	1.53 H	66	36.72	10.88
8	7251.00	37.1 AV	54.0	-16.9	1.53 H	66	26.22	10.88

ANTENNA POLARITY & TEST DISTANCE: VERTICAL AT 3 M

NO.	FREQ. (MHz)	EMISSION LEVEL (dBuV/m)	LIMIT (dBuV/m)	MARGIN (dB)	ANTENNA HEIGHT (m)	TABLE ANGLE (Degree)	RAW VALUE (dBuV)	CORRECTION FACTOR (dB/m)
1	2390.00	54.0 PK	74.0	-20.0	2.13 V	81	57.19	-3.19
2	2390.00	43.0 AV	54.0	-11.0	2.13 V	81	46.19	-3.19
3	*2417.00	108.8 PK			2.13 V	81	111.91	-3.11
4	*2417.00	105.7 AV			2.13 V	81	108.81	-3.11
5	4834.00	51.8 PK	74.0	-22.2	1.42 V	229	45.81	5.99
6	4834.00	49.3 AV	54.0	-4.7	1.42 V	229	43.31	5.99
7	7251.00	51.5 PK	74.0	-22.5	1.01 V	113	40.62	10.88
8	7251.00	44.1 AV	54.0	-9.9	1.01 V	113	33.22	10.88

REMARKS:

1. Emission Level(dBuV/m) = Raw Value(dBuV) + Correction Factor(dB/m)
2. Correction Factor(dB/m) = Antenna Factor(dB/m) + Cable Factor(dB) – Pre-Amplifier Factor(dB)
3. The other emission levels were very low against the limit.
4. Margin value = Emission Level – Limit value
5. " * ": Fundamental frequency.

CHANNEL	TX Channel 6	DETECTOR FUNCTION	Peak (PK)
FREQUENCY RANGE	1GHz ~ 25GHz		Average (AV)

ANTENNA POLARITY & TEST DISTANCE: HORIZONTAL AT 3 M

NO.	FREQ. (MHz)	EMISSION LEVEL (dBuV/m)	LIMIT (dBuV/m)	MARGIN (dB)	ANTENNA HEIGHT (m)	TABLE ANGLE (Degree)	RAW VALUE (dBuV)	CORRECTION FACTOR (dB/m)
1	*2437.00	104.4 PK			2.30 H	329	107.44	-3.04
2	*2437.00	101.0 AV			2.30 H	329	104.04	-3.04
3	4874.00	49.6 PK	74.0	-24.4	1.78 H	360	43.55	6.05
4	4874.00	45.8 AV	54.0	-8.2	1.78 H	360	39.75	6.05
5	7311.00	48.1 PK	74.0	-25.9	1.50 H	80	37.16	10.94
6	7311.00	37.7 AV	54.0	-16.3	1.50 H	80	26.76	10.94

ANTENNA POLARITY & TEST DISTANCE: VERTICAL AT 3 M

NO.	FREQ. (MHz)	EMISSION LEVEL (dBuV/m)	LIMIT (dBuV/m)	MARGIN (dB)	ANTENNA HEIGHT (m)	TABLE ANGLE (Degree)	RAW VALUE (dBuV)	CORRECTION FACTOR (dB/m)
1	*2437.00	107.6 PK			1.52 V	210	110.64	-3.04
2	*2437.00	104.2 AV			1.52 V	210	107.24	-3.04
3	4874.00	53.3 PK	74.0	-20.7	1.46 V	58	47.25	6.05
4	4874.00	50.8 AV	54.0	-3.2	1.46 V	58	44.75	6.05
5	7311.00	51.5 PK	74.0	-22.5	1.00 V	98	40.56	10.94
6	7311.00	43.9 AV	54.0	-10.1	1.00 V	98	32.96	10.94

REMARKS:

1. Emission Level(dBuV/m) = Raw Value(dBuV) + Correction Factor(dB/m)
2. Correction Factor(dB/m) = Antenna Factor(dB/m) + Cable Factor(dB) – Pre-Amplifier Factor(dB)
3. The other emission levels were very low against the limit.
4. Margin value = Emission Level – Limit value
5. " * ": Fundamental frequency.

CHANNEL	TX Channel 10	DETECTOR FUNCTION	Peak (PK)
FREQUENCY RANGE	1GHz ~ 25GHz		Average (AV)

ANTENNA POLARITY & TEST DISTANCE: HORIZONTAL AT 3 M

NO.	FREQ. (MHz)	EMISSION LEVEL (dBuV/m)	LIMIT (dBuV/m)	MARGIN (dB)	ANTENNA HEIGHT (m)	TABLE ANGLE (Degree)	RAW VALUE (dBuV)	CORRECTION FACTOR (dB/m)
1	*2457.00	104.4 PK			2.31 H	312	107.37	-2.97
2	*2457.00	101.3 AV			2.31 H	312	104.27	-2.97
3	2483.50	58.6 PK	74.0	-15.4	2.31 H	312	61.47	-2.87
4	2483.50	41.5 AV	54.0	-12.5	2.31 H	312	44.37	-2.87
5	4914.00	49.7 PK	74.0	-24.3	1.73 H	360	43.63	6.07
6	4914.00	46.1 AV	54.0	-7.9	1.73 H	360	40.03	6.07
7	7371.00	48.4 PK	74.0	-25.6	1.49 H	58	37.08	11.32
8	7371.00	37.6 AV	54.0	-16.4	1.49 H	58	26.28	11.32

ANTENNA POLARITY & TEST DISTANCE: VERTICAL AT 3 M

NO.	FREQ. (MHz)	EMISSION LEVEL (dBuV/m)	LIMIT (dBuV/m)	MARGIN (dB)	ANTENNA HEIGHT (m)	TABLE ANGLE (Degree)	RAW VALUE (dBuV)	CORRECTION FACTOR (dB/m)
1	*2457.00	108.1 PK			1.89 V	85	111.07	-2.97
2	*2457.00	105.0 AV			1.89 V	85	107.97	-2.97
3	2483.50	57.1 PK	74.0	-16.9	1.89 V	85	59.97	-2.87
4	2483.50	47.2 AV	54.0	-6.8	1.89 V	85	50.07	-2.87
5	4914.00	54.7 PK	74.0	-19.3	1.29 V	38	48.63	6.07
6	4914.00	50.6 AV	54.0	-3.4	1.29 V	38	44.53	6.07
7	7371.00	50.7 PK	74.0	-23.3	1.07 V	89	39.38	11.32
8	7371.00	43.5 AV	54.0	-10.5	1.07 V	89	32.18	11.32

REMARKS:

1. Emission Level(dBuV/m) = Raw Value(dBuV) + Correction Factor(dB/m)
2. Correction Factor(dB/m) = Antenna Factor(dB/m) + Cable Factor(dB) – Pre-Amplifier Factor(dB)
3. The other emission levels were very low against the limit.
4. Margin value = Emission Level – Limit value
5. " * ": Fundamental frequency.

CHANNEL	TX Channel 11	DETECTOR FUNCTION	Peak (PK)
FREQUENCY RANGE	1GHz ~ 25GHz		Average (AV)

ANTENNA POLARITY & TEST DISTANCE: HORIZONTAL AT 3 M

NO.	FREQ. (MHz)	EMISSION LEVEL (dBuV/m)	LIMIT (dBuV/m)	MARGIN (dB)	ANTENNA HEIGHT (m)	TABLE ANGLE (Degree)	RAW VALUE (dBuV)	CORRECTION FACTOR (dB/m)
1	*2462.00	104.6 PK			2.32 H	320	107.54	-2.94
2	*2462.00	101.2 AV			2.32 H	320	104.14	-2.94
3	2483.50	58.3 PK	74.0	-15.7	2.32 H	320	61.17	-2.87
4	2483.50	41.1 AV	54.0	-12.9	2.32 H	320	43.97	-2.87
5	4924.00	49.4 PK	74.0	-24.6	1.78 H	360	43.33	6.07
6	4924.00	45.6 AV	54.0	-8.4	1.78 H	360	39.53	6.07
7	7386.00	47.7 PK	74.0	-26.3	1.50 H	65	36.28	11.42
8	7386.00	37.2 AV	54.0	-16.8	1.50 H	65	25.78	11.42

ANTENNA POLARITY & TEST DISTANCE: VERTICAL AT 3 M

NO.	FREQ. (MHz)	EMISSION LEVEL (dBuV/m)	LIMIT (dBuV/m)	MARGIN (dB)	ANTENNA HEIGHT (m)	TABLE ANGLE (Degree)	RAW VALUE (dBuV)	CORRECTION FACTOR (dB/m)
1	*2462.00	107.4 PK			1.52 V	99	110.34	-2.94
2	*2462.00	104.4 AV			1.52 V	99	107.34	-2.94
3	2483.50	57.1 PK	74.0	-16.9	1.52 V	99	59.97	-2.87
4	2483.50	48.1 AV	54.0	-5.9	1.52 V	99	50.97	-2.87
5	4924.00	55.0 PK	74.0	-19.0	1.44 V	58	48.93	6.07
6	4924.00	50.6 AV	54.0	-3.4	1.44 V	58	44.53	6.07
7	7386.00	51.3 PK	74.0	-22.7	1.02 V	98	39.88	11.42
8	7386.00	43.9 AV	54.0	-10.1	1.02 V	98	32.48	11.42

REMARKS:

1. Emission Level(dBuV/m) = Raw Value(dBuV) + Correction Factor(dB/m)
2. Correction Factor(dB/m) = Antenna Factor(dB/m) + Cable Factor(dB) – Pre-Amplifier Factor(dB)
3. The other emission levels were very low against the limit.
4. Margin value = Emission Level – Limit value
5. " * ": Fundamental frequency.

802.11g

CHANNEL	TX Channel 1	DETECTOR FUNCTION	Peak (PK)
FREQUENCY RANGE	1GHz ~ 25GHz		Average (AV)

ANTENNA POLARITY & TEST DISTANCE: HORIZONTAL AT 3 M

NO.	FREQ. (MHz)	EMISSION LEVEL (dBuV/m)	LIMIT (dBuV/m)	MARGIN (dB)	ANTENNA HEIGHT (m)	TABLE ANGLE (Degree)	RAW VALUE (dBuV)	CORRECTION FACTOR (dB/m)
1	2390.00	68.1 PK	74.0	-5.9	2.36 H	334	71.29	-3.19
2	2390.00	46.4 AV	54.0	-7.6	2.36 H	334	49.59	-3.19
3	*2412.00	101.6 PK			2.36 H	334	104.73	-3.13
4	*2412.00	91.4 AV			2.36 H	334	94.53	-3.13
5	4824.00	47.9 PK	74.0	-26.1	2.12 H	312	41.93	5.97
6	4824.00	34.1 AV	54.0	-19.9	2.12 H	312	28.13	5.97

ANTENNA POLARITY & TEST DISTANCE: VERTICAL AT 3 M

NO.	FREQ. (MHz)	EMISSION LEVEL (dBuV/m)	LIMIT (dBuV/m)	MARGIN (dB)	ANTENNA HEIGHT (m)	TABLE ANGLE (Degree)	RAW VALUE (dBuV)	CORRECTION FACTOR (dB/m)
1	2390.00	72.1 PK	74.0	-1.9	1.80 V	45	75.29	-3.19
2	2390.00	50.5 AV	54.0	-3.5	1.80 V	45	53.69	-3.19
3	*2412.00	106.3 PK			1.80 V	45	109.43	-3.13
4	*2412.00	96.0 AV			1.80 V	45	99.13	-3.13
5	4824.00	49.0 PK	74.0	-25.0	1.82 V	134	43.03	5.97
6	4824.00	35.5 AV	54.0	-18.5	1.82 V	134	29.53	5.97

REMARKS:

1. Emission Level(dBuV/m) = Raw Value(dBuV) + Correction Factor(dB/m)
2. Correction Factor(dB/m) = Antenna Factor(dB/m) + Cable Factor(dB) – Pre-Amplifier Factor(dB)
3. The other emission levels were very low against the limit.
4. Margin value = Emission Level – Limit value
5. " * ": Fundamental frequency.

CHANNEL	TX Channel 2	DETECTOR FUNCTION	Peak (PK)
FREQUENCY RANGE	1GHz ~ 25GHz		Average (AV)

ANTENNA POLARITY & TEST DISTANCE: HORIZONTAL AT 3 M

NO.	FREQ. (MHz)	EMISSION LEVEL (dBuV/m)	LIMIT (dBuV/m)	MARGIN (dB)	ANTENNA HEIGHT (m)	TABLE ANGLE (Degree)	RAW VALUE (dBuV)	CORRECTION FACTOR (dB/m)
1	2390.00	67.8 PK	74.0	-6.2	2.36 H	334	70.99	-3.19
2	2390.00	46.3 AV	54.0	-7.7	2.36 H	334	49.49	-3.19
3	*2417.00	104.1 PK			2.36 H	334	107.21	-3.11
4	*2417.00	93.8 AV			2.36 H	334	96.91	-3.11
5	4834.00	47.9 PK	74.0	-26.1	2.19 H	295	41.91	5.99
6	4834.00	34.0 AV	54.0	-20.0	2.19 H	295	28.01	5.99
7	7251.00	48.8 PK	74.0	-25.2	2.08 H	323	37.92	10.88
8	7251.00	36.1 AV	54.0	-17.9	2.08 H	323	25.22	10.88

ANTENNA POLARITY & TEST DISTANCE: VERTICAL AT 3 M

NO.	FREQ. (MHz)	EMISSION LEVEL (dBuV/m)	LIMIT (dBuV/m)	MARGIN (dB)	ANTENNA HEIGHT (m)	TABLE ANGLE (Degree)	RAW VALUE (dBuV)	CORRECTION FACTOR (dB/m)
1	2390.00	69.5 PK	74.0	-4.5	1.85 V	72	72.69	-3.19
2	2390.00	50.8 AV	54.0	-3.2	1.85 V	72	53.99	-3.19
3	*2417.00	108.8 PK			1.85 V	72	111.91	-3.11
4	*2417.00	98.8 AV			1.85 V	72	101.91	-3.11
5	4834.00	48.4 PK	74.0	-25.6	1.82 V	146	42.41	5.99
6	4834.00	35.2 AV	54.0	-18.8	1.82 V	146	29.21	5.99
7	7251.00	51.4 PK	74.0	-22.6	1.86 V	313	40.52	10.88
8	7251.00	37.8 AV	54.0	-16.2	1.86 V	313	26.92	10.88

REMARKS:

1. Emission Level(dBuV/m) = Raw Value(dBuV) + Correction Factor(dB/m)
2. Correction Factor(dB/m) = Antenna Factor(dB/m) + Cable Factor(dB) – Pre-Amplifier Factor(dB)
3. The other emission levels were very low against the limit.
4. Margin value = Emission Level – Limit value
5. " * ": Fundamental frequency.

CHANNEL	TX Channel 6	DETECTOR FUNCTION	Peak (PK)
FREQUENCY RANGE	1GHz ~ 25GHz		Average (AV)

ANTENNA POLARITY & TEST DISTANCE: HORIZONTAL AT 3 M

NO.	FREQ. (MHz)	EMISSION LEVEL (dBuV/m)	LIMIT (dBuV/m)	MARGIN (dB)	ANTENNA HEIGHT (m)	TABLE ANGLE (Degree)	RAW VALUE (dBuV)	CORRECTION FACTOR (dB/m)
1	*2437.00	104.3 PK			2.36 H	334	107.34	-3.04
2	*2437.00	93.7 AV			2.36 H	334	96.74	-3.04
3	4874.00	48.1 PK	74.0	-25.9	2.15 H	304	42.05	6.05
4	4874.00	34.4 AV	54.0	-19.6	2.15 H	304	28.35	6.05
5	7311.00	48.9 PK	74.0	-25.1	2.10 H	319	37.96	10.94
6	7311.00	36.2 AV	54.0	-17.8	2.10 H	319	25.26	10.94

ANTENNA POLARITY & TEST DISTANCE: VERTICAL AT 3 M

NO.	FREQ. (MHz)	EMISSION LEVEL (dBuV/m)	LIMIT (dBuV/m)	MARGIN (dB)	ANTENNA HEIGHT (m)	TABLE ANGLE (Degree)	RAW VALUE (dBuV)	CORRECTION FACTOR (dB/m)
1	*2437.00	109.8 PK			1.76 V	77	112.84	-3.04
2	*2437.00	99.5 AV			1.76 V	77	102.54	-3.04
3	4874.00	48.3 PK	74.0	-25.7	1.81 V	144	42.25	6.05
4	4874.00	35.4 AV	54.0	-18.6	1.81 V	144	29.35	6.05
5	7311.00	51.7 PK	74.0	-22.3	1.80 V	303	40.76	10.94
6	7311.00	37.9 AV	54.0	-16.1	1.80 V	303	26.96	10.94

REMARKS:

1. Emission Level(dBuV/m) = Raw Value(dBuV) + Correction Factor(dB/m)
2. Correction Factor(dB/m) = Antenna Factor(dB/m) + Cable Factor(dB) – Pre-Amplifier Factor(dB)
3. The other emission levels were very low against the limit.
4. Margin value = Emission Level – Limit value
5. " * ": Fundamental frequency.

CHANNEL	TX Channel 10	DETECTOR FUNCTION	Peak (PK)
FREQUENCY RANGE	1GHz ~ 25GHz		Average (AV)

ANTENNA POLARITY & TEST DISTANCE: HORIZONTAL AT 3 M

NO.	FREQ. (MHz)	EMISSION LEVEL (dBuV/m)	LIMIT (dBuV/m)	MARGIN (dB)	ANTENNA HEIGHT (m)	TABLE ANGLE (Degree)	RAW VALUE (dBuV)	CORRECTION FACTOR (dB/m)
1	*2457.00	104.0 PK			2.36 H	334	106.97	-2.97
2	*2457.00	93.6 AV			2.36 H	334	96.57	-2.97
3	2483.50	58.9 PK	74.0	-15.1	2.36 H	334	61.77	-2.87
4	2483.50	41.6 AV	54.0	-12.4	2.36 H	334	44.47	-2.87
5	4914.00	47.8 PK	74.0	-26.2	2.20 H	283	41.73	6.07
6	4914.00	33.9 AV	54.0	-20.1	2.20 H	283	27.83	6.07
7	7371.00	48.2 PK	74.0	-25.8	2.10 H	330	36.88	11.32
8	7371.00	35.7 AV	54.0	-18.3	2.10 H	330	24.38	11.32

ANTENNA POLARITY & TEST DISTANCE: VERTICAL AT 3 M

NO.	FREQ. (MHz)	EMISSION LEVEL (dBuV/m)	LIMIT (dBuV/m)	MARGIN (dB)	ANTENNA HEIGHT (m)	TABLE ANGLE (Degree)	RAW VALUE (dBuV)	CORRECTION FACTOR (dB/m)
1	*2457.00	109.2 PK			1.80 V	339	112.17	-2.97
2	*2457.00	98.9 AV			1.80 V	339	101.87	-2.97
3	2483.50	65.6 PK	74.0	-8.4	1.80 V	339	68.47	-2.87
4	2483.50	48.4 AV	54.0	-5.6	1.80 V	339	51.27	-2.87
5	4914.00	49.0 PK	74.0	-25.0	1.83 V	145	42.93	6.07
6	4914.00	35.7 AV	54.0	-18.3	1.83 V	145	29.63	6.07
7	7371.00	52.5 PK	74.0	-21.5	1.76 V	291	41.18	11.32
8	7371.00	38.4 AV	54.0	-15.6	1.76 V	291	27.08	11.32

REMARKS:

1. Emission Level(dBuV/m) = Raw Value(dBuV) + Correction Factor(dB/m)
2. Correction Factor(dB/m) = Antenna Factor(dB/m) + Cable Factor(dB) – Pre-Amplifier Factor(dB)
3. The other emission levels were very low against the limit.
4. Margin value = Emission Level – Limit value
5. " * ": Fundamental frequency.

CHANNEL	TX Channel 11	DETECTOR FUNCTION	Peak (PK)
FREQUENCY RANGE	1GHz ~ 25GHz		Average (AV)

ANTENNA POLARITY & TEST DISTANCE: HORIZONTAL AT 3 M

NO.	FREQ. (MHz)	EMISSION LEVEL (dBuV/m)	LIMIT (dBuV/m)	MARGIN (dB)	ANTENNA HEIGHT (m)	TABLE ANGLE (Degree)	RAW VALUE (dBuV)	CORRECTION FACTOR (dB/m)
1	*2462.00	101.4 PK			2.36 H	334	104.34	-2.94
2	*2462.00	91.7 AV			2.36 H	334	94.64	-2.94
3	2483.50	67.5 PK	74.0	-6.5	2.36 H	334	70.37	-2.87
4	2483.50	46.0 AV	54.0	-8.0	2.36 H	334	48.87	-2.87
5	4924.00	47.7 PK	74.0	-26.3	2.14 H	309	41.63	6.07
6	4924.00	33.5 AV	54.0	-20.5	2.14 H	309	27.43	6.07
7	7386.00	48.9 PK	74.0	-25.1	2.02 H	308	37.48	11.42
8	7386.00	36.5 AV	54.0	-17.5	2.02 H	308	25.08	11.42

ANTENNA POLARITY & TEST DISTANCE: VERTICAL AT 3 M

NO.	FREQ. (MHz)	EMISSION LEVEL (dBuV/m)	LIMIT (dBuV/m)	MARGIN (dB)	ANTENNA HEIGHT (m)	TABLE ANGLE (Degree)	RAW VALUE (dBuV)	CORRECTION FACTOR (dB/m)
1	*2462.00	106.5 PK			1.73 V	52	109.44	-2.94
2	*2462.00	96.1 AV			1.73 V	52	99.04	-2.94
3	2483.50	72.3 PK	74.0	-1.7	1.73 V	52	75.17	-2.87
4	2483.50	50.0 AV	54.0	-4.0	1.73 V	52	52.87	-2.87
5	4924.00	48.4 PK	74.0	-25.6	1.84 V	135	42.33	6.07
6	4924.00	34.9 AV	54.0	-19.1	1.84 V	135	28.83	6.07
7	7386.00	52.3 PK	74.0	-21.7	1.74 V	295	40.88	11.42
8	7386.00	38.3 AV	54.0	-15.7	1.74 V	295	26.88	11.42

REMARKS:

1. Emission Level(dBuV/m) = Raw Value(dBuV) + Correction Factor(dB/m)
2. Correction Factor(dB/m) = Antenna Factor(dB/m) + Cable Factor(dB) – Pre-Amplifier Factor(dB)
3. The other emission levels were very low against the limit.
4. Margin value = Emission Level – Limit value
5. " * ": Fundamental frequency.

802.11n (HT20)

CHANNEL	TX Channel 1	DETECTOR FUNCTION	Peak (PK)
FREQUENCY RANGE	1GHz ~ 25GHz		Average (AV)

ANTENNA POLARITY & TEST DISTANCE: HORIZONTAL AT 3 M

NO.	FREQ. (MHz)	EMISSION LEVEL (dBuV/m)	LIMIT (dBuV/m)	MARGIN (dB)	ANTENNA HEIGHT (m)	TABLE ANGLE (Degree)	RAW VALUE (dBuV)	CORRECTION FACTOR (dB/m)
1	2390.00	67.5 PK	74.0	-6.5	2.36 H	334	70.69	-3.19
2	2390.00	46.1 AV	54.0	-7.9	2.36 H	334	49.29	-3.19
3	*2412.00	104.6 PK			2.36 H	334	107.73	-3.13
4	*2412.00	92.4 AV			2.36 H	334	95.53	-3.13
5	4824.00	48.0 PK	74.0	-26.0	2.19 H	296	42.03	5.97
6	4824.00	34.3 AV	54.0	-19.7	2.19 H	296	28.33	5.97

ANTENNA POLARITY & TEST DISTANCE: VERTICAL AT 3 M

NO.	FREQ. (MHz)	EMISSION LEVEL (dBuV/m)	LIMIT (dBuV/m)	MARGIN (dB)	ANTENNA HEIGHT (m)	TABLE ANGLE (Degree)	RAW VALUE (dBuV)	CORRECTION FACTOR (dB/m)
1	2390.00	72.5 PK	74.0	-1.5	1.85 V	333	75.69	-3.19
2	2390.00	51.7 AV	54.0	-2.3	1.85 V	333	54.89	-3.19
3	*2412.00	110.0 PK			1.85 V	333	113.13	-3.13
4	*2412.00	97.6 AV			1.85 V	333	100.73	-3.13
5	4824.00	47.1 PK	74.0	-26.9	2.15 V	115	41.13	5.97
6	4824.00	33.0 AV	54.0	-21.0	2.15 V	115	27.03	5.97

REMARKS:

1. Emission Level(dBuV/m) = Raw Value(dBuV) + Correction Factor(dB/m)
2. Correction Factor(dB/m) = Antenna Factor(dB/m) + Cable Factor(dB) – Pre-Amplifier Factor(dB)
3. The other emission levels were very low against the limit.
4. Margin value = Emission Level – Limit value
5. " * ": Fundamental frequency.

CHANNEL	TX Channel 2	DETECTOR FUNCTION	Peak (PK)
FREQUENCY RANGE	1GHz ~ 25GHz		Average (AV)

ANTENNA POLARITY & TEST DISTANCE: HORIZONTAL AT 3 M

NO.	FREQ. (MHz)	EMISSION LEVEL (dBuV/m)	LIMIT (dBuV/m)	MARGIN (dB)	ANTENNA HEIGHT (m)	TABLE ANGLE (Degree)	RAW VALUE (dBuV)	CORRECTION FACTOR (dB/m)
1	2390.00	67.5 PK	74.0	-6.5	2.36 H	334	70.69	-3.19
2	2390.00	45.9 AV	54.0	-8.1	2.36 H	334	49.09	-3.19
3	*2417.00	108.9 PK			2.36 H	334	112.01	-3.11
4	*2417.00	96.3 AV			2.36 H	334	99.41	-3.11
5	4834.00	48.4 PK	74.0	-25.6	2.22 H	306	42.41	5.99
6	4834.00	34.5 AV	54.0	-19.5	2.22 H	306	28.51	5.99
7	7251.00	49.1 PK	74.0	-24.9	2.11 H	333	38.22	10.88
8	7251.00	36.1 AV	54.0	-17.9	2.11 H	333	25.22	10.88

ANTENNA POLARITY & TEST DISTANCE: VERTICAL AT 3 M

NO.	FREQ. (MHz)	EMISSION LEVEL (dBuV/m)	LIMIT (dBuV/m)	MARGIN (dB)	ANTENNA HEIGHT (m)	TABLE ANGLE (Degree)	RAW VALUE (dBuV)	CORRECTION FACTOR (dB/m)
1	2390.00	67.0 PK	74.0	-7.0	1.90 V	335	70.19	-3.19
2	2390.00	50.4 AV	54.0	-3.6	1.90 V	335	53.59	-3.19
3	*2417.00	113.1 PK			1.90 V	335	116.21	-3.11
4	*2417.00	100.9 AV			1.90 V	335	104.01	-3.11
5	4834.00	48.6 PK	74.0	-25.4	1.80 V	140	42.61	5.99
6	4834.00	35.2 AV	54.0	-18.8	1.80 V	140	29.21	5.99
7	7251.00	51.9 PK	74.0	-22.1	1.76 V	305	41.02	10.88
8	7251.00	38.0 AV	54.0	-16.0	1.76 V	305	27.12	10.88

REMARKS:

1. Emission Level(dBuV/m) = Raw Value(dBuV) + Correction Factor(dB/m)
2. Correction Factor(dB/m) = Antenna Factor(dB/m) + Cable Factor(dB) – Pre-Amplifier Factor(dB)
3. The other emission levels were very low against the limit.
4. Margin value = Emission Level – Limit value
5. " * ": Fundamental frequency.

CHANNEL	TX Channel 6	DETECTOR FUNCTION	Peak (PK)
FREQUENCY RANGE	1GHz ~ 25GHz		Average (AV)

ANTENNA POLARITY & TEST DISTANCE: HORIZONTAL AT 3 M

NO.	FREQ. (MHz)	EMISSION LEVEL (dBuV/m)	LIMIT (dBuV/m)	MARGIN (dB)	ANTENNA HEIGHT (m)	TABLE ANGLE (Degree)	RAW VALUE (dBuV)	CORRECTION FACTOR (dB/m)
1	2390.00	52.4 PK	74.0	-21.6	2.36 H	334	55.59	-3.19
2	2390.00	39.5 AV	54.0	-14.5	2.36 H	334	42.69	-3.19
3	*2437.00	111.4 PK			2.36 H	334	114.44	-3.04
4	*2437.00	98.7 AV			2.36 H	334	101.74	-3.04
5	2483.50	51.5 PK	74.0	-22.5	2.36 H	334	54.37	-2.87
6	2483.50	39.2 AV	54.0	-14.8	2.36 H	334	42.07	-2.87
7	4874.00	48.1 PK	74.0	-25.9	2.14 H	309	42.05	6.05
8	4874.00	34.4 AV	54.0	-19.6	2.14 H	309	28.35	6.05
9	7311.00	49.1 PK	74.0	-24.9	2.07 H	315	38.16	10.94
10	7311.00	36.4 AV	54.0	-17.6	2.07 H	315	25.46	10.94

ANTENNA POLARITY & TEST DISTANCE: VERTICAL AT 3 M

NO.	FREQ. (MHz)	EMISSION LEVEL (dBuV/m)	LIMIT (dBuV/m)	MARGIN (dB)	ANTENNA HEIGHT (m)	TABLE ANGLE (Degree)	RAW VALUE (dBuV)	CORRECTION FACTOR (dB/m)
1	2390.00	62.1 PK	74.0	-11.9	1.66 V	336	65.29	-3.19
2	2390.00	44.7 AV	54.0	-9.3	1.66 V	336	47.89	-3.19
3	*2437.00	115.7 PK			1.66 V	336	118.74	-3.04
4	*2437.00	103.3 AV			1.66 V	336	106.34	-3.04
5	2483.50	60.4 PK	74.0	-13.6	1.66 V	336	63.27	-2.87
6	2483.50	45.0 AV	54.0	-9.0	1.66 V	336	47.87	-2.87
7	4874.00	48.3 PK	74.0	-25.7	1.79 V	134	42.25	6.05
8	4874.00	34.8 AV	54.0	-19.2	1.79 V	134	28.75	6.05
9	7311.00	52.3 PK	74.0	-21.7	1.75 V	314	41.36	10.94
10	7311.00	38.3 AV	54.0	-15.7	1.75 V	314	27.36	10.94

REMARKS:

1. Emission Level(dBuV/m) = Raw Value(dBuV) + Correction Factor(dB/m)
2. Correction Factor(dB/m) = Antenna Factor(dB/m) + Cable Factor(dB) – Pre-Amplifier Factor(dB)
3. The other emission levels were very low against the limit.
4. Margin value = Emission Level – Limit value
5. " * ": Fundamental frequency.

CHANNEL	TX Channel 10	DETECTOR FUNCTION	Peak (PK)
FREQUENCY RANGE	1GHz ~ 25GHz		Average (AV)

ANTENNA POLARITY & TEST DISTANCE: HORIZONTAL AT 3 M

NO.	FREQ. (MHz)	EMISSION LEVEL (dBuV/m)	LIMIT (dBuV/m)	MARGIN (dB)	ANTENNA HEIGHT (m)	TABLE ANGLE (Degree)	RAW VALUE (dBuV)	CORRECTION FACTOR (dB/m)
1	*2457.00	109.7 PK			2.36 H	334	112.67	-2.97
2	*2457.00	96.7 AV			2.36 H	334	99.67	-2.97
3	2483.50	58.5 PK	74.0	-15.5	2.36 H	334	61.37	-2.87
4	2483.50	41.4 AV	54.0	-12.6	2.36 H	334	44.27	-2.87
5	4914.00	47.9 PK	74.0	-26.1	2.22 H	292	41.83	6.07
6	4914.00	34.1 AV	54.0	-19.9	2.22 H	292	28.03	6.07
7	7371.00	49.3 PK	74.0	-24.7	2.04 H	333	37.98	11.32
8	7371.00	36.3 AV	54.0	-17.7	2.04 H	333	24.98	11.32

ANTENNA POLARITY & TEST DISTANCE: VERTICAL AT 3 M

NO.	FREQ. (MHz)	EMISSION LEVEL (dBuV/m)	LIMIT (dBuV/m)	MARGIN (dB)	ANTENNA HEIGHT (m)	TABLE ANGLE (Degree)	RAW VALUE (dBuV)	CORRECTION FACTOR (dB/m)
1	*2457.00	113.4 PK			1.80 V	340	116.37	-2.97
2	*2457.00	101.2 AV			1.80 V	340	104.17	-2.97
3	2483.50	66.0 PK	74.0	-8.0	1.80 V	340	68.87	-2.87
4	2483.50	47.8 AV	54.0	-6.2	1.80 V	340	50.67	-2.87
5	4914.00	48.6 PK	74.0	-25.4	1.76 V	149	42.53	6.07
6	4914.00	35.1 AV	54.0	-18.9	1.76 V	149	29.03	6.07
7	7371.00	51.8 PK	74.0	-22.2	1.81 V	318	40.48	11.32
8	7371.00	37.7 AV	54.0	-16.3	1.81 V	318	26.38	11.32

REMARKS:

1. Emission Level(dBuV/m) = Raw Value(dBuV) + Correction Factor(dB/m)
2. Correction Factor(dB/m) = Antenna Factor(dB/m) + Cable Factor(dB) – Pre-Amplifier Factor(dB)
3. The other emission levels were very low against the limit.
4. Margin value = Emission Level – Limit value
5. " * ": Fundamental frequency.

CHANNEL	TX Channel 11	DETECTOR FUNCTION	Peak (PK)
FREQUENCY RANGE	1GHz ~ 25GHz		Average (AV)

ANTENNA POLARITY & TEST DISTANCE: HORIZONTAL AT 3 M

NO.	FREQ. (MHz)	EMISSION LEVEL (dBuV/m)	LIMIT (dBuV/m)	MARGIN (dB)	ANTENNA HEIGHT (m)	TABLE ANGLE (Degree)	RAW VALUE (dBuV)	CORRECTION FACTOR (dB/m)
1	*2462.00	106.2 PK			2.36 H	334	109.14	-2.94
2	*2462.00	93.2 AV			2.36 H	334	96.14	-2.94
3	2483.50	68.8 PK	74.0	-5.2	2.36 H	334	71.67	-2.87
4	2483.50	46.9 AV	54.0	-7.1	2.36 H	334	49.77	-2.87
5	4924.00	47.4 PK	74.0	-26.6	2.22 H	285	41.33	6.07
6	4924.00	33.7 AV	54.0	-20.3	2.22 H	285	27.63	6.07
7	7386.00	48.8 PK	74.0	-25.2	2.08 H	311	37.38	11.42
8	7386.00	36.1 AV	54.0	-17.9	2.08 H	311	24.68	11.42

ANTENNA POLARITY & TEST DISTANCE: VERTICAL AT 3 M

NO.	FREQ. (MHz)	EMISSION LEVEL (dBuV/m)	LIMIT (dBuV/m)	MARGIN (dB)	ANTENNA HEIGHT (m)	TABLE ANGLE (Degree)	RAW VALUE (dBuV)	CORRECTION FACTOR (dB/m)
1	*2462.00	110.6 PK			1.80 V	338	113.54	-2.94
2	*2462.00	98.2 AV			1.80 V	338	101.14	-2.94
3	2483.50	70.1 PK	74.0	-3.9	1.80 V	338	72.97	-2.87
4	2483.50	49.6 AV	54.0	-4.4	1.80 V	338	52.47	-2.87
5	4924.00	48.7 PK	74.0	-25.3	1.76 V	128	42.63	6.07
6	4924.00	35.2 AV	54.0	-18.8	1.76 V	128	29.13	6.07
7	7386.00	52.0 PK	74.0	-22.0	1.77 V	291	40.58	11.42
8	7386.00	37.8 AV	54.0	-16.2	1.77 V	291	26.38	11.42

REMARKS:

1. Emission Level(dBuV/m) = Raw Value(dBuV) + Correction Factor(dB/m)
2. Correction Factor(dB/m) = Antenna Factor(dB/m) + Cable Factor(dB) – Pre-Amplifier Factor(dB)
3. The other emission levels were very low against the limit.
4. Margin value = Emission Level – Limit value
5. " * ": Fundamental frequency.

802.11n (HT40)

CHANNEL	TX Channel 3	DETECTOR FUNCTION	Peak (PK)
FREQUENCY RANGE	1GHz ~ 25GHz		Average (AV)

ANTENNA POLARITY & TEST DISTANCE: HORIZONTAL AT 3 M								
NO.	FREQ. (MHz)	EMISSION LEVEL (dBuV/m)	LIMIT (dBuV/m)	MARGIN (dB)	ANTENNA HEIGHT (m)	TABLE ANGLE (Degree)	RAW VALUE (dBuV)	CORRECTION FACTOR (dB/m)
1	2390.00	67.8 PK	74.0	-6.2	2.36 H	334	70.99	-3.19
2	2390.00	46.1 AV	54.0	-7.9	2.36 H	334	49.29	-3.19
3	*2422.00	102.7 PK			2.36 H	334	105.79	-3.09
4	*2422.00	89.7 AV			2.36 H	334	92.79	-3.09
5	4844.00	46.4 PK	74.0	-27.6	2.18 H	300	40.41	5.99
6	4844.00	32.4 AV	54.0	-21.6	2.18 H	300	26.41	5.99
7	7266.00	48.8 PK	74.0	-25.2	2.03 H	317	37.91	10.89
8	7266.00	36.0 AV	54.0	-18.0	2.03 H	317	25.11	10.89

ANTENNA POLARITY & TEST DISTANCE: VERTICAL AT 3 M								
NO.	FREQ. (MHz)	EMISSION LEVEL (dBuV/m)	LIMIT (dBuV/m)	MARGIN (dB)	ANTENNA HEIGHT (m)	TABLE ANGLE (Degree)	RAW VALUE (dBuV)	CORRECTION FACTOR (dB/m)
1	2390.00	67.1 PK	74.0	-6.9	1.80 V	334	70.29	-3.19
2	2390.00	50.5 AV	54.0	-3.5	1.80 V	334	53.69	-3.19
3	*2422.00	107.2 PK			1.80 V	334	110.29	-3.09
4	*2422.00	94.7 AV			1.80 V	334	97.79	-3.09
5	4844.00	45.7 PK	74.0	-28.3	2.13 V	96	39.71	5.99
6	4844.00	32.2 AV	54.0	-21.8	2.13 V	96	26.21	5.99
7	7266.00	47.2 PK	74.0	-26.8	2.62 V	126	36.31	10.89
8	7266.00	36.8 AV	54.0	-17.2	2.62 V	126	25.91	10.89

REMARKS:

1. Emission Level(dBuV/m) = Raw Value(dBuV) + Correction Factor(dB/m)
2. Correction Factor(dB/m) = Antenna Factor(dB/m) + Cable Factor(dB) – Pre-Amplifier Factor(dB)
3. The other emission levels were very low against the limit.
4. Margin value = Emission Level – Limit value
5. " * ": Fundamental frequency.

CHANNEL	TX Channel 4	DETECTOR FUNCTION	Peak (PK)
FREQUENCY RANGE	1GHz ~ 25GHz		Average (AV)

ANTENNA POLARITY & TEST DISTANCE: HORIZONTAL AT 3 M

NO.	FREQ. (MHz)	EMISSION LEVEL (dBuV/m)	LIMIT (dBuV/m)	MARGIN (dB)	ANTENNA HEIGHT (m)	TABLE ANGLE (Degree)	RAW VALUE (dBuV)	CORRECTION FACTOR (dB/m)
1	2390.00	68.5 PK	74.0	-5.5	2.36 H	334	71.69	-3.19
2	2390.00	46.7 AV	54.0	-7.3	2.36 H	334	49.89	-3.19
3	*2427.00	101.5 PK			2.36 H	334	104.57	-3.07
4	*2427.00	91.5 AV			2.36 H	334	94.57	-3.07
5	4854.00	46.7 PK	74.0	-27.3	2.15 H	292	40.68	6.02
6	4854.00	32.7 AV	54.0	-21.3	2.15 H	292	26.68	6.02
7	7281.00	48.4 PK	74.0	-25.6	2.02 H	331	37.52	10.88
8	7281.00	35.7 AV	54.0	-18.3	2.02 H	331	24.82	10.88

ANTENNA POLARITY & TEST DISTANCE: VERTICAL AT 3 M

NO.	FREQ. (MHz)	EMISSION LEVEL (dBuV/m)	LIMIT (dBuV/m)	MARGIN (dB)	ANTENNA HEIGHT (m)	TABLE ANGLE (Degree)	RAW VALUE (dBuV)	CORRECTION FACTOR (dB/m)
1	2390.00	66.8 PK	74.0	-7.2	1.81 V	340	69.99	-3.19
2	2390.00	51.4 AV	54.0	-2.6	1.81 V	340	54.59	-3.19
3	*2427.00	108.4 PK			1.81 V	340	111.47	-3.07
4	*2427.00	95.9 AV			1.81 V	340	98.97	-3.07
5	4854.00	45.7 PK	74.0	-28.3	2.12 V	103	39.68	6.02
6	4854.00	32.0 AV	54.0	-22.0	2.12 V	103	25.98	6.02
7	7281.00	47.4 PK	74.0	-26.6	2.58 V	113	36.52	10.88
8	7281.00	36.9 AV	54.0	-17.1	2.58 V	113	26.02	10.88

REMARKS:

1. Emission Level(dBuV/m) = Raw Value(dBuV) + Correction Factor(dB/m)
2. Correction Factor(dB/m) = Antenna Factor(dB/m) + Cable Factor(dB) – Pre-Amplifier Factor(dB)
3. The other emission levels were very low against the limit.
4. Margin value = Emission Level – Limit value
5. " * ": Fundamental frequency.

CHANNEL	TX Channel 6	DETECTOR FUNCTION	Peak (PK)
FREQUENCY RANGE	1GHz ~ 25GHz		Average (AV)

ANTENNA POLARITY & TEST DISTANCE: HORIZONTAL AT 3 M

NO.	FREQ. (MHz)	EMISSION LEVEL (dBuV/m)	LIMIT (dBuV/m)	MARGIN (dB)	ANTENNA HEIGHT (m)	TABLE ANGLE (Degree)	RAW VALUE (dBuV)	CORRECTION FACTOR (dB/m)
1	2390.00	59.8 PK	74.0	-14.2	2.36 H	334	62.99	-3.19
2	2390.00	42.1 AV	54.0	-11.9	2.36 H	334	45.29	-3.19
3	*2437.00	101.7 PK			2.36 H	334	104.74	-3.04
4	*2437.00	92.1 AV			2.36 H	334	95.14	-3.04
5	2483.50	64.3 PK	74.0	-9.7	2.36 H	334	67.17	-2.87
6	2483.50	43.4 AV	54.0	-10.6	2.36 H	334	46.27	-2.87
7	4874.00	46.6 PK	74.0	-27.4	2.16 H	308	40.55	6.05
8	4874.00	32.8 AV	54.0	-21.2	2.16 H	308	26.75	6.05
9	7311.00	49.1 PK	74.0	-24.9	2.09 H	318	38.16	10.94
10	7311.00	36.3 AV	54.0	-17.7	2.09 H	318	25.36	10.94

ANTENNA POLARITY & TEST DISTANCE: VERTICAL AT 3 M

NO.	FREQ. (MHz)	EMISSION LEVEL (dBuV/m)	LIMIT (dBuV/m)	MARGIN (dB)	ANTENNA HEIGHT (m)	TABLE ANGLE (Degree)	RAW VALUE (dBuV)	CORRECTION FACTOR (dB/m)
1	2390.00	64.0 PK	74.0	-10.0	1.70 V	337	67.19	-3.19
2	2390.00	47.5 AV	54.0	-6.5	1.70 V	337	50.69	-3.19
3	*2437.00	109.4 PK			1.70 V	337	112.44	-3.04
4	*2437.00	96.6 AV			1.70 V	337	99.64	-3.04
5	2483.50	67.9 PK	74.0	-6.1	1.70 V	337	70.77	-2.87
6	2483.50	48.9 AV	54.0	-5.1	1.70 V	337	51.77	-2.87
7	4874.00	45.3 PK	74.0	-28.7	2.15 V	103	39.25	6.05
8	4874.00	31.9 AV	54.0	-22.1	2.15 V	103	25.85	6.05
9	7311.00	46.7 PK	74.0	-27.3	2.61 V	121	35.76	10.94
10	7311.00	36.5 AV	54.0	-17.5	2.61 V	121	25.56	10.94

REMARKS:

1. Emission Level(dBuV/m) = Raw Value(dBuV) + Correction Factor(dB/m)
2. Correction Factor(dB/m) = Antenna Factor(dB/m) + Cable Factor(dB) – Pre-Amplifier Factor(dB)
3. The other emission levels were very low against the limit.
4. Margin value = Emission Level – Limit value
5. " * ": Fundamental frequency.

CHANNEL	TX Channel 8	DETECTOR FUNCTION	Peak (PK)
FREQUENCY RANGE	1GHz ~ 25GHz		Average (AV)

ANTENNA POLARITY & TEST DISTANCE: HORIZONTAL AT 3 M

NO.	FREQ. (MHz)	EMISSION LEVEL (dBuV/m)	LIMIT (dBuV/m)	MARGIN (dB)	ANTENNA HEIGHT (m)	TABLE ANGLE (Degree)	RAW VALUE (dBuV)	CORRECTION FACTOR (dB/m)
1	*2447.00	103.2 PK			2.36 H	334	106.20	-3.00
2	*2447.00	90.1 AV			2.36 H	334	93.10	-3.00
3	2483.50	68.8 PK	74.0	-5.2	2.36 H	334	71.67	-2.87
4	2483.50	46.9 AV	54.0	-7.1	2.36 H	334	49.77	-2.87
5	4894.00	46.5 PK	74.0	-27.5	2.21 H	308	40.43	6.07
6	4894.00	32.6 AV	54.0	-21.4	2.21 H	308	26.53	6.07
7	7341.00	48.6 PK	74.0	-25.4	2.08 H	332	37.47	11.13
8	7341.00	35.7 AV	54.0	-18.3	2.08 H	332	24.57	11.13

ANTENNA POLARITY & TEST DISTANCE: VERTICAL AT 3 M

NO.	FREQ. (MHz)	EMISSION LEVEL (dBuV/m)	LIMIT (dBuV/m)	MARGIN (dB)	ANTENNA HEIGHT (m)	TABLE ANGLE (Degree)	RAW VALUE (dBuV)	CORRECTION FACTOR (dB/m)
1	*2447.00	107.9 PK			1.82 V	337	110.90	-3.00
2	*2447.00	94.8 AV			1.82 V	337	97.80	-3.00
3	2483.50	68.8 PK	74.0	-5.2	1.82 V	337	71.67	-2.87
4	2483.50	49.9 AV	54.0	-4.1	1.82 V	337	52.77	-2.87
5	4894.00	45.6 PK	74.0	-28.4	2.14 V	101	39.53	6.07
6	4894.00	32.2 AV	54.0	-21.8	2.14 V	101	26.13	6.07
7	7341.00	47.6 PK	74.0	-26.4	2.63 V	123	36.47	11.13
8	7341.00	37.2 AV	54.0	-16.8	2.63 V	123	26.07	11.13

REMARKS:

1. Emission Level(dBuV/m) = Raw Value(dBuV) + Correction Factor(dB/m)
2. Correction Factor(dB/m) = Antenna Factor(dB/m) + Cable Factor(dB) – Pre-Amplifier Factor(dB)
3. The other emission levels were very low against the limit.
4. Margin value = Emission Level – Limit value
5. " * ": Fundamental frequency.

CHANNEL	TX Channel 9	DETECTOR FUNCTION	Peak (PK)
FREQUENCY RANGE	1GHz ~ 25GHz		Average (AV)

ANTENNA POLARITY & TEST DISTANCE: HORIZONTAL AT 3 M

NO.	FREQ. (MHz)	EMISSION LEVEL (dBuV/m)	LIMIT (dBuV/m)	MARGIN (dB)	ANTENNA HEIGHT (m)	TABLE ANGLE (Degree)	RAW VALUE (dBuV)	CORRECTION FACTOR (dB/m)
1	*2452.00	103.0 PK			2.36 H	334	105.98	-2.98
2	*2452.00	89.8 AV			2.36 H	334	92.78	-2.98
3	2483.50	68.3 PK	74.0	-5.7	2.36 H	334	71.17	-2.87
4	2483.50	46.4 AV	54.0	-7.6	2.36 H	334	49.27	-2.87
5	4904.00	46.3 PK	74.0	-27.7	2.14 H	285	40.22	6.08
6	4904.00	32.5 AV	54.0	-21.5	2.14 H	285	26.42	6.08
7	7356.00	48.6 PK	74.0	-25.4	1.98 H	319	37.38	11.22
8	7356.00	35.8 AV	54.0	-18.2	1.98 H	319	24.58	11.22

ANTENNA POLARITY & TEST DISTANCE: VERTICAL AT 3 M

NO.	FREQ. (MHz)	EMISSION LEVEL (dBuV/m)	LIMIT (dBuV/m)	MARGIN (dB)	ANTENNA HEIGHT (m)	TABLE ANGLE (Degree)	RAW VALUE (dBuV)	CORRECTION FACTOR (dB/m)
1	*2452.00	106.9 PK			1.85 V	338	109.88	-2.98
2	*2452.00	94.2 AV			1.85 V	338	97.18	-2.98
3	2483.50	69.3 PK	74.0	-4.7	1.85 V	338	72.17	-2.87
4	2483.50	50.4 AV	54.0	-3.6	1.85 V	338	53.27	-2.87
5	4904.00	46.1 PK	74.0	-27.9	2.16 V	85	40.02	6.08
6	4904.00	32.5 AV	54.0	-21.5	2.16 V	85	26.42	6.08
7	7356.00	47.1 PK	74.0	-26.9	2.56 V	115	35.88	11.22
8	7356.00	36.5 AV	54.0	-17.5	2.56 V	115	25.28	11.22

REMARKS:

1. Emission Level(dBuV/m) = Raw Value(dBuV) + Correction Factor(dB/m)
2. Correction Factor(dB/m) = Antenna Factor(dB/m) + Cable Factor(dB) – Pre-Amplifier Factor(dB)
3. The other emission levels were very low against the limit.
4. Margin value = Emission Level – Limit value
5. " * ": Fundamental frequency.

Below 1GHz Data:

802.11b

CHANNEL	TX Channel 1	DETECTOR FUNCTION	Quasi-Peak (QP)
FREQUENCY RANGE	Below 1GHz		

ANTENNA POLARITY & TEST DISTANCE: HORIZONTAL AT 3 M

NO.	FREQ. (MHz)	EMISSION LEVEL (dBuV/m)	LIMIT (dBuV/m)	MARGIN (dB)	ANTENNA HEIGHT (m)	TABLE ANGLE (Degree)	RAW VALUE (dBuV)	CORRECTION FACTOR (dB/m)
1	33.67	24.3 QP	40.0	-15.7	1.52 H	153	33.90	-9.60
2	195.18	40.2 QP	43.5	-3.3	1.50 H	18	51.50	-11.30
3	260.07	42.5 QP	46.0	-3.5	1.41 H	72	51.40	-8.90
4	379.68	32.7 QP	46.0	-13.3	1.13 H	355	38.00	-5.30
5	695.51	37.8 QP	46.0	-8.2	1.08 H	341	36.40	1.40
6	1000.00	41.0 QP	54.0	-13.0	1.90 H	254	35.30	5.70

ANTENNA POLARITY & TEST DISTANCE: VERTICAL AT 3 M

NO.	FREQ. (MHz)	EMISSION LEVEL (dBuV/m)	LIMIT (dBuV/m)	MARGIN (dB)	ANTENNA HEIGHT (m)	TABLE ANGLE (Degree)	RAW VALUE (dBuV)	CORRECTION FACTOR (dB/m)
1	98.16	25.5 QP	43.5	-18.0	2.01 V	324	38.90	-13.40
2	195.96	33.7 QP	43.5	-9.8	1.59 V	236	45.10	-11.40
3	259.52	38.6 QP	46.0	-7.4	2.00 V	139	47.70	-9.10
4	325.56	32.0 QP	46.0	-14.0	1.03 V	54	38.40	-6.40
5	749.93	37.1 QP	46.0	-8.9	1.64 V	341	34.70	2.40
6	1000.00	38.5 QP	54.0	-15.5	1.00 V	294	32.80	5.70

REMARKS:

1. Emission Level(dBuV/m) = Raw Value(dBuV) + Correction Factor(dB/m)
2. Correction Factor(dB/m) = Antenna Factor(dB/m) + Cable Factor(dB) – Pre-Amplifier Factor(dB)
3. The other emission levels were very low against the limit.
4. Margin value = Emission Level – Limit value

CHANNEL	TX Channel 2	DETECTOR FUNCTION	Quasi-Peak (QP)
FREQUENCY RANGE	Below 1GHz		

ANTENNA POLARITY & TEST DISTANCE: HORIZONTAL AT 3 M

NO.	FREQ. (MHz)	EMISSION LEVEL (dBuV/m)	LIMIT (dBuV/m)	MARGIN (dB)	ANTENNA HEIGHT (m)	TABLE ANGLE (Degree)	RAW VALUE (dBuV)	CORRECTION FACTOR (dB/m)
1	33.90	23.9 QP	40.0	-16.1	1.48 H	169	33.40	-9.50
2	194.93	40.0 QP	43.5	-3.5	1.48 H	43	51.30	-11.30
3	260.03	42.4 QP	46.0	-3.6	1.47 H	66	51.30	-8.90
4	380.01	32.9 QP	46.0	-13.1	1.15 H	328	38.20	-5.30
5	695.83	37.7 QP	46.0	-8.3	1.00 H	311	36.30	1.40
6	1000.00	40.8 QP	54.0	-13.2	1.96 H	259	35.10	5.70

ANTENNA POLARITY & TEST DISTANCE: VERTICAL AT 3 M

NO.	FREQ. (MHz)	EMISSION LEVEL (dBuV/m)	LIMIT (dBuV/m)	MARGIN (dB)	ANTENNA HEIGHT (m)	TABLE ANGLE (Degree)	RAW VALUE (dBuV)	CORRECTION FACTOR (dB/m)
1	97.95	25.6 QP	43.5	-17.9	1.95 V	294	39.10	-13.50
2	196.06	34.1 QP	43.5	-9.4	1.66 V	224	45.50	-11.40
3	259.64	38.6 QP	46.0	-7.4	1.99 V	136	47.70	-9.10
4	325.59	32.5 QP	46.0	-13.5	1.00 V	44	38.90	-6.40
5	749.50	36.6 QP	46.0	-9.4	1.58 V	343	34.20	2.40
6	1000.00	38.9 QP	54.0	-15.1	1.02 V	303	33.20	5.70

REMARKS:

1. Emission Level(dBuV/m) = Raw Value(dBuV) + Correction Factor(dB/m)
2. Correction Factor(dB/m) = Antenna Factor(dB/m) + Cable Factor(dB) – Pre-Amplifier Factor(dB)
3. The other emission levels were very low against the limit.
4. Margin value = Emission Level – Limit value

CHANNEL	TX Channel 6	DETECTOR FUNCTION	Quasi-Peak (QP)
FREQUENCY RANGE	Below 1GHz		

ANTENNA POLARITY & TEST DISTANCE: HORIZONTAL AT 3 M

NO.	FREQ. (MHz)	EMISSION LEVEL (dBuV/m)	LIMIT (dBuV/m)	MARGIN (dB)	ANTENNA HEIGHT (m)	TABLE ANGLE (Degree)	RAW VALUE (dBuV)	CORRECTION FACTOR (dB/m)
1	33.75	24.0 QP	40.0	-16.0	1.50 H	164	33.60	-9.60
2	195.17	40.3 QP	43.5	-3.2	1.50 H	35	51.60	-11.30
3	260.05	42.6 QP	46.0	-3.4	1.47 H	83	51.50	-8.90
4	379.90	32.9 QP	46.0	-13.1	1.09 H	356	38.20	-5.30
5	695.49	37.9 QP	46.0	-8.1	1.03 H	338	36.50	1.40
6	1000.00	41.2 QP	54.0	-12.8	1.90 H	259	35.50	5.70

ANTENNA POLARITY & TEST DISTANCE: VERTICAL AT 3 M

NO.	FREQ. (MHz)	EMISSION LEVEL (dBuV/m)	LIMIT (dBuV/m)	MARGIN (dB)	ANTENNA HEIGHT (m)	TABLE ANGLE (Degree)	RAW VALUE (dBuV)	CORRECTION FACTOR (dB/m)
1	98.15	25.8 QP	43.5	-17.7	2.01 V	318	39.20	-13.40
2	195.51	33.7 QP	43.5	-9.8	1.62 V	213	45.10	-11.40
3	259.95	38.5 QP	46.0	-7.5	1.98 V	138	47.50	-9.00
4	325.94	32.2 QP	46.0	-13.8	1.00 V	39	38.60	-6.40
5	749.83	36.6 QP	46.0	-9.4	1.56 V	354	34.20	2.40
6	1000.00	38.8 QP	54.0	-15.2	1.00 V	291	33.10	5.70

REMARKS:

1. Emission Level(dBuV/m) = Raw Value(dBuV) + Correction Factor(dB/m)
2. Correction Factor(dB/m) = Antenna Factor(dB/m) + Cable Factor(dB) – Pre-Amplifier Factor(dB)
3. The other emission levels were very low against the limit.
4. Margin value = Emission Level – Limit value

CHANNEL	TX Channel 10	DETECTOR FUNCTION	Quasi-Peak (QP)
FREQUENCY RANGE	Below 1GHz		

ANTENNA POLARITY & TEST DISTANCE: HORIZONTAL AT 3 M

NO.	FREQ. (MHz)	EMISSION LEVEL (dBuV/m)	LIMIT (dBuV/m)	MARGIN (dB)	ANTENNA HEIGHT (m)	TABLE ANGLE (Degree)	RAW VALUE (dBuV)	CORRECTION FACTOR (dB/m)
1	33.78	24.0 QP	40.0	-16.0	1.55 H	167	33.60	-9.60
2	194.67	39.9 QP	43.5	-3.6	1.48 H	48	51.20	-11.30
3	260.50	42.5 QP	46.0	-3.5	1.38 H	69	51.40	-8.90
4	380.03	32.5 QP	46.0	-13.5	1.19 H	358	37.80	-5.30
5	695.47	37.6 QP	46.0	-8.4	1.01 H	333	36.20	1.40
6	1000.00	41.1 QP	54.0	-12.9	1.88 H	276	35.40	5.70

ANTENNA POLARITY & TEST DISTANCE: VERTICAL AT 3 M

NO.	FREQ. (MHz)	EMISSION LEVEL (dBuV/m)	LIMIT (dBuV/m)	MARGIN (dB)	ANTENNA HEIGHT (m)	TABLE ANGLE (Degree)	RAW VALUE (dBuV)	CORRECTION FACTOR (dB/m)
1	97.72	25.8 QP	43.5	-17.7	2.00 V	312	39.30	-13.50
2	195.60	33.6 QP	43.5	-9.9	1.63 V	214	45.00	-11.40
3	259.96	39.0 QP	46.0	-7.0	1.94 V	140	48.00	-9.00
4	325.64	32.5 QP	46.0	-13.5	1.02 V	44	38.90	-6.40
5	749.46	37.0 QP	46.0	-9.0	1.59 V	331	34.60	2.40
6	1000.00	38.8 QP	54.0	-15.2	1.03 V	299	33.10	5.70

REMARKS:

1. Emission Level(dBuV/m) = Raw Value(dBuV) + Correction Factor(dB/m)
2. Correction Factor(dB/m) = Antenna Factor(dB/m) + Cable Factor(dB) – Pre-Amplifier Factor(dB)
3. The other emission levels were very low against the limit.
4. Margin value = Emission Level – Limit value

CHANNEL	TX Channel 11	DETECTOR FUNCTION	Quasi-Peak (QP)
FREQUENCY RANGE	Below 1GHz		

ANTENNA POLARITY & TEST DISTANCE: HORIZONTAL AT 3 M

NO.	FREQ. (MHz)	EMISSION LEVEL (dBuV/m)	LIMIT (dBuV/m)	MARGIN (dB)	ANTENNA HEIGHT (m)	TABLE ANGLE (Degree)	RAW VALUE (dBuV)	CORRECTION FACTOR (dB/m)
1	33.84	23.8 QP	40.0	-16.2	1.49 H	181	33.40	-9.60
2	194.64	40.3 QP	43.5	-3.2	1.48 H	23	51.60	-11.30
3	260.00	42.9 QP	46.0	-3.1	1.40 H	64	51.90	-9.00
4	380.10	32.7 QP	46.0	-13.3	1.16 H	342	38.00	-5.30
5	695.61	37.5 QP	46.0	-8.5	1.07 H	311	36.10	1.40
6	1000.00	41.0 QP	54.0	-13.0	1.88 H	284	35.30	5.70

ANTENNA POLARITY & TEST DISTANCE: VERTICAL AT 3 M

NO.	FREQ. (MHz)	EMISSION LEVEL (dBuV/m)	LIMIT (dBuV/m)	MARGIN (dB)	ANTENNA HEIGHT (m)	TABLE ANGLE (Degree)	RAW VALUE (dBuV)	CORRECTION FACTOR (dB/m)
1	97.94	25.2 QP	43.5	-18.3	1.92 V	305	38.70	-13.50
2	196.00	33.8 QP	43.5	-9.7	1.67 V	223	45.20	-11.40
3	260.01	38.9 QP	46.0	-7.1	1.99 V	158	47.80	-8.90
4	325.83	32.2 QP	46.0	-13.8	1.00 V	32	38.60	-6.40
5	749.89	36.9 QP	46.0	-9.1	1.55 V	346	34.50	2.40
6	1000.00	38.6 QP	54.0	-15.4	1.01 V	273	32.90	5.70

REMARKS:

1. Emission Level(dBuV/m) = Raw Value(dBuV) + Correction Factor(dB/m)
2. Correction Factor(dB/m) = Antenna Factor(dB/m) + Cable Factor(dB) – Pre-Amplifier Factor(dB)
3. The other emission levels were very low against the limit.
4. Margin value = Emission Level – Limit value

802.11g

CHANNEL	TX Channel 1	DETECTOR FUNCTION	Quasi-Peak (QP)
FREQUENCY RANGE	Below 1GHz		

ANTENNA POLARITY & TEST DISTANCE: HORIZONTAL AT 3 M

NO.	FREQ. (MHz)	EMISSION LEVEL (dBuV/m)	LIMIT (dBuV/m)	MARGIN (dB)	ANTENNA HEIGHT (m)	TABLE ANGLE (Degree)	RAW VALUE (dBuV)	CORRECTION FACTOR (dB/m)
1	33.73	24.3 QP	40.0	-15.7	1.53 H	162	33.90	-9.60
2	194.75	40.1 QP	43.5	-3.4	1.46 H	37	51.40	-11.30
3	260.39	42.5 QP	46.0	-3.5	1.47 H	79	51.40	-8.90
4	379.68	32.8 QP	46.0	-13.2	1.20 H	358	38.10	-5.30
5	695.63	37.5 QP	46.0	-8.5	1.02 H	319	36.10	1.40
6	1000.00	41.2 QP	54.0	-12.8	1.90 H	280	35.50	5.70

ANTENNA POLARITY & TEST DISTANCE: VERTICAL AT 3 M

NO.	FREQ. (MHz)	EMISSION LEVEL (dBuV/m)	LIMIT (dBuV/m)	MARGIN (dB)	ANTENNA HEIGHT (m)	TABLE ANGLE (Degree)	RAW VALUE (dBuV)	CORRECTION FACTOR (dB/m)
1	98.07	25.4 QP	43.5	-18.1	2.02 V	317	38.90	-13.50
2	195.89	33.7 QP	43.5	-9.8	1.67 V	211	45.10	-11.40
3	260.07	39.0 QP	46.0	-7.0	1.98 V	153	47.90	-8.90
4	325.81	32.2 QP	46.0	-13.8	1.00 V	51	38.60	-6.40
5	749.86	36.5 QP	46.0	-9.5	1.64 V	334	34.10	2.40
6	1000.00	39.0 QP	54.0	-15.0	1.04 V	300	33.30	5.70

REMARKS:

1. Emission Level(dBuV/m) = Raw Value(dBuV) + Correction Factor(dB/m)
2. Correction Factor(dB/m) = Antenna Factor(dB/m) + Cable Factor(dB) – Pre-Amplifier Factor(dB)
3. The other emission levels were very low against the limit.
4. Margin value = Emission Level – Limit value

CHANNEL	TX Channel 2	DETECTOR FUNCTION	Quasi-Peak (QP)
FREQUENCY RANGE	Below 1GHz		

ANTENNA POLARITY & TEST DISTANCE: HORIZONTAL AT 3 M

NO.	FREQ. (MHz)	EMISSION LEVEL (dBuV/m)	LIMIT (dBuV/m)	MARGIN (dB)	ANTENNA HEIGHT (m)	TABLE ANGLE (Degree)	RAW VALUE (dBuV)	CORRECTION FACTOR (dB/m)
1	33.64	24.3 QP	40.0	-15.7	1.46 H	165	33.90	-9.60
2	195.19	40.1 QP	43.5	-3.4	1.43 H	43	51.40	-11.30
3	260.04	42.5 QP	46.0	-3.5	1.41 H	68	51.40	-8.90
4	380.01	32.7 QP	46.0	-13.3	1.15 H	348	38.00	-5.30
5	695.91	37.6 QP	46.0	-8.4	1.00 H	312	36.20	1.40
6	1000.00	41.4 QP	54.0	-12.6	1.90 H	276	35.70	5.70

ANTENNA POLARITY & TEST DISTANCE: VERTICAL AT 3 M

NO.	FREQ. (MHz)	EMISSION LEVEL (dBuV/m)	LIMIT (dBuV/m)	MARGIN (dB)	ANTENNA HEIGHT (m)	TABLE ANGLE (Degree)	RAW VALUE (dBuV)	CORRECTION FACTOR (dB/m)
1	98.13	25.3 QP	43.5	-18.2	1.95 V	301	38.70	-13.40
2	196.07	33.6 QP	43.5	-9.9	1.64 V	231	45.00	-11.40
3	259.77	38.6 QP	46.0	-7.4	1.98 V	135	47.70	-9.10
4	325.69	32.0 QP	46.0	-14.0	1.04 V	55	38.40	-6.40
5	749.76	36.7 QP	46.0	-9.3	1.58 V	345	34.30	2.40
6	1000.00	38.7 QP	54.0	-15.3	1.00 V	300	33.00	5.70

REMARKS:

1. Emission Level(dBuV/m) = Raw Value(dBuV) + Correction Factor(dB/m)
2. Correction Factor(dB/m) = Antenna Factor(dB/m) + Cable Factor(dB) – Pre-Amplifier Factor(dB)
3. The other emission levels were very low against the limit.
4. Margin value = Emission Level – Limit value

CHANNEL	TX Channel 6	DETECTOR FUNCTION	Quasi-Peak (QP)
FREQUENCY RANGE	Below 1GHz		

ANTENNA POLARITY & TEST DISTANCE: HORIZONTAL AT 3 M

NO.	FREQ. (MHz)	EMISSION LEVEL (dBuV/m)	LIMIT (dBuV/m)	MARGIN (dB)	ANTENNA HEIGHT (m)	TABLE ANGLE (Degree)	RAW VALUE (dBuV)	CORRECTION FACTOR (dB/m)
1	33.93	23.8 QP	40.0	-16.2	1.55 H	160	33.30	-9.50
2	194.65	40.3 QP	43.5	-3.2	1.51 H	49	51.60	-11.30
3	260.13	42.5 QP	46.0	-3.5	1.36 H	77	51.40	-8.90
4	380.05	32.9 QP	46.0	-13.1	1.19 H	329	38.20	-5.30
5	695.71	37.8 QP	46.0	-8.2	1.00 H	315	36.40	1.40
6	1000.00	40.8 QP	54.0	-13.2	1.98 H	281	35.10	5.70

ANTENNA POLARITY & TEST DISTANCE: VERTICAL AT 3 M

NO.	FREQ. (MHz)	EMISSION LEVEL (dBuV/m)	LIMIT (dBuV/m)	MARGIN (dB)	ANTENNA HEIGHT (m)	TABLE ANGLE (Degree)	RAW VALUE (dBuV)	CORRECTION FACTOR (dB/m)
1	97.91	25.4 QP	43.5	-18.1	1.94 V	305	38.90	-13.50
2	195.53	33.7 QP	43.5	-9.8	1.62 V	213	45.10	-11.40
3	259.78	38.9 QP	46.0	-7.1	2.00 V	151	47.90	-9.00
4	325.70	32.1 QP	46.0	-13.9	1.00 V	40	38.50	-6.40
5	749.82	37.0 QP	46.0	-9.0	1.57 V	346	34.60	2.40
6	1000.00	38.6 QP	54.0	-15.4	1.00 V	293	32.90	5.70

REMARKS:

1. Emission Level(dBuV/m) = Raw Value(dBuV) + Correction Factor(dB/m)
2. Correction Factor(dB/m) = Antenna Factor(dB/m) + Cable Factor(dB) – Pre-Amplifier Factor(dB)
3. The other emission levels were very low against the limit.
4. Margin value = Emission Level – Limit value

CHANNEL	TX Channel 10	DETECTOR FUNCTION	Quasi-Peak (QP)
FREQUENCY RANGE	Below 1GHz		

ANTENNA POLARITY & TEST DISTANCE: HORIZONTAL AT 3 M

NO.	FREQ. (MHz)	EMISSION LEVEL (dBuV/m)	LIMIT (dBuV/m)	MARGIN (dB)	ANTENNA HEIGHT (m)	TABLE ANGLE (Degree)	RAW VALUE (dBuV)	CORRECTION FACTOR (dB/m)
1	33.48	23.9 QP	40.0	-16.1	1.52 H	173	33.50	-9.60
2	194.77	40.0 QP	43.5	-3.5	1.44 H	25	51.30	-11.30
3	260.27	42.9 QP	46.0	-3.1	1.35 H	60	51.80	-8.90
4	380.11	32.9 QP	46.0	-13.1	1.11 H	337	38.20	-5.30
5	695.59	37.4 QP	46.0	-8.6	1.00 H	330	36.00	1.40
6	1000.00	41.1 QP	54.0	-12.9	1.91 H	256	35.40	5.70

ANTENNA POLARITY & TEST DISTANCE: VERTICAL AT 3 M

NO.	FREQ. (MHz)	EMISSION LEVEL (dBuV/m)	LIMIT (dBuV/m)	MARGIN (dB)	ANTENNA HEIGHT (m)	TABLE ANGLE (Degree)	RAW VALUE (dBuV)	CORRECTION FACTOR (dB/m)
1	97.88	25.6 QP	43.5	-17.9	1.96 V	297	39.10	-13.50
2	195.99	34.1 QP	43.5	-9.4	1.66 V	212	45.50	-11.40
3	259.50	38.6 QP	46.0	-7.4	2.05 V	129	47.70	-9.10
4	325.74	32.0 QP	46.0	-14.0	1.00 V	34	38.40	-6.40
5	749.78	36.7 QP	46.0	-9.3	1.54 V	343	34.30	2.40
6	1000.00	38.8 QP	54.0	-15.2	1.00 V	288	33.10	5.70

REMARKS:

1. Emission Level(dBuV/m) = Raw Value(dBuV) + Correction Factor(dB/m)
2. Correction Factor(dB/m) = Antenna Factor(dB/m) + Cable Factor(dB) – Pre-Amplifier Factor(dB)
3. The other emission levels were very low against the limit.
4. Margin value = Emission Level – Limit value

CHANNEL	TX Channel 11	DETECTOR FUNCTION	Quasi-Peak (QP)
FREQUENCY RANGE	Below 1GHz		

ANTENNA POLARITY & TEST DISTANCE: HORIZONTAL AT 3 M

NO.	FREQ. (MHz)	EMISSION LEVEL (dBuV/m)	LIMIT (dBuV/m)	MARGIN (dB)	ANTENNA HEIGHT (m)	TABLE ANGLE (Degree)	RAW VALUE (dBuV)	CORRECTION FACTOR (dB/m)
1	34.05	24.0 QP	40.0	-16.0	1.53 H	175	33.50	-9.50
2	195.08	40.1 QP	43.5	-3.4	1.48 H	33	51.40	-11.30
3	260.52	43.0 QP	46.0	-3.0	1.40 H	69	51.90	-8.90
4	379.93	32.4 QP	46.0	-13.6	1.10 H	344	37.70	-5.30
5	696.07	38.0 QP	46.0	-8.0	1.02 H	313	36.60	1.40
6	1000.00	40.9 QP	54.0	-13.1	1.95 H	275	35.20	5.70

ANTENNA POLARITY & TEST DISTANCE: VERTICAL AT 3 M

NO.	FREQ. (MHz)	EMISSION LEVEL (dBuV/m)	LIMIT (dBuV/m)	MARGIN (dB)	ANTENNA HEIGHT (m)	TABLE ANGLE (Degree)	RAW VALUE (dBuV)	CORRECTION FACTOR (dB/m)
1	97.81	25.4 QP	43.5	-18.1	1.91 V	325	38.90	-13.50
2	195.90	34.1 QP	43.5	-9.4	1.59 V	213	45.50	-11.40
3	259.90	38.7 QP	46.0	-7.3	1.98 V	132	47.70	-9.00
4	325.99	32.5 QP	46.0	-13.5	1.03 V	61	38.90	-6.40
5	749.50	36.9 QP	46.0	-9.1	1.58 V	354	34.50	2.40
6	1000.00	38.9 QP	54.0	-15.1	1.02 V	287	33.20	5.70

REMARKS:

1. Emission Level(dBuV/m) = Raw Value(dBuV) + Correction Factor(dB/m)
2. Correction Factor(dB/m) = Antenna Factor(dB/m) + Cable Factor(dB) – Pre-Amplifier Factor(dB)
3. The other emission levels were very low against the limit.
4. Margin value = Emission Level – Limit value

802.11n (HT20)

CHANNEL	TX Channel 1	DETECTOR FUNCTION	Quasi-Peak (QP)
FREQUENCY RANGE	Below 1GHz		

ANTENNA POLARITY & TEST DISTANCE: HORIZONTAL AT 3 M

NO.	FREQ. (MHz)	EMISSION LEVEL (dBuV/m)	LIMIT (dBuV/m)	MARGIN (dB)	ANTENNA HEIGHT (m)	TABLE ANGLE (Degree)	RAW VALUE (dBuV)	CORRECTION FACTOR (dB/m)
1	33.78	24.4 QP	40.0	-15.6	1.46 H	180	34.00	-9.60
2	194.76	40.4 QP	43.5	-3.1	1.44 H	21	51.70	-11.30
3	260.01	42.4 QP	46.0	-3.6	1.44 H	81	51.30	-8.90
4	379.78	32.5 QP	46.0	-13.5	1.17 H	333	37.80	-5.30
5	695.55	37.9 QP	46.0	-8.1	1.04 H	339	36.50	1.40
6	1000.00	40.8 QP	54.0	-13.2	1.98 H	274	35.10	5.70

ANTENNA POLARITY & TEST DISTANCE: VERTICAL AT 3 M

NO.	FREQ. (MHz)	EMISSION LEVEL (dBuV/m)	LIMIT (dBuV/m)	MARGIN (dB)	ANTENNA HEIGHT (m)	TABLE ANGLE (Degree)	RAW VALUE (dBuV)	CORRECTION FACTOR (dB/m)
1	97.82	25.6 QP	43.5	-17.9	1.92 V	314	39.10	-13.50
2	195.49	33.7 QP	43.5	-9.8	1.65 V	225	45.10	-11.40
3	259.99	38.9 QP	46.0	-7.1	1.99 V	140	47.90	-9.00
4	325.83	32.0 QP	46.0	-14.0	1.00 V	54	38.40	-6.40
5	749.52	36.8 QP	46.0	-9.2	1.59 V	326	34.40	2.40
6	1000.00	39.0 QP	54.0	-15.0	1.04 V	297	33.30	5.70

REMARKS:

1. Emission Level(dBuV/m) = Raw Value(dBuV) + Correction Factor(dB/m)
2. Correction Factor(dB/m) = Antenna Factor(dB/m) + Cable Factor(dB) – Pre-Amplifier Factor(dB)
3. The other emission levels were very low against the limit.
4. Margin value = Emission Level – Limit value

CHANNEL	TX Channel 2	DETECTOR FUNCTION	Quasi-Peak (QP)
FREQUENCY RANGE	Below 1GHz		

ANTENNA POLARITY & TEST DISTANCE: HORIZONTAL AT 3 M

NO.	FREQ. (MHz)	EMISSION LEVEL (dBuV/m)	LIMIT (dBuV/m)	MARGIN (dB)	ANTENNA HEIGHT (m)	TABLE ANGLE (Degree)	RAW VALUE (dBuV)	CORRECTION FACTOR (dB/m)
1	33.54	23.9 QP	40.0	-16.1	1.53 H	181	33.50	-9.60
2	194.95	40.2 QP	43.5	-3.3	1.52 H	35	51.50	-11.30
3	260.48	42.4 QP	46.0	-3.6	1.38 H	83	51.30	-8.90
4	380.04	32.8 QP	46.0	-13.2	1.21 H	331	38.10	-5.30
5	695.77	37.6 QP	46.0	-8.4	1.03 H	322	36.20	1.40
6	1000.00	41.0 QP	54.0	-13.0	1.91 H	265	35.30	5.70

ANTENNA POLARITY & TEST DISTANCE: VERTICAL AT 3 M

NO.	FREQ. (MHz)	EMISSION LEVEL (dBuV/m)	LIMIT (dBuV/m)	MARGIN (dB)	ANTENNA HEIGHT (m)	TABLE ANGLE (Degree)	RAW VALUE (dBuV)	CORRECTION FACTOR (dB/m)
1	98.18	25.7 QP	43.5	-17.8	1.96 V	310	39.10	-13.40
2	195.82	33.7 QP	43.5	-9.8	1.59 V	228	45.10	-11.40
3	259.87	38.8 QP	46.0	-7.2	1.95 V	155	47.80	-9.00
4	325.86	32.6 QP	46.0	-13.4	1.00 V	50	39.00	-6.40
5	749.95	36.7 QP	46.0	-9.3	1.62 V	353	34.30	2.40
6	1000.00	38.6 QP	54.0	-15.4	1.03 V	285	32.90	5.70

REMARKS:

1. Emission Level(dBuV/m) = Raw Value(dBuV) + Correction Factor(dB/m)
2. Correction Factor(dB/m) = Antenna Factor(dB/m) + Cable Factor(dB) – Pre-Amplifier Factor(dB)
3. The other emission levels were very low against the limit.
4. Margin value = Emission Level – Limit value

CHANNEL	TX Channel 6	DETECTOR FUNCTION	Quasi-Peak (QP)
FREQUENCY RANGE	Below 1GHz		

ANTENNA POLARITY & TEST DISTANCE: HORIZONTAL AT 3 M

NO.	FREQ. (MHz)	EMISSION LEVEL (dBuV/m)	LIMIT (dBuV/m)	MARGIN (dB)	ANTENNA HEIGHT (m)	TABLE ANGLE (Degree)	RAW VALUE (dBuV)	CORRECTION FACTOR (dB/m)
1	33.74	24.0 QP	40.0	-16.0	1.50 H	172	33.60	-9.60
2	194.75	39.9 QP	43.5	-3.6	1.47 H	24	51.20	-11.30
3	260.49	42.4 QP	46.0	-3.6	1.43 H	55	51.30	-8.90
4	379.99	32.7 QP	46.0	-13.3	1.12 H	332	38.00	-5.30
5	695.52	38.0 QP	46.0	-8.0	1.01 H	340	36.60	1.40
6	1000.00	41.0 QP	54.0	-13.0	1.93 H	270	35.30	5.70

ANTENNA POLARITY & TEST DISTANCE: VERTICAL AT 3 M

NO.	FREQ. (MHz)	EMISSION LEVEL (dBuV/m)	LIMIT (dBuV/m)	MARGIN (dB)	ANTENNA HEIGHT (m)	TABLE ANGLE (Degree)	RAW VALUE (dBuV)	CORRECTION FACTOR (dB/m)
1	97.97	25.3 QP	43.5	-18.2	2.02 V	307	38.80	-13.50
2	195.94	33.9 QP	43.5	-9.6	1.66 V	229	45.30	-11.40
3	259.78	38.9 QP	46.0	-7.1	1.93 V	147	47.90	-9.00
4	325.65	32.5 QP	46.0	-13.5	1.00 V	62	38.90	-6.40
5	749.62	36.6 QP	46.0	-9.4	1.60 V	355	34.20	2.40
6	1000.00	39.0 QP	54.0	-15.0	1.00 V	281	33.30	5.70

REMARKS:

1. Emission Level(dBuV/m) = Raw Value(dBuV) + Correction Factor(dB/m)
2. Correction Factor(dB/m) = Antenna Factor(dB/m) + Cable Factor(dB) – Pre-Amplifier Factor(dB)
3. The other emission levels were very low against the limit.
4. Margin value = Emission Level – Limit value

CHANNEL	TX Channel 10	DETECTOR FUNCTION	Quasi-Peak (QP)
FREQUENCY RANGE	Below 1GHz		

ANTENNA POLARITY & TEST DISTANCE: HORIZONTAL AT 3 M

NO.	FREQ. (MHz)	EMISSION LEVEL (dBuV/m)	LIMIT (dBuV/m)	MARGIN (dB)	ANTENNA HEIGHT (m)	TABLE ANGLE (Degree)	RAW VALUE (dBuV)	CORRECTION FACTOR (dB/m)
1	34.06	24.0 QP	40.0	-16.0	1.53 H	154	33.50	-9.50
2	194.87	39.9 QP	43.5	-3.6	1.50 H	40	51.20	-11.30
3	260.30	42.8 QP	46.0	-3.2	1.36 H	63	51.70	-8.90
4	379.62	33.0 QP	46.0	-13.0	1.19 H	359	38.30	-5.30
5	695.72	37.7 QP	46.0	-8.3	1.00 H	331	36.30	1.40
6	1000.00	41.2 QP	54.0	-12.8	1.94 H	259	35.50	5.70

ANTENNA POLARITY & TEST DISTANCE: VERTICAL AT 3 M

NO.	FREQ. (MHz)	EMISSION LEVEL (dBuV/m)	LIMIT (dBuV/m)	MARGIN (dB)	ANTENNA HEIGHT (m)	TABLE ANGLE (Degree)	RAW VALUE (dBuV)	CORRECTION FACTOR (dB/m)
1	97.69	25.3 QP	43.5	-18.2	1.92 V	297	38.80	-13.50
2	195.70	33.7 QP	43.5	-9.8	1.64 V	233	45.10	-11.40
3	260.03	38.6 QP	46.0	-7.4	1.95 V	150	47.50	-8.90
4	325.73	32.0 QP	46.0	-14.0	1.06 V	54	38.40	-6.40
5	749.52	36.7 QP	46.0	-9.3	1.58 V	349	34.30	2.40
6	1000.00	38.7 QP	54.0	-15.3	1.00 V	298	33.00	5.70

REMARKS:

1. Emission Level(dBuV/m) = Raw Value(dBuV) + Correction Factor(dB/m)
2. Correction Factor(dB/m) = Antenna Factor(dB/m) + Cable Factor(dB) – Pre-Amplifier Factor(dB)
3. The other emission levels were very low against the limit.
4. Margin value = Emission Level – Limit value

CHANNEL	TX Channel 11	DETECTOR FUNCTION	Quasi-Peak (QP)
FREQUENCY RANGE	Below 1GHz		

ANTENNA POLARITY & TEST DISTANCE: HORIZONTAL AT 3 M

NO.	FREQ. (MHz)	EMISSION LEVEL (dBuV/m)	LIMIT (dBuV/m)	MARGIN (dB)	ANTENNA HEIGHT (m)	TABLE ANGLE (Degree)	RAW VALUE (dBuV)	CORRECTION FACTOR (dB/m)
1	34.02	24.2 QP	40.0	-15.8	1.44 H	179	33.70	-9.50
2	195.07	40.5 QP	43.5	-3.0	1.44 H	19	51.80	-11.30
3	260.40	42.6 QP	46.0	-3.4	1.42 H	75	51.50	-8.90
4	380.12	32.7 QP	46.0	-13.3	1.11 H	334	38.00	-5.30
5	695.52	37.9 QP	46.0	-8.1	1.05 H	320	36.50	1.40
6	1000.00	41.0 QP	54.0	-13.0	1.93 H	255	35.30	5.70

ANTENNA POLARITY & TEST DISTANCE: VERTICAL AT 3 M

NO.	FREQ. (MHz)	EMISSION LEVEL (dBuV/m)	LIMIT (dBuV/m)	MARGIN (dB)	ANTENNA HEIGHT (m)	TABLE ANGLE (Degree)	RAW VALUE (dBuV)	CORRECTION FACTOR (dB/m)
1	98.18	25.5 QP	43.5	-18.0	1.98 V	320	38.90	-13.40
2	195.89	33.8 QP	43.5	-9.7	1.67 V	222	45.20	-11.40
3	259.50	38.8 QP	46.0	-7.2	2.05 V	129	47.90	-9.10
4	325.60	32.2 QP	46.0	-13.8	1.00 V	51	38.60	-6.40
5	749.84	37.1 QP	46.0	-8.9	1.56 V	329	34.70	2.40
6	1000.00	38.9 QP	54.0	-15.1	1.00 V	287	33.20	5.70

REMARKS:

1. Emission Level(dBuV/m) = Raw Value(dBuV) + Correction Factor(dB/m)
2. Correction Factor(dB/m) = Antenna Factor(dB/m) + Cable Factor(dB) – Pre-Amplifier Factor(dB)
3. The other emission levels were very low against the limit.
4. Margin value = Emission Level – Limit value

802.11n (HT40)

CHANNEL	TX Channel 3	DETECTOR FUNCTION	Quasi-Peak (QP)
FREQUENCY RANGE	Below 1GHz		

ANTENNA POLARITY & TEST DISTANCE: HORIZONTAL AT 3 M

NO.	FREQ. (MHz)	EMISSION LEVEL (dBuV/m)	LIMIT (dBuV/m)	MARGIN (dB)	ANTENNA HEIGHT (m)	TABLE ANGLE (Degree)	RAW VALUE (dBuV)	CORRECTION FACTOR (dB/m)
1	33.84	24.2 QP	40.0	-15.8	1.45 H	168	33.80	-9.60
2	195.03	40.5 QP	43.5	-3.0	1.53 H	30	51.80	-11.30
3	260.02	42.8 QP	46.0	-3.2	1.39 H	75	51.70	-8.90
4	379.87	32.6 QP	46.0	-13.4	1.11 H	334	37.90	-5.30
5	695.96	37.6 QP	46.0	-8.4	1.07 H	333	36.20	1.40
6	1000.00	41.0 QP	54.0	-13.0	1.89 H	271	35.30	5.70

ANTENNA POLARITY & TEST DISTANCE: VERTICAL AT 3 M

NO.	FREQ. (MHz)	EMISSION LEVEL (dBuV/m)	LIMIT (dBuV/m)	MARGIN (dB)	ANTENNA HEIGHT (m)	TABLE ANGLE (Degree)	RAW VALUE (dBuV)	CORRECTION FACTOR (dB/m)
1	97.84	25.8 QP	43.5	-17.7	2.02 V	322	39.30	-13.50
2	195.93	33.5 QP	43.5	-10.0	1.63 V	230	44.90	-11.40
3	259.94	38.5 QP	46.0	-7.5	2.05 V	137	47.50	-9.00
4	325.49	32.1 QP	46.0	-13.9	1.00 V	32	38.50	-6.40
5	749.63	37.0 QP	46.0	-9.0	1.62 V	331	34.60	2.40
6	1000.00	38.5 QP	54.0	-15.5	1.00 V	296	32.80	5.70

REMARKS:

1. Emission Level(dBuV/m) = Raw Value(dBuV) + Correction Factor(dB/m)
2. Correction Factor(dB/m) = Antenna Factor(dB/m) + Cable Factor(dB) – Pre-Amplifier Factor(dB)
3. The other emission levels were very low against the limit.
4. Margin value = Emission Level – Limit value

CHANNEL	TX Channel 4	DETECTOR FUNCTION	Quasi-Peak (QP)
FREQUENCY RANGE	Below 1GHz		

ANTENNA POLARITY & TEST DISTANCE: HORIZONTAL AT 3 M

NO.	FREQ. (MHz)	EMISSION LEVEL (dBuV/m)	LIMIT (dBuV/m)	MARGIN (dB)	ANTENNA HEIGHT (m)	TABLE ANGLE (Degree)	RAW VALUE (dBuV)	CORRECTION FACTOR (dB/m)
1	33.87	23.9 QP	40.0	-16.1	1.50 H	156	33.50	-9.60
2	195.02	40.1 QP	43.5	-3.4	1.47 H	20	51.40	-11.30
3	260.43	42.6 QP	46.0	-3.4	1.43 H	85	51.50	-8.90
4	380.04	32.4 QP	46.0	-13.6	1.13 H	344	37.70	-5.30
5	696.00	37.5 QP	46.0	-8.5	1.06 H	312	36.10	1.40
6	1000.00	41.1 QP	54.0	-12.9	1.91 H	262	35.40	5.70

ANTENNA POLARITY & TEST DISTANCE: VERTICAL AT 3 M

NO.	FREQ. (MHz)	EMISSION LEVEL (dBuV/m)	LIMIT (dBuV/m)	MARGIN (dB)	ANTENNA HEIGHT (m)	TABLE ANGLE (Degree)	RAW VALUE (dBuV)	CORRECTION FACTOR (dB/m)
1	98.07	25.2 QP	43.5	-18.3	1.97 V	312	38.70	-13.50
2	196.08	33.9 QP	43.5	-9.6	1.63 V	215	45.30	-11.40
3	259.72	38.5 QP	46.0	-7.5	1.95 V	134	47.60	-9.10
4	325.59	32.1 QP	46.0	-13.9	1.00 V	42	38.50	-6.40
5	749.64	37.0 QP	46.0	-9.0	1.57 V	342	34.60	2.40
6	1000.00	39.1 QP	54.0	-14.9	1.00 V	285	33.40	5.70

REMARKS:

1. Emission Level(dBuV/m) = Raw Value(dBuV) + Correction Factor(dB/m)
2. Correction Factor(dB/m) = Antenna Factor(dB/m) + Cable Factor(dB) – Pre-Amplifier Factor(dB)
3. The other emission levels were very low against the limit.
4. Margin value = Emission Level – Limit value

CHANNEL	TX Channel 6	DETECTOR FUNCTION	Quasi-Peak (QP)
FREQUENCY RANGE	Below 1GHz		

ANTENNA POLARITY & TEST DISTANCE: HORIZONTAL AT 3 M

NO.	FREQ. (MHz)	EMISSION LEVEL (dBuV/m)	LIMIT (dBuV/m)	MARGIN (dB)	ANTENNA HEIGHT (m)	TABLE ANGLE (Degree)	RAW VALUE (dBuV)	CORRECTION FACTOR (dB/m)
1	33.80	24.0 QP	40.0	-16.0	1.49 H	171	33.60	-9.60
2	194.63	40.3 QP	43.5	-3.2	1.49 H	18	51.60	-11.30
3	260.35	42.7 QP	46.0	-3.3	1.46 H	62	51.60	-8.90
4	379.92	32.9 QP	46.0	-13.1	1.14 H	341	38.20	-5.30
5	695.63	37.5 QP	46.0	-8.5	1.00 H	339	36.10	1.40
6	1000.00	40.9 QP	54.0	-13.1	1.87 H	279	35.20	5.70

ANTENNA POLARITY & TEST DISTANCE: VERTICAL AT 3 M

NO.	FREQ. (MHz)	EMISSION LEVEL (dBuV/m)	LIMIT (dBuV/m)	MARGIN (dB)	ANTENNA HEIGHT (m)	TABLE ANGLE (Degree)	RAW VALUE (dBuV)	CORRECTION FACTOR (dB/m)
1	97.84	25.6 QP	43.5	-17.9	1.96 V	299	39.10	-13.50
2	195.96	34.0 QP	43.5	-9.5	1.58 V	218	45.40	-11.40
3	259.79	39.0 QP	46.0	-7.0	2.00 V	143	48.00	-9.00
4	325.71	32.1 QP	46.0	-13.9	1.00 V	37	38.50	-6.40
5	749.47	37.0 QP	46.0	-9.0	1.64 V	342	34.60	2.40
6	1000.00	38.6 QP	54.0	-15.4	1.04 V	278	32.90	5.70

REMARKS:

1. Emission Level(dBuV/m) = Raw Value(dBuV) + Correction Factor(dB/m)
2. Correction Factor(dB/m) = Antenna Factor(dB/m) + Cable Factor(dB) – Pre-Amplifier Factor(dB)
3. The other emission levels were very low against the limit.
4. Margin value = Emission Level – Limit value

CHANNEL	TX Channel 8	DETECTOR FUNCTION	Quasi-Peak (QP)
FREQUENCY RANGE	Below 1GHz		

ANTENNA POLARITY & TEST DISTANCE: HORIZONTAL AT 3 M

NO.	FREQ. (MHz)	EMISSION LEVEL (dBuV/m)	LIMIT (dBuV/m)	MARGIN (dB)	ANTENNA HEIGHT (m)	TABLE ANGLE (Degree)	RAW VALUE (dBuV)	CORRECTION FACTOR (dB/m)
1	33.77	24.3 QP	40.0	-15.7	1.56 H	173	33.90	-9.60
2	194.65	40.2 QP	43.5	-3.3	1.41 H	37	51.50	-11.30
3	260.45	42.9 QP	46.0	-3.1	1.42 H	71	51.80	-8.90
4	379.85	32.5 QP	46.0	-13.5	1.20 H	343	37.80	-5.30
5	695.79	37.5 QP	46.0	-8.5	1.00 H	326	36.10	1.40
6	1000.00	40.9 QP	54.0	-13.1	1.92 H	268	35.20	5.70

ANTENNA POLARITY & TEST DISTANCE: VERTICAL AT 3 M

NO.	FREQ. (MHz)	EMISSION LEVEL (dBuV/m)	LIMIT (dBuV/m)	MARGIN (dB)	ANTENNA HEIGHT (m)	TABLE ANGLE (Degree)	RAW VALUE (dBuV)	CORRECTION FACTOR (dB/m)
1	97.71	25.7 QP	43.5	-17.8	1.97 V	313	39.20	-13.50
2	196.01	33.8 QP	43.5	-9.7	1.64 V	229	45.20	-11.40
3	259.60	38.5 QP	46.0	-7.5	2.05 V	150	47.60	-9.10
4	325.59	32.5 QP	46.0	-13.5	1.00 V	30	38.90	-6.40
5	749.40	36.7 QP	46.0	-9.3	1.61 V	330	34.30	2.40
6	1000.00	38.6 QP	54.0	-15.4	1.01 V	283	32.90	5.70

REMARKS:

1. Emission Level(dBuV/m) = Raw Value(dBuV) + Correction Factor(dB/m)
2. Correction Factor(dB/m) = Antenna Factor(dB/m) + Cable Factor(dB) – Pre-Amplifier Factor(dB)
3. The other emission levels were very low against the limit.
4. Margin value = Emission Level – Limit value

CHANNEL	TX Channel 9	DETECTOR FUNCTION	Quasi-Peak (QP)
FREQUENCY RANGE	Below 1GHz		

ANTENNA POLARITY & TEST DISTANCE: HORIZONTAL AT 3 M

NO.	FREQ. (MHz)	EMISSION LEVEL (dBuV/m)	LIMIT (dBuV/m)	MARGIN (dB)	ANTENNA HEIGHT (m)	TABLE ANGLE (Degree)	RAW VALUE (dBuV)	CORRECTION FACTOR (dB/m)
1	34.05	23.9 QP	40.0	-16.1	1.52 H	167	33.40	-9.50
2	195.06	40.4 QP	43.5	-3.1	1.52 H	29	51.70	-11.30
3	260.04	42.8 QP	46.0	-3.2	1.41 H	62	51.70	-8.90
4	379.62	32.6 QP	46.0	-13.4	1.18 H	338	37.90	-5.30
5	695.50	38.0 QP	46.0	-8.0	1.08 H	333	36.60	1.40
6	1000.00	41.1 QP	54.0	-12.9	1.97 H	276	35.40	5.70

ANTENNA POLARITY & TEST DISTANCE: VERTICAL AT 3 M

NO.	FREQ. (MHz)	EMISSION LEVEL (dBuV/m)	LIMIT (dBuV/m)	MARGIN (dB)	ANTENNA HEIGHT (m)	TABLE ANGLE (Degree)	RAW VALUE (dBuV)	CORRECTION FACTOR (dB/m)
1	97.85	25.2 QP	43.5	-18.3	2.01 V	311	38.70	-13.50
2	195.84	33.9 QP	43.5	-9.6	1.64 V	207	45.30	-11.40
3	260.05	38.7 QP	46.0	-7.3	2.01 V	144	47.60	-8.90
4	325.88	32.3 QP	46.0	-13.7	1.00 V	48	38.70	-6.40
5	749.96	36.8 QP	46.0	-9.2	1.63 V	327	34.40	2.40
6	1000.00	39.0 QP	54.0	-15.0	1.00 V	292	33.30	5.70

REMARKS:

1. Emission Level(dBuV/m) = Raw Value(dBuV) + Correction Factor(dB/m)
2. Correction Factor(dB/m) = Antenna Factor(dB/m) + Cable Factor(dB) – Pre-Amplifier Factor(dB)
3. The other emission levels were very low against the limit.
4. Margin value = Emission Level – Limit value

4.2 Conducted Emission Measurement

4.2.1 Limits of Conducted Emission Measurement

Frequency (MHz)	Conducted Limit (dBuV)	
	Quasi-peak	Average
0.15 - 0.5	66 - 56	56 - 46
0.50 - 5.0	56	46
5.0 - 30.0	60	50

Note: 1. The lower limit shall apply at the transition frequencies.

2. The limit decreases in line with the logarithm of the frequency in the range of 0.15 to 0.50MHz.

4.2.2 Test Instruments

DESCRIPTION & MANUFACTURER	MODEL NO.	SERIAL NO.	CALIBRATED DATE	CALIBRATED UNTIL
Test Receiver R&S	ESCS 30	100375	May 06, 2015	May 05, 2016
Line-Impedance Stabilization Network (for EUT) SCHWARZBECK	NSLK-8127	8127-522	Sep. 01, 2015	Aug. 31, 2016
Line-Impedance Stabilization Network (for Peripheral) R&S	ENV216	100072	June 11, 2015	June 10, 2016
RF Cable	5D-FB	COCCAB-001	Mar. 09, 2015	Mar. 08, 2016
50 ohms Terminator	N/A	EMC-03	Sep. 23, 2015	Sep. 22, 2016
50 ohms Terminator	N/A	EMC-02	Oct. 01, 2015	Sep. 30, 2016
Software BVADT	BVADT_Cond_ V7.3.7.3	NA	NA	NA

Note:

1. The calibration interval of the above test instruments are 12 months and the calibrations are traceable to NML/ROC and NIST/USA.
2. The test was performed in Shielded Room No. C.
- 3 The VCCI Con C Registration No. is C-3611.
- 4 Tested Date: Nov. 20 to 28, 2015

4.2.3 Test Procedures

- a. The EUT was placed 0.4 meters from the conducting wall of the shielded room with EUT being connected to the power mains through a line impedance stabilization network (LISN). Other support units were connected to the power mains through another LISN. The two LISNs provide 50 ohm/ 50uH of coupling impedance for the measuring instrument.
- b. Both lines of the power mains connected to the EUT were checked for maximum conducted interference.
- c. The frequency range from 150kHz to 30MHz was searched. Emission levels under (Limit - 20dB) was not recorded.

NOTE: The resolution bandwidth and video bandwidth of test receiver is 9kHz for quasi-peak detection (QP) and average detection (AV) at frequency 0.15MHz-30MHz.

4.2.4 Deviation from Test Standard

No deviation.

4.2.5 Test Setup

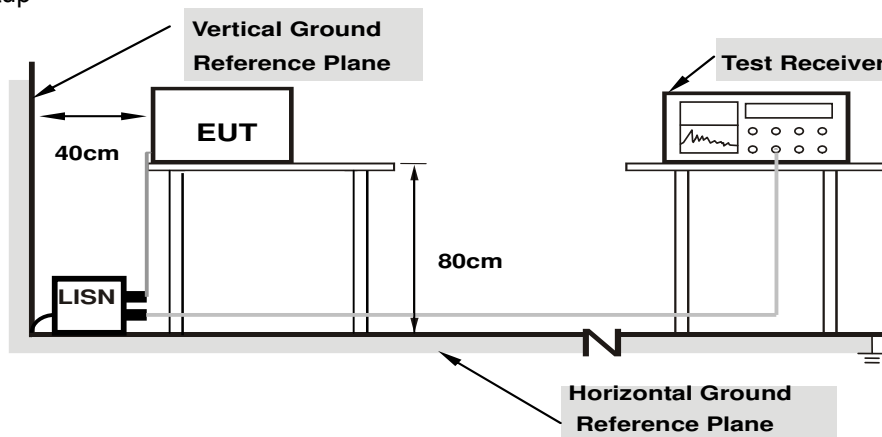

Note: 1.Support units were connected to second LISN.

For the actual test configuration, please refer to the attached file (Test Setup Photo).

4.2.6 EUT Operating Conditions

Same as 4.1.6.

4.2.7 Test Results (Mode 2)

Phase	Line (L)	Detector Function	Quasi-Peak (QP) / Average (AV)
-------	----------	-------------------	--------------------------------

No	Freq. [MHz]	Corr. Factor	Reading Value [dB (uV)]		Emission Level [dB (uV)]		Limit [dB (uV)]		Margin (dB)	
		(dB)	Q.P.	AV.	Q.P.	AV.	Q.P.	AV.	Q.P.	AV.
	1	0.23593	10.22	42.11	36.31	52.33	46.53	62.24	52.24	-9.90
2	0.35311	10.24	39.03	35.13	49.27	45.37	58.89	48.89	-9.62	-3.52
3	0.46280	10.23	35.95	24.35	46.18	34.58	56.64	46.64	-10.46	-12.06
4	0.58361	10.22	40.03	32.66	50.25	42.88	56.00	46.00	-5.75	-3.12
5	0.70070	10.20	35.97	26.64	46.17	36.84	56.00	46.00	-9.83	-9.16
6	1.05076	10.17	34.21	29.03	44.38	39.20	56.00	46.00	-11.62	-6.80

REMARKS:

1. Q.P. and AV. are abbreviations of quasi-peak and average individually.
2. The emission levels of other frequencies were very low against the limit.
3. Margin value = Emission level - Limit value
4. Correction factor = Insertion loss + Cable loss
5. Emission Level = Correction Factor + Reading Value

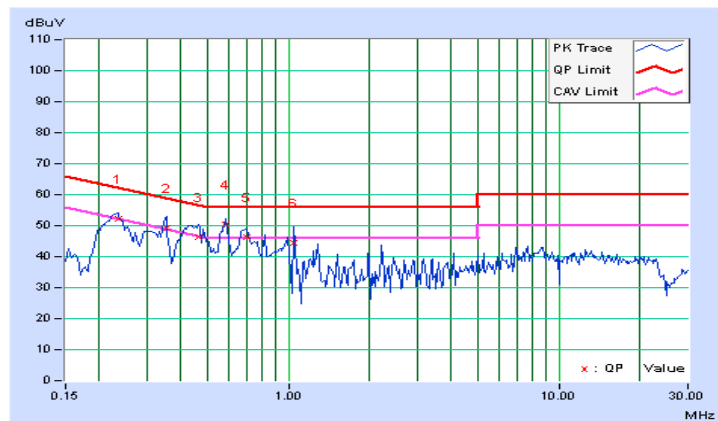

Phase	Neutral (N)	Detector Function	Quasi-Peak (QP) / Average (AV)
-------	-------------	-------------------	--------------------------------

No	Freq. [MHz]	Corr. Factor	Reading Value [dB (uV)]		Emission Level [dB (uV)]		Limit [dB (uV)]		Margin (dB)	
		(dB)	Q.P.	AV.	Q.P.	AV.	Q.P.	AV.	Q.P.	AV.
	1	0.15000	10.24	42.83	23.42	53.07	33.66	66.00	56.00	-12.93
2	0.18512	10.21	39.13	22.20	49.34	32.41	64.25	54.25	-14.91	-21.84
3	0.23982	10.20	36.76	25.01	46.96	35.21	62.10	52.10	-15.14	-16.89
4	0.57962	10.20	29.56	20.41	39.76	30.61	56.00	46.00	-16.24	-15.39
5	0.75153	10.18	29.20	18.92	39.38	29.10	56.00	46.00	-16.62	-16.90
6	22.09764	10.97	29.22	13.98	40.19	24.95	60.00	50.00	-19.81	-25.05

REMARKS:

1. Q.P. and AV. are abbreviations of quasi-peak and average individually.
2. The emission levels of other frequencies were very low against the limit.
3. Margin value = Emission level - Limit value
4. Correction factor = Insertion loss + Cable loss
5. Emission Level = Correction Factor + Reading Value

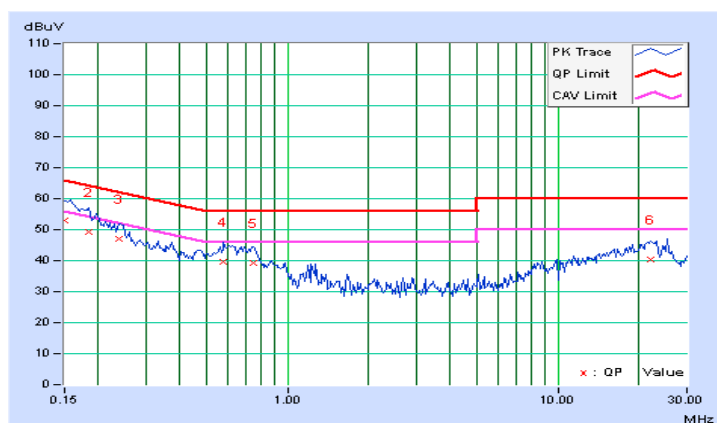

4.2.8 Test Results (Mode 4)

Phase	Line (L)	Detector Function	Quasi-Peak (QP) / Average (AV)
-------	----------	-------------------	--------------------------------

No	Freq. [MHz]	Corr.	Reading Value		Emission Level		Limit		Margin	
		Factor	[dB (uV)]		[dB (uV)]		[dB (uV)]		(dB)	
	(dB)	Q.P.	AV.	Q.P.	AV.	Q.P.	AV.	Q.P.	AV.	
1	0.15000	10.26	42.66	14.21	52.92	24.47	66.00	56.00	-13.08	-31.53
2	0.17735	10.24	39.71	10.11	49.95	20.35	64.61	54.61	-14.66	-34.26
3	0.20860	10.22	34.84	6.05	45.06	16.27	63.26	53.26	-18.20	-36.99
4	0.37656	10.24	20.18	18.23	30.42	28.47	58.35	48.35	-27.94	-19.89
5	10.65625	10.55	24.38	24.67	34.93	35.22	60.00	50.00	-25.07	-14.78
6	23.23045	10.96	35.26	33.52	46.22	44.48	60.00	50.00	-13.78	-5.52

REMARKS:

1. Q.P. and AV. are abbreviations of quasi-peak and average individually.
2. The emission levels of other frequencies were very low against the limit.
3. Margin value = Emission level - Limit value
4. Correction factor = Insertion loss + Cable loss
5. Emission Level = Correction Factor + Reading Value

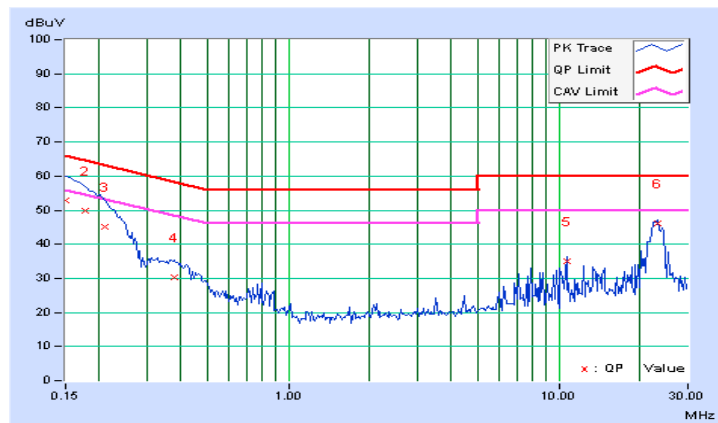

Phase	Neutral (N)	Detector Function	Quasi-Peak (QP) / Average (AV)
-------	-------------	-------------------	--------------------------------

No	Freq. [MHz]	Corr.	Reading Value		Emission Level		Limit		Margin	
		Factor	[dB (uV)]		[dB (uV)]		[dB (uV)]		(dB)	
	(dB)	Q.P.	AV.	Q.P.	AV.	Q.P.	AV.	Q.P.	AV.	
1	0.15000	10.24	43.84	14.41	54.08	24.65	66.00	56.00	-11.92	-31.35
2	0.18126	10.21	40.36	11.22	50.57	21.43	64.43	54.43	-13.85	-32.99
3	0.23206	10.20	35.14	9.12	45.34	19.32	62.38	52.38	-17.03	-33.05
4	8.74608	10.50	23.38	22.71	33.88	33.21	60.00	50.00	-26.12	-16.79
5	23.23049	10.98	32.56	32.16	43.54	43.14	60.00	50.00	-16.46	-6.86
6	24.32424	10.99	30.43	29.92	41.42	40.91	60.00	50.00	-18.58	-9.09

REMARKS:

1. Q.P. and AV. are abbreviations of quasi-peak and average individually.
2. The emission levels of other frequencies were very low against the limit.
3. Margin value = Emission level - Limit value
4. Correction factor = Insertion loss + Cable loss
5. Emission Level = Correction Factor + Reading Value

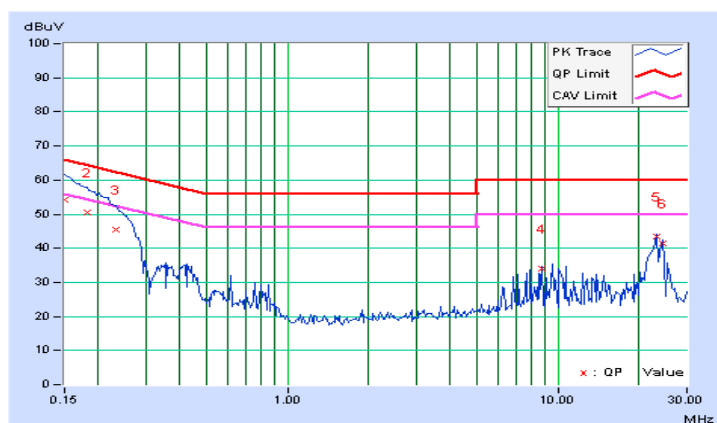

4.2.9 Test Results (Mode 5)

Phase	Line (L)	Detector Function	Quasi-Peak (QP) / Average (AV)
-------	----------	-------------------	--------------------------------

No	Freq. [MHz]	Corr.	Reading Value		Emission Level		Limit		Margin	
		Factor	[dB (uV)]		[dB (uV)]		[dB (uV)]		(dB)	
	(dB)	Q.P.	AV.	Q.P.	AV.	Q.P.	AV.	Q.P.	AV.	
1	0.15000	10.26	47.11	17.78	57.37	28.04	66.00	56.00	-8.63	-27.96
2	0.18126	10.23	42.43	13.22	52.66	23.45	64.43	54.43	-11.76	-30.97
3	0.24374	10.22	32.72	8.22	42.94	18.44	61.97	51.97	-19.02	-33.52
4	22.14062	10.95	34.25	32.56	45.20	43.51	60.00	50.00	-14.80	-6.49
5	23.23439	10.96	35.22	33.48	46.18	44.44	60.00	50.00	-13.82	-5.56
6	24.32812	10.97	32.21	31.61	43.18	42.58	60.00	50.00	-16.82	-7.42

REMARKS:

1. Q.P. and AV. are abbreviations of quasi-peak and average individually.
2. The emission levels of other frequencies were very low against the limit.
3. Margin value = Emission level - Limit value
4. Correction factor = Insertion loss + Cable loss
5. Emission Level = Correction Factor + Reading Value

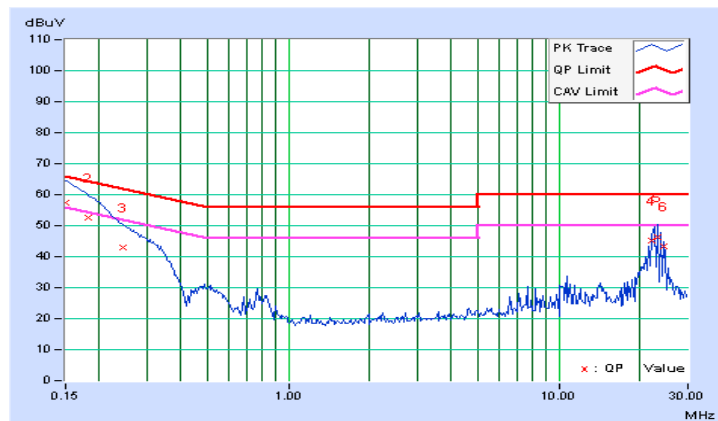

Phase	Neutral (N)	Detector Function	Quasi-Peak (QP) / Average (AV)
-------	-------------	-------------------	--------------------------------

No	Freq. [MHz]	Corr.	Reading Value		Emission Level		Limit		Margin	
		Factor	[dB (uV)]		[dB (uV)]		[dB (uV)]		(dB)	
	(dB)	Q.P.	AV.	Q.P.	AV.	Q.P.	AV.	Q.P.	AV.	
1	0.15000	10.24	46.86	17.62	57.10	27.86	66.00	56.00	-8.90	-28.14
2	0.18124	10.22	42.44	13.59	52.66	23.81	64.43	54.43	-11.77	-30.62
3	0.22813	10.20	34.68	6.97	44.88	17.17	62.52	52.52	-17.63	-35.34
4	0.30626	10.21	28.68	2.68	38.89	12.89	60.07	50.07	-21.18	-37.18
5	22.68751	10.97	30.86	30.46	41.83	41.43	60.00	50.00	-18.17	-8.57
6	23.23439	10.98	30.83	30.39	41.81	41.37	60.00	50.00	-18.19	-8.63

REMARKS:

1. Q.P. and AV. are abbreviations of quasi-peak and average individually.
2. The emission levels of other frequencies were very low against the limit.
3. Margin value = Emission level - Limit value
4. Correction factor = Insertion loss + Cable loss
5. Emission Level = Correction Factor + Reading Value

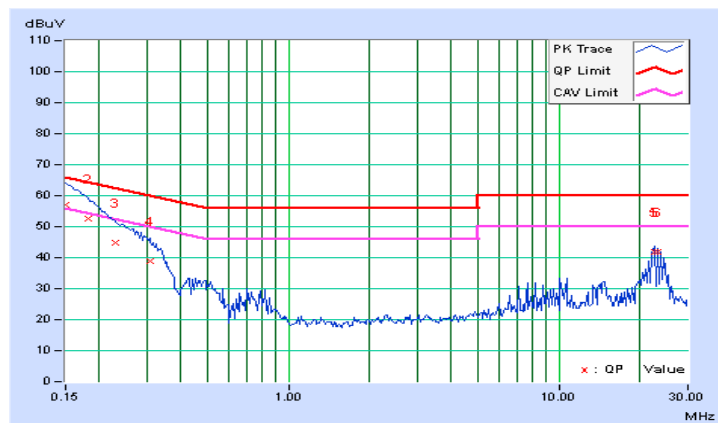

4.3 6dB Bandwidth Measurement

4.3.1 Limits of 6dB Bandwidth Measurement

The minimum of 6dB Bandwidth Measurement is 0.5 MHz.

4.3.2 Test Setup

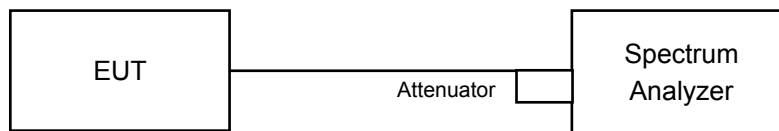

4.3.3 Test Instruments

Refer to section 4.1.2 to get information of above instrument.

4.3.4 Test Procedure

- a. Set resolution bandwidth (RBW) = 100kHz
- b. Set the video bandwidth (VBW) $\geq 3 \times$ RBW, Detector = Peak.
- c. Trace mode = max hold.
- d. Sweep = auto couple.
- e. Measure the maximum width of the emission that is constrained by the frequencies associated with the two amplitude points (upper and lower) that are attenuated by 6 dB relative to the maximum level measured in the fundamental emission

4.3.5 Deviation from Test Standard

No deviation.

4.3.6 EUT Operating Conditions

The software provided by client to enable the EUT under transmission condition continuously at lowest, middle and highest channel frequencies individually.

4.3.7 Test Result

802.11b

Channel	Frequency (MHz)	6dB Bandwidth (MHz)	Minimum Limit (MHz)	Pass / Fail
1	2412	8.60	0.5	PASS
2	2417	8.57	0.5	PASS
6	2437	9.11	0.5	PASS
10	2457	9.03	0.5	PASS
11	2462	9.05	0.5	PASS

802.11g

Channel	Frequency (MHz)	6dB Bandwidth (MHz)	Minimum Limit (MHz)	Pass / Fail
1	2412	16.39	0.5	PASS
2	2417	16.41	0.5	PASS
6	2437	16.40	0.5	PASS
10	2457	16.42	0.5	PASS
11	2462	16.41	0.5	PASS

802.11n (HT20)

Channel	Frequency (MHz)	6dB Bandwidth (MHz)		Minimum Limit (MHz)	Pass / Fail
		Chain 0	Chain 1		
1	2412	17.63	17.63	0.5	PASS
2	2417	17.63	17.65	0.5	PASS
6	2437	17.63	17.62	0.5	PASS
10	2457	17.63	17.63	0.5	PASS
11	2462	17.63	17.65	0.5	PASS

802.11n (HT40)

Channel	Frequency (MHz)	6dB Bandwidth (MHz)		Minimum Limit (MHz)	Pass / Fail
		Chain 0	Chain 1		
3	2422	36.13	36.03	0.5	PASS
4	2427	35.91	36.11	0.5	PASS
6	2437	35.88	35.88	0.5	PASS
8	2447	36.09	36.06	0.5	PASS
9	2452	36.14	36.00	0.5	PASS

Spectrum Plot of Worst Value

802.11b: CH2

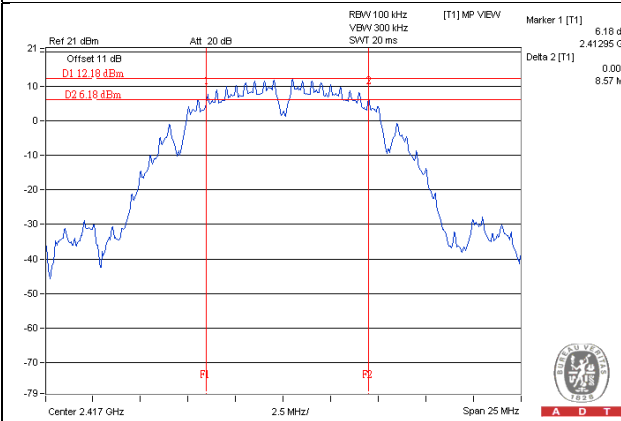

802.11g: CH1

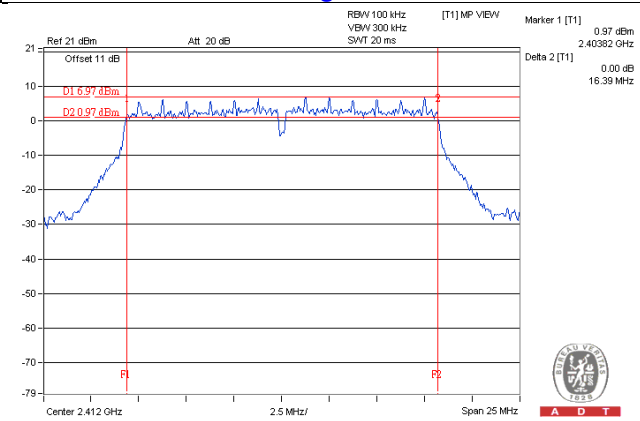

802.11n (HT20)-Chain (1): CH6

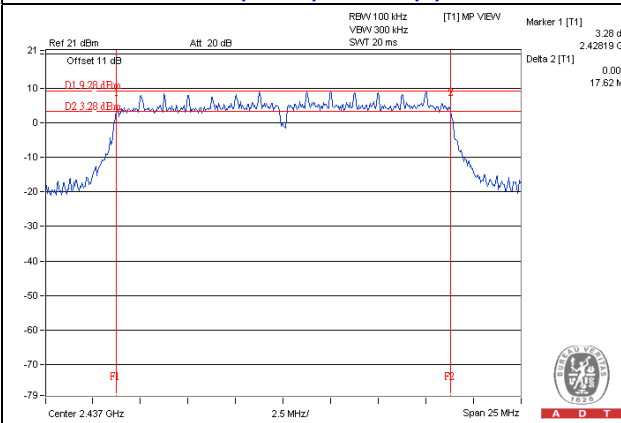

802.11n (HT40)-Chain (0): CH6

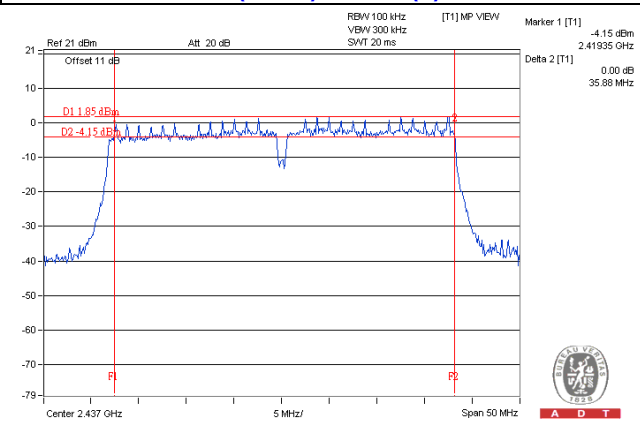

4.4 Conducted Output Power Measurement

4.4.1 Limits of Conducted Output Power Measurement

For systems using digital modulation in the 2400–2483.5 MHz bands: 1 Watt (30dBm)

Per KDB 662911 D01 Multiple Transmitter Output Method of conducted output power measurement on IEEE 802.11 devices,

Array Gain = 0 dB (i.e., no array gain) for $NANT \leq 4$;

Array Gain = 0 dB (i.e., no array gain) for channel widths ≥ 40 MHz for any NANT;

Array Gain = $5 \log(NANT/NSS)$ dB or 3 dB, whichever is less for 20-MHz channel widths with $NANT \geq 5$.

For power measurements on all other devices: Array Gain = $10 \log(NANT/NSS)$ dB.

4.4.2 Test Setup

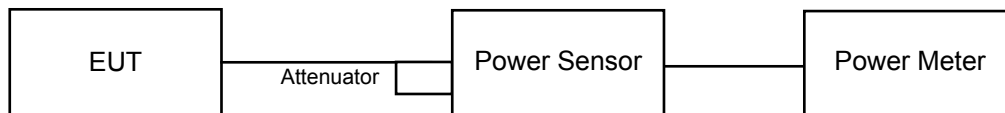

4.4.3 Test Instruments

Refer to section 4.1.2 to get information of above instrument.

4.4.4 Test Procedures

A peak power sensor was used on the output port of the EUT. A power meter was used to read the response of the peak power sensor and set the detector to PEAK . Record the power level.

A average power sensor was used on the output port of the EUT. A power meter was used to read the response of the average power senso and set the detector to AVERAGE . Record the power level.

4.4.5 Deviation from Test Standard

No deviation.

4.4.6 EUT Operating Conditions

Same as Item 4.3.6.

4.4.7 Test Results

FOR PEAK POWER

802.11b

Channel	Frequency (MHz)	Peak Power (mW)	Peak Power (dBm)	Limit (dBm)	Pass/Fail
1	2412	252.348	24.02	30	Pass
2	2417	248.886	23.96	30	Pass
6	2437	256.448	24.09	30	Pass
10	2457	261.216	24.17	30	Pass
11	2462	275.423	24.40	30	Pass

802.11g

Channel	Frequency (MHz)	Peak Power (mW)	Peak Power (dBm)	Limit (dBm)	Pass/Fail
1	2412	315.5	24.99	30	Pass
2	2417	390.841	25.92	30	Pass
6	2437	375.837	25.75	30	Pass
10	2457	383.707	25.84	30	Pass
11	2462	225.944	23.54	30	Pass

802.11n (HT20)

Channel	Frequency (MHz)	Peak Power (dBm)		Total Power (mW)	Total Power (dBm)	Limit (dBm)	Pass / Fail
		Chain 0	Chain 1				
1	2412	24.33	24.99	586.519	27.68	30	Pass
2	2417	25.06	26.00	718.734	28.57	30	Pass
6	2437	25.57	26.06	764.224	28.83	30	Pass
10	2457	25.31	25.50	694.438	28.42	30	Pass
11	2462	23.64	24.15	491.222	26.91	30	Pass

802.11n (HT40)

Channel	Frequency (MHz)	Peak Power (dBm)		Total Power (mW)	Total Power (dBm)	Limit (dBm)	Pass / Fail
		Chain 0	Chain 1				
3	2422	23.03	23.24	411.772	26.15	30	Pass
4	2427	23.47	24.45	500.943	27.00	30	Pass
6	2437	24.21	24.33	534.652	27.28	30	Pass
8	2447	22.83	23.01	391.853	25.93	30	Pass
9	2452	22.45	23.18	383.762	25.84	30	Pass

FOR AVERAGE POWER
802.11b

Channel	Frequency (MHz)	Average Power (mW)	Average Power (dBm)
1	2412	134.276	21.28
2	2417	133.045	21.24
6	2437	135.519	21.32
10	2457	137.088	21.37
11	2462	137.404	21.38

802.11g

Channel	Frequency (MHz)	Average Power (mW)	Average Power (dBm)
1	2412	67.298	18.28
2	2417	122.180	20.87
6	2437	129.718	21.13
10	2457	129.718	21.13
11	2462	59.979	17.78

802.11n (HT20)

Chan.	Chan. Freq. (MHz)	Average Power (dBm)		Total Power (mW)	Total Power (dBm)
		Chain 0	Chain 1		
1	2412	17.17	17.66	110.464	20.43
2	2417	18.41	18.88	146.611	21.66
6	2437	20.88	21.05	249.812	23.98
10	2457	18.50	18.54	142.245	21.53
11	2462	15.64	15.54	72.454	18.60

802.11n (HT40)

Chan.	Chan. Freq. (MHz)	Average Power (dBm)		Total Power (mW)	Total Power (dBm)
		Chain 0	Chain 1		
3	2422	14.35	14.71	56.807	17.54
4	2427	15.37	15.98	74.063	18.70
6	2437	16.15	16.45	85.367	19.31
8	2447	14.86	14.91	61.594	17.90
9	2452	13.73	14.01	48.782	16.88

※Add test for each data rate output power (require by manufacturer):

802.11b

Chan.	Chan. Freq. (MHz)	Peak Power (dBm)			
		Data rate			
		1Mbps	2Mbps	5.5Mbps	11Mbps
1	2412	24.02	23.91	24.01	23.99
2	2417	23.96	23.86	23.78	23.68
6	2437	24.09	24.08	24.03	23.85
10	2457	24.17	24.09	24.08	23.97
11	2462	24.40	24.33	24.22	24.32

802.11g

Chan.	Chan. Freq. (MHz)	Peak Power (dBm)							
		Data rate							
		6Mbps	9Mbps	12Mbps	18Mbps	24Mbps	36Mbps	48Mbps	54Mbps
1	2412	24.99	24.89	24.82	24.95	24.98	24.83	24.65	24.77
2	2417	25.92	25.83	25.72	25.55	25.74	25.63	25.53	25.65
6	2437	25.75	25.61	25.42	25.31	25.38	25.30	25.41	25.36
10	2457	25.84	25.64	25.83	25.73	25.54	25.75	25.57	25.77
11	2462	23.54	23.53	23.32	23.26	23.19	23.26	23.19	23.00

802.11n (HT20)

NSS=1

Chan.	Chan. Freq. (MHz)	Peak Power (dBm)							
		Data rate							
		MCS0	MCS1	MCS2	MCS3	MCS4	MCS5	MCS6	MCS7
1	2412	27.65	27.53	27.44	27.23	27.23	27.24	27.38	27.51
2	2417	28.55	28.53	28.36	28.41	28.22	28.01	28.07	27.93
6	2437	28.79	28.79	28.68	28.72	28.78	28.68	28.60	28.72
10	2457	28.39	28.33	28.26	28.28	28.29	28.26	28.28	28.09
11	2462	26.86	26.82	26.85	26.82	26.74	26.62	26.46	26.40

NSS=2

Chan.	Chan. Freq. (MHz)	Peak Power (dBm)							
		Data rate							
		MCS8	MCS9	MCS10	MCS11	MCS12	MCS13	MCS14	MCS15
1	2412	27.68	27.57	27.37	27.37	27.57	27.39	27.33	27.51
2	2417	28.57	28.51	28.45	28.25	28.30	28.09	28.18	28.16
6	2437	28.83	28.82	28.62	28.74	28.82	28.62	28.76	28.67
10	2457	28.42	28.20	28.35	28.23	28.18	28.02	28.06	28.15
11	2462	26.91	26.70	26.69	26.73	26.52	26.62	26.56	26.43

802.11n (HT40)
NSS=1

Chan.	Chan. Freq. (MHz)	Peak Power (dBm)							
		Data rate							
		MCS0	MCS1	MCS2	MCS3	MCS4	MCS5	MCS6	MCS7
3	2422	26.12	25.95	25.80	25.91	25.73	25.87	26.01	25.81
4	2427	26.99	26.97	26.85	26.81	26.98	26.95	26.80	26.68
6	2437	27.25	27.25	27.27	27.16	27.23	27.12	27.17	27.10
8	2447	25.90	25.79	25.76	25.60	25.65	25.70	25.84	25.80
9	2452	25.83	25.63	25.76	25.67	25.51	25.59	25.74	25.63

NSS=2

Chan.	Chan. Freq. (MHz)	Peak Power (dBm)							
		Data rate							
		MCS8	MCS9	MCS10	MCS11	MCS12	MCS13	MCS14	MCS15
3	2422	26.15	26.04	25.94	25.72	25.53	25.73	25.67	25.61
4	2427	27.00	26.88	26.66	26.74	26.94	26.78	26.86	26.71
6	2437	27.28	27.09	26.98	26.86	26.76	26.92	27.07	27.14
8	2447	25.93	25.89	25.91	25.89	25.82	25.80	25.74	25.87
9	2452	25.84	25.78	25.81	25.63	25.54	25.52	25.46	25.40

4.5 Power Spectral Density Measurement

4.5.1 Limits of Power Spectral Density Measurement

The Maximum of Power Spectral Density Measurement is 8dBm.

4.5.2 Test Setup

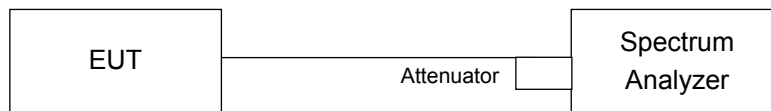

4.5.3 Test Instruments

Refer to section 4.1.2 to get information of above instrument.

4.5.4 Test Procedure

- a. Set analyzer center frequency to DTS channel center frequency.
- b. Set the span to 1.5 times the DTS bandwidth.
- c. Set the RBW to: $3 \text{ kHz} \leq \text{RBW} \leq 100 \text{ kHz}$.
- d. Set the VBW $\geq 3 \times \text{RBW}$.
- e. Detector = peak.
- f. Sweep time = auto couple.
- g. Trace mode = max hold.
- h. Allow trace to fully stabilize.
- i. Use the peak marker function to determine the maximum amplitude level within the RBW.

4.5.5 Deviation from Test Standard

No deviation.

4.5.6 EUT Operating Condition

Same as Item 4.3.6

4.5.7 Test Results

802.11b

Channel	Frequency (MHz)	PSD (dBm/3kHz)	Limit (dBm/3kHz)	Pass /Fail
1	2412	-2.03	8	Pass
2	2417	-2.14	8	Pass
6	2437	-2.79	8	Pass
10	2457	-1.31	8	Pass
11	2462	-0.46	8	Pass

802.11g

Channel	Frequency (MHz)	PSD (dBm/3kHz)	Limit (dBm/3kHz)	Pass /Fail
1	2412	-6.40	8	Pass
2	2417	-5.66	8	Pass
6	2437	-5.80	8	Pass
10	2457	-4.85	8	Pass
11	2462	-6.51	8	Pass

802.11n (HT20)

TX chain	Channel	Frequency (MHz)	PSD (dBm/3kHz)	10 log (N=2) dB	Total PSD (dBm/3kHz)	Limit (dBm/3kHz)	Pass /Fail
0	1	2412	-9.96	3.01	-6.95	8	Pass
	2	2417	-7.53	3.01	-4.52	8	Pass
	6	2437	-5.85	3.01	-2.84	8	Pass
	10	2457	-6.14	3.01	-3.13	8	Pass
	11	2462	-10.84	3.01	-7.83	8	Pass
1	1	2412	-9.84	3.01	-6.83	8	Pass
	2	2417	-8.85	3.01	-5.84	8	Pass
	6	2437	-6.80	3.01	-3.79	8	Pass
	10	2457	-8.58	3.01	-5.57	8	Pass
	11	2462	-11.58	3.01	-8.57	8	Pass

802.11n (HT40)

TX chain	Channel	Frequency (MHz)	PSD (dBm/3kHz)	10 log (N=2) dB	Total PSD (dBm/3kHz)	Limit (dBm/3kHz)	Pass /Fail
0	3	2422	-14.82	3.01	-11.81	8	Pass
	4	2427	-13.48	3.01	-10.47	8	Pass
	6	2437	-13.37	3.01	-10.36	8	Pass
	8	2447	-14.07	3.01	-11.06	8	Pass
	9	2452	-15.49	3.01	-12.48	8	Pass
1	3	2422	-13.40	3.01	-10.39	8	Pass
	4	2427	-13.68	3.01	-10.67	8	Pass
	6	2437	-12.17	3.01	-9.16	8	Pass
	8	2447	-14.58	3.01	-11.57	8	Pass
	9	2452	-15.53	3.01	-12.52	8	Pass

Spectrum Plot of Worst Value

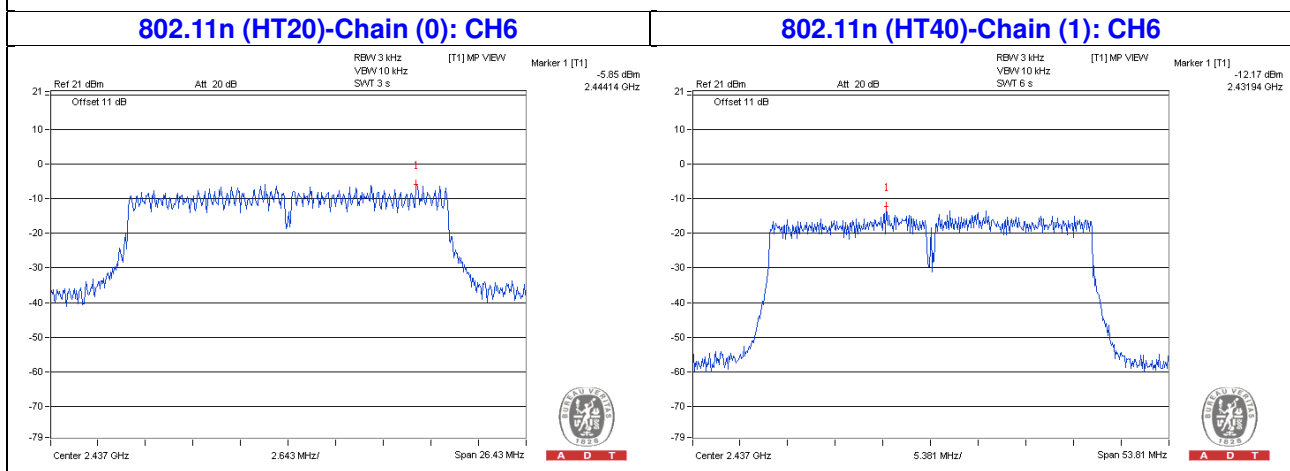
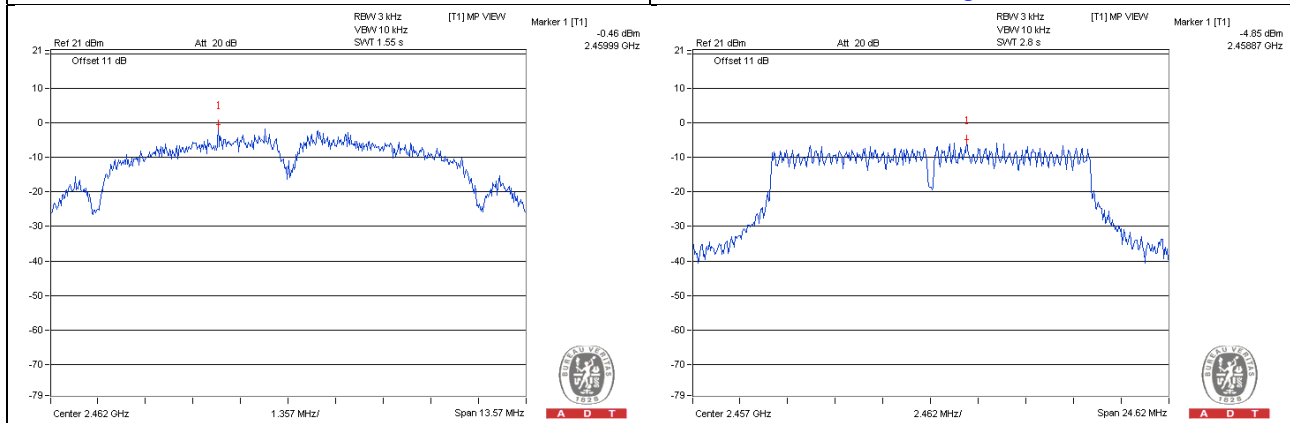

4.6 Conducted Out of Band Emission Measurement

4.6.1 Limits of Conducted Out of Band Emission Measurement

Below 20dB of the highest emission level of operating band (in 100kHz Resolution Bandwidth).

4.6.2 Test Setup

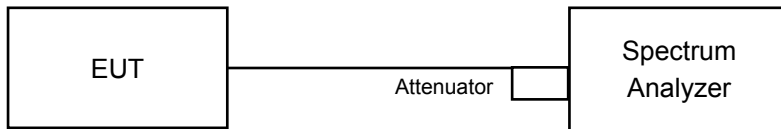

4.6.3 Test Instruments

Refer to section 4.1.2 to get information of above instrument.

4.6.4 Test Procedure

MEASUREMENT PROCEDURE REF

1. Set the RBW = 100 kHz.
2. Set the VBW ≥ 300 kHz.
3. Detector = peak.
4. Sweep time = auto couple.
5. Trace mode = max hold.
6. Allow trace to fully stabilize.
7. Use the peak marker function to determine the maximum power level in any 100 kHz band segment within the fundamental EBW.

MEASUREMENT PROCEDURE OOBE

1. Set RBW = 100 kHz.
2. Set VBW ≥ 300 kHz.
3. Detector = peak.
4. Sweep = auto couple.
5. Trace Mode = max hold.
6. Allow trace to fully stabilize.
7. Use the peak marker function to determine the maximum amplitude level.

4.6.5 Deviation from Test Standard

No deviation.

4.6.6 EUT Operating Condition

Same as Item 4.3.6

4.6.7 Test Results

The spectrum plots are attached on the following pages. D1 line indicates the highest level, and D2 line indicates the 20dB offset below D1. It shows compliance with the requirement.

802.11b

CH 1

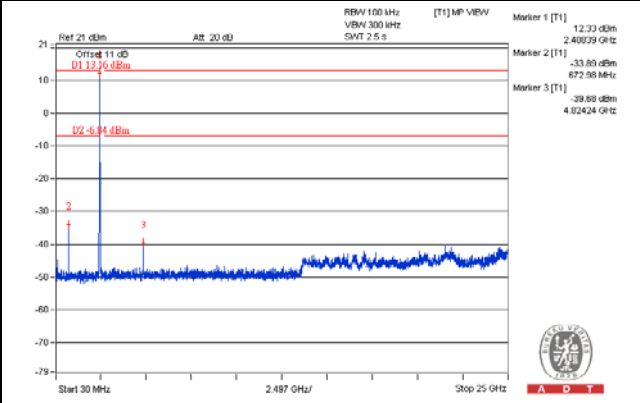
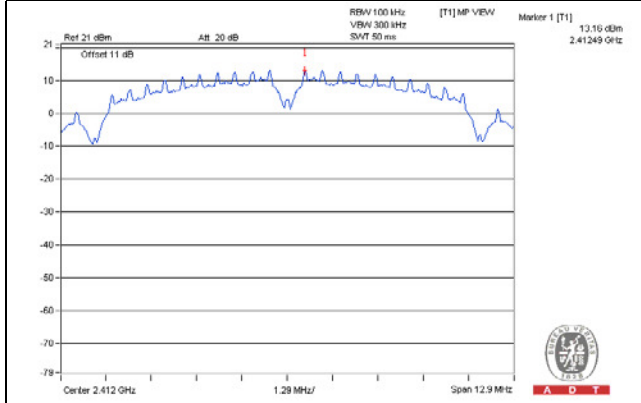

CH 2

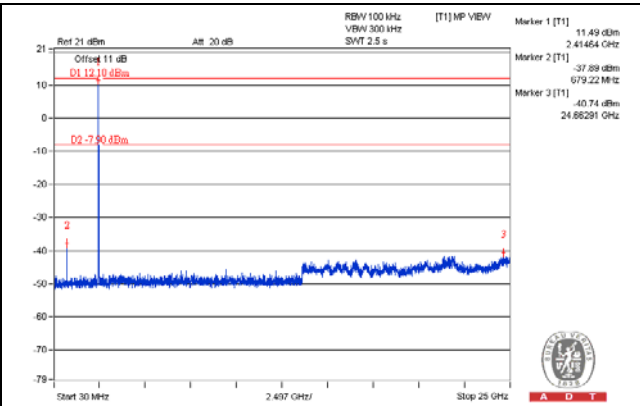
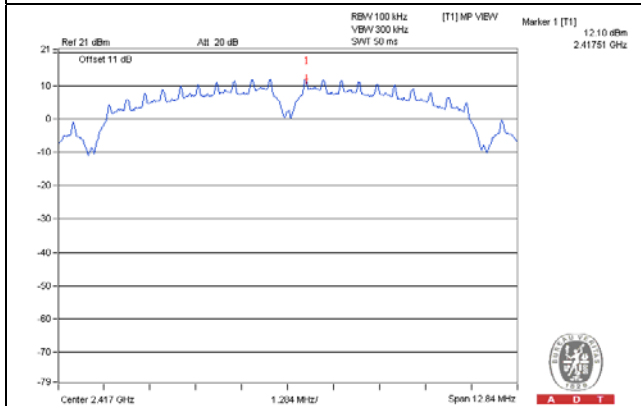

CH 6

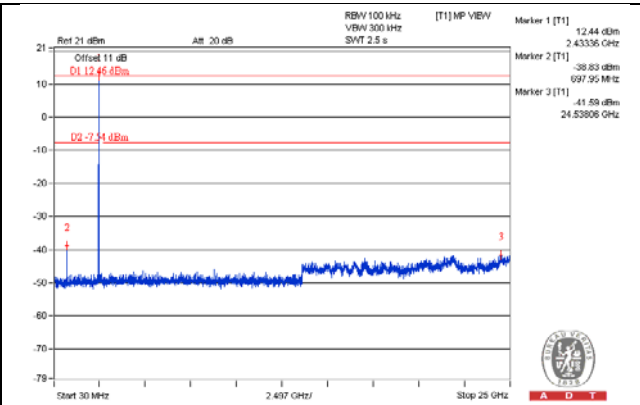
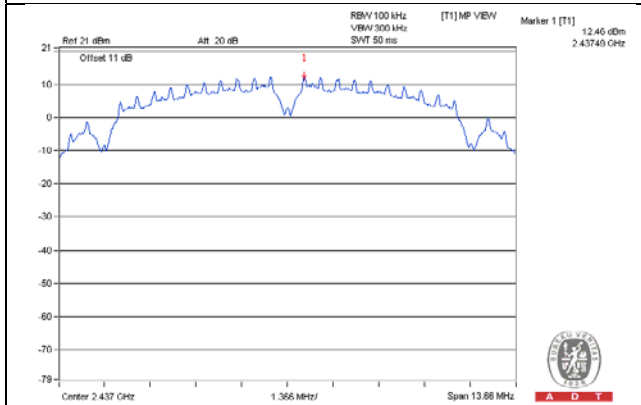

CH 10

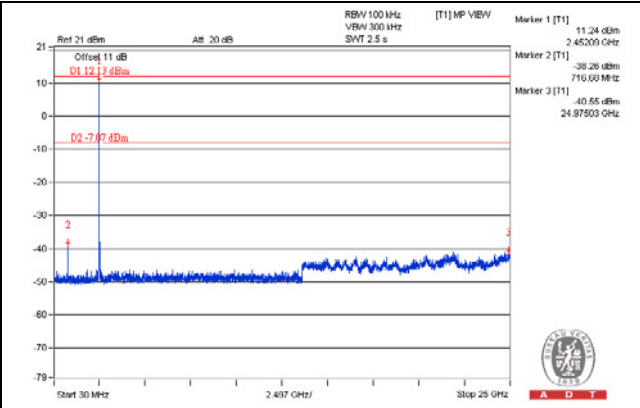
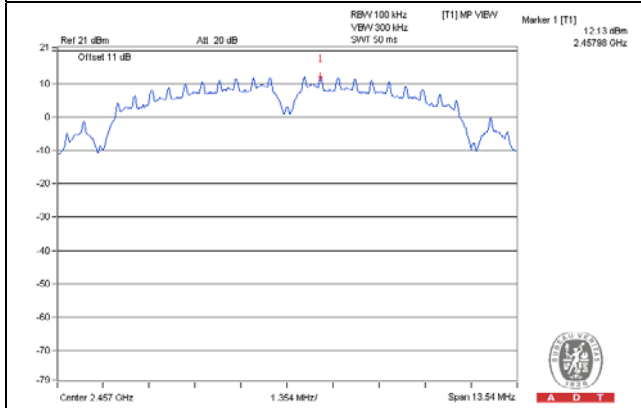

CH 11

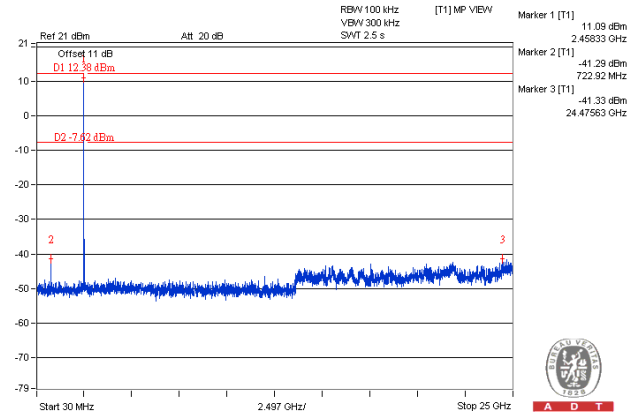
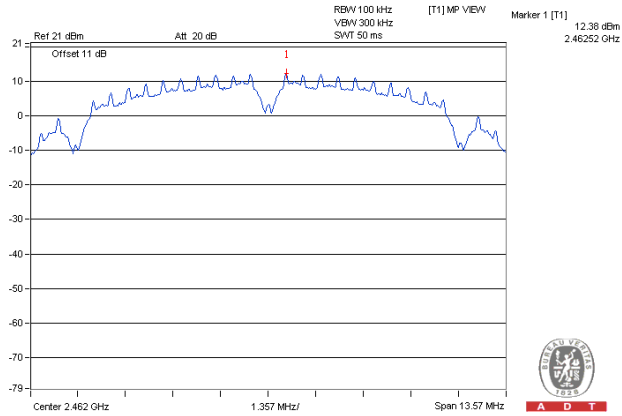

CH 1 Band edge

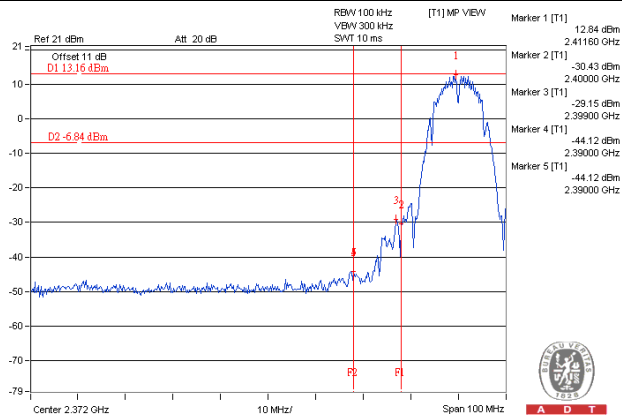

CH 2 Band edge

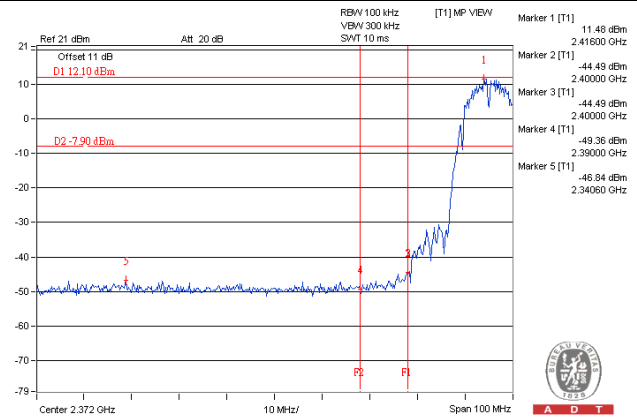

CH 11 Band edge

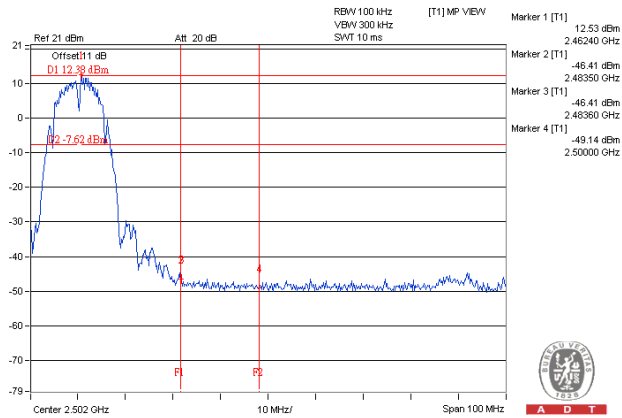

802.11g
CH 1

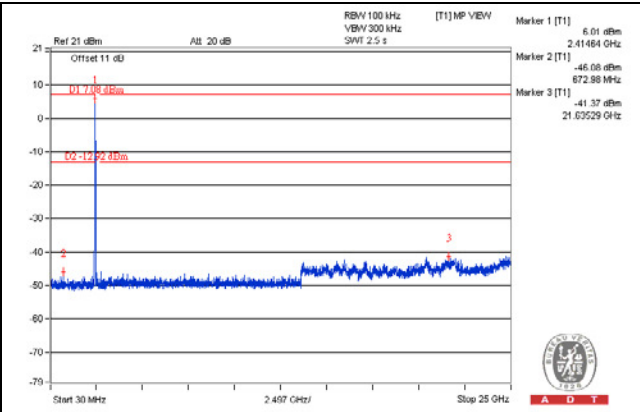
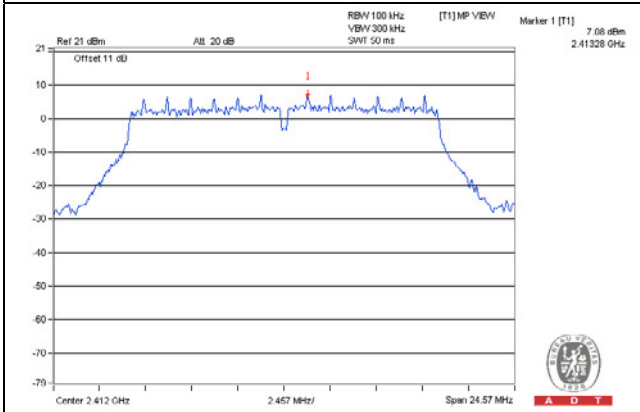

CH 2

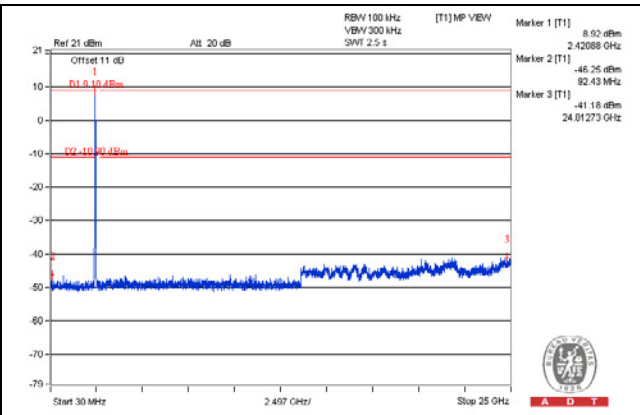
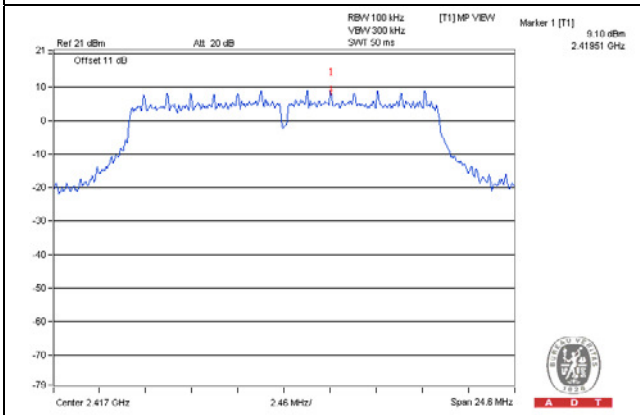

CH 6

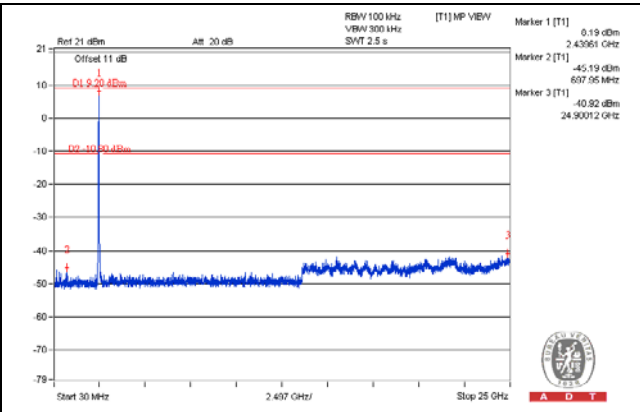
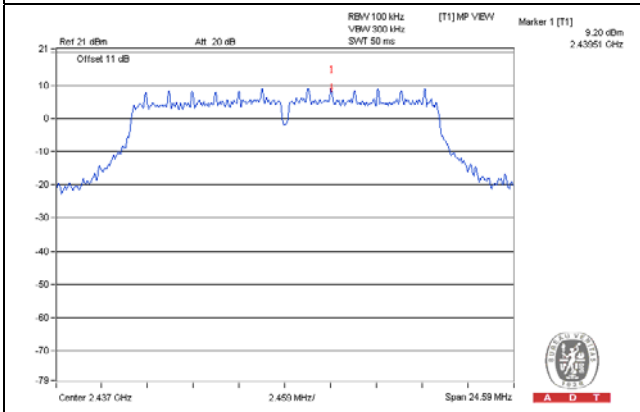

CH 10

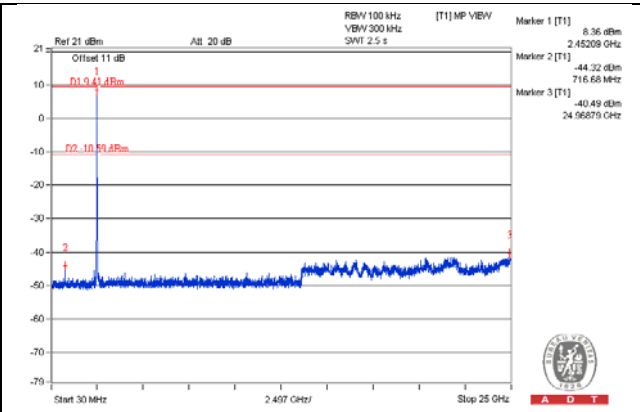
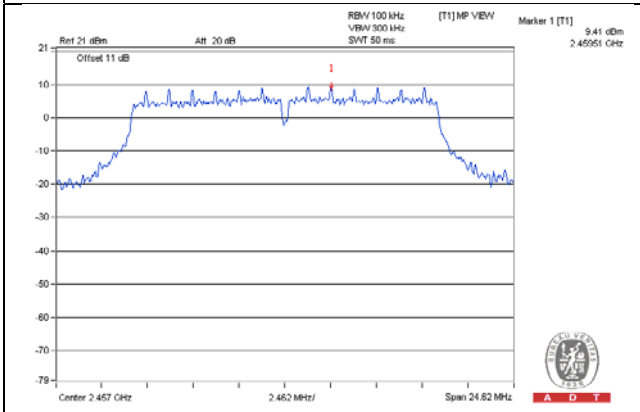

CH 11

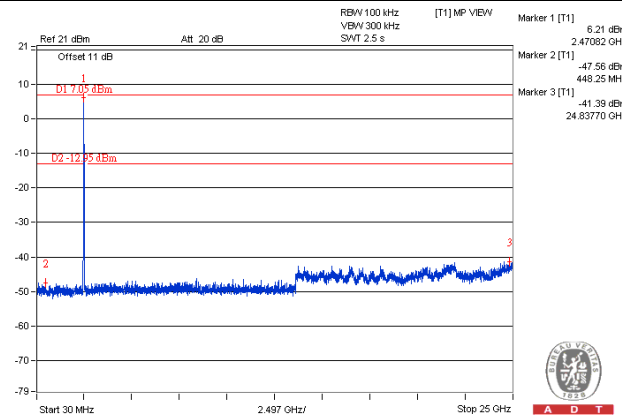
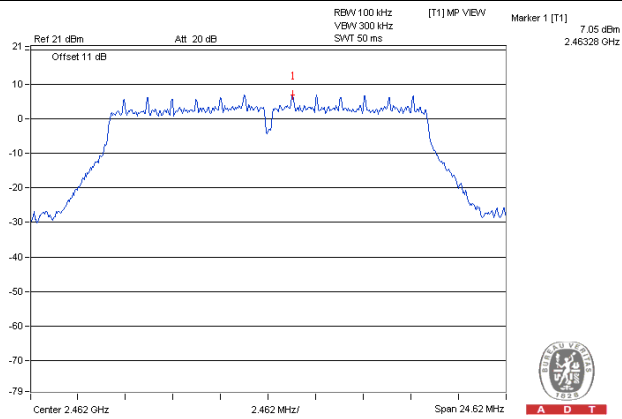

CH 1 Band edge

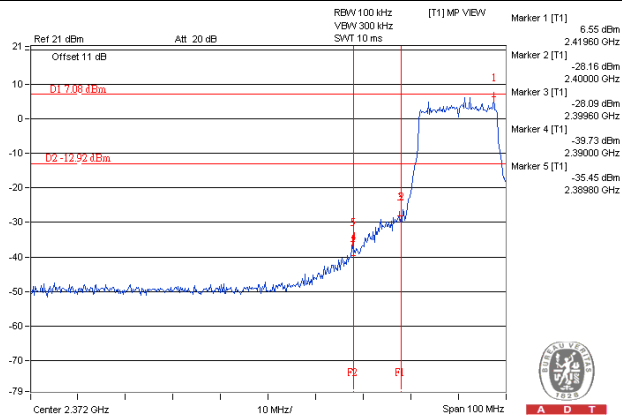

CH 2 Band edge

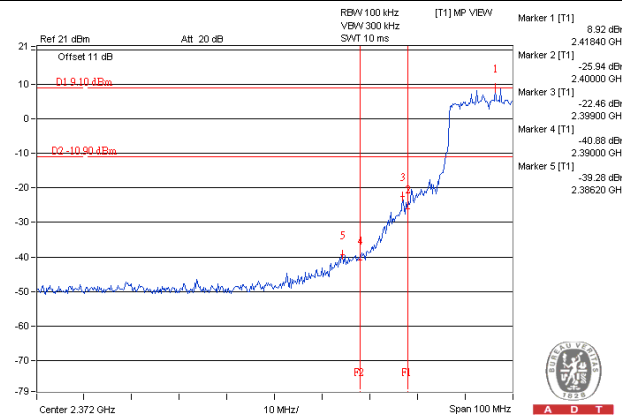

CH 11 Band edge

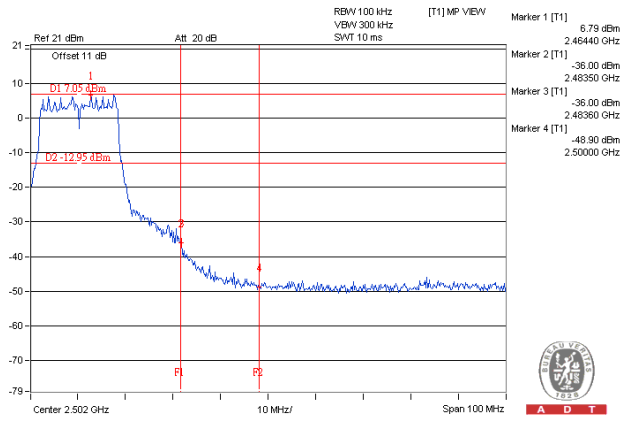

802.11n (HT20)

Chain 0

CH 1

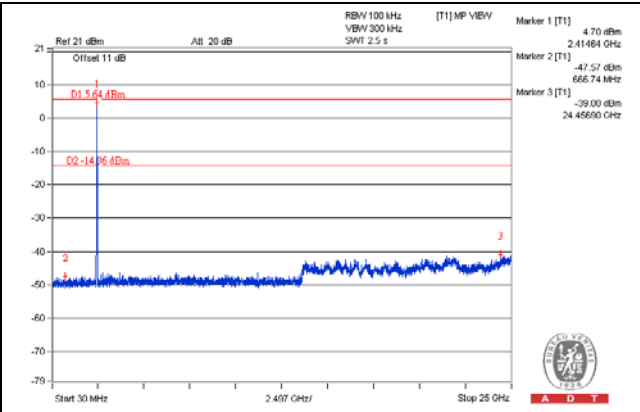
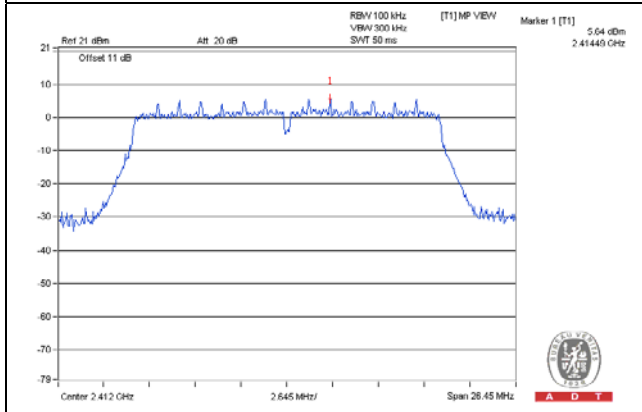

CH 2

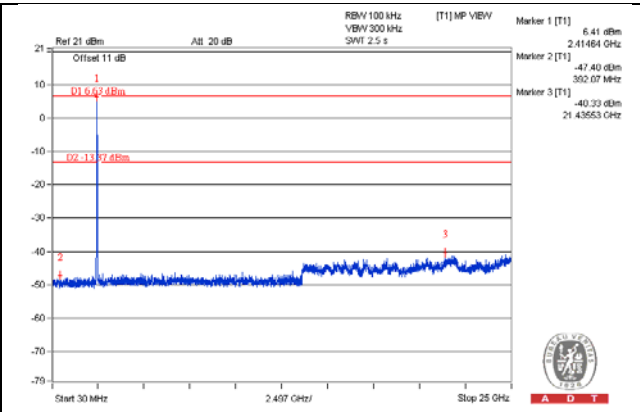
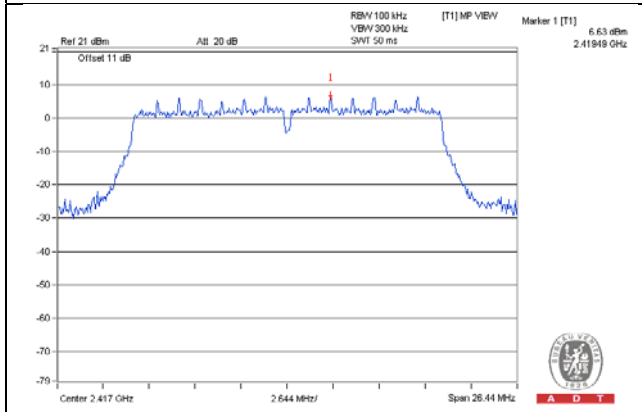

CH 6

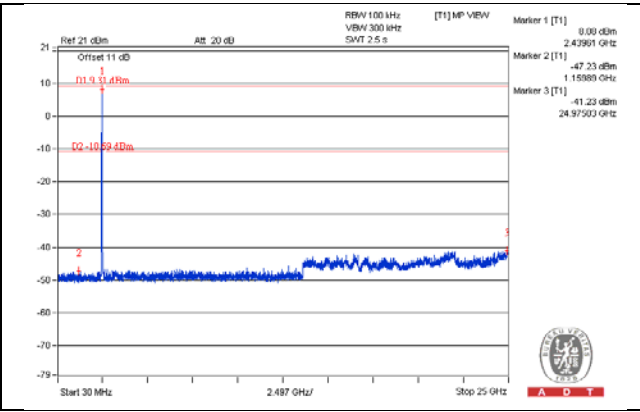
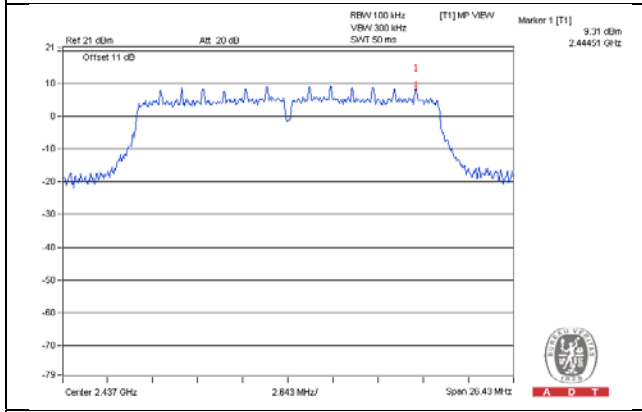

CH 10

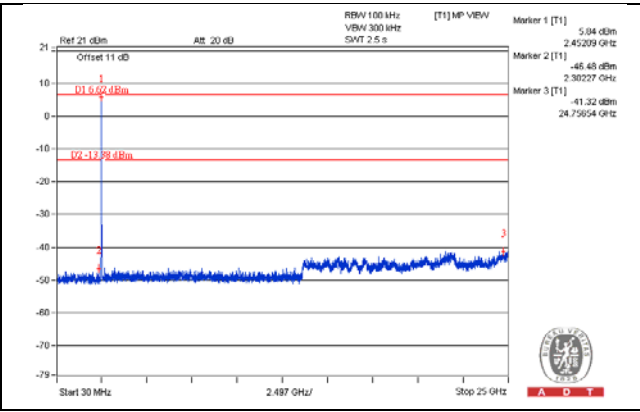
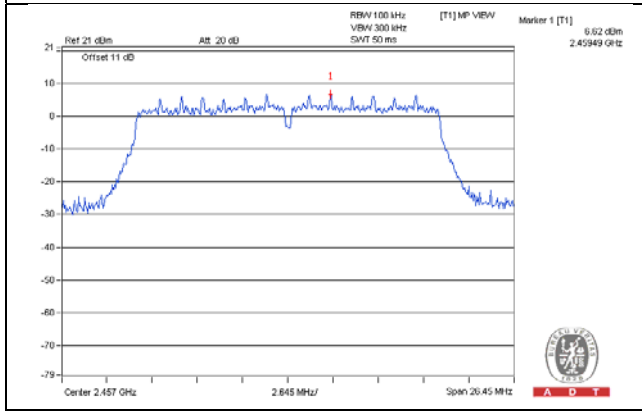

CH 11

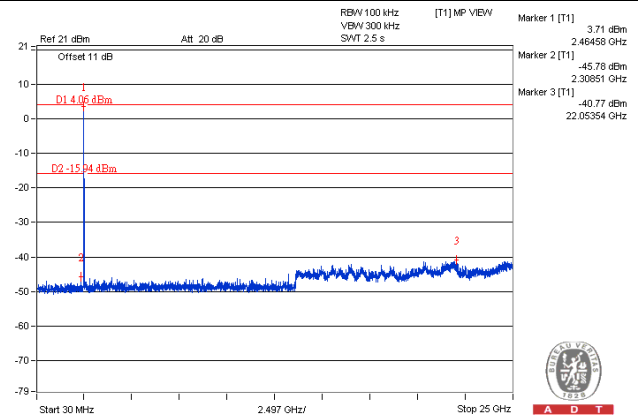
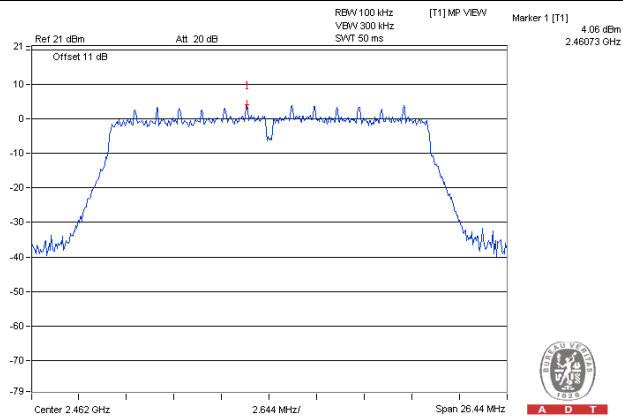

CH 1 Band edge

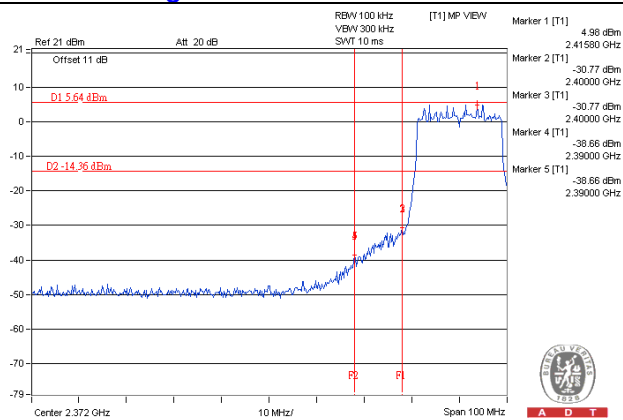

CH 2 Band edge

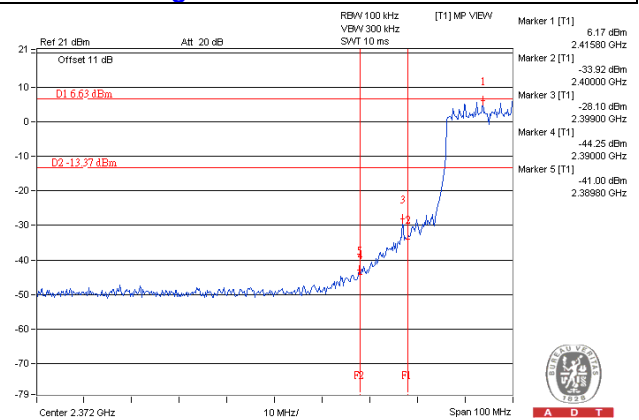

CH 11 Band edge

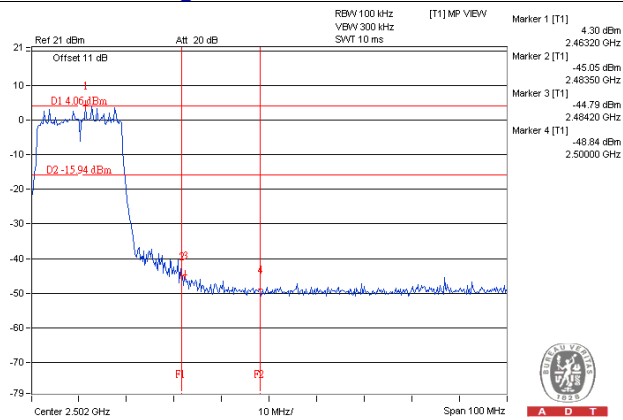

Chain 1 CH 1

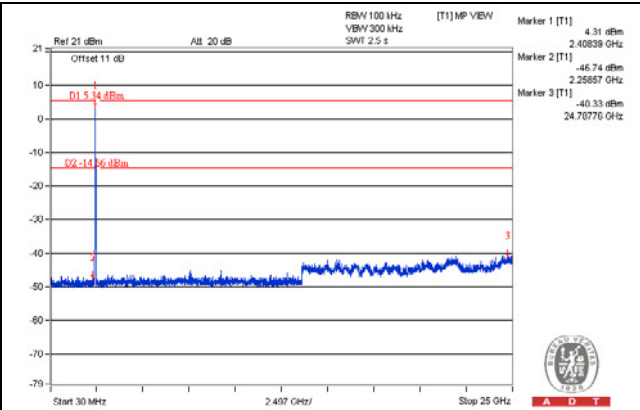
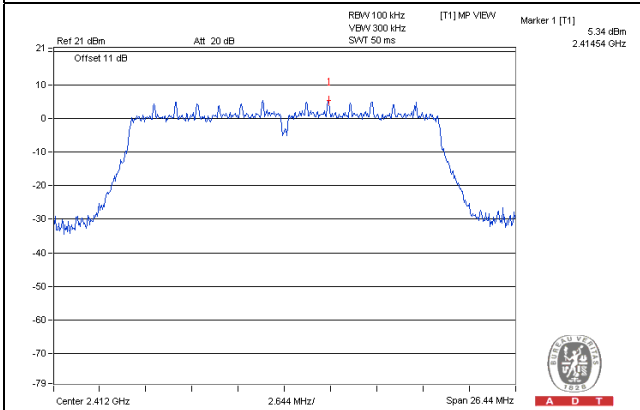

CH 2

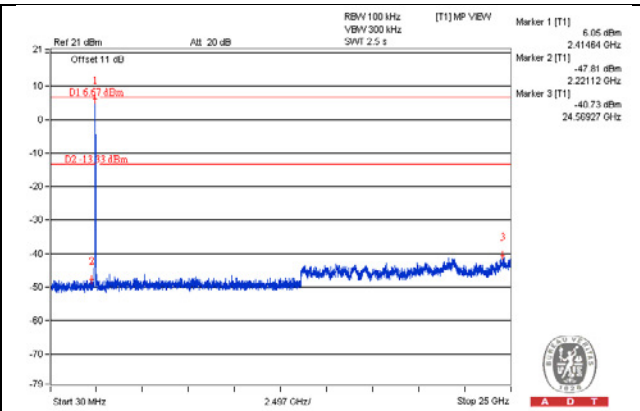
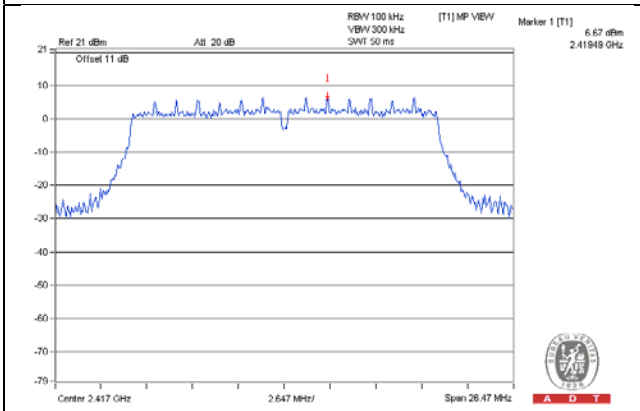

CH 6

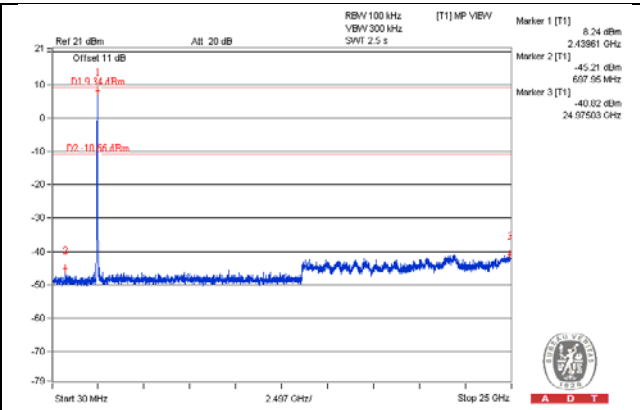
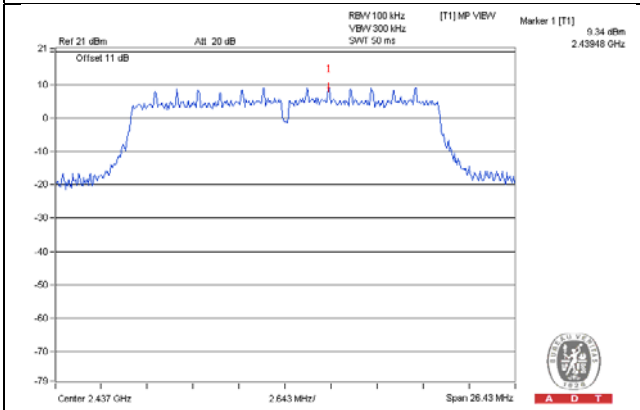

CH 10

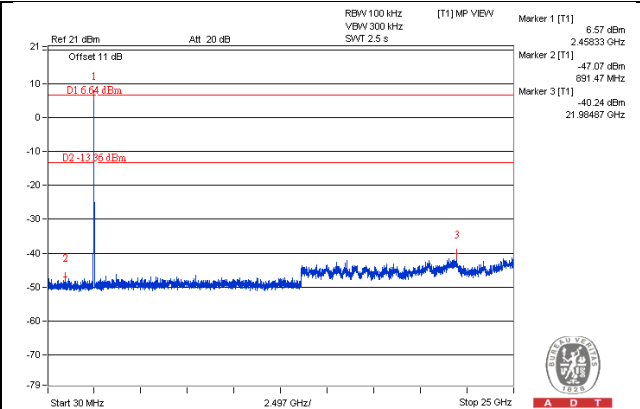
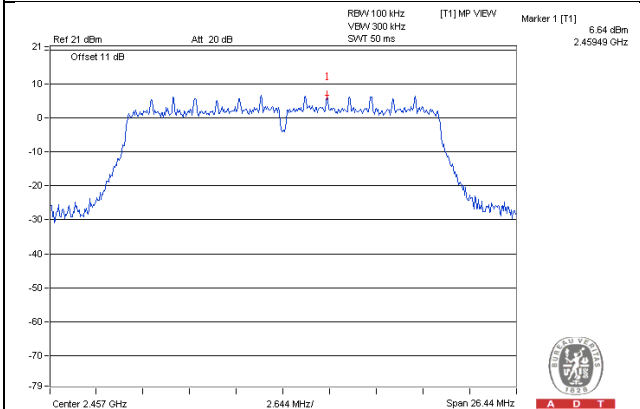

CH 11

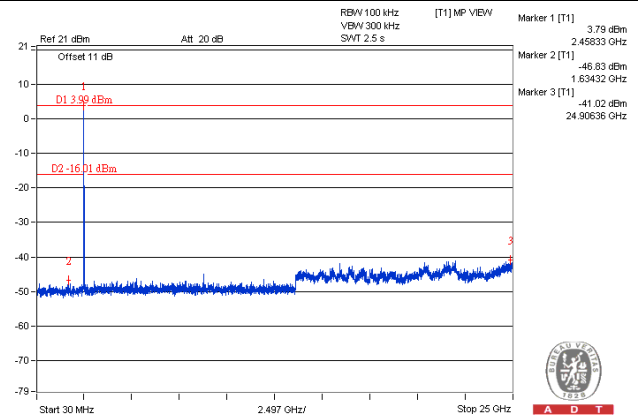
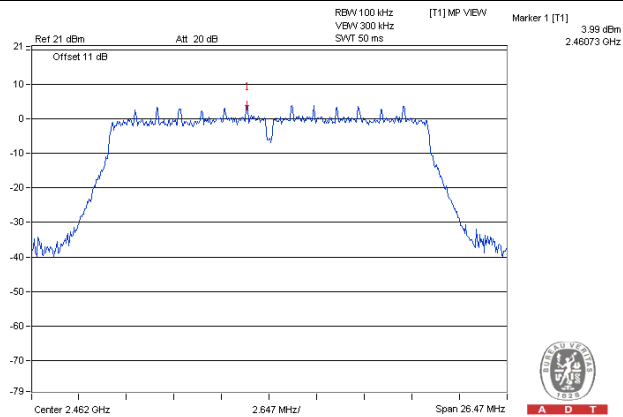

CH 1 Band edge

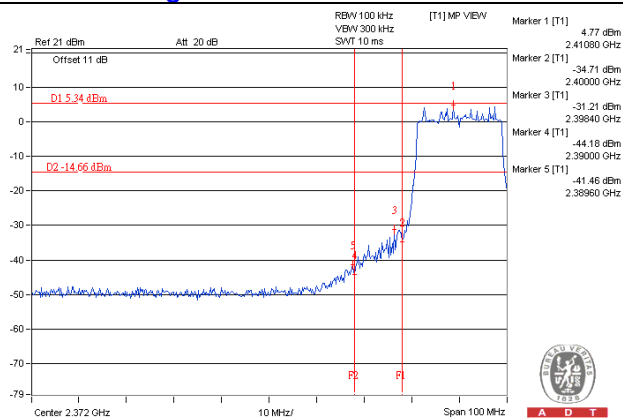

CH 2 Band edge

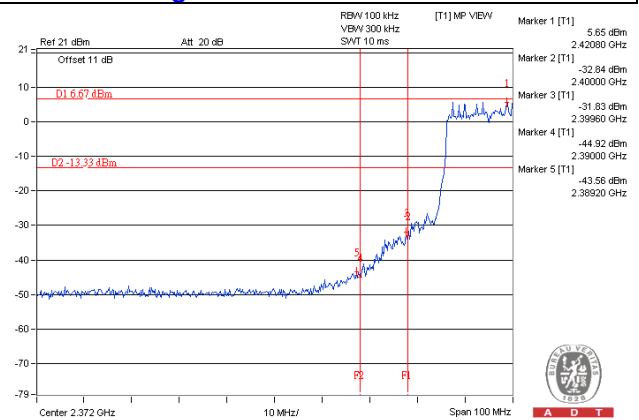

CH 11 Band edge

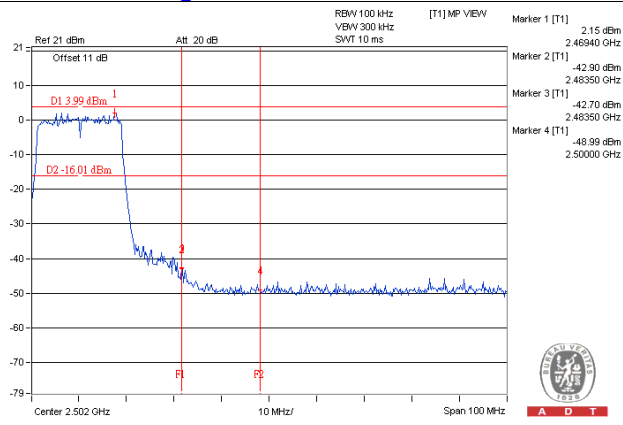

802.11n (HT40)

Chain 0

CH 3

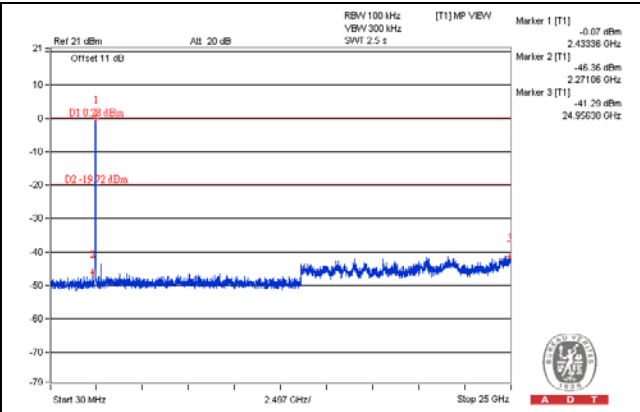
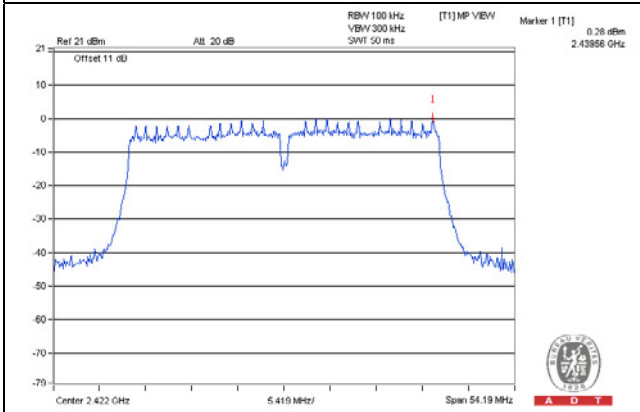

CH 4

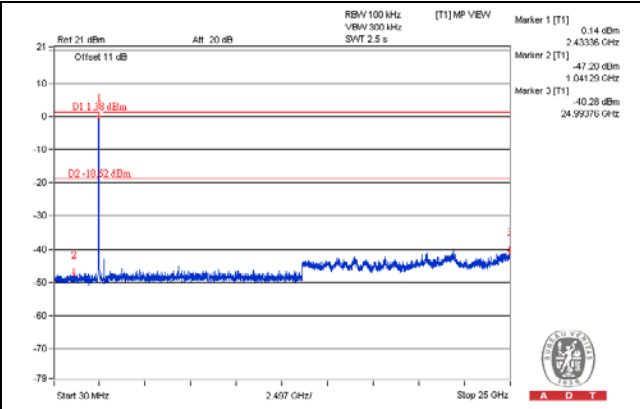
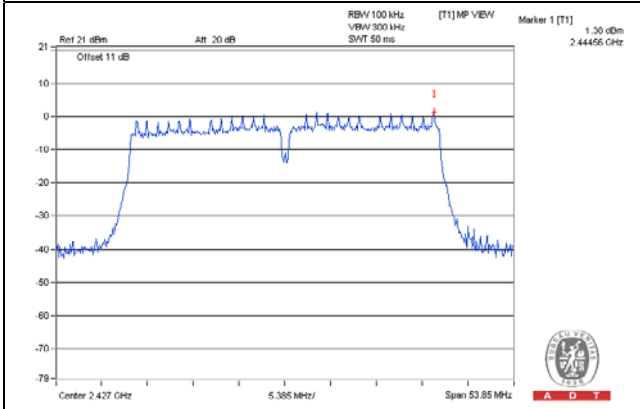

CH 6

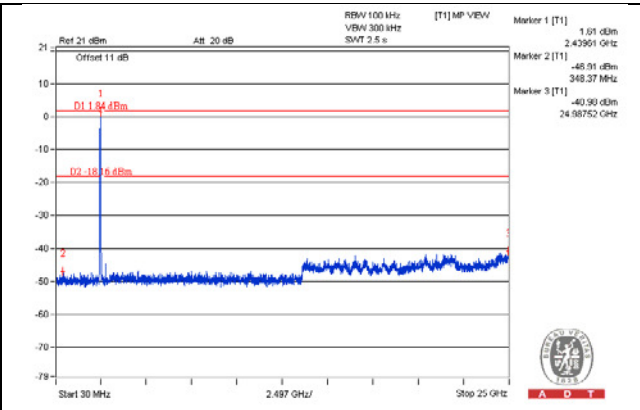
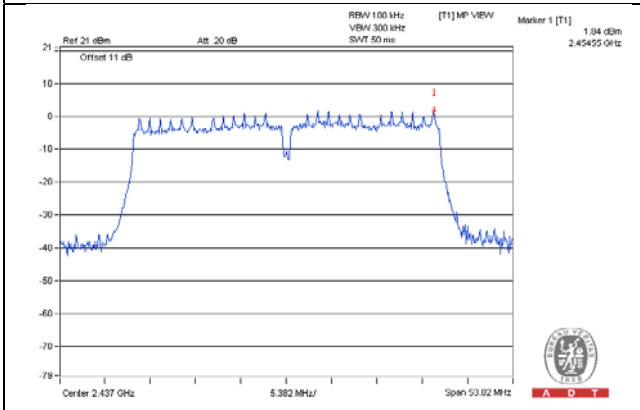

CH 8

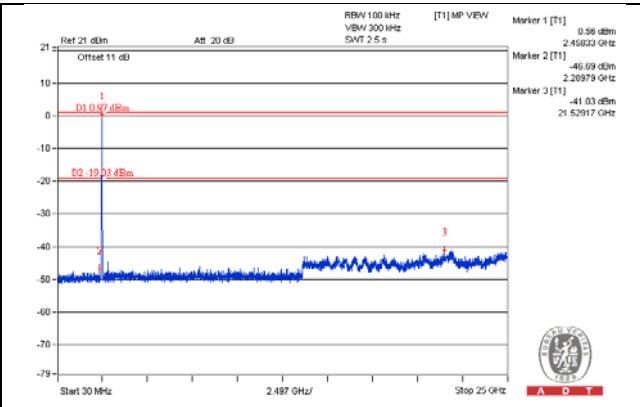
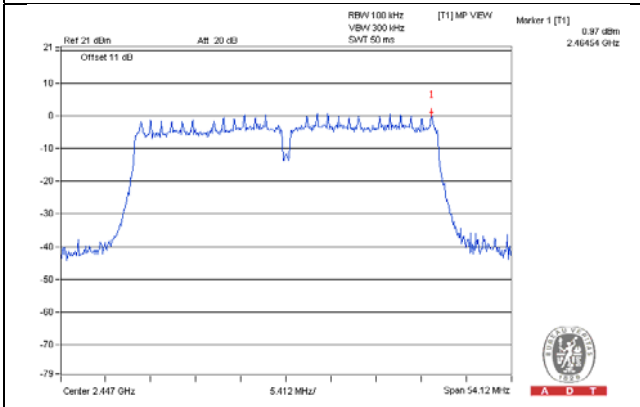

CH 9

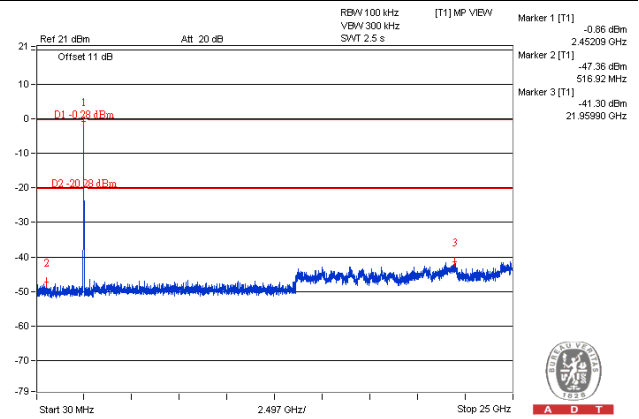
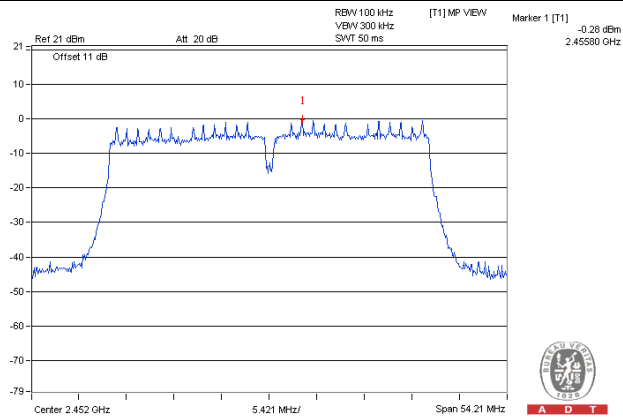

CH 3 Band edge

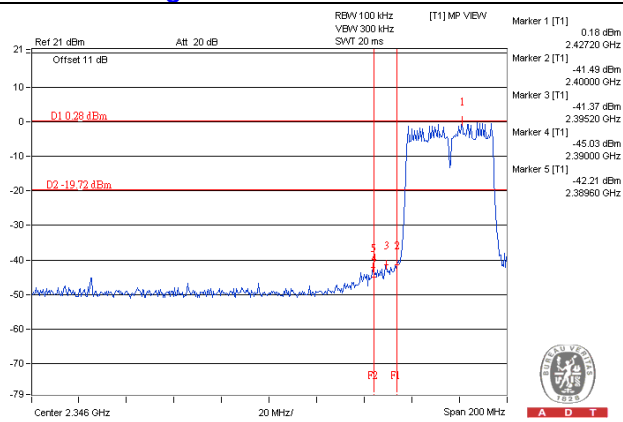

CH 4 Band edge

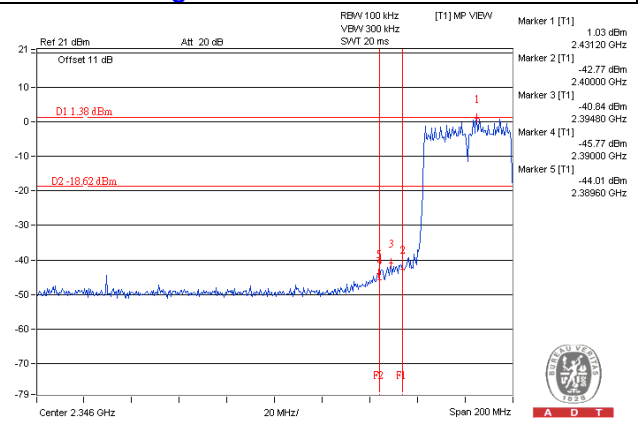

CH 9 Band edge

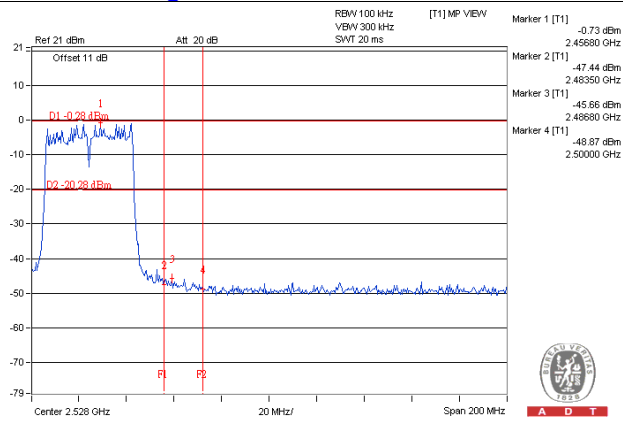

Chain 1 CH 3

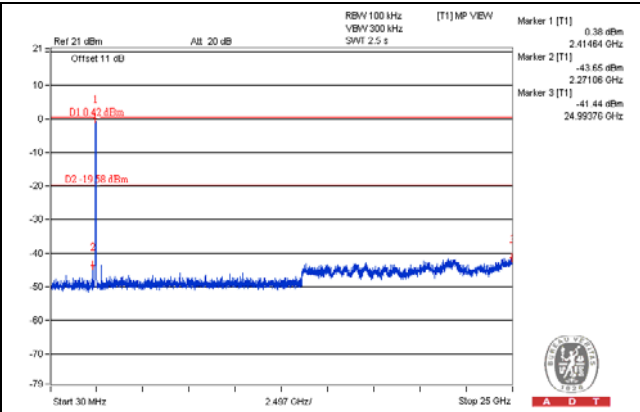
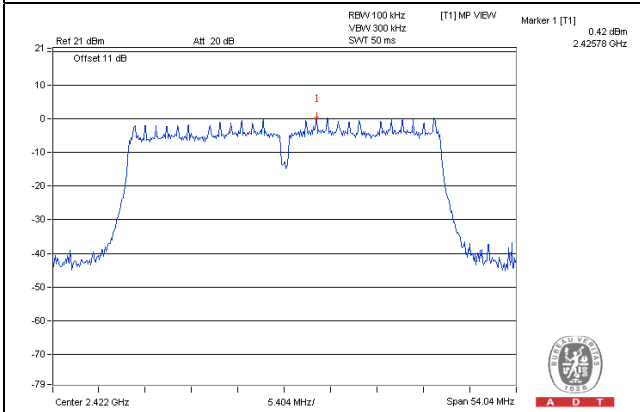

CH 4

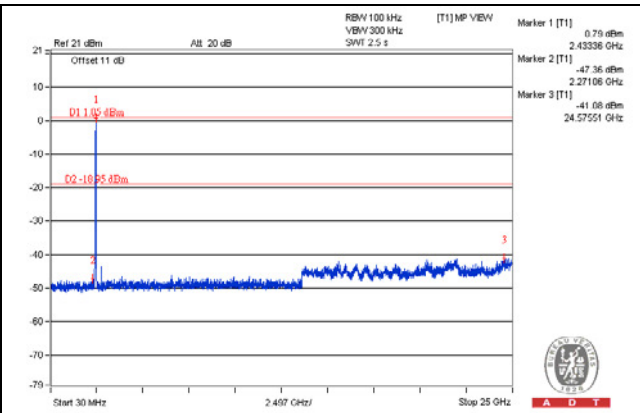
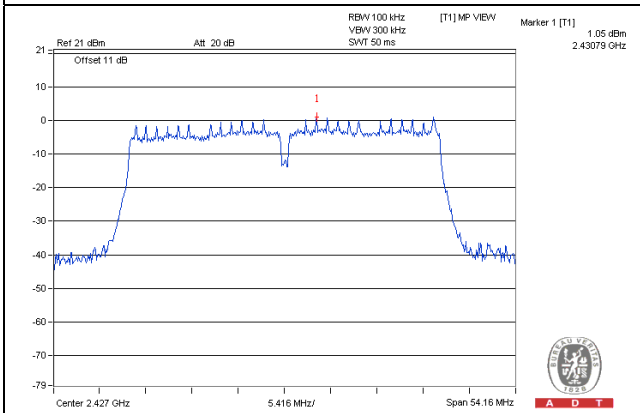

CH 6

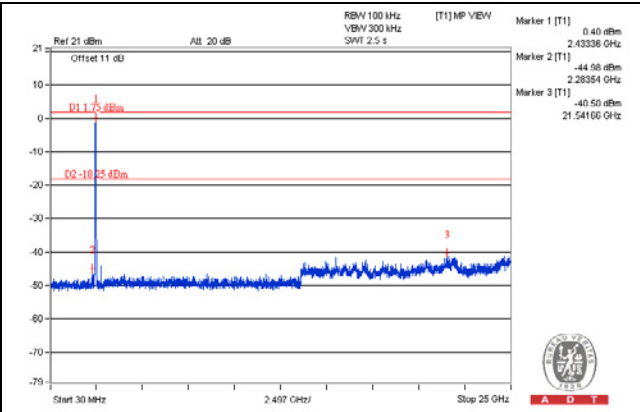
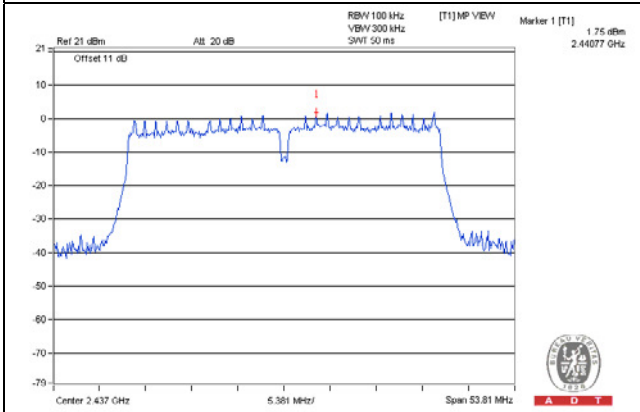

CH 8

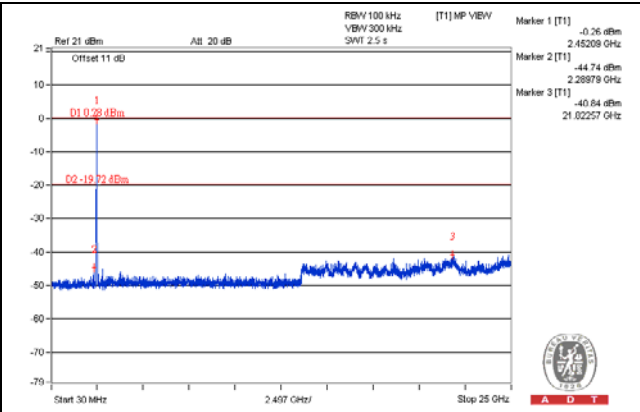
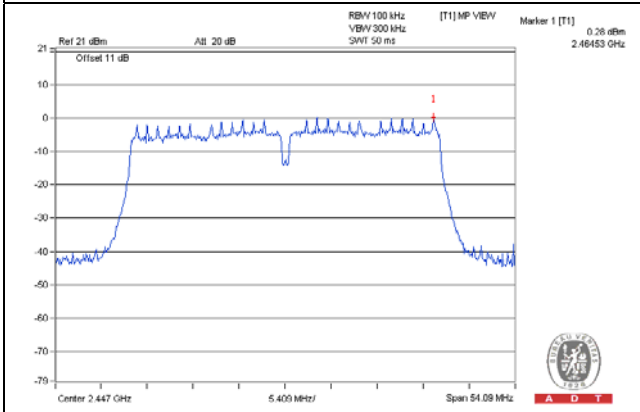

CH 9

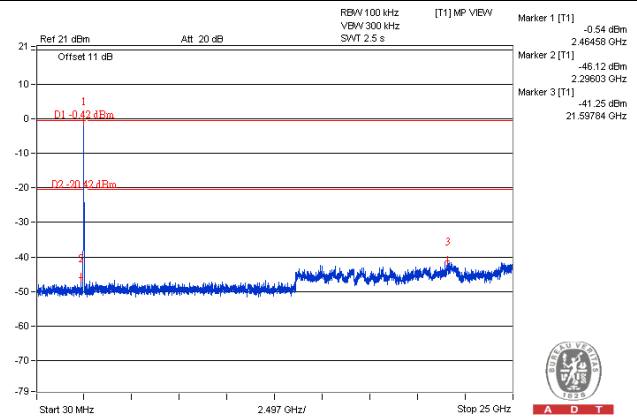
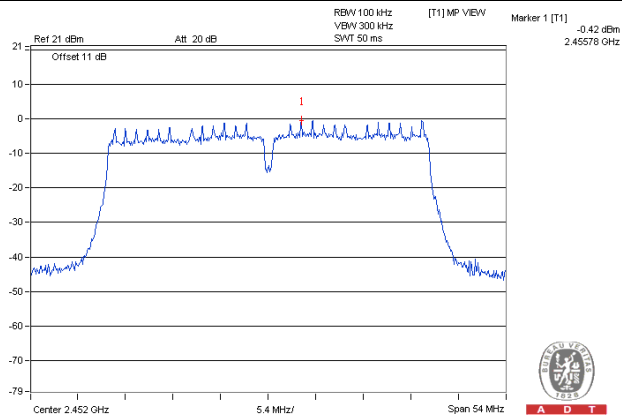

CH 3 Band edge

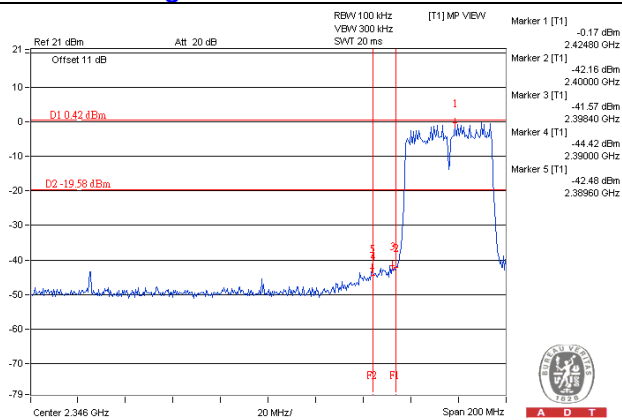

CH 4 Band edge

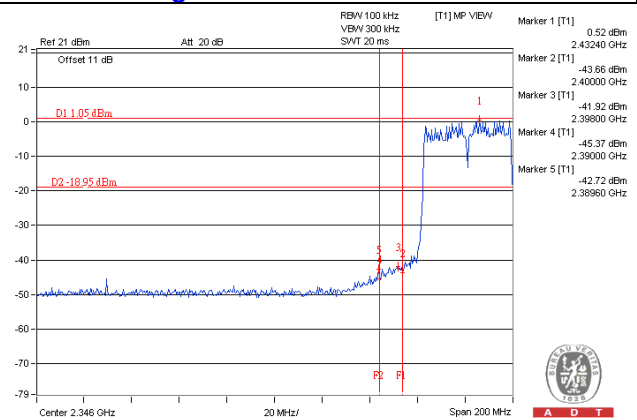

CH 9 Band edge

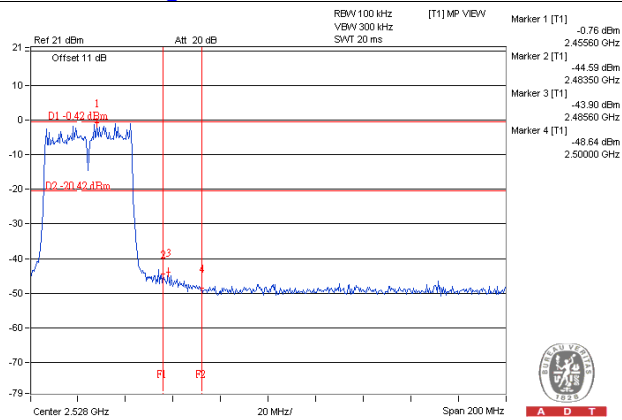

5 Pictures of Test Arrangements

Please refer to the attached file (Test Setup Photo).



Appendix – Information on the Testing Laboratories

We, Bureau Veritas Consumer Products Services (H.K.) Ltd., Taoyuan Branch, were founded in 1988 to provide our best service in EMC, Radio, Telecom and Safety consultation. Our laboratories are accredited and approved according to ISO/IEC 17025.

If you have any comments, please feel free to contact us at the following:

Linko EMC/RF Lab

Tel: 886-2-26052180

Fax: 886-2-26051924

Hsin Chu EMC/RF/Telecom Lab

Tel: 886-3-6668565

Fax: 886-3-6668323

Hwa Ya EMC/RF/Safety Lab

Tel: 886-3-3183232

Fax: 886-3-3270892

Email: service.adt@tw.bureauveritas.com

Web Site: www.bureauveritas-adt.com

The address and road map of all our labs can be found in our web site also.

--- END ---