

Supplementary FCC Test Report

Report No.: RF120720E09K-1

FCC ID: UZ7VC70N0

Test Model: VC70N0

Received Date: Apr. 24, 2015

Test Date: May 14 to June 15, 2015

Issued Date: June 24, 2015

Applicant: Zebra Technologies Corporation

Address: 1 Zebra Plaza, Holtsville, NY 1174

Manufacturer: Zebra Technologies Corporation

Address: 1 Zebra Plaza, Holtsville, NY 11742

Issued By: Bureau Veritas Consumer Products Services (H.K.) Ltd., Taoyuan Branch
Hsin Chu Laboratory

Lab Address: No. 81-1, Lu Liao Keng, 9th Ling, Wu Lung Tsuen, Chiung Lin Hsiang, Hsin
Chu Hsien 307, Taiwan R.O.C.

Test Location (1): No. 81-1, Lu Liao Keng, 9th Ling, Wu Lung Tsuen, Chiung Lin Hsiang, Hsin
Chu Hsien 307, Taiwan R.O.C.

Test Location (2): No. 49, Ln. 206, Wende Rd., Shangshan Tsuen, Chiung Lin Hsiang, Hsin
Chu Hsien 307, Taiwan R.O.C.



This report is for your exclusive use. Any copying or replication of this report to or for any other person or entity, or use of our name or trademark, is permitted only with our prior written permission. This report sets forth our findings solely with respect to the test samples identified herein. The results set forth in this report are not indicative or representative of the quality or characteristics of the lot from which a test sample was taken or any similar or identical product unless specifically and expressly noted. Our report includes all of the tests requested by you and the results thereof based upon the information that you provided to us. You have 60 days from date of issuance of this report to notify us of any material error or omission caused by our negligence, provided, however, that such notice shall be in writing and shall specifically address the issue you wish to raise. A failure to raise such issue within the prescribed time shall constitute your unqualified acceptance of the completeness of this report, the tests conducted and the correctness of the report contents. Unless specific mention, the uncertainty of measurement has been explicitly taken into account to declare the compliance or non-compliance to the specification. The report must not be used by the client to claim product certification, approval, or endorsement by TAF or any government agencies.

Table of Contents

Report Issue History Record of EUT (VC70N0)	4
Release Control Record	4
1 Certificate of Conformity	5
2 Summary of Test Results	6
2.1 Measurement Uncertainty	7
2.2 Modification Record	7
3 General Information	8
3.1 General Description of EUT	8
3.2 Description of Test Modes	11
3.2.1 Test Mode Applicability and Tested Channel Detail	12
3.3 Duty Cycle of Test Signal	14
3.4 Description of Support Units	15
3.4.1 Configuration of System under Test	16
3.5 General Description of Applied Standards	17
4 Test Types and Results	18
4.1 Radiated Emission and Bandedge Measurement	18
4.1.1 Limits of Radiated Emission and Bandedge Measurement	18
4.1.2 Test Instruments	19
4.1.3 Test Procedures	20
4.1.4 Deviation from Test Standard	20
4.1.5 Test Setup	21
4.1.6 EUT Operating Conditions	21
4.1.7 Test Results	22
4.2 Transmit Power Measurement	46
4.2.1 Limits of Transmit Power Measurement	46
4.2.2 Test Setup	46
4.2.3 Test Instruments	46
4.2.4 Test Procedures	46
4.2.5 Deviation from Test Standard	46
4.2.6 EUT Operating Conditions	46
4.2.7 Test Result	47
4.3 Peak Power Spectral Density Measurement	49
4.3.1 Limits of Peak Power Spectral Density Measurement	49
4.3.2 Test Setup	49
4.3.3 Test Instruments	49
4.3.4 Test Procedures	49
4.3.5 Deviation from Test Standard	50
4.3.6 EUT Operating Conditions	50
4.3.7 Test Results	51
4.4 Frequency Stability Measurement	53
4.4.1 Limits of Frequency Stability Measurement	53
4.4.2 Test Setup	53
4.4.3 Test Instruments	53
4.4.4 Test Procedures	53
4.4.5 Deviation from Test Standard	53
4.4.6 EUT Operating Conditions	53
4.4.7 Test Results	54
4.5 6dB Bandwidth Measurement	55
4.5.1 Limits of 6dB Bandwidth Measurement	55
4.5.2 Test Setup	55
4.5.3 Test Instruments	55
4.5.4 Test Procedures	55



4.5.5 Deviation from Test Standard 55

4.5.6 EUT Operating Conditions..... 55

4.5.7 Test Results 56

5 Pictures of Test Arrangements..... 57

Appendix – Information on the Testing Laboratories 58



Report Issue History Record of EUT (VC70N0)

Attachment No.	Issue Date	Description
120720E09D	Sep. 11, 2013	Original
120720E09K	June 24, 2015	Upgraded the versions of the standard to section 15.407 under new rule.

Release Control Record

Issue No.	Description	Date Issued
RF120720E09K-1	Original release.	June 24, 2015

2 Summary of Test Results

47 CFR FCC Part 15, Subpart E (SECTION 15.407 Under New Rule)			
FCC Clause	Test Item	Result	Remarks
15.407(b) (1/2/3/4/6)	Radiated Emissions & Band Edge Measurement	PASS	Meet the requirement of limit. Minimum passing margin is -1.0dB at 5150.00MHz & 5725.00MHz & 5860.00MHz.
15.407(a)(1/2 /3)	Max Average Transmit Power	PASS	Meet the requirement of limit.
15.407(a)(1/2 /3)	Peak Power Spectral Density	PASS	Meet the requirement of limit.
15.407(e)	6dB bandwidth	PASS	Meet the requirement of limit. (U-NII-3 Band only)
15.407(g)	Frequency Stability	PASS	Meet the requirement of limit.
15.203	Antenna Requirement	PASS	Antenna connector is Hirose U.FL not a standard connector.

- NOTE:**
1. For WLAN: The EUT was operating in 2400~2483.5MHz, 5.15~5.35GHz, 5.47~5.6GHz & 5.65~5.725GHz and 5.725~5.850GHz frequencies band. This report was recorded the RF parameters including 5.15~5.25GHz & 5.725~5.850GHz.
 2. The DFS report was recorded in another test report.
 3. This report is prepared for FCC Class II change. (Upgrade the versions of the standard to section 15.407 under new rule).

2.1 Measurement Uncertainty

Where relevant, the following measurement uncertainty levels have been estimated for tests performed on the EUT as specified in CISPR 16-4-2:

Measurement	Frequency	Expanded Uncertainty (k=2) (\pm)
Radiated Emissions up to 1 GHz	30MHz ~ 1GHz	5.37 dB
	1GHz ~6GHz	3.65 dB
Radiated Emissions above 1 GHz	6GHz ~ 18GHz	3.88 dB
	18GHz ~ 40GHz	4.11 dB

2.2 Modification Record

There were no modifications required for compliance.

3 General Information

3.1 General Description of EUT

Product	Vehicle Computer
Brand	Zebra
Test Model	VC70N0
Status of EUT	MASS-PRODUCTION
Power Supply Rating	DC 12V from power supply
Modulation Type	CCK, DQPSK, DBPSK for DSSS 64QAM, 16QAM, QPSK, BPSK for OFDM
Modulation Technology	DSSS, OFDM
Transfer Rate	802.11b: up to 11Mbps 802.11g / a: up to 54Mbps 802.11n (HT20): up to 72.2Mbps
Operating Frequency	For 15.407 5.18 ~ 5.24GHz, 5.26 ~ 5.32GHz, 5.5~5.7GHz, 5.745~5.825GHz For 15.247 2.412 ~ 2.472GHz
Number of Channel	For 15.407 24 for 802.11a, 802.11n (HT20) For 15.247 13 for 802.11b, 802.11g, 802.11n (HT20)
Output Power	802.11a: 73.282 mW 802.11n (HT20): 68.391 mW
Antenna Type	Please see next page
Antenna Connector	Please see next page
Accessory Device	Battery x 1 (Part No.: 82-161178-01)
Data Cable Supplied	NA

Note:

- This report is prepared for FCC Class II change. The difference compared with the Report No.: RF 120720E09D-1 design is as the following:
 - ◆ Upgraded the versions of the standard to section 15.407 under new rule.
- According to above conditions, all test items of U-NII band 1 and U-NII band 3 and Dynamic Frequency Selection test item need to be performed (except for Conducted Emission test item). And all data was verified to meet the requirements.
- For WLAN: 2.4GHz and 5GHz technology cannot transmit at same time.

4. The antennas provided to the EUT, please refer to the following table:

No.	Brand	Model	ANT Type	Connector Type (External only)	Freq. Range (MHz to MHz)	Gain (dBi) (Including cable loss)	Cable Loss (dB)	Cable Length
1	Aristotle	RFA-02-G78-1	PIFA	N/A	2400-2500	1.7 (for BT)	0.783	27cm
2	Aristotle	RFA-02-G78-1	PIFA	N/A	2400-2500	1.1 (for Main WLAN)	0.58	20cm
3	Aristotle	RFA-02-G78-1	PIFA	N/A	4900-5850	4.7 (for Main WLAN)	0.96 ~ 1.06	20cm
4	Aristotle	RFA-02-G78-1	PIFA	N/A	2400-2500	-0.5 (for Aux WLAN)	0.783	27cm
5	Aristotle	RFA-02-G78-1	PIFA	N/A	4900-5850	4.3 (for Aux WLAN)	1.296 ~ 1.431	27cm
6	PCTEL	GPSDBHF	Shark-shape	RRSMA	2400-2500	1.18 (for External WLAN)	2.28	12ft
7	PCTEL	GPSDBHF	Shark-shape	RRSMA	4900-5850	0.24 (for External WLAN)	3.36 ~ 3.84	12ft
8	CENTURION	WTS2450-RPSMA	Dipole (for External WLAN)	Reverse Polarity SMA-Male	2400-2500	2.1	NA	NA
					5150-5350	2.6		
					5470-5725	3.4		
					5725-5850	3.4		

5. The associated devices(optional) of EUT information are as below:

Accessory	Model	Part No.	Description	Connector
Wired Scanner 1	LS 3408	LS 3408-ER20105R	LS 3408 serial/USB laser scanner	USB
Wired Scanner 2	DS3508	DS3508-ER20005R	DS3508 USB scanner	USB
Wired Scanner 3	DS457	DS457-SR20009	DS457 USB scanner	USB
Wireless Scanner 1	RS507	RS507-IM20000CTWR	RS507 BT Hands Free Imager (FCC ID: UZ7RS507)	NA (BT wireless connection)
Wireless Scanner 2	LS3578	LS3578-ER20005WR	LS3578 BT scanner (FCC ID: H9PLMX5452)	NA (BT wireless connection)
Wireless Scanner 3	DS3578	DS3578-ER2F005WR	DS3578 BT scanner (FCC ID: H9PDS3578)	NA (BT wireless connection)
External Speaker	HSN4040A	HSN4040A	Motorola HSN4040A 13 Watt water-resistant loudspeaker	special speaker connector
PTT mic	HMN1089B	HMN1089B	Motorola HMN1089B Water-resistant Palm Microphone or equivalent	special MIC connector
Keyboard 1	KYBD-QW-VC70-01R	59-160663-01	VC70_QWERTY keyboard	USB
Keyboard 2	KYBD-NU-VC70-01R	59-160661-01	VC70_21 keys_Functional/Numeri c keyboard	USB
Keyboard 3	VC5090KYBD-00R	VC5090KYBD-02R	VC50_QWERTY keyboard	USB
Printer 1	RW420	R4D-0UBA000N-00	RW420 / Zebra, Printer.	RS232
Printer 2	MF2TE	200380-100	Microflash Series MF 2T, O'Neil, Easy Print	NA (BT wireless connection)
Power Supply 1	AA27410L	PWRS-9-60VDC-01R	Input Voltage: 9-60Vdc; Output Voltage: 12Vdc	DC input connector
Power Supply 2	50-14000-241R	PWRS-14000-241R	Input Voltage: 110-240Vac; Output Voltage: 12Vdc	DC input connector

Wired Scanner 1, Wireless Scanner 1 and Printer 1 were chosen for final test.

6. The EUT has two variants, which are identical to each other in all aspects except for the following table:

Sample	Brand	Model	Difference
1	MOTOROLA / Zebra	VC70N0	Heater
2	MOTOROLA / Zebra	VC70N0	Non-heater

From the above samples, test **sample 1** was selected as representative model for the test and its data was recorded in this report.

7. The Version of EUT information are as below:

OS Version	7.00.2806
OEM Name	Motorola VC70N0
OEM Version	0.34.0005
Wireless(Fusion) Version	X_2.01.0.0.049R
Wireless(Fusion) Firmwave	_2.01.0.0.130
XW2DMT Version	X_2.01.0.0.3
Motorola version	X_2.01.0.0.118

8. The EUT could be supplied from a battery, the information are listed as below:

Brand:	Palladium
Part No.:	82-161178-01
Rating:	3.7V, 1880mAh

9. The EUT incorporates a SISO function. Both, main and diversity (aux.) antennas path can transmit but only one can transmit at given time while the other is RX only.

MODULATION MODE	DATA RATE (MCS)	TX & RX CONFIGURATION	
802.11b	1 ~ 11Mbps	1TX (Diversity)	1RX
802.11g	6 ~ 54Mbps	1TX (Diversity)	1RX
802.11a	6 ~ 54Mbps	1TX (Diversity)	1RX
802.11n (HT20)	MCS 0~7	1TX (Diversity)	1RX

10. The above EUT information is declared by manufacturer and for more detailed features description, please refer to the manufacturer's specifications or user's manual.

3.2 Description of Test Modes

FOR 5180 ~ 5240MHz

4 channels are provided for 802.11a, 802.11n (HT20):

Channel	Frequency	Channel	Frequency
36	5180 MHz	44	5220 MHz
40	5200 MHz	48	5240 MHz

FOR 5745 ~ 5825MHz

5 channels are provided for 802.11a, 802.11n (HT20):

Channel	Frequency	Channel	Frequency
149	5745MHz	161	5805MHz
153	5765MHz	165	5825MHz
157	5785MHz		

3.2.1 Test Mode Applicability and Tested Channel Detail

EUT CONFIGURE MODE	APPLICABLE TO			DESCRIPTION
	RE \geq 1G	RE<1G	APCM	
-	√	√	√	-

Where **RE \geq 1G**: Radiated Emission above 1GHz **RE<1G**: Radiated Emission below 1GHz
APCM: Antenna Port Conducted Measurement

NOTE:

1. The test mode was reference to the worst case in the original test report.

Radiated Emission Test (Above 1GHz):

- Pre-Scan has been conducted to determine the worst-case mode from all possible combinations between available modulations, data rates and antenna ports (if EUT with antenna diversity architecture).
- Following channel(s) was (were) selected for the final test as listed below.

MODE	FREQ. BAND (MHz)	AVAILABLE CHANNEL	TESTED CHANNEL	MODULATION TECHNOLOGY	MODULATION TYPE	DATA RATE (Mbps)
802.11a	5180-5240	36 to 48	36, 40, 48	OFDM	BPSK	6
802.11n (HT20)		36 to 48	36, 40, 48	OFDM	BPSK	6.5
802.11a	5745-5825	149 to 165	149, 157, 165	OFDM	BPSK	6
802.11n (HT20)		149 to 165	149, 157, 165	OFDM	BPSK	6.5

Radiated Emission Test (Below 1GHz):

- Pre-Scan has been conducted to determine the worst-case mode from all possible combinations between available modulations, data rates and antenna ports (if EUT with antenna diversity architecture).
- Following channel(s) was (were) selected for the final test as listed below.

MODE	FREQ. BAND (MHz)	AVAILABLE CHANNEL	TESTED CHANNEL	MODULATION TECHNOLOGY	MODULATION TYPE	DATA RATE (Mbps)
802.11a	5180-5240	36 to 48	36, 40, 48	OFDM	BPSK	6
802.11n (HT20)		36 to 48	36, 40, 48	OFDM	BPSK	6.5
802.11a	5745-5825	149 to 165	149, 157, 165	OFDM	BPSK	6
802.11n (HT20)		149 to 165	149, 157, 165	OFDM	BPSK	6.5

Antenna Port Conducted Measurement:

- This item includes all test value of each mode, but only includes spectrum plot of worst value of each mode.
- Pre-Scan has been conducted to determine the worst-case mode from all possible combinations between available modulations, data rates and antenna ports (if EUT with antenna diversity architecture).
- Following channel(s) was (were) selected for the final test as listed below.

MODE	FREQ. BAND (MHz)	AVAILABLE CHANNEL	TESTED CHANNEL	MODULATION TECHNOLOGY	MODULATION TYPE	DATA RATE (Mbps)
802.11a	5180-5240	36 to 48	36, 40, 48	OFDM	BPSK	6
802.11n (HT20)		36 to 48	36, 40, 48	OFDM	BPSK	6.5
802.11a	5745-5825	149 to 165	149, 157, 165	OFDM	BPSK	6
802.11n (HT20)		149 to 165	149, 157, 165	OFDM	BPSK	6.5

Test Condition:

APPLICABLE TO	ENVIRONMENTAL CONDITIONS	INPUT POWER	TESTED BY
RE\geq1G	23deg. C, 68%RH	120Vac, 60Hz	Tim Ho
RE$<$1G	23deg. C, 68%RH	120Vac, 60Hz	Tim Ho
APCM	25deg. C, 60%RH	120Vac, 60Hz	Anderson Chen

3.3 Duty Cycle of Test Signal

If duty cycle of test signal is $\geq 98\%$, duty factor is not required.

802.11a: Duty cycle = $1.427\text{ ms} / 1.451\text{ ms} = 0.983$

802.11n (HT20): Duty cycle = $1.206\text{ ms} / 1.223\text{ ms} = 0.986$

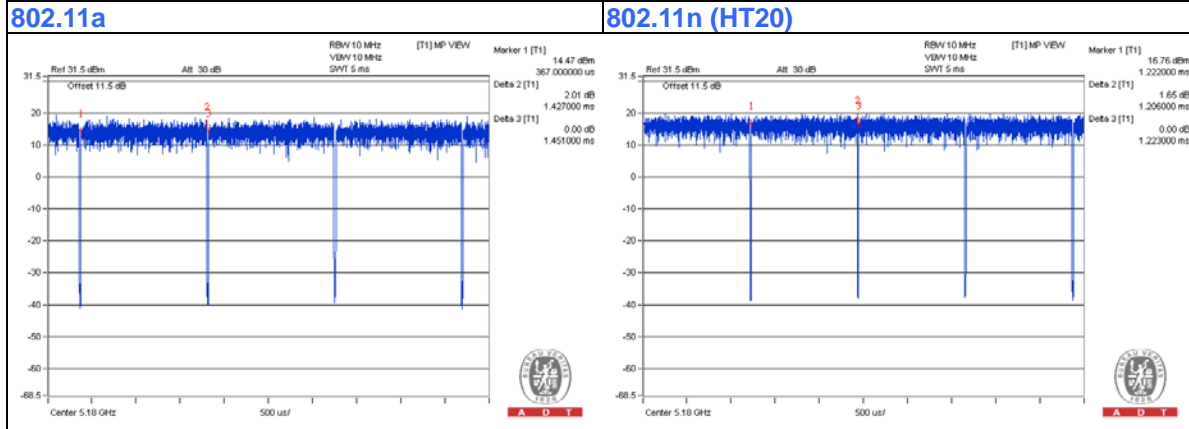

3.4 Description of Support Units

The EUT has been tested as an independent unit together with other necessary accessories or support units. The following support units or accessories were used to form a representative test configuration during the tests.

ID	Product	Brand	Model No.	Serial No.	FCC ID	Remarks
A.	PRINTER	Zebra	RW 420	XXRCJ114801438	NA	Supplied by client
B.	SPEAKER	Motorola	HSN4040A	N/A	NA	Supplied by client
C.	ADAPTER	Motorola	50-14000-241R	G943H402VA03P	NA	Supplied by client
D.	KEYBOARD	Prehkeytec	VC70 QWERTYY	12301-8001167	NA	Supplied by client
E.	PTT MIC	Motorola	HMN1098B	NA	NA	Supplied by client
F.	WIRED SCANNER	LEX	LS3408	1130000502591	NA	Supplied by client
G.	WIRELESS SCANNER	Motorola	RS507	1131900504941	NA	Supplied by client
H.	NOTEBOOK COMPUTER	DELL	E6420	H62T3R1	FCC DoC	Provided by Lab

Note:

1. All power cords of the above support units are non-shielded (1.8m).

ID	Descriptions	Qty.	Length (m)	Shielding (Yes/No)	Cores (Qty.)	Remarks
1.	RS232	1	1.8	No	1	Supplied by client
2.	AUDIO	1	2015	No	0	Supplied by client
3.	USB	1	0.9	No	1	Supplied by client
4.	AUDIO	1	0.65	No	0	Supplied by client
5.	USB	1	1.3	No	0	Supplied by client
6.	UTP	1	10	No	0	Provided by Lab
7.	DC	1	1.8	No	2	Supplied by client
8.	AC	1	1.8	No	0	Provided by Lab

NOTE: All power cords of the above support units are non shielded (1.8m).

3.4.1 Configuration of System under Test

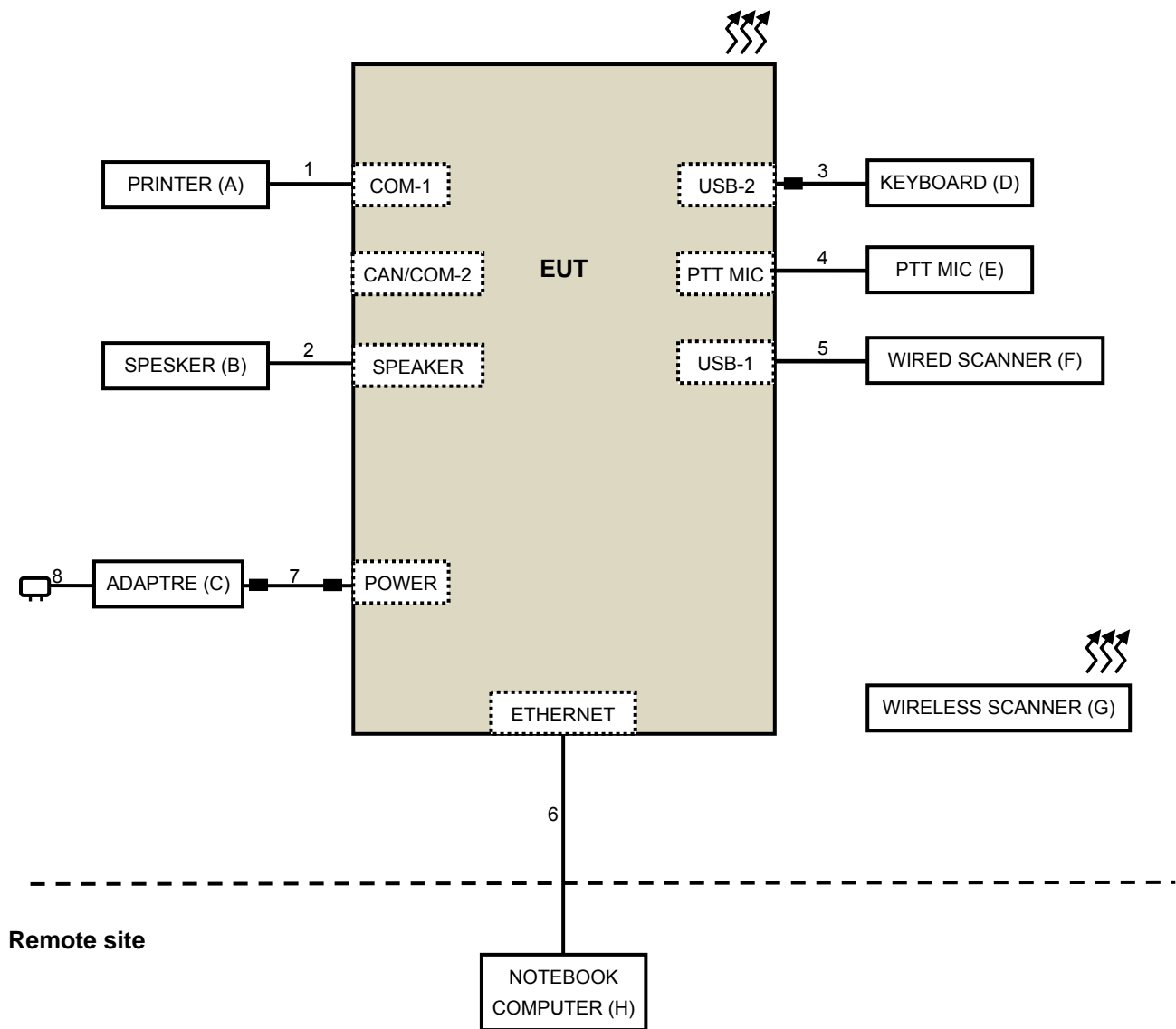

3.5 General Description of Applied Standards

The EUT is a RF Product. According to the specifications of the manufacturer, it must comply with the requirements of the following standards:

FCC Part 15, Subpart E (15.407)

789033 D02 General UNII Test Procedures New Rules v01

ANSI C63.10-2009

All test items have been performed and recorded as per the above standards.

Note: The EUT has been verified to comply with the requirements of FCC Part 15, Subpart B, Class B (DoC). The test report has been issued separately.

4 Test Types and Results

4.1 Radiated Emission and Bandedge Measurement

4.1.1 Limits of Radiated Emission and Bandedge Measurement

Radiated emissions which fall in the restricted bands must comply with the radiated emission limits specified as below table. Other emissions shall be at least 20dB below the highest level of the desired power:

Frequencies (MHz)	Field Strength (microvolts/meter)	Measurement Distance (meters)
0.009 ~ 0.490	2400/F(kHz)	300
0.490 ~ 1.705	24000/F(kHz)	30
1.705 ~ 30.0	30	30
30 ~ 88	100	3
88 ~ 216	150	3
216 ~ 960	200	3
Above 960	500	3

NOTE:

1. The lower limit shall apply at the transition frequencies.
2. Emission level (dBuV/m) = 20 log Emission level (uV/m).
3. For frequencies above 1000MHz, the field strength limits are based on average detector, however, the peak field strength of any emission shall not exceed the maximum permitted average limits, specified above by more than 20dB under any condition of modulation.

LIMITS OF UNWANTED EMISSION OUT OF THE RESTRICTED BANDS

APPLICABLE TO	LIMIT	
789033 D02 General UNII Test Procedures New Rules v01	FIELD STRENGTH AT 3m	
	PK:74 (dBuV/m)	AV:54 (dBuV/m)
APPLICABLE TO	EIRP LIMIT	EQUIVALENT FIELD STRENGTH AT 3m
15.407(b)(1)	PK:-27 (dBm/MHz)	PK:68.2(dBuV/m)
15.407(b)(2)		
15.407(b)(3)		
15.407(b)(4)	PK:-27 (dBm/MHz) ^{*1} PK:-17 (dBm/MHz) ^{*2}	PK: 68.2(dBuV/m) ^{*1} PK:78.2 (dBuV/m) ^{*2}

NOTE: ^{*1} beyond 10MHz of the band edge ^{*2} within 10 MHz of band edge

The following formula is used to convert the equipment isotropic radiated power (eirp) to field strength:

$$E = \frac{1000000\sqrt{30P}}{3} \mu\text{V/m, where P is the eirp (Watts).$$

4.1.2 Test Instruments

DESCRIPTION & MANUFACTURER	MODEL NO.	SERIAL NO.	CALIBRATED DATE	CALIBRATED UNTIL
Test Receiver Agilent	N9038A	MY51210105	July 21, 2014	July 20, 2015
Pre-Amplifier Mini-Circuits	ZFL-1000VH2B	AMP-ZFL-03	Nov. 12, 2014	Nov. 11, 2015
Trilog Broadband Antenna SCHWARZBECK	VULB 9168	9168-360	Feb. 06, 2015	Feb. 05, 2016
RF Cable	8D-FB	CHGCAB-001-1 CHGCAB-001-2	Oct. 04, 2014	Oct. 03, 2015
	RF-141	CHGCAB-004	Oct. 04, 2014	Oct. 03, 2015
Horn_Antenna AISL	AIH.8018	0000320091110	Feb. 09, 2015	Feb. 08, 2016
Pre-Amplifier Agilent	8449B	3008A02578	June 24, 2014	June 23, 2015
RF Cable	NA	131205 131216 131217 SNMY23684/4	Jan. 16, 2015	Jan. 15, 2016
Spectrum Analyzer R&S	FSV40	100964	July 05, 2014	July 04, 2015
Pre-Amplifier SPACEK LABS	SLKKa-48-6	9K16	Dec. 12, 2014	Dec. 11, 2015
Horn_Antenna SCHWARZBECK	BBHA 9170	9170-424	Feb. 05, 2015	Feb. 04, 2016
RF Cable	NA	329751/4 RF104-204	Dec. 11, 2014	Dec. 10, 2015
Software	ADT_Radiated_V8.7.07	NA	NA	NA
Antenna Tower & Turn Table CT	NA	NA	NA	NA
Power Meter Anritsu	ML2495A	1014008	Apr. 28, 2015	Apr. 27, 2016
Power Sensor Anritsu	MA2411B	0917122	Apr. 28, 2015	Apr. 27, 2016
SPECTRUM ANALYZER R&S	FSV 40	100964	July 05, 2014	July 04, 2015
True RMS Multimeter FLUKE	87III	73680266	Nov. 07, 2014	Nov. 06, 2015
Temperature & Humidity Chamber GIANTFORCE	GTH-150-40-SP-AR	MAA0812-008	Jan. 12, 2015	Jan. 11, 2016

Note:

1. The calibration interval of the above test instruments is 12 months and the calibrations are traceable to NML/ROC and NIST/USA.
2. The test was performed in 966 Chamber No. G.
3. The FCC Site Registration No. is 966073.
4. The VCCI Site Registration No. is G-137.
5. The CANADA Site Registration No. is IC 7450H-2.
6. Tested Date: May 14 to June 15, 2015

4.1.3 Test Procedures

- a. The EUT was placed on the top of a rotating table 0.8 meters above the ground at 3 meter chamber room for test. The table was rotated 360 degrees to determine the position of the highest radiation.
- b. The EUT was set 3 meters away from the interference-receiving antenna, which was mounted on the top of a variable-height antenna tower.
- c. The height of antenna is varied from one meter to four meters above the ground to determine the maximum value of the field strength. Both horizontal and vertical polarizations of the antenna are set to make the measurement.
- d. For each suspected emission, the EUT was arranged to its worst case and then the antenna was tuned to heights from 1 meter to 4 meters and the rotatable table was turned from 0 degrees to 360 degrees to find the maximum reading.
- e. The test-receiver system was set to quasi-peak detect function and specified bandwidth with maximum hold mode when the test frequency is below 1 GHz.
- f. The test-receiver system was set to peak and average detect function and specified bandwidth with maximum hold mode when the test frequency is above 1 GHz. If the peak reading value also meets average limit, measurement with the average detector is unnecessary.

Note:

1. The resolution bandwidth and video bandwidth of test receiver/spectrum analyzer is 120kHz for Quasi-peak detection (QP) at frequency below 1GHz.
2. The resolution bandwidth of test receiver/spectrum analyzer is 1 MHz and the video bandwidth is 3 MHz for Peak detection (PK) at frequency above 1GHz.
3. The resolution bandwidth of test receiver/spectrum analyzer is 1MHz and the video bandwidth is 3MHz for RMS Average (Duty cycle < 98%) for Average detection (AV) at frequency above 1GHz, then the measurement results was added to a correction factor ($10 \log(1/\text{duty cycle})$).
4. The resolution bandwidth of test receiver/spectrum analyzer is 1MHz and the video bandwidth is 10Hz (Duty cycle $\geq 98\%$) for Average detection (AV) at frequency above 1GHz.
5. All modes of operation were investigated and the worst-case emissions are reported.

4.1.4 Deviation from Test Standard

No deviation.

4.1.5 Test Setup

<Frequency Range below 1GHz>

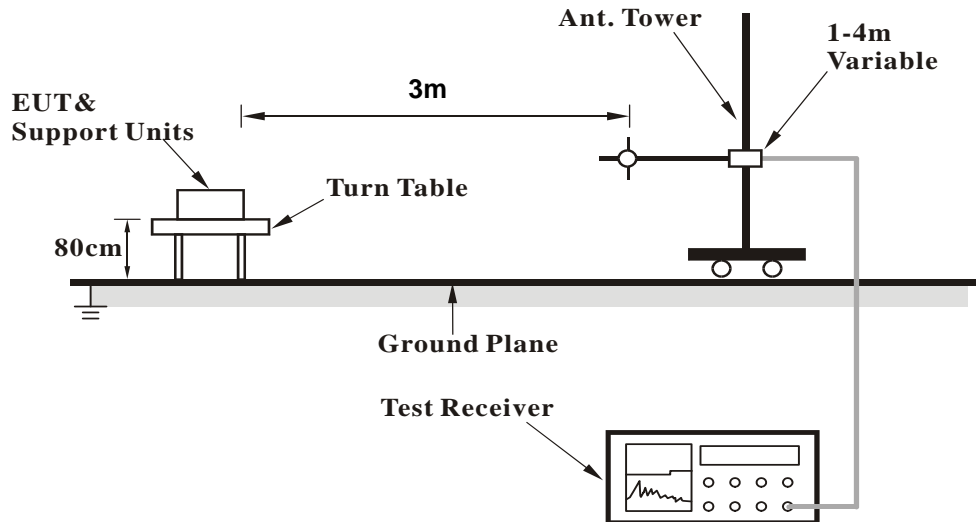

<Frequency Range above 1GHz>

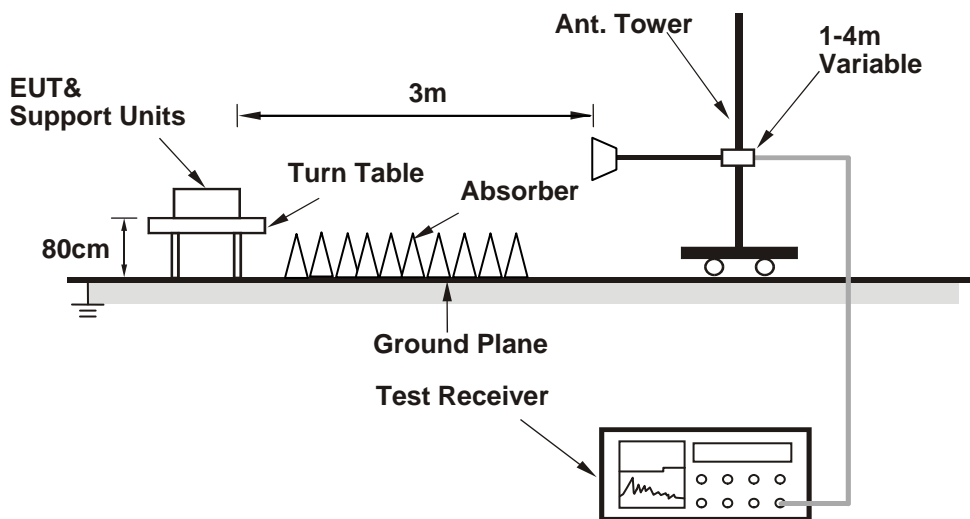

For the actual test configuration, please refer to the attached file (Test Setup Photo).

4.1.6 EUT Operating Conditions

1. Turn on the power of EUT.
2. The communication partner run test program "XW2DMT.exe" to enable EUT under transmission/receiving condition continuously at specific channel frequency.

4.1.7 Test Results
Above 1GHz Data
802.11a

CHANNEL	TX Channel 36	DETECTOR FUNCTION	Peak (PK)
FREQUENCY RANGE	1GHz ~ 40GHz		Average (AV)

ANTENNA POLARITY & TEST DISTANCE: HORIZONTAL AT 3 M

NO.	FREQ. (MHz)	EMISSION LEVEL (dBuV/m)	LIMIT (dBuV/m)	MARGIN (dB)	ANTENNA HEIGHT (m)	TABLE ANGLE (Degree)	RAW VALUE (dBuV)	CORRECTION FACTOR (dB/m)
1	5150.00	63.2 PK	74.0	-10.8	1.00 H	74	53.23	9.97
2	5150.00	46.8 AV	54.0	-7.2	1.00 H	74	36.83	9.97
3	*5180.00	107.3 PK			1.00 H	74	97.14	10.16
4	*5180.00	97.4 AV			1.00 H	74	87.24	10.16
5	#10360.00	57.1 PK	74.0	-16.9	1.21 H	135	40.12	16.98
6	#10360.00	44.2 AV	54.0	-9.8	1.21 H	135	27.22	16.98
7	15540.00	61.4 PK	74.0	-12.6	1.35 H	162	39.47	21.93
8	15540.00	49.8 AV	54.0	-4.2	1.35 H	162	27.87	21.93

ANTENNA POLARITY & TEST DISTANCE: VERTICAL AT 3 M

NO.	FREQ. (MHz)	EMISSION LEVEL (dBuV/m)	LIMIT (dBuV/m)	MARGIN (dB)	ANTENNA HEIGHT (m)	TABLE ANGLE (Degree)	RAW VALUE (dBuV)	CORRECTION FACTOR (dB/m)
1	5150.00	71.3 PK	74.0	-2.7	1.09 V	346	61.33	9.97
2	5150.00	52.7 AV	54.0	-1.3	1.09 V	346	42.73	9.97
3	*5180.00	115.4 PK			1.09 V	346	105.24	10.16
4	*5180.00	105.3 AV			1.09 V	346	95.14	10.16
5	#10360.00	56.4 PK	74.0	-17.6	1.33 V	162	39.42	16.98
6	#10360.00	43.6 AV	54.0	-10.4	1.33 V	162	26.62	16.98
7	15540.00	60.6 PK	74.0	-13.4	1.02 V	165	38.67	21.93
8	15540.00	49.1 AV	54.0	-4.9	1.02 V	165	27.17	21.93

REMARKS:

1. Emission Level(dBuV/m) = Raw Value(dBuV) + Correction Factor(dB/m)
2. Correction Factor(dB/m) = Antenna Factor(dB/m) + Cable Factor(dB) – Pre-Amplifier Factor(dB)
3. The other emission levels were very low against the limit.
4. Margin value = Emission Level – Limit value
5. " * ": Fundamental frequency.
6. " # ": The radiated frequency is out of the restricted band.

CHANNEL	TX Channel 40	DETECTOR FUNCTION	Peak (PK)
FREQUENCY RANGE	1GHz ~ 40GHz		Average (AV)

ANTENNA POLARITY & TEST DISTANCE: HORIZONTAL AT 3 M

NO.	FREQ. (MHz)	EMISSION LEVEL (dBuV/m)	LIMIT (dBuV/m)	MARGIN (dB)	ANTENNA HEIGHT (m)	TABLE ANGLE (Degree)	RAW VALUE (dBuV)	CORRECTION FACTOR (dB/m)
1	5150.00	59.7 PK	74.0	-14.3	1.02 H	78	49.73	9.97
2	5150.00	45.9 AV	54.0	-8.1	1.02 H	78	35.93	9.97
3	*5200.00	110.3 PK			1.02 H	78	100.04	10.26
4	*5200.00	100.2 AV			1.02 H	78	89.94	10.26
5	#10400.00	57.4 PK	74.0	-16.6	1.23 H	130	40.34	17.06
6	#10400.00	45.3 AV	54.0	-8.7	1.23 H	130	28.24	17.06
7	15600.00	61.5 PK	74.0	-12.5	1.32 H	178	39.22	22.28
8	15600.00	50.6 AV	54.0	-3.4	1.32 H	178	28.32	22.28

ANTENNA POLARITY & TEST DISTANCE: VERTICAL AT 3 M

NO.	FREQ. (MHz)	EMISSION LEVEL (dBuV/m)	LIMIT (dBuV/m)	MARGIN (dB)	ANTENNA HEIGHT (m)	TABLE ANGLE (Degree)	RAW VALUE (dBuV)	CORRECTION FACTOR (dB/m)
1	5150.00	67.7 PK	74.0	-6.3	1.09 V	346	57.73	9.97
2	5150.00	51.7 AV	54.0	-2.3	1.09 V	346	41.73	9.97
3	*5200.00	118.3 PK			1.09 V	346	108.04	10.26
4	*5200.00	108.0 AV			1.09 V	346	97.74	10.26
5	#10400.00	58.0 PK	74.0	-16.0	1.35 V	170	40.94	17.06
6	#10400.00	44.7 AV	54.0	-9.3	1.35 V	170	27.64	17.06
7	15600.00	61.2 PK	74.0	-12.8	1.02 V	153	38.92	22.28
8	15600.00	49.1 AV	54.0	-4.9	1.02 V	153	26.82	22.28

REMARKS:

1. Emission Level(dBuV/m) = Raw Value(dBuV) + Correction Factor(dB/m)
2. Correction Factor(dB/m) = Antenna Factor(dB/m) + Cable Factor(dB) – Pre-Amplifier Factor(dB)
3. The other emission levels were very low against the limit.
4. Margin value = Emission Level – Limit value
5. " * ": Fundamental frequency.
6. " # ": The radiated frequency is out of the restricted band.

CHANNEL	TX Channel 48	DETECTOR FUNCTION	Peak (PK)
FREQUENCY RANGE	1GHz ~ 40GHz		Average (AV)

ANTENNA POLARITY & TEST DISTANCE: HORIZONTAL AT 3 M

NO.	FREQ. (MHz)	EMISSION LEVEL (dBuV/m)	LIMIT (dBuV/m)	MARGIN (dB)	ANTENNA HEIGHT (m)	TABLE ANGLE (Degree)	RAW VALUE (dBuV)	CORRECTION FACTOR (dB/m)
1	5150.00	59.6 PK	74.0	-14.4	1.03 H	88	49.63	9.97
2	5150.00	45.9 AV	54.0	-8.1	1.03 H	88	35.93	9.97
3	*5240.00	110.1 PK			1.03 H	88	99.77	10.33
4	*5240.00	99.8 AV			1.03 H	88	89.47	10.33
5	5350.00	48.3 PK	74.0	-25.7	1.03 H	88	37.75	10.55
6	5350.00	37.4 AV	54.0	-16.6	1.03 H	88	26.85	10.55
7	#10480.00	57.3 PK	74.0	-16.7	1.26 H	143	40.57	16.73
8	#10480.00	45.5 AV	54.0	-8.5	1.26 H	143	28.77	16.73
9	15720.00	61.9 PK	74.0	-12.1	1.28 H	185	39.27	22.63
10	15720.00	50.6 AV	54.0	-3.4	1.28 H	185	27.97	22.63

ANTENNA POLARITY & TEST DISTANCE: VERTICAL AT 3 M

NO.	FREQ. (MHz)	EMISSION LEVEL (dBuV/m)	LIMIT (dBuV/m)	MARGIN (dB)	ANTENNA HEIGHT (m)	TABLE ANGLE (Degree)	RAW VALUE (dBuV)	CORRECTION FACTOR (dB/m)
1	5150.00	58.8 PK	74.0	-15.2	1.08 V	346	48.83	9.97
2	5150.00	45.4 AV	54.0	-8.6	1.08 V	346	35.43	9.97
3	*5240.00	118.3 PK			1.08 V	346	107.97	10.33
4	*5240.00	107.7 AV			1.08 V	346	97.37	10.33
5	5350.00	56.2 PK	74.0	-17.8	1.08 V	346	45.65	10.55
6	5350.00	43.1 AV	54.0	-10.9	1.08 V	346	32.55	10.55
7	#10480.00	58.2 PK	74.0	-15.8	1.36 V	169	41.47	16.73
8	#10480.00	44.9 AV	54.0	-9.1	1.36 V	169	28.17	16.73
9	15720.00	61.5 PK	74.0	-12.5	1.00 V	163	38.87	22.63
10	15720.00	49.4 AV	54.0	-4.6	1.00 V	163	26.77	22.63

REMARKS:

1. Emission Level(dBuV/m) = Raw Value(dBuV) + Correction Factor(dB/m)
2. Correction Factor(dB/m) = Antenna Factor(dB/m) + Cable Factor(dB) – Pre-Amplifier Factor(dB)
3. The other emission levels were very low against the limit.
4. Margin value = Emission Level – Limit value
5. " * ": Fundamental frequency.
6. " # ": The radiated frequency is out of the restricted band.

CHANNEL	TX Channel 149	DETECTOR FUNCTION	Peak (PK)
FREQUENCY RANGE	1GHz ~ 40GHz		Average (AV)

ANTENNA POLARITY & TEST DISTANCE: HORIZONTAL AT 3 M

NO.	FREQ. (MHz)	EMISSION LEVEL (dBuV/m)	LIMIT (dBuV/m)	MARGIN (dB)	ANTENNA HEIGHT (m)	TABLE ANGLE (Degree)	RAW VALUE (dBuV)	CORRECTION FACTOR (dB/m)
1	#5715.00	62.5 PK	74.0	-11.5	1.17 H	112	50.97	11.53
2	#5715.00	46.7 AV	54.0	-7.3	1.17 H	112	35.17	11.53
3	#5725.00	74.6 PK	78.2	-3.6	1.17 H	112	63.05	11.55
4	*5745.00	103.8 PK			1.17 H	112	92.17	11.63
5	*5745.00	94.1 AV			1.17 H	112	82.47	11.63
6	11490.00	57.0 PK	74.0	-17.0	1.16 H	149	39.70	17.30
7	11490.00	44.3 AV	54.0	-9.7	1.16 H	149	27.00	17.30
8	#17235.00	61.2 PK	74.0	-12.8	1.39 H	163	34.39	26.81
9	#17235.00	49.7 AV	54.0	-4.3	1.39 H	163	22.89	26.81

ANTENNA POLARITY & TEST DISTANCE: VERTICAL AT 3 M

NO.	FREQ. (MHz)	EMISSION LEVEL (dBuV/m)	LIMIT (dBuV/m)	MARGIN (dB)	ANTENNA HEIGHT (m)	TABLE ANGLE (Degree)	RAW VALUE (dBuV)	CORRECTION FACTOR (dB/m)
1	#5715.00	65.1 PK	74.0	-8.9	1.16 V	348	53.57	11.53
2	#5715.00	49.9 AV	54.0	-4.1	1.16 V	348	38.37	11.53
3	#5725.00	77.2 PK	78.2	-1.0	1.16 V	348	65.65	11.55
4	*5745.00	108.9 PK			1.16 V	348	97.27	11.63
5	*5745.00	98.6 AV			1.16 V	348	86.97	11.63
6	11490.00	56.1 PK	74.0	-17.9	1.29 V	158	38.80	17.30
7	11490.00	43.5 AV	54.0	-10.5	1.29 V	158	26.20	17.30
8	#17235.00	60.7 PK	74.0	-13.3	1.00 V	163	33.89	26.81
9	#17235.00	49.2 AV	54.0	-4.8	1.00 V	163	22.39	26.81

REMARKS:

- Emission Level(dBuV/m) = Raw Value(dBuV) + Correction Factor(dB/m)
- Correction Factor(dB/m) = Antenna Factor(dB/m) + Cable Factor(dB) – Pre-Amplifier Factor(dB)
- The other emission levels were very low against the limit.
- Margin value = Emission Level – Limit value
- " * ": Fundamental frequency.
- " # ": The radiated frequency is out of the restricted band.

CHANNEL	TX Channel 157	DETECTOR FUNCTION	Peak (PK)
FREQUENCY RANGE	1GHz ~ 40GHz		Average (AV)

ANTENNA POLARITY & TEST DISTANCE: HORIZONTAL AT 3 M

NO.	FREQ. (MHz)	EMISSION LEVEL (dBuV/m)	LIMIT (dBuV/m)	MARGIN (dB)	ANTENNA HEIGHT (m)	TABLE ANGLE (Degree)	RAW VALUE (dBuV)	CORRECTION FACTOR (dB/m)
1	#5715.00	54.5 PK	74.0	-19.5	1.20 H	122	42.97	11.53
2	#5715.00	41.6 AV	54.0	-12.4	1.20 H	122	30.07	11.53
3	#5725.00	57.7 PK	78.2	-20.5	1.20 H	122	46.15	11.55
4	*5785.00	107.0 PK			1.20 H	122	95.26	11.74
5	*5785.00	96.8 AV			1.20 H	122	85.06	11.74
6	#5850.00	57.0 PK	78.2	-21.2	1.20 H	122	45.25	11.75
7	#5860.00	54.5 PK	74.0	-19.5	1.20 H	122	42.75	11.75
8	#5860.00	41.1 AV	54.0	-12.9	1.20 H	122	29.35	11.75
9	11570.00	57.0 PK	74.0	-17.0	1.18 H	143	39.09	17.91
10	11570.00	44.8 AV	54.0	-9.2	1.18 H	143	26.89	17.91
11	#17355.00	61.6 PK	74.0	-12.4	1.27 H	192	34.46	27.14
12	#17355.00	50.6 AV	54.0	-3.4	1.27 H	192	23.46	27.14

ANTENNA POLARITY & TEST DISTANCE: VERTICAL AT 3 M

NO.	FREQ. (MHz)	EMISSION LEVEL (dBuV/m)	LIMIT (dBuV/m)	MARGIN (dB)	ANTENNA HEIGHT (m)	TABLE ANGLE (Degree)	RAW VALUE (dBuV)	CORRECTION FACTOR (dB/m)
1	#5715.00	57.1 PK	74.0	-16.9	1.15 V	346	45.57	11.53
2	#5715.00	44.8 AV	54.0	-9.2	1.15 V	346	33.27	11.53
3	#5725.00	60.3 PK	78.2	-17.9	1.15 V	346	48.75	11.55
4	*5785.00	112.1 PK			1.15 V	346	100.36	11.74
5	*5785.00	101.3 AV			1.15 V	346	89.56	11.74
6	#5850.00	59.6 PK	78.2	-18.6	1.15 V	346	47.85	11.75
7	#5860.00	57.1 PK	74.0	-16.9	1.15 V	346	45.35	11.75
8	#5860.00	44.6 AV	54.0	-9.4	1.15 V	346	32.85	11.75
9	11570.00	58.5 PK	74.0	-15.5	1.38 V	178	40.59	17.91
10	11570.00	45.2 AV	54.0	-8.8	1.38 V	178	27.29	17.91
11	#17355.00	61.4 PK	74.0	-12.6	1.04 V	153	34.26	27.14
12	#17355.00	49.2 AV	54.0	-4.8	1.04 V	153	22.06	27.14

REMARKS:

1. Emission Level(dBuV/m) = Raw Value(dBuV) + Correction Factor(dB/m)
2. Correction Factor(dB/m) = Antenna Factor(dB/m) + Cable Factor(dB) – Pre-Amplifier Factor(dB)
3. The other emission levels were very low against the limit.
4. Margin value = Emission Level – Limit value
5. " * ": Fundamental frequency.
6. " # ": The radiated frequency is out of the restricted band.

CHANNEL	TX Channel 165	DETECTOR FUNCTION	Peak (PK)
FREQUENCY RANGE	1GHz ~ 40GHz		Average (AV)

ANTENNA POLARITY & TEST DISTANCE: HORIZONTAL AT 3 M

NO.	FREQ. (MHz)	EMISSION LEVEL (dBuV/m)	LIMIT (dBuV/m)	MARGIN (dB)	ANTENNA HEIGHT (m)	TABLE ANGLE (Degree)	RAW VALUE (dBuV)	CORRECTION FACTOR (dB/m)
1	*5825.00	105.8 PK			1.22 H	100	94.02	11.78
2	*5825.00	96.1 AV			1.22 H	100	84.32	11.78
3	#5850.00	74.3 PK	78.2	-3.9	1.22 H	100	62.55	11.75
4	#5860.00	63.9 PK	74.0	-10.1	1.22 H	100	52.15	11.75
5	#5860.00	49.4 AV	54.0	-4.6	1.22 H	100	37.65	11.75
6	11650.00	57.5 PK	74.0	-16.5	1.23 H	136	39.34	18.16
7	11650.00	45.7 AV	54.0	-8.3	1.23 H	136	27.54	18.16
8	#17475.00	61.1 PK	74.0	-12.9	1.23 H	178	33.18	27.92
9	#17475.00	50.4 AV	54.0	-3.6	1.23 H	178	22.48	27.92

ANTENNA POLARITY & TEST DISTANCE: VERTICAL AT 3 M

NO.	FREQ. (MHz)	EMISSION LEVEL (dBuV/m)	LIMIT (dBuV/m)	MARGIN (dB)	ANTENNA HEIGHT (m)	TABLE ANGLE (Degree)	RAW VALUE (dBuV)	CORRECTION FACTOR (dB/m)
1	*5825.00	110.9 PK			1.16 V	348	99.12	11.78
2	*5825.00	100.6 AV			1.16 V	348	88.82	11.78
3	#5850.00	76.9 PK	78.2	-1.3	1.16 V	348	65.15	11.75
4	#5860.00	66.5 PK	74.0	-7.5	1.16 V	348	54.75	11.75
5	#5860.00	52.6 AV	54.0	-1.4	1.16 V	348	40.85	11.75
6	11650.00	61.0 PK	74.0	-13.0	1.32 V	181	42.84	18.16
7	11650.00	44.5 AV	54.0	-9.5	1.32 V	181	26.34	18.16
8	#17475.00	60.6 PK	74.0	-13.4	1.02 V	154	32.68	27.92
9	#17475.00	48.4 AV	54.0	-5.6	1.02 V	154	20.48	27.92

REMARKS:

1. Emission Level(dBuV/m) = Raw Value(dBuV) + Correction Factor(dB/m)
2. Correction Factor(dB/m) = Antenna Factor(dB/m) + Cable Factor(dB) – Pre-Amplifier Factor(dB)
3. The other emission levels were very low against the limit.
4. Margin value = Emission Level – Limit value
5. " * ": Fundamental frequency.
6. " # ": The radiated frequency is out of the restricted band.

802.11n (HT20)

CHANNEL	TX Channel 36	DETECTOR FUNCTION	Peak (PK)
FREQUENCY RANGE	1GHz ~ 40GHz		Average (AV)

ANTENNA POLARITY & TEST DISTANCE: HORIZONTAL AT 3 M

NO.	FREQ. (MHz)	EMISSION LEVEL (dBuV/m)	LIMIT (dBuV/m)	MARGIN (dB)	ANTENNA HEIGHT (m)	TABLE ANGLE (Degree)	RAW VALUE (dBuV)	CORRECTION FACTOR (dB/m)
1	5150.00	63.1 PK	74.0	-10.9	1.05 H	69	53.13	9.97
2	5150.00	46.2 AV	54.0	-7.8	1.05 H	69	36.23	9.97
3	*5180.00	111.6 PK			1.05 H	69	101.44	10.16
4	*5180.00	96.1 AV			1.05 H	69	85.94	10.16
5	#10360.00	58.2 PK	74.0	-15.8	1.19 H	133	41.22	16.98
6	#10360.00	45.0 AV	54.0	-9.0	1.19 H	133	28.02	16.98
7	15540.00	60.9 PK	74.0	-13.1	1.36 H	140	38.97	21.93
8	15540.00	49.1 AV	54.0	-4.9	1.36 H	140	27.17	21.93

ANTENNA POLARITY & TEST DISTANCE: VERTICAL AT 3 M

NO.	FREQ. (MHz)	EMISSION LEVEL (dBuV/m)	LIMIT (dBuV/m)	MARGIN (dB)	ANTENNA HEIGHT (m)	TABLE ANGLE (Degree)	RAW VALUE (dBuV)	CORRECTION FACTOR (dB/m)
1	5150.00	71.9 PK	74.0	-2.1	1.08 V	346	61.93	9.97
2	5150.00	53.0 AV	54.0	-1.0	1.08 V	346	43.03	9.97
3	*5180.00	116.4 PK			1.08 V	346	106.24	10.16
4	*5180.00	104.9 AV			1.08 V	346	94.74	10.16
5	#10360.00	56.9 PK	74.0	-17.1	1.27 V	163	39.92	16.98
6	#10360.00	44.0 AV	54.0	-10.0	1.27 V	163	27.02	16.98
7	15540.00	60.3 PK	74.0	-13.7	1.04 V	153	38.37	21.93
8	15540.00	48.7 AV	54.0	-5.3	1.04 V	153	26.77	21.93

REMARKS:

- Emission Level(dBuV/m) = Raw Value(dBuV) + Correction Factor(dB/m)
- Correction Factor(dB/m) = Antenna Factor(dB/m) + Cable Factor(dB) – Pre-Amplifier Factor(dB)
- The other emission levels were very low against the limit.
- Margin value = Emission Level – Limit value
- " * ": Fundamental frequency.
- " # ": The radiated frequency is out of the restricted band.

CHANNEL	TX Channel 40	DETECTOR FUNCTION	Peak (PK)
FREQUENCY RANGE	1GHz ~ 40GHz		Average (AV)

ANTENNA POLARITY & TEST DISTANCE: HORIZONTAL AT 3 M

NO.	FREQ. (MHz)	EMISSION LEVEL (dBuV/m)	LIMIT (dBuV/m)	MARGIN (dB)	ANTENNA HEIGHT (m)	TABLE ANGLE (Degree)	RAW VALUE (dBuV)	CORRECTION FACTOR (dB/m)
1	*5200.00	113.6 PK			1.06 H	78	103.34	10.26
2	*5200.00	98.8 AV			1.06 H	78	88.54	10.26
3	#10400.00	57.5 PK	74.0	-16.5	1.29 H	140	40.44	17.06
4	#10400.00	45.6 AV	54.0	-8.4	1.29 H	140	28.54	17.06
5	15600.00	61.5 PK	74.0	-12.5	1.28 H	186	39.22	22.28
6	15600.00	50.6 AV	54.0	-3.4	1.28 H	186	28.32	22.28

ANTENNA POLARITY & TEST DISTANCE: VERTICAL AT 3 M

NO.	FREQ. (MHz)	EMISSION LEVEL (dBuV/m)	LIMIT (dBuV/m)	MARGIN (dB)	ANTENNA HEIGHT (m)	TABLE ANGLE (Degree)	RAW VALUE (dBuV)	CORRECTION FACTOR (dB/m)
1	*5200.00	118.4 PK			1.12 V	338	108.14	10.26
2	*5200.00	107.6 AV			1.12 V	338	97.34	10.26
3	#10400.00	60.8 PK	74.0	-13.2	1.29 V	176	43.74	17.06
4	#10400.00	44.6 AV	54.0	-9.4	1.29 V	176	27.54	17.06
5	15600.00	61.0 PK	74.0	-13.0	1.00 V	138	38.72	22.28
6	15600.00	48.7 AV	54.0	-5.3	1.00 V	138	26.42	22.28

REMARKS:

1. Emission Level(dBuV/m) = Raw Value(dBuV) + Correction Factor(dB/m)
2. Correction Factor(dB/m) = Antenna Factor(dB/m) + Cable Factor(dB) – Pre-Amplifier Factor(dB)
3. The other emission levels were very low against the limit.
4. Margin value = Emission Level – Limit value
5. " * ": Fundamental frequency.
6. " # ": The radiated frequency is out of the restricted band.

CHANNEL	TX Channel 48	DETECTOR FUNCTION	Peak (PK)
FREQUENCY RANGE	1GHz ~ 40GHz		Average (AV)

ANTENNA POLARITY & TEST DISTANCE: HORIZONTAL AT 3 M

NO.	FREQ. (MHz)	EMISSION LEVEL (dBuV/m)	LIMIT (dBuV/m)	MARGIN (dB)	ANTENNA HEIGHT (m)	TABLE ANGLE (Degree)	RAW VALUE (dBuV)	CORRECTION FACTOR (dB/m)
1	*5240.00	114.2 PK			1.04 H	99	103.87	10.33
2	*5240.00	98.9 AV			1.04 H	99	88.57	10.33
3	5350.00	48.0 PK	74.0	-26.0	1.04 H	99	37.45	10.55
4	5350.00	37.0 AV	54.0	-17.0	1.04 H	99	26.45	10.55
5	#10480.00	57.5 PK	74.0	-16.5	1.32 H	153	40.77	16.73
6	#10480.00	45.7 AV	54.0	-8.3	1.32 H	153	28.97	16.73
7	15720.00	61.4 PK	74.0	-12.6	1.24 H	189	38.77	22.63
8	15720.00	50.5 AV	54.0	-3.5	1.24 H	189	27.87	22.63

ANTENNA POLARITY & TEST DISTANCE: VERTICAL AT 3 M

NO.	FREQ. (MHz)	EMISSION LEVEL (dBuV/m)	LIMIT (dBuV/m)	MARGIN (dB)	ANTENNA HEIGHT (m)	TABLE ANGLE (Degree)	RAW VALUE (dBuV)	CORRECTION FACTOR (dB/m)
1	*5240.00	119.0 PK			1.08 V	345	108.67	10.33
2	*5240.00	107.7 AV			1.08 V	345	97.37	10.33
3	5350.00	56.6 PK	74.0	-17.4	1.08 V	345	46.05	10.55
4	5350.00	43.5 AV	54.0	-10.5	1.08 V	345	32.95	10.55
5	#10480.00	60.5 PK	74.0	-13.5	1.28 V	161	43.77	16.73
6	#10480.00	45.0 AV	54.0	-9.0	1.28 V	161	28.27	16.73
7	15720.00	61.4 PK	74.0	-12.6	1.01 V	139	38.77	22.63
8	15720.00	48.9 AV	54.0	-5.1	1.01 V	139	26.27	22.63

REMARKS:

1. Emission Level(dBuV/m) = Raw Value(dBuV) + Correction Factor(dB/m)
2. Correction Factor(dB/m) = Antenna Factor(dB/m) + Cable Factor(dB) – Pre-Amplifier Factor(dB)
3. The other emission levels were very low against the limit.
4. Margin value = Emission Level – Limit value
5. " * ": Fundamental frequency.
6. " # ": The radiated frequency is out of the restricted band.

CHANNEL	TX Channel 149	DETECTOR FUNCTION	Peak (PK)
FREQUENCY RANGE	1GHz ~ 40GHz		Average (AV)

ANTENNA POLARITY & TEST DISTANCE: HORIZONTAL AT 3 M

NO.	FREQ. (MHz)	EMISSION LEVEL (dBuV/m)	LIMIT (dBuV/m)	MARGIN (dB)	ANTENNA HEIGHT (m)	TABLE ANGLE (Degree)	RAW VALUE (dBuV)	CORRECTION FACTOR (dB/m)
1	#5715.00	59.7 PK	74.0	-14.3	1.20 H	122	48.17	11.53
2	#5715.00	44.5 AV	54.0	-9.5	1.20 H	122	32.97	11.53
3	#5725.00	73.3 PK	78.2	-4.9	1.20 H	122	61.75	11.55
4	*5745.00	103.0 PK			1.20 H	122	91.37	11.63
5	*5745.00	92.0 AV			1.20 H	122	80.37	11.63
6	11490.00	58.6 PK	74.0	-15.4	1.16 H	149	41.30	17.30
7	11490.00	45.3 AV	54.0	-8.7	1.16 H	149	28.00	17.30
8	#17235.00	60.8 PK	74.0	-13.2	1.34 H	132	33.99	26.81
9	#17235.00	49.2 AV	54.0	-4.8	1.34 H	132	22.39	26.81

ANTENNA POLARITY & TEST DISTANCE: VERTICAL AT 3 M

NO.	FREQ. (MHz)	EMISSION LEVEL (dBuV/m)	LIMIT (dBuV/m)	MARGIN (dB)	ANTENNA HEIGHT (m)	TABLE ANGLE (Degree)	RAW VALUE (dBuV)	CORRECTION FACTOR (dB/m)
1	#5715.00	63.3 PK	74.0	-10.7	1.16 V	348	51.77	11.53
2	#5715.00	48.7 AV	54.0	-5.3	1.16 V	348	37.17	11.53
3	#5725.00	76.9 PK	78.2	-1.3	1.16 V	348	65.35	11.55
4	*5745.00	109.1 PK			1.16 V	348	97.47	11.63
5	*5745.00	97.5 AV			1.16 V	348	85.87	11.63
6	11490.00	57.2 PK	74.0	-16.8	1.30 V	154	39.90	17.30
7	11490.00	44.2 AV	54.0	-9.8	1.30 V	154	26.90	17.30
8	#17235.00	60.7 PK	74.0	-13.3	1.10 V	141	33.89	26.81
9	#17235.00	49.0 AV	54.0	-5.0	1.10 V	141	22.19	26.81

REMARKS:

- Emission Level(dBuV/m) = Raw Value(dBuV) + Correction Factor(dB/m)
- Correction Factor(dB/m) = Antenna Factor(dB/m) + Cable Factor(dB) – Pre-Amplifier Factor(dB)
- The other emission levels were very low against the limit.
- Margin value = Emission Level – Limit value
- " * ": Fundamental frequency.
- " # ": The radiated frequency is out of the restricted band.

CHANNEL	TX Channel 157	DETECTOR FUNCTION	Peak (PK)
FREQUENCY RANGE	1GHz ~ 40GHz		Average (AV)

ANTENNA POLARITY & TEST DISTANCE: HORIZONTAL AT 3 M

NO.	FREQ. (MHz)	EMISSION LEVEL (dBuV/m)	LIMIT (dBuV/m)	MARGIN (dB)	ANTENNA HEIGHT (m)	TABLE ANGLE (Degree)	RAW VALUE (dBuV)	CORRECTION FACTOR (dB/m)
1	*5785.00	105.7 PK			1.10 H	132	93.96	11.74
2	*5785.00	95.6 AV			1.10 H	132	83.86	11.74
3	11570.00	57.0 PK	74.0	-17.0	1.21 H	129	39.09	17.91
4	11570.00	45.1 AV	54.0	-8.9	1.21 H	129	27.19	17.91
5	#17355.00	62.4 PK	74.0	-11.6	1.27 H	184	35.26	27.14
6	#17355.00	50.8 AV	54.0	-3.2	1.27 H	184	23.66	27.14

ANTENNA POLARITY & TEST DISTANCE: VERTICAL AT 3 M

NO.	FREQ. (MHz)	EMISSION LEVEL (dBuV/m)	LIMIT (dBuV/m)	MARGIN (dB)	ANTENNA HEIGHT (m)	TABLE ANGLE (Degree)	RAW VALUE (dBuV)	CORRECTION FACTOR (dB/m)
1	*5785.00	111.8 PK			1.20 V	360	100.06	11.74
2	*5785.00	101.1 AV			1.20 V	360	89.36	11.74
3	11570.00	59.1 PK	74.0	-14.9	1.37 V	162	41.19	17.91
4	11570.00	45.5 AV	54.0	-8.5	1.37 V	162	27.59	17.91
5	#17355.00	61.0 PK	74.0	-13.0	1.08 V	163	33.86	27.14
6	#17355.00	49.1 AV	54.0	-4.9	1.08 V	163	21.96	27.14

REMARKS:

1. Emission Level(dBuV/m) = Raw Value(dBuV) + Correction Factor(dB/m)
2. Correction Factor(dB/m) = Antenna Factor(dB/m) + Cable Factor(dB) – Pre-Amplifier Factor(dB)
3. The other emission levels were very low against the limit.
4. Margin value = Emission Level – Limit value
5. " * ": Fundamental frequency.
6. " # ": The radiated frequency is out of the restricted band.

CHANNEL	TX Channel 165	DETECTOR FUNCTION	Peak (PK)
FREQUENCY RANGE	1GHz ~ 40GHz		Average (AV)

ANTENNA POLARITY & TEST DISTANCE: HORIZONTAL AT 3 M

NO.	FREQ. (MHz)	EMISSION LEVEL (dBuV/m)	LIMIT (dBuV/m)	MARGIN (dB)	ANTENNA HEIGHT (m)	TABLE ANGLE (Degree)	RAW VALUE (dBuV)	CORRECTION FACTOR (dB/m)
1	*5825.00	104.7 PK			1.11 H	123	92.92	11.78
2	*5825.00	94.3 AV			1.11 H	123	82.52	11.78
3	#5850.00	73.3 PK	78.2	-4.9	1.11 H	123	61.55	11.75
4	#5860.00	62.9 PK	74.0	-11.1	1.11 H	123	51.15	11.75
5	#5860.00	48.8 AV	54.0	-5.2	1.11 H	123	37.05	11.75
6	11650.00	56.9 PK	74.0	-17.1	1.20 H	122	38.74	18.16
7	11650.00	44.8 AV	54.0	-9.2	1.20 H	122	26.64	18.16
8	#17475.00	58.6 PK	74.0	-15.4	1.25 H	100	30.68	27.92
9	#17475.00	47.9 AV	54.0	-6.1	1.25 H	100	19.98	27.92

ANTENNA POLARITY & TEST DISTANCE: VERTICAL AT 3 M

NO.	FREQ. (MHz)	EMISSION LEVEL (dBuV/m)	LIMIT (dBuV/m)	MARGIN (dB)	ANTENNA HEIGHT (m)	TABLE ANGLE (Degree)	RAW VALUE (dBuV)	CORRECTION FACTOR (dB/m)
1	*5825.00	110.8 PK			1.14 V	346	99.02	11.78
2	*5825.00	99.8 AV			1.14 V	346	88.02	11.78
3	#5850.00	76.9 PK	78.2	-1.3	1.14 V	346	65.15	11.75
4	#5860.00	66.5 PK	74.0	-7.5	1.14 V	346	54.75	11.75
5	#5860.00	53.0 AV	54.0	-1.0	1.14 V	346	41.25	11.75
6	11650.00	58.6 PK	74.0	-15.4	1.32 V	125	40.44	18.16
7	11650.00	45.0 AV	54.0	-9.0	1.32 V	125	26.84	18.16
8	#17475.00	59.7 PK	74.0	-14.3	1.02 V	120	31.78	27.92
9	#17475.00	48.7 AV	54.0	-5.3	1.02 V	120	20.78	27.92

REMARKS:

- Emission Level(dBuV/m) = Raw Value(dBuV) + Correction Factor(dB/m)
- Correction Factor(dB/m) = Antenna Factor(dB/m) + Cable Factor(dB) – Pre-Amplifier Factor(dB)
- The other emission levels were very low against the limit.
- Margin value = Emission Level – Limit value
- " * ": Fundamental frequency.
- " # ": The radiated frequency is out of the restricted band.

Below 1GHz Worst-Case Data
802.11a

CHANNEL	TX Channel 36	DETECTOR FUNCTION	Quasi-Peak (QP)
FREQUENCY RANGE	Below 1GHz		

ANTENNA POLARITY & TEST DISTANCE: HORIZONTAL AT 3 M

NO.	FREQ. (MHz)	EMISSION LEVEL (dBuV/m)	LIMIT (dBuV/m)	MARGIN (dB)	ANTENNA HEIGHT (m)	TABLE ANGLE (Degree)	RAW VALUE (dBuV)	CORRECTION FACTOR (dB/m)
1	143.98	38.5 QP	43.5	-5.1	1.50 H	267	51.51	-13.06
2	180.30	39.1 QP	43.5	-4.4	1.00 H	289	53.60	-14.50
3	404.52	39.7 QP	46.0	-6.3	1.00 H	20	48.97	-9.31
4	704.01	40.8 QP	46.0	-5.2	1.00 H	260	43.56	-2.72
5	896.02	42.7 QP	46.0	-3.3	1.50 H	330	42.05	0.62
6	930.40	41.9 QP	46.0	-4.1	1.50 H	360	40.46	1.44

ANTENNA POLARITY & TEST DISTANCE: VERTICAL AT 3 M

NO.	FREQ. (MHz)	EMISSION LEVEL (dBuV/m)	LIMIT (dBuV/m)	MARGIN (dB)	ANTENNA HEIGHT (m)	TABLE ANGLE (Degree)	RAW VALUE (dBuV)	CORRECTION FACTOR (dB/m)
1	39.49	35.5 QP	40.0	-4.5	1.00 V	72	49.08	-13.54
2	72.63	35.5 QP	40.0	-4.5	1.00 V	225	51.65	-16.11
3	448.02	41.5 QP	46.0	-4.6	1.00 V	244	49.25	-7.80
4	849.51	40.5 QP	46.0	-5.5	1.00 V	324	40.51	-0.04
5	896.02	42.9 QP	46.0	-3.1	1.50 V	8	42.25	0.62
6	930.44	43.0 QP	46.0	-3.0	1.00 V	335	41.53	1.45

REMARKS:

1. Emission Level(dBuV/m) = Raw Value(dBuV) + Correction Factor(dB/m)
2. Correction Factor(dB/m) = Antenna Factor(dB/m) + Cable Factor(dB) – Pre-Amplifier Factor(dB)
3. The other emission levels were very low against the limit.
4. Margin value = Emission Level – Limit value

CHANNEL	TX Channel 40	DETECTOR FUNCTION	Quasi-Peak (QP)
FREQUENCY RANGE	Below 1GHz		

ANTENNA POLARITY & TEST DISTANCE: HORIZONTAL AT 3 M

NO.	FREQ. (MHz)	EMISSION LEVEL (dBuV/m)	LIMIT (dBuV/m)	MARGIN (dB)	ANTENNA HEIGHT (m)	TABLE ANGLE (Degree)	RAW VALUE (dBuV)	CORRECTION FACTOR (dB/m)
1	143.90	38.5 QP	43.5	-5.0	1.10 H	217	51.59	-13.07
2	180.30	39.0 QP	43.5	-4.5	1.10 H	272	53.52	-14.50
3	404.50	39.7 QP	46.0	-6.3	1.10 H	120	49.03	-9.31
4	704.00	40.7 QP	46.0	-5.3	1.10 H	200	43.44	-2.72
5	896.00	42.7 QP	46.0	-3.3	1.10 H	310	42.10	0.62
6	930.40	41.8 QP	46.0	-4.2	1.10 H	310	40.34	1.44

ANTENNA POLARITY & TEST DISTANCE: VERTICAL AT 3 M

NO.	FREQ. (MHz)	EMISSION LEVEL (dBuV/m)	LIMIT (dBuV/m)	MARGIN (dB)	ANTENNA HEIGHT (m)	TABLE ANGLE (Degree)	RAW VALUE (dBuV)	CORRECTION FACTOR (dB/m)
1	39.48	35.5 QP	40.0	-4.5	1.10 V	71	49.04	-13.54
2	72.63	35.5 QP	40.0	-4.5	1.10 V	215	51.61	-16.11
3	448.02	41.4 QP	46.0	-4.6	1.10 V	214	49.20	-7.80
4	849.50	40.5 QP	46.0	-5.5	1.10 V	314	40.56	-0.04
5	896.06	42.9 QP	46.0	-3.1	1.42 V	18	42.30	0.62
6	930.40	42.9 QP	46.0	-3.1	1.10 V	315	41.47	1.44

REMARKS:

1. Emission Level(dBuV/m) = Raw Value(dBuV) + Correction Factor(dB/m)
2. Correction Factor(dB/m) = Antenna Factor(dB/m) + Cable Factor(dB) – Pre-Amplifier Factor(dB)
3. The other emission levels were very low against the limit.
4. Margin value = Emission Level – Limit value

CHANNEL	TX Channel 48	DETECTOR FUNCTION	Quasi-Peak (QP)
FREQUENCY RANGE	Below 1GHz		

ANTENNA POLARITY & TEST DISTANCE: HORIZONTAL AT 3 M

NO.	FREQ. (MHz)	EMISSION LEVEL (dBuV/m)	LIMIT (dBuV/m)	MARGIN (dB)	ANTENNA HEIGHT (m)	TABLE ANGLE (Degree)	RAW VALUE (dBuV)	CORRECTION FACTOR (dB/m)
1	143.71	38.2 QP	43.5	-5.3	1.24 H	304	51.22	-13.01
2	180.11	39.0 QP	43.5	-4.5	1.24 H	211	53.50	-14.49
3	404.34	39.4 QP	46.0	-6.6	1.22 H	244	48.93	-9.51
4	704.12	40.7 QP	46.0	-5.3	1.67 H	77	44.05	-3.34
5	896.11	42.4 QP	46.0	-3.6	1.34 H	244	42.36	0.06
6	930.21	41.7 QP	46.0	-4.3	1.34 H	241	40.80	0.94

ANTENNA POLARITY & TEST DISTANCE: VERTICAL AT 3 M

NO.	FREQ. (MHz)	EMISSION LEVEL (dBuV/m)	LIMIT (dBuV/m)	MARGIN (dB)	ANTENNA HEIGHT (m)	TABLE ANGLE (Degree)	RAW VALUE (dBuV)	CORRECTION FACTOR (dB/m)
1	39.61	35.4 QP	40.0	-4.6	1.11 V	22	49.22	-13.81
2	72.41	35.8 QP	40.0	-4.2	1.34 V	66	51.72	-15.94
3	448.14	41.5 QP	46.0	-4.5	1.64 V	304	49.64	-8.13
4	849.81	40.8 QP	46.0	-5.3	1.24 V	241	41.47	-0.72
5	896.15	43.0 QP	46.0	-3.0	1.24 V	111	42.93	0.06
6	930.69	42.8 QP	46.0	-3.3	1.44 V	301	41.82	0.93

REMARKS:

1. Emission Level(dBuV/m) = Raw Value(dBuV) + Correction Factor(dB/m)
2. Correction Factor(dB/m) = Antenna Factor(dB/m) + Cable Factor(dB) – Pre-Amplifier Factor(dB)
3. The other emission levels were very low against the limit.
4. Margin value = Emission Level – Limit value

CHANNEL	TX Channel 149	DETECTOR FUNCTION	Quasi-Peak (QP)
FREQUENCY RANGE	Below 1GHz		

ANTENNA POLARITY & TEST DISTANCE: HORIZONTAL AT 3 M

NO.	FREQ. (MHz)	EMISSION LEVEL (dBuV/m)	LIMIT (dBuV/m)	MARGIN (dB)	ANTENNA HEIGHT (m)	TABLE ANGLE (Degree)	RAW VALUE (dBuV)	CORRECTION FACTOR (dB/m)
1	143.28	38.1 QP	43.5	-5.4	1.64 H	277	51.19	-13.08
2	180.30	39.2 QP	43.5	-4.3	1.34 H	66	53.76	-14.52
3	404.11	39.2 QP	46.0	-6.8	1.78 H	304	48.73	-9.52
4	704.48	40.3 QP	46.0	-5.7	1.42 H	304	43.63	-3.32
5	896.30	42.2 QP	46.0	-3.8	1.67 H	304	42.16	0.08
6	930.14	41.5 QP	46.0	-4.5	1.64 H	144	40.57	0.94

ANTENNA POLARITY & TEST DISTANCE: VERTICAL AT 3 M

NO.	FREQ. (MHz)	EMISSION LEVEL (dBuV/m)	LIMIT (dBuV/m)	MARGIN (dB)	ANTENNA HEIGHT (m)	TABLE ANGLE (Degree)	RAW VALUE (dBuV)	CORRECTION FACTOR (dB/m)
1	39.11	35.7 QP	40.0	-4.3	1.34 V	41	49.55	-13.84
2	72.61	36.0 QP	40.0	-4.0	1.42 V	24	51.92	-15.96
3	448.50	41.8 QP	46.0	-4.2	1.00 V	15	49.94	-8.13
4	849.51	40.8 QP	46.0	-5.2	1.42 V	144	41.53	-0.72
5	896.30	42.7 QP	46.0	-3.3	1.64 V	54	42.63	0.08
6	930.88	42.4 QP	46.0	-3.6	1.75 V	57	41.49	0.93

REMARKS:

1. Emission Level(dBuV/m) = Raw Value(dBuV) + Correction Factor(dB/m)
2. Correction Factor(dB/m) = Antenna Factor(dB/m) + Cable Factor(dB) – Pre-Amplifier Factor(dB)
3. The other emission levels were very low against the limit.
4. Margin value = Emission Level – Limit value

CHANNEL	TX Channel 157	DETECTOR FUNCTION	Quasi-Peak (QP)
FREQUENCY RANGE	Below 1GHz		

ANTENNA POLARITY & TEST DISTANCE: HORIZONTAL AT 3 M

NO.	FREQ. (MHz)	EMISSION LEVEL (dBuV/m)	LIMIT (dBuV/m)	MARGIN (dB)	ANTENNA HEIGHT (m)	TABLE ANGLE (Degree)	RAW VALUE (dBuV)	CORRECTION FACTOR (dB/m)
1	143.34	38.4 QP	43.5	-5.1	1.24 H	201	51.50	-13.06
2	180.51	39.4 QP	43.5	-4.1	1.64 H	100	53.97	-14.55
3	404.24	39.5 QP	46.0	-6.6	1.24 H	244	48.96	-9.51
4	704.51	40.5 QP	46.0	-5.5	1.67 H	244	43.83	-3.32
5	896.21	42.4 QP	46.0	-3.6	1.62 H	244	42.35	0.07
6	930.14	41.8 QP	46.0	-4.2	1.44 H	66	40.84	0.94

ANTENNA POLARITY & TEST DISTANCE: VERTICAL AT 3 M

NO.	FREQ. (MHz)	EMISSION LEVEL (dBuV/m)	LIMIT (dBuV/m)	MARGIN (dB)	ANTENNA HEIGHT (m)	TABLE ANGLE (Degree)	RAW VALUE (dBuV)	CORRECTION FACTOR (dB/m)
1	39.33	35.5 QP	40.0	-4.5	1.74 V	63	49.34	-13.83
2	72.47	35.7 QP	40.0	-4.3	1.24 V	42	51.66	-15.95
3	448.64	41.7 QP	46.0	-4.3	1.45 V	24	49.87	-8.13
4	849.41	40.6 QP	46.0	-5.4	1.77 V	47	41.33	-0.72
5	896.81	42.6 QP	46.0	-3.4	1.34 V	74	42.53	0.09
6	930.74	42.6 QP	46.0	-3.4	1.55 V	64	41.63	0.93

REMARKS:

1. Emission Level(dBuV/m) = Raw Value(dBuV) + Correction Factor(dB/m)
2. Correction Factor(dB/m) = Antenna Factor(dB/m) + Cable Factor(dB) – Pre-Amplifier Factor(dB)
3. The other emission levels were very low against the limit.
4. Margin value = Emission Level – Limit value

CHANNEL	TX Channel 165	DETECTOR FUNCTION	Quasi-Peak (QP)
FREQUENCY RANGE	Below 1GHz		

ANTENNA POLARITY & TEST DISTANCE: HORIZONTAL AT 3 M

NO.	FREQ. (MHz)	EMISSION LEVEL (dBuV/m)	LIMIT (dBuV/m)	MARGIN (dB)	ANTENNA HEIGHT (m)	TABLE ANGLE (Degree)	RAW VALUE (dBuV)	CORRECTION FACTOR (dB/m)
1	143.61	38.8 QP	43.5	-4.7	1.99 H	44	51.84	-13.03
2	180.71	39.6 QP	43.5	-3.9	1.74 H	67	54.14	-14.58
3	404.41	39.7 QP	46.0	-6.3	1.67 H	34	49.22	-9.51
4	704.14	40.7 QP	46.0	-5.3	1.88 H	98	44.06	-3.34
5	896.34	42.5 QP	46.0	-3.5	1.24 H	67	42.43	0.08
6	930.34	41.5 QP	46.0	-4.5	1.42 H	134	40.57	0.94

ANTENNA POLARITY & TEST DISTANCE: VERTICAL AT 3 M

NO.	FREQ. (MHz)	EMISSION LEVEL (dBuV/m)	LIMIT (dBuV/m)	MARGIN (dB)	ANTENNA HEIGHT (m)	TABLE ANGLE (Degree)	RAW VALUE (dBuV)	CORRECTION FACTOR (dB/m)
1	39.51	35.7 QP	40.0	-4.3	1.24 V	111	49.53	-13.82
2	72.51	35.5 QP	40.0	-4.5	1.63 V	36	51.45	-15.94
3	448.41	41.8 QP	46.0	-4.2	1.24 V	144	49.94	-8.13
4	849.57	40.8 QP	46.0	-5.2	1.41 V	14	41.50	-0.72
5	896.71	42.8 QP	46.0	-3.2	1.00 V	96	42.75	0.09
6	930.51	42.3 QP	46.0	-3.7	1.45 V	69	41.41	0.93

REMARKS:

1. Emission Level(dBuV/m) = Raw Value(dBuV) + Correction Factor(dB/m)
2. Correction Factor(dB/m) = Antenna Factor(dB/m) + Cable Factor(dB) – Pre-Amplifier Factor(dB)
3. The other emission levels were very low against the limit.
4. Margin value = Emission Level – Limit value

802.11n (HT20)

CHANNEL	TX Channel 36	DETECTOR FUNCTION	Quasi-Peak (QP)
FREQUENCY RANGE	Below 1GHz		

ANTENNA POLARITY & TEST DISTANCE: HORIZONTAL AT 3 M

NO.	FREQ. (MHz)	EMISSION LEVEL (dBuV/m)	LIMIT (dBuV/m)	MARGIN (dB)	ANTENNA HEIGHT (m)	TABLE ANGLE (Degree)	RAW VALUE (dBuV)	CORRECTION FACTOR (dB/m)
1	143.71	39.0 QP	43.5	-4.6	1.34 H	304	51.96	-13.01
2	180.51	39.4 QP	43.5	-4.1	1.24 H	30	53.96	-14.55
3	404.21	39.5 QP	46.0	-6.5	1.55 H	61	49.02	-9.51
4	704.34	40.5 QP	46.0	-5.5	1.54 H	133	43.85	-3.33
5	896.41	42.6 QP	46.0	-3.4	1.11 H	65	42.53	0.08
6	930.51	41.8 QP	46.0	-4.3	1.67 H	111	40.82	0.93

ANTENNA POLARITY & TEST DISTANCE: VERTICAL AT 3 M

NO.	FREQ. (MHz)	EMISSION LEVEL (dBuV/m)	LIMIT (dBuV/m)	MARGIN (dB)	ANTENNA HEIGHT (m)	TABLE ANGLE (Degree)	RAW VALUE (dBuV)	CORRECTION FACTOR (dB/m)
1	39.44	35.4 QP	40.0	-4.6	1.87 V	78	49.24	-13.82
2	72.34	35.4 QP	40.0	-4.6	1.45 V	100	51.35	-15.93
3	448.24	41.7 QP	46.0	-4.3	1.67 V	360	49.84	-8.13
4	849.41	40.5 QP	46.0	-5.5	1.00 V	88	41.24	-0.72
5	896.51	42.7 QP	46.0	-3.3	1.34 V	64	42.63	0.08
6	930.24	42.4 QP	46.0	-3.6	1.44 V	98	41.48	0.94

REMARKS:

1. Emission Level(dBuV/m) = Raw Value(dBuV) + Correction Factor(dB/m)
2. Correction Factor(dB/m) = Antenna Factor(dB/m) + Cable Factor(dB) – Pre-Amplifier Factor(dB)
3. The other emission levels were very low against the limit.
4. Margin value = Emission Level – Limit value

CHANNEL	TX Channel 40	DETECTOR FUNCTION	Quasi-Peak (QP)
FREQUENCY RANGE	Below 1GHz		

ANTENNA POLARITY & TEST DISTANCE: HORIZONTAL AT 3 M

NO.	FREQ. (MHz)	EMISSION LEVEL (dBuV/m)	LIMIT (dBuV/m)	MARGIN (dB)	ANTENNA HEIGHT (m)	TABLE ANGLE (Degree)	RAW VALUE (dBuV)	CORRECTION FACTOR (dB/m)
1	143.51	39.1 QP	43.5	-4.4	1.45 H	122	52.15	-13.04
2	180.71	39.6 QP	43.5	-3.9	1.47 H	255	54.19	-14.58
3	404.34	40.1 QP	46.0	-5.9	1.24 H	147	49.63	-9.51
4	704.52	40.6 QP	46.0	-5.4	1.74 H	244	43.93	-3.32
5	896.56	42.8 QP	46.0	-3.3	1.70 H	88	42.67	0.08
6	930.41	41.9 QP	46.0	-4.1	1.24 H	304	40.95	0.94

ANTENNA POLARITY & TEST DISTANCE: VERTICAL AT 3 M

NO.	FREQ. (MHz)	EMISSION LEVEL (dBuV/m)	LIMIT (dBuV/m)	MARGIN (dB)	ANTENNA HEIGHT (m)	TABLE ANGLE (Degree)	RAW VALUE (dBuV)	CORRECTION FACTOR (dB/m)
1	39.14	35.2 QP	40.0	-4.8	1.66 V	347	49.04	-13.83
2	72.54	35.2 QP	40.0	-4.8	1.44 V	69	51.16	-15.95
3	448.41	41.6 QP	46.0	-4.4	1.55 V	25	49.75	-8.13
4	849.24	40.7 QP	46.0	-5.3	1.58 V	85	41.40	-0.72
5	896.24	42.7 QP	46.0	-3.3	1.55 V	75	42.62	0.07
6	930.74	42.6 QP	46.0	-3.4	1.64 V	94	41.71	0.93

REMARKS:

1. Emission Level(dBuV/m) = Raw Value(dBuV) + Correction Factor(dB/m)
2. Correction Factor(dB/m) = Antenna Factor(dB/m) + Cable Factor(dB) – Pre-Amplifier Factor(dB)
3. The other emission levels were very low against the limit.
4. Margin value = Emission Level – Limit value

CHANNEL	TX Channel 48	DETECTOR FUNCTION	Quasi-Peak (QP)
FREQUENCY RANGE	Below 1GHz		

ANTENNA POLARITY & TEST DISTANCE: HORIZONTAL AT 3 M

NO.	FREQ. (MHz)	EMISSION LEVEL (dBuV/m)	LIMIT (dBuV/m)	MARGIN (dB)	ANTENNA HEIGHT (m)	TABLE ANGLE (Degree)	RAW VALUE (dBuV)	CORRECTION FACTOR (dB/m)
1	143.32	39.2 QP	43.5	-4.3	1.42 H	323	52.31	-13.07
2	180.96	39.5 QP	43.5	-4.0	1.46 H	354	54.13	-14.62
3	404.45	40.2 QP	46.0	-5.8	1.74 H	266	49.74	-9.50
4	704.24	40.5 QP	46.0	-5.6	1.44 H	304	43.79	-3.34
5	896.41	42.4 QP	46.0	-3.6	1.44 H	100	42.33	0.08
6	930.57	41.7 QP	46.0	-4.3	1.66 H	304	40.78	0.93

ANTENNA POLARITY & TEST DISTANCE: VERTICAL AT 3 M

NO.	FREQ. (MHz)	EMISSION LEVEL (dBuV/m)	LIMIT (dBuV/m)	MARGIN (dB)	ANTENNA HEIGHT (m)	TABLE ANGLE (Degree)	RAW VALUE (dBuV)	CORRECTION FACTOR (dB/m)
1	39.24	35.5 QP	40.0	-4.5	1.24 V	24	49.37	-13.83
2	72.41	35.4 QP	40.0	-4.6	1.74 V	47	51.36	-15.94
3	448.31	41.4 QP	46.0	-4.6	1.24 V	100	49.55	-8.13
4	849.42	40.4 QP	46.0	-5.6	1.41 V	28	41.14	-0.72
5	896.41	42.7 QP	46.0	-3.3	1.45 V	54	42.65	0.08
6	930.51	42.4 QP	46.0	-3.6	1.47 V	98	41.49	0.93

REMARKS:

1. Emission Level(dBuV/m) = Raw Value(dBuV) + Correction Factor(dB/m)
2. Correction Factor(dB/m) = Antenna Factor(dB/m) + Cable Factor(dB) – Pre-Amplifier Factor(dB)
3. The other emission levels were very low against the limit.
4. Margin value = Emission Level – Limit value

CHANNEL	TX Channel 149	DETECTOR FUNCTION	Quasi-Peak (QP)
FREQUENCY RANGE	Below 1GHz		

ANTENNA POLARITY & TEST DISTANCE: HORIZONTAL AT 3 M

NO.	FREQ. (MHz)	EMISSION LEVEL (dBuV/m)	LIMIT (dBuV/m)	MARGIN (dB)	ANTENNA HEIGHT (m)	TABLE ANGLE (Degree)	RAW VALUE (dBuV)	CORRECTION FACTOR (dB/m)
1	143.51	39.4 QP	43.5	-4.1	1.34 H	201	52.46	-13.04
2	180.74	39.7 QP	43.5	-3.8	1.55 H	66	54.29	-14.58
3	404.24	40.4 QP	46.0	-5.6	1.34 H	306	49.92	-9.51
4	704.47	40.8 QP	46.0	-5.3	1.24 H	244	44.07	-3.32
5	896.57	42.2 QP	46.0	-3.8	1.99 H	89	42.16	0.08
6	930.11	41.6 QP	46.0	-4.4	1.25 H	52	40.67	0.94

ANTENNA POLARITY & TEST DISTANCE: VERTICAL AT 3 M

NO.	FREQ. (MHz)	EMISSION LEVEL (dBuV/m)	LIMIT (dBuV/m)	MARGIN (dB)	ANTENNA HEIGHT (m)	TABLE ANGLE (Degree)	RAW VALUE (dBuV)	CORRECTION FACTOR (dB/m)
1	39.30	36.0 QP	40.0	-4.0	1.54 V	45	49.82	-13.83
2	72.57	35.6 QP	40.0	-4.4	1.33 V	63	51.56	-15.95
3	448.67	41.2 QP	46.0	-4.8	1.75 V	57	49.37	-8.13
4	849.24	40.5 QP	46.0	-5.5	1.96 V	69	41.24	-0.72
5	896.24	42.6 QP	46.0	-3.4	4.00 V	87	42.54	0.07
6	930.85	42.6 QP	46.0	-3.4	1.23 V	32	41.71	0.93

REMARKS:

1. Emission Level(dBuV/m) = Raw Value(dBuV) + Correction Factor(dB/m)
2. Correction Factor(dB/m) = Antenna Factor(dB/m) + Cable Factor(dB) – Pre-Amplifier Factor(dB)
3. The other emission levels were very low against the limit.
4. Margin value = Emission Level – Limit value

CHANNEL	TX Channel 157	DETECTOR FUNCTION	Quasi-Peak (QP)
FREQUENCY RANGE	Below 1GHz		

ANTENNA POLARITY & TEST DISTANCE: HORIZONTAL AT 3 M

NO.	FREQ. (MHz)	EMISSION LEVEL (dBuV/m)	LIMIT (dBuV/m)	MARGIN (dB)	ANTENNA HEIGHT (m)	TABLE ANGLE (Degree)	RAW VALUE (dBuV)	CORRECTION FACTOR (dB/m)
1	143.15	39.2 QP	43.5	-4.3	1.64 H	71	52.33	-13.09
2	180.41	39.6 QP	43.5	-3.9	1.24 H	99	54.15	-14.53
3	404.11	40.1 QP	46.0	-5.9	1.50 H	32	49.63	-9.52
4	704.21	40.5 QP	46.0	-5.5	1.64 H	201	43.85	-3.34
5	896.41	42.1 QP	46.0	-3.9	1.24 H	244	42.03	0.08
6	930.24	41.4 QP	46.0	-4.6	1.64 H	360	40.47	0.94

ANTENNA POLARITY & TEST DISTANCE: VERTICAL AT 3 M

NO.	FREQ. (MHz)	EMISSION LEVEL (dBuV/m)	LIMIT (dBuV/m)	MARGIN (dB)	ANTENNA HEIGHT (m)	TABLE ANGLE (Degree)	RAW VALUE (dBuV)	CORRECTION FACTOR (dB/m)
1	39.51	35.7 QP	40.0	-4.4	1.42 V	56	49.47	-13.82
2	72.57	35.6 QP	40.0	-4.4	1.88 V	54	51.56	-15.95
3	448.51	41.4 QP	46.0	-4.6	1.24 V	35	49.55	-8.13
4	849.34	40.4 QP	46.0	-5.6	1.87 V	54	41.13	-0.72
5	896.34	42.5 QP	46.0	-3.5	1.24 V	69	42.43	0.08
6	930.47	42.4 QP	46.0	-3.6	1.57 V	67	41.48	0.94

REMARKS:

1. Emission Level(dBuV/m) = Raw Value(dBuV) + Correction Factor(dB/m)
2. Correction Factor(dB/m) = Antenna Factor(dB/m) + Cable Factor(dB) – Pre-Amplifier Factor(dB)
3. The other emission levels were very low against the limit.
4. Margin value = Emission Level – Limit value

CHANNEL	TX Channel 165	DETECTOR FUNCTION	Quasi-Peak (QP)
FREQUENCY RANGE	Below 1GHz		

ANTENNA POLARITY & TEST DISTANCE: HORIZONTAL AT 3 M

NO.	FREQ. (MHz)	EMISSION LEVEL (dBuV/m)	LIMIT (dBuV/m)	MARGIN (dB)	ANTENNA HEIGHT (m)	TABLE ANGLE (Degree)	RAW VALUE (dBuV)	CORRECTION FACTOR (dB/m)
1	143.01	39.0 QP	43.5	-4.5	1.24 H	69	52.12	-13.11
2	180.12	39.4 QP	43.5	-4.1	1.33 H	55	53.90	-14.49
3	404.07	40.3 QP	46.0	-5.7	1.24 H	44	49.86	-9.52
4	704.51	40.2 QP	46.0	-5.8	1.24 H	24	43.53	-3.32
5	896.11	42.0 QP	46.0	-4.0	1.22 H	64	41.95	0.06
6	930.51	41.1 QP	46.0	-4.9	1.28 H	81	40.17	0.93

ANTENNA POLARITY & TEST DISTANCE: VERTICAL AT 3 M

NO.	FREQ. (MHz)	EMISSION LEVEL (dBuV/m)	LIMIT (dBuV/m)	MARGIN (dB)	ANTENNA HEIGHT (m)	TABLE ANGLE (Degree)	RAW VALUE (dBuV)	CORRECTION FACTOR (dB/m)
1	39.41	35.3 QP	40.0	-4.7	1.24 V	45	49.13	-13.82
2	72.64	35.3 QP	40.0	-4.7	1.75 V	100	51.31	-15.97
3	448.41	41.2 QP	46.0	-4.8	1.78 V	67	49.37	-8.13
4	849.40	40.6 QP	46.0	-5.4	1.55 V	98	41.29	-0.72
5	896.77	42.8 QP	46.0	-3.2	1.64 V	75	42.69	0.09
6	930.68	42.2 QP	46.0	-3.8	1.24 V	37	41.31	0.93

REMARKS:

1. Emission Level(dBuV/m) = Raw Value(dBuV) + Correction Factor(dB/m)
2. Correction Factor(dB/m) = Antenna Factor(dB/m) + Cable Factor(dB) – Pre-Amplifier Factor(dB)
3. The other emission levels were very low against the limit.
4. Margin value = Emission Level – Limit value

4.2 Transmit Power Measurement

4.2.1 Limits of Transmit Power Measurement

Operation Band	EUT Category		Limit
U-NII-1		Outdoor Access Point	1 Watt (30 dBm) (Max. e.i.r.p \leq 125mW(21 dBm) at any elevation angle above 30 degrees as measured from the horizon)
		Fixed point-to-point Access Point	1 Watt (30 dBm)
		Indoor Access Point	1 Watt (30 dBm)
	√	Mobile and Portable client device	250mW (24 dBm)
U-NII-2A			250mW (24 dBm) or 11 dBm+10 log B*
U-NII-2C			250mW (24 dBm) or 11 dBm+10 log B*
U-NII-3	√		1 Watt (30 dBm)

*B is the 26 dB emission bandwidth in megahertz

4.2.2 Test Setup

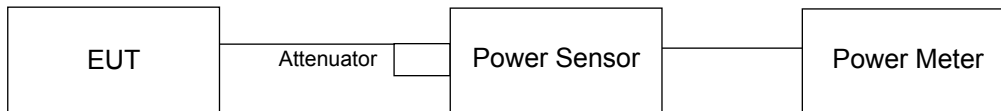

4.2.3 Test Instruments

Refer to section 4.1.2 to get information of above instrument.

4.2.4 Test Procedures

Method PM is used to perform output power measurement, trigger and gating function of wide band power meter is enabled to measure max output power of TX on burst. Duty factor is not added to measured value.

4.2.5 Deviation from Test Standard

No deviation.

4.2.6 EUT Operating Conditions

The software provided by client to enable the EUT under transmission condition continuously at lowest, middle and highest channel frequencies individually.

4.2.7 Test Result

802.11a

Chan.	Chan. Freq. (MHz)	Average Power (mW)	Average Power (dBm)	Limit (dBm)	Pass / Fail
36	5180	39.811	16.00	24	Pass
40	5200	71.779	18.56	24	Pass
48	5240	73.282	18.65	24	Pass
149	5745	40.644	16.09	30	Pass
157	5785	72.946	18.63	30	Pass
165	5825	66.681	18.24	30	Pass

802.11n (HT20)

Chan.	Chan. Freq. (MHz)	Average Power (mW)	Average Power (dBm)	Limit (dBm)	Pass / Fail
36	5180	36.728	15.65	24	Pass
40	5200	66.374	18.22	24	Pass
48	5240	66.988	18.26	24	Pass
149	5745	29.648	14.72	30	Pass
157	5785	68.391	18.35	30	Pass
165	5825	61.518	17.89	30	Pass

※Add test for each data rate output power (require by manufacturer):

802.11a

CHANNEL	FREQUENCY (MHz)	AVERAGE POWER (dBm)							
		Data rate							
		6Mbps	9Mbps	12Mbps	18Mbps	24Mbps	36Mbps	48Mbps	54Mbps
36	5180	16.00	15.97	15.86	15.92	15.98	15.82	15.84	15.92
40	5200	18.56	18.46	18.54	18.38	18.38	18.55	18.44	18.43
48	5240	18.65	18.47	18.59	18.48	18.57	18.55	18.52	18.49
149	5745	16.09	15.97	15.90	15.98	16.05	15.89	16.01	16.04
157	5785	18.63	18.50	18.56	18.58	18.52	18.52	18.59	18.46
165	5825	18.24	18.05	18.07	18.23	18.1	18.16	18.08	18.16

802.11n (HT20)

CHANNEL	FREQUENCY (MHz)	AVERAGE POWER (dBm)							
		Data rate							
		MCS0	MCS1	MCS2	MCS3	MCS4	MCS5	MCS6	MCS7
36	5180	15.65	15.63	15.50	15.60	15.56	15.55	15.56	15.49
40	5200	18.22	18.19	18.15	18.20	18.03	18.04	18.19	18.09
48	5240	18.26	18.17	18.16	18.20	18.18	18.14	18.18	18.19
149	5745	14.72	14.67	14.55	14.66	14.58	14.64	14.68	14.68
157	5785	18.35	18.31	18.22	18.29	18.29	18.26	18.25	18.27
165	5825	17.89	17.86	17.83	17.72	17.86	17.86	17.88	17.75

4.3 Peak Power Spectral Density Measurement

4.3.1 Limits of Peak Power Spectral Density Measurement

Operation Band	EUT Category		Limit
U-NII-1		Outdoor Access Point	17dBm/ MHz
		Fixed point-to-point Access Point	
		Indoor Access Point	
	√	Mobile and Portable client device	11dBm/ MHz
U-NII-2A			11dBm/ MHz
U-NII-2C			11dBm/ MHz
U-NII-3		√	30dBm/ 500kHz

4.3.2 Test Setup

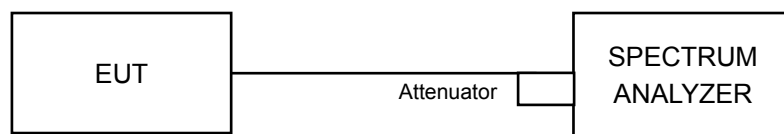

4.3.3 Test Instruments

Refer to section 4.1.2 to get information of above instrument.

4.3.4 Test Procedures

For U-NII-1 band:

Using method SA-1

1. Set span to encompass the entire emission bandwidth (EBW) of the signal.
2. Set RBW = 1 MHz, Set VBW ≥ 3 MHz, Detector = RMS
3. Sweep time = auto, trigger set to “free run”.
4. Trace average at least 100 traces in power averaging mode.
5. Record the max value

For U-NII-3 band:

1. Set span to encompass the entire emission bandwidth (EBW) of the signal.
2. Set RBW = 300 kHz, Set VBW ≥ 1 MHz, Detector = RMS
3. Use the peak marker function to determine the maximum power level in any 300 kHz band segment within the fundamental EBW.
4. Scale the observed power level to an equivalent value in 500 kHz by adjusting (reducing) the measured power by a bandwidth correction factor (BWCF) where $BWCF = 10\log(500\text{ kHz}/300\text{kHz})$
5. Sweep time = auto, trigger set to “free run”.
6. Trace average at least 100 traces in power averaging mode.
7. Record the max value

4.3.5 Deviation from Test Standard

No deviation.

4.3.6 EUT Operating Conditions

Same as Item 4.2.6

4.3.7 Test Results

For U-NII-1:

802.11a

Chan.	Chan. Freq. (MHz)	PSD (dBm)	MAX. Limit (dBm)	Pass / Fail
36	5180	-0.61	11	Pass
40	5200	3.86	11	Pass
48	5240	5.13	11	Pass

802.11n (HT20)

Chan.	Chan. Freq. (MHz)	PSD (dBm)	MAX. Limit (dBm)	Pass / Fail
36	5180	1.65	11	Pass
40	5200	4.84	11	Pass
48	5240	4.67	11	Pass

Spectrum Plot of Worst Value

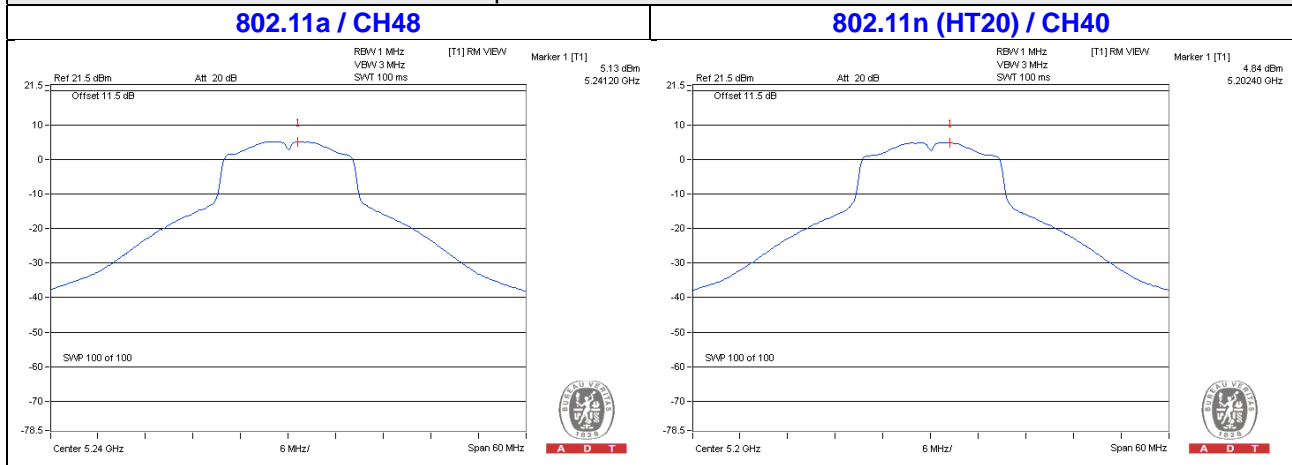

For U-NII-3:

802.11a

Chan.	Chan. Freq. (MHz)	PSD (dBm/300kHz)	PSD (dBm/500kHz)	Limit (dBm/500kHz)	Pass /Fail
149	5745	-5.57	-3.35	30	Pass
157	5785	-2.39	-0.17	30	Pass
165	5825	-2.63	-0.41	30	Pass

802.11n (HT20)

Chan.	Chan. Freq. (MHz)	PSD (dBm/300kHz)	PSD (dBm/500kHz)	Limit (dBm/500kHz)	Pass /Fail
149	5745	-6.95	-4.73	30	Pass
157	5785	-3.24	-1.02	30	Pass
165	5825	-3.51	-1.29	30	Pass

Spectrum Plot of Worst Value

802.11a / CH157

802.11n (HT20) / CH157

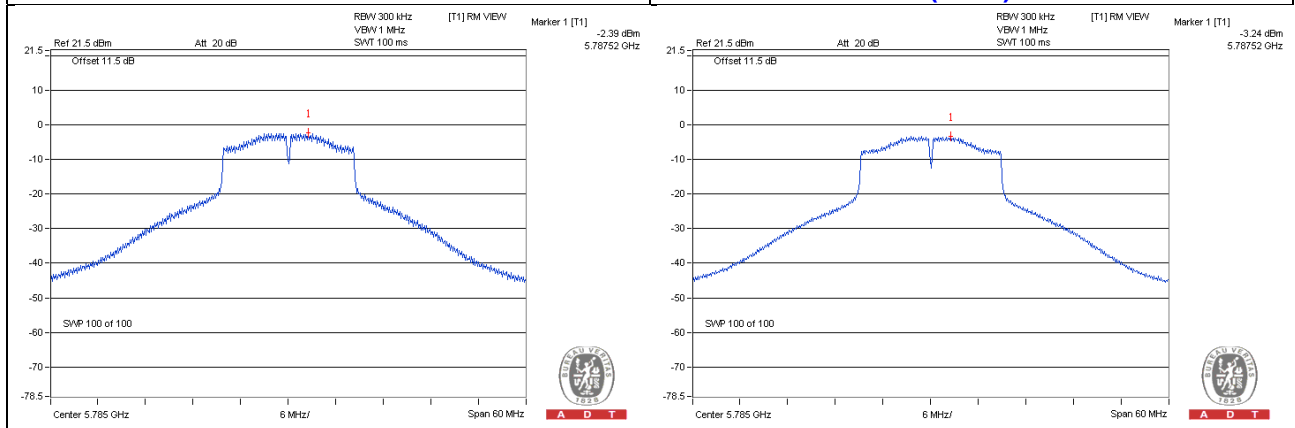

4.4 Frequency Stability Measurement

4.4.1 Limits of Frequency Stability Measurement

The frequency of the carrier signal shall be maintained within band of operation

4.4.2 Test Setup

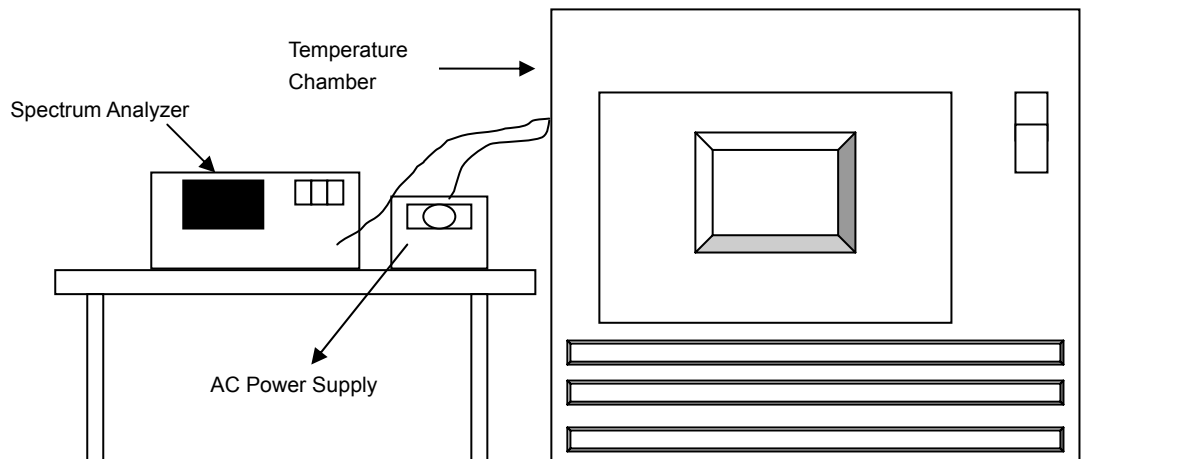

4.4.3 Test Instruments

Refer to section 4.1.2 to get information of above instrument.

4.4.4 Test Procedures

- The EUT was placed inside the environmental test chamber and powered by nominal AC voltage.
- Turn the EUT on and couple its output to a spectrum analyzer.
- Turn the EUT off and set the chamber to the highest temperature specified.
- Allow sufficient time (approximately 30 min) for the temperature of the chamber to stabilize, turn the EUT on and measure the operating frequency after 2, 5, and 10 minutes.
- Repeat step 2 and 3 with the temperature chamber set to the lowest temperature.
- The test chamber was allowed to stabilize at +20 degree C for a minimum of 30 minutes. The supply voltage was then adjusted on the EUT from 85% to 115% and the frequency record.

4.4.5 Deviation from Test Standard

No deviation.

4.4.6 EUT Operating Conditions

Set the EUT transmit at un-modulation mode to test frequency stability.

4.4.7 Test Results

Frequency Stability Versus Temp.									
Operating Frequency: 5180MHz									
Temp. (°C)	Power Supply (Vac)	0 Minute		2 Minute		5 Minute		10 Minute	
		Measured Frequency (MHz)	Frequency Drift (%)	Measured Frequency (MHz)	Frequency Drift (%)	Measured Frequency (MHz)	Frequency Drift (%)	Measured Frequency (MHz)	Frequency Drift (%)
50	120	5179.9779	-0.00043	5179.9755	-0.00047	5179.9758	-0.00047	5179.9786	-0.00041
40	120	5179.9753	-0.00048	5179.9791	-0.00040	5179.9774	-0.00044	5179.9792	-0.00040
30	120	5179.9737	-0.00051	5179.9743	-0.00050	5179.9756	-0.00047	5179.9739	-0.00050
20	120	5179.9829	-0.00033	5179.9869	-0.00025	5179.9878	-0.00024	5179.9847	-0.00030
10	120	5179.9836	-0.00032	5179.9827	-0.00033	5179.9813	-0.00036	5179.9807	-0.00037
0	120	5180.0003	0.00001	5179.9973	-0.00005	5179.9972	-0.00005	5179.9986	-0.00003
-10	120	5179.9964	-0.00007	5179.9947	-0.00010	5179.9998	0.00000	5179.9958	-0.00008
-20	120	5179.9972	-0.00005	5179.9963	-0.00007	5179.9946	-0.00010	5179.9942	-0.00011
-30	120	5179.9979	-0.00004	5179.9952	-0.00009	5179.9991	-0.00002	5179.9984	-0.00003

Frequency Stability Versus Temp.									
Operating Frequency: 5180MHz									
Temp. (°C)	Power Supply (Vac)	0 Minute		2 Minute		5 Minute		10 Minute	
		Measured Frequency (MHz)	Frequency Drift (%)	Measured Frequency (MHz)	Frequency Drift (%)	Measured Frequency (MHz)	Frequency Drift (%)	Measured Frequency (MHz)	Frequency Drift (%)
20	138	5179.9835	-0.00032	5179.9874	-0.00024	5179.9888	-0.00022	5179.9856	-0.00028
	120	5179.9829	-0.00033	5179.9869	-0.00025	5179.9878	-0.00024	5179.9847	-0.00030
	102	5179.9831	-0.00033	5179.9867	-0.00026	5179.9885	-0.00022	5179.9844	-0.00030

4.5 6dB Bandwidth Measurement

4.5.1 Limits of 6dB Bandwidth Measurement

The minimum of 6dB Bandwidth Measurement is 0.5MHz.

4.5.2 Test Setup

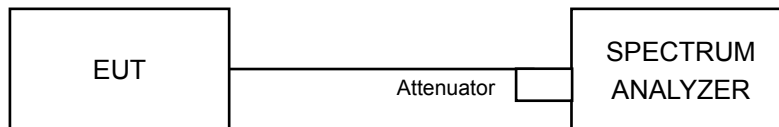

4.5.3 Test Instruments

Refer to section 4.1.2 to get information of above instrument.

4.5.4 Test Procedures

MEASUREMENT PROCEDURE REF

- a. Set resolution bandwidth (RBW) = 100kHz
- b. Set the video bandwidth (VBW) $\geq 3 \times$ RBW, Detector = Peak.
- c. Trace mode = max hold.
- d. Sweep = auto couple.
- e. Measure the maximum width of the emission that is constrained by the frequencies associated with the two amplitude points (upper and lower) that are attenuated by 6 dB relative to the maximum level measured in the fundamental emission

4.5.5 Deviation from Test Standard

No deviation.

4.5.6 EUT Operating Conditions

The software provided by client to enable the EUT under transmission condition continuously at lowest, middle and highest channel frequencies individually.

4.5.7 Test Results

802.11a

Channel	Frequency (MHz)	6dB Bandwidth (MHz)	Minimum Limit (MHz)	Pass / Fail
149	5745	15.16	0.5	Pass
157	5785	15.35	0.5	Pass
165	5825	15.18	0.5	Pass

802.11n (HT20)

Channel	Frequency (MHz)	6dB Bandwidth (MHz)	Minimum Limit (MHz)	Pass / Fail
149	5745	15.20	0.5	Pass
157	5785	15.17	0.5	Pass
165	5825	15.16	0.5	Pass

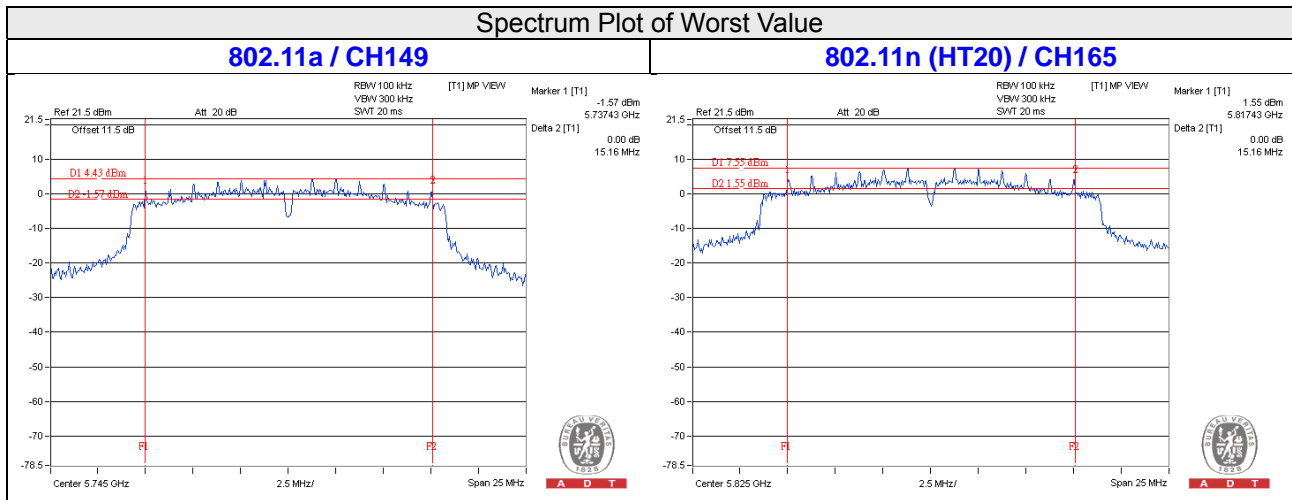

5 Pictures of Test Arrangements

Please refer to the attached file (Test Setup Photo).

Appendix – Information on the Testing Laboratories

We, Bureau Veritas Consumer Products Services (H.K.) Ltd., Taoyuan Branch, were founded in 1988 to provide our best service in EMC, Radio, Telecom and Safety consultation. Our laboratories are accredited and approved according to ISO/IEC 17025.

If you have any comments, please feel free to contact us at the following:

Linko EMC/RF Lab

Tel: 886-2-26052180

Fax: 886-2-26051924

Hsin Chu EMC/RF Lab/Telecom Lab

Tel: 886-3-5935343

Fax: 886-3-5935342

Hwa Ya EMC/RF/Safety

Tel: 886-3-3183232

Fax: 886-3-3270892

Email: service.adt@tw.bureauveritas.com

Web Site: www.bureauveritas-adt.com

The address and road map of all our labs can be found in our web site also.

--- END ---