

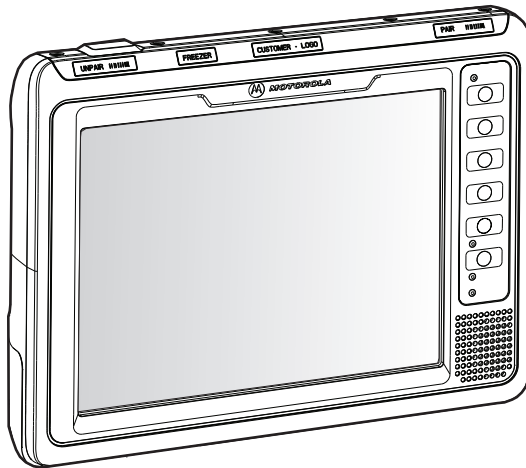

VC70N0 Vehicle Computer

Quick Reference Guide





© 2012 MOTOROLA SOLUTIONS, INC. All rights reserved.

Motorola reserves the right to make changes to any product to improve reliability, function, or design.

Motorola does not assume any product liability arising out of, or in connection with, the application or use of any product, circuit, or application described herein.

No license is granted, either expressly or by implication, estoppel, or otherwise under any patent right or patent, covering or relating to any combination, system, apparatus, machine, material, method, or process in which Motorola products might be used. An implied license exists only for equipment, circuits, and subsystems contained in Motorola products.

MOTOROLA, MOTO, MOTOROLA SOLUTIONS and the Stylized M Logo are trademarks or registered trademarks of Motorola Trademark Holdings, LLC and are used under license. All other trademarks are the property of their respective owners.

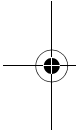

Motorola Solutions, Inc.
One Motorola Plaza
Holtsville, N.Y. 11742-1300, USA

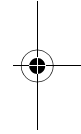

<http://www.motorolasolutions.com>

Warranty

Subject to the terms of Motorola's hardware warranty statement, the VC70 Vehicle Computer products are warranted against defects in workmanship and materials for a period of one year from the date of shipment. For the complete Motorola hardware product warranty statement, go to: <http://www.motorolasolutions.com/warranty>.



Introduction

The VC70 is Motorola's ultra-rugged forklift mounted computer. It is designed to maximize productivity in harsh environments. Its rugged construction and high-performance wireless networking enables real-time data access and collection in a wide range of environments — from the loading dock and freezer to the warehouse.

The VC70's compact design improves visibility and reduces safety concerns while retaining large screen size (10.4"). Its 802.11 a/b/g/n WLAN provides real-time information that improves decision making, reduces errors, and enhances productivity. Its rugged design with integrated shock-mount and MIL-STD 810 military rating for shock and vibration ensures dependable operation in challenging environments. Its IP66 sealing, display, defroster and wide temperature range ensure operation in and out of -30°C freezer storage warehouse.

With its high-resolution and high-brightness display, the VC70 provides the user access to more information in low ambient light warehouse and outdoors.

The VC70 accessories allow backward compatibility with the VC5090 for easy and gradual migration.

About This Guide

This guide contains the following:

- [Features on page 4](#)
- [Unpacking on page 5](#)
- [Installation on page 5](#)
- [Powering the VC70 On/Off on page 18](#)
- [Connecting Accessories on page 22](#)
- [Maintenance on page 22](#)
- [Troubleshooting on page 25](#)
- [Regulatory Information on page 27.](#)

For more information including installation instructions, refer to the *VC70 Product Reference Guide*, p/n 72-164686-01 available at <http://supportcentral.motorola.com>.

Features

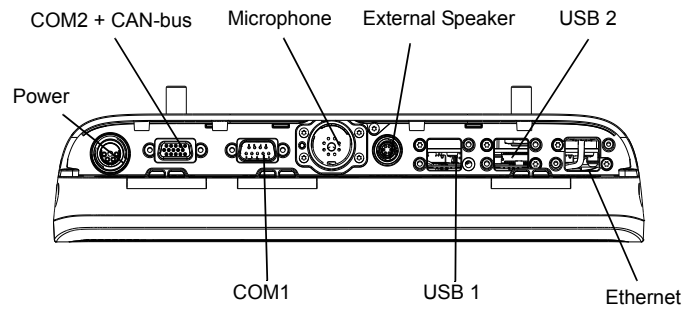
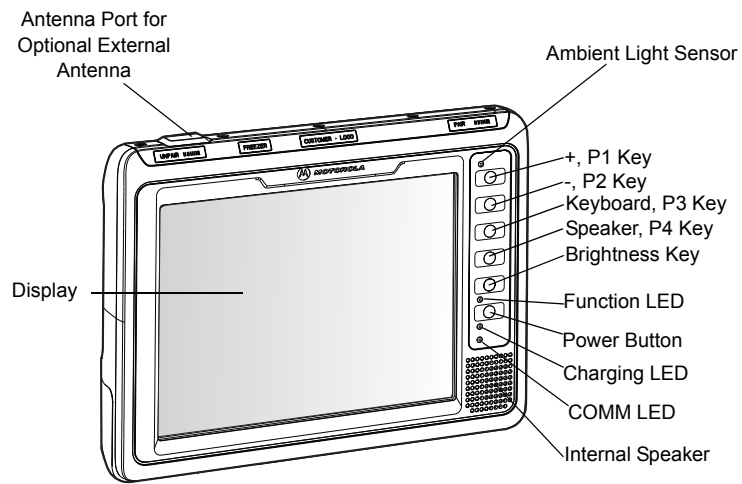

Bottom Connectors

Unpacking

The following items are contained in the box:

- VC70 vehicle computer
- this guide.

Optional Accessories

- Scanners (corded and wireless) and scanner cables
- External speaker
- DC and AC power supplies and cables
- External keyboards - QWERTY, AZERTY or numeric with mounting kits

Installation

Installing a Micro SD Card

A micro SD (Secure Digital) card provides secondary non-volatile storage. The card holder is located on the right side of the VC70 under the Service door.

To install a micro SD card:

1. Open the two screws securing the Service door.
2. Push the memory card, with the contacts up, into the card slot until it locks.

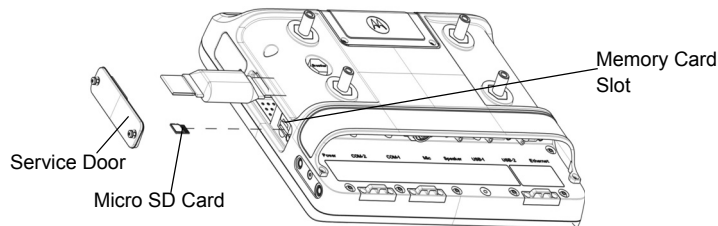

3. Replace the Service door and secure using two captive screws.

CAUTION Ensure to torque the screws to seal the device properly. Otherwise, sealing can be compromised.

4. Torque the torx head screws to $4.0 \pm 10\%$ kgf-cm ($3.5 \pm 10\%$ lbs-in).

U Mount Installation

- ✓ **NOTE** The vehicle computer and bracket must be firmly secured to a surface that can support the vehicle computer's weight.

Assemble the U mount bracket onto the vehicle computer as shown below.

Torque the M12x40mm hex head screws to $350 \pm 10\%$ kgf-cm ($300 \pm 10\%$ lbs-in).

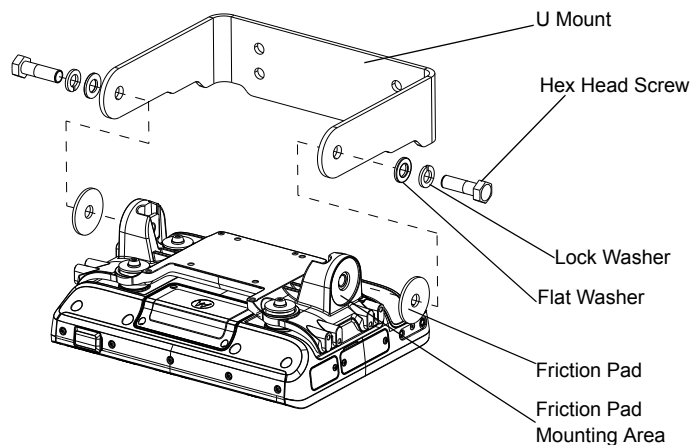

Installing the VC70 on a Forklift

- ⚠ **CAUTION** A qualified engineer must perform the installation in a vehicle. Improper installation can injure the operator or damage the vehicle and/or VC70.

Follow the instructions below to properly install the VC70 on a forklift.

- Determine the best location for mounting the vehicle computer taking into consideration the driver's field of view and ease of accessing the vehicle computer.
- Install the appropriate mounting hardware. The VC70 ships with four No. 8 Allen head screws (M10x50mm) for securing the mounting

Quick Reference Guide

7

bracket. If the supplied cap screws are not long enough, use M10 - X stainless steel Allen head screws where X represents the length in millimeters of the required screws.

Positioning the Vehicle Computer

- Position the vehicle computer to ensure proper ventilation around the device.
- Determine the best position for the vehicle computer and all the associated components. If a similar vehicle computer was previously installed, check to see if the position it used is suitable for the VC70.
- Test the installation for at least 30 minutes before installing on another vehicle:

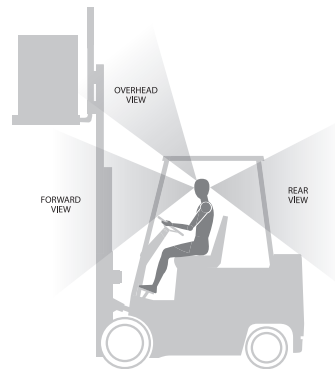

-Check that the position of the vehicle computer does not adversely obstruct vehicle controls.

-Check that the vehicle computer does not adversely obstruct the driver's view.

-Check the position of the vehicle computer for user comfort over long periods.

-Check positioning to avoid extreme wrist angles that may cause injury.

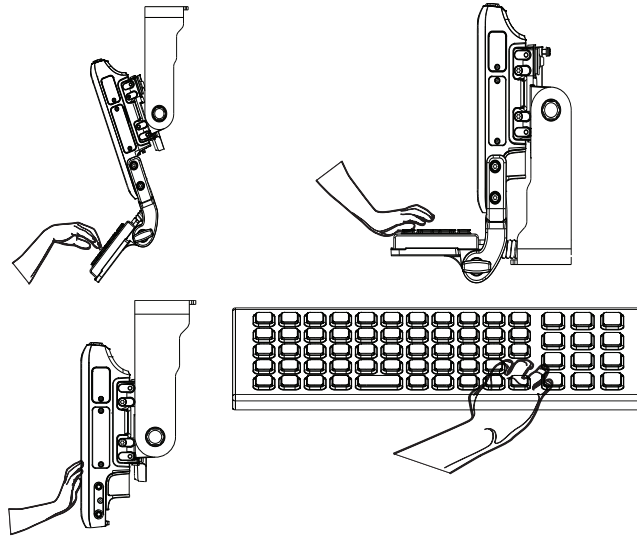

Avoid Extreme Wrist Angles

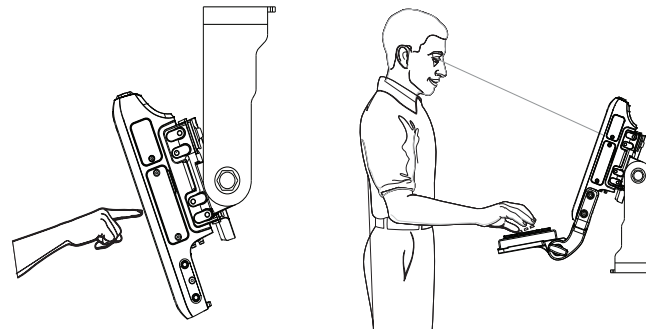

Optimum Wrist Position



**Mounting the Vehicle Computer**

Forklifts tend to generate very large shock and vibration pulses due to the hydraulics and the lack of suspension coupled with (usually) very hard wheels. The mounting bracket provided with the VC70 is designed as an isolator. In order for it to be effective, the bracket base must be securely mounted to a rigid and strong structure that fully supports the entire base of the bracket.

Most forklifts have a very rigid and durable chassis and outer body panels but top facing surfaces may be sheet metal or plastic. These thin sheet metal or plastic surfaces are not suitable for mounting surfaces due to their non-rigid nature.

Important Fixing Information

CAUTION Any modification to supplied mounting bracket could cause failure of the unit and/or mountings.

- Mounting surface must be flat and stiff and it must extend evenly for the entire length of the mounting bracket surface.
- All four mounting holes must be used.
- All nuts and bolts must be checked periodically and tightened if required.
- When installing the vehicle computer, care must be taken to ensure that the mounting bracket footprint is fully supported. Additional plates may be required to achieve this.

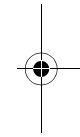
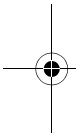
**Mounting Bracket Template**

Refer to the *VC70N0 Product Reference Guide P/N 72-164686-01* for mounting template.

Mounting onto an Over-Head Cross-Beam Example

The diagram below illustrates a typical installation where the vehicle computer is mounted onto a cross-beam.



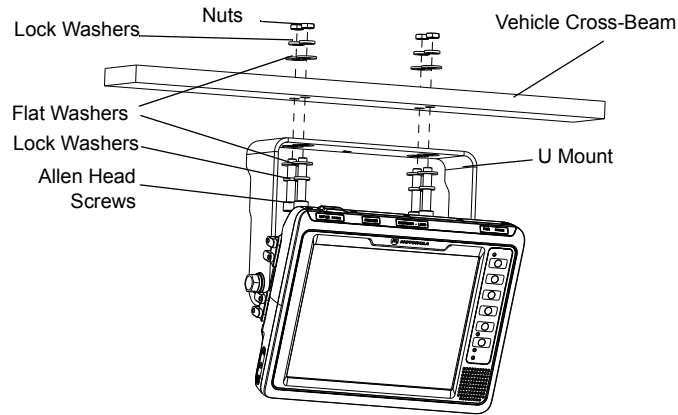

Mounting onto an Over-Head Cage Example

The diagrams below illustrates a typical installation where the vehicle computer is mounted on an overhead cage. A customer supplied mounting plate must be used that can withstand the weight of the vehicle computer under vibration and shock. The plate must be made of stainless steel or hardened steel with the following dimensions: 3.0 in. (76.0 mm) wide, 8.66 in. (220.0 mm) long and 0.2 in. (5.0 mm) thick. The mounting plate must be secured with hardware or to the underside of the cage by welding.

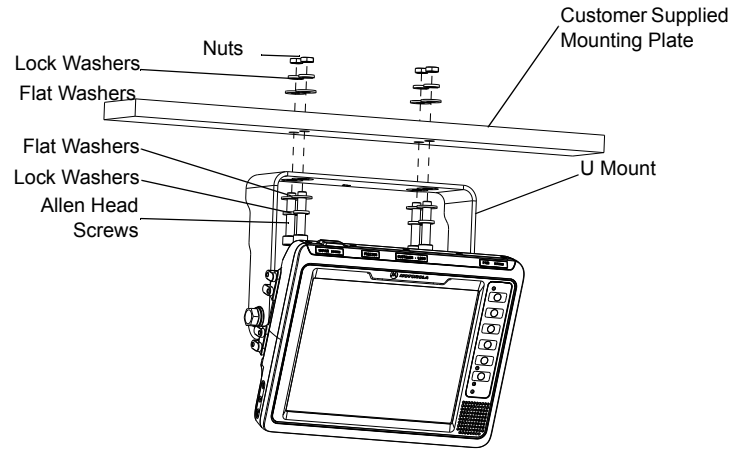

Mounting on Flat Overhead Beams

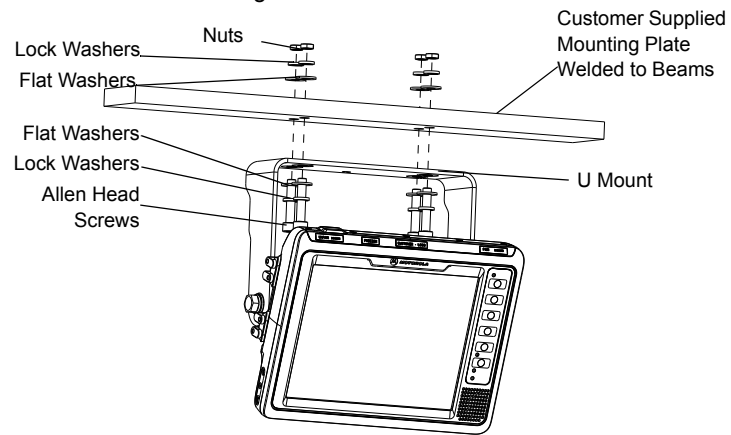

Mounting on Transverse Overhead Beams

Mounting on a Dashboard or Horizontal Surface Example

The diagram below illustrates a typical installation where the vehicle computer is mounted on a dashboard or horizontal flat surface.

CAUTION If mounting to a thin surface, a reinforcing plate is required.

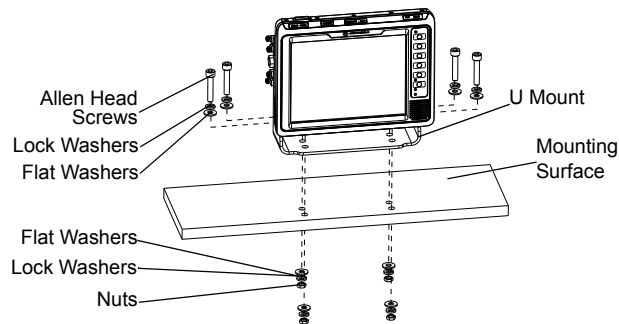
**Routing Electrical Cables**

- Establish a neat route for the cable, staying clear of moving parts or hot surfaces whenever possible.
- Fix the cable to existing cable runs inside the vehicle using cable ties, but make sure they are away from any moving or hot surfaces.
- When the cabling must go through a panel, use a suitable gland.
- When fixing the conduit or cable on the outside of a vehicle, use P-Clips. Either drill and tap the hole or use a nut and bolt to secure the clip.
- Ensure the cable does not have tight bends. The minimum recommended radius is 63.5mm (2.5"). Do not allow the power cable to bend against mounting hardware. Use the optional right angled DC power cable.
- Ensure cables do not swing or chafe on the structure. This often requires using cable ties approximately every foot, and ensuring the cables do not flex often, especially where they connect to the VC70. However, if you must re-position the VC70 occasionally, ensure there

Quick Reference Guide

13

is enough slack in the cable to accommodate movement without putting tension on the cable.

- DO NOT wind a cable in and out of the mesh on a cage.
- On electric vehicles, take the power from as close to the battery as possible, but not directly from the battery terminals, and not before any main fuse.
- On gasoline, diesel or propane vehicles, take the power from as close to the battery terminals as possible, and avoid using existing wiring.
- Ensure that all fuses are as close as possible to the power source.

Internal Combustion Engine Forklifts

- All power wiring must use the supplied power cable.
- Fuses:
 - one 3AB, 15A, 250V, FST BLO fuse - 9-60V DC
 - one 3AB, 6A, 250V, FST BLO fuse - 36-96V DC.
- Keep the path between the battery and the vehicle computer as short as possible, and away from any part of the ignition high tension system.

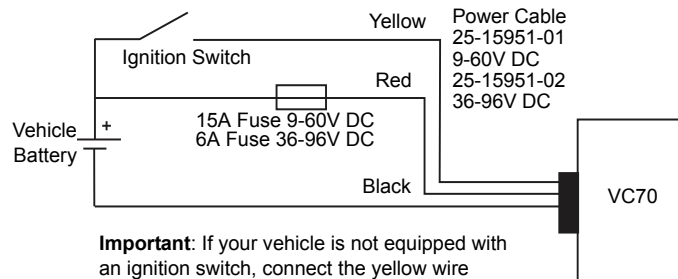

Important: If your vehicle is not equipped with an ignition switch, connect the yellow wire directly to the vehicle's positive source. Failure to comply, will not enable the computer operation.

You can use your old VC5090 power cable. When employing this option, use VC5090 Bridge Cable, PN 25-159553-01. You must also replace the fuses on the red and black wires of the old cable with the new fuses supplied with the bridge cable kit.

Electric Forklifts

- ✓ **NOTE** See the vehicle Owner's Manual for specific wiring information.

Connecting the Power Cable

- ✓ **NOTE** See the vehicle Owner's Manual for specific wiring information.

1. Disconnect the vehicle battery.
2. Connect the red wire to the vehicle's positive power source. Connect the black wire to the vehicle's negative power source.
3. Connect the yellow wire to the vehicle's positive power source.
4. Ensure the wiring connections created are sufficiently insulated from each other.
5. Re-connect the vehicle battery.
6. Connect the power cable connector into the vehicle computer's Power port.

Installing the VC70 on a Cart, a Wall, or a Desktop

To mount the vehicle computer on a cart, a wall, or a desktop:

- ⚠ **CAUTION** If mounting to a thin surface such as drywall or plywood, a reinforcing plate is required.

1. Install the mounting bracket to the desktop using four cap screws, eight washers and four nuts.

- ✓ **NOTE** The VC70 ships with four No. 8 Allen head screws (M10x50mm) for securing the mounting bracket. If the supplied cap screws are not long enough, use M10 - X stainless steel Allen head screws where X represents the length in millimeters of the required screws.

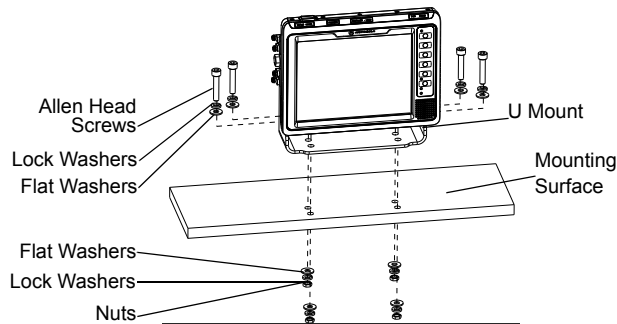

2. Insert the DC power cable into the DC connector on the universal power supply.
3. Plug the other end of the cable into the vehicle computer's power port.
4. Insert the AC line cord into the AC connector on the universal power supply.

✓ **NOTE** When using the optional AC power supply, the vehicle computer operating temperature range is 50°F to 104°F (10°C to 40°C).

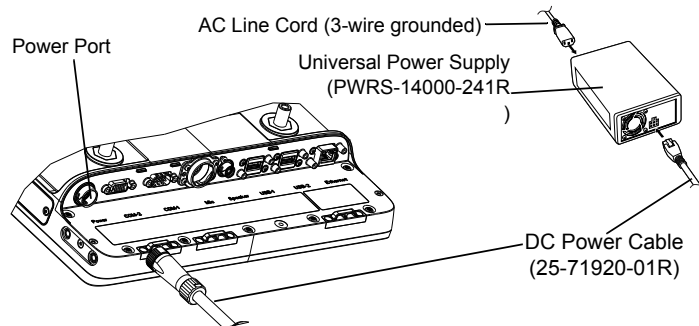

5. Plug the other end of the AC power cable into a wall outlet.

Installing the Optional QWERTY/AZERTY Keyboard

The keyboard kit contains the following items:

- keyboard
- right and left mounting arms
- four torx head screws with flat and lock washers
- six screws with captive flat and lock washers (for keyboard fastening)
- two locking knobs, two flat washers and two lock washers.

1. Position the keyboard on the tray and fasten six M4x10mm screws.

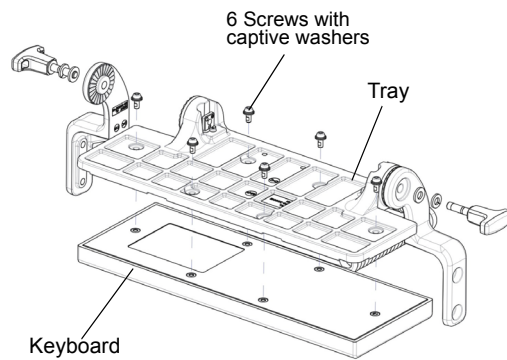

2. Attach the left and right mounting arms to both sides of the VC70, using the M5x14mm torx head screws with flat and lock washers. Only tighten the cap screws three turns.

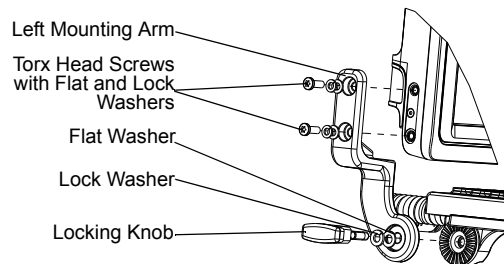

Quick Reference Guide**17**

3. Insert the keyboard locking knobs through the washers and brackets and screw into the keyboard tray. Tighten fully to lock into place.
4. Torque the mounting arms torx head screws to $40 \pm 10\%$ kgf-cm ($35 \pm 10\%$ lbs-in).
5. To adjust keyboard tray position, loosen the right and left locking knobs two full turns and rotate the keyboard tray to the desired position. The keyboard tray snaps into possible positions as it is rotated.

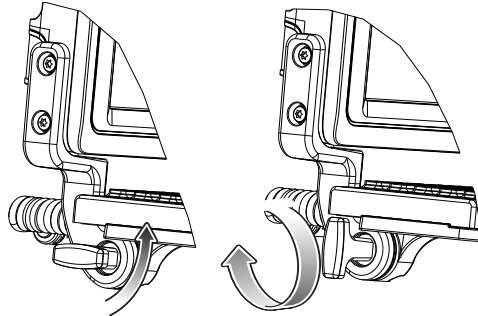

6. Tighten the keyboard tray locking knobs to secure the tray in position.
7. Plug the keyboard cable into one of the USB connectors and carefully screw the locking screws using a flat head screw driver.

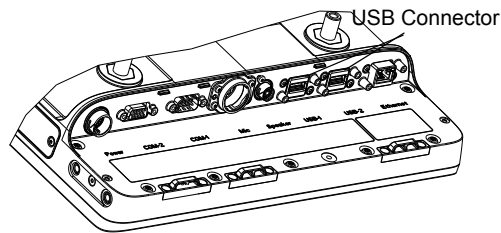

Installing the External Roof-mounted Antenna

WARNING! The antenna must be installed in a location that will ensure a distance of at least 8" (20cm) between the antenna and any bystander.

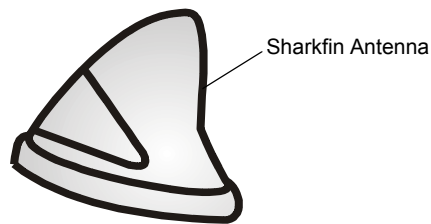

For general antenna installation instructions refer to the Installation Guide supplied with the antenna.

✓ **IMPORTANT** If not installed on a metal roof, the antenna must be installed in the middle of a flat metal surface (minimum size 2.56" (65 mm)x2.56" (65 mm)).

Powering the VC70 On/Off

✓ **NOTE** Only use the Main Power switch when removing power completely from the VC70. The power switch cover door can be safely removed without affecting the unit seal in case the user prefer to switch the unit off completely.

To power on, place the Main Power switch on the top of the VC70 to the on (|) position.

To power off, place the Main Power switch on the top of the VC70 to the off (O) position.

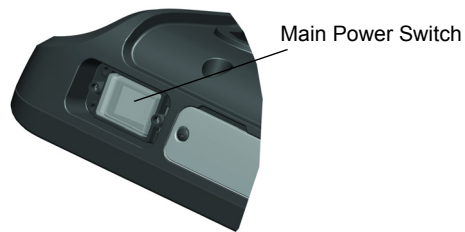

Use the Power button on the Quick Access Panel to place the VC70 into Suspend mode or wake the VC70 from Suspend mode.



This is usually enough to conserve battery power while the VC70 is idle during off time in normal operation.



Charging the Internal Backup Battery

After installing the VC70, leave it powered on for 6 hours to fully charge the internal backup battery. Note that the VC70 can charge the backup battery while in Suspend mode, but not if power is turned Off with the power switch.

The internal battery provides up to 30 minutes of VC70 operation with reduced functionality (no heaters, USB, Serial, Ethernet, external speaker interfaces and dimmed display backlight, and lower internal speaker volume) to enable forklift battery replacement when drained. Backup battery will also maintain the RAM memory for 72 hours when fully charged. The data in the Flash memory or Flash file system is not affected by the state of charge.

Calibrating the Touch Screen

The VC70 prompts you to calibrate the touch screen when you first power on the VC70 or after a cold-boot.



CAUTION Do not use sharp objects when touching the screen. Use your finger tip or a stylus when touching the screen.

1. Carefully touch and hold the center of each target. Repeat as the target moves around the screen.
2. Tap the screen to accept the settings when the calibration is complete.

Controlling Screen Brightness

There are five levels of screen brightness. To adjust the brightness of the screen, press the Brightness button on the Quick Access Panel. The amber Function LED lights indicating that the VC70 is in the backlight control mode. Press the P1 (+) button to increase the brightness or the P2 (-) button to decrease the brightness. Press the Brightness (☀️) button to exit this mode (or after five seconds of inactivity the VC70 automatically returns to normal operation).



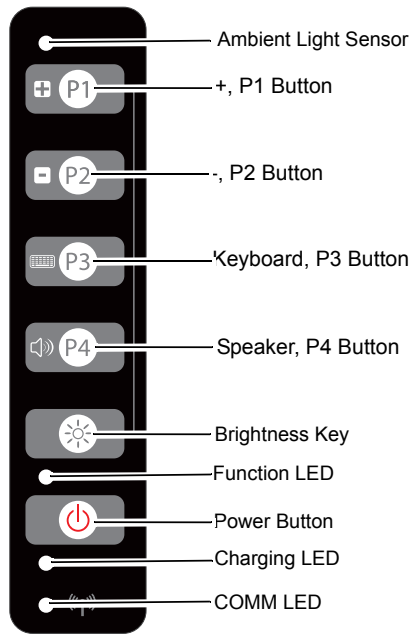

Resetting the Vehicle Computer

If the vehicle computer stops responding to inputs, perform a warm boot or cold boot.

Performing a Warm Boot

A warm boot restarts the vehicle computer and saves all stored records and entries.

- ✓ **NOTE** Verify that all open files are closed. Files that remain open during a warm boot may not be retained.

To perform a warm boot, press the Power button () on the Quick Access Panel continuously for 5 seconds.

Performing a Cold Boot

A cold boot restarts the vehicle computer, but erases all stored records and entries in RAM. Data saved in flash memory or a memory card is not lost. In addition it returns formats, preferences and other settings to the factory default settings. There are two ways to perform a cold boot:

- Simultaneously press and hold the Power, P1 and P3 buttons.
- Turn off the Main Power switch on the right side of the vehicle computer, press the Power, P1 and P3 buttons simultaneously then turn the Main Power switch to the on position.

Programmable Keys

The programmable keys on the Quick Access Panel (P1, P2, P3, P4) can be set to perform certain functions, such as switching between applications or emulator sessions.

To set a programmable key:

1. From the Start menu, select **Settings > Control Panel**.
2. Select the **Programmable Keys** icon.
3. In the **Key:** drop-down list, select the key to program.
4. In the **Action** drop-down list, select the function to assign to the key to perform.
5. Tap **OK**.

Connecting Accessories

Connect an optional scanner, ActiveSync serial or USB cable, audio or USB device using the appropriate connector on the bottom of the VC70. Cables are available from Motorola.

You may also use the USB port for ActiveSync connection, if the serial ports are used for another purpose. This cable is also available from Motorola. Refer to the *VC70 Product Reference Guide, P/N 72-164686-01* for information about additional accessories.

Maintenance

The vehicle computer is factory-sealed. There are 3 user accessible areas:

- Service door - provides access to the micro USB On-The-Go for ActiveSync without the need to disconnect any accessory, access to the Micro SD card slot and access to the desiccant.
- Access to the On/Off switch (the door can be removed without affecting the sealing).
- Access to the backup battery.

For general cleaning:

- Clean the casing, keyboard, and display window by wiping with a soft cloth. Use a damp cloth if necessary.
- Never use solvents or abrasive cleaners. You may damage the display or keyboard.

Replacing the Desiccant Bag

1. The VC70 ships with a desiccant bag installed. The installer may wish to replace the desiccant in the VC70 with a new bag prior to installing the VC70 on the vehicle, as transit and storage may have saturated the desiccant.
2. Open the two screws securing the service door and remove the door.
3. Pull out the old desiccant bag.
4. Open the new desiccant package and remove the desiccant bag.
5. Fold the four corners of the bag under to form a pillow.
6. Place the desiccant bag in the desiccant well.

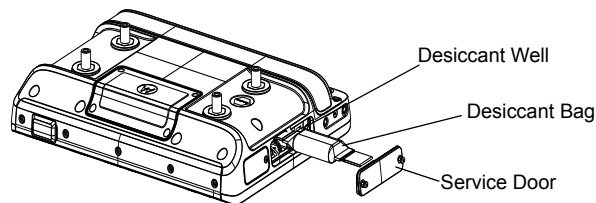

7. Carefully place the service door onto the right side of the housing.

CAUTION Be sure to torque the screws to seal the device properly. Otherwise, sealing can be compromised.

8. Torque the torx head screws to $4.0 \pm 10\%$ kgf-cm ($3.5 \pm 10\%$ lbs-in).

Replacing the Backup Battery

To replace the backup battery:

CAUTION Use ESD precautions when installing the backup battery.

1. Place the Main Power switch on the right side of the vehicle computer to the off position and perform cold boot to electrically disconnect the battery from the unit.
2. Open the four screws securing the Backup Battery door on the back of the vehicle computer and remove the door.
3. Open the four screws securing the Backup Battery and disconnect the Backup Battery connector.
4. Carefully pull the Backup Battery out of the computer.
5. Place the new backup battery into the well.

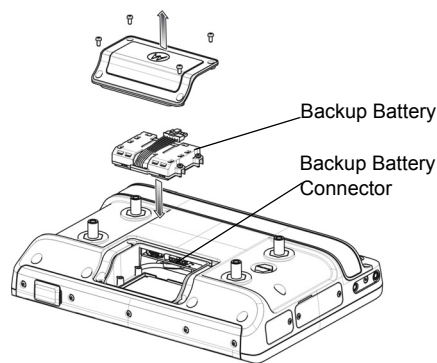

6. Connect the Backup Battery connector to the connector inside the Backup Battery well.
7. Secure the battery into location using four screws.
8. Place the Backup Battery door over the battery and secure using the four captive screws.

CAUTION Be sure to torque the screws to seal the device properly. Otherwise, sealing can be compromised.

Quick Reference Guide

9. Torque the screws to 9 +/- 0.5 kgf.cm (7.8 ± 0.4 in-lbs).

10. Place the Main Power switch to the on position.

It takes four hours to fully charge the Backup Battery.

Troubleshooting

Problem	Cause	Solution
VC70 does not power on or shuts off suddenly.	The power cable ignition sense wire (yellow) is not connected properly.	Verify that the power cable is connected properly. See Routing Electrical Cables on page 12 .
	Main Power switch on the right side of the vehicle computer is in the off position.	Turn the Main Power switch to the on position.
	Power cable not connected or unplugged.	Connect power cable to power cable port on bottom of the vehicle computer. Press the Power button to wake up the VC70.
	If VC70 is powered by a vehicle battery, the vehicle battery is depleted.	Replace or charge the vehicle battery.
Cannot see characters on display.	VC70 not powered on.	Check that the Main Power switch on the top of the VC70 is in the on position. Press the Power button.
	Screen is too bright or too dark.	Adjust the brightness; see Controlling Screen Brightness on page 20 .
	VC70 is in Suspend mode (green Power LED is off)	Press the Power button to wake up the VC70.
Application does not respond.	VC70 is not communicating with the AP (Communication LED is off).	Bring the VC70 closer to the AP. If problem continues, contact your System Administrator.

Problem	Cause	Solution
Optional scanner does not operate.	Scanner is not properly connected to the VC70.	Connect the scanner to the COM1 port and power up the vehicle computer. If the problem continues, refer to the scanner Product Reference Guide or see your System Administrator.
	DataWedge application is not enabled or set to the correct COM Port.	Ensure that the DataWedge application is enabled and set to the correct port. See <i>VC70 Product Reference Guide P/N 72-164686-01</i> for more information.
	External power is not connected.	Verify external power connection.



Regulatory Information

All Motorola Solutions devices are designed to be compliant with rules and regulations in locations they are sold and will be labeled as required.

This device is approved under Motorola Solutions, Inc.

This guide applies to Model Number VC70N0

Local language translations are available at the following website:

<http://supportcentral.motorola.com>.

Any changes or modifications to Motorola Solutions equipment, not expressly approved by Motorola Solutions, could void the user's authority to operate the equipment.

Antennas: Use only the supplied or an approved replacement antenna.

Unauthorized antennas, modifications, or attachments could cause damage and may violate regulations.

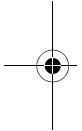

CAUTION Only use Motorola Solutions approved and UL Listed accessories, battery packs and battery chargers.

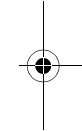

Do NOT attempt to charge damp/wet mobile computers or batteries. All components must be dry before connecting to an external power source.

Radio Modules

The device contains approved radio module. This module is identified below.

Motorola WLAN radio 802.11 a/b/g/n and BT Technology, Type(s): 21-148603.

Bluetooth® Wireless Technology

This is an approved Bluetooth® product. For more information or to view End Product Listing, please visit <https://www.bluetooth.org/tpg/listings.cfm>



Wireless Device Country Approvals

Regulatory markings, subject to certification, are applied to the device signifying the radio(s) is/are approved for use in the following countries: United States, Canada, Japan, China, Australia, and Europe¹.

Please refer to the Declaration of Conformity (DoC) for details of other country markings. This is available at <http://www.motorola.com/doc>.

Note 1: For 2.4GHz or 5GHz Products: Europe includes, Austria, Belgium, Bulgaria, Czech Republic, Cyprus, Denmark, Estonia, Finland, France, Germany, Greece, Hungary, Iceland, Ireland, Italy, Latvia, Liechtenstein, Lithuania, Luxembourg, Malta, Netherlands, Norway, Poland, Portugal, Romania, Slovak Republic, Slovenia, Spain, Sweden, Switzerland and the United Kingdom.

 **CAUTION** Operation of the device without regulatory approval is illegal.

Country Roaming

This device incorporates the International Roaming feature (IEEE802.11d) which will ensure the product operates on the correct channels for the particular country of use.

Ad-Hoc Operation (5 GHz band)

Ad-Hoc operation is not supported.

Frequency of Operation - FCC and IC

5 GHz Only

The use in the UNII (Unlicensed National Information Infrastructure) band 1 (5150-5250 MHz) is restricted to Indoor Use Only; any other use will make the operation of this device illegal.

Industry Canada Statement:

 **CAUTION** The device for the band 5150-5250 MHz is only for indoor usage to reduce potential for harmful interference to co-Channel mobile satellite systems. High power radars are allocated as primary users (meaning they have priority) of 5250-5350 MHz and 5650-5850 MHz and these radars could cause interference and/or damage to LE-LAN devices.

Avertissement: Le dispositif fonctionnant dans la bande 5150-5250 MHz est réservé uniquement pour une utilisation à l'intérieur afin de réduire les risques de brouillage préjudiciable aux systèmes de satellites mobiles utilisant les mêmes canaux.

Les utilisateurs de radars de haute puissance sont désignés utilisateurs principaux (c.-à-d., qu'ils ont la priorité) pour les bandes 5250-5350 MHz et 5650-5850 MHz et que ces radars pourraient causer du brouillage et/ou des dommages aux dispositifs LAN-EL.

2.4 GHz Only

The available channels for 802.11 b/g/n operation in the US are Channels 1 to 13. The range of channels is limited by firmware.

Health and Safety Recommendations

Ergonomic Recommendations



CAUTION In order to avoid or minimize the potential risk of ergonomic injury follow the recommendations below. Consult with your local Health & Safety Manager to ensure that you are adhering to your company's safety programs to prevent employee injury.

- Reduce or eliminate repetitive motion
- Maintain a natural position
- Reduce or eliminate excessive force
- Keep objects that are used frequently within easy reach
- Perform tasks at correct heights
- Reduce or eliminate vibration
- Reduce or eliminate direct pressure
- Provide adjustable workstations
- Provide adequate clearance
- Provide a suitable working environment
- Improve work procedures.

Vehicle Installation

RF signals may affect improperly installed or inadequately shielded electronic systems in motor vehicles (including safety systems). Check with the

manufacturer or its representative regarding your vehicle. You should also consult the manufacturer of any equipment that has been added to your vehicle.

An air bag inflates with great force. DO NOT place objects, including either installed or portable wireless equipment, in the area over the air bag or in the air bag deployment area. If in-vehicle wireless equipment is improperly installed and the air bag inflates, serious injury could result.

Position your device within easy reach. Be able to access your device without removing your eyes from the road.

✓ **NOTE** Connection to an alert device that will cause a vehicle horn to sound or lights to flash, on receipt of a call on public roads, is not permitted.

⚠ **IMPORTANT** Before installing or using, check state and local laws regarding windshield mounting and use of equipment.

Warnings for Use of Wireless Devices

Please observe all warning notices with regard to the usage of wireless devices.

Potentially Hazardous Atmospheres

You are reminded of the need to observe restrictions on the use of radio devices in fuel depots, chemical plants etc. and areas where the air contains chemicals or particles (such as grain, dust, or metal powders) and any other area where you would normally be advised to turn off your vehicle engine.

Hearing Aids

When some wireless devices are used near some hearing devices (hearing aids and cochlear implants), users may detect a buzzing, humming, or whining noise. Some hearing devices are more immune than others to this interference noise, and wireless devices also vary in the amount of interference they generate. In the event of interference you may want to consult your hearing aid supplier to discuss solutions.

Hearing Aid Compatibility

This device is not HAC compliant during Voice Over IP (VOIP) calls.

Pacemakers

Pacemaker manufacturers recommended that a minimum of 15cm (6 inches) be maintained between a handheld wireless device and a

Quick Reference Guide

31

pacemaker to avoid potential interference with the pacemaker. These recommendations are consistent with independent research and recommendations by Wireless Technology Research.

Persons with Pacemakers:

- Should ALWAYS keep the device more than 15cm (6 inches) from their pacemaker when turned ON.
- Should not carry the device in a breast pocket.
- Should use the ear furthest from the pacemaker to minimise the potential for interference.
- If you have any reason to suspect that interference is taking place, turn OFF your device.

Other Medical Devices

Please consult your physician or the manufacturer of the medical device, to determine if the operation of your wireless product may interfere with the medical device.



RF Exposure Guidelines

Safety Information

Reducing RF Exposure - Use Properly

Only operate the device in accordance with the instructions supplied.

International

The device complies with internationally recognized standards covering human exposure to electromagnetic fields from radio devices. For information on "International" human exposure to electromagnetic fields refer to the Motorola/Symbol Declaration of Conformity (DoC) at <http://www.motorola.com/doc>

Europe

To satisfy EU RF exposure requirements, a mobile transmitting device must operate with a minimum separation distance of 20cm or more from a person's body.

Remote and Standalone Antenna Configurations

To comply with EU RF exposure requirements, antennas that are mounted externally at remote locations or operating near users at stand-alone desktop of



similar configurations must operate with a minimum separation distance of 20 cm from all persons.

US and Canada

Co-located Statement

To comply with FCC RF exposure compliance requirement, the antenna used for this transmitter must not be co-located or operating in conjunction with any other transmitter/antenna except those already approved in this filing.

Industry Canada Statement

IMPORTANT NOTE: Radiation Exposure Statement:

This equipment complies with IC radiation exposure limits set forth for uncontrolled environment. This equipment should be installed and operated with minimum distance 20cm between the radiator and your body.

NOTE IMPORTANTE:

Déclaration d'exposition aux radiations:

Cet équipement est conforme aux limites d'exposition aux rayonnements IC établies pour un environnement non

contrôlé. Cet équipement doit être installé et utilisé avec un minimum de 20 cm de distance entre la source de rayonnement et votre corps.

Remote and Standalone Antenna Configurations

To comply with FCC RF exposure requirements, antennas that are mounted externally at remote locations or operating near users at stand-alone desktop of similar configurations must operate with a minimum separation distance of 20 cm from all persons.

To satisfy FCC RF exposure requirements, a mobile transmitting device must operate with a minimum separation distance of 20 cm or more from a person's body.

Power Supply

Use ONLY a LISTED Motorola, Type no. PWRS-14000 (12Vdc, 9A), PWRS-9-60VDC (12Vdc, 9A) power supply, marked Class 2 or LPS (IEC60950-1, SELV). Use of alternative Power Supply will invalidate any approvals given to this unit and may be dangerous.

Batteries

Please follow the local regulations when disposing of re-chargeable batteries.



Taiwan - Recycling

「廢電池請回收」

EPA (Environmental Protection Administration) requires dry battery producing or importing firms in accordance with Article 15 of the Waste Disposal Act are required to indicate the recycling marks on the batteries used in sales, giveaway or promotion. Contact a qualified Taiwanese recycler for proper battery disposal.

Battery Information

Use only Motorola approved batteries. Accessories which have battery charging capability are approved for use with the following battery models:

Motorola 82-161178-01 (3.7 Vdc, 1880mAh)

Motorola rechargeable battery packs are designed and constructed to the highest standards within the industry.

However, there are limitations to how long a battery can operate or be stored before needing replacement. Many factors affect the actual life cycle of a battery pack, such as heat, cold, harsh environmental conditions and severe drops.

When batteries are stored over six (6) months, some irreversible deterioration in overall battery quality may occur. Store batteries at half of full charge in a dry, cool place, removed from the equipment to prevent loss of capacity, rusting of metallic parts and electrolyte leakage. When storing batteries for one year or longer, the charge level should be verified at least once a year and charged to half of full charge.

Replace the battery when a significant loss of run time is detected.

Standard warranty period for all Motorola batteries is 30 days, regardless if the battery was purchased separately or included as part of the mobile computer or bar code scanner. For more information on Symbol batteries, please visit: <http://mysymbolcare.symbol.com/battery/batbasics1.html>.

Battery Safety Guidelines

- The area in which the units are charged should be clear of debris and combustible materials or chemicals. Particular care should be taken where the device is charged in a non commercial environment.
- Follow battery usage, storage, and charging guidelines found in the user's guide.
- Improper battery use may result in a fire, explosion, or other hazard.
- To charge the mobile device battery, the battery and charger temperatures must be between +32 °F and +104 °F (0 °C and +40 °C)

- Do not use incompatible batteries and chargers. Use of an incompatible battery or charger may present a risk of fire, explosion, leakage, or other hazard. If you have any questions about the compatibility of a battery or a charger, contact Motorola Enterprise Mobility support.
- Do not disassemble or open, crush, bend or deform, puncture, or shred.
- Severe impact from dropping any battery-operated device on a hard surface could cause the battery to overheat.
- Do not short circuit a battery or allow metallic or conductive objects to contact the battery terminals.
- Do not modify or remanufacture, attempt to insert foreign objects into the battery, immerse or expose to water or other liquids, or expose to fire, explosion, or other hazard.
- Do not leave or store the equipment in or near areas that might get very hot, such as in a parked vehicle or near a radiator or other heat source. Do not place battery into a microwave oven or dryer.
- Battery usage by children should be supervised.
- Please follow local regulations to promptly dispose of used re-chargeable batteries.
- Do not dispose of batteries in fire.
- Seek medical advice immediately if a battery has been swallowed.
- In the event of a battery leak, do not allow the liquid to come in contact with the skin or eyes. If contact has been made, wash the affected area with large amounts of water and seek medical advice.
- If you suspect damage to your equipment or battery, contact Motorola Enterprise Mobility support to arrange for inspection.

Radio Frequency Interference Requirements - FCC

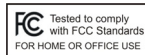

Note: This equipment has been tested and found to comply with the limits for a Class B digital device, pursuant to Part 15 of the FCC rules. These limits are designed to provide reasonable protection against harmful interference in a residential installation. This equipment generates, uses, and can radiate radio frequency energy and, if not installed and used in accordance with the instructions, may cause harmful interference to radio communications. However there is no guarantee that interference will not occur in a particular installation. If this equipment does cause harmful interference to radio

Quick Reference Guide

35

or television reception, which can be determined by turning the equipment off and on, the user is encouraged to try to correct the interference by one or more of the following measures:

- Reorient or relocate the receiving antenna
- Increase the separation between the equipment and receiver
- Connect the equipment into an outlet on a circuit different from that to which the receiver is connected
- Consult the dealer or an experienced radio/TV technician for help.

Radio Transmitters (Part 15)

This device complies with Part 15 of the FCC Rules. Operation is subject to the following two conditions: (1) this device may not cause harmful interference, and (2) this device must accept any interference received, including interference that may cause undesired operation.

The use of 5 GHz WLAN's (in the US), have the following restrictions:

- Notched Band 5.60 - 5.65 GHz

Radio Frequency Interference Requirements - Canada

This Class B digital apparatus complies with Canadian ICES-003. Cet appareil numérique de la classe B est conforme à la norme NMB-003 du Canada.

Radio Transmitters

The use of 5 GHz WLAN's (in Canada), have the following restrictions:

- Restricted Band 5.60 - 5.65 GHz

This device complies with RSS 210 of Industry & Science Canada. Operation is subject to the following two conditions: (1) this device may not cause harmful interference and (2) this device must accept any interference received, including interference that may cause undesired operation.

Ce dispositif est conforme à la norme CNR-210 d'Industrie Canada applicable aux appareils radio exempts de licence. Son fonctionnement est sujet aux deux conditions suivantes: (1) le dispositif ne doit pas produire de brouillage préjudiciable, et (2) ce dispositif doit accepter tout brouillage reçu, y compris un brouillage susceptible de provoquer un fonctionnement indésirable.

Label Marking: The Term "IC:" before the radio certification only signifies that Industry Canada technical specifications were met.

To reduce potential radio interference to other users, the antenna type and its gain should be so chosen that the equivalent isotropically



radiated power (EIRP) is not more than that permitted for successful communication.

Marking and European Economic Area (EEA)



CAUTION This is a Class B product. In a domestic environment this product may cause radio interference in which case the user may be required to take adequate measures.

The use of 2.4 GHz RLAN's (through the EEA), have the following restrictions:

- Maximum radiated transmit power of 100 mW EIRP in the frequency range 2.400 -2.4835 GHz

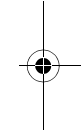
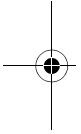

Statement of Compliance

Motorola Solutions, Inc., hereby, declares that this device is in compliance with the essential requirements and other relevant provisions of Directives 1999/5/EC. A declaration of Conformity may be obtained from <http://www.motorola.com/doc/>

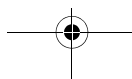

Japan (VCCI) - Voluntary Control Council for Interference

Class B ITE

この装置は、情報処理装置等電波障害自主規制協議会（VCCI）の基準に基づくクラスB情報技術装置です。この装置は、家庭環境で使用することを目的としていますが、この装置がラジオやテレビジョン受信機に近接して使用されると、受信障害を引き起こすことがあります。取扱説明書に従って正しい取り扱いをして下さい。

Other Countries

Australia-Use of 5 GHz RLAN's in Australia is restricted in the following band 5.50 - 5.65GHz.

Brazil-Nota: A marca de certificação se aplica ao Transceptor, modelo **VC70N0**. Este equipamento opera em caráter secundário, isto é, não tem direito a proteção contra interferência prejudicial, mesmo de estações do mesmo tipo, e não pode causar interferência a sistemas operando em caráter primário.

Para maiores informações sobre ANATEL consulte o site: www.anatel.gov.br

Chile-Este equipo cumple con la Resolución No 403 de 2008, de la Subsecretaria de telecomunicaciones, relativa a radiaciones electromagnéticas.

China-



Mexico- Restrict Frequency Range to: 2.450 - 2.4835 GHz.

South Korea-For a radio equipment using 2400~2483.5MHz or 5725~5825MHz, the following two expression should be displayed;

해당 무선설비는 운용 중 전파혼신 가능성이 있음

당해 무선설비는 전파혼신 가능성이 있으므로 인명안전과 관련된 서비스는 할 수 없습니다.

Taiwan-

臺灣

低功率電波輻射性電機管理辦法

第十二條

經型式認證合格之低功率射頻電機，非經許可，公司、商號或使用者均不得擅自變更頻率、加大功率或變更原設計之特性及功能。

第十四條

低功率射頻電機之使用不得影響飛航安全及干擾合法通信；經發現有干擾現象時，應立即停用，並改善至無干擾時方得繼續使用。

前項合法通信，指依電信規定作業之無線電通信。

低功率射頻電機須忍受合法通信或工業、科學及醫療用電波輻射性電機設備之干擾。

在 5.25-5.35 兆赫頻帶內操作之無線資訊傳輸設備，限於室內使用。

Turkey-Bu cihaz Türkçe karakterlerin tamamını ihtiva eden ETSI TS 123.038 V8.0.0 (veya sonraki sürümün kodu) ve ETSI TS 123.040 V8.1.0 (veya sonraki sürümün kodu) teknik özelliklerine uygundur.

Ukraine-This equipment corresponds to requirements of the Technical Regulation No. 1057, 2008 on restrictions as to the use of some dangerous substances in electric and electronic devices.

Thailand-เครื่องโทรคมนาคมและอุปกรณ์นี้ มีความสอดคล้องตามข้อกำหนดของ กทช.



Waste Electrical and Electronic Equipment (WEEE)

English: For EU Customers: All products at the end of their life must be returned to Motorola for recycling. For information on how to return product, please go to: <http://www.motorola.com/recycle/weee>.

Français: Clients de l'Union Européenne: Tous les produits en fin de cycle de vie doivent être retournés à Motorola pour recyclage. Pour de plus amples informations sur le retour de produits, consultez : <http://www.motorola.com/recycle/weee>.

Español: Para clientes en la Unión Europea: todos los productos deberán entregarse a Motorola al final de su ciclo de vida para que sean reciclados. Si desea más información sobre cómo devolver un producto, visite: <http://www.motorola.com/recycle/weee>.

Deutsch: Für Kunden innerhalb der EU: Alle Produkte müssen am Ende ihrer Lebensdauer zum Recycling an Motorola zurückgesandt werden. Informationen zur Rücksendung von Produkten finden Sie unter <http://www.motorola.com/recycle/weee>.

Italiano: per i clienti dell'UE: tutti i prodotti che sono giunti al termine del rispettivo ciclo di vita devono essere restituiti a Motorola al fine di consentirne il riciclaggio.

Quick Reference Guide

39

Per informazioni sulle modalità di restituzione, visitare il seguente sito Web:
<http://www.motorola.com/recycle/weee>.

Português: Para clientes da UE: todos os produtos no fim de vida devem ser devolvidos à Motorola para reciclagem. Para obter informações sobre como devolver o produto, visite: <http://www.motorola.com/recycle/weee>.

Nederlands: Voor klanten in de EU: alle producten dienen aan het einde van hun levensduur naar Motorola te worden teruggezonden voor recycling. Raadpleeg <http://www.motorola.com/recycle/weee> voor meer informatie over het terugzenden van producten.

Polski: Klienci z obszaru Unii Europejskiej: Produkty wycofane z eksploatacji należy zwrócić do firmy Motorola w celu ich utylizacji. Informacje na temat zwrotu produktów znajdują się na stronie internetowej <http://www.motorola.com/recycle/weee>.

Čeština: Pro zákazníky z EU: Všechny produkty je nutné po skončení jejich životnosti vrátit společnosti Motorola k recyklaci. Informace o způsobu vrácení produktu najdete na webové stránce: <http://www.motorola.com/recycle/weee>.

Eesti: EL klientidele: kõik tooted tuleb nende eluea lõppedes tagastada taaskasutamise eesmärgil Motorola'ile. Lisainformatsiooni saamiseks toote tagastamise kohta külastage palun aadressi: <http://www.motorola.com/recycle/weee>.

Magyar: Az EU-ban vásárlóknak: Minden tönkrement terméket a Motorola vállalatához kell eljuttatni újrahasznosítás céljából. A termék visszajuttatásának módjával kapcsolatos tudnivalóként látogasson el a <http://www.motorola.com/recycle/weee> weboldalra.

Slovenski: Za kupce v EU: vsi izdelki se morajo po poteku življenjske dobe vrniti podjetju Motorola za reciklažo. Za informacije o vračilu izdelka obiščite: <http://www.motorola.com/recycle/weee>.

Svenska: För kunder inom EU: Alla produkter som uppnått sin livslängd måste returneras till Motorola för återvinning. Information om hur du returnerar produkten finns på <http://www.motorola.com/recycle/weee>.

Suomi: Asiakkaat Euroopan unionin alueella: Kaikki tuotteet on palautettava kierrätettäväksi Motorola-yhtiöön, kun tuotetta ei enää käytetä. Lisätietoja tuotteen palauttamisesta on osoitteessa <http://www.motorola.com/recycle/weee>.

Dansk: Til kunder i EU: Alle produkter skal returneres til Motorola til recirkulering, når de er udtjent. Læs oplysningerne om returnering af produkter på: <http://www.motorola.com/recycle/weee>.

Ελληνικά: Για πελάτες στην Ε.Ε.: Όλα τα προϊόντα, στο τέλος της διάρκειας ζωής τους, πρέπει να επιστρέφονται στην Motorola για ανακύκλωση. Για περισσότερες

πληροφορίες σχετικά με την επιστροφή ενός προϊόντος, επισκεφθείτε τη διεύθυνση <http://www.motorola.com/recycle/weee> στο Διαδίκτυο.

Malti: Għal klijenti fl-UE: il-prodotti kollha li jkunu waslu fl-aħħar tal-ħajja ta' l-użu tagħhom, iridu jiġu rritornati għand Motorola għar-riċiklaġġ. Għal aktar tagħrif dwar kif għandek tirritorna l-prodott, jekk jogħġbok żur: <http://www.motorola.com/recycle/weee>.

Slovenski: Za kupce v EU: vsi izdelki se morajo po poteku življenjske dobe vrniti podjetju Motorola za reciklažo. Za informacije o vračilu izdelka obiščite: <http://www.motorola.com/recycle/weee>.

Slovenčina: Pre zákazníkov z krajín EU: Všetky výrobky musia byť po uplynutí doby ich životnosti vrátené spoločnosti Motorola na recykláciu. Bližšie informácie o vrátení výrobkov nájdete na: <http://www.motorola.com/recycle/weee>.

Lietuvių: ES vartotojams: visi gaminiai, pasibaigus jų eksploatacijos laikui, turi būti gražinti utilizuoti į kompaniją „Motorola“. Daugiau informacijos, kaip gražinti gaminį, rasite: <http://www.motorola.com/recycle/weee>.

Latviešu: ES klientiem: visi produkti pēc to kalpošanas mūža beigām ir jānogādā atpakaļ Motorola otrreizējai pārstrādei. Lai iegūtu informāciju par produktu nogādāšanu Motorola, lūdzu, skatiet: <http://www.motorola.com/recycle/weee>.

Software Support

Motorola wants to ensure that customers have the latest release of entitled software at the time of product purchase.

To confirm that your Motorola Enterprise Mobility device shipped with the latest release of entitled software, visit: www.motorola.com/enterprisemobility/support. Check for the latest software from *Software Downloads > Product Line/Product > Go*.

If your device does not have the latest entitled software release as of your product purchase date, please e-mail a request to Motorola at: entitlementservices@motorola.com.

You must include the following essential device information with your request:

- Model number
- Serial number
- Proof of purchase
- Title of the software download you are requesting.

If it is determined by Motorola that your device is entitled to the latest software release, you will receive an e-mail containing a link directing you to a Motorola Web site to download the appropriate software.



Quick Reference Guide

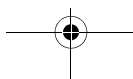
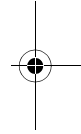
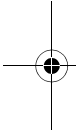



Service Information

If you have a problem using the equipment, contact your facility's Technical or Systems Support. If there is a problem with the equipment, they will contact the Motorola Solutions Support at: <http://supportcentral.motorola.com>.

For the latest version of this guide go to: <http://supportcentral.motorola.com>.

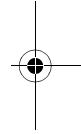
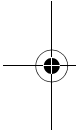

MOTOROLA

Motorola Solutions, Inc.
One Motorola Plaza
Holtsville, New York 11742, USA
1-800-927-9626
<http://www.motorolasolutions.com>

MOTOROLA, MOTO, MOTOROLA SOLUTIONS and the Stylized M Logo are trademarks or registered trademarks of Motorola Trademark Holdings, LLC and are used under license. All other trademarks are the property of their respective owners. © 2012 Motorola Solutions, Inc. All rights reserved.



72-164687-01 Revision A - October 2012

