



# FCC TEST REPORT (15.407)

**REPORT NO.:** RF120717C06-1  
**MODEL NO.:** VC6090  
**FCC ID:** UZ7VC6090  
**RECEIVED:** Jul. 17, 2012  
**TESTED:** Jul. 17 ~ Jul. 24, 2012  
**ISSUED:** Jul. 25, 2012

**APPLICANT:** Motorola Solutions, Inc.

**ADDRESS:** One Motorola Plaza, Holtsville, NY 11742-1300  
USA

**ISSUED BY:** Bureau Veritas Consumer Products Services  
(H.K.) Ltd., Taoyuan Branch

**LAB ADDRESS:** No. 47, 14th Ling, Chia Pau Vil., Lin Kou Dist.,  
New Taipei City, Taiwan, R.O.C.

**TEST LOCATION:** No. 19, Hwa Ya 2nd Rd, Wen Hwa Tsuen, Kwei  
Shan Hsiang, Taoyuan Hsien 333, Taiwan, R.O.C.

This report should not be used by the client to claim product certification, approval, or endorsement by TAF or any government agencies.



This report is for your exclusive use. Any copying or replication of this report to or for any other person or entity, or use of our name or trademark, is permitted only with our prior written permission. This report sets forth our findings solely with respect to the test samples identified herein. The results set forth in this report are not indicative or representative of the quality or characteristics of the lot from which a test sample was taken or any similar or identical product unless specifically and expressly noted. Our report includes all of the tests requested by you and the results thereof based upon the information that you provided to us. You have 60 days from date of issuance of this report to notify us of any material error or omission caused by our negligence, provided, however, that such notice shall be in writing and shall specifically address the issue you wish to raise. A failure to raise such issue within the prescribed time shall constitute your unqualified acceptance of the completeness of this report, the tests conducted and the correctness of the report contents. Unless specific mention, the uncertainty of measurement has been explicitly taken into account to declare the compliance or non-compliance to the specification.



## TABLE OF CONTENTS

RELEASE CONTROL RECORD.....	4
1. CERTIFICATION.....	5
2. SUMMARY OF TEST RESULTS .....	6
2.1 MEASUREMENT UNCERTAINTY.....	6
3. GENERAL INFORMATION.....	7
3.1 GENERAL DESCRIPTION OF EUT .....	7
3.2 DESCRIPTION OF TEST MODES .....	8
3.2.1 TEST MODE APPLICABILITY AND TESTED CHANNEL DETAIL .....	9
3.3 DUTY CYCLE OF TEST SIGNAL.....	10
3.4 DESCRIPTION OF SUPPORT UNITS .....	10
3.4.1 CONFIGURATION OF SYSTEM UNDER TEST .....	11
3.5 GENERAL DESCRIPTION OF APPLIED STANDARDS .....	11
4. TEST TYPES AND RESULTS .....	12
4.1 RADIATED EMISSION AND BANDEDGE MEASUREMENT .....	12
4.1.1 LIMITS OF RADIATED EMISSION AND BANDEDGE MEASUREMENT .....	12
4.1.2 LIMITS OF UNWANTED EMISSION OUT OF THE RESTRICTED BANDS .....	12
4.1.3 TEST INSTRUMENTS.....	13
4.1.4 TEST PROCEDURES .....	14
4.1.5 DEVIATION FROM TEST STANDARD .....	14
4.1.6 TEST SETUP.....	15
4.1.7 EUT OPERATING CONDITION.....	15
4.1.8 TEST RESULTS .....	16
4.2 PEAK TRANSMIT POWER MEASUREMENT .....	27
4.2.1 LIMITS OF PEAK TRANSMIT POWER MEASUREMENT .....	27
4.2.2 TEST SETUP.....	27
4.2.3 TEST INSTRUMENTS.....	27
4.2.4 TEST PROCEDURE.....	28
4.2.5 DEVIATION FROM TEST STANDARD .....	28
4.2.6 EUT OPERATING CONDITIONS .....	28
4.2.7 TEST RESULTS .....	29
4.3 PEAK POWER SPECTRAL DENSITY MEASUREMENT .....	30
4.3.1 LIMITS OF PEAK POWER SPECTRAL DENSITY MEASUREMENT .....	30
4.3.2 TEST SETUP.....	30
4.3.3 TEST INSTRUMENTS.....	30
4.3.4 TEST PROCEDURES .....	30



4.3.5	DEVIATION FROM TEST STANDARD .....	30
4.3.6	EUT OPERATING CONDITIONS .....	30
4.3.7	TEST RESULTS .....	31
4.4	PEAK POWER EXCURSION MEASUREMENT .....	32
4.4.1	LIMITS OF PEAK POWER EXCURSION MEASUREMENT .....	32
4.4.2	TEST SETUP .....	32
4.4.3	TEST INSTRUMENTS.....	32
4.4.4	TEST PROCEDURE.....	32
4.4.5	DEVIATION FROM TEST STANDARD .....	32
4.4.6	EUT OPERATING CONDITIONS .....	32
4.4.7	TEST RESULTS .....	33
4.5	FREQUENCY STABILITY.....	34
4.5.1	LIMITS OF FREQUENCY STABILITY MEASUREMENT .....	34
4.5.2	TEST SETUP .....	34
4.5.3	TEST INSTRUMENTS.....	34
4.5.4	TEST PROCEDURE.....	35
4.5.5	DEVIATION FROM TEST STANDARD .....	35
4.5.6	EUT OPERATING CONDITION.....	35
4.5.7	TEST RESULTS .....	36
5.	PHOTOGRAPHS OF THE TEST CONFIGURATION.....	37
6.	INFORMATION ON THE TESTING LABORATORIES .....	38
7.	APPENDIX A - MODIFICATIONS RECORDERS FOR ENGINEERING CHANGES TO THE EUT BY THE LAB .....	39



A D T

## RELEASE CONTROL RECORD

ISSUE NO.	REASON FOR CHANGE	DATE ISSUED
RF120717C06-1	Original release	Jul. 25, 2012



## 1. CERTIFICATION

**PRODUCT:** Vehicle Computer

**MODEL:** VC6090

**BRAND:** Motorola

**APPLICANT:** Motorola Solutions, Inc.

**TESTED:** Jul. 17 ~ Jul. 24, 2012

**TEST SAMPLE:** Identical Prototype

**STANDARDS: FCC Part 15, Subpart E (Section 15.407)**

ANSI C63.10-2009

The above equipment (model: VC6090) has been tested by **Bureau Veritas Consumer Products Services (H.K.) Ltd., Taoyuan Branch**, and found compliance with the requirement of the above standards. The test record, data evaluation & Equipment Under Test (EUT) configurations represented herein are true and accurate accounts of the measurements of the sample's EMC characteristics under the conditions specified in this report.

**PREPARED BY** :  , **DATE** : Jul. 25, 2012  
Pettie Chen / Specialist

**APPROVED BY** :  , **DATE** : Jul. 25, 2012  
Gary Chang / Technical Manager

## 2. SUMMARY OF TEST RESULTS

The EUT has been tested according to the following specifications:

APPLIED STANDARD: FCC PART 15, SUBPART E (SECTION 15.407)			
STANDARD SECTION	TEST TYPE	RESULT	REMARK
15.407(b)(6)	AC Power Conducted Emission	NA	Power supply is 12Vdc from car battery
15.407(b/1/2/3) (b)(6)	Spurious Emissions	PASS	Meet the requirement of limit. Minimum passing margin is -5.3dB at 11000.00MHz.
15.407(a/1/2)	Peak Transmit Power	PASS	Meet the requirement of limit.
15.407(a)(6)	Peak Power Excursion	PASS	Meet the requirement of limit.
15.407(a/1/2)	Peak Power Spectral Density	PASS	Meet the requirement of limit.
15.407(g)	Frequency Stability	PASS	Meet the requirement of limit.
15.203	Antenna Requirement	PASS	Antenna connector is I-PEX not a standard connector.

### 2.1 MEASUREMENT UNCERTAINTY

Where relevant, the following measurement uncertainty levels have been estimated for tests performed on the EUT as specified in CISPR 16-4-2:

MEASUREMENT	FREQUENCY	UNCERTAINTY
Radiated emissions	30MHz ~ 200MHz	3.34 dB
	200MHz ~1000MHz	3.35 dB
	1GHz ~ 18GHz	2.26 dB
	18GHz ~ 40GHz	1.94 dB

This uncertainty represents an expanded uncertainty expressed at approximately the 95% confidence level using a coverage factor of  $k = 2$ .



### 3. GENERAL INFORMATION

#### 3.1 GENERAL DESCRIPTION OF EUT

<b>EUT</b>	Vehicle Computer
<b>MODEL NO.</b>	VC6090
<b>HW VERSION</b>	Rev A
<b>SW VERSION</b>	05.02.23096
<b>FUSION VERSION</b>	5.2.5302.38000
<b>BSP VERSION</b>	81.38.0007
<b>POWER SUPPLY</b>	12Vdc
<b>MODULATION TYPE</b>	64QAM, 16QAM, QPSK, BPSK
<b>MODULATION TECHNOLOGY</b>	OFDM
<b>TRANSFER RATE</b>	802.11a: 54.0/ 48.0/ 36.0/ 24.0/ 18.0/ 12.0/ 9.0/ 6.0Mbps
<b>OPERATING FREQUENCY</b>	5180 ~ 5240MHz, 5260 ~ 5320MHz & 5500 ~ 5700MHz
<b>NUMBER OF CHANNEL</b>	5180 ~ 5240MHz: 4 5260 ~ 5320MHz: 4 5500 ~ 5700MHz: 11
<b>OUTPUT POWER</b>	27.102mW for 5180 ~ 5240MHz 24.210mW for 5260 ~ 5320MHz 24.099mW for 5500 ~ 5700MHz
<b>ANTENNA TYPE</b>	PIFA antenna with 4dBi gain
<b>ANTENNA CONNECTOR</b>	I-PEX
<b>I/O PORTS</b>	Refer to user's manual
<b>DATA CABLE</b>	NA
<b>ACCESSORY DEVICES</b>	DC-to-DC Converter

**NOTE:**

1. The EUT provides one completed transmitter and one receiver.

<b>MODULATION MODE</b>	<b>TX FUNCTION</b>
802.11b	1TX
802.11g	1TX
802.11a	1TX

2. The EUT consumes power from the following accessory.

<b>DC-to-DC Converter</b>	
<b>BRAND:</b>	Motorola
<b>MODEL:</b>	50-14000-251R
<b>PART NUMBER:</b>	PWRS-14000-251R
<b>INPUT:</b>	18-75Vdc, 2.4A
<b>OUTPUT:</b>	12Vdc, 2.5A

3. AC power adapter is not available for this product.
4. The above EUT information is declared by manufacturer and for more detailed features description, please refer to the manufacturer's specifications or user's manual.

### 3.2 DESCRIPTION OF TEST MODES

#### FOR 5180 ~ 5240MHz

4 channels are provided for 802.11a:

CHANNEL	FREQUENCY	CHANNEL	FREQUENCY
36	5180 MHz	44	5220 MHz
40	5200 MHz	48	5240 MHz

#### FOR 5260 ~ 5320MHz

4 channels are provided for 802.11a:

CHANNEL	FREQUENCY	CHANNEL	FREQUENCY
52	5260 MHz	60	5300 MHz
56	5280 MHz	64	5320 MHz

#### FOR 5500 ~ 5700MHz

11 channels are provided for 802.11a:

CHANNEL	FREQUENCY	CHANNEL	FREQUENCY
100	5500MHz	124	5620MHz
104	5520MHz	128	5640MHz
108	5540MHz	132	5660MHz
112	5560MHz	136	5680MHz
116	5580MHz	140	5700MHz
120	5600MHz		



### 3.2.1 TEST MODE APPLICABILITY AND TESTED CHANNEL DETAIL

EUT CONFIGURE MODE	APPLICABLE TO				DESCRIPTION
	RE $\geq$ 1G	RE<1G	PLC	APCM	
-	√	√	NOTE 2	√	-

Where **RE $\geq$ 1G**: Radiated Emission above 1GHz **RE<1G**: Radiated Emission below 1GHz  
**PLC**: Power Line Conducted Emission **APCM**: Antenna Port Conducted Measurement

**NOTE 1:**  
The EUT had been pre-tested on the positioned of each 3 axis. The worst case was found when positioned on **Z-plane**.  
**NOTE 2:** No need to concern of Conducted Emission due to the EUT is powered by car battery.

#### RADIATED EMISSION TEST (ABOVE 1GHz):

- Pre-Scan has been conducted to determine the worst-case mode from all possible combinations between available modulations, data rates and antenna ports (if EUT with antenna diversity architecture).
- Following channel(s) was (were) selected for the final test as listed below.

EUT CONFIGURE MODE	MODE	FREQ. BAND (MHz)	AVAILABLE CHANNEL	TESTED CHANNEL	MODULATION TECHNOLOGY	MODULATION TYPE	DATA RATE (Mbps)
-	802.11a	5180-5240	36 to 48	36, 40, 48	OFDM	BPSK	6.0
-	802.11a	5260-5320	52 to 64	52, 60, 64	OFDM	BPSK	6.0
-	802.11a	5500-5700	100 to 140	100, 116, 140	OFDM	BPSK	6.0

#### RADIATED EMISSION TEST (BELOW 1GHz):

- Pre-Scan has been conducted to determine the worst-case mode from all possible combinations between available modulations, data rates and antenna ports (if EUT with antenna diversity architecture).
- Following channel(s) was (were) selected for the final test as listed below.

EUT CONFIGURE MODE	MODE	FREQ. BAND (MHz)	AVAILABLE CHANNEL	TESTED CHANNEL	MODULATION TECHNOLOGY	MODULATION TYPE	DATA RATE (Mbps)
-	802.11a	5180-5320	36 to 64	40	OFDM	BPSK	6.0
-	802.11a	5500-5700	100 to 140	116	OFDM	BPSK	6.0

#### ANTENNA PORT CONDUCTED MEASUREMENT:

- This item includes all test value of each mode, but only includes spectrum plot of worst value of each mode.
- Pre-Scan has been conducted to determine the worst-case mode from all possible combinations between available modulations, data rates and antenna ports (if EUT with antenna diversity architecture).
- Following channel(s) was (were) selected for the final test as listed below.

EUT CONFIGURE MODE	MODE	FREQ. BAND (MHz)	AVAILABLE CHANNEL	TESTED CHANNEL	MODULATION TECHNOLOGY	MODULATION TYPE	DATA RATE (Mbps)
-	802.11a	5180-5240	36 to 48	36, 40, 48	OFDM	BPSK	6.0
-	802.11a	5260-5320	52 to 64	52, 60, 64	OFDM	BPSK	6.0
-	802.11a	5500-5700	100 to 140	100, 116, 140	OFDM	BPSK	6.0

**TEST CONDITION:**

APPLICABLE TO	ENVIRONMENTAL CONDITIONS	INPUT POWER	TESTED BY
RE≥1G	25deg. C, 65%RH	12Vdc	Haru Yang
RE<1G	25deg. C, 65%RH	12Vdc	Haru Yang
APCM	25deg. C, 65%RH	12Vdc	Haru Yang

**3.3 DUTY CYCLE OF TEST SIGNAL**

Duty cycle of test signal is = 100 %, duty factor is not required.

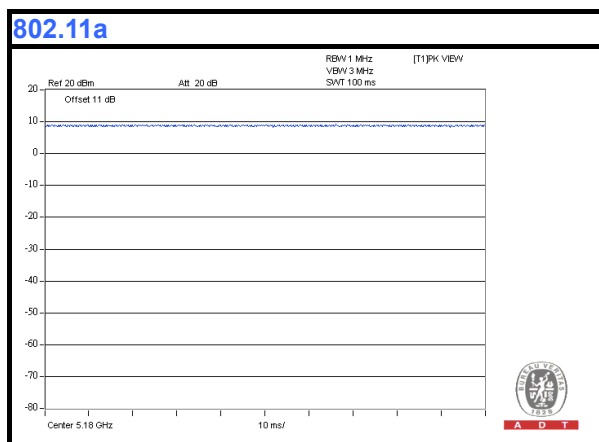

**3.4 DESCRIPTION OF SUPPORT UNITS**

The EUT has been tested as an independent unit together with other necessary accessories or support units. The following support units or accessories were used to form a representative test configuration during the tests.

NO.	PRODUCT	BRAND	MODEL NO.	SERIAL NO.	FCC ID
1	USB DONGLE	Transcend	V85	569992-8208	NA
2	USB DONGLE	Transcend	V85	569992-8271	NA
3	NOTEBOOK	Dell	E5420	33MJMQ1	FCC DoC Approved
4	POWER SUPPLY	TOPWARD	6303D	802236	NA

NO.	SIGNAL CABLE DESCRIPTION OF THE ABOVE SUPPORT UNITS
1	NA
2	NA
3	10m RJ45 UTP cable
4	NA

**NOTE:**

1. All power cords of the above support units are non shielded (1.8m).
2. Item 3 acted as communication partner to transfer data.
3. Item 4 was placed under the testing table.

### 3.4.1 CONFIGURATION OF SYSTEM UNDER TEST

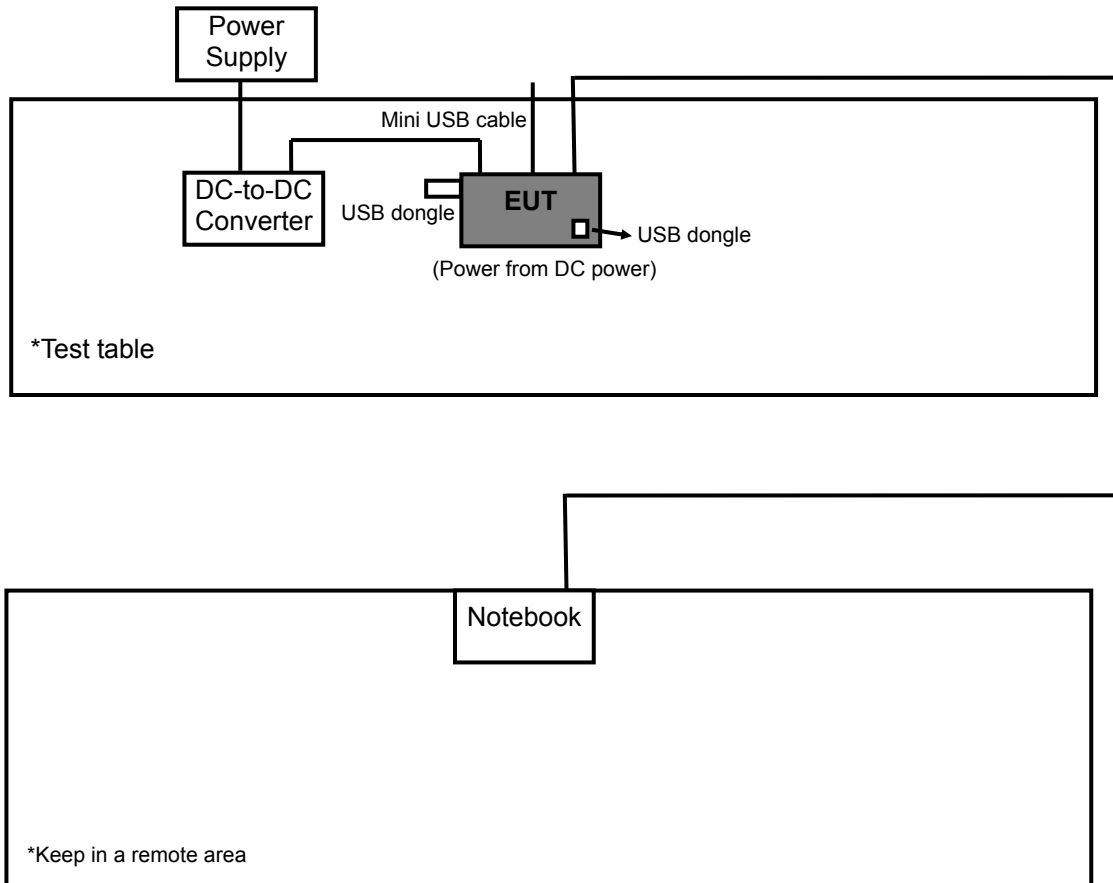

### 3.5 GENERAL DESCRIPTION OF APPLIED STANDARDS

The EUT is a RF Product. According to the specifications of the manufacturer, it must comply with the requirements of the following standards:

**FCC Part 15, Subpart E (15.407)**

**789033 D01 General UNII Test Procedures v01r01**

ANSI C63.10-2009

All test items have been performed and recorded as per the above standards.

## 4. TEST TYPES AND RESULTS

### 4.1 RADIATED EMISSION AND BANDEDGE MEASUREMENT

#### 4.1.1 LIMITS OF RADIATED EMISSION AND BANDEDGE MEASUREMENT

Radiated emissions which fall in the restricted bands must comply with the radiated emission limits specified as below table:

FREQUENCIES (MHz)	FIELD STRENGTH (microvolts/meter)	MEASUREMENT DISTANCE (meters)
0.009 ~ 0.490	2400/F(kHz)	300
0.490 ~ 1.705	24000/F(kHz)	30
1.705 ~ 30.0	30	30
30 ~ 88	100	3
88 ~ 216	150	3
216 ~ 960	200	3
Above 960	500	3

**NOTE:**

1. The lower limit shall apply at the transition frequencies.
2. Emission level (dBuV/m) = 20 log Emission level (uV/m).
3. For frequencies above 1000MHz, the field strength limits are based on average detector, however, the peak field strength of any emission shall not exceed the maximum permitted average limits, specified above by more than 20dB under any condition of modulation.

#### 4.1.2 LIMITS OF UNWANTED EMISSION OUT OF THE RESTRICTED BANDS

EIRP LIMIT (dBm)	EQUIVALENT FIELD STRENGTH AT 3m (dBµV/m)
<b>PK</b>	<b>PK</b>
-27	68.3

**NOTE:** The following formula is used to convert the equipment isotropic radiated power (eirp) to field strength:

$$E = \frac{1000000\sqrt{30P}}{3} \mu\text{V/m, where P is the eirp (Watts).}$$

#### 4.1.3 TEST INSTRUMENTS

DESCRIPTION & MANUFACTURER	MODEL NO.	SERIAL NO.	DATE OF CALIBRATION	DUE DATE OF CALIBRATION
Test Receiver ROHDE & SCHWARZ	ESIB7	100212	Aug. 02, 2011	Aug. 01, 2012
Spectrum Analyzer ROHDE & SCHWARZ	FSP40	100039	Feb. 03, 2012	Feb. 02, 2013
BILOG Antenna SCHWARZBECK	VULB9168	9168-160	Apr. 06, 2012	Apr. 05, 2013
HORN Antenna SCHWARZBECK	9120D	209	Aug. 25, 2011	Aug. 24, 2012
HORN Antenna SCHWARZBECK	BBHA 9170	148	Jul. 11, 2012	Jul. 10, 2013
Loop Antenna	HFH2-Z2	100070	Jan. 31, 2012	Jan. 30, 2014
Preamplifier Agilent	8447D	2944A10633	Oct. 29, 2011	Oct. 28, 2012
Preamplifier Agilent	8449B	3008A01964	Oct. 29, 2011	Oct. 28, 2012
RF signal cable HUBER+SUHNNER	SUCOFLEX 104	250723/4	Aug. 30, 2011	Aug. 29, 2012
RF signal cable HUBER+SUHNNER	SUCOFLEX 106	12738/6+309224/4	Aug. 30, 2011	Aug. 29, 2012
Software ADT.	ADT_Radiated_ V7.6.15.9.2	NA	NA	NA
Antenna Tower inn-co GmbH	MA 4000	013303	NA	NA
Antenna Tower Controller inn-co GmbH	CO2000	017303	NA	NA
Turn Table ADT.	TT100	TT93021703	NA	NA
Turn Table Controller ADT.	SC100	SC93021703	NA	NA
Turn Table Controller ADT.	SC100.	SC93021704	NA	NA
High Speed Peak Power Meter	ML2495A	0842014	Apr. 28, 2012	Apr. 27, 2013
Power Sensor	MA2411B	0738404	Apr. 28, 2012	Apr. 27, 2013

- NOTE:**
1. The calibration interval of the above test instruments is 12 months and the calibrations are traceable to NML/ROC and NIST/USA.
  2. The calibration interval of the loop antenna is 24 months and the calibrations are traceable to NML/ROC and NIST/USA.
  3. The test was performed in HwaYa Chamber 3.
  4. The horn antenna and HP preamplifier (model: 8449B) are used only for the measurement of emission frequency above 1GHz if tested.
  5. The FCC Site Registration No. is 988962.
  6. The IC Site Registration No. is IC 7450F-3.

#### 4.1.4 TEST PROCEDURES

- a. The EUT was placed on the top of a rotating table 0.8 meters above the ground at a 3 meter semi-anechoic chamber. The table was rotated 360 degrees to determine the position of the highest radiation.
- b. The EUT was set 3 meters away from the interference-receiving antenna, which was mounted on the top of a variable-height antenna tower.
- c. The antenna is a broadband antenna, and its height is varied from one meter to four meters above the ground to determine the maximum value of the field strength. Both horizontal and vertical polarizations of the antenna are set to make the measurement.
- d. For each suspected emission, the EUT was arranged to its worst case and then the antenna was tuned to heights from 1 meter to 4 meters and the rotatable table was turned from 0 degrees to 360 degrees to find the maximum reading.
- e. The test-receiver system was set to Peak Detect Function and Specified Bandwidth with Maximum Hold Mode.
- f. If the emission level of the EUT in peak mode was 10dB lower than the limit specified, then testing could be stopped and the peak values of the EUT would be reported. Otherwise the emissions that did not have 10dB margin would be re-tested one by one using peak, quasi-peak or average method as specified and then reported in a data sheet.

**NOTE:**

1. The resolution bandwidth and video bandwidth of test receiver/spectrum analyzer is 120kHz for Peak detection (PK) and Quasi-peak detection (QP) at frequency below 1GHz.
2. The resolution bandwidth of test receiver/spectrum analyzer is 1MHz and video bandwidth is 3MHz for Peak detection at frequency above 1GHz.
3. The resolution bandwidth of test receiver/spectrum analyzer is 1MHz and the video bandwidth is 1kHz for Average detection (AV) at frequency above 1GHz.
4. All modes of operation were investigated and the worst-case emissions are reported.

#### 4.1.5 DEVIATION FROM TEST STANDARD

No deviation.

#### 4.1.6 TEST SETUP

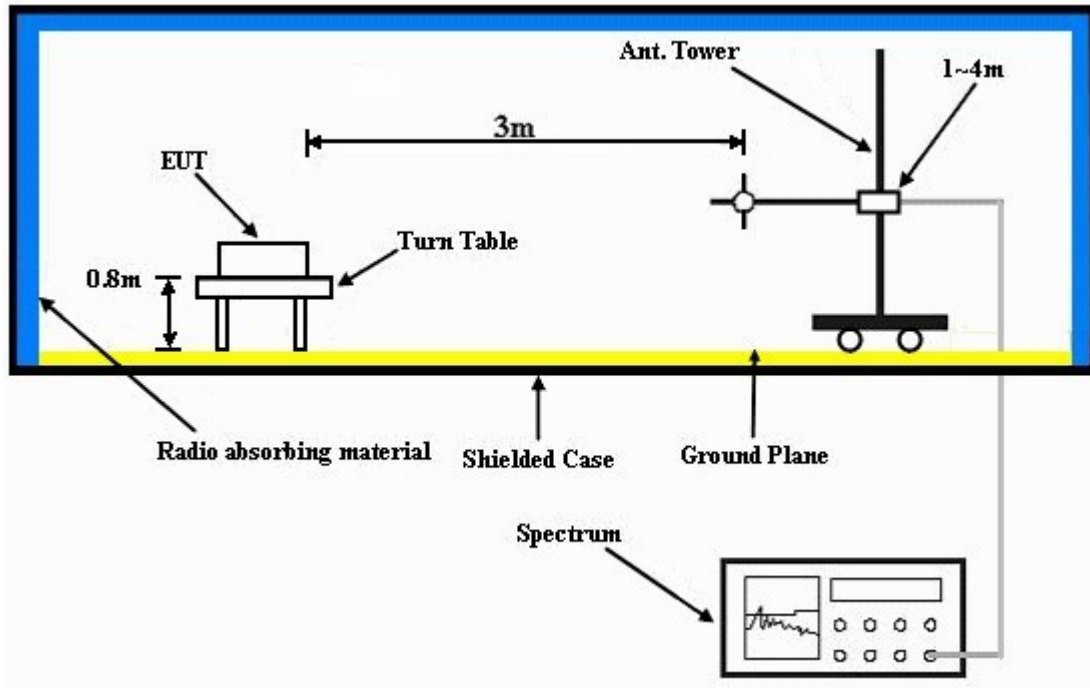

For the actual test configuration, please refer to the attached file (Test Setup Photo).

#### 4.1.7 EUT OPERATING CONDITION

- a. Placed the EUT on the testing table.
- b. Prepared notebook to act as communication partner and placed it outside of testing area.
- c. The communication partner connected with EUT via a RJ45 cable and run a test program (provided by manufacturer) to enable EUT under transmission condition continuously at specific channel frequency.



### 4.1.8 TEST RESULTS

#### 802.11a

EUT TEST CONDITION		MEASUREMENT DETAIL	
CHANNEL	Channel 36	FREQUENCY RANGE	1 ~ 40GHz
INPUT POWER (SYSTEM)	120Vac, 60 Hz	DETECTOR FUNCTION	Peak (PK) Average (AV)
ENVIRONMENTAL CONDITIONS	25deg. C, 65%RH	TESTED BY	Haru Yang

ANTENNA POLARITY & TEST DISTANCE: HORIZONTAL AT 3 M								
NO.	FREQ. (MHz)	EMISSION LEVEL (dBuV/m)	LIMIT (dBuV/m)	MARGIN (dB)	ANTENNA HEIGHT (m)	TABLE ANGLE (Degree)	RAW VALUE (dBuV)	CORRECTION FACTOR (dB/m)
1	5150.00	58.3 PK	74.0	-15.7	1.17 H	279	20.50	37.80
2	5150.00	46.2 AV	54.0	-7.8	1.17 H	279	8.40	37.80
3	*5180.00	107.5 PK			1.17 H	279	69.60	37.90
4	*5180.00	96.4 AV			1.17 H	279	58.50	37.90
5	#10360.00	60.6 PK	68.3	-7.7	1.08 H	211	11.50	49.10
ANTENNA POLARITY & TEST DISTANCE: VERTICAL AT 3 M								
NO.	FREQ. (MHz)	EMISSION LEVEL (dBuV/m)	LIMIT (dBuV/m)	MARGIN (dB)	ANTENNA HEIGHT (m)	TABLE ANGLE (Degree)	RAW VALUE (dBuV)	CORRECTION FACTOR (dB/m)
1	5150.00	60.7 PK	74.0	-13.3	1.42 V	255	22.90	37.80
2	5150.00	47.2 AV	54.0	-6.8	1.42 V	255	9.40	37.80
3	*5180.00	108.5 PK			1.30 V	256	70.60	37.90
4	*5180.00	97.3 AV			1.30 V	256	59.40	37.90
5	#10360.00	59.8 PK	68.3	-8.5	1.18 V	276	10.70	49.10

#### REMARKS:

1. Emission level (dBuV/m) = Raw Value (dBuV) + Correction Factor (dB/m).
2. Correction Factor (dB/m) = Antenna Factor (dB/m) + Cable Factor (dB).
3. The other emission levels were very low against the limit.
4. Margin value = Emission level – Limit value.
5. “ \* “: Fundamental frequency.
6. “#“: The radiated frequency is out the restricted band.





A D T

EUT TEST CONDITION		MEASUREMENT DETAIL	
CHANNEL	Channel 40	FREQUENCY RANGE	1 ~ 40GHz
INPUT POWER (SYSTEM)	120Vac, 60 Hz	DETECTOR FUNCTION	Peak (PK) Average (AV)
ENVIRONMENTAL CONDITIONS	25deg. C, 65%RH	TESTED BY	Haru Yang

ANTENNA POLARITY & TEST DISTANCE: HORIZONTAL AT 3 M								
NO.	FREQ. (MHz)	EMISSION LEVEL (dBuV/m)	LIMIT (dBuV/m)	MARGIN (dB)	ANTENNA HEIGHT (m)	TABLE ANGLE (Degree)	RAW VALUE (dBuV)	CORRECTION FACTOR (dB/m)
1	5150.00	58.2 PK	74.0	-15.8	1.05 H	280	20.40	37.80
2	5150.00	45.6 AV	54.0	-8.4	1.05 H	280	7.80	37.80
3	*5200.00	107.9 PK			1.05 H	280	70.00	37.90
4	*5200.00	97.1 AV			1.05 H	280	59.20	37.90
5	#10400.00	58.4 PK	68.3	-9.9	1.07 H	276	9.30	49.10
ANTENNA POLARITY & TEST DISTANCE: VERTICAL AT 3 M								
NO.	FREQ. (MHz)	EMISSION LEVEL (dBuV/m)	LIMIT (dBuV/m)	MARGIN (dB)	ANTENNA HEIGHT (m)	TABLE ANGLE (Degree)	RAW VALUE (dBuV)	CORRECTION FACTOR (dB/m)
1	5150.00	56.9 PK	74.0	-17.1	1.35 V	213	19.10	37.80
2	5150.00	46.2 AV	54.0	-7.8	1.35 V	213	8.40	37.80
3	*5200.00	109.2 PK			1.35 V	213	71.30	37.90
4	*5200.00	98.3 AV			1.35 V	213	60.40	37.90
5	#10400.00	58.9 PK	68.3	-9.4	1.16 V	238	9.80	49.10

**REMARKS:**

1. Emission level (dBuV/m) = Raw Value (dBuV) + Correction Factor (dB/m).
2. Correction Factor (dB/m) = Antenna Factor (dB/m) + Cable Factor (dB).
3. The other emission levels were very low against the limit.
4. Margin value = Emission level – Limit value.
5. " \* ": Fundamental frequency.
6. "#":The radiated frequency is out the restricted band.



A D T

EUT TEST CONDITION		MEASUREMENT DETAIL	
CHANNEL	Channel 48	FREQUENCY RANGE	1 ~ 40GHz
INPUT POWER (SYSTEM)	120Vac, 60 Hz	DETECTOR FUNCTION	Peak (PK) Average (AV)
ENVIRONMENTAL CONDITIONS	25deg. C, 65%RH	TESTED BY	Haru Yang

ANTENNA POLARITY & TEST DISTANCE: HORIZONTAL AT 3 M								
NO.	FREQ. (MHz)	EMISSION LEVEL (dBuV/m)	LIMIT (dBuV/m)	MARGIN (dB)	ANTENNA HEIGHT (m)	TABLE ANGLE (Degree)	RAW VALUE (dBuV)	CORRECTION FACTOR (dB/m)
1	5150.00	56.2 PK	74.0	-17.8	1.04 H	281	18.40	37.80
2	5150.00	44.9 AV	54.0	-9.1	1.04 H	281	7.10	37.80
3	*5240.00	106.7 PK			1.04 H	281	68.80	37.90
4	*5240.00	95.6 AV			1.04 H	281	57.70	37.90
5	#10480.00	61.5 PK	68.3	-6.8	1.24 H	332	12.00	49.50
ANTENNA POLARITY & TEST DISTANCE: VERTICAL AT 3 M								
NO.	FREQ. (MHz)	EMISSION LEVEL (dBuV/m)	LIMIT (dBuV/m)	MARGIN (dB)	ANTENNA HEIGHT (m)	TABLE ANGLE (Degree)	RAW VALUE (dBuV)	CORRECTION FACTOR (dB/m)
1	5150.00	59.6 PK	74.0	-14.4	1.41 V	258	21.80	37.80
2	5150.00	45.5 AV	54.0	-8.5	1.41 V	258	7.70	37.80
3	*5240.00	107.5 PK			1.41 V	258	69.60	37.90
4	*5240.00	96.7 AV			1.41 V	258	58.80	37.90
5	#10480.00	60.3 PK	68.3	-8.0	1.27 V	288	10.80	49.50

**REMARKS:**

1. Emission level (dBuV/m) = Raw Value (dBuV) + Correction Factor (dB/m).
2. Correction Factor (dB/m) = Antenna Factor (dB/m) + Cable Factor (dB).
3. The other emission levels were very low against the limit.
4. Margin value = Emission level – Limit value.
5. " \* ": Fundamental frequency.
6. "#": The radiated frequency is out the restricted band.



A D T

EUT TEST CONDITION		MEASUREMENT DETAIL	
CHANNEL	Channel 52	FREQUENCY RANGE	1 ~ 40GHz
INPUT POWER (SYSTEM)	120Vac, 60 Hz	DETECTOR FUNCTION	Peak (PK) Average (AV)
ENVIRONMENTAL CONDITIONS	25deg. C, 65%RH	TESTED BY	Haru Yang

ANTENNA POLARITY & TEST DISTANCE: HORIZONTAL AT 3 M								
NO.	FREQ. (MHz)	EMISSION LEVEL (dBuV/m)	LIMIT (dBuV/m)	MARGIN (dB)	ANTENNA HEIGHT (m)	TABLE ANGLE (Degree)	RAW VALUE (dBuV)	CORRECTION FACTOR (dB/m)
1	5150.00	57.2 PK	74.0	-16.8	1.05 H	283	19.40	37.80
2	5150.00	45.0 AV	54.0	-9.0	1.05 H	283	7.20	37.80
3	*5260.00	108.7 PK			1.05 H	283	70.70	38.00
4	*5260.00	97.7 AV			1.05 H	283	59.70	38.00
5	#10520.00	60.6 PK	68.3	-7.7	1.12 H	337	11.00	49.60
ANTENNA POLARITY & TEST DISTANCE: VERTICAL AT 3 M								
NO.	FREQ. (MHz)	EMISSION LEVEL (dBuV/m)	LIMIT (dBuV/m)	MARGIN (dB)	ANTENNA HEIGHT (m)	TABLE ANGLE (Degree)	RAW VALUE (dBuV)	CORRECTION FACTOR (dB/m)
1	5150.00	57.6 PK	74.0	-16.4	1.34 V	209	19.80	37.80
2	5150.00	45.1 AV	54.0	-8.9	1.34 V	209	7.30	37.80
3	*5260.00	109.7 PK			1.00 V	209	71.70	38.00
4	*5260.00	98.8 AV			1.00 V	209	60.80	38.00
5	#10520.00	60.4 PK	68.3	-7.9	1.07 V	210	10.80	49.60

**REMARKS:**

1. Emission level (dBuV/m) = Raw Value (dBuV) + Correction Factor (dB/m).
2. Correction Factor (dB/m) = Antenna Factor (dB/m) + Cable Factor (dB).
3. The other emission levels were very low against the limit.
4. Margin value = Emission level – Limit value.
5. " \* ": Fundamental frequency.
6. "#":The radiated frequency is out the restricted band.



A D T

EUT TEST CONDITION		MEASUREMENT DETAIL	
CHANNEL	Channel 60	FREQUENCY RANGE	1 ~ 40GHz
INPUT POWER (SYSTEM)	120Vac, 60 Hz	DETECTOR FUNCTION	Peak (PK) Average (AV)
ENVIRONMENTAL CONDITIONS	25deg. C, 65%RH	TESTED BY	Haru Yang

ANTENNA POLARITY & TEST DISTANCE: HORIZONTAL AT 3 M								
NO.	FREQ. (MHz)	EMISSION LEVEL (dBuV/m)	LIMIT (dBuV/m)	MARGIN (dB)	ANTENNA HEIGHT (m)	TABLE ANGLE (Degree)	RAW VALUE (dBuV)	CORRECTION FACTOR (dB/m)
1	*5300.00	108.0 PK			1.02 H	282	70.00	38.00
2	*5300.00	97.2 AV			1.02 H	282	59.20	38.00
3	5350.00	57.1 PK	74.0	-16.9	1.02 H	282	19.00	38.10
4	5350.00	45.0 AV	54.0	-9.0	1.02 H	282	6.90	38.10
5	10600.00	60.2 PK	74.0	-13.8	1.11 H	302	10.60	49.60
6	10600.00	48.2 AV	54.0	-5.8	1.11 H	302	-1.40	49.60
ANTENNA POLARITY & TEST DISTANCE: VERTICAL AT 3 M								
NO.	FREQ. (MHz)	EMISSION LEVEL (dBuV/m)	LIMIT (dBuV/m)	MARGIN (dB)	ANTENNA HEIGHT (m)	TABLE ANGLE (Degree)	RAW VALUE (dBuV)	CORRECTION FACTOR (dB/m)
1	*5300.00	109.9 PK			1.23 V	198	71.90	38.00
2	*5300.00	98.9 AV			1.23 V	198	60.90	38.00
3	5350.00	58.7 PK	74.0	-15.3	1.23 V	198	20.60	38.10
4	5350.00	46.4 AV	54.0	-7.6	1.23 V	198	8.30	38.10
5	10600.00	59.2 PK	74.0	-14.8	1.14 V	255	9.60	49.60
6	10600.00	48.0 AV	54.0	-6.0	1.14 V	255	-1.60	49.60

**REMARKS:**

1. Emission level (dBuV/m) = Raw Value (dBuV) + Correction Factor (dB/m).
2. Correction Factor (dB/m) = Antenna Factor (dB/m) + Cable Factor (dB).
3. The other emission levels were very low against the limit.
4. Margin value = Emission level – Limit value.
5. “ \* “: Fundamental frequency.



A D T

EUT TEST CONDITION		MEASUREMENT DETAIL	
CHANNEL	Channel 64	FREQUENCY RANGE	1 ~ 40GHz
INPUT POWER (SYSTEM)	120Vac, 60 Hz	DETECTOR FUNCTION	Peak (PK) Average (AV)
ENVIRONMENTAL CONDITIONS	25deg. C, 65%RH	TESTED BY	Haru Yang

ANTENNA POLARITY & TEST DISTANCE: HORIZONTAL AT 3 M								
NO.	FREQ. (MHz)	EMISSION LEVEL (dBuV/m)	LIMIT (dBuV/m)	MARGIN (dB)	ANTENNA HEIGHT (m)	TABLE ANGLE (Degree)	RAW VALUE (dBuV)	CORRECTION FACTOR (dB/m)
1	*5320.00	105.2 PK			1.04 H	278	67.10	38.10
2	*5320.00	94.3 AV			1.04 H	278	56.20	38.10
3	5350.00	59.3 PK	74.0	-14.7	1.04 H	278	21.20	38.10
4	5350.00	46.0 AV	54.0	-8.0	1.04 H	278	7.90	38.10
5	10640.00	61.1 PK	74.0	-12.9	1.12 H	354	11.50	49.60
6	10640.00	48.3 AV	54.0	-5.7	1.12 H	354	-1.30	49.60

ANTENNA POLARITY & TEST DISTANCE: VERTICAL AT 3 M								
NO.	FREQ. (MHz)	EMISSION LEVEL (dBuV/m)	LIMIT (dBuV/m)	MARGIN (dB)	ANTENNA HEIGHT (m)	TABLE ANGLE (Degree)	RAW VALUE (dBuV)	CORRECTION FACTOR (dB/m)
1	*5320.00	107.7 PK			1.24 V	201	69.60	38.10
2	*5320.00	96.6 AV			1.24 V	201	58.50	38.10
3	5350.00	58.3 PK	74.0	-15.7	1.22 V	201	20.20	38.10
4	5350.00	47.3 AV	54.0	-6.7	1.22 V	201	9.20	38.10
5	10640.00	61.5 PK	74.0	-12.5	1.21 V	250	11.90	49.60
6	10640.00	48.4 AV	54.0	-5.6	1.21 V	250	-1.20	49.60

**REMARKS:**

1. Emission level (dBuV/m) = Raw Value (dBuV) + Correction Factor (dB/m).
2. Correction Factor (dB/m) = Antenna Factor (dB/m) + Cable Factor (dB).
3. The other emission levels were very low against the limit.
4. Margin value = Emission level – Limit value.
5. “ \* “: Fundamental frequency.



A D T

EUT TEST CONDITION		MEASUREMENT DETAIL	
CHANNEL	Channel 100	FREQUENCY RANGE	1 ~ 40GHz
INPUT POWER (SYSTEM)	120Vac, 60 Hz	DETECTOR FUNCTION	Peak (PK) Average (AV)
ENVIRONMENTAL CONDITIONS	25deg. C, 65%RH	TESTED BY	Haru Yang

ANTENNA POLARITY & TEST DISTANCE: HORIZONTAL AT 3 M								
NO.	FREQ. (MHz)	EMISSION LEVEL (dBuV/m)	LIMIT (dBuV/m)	MARGIN (dB)	ANTENNA HEIGHT (m)	TABLE ANGLE (Degree)	RAW VALUE (dBuV)	CORRECTION FACTOR (dB/m)
1	5460.00	58.7 PK	74.0	-15.3	1.00 H	279	20.40	38.30
2	5460.00	45.1 AV	54.0	-8.9	1.00 H	279	6.80	38.30
3	#5470.00	59.2 PK	68.3	-9.1	1.00 H	279	20.90	38.30
4	*5500.00	105.5 PK			1.00 H	279	67.10	38.40
5	*5500.00	94.5 AV			1.00 H	279	56.10	38.40
6	11000.00	60.3 PK	74.0	-13.7	1.11 H	352	10.00	50.30
7	11000.00	48.7 AV	54.0	-5.3	1.11 H	352	-1.60	50.30

ANTENNA POLARITY & TEST DISTANCE: VERTICAL AT 3 M								
NO.	FREQ. (MHz)	EMISSION LEVEL (dBuV/m)	LIMIT (dBuV/m)	MARGIN (dB)	ANTENNA HEIGHT (m)	TABLE ANGLE (Degree)	RAW VALUE (dBuV)	CORRECTION FACTOR (dB/m)
1	5460.00	58.3 PK	74.0	-15.7	1.15 V	260	20.00	38.30
2	5460.00	45.7 AV	54.0	-8.3	1.15 V	260	7.40	38.30
3	#5470.00	58.4 PK	68.3	-9.9	1.15 V	260	20.10	38.30
4	*5500.00	106.7 PK			1.13 V	255	68.30	38.40
5	*5500.00	95.9 AV			1.13 V	255	57.50	38.40
6	11000.00	59.8 PK	74.0	-14.2	1.27 V	253	9.50	50.30
7	11000.00	48.5 AV	54.0	-5.5	1.27 V	253	-1.80	50.30

**REMARKS:**

1. Emission level (dBuV/m) = Raw Value (dBuV) + Correction Factor (dB/m).
2. Correction Factor (dB/m) = Antenna Factor (dB/m) + Cable Factor (dB).
3. The other emission levels were very low against the limit.
4. Margin value = Emission level – Limit value.
5. " \* ": Fundamental frequency.
6. "#": The radiated frequency is out the restricted band.



A D T

EUT TEST CONDITION		MEASUREMENT DETAIL	
CHANNEL	Channel 116	FREQUENCY RANGE	1 ~ 40GHz
INPUT POWER (SYSTEM)	120Vac, 60 Hz	DETECTOR FUNCTION	Peak (PK) Average (AV)
ENVIRONMENTAL CONDITIONS	25deg. C, 65%RH	TESTED BY	Haru Yang

ANTENNA POLARITY & TEST DISTANCE: HORIZONTAL AT 3 M								
NO.	FREQ. (MHz)	EMISSION LEVEL (dBuV/m)	LIMIT (dBuV/m)	MARGIN (dB)	ANTENNA HEIGHT (m)	TABLE ANGLE (Degree)	RAW VALUE (dBuV)	CORRECTION FACTOR (dB/m)
1	5460.00	57.1 PK	74.0	-16.9	1.00 H	281	18.80	38.30
2	5460.00	45.0 AV	54.0	-9.0	1.00 H	281	6.70	38.30
3	*5580.00	106.4 PK			1.00 H	281	68.00	38.40
4	*5580.00	95.6 AV			1.00 H	281	57.20	38.40
5	11160.00	61.2 PK	74.0	-12.8	1.05 H	349	11.10	50.10
6	11160.00	48.6 AV	54.0	-5.4	1.05 H	349	-1.50	50.10
ANTENNA POLARITY & TEST DISTANCE: VERTICAL AT 3 M								
NO.	FREQ. (MHz)	EMISSION LEVEL (dBuV/m)	LIMIT (dBuV/m)	MARGIN (dB)	ANTENNA HEIGHT (m)	TABLE ANGLE (Degree)	RAW VALUE (dBuV)	CORRECTION FACTOR (dB/m)
1	5460.00	57.3 PK	74.0	-16.7	1.55 V	220	19.00	38.30
2	5460.00	44.8 AV	54.0	-9.2	1.55 V	220	6.50	38.30
3	*5580.00	109.2 PK			1.55 V	220	70.80	38.40
4	*5580.00	98.2 AV			1.55 V	220	59.80	38.40
5	11160.00	61.6 PK	74.0	-12.4	1.29 V	281	11.50	50.10
6	11160.00	48.3 AV	54.0	-5.7	1.29 V	281	-1.80	50.10

**REMARKS:**

1. Emission level (dBuV/m) = Raw Value (dBuV) + Correction Factor (dB/m).
2. Correction Factor (dB/m) = Antenna Factor (dB/m) + Cable Factor (dB).
3. The other emission levels were very low against the limit.
4. Margin value = Emission level – Limit value.
5. “ \* “: Fundamental frequency.
6. “#”:The radiated frequency is out the restricted band.



A D T

EUT TEST CONDITION		MEASUREMENT DETAIL	
CHANNEL	Channel 140	FREQUENCY RANGE	1 ~ 40GHz
INPUT POWER (SYSTEM)	120Vac, 60 Hz	DETECTOR FUNCTION	Peak (PK) Average (AV)
ENVIRONMENTAL CONDITIONS	25deg. C, 65%RH	TESTED BY	Haru Yang

ANTENNA POLARITY & TEST DISTANCE: HORIZONTAL AT 3 M								
NO.	FREQ. (MHz)	EMISSION LEVEL (dBuV/m)	LIMIT (dBuV/m)	MARGIN (dB)	ANTENNA HEIGHT (m)	TABLE ANGLE (Degree)	RAW VALUE (dBuV)	CORRECTION FACTOR (dB/m)
1	*5700.00	101.8 PK			1.00 H	278	63.10	38.70
2	*5700.00	91.4 AV			1.00 H	278	52.70	38.70
3	#5725.00	59.8 PK	68.3	-8.5	1.00 H	278	21.00	38.80
4	11400.00	59.5 PK	74.0	-14.5	1.15 H	347	9.40	50.10
5	11400.00	47.7 AV	54.0	-6.3	1.15 H	347	-2.40	50.10
ANTENNA POLARITY & TEST DISTANCE: VERTICAL AT 3 M								
NO.	FREQ. (MHz)	EMISSION LEVEL (dBuV/m)	LIMIT (dBuV/m)	MARGIN (dB)	ANTENNA HEIGHT (m)	TABLE ANGLE (Degree)	RAW VALUE (dBuV)	CORRECTION FACTOR (dB/m)
1	*5700.00	104.1 PK			1.32 V	208	65.40	38.70
2	*5700.00	94.0 AV			1.32 V	208	55.30	38.70
3	#5725.00	61.1 PK	68.3	-7.2	1.13 V	211	22.30	38.80
4	11400.00	60.8 PK	74.0	-13.2	1.26 V	279	10.70	50.10
5	11400.00	47.6 AV	54.0	-6.4	1.26 V	279	-2.50	50.10

**REMARKS:**

1. Emission level (dBuV/m) = Raw Value (dBuV) + Correction Factor (dB/m).
2. Correction Factor (dB/m) = Antenna Factor (dB/m) + Cable Factor (dB).
3. The other emission levels were very low against the limit.
4. Margin value = Emission level – Limit value.
5. “ \* “: Fundamental frequency.
6. “#”:The radiated frequency is out the restricted band.





A D T

**BELOW 1GHz WORST-CASE DATA : 802.11a**

EUT TEST CONDITION		MEASUREMENT DETAIL	
CHANNEL	Channel 40	FREQUENCY RANGE	Below 1000MHz
INPUT POWER (SYSTEM)	120Vac, 60 Hz	DETECTOR FUNCTION	Quasi-Peak
ENVIRONMENTAL CONDITIONS	25deg. C, 65%RH	TESTED BY	Haru Yang

ANTENNA POLARITY & TEST DISTANCE: HORIZONTAL AT 3 M								
NO.	FREQ. (MHz)	EMISSION LEVEL (dBuV/m)	LIMIT (dBuV/m)	MARGIN (dB)	ANTENNA HEIGHT (m)	TABLE ANGLE (Degree)	RAW VALUE (dBuV)	CORRECTION FACTOR (dB/m)
1	129.06	37.2 QP	43.5	-6.3	1.74 H	256	24.60	12.60
2	234.05	32.0 QP	46.0	-14.0	1.24 H	271	19.60	12.40
3	292.38	27.5 QP	46.0	-18.5	1.00 H	231	12.80	14.70
4	370.15	25.9 QP	46.0	-20.1	1.00 H	69	9.10	16.80
5	486.81	23.7 QP	46.0	-22.3	1.24 H	207	4.10	19.60
6	786.23	24.8 QP	46.0	-21.2	1.74 H	296	-0.50	25.30
ANTENNA POLARITY & TEST DISTANCE: VERTICAL AT 3 M								
NO.	FREQ. (MHz)	EMISSION LEVEL (dBuV/m)	LIMIT (dBuV/m)	MARGIN (dB)	ANTENNA HEIGHT (m)	TABLE ANGLE (Degree)	RAW VALUE (dBuV)	CORRECTION FACTOR (dB/m)
1	62.95	29.6 QP	40.0	-10.4	1.00 V	0	16.50	13.10
2	162.11	36.9 QP	43.5	-6.6	1.00 V	0	22.90	14.00
3	234.05	28.6 QP	46.0	-17.4	1.74 V	155	16.20	12.40
4	370.15	28.2 QP	46.0	-17.8	1.50 V	322	11.40	16.80
5	486.81	28.1 QP	46.0	-17.9	1.50 V	61	8.50	19.60
6	727.90	27.0 QP	46.0	-19.0	1.25 V	345	3.30	23.70

**REMARKS:**

1. Emission level (dBuV/m) = Raw Value (dBuV) + Correction Factor (dB/m).
2. Correction Factor (dB/m) = Antenna Factor (dB/m) + Cable Factor (dB).
3. The other emission levels were very low against the limit.
4. Margin value = Emission level – Limit value.



A D T

EUT TEST CONDITION		MEASUREMENT DETAIL	
CHANNEL	Channel 116	FREQUENCY RANGE	Below 1000MHz
INPUT POWER (SYSTEM)	120Vac, 60 Hz	DETECTOR FUNCTION	Quasi-Peak
ENVIRONMENTAL CONDITIONS	25deg. C, 65%RH	TESTED BY	Haru Yang

ANTENNA POLARITY & TEST DISTANCE: HORIZONTAL AT 3 M								
NO.	FREQ. (MHz)	EMISSION LEVEL (dBuV/m)	LIMIT (dBuV/m)	MARGIN (dB)	ANTENNA HEIGHT (m)	TABLE ANGLE (Degree)	RAW VALUE (dBuV)	CORRECTION FACTOR (dB/m)
1	131.00	37.2 QP	43.5	-6.3	1.74 H	268	24.40	12.80
2	234.05	32.2 QP	46.0	-13.8	1.49 H	261	19.80	12.40
3	292.38	28.0 QP	46.0	-18.0	1.00 H	225	13.30	14.70
4	370.15	26.3 QP	46.0	-19.7	1.00 H	83	9.50	16.80
5	486.81	23.9 QP	46.0	-22.1	1.25 H	205	4.30	19.60
6	759.01	25.1 QP	46.0	-20.9	1.00 H	16	0.50	24.60

ANTENNA POLARITY & TEST DISTANCE: VERTICAL AT 3 M								
NO.	FREQ. (MHz)	EMISSION LEVEL (dBuV/m)	LIMIT (dBuV/m)	MARGIN (dB)	ANTENNA HEIGHT (m)	TABLE ANGLE (Degree)	RAW VALUE (dBuV)	CORRECTION FACTOR (dB/m)
1	62.95	30.1 QP	40.0	-9.9	1.00 V	3	17.00	13.10
2	156.28	36.4 QP	43.5	-7.1	1.00 V	278	22.30	14.10
3	234.05	27.5 QP	46.0	-18.5	1.74 V	194	15.10	12.40
4	370.15	27.4 QP	46.0	-18.6	1.25 V	334	10.60	16.80
5	531.53	29.5 QP	46.0	-16.5	1.50 V	4	8.90	20.60
6	727.90	25.6 QP	46.0	-20.4	1.25 V	16	1.90	23.70

**REMARKS:**

1. Emission level (dBuV/m) = Raw Value (dBuV) + Correction Factor (dB/m).
2. Correction Factor (dB/m) = Antenna Factor (dB/m) + Cable Factor (dB).
3. The other emission levels were very low against the limit.
4. Margin value = Emission level – Limit value.

## 4.2 PEAK TRANSMIT POWER MEASUREMENT

### 4.2.1 LIMITS OF PEAK TRANSMIT POWER MEASUREMENT

FREQUENCY BAND	LIMIT
5.150 ~ 5.250GHz	The lesser of 50mW (17dBm) or 4dBm + 10logB
5.250 ~ 5.350GHz	The lesser of 250mW (24dBm) or 11dBm + 10logB
5.470 ~ 5.725GHz	The lesser of 250mW (24dBm) or 11dBm + 10logB

**NOTE:** Where B is the 26dB emission bandwidth in MHz.

### 4.2.2 TEST SETUP

#### FOR POWER OUTPUT MEASUREMENT

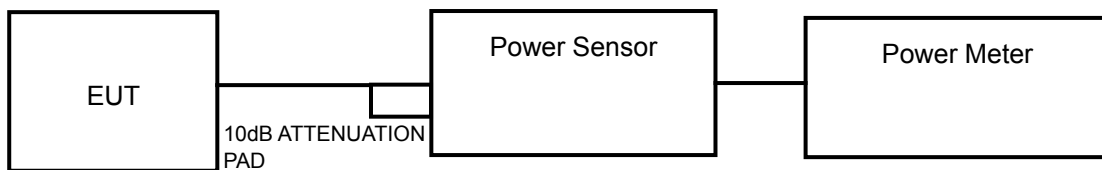

#### FOR 26dB BANDWIDTH

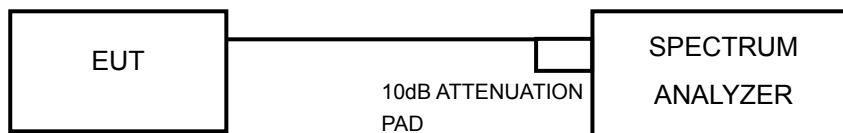

### 4.2.3 TEST INSTRUMENTS

Refer to section 4.1.3 to get information of above instrument.

#### 4.2.4 TEST PROCEDURE

##### FOR AVERAGE POWER MEASUREMENT

Method PM is used to perform output power measurement, trigger and gating function of wide band power meter is enabled to measure max output power of TX on burst. Duty factor is not added to measured value.

##### FOR 26dB BANDWIDTH

- 1) Set RBW = approximately 1% of the emission bandwidth.
- 2) Set the VBW > RBW.
- 3) Detector = Peak.
- 4) Trace mode = max hold.
- 5) Measure the maximum width of the emission that is 26 dB down from the peak of the emission. Compare this with the RBW setting of the analyzer. Readjust RBW and repeat measurement as needed until the RBW/EBW ratio is approximately 1%.

#### 4.2.5 DEVIATION FROM TEST STANDARD

No deviation.

#### 4.2.6 EUT OPERATING CONDITIONS

The software provided by client to enable the EUT under transmission condition continuously at specific channel frequencies individually.



#### 4.2.7 TEST RESULTS

##### POWER OUTPUT: 802.11a

CHANNEL	FREQUENCY (MHz)	POWER (dBm)							
		Data Rate							
		6Mbps	9Mbps	12Mbps	18Mbps	24Mbps	36Mbps	48Mbps	54Mbps
36	Power Setting	13/212	13/212	13/212	13/212	13/212	13/212	12/199	12/199
	5180 MHz	13.39	12.87	12.92	12.94	12.84	12.78	12.09	12.06
40	Power Setting	15/240	15/240	15/240	15/240	14/235	14/235	12/199	12/199
	5200 MHz	14.33	14.21	14.19	14.22	13.91	13.79	11.91	11.96
48	Power Setting	13/212	13/212	13/212	13/212	13/212	13/212	12/199	12/199
	5240 MHz	12.81	12.64	12.74	12.69	12.66	12.64	11.86	11.84
52	Power Setting	15/240	15/240	15/240	15/240	14/233	14/233	12/198	12/198
	5260 MHz	13.84	13.70	13.76	13.74	13.48	13.39	11.44	11.53
60	Power Setting	15/240	15/240	15/240	15/240	14/231	14/231	12/196	12/196
	5300 MHz	13.78	13.71	13.64	13.72	13.25	13.16	11.3	11.24
64	Power Setting	12/196	12/196	12/196	12/196	12/196	12/196	12/195	12/195
	5320 MHz	11.19	11.12	11.07	11.05	11.17	11.04	11.05	11.03
100	Power Setting	12/200	12/200	12/200	12/200	12/200	12/200	11/179	11/179
	5500 MHz	11.82	11.79	11.68	11.73	11.66	11.62	10.56	10.51
116	Power Setting	14/228	14/228	14/228	14/228	13/208	13/208	10/169	10/169
	5580 MHz	13.82	13.67	13.69	13.76	12.09	12.44	10.41	10.17
140	Power Setting	9/144	9/144	9/144	9/144	9/144	9/144	9/144	9/144
	5700 MHz	8.32	8.27	8.25	8.15	8.17	8.02	8.04	8.22

##### 26dB BANDWIDTH: 802.11a

CHANNEL	CHANNEL FREQUENCY (MHz)	26dBc BANDWIDTH (MHz)	PASS / FAIL
36	5180	20.91	PASS
40	5200	23.23	PASS
48	5240	20.91	PASS
52	5260	23.29	PASS
60	5300	23.23	PASS
64	5320	20.91	PASS
100	5500	21.04	PASS
116	5580	24.73	PASS
140	5700	20.80	PASS

### 4.3 PEAK POWER SPECTRAL DENSITY MEASUREMENT

#### 4.3.1 LIMITS OF PEAK POWER SPECTRAL DENSITY MEASUREMENT

FREQUENCY BAND	LIMIT
5.150 ~ 5.250GHz	4dBm
5.250 ~ 5.350GHz	11dBm
5.470 ~ 5.725GHz	11dBm

#### 4.3.2 TEST SETUP

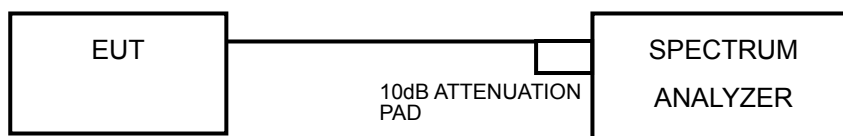

#### 4.3.3 TEST INSTRUMENTS

Refer to section 4.1.3 to get information of above instrument.

#### 4.3.4 TEST PROCEDURES

Using method SA-1 alternative

- 1) Set span to encompass the entire emission bandwidth (EBW) of the signal.
- 2) Set RBW = 1 MHz, Set VBW  $\geq$  3 MHz, Detector = RMS
- 3) Sweep time = 26 second.
- 4) Perform a single sweep.
- 5) Record the max value

#### 4.3.5 DEVIATION FROM TEST STANDARD

No deviation.

#### 4.3.6 EUT OPERATING CONDITIONS

Same as 4.3.6.



### 4.3.7 TEST RESULTS

#### 802.11a

CHANNEL	FREQUENCY (MHz)	PSD (dBm)	MAXIMUM LIMIT (dBm)	PASS/FAIL
36	5180	2.57	4	PASS
40	5200	3.80	4	PASS
48	5240	2.65	4	PASS
52	5260	3.92	11	PASS
60	5300	3.52	11	PASS
64	5320	0.82	11	PASS
100	5500	1.30	11	PASS
116	5580	3.02	11	PASS
140	5700	-2.20	11	PASS

## 4.4 PEAK POWER EXCURSION MEASUREMENT

### 4.4.1 LIMITS OF PEAK POWER EXCURSION MEASUREMENT

Shall not exceed 13 dB.

### 4.4.2 TEST SETUP

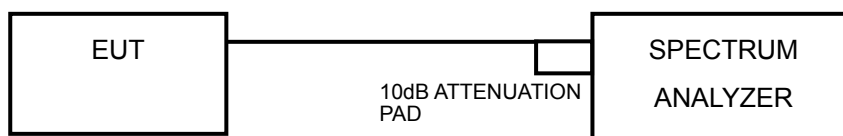

### 4.4.3 TEST INSTRUMENTS

Refer to section 4.1.3 to get information of above instrument.

### 4.4.4 TEST PROCEDURE

- 1) Set RBW = 1 MHz, VBW  $\geq$  3 MHz, Detector = peak.
- 2) Trace mode = max-hold. Allow the sweeps to continue until the trace stabilizes.
- 3) Use the peak search function to find the peak of the spectrum.
- 4) Measure the PPSD.
- 5) Compute the ratio of the maximum of the peak-max-hold spectrum to the PPSD.

### 4.4.5 DEVIATION FROM TEST STANDARD

No deviation.

### 4.4.6 EUT OPERATING CONDITIONS

Same as 4.2.6





A D T

### 4.4.7 TEST RESULTS

#### 802.11a

CHANNEL	CHANNEL FREQUENCY (MHz)	PEAK VALUE (dBm)	PPSD (dBm)	PEAK EXCURSION (dB)	LIMIT (dB)	PASS/FAIL
36	5180	11.33	2.57	8.76	13	PASS
40	5200	12.46	3.80	8.66	13	PASS
48	5240	11.34	2.65	8.69	13	PASS
52	5260	12.55	3.92	8.63	13	PASS
60	5300	12.13	3.52	8.61	13	PASS
64	5320	9.61	0.82	8.79	13	PASS
100	5500	10.04	1.30	8.74	13	PASS
116	5580	11.59	3.02	8.57	13	PASS
140	5700	6.35	-2.20	8.55	13	PASS

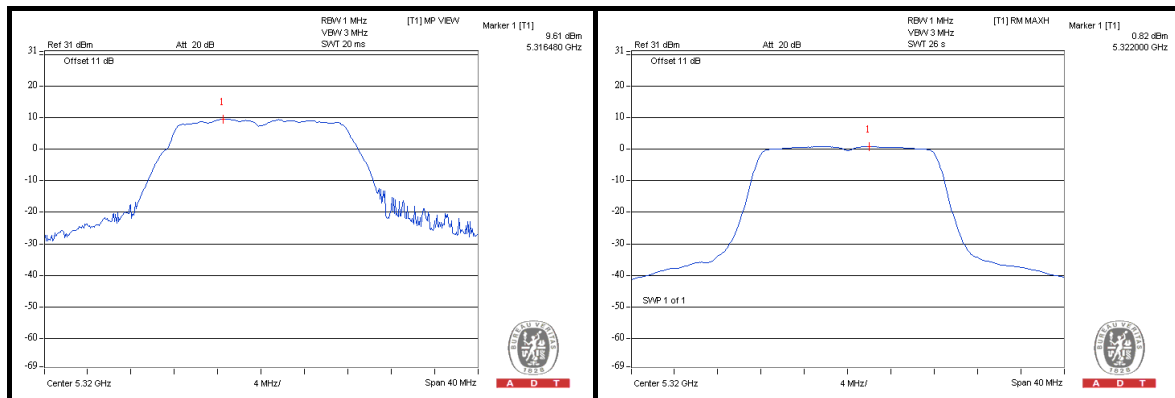

## 4.5 FREQUENCY STABILITY

### 4.5.1 LIMITS OF FREQUENCY STABILITY MEASUREMENT

The frequency of the carrier signal shall be maintained within band of operation

### 4.5.2 TEST SETUP

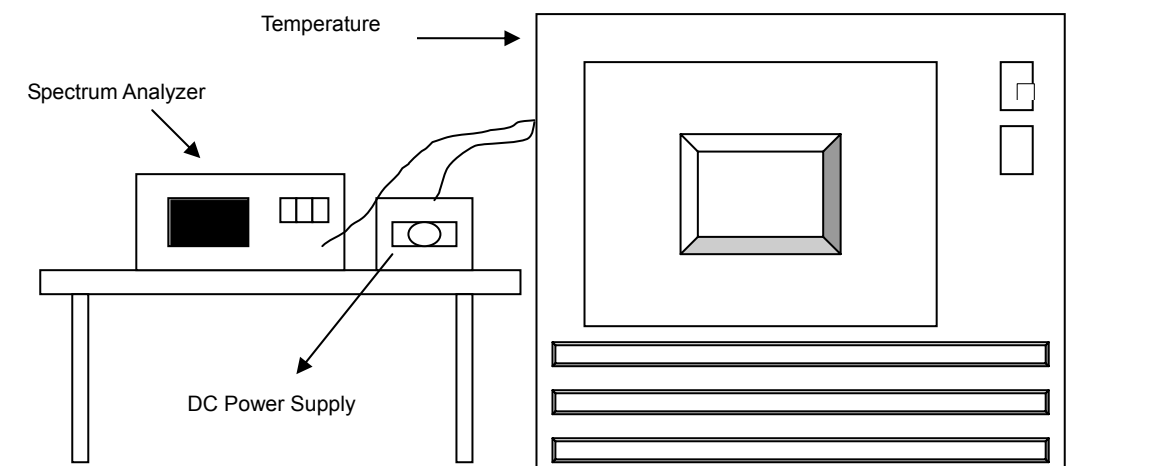

### 4.5.3 TEST INSTRUMENTS

Refer to section 4.1.3 to get information of above instrument.

#### 4.5.4 TEST PROCEDURE

- a. The EUT was placed inside the environmental test chamber and powered by nominal DC voltage.
- b. Turn the EUT on and couple its output to a spectrum analyzer.
- c. Turn the EUT off and set the chamber to the highest temperature specified.
- d. Allow sufficient time (approximately 30 min) for the temperature of the chamber to stabilize, turn the EUT on and measure the operating frequency after 2, 5, and 10 minutes.
- e. Repeat step 2 and 3 with the temperature chamber set to the lowest temperature.
- f. The test chamber was allowed to stabilize at +20 degree C for a minimum of 30 minutes. The supply voltage was then adjusted on the EUT from 85% to 115% and the frequency record.

#### 4.5.5 DEVIATION FROM TEST STANDARD

No deviation.

#### 4.5.6 EUT OPERATING CONDITION

Set the EUT transmit at un-modulation mode to test frequency stability.



#### 4.5.7 TEST RESULTS

FREQUENCY STABILITY VERSUS TEMP.									
OPERATING FREQUENCY: 5320MHz									
TEMP. (°C)	POWER SUPPLY (Vdc)	0 MINUTE		2 MINUTE		5 MINUTE		10 MINUTE	
		Measured Frequency (MHz)	Frequency Drift (ppm)	Measured Frequency (MHz)	Frequency Drift (ppm)	Measured Frequency (MHz)	Frequency Drift (ppm)	Measured Frequency (MHz)	Frequency Drift (ppm)
60	24.0	5319.986230	-2.588	5319.986658	-2.508	5319.986516	-2.535	5319.986331	-2.569
50	24.0	5319.990212	-1.840	5319.990540	-1.778	5319.990168	-1.848	5319.990321	-1.819
40	24.0	5319.992512	-1.408	5319.992975	-1.320	5319.993109	-1.295	5319.992345	-1.439
30	24.0	5319.996861	-0.590	5319.997076	-0.550	5319.997035	-0.557	5319.996638	-0.632
20	24.0	5319.999929	-0.013	5320.000445	0.084	5320.000301	0.057	5320.000406	0.076
10	24.0	5320.003052	0.574	5320.003348	0.629	5320.002777	0.522	5320.002940	0.553
0	24.0	5320.012157	2.285	5320.012111	2.277	5320.012042	2.264	5320.012226	2.298
-10	24.0	5320.018386	3.456	5320.018652	3.506	5320.018968	3.565	5320.018890	3.551
-20	24.0	5320.021955	4.127	5320.022069	4.148	5320.022399	4.210	5320.022526	4.234
-30	24.0	5320.032559	6.120	5320.032372	6.085	5320.032683	6.143	5320.032729	6.152

FREQUENCY STABILITY VERSUS VOLTAGE									
OPERATING FREQUENCY: 5320MHz									
TEMP. (°C)	POWER SUPPLY (Vdc)	0 MINUTE		2 MINUTE		5 MINUTE		10 MINUTE	
		Measured Frequency (MHz)	Frequency Drift (ppm)	Measured Frequency (MHz)	Frequency Drift (ppm)	Measured Frequency (MHz)	Frequency Drift (ppm)	Measured Frequency (MHz)	Frequency Drift (ppm)
20	18.0	5319.999765	-0.044	5319.999985	-0.003	5319.999601	-0.075	5319.999724	-0.052
	24.0	5319.999929	-0.013	5320.000445	0.084	5320.000301	0.057	5320.000406	0.076
	75.0	5319.999679	-0.060	5319.999953	-0.009	5319.999746	-0.048	5319.999923	-0.014



A D T

## 5. PHOTOGRAPHS OF THE TEST CONFIGURATION

Please refer to the attached file (Test Setup Photo).



## 6. INFORMATION ON THE TESTING LABORATORIES

We, Bureau Veritas Consumer Products Services (H.K.) Ltd., Taoyuan Branch, were founded in 1988 to provide our best service in EMC, Radio, Telecom and Safety consultation. Our laboratories are accredited and approved according to ISO/IEC 17025.

If you have any comments, please feel free to contact us at the following:

**Linko EMC/RF Lab:**  
Tel: 886-2-26052180  
Fax: 886-2-26051924

**Hsin Chu EMC/RF Lab:**  
Tel: 886-3-5935343  
Fax: 886-3-5935342

**Hwa Ya EMC/RF/Safety Telecom Lab:**  
Tel: 886-3-3183232  
Fax: 886-3-3270892

**Email:** [service.adt@tw.bureauveritas.com](mailto:service.adt@tw.bureauveritas.com)

**Web Site:** [www.adt.com.tw](http://www.adt.com.tw)

The address and road map of all our labs can be found in our web site also.



A D T

## 7. APPENDIX A - MODIFICATIONS RECORDERS FOR ENGINEERING CHANGES TO THE EUT BY THE LAB

No modifications were made to the EUT by the lab during the test.

---END---