

### #01\_WLAN2.4GHz\_802.11b 1Mbps\_Right Side\_0mm\_Ch1

Communication System: 802.11b; Frequency: 2412 MHz; Duty Cycle: 1:1

Medium: MSL\_2450\_150902 Medium parameters used:  $f = 2412$  MHz;  $\sigma = 1.845$  S/m;  $\epsilon_r = 54.066$ ;  $\rho = 1000$  kg/m<sup>3</sup>

Ambient Temperature : 23.2 °C; Liquid Temperature : 22.2 °C

**DASY5 Configuration:**

- Probe: EX3DV4 - SN3931; ConvF(7.36, 7.36, 7.36); Calibrated: 2014/9/25;
- Sensor-Surface: 1.4mm (Mechanical Surface Detection)
- Electronics: DAE3 Sn577; Calibrated: 2014/10/6
- Phantom: SAM-Right; Type: SAM; Serial: 1795
- Measurement SW: DASY52, Version 52.8 (8); SEMCAD X Version 14.6.10 (7331)

**Configuration/Ch1/Area Scan (11x141x1):** Interpolated grid: dx=1.200 mm, dy=1.200 mm  
 Maximum value of SAR (interpolated) = 0.549 W/kg

**Configuration/Ch1/Zoom Scan (7x7x7)/Cube 0:** Measurement grid: dx=5mm, dy=5mm, dz=5mm

Reference Value = 18.02 V/m; Power Drift = -0.05 dB

Peak SAR (extrapolated) = 0.676 W/kg

**SAR(1 g) = 0.367 W/kg; SAR(10 g) = 0.204 W/kg**

Maximum value of SAR (measured) = 0.558 W/kg

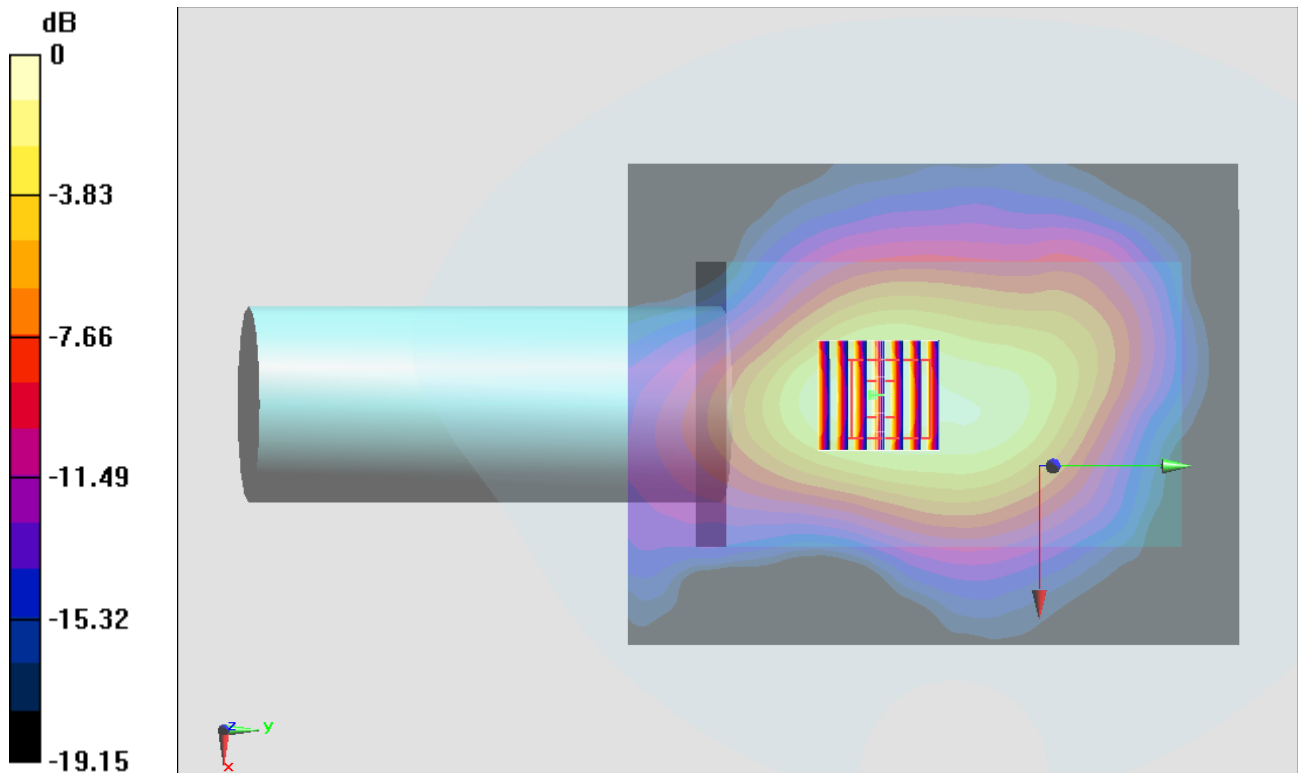

0 dB = 0.558 W/kg = -2.53 dBW/kg

## #02\_WLAN5GHz\_802.11a\_6Mbps\_Right Side\_0mm\_Ch52

Communication System: 802.11a ; Frequency: 5260 MHz; Duty Cycle: 1:1.009

Medium: MSL\_5G\_150902 Medium parameters used:  $f = 5260$  MHz;  $\sigma = 5.482$  S/m;  $\epsilon_r = 47.95$ ;  $\rho = 1000$  kg/m<sup>3</sup>

Ambient Temperature : 23.2 °C; Liquid Temperature : 22.2 °C

DASY5 Configuration:

- Probe: EX3DV4 - SN3954; ConvF(4.15, 4.15, 4.15); Calibrated: 2014/11/21;
- Sensor-Surface: 1.4mm (Mechanical Surface Detection)
- Electronics: DAE4 Sn1279; Calibrated: 2015/7/21
- Phantom: SAM\_Left; Type: QD000P40CD; Serial: TP:1644
- Measurement SW: DASY52, Version 52.8 (8); SEMCAD X Version 14.6.10 (7331)

**Configuration/Ch52/Area Scan (101x161x1):** Interpolated grid: dx=1.000 mm, dy=1.000 mm  
 Maximum value of SAR (interpolated) = 2.68 W/kg

**Configuration/Ch52/Zoom Scan (7x7x7)/Cube 0:** Measurement grid: dx=4mm, dy=4mm, dz=1.4mm

Reference Value = 22.54 V/m; Power Drift = -0.13 dB

Peak SAR (extrapolated) = 3.49 W/kg

**SAR(1 g) = 1.07 W/kg; SAR(10 g) = 0.433 W/kg**

Maximum value of SAR (measured) = 2.27 W/kg

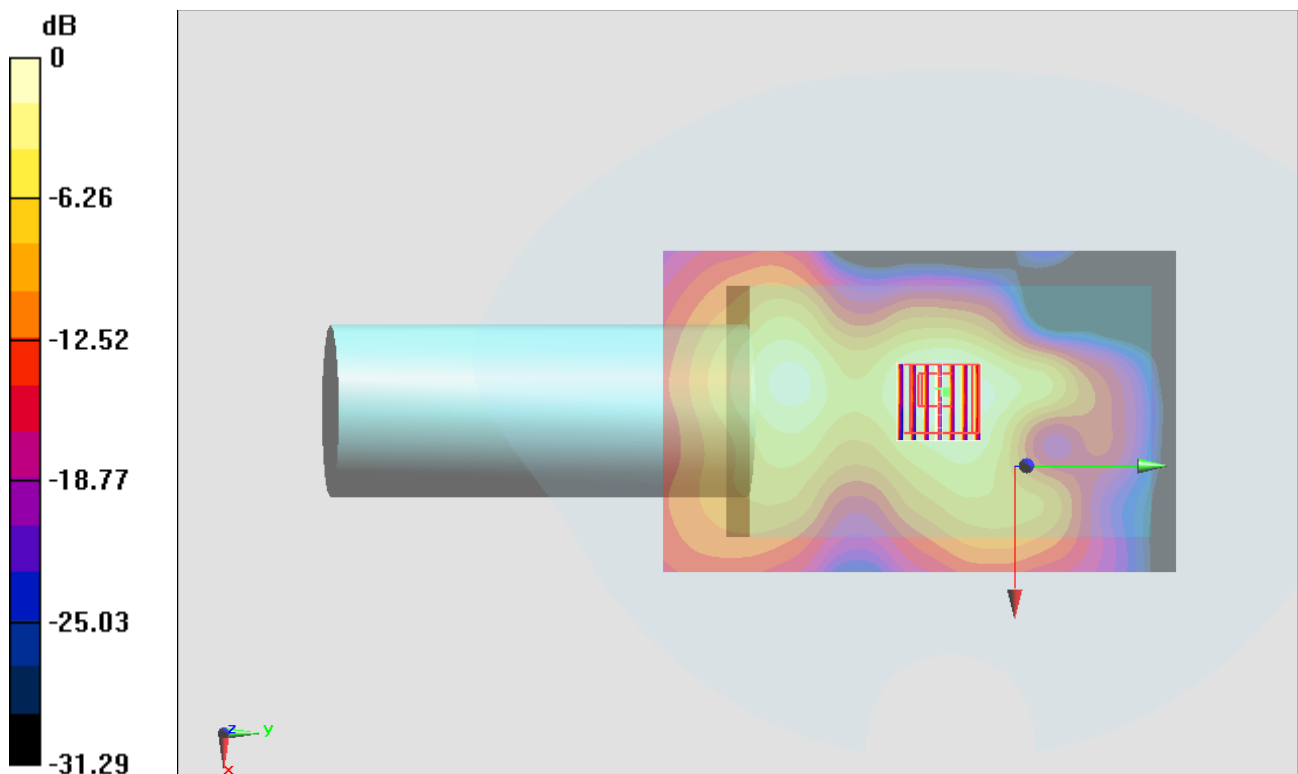

0 dB = 2.27 W/kg = 3.56 dBW/kg

### #03\_WLAN5GHz\_802.11a 6Mbps\_Right Side\_0mm\_Ch116

Communication System: 802.11a ; Frequency: 5580 MHz;Duty Cycle: 1:1.009

Medium: MSL\_5G\_150903 Medium parameters used :  $f = 5580$  MHz;  $\sigma = 5.911$  S/m;  $\epsilon_r = 47.172$ ;  $\rho = 1000$  kg/m<sup>3</sup>

Ambient Temperature : 23.2 °C; Liquid Temperature : 22.2 °C

#### DASY5 Configuration:

- Probe: EX3DV4 - SN3925; ConvF(4.1, 4.1, 4.1); Calibrated: 2015/5/27;
- Sensor-Surface: 1.4mm (Mechanical Surface Detection)
- Electronics: DAE3 Sn495; Calibrated: 2015/5/22
- Phantom: SAM-Right; Type: QD 000 P40 C; Serial: TP-1446
- Measurement SW: DASY52, Version 52.8 (8);SEMCAD X Version 14.6.10 (7331)

**Configuration/Ch116/Area Scan (101x161x1):** Interpolated grid: dx=1.000 mm, dy=1.000 mm

Maximum value of SAR (interpolated) = 3.66 W/kg

**Configuration/Ch116/Zoom Scan (7x7x7)/Cube 0:** Measurement grid: dx=4mm, dy=4mm, dz=1.4mm

Reference Value = 19.95 V/m; Power Drift = -0.06 dB

Peak SAR (extrapolated) = 4.42 W/kg

**SAR(1 g) = 1.19 W/kg; SAR(10 g) = 0.403 W/kg**

Maximum value of SAR (measured) = 2.85 W/kg

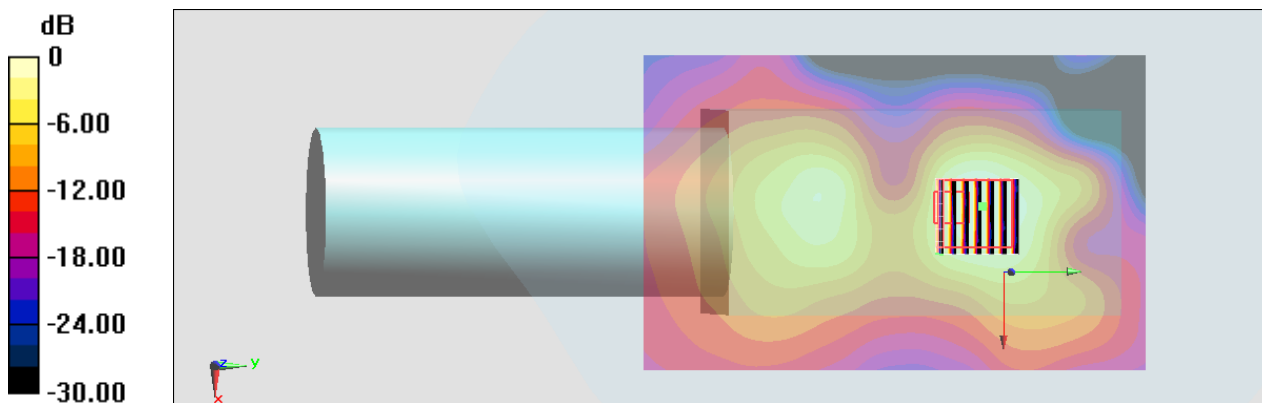

0 dB = 2.85 W/kg = 4.59 dBW/kg

### #04\_WLAN5GHz\_802.11a 6Mbps\_Right Side\_0mm\_Ch157

Communication System: 802.11a ; Frequency: 5785 MHz;Duty Cycle: 1:1.009  
Medium: MSL\_5G\_150904 Medium parameters used:  $f = 5785$  MHz;  $\sigma = 6.186$  S/m;  $\epsilon_r = 46.889$ ;  $\rho = 1000$  kg/m<sup>3</sup>  
Ambient Temperature : 23.2 °C; Liquid Temperature : 22.2 °C

#### DASY5 Configuration:

- Probe: EX3DV4 - SN3925; ConvF(4.16, 4.16, 4.16); Calibrated: 2015/5/27;
- Sensor-Surface: 1.4mm (Mechanical Surface Detection)
- Electronics: DAE3 Sn495; Calibrated: 2015/5/22
- Phantom: SAM-Right; Type: QD 000 P40 C; Serial: TP-1446
- Measurement SW: DASY52, Version 52.8 (8);SEMCAD X Version 14.6.10 (7331)

**Configuration/Ch157/Area Scan (81x181x1):** Interpolated grid: dx=1.000 mm, dy=1.000 mm

Maximum value of SAR (interpolated) = 2.95 W/kg

**Configuration/Ch157/Zoom Scan (7x7x7)/Cube 0:** Measurement grid: dx=4mm, dy=4mm, dz=1.4mm

Reference Value = 20.43 V/m; Power Drift = 0.12 dB

Peak SAR (extrapolated) = 4.56 W/kg

**SAR(1 g) = 1.17 W/kg; SAR(10 g) = 0.419 W/kg**

Maximum value of SAR (measured) = 2.67 W/kg

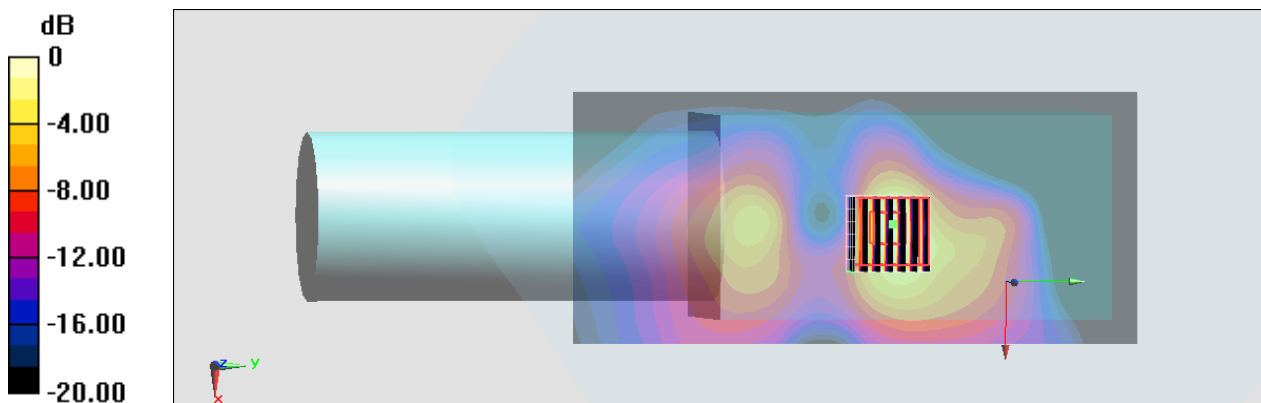

0 dB = 2.67 W/kg = 4.27 dBW/kg