



FCC RF Test Report

APPLICANT : Zebra Technologies Corporation
EQUIPMENT : Touch computer
BRAND NAME : Zebra
MODEL NAME : TC700J
FCC ID : UZ7TC700J
STANDARD : FCC Part 15 Subpart E §15.407
CLASSIFICATION : (NII) Unlicensed National Information Infrastructure

The product was received on Jun. 18, 2016 and testing was completed on Jul. 22, 2016. We, SPORTON INTERNATIONAL INC., would like to declare that the tested sample has been evaluated in accordance with the test procedures and has been in compliance with the applicable technical standards.

The test results in this report apply exclusively to the tested model / sample. Without written approval of SPORTON INTERNATIONAL INC., the test report shall not be reproduced except in full.

Reviewed by: Joseph Lin / Supervisor

Approved by: Jones Tsai / Manager



SPORTON INTERNATIONAL INC.

No. 52, Hwa Ya 1st Rd., Hwa Ya Technology Park, Kwei-Shan District, Tao Yuan City, Taiwan, R.O.C.



TABLE OF CONTENTS

REVISION HISTORY 3

SUMMARY OF TEST RESULT 4

1 GENERAL DESCRIPTION 5

 1.1 Applicant 5

 1.2 Manufacturer 5

 1.3 Product Feature of Equipment Under Test 5

 1.4 Product Specification of Equipment Under Test 6

 1.5 Modification of EUT 8

 1.6 Testing Location 9

 1.7 Applicable Standards 9

2 TEST CONFIGURATION OF EQUIPMENT UNDER TEST 10

 2.1 Carrier Frequency and Channel 11

 2.2 Pre-Scanned RF Power 12

 2.3 Test Mode 17

 2.4 Connection Diagram of Test System 20

 2.5 Support Unit used in test configuration and system 22

 2.6 EUT Operation Test Setup 22

 2.7 Measurement Results Explanation Example 22

3 TEST RESULT 23

 3.1 26dB & 99% Occupied Bandwidth Measurement 23

 3.2 Maximum Conducted Output Power Measurement 25

 3.3 Power Spectral Density Measurement 29

 3.4 Unwanted Emissions Measurement 33

 3.5 AC Conducted Emission Measurement 38

 3.6 Frequency Stability Measurement 53

 3.7 Automatically Discontinue Transmission 54

 3.8 Antenna Requirements 55

4 LIST OF MEASURING EQUIPMENT 56

5 UNCERTAINTY OF EVALUATION 57

APPENDIX A. CONDUCTED TEST RESULTS

APPENDIX B. RADIATED SPURIOUS EMISSION

APPENDIX C. RADIATED SPURIOUS EMISSION PLOTS

APPENDIX D. DUTY CYCLE PLOTS

APPENDIX E. SETUP PHOTOGRAPHS



REVISION HISTORY

REPORT NO.	VERSION	DESCRIPTION	ISSUED DATE
FR661812E	Rev. 01	Initial issue of report	Aug. 04, 2016
FR661812E	Rev. 02	Revising the maximum output power in section 1.4	Aug. 08, 2016



SUMMARY OF TEST RESULT

Report Section	FCC Rule	Description	Limit	Result	Remark
3.1	2.1049 15.403(i)	26dB & 99% Bandwidth	-	Pass	-
3.2	15.407(a)	Maximum Conducted Output Power	≤ 24 dBm (depend on band)	Pass	-
3.3	15.407(a)	Power Spectral Density	≤ 11 dBm (depend on band)	Pass	-
3.4	15.407(b)	Unwanted Emissions	≤ -17, -27 dBm (depend on band)&15.209(a)	Pass	Under limit 1.05 dB at 5145.080 MHz
3.5	15.207	AC Conducted Emission	15.207(a)	Pass	Under limit 10.90 dB at 27.118 MHz
3.6	15.407(g)	Frequency Stability	Within Operation Band	Pass	-
3.7	15.407(c)	Automatically Discontinue Transmission	Discontinue Transmission	Pass	-
3.8	15.203 & 15.407(a)	Antenna Requirement	N/A	Pass	-



1 General Description

1.1 Applicant

Zebra Technologies Corporation
1 Zebra Plaza Holtsville, NY 11742

1.2 Manufacturer

Wistron Corporation
21F, No. 88, Sec. 1, Hsin Tai Wu Rd., Hsichih Dist, New Taipei City 221, Taiwan R.O.C.

1.3 Product Feature of Equipment Under Test

Product Feature	
Equipment	Touch computer
Brand Name	Zebra
Model Name	TC700J
FCC ID	UZ7TC700J
EUT supports Radios application	NFC WLAN 11a/b/g/n HT20/HT40 WLAN 11ac VHT20/VHT40/VHT80 Bluetooth v4.1 EDR/LE
HW Version	DV1
SW Version	10.0.10586.242
FW Version	01078.00161.09001.07002
MFD	04JUN16
EUT Stage	Engineering sample

Remark: The above EUT's information was declared by manufacturer. Please refer to the specifications or user's manual for more detailed description.



1.4 Product Specification of Equipment Under Test

Standards-related Product Specification	
Tx/Rx Channel Frequency Range	5180 MHz ~ 5240 MHz 5260 MHz ~ 5320 MHz 5500 MHz ~ 5580 MHz and 5660 MHz ~ 5700 MHz
Maximum Output Power	<p><5180 MHz ~ 5240 MHz></p> <p>SISO <Ant. 1> 802.11a : 18.37 dBm / 0.0687 W 802.11n HT20 : 18.41 dBm / 0.0693 W 802.11n HT40 : 18.54 dBm / 0.0714 W 802.11ac VHT20: 18.35 dBm / 0.0684 W 802.11ac VHT40: 18.50 dBm / 0.0708 W 802.11ac VHT80: 12.71 dBm / 0.0187 W</p> <p>SISO <Ant. 2> 802.11a : 17.10 dBm / 0.0513 W 802.11n HT20 : 17.33 dBm / 0.0541 W 802.11n HT40 : 17.47 dBm / 0.0558 W 802.11ac VHT20: 17.29 dBm / 0.0536 W 802.11ac VHT40: 17.44 dBm / 0.0555 W 802.11ac VHT80: 11.69 dBm / 0.0148 W</p> <p>MIMO <Ant. 1 + 2> 802.11a : 20.90 dBm / 0.1230 W 802.11n HT20 : 20.92 dBm / 0.1236 W 802.11n HT40 : 21.18 dBm / 0.1312 W 802.11ac VHT20: 20.90 dBm / 0.1230 W 802.11ac VHT40: 21.12 dBm / 0.1294 W 802.11ac VHT80: 15.38 dBm / 0.0345 W</p>



Product Specification subjective to this standard	
Maximum Output Power	<5260 MHz ~ 5320 MHz>
	SISO <Ant. Port 1>
	802.11a : 18.49 dBm / 0.0706 W 802.11n HT20 : 18.34 dBm / 0.0682 W 802.11n HT40 : 18.29 dBm / 0.0675 W 802.11ac VHT20: 18.12 dBm / 0.0649 W 802.11ac VHT40: 18.18 dBm / 0.0658 W 802.11ac VHT80: 14.91 dBm / 0.0310 W
	SISO <Ant. Port 2>
	802.11a : 17.34 dBm / 0.0542 W 802.11n HT20 : 16.93 dBm / 0.0493 W 802.11n HT40 : 17.10 dBm / 0.0513 W 802.11ac VHT20: 16.89 dBm / 0.0489 W 802.11ac VHT40: 17.07 dBm / 0.0509 W 802.11ac VHT80: 13.89 dBm / 0.0245 W
	MIMO <Ant. Port 1 + 2>
	802.11a : 21.04 dBm / 0.1271 W 802.11n HT20 : 20.82 dBm / 0.1208 W 802.11n HT40 : 20.91 dBm / 0.1233 W 802.11ac VHT20: 20.67 dBm / 0.1167 W 802.11ac VHT40: 20.78 dBm / 0.1197 W 802.11ac VHT80: 17.49 dBm / 0.0561 W
	5500 MHz ~ 5580 MHz and 5660 MHz ~ 5700 MHz
	SISO <Ant. Port 1>
	802.11a : 17.13 dBm / 0.0516 W 802.11n HT20 : 17.57 dBm / 0.0571 W 802.11n HT40 : 19.67 dBm / 0.0927 W 802.11ac VHT20: 17.49 dBm / 0.0561 W 802.11ac VHT40: 19.53 dBm / 0.0897 W 802.11ac VHT80: 13.59 dBm / 0.0229 W
	SISO <Ant. Port 2>
	802.11a : 15.82 dBm / 0.0382 W 802.11n HT20 : 16.19 dBm / 0.0416 W 802.11n HT40 : 17.81 dBm / 0.0604 W 802.11ac VHT20: 16.15 dBm / 0.0412 W 802.11ac VHT40: 17.84 dBm / 0.0608 W 802.11ac VHT80: 12.03 dBm / 0.0160 W
	MIMO <Ant. Port 1 + 2>
	802.11a : 19.64 dBm / 0.0920 W 802.11n HT20 : 19.96 dBm / 0.0991 W 802.11n HT40 : 21.92 dBm / 0.1556 W 802.11ac VHT20: 19.94 dBm / 0.0986 W 802.11ac VHT40: 21.85 dBm / 0.1531 W 802.11ac VHT80: 16.03 dBm / 0.0401 W



Product Specification subjective to this standard													
99% Occupied Bandwidth	802.11a : 18.70 MHz 802.11n HT20 : 18.40 MHz 802.11n HT40 : 38.10 MHz 802.11ac VHT20 : 18.35 MHz 802.11ac VHT40 : 37.90 MHz 802.11ac VHT80 : 76.32 MHz												
Type of Modulation	802.11a/n : OFDM (BPSK / QPSK / 16QAM / 64QAM) 802.11ac : OFDM (BPSK / QPSK / 16QAM / 64QAM / 256QAM)												
Antenna Type	Ant. 1 : PIFA Antenna Ant. 2 : Monopole Antenna												
Antenna Gain	<5150 MHz ~ 5250 MHz> Ant. 1 : 2.70 dBi Ant. 2 : 4.37 dBi <5250 MHz ~ 5350 MHz> Ant. 1 : 2.79 dBi Ant. 2 : 4.54 dBi <5470 MHz ~ 5725 MHz> Ant. 1 : 4.43 dBi Ant. 2 : 5.41 dBi												
Antenna Function Description	<table border="1"> <thead> <tr> <th></th> <th>Ant. 1</th> <th>Ant. 2</th> </tr> </thead> <tbody> <tr> <td>802.11 a</td> <td>V</td> <td>V</td> </tr> <tr> <td>802.11 n/ac SISO</td> <td>V</td> <td>V</td> </tr> <tr> <td>802.11 n/ac MIMO</td> <td>V</td> <td>V</td> </tr> </tbody> </table>		Ant. 1	Ant. 2	802.11 a	V	V	802.11 n/ac SISO	V	V	802.11 n/ac MIMO	V	V
	Ant. 1	Ant. 2											
802.11 a	V	V											
802.11 n/ac SISO	V	V											
802.11 n/ac MIMO	V	V											

Specification of Accessories			
AC Adapter	Brand Name	Symbol	Part Number
	Power Cord	1.75 meter, non-shielded cable, without ferrite core	
Snap-On USB/Charge Cable	Brand Name	Symbol	Part Number
	Signal Line	0.15 meter, non-shielded cable, with w/o ferrite core	
Snap-On Charging Cable Cup	Brand Name	Symbol	Part Number
	Signal Line	1.85 meter, non-shielded cable, with w/o ferrite core	
Battery	Brand Name	Symbol	Part Number
Earphone 1 (3.5mm Headset for PTT + VoIP)	Brand Name	Zebra	Part Number
Earphone 2	Brand Name	Zebra	Part Number
3.5mm to QD Audio Cable Adapter	Brand Name	Zebra	Part Number
Snap-on 3.5MM Audio Nugget	Brand Name	Symbol	Part Number

1.5 Modification of EUT

No modifications are made to the EUT during all test items.



1.6 Testing Location

Sporton Lab is accredited to ISO 17025 by Taiwan Accreditation Foundation (TAF code : 1190) and the FCC designation No. TW1022 under the FCC 2.948(e) by Mutual Recognition Agreement (MRA) in FCC Test.

Test Site	SPORTON INTERNATIONAL INC.		
Test Site Location	No. 52, Hwa Ya 1 st Rd., Hwa Ya Technology Park, Kwei-Shan District, Tao Yuan City, Taiwan, R.O.C. TEL: +886-3-327-3456 FAX: +886-3-328-4978		
Test Site No.	Sporton Site No.		
	TH05-HY	CO05-HY	03CH07-HY

Note: The test site complies with ANSI C63.4 2014 requirement.

1.7 Applicable Standards

According to the specifications of the manufacturer, the EUT must comply with the requirements of the following standards:

- ♦ FCC Part 15 Subpart E
- ♦ FCC KDB 789033 D02 General UNII Test Procedures New Rules v01r02
- ♦ FCC KDB 662911 D01 Multiple Transmitter Output v02r01.
- ♦ FCC KDB 644545 D03 Guidance for IEEE 802 11ac New Rules v01
- ♦ ANSI C63.10-2013

Remark: All test items were verified and recorded according to the standards and without any deviation during the test.



2 Test Configuration of Equipment Under Test

The EUT has been associated with peripherals and configuration operated in a manner tended to maximize its emission characteristics in a typical application. Frequency range investigated: conducted emission (150 kHz to 30 MHz) and radiated emission (9 kHz to the 10th harmonic of the highest fundamental frequency or to 40 GHz, whichever is lower). For radiated measurement, pre-scanned in three orthogonal panels, X, Y, Z. The worst cases (Y plane) were recorded in this report.



2.1 Carrier Frequency and Channel

Frequency Band	Channel	Freq. (MHz)	Channel	Freq. (MHz)
5150-5250 MHz Band 1 (U-NII-1)	36	5180	44	5220
	38	5190	46	5230
	40	5200	48	5240
	42	5210		

Frequency Band	Channel	Freq. (MHz)	Channel	Freq. (MHz)
5250-5350 MHz Band 2 (U-NII-2A)	52	5260	60	5300
	54	5270	62	5310
	56	5280	64	5320
	58	5290		

Frequency Band	Channel	Freq. (MHz)	Channel	Freq. (MHz)
5470-5600 MHz and 5650-5725 MHz Band 3 (U-NII-2C)	100	5500	112	5560
	102	5510	116	5580
	104	5520	132	5660
	106	5530	134	5670
	108	5540	136	5680
	110	5550	140	5700

Frequency Band	Channel	Freq. (MHz)	Channel	Freq. (MHz)
Straddle Channel	138	5690	144	5720
	142	5710		

Note: The above Frequency and Channel in boldface were 802.11n HT40.



2.2 Pre-Scanned RF Power

Preliminary tests were performed in different data rate and data rate associated with the highest power were chosen for full test in the following tables.

SISO <Ant. 1>

5GHz 802.11a									
Channel	Frequency	6M bps	9M bps	12M bps	18M bps	24M bps	36M bps	48M bps	54M bps
CH 36	5180 MHz	18.37	17.84	18.17	18.30	18.23	18.24	17.85	16.46
CH 64	5320 MHz	18.49	17.77	18.27	18.19	18.24	18.25	17.85	16.53
CH 100	5500 MHz	17.13	16.96	17.01	16.90	16.82	16.79	16.71	16.83

5GHz 802.11n HT20									
Channel	Frequency	MCS0	MCS1	MCS2	MCS3	MCS4	MCS5	MCS6	MCS7
CH 44	5220 MHz	18.41	18.10	18.19	17.99	18.18	18.19	17.38	15.66
CH 52	5260 MHz	18.34	18.18	18.26	17.81	17.74	17.81	17.22	15.48
CH 140	5700 MHz	17.57	17.27	17.28	17.06	16.93	17.15	17.10	16.11

5GHz 802.11n HT40									
Channel	Frequency	MCS0	MCS1	MCS2	MCS3	MCS4	MCS5	MCS6	MCS7
CH 46	5230MHz	18.54	18.43	18.48	18.32	18.43	17.93	17.25	15.73
CH 54	5270MHz	18.29	18.25	18.28	18.05	18.28	17.80	17.23	15.57
CH 134	5670MHz	19.67	19.39	19.41	18.43	18.49	18.07	17.69	16.53



5GHz 802.11ac VHT20										
Channel	Frequency	MCS 0	MCS 1	MCS 2	MCS 3	MCS 4	MCS 5	MCS 6	MCS 7	MCS 8
CH 36	5180 MHz	18.35	18.12	18.08	18.09	18.27	17.94	17.55	15.74	14.16
CH 52	5260 MHz	18.12	17.98	17.86	17.38	17.47	17.54	17.07	15.26	13.84
CH 100	5500 MHz	17.49	17.07	17.16	17.13	17.11	17.23	17.07	16.25	15.66

5GHz 802.11ac VHT40											
Channel	Frequency	MCS 0	MCS 1	MCS 2	MCS 3	MCS 4	MCS 5	MCS 6	MCS 7	MCS 8	MCS 9
CH 46	5230MHz	18.50	18.38	18.38	18.12	18.00	17.98	17.12	15.77	14.09	11.99
CH 54	5270MHz	18.18	18.02	18.01	17.89	17.67	17.63	16.85	15.50	13.79	11.67
CH 134	5670MHz	19.53	19.18	19.30	19.26	19.23	17.76	17.12	16.63	15.46	13.88

5GHz 802.11ac VHT80											
Channel	Frequency	MCS 0	MCS 1	MCS 2	MCS 3	MCS 4	MCS 5	MCS 6	MCS 7	MCS 8	MCS 9
CH 42	5210MHz	12.71	12.66	12.57	12.44	12.40	12.41	12.60	12.55	12.67	12.63
CH 58	5290MHz	14.91	14.85	14.84	14.63	14.63	14.69	14.89	14.79	14.03	12.61
CH 106	5530MHz	13.59	13.04	13.00	12.81	12.80	13.00	13.14	13.15	13.21	13.22



SISO <Ant. 2>

5GHz 802.11a									
Channel	Frequency	6M bps	9M bps	12M bps	18M bps	24M bps	36M bps	48M bps	54M bps
CH 36	5180 MHz	17.10	16.81	16.86	16.91	16.92	16.87	16.46	15.59
CH 64	5320 MHz	17.34	16.74	16.93	16.85	16.86	16.96	16.40	15.48
CH 100	5500 MHz	15.82	15.58	15.59	15.57	15.48	15.44	15.47	15.54

5GHz 802.11n HT20									
Channel	Frequency	MCS0	MCS1	MCS2	MCS3	MCS4	MCS5	MCS6	MCS7
CH 36	5180 MHz	17.33	17.26	17.12	16.70	16.66	16.75	16.28	14.27
CH 52	5260 MHz	16.93	16.92	16.68	16.75	16.86	16.89	16.30	14.36
CH 100	5500 MHz	16.19	15.67	15.71	15.64	15.98	16.01	15.49	14.66

5GHz 802.11n HT40									
Channel	Frequency	MCS0	MCS1	MCS2	MCS3	MCS4	MCS5	MCS6	MCS7
CH 46	5230MHz	17.47	17.40	17.27	17.31	17.17	17.02	16.15	14.71
CH 54	5270MHz	17.10	17.03	16.84	16.97	16.87	16.77	15.69	14.24
CH 134	5670MHz	17.81	17.57	17.64	16.67	16.77	16.44	16.06	15.03



5GHz 802.11ac VHT20										
Channel	Frequency	MCS 0	MCS 1	MCS 2	MCS 3	MCS 4	MCS 5	MCS 6	MCS 7	MCS 8
CH 36	5180 MHz	17.29	17.01	17.11	17.12	17.02	16.71	16.46	14.26	13.14
CH 52	5260 MHz	16.89	16.72	16.78	16.16	16.25	16.49	16.10	14.21	12.75
CH 100	5500 MHz	16.15	15.81	15.65	15.86	15.92	15.42	15.80	14.80	14.33

5GHz 802.11ac VHT40											
Channel	Frequency	MCS 0	MCS 1	MCS 2	MCS 3	MCS 4	MCS 5	MCS 6	MCS 7	MCS 8	MCS 9
CH 46	5230MHz	17.44	17.29	17.30	17.06	17.26	17.07	16.24	14.64	12.98	10.83
CH 54	5270MHz	17.07	16.95	16.93	16.63	16.96	16.59	15.96	14.38	12.45	10.40
CH 134	5670MHz	17.84	17.70	17.68	17.64	17.70	16.50	15.71	15.27	13.88	12.21

5GHz 802.11ac VHT80											
Channel	Frequency	MCS 0	MCS 1	MCS 2	MCS 3	MCS 4	MCS 5	MCS 6	MCS 7	MCS 8	MCS 9
CH 42	5210MHz	11.69	11.36	11.53	11.42	11.51	11.46	11.56	11.59	11.62	11.54
CH 58	5290MHz	13.89	13.63	13.83	13.52	13.65	13.75	13.67	13.75	12.81	11.36
CH 106	5530MHz	12.03	12.00	11.67	11.96	12.01	11.96	12.01	11.70	12.01	11.62



MIMO <Ant. 1+2>

5GHz 802.11a									
Channel	Frequency	6M bps	9M bps	12M bps	18M bps	24M bps	36M bps	48M bps	54M bps
CH 36	5180 MHz	20.90	20.63	20.80	20.88	20.89	20.88	20.53	19.31
CH 64	5320 MHz	21.04	20.56	20.79	20.82	20.88	20.86	20.51	19.30
CH 100	5500 MHz	19.64	19.61	19.53	19.57	19.38	19.39	19.42	19.51

5GHz 802.11n HT20									
Channel	Frequency	MCS0	MCS1	MCS2	MCS3	MCS4	MCS5	MCS6	MCS7
CH 36	5180 MHz	20.92	20.89	20.91	20.68	20.76	20.83	20.17	18.27
CH 52	5260 MHz	20.82	20.81	20.77	20.59	20.66	20.71	20.05	18.22
CH 100	5500 MHz	19.96	19.80	19.80	19.70	19.72	19.92	19.70	18.65

5GHz 802.11n HT40									
Channel	Frequency	MCS0	MCS1	MCS2	MCS3	MCS4	MCS5	MCS6	MCS7
CH 46	5230MHz	21.18	21.17	21.17	21.16	21.16	20.87	19.94	18.41
CH 54	5270MHz	20.91	20.90	20.86	20.83	20.89	20.60	19.70	18.09
CH 134	5670MHz	21.92	21.86	21.92	20.98	21.01	20.60	20.12	19.07

5GHz 802.11ac VHT20										
Channel	Frequency	MCS 0	MCS 1	MCS 2	MCS 3	MCS 4	MCS 5	MCS 6	MCS 7	MCS 8
CH 36	5180 MHz	20.90	20.82	20.80	20.89	20.89	20.59	20.22	18.27	16.92
CH 52	5260 MHz	20.67	20.65	20.61	19.99	20.14	20.27	19.90	17.97	16.58
CH 100	5500 MHz	19.94	19.75	19.71	19.77	19.72	19.68	19.68	18.77	18.30

5GHz 802.11ac VHT40											
Channel	Frequency	MCS 0	MCS 1	MCS 2	MCS 3	MCS 4	MCS 5	MCS 6	MCS 7	MCS 8	MCS 9
CH 46	5230MHz	21.12	21.09	21.02	20.87	20.86	20.71	19.88	18.53	16.81	14.74
CH 54	5270MHz	20.78	20.74	20.68	20.52	20.51	20.39	19.54	18.18	16.44	14.38
CH 134	5670MHz	21.85	21.82	21.84	21.83	21.83	20.44	19.56	19.26	18.01	16.48

5GHz 802.11ac VHT80											
Channel	Frequency	MCS 0	MCS 1	MCS 2	MCS 3	MCS 4	MCS 5	MCS 6	MCS 7	MCS 8	MCS 9
CH 42	5210MHz	15.38	15.36	15.32	15.16	15.27	15.24	15.35	15.31	15.17	15.20
CH 58	5290MHz	17.49	17.47	17.43	17.34	17.43	17.43	17.47	17.48	16.49	15.02
CH 106	5530MHz	16.03	15.65	15.66	15.48	15.70	15.63	15.73	15.55	15.57	15.58

Note: MIMO Ant. 1+2 is a calculated result from sum of the power MIMO Ant. 1 and MIMO Ant. 2.



2.3 Test Mode

Final test mode of conducted test items and radiated spurious emissions are considering the modulation and worse data rates from the power table described in section 2.2.

Single Antenna

Modulation	Data Rate
802.11a	6 Mbps
802.11n HT20	MCS0
802.11n HT40	MCS0
802.11ac VHT20	MCS0
802.11ac VHT40	MCS0
802.11ac VHT80	MCS0

MIMO Antenna

Modulation	Data Rate
802.11a	6 Mbps
802.11n HT20	MCS0
802.11n HT40	MCS0
802.11ac VHT20	MCS0
802.11ac VHT40	MCS0
802.11ac VHT80	MCS0

Test Cases	
AC Conducted Emission	<p>Mode 1 : WLAN (5GHz) Link + Bluetooth Link + NFC On + Earphone 1 with Audio Adapter connect to EDA + Charging Only Cable + Adapter</p> <p>Mode 2 : WLAN (5GHz) Link + Bluetooth Link + NFC On + Snap on USB Cable Data link with Notebook + Copy Data from EDA (eMMC) to Notebook + Adapter</p> <p>Mode 3 : WLAN (5GHz) Link + Bluetooth Link + NFC On + Earphone 2 with Audio Adapter connect to EDA + Charging Only Cable + Adapter</p>



Ch. #		Band I : 5150-5250 MHz	Band II : 5250-5350 MHz	Band III : 5470-5600 MHz and 5650-5725MHz
		802.11a	802.11a	802.11a
L	Low	36	52	100
M	Middle	44	60	116
H	High	48	64	140
Straddle		-	-	144

Ch. #		Band I : 5150-5250 MHz	Band II : 5250-5350 MHz	Band III : 5470-5600 MHz and 5650-5725MHz
		802.11n HT20	802.11n HT20	802.11n HT20
L	Low	36	52	100
M	Middle	44	60	116
H	High	48	64	140
Straddle		-	-	144

Ch. #		Band I : 5150-5250 MHz	Band II : 5250-5350 MHz	Band III : 5470-5600 MHz and 5650-5725MHz
		802.11n HT40	802.11n HT40	802.11n HT40
L	Low	38	54	102
M	Middle	-	-	110
H	High	46	62	134
Straddle		-	-	142



Ch. #		Band I : 5150-5250 MHz	Band II : 5250-5350 MHz	Band III : 5470-5600 MHz and 5650-5725MHz
		802.11ac VHT20	802.11ac VHT20	802.11ac VHT20
L	Low	36	52	100
M	Middle	44	60	116
H	High	48	64	140
Straddle		-	-	144

Ch. #		Band I : 5150-5250 MHz	Band II : 5250-5350 MHz	Band III : 5470-5600 MHz and 5650-5725MHz
		802.11ac VHT40	802.11ac VHT40	802.11ac VHT40
L	Low	38	54	102
M	Middle	-	-	110
H	High	46	62	134
Straddle		-	-	144

Ch. #		Band I : 5150-5250 MHz	Band II : 5250-5350 MHz	Band III : 5470-5600 MHz and 5650-5725MHz
		802.11ac VHT80	802.11ac VHT80	802.11ac VHT80
L	Low	-	-	-
M	Middle	42	58	106
H	High	-	-	-
Straddle		-	-	142

2.4 Connection Diagram of Test System

<WLAN Tx Mode with Earphone>

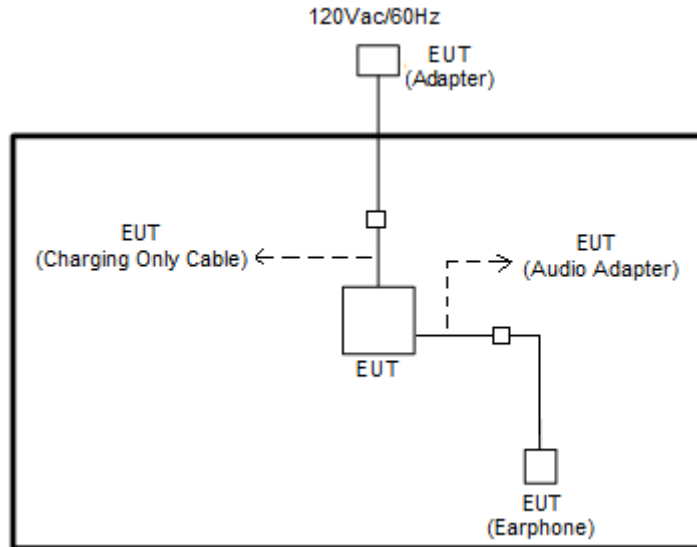

<WLAN Tx Mode with Notebook>

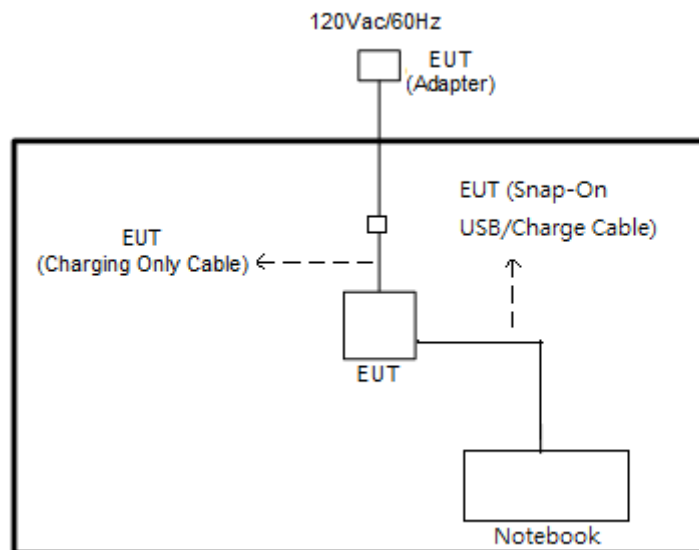

<AC Conducted Emission for charging mode>

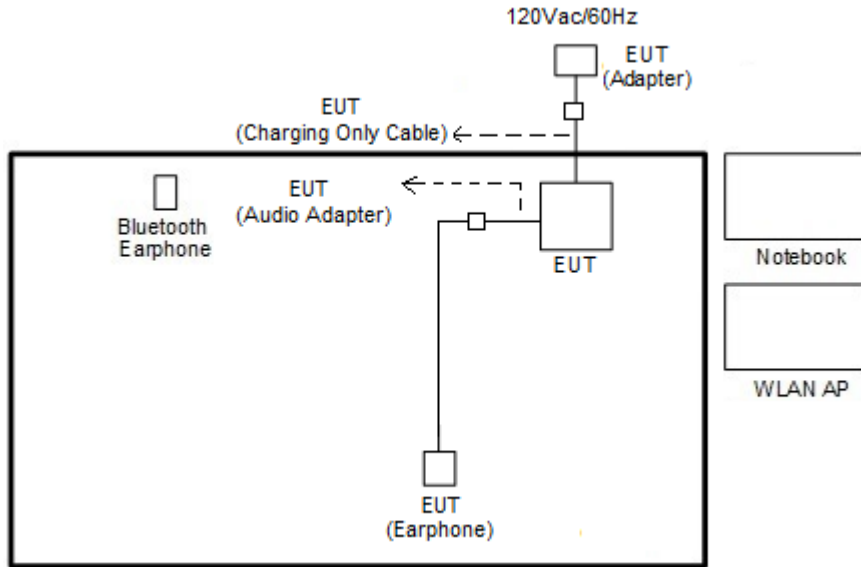

<AC Conducted Emission for data link mode>

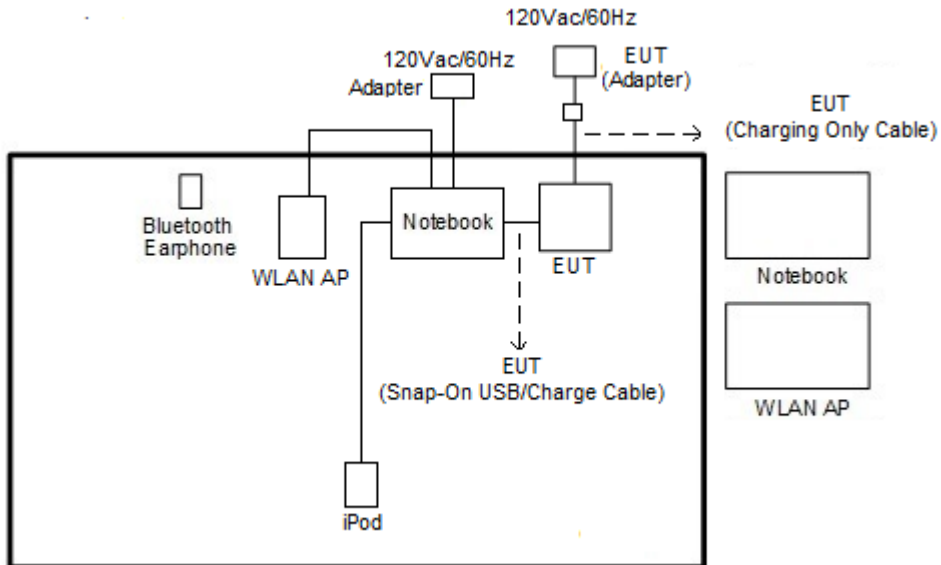



2.5 Support Unit used in test configuration and system

Item	Equipment	Trade Name	Model Name	FCC ID	Data Cable	Power Cord
1.	WLAN AP	D-Link	DIR-628	KA2DIR628A2	N/A	Unshielded, 1.8 m
2.	Notebook	DELL	Latitude E6320	FCC DoC/ Contains FCC ID: QDS-BRCM1054	N/A	AC I/P: Unshielded, 1.2 m DC O/P: Shielded, 1.8 m
3.	Bluetooth Earphone	Sony Ericsson	MW600	PY7DDA-2029	N/A	N/A
4.	iPod	Apple	A1285	FCC DoC	Shielded, 1.0 m	N/A
5.	SD Card	SanDisk	MicroSD HC	FCC DoC	N/A	N/A
6.	NFC Card	Metro Taipei	Easy Card	N/A	N/A	N/A

2.6 EUT Operation Test Setup

For WLAN function, programmed RF utility, “QRCT” installed in the notebook make the EUT provide functions like channel selection and power level for continuous transmitting and receiving signals.

2.7 Measurement Results Explanation Example

For all conducted test items:

The offset level is set in the spectrum analyzer to compensate the RF cable loss and attenuator factor between EUT conducted output port and spectrum analyzer. With the offset compensation, the spectrum analyzer reading level is exactly the EUT RF output level.

Example :

The spectrum analyzer offset is derived from RF cable loss and attenuator factor.

Offset = RF cable loss + attenuator factor.

Following shows an offset computation example with cable loss 4.2 dB and 10dB attenuator.

$$\begin{aligned} \text{Offset(dB)} &= \text{RF cable loss(dB)} + \text{attenuator factor(dB)}. \\ &= 4.2 + 10 = 14.2 \text{ (dB)} \end{aligned}$$

3 Test Result

3.1 26dB & 99% Occupied Bandwidth Measurement

3.1.1 Description of 26dB & 99% Occupied Bandwidth

This section is for reporting purpose only.

There is no restriction limits for bandwidth.

For Straddle Channel, U-NII procedures were applied for operations in the frequency band in accordance with FCC KDB 644545 D03.

3.1.2 Measuring Instruments

The measuring equipment is listed in the section 4 of this test report.

3.1.3 Test Procedures

1. The testing follows FCC KDB 789033 D02 General UNII Test Procedures New Rules v01r02. Section C) Emission bandwidth
2. Set RBW = approximately 1% of the emission bandwidth.
3. Set the VBW > RBW.
4. Detector = Peak.
5. Trace mode = max hold
6. Measure the maximum width of the emission that is 26 dB down from the peak of the emission. Compare this with the RBW setting of the analyzer. Readjust RBW and repeat measurement as needed until the RBW/EBW ratio is approximately 1%.
7. For 99% Bandwidth Measurement, the spectrum analyzer's resolution bandwidth (RBW) is set 1MHz and set the Video bandwidth (VBW) $\geq 3 * RBW$.
8. Measure and record the results in the test report.

3.1.4 Test Setup

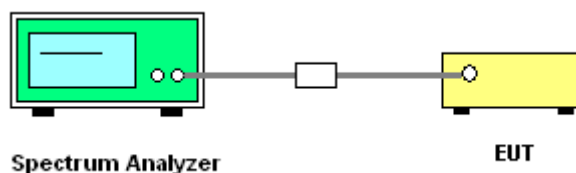



3.1.5 Test Result of 26dB & 99% Occupied Bandwidth

Please refer to Appendix A.

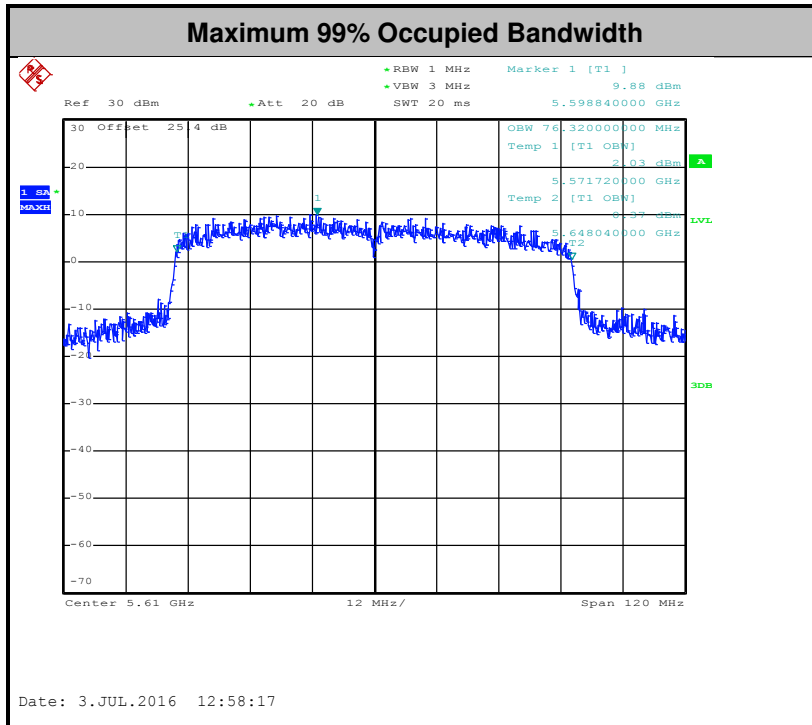
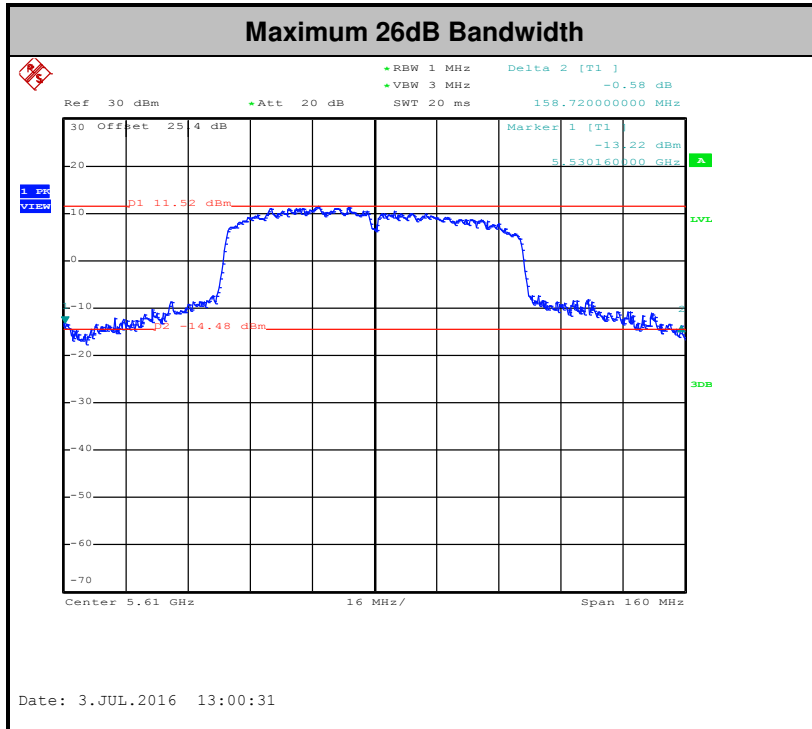

Note: The occupied channel bandwidth is maintained within the band of operation for all of the modulations.



3.2 Maximum Conducted Output Power Measurement

3.2.1 Limit of Maximum Conducted Output Power

<FCC 14-30 CFR 15.407>

For mobile and portable client devices in the 5.15–5.25 GHz band, the maximum conducted output power over the frequency band of operation shall not exceed 250 mW.

For the 5.25–5.35 GHz and 5.47–5.725 GHz bands, the maximum conducted output power over the frequency bands of operation shall not exceed the lesser of 250 mW or $11 \text{ dBm} + 10 \log B$, where B is the 26 dB emission bandwidth in megahertz.

For Straddle Channel, U-NII procedures and limits were applied for operations in the frequency band in accordance with FCC KDB 644545 D03.

If transmitting antennas of directional gain greater than 6 dBi are used, the peak output power shall be reduced by the amount in dB that the directional gain of the antenna exceeds 6 dBi.

Note that U-NII-2 band, devices with a maximum e.i.r.p. greater than 500 mW shall implement TPC in order to have the capability to operate at least 6 dB below the maximum permitted e.i.r.p. of 1 W.

3.2.2 Measuring Instruments

The measuring equipment is listed in the section 4 of this test report.

3.2.3 Test Procedures

The testing follows Method PM of FCC KDB 789033 D02 General UNII Test Procedures New Rules v01r02.

Method PM (Measurement using an RF average power meter):

1. Measurement is performed using a wideband RF power meter.
2. The EUT is configured to transmit continuously with a consistent duty cycle at its maximum power control level.
3. Measure the average power of the transmitter, and the average power is corrected with duty factor, $10 \log(1/x)$, where x is the duty cycle.

For straddle channel, the testing follows Method SA-3 (RMS detection with max hold) of FCC KDB 789033 D02 General UNII Test Procedures New Rules v01r02.

Compute power by integrating the spectrum across the 99% occupied bandwidth of the signal using the instrument's band power measurement function.

3.2.4 Test Setup

For normal channel:

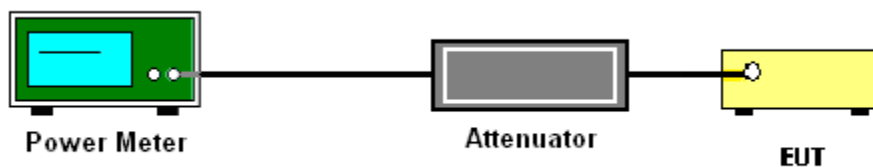

For straddle channel:

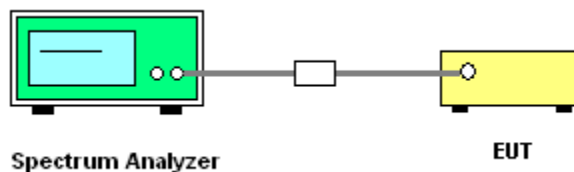



3.2.5 Test Result of Maximum Conducted Output Power

Please refer to Appendix A.

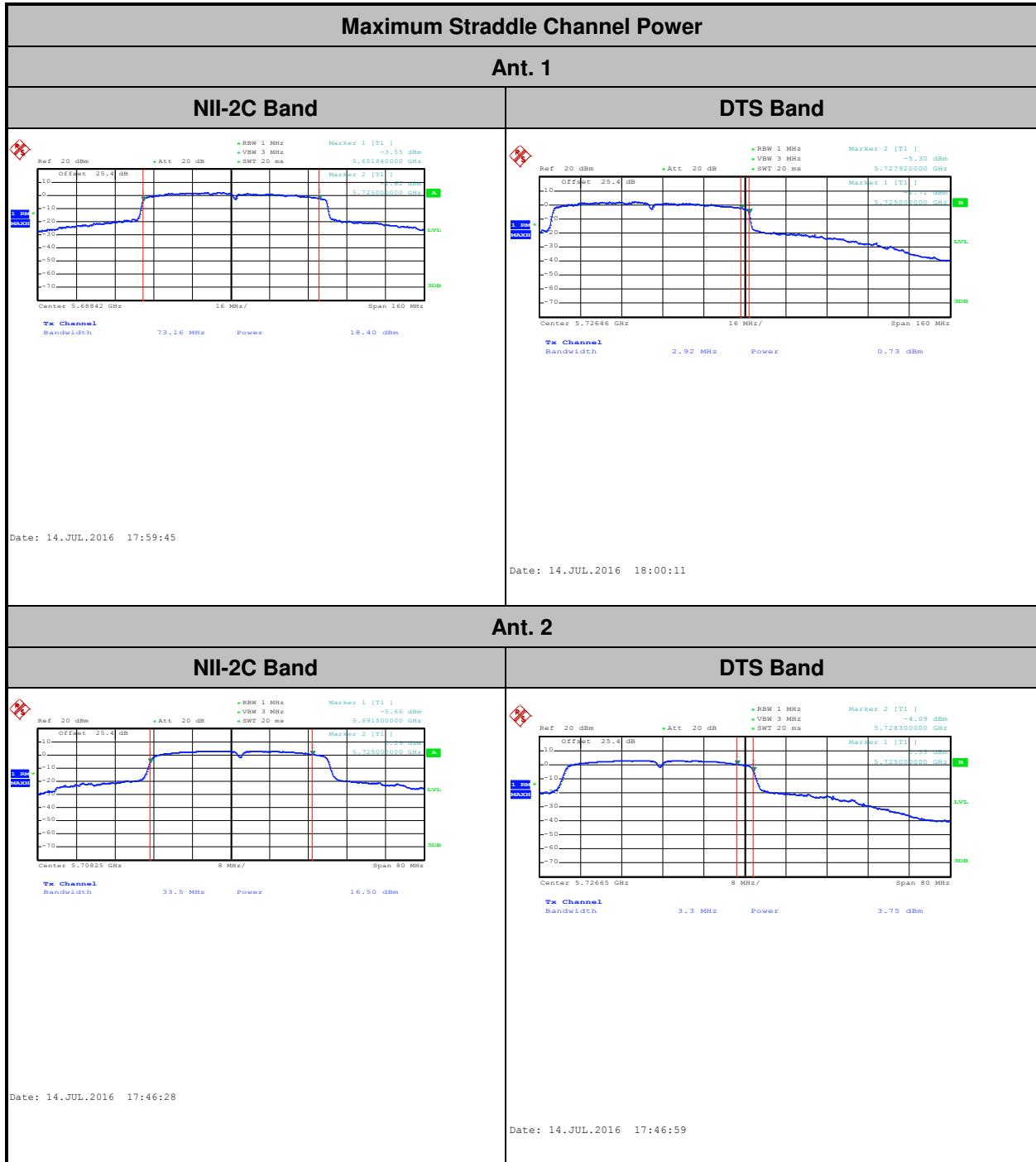



Maximum Straddle Channel Power

MIMO Ant. 1+2 (1)

NII-2C Band

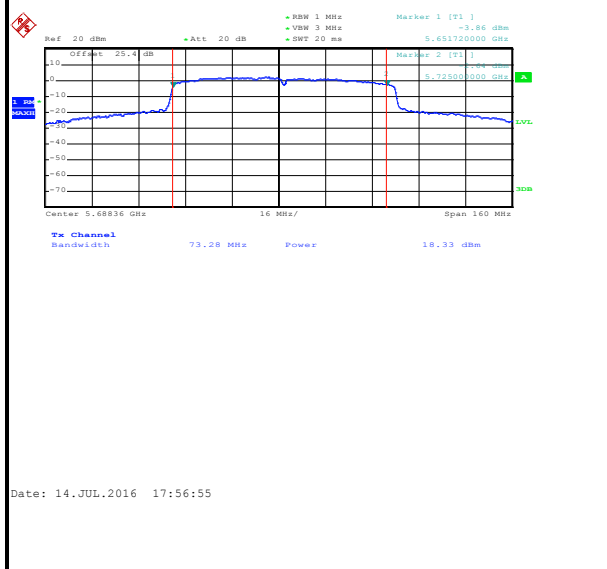

DTS Band

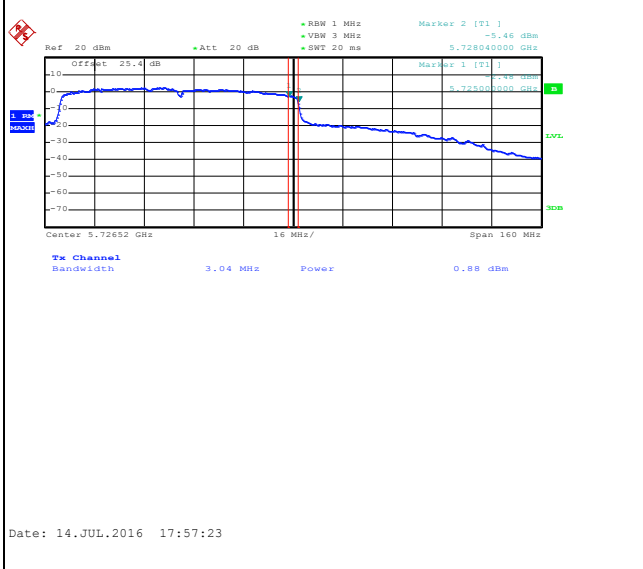

MIMO Ant. 1+2 (2)

NII-2C Band

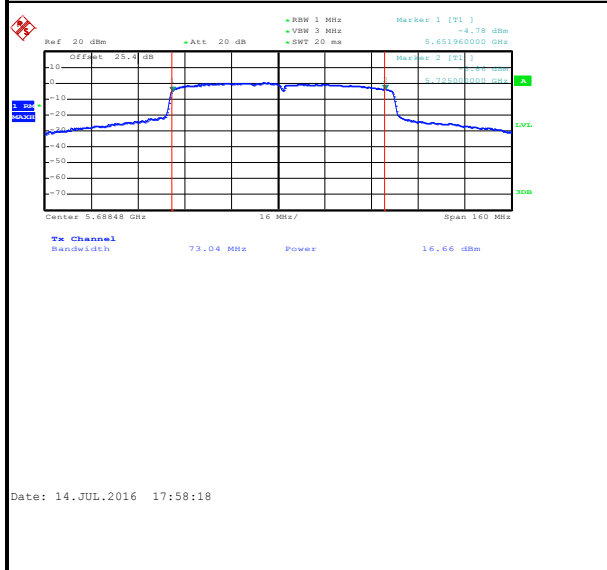

DTS Band

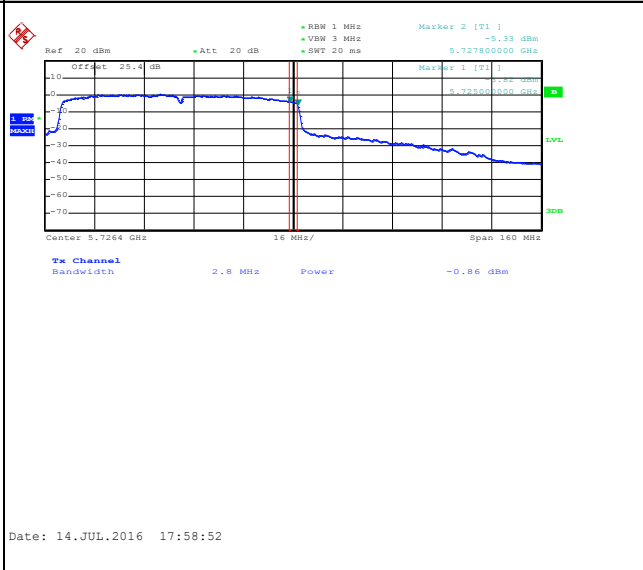



3.3 Power Spectral Density Measurement

3.3.1 Limit of Power Spectral Density

<FCC 14-30 CFR 15.407>

For mobile and portable client devices in the 5.15–5.25 GHz band, the maximum power spectral density shall not exceed 11dBm in any 1 megahertz band.

For the 5.25–5.35 GHz and 5.47–5.725 GHz bands, the maximum power spectral density shall not exceed 11 dBm in any 1 megahertz band.

For Straddle Channel, U-NII procedures and limits were applied for operations in the frequency band in accordance with FCC KDB 644545 D03.

If transmitting antennas of directional gain greater than 6 dBi are used, the peak output power shall be reduced by the amount in dB that the directional gain of the antenna exceeds 6 dBi.

3.3.2 Measuring Instruments

The measuring equipment is listed in the section 4 of this test report.



3.3.3 Test Procedures

The testing follows FCC KDB 789033 D02 General UNII Test Procedures New Rules v01r02.
Section F) Maximum power spectral density.

Method SA-2

(trace averaging across on and off times of the EUT transmissions, followed by duty cycle correction).

1. The testing follows Method SA-2 of FCC KDB 789033 D02 General UNII Test Procedures New Rules v01r02.
 - Measure the duty cycle.
 - Set span to encompass the entire emission bandwidth (EBW) of the signal.
 - Set RBW = 1 MHz.
 - Set VBW \geq 3 MHz.
 - Number of points in sweep \geq 2 Span / RBW.
 - Sweep time = auto.
 - Detector = RMS
 - Trace average at least 100 traces in power averaging mode.
 - Add $10 \log(1/x)$, where x is the duty cycle, to the measured power in order to compute the average power during the actual transmission times. For example, add $10 \log(1/0.25) = 6$ dB if the duty cycle is 25 percent.

2. The RF output of EUT was connected to the spectrum analyzer by a low loss cable.
3. Each plot has already offset with cable loss, and attenuator loss. Measure the PPSD and record it.
4. For MIMO mode, calculation method follows FCC KDB 662911 D01 Multiple Transmitter Output v02r01.

Method (1): Measure and sum the spectra across the outputs.

The total final Power Spectral Density is from a device with 2 transmitter outputs. The spectrum measurements of the individual outputs are all performed with the same span and number of points, the spectrum value in the first spectral bin of output 1 is summed with that in the first spectral bin of output 2 to obtain the value for the first frequency bin of the summed spectrum.

3.3.4 Test Setup

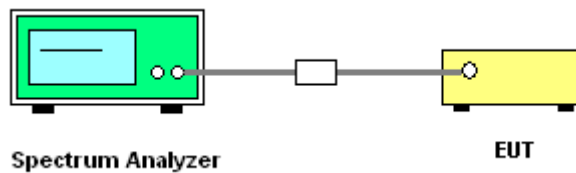



3.3.5 Test Result of Power Spectral Density

Please refer to Appendix A.

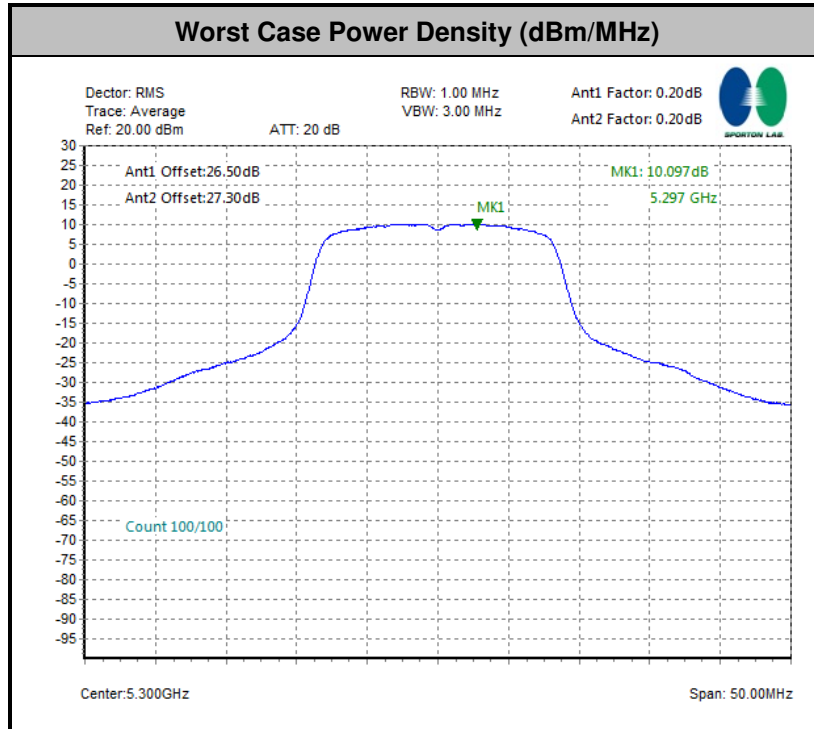

Note: Average Power Density (dB) = Measured value + Duty Factor



3.4 Unwanted Emissions Measurement

This section as specified in FCC Part 15.407(b) is to measure unwanted emissions through radiated measurement for band edge spurious emissions and out of band emissions measurement. The unwanted emissions shall comply with 15.407(b)(1) to (6), and restricted bands per FCC Part15.205.

3.4.1 Limit of Unwanted Emissions

(1) For transmitters operating in the 5150-5250 MHz band: all emissions outside of the 5150-5350 MHz band shall not exceed an EIRP of -27dBm/MHz.

For transmitters operating in the 5250-5350 MHz band: all emissions outside of the 5150-5350 MHz band shall not exceed an EIRP of -27 dBm/MHz. Devices operating in the 5250-5350 MHz band that generate emissions in the 5150-5250 MHz band must meet all applicable technical requirements for operation in the 5150-5250 MHz band (including indoor use) or alternatively meet an out-of-band emission EIRP limit of -27 dBm/MHz in the 5150-5250 MHz band.

For transmitters operating in the 5470-5600 MHz and 5650-5725MHz band: all emissions outside of the 5470-5600 MHz and 5650-5725MHz band shall not exceed an EIRP of -27 dBm/MHz.

(2) Unwanted spurious emissions fallen in restricted bands per FCC Part15.205 shall comply with the general field strength limits set forth in § 15.209 as below table,

Frequency (MHz)	Field Strength (microvolts/meter)	Measurement Distance (meters)
0.009 – 0.490	2400/F(kHz)	300
0.490 – 1.705	24000/F(kHz)	30
1.705 – 30.0	30	30
30 – 88	100	3
88 – 216	150	3
216 - 960	200	3
Above 960	500	3

Note: The following formula is used to convert the EIRP to field strength.

$$E = \frac{1000000\sqrt{30P}}{3} \mu\text{V/m, where P is the eirp (Watts)}$$

EIRP (dBm)	Field Strength at 3m (dBμV/m)
-17	78.3
- 27	68.3



- (3) KDB789033 D02 v01r02 G)2)c) As specified in 15.407(b), emissions above 1000 MHz that are outside of the restricted bands are subject to a peak emission limit of -27 dBm/MHz (or -17 dBm/MHz as specified in 15.407(b)(4)). However, an out-of-band emission that complies with both the average and peak limits of 15.209 is not required to satisfy the -27 dBm/MHz or -17 dBm/MHz peak emission limit.

3.4.2 Measuring Instruments

The measuring equipment is listed in the section 4 of this test report.

3.4.3 Test Procedures

1. The testing follows FCC KDB 789033 D02 General UNII Test Procedures New Rules v01r02. Section G) Unwanted emissions measurement.
 - (1) Procedure for Unwanted Emissions Measurements Below 1000MHz
 - RBW = 120 kHz
 - VBW = 300 kHz
 - Detector = Peak
 - Trace mode = max hold
 - (2) Procedure for Peak Unwanted Emissions Measurements Above 1000 MHz
 - RBW = 1 MHz
 - VBW ≥ 3 MHz
 - Detector = Peak
 - Sweep time = auto
 - Trace mode = max hold



(3) Procedures for Average Unwanted Emissions Measurements Above 1000MHz

- RBW = 1 MHz
 - VBW = 10 Hz, when duty cycle is no less than 98 percent.
 - $VBW \geq 1/T$, when duty cycle is less than 98 percent where T is the minimum transmission duration over which the transmitter is on and is transmitting at its maximum power control level for the tested mode of operation.
2. The EUT was placed on a turntable with 0.8 meter for frequency below 1GHz and 1.5 meter for frequency above 1GHz respectively above ground.
 3. The EUT was set 3 meters from the interference receiving antenna which was mounted on the top of a variable height antenna tower.
 4. The antenna is a broadband antenna and its height is adjusted between one meter and four meters above ground to find the maximum value of the field strength for both horizontal polarization and vertical polarization of the antenna.
 5. For each suspected emission, the EUT was arranged to its worst case and then adjust the antenna tower (from 1 m to 4 m) and turntable (from 0 degree to 360 degrees) to find the maximum reading.
 6. For testing below 1GHz, if the emission level of the EUT in peak mode was 3 dB lower than the limit specified, then peak values of EUT will be reported, otherwise, the emissions will be repeated one by one using the CISPR quasi-peak method and reported.
 7. For testing above 1GHz, the emission level of the EUT in peak mode was 20dB lower than average limit (that means the emission level in average mode also complies with the limit in average mode), then peak values of EUT will be reported, otherwise, the emissions will be measured in average mode again and reported.

3.4.4 Test Setup

For radiated emissions below 30MHz



For radiated emissions from 30MHz to 1GHz

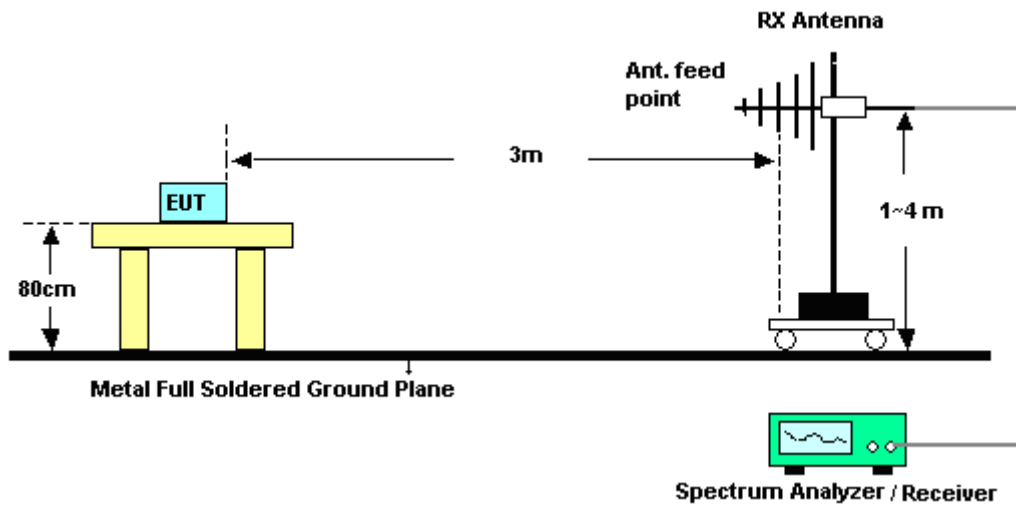

For radiated emissions above 1GHz

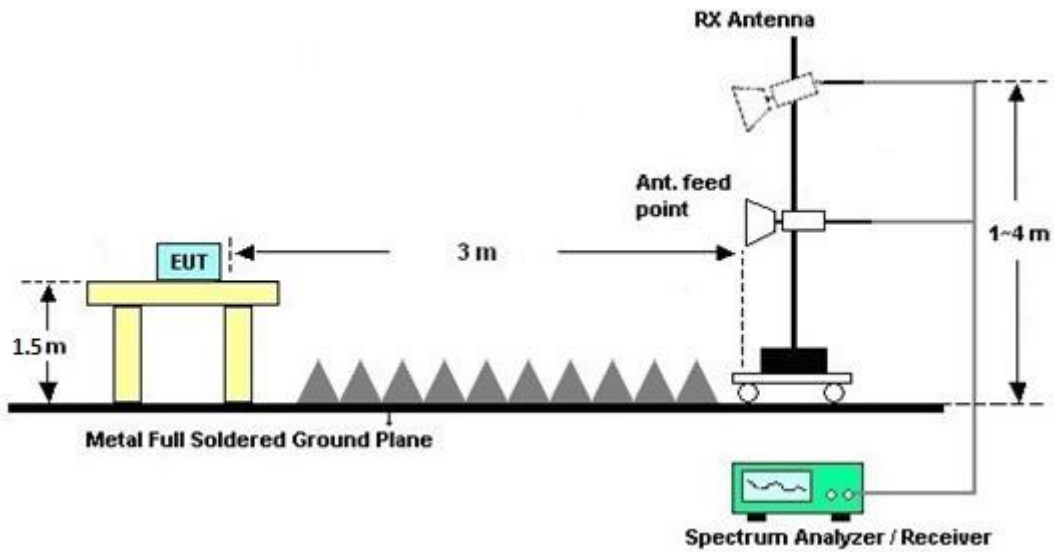

3.4.5 Test Results of Radiated Emissions (9 kHz ~ 30 MHz)

The low frequency, which started from 9 kHz to 30MHz, was pre-scanned and the result which was 20dB lower than the limit line per 15.31(o) was not reported.

3.4.6 Test Result of Radiated Band Edges

Please refer to Appendix B and C.

3.4.7 Duty Cycle

Please refer to Appendix D.

3.4.8 Test Result of Unwanted Radiated Emission (30MHz ~ 10th Harmonic)

Please refer to Appendix B and C.



3.5 AC Conducted Emission Measurement

3.5.1 Limit of AC Conducted Emission

For equipment that is designed to be connected to the public utility (AC) power line, the radio frequency voltage that is conducted back onto the AC power line on any frequency or frequencies within the band 150 kHz to 30 MHz shall not exceed the limits in the following table.

Frequency of emission (MHz)	Conducted limit (dB μ V)	
	Quasi-peak	Average
0.15-0.5	66 to 56*	56 to 46*
0.5-5	56	46
5-30	60	50

*Decreases with the logarithm of the frequency.

For terminal test result, the testing follows FCC KDB 174176.

3.5.2 Measuring Instruments

The measuring equipment is listed in the section 4 of this test report.

3.5.3 Test Procedures

1. The EUT was placed 0.4 meter from the conducting wall of the shielding room was kept at least 80 centimeters from any other grounded conducting surface.
2. Connect EUT to the power mains through a line impedance stabilization network (LISN).
3. All the support units are connecting to the other LISN.
4. The LISN provides 50 ohm coupling impedance for the measuring instrument.
5. The FCC states that a 50 ohm, 50 microhenry LISN should be used.
6. Both sides of AC line were checked for maximum conducted interference.
7. The frequency range from 150 kHz to 30 MHz was searched.
8. Set the test-receiver system to Peak Detect Function and specified bandwidth with Maximum Hold Mode.

3.5.4 Test Setup

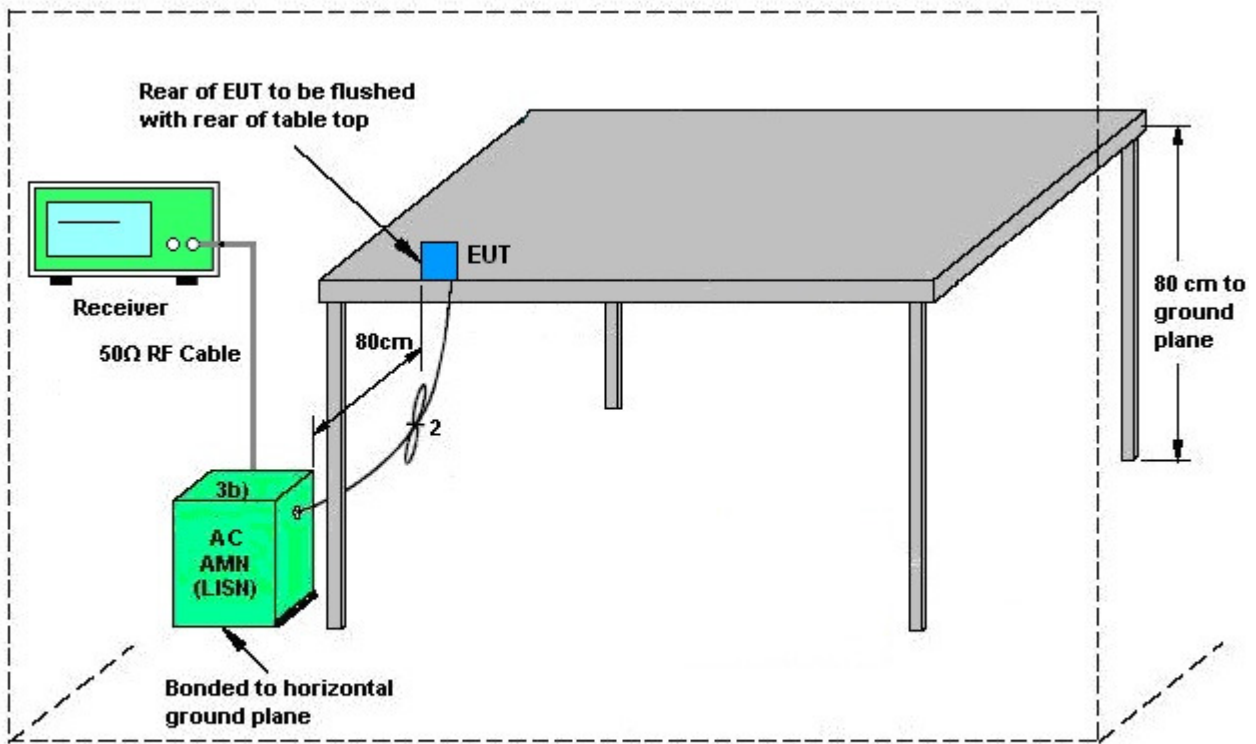

AMN = Artificial mains network (LISN)
AE = Associated equipment
EUT = Equipment under test
ISN = Impedance stabilization network



3.5.5 Test Result of AC Conducted Emission

<Original Test Result>

Test Mode :	Mode 1	Temperature :	23~24°C
Test Engineer :	Arthur Hsieh	Relative Humidity :	51~52%
Test Voltage :	120Vac / 60Hz	Phase :	Line
Function Type :	WLAN (5GHz) Link + Bluetooth Link + NFC On + Earphone 1 with Audio Adapter connect to EDA + Charging Only Cable + Adapter		

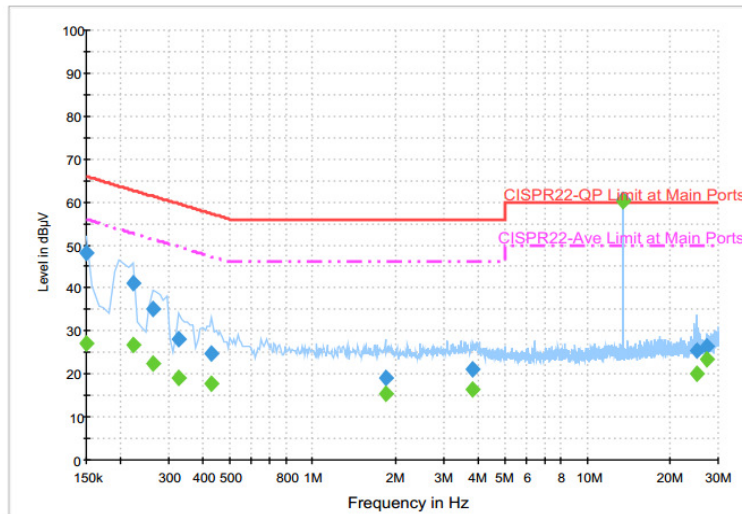

Final Result : QuasiPeak

Frequency (MHz)	QuasiPeak (dBµV)	Filter	Line	Corr. (dB)	Margin (dB)	Limit (dBµV)
0.150000	48.2	Off	L1	19.6	17.8	66.0
0.222000	41.3	Off	L1	19.6	21.4	62.7
0.262000	35.2	Off	L1	19.6	26.2	61.4
0.326000	28.1	Off	L1	19.6	31.5	59.6
0.430000	24.7	Off	L1	19.6	32.6	57.3
1.846000	18.9	Off	L1	19.6	37.1	56.0
3.846000	21.2	Off	L1	19.7	34.8	56.0
13.558000	60.4	Off	L1	19.8	-0.4	60.0
25.030000	25.3	Off	L1	19.9	34.7	60.0
27.118000	26.4	Off	L1	19.9	33.6	60.0



Test Mode :	Mode 1	Temperature :	23~24°C
Test Engineer :	Arthur Hsieh	Relative Humidity :	51~52%
Test Voltage :	120Vac / 60Hz	Phase :	Line
Function Type :	WLAN (5GHz) Link + Bluetooth Link + NFC On + Earphone 1 with Audio Adapter connect to EDA + Charging Only Cable + Adapter		

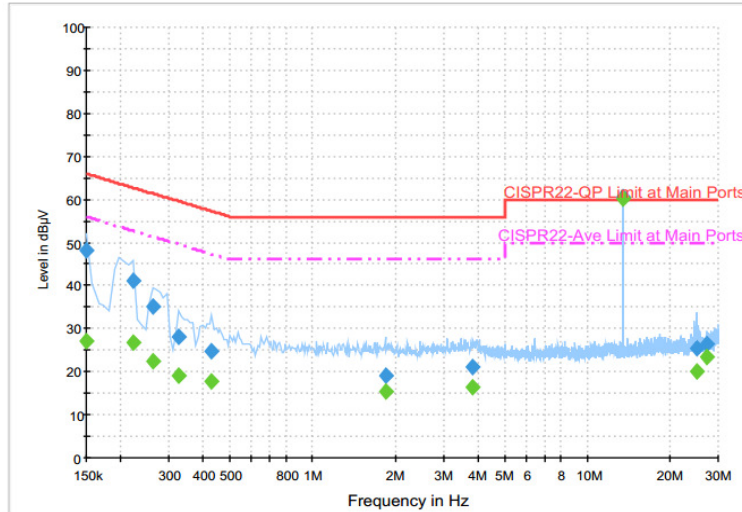

Final Result : Average

Frequency (MHz)	Average (dBµV)	Filter	Line	Corr. (dB)	Margin (dB)	Limit (dBµV)
0.150000	27.0	Off	L1	19.6	29.0	56.0
0.222000	26.9	Off	L1	19.6	25.8	52.7
0.262000	22.4	Off	L1	19.6	29.0	51.4
0.326000	19.1	Off	L1	19.6	30.5	49.6
0.430000	17.9	Off	L1	19.6	29.4	47.3
1.846000	15.5	Off	L1	19.6	30.5	46.0
3.846000	16.4	Off	L1	19.7	29.6	46.0
13.558000	60.1	Off	L1	19.8	-10.1	50.0
25.030000	20.0	Off	L1	19.9	30.0	50.0
27.118000	23.4	Off	L1	19.9	26.6	50.0



Test Mode :	Mode 1	Temperature :	23~24°C
Test Engineer :	Arthur Hsieh	Relative Humidity :	51~52%
Test Voltage :	120Vac / 60Hz	Phase :	Neutral
Function Type :	WLAN (5GHz) Link + Bluetooth Link + NFC On + Earphone 1 with Audio Adapter connect to EDA + Charging Only Cable + Adapter		

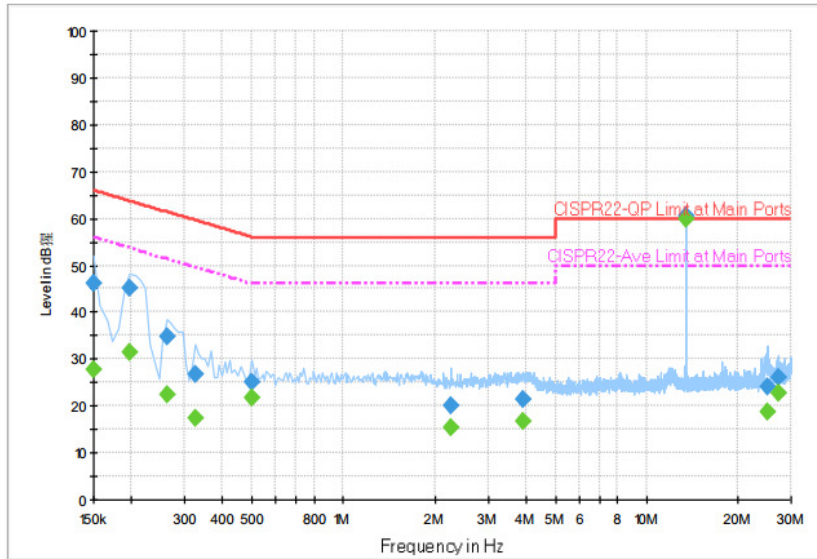

Final Result : Quasi-Peak

Frequency (MHz)	Quasi-Peak (dBµV)	Filter	Line	Corr. (dB)	Margin (dB)	Limit (dBµV)
0.150000	46.0	Off	N	19.6	20.0	66.0
0.198000	45.1	Off	N	19.6	18.6	63.7
0.262000	34.8	Off	N	19.6	26.6	61.4
0.326000	26.9	Off	N	19.6	32.7	59.6
0.502000	25.0	Off	N	19.6	31.0	56.0
2.262000	19.9	Off	N	19.5	36.1	56.0
3.926000	21.5	Off	N	19.6	34.5	56.0
13.558000	60.5	Off	N	19.8	-0.5	60.0
24.990000	24.2	Off	N	20.0	35.8	60.0
27.118000	26.2	Off	N	20.1	33.8	60.0

Final Result : Average

Frequency (MHz)	Average (dBµV)	Filter	Line	Corr. (dB)	Margin (dB)	Limit (dBµV)
0.150000	27.9	Off	N	19.6	28.1	56.0
0.198000	31.3	Off	N	19.6	22.4	53.7
0.262000	22.3	Off	N	19.6	29.1	51.4
0.326000	17.5	Off	N	19.6	32.1	49.6
0.502000	21.6	Off	N	19.6	24.4	46.0
2.262000	15.3	Off	N	19.5	30.7	46.0
3.926000	16.6	Off	N	19.6	29.4	46.0
13.558000	59.9	Off	N	19.8	-9.9	50.0
24.990000	18.9	Off	N	20.0	31.1	50.0
27.118000	22.8	Off	N	20.1	27.2	50.0



<Terminal Test Result>

Test Mode :	Mode 1	Temperature :	23~24°C
Test Engineer :	Arthur Hsieh	Relative Humidity :	51~52%
Test Voltage :	120Vac / 60Hz	Phase :	Line
Function Type :	WLAN (5GHz) Link + Bluetooth Link + NFC On + Earphone 1 with Audio Adapter connect to EDA + Charging Only Cable + Adapter		

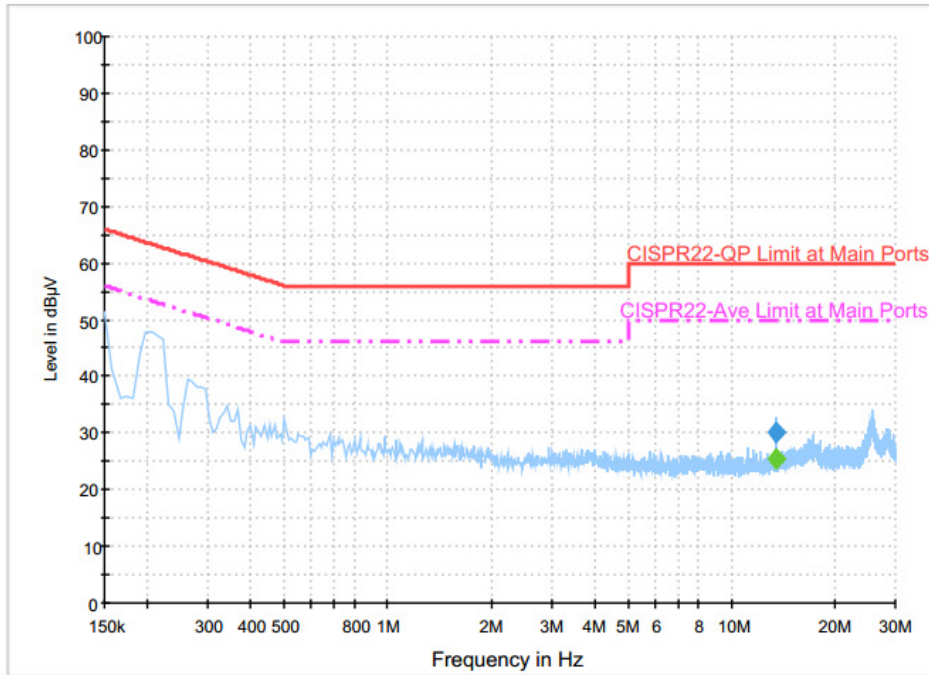

Final Result : Quasi-Peak

Frequency (MHz)	Quasi-Peak (dBµV)	Filter	Line	Corr. (dB)	Margin (dB)	Limit (dBµV)
13.558000	30.0	Off	L1	19.8	30.0	60.0

Final Result : Average

Frequency (MHz)	Average (dBµV)	Filter	Line	Corr. (dB)	Margin (dB)	Limit (dBµV)
13.558000	25.4	Off	L1	19.8	24.6	50.0



Test Mode :	Mode 1	Temperature :	23~24°C
Test Engineer :	Arthur Hsieh	Relative Humidity :	51~52%
Test Voltage :	120Vac / 60Hz	Phase :	Neutral
Function Type :	WLAN (5GHz) Link + Bluetooth Link + NFC On + Earphone 1 with Audio Adapter connect to EDA + Charging Only Cable + Adapter		

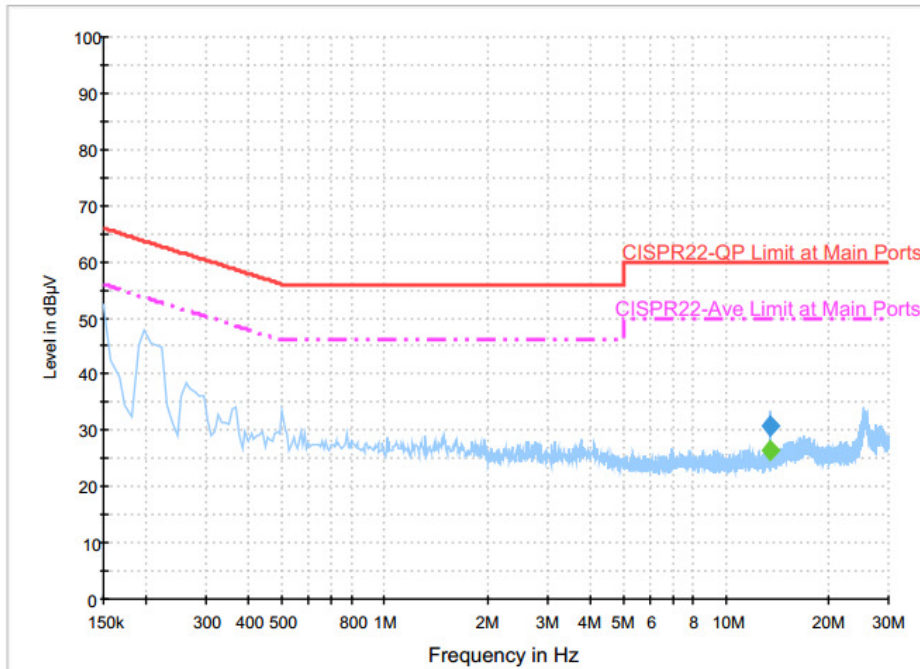

Final Result : Quasi-Peak

Frequency (MHz)	Quasi-Peak (dBµV)	Filter	Line	Corr. (dB)	Margin (dB)	Limit (dBµV)
13.558000	30.6	Off	N	19.8	29.4	60.0

Final Result : Average

Frequency (MHz)	Average (dBµV)	Filter	Line	Corr. (dB)	Margin (dB)	Limit (dBµV)
13.558000	26.5	Off	N	19.8	23.5	50.0



<Original Test Result>

Test Mode :	Mode 2	Temperature :	23~24°C
Test Engineer :	Arthur Hsieh	Relative Humidity :	51~52%
Test Voltage :	120Vac / 60Hz	Phase :	Line
Function Type :	WLAN (5GHz) Link + Bluetooth Link + NFC On + Snap on USB Cable Data link with Notebook + Copy Data from EDA (eMMC) to Notebook + Adapter		

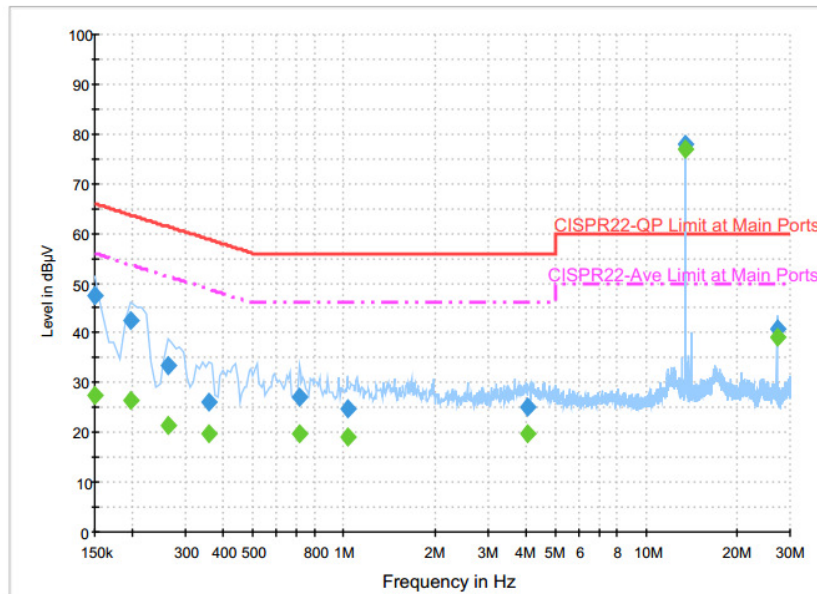

Final Result : Quasi-Peak

Frequency (MHz)	Quasi-Peak (dBµV)	Filter	Line	Corr. (dB)	Margin (dB)	Limit (dBµV)
0.150000	47.6	Off	L1	19.6	18.4	66.0
0.198000	42.6	Off	L1	19.6	21.1	63.7
0.262000	33.4	Off	L1	19.6	28.0	61.4
0.358000	26.1	Off	L1	19.6	32.7	58.8
0.710000	27.2	Off	L1	19.6	28.8	56.0
1.030000	24.9	Off	L1	19.6	31.1	56.0
4.046000	25.0	Off	L1	19.7	31.0	56.0
13.558000	78.1	Off	L1	19.8	-18.1	60.0
27.118000	40.7	Off	L1	19.9	19.3	60.0

Final Result : Average

Frequency (MHz)	Average (dBµV)	Filter	Line	Corr. (dB)	Margin (dB)	Limit (dBµV)
0.150000	27.5	Off	L1	19.6	28.5	56.0
0.198000	26.5	Off	L1	19.6	27.2	53.7
0.262000	21.5	Off	L1	19.6	29.9	51.4
0.358000	19.6	Off	L1	19.6	29.2	48.8
0.710000	19.7	Off	L1	19.6	26.3	46.0
1.030000	19.0	Off	L1	19.6	27.0	46.0
4.046000	19.9	Off	L1	19.7	26.1	46.0
13.558000	76.9	Off	L1	19.8	-26.9	50.0
27.118000	39.1	Off	L1	19.9	10.9	50.0



Test Mode :	Mode 2	Temperature :	23~24°C
Test Engineer :	Arthur Hsieh	Relative Humidity :	51~52%
Test Voltage :	120Vac / 60Hz	Phase :	Neutral
Function Type :	WLAN (5GHz) Link + Bluetooth Link + NFC On + Snap on USB Cable Data link with Notebook + Copy Data from EDA (eMMC) to Notebook + Adapter		

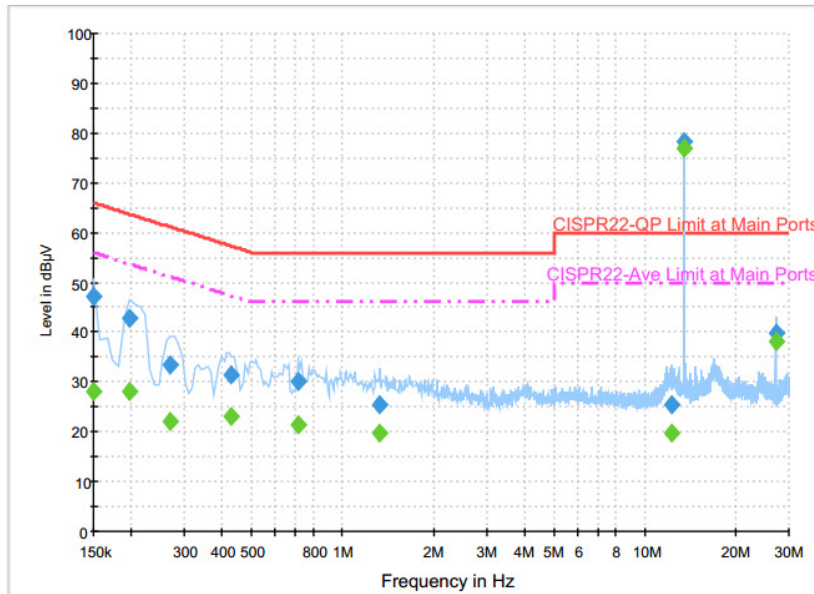

Final Result : Quasi-Peak

Frequency (MHz)	Quasi-Peak (dBµV)	Filter	Line	Corr. (dB)	Margin (dB)	Limit (dBµV)
0.150000	47.1	Off	N	19.6	18.9	66.0
0.198000	42.8	Off	N	19.6	20.9	63.7
0.270000	33.6	Off	N	19.6	27.5	61.1
0.430000	31.6	Off	N	19.6	25.7	57.3
0.710000	30.2	Off	N	19.6	25.8	56.0
1.326000	25.4	Off	N	19.6	30.6	56.0
12.222000	25.4	Off	N	19.8	34.6	60.0
13.558000	78.2	Off	N	19.8	-18.2	60.0
27.118000	39.7	Off	N	20.1	20.3	60.0

Final Result : Average

Frequency (MHz)	Average (dBµV)	Filter	Line	Corr. (dB)	Margin (dB)	Limit (dBµV)
0.150000	28.2	Off	N	19.6	27.8	56.0
0.198000	28.2	Off	N	19.6	25.5	53.7
0.270000	22.0	Off	N	19.6	29.1	51.1
0.430000	22.9	Off	N	19.6	24.4	47.3
0.710000	21.5	Off	N	19.6	24.5	46.0
1.326000	19.7	Off	N	19.6	26.3	46.0
12.222000	19.7	Off	N	19.8	30.3	50.0
13.558000	77.0	Off	N	19.8	-27.0	50.0
27.118000	38.1	Off	N	20.1	11.9	50.0



<Terminal Test Result>

Test Mode :	Mode 2	Temperature :	23~24°C
Test Engineer :	Arthur Hsieh	Relative Humidity :	51~52%
Test Voltage :	120Vac / 60Hz	Phase :	Line
Function Type :	WLAN (5GHz) Link + Bluetooth Link + NFC On + Snap on USB Cable Data link with Notebook + Copy Data from EDA (eMMC) to Notebook + Adapter		

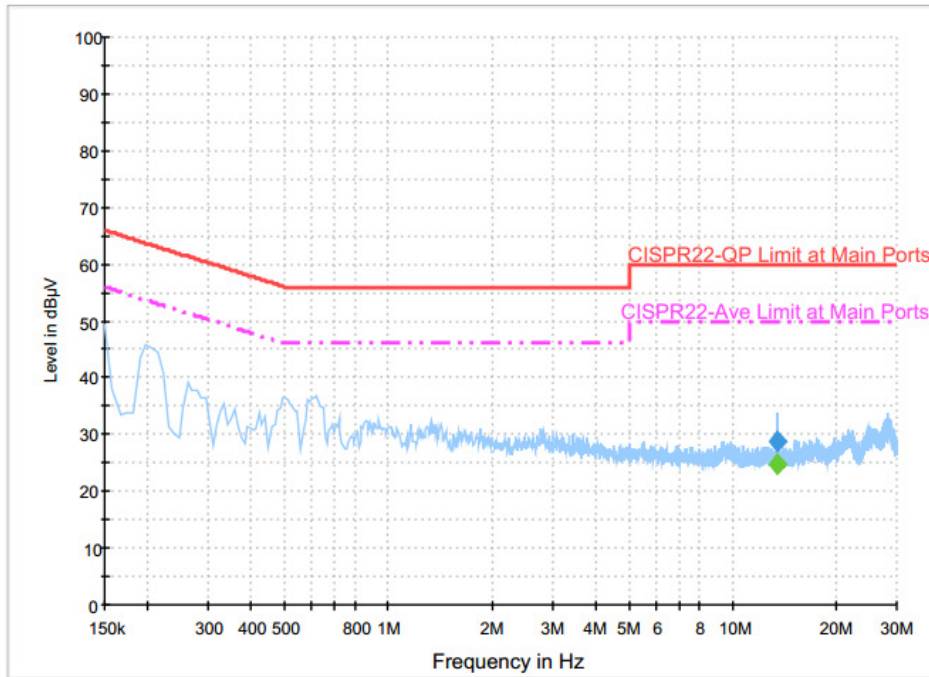

Final Result : Quasi-Peak

Frequency (MHz)	Quasi-Peak (dBµV)	Filter	Line	Corr. (dB)	Margin (dB)	Limit (dBµV)
13.558000	28.7	Off	L1	19.8	31.3	60.0

Final Result : Average

Frequency (MHz)	Average (dBµV)	Filter	Line	Corr. (dB)	Margin (dB)	Limit (dBµV)
13.558000	24.7	Off	L1	19.8	25.3	50.0



Test Mode :	Mode 2	Temperature :	23~24°C
Test Engineer :	Arthur Hsieh	Relative Humidity :	51~52%
Test Voltage :	120Vac / 60Hz	Phase :	Neutral
Function Type :	WLAN (5GHz) Link + Bluetooth Link + NFC On + Snap on USB Cable Data link with Notebook + Copy Data from EDA (eMMC) to Notebook + Adapter		

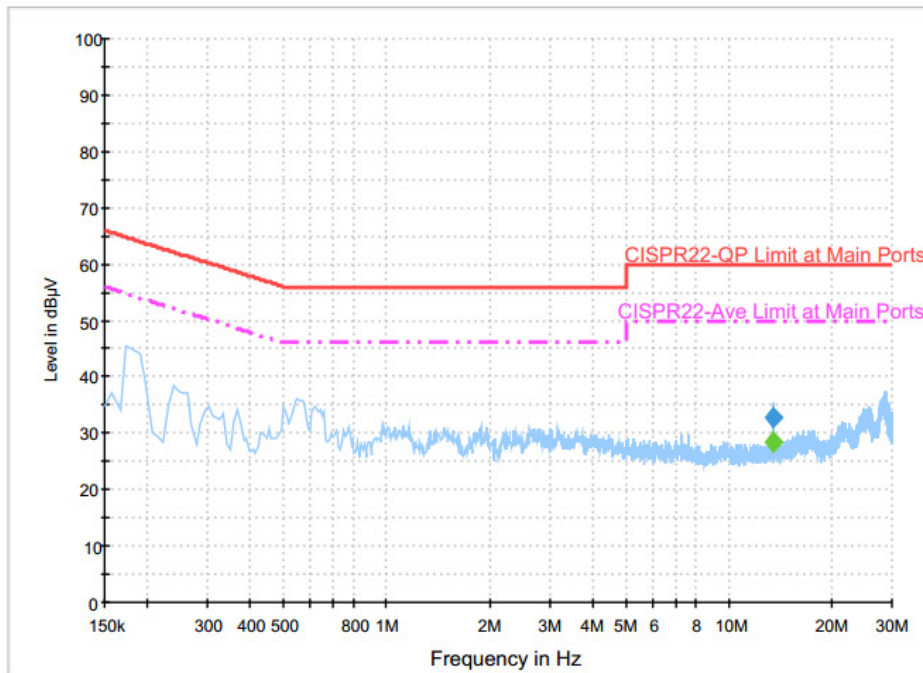

Final Result : Quasi-Peak

Frequency (MHz)	Quasi-Peak (dBµV)	Filter	Line	Corr. (dB)	Margin (dB)	Limit (dBµV)
13.558000	32.7	Off	N	19.8	27.3	60.0

Final Result : Average

Frequency (MHz)	Average (dBµV)	Filter	Line	Corr. (dB)	Margin (dB)	Limit (dBµV)
13.558000	28.5	Off	N	19.8	21.5	50.0



<Original Test Result>

Test Mode :	Mode 3	Temperature :	23~24°C
Test Engineer :	Arthur Hsieh	Relative Humidity :	51~52%
Test Voltage :	120Vac / 60Hz	Phase :	Line
Function Type :	WLAN (5GHz) Link + Bluetooth Link + NFC On + Earphone 2 with Audio Adapter connect to EDA + Charging Only Cable + Adapter		

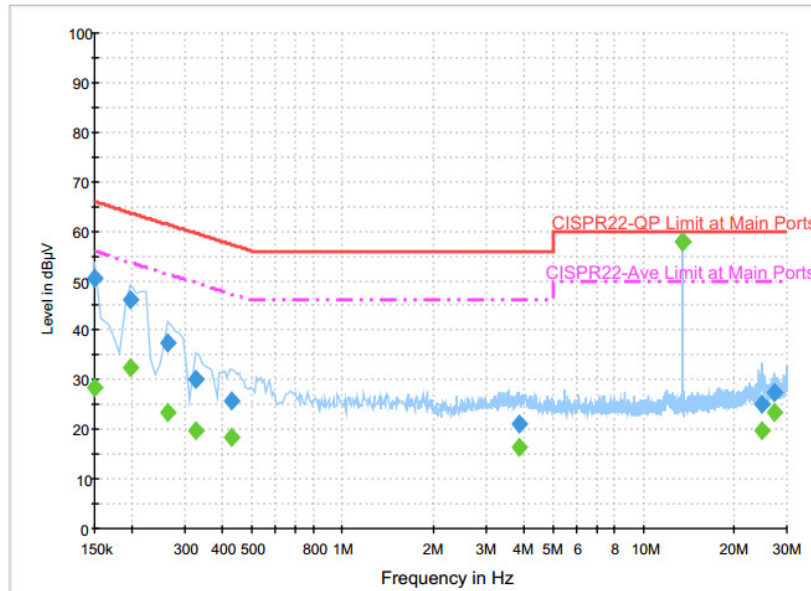

Final Result : Quasi-Peak

Frequency (MHz)	Quasi-Peak (dBµV)	Filter	Line	Corr. (dB)	Margin (dB)	Limit (dBµV)
0.150000	50.4	Off	L1	19.6	15.6	66.0
0.198000	46.0	Off	L1	19.6	17.7	63.7
0.262000	37.4	Off	L1	19.6	24.0	61.4
0.326000	30.1	Off	L1	19.6	29.5	59.6
0.430000	25.9	Off	L1	19.6	31.4	57.3
3.862000	21.2	Off	L1	19.7	34.8	56.0
13.558000	57.9	Off	L1	19.8	2.1	60.0
24.702000	25.0	Off	L1	19.9	35.0	60.0
27.118000	27.5	Off	L1	19.9	32.5	60.0

Final Result : Average

Frequency (MHz)	Average (dBµV)	Filter	Line	Corr. (dB)	Margin (dB)	Limit (dBµV)
0.150000	28.6	Off	L1	19.6	27.4	56.0
0.198000	32.6	Off	L1	19.6	21.1	53.7
0.262000	23.3	Off	L1	19.6	28.1	51.4
0.326000	19.6	Off	L1	19.6	30.0	49.6
0.430000	18.4	Off	L1	19.6	28.9	47.3
3.862000	16.3	Off	L1	19.7	29.7	46.0
13.558000	57.8	Off	L1	19.8	-7.8	50.0
24.702000	19.9	Off	L1	19.9	30.1	50.0
27.118000	23.5	Off	L1	19.9	26.5	50.0



Test Mode :	Mode 3	Temperature :	23~24°C
Test Engineer :	Arthur Hsieh	Relative Humidity :	51~52%
Test Voltage :	120Vac / 60Hz	Phase :	Neutral
Function Type :	WLAN (5GHz) Link + Bluetooth Link + NFC On + Earphone 2 with Audio Adapter connect to EDA + Charging Only Cable + Adapter		

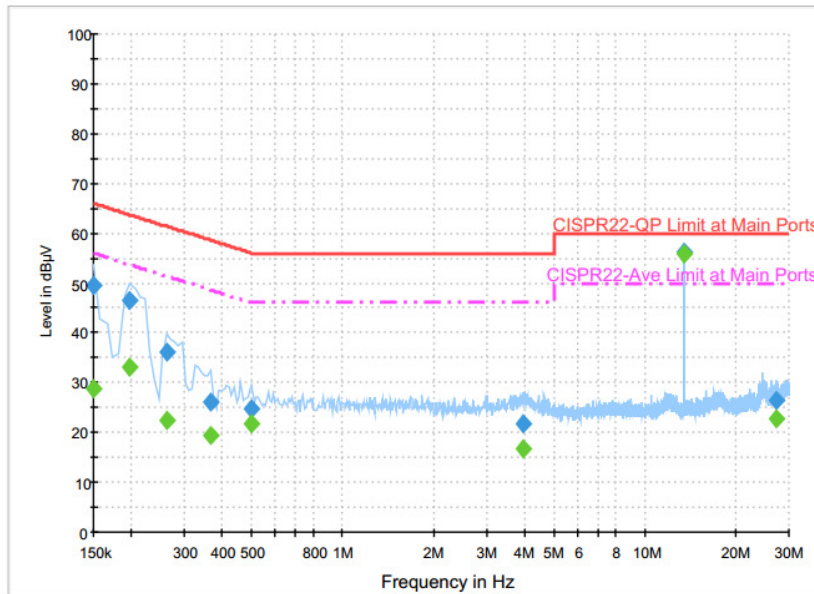

Final Result : Quasi-Peak

Frequency (MHz)	Quasi-Peak (dBµV)	Filter	Line	Corr. (dB)	Margin (dB)	Limit (dBµV)
0.150000	49.4	Off	N	19.6	16.6	66.0
0.198000	46.5	Off	N	19.6	17.2	63.7
0.262000	36.1	Off	N	19.6	25.3	61.4
0.366000	26.0	Off	N	19.6	32.6	58.6
0.502000	24.9	Off	N	19.6	31.1	56.0
3.974000	21.7	Off	N	19.6	34.3	56.0
13.558000	56.1	Off	N	19.8	3.9	60.0
27.118000	26.5	Off	N	20.1	33.5	60.0

Final Result : Average

Frequency (MHz)	Average (dBµV)	Filter	Line	Corr. (dB)	Margin (dB)	Limit (dBµV)
0.150000	28.8	Off	N	19.6	27.2	56.0
0.198000	33.0	Off	N	19.6	20.7	53.7
0.262000	22.5	Off	N	19.6	28.9	51.4
0.366000	19.5	Off	N	19.6	29.1	48.6
0.502000	21.8	Off	N	19.6	24.2	46.0
3.974000	16.7	Off	N	19.6	29.3	46.0
13.558000	55.9	Off	N	19.8	-5.9	50.0
27.118000	22.6	Off	N	20.1	27.4	50.0



<Terminal Test Result>

Test Mode :	Mode 3	Temperature :	23~24°C
Test Engineer :	Arthur Hsieh	Relative Humidity :	51~52%
Test Voltage :	120Vac / 60Hz	Phase :	Line
Function Type :	WLAN (5GHz) Link + Bluetooth Link + NFC On + Earphone 2 with Audio Adapter connect to EDA + Charging Only Cable + Adapter		

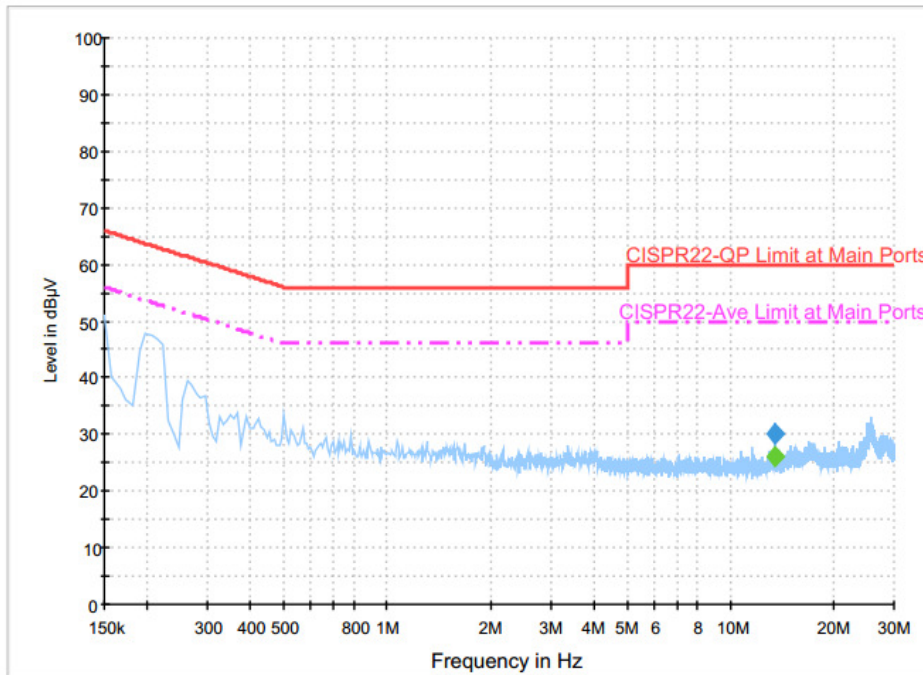

Final Result : Quasi-Peak

Frequency (MHz)	Quasi-Peak (dBµV)	Filter	Line	Corr. (dB)	Margin (dB)	Limit (dBµV)
13.558000	30.2	Off	L1	19.8	29.8	60.0

Final Result : Average

Frequency (MHz)	Average (dBµV)	Filter	Line	Corr. (dB)	Margin (dB)	Limit (dBµV)
13.558000	26.0	Off	L1	19.8	24.0	50.0



Test Mode :	Mode 3	Temperature :	23~24°C
Test Engineer :	Arthur Hsieh	Relative Humidity :	51~52%
Test Voltage :	120Vac / 60Hz	Phase :	Neutral
Function Type :	WLAN (5GHz) Link + Bluetooth Link + NFC On + Earphone 2 with Audio Adapter connect to EDA + Charging Only Cable + Adapter		

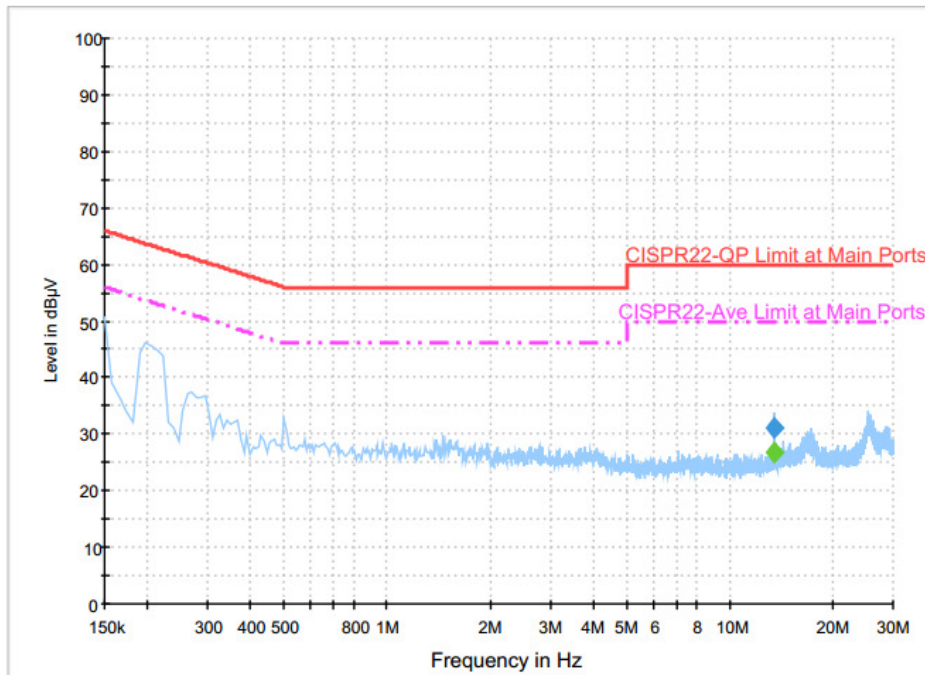

Final Result : Quasi-Peak

Frequency (MHz)	Quasi-Peak (dBµV)	Filter	Line	Corr. (dB)	Margin (dB)	Limit (dBµV)
13.558000	31.1	Off	N	19.8	28.9	60.0

Final Result : Average

Frequency (MHz)	Average (dBµV)	Filter	Line	Corr. (dB)	Margin (dB)	Limit (dBµV)
13.558000	26.6	Off	N	19.8	23.4	50.0

3.6 Frequency Stability Measurement

3.6.1 Limit of Frequency Stability

Manufacturers of U-NII devices are responsible for ensuring frequency stability such that an emission is maintained within the band of operation under all conditions of normal operation as specified in the user's manual.

3.6.2 Measuring Instruments

The measuring equipment is listed in the section 4 of this test report.

3.6.3 Test Procedures

1. To ensure emission at the band edge is maintained within the authorized band, those values shall be measured by radiation emissions at upper and lower frequency points, and finally compensated by frequency deviation as procedures below.
2. The EUT was operated at the maximum output power, and connected to the spectrum analyzer, which is set to maximum hold function and peak detector. The peak value of the power envelope was measured and noted. The upper and lower frequency points were respectively measured relatively 10dB lower than the measured peak value.
3. The frequency deviation was calculated by adding the upper frequency point and the lower frequency point divided by two. Those detailed values of frequency deviation are provided in table below.

3.6.4 Test Setup



3.6.5 Test Result of Frequency Stability

Please refer to Appendix A.



3.7 Automatically Discontinue Transmission

3.7.1 Limit of Automatically Discontinue Transmission

The device shall automatically discontinue transmission in case of either absence of information to transmit or operational failure. These provisions are not intended to preclude the transmission of control or signaling information or the use of repetitive codes used by certain digital technologies to complete frame or burst intervals. Applicants shall include in their application for equipment authorization to describe how this requirement is met.

3.7.2 Measuring Instruments

The measuring equipment is listed in the section 4 of this test report.

3.7.3 Test Result of Automatically Discontinue Transmission

While the EUT is not transmitting any information, the EUT can automatically discontinue transmission and become standby mode for power saving. The EUT can detect the controlling signal of ACK message transmitting from remote device and verify whether it shall resend or discontinue transmission.



3.8 Antenna Requirements

3.8.1 Standard Applicable

According to FCC 47 CFR Section 15.407(a)(1)(2) ,if transmitting antenna directional gain is greater than 6 dBi, both the peak transmit power and the peak power spectral density shall be reduced by the amount in dB that the directional gain of the antenna exceeds 6 dBi.

3.8.2 Antenna Anti-Replacement Construction

An embedded-in antenna design is used.

3.8.3 Antenna Gain

FCC KDB 662911 D01 Multiple Transmitter Output v02r01

For CDD transmissions, directional gain is calculated as

Directional gain = $G_{ANT} + \text{Array Gain}$, where Array Gain is as follows.

For power spectral density (PSD) measurements on all devices,

Array Gain = $10 \log(N_{ANT}/N_{SS}=1)$ dB.

For power measurements on IEEE 802.11 devices,

Array Gain = 0 dB (i.e., no array gain) for $N_{ANT} \leq 4$.

Directional gain may be calculated by using the formulas applicable to equal gain antennas with G_{ANT} set equal to the gain of the antenna having the highest gain;

The EUT supports CDD mode.

For power, the directional gain G_{ANT} is set equal to the antenna having the highest gain, i.e., F)2)f)i).

For PSD, the directional gain calculation is following F)2)f)ii) of KDB 662911 D01 v02r01.

The power and PSD limit should be modified if the directional gain of EUT is over 6 dBi,

The directional gain “DG” is calculated as following table.

	Ant 1 (dBi)	Ant 2 (dBi)	DG for Power (dBi)	DG for PSD (dBi)	Power Limit Reduction (dB)	PSD Limit Reduction (dB)
Band I	2.70	4.37	4.37	6.59	0.00	0.59
Band II	2.79	4.54	4.54	6.72	0.00	0.72
Band III	4.43	5.41	5.41	7.94	0.00	1.94

Power limit reduction = Composite gain – 6dBi, (min = 0)

PSD limit reduction = Composite gain + PSD Array gain – 6dBi, (min = 0)



4 List of Measuring Equipment

Instrument	Manufacturer	Model No.	Serial No.	Characteristics	Calibration Date	Test Date	Due Date	Remark
Power Meter	Anritsu	ML2495A	1132003	300MHz~40GHz	Aug. 12, 2015	Jun. 27, 2016 ~ Jul. 22, 2016	Aug. 11, 2016	Conducted (TH05-HY)
Power Sensor	Anritsu	MA2411B	1126017	300MHz~40GHz	Aug. 12, 2015	Jun. 27, 2016 ~ Jul. 22, 2016	Aug. 11, 2016	Conducted (TH05-HY)
Signal Generator	Agilent	E4438C	MY49070755	250kHz~6GHz	Oct. 01, 2015	Jun. 27, 2016 ~ Jul. 22, 2016	Sep. 30, 2016	Conducted (TH05-HY)
Spectrum Analyzer	Rohde & Schwarz	FSP40	100057	9kHz-40GHz	Nov. 23, 2015	Jun. 27, 2016 ~ Jul. 22, 2016	Nov. 22, 2016	Conducted (TH05-HY)
Temperature Chamber	ESPEC	SU-241	92003713	-30℃ ~95℃	Jun. 06, 2016	Jun. 27, 2016 ~ Jul. 22, 2016	Jun. 05, 2017	Conducted (TH05-HY)
Programmable Power Supply	GW Instek	PSS-2005	GEO821763	N/A	Nov. 13, 2015	Jun. 27, 2016 ~ Jul. 22, 2016	Nov. 12, 2016	Conducted (TH05-HY)
Bilog Antenna	TESEQ	CBL 6111D	35419	30MHz to 1GHz	Jan. 13, 2016	Jun. 24, 2016 ~ Jul. 19, 2016	Jan. 12, 2017	Radiation (03CH07-HY)
Double Ridge Horn Antenna	ESCO	3117	00075962	1GHz ~ 18GHz	Aug. 21, 2015	Jun. 24, 2016 ~ Jul. 19, 2016	Aug. 20, 2016	Radiation (03CH07-HY)
EMI Test Receiver	Keysight	N9038A(MXE)	MY54130085	20Hz ~ 8.4GHz	Nov. 04, 2015	Jun. 24, 2016 ~ Jul. 19, 2016	Nov. 03, 2016	Radiation (03CH07-HY)
Loop Antenna	Rohde & Schwarz	HFH2-Z2	100315	9 kHz~30 MHz	Sep. 02, 2015	Jun. 24, 2016 ~ Jul. 19, 2016	Sep. 01, 2016	Radiation (03CH07-HY)
Preamplifier	MITEQ	AMF-7D-0010 1800-30-10P	1590075	1GHz ~ 18GHz	Apr. 15, 2016	Jun. 24, 2016 ~ Jul. 19, 2016	Apr. 14, 2017	Radiation (03CH07-HY)
Preamplifier	COM-POWER	PA-103A	161241	10MHz-1GHz	Mar. 18, 2016	Jun. 24, 2016 ~ Jul. 19, 2016	Mar. 17, 2017	Radiation (03CH07-HY)
Preamplifier	Agilent	8449B	3008A02362	1GHz~ 26.5GHz	Oct. 19, 2015	Jun. 24, 2016 ~ Jul. 19, 2016	Oct. 18, 2016	Radiation (03CH07-HY)
Spectrum Analyzer	Agilent	N9010A	MY53470118	10Hz~44GHz	Feb. 27, 2016	Jun. 24, 2016 ~ Jul. 19, 2016	Feb. 26, 2017	Radiation (03CH07-HY)
Antenna Mast	Max-Full	MFA520BS	N/A	1m~4m	N/A	Jun. 24, 2016 ~ Jul. 19, 2016	N/A	Radiation (03CH07-HY)
Turn Table	ChainTek	Chaintek 3000	N/A	0~360 Degree	N/A	Jun. 24, 2016 ~ Jul. 19, 2016	N/A	Radiation (03CH07-HY)
Loop Cable	Rohde & Schwarz	N/A	N/A	9KHz~30MHz	Dec. 03, 2015	Jun. 24, 2016 ~ Jul. 19, 2016	Dec. 02, 2016	Radiation (03CH07-HY)
Preamplifier	MITEQ	JS44-1800400 0-33-8P	1840917	18GHz ~ 40GHz	Jun. 14, 2016	Jun. 24, 2016 ~ Jul. 19, 2016	Jun. 13, 2017	Radiation (03CH07-HY)
SHF-EHF Horn Antenna	SCHWARZBECK	BBHA 9170	BBHA917058 4	18GHz- 40GHz	Nov. 02, 2015	Jun. 24, 2016 ~ Jul. 19, 2016	Nov. 01, 2016	Radiation (03CH07-HY)
AC Power Source	ChainTek	APC-1000W	N/A	N/A	N/A	Jun. 27, 2016 ~ Jul. 11, 2016	N/A	Conduction (CO05-HY)
EMI Test Receiver	Rohde & Schwarz	ESCI 7	100724	9kHz~7GHz	Aug. 26, 2015	Jun. 27, 2016 ~ Jul. 11, 2016	Aug. 25, 2016	Conduction (CO05-HY)
LISN	Rohde & Schwarz	ENV216	100080	9kHz~30MHz	Dec. 02, 2015	Jun. 27, 2016 ~ Jul. 11, 2016	Dec. 01, 2016	Conduction (CO05-HY)
LISN	Rohde & Schwarz	ENV216	100081	9kHz~30MHz	Dec. 14, 2015	Jun. 27, 2016 ~ Jul. 11, 2016	Dec. 13, 2016	Conduction (CO05-HY)



5 Uncertainty of Evaluation

Uncertainty of Conducted Emission Measurement (150kHz ~ 30MHz)

Measuring Uncertainty for a Level of Confidence of 95% ($U = 2Uc(y)$)	2.26
---	------

Uncertainty of Radiated Emission Measurement (30 MHz ~ 1000 MHz)

Measuring Uncertainty for a Level of Confidence of 95% ($U = 2Uc(y)$)	5.60
---	------

Uncertainty of Radiated Emission Measurement (1000 MHz ~ 40 GHz)

Measuring Uncertainty for a Level of Confidence of 95% ($U = 2Uc(y)$)	5.50
---	------



Appendix A. Conducted Test Results