



FCC TEST REPORT (15.407)

REPORT NO.: RF140219C09-3
MODEL NO.: TC700H
FCC ID: UZ7TC700H
RECEIVED: Feb. 19, 2014
TESTED: Mar. 19, 2014 ~ Apr. 16, 2014
ISSUED: Apr. 17, 2014

APPLICANT: Motorola Solutions, Inc.

ADDRESS: One Motorola Plaza, Holtsville, NY 11742-1300 USA

ISSUED BY: Bureau Veritas Consumer Products Services
(H.K.) Ltd., Taoyuan Branch

LAB ADDRESS: No. 47, 14th Ling, Chia Pau Vil., Lin Kou Dist.,
New Taipei City, Taiwan (R.O.C)

TEST LOCATION: No. 19, Hwa Ya 2nd Rd, Wen Hwa Tsuen, Kwei
Shan Hsiang, Taoyuan Hsien 333, Taiwan, R.O.C.

This report should not be used by the client to claim product certification, approval, or endorsement by TAF or any government agencies.



This report is for your exclusive use. Any copying or replication of this report to or for any other person or entity, or use of our name or trademark, is permitted only with our prior written permission. This report sets forth our findings solely with respect to the test samples identified herein. The results set forth in this report are not indicative or representative of the quality or characteristics of the lot from which a test sample was taken or any similar or identical product unless specifically and expressly noted. Our report includes all of the tests requested by you and the results thereof based upon the information that you provided to us. You have 60 days from date of issuance of this report to notify us of any material error or omission caused by our negligence, provided, however, that such notice shall be in writing and shall specifically address the issue you wish to raise. A failure to raise such issue within the prescribed time shall constitute your unqualified acceptance of the completeness of this report, the tests conducted and the correctness of the report contents. Unless specific mention, the uncertainty of measurement has been explicitly taken into account to declare the compliance or non-compliance to the specification.



TABLE OF CONTENTS

RELEASE CONTROL RECORD	4
1. CERTIFICATION.....	5
2. SUMMARY OF TEST RESULTS	6
2.1 MEASUREMENT UNCERTAINTY	6
3. GENERAL INFORMATION.....	7
3.1 GENERAL DESCRIPTION OF EUT.....	7
3.2 DESCRIPTION OF TEST MODES.....	9
3.2.1 TEST MODE APPLICABILITY AND TESTED CHANNEL DETAIL.....	10
3.3 DESCRIPTION OF SUPPORT UNITS.....	12
3.3.1 CONFIGURATION OF SYSTEM UNDER TEST	12
3.4 DUTY CYCLE TEST SIGNAL.....	13
3.5 GENERAL DESCRIPTION OF APPLIED STANDARDS.....	16
4. TEST TYPES AND RESULTS	17
4.1 RADIATED EMISSION AND BANDEDGE MEASUREMENT	17
4.1.1 LIMITS OF RADIATED EMISSION AND BANDEDGE MEASUREMENT.....	17
4.1.2 LIMITS OF UNWANTED EMISSION OUT OF THE RESTRICTED BANDS	17
4.1.3 TEST INSTRUMENTS.....	18
4.1.4 TEST PROCEDURES	19
4.1.5 DEVIATION FROM TEST STANDARD	19
4.1.6 TEST SETUP.....	20
4.1.7 EUT OPERATING CONDITIONS	20
4.1.8 TEST RESULTS.....	21
4.2 CONDUCTED EMISSION MEASUREMENT	71
4.2.1 LIMITS OF CONDUCTED EMISSION MEASUREMENT	71
4.2.2 TEST INSTRUMENTS.....	71
4.2.3 TEST PROCEDURES	72
4.2.4 DEVIATION FROM TEST STANDARD	72
4.2.5 TEST SETUP.....	73
4.2.6 EUT OPERATING CONDITIONS	73
4.2.7 TEST RESULTS.....	74
4.3 PEAK TRANSMIT POWER MEASUREMENT	78
4.3.1 LIMITS OF PEAK TRANSMIT POWER MEASUREMENT.....	78
4.3.2 TEST SETUP.....	78
4.3.3 TEST INSTRUMENTS.....	78
4.3.4 TEST PROCEDURE.....	79
4.3.5 DEVIATION FROM TEST STANDARD	79
4.3.6 EUT OPERATING CONDITIONS	79
4.3.7 TEST RESULTS.....	80
4.4 PEAK POWER SPECTRAL DENSITY MEASUREMENT	85
4.4.1 LIMITS OF PEAK POWER SPECTRAL DENSITY MEASUREMENT	85
4.4.2 TEST SETUP.....	85
4.4.3 TEST INSTRUMENTS.....	85
4.4.4 TEST PROCEDURES	85
4.4.5 DEVIATION FROM TEST STANDARD	85
4.4.6 EUT OPERATING CONDITIONS	85
4.4.7 TEST RESULTS.....	86
4.5 PEAK POWER EXCURSION MEASUREMENT	88
4.5.1 LIMITS OF POWER SPECTRAL DENSITY MEASUREMENT	88
4.5.2 TEST SETUP.....	88
4.5.3 TEST INSTRUMENTS.....	88
4.5.4 TEST PROCEDURE.....	88
4.5.5 DEVIATION FROM TEST STANDARD	88



A D T

4.5.6	EUT OPERATING CONDITION.....	88
4.5.7	TEST RESULTS.....	89
4.6	FREQUENCY STABILITY	90
4.6.1	LIMITS OF FREQUENCY STABILITY MEASUREMENT	90
4.6.2	TEST SETUP	90
4.6.3	TEST INSTRUMENTS	90
4.6.4	TEST PROCEDURE	91
4.6.5	DEVIATION FROM TEST STANDARD	91
4.6.6	EUT OPERATING CONDITION.....	91
4.6.7	TEST RESULTS.....	92
4.7	20dBc BANDWIDTH MEASUREMENT.....	93
4.7.1	LIMITS OF 20dBc BANDWIDTH MEASUREMENT	93
4.7.2	TEST SETUP	93
4.7.3	TEST INSTRUMENTS.....	93
4.7.4	TEST PROCEDURES	93
4.7.5	TEST RESULTS.....	94
5.	PHOTOGRAPHS OF THE TEST CONFIGURATION.....	100
6.	INFORMATION ON THE TESTING LABORATORIES	101
7.	APPENDIX A - MODIFICATIONS RECORDERS FOR ENGINEERING CHANGES TO THE EUT BY THE LAB	102



A D T

RELEASE CONTROL RECORD

ISSUE NO.	REASON FOR CHANGE	DATE ISSUED
RF140219C09-3	Original release	Apr. 17, 2014



A D T

1. CERTIFICATION

PRODUCT: Touch Computer
MODEL NO.: TC700H
BRAND: Motorola
APPLICANT: Motorola Solutions, Inc.
TESTED: Mar. 19, 2014 ~ Apr. 16, 2014
TEST SAMPLE: ENGINEERING SAMPLE
STANDARDS: **FCC Part 15, Subpart E (Section 15.407)**
ANSI C63.10-2009

The above equipment (model: TC700H) has been tested by **Bureau Veritas Consumer Products Services (H.K.) Ltd., Taoyuan Branch**, and found compliance with the requirement of the above standards. The test record, data evaluation & Equipment Under Test (EUT) configurations represented herein are true and accurate accounts of the measurements of the sample's EMC characteristics under the conditions specified in this report.

PREPARED BY : Vera Huang , **DATE** : Apr. 17, 2014
Vera Huang / Specialist

APPROVED BY : Sam chen , **DATE** : Apr. 17, 2014
Sam Chen / Senior Project Engineer

2. SUMMARY OF TEST RESULTS

The EUT has been tested according to the following specifications:

APPLIED STANDARD: FCC PART 15, SUBPART E (SECTION 15.407)			
STANDARD SECTION	TEST TYPE	RESULT	REMARK
15.407(b)(6)	AC Power Conducted Emission	PASS	Meet the requirement of limit. Minimum passing margin is -3.49dB at 13.56250MHz.
15.407(b/1/2/3) (b)(6)	Spurious Emissions	PASS	Meet the requirement of limit. Minimum passing margin is -1.09dB at 5470MHz.
15.407(a/1/2)	Peak Transmit Power	PASS	Meet the requirement of limit.
15.407(a)(6)	Peak Power Excursion	PASS	Meet the requirement of limit.
15.407(a/1/2)	Peak Power Spectral Density	PASS	Meet the requirement of limit.
15.407(g)	Frequency Stability	PASS	Meet the requirement of limit.
15.203	Antenna Requirement	PASS	No antenna connector is used.

2.1 MEASUREMENT UNCERTAINTY

Where relevant, the following measurement uncertainty levels have been estimated for tests performed on the EUT as specified in CISPR 16-4-2:

MEASUREMENT	FREQUENCY	UNCERTAINTY
Conducted emissions	9kHz~30MHz	2.44 dB
Radiated emissions	30MHz ~ 200MHz	2.93 dB
	200MHz ~1000MHz	2.95 dB
	1GHz ~ 18GHz	2.26 dB
	18GHz ~ 40GHz	1.94 dB

This uncertainty represents an expanded uncertainty expressed at approximately the 95% confidence level using a coverage factor of $k = 2$.



A D T

3. GENERAL INFORMATION

3.1 GENERAL DESCRIPTION OF EUT

EUT	Touch Computer
MODEL NO.	TC700H
POWER SUPPLY	5.4Vdc (adapter or host equipment) 3.7Vdc (Li-ion battery)
MODULATION TYPE	64QAM, 16QAM, QPSK, BPSK
MODULATION TECHNOLOGY	OFDM
TRANSFER RATE	802.11a: 54.0/ 48.0/ 36.0/ 24.0/ 18.0/ 12.0/ 9.0/ 6.0Mbps 802.11n: up to MCS7
OPERATING FREQUENCY	5180 ~ 5240MHz, 5260 ~ 5320MHz & 5500 ~ 5700MHz
NUMBER OF CHANNEL	5180 ~ 5240MHz: 4 for 802.11a, 802.11n (20MHz) 2 for 802.11n (40MHz) 5260 ~ 5320MHz: 4 for 802.11a, 802.11n (20MHz) 2 for 802.11n (40MHz) 5500 ~ 5700MHz: 8 for 802.11a, 802.11n (20MHz) 3 for 802.11n (40MHz)
OUTPUT POWER	48.195mW for 5180 ~ 5240MHz 50.00mW for 5260 ~ 5320MHz 41.88mW for 5500 ~ 5700MHz
ANTENNA TYPE	PIFA antenna with 3.62dBi gain (5180 ~ 5240MHz) PIFA antenna with 2.95dBi gain (5260 ~ 5320MHz) PIFA antenna with 2.65dBi gain (5500 ~ 5700MHz)
ANTENNA CONNECTOR	NA
DATA CABLE	Refer to Note as below
I/O PORTS	Refer to user's manual
ACCESSORY DEVICES	Refer to Note as below
HW VERSION	EV1b
SW VERSION	Android Version: 4.4.2 Build Number: 99-23245-K-03-05-01-E1-030114



NOTE:

- 1. The EUT contains following accessory devices.

ITEM	BRAND	MODEL	SPECIFICATION
Adapter	Motorola	86-14000-249R	I/P: 100-240Vac, 50/60Hz, 0.6A O/P: 5.4Vdc, 3A
Battery	Motorola	82-171249-01	3.7Vdc, 4500mAh
Snap On USB Cable	Motorola	CBL-TC7X-USB1-01	1.8m non-shielded cable with core
Holster	Motorola	SG-TC7X-HLSTR1-01	--
Hand-Strap	Motorola	SG-TC7X-HSTRP1-03	--

- 2. The EUT provides one completed transmitter and one receiver.

MODULATION MODE	TX FUNCTION
802.11b	1TX
802.11g	1TX
802.11a	1TX
802.11n (20MHz)	1TX
802.11n (40MHz)	1TX

- 3. The above EUT information is declared by the manufacturer and for more detailed features description, please refer to the manufacturer's specifications or User's Manual.

3.2 DESCRIPTION OF TEST MODES

WLAN 5180 ~ 5240MHz

4 channels are provided for 802.11a, 802.11n (20MHz):

CHANNEL	FREQUENCY	CHANNEL	FREQUENCY
36	5180 MHz	44	5220 MHz
40	5200 MHz	48	5240 MHz

2 channels are provided for 802.11n (40MHz):

CHANNEL	FREQUENCY	CHANNEL	FREQUENCY
38	5190 MHz	46	5230 MHz

WLAN 5260 ~ 5320MHz

4 channels are provided for 802.11a, 802.11n (20MHz):

CHANNEL	FREQUENCY	CHANNEL	FREQUENCY
52	5260 MHz	60	5300 MHz
56	5280 MHz	64	5320 MHz

2 channels are provided for 802.11n (40MHz):

CHANNEL	FREQUENCY	CHANNEL	FREQUENCY
54	5270 MHz	62	5310 MHz

WLAN 5500 ~ 5700MHz

8 channels are provided for 802.11a, 802.11n (20MHz):

CHANNEL	FREQUENCY	CHANNEL	FREQUENCY
100	5500MHz	116	5580MHz
104	5520MHz	132	5660MHz
108	5540MHz	136	5680MHz
112	5560MHz	140	5700MHz

3 channels are provided for 802.11n (40MHz):

CHANNEL	FREQUENCY	CHANNEL	FREQUENCY
102	5510MHz	134	5670MHz
110	5550MHz		



A D T

3.2.1 TEST MODE APPLICABILITY AND TESTED CHANNEL DETAIL

EUT CONFIGURE MODE	APPLICABLE TO				DESCRIPTION
	RE \geq 1G	RE $<$ 1G	PLC	APCM	
-	√	√	√	√	-

Where **RE \geq 1G**: Radiated Emission above 1GHz **RE $<$ 1G**: Radiated Emission below 1GHz
PLC: Power Line Conducted Emission **APCM**: Antenna Port Conducted Measurement

NOTE: The EUT had been pre-tested on the positioned of each 3 axis. The worst case was found when positioned on **Z-plane** for 5180-5320 MHz and **X-plane** for 5500-5700 MHz.

RADIATED EMISSION TEST (ABOVE 1GHz):

- Pre-Scan has been conducted to determine the worst-case mode from all possible combinations between available modulations, data rates and antenna ports (if EUT with antenna diversity architecture).
- Following channel(s) was (were) selected for the final test as listed below.

MODE	FREQ. BAND (MHz)	AVAILABLE CHANNEL	TESTED CHANNEL	MODULATION TECHNOLOGY	MODULATION TYPE	DATA RATE (Mbps)
802.11a	5180-5240	36 to 48	36, 44, 48	OFDM	BPSK	6.0
802.11n (20MHz)		36 to 48	36, 44, 48	OFDM	BPSK	MCS0
802.11n (40MHz)		38 to 46	38, 46	OFDM	BPSK	MCS0
802.11a	5260-5320	52 to 64	52, 60, 64	OFDM	BPSK	6.0
802.11n (20MHz)		52 to 64	52, 60, 64	OFDM	BPSK	MCS0
802.11n (40MHz)		54 to 62	54, 62	OFDM	BPSK	MCS0
802.11a	5500-5700	100 to 140	100, 116, 140	OFDM	BPSK	6.0
802.11n (20MHz)		100 to 140	100, 116, 140	OFDM	BPSK	MCS0
802.11n (40MHz)		102 to 134	102, 110, 134	OFDM	BPSK	MCS0

RADIATED EMISSION TEST (BELOW 1GHz):

- Pre-Scan has been conducted to determine the worst-case mode from all possible combinations between available modulations, data rates and antenna ports (if EUT with antenna diversity architecture).
- Following channel(s) was (were) selected for the final test as listed below.

MODE	FREQ. BAND (MHz)	AVAILABLE CHANNEL	TESTED CHANNEL	MODULATION TECHNOLOGY	MODULATION TYPE	DATA RATE (Mbps)
802.11a	5180-5240	36 to 48	36, 44, 48	OFDM	BPSK	6.0
802.11n (20MHz)		36 to 48	36, 44, 48	OFDM	BPSK	MCS0
802.11n (40MHz)		38 to 46	38, 46	OFDM	BPSK	MCS0
802.11a	5260-5320	52 to 64	52, 60, 64	OFDM	BPSK	6.0
802.11n (20MHz)		52 to 64	52, 60, 64	OFDM	BPSK	MCS0
802.11n (40MHz)		54 to 62	54, 62	OFDM	BPSK	MCS0
802.11a	5500-5700	100 to 140	100, 116, 140	OFDM	BPSK	6.0
802.11n (20MHz)		100 to 140	100, 116, 140	OFDM	BPSK	MCS0
802.11n (40MHz)		102 to 134	102, 110, 134	OFDM	BPSK	MCS0



A D T

POWER LINE CONDUCTED EMISSION TEST:

MODE	FREQ. BAND (MHz)	AVAILABLE CHANNEL	TESTED CHANNEL	MODULATION TECHNOLOGY	MODULATION TYPE	DATA RATE (Mbps)
802.11n (40MHz)	5500-5700	102 to 134	102	OFDM	BPSK	MCS0

BANDEDGE MEASUREMENT:

- Pre-Scan has been conducted to determine the worst-case mode from all possible combinations between available modulations, data rates and antenna ports (if EUT with antenna diversity architecture).
- Following channel(s) was (were) selected for the final test as listed below.

MODE	FREQ. BAND (MHz)	AVAILABLE CHANNEL	TESTED CHANNEL	MODULATION TECHNOLOGY	MODULATION TYPE	DATA RATE (Mbps)
802.11a	5180-5240	36 to 48	36, 48	OFDM	BPSK	6.0
802.11n (20MHz)		36 to 48	36, 48	OFDM	BPSK	MCS0
802.11n (40MHz)		38 to 46	38, 46	OFDM	BPSK	MCS0
802.11a	5260-5320	52 to 64	52, 64	OFDM	BPSK	6.0
802.11n (20MHz)		52 to 64	52, 64	OFDM	BPSK	MCS0
802.11n (40MHz)		54 to 62	54, 62	OFDM	BPSK	MCS0
802.11a	5500-5700	100 to 140	100, 140	OFDM	BPSK	6.0
802.11n (20MHz)		100 to 140	100, 140	OFDM	BPSK	MCS0
802.11n (40MHz)		102 to 134	102, 134	OFDM	BPSK	MCS0

ANTENNA PORT CONDUCTED MEASUREMENT:

- This item includes all test value of each mode, but only includes spectrum plot of worst value of each mode.
- Pre-Scan has been conducted to determine the worst-case mode from all possible combinations between available modulations, data rates and antenna ports (if EUT with antenna diversity architecture).
- Following channel(s) was (were) selected for the final test as listed below.

MODE	FREQ. BAND (MHz)	AVAILABLE CHANNEL	TESTED CHANNEL	MODULATION TECHNOLOGY	MODULATION TYPE	DATA RATE (Mbps)
802.11a	5180-5240	36 to 48	36, 44, 48	OFDM	BPSK	6.0
802.11n (20MHz)		36 to 48	36, 44, 48	OFDM	BPSK	MCS0
802.11n (40MHz)		38 to 46	38, 46	OFDM	BPSK	MCS0
802.11a	5260-5320	52 to 64	52, 60, 64	OFDM	BPSK	6.0
802.11n (20MHz)		52 to 64	52, 60, 64	OFDM	BPSK	MCS0
802.11n (40MHz)		54 to 62	54, 62	OFDM	BPSK	MCS0
802.11a	5500-5700	100 to 140	100, 116, 140	OFDM	BPSK	6.0
802.11n (20MHz)		100 to 140	100, 116, 140	OFDM	BPSK	MCS0
802.11n (40MHz)		102 to 134	102, 110, 134	OFDM	BPSK	MCS0

Test CONDITION:

APPLICABLE TO	ENVIRONMENTAL CONDITIONS	INPUT POWER	TESTED BY
RE≥1G	25deg. C, 65%RH	120Vac, 60Hz	Peter Weng
RE<1G	25deg. C, 65%RH	120Vac, 60Hz	Johnson Liao
PLC	25deg. C, 65%RH	120Vac, 60Hz	Peter Weng
APCM	25deg. C, 65%RH	120Vac, 60Hz	Howard Kao

3.3 DESCRIPTION OF SUPPORT UNITS

The EUT has been tested as an independent unit together with other necessary accessories or support units. The following support units or accessories were used to form a representative test configuration during the tests.

NO.	PRODUCT	BRAND	MODEL NO.	SERIAL NO.	FCC ID
1	NOTEBOOK	DELL	Inspiron 14R	8LRKKW1	NA

NO.	SIGNAL CABLE DESCRIPTION OF THE ABOVE SUPPORT UNITS
1	NA

NOTE:

1. All power cords of the above support units are non shielded (1.8m).
2. Item 1 acted as a communication partner to transfer data.

3.3.1 CONFIGURATION OF SYSTEM UNDER TEST

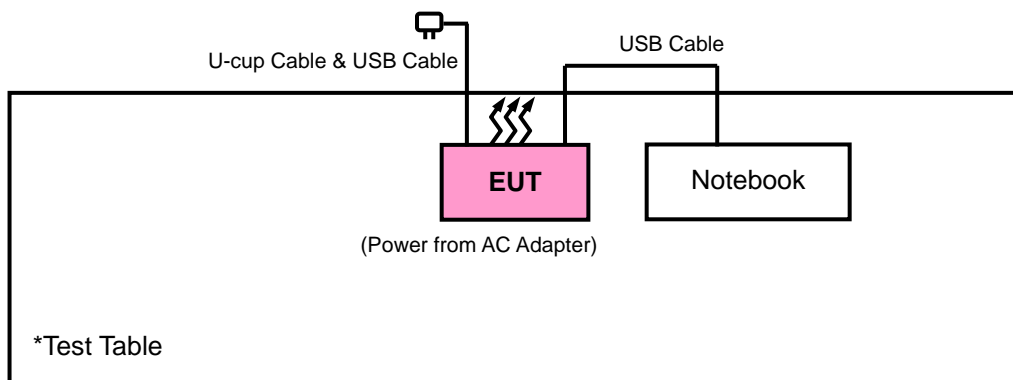

3.4 DUTY CYCLE TEST SIGNAL

MODULATION TYPE: BPSK

802.11a: Duty cycle = Duty cycle of test signal is > 98 %, duty factor is not required.

802.11n (20MHz): Duty cycle = Duty cycle of test signal is > 98 %, duty factor is not required.

802.11n (40MHz): If duty cycle is < 98%, duty factor shall be considered.

$$\text{Duty cycle} = 608.97/644.23 = 0.945, \text{Duty factor} = 10 * \log(1/0.945) = 0.25$$

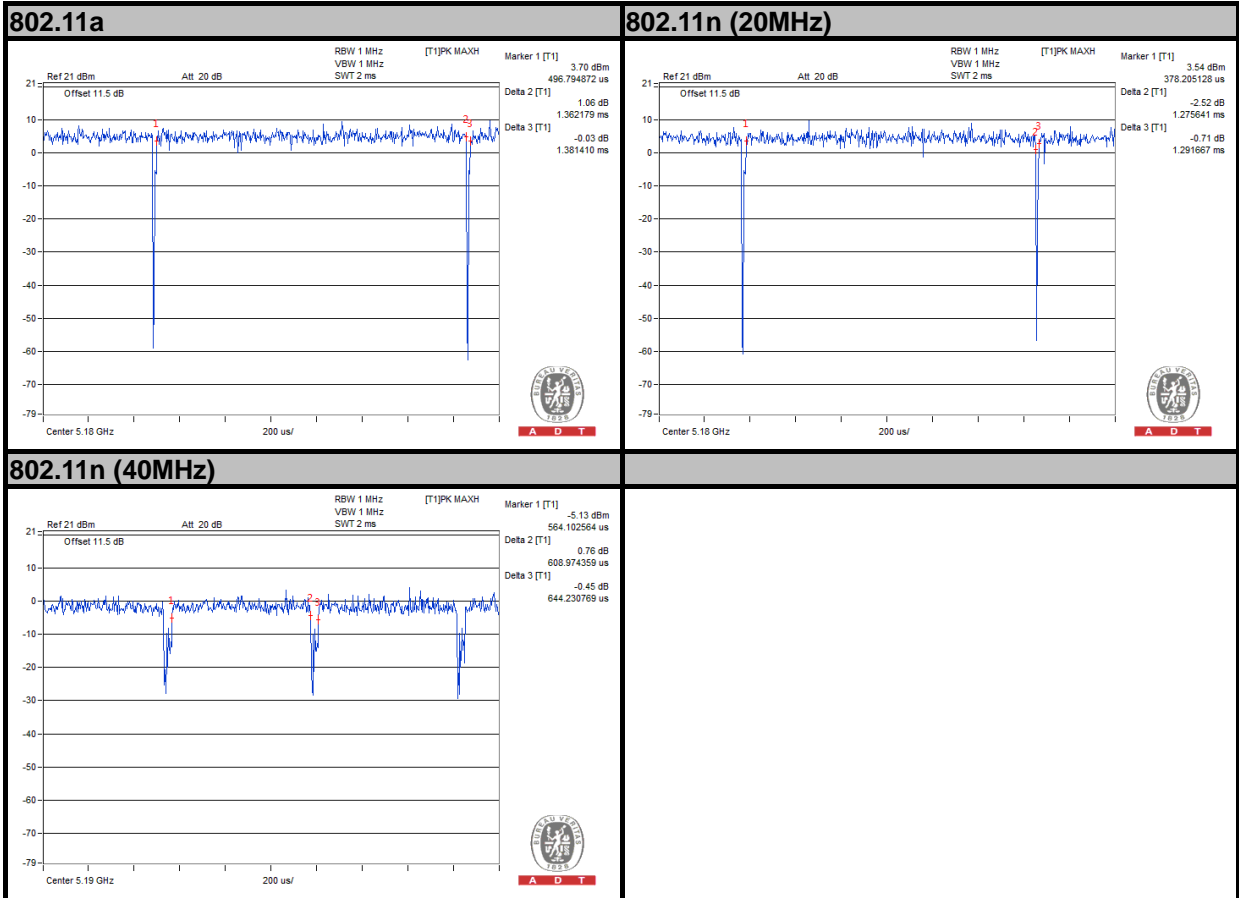



A D T

MODULATION TYPE: QPSK

If duty cycle is < 98%, duty factor shall be considered.

802.11a: Duty cycle = 689.10/708.33 = 0.973, Duty factor = 10 * log(1/0.973) = 0.12

802.11n (20MHz): Duty cycle = 650.64/669.87 = 0.971, Duty factor = 10 * log(1/0.971) = 0.13

802.11n (40MHz): Duty cycle = 304.48/342.94 = 0.888, Duty factor = 10 * log(1/0.888) = 0.52

802.11a

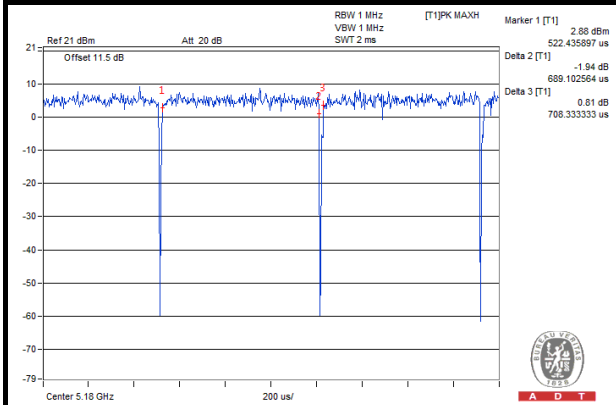

802.11n (20MHz)

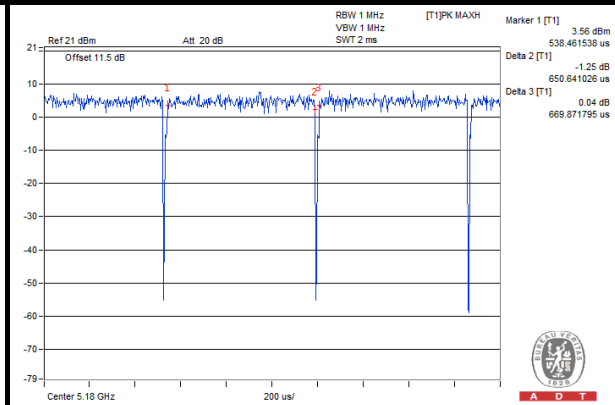

802.11n (40MHz)

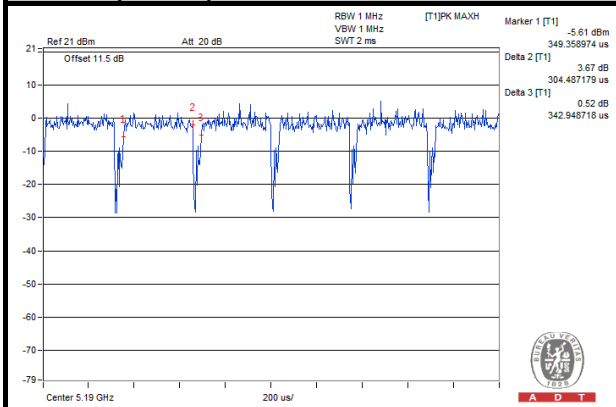



A D T

MODULATION TYPE: 16QAM

If duty cycle is < 98%, duty factor shall be considered.

802.11a: Duty cycle = 349.35/368.58 = 0.948, Duty factor = $10 * \log(1/0.948) = 0.23$

802.11n (20MHz): Duty cycle = 339.74/358.97 = 0.946, Duty factor = $10 * \log(1/0.946) = 0.24$

802.11n (40MHz): Duty cycle = 157.05/193.91 = 0.81, Duty factor = $10 * \log(1/0.81) = 0.92$

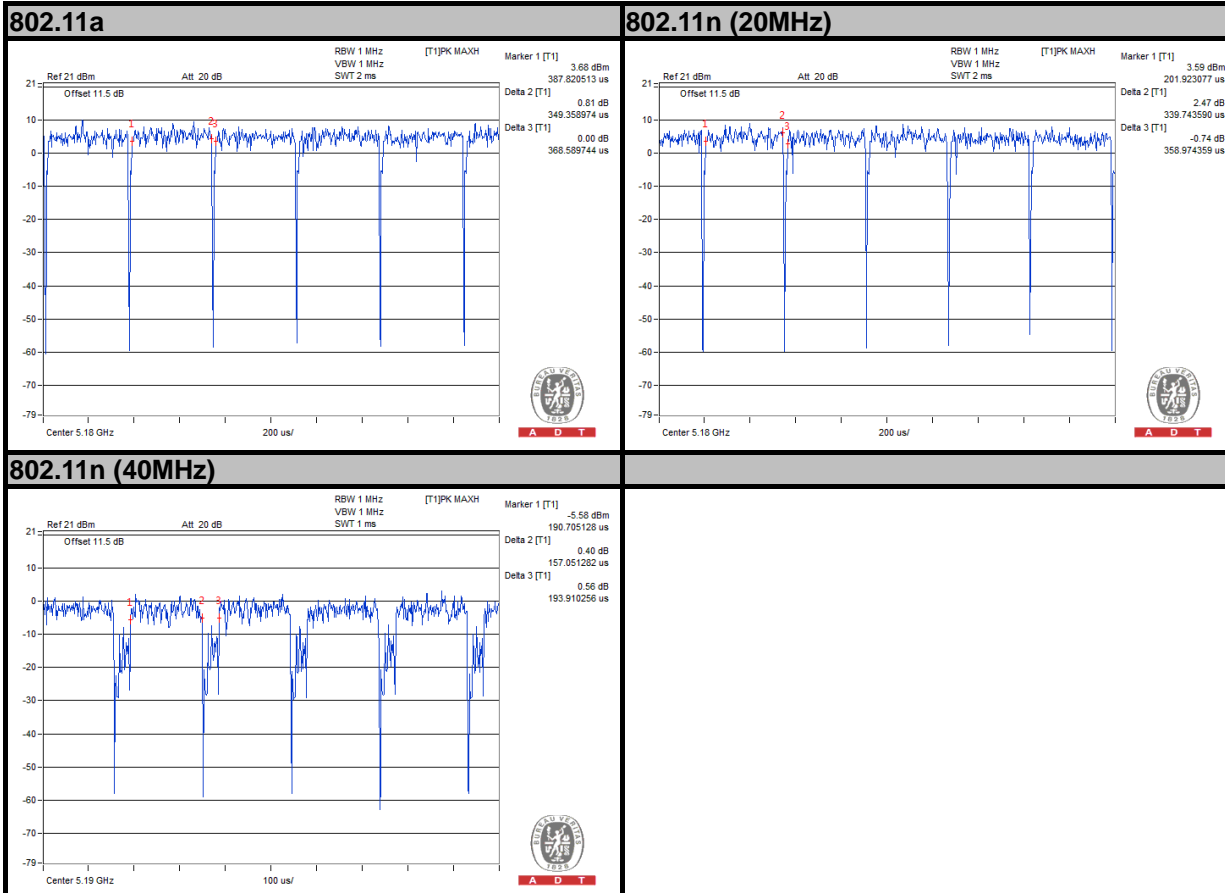



A D T

MODULATION TYPE: 64QAM

If duty cycle is < 98%, duty factor shall be considered.

802.11a: Duty cycle = 179.48/198.71 = 0.903, Duty factor = 10 * log(1/0.903) = 0.44

802.11n (20MHz): Duty cycle = 182.69/201.92 = 0.905, Duty factor = 10 * log(1/0.905) = 0.43

802.11n (40MHz): Duty cycle = 80.12/118.58 = 0.676, Duty factor = 10 * log(1/0.676) = 1.70

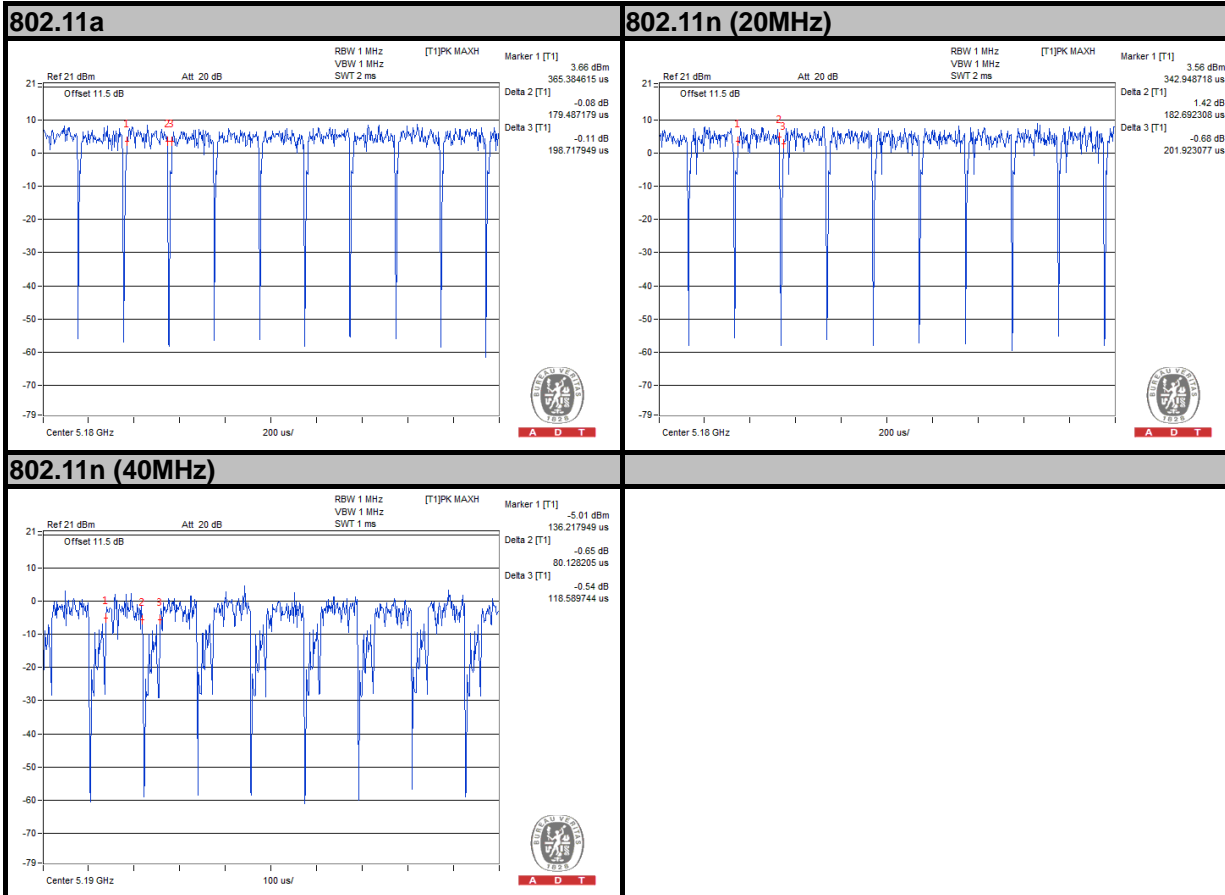

3.5 GENERAL DESCRIPTION OF APPLIED STANDARDS

The EUT is a RF Product. According to the specifications of the manufacturer, it must comply with the requirements of the following standards:

- FCC Part 15, Subpart E (15.407)**
- KDB 789033 D01 General UNII Test Procedures v01r03**
- ANSI C63.10-2009**

All test items have been performed and recorded as per the above standards.

NOTE: The EUT is also considered as a kind of computer peripheral, because the connection to computer is necessary for typical use. It has been verified to comply with the requirements of FCC Part 15, Subpart B, Class B (DoC). The test report has been issued separately.

4. TEST TYPES AND RESULTS

4.1 RADIATED EMISSION AND BANDEDGE MEASUREMENT

4.1.1 LIMITS OF RADIATED EMISSION AND BANDEDGE MEASUREMENT

Radiated emissions which fall in the restricted bands must comply with the radiated emission limits specified as below table:

FREQUENCIES (MHz)	FIELD STRENGTH (microvolts/meter)	MEASUREMENT DISTANCE (meters)
0.009 ~ 0.490	2400/F(kHz)	300
0.490 ~ 1.705	24000/F(kHz)	30
1.705 ~ 30.0	30	30
30 ~ 88	100	3
88 ~ 216	150	3
216 ~ 960	200	3
Above 960	500	3

NOTE:

1. The lower limit shall apply at the transition frequencies.
2. Emission level (dBuV/m) = 20 log Emission level (uV/m).
3. For frequencies above 1000MHz, the field strength limits are based on average detector, however, the peak field strength of any emission shall not exceed the maximum permitted average limits, specified above by more than 20dB under any condition of modulation.

4.1.2 LIMITS OF UNWANTED EMISSION OUT OF THE RESTRICTED BANDS

APPLICABLE TO	LIMIT	
	FIELD STRENGTH AT 3m (dBµV/m)	
	PK	AV
	74	54
√	EIRP LIMIT (dBm)	EQUIVALENT FIELD STRENGTH AT 3m (dBµV/m)
	PK	PK
	-27	68.3

NOTE: The following formula is used to convert the equipment isotropic radiated power (eirp) to field strength:

$$E = \frac{1000000\sqrt{30P}}{3} \mu\text{V/m, where } P \text{ is the eirp (Watts).}$$



A D T

4.1.3 TEST INSTRUMENTS

DESCRIPTION & MANUFACTURER	MODEL NO.	SERIAL NO.	DATE OF CALIBRATION	DUE DATE OF CALIBRATION
Test Receiver ROHDE & SCHWARZ	ESCI	100412	Sep. 13, 2013	Sep. 12, 2014
Spectrum Analyzer ROHDE & SCHWARZ	FSU43	101261	Dec. 21, 2013	Dec. 20, 2014
BILOG Antenna SCHWARZBECK	VULB9168	9168-472	Feb. 27, 2014	Feb. 26, 2015
HORN Antenna SCHWARZBECK	BBHA 9120 D	9120D- 209	Sep. 12, 2013	Sep. 11, 2014
HORN Antenna SCHWARZBECK	BBHA 9170	9170-480	Dec. 18, 2013	Dec. 17, 2014
Loop Antenna	3127-836	00099258	Aug. 09, 2013	Aug. 08, 2014
Preamplifier EMCI	EMC 012645	980115	Dec. 26, 2013	Dec. 25, 2014
Preamplifier EMCI	EMC 184045	980116	Jan. 13, 2014	Jan. 12, 2015
Preamplifier EMCI	EMC 330H	980112	Dec. 27, 2013	Dec. 26, 2014
RF signal cable HUBER+SUHNNER	SUCOFLEX 104	309219/4	Oct. 18, 2013	Oct. 17, 2014
RF signal cable HUBER+SUHNNER	SUCOFLEX 104	250130/4	Oct. 18, 2013	Oct. 17, 2014
RF signal cable Worken	RG-213	NA	Nov. 07, 2013	Nov. 06, 2014
Software BV ADT	E3 6.120103	NA	NA	NA
Antenna Tower MF	MFA-440H	NA	NA	NA
Turn Table MF	MFT-201SS	NA	NA	NA
Antenna Tower & Turn Table Controller MF	MF-7802	NA	NA	NA
Power Meter	ML2495A	1232002	Aug. 23, 2013	Aug. 22, 2014
Power Sensor	MA2411B	1207325	Aug. 23, 2013	Aug. 22, 2014

- NOTE:**
1. The calibration interval of the above test instruments is 12 months and the calibrations are traceable to NML/ROC and NIST/USA.
 2. The calibration interval of the loop antenna is 24 months and the calibrations are traceable to NML/ROC and NIST/USA.
 3. The test was performed in HwaYa Chamber 10.
 4. The horn antenna and HP preamplifier (model: 8449B) are used only for the measurement of emission frequency above 1GHz if tested.
 5. The FCC Site Registration No. is 690701.
 6. The IC Site Registration No. is IC 7450F-10.

4.1.4 TEST PROCEDURES

- a. The EUT was placed on the top of a rotating table 0.8 meters above the ground at a 3 meters semi-anechoic chamber. The table was rotated 360 degrees to determine the position of the highest radiation.
- b. The EUT was set 3 meters away from the interference-receiving antenna, which was mounted on the top of a variable-height antenna tower.
- c. The antenna is a broadband antenna, and its height is varied from one meter to four meters above the ground to determine the maximum value of the field strength. Both horizontal and vertical polarizations of the antenna are set to make the measurement.
- d. For each suspected emission, the EUT was arranged to its worst case and then the antenna was tuned to heights from 1 meter to 4 meters and the rotatable table was turned from 0 degrees to 360 degrees to find the maximum reading.
- e. The test-receiver system was set to Peak Detect Function and Specified Bandwidth with Maximum Hold Mode.
- f. If the emission level of the EUT in peak mode was 10dB lower than the limit specified, then testing could be stopped and the peak values of the EUT would be reported. Otherwise the emissions that did not have 10dB margin would be re-tested one by one using peak, quasi-peak or average method as specified and then reported in a data sheet.

NOTE:

1. The resolution bandwidth and video bandwidth of test receiver/spectrum analyzer is 120kHz for Peak detection (PK) and Quasi-peak detection (QP) at frequency below 1GHz.
2. The resolution bandwidth of test receiver/spectrum analyzer is 1MHz and video bandwidth is 3MHz for Peak detection at frequency above 1GHz.
3. The resolution bandwidth of test receiver/spectrum analyzer is 1MHz and the video bandwidth is 1kHz (Duty cycle < 98%) or 10Hz (Duty cycle > 98%) for Average detection (AV) at frequency above 1GHz.
4. All modes of operation were investigated and the worst-case emissions are reported.

4.1.5 DEVIATION FROM TEST STANDARD

No deviation.

4.1.6 TEST SETUP

Frequency Range 30MHz ~ 1GHz

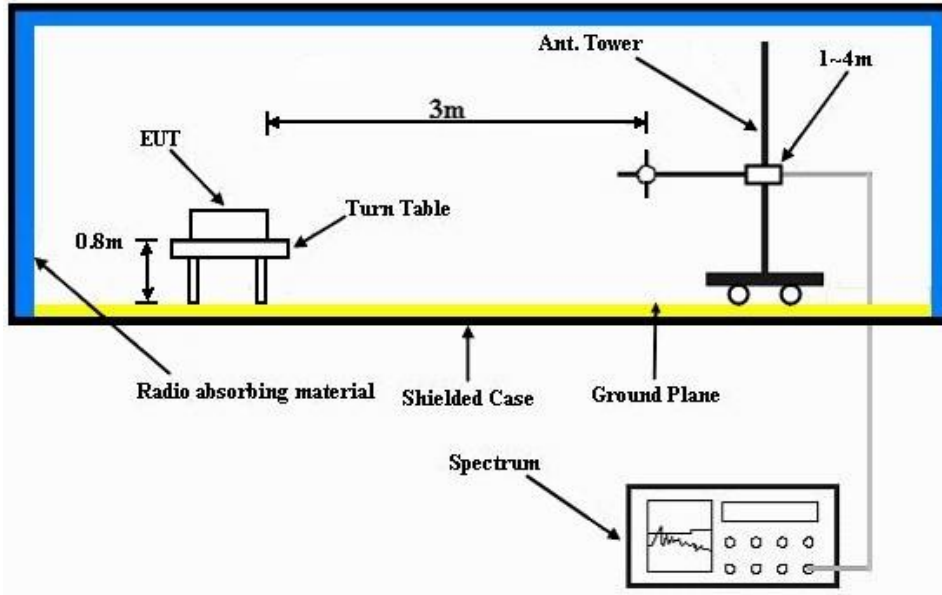

Frequency Range above 1GHz

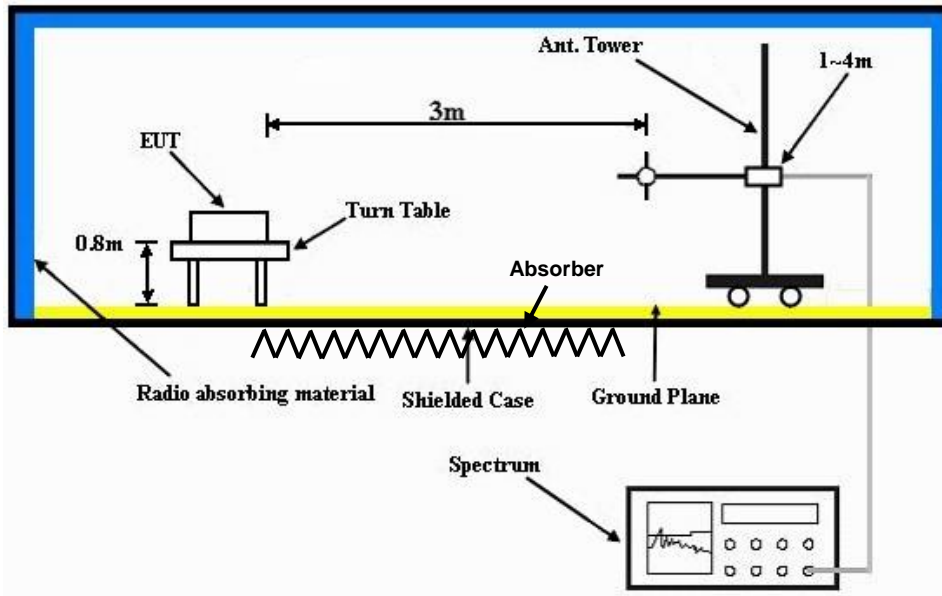

For the actual test configuration, please refer to the attached file (Test Setup Photo).

4.1.7 EUT OPERATING CONDITIONS

- a. Placed the EUT on a testing table.
- b. Use the software to control the EUT under transmission condition continuously at specific channel frequency.



A D T

4.1.8 TEST RESULTS

ABOVE 1GHz WORST-CASE DATA

802.11a

EUT TEST CONDITION		MEASUREMENT DETAIL	
CHANNEL	Channel 36	FREQUENCY RANGE	1GHz ~ 40GHz
INPUT POWER	120Vac, 60 Hz	DETECTOR FUNCTION	Peak (PK) Average (AV)
ENVIRONMENTAL CONDITIONS	25deg. C, 65%RH	TESTED BY	Peter Weng

ANTENNA POLARITY & TEST DISTANCE: HORIZONTAL AT 3 M										
FREQ. (MHz)	EMISSION LEVEL (dBuV/m)	READ LEVEL (dBuV)	LIMIT (dBuV/m)	MARGIN (dB)	ANTENNA FACTOR (dB/m)	CABLE LOSS (dB)	PREAMP FACTOR (dB)	ANTENNA HEIGHT (cm)	TABLE ANGLE (Degree)	REMARK
5150	49.08	49.79	54	-4.92	31.32	5.29	37.32	100	137	Average
5150	67.59	68.3	74	-6.41	31.32	5.29	37.32	100	137	Peak
5180	99.22	99.9			31.35	5.31	37.34	100	137	Average
5180	108.39	109.07			31.35	5.31	37.34	100	137	Peak
5350	37.82	38.13	54	-16.18	31.48	5.39	37.18	100	137	Average
5350	59.43	59.74	74	-14.57	31.48	5.39	37.18	100	137	Peak
ANTENNA POLARITY & TEST DISTANCE: VERTICAL AT 3 M										
FREQ. (MHz)	EMISSION LEVEL (dBuV/m)	READ LEVEL (dBuV)	LIMIT (dBuV/m)	MARGIN (dB)	ANTENNA FACTOR (dB/m)	CABLE LOSS (dB)	PREAMP FACTOR (dB)	ANTENNA HEIGHT (cm)	TABLE ANGLE (Degree)	REMARK
5150	51.53	52.24	54	-2.47	31.32	5.29	37.32	100	101	Average
5150	68.33	69.04	74	-5.67	31.32	5.29	37.32	100	101	Peak
5180	101.3	101.98			31.35	5.31	37.34	100	101	Average
5180	110.42	111.1			31.35	5.31	37.34	100	101	Peak
5350	38.91	39.22	54	-15.09	31.48	5.39	37.18	100	101	Average
5350	57.54	57.85	74	-16.46	31.48	5.39	37.18	100	101	Peak

REMARKS:

- Emission Level = Read Level + Antenna Factor + Cable Loss - Preamp Factor
Margin value = Emission level – Limit value
- 5180MHz: Fundamental frequency.



A D T

EUT TEST CONDITION		MEASUREMENT DETAIL	
CHANNEL	Channel 44	FREQUENCY RANGE	1GHz ~ 40GHz
INPUT POWER	120Vac, 60 Hz	DETECTOR FUNCTION	Peak (PK) Average (AV)
ENVIRONMENTAL CONDITIONS	25deg. C, 65%RH	TESTED BY	Peter Weng

ANTENNA POLARITY & TEST DISTANCE: HORIZONTAL AT 3 M										
FREQ. (MHz)	EMISSION LEVEL (dBuV/m)	READ LEVEL (dBuV)	LIMIT (dBuV/m)	MARGIN (dB)	ANTENNA FACTOR (dB/m)	CABLE LOSS (dB)	PREAMP FACTOR (dB)	ANTENNA HEIGHT (cm)	TABLE ANGLE (Degree)	REMARK
5150	37.83	38.54	54	-16.17	31.32	5.29	37.32	100	137	Average
5150	58.2	58.91	74	-15.8	31.32	5.29	37.32	100	137	Peak
5220	99.65	100.31			31.37	5.33	37.36	100	137	Average
5220	108.85	109.51			31.37	5.33	37.36	100	137	Peak
5388	38.01	38.27	54	-15.99	31.51	5.41	37.18	100	137	Average
5388	59.72	59.98	74	-14.28	31.51	5.41	37.18	100	137	Peak

ANTENNA POLARITY & TEST DISTANCE: VERTICAL AT 3 M										
FREQ. (MHz)	EMISSION LEVEL (dBuV/m)	READ LEVEL (dBuV)	LIMIT (dBuV/m)	MARGIN (dB)	ANTENNA FACTOR (dB/m)	CABLE LOSS (dB)	PREAMP FACTOR (dB)	ANTENNA HEIGHT (cm)	TABLE ANGLE (Degree)	REMARK
5130	37.97	38.68	54	-16.03	31.31	5.28	37.3	100	101	Average
5130	59.2	59.91	74	-14.8	31.31	5.28	37.3	100	101	Peak
5220	100.64	101.3			31.37	5.33	37.36	100	101	Average
5220	110.37	111.03			31.37	5.33	37.36	100	101	Peak
5376	37.74	38.03	54	-16.26	31.49	5.4	37.18	100	101	Average
5376	58.88	59.17	74	-15.12	31.49	5.4	37.18	100	101	Peak

REMARKS:

- Emission Level = Read Level + Antenna Factor + Cable Loss - Preamp Factor
Margin value = Emission level – Limit value
- 5220MHz: Fundamental frequency.



A D T

EUT TEST CONDITION		MEASUREMENT DETAIL	
CHANNEL	Channel 48	FREQUENCY RANGE	1GHz ~ 40GHz
INPUT POWER	120Vac, 60 Hz	DETECTOR FUNCTION	Peak (PK) Average (AV)
ENVIRONMENTAL CONDITIONS	25deg. C, 65%RH	TESTED BY	Peter Weng

ANTENNA POLARITY & TEST DISTANCE: HORIZONTAL AT 3 M										
FREQ. (MHz)	EMISSION LEVEL (dBuV/m)	READ LEVEL (dBuV)	LIMIT (dBuV/m)	MARGIN (dB)	ANTENNA FACTOR (dB/m)	CABLE LOSS (dB)	PREAMP FACTOR (dB)	ANTENNA HEIGHT (cm)	TABLE ANGLE (Degree)	REMARK
5146	37.85	38.56	54	-16.15	31.32	5.29	37.32	100	137	Average
5146	59.3	60.01	74	-14.7	31.32	5.29	37.32	100	137	Peak
5240	98.32	98.91			31.39	5.34	37.32	100	137	Average
5240	107.88	108.47			31.39	5.34	37.32	100	137	Peak
5350	37.79	38.1	54	-16.21	31.48	5.39	37.18	100	137	Average
5350	58.83	59.14	74	-15.17	31.48	5.39	37.18	100	137	Peak

ANTENNA POLARITY & TEST DISTANCE: VERTICAL AT 3 M										
FREQ. (MHz)	EMISSION LEVEL (dBuV/m)	READ LEVEL (dBuV)	LIMIT (dBuV/m)	MARGIN (dB)	ANTENNA FACTOR (dB/m)	CABLE LOSS (dB)	PREAMP FACTOR (dB)	ANTENNA HEIGHT (cm)	TABLE ANGLE (Degree)	REMARK
5136	37.85	38.56	54	-16.15	31.31	5.28	37.3	100	101	Average
5136	59.87	60.58	74	-14.13	31.31	5.28	37.3	100	101	Peak
5240	100.68	101.27			31.39	5.34	37.32	100	101	Average
5240	109.77	110.36			31.39	5.34	37.32	100	101	Peak
5426	37.83	38.01	54	-16.17	31.53	5.42	37.13	100	101	Average
5426	59.84	60.02	74	-14.16	31.53	5.42	37.13	100	101	Peak

REMARKS:

- Emission Level = Read Level + Antenna Factor + Cable Loss - Preamp Factor
Margin value = Emission level – Limit value
- 5240MHz: Fundamental frequency.



A D T

EUT TEST CONDITION		MEASUREMENT DETAIL	
CHANNEL	Channel 52	FREQUENCY RANGE	1GHz ~ 40GHz
INPUT POWER	120Vac, 60 Hz	DETECTOR FUNCTION	Peak (PK) Average (AV)
ENVIRONMENTAL CONDITIONS	25deg. C, 65%RH	TESTED BY	Peter Weng

ANTENNA POLARITY & TEST DISTANCE: HORIZONTAL AT 3 M										
FREQ. (MHz)	EMISSION LEVEL (dBuV/m)	READ LEVEL (dBuV)	LIMIT (dBuV/m)	MARGIN (dB)	ANTENNA FACTOR (dB/m)	CABLE LOSS (dB)	PREAMP FACTOR (dB)	ANTENNA HEIGHT (cm)	TABLE ANGLE (Degree)	REMARK
5026	37.43	38.2	54	-16.57	31.23	5.24	37.24	113	116	Average
5026	59.66	60.43	74	-14.34	31.23	5.24	37.24	113	116	Peak
5260	97.79	98.31			31.41	5.34	37.27	113	116	Average
5260	107.82	108.34			31.41	5.34	37.27	113	116	Peak
5426	37.9	38.08	54	-16.1	31.53	5.42	37.13	113	116	Average
5426	60.07	60.25	74	-13.93	31.53	5.42	37.13	113	116	Peak
ANTENNA POLARITY & TEST DISTANCE: VERTICAL AT 3 M										
FREQ. (MHz)	EMISSION LEVEL (dBuV/m)	READ LEVEL (dBuV)	LIMIT (dBuV/m)	MARGIN (dB)	ANTENNA FACTOR (dB/m)	CABLE LOSS (dB)	PREAMP FACTOR (dB)	ANTENNA HEIGHT (cm)	TABLE ANGLE (Degree)	REMARK
5144	37.85	38.56	54	-16.15	31.32	5.29	37.32	108	106	Average
5144	59.53	60.24	74	-14.47	31.32	5.29	37.32	108	106	Peak
5260	99.27	99.79			31.41	5.34	37.27	108	106	Average
5260	109.76	110.28			31.41	5.34	37.27	108	106	Peak
5360	37.94	38.25	54	-16.06	31.48	5.39	37.18	108	106	Average
5360	59.71	60.02	74	-14.29	31.48	5.39	37.18	108	106	Peak

REMARKS:

- Emission Level = Read Level + Antenna Factor + Cable Loss - Preamp Factor
Margin value = Emission level – Limit value
- 5260MHz: Fundamental frequency.



A D T

EUT TEST CONDITION		MEASUREMENT DETAIL	
CHANNEL	Channel 60	FREQUENCY RANGE	1GHz ~ 40GHz
INPUT POWER	120Vac, 60 Hz	DETECTOR FUNCTION	Peak (PK) Average (AV)
ENVIRONMENTAL CONDITIONS	25deg. C, 65%RH	TESTED BY	Peter Weng

ANTENNA POLARITY & TEST DISTANCE: HORIZONTAL AT 3 M										
FREQ. (MHz)	EMISSION LEVEL (dBuV/m)	READ LEVEL (dBuV)	LIMIT (dBuV/m)	MARGIN (dB)	ANTENNA FACTOR (dB/m)	CABLE LOSS (dB)	PREAMP FACTOR (dB)	ANTENNA HEIGHT (cm)	TABLE ANGLE (Degree)	REMARK
5130	37.77	38.48	54	-16.23	31.31	5.28	37.3	113	116	Average
5130	59.57	60.28	74	-14.43	31.31	5.28	37.3	113	116	Peak
5300	98.09	98.47			31.44	5.37	37.19	113	116	Average
5300	107.37	107.75			31.44	5.37	37.19	113	116	Peak
5350	44.1	44.41	54	-9.9	31.48	5.39	37.18	113	116	Average
5350	58.68	58.99	74	-15.32	31.48	5.39	37.18	113	116	Peak
10600	42.79	47.35	54	-11.21	39.57	8.28	52.41	112	108	Average
10600	55	59.56	74	-19	39.57	8.28	52.41	112	108	Peak
ANTENNA POLARITY & TEST DISTANCE: VERTICAL AT 3 M										
FREQ. (MHz)	EMISSION LEVEL (dBuV/m)	READ LEVEL (dBuV)	LIMIT (dBuV/m)	MARGIN (dB)	ANTENNA FACTOR (dB/m)	CABLE LOSS (dB)	PREAMP FACTOR (dB)	ANTENNA HEIGHT (cm)	TABLE ANGLE (Degree)	REMARK
5150	37.97	38.68	54	-16.03	31.32	5.29	37.32	108	106	Average
5150	58.09	58.8	74	-15.91	31.32	5.29	37.32	108	106	Peak
5300	98.64	99.02			31.44	5.37	37.19	108	106	Average
5300	108	108.38			31.44	5.37	37.19	108	106	Peak
5350	44.69	45	54	-9.31	31.48	5.39	37.18	108	106	Average
5350	59.86	60.17	74	-14.14	31.48	5.39	37.18	108	106	Peak
10600	42.6	47.16	54	-11.4	39.57	8.28	52.41	100	172	Average
10600	54.29	58.85	74	-19.71	39.57	8.28	52.41	100	172	Peak

REMARKS:

- Emission Level = Read Level + Antenna Factor + Cable Loss - Preamp Factor
Margin value = Emission level – Limit value
- 5300MHz: Fundamental frequency.



A D T

EUT TEST CONDITION		MEASUREMENT DETAIL	
CHANNEL	Channel 64	FREQUENCY RANGE	1GHz ~ 40GHz
INPUT POWER	120Vac, 60 Hz	DETECTOR FUNCTION	Peak (PK) Average (AV)
ENVIRONMENTAL CONDITIONS	25deg. C, 65%RH	TESTED BY	Peter Weng

ANTENNA POLARITY & TEST DISTANCE: HORIZONTAL AT 3 M										
FREQ. (MHz)	EMISSION LEVEL (dBuV/m)	READ LEVEL (dBuV)	LIMIT (dBuV/m)	MARGIN (dB)	ANTENNA FACTOR (dB/m)	CABLE LOSS (dB)	PREAMP FACTOR (dB)	ANTENNA HEIGHT (cm)	TABLE ANGLE (Degree)	REMARK
5050	37.56	38.32	54	-16.44	31.24	5.25	37.25	113	116	Average
5050	59.03	59.79	74	-14.97	31.24	5.25	37.25	113	116	Peak
5320	99.24	99.6			31.45	5.38	37.19	113	116	Average
5320	107.69	108.05			31.45	5.38	37.19	113	116	Peak
5352	48.55	48.86	54	-5.45	31.48	5.39	37.18	113	116	Average
5352	69.03	69.34	74	-4.97	31.48	5.39	37.18	113	116	Peak
10640	42.73	47.06	54	-11.27	39.62	8.32	52.27	122	105	Average
10640	54.07	58.4	74	-19.93	39.62	8.32	52.27	122	105	Peak
ANTENNA POLARITY & TEST DISTANCE: VERTICAL AT 3 M										
FREQ. (MHz)	EMISSION LEVEL (dBuV/m)	READ LEVEL (dBuV)	LIMIT (dBuV/m)	MARGIN (dB)	ANTENNA FACTOR (dB/m)	CABLE LOSS (dB)	PREAMP FACTOR (dB)	ANTENNA HEIGHT (cm)	TABLE ANGLE (Degree)	REMARK
5150	39.04	39.75	54	-14.96	31.32	5.29	37.32	108	106	Average
5150	58.78	59.49	74	-15.22	31.32	5.29	37.32	108	106	Peak
5320	100.54	100.9			31.45	5.38	37.19	108	106	Average
5320	109.76	110.12			31.45	5.38	37.19	108	106	Peak
5350	52.13	52.44	54	-1.87	31.48	5.39	37.18	108	106	Average
5350	71.27	71.58	74	-2.73	31.48	5.39	37.18	108	106	Peak
10640	42.56	46.89	54	-11.44	39.62	8.32	52.27	100	170	Average
10640	55.52	59.85	74	-18.48	39.62	8.32	52.27	100	170	Peak

REMARKS:

- Emission Level = Read Level + Antenna Factor + Cable Loss - Preamp Factor
Margin value = Emission level – Limit value
- 5320MHz: Fundamental frequency.



A D T

EUT TEST CONDITION		MEASUREMENT DETAIL	
CHANNEL	Channel 100	FREQUENCY RANGE	1GHz ~ 40GHz
INPUT POWER	120Vac, 60 Hz	DETECTOR FUNCTION	Peak (PK) Average (AV)
ENVIRONMENTAL CONDITIONS	25deg. C, 65%RH	TESTED BY	Peter Weng

ANTENNA POLARITY & TEST DISTANCE: HORIZONTAL AT 3 M										
FREQ. (MHz)	EMISSION LEVEL (dBuV/m)	READ LEVEL (dBuV)	LIMIT (dBuV/m)	MARGIN (dB)	ANTENNA FACTOR (dB/m)	CABLE LOSS (dB)	PREAMP FACTOR (dB)	ANTENNA HEIGHT (cm)	TABLE ANGLE (Degree)	REMARK
5430	39.49	39.65	54	-14.51	31.55	5.42	37.13	100	166	Average
5430	60.37	60.53	74	-13.63	31.55	5.42	37.13	100	166	Peak
5470	58.24	58.3	68.3	-10.06	31.57	5.45	37.08	100	166	Peak
5500	90.22	90.19			31.6	5.46	37.03	100	166	Average
5500	99.64	99.61			31.6	5.46	37.03	100	166	Peak
5725	59.41	59.29	68.3	-8.89	31.96	5.59	37.43	100	166	Peak
11000	42.69	47.38	54	-11.31	40.2	8.56	53.45	100	152	Average
11000	52.3	56.99	74	-21.7	40.2	8.56	53.45	100	152	Peak
ANTENNA POLARITY & TEST DISTANCE: VERTICAL AT 3 M										
FREQ. (MHz)	EMISSION LEVEL (dBuV/m)	READ LEVEL (dBuV)	LIMIT (dBuV/m)	MARGIN (dB)	ANTENNA FACTOR (dB/m)	CABLE LOSS (dB)	PREAMP FACTOR (dB)	ANTENNA HEIGHT (cm)	TABLE ANGLE (Degree)	REMARK
5448	43.2	43.33	54	-10.8	31.56	5.44	37.13	100	62	Average
5448	59.4	59.53	74	-14.6	31.56	5.44	37.13	100	62	Peak
5470	61.37	61.43	68.3	-6.93	31.57	5.45	37.08	100	62	Peak
5500	96.55	96.52			31.6	5.46	37.03	100	62	Average
5500	106.29	106.26			31.6	5.46	37.03	100	62	Peak
5725	58.2	58.08	68.3	-10.1	31.96	5.59	37.43	100	62	Peak
11000	42.5	47.19	54	-11.5	40.2	8.56	53.45	100	154	Average
11000	53.05	57.74	74	-20.95	40.2	8.56	53.45	100	154	Peak

REMARKS:

- Emission Level = Read Level + Antenna Factor + Cable Loss - Preamp Factor
Margin value = Emission level – Limit value
- 5500MHz: Fundamental frequency.
- 5470MHz & 5725MHz: Out of restricted band



A D T

EUT TEST CONDITION		MEASUREMENT DETAIL	
CHANNEL	Channel 116	FREQUENCY RANGE	1GHz ~ 40GHz
INPUT POWER	120Vac, 60 Hz	DETECTOR FUNCTION	Peak (PK) Average (AV)
ENVIRONMENTAL CONDITIONS	25deg. C, 65%RH	TESTED BY	Peter Weng

ANTENNA POLARITY & TEST DISTANCE: HORIZONTAL AT 3 M										
FREQ. (MHz)	EMISSION LEVEL (dBuV/m)	READ LEVEL (dBuV)	LIMIT (dBuV/m)	MARGIN (dB)	ANTENNA FACTOR (dB/m)	CABLE LOSS (dB)	PREAMP FACTOR (dB)	ANTENNA HEIGHT (cm)	TABLE ANGLE (Degree)	REMARK
5366	37.58	37.87	54	-16.42	31.49	5.4	37.18	100	177	Average
5366	59.12	59.41	74	-14.88	31.49	5.4	37.18	100	177	Peak
5470	59.06	59.12	68.3	-9.24	31.57	5.45	37.08	100	177	Peak
5580	92.36	92.31			31.71	5.5	37.16	100	177	Average
5580	102.62	102.57			31.71	5.5	37.16	100	177	Peak
5725	58.24	58.12	68.3	-10.06	31.96	5.59	37.43	100	177	Peak
11160	43.54	48.12	54	-10.46	40.1	8.71	53.39	100	184	Average
11160	53.55	58.13	74	-20.45	40.1	8.71	53.39	100	184	Peak
ANTENNA POLARITY & TEST DISTANCE: VERTICAL AT 3 M										
FREQ. (MHz)	EMISSION LEVEL (dBuV/m)	READ LEVEL (dBuV)	LIMIT (dBuV/m)	MARGIN (dB)	ANTENNA FACTOR (dB/m)	CABLE LOSS (dB)	PREAMP FACTOR (dB)	ANTENNA HEIGHT (cm)	TABLE ANGLE (Degree)	REMARK
5430	37.88	38.04	54	-16.12	31.55	5.42	37.13	100	65	Average
5430	59.67	59.83	74	-14.33	31.55	5.42	37.13	100	65	Peak
5470	57.64	57.7	68.3	-10.66	31.57	5.45	37.08	100	65	Peak
5580	99.57	99.52			31.71	5.5	37.16	100	65	Average
5580	108.07	108.02			31.71	5.5	37.16	100	65	Peak
5725	58.97	58.85	68.3	-9.33	31.96	5.59	37.43	100	65	Peak
11160	43.05	47.63	54	-10.95	40.1	8.71	53.39	100	84	Average
11160	54.05	58.63	74	-19.95	40.1	8.71	53.39	100	84	Peak

REMARKS:

- Emission Level = Read Level + Antenna Factor + Cable Loss - Preamp Factor
Margin value = Emission level – Limit value
- 5580MHz: Fundamental frequency.
- 5470MHz & 5725MHz: Out of restricted band



A D T

EUT TEST CONDITION		MEASUREMENT DETAIL	
CHANNEL	Channel 140	FREQUENCY RANGE	1GHz ~ 40GHz
INPUT POWER	120Vac, 60 Hz	DETECTOR FUNCTION	Peak (PK) Average (AV)
ENVIRONMENTAL CONDITIONS	25deg. C, 65%RH	TESTED BY	Peter Weng

ANTENNA POLARITY & TEST DISTANCE: HORIZONTAL AT 3 M										
FREQ. (MHz)	EMISSION LEVEL (dBuV/m)	READ LEVEL (dBuV)	LIMIT (dBuV/m)	MARGIN (dB)	ANTENNA FACTOR (dB/m)	CABLE LOSS (dB)	PREAMP FACTOR (dB)	ANTENNA HEIGHT (cm)	TABLE ANGLE (Degree)	REMARK
5350	37.58	37.89	54	-16.42	31.48	5.39	37.18	102	115	Average
5350	57.32	57.63	74	-16.68	31.48	5.39	37.18	102	115	Peak
5470	57.73	57.79	68.3	-10.57	31.57	5.45	37.08	102	115	Peak
5700	90.94	90.87			31.9	5.57	37.4	102	115	Average
5700	100	99.93			31.9	5.57	37.4	102	115	Peak
5725	59.35	59.23	68.3	-8.95	31.96	5.59	37.43	102	115	Peak
11400	44.94	48.16	54	-9.06	39.96	8.95	52.13	105	147	Average
11400	58.16	61.38	74	-15.84	39.96	8.95	52.13	105	147	Peak
ANTENNA POLARITY & TEST DISTANCE: VERTICAL AT 3 M										
FREQ. (MHz)	EMISSION LEVEL (dBuV/m)	READ LEVEL (dBuV)	LIMIT (dBuV/m)	MARGIN (dB)	ANTENNA FACTOR (dB/m)	CABLE LOSS (dB)	PREAMP FACTOR (dB)	ANTENNA HEIGHT (cm)	TABLE ANGLE (Degree)	REMARK
5460	37.83	37.91	54	-16.17	31.56	5.44	37.08	100	50	Average
5460	57.83	57.91	74	-16.17	31.56	5.44	37.08	100	50	Peak
5470	58.98	59.04	68.3	-9.32	31.57	5.45	37.08	100	50	Peak
5700	95.94	95.87			31.9	5.57	37.4	100	50	Average
5700	105.28	105.21			31.9	5.57	37.4	100	50	Peak
5725	65.56	65.44	68.3	-2.74	31.96	5.59	37.43	100	50	Peak
11400	44.38	47.6	54	-9.62	39.96	8.95	52.13	100	192	Average
11400	57.54	60.76	74	-16.46	39.96	8.95	52.13	100	192	Peak

REMARKS:

- Emission Level = Read Level + Antenna Factor + Cable Loss - Preamp Factor
Margin value = Emission level – Limit value
- 5700MHz: Fundamental frequency.
- 5470MHz & 5725MHz: Out of restricted band



A D T

802.11n (20MHz)

EUT TEST CONDITION		MEASUREMENT DETAIL	
CHANNEL	Channel 36	FREQUENCY RANGE	1GHz ~ 40GHz
INPUT POWER	120Vac, 60 Hz	DETECTOR FUNCTION	Peak (PK) Average (AV)
ENVIRONMENTAL CONDITIONS	25deg. C, 65%RH	TESTED BY	Peter Weng

ANTENNA POLARITY & TEST DISTANCE: HORIZONTAL AT 3 M										
FREQ. (MHz)	EMISSION LEVEL (dBuV/m)	READ LEVEL (dBuV)	LIMIT (dBuV/m)	MARGIN (dB)	ANTENNA FACTOR (dB/m)	CABLE LOSS (dB)	PREAMP FACTOR (dB)	ANTENNA HEIGHT (cm)	TABLE ANGLE (Degree)	REMARK
5150	49.19	49.9	54	-4.81	31.32	5.29	37.32	100	137	Average
5150	66.95	67.66	74	-7.05	31.32	5.29	37.32	100	137	Peak
5180	99.22	99.9			31.35	5.31	37.34	100	137	Average
5180	108.69	109.37			31.35	5.31	37.34	100	137	Peak
5350	37.69	38	54	-16.31	31.48	5.39	37.18	100	137	Average
5350	58.99	59.3	74	-15.01	31.48	5.39	37.18	100	137	Peak
ANTENNA POLARITY & TEST DISTANCE: VERTICAL AT 3 M										
FREQ. (MHz)	EMISSION LEVEL (dBuV/m)	READ LEVEL (dBuV)	LIMIT (dBuV/m)	MARGIN (dB)	ANTENNA FACTOR (dB/m)	CABLE LOSS (dB)	PREAMP FACTOR (dB)	ANTENNA HEIGHT (cm)	TABLE ANGLE (Degree)	REMARK
5150	52.54	53.25	54	-1.46	31.32	5.29	37.32	100	100	Average
5150	69.54	70.25	74	-4.46	31.32	5.29	37.32	100	100	Peak
5180	101.08	101.76			31.35	5.31	37.34	100	100	Average
5180	110.14	110.82			31.35	5.31	37.34	100	100	Peak
5350	38.56	38.87	54	-15.44	31.48	5.39	37.18	100	100	Average
5350	57.37	57.68	74	-16.63	31.48	5.39	37.18	100	100	Peak

REMARKS:

- Emission Level = Read Level + Antenna Factor + Cable Loss - Preamp Factor
Margin value = Emission level – Limit value
- 5180MHz: Fundamental frequency.



A D T

EUT TEST CONDITION		MEASUREMENT DETAIL	
CHANNEL	Channel 44	FREQUENCY RANGE	1GHz ~ 40GHz
INPUT POWER	120Vac, 60 Hz	DETECTOR FUNCTION	Peak (PK) Average (AV)
ENVIRONMENTAL CONDITIONS	25deg. C, 65%RH	TESTED BY	Peter Weng

ANTENNA POLARITY & TEST DISTANCE: HORIZONTAL AT 3 M										
FREQ. (MHz)	EMISSION LEVEL (dBuV/m)	READ LEVEL (dBuV)	LIMIT (dBuV/m)	MARGIN (dB)	ANTENNA FACTOR (dB/m)	CABLE LOSS (dB)	PREAMP FACTOR (dB)	ANTENNA HEIGHT (cm)	TABLE ANGLE (Degree)	REMARK
5150	37.84	38.55	54	-16.16	31.32	5.29	37.32	100	134	Average
5150	58.68	59.39	74	-15.32	31.32	5.29	37.32	100	134	Peak
5220	98.39	99.05			31.37	5.33	37.36	100	134	Average
5220	107.84	108.5			31.37	5.33	37.36	100	134	Peak
5350	37.79	38.1	54	-16.21	31.48	5.39	37.18	100	134	Average
5350	58.7	59.01	74	-15.3	31.48	5.39	37.18	100	134	Peak
ANTENNA POLARITY & TEST DISTANCE: VERTICAL AT 3 M										
FREQ. (MHz)	EMISSION LEVEL (dBuV/m)	READ LEVEL (dBuV)	LIMIT (dBuV/m)	MARGIN (dB)	ANTENNA FACTOR (dB/m)	CABLE LOSS (dB)	PREAMP FACTOR (dB)	ANTENNA HEIGHT (cm)	TABLE ANGLE (Degree)	REMARK
5126	38.56	39.27	54	-15.44	31.31	5.28	37.3	100	101	Average
5126	59.27	59.98	74	-14.73	31.31	5.28	37.3	100	101	Peak
5220	99.91	100.57			31.37	5.33	37.36	100	101	Average
5220	109.36	110.02			31.37	5.33	37.36	100	101	Peak
5398	37.8	38.05	54	-16.2	31.52	5.41	37.18	100	101	Average
5398	59.69	59.94	74	-14.31	31.52	5.41	37.18	100	101	Peak

REMARKS:

- Emission Level = Read Level + Antenna Factor + Cable Loss - Preamp Factor
Margin value = Emission level – Limit value
- 5220MHz: Fundamental frequency.



A D T

EUT TEST CONDITION		MEASUREMENT DETAIL	
CHANNEL	Channel 48	FREQUENCY RANGE	1GHz ~ 40GHz
INPUT POWER	120Vac, 60 Hz	DETECTOR FUNCTION	Peak (PK) Average (AV)
ENVIRONMENTAL CONDITIONS	25deg. C, 65%RH	TESTED BY	Peter Weng

ANTENNA POLARITY & TEST DISTANCE: HORIZONTAL AT 3 M										
FREQ. (MHz)	EMISSION LEVEL (dBuV/m)	READ LEVEL (dBuV)	LIMIT (dBuV/m)	MARGIN (dB)	ANTENNA FACTOR (dB/m)	CABLE LOSS (dB)	PREAMP FACTOR (dB)	ANTENNA HEIGHT (cm)	TABLE ANGLE (Degree)	REMARK
5150	37.95	38.66	54	-16.05	31.32	5.29	37.32	100	134	Average
5150	59.25	59.96	74	-14.75	31.32	5.29	37.32	100	134	Peak
5240	98.56	99.15			31.39	5.34	37.32	100	134	Average
5240	107.65	108.24			31.39	5.34	37.32	100	134	Peak
5350	37.74	38.05	54	-16.26	31.48	5.39	37.18	100	134	Average
5350	57.9	58.21	74	-16.1	31.48	5.39	37.18	100	134	Peak

ANTENNA POLARITY & TEST DISTANCE: VERTICAL AT 3 M										
FREQ. (MHz)	EMISSION LEVEL (dBuV/m)	READ LEVEL (dBuV)	LIMIT (dBuV/m)	MARGIN (dB)	ANTENNA FACTOR (dB/m)	CABLE LOSS (dB)	PREAMP FACTOR (dB)	ANTENNA HEIGHT (cm)	TABLE ANGLE (Degree)	REMARK
5036	37.77	38.54	54	-16.23	31.23	5.24	37.24	100	100	Average
5036	60.6	61.37	74	-13.4	31.23	5.24	37.24	100	101	Peak
5240	100.54	101.13			31.39	5.34	37.32	100	100	Average
5240	109.41	110			31.39	5.34	37.32	100	100	Peak
5372	37.74	38.03	54	-16.26	31.49	5.4	37.18	100	100	Average
5372	59.59	59.88	74	-14.41	31.49	5.4	37.18	100	100	Peak

REMARKS:

- Emission Level = Read Level + Antenna Factor + Cable Loss - Preamp Factor
Margin value = Emission level – Limit value
- 5240MHz: Fundamental frequency.



A D T

EUT TEST CONDITION		MEASUREMENT DETAIL	
CHANNEL	Channel 52	FREQUENCY RANGE	1GHz ~ 40GHz
INPUT POWER	120Vac, 60 Hz	DETECTOR FUNCTION	Peak (PK) Average (AV)
ENVIRONMENTAL CONDITIONS	25deg. C, 65%RH	TESTED BY	Peter Weng

ANTENNA POLARITY & TEST DISTANCE: HORIZONTAL AT 3 M										
FREQ. (MHz)	EMISSION LEVEL (dBuV/m)	READ LEVEL (dBuV)	LIMIT (dBuV/m)	MARGIN (dB)	ANTENNA FACTOR (dB/m)	CABLE LOSS (dB)	PREAMP FACTOR (dB)	ANTENNA HEIGHT (cm)	TABLE ANGLE (Degree)	REMARK
5102	37.61	38.34	54	-16.39	31.28	5.27	37.28	113	116	Average
5102	59.36	60.09	74	-14.64	31.28	5.27	37.28	113	116	Peak
5260	98.43	98.95			31.41	5.34	37.27	113	116	Average
5260	107.69	108.21			31.41	5.34	37.27	113	116	Peak
5366	37.78	38.07	54	-16.22	31.49	5.4	37.18	113	116	Average
5366	59.23	59.52	74	-14.77	31.49	5.4	37.18	113	116	Peak
ANTENNA POLARITY & TEST DISTANCE: VERTICAL AT 3 M										
FREQ. (MHz)	EMISSION LEVEL (dBuV/m)	READ LEVEL (dBuV)	LIMIT (dBuV/m)	MARGIN (dB)	ANTENNA FACTOR (dB/m)	CABLE LOSS (dB)	PREAMP FACTOR (dB)	ANTENNA HEIGHT (cm)	TABLE ANGLE (Degree)	REMARK
5138	37.79	38.49	54	-16.21	31.31	5.29	37.3	109	102	Average
5138	59.16	59.86	74	-14.84	31.31	5.29	37.3	109	102	Peak
5260	99.59	100.11			31.41	5.34	37.27	109	102	Average
5260	109.07	109.59			31.41	5.34	37.27	109	102	Peak
5360	37.9	38.21	54	-16.1	31.48	5.39	37.18	109	102	Average
5360	59.77	60.08	74	-14.23	31.48	5.39	37.18	109	102	Peak

REMARKS:

- Emission Level = Read Level + Antenna Factor + Cable Loss - Preamp Factor
Margin value = Emission level – Limit value
- 5260MHz: Fundamental frequency.



A D T

EUT TEST CONDITION		MEASUREMENT DETAIL	
CHANNEL	Channel 60	FREQUENCY RANGE	1GHz ~ 40GHz
INPUT POWER	120Vac, 60 Hz	DETECTOR FUNCTION	Peak (PK) Average (AV)
ENVIRONMENTAL CONDITIONS	25deg. C, 65%RH	TESTED BY	Peter Weng

ANTENNA POLARITY & TEST DISTANCE: HORIZONTAL AT 3 M										
FREQ. (MHz)	EMISSION LEVEL (dBuV/m)	READ LEVEL (dBuV)	LIMIT (dBuV/m)	MARGIN (dB)	ANTENNA FACTOR (dB/m)	CABLE LOSS (dB)	PREAMP FACTOR (dB)	ANTENNA HEIGHT (cm)	TABLE ANGLE (Degree)	REMARK
5110	37.64	38.36	54	-16.36	31.29	5.27	37.28	113	116	Average
5110	59.03	59.75	74	-14.97	31.29	5.27	37.28	113	116	Peak
5300	98.41	98.79			31.44	5.37	37.19	113	116	Average
5300	107.76	108.14			31.44	5.37	37.19	113	116	Peak
5352	44.86	45.17	54	-9.14	31.48	5.39	37.18	113	116	Average
5352	60.26	60.57	74	-13.74	31.48	5.39	37.18	113	116	Peak
10600	42.3	46.86	54	-11.7	39.57	8.28	52.41	117	170	Average
10600	53.23	57.79	74	-20.77	39.57	8.28	52.41	117	170	Peak
ANTENNA POLARITY & TEST DISTANCE: VERTICAL AT 3 M										
FREQ. (MHz)	EMISSION LEVEL (dBuV/m)	READ LEVEL (dBuV)	LIMIT (dBuV/m)	MARGIN (dB)	ANTENNA FACTOR (dB/m)	CABLE LOSS (dB)	PREAMP FACTOR (dB)	ANTENNA HEIGHT (cm)	TABLE ANGLE (Degree)	REMARK
5122	37.85	38.58	54	-16.15	31.29	5.28	37.3	109	102	Average
5122	60.16	60.89	74	-13.84	31.29	5.28	37.3	109	102	Peak
5300	99.14	99.52			31.44	5.37	37.19	109	102	Average
5300	109.58	109.96			31.44	5.37	37.19	109	102	Peak
5382	44.63	44.9	54	-9.37	31.51	5.4	37.18	109	102	Average
5382	60.05	60.32	74	-13.95	31.51	5.4	37.18	109	102	Peak
10600	42.7	47.26	54	-11.3	39.57	8.28	52.41	100	86	Average
10600	54.08	58.64	74	-19.92	39.57	8.28	52.41	100	86	Peak

REMARKS:

- Emission Level = Read Level + Antenna Factor + Cable Loss - Preamp Factor
Margin value = Emission level – Limit value
- 5300MHz: Fundamental frequency.



A D T

EUT TEST CONDITION		MEASUREMENT DETAIL	
CHANNEL	Channel 64	FREQUENCY RANGE	1GHz ~ 40GHz
INPUT POWER	120Vac, 60 Hz	DETECTOR FUNCTION	Peak (PK) Average (AV)
ENVIRONMENTAL CONDITIONS	25deg. C, 65%RH	TESTED BY	Peter Weng

ANTENNA POLARITY & TEST DISTANCE: HORIZONTAL AT 3 M										
FREQ. (MHz)	EMISSION LEVEL (dBuV/m)	READ LEVEL (dBuV)	LIMIT (dBuV/m)	MARGIN (dB)	ANTENNA FACTOR (dB/m)	CABLE LOSS (dB)	PREAMP FACTOR (dB)	ANTENNA HEIGHT (cm)	TABLE ANGLE (Degree)	REMARK
5066	37.55	38.29	54	-16.45	31.25	5.26	37.25	113	116	Average
5066	59.39	60.13	74	-14.61	31.25	5.26	37.25	113	116	Peak
5320	99.17	99.53			31.45	5.38	37.19	113	116	Average
5320	108	108.36			31.45	5.38	37.19	113	116	Peak
5350	50.26	50.57	54	-3.74	31.48	5.39	37.18	113	116	Average
5350	68.47	68.78	74	-5.53	31.48	5.39	37.18	113	116	Peak
10640	42.05	46.38	54	-11.95	39.62	8.32	52.27	129	184	Average
10640	54.53	58.86	74	-19.47	39.62	8.32	52.27	129	184	Peak
ANTENNA POLARITY & TEST DISTANCE: VERTICAL AT 3 M										
FREQ. (MHz)	EMISSION LEVEL (dBuV/m)	READ LEVEL (dBuV)	LIMIT (dBuV/m)	MARGIN (dB)	ANTENNA FACTOR (dB/m)	CABLE LOSS (dB)	PREAMP FACTOR (dB)	ANTENNA HEIGHT (cm)	TABLE ANGLE (Degree)	REMARK
5150	38.95	39.66	54	-15.05	31.32	5.29	37.32	109	102	Average
5150	59.29	60	74	-14.71	31.32	5.29	37.32	109	102	Peak
5320	100.57	100.93			31.45	5.38	37.19	109	102	Average
5320	110.17	110.53			31.45	5.38	37.19	109	102	Peak
5350	52.25	52.56	54	-1.75	31.48	5.39	37.18	109	102	Average
5350	68.96	69.27	74	-5.04	31.48	5.39	37.18	109	102	Peak
10640	42.89	47.22	54	-11.11	39.62	8.32	52.27	100	252	Average
10642	55.23	59.56	74	-18.77	39.62	8.32	52.27	100	252	Peak

REMARKS:

- Emission Level = Read Level + Antenna Factor + Cable Loss - Preamp Factor
Margin value = Emission level – Limit value
- 5320MHz: Fundamental frequency.



A D T

EUT TEST CONDITION		MEASUREMENT DETAIL	
CHANNEL	Channel 100	FREQUENCY RANGE	1GHz ~ 40GHz
INPUT POWER	120Vac, 60 Hz	DETECTOR FUNCTION	Peak (PK) Average (AV)
ENVIRONMENTAL CONDITIONS	25deg. C, 65%RH	TESTED BY	Peter Weng

ANTENNA POLARITY & TEST DISTANCE: HORIZONTAL AT 3 M										
FREQ. (MHz)	EMISSION LEVEL (dBuV/m)	READ LEVEL (dBuV)	LIMIT (dBuV/m)	MARGIN (dB)	ANTENNA FACTOR (dB/m)	CABLE LOSS (dB)	PREAMP FACTOR (dB)	ANTENNA HEIGHT (cm)	TABLE ANGLE (Degree)	REMARK
5460	40.78	40.25	54	-13.22	31.56	6.05	37.08	100	166	Average
5460	57.92	57.39	74	-16.08	31.56	6.05	37.08	100	166	Peak
5470	60.73	60.18	68.3	-7.57	31.57	6.06	37.08	100	166	Peak
5500	90.46	89.82			31.6	6.07	37.03	100	166	Average
5500	99.94	99.3			31.6	6.07	37.03	100	166	Peak
5725	60.34	59.59	68.3	-7.96	31.96	6.22	37.43	100	166	Peak
11000	43.22	47.91	54	-10.78	40.2	8.56	53.45	100	103	Average
11000	52.84	57.53	74	-21.16	40.2	8.56	53.45	100	103	Peak
ANTENNA POLARITY & TEST DISTANCE: VERTICAL AT 3 M										
FREQ. (MHz)	EMISSION LEVEL (dBuV/m)	READ LEVEL (dBuV)	LIMIT (dBuV/m)	MARGIN (dB)	ANTENNA FACTOR (dB/m)	CABLE LOSS (dB)	PREAMP FACTOR (dB)	ANTENNA HEIGHT (cm)	TABLE ANGLE (Degree)	REMARK
5460	45.72	45.19	54	-8.28	31.56	6.05	37.08	102	63	Average
5460	61.12	60.59	74	-12.88	31.56	6.05	37.08	102	63	Peak
5470	63.65	63.1	68.3	-4.65	31.57	6.06	37.08	102	63	Peak
5500	96.91	96.27			31.6	6.07	37.03	102	63	Average
5500	106.15	105.51			31.6	6.07	37.03	102	63	Peak
5725	58.32	57.57	68.3	-9.98	31.96	6.22	37.43	102	63	Peak
11000	42.62	47.31	54	-11.38	40.2	8.56	53.45	130	137	Average
11000	52.39	57.08	74	-21.61	40.2	8.56	53.45	130	137	Peak

REMARKS:

- Emission Level = Read Level + Antenna Factor + Cable Loss - Preamp Factor
Margin value = Emission level – Limit value
- 5500MHz: Fundamental frequency.
- 5470MHz & 5725MHz: Out of restricted band



A D T

EUT TEST CONDITION		MEASUREMENT DETAIL	
CHANNEL	Channel 116	FREQUENCY RANGE	1GHz ~ 40GHz
INPUT POWER	120Vac, 60 Hz	DETECTOR FUNCTION	Peak (PK) Average (AV)
ENVIRONMENTAL CONDITIONS	25deg. C, 65%RH	TESTED BY	Peter Weng

ANTENNA POLARITY & TEST DISTANCE: HORIZONTAL AT 3 M										
FREQ. (MHz)	EMISSION LEVEL (dBuV/m)	READ LEVEL (dBuV)	LIMIT (dBuV/m)	MARGIN (dB)	ANTENNA FACTOR (dB/m)	CABLE LOSS (dB)	PREAMP FACTOR (dB)	ANTENNA HEIGHT (cm)	TABLE ANGLE (Degree)	REMARK
5460	38.34	37.81	54	-15.66	31.56	6.05	37.08	100	177	Average
5460	57.55	57.02	74	-16.45	31.56	6.05	37.08	100	177	Peak
5470	59.12	58.57	68.3	-9.18	31.57	6.06	37.08	100	177	Peak
5580	91.54	90.87			31.71	6.12	37.16	100	177	Average
5580	101.6	100.93			31.71	6.12	37.16	100	177	Peak
5725	59.93	59.18	68.3	-8.37	31.96	6.22	37.43	100	177	Peak
11160	43.44	48.02	54	-10.56	40.1	8.71	53.39	104	107	Average
11160	53.89	58.47	74	-20.11	40.1	8.71	53.39	104	107	Peak
ANTENNA POLARITY & TEST DISTANCE: VERTICAL AT 3 M										
FREQ. (MHz)	EMISSION LEVEL (dBuV/m)	READ LEVEL (dBuV)	LIMIT (dBuV/m)	MARGIN (dB)	ANTENNA FACTOR (dB/m)	CABLE LOSS (dB)	PREAMP FACTOR (dB)	ANTENNA HEIGHT (cm)	TABLE ANGLE (Degree)	REMARK
5442	38.4	37.93	54	-15.6	31.55	6.05	37.13	100	63	Average
5442	60.28	59.81	74	-13.72	31.55	6.05	37.13	100	63	Peak
5470	58.75	58.2	68.3	-9.55	31.57	6.06	37.08	100	63	Peak
5580	99.51	98.84			31.71	6.12	37.16	100	63	Average
5580	108.56	107.89			31.71	6.12	37.16	100	63	Peak
5725	59.6	58.85	68.3	-8.7	31.96	6.22	37.43	100	63	Peak
11160	42.31	46.89	54	-11.69	40.1	8.71	53.39	100	128	Average
11160	54.46	59.04	74	-19.54	40.1	8.71	53.39	100	128	Peak

REMARKS:

- Emission Level = Read Level + Antenna Factor + Cable Loss - Preamp Factor
Margin value = Emission level – Limit value
- 5580MHz: Fundamental frequency.
- 5470MHz & 5725MHz: Out of restricted band



A D T

EUT TEST CONDITION		MEASUREMENT DETAIL	
CHANNEL	Channel 140	FREQUENCY RANGE	1GHz ~ 40GHz
INPUT POWER	120Vac, 60 Hz	DETECTOR FUNCTION	Peak (PK) Average (AV)
ENVIRONMENTAL CONDITIONS	25deg. C, 65%RH	TESTED BY	Peter Weng

ANTENNA POLARITY & TEST DISTANCE: HORIZONTAL AT 3 M										
FREQ. (MHz)	EMISSION LEVEL (dBuV/m)	READ LEVEL (dBuV)	LIMIT (dBuV/m)	MARGIN (dB)	ANTENNA FACTOR (dB/m)	CABLE LOSS (dB)	PREAMP FACTOR (dB)	ANTENNA HEIGHT (cm)	TABLE ANGLE (Degree)	REMARK
5446	38.38	37.9	54	-15.62	31.56	6.05	37.13	102	114	Average
5446	60.72	60.24	74	-13.28	31.56	6.05	37.13	102	114	Peak
5470	58.49	57.94	68.3	-9.81	31.57	6.06	37.08	102	114	Peak
5700	91.16	90.46			31.9	6.2	37.4	102	114	Average
5700	100.54	99.84			31.9	6.2	37.4	102	114	Peak
5725	60.74	59.99	68.3	-7.56	31.96	6.22	37.43	102	114	Peak
11400	44.38	47.6	54	-9.62	39.96	8.95	52.13	100	114	Average
11400	57.21	60.43	74	-16.79	39.96	8.95	52.13	100	114	Peak
ANTENNA POLARITY & TEST DISTANCE: VERTICAL AT 3 M										
FREQ. (MHz)	EMISSION LEVEL (dBuV/m)	READ LEVEL (dBuV)	LIMIT (dBuV/m)	MARGIN (dB)	ANTENNA FACTOR (dB/m)	CABLE LOSS (dB)	PREAMP FACTOR (dB)	ANTENNA HEIGHT (cm)	TABLE ANGLE (Degree)	REMARK
5444	38.36	37.89	54	-15.64	31.55	6.05	37.13	100	50	Average
5444	60.35	59.88	74	-13.65	31.55	6.05	37.13	100	50	Peak
5470	58.59	58.04	68.3	-9.71	31.57	6.06	37.08	100	50	Peak
5700	96.26	95.56			31.9	6.2	37.4	100	50	Average
5700	105.97	105.27			31.9	6.2	37.4	100	50	Peak
5725	62.24	61.49	68.3	-6.06	31.96	6.22	37.43	100	50	Peak
11400	44.9	48.12	54	-9.1	39.96	8.95	52.13	100	156	Average
11400	56.88	60.1	74	-17.12	39.96	8.95	52.13	100	156	Peak

REMARKS:

- Emission Level = Read Level + Antenna Factor + Cable Loss - Preamp Factor
Margin value = Emission level – Limit value
- 5700MHz: Fundamental frequency.
- 5470MHz & 5725MHz: Out of restricted band



A D T

802.11n (40MHz)

EUT TEST CONDITION		MEASUREMENT DETAIL	
CHANNEL	Channel 38	FREQUENCY RANGE	1GHz ~ 40GHz
INPUT POWER	120Vac, 60 Hz	DETECTOR FUNCTION	Peak (PK) Average (AV)
ENVIRONMENTAL CONDITIONS	25deg. C, 65%RH	TESTED BY	Peter Weng

ANTENNA POLARITY & TEST DISTANCE: HORIZONTAL AT 3 M										
FREQ. (MHz)	EMISSION LEVEL (dBuV/m)	READ LEVEL (dBuV)	LIMIT (dBuV/m)	MARGIN (dB)	ANTENNA FACTOR (dB/m)	CABLE LOSS (dB)	PREAMP FACTOR (dB)	ANTENNA HEIGHT (cm)	TABLE ANGLE (Degree)	REMARK
5150	50.87	51.58	54	-3.13	31.32	5.29	37.32	100	137	Average
5150	63.56	64.27	74	-10.44	31.32	5.29	37.32	100	137	Peak
5190	90.83	91.5			31.35	5.32	37.34	100	137	Average
5190	100.68	101.35			31.35	5.32	37.34	100	137	Peak
5350	38.7	39.01	54	-15.3	31.48	5.39	37.18	100	137	Average
5350	58.05	58.36	74	-15.95	31.48	5.39	37.18	100	137	Peak
ANTENNA POLARITY & TEST DISTANCE: VERTICAL AT 3 M										
FREQ. (MHz)	EMISSION LEVEL (dBuV/m)	READ LEVEL (dBuV)	LIMIT (dBuV/m)	MARGIN (dB)	ANTENNA FACTOR (dB/m)	CABLE LOSS (dB)	PREAMP FACTOR (dB)	ANTENNA HEIGHT (cm)	TABLE ANGLE (Degree)	REMARK
5150	51.28	51.99	54	-2.72	31.32	5.29	37.32	100	100	Average
5150	64.2	64.91	74	-9.8	31.32	5.29	37.32	100	100	Peak
5190	92.86	93.53			31.35	5.32	37.34	100	100	Average
5190	102.15	102.82			31.35	5.32	37.34	100	100	Peak
5356	38.81	39.12	54	-15.19	31.48	5.39	37.18	100	100	Average
5356	58.34	58.65	74	-15.66	31.48	5.39	37.18	100	100	Peak

REMARKS:

- Emission Level = Read Level + Antenna Factor + Cable Loss - Preamp Factor
Margin value = Emission level – Limit value
- 5190MHz: Fundamental frequency.



A D T

EUT TEST CONDITION		MEASUREMENT DETAIL	
CHANNEL	Channel 46	FREQUENCY RANGE	1GHz ~ 40GHz
INPUT POWER	120Vac, 60 Hz	DETECTOR FUNCTION	Peak (PK) Average (AV)
ENVIRONMENTAL CONDITIONS	25deg. C, 65%RH	TESTED BY	Peter Weng

ANTENNA POLARITY & TEST DISTANCE: HORIZONTAL AT 3 M										
FREQ. (MHz)	EMISSION LEVEL (dBuV/m)	READ LEVEL (dBuV)	LIMIT (dBuV/m)	MARGIN (dB)	ANTENNA FACTOR (dB/m)	CABLE LOSS (dB)	PREAMP FACTOR (dB)	ANTENNA HEIGHT (cm)	TABLE ANGLE (Degree)	REMARK
5132	42.78	43.49	54	-11.22	31.31	5.28	37.3	100	137	Average
5132	59.36	60.07	74	-14.64	31.31	5.28	37.3	100	137	Peak
5230	94.58	95.18			31.39	5.33	37.32	100	137	Average
5230	103.82	104.42			31.39	5.33	37.32	100	137	Peak
5390	38.3	38.56	54	-15.7	31.51	5.41	37.18	100	137	Average
5390	59.62	59.88	74	-14.38	31.51	5.41	37.18	100	137	Peak
ANTENNA POLARITY & TEST DISTANCE: VERTICAL AT 3 M										
FREQ. (MHz)	EMISSION LEVEL (dBuV/m)	READ LEVEL (dBuV)	LIMIT (dBuV/m)	MARGIN (dB)	ANTENNA FACTOR (dB/m)	CABLE LOSS (dB)	PREAMP FACTOR (dB)	ANTENNA HEIGHT (cm)	TABLE ANGLE (Degree)	REMARK
5142	42.29	42.98	54	-11.71	31.32	5.29	37.3	100	100	Average
5142	59.94	60.63	74	-14.06	31.32	5.29	37.3	100	100	Peak
5230	95.87	96.47			31.39	5.33	37.32	100	100	Average
5230	105.3	105.9			31.39	5.33	37.32	100	100	Peak
5378	37.92	38.19	54	-16.08	31.51	5.4	37.18	100	100	Average
5378	59.61	59.88	74	-14.39	31.51	5.4	37.18	100	100	Peak

REMARKS:

- Emission Level = Read Level + Antenna Factor + Cable Loss - Preamp Factor
Margin value = Emission level – Limit value
- 5230MHz: Fundamental frequency.



A D T

EUT TEST CONDITION		MEASUREMENT DETAIL	
CHANNEL	Channel 54	FREQUENCY RANGE	1GHz ~ 40GHz
INPUT POWER	120Vac, 60 Hz	DETECTOR FUNCTION	Peak (PK) Average (AV)
ENVIRONMENTAL CONDITIONS	25deg. C, 65%RH	TESTED BY	Peter Weng

ANTENNA POLARITY & TEST DISTANCE: HORIZONTAL AT 3 M										
FREQ. (MHz)	EMISSION LEVEL (dBuV/m)	READ LEVEL (dBuV)	LIMIT (dBuV/m)	MARGIN (dB)	ANTENNA FACTOR (dB/m)	CABLE LOSS (dB)	PREAMP FACTOR (dB)	ANTENNA HEIGHT (cm)	TABLE ANGLE (Degree)	REMARK
5008	39.71	40.51	54	-14.29	31.21	5.22	37.23	102	114	Average
5008	59.41	60.21	74	-14.59	31.21	5.22	37.23	102	114	Peak
5270	96.41	96.92			31.41	5.35	37.27	102	114	Average
5270	105.79	106.3			31.41	5.35	37.27	102	114	Peak
5356	43.61	43.92	54	-10.39	31.48	5.39	37.18	102	114	Average
5356	60.2	60.51	74	-13.8	31.48	5.39	37.18	102	114	Peak
ANTENNA POLARITY & TEST DISTANCE: VERTICAL AT 3 M										
FREQ. (MHz)	EMISSION LEVEL (dBuV/m)	READ LEVEL (dBuV)	LIMIT (dBuV/m)	MARGIN (dB)	ANTENNA FACTOR (dB/m)	CABLE LOSS (dB)	PREAMP FACTOR (dB)	ANTENNA HEIGHT (cm)	TABLE ANGLE (Degree)	REMARK
5150	39.14	39.85	54	-14.86	31.32	5.29	37.32	109	102	Average
5150	57.95	58.66	74	-16.05	31.32	5.29	37.32	109	102	Peak
5270	98.13	98.64			31.41	5.35	37.27	109	102	Average
5270	107.41	107.92			31.41	5.35	37.27	109	102	Peak
5350	44.16	44.47	54	-9.84	31.48	5.39	37.18	109	102	Average
5350	60.36	60.67	74	-13.64	31.48	5.39	37.18	109	102	Peak

REMARKS:

- Emission Level = Read Level + Antenna Factor + Cable Loss - Preamp Factor
Margin value = Emission level – Limit value
- 5270MHz: Fundamental frequency.



A D T

EUT TEST CONDITION		MEASUREMENT DETAIL	
CHANNEL	Channel 62	FREQUENCY RANGE	1GHz ~ 40GHz
INPUT POWER	120Vac, 60 Hz	DETECTOR FUNCTION	Peak (PK) Average (AV)
ENVIRONMENTAL CONDITIONS	25deg. C, 65%RH	TESTED BY	Peter Weng

ANTENNA POLARITY & TEST DISTANCE: HORIZONTAL AT 3 M										
FREQ. (MHz)	EMISSION LEVEL (dBuV/m)	READ LEVEL (dBuV)	LIMIT (dBuV/m)	MARGIN (dB)	ANTENNA FACTOR (dB/m)	CABLE LOSS (dB)	PREAMP FACTOR (dB)	ANTENNA HEIGHT (cm)	TABLE ANGLE (Degree)	REMARK
5078	37.88	38.62	54	-16.12	31.27	5.26	37.27	113	116	Average
5078	58.9	59.64	74	-15.1	31.27	5.26	37.27	113	116	Peak
5310	91.45	91.82			31.45	5.37	37.19	113	116	Average
5310	100.34	100.71			31.45	5.37	37.19	113	116	Peak
5350	49.86	50.17	54	-4.14	31.48	5.39	37.18	113	116	Average
5350	66.28	66.59	74	-7.72	31.48	5.39	37.18	113	116	Peak
10620	42.27	46.72	54	-11.73	39.59	8.3	52.34	107	104	Average
10620	53.99	58.44	74	-20.01	39.59	8.3	52.34	107	104	Peak
ANTENNA POLARITY & TEST DISTANCE: VERTICAL AT 3 M										
FREQ. (MHz)	EMISSION LEVEL (dBuV/m)	READ LEVEL (dBuV)	LIMIT (dBuV/m)	MARGIN (dB)	ANTENNA FACTOR (dB/m)	CABLE LOSS (dB)	PREAMP FACTOR (dB)	ANTENNA HEIGHT (cm)	TABLE ANGLE (Degree)	REMARK
5150	38.25	38.96	54	-15.75	31.32	5.29	37.32	109	102	Average
5150	57.36	58.07	74	-16.64	31.32	5.29	37.32	109	102	Peak
5310	92.84	93.21			31.45	5.37	37.19	109	102	Average
5310	103.04	103.41			31.45	5.37	37.19	109	102	Peak
5350	51.56	51.87	54	-2.44	31.48	5.39	37.18	109	102	Average
5350	66.11	66.42	74	-7.89	31.48	5.39	37.18	109	102	Peak
10620	42.19	46.64	54	-11.81	39.59	8.3	52.34	100	223	Average
10620	53.6	58.05	74	-20.4	39.59	8.3	52.34	100	223	Peak

REMARKS:

- Emission Level = Read Level + Antenna Factor + Cable Loss - Preamp Factor
Margin value = Emission level – Limit value
- 5310MHz: Fundamental frequency.



A D T

EUT TEST CONDITION		MEASUREMENT DETAIL	
CHANNEL	Channel 102	FREQUENCY RANGE	1GHz ~ 40GHz
INPUT POWER	120Vac, 60 Hz	DETECTOR FUNCTION	Peak (PK) Average (AV)
ENVIRONMENTAL CONDITIONS	25deg. C, 65%RH	TESTED BY	Peter Weng

ANTENNA POLARITY & TEST DISTANCE: HORIZONTAL AT 3 M										
FREQ. (MHz)	EMISSION LEVEL (dBuV/m)	READ LEVEL (dBuV)	LIMIT (dBuV/m)	MARGIN (dB)	ANTENNA FACTOR (dB/m)	CABLE LOSS (dB)	PREAMP FACTOR (dB)	ANTENNA HEIGHT (cm)	TABLE ANGLE (Degree)	REMARK
5460	42.95	42.42	54	-11.05	31.56	6.05	37.08	136	87	Average
5460	60.64	60.11	74	-13.36	31.56	6.05	37.08	136	87	Peak
5470	62.93	62.38	68.3	-5.37	31.57	6.06	37.08	136	87	Peak
5510	87.66	87.05			31.6	6.07	37.06	136	87	Average
5510	96.46	95.85			31.6	6.07	37.06	136	87	Peak
5725	59.35	58.6	68.3	-8.95	31.96	6.22	37.43	136	87	Peak
11020	42.4	47.12	54	-11.6	40.19	8.58	53.49	100	164	Average
11020	54.23	58.95	74	-19.77	40.19	8.58	53.49	100	164	Peak
ANTENNA POLARITY & TEST DISTANCE: VERTICAL AT 3 M										
FREQ. (MHz)	EMISSION LEVEL (dBuV/m)	READ LEVEL (dBuV)	LIMIT (dBuV/m)	MARGIN (dB)	ANTENNA FACTOR (dB/m)	CABLE LOSS (dB)	PREAMP FACTOR (dB)	ANTENNA HEIGHT (cm)	TABLE ANGLE (Degree)	REMARK
5452	47.19	46.66	54	-6.81	31.56	6.05	37.08	100	63	Average
5452	61.26	60.73	74	-12.74	31.56	6.05	37.08	100	63	Peak
5470	67.21	66.66	68.3	-1.09	31.57	6.06	37.08	100	63	Peak
5510	92.47	91.86			31.6	6.07	37.06	100	63	Average
5510	101.25	100.64			31.6	6.07	37.06	100	63	Peak
5725	59.31	58.56	68.3	-8.99	31.96	6.22	37.43	100	63	Peak
11020	42.59	47.31	54	-11.41	40.19	8.58	53.49	100	201	Average
11020	53.87	58.59	74	-20.13	40.19	8.58	53.49	100	201	Peak

REMARKS:

- Emission Level = Read Level + Antenna Factor + Cable Loss - Preamp Factor
Margin value = Emission level – Limit value
- 5510MHz: Fundamental frequency.
- 5470MHz & 5725MHz: Out of restricted band



A D T

EUT TEST CONDITION		MEASUREMENT DETAIL	
CHANNEL	Channel 110	FREQUENCY RANGE	1GHz ~ 40GHz
INPUT POWER	120Vac, 60 Hz	DETECTOR FUNCTION	Peak (PK) Average (AV)
ENVIRONMENTAL CONDITIONS	25deg. C, 65%RH	TESTED BY	Peter Weng

ANTENNA POLARITY & TEST DISTANCE: HORIZONTAL AT 3 M										
FREQ. (MHz)	EMISSION LEVEL (dBuV/m)	READ LEVEL (dBuV)	LIMIT (dBuV/m)	MARGIN (dB)	ANTENNA FACTOR (dB/m)	CABLE LOSS (dB)	PREAMP FACTOR (dB)	ANTENNA HEIGHT (cm)	TABLE ANGLE (Degree)	REMARK
5440	41.94	41.47	54	-12.06	31.55	6.05	37.13	100	74	Average
5440	60.01	59.54	74	-13.99	31.55	6.05	37.13	100	74	Peak
5470	60.03	59.48	68.3	-8.27	31.57	6.06	37.08	100	74	Peak
5550	91.28	90.58			31.68	6.11	37.09	100	74	Average
5550	100.57	99.87			31.68	6.11	37.09	100	74	Peak
5725	59.33	58.58	68.3	-8.97	31.96	6.22	37.43	100	74	Peak
11100	43.2	48.01	54	-10.8	40.14	8.66	53.61	100	257	Average
11100	52.78	57.59	74	-21.22	40.14	8.66	53.61	100	257	Peak
ANTENNA POLARITY & TEST DISTANCE: VERTICAL AT 3 M										
FREQ. (MHz)	EMISSION LEVEL (dBuV/m)	READ LEVEL (dBuV)	LIMIT (dBuV/m)	MARGIN (dB)	ANTENNA FACTOR (dB/m)	CABLE LOSS (dB)	PREAMP FACTOR (dB)	ANTENNA HEIGHT (cm)	TABLE ANGLE (Degree)	REMARK
5454	46.43	45.9	54	-7.57	31.56	6.05	37.08	100	63	Average
5454	60.74	60.21	74	-13.26	31.56	6.05	37.08	100	63	Peak
5470	64.87	64.32	68.3	-3.43	31.57	6.06	37.08	100	63	Peak
5550	98.14	97.44			31.68	6.11	37.09	100	63	Average
5550	108.58	107.88			31.68	6.11	37.09	100	63	Peak
5725	58.1	57.35	68.3	-10.2	31.96	6.22	37.43	100	63	Peak
11100	42.48	47.29	54	-11.52	40.14	8.66	53.61	100	169	Average
11100	52.58	57.39	74	-21.42	40.14	8.66	53.61	100	169	Peak

REMARKS:

- Emission Level = Read Level + Antenna Factor + Cable Loss - Preamp Factor
Margin value = Emission level – Limit value
- 5550MHz: Fundamental frequency.
- 5470MHz & 5725MHz: Out of restricted band



A D T

EUT TEST CONDITION		MEASUREMENT DETAIL	
CHANNEL	Channel 134	FREQUENCY RANGE	1GHz ~ 40GHz
INPUT POWER	120Vac, 60 Hz	DETECTOR FUNCTION	Peak (PK) Average (AV)
ENVIRONMENTAL CONDITIONS	25deg. C, 65%RH	TESTED BY	Peter Weng

ANTENNA POLARITY & TEST DISTANCE: HORIZONTAL AT 3 M

FREQ. (MHz)	EMISSION LEVEL (dBuV/m)	READ LEVEL (dBuV)	LIMIT (dBuV/m)	MARGIN (dB)	ANTENNA FACTOR (dB/m)	CABLE LOSS (dB)	PREAMP FACTOR (dB)	ANTENNA HEIGHT (cm)	TABLE ANGLE (Degree)	REMARK
5432	38.7	38.24	54	-15.3	31.55	6.04	37.13	103	115	Average
5432	60.1	59.64	74	-13.9	31.55	6.04	37.13	103	115	Peak
5470	58.76	58.21	68.3	-9.54	31.57	6.06	37.08	103	115	Peak
5670	92.38	91.65			31.88	6.19	37.34	103	115	Average
5670	101.73	101			31.88	6.19	37.34	103	115	Peak
5725	64.82	64.07	68.3	-3.48	31.96	6.22	37.43	103	115	Peak
11340	43.49	47.1	54	-10.51	40	8.9	52.51	102	127	Average
11340	56.85	60.46	74	-17.15	40	8.9	52.51	102	127	Peak

ANTENNA POLARITY & TEST DISTANCE: VERTICAL AT 3 M

FREQ. (MHz)	EMISSION LEVEL (dBuV/m)	READ LEVEL (dBuV)	LIMIT (dBuV/m)	MARGIN (dB)	ANTENNA FACTOR (dB/m)	CABLE LOSS (dB)	PREAMP FACTOR (dB)	ANTENNA HEIGHT (cm)	TABLE ANGLE (Degree)	REMARK
5404	40.76	40.39	54	-13.24	31.52	6.03	37.18	100	50	Average
5404	60.02	59.65	74	-13.98	31.52	6.03	37.18	100	50	Peak
5470	58.2	57.65	68.3	-10.1	31.57	6.06	37.08	100	50	Peak
5670	97.96	97.23			31.88	6.19	37.34	100	50	Average
5670	106.7	105.97			31.88	6.19	37.34	100	50	Peak
5725	65.9	65.15	68.3	-2.4	31.96	6.22	37.43	100	50	Peak
11340	43.81	47.42	54	-10.19	40	8.9	52.51	100	183	Average
11340	57.04	60.65	74	-16.96	40	8.9	52.51	100	183	Peak

REMARKS:

- Emission Level = Read Level + Antenna Factor + Cable Loss - Preamp Factor
Margin value = Emission level – Limit value
- 5670MHz: Fundamental frequency.
- 5470MHz & 5725MHz: Out of restricted band



A D T

BELOW 1GHz WORST-CASE DATA:

802.11a

EUT TEST CONDITION		MEASUREMENT DETAIL	
CHANNEL	Channel 36	FREQUENCY RANGE	30MHz ~ 1GHz
INPUT POWER	120Vac, 60 Hz	DETECTOR FUNCTION	Peak (PK) Quasi-peak (QP)
ENVIRONMENTAL CONDITIONS	25deg. C, 65%RH	TESTED BY	Peter Weng

ANTENNA POLARITY & TEST DISTANCE: HORIZONTAL AT 3 M										
FREQ. (MHz)	EMISSION LEVEL (dBuV/m)	READ LEVEL (dBuV)	LIMIT (dBuV/m)	MARGIN (dB)	ANTENNA FACTOR (dB/m)	CABLE LOSS (dB)	PREAMP FACTOR (dB)	ANTENNA HEIGHT (cm)	TABLE ANGLE (Degree)	REMARK
54.57	24.94	42.92	40	-15.06	12.56	0.79	31.33	116	314	Peak
126.93	26.76	45.95	43.5	-16.74	11.48	1.22	31.89	117	187	Peak
254.37	18.91	37.37	46	-27.09	11.59	1.85	31.9	107	237	Peak
395.2	29.32	43.79	46	-16.68	15.21	2.4	32.08	131	110	Peak
615	23.87	33.07	46	-22.13	19.79	3.13	32.12	133	105	Peak
785.1	27.13	32.88	46	-18.87	22.01	3.66	31.42	138	61	Peak
ANTENNA POLARITY & TEST DISTANCE: VERTICAL AT 3 M										
FREQ. (MHz)	EMISSION LEVEL (dBuV/m)	READ LEVEL (dBuV)	LIMIT (dBuV/m)	MARGIN (dB)	ANTENNA FACTOR (dB/m)	CABLE LOSS (dB)	PREAMP FACTOR (dB)	ANTENNA HEIGHT (cm)	TABLE ANGLE (Degree)	REMARK
30.27	33.28	51.87	40	-6.72	11.98	0.57	31.14	120	114	Peak
127.47	31.34	50.53	43.5	-12.16	11.48	1.22	31.89	137	257	Peak
179.85	21.93	41.43	43.5	-21.57	10.83	1.5	31.83	107	189	Peak
411.3	28.59	42.56	46	-17.41	15.56	2.47	32	110	279	Peak
657.7	25.15	33.54	46	-20.85	20.3	3.27	31.96	106	180	Peak
752.2	27.6	33.8	46	-18.4	21.56	3.58	31.34	116	225	Peak

REMARKS: Emission Level = Read Level + Antenna Factor + Cable Loss - Preamp Factor

Margin value = Emission level – Limit value



A D T

EUT TEST CONDITION		MEASUREMENT DETAIL	
CHANNEL	Channel 44	FREQUENCY RANGE	30MHz ~ 1GHz
INPUT POWER	120Vac, 60 Hz	DETECTOR FUNCTION	Peak (PK) Quasi-peak (QP)
ENVIRONMENTAL CONDITIONS	25deg. C, 65%RH	TESTED BY	Peter Weng

ANTENNA POLARITY & TEST DISTANCE: HORIZONTAL AT 3 M										
FREQ. (MHz)	EMISSION LEVEL (dBuV/m)	READ LEVEL (dBuV)	LIMIT (dBuV/m)	MARGIN (dB)	ANTENNA FACTOR (dB/m)	CABLE LOSS (dB)	PREAMP FACTOR (dB)	ANTENNA HEIGHT (cm)	TABLE ANGLE (Degree)	REMARK
54.03	23.3	41.28	40	-16.7	12.56	0.79	31.33	101	112	Peak
127.2	24.47	43.66	43.5	-19.03	11.48	1.22	31.89	120	10	Peak
287.04	19.63	36.79	46	-26.37	12.57	1.99	31.72	136	168	Peak
395.2	27.75	42.22	46	-18.25	15.21	2.4	32.08	112	330	Peak
567.4	22.71	32.92	46	-23.29	18.86	3	32.07	106	47	Peak
768.3	27.02	32.95	46	-18.98	21.78	3.62	31.33	134	98	Peak

ANTENNA POLARITY & TEST DISTANCE: VERTICAL AT 3 M										
FREQ. (MHz)	EMISSION LEVEL (dBuV/m)	READ LEVEL (dBuV)	LIMIT (dBuV/m)	MARGIN (dB)	ANTENNA FACTOR (dB/m)	CABLE LOSS (dB)	PREAMP FACTOR (dB)	ANTENNA HEIGHT (cm)	TABLE ANGLE (Degree)	REMARK
30.54	32.17	50.58	40	-7.83	12.14	0.57	31.12	101	38	Peak
126.12	31.68	50.93	43.5	-11.82	11.42	1.22	31.89	114	244	Peak
181.47	21.47	41.11	43.5	-22.03	10.67	1.51	31.82	130	221	Peak
411.3	27.92	41.89	46	-18.08	15.56	2.47	32	102	217	Peak
604.5	23.16	32.58	46	-22.84	19.66	3.1	32.18	120	227	Peak
750.8	26.1	32.3	46	-19.9	21.53	3.58	31.31	104	283	Peak

REMARKS: Emission Level = Read Level + Antenna Factor + Cable Loss - Preamp Factor
Margin value = Emission level – Limit value



A D T

EUT TEST CONDITION		MEASUREMENT DETAIL	
CHANNEL	Channel 48	FREQUENCY RANGE	30MHz ~ 1GHz
INPUT POWER	120Vac, 60 Hz	DETECTOR FUNCTION	Peak (PK) Quasi-peak (QP)
ENVIRONMENTAL CONDITIONS	25deg. C, 65%RH	TESTED BY	Peter Weng

ANTENNA POLARITY & TEST DISTANCE: HORIZONTAL AT 3 M										
FREQ. (MHz)	EMISSION LEVEL (dBuV/m)	READ LEVEL (dBuV)	LIMIT (dBuV/m)	MARGIN (dB)	ANTENNA FACTOR (dB/m)	CABLE LOSS (dB)	PREAMP FACTOR (dB)	ANTENNA HEIGHT (cm)	TABLE ANGLE (Degree)	REMARK
56.73	23.75	42.04	40	-16.25	12.25	0.81	31.35	100	125	Peak
132.06	24.68	43.45	43.5	-18.82	11.81	1.25	31.83	112	348	Peak
274.35	18.87	36.67	46	-27.13	12.2	1.93	31.93	109	228	Peak
395.2	28.96	43.43	46	-17.04	15.21	2.4	32.08	134	117	Peak
595.4	23.43	33.06	46	-22.57	19.5	3.07	32.2	102	237	Peak
777.4	27.74	33.58	46	-18.26	21.92	3.64	31.4	135	356	Peak

ANTENNA POLARITY & TEST DISTANCE: VERTICAL AT 3 M										
FREQ. (MHz)	EMISSION LEVEL (dBuV/m)	READ LEVEL (dBuV)	LIMIT (dBuV/m)	MARGIN (dB)	ANTENNA FACTOR (dB/m)	CABLE LOSS (dB)	PREAMP FACTOR (dB)	ANTENNA HEIGHT (cm)	TABLE ANGLE (Degree)	REMARK
31.08	33.06	51.47	40	-6.94	12.14	0.57	31.12	138	141	Peak
127.2	31.49	50.68	43.5	-12.01	11.48	1.22	31.89	135	109	Peak
177.42	21.72	41.03	43.5	-21.78	11.01	1.49	31.81	120	28	Peak
411.3	29.3	43.27	46	-16.7	15.56	2.47	32	124	262	Peak
588.4	24.12	33.86	46	-21.88	19.34	3.06	32.14	124	310	Peak
780.2	27.39	33.23	46	-18.61	21.94	3.65	31.43	108	97	Peak

REMARKS: Emission Level = Read Level + Antenna Factor + Cable Loss - Preamp Factor
Margin value = Emission level – Limit value



A D T

EUT TEST CONDITION		MEASUREMENT DETAIL	
CHANNEL	Channel 52	FREQUENCY RANGE	30MHz ~ 1GHz
INPUT POWER	120Vac, 60 Hz	DETECTOR FUNCTION	Peak (PK) Quasi-peak (QP)
ENVIRONMENTAL CONDITIONS	25deg. C, 65%RH	TESTED BY	Peter Weng

ANTENNA POLARITY & TEST DISTANCE: HORIZONTAL AT 3 M										
FREQ. (MHz)	EMISSION LEVEL (dBuV/m)	READ LEVEL (dBuV)	LIMIT (dBuV/m)	MARGIN (dB)	ANTENNA FACTOR (dB/m)	CABLE LOSS (dB)	PREAMP FACTOR (dB)	ANTENNA HEIGHT (cm)	TABLE ANGLE (Degree)	REMARK
57.81	22.89	41.28	40	-17.11	12.15	0.81	31.35	100	104	Peak
131.25	24.7	43.56	43.5	-18.8	11.75	1.25	31.86	100	126	Peak
226.02	17.95	37.57	46	-28.05	10.46	1.72	31.8	100	75	Peak
407.8	26.27	40.37	46	-19.73	15.48	2.45	32.03	100	186	Peak
564.6	22.57	32.86	46	-23.43	18.79	2.99	32.07	100	198	Peak
757.8	26.29	32.48	46	-19.71	21.63	3.59	31.41	100	56	Peak

ANTENNA POLARITY & TEST DISTANCE: VERTICAL AT 3 M										
FREQ. (MHz)	EMISSION LEVEL (dBuV/m)	READ LEVEL (dBuV)	LIMIT (dBuV/m)	MARGIN (dB)	ANTENNA FACTOR (dB/m)	CABLE LOSS (dB)	PREAMP FACTOR (dB)	ANTENNA HEIGHT (cm)	TABLE ANGLE (Degree)	REMARK
54.57	30.01	47.99	40	-9.99	12.56	0.79	31.33	100	127	Peak
131.25	29.56	48.42	43.5	-13.94	11.75	1.25	31.86	100	211	Peak
188.22	20.96	40.93	43.5	-22.54	10.19	1.54	31.7	100	310	Peak
427.4	26.15	39.75	46	-19.85	15.89	2.53	32.02	100	156	Peak
628.3	23.27	32.3	46	-22.73	19.95	3.17	32.15	100	234	Peak
780.9	27.05	32.87	46	-18.95	21.96	3.65	31.43	100	333	Peak

REMARKS: Emission Level = Read Level + Antenna Factor + Cable Loss - Preamp Factor
Margin value = Emission level – Limit value



A D T

EUT TEST CONDITION		MEASUREMENT DETAIL	
CHANNEL	Channel 60	FREQUENCY RANGE	30MHz ~ 1GHz
INPUT POWER	120Vac, 60 Hz	DETECTOR FUNCTION	Peak (PK) Quasi-peak (QP)
ENVIRONMENTAL CONDITIONS	25deg. C, 65%RH	TESTED BY	Peter Weng

ANTENNA POLARITY & TEST DISTANCE: HORIZONTAL AT 3 M										
FREQ. (MHz)	EMISSION LEVEL (dBuV/m)	READ LEVEL (dBuV)	LIMIT (dBuV/m)	MARGIN (dB)	ANTENNA FACTOR (dB/m)	CABLE LOSS (dB)	PREAMP FACTOR (dB)	ANTENNA HEIGHT (cm)	TABLE ANGLE (Degree)	REMARK
70.23	20.02	40.17	40	-19.98	10.77	0.9	31.82	100	122	Peak
126.39	23.9	43.15	43.5	-19.6	11.42	1.22	31.89	100	104	Peak
248.43	17.5	36.18	46	-28.5	11.4	1.83	31.91	100	271	Peak
412	28.02	41.97	46	-17.98	15.58	2.47	32	100	117	Peak
769	26	31.9	46	-20	21.79	3.62	31.31	100	163	Peak
937	29.51	33.69	46	-16.49	23.72	4.05	31.95	100	94	Peak

ANTENNA POLARITY & TEST DISTANCE: VERTICAL AT 3 M										
FREQ. (MHz)	EMISSION LEVEL (dBuV/m)	READ LEVEL (dBuV)	LIMIT (dBuV/m)	MARGIN (dB)	ANTENNA FACTOR (dB/m)	CABLE LOSS (dB)	PREAMP FACTOR (dB)	ANTENNA HEIGHT (cm)	TABLE ANGLE (Degree)	REMARK
54.84	30.67	48.75	40	-9.33	12.45	0.8	31.33	100	244	Peak
126.93	31.13	50.32	43.5	-12.37	11.48	1.22	31.89	100	108	Peak
187.41	20.81	40.74	43.5	-22.69	10.26	1.53	31.72	100	126	Peak
411.3	26.97	40.94	46	-19.03	15.56	2.47	32	100	49	Peak
590.5	23.07	32.77	46	-22.93	19.39	3.06	32.15	100	82	Peak
874.7	28.13	33.04	46	-17.87	23.19	3.89	31.99	100	155	Peak

REMARKS: Emission Level = Read Level + Antenna Factor + Cable Loss - Preamp Factor
Margin value = Emission level – Limit value



A D T

EUT TEST CONDITION		MEASUREMENT DETAIL	
CHANNEL	Channel 64	FREQUENCY RANGE	30MHz ~ 1GHz
INPUT POWER	120Vac, 60 Hz	DETECTOR FUNCTION	Peak (PK) Quasi-peak (QP)
ENVIRONMENTAL CONDITIONS	25deg. C, 65%RH	TESTED BY	Peter Weng

ANTENNA POLARITY & TEST DISTANCE: HORIZONTAL AT 3 M										
FREQ. (MHz)	EMISSION LEVEL (dBuV/m)	READ LEVEL (dBuV)	LIMIT (dBuV/m)	MARGIN (dB)	ANTENNA FACTOR (dB/m)	CABLE LOSS (dB)	PREAMP FACTOR (dB)	ANTENNA HEIGHT (cm)	TABLE ANGLE (Degree)	REMARK
54.03	21.81	39.79	40	-18.19	12.56	0.79	31.33	100	214	Peak
130.17	24.16	43.12	43.5	-19.34	11.68	1.24	31.88	100	114	Peak
265.71	18.98	37.11	46	-27.02	11.94	1.89	31.96	100	193	Peak
379.1	25.29	40.06	46	-20.71	14.84	2.34	31.95	100	150	Peak
650.7	24.44	32.99	46	-21.56	20.22	3.24	32.01	100	182	Peak
892.9	28.4	33.03	46	-17.6	23.42	3.95	32	100	231	Peak

ANTENNA POLARITY & TEST DISTANCE: VERTICAL AT 3 M										
FREQ. (MHz)	EMISSION LEVEL (dBuV/m)	READ LEVEL (dBuV)	LIMIT (dBuV/m)	MARGIN (dB)	ANTENNA FACTOR (dB/m)	CABLE LOSS (dB)	PREAMP FACTOR (dB)	ANTENNA HEIGHT (cm)	TABLE ANGLE (Degree)	REMARK
56.19	29.71	47.9	40	-10.29	12.35	0.8	31.34	100	89	Peak
126.39	31.67	50.92	43.5	-11.83	11.42	1.22	31.89	100	186	Peak
207.12	16.35	36.67	43.5	-27.15	9.69	1.63	31.64	100	191	Peak
423.9	23.21	36.91	46	-22.79	15.81	2.52	32.03	100	193	Peak
676.6	24.96	32.91	46	-21.04	20.54	3.34	31.83	100	305	Peak
914.6	28.6	33.04	46	-17.4	23.59	4	32.03	100	220	Peak

REMARKS: Emission Level = Read Level + Antenna Factor + Cable Loss - Preamp Factor
Margin value = Emission level – Limit value



A D T

EUT TEST CONDITION		MEASUREMENT DETAIL	
CHANNEL	Channel 100	FREQUENCY RANGE	30MHz ~ 1GHz
INPUT POWER	120Vac, 60 Hz	DETECTOR FUNCTION	Peak (PK) Quasi-peak (QP)
ENVIRONMENTAL CONDITIONS	25deg. C, 65%RH	TESTED BY	Peter Weng

ANTENNA POLARITY & TEST DISTANCE: HORIZONTAL AT 3 M										
FREQ. (MHz)	EMISSION LEVEL (dBuV/m)	READ LEVEL (dBuV)	LIMIT (dBuV/m)	MARGIN (dB)	ANTENNA FACTOR (dB/m)	CABLE LOSS (dB)	PREAMP FACTOR (dB)	ANTENNA HEIGHT (cm)	TABLE ANGLE (Degree)	REMARK
57.81	20.93	39.32	40	-19.07	12.15	0.81	31.35	100	118	Peak
126.66	23.69	42.88	43.5	-19.81	11.48	1.22	31.89	100	221	Peak
205.23	15.79	36.24	43.5	-27.71	9.6	1.62	31.67	100	105	Peak
379.1	25.74	40.51	46	-20.26	14.84	2.34	31.95	100	296	Peak
619.9	23.96	33.14	46	-22.04	19.84	3.15	32.17	100	165	Peak
824.3	29.1	34.46	46	-16.9	22.54	3.75	31.65	100	189	Peak

ANTENNA POLARITY & TEST DISTANCE: VERTICAL AT 3 M										
FREQ. (MHz)	EMISSION LEVEL (dBuV/m)	READ LEVEL (dBuV)	LIMIT (dBuV/m)	MARGIN (dB)	ANTENNA FACTOR (dB/m)	CABLE LOSS (dB)	PREAMP FACTOR (dB)	ANTENNA HEIGHT (cm)	TABLE ANGLE (Degree)	REMARK
73.2	30.26	51.23	40	-9.74	9.81	0.93	31.71	100	302	Peak
131.52	29.98	48.75	43.5	-13.52	11.81	1.25	31.83	100	59	Peak
181.2	21.86	41.5	43.5	-21.64	10.67	1.51	31.82	100	237	Peak
395.2	25.8	40.27	46	-20.2	15.21	2.4	32.08	100	115	Peak
635.3	24.22	33.1	46	-21.78	20.03	3.2	32.11	100	311	Peak
770.4	26.47	32.34	46	-19.53	21.81	3.62	31.3	100	62	Peak

REMARKS: Emission Level = Read Level + Antenna Factor + Cable Loss - Preamp Factor
Margin value = Emission level – Limit value



A D T

EUT TEST CONDITION		MEASUREMENT DETAIL	
CHANNEL	Channel 116	FREQUENCY RANGE	30MHz ~ 1GHz
INPUT POWER	120Vac, 60 Hz	DETECTOR FUNCTION	Peak (PK) Quasi-peak (QP)
ENVIRONMENTAL CONDITIONS	25deg. C, 65%RH	TESTED BY	Peter Weng

ANTENNA POLARITY & TEST DISTANCE: HORIZONTAL AT 3 M										
FREQ. (MHz)	EMISSION LEVEL (dBuV/m)	READ LEVEL (dBuV)	LIMIT (dBuV/m)	MARGIN (dB)	ANTENNA FACTOR (dB/m)	CABLE LOSS (dB)	PREAMP FACTOR (dB)	ANTENNA HEIGHT (cm)	TABLE ANGLE (Degree)	REMARK
126.39	24.79	44.04	43.5	-18.71	11.42	1.22	31.89	100	126	Peak
167.16	16.98	35.27	43.5	-26.52	12.05	1.43	31.77	100	79	Peak
234.12	17.11	36.39	46	-28.89	10.79	1.76	31.83	100	331	Peak
412	25.16	39.11	46	-20.84	15.58	2.47	32	100	255	Peak
603.1	22.88	32.33	46	-23.12	19.65	3.1	32.2	100	147	Peak
815.9	27.37	32.75	46	-18.63	22.43	3.73	31.54	100	279	Peak

ANTENNA POLARITY & TEST DISTANCE: VERTICAL AT 3 M										
FREQ. (MHz)	EMISSION LEVEL (dBuV/m)	READ LEVEL (dBuV)	LIMIT (dBuV/m)	MARGIN (dB)	ANTENNA FACTOR (dB/m)	CABLE LOSS (dB)	PREAMP FACTOR (dB)	ANTENNA HEIGHT (cm)	TABLE ANGLE (Degree)	REMARK
55.65	30.47	48.55	40	-9.53	12.45	0.8	31.33	100	83	Peak
132.06	29.81	48.58	43.5	-13.69	11.81	1.25	31.83	100	129	Peak
154.74	21.93	39.58	43.5	-21.57	12.72	1.37	31.74	100	119	Peak
456.1	22.88	35.78	46	-23.12	16.45	2.64	31.99	100	209	Peak
613.6	23.73	32.95	46	-22.27	19.77	3.13	32.12	100	213	Peak
784.4	27.41	33.16	46	-18.59	22.01	3.66	31.42	100	245	Peak

REMARKS: Emission Level = Read Level + Antenna Factor + Cable Loss - Preamp Factor
Margin value = Emission level – Limit value



A D T

EUT TEST CONDITION		MEASUREMENT DETAIL	
CHANNEL	Channel 140	FREQUENCY RANGE	30MHz ~ 1GHz
INPUT POWER	120Vac, 60 Hz	DETECTOR FUNCTION	Peak (PK) Quasi-peak (QP)
ENVIRONMENTAL CONDITIONS	25deg. C, 65%RH	TESTED BY	Peter Weng

ANTENNA POLARITY & TEST DISTANCE: HORIZONTAL AT 3 M										
FREQ. (MHz)	EMISSION LEVEL (dBuV/m)	READ LEVEL (dBuV)	LIMIT (dBuV/m)	MARGIN (dB)	ANTENNA FACTOR (dB/m)	CABLE LOSS (dB)	PREAMP FACTOR (dB)	ANTENNA HEIGHT (cm)	TABLE ANGLE (Degree)	REMARK
72.66	20.18	40.95	40	-19.82	10.05	0.92	31.74	116	144	Peak
138.81	21.29	39.39	43.5	-22.21	12.27	1.29	31.66	102	38	Peak
232.77	16.32	35.66	46	-29.68	10.75	1.75	31.84	105	246	Peak
411.3	27.39	41.36	46	-18.61	15.56	2.47	32	100	107	Peak
524.7	20.3	31.19	46	-25.7	17.88	2.86	31.63	100	251	Peak
720	24.95	32.03	46	-21.05	21.09	3.49	31.66	100	332	Peak

ANTENNA POLARITY & TEST DISTANCE: VERTICAL AT 3 M										
FREQ. (MHz)	EMISSION LEVEL (dBuV/m)	READ LEVEL (dBuV)	LIMIT (dBuV/m)	MARGIN (dB)	ANTENNA FACTOR (dB/m)	CABLE LOSS (dB)	PREAMP FACTOR (dB)	ANTENNA HEIGHT (cm)	TABLE ANGLE (Degree)	REMARK
31.89	27.97	46.2	40	-12.03	12.3	0.58	31.11	100	108	Peak
126.12	29.81	49.06	43.5	-13.69	11.42	1.22	31.89	100	208	Peak
186.06	19.13	39.01	43.5	-24.37	10.33	1.53	31.74	100	221	Peak
427.4	24.55	38.15	46	-21.45	15.89	2.53	32.02	100	325	Peak
592.6	22.89	32.56	46	-23.11	19.43	3.07	32.17	100	213	Peak
883.8	27.96	32.72	46	-18.04	23.3	3.92	31.98	100	195	Peak

REMARKS: Emission Level = Read Level + Antenna Factor + Cable Loss - Preamp Factor
Margin value = Emission level – Limit value



A D T

802.11n (20MHz)

EUT TEST CONDITION		MEASUREMENT DETAIL	
CHANNEL	Channel 36	FREQUENCY RANGE	30MHz ~ 1GHz
INPUT POWER	120Vac, 60 Hz	DETECTOR FUNCTION	Peak (PK) Quasi-peak (QP)
ENVIRONMENTAL CONDITIONS	25deg. C, 65%RH	TESTED BY	Peter Weng

ANTENNA POLARITY & TEST DISTANCE: HORIZONTAL AT 3 M										
FREQ. (MHz)	EMISSION LEVEL (dBuV/m)	READ LEVEL (dBuV)	LIMIT (dBuV/m)	MARGIN (dB)	ANTENNA FACTOR (dB/m)	CABLE LOSS (dB)	PREAMP FACTOR (dB)	ANTENNA HEIGHT (cm)	TABLE ANGLE (Degree)	REMARK
55.65	23.41	41.49	40	-16.59	12.45	0.8	31.33	120	250	Peak
133.14	26.28	44.95	43.5	-17.22	11.88	1.26	31.81	104	257	Peak
273	19.17	37.02	46	-26.83	12.17	1.93	31.95	118	107	Peak
412	25.96	39.91	46	-20.04	15.58	2.47	32	113	210	Peak
617.1	24	33.19	46	-22	19.81	3.14	32.14	137	182	Peak
766.9	27.75	33.72	46	-18.25	21.76	3.61	31.34	112	164	Peak
ANTENNA POLARITY & TEST DISTANCE: VERTICAL AT 3 M										
FREQ. (MHz)	EMISSION LEVEL (dBuV/m)	READ LEVEL (dBuV)	LIMIT (dBuV/m)	MARGIN (dB)	ANTENNA FACTOR (dB/m)	CABLE LOSS (dB)	PREAMP FACTOR (dB)	ANTENNA HEIGHT (cm)	TABLE ANGLE (Degree)	REMARK
30.54	32.28	50.69	40	-7.72	12.14	0.57	31.12	117	205	Peak
127.74	31.49	50.59	43.5	-12.01	11.55	1.23	31.88	120	266	Peak
179.04	21.83	41.33	43.5	-21.67	10.83	1.5	31.83	131	19	Peak
395.2	25.91	40.38	46	-20.09	15.21	2.4	32.08	114	342	Peak
654.2	24.63	33.09	46	-21.37	20.27	3.26	31.99	133	351	Peak
779.5	27.6	33.44	46	-18.4	21.94	3.65	31.43	111	120	Peak

REMARKS: Emission Level = Read Level + Antenna Factor + Cable Loss - Preamp Factor
Margin value = Emission level – Limit value



A D T

EUT TEST CONDITION		MEASUREMENT DETAIL	
CHANNEL	Channel 44	FREQUENCY RANGE	30MHz ~ 1GHz
INPUT POWER	120Vac, 60 Hz	DETECTOR FUNCTION	Peak (PK) Quasi-peak (QP)
ENVIRONMENTAL CONDITIONS	25deg. C, 65%RH	TESTED BY	Peter Weng

ANTENNA POLARITY & TEST DISTANCE: HORIZONTAL AT 3 M										
FREQ. (MHz)	EMISSION LEVEL (dBuV/m)	READ LEVEL (dBuV)	LIMIT (dBuV/m)	MARGIN (dB)	ANTENNA FACTOR (dB/m)	CABLE LOSS (dB)	PREAMP FACTOR (dB)	ANTENNA HEIGHT (cm)	TABLE ANGLE (Degree)	REMARK
56.73	23.41	41.7	40	-16.59	12.25	0.81	31.35	118	28	Peak
132.6	25.03	43.7	43.5	-18.47	11.88	1.26	31.81	101	227	Peak
260.85	19.46	37.67	46	-26.54	11.79	1.87	31.87	101	73	Peak
395.9	30.48	44.92	46	-15.52	15.24	2.41	32.09	124	336	Peak
638.1	24.16	32.99	46	-21.84	20.07	3.2	32.1	126	237	Peak
800.5	27.47	32.98	46	-18.53	22.23	3.69	31.43	117	346	Peak

ANTENNA POLARITY & TEST DISTANCE: VERTICAL AT 3 M										
FREQ. (MHz)	EMISSION LEVEL (dBuV/m)	READ LEVEL (dBuV)	LIMIT (dBuV/m)	MARGIN (dB)	ANTENNA FACTOR (dB/m)	CABLE LOSS (dB)	PREAMP FACTOR (dB)	ANTENNA HEIGHT (cm)	TABLE ANGLE (Degree)	REMARK
31.35	32.38	50.79	40	-7.62	12.14	0.57	31.12	111	7	Peak
126.39	31.61	50.86	43.5	-11.89	11.42	1.22	31.89	117	127	Peak
177.96	21.72	41.13	43.5	-21.78	10.92	1.49	31.82	130	342	Peak
444.2	27.48	40.67	46	-18.52	16.21	2.59	31.99	116	123	Peak
649.3	24.64	33.23	46	-21.36	20.2	3.24	32.03	140	198	Peak
813.8	26.91	32.29	46	-19.09	22.4	3.73	31.51	127	47	Peak

REMARKS: Emission Level = Read Level + Antenna Factor + Cable Loss - Preamp Factor
Margin value = Emission level – Limit value



A D T

EUT TEST CONDITION		MEASUREMENT DETAIL	
CHANNEL	Channel 48	FREQUENCY RANGE	30MHz ~ 1GHz
INPUT POWER	120Vac, 60 Hz	DETECTOR FUNCTION	Peak (PK) Quasi-peak (QP)
ENVIRONMENTAL CONDITIONS	25deg. C, 65%RH	TESTED BY	Peter Weng

ANTENNA POLARITY & TEST DISTANCE: HORIZONTAL AT 3 M										
FREQ. (MHz)	EMISSION LEVEL (dBuV/m)	READ LEVEL (dBuV)	LIMIT (dBuV/m)	MARGIN (dB)	ANTENNA FACTOR (dB/m)	CABLE LOSS (dB)	PREAMP FACTOR (dB)	ANTENNA HEIGHT (cm)	TABLE ANGLE (Degree)	REMARK
54.03	22.95	40.93	40	-17.05	12.56	0.79	31.33	120	46	Peak
133.68	24.99	43.57	43.5	-18.51	11.94	1.26	31.78	100	208	Peak
283.26	18.78	36.13	46	-27.22	12.45	1.97	31.77	139	295	Peak
395.2	27.94	42.41	46	-18.06	15.21	2.4	32.08	115	94	Peak
630.4	24.44	33.43	46	-21.56	19.97	3.18	32.14	129	333	Peak
817.3	27.56	32.94	46	-18.44	22.45	3.74	31.57	108	275	Peak

ANTENNA POLARITY & TEST DISTANCE: VERTICAL AT 3 M										
FREQ. (MHz)	EMISSION LEVEL (dBuV/m)	READ LEVEL (dBuV)	LIMIT (dBuV/m)	MARGIN (dB)	ANTENNA FACTOR (dB/m)	CABLE LOSS (dB)	PREAMP FACTOR (dB)	ANTENNA HEIGHT (cm)	TABLE ANGLE (Degree)	REMARK
30.81	32.27	50.68	40	-7.73	12.14	0.57	31.12	132	303	Peak
126.39	31.32	50.57	43.5	-12.18	11.42	1.22	31.89	105	353	Peak
180.66	22.04	41.64	43.5	-21.46	10.74	1.5	31.84	103	49	Peak
395.2	28.47	42.94	46	-17.53	15.21	2.4	32.08	116	218	Peak
667.5	24.38	32.5	46	-21.62	20.42	3.31	31.85	126	230	Peak
801.2	26.96	32.45	46	-19.04	22.24	3.7	31.43	113	308	Peak

REMARKS: Emission Level = Read Level + Antenna Factor + Cable Loss - Preamp Factor
Margin value = Emission level – Limit value



A D T

EUT TEST CONDITION		MEASUREMENT DETAIL	
CHANNEL	Channel 52	FREQUENCY RANGE	30MHz ~ 1GHz
INPUT POWER	120Vac, 60 Hz	DETECTOR FUNCTION	Peak (PK) Quasi-peak (QP)
ENVIRONMENTAL CONDITIONS	25deg. C, 65%RH	TESTED BY	Peter Weng

ANTENNA POLARITY & TEST DISTANCE: HORIZONTAL AT 3 M										
FREQ. (MHz)	EMISSION LEVEL (dBuV/m)	READ LEVEL (dBuV)	LIMIT (dBuV/m)	MARGIN (dB)	ANTENNA FACTOR (dB/m)	CABLE LOSS (dB)	PREAMP FACTOR (dB)	ANTENNA HEIGHT (cm)	TABLE ANGLE (Degree)	REMARK
77.52	17.71	39.5	40	-22.29	8.85	0.95	31.59	100	140	Peak
135.3	22.18	40.57	43.5	-21.32	12.08	1.27	31.74	100	80	Peak
255.18	17.02	35.45	46	-28.98	11.62	1.85	31.9	100	116	Peak
427.4	21.83	35.43	46	-24.17	15.89	2.53	32.02	100	102	Peak
618.5	23.77	32.96	46	-22.23	19.83	3.14	32.16	100	357	Peak
900.6	28.81	33.33	46	-17.19	23.52	3.97	32.01	100	159	Peak

ANTENNA POLARITY & TEST DISTANCE: VERTICAL AT 3 M										
FREQ. (MHz)	EMISSION LEVEL (dBuV/m)	READ LEVEL (dBuV)	LIMIT (dBuV/m)	MARGIN (dB)	ANTENNA FACTOR (dB/m)	CABLE LOSS (dB)	PREAMP FACTOR (dB)	ANTENNA HEIGHT (cm)	TABLE ANGLE (Degree)	REMARK
57.27	28.44	46.73	40	-11.56	12.25	0.81	31.35	100	266	Peak
90.21	27.87	50.51	43.5	-15.63	8.3	1.02	31.96	100	118	Peak
131.52	28.79	47.56	43.5	-14.71	11.81	1.25	31.83	100	19	Peak
427.4	24.57	38.17	46	-21.43	15.89	2.53	32.02	100	174	Peak
492.5	22.73	34.53	46	-23.27	17.18	2.75	31.73	100	245	Peak
844.6	27.13	32.35	46	-18.87	22.8	3.81	31.83	100	335	Peak

REMARKS: Emission Level = Read Level + Antenna Factor + Cable Loss - Preamp Factor
Margin value = Emission level – Limit value



A D T

EUT TEST CONDITION		MEASUREMENT DETAIL	
CHANNEL	Channel 60	FREQUENCY RANGE	30MHz ~ 1GHz
INPUT POWER	120Vac, 60 Hz	DETECTOR FUNCTION	Peak (PK) Quasi-peak (QP)
ENVIRONMENTAL CONDITIONS	25deg. C, 65%RH	TESTED BY	Peter Weng

ANTENNA POLARITY & TEST DISTANCE: HORIZONTAL AT 3 M										
FREQ. (MHz)	EMISSION LEVEL (dBuV/m)	READ LEVEL (dBuV)	LIMIT (dBuV/m)	MARGIN (dB)	ANTENNA FACTOR (dB/m)	CABLE LOSS (dB)	PREAMP FACTOR (dB)	ANTENNA HEIGHT (cm)	TABLE ANGLE (Degree)	REMARK
57.81	22.31	40.7	40	-17.69	12.15	0.81	31.35	100	127	Peak
130.98	25.04	43.9	43.5	-18.46	11.75	1.25	31.86	100	137	Peak
166.62	18.42	36.71	43.5	-25.08	12.05	1.43	31.77	100	169	Peak
346.9	21.42	36.95	46	-24.58	14.08	2.22	31.83	100	142	Peak
516.3	21.72	32.79	46	-24.28	17.68	2.83	31.58	100	228	Peak
701.8	25.18	32.67	46	-20.82	20.85	3.44	31.78	100	170	Peak

ANTENNA POLARITY & TEST DISTANCE: VERTICAL AT 3 M										
FREQ. (MHz)	EMISSION LEVEL (dBuV/m)	READ LEVEL (dBuV)	LIMIT (dBuV/m)	MARGIN (dB)	ANTENNA FACTOR (dB/m)	CABLE LOSS (dB)	PREAMP FACTOR (dB)	ANTENNA HEIGHT (cm)	TABLE ANGLE (Degree)	REMARK
31.35	30.91	49.32	40	-9.09	12.14	0.57	31.12	100	198	Peak
89.13	27.62	50.23	43.5	-15.88	8.28	1.02	31.91	100	285	Peak
140.16	24.31	42.28	43.5	-19.19	12.37	1.3	31.64	100	205	Peak
427.4	26.65	40.25	46	-19.35	15.89	2.53	32.02	100	295	Peak
604.5	23.49	32.91	46	-22.51	19.66	3.1	32.18	100	88	Peak
749.4	27.38	33.59	46	-18.62	21.52	3.57	31.3	100	136	Peak

REMARKS: Emission Level = Read Level + Antenna Factor + Cable Loss - Preamp Factor
Margin value = Emission level – Limit value



A D T

EUT TEST CONDITION		MEASUREMENT DETAIL	
CHANNEL	Channel 64	FREQUENCY RANGE	30MHz ~ 1GHz
INPUT POWER	120Vac, 60 Hz	DETECTOR FUNCTION	Peak (PK) Quasi-peak (QP)
ENVIRONMENTAL CONDITIONS	25deg. C, 65%RH	TESTED BY	Peter Weng

ANTENNA POLARITY & TEST DISTANCE: HORIZONTAL AT 3 M										
FREQ. (MHz)	EMISSION LEVEL (dBuV/m)	READ LEVEL (dBuV)	LIMIT (dBuV/m)	MARGIN (dB)	ANTENNA FACTOR (dB/m)	CABLE LOSS (dB)	PREAMP FACTOR (dB)	ANTENNA HEIGHT (cm)	TABLE ANGLE (Degree)	REMARK
132.6	24.75	43.42	43.5	-18.75	11.88	1.26	31.81	100	293	Peak
157.17	18.26	35.96	43.5	-25.24	12.72	1.38	31.8	100	137	Peak
271.92	18.79	36.75	46	-27.21	12.11	1.92	31.99	100	270	Peak
379.1	27.1	41.87	46	-18.9	14.84	2.34	31.95	100	31	Peak
680.8	25.17	33.06	46	-20.83	20.59	3.36	31.84	100	156	Peak
904.8	27.71	32.22	46	-18.29	23.54	3.98	32.03	100	92	Peak

ANTENNA POLARITY & TEST DISTANCE: VERTICAL AT 3 M										
FREQ. (MHz)	EMISSION LEVEL (dBuV/m)	READ LEVEL (dBuV)	LIMIT (dBuV/m)	MARGIN (dB)	ANTENNA FACTOR (dB/m)	CABLE LOSS (dB)	PREAMP FACTOR (dB)	ANTENNA HEIGHT (cm)	TABLE ANGLE (Degree)	REMARK
57.54	29.31	47.6	40	-10.69	12.25	0.81	31.35	100	233	Peak
140.43	25.07	43.04	43.5	-18.43	12.37	1.3	31.64	100	86	Peak
187.41	20.33	40.26	43.5	-23.17	10.26	1.53	31.72	100	166	Peak
444.2	27.77	40.96	46	-18.23	16.21	2.59	31.99	100	148	Peak
547.8	22.31	32.87	46	-23.69	18.41	2.94	31.91	100	152	Peak
773.2	26.63	32.49	46	-19.37	21.85	3.63	31.34	100	184	Peak

REMARKS: Emission Level = Read Level + Antenna Factor + Cable Loss - Preamp Factor
Margin value = Emission level – Limit value



A D T

EUT TEST CONDITION		MEASUREMENT DETAIL	
CHANNEL	Channel 100	FREQUENCY RANGE	30MHz ~ 1GHz
INPUT POWER	120Vac, 60 Hz	DETECTOR FUNCTION	Peak (PK) Quasi-peak (QP)
ENVIRONMENTAL CONDITIONS	25deg. C, 65%RH	TESTED BY	Peter Weng

ANTENNA POLARITY & TEST DISTANCE: HORIZONTAL AT 3 M										
FREQ. (MHz)	EMISSION LEVEL (dBuV/m)	READ LEVEL (dBuV)	LIMIT (dBuV/m)	MARGIN (dB)	ANTENNA FACTOR (dB/m)	CABLE LOSS (dB)	PREAMP FACTOR (dB)	ANTENNA HEIGHT (cm)	TABLE ANGLE (Degree)	REMARK
57.54	22.61	40.9	40	-17.39	12.25	0.81	31.35	100	194	Peak
126.93	24.11	43.3	43.5	-19.39	11.48	1.22	31.89	100	116	Peak
277.86	18.94	36.54	46	-27.06	12.31	1.95	31.86	100	200	Peak
379.1	25.29	40.06	46	-20.71	14.84	2.34	31.95	100	253	Peak
617.8	23.47	32.66	46	-22.53	19.82	3.14	32.15	100	141	Peak
857.2	28.28	33.37	46	-17.72	22.96	3.84	31.89	100	192	Peak

ANTENNA POLARITY & TEST DISTANCE: VERTICAL AT 3 M										
FREQ. (MHz)	EMISSION LEVEL (dBuV/m)	READ LEVEL (dBuV)	LIMIT (dBuV/m)	MARGIN (dB)	ANTENNA FACTOR (dB/m)	CABLE LOSS (dB)	PREAMP FACTOR (dB)	ANTENNA HEIGHT (cm)	TABLE ANGLE (Degree)	REMARK
73.47	29.15	50.12	40	-10.85	9.81	0.93	31.71	100	129	Peak
132.33	29.92	48.69	43.5	-13.58	11.81	1.25	31.83	100	81	Peak
166.62	21.04	39.33	43.5	-22.46	12.05	1.43	31.77	100	158	Peak
395.2	22.84	37.31	46	-23.16	15.21	2.4	32.08	100	203	Peak
596.8	22.93	32.54	46	-23.07	19.52	3.08	32.21	100	142	Peak
850.9	27.59	32.76	46	-18.41	22.88	3.82	31.87	100	127	Peak

REMARKS: Emission Level = Read Level + Antenna Factor + Cable Loss - Preamp Factor
Margin value = Emission level – Limit value



A D T

EUT TEST CONDITION		MEASUREMENT DETAIL	
CHANNEL	Channel 116	FREQUENCY RANGE	30MHz ~ 1GHz
INPUT POWER	120Vac, 60 Hz	DETECTOR FUNCTION	Peak (PK) Quasi-peak (QP)
ENVIRONMENTAL CONDITIONS	25deg. C, 65%RH	TESTED BY	Peter Weng

ANTENNA POLARITY & TEST DISTANCE: HORIZONTAL AT 3 M										
FREQ. (MHz)	EMISSION LEVEL (dBuV/m)	READ LEVEL (dBuV)	LIMIT (dBuV/m)	MARGIN (dB)	ANTENNA FACTOR (dB/m)	CABLE LOSS (dB)	PREAMP FACTOR (dB)	ANTENNA HEIGHT (cm)	TABLE ANGLE (Degree)	REMARK
57	22.78	41.07	40	-17.22	12.25	0.81	31.35	100	138	Peak
132.06	24.78	43.55	43.5	-18.72	11.81	1.25	31.83	100	124	Peak
217.92	15.44	35.32	46	-30.56	10.13	1.68	31.69	100	105	Peak
379.1	22.83	37.6	46	-23.17	14.84	2.34	31.95	100	128	Peak
608.7	23.71	32.97	46	-22.29	19.72	3.12	32.1	100	133	Peak
767.6	27.24	33.21	46	-18.76	21.76	3.61	31.34	100	146	Peak

ANTENNA POLARITY & TEST DISTANCE: VERTICAL AT 3 M										
FREQ. (MHz)	EMISSION LEVEL (dBuV/m)	READ LEVEL (dBuV)	LIMIT (dBuV/m)	MARGIN (dB)	ANTENNA FACTOR (dB/m)	CABLE LOSS (dB)	PREAMP FACTOR (dB)	ANTENNA HEIGHT (cm)	TABLE ANGLE (Degree)	REMARK
31.35	31.03	49.44	40	-8.97	12.14	0.57	31.12	100	193	Peak
105.33	25.59	46.76	43.5	-17.91	9.62	1.1	31.89	100	159	Peak
141.51	24.04	41.96	43.5	-19.46	12.41	1.3	31.63	100	161	Peak
395.2	24.73	39.2	46	-21.27	15.21	2.4	32.08	100	184	Peak
542.2	21.74	32.31	46	-24.26	18.28	2.92	31.77	100	253	Peak
713.7	25.81	33.04	46	-20.19	21.01	3.47	31.71	100	248	Peak

REMARKS: Emission Level = Read Level + Antenna Factor + Cable Loss - Preamp Factor
Margin value = Emission level – Limit value



A D T

EUT TEST CONDITION		MEASUREMENT DETAIL	
CHANNEL	Channel 140	FREQUENCY RANGE	30MHz ~ 1GHz
INPUT POWER	120Vac, 60 Hz	DETECTOR FUNCTION	Peak (PK) Quasi-peak (QP)
ENVIRONMENTAL CONDITIONS	25deg. C, 65%RH	TESTED BY	Peter Weng

ANTENNA POLARITY & TEST DISTANCE: HORIZONTAL AT 3 M										
FREQ. (MHz)	EMISSION LEVEL (dBuV/m)	READ LEVEL (dBuV)	LIMIT (dBuV/m)	MARGIN (dB)	ANTENNA FACTOR (dB/m)	CABLE LOSS (dB)	PREAMP FACTOR (dB)	ANTENNA HEIGHT (cm)	TABLE ANGLE (Degree)	REMARK
56.73	23.55	41.84	40	-16.45	12.25	0.81	31.35	100	118	Peak
127.2	24	43.19	43.5	-19.5	11.48	1.22	31.89	100	152	Peak
236.55	17.05	36.17	46	-28.95	10.91	1.77	31.8	100	109	Peak
407.8	24.57	38.67	46	-21.43	15.48	2.45	32.03	100	144	Peak
595.4	23.44	33.07	46	-22.56	19.5	3.07	32.2	100	257	Peak
811	28.07	33.45	46	-17.93	22.37	3.72	31.47	100	264	Peak

ANTENNA POLARITY & TEST DISTANCE: VERTICAL AT 3 M										
FREQ. (MHz)	EMISSION LEVEL (dBuV/m)	READ LEVEL (dBuV)	LIMIT (dBuV/m)	MARGIN (dB)	ANTENNA FACTOR (dB/m)	CABLE LOSS (dB)	PREAMP FACTOR (dB)	ANTENNA HEIGHT (cm)	TABLE ANGLE (Degree)	REMARK
78.33	30.85	52.85	40	-9.15	8.61	0.96	31.57	100	103	Peak
127.2	32.09	51.28	43.5	-11.41	11.48	1.22	31.89	100	28	Peak
140.7	24.41	42.38	43.5	-19.09	12.37	1.3	31.64	100	317	Peak
363	23.02	38.25	46	-22.98	14.45	2.28	31.96	100	201	Peak
395.2	27.75	42.22	46	-18.25	15.21	2.4	32.08	100	197	Peak
599.6	23.3	32.86	46	-22.7	19.59	3.09	32.24	100	182	Peak

REMARKS: Emission Level = Read Level + Antenna Factor + Cable Loss - Preamp Factor
Margin value = Emission level – Limit value



A D T

802.11n (40MHz)

EUT TEST CONDITION		MEASUREMENT DETAIL	
CHANNEL	Channel 38	FREQUENCY RANGE	30MHz ~ 1GHz
INPUT POWER	120Vac, 60 Hz	DETECTOR FUNCTION	Peak (PK) Quasi-peak (QP)
ENVIRONMENTAL CONDITIONS	25deg. C, 65%RH	TESTED BY	Peter Weng

ANTENNA POLARITY & TEST DISTANCE: HORIZONTAL AT 3 M										
FREQ. (MHz)	EMISSION LEVEL (dBuV/m)	READ LEVEL (dBuV)	LIMIT (dBuV/m)	MARGIN (dB)	ANTENNA FACTOR (dB/m)	CABLE LOSS (dB)	PREAMP FACTOR (dB)	ANTENNA HEIGHT (cm)	TABLE ANGLE (Degree)	REMARK
55.65	23.76	41.84	40	-16.24	12.45	0.8	31.33	111	123	Peak
131.52	24.89	43.66	43.5	-18.61	11.81	1.25	31.83	127	334	Peak
258.42	19.19	37.49	46	-26.81	11.71	1.86	31.87	101	92	Peak
411.3	28.22	42.19	46	-17.78	15.56	2.47	32	132	70	Peak
581.4	23.68	33.6	46	-22.32	19.17	3.03	32.12	107	101	Peak
776.7	27.16	33.01	46	-18.84	21.9	3.64	31.39	120	255	Peak
ANTENNA POLARITY & TEST DISTANCE: VERTICAL AT 3 M										
FREQ. (MHz)	EMISSION LEVEL (dBuV/m)	READ LEVEL (dBuV)	LIMIT (dBuV/m)	MARGIN (dB)	ANTENNA FACTOR (dB/m)	CABLE LOSS (dB)	PREAMP FACTOR (dB)	ANTENNA HEIGHT (cm)	TABLE ANGLE (Degree)	REMARK
30.54	32.94	51.35	40	-7.06	12.14	0.57	31.12	130	171	Peak
126.12	31.23	50.48	43.5	-12.27	11.42	1.22	31.89	103	24	Peak
167.97	21.55	39.92	43.5	-21.95	11.96	1.43	31.76	109	257	Peak
412	28.23	42.18	46	-17.77	15.58	2.47	32	100	285	Peak
605.2	24.18	33.58	46	-21.82	19.67	3.1	32.17	104	357	Peak
761.3	26.24	32.4	46	-19.76	21.68	3.6	31.44	105	54	Peak

REMARKS: Emission Level = Read Level + Antenna Factor + Cable Loss - Preamp Factor
Margin value = Emission level – Limit value



A D T

EUT TEST CONDITION		MEASUREMENT DETAIL	
CHANNEL	Channel 46	FREQUENCY RANGE	30MHz ~ 1GHz
INPUT POWER	120Vac, 60 Hz	DETECTOR FUNCTION	Peak (PK) Quasi-peak (QP)
ENVIRONMENTAL CONDITIONS	25deg. C, 65%RH	TESTED BY	Peter Weng

ANTENNA POLARITY & TEST DISTANCE: HORIZONTAL AT 3 M										
FREQ. (MHz)	EMISSION LEVEL (dBuV/m)	READ LEVEL (dBuV)	LIMIT (dBuV/m)	MARGIN (dB)	ANTENNA FACTOR (dB/m)	CABLE LOSS (dB)	PREAMP FACTOR (dB)	ANTENNA HEIGHT (cm)	TABLE ANGLE (Degree)	REMARK
57.27	23.9	42.19	40	-16.1	12.25	0.81	31.35	124	231	Peak
133.41	25.21	43.79	43.5	-18.29	11.94	1.26	31.78	117	103	Peak
282.72	19.13	36.48	46	-26.87	12.45	1.97	31.77	104	232	Peak
395.2	29.58	44.05	46	-16.42	15.21	2.4	32.08	112	77	Peak
580.7	23	32.92	46	-23	19.17	3.03	32.12	100	142	Peak
811.7	27.5	32.88	46	-18.5	22.38	3.72	31.48	131	136	Peak

ANTENNA POLARITY & TEST DISTANCE: VERTICAL AT 3 M										
FREQ. (MHz)	EMISSION LEVEL (dBuV/m)	READ LEVEL (dBuV)	LIMIT (dBuV/m)	MARGIN (dB)	ANTENNA FACTOR (dB/m)	CABLE LOSS (dB)	PREAMP FACTOR (dB)	ANTENNA HEIGHT (cm)	TABLE ANGLE (Degree)	REMARK
30.81	32.26	50.67	40	-7.74	12.14	0.57	31.12	113	321	Peak
126.66	31.1	50.29	43.5	-12.4	11.48	1.22	31.89	121	77	Peak
179.04	21.35	40.85	43.5	-22.15	10.83	1.5	31.83	113	230	Peak
395.2	28.56	43.03	46	-17.44	15.21	2.4	32.08	139	9	Peak
626.9	24.44	33.49	46	-21.56	19.93	3.17	32.15	127	86	Peak
797	27.18	32.72	46	-18.82	22.19	3.69	31.42	100	118	Peak

REMARKS: Emission Level = Read Level + Antenna Factor + Cable Loss - Preamp Factor
Margin value = Emission level – Limit value



A D T

EUT TEST CONDITION		MEASUREMENT DETAIL	
CHANNEL	Channel 54	FREQUENCY RANGE	30MHz ~ 1GHz
INPUT POWER	120Vac, 60 Hz	DETECTOR FUNCTION	Peak (PK) Quasi-peak (QP)
ENVIRONMENTAL CONDITIONS	25deg. C, 65%RH	TESTED BY	Peter Weng

ANTENNA POLARITY & TEST DISTANCE: HORIZONTAL AT 3 M										
FREQ. (MHz)	EMISSION LEVEL (dBuV/m)	READ LEVEL (dBuV)	LIMIT (dBuV/m)	MARGIN (dB)	ANTENNA FACTOR (dB/m)	CABLE LOSS (dB)	PREAMP FACTOR (dB)	ANTENNA HEIGHT (cm)	TABLE ANGLE (Degree)	REMARK
70.5	21.36	41.71	40	-18.64	10.53	0.91	31.79	100	203	Peak
134.49	22.53	41.01	43.5	-20.97	12.01	1.27	31.76	100	65	Peak
233.85	17.22	36.5	46	-28.78	10.79	1.76	31.83	100	260	Peak
379.1	26.11	40.88	46	-19.89	14.84	2.34	31.95	100	225	Peak
657	24.71	33.12	46	-21.29	20.29	3.27	31.97	100	138	Peak
802.6	27.26	32.74	46	-18.74	22.25	3.7	31.43	100	249	Peak

ANTENNA POLARITY & TEST DISTANCE: VERTICAL AT 3 M										
FREQ. (MHz)	EMISSION LEVEL (dBuV/m)	READ LEVEL (dBuV)	LIMIT (dBuV/m)	MARGIN (dB)	ANTENNA FACTOR (dB/m)	CABLE LOSS (dB)	PREAMP FACTOR (dB)	ANTENNA HEIGHT (cm)	TABLE ANGLE (Degree)	REMARK
31.08	31.87	50.28	40	-8.13	12.14	0.57	31.12	100	87	Peak
88.59	27.65	50.24	43.5	-15.85	8.27	1.01	31.87	100	184	Peak
147.18	21.57	39.25	43.5	-21.93	12.61	1.33	31.62	100	28	Peak
427.4	24.74	38.34	46	-21.26	15.89	2.53	32.02	100	165	Peak
460.3	24.14	36.93	46	-21.86	16.54	2.65	31.98	100	204	Peak
677.3	25.58	33.53	46	-20.42	20.54	3.34	31.83	100	154	Peak

REMARKS: Emission Level = Read Level + Antenna Factor + Cable Loss - Preamp Factor
Margin value = Emission level – Limit value



A D T

EUT TEST CONDITION		MEASUREMENT DETAIL	
CHANNEL	Channel 62	FREQUENCY RANGE	30MHz ~ 1GHz
INPUT POWER	120Vac, 60 Hz	DETECTOR FUNCTION	Peak (PK) Quasi-peak (QP)
ENVIRONMENTAL CONDITIONS	25deg. C, 65%RH	TESTED BY	Peter Weng

ANTENNA POLARITY & TEST DISTANCE: HORIZONTAL AT 3 M

FREQ. (MHz)	EMISSION LEVEL (dBuV/m)	READ LEVEL (dBuV)	LIMIT (dBuV/m)	MARGIN (dB)	ANTENNA FACTOR (dB/m)	CABLE LOSS (dB)	PREAMP FACTOR (dB)	ANTENNA HEIGHT (cm)	TABLE ANGLE (Degree)	REMARK
54.57	22.6	40.58	40	-17.4	12.56	0.79	31.33	100	126	Peak
127.2	24.03	43.22	43.5	-19.47	11.48	1.22	31.89	100	140	Peak
275.97	18.57	36.28	46	-27.43	12.25	1.94	31.9	100	305	Peak
346.9	24.06	39.59	46	-21.94	14.08	2.22	31.83	100	293	Peak
642.3	24.6	33.34	46	-21.4	20.12	3.22	32.08	100	318	Peak
818	27.21	32.59	46	-18.79	22.45	3.74	31.57	100	207	Peak

ANTENNA POLARITY & TEST DISTANCE: VERTICAL AT 3 M

FREQ. (MHz)	EMISSION LEVEL (dBuV/m)	READ LEVEL (dBuV)	LIMIT (dBuV/m)	MARGIN (dB)	ANTENNA FACTOR (dB/m)	CABLE LOSS (dB)	PREAMP FACTOR (dB)	ANTENNA HEIGHT (cm)	TABLE ANGLE (Degree)	REMARK
73.2	29.12	50.09	40	-10.88	9.81	0.93	31.71	100	129	Peak
130.98	29.78	48.64	43.5	-13.72	11.75	1.25	31.86	100	118	Peak
155.01	21.62	39.27	43.5	-21.88	12.72	1.37	31.74	100	72	Peak
395.2	25.07	39.54	46	-20.93	15.21	2.4	32.08	100	216	Peak
614.3	23.85	33.07	46	-22.15	19.77	3.13	32.12	100	164	Peak
723.5	25.27	32.25	46	-20.73	21.15	3.5	31.63	100	351	Peak

REMARKS: Emission Level = Read Level + Antenna Factor + Cable Loss - Preamp Factor
Margin value = Emission level – Limit value



A D T

EUT TEST CONDITION		MEASUREMENT DETAIL	
CHANNEL	Channel 102	FREQUENCY RANGE	30MHz ~ 1GHz
INPUT POWER	120Vac, 60 Hz	DETECTOR FUNCTION	Peak (PK) Quasi-peak (QP)
ENVIRONMENTAL CONDITIONS	25deg. C, 65%RH	TESTED BY	Peter Weng

ANTENNA POLARITY & TEST DISTANCE: HORIZONTAL AT 3 M										
FREQ. (MHz)	EMISSION LEVEL (dBuV/m)	READ LEVEL (dBuV)	LIMIT (dBuV/m)	MARGIN (dB)	ANTENNA FACTOR (dB/m)	CABLE LOSS (dB)	PREAMP FACTOR (dB)	ANTENNA HEIGHT (cm)	TABLE ANGLE (Degree)	REMARK
55.92	22.87	41.06	40	-17.13	12.35	0.8	31.34	100	240	Peak
138	20.78	38.98	43.5	-22.72	12.21	1.28	31.69	100	311	Peak
226.02	16.87	36.49	46	-29.13	10.46	1.72	31.8	100	57	Peak
411.3	26.98	40.95	46	-19.02	15.56	2.47	32	100	256	Peak
601	23.06	32.58	46	-22.94	19.62	3.09	32.23	100	267	Peak
839.7	27.28	32.55	46	-18.72	22.74	3.79	31.8	100	217	Peak

ANTENNA POLARITY & TEST DISTANCE: VERTICAL AT 3 M										
FREQ. (MHz)	EMISSION LEVEL (dBuV/m)	READ LEVEL (dBuV)	LIMIT (dBuV/m)	MARGIN (dB)	ANTENNA FACTOR (dB/m)	CABLE LOSS (dB)	PREAMP FACTOR (dB)	ANTENNA HEIGHT (cm)	TABLE ANGLE (Degree)	REMARK
57	29.63	47.92	40	-10.37	12.25	0.81	31.35	100	158	Peak
133.14	29.36	48.03	43.5	-14.14	11.88	1.26	31.81	100	107	Peak
179.31	21.34	40.84	43.5	-22.16	10.83	1.5	31.83	100	66	Peak
395.9	26.94	41.38	46	-19.06	15.24	2.41	32.09	100	198	Peak
603.1	23.45	32.9	46	-22.55	19.65	3.1	32.2	100	277	Peak
789.3	27.25	32.9	46	-18.75	22.08	3.67	31.4	100	314	Peak

REMARKS: Emission Level = Read Level + Antenna Factor + Cable Loss - Preamp Factor
Margin value = Emission level – Limit value



A D T

EUT TEST CONDITION		MEASUREMENT DETAIL	
CHANNEL	Channel 110	FREQUENCY RANGE	30MHz ~ 1GHz
INPUT POWER	120Vac, 60 Hz	DETECTOR FUNCTION	Peak (PK) Quasi-peak (QP)
ENVIRONMENTAL CONDITIONS	25deg. C, 65%RH	TESTED BY	Peter Weng

ANTENNA POLARITY & TEST DISTANCE: HORIZONTAL AT 3 M										
FREQ. (MHz)	EMISSION LEVEL (dBuV/m)	READ LEVEL (dBuV)	LIMIT (dBuV/m)	MARGIN (dB)	ANTENNA FACTOR (dB/m)	CABLE LOSS (dB)	PREAMP FACTOR (dB)	ANTENNA HEIGHT (cm)	TABLE ANGLE (Degree)	REMARK
57.81	23.21	41.6	40	-16.79	12.15	0.81	31.35	100	124	Peak
126.39	23.9	43.15	43.5	-19.6	11.42	1.22	31.89	100	78	Peak
161.22	17.73	35.57	43.5	-25.77	12.63	1.39	31.86	100	252	Peak
407.1	26.04	40.14	46	-19.96	15.48	2.45	32.03	114	201	Peak
647.2	23.98	32.62	46	-22.02	20.17	3.23	32.04	100	146	Peak
846.7	27.67	32.88	46	-18.33	22.83	3.81	31.85	108	289	Peak

ANTENNA POLARITY & TEST DISTANCE: VERTICAL AT 3 M										
FREQ. (MHz)	EMISSION LEVEL (dBuV/m)	READ LEVEL (dBuV)	LIMIT (dBuV/m)	MARGIN (dB)	ANTENNA FACTOR (dB/m)	CABLE LOSS (dB)	PREAMP FACTOR (dB)	ANTENNA HEIGHT (cm)	TABLE ANGLE (Degree)	REMARK
30.81	33.1	51.51	40	-6.9	12.14	0.57	31.12	100	114	Peak
126.66	30.95	50.14	43.5	-12.55	11.48	1.22	31.89	100	209	Peak
237.09	16.89	36.01	46	-29.11	10.91	1.77	31.8	100	113	Peak
444.2	29.41	42.6	46	-16.59	16.21	2.59	31.99	105	137	Peak
731.2	26.43	33.23	46	-19.57	21.26	3.52	31.58	122	169	Peak
959.4	29.12	33.11	46	-16.88	23.84	4.09	31.92	115	248	Peak

REMARKS: Emission Level = Read Level + Antenna Factor + Cable Loss - Preamp Factor
Margin value = Emission level – Limit value



A D T

EUT TEST CONDITION		MEASUREMENT DETAIL	
CHANNEL	Channel 134	FREQUENCY RANGE	30MHz ~ 1GHz
INPUT POWER	120Vac, 60 Hz	DETECTOR FUNCTION	Peak (PK) Quasi-peak (QP)
ENVIRONMENTAL CONDITIONS	25deg. C, 65%RH	TESTED BY	Peter Weng

ANTENNA POLARITY & TEST DISTANCE: HORIZONTAL AT 3 M										
FREQ. (MHz)	EMISSION LEVEL (dBuV/m)	READ LEVEL (dBuV)	LIMIT (dBuV/m)	MARGIN (dB)	ANTENNA FACTOR (dB/m)	CABLE LOSS (dB)	PREAMP FACTOR (dB)	ANTENNA HEIGHT (cm)	TABLE ANGLE (Degree)	REMARK
70.5	20.46	40.81	40	-19.54	10.53	0.91	31.79	100	116	Peak
131.52	24.61	43.38	43.5	-18.89	11.81	1.25	31.83	100	209	Peak
288.93	18.7	35.75	46	-27.3	12.63	2	31.68	100	53	Peak
395.2	30.84	45.31	46	-15.16	15.21	2.4	32.08	100	303	Peak
647.2	24.31	32.95	46	-21.69	20.17	3.23	32.04	100	171	Peak
853.7	28.09	33.23	46	-17.91	22.91	3.83	31.88	100	142	Peak

ANTENNA POLARITY & TEST DISTANCE: VERTICAL AT 3 M										
FREQ. (MHz)	EMISSION LEVEL (dBuV/m)	READ LEVEL (dBuV)	LIMIT (dBuV/m)	MARGIN (dB)	ANTENNA FACTOR (dB/m)	CABLE LOSS (dB)	PREAMP FACTOR (dB)	ANTENNA HEIGHT (cm)	TABLE ANGLE (Degree)	REMARK
54.84	29.85	47.93	40	-10.15	12.45	0.8	31.33	100	72	Peak
85.35	29.31	51.83	40	-10.69	8.22	1	31.74	100	250	Peak
132.33	30.21	48.98	43.5	-13.29	11.81	1.25	31.83	100	317	Peak
395.2	26.08	40.55	46	-19.92	15.21	2.4	32.08	100	281	Peak
492.5	23.69	35.49	46	-22.31	17.18	2.75	31.73	100	328	Peak
735.4	25.62	32.31	46	-20.38	21.31	3.53	31.53	100	54	Peak

REMARKS: Emission Level = Read Level + Antenna Factor + Cable Loss - Preamp Factor
Margin value = Emission level – Limit value

4.2 CONDUCTED EMISSION MEASUREMENT

4.2.1 LIMITS OF CONDUCTED EMISSION MEASUREMENT

FREQUENCY OF EMISSION (MHz)	CONDUCTED LIMIT (dB μ V)	
	Quasi-peak	Average
0.15 ~ 0.5	66 to 56	56 to 46
0.5 ~ 5	56	46
5 ~ 30	60	50

NOTE:

1. The lower limit shall apply at the transition frequencies.
2. The limit decreases in line with the logarithm of the frequency in the range of 0.15 to 0.50MHz.
3. All emanations from a class A/B digital device or system, including any network of conductors and apparatus connected thereto, shall not exceed the level of field strengths specified above.

4.2.2 TEST INSTRUMENTS

DESCRIPTION & MANUFACTURER	MODEL NO.	SERIAL NO.	DATE OF CALIBRATION	DUE DATE OF CALIBRATION
Test Receiver ROHDE & SCHWARZ	ESCS30	100288	Nov. 17, 2013	Nov. 16, 2014
RF signal cable Woken	5D-FB	Cable-HYCO2-01	Dec. 27, 2013	Dec. 26, 2014
LISN ROHDE & SCHWARZ (EUT)	ESH2-Z5	100100	Dec. 23, 2013	Dec. 22, 2014
LISN ROHDE & SCHWARZ (Peripheral)	ESH3-Z5	100311	Jul. 17, 2013	Jul. 16, 2014
Software ADT	BV ADT_Cond_ V7.3.7.3	NA	NA	NA

- NOTE:**
1. The calibration interval of the above test instruments is 12 months and the calibrations are traceable to NML/ROC and NIST/USA.
 2. The test was performed in HwaYa Shielded Room 2.
 3. The VCCI Site Registration No. is C-2047.

4.2.3 TEST PROCEDURES

- a. The EUT was placed 0.4 meters from the conducting wall of the shielded room with EUT being connected to the power mains through a line impedance stabilization network (LISN). Other support units were connected to the power mains through another LISN. The two LISNs provide 50 ohm/ 50uH of coupling impedance for the measuring instrument.
- b. Both lines of the power mains connected to the EUT were checked for maximum conducted interference.
- c. The frequency range from 150kHz to 30MHz was searched. Emission levels under (Limit - 20dB) was not recorded.

NOTE: All modes of operation were investigated and the worst-case emissions are reported.

4.2.4 DEVIATION FROM TEST STANDARD

No deviation.

4.2.5 TEST SETUP

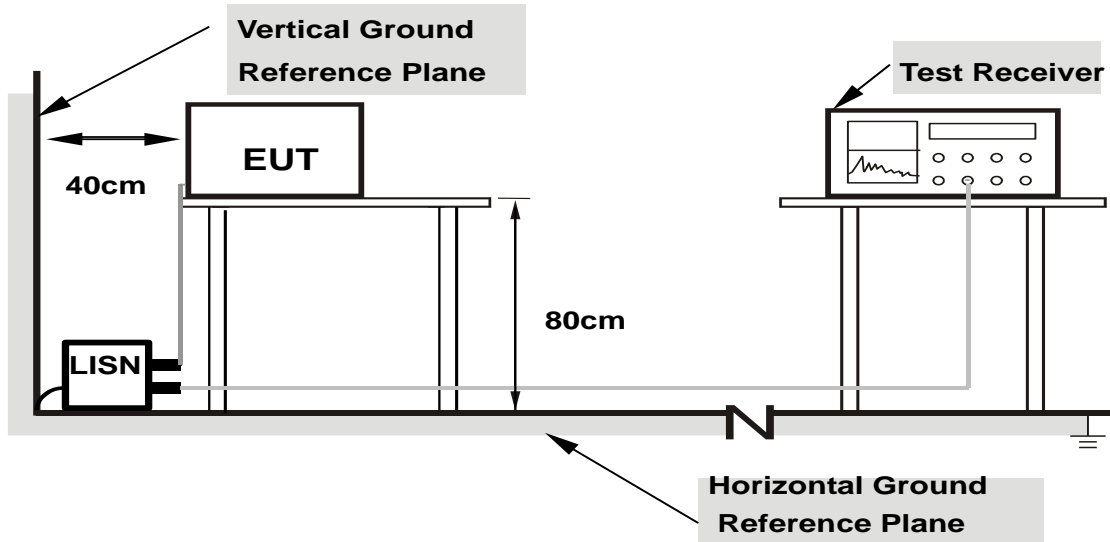

- Note:**
- 1.Support units were connected to second LISN.
 - 2.Both of LISNs (AMN) are 80 cm from EUT and at least 80 from other units and other metal planes

For the actual test configuration, please refer to the attached file (Test Setup Photo).

4.2.6 EUT OPERATING CONDITIONS

Same as 4.1.6.

4.2.7 TEST RESULTS

CONDUCTED WORST-CASE DATA :

PHASE	Line 1	6dB BANDWIDTH	9kHz
FUNCTION TYPE	GSM1900 Idle + BT Link + WLAN 5G Link + Adapter + U-Cup Cable + NFC Link		

No	Freq. [MHz]	Corr. Factor (dB)	Reading Value		Emission Level		Limit		Margin	
			[dB (uV)]		[dB (uV)]		[dB (uV)]		(dB)	
			Q.P.	AV.	Q.P.	AV.	Q.P.	AV.	Q.P.	AV.
1	0.17344	0.27	48.14	29.45	48.41	29.72	64.79	54.79	-16.38	-25.07
2	0.55234	0.31	34.28	23.82	34.59	24.13	56.00	46.00	-21.41	-21.87
3	3.00781	0.40	32.53	24.13	32.93	24.53	56.00	46.00	-23.07	-21.47
4	7.60938	0.47	31.37	24.17	31.84	24.64	60.00	50.00	-28.16	-25.36
5	13.55859	0.52	50.78	45.58	51.30	46.10	60.00	50.00	-8.70	-3.90

REMARKS:

1. Q.P. and AV. are abbreviations of quasi-peak and average individually.
2. The emission levels of other frequencies were very low against the limit.
3. Margin value = Emission level - Limit value
4. Correction factor = Insertion loss + Cable loss
5. Emission Level = Correction Factor + Reading Value

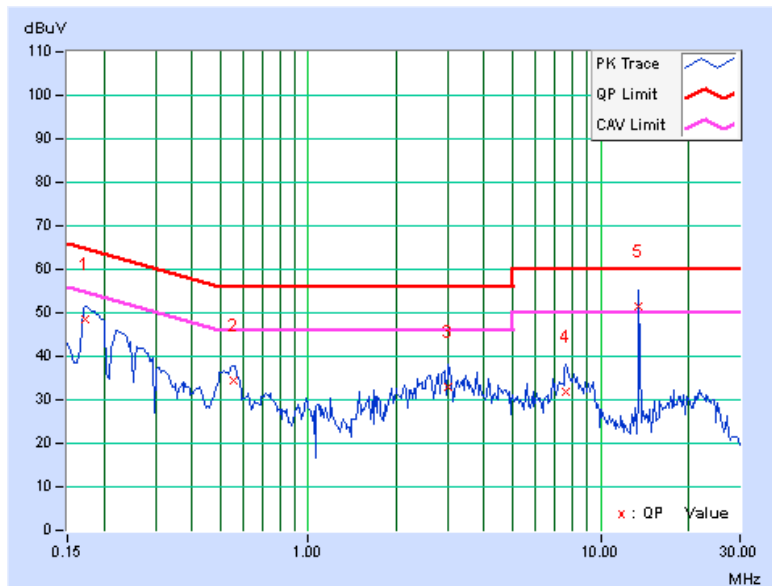

PHASE	Line 2	6dB BANDWIDTH	9kHz
FUNCTION TYPE	GSM1900 Idle + BT Link + WLAN 5G Link + Adapter + U-Cup Cable + NFC Link		

No	Freq.	Corr. Factor	Reading Value		Emission Level		Limit		Margin	
	[MHz]		[dB (uV)]		[dB (uV)]		[dB (uV)]		(dB)	
			Q.P.	AV.	Q.P.	AV.	Q.P.	AV.	Q.P.	AV.
1	0.15391	0.27	43.50	27.90	43.77	28.17	65.79	55.79	-22.02	-27.62
2	0.17734	0.27	47.95	30.30	48.22	30.57	64.61	54.61	-16.39	-24.04
3	0.55625	0.31	34.44	24.83	34.75	25.14	56.00	46.00	-21.25	-20.86
4	2.53125	0.39	33.80	24.60	34.19	24.99	56.00	46.00	-21.81	-21.01
5	7.60938	0.49	31.35	24.07	31.84	24.56	60.00	50.00	-28.16	-25.44
6	13.56250	0.55	50.20	45.96	50.75	46.51	60.00	50.00	-9.25	-3.49

REMARKS:

1. Q.P. and AV. are abbreviations of quasi-peak and average individually.
2. The emission levels of other frequencies were very low against the limit.
3. Margin value = Emission level - Limit value
4. Correction factor = Insertion loss + Cable loss
5. Emission Level = Correction Factor + Reading Value

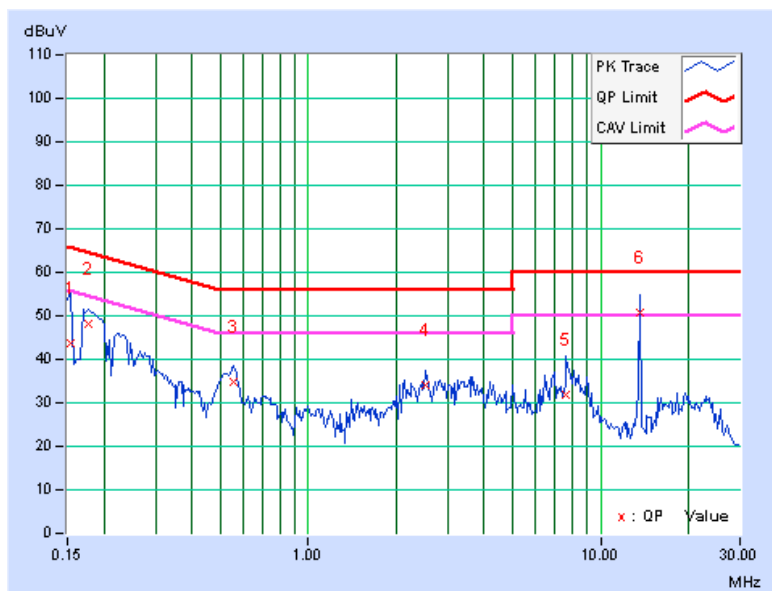

PHASE	Line 1	6dB BANDWIDTH	9kHz
FUNCTION TYPE	GSM1900 Idle + BT Link + WLAN 5G Link + Adapter + USB Cable + NFC Link		

No	Freq. [MHz]	Corr. Factor (dB)	Reading Value [dB (uV)]		Emission Level [dB (uV)]		Limit [dB (uV)]		Margin (dB)	
			Q.P.	AV.	Q.P.	AV.	Q.P.	AV.	Q.P.	AV.
			1	0.15781	0.27	46.07	27.31	46.34	27.58	65.58
2	0.52891	0.31	35.12	28.84	35.43	29.15	56.00	46.00	-20.57	-16.85
3	2.96484	0.39	32.98	23.94	33.37	24.33	56.00	46.00	-22.63	-21.67
4	7.82813	0.47	30.92	22.95	31.39	23.42	60.00	50.00	-28.61	-26.58
5	13.55859	0.52	50.66	45.82	51.18	46.34	60.00	50.00	-8.82	-3.66
6	17.20703	0.56	31.98	23.49	32.54	24.05	60.00	50.00	-27.46	-25.95

REMARKS:

1. Q.P. and AV. are abbreviations of quasi-peak and average individually.
2. The emission levels of other frequencies were very low against the limit.
3. Margin value = Emission level - Limit value
4. Correction factor = Insertion loss + Cable loss
5. Emission Level = Correction Factor + Reading Value

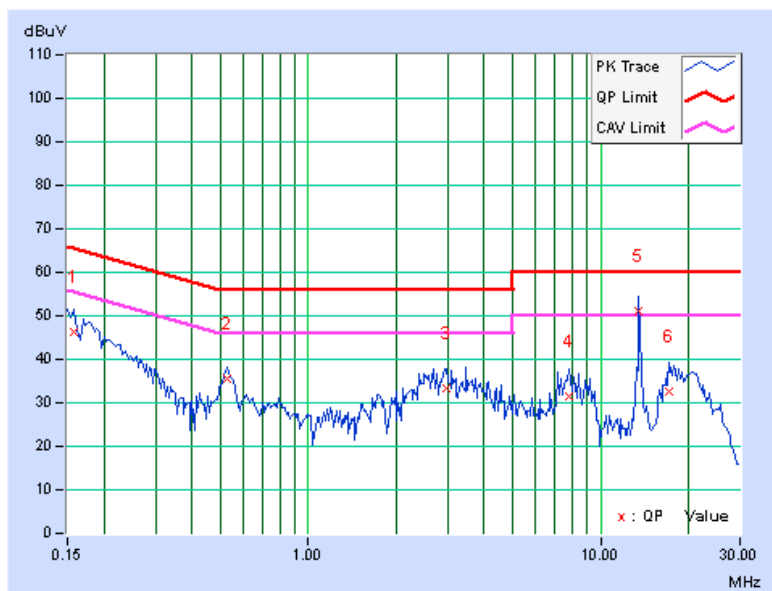

PHASE	Line 2	6dB BANDWIDTH	9kHz
FUNCTION TYPE	GSM1900 Idle + BT Link + WLAN 5G Link + Adapter + USB Cable + NFC Link		

No	Freq.	Corr. Factor	Reading Value		Emission Level		Limit		Margin	
	[MHz]		[dB (uV)]		[dB (uV)]		[dB (uV)]		(dB)	
			Q.P.	AV.	Q.P.	AV.	Q.P.	AV.	Q.P.	AV.
1	0.15000	0.26	48.65	31.29	48.91	31.55	66.00	56.00	-17.09	-24.45
2	0.52891	0.31	35.10	28.98	35.41	29.29	56.00	46.00	-20.59	-16.71
3	3.02344	0.41	32.51	24.49	32.92	24.90	56.00	46.00	-23.08	-21.10
4	7.83203	0.49	32.12	22.93	32.61	23.42	60.00	50.00	-27.39	-26.58
5	13.55859	0.55	50.36	45.80	50.91	46.35	60.00	50.00	-9.09	-3.65
6	17.53516	0.60	32.25	24.76	32.85	25.36	60.00	50.00	-27.15	-24.64

REMARKS:

1. Q.P. and AV. are abbreviations of quasi-peak and average individually.
2. The emission levels of other frequencies were very low against the limit.
3. Margin value = Emission level - Limit value
4. Correction factor = Insertion loss + Cable loss
5. Emission Level = Correction Factor + Reading Value

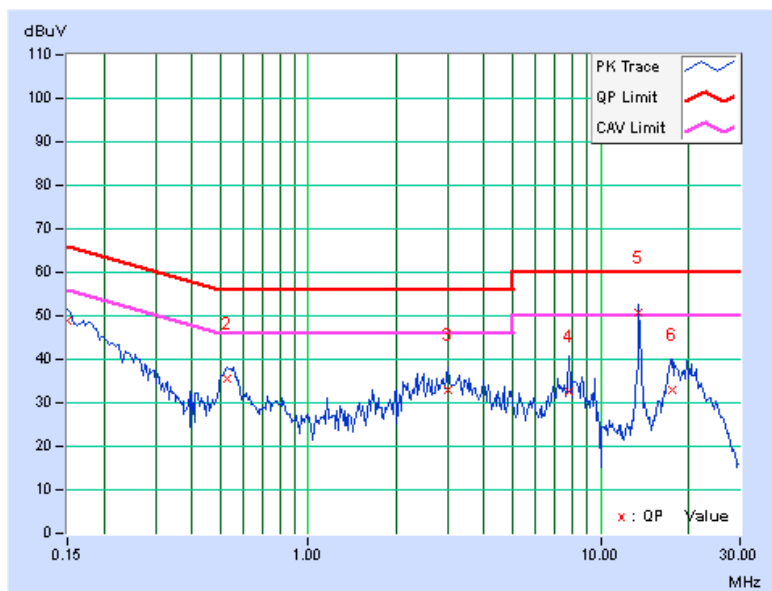

4.3 PEAK TRANSMIT POWER MEASUREMENT

4.3.1 LIMITS OF PEAK TRANSMIT POWER MEASUREMENT

FREQUENCY BAND	LIMIT
5.150 ~ 5.250GHz	The lesser of 50mW (17dBm) or 4dBm + 10logB
5.250 ~ 5.350GHz	The lesser of 250mW (24dBm) or 11dBm + 10logB
5.470 ~ 5.725GHz	The lesser of 250mW (24dBm) or 11dBm + 10logB

NOTE: Where B is the 26dB emission bandwidth in MHz.

4.3.2 TEST SETUP

FOR POWER OUTPUT MEASUREMENT

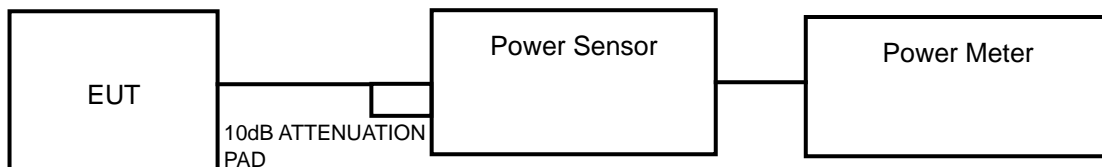

FOR 26dB BANDWIDTH

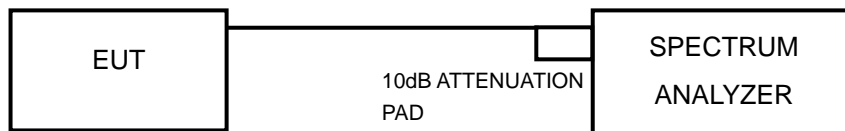

4.3.3 TEST INSTRUMENTS

Refer to section 4.1.3 to get information of above instrument.

4.3.4 TEST PROCEDURE

FOR AVERAGE POWER MEASUREMENT

<802.11a, 802.11n (20MHz), 802.11n (40MHz)>

Method PM is used to perform output power measurement, trigger and gating function of wide band power meter is enabled to measure max output power of TX on burst. Duty factor is not added to measured value.

FOR 26dB BANDWIDTH

- 1) Set RBW = approximately 1% of the emission bandwidth.
- 2) Set the VBW > RBW.
- 3) Detector = Peak.
- 4) Trace mode = max hold.
- 5) Measure the maximum width of the emission that is 26 dB down from the peak of the emission.
Compare this with the RBW setting of the analyzer. Readjust RBW and repeat measurement as needed until the RBW/EBW ratio is approximately 1%.

4.3.5 DEVIATION FROM TEST STANDARD

No deviation.

4.3.6 EUT OPERATING CONDITIONS

The software provided by client to enable the EUT under transmission condition continuously at specific channel frequencies individually.



A D T

4.3.7 TEST RESULTS

POWER OUTPUT

802.11a

CHANNEL	FREQUENCY (MHz)	DATA RATE							
		6M bps	9M bps	12M bps	18M bps	24M bps	36M bps	48M bps	54M bps
36	5180	16.09	16.06	15.94	15.97	15.99	16.01	14.33	14.36
44	5220	15.94	15.93	15.93	15.91	15.92	15.93	14.54	14.58
48	5240	15.76	15.72	15.75	15.73	15.74	15.75	14.41	14.43
52	5260	16.96	16.91	16.92	16.95	16.95	16.55	14.43	14.42
60	5300	16.99	16.89	16.91	16.94	16.97	16.53	14.41	14.44
64	5320	16.44	15.91	15.88	15.89	15.95	15.99	14.47	14.56
100	5500	14.47	14.42	14.44	14.45	14.46	14.36	14.45	14.01
116	5580	16.22	16.17	16.17	15.90	15.90	15.49	13.62	13.88
140	5700	12.31	12.29	12.30	12.05	12.09	12.14	12.22	12.18

CHANNEL	CHANNEL FREQUENCY (MHz)	MAX. AVERAGE POWER (mW)	MAX. AVERAGE POWER (dBm)	POWER LIMIT (dBm)	PASS/FAIL
36	5180	40.64	16.09	17	PASS
44	5220	39.26	15.94	17	PASS
48	5240	37.67	15.76	17	PASS
52	5260	49.66	16.96	24	PASS
60	5300	50.00	16.99	24	PASS
64	5320	44.06	16.44	24	PASS
100	5500	27.99	14.47	24	PASS
116	5580	41.88	16.22	24	PASS
140	5700	17.022	12.31	24	PASS



A D T

802.11n (20MHz)

CHANNEL	FREQUENCY (MHz)	DATA RATE							
		MCS0	MCS1	MCS2	MCS3	MCS4	MCS5	MCS6	MCS7
36	5180	16.11	16.10	16.01	16.00	16.09	16.05	15.13	13.58
44	5220	16.01	15.98	16.00	15.97	15.98	15.99	15.19	13.57
48	5240	15.84	15.83	15.83	15.82	15.81	15.82	15.15	13.62
52	5260	16.62	16.45	16.49	16.55	16.58	16.14	14.96	13.37
60	5300	16.64	16.58	16.59	16.47	16.45	16.16	15.24	13.40
64	5320	16.05	15.92	15.96	15.97	15.98	16.02	14.89	13.37
100	5500	14.61	14.60	14.47	14.51	14.57	14.52	14.58	13.06
116	5580	15.86	15.82	15.80	15.76	15.69	15.26	14.43	12.76
140	5700	12.12	12.11	12.10	12.09	12.08	12.08	12.07	12.06

CHANNEL	CHANNEL FREQUENCY (MHz)	MAX. AVERAGE POWER (mW)	MAX. AVERAGE POWER (dBm)	POWER LIMIT (dBm)	PASS/FAIL
36	5180	40.83	16.11	17	PASS
44	5220	39.90	16.01	17	PASS
48	5240	38.37	15.84	17	PASS
52	5260	45.92	16.62	24	PASS
60	5300	46.13	16.64	24	PASS
64	5320	40.27	16.05	24	PASS
100	5500	28.91	14.61	24	PASS
116	5580	38.55	15.86	24	PASS
140	5700	16.29	12.12	24	PASS



A D T

802.11n (40MHz)

CHANNEL	FREQUENCY (MHz)	DATA RATE							
		MCS0	MCS1	MCS2	MCS3	MCS4	MCS5	MCS6	MCS7
38	5190	12.43	12.42	12.40	12.42	12.39	12.40	12.38	12.39
46	5230	16.83	16.78	16.80	16.08	15.67	15.05	13.95	13.03
54	5270	16.49	16.41	16.45	15.98	15.57	15.09	13.94	13.02
62	5310	11.63	11.57	11.54	11.60	11.61	11.56	11.58	11.52
102	5510	11.15	11.08	11.04	11.11	11.09	11.07	11.12	11.06
110	5550	15.76	15.69	15.72	15.47	15.04	14.22	13.34	12.32
134	5670	15.33	15.28	15.30	15.31	14.73	14.11	13.32	12.39

CHANNEL	CHANNEL FREQUENCY (MHz)	MAX. AVERAGE POWER (mW)	MAX. AVERAGE POWER (dBm)	POWER LIMIT (dBm)	PASS/FAIL
38	5190	17.498	12.43	17	PASS
46	5230	48.195	16.83	17	PASS
54	5270	44.566	16.49	24	PASS
62	5310	14.555	11.63	24	PASS
102	5510	13.032	11.15	24	PASS
110	5550	37.670	15.76	24	PASS
134	5670	34.119	15.33	24	PASS



A D T

26dB BANDWIDTH

802.11a

CHANNEL	CHANNEL FREQUENCY (MHz)	26dBc BANDWIDTH (MHz)	PASS / FAIL
36	5180	42.75	PASS
44	5220	42.38	PASS
48	5240	42.65	PASS
52	5260	43.28	PASS
60	5300	44.50	PASS
64	5320	44.44	PASS
100	5500	42.11	PASS
116	5580	45.24	PASS
140	5700	43.25	PASS

802.11n (20MHz)

CHANNEL	CHANNEL FREQUENCY (MHz)	26dBc BANDWIDTH (MHz)	PASS / FAIL
36	5180	45.65	PASS
44	5220	46.40	PASS
48	5240	45.68	PASS
52	5260	46.74	PASS
60	5300	45.82	PASS
64	5320	46.07	PASS
100	5500	45.02	PASS
116	5580	47.58	PASS
140	5700	47.43	PASS

802.11n (40MHz)

CHANNEL	CHANNEL FREQUENCY (MHz)	26dBc BANDWIDTH (MHz)	PASS / FAIL
38	5190	45.68	PASS
46	5230	83.46	PASS
54	5270	71.99	PASS
62	5310	46.68	PASS
102	5510	46.41	PASS
110	5550	80.05	PASS
134	5670	89.50	PASS



A D T

SPECTRUM PLOT OF WORST VALUE

802.11a

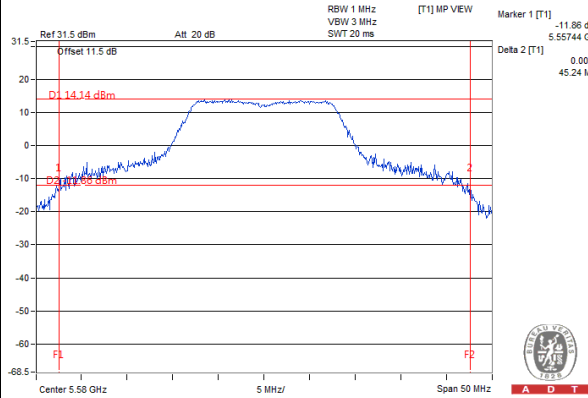

802.11n (20MHz)

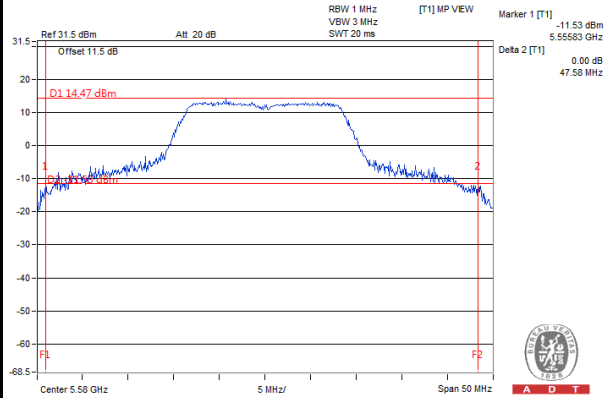

802.11n (40MHz)

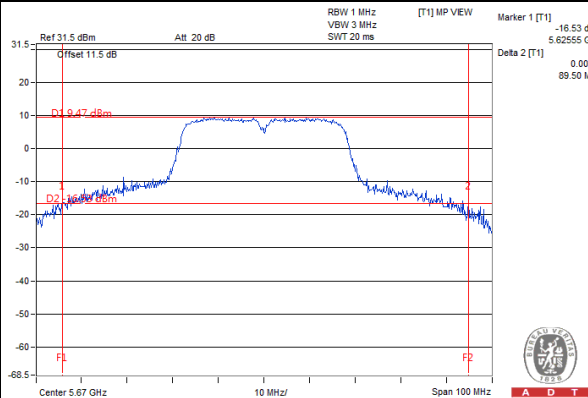

4.4 PEAK POWER SPECTRAL DENSITY MEASUREMENT

4.4.1 LIMITS OF PEAK POWER SPECTRAL DENSITY MEASUREMENT

FREQUENCY BAND	LIMIT
5.150 ~ 5.250GHz	4dBm
5.250 ~ 5.350GHz	11dBm
5.470 ~ 5.725GHz	11dBm

4.4.2 TEST SETUP

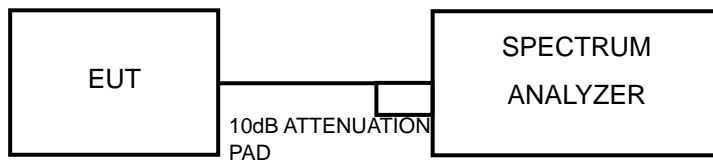

4.4.3 TEST INSTRUMENTS

Refer to section 4.1.3 to get information of above instrument.

4.4.4 TEST PROCEDURES

<802.11a, 802.11n (20MHz), 802.11n (40MHz)>

Using method SA-2 alternative

- 1) Set span to encompass the entire emission bandwidth (EBW) of the signal.
- 2) Set RBW = 1 MHz, Set VBW \geq 3 MHz, Detector = RMS
- 3) Sweep time = 4second.
- 4) Perform a single sweep.
- 5) Record the max value and add 10 log (1/duty cycle)

4.4.5 DEVIATION FROM TEST STANDARD

No deviation.

4.4.6 EUT OPERATING CONDITIONS

Same as Item 4.3.6.



A D T

4.4.7 TEST RESULTS

802.11a

CHANNEL	FREQUENCY (MHz)	PSD (dBm)	MAXIMUM LIMIT (dBm)	PASS/FAIL
36	5180	3.73	4	PASS
44	5220	3.90	4	PASS
48	5240	3.97	4	PASS
52	5260	5.08	11	PASS
60	5300	5.14	11	PASS
64	5320	4.83	11	PASS
100	5500	3.34	11	PASS
116	5580	4.79	11	PASS
140	5700	2.38	11	PASS

802.11n (20MHz)

CHANNEL	FREQUENCY (MHz)	PSD (dBm)	MAXIMUM LIMIT (dBm)	PASS/FAIL
36	5180	3.43	4	PASS
44	5220	3.65	4	PASS
48	5240	3.65	4	PASS
52	5260	4.21	11	PASS
60	5300	4.50	11	PASS
64	5320	4.10	11	PASS
100	5500	3.08	11	PASS
116	5580	4.23	11	PASS
140	5700	0.08	11	PASS



A D T

802.11n (40MHz)

CHANNEL	FREQUENCY (MHz)	PSD W/O DUTY FACTOR (dBm)	DUTY FACTOR	PSD WITH DUTY FACTOR (dBm)	MAXIMUM LIMIT (dBm)	PASS/FAIL
38	5190	-2.98	0.25	-2.73	4	PASS
46	5230	1.22	0.25	1.47	4	PASS
54	5270	0.37	0.25	0.62	11	PASS
62	5310	-3.44	0.25	-3.19	11	PASS
102	5510	-3.16	0.25	-2.91	11	PASS
110	5550	1.25	0.25	1.50	11	PASS
134	5670	0.26	0.25	0.51	11	PASS

NOTE: Refer to section 3.3 for duty cycle spectrum plot.

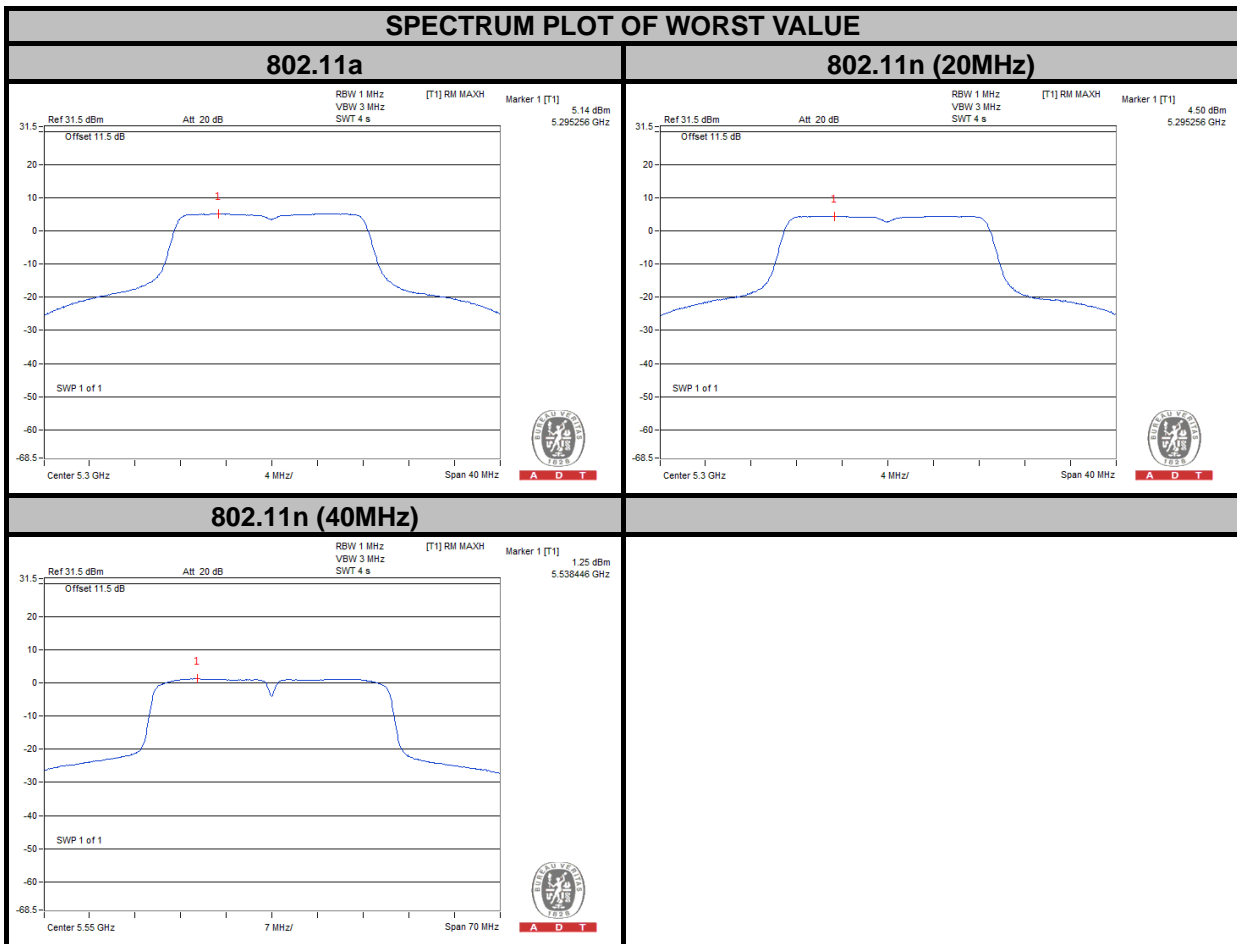

4.5 PEAK POWER EXCURSION MEASUREMENT

4.5.1 LIMITS OF POWER SPECTRAL DENSITY MEASUREMENT

Shall not exceed 13 dB.

4.5.2 TEST SETUP

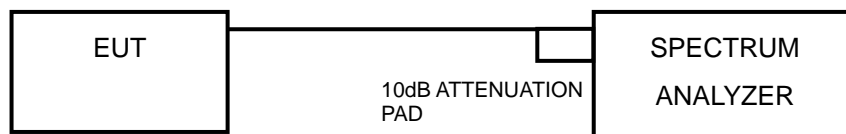

4.5.3 TEST INSTRUMENTS

Refer to section 4.1.3 to get information of above instrument.

4.5.4 TEST PROCEDURE

- Set the RBW = 1 kHz, VBW \geq 3 MHz, Detector = peak.
- Trace mode = max-hold. Allow the sweeps to continue until the trace stabilizes.
- Use the peak search function to find the peak of the spectrum.
- Measure the PPSD.
- Compute the ratio of the maximum of the peak-max-hold spectrum to the PPSD.
Find the worst channel and modulation mode as above test procedure, and follow KDB 789033 D01 General UNII Test Procedures v01r03 and repeat step 1 to 5 for final testing of each modulation mode on a single channel (all modulation types) in a single operating band to compliance with the peak excursion requirement.

4.5.5 DEVIATION FROM TEST STANDARD

No deviation.

4.5.6 EUT OPERATING CONDITION

Same as Item 4.3.6.



A D T

4.5.7 TEST RESULTS

MODULATION MODE	MODULATION TYPE	CHAN. FREQ. (MHz)	PEAK VALUE (dBm)	PPSD WITHOUT DUTY FACTOR (dBm)	PPSD WITH DUTY FACTOR (dBm)	PEAK EXCURSION (dB)	LIMIT (dB)	PASS/FAIL
802.11a	BPSK	5300	14.29	5.14	5.14	9.15	13	PASS
	QPSK		15.28	5.09	5.21	10.07	13	PASS
	16QAM		15.09	5.01	5.24	9.85	13	PASS
	64QAM		12.70	2.55	2.99	9.71	13	PASS
802.11n (20MHz)	BPSK	5300	13.76	4.50	4.50	9.26	13	PASS
	QPSK		14.45	4.50	4.63	9.82	13	PASS
	16QAM		14.37	4.49	4.73	9.64	13	PASS
	64QAM		14.15	3.98	4.41	9.74	13	PASS
802.11n (40MHz)	BPSK	5230	10.48	1.22	1.47	9.01	13	PASS
	QPSK		11.36	1.32	1.84	9.52	13	PASS
	16QAM		11.51	0.80	1.72	9.79	13	PASS
	64QAM		9.48	-0.23	1.47	8.01	13	PASS

NOTE: Refer to section 3.3 for duty cycle spectrum plot.

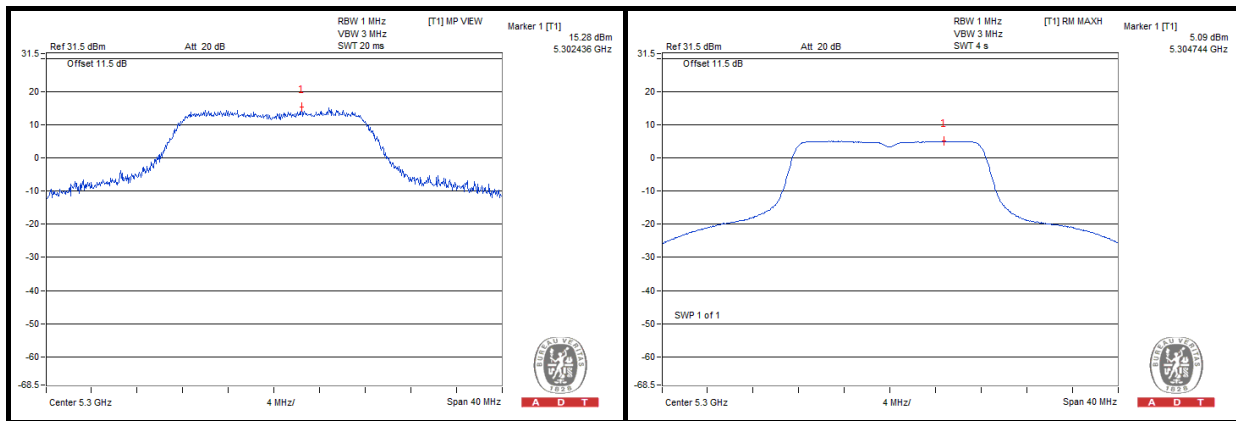

4.6 FREQUENCY STABILITY

4.6.1 LIMITS OF FREQUENCY STABILITY MEASUREMENT

The frequency of the carrier signal shall be maintained within band of operation.

4.6.2 TEST SETUP

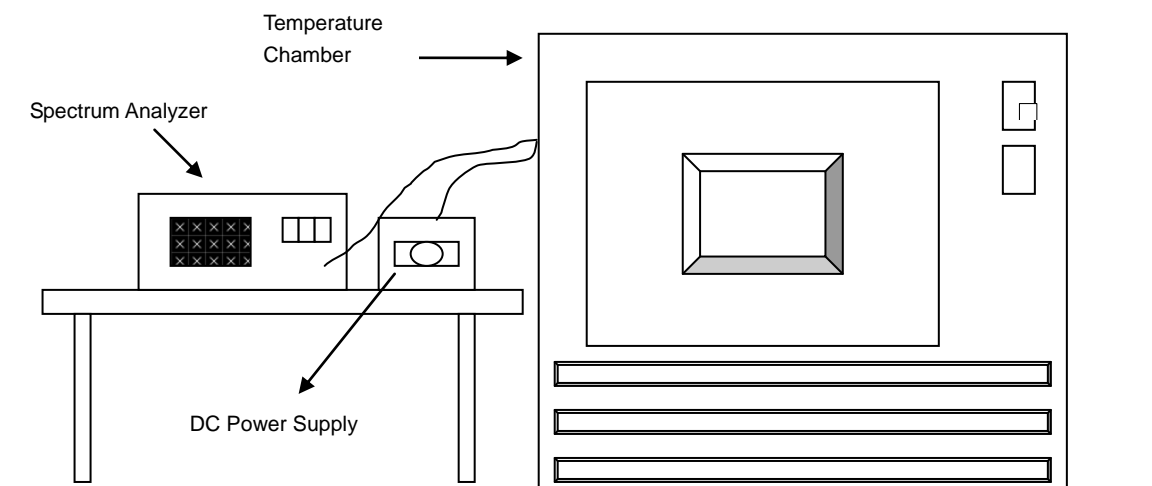

4.6.3 TEST INSTRUMENTS

Refer to section 4.1.3 to get information of above instrument.

4.6.4 TEST PROCEDURE

- a. To ensure emission at the band edge is maintained within the authorized band, those values shall be measured by radiation emissions at upper and lower frequency points, and finally compensated by frequency deviation as procedures below.
- b. The EUT was operated at the maximum output power, and connected to the spectrum analyzer, which is set to maximum hold function and peak detector. The peak value of the power envelope was measured and noted. The upper and lower frequency points were respectively measured relatively 10dB lower than the measured peak value.
- c. The frequency deviation was calculated by adding the upper frequency point and the lower frequency point divided by two. Those detailed values of frequency deviation are provided in table below.

4.6.5 DEVIATION FROM TEST STANDARD

No deviation.

4.6.6 EUT OPERATING CONDITION

Set the EUT transmit at un-modulation mode to test frequency stability.



A D T

4.6.7 TEST RESULTS

FREQUENCY STABILITY VERSUS TEMP.									
OPERATING FREQUENCY: 5320MHz									
TEMP. (°C)	POWER SUPPLY (Vdc)	0 MINUTE		2 MINUTE		5 MINUTE		10 MINUTE	
		Measured Frequency (MHz)	Frequency Drift (ppm)	Measured Frequency (MHz)	Frequency Drift (ppm)	Measured Frequency (MHz)	Frequency Drift (ppm)	Measured Frequency (MHz)	Frequency Drift (ppm)
50	3.7	5320.041338	7.770	5320.041293	7.762	5320.041057	7.717	5320.041066	7.719
40	3.7	5320.041762	7.850	5320.042132	7.920	5320.042197	7.932	5320.041799	7.857
30	3.7	5320.043390	8.156	5320.043091	8.100	5320.042725	8.031	5320.043098	8.101
20	3.7	5320.045488	8.550	5320.045099	8.477	5320.044951	8.449	5320.045445	8.542
10	3.7	5320.045431	8.540	5320.045689	8.588	5320.045332	8.521	5320.045451	8.543
0	3.7	5320.044602	8.384	5320.044084	8.286	5320.044212	8.311	5320.044115	8.292
-10	3.7	5320.042709	8.028	5320.042207	7.934	5320.042150	7.923	5320.042766	8.039
-20	3.7	5320.042309	7.953	5320.042156	7.924	5320.042460	7.981	5320.042261	7.944
-30	3.7	5320.041318	7.767	5320.041316	7.766	5320.041103	7.726	5320.040607	7.633

FREQUENCY STABILITY VERSUS VOLTAGE									
OPERATING FREQUENCY: 5320MHz									
TEMP. (°C)	POWER SUPPLY (Vdc)	0 MINUTE		2 MINUTE		5 MINUTE		10 MINUTE	
		Measured Frequency (MHz)	Frequency Drift (ppm)	Measured Frequency (MHz)	Frequency Drift (ppm)	Measured Frequency (MHz)	Frequency Drift (ppm)	Measured Frequency (MHz)	Frequency Drift (ppm)
20	3.4	5320.044310	8.329	5320.044512	8.367	5320.044495	8.364	5320.044549	8.374
	3.7	5320.045488	8.550	5320.045099	8.477	5320.044951	8.449	5320.045445	8.542
	4.2	5320.046423	8.726	5320.046518	8.744	5320.046345	8.711	5320.046543	8.749

4.7 20dBc BANDWIDTH MEASUREMENT

4.7.1 LIMITS OF 20dBc BANDWIDTH MEASUREMENT

20dBc point shall not overlap in 5150~5700MHz.

4.7.2 TEST SETUP

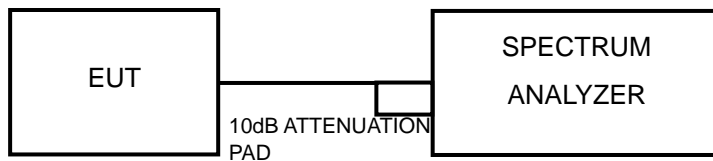

4.7.3 TEST INSTRUMENTS

Refer to section 4.1.3 to get information of above instrument.

4.7.4 TEST PROCEDURES

789033 D01 General UNII Test Procedures v01r03

Emission bandwidth

- 1) Set RBW = approximately 1% of the emission bandwidth.
- 2) Set the VBW > RBW.
- 3) Detector = Peak
- 4) Trace mode = max hold.
- 5) Measurement the maximum width of the emission that is 20dB down from the peak of the emission. Compare this with RBW setting of the analyzer. Readjust RBW and repeat measurement as needed until the RBW/EBW ratio is approximately 1%.



A D T

4.7.5 TEST RESULTS

802.11a

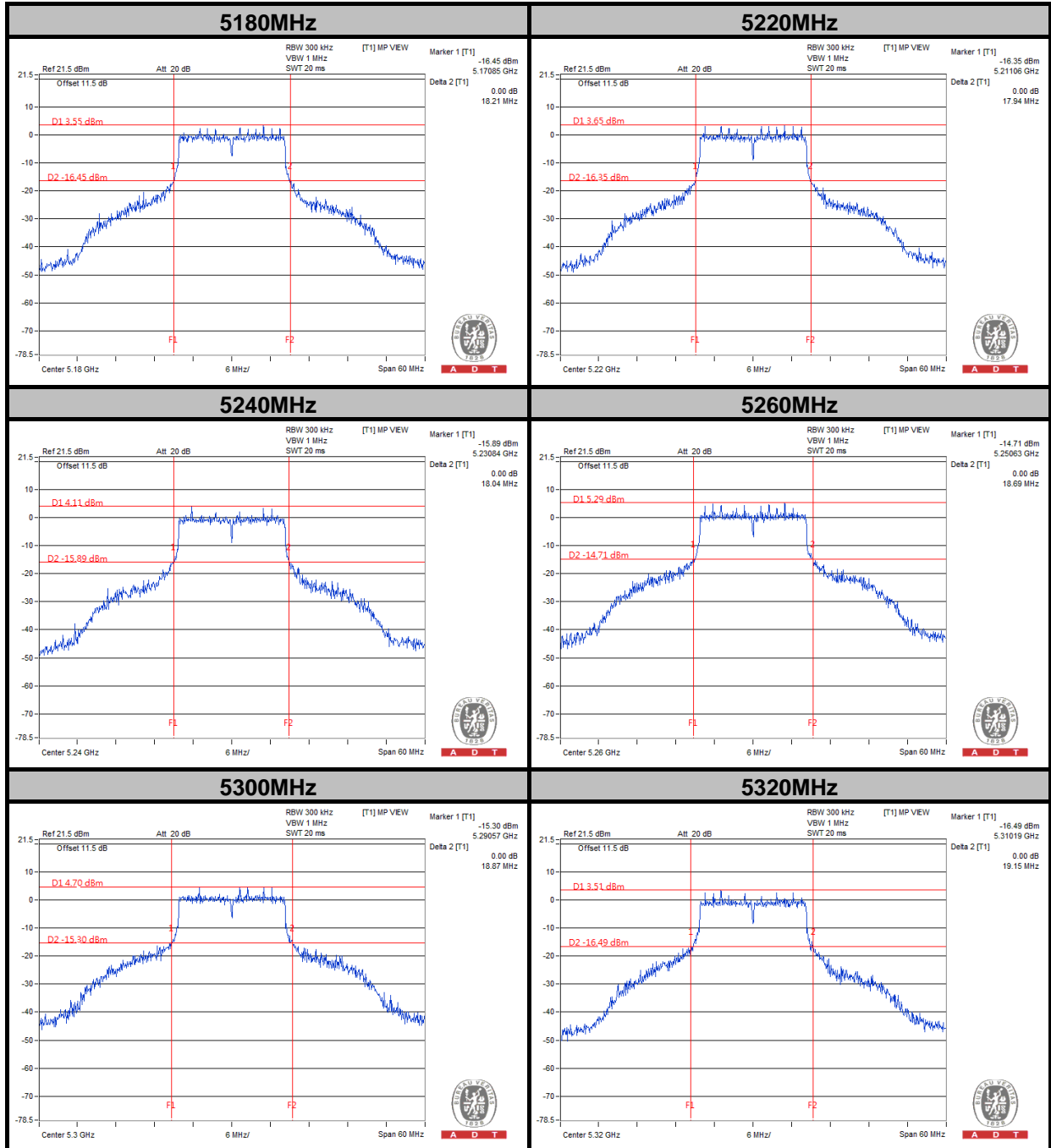



A D T

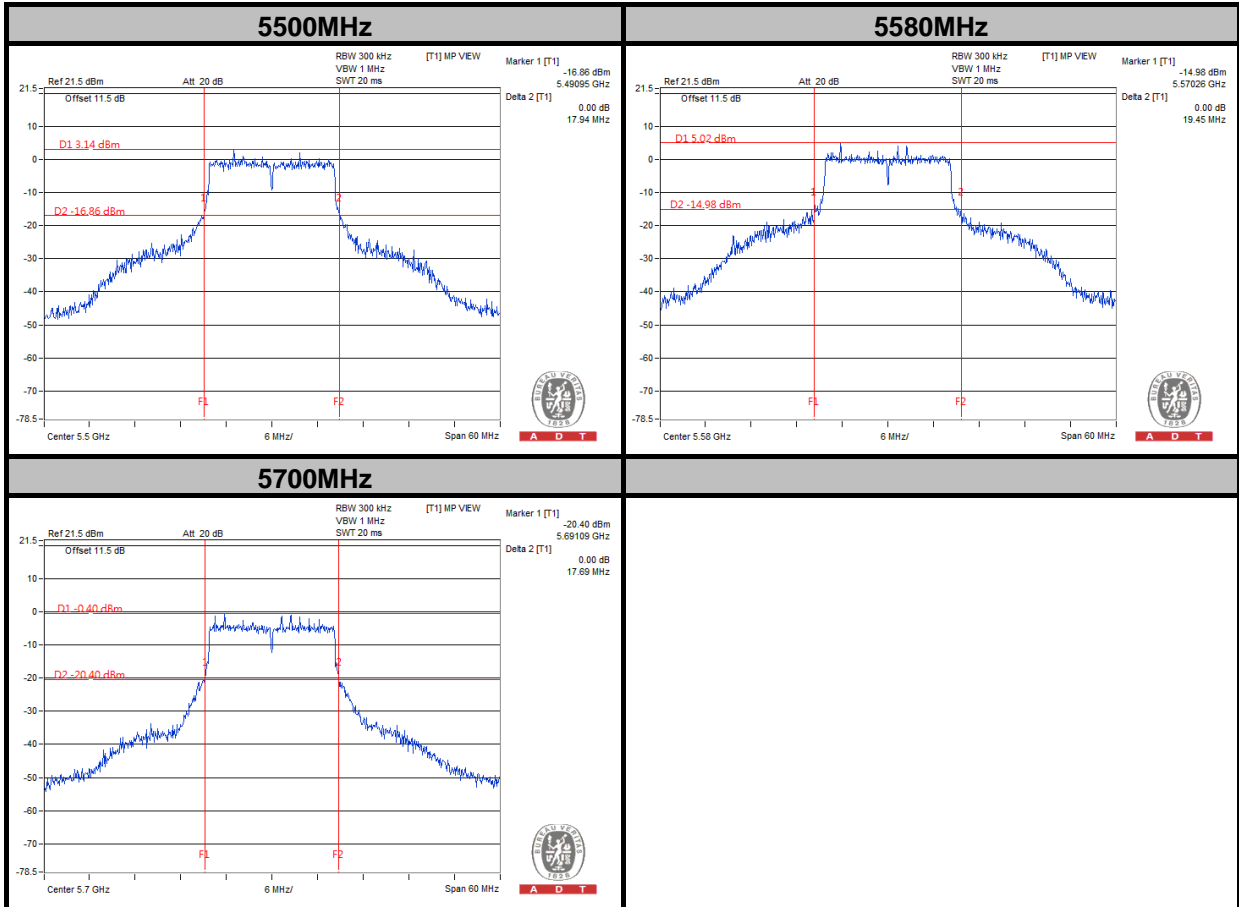



A D T

802.11n (20MHz)

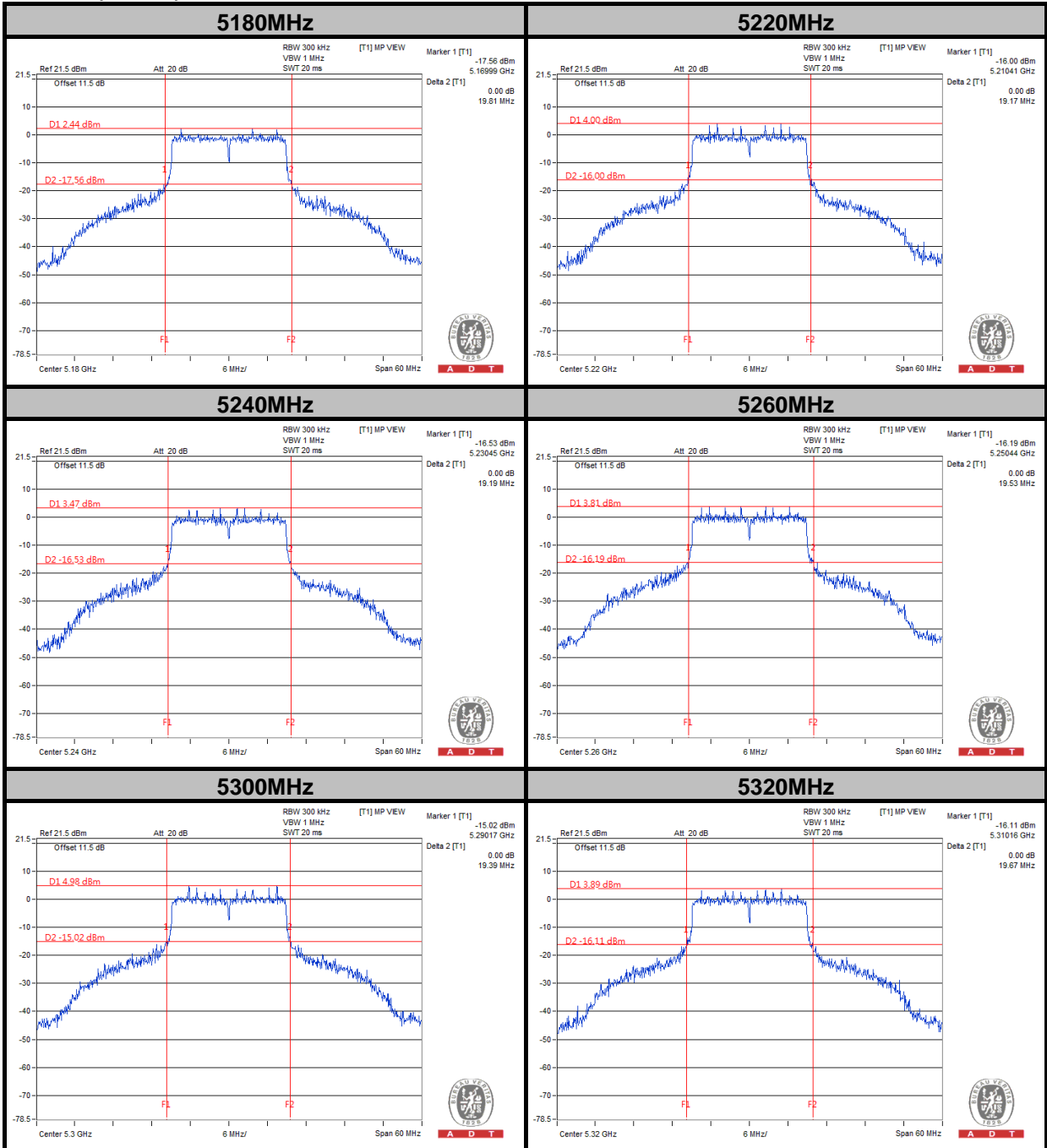



A D T

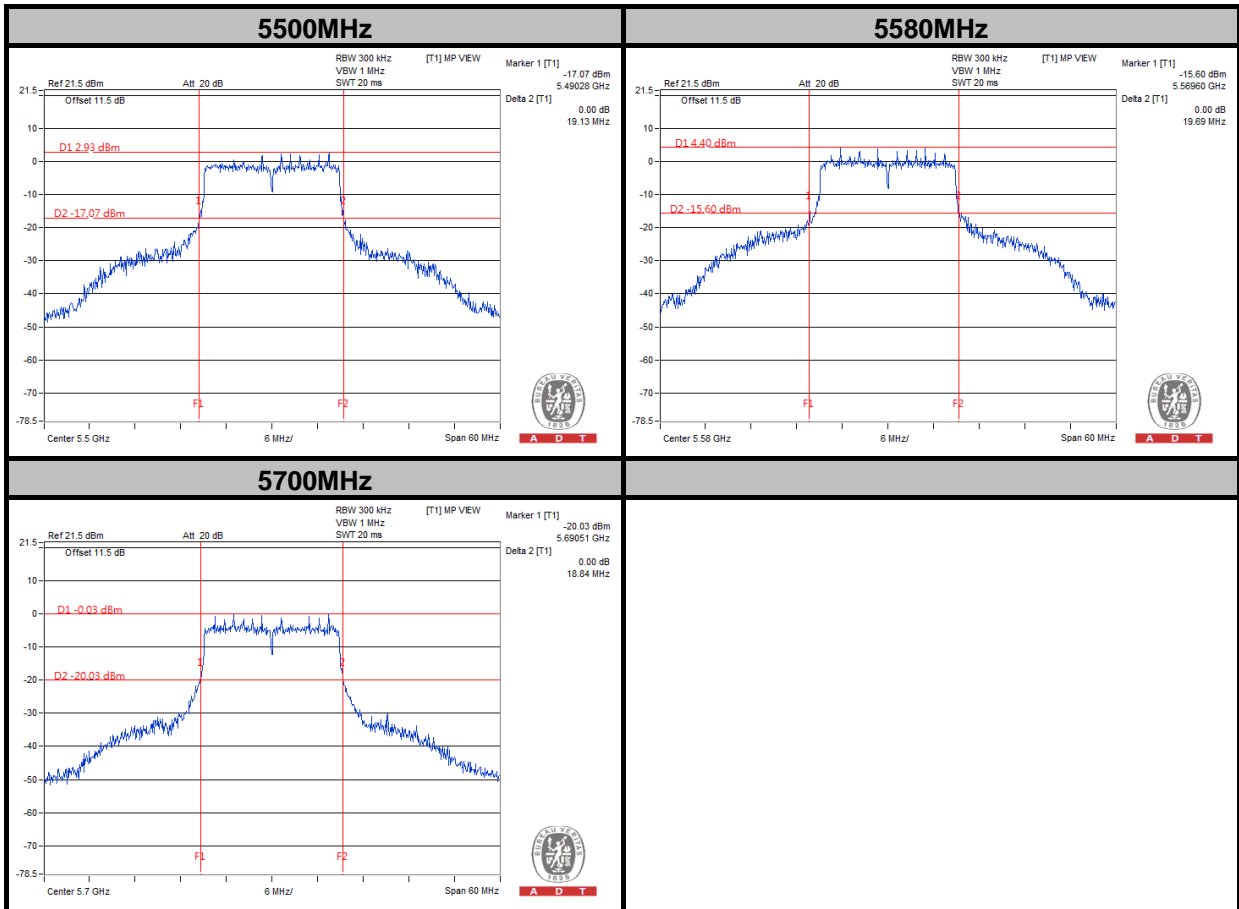



A D T

802.11n (40MHz)

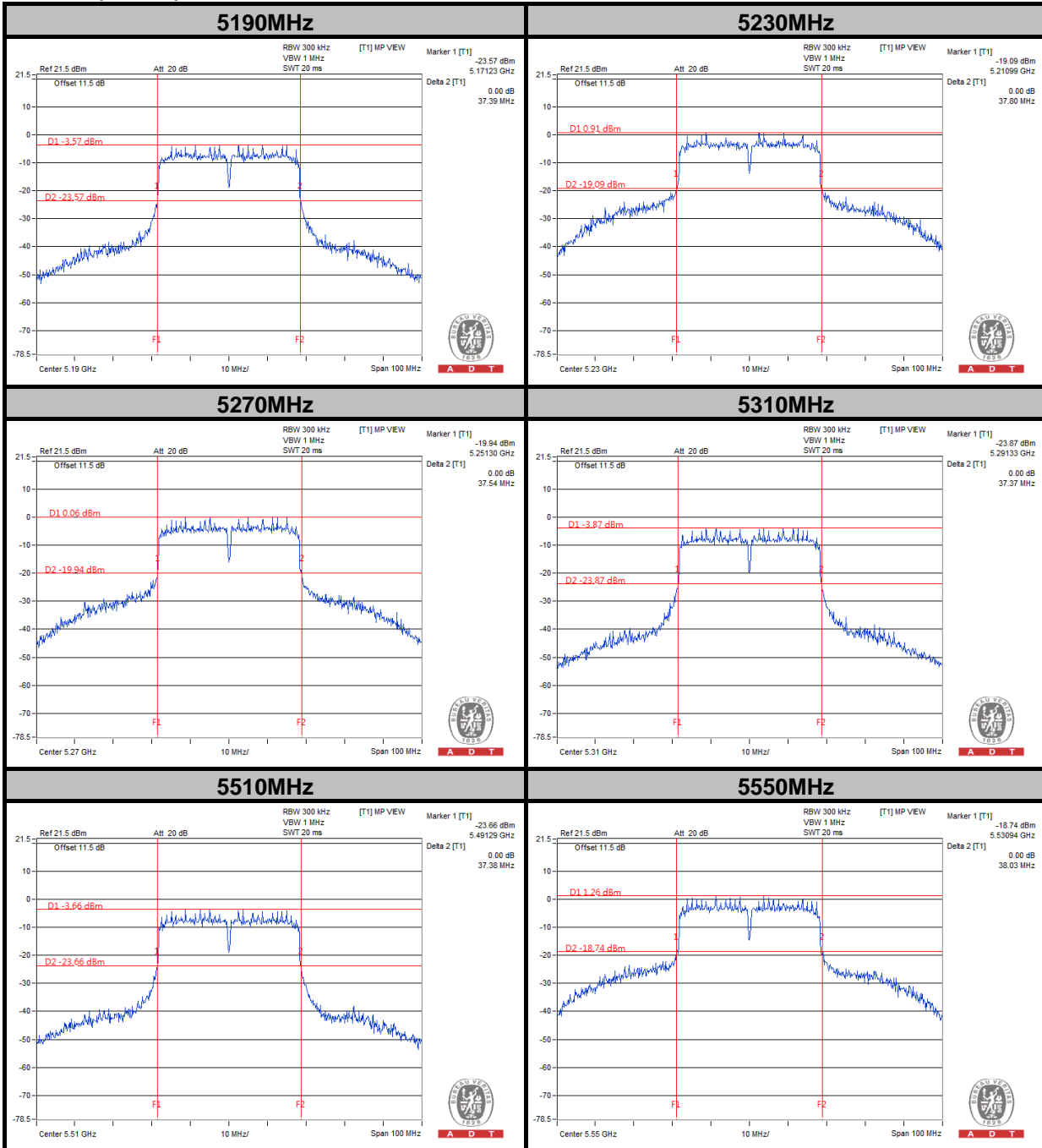



A D T

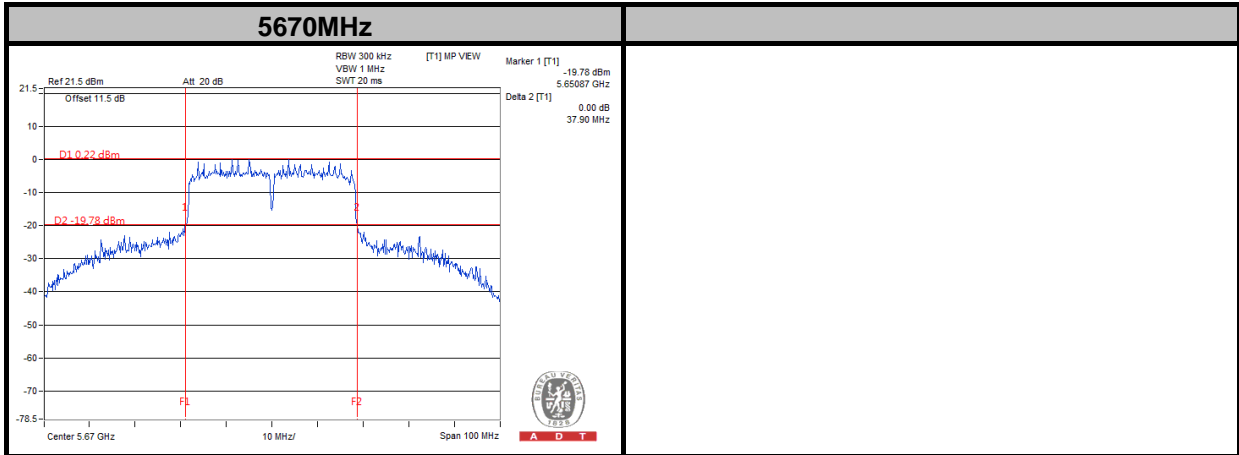



A D T

5. PHOTOGRAPHS OF THE TEST CONFIGURATION

Please refer to the attached file (Test Setup Photo).



6. INFORMATION ON THE TESTING LABORATORIES

We, Bureau Veritas Consumer Products Services (H.K.) Ltd., Taoyuan Branch, were founded in 1988 to provide our best service in EMC, Radio, Telecom and Safety consultation. Our laboratories are accredited and approved according to ISO/IEC 17025.

If you have any comments, please feel free to contact us at the following:

Linko EMC/RF Lab:

Tel: 886-2-26052180

Fax: 886-2-26051924

Hsin Chu EMC/RF Lab:

Tel: 886-3-5935343

Fax: 886-3-5935342

Hwa Ya EMC/RF/Safety Telecom Lab:

Tel: 886-3-3183232

Fax: 886-3-3270892

Email: service.adt@tw.bureauveritas.com

Web Site: www.bureauveritas-adt.com

The address and road map of all our labs can be found in our web site also.



A D T

7. APPENDIX A - MODIFICATIONS RECORDERS FOR ENGINEERING CHANGES TO THE EUT BY THE LAB

No any modifications are made to the EUT by the lab during the test.

---END---