



Table of Contents

History of this test report..... 3

Summary of Test Result..... 4

1 General Description 5

 1.1 Product Feature 5

 1.2 EUT Information (Referenced Model)..... 5

 1.3 Product Specification of Equipment Under Test..... 7

 1.4 Modification of EUT 9

 1.5 Testing Location 10

 1.6 Applicable Standards..... 10

2 Test Configuration of Equipment Under Test 11

 2.1 Carrier Frequency and Channel 11

 2.2 Test Mode 12

 2.3 Connection Diagram of Test System 13

 2.4 Support Unit used in test configuration and system 15

 2.5 EUT Operation Test Setup 15

 2.6 Measurement Results Explanation Example..... 15

3 Test Result 16

 3.1 6dB and 26dB and 99% Occupied Bandwidth Measurement 16

 3.2 Maximum Conducted Output Power Measurement 17

 3.3 Power Spectral Density Measurement 18

 3.4 Unwanted Emissions Measurement 20

 3.5 AC Conducted Emission Measurement..... 25

 3.6 Antenna Requirements 27

4 List of Measuring Equipment..... 28

5 Measurement Uncertainty 29

Appendix A. Conducted Test Results

Appendix B. AC Conducted Emission Test Result

Appendix C. Radiated Spurious Emission

Appendix D. Radiated Spurious Emission Plots

Appendix E. Duty Cycle Plots

Appendix F. Setup Photographs

Appendix G. Spot Check Evaluation on TC58BE



Summary of Test Result

Report Clause	Ref Std. Clause	Test Items	Result (PASS/FAIL)	Remark
3.1	15.403(i)	6dB & 26dB Bandwidth	Pass	-
3.1	2.1049	99% Occupied Bandwidth	Reporting only	-
3.2	15.407(a)	Maximum Conducted Output Power	Pass	-
3.3	15.407(a)	Power Spectral Density	Pass	-
3.4	15.407(b)	Unwanted Emissions	Pass	1.75 dB under the limit at 5938.25 MHz
3.5	15.207	AC Conducted Emission	Pass	18.52 dB under the limit at 0.16 MHz
3.6	15.203	Antenna Requirement	Pass	-

Conformity Assessment Condition:

- ECR inquiry for data referencing from UZ7TC58AE has been approved by FCC. The ECR inquiry and the associated document are submitted in the confidential exhibit.
- UZ7TC58BE is different from FCC ID: UZ7TC58AE (Reference model), in the following:
 - The only difference between UZ7TC58AE and UZ7TC58BE are the WWAN support bands, which is controlled by software.
- All the test results are referenced from UZ7TC58AE (Sporton Test Report FR411111F), and spot check results to justify data referencing is presented in the Appendix G.
- The test results (PASS/FAIL) with all measurement uncertainty excluded are presented against the regulation limits or in accordance with the requirements stipulated by the applicant/manufacturer who shall bear all the risks of non-compliance that may potentially occur if measurement uncertainty is taken into account.
- The measurement uncertainty please refer to each test result in the section "Measurement Uncertainty".

Disclaimer:

The product specifications of the EUT presented in the test report that may affect the test assessments are declared by the manufacturer who shall take full responsibility for the authenticity.

Reviewed by: Wei Chen
Report Producer: Ming Chen



1 General Description

1.1 Product Feature

Product Feature	
Equipment	Touch Computer
Brand Name	Zebra
Model Name	TC58BE
FCC ID	UZ7TC58BE
Supports Radios application	WCDMA/HSPA/LTE/5G NR/NFC/GNSS WLAN 11a/b/g/n HT20/HT40 WLAN 11ac VHT20/VHT40/VHT80/VHT160 WLAN 11ax HE20/HE40/HE80/HE160 Bluetooth BR/EDR/LE

1.2 EUT Information (Referenced Model)

Product Feature	
FCC ID	UZ7TC58AE
Sample 1	SE55 + 8GB 128G (Samsung/SK Hynix)
Sample 2	SE4720 + 6GB 64G (SK Hynix/WD)
Sample 3	SE4770 + 6GB 64G (SK Hynix/WD)
EUT supports Radios application	WCDMA/HSPA/LTE/5G NR/NFC/GNSS WLAN 11a/b/g/n HT20/HT40 WLAN 11ac VHT20/VHT40/VHT80/VHT160 WLAN 11ax HE20/HE40/HE80/HE160 Bluetooth BR/EDR/LE
HW Version	DV1-2
SW Version	nemesis_A13_userdebug_GMS_RelKey_2023-12-12-0451_main_SE
FW Version	FUSION_QA_6_1.1.0.004_T
MFD	06DEC23
EUT Stage	Identical Prototype

Remark: The EUT's information above is declared by manufacturer.



Specification of Accessories				
Adapter	Brand Name	Zebra	Part Number	PWR-WUA5V12W0US
Battery 1 (1x)	Brand Name	Zebra	Part Number	BT-000442-0020
Battery 2 (1.5x)	Brand Name	Zebra	Part Number	BT-000442-0820
Battery 3 (BLE battery)	Brand Name	Zebra	Part Number	BT-000442-002B
Battery 4 (Wireless Battery)	Brand Name	Zebra	Part Number	BT-000442-002A
Battery 5 (1x)	Brand Name	Zebra	Part Number	BT-000442-1020
USB TYPE A to TYPE C cable	Brand Name	Zebra	Part Number	CBL-TC5X-USBC2A-01
USB TYPE C to 3.5mm audio connector	Brand Name	Zebra	Part Number	ADP-USBC-35MM1-01
3.5mm Earphone	Brand Name	Zebra	Part Number	HDST-35MM-PTT1-01
Rugged Headset	Brand Name	Zebra	Part Number	HS2100-OTH
USB TYPE C Earphone	Brand Name	Zebra	Part Number	HPST-USBC-PTT1-01
Trigger Handle	Brand Name	Zebra	Part Number	TRG-NGTC5-ELEC-01
Soft Holster	Brand Name	Zebra	Part Number	SG-NGTC5TC7-HLSTR-01
TC53/TC58 RUGGED BOOT	Brand Name	Zebra	Part Number	SG-NGTC5EXO1-01
3.5mm to 3.5mm audio connector	Brand Name	Zebra	Part Number	CBL-HS2100-3MS1-01



1.3 Product Specification of Equipment Under Test

Product Specification is subject to this standard			
Tx/Rx Frequency Range	5745 MHz ~ 5825 MHz		
Maximum Output Power	802.11a: 23.56 dBm / 0.2270 W 802.11n HT20: 23.66 dBm / 0.2323 W 802.11n HT40: 23.46 dBm / 0.2218 W 802.11ac VHT20: 23.76 dBm / 0.2377 W 802.11ac VHT40: 23.56 dBm / 0.2270 W 802.11ac VHT80: 23.56 dBm / 0.2270 W 802.11ax HE20: 23.86 dBm / 0.2432 W 802.11ax HE40: 23.66 dBm / 0.2323 W 802.11ax HE80: 23.66 dBm / 0.2323 W		
99% Occupied Bandwidth	MIMO <Ant. 6> 802.11a: 16.38 MHz 802.11ac VHT20: 17.63 MHz 802.11ac VHT40: 36.26 MHz 802.11ac VHT80: 75.16 MHz 802.11ax HE20: 19.03 MHz 802.11ax HE40: 37.86 MHz 802.11ax HE80: 76.96 MHz MIMO <Ant. 7> 802.11a: 16.43 MHz 802.11ac VHT20: 17.68 MHz 802.11ac VHT40: 36.66 MHz 802.11ac VHT80: 75.28 MHz 802.11ax HE20: 19.13 MHz 802.11ax HE40: 37.96 MHz 802.11ax HE80: 76.96 MHz		
Antenna Type / Gain	<Ant. 6> : PIFA Antenna with gain 3.46 dBi <Ant. 7> : PIFA Antenna with gain 2.24 dBi		
Type of Modulation	802.11a/n: OFDM (BPSK/QPSK/16QAM/64QAM) 802.11ac: OFDM (BPSK/QPSK/16QAM/64QAM/256QAM) 802.11ax: OFDMA (BPSK/QPSK/16QAM/64QAM/256QAM/1024QAM)		
Antenna Function Description		Ant. 6	Ant. 7
	802.11 a/n/ac/ax MIMO	V	V
	802.11ax TXBF	V	V

Remark:

1. MIMO Ant. 6+7 Directional Gain is a calculated result from MIMO Ant. 6 and MIMO Ant. 7. The formula used in calculation is documented in section 1.2.1.
2. Power of MIMO Ant. 6 + Ant. 7 is a calculated result from sum of the power MIMO Ant. 6 and MIMO Ant. 7.
3. 802.11ax Support Tx Beamforming mode, and the manufacturer declares that Tx Beamforming power/EIRP is less than CDD mode 3dbm, so CDD mode cover Tx Beamforming mode.
4. The EUT's information above is declared by manufacturer. Please refer to Disclaimer in report summary.



1.3.1 Antenna Directional Gain

<For CDD Mode>

Follows FCC KDB 662911 D01 Multiple Transmitter Output v02r01 F)2)f)ii)

Directional gain = G_{ANT} + Array Gain, where Array Gain is as follows:

For power measurements on IEEE 802.11 devices,

Array Gain = 0 dB (i.e., no array gain) for N_{ANT} ≤ 4.

G_{ANT} is set equal to the gain of the antenna having the highest gain.

For PSD measurements, the directional gain calculation.

$$DirectionalGain = 10 \cdot \log \left[\frac{\sum_{j=1}^{N_{SS}} \left\{ \sum_{k=1}^{N_{ANT}} g_{j,k} \right\}^2}{N_{ANT}} \right]$$

where

Each antenna is driven by no more than one spatial stream;

N_{SS} = the number of independent spatial streams of data;

N_{ANT} = the total number of antennas

$g_{j,k} = 10^{G_k / 20}$ if the kth antenna is being fed by spatial stream j, or zero if it is not; G_k is the gain in dBi of the kth antenna.

As minimum N_{SS}=1 is supported by EUT, the formula can be simplified as:

$$Directional\ gain = 10 \cdot \log \left[\left(10^{G_1 / 20} + 10^{G_2 / 20} + \dots + 10^{G_N / 20} \right)^2 / N_{ANT} \right] \text{ dBi}$$

Where G1, G2...GN denote single antenna gain.

The directional gain "DG" is calculated as following table.

			DG for Power (dBi)	DG for PSD (dBi)	Power Limit Reduction (dB)	PSD Limit Reduction (dB)
	Ant 6 (dBi)	Ant 7 (dBi)				
Band IV	3.46	2.24	3.46	5.88	0.00	0.00

Calculation example:

If a device has two antenna, G_{ANT6}= 3.46dBi; G_{ANT7}=2.24dBi

Directional gain of power measurement = max(3.46, 2.24) + 0 = 3.46 dBi

Directional gain of PSD derived from formula which is

$$10 \times \log \left\{ \left[10^{(3.46 \text{ dBi} / 20)} + 10^{(2.24 \text{ dBi} / 20)} \right]^2 / 2 \right\} = 5.88 \text{ dBi}$$

Power and PSD limit reduction = Composite gain – 6dBi, (min = 0)

<For TXBF Modes>

The EUT supports beamforming modes , then

Follows FCC KDB 662911 D01 Multiple Transmitter Output v02r01 F)2)e)ii)

$$DirectionalGain = 10 \cdot \log \left[\frac{\sum_{j=1}^{N_{SS}} \left\{ \sum_{k=1}^{N_{ANT}} g_{j,k} \right\}^2}{N_{ANT}} \right]$$

where

Each antenna is driven by no more than one spatial stream;

N_{SS} = the number of independent spatial streams of data;

N_{ANT} = the total number of antennas

$g_{j,k} = 10^{G_k / 20}$ if the k th antenna is being fed by spatial stream j , or zero if it is not;
 G_k is the gain in dBi of the k th antenna.

The directional gain “DG” is calculated as following table.

			DG	DG	Power	PSD
			for	for	Limit	Limit
	Ant 6	Ant 7	Power	PSD	Reduction	Reduction
	(dBi)	(dBi)	(dBi)	(dBi)	(dB)	(dB)
Band IV	3.46	2.24	5.88	5.88	0.00	0.00

Calculation example:

Directional gain is derived from formula which is

$$10 \times \log \left\{ \left[10^{(3.46 \text{ dBi} / 20)} + 10^{(2.24 \text{ dBi} / 20)} \right]^2 / 2 \right\}$$

$$= 5.88 \text{ dBi}$$

Power and PSD limit reduction = Composite gain – 6dBi, (min = 0)

1.4 Modification of EUT

No modifications made to the EUT during the testing.



1.5 Testing Location

Test Site	Sporton International Inc. EMC & Wireless Communications Laboratory
Test Site Location	No.52, Huaya 1st Rd., Guishan Dist., Taoyuan City 333, Taiwan (R.O.C.) TEL: +886-3-327-3456 FAX: +886-3-328-4978
Test Site No.	Sporton Site No. CO05-HY (TAF Code: 1190)
Remark	The AC Conducted Emission test item subcontracted to Sporton International Inc. EMC & Wireless Communications Laboratory.

Note: The test site complies with ANSI C63.4 2014 requirement.

Test Site	Sporton International Inc. Wensan Laboratory
Test Site Location	No.58, Aly. 75, Ln. 564, Wenhua 3rd, Rd., Guishan Dist., Taoyuan City 333010, Taiwan (R.O.C.) TEL: +886-3-327-0868 FAX: +886-3-327-0855
Test Site No.	Sporton Site No. TH05-HY, 03CH20-HY

Note: The test site complies with ANSI C63.4 2014 requirement.

FCC designation No.: TW1190 and TW3786

1.6 Applicable Standards

According to the specifications declared by the manufacturer, the EUT must comply with the requirements of the following standards:

- ♦ FCC Part 15 Subpart E
- ♦ FCC KDB 789033 D02 General UNII Test Procedures New Rules v02r01.
- ♦ FCC KDB 414788 D01 Radiated Test Site v01r01.
- ♦ FCC KDB 662911 D01 Multiple Transmitter Output v02r01.
- ♦ ANSI C63.10-2013

Remark:

1. All the test items were validated and recorded in accordance with the standards without any modification during the testing.
2. The TAF code is not including all the FCC KDB listed without accreditation.
3. This EUT has also been tested and complied with the requirements of FCC Part 15, Subpart B, recorded in a separate test report.



2 Test Configuration of Equipment Under Test

- a. The EUT has been associated with peripherals and configuration operated in a manner tended to maximize its emission characteristics in a typical application. Frequency range investigated: conduction emission (150 kHz to 30 MHz), radiation emission (9 kHz to the 10th harmonic of the highest fundamental frequency or to 40 GHz, whichever is lower). For radiated measurement, the measured emission level of the EUT was maximized by rotating the EUT on a turntable, adjusting the orientation of the EUT and EUT antenna in three orthogonal axis (X: flat, Y: portrait, Z: landscape) and Accessory (Adapter or Earphone), and adjusting the measurement antenna orientation, following C63.10 exploratory test procedures and only the worst case emissions were reported in this report.
- b. AC power line Conducted Emission was tested under maximum output power.

2.1 Carrier Frequency and Channel

Frequency Band	Channel	Freq. (MHz)	Channel	Freq. (MHz)
5725-5850 MHz Band 4 (U-NII-3)	149	5745	157	5785
	151*	5755	159*	5795
	153	5765	161	5805
	155#	5775	165	5825

Note:

1. The above Frequency and Channel with "*" are 802.11n HT40 and 802.11ac VHT40 and 802.11ax HE40.
2. The above Frequency and Channel with "#" are 802.11ac VHT80 and 802.11ax HE80.



2.2 Test Mode

This device support 26/52/106/242/484/996-tone RU.

The PSD of partial RU is reduced to be smaller than full RU according to TCB workshop interim guidance Oct. 2018.

The 802.11ax mode is investigated among different tones, full resource units (RU), partial resource units. The partial RU has no higher power than full RU's, thus the full RU is chosen as main test configuration.

The 242-tone RU is covered by 20MHz channel, and 484-tone RU is covered by 40MHz channel and 996-tone RU is covered by 80MHz channel.

The SISO mode conducted power is covered by MIMO mode per chain, so only the MIMO mode is tested.

The power for 802.11n mode is smaller than 802.11ac mode, so all other conducted test is covered by 802.11ac mode.

The power for 802.11n and 802.11 ac mode is smaller than 802.11ax mode, so all other radiated test is covered by 802.11ax mode.

The final test modes include the worst data rates for each modulation shown in the table below.

MIMO Mode

Modulation	Data Rate
802.11a	6 Mbps
802.11n HT20 (Covered by VHT20)	MCS0
802.11n HT40 (Covered by VHT40)	MCS0
802.11ac VHT20	MCS0
802.11ac VHT40	MCS0
802.11ac VHT80	MCS0
802.11ax HE20	MCS0
802.11ax HE40	MCS0
802.11ax HE80	MCS0

Remark: The conducted power level of each chain in MIMO mode is equal or higher than SISO mode.

Test Cases	
AC Conducted Emission	Mode 1 : WLAN (5GHz) Link + Bluetooth Link + USB TYPE A to TYPE C cable (Charging from Adapter) + Battery 2 (1.5) for Sample 1
Remark: For Radiated Test Cases, the tests were performed with Battery 1 (1x) and Sample 1.	

Ch. #		Band IV : 5725-5850 MHz			
		802.11a	802.11ax HE20	802.11ax HE40	802.11ax HE80
L	Low	149	149	151	-
M	Middle	157	157	-	155
H	High	165	165	159	-

Remark: For radiation spurious emission, the modulation and the data rate picked for testing are determined by the Max. RF conducted power.

2.3 Connection Diagram of Test System

<AC Conducted Emission Mode>

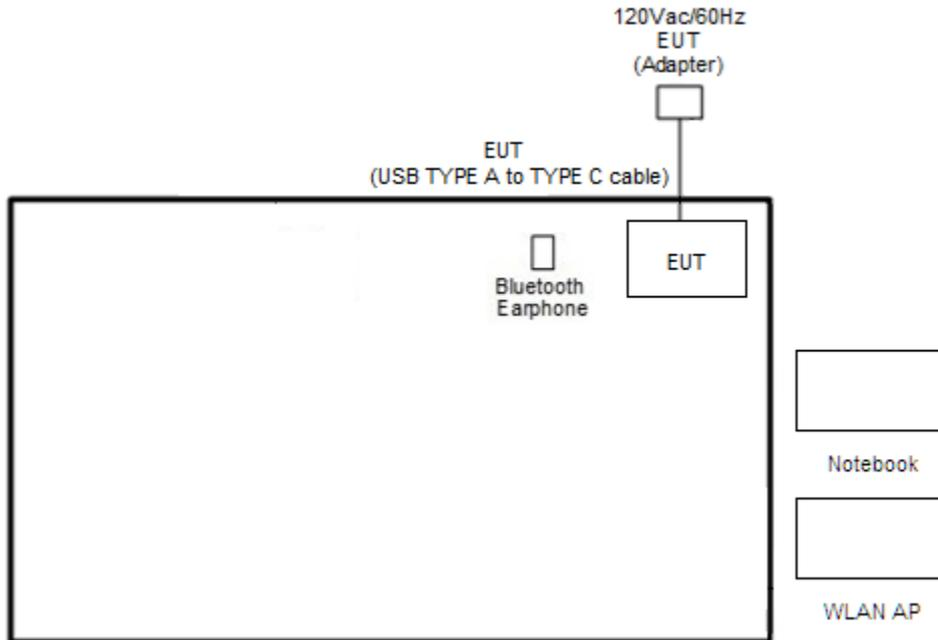

<WLAN Tx with Adapter Mode>

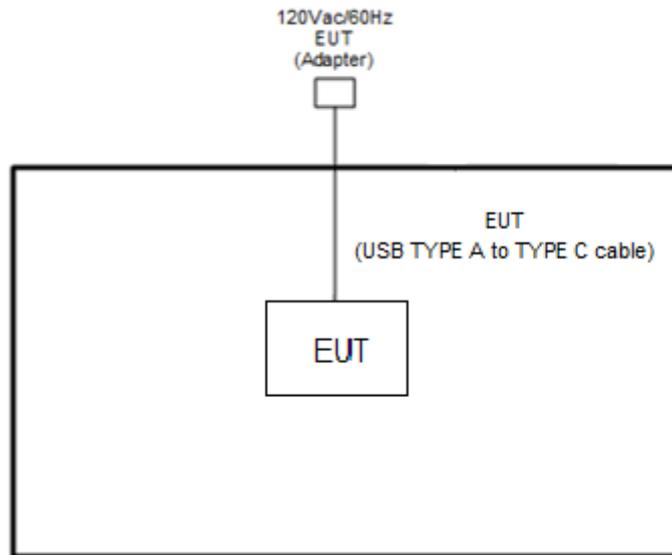

<WLAN Tx with Earphone Mode>

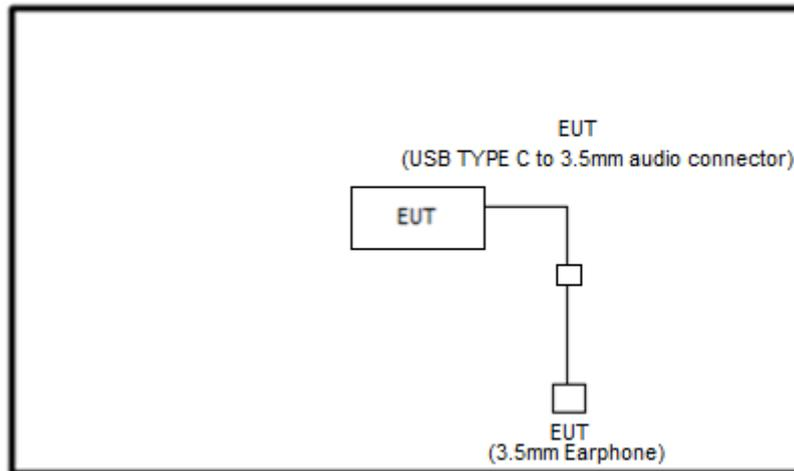



2.4 Support Unit used in test configuration and system

Item	Equipment	Brand Name	Model Name	FCC ID	Data Cable	Power Cord
1.	Bluetooth Earphone	Sony Ericsson	MW600	PY7DDA-2029	N/A	N/A
2.	WLAN AP	ASUS	RT-AC66U	MSQ-RTAC66U	N/A	Unshielded, 1.8 m
3.	Notebook	DELL	Latitude 3420	FCC DoC	N/A	AC I/P: Unshielded, 1.2 m DC O/P: Shielded, 1.8 m
4.	Notebook	DELL	Latitude 5310	FCC DoC	N/A	AC I/P: Unshielded, 1.2 m DC O/P: Shielded, 1.8 m
5.	SD Card	SanDisk	MicroSD HC	FCC DoC	N/A	N/A

2.5 EUT Operation Test Setup

The RF test items, utility "QRCT Version 4.0.211.0" was installed in Notebook which was programmed in order to make the EUT get into the engineering modes to provide channel selection, power level, data rate and the application type and for continuous transmitting signals.

2.6 Measurement Results Explanation Example

For all conducted test items:

The offset level is set in the spectrum analyzer to compensate the RF cable loss and attenuator factor between EUT conducted output port and spectrum analyzer. With the offset compensation, the spectrum analyzer reading level is exactly the EUT RF output level.

Example :

The spectrum analyzer offset is derived from RF cable loss and attenuator factor.

Offset = RF cable loss + attenuator factor.

Following shows an offset computation example with cable loss 4.2 dB and 10 dB attenuator.

$$\begin{aligned} \text{Offset(dB)} &= \text{RF cable loss(dB)} + \text{attenuator factor(dB)}. \\ &= 4.2 + 10 = 14.2 \text{ (dB)} \end{aligned}$$

3 Test Result

3.1 6dB and 26dB and 99% Occupied Bandwidth Measurement

3.1.1 Description of 6dB and 26dB and 99% Occupied Bandwidth

The minimum 6 dB bandwidth shall be at least 500 kHz.

26dB and 99% Occupied bandwidth are reporting only.

3.1.2 Measuring Instruments

Please refer to the measuring equipment list in this test report.

3.1.3 Test Procedures

1. The testing follows FCC KDB 789033 D02 General UNII Test Procedures New Rules v02r01. Section C) Emission bandwidth for the band 5.725-5.85 GHz
2. Set RBW = 100 kHz.
3. Set the VBW $\geq 3 \times$ RBW.
4. Detector = Peak.
5. Trace mode = max hold
6. Measure the maximum width of the emission that is 6 dB down from the peak of the emission.
7. Measure and record the results in the test report.

3.1.4 Test Setup

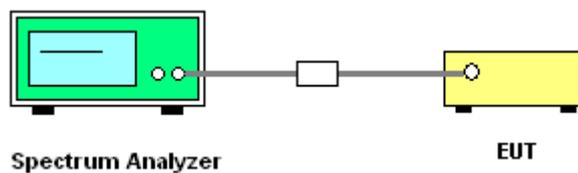

3.1.5 Test Result of 6dB and 26dB and 99% Occupied Bandwidth

Please refer to Appendix A.

3.2 Maximum Conducted Output Power Measurement

3.2.1 Limit of Maximum Conducted Output Power

For the band 5.725–5.85 GHz, the maximum conducted output power over the frequency band of operation shall not exceed 1 W.

If transmitting antennas of directional gain greater than 6 dBi are used, the peak output power shall be reduced by the amount in dB that the directional gain of the antenna exceeds 6 dBi.

3.2.2 Measuring Instruments

Please refer to the measuring equipment list in this test report.

3.2.3 Test Procedures

The testing follows Method PM-G of FCC KDB 789033 D02 General UNII Test Procedures New Rules v02r01.

Method PM-G (Measurement using a gated RF average power meter):

1. Measurement is performed using a wideband RF power meter.
2. The EUT is configured to transmit at its maximum power control level.
3. Measure the average power of the transmitter.
4. Since the measurement is made only during the ON time of the transmitter, no duty cycle correction factor is required.
5. For MIMO mode, calculation method follows FCC KDB 662911 D01 Multiple Transmitter Output v02r01

3.2.4 Test Setup

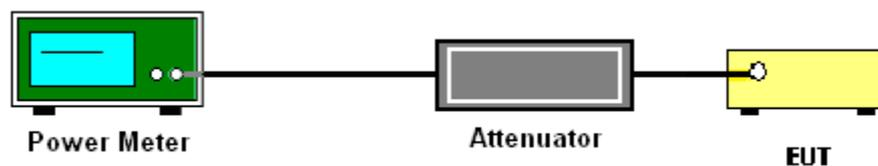

3.2.5 Test Result of Maximum Conducted Output Power

Please refer to Appendix A.



3.3 Power Spectral Density Measurement

3.3.1 Limit of Power Spectral Density

For the band 5.725–5.85 GHz, the maximum power spectral density shall not exceed 30 dBm in any 500-kHz band.

If transmitting antennas of directional gain greater than 6 dBi are used, the peak output power shall be reduced by the amount in dB that the directional gain of the antenna exceeds 6 dBi.

3.3.2 Measuring Instruments

Please refer to the measuring equipment list in this test report.

3.3.3 Test Procedures

The testing follows FCC KDB 789033 D02 General UNII Test Procedures New Rules v02r01. Section F) Maximum power spectral density.

Method SA-2

(trace averaging across on and off times of the EUT transmissions, followed by duty cycle correction).

- Measure the duty cycle.
 - Set span to encompass the entire emission bandwidth (EBW) of the signal.
 - Set RBW = 300kHz.
 - Set VBW \geq 1 MHz.
 - Add $10 \log(500 \text{ kHz}/\text{RBW})$ to the measured result, whereas RBW (<500 kHz) is the reduced resolution bandwidth of the spectrum analyzer set during measurement
 - Number of points in sweep \geq 2 Span / RBW.
 - Sweep time = auto.
 - Detector = RMS
 - Trace average at least 100 traces in power averaging mode.
 - Add $10 \log(1/x)$, where x is the duty cycle, to the measured power in order to compute the average power during the actual transmission times. For example, add $10 \log(1/0.25) = 6 \text{ dB}$ if the duty cycle is 25 percent.
1. The RF output of EUT is connected to the spectrum analyzer by a low loss cable.
 2. Each plot has already offset with cable loss, and attenuator loss. Measure the PPSD and record it.
 3. For MIMO mode, calculation method follows FCC KDB 662911 D01 Multiple Transmitter Output v02r01.

Method (c): Measure and add $10 \log(N_{\text{ANT}})$ dB.

With this technique, spectrum measurements are performed at each output of the device, but rather than summing the spectra or the spectral peaks across the outputs, the quantity $10 \log(N_{\text{ANT}})$ dB is added to each spectrum value before comparing to the emission limit. The addition of $10 \log(N_{\text{ANT}})$ dB serves to apportion the emission limit among the N_{ANT} outputs so that each output is permitted to contribute no more than $1/N_{\text{ANT}}^{\text{th}}$ of the PSD limit.

3.3.4 Test Setup

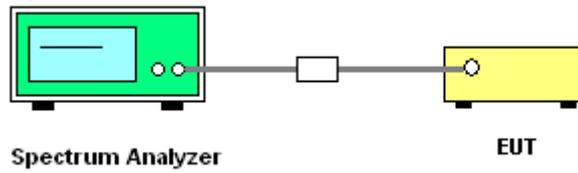

3.3.5 Test Result of Power Spectral Density

Please refer to Appendix A.



3.4 Unwanted Emissions Measurement

This section is to measure unwanted emissions through radiated measurement for band edge spurious emissions and out of band emissions measurement.

3.4.1 Limit of Unwanted Emissions

(1) For transmitters operating in the 5.725-5.85 GHz band:

15.407(b)(4)(i) All emissions shall be limited to a level of -27 dBm/MHz at 75 MHz or more above or below the band edge increasing linearly to 10 dBm/MHz at 25 MHz above or below the band edge, and from 25 MHz above or below the band edge increasing linearly to a level of 15.6 dBm/MHz at 5 MHz above or below the band edge, and from 5 MHz above or below the band edge increasing linearly to a level of 27 dBm/MHz at the band edge.

(2) Unwanted spurious emissions falls in restricted bands shall comply with the general field strength limits as below table,

Frequency (MHz)	Field Strength (microvolts/meter)	Measurement Distance (meters)
0.009 – 0.490	2400/F(kHz)	300
0.490 – 1.705	24000/F(kHz)	30
1.705 – 30.0	30	30
30 – 88	100	3
88 – 216	150	3
216 - 960	200	3
Above 960	500	3

Note: The following formula is used to convert the EIRP to field strength.

$$E = \frac{1000000\sqrt{30P}}{3} \text{ } \mu\text{V/m, where P is the eirp (Watts)}$$

EIRP (dBm)	Field Strength at 3m (dBμV/m)
- 27	68.3

(3) KDB789033 D02 v02r01 G)2)c)

(i) Sections 15.407(b)(1-3) specifies the unwanted emissions limit for the U-NII-1 and U-NII-2 bands. As specified, emissions above 1000 MHz that are outside of the restricted bands are subject to a peak emission limit of -27 dBm/MHz.

(ii) Section 15.407(b)(4) specifies the unwanted emissions limit for the U-NII-3 band. A band emissions mask is specified in Section 15.407(b)(4)(i). The emission limits are based on the use of a peak detector.



3.4.2 Measuring Instruments

Please refer to the measuring equipment list in this test report.

3.4.3 Test Procedures

1. The testing follows FCC KDB 789033 D02 General UNII Test Procedures New Rules v02r01. Section G) Unwanted emissions measurement.
 - (1) Procedure for Unwanted Emissions Measurements Below 1000 MHz
 - RBW = 120 kHz
 - VBW = 300 kHz
 - Detector = Peak
 - Trace mode = max hold
 - (2) Procedure for Peak Unwanted Emissions Measurements Above 1000 MHz
 - RBW = 1 MHz
 - VBW \geq 3 MHz
 - Detector = Peak
 - Sweep time = auto
 - Trace mode = max hold
 - (3) Procedures for Average Unwanted Emissions Measurements Above 1000 MHz
 - RBW = 1 MHz
 - VBW = 10 Hz, when duty cycle is no less than 98 percent.
 - VBW \geq 1/T, when duty cycle is less than 98 percent where T is the minimum transmission duration over which the transmitter is on and is transmitting at its maximum power control level for the tested mode of operation.
2. The EUT is placed on a turntable with 0.8 meter for frequency below 1 GHz and 1.5 meter for frequency above 1 GHz respectively above ground.
3. The EUT is set 3 meters away from the receiving antenna which is mounted on the top of a variable height antenna tower.
4. The antenna is a broadband antenna and its height is adjusted between one meter and four meters above ground to find the maximum value of the field strength for both horizontal polarization and vertical polarization of the antenna.
5. For each suspected emission, the EUT is arranged to its worst case and then adjust the antenna tower (from 1 m to 4 m) and turntable (from 0 degree to 360 degrees) to find the maximum reading.

6. Radiated testing below 1 GHz is performed by adjusting the antenna tower from 1 m to 4 m and by rotating the turn table from 0 degree to 360 degrees to find the peak maximum hold reading. When there is no suspected emission found and the emission level is with at least 6 dB margin against QP limit line, the position is marked as “-”.
7. Radiated testing above 1 GHz is performed by adjusting the antenna tower from 1 m to 4 m and by rotating the turn table from 0 degree to 360 degrees to find the peak maximum hold reading for scanning all frequencies. When there is no suspected emission found and the harmonic emission level is with at least 6 dB margin against average limit line, the position is marked as “-”.

3.4.4 Test Setup

For radiated emissions below 30MHz

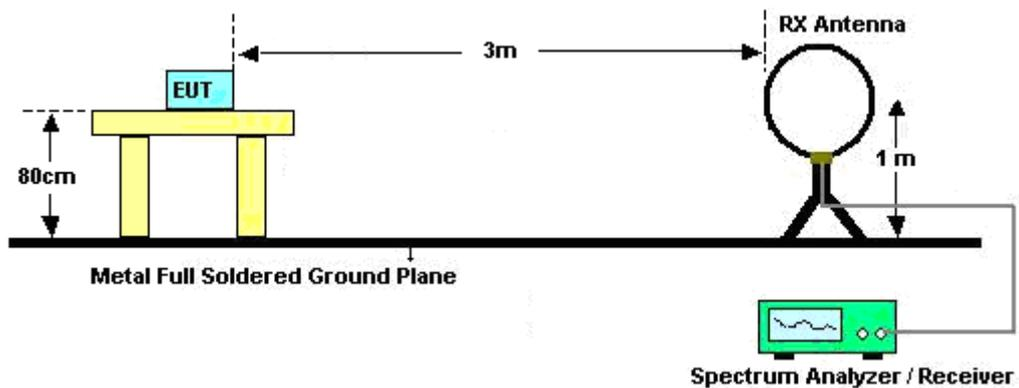

For radiated emissions from 30MHz to 1GHz

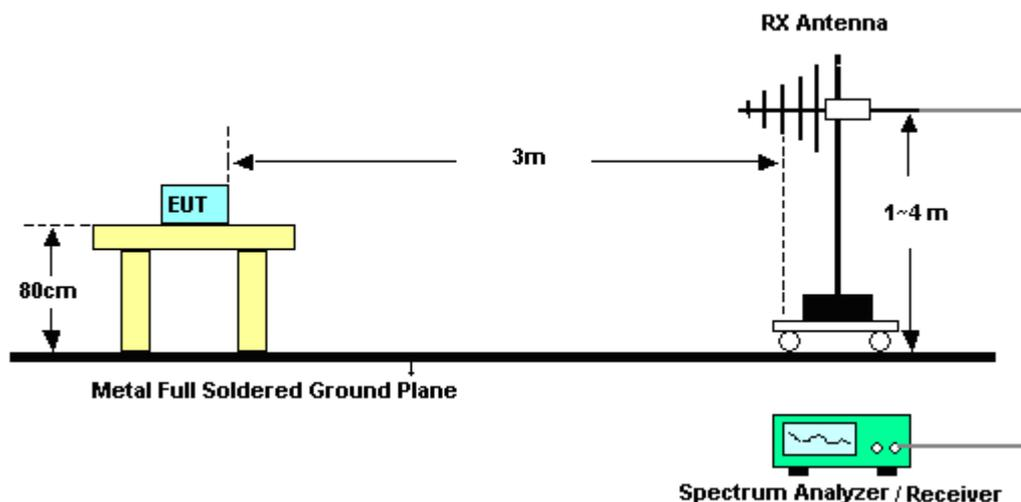

For radiated test from 1GHz to 18GHz

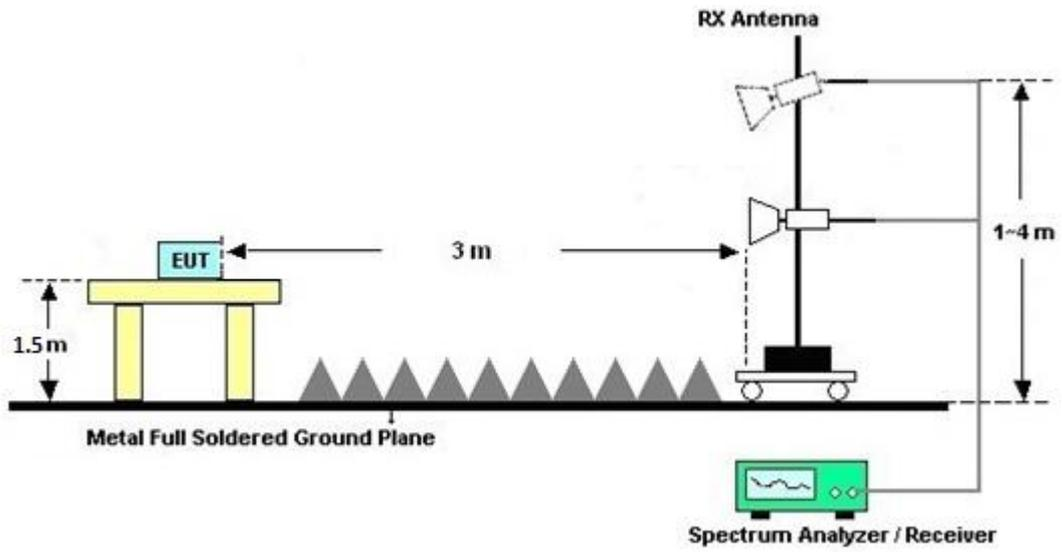

For radiated test above 18GHz

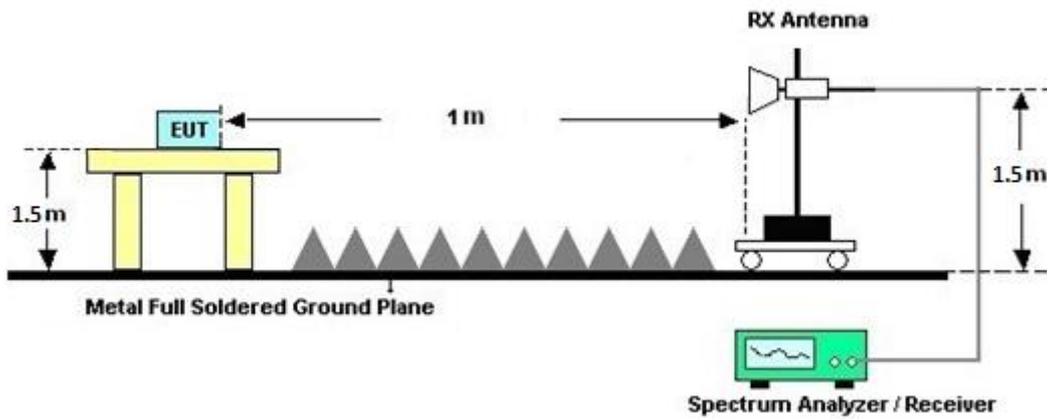



3.4.5 Test Results of Radiated Emissions (9 kHz ~ 30 MHz)

The low frequency, which starts from 9 kHz to 30 MHz, is pre-scanned and the result which is 20 dB lower than the limit line is not reported.

There is adequate comparison measurement of both open-field test site and alternative test site - semi-Anechoic chamber according to 414788 D01 Radiated Test Site v01r01, and the result came out very similar.

3.4.6 Test Result of Radiated Band Edges

Please refer to Appendix C and D.

3.4.7 Duty Cycle

Please refer to Appendix E.

3.4.8 Test Result of Unwanted Radiated Emission (30MHz ~ 10th Harmonic)

Please refer to Appendix C and D.



3.5 AC Conducted Emission Measurement

3.5.1 Limit of AC Conducted Emission

For equipment that is designed to be connected to the public utility (AC) power line, the radio frequency voltage that is conducted back onto the AC power line on any frequency or frequencies within the band 150 kHz to 30 MHz shall not exceed the limits in the following table.

Frequency of emission (MHz)	Conducted limit (dB μ V)	
	Quasi-peak	Average
0.15-0.5	66 to 56*	56 to 46*
0.5-5	56	46
5-30	60	50

*Decreases with the logarithm of the frequency.

3.5.2 Measuring Instruments

Please refer to the measuring equipment list in this test report.

3.5.3 Test Procedures

1. The EUT is placed 0.4 meter away from the conducting wall of the shielding room, and is kept at least 80 centimeters from any other grounded conducting surface.
2. Connect EUT to the power mains through a line impedance stabilization network (LISN).
3. All the support units are connecting to the other LISN.
4. The LISN provides 50 ohm coupling impedance for the measuring instrument.
5. The FCC states that a 50 ohm, 50 microhenry LISN shall be used.
6. Both Line and Neutral shall be tested in order to find out the maximum conducted emission.
7. The frequency range from 150 kHz to 30 MHz is scanned.
8. Set the test-receiver system to Peak Detect Function and specified bandwidth with Maximum Hold Mode.

3.5.4 Test Setup

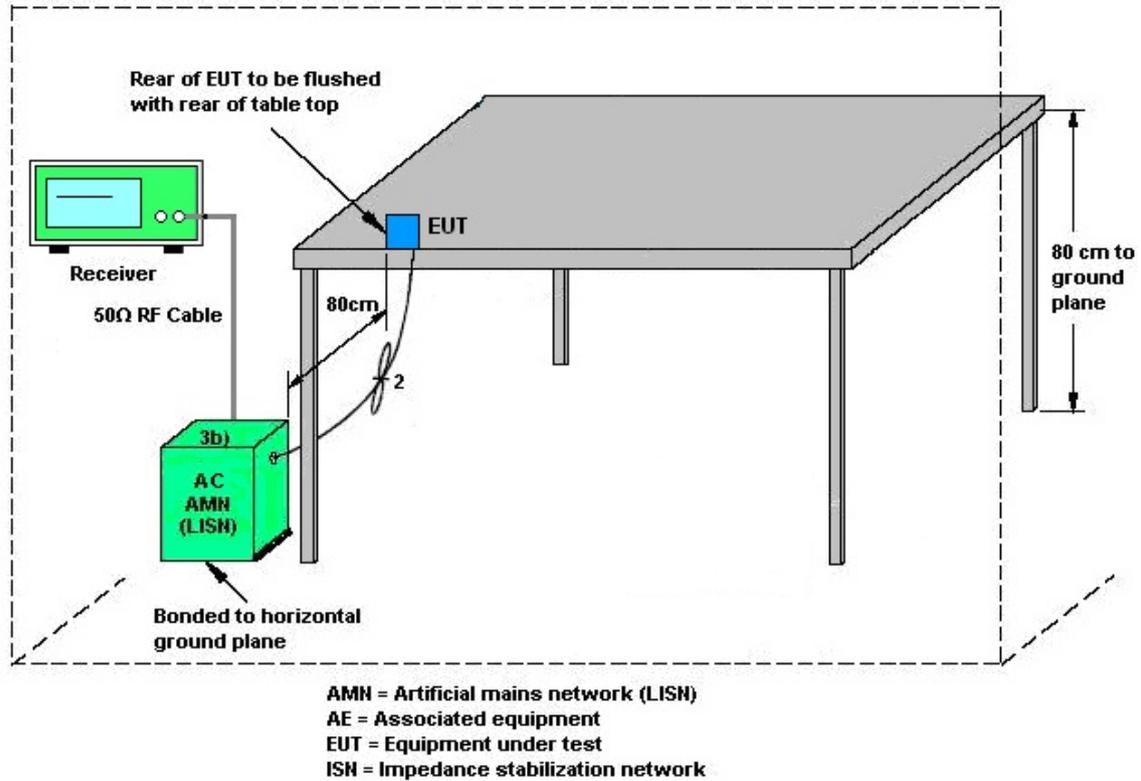

3.5.5 Test Result of AC Conducted Emission

Please refer to Appendix B.



3.6 Antenna Requirements

3.6.1 Standard Applicable

The use of a permanently attached antenna or of an antenna that uses a unique coupling to the intentional radiator shall be considered sufficient to comply with the rule.

3.6.2 Antenna Anti-Replacement Construction

An embedded-in antenna design is used.



4 List of Measuring Equipment

Instrument	Brand Name	Model No.	Serial No.	Characteristics	Calibration Date	Test Date	Due Date	Remark
EMI Test Receiver	Keysight	N9038A(MXE)	MY54130085	N/A	Oct. 06, 2023	Feb. 11, 2024~ Apr. 16, 2024	Oct. 05, 2024	Radiation (03CH20-HY)
Loop Antenna	Rohde & Schwarz	HFH2-Z2	100488	9 kHz~30 MHz	Sep. 12, 2023	Feb. 11, 2024~ Apr. 16, 2024	Sep. 11, 2024	Radiation (03CH20-HY)
Preamplifier	EMEC	EM18G40G	060801	18GHz~40GHz	Jun. 27, 2023	Feb. 11, 2024~ Apr. 16, 2024	Jun. 26, 2024	Radiation (03CH20-HY)
Controller	ChainTek	3000-1	N/A	Control Turn table & Ant Mast	N/A	Feb. 11, 2024~ Apr. 16, 2024	N/A	Radiation (03CH20-HY)
Antenna Mast	ChainTek	MBS-520-1	N/A	1m~4m	N/A	Feb. 11, 2024~ Apr. 16, 2024	N/A	Radiation (03CH20-HY)
Turn Table	ChainTek	T-200-S-1	N/A	0~360 Degree	N/A	Feb. 11, 2024~ Apr. 16, 2024	N/A	Radiation (03CH20-HY)
Signal Analyzer	Keysight	N9010B	MY60240520	N/A	Dec. 12, 2023	Feb. 11, 2024~ Apr. 16, 2024	Dec. 11, 2024	Radiation (03CH20-HY)
Bilog Antenna	TESEQ	CBL 6111D&00802N 1D01N-06	55606 & 08	30MHz~1GHz	Oct. 20, 2023	Feb. 11, 2024~ Apr. 16, 2024	Oct. 19, 2024	Radiation (03CH20-HY)
Horn Antenna	SCHWARZBE CK	BBHA 9120 D	02360	1GHz-18GHz	Oct. 30, 2023	Feb. 11, 2024~ Apr. 16, 2024	Oct. 29, 2024	Radiation (03CH20-HY)
SHF-EHF Horn Antenna	SCHWARZBE CK	BBHA 9170	1224	18GHz-40GHz	Jul. 10, 2023	Feb. 11, 2024~ Apr. 16, 2024	Jul. 09, 2024	Radiation (03CH20-HY)
Preamplifier	COM-POWER	PAM-103	18020201	1MHz-1000MHz	Jan. 01, 2024	Feb. 11, 2024~ Apr. 16, 2024	Dec. 31, 2024	Radiation (03CH20-HY)
Amplifier	EMCI	EMC118A45SE	980792	N/A	Nov. 13, 2023	Feb. 11, 2024~ Apr. 16, 2024	Nov. 12, 2024	Radiation (03CH20-HY)
RF Cable	HUBER + SUHNER	SUCOFLEX 102	519229/2,8040 15/2,804027/2	N/A	Jan. 17, 2024	Feb. 11, 2024~ Apr. 16, 2024	Jan. 16, 2025	Radiation (03CH20-HY)
Hygrometer	TECPEL	DTM-303B	TP200728	N/A	Mar. 28, 2023	Feb. 11, 2024~ Apr. 16, 2024	Mar. 27, 2024	Radiation (03CH20-HY)
Hygrometer	TECPEL	DTM-303A	TP211382	N/A	Mar. 27, 2024	Feb. 11, 2024~ Apr. 16, 2024	Mar. 26, 2025	Radiation (03CH20-HY)
Software	Audix	N/A	RK-002156	N/A	N/A	Feb. 11, 2024~ Apr. 16, 2024	N/A	Radiation (03CH20-HY)
AC Power Source	ChainTek	APC-1000W	N/A	N/A	N/A	Feb. 02, 2024	N/A	Conduction (CO05-HY)
EMI Test Receiver	Rohde & Schwarz	ESR3	102388	9kHz~3.6GHz	Dec. 06, 2023	Feb. 02, 2024	Dec. 05, 2024	Conduction (CO05-HY)
Hygrometer	Testo	608-H1	34913912	N/A	Oct. 26, 2023	Feb. 02, 2024	Oct. 25, 2024	Conduction (CO05-HY)
LISN	Rohde & Schwarz	ENV216	100081	9kHz~30MHz	Nov. 22, 2023	Feb. 02, 2024	Nov. 21, 2024	Conduction (CO05-HY)
Software	Rohde & Schwarz	EMC32	N/A	N/A	N/A	Feb. 02, 2024	N/A	Conduction (CO05-HY)
ISN Cable	MVE	RG-400	200260	N/A	Dec. 28, 2023	Feb. 02, 2024	Dec. 27, 2024	Conduction (CO05-HY)
Pulse Limiter	SCHWARZBE CK	VTSD 9561-F N	00691	9kHz-200MHz	Jul. 28, 2023	Feb. 02, 2024	Jul. 27, 2024	Conduction (CO05-HY)
LISN Cable	MVE	RG-400	260260	N/A	Dec. 28, 2023	Feb. 02, 2024	Dec. 27, 2024	Conduction (CO05-HY)
Hygrometer	TECPEL	DTM-303A	TP201996	N/A	Nov. 07, 2023	Jan. 26, 2024~ Mar. 15, 2024	Nov. 06, 2024	Conducted (TH05-HY)
Power Sensor	DARE	RPR3006W	17100015SNO 36 (NO:35)	10MHz~6GHz	Aug. 23, 2023	Jan. 26, 2024~ Mar. 15, 2024	Aug. 22, 2024	Conducted (TH05-HY)
Signal Analyzer	Rohde & Schwarz	FSV40	101564	10Hz ~ 40GHz	Sep. 12, 2023	Jan. 26, 2024~ Mar. 15, 2024	Sep. 11, 2024	Conducted (TH05-HY)



5 Measurement Uncertainty

Uncertainty of Conducted Emission Measurement (150kHz ~ 30MHz)

Measuring Uncertainty for a Level of Confidence of 95% ($U = 2Uc(y)$)	3.5 dB
---	--------

Uncertainty of Radiated Emission Measurement (30 MHz ~ 1000 MHz)

Measuring Uncertainty for a Level of Confidence of 95% ($U = 2Uc(y)$)	6.4 dB
---	--------

Uncertainty of Radiated Emission Measurement (1000 MHz ~ 6000 MHz)

Measuring Uncertainty for a Level of Confidence of 95% ($U = 2Uc(y)$)	4.5 dB
---	--------

Uncertainty of Radiated Emission Measurement (6000 MHz ~ 18000 MHz)

Measuring Uncertainty for a Level of Confidence of 95% ($U = 2Uc(y)$)	4.6 dB
---	--------

Uncertainty of Radiated Emission Measurement (18000 MHz ~ 40000 MHz)

Measuring Uncertainty for a Level of Confidence of 95% ($U = 2Uc(y)$)	5.4 dB
---	--------

Appendix A. Test Result of Conducted Test Items

Test Engineer:	Sylvia Li	Temperature:	21~25	°C
Test Date:	2024/01/26 ~ 2024/05/06	Relative Humidity:	51~54	%

TEST RESULTS DATA
6dB and 26dB EBW and 99% OBW

U-NII-3 MIMO												
Mod.	Data Rate	NTX	CH.	Freq. (MHz)	99% Bandwidth (MHz)		26dB Bandwidth (MHz)		6 dB Bandwidth (MHz)		6 dB Bandwidth Min. Limit (MHz)	Pass/Fail
					Ant 6	Ant 7	Ant 6	Ant 7	Ant 6	Ant 7		
11a	6Mbps	2	149	5745	16.33	16.38	19.56	20.05	15.05	14.41	0.5	Pass
11a	6Mbps	2	157	5785	16.38	16.43	19.63	20.61	15.10	15.03	0.5	Pass
11a	6Mbps	2	165	5825	16.38	16.43	20.41	21.22	15.09	15.09	0.5	Pass
VHT20	MCS0	2	149	5745	17.53	17.63	20.65	23.74	12.49	15.04	0.5	Pass
VHT20	MCS0	2	157	5785	17.58	17.63	21.14	23.10	15.12	14.39	0.5	Pass
VHT20	MCS0	2	165	5825	17.63	17.68	23.35	23.54	14.88	15.06	0.5	Pass
VHT40	MCS0	2	151	5755	36.26	36.66	41.26	63.57	35.07	35.10	0.5	Pass
VHT40	MCS0	2	159	5795	36.26	36.56	54.05	65.34	33.81	35.03	0.5	Pass
VHT80	MCS0	2	155	5775	75.16	75.28	81.98	84.51	75.07	61.36	0.5	Pass

TEST RESULTS DATA
Average Power Table

U-NII-3 MIMO												
Mod.	Data Rate	NTX	CH.	Freq. (MHz)	Average Conducted Power (dBm)			FCC Conducted Power Limit (dBm)		DG (dBi)		Pass/Fail
					Ant 6	Ant 7	SUM	Ant 6	Ant 7	Ant 6	Ant 7	
11a	6Mbps	2	149	5745	20.50	20.40	23.46	30.00		3.46		Pass
11a	6Mbps	2	157	5785	20.50	20.60	23.56	30.00		3.46		Pass
11a	6Mbps	2	165	5825	20.50	20.60	23.56	30.00		3.46		Pass
HT20	MCS0	2	149	5745	20.70	20.60	23.66	30.00		3.46		Pass
HT20	MCS0	2	157	5785	20.50	20.70	23.61	30.00		3.46		Pass
HT20	MCS0	2	165	5825	20.60	20.70	23.66	30.00		3.46		Pass
HT40	MCS0	2	151	5755	20.20	20.50	23.36	30.00		3.46		Pass
HT40	MCS0	2	159	5795	20.40	20.50	23.46	30.00		3.46		Pass
VHT20	MCS0	2	149	5745	20.80	20.70	23.76	30.00		3.46		Pass
VHT20	MCS0	2	157	5785	20.60	20.80	23.71	30.00		3.46		Pass
VHT20	MCS0	2	165	5825	20.70	20.80	23.76	30.00		3.46		Pass
VHT40	MCS0	2	151	5755	20.30	20.60	23.46	30.00		3.46		Pass
VHT40	MCS0	2	159	5795	20.50	20.60	23.56	30.00		3.46		Pass
VHT80	MCS0	2	155	5775	20.40	20.70	23.56	30.00		3.46		Pass

TEST RESULTS DATA
Power Spectral Density

U-NII-3 MIMO																
Mod.	Data Rate	NTX	CH.	Freq. (MHz)	Duty Factor (dB)		10log (500kHz /RBW) Factor (dB)		Average Power Density (dBm/500kHz)			Average PSD Limit (dBm/500kHz)		DG (dBi)		Pass /Fail
					Ant 6	Ant 7	Ant 6	Ant 7	Ant 6	Ant 7	SUM	Ant 6	Ant 7	Ant 6	Ant 7	
11a	6Mbps	2	149	5745	0.65	0.68	2.22	6.45	6.34	9.46	30.00	5.88	Pass			
11a	6Mbps	2	157	5785	0.65	0.68	2.22	6.05	6.30	9.31	30.00	5.88	Pass			
11a	6Mbps	2	165	5825	0.65	0.68	2.22	6.11	6.18	9.19	30.00	5.88	Pass			
VHT20	MCS0	2	149	5745	0.66	0.65	2.22	6.87	6.36	9.88	30.00	5.88	Pass			
VHT20	MCS0	2	157	5785	0.66	0.65	2.22	6.23	6.40	9.41	30.00	5.88	Pass			
VHT20	MCS0	2	165	5825	0.66	0.65	2.22	6.33	6.45	9.46	30.00	5.88	Pass			
VHT40	MCS0	2	151	5755	0.66	0.66	2.22	3.87	3.97	6.98	30.00	5.88	Pass			
VHT40	MCS0	2	159	5795	0.66	0.66	2.22	3.90	3.92	6.93	30.00	5.88	Pass			
VHT80	MCS0	2	155	5775	0.65	0.69	2.22	1.12	1.25	4.26	30.00	5.88	Pass			

Note: PSD Sum = Max PSD(Ant. 6, Ant. 7) + 10 log (n)

TEST RESULTS DATA
6dB and 26dB EBW and 99% OBW

U-NII-3 MIMO													
Mod.	Data Rate	NTX	CH.	Freq. (MHz)	RU Config	99% Bandwidth (MHz)		26dB Bandwidth (MHz)		6 dB Bandwidth (MHz)		6 dB Bandwidth Min. Limit (MHz)	Pass/Fail
						Ant 6	Ant 7	Ant 6	Ant 7	Ant 6	Ant 7		
HE20	MCS0	2	149	5745	Full	18.93	19.13	22.94	26.55	18.17	18.58	0.5	Pass
HE20	MCS0	2	157	5785	Full	18.98	19.03	22.62	30.49	18.50	14.98	0.5	Pass
HE20	MCS0	2	165	5825	Full	19.03	19.13	26.46	28.85	15.45	15.11	0.5	Pass
HE40	MCS0	2	151	5755	Full	37.86	37.96	41.06	41.14	35.15	33.89	0.5	Pass
HE40	MCS0	2	159	5795	Full	37.86	37.96	41.73	41.22	34.25	35.28	0.5	Pass
HE80	MCS0	2	155	5775	Full	76.96	76.96	81.60	88.48	75.09	70.08	0.5	Pass

TEST RESULTS DATA
Average Power Table

U-NII-3 MIMO													
Mod.	Data Rate	NTX	CH.	Freq. (MHz)	RU Config	Average Conducted Power (dBm)			FCC Conducted Power Limit (dBm)		DG (dBi)		Pass/Fail
						Ant 6	Ant 7	SUM	Ant 6	Ant 7	Ant 6	Ant 7	
HE20	MCS0	2	149	5745	Full	20.90	20.80	23.86	30.00		3.46		Pass
HE20	MCS0	2	149	5745	26/0	13.00	13.20	16.11	30.00		3.46		Pass
HE20	MCS0	2	149	5745	52/37	15.70	15.60	18.66	30.00		3.46		Pass
HE20	MCS0	2	149	5745	106/53	17.30	17.00	20.16	30.00		3.46		Pass
HE20	MCS0	2	157	5785	Full	20.70	20.90	23.81	30.00		3.46		Pass
HE20	MCS0	2	157	5785	26/4	12.80	13.10	15.96	30.00		3.46		Pass
HE20	MCS0	2	157	5785	52/38	15.90	15.80	18.86	30.00		3.46		Pass
HE20	MCS0	2	157	5785	106/53	18.60	18.80	21.71	30.00		3.46		Pass
HE20	MCS0	2	165	5825	Full	20.80	20.90	23.86	30.00		3.46		Pass
HE20	MCS0	2	165	5825	26/8	13.10	13.00	16.06	30.00		3.46		Pass
HE20	MCS0	2	165	5825	52/40	16.10	16.00	19.06	30.00		3.46		Pass
HE20	MCS0	2	165	5825	106/54	17.60	17.70	20.66	30.00		3.46		Pass
HE40	MCS0	2	151	5755	Full	20.40	20.70	23.56	30.00		3.46		Pass
HE40	MCS0	2	151	5755	242/61	17.10	16.70	19.91	30.00		3.46		Pass
HE40	MCS0	2	159	5795	Full	20.60	20.70	23.66	30.00		3.46		Pass
HE40	MCS0	2	159	5795	242/62	17.40	17.30	20.36	30.00		3.46		Pass
HE80	MCS0	2	155	5775	Full	20.50	20.80	23.66	30.00		3.46		Pass
HE80	MCS0	2	155	5775	484/65	17.30	17.00	20.16	30.00		3.46		Pass
HE80	MCS0	2	155	5775	484/66	16.40	15.90	19.17	30.00		3.46		Pass

TEST RESULTS DATA
Power Spectral Density

U-NII-3 MIMO																	
Mod.	Data Rate	NTX	CH.	Freq. (MHz)	RU Config	Duty Factor (dB)		10log (500kHz /RBW) Factor (dB)		Average Power Density (dBm/500kHz)			Average PSD Limit (dBm/500kHz)		DG (dBi)		Pass /Fail
						Ant 6	Ant 7	Ant 6	Ant 7	Ant 6	Ant 7	SUM	Ant 6	Ant 7	Ant 6	Ant 7	
HE20	MCS0	2	149	5745	Full	0.66	0.66	2.22	6.25	6.01	9.26	30.00	5.88	Pass			
HE20	MCS0	2	149	5745	26/0	0.66	0.66	2.22	6.07	5.98	9.08	30.00	5.88	Pass			
HE20	MCS0	2	149	5745	52/37	0.66	0.66	2.22	5.76	5.67	8.77	30.00	5.88	Pass			
HE20	MCS0	2	149	5745	106/53	0.66	0.66	2.22	4.20	3.89	7.21	30.00	5.88	Pass			
HE20	MCS0	2	157	5785	Full	0.66	0.66	2.22	5.89	6.05	9.06	30.00	5.88	Pass			
HE20	MCS0	2	157	5785	26/4	0.66	0.66	2.22	5.70	5.87	8.88	30.00	5.88	Pass			
HE20	MCS0	2	157	5785	52/38	0.66	0.66	2.22	5.82	5.75	8.83	30.00	5.88	Pass			
HE20	MCS0	2	157	5785	106/53	0.66	0.66	2.22	5.52	5.76	8.77	30.00	5.88	Pass			
HE20	MCS0	2	165	5825	Full	0.66	0.66	2.22	6.08	6.15	9.16	30.00	5.88	Pass			
HE20	MCS0	2	165	5825	26/8	0.66	0.66	2.22	6.00	5.77	9.01	30.00	5.88	Pass			
HE20	MCS0	2	165	5825	52/40	0.66	0.66	2.22	6.07	5.87	9.08	30.00	5.88	Pass			
HE20	MCS0	2	165	5825	106/54	0.66	0.66	2.22	4.77	4.79	7.80	30.00	5.88	Pass			
HE40	MCS0	2	151	5755	Full	0.67	0.65	2.22	3.39	3.59	6.60	30.00	5.88	Pass			
HE40	MCS0	2	151	5755	242/61	0.67	0.65	2.22	0.76	0.14	3.77	30.00	5.88	Pass			
HE40	MCS0	2	159	5795	Full	0.67	0.65	2.22	2.97	2.94	5.98	30.00	5.88	Pass			
HE40	MCS0	2	159	5795	242/62	0.67	0.65	2.22	0.75	0.48	3.76	30.00	5.88	Pass			
HE80	MCS0	2	155	5775	Full	0.69	0.69	2.22	0.83	1.09	4.10	30.00	5.88	Pass			
HE80	MCS0	2	155	5775	484/65	0.69	0.69	2.22	-2.11	-2.56	0.90	30.00	5.88	Pass			
HE80	MCS0	2	155	5775	484/66	0.69	0.69	2.22	-3.34	-3.74	-0.33	30.00	5.88	Pass			

Note: PSD Sum = Max PSD(Ant. 6, Ant. 7) + 10 log (n)



Test Result of 6dB and 26dB and 99% Occupied Bandwidth

MIMO <Ant. 6+7>

<802.11a>

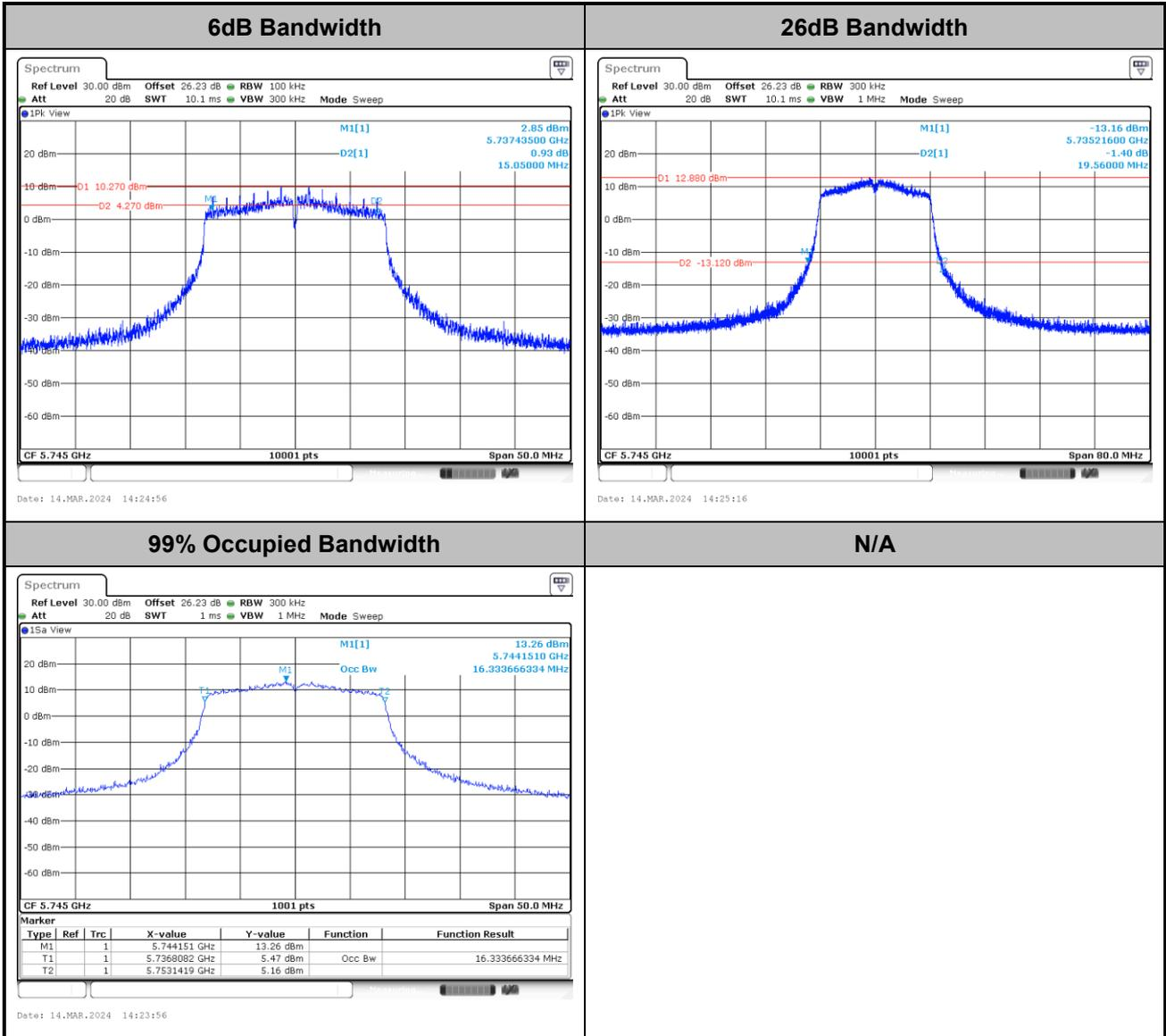



<802.11ac VHT20>

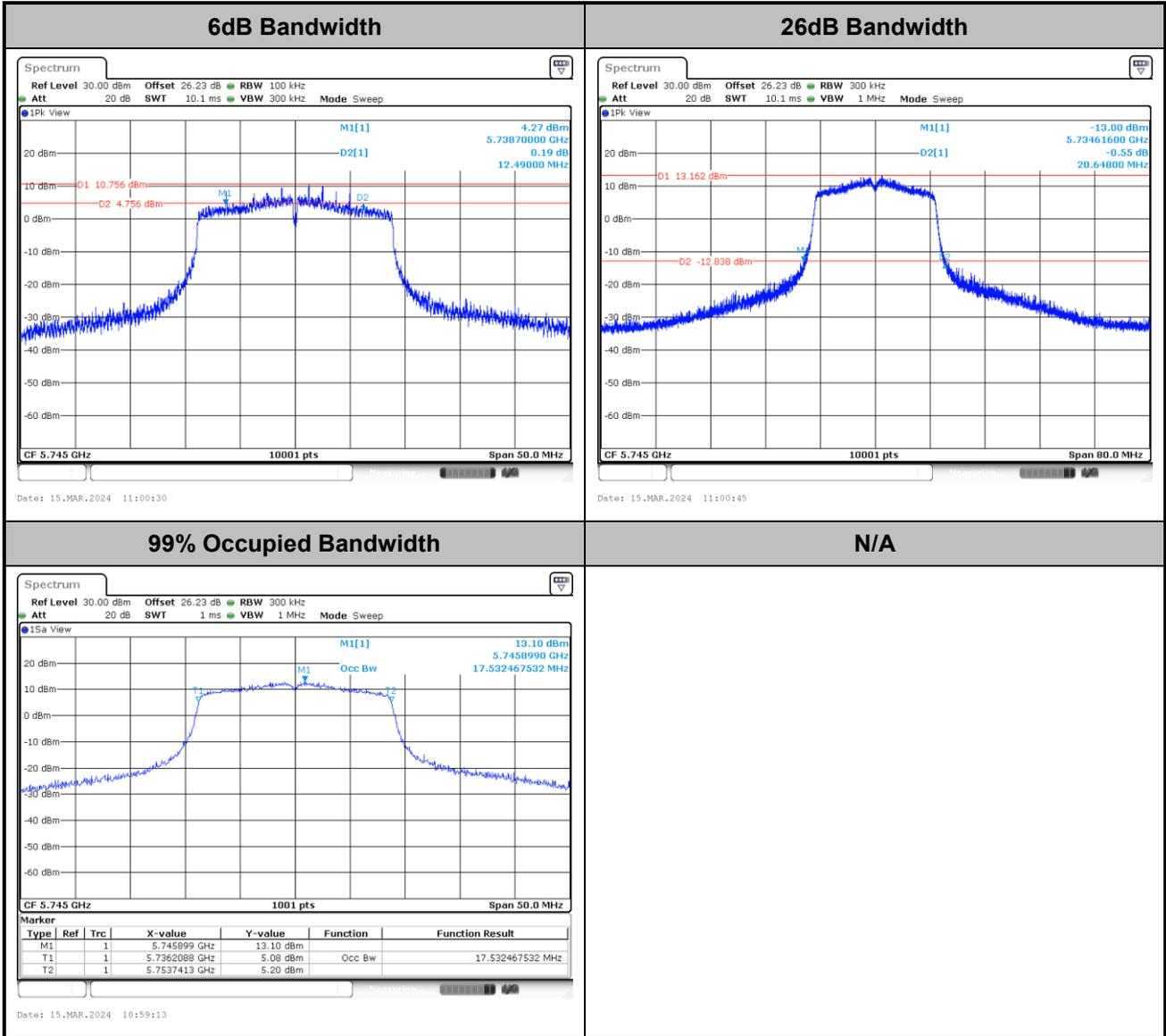



<802.11ac VHT40>

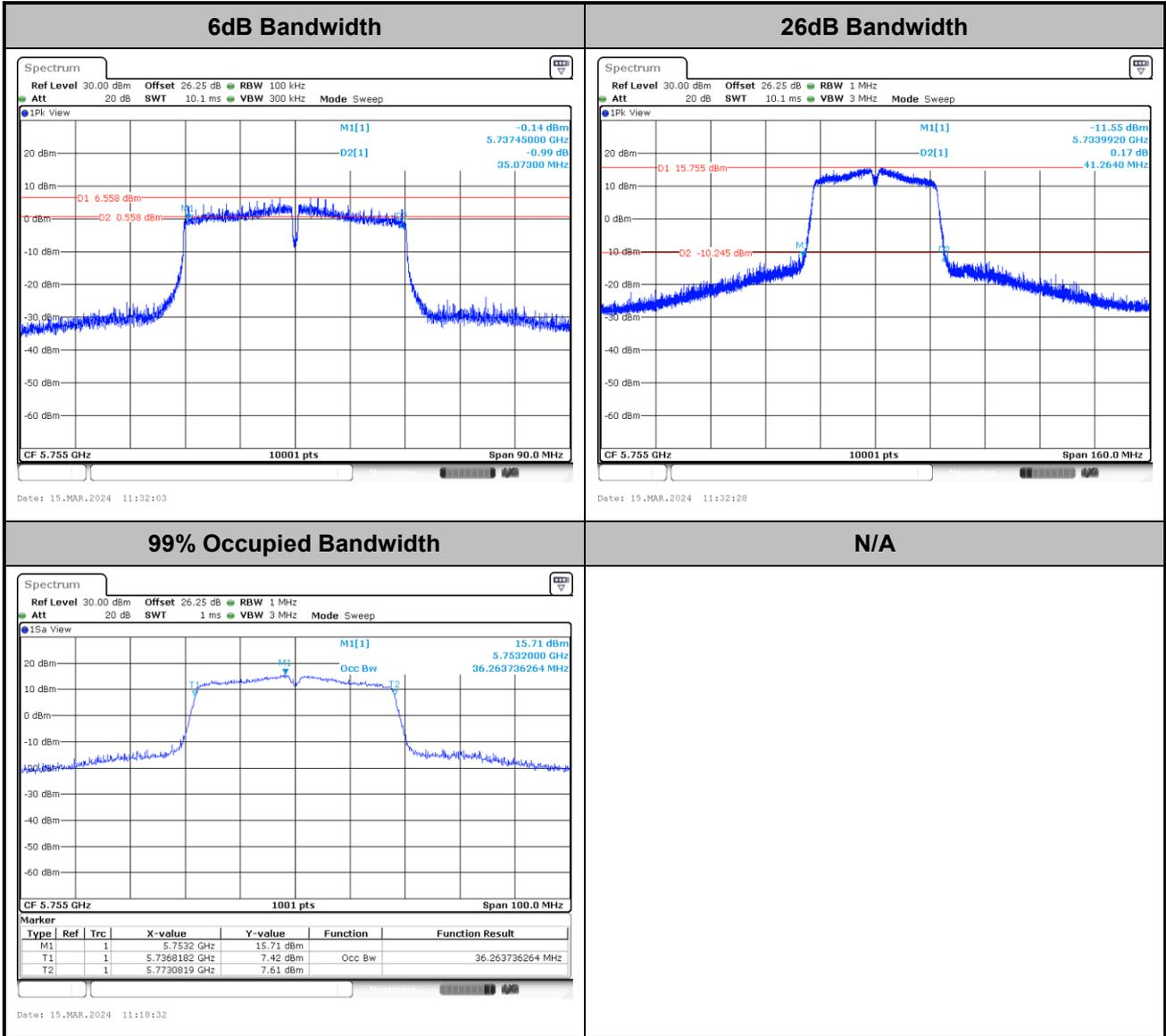



<802.11ac VHT80>

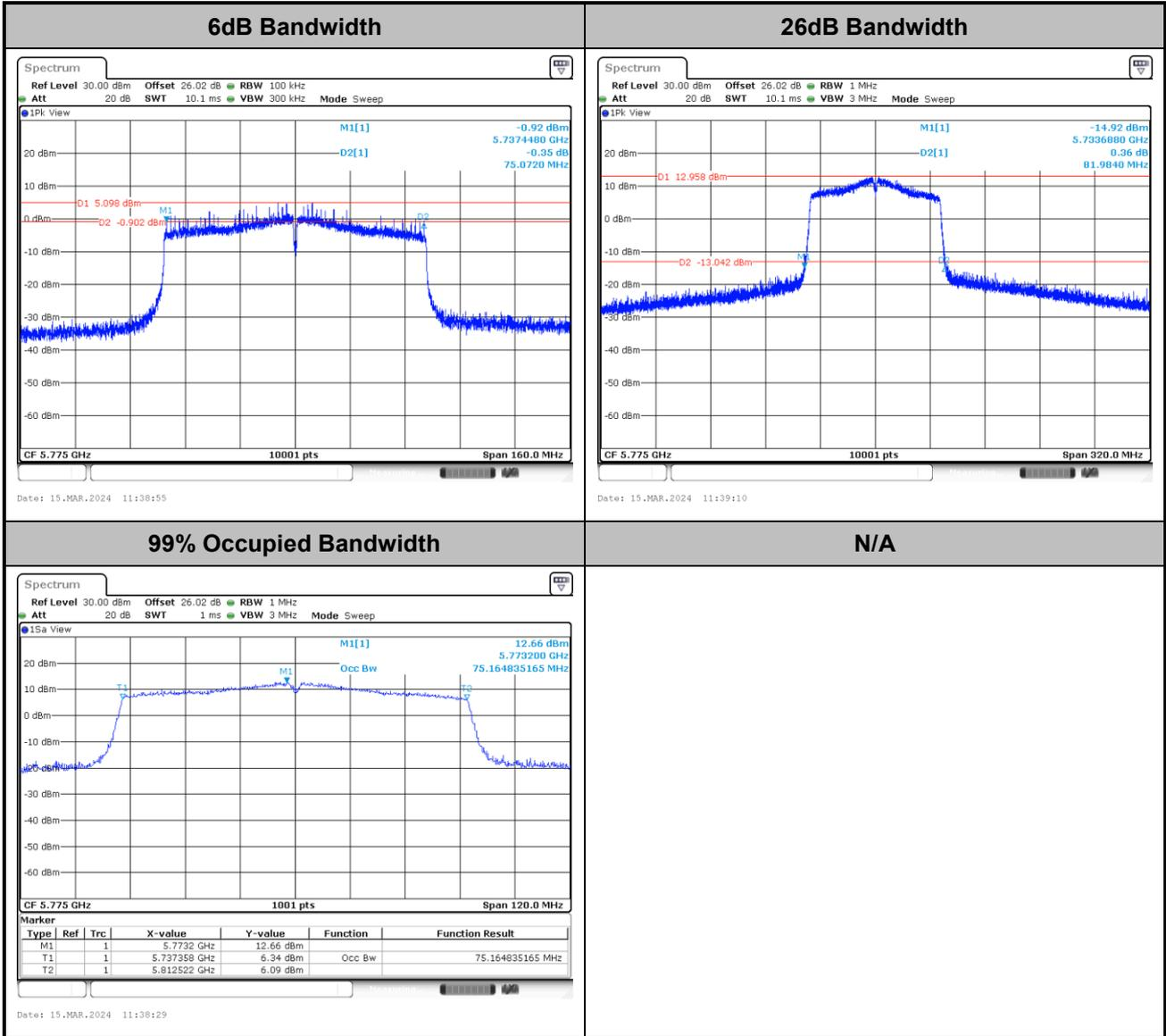



<802.11ax HE20>

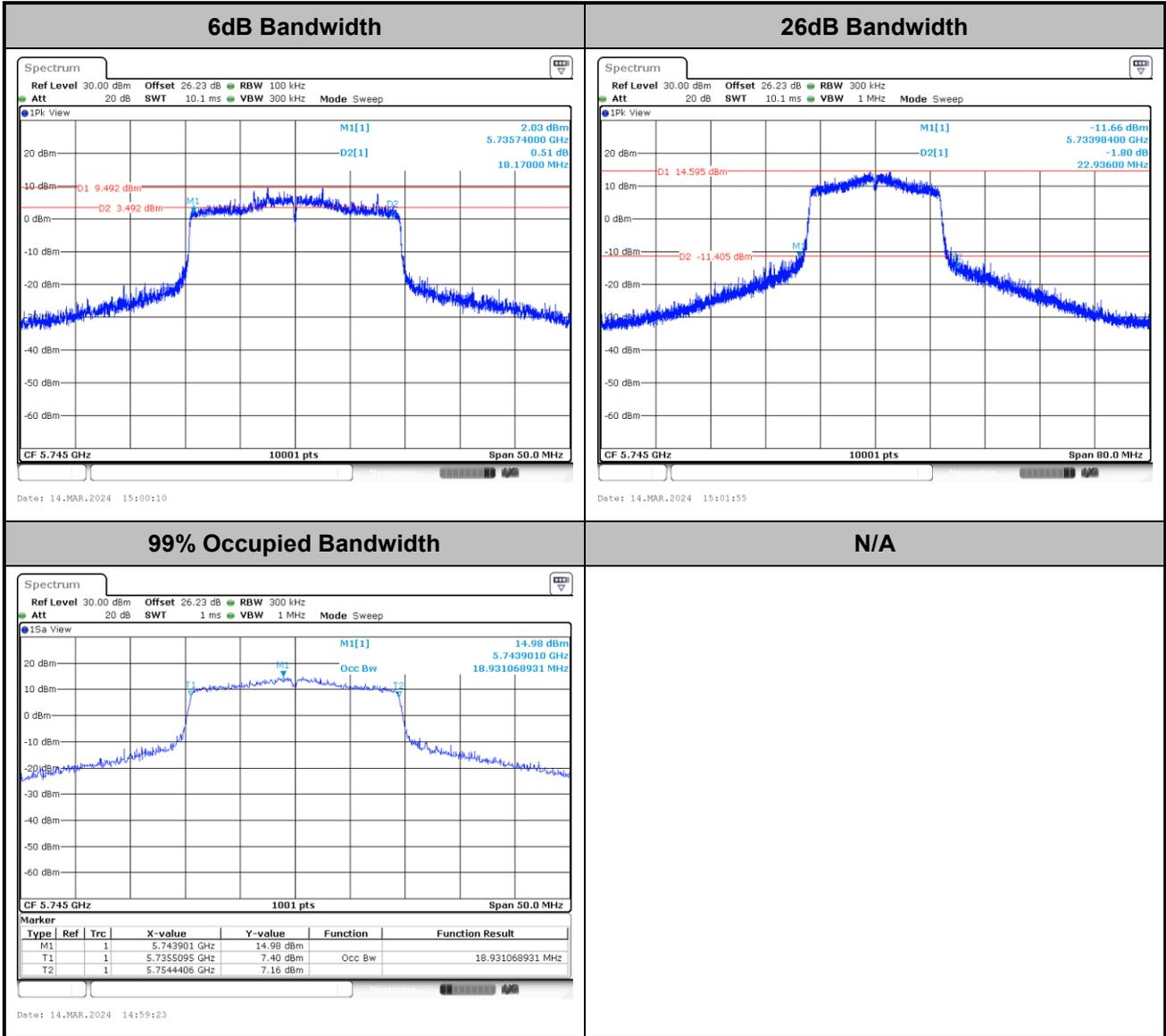



<802.11ax HE40>

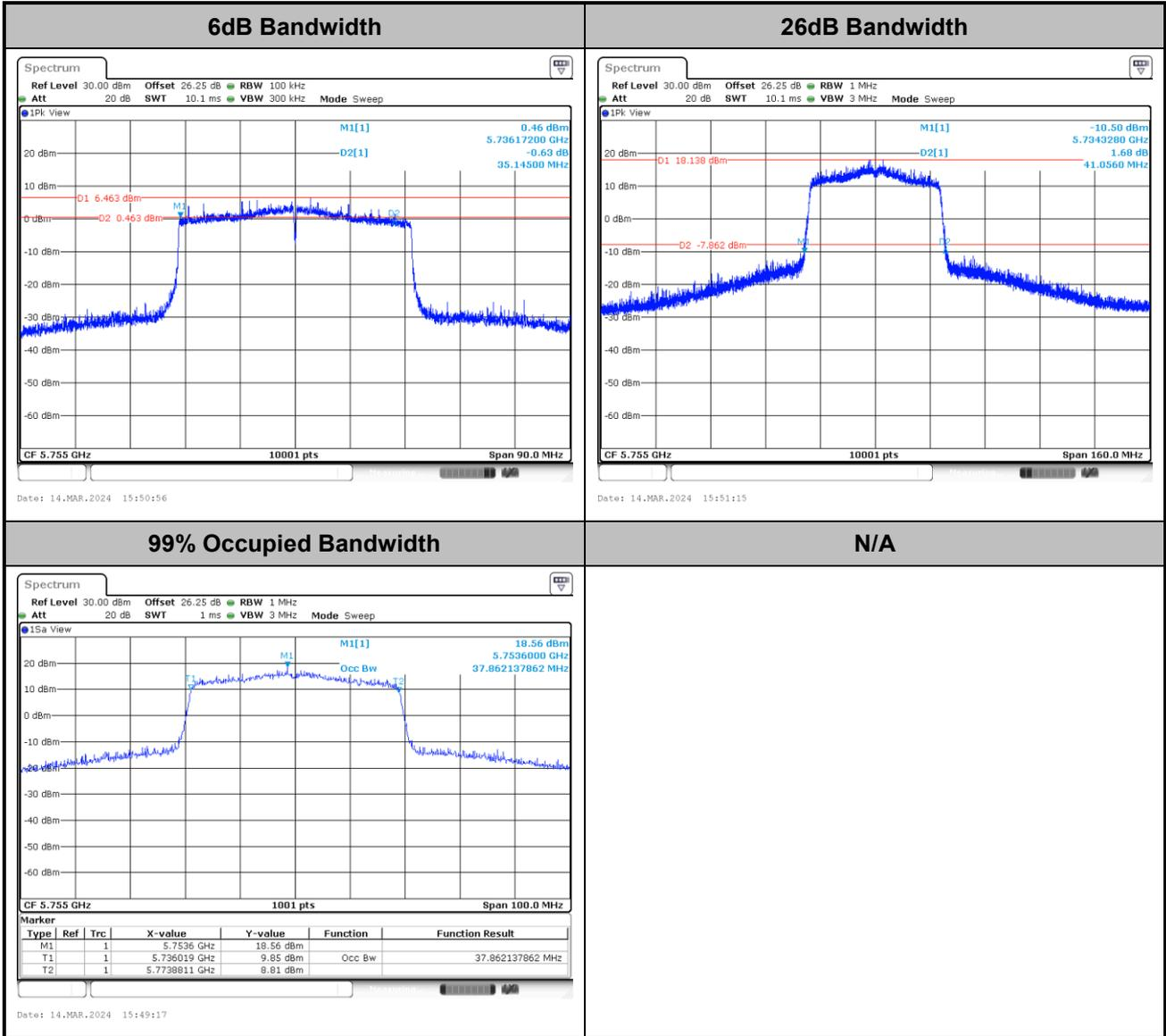



<802.11ax HE80>

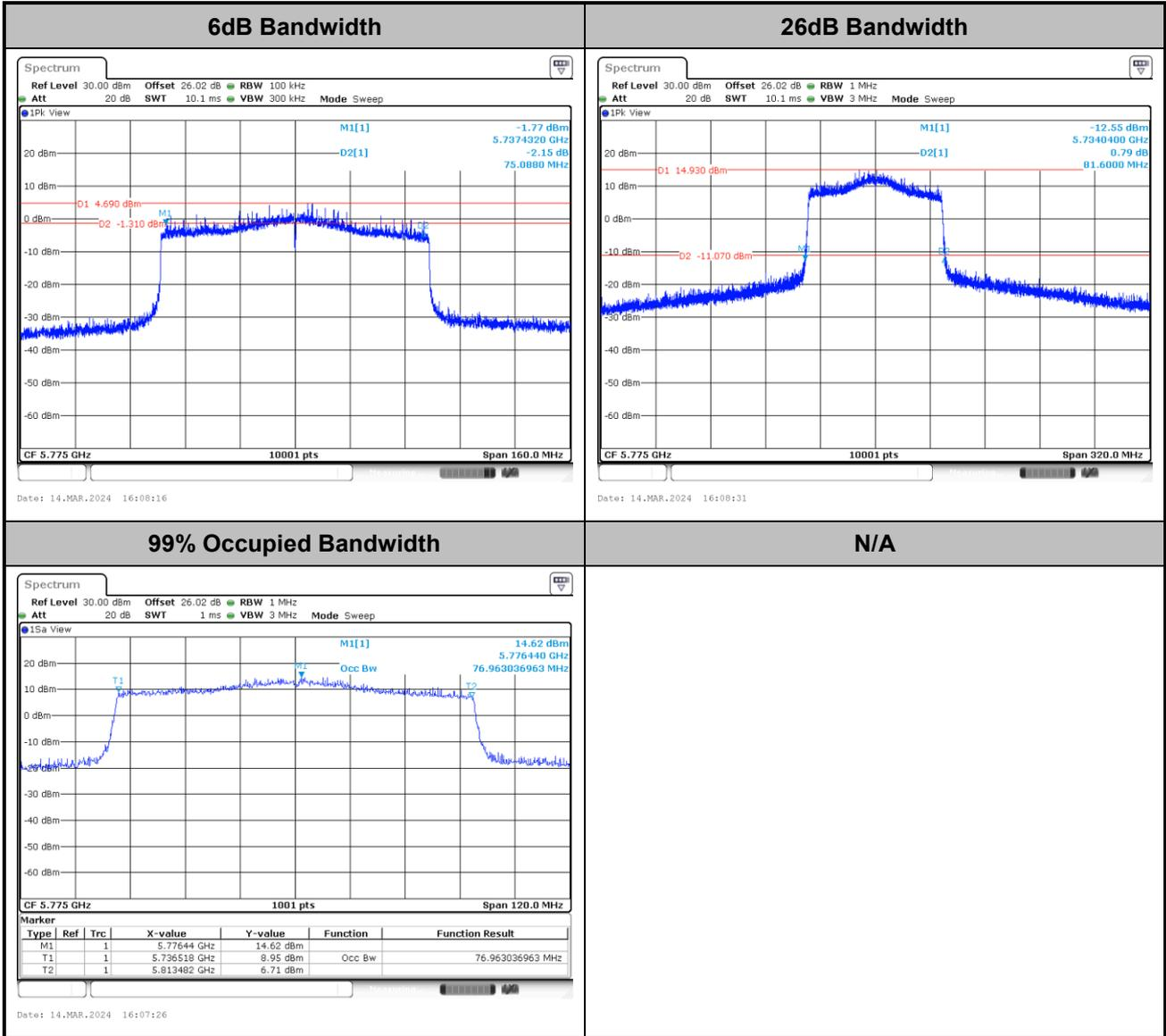



Test Result of Power Spectral Density

<802.11a>

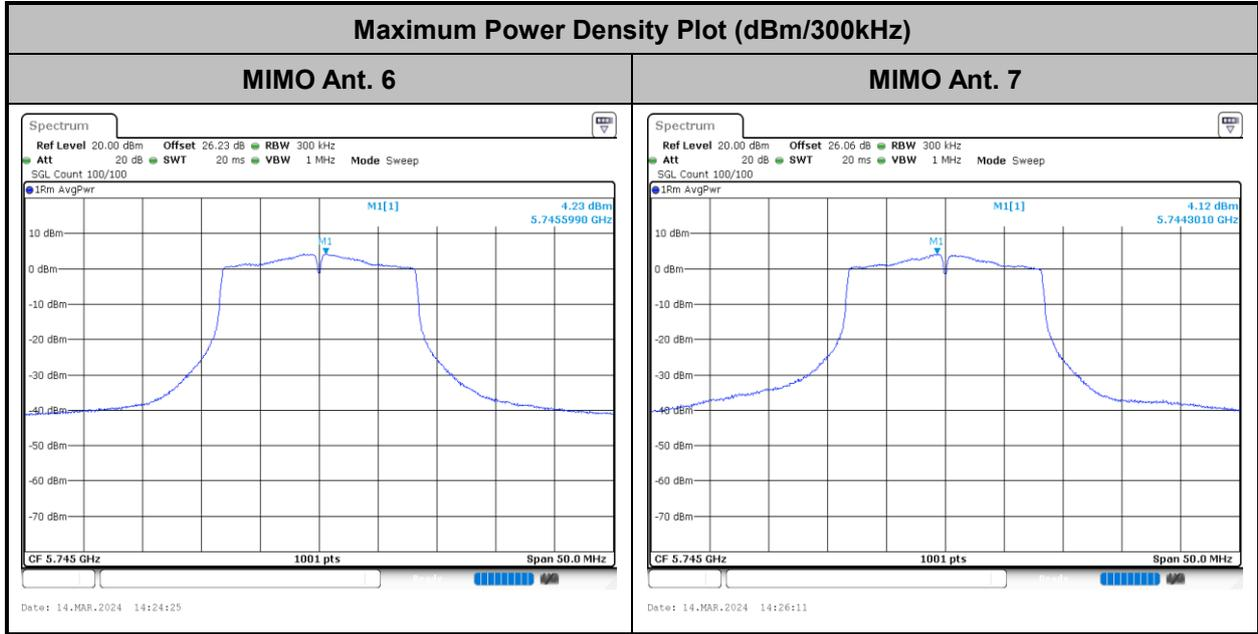

<802.11ac VHT20>

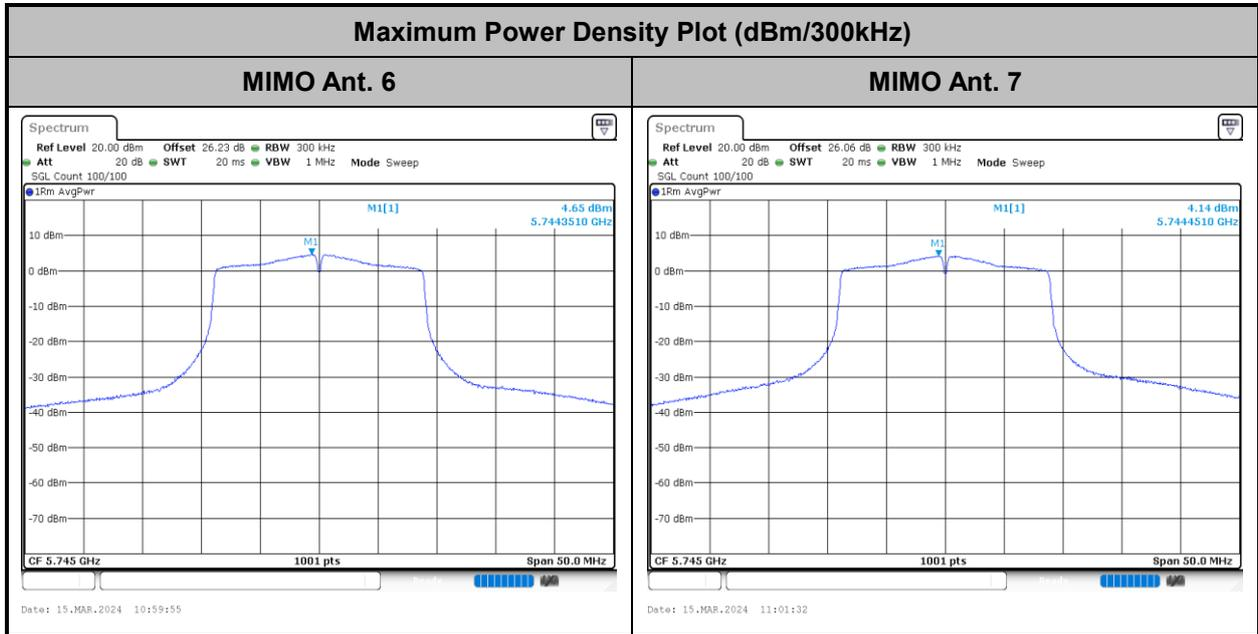



<802.11ac VHT40>

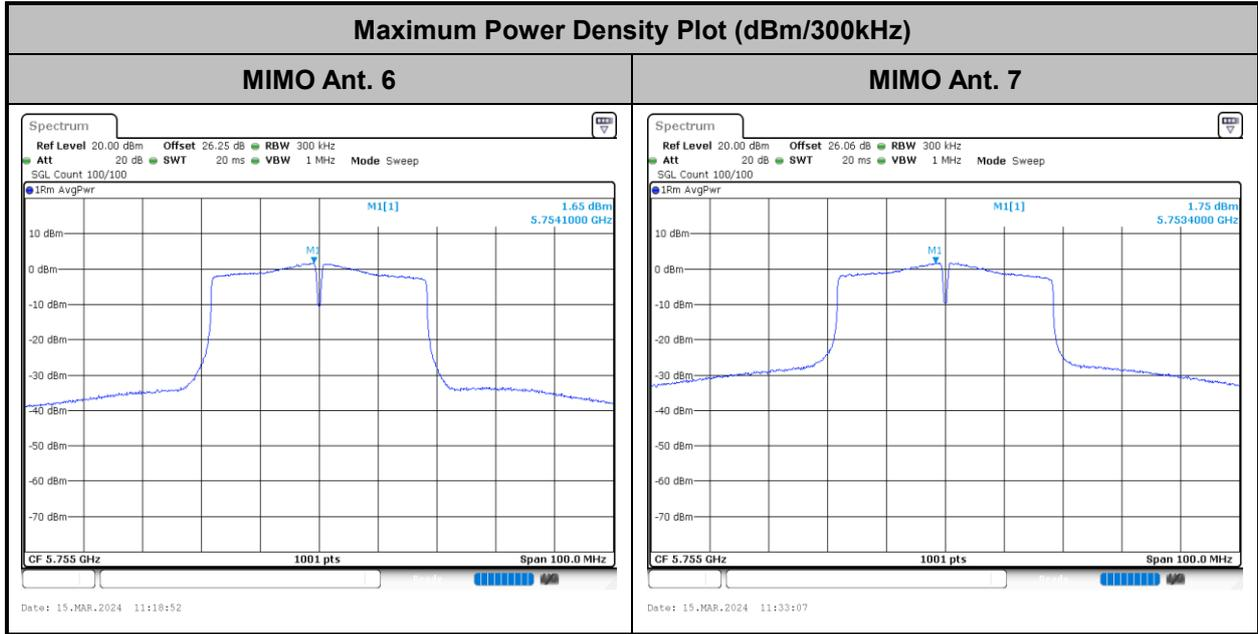

<802.11ac VHT80>

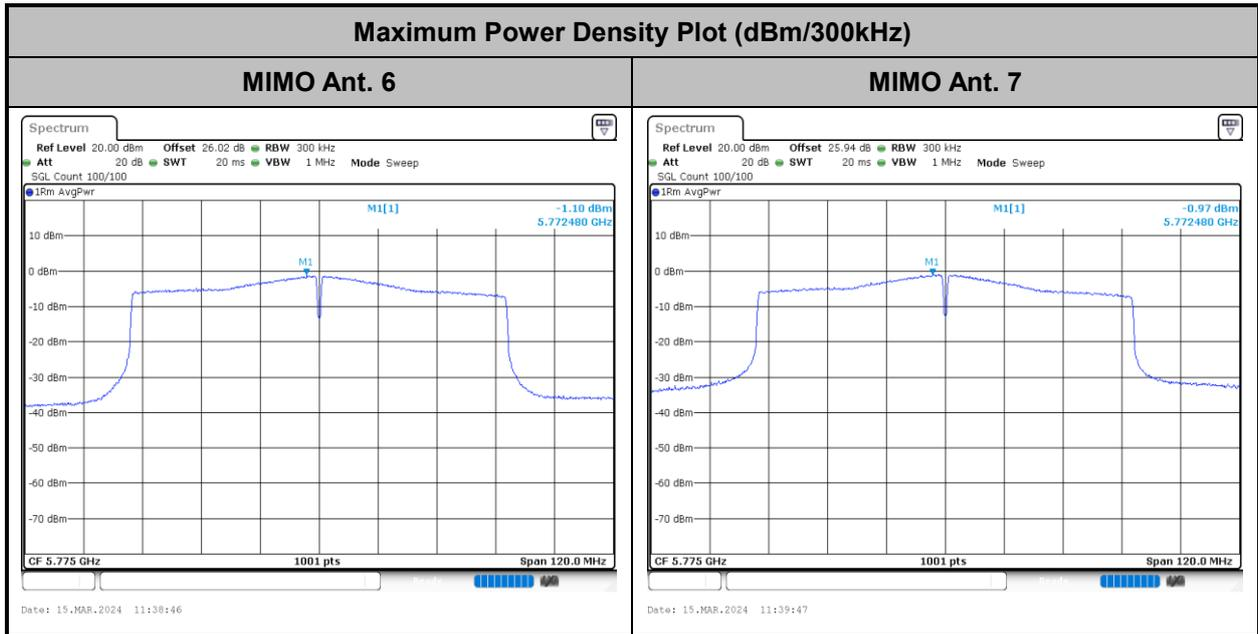



<802.11ax HE20>

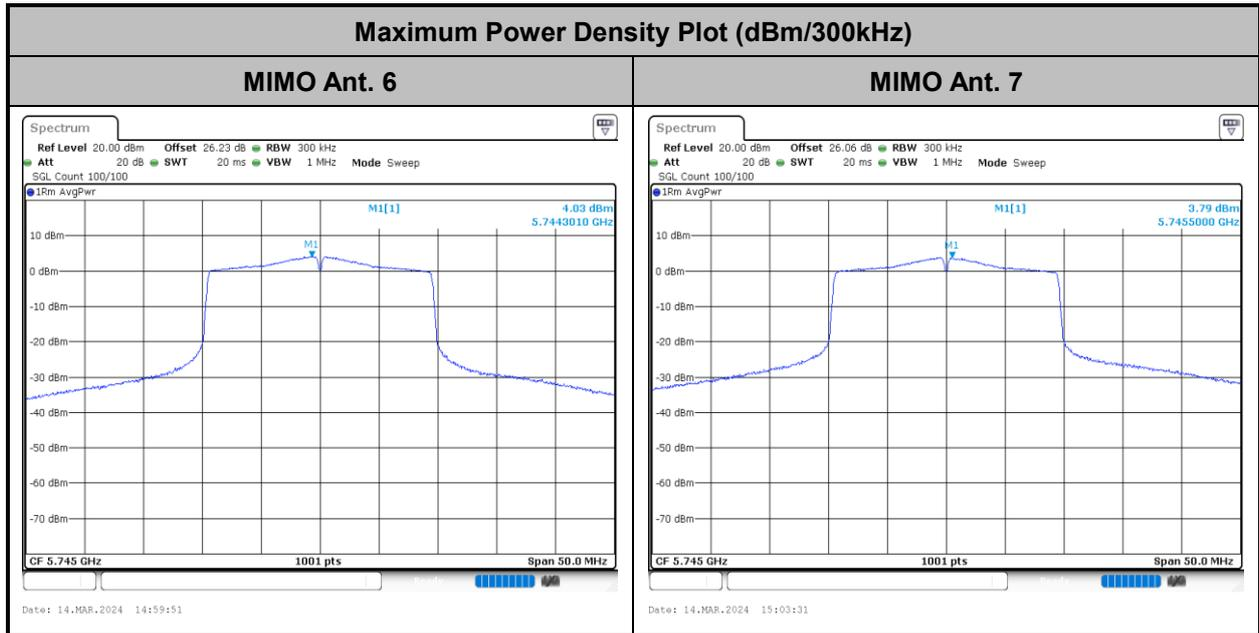

<802.11ax HE40>

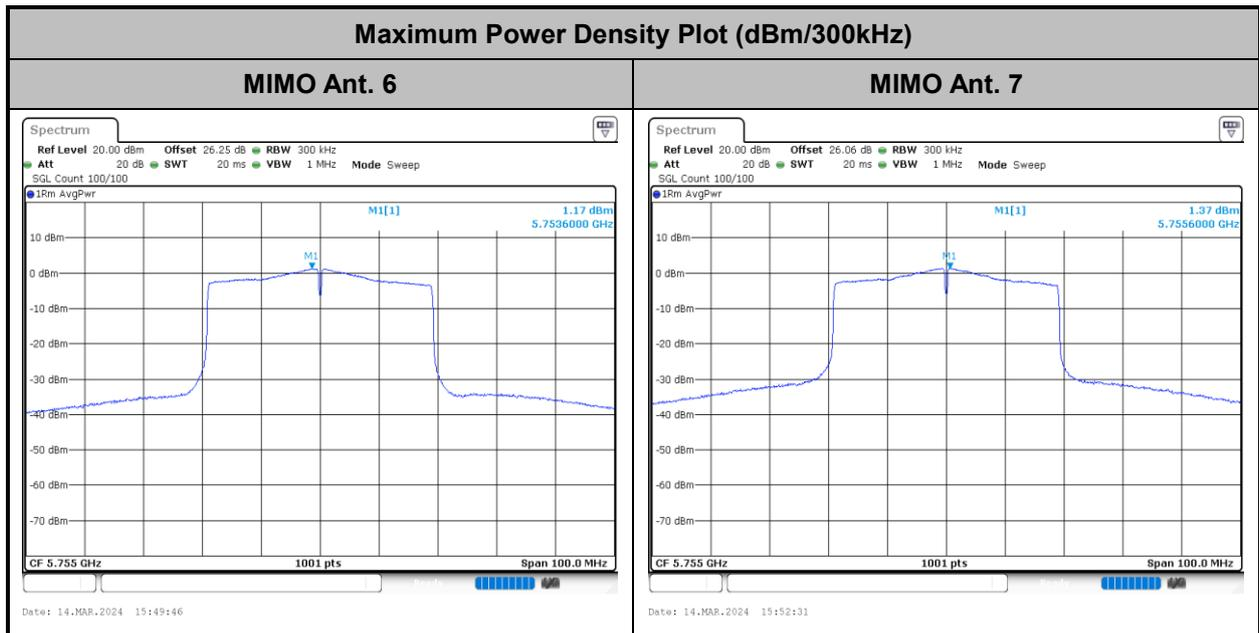



<802.11ax HE80>

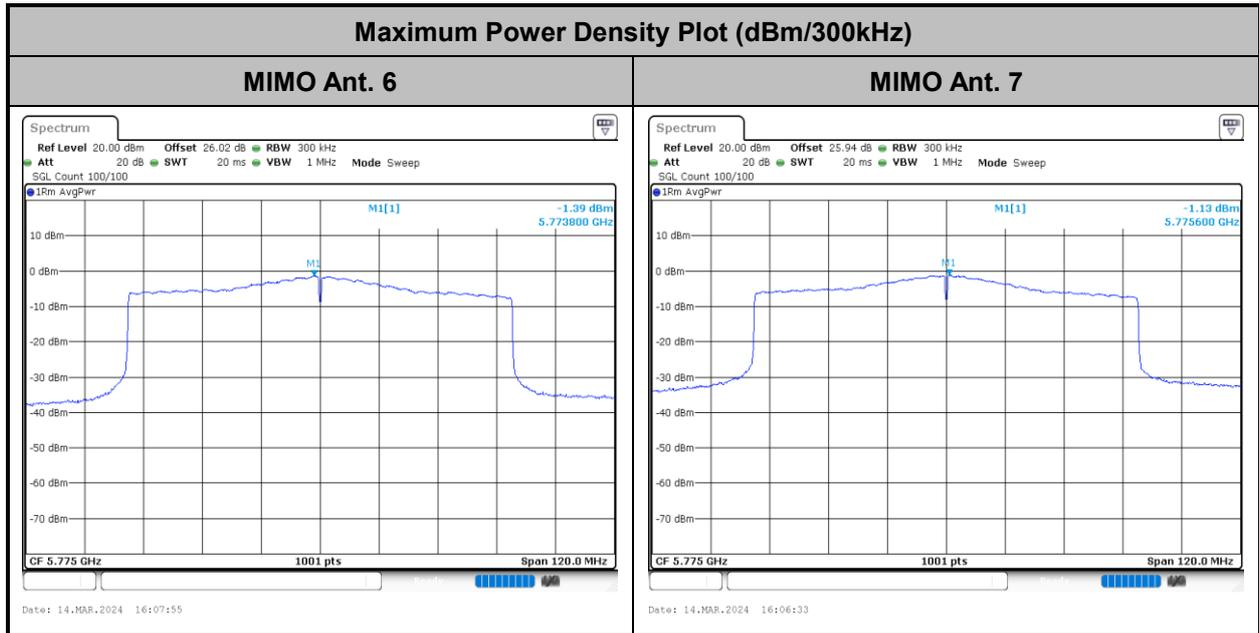



Appendix B. AC Conducted Emission Test Results

Test Engineer :	Calvin Wang	Temperature :	23~26°C
		Relative Humidity :	45~55%

EUT Information

Test Mode : Mode 1
 Test Voltage : 120Vac/60Hz
 Phase : Line

Full Spectrum

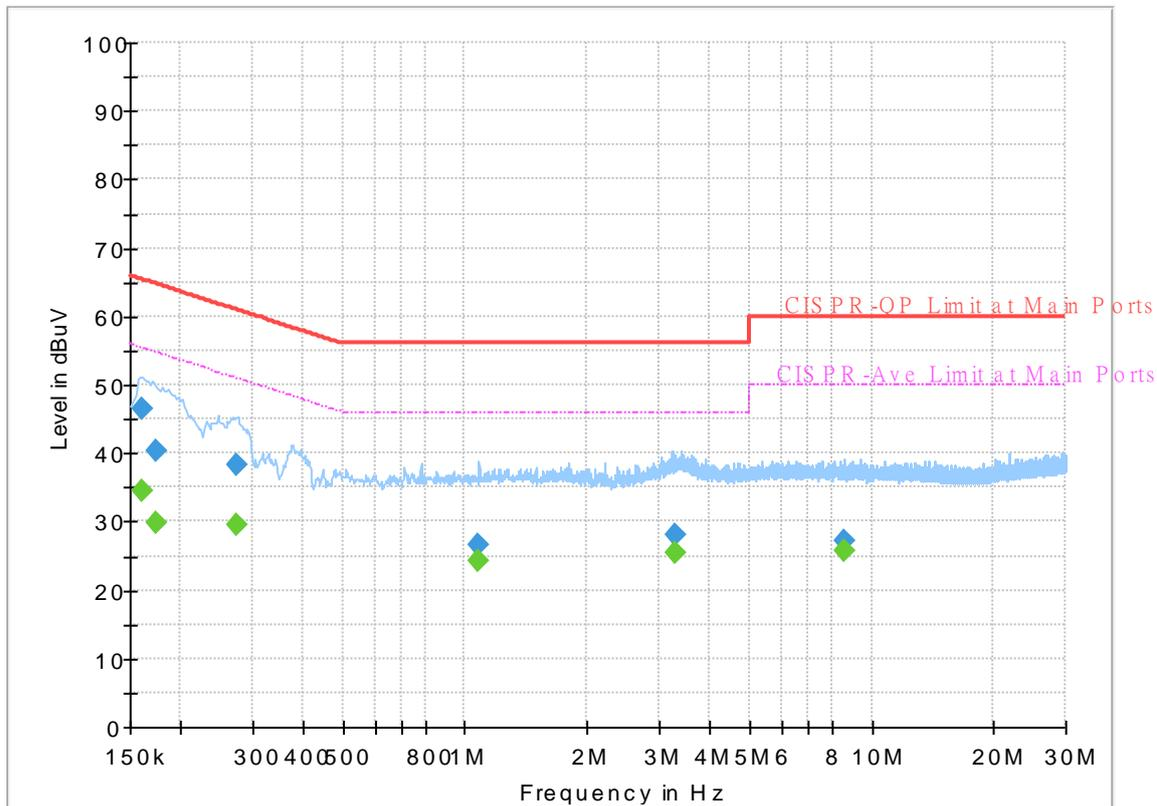

Final_Result

Frequency (MHz)	QuasiPeak (dBuV)	CAverage (dBuV)	Limit (dBuV)	Margin (dB)	Line	Filter	Corr. (dB)
0.161250	---	34.39	55.40	21.01	L1	OFF	19.8
0.161250	46.62	---	65.40	18.78	L1	OFF	19.8
0.174750	---	29.88	54.73	24.85	L1	OFF	19.8
0.174750	40.27	---	64.73	24.46	L1	OFF	19.8
0.273750	---	29.48	51.00	21.52	L1	OFF	19.8
0.273750	38.21	---	61.00	22.79	L1	OFF	19.8
1.081500	---	24.27	46.00	21.73	L1	OFF	19.8
1.081500	26.72	---	56.00	29.28	L1	OFF	19.8
3.293250	---	25.33	46.00	20.67	L1	OFF	19.9
3.293250	28.15	---	56.00	27.85	L1	OFF	19.9
8.596500	---	25.73	50.00	24.27	L1	OFF	20.1
8.596500	27.06	---	60.00	32.94	L1	OFF	20.1

EUT Information

Test Mode : Mode 1
 Test Voltage : 120Vac/60Hz
 Phase : Neutral

Full Spectrum

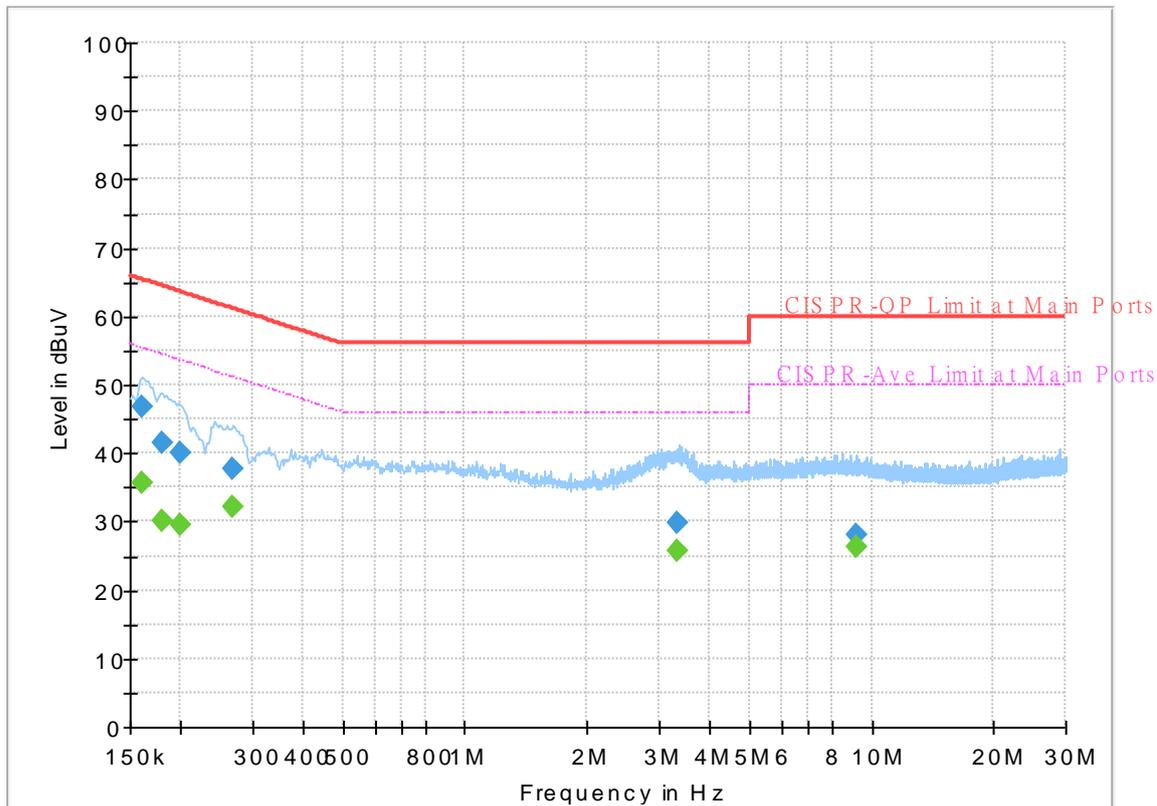

Final_Result

Frequency (MHz)	QuasiPeak (dBuV)	CAverage (dBuV)	Limit (dBuV)	Margin (dB)	Line	Filter	Corr. (dB)
0.161250	---	35.66	55.40	19.74	N	OFF	19.8
0.161250	46.88	---	65.40	18.52	N	OFF	19.8
0.179250	---	30.26	54.52	24.26	N	OFF	19.8
0.179250	41.47	---	64.52	23.05	N	OFF	19.8
0.199500	---	29.62	53.63	24.01	N	OFF	19.8
0.199500	40.11	---	63.63	23.52	N	OFF	19.8
0.269250	---	32.29	51.14	18.85	N	OFF	19.8
0.269250	37.82	---	61.14	23.32	N	OFF	19.8
3.309000	---	25.67	46.00	20.33	N	OFF	19.9
3.309000	29.86	---	56.00	26.14	N	OFF	19.9
9.154500	---	26.27	50.00	23.73	N	OFF	20.2
9.154500	27.93	---	60.00	32.07	N	OFF	20.2



Appendix C. Radiated Spurious Emission

Test Engineer :	John Chuang, David Dai, and Howard Huang	Temperature :	19.5~23.5°C
		Relative Humidity :	64.9~70.7%

Band 4 - 5725~5850MHz
WIFI 802.11a (Band Edge @ 3m)

WIFI Ant.	Note	Frequency (MHz)	Level (dBμV/m)	Margin (dB)	Limit Line (dBμV/m)	Read Level (dBμV)	Antenna Factor (dB/m)	Path Loss (dB)	Preamp Factor (dB)	Ant Pos (cm)	Table Pos (deg)	Peak Avg. (P/A)	Pol. (H/V)	
802.11a CH 149 5745MHz		5645.675	48.97	-19.23	68.2	40.22	33.2	13.55	38	100	120	P	H	
		5696.3	52.52	-49.95	102.47	43.49	33.39	13.62	37.98	100	120	P	H	
		5718.8	58.46	-52	110.46	49.24	33.55	13.65	37.98	100	120	P	H	
		5723.975	64.4	-55.46	119.86	55.13	33.59	13.66	37.98	100	120	P	H	
	*	5745	115.04	-	-	105.56	33.76	13.69	37.97	100	120	P	H	
	*	5745	108.06	-	-	98.58	33.76	13.69	37.97	100	120	A	H	
														H
														H
			5628.8	47.91	-20.29	68.2	39.18	33.2	13.53	38	239	98	P	V
			5686.175	50.26	-44.74	95	41.3	33.34	13.61	37.99	239	98	P	V
			5719.025	54.69	-55.84	110.53	45.47	33.55	13.65	37.98	239	98	P	V
			5723.75	58.33	-61.02	119.35	49.06	33.59	13.66	37.98	239	98	P	V
	*	5745	111.11	-	-	101.63	33.76	13.69	37.97	239	98	P	V	
	*	5745	105.67	-	-	96.19	33.76	13.69	37.97	239	98	A	V	
														V
														V



WIFI Ant. 6+7	Note	Frequency (MHz)	Level (dBμV/m)	Margin (dB)	Limit Line (dBμV/m)	Read Level (dBμV)	Antenna Factor (dB/m)	Path Loss (dB)	Preamp Factor (dB)	Ant Pos (cm)	Table Pos (deg)	Peak Avg. (P/A)	Pol. (H/V)
		5632.25	48.18	-20.02	68.2	39.45	33.2	13.53	38	100	119	P	H
		5700	48.9	-56.3	105.2	39.86	33.4	13.62	37.98	100	119	P	H
		5701	50.86	-54.62	105.48	41.8	33.41	13.63	37.98	100	119	P	H
		5720.5	50.47	-61.47	111.94	41.24	33.56	13.65	37.98	100	119	P	H
	*	5785	115.49	-	-	105.77	33.94	13.74	37.96	100	119	P	H
	*	5785	108.57	-	-	98.85	33.94	13.74	37.96	100	119	A	H
		5850	51.42	-70.78	122.2	41.23	34.3	13.84	37.95	100	119	P	H
		5867.75	50.99	-56.24	107.23	40.76	34.3	13.87	37.94	100	119	P	H
		5895.5	50.57	-39.42	89.99	40.3	34.3	13.91	37.94	100	119	P	H
		5928.25	49.61	-18.59	68.2	39.27	34.3	13.97	37.93	100	119	P	H
													H
													H
802.11a													
CH 157													
5785MHz		5621.25	48.1	-20.1	68.2	39.38	33.2	13.52	38	100	298	P	V
		5671.75	48.81	-35.53	84.34	39.92	33.29	13.59	37.99	100	298	P	V
		5719	50.29	-60.23	110.52	41.07	33.55	13.65	37.98	100	298	P	V
		5721.5	51.31	-62.91	114.22	42.07	33.57	13.65	37.98	100	298	P	V
	*	5785	113.28	-	-	103.56	33.94	13.74	37.96	100	298	P	V
	*	5785	106.7	-	-	96.98	33.94	13.74	37.96	100	298	A	V
		5853.25	49.74	-65.05	114.79	39.54	34.3	13.85	37.95	100	298	P	V
		5862.75	51.51	-57.12	108.63	41.29	34.3	13.86	37.94	100	298	P	V
		5887.5	49.97	-45.95	95.92	39.71	34.3	13.9	37.94	100	298	P	V
		5936.5	50.06	-18.14	68.2	39.71	34.3	13.98	37.93	100	298	P	V
													V
													V



WiFi Ant. 6+7	Note	Frequency (MHz)	Level (dBµV/m)	Margin (dB)	Limit Line (dBµV/m)	Read Level (dBµV)	Antenna Factor (dB/m)	Path Loss (dB)	Preamp Factor (dB)	Ant Pos (cm)	Table Pos (deg)	Peak Avg. (P/A)	Pol. (H/V)	
802.11a CH 165 5825MHz	*	5825	116.45	-	-	106.45	34.15	13.8	37.95	101	119	P	H	
	*	5825	108.67	-	-	98.67	34.15	13.8	37.95	101	119	A	H	
		5850	59.98	-62.22	122.2	49.79	34.3	13.84	37.95	101	119	P	H	
		5855.2	57.42	-53.32	110.74	47.21	34.3	13.85	37.94	101	119	P	H	
		5875.8	52.81	-51.8	104.61	42.57	34.3	13.88	37.94	101	119	P	H	
		5925	51.11	-17.09	68.2	40.78	34.3	13.96	37.93	101	119	P	H	
														H
														H
	*	5825	113.38	-	-	103.38	34.15	13.8	37.95	100	299	299	P	V
	*	5825	106.48	-	-	96.48	34.15	13.8	37.95	100	299	299	A	V
		5851	62.79	-57.13	119.92	52.6	34.3	13.84	37.95	100	299	299	P	V
		5855.4	58.81	-51.88	110.69	48.6	34.3	13.85	37.94	100	299	299	P	V
		5886	52.73	-44.3	97.03	42.47	34.3	13.9	37.94	100	299	299	P	V
		5938.6	49.83	-18.37	68.2	39.47	34.3	13.98	37.92	100	299	299	P	V
														V
														V
													V	
Remark	1. No other spurious found. 2. All results are PASS against Peak and Average limit line.													



Band 4 5725~5850MHz
WIFI 802.11a (Harmonic @ 3m)

WIFI Ant. 6+7	Note	Frequency (MHz)	Level (dBμV/m)	Margin (dB)	Limit Line (dBμV/m)	Read Level (dBμV)	Antenna Factor (dB/m)	Path Loss (dB)	Preamp Factor (dB)	Ant Pos (cm)	Table Pos (deg)	Peak Avg. (P/A)	Pol. (H/V)	
802.11a CH 149 5745MHz		11490	52.1	-21.9	74	35.68	39.13	19.93	42.64	100	3	P	H	
		11490	41.54	-12.46	54	25.12	39.13	19.93	42.64	100	3	A	H	
		17235	51.94	-16.26	68.2	34.16	37.97	24.58	44.77	-	-	P	H	
													H	
													H	
													H	
													H	
													H	
													H	
													H	
													H	
													H	
													H	
													H	
													H	
													H	
													H	
													H	
			11490	51.4	-22.6	74	34.98	39.13	19.93	42.64	200	14	P	V
			11490	41.41	-12.59	54	24.99	39.13	19.93	42.64	200	14	A	V
		17235	51.71	-16.49	68.2	33.93	37.97	24.58	44.77	-	-	P	V	
													V	
													V	
													V	
													V	
													V	
													V	
													V	
													V	
													V	



WiFi Ant. 6+7	Note	Frequency (MHz)	Level (dBμV/m)	Margin (dB)	Limit Line (dBμV/m)	Read Level (dBμV)	Antenna Factor (dB/m)	Path Loss (dB)	Preamp Factor (dB)	Ant Pos (cm)	Table Pos (deg)	Peak Avg. (P/A)	Pol. (H/V)	
802.11a CH 165 5825MHz		11650	50.61	-23.39	74	34.38	38.95	20.06	42.78	300	100	P	H	
		11650	41.05	-12.95	54	24.82	38.95	20.06	42.78	300	100	A	H	
		17475	52.18	-16.02	68.2	33.97	38.45	24.75	44.99	-	-	P	H	
													H	
													H	
													H	
													H	
													H	
													H	
													H	
													H	
			11650	51.62	-22.38	74	35.39	38.95	20.06	42.78	200	19	P	V
			11650	41.04	-12.96	54	24.81	38.95	20.06	42.78	200	19	A	V
			17475	51.47	-16.73	68.2	33.26	38.45	24.75	44.99	-	-	P	V
														V
														V
														V
														V
														V
														V
													V	
Remark	<ol style="list-style-type: none"> No other spurious found. All results are PASS against Peak and Average limit line. The emission position marked as "-" means no suspected emission found with sufficient margin against limit line or noise floor only. 													



Band 4 5725~5850MHz
WIFI 802.11ax HE20_Full (Band Edge @ 3m)

WIFI Ant. 6+7	Note	Frequency (MHz)	Level (dBμV/m)	Margin (dB)	Limit Line (dBμV/m)	Read Level (dBμV)	Antenna Factor (dB/m)	Path Loss (dB)	Preamp Factor (dB)	Ant Pos (cm)	Table Pos (deg)	Peak Avg. (P/A)	Pol. (H/V)	
802.11ax HE20 Full CH 149 5745MHz		5648.15	52.31	-15.89	68.2	43.54	33.2	13.56	37.99	100	121	P	H	
		5699.225	67.08	-37.55	104.63	58.04	33.4	13.62	37.98	100	121	P	H	
		5716.325	75.33	-34.44	109.77	66.13	33.53	13.65	37.98	100	121	P	H	
		5724.65	80.81	-40.59	121.4	71.53	33.6	13.66	37.98	100	121	P	H	
	*	5745	117.53	-	-	108.05	33.76	13.69	37.97	100	121	P	H	
	*	5745	109.85	-	-	100.37	33.76	13.69	37.97	100	121	A	H	
														H
														H
			5629.025	50.29	-17.91	68.2	41.56	33.2	13.53	38	102	299	P	V
			5699.675	62.04	-42.92	104.96	53	33.4	13.62	37.98	102	299	P	V
			5719.25	74.03	-36.56	110.59	64.81	33.55	13.65	37.98	102	299	P	V
			5724.65	77.18	-44.22	121.4	67.9	33.6	13.66	37.98	102	299	P	V
	*		5745	113.84	-	-	104.36	33.76	13.69	37.97	102	299	P	V
	*		5745	107.4	-	-	97.92	33.76	13.69	37.97	102	299	A	V
													V	
													V	



WiFi Ant. 6+7	Note	Frequency (MHz)	Level (dBμV/m)	Margin (dB)	Limit Line (dBμV/m)	Read Level (dBμV)	Antenna Factor (dB/m)	Path Loss (dB)	Preamp Factor (dB)	Ant Pos (cm)	Table Pos (deg)	Peak Avg. (P/A)	Pol. (H/V)
		5644.75	49.14	-19.06	68.2	40.39	33.2	13.55	38	100	121	P	H
		5697.5	53.96	-49.4	103.36	44.93	33.39	13.62	37.98	100	121	P	H
		5719.25	56.75	-53.84	110.59	47.53	33.55	13.65	37.98	100	121	P	H
		5720.75	58.32	-54.19	112.51	49.08	33.57	13.65	37.98	100	121	P	H
	*	5785	118.85	-	-	109.13	33.94	13.74	37.96	100	121	P	H
	*	5785	109.63	-	-	99.91	33.94	13.74	37.96	100	121	A	H
		5850.25	57.85	-63.78	121.63	47.66	34.3	13.84	37.95	100	121	P	H
		5856.25	56.36	-54.09	110.45	46.15	34.3	13.85	37.94	100	121	P	H
		5875.25	53.73	-51.28	105.01	43.49	34.3	13.88	37.94	100	121	P	H
		5929.75	49.53	-18.67	68.2	39.19	34.3	13.97	37.93	100	121	P	H
802.11ax													H
HE20 Full													H
CH 157		5626.25	48.68	-19.52	68.2	39.95	33.2	13.53	38	100	299	P	V
5785MHz		5695.5	51.96	-49.92	101.88	42.94	33.38	13.62	37.98	100	299	P	V
		5719	57.64	-52.88	110.52	48.42	33.55	13.65	37.98	100	299	P	V
		5723.75	56.44	-62.91	119.35	47.17	33.59	13.66	37.98	100	299	P	V
	*	5785	116.5	-	-	106.78	33.94	13.74	37.96	100	299	P	V
	*	5785	108.38	-	-	98.66	33.94	13.74	37.96	100	299	A	V
		5852.5	57.05	-59.45	116.5	46.86	34.3	13.84	37.95	100	299	P	V
		5855	56.68	-54.12	110.8	46.47	34.3	13.85	37.94	100	299	P	V
		5885.25	51.72	-45.87	97.59	41.46	34.3	13.9	37.94	100	299	P	V
		5945.75	50.13	-18.07	68.2	39.76	34.3	13.99	37.92	100	299	P	V
													V
													V



WiFi Ant. 6+7	Note	Frequency (MHz)	Level (dBμV/m)	Margin (dB)	Limit Line (dBμV/m)	Read Level (dBμV)	Antenna Factor (dB/m)	Path Loss (dB)	Preamp Factor (dB)	Ant Pos (cm)	Table Pos (deg)	Peak Avg. (P/A)	Pol. (H/V)	
802.11ax HE20 Full CH 165 5825MHz	*	5825	118.4	-	-	108.4	34.15	13.8	37.95	100	119	P	H	
	*	5825	110.07	-	-	100.07	34.15	13.8	37.95	100	119	A	H	
		5854.2	76.5	-36.12	112.62	66.29	34.3	13.85	37.94	100	119	P	H	
		5855	71.88	-38.92	110.8	61.67	34.3	13.85	37.94	100	119	P	H	
		5878.2	61.96	-40.86	102.82	51.71	34.3	13.89	37.94	100	119	P	H	
		5925.2	51.67	-16.53	68.2	41.34	34.3	13.96	37.93	100	119	P	H	
														H
														H
	*	5825	115.4	-	-	105.4	34.15	13.8	37.95	101	301	P	V	
	*	5825	108.36	-	-	98.36	34.15	13.8	37.95	101	301	A	V	
		5852.2	74.49	-42.69	117.18	64.3	34.3	13.84	37.95	101	301	P	V	
		5855	74.07	-36.73	110.8	63.86	34.3	13.85	37.94	101	301	P	V	
		5880.2	61.33	-40.01	101.34	51.08	34.3	13.89	37.94	101	301	P	V	
		5934.6	51.16	-17.04	68.2	40.81	34.3	13.98	37.93	101	301	P	V	
														V
													V	
Remark	1. No other spurious found. 2. All results are PASS against Peak and Average limit line.													



WIFI Ant. 6+7	Note	Frequency (MHz)	Level (dBμV/m)	Margin (dB)	Limit Line (dBμV/m)	Read Level (dBμV)	Antenna Factor (dB/m)	Path Loss (dB)	Preamp Factor (dB)	Ant Pos (cm)	Table Pos (deg)	Peak Avg. (P/A)	Pol. (H/V)	
802.11ax HE20 Full CH 165 5825MHz		11650	51.04	-22.96	74	34.81	38.95	20.06	42.78	100	52	P	H	
		11650	40.97	-13.03	54	24.74	38.95	20.06	42.78	100	52	A	H	
		17475	51.97	-16.23	68.2	33.76	38.45	24.75	44.99	-	-	P	H	
													H	
													H	
													H	
													H	
													H	
													H	
													H	
													H	
			11650	51.1	-22.9	74	34.87	38.95	20.06	42.78	300	91	P	V
			11650	40.96	-13.04	54	24.73	38.95	20.06	42.78	300	91	A	V
			17475	52.46	-15.74	68.2	34.25	38.45	24.75	44.99	-	-	P	V
														V
														V
														V
														V
														V
													V	
													V	
Remark	<ol style="list-style-type: none"> No other spurious found. All results are PASS against Peak and Average limit line. The emission position marked as "-" means no suspected emission found with sufficient margin against limit line or noise floor only. 													



Band 4 5725~5850MHz
WIFI 802.11ax HE20_Partial 106 (Band Edge @ 3m)

WIFI Ant. 6+7	Note	Frequency (MHz)	Level (dBμV/m)	Margin (dB)	Limit Line (dBμV/m)	Read Level (dBμV)	Antenna Factor (dB/m)	Path Loss (dB)	Preamp Factor (dB)	Ant Pos (cm)	Table Pos (deg)	Peak Avg. (P/A)	Pol. (H/V)	
802.11ax HE20 Partial 106/53 CH 149 5745MHz		5645	66.04	-2.16	68.2	57.29	33.2	13.55	38	101	0	P	H	
		5696.3	82.59	-19.88	102.47	73.56	33.39	13.62	37.98	101	0	P	H	
		5717.225	89.49	-20.53	110.02	80.28	33.54	13.65	37.98	101	0	P	H	
		5720.15	84.65	-26.49	111.14	75.42	33.56	13.65	37.98	101	0	P	H	
	*	5745	115.76	-	-	106.28	33.76	13.69	37.97	101	0	P	H	
	*	5745	107.92	-	-	98.44	33.76	13.69	37.97	101	0	A	H	
														H
														H
			5644.775	62.35	-5.85	68.2	53.6	33.2	13.55	38	100	297	P	V
			5692.925	80.63	-19.35	99.98	71.62	33.37	13.62	37.98	100	297	P	V
			5713.85	89.08	-20	109.08	79.91	33.51	13.64	37.98	100	297	P	V
			5723.75	82.93	-36.42	119.35	73.66	33.59	13.66	37.98	100	297	P	V
		*	5745	112.91	-	-	103.43	33.76	13.69	37.97	100	297	P	V
		*	5745	104.99	-	-	95.51	33.76	13.69	37.97	100	297	A	V
														V
														V



WIFI Ant. 6+7	Note	Frequency (MHz)	Level (dBμV/m)	Margin (dB)	Limit Line (dBμV/m)	Read Level (dBμV)	Antenna Factor (dB/m)	Path Loss (dB)	Preamp Factor (dB)	Ant Pos (cm)	Table Pos (deg)	Peak Avg. (P/A)	Pol. (H/V)	
802.11ax HE20 Partial 106/54 CH 165 5825MHz	*	5825	116.64	-	-	106.64	34.15	13.8	37.95	102	117	P	H	
	*	5825	109.43	-	-	99.43	34.15	13.8	37.95	102	117	A	H	
		5851.8	91.33	-26.77	118.1	81.14	34.3	13.84	37.95	102	117	P	H	
		5855.4	86.77	-23.92	110.69	76.56	34.3	13.85	37.94	102	117	P	H	
		5875	81.8	-23.4	105.2	71.56	34.3	13.88	37.94	102	117	P	H	
		5929.2	63.39	-4.81	68.2	53.05	34.3	13.97	37.93	102	117	P	H	
														H
														H
	*	5825	115.96	-	-	105.96	34.15	13.8	37.95	300	98	98	P	V
	*	5825	107.29	-	-	97.29	34.15	13.8	37.95	300	98	98	A	V
		5850.8	89.48	-30.9	120.38	79.29	34.3	13.84	37.95	300	98	98	P	V
		5858	89.75	-20.21	109.96	79.54	34.3	13.85	37.94	300	98	98	P	V
		5877	81.14	-22.57	103.71	70.9	34.3	13.88	37.94	300	98	98	P	V
		5925.6	65.85	-2.35	68.2	55.52	34.3	13.96	37.93	300	98	98	P	V
														V
													V	
Remark	1. No other spurious found. 2. All results are PASS against Peak and Average limit line.													



Band 4 5725~5850MHz
WIFI 802.11ax HE40_Full (Band Edge @ 3m)

WIFI Ant. 6+7	Note	Frequency (MHz)	Level (dBμV/m)	Margin (dB)	Limit Line (dBμV/m)	Read Level (dBμV)	Antenna Factor (dB/m)	Path Loss (dB)	Preamp Factor (dB)	Ant Pos (cm)	Table Pos (deg)	Peak Avg. (P/A)	Pol. (H/V)
		5629.75	51.16	-17.04	68.2	42.43	33.2	13.53	38	100	121	P	H
		5696.25	60.49	-41.95	102.44	51.46	33.39	13.62	37.98	100	121	P	H
		5715.25	67.08	-42.39	109.47	57.89	33.52	13.65	37.98	100	121	P	H
		5724.5	65.6	-55.46	121.06	56.32	33.6	13.66	37.98	100	121	P	H
	*	5755	113.07	-	-	103.52	33.82	13.7	37.97	100	121	P	H
	*	5755	105.36	-	-	95.81	33.82	13.7	37.97	100	121	A	H
		5850	53.14	-69.06	122.2	42.95	34.3	13.84	37.95	100	121	P	H
		5864	53.84	-54.44	108.28	43.62	34.3	13.86	37.94	100	121	P	H
		5877	53.17	-50.54	103.71	42.93	34.3	13.88	37.94	100	121	P	H
		5934.75	49.8	-18.4	68.2	39.45	34.3	13.98	37.93	100	121	P	H
802.11ax													H
HE40 Full													H
CH 151		5636.75	50.91	-17.29	68.2	42.17	33.2	13.54	38	100	297	P	V
5755MHz		5697.75	57.24	-46.3	103.54	48.21	33.39	13.62	37.98	100	297	P	V
		5720	62.49	-48.31	110.8	53.26	33.56	13.65	37.98	100	297	P	V
		5723	66.1	-51.54	117.64	56.84	33.58	13.66	37.98	100	297	P	V
	*	5755	110.02	-	-	100.47	33.82	13.7	37.97	100	297	P	V
	*	5755	102.31	-	-	92.76	33.82	13.7	37.97	100	297	A	V
		5854	52.1	-60.98	113.08	41.9	34.3	13.85	37.95	100	297	P	V
		5857.25	52.52	-57.65	110.17	42.31	34.3	13.85	37.94	100	297	P	V
		5891	53.08	-40.25	93.33	42.81	34.3	13.91	37.94	100	297	P	V
		5929.5	49.43	-18.77	68.2	39.09	34.3	13.97	37.93	100	297	P	V
													V
													V



WiFi Ant. 6+7	Note	Frequency (MHz)	Level (dBμV/m)	Margin (dB)	Limit Line (dBμV/m)	Read Level (dBμV)	Antenna Factor (dB/m)	Path Loss (dB)	Preamp Factor (dB)	Ant Pos (cm)	Table Pos (deg)	Peak Avg. (P/A)	Pol. (H/V)
		5624.75	50.07	-18.13	68.2	41.35	33.2	13.52	38	102	119	P	H
		5692	53.01	-46.29	99.3	44.01	33.37	13.61	37.98	102	119	P	H
		5716.75	53.89	-56	109.89	44.69	33.53	13.65	37.98	102	119	P	H
		5724.5	53.43	-67.63	121.06	44.15	33.6	13.66	37.98	102	119	P	H
	*	5795	114.22	-	-	104.45	33.98	13.75	37.96	102	119	P	H
	*	5795	105.8	-	-	96.03	33.98	13.75	37.96	102	119	A	H
		5854.5	56.03	-55.91	111.94	45.82	34.3	13.85	37.94	102	119	P	H
		5864.5	55.23	-52.91	108.14	45.01	34.3	13.86	37.94	102	119	P	H
		5891.25	54.2	-38.94	93.14	43.93	34.3	13.91	37.94	102	119	P	H
		5933.25	51.97	-16.23	68.2	41.63	34.3	13.97	37.93	102	119	P	H
802.11ax													H
HE40 Full													H
CH 159		5645.5	49.96	-18.24	68.2	41.21	33.2	13.55	38	100	300	P	V
5795MHz		5683	52.03	-40.63	92.66	43.09	33.33	13.6	37.99	100	300	P	V
		5707.5	51.87	-55.43	107.3	42.75	33.46	13.64	37.98	100	300	P	V
		5724.75	52.07	-69.56	121.63	42.79	33.6	13.66	37.98	100	300	P	V
	*	5795	111.39	-	-	101.62	33.98	13.75	37.96	100	300	P	V
	*	5795	103.62	-	-	93.85	33.98	13.75	37.96	100	300	A	V
		5851.25	56.58	-62.77	119.35	46.39	34.3	13.84	37.95	100	300	P	V
		5866.25	56.47	-51.18	107.65	46.24	34.3	13.87	37.94	100	300	P	V
		5878	53.72	-49.25	102.97	43.48	34.3	13.88	37.94	100	300	P	V
		5925.5	52.53	-15.67	68.2	42.2	34.3	13.96	37.93	100	300	P	V
													V
													V
Remark	1. No other spurious found. 2. All results are PASS against Peak and Average limit line.												



Band 4 5725~5850MHz

WIFI 802.11ax HE40_Full (Harmonic @ 3m)

WIFI Ant. 6+7	Note	Frequency (MHz)	Level (dBμV/m)	Margin (dB)	Limit Line (dBμV/m)	Read Level (dBμV)	Antenna Factor (dB/m)	Path Loss (dB)	Preamp Factor (dB)	Ant Pos (cm)	Table Pos (deg)	Peak Avg. (P/A)	Pol. (H/V)	
802.11ax HE40 Full CH 151 5755MHz		11510	50.26	-23.74	74	33.88	39.09	19.95	42.66	300	346	P	H	
		11510	40.4	-13.6	54	24.02	39.09	19.95	42.66	300	346	A	H	
		17265	51.96	-16.24	68.2	34.12	38.03	24.6	44.79	-	-	P	H	
													H	
													H	
													H	
													H	
													H	
													H	
													H	
													H	
			11510	50.47	-23.53	74	34.09	39.09	19.95	42.66	200	206	P	V
			11510	40.38	-13.62	54	24	39.09	19.95	42.66	200	206	A	V
			17265	50.89	-17.31	68.2	33.05	38.03	24.6	44.79	-	-	P	V
														V
														V
														V
														V
													V	



Band 4 5725~5850MHz

WIFI 802.11ax HE40_Partial 242 (Band Edge @ 3m)

WIFI Ant. 6+7	Note	Frequency (MHz)	Level (dBμV/m)	Margin (dB)	Limit Line (dBμV/m)	Read Level (dBμV)	Antenna Factor (dB/m)	Path Loss (dB)	Preamp Factor (dB)	Ant Pos (cm)	Table Pos (deg)	Peak Avg. (P/A)	Pol. (H/V)
		5645.25	66.13	-2.07	68.2	57.38	33.2	13.55	38	100	299	P	H
		5700	78	-27.2	105.2	68.96	33.4	13.62	37.98	100	299	P	H
		5717	81.18	-28.78	109.96	71.97	33.54	13.65	37.98	100	299	P	H
		5722.25	82.96	-32.97	115.93	73.7	33.58	13.66	37.98	100	299	P	H
	*	5755	111.46	-	-	101.91	33.82	13.7	37.97	100	299	P	H
	*	5755	103	-	-	93.45	33.82	13.7	37.97	100	299	A	H
		5850.5	51.89	-69.17	121.06	41.7	34.3	13.84	37.95	100	299	P	H
		5869.25	58.67	-48.14	106.81	48.44	34.3	13.87	37.94	100	299	P	H
		5878.25	57.66	-45.13	102.79	47.41	34.3	13.89	37.94	100	299	P	H
		5935.25	51.15	-17.05	68.2	40.8	34.3	13.98	37.93	100	299	P	H
802.11ax													H
HE40													H
Partial													H
242/61		5635.5	62.88	-5.32	68.2	54.14	33.2	13.54	38	100	302	P	V
CH 151		5696	75.67	-26.58	102.25	66.65	33.38	13.62	37.98	100	302	P	V
5755MHz		5719.5	77.03	-33.63	110.66	67.8	33.56	13.65	37.98	100	302	P	V
		5724.5	79.21	-41.85	121.06	69.93	33.6	13.66	37.98	100	302	P	V
	*	5755	110.02	-	-	100.54	33.76	13.69	37.97	100	302	P	V
	*	5755	102.43	-	-	92.95	33.76	13.69	37.97	100	302	A	V
		5854	60.53	-52.55	113.08	50.33	34.3	13.85	37.95	100	302	P	V
		5864.5	62.76	-45.38	108.14	52.54	34.3	13.86	37.94	100	302	P	V
		5881.75	61.5	-38.69	100.19	51.25	34.3	13.89	37.94	100	302	P	V
		5938.5	53.18	-15.02	68.2	42.82	34.3	13.98	37.92	100	302	P	V
													V
													V



WiFi Ant. 6+7	Note	Frequency (MHz)	Level (dBμV/m)	Margin (dB)	Limit Line (dBμV/m)	Read Level (dBμV)	Antenna Factor (dB/m)	Path Loss (dB)	Preamp Factor (dB)	Ant Pos (cm)	Table Pos (deg)	Peak Avg. (P/A)	Pol. (H/V)	
802.11ax HE40 Partial 242/62 CH 159 5795MHz		5646.5	56.32	-11.88	68.2	47.56	33.2	13.55	37.99	100	78	P	H	
		5699.75	64.26	-40.76	105.02	55.22	33.4	13.62	37.98	100	78	P	H	
		5716	68.64	-41.04	109.68	59.44	33.53	13.65	37.98	100	78	P	H	
		5725	69.24	-52.96	122.2	59.96	33.6	13.66	37.98	100	78	P	H	
	*	5795	112.73	-	-	102.96	33.98	13.75	37.96	100	78	P	H	
	*	5795	104.4	-	-	94.63	33.98	13.75	37.96	100	78	A	H	
		5852.5	79.57	-36.93	116.5	69.38	34.3	13.84	37.95	100	78	P	H	
		5855.25	79.92	-30.81	110.73	69.71	34.3	13.85	37.94	100	78	P	H	
		5882.75	74.26	-25.18	99.44	64.01	34.3	13.89	37.94	100	78	P	H	
		5944.5	63.51	-4.69	68.2	53.14	34.3	13.99	37.92	100	78	P	H	
														H
														H
			5650	58.92	-9.28	68.2	50.15	33.2	13.56	37.99	100	298	P	V
			5695.75	66.62	-35.45	102.07	57.6	33.38	13.62	37.98	100	298	P	V
			5720	69.75	-41.05	110.8	60.52	33.56	13.65	37.98	100	298	P	V
			5725	71.14	-51.06	122.2	61.86	33.6	13.66	37.98	100	298	P	V
	*		5795	113.37	-	-	103.6	33.98	13.75	37.96	100	298	P	V
	*		5795	103.01	-	-	93.24	33.98	13.75	37.96	100	298	A	V
			5854.5	76.32	-35.62	111.94	66.11	34.3	13.85	37.94	100	298	P	V
			5855.75	77.65	-32.94	110.59	67.44	34.3	13.85	37.94	100	298	P	V
		5885.25	74.83	-22.76	97.59	64.57	34.3	13.9	37.94	100	298	P	V	
		5927.25	66.33	-1.87	68.2	56	34.3	13.96	37.93	100	298	P	V	
													V	
													V	
Remark	1. No other spurious found. 2. All results are PASS against Peak and Average limit line.													



Band 4 5725~5850MHz
WIFI 802.11ax HE80_Full (Band Edge @ 3m)

WIFI Ant. 6+7	Note	Frequency (MHz)	Level (dBμV/m)	Margin (dB)	Limit Line (dBμV/m)	Read Level (dBμV)	Antenna Factor (dB/m)	Path Loss (dB)	Preamp Factor (dB)	Ant Pos (cm)	Table Pos (deg)	Peak Avg. (P/A)	Pol. (H/V)
		5627	56.8	-11.4	68.2	48.07	33.2	13.53	38	100	115	P	H
		5694.25	65.56	-35.4	100.96	56.54	33.38	13.62	37.98	100	115	P	H
		5714.5	69.71	-39.55	109.26	60.53	33.52	13.64	37.98	100	115	P	H
		5724	70.26	-49.66	119.92	60.99	33.59	13.66	37.98	100	115	P	H
	*	5775	110.09	-	-	100.42	33.9	13.73	37.96	100	115	P	H
	*	5775	102.11	-	-	92.44	33.9	13.73	37.96	100	115	A	H
		5852.75	67.18	-48.75	115.93	56.99	34.3	13.84	37.95	100	115	P	H
		5855.25	64.83	-45.9	110.73	54.62	34.3	13.85	37.94	100	115	P	H
		5883.75	61.69	-37.01	98.7	51.44	34.3	13.89	37.94	100	115	P	H
		5941	54.75	-13.45	68.2	44.38	34.3	13.99	37.92	100	115	P	H
802.11ax													H
HE80 Full													H
CH 155		5639.5	56.94	-11.26	68.2	48.2	33.2	13.54	38	100	83	P	V
5775MHz		5699.75	63.82	-41.2	105.02	54.78	33.4	13.62	37.98	100	83	P	V
		5709.25	67.66	-40.13	107.79	58.53	33.47	13.64	37.98	100	83	P	V
		5720.75	67.07	-45.44	112.51	57.83	33.57	13.65	37.98	100	83	P	V
	*	5775	106.92	-	-	97.25	33.9	13.73	37.96	100	83	P	V
	*	5775	99.53	-	-	89.86	33.9	13.73	37.96	100	83	A	V
		5850	63.62	-58.58	122.2	53.43	34.3	13.84	37.95	100	83	P	V
		5861.5	63.2	-45.78	108.98	52.98	34.3	13.86	37.94	100	83	P	V
		5899	60.93	-26.47	87.4	50.64	34.3	13.92	37.93	100	83	P	V
		5938.5	53.98	-14.22	68.2	43.62	34.3	13.98	37.92	100	83	P	V
													V
													V
Remark	1. No other spurious found. 2. All results are PASS against Peak and Average limit line.												



Band 4 5725~5850MHz

WIFI 802.11ax HE80_Full (Harmonic @ 3m)

WIFI Ant. 6+7	Note	Frequency (MHz)	Level (dBμV/m)	Margin (dB)	Limit Line (dBμV/m)	Read Level (dBμV)	Antenna Factor (dB/m)	Path Loss (dB)	Preamp Factor (dB)	Ant Pos (cm)	Table Pos (deg)	Peak Avg. (P/A)	Pol. (H/V)	
802.11ax HE80 Full CH 155 5775MHz		11550	50.98	-23.02	74	34.64	39.05	19.98	42.69	300	152	P	H	
		11550	40.16	-13.84	54	23.82	39.05	19.98	42.69	300	152	A	H	
		17325	50.78	-17.42	68.2	32.84	38.15	24.64	44.85	-	-	P	H	
													H	
													H	
													H	
													H	
													H	
													H	
													H	
													H	
			11550	50.52	-23.48	74	34.18	39.05	19.98	42.69	385	175	P	V
			11550	40.17	-13.83	54	23.83	39.05	19.98	42.69	385	175	A	V
			17325	51.01	-17.19	68.2	33.07	38.15	24.64	44.85	-	-	P	V
														V
														V
														V
														V
													V	
Remark	<ol style="list-style-type: none"> No other spurious found. All results are PASS against Peak and Average limit line. The emission position marked as "-" means no suspected emission found with sufficient margin against limit line or noise floor only. 													



Band 4 5725~5850MHz
WIFI 802.11ax HE80_Partial 484 (Band Edge @ 3m)

WIFI Ant. 6+7	Note	Frequency (MHz)	Level (dBμV/m)	Margin (dB)	Limit Line (dBμV/m)	Read Level (dBμV)	Antenna Factor (dB/m)	Path Loss (dB)	Preamp Factor (dB)	Ant Pos (cm)	Table Pos (deg)	Peak Avg. (P/A)	Pol. (H/V)
		5646.25	65.08	-3.12	68.2	56.32	33.2	13.55	37.99	100	118	P	H
		5696.5	71.61	-31.01	102.62	62.58	33.39	13.62	37.98	100	118	P	H
		5715.25	76.38	-33.09	109.47	67.19	33.52	13.65	37.98	100	118	P	H
		5723.75	76.4	-42.95	119.35	67.13	33.59	13.66	37.98	100	118	P	H
	*	5775	109.96	-	-	100.29	33.9	13.73	37.96	100	118	P	H
	*	5775	101.56	-	-	91.89	33.9	13.73	37.96	100	118	A	H
		5855	75.9	-34.9	110.8	65.69	34.3	13.85	37.94	100	118	P	H
		5864.75	77.76	-30.31	108.07	67.54	34.3	13.86	37.94	100	118	P	H
		5879.5	75.56	-26.3	101.86	65.31	34.3	13.89	37.94	100	118	P	H
802.11ax		5938.25	66.45	-1.75	68.2	56.09	34.3	13.98	37.92	100	118	P	H
HE80													H
Partial													H
484/65		5643.25	62.41	-5.79	68.2	53.66	33.2	13.55	38	300	90	P	V
CH 155		5692.5	69.78	-29.89	99.67	60.78	33.37	13.61	37.98	300	90	P	V
5775MHz		5712.5	73.02	-35.68	108.7	63.86	33.5	13.64	37.98	300	90	P	V
		5723.5	74.67	-44.11	118.78	65.4	33.59	13.66	37.98	300	90	P	V
	*	5775	108.13	-	-	98.46	33.9	13.73	37.96	300	90	P	V
	*	5775	99.73	-	-	90.06	33.9	13.73	37.96	300	90	A	V
		5853	76.32	-39.04	115.36	66.13	34.3	13.84	37.95	300	90	P	V
		5868	75.81	-31.35	107.16	65.58	34.3	13.87	37.94	300	90	P	V
		5878	72.6	-30.37	102.97	62.36	34.3	13.88	37.94	300	90	P	V
		5927.25	64.56	-3.64	68.2	54.23	34.3	13.96	37.93	300	90	P	V
													V
													V
Remark	1. No other spurious found. 2. All results are PASS against Peak and Average limit line.												



WiFi Ant. 6+7	Note	Frequency (MHz)	Level (dBµV/m)	Margin (dB)	Limit Line (dBµV/m)	Read Level (dBµV)	Antenna Factor (dB/m)	Path Loss (dB)	Preamp Factor (dB)	Ant Pos (cm)	Table Pos (deg)	Peak Avg. (P/A)	Pol. (H/V)
		5649.75	66.1	-2.1	68.2	57.33	33.2	13.56	37.99	108	118	P	H
		5700	72.06	-33.14	105.2	63.02	33.4	13.62	37.98	108	118	P	H
		5719.75	79.29	-31.44	110.73	70.06	33.56	13.65	37.98	108	118	P	H
		5724.75	79.71	-41.92	121.63	70.43	33.6	13.66	37.98	108	118	P	H
	*	5775	109.45	-	-	99.78	33.9	13.73	37.96	108	118	P	H
	*	5775	101.36	-	-	91.69	33.9	13.73	37.96	108	118	A	H
		5854.25	76.92	-35.59	112.51	66.71	34.3	13.85	37.94	108	118	P	H
		5869.25	77.8	-29.01	106.81	67.57	34.3	13.87	37.94	108	118	P	H
		5883.25	72.33	-26.74	99.07	62.08	34.3	13.89	37.94	108	118	P	H
		5929.75	65.39	-2.81	68.2	55.05	34.3	13.97	37.93	108	118	P	H
802.11ax													H
HE80													H
Partial													H
484/66		5649.75	65.51	-2.69	68.2	56.74	33.2	13.56	37.99	100	300	P	V
CH 155		5700	72.44	-32.76	105.2	63.4	33.4	13.62	37.98	100	300	P	V
5775MHz		5720	78.25	-32.55	110.8	69.02	33.56	13.65	37.98	100	300	P	V
		5720	78.25	-32.55	110.8	69.02	33.56	13.65	37.98	100	300	P	V
	*	5775	108.41	-	-	98.74	33.9	13.73	37.96	100	300	P	V
	*	5775	99.95	-	-	90.28	33.9	13.73	37.96	100	300	A	V
		5851.75	73.65	-44.56	118.21	63.46	34.3	13.84	37.95	100	300	P	V
		5861.25	76.44	-32.61	109.05	66.22	34.3	13.86	37.94	100	300	P	V
		5880.75	72.84	-28.09	100.93	62.59	34.3	13.89	37.94	100	300	P	V
		5929.5	66.41	-1.79	68.2	56.07	34.3	13.97	37.93	100	300	P	V
													V
													V
Remark	1. No other spurious found. 2. All results are PASS against Peak and Average limit line.												



Emission below 1GHz

5GHz WIFI 802.11ax HE80 Full (LF @ 3m)

WIFI	Note	Frequency	Level	Margin	Limit	Read	Antenna	Path	Preamp	Ant	Table	Peak	Pol.	
Ant.					Line	Level	Factor	Loss	Factor	Pos	Pos	Avg.		
6+7		(MHz)	(dBμV/m)	(dB)	(dBμV/m)	(dBμV)	(dB/m)	(dB)	(dB)	(cm)	(deg)	(P/A)	(H/V)	
802.11ax HE80 Full LF		30.68	24.24	-15.76	40	33.89	24.64	1.3	35.59	-	-	P	H	
		75.39	22.79	-17.21	40	43.22	13.4	1.72	35.55	-	-	P	H	
		148.49	29.13	-14.37	43.5	44.62	17.56	2.38	35.43	-	-	P	H	
		272	31.01	-14.99	46	44.08	19	3.11	35.18	-	-	P	H	
		471.2	29.1	-16.9	46	36.33	23.37	4.08	34.68	-	-	P	H	
		955.2	35.64	-10.36	46	31.86	30.95	5.79	32.96	-	-	P	H	
														H
														H
														H
														H
														H
														H
			52.27	33.09	-6.91	40	53.48	13.72	1.45	35.56	-	-	P	V
			92.39	29.29	-14.21	43.5	47.93	15	1.88	35.52	-	-	P	V
			179.09	25.52	-17.98	43.5	43.12	15.2	2.57	35.37	-	-	P	V
			262.4	24.14	-21.86	46	36.03	20.25	3.06	35.2	-	-	P	V
			563.2	30.13	-15.87	46	33.64	26.35	4.49	34.35	-	-	P	V
			896	36.32	-9.68	46	35.08	28.85	5.58	33.19	-	-	P	V
														V
														V
													V	
													V	
													V	
													V	

Remark

- No other spurious found.
- All results are PASS against limit line.
- The emission position marked as "-" means no suspected emission found and emission level has at least 6dB margin against limit or emission is noise floor only.



Note symbol

*	Fundamental Frequency which can be ignored. However, the level of any unwanted emissions shall not exceed the level of the fundamental frequency.
!	Test result is Margin line.
P/A	Peak or Average
H/V	Horizontal or Vertical



A calculation example for radiated spurious emission is shown as below:

WIFI	Note	Frequency	Level	Margin	Limit	Read	Antenna	Path	Preamp	Ant	Table	Peak	Pol.
Ant.					Line	Level	Factor	Loss	Factor	Pos	Pos	Avg.	
6+7		(MHz)	(dBμV/m)	(dB)	(dBμV/m)	(dBμV)	(dB/m)	(dB)	(dB)	(cm)	(deg)	(P/A)	(H/V)
802.11ax HE80 Full CH 155 5775MHz		5941	55.45	-18.55	74	54.51	32.22	4.58	35.86	103	308	P	H
		5941	43.54	-10.46	54	42.6	32.22	4.58	35.86	103	308	A	H

1. Path Loss(dB) = Cable loss(dB) + Filter loss(dB) + Attenuator loss(dB)
2. Level(dBμV/m) = Antenna Factor(dB/m) + Path Loss(dB) + Read Level(dBμV) - Preamp Factor(dB)
3. Margin (dB) = Level(dBμV/m) – Limit Line(dBμV/m)
- 4.

For Peak Limit @ 5941MHz:

1. Level(dBμV/m)
= Antenna Factor(dB/m) + Path Loss(dB) + Read Level(dBμV) - Preamp Factor(dB)
= 32.22(dB/m) + 4.58(dB) + 54.51(dBμV) – 35.86 (dB)
= 55.45 (dBμV/m)
2. Margin (dB)
= Level(dBμV/m) – Limit Line(dBμV/m)
= 55.45(dBμV/m) – 74(dBμV/m)
= -18.55(dB)

For Average Limit @ 5941MHz:

1. Level(dBμV/m)
= Antenna Factor(dB/m) + Path Loss(dB) + Read Level(dBμV) - Preamp Factor(dB)
= 32.22(dB/m) + 4.58(dB) + 42.6(dBμV) – 35.86 (dB)
= 43.54 (dBμV/m)
2. Margin (dB)
= Level(dBμV/m) – Limit Line(dBμV/m)
= 43.54 (dBμV/m) – 54(dBμV/m)
= -10.46(dB)

Both peak and average measured complies with the limit line, so test result is “PASS”.



Appendix D. Radiated Spurious Emission Plots

Test Engineer :	John Chuang, David Dai, and Howard Huang	Temperature :	19.5~23.5°C
		Relative Humidity :	64.9~70.7%

Band 4 - 5725~5850MHz
WIFI 802.11a (Band Edge @ 3m)

WIFI	Band 4 5725~5850MHz Band Edge @ 3m	
ANT	802.11a CH149 5745MHz	
6+7	Horizontal	Fundamental
Peak		
Avg	Left blank	



WIFI	Band 4 5725~5850MHz Band Edge @ 3m	
ANT	802.11a CH149 5745MHz	
6+7	Vertical	Fundamental
Peak	<p>Site : 03CH20-HY Condition : PEAK_85(B4)_16-24 3m 91200_02360_231030 VERTICAL : RBW:1000.000KHz VBW:3000.000KHz SWT:Auto</p>	<p>Site : 03CH20-HY Condition : PEAK(LINE) 3m 91200_02360_231030 VERTICAL : RBW:1000.000KHz VBW:3000.000KHz SWT:Auto</p>
Avg	Left blank	<p>Site : 03CH20-HY Condition : AVG_54 3m 91200_02360_231030 VERTICAL : RBW:1000.000KHz VBW:0.200KHz SWT:Auto</p>



WIFI	Band 4 5725~5850MHz Band Edge @ 3m	
ANT	802.11a CH157 5785MHz	
6+7	Horizontal	Fundamental
Peak	<p>Site : 03CH20-HY Condition : PEAK_DE(B4)_16-24 3m 91200_02360_231030 HORIZONTAL : RBW:1000.000KHz VBW:3000.000KHz SWT:Auto</p>	<p>Site : 03CH20-HY Condition : PEAK(LINE) 3m 91200_02360_231030 HORIZONTAL : RBW:1000.000KHz VBW:3000.000KHz SWT:Auto</p>
Avg	Left blank	<p>Site : 03CH20-HY Condition : AVG_S1 3m 91200_02360_231030 HORIZONTAL : RBW:1000.000KHz VBW:0.200KHz SWT:Auto</p>



WIFI	Band 4 5725~5850MHz Band Edge @ 3m	
ANT	802.11a CH157 5785MHz	
6+7	Horizontal	Fundamental
Peak	<p>Site : DACH2014Y Condition : PEAK_85(B4)_16-24 3m 9120D_02360_231030 HORIZONTAL : RBW:1000.000KHz VBW:3000.000KHz SWF:Auto</p>	Left blank



WIFI	Band 4 5725~5850MHz Band Edge @ 3m	
ANT	802.11a CH157 5785MHz	
6+7	Vertical	Fundamental
Peak	<p>Site : 03CH20-HY Condition : PEAK_DE(B4)_16-24 3m 91200_02360_231030 VERTICAL : RBW:1000.000KHz VBW:3000.000KHz SWT:Auto</p>	<p>Site : 03CH20-HY Condition : PEAK(LINE) 3m 91200_02360_231030 VERTICAL : RBW:1000.000KHz VBW:3000.000KHz SWT:Auto</p>
Avg	Left blank	<p>Site : 03CH20-HY Condition : AVG_S1 3m 91200_02360_231030 VERTICAL : RBW:1000.000KHz VBW:0.200KHz SWT:Auto</p>

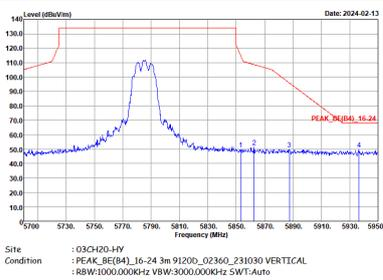

WIFI	Band 4 5725~5850MHz Band Edge @ 3m	
ANT	802.11a CH157 5785MHz	
6+7	Vertical	Fundamental
Peak	 <p>Site : DACH2014Y Condition : PEAK_85(B4)_16-24 3m 9120D_02360_231030 VERTICAL : RBW:1000.000KHz VBW:3000.000KHz SWF:Auto</p>	Left blank

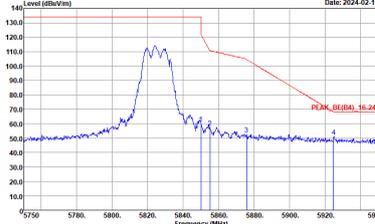
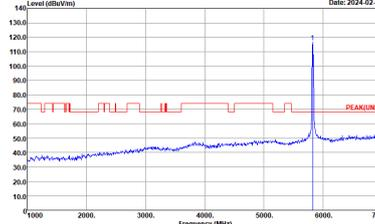

WIFI	Band 4 5725~5850MHz Band Edge @ 3m	
ANT	802.11a CH165 5825MHz	
6+7	Horizontal	Fundamental
Peak	 <p>Site : 03CH20-HY Condition : PEAK_85(B4)_16-24 3m 91200_02360_231030 HORIZONTAL : RBW:1000.000KHz VBW:3000.000KHz SWT:Auto</p>	 <p>Site : 03CH20-HY Condition : PEAK(LINE) 3m 91200_02360_231030 HORIZONTAL : RBW:1000.000KHz VBW:3000.000KHz SWT:Auto</p>
Avg	Left blank	 <p>Site : 03CH20-HY Condition : AVG_54 3m 91200_02360_231030 HORIZONTAL : RBW:1000.000KHz VBW:0.200KHz SWT:Auto</p>



WIFI	Band 4 5725~5850MHz Band Edge @ 3m	
ANT	802.11a CH165 5825MHz	
6+7	Vertical	Fundamental
Peak	<p>Site : 03CH20-HY Condition : PEAK_85(B4)_16-24 3m 91200_02360_231030 VERTICAL : RBW:1000.000KHz VBW:3000.000KHz SWT:Auto</p>	<p>Site : 03CH20-HY Condition : PEAK(LINE) 3m 91200_02360_231030 VERTICAL : RBW:1000.000KHz VBW:3000.000KHz SWT:Auto</p>
Avg	Left blank	<p>Site : 03CH20-HY Condition : AVG_54 3m 91200_02360_231030 VERTICAL : RBW:1000.000KHz VBW:0.200KHz SWT:Auto</p>

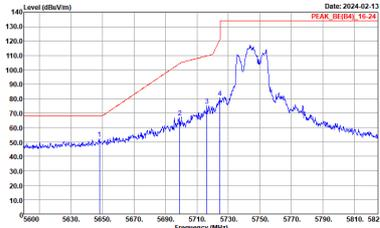
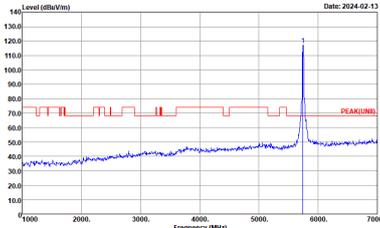
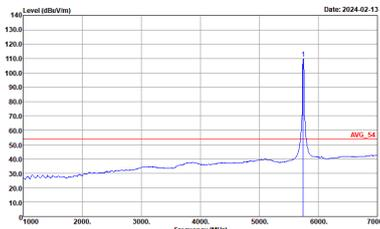

Band 4 5725~5850MHz
WIFI 802.11ax HE20 Full (Band Edge @ 3m)

WIFI	Band 4 5725~5850MHz Band Edge @ 3m	
ANT	802.11ax HE20 Full CH149 5745MHz	
6+7	Horizontal	Fundamental
Peak	 <p>Site : 03CH20-HY Condition : PEAK_BE(B4)_16-24 3m 91200_02360_231030 HORIZONTAL : RBW:1000.000KHz VBW:3000.000KHz SWT:Auto</p>	 <p>Site : 03CH20-HY Condition : PEAK(UNIT) 3m 91200_02360_231030 HORIZONTAL : RBW:1000.000KHz VBW:3000.000KHz SWT:Auto</p>
Avg	Left blank	 <p>Site : 03CH20-HY Condition : AVG_54 3m 91200_02360_231030 HORIZONTAL : RBW:1000.000KHz VBW:0.270KHz SWT:Auto</p>



WIFI	Band 4 5725~5850MHz Band Edge @ 3m	
ANT	802.11ax HE20 Full CH149 5745MHz	
6+7	Vertical	Fundamental
Peak	<p>Site : 03CH20-HY Condition : PEAK_85(B4)_16-24 3m 91200_02360_231030 VERTICAL : RBW:1000.000KHz VBW:3000.000KHz SWT:Auto</p>	<p>Site : 03CH20-HY Condition : PEAK(LINE) 3m 91200_02360_231030 VERTICAL : RBW:1000.000KHz VBW:3000.000KHz SWT:Auto</p>
Avg	Left blank	<p>Site : 03CH20-HY Condition : AVG_54 3m 91200_02360_231030 VERTICAL : RBW:1000.000KHz VBW:0.270KHz SWT:Auto</p>

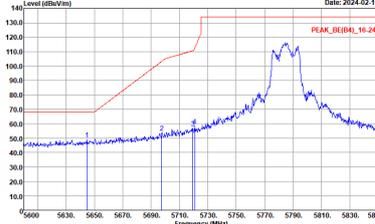
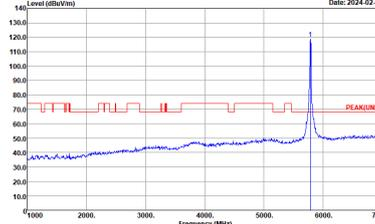
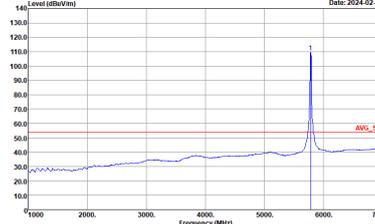

WIFI	Band 4 5725~5850MHz Band Edge @ 3m	
ANT	802.11ax HE20 Full CH157 5785MHz	
6+7	Horizontal	Fundamental
Peak	 <p>Site : 03CH20-HY Condition : PEAK_DE(B4)_16-24 3m 91200_02360_231030 HORIZONTAL : RBW:1000.000KHz VBW:3000.000KHz SWT:Auto</p>	 <p>Site : 03CH20-HY Condition : PEAK(LINE) 3m 91200_02360_231030 HORIZONTAL : RBW:1000.000KHz VBW:3000.000KHz SWT:Auto</p>
Avg	Left blank	 <p>Site : 03CH20-HY Condition : AVG_S1 3m 91200_02360_231030 HORIZONTAL : RBW:1000.000KHz VBW:0.270KHz SWT:Auto</p>



WIFI	Band 4 5725~5850MHz Band Edge @ 3m	
ANT	802.11ax HE20 Full CH157 5785MHz	
6+7	Horizontal	Fundamental
Peak	<p>Site : DACH2014Y Condition : PEAK_85(B4)_16-24 3m 9120D_02360_231030 HORIZONTAL : RBW:1000.000KHz VBW:3000.000KHz SWF:Auto</p>	Left blank



WIFI	Band 4 5725~5850MHz Band Edge @ 3m	
ANT	802.11ax HE20 Full CH157 5785MHz	
6+7	Vertical	Fundamental
Peak	<p>Site : 03CH20-HY Condition : PEAK_DE(B4)_16-24 3m 91200_02360_231030 VERTICAL : RBW:1000.000KHz VBW:3000.000KHz SWT:Auto</p>	<p>Site : 03CH20-HY Condition : PEAK(LINE) 3m 91200_02360_231030 VERTICAL : RBW:1000.000KHz VBW:3000.000KHz SWT:Auto</p>
Avg	Left blank	<p>Site : 03CH20-HY Condition : AVG_S1 3m 91200_02360_231030 VERTICAL : RBW:1000.000KHz VBW:0.270KHz SWT:Auto</p>



WIFI	Band 4 5725~5850MHz Band Edge @ 3m	
ANT	802.11ax HE20 Full CH157 5785MHz	
6+7	Vertical	Fundamental
Peak	<p>Site : DACH2014Y Condition : PEAK_85(B4)_16-24 3m 9120D_02360_231030 VERTICAL : RBW:1000.000KHz VBW:3000.000KHz SWF:Auto</p>	Left blank

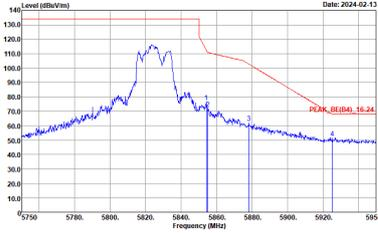
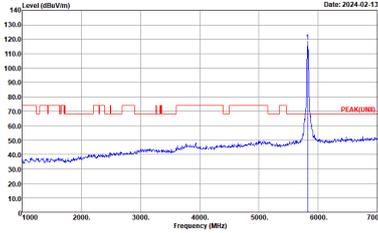
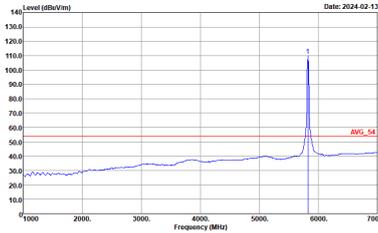

WIFI	Band 4 5725~5850MHz Band Edge @ 3m	
ANT	802.11ax HE20 Full CH165 5825MHz	
6+7	Horizontal	Fundamental
Peak	 <p>Site : 03CH20-HY Condition : PEAK_85(B4)_16-24 3m 91200_02360_231030 HORIZONTAL : RBW:1000.000KHz VBW:3000.000KHz SWT:Auto</p>	 <p>Site : 03CH20-HY Condition : PEAK(LINE) 3m 91200_02360_231030 HORIZONTAL : RBW:1000.000KHz VBW:3000.000KHz SWT:Auto</p>
Avg	Left blank	 <p>Site : 03CH20-HY Condition : AVG_54 3m 91200_02360_231030 HORIZONTAL : RBW:1000.000KHz VBW:0.270KHz SWT:Auto</p>

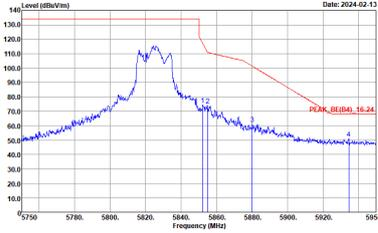
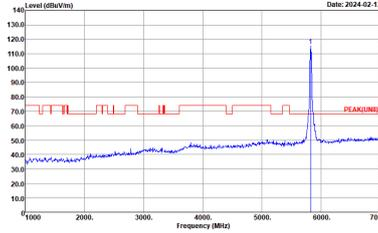
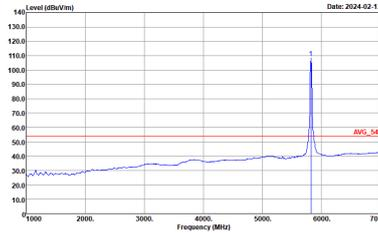

WIFI	Band 4 5725~5850MHz Band Edge @ 3m	
ANT	802.11ax HE20 Full CH165 5825MHz	
6+7	Vertical	Fundamental
Peak	 <p>Site : 03CH20-HY Condition : PEAK_BU(B4)_16-24 3m 91200_02360_231030 VERTICAL : RBW:1000.000KHz VBW:3000.000KHz SWT:Auto</p>	 <p>Site : 03CH20-HY Condition : PEAK(LINE) 3m 91200_02360_231030 VERTICAL : RBW:1000.000KHz VBW:3000.000KHz SWT:Auto</p>
Avg	Left blank	 <p>Site : 03CH20-HY Condition : AVG_S1 3m 91200_02360_231030 VERTICAL : RBW:1000.000KHz VBW:0.270KHz SWT:Auto</p>



Band 4 5725~5850MHz
WIFI 802.11ax HE20 Partial 106 (Band Edge @ 3m)

Table with 2 columns (WIFI, ANT) and 2 rows (6+7, Peak, Avg). It contains spectral analysis graphs for Horizontal and Fundamental frequencies, and a 'Left blank' section for the average measurement.

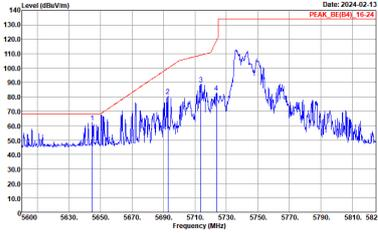
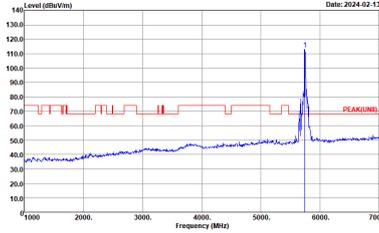
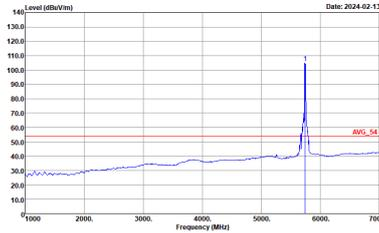

WIFI	Band 4 5725~5850MHz Band Edge @ 3m	
ANT	802.11ax HE20 Partial 106/53 CH149 5745MHz	
6+7	Vertical	Fundamental
Peak	 <p>Site : 03CH20-HY Condition : PEAK_85(B4)_16-24 3m 91200_02360_231030 VERTICAL : RBW:1000.000KHz VBW:3000.000KHz SWT:Auto</p>	 <p>Site : 03CH20-HY Condition : PEAK(LINE) 3m 91200_02360_231030 VERTICAL : RBW:1000.000KHz VBW:3000.000KHz SWT:Auto</p>
Avg	Left blank	 <p>Site : 03CH20-HY Condition : AVG_54 3m 91200_02360_231030 VERTICAL : RBW:1000.000KHz VBW:0.270KHz SWT:Auto</p>

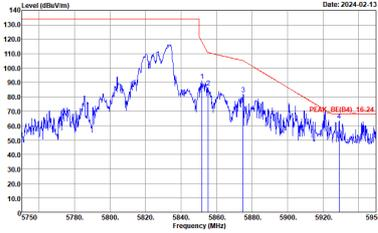
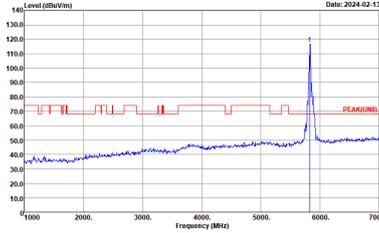
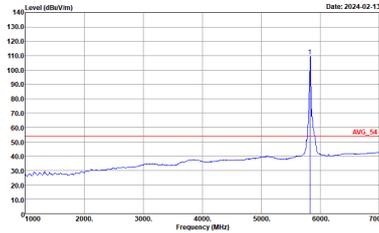

WIFI	Band 4 5725~5850MHz Band Edge @ 3m	
ANT	802.11ax HE20 Partial 106/54 CH165 5825MHz	
6+7	Horizontal	Fundamental
Peak	 <p>Site : 03CH20-HY Condition : PEAK_85(B4)_16-24 3m 91200_02360_231030 HORIZONTAL : RBW:1000.000KHz VBW:3000.000KHz SWT:Auto</p>	 <p>Site : 03CH20-HY Condition : PEAK(LINE) 3m 91200_02360_231030 HORIZONTAL : RBW:1000.000KHz VBW:3000.000KHz SWT:Auto</p>
Avg	Left blank	 <p>Site : 03CH20-HY Condition : AVG_54 3m 91200_02360_231030 HORIZONTAL : RBW:1000.000KHz VBW:0.270KHz SWT:Auto</p>

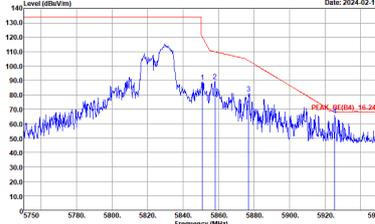
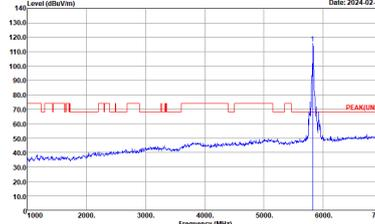

WIFI	Band 4 5725~5850MHz Band Edge @ 3m	
ANT	802.11ax HE20 Partial 106/54 CH165 5825MHz	
6+7	Vertical	Fundamental
Peak	 <p>Site : 03CH20-HY Condition : PEAK_85(B4)_16-24 3m 91200_02360_231030 VERTICAL : RBW:1000.000KHz VBW:3000.000KHz SWT:Auto</p>	 <p>Site : 03CH20-HY Condition : PEAK(LINE) 3m 91200_02360_231030 VERTICAL : RBW:1000.000KHz VBW:3000.000KHz SWT:Auto</p>
Avg	Left blank	 <p>Site : 03CH20-HY Condition : AVG_54 3m 91200_02360_231030 VERTICAL : RBW:1000.000KHz VBW:0.270KHz SWT:Auto</p>

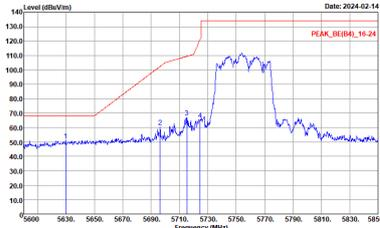
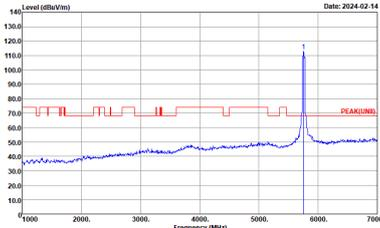
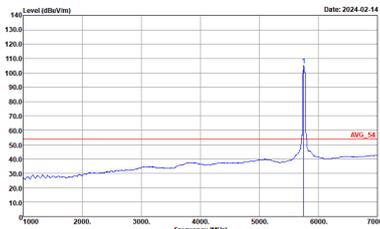

Band 4 5725~5850MHz
WIFI 802.11ax HE40 Full (Band Edge @ 3m)

WIFI	Band 4 5725~5850MHz Band Edge @ 3m	
ANT	802.11ax HE40 Full CH151 5755MHz	
6+7	Horizontal	Fundamental
Peak	 <p>Site : 03CH20-HY Condition : PEAK_BE(B4)_16-24 3m 91200_02360_231030 HORIZONTAL : RBW:1000.000KHz VBW:3000.000KHz SWT:Auto</p>	 <p>Site : 03CH20-HY Condition : PEAK(UNIT) 3m 91200_02360_231030 HORIZONTAL : RBW:1000.000KHz VBW:3000.000KHz SWT:Auto</p>
Avg	Left blank	 <p>Site : 03CH20-HY Condition : AVG_54 3m 91200_02360_231030 HORIZONTAL : RBW:1000.000KHz VBW:0.270KHz SWT:Auto</p>



WIFI	Band 4 5725~5850MHz Band Edge @ 3m	
ANT	802.11ax HE40 Full CH151 5755MHz	
6+7	Horizontal	Fundamental
Peak	<p>Site : DACH2014Y Condition : PEAK_85(B4)_16-24 3m 9120D_02360_231030 HORIZONTAL : RBW:1000.000KHz VBW:3000.000KHz SWF:Auto</p>	Left blank

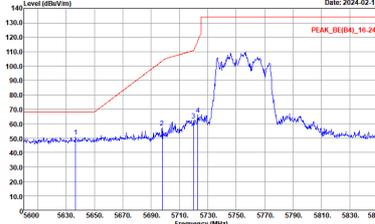
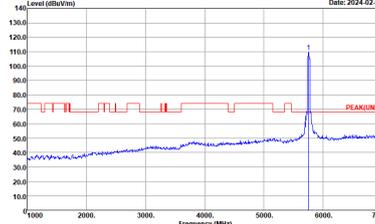

WIFI	Band 4 5725~5850MHz Band Edge @ 3m	
ANT	802.11ax HE40 Full CH151 5755MHz	
6+7	Vertical	Fundamental
Peak	 <p>Site : 03CH20-HY Condition : PEAK_DE(B4)_16-24 3m 91200_02360_231030 VERTICAL : RBW:1000.000KHz VBW:3000.000KHz SWT:Auto</p>	 <p>Site : 03CH20-HY Condition : PEAK(LINE) 3m 91200_02360_231030 VERTICAL : RBW:1000.000KHz VBW:3000.000KHz SWT:Auto</p>
Avg	Left blank	 <p>Site : 03CH20-HY Condition : AVG_S1 3m 91200_02360_231030 VERTICAL : RBW:1000.000KHz VBW:0.270KHz SWT:Auto</p>

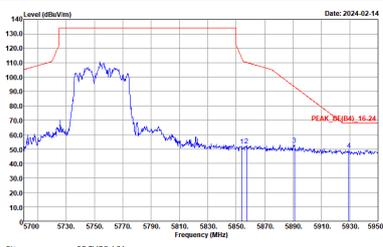

WIFI	Band 4 5725~5850MHz Band Edge @ 3m	
ANT	802.11ax HE40 Full CH151 5755MHz	
6+7	Vertical	Fundamental
Peak	 <p>Site : DACH2014Y Condition : PEAK_85(B4)_16-24 3m 9120D_02360_231030 VERTICAL : RBW:1000.000KHz VBW:3000.000KHz SWF:Auto</p>	Left blank

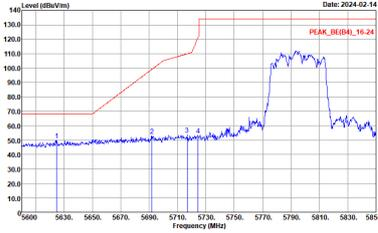
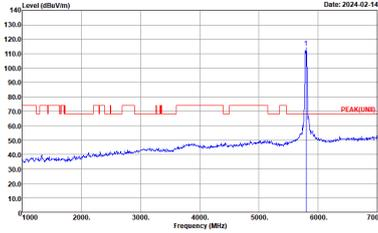
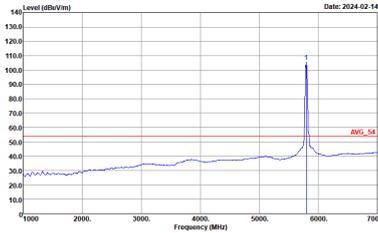

WIFI	Band 4 5725~5850MHz Band Edge @ 3m	
ANT	802.11ax HE40 Full HT40 CH159 5795MHz	
6+7	Horizontal	Fundamental
Peak	 <p>Site : 03CH20-HY Condition : PEAK_85(B4)_16-24 3m 91200_02360_231030 HORIZONTAL : RBW:1000.000KHz VBW:3000.000KHz SWT:Auto</p>	 <p>Site : 03CH20-HY Condition : PEAK(LINE) 3m 91200_02360_231030 HORIZONTAL : RBW:1000.000KHz VBW:3000.000KHz SWT:Auto</p>
Avg	Left blank	 <p>Site : 03CH20-HY Condition : AVG_54 3m 91200_02360_231030 HORIZONTAL : RBW:1000.000KHz VBW:0.270KHz SWT:Auto</p>



WIFI	Band 4 5725~5850MHz Band Edge @ 3m	
ANT	802.11ax HE40 Full HT40 CH159 5795MHz	
6+7	Horizontal	Fundamental
Peak	<p>Site : DACH2014Y Condition : PEAK_85(B4)_16-24 3m 9120D_02360_231030 HORIZONTAL RBW:1000.000KHz VBW:3000.000KHz SWF:Auto</p>	Left blank

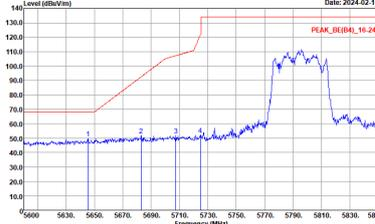
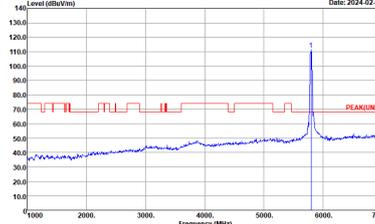

WIFI	Band 4 5725~5850MHz Band Edge @ 3m	
ANT	802.11ax HE40 Full CH159 5795MHz	
6+7	Vertical	Fundamental
Peak	 <p>Site : 03CH20-HY Condition : PEAK_DE(B4)_16-24 3m 91200_02360_231030 VERTICAL : RBW:1000.000KHz VBW:3000.000KHz SWT:Auto</p>	 <p>Site : 03CH20-HY Condition : PEAK(LINE) 3m 91200_02360_231030 VERTICAL : RBW:1000.000KHz VBW:3000.000KHz SWT:Auto</p>
Avg	Left blank	 <p>Site : 03CH20-HY Condition : AVG_S1 3m 91200_02360_231030 VERTICAL : RBW:1000.000KHz VBW:0.270KHz SWT:Auto</p>



WIFI	Band 4 5725~5850MHz Band Edge @ 3m	
ANT	802.11ax HE40 Full CH159 5795MHz	
6+7	Vertical	Fundamental
Peak	<p>Site : DACH2014Y Condition : PEAK_85(B4)_16-24 3m 9120D_02360_231030 VERTICAL : RBW:1000.000KHz VBW:3000.000KHz SWF:Auto</p>	Left blank

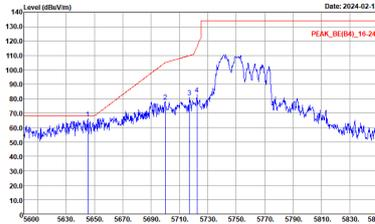
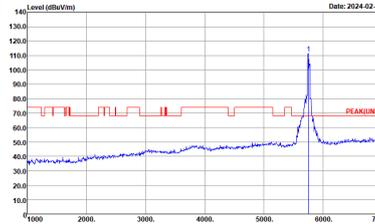

Band 4 5725~5850MHz
WIFI 802.11ax HE40 Partial 242 (Band Edge @ 3m)

WIFI	Band 4 5725~5850MHz Band Edge @ 3m	
ANT	802.11ax HE40 Partial 242/61 CH151 5755MHz	
6+7	Horizontal	Fundamental
Peak	 <p>Site : 03CH20-HY Condition : PEAK_BE(84)_16-24 3m 91200_02360_231030 HORIZONTAL : RBW:1000.000KHz VBW:3000.000KHz SWT:Auto</p>	 <p>Site : 03CH20-HY Condition : PEAK(UNIT) 3m 91200_02360_231030 HORIZONTAL : RBW:1000.000KHz VBW:3000.000KHz SWT:Auto</p>
Avg	Left blank	 <p>Site : 03CH20-HY Condition : AVG_54 3m 91200_02360_231030 HORIZONTAL : RBW:1000.000KHz VBW:0.620KHz SWT:Auto</p>



WIFI	Band 4 5725~5850MHz Band Edge @ 3m	
ANT	802.11ax HE40 Partial 242/61 CH151 5755MHz	
6+7	Horizontal	Fundamental
Peak	<p>Site : DACH2014Y Condition : PEAK_85(B4)_16-24 3m 9120D_02360_231030 HORIZONTAL : RBW:1000.000KHz VBW:3000.000KHz SWF:Auto</p>	Left blank

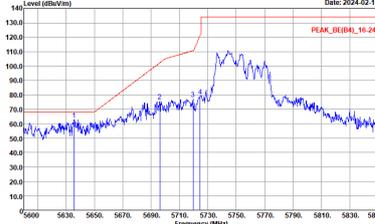
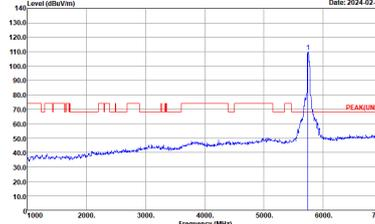

WIFI	Band 4 5725~5850MHz Band Edge @ 3m	
ANT	802.11ax HE40 Partial 242/61 CH151 5755MHz	
6+7	Vertical	Fundamental
Peak	 <p>Site : 03CH20-HY Condition : PEAK_DE(B4)_16-24 3m 91200_02360_231030 VERTICAL : RBW:1000.000KHz VBW:3000.000KHz SWT:Auto</p>	 <p>Site : 03CH20-HY Condition : PEAK(LINE) 3m 91200_02360_231030 VERTICAL : RBW:1000.000KHz VBW:3000.000KHz SWT:Auto</p>
Avg	Left blank	 <p>Site : 03CH20-HY Condition : AVG_S1 3m 91200_02360_231030 VERTICAL : RBW:1000.000KHz VBW:0.200KHz SWT:Auto</p>



WIFI	Band 4 5725~5850MHz Band Edge @ 3m	
ANT	802.11ax HE40 Partial 242/61 CH151 5755MHz	
6+7	Vertical	Fundamental
Peak	<p>Site : DACH2014Y Condition : PEAK_01(B4)_16-24 3m 9120D_02360_231030 VERTICAL : RBW:1000.000KHz VBW:3000.000KHz SWF:Auto</p>	Left blank

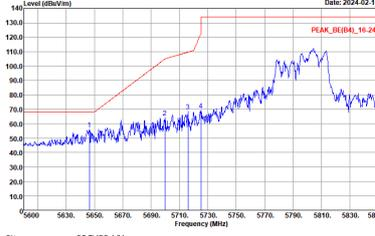
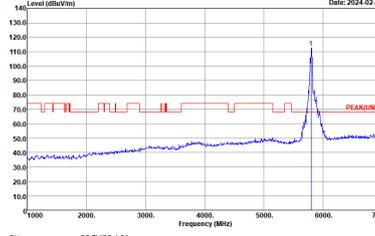
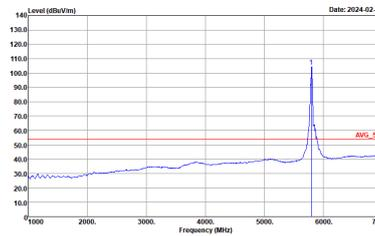

WIFI	Band 4 5725~5850MHz Band Edge @ 3m	
ANT	802.11ax HE40 Partial 242/62 CH159 5795MHz	
6+7	Horizontal	Fundamental
Peak	 <p>Site : 03CH20-HY Condition : PEAK_RE(B4)_16-24 3m 91200_02360_231030 HORIZONTAL : RBW:1000.000KHz VBW:3000.000KHz SWT:Auto</p>	 <p>Site : 03CH20-HY Condition : PEAK(LINE) 3m 91200_02360_231030 HORIZONTAL : RBW:1000.000KHz VBW:3000.000KHz SWT:Auto</p>
Avg	Left blank	 <p>Site : 03CH20-HY Condition : AVG_54 3m 91200_02360_231030 HORIZONTAL : RBW:1000.000KHz VBW:0.200KHz SWT:Auto</p>



WIFI	Band 4 5725~5850MHz Band Edge @ 3m	
ANT	802.11ax HE40 Partial 242/62 CH159 5795MHz	
6+7	Horizontal	Fundamental
Peak	<p>Site : DACH2014Y Condition : PEAK_85(B4)_16-24 3m 9120D_02360_231030 HORIZONTAL : RBW:1000.000KHz VBW:3000.000KHz SWF:Auto</p>	Left blank

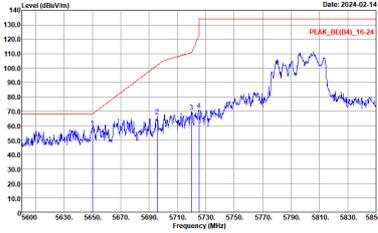
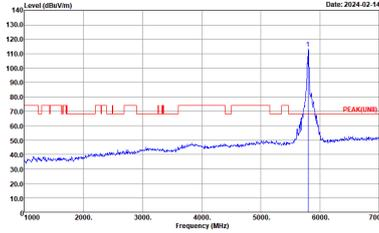
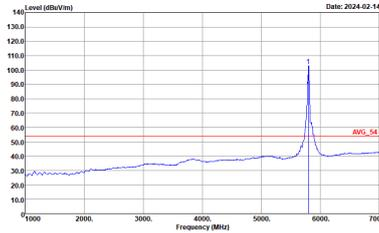

WIFI	Band 4 5725~5850MHz Band Edge @ 3m	
ANT	802.11ax HE40 Partial 242/62 CH159 5795MHz	
6+7	Vertical	Fundamental
Peak	 <p>Site : 03CH20-HY Condition : PEAK_DE(B4)_16-24 3m 91200_02360_231030 VERTICAL : RBW:1000.000KHz VBW:3000.000KHz SWT:Auto</p>	 <p>Site : 03CH20-HY Condition : PEAK(LINE) 3m 91200_02360_231030 VERTICAL : RBW:1000.000KHz VBW:3000.000KHz SWT:Auto</p>
Avg	Left blank	 <p>Site : 03CH20-HY Condition : AVG_S1 3m 91200_02360_231030 VERTICAL : RBW:1000.000KHz VBW:0.200KHz SWT:Auto</p>



WIFI	Band 4 5725~5850MHz Band Edge @ 3m	
ANT	802.11ax HE40 Partial 242/62 CH159 5795MHz	
6+7	Vertical	Fundamental
Peak	<p>Site : DACH20-144 Condition : PEAK_85(B4)_16-24 3m 9120D_02360_231030 VERTICAL : RBW:1000.000KHz VBW:3000.000KHz SWF:Auto</p>	Left blank



Band 4 5725~5850MHz
WIFI 802.11ax HE80 Full (Band Edge @ 3m)

WIFI	Band 4 5725~5850MHz Band Edge @ 3m	
ANT	802.11ax HE80 Full CH155 5775MHz	
6+7	Horizontal	Fundamental
Peak	<p>Site : 03CH20-HY Condition : PEAK_BE(84)_16-24 3m 91200_02360_231030 HORIZONTAL : RBW:1000.000KHz VBW:3000.000KHz SWT:Auto</p>	<p>Site : 03CH20-HY Condition : PEAK(UNIT) 3m 91200_02360_231030 HORIZONTAL : RBW:1000.000KHz VBW:3000.000KHz SWT:Auto</p>
Avg	Left blank	<p>Site : 03CH20-HY Condition : AVG_54 3m 91200_02360_231030 HORIZONTAL : RBW:1000.000KHz VBW:1100KHz SWT:Auto</p>



WIFI	Band 4 5725~5850MHz Band Edge @ 3m	
ANT	802.11ax HE80 Full CH155 5775MHz	
6+7	Horizontal	Fundamental
Peak	<p>Site : DACH2014Y Condition : PEAK_ME(B4)_16-24 3m 9120D_02360_231030 HORIZONTAL : RBW:1000.000KHz VBW:3000.000KHz SWF:Auto</p>	Left blank



WIFI	Band 4 5725~5850MHz Band Edge @ 3m	
ANT	802.11ax HE80 Full CH155 5775MHz	
6+7	Vertical	Fundamental
Peak		
Avg	Left blank	



WIFI	Band 4 5725~5850MHz Band Edge @ 3m	
ANT	802.11ax HE80 Full CH155 5775MHz	
6+7	Vertical	Fundamental
Peak	<p>Site : DACH2014Y Condition : PEAK_85(B4)_16-24 3m 9120D_02360_231030 VERTICAL : RBW:1000.000KHz VBW:3000.000KHz SWF:Auto</p>	Left blank

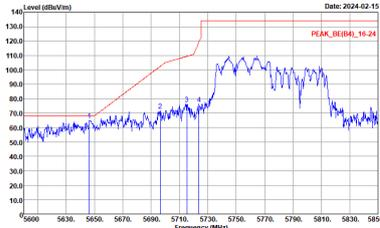
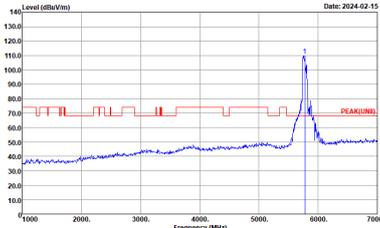
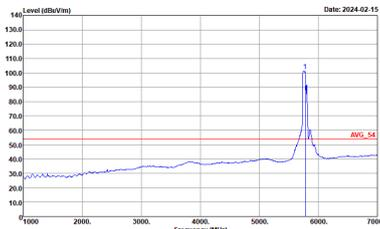

Band 4 5725~5850MHz
WIFI 802.11ax HE80 Partial 484 (Band Edge @ 3m)

WIFI	Band 4 5725~5850MHz Band Edge @ 3m	
ANT	802.11ax HE80 Partial 484/65 CH155 5775MHz	
6+7	Horizontal	Fundamental
Peak	 <p>Site : 03CH20-HY Condition : PEAK_BE(84)_16-24 3m 91200_02360_231030 HORIZONTAL : RBW:1000.000KHz VBW:3000.000KHz SWT:Auto</p>	 <p>Site : 03CH20-HY Condition : PEAK(UNIT) 3m 91200_02360_231030 HORIZONTAL : RBW:1000.000KHz VBW:3000.000KHz SWT:Auto</p>
Avg	Left blank	 <p>Site : 03CH20-HY Condition : AVG_04 3m 91200_02360_231030 HORIZONTAL : RBW:1000.000KHz VBW:1200KHz SWT:Auto</p>



WIFI	Band 4 5725~5850MHz Band Edge @ 3m	
ANT	802.11ax HE80 Partial 484/65 CH155 5775MHz	
6+7	Horizontal	Fundamental
Peak	<p>Site : DACH2014Y Condition : PEAK_85(B4)_16-24 3m 9120D_02360_231030 HORIZONTAL : RBW:1000.000KHz VBW:3000.000KHz SWF:Auto</p>	Left blank

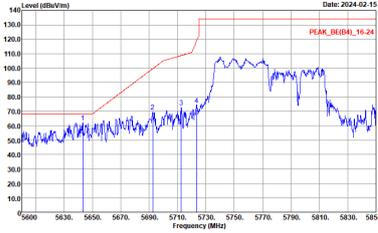
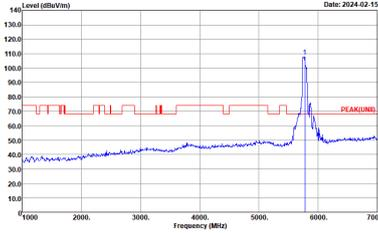
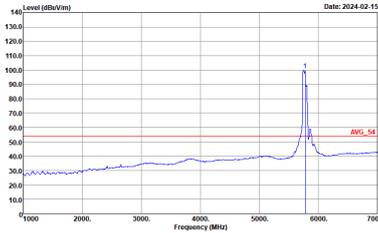

WIFI	Band 4 5725~5850MHz Band Edge @ 3m	
ANT	802.11ax HE80 Partial 484/65 CH155 5775MHz	
6+7	Vertical	Fundamental
Peak	 <p>Site : 03CH20-HY Condition : PEAK_DE(B4)_16-24 3m 91200_02360_231030 VERTICAL : RBW:1000.000KHz VBW:3000.000KHz SWT:Auto</p>	 <p>Site : 03CH20-HY Condition : PEAK(LINE) 3m 91200_02360_231030 VERTICAL : RBW:1000.000KHz VBW:3000.000KHz SWT:Auto</p>
Avg	Left blank	 <p>Site : 03CH20-HY Condition : AVG_S1 3m 91200_02360_231030 VERTICAL : RBW:1000.000KHz VBW:1.200KHz SWT:Auto</p>



WIFI	Band 4 5725~5850MHz Band Edge @ 3m	
ANT	802.11ax HE80 Partial 484/65 CH155 5775MHz	
6+7	Vertical	Fundamental
Peak	<p>Site : DACH2014Y Condition : PEAK_85(B4)_16-24 3m 9120D_02360_231030 VERTICAL : RBW:1000.000KHz VBW:3000.000KHz SWF:Auto</p>	Left blank

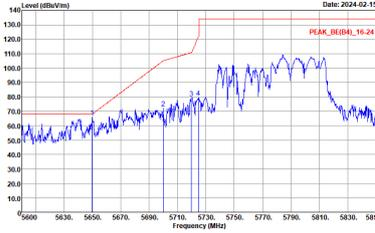
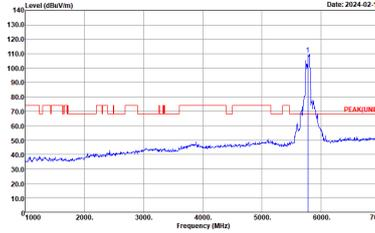
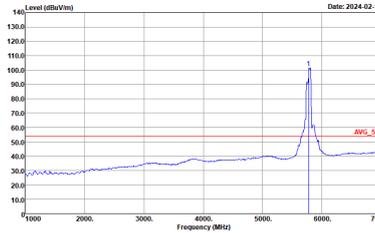

WIFI	Band 4 5725~5850MHz Band Edge @ 3m	
ANT	802.11ax HE80 Partial 484/66 CH155 5775MHz	
6+7	Horizontal	Fundamental
Peak	 <p>Site : 03CH20-HY Condition : PEAK_DE(B4)_16-24 3m 91200_02360_231030 HORIZONTAL : RBW:1000.000KHz VBW:3000.000KHz SWT:Auto</p>	 <p>Site : 03CH20-HY Condition : PEAK(LINE) 3m 91200_02360_231030 HORIZONTAL : RBW:1000.000KHz VBW:3000.000KHz SWT:Auto</p>
Avg	Left blank	 <p>Site : 03CH20-HY Condition : AVG_54 3m 91200_02360_231030 HORIZONTAL : RBW:1000.000KHz VBW:1.200KHz SWT:Auto</p>



WIFI	Band 4 5725~5850MHz Band Edge @ 3m	
ANT	802.11ax HE80 Partial 484/66 CH155 5775MHz	
6+7	Horizontal	Fundamental
Peak	<p>Site : DACH2014Y Condition : PEAK_85(B4)_16-24 3m 9120D_02360_231030 HORIZONTAL : RBW:1000.000KHz VBW:3000.000KHz SWF:Auto</p>	Left blank

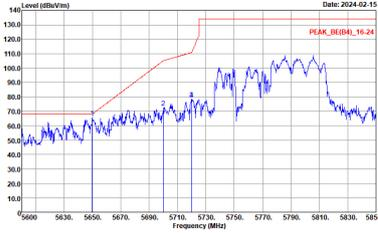
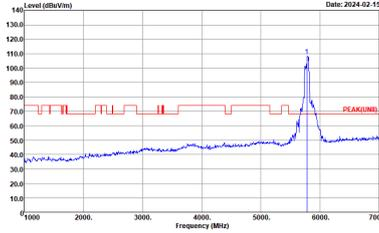
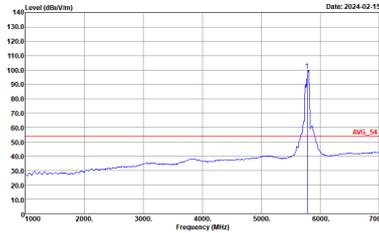

WIFI	Band 4 5725~5850MHz Band Edge @ 3m	
ANT	802.11ax HE80 Partial 484/66 CH155 5775MHz	
6+7	Vertical	Fundamental
Peak	 <p>Site : 03CH20-HY Condition : PEAK_DE(B4)_16-24 3m 91200_02360_231030 VERTICAL : RBW:1000.000KHz VBW:3000.000KHz SWT:Auto</p>	 <p>Site : 03CH20-HY Condition : PEAK(LINE) 3m 91200_02360_231030 VERTICAL : RBW:1000.000KHz VBW:3000.000KHz SWT:Auto</p>
Avg	Left blank	 <p>Site : 03CH20-HY Condition : AVG_S1 3m 91200_02360_231030 VERTICAL : RBW:1000.000KHz VBW:1.200KHz SWT:Auto</p>



WIFI	Band 4 5725~5850MHz Band Edge @ 3m	
ANT	802.11ax HE80 Partial 484/66 CH155 5775MHz	
6+7	Vertical	Fundamental
Peak	<p>Site : DACH2014Y Condition : PEAK_85(B4)_16-24 3m 9120D_02360_231030 VERTICAL : RBW:1000.000KHz VBW:3000.000KHz SWF:Auto</p>	Left blank



Band 4 - 5725~5850MHz
WIFI 802.11a (Harmonic @ 3m)

Table with 3 columns: WIFI (Band 4 5725~5850MHz Harmonic @ 3m), ANT (802.11a CH149 5745MHz), and 6+7 (Horizontal/Vertical). It contains two spectral plots showing Level (dBuV/m) vs Frequency (MHz) for Peak and Avg. measurements.



WIFI	Band 4 5725~5850MHz Harmonic @ 3m	
ANT	802.11a CH157 5785MHz	
6+7	Horizontal	Vertical
<p>Peak Avg.</p>		



WIFI	Band 4 5725~5850MHz Harmonic @ 3m	
ANT	802.11a CH165 5825MHz	
6+7	Horizontal	Vertical
Peak Avg.	<p>Site : 03CH120-14Y Condition : PEAK(LINE) 3m 91200_02360_231030 HORIZONTAL</p>	<p>Site : 03CH120-14Y Condition : PEAK(LINE) 3m 91200_02360_231030 VERTICAL</p>



Band 4 5725~5850MHz
WIFI 802.11ax HE20 Full (Harmonic @ 3m)

Table with 4 columns: WIFI, ANT, 6+7, and two graph columns (Horizontal and Vertical). The graphs show Level (dBm/10m) vs Frequency (MHz) with peak and average values.

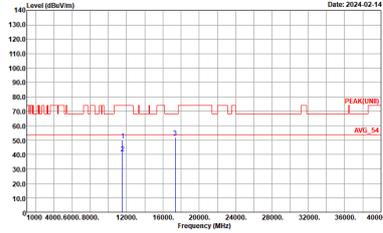
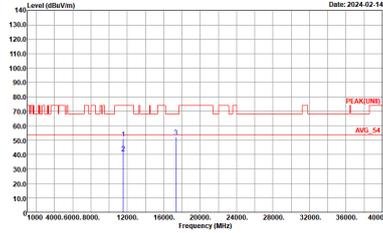

WIFI	Band 4 5725~5850MHz Harmonic @ 3m	
ANT	802.11ax HE20 Full CH157 5785MHz	
6+7	Horizontal	Vertical
<p>Peak Avg.</p>	 <p>Site : 03CH20-14Y Condition : PEAK(LINE) 3m 91200_02360_231030 HORIZONTAL</p>	 <p>Site : 03CH20-14Y Condition : PEAK(LINE) 3m 91200_02360_231030 VERTICAL</p>

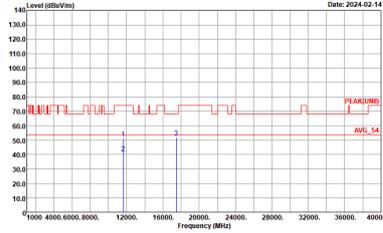
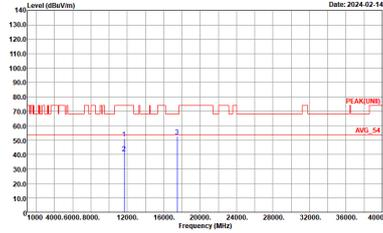

WIFI	Band 4 5725~5850MHz Harmonic @ 3m	
ANT	802.11ax HE20 Full CH165 5825MHz	
6+7	Horizontal	Vertical
Peak Avg.	 <p>Site : 03CH20-14Y Condition : PEAK(LINE) 3m 91200_02360_231030 HORIZONTAL</p>	 <p>Site : 03CH20-14Y Condition : PEAK(LINE) 3m 91200_02360_231030 VERTICAL</p>



Band 4 5725~5850MHz
WIFI 802.11ax HE40 Full (Harmonic @ 3m)

WIFI	Band 4 5725~5850MHz Harmonic @ 3m	
ANT	802.11ax HE40 Full CH151 5755MHz	
6+7	Horizontal	Vertical
Peak Avg.	<p>Site : 03CH20-HY Condition : PEAK(UNIT) 3m 91200_02360_231030 HORIZONTAL</p>	<p>Site : 03CH20-HY Condition : PEAK(UNIT) 3m 91200_02360_231030 VERTICAL</p>

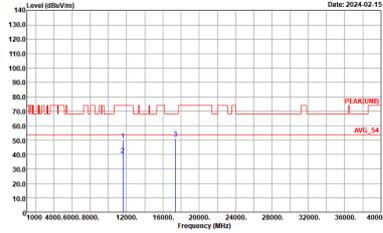
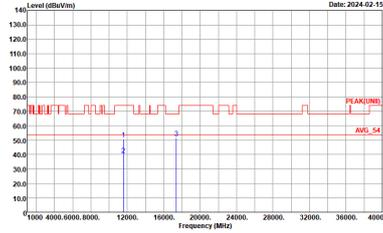

WIFI	Band 4 5725~5850MHz Harmonic @ 3m	
ANT	802.11ax HE40 Full CH159 5795MHz	
6+7	Horizontal	Vertical
Peak Avg.	 <p>Site : 03CH120-14Y Condition : PEAK(LINE) 3m 91200_02360_231030 HORIZONTAL</p>	 <p>Site : 03CH120-14Y Condition : PEAK(LINE) 3m 91200_02360_231030 VERTICAL</p>



Band 4 5725~5850MHz
WIFI 802.11ax HE80 Full (Harmonic @ 3m)

WIFI	Band 4 5725~5850MHz Harmonic @ 3m	
ANT	802.11ax HE80 Full CH155 5775MHz	
6+7	Horizontal	Vertical
Peak Avg.	<p>Site : 03CH20-HY Condition : PEAK(UNII) 3m 91200_02360_231030 HORIZONTAL :</p>	<p>Site : 03CH20-HY Condition : PEAK(UNII) 3m 91200_02360_231030 VERTICAL :</p>



Emission above 18GHz

5GHz WIFI 802.11ax HE80 Full (SHF @ 1m)

WIFI	5GHz WIFI	
ANT	802.11ax HE80 Full SHF	
6+7	Horizontal	Vertical
<p>Peak</p> <p>Avg.</p>	<p>Site : 03CH20-HY Condition : PEAK(LINE) 1m SHF_1224_230710 HORIZONTAL</p>	<p>Site : 03CH20-HY Condition : PEAK(LINE) 1m SHF_1224_230710 VERTICAL</p>



Emission below 1GHz

5GHz WIFI 802.11ax HE80 Full (LF @ 3m)

WIFI	5GHz WIFI	
ANT	802.11ax HE80 Full LF	
6+7	Horizontal	Vertical
QP / Peak	<p>Site : 03CH20-HV Condition : QP-3m LF_55606_231020_200 HORIZONTAL</p>	<p>Site : 03CH20-HV Condition : QP-3m LF_55606_231020_200 VERTICAL</p>



Appendix E. Duty Cycle Plots

Antenna	Band	Duty Cycle(%)	T(us)	1/T(kHz)	VBW Setting																							
6+7	802.11a	85.37	1710	0.58	620Hz																							
6+7	5GHz 802.11ax HE20 Full RU	85.88	3710	0.27	270Hz																							
6+7	5GHz 802.11ax HE20 106 RU	85.90	3900	270Hz	6+7	5GHz 802.11ax HE40 Full RU	85.76	2222	0.45	470Hz	6+7	5GHz 802.11ax HE40 242 RU	85.71	1740	0.57	620Hz	6+7	5GHz 802.11ax HE80 Full RU	85.56	930	1.08	1.1Hz	6+7	5GHz 802.11ax HE80 484 RU	85.55	906	1.10	1.2kHz
6+7	5GHz 802.11ax HE40 Full RU	85.76	2222	0.45	470Hz																							
6+7	5GHz 802.11ax HE40 242 RU	85.71	1740	0.57	620Hz																							
6+7	5GHz 802.11ax HE80 Full RU	85.56	930	1.08	1.1Hz																							
6+7	5GHz 802.11ax HE80 484 RU	85.55	906	1.10	1.2kHz																							

MIMO <Ant. 6+7>

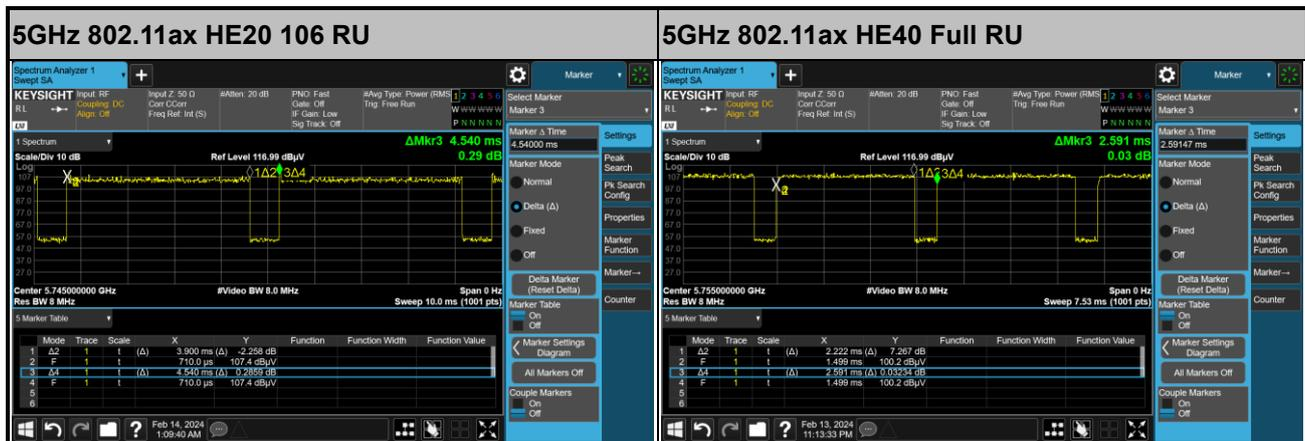

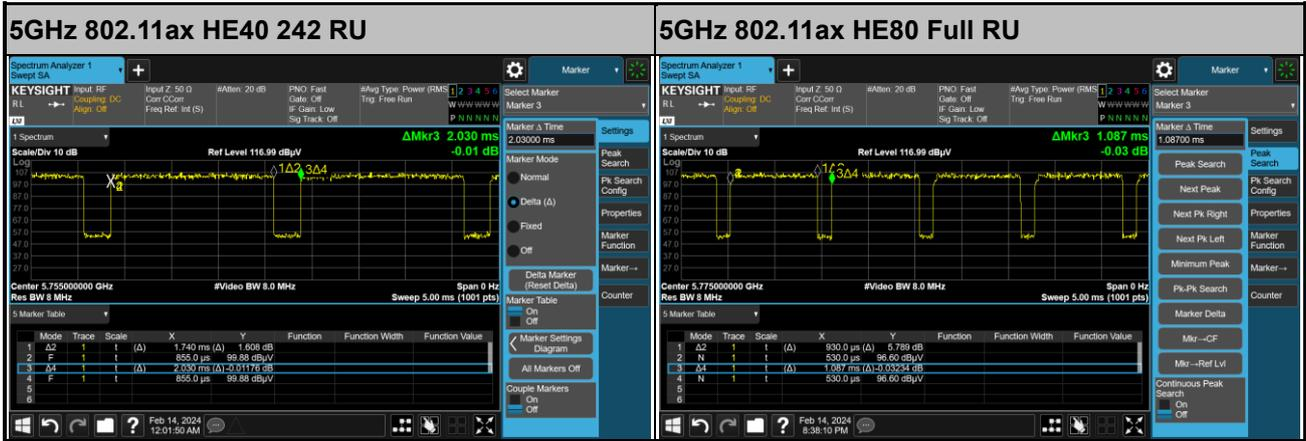



Appendix G. Spot Check Evaluation on TC58BE

Conducted power test and radiated spurious emission test configurations were selected from the worst cases identified in the reference model and tested to demonstrate the test data from reference model remains representative for the variant model.

The deviation between the spot check and the referenced values is within 3dB, therefore data referencing is justified according to the guidance in the ECR inquiry

Mode	Test Item	UZ7TC58AE Reference Worst mode Test Result	UZ7TC58BE Variant Check Test Result	Deviation	Limit (dB)
BT	Number of Channels	79	79	0	Within the authorized block
	Hopping Channel Separation	1.007	1.303	0.296	Within the authorized block
	Dwell Time of Each Channel	0.31	0.31	0	Within the authorized block
	20dB Bandwidth	0.872	0.87	0.002	Within the authorized frequency block
	99% Bandwidth	0.803	0.798	0.005	Within the authorized frequency block
	Conducted Band Edges	-43.53	-45.87	2.34	Deviation (ddB) < 3 dB
	Conducted Spurious Emission	-36.86	-38.91	2.05	Deviation (ddB) < 3 dB
	Peak Output Power	7.18	6.7	0.48	Deviation (ddB) < 3 dB
	Radiated Band Edges and Radiated Spurious Emission	48.41	47.65	0.76	Deviation (ddB) < 3 dB
	AC Conducted Emission	17.48	19.72	2.24	Deviation (ddB) < 3 dB
BLE	6dB Bandwidth	1.142	1.155	0.013	Within the authorized frequency block
	99% Bandwidth	1.998	1.996	0.002	Within the authorized frequency block
	Power Spectral Density	5.44	6.07	0.63	Deviation (ddB) < 3 dB
	Conducted Band Edges	-43.68	-46.24	2.56	Deviation (ddB) < 3 dB
	Conducted Spurious Emission	-41.5	-38.88	2.62	Deviation (ddB) < 3 dB
	Peak Output Power	6.3	5.9	0.4	Deviation (ddB) < 3 dB
	Radiated Band Edges and Spurious Emission	50.56	50.49	0.07	Deviation (ddB) < 3 dB
	AC Conducted Emission	17.48	19.72	2.24	Deviation (ddB) < 3 dB
WIFI 2.4G	6dB Bandwidth	9.03	8.54	0.47	Within the authorized frequency block
	99% Bandwidth	13.59	13.52	0.07	Within the authorized frequency block
	Power Spectral Density	1.78	1.06	0.72	Deviation (ddB) < 3 dB
	Conducted Band Edges	-30.53	-30.89	0.36	Deviation (ddB) < 3 dB
	Conducted Spurious Emission	-46.39	-48.89	2.50	Deviation (ddB) < 3 dB
	Peak Output Power	23.41	23.31	0.1	Deviation (ddB) < 3 dB
	Radiated Band Edges and Spurious Emission	59.99	59.85	0.14	Deviation (ddB) < 3 dB
	AC Conducted Emission	17.48	19.72	2.24	Deviation (ddB) < 3 dB



Mode	Test Item	UZ7TC58AE Reference Worst mode Test Result	UZ7TC58BE Variant Check Test Result	Deviation	Limit (dB)
WIFI 5G	26dB Bandwidth	167.75	165.22	2.53	Within the authorized frequency block
	99% Bandwidth	154.89	155.47	0.58	Within the authorized frequency block
	Power Spectral Density	-2.9	-1.17	1.73	Deviation (ddB) < 3 dB
	Conducted Output Power	17.81	17.71	0.1	Deviation (ddB) < 3 dB
	Unwanted Emissions	63.2	64.81	1.61	Deviation (ddB) < 3 dB
	AC Conducted Emission	18.52	19.96	1.44	Deviation (ddB) < 3 dB
WIFI 6G UNII-8 (802.11ax HE20 CH189 6895MHz)	26dB Emission Bandwidth	20.75	21.14	0.39	Within the authorized frequency block
	99% Occupied Bandwidth	18.88	18.92	0.04	Within the authorized frequency block
	Conducted Output Power	7.66	7.56	0.1	Deviation (ddB) < 3 dB
	Fundamental Maximum EIRP	9.8	9.7	0.1	Deviation (ddB) < 3 dB
	Fundamental Power Spectral Density	-1.04	-1.41	0.37	Deviation (ddB) < 3 dB
	In-Band Emissions	-10.04	-12.35	2.31	Deviation (ddB) < 3 dB
WIFI 6G UNII-8 (802.11ax HE80 CH215 7025MHz)	Unwanted Emissions	72.37	72.28	0.09	Deviation (ddB) < 3 dB
WIFI 6G	AC Conducted Emission	18.52	19.96	1.44	Deviation (ddB) < 3 dB



List of Measuring Equipment

Instrument	Brand Name	Model No.	Serial No.	Characteristics	Calibration Date	Test Date	Due Date	Remark
AC Power Source	ChainTek	APC-1000W	N/A	N/A	N/A	Feb. 08, 2024	N/A	Conduction (CO05-HY)
EMI Test Receiver	Rohde & Schwarz	ESR3	102388	9kHz~3.6GHz	Dec. 06, 2023	Feb. 08, 2024	Dec. 05, 2024	Conduction (CO05-HY)
Hygrometer	Testo	608-H1	34913912	N/A	Oct. 26, 2023	Feb. 08, 2024	Oct. 25, 2024	Conduction (CO05-HY)
LISN	Rohde & Schwarz	ENV216	100081	9kHz~30MHz	Nov. 22, 2023	Feb. 08, 2024	Nov. 21, 2024	Conduction (CO05-HY)
Software	Rohde & Schwarz	EMC32	N/A	N/A	N/A	Feb. 08, 2024	N/A	Conduction (CO05-HY)
ISN Cable	MVE	RG-400	200260	N/A	Dec. 28, 2023	Feb. 08, 2024	Dec. 27, 2024	Conduction (CO05-HY)
Pulse Limiter	SCHWARZBECK	VTSD 9561-F N	00691	9kHz-200MHz	Jul. 28, 2023	Feb. 08, 2024	Jul. 27, 2024	Conduction (CO05-HY)
LISN Cable	MVE	RG-400	260260	N/A	Dec. 28, 2023	Feb. 08, 2024	Dec. 27, 2024	Conduction (CO05-HY)
Hygrometer	TECPEL	DTM-303A	TP201996	N/A	Nov. 07, 2023	Apr. 23, 2024~ May 06, 2024	Nov. 06, 2024	Conducted (TH05-HY)
Power Sensor	DARE	RPR3006W	17100015SN 36 (NO:35_ 144)	10MHz~6GHz	Aug. 23, 2023	Apr. 23, 2024~ May 06, 2024	Aug. 22, 2024	Conducted (TH05-HY)
Signal Analyzer	Rohde & Schwarz	FSV3044	101466	10HZ~44GHZ	Jan. 24, 2024	Apr. 23, 2024~ May 06, 2024	Jan. 23, 2025	Conducted (TH05-HY)

————THE END————