



FCC RF Test Report

APPLICANT : Zebra Technologies Corporation
EQUIPMENT : Touch computer
BRAND NAME : Zebra
MODEL NAME : TC56CJ
FCC ID : UZ7TC56CJ
STANDARD : FCC Part 15 Subpart E §15.407
CLASSIFICATION : (NII) Unlicensed National Information Infrastructure

The product was received on Oct. 13, 2016 and testing was completed on Nov. 30, 2016. We, SPORTON INTERNATIONAL INC., would like to declare that the tested sample has been evaluated in accordance with the test procedures and has been in compliance with the applicable technical standards.

The test results in this report apply exclusively to the tested model / sample. Without written approval of SPORTON INTERNATIONAL INC., the test report shall not be reproduced except in full.

Reviewed by: Joseph Lin / Supervisor

Approved by: Jones Tsai / Manager



SPORTON INTERNATIONAL INC.

No. 52, Hwa Ya 1st Rd., Hwa Ya Technology Park, Kwei-Shan District, Tao Yuan City, Taiwan, R.O.C.

SPORTON INTERNATIONAL INC.

TEL : 886-3-327-3456

FAX : 886-3-328-4978

FCC ID : UZ7TC56CJ

Page Number : 1 of 50

Report Issued Date : Jan. 04, 2017

Report Version : Rev. 01

Report Template No.: BU5-FR15EWL AC Version 1.4



TABLE OF CONTENTS

REVISION HISTORY..... 3

SUMMARY OF TEST RESULT 4

1 GENERAL DESCRIPTION 5

 1.1 Applicant 5

 1.2 Manufacturer 5

 1.3 Product Feature of Equipment Under Test 5

 1.4 Product Specification of Equipment Under Test 6

 1.5 Modification of EUT 7

 1.6 Testing Location 7

 1.7 Applicable Standards 8

2 TEST CONFIGURATION OF EQUIPMENT UNDER TEST 9

 2.1 Carrier Frequency Channel 9

 2.2 Pre-Scanned RF Power 11

 2.3 Test Mode 14

 2.4 Connection Diagram of Test System 17

 2.5 Support Unit used in test configuration and system 18

 2.6 EUT Operation Test Setup 18

 2.7 Measurement Results Explanation Example 18

3 TEST RESULT 19

 3.1 26dB & 99% Occupied Bandwidth Measurement 19

 3.2 Maximum Conducted Output Power Measurement 24

 3.3 Power Spectral Density Measurement 31

 3.4 Unwanted Radiated Emission Measurement 36

 3.5 AC Conducted Emission Measurement 41

 3.6 Frequency Stability Measurement 45

 3.7 Automatically Discontinue Transmission 47

 3.8 Antenna Requirements 48

4 LIST OF MEASURING EQUIPMENTS 49

5 UNCERTAINTY OF EVALUATION 50

APPENDIX A. RADIATED SPURIOUS EMISSION

APPENDIX B. RADIATED SPURIOUS EMISSION PLOTS

APPENDIX C. DUTY CYCLE PLOTS

APPENDIX D. SETUP PHOTOGRAPHS

**SUMMARY OF TEST RESULT**

Report Section	FCC Rule	Description	Limit	Result	Remark
3.1	2.1049 15.403(i)	26dB & 99% Bandwidth	-	Pass	-
3.2	15.407(a)	Maximum Conducted Output Power	≤ 24 dBm (depend on band)	Pass	-
3.3	15.407(a)	Power Spectral Density	≤ 11 dBm (depend on band)	Pass	-
3.4	15.407(b)	Unwanted Emissions	$\leq -17, -27$ dBm (depend on band) & 15.209(a)	Pass	Under limit 1.09 dB at 5350.080 MHz
3.5	15.207	AC Conducted Emission	15.207(a)	Pass	Under limit 14.50 dB at 0.286 MHz
3.6	15.407(g)	Frequency Stability	Within Operation Band	Pass	-
3.7	15.407(c)	Automatically Discontinue Transmission	Discontinue Transmission	Pass	-
3.8	15.203 & 15.407(a)	Antenna Requirement	N/A	Pass	-



1 General Description

1.1 Applicant

Zebra Technologies Corporation
1 Zebra Plaza Holtsville, NY 11742

1.2 Manufacturer

Wistron Corporation
21F, No. 88, Sec. 1, Hsin Tai Wu Rd., Hsichih Dist, New Taipei City 221, Taiwan R.O.C.

1.3 Product Feature of Equipment Under Test

Product Feature	
Equipment	Touch computer
Brand Name	Zebra
Model Name	TC56CJ
FCC ID	UZ7TC56CJ
EUT supports Radios application	CDMA/EV-DO/GSM/EGPRS/WCDMA/HSPA/LTE/NFC WLAN 11a/b/g/n HT20/HT40 WLAN 11ac VHT20/VHT40/VHT80 Bluetooth BR/EDR/LE
HW Version	DV1
SW Version	91-12-04.4-MG-00
FW Version	FUSION_BA_2_00.0.0.022
MFD	17OCT16
EUT Stage	Engineering sample

Remark: The above EUT's information was declared by manufacturer. Please refer to the specifications or user's manual for more detailed description.

Specification of Accessories				
Adapter (5V/2.5A)	Brand Name	Zebra	Model Number	SAWA-65-20005A
Headset Jumper 1	Brand Name	Zebra	Part Number	CBL-TC51-HDST25-01
Headset Jumper 2	Brand Name	Zebra	Part Number	CBL-TC51-HDST35-01
Battery	Brand Name	Zebra	Model Number	BT-000314
2.5mm Earphone	Brand Name	Zebra	Part Number	HDST-25MM-PTVP-01
3.5mm Earphone	Brand Name	Zebra	Part Number	HDST-35MM-PTVP-01
Trigger Handle	Brand Name	Zebra	Part Number	TRG-TC51-SNP1-01
Rugged Charge/USB cable	Brand Name	Zebra	Part Number	CBL-TC51-USB1-01
Soft Holster	Brand Name	Zebra	Part Number	SG-TC51-HLSTR1-01
Exoskeleton	Brand Name	Zebra	Part Number	SG-TC51-EX01-01
Hand strap	Brand Name	Zebra	Part Number	SG-TC51-BHDSTP1-03



1.4 Product Specification of Equipment Under Test

Standards-related Product Specification	
Tx/Rx Frequency Range	5180 MHz ~ 5240 MHz 5260 MHz ~ 5320 MHz 5500 MHz ~ 5720 MHz
Maximum Output Power to Antenna	<p><5180 MHz ~ 5240 MHz> 802.11a : 16.59 dBm / 0.0456 W 802.11n HT20 : 16.65 dBm / 0.0462 W 802.11n HT40 : 15.86 dBm / 0.0385 W 802.11ac VHT20 : 16.66 dBm / 0.0463 W 802.11ac VHT40 : 15.89 dBm / 0.0388 W 802.11ac VHT80 : 14.42 dBm / 0.0277 W</p> <p><5260 MHz ~ 5320 MHz> 802.11a : 16.50 dBm / 0.0447 W 802.11n HT20 : 16.44 dBm / 0.0441 W 802.11n HT40 : 15.88 dBm / 0.0387 W 802.11ac VHT20 : 16.46 dBm / 0.0443 W 802.11ac VHT40 : 15.89 dBm / 0.0388 W 802.11ac VHT80 : 14.14 dBm / 0.0259 W</p> <p><5500 MHz ~ 5720 MHz> 802.11a : 16.64 dBm / 0.0461 W 802.11n HT20 : 16.62 dBm / 0.0459 W 802.11n HT40 : 15.96 dBm / 0.0394 W 802.11ac VHT20 : 16.64 dBm / 0.0461 W 802.11ac VHT40 : 15.98 dBm / 0.0396 W 802.11ac VHT80 : 14.85 dBm / 0.0305 W</p>
Maximum Output Power to Antenna for Straddle Channel	802.11a : 16.50 dBm / 0.0447 W 802.11n HT20 : 16.59 dBm / 0.0456 W 802.11n HT40 : 16.15 dBm / 0.0412 W 802.11ac VHT20 : 16.60 dBm / 0.0457 W 802.11ac VHT40 : 16.18 dBm / 0.0415 W 802.11ac VHT80 : 14.89 dBm / 0.0308 W
99% Occupied Bandwidth	802.11a : 18.60 MHz 802.11ac VHT20 : 19.20 MHz 802.11ac VHT40 : 36.90 MHz 802.11ac VHT80 : 75.96 MHz
99% Occupied Bandwidth for Straddle Channel	802.11a : 18.65 MHz 802.11ac VHT20 : 19.10 MHz 802.11ac VHT40 : 37.00 MHz 802.11ac VHT80 : 75.96 MHz
Antenna Gain / Gain	<p><5180 MHz ~ 5240 MHz> Loop Antenna with gain 2.20 dBi</p> <p><5260 MHz ~ 5320 MHz> Loop Antenna with gain 2.60 dBi</p> <p><5500 MHz ~ 5720 MHz> Loop Antenna with gain 2.60 dBi</p>
Type of Modulation	802.11a/n : OFDM (BPSK / QPSK / 16QAM / 64QAM) 802.11ac : OFDM (BPSK / QPSK / 16QAM / 64QAM / 256QAM)



1.5 Modification of EUT

No modifications are made to the EUT during all test items.

1.6 Testing Location

Sporton Lab is accredited to ISO 17025 by Taiwan Accreditation Foundation (TAF code : 1190) and the FCC designation No. TW1022 under the FCC 2.948(e) by Mutual Recognition Agreement (MRA) in FCC Test.

Test Site	SPORTON INTERNATIONAL INC.	
Test Site Location	No. 52, Hwa Ya 1 st Rd., Hwa Ya Technology Park, Kwei-Shan District, Tao Yuan City, Taiwan, R.O.C. TEL: +886-3-327-3456 FAX: +886-3-328-4978	
Test Site No.	Sporton Site No.	
	TH05-HY	CO05-HY

Note: The test site complies with ANSI C63.4 2014 requirement.

Test Site	SPORTON INTERNATIONAL INC.	
Test Site Location	No.58, Aly. 75, Ln. 564, Wenhua 3rd Rd. Guishan Dist, Taoyuan City, Taiwan (R.O.C.) TEL: +886-3-327-0868 FAX: +886-3-327-0855	
Test Site No.	Sporton Site No.	
	03CH12-HY	

Note: The test site complies with ANSI C63.4 2014 requirement.



1.7 Applicable Standards

According to the specifications of the manufacturer, the EUT must comply with the requirements of the following standards:

- ♦ FCC Part 15 Subpart E
- ♦ FCC KDB 789033 D02 General UNII Test Procedures New Rules v01r03
- ♦ FCC KDB 644545 D03 Guidance for IEEE 802.11ac New Rules v01
- ♦ ANSI C63.10-2013

Remark:

1. All test items were verified and recorded according to the standards and without any deviation during the test.
2. This EUT has also been tested and complied with the requirements of FCC Part 15, Subpart B, recorded in a separate test report.



2 Test Configuration of Equipment Under Test

The EUT has been associated with peripherals and configuration operated in a manner tended to maximize its emission characteristics in a typical application. Frequency range investigated: conducted emission (150 kHz to 30 MHz) and radiated emission (9 kHz to the 10th harmonic of the highest fundamental frequency or to 40 GHz, whichever is lower). For radiated measurement, pre-scanned in three orthogonal panels, X, Y, Z. The worst cases (X plane) were recorded in this report.

2.1 Carrier Frequency Channel

Frequency Band	Channel	Freq. (MHz)	Channel	Freq. (MHz)
5150-5250 MHz Band 1 (U-NII-1)	36	5180	44	5220
	38*	5190	46*	5230
	40	5200	48	5240
	42 [#]	5210		

Frequency Band	Channel	Freq. (MHz)	Channel	Freq. (MHz)
5250-5350 MHz Band 2 (U-NII-2A)	52	5260	60	5300
	54*	5270	62*	5310
	56	5280	64	5320
	58 [#]	5290		

Frequency Band	Channel	Freq. (MHz)	Channel	Freq. (MHz)
5470-5725 MHz Band 3 (U-NII-2C)	100	5500	112	5560
	102*	5510	116	5580
	104	5520	132	5660
	106 [#]	5530	134*	5670
	108	5540	136	5680
	110*	5550	140	5700



Frequency Band	Channel	Freq. (MHz)	Channel	Freq. (MHz)
TDWR Channel	118*	5590	124	5620
	120	5600	126*	5630
	122 [#]	5610	128	5640

Frequency Band	Channel	Freq. (MHz)	Channel	Freq. (MHz)
Straddle Channel	138 [#]	5690	144	5720
	142*	5710		

Note:

1. The above Frequency and Channel in "*" were 802.11n HT40 and 802.11ac VHT40.
2. The above Frequency and Channel in "[#]" were 802.11ac VHT80.



2.2 Pre-Scanned RF Power

Preliminary tests were performed in different data rate and data rate associated with the highest power were chosen for full test in the following tables. Final Output Power equals to Measured Output Power adds the duty factor.

802.11a mode										
Power vs. Channel			Power vs. Data Rate							
Channel	Frequency (MHz)	Data Rate (bps)	Channel	Data Rate (bps)						
		6M		9M	12M	18M	24M	36M	48M	54M
CH 36	5180	16.59	CH 36	16.55	16.51	16.53	16.57	16.56	16.55	16.56
CH 44	5220	16.41								
CH 48	5240	16.58								
CH 52	5260	16.50	CH 52	16.48	16.40	16.41	16.47	16.39	16.48	16.38
CH 60	5300	16.34								
CH 64	5320	16.33								
CH 100	5500	16.64	CH 100	16.53	16.60	16.58	16.52	16.59	16.60	16.56
CH 116	5580	16.57								
CH 140	5700	15.74								
CH 144*	5720	16.50								

Note: The above Frequency and Channel in "*" were straddle channel.



802.11n HT20 mode										
Power vs. Channel			Power vs. Data Rate							
Channel	Frequency (MHz)	MCS Index	Channel	MCS Index						
		MCS0		MCS1	MCS2	MCS3	MCS4	MCS5	MCS6	MCS7
CH 36	5180	16.65	CH 36	16.53	16.57	16.49	16.54	16.53	16.55	16.60
CH 44	5220	16.41								
CH 48	5240	16.45								
CH 52	5260	16.44	CH 52	16.28	16.32	16.28	16.24	16.28	16.40	16.40
CH 60	5300	16.34								
CH 64	5320	16.30								
CH 100	5500	16.62	CH 100	16.46	16.52	16.41	16.47	16.39	16.40	16.50
CH 116	5580	16.44								
CH 140	5700	15.32								
CH 144*	5720	16.59								

Note: The above Frequency and Channel in "*" were straddle channel.

802.11n HT40 mode										
Power vs. Channel			Power vs. Data Rate							
Channel	Frequency (MHz)	MCS Index	Channel	MCS Index						
		MCS0		MCS1	MCS2	MCS3	MCS4	MCS5	MCS6	MCS7
CH 38	5190	14.06	CH 46	15.78	15.66	15.60	15.71	15.60	15.57	15.66
CH 46	5230	15.86								
CH 54	5270	15.88	CH 54	15.78	15.78	15.72	15.77	15.73	15.69	15.76
CH 62	5310	13.86								
CH 102	5510	13.75	CH 110	15.88	15.88	15.93	15.86	15.83	15.81	15.86
CH 110	5550	15.96								
CH 134	5670	15.87								
CH 142*	5710	16.15								

Note: The above Frequency and Channel in "*" were straddle channel.



802.11ac VHT20 mode											
Power vs. Channel			Power vs. Data Rate								
Channel	Frequency (MHz)	MCS Index	Channel	MCS Index							
		MCS0		MCS1	MCS2	MCS3	MCS4	MCS5	MCS6	MCS7	MCS8
CH 36	5180	16.66	CH 36	16.63	16.65	16.65	16.64	16.64	16.60	16.65	16.63
CH 44	5220	16.43									
CH 48	5240	16.47									
CH 52	5260	16.46	CH 52	16.38	16.45	16.45	16.37	16.39	16.45	16.41	16.38
CH 60	5300	16.37									
CH 64	5320	16.37									
CH 100	5500	16.64	CH 100	16.58	16.57	16.59	16.54	16.60	16.56	16.59	16.60
CH 116	5580	16.47									
CH 140	5700	15.36									
CH 144*	5720	16.60									

Note: The above Frequency and Channel in "*" were straddle channel.

802.11ac VHT40 mode												
Power vs. Channel			Power vs. Data Rate									
Channel	Frequency (MHz)	MCS Index	Channel	MCS Index								
		MCS0		MCS1	MCS2	MCS3	MCS4	MCS5	MCS6	MCS7	MCS8	MCS9
CH 38	5190	14.15	CH 46	15.84	15.88	15.82	15.85	15.83	15.80	15.84	15.87	15.82
CH 46	5230	15.89										
CH 54	5270	15.89	CH 54	15.82	15.88	15.81	15.86	15.85	15.82	15.86	15.87	15.87
CH 62	5310	13.90										
CH 102	5510	13.77	CH 110	15.92	15.93	15.97	15.95	15.95	15.94	15.94	15.93	15.97
CH 110	5550	15.98										
CH 134	5670	15.88										
CH 142*	5710	16.18										

Note: The above Frequency and Channel in "*" were straddle channel.



802.11ac VHT80 mode												
Power vs. Channel			Power vs. Data Rate									
Channel	Frequency (MHz)	MCS Index	Channel	MCS Index								
		MCS0		MCS1	MCS2	MCS3	MCS4	MCS5	MCS6	MCS7	MCS8	MCS9
CH 042	5210	14.42	CH 42	14.11	14.14	14.14	14.10	14.15	14.15	14.15	14.14	14.15
CH 058	5290	14.14	CH 58	14.06	14.04	14.02	14.10	14.05	13.94	14.05	14.04	13.95
CH 106	5530	13.12	CH 122	14.82	14.79	14.82	14.83	14.80	14.80	14.83	14.79	14.80
CH 122	5610	14.85										
CH 138*	5690	14.89										

Note: The above Frequency and Channel in "*" were straddle channel.

2.3 Test Mode

Final test mode of conducted test items and radiated spurious emissions are considering the modulation and worse data rates from the power table described in section 2.2.

Modulation	Data Rate
802.11a	6 Mbps
802.11n HT20	MCS0
802.11n HT40	MCS0
802.11ac VHT20	MCS0
802.11ac VHT40	MCS0
802.11ac VHT80	MCS0

Test Cases	
AC Conducted Emission	Mode 1 : GSM850 Idle + WLAN (5GHz) Link + Bluetooth Link + NFC active + Battery + Scanner + without Exoskeleton + Rugged Charge/USB cable + Adapter (SAWA-65-20005A (5V/2.5A)) + Headset Jumper (CBL-TC51-HDST25-01) + Earphone (HDST-25MM-PTVP-01)



Ch. #		Band I : 5150-5250 MHz	Band II : 5250-5350 MHz	Band III : 5470-5725MHz
		802.11a	802.11a	802.11a
L	Low	36	52	100
M	Middle	44	60	116
H	High	48	64	140
Straddle		-	-	144

Ch. #		Band I : 5150-5250 MHz	Band II : 5250-5350 MHz	Band III : 5470-5725MHz
		802.11n HT20	802.11n HT20	802.11n HT20
L	Low	36	52	100
M	Middle	44	60	116
H	High	48	64	140
Straddle		-	-	144

Ch. #		Band I : 5150-5250 MHz	Band II : 5250-5350 MHz	Band III : 5470-5725MHz
		802.11n HT40	802.11n HT40	802.11n HT40
L	Low	38	54	102
M	Middle	-	-	110
H	High	46	62	134
Straddle		-	-	142



Ch. #		Band I : 5150-5250 MHz	Band II : 5250-5350 MHz	Band III : 5470-5725MHz
		802.11ac VHT20	802.11ac VHT20	802.11ac VHT20
L	Low	36	52	100
M	Middle	44	60	116
H	High	48	64	140
Straddle		-	-	144

Ch. #		Band I : 5150-5250 MHz	Band II : 5250-5350 MHz	Band III : 5470-5725MHz
		802.11ac VHT40	802.11ac VHT40	802.11ac VHT40
L	Low	38	54	102
M	Middle	-	-	110
H	High	46	62	134
Straddle		-	-	142

Ch. #		Band I : 5150-5250 MHz	Band II : 5250-5350 MHz	Band III : 5470-5725MHz
		802.11ac VHT80	802.11ac VHT80	802.11ac VHT80
L	Low	-	-	106
M	Middle	42	58	122
H	High	-	-	-
Straddle		-	-	138

2.4 Connection Diagram of Test System

<Radiated Emission Mode>

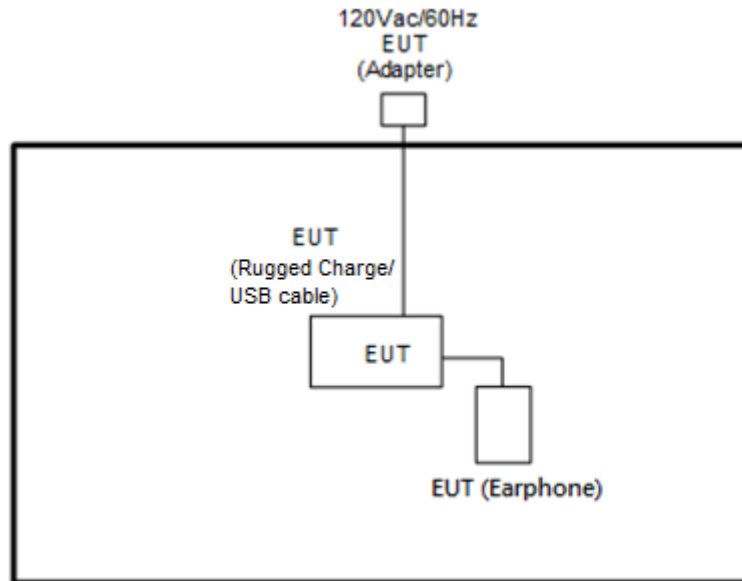

<AC Conducted Emission Mode>

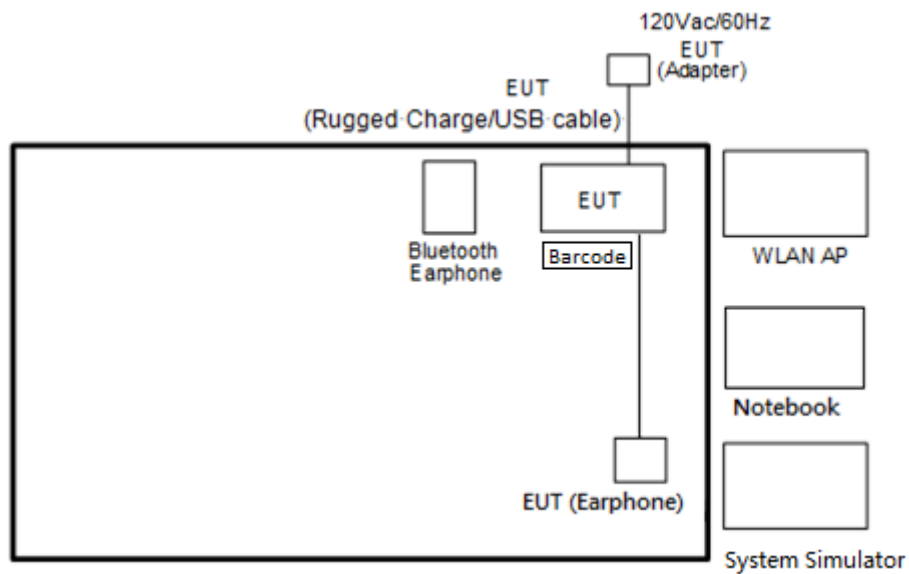



2.5 Support Unit used in test configuration and system

Item	Equipment	Trade Name	Model Name	FCC ID	Data Cable	Power Cord
1.	System Simulator	Anritsu	MT8820C	N/A	N/A	Unshielded, 1.8 m
2.	Bluetooth Earphone	Sony Ericsson	MW600	PY7DDA-2029	N/A	N/A
3.	WLAN AP	ASUS	RT-AC66U	MSQ-RTAC66U	N/A	Unshielded, 1.8 m
4.	Notebook	DELL	Latitude E6320	FCC DoC/ Contains FCC ID: QDS-BRCM1054	N/A	AC I/P: Unshielded, 1.2 m DC O/P: Shielded, 1.8 m
5.	SD Card	SanDisk	MicroSD HC	FCC DoC	N/A	N/A
6.	Barcode	N/A	N/A	N/A	N/A	N/A

2.6 EUT Operation Test Setup

For WLAN function, programmed RF utility, “ADB” installed in the notebook make the EUT provide functions like channel selection and power level for continuous transmitting and receiving signals.

2.7 Measurement Results Explanation Example

For all conducted test items:

The offset level is set in the spectrum analyzer to compensate the RF cable loss and attenuator factor between EUT conducted output port and spectrum analyzer. With the offset compensation, the spectrum analyzer reading level is exactly the EUT RF output level.

Example :

The spectrum analyzer offset is derived from RF cable loss and attenuator factor.

Offset = RF cable loss + attenuator factor.

Following shows an offset computation example with cable loss 4.2 dB and 10dB attenuator.

$$\begin{aligned} \text{Offset(dB)} &= \text{RF cable loss(dB)} + \text{attenuator factor(dB)}. \\ &= 4.2 + 10 = 14.2 \text{ (dB)} \end{aligned}$$

3 Test Result

3.1 26dB & 99% Occupied Bandwidth Measurement

3.1.1 Description of 26dB & 99% Occupied Bandwidth

This section is for reporting purpose only.

There is no restriction limits for bandwidth.

For Straddle Channel, U-NII procedures were applied for operations in the frequency band in accordance with FCC KDB 644545 D03.

3.1.2 Measuring Instruments

The measuring equipment is listed in the section 4 of this test report.

3.1.3 Test Procedures

1. The testing follows FCC KDB 789033 D02 General UNII Test Procedures New Rules v01r03. Section C) Emission bandwidth
2. Set RBW = approximately 1% of the emission bandwidth.
3. Set the VBW > RBW.
4. Detector = Peak.
5. Trace mode = max hold
6. Measure the maximum width of the emission that is 26 dB down from the peak of the emission. Compare this with the RBW setting of the analyzer. Readjust RBW and repeat measurement as needed until the RBW/EBW ratio is approximately 1%.
7. For 99% Bandwidth Measurement, the spectrum analyzer's resolution bandwidth (RBW) is set 1MHz and set the Video bandwidth (VBW) $\geq 3 * RBW$.
8. Measure and record the results in the test report.

3.1.4 Test Setup

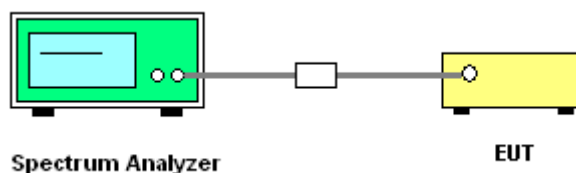



3.1.5 Test Result of 26dB & 99% Occupied Bandwidth Plots

Band I								
Mod.	Data Rate	NTX	CH.	Freq. (MHz)	99% Bandwidth (MHz)	26 dB Bandwidth (MHz)	IC 99% Bandwidth Power Limit (dBm)	IC 99% Bandwidth EIRP Limit (dBm)
11a	6Mbps	1	36	5180	18.40	22.80	-	22.65
11a	6Mbps	1	44	5220	18.60	23.10	-	22.70
11a	6Mbps	1	48	5240	17.25	20.70	-	22.37
VHT20	MCS0	1	36	5180	19.20	23.20	-	22.83
VHT20	MCS0	1	44	5220	19.15	23.00	-	22.82
VHT20	MCS0	1	48	5240	18.10	27.20	-	22.58
VHT40	MCS0	1	38	5190	36.70	41.58	-	23.01
VHT40	MCS0	1	46	5230	36.70	41.58	-	23.01
VHT80	MCS0	1	42	5210	75.96	82.24	-	23.01

Band II									
Mod.	Data Rate	NTX	CH.	Freq. (MHz)	99% Bandwidth (MHz)	26 dB Bandwidth (MHz)	IC 99% Bandwidth Power Limit (dBm)	IC 99% Bandwidth EIRP Limit (dBm)	FCC 26dB Bandwidth Power Limit (dBm)
11a	6M bps	1	52	5260	17.30	20.70	23.38	29.38	23.98
11a	6M bps	1	60	5300	18.25	23.20	23.61	29.61	23.98
11a	6M bps	1	64	5320	18.25	23.30	23.61	29.61	23.98
VHT20	MCS 0	1	52	5260	18.05	24.90	23.56	29.56	23.98
VHT20	MCS 0	1	60	5300	19.05	23.30	23.80	29.80	23.98
VHT20	MCS 0	1	64	5320	19.20	23.20	23.83	29.83	23.98
VHT40	MCS 0	1	54	5270	36.80	48.60	23.98	30.00	23.98
VHT40	MCS 0	1	62	5310	36.80	41.40	23.98	30.00	23.98
VHT80	MCS 0	1	58	5290	75.96	82.56	23.98	30.00	23.98



Band III									
Mod.	Data Rate	NTX	CH.	Freq. (MHz)	99% Bandwidth (MHz)	26 dB Bandwidth (MHz)	IC 99% Bandwidth Power Limit (dBm)	IC 99% Bandwidth EIRP Limit (dBm)	FCC 26dB Bandwidth Power Limit (dBm)
11a	6M bps	1	100	5500	18.40	27.10	23.65	29.65	23.98
11a	6M bps	1	116	5580	17.50	26.10	23.43	29.43	23.98
11a	6M bps	1	140	5700	18.45	23.20	23.66	29.66	23.98
VHT20	MCS 0	1	100	5500	19.10	24.10	23.81	29.81	23.98
VHT20	MCS 0	1	116	5580	18.10	27.90	23.58	29.58	23.98
VHT20	MCS 0	1	140	5700	19.20	23.20	23.83	29.83	23.98
VHT40	MCS 0	1	102	5510	36.70	41.40	23.98	30.00	23.98
VHT40	MCS 0	1	110	5550	36.90	52.20	23.98	30.00	23.98
VHT40	MCS 0	1	134	5670	36.90	65.52	23.98	30.00	23.98
VHT80	MCS 0	1	106	5530	75.84	81.60	23.98	30.00	23.98
VHT80	MCS 0	1	122	5610	75.84	82.56	23.98	30.00	23.98



Straddle Channel										
Mod.	Data Rate	NTX	CH.	Freq. (MHz)	99% Bandwidth (MHz)	26dB Emission Bandwidth (MHz)	IC 99% Bandwidth Power Limit (dBm)	IC 99% Bandwidth EIRP Limit (dBm)	FCC 26dB Bandwidth Power Limit (dBm)	6dB Emission Bandwidth (MHz)
11a	6Mbps	1	144	5720	18.65	38.06	-	-	-	16.28
				NII-2C	14.35	22.95	22.57	28.57	23.98	12.94
				NII-3	4.3	15.11	30.00	36.02	-	3.34
VHT20	MCS0	1	144	5720	19.10	30.80	-	-	-	17.56
				NII-2C	14.55	16.65	22.63	28.63	23.21	13.74
				NII-3	4.55	14.15	30.00	36.02	-	3.82
VHT40	MCS0	1	142	5710	37.00	83.88	-	-	-	36.32
				NII-2C	33.6	55.32	23.98	30.00	23.98	33.12
				NII-3	3.4	28.56	30.00	36.02	-	3.2
VHT80	MCS0	1	138	5690	75.96	87.68	-	-	-	76.32
				NII-2C	73.04	78.2	23.98	30.00	23.98	73.16
				NII-3	2.92	9.48	30.00	36.02	-	3.16

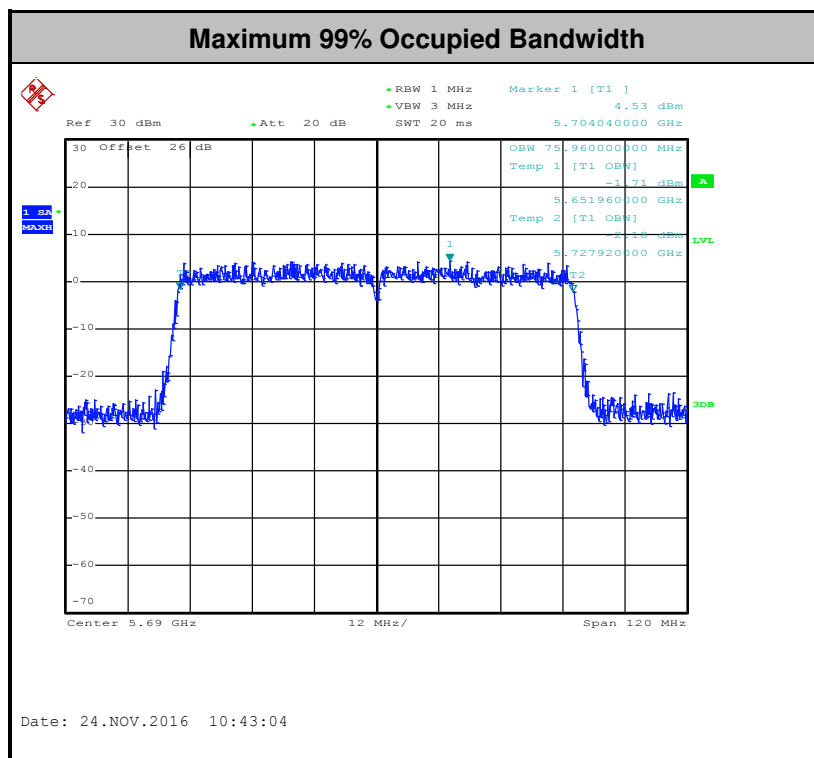
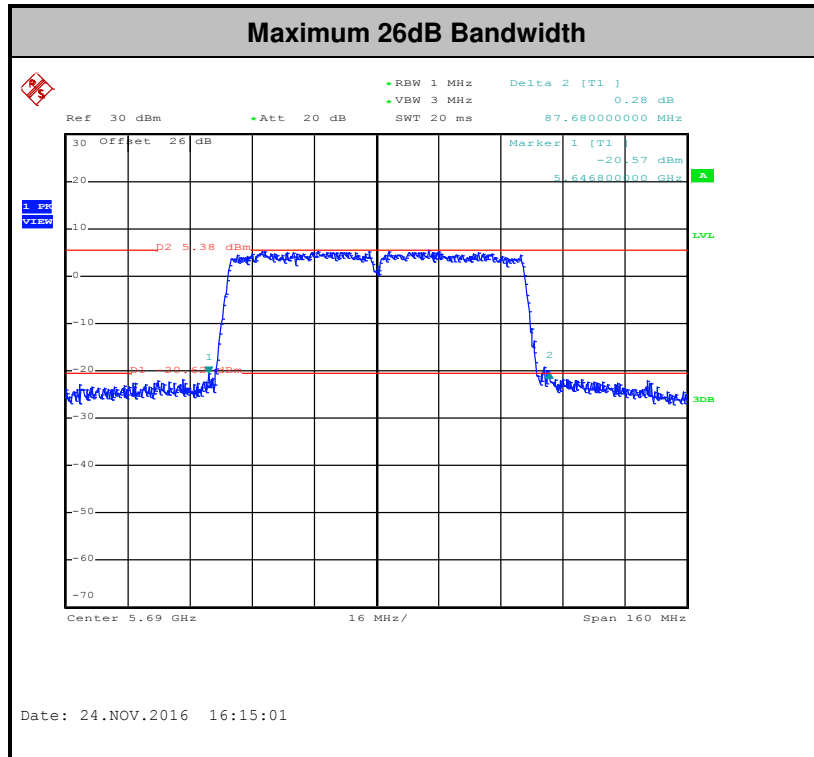

Note: The occupied channel bandwidth is maintained within the band of operation for all of the modulations.



3.2 Maximum Conducted Output Power Measurement

3.2.1 Limit of Maximum Conducted Output Power

For mobile and portable client devices in the 5.15–5.25 GHz band, the maximum conducted output power over the frequency band of operation shall not exceed 250 mW.

For the 5.25–5.725 GHz bands, the maximum conducted output power over the frequency bands of operation shall not exceed the lesser of 250 mW or $11 \text{ dBm} + 10 \log B$, where B is the 26 dB emission bandwidth in megahertz.

For Straddle Channel, U-NII procedures and limits were applied for operations in the frequency band in accordance with FCC KDB 644545 D03.

If transmitting antennas of directional gain greater than 6 dBi are used, the peak output power shall be reduced by the amount in dB that the directional gain of the antenna exceeds 6 dBi.

Note that U-NII-2 band, devices with a maximum e.i.r.p. greater than 500 mW shall implement TPC in order to have the capability to operate at least 6 dB below the maximum permitted e.i.r.p. of 1 W.

3.2.2 Measuring Instruments

The measuring equipment is listed in the section 4 of this test report.

3.2.3 Test Procedures

The testing follows Method PM of FCC KDB 789033 D02 General UNII Test Procedures New Rules v01r03.

Method PM (Measurement using an RF average power meter):

1. Measurement is performed using a wideband RF power meter.
2. The EUT is configured to transmit continuously with a consistent duty cycle at its maximum power control level.
3. Measure the average power of the transmitter, and the average power is corrected with duty factor, $10 \log(1/x)$, where x is the duty cycle.

For straddle channel, the testing follows Method SA-3 (RMS detection with max hold) of FCC KDB 789033 D02 General UNII Test Procedures New Rules v01r03.

Compute power by integrating the spectrum across the 99% occupied bandwidth of the signal using the instrument's band power measurement function.

3.2.4 Test Setup

For normal channel:

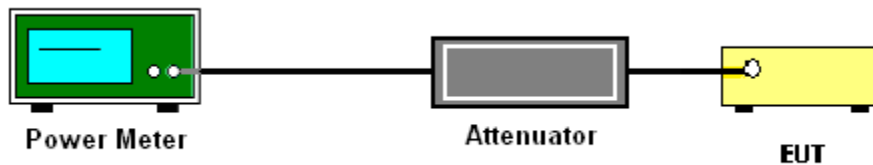

For straddle channel:

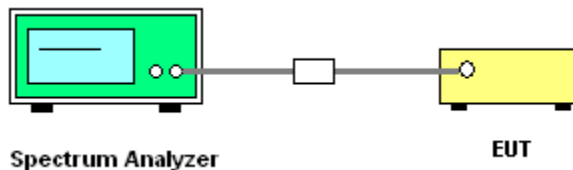



3.2.5 Test Result of Maximum Conducted Output Power

FCC Band I									
Mod.	Data Rate	NTX	CH.	Freq. (MHz)	Duty Factor (dB)	Average Conducted Power (dBm)	FCC Conducted Power Limit (dBm)	DG (dBi)	Pass/Fail
11a	6Mbps	1	36	5180	0.29	16.59	24.00	2.20	Pass
11a	6Mbps	1	44	5220	0.29	16.41	24.00	2.20	Pass
11a	6Mbps	1	48	5240	0.29	16.58	24.00	2.20	Pass
HT20	MCS0	1	36	5180	0.34	16.65	24.00	2.20	Pass
HT20	MCS0	1	44	5220	0.34	16.41	24.00	2.20	Pass
HT20	MCS0	1	48	5240	0.34	16.45	24.00	2.20	Pass
HT40	MCS0	1	38	5190	0.14	14.06	24.00	2.20	Pass
HT40	MCS0	1	46	5230	0.14	15.86	24.00	2.20	Pass
VHT20	MCS0	1	36	5180	0.34	16.66	24.00	2.20	Pass
VHT20	MCS0	1	44	5220	0.34	16.43	24.00	2.20	Pass
VHT20	MCS0	1	48	5240	0.34	16.47	24.00	2.20	Pass
VHT40	MCS0	1	38	5190	0.14	14.15	24.00	2.20	Pass
VHT40	MCS0	1	46	5230	0.14	15.89	24.00	2.20	Pass
VHT80	MCS0	1	42	5210	0.18	14.42	24.00	2.20	Pass



FCC Band II										
Mod.	Data Rate	N _{TX}	CH.	Freq. (MHz)	Duty Factor (dB)	Average Conducted Power (dBm)	FCC Conducted Power Limit (dBm)	DG (dBi)	EIRP Power Limit (dBm)	Pass/Fail
11a	6M bps	1	52	5260	0.29	16.50	23.98	2.60	26.99	Pass
11a	6M bps	1	60	5300	0.29	16.34	23.98	2.60	26.99	Pass
11a	6M bps	1	64	5320	0.29	16.33	23.98	2.60	26.99	Pass
HT20	MCS 0	1	52	5260	0.34	16.44	23.98	2.60	26.99	Pass
HT20	MCS 0	1	60	5300	0.34	16.34	23.98	2.60	26.99	Pass
HT20	MCS 0	1	64	5320	0.34	16.30	23.98	2.60	26.99	Pass
HT40	MCS 0	1	54	5270	0.14	15.88	23.98	2.60	26.99	Pass
HT40	MCS 0	1	62	5310	0.14	13.86	23.98	2.60	26.99	Pass
VHT20	MCS 0	1	52	5260	0.34	16.46	23.98	2.60	26.99	Pass
VHT20	MCS 0	1	60	5300	0.34	16.37	23.98	2.60	26.99	Pass
VHT20	MCS 0	1	64	5320	0.34	16.37	23.98	2.60	26.99	Pass
VHT40	MCS 0	1	54	5270	0.14	15.89	23.98	2.60	26.99	Pass
VHT40	MCS 0	1	62	5310	0.14	13.90	23.98	2.60	26.99	Pass
VHT80	MCS 0	1	58	5290	0.18	14.14	23.98	2.60	26.99	Pass



FCC Band III										
Mod.	Data Rate	N _{TX}	CH.	Freq. (MHz)	Duty Factor (dB)	Average Conducted Power (dBm)	FCC Conducted Power Limit (dBm)	DG (dBi)	EIRP Power Limit (dBm)	Pass/Fail
11a	6M bps	1	100	5500	0.29	16.64	23.98	2.60	26.99	Pass
11a	6M bps	1	116	5580	0.29	16.57	23.98	2.60	26.99	Pass
11a	6M bps	1	140	5700	0.29	15.74	23.98	2.60	26.99	Pass
HT20	MCS 0	1	100	5500	0.34	16.62	23.98	2.60	26.99	Pass
HT20	MCS 0	1	116	5580	0.34	16.44	23.98	2.60	26.99	Pass
HT20	MCS 0	1	140	5700	0.34	15.32	23.98	2.60	26.99	Pass
HT40	MCS 0	1	102	5510	0.14	13.75	23.98	2.60	26.99	Pass
HT40	MCS 0	1	110	5550	0.14	15.96	23.98	2.60	26.99	Pass
HT40	MCS 0	1	134	5670	0.14	15.87	23.98	2.60	26.99	Pass
VHT20	MCS 0	1	100	5500	0.34	16.64	23.98	2.60	26.99	Pass
VHT20	MCS 0	1	116	5580	0.34	16.47	23.98	2.60	26.99	Pass
VHT20	MCS 0	1	140	5700	0.34	15.36	23.98	2.60	26.99	Pass
VHT40	MCS 0	1	102	5510	0.14	13.77	23.98	2.60	26.99	Pass
VHT40	MCS 0	1	110	5550	0.14	15.98	23.98	2.60	26.99	Pass
VHT40	MCS 0	1	134	5670	0.14	15.88	23.98	2.60	26.99	Pass
VHT80	MCS 0	1	106	5530	0.18	13.12	23.98	2.60	26.99	Pass
VHT80	MCS 0	1	122	5610	0.18	14.85	23.98	2.60	26.99	Pass



FCC Straddle Channel									
Mod.	Data Rate	NTX	CH.	Freq. (MHz)	Duty Factor (dB)	Average Conducted Power (dBm)	FCC Conducted Power Limit (dBm)	DG (dBi)	Pass/Fail
11a	6Mbps	1	144	5720	0.29	16.50	-	2.60	Pass
				NII-2C	0.29	15.42	23.98	2.60	Pass
				NII-3	0.29	9.91	30.00	2.60	Pass
HT20	MCS0	1	144	5720	0.34	16.59	-	2.60	Pass
				NII-2C	0.34	15.54	23.98	2.60	Pass
				NII-3	0.34	9.89	30.00	2.60	Pass
HT40	MCS0	1	142	5710	0.14	16.15	-	2.60	Pass
				NII-2C	0.14	15.77	23.98	2.60	Pass
				NII-3	0.14	5.33	30.00	2.60	Pass
VHT20	MCS0	1	144	5720	0.34	16.60	-	2.60	Pass
				NII-2C	0.34	15.61	23.21	2.60	Pass
				NII-3	0.34	9.70	30.00	2.60	Pass
VHT40	MCS0	1	142	5710	0.14	16.18	-	2.60	Pass
				NII-2C	0.14	15.80	23.98	2.60	Pass
				NII-3	0.14	5.39	30.00	2.60	Pass
VHT80	MCS0	1	138	5690	0.18	14.89	-	2.60	Pass
				NII-2C	0.18	14.75	23.98	2.60	Pass
				NII-3	0.18	-0.06	30.00	2.60	Pass

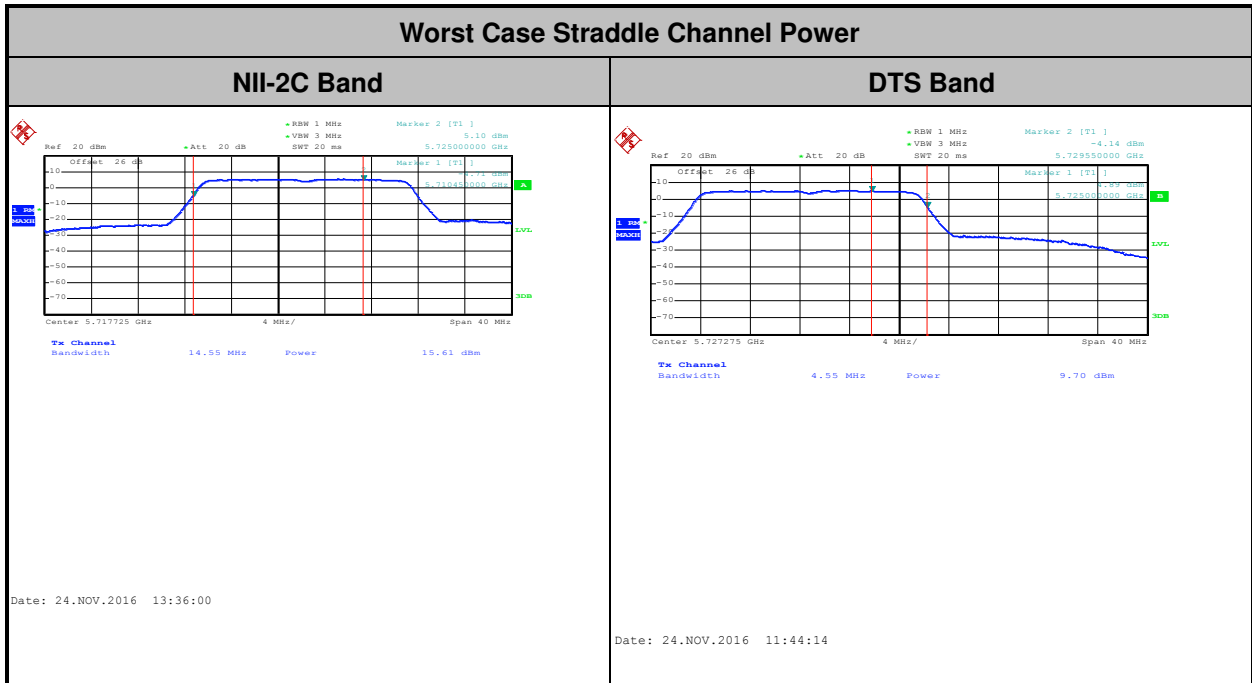



3.3 Power Spectral Density Measurement

3.3.1 Limit of Power Spectral Density

For mobile and portable client devices in the 5.15–5.25 GHz band, the maximum power spectral density shall not exceed 11dBm in any 1 megahertz band.

For the 5.25–5.725 GHz bands, the maximum power spectral density shall not exceed 11 dBm in any 1 megahertz band.

For Straddle Channel, U-NII procedures and limits were applied for operations in the frequency band in accordance with FCC KDB 644545 D03.

If transmitting antennas of directional gain greater than 6 dBi are used, the peak output power shall be reduced by the amount in dB that the directional gain of the antenna exceeds 6 dBi.

3.3.2 Measuring Instruments

The measuring equipment is listed in the section 4 of this test report.

3.3.3 Test Procedures

The testing follows FCC KDB 789033 D02 General UNII Test Procedures New Rules v01r03.
Section F) Maximum power spectral density.

Method SA-2

(trace averaging across on and off times of the EUT transmissions, followed by duty cycle correction).

1. The testing follows Method SA-2 of FCC KDB 789033 D02 General UNII Test Procedures New Rules v01r03.
 - Measure the duty cycle.
 - Set span to encompass the entire emission bandwidth (EBW) of the signal.
 - Set RBW = 1 MHz.
 - Set VBW \geq 3 MHz.
 - Number of points in sweep \geq 2 Span / RBW.
 - Sweep time = auto.
 - Detector = RMS
 - Trace average at least 100 traces in power averaging mode.
 - Add $10 \log(1/x)$, where x is the duty cycle, to the measured power in order to compute the average power during the actual transmission times. For example, add $10 \log(1/0.25) = 6$ dB if the duty cycle is 25 percent.
2. The RF output of EUT was connected to the spectrum analyzer by a low loss cable.
3. Each plot has already offset with cable loss, and attenuator loss. Measure the PPSD and record it.

3.3.4 Test Setup

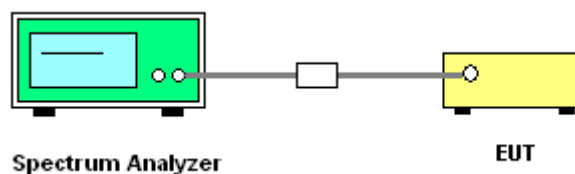



3.3.5 Test Result of Power Spectral Density

FCC Band I									
Mod.	Data Rate	NTX	CH.	Freq. (MHz)	Duty Factor (dB)	Average Power Density (dBm/MHz)	Average PSD Limit (dBm/MHz)	DG (dBi)	Pass/Fail
11a	6Mbps	1	36	5180	0.29	4.55	11.00	2.20	Pass
11a	6Mbps	1	44	5220	0.29	4.68	11.00	2.20	Pass
11a	6Mbps	1	48	5240	0.29	4.94	11.00	2.20	Pass
VHT20	MCS0	1	36	5180	0.34	4.30	11.00	2.20	Pass
VHT20	MCS0	1	44	5220	0.34	4.59	11.00	2.20	Pass
VHT20	MCS0	1	48	5240	0.34	4.76	11.00	2.20	Pass
VHT40	MCS0	1	38	5190	0.14	-0.88	11.00	2.20	Pass
VHT40	MCS0	1	46	5230	0.14	1.16	11.00	2.20	Pass
VHT80	MCS0	1	42	5210	0.18	-3.59	11.00	2.20	Pass

Band II									
Mod.	Data Rate	NTX	CH.	Freq. (MHz)	Duty Factor (dB)	Average Power Density (dBm/MHz)	Average PSD Limit (dBm/MHz)	DG (dBi)	Pass/Fail
11a	6M bps	1	52	5260	0.29	5.08	11.00	2.60	Pass
11a	6M bps	1	60	5300	0.29	4.64	11.00	2.60	Pass
11a	6M bps	1	64	5320	0.29	4.85	11.00	2.60	Pass
VHT20	MCS 0	1	52	5260	0.34	4.82	11.00	2.60	Pass
VHT20	MCS 0	1	60	5300	0.34	4.29	11.00	2.60	Pass
VHT20	MCS 0	1	64	5320	0.34	2.77	11.00	2.60	Pass
VHT40	MCS 0	1	54	5270	0.14	0.94	11.00	2.60	Pass
VHT40	MCS 0	1	62	5310	0.14	-0.55	11.00	2.60	Pass
VHT80	MCS 0	1	58	5290	0.18	-3.12	11.00	2.60	Pass



Band III									
Mod.	Data Rate	NTX	CH.	Freq. (MHz)	Duty Factor (dB)	Average Power Density (dBm/MHz)	Average PSD Limit (dBm/MHz)	DG (dBi)	Pass/Fail
11a	6M bps	1	100	5500	0.29	5.77	11.00	2.60	Pass
11a	6M bps	1	116	5580	0.29	5.87	11.00	2.60	Pass
11a	6M bps	1	140	5700	0.29	3.81	11.00	2.60	Pass
VHT20	MCS 0	1	100	5500	0.34	5.50	11.00	2.60	Pass
VHT20	MCS 0	1	116	5580	0.34	5.50	11.00	2.60	Pass
VHT20	MCS 0	1	140	5700	0.34	3.25	11.00	2.60	Pass
VHT40	MCS 0	1	102	5510	0.14	-0.29	11.00	2.60	Pass
VHT40	MCS 0	1	110	5550	0.14	1.97	11.00	2.60	Pass
VHT40	MCS 0	1	134	5670	0.14	0.56	11.00	2.60	Pass
VHT80	MCS 0	1	106	5530	0.18	-3.90	11.00	2.60	Pass
VHT80	MCS 0	1	122	5610	0.18	-2.38	11.00	2.60	Pass

Straddle Channel									
Mod.	Data Rate	NTX	CH.	Freq. (MHz)	Duty Factor (dB)	Average Power Density (dBm/MHz)	Average PSD Limit (dBm/MHz)	DG (dBi)	Pass/Fail
11a	6Mbps	1	144	NII-2C	0.29	4.47	11.00	2.60	Pass
				NII-3	0.29	4.47	30.00	2.60	Pass
VHT20	MCS0	1	144	NII-2C	0.34	4.18	11.00	2.60	Pass
				NII-3	0.34	4.18	30.00	2.60	Pass
VHT40	MCS0	1	142	NII-2C	0.14	0.89	11.00	2.60	Pass
				NII-3	0.14	0.89	30.00	2.60	Pass
VHT80	MCS0	1	138	NII-2C	0.18	-3.34	11.00	2.60	Pass
				NII-3	0.18	-3.34	30.00	2.60	Pass

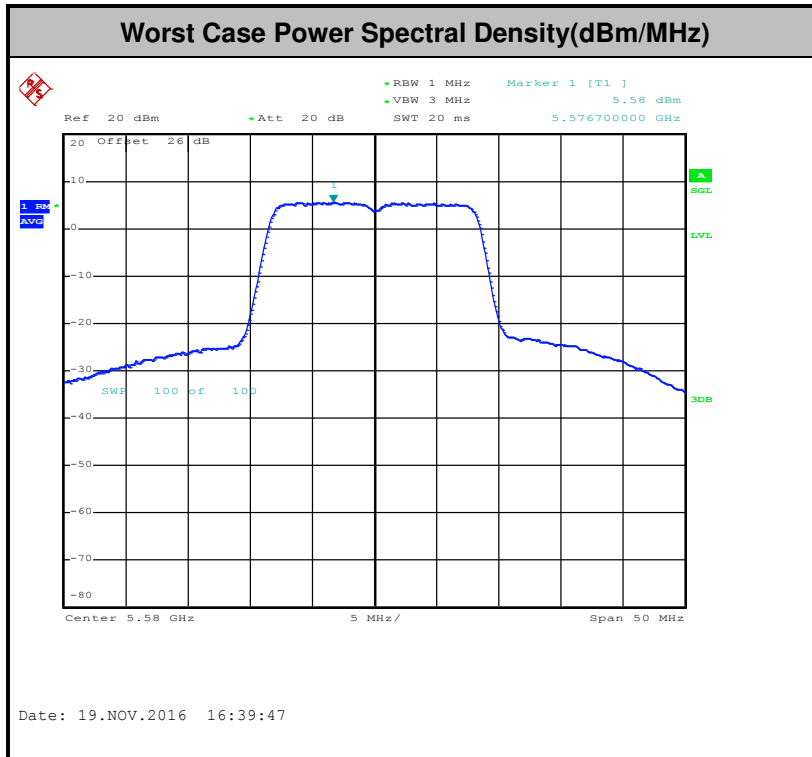

Note: Average Power Density (dB) = Measured value+ Duty Factor



3.4 Unwanted Radiated Emission Measurement

This section as specified in FCC Part 15.407(b) is to measure unwanted emissions through radiated measurement for band edge spurious emissions and out of band emissions measurement. The unwanted emissions shall comply with 15.407(b)(1) to (6), and restricted bands per FCC Part15.205.

3.4.1 Limit of Unwanted Emissions

- (1) For transmitters operating in the 5150-5250 MHz band: all emissions outside of the 5150-5350 MHz band shall not exceed an EIRP of -27dBm/MHz.

For transmitters operating in the 5250-5350 MHz band: all emissions outside of the 5150-5350 MHz band shall not exceed an EIRP of -27 dBm/MHz. Devices operating in the 5250-5350 MHz band that generate emissions in the 5150-5250 MHz band must meet all applicable technical requirements for operation in the 5150-5250 MHz band (including indoor use) or alternatively meet an out-of-band emission EIRP limit of -27 dBm/MHz in the 5150-5250 MHz band.

For transmitters operating in the 5470-5725MHz band: all emissions outside of the 5470-5725MHz band shall not exceed an EIRP of -27 dBm/MHz.

- (2) Unwanted spurious emissions fallen in restricted bands per FCC Part15.205 shall comply with the general field strength limits set forth in § 15.209 as below table,

Frequency (MHz)	Field Strength (microvolts/meter)	Measurement Distance (meters)
0.009 – 0.490	2400/F(kHz)	300
0.490 – 1.705	24000/F(kHz)	30
1.705 – 30.0	30	30
30 – 88	100	3
88 – 216	150	3
216 - 960	200	3
Above 960	500	3

Note: The following formula is used to convert the EIRP to field strength.

$$E = \frac{1000000\sqrt{30P}}{3} \text{ } \mu\text{V/m, where P is the eirp (Watts)}$$

EIRP (dBm)	Field Strength at 3m (dBμV/m)
-17	78.3
- 27	68.3



- (3) KDB789033 D02 v01r03 G)2)c) As specified in 15.407(b), emissions above 1000 MHz that are outside of the restricted bands are subject to a peak emission limit of -27 dBm/MHz (or -17 dBm/MHz as specified in 15.407(b)(4)). However, an out-of-band emission that complies with both the average and peak limits of 15.209 is not required to satisfy the -27 dBm/MHz or -17 dBm/MHz peak emission limit.

3.4.2 Measuring Instruments

The measuring equipment is listed in the section 4 of this test report.

3.4.3 Test Procedures

1. The testing follows FCC KDB 789033 D02 General UNII Test Procedures New Rules v01r03. Section G) Unwanted emissions measurement.
 - (1) Procedure for Unwanted Emissions Measurements Below 1000MHz
 - RBW = 120 kHz
 - VBW = 300 kHz
 - Detector = Peak
 - Trace mode = max hold
 - (2) Procedure for Peak Unwanted Emissions Measurements Above 1000 MHz
 - RBW = 1 MHz
 - VBW \geq 3 MHz
 - Detector = Peak
 - Sweep time = auto
 - Trace mode = max hold
 - (3) Procedures for Average Unwanted Emissions Measurements Above 1000MHz
 - RBW = 1 MHz
 - VBW = 10 Hz, when duty cycle is no less than 98 percent.
 - VBW \geq 1/T, when duty cycle is less than 98 percent where T is the minimum transmission duration over which the transmitter is on and is transmitting at its maximum power control level for the tested mode of operation.



2. The EUT was placed on a turntable with 0.8 meter for frequency below 1GHz and 1.5 meter for frequency above 1GHz respectively above ground.
3. The EUT was set 3 meters from the interference receiving antenna which was mounted on the top of a variable height antenna tower.
4. The antenna is a broadband antenna and its height is adjusted between one meter and four meters above ground to find the maximum value of the field strength for both horizontal polarization and vertical polarization of the antenna.
5. For each suspected emission, the EUT was arranged to its worst case and then adjust the antenna tower (from 1 m to 4 m) and turntable (from 0 degree to 360 degrees) to find the maximum reading.
6. For testing below 1GHz, if the emission level of the EUT in peak mode was 3 dB lower than the limit specified, then peak values of EUT will be reported, otherwise, the emissions will be repeated one by one using the CISPR quasi-peak method and reported.
7. For testing above 1GHz, the emission level of the EUT in peak mode was 20dB lower than average limit (that means the emission level in average mode also complies with the limit in average mode), then peak values of EUT will be reported, otherwise, the emissions will be measured in average mode again and reported.

3.4.4 Test Setup

For radiated emissions below 30MHz

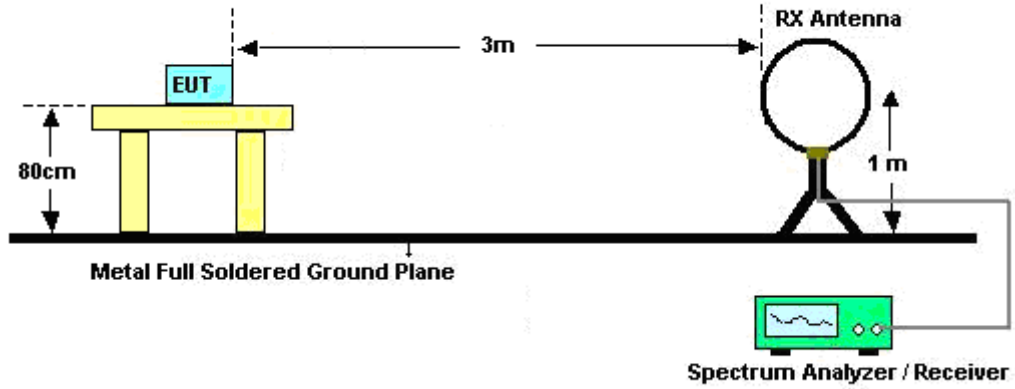

For radiated emissions from 30MHz to 1GHz

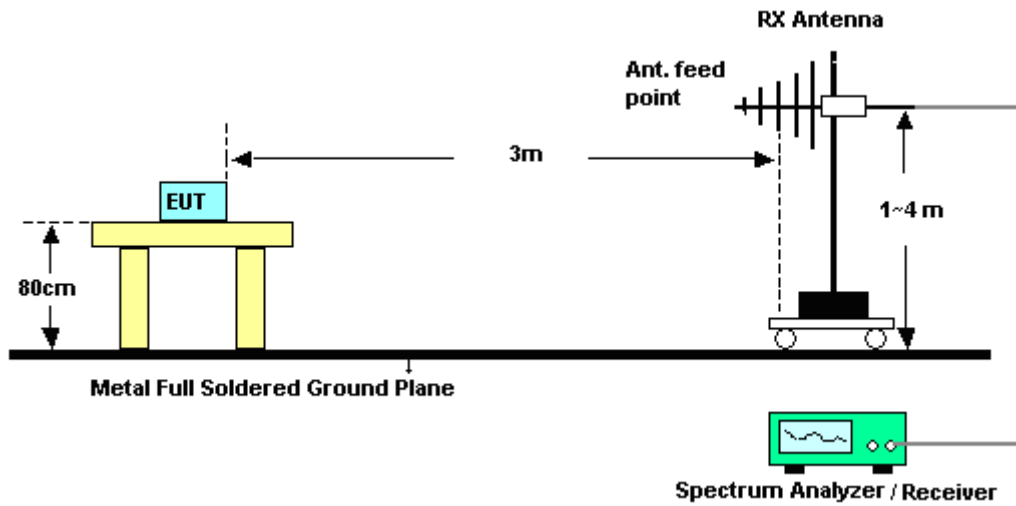

For radiated emissions above 1GHz

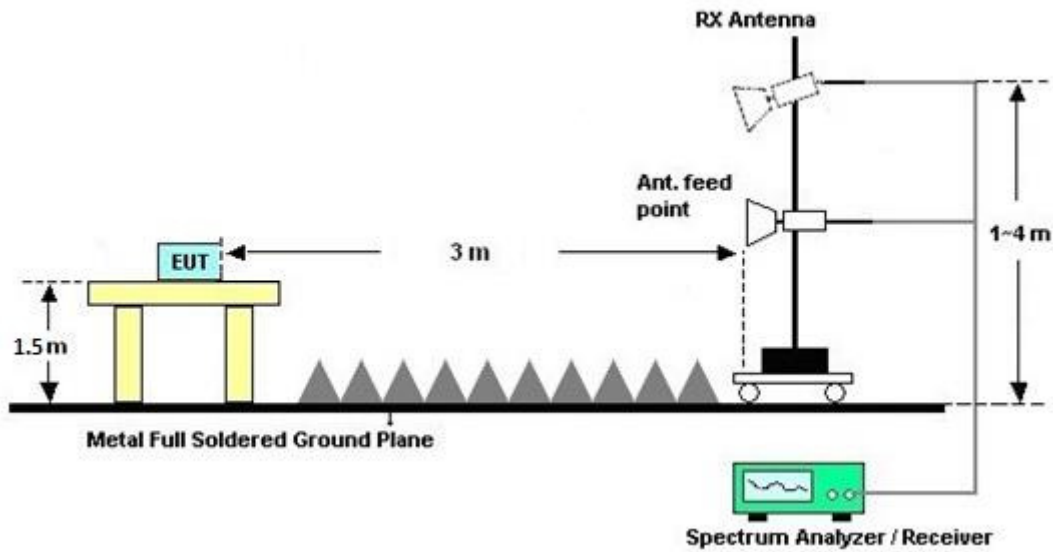

3.4.5 Test Results of Radiated Spurious Emissions (9 kHz ~ 30 MHz)

The low frequency, which started from 9 kHz to 30MHz, was pre-scanned and the result which was 20dB lower than the limit line per 15.31(o) was not reported.

3.4.6 Test Result of Radiated Spurious at Band Edges

Please refer to Appendix A and B.

3.4.7 Duty Cycle

Please refer to Appendix C.

3.4.8 Test Result of Radiated Spurious Emission (30MHz ~ 10th Harmonic)

Please refer to Appendix A and B.



3.5 AC Conducted Emission Measurement

3.5.1 Limit of AC Conducted Emission

For equipment that is designed to be connected to the public utility (AC) power line, the radio frequency voltage that is conducted back onto the AC power line on any frequency or frequencies within the band 150 kHz to 30 MHz shall not exceed the limits in the following table.

Frequency of emission (MHz)	Conducted limit (dB μ V)	
	Quasi-peak	Average
0.15-0.5	66 to 56*	56 to 46*
0.5-5	56	46
5-30	60	50

*Decreases with the logarithm of the frequency.

3.5.2 Measuring Instruments

The measuring equipment is listed in the section 4 of this test report.

3.5.3 Test Procedures

1. The EUT was placed 0.4 meter from the conducting wall of the shielding room was kept at least 80 centimeters from any other grounded conducting surface.
2. Connect EUT to the power mains through a line impedance stabilization network (LISN).
3. All the support units are connecting to the other LISN.
4. The LISN provides 50 ohm coupling impedance for the measuring instrument.
5. The FCC states that a 50 ohm, 50 microhenry LISN should be used.
6. Both sides of AC line were checked for maximum conducted interference.
7. The frequency range from 150 kHz to 30 MHz was searched.
8. Set the test-receiver system to Peak Detect Function and specified bandwidth with Maximum Hold Mode.

3.5.4 Test Setup

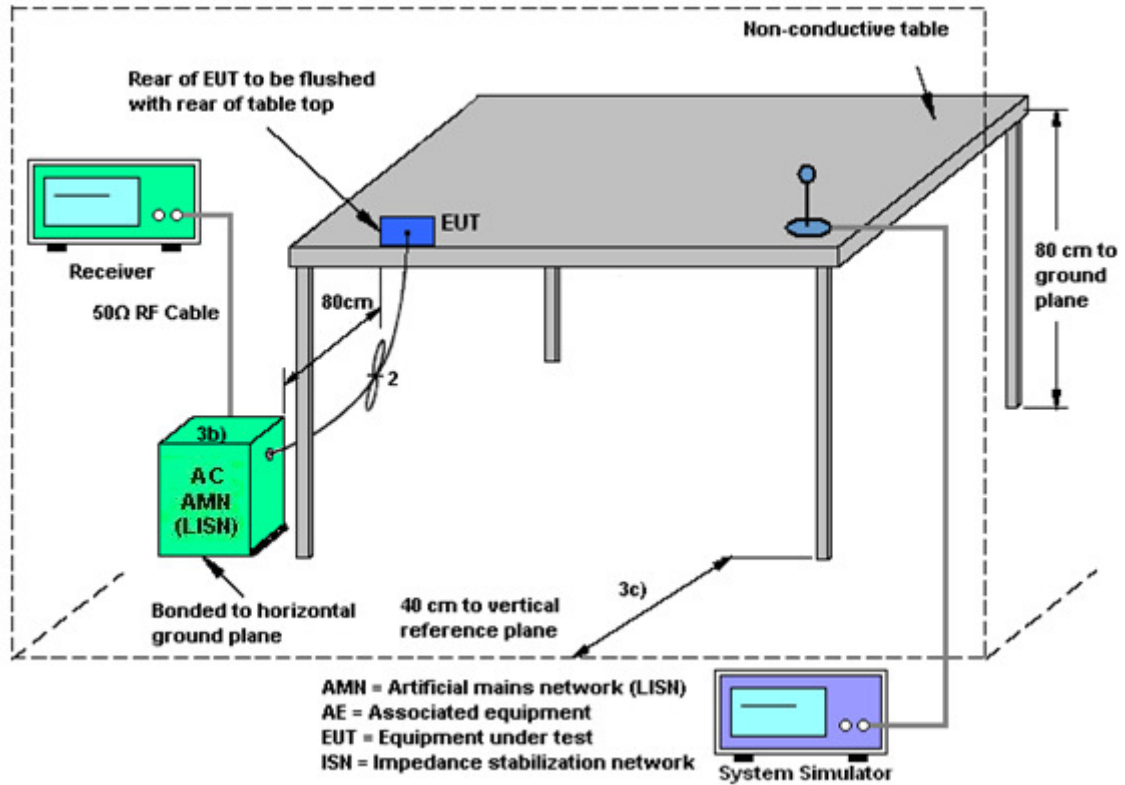



3.5.5 Test Result of AC Conducted Emission

Test Mode :	Mode 1	Temperature :	23~24°C
Test Engineer :	Arthur Hsieh	Relative Humidity :	51~52%
Test Voltage :	120Vac / 60Hz	Phase :	Line
Function Type :	GSM850 Idle + WLAN (5GHz) Link + Bluetooth Link + NFC active + Battery + Scanner + without Exoskeleton + Rugged Charge/USB cable + Adapter (SAWA-65-20005A (5V/2.5A)) + Headset Jumper (CBL-TC51-HDST25-01) + Earphone (HDST-25MM-PTVP-01)		

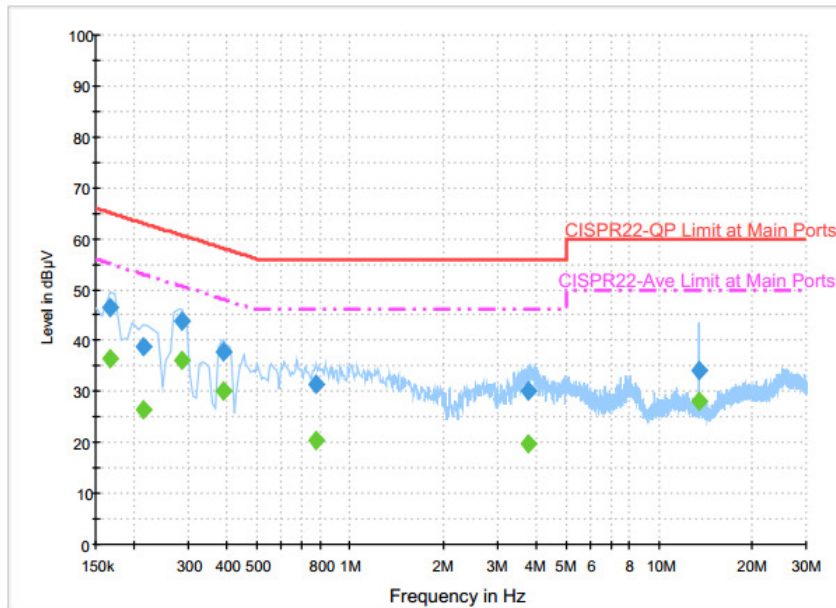

Final Result : QuasiPeak

Frequency (MHz)	QuasiPeak (dBµV)	Filter	Line	Corr. (dB)	Margin (dB)	Limit (dBµV)
0.166000	46.5	Off	L1	19.6	18.7	65.2
0.214000	38.8	Off	L1	19.6	24.2	63.0
0.286000	43.9	Off	L1	19.6	16.7	60.6
0.390000	37.9	Off	L1	19.6	20.2	58.1
0.774000	31.5	Off	L1	19.6	24.5	56.0
3.782000	30.1	Off	L1	19.8	25.9	56.0
13.558000	34.1	Off	L1	20.3	25.9	60.0

Final Result : Average

Frequency (MHz)	Average (dBµV)	Filter	Line	Corr. (dB)	Margin (dB)	Limit (dBµV)
0.166000	36.5	Off	L1	19.6	18.7	55.2
0.214000	26.5	Off	L1	19.6	26.5	53.0
0.286000	36.1	Off	L1	19.6	14.5	50.6
0.390000	30.2	Off	L1	19.6	17.9	48.1
0.774000	20.5	Off	L1	19.6	25.5	46.0
3.782000	19.7	Off	L1	19.8	26.3	46.0
13.558000	28.0	Off	L1	20.3	22.0	50.0



Test Mode :	Mode 1	Temperature :	23~24°C
Test Engineer :	Arthur Hsieh	Relative Humidity :	51~52%
Test Voltage :	120Vac / 60Hz	Phase :	Neutral
Function Type :	GSM850 Idle + WLAN (5GHz) Link + Bluetooth Link + NFC active + Battery + Scanner + without Exoskeleton + Rugged Charge/USB cable + Adapter (SAWA-65-20005A (5V/2.5A)) + Headset Jumper (CBL-TC51-HDST25-01) + Earphone (HDST-25MM-PTVP-01)		

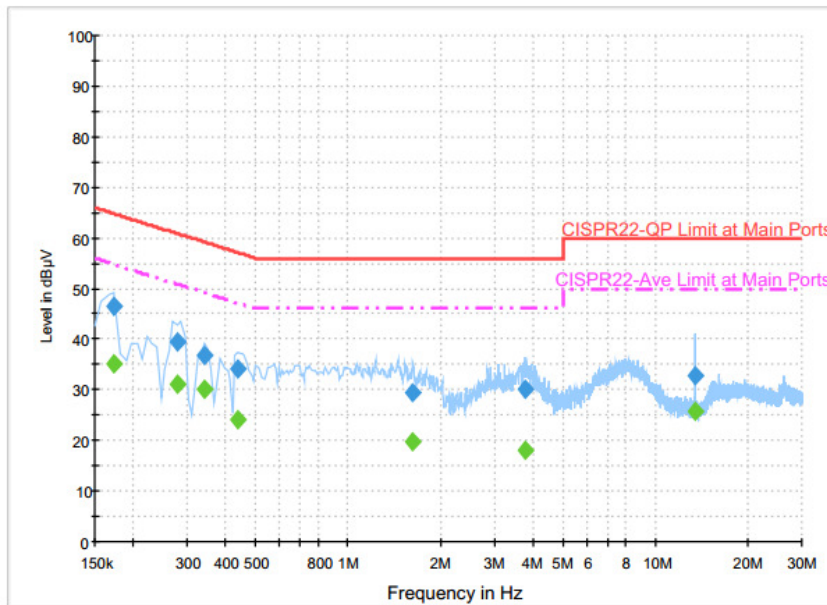

Final Result : QuasiPeak

Frequency (MHz)	QuasiPeak (dBµV)	Filter	Line	Corr. (dB)	Margin (dB)	Limit (dBµV)
0.174000	46.4	Off	N	19.6	18.4	64.8
0.278000	39.4	Off	N	19.6	21.5	60.9
0.342000	37.0	Off	N	19.6	22.2	59.2
0.438000	34.2	Off	N	19.6	22.9	57.1
1.630000	29.5	Off	N	19.7	26.5	56.0
3.774000	30.0	Off	N	19.7	26.0	56.0
13.558000	32.8	Off	N	20.4	27.2	60.0

Final Result : Average

Frequency (MHz)	Average (dBµV)	Filter	Line	Corr. (dB)	Margin (dB)	Limit (dBµV)
0.174000	35.2	Off	N	19.6	19.6	54.8
0.278000	31.1	Off	N	19.6	19.8	50.9
0.342000	30.1	Off	N	19.6	19.1	49.2
0.438000	24.1	Off	N	19.6	23.0	47.1
1.630000	19.8	Off	N	19.7	26.2	46.0
3.774000	17.9	Off	N	19.7	28.1	46.0
13.558000	25.9	Off	N	20.4	24.1	50.0

3.6 Frequency Stability Measurement

3.6.1 Limit of Frequency Stability

Manufacturers of U-NII devices are responsible for ensuring frequency stability such that an emission is maintained within the band of operation under all conditions of normal operation as specified in the user's manual.

3.6.2 Measuring Instruments

The measuring equipment is listed in the section 4 of this test report.

3.6.3 Test Procedures

1. To ensure emission at the band edge is maintained within the authorized band, those values shall be measured by radiation emissions at upper and lower frequency points, and finally compensated by frequency deviation as procedures below.
2. The EUT was operated at the maximum output power, and connected to the spectrum analyzer, which is set to maximum hold function and peak detector. The peak value of the power envelope was measured and noted. The upper and lower frequency points were respectively measured relatively 10dB lower than the measured peak value.
3. The frequency deviation was calculated by adding the upper frequency point and the lower frequency point divided by two. Those detailed values of frequency deviation are provided in table below.

3.6.4 Test Setup

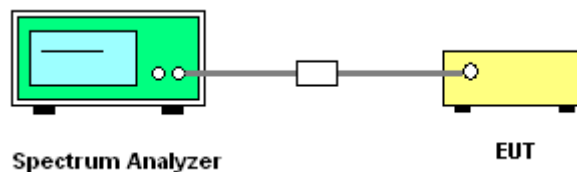



3.6.5 Test Result of Frequency Stability

Band I									
Mod.	Data Rate	NTX	CH.	Freq. (MHz)	Center Frequency (MHz)	Frequency Deviation (MHz)	Frequency Stability (ppm)	Temperature (°C)	Voltage (V)
11a	6Mbps	1	36	5180	5180.050	0.050	9.65	50	3.6
11a	6Mbps	1	36	5180	5180.050	0.050	9.65	-30	3.6
11a	6Mbps	1	36	5180	5180.000	0.000	0.00	20	4.2
11a	6Mbps	1	36	5180	5180.000	0.000	0.00	20	3.45
11a	6Mbps	1	36	5180	5180.000	0.000	0.00	20	3.6

Band II									
Mod.	Data Rate	NTX	CH.	Freq. (MHz)	Center Frequency (MHz)	Frequency Deviation (MHz)	Frequency Stability (ppm)	Temperature (°C)	Voltage (V)
11a	6Mbps	1	64	5320	5320.025	0.025	4.70	50	3.6
11a	6Mbps	1	64	5320	5320.050	0.050	9.40	-30	3.6
11a	6Mbps	1	64	5320	5320.000	0.000	0.00	20	4.2
11a	6Mbps	1	64	5320	5320.000	0.000	0.00	20	3.45
11a	6Mbps	1	64	5320	5320.000	0.000	0.00	20	3.6

Band III									
Mod.	Data Rate	NTX	CH.	Freq. (MHz)	Center Frequency (MHz)	Frequency Deviation (MHz)	Frequency Stability (ppm)	Temperature (°C)	Voltage (V)
11a	6Mbps	1	100	5500	5500.050	0.050	9.09	50	3.6
11a	6Mbps	1	100	5500	5500.050	0.050	9.09	-30	3.6
11a	6Mbps	1	100	5500	5500.050	0.050	9.09	20	4.2
11a	6Mbps	1	100	5500	5500.050	0.050	9.09	20	3.45
11a	6Mbps	1	100	5500	5500.050	0.050	9.09	20	3.6



3.7 Automatically Discontinue Transmission

3.7.1 Limit of Automatically Discontinue Transmission

The device shall automatically discontinue transmission in case of either absence of information to transmit or operational failure. These provisions are not intended to preclude the transmission of control or signaling information or the use of repetitive codes used by certain digital technologies to complete frame or burst intervals. Applicants shall include in their application for equipment authorization to describe how this requirement is met.

3.7.2 Measuring Instruments

The measuring equipment is listed in the section 4 of this test report.

3.7.3 Test Result of Automatically Discontinue Transmission

While the EUT is not transmitting any information, the EUT can automatically discontinue transmission and become standby mode for power saving. The EUT can detect the controlling signal of ACK message transmitting from remote device and verify whether it shall resend or discontinue transmission.



3.8 Antenna Requirements

3.8.1 Standard Applicable

According to FCC 47 CFR Section 15.407(a)(1)(2) ,if transmitting antenna directional gain is greater than 6 dBi, both the peak transmit power and the peak power spectral density shall be reduced by the amount in dB that the directional gain of the antenna exceeds 6 dBi.

3.8.2 Antenna Anti-Replacement Construction

An embedded-in antenna design is used.

3.8.3 Antenna Gain

The antenna gain is less than 6 dBi. Therefore, it is not necessary to reduce maximum peak output power limit.



4 List of Measuring Equipments

Instrument	Manufacturer	Model No.	Serial No.	Characteristics	Calibration Date	Test Date	Due Date	Remark
Power Meter	Agilent	E4416A	GB41292344	300MHz~40GHz	Jan. 08, 2016	Nov. 08, 2016 ~ Nov. 30, 2016	Jan. 07, 2017	Conducted (TH05-HY)
Power Sensor	Agilent	E9327A	US40441548	300MHz~40GHz	Jan. 07, 2016	Nov. 08, 2016 ~ Nov. 30, 2016	Jan. 06, 2017	Conducted (TH05-HY)
Spectrum Analyzer	Rohde & Schwarz	FSP40	100055	9kHz~40GHz	Jun. 17, 2016	Nov. 08, 2016 ~ Nov. 30, 2016	Jun. 16, 2017	Conducted (TH05-HY)
Temperature Chamber	ESPEC	SH-641	92013720	-40℃ ~90℃	Sep. 01, 2016	Nov. 08, 2016 ~ Nov. 30, 2016	Aug. 31, 2017	Conducted (TH05-HY)
Loop Antenna	Rohde & Schwarz	HFH2-Z2	100315	9 kHz~30 MHz	Sep. 02, 2015	Nov. 13, 2016 ~ Nov. 20, 2016	Sep. 01, 2017	Radiation (03CH12-HY)
Amplifier	SONOMA	310N	187312	9kHz~1GHz	Nov. 10, 2016	Nov. 13, 2016 ~ Nov. 20, 2016	Nov. 09, 2017	Radiation (03CH12-HY)
Spectrum Analyzer	Keysight	N9010A	MY54200486	10Hz ~ 44GHz	Oct. 12, 2016	Nov. 13, 2016 ~ Nov. 20, 2016	Oct. 11, 2017	Radiation (03CH12-HY)
Bilog Antenna	TESEQ	CBL 6111D&00800 N1D01N-06	37059&01	30MHz~1GHz	Oct. 15, 2016	Nov. 13, 2016 ~ Nov. 20, 2016	Oct. 14, 2017	Radiation (03CH12-HY)
EMI Test Receiver	Rohde & Schwarz	ESU26	100390	20Hz~26.5GHz	Dec. 21, 2015	Nov. 13, 2016 ~ Nov. 20, 2016	Dec. 20, 2016	Radiation (03CH12-HY)
Preamplifier	MITEQ	TTA0204	1872107	2GHz~40GHz	Feb. 15, 2016	Nov. 13, 2016 ~ Nov. 20, 2016	Feb. 14, 2017	Radiation (03CH12-HY)
Horn Antenna	SCHWARZBECK	BBHA 9120D	9120D-1328	1GHz ~ 18GHz	Oct. 25, 2016	Nov. 13, 2016 ~ Nov. 20, 2016	Oct. 24, 2017	Radiation (03CH12-HY)
Preamplifier	MITEQ	AMF-7D-0010 1800-30-10P	1815698	1GHz~18GHz	Dec. 14, 2015	Nov. 13, 2016 ~ Nov. 20, 2016	Dec. 13, 2016	Radiation (03CH12-HY)
Preamplifier	Keysight	83017A	MY53270148	1GHz~26.5GHz	Jan. 30, 2016	Nov. 13, 2016 ~ Nov. 20, 2016	Jan. 29, 2017	Radiation (03CH12-HY)
Antenna Mast	EMEC	AM-BS-4500-B	N/A	1m~4m	N/A	Nov. 13, 2016 ~ Nov. 20, 2016	N/A	Radiation (03CH12-HY)
Turn Table	EMEC	TT2000	N/A	0~360 Degree	N/A	Nov. 13, 2016 ~ Nov. 20, 2016	N/A	Radiation (03CH12-HY)
Preamplifier	MITEQ	TTA0204	1872107	2GHz~40GHz	Feb. 15, 2016	Nov. 13, 2016 ~ Nov. 20, 2016	Feb. 14, 2017	Radiation (03CH12-HY)
SHF-EHF Horn Antenna	SCHWARZBECK	BBHA 9170	BBHA9170576	18GHz ~ 40GHz	Apr. 15, 2016	Nov. 13, 2016 ~ Nov. 20, 2016	Apr. 14, 2017	Radiation (03CH12-HY)
AC Power Source	ChainTek	APC-1000W	N/A	N/A	N/A	Oct. 22, 2016	N/A	Conduction (CO05-HY)
EMI Test Receiver	Rohde & Schwarz	ESCI 7	100724	9kHz~7GHz	Aug. 30, 2016	Oct. 22, 2016	Aug. 29, 2017	Conduction (CO05-HY)
LISN	Rohde & Schwarz	ENV216	100080	9kHz~30MHz	Dec. 02, 2015	Oct. 22, 2016	Dec. 01, 2016	Conduction (CO05-HY)



5 Uncertainty of Evaluation

Uncertainty of Conducted Emission Measurement (150kHz ~ 30MHz)

Measuring Uncertainty for a Level of Confidence of 95% ($U = 2Uc(y)$)	2.7
---	-----

Uncertainty of Radiated Emission Measurement (30 MHz ~ 1000 MHz)

Measuring Uncertainty for a Level of Confidence of 95% ($U = 2Uc(y)$)	5.1
---	-----

Uncertainty of Radiated Emission Measurement (1000 MHz ~ 18000 MHz)

Measuring Uncertainty for a Level of Confidence of 95% ($U = 2Uc(y)$)	5.2
---	-----

Uncertainty of Radiated Emission Measurement (18000 MHz ~ 40000 MHz)

Measuring Uncertainty for a Level of Confidence of 95% ($U = 2Uc(y)$)	4.7
---	-----



Appendix A. Radiated Spurious Emission

Test Engineer :	Peter Chiu, Karl Hou, Nick Yu, and Citta Ke	Temperature :	23~24°C
		Relative Humidity :	51~54%

Band 1 - 5150~5250MHz

WiFi 802.11a (Band Edge @ 3m)

WiFi Ant. 1	Note	Frequency (MHz)	Level (dBμV/m)	Over Limit (dB)	Limit Line (dBμV/m)	Read Level (dBμV)	Antenna Factor (dB/m)	Cable Loss (dB)	Preamp Factor (dB)	Ant Pos (cm)	Table Pos (deg)	Peak Avg. (P/A)	Pol. (H/V)	
802.11a CH 36 5180MHz		5150	63.45	-10.55	74	51.54	31.65	11.21	30.95	100	187	P	H	
		5150	51.55	-2.45	54	39.64	31.65	11.21	30.95	100	187	A	H	
	*	5180	109.46	-	-	97.52	31.68	11.21	30.95	100	187	P	H	
	*	5180	99.21	-	-	87.27	31.68	11.21	30.95	100	187	A	H	
													H	
													H	
			5148.72	62.53	-11.47	74	50.62	31.65	11.21	30.95	119	176	P	V
			5150	50.81	-3.19	54	38.9	31.65	11.21	30.95	119	176	A	V
	*		5180	108.78	-	-	96.84	31.68	11.21	30.95	119	176	P	V
	*		5180	98	-	-	86.06	31.68	11.21	30.95	119	176	A	V
													V	
													V	
802.11a CH 44 5220MHz		5099.32	58.78	-15.22	74	46.86	31.6	11.27	30.95	100	190	P	H	
		5145.08	47.69	-6.31	54	35.78	31.65	11.21	30.95	100	190	A	H	
	*	5220	109.79	-	-	97.84	31.72	11.18	30.95	100	190	P	H	
	*	5220	99.36	-	-	87.41	31.72	11.18	30.95	100	190	A	H	
			5361.6	60.2	-13.8	74	47.76	31.87	11.52	30.95	100	190	P	H
			5442.96	48.24	-5.76	54	35.62	31.93	11.64	30.95	100	190	A	H
			5066.82	58.75	-15.25	74	46.86	31.57	11.27	30.95	100	174	P	V
			5124.54	47.58	-6.42	54	35.66	31.63	11.24	30.95	100	174	A	V
	*		5220	108.49	-	-	96.54	31.72	11.18	30.95	100	174	P	V
	*		5220	98.61	-	-	86.66	31.72	11.18	30.95	100	174	A	V
			5365.2	60.12	-13.88	74	47.68	31.87	11.52	30.95	100	174	P	V
			5434.32	48.36	-5.64	54	35.74	31.93	11.64	30.95	100	174	A	V



WIFI Ant. 1	Note	Frequency (MHz)	Level (dBμV/m)	Over Limit (dB)	Limit Line (dBμV/m)	Read Level (dBμV)	Antenna Factor (dB/m)	Cable Loss (dB)	Preamp Factor (dB)	Ant Pos (cm)	Table Pos (deg)	Peak Avg. (P/A)	Pol. (H/V)
802.11a CH 48 5240MHz		5070.72	60.51	-13.49	74	47.7	32.49	11.27	30.95	100	157	P	H
		5088.4	48.28	-5.72	54	35.48	32.48	11.27	30.95	100	157	A	H
	*	5240	111.55	-	-	98.79	32.45	11.26	30.95	100	157	P	H
	*	5240	100.4	-	-	87.64	32.45	11.26	30.95	100	157	A	H
		5451.84	60.14	-13.86	74	47.04	32.41	11.64	30.95	100	157	P	H
		5458.8	48.74	-5.26	54	35.64	32.41	11.64	30.95	100	157	A	H
		5100.1	60.27	-13.73	74	47.5	32.48	11.24	30.95	114	176	P	V
		5020.54	48.52	-5.48	54	35.66	32.5	11.31	30.95	114	176	A	V
	*	5240	112.04	-	-	99.28	32.45	11.26	30.95	114	176	P	V
	*	5240	100.85	-	-	88.09	32.45	11.26	30.95	114	176	A	V
		5383.68	59.94	-14.06	74	46.87	32.42	11.6	30.95	114	176	P	V
		5388.72	48.82	-5.18	54	35.75	32.42	11.6	30.95	114	176	A	V
Remark	1. No other spurious found. 2. All results are PASS against Peak and Average limit line.												



Band 1 5150~5250MHz
WIFI 802.11a (Harmonic @ 3m)

WIFI Ant. 1	Note	Frequency (MHz)	Level (dBμV/m)	Over Limit (dB)	Limit Line (dBμV/m)	Read Level (dBμV)	Antenna Factor (dB/m)	Cable Loss (dB)	Preamp Factor (dB)	Ant Pos (cm)	Table Pos (deg)	Peak Avg. (P/A)	Pol. (H/V)
802.11a CH 36 5180MHz		10360	46.14	-27.86	74	46.73	39.75	17.13	57.47	100	0	P	H
		15540	46.35	-27.65	74	43.89	39.38	21.61	58.53	100	0	P	H
													H
													H
		10360	45.82	-28.18	74	46.41	39.75	17.13	57.47	100	0	P	V
		15540	46.67	-27.33	74	44.21	39.38	21.61	58.53	100	0	P	V
													V
													V
802.11a CH 44 5220MHz		10440	45.92	-28.08	74	46.34	39.69	17.22	57.33	100	0	P	H
		15660	46.26	-27.74	74	44.74	38.11	21.7	58.29	100	0	P	H
													H
													H
		10440	45.65	-28.35	74	46.07	39.69	17.22	57.33	100	0	P	V
		15660	45	-29	74	43.48	38.11	21.7	58.29	100	0	P	V
													V
													V
802.11a CH 48 5240MHz		10480	46.32	-27.68	74	46.32	39.96	17.27	57.23	100	0	P	H
		15720	46.71	-27.29	74	44.26	38.84	21.76	58.15	100	0	P	H
													H
													H
		10480	46.28	-27.72	74	46.28	39.96	17.27	57.23	100	0	P	V
		15720	47.46	-26.54	74	45.01	38.84	21.76	58.15	100	0	P	V
													V
													V
Remark	1. No other spurious found. 2. All results are PASS against Peak and Average limit line.												



Band 1 5150~5250MHz
WIFI 802.11ac VHT20 (Band Edge @ 3m)

WIFI Ant. 1	Note	Frequency (MHz)	Level (dBμV/m)	Over Limit (dB)	Limit Line (dBμV/m)	Read Level (dBμV)	Antenna Factor (dB/m)	Cable Loss (dB)	Preamp Factor (dB)	Ant Pos (cm)	Table Pos (deg)	Peak Avg. (P/A)	Pol. (H/V)	
802.11ac VHT20 CH 36 5180MHz		5149.76	64.76	-9.24	74	52.85	31.65	11.21	30.95	100	186	P	H	
		5148.72	52.57	-1.43	54	40.66	31.65	11.21	30.95	100	186	A	H	
	*	5180	109.85	-	-	97.91	31.68	11.21	30.95	100	186	P	H	
	*	5180	99.36	-	-	87.42	31.68	11.21	30.95	100	186	A	H	
													H	
														H
			5146.38	62.16	-11.84	74	50.25	31.65	11.21	30.95	153	178	P	V
			5150	51.1	-2.9	54	39.19	31.65	11.21	30.95	153	178	A	V
		*	5180	108.38	-	-	96.44	31.68	11.21	30.95	153	178	P	V
		*	5180	98.51	-	-	86.57	31.68	11.21	30.95	153	178	A	V
													V	
													V	
802.11ac VHT20 CH 44 5220MHz		5146.64	59.66	-14.34	74	46.93	32.47	11.21	30.95	100	174	P	H	
		5149.24	48.59	-5.41	54	35.86	32.47	11.21	30.95	100	174	A	H	
		* 5220	111	-	-	98.31	32.46	11.18	30.95	100	174	P	H	
		* 5220	99.89	-	-	87.2	32.46	11.18	30.95	100	174	A	H	
			5380.32	60.15	-13.85	74	47.08	32.42	11.6	30.95	100	174	P	H
			5430.96	48.95	-5.05	54	35.85	32.41	11.64	30.95	100	174	A	H
			5080.34	60.52	-13.48	74	47.72	32.48	11.27	30.95	129	175	P	V
			5148.2	48.48	-5.52	54	35.75	32.47	11.21	30.95	129	175	A	V
		*	5220	111.1	-	-	98.41	32.46	11.18	30.95	129	175	P	V
		*	5220	99.86	-	-	87.17	32.46	11.18	30.95	129	175	A	V
		5423.04	60.5	-13.5	74	47.39	32.42	11.64	30.95	129	175	P	V	
		5430.24	48.99	-5.01	54	35.89	32.41	11.64	30.95	129	175	A	V	



WIFI Ant. 1	Note	Frequency (MHz)	Level (dBμV/m)	Over Limit (dB)	Limit Line (dBμV/m)	Read Level (dBμV)	Antenna Factor (dB/m)	Cable Loss (dB)	Preamp Factor (dB)	Ant Pos (cm)	Table Pos (deg)	Peak Avg. (P/A)	Pol. (H/V)
802.11ac VHT20 CH 48 5240MHz		5049.4	59.68	-14.32	74	46.83	32.49	11.31	30.95	107	159	P	H
		5147.16	48.44	-5.56	54	35.71	32.47	11.21	30.95	107	159	A	H
	*	5240	111.44	-	-	98.68	32.45	11.26	30.95	107	159	P	H
	*	5240	100.52	-	-	87.76	32.45	11.26	30.95	107	159	A	H
		5447.04	60.26	-13.74	74	47.16	32.41	11.64	30.95	107	159	P	H
		5368.08	48.75	-5.25	54	35.75	32.43	11.52	30.95	107	159	A	H
		5127.14	59.94	-14.06	74	47.18	32.47	11.24	30.95	126	174	P	V
		5093.34	48.25	-5.75	54	35.45	32.48	11.27	30.95	126	174	A	V
	*	5240	111.81	-	-	99.05	32.45	11.26	30.95	126	174	P	V
	*	5240	100.29	-	-	87.53	32.45	11.26	30.95	126	174	A	V
		5386.32	60.14	-13.86	74	47.07	32.42	11.6	30.95	126	174	P	V
		5451.12	48.66	-5.34	54	35.56	32.41	11.64	30.95	126	174	A	V
Remark	1. No other spurious found. 2. All results are PASS against Peak and Average limit line.												



Band 1 5150~5250MHz
WIFI 802.11ac VHT20 (Harmonic @ 3m)

WIFI Ant. 1	Note	Frequency (MHz)	Level (dBμV/m)	Over Limit (dB)	Limit Line (dBμV/m)	Read Level (dBμV)	Antenna Factor (dB/m)	Cable Loss (dB)	Preamp Factor (dB)	Ant Pos (cm)	Table Pos (deg)	Peak Avg. (P/A)	Pol. (H/V)
802.11ac VHT20 CH 36 5180MHz		10360	46.58	-27.42	74	47.17	39.75	17.13	57.47	100	0	P	H
		15540	47.26	-26.74	74	44.8	39.38	21.61	58.53	100	0	P	H
													H
													H
		10360	45.99	-28.01	74	46.58	39.75	17.13	57.47	100	0	P	V
		15540	46.62	-27.38	74	44.16	39.38	21.61	58.53	100	0	P	V
													V
802.11ac VHT20 CH 44 5220MHz		10440	46.68	-27.32	74	46.9	39.89	17.22	57.33	100	0	P	H
		15660	47.06	-26.94	74	44.63	39.02	21.7	58.29	100	0	P	H
													H
													H
		10440	46.79	-27.21	74	47.01	39.89	17.22	57.33	100	0	P	V
		15660	46.97	-27.03	74	44.54	39.02	21.7	58.29	100	0	P	V
													V
802.11ac VHT20 CH 48 5240MHz		10480	46.62	-27.38	74	46.62	39.96	17.27	57.23	100	0	P	H
		15720	45.93	-28.07	74	43.48	38.84	21.76	58.15	100	0	P	H
													H
													H
		10480	47.81	-26.19	74	47.81	39.96	17.27	57.23	100	0	P	V
		15720	45.67	-28.33	74	43.22	38.84	21.76	58.15	100	0	P	V
													V
Remark	1. No other spurious found.												
	2. All results are PASS against Peak and Average limit line.												



Band 1 5150~5250MHz
WIFI 802.11ac VHT40 (Band Edge @ 3m)

WIFI Ant. 1	Note	Frequency (MHz)	Level (dBμV/m)	Over Limit (dB)	Limit Line (dBμV/m)	Read Level (dBμV)	Antenna Factor (dB/m)	Cable Loss (dB)	Preamp Factor (dB)	Ant Pos (cm)	Table Pos (deg)	Peak Avg. (P/A)	Pol. (H/V)
802.11ac VHT40 CH 38 5190MHz		5149.76	63.06	-10.94	74	51.15	31.65	11.21	30.95	100	189	P	H
		5149.5	52.71	-1.29	54	40.8	31.65	11.21	30.95	100	189	A	H
	*	5190	104.62	-	-	92.71	31.68	11.18	30.95	100	189	P	H
	*	5190	94.52	-	-	82.61	31.68	11.18	30.95	100	189	A	H
		5365.92	59.31	-14.69	74	46.87	31.87	11.52	30.95	100	189	P	H
		5382.72	48.75	-5.25	54	36.22	31.88	11.6	30.95	100	189	A	H
		5144.04	63.47	-10.53	74	51.56	31.65	11.21	30.95	151	176	P	V
		5149.5	51.81	-2.19	54	39.9	31.65	11.21	30.95	151	176	A	V
	*	5190	102.82	-	-	90.91	31.68	11.18	30.95	151	176	P	V
	*	5190	93.27	-	-	81.36	31.68	11.18	30.95	151	176	A	V
		5424.48	59.26	-14.74	74	46.65	31.92	11.64	30.95	151	176	P	V
		5397.6	48.88	-5.12	54	36.33	31.9	11.6	30.95	151	176	A	V
802.11ac VHT40 CH 46 5230MHz		5029.9	60.75	-13.25	74	47.9	32.49	11.31	30.95	100	159	P	H
		5149.24	49.97	-4.03	54	37.24	32.47	11.21	30.95	100	159	A	H
	*	5230	108.51	-	-	95.75	32.45	11.26	30.95	100	159	P	H
	*	5230	97.05	-	-	84.29	32.45	11.26	30.95	100	159	A	H
		5427.84	60.23	-13.77	74	47.13	32.41	11.64	30.95	100	159	P	H
		5397.6	49.45	-4.55	54	36.38	32.42	11.6	30.95	100	159	A	H
		5140.66	60.39	-13.61	74	47.66	32.47	11.21	30.95	129	175	P	V
		5150	50.29	-3.71	54	37.56	32.47	11.21	30.95	129	175	A	V
	*	5230	108.6	-	-	95.84	32.45	11.26	30.95	129	175	P	V
	*	5230	97.44	-	-	84.68	32.45	11.26	30.95	129	175	A	V
	5437.44	59.61	-14.39	74	46.51	32.41	11.64	30.95	129	175	P	V	
	5357.28	49.46	-4.54	54	36.46	32.43	11.52	30.95	129	175	A	V	
Remark	1. No other spurious found. 2. All results are PASS against Peak and Average limit line.												



Band 1 5150~5250MHz
WIFI 802.11ac VHT40 (Harmonic @ 3m)

WIFI Ant. 1	Note	Frequency (MHz)	Level (dBμV/m)	Over Limit (dB)	Limit Line (dBμV/m)	Read Level (dBμV)	Antenna Factor (dB/m)	Cable Loss (dB)	Preamp Factor (dB)	Ant Pos (cm)	Table Pos (deg)	Peak Avg. (P/A)	Pol. (H/V)
802.11ac VHT40 CH 38 5190MHz		10380	47.4	-26.6	74	47.92	39.78	17.13	57.43	100	0	P	H
		15570	44.38	-29.62	74	41.91	39.29	21.64	58.46	100	0	P	H
													H
													H
		10380	46.2	-27.8	74	46.72	39.78	17.13	57.43	100	0	P	V
		15570	43.56	-30.44	74	41.09	39.29	21.64	58.46	100	0	P	V
802.11ac VHT40 CH 46 5230MHz		10460	46.06	-27.94	74	46.21	39.93	17.22	57.3	100	0	P	H
		15690	45.15	-28.85	74	42.71	38.93	21.73	58.22	100	0	P	H
													H
													H
		10460	47.32	-26.68	74	47.47	39.93	17.22	57.3	100	0	P	V
		15690	44.34	-29.66	74	41.9	38.93	21.73	58.22	100	0	P	V
Remark	1. No other spurious found.												
	2. All results are PASS against Peak and Average limit line.												



Band 1 5150~5250MHz
WIFI 802.11ac VHT80 (Band Edge @ 3m)

WIFI Ant. 1	Note	Frequency (MHz)	Level (dBμV/m)	Over Limit (dB)	Limit Line (dBμV/m)	Read Level (dBμV)	Antenna Factor (dB/m)	Cable Loss (dB)	Preamp Factor (dB)	Ant Pos (cm)	Table Pos (deg)	Peak Avg. (P/A)	Pol. (H/V)
802.11ac VHT80 CH 42 5210MHz		5143.52	62.57	-11.43	74	50.66	31.65	11.21	30.95	100	190	P	H
		5144.3	52.68	-1.32	54	40.77	31.65	11.21	30.95	100	190	A	H
	*	5210	101.86	-	-	89.91	31.72	11.18	30.95	100	190	P	H
	*	5210	91.77	-	-	79.82	31.72	11.18	30.95	100	190	A	H
		5457.6	59.75	-14.25	74	47.11	31.95	11.64	30.95	100	190	P	H
		5445.12	49.04	-4.96	54	36.42	31.93	11.64	30.95	100	190	A	H
		5145.86	62.19	-11.81	74	50.28	31.65	11.21	30.95	116	174	P	V
		5135.46	51.63	-2.37	54	39.71	31.63	11.24	30.95	116	174	A	V
	*	5210	100.49	-	-	88.54	31.72	11.18	30.95	116	174	P	V
	*	5210	90.42	-	-	78.47	31.72	11.18	30.95	116	174	A	V
		5441.52	59.69	-14.31	74	47.07	31.93	11.64	30.95	116	174	P	V
	5355.84	48.85	-5.15	54	36.43	31.85	11.52	30.95	116	174	A	V	
Remark	1. No other spurious found. 2. All results are PASS against Peak and Average limit line.												



Band 1 5150~5250MHz
WIFI 802.11ac VHT80 (Harmonic @ 3m)

WIFI Ant. 1	Note	Frequency (MHz)	Level (dBμV/m)	Over Limit (dB)	Limit Line (dBμV/m)	Read Level (dBμV)	Antenna Factor (dB/m)	Cable Loss (dB)	Preamp Factor (dB)	Ant Pos (cm)	Table Pos (deg)	Peak Avg. (P/A)	Pol. (H/V)	
802.11ac VHT80 CH 42 5210MHz		10420	47.36	-26.64	74	47.69	39.86	17.18	57.37	100	0	P	H	
		15630	45.98	-28.02	74	43.49	39.11	21.7	58.32	100	0	P	H	
													H	
													H	
			10420	47.61	-26.39	74	47.94	39.86	17.18	57.37	100	0	P	V
			15630	46.48	-27.52	74	43.99	39.11	21.7	58.32	100	0	P	V
														V
													V	
Remark	1. No other spurious found. 2. All results are PASS against Peak and Average limit line.													



Band 2 - 5250~5350MHz
WIFI 802.11a (Band Edge @ 3m)

WIFI	Note	Frequency	Level	Over	Limit	Read	Antenna	Cable	Preamp	Ant	Table	Peak	Pol.
Ant.				Limit	Line	Level	Factor	Loss	Factor	Pos	Pos	Avg.	
1		(MHz)	(dBμV/m)	(dB)	(dBμV/m)	(dBμV)	(dB/m)	(dB)	(dB)	(cm)	(deg)	(P/A)	(H/V)
802.11a CH 52 5260MHz		5138.84	59.65	-14.35	74	46.89	32.47	11.24	30.95	100	160	P	H
		5025.48	48.5	-5.5	54	35.65	32.49	11.31	30.95	100	160	A	H
	*	5260	110.84	-	-	98.08	32.45	11.26	30.95	100	160	P	H
	*	5260	99.85	-	-	87.09	32.45	11.26	30.95	100	160	A	H
		5378.64	60.35	-13.65	74	47.36	32.42	11.52	30.95	100	160	P	H
		5394.96	48.76	-5.24	54	35.69	32.42	11.6	30.95	100	160	A	H
		5007.28	59.38	-14.62	74	46.49	32.5	11.34	30.95	152	175	P	V
		5031.72	48.33	-5.67	54	35.48	32.49	11.31	30.95	152	175	A	V
	*	5260	111.11	-	-	98.35	32.45	11.26	30.95	152	175	P	V
	*	5260	100.22	-	-	87.46	32.45	11.26	30.95	152	175	A	V
		5392.32	60.74	-13.26	74	47.67	32.42	11.6	30.95	152	175	P	V
		5356.56	48.83	-5.17	54	35.83	32.43	11.52	30.95	152	175	A	V
802.11a CH 60 5300MHz		5008.84	58.8	-15.2	74	46.89	31.52	11.34	30.95	105	188	P	H
		5142.22	47.43	-6.57	54	35.52	31.65	11.21	30.95	105	188	A	H
	*	5300	109.93	-	-	97.73	31.8	11.35	30.95	105	188	P	H
	*	5300	99.54	-	-	87.34	31.8	11.35	30.95	105	188	A	H
		5436.96	59.56	-14.44	74	46.94	31.93	11.64	30.95	105	188	P	H
		5353.68	48.98	-5.02	54	36.56	31.85	11.52	30.95	105	188	A	H
		5087.1	58.61	-15.39	74	46.71	31.58	11.27	30.95	113	170	P	V
		5127.92	47.47	-6.53	54	35.55	31.63	11.24	30.95	113	170	A	V
	*	5300	108.87	-	-	96.67	31.8	11.35	30.95	113	170	P	V
	*	5300	98.63	-	-	86.43	31.8	11.35	30.95	113	170	A	V
		5350.08	60.08	-13.92	74	47.66	31.85	11.52	30.95	113	170	P	V
		5351.76	49.21	-4.79	54	36.79	31.85	11.52	30.95	113	170	A	V



WIFI Ant. 1	Note	Frequency (MHz)	Level (dBμV/m)	Over Limit (dB)	Limit Line (dBμV/m)	Read Level (dBμV)	Antenna Factor (dB/m)	Cable Loss (dB)	Preamp Factor (dB)	Ant Pos (cm)	Table Pos (deg)	Peak Avg. (P/A)	Pol. (H/V)	
802.11a CH 64 5320MHz	*	5320	109.84	-	-	97.54	31.82	11.43	30.95	107	190	P	H	
	*	5320	99.35	-	-	87.05	31.82	11.43	30.95	107	190	A	H	
		5351.04	64.61	-9.39	74	52.19	31.85	11.52	30.95	107	190	P	H	
		5350.56	52.21	-1.79	54	39.79	31.85	11.52	30.95	107	190	A	H	
													H	
													H	
	*	5320	109.97	-	-	97.67	31.82	11.43	30.95	101	174	P	V	
	*	5320	99.66	-	-	87.36	31.82	11.43	30.95	101	174	A	V	
		5352	66.73	-7.27	74	54.31	31.85	11.52	30.95	101	174	P	V	
		5350.24	52.89	-1.11	54	40.47	31.85	11.52	30.95	101	174	A	V	
													V	
													V	
	Remark	1. No other spurious found. 2. All results are PASS against Peak and Average limit line.												



Band 2 5250~5350MHz
WIFI 802.11a (Harmonic @ 3m)

WIFI Ant. 1	Note	Frequency (MHz)	Level (dBμV/m)	Over Limit (dB)	Limit Line (dBμV/m)	Read Level (dBμV)	Antenna Factor (dB/m)	Cable Loss (dB)	Preamp Factor (dB)	Ant Pos (cm)	Table Pos (deg)	Peak Avg. (P/A)	Pol. (H/V)
802.11a CH 52 5260MHz		10520	47.22	-26.78	74	47.1	40.01	17.31	57.2	100	0	P	H
		15780	45.39	-28.61	74	42.99	38.66	21.79	58.05	100	0	P	H
													H
													H
		10520	47.03	-26.97	74	46.91	40.01	17.31	57.2	100	0	P	V
		15780	45.57	-28.43	74	43.17	38.66	21.79	58.05	100	0	P	V
													V
													V
802.11a CH 60 5300MHz		10600	46.37	-27.63	74	46.23	39.92	17.4	57.18	100	0	P	H
		15900	45.13	-28.87	74	43.24	37.82	21.88	57.81	100	0	P	H
													H
													H
		10600	47.55	-26.45	74	47.41	39.92	17.4	57.18	100	0	P	V
		15900	44.83	-29.17	74	42.94	37.82	21.88	57.81	100	0	P	V
													V
													V
802.11a CH 64 5320MHz		10640	46.41	-27.59	74	46.07	40.06	17.45	57.17	100	0	P	H
		15960	45.41	-28.59	74	43.02	38.12	21.94	57.67	100	0	P	H
													H
													H
		10640	46.98	-27.02	74	46.64	40.06	17.45	57.17	100	0	P	V
		15960	44.74	-29.26	74	42.35	38.12	21.94	57.67	100	0	P	V
													V
													V
Remark	1. No other spurious found. 2. All results are PASS against Peak and Average limit line.												



Band 2 5250~5350MHz
WIFI 802.11ac VHT20 (Band Edge @ 3m)

WIFI Ant. 1	Note	Frequency (MHz)	Level (dBμV/m)	Over Limit (dB)	Limit Line (dBμV/m)	Read Level (dBμV)	Antenna Factor (dB/m)	Cable Loss (dB)	Preamp Factor (dB)	Ant Pos (cm)	Table Pos (deg)	Peak Avg. (P/A)	Pol. (H/V)
802.11ac VHT20 CH 52 5260MHz		5004.42	59.29	-14.71	74	46.4	32.5	11.34	30.95	100	172	P	H
		5019.24	48.3	-5.7	54	35.41	32.5	11.34	30.95	100	172	A	H
	*	5260	111.37	-	-	98.61	32.45	11.26	30.95	100	172	P	H
	*	5260	99.87	-	-	87.11	32.45	11.26	30.95	100	172	A	H
		5438.16	60.17	-13.83	74	47.07	32.41	11.64	30.95	100	172	P	H
		5383.92	48.79	-5.21	54	35.72	32.42	11.6	30.95	100	172	A	H
		5012.48	60.27	-13.73	74	47.38	32.5	11.34	30.95	100	174	P	V
		5096.2	48.38	-5.62	54	35.58	32.48	11.27	30.95	100	174	A	V
	*	5260	111.5	-	-	98.74	32.45	11.26	30.95	100	174	P	V
	*	5260	100.01	-	-	87.25	32.45	11.26	30.95	100	174	A	V
		5429.52	59.41	-14.59	74	46.31	32.41	11.64	30.95	100	174	P	V
		5370.48	48.77	-5.23	54	35.77	32.43	11.52	30.95	100	174	A	V
802.11ac VHT20 CH 60 5300MHz		5006.5	60.12	-13.88	74	47.23	32.5	11.34	30.95	120	174	P	H
		5059.02	48.51	-5.49	54	35.66	32.49	11.31	30.95	120	174	A	H
	*	5300	111.75	-	-	98.91	32.44	11.35	30.95	120	174	P	H
	*	5300	100.07	-	-	87.23	32.44	11.35	30.95	120	174	A	H
		5354.4	60.88	-13.12	74	47.88	32.43	11.52	30.95	120	174	P	H
		5352	49.9	-4.1	54	36.9	32.43	11.52	30.95	120	174	A	H
		5145.08	60.38	-13.62	74	47.65	32.47	11.21	30.95	134	174	P	V
		5026.52	48.41	-5.59	54	35.56	32.49	11.31	30.95	134	174	A	V
	*	5300	111.77	-	-	98.93	32.44	11.35	30.95	134	174	P	V
	*	5300	100.31	-	-	87.47	32.44	11.35	30.95	134	174	A	V
		5354.16	60.52	-13.48	74	47.52	32.43	11.52	30.95	134	174	P	V
		5350.56	50.22	-3.78	54	37.22	32.43	11.52	30.95	134	174	A	V



WIFI Ant. 1	Note	Frequency (MHz)	Level (dBμV/m)	Over Limit (dB)	Limit Line (dBμV/m)	Read Level (dBμV)	Antenna Factor (dB/m)	Cable Loss (dB)	Preamp Factor (dB)	Ant Pos (cm)	Table Pos (deg)	Peak Avg. (P/A)	Pol. (H/V)
802.11ac VHT20 CH 64 5320MHz	*	5320	109.64	-	-	97.34	31.82	11.43	30.95	116	191	P	H
	*	5320	99.74	-	-	87.44	31.82	11.43	30.95	116	191	A	H
		5350.24	63.34	-10.66	74	50.92	31.85	11.52	30.95	116	191	P	H
		5351.04	52.57	-1.43	54	40.15	31.85	11.52	30.95	116	191	A	H
													H
													H
	*	5320	109.17	-	-	96.87	31.82	11.43	30.95	124	172	P	V
	*	5320	99.21	-	-	86.91	31.82	11.43	30.95	124	172	A	V
		5350.72	64.35	-9.65	74	51.93	31.85	11.52	30.95	124	172	P	V
		5350.08	52.91	-1.09	54	40.49	31.85	11.52	30.95	124	172	A	V
												V	
												V	
Remark	1. No other spurious found. 2. All results are PASS against Peak and Average limit line.												



Band 2 5250~5350MHz
WIFI 802.11ac VHT20 (Harmonic @ 3m)

WIFI Ant. 1	Note	Frequency (MHz)	Level (dBμV/m)	Over Limit (dB)	Limit Line (dBμV/m)	Read Level (dBμV)	Antenna Factor (dB/m)	Cable Loss (dB)	Preamp Factor (dB)	Ant Pos (cm)	Table Pos (deg)	Peak Avg. (P/A)	Pol. (H/V)
802.11ac VHT20 CH 52 5260MHz		10520	46.24	-27.76	74	46.12	40.01	17.31	57.2	100	0	P	H
		15780	46.51	-27.49	74	44.11	38.66	21.79	58.05	100	0	P	H
													H
													H
		10520	46.48	-27.52	74	46.36	40.01	17.31	57.2	100	0	P	V
		15780	45.74	-28.26	74	43.34	38.66	21.79	58.05	100	0	P	V
													V
802.11ac VHT20 CH 60 5300MHz		10600	47.75	-26.25	74	47.49	40.04	17.4	57.18	100	0	P	H
		15900	45.32	-28.68	74	42.95	38.3	21.88	57.81	100	0	P	H
													H
													H
		10600	47.15	-26.85	74	46.89	40.04	17.4	57.18	100	0	P	V
		15900	44.63	-29.37	74	42.26	38.3	21.88	57.81	100	0	P	V
													V
802.11ac VHT20 CH 64 5320MHz		10640	46.05	-27.95	74	45.71	40.06	17.45	57.17	100	0	P	H
		15960	45.83	-28.17	74	43.44	38.12	21.94	57.67	100	0	P	H
													H
													H
		10640	46.45	-27.55	74	46.11	40.06	17.45	57.17	100	0	P	V
		15960	45.05	-28.95	74	42.66	38.12	21.94	57.67	100	0	P	V
													V
Remark	1. No other spurious found.												
	2. All results are PASS against Peak and Average limit line.												



Band 2 5250~5350MHz
WIFI 802.11ac VHT40 (Band Edge @ 3m)

WIFI Ant. 1	Note	Frequency (MHz)	Level (dBμV/m)	Over Limit (dB)	Limit Line (dBμV/m)	Read Level (dBμV)	Antenna Factor (dB/m)	Cable Loss (dB)	Preamp Factor (dB)	Ant Pos (cm)	Table Pos (deg)	Peak Avg. (P/A)	Pol. (H/V)
802.11ac VHT40 CH 54 5270MHz		5069.68	59.59	-14.41	74	46.78	32.49	11.27	30.95	104	176	P	H
		5131.56	49.15	-4.85	54	36.39	32.47	11.24	30.95	104	176	A	H
	*	5270	108.91	-	-	96.06	32.45	11.35	30.95	104	176	P	H
	*	5270	97.87	-	-	85.02	32.45	11.35	30.95	104	176	A	H
		5413.92	61.24	-12.76	74	48.17	32.42	11.6	30.95	104	176	P	H
		5350.8	50.63	-3.37	54	37.63	32.43	11.52	30.95	104	176	A	H
		5119.6	59.95	-14.05	74	47.18	32.48	11.24	30.95	122	176	P	V
		5034.06	49.18	-4.82	54	36.33	32.49	11.31	30.95	122	176	A	V
	*	5270	108.87	-	-	96.02	32.45	11.35	30.95	122	176	P	V
	*	5270	97.65	-	-	84.8	32.45	11.35	30.95	122	176	A	V
		5401.92	60.8	-13.2	74	47.73	32.42	11.6	30.95	122	176	P	V
		5351.52	50.33	-3.67	54	37.33	32.43	11.52	30.95	122	176	A	V
802.11ac VHT40 CH 62 5310MHz		5117.26	59.01	-14.99	74	47.1	31.62	11.24	30.95	115	190	P	H
		5055.12	48.32	-5.68	54	36.39	31.57	11.31	30.95	115	190	A	H
	*	5310	106.05	-	-	93.13	32.44	11.43	30.95	115	190	P	H
	*	5310	94.83	-	-	81.91	32.44	11.43	30.95	115	190	A	H
		5350.32	62.83	-11.17	74	50.41	31.85	11.52	30.95	115	190	P	H
		5350.08	52.8	-1.2	54	40.38	31.85	11.52	30.95	115	190	A	H
		5007.8	58.6	-15.4	74	46.69	31.52	11.34	30.95	100	176	P	V
		5031.46	48.24	-5.76	54	36.35	31.53	11.31	30.95	100	176	A	V
	*	5310	104.17	-	-	91.25	32.44	11.43	30.95	100	176	P	V
	*	5310	94.06	-	-	81.14	32.44	11.43	30.95	100	176	A	V
	5356.32	63.13	-10.87	74	50.71	31.85	11.52	30.95	100	176	P	V	
	5352.48	52.57	-1.43	54	40.15	31.85	11.52	30.95	100	176	A	V	
Remark	1. No other spurious found. 2. All results are PASS against Peak and Average limit line.												



Band 2 5250~5350MHz
WIFI 802.11ac VHT40 (Harmonic @ 3m)

WIFI Ant. 1	Note	Frequency (MHz)	Level (dBμV/m)	Over Limit (dB)	Limit Line (dBμV/m)	Read Level (dBμV)	Antenna Factor (dB/m)	Cable Loss (dB)	Preamp Factor (dB)	Ant Pos (cm)	Table Pos (deg)	Peak Avg. (P/A)	Pol. (H/V)	
802.11ac VHT40 CH 54 5270MHz		10540	47.05	-26.95	74	46.91	40.02	17.31	57.19	100	0	P	H	
		15810	45.8	-28.2	74	43.39	38.57	21.82	57.98	100	0	P	H	
													H	
													H	
			10540	46.61	-27.39	74	46.47	40.02	17.31	57.19	100	0	P	V
			15810	45.21	-28.79	74	42.8	38.57	21.82	57.98	100	0	P	V
														V
802.11ac VHT40 CH 62 5310MHz		10620	46.81	-27.19	74	46.54	40.05	17.4	57.18	100	0	P	H	
		15930	44.28	-29.72	74	41.9	38.21	21.91	57.74	100	0	P	H	
													H	
													H	
			10620	47.19	-26.81	74	46.92	40.05	17.4	57.18	100	0	P	V
			15930	43.03	-30.97	74	40.65	38.21	21.91	57.74	100	0	P	V
														V
Remark	1. No other spurious found.													
	2. All results are PASS against Peak and Average limit line.													



Band 2 5250~5350MHz
WIFI 802.11ac VHT80 (Band Edge @ 3m)

WIFI Ant. 1	Note	Frequency (MHz)	Level (dBμV/m)	Over Limit (dB)	Limit Line (dBμV/m)	Read Level (dBμV)	Antenna Factor (dB/m)	Cable Loss (dB)	Preamp Factor (dB)	Ant Pos (cm)	Table Pos (deg)	Peak Avg. (P/A)	Pol. (H/V)
802.11ac VHT80 CH 58 5290MHz		5125.84	60.33	-13.67	74	48.41	31.63	11.24	30.95	114	160	P	H
		5148.72	48.88	-5.12	54	36.97	31.65	11.21	30.95	114	160	A	H
	*	5290	103.74	-	-	90.9	32.44	11.35	30.95	114	160	P	H
	*	5290	92.93	-	-	80.09	32.44	11.35	30.95	114	160	A	H
		5352	65.27	-8.73	74	52.85	31.85	11.52	30.95	114	160	P	H
		5352.24	52.77	-1.23	54	40.35	31.85	11.52	30.95	114	160	A	H
		5147.16	59.48	-14.52	74	47.57	31.65	11.21	30.95	116	180	P	V
		5147.42	48.63	-5.37	54	36.72	31.65	11.21	30.95	116	180	A	V
	*	5290	103.36	-	-	90.52	32.44	11.35	30.95	116	180	P	V
	*	5290	92.1	-	-	79.26	32.44	11.35	30.95	116	180	A	V
		5351.04	65.52	-8.48	74	53.1	31.85	11.52	30.95	116	180	P	V
	5351.04	52.58	-1.42	54	40.16	31.85	11.52	30.95	116	180	A	V	
Remark	1. No other spurious found. 2. All results are PASS against Peak and Average limit line.												



Band 2 5250~5350MHz
WIFI 802.11ac VHT80 (Harmonic @ 3m)

Table with 14 columns: WIFI Ant. 1, Note, Frequency (MHz), Level (dBµV/m), Over Limit (dB), Limit Line (dBµV/m), Read Level (dBµV), Antenna Factor (dB/m), Cable Loss (dB), Preamp Factor (dB), Ant Pos (cm), Table Pos (deg), Peak Avg. (P/A), Pol. (H/V). Rows include data for 802.11ac VHT80 CH 58 at 10580 and 15870 MHz, and a Remark section.



Band 3 - 5470~5725MHz
WIFI 802.11a (Band Edge @ 3m)

WIFI	Note	Frequency	Level	Over	Limit	Read	Antenna	Cable	Preamp	Ant	Table	Peak	Pol.	
Ant.				Limit	Line	Level	Factor	Loss	Factor	Pos	Pos	Avg.		
1		(MHz)	(dBμV/m)	(dB)	(dBμV/m)	(dBμV)	(dB/m)	(dB)	(dB)	(cm)	(deg)	(P/A)	(H/V)	
802.11a CH 100 5500MHz		5455.12	62.1	-11.9	74	49.46	31.95	11.64	30.95	100	170	P	H	
		5469.2	66.22	-1.98	68.2	53.53	31.97	11.67	30.95	100	170	P	H	
		5459.12	50.31	-3.69	54	37.67	31.95	11.64	30.95	100	170	A	H	
	*	5500	110.08	-	-	97.36	32	11.67	30.95	100	170	P	H	
	*	5500	99.02	-	-	86.3	32	11.67	30.95	100	170	A	H	
														H
			5455.12	61.8	-12.2	74	49.16	31.95	11.64	30.95	110	166	P	V
			5468.56	66.56	-1.64	68.2	53.87	31.97	11.67	30.95	110	166	P	V
			5460	50.57	-3.43	54	37.93	31.95	11.64	30.95	110	166	A	V
	*		5500	110.17	-	-	97.45	32	11.67	30.95	110	166	P	V
	*		5500	99.03	-	-	86.31	32	11.67	30.95	110	166	A	V
														V
802.11a CH 116 5580MHz		5451.76	59.46	-14.54	74	46.82	31.95	11.64	30.95	100	158	P	H	
		5462.56	48.32	-5.68	54	35.63	31.97	11.67	30.95	100	158	A	H	
	*	5580	110.66	-	-	97.8	32.1	11.74	30.98	100	158	P	H	
	*	5580	99.7	-	-	86.84	32.1	11.74	30.98	100	158	A	H	
			5735.78	60.14	-13.86	74	46.99	32.34	11.84	31.03	100	158	P	H
			5749.95	48.7	-5.3	54	35.53	32.34	11.86	31.03	100	158	A	H
			5413.84	60.07	-13.93	74	47.5	31.92	11.6	30.95	100	165	P	V
			5465.68	48.26	-5.74	54	35.57	31.97	11.67	30.95	100	165	A	V
	*		5580	110.24	-	-	96.86	32.62	11.74	30.98	100	165	P	V
	*		5580	99.16	-	-	85.78	32.62	11.74	30.98	100	165	A	V
			5754.68	59.26	-14.74	74	46.07	32.36	11.86	31.03	100	165	P	V
			5733.5	48.72	-5.28	54	35.6	32.31	11.84	31.03	100	165	A	V



WiFi Ant. 1	Note	Frequency (MHz)	Level (dBμV/m)	Over Limit (dB)	Limit Line (dBμV/m)	Read Level (dBμV)	Antenna Factor (dB/m)	Cable Loss (dB)	Preamp Factor (dB)	Ant Pos (cm)	Table Pos (deg)	Peak Avg. (P/A)	Pol. (H/V)
802.11a CH 140 5700MHz	*	5700	110.24	-	-	97.16	32.27	11.82	31.01	100	159	P	H
	*	5700	99.27	-	-	86.19	32.27	11.82	31.01	100	159	A	H
		5725.56	66.75	-1.45	68.2	53.62	32.31	11.84	31.02	100	159	P	H
													H
													H
													H
	*	5700	108.23	-	-	94.46	32.96	11.82	31.01	100	153	P	V
	*	5700	97.22	-	-	83.45	32.96	11.82	31.01	100	153	A	V
		5727.48	64.66	-3.54	68.2	51.53	32.31	11.84	31.02	100	153	P	V
													V
													V
													V
Remark	1. No other spurious found. 2. All results are PASS against Peak and Average limit line.												



Band 3 - 5470~5725MHz
WIFI 802.11a (Harmonic @ 3m)

WIFI Ant. 1	Note	Frequency (MHz)	Level (dBμV/m)	Over Limit (dB)	Limit Line (dBμV/m)	Read Level (dBμV)	Antenna Factor (dB/m)	Cable Loss (dB)	Preamp Factor (dB)	Ant Pos (cm)	Table Pos (deg)	Peak Avg. (P/A)	Pol. (H/V)
802.11a CH 100 5500MHz		11000	46.42	-27.58	74	45.46	40.2	17.86	57.1	100	0	P	H
		16500	46.16	-22.04	68.2	40.24	39.5	22.42	56	100	0	P	H
													H
													H
		11000	46.57	-27.43	74	45.61	40.2	17.86	57.1	100	0	P	V
		16500	46.21	-21.99	68.2	40.29	39.5	22.42	56	100	0	P	V
													V
													V
802.11a CH 116 5580MHz		11160	46.04	-27.96	74	45.03	40.3	18.04	57.33	100	0	P	H
		16740	48.28	-25.72	74	41.7	40.07	22.65	56.14	100	0	P	H
													H
													H
		11160	46.16	-27.84	74	45.15	40.3	18.04	57.33	100	0	P	V
		16740	47.39	-26.61	74	40.81	40.07	22.65	56.14	100	0	P	V
													V
													V
802.11a CH 140 5700MHz		11400	46.66	-27.34	74	45.81	40.2	18.31	57.66	100	0	P	H
		17100	49.3	-18.9	68.2	41.35	41.62	22.99	56.66	100	0	P	H
													H
													H
		11400	46.73	-27.27	74	45.88	40.2	18.31	57.66	100	0	P	V
		17100	48.93	-19.27	68.2	40.98	41.62	22.99	56.66	100	0	P	V
													V
													V
Remark	1. No other spurious found. 2. All results are PASS against Peak and Average limit line.												



Band 3 - 5470~5725MHz
WIFI 802.11ac VHT20 (Band Edge @ 3m)

WIFI Ant. 1	Note	Frequency (MHz)	Level (dBμV/m)	Over Limit (dB)	Limit Line (dBμV/m)	Read Level (dBμV)	Antenna Factor (dB/m)	Cable Loss (dB)	Preamp Factor (dB)	Ant Pos (cm)	Table Pos (deg)	Peak Avg. (P/A)	Pol. (H/V)	
802.11ac VHT20 CH 100 5500MHz		5459.76	61.38	-12.62	74	48.74	31.95	11.64	30.95	100	173	P	H	
		5469.2	66.36	-1.84	68.2	53.67	31.97	11.67	30.95	100	173	P	H	
		5460	50.43	-3.57	54	37.79	31.95	11.64	30.95	100	173	A	H	
	*	5500	109.82	-	-	97.1	32	11.67	30.95	100	173	P	H	
	*	5500	98.7	-	-	85.98	32	11.67	30.95	100	173	A	H	
														H
			5459.92	61.32	-12.68	74	48.68	31.95	11.64	30.95	124	169	P	V
			5469.52	66.87	-1.33	68.2	54.18	31.97	11.67	30.95	124	169	P	V
			5459.92	50.45	-3.55	54	37.81	31.95	11.64	30.95	124	169	A	V
	*		5500	111.11	-	-	98.39	32	11.67	30.95	124	169	P	V
	*		5500	99.46	-	-	86.74	32	11.67	30.95	124	169	A	V
														V
802.11ac VHT20 CH 116 5580MHz		5402.8	59.17	-14.83	74	46.62	31.9	11.6	30.95	100	158	P	H	
		5461.36	58.7	-9.5	68.2	46.03	31.95	11.67	30.95	100	158	P	H	
		5447.68	48.22	-5.78	54	35.58	31.95	11.64	30.95	100	158	A	H	
	*	5580	110.39	-	-	97.01	32.62	11.74	30.98	100	158	P	H	
	*	5580	99.06	-	-	85.68	32.62	11.74	30.98	100	158	A	H	
			5732.63	59.58	-8.62	68.2	46.46	32.31	11.84	31.03	100	158	P	H
			5455.36	58.94	-15.06	74	46.3	31.95	11.64	30.95	100	158	P	V
			5464	58.64	-9.56	68.2	45.95	31.97	11.67	30.95	100	158	P	V
			5422.96	48.24	-5.76	54	35.63	31.92	11.64	30.95	100	158	A	V
	*		5580	109.88	-	-	96.5	32.62	11.74	30.98	100	158	P	V
	*		5580	98.92	-	-	85.54	32.62	11.74	30.98	100	158	A	V
			5735.425	60.74	-7.46	68.2	47.59	32.34	11.84	31.03	100	158	P	V



WIFI Ant. 1	Note	Frequency (MHz)	Level (dBμV/m)	Over Limit (dB)	Limit Line (dBμV/m)	Read Level (dBμV)	Antenna Factor (dB/m)	Cable Loss (dB)	Preamp Factor (dB)	Ant Pos (cm)	Table Pos (deg)	Peak Avg. (P/A)	Pol. (H/V)
802.11ac VHT20 CH 140 5700MHz	*	5700	109.16	-	-	95.39	32.96	11.82	31.01	100	159	P	H
	*	5700	98.04	-	-	84.27	32.96	11.82	31.01	100	159	A	H
		5725.4	66.69	-1.51	68.2	53.56	32.31	11.84	31.02	100	159	P	H
													H
													H
													H
	*	5700	107.37	-	-	94.29	32.27	11.82	31.01	100	153	P	V
	*	5700	96.12	-	-	83.04	32.27	11.82	31.01	100	153	A	V
		5725.32	64.65	-3.55	68.2	51.52	32.31	11.84	31.02	100	153	P	V
													V
												V	
												V	
Remark	1. No other spurious found. 2. All results are PASS against Peak and Average limit line.												



Band 3 - 5470~5725MHz
WIFI 802.11ac VHT20 (Harmonic @ 3m)

WIFI Ant. 1	Note	Frequency (MHz)	Level (dBμV/m)	Over Limit (dB)	Limit Line (dBμV/m)	Read Level (dBμV)	Antenna Factor (dB/m)	Cable Loss (dB)	Preamp Factor (dB)	Ant Pos (cm)	Table Pos (deg)	Peak Avg. (P/A)	Pol. (H/V)
802.11ac VHT20 CH 100 5500MHz		11000	46.91	-27.09	74	45.95	40.2	17.86	57.1	100	0	P	H
		16500	44.55	-23.65	68.2	38.63	39.5	22.42	56	100	0	P	H
													H
													H
		11000	48.38	-25.62	74	47.42	40.2	17.86	57.1	100	0	P	V
		16500	43.72	-24.48	68.2	37.8	39.5	22.42	56	100	0	P	V
													V
802.11ac VHT20 CH 116 5580MHz		11160	46.58	-27.42	74	45.67	40.2	18.04	57.33	100	0	P	H
		16740	45.63	-22.57	68.2	38.71	40.41	22.65	56.14	100	0	P	H
													H
													H
		11160	46.58	-27.42	74	45.67	40.2	18.04	57.33	100	0	P	V
		16740	46.94	-21.26	68.2	40.02	40.41	22.65	56.14	100	0	P	V
													V
802.11ac VHT20 CH 140 5700MHz		11400	46.17	-27.83	74	45.32	40.2	18.31	57.66	100	0	P	H
		17100	48.14	-20.06	68.2	40.19	41.62	22.99	56.66	100	0	P	H
													H
													H
		11400	46.72	-27.28	74	45.87	40.2	18.31	57.66	100	0	P	V
		17100	47.24	-20.96	68.2	39.29	41.62	22.99	56.66	100	0	P	V
													V
Remark	1. No other spurious found.												
	2. All results are PASS against Peak and Average limit line.												



Band 3 - 5470~5725MHz
WIFI 802.11ac VHT40 (Band Edge @ 3m)

WIFI Ant. 1	Note	Frequency (MHz)	Level (dBμV/m)	Over Limit (dB)	Limit Line (dBμV/m)	Read Level (dBμV)	Antenna Factor (dB/m)	Cable Loss (dB)	Preamp Factor (dB)	Ant Pos (cm)	Table Pos (deg)	Peak Avg. (P/A)	Pol. (H/V)
802.11ac VHT40 CH 102 5510MHz		5459.2	62.32	-11.68	74	49.68	31.95	11.64	30.95	111	158	P	H
		5468.32	65.64	-2.56	68.2	52.95	31.97	11.67	30.95	111	158	P	H
		5458.96	51.93	-2.07	54	39.29	31.95	11.64	30.95	111	158	A	H
	*	5510	103.38	-	-	90.64	32	11.7	30.96	111	158	P	H
	*	5510	93.46	-	-	80.72	32	11.7	30.96	111	158	A	H
		5743.3	59.52	-8.68	68.2	46.35	32.34	11.86	31.03	111	158	P	H
		5459.92	61.44	-12.56	74	48.8	31.95	11.64	30.95	122	171	P	V
		5464.24	66.93	-1.27	68.2	54.24	31.97	11.67	30.95	122	171	P	V
		5459.68	51.88	-2.12	54	39.24	31.95	11.64	30.95	122	171	A	V
	*	5510	104.12	-	-	91.38	32	11.7	30.96	122	171	P	V
	*	5510	94.57	-	-	81.83	32	11.7	30.96	122	171	A	V
	5727.55	60.06	-8.14	68.2	46.93	32.31	11.84	31.02	122	171	P	V	
802.11ac VHT40 CH 110 5550MHz		5468.8	60.87	-13.13	74	48.18	31.97	11.67	30.95	100	168	P	H
		5468.8	50.4	-3.6	54	37.71	31.97	11.67	30.95	100	168	A	H
	*	5550	107.18	-	-	93.87	32.54	11.74	30.97	100	168	P	H
	*	5550	96.11	-	-	82.8	32.54	11.74	30.97	100	168	A	H
		5741.9	59.96	-14.04	74	46.79	32.34	11.86	31.03	100	168	P	H
		5741.2	49.44	-4.56	54	36.27	32.34	11.86	31.03	100	168	A	H
		5467.6	62.15	-11.85	74	49.46	31.97	11.67	30.95	127	172	P	V
		5465.92	50.46	-3.54	54	37.77	31.97	11.67	30.95	127	172	A	V
	*	5550	107.9	-	-	94.59	32.54	11.74	30.97	127	172	P	V
	*	5550	96.86	-	-	83.55	32.54	11.74	30.97	127	172	A	V
		5757.48	60.12	-13.88	74	46.94	32.36	11.86	31.04	127	172	P	V
	5764.13	49.53	-4.47	54	36.35	32.36	11.86	31.04	127	172	A	V	



WIFI Ant. 1	Note	Frequency (MHz)	Level (dBµV/m)	Over Limit (dB)	Limit Line (dBµV/m)	Read Level (dBµV)	Antenna Factor (dB/m)	Cable Loss (dB)	Preamp Factor (dB)	Ant Pos (cm)	Table Pos (deg)	Peak Avg. (P/A)	Pol. (H/V)
802.11ac VHT40 CH 134 5670MHz		5425.6	60.32	-13.68	74	47.71	31.92	11.64	30.95	100	159	P	H
		5390.56	48.8	-5.2	54	36.27	31.88	11.6	30.95	100	159	A	H
	*	5670	105.77	-	-	92.72	32.24	11.82	31.01	100	159	P	H
	*	5670	95.94	-	-	82.89	32.24	11.82	31.01	100	159	A	H
		5725	62.86	-11.14	74	49.01	33.03	11.84	31.02	100	159	P	H
		5726.33	52.69	-1.31	54	39.56	32.31	11.84	31.02	100	159	A	H
		5358.4	59.27	-14.73	74	46.85	31.85	11.52	30.95	114	172	P	V
		5446.48	48.97	-5.03	54	36.33	31.95	11.64	30.95	114	172	A	V
	*	5670	105.25	-	-	92.2	32.24	11.82	31.01	114	172	P	V
	*	5670	95.96	-	-	82.91	32.24	11.82	31.01	114	172	A	V
		5726.5	61.72	-12.28	74	48.59	32.31	11.84	31.02	114	172	P	V
		5725.98	52.13	-1.87	54	39	32.31	11.84	31.02	114	172	A	V
Remark	1. No other spurious found. 2. All results are PASS against Peak and Average limit line.												



Band 3 - 5470~5725MHz
WIFI 802.11ac VHT40 (Harmonic @ 3m)

WIFI Ant. 1	Note	Frequency (MHz)	Level (dBμV/m)	Over Limit (dB)	Limit Line (dBμV/m)	Read Level (dBμV)	Antenna Factor (dB/m)	Cable Loss (dB)	Preamp Factor (dB)	Ant Pos (cm)	Table Pos (deg)	Peak Avg. (P/A)	Pol. (H/V)	
802.11ac VHT40 CH 102 5510MHz		11020	46.9	-27.1	74	45.96	40.2	17.86	57.12	100	0	P	H	
		16530	46.7	-21.5	68.2	40.65	39.61	22.46	56.02	100	0	P	H	
													H	
													H	
			11020	46.81	-27.19	74	45.87	40.2	17.86	57.12	100	0	P	V
			16530	45.75	-22.45	68.2	39.7	39.61	22.46	56.02	100	0	P	V
														V
802.11ac VHT40 CH 110 5550MHz		11100	46.63	-27.37	74	45.72	40.2	17.95	57.24	100	0	P	H	
		16650	45.93	-28.07	74	39.38	40.07	22.57	56.09	100	0	P	H	
													H	
													H	
			11100	46.48	-27.52	74	45.57	40.2	17.95	57.24	100	0	P	V
			16650	45.17	-28.83	74	38.62	40.07	22.57	56.09	100	0	P	V
														V
802.11ac VHT40 CH 134 5670MHz		11340	46.96	-27.04	74	46.11	40.2	18.22	57.57	100	0	P	H	
		17010	46.98	-27.02	74	39.01	41.42	22.91	56.36	100	0	P	H	
													H	
													H	
			11340	46.95	-27.05	74	46.1	40.2	18.22	57.57	100	0	P	V
			17010	45.73	-28.27	74	37.76	41.42	22.91	56.36	100	0	P	V
														V
Remark	1. No other spurious found.													
	2. All results are PASS against Peak and Average limit line.													



Band 3 5470~5725MHz
WIFI 802.11ac VHT80 (Band Edge @ 3m)

WIFI Ant. 1	Note	Frequency (MHz)	Level (dBμV/m)	Over Limit (dB)	Limit Line (dBμV/m)	Read Level (dBμV)	Antenna Factor (dB/m)	Cable Loss (dB)	Preamp Factor (dB)	Ant Pos (cm)	Table Pos (deg)	Peak Avg. (P/A)	Pol. (H/V)
802.11ac VHT80 CH 106 5530MHz		5442.16	63.85	-10.15	74	51.23	31.93	11.64	30.95	100	122	P	H
		5464.72	62.58	-5.62	68.2	49.89	31.97	11.67	30.95	100	122	P	H
		5453.44	52.63	-1.37	54	39.99	31.95	11.64	30.95	100	122	A	H
	*	5530	100.12	-	-	87.37	32.02	11.7	30.97	100	122	P	H
	*	5530	90.06	-	-	77.31	32.02	11.7	30.97	100	122	A	H
		5746.28	60.44	-7.76	68.2	47.27	32.34	11.86	31.03	100	122	P	H
		5445.04	63.17	-10.83	74	50.55	31.93	11.64	30.95	123	191	P	V
		5467.36	63.42	-4.78	68.2	50.73	31.97	11.67	30.95	123	191	P	V
		5442.64	52.56	-1.44	54	39.94	31.93	11.64	30.95	123	191	A	V
	*	5530	99.53	-	-	86.78	32.02	11.7	30.97	123	191	P	V
	*	5530	89.31	-	-	76.56	32.02	11.7	30.97	123	191	A	V
		5742.6	59.56	-8.64	68.2	46.39	32.34	11.86	31.03	123	191	P	V
802.11ac VHT80 CH 122 5610MHz		5463.28	61.32	-12.68	74	48.63	31.97	11.67	30.95	126	161	P	H
		5468.56	50.97	-3.03	54	38.28	31.97	11.67	30.95	126	161	A	H
	*	5610	104.3	-	-	90.81	32.71	11.77	30.99	126	161	P	H
	*	5610	93.45	-	-	79.96	32.71	11.77	30.99	126	161	A	H
		5744.18	62.5	-11.5	74	49.33	32.34	11.86	31.03	126	161	P	H
		5725	51.08	-2.92	54	37.95	32.31	11.84	31.02	126	161	A	H
		5470	61.6	-12.4	74	48.91	31.97	11.67	30.95	145	171	P	V
		5444.08	50.49	-3.51	54	37.87	31.93	11.64	30.95	145	171	A	V
	*	5610	103.37	-	-	89.88	32.71	11.77	30.99	145	171	P	V
	*	5610	92.41	-	-	78.92	32.71	11.77	30.99	145	171	A	V
	5727.9	61.14	-12.86	74	48.01	32.31	11.84	31.02	145	171	P	V	
	5727.73	50.12	-3.88	54	36.99	32.31	11.84	31.02	145	171	A	V	
Remark	1. No other spurious found. 2. All results are PASS against Peak and Average limit line.												



Band 3 5470~5725MHz
WIFI 802.11ac VHT80 (Harmonic @ 3m)

WIFI Ant. 1	Note	Frequency (MHz)	Level (dBμV/m)	Over Limit (dB)	Limit Line (dBμV/m)	Read Level (dBμV)	Antenna Factor (dB/m)	Cable Loss (dB)	Preamp Factor (dB)	Ant Pos (cm)	Table Pos (deg)	Peak Avg. (P/A)	Pol. (H/V)	
802.11ac VHT80 CH 106 5530MHz		11060	48.05	-25.95	74	47.14	40.2	17.9	57.19	100	0	P	H	
		16590	45.82	-22.38	68.2	39.49	39.84	22.54	56.05	100	0	P	H	
													H	
													H	
			11060	48.06	-25.94	74	47.15	40.2	17.9	57.19	100	0	P	V
			16590	45.44	-22.76	68.2	39.11	39.84	22.54	56.05	100	0	P	V
														V
802.11ac VHT80 CH 122 5610MHz		11220	46.64	-27.36	74	45.76	40.2	18.08	57.4	100	0	P	H	
		16830	46.52	-27.48	74	39.21	40.75	22.76	56.2	100	0	P	H	
													H	
													H	
			11220	47.2	-26.8	74	46.32	40.2	18.08	57.4	100	0	P	V
			16830	46.84	-27.16	74	39.53	40.75	22.76	56.2	100	0	P	V
														V
Remark	1. No other spurious found.													
	2. All results are PASS against Peak and Average limit line.													



Band 3 - Straddle Channel
WIFI 802.11a (Band Edge @ 3m)

WIFI	Note	Frequency	Level	Over	Limit	Read	Antenna	Cable	Preamp	Ant	Table	Peak	Pol.
Ant.				Limit	Line	Level	Factor	Loss	Factor	Pos	Pos	Avg.	
1		(MHz)	(dBμV/m)	(dB)	(dBμV/m)	(dBμV)	(dB/m)	(dB)	(dB)	(cm)	(deg)	(P/A)	(H/V)
802.11a CH 144 5720MHz	*	5720	111.26	-	-	97.42	33.02	11.84	31.02	100	160	P	H
	*	5720	100.22	-	-	86.38	33.02	11.84	31.02	100	160	A	H
													H
													H
													H
	*	5720	110.41	-	-	96.57	33.02	11.84	31.02	126	155	P	V
	*	5720	99.47	-	-	85.63	33.02	11.84	31.02	126	155	A	V
													V
													V
													V
													V
	Remark	1. No other spurious found. 2. All results are PASS against Peak and Average limit line.											



Band 3 - Straddle Channel
WIFI 802.11a (Harmonic @ 3m)

WIFI Ant. 1	Note	Frequency (MHz)	Level (dBµV/m)	Over Limit (dB)	Limit Line (dBµV/m)	Read Level (dBµV)	Antenna Factor (dB/m)	Cable Loss (dB)	Preamp Factor (dB)	Ant Pos (cm)	Table Pos (deg)	Peak Avg. (P/A)	Pol. (H/V)	
802.11a CH 144 5720MHz		11440	46.51	-27.49	74	45.66	40.2	18.36	57.71	100	0	P	H	
		17160	49.26	-24.74	74	41.35	41.75	23.06	56.9	100	0	P	H	
													H	
													H	
			11440	46.97	-27.03	74	46.12	40.2	18.36	57.71	100	0	P	V
			17160	49.27	-24.73	74	41.36	41.75	23.06	56.9	100	0	P	V
														V
														V
Remark	1. No other spurious found. 2. All results are PASS against Peak and Average limit line.													



Band 3 - Straddle Channel
WIFI 802.11ac VHT20 (Band Edge @ 3m)

WIFI Ant. 1	Note	Frequency (MHz)	Level (dBμV/m)	Over Limit (dB)	Limit Line (dBμV/m)	Read Level (dBμV)	Antenna Factor (dB/m)	Cable Loss (dB)	Preamp Factor (dB)	Ant Pos (cm)	Table Pos (deg)	Peak Avg. (P/A)	Pol. (H/V)
802.11ac VHT20 CH 144 5720MHz	*	5720	111.25	-	-	97.41	33.02	11.84	31.02	100	160	P	H
	*	5720	100.04	-	-	86.2	33.02	11.84	31.02	100	160	A	H
													H
													H
													H
													H
	*	5720	110.59	-	-	96.75	33.02	11.84	31.02	100	173	P	V
	*	5720	99.33	-	-	85.49	33.02	11.84	31.02	100	173	A	V
													V
													V
												V	
												V	
Remark	1. No other spurious found. 2. All results are PASS against Peak and Average limit line.												



Band 3 - Straddle Channel
WIFI 802.11ac VHT20 (Harmonic @ 3m)

WIFI Ant. 1	Note	Frequency (MHz)	Level (dBμV/m)	Over Limit (dB)	Limit Line (dBμV/m)	Read Level (dBμV)	Antenna Factor (dB/m)	Cable Loss (dB)	Preamp Factor (dB)	Ant Pos (cm)	Table Pos (deg)	Peak Avg. (P/A)	Pol. (H/V)	
802.11ac VHT20 CH 144 5720MHz		11440	47.1	-26.9	74	46.25	40.2	18.36	57.71	100	0	P	H	
		17160	48.97	-25.03	74	41.06	41.75	23.06	56.9	100	0	P	H	
													H	
													H	
			11440	47.21	-26.79	74	46.36	40.2	18.36	57.71	100	0	P	V
			17160	48.4	-25.6	74	40.49	41.75	23.06	56.9	100	0	P	V
														V
													V	
Remark	1. No other spurious found. 2. All results are PASS against Peak and Average limit line.													



Band 3 - Straddle Channel
WIFI 802.11ac VHT40 (Band Edge @ 3m)

WIFI Ant. 1	Note	Frequency (MHz)	Level (dBμV/m)	Over Limit (dB)	Limit Line (dBμV/m)	Read Level (dBμV)	Antenna Factor (dB/m)	Cable Loss (dB)	Preamp Factor (dB)	Ant Pos (cm)	Table Pos (deg)	Peak Avg. (P/A)	Pol. (H/V)
802.11ac VHT40 CH 142 5710MHz	*	5710	108.44	-	-	94.63	32.99	11.84	31.02	100	159	P	H
	*	5710	96.78	-	-	82.97	32.99	11.84	31.02	100	159	A	H
													H
													H
													H
													H
	*	5710	107.08	-	-	93.27	32.99	11.84	31.02	152	159	P	V
	*	5710	96.1	-	-	82.29	32.99	11.84	31.02	152	159	A	V
													V
													V
												V	
												V	
Remark	1. No other spurious found. 2. All results are PASS against Peak and Average limit line.												



Band 3 - Straddle Channel
WIFI 802.11ac VHT40 (Harmonic @ 3m)

Table with 14 columns: WIFI Ant. 1, Note, Frequency (MHz), Level (dBµV/m), Over Limit (dB), Limit Line (dBµV/m), Read Level (dBµV), Antenna Factor (dB/m), Cable Loss (dB), Preamp Factor (dB), Ant Pos (cm), Table Pos (deg), Peak Avg. (P/A), Pol. (H/V). Rows include data for 802.11ac VHT40 CH 142 5710MHz and a Remark section.



Band 3 - Straddle Channel
WIFI 802.11ac VHT80 (Band Edge @ 3m)

WIFI Ant. 1	Note	Frequency (MHz)	Level (dBμV/m)	Over Limit (dB)	Limit Line (dBμV/m)	Read Level (dBμV)	Antenna Factor (dB/m)	Cable Loss (dB)	Preamp Factor (dB)	Ant Pos (cm)	Table Pos (deg)	Peak Avg. (P/A)	Pol. (H/V)
802.11ac VHT80 CH 138 5690MHz	*	5690	103.94	-	-	90.2	32.93	11.82	31.01	100	160	P	H
	*	5690	92.91	-	-	79.17	32.93	11.82	31.01	100	160	A	H
													H
													H
													H
													H
	*	5690	103.14	-	-	89.4	32.93	11.82	31.01	144	160	P	V
	*	5690	92.23	-	-	78.49	32.93	11.82	31.01	144	160	A	V
													V
													V
												V	
												V	
Remark	1. No other spurious found. 2. All results are PASS against Peak and Average limit line.												



Band 3 - Straddle Channel
WIFI 802.11ac VHT80 (Harmonic @ 3m)

WIFI Ant. 1	Note	Frequency (MHz)	Level (dBμV/m)	Over Limit (dB)	Limit Line (dBμV/m)	Read Level (dBμV)	Antenna Factor (dB/m)	Cable Loss (dB)	Preamp Factor (dB)	Ant Pos (cm)	Table Pos (deg)	Peak Avg. (P/A)	Pol. (H/V)	
802.11ac VHT80 CH 138 5690MHz		11380	47.59	-26.41	74	46.76	40.2	18.27	57.64	100	0	P	H	
		17070	49.04	-24.96	74	41.04	41.55	22.99	56.54	100	0	P	H	
													H	
													H	
			11380	47.21	-26.79	74	46.38	40.2	18.27	57.64	100	0	P	V
			17070	49.17	-24.83	74	41.17	41.55	22.99	56.54	100	0	P	V
														V
														V
Remark	1. No other spurious found. 2. All results are PASS against Peak and Average limit line.													



Emission below 1GHz
WIFI 802.11ac VHT20 (LF @ 3m)

WIFI	Note	Frequency	Level	Over	Limit	Read	Antenna	Cable	Preamp	Ant	Table	Peak	Pol.	
Ant.				Limit	Line	Level	Factor	Loss	Factor	Pos	Pos	Avg.		
1		(MHz)	(dBμV/m)	(dB)	(dBμV/m)	(dBμV)	(dB/m)	(dB)	(dB)	(cm)	(deg)	(P/A)	(H/V)	
802.11ac VHT20 LF		35.94	30.11	-9.89	40	39.25	22.54	0.78	32.46	100	0	P	H	
		81.03	22.48	-17.52	40	40.05	13.81	1.06	32.44	-	-	P	H	
		106.68	32.39	-11.11	43.5	46.62	16.77	1.43	32.43	-	-	P	H	
		172.29	21.64	-21.86	43.5	36.57	15.74	1.75	32.42	-	-	P	H	
		229.8	18.67	-27.33	46	32.5	16.7	1.83	32.36	-	-	P	H	
		659.1	26.9	-19.1	46	29.62	26.08	3.61	32.41	-	-	P	H	
														H
														H
														H
														H
														H
														H
			34.32	35.97	-4.03	40	44.01	23.64	0.78	32.46	100	260	QP	V
			34.32	38.54	-	-	46.58	23.64	0.78	32.46	100	260	P	V
			35.94	36.76	-3.24	40	45.9	22.54	0.78	32.46	100	278	QP	V
			35.94	40.42	-	-	49.56	22.54	0.78	32.46	100	278	P	V
			63.21	28.75	-11.25	40	48.19	11.95	1.06	32.45	-	-	P	V
			106.41	29.18	-14.32	43.5	43.41	16.77	1.43	32.43	-	-	P	V
			633.2	26.28	-19.72	46	29.27	25.8	3.61	32.4	-	-	P	V
			939.8	31.41	-14.59	46	28	30.03	4.6	31.22	-	-	P	V
													V	
													V	
													V	
													V	
Remark	1. No other spurious found. 2. All results are PASS against limit line.													



Note symbol

*	Fundamental Frequency which can be ignored. However, the level of any unwanted emissions shall not exceed the level of the fundamental frequency.
!	Test result is over limit line.
P/A	Peak or Average
H/V	Horizontal or Vertical



A calculation example for radiated spurious emission is shown as below:

WIFI	Note	Frequency	Level	Over	Limit	Read	Antenna	Cable	Preamp	Ant	Table	Peak	Pol.
Ant.				Limit	Line	Level	Factor	Loss	Factor	Pos	Pos	Avg.	
1		(MHz)	(dBμV/m)	(dB)	(dBμV/m)	(dBμV)	(dB/m)	(dB)	(dB)	(cm)	(deg)	(P/A)	(H/V)
802.11b		2390	55.45	-18.55	74	54.51	32.22	4.58	35.86	103	308	P	H
CH 01													
2412MHz		2390	43.54	-10.46	54	42.6	32.22	4.58	35.86	103	308	A	H

- Level(dBμV/m) =
Antenna Factor(dB/m) + Cable Loss(dB) + Read Level(dBμV) - Preamp Factor(dB)
- Over Limit(dB) = Level(dBμV/m) – Limit Line(dBμV/m)

For Peak Limit @ 2390MHz:

- Level(dBμV/m)
= Antenna Factor(dB/m) + Cable Loss(dB) + Read Level(dBμV) - Preamp Factor(dB)
= 32.22(dB/m) + 4.58(dB) + 54.51(dBμV) – 35.86 (dB)
= 55.45 (dBμV/m)
- Over Limit(dB)
= Level(dBμV/m) – Limit Line(dBμV/m)
= 55.45(dBμV/m) – 74(dBμV/m)
= -18.55(dB)

For Average Limit @ 2390MHz:

- Level(dBμV/m)
= Antenna Factor(dB/m) + Cable Loss(dB) + Read Level(dBμV) - Preamp Factor(dB)
= 32.22(dB/m) + 4.58(dB) + 42.6(dBμV) – 35.86 (dB)
= 43.54 (dBμV/m)
- Over Limit(dB)
= Level(dBμV/m) – Limit Line(dBμV/m)
= 43.54(dBμV/m) – 54(dBμV/m)
= -10.46(dB)

Both peak and average measured complies with the limit line, so test result is “PASS”.



Appendix B. Radiated Spurious Emission Plots

Test Engineer :	Peter Chiu, Karl Hou, Nick Yu, and Citta Ke	Temperature :	23~24°C
		Relative Humidity :	51~54%

Note symbol

-L	Low channel location
-R	High channel location



Band 1 - 5150~5250MHz
WIFI 802.11a (Band Edge @ 3m)

WIFI	Band 1 5150~5250MHz Band Edge @ 3m	
ANT	802.11a CH36 5180MHz	
1	Horizontal	Fundamental
Peak	<p>Site : 03CH12-HY Condition : PEAK_BE_74 3m HORN_9120D_1328 HORIZONTAL Detector : RBW:1000.000KHz VBW:3000.000KHz SWT:Auto Project : Peak Mode : :672014-10 Setting : :1 : :72</p>	<p>Site : 03CH12-HY Condition : PEAK_74 3m HORN_9120D_1328 HORIZONTAL Detector : RBW:1000.000KHz VBW:3000.000KHz SWT:Auto Project : Peak Mode : :672014-10 Setting : :1 : :72</p>
Avg.	<p>Site : 03CH12-HY Condition : AVG_BE_54 3m HORN_9120D_1328 HORIZONTAL Detector : RBW:1000.000KHz VBW:1.000KHz SWT:Auto Project : Peak Mode : :672014-10 Setting : :1 : :72</p>	Left blank

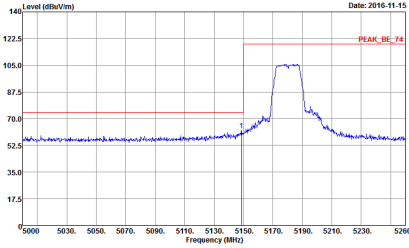
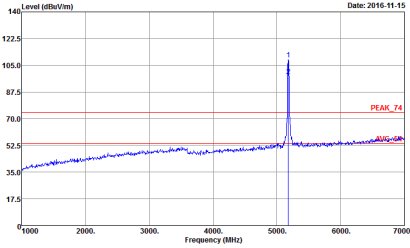
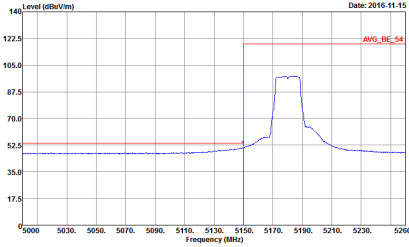

WIFI	Band 1 5150~5250MHz Band Edge @ 3m	
ANT	802.11a CH36 5180MHz	
1	Vertical	Fundamental
Peak	 <p>Site : 03CH12-HY Condition : PEAK_BE_74 3m HORN_9120D_1328 VERTICAL Detector : Peak Project : 672014-10 Mode : 1 Setting : 72</p>	 <p>Site : 03CH12-HY Condition : PEAK_74 3m HORN_9120D_1328 VERTICAL Detector : Peak Project : 672014-10 Mode : 1 Setting : 72</p>
Avg.	 <p>Site : 03CH12-HY Condition : AVG_BE_54 3m HORN_9120D_1328 VERTICAL Detector : Peak Project : 672014-10 Mode : 1 Setting : 72</p>	Left blank

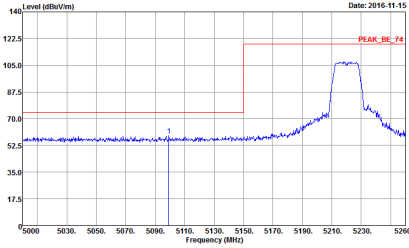
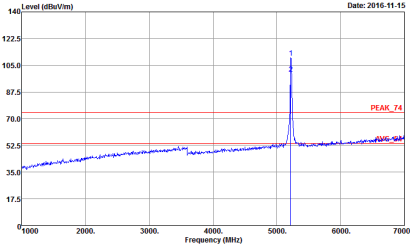
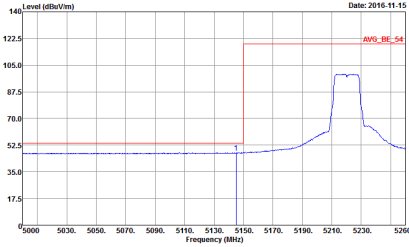

WIFI	Band 1 5150~5250MHz Band Edge @ 3m	
ANT	802.11a CH44 5220MHz - L	
1	Horizontal	Fundamental
Peak	 <p>Date: 2016-11-15</p> <p>Site : 03CH12-HY Condition : PEAK_BE_74 3m HORN_9120D_1328 HORIZONTAL : RBW:1000.000KHz VBW:3000.000KHz SWT:Auto Detector : Peak Project : 672014-10 Mode : 2 Setting : 72</p>	 <p>Date: 2016-11-15</p> <p>Site : 03CH12-HY Condition : PEAK_74 3m HORN_9120D_1328 HORIZONTAL : RBW:1000.000KHz VBW:3000.000KHz SWT:Auto Detector : Peak Project : 672014-10 Mode : 2 Setting : 72</p>
Avg.	 <p>Date: 2016-11-15</p> <p>Site : 03CH12-HY Condition : AVG_BE_54 3m HORN_9120D_1328 HORIZONTAL : RBW:1000.000KHz VBW:1.000KHz SWT:Auto Detector : Peak Project : 672014-10 Mode : 2 Setting : 72</p>	Left blank

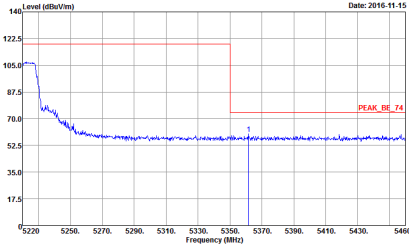
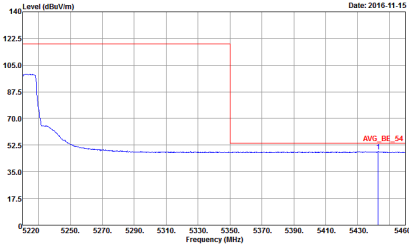

WIFI	Band 1 5150~5250MHz Band Edge @ 3m	
ANT	802.11a CH44 5220MHz - R	
1	Horizontal	Fundamental
Peak	 <p>Date: 2016-11-15</p> <p>Site : 03CH12-HY Condition : PEAK_BE_74 3m HORN_9120D_1328 HORIZONTAL : RBW:1000.000KHz VBW:3000.000KHz SWT:Auto Detector : Peak Project : 672014-10 Mode : 2 Setting : 72</p>	Left blank
Avg.	 <p>Date: 2016-11-15</p> <p>Site : 03CH12-HY Condition : AVG_BE_54 3m HORN_9120D_1328 HORIZONTAL : RBW:1000.000KHz VBW:1.000KHz SWT:Auto Detector : Peak Project : 672014-10 Mode : 2 Setting : 72</p>	Left blank

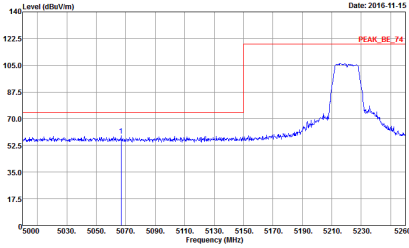
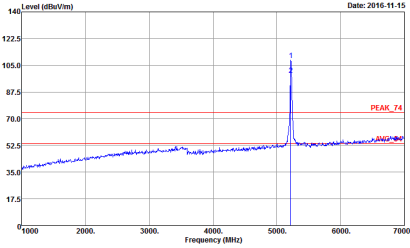
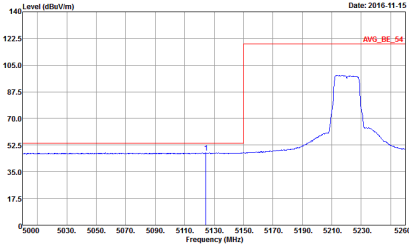

WIFI	Band 1 5150~5250MHz Band Edge @ 3m	
ANT	802.11a CH44 5220MHz - L	
1	Vertical	Fundamental
Peak	 <p>Level (dBuV/m) vs Frequency (MHz) plot showing a peak at 5220 MHz. The peak level is approximately 105 dBuV/m. A red box highlights the peak area, labeled 'PEAK_BE_74'.</p> <p>Site : 03CH12-HY Condition : PEAK_BE_74 3m HORN_9120D_1328 VERTICAL : RBW:1000.000KHz VBW:3000.000KHz SWT:Auto Detector : Peak Project : 672014-10 Mode : 2 Setting : 72</p>	 <p>Level (dBuV/m) vs Frequency (MHz) plot showing a sharp peak at 5220 MHz. The peak level is approximately 105 dBuV/m. A red box highlights the peak area, labeled 'PEAK_74'.</p> <p>Site : 03CH12-HY Condition : PEAK_74 3m HORN_9120D_1328 VERTICAL : RBW:1000.000KHz VBW:3000.000KHz SWT:Auto Detector : Peak Project : 672014-10 Mode : 2 Setting : 72</p>
Avg.	 <p>Level (dBuV/m) vs Frequency (MHz) plot showing an average spectrum with a peak at 5220 MHz. The peak level is approximately 105 dBuV/m. A red box highlights the peak area, labeled 'AVG_BE_54'.</p> <p>Site : 03CH12-HY Condition : AVG_BE_54 3m HORN_9120D_1328 VERTICAL : RBW:1000.000KHz VBW:1.000KHz SWT:Auto Detector : Peak Project : 672014-10 Mode : 2 Setting : 72</p>	Left blank

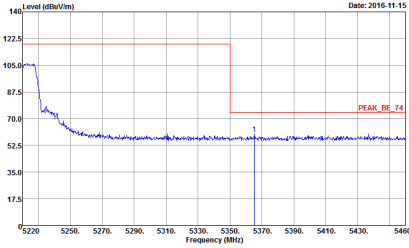
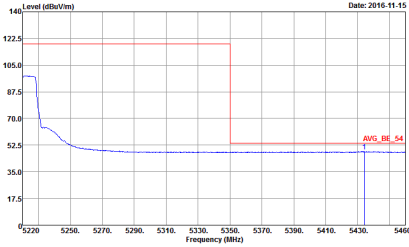

WIFI	Band 1 5150~5250MHz Band Edge @ 3m	
ANT	802.11a CH44 5220MHz - R	
1	Vertical	Fundamental
Peak	 <p> Site : 03CH12-HY Condition : PEAK_BE_74 3m HORN_9120D_1328 VERTICAL : RBW:1000.000KHz VBW:3000.000KHz SWT:Auto Detector : Peak Project : 672014-10 Mode : 2 Setting : 72 </p>	Left blank
Avg.	 <p> Site : 03CH12-HY Condition : AVG_BE_54 3m HORN_9120D_1328 VERTICAL : RBW:1000.000KHz VBW:1.000KHz SWT:Auto Detector : Peak Project : 672014-10 Mode : 2 Setting : 72 </p>	Left blank

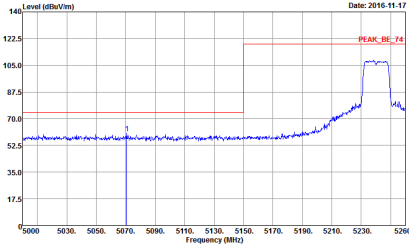
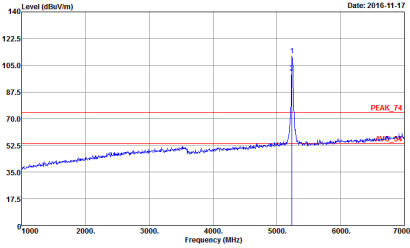
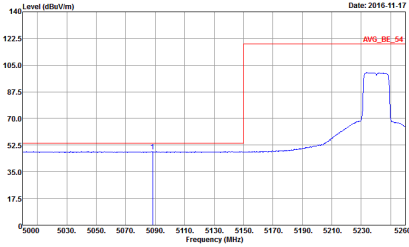

WIFI	Band 1 5150~5250MHz Band Edge @ 3m	
ANT	802.11a CH48 5240MHz - L	
1	Horizontal	Fundamental
Peak	 <p>Date: 2016-11-17</p> <p>Site : 03CH12-HY Condition : PEAK_BE_74 3m HORN_9120D_1328 HORIZONTAL Detector : Peak Project : 672014-10 Mode : 3</p>	 <p>Date: 2016-11-17</p> <p>Site : 03CH12-HY Condition : PEAK_74 3m HORN_9120D_1328 HORIZONTAL Detector : Peak Project : 672014-10 Mode : 3</p>
Avg.	 <p>Date: 2016-11-17</p> <p>Site : 03CH12-HY Condition : AVG_BE_54 3m HORN_9120D_1328 HORIZONTAL Detector : Peak Project : 672014-10 Mode : 3</p>	Left blank



WIFI	Band 1 5150~5250MHz Band Edge @ 3m	
ANT	802.11a CH48 5240MHz - R	
1	Horizontal	Fundamental
Peak		Left blank
Avg.		Left blank

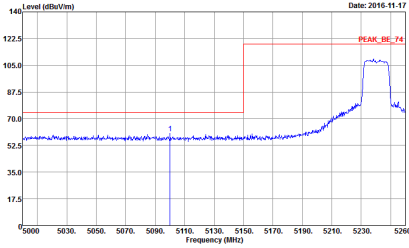
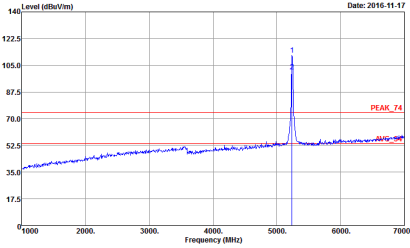
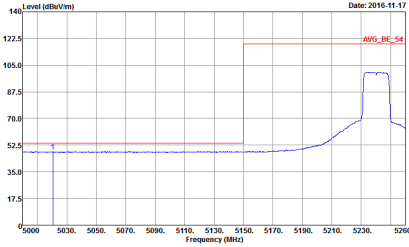

WIFI	Band 1 5150~5250MHz Band Edge @ 3m	
ANT	802.11a CH48 5240MHz - L	
1	Vertical	Fundamental
Peak	 <p>Level (dBuV/m) vs Frequency (MHz) plot showing a peak at 5240 MHz. The y-axis ranges from 17.5 to 140 dBuV/m, and the x-axis ranges from 5000 to 5260 MHz. A red box highlights the peak area, labeled 'PEAK_BE_74'.</p> <p>Site : 03CH12-HY Condition : PEAK_BE_74 3m HORN_9120D_1328 VERTICAL : RBW:1000.000KHz VBW:3000.000KHz SWT:Auto Detector : Peak Project : 672014-10 Mode : 3</p>	 <p>Level (dBuV/m) vs Frequency (MHz) plot showing a peak at 5240 MHz. The y-axis ranges from 17.5 to 140 dBuV/m, and the x-axis ranges from 1000 to 7000 MHz. A red box highlights the peak area, labeled 'PEAK_74'.</p> <p>Site : 03CH12-HY Condition : PEAK_74 3m HORN_9120D_1328 VERTICAL : RBW:1000.000KHz VBW:3000.000KHz SWT:Auto Detector : Peak Project : 672014-10 Mode : 3</p>
Avg.	 <p>Level (dBuV/m) vs Frequency (MHz) plot showing an average level at 5240 MHz. The y-axis ranges from 17.5 to 140 dBuV/m, and the x-axis ranges from 5000 to 5260 MHz. A red box highlights the average level area, labeled 'AVG_BE_54'.</p> <p>Site : 03CH12-HY Condition : AVG_BE_54 3m HORN_9120D_1328 VERTICAL : RBW:1000.000KHz VBW:1.000KHz SWT:Auto Detector : Peak Project : 672014-10 Mode : 3</p>	Left blank

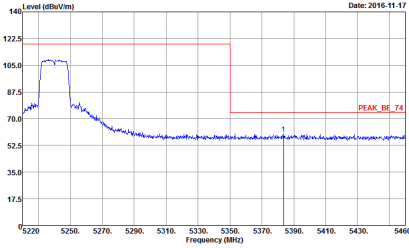
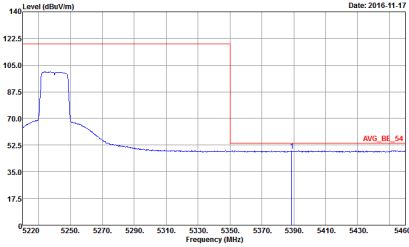

WIFI	Band 1 5150~5250MHz Band Edge @ 3m	
ANT	802.11a CH48 5240MHz - R	
1	Vertical	Fundamental
Peak	 <p> Site : 03CH12-HY Condition : PEAK_BE_74 3m HORN_9120D_1328 VERTICAL : RBW:1000.000KHz VBW:3000.000KHz SWT:Auto Detector : Peak Project : 672014-10 Mode : 3 </p>	Left blank
Avg.	 <p> Site : 03CH12-HY Condition : AVG_BE_54 3m HORN_9120D_1328 VERTICAL : RBW:1000.000KHz VBW:1.000KHz SWT:Auto Detector : Peak Project : 672014-10 Mode : 3 </p>	Left blank



Band 1 5150~5250MHz
WIFI 802.11ac VHT20 (Band Edge @ 3m)

Table with 2 columns (WIFI, ANT) and 2 rows (Peak, Avg.). Contains spectral plots for Horizontal and Fundamental views, and a 'Left blank' plot. Includes technical details like Site, Condition, Detector, Project, Mode, and Setting.

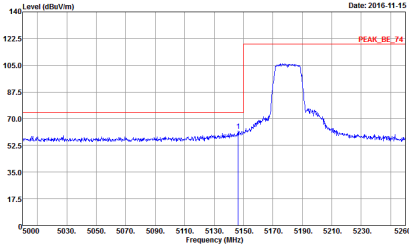
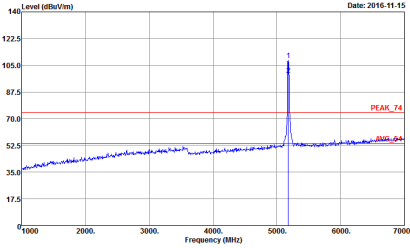
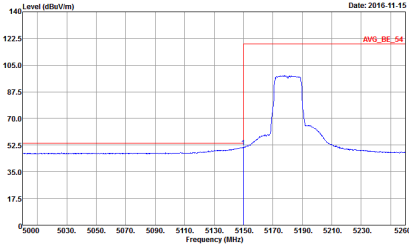

WIFI	Band 1 5150~5250MHz Band Edge @ 3m	
ANT	802.11ac VHT20 CH36 5180MHz	
1	Vertical	Fundamental
Peak	 <p>Level (dBuV/m) vs Frequency (MHz) plot showing a peak at 5180 MHz. The y-axis ranges from 17.5 to 140 dBuV/m, and the x-axis ranges from 5000 to 5260 MHz. A red box highlights the peak, labeled 'PEAK_BE_74'.</p> <p>Site : 03CH12-HY Condition : PEAK_BE_74 3m HORN_9120D_1328 VERTICAL : RBW:1000.000KHz VBW:3000.000KHz SWT:Auto Detector : Peak Project : 672014-10 Mode : 4 Setting : 73</p>	 <p>Level (dBuV/m) vs Frequency (MHz) plot showing a sharp peak at 5180 MHz. The y-axis ranges from 17.5 to 140 dBuV/m, and the x-axis ranges from 1000 to 7000 MHz. A red box highlights the peak, labeled 'PEAK_74'.</p> <p>Site : 03CH12-HY Condition : PEAK_74 3m HORN_9120D_1328 VERTICAL : RBW:1000.000KHz VBW:3000.000KHz SWT:Auto Detector : Peak Project : 672014-10 Mode : 4 Setting : 73</p>
Avg.	 <p>Level (dBuV/m) vs Frequency (MHz) plot showing the average spectrum. The y-axis ranges from 17.5 to 140 dBuV/m, and the x-axis ranges from 5000 to 5260 MHz. A red box highlights the peak, labeled 'AVG_BE_54'.</p> <p>Site : 03CH12-HY Condition : AVG_BE_54 3m HORN_9120D_1328 VERTICAL : RBW:1000.000KHz VBW:1.000KHz SWT:Auto Detector : Peak Project : 672014-10 Mode : 4 Setting : 73</p>	Left blank

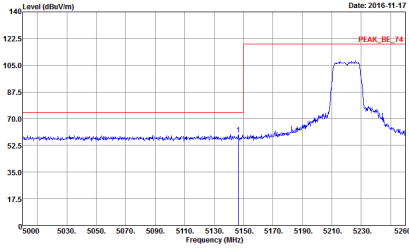
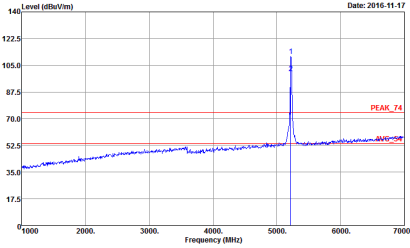
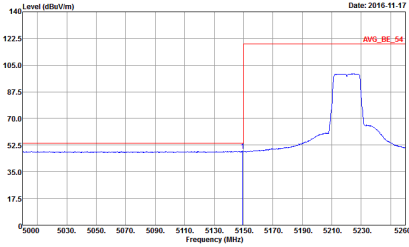

WIFI	Band 1 5150~5250MHz Band Edge @ 3m	
ANT	802.11ac VHT20 CH44 5220MHz - L	
1	Horizontal	Fundamental
Peak	 <p>Date: 2016-11-17</p> <p>Site : 03CH12-HY Condition : PEAK_BE_74 3m HORN_9120D_1328 HORIZONTAL Detector : Peak Project : 672014-10 Mode : 5</p>	 <p>Date: 2016-11-17</p> <p>Site : 03CH12-HY Condition : PEAK_74 3m HORN_9120D_1328 HORIZONTAL Detector : Peak Project : 672014-10 Mode : 5</p>
Avg.	 <p>Date: 2016-11-17</p> <p>Site : 03CH12-HY Condition : AVG_BE_54 3m HORN_9120D_1328 HORIZONTAL Detector : Peak Project : 672014-10 Mode : 5</p>	Left blank

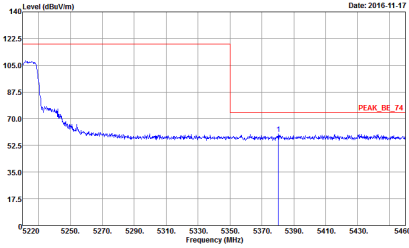
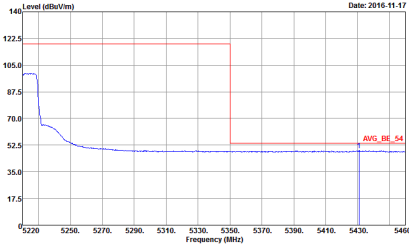

WIFI	Band 1 5150~5250MHz Band Edge @ 3m	
ANT	802.11ac VHT20 CH44 5220MHz - R	
1	Horizontal	Fundamental
Peak	 <p>Site : 03CH12-HY Condition : PEAK_BE_74 3m HORN_9120D_1328 HORIZONTAL RBW:1000.000KHz VBW:3000.000KHz SWT:Auto Detector : Peak Project : 672014-10 Mode : 5</p>	Left blank
Avg.	 <p>Site : 03CH12-HY Condition : AVG_BE_54 3m HORN_9120D_1328 HORIZONTAL RBW:1000.000KHz VBW:1.000KHz SWT:Auto Detector : Peak Project : 672014-10 Mode : 5</p>	Left blank

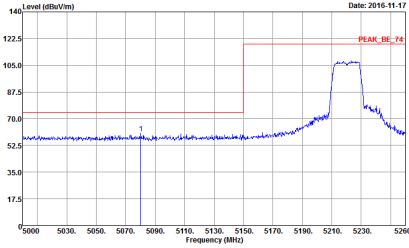
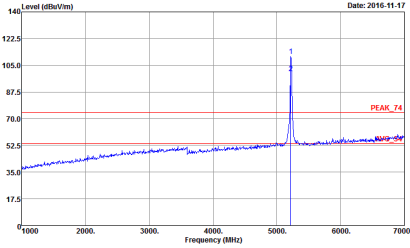
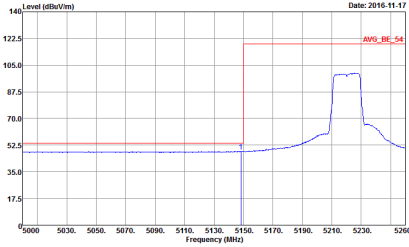

WIFI	Band 1 5150~5250MHz Band Edge @ 3m	
ANT	802.11ac VHT20 CH44 5220MHz - L	
1	Vertical	Fundamental
Peak	 <p>Level (dBuV/m) vs Frequency (MHz) plot showing a peak at approximately 5220 MHz. The peak level is indicated as PEAK_BE_74.</p> <p>Site : 03CH12-HY Condition : PEAK_BE_74 3m HORN_9120D_1328 VERTICAL Detector : Peak Project : 672014-10 Mode : 5</p>	 <p>Level (dBuV/m) vs Frequency (MHz) plot showing a sharp peak at approximately 5220 MHz. The peak level is indicated as PEAK_74.</p> <p>Site : 03CH12-HY Condition : PEAK_74 3m HORN_9120D_1328 VERTICAL Detector : Peak Project : 672014-10 Mode : 5</p>
Avg.	 <p>Level (dBuV/m) vs Frequency (MHz) plot showing the average level across the frequency range. A red line indicates the average level, labeled AVG_BE_54.</p> <p>Site : 03CH12-HY Condition : AVG_BE_54 3m HORN_9120D_1328 VERTICAL Detector : Peak Project : 672014-10 Mode : 5</p>	Left blank

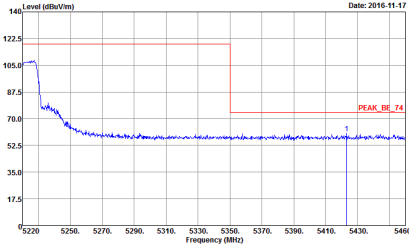
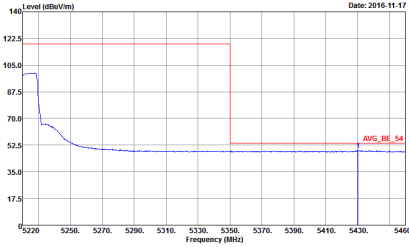

WIFI	Band 1 5150~5250MHz Band Edge @ 3m	
ANT	802.11ac VHT20 CH44 5220MHz - R	
1	Vertical	Fundamental
Peak	 <p> Site : 03CH12-HY Condition : PEAK_BE_74 3m HORN_9120D_1328 VERTICAL Detector : RBW:1000.000KHz VBW:3000.000KHz SWT:Auto Project : Peak Mode : :5 Date: 2016-11-17 </p>	Left blank
Avg.	 <p> Site : 03CH12-HY Condition : AVG_BE_54 3m HORN_9120D_1328 VERTICAL Detector : RBW:1000.000KHz VBW:1.000KHz SWT:Auto Project : Peak Mode : :5 Date: 2016-11-17 </p>	Left blank

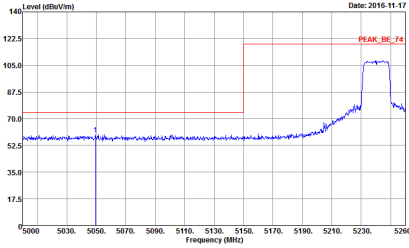
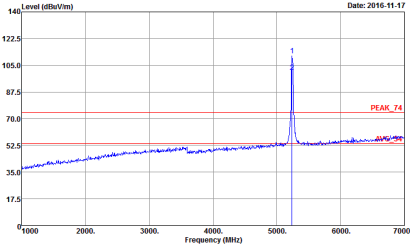
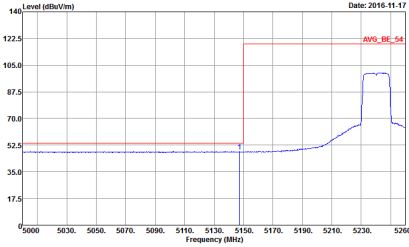

WIFI	Band 1 5150~5250MHz Band Edge @ 3m	
ANT	802.11ac VHT20 CH48 5240MHz - L	
1	Horizontal	Fundamental
Peak	 <p>Date: 2016-11-17</p> <p>Site : 03CH12-HY Condition : PEAK_BE_74 3m HORN_9120D_1328 HORIZONTAL Detector : Peak Project : 672014-10 Mode : 6</p>	 <p>Date: 2016-11-17</p> <p>Site : 03CH12-HY Condition : PEAK_74 3m HORN_9120D_1328 HORIZONTAL Detector : Peak Project : 672014-10 Mode : 6</p>
Avg.	 <p>Date: 2016-11-17</p> <p>Site : 03CH12-HY Condition : AVG_BE_54 3m HORN_9120D_1328 HORIZONTAL Detector : Peak Project : 672014-10 Mode : 6</p>	Left blank

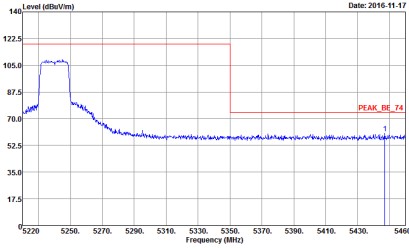
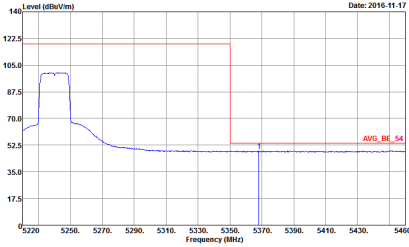

WIFI	Band 1 5150~5250MHz Band Edge @ 3m	
ANT	802.11ac VHT20 CH48 5240MHz - R	
1	Horizontal	Fundamental
Peak	 <p>Site : 03CH12-HY Condition : PEAK_BE_74 3m HORN_9120D_1328 HORIZONTAL : RBW:1000.000KHz VBW:3000.000KHz SWT:Auto Detector : Peak Project : 672014-10 Mode : 6</p>	Left blank
Avg.	 <p>Site : 03CH12-HY Condition : AVG_BE_54 3m HORN_9120D_1328 HORIZONTAL : RBW:1000.000KHz VBW:1.000KHz SWT:Auto Detector : Peak Project : 672014-10 Mode : 6</p>	Left blank

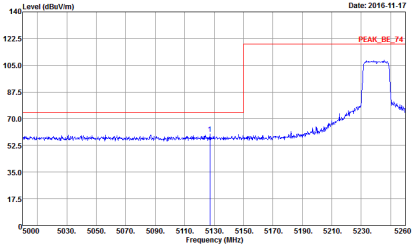
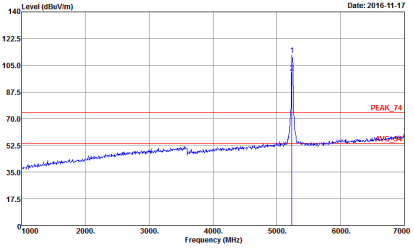
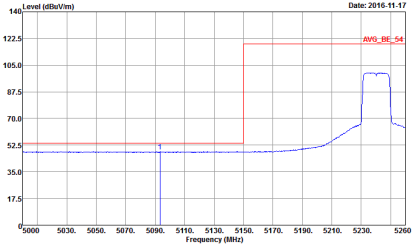

WIFI	Band 1 5150~5250MHz Band Edge @ 3m	
ANT	802.11ac VHT20 CH48 5240MHz - L	
1	Vertical	Fundamental
Peak	 <p>Level (dBuV/m) vs Frequency (MHz) plot showing a peak at approximately 5240 MHz. The peak level is around 105 dBuV/m. The plot is dated 2016-11-17.</p> <p>Site : 03CH12-HY Condition : PEAK_BE_74 3m HORN_9120D_1328 VERTICAL : RBW:1000.000KHz VBW:3000.000KHz SWT:Auto Detector : Peak Project : 672014-10 Mode : 6</p>	 <p>Level (dBuV/m) vs Frequency (MHz) plot showing a sharp peak at approximately 5240 MHz. The peak level is around 105 dBuV/m. The plot is dated 2016-11-17.</p> <p>Site : 03CH12-HY Condition : PEAK_74 3m HORN_9120D_1328 VERTICAL : RBW:1000.000KHz VBW:3000.000KHz SWT:Auto Detector : Peak Project : 672014-10 Mode : 6</p>
Avg.	 <p>Level (dBuV/m) vs Frequency (MHz) plot showing an average level across the frequency range. A peak is visible at approximately 5240 MHz. The plot is dated 2016-11-17.</p> <p>Site : 03CH12-HY Condition : AVG_BE_54 3m HORN_9120D_1328 VERTICAL : RBW:1000.000KHz VBW:1.000KHz SWT:Auto Detector : Peak Project : 672014-10 Mode : 6</p>	Left blank

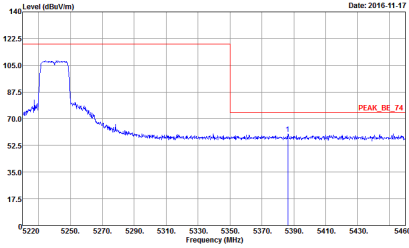
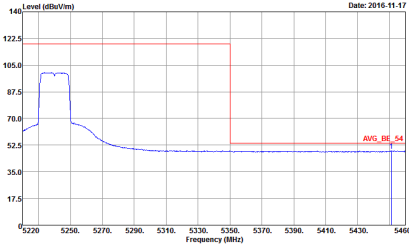

WIFI	Band 1 5150~5250MHz Band Edge @ 3m	
ANT	802.11ac VHT20 CH48 5240MHz - R	
1	Vertical	Fundamental
Peak	 <p> Site : 03CH12-HY Condition : PEAK_BE_74 3m HORN_9120D_1328 VERTICAL Detector : Peak Project : 672014-10 Mode : 6 </p>	Left blank
Avg.	 <p> Site : 03CH12-HY Condition : AVG_BE_54 3m HORN_9120D_1328 VERTICAL Detector : Peak Project : 672014-10 Mode : 6 </p>	Left blank



Band 1 5150~5250MHz
WIFI 802.11ac VHT40 (Band Edge @ 3m)

Table with 2 columns (WIFI, ANT) and 2 rows (Peak, Avg.). The table contains spectral analysis plots for 'Horizontal' and 'Fundamental' views, showing Level (dBu/m) vs Frequency (MHz) with various technical parameters and site information.

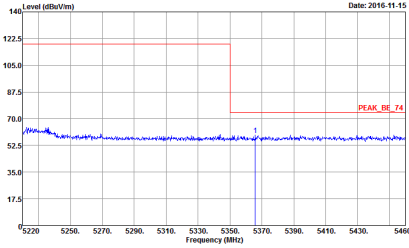
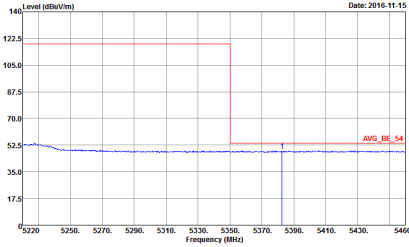

WIFI	Band 1 5150~5250MHz Band Edge @ 3m	
ANT	802.11ac VHT40 CH38 5190MHz - R	
1	Horizontal	Fundamental
Peak	 <p>Date: 2016-11-15</p> <p>Site : 03CH12-HY Condition : PEAK_BE_74 3m HORN_9120D_1328 HORIZONTAL : RBW:1000.000KHz VBW:3000.000KHz SWT:Auto Detector : Peak Project : 672014-10 Mode : 7 Setting : 59</p>	Left blank
Avg.	 <p>Date: 2016-11-15</p> <p>Site : 03CH12-HY Condition : AVG_BE_54 3m HORN_9120D_1328 HORIZONTAL : RBW:1000.000KHz VBW:3.000KHz SWT:Auto Detector : Peak Project : 672014-10 Mode : 7 Setting : 59</p>	Left blank

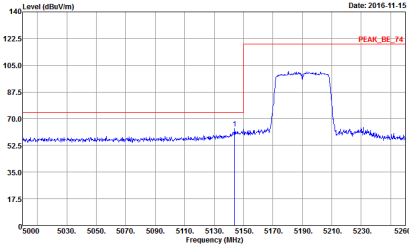
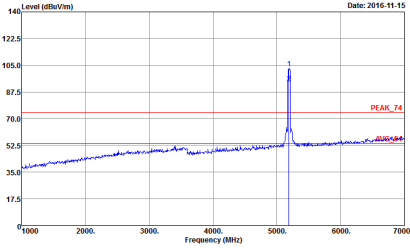
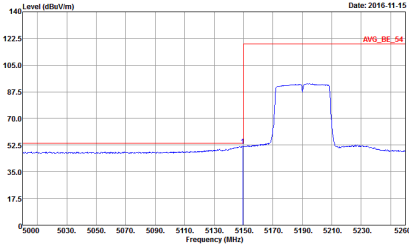

WIFI	Band 1 5150~5250MHz Band Edge @ 3m	
ANT	802.11ac VHT40 CH38 5190MHz - L	
1	Vertical	Fundamental
Peak	 <p>Level (dBuV/m) vs Frequency (MHz) plot showing a peak at 5190 MHz. The peak level is approximately 105 dBuV/m. The plot is titled 'Date: 2016-11-15' and 'PEAK_BE_74'.</p> <p>Site : 03CH12-HY Condition : PEAK_BE_74 3m HORN_9120D_1328 VERTICAL : RBW:1000.000KHz VBW:3000.000KHz SWT:Auto Detector : Peak Project : 672014-10 Mode : 7 Setting : 59</p>	 <p>Level (dBuV/m) vs Frequency (MHz) plot showing a sharp peak at 5190 MHz. The peak level is approximately 105 dBuV/m. The plot is titled 'Date: 2016-11-15' and 'PEAK_74'.</p> <p>Site : 03CH12-HY Condition : PEAK_74 3m HORN_9120D_1328 VERTICAL : RBW:1000.000KHz VBW:3000.000KHz SWT:Auto Detector : Peak Project : 672014-10 Mode : 7 Setting : 59</p>
Avg.	 <p>Level (dBuV/m) vs Frequency (MHz) plot showing the average level. The level is approximately 105 dBuV/m at 5190 MHz. The plot is titled 'Date: 2016-11-15' and 'AVG_BE_54'.</p> <p>Site : 03CH12-HY Condition : AVG_BE_54 3m HORN_9120D_1328 VERTICAL : RBW:1000.000KHz VBW:3.000KHz SWT:Auto Detector : Peak Project : 672014-10 Mode : 7 Setting : 59</p>	Left blank

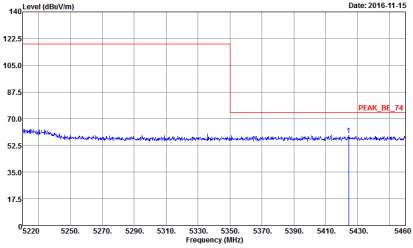
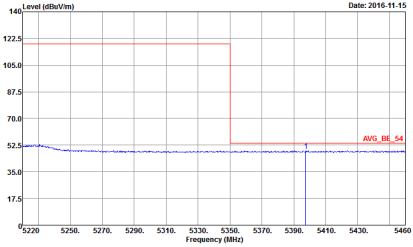

WIFI	Band 1 5150~5250MHz Band Edge @ 3m	
ANT	802.11ac VHT40 CH38 5190MHz - R	
1	Vertical	Fundamental
Peak	 <p>Date: 2016-11-15</p> <p>Site : 03CH12-HY Condition : PEAK_BE_74 3m HORN_9120D_1328 VERTICAL : RBW:1000.000KHz VBW:3000.000KHz SWT:Auto Detector : Peak Project : 672014-10 Mode : 7 Setting : 59</p>	Left blank
Avg.	 <p>Date: 2016-11-15</p> <p>Site : 03CH12-HY Condition : AVG_BE_54 3m HORN_9120D_1328 VERTICAL : RBW:1000.000KHz VBW:3.000KHz SWT:Auto Detector : Peak Project : 672014-10 Mode : 7 Setting : 59</p>	Left blank

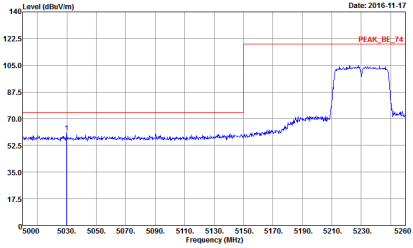
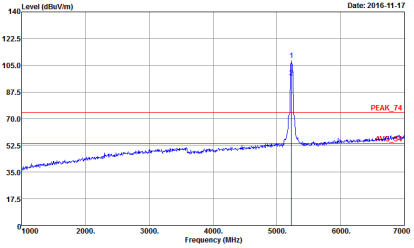
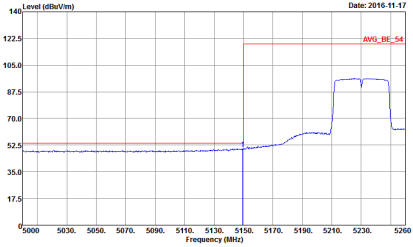

WIFI	Band 1 5150~5250MHz Band Edge @ 3m	
ANT	802.11ac VHT40 CH46 5230MHz - L	
1	Horizontal	Fundamental
Peak	 <p>Date: 2016-11-17</p> <p>Site : 03CH12-HY Condition : PEAK_BE_74 3m HORN_9120D_1328 HORIZONTAL Detector : Peak Project : 672014-10 Mode : 8</p>	 <p>Date: 2016-11-17</p> <p>Site : 03CH12-HY Condition : PEAK_74 3m HORN_9120D_1328 HORIZONTAL Detector : Peak Project : 672014-10 Mode : 8</p>
Avg.	 <p>Date: 2016-11-17</p> <p>Site : 03CH12-HY Condition : AVG_BE_54 3m HORN_9120D_1328 HORIZONTAL Detector : Peak Project : 672014-10 Mode : 8</p>	Left blank

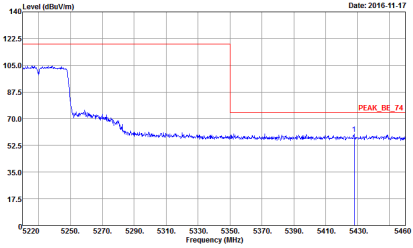
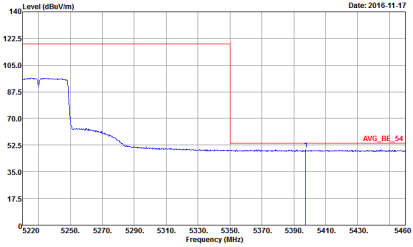

WIFI	Band 1 5150~5250MHz Band Edge @ 3m	
ANT	802.11ac VHT40 CH46 5230MHz - R	
1	Horizontal	Fundamental
Peak	 <p>Site : 03CH12-HY Condition : PEAK_BE_74 3m HORN_9120D_1328 HORIZONTAL RBW:1000.000kHz VBW:3000.000kHz SWT:Auto Detector : Peak Project : 672014-10 Mode : 8</p>	Left blank
Avg.	 <p>Site : 03CH12-HY Condition : AVG_BE_54 3m HORN_9120D_1328 HORIZONTAL RBW:1000.000kHz VBW:3.000kHz SWT:Auto Detector : Peak Project : 672014-10 Mode : 8</p>	Left blank

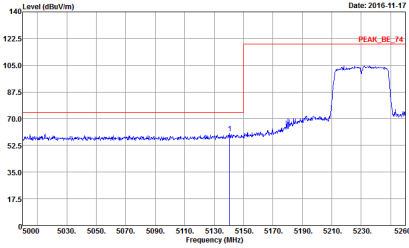
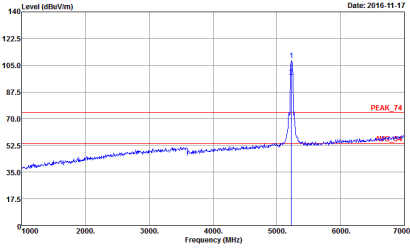
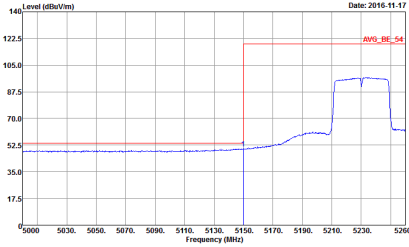

WIFI	Band 1 5150~5250MHz Band Edge @ 3m	
ANT	802.11ac VHT40 CH46 5230MHz - L	
1	Vertical	Fundamental
Peak	 <p>Date: 2016-11-17</p> <p>Site : 03CH12-HY Condition : PEAK_BE_74 3m HORN_9120D_1328 VERTICAL : RBW:1000.000KHz VBW:3000.000KHz SWT:Auto Detector : Peak Project : 672014-10 Mode : 8</p>	 <p>Date: 2016-11-17</p> <p>Site : 03CH12-HY Condition : PEAK_74 3m HORN_9120D_1328 VERTICAL : RBW:1000.000KHz VBW:3000.000KHz SWT:Auto Detector : Peak Project : 672014-10 Mode : 8</p>
Avg.	 <p>Date: 2016-11-17</p> <p>Site : 03CH12-HY Condition : AVG_BE_54 3m HORN_9120D_1328 VERTICAL : RBW:1000.000KHz VBW:3.000KHz SWT:Auto Detector : Peak Project : 672014-10 Mode : 8</p>	Left blank

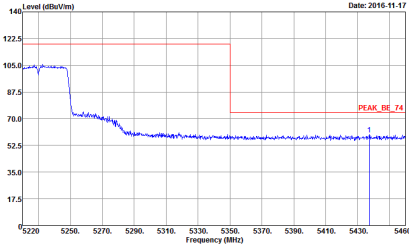
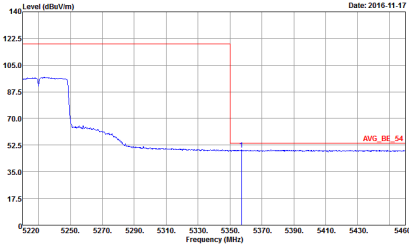

WIFI	Band 1 5150~5250MHz Band Edge @ 3m	
ANT	802.11ac VHT40 CH46 5230MHz - R	
1	Vertical	Fundamental
Peak	 <p>Site : 03CH12-HY Condition : PEAK_BE_74 3m HORN_9120D_1328 VERTICAL Detector : RBW:1000.000KHz VBW:3000.000KHz SWT:Auto Project : Peak Mode : :672014-10 :8</p>	Left blank
Avg.	 <p>Site : 03CH12-HY Condition : AVG_BE_54 3m HORN_9120D_1328 VERTICAL Detector : RBW:1000.000KHz VBW:3.000KHz SWT:Auto Project : Peak Mode : :672014-10 :8</p>	Left blank



Band 1 5150~5250MHz
WIFI 802.11ac VHT80 (Band Edge @ 3m)

WIFI	Band 1 5150~5250MHz Band Edge @ 3m	
ANT	802.11ac VHT80 CH42 5210MHz - L	
1	Horizontal	Fundamental
<p>Peak</p>	<p>Date: 2016-11-15</p> <p>Site : 03CH12-HY Condition : PEAK_BE_74 3m HORN_9120D_1328 HORIZONTAL RBW:1000.000KHz VBW:3000.000KHz SWT:Auto Detector : Peak Project : 672014-10 Mode : 9 Setting : 62</p>	<p>Date: 2016-11-15</p> <p>Site : 03CH12-HY Condition : PEAK_74 3m HORN_9120D_1328 HORIZONTAL RBW:1000.000KHz VBW:3000.000KHz SWT:Auto Detector : Peak Project : 672014-10 Mode : 9 Setting : 62</p>
<p>Avg.</p>	<p>Date: 2016-11-15</p> <p>Site : 03CH12-HY Condition : AVG_BE_54 3m HORN_9120D_1328 HORIZONTAL RBW:1000.000KHz VBW:3.000KHz SWT:Auto Detector : Peak Project : 672014-10 Mode : 9 Setting : 62</p>	<p align="center">Left blank</p>

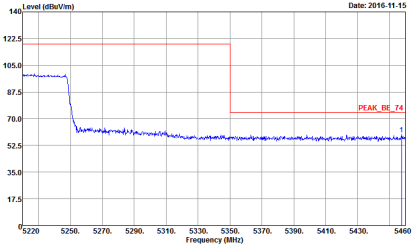
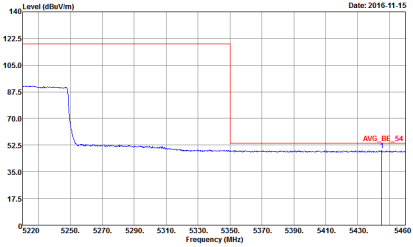

WIFI	Band 1 5150~5250MHz Band Edge @ 3m	
ANT	802.11ac VHT80 CH42 5210MHz - R	
1	Horizontal	Fundamental
Peak	 <p> Date: 2016-11-15 Site : 03CH12-HY Condition : PEAK_BE_74 3m HORN_9120D_1328 HORIZONTAL : RBW:1000.000KHz VBW:3000.000KHz SWT:Auto Detector : Peak Project : 672014-10 Mode : 9 Setting : 62 </p>	Left blank
Avg.	 <p> Date: 2016-11-15 Site : 03CH12-HY Condition : AVG_BE_54 3m HORN_9120D_1328 HORIZONTAL : RBW:1000.000KHz VBW:3.000KHz SWT:Auto Detector : Peak Project : 672014-10 Mode : 9 Setting : 62 </p>	Left blank

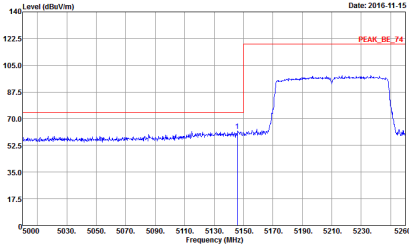
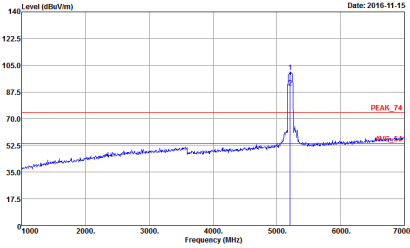
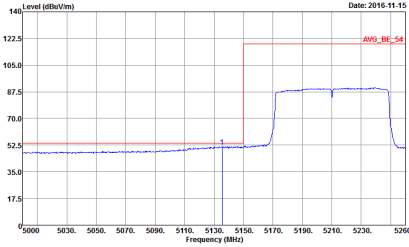

WIFI	Band 1 5150~5250MHz Band Edge @ 3m	
ANT	802.11ac VHT80 CH42 5210MHz - L	
1	Vertical	Fundamental
Peak	 <p>Level (dBuV/m) vs Frequency (MHz) plot showing a peak at 5210 MHz. The y-axis ranges from 17.5 to 140 dBuV/m, and the x-axis ranges from 5000 to 5260 MHz. A red line indicates the peak level at approximately 122.5 dBuV/m.</p> <p>Site : 03CH12-HY Condition : PEAK_BE_74 3m HORN_9120D_1328 VERTICAL : RBW:1000.000KHz VBW:3000.000KHz SWT:Auto Detector : Peak Project : 672014-10 Mode : 9 Setting : 62</p>	 <p>Level (dBuV/m) vs Frequency (MHz) plot showing a sharp peak at 5210 MHz. The y-axis ranges from 17.5 to 140 dBuV/m, and the x-axis ranges from 1000 to 7000 MHz. A red line indicates the peak level at approximately 70.0 dBuV/m.</p> <p>Site : 03CH12-HY Condition : PEAK_74 3m HORN_9120D_1328 VERTICAL : RBW:1000.000KHz VBW:3000.000KHz SWT:Auto Detector : Peak Project : 672014-10 Mode : 9 Setting : 62</p>
Avg.	 <p>Level (dBuV/m) vs Frequency (MHz) plot showing an average level at 5210 MHz. The y-axis ranges from 17.5 to 140 dBuV/m, and the x-axis ranges from 5000 to 5260 MHz. A red line indicates the average level at approximately 122.5 dBuV/m.</p> <p>Site : 03CH12-HY Condition : AVG_BE_54 3m HORN_9120D_1328 VERTICAL : RBW:1000.000KHz VBW:3.000KHz SWT:Auto Detector : Peak Project : 672014-10 Mode : 9 Setting : 62</p>	Left blank

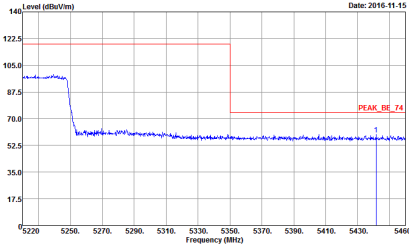
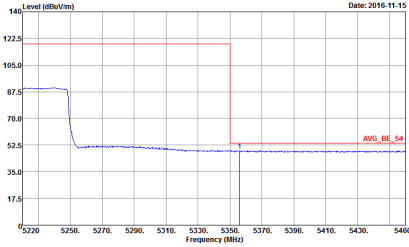

WIFI	Band 1 5150~5250MHz Band Edge @ 3m	
ANT	802.11ac VHT80 CH42 5210MHz - R	
1	Vertical	Fundamental
Peak	 <p>Date: 2016-11-15</p> <p>Site : 03CH12-HY Condition : PEAK_BE_74 3m HORN_9120D_1328 VERTICAL : RBW:1000.000KHz VBW:3000.000KHz SWT:Auto Detector : Peak Project : 672014-10 Mode : 9 Setting : 62</p>	Left blank
Avg.	 <p>Date: 2016-11-15</p> <p>Site : 03CH12-HY Condition : AVG_BE_54 3m HORN_9120D_1328 VERTICAL : RBW:1000.000KHz VBW:3.000KHz SWT:Auto Detector : Peak Project : 672014-10 Mode : 9 Setting : 62</p>	Left blank

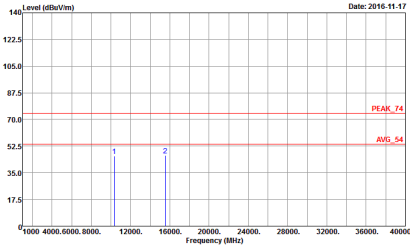
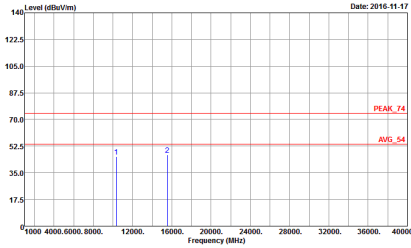

Band 1 - 5150~5250MHz
WIFI 802.11a (Harmonic @ 3m)

WIFI	Band 1 5150~5250MHz Harmonic @ 3m	
ANT	802.11a CH36 5180MHz	
1	Horizontal	Vertical
<p>Peak</p> <p>Avg.</p>	 <p>Site : 03CH12-HY Condition : PEAK_74 3m HORN_9120D_1328 HORIZONTAL Project : 672014-10 Mode : 1</p>	 <p>Site : 03CH12-HY Condition : PEAK_74 3m HORN_9120D_1328 VERTICAL Project : 672014-10 Mode : 1</p>

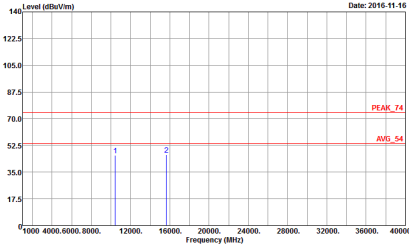
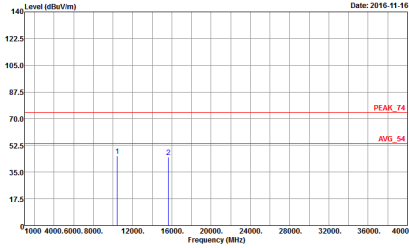

WIFI	Band 1 5150~5250MHz Harmonic @ 3m	
ANT	802.11a CH44 5220MHz	
1	Horizontal	Vertical
<p>Peak</p> <p>Avg.</p>	 <p>Site : 03CH12-HY Condition : PEAK_74 3m HORN_9120D_1328 HORIZONTAL Project : 672014-10 Mode : 2</p>	 <p>Site : 03CH12-HY Condition : PEAK_74 3m HORN_9120D_1328 VERTICAL Project : 672014-10 Mode : 2</p>

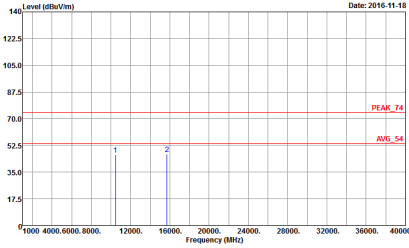
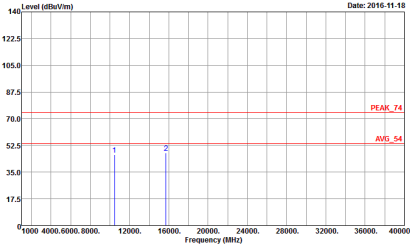

WIFI	Band 1 5150~5250MHz Harmonic @ 3m	
ANT	802.11a CH48 5240MHz	
1	Horizontal	Vertical
<p>Peak</p> <p>Avg.</p>	 <p>Site : 03CH12-HY Condition : PEAK_74 3m HORN_9120D_1328 HORIZONTAL Project : 672014-10 Mode : 3</p>	 <p>Site : 03CH12-HY Condition : PEAK_74 3m HORN_9120D_1328 VERTICAL Project : 672014-10 Mode : 3</p>



Band 1 5150~5250MHz
WIFI 802.11ac VHT20 (Harmonic @ 3m)

Table with 2 columns: Horizontal and Vertical. Each column contains a graph of Level (dBm/m) vs Frequency (MHz) and associated metadata. The graphs show two peaks labeled '1' and '2' with a 'PEAK_74' label and an 'AVG_54' label. The metadata includes Site, Condition, Project, and Mode information.



WIFI	Band 1 5150~5250MHz Harmonic @ 3m	
ANT	802.11ac VHT20 CH44 5220MHz	
1	Horizontal	Vertical
Peak Avg.	<p>Site : 03CH12-HY Condition : PEAK_74 3m HORN_9120D_1328 HORIZONTAL Project : 672014-10 Mode : S</p>	<p>Site : 03CH12-HY Condition : PEAK_74 3m HORN_9120D_1328 VERTICAL Project : 672014-10 Mode : S</p>



WIFI	Band 1 5150~5250MHz Harmonic @ 3m	
ANT	802.11ac VHT20 CH48 5240MHz	
1	Horizontal	Vertical
Peak Avg.	<p>Site : 03CH12-HY Condition : PEAK_74 3m HORN_9120D_1328 HORIZONTAL Project : 672014-10 Mode : 6</p>	<p>Site : 03CH12-HY Condition : PEAK_74 3m HORN_9120D_1328 VERTICAL Project : 672014-10 Mode : 6</p>



Band 1 5150~5250MHz
WIFI 802.11ac VHT40 (Harmonic @ 3m)

WIFI	Band 1 5150~5250MHz Harmonic @ 3m	
ANT	802.11ac VHT40 CH38 5190MHz	
1	Horizontal	Vertical
<p>Peak</p> <p>Avg.</p>	<p>Site : 03CH12-HY Condition : PEAK_74 3m HORN_9120D_1328 HORIZONTAL Project : 672014-10 Mode : 7</p>	<p>Site : 03CH12-HY Condition : PEAK_74 3m HORN_9120D_1328 VERTICAL Project : 672014-10 Mode : 7</p>

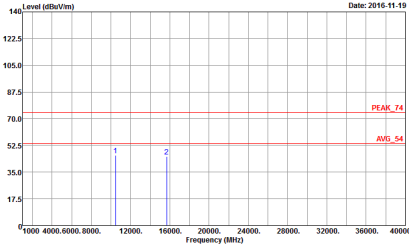
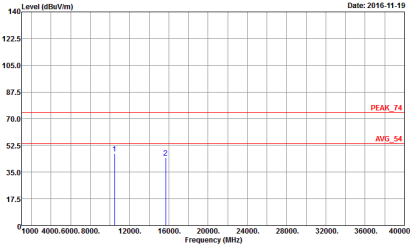

WIFI	Band 1 5150~5250MHz Harmonic @ 3m	
ANT	802.11ac VHT40 CH46 5230MHz	
1	Horizontal	Vertical
<p>Peak</p> <p>Avg.</p>	 <p>Site : 03CH12-HY Condition : PEAK_74 3m HORN_9120D_1328 HORIZONTAL Project : 672014-10 Mode : S</p>	 <p>Site : 03CH12-HY Condition : PEAK_74 3m HORN_9120D_1328 VERTICAL Project : 672014-10 Mode : S</p>

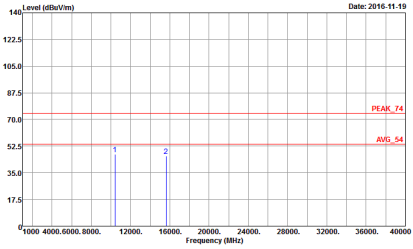
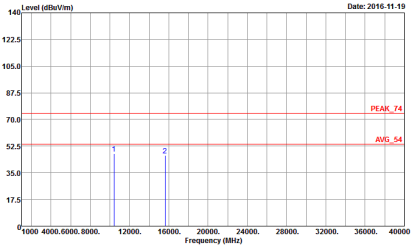

Band 1 5150~5250MHz
WIFI 802.11ac VHT80 (Harmonic @ 3m)

WIFI	Band 1 5150~5250MHz Harmonic @ 3m	
ANT	802.11ac VHT80 CH42 5210MHz	
1	Horizontal	Vertical
<p>Peak</p> <p>Avg.</p>	 <p>Site : 03CH12-HY Condition : PEAK_74 3m HORN_9120D_132B HORIZONTAL Project : 672014-10 Mode : 9</p>	 <p>Site : 03CH12-HY Condition : PEAK_74 3m HORN_9120D_132B VERTICAL Project : 672014-10 Mode : 9</p>

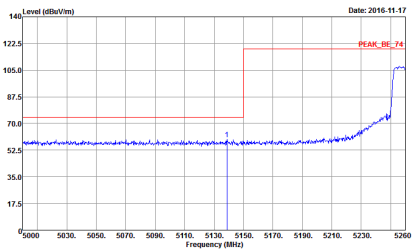
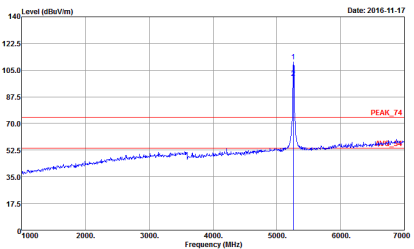
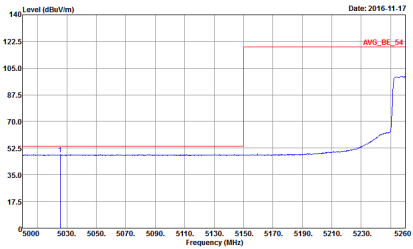

Band 2 - 5250~5350MHz
WIFI 802.11a (Band Edge @ 3m)

WIFI	Band 2 5250~5350MHz Band Edge @ 3m	
ANT	802.11a CH52 5260MHz - L	
<p align="center">1</p>	<p align="center">Horizontal</p>  <p>Site : 03CH12-HY Condition : PEAK_BE_74 3m HORN_9120D_1328 HORIZONTAL Detector : RBW:1000.000KHz VBW:3000.000KHz SWT:Auto Project : Peak Mode : 672014-10 : 10</p>	<p align="center">Fundamental</p>  <p>Site : 03CH12-HY Condition : PEAK_74 3m HORN_9120D_1328 HORIZONTAL Detector : RBW:1000.000KHz VBW:3000.000KHz SWT:Auto Project : Peak Mode : 672014-10 : 10</p>
<p align="center">Peak</p>	<p align="center">Avg.</p>  <p>Site : 03CH12-HY Condition : AVG_BE_54 3m HORN_9120D_1328 HORIZONTAL Detector : RBW:1000.000KHz VBW:1.000KHz SWT:Auto Project : Peak Mode : 672014-10 : 10</p>	<p align="center">Left blank</p>

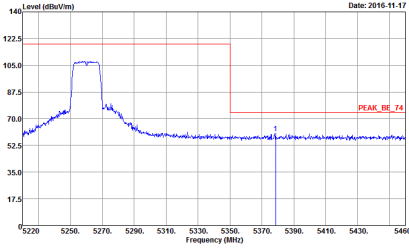
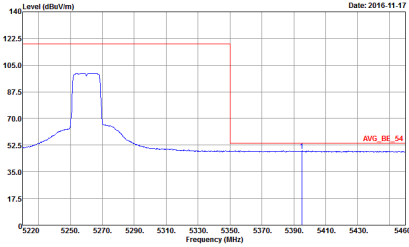

WIFI	Band 2 5250~5350MHz Band Edge @ 3m	
ANT	802.11a CH52 5260MHz - R	
1	Horizontal	Fundamental
Peak	 <p> Site : 03CH12-HY Condition : PEAK_BE_74 3m HORN_9120D_1328 HORIZONTAL Detector : Peak Project : 672014-10 Mode : 10 </p>	Left blank
Avg.	 <p> Site : 03CH12-HY Condition : AVG_BE_54 3m HORN_9120D_1328 HORIZONTAL Detector : Peak Project : 672014-10 Mode : 10 </p>	Left blank

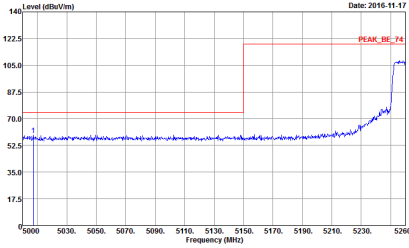
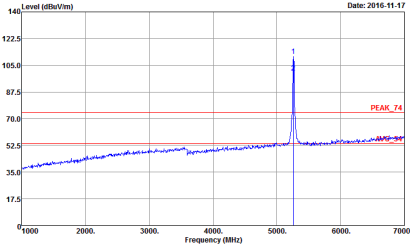
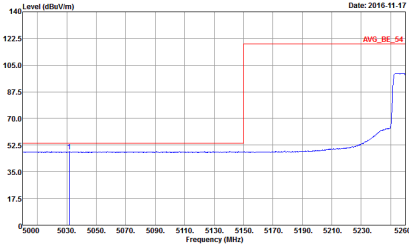

WIFI	Band 2 5250~5350MHz Band Edge @ 3m	
ANT	802.11a CH52 5260MHz - L	
1	Vertical	Fundamental
Peak	 <p>Date: 2016-11-17</p> <p>Site : 03CH12-HY Condition : PEAK_BE_74 3m HORN_9120D_1328 VERTICAL : RBW:1000.000KHz VBW:3000.000KHz SWT:Auto Detector : Peak Project : 672014-10 Mode : 10</p>	 <p>Date: 2016-11-17</p> <p>Site : 03CH12-HY Condition : PEAK_74 3m HORN_9120D_1328 VERTICAL : RBW:1000.000KHz VBW:3000.000KHz SWT:Auto Detector : Peak Project : 672014-10 Mode : 10</p>
Avg.	 <p>Date: 2016-11-17</p> <p>Site : 03CH12-HY Condition : AVG_BE_54 3m HORN_9120D_1328 VERTICAL : RBW:1000.000KHz VBW:1.000KHz SWT:Auto Detector : Peak Project : 672014-10 Mode : 10</p>	Left blank

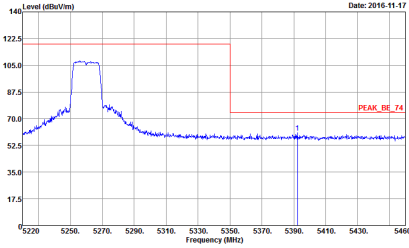
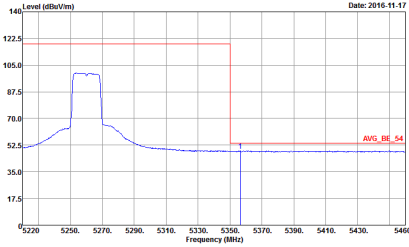

WIFI	Band 2 5250~5350MHz Band Edge @ 3m	
ANT	802.11a CH52 5260MHz - R	
1	Vertical	Fundamental
Peak	 <p> Site : 03CH12-HY Condition : PEAK_BE_74 3m HORN_9120D_1328 VERTICAL Detector : Peak Project : 672014-10 Mode : 10 </p>	Left blank
Avg.	 <p> Site : 03CH12-HY Condition : AVG_BE_54 3m HORN_9120D_1328 VERTICAL Detector : Peak Project : 672014-10 Mode : 10 </p>	Left blank



WIFI	Band 2 5250~5350MHz Band Edge @ 3m	
ANT	802.11a CH60 5300MHz - L	
1	Horizontal	Fundamental
Peak	<p>Date: 2016-11-15</p> <p>Site : 03CH12-HY Condition : PEAK_BE_74 3m HORN_9120D_1328 HORIZONTAL Detector : Peak Project : 672014-10 Mode : 11 Setting : 72</p>	<p>Date: 2016-11-15</p> <p>Site : 03CH12-HY Condition : PEAK_74 3m HORN_9120D_1328 HORIZONTAL Detector : Peak Project : 672014-10 Mode : 11 Setting : 72</p>
Avg.	<p>Date: 2016-11-15</p> <p>Site : 03CH12-HY Condition : AVG_BE_54 3m HORN_9120D_1328 HORIZONTAL Detector : Peak Project : 672014-10 Mode : 11 Setting : 72</p>	Left blank

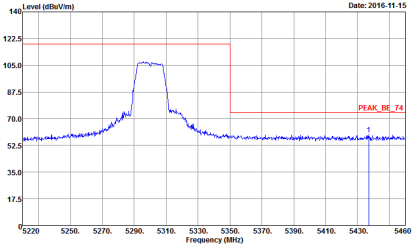
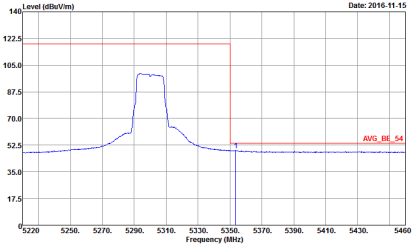

WIFI	Band 2 5250~5350MHz Band Edge @ 3m	
ANT	802.11a CH60 5300MHz - R	
1	Horizontal	Fundamental
Peak	 <p> Site : 03CH12-HY Condition : PEAK_BE_74 3m HORN_9120D_1328 HORIZONTAL : RBW:1000.000KHz VBW:3000.000KHz SWT:Auto Detector : Peak Project : 672014-10 Mode : 11 Setting : 72 </p>	Left blank
Avg.	 <p> Site : 03CH12-HY Condition : AVG_BE_54 3m HORN_9120D_1328 HORIZONTAL : RBW:1000.000KHz VBW:1.000KHz SWT:Auto Detector : Peak Project : 672014-10 Mode : 11 Setting : 72 </p>	Left blank

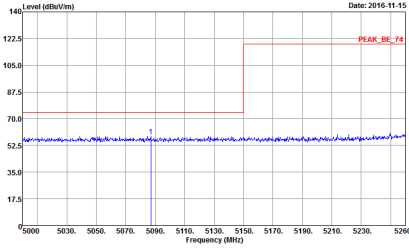
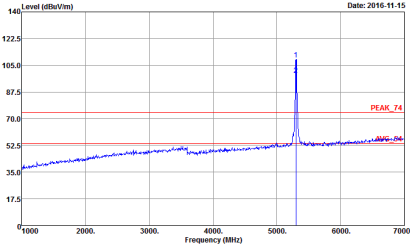
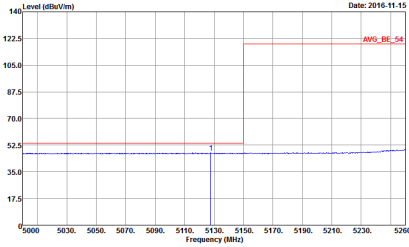

WIFI	Band 2 5250~5350MHz Band Edge @ 3m	
ANT	802.11a CH60 5300MHz - L	
1	Vertical	Fundamental
Peak	 <p>Level (dBuV/m) vs Frequency (MHz) plot showing a peak at 5130 MHz. The peak level is approximately 122.5 dBuV/m. The plot includes a red step function labeled 'PEAK_BE_74' and a blue signal trace.</p> <p>Site : 03CH12-HY Condition : PEAK_BE_74 3m HORN_9120D_1328 VERTICAL : RBW:1000.000KHz VBW:3000.000KHz SWT:Auto Detector : Peak Project : 672014-10 Mode : 11 Setting : 72</p>	 <p>Level (dBuV/m) vs Frequency (MHz) plot showing a peak at 5130 MHz. The peak level is approximately 122.5 dBuV/m. The plot includes a red step function labeled 'PEAK_74' and a blue signal trace.</p> <p>Site : 03CH12-HY Condition : PEAK_74 3m HORN_9120D_1328 VERTICAL : RBW:1000.000KHz VBW:3000.000KHz SWT:Auto Detector : Peak Project : 672014-10 Mode : 11 Setting : 72</p>
Avg.	 <p>Level (dBuV/m) vs Frequency (MHz) plot showing an average level of approximately 52.5 dBuV/m. The plot includes a red step function labeled 'AVG_BE_54' and a blue signal trace.</p> <p>Site : 03CH12-HY Condition : AVG_BE_54 3m HORN_9120D_1328 VERTICAL : RBW:1000.000KHz VBW:1.000KHz SWT:Auto Detector : Peak Project : 672014-10 Mode : 11 Setting : 72</p>	Left blank

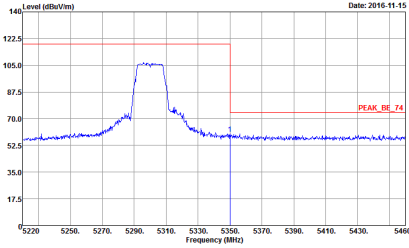
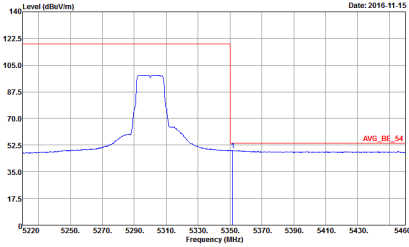

WIFI	Band 2 5250~5350MHz Band Edge @ 3m	
ANT	802.11a CH60 5300MHz - R	
1	Vertical	Fundamental
Peak	 <p> Site : 03CH12-HY Condition : PEAK_BE_74 3m HORN_9120D_1328 VERTICAL : RBW:1000.000KHz VBW:3000.000KHz SWT:Auto Detector : Peak Project : 672014-10 Mode : 11 Setting : 72 </p>	Left blank
Avg.	 <p> Site : 03CH12-HY Condition : AVG_BE_54 3m HORN_9120D_1328 VERTICAL : RBW:1000.000KHz VBW:1.000KHz SWT:Auto Detector : Peak Project : 672014-10 Mode : 11 Setting : 72 </p>	Left blank

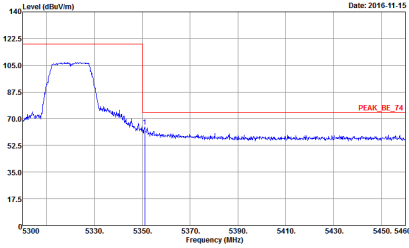
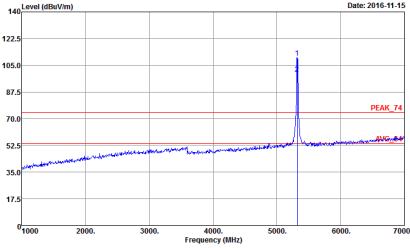
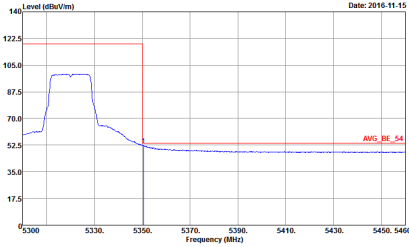

WIFI	Band 2 5250~5350MHz Band Edge @ 3m	
ANT	802.11a CH64 5320MHz	
1	Horizontal	Fundamental
Peak	 <p>Date: 2016-11-15</p> <p>Site : 03CH12-HY Condition : PEAK_BE_74 3m HORN_9120D_1328 HORIZONTAL : RBW:1000.000KHz VBW:3000.000KHz SWT:Auto Detector : Peak Project : 672014-10 Mode : 12 Setting : 72</p>	 <p>Date: 2016-11-15</p> <p>Site : 03CH12-HY Condition : PEAK_74 3m HORN_9120D_1328 HORIZONTAL : RBW:1000.000KHz VBW:3000.000KHz SWT:Auto Detector : Peak Project : 672014-10 Mode : 12 Setting : 72</p>
Avg.	 <p>Date: 2016-11-15</p> <p>Site : 03CH12-HY Condition : AVG_BE_54 3m HORN_9120D_1328 HORIZONTAL : RBW:1000.000KHz VBW:1.000KHz SWT:Auto Detector : Peak Project : 672014-10 Mode : 12 Setting : 72</p>	Left blank

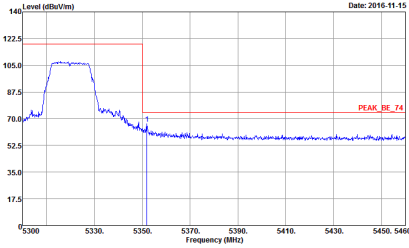
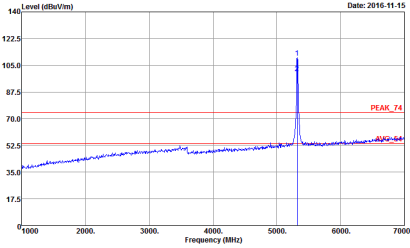
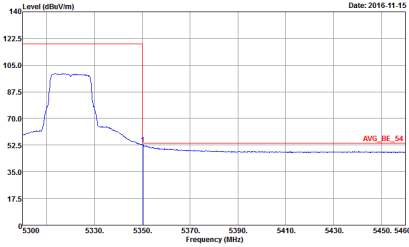

WIFI	Band 2 5250~5350MHz Band Edge @ 3m	
ANT	802.11a CH64 5320MHz	
1	Vertical	Fundamental
Peak	 <p>Level (dBuV/m) vs Frequency (MHz) plot showing a peak at 5320 MHz. The y-axis ranges from 17.5 to 140 dBuV/m, and the x-axis ranges from 5300 to 5460 MHz. A red horizontal line indicates the peak level at approximately 122.5 dBuV/m.</p> <p>Site : 03CH12-HY Condition : PEAK_BE_74 3m HORN_9120D_1328 VERTICAL Detector : Peak Project : 672014-10 Mode : 12 Setting : 72</p>	 <p>Level (dBuV/m) vs Frequency (MHz) plot showing a sharp peak at 5320 MHz. The y-axis ranges from 17.5 to 140 dBuV/m, and the x-axis ranges from 1000 to 7000 MHz. A red horizontal line indicates the peak level at approximately 122.5 dBuV/m.</p> <p>Site : 03CH12-HY Condition : PEAK_74 3m HORN_9120D_1328 VERTICAL Detector : Peak Project : 672014-10 Mode : 12 Setting : 72</p>
Avg.	 <p>Level (dBuV/m) vs Frequency (MHz) plot showing the average level. The y-axis ranges from 17.5 to 140 dBuV/m, and the x-axis ranges from 5300 to 5460 MHz. A red horizontal line indicates the average level at approximately 52.5 dBuV/m.</p> <p>Site : 03CH12-HY Condition : AVG_BE_54 3m HORN_9120D_1328 VERTICAL Detector : Peak Project : 672014-10 Mode : 12 Setting : 72</p>	Left blank



Band 2 5250~5350MHz
WIFI 802.11ac VHT20 (Band Edge @ 3m)

WIFI	Band 2 5250~5350MHz Band Edge @ 3m	
ANT	802.11ac VHT20 CH52 5260MHz - L	
1	Horizontal	Fundamental
<p>Peak</p>	<p>Site : 03CH12-HY Condition : PEAK_BE_74 3m HORN_9120D_1328 HORIZONTAL RBW:1000.000KHz VBW:3000.000KHz SWT:Auto Detector : Peak Project : 672014-10 Mode : 13</p>	<p>Site : 03CH12-HY Condition : PEAK_74 3m HORN_9120D_1328 HORIZONTAL RBW:1000.000KHz VBW:3000.000KHz SWT:Auto Detector : Peak Project : 672014-10 Mode : 13</p>
<p>Avg.</p>	<p>Site : 03CH12-HY Condition : AVG_BE_54 3m HORN_9120D_1328 HORIZONTAL RBW:1000.000KHz VBW:1.000KHz SWT:Auto Detector : Peak Project : 672014-10 Mode : 13</p>	<p>Left blank</p>

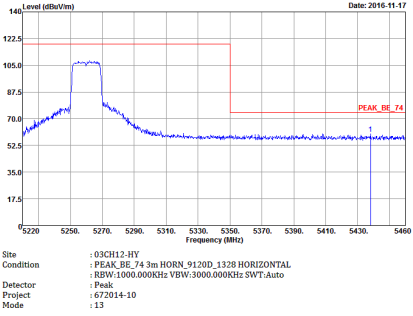
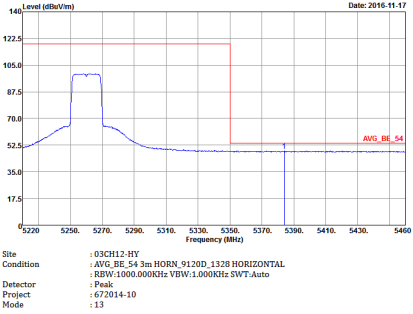

WIFI	Band 2 5250~5350MHz Band Edge @ 3m	
ANT	802.11ac VHT20 CH52 5260MHz - R	
1	Horizontal	Fundamental
Peak	 <p>Site : 03CH12-HY Condition : PEAK_BE_74 3m HORN_9120D_1328 HORIZONTAL Detector : Peak Project : 672014-10 Mode : 13</p>	Left blank
Avg.	 <p>Site : 03CH12-HY Condition : AVG_BE_54 3m HORN_9120D_1328 HORIZONTAL Detector : Peak Project : 672014-10 Mode : 13</p>	Left blank

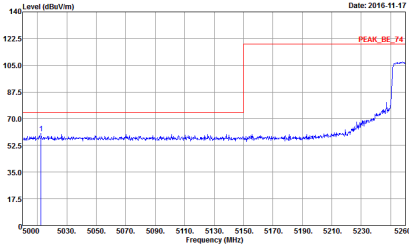
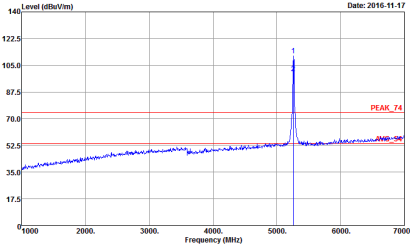
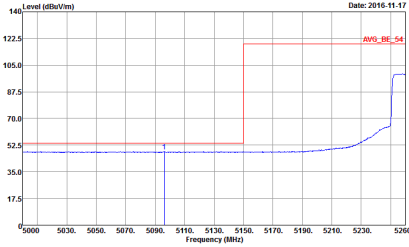

WIFI	Band 2 5250~5350MHz Band Edge @ 3m	
ANT	802.11ac VHT20 CH52 5260MHz - L	
1	Vertical	Fundamental
Peak	 <p>Date: 2016-11-17</p> <p>Site : 03CH12-HY Condition : PEAK_BE_74 3m HORN_9120D_1328 VERTICAL : RBW:1000.000KHz VBW:3000.000KHz SWT:Auto Detector : Peak Project : 672014-10 Mode : 13</p>	 <p>Date: 2016-11-17</p> <p>Site : 03CH12-HY Condition : PEAK_74 3m HORN_9120D_1328 VERTICAL : RBW:1000.000KHz VBW:3000.000KHz SWT:Auto Detector : Peak Project : 672014-10 Mode : 13</p>
Avg.	 <p>Date: 2016-11-17</p> <p>Site : 03CH12-HY Condition : AVG_BE_54 3m HORN_9120D_1328 VERTICAL : RBW:1000.000KHz VBW:1.000KHz SWT:Auto Detector : Peak Project : 672014-10 Mode : 13</p>	Left blank

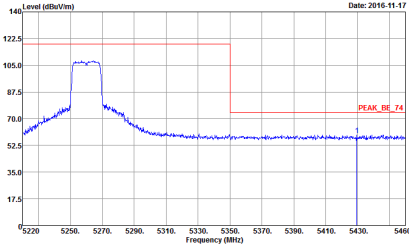
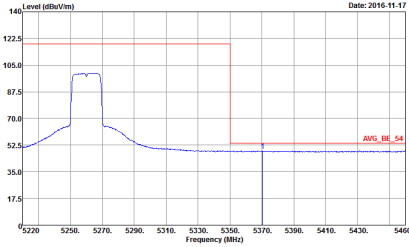

WIFI	Band 2 5250~5350MHz Band Edge @ 3m	
ANT	802.11ac VHT20 CH52 5260MHz - R	
1	Vertical	Fundamental
Peak	 <p> Date: 2016-11-17 Site : 03CH12-HY Condition : PEAK_BE_74 3m HORN_9120D_1328 VERTICAL Detector : Peak Project : 672014-10 Mode : 13 </p>	Left blank
Avg.	 <p> Date: 2016-11-17 Site : 03CH12-HY Condition : AVG_BE_54 3m HORN_9120D_1328 VERTICAL Detector : Peak Project : 672014-10 Mode : 13 </p>	Left blank

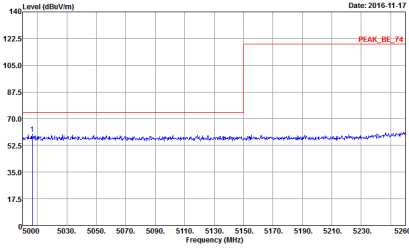
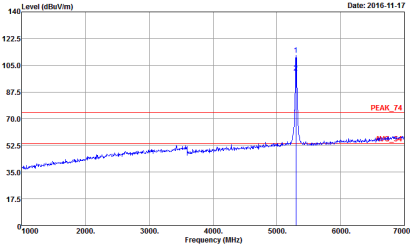
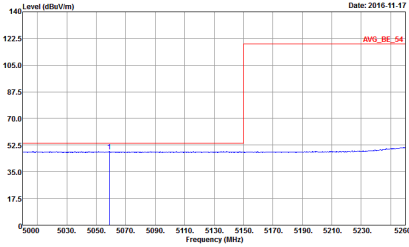

WIFI	Band 2 5250~5350MHz Band Edge @ 3m	
ANT	802.11ac VHT20 CH60 5300MHz - L	
1	Horizontal	Fundamental
Peak	 <p>Date: 2016-11-17</p> <p>Site : 03CH12-HY Condition : PEAK_BE_74 3m HORN_9120D_1328 HORIZONTAL Detector : Peak Project : 672014-10 Mode : 14</p>	 <p>Date: 2016-11-17</p> <p>Site : 03CH12-HY Condition : PEAK_74 3m HORN_9120D_1328 HORIZONTAL Detector : Peak Project : 672014-10 Mode : 14</p>
Avg.	 <p>Date: 2016-11-17</p> <p>Site : 03CH12-HY Condition : AVG_BE_54 3m HORN_9120D_1328 HORIZONTAL Detector : Peak Project : 672014-10 Mode : 14</p>	Left blank

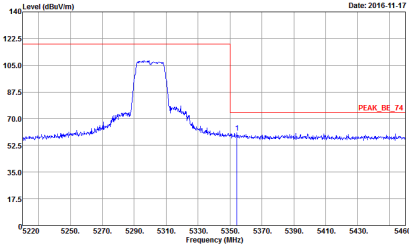
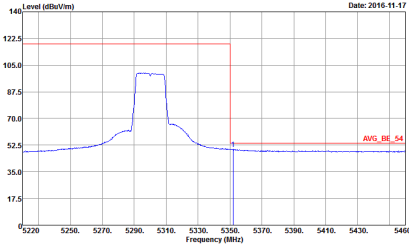

WIFI	Band 2 5250~5350MHz Band Edge @ 3m	
ANT	802.11ac VHT20 CH60 5300MHz - R	
1	Horizontal	Fundamental
Peak	 <p>Site : 03CH12-HY Condition : PEAK_BE_74 3m HORN_9120D_1328 HORIZONTAL : RBW:1000.000KHz VBW:3000.000KHz SWT:Auto Detector : Peak Project : 672014-10 Mode : 14</p>	Left blank
Avg.	 <p>Site : 03CH12-HY Condition : AVG_BE_54 3m HORN_9120D_1328 HORIZONTAL : RBW:1000.000KHz VBW:1.000KHz SWT:Auto Detector : Peak Project : 672014-10 Mode : 14</p>	Left blank

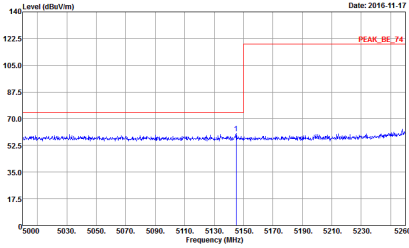
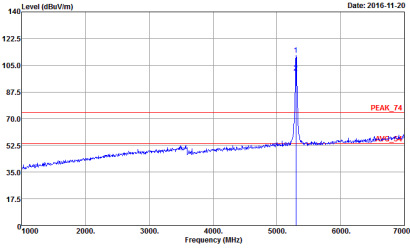
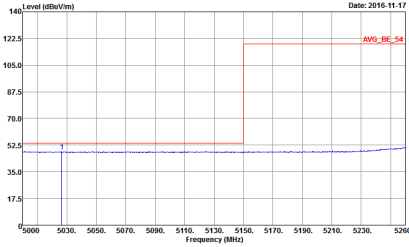

WIFI	Band 2 5250~5350MHz Band Edge @ 3m	
ANT	802.11ac VHT20 CH60 5300MHz - L	
1	Vertical	Fundamental
Peak	 <p>Date: 2016-11-17</p> <p>Site : 03CH12-HY Condition : PEAK_BE_74 3m HORN_9120D_1328 VERTICAL : RBW:1000.000KHz VBW:3000.000KHz SWT:Auto Detector : Peak Project : 672014-10 Mode : 14</p>	 <p>Date: 2016-11-20</p> <p>Site : 03CH12-HY Condition : PEAK_74 3m HORN_9120D_1328 VERTICAL : RBW:1000.000KHz VBW:3000.000KHz SWT:Auto Detector : Peak Project : 672014-10 Mode : 14</p>
Avg.	 <p>Date: 2016-11-17</p> <p>Site : 03CH12-HY Condition : AVG_BE_54 3m HORN_9120D_1328 VERTICAL : RBW:1000.000KHz VBW:1.000KHz SWT:Auto Detector : Peak Project : 672014-10 Mode : 14</p>	Left blank

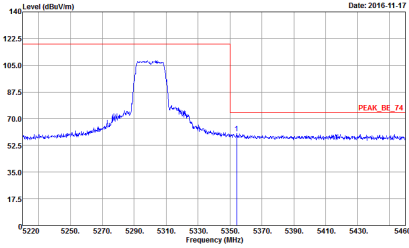
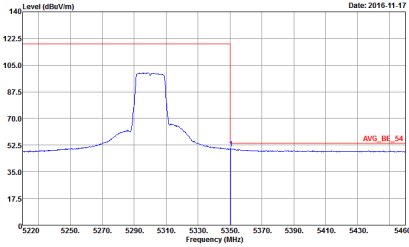

WIFI	Band 2 5250~5350MHz Band Edge @ 3m	
ANT	802.11ac VHT20 CH60 5300MHz - R	
1	Vertical	Fundamental
Peak	 <p> Date: 2016-11-17 Site : 03CH12-HY Condition : PEAK_BE_74 3m HORN_9120D_1328 VERTICAL : RBW:1000.000KHz VBW:3000.000KHz SWT:Auto Detector : Peak Project : 672014-10 Mode : 14 </p>	Left blank
Avg.	 <p> Date: 2016-11-17 Site : 03CH12-HY Condition : AVG_BE_54 3m HORN_9120D_1328 VERTICAL : RBW:1000.000KHz VBW:1.000KHz SWT:Auto Detector : Peak Project : 672014-10 Mode : 14 </p>	Left blank

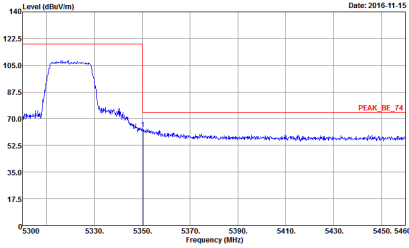
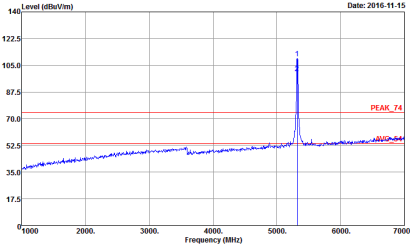
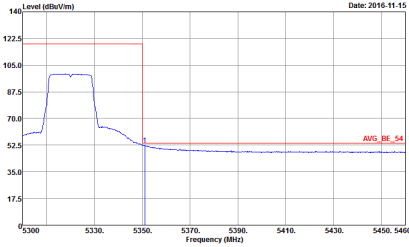

WIFI	Band 2 5250~5350MHz Band Edge @ 3m	
ANT	802.11ac VHT20 CH64 5320MHz	
1	Horizontal	Fundamental
Peak	 <p>Date: 2016-11-15</p> <p>Site : 03CH12-HY Condition : PEAK_BE_74 3m HORN_9120D_1328 HORIZONTAL : RBW:1000.000KHz VBW:3000.000KHz SWT:Auto Detector : Peak Project : 672014-10 Mode : :15 Setting : :72</p>	 <p>Date: 2016-11-15</p> <p>Site : 03CH12-HY Condition : PEAK_74 3m HORN_9120D_1328 HORIZONTAL : RBW:1000.000KHz VBW:3000.000KHz SWT:Auto Detector : Peak Project : 672014-10 Mode : :15 Setting : :72</p>
Avg.	 <p>Date: 2016-11-15</p> <p>Site : 03CH12-HY Condition : AVG_BE_54 3m HORN_9120D_1328 HORIZONTAL : RBW:1000.000KHz VBW:1.000KHz SWT:Auto Detector : Peak Project : 672014-10 Mode : :15 Setting : :72</p>	Left blank

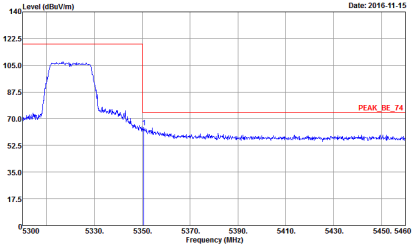
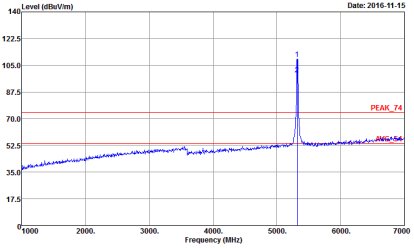
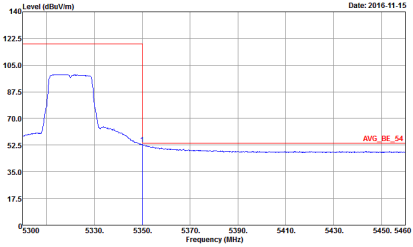

WIFI	Band 2 5250~5350MHz Band Edge @ 3m	
ANT	802.11ac VHT20 CH64 5320MHz	
1	Vertical	Fundamental
Peak	 <p>Site : 03CH12-HY Condition : PEAK_BE_74 3m HORN_9120D_1328 VERTICAL Detector : Peak Project : 672014-10 Mode : 15 Setting : 72</p>	 <p>Site : 03CH12-HY Condition : PEAK_74 3m HORN_9120D_1328 VERTICAL Detector : Peak Project : 672014-10 Mode : 15 Setting : 72</p>
Avg.	 <p>Site : 03CH12-HY Condition : AVG_BE_54 3m HORN_9120D_1328 VERTICAL Detector : Peak Project : 672014-10 Mode : 15 Setting : 72</p>	Left blank



Band 2 5250~5350MHz
WIFI 802.11ac VHT40 (Band Edge @ 3m)

WIFI	Band 2 5250~5350MHz Band Edge @ 3m	
ANT	802.11ac VHT40 CH54 5270 - L	
1	Horizontal	Fundamental
Peak	<p>Site : 03CH12-HY Condition : PEAK_BE_74 3m HORN_9120D_1328 HORIZONTAL RBW:1000.000KHz VBW:3000.000KHz SWT:Auto Detector : Peak Project : 672014-10 Mode : 16</p>	<p>Site : 03CH12-HY Condition : PEAK_74 3m HORN_9120D_1328 HORIZONTAL RBW:1000.000KHz VBW:3000.000KHz SWT:Auto Detector : Peak Project : 672014-10 Mode : 16</p>
Avg.	<p>Site : 03CH12-HY Condition : AVG_BE_54 3m HORN_9120D_1328 HORIZONTAL RBW:1000.000KHz VBW:3.000KHz SWT:Auto Detector : Peak Project : 672014-10 Mode : 16</p>	Left blank

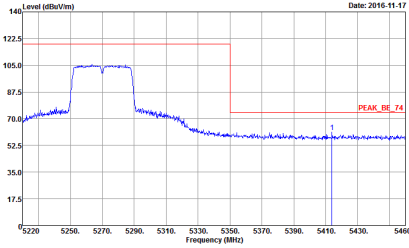
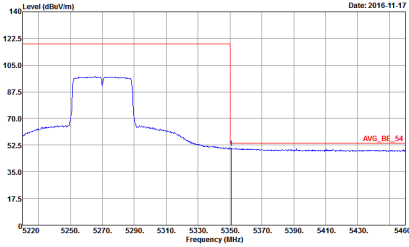

WIFI	Band 2 5250~5350MHz Band Edge @ 3m	
ANT	802.11ac VHT40 CH54 5270 - R	
1	Horizontal	Fundamental
Peak	 <p>Site : 03CH12-HY Condition : PEAK_BE_74 3m HORN_9120D_1328 HORIZONTAL Detector : RBW:1000.000KHz VBW:3000.000KHz SWT:Auto Project : Peak Mode : 672014-10 Date: 2016-11-17</p>	Left blank
Avg.	 <p>Site : 03CH12-HY Condition : AVG_BE_54 3m HORN_9120D_1328 HORIZONTAL Detector : RBW:1000.000KHz VBW:3.000KHz SWT:Auto Project : Peak Mode : 672014-10 Date: 2016-11-17</p>	Left blank

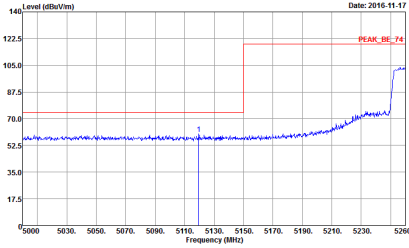
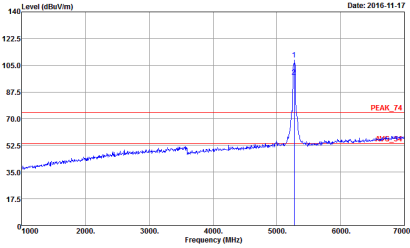
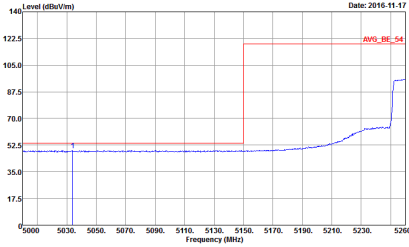

WIFI	Band 2 5250~5350MHz Band Edge @ 3m	
ANT	802.11ac VHT40 CH54 5270 - L	
1	Vertical	Fundamental
Peak	 <p>Site : 03CH12-HY Condition : PEAK_BE_74 3m HORN_9120D_1328 VERTICAL : RBW:1000.000KHz VBW:3000.000KHz SWT:Auto Detector : Peak Project : 672014-10 Mode : 16</p>	 <p>Site : 03CH12-HY Condition : PEAK_74 3m HORN_9120D_1328 VERTICAL : RBW:1000.000KHz VBW:3000.000KHz SWT:Auto Detector : Peak Project : 672014-10 Mode : 16</p>
Avg.	 <p>Site : 03CH12-HY Condition : AVG_BE_54 3m HORN_9120D_1328 VERTICAL : RBW:1000.000KHz VBW:3.000KHz SWT:Auto Detector : Peak Project : 672014-10 Mode : 16</p>	Left blank

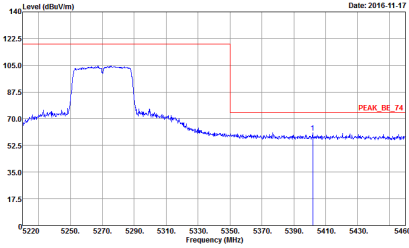
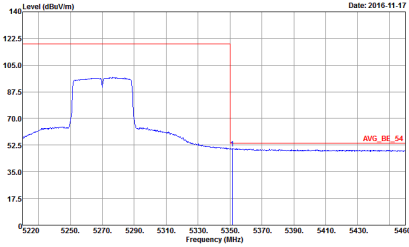

WIFI	Band 2 5250~5350MHz Band Edge @ 3m	
ANT	802.11ac VHT40 CH54 5270 - R	
1	Vertical	Fundamental
Peak	 <p> Site : 03CH12-HY Condition : PEAK_BE_74 3m HORN_9120D_1328 VERTICAL : RBW:1000.000KHz VBW:3000.000KHz SWT:Auto Detector : Peak Project : 672014-10 Mode : 16 </p>	Left blank
Avg.	 <p> Site : 03CH12-HY Condition : AVG_BE_54 3m HORN_9120D_1328 VERTICAL : RBW:1000.000KHz VBW:3.000KHz SWT:Auto Detector : Peak Project : 672014-10 Mode : 16 </p>	Left blank

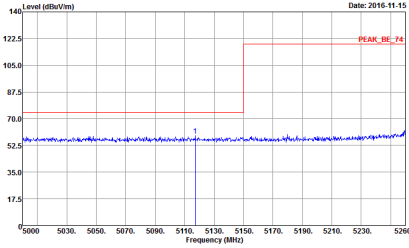
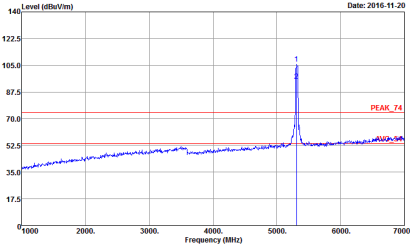
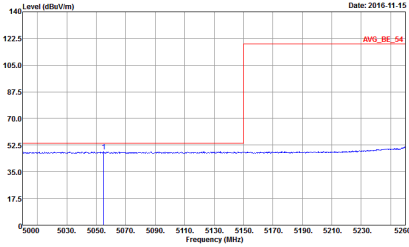

WIFI	Band 2 5250~5350MHz Band Edge @ 3m	
ANT	802.11ac VHT40 CH62 5310 - L	
1	Horizontal	Fundamental
Peak	 <p>Date: 2016-11-15</p> <p>Site : 03CH12-HY Condition : PEAK_BE_74 3m HORN_9120D_1328 HORIZONTAL : RBW:1000.000KHz VBW:3000.000KHz SWT:Auto Detector : Peak Project : 672014-10 Mode : 17 Setting : 58</p>	 <p>Date: 2016-11-20</p> <p>Site : 03CH12-HY Condition : PEAK_74 3m HORN_9120D_1328 HORIZONTAL : RBW:1000.000KHz VBW:3000.000KHz SWT:Auto Detector : Peak Project : 672014-10 Mode : 17 Setting : 58</p>
Avg.	 <p>Date: 2016-11-15</p> <p>Site : 03CH12-HY Condition : AVG_BE_54 3m HORN_9120D_1328 HORIZONTAL : RBW:1000.000KHz VBW:3.000KHz SWT:Auto Detector : Peak Project : 672014-10 Mode : 17 Setting : 58</p>	Left blank

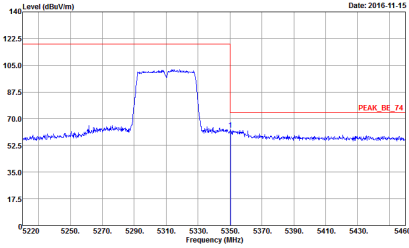
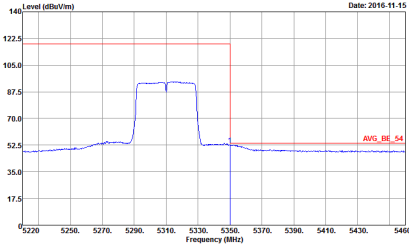

WIFI	Band 2 5250~5350MHz Band Edge @ 3m	
ANT	802.11ac VHT40 CH62 5310 - R	
1	Horizontal	Fundamental
Peak	 <p> Date: 2016-11-15 Site : 03CH12-HY Condition : PEAK_BE_74 3m HORN_9120D_1328 HORIZONTAL : RBW:1000.000KHz VBW:3000.000KHz SWT:Auto Detector : Peak Project : 672014-10 Mode : 17 Setting : 58 </p>	Left blank
Avg.	 <p> Date: 2016-11-15 Site : 03CH12-HY Condition : AVG_BE_54 3m HORN_9120D_1328 HORIZONTAL : RBW:1000.000KHz VBW:3.000KHz SWT:Auto Detector : Peak Project : 672014-10 Mode : 17 Setting : 58 </p>	Left blank

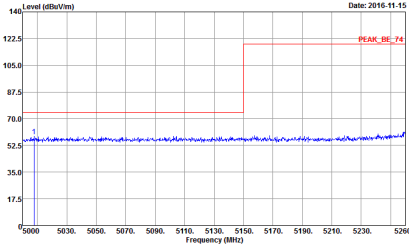
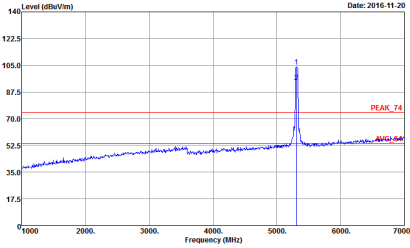
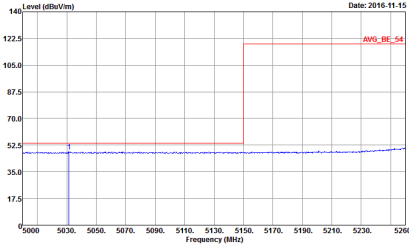

WIFI	Band 2 5250~5350MHz Band Edge @ 3m	
ANT	802.11ac VHT40 CH62 5310 - L	
1	Vertical	Fundamental
Peak	 <p>Date: 2016-11-15</p> <p>Site : 03CH12-HY Condition : PEAK_BE_74 3m HORN_9120D_1328 VERTICAL : RBW:1000.000KHz VBW:3000.000KHz SWT:Auto Detector : Peak Project : 672014-10 Mode : 17 Setting : 58</p>	 <p>Date: 2016-11-20</p> <p>Site : 03CH12-HY Condition : PEAK_74 3m HORN_9120D_1328 VERTICAL : RBW:1000.000KHz VBW:3000.000KHz SWT:Auto Detector : Peak Project : 672014-10 Mode : 17 Setting : 58</p>
Avg.	 <p>Date: 2016-11-15</p> <p>Site : 03CH12-HY Condition : AVG_BE_54 3m HORN_9120D_1328 VERTICAL : RBW:1000.000KHz VBW:3.000KHz SWT:Auto Detector : Peak Project : 672014-10 Mode : 17 Setting : 58</p>	Left blank

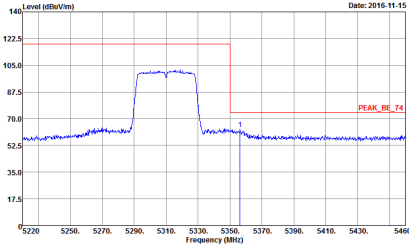
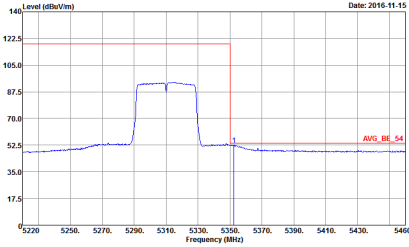

WIFI	Band 2 5250~5350MHz Band Edge @ 3m	
ANT	802.11ac VHT40 CH62 5310 - R	
1	Vertical	Fundamental
Peak	 <p> Site : 03CH12-HY Condition : PEAK_BE_74 3m HORN_9120D_1328 VERTICAL : RBW:1000.000KHz VBW:3000.000KHz SWT:Auto Detector : Peak Project : 672014-10 Mode : 17 Setting : 58 </p>	Left blank
Avg.	 <p> Site : 03CH12-HY Condition : AVG_BE_54 3m HORN_9120D_1328 VERTICAL : RBW:1000.000KHz VBW:3.000KHz SWT:Auto Detector : Peak Project : 672014-10 Mode : 17 Setting : 58 </p>	Left blank

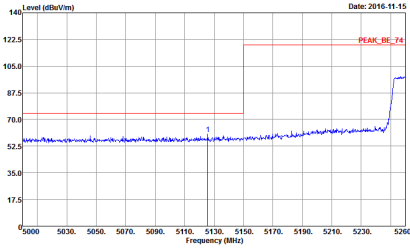
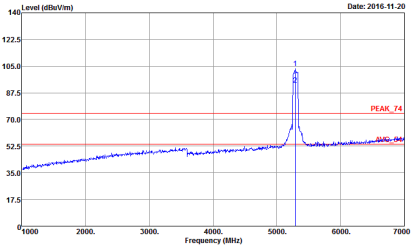
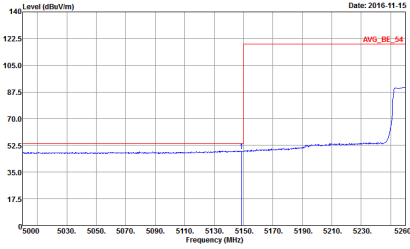

Band 2 5250~5350MHz
WIFI 802.11ac VHT80 (Band Edge @ 3m)

WIFI	Band 2 5250~5350MHz Band Edge @ 3m	
ANT	802.11ac VHT80 CH58 5290MHz - L	
<p align="center">1</p>	<p align="center">Horizontal</p>  <p>Site : 03CH12-HY Condition : PEAK_BE_74 3m HORN_9120D_1328 HORIZONTAL Detector : Peak Project : 672014-10 Mode : 18 Setting : 62</p>	<p align="center">Fundamental</p>  <p>Site : 03CH12-HY Condition : PEAK_74 3m HORN_9120D_1328 HORIZONTAL Detector : Peak Project : 672014-10 Mode : 18 Setting : 62</p>
<p align="center">Peak</p>	 <p>Site : 03CH12-HY Condition : AVG_BE_54 3m HORN_9120D_1328 HORIZONTAL Detector : Peak Project : 672014-10 Mode : 18 Setting : 62</p>	<p align="center">Left blank</p>

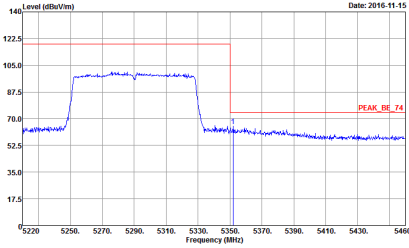
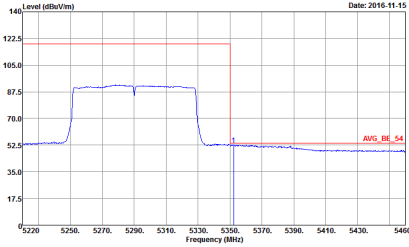

WIFI	Band 2 5250~5350MHz Band Edge @ 3m	
ANT	802.11ac VHT80 CH58 5290MHz - R	
1	Horizontal	Fundamental
Peak	 <p data-bbox="347 728 638 806">Date: 2016-11-15 Site : 03CH12-HY Condition : PEAK_BE_74 3m HORN_9120D_1328 HORIZONTAL Detector : Peak Project : 672014-10 Mode : 18 Setting : 62</p>	Left blank
Avg.	 <p data-bbox="347 1406 638 1485">Date: 2016-11-15 Site : 03CH12-HY Condition : AVG_BE_54 3m HORN_9120D_1328 HORIZONTAL Detector : Peak Project : 672014-10 Mode : 18 Setting : 62</p>	Left blank

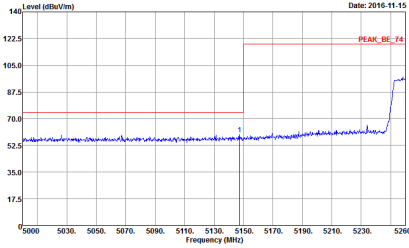
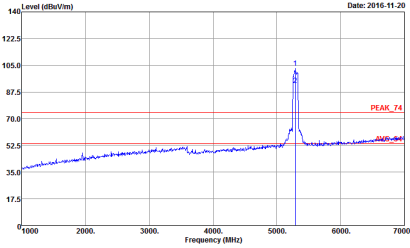
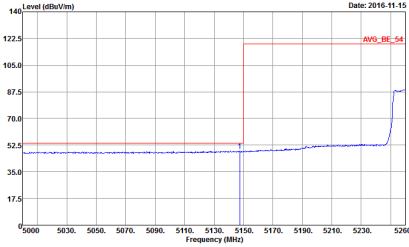

WIFI	Band 2 5250~5350MHz Band Edge @ 3m	
ANT	802.11ac VHT80 CH58 5290MHz - L	
1	Vertical	Fundamental
Peak	 <p>Date: 2016-11-15</p> <p>Site : 03CH12-HY Condition : PEAK_BE_74 3m HORN_9120D_1328 VERTICAL : RBW:1000.000KHz VBW:3000.000KHz SWT:Auto Detector : Peak Project : 672014-10 Mode : 18 Setting : 62</p>	 <p>Date: 2016-11-20</p> <p>Site : 03CH12-HY Condition : PEAK_74 3m HORN_9120D_1328 VERTICAL : RBW:1000.000KHz VBW:3000.000KHz SWT:Auto Detector : Peak Project : 672014-10 Mode : 18 Setting : 62</p>
Avg.	 <p>Date: 2016-11-15</p> <p>Site : 03CH12-HY Condition : AVG_BE_54 3m HORN_9120D_1328 VERTICAL : RBW:1000.000KHz VBW:3.000KHz SWT:Auto Detector : Peak Project : 672014-10 Mode : 18 Setting : 62</p>	Left blank

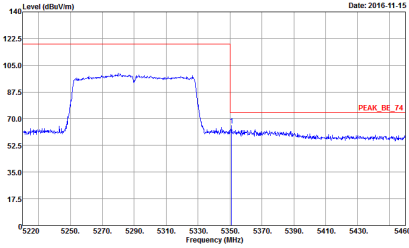
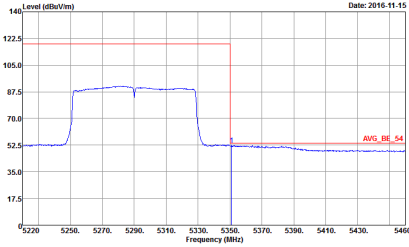

WIFI	Band 2 5250~5350MHz Band Edge @ 3m	
ANT	802.11ac VHT80 CH58 5290MHz - R	
1	Vertical	Fundamental
Peak	 <p> Date: 2016-11-15 Site : 03CH12-HY Condition : PEAK_BE_74 3m HORN_9120D_1328 VERTICAL : RBW:1000.000KHz VBW:3000.000KHz SWT:Auto Detector : Peak Project : 672014-10 Mode : 18 Setting : 62 </p>	Left blank
Avg.	 <p> Date: 2016-11-15 Site : 03CH12-HY Condition : AVG_BE_54 3m HORN_9120D_1328 VERTICAL : RBW:1000.000KHz VBW:3.000KHz SWT:Auto Detector : Peak Project : 672014-10 Mode : 18 Setting : 62 </p>	Left blank



Band 2 - 5250~5350MHz
WIFI 802.11a (Harmonic @ 3m)

Table with 2 columns: WIFI, ANT. Row 1: Band 2 5250~5350MHz Harmonic @ 3m. Row 2: 802.11a CH52 5260MHz. Row 3: 1, Horizontal, Vertical. Row 4: Peak, Avg. (with graphs and data for both orientations).

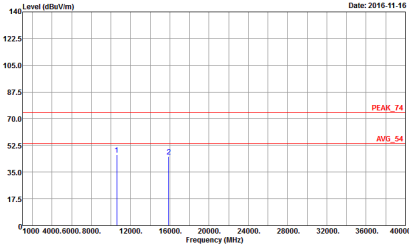
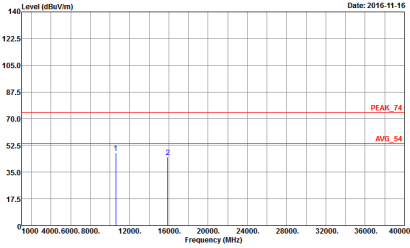

WIFI	Band 2 5250~5350MHz Harmonic @ 3m	
ANT	802.11a CH60 5300MHz	
1	Horizontal	Vertical
<p>Peak</p> <p>Avg.</p>	 <p>Site : 03CH12-HY Condition : PEAK_74 3m HORN_9120D_1328 HORIZONTAL Project : 672014-10 Mode : 11</p>	 <p>Site : 03CH12-HY Condition : PEAK_74 3m HORN_9120D_1328 VERTICAL Project : 672014-10 Mode : 11</p>



WIFI	Band 2 5250~5350MHz Harmonic @ 3m	
ANT	802.11a CH64 5320MHz	
1	Horizontal	Vertical
Peak Avg.	<p>Site : 03CH12-HY Condition : PEAK_74 3m HORN_9120D_1328 HORIZONTAL Project : 672014-10 Mode : 12</p>	<p>Site : 03CH12-HY Condition : PEAK_74 3m HORN_9120D_1328 VERTICAL Project : 672014-10 Mode : 12</p>

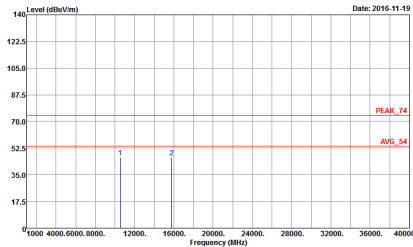
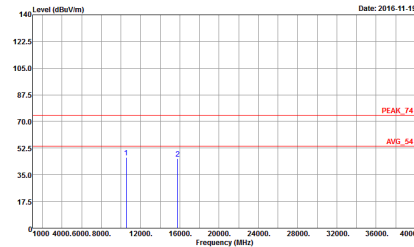

Band 2 5250~5350MHz
WIFI 802.11ac VHT20 (Harmonic @ 3m)

WIFI	Band 2 5250~5350MHz Harmonic @ 3m	
ANT	802.11ac VHT20 CH52 5260MHz	
1	Horizontal	Vertical
<p>Peak</p> <p>Avg.</p>	 <p>Site : 03CH12-HY Condition : PEAK_74 3m HORN_9120D_1320 HORIZONTAL Project : 672014-10 Mode : 13</p>	 <p>Site : 03CH12-HY Condition : PEAK_74 3m HORN_9120D_1320 VERTICAL Project : 672014-10 Mode : 13</p>

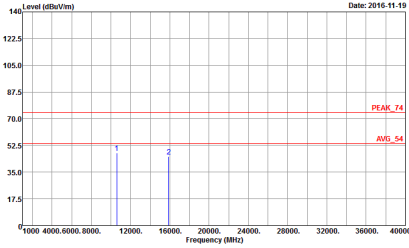
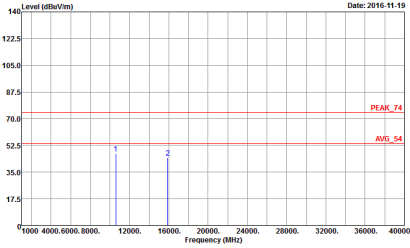

WIFI	Band 2 5250~5350MHz Harmonic @ 3m	
ANT	802.11ac VHT20 CH60 5300MHz	
1	Horizontal	Vertical
<p>Peak</p> <p>Avg.</p>	 <p>Site : 03CH12-HY Condition : PEAK_74 3m HORN_9120D_1328 HORIZONTAL Project : 672014-10 Mode : 14</p>	 <p>Site : 03CH12-HY Condition : PEAK_74 3m HORN_9120D_1328 VERTICAL Project : 672014-10 Mode : 14</p>

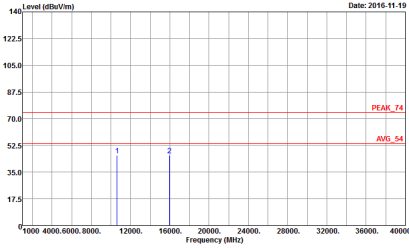
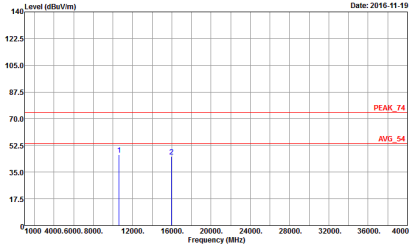

WIFI	Band 2 5250~5350MHz Harmonic @ 3m	
ANT	802.11ac VHT20 CH64 5320MHz	
1	Horizontal	Vertical
<p>Peak</p> <p>Avg.</p>	 <p>Site : 03CH12-HY Condition : PEAK_74 3m HORN_9120D_1328 HORIZONTAL Project : 672014-10 Mode : 15</p>	 <p>Site : 03CH12-HY Condition : PEAK_74 3m HORN_9120D_1328 VERTICAL Project : 672014-10 Mode : 15</p>

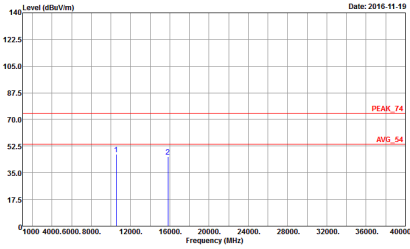
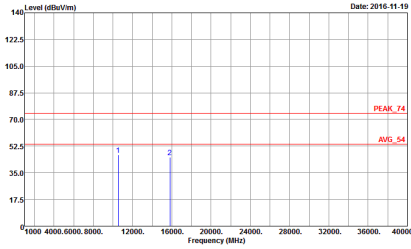

Band 2 5250~5350MHz
WIFI 802.11ac VHT40 (Harmonic @ 3m)

WIFI	Band 2 5250~5350MHz Harmonic @ 3m	
ANT	802.11ac VHT40 CH54 5270	
1	Horizontal	Vertical
<p>Peak</p> <p>Avg.</p>	 <p>Site : 03CH12-HY Condition : PEAK_74 3m HORN_9120D_1328 HORIZONTAL Project : 672014-10 Mode : 16</p>	 <p>Site : 03CH12-HY Condition : PEAK_74 3m HORN_9120D_1328 VERTICAL Project : 672014-10 Mode : 16</p>

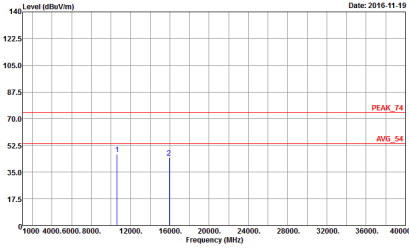
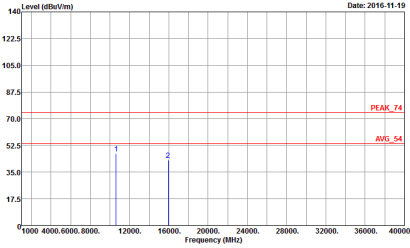

WIFI	Band 2 5250~5350MHz Harmonic @ 3m	
ANT	802.11ac VHT40 CH62 5310	
1	Horizontal	Vertical
<p>Peak</p> <p>Avg.</p>	 <p>Site : 03CH12-HY Condition : PEAK_74 3m HORN_9120D_1328 HORIZONTAL Project : 672014-10 Mode : 17</p>	 <p>Site : 03CH12-HY Condition : PEAK_74 3m HORN_9120D_1328 VERTICAL Project : 672014-10 Mode : 17</p>



Band 2 5250~5350MHz
WIFI 802.11ac VHT80 (Harmonic @ 3m)

WIFI	Band 2 5250~5350MHz Harmonic @ 3m	
ANT	802.11ac VHT80 CH58 5290MHz	
1	Horizontal	Vertical
<p>Peak</p> <p>Avg.</p>	<p>Site : 03CH12-HY Condition : PEAK_74 3m HORN_9120D_1328 HORIZONTAL Project : 672014-10 Mode : 18</p>	<p>Site : 03CH12-HY Condition : PEAK_74 3m HORN_9120D_1328 VERTICAL Project : 672014-10 Mode : 18</p>



Band 3 - 5470~5725MHz
WIFI 802.11a (Band Edge @ 3m)

WIFI	Band 3 5470~5725MHz Band Edge @ 3m	
ANT	802.11a CH100 5500MHz	
1	Horizontal	Fundamental
Peak	<p>Date: 2016-11-15</p> <p>Site : 03CH12-HY Condition : PEAK_BE(UNI)_B3 3m HORN_9120D_1328 HORIZONTAL Detector : RBW:1000.000KHz VBW:3000.000KHz SWT:Auto Project : Peak Mode : 672014-10 : 19</p>	<p>Date: 2016-11-15</p> <p>Site : 03CH12-HY Condition : PEAK(UNI) 3m HORN_9120D_1328 HORIZONTAL Detector : RBW:1000.000KHz VBW:3000.000KHz SWT:Auto Project : Peak Mode : 672014-10 : 19</p>
Avg.	<p>Date: 2016-11-15</p> <p>Site : 03CH12-HY Condition : AVG_BE(UNI)_B3 3m HORN_9120D_1328 HORIZONTAL Detector : RBW:1000.000KHz VBW:1.000KHz SWT:Auto Project : Peak Mode : 672014-10 : 19</p>	Left blank

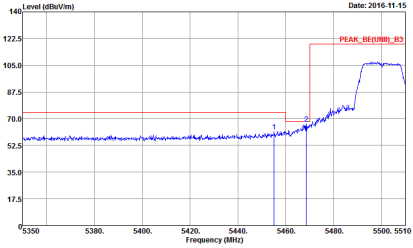
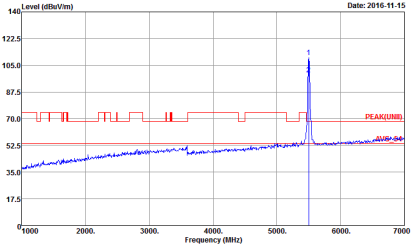
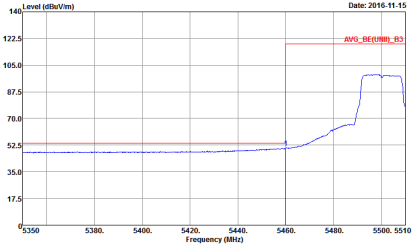

WIFI	Band 3 5470~5725MHz Band Edge @ 3m	
ANT	802.11a CH100 5500MHz	
1	Vertical	Fundamental
Peak	 <p>Level (dBuV/m) vs Frequency (MHz) plot showing a peak at 5500 MHz. The y-axis ranges from 17.5 to 140 dBuV/m, and the x-axis ranges from 5350 to 5510 MHz. A red box highlights the peak labeled 'PEAK_BE(UMI)_B3'.</p> <p>Site : 03CH12-HY Condition : PEAK_BE(UMI)_B3 3m HORN_9120D_1328 VERTICAL : RBW:1000.000KHz VBW:3000.000KHz SWT:Auto Detector : Peak Project : 672014-10 Mode : 19</p>	 <p>Level (dBuV/m) vs Frequency (MHz) plot showing a peak at 5500 MHz. The y-axis ranges from 17.5 to 140 dBuV/m, and the x-axis ranges from 1000 to 7000 MHz. A red box highlights the peak labeled 'PEAK(UMI)'.</p> <p>Site : 03CH12-HY Condition : PEAK(UMI) 3m HORN_9120D_1328 VERTICAL : RBW:1000.000KHz VBW:3000.000KHz SWT:Auto Detector : Peak Project : 672014-10 Mode : 19</p>
Avg.	 <p>Level (dBuV/m) vs Frequency (MHz) plot showing the average spectrum. The y-axis ranges from 17.5 to 140 dBuV/m, and the x-axis ranges from 5350 to 5510 MHz. A red box highlights the average level labeled 'AVG_BE(UMI)_B3'.</p> <p>Site : 03CH12-HY Condition : AVG_BE(UMI)_B3 3m HORN_9120D_1328 VERTICAL : RBW:1000.000KHz VBW:1.000KHz SWT:Auto Detector : Peak Project : 672014-10 Mode : 19</p>	Left blank

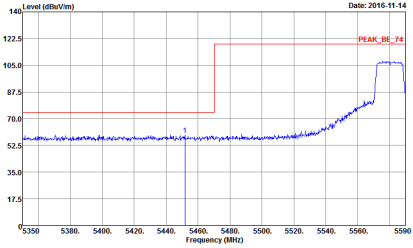
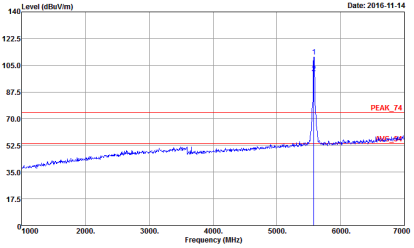
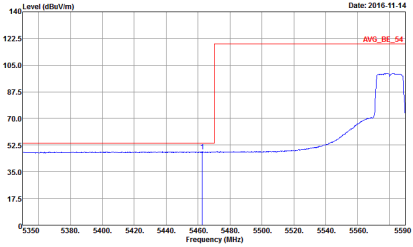

WIFI	Band 3 5470~5725MHz Band Edge @ 3m	
ANT	802.11a CH116 5580MHz - L	
1	Horizontal	Fundamental
Peak	 <p>Date: 2016-11-14</p> <p>Site : 03CH12-HY Condition : PEAK_BE_74 3m HORN_9120D_1328 HORIZONTAL : RBW:1000.000KHz VBW:3000.000KHz SWT:Auto Detector : Peak Project : 672014-10 Mode : 20</p>	 <p>Date: 2016-11-14</p> <p>Site : 03CH12-HY Condition : PEAK_74 3m HORN_9120D_1328 HORIZONTAL : RBW:1000.000KHz VBW:3000.000KHz SWT:Auto Detector : Peak Project : 672014-10 Mode : 20</p>
Avg.	 <p>Date: 2016-11-14</p> <p>Site : 03CH12-HY Condition : AVG_BE_54 3m HORN_9120D_1328 HORIZONTAL : RBW:1000.000KHz VBW:1.000KHz SWT:Auto Detector : Peak Project : 672014-10 Mode : 20</p>	Left blank

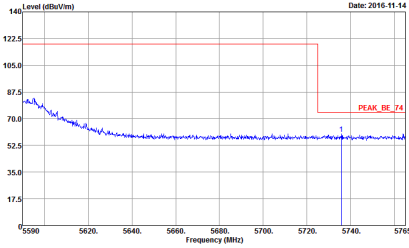
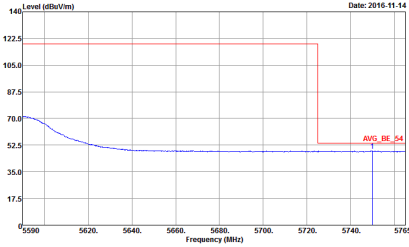

WIFI	Band 3 5470~5725MHz Band Edge @ 3m	
ANT	802.11a CH116 5580MHz - R	
1	Horizontal	Fundamental
Peak	 <p> Site : 03CH12-HY Condition : PEAK_BE_74 3m HORN_9120D_1328 HORIZONTAL Detector : Peak Project : 672014-10 Mode : 20 </p>	Left blank
Avg.	 <p> Site : 03CH12-HY Condition : AVG_BE_54 3m HORN_9120D_1328 HORIZONTAL Detector : Peak Project : 672014-10 Mode : 20 </p>	Left blank

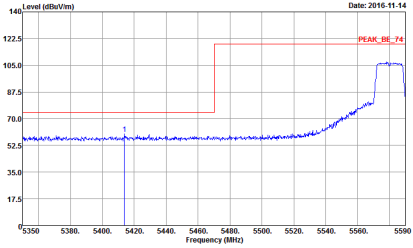
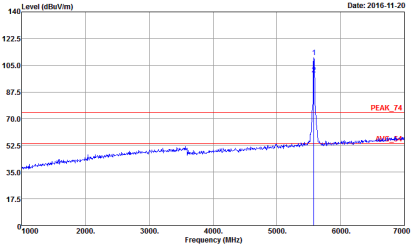
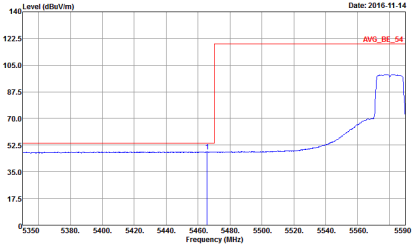

WIFI	Band 3 5470~5725MHz Band Edge @ 3m	
ANT	802.11a CH116 5580MHz - L	
1	Vertical	Fundamental
Peak	 <p>Date: 2016-11-14</p> <p>Level (dBuV/m)</p> <p>Frequency (MHz)</p> <p>PEAK_BE_74</p> <p>Site : 03CH12-HY Condition : PEAK_BE_74 3m HORN_9120D_1328 VERTICAL : RBW:1000.000KHz VBW:3000.000KHz SWT:Auto Detector : Peak Project : 672014-10 Mode : 20</p>	 <p>Date: 2016-11-20</p> <p>Level (dBuV/m)</p> <p>Frequency (MHz)</p> <p>PEAK_74</p> <p>Site : 03CH12-HY Condition : PEAK_74 3m HORN_9120D_1328 VERTICAL : RBW:1000.000KHz VBW:3000.000KHz SWT:Auto Detector : Peak Project : 672014-10 Mode : 20</p>
Avg.	 <p>Date: 2016-11-14</p> <p>Level (dBuV/m)</p> <p>Frequency (MHz)</p> <p>AVG_BE_54</p> <p>Site : 03CH12-HY Condition : AVG_BE_54 3m HORN_9120D_1328 VERTICAL : RBW:1000.000KHz VBW:1.000KHz SWT:Auto Detector : Peak Project : 672014-10 Mode : 20</p>	Left blank

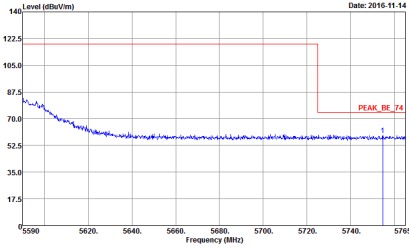
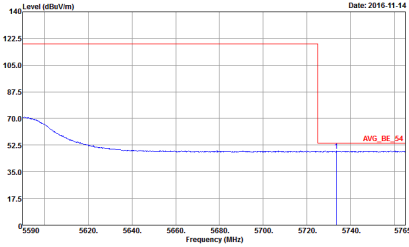

WIFI	Band 3 5470~5725MHz Band Edge @ 3m	
ANT	802.11a CH116 5580MHz - R	
1	Vertical	Fundamental
Peak	 <p>Site : 03CH12-HY Condition : PEAK_BE_74 3m HORN_9120D_1328 VERTICAL Detector : Peak Project : 672014-10 Mode : 20</p>	Left blank
Avg.	 <p>Site : 03CH12-HY Condition : AVG_BE_54 3m HORN_9120D_1328 VERTICAL Detector : Peak Project : 672014-10 Mode : 20</p>	Left blank

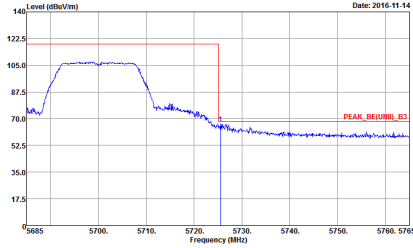
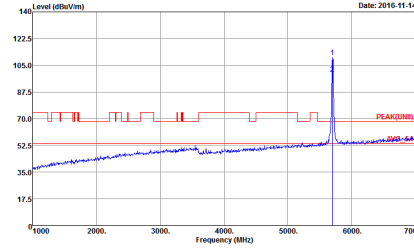

WIFI	Band 3 5470~5725MHz Band Edge @ 3m	
ANT	802.11a CH140 5700MHz	
1	Horizontal	Fundamental
Peak	 <p>Site : 03CH12-HY Condition : PEAK_BE(UNI)_B3 3m HORN_9120D_1328 HORIZONTAL : RBW:1000.000KHz VBW:3000.000KHz SWT:Auto Detector : Peak Project : 672014-10 Mode : 21 Setting : 67</p>	 <p>Site : 03CH12-HY Condition : PEAK(UNI) 3m HORN_9120D_1328 HORIZONTAL : RBW:1000.000KHz VBW:3000.000KHz SWT:Auto Detector : Peak Project : 672014-10 Mode : 21 Setting : 67</p>

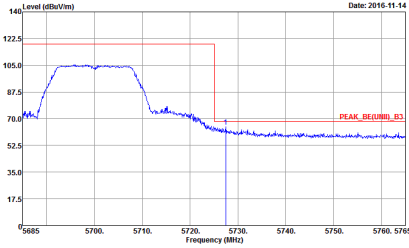
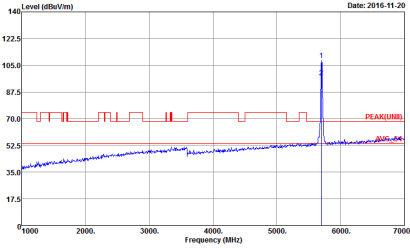

WIFI	Band 3 5470~5725MHz Band Edge @ 3m	
ANT	802.11a CH140 5700MHz	
1	Vertical	Fundamental
Peak	 <p>Date: 2016-11-14</p> <p>Site : 03CH12-HY Condition : PEAK_BE(UNI)_B3 3m HORN_9120D_1328 VERTICAL RBW:1000.000KHz VBW:3000.000KHz SWT:Auto Detector : Peak Project : 672014-10 Mode : 21 Setting : 67</p>	 <p>Date: 2016-11-20</p> <p>Site : 03CH12-HY Condition : PEAK(UNI) 3m HORN_9120D_1328 VERTICAL RBW:1000.000KHz VBW:3000.000KHz SWT:Auto Detector : Peak Project : 672014-10 Mode : 21 Setting : 67</p>

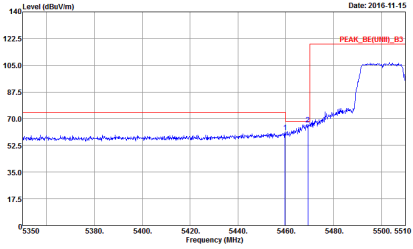
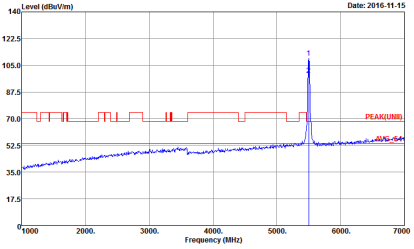
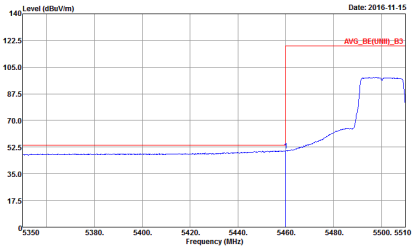

Band 3 5470~5725MHz
WIFI 802.11ac VHT20 (Band Edge @ 3m)

WIFI	Band 3 5470~5725MHz Band Edge @ 3m	
ANT	802.11ac VHT20 CH100 5500MHz	
1	Horizontal	Fundamental
Peak	 <p>Date: 2016-11-15</p> <p>Level (dBuV/m)</p> <p>Frequency (MHz)</p> <p>PEAK_BE(UMI)_B3</p> <p>Site : 03CH12-HY Condition : PEAK_BE(UMI)_B3 3m HORN_9120D_1328 HORIZONTAL RBW:1000.000kHz VBW:3000.000kHz SWT:Auto Detector : Peak Project : 672014-10 Mode : 22</p>	 <p>Date: 2016-11-15</p> <p>Level (dBuV/m)</p> <p>Frequency (MHz)</p> <p>PEAK(UMI)</p> <p>Site : 03CH12-HY Condition : PEAK(UMI) 3m HORN_9120D_1328 HORIZONTAL RBW:1000.000kHz VBW:3000.000kHz SWT:Auto Detector : Peak Project : 672014-10 Mode : 22</p>
Avg.	 <p>Date: 2016-11-15</p> <p>Level (dBuV/m)</p> <p>Frequency (MHz)</p> <p>AVG_BE(UMI)_B3</p> <p>Site : 03CH12-HY Condition : AVG_BE(UMI)_B3 3m HORN_9120D_1328 HORIZONTAL RBW:1000.000kHz VBW:1.000kHz SWT:Auto Detector : Peak Project : 672014-10 Mode : 22</p>	Left blank

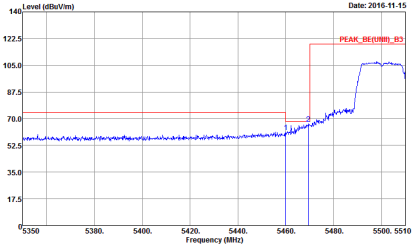
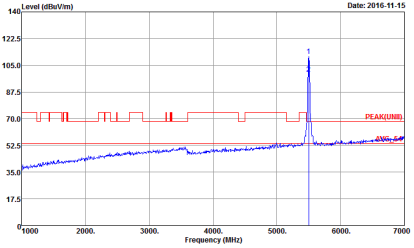
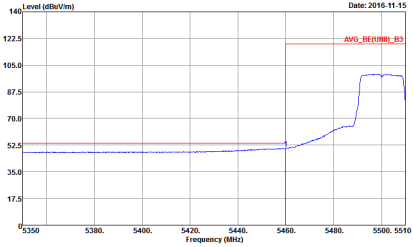

WIFI	Band 3 5470~5725MHz Band Edge @ 3m	
ANT	802.11ac VHT20 CH100 5500MHz	
1	Vertical	Fundamental
Peak	 <p>Date: 2016-11-15</p> <p>Site : 03CH12-HY Condition : PEAK_BE(UMH)_B3 3m HORN_9120D_1328 VERTICAL : RBW:1000.000KHz VBW:3000.000KHz SWT:Auto Detector : Peak Project : 672014-10 Mode : 22</p>	 <p>Date: 2016-11-15</p> <p>Site : 03CH12-HY Condition : PEAK(UMH) 3m HORN_9120D_1328 VERTICAL : RBW:1000.000KHz VBW:3000.000KHz SWT:Auto Detector : Peak Project : 672014-10 Mode : 22</p>
Avg.	 <p>Date: 2016-11-15</p> <p>Site : 03CH12-HY Condition : AVG_BE(UMH)_B3 3m HORN_9120D_1328 VERTICAL : RBW:1000.000KHz VBW:1.000KHz SWT:Auto Detector : Peak Project : 672014-10 Mode : 22</p>	Left blank

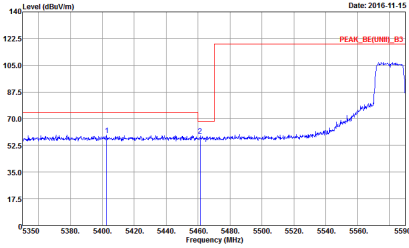
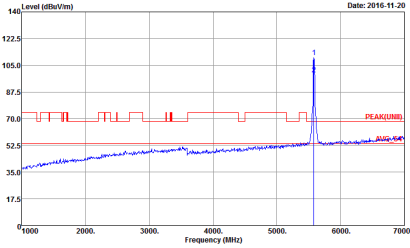
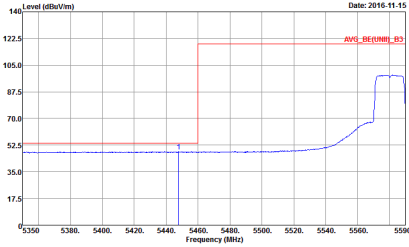

WIFI	Band 3 5470~5725MHz Band Edge @ 3m	
ANT	802.11ac VHT20 CH116 5580MHz - L	
1	Horizontal	Fundamental
Peak	 <p>Date: 2016-11-15</p> <p>Site : 03CH12-HY Condition : PEAK_BE(UNI)_B3 3m HORN_9120D_1328 HORIZONTAL : RBW:1000.000KHz VBW:3000.000KHz SWT:Auto Detector : Peak Project : 672014-10 Mode : 23</p>	 <p>Date: 2016-11-20</p> <p>Site : 03CH12-HY Condition : PEAK(UNI) 3m HORN_9120D_1328 HORIZONTAL : RBW:1000.000KHz VBW:3000.000KHz SWT:Auto Detector : Peak Project : 672014-10 Mode : 23</p>
Avg.	 <p>Date: 2016-11-15</p> <p>Site : 03CH12-HY Condition : AVG_BE(UNI)_B3 3m HORN_9120D_1328 HORIZONTAL : RBW:1000.000KHz VBW:1.000KHz SWT:Auto Detector : Peak Project : 672014-10 Mode : 23</p>	Left blank

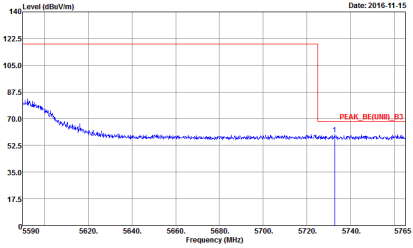

WIFI	Band 3 5470~5725MHz Band Edge @ 3m	
ANT	802.11ac VHT20 CH116 5580MHz - R	
1	Horizontal	Fundamental
Peak	 <p>Site : 03CH12-HY Condition : PEAK_BE(UND)_B3 3m HORN_9120D_1328 HORIZONTAL Detector : RBW:1000.000KHz VBW:3000.000KHz SWT:Auto Project : Peak : 672014-10 Mode : : 23</p>	Left blank

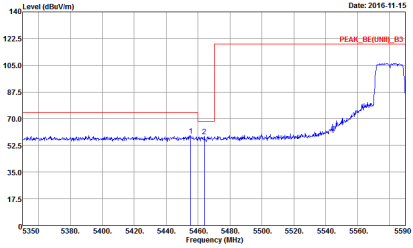
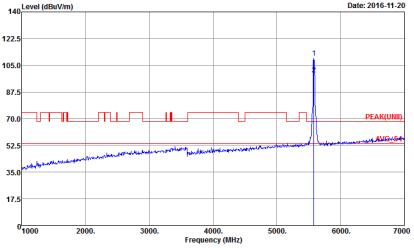
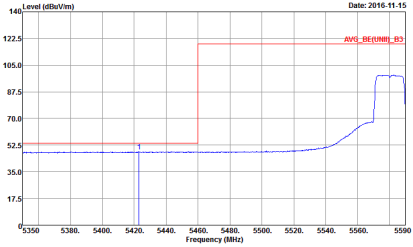

WIFI	Band 3 5470~5725MHz Band Edge @ 3m	
ANT	802.11ac VHT20 CH116 5580MHz - L	
1	Vertical	Fundamental
Peak	 <p>Level (dBuV/m) vs Frequency (MHz) plot for Vertical Peak. The plot shows a signal level around 70 dBuV/m from 5350 to 5460 MHz, then a sharp peak at approximately 5470 MHz reaching about 125 dBuV/m, and another peak at 5580 MHz reaching about 105 dBuV/m. The x-axis ranges from 5350 to 5590 MHz, and the y-axis ranges from 17.5 to 140 dBuV/m.</p> <p>Site : 03CH12-HY Condition : PEAK_BE(UNI)_B3 3m HORN_9120D_1328 VERTICAL : RBW:1000.000KHz VBW:3000.000KHz SWT:Auto Detector : Peak Project : 672014-10 Mode : 23</p>	 <p>Level (dBuV/m) vs Frequency (MHz) plot for Fundamental Peak. The plot shows a signal level around 70 dBuV/m from 1000 to 5500 MHz, then a sharp peak at approximately 5580 MHz reaching about 125 dBuV/m. The x-axis ranges from 1000 to 7000 MHz, and the y-axis ranges from 17.5 to 140 dBuV/m.</p> <p>Site : 03CH12-HY Condition : PEAK(UNI) 3m HORN_9120D_1328 VERTICAL : RBW:1000.000KHz VBW:3000.000KHz SWT:Auto Detector : Peak Project : 672014-10 Mode : 23</p>
Avg.	 <p>Level (dBuV/m) vs Frequency (MHz) plot for Vertical Avg. The plot shows a signal level around 70 dBuV/m from 5350 to 5460 MHz, then a sharp peak at approximately 5470 MHz reaching about 125 dBuV/m, and another peak at 5580 MHz reaching about 105 dBuV/m. The x-axis ranges from 5350 to 5590 MHz, and the y-axis ranges from 17.5 to 140 dBuV/m.</p> <p>Site : 03CH12-HY Condition : AVG_BE(UNI)_B3 3m HORN_9120D_1328 VERTICAL : RBW:1000.000KHz VBW:1.000KHz SWT:Auto Detector : Peak Project : 672014-10 Mode : 23</p>	Left blank



WIFI	Band 3 5470~5725MHz Band Edge @ 3m	
ANT	802.11ac VHT20 CH116 5580MHz - R	
1	Vertical	Fundamental
Peak	<p>Site : 03CH12-HY Condition : PEAK_BE(UND)_B3 3m HORN_9120D_1328 VERTICAL Detector : RBW:1000.000KHz VBW:3000.000KHz SWT:Auto Project : Peak Mode : 672014-10 : 23</p>	Left blank



WIFI	Band 3 5470~5725MHz Band Edge @ 3m	
ANT	802.11ac VHT20 CH140 5700MHz	
1	Horizontal	Fundamental
Peak	<p>Site : 03CH12-HY Condition : PEAK_BE(UNI)_B3 3m HORN_9120D_1328 HORIZONTAL : RBW:1000.000KHz VBW:3000.000KHz SWT:Auto Detector : Peak Project : 672014-10 Mode : 24 Setting : 66</p>	<p>Site : 03CH12-HY Condition : PEAK(UNI) 3m HORN_9120D_1328 HORIZONTAL : RBW:1000.000KHz VBW:3000.000KHz SWT:Auto Detector : Peak Project : 672014-10 Mode : 24 Setting : 66</p>

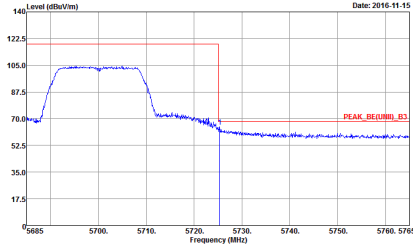
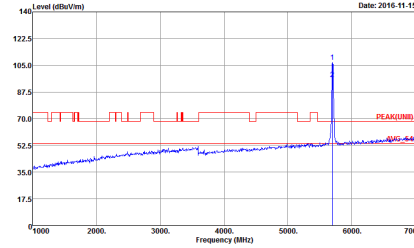

WIFI	Band 3 5470~5725MHz Band Edge @ 3m	
ANT	802.11ac VHT20 CH140 5700MHz	
1	Vertical	Fundamental
Peak	 <p>Site : 03CH12-HY Condition : PEAK_BE(UNII)_B3 3m HORN_9120D_1328 VERTICAL : RBW:1000.000KHz VBW:3000.000KHz SWT:Auto Detector : Peak Project : 672014-10 Mode : 24 Setting : 66</p>	 <p>Site : 03CH12-HY Condition : PEAK(UNII) 3m HORN_9120D_1328 VERTICAL : RBW:1000.000KHz VBW:3000.000KHz SWT:Auto Detector : Peak Project : 672014-10 Mode : 24 Setting : 66</p>

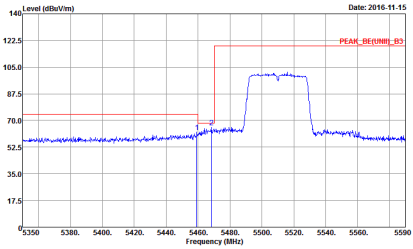
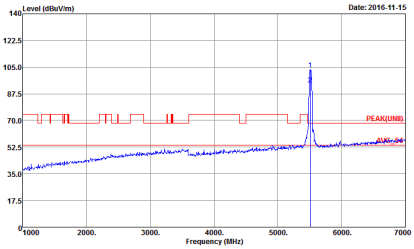
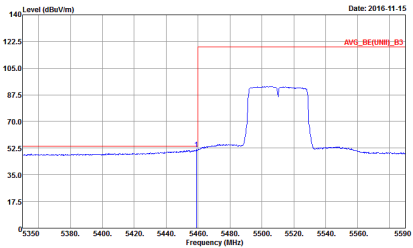

Band 3 5470~5725MHz
WIFI 802.11ac VHT40 (Band Edge @ 3m)

WIFI	Band 3 5470~5725MHz Band Edge @ 3m	
ANT	802.11ac VHT40 CH102 5510MHz - L	
1	Horizontal	Fundamental
Peak	 <p>Site : 03CH12-HY Condition : PEAK_BE(UNII)_B3 3m HORN_9120D_1328 HORIZONTAL RBW:1000.000kHz VBW:3000.000kHz SWT:Auto Detector : Peak Project : 672014-10 Mode : 25 Setting : 54</p>	 <p>Site : 03CH12-HY Condition : PEAK(UNII) 3m HORN_9120D_1328 HORIZONTAL RBW:1000.000kHz VBW:3000.000kHz SWT:Auto Detector : Peak Project : 672014-10 Mode : 25 Setting : 54</p>
Avg.	 <p>Site : 03CH12-HY Condition : AVG_BE(UNII)_B3 3m HORN_9120D_1328 HORIZONTAL RBW:1000.000kHz VBW:3000.000kHz SWT:Auto Detector : Peak Project : 672014-10 Mode : 25 Setting : 54</p>	Left blank



WIFI	Band 3 5470~5725MHz Band Edge @ 3m	
ANT	802.11ac VHT40 CH102 5510MHz - R	
1	Horizontal	Fundamental
Peak	<p>Site : 03CH12-HY Condition : PEAK_BE(UNH)_B3 3m HORN_9120D_1328 HORIZONTAL Detector : Peak Project : 672014-10 Mode : 25 Setting : 54</p>	Left blank

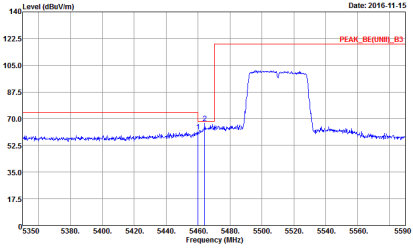
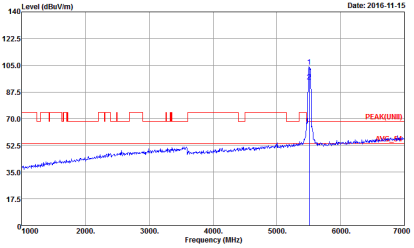
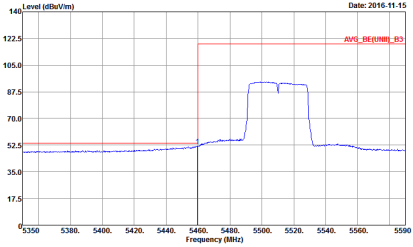

WIFI	Band 3 5470~5725MHz Band Edge @ 3m	
ANT	802.11ac VHT40 CH102 5510MHz - L	
1	Vertical	Fundamental
Peak	 <p>Level (dBuV/m) vs Frequency (MHz) plot showing a peak at approximately 5470 MHz. The peak level is around 122.5 dBuV/m. The plot includes a red line for the peak and a blue line for the average. The x-axis ranges from 5350 to 5590 MHz, and the y-axis ranges from 17.5 to 140 dBuV/m.</p> <p>Site : 03CH12-HY Condition : PEAK_BE(UNII)_B3 3m HORN_9120D_1328 VERTICAL : RBW:1000.000KHz VBW:3000.000KHz SWT:Auto Detector : Peak Project : 672014-10 Mode : 25 Setting : 54</p>	 <p>Level (dBuV/m) vs Frequency (MHz) plot showing a peak at approximately 5510 MHz. The peak level is around 105.0 dBuV/m. The plot includes a red line for the peak and a blue line for the average. The x-axis ranges from 1000 to 7000 MHz, and the y-axis ranges from 17.5 to 140 dBuV/m.</p> <p>Site : 03CH12-HY Condition : PEAK(UNII) 3m HORN_9120D_1328 VERTICAL : RBW:1000.000KHz VBW:3000.000KHz SWT:Auto Detector : Peak Project : 672014-10 Mode : 25 Setting : 54</p>
Avg.	 <p>Level (dBuV/m) vs Frequency (MHz) plot showing the average level across the frequency range. The average level is around 70.0 dBuV/m. The plot includes a red line for the average and a blue line for the peak. The x-axis ranges from 5350 to 5590 MHz, and the y-axis ranges from 17.5 to 140 dBuV/m.</p> <p>Site : 03CH12-HY Condition : AVG_BE(UNII)_B3 3m HORN_9120D_1328 VERTICAL : RBW:1000.000KHz VBW:3.000KHz SWT:Auto Detector : Peak Project : 672014-10 Mode : 25 Setting : 54</p>	Left blank

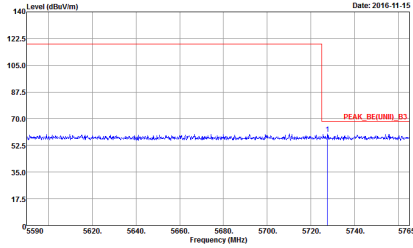

WIFI	Band 3 5470~5725MHz Band Edge @ 3m	
ANT	802.11ac VHT40 CH102 5510MHz - R	
1	Vertical	Fundamental
Peak	 <p>Site Condition : -03CH12-HY : PEAK_BE(UND)_B3 3m HORN_9120D_1328 VERTICAL : RBW:1000.000KHz VBW:3000.000KHz SWT:Auto Detector : Peak Project : 672014-10 Mode : 25 Setting : 54</p>	Left blank

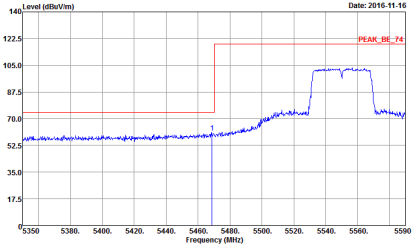
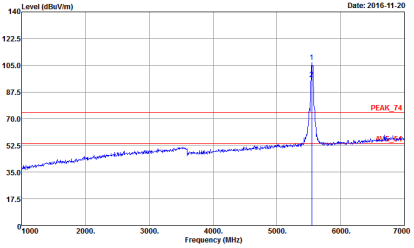
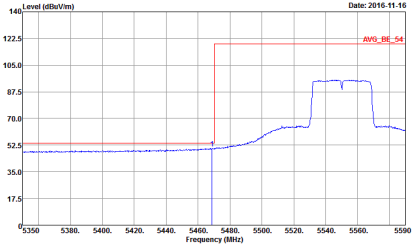

WIFI	Band 3 5470~5725MHz Band Edge @ 3m	
ANT	802.11ac VHT40 CH110 5550MHz - L	
1	Horizontal	Fundamental
Peak	 <p>Date: 2016-11-16</p> <p>Site : 03CH12-HY Condition : PEAK_BE_74 3m HORN_9120D_1328 HORIZONTAL : RBW:1000.000KHz VBW:3000.000KHz SWT:Auto Detector : Peak Project : 672014-10 Mode : 26</p>	 <p>Date: 2016-11-20</p> <p>Site : 03CH12-HY Condition : PEAK_74 3m HORN_9120D_1328 HORIZONTAL : RBW:1000.000KHz VBW:3000.000KHz SWT:Auto Detector : Peak Project : 672014-10 Mode : 26</p>
Avg.	 <p>Date: 2016-11-16</p> <p>Site : 03CH12-HY Condition : AVG_BE_54 3m HORN_9120D_1328 HORIZONTAL : RBW:1000.000KHz VBW:3.000KHz SWT:Auto Detector : Peak Project : 672014-10 Mode : 26</p>	Left blank

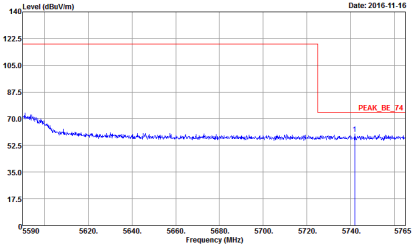
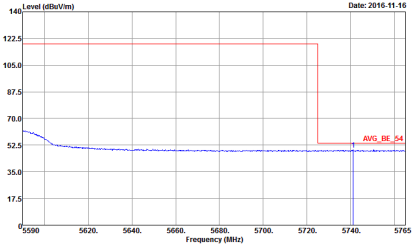

WIFI	Band 3 5470~5725MHz Band Edge @ 3m	
ANT	802.11ac VHT40 CH110 5550MHz - R	
1	Horizontal	Fundamental
Peak	 <p>Site : 03CH12-HY Condition : PEAK_BE_74 3m HORN_9120D_1328 HORIZONTAL : RBW:1000.000KHz VBW:3000.000KHz SWT:Auto Detector : Peak Project : 672014-10 Mode : 26</p>	Left blank
Avg.	 <p>Site : 03CH12-HY Condition : AVG_BE_54 3m HORN_9120D_1328 HORIZONTAL : RBW:1000.000KHz VBW:3.000KHz SWT:Auto Detector : Peak Project : 672014-10 Mode : 26</p>	Left blank

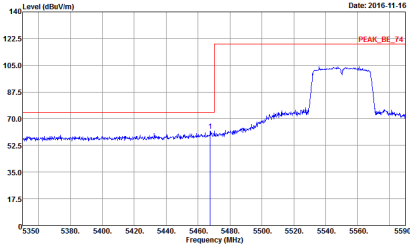
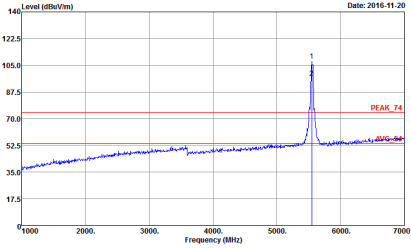
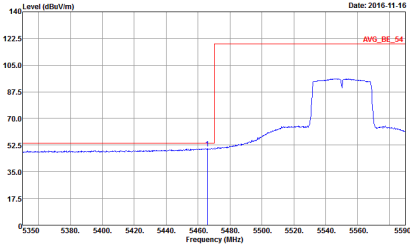

WIFI	Band 3 5470~5725MHz Band Edge @ 3m	
ANT	802.11ac VHT40 CH110 5550MHz - L	
1	Vertical	Fundamental
Peak	 <p>Level (dBuV/m) vs Frequency (MHz) plot showing a peak at approximately 5470 MHz. The peak level is indicated by a red line labeled 'PEAK_BE_74' at approximately 122.5 dBuV/m. The plot shows a blue trace of the spectrum with a red line indicating the peak level. The x-axis ranges from 5350 to 5590 MHz, and the y-axis ranges from 17.5 to 140 dBuV/m.</p> <p>Site : 03CH12-HY Condition : PEAK_BE_74 3m HORN_9120D_1328 VERTICAL Detector : Peak Project : 672014-10 Mode : 26</p>	 <p>Level (dBuV/m) vs Frequency (MHz) plot showing a peak at approximately 5470 MHz. The peak level is indicated by a red line labeled 'PEAK_74' at approximately 122.5 dBuV/m. The plot shows a blue trace of the spectrum with a red line indicating the peak level. The x-axis ranges from 1000 to 7000 MHz, and the y-axis ranges from 17.5 to 140 dBuV/m.</p> <p>Site : 03CH12-HY Condition : PEAK_74 3m HORN_9120D_1328 VERTICAL Detector : Peak Project : 672014-10 Mode : 26</p>
Avg.	 <p>Level (dBuV/m) vs Frequency (MHz) plot showing an average level at approximately 5470 MHz. The average level is indicated by a red line labeled 'AVG_BE_54' at approximately 122.5 dBuV/m. The plot shows a blue trace of the spectrum with a red line indicating the average level. The x-axis ranges from 5350 to 5590 MHz, and the y-axis ranges from 17.5 to 140 dBuV/m.</p> <p>Site : 03CH12-HY Condition : AVG_BE_54 3m HORN_9120D_1328 VERTICAL Detector : Peak Project : 672014-10 Mode : 26</p>	Left blank

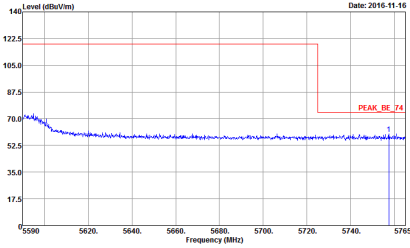
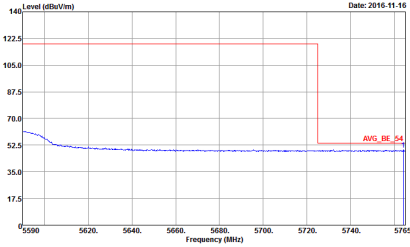

WIFI	Band 3 5470~5725MHz Band Edge @ 3m	
ANT	802.11ac VHT40 CH110 5550MHz - R	
1	Vertical	Fundamental
Peak	 <p>Site : 03CH12-HY Condition : PEAK_BE_74 3m HORN_9120D_1328 VERTICAL RBW:1000.000KHz VBW:3000.000KHz SWT:Auto Detector : Peak Project : 672014-10 Mode : 26</p>	Left blank
Avg.	 <p>Site : 03CH12-HY Condition : AVG_BE_54 3m HORN_9120D_1328 VERTICAL RBW:1000.000KHz VBW:3.000KHz SWT:Auto Detector : Peak Project : 672014-10 Mode : 26</p>	Left blank

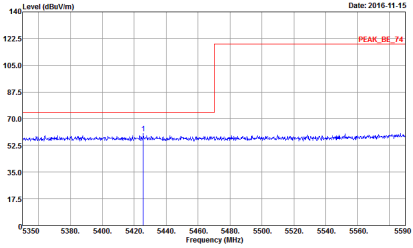
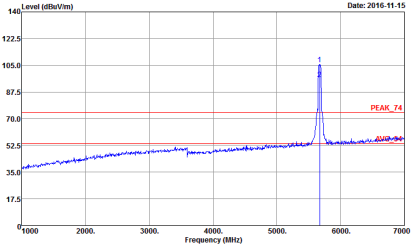
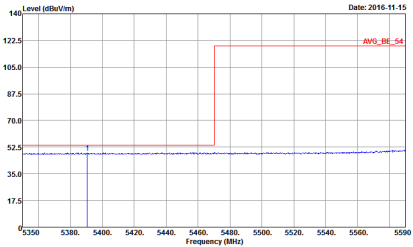

WIFI	Band 3 5470~5725MHz Band Edge @ 3m	
ANT	802.11ac VHT40 CH134 5670MHz - L	
1	Horizontal	Fundamental
Peak	 <p>Date: 2016-11-15</p> <p>Site : 03CH12-HY Condition : PEAK_BE_74 3m HORN_9120D_1328 HORIZONTAL Detector : Peak Project : 672014-10 Mode : 27 Setting : 65 : 74_54</p>	 <p>Date: 2016-11-15</p> <p>Site : 03CH12-HY Condition : PEAK_74 3m HORN_9120D_1328 HORIZONTAL Detector : Peak Project : 672014-10 Mode : 27 Setting : 65 : 74_54</p>
Avg.	 <p>Date: 2016-11-15</p> <p>Site : 03CH12-HY Condition : AVG_BE_54 3m HORN_9120D_1328 HORIZONTAL Detector : Peak Project : 672014-10 Mode : 27 Setting : 65 : 74_54</p>	Left blank

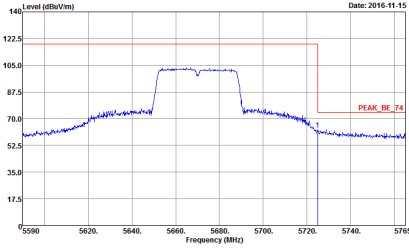
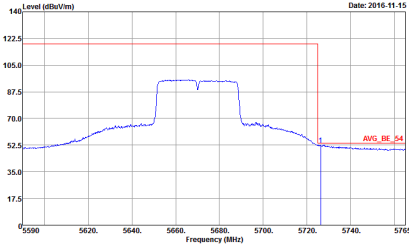

WIFI	Band 3 5470~5725MHz Band Edge @ 3m	
ANT	802.11ac VHT40 CH134 5670MHz - R	
1	Horizontal	Fundamental
Peak	 <p>Site : 03CH12-HY Condition : PEAK_BE_74 3m HORN_9120D_1328 HORIZONTAL : RBW:1000.000KHz VBW:3000.000KHz SWT:Auto Detector : Peak Project : 672014-10 Mode : 27 Setting : 65 : 74_54</p>	Left blank
Avg.	 <p>Site : 03CH12-HY Condition : AVG_BE_54 3m HORN_9120D_1328 HORIZONTAL : RBW:1000.000KHz VBW:3.000KHz SWT:Auto Detector : Peak Project : 672014-10 Mode : 27 Setting : 65 : 74_54</p>	Left blank

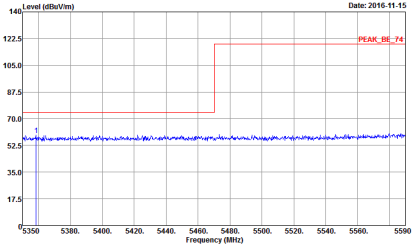
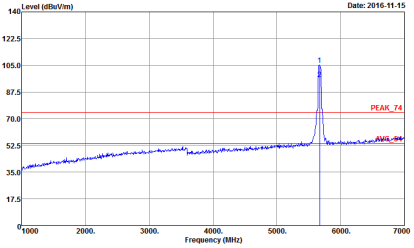
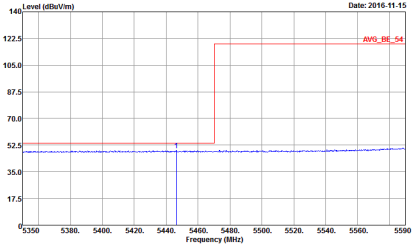

WIFI	Band 3 5470~5725MHz Band Edge @ 3m	
ANT	802.11ac VHT40 CH134 5670MHz - L	
1	Vertical	Fundamental
Peak	 <p>Level (dBuV/m) vs Frequency (MHz) plot showing a peak at 5670 MHz. The y-axis ranges from 17.5 to 140 dBuV/m, and the x-axis ranges from 5350 to 5590 MHz. A red line indicates the peak level at approximately 122.5 dBuV/m.</p> <p>Site : 03CH12-HY Condition : PEAK_BE_74 3m HORN_9120D_1328 VERTICAL : RBW:1000.000KHz VBW:3000.000KHz SWT:Auto Detector : Peak Project : 672014-10 Mode : 27 Setting : 65 : 74_54</p>	 <p>Level (dBuV/m) vs Frequency (MHz) plot showing a sharp peak at 5670 MHz. The y-axis ranges from 17.5 to 140 dBuV/m, and the x-axis ranges from 1000 to 7000 MHz. A red line indicates the peak level at approximately 70.0 dBuV/m.</p> <p>Site : 03CH12-HY Condition : PEAK_74 3m HORN_9120D_1328 VERTICAL : RBW:1000.000KHz VBW:3000.000KHz SWT:Auto Detector : Peak Project : 672014-10 Mode : 27 Setting : 65 : 74_54</p>
Avg.	 <p>Level (dBuV/m) vs Frequency (MHz) plot showing a peak at 5670 MHz. The y-axis ranges from 17.5 to 140 dBuV/m, and the x-axis ranges from 5350 to 5590 MHz. A red line indicates the average level at approximately 122.5 dBuV/m.</p> <p>Site : 03CH12-HY Condition : AVG_BE_54 3m HORN_9120D_1328 VERTICAL : RBW:1000.000KHz VBW:3.000KHz SWT:Auto Detector : Peak Project : 672014-10 Mode : 27 Setting : 65 : 74_54</p>	Left blank

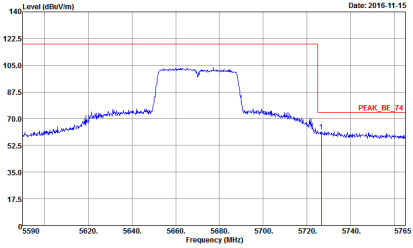
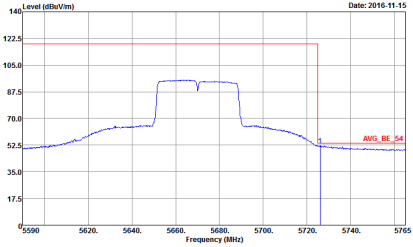

WIFI	Band 3 5470~5725MHz Band Edge @ 3m	
ANT	802.11ac VHT40 CH134 5670MHz - R	
1	Vertical	Fundamental
Peak	 <p>Date: 2016-11-15</p> <p>Site : 03CH12-HY Condition : PEAK_BE_74 3m HORN_9120D_1328 VERTICAL : RBW:1000.000KHz VBW:3000.000KHz SWT:Auto Detector : Peak Project : 672014-10 Mode : 27 Setting : 65 : 74_54</p>	Left blank
Avg.	 <p>Date: 2016-11-15</p> <p>Site : 03CH12-HY Condition : AVG_BE_54 3m HORN_9120D_1328 VERTICAL : RBW:1000.000KHz VBW:3.000KHz SWT:Auto Detector : Peak Project : 672014-10 Mode : 27 Setting : 65 : 74_54</p>	Left blank

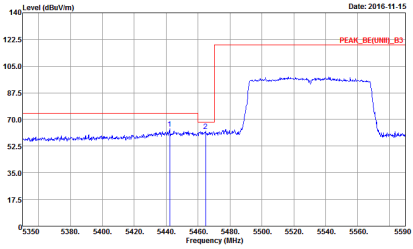
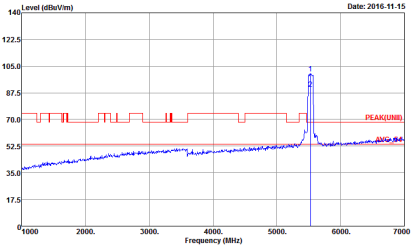
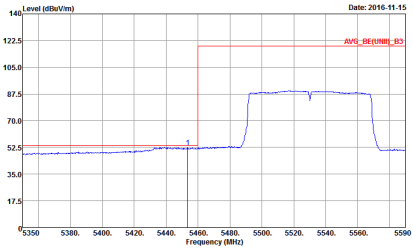

Band 3 5470~5725MHz
WIFI 802.11ac VHT80 (Band Edge @ 3m)

WIFI	Band 3 5470~5725MHz Band Edge @ 3m	
ANT	802.11ac VHT80 CH106 5530MHz - L	
1	Horizontal	Fundamental
Peak	 <p>Date: 2016-11-15</p> <p>Level (dBu/m) vs Frequency (MHz)</p> <p>PEAK_BE(UNII)_B3</p> <p>Site Condition: :03CH12-HY :PEAK_BE(UNII)_B3 3m HORN_9120D_1328 HORIZONTAL :RBW:1000.000kHz VBW:3000.000kHz SWT:Auto</p> <p>Detector: :Peak Project: :672014-10 Mode: :28 Setting: :53 :68.2_78.2</p>	 <p>Date: 2016-11-15</p> <p>Level (dBu/m) vs Frequency (MHz)</p> <p>PEAK(UNII)</p> <p>Site Condition: :03CH12-HY :PEAK(UNII) 3m HORN_9120D_1328 HORIZONTAL :RBW:1000.000kHz VBW:3000.000kHz SWT:Auto</p> <p>Detector: :Peak Project: :672014-10 Mode: :28 Setting: :53 :68.2_78.2</p>
Avg.	 <p>Date: 2016-11-15</p> <p>Level (dBu/m) vs Frequency (MHz)</p> <p>AVG_BE(UNII)_B3</p> <p>Site Condition: :03CH12-HY :AVG_BE(UNII)_B3 3m HORN_9120D_1328 HORIZONTAL :RBW:1000.000kHz VBW:3.000kHz SWT:Auto</p> <p>Detector: :Peak Project: :672014-10 Mode: :28 Setting: :53 :68.2_78.2</p>	Left blank



WIFI	Band 3 5470~5725MHz Band Edge @ 3m	
ANT	802.11ac VHT80 CH106 5530MHz - R	
1	Horizontal	Fundamental
Peak	<p>Site : 03CH12-HY Condition : PEAK_BE(UNH)_B3 3m HORN_9120D_1328 HORIZONTAL Detector : Peak Project : 672014-10 Mode : 20 Setting : 53 : 68.2, 78.2</p>	Left blank

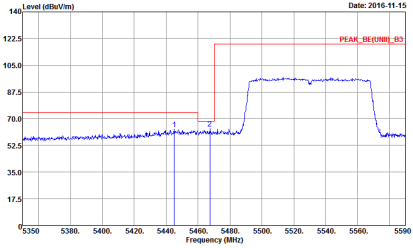
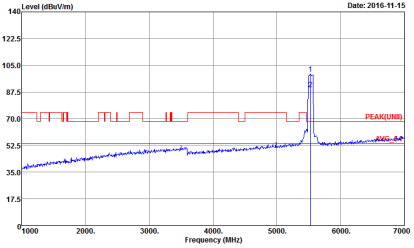
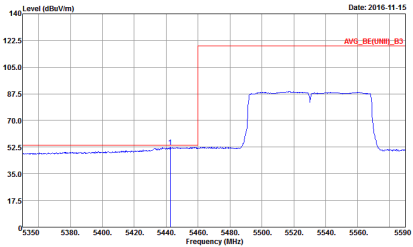

WIFI	Band 3 5470~5725MHz Band Edge @ 3m	
ANT	802.11ac VHT80 CH106 5530MHz - L	
1	Vertical	Fundamental
Peak	 <p>Level (dBuV/m) vs Frequency (MHz) plot showing a peak at approximately 5470 MHz. The y-axis ranges from 17.5 to 140 dBuV/m, and the x-axis ranges from 5350 to 5590 MHz. A red line indicates the peak level at approximately 122.5 dBuV/m.</p> <p>Site : 03CH12-HY Condition : PEAK_BE(UNII)_B3 3m HORN_9120D_1328 VERTICAL : RBW:1000.000KHz VBW:3000.000KHz SWT:Auto Detector : Peak Project : 672014-10 Mode : 28 Setting : 53 : 68.2_78.2</p>	 <p>Level (dBuV/m) vs Frequency (MHz) plot showing a peak at approximately 5530 MHz. The y-axis ranges from 17.5 to 140 dBuV/m, and the x-axis ranges from 1000 to 7000 MHz. A red line indicates the peak level at approximately 70.0 dBuV/m.</p> <p>Site : 03CH12-HY Condition : PEAK(UNII) 3m HORN_9120D_1328 VERTICAL : RBW:1000.000KHz VBW:3000.000KHz SWT:Auto Detector : Peak Project : 672014-10 Mode : 28 Setting : 53 : 68.2_78.2</p>
Avg.	 <p>Level (dBuV/m) vs Frequency (MHz) plot showing an average level at approximately 5470 MHz. The y-axis ranges from 17.5 to 140 dBuV/m, and the x-axis ranges from 5350 to 5590 MHz. A red line indicates the average level at approximately 122.5 dBuV/m.</p> <p>Site : 03CH12-HY Condition : AVG_BE(UNII)_B3 3m HORN_9120D_1328 VERTICAL : RBW:1000.000KHz VBW:3.000KHz SWT:Auto Detector : Peak Project : 672014-10 Mode : 28 Setting : 53 : 68.2_78.2</p>	Left blank

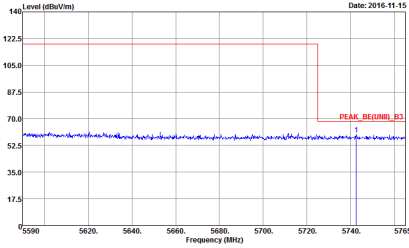

WIFI	Band 3 5470~5725MHz Band Edge @ 3m	
ANT	802.11ac VHT80 CH106 5530MHz - R	
1	Vertical	Fundamental
Peak	 <p data-bbox="347 728 651 817">Date: 2016-11-15 Site : 03CH12-HY Condition : PEAK_BE(UNH)_B3 3m HORN_9120D_1328 VERTICAL Detector : Peak Project : 672014-10 Mode : 20 Setting : 53 : 68.2, 78.2</p>	Left blank

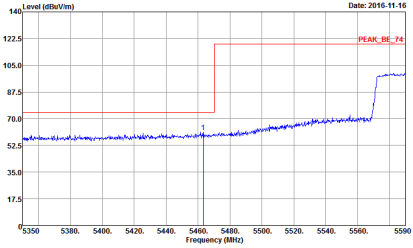
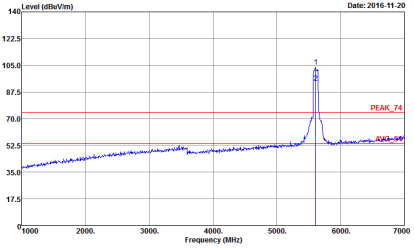
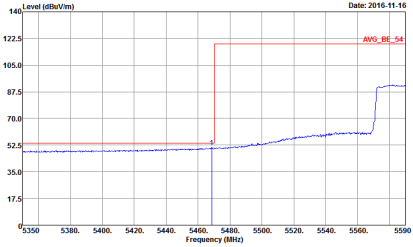

WIFI	Band 3 5470~5725MHz Band Edge @ 3m	
ANT	802.11ac VHT80 CH122 5610MHz - L	
1	Horizontal	Fundamental
Peak	 <p>Date: 2016-11-16</p> <p>Site : 03CH12-HY Condition : PEAK_BE_74 3m HORN_9120D_1328 HORIZONTAL Detector : Peak Project : 672014-10 Mode : 29</p>	 <p>Date: 2016-11-20</p> <p>Site : 03CH12-HY Condition : PEAK_74 3m HORN_9120D_1328 HORIZONTAL Detector : Peak Project : 672014-10 Mode : 29</p>
Avg.	 <p>Date: 2016-11-16</p> <p>Site : 03CH12-HY Condition : AVG_BE_54 3m HORN_9120D_1328 HORIZONTAL Detector : Peak Project : 672014-10 Mode : 29</p>	Left blank

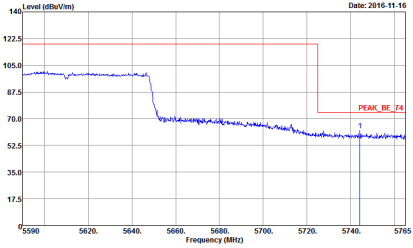
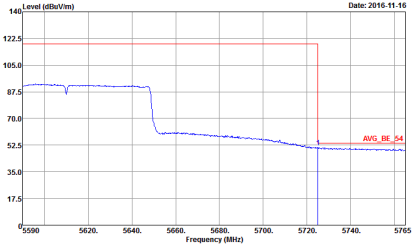

WIFI	Band 3 5470~5725MHz Band Edge @ 3m	
ANT	802.11ac VHT80 CH122 5610MHz - R	
1	Horizontal	Fundamental
Peak	 <p>Site : 03CH12-HY Condition : PEAK_BE_74 3m HORN_9120D_1328 HORIZONTAL Detector : Peak Project : 672014-10 Mode : 29</p>	Left blank
Avg.	 <p>Site : 03CH12-HY Condition : AVG_BE_54 3m HORN_9120D_1328 HORIZONTAL Detector : Peak Project : 672014-10 Mode : 29</p>	Left blank

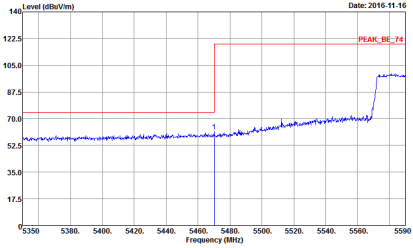
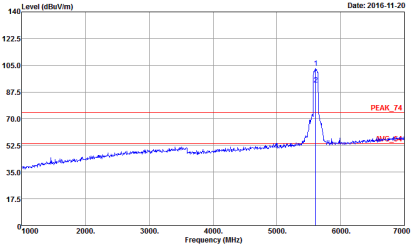
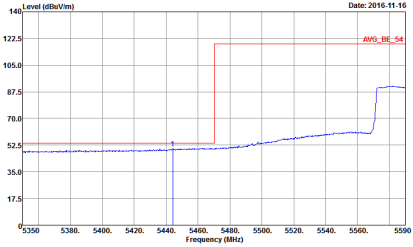

WIFI	Band 3 5470~5725MHz Band Edge @ 3m	
ANT	802.11ac VHT80 CH122 5610MHz - L	
1	Vertical	Fundamental
Peak	 <p>Date: 2016-11-16</p> <p>Site : 03CH12-HY Condition : PEAK_BE_74 3m HORN_9120D_1328 VERTICAL : RBW:1000.000KHz VBW:3000.000KHz SWT:Auto Detector : Peak Project : 672014-10 Mode : 29</p>	 <p>Date: 2016-11-20</p> <p>Site : 03CH12-HY Condition : PEAK_74 3m HORN_9120D_1328 VERTICAL : RBW:1000.000KHz VBW:3000.000KHz SWT:Auto Detector : Peak Project : 672014-10 Mode : 29</p>
Avg.	 <p>Date: 2016-11-16</p> <p>Site : 03CH12-HY Condition : AVG_BE_54 3m HORN_9120D_1328 VERTICAL : RBW:1000.000KHz VBW:3.000KHz SWT:Auto Detector : Peak Project : 672014-10 Mode : 29</p>	Left blank

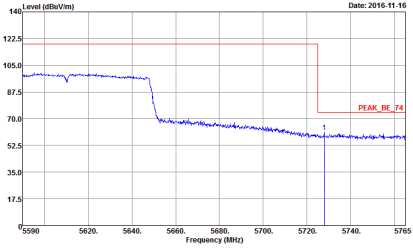
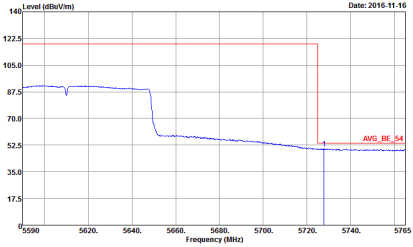

WIFI	Band 3 5470~5725MHz Band Edge @ 3m	
ANT	802.11ac VHT80 CH122 5610MHz - R	
1	Vertical	Fundamental
Peak	 <p>Site : 03CH12-HY Condition : PEAK_BE_74 3m HORN_9120D_1328 VERTICAL RBW:1000.000KHz VBW:3000.000KHz SWT:Auto Detector : Peak Project : 672014-10 Mode : 29</p>	Left blank
Avg.	 <p>Site : 03CH12-HY Condition : AVG_BE_54 3m HORN_9120D_1328 VERTICAL RBW:1000.000KHz VBW:3.000KHz SWT:Auto Detector : Peak Project : 672014-10 Mode : 29</p>	Left blank

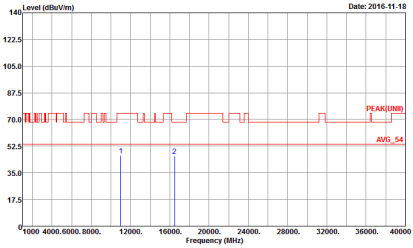
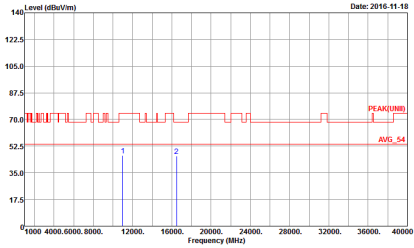

Band 3 - 5470~5725MHz
WIFI 802.11a (Harmonic @ 3m)

WIFI	Band 3 5470~5725MHz Harmonic @ 3m	
ANT	802.11a CH100 5500MHz	
1	Horizontal	Vertical
<p>Peak</p> <p>Avg.</p>	 <p>Site : 03CH12-HY Condition : PEAK(UNI) 3m HORN_9120D_1328 HORIZONTAL Project : 672014-10 Mode : 19</p>	 <p>Site : 03CH12-HY Condition : PEAK(UNI) 3m HORN_9120D_1328 VERTICAL Project : 672014-10 Mode : 19</p>

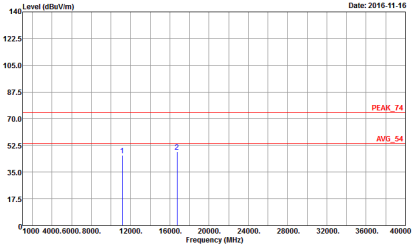
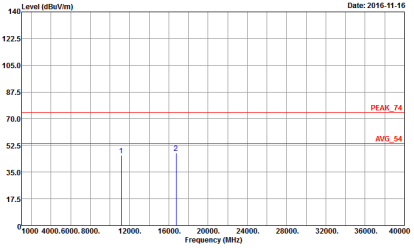

WIFI	Band 3 5470~5725MHz Harmonic @ 3m	
ANT	802.11a CH116 5580MHz	
1	Horizontal	Vertical
Peak Avg.	 <p>Site : 03CH12-HY Condition : PEAK_74 3m HORN_9120D_1328 HORIZONTAL Project : 672014-10 Mode : 20</p>	 <p>Site : 03CH12-HY Condition : PEAK_74 3m HORN_9120D_1328 VERTICAL Project : 672014-10 Mode : 20</p>

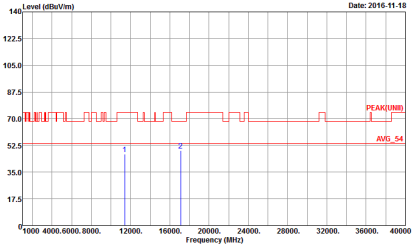
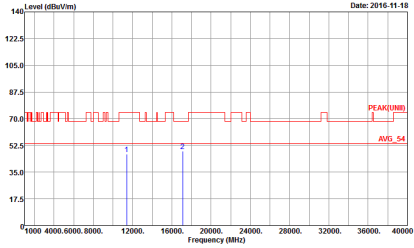

WIFI	Band 3 5470~5725MHz Harmonic @ 3m	
ANT	802.11a CH140 5700MHz	
1	Horizontal	Vertical
Peak Avg.	 <p>Site : 03CH12-HY Condition : PEAK(UNI) 3m HORN_9120D_1328 HORIZONTAL Project : 672014-10 Mode : 21</p>	 <p>Site : 03CH12-HY Condition : PEAK(UNI) 3m HORN_9120D_1328 VERTICAL Project : 672014-10 Mode : 21</p>



Band 3 5470~5725MHz
WIFI 802.11ac VHT20 (Harmonic @ 3m)

Table with 2 columns: Horizontal and Vertical. Each column contains a spectral plot showing Level (dBu/m) vs Frequency (MHz) with peak and average markers. Includes metadata like Site, Condition, Project, and Mode.

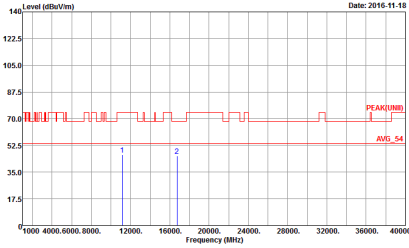
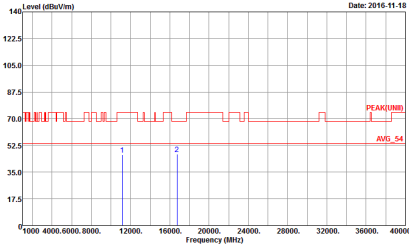

WIFI	Band 3 5470~5725MHz Harmonic @ 3m	
ANT	802.11ac VHT20 CH116 5580MHz	
1	Horizontal	Vertical
Peak Avg.	 <p>Site : 03CH12-HY Condition : PEAK(UNI) 3m HORN_9120D_1328 HORIZONTAL Project : 672014-10 Mode : 23</p>	 <p>Site : 03CH12-HY Condition : PEAK(UNI) 3m HORN_9120D_1328 VERTICAL Project : 672014-10 Mode : 23</p>

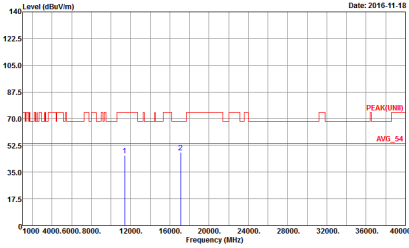
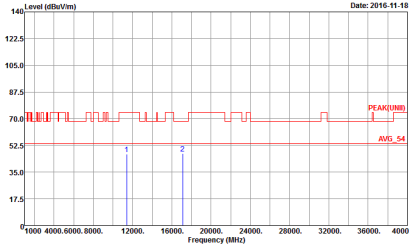

WIFI	Band 3 5470~5725MHz Harmonic @ 3m	
ANT	802.11ac VHT20 CH140 5700MHz	
1	Horizontal	Vertical
<p>Peak Avg.</p>	 <p>Site : 03CH12-HY Condition : PEAK(UNI) 3m HORN_9120D_1328 HORIZONTAL Project : 672014-10 Mode : 24</p>	 <p>Site : 03CH12-HY Condition : PEAK(UNI) 3m HORN_9120D_1328 VERTICAL Project : 672014-10 Mode : 24</p>



Band 3 5470~5725MHz
WIFI 802.11ac VHT40 (Harmonic @ 3m)

Table with 2 columns: Horizontal and Vertical. It contains two spectral plots showing Level (dBm/m) vs Frequency (MHz) for Peak and Avg. measurements. The plots show a noise floor around 70 dBm/m with two distinct peaks labeled 1 and 2. The horizontal plot is for a HORN antenna and the vertical plot is for a VERTICAL antenna.

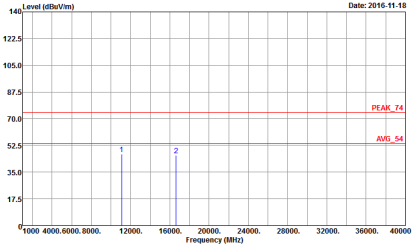
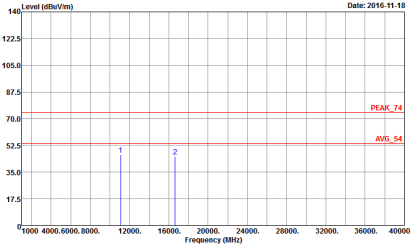

WIFI	Band 3 5470~5725MHz Harmonic @ 3m	
ANT	802.11ac VHT40 CH110 5550MHz	
1	Horizontal	Vertical
<p>Peak</p> <p>Avg.</p>	 <p>Site : 03CH12-HY Condition : PEAK_74 3m HORN_9120D_1328 HORIZONTAL Project : 672014-10 Mode : 25</p>	 <p>Site : 03CH12-HY Condition : PEAK_74 3m HORN_9120D_1328 VERTICAL Project : 672014-10 Mode : 25</p>

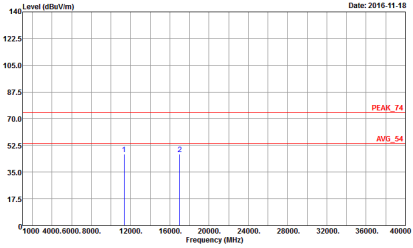
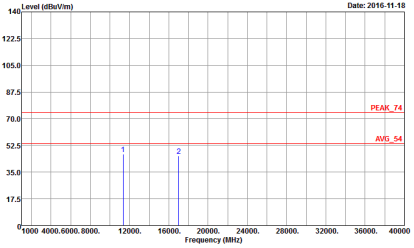

WIFI	Band 3 5470~5725MHz Harmonic @ 3m	
ANT	802.11ac VHT40 CH134 5670MHz	
1	Horizontal	Vertical
Peak Avg.	 <p>Site : 03CH12-HY Condition : PEAK_74 3m HORN_9120D_1328 HORIZONTAL Project : 672014-10 Mode : 27</p>	 <p>Site : 03CH12-HY Condition : PEAK_74 3m HORN_9120D_1328 VERTICAL Project : 672014-10 Mode : 27</p>



Band 3 5470~5725MHz
WIFI 802.11ac VHT80 (Harmonic @ 3m)

Table with 2 columns: Horizontal and Vertical. It contains two graphs showing Level (dBu/m) vs Frequency (MHz) for Peak and Avg. measurements. Includes metadata like Site, Condition, Project, and Mode.

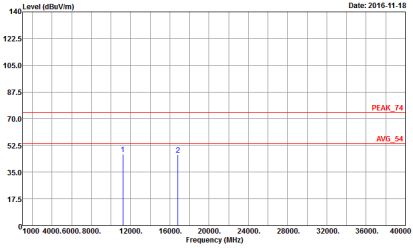
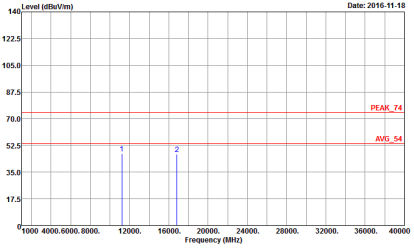

WIFI	Band 3 5470~5725MHz Harmonic @ 3m	
ANT	802.11ac VHT80 CH122 5610MHz	
1	Horizontal	Vertical
<p>Peak</p> <p>Avg.</p>	 <p>Site : 03CH12-HY Condition : PEAK_74 3m HORN_9120D_1328 HORIZONTAL Project : 672014-10 Mode : 29</p>	 <p>Site : 03CH12-HY Condition : PEAK_74 3m HORN_9120D_1328 VERTICAL Project : 672014-10 Mode : 29</p>



Band 3 - Straddle Channel
WIFI 802.11a (Fundamental @ 3m)

Table with 2 columns: Horizontal and Vertical. Each column contains a spectral plot showing Level (dBuV/m) vs Frequency (MHz) with a peak at approximately 5720 MHz. The table also includes a 'Peak Avg.' label and detailed test parameters for both orientations.



Band 3 – Straddle Channel
WIFI 802.11ac VHT20 (Fundamental @ 3m)

Table with 2 columns: WIFI, ANT and 2 main columns: Horizontal, Vertical. It contains two spectral plots showing Level (dBm/m) vs Frequency (MHz) for a peak at approximately 5720 MHz. The left plot is for a horizontal antenna and the right for a vertical antenna. Both show a peak level of approximately 110 dBm/m.

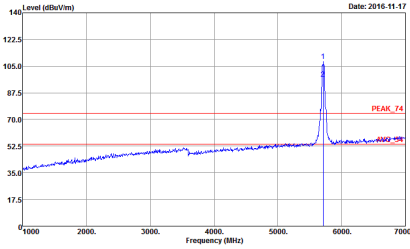
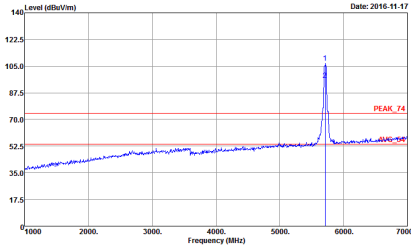

**Band 3 – Straddle Channel
WIFI 802.11ac VHT40 (Fundamental @ 3m)**

WIFI	Band 3 Straddle Channel Fundamental @ 3m	
ANT	802.11ac VHT40 CH142 5710MHz	
1	Horizontal	Vertical
<p>Peak</p> <p>Avg.</p>	 <p>Date: 2016-11-17</p> <pre> Site : 03CH12-HY Condition : PEAK_74 3m HORN 9120D 1320 HORIZONTAL Detector : Peak Project : 672014-10 Mode : 32 </pre>	 <p>Date: 2016-11-17</p> <pre> Site : 03CH12-HY Condition : PEAK_74 3m HORN 9120D 1320 VERTICAL Detector : Peak Project : 672014-10 Mode : 32 </pre>



Band 3 – Straddle Channel
WIFI 802.11ac VHT80 (Fundamental @ 3m)

Table with 2 columns: WIFI (Band 3 Straddle Channel Fundamental @ 3m), ANT (802.11ac VHT80 CH138 5690MHz). Row 1: 1, Horizontal, Vertical. Each plot shows Level (dBm/1m) vs Frequency (MHz) with a peak at 5690MHz. Includes metadata like Site, Condition, Detector, Project, Mode.

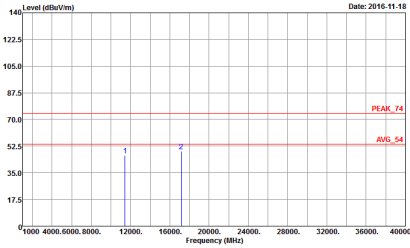
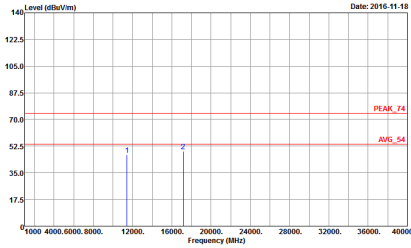

Band 3 - Straddle Channel
WIFI 802.11a (Harmonic @ 3m)

WIFI	Band 3 Straddle Channel Harmonic @ 3m	
ANT	802.11a CH144 5720MHz	
1	Horizontal	Vertical
<p>Peak</p> <p>Avg.</p>	 <p>Site : 03CH12-HY Condition : PEAK_74 3m HORN_9120D_1328 HORIZONTAL Project : 672014-10 Mode : 30</p>	 <p>Site : 03CH12-HY Condition : PEAK_74 3m HORN_9120D_1328 VERTICAL Project : 672014-10 Mode : 30</p>



Band 3 – Straddle Channel
WIFI 802.11ac VHT20 (Harmonic @ 3m)

Table with 2 columns: Horizontal and Vertical. Each column contains a spectral plot showing Level (dBm/m) vs Frequency (MHz) with peak and average markers. Includes metadata for Site, Condition, Project, and Mode.



Band 3 – Straddle Channel
WIFI 802.11ac VHT40 (Harmonic @ 3m)

WIFI	Band 3 Straddle Channel Harmonic @ 3m	
ANT	802.11ac VHT40 CH142 5710MHz	
1	Horizontal	Vertical
Peak Avg.	<p>Site : 03CH12-HY Condition : PEAK_74 3m HORN_9120D_1328 HORIZONTAL Project : 672014-10 Mode : 32</p>	<p>Site : 03CH12-HY Condition : PEAK_74 3m HORN_9120D_1328 VERTICAL Project : 672014-10 Mode : 32</p>



Band 3 – Straddle Channel
WIFI 802.11ac VHT80 (Harmonic @ 3m)

WIFI	Band 3 Straddle Channel Harmonic @ 3m	
ANT	802.11ac VHT80 CH138 5690MHz	
1	Horizontal	Vertical
Peak Avg.	<p>Site : 03CH12-HY Condition : PEAK_74 3m HORN_9120D_1328 HORIZONTAL Project : 672014-10 Mode : 33</p>	<p>Site : 03CH12-HY Condition : PEAK_74 3m HORN_9120D_1328 VERTICAL Project : 672014-10 Mode : 33</p>



Emission below 1GHz
5GHz WIFI 802.11ac VHT20 (LF)

WIFI	5GHz WIFI	
ANT	802.11ac VHT20 LF	
1	Horizontal	Vertical
QP / Peak	<p>Site : 03CH12-HY Condition : QP 3m BIL0G_6111D_37059 HORIZONTAL Detector : Peak Project : 672014-10 Mode : 34</p>	<p>Site : 03CH12-HY Condition : QP 3m BIL0G_6111D_37059 VERTICAL Detector : Peak Project : 672014-10 Mode : 34</p>



Appendix C. Duty Cycle Plots

Antenna	Band	Duty Cycle(%)	T(us)	1/T(kHz)	VBW Setting
1	802.11a	93.46	1430.00	0.70	1kHz
1	5GHz 802.11ac VHT20	92.47	1350.00	0.74	1kHz
1	5GHz 802.11ac VHT40	96.94	950.00	1.05	3kHz
1	5GHz 802.11ac VHT80	95.83	460.00	2.17	3kHz



802.11a

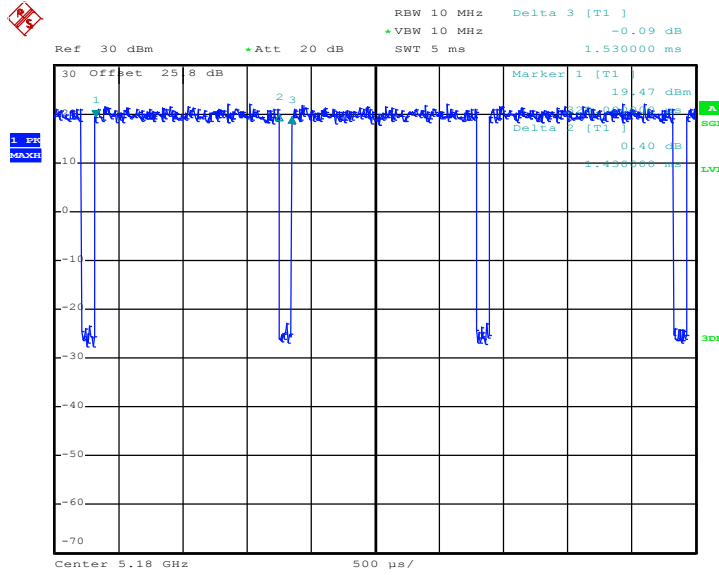

Date: 8.NOV.2016 20:53:54

802.11ac VHT20

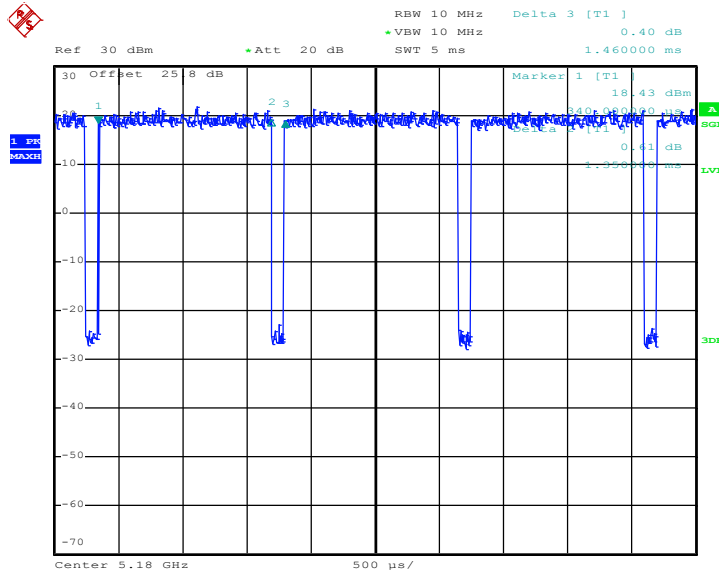

Date: 8.NOV.2016 22:53:42



802.11ac VHT40

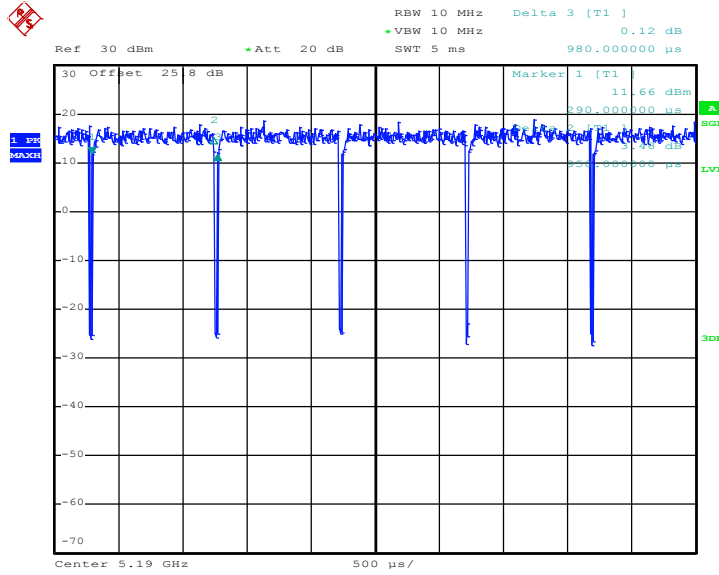

Date: 8.NOV.2016 22:58:56

802.11ac VHT80

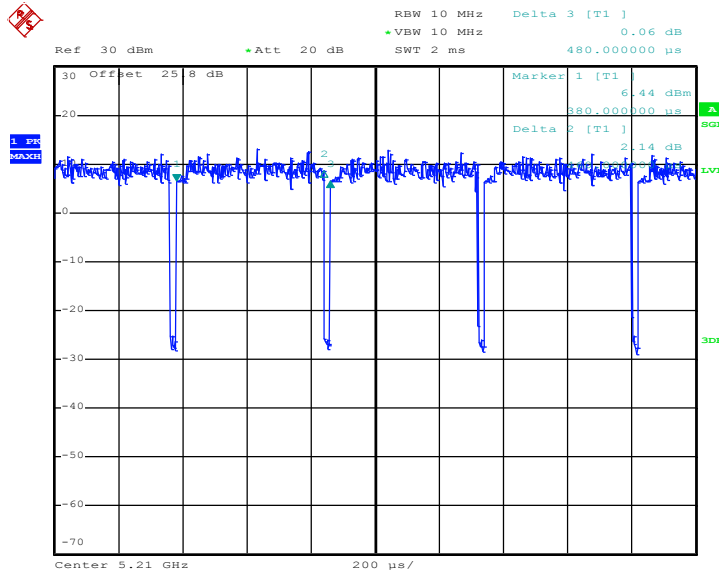

Date: 8.NOV.2016 23:39:29