



Variant FCC RF Test Report

APPLICANT : Motorola Solutions, Inc.
EQUIPMENT : Touch Computer
BRAND NAME : Motorola
MODEL NAME : TC55AH
FCC ID : UZ7TC55AH
STANDARD : 47 CFR Part 2, 22(H), 24(E), 27
CLASSIFICATION : PCS Licensed Transmitter Held to Ear (PCE)

The product was received on May 22, 2014 and testing was completed on Jun. 05, 2014. We, SPORTON INTERNATIONAL INC., would like to declare that the tested sample has been evaluated in accordance with the test procedures given in ANSI / TIA / EIA-603-C-2004 and the testing has shown the tested sample to be in compliance with the applicable technical standards.

The test results in this report apply exclusively to the tested model / sample. Without written approval of SPORTON INTERNATIONAL INC., the test report shall not be reproduced except in full.

Reviewed by: Joseph Lin / Supervisor

Approved by: Jones Tsai / Manager



SPORTON INTERNATIONAL INC.

No. 52, Hwa Ya 1st Rd., Hwa Ya Technology Park, Kwei-Shan Hsiang, Tao Yuan Hsien, Taiwan, R.O.C.



TABLE OF CONTENTS

REVISION HISTORY..... 3

SUMMARY OF TEST RESULT 4

1 GENERAL DESCRIPTION 6

 1.1 Applicant 6

 1.2 Manufacturer..... 6

 1.3 Product Feature of Equipment Under Test..... 6

 1.4 Product Specification subjective to this standard 7

 1.5 Modification of EUT 7

 1.6 Maximum ERP/EIRP Power and Emission Designator 8

 1.7 Testing Location 9

 1.8 Applicable Standards..... 9

2 TEST CONFIGURATION OF EQUIPMENT UNDER TEST 10

 2.1 Test Mode 10

 2.2 Connection Diagram of Test System 12

 2.3 Support Unit used in test configuration and system 12

 2.4 Measurement Results Explanation Example..... 12

3 TEST RESULT..... 13

 3.1 Conducted Output Power Measurement 13

 3.2 Peak-to-Average Ratio 22

 3.3 Effective Radiated Power and Equivalent Isotropic Radiated Power Measurement..... 33

 3.4 Occupied Bandwidth..... 45

 3.5 Conducted Band Edge Measurement 106

 3.6 Conducted Spurious Emission Measurement 148

 3.7 Radiated Spurious Emission Measurement 180

 3.8 Frequency Stability Measurement..... 242

4 LIST OF MEASURING EQUIPMENT 256

5 UNCERTAINTY OF EVALUATION 257

APPENDIX A. SETUP PHOTOGRAPHS



REVISION HISTORY

REPORT NO.	VERSION	DESCRIPTION	ISSUED DATE
FG322304-19	Rev. 01	This is a variant report for enabling LTE BW of Band II IV V by software, please refer Product Equality Declaration. The original report which can be referred to Sporton Report Number(Sporton Report No. FG322304-07B)	Jun. 16, 2014



SUMMARY OF TEST RESULT

Report Section	FCC Rule	Description	Limit	Result	Remark
3.1	§2.1046	Conducted Output Power	Reporting Only	PASS	-
3.2	§24.232(d) §27.50(d)(5)	Peak-to-Average Ratio	<13 dB	PASS	-
3.3	§22.913(a)(2)	Effective Radiated Power (Band 5)	ERP < 7 Watt	PASS	-
	§24.232(c)	Equivalent Isotropic Radiated Power (Band 2)	EIRP < 2Watt		
	§27.50(d)(4)	Equivalent Isotropic Radiated Power (Band 4)	EIRP < 1Watt		



Report Section	FCC Rule	Description	Limit	Result	Remark
3.4	§2.1049 §22.917(b) §24.238(b) §27.53(g)(3)	Occupied Bandwidth	Reporting Only	PASS	-
3.5	§2.1051 §22.917(a) §24.238(a) §27.53(g)	Conducted Band Edge Measurement (Band 2) (Band 4) (Band 5)	$< 43+10\log_{10}(P[\text{Watt}])$	PASS	-
3.6	§2.1051 §22.917(a) §24.238(a) §27.53(g)	Conducted Spurious Emission (Band 2) (Band 4) (Band 5)	$< 43+10\log_{10}(P[\text{Watts}])$	PASS	-
3.7	§2.1053 §22.917(a) §24.238(a) §27.53(g)	Radiated Spurious Emission (Band 2) (Band 4) (Band 5)	$< 43+10\log_{10}(P[\text{Watts}])$	PASS	Under limit 18.12 dB at 3784.000 MHz
3.8	§2.1055 §22.355 §24.235 §27.54	Frequency Stability Temperature & Voltage	$< 2.5 \text{ ppm}$	PASS	



1 General Description

1.1 Applicant

Motorola Solutions, Inc.
One Motorola Plaza, Holtsville, NY 11742-1300 USA

1.2 Manufacturer

Motorola Solutions, Inc.
One Motorola Plaza, Holtsville, NY 11742-1300 USA

1.3 Product Feature of Equipment Under Test

Product Feature	
Equipment	Touch Computer
Brand Name	Motorola
Model Name	TC55AH
FCC ID	UZ7TC55AH
EUT supports Radios application	GSM/EGPRS/WCDMA/HSPA/LTE/NFC/GPS WLAN 11b/g/n HT20 WALN 11a/n HT20/HT40 Bluetooth v4.0 EDR/LE
HW Version	DV1
SW Version	Android 4.1.2
FW Version	BSP 1.27
EUT Stage	Identical Prototype

Remark: The above EUT's information was declared by manufacturer. Please refer to the specifications or user's manual for more detailed description.



1.4 Product Specification subjective to this standard

Product Specification subjective to this standard	
Tx Frequency	LTE Band 2 : 1850.7 MHz ~ 1909.3 MHz LTE Band 4 : 1710.7 MHz ~ 1754.3 MHz LTE Band 5 : 824.7 MHz ~ 848.3 MHz
Rx Frequency	LTE Band 2 : 1930.7 MHz ~ 1989.3 MHz LTE Band 4 : 2110.7 MHz ~ 2154.3 MHz LTE Band 5 : 869.7 MHz ~ 893.3 MHz
Bandwidth	LTE Band 2 : 1.4MHz / 3MHz / 5MHz / 10MHz / 15MHz / 20MHz LTE Band 4 : 1.4MHz / 3MHz / 5MHz / 10MHz / 15MHz / 20MHz LTE Band 5 : 1.4MHz / 3MHz / 5MHz / 10MHz
Maximum Output Power to Antenna	LTE Band 2 : 24.41 dBm LTE Band 4 : 24.40 dBm LTE Band 5 : 24.36 dBm
Antenna Type	Monopole
Type of Modulation	QPSK / 16QAM

1.5 Modification of EUT

No modifications are made to the EUT during all test items.



1.6 Maximum ERP/EIRP Power and Emission Designator

FCC Rule	System	Type of Modulation	BW	Emission Designator	Frequency Tolerance (ppm)	Maximum ERP/EIRP
Part 22	LTE Band 5	QPSK	1.4 MHz	1M10G7D	0.022 ppm	0.13 W
Part 22	LTE Band 5	16QAM	1.4 MHz	1M10D7W	0.020 ppm	0.09 W
Part 22	LTE Band 5	QPSK	3 MHz	2M73G7D	0.022 ppm	0.13 W
Part 22	LTE Band 5	16QAM	3 MHz	2M72D7W	0.020 ppm	0.09 W
Part 24	LTE Band 2	QPSK	1.4 MHz	1M10G7D	0.022 ppm	0.33 W
Part 24	LTE Band 2	16QAM	1.4 MHz	1M10D7W	0.021 ppm	0.27 W
Part 24	LTE Band 2	QPSK	3 MHz	2M72G7D	0.022 ppm	0.32 W
Part 24	LTE Band 2	16QAM	3 MHz	2M74D7W	0.023 ppm	0.24 W
Part 24	LTE Band 2	QPSK	15 MHz	13M5G7D	0.021 ppm	0.35 W
Part 24	LTE Band 2	16QAM	15 MHz	13M5D7W	0.023 ppm	0.26 W
Part 24	LTE Band 2	QPSK	20 MHz	18M5G7D	0.023 ppm	0.32 W
Part 24	LTE Band 2	16QAM	20 MHz	18M5D7W	0.021 ppm	0.25 W
Part 27	LTE Band 4	QPSK	1.4 MHz	1M10G7D	0.021 ppm	0.19 W
Part 27	LTE Band 4	16QAM	1.4 MHz	1M10D7W	0.022 ppm	0.14 W
Part 27	LTE Band 4	QPSK	3 MHz	2M73G7D	0.022 ppm	0.19 W
Part 27	LTE Band 4	16QAM	3 MHz	2M73D7W	0.023 ppm	0.15 W
Part 27	LTE Band 4	QPSK	15MHz	13M5G7D	0.023 ppm	0.19 W
Part 27	LTE Band 4	16QAM	15MHz	13M5D7W	0.021 ppm	0.15 W
Part 27	LTE Band 4	QPSK	20MHz	18M5G7D	0.024 ppm	0.20 W
Part 27	LTE Band 4	16QAM	20MHz	18M4D7W	0.020 ppm	0.16 W



1.7 Testing Location

Sporton Lab is accredited to ISO 17025 by Taiwan Accreditation Foundation (TAF code : 1190) and the FCC designation No. TW1022 under the FCC 2.948(e) by Mutual Recognition Agreement (MRA) in FCC Test.

Test Site	SPORTON INTERNATIONAL INC.	
Test Site Location	No. 52, Hwa Ya 1 st Rd., Hwa Ya Technology Park, Kwei-Shan Hsiang, Tao Yuan Hsien, Taiwan, R.O.C. TEL: +886-3-327-3456 FAX: +886-3-328-4978	
Test Site No.	Sporton Site No.	
	TH02-HY	03CH07-HY

1.8 Applicable Standards

According to the specifications of the manufacturer, the EUT must comply with the requirements of the following standards:

- 47 CFR Part 2, 22(H), 24(E), 27
- ANSI / TIA / EIA-603-C-2004
- FCC KDB 971168 D01 Power Meas. License Digital Systems v02r01

Remark: All test items were verified and recorded according to the standards and without any deviation during the test.



2 Test Configuration of Equipment Under Test

2.1 Test Mode

Antenna port conducted and radiated test items listed below are performed according to KDB 971168 D01 Power Meas. License Digital Systems v02r01 with maximum output power.

Radiated measurements are performed by rotating the EUT in three different orthogonal test planes to find the maximum emission.

Test Items	Band	Bandwidth (MHz)						Modulation		RB #			Test Channel		
		1.4	3	5	10	15	20	QPSK	16QAM	1	Half	Full	L	M	H
Max. Output Power	2	v	v			v	v	v	v	v	v	v	v	v	v
	4	v	v			v	v	v	v	v	v	v	v	v	v
	5	v	v			-	-	v	v	v	v	v	v	v	v
Peak-to-Average Ratio	2						v		v	v		v	v	v	v
	4						v		v	v		v	v	v	v
	5				v				v	v		v	v	v	v
26dB and 99% Bandwidth	2	v	v			v	v	v	v			v	v	v	v
	4	v	v			v	v	v	v			v	v	v	v
	5	v	v			-	-	v	v			v	v	v	v
Conducted Band Edge	2	v	v			v	v	v	v	v		v	v		v
	4	v	v			v	v	v	v	v		v	v		v
	5	v	v			-	-	v	v	v		v	v		v



Test Items	Band	Bandwidth (MHz)						Modulation		RB #			Test Channel		
		1.4	3	5	10	15	20	QPSK	16QAM	1	Half	Full	L	M	H
Conducted Spurious Emission	2	√	√			√	√	√	√	√			√	√	√
	4	√	√			√	√	√	√	√			√	√	√
	5	√	√			-	-	√	√	√			√	√	√
Frequency Stability	2	√	√			√	√	√	√			√		√	
	4	√	√			√	√	√	√			√		√	
	5	√	√			-	-	√	√			√		√	
E.R.P./ E.I.R.P.	2	√	√			√	√	√	√	√			√	√	√
	4	√	√			√	√	√	√	√			√	√	√
	5	√	√			-	-	√	√	√			√	√	√
Radiated Spurious Emission	2	√	√			√	√	√		√			√	√	√
	4	√	√			√	√	√		√			√	√	√
	5	√	√			-	-	√		√			√	√	√
Note	1. The mark "√" means that this configuration is chosen for testing 2. The mark "-" means that this bandwidth is not supported.														

2.2 Connection Diagram of Test System

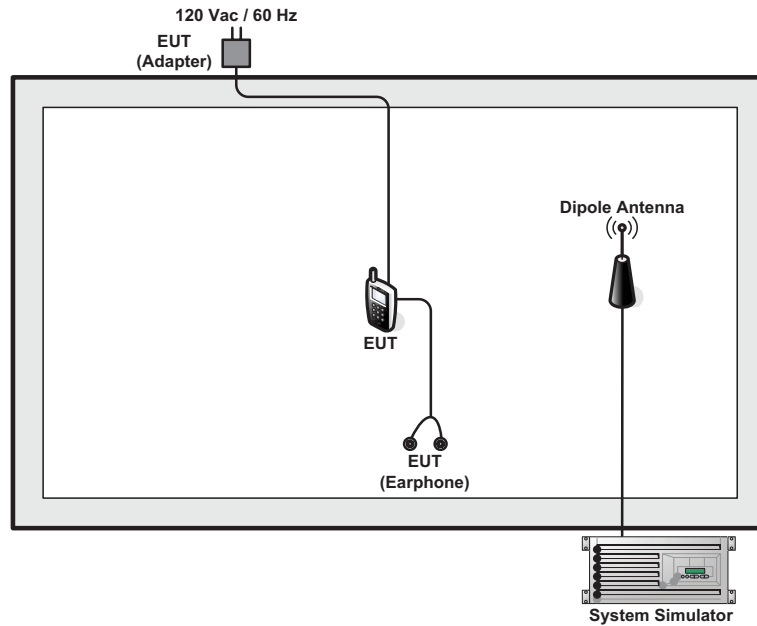

2.3 Support Unit used in test configuration and system

Item	Equipment	Trade Name	Model No.	FCC ID	Data Cable	Power Cord
1.	System Simulator	Anritsu	MT8820C	N/A	N/A	Unshielded, 1.8 m

2.4 Measurement Results Explanation Example

For all conducted test items:

The offset level is set in the spectrum analyzer to compensate the RF cable loss and attenuator factor between EUT conducted output port and spectrum analyzer. With the offset compensation, the spectrum analyzer reading level is exactly the EUT RF output level.

The spectrum analyzer offset is derived from RF cable loss and attenuator factor.

Offset = RF cable loss + attenuator factor.

Following shows an offset computation example with cable loss 4.2 dB and 10dB attenuator.

Example :

$$\begin{aligned} \text{Offset(dB)} &= \text{RF cable loss(dB)} + \text{attenuator factor(dB)}. \\ &= 4.2 + 10 = 14.2 \text{ (dB)} \end{aligned}$$

3 Test Result

3.1 Conducted Output Power Measurement

3.1.1 Description of the Conducted Output Power Measurement

A system simulator was used to establish communication with the EUT. Its parameters were set to force the EUT transmitting at maximum output power. The measured power in the radio frequency on the transmitter output terminals shall be reported.

3.1.2 Measuring Instruments

The measuring equipment is listed in the section 4 of this test report.

3.1.3 Test Procedures

1. The transmitter output port was connected to the system simulator.
2. Set EUT at maximum power through the system simulator.
3. Select lowest, middle, and highest channels for each band and different modulation.
4. Measure and record the power level from the system simulator.

3.1.4 Test Setup





3.1.5 Test Result of Conducted Output Power

<LTE Band 5 Conducted Power>

BW [MHz]	Modulation	RB Size	RB Offset	Power (dBm) Low Ch. / Freq.	Power (dBm) Middle Ch. / Freq.	Power (dBm) High Ch. / Freq.
Channel				20450	20525	20600
Frequency (MHz)				829	836.5	844
10	QPSK	1	0	24.36	24.30	24.09
10	QPSK	1	24	24.31	24.29	23.82
10	QPSK	1	49	24.35	23.95	23.97
10	QPSK	25	0	23.33	23.21	22.95
10	QPSK	25	12	23.26	23.25	22.83
10	QPSK	25	24	23.24	23.09	22.81
10	QPSK	50	0	23.24	23.10	22.86
10	16QAM	1	0	23.33	23.31	23.11
10	16QAM	1	24	23.37	23.30	22.97
10	16QAM	1	49	23.38	22.93	23.04
10	16QAM	25	0	22.19	22.19	21.84
10	16QAM	25	12	22.20	22.13	21.79
10	16QAM	25	24	22.19	22.00	21.76
10	16QAM	50	0	22.09	21.99	21.76
Channel				20425	20525	20625
Frequency (MHz)				826.5	836.5	846.5
5	QPSK	1	0	24.30	24.28	23.90
5	QPSK	1	12	24.27	24.27	23.95
5	QPSK	1	24	24.31	24.21	23.95
5	QPSK	12	0	23.41	23.36	22.99
5	QPSK	12	6	23.36	23.20	23.01
5	QPSK	12	11	23.30	23.15	23.04
5	QPSK	25	0	23.35	23.20	22.92
5	16QAM	1	0	23.23	23.30	22.93
5	16QAM	1	12	23.30	23.34	23.00
5	16QAM	1	24	23.33	23.21	23.00
5	16QAM	12	0	22.38	22.35	21.89
5	16QAM	12	6	22.34	22.21	21.95
5	16QAM	12	11	22.29	22.16	21.99
5	16QAM	25	0	22.23	22.15	21.81



BW [MHz]	Modulation	RB Size	RB Offset	Power (dBm) Low Ch. / Freq.	Power (dBm) Middle Ch. / Freq.	Power (dBm) High Ch. / Freq.
Channel				20415	20525	20635
Frequency (MHz)				825.5	836.5	847.5
3	QPSK	1	0	24.32	24.26	24.05
3	QPSK	1	7	24.22	24.20	23.70
3	QPSK	1	14	24.27	23.86	23.90
3	QPSK	8	0	23.28	23.14	22.89
3	QPSK	8	4	23.21	23.17	22.70
3	QPSK	8	7	23.13	22.96	22.73
3	QPSK	15	0	23.11	23.03	22.81
3	16QAM	1	0	23.24	23.22	22.99
3	16QAM	1	7	23.32	23.23	22.84
3	16QAM	1	14	23.27	22.89	22.96
3	16QAM	8	0	22.15	22.06	21.76
3	16QAM	8	4	22.11	22.09	21.75
3	16QAM	8	7	22.07	21.91	21.72
3	16QAM	15	0	22.03	21.92	21.69
Channel				20407	20525	20643
Frequency (MHz)				824.7	836.5	848.3
1.4	QPSK	1	0	24.29	24.24	24.02
1.4	QPSK	1	2	24.18	24.15	23.70
1.4	QPSK	1	5	24.25	23.80	23.90
1.4	QPSK	3	0	23.25	23.06	22.88
1.4	QPSK	3	1	23.14	23.11	22.77
1.4	QPSK	3	2	23.18	22.95	22.75
1.4	QPSK	6	0	23.14	22.96	22.72
1.4	16QAM	1	0	23.23	23.21	22.97
1.4	16QAM	1	2	23.30	23.22	22.85
1.4	16QAM	1	5	23.28	22.81	22.88
1.4	16QAM	3	0	22.06	22.03	21.77
1.4	16QAM	3	1	22.09	22.01	21.65
1.4	16QAM	3	2	22.10	21.85	21.69
1.4	16QAM	6	0	22.02	21.93	21.60



<LTE Band 2 Conducted Power>

BW [MHz]	Modulation	RB Size	RB Offset	Power (dBm) Low Ch. / Freq.	Power (dBm) Middle Ch. / Freq.	Power (dBm) High Ch. / Freq.
Channel				18700	18900	19100
Frequency (MHz)				1860	1880	1900
20	QPSK	1	0	24.24	24.13	24.10
20	QPSK	1	49	23.99	24.00	23.82
20	QPSK	1	99	24.07	23.90	23.80
20	QPSK	50	0	23.00	22.99	22.95
20	QPSK	50	24	22.85	22.92	22.90
20	QPSK	50	49	22.94	22.96	22.94
20	QPSK	100	0	22.90	22.89	22.76
20	16QAM	1	0	22.93	23.08	22.95
20	16QAM	1	49	22.88	23.02	22.94
20	16QAM	1	99	22.78	23.02	22.84
20	16QAM	50	0	21.86	22.01	21.93
20	16QAM	50	24	21.90	21.97	21.79
20	16QAM	50	49	21.81	21.98	21.90
20	16QAM	100	0	21.70	21.89	21.75
Channel				18675	18900	19125
Frequency (MHz)				1857.5	1880	1902.5
15	QPSK	1	0	24.05	23.97	23.96
15	QPSK	1	37	23.91	23.92	23.68
15	QPSK	1	74	23.95	23.76	23.76
15	QPSK	36	0	22.83	22.93	22.75
15	QPSK	36	18	22.73	22.82	22.74
15	QPSK	36	37	22.81	22.90	22.76
15	QPSK	75	0	22.54	22.78	22.62
15	16QAM	1	0	22.85	23.03	22.81
15	16QAM	1	37	22.69	22.90	22.87
15	16QAM	1	74	22.76	22.90	22.71
15	16QAM	36	0	21.82	21.86	21.79
15	16QAM	36	18	21.68	21.84	21.72
15	16QAM	36	37	21.68	21.86	21.81
15	16QAM	75	0	21.59	21.78	21.57



BW [MHz]	Modulation	RB Size	RB Offset	Power (dBm) Low Ch. / Freq.	Power (dBm) Middle Ch. / Freq.	Power (dBm) High Ch. / Freq.
Channel				18650	18900	19150
Frequency (MHz)				1855	1880	1905
10	QPSK	1	0	24.41	24.33	24.32
10	QPSK	1	24	24.30	24.31	24.12
10	QPSK	1	49	24.35	24.19	24.14
10	QPSK	25	0	23.21	23.33	23.18
10	QPSK	25	12	23.09	23.24	23.17
10	QPSK	25	24	23.18	23.30	23.19
10	QPSK	50	0	22.96	23.15	23.01
10	16QAM	1	0	23.22	23.41	23.24
10	16QAM	1	24	23.14	23.33	23.23
10	16QAM	1	49	23.12	23.26	23.16
10	16QAM	25	0	22.19	22.32	22.25
10	16QAM	25	12	22.14	22.30	22.13
10	16QAM	25	24	22.13	22.29	22.17
10	16QAM	50	0	21.96	22.14	22.02
Channel				18625	18900	19175
Frequency (MHz)				1852.5	1880	1907.5
5	QPSK	1	0	24.15	24.28	24.10
5	QPSK	1	12	24.19	24.25	24.11
5	QPSK	1	24	24.05	24.20	24.07
5	QPSK	12	0	23.28	23.34	23.14
5	QPSK	12	6	23.39	23.31	23.19
5	QPSK	12	11	23.30	23.29	23.14
5	QPSK	25	0	23.33	23.23	23.11
5	16QAM	1	0	23.24	23.33	23.19
5	16QAM	1	12	23.26	23.33	23.14
5	16QAM	1	24	23.13	23.33	23.14
5	16QAM	12	0	22.33	22.36	22.27
5	16QAM	12	6	22.44	22.29	22.28
5	16QAM	12	11	22.36	22.39	22.16
5	16QAM	25	0	22.22	22.23	22.11



BW [MHz]	Modulation	RB Size	RB Offset	Power (dBm) Low Ch. / Freq.	Power (dBm) Middle Ch. / Freq.	Power (dBm) High Ch. / Freq.
Channel				18615	18900	19185
Frequency (MHz)				1851.5	1880	1908.5
3	QPSK	1	0	24.23	24.19	24.19
3	QPSK	1	7	24.14	24.16	23.97
3	QPSK	1	14	24.20	24.10	24.02
3	QPSK	8	0	23.09	23.18	23.04
3	QPSK	8	4	22.94	23.11	23.02
3	QPSK	8	7	23.03	23.15	23.07
3	QPSK	15	0	22.81	22.97	22.86
3	16QAM	1	0	23.08	23.25	23.10
3	16QAM	1	7	22.99	23.18	23.08
3	16QAM	1	14	22.96	23.10	22.97
3	16QAM	8	0	22.04	22.19	22.12
3	16QAM	8	4	21.97	22.15	21.98
3	16QAM	8	7	21.98	22.17	21.98
3	16QAM	15	0	21.85	22.00	21.87
Channel				18607	18900	19193
Frequency (MHz)				1850.7	1880	1909.3
1.4	QPSK	1	0	24.20	24.12	24.14
1.4	QPSK	1	2	24.10	24.09	23.91
1.4	QPSK	1	5	23.84	23.95	23.94
1.4	QPSK	3	0	23.00	23.12	22.97
1.4	QPSK	3	1	22.90	23.00	22.99
1.4	QPSK	3	2	22.94	23.09	22.98
1.4	QPSK	6	0	22.75	22.97	22.84
1.4	16QAM	1	0	23.01	23.23	23.04
1.4	16QAM	1	2	22.96	23.12	23.00
1.4	16QAM	1	5	22.90	23.07	22.95
1.4	16QAM	3	0	21.98	22.11	22.09
1.4	16QAM	3	1	21.94	22.09	21.94
1.4	16QAM	3	2	21.92	22.06	21.96
1.4	16QAM	6	0	21.80	21.97	21.82



<LTE Band 4 Conducted Power>

BW [MHz]	Modulation	RB Size	RB Offset	Power (dBm) Low Ch. / Freq.	Power (dBm) Middle Ch. / Freq.	Power (dBm) High Ch. / Freq.
Channel				20050	20175	20300
Frequency (MHz)				1720	1732.5	1745
20	QPSK	1	0	24.27	23.95	23.89
20	QPSK	1	49	24.25	23.94	23.88
20	QPSK	1	99	24.23	23.90	23.87
20	QPSK	50	0	23.30	22.92	22.92
20	QPSK	50	24	23.26	22.91	22.87
20	QPSK	50	49	23.29	22.90	22.91
20	QPSK	100	0	23.16	22.83	22.71
20	16QAM	1	0	23.25	23.23	22.94
20	16QAM	1	49	23.28	23.02	23.03
20	16QAM	1	99	23.17	22.93	22.92
20	16QAM	50	0	22.16	21.95	21.82
20	16QAM	50	24	22.28	21.86	21.87
20	16QAM	50	49	22.36	21.90	21.91
20	16QAM	100	0	22.16	21.86	21.73
Channel				20025	20175	20325
Frequency (MHz)				1717.5	1732.5	1747.5
15	QPSK	1	0	24.23	24.19	23.93
15	QPSK	1	37	24.26	23.97	23.90
15	QPSK	1	74	24.25	23.90	23.89
15	QPSK	36	0	23.22	23.03	22.86
15	QPSK	36	18	23.23	22.95	22.98
15	QPSK	36	37	23.32	22.88	22.95
15	QPSK	75	0	23.12	22.86	22.79
15	16QAM	1	0	23.29	23.23	23.00
15	16QAM	1	37	23.30	23.04	23.07
15	16QAM	1	74	23.18	22.94	22.99
15	16QAM	36	0	22.15	21.98	21.83
15	16QAM	36	18	22.26	21.87	21.95
15	16QAM	36	37	22.36	21.90	22.44
15	16QAM	75	0	22.13	21.83	21.81



BW [MHz]	Modulation	RB Size	RB Offset	Power (dBm) Low Ch. / Freq.	Power (dBm) Middle Ch. / Freq.	Power (dBm) High Ch. / Freq.
Channel				20000	20175	20350
Frequency (MHz)				1715	1732.5	1750
10	QPSK	1	0	24.34	24.32	23.94
10	QPSK	1	24	24.40	24.10	23.92
10	QPSK	1	49	24.39	24.01	23.93
10	QPSK	25	0	23.33	23.14	22.88
10	QPSK	25	12	23.38	23.05	22.96
10	QPSK	25	24	23.44	23.04	22.97
10	QPSK	50	0	23.22	22.97	22.77
10	16QAM	1	0	23.41	23.38	23.00
10	16QAM	1	24	23.42	23.19	23.09
10	16QAM	1	49	23.32	23.07	22.98
10	16QAM	25	0	22.30	22.10	21.85
10	16QAM	25	12	22.42	22.00	21.93
10	16QAM	25	24	22.45	22.01	21.96
10	16QAM	50	0	22.26	21.95	21.80
Channel				19975	20175	20375
Frequency (MHz)				1712.5	1732.5	1752.5
5	QPSK	1	0	24.32	24.15	23.87
5	QPSK	1	12	24.26	24.10	23.95
5	QPSK	1	24	24.38	24.02	23.94
5	QPSK	12	0	23.41	23.24	22.97
5	QPSK	12	6	23.32	23.13	22.99
5	QPSK	12	11	23.32	23.11	22.94
5	QPSK	25	0	23.28	23.09	22.93
5	16QAM	1	0	23.35	23.18	22.90
5	16QAM	1	12	23.31	23.10	22.99
5	16QAM	1	24	23.30	23.04	22.92
5	16QAM	12	0	22.45	22.19	21.98
5	16QAM	12	6	22.37	22.21	22.02
5	16QAM	12	11	22.40	22.16	22.03
5	16QAM	25	0	22.32	22.07	21.92



BW [MHz]	Modulation	RB Size	RB Offset	Power (dBm) Low Ch. / Freq.	Power (dBm) Middle Ch. / Freq.	Power (dBm) High Ch. / Freq.
Channel				19965	20175	20385
Frequency (MHz)				1711.5	1732.5	1753.5
3	QPSK	1	0	24.22	24.20	23.83
3	QPSK	1	7	24.26	24.02	23.79
3	QPSK	1	14	24.24	23.89	23.82
3	QPSK	8	0	23.19	22.99	22.74
3	QPSK	8	4	23.23	22.93	22.84
3	QPSK	8	7	23.30	22.94	22.88
3	QPSK	15	0	23.06	22.85	22.65
3	16QAM	1	0	23.27	23.28	22.89
3	16QAM	1	7	23.29	23.09	22.97
3	16QAM	1	14	23.18	22.96	22.86
3	16QAM	8	0	22.18	21.98	21.76
3	16QAM	8	4	22.28	21.91	21.81
3	16QAM	8	7	22.33	21.92	21.79
3	16QAM	15	0	22.14	21.81	21.69
Channel				19957	20175	20393
Frequency (MHz)				1710.7	1732.5	1754.3
1.4	QPSK	1	0	24.23	24.21	23.86
1.4	QPSK	1	2	24.21	23.99	23.81
1.4	QPSK	1	5	24.22	23.90	23.84
1.4	QPSK	3	0	23.21	23.06	22.77
1.4	QPSK	3	1	23.21	22.96	22.81
1.4	QPSK	3	2	23.29	22.93	22.91
1.4	QPSK	6	0	23.05	22.88	22.66
1.4	16QAM	1	0	23.25	23.27	22.95
1.4	16QAM	1	2	23.24	23.12	22.98
1.4	16QAM	1	5	23.16	23.04	22.84
1.4	16QAM	3	0	22.13	22.01	21.74
1.4	16QAM	3	1	22.26	21.92	21.84
1.4	16QAM	3	2	22.29	21.90	21.88
1.4	16QAM	6	0	22.09	21.89	21.67

Note: maximum average power for LTE.

3.2 Peak-to-Average Ratio

3.2.1 Description of the PAR Measurement

Power Complementary Cumulative Distribution Function (CCDF) curves provide a means for characterizing the power peaks of a digitally modulated signal on a statistical basis. A CCDF curve depicts the probability of the peak signal amplitude exceeding the average power level. Most contemporary measurement instrumentation include the capability to produce CCDF curves for an input signal provided that the instrument's resolution bandwidth can be set wide enough to accommodate the entire input signal bandwidth. In measuring transmissions in this band using an average power technique, the peak-to-average ratio (PAR) of the transmission may not exceed 13 dB.

3.2.2 Measuring Instruments

The measuring equipment is listed in the section 4 of this test report.

3.2.3 Test Procedures

1. The EUT was connected to spectrum and system simulator via a power divider.
2. Set the CCDF (Complementary Cumulative Distribution Function) option in spectrum analyzer.
3. The highest RF powers were measured and recorded the maximum PAPR level associated with a probability of 0.1 %.
4. Record the deviation as Peak to Average Ratio.

3.2.4 Test Setup

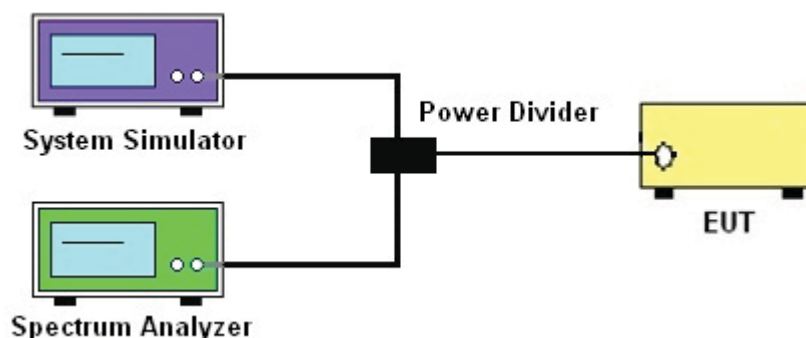



3.2.5 Test Result of Peak-to-Average Ratio

LTE Band 5						
BW [MHz]	Modulation	RB Size	RB Offset	Power (dBm) Low Ch. / Freq.	Power (dBm) Middle Ch. / Freq.	Power (dBm) High Ch. / Freq.
Channel				20450	20525	20600
Frequency (MHz)				829	836.5	844
10	16QAM	1	0	6.41	6.76	7.12
10	16QAM	50	0	6.44	6.67	6.60

LTE Band 2						
BW [MHz]	Modulation	RB Size	RB Offset	Power (dBm) Low Ch. / Freq.	Power (dBm) Middle Ch. / Freq.	Power (dBm) High Ch. / Freq.
Channel				18700	18900	19100
Frequency (MHz)				1860	1880	1900
20	16QAM	1	0	6.28	6.19	6.06
20	16QAM	100	0	6.28	6.63	6.44

LTE Band 4						
BW [MHz]	Modulation	RB Size	RB Offset	Power (dBm) Low Ch. / Freq.	Power (dBm) Middle Ch. / Freq.	Power (dBm) High Ch. / Freq.
Channel				20050	20175	20300
Frequency (MHz)				1720	1732.5	1745
20	16QAM	1	0	6.19	6.57	6.86
20	16QAM	100	0	6.41	6.35	6.41



3.2.6 Peak to Average Power Ratio

Peak-to-Average Ratio on LTE Band 5

10MHz / 16QAM in Ch. 20450 (1RB Size)

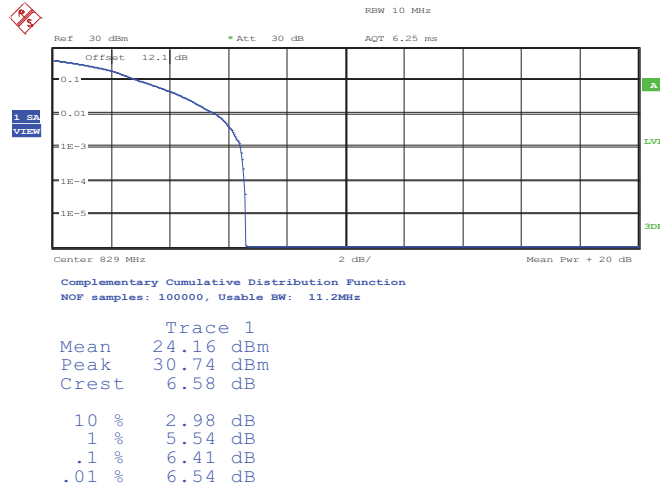

Date: 5.JUN.2014 00:27:38

Peak-to-Average Ratio on LTE Band 5

10MHz / 16QAM in Ch. 20525 (1RB Size)

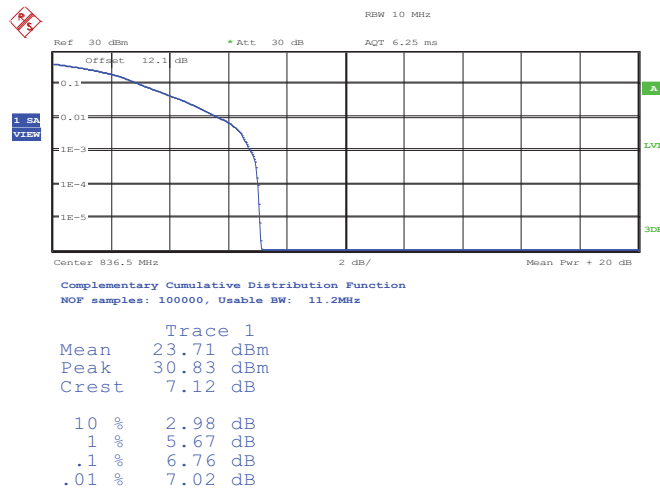

Date: 5.JUN.2014 00:28:52



Peak-to-Average Ratio on LTE Band 5

10MHz / 16QAM in Ch. 20600 (1RB Size)

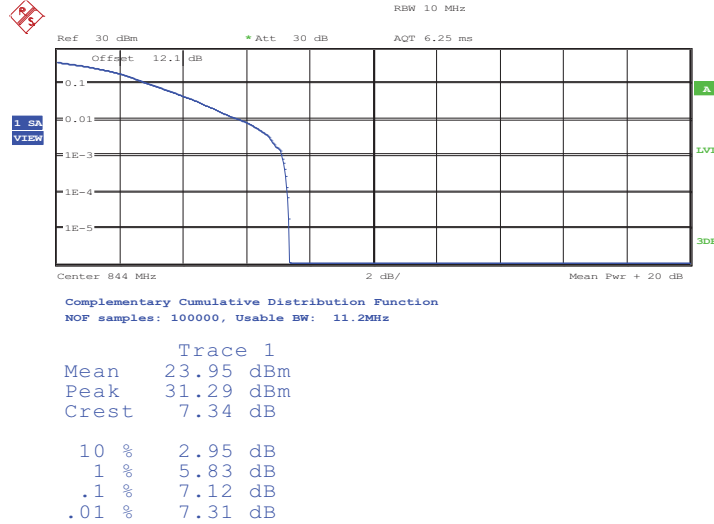

Date: 5.JUN.2014 00:29:41

Peak-to-Average Ratio on LTE Band 5

10MHz / 16QAM in Ch. 20450 (50RB Size)

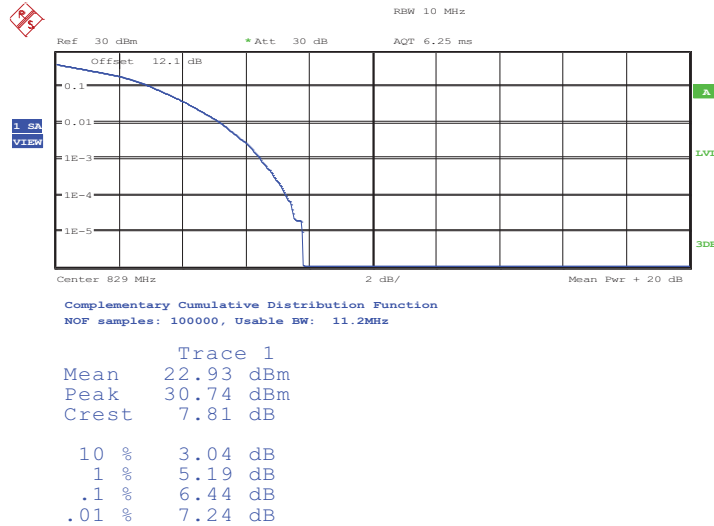

Date: 5.JUN.2014 00:28:36



Peak-to-Average Ratio on LTE Band 5
10MHz / 16QAM in Ch. 20525 (50RB Size)

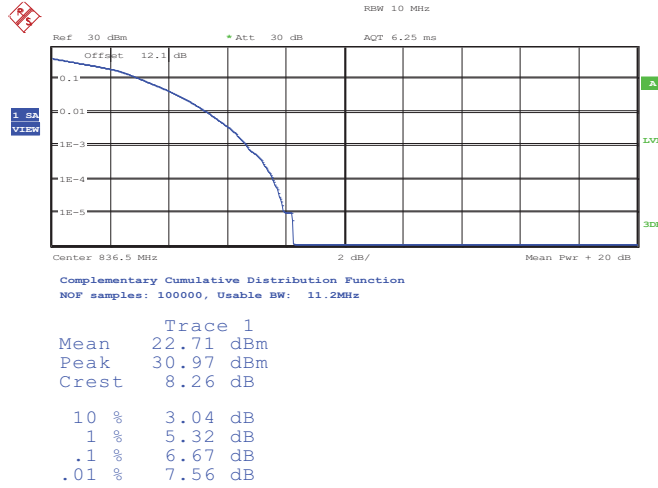

Date: 5.JUN.2014 00:29:18

Peak-to-Average Ratio on LTE Band 5
10MHz / 16QAM in Ch. 20600 (50RB Size)

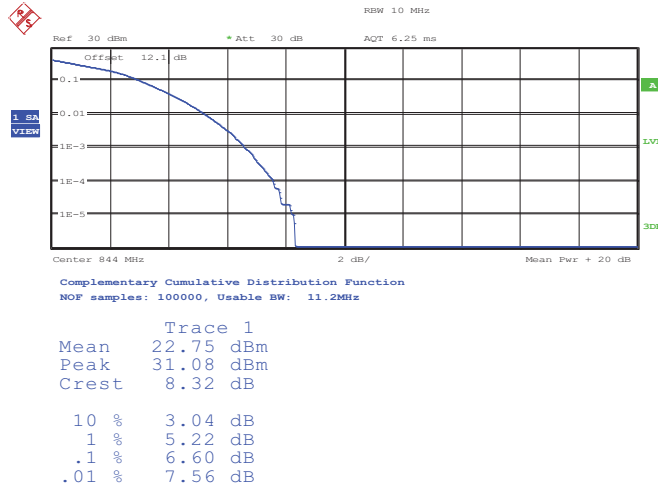

Date: 5.JUN.2014 00:29:58



Peak-to-Average Ratio on LTE Band 2
20MHz / 16QAM in Ch. 18700 (1RB Size)

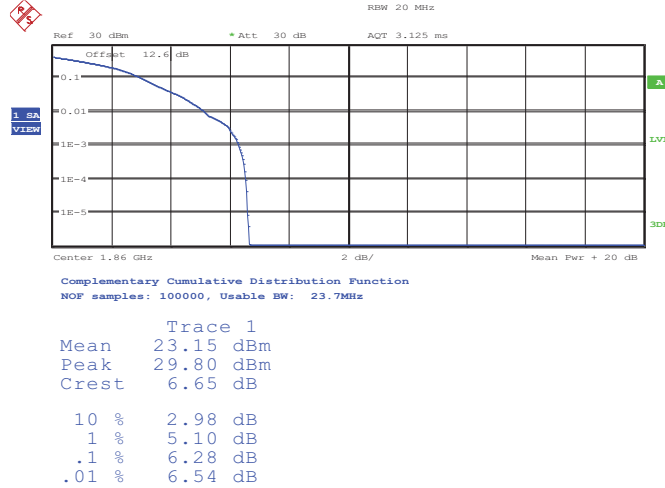

Date: 4.JUN.2014 19:19:54

Peak-to-Average Ratio on LTE Band 2
20MHz / 16QAM in Ch. 18900 (1RB Size)

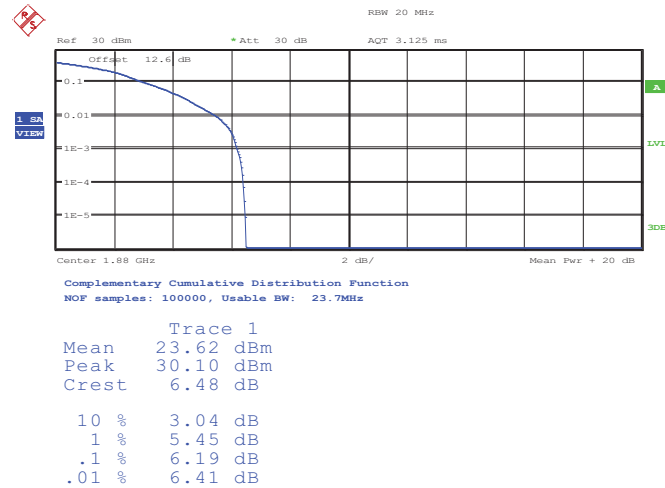

Date: 4.JUN.2014 19:20:28



Peak-to-Average Ratio on LTE Band 2
20MHz / 16QAM in Ch. 19100 (1RB Size)

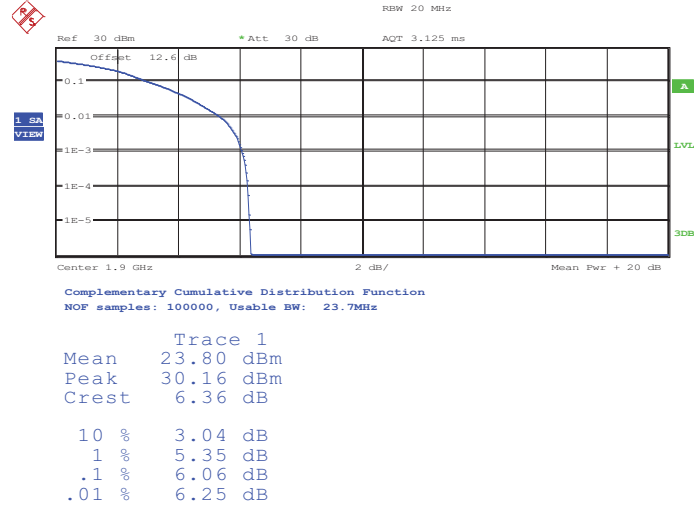

Date: 4.JUN.2014 19:21:06

Peak-to-Average Ratio on LTE Band 2
20MHz / 16QAM in Ch. 18700 (100RB Size)

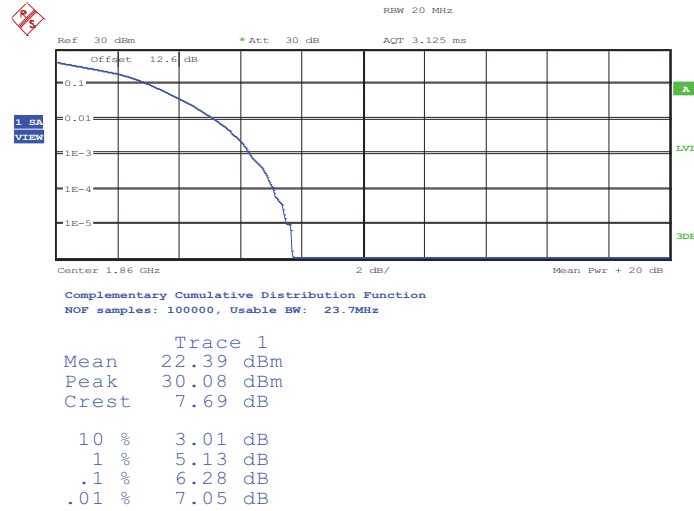

Date: 4.JUN.2014 19:20:11



Peak-to-Average Ratio on LTE Band 2
20MHz / 16QAM in Ch. 18900 (100RB Size)

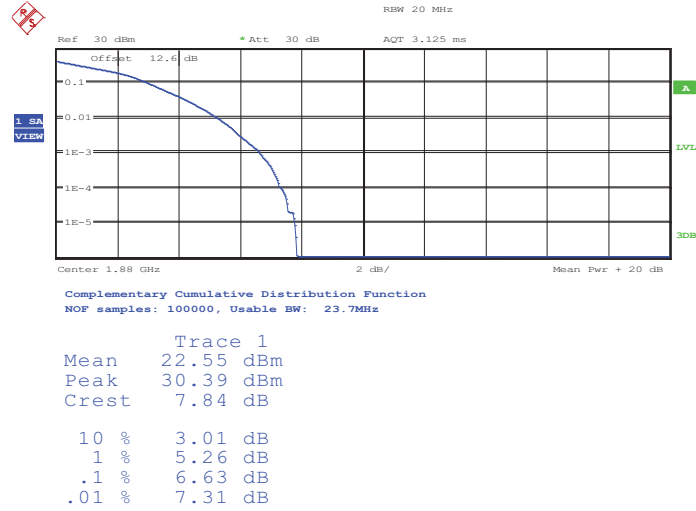

Date: 4.JUN.2014 19:20:45

Peak-to-Average Ratio on LTE Band 2
20MHz / 16QAM in Ch. 19100 (100RB Size)

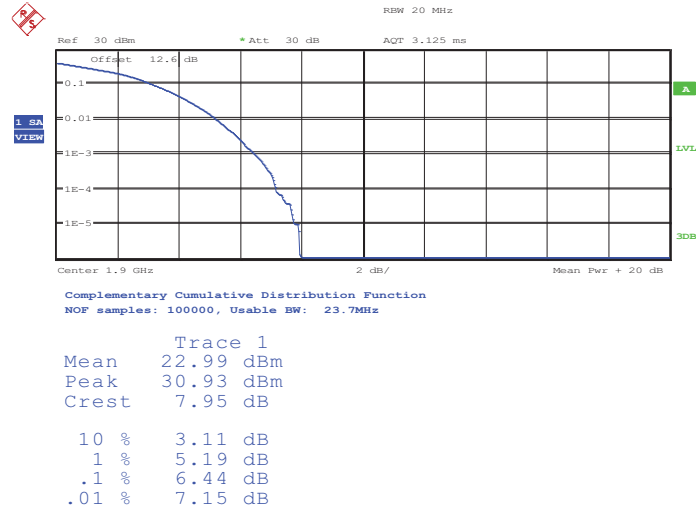

Date: 4.JUN.2014 19:22:07



Peak-to-Average Ratio on LTE Band 4
20MHz / 16QAM in Ch. 20050 (1RB Size)

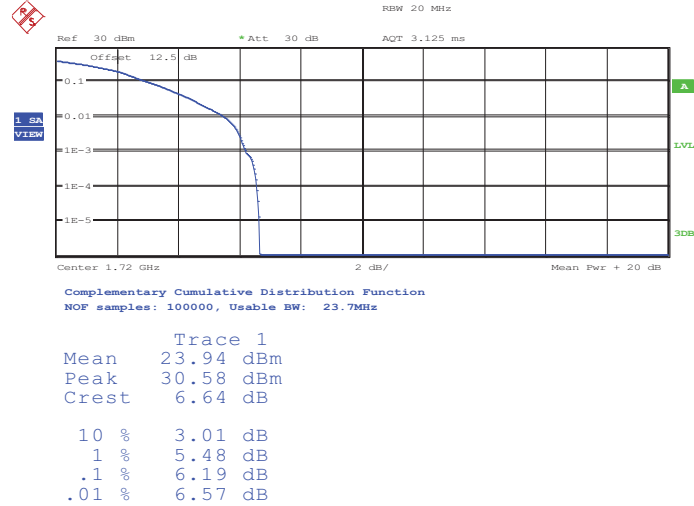

Date: 4.JUN.2014 22:30:13

Peak-to-Average Ratio on LTE Band 4
20MHz / 16QAM in Ch. 20175 (1RB Size)

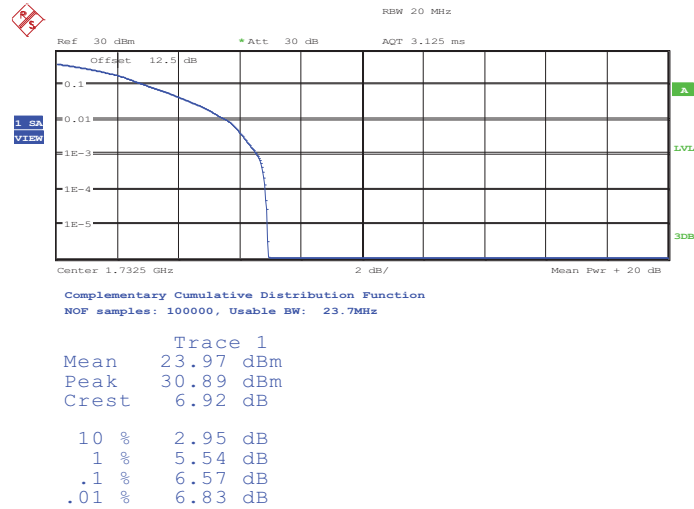

Date: 4.JUN.2014 22:30:46



Peak-to-Average Ratio on LTE Band 4
20MHz / 16QAM in Ch. 20300 (1RB Size)

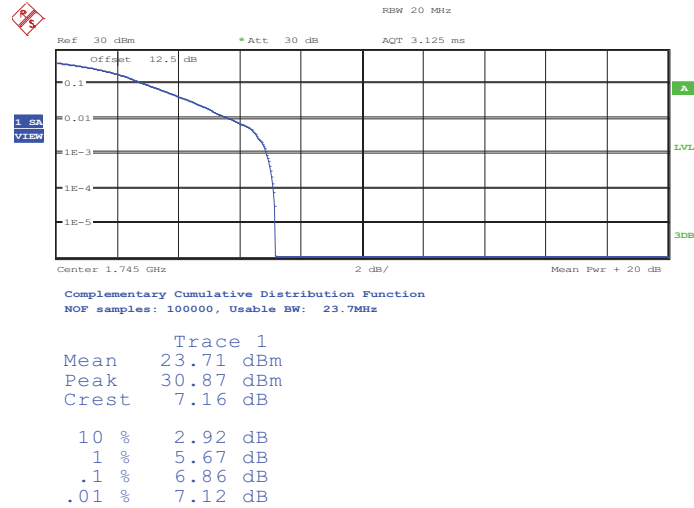

Date: 4.JUN.2014 22:31:53

Peak-to-Average Ratio on LTE Band 4
20MHz / 16QAM in Ch. 20050 (100RB Size)

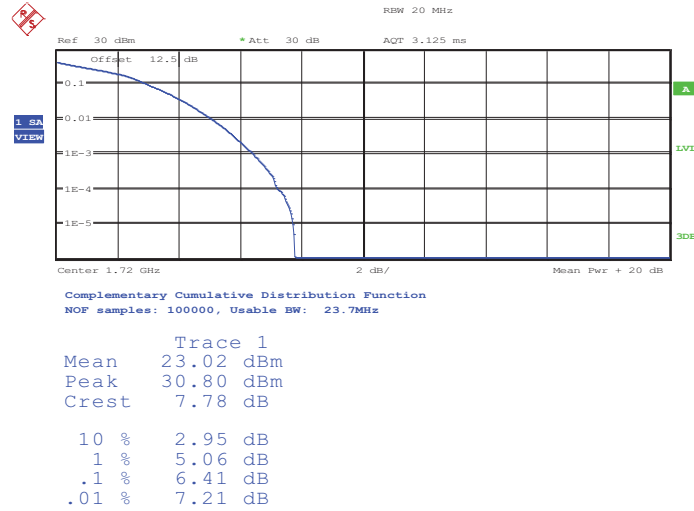

Date: 4.JUN.2014 22:30:30



Peak-to-Average Ratio on LTE Band 4
20MHz / 16QAM in Ch. 201750 (100RB Size)

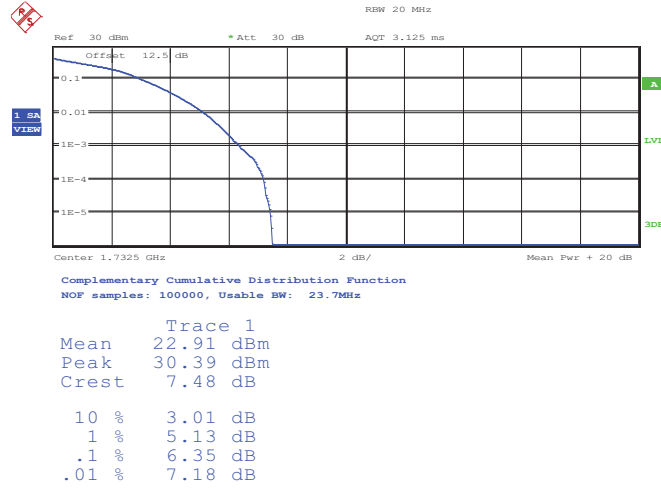

Date: 4.JUN.2014 22:31:26

Peak-to-Average Ratio on LTE Band 4
20MHz / 16QAM in Ch. 20300 (100RB Size)

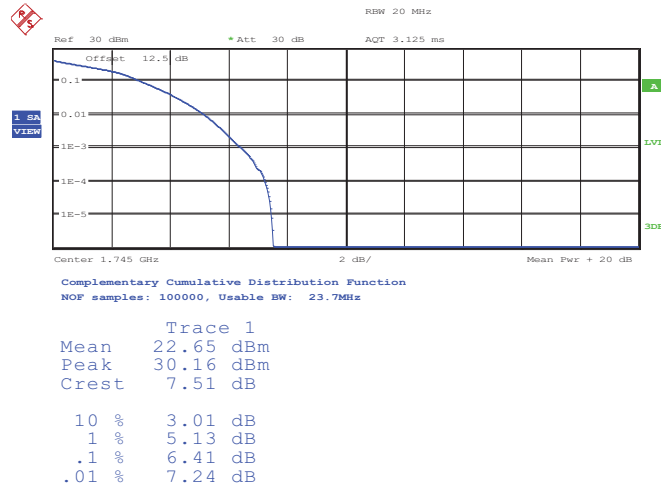

Date: 4.JUN.2014 22:32:15



3.3 Effective Radiated Power and Equivalent Isotropic Radiated Power Measurement

3.3.1 Description of the ERP/EIRP Measurement

Effective radiated power output measurements by substitution method according to ANSI / TIA / EIA-603-C-2004, and the spectrum analyzer configuration follows KDB 971168 D01 Power Meas. License Digital Systems v02r01. Mobile and portable (hand-held) stations operating are limited to average ERP of 7 watts with LTE band 5 and 3 watts with LTE band 17.

Equivalent isotropic radiated power output measurements by substitution method according to ANSI / TIA / EIA-603-C-2004, and the spectrum analyzer configuration follows KDB 971168 D01 Power Meas. License Digital Systems v02r01. Mobile and portable (hand-held) stations operating are limited to average EIRP of 2 watts with LTE band 2 / 7 and 1 watt with LTE band 4.

3.3.2 Measuring Instruments

The measuring equipment is listed in the section 4 of this test report.

3.3.3 Test Procedures

1. The EUT was placed on a non-conductive rotating platform 0.8 meters high in a semi-anechoic chamber. The radiated emission at the fundamental frequency was measured at 3 m with a test antenna and a spectrum analyzer with RMS detector per section 5. of KDB 971168 D01.
2. During the measurement, the system simulator parameters were set to force the EUT transmitting at maximum output power. The maximum emission was recorded from analyzer power level (LVL) from the 360 degrees rotation of the turntable and the test antenna raised and lowered over a range from 1 to 4 meters in both horizontally and vertically polarized orientations.
3. Effective Isotropic Radiated Power (EIRP) was measured by substitution method according to TIA/EIA-603-C. The EUT was replaced by dipole antenna (substitution antenna) at same location, and then a known power from S.G. was applied into the dipole antenna through a Tx cable, and then recorded the maximum Analyzer reading through raised and lowered the test antenna. The correction factor (in dB) = S.G. - Tx Cable loss + Substitution antenna gain - Analyzer reading. Then the EUT's EIRP was calculated with the correction factor, $EIRP = LVL + \text{Correction factor}$ and $ERP = EIRP - 2.15$.

3.3.4 Test Setup

For Effective Radiated Power

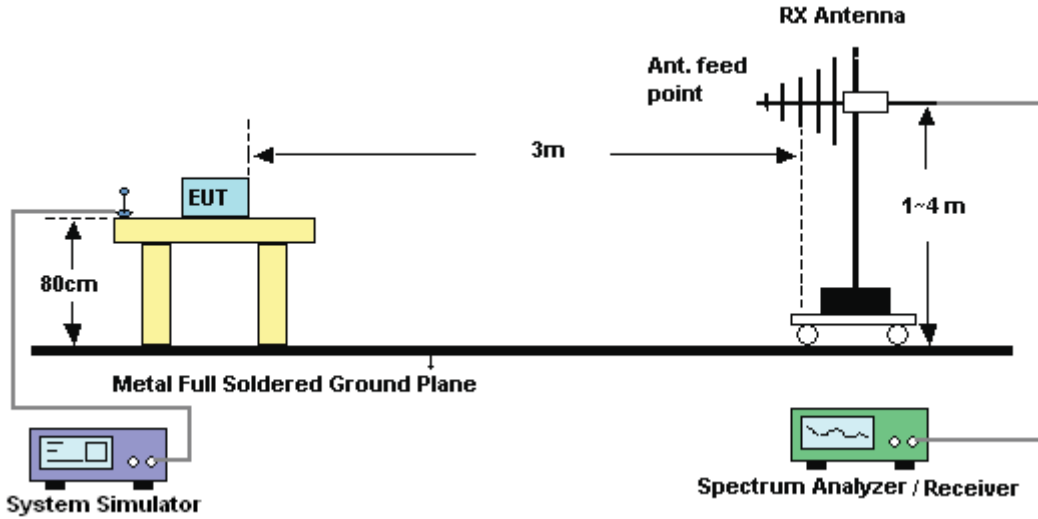

For Equivalent Isotropic Radiated Power

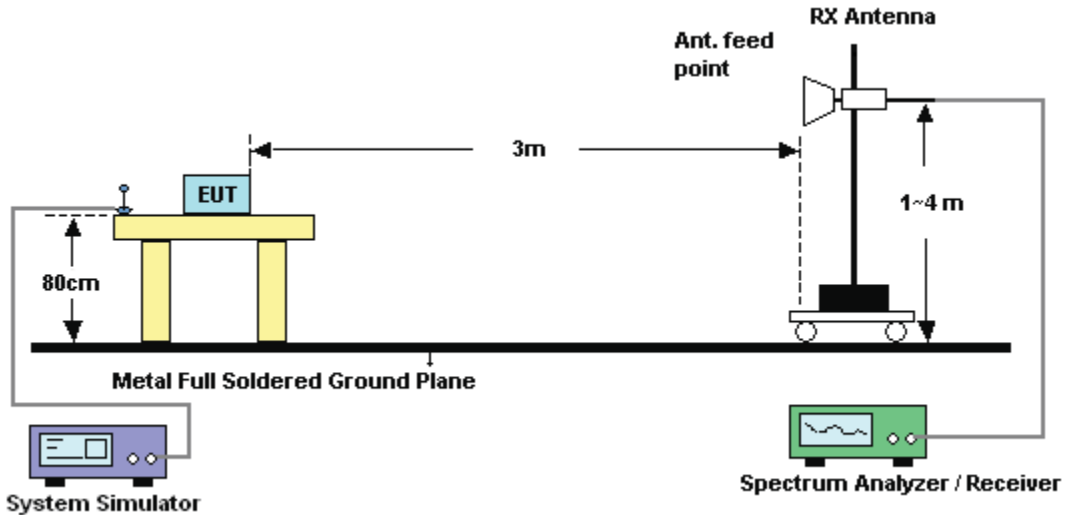



3.3.5 Test Result of ERP/EIRP

LTE Band 5 Radiated Power ERP for BW 1.4MHz / QPSK				
Horizontal Polarization				
Frequency (MHz)	LVL (dBm)	Correction Factor (dB)	ERP (dBm)	ERP (W)
824.7	-8.34	31.54	21.05	0.13
836.5	-9.75	32.04	20.14	0.10
848.3	-10.96	32.59	19.48	0.09
Vertical Polarization				
Frequency (MHz)	LVL (dBm)	Correction Factor (dB)	ERP (dBm)	ERP (W)
824.7	-18.84	32.93	11.94	0.02
836.5	-18.22	32.82	12.45	0.02
848.3	-19.96	33.62	11.51	0.01

* ERP = LVL (dBm) + Correction Factor (dB) - 2.15

LTE Band 5 Radiated Power ERP for BW 1.4MHz / 16QAM				
Horizontal Polarization				
Frequency (MHz)	LVL (dBm)	Correction Factor (dB)	ERP (dBm)	ERP (W)
824.7	-9.63	31.54	19.76	0.09
836.5	-10.77	32.04	19.12	0.08
848.3	-12.20	32.59	18.24	0.07
Vertical Polarization				
Frequency (MHz)	LVL (dBm)	Correction Factor (dB)	ERP (dBm)	ERP (W)
824.7	-19.89	32.93	10.89	0.01
836.5	-18.90	32.82	11.77	0.02
848.3	-21.19	33.62	10.28	0.01

* ERP = LVL (dBm) + Correction Factor (dB) - 2.15



LTE Band 5 Radiated Power ERP for BW 3MHz / QPSK				
Horizontal Polarization				
Frequency (MHz)	LVL (dBm)	Correction Factor (dB)	ERP (dBm)	ERP (W)
825.5	-8.32	31.54	21.07	0.13
836.5	-9.70	32.04	20.19	0.10
847.5	-10.93	32.59	19.51	0.09
Vertical Polarization				
Frequency (MHz)	LVL (dBm)	Correction Factor (dB)	ERP (dBm)	ERP (W)
825.5	-18.75	32.93	12.03	0.02
836.5	-18.18	32.82	12.49	0.02
847.5	-19.73	33.62	11.74	0.01

* ERP = LVL (dBm) + Correction Factor (dB) - 2.15

LTE Band 5 Radiated Power ERP for BW 3MHz / 16QAM				
Horizontal Polarization				
Frequency (MHz)	LVL (dBm)	Correction Factor (dB)	ERP (dBm)	ERP (W)
825.5	-9.55	31.44	19.74	0.09
836.5	-10.41	32.04	19.48	0.09
847.5	-12.25	32.63	18.23	0.07
Vertical Polarization				
Frequency (MHz)	LVL (dBm)	Correction Factor (dB)	ERP (dBm)	ERP (W)
825.5	-20.01	32.78	10.62	0.01
836.5	-18.75	32.82	11.92	0.02
847.5	-21.09	33.4	10.16	0.01

* ERP = LVL (dBm) + Correction Factor (dB) - 2.15



LTE Band 2 Radiated Power EIRP for BW 1.4MHz / QPSK				
Horizontal Polarization				
Frequency (MHz)	LVL (dBm)	Correction Factor (dB)	EIRP (dBm)	EIRP (W)
1850.7	-20.53	45.68	25.15	0.33
1880.0	-20.94	46.01	25.07	0.32
1909.3	-20.91	45.76	24.85	0.31
Vertical Polarization				
Frequency (MHz)	LVL (dBm)	Correction Factor (dB)	EIRP (dBm)	EIRP (W)
1850.7	-32.23	49.18	16.95	0.05
1880.0	-33.69	50.42	16.73	0.05
1909.3	-31.28	48.94	17.66	0.06

LTE Band 2 Radiated Power EIRP for BW 1.4MHz / 16QAM				
Horizontal Polarization				
Frequency (MHz)	LVL (dBm)	Correction Factor (dB)	EIRP (dBm)	EIRP (W)
1850.7	-21.41	45.68	24.27	0.27
1880.0	-22.02	46.01	23.99	0.25
1909.3	-21.99	45.76	23.77	0.24
Vertical Polarization				
Frequency (MHz)	LVL (dBm)	Correction Factor (dB)	EIRP (dBm)	EIRP (W)
1850.7	-33.14	49.18	16.04	0.04
1880.0	-34.36	50.42	16.06	0.04
1909.3	-32.61	48.94	16.33	0.04



LTE Band 2 Radiated Power EIRP for BW 3MHz / QPSK				
Horizontal Polarization				
Frequency (MHz)	LVL (dBm)	Correction Factor (dB)	EIRP (dBm)	EIRP (W)
1851.5	-20.67	45.76	25.09	0.32
1880.0	-21.06	46.01	24.95	0.31
1908.5	-21.30	45.95	24.65	0.29
Vertical Polarization				
Frequency (MHz)	LVL (dBm)	Correction Factor (dB)	EIRP (dBm)	EIRP (W)
1851.5	-31.42	49.03	17.61	0.06
1880.0	-32.93	50.42	17.49	0.06
1908.5	-31.84	48.86	17.02	0.05

LTE Band 2 Radiated Power EIRP for BW 3MHz / 16QAM				
Horizontal Polarization				
Frequency (MHz)	LVL (dBm)	Correction Factor (dB)	EIRP (dBm)	EIRP (W)
1851.5	-21.92	45.76	23.84	0.24
1880.0	-22.23	46.01	23.78	0.24
1908.5	-22.48	45.95	23.47	0.22
Vertical Polarization				
Frequency (MHz)	LVL (dBm)	Correction Factor (dB)	EIRP (dBm)	EIRP (W)
1851.5	-32.27	49.03	16.76	0.05
1880.0	-33.98	50.42	16.44	0.04
1908.5	-32.64	48.86	16.22	0.04



LTE Band 2 Radiated Power EIRP for BW 15MHz / QPSK				
Horizontal Polarization				
Frequency (MHz)	LVL (dBm)	Correction Factor (dB)	EIRP (dBm)	EIRP (W)
1857.5	-20.86	46.24	25.38	0.35
1880.0	-21.63	46.01	24.38	0.27
1902.5	-21.14	46.18	25.04	0.32
Vertical Polarization				
Frequency (MHz)	LVL (dBm)	Correction Factor (dB)	EIRP (dBm)	EIRP (W)
1857.5	-31.81	49.68	17.87	0.06
1880.0	-32.17	50.42	18.25	0.07
1902.5	-31.24	48.20	16.96	0.05

LTE Band 2 Radiated Power EIRP for BW 15MHz / 16QAM				
Horizontal Polarization				
Frequency (MHz)	LVL (dBm)	Correction Factor (dB)	EIRP (dBm)	EIRP (W)
1857.5	-22.01	46.24	24.23	0.26
1880.0	-22.41	46.01	23.60	0.23
1902.5	-22.15	46.18	24.03	0.25
Vertical Polarization				
Frequency (MHz)	LVL (dBm)	Correction Factor (dB)	EIRP (dBm)	EIRP (W)
1857.5	-32.52	49.68	17.16	0.05
1880.0	-33.19	50.42	17.23	0.05
1902.5	-32.10	48.20	16.10	0.04



LTE Band 2 Radiated Power EIRP for BW 20MHz / QPSK				
Horizontal Polarization				
Frequency (MHz)	LVL (dBm)	Correction Factor (dB)	EIRP (dBm)	EIRP (W)
1860.0	-21.84	46.88	25.04	0.32
1880.0	-21.93	46.01	24.08	0.26
1900.0	-21.56	46.57	25.01	0.32
Vertical Polarization				
Frequency (MHz)	LVL (dBm)	Correction Factor (dB)	EIRP (dBm)	EIRP (W)
1860.0	-31.78	49.69	17.91	0.06
1880.0	-32.33	50.42	18.09	0.06
1900.0	-31.05	48.87	17.82	0.06

LTE Band 2 Radiated Power EIRP for BW 20MHz / 16QAM				
Horizontal Polarization				
Frequency (MHz)	LVL (dBm)	Correction Factor (dB)	EIRP (dBm)	EIRP (W)
1860.0	-22.89	46.88	23.99	0.25
1880.0	-22.90	46.01	23.11	0.20
1900.0	-22.57	46.57	24.00	0.25
Vertical Polarization				
Frequency (MHz)	LVL (dBm)	Correction Factor (dB)	EIRP (dBm)	EIRP (W)
1860.0	-32.77	49.69	16.92	0.05
1880.0	-33.16	50.42	17.26	0.05
1900.0	-31.98	48.87	16.89	0.05



LTE Band 4 Radiated Power EIRP for BW 1.4MHz / QPSK				
Horizontal Polarization				
Frequency (MHz)	LVL (dBm)	Correction Factor (dB)	EIRP (dBm)	EIRP (W)
1710.7	-20.91	43.43	22.52	0.18
1732.5	-20.48	43.34	22.86	0.19
1754.3	-21.27	43.65	22.38	0.17
Vertical Polarization				
Frequency (MHz)	LVL (dBm)	Correction Factor (dB)	EIRP (dBm)	EIRP (W)
1710.7	-29.34	46.93	17.59	0.06
1732.5	-28.83	46.19	17.36	0.05
1754.3	-29.22	47.3	18.08	0.06

LTE Band 4 Radiated Power EIRP for BW 1.4MHz / 16QAM				
Horizontal Polarization				
Frequency (MHz)	LVL (dBm)	Correction Factor (dB)	EIRP (dBm)	EIRP (W)
1710.7	-22.06	43.43	21.37	0.14
1732.5	-22.06	43.34	21.28	0.13
1754.3	-22.08	43.65	21.57	0.14
Vertical Polarization				
Frequency (MHz)	LVL (dBm)	Correction Factor (dB)	EIRP (dBm)	EIRP (W)
1710.7	-30.31	46.93	16.62	0.05
1732.5	-29.69	46.19	16.50	0.04
1754.3	-30.19	47.3	17.11	0.05



LTE Band 4 Radiated Power EIRP for BW 3MHz / QPSK				
Horizontal Polarization				
Frequency (MHz)	LVL (dBm)	Correction Factor (dB)	EIRP (dBm)	EIRP (W)
1711.5	-21.02	43.38	22.36	0.17
1732.5	-20.62	43.34	22.72	0.19
1753.5	-21.50	43.51	22.01	0.16
Vertical Polarization				
Frequency (MHz)	LVL (dBm)	Correction Factor (dB)	EIRP (dBm)	EIRP (W)
1711.5	-28.80	46.65	17.85	0.06
1732.5	-29.08	46.19	17.11	0.05
1753.5	-30.10	47.65	17.55	0.06

LTE Band 4 Radiated Power EIRP for BW 3MHz / 16QAM				
Horizontal Polarization				
Frequency (MHz)	LVL (dBm)	Correction Factor (dB)	EIRP (dBm)	EIRP (W)
1711.5	-22.15	43.38	21.23	0.13
1732.5	-21.60	43.34	21.74	0.15
1753.5	-22.55	43.51	20.96	0.12
Vertical Polarization				
Frequency (MHz)	LVL (dBm)	Correction Factor (dB)	EIRP (dBm)	EIRP (W)
1711.5	-29.84	46.65	16.81	0.05
1732.5	-30.01	46.19	16.18	0.04
1753.5	-30.89	47.65	16.76	0.05



LTE Band 4 Radiated Power EIRP for BW 15MHz / QPSK				
Horizontal Polarization				
Frequency (MHz)	LVL (dBm)	Correction Factor (dB)	EIRP (dBm)	EIRP (W)
1717.5	-20.72	42.93	22.21	0.17
1732.5	-20.51	43.34	22.83	0.19
1747.5	-21.19	43.58	22.39	0.17
Vertical Polarization				
Frequency (MHz)	LVL (dBm)	Correction Factor (dB)	EIRP (dBm)	EIRP (W)
1717.5	-28.53	46.52	17.99	0.06
1732.5	-29.12	46.19	17.07	0.05
1747.5	-29.88	47.08	17.20	0.05

LTE Band 4 Radiated Power EIRP for BW 15MHz / 16QAM				
Horizontal Polarization				
Frequency (MHz)	LVL (dBm)	Correction Factor (dB)	EIRP (dBm)	EIRP (W)
1717.5	-21.59	42.93	21.34	0.14
1732.5	-21.73	43.34	21.61	0.14
1747.5	-21.83	43.58	21.75	0.15
Vertical Polarization				
Frequency (MHz)	LVL (dBm)	Correction Factor (dB)	EIRP (dBm)	EIRP (W)
1717.5	-29.58	46.52	16.94	0.05
1732.5	-29.86	46.19	16.33	0.04
1747.5	-31.18	47.08	15.90	0.04



LTE Band 4 Radiated Power EIRP for BW 20MHz / QPSK				
Horizontal Polarization				
Frequency (MHz)	LVL (dBm)	Correction Factor (dB)	EIRP (dBm)	EIRP (W)
1720.0	-20.87	43.42	22.55	0.18
1732.5	-20.39	43.34	22.95	0.20
1745.0	-21.31	43.62	22.31	0.17
Vertical Polarization				
Frequency (MHz)	LVL (dBm)	Correction Factor (dB)	EIRP (dBm)	EIRP (W)
1720.0	-28.34	46.18	17.84	0.06
1732.5	-28.96	46.19	17.23	0.05
1745.0	-29.20	46.54	17.34	0.05

LTE Band 4 Radiated Power EIRP for BW 20MHz / 16QAM				
Horizontal Polarization				
Frequency (MHz)	LVL (dBm)	Correction Factor (dB)	EIRP (dBm)	EIRP (W)
1720.0	-21.53	43.42	21.89	0.15
1732.5	-21.35	43.34	21.99	0.16
1745.0	-22.35	43.62	21.27	0.13
Vertical Polarization				
Frequency (MHz)	LVL (dBm)	Correction Factor (dB)	EIRP (dBm)	EIRP (W)
1720.0	-29.45	46.18	16.73	0.05
1732.5	-29.63	46.19	16.56	0.05
1745.0	-30.34	46.54	16.20	0.04

3.4 Occupied Bandwidth

3.4.1 Description of Occupied Bandwidth Measurement

The occupied bandwidth is the width of a frequency band such that, below the lower and above the upper frequency limits, the mean powers emitted are each equal to a specified percentage 0.5% of the total mean transmitted power.

The 26 dB emission bandwidth is defined as the frequency range between two points, one above and one below the carrier frequency, at which the spectral density of the emission is attenuated 26 dB below the maximum in-band spectral density of the modulated signal. Spectral density (power per unit bandwidth) is to be measured with a detector of resolution bandwidth equal to approximately 1.0% of the emission bandwidth.

3.4.2 Measuring Instruments

The measuring equipment is listed in the section 4 of this test report.

3.4.3 Test Procedures

1. The EUT was connected to spectrum analyzer and system simulator via a power divider.
2. The 26dB and 99% occupied bandwidth (BW) of the middle channel for the highest RF power with full RB sizes were measured.

3.4.4 Test Setup

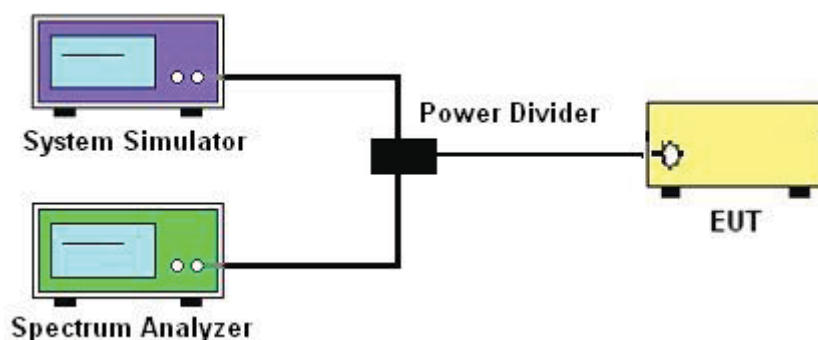



3.4.5 Test Result (Plots) of Occupied Bandwidth

Band :	LTE Band 5	BW / Mod. :	1.4MHz / QPSK
--------	------------	-------------	---------------

99% Occupied Bandwidth Plot on Channel 20407

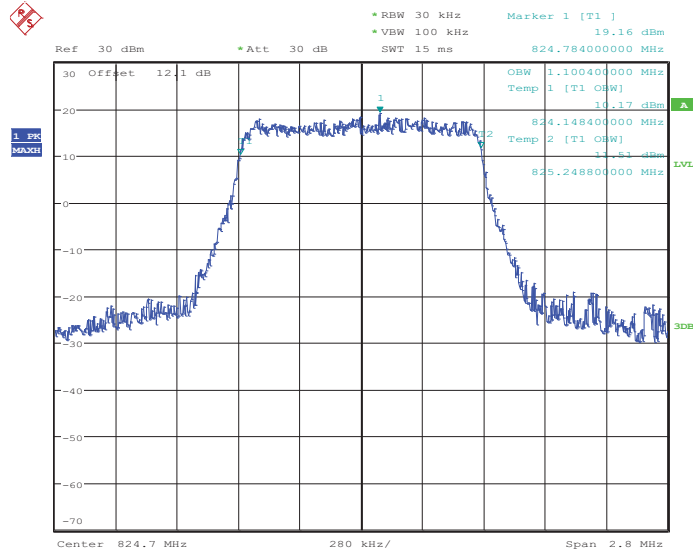

Date: 4.JUN.2014 23:07:10

26dB Bandwidth Plot on Channel 20407

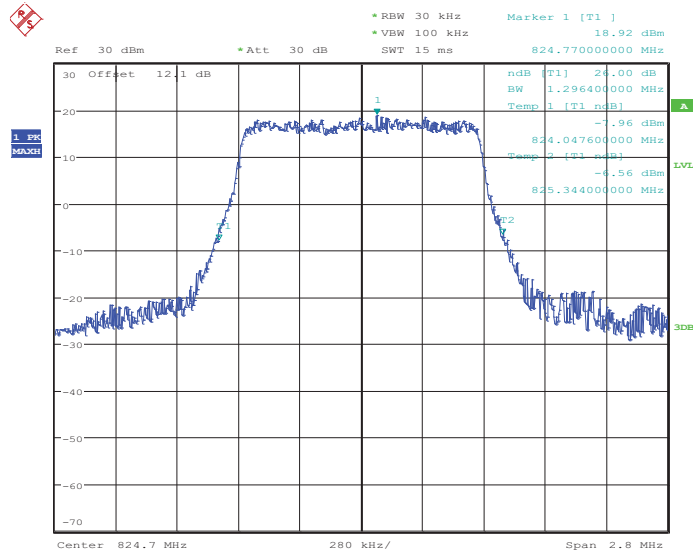

Date: 4.JUN.2014 23:08:04



99% Occupied Bandwidth Plot on Channel 20525

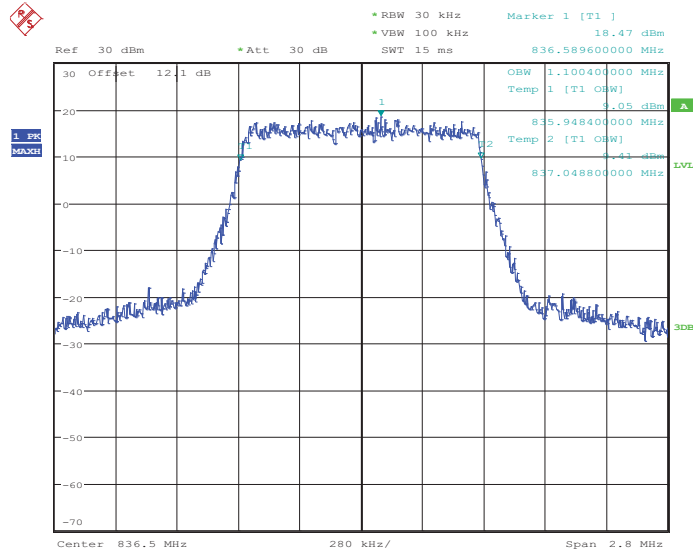

Date: 4.JUN.2014 23:13:31

26dB Bandwidth Plot on Channel 20525

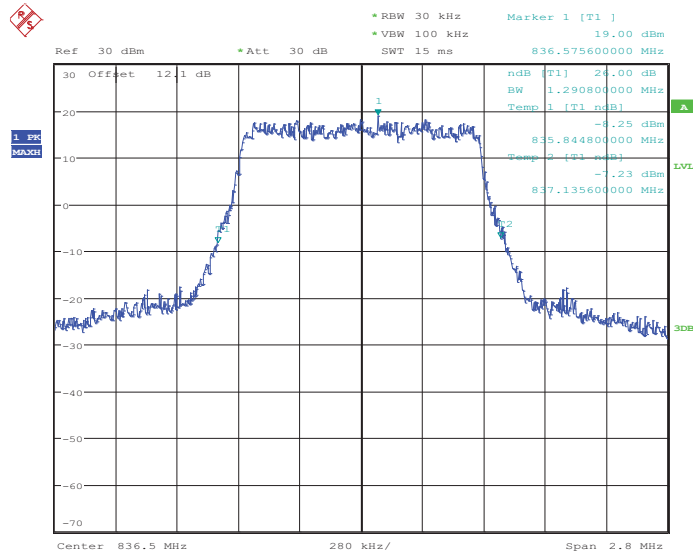

Date: 4.JUN.2014 23:14:06



99% Occupied Bandwidth Plot on Channel 20643

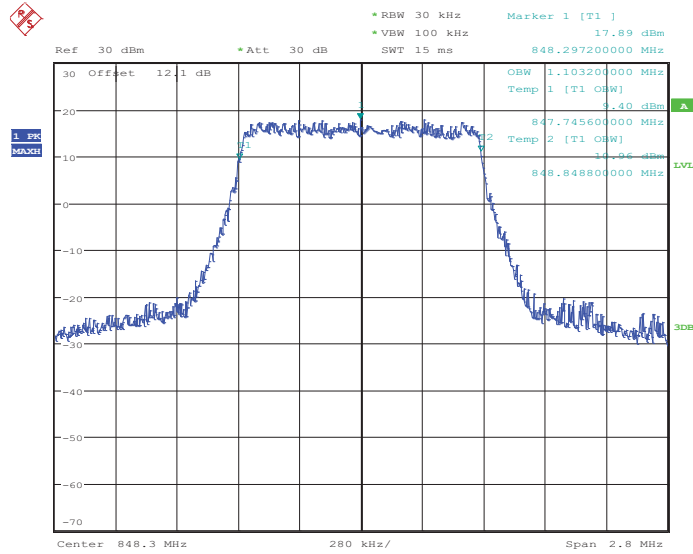

Date: 4.JUN.2014 23:16:43

26dB Bandwidth Plot on Channel 20643

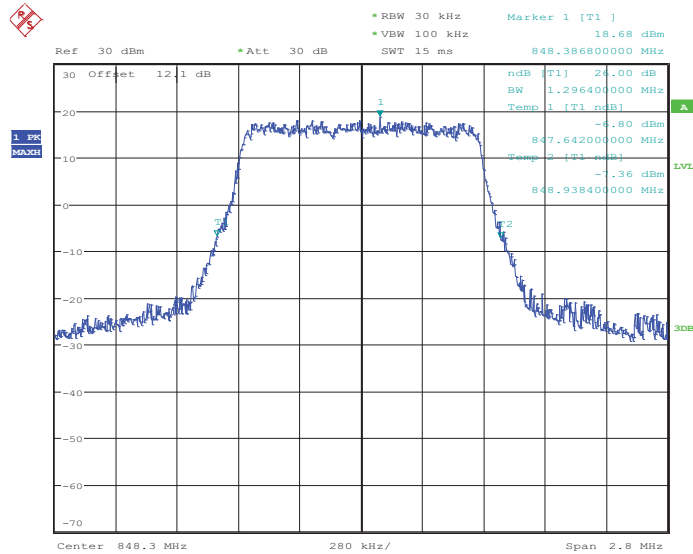

Date: 4.JUN.2014 23:17:18



Band :	LTE Band 5	BW / Mod. :	1.4MHz / 16QAM
--------	------------	-------------	----------------

99% Occupied Bandwidth Plot on Channel 20407

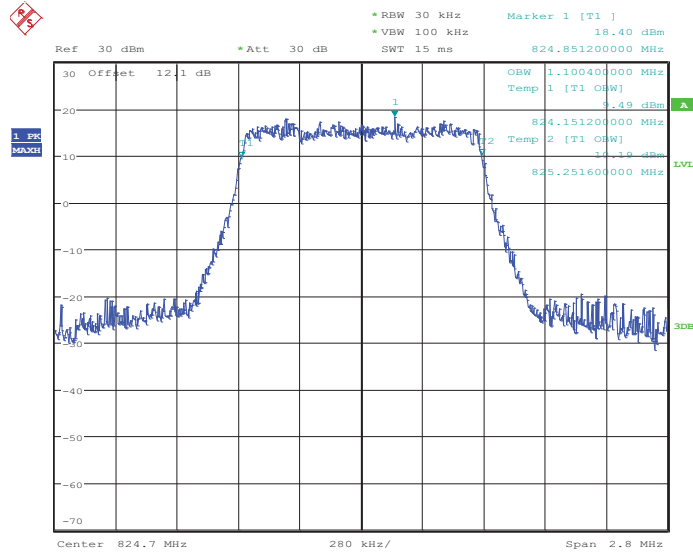

Date: 4.JUN.2014 23:07:27

26dB Bandwidth Plot on Channel 20407

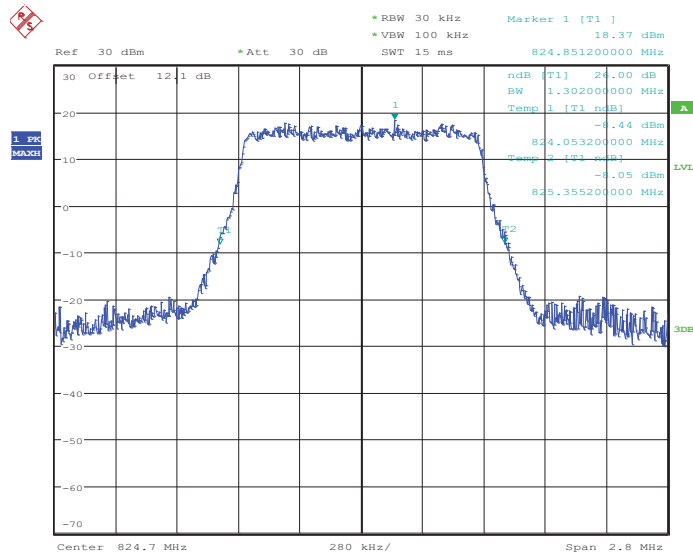

Date: 4.JUN.2014 23:07:45



99% Occupied Bandwidth Plot on Channel 20525

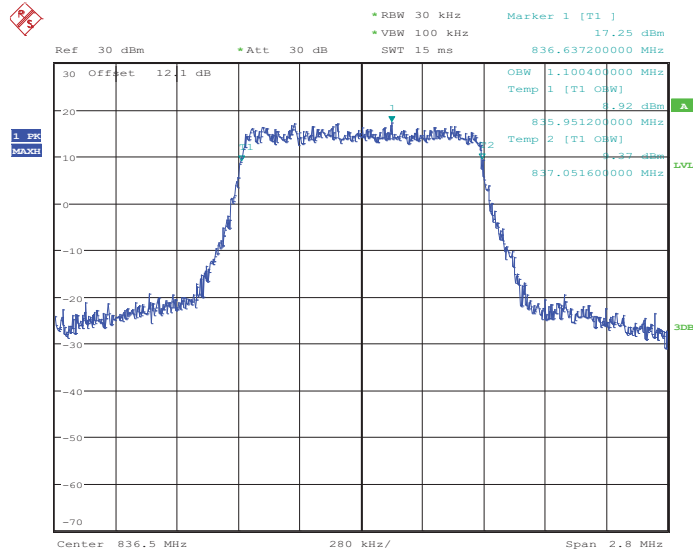

Date: 4.JUN.2014 23:13:48

26dB Bandwidth Plot on Channel 20525

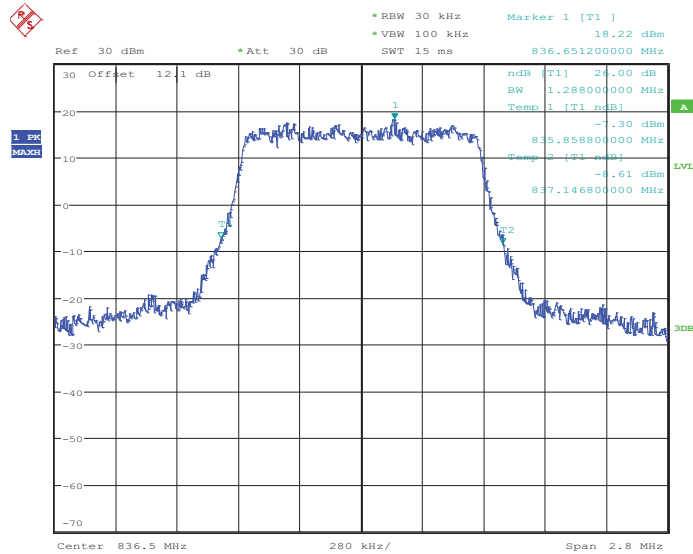

Date: 4.JUN.2014 23:14:25



99% Occupied Bandwidth Plot on Channel 20643

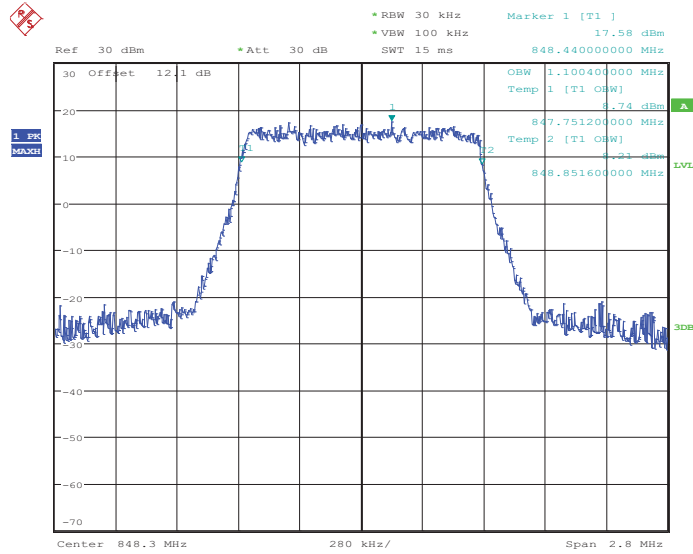

Date: 4.JUN.2014 23:17:00

26dB Bandwidth Plot on Channel 20643

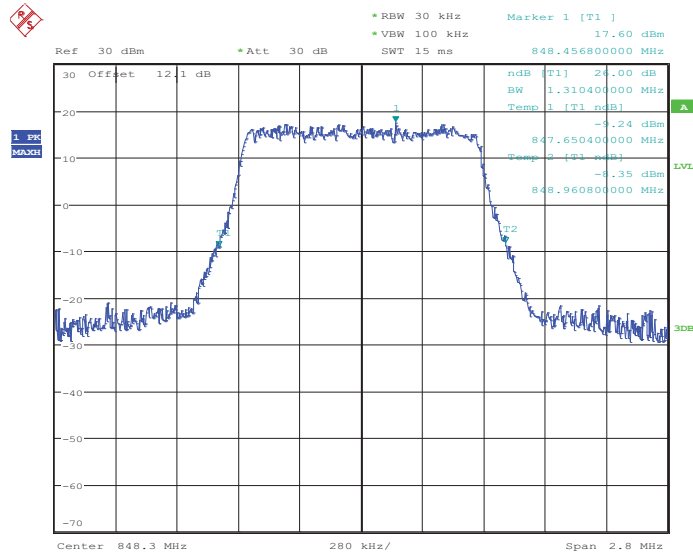

Date: 4.JUN.2014 23:17:38



Band :	LTE Band 5	BW / Mod. :	3MHz / QPSK
--------	------------	-------------	-------------

99% Occupied Bandwidth Plot on Channel 20415

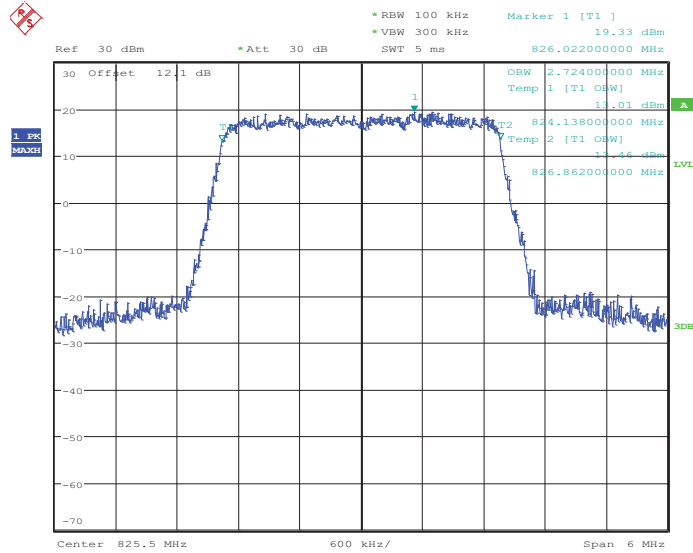

Date: 4.JUN.2014 23:23:05

26dB Bandwidth Plot on Channel 20415

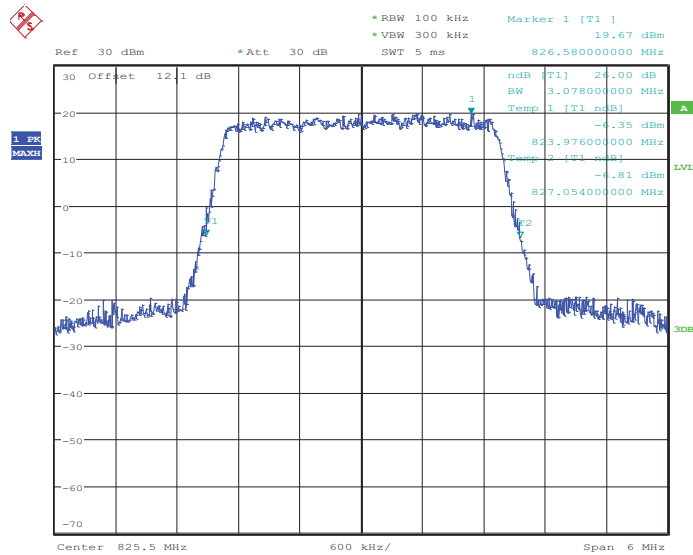

Date: 4.JUN.2014 23:23:40



99% Occupied Bandwidth Plot on Channel 20525

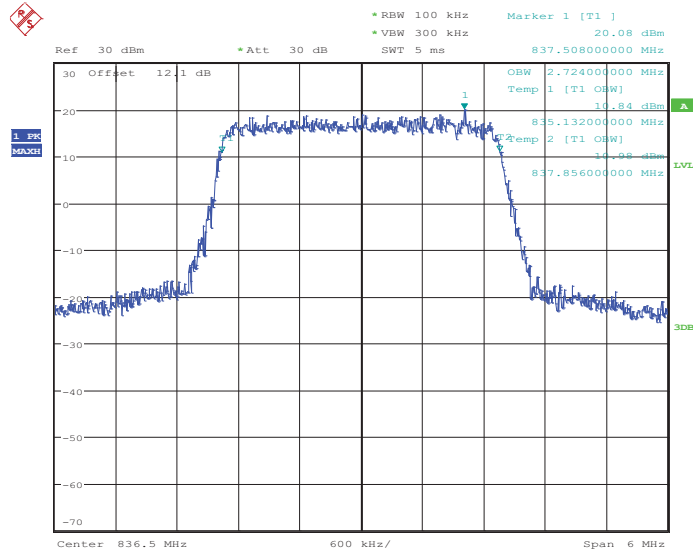

Date: 4.JUN.2014 23:29:27

26dB Bandwidth Plot on Channel 20525

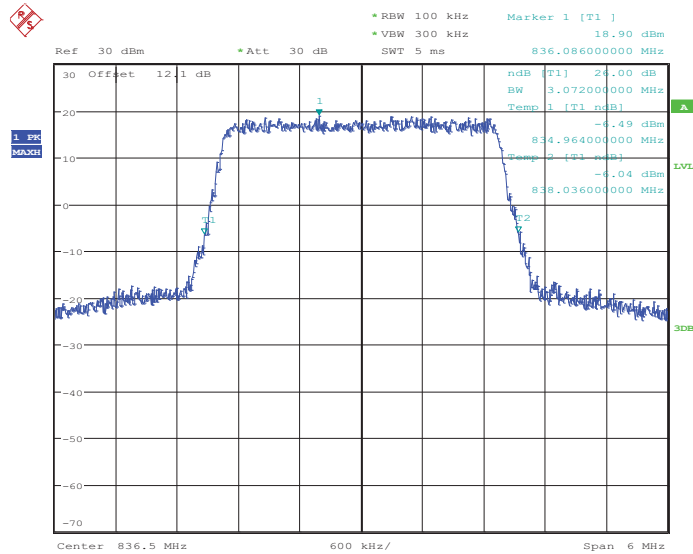

Date: 4.JUN.2014 23:30:02



99% Occupied Bandwidth Plot on Channel 20635

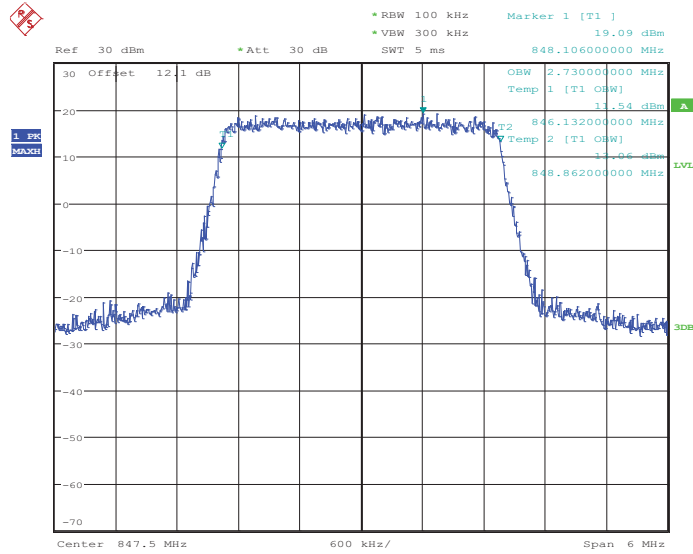

Date: 4.JUN.2014 23:32:38

26dB Bandwidth Plot on Channel 20635

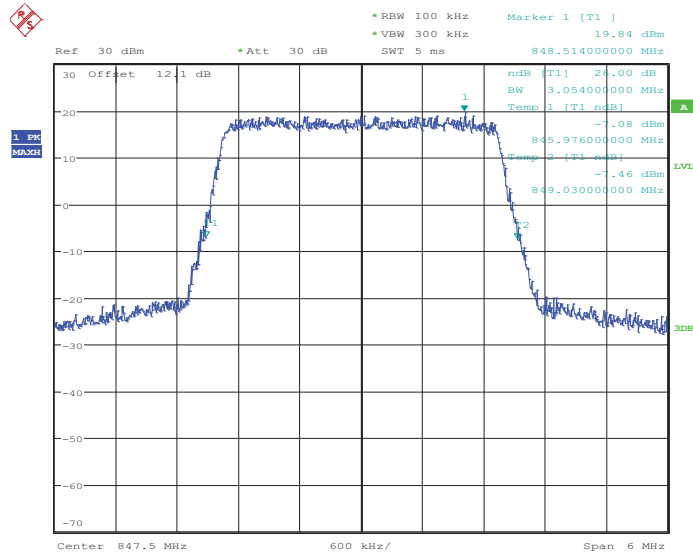

Date: 4.JUN.2014 23:33:14



Band :	LTE Band 5	BW / Mod. :	3MHz / 16QAM
--------	------------	-------------	--------------

99% Occupied Bandwidth Plot on Channel 20415

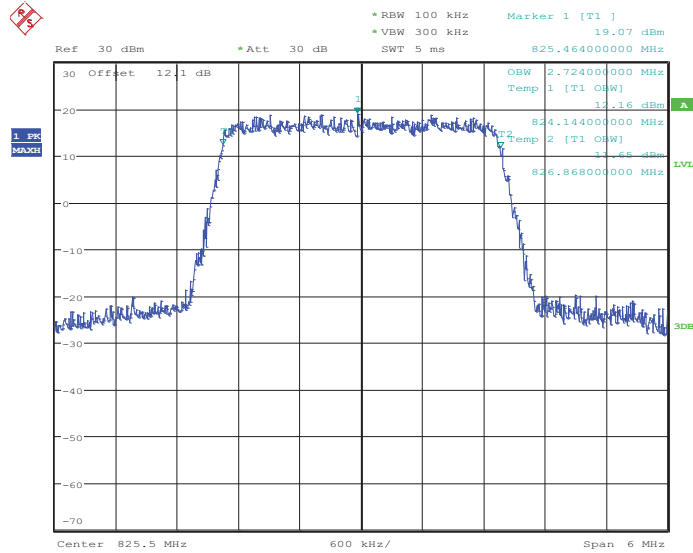

Date: 4.JUN.2014 23:23:22

26dB Bandwidth Plot on Channel 20415

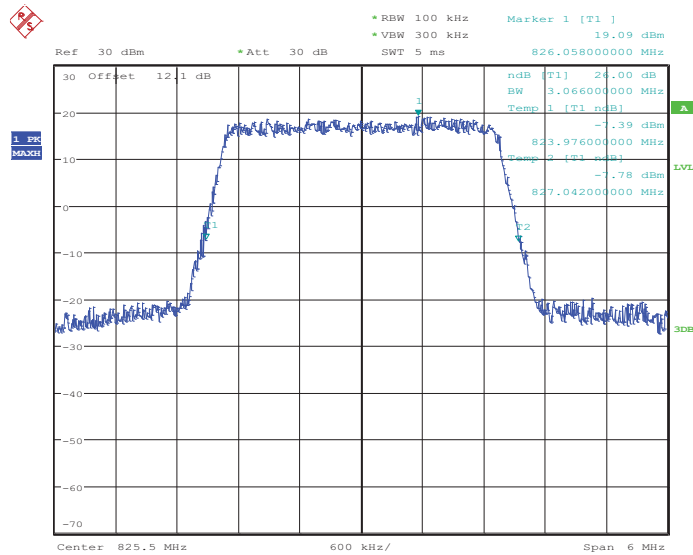

Date: 4.JUN.2014 23:23:59



99% Occupied Bandwidth Plot on Channel 20525

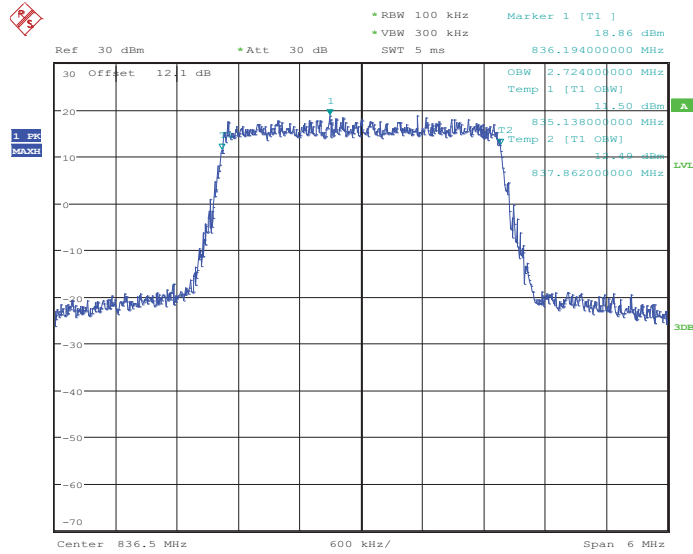

Date: 4.JUN.2014 23:29:44

26dB Bandwidth Plot on Channel 20525

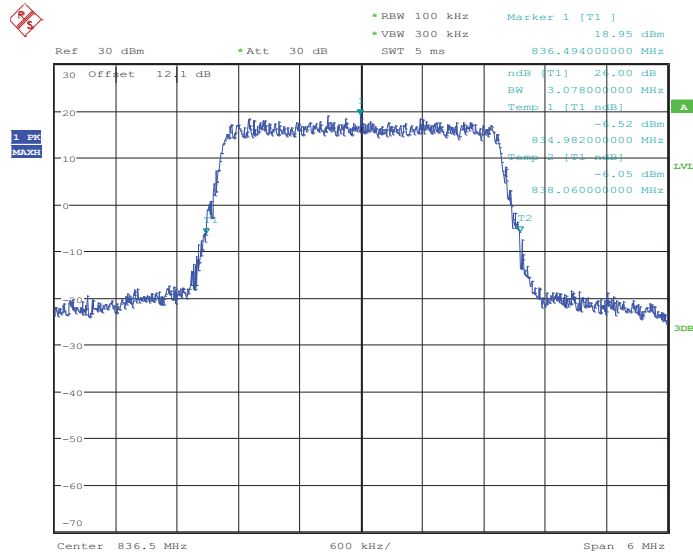

Date: 4.JUN.2014 23:30:21



99% Occupied Bandwidth Plot on Channel 20635

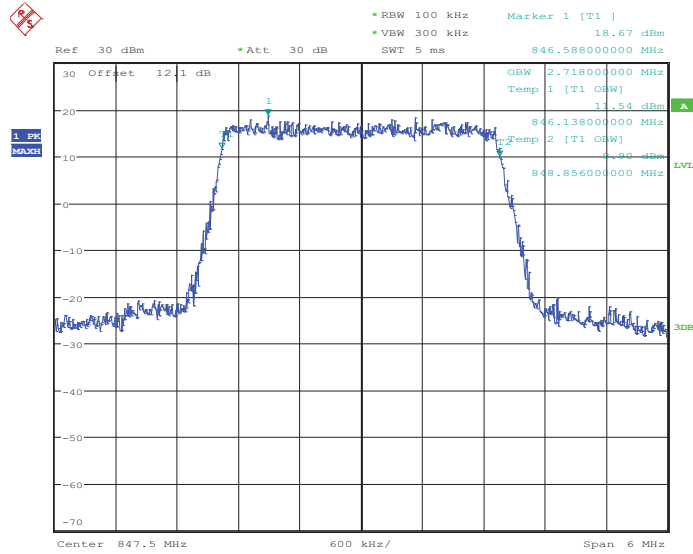

Date: 4.JUN.2014 23:32:55

26dB Bandwidth Plot on Channel 20635

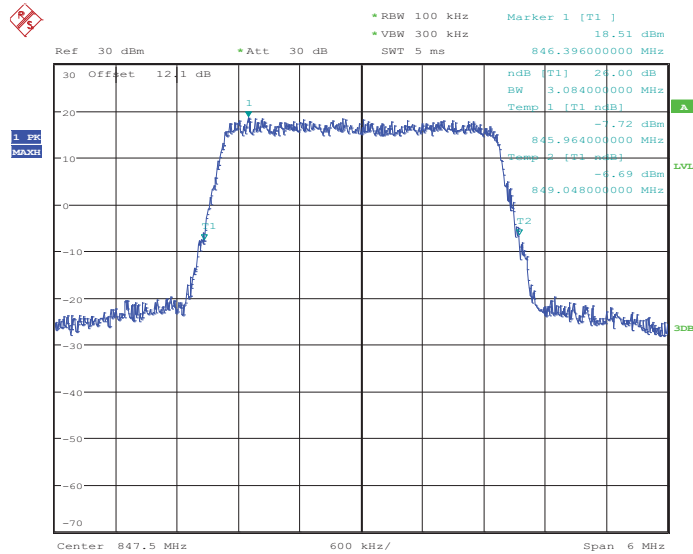

Date: 4.JUN.2014 23:33:32



Band :	LTE Band 2	BW / Mod. :	1.4MHz / QPSK
---------------	------------	--------------------	---------------

99% Occupied Bandwidth Plot on Channel 18607

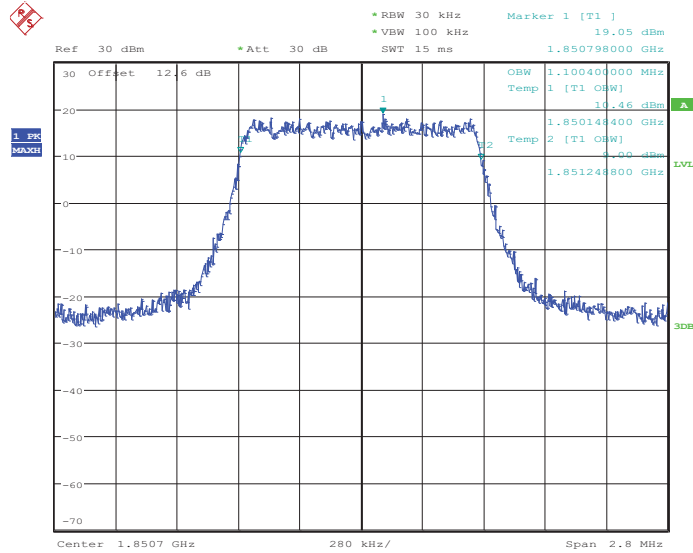

Date: 4.JUN.2014 16:23:20

26dB Bandwidth Plot on Channel 18607

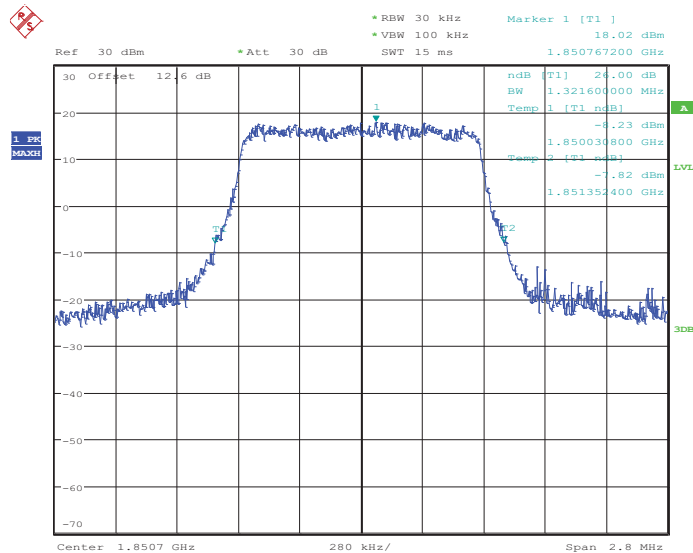

Date: 4.JUN.2014 16:23:57



99% Occupied Bandwidth Plot on Channel 18900

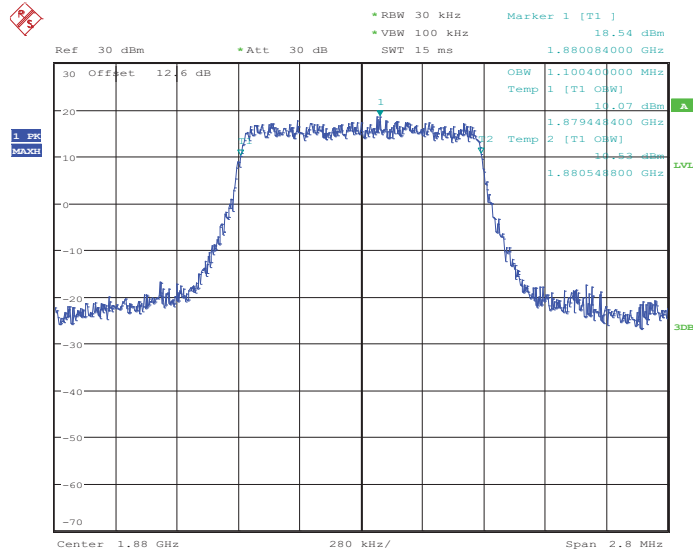

Date: 4.JUN.2014 16:29:45

26dB Bandwidth Plot on Channel 18900

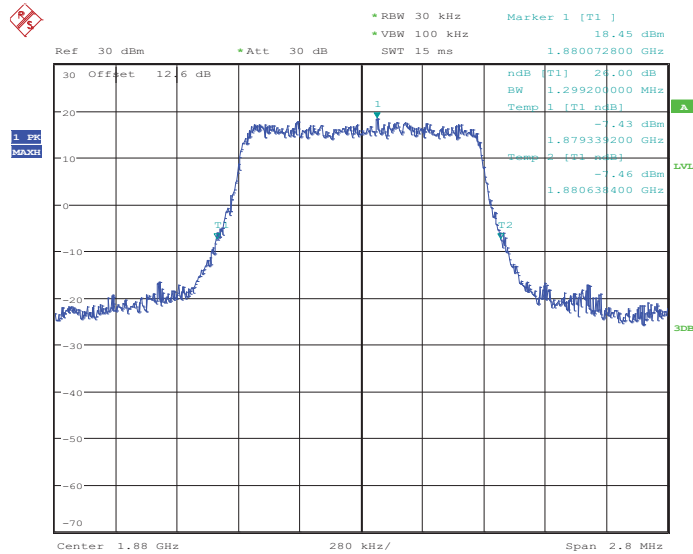

Date: 4.JUN.2014 16:30:21



99% Occupied Bandwidth Plot on Channel 19193

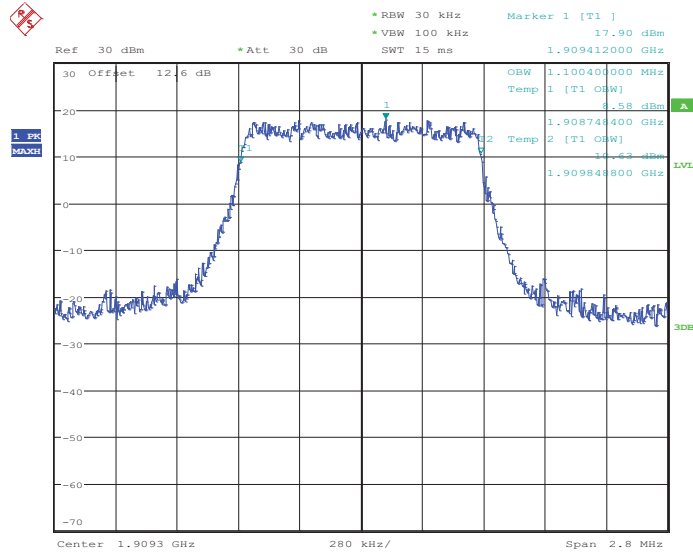

Date: 4.JUN.2014 16:32:58

26dB Bandwidth Plot on Channel 19193

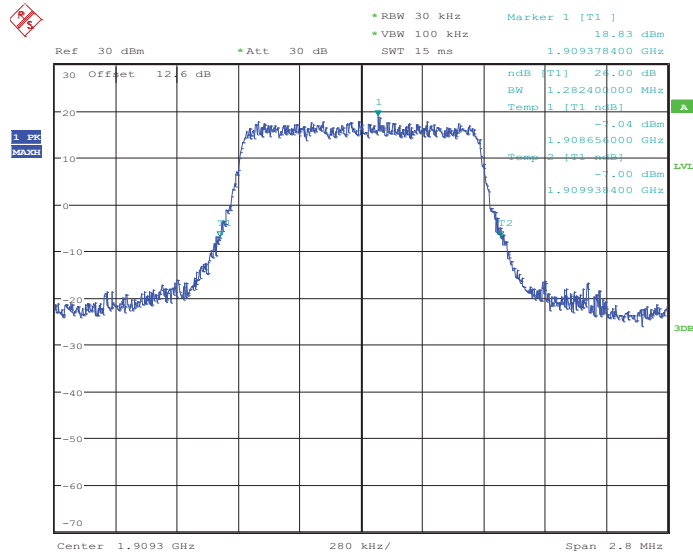

Date: 4.JUN.2014 16:33:34



Band :	LTE Band 2	BW / Mod. :	1.4MHz / 16QAM
---------------	------------	--------------------	----------------

99% Occupied Bandwidth Plot on Channel 18607

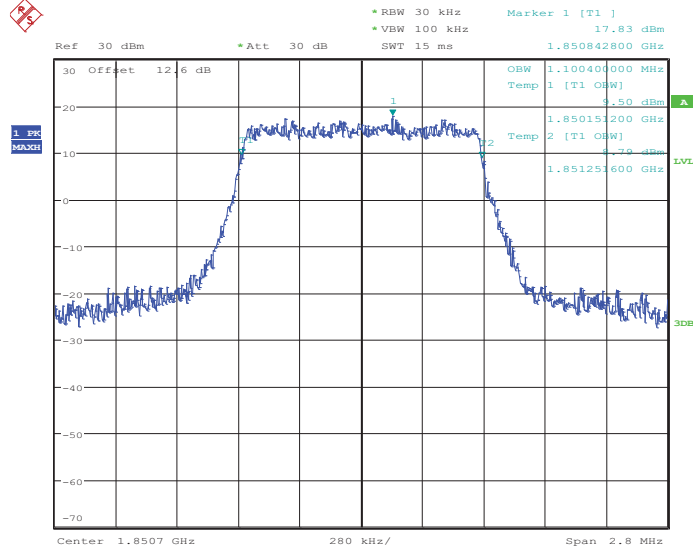

Date: 4.JUN.2014 16:23:39

26dB Bandwidth Plot on Channel 18607

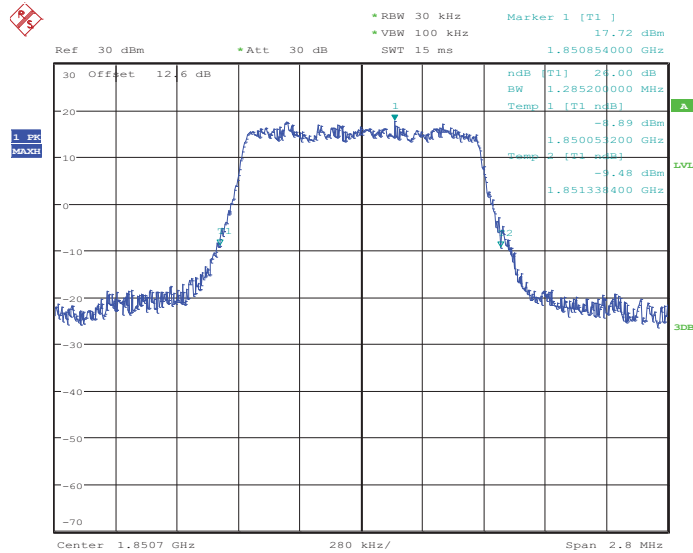

Date: 4.JUN.2014 16:24:16



99% Occupied Bandwidth Plot on Channel 18900

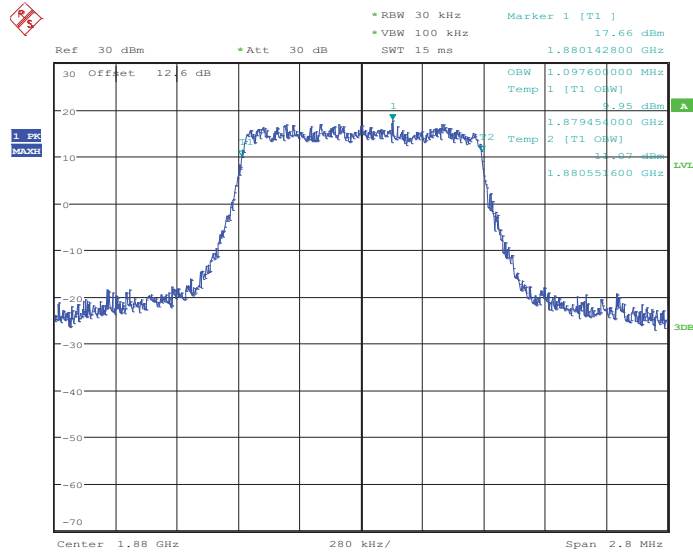

Date: 4.JUN.2014 16:30:02

26dB Bandwidth Plot on Channel 18900

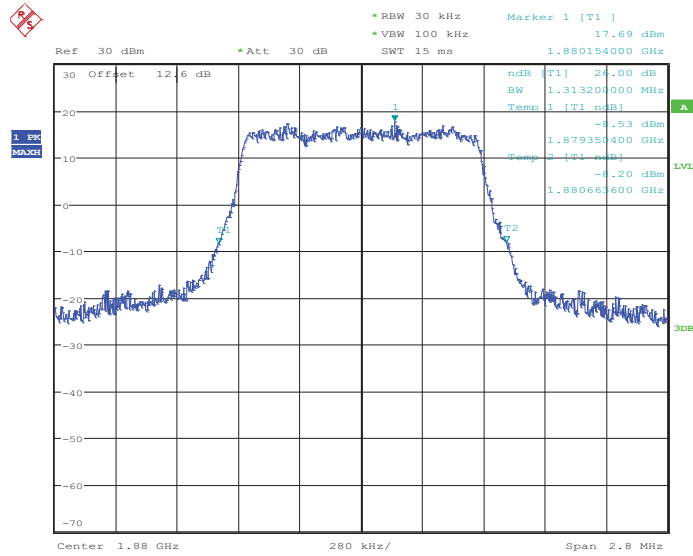

Date: 4.JUN.2014 16:30:40



99% Occupied Bandwidth Plot on Channel 19193

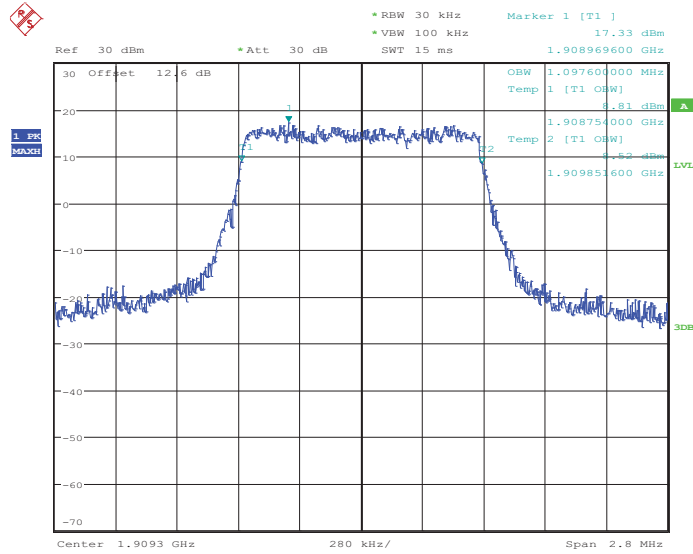

Date: 4.JUN.2014 16:33:15

26dB Bandwidth Plot on Channel 19193

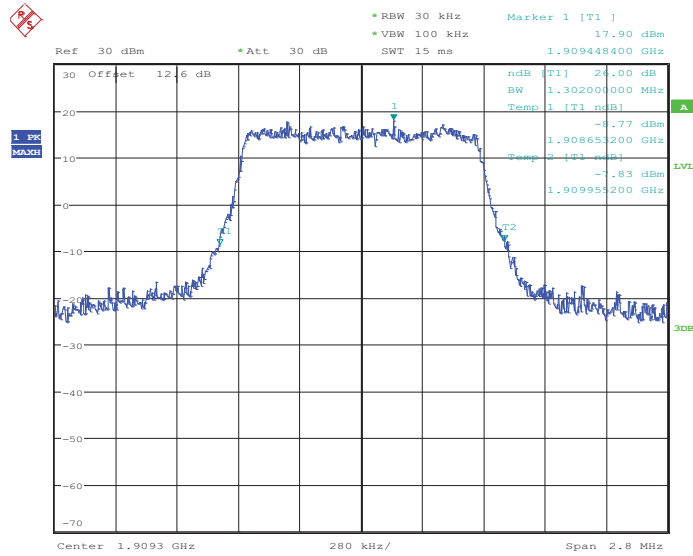

Date: 4.JUN.2014 16:33:52



Band :	LTE Band 2	BW / Mod. :	3MHz / QPSK
--------	------------	-------------	-------------

99% Occupied Bandwidth Plot on Channel 18615

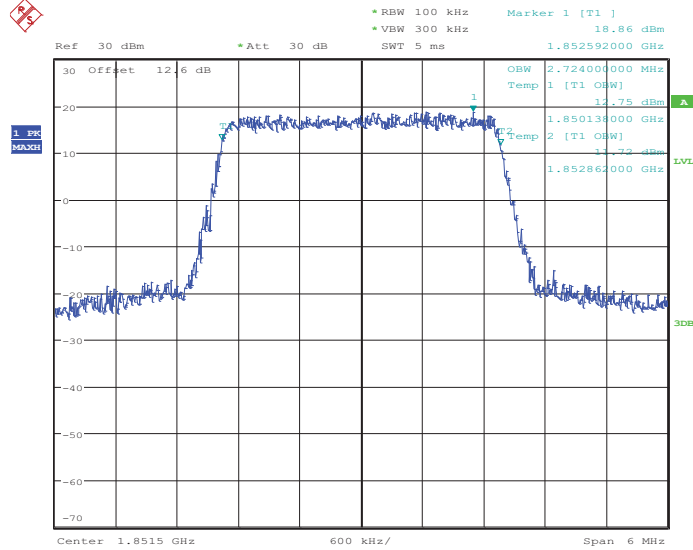

Date: 4.JUN.2014 16:39:22

26dB Bandwidth Plot on Channel 18615

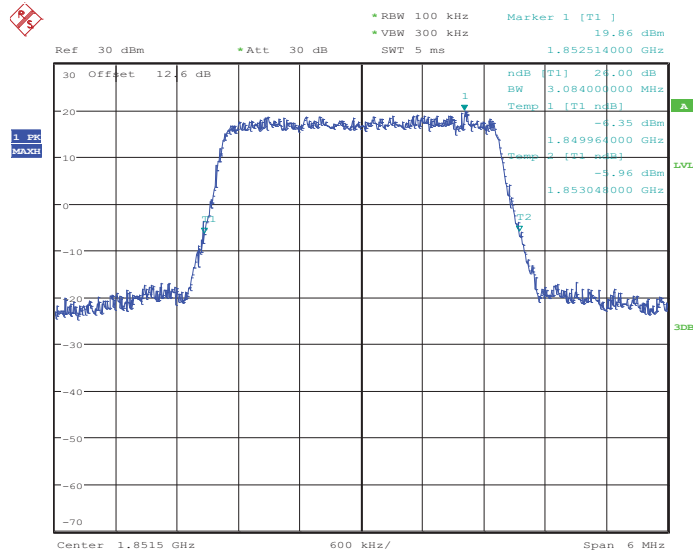

Date: 4.JUN.2014 16:39:58



99% Occupied Bandwidth Plot on Channel 18900

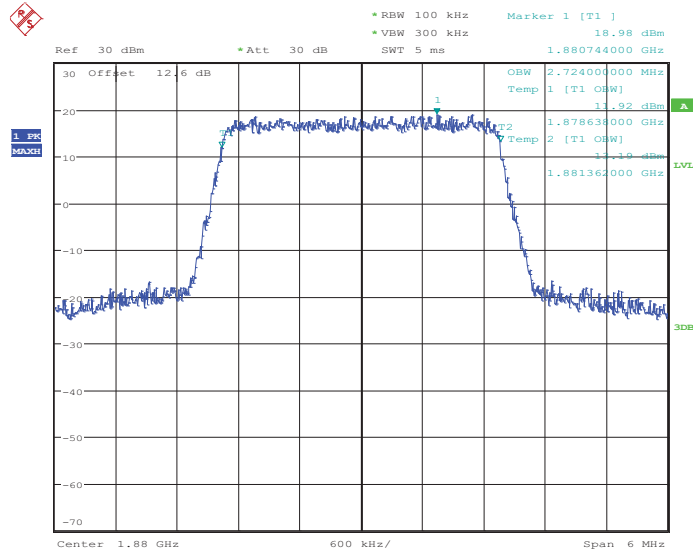

Date: 4.JUN.2014 16:45:47

26dB Bandwidth Plot on Channel 18900

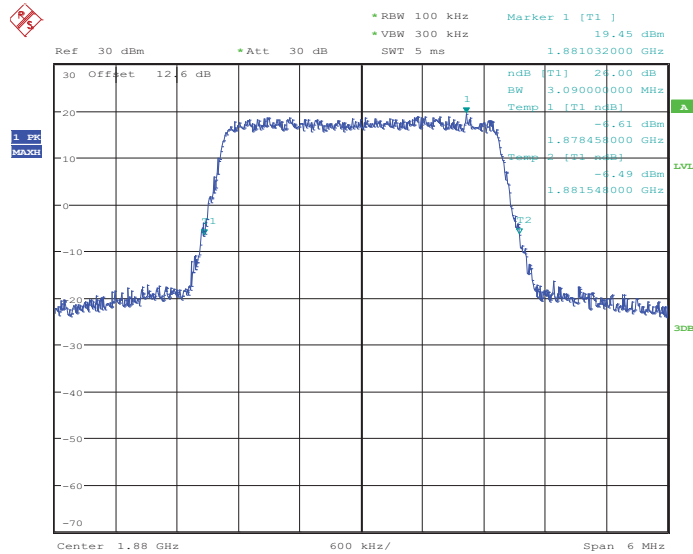

Date: 4.JUN.2014 16:46:23



99% Occupied Bandwidth Plot on Channel 19185

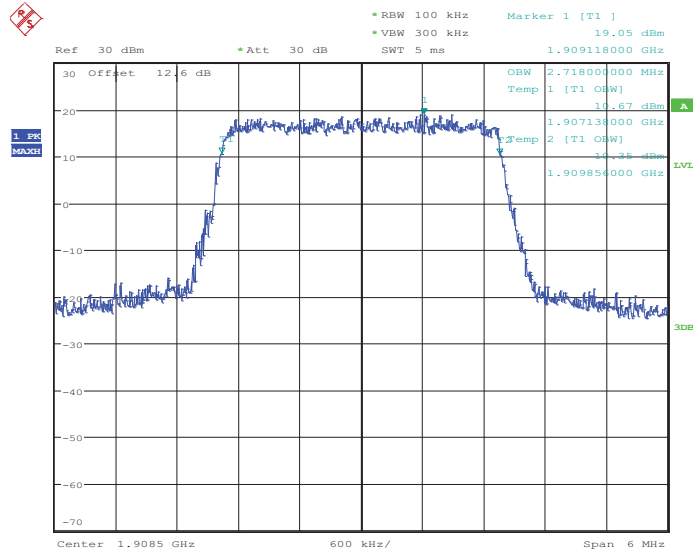

Date: 4.JUN.2014 16:49:00

26dB Bandwidth Plot on Channel 19185

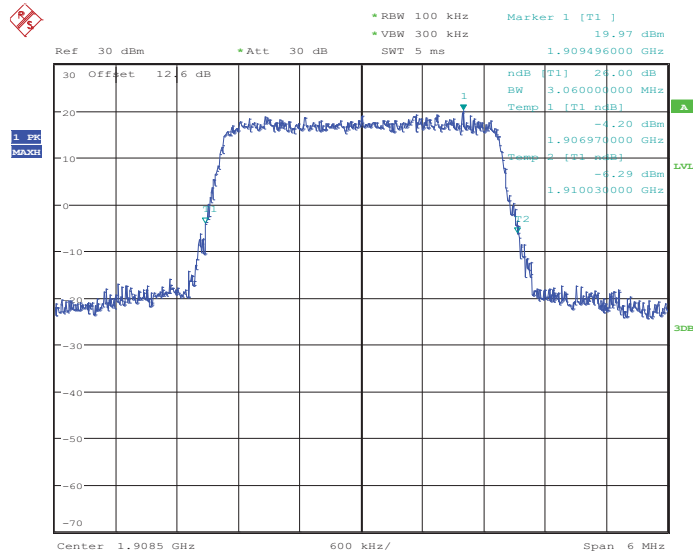

Date: 4.JUN.2014 16:49:36



Band :	LTE Band 2	BW / Mod. :	3MHz / 16QAM
--------	------------	-------------	--------------

99% Occupied Bandwidth Plot on Channel 18615

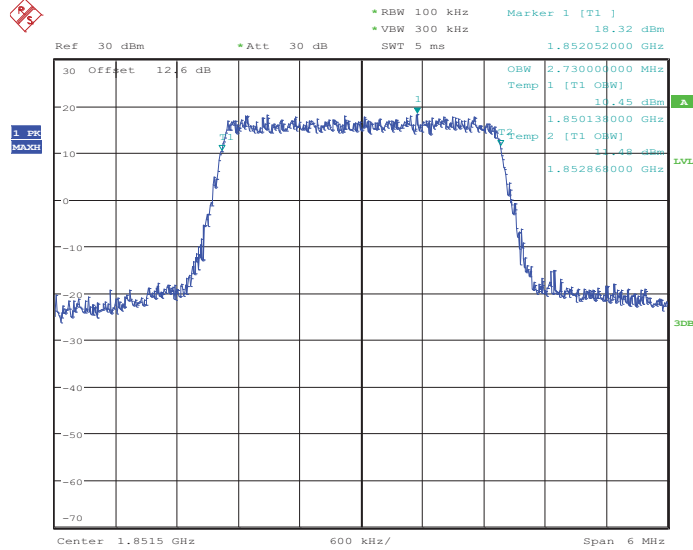

Date: 4.JUN.2014 16:39:39

26dB Bandwidth Plot on Channel 18615

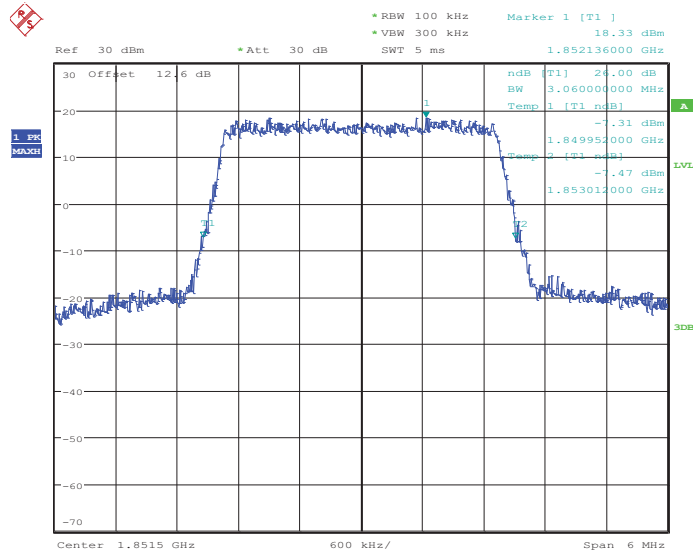

Date: 4.JUN.2014 16:40:17



99% Occupied Bandwidth Plot on Channel 18900

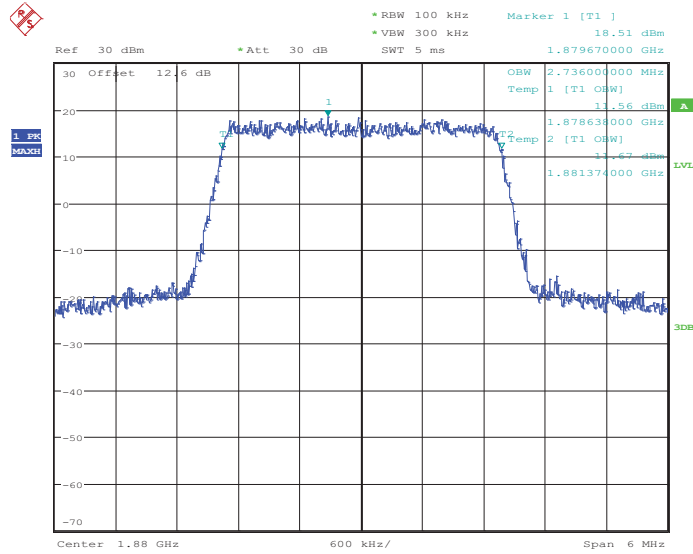

Date: 4.JUN.2014 16:46:04

26dB Bandwidth Plot on Channel 18900

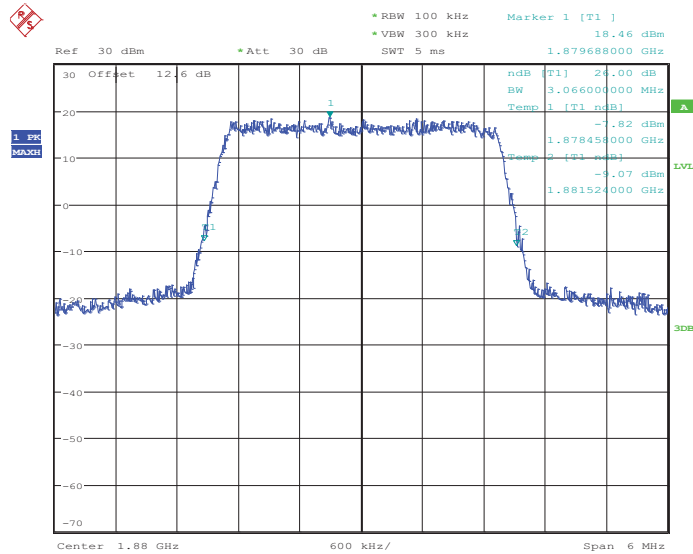

Date: 4.JUN.2014 16:46:41



99% Occupied Bandwidth Plot on Channel 19185

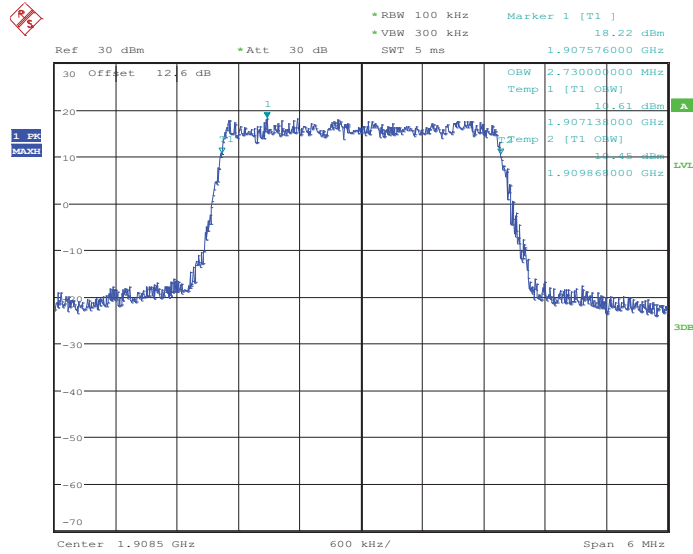

Date: 4.JUN.2014 16:49:17

26dB Bandwidth Plot on Channel 19185

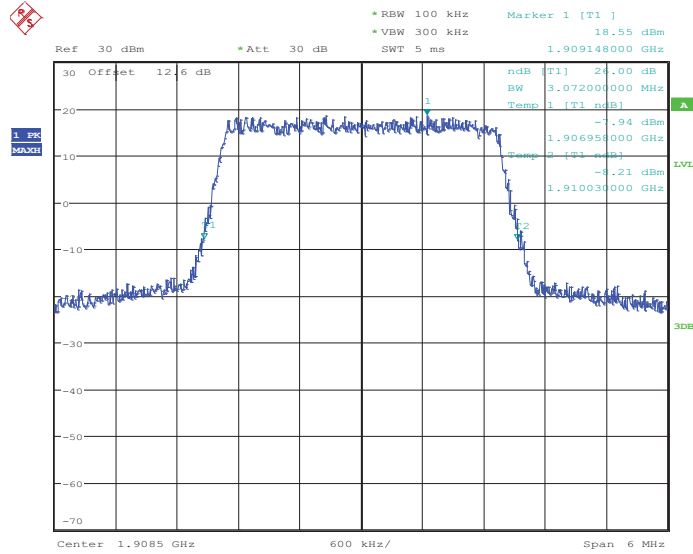

Date: 4.JUN.2014 16:49:55



Band :	LTE Band 2	BW / Mod. :	15MHz / QPSK
--------	------------	-------------	--------------

99% Occupied Bandwidth Plot on Channel 18675

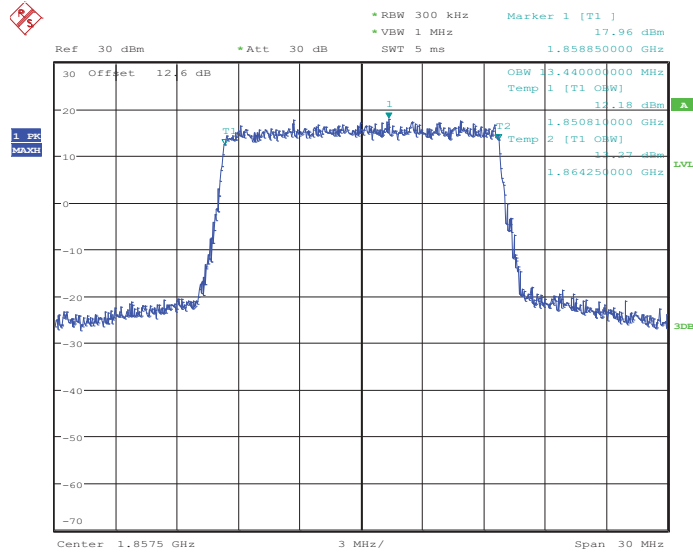

Date: 4.JUN.2014 17:49:06

26dB Bandwidth Plot on Channel 18675

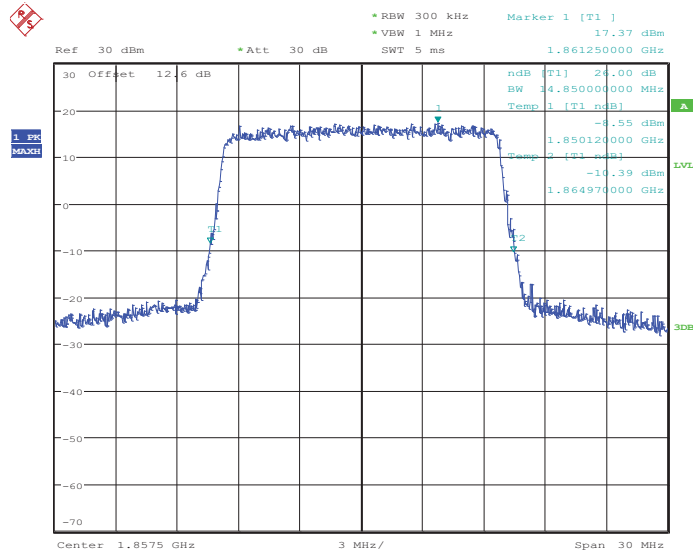

Date: 4.JUN.2014 17:49:41



99% Occupied Bandwidth Plot on Channel 18900

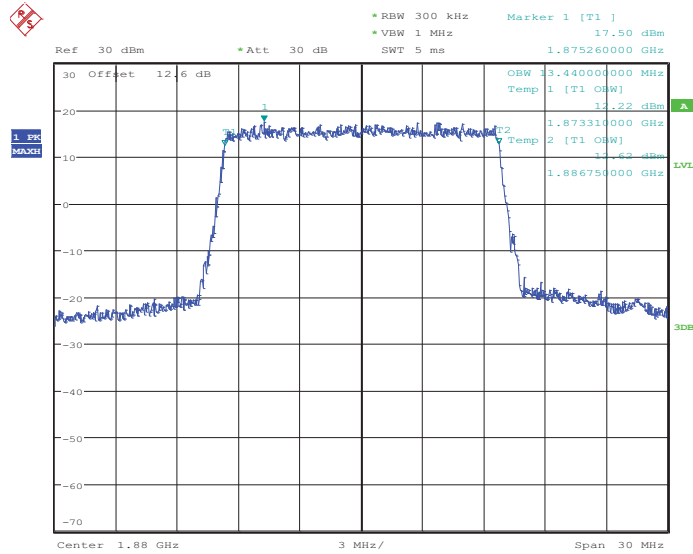

Date: 4.JUN.2014 17:55:28

26dB Bandwidth Plot on Channel 18900

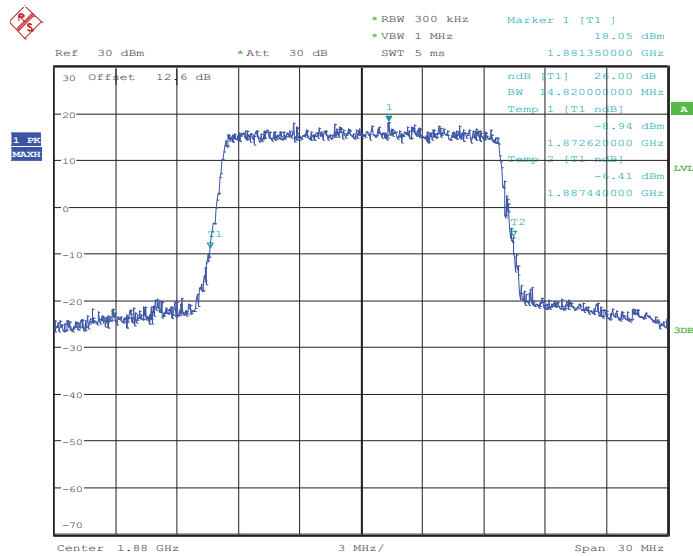

Date: 4.JUN.2014 17:56:03



99% Occupied Bandwidth Plot on Channel 19125

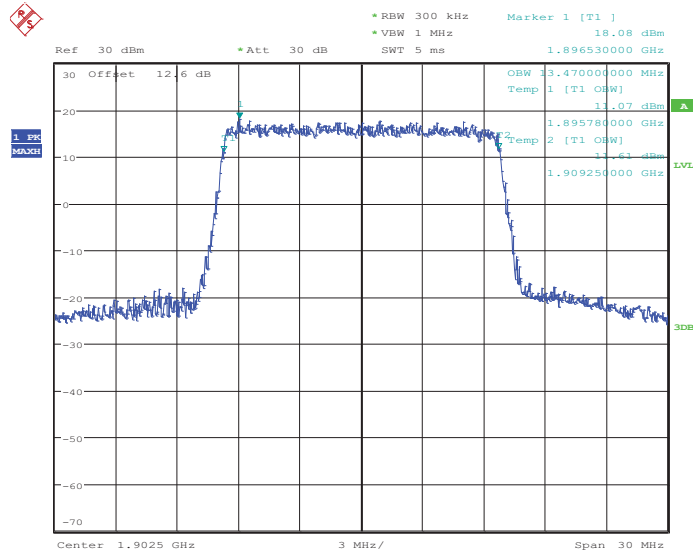

Date: 4.JUN.2014 17:58:40

26dB Bandwidth Plot on Channel 19125

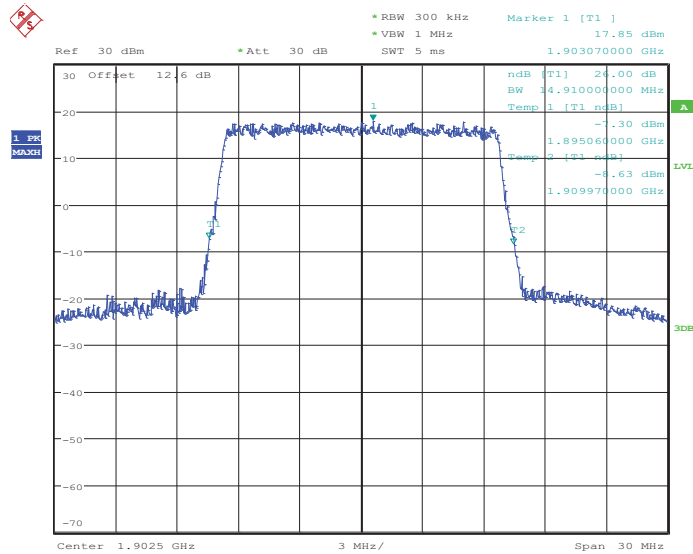

Date: 4.JUN.2014 17:59:15



Band :	LTE Band 2	BW / Mod. :	15MHz / 16QAM
--------	------------	-------------	---------------

99% Occupied Bandwidth Plot on Channel 18675

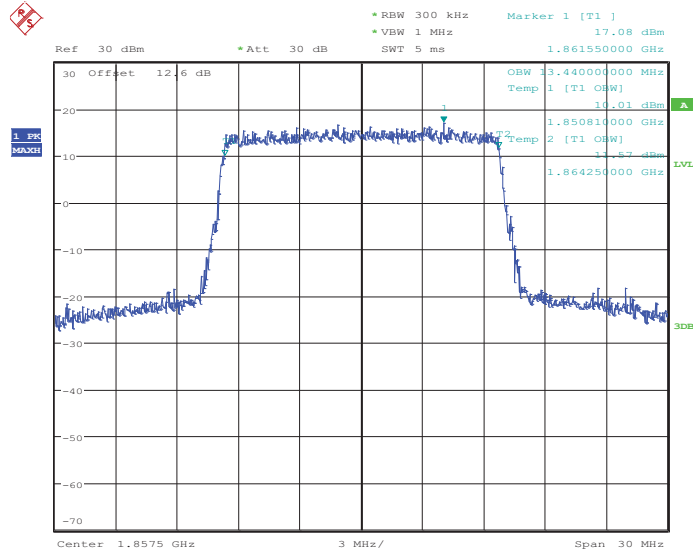

Date: 4.JUN.2014 17:49:22

26dB Bandwidth Plot on Channel 18675

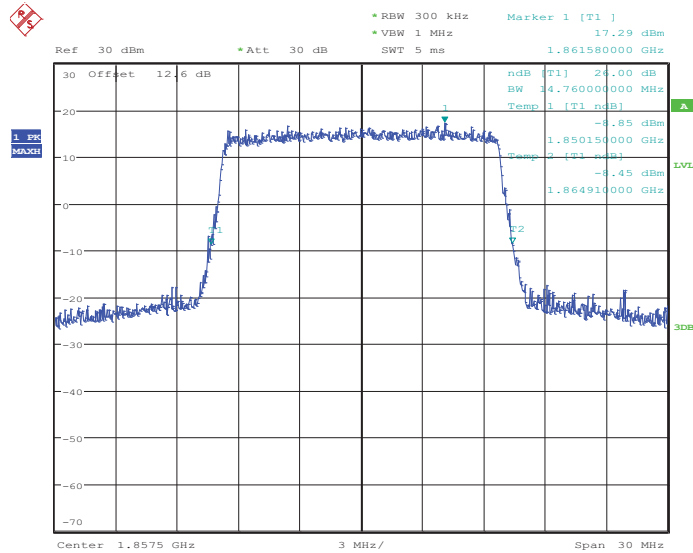

Date: 4.JUN.2014 17:50:00



99% Occupied Bandwidth Plot on Channel 18900

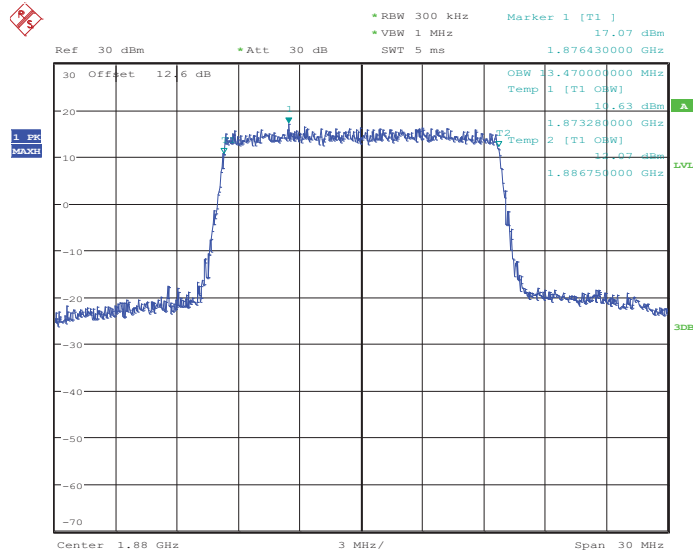

Date: 4.JUN.2014 17:55:45

26dB Bandwidth Plot on Channel 18900

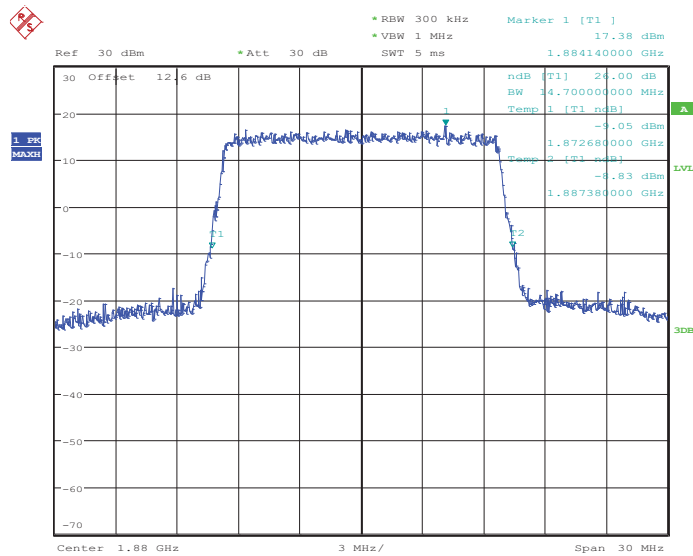

Date: 4.JUN.2014 17:56:22



99% Occupied Bandwidth Plot on Channel 19125

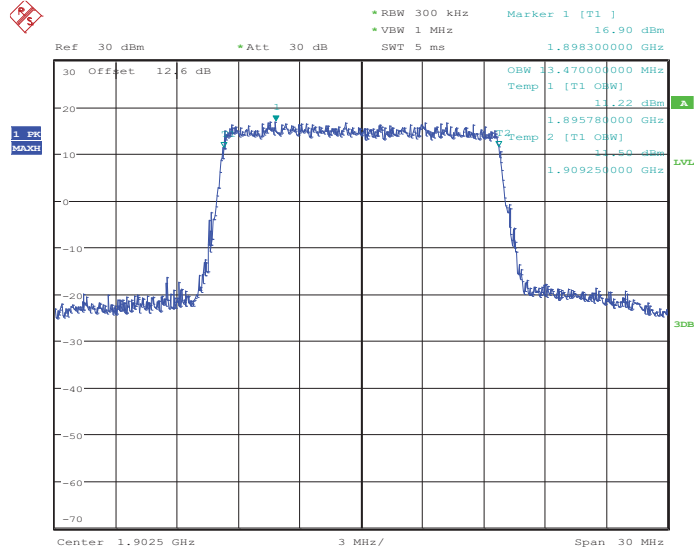

Date: 4.JUN.2014 17:58:57

26dB Bandwidth Plot on Channel 19125

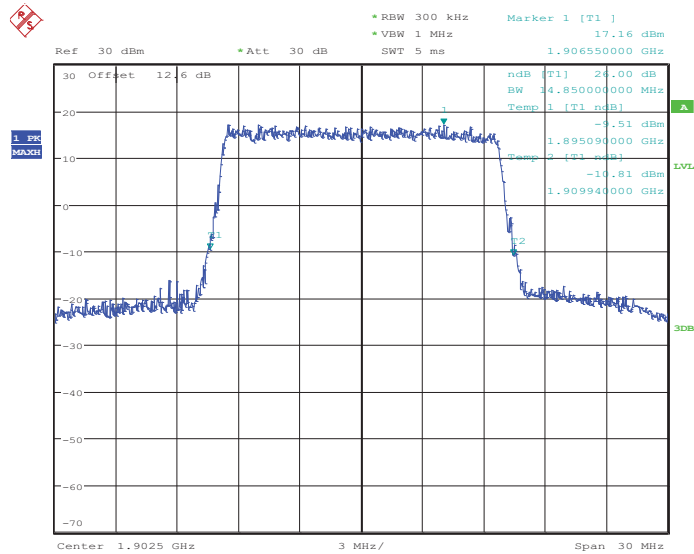

Date: 4.JUN.2014 17:59:34



Band :	LTE Band 2	BW / Mod. :	20MHz / QPSK
--------	------------	-------------	--------------

99% Occupied Bandwidth Plot on Channel 18700

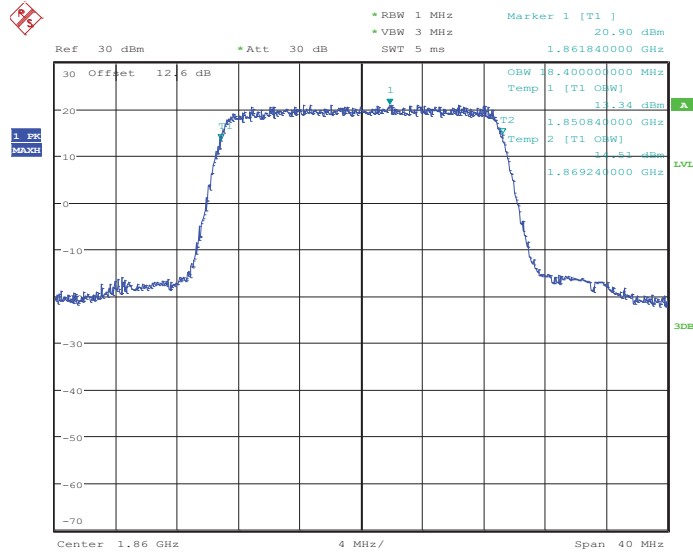

Date: 4.JUN.2014 18:56:46

26dB Bandwidth Plot on Channel 18700

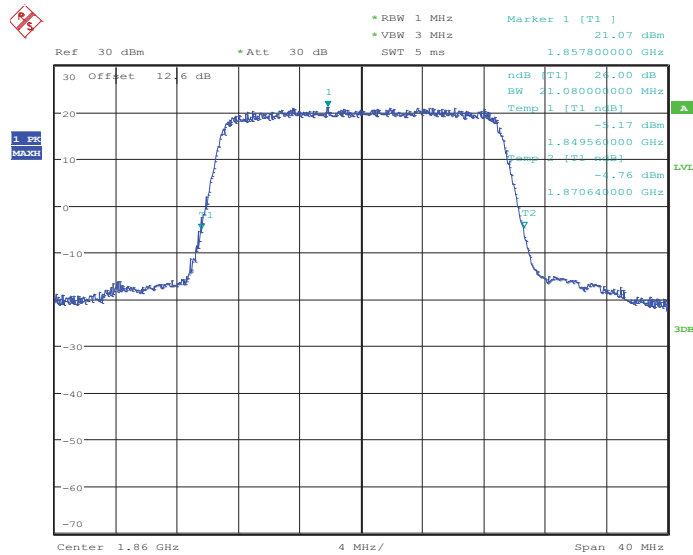

Date: 4.JUN.2014 18:57:22



99% Occupied Bandwidth Plot on Channel 18900

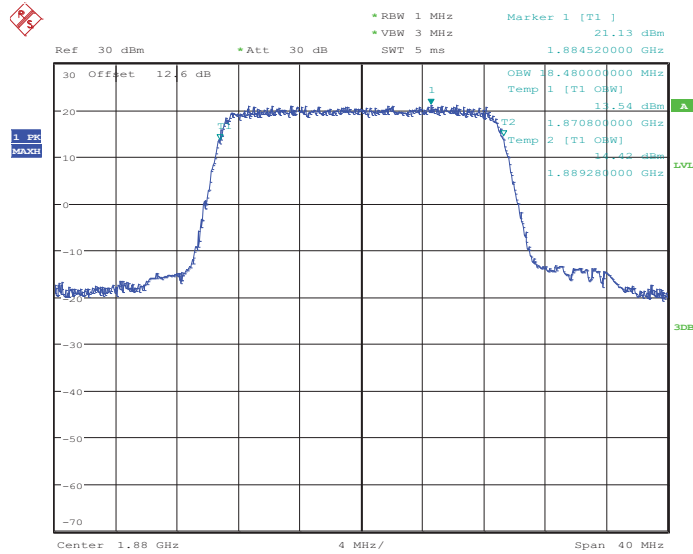

Date: 4.JUN.2014 19:03:09

26dB Bandwidth Plot on Channel 18900

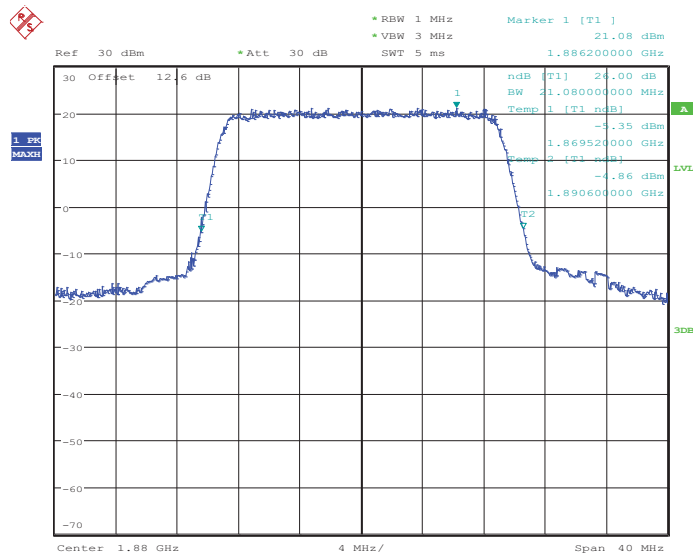

Date: 4.JUN.2014 19:03:44



99% Occupied Bandwidth Plot on Channel 19100

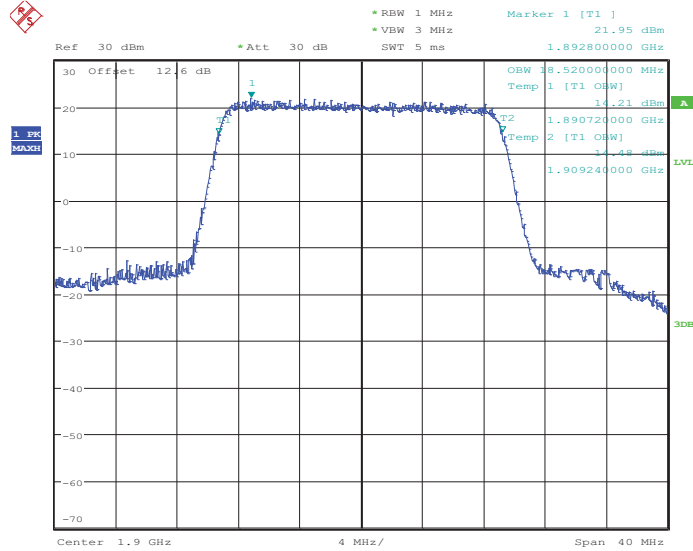

Date: 4.JUN.2014 19:06:20

26dB Bandwidth Plot on Channel 19100

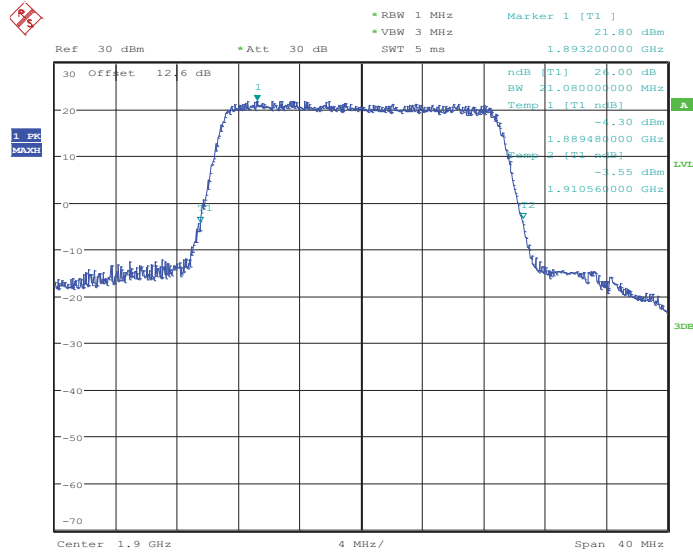

Date: 4.JUN.2014 19:06:55



Band :	LTE Band 2	BW / Mod. :	20MHz / 16QAM
--------	------------	-------------	---------------

99% Occupied Bandwidth Plot on Channel 18700

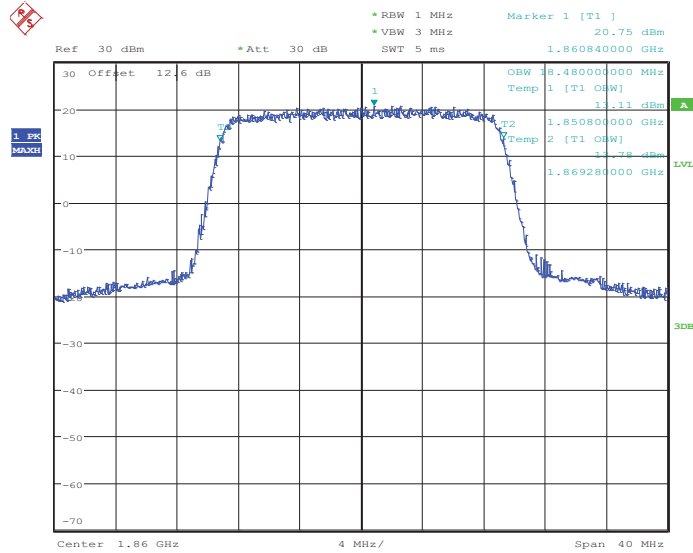

Date: 4.JUN.2014 18:57:04

26dB Bandwidth Plot on Channel 18700

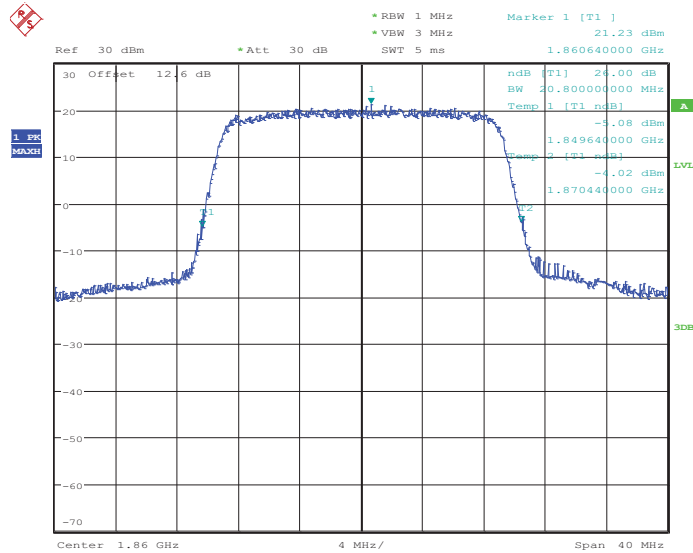

Date: 4.JUN.2014 18:57:41



99% Occupied Bandwidth Plot on Channel 18900

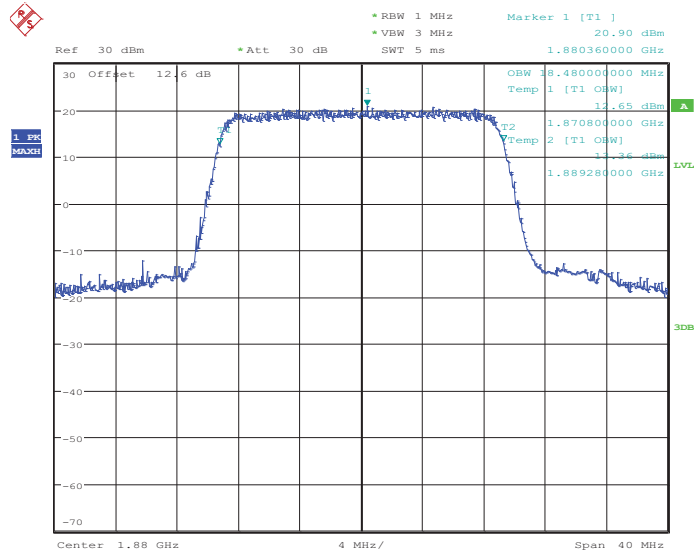

Date: 4.JUN.2014 19:03:26

26dB Bandwidth Plot on Channel 18900

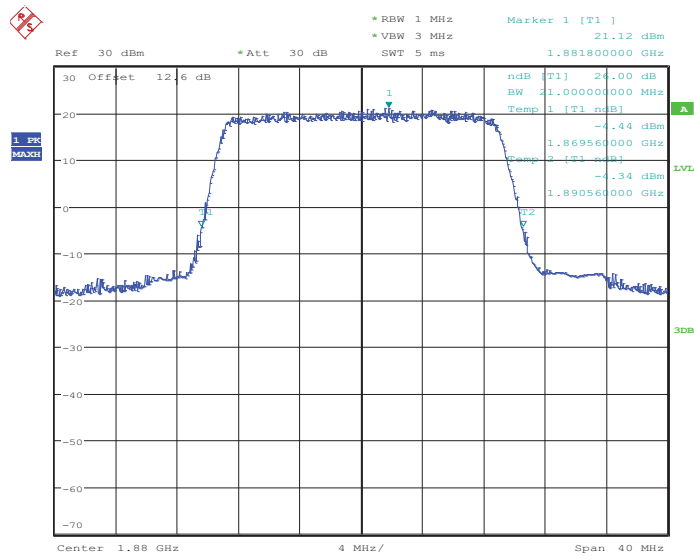

Date: 4.JUN.2014 19:04:03



99% Occupied Bandwidth Plot on Channel 19100

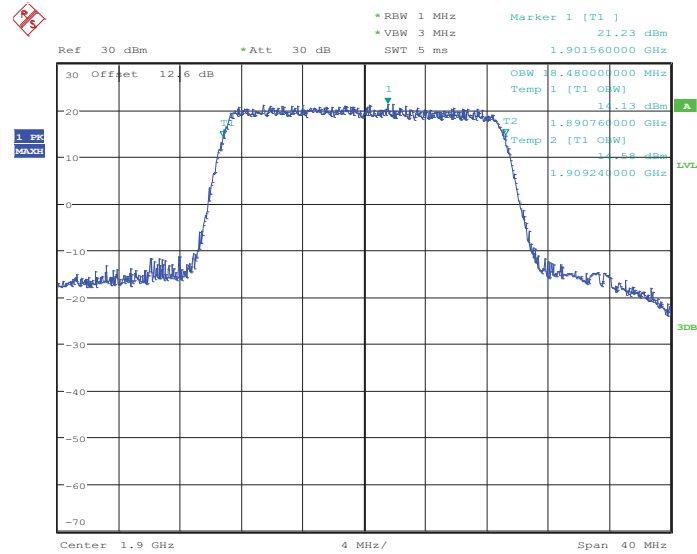

Date: 4.JUN.2014 19:06:37

26dB Bandwidth Plot on Channel 19100

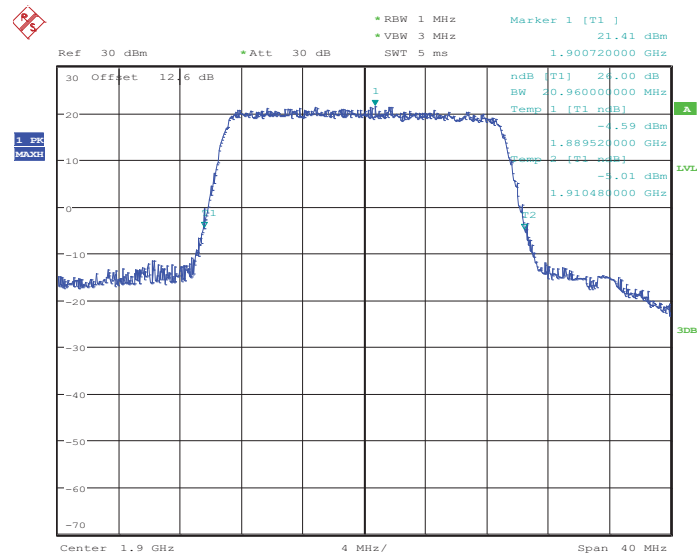

Date: 4.JUN.2014 19:07:14



Band :	LTE Band 4	BW / Mod. :	1.4MHz / QPSK
--------	------------	-------------	---------------

99% Occupied Bandwidth Plot on Channel 1957

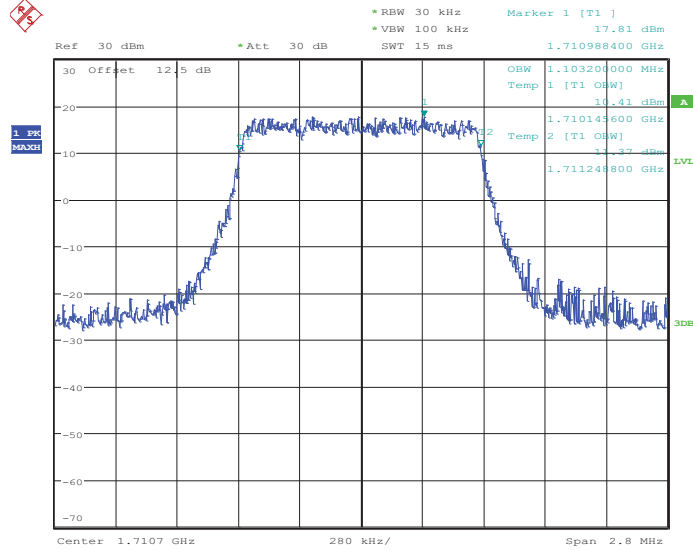

Date: 4.JUN.2014 20:27:41

26dB Bandwidth Plot on Channel 1957

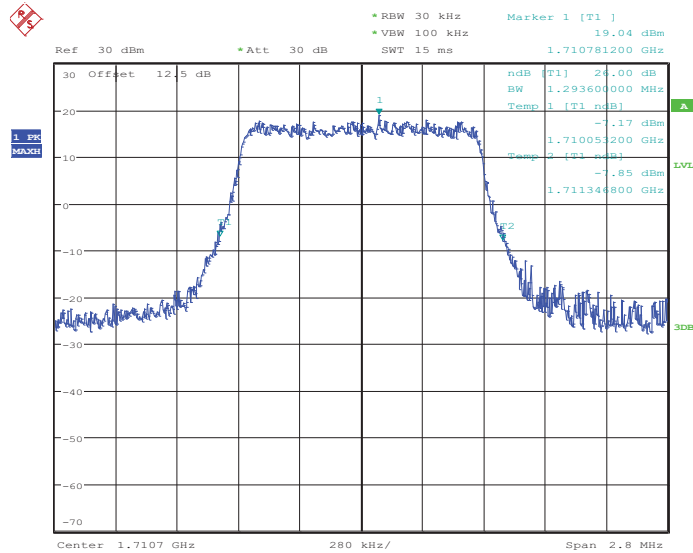

Date: 4.JUN.2014 20:28:18



99% Occupied Bandwidth Plot on Channel 20175

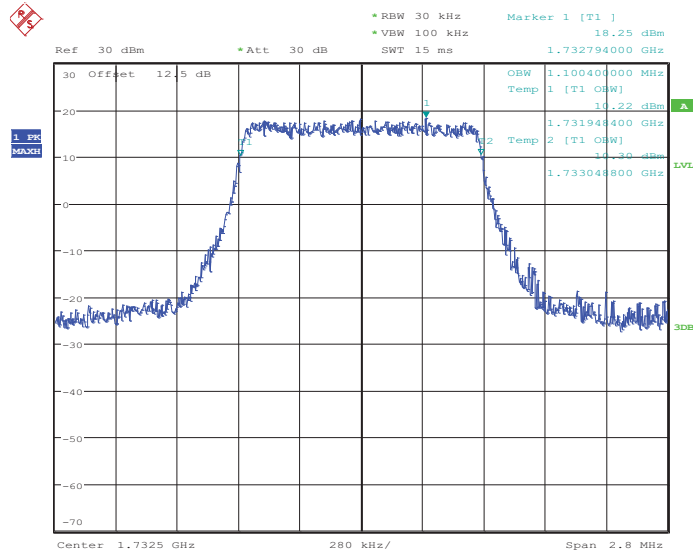

Date: 4.JUN.2014 20:34:04

26dB Bandwidth Plot on Channel 20175

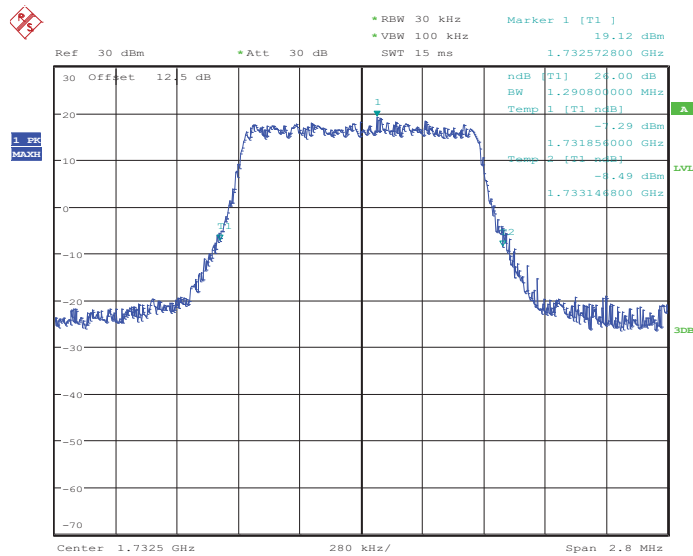

Date: 4.JUN.2014 20:34:39



99% Occupied Bandwidth Plot on Channel 20393

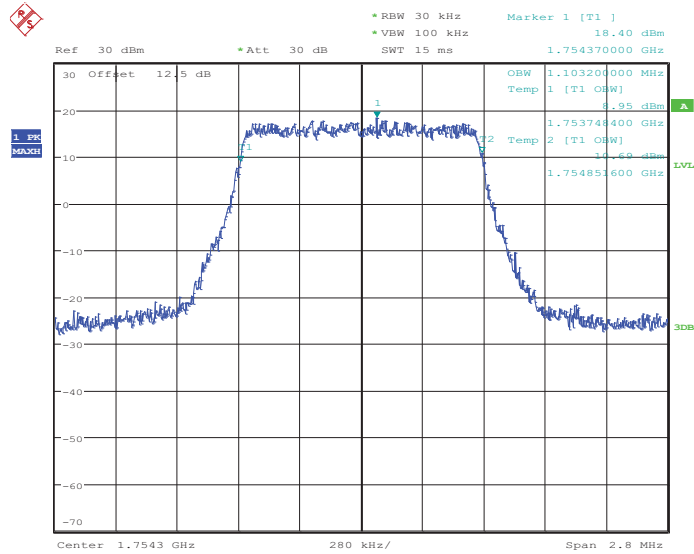

Date: 4.JUN.2014 20:37:15

26dB Bandwidth Plot on Channel 20393

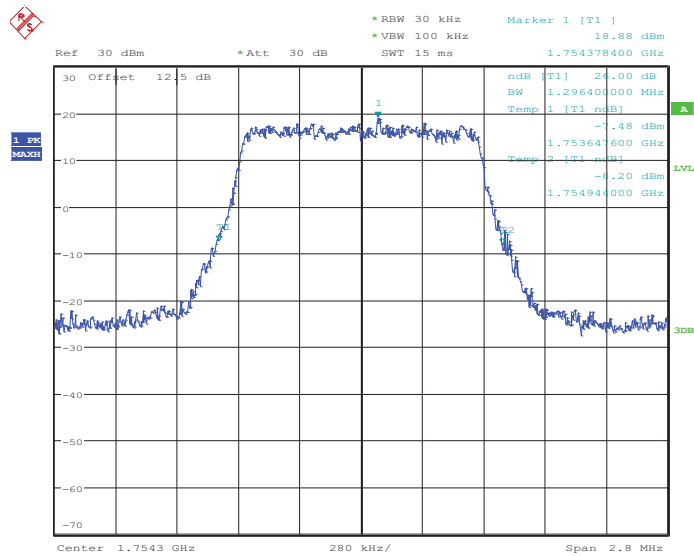

Date: 4.JUN.2014 20:37:51



Band :	LTE Band 4	BW / Mod. :	1.4MHz / 16QAM
--------	------------	-------------	----------------

99% Occupied Bandwidth Plot on Channel 1957

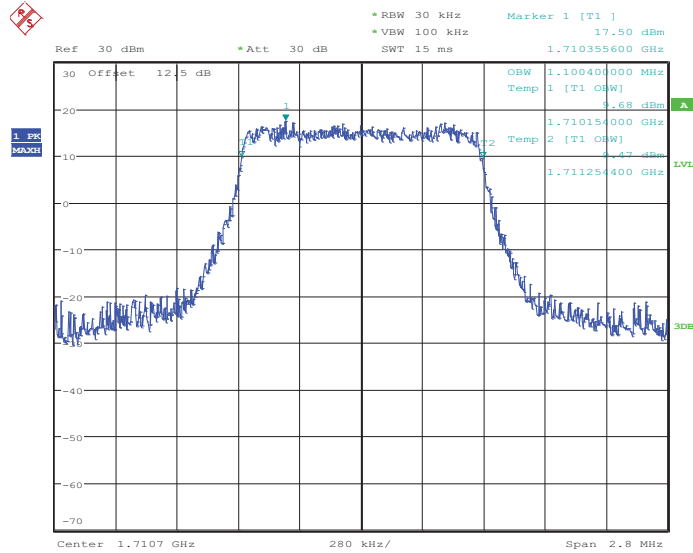

Date: 4.JUN.2014 20:27:59

26dB Bandwidth Plot on Channel 1957

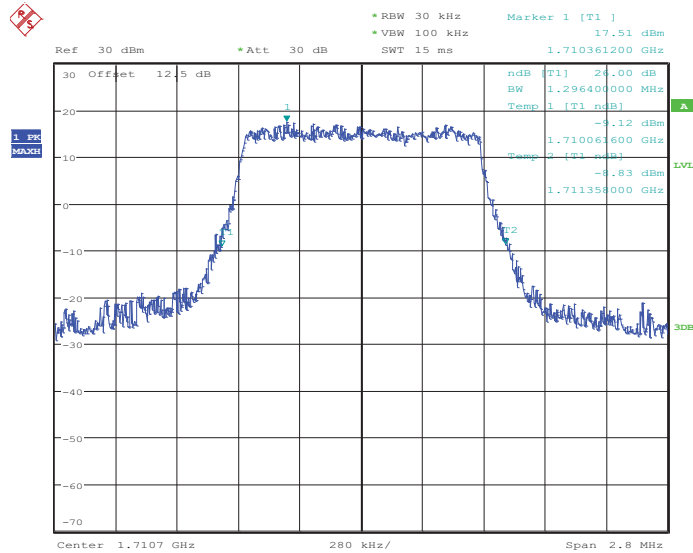

Date: 4.JUN.2014 20:28:36



99% Occupied Bandwidth Plot on Channel 20175

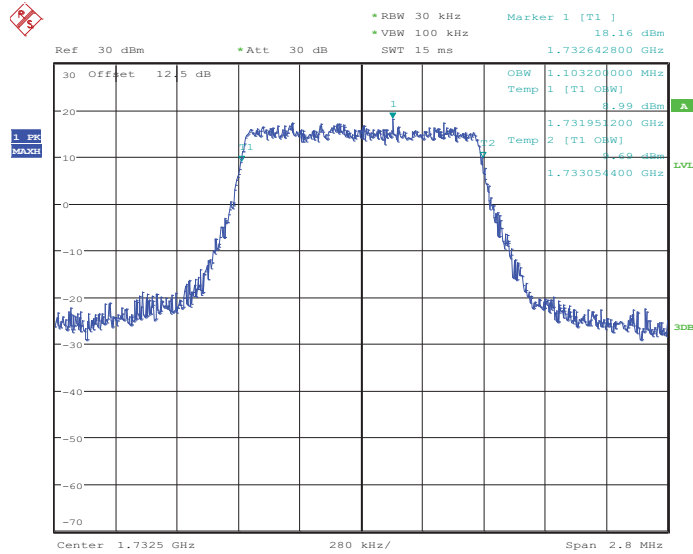

Date: 4.JUN.2014 20:34:20

26dB Bandwidth Plot on Channel 20175

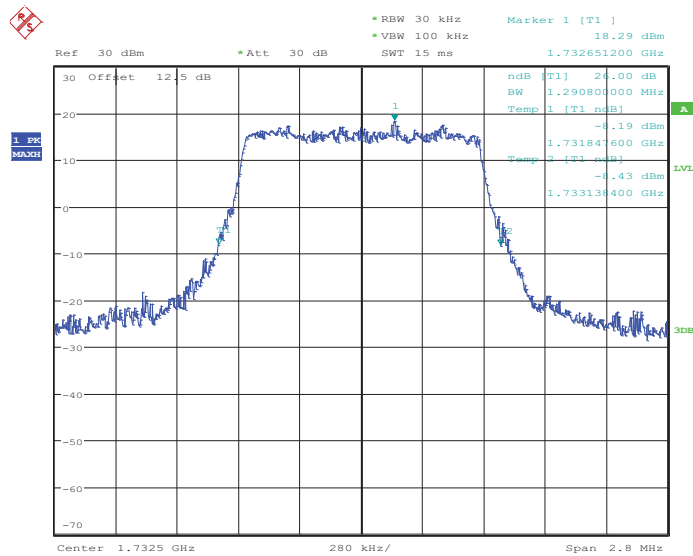

Date: 4.JUN.2014 20:34:58



99% Occupied Bandwidth Plot on Channel 20393

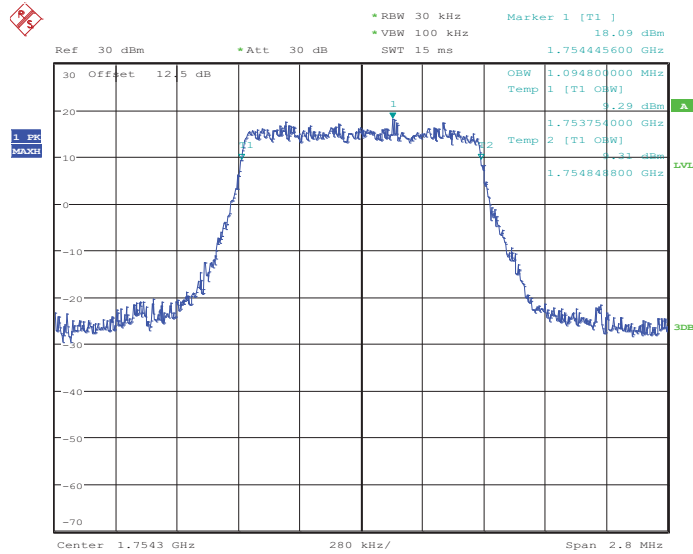

Date: 4.JUN.2014 20:37:32

26dB Bandwidth Plot on Channel 20393

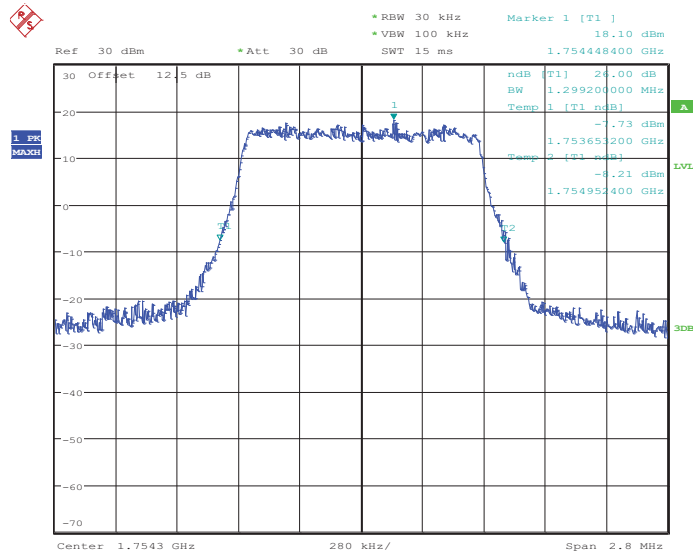

Date: 4.JUN.2014 20:38:09



Band :	LTE Band 4	BW / Mod. :	3MHz / QPSK
--------	------------	-------------	-------------

99% Occupied Bandwidth Plot on Channel 19965

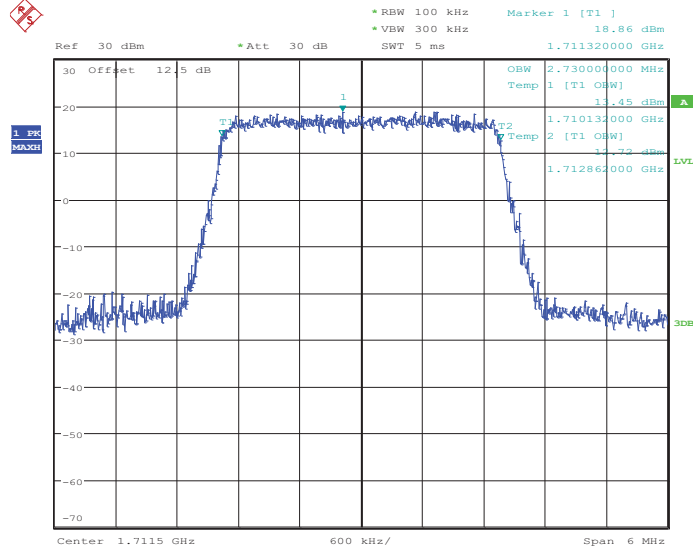

Date: 4.JUN.2014 20:43:37

26dB Bandwidth Plot on Channel 19965

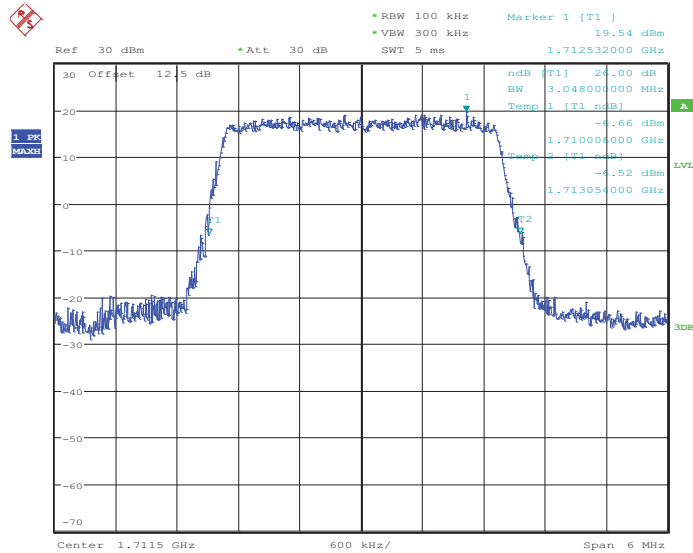

Date: 4.JUN.2014 20:44:12



99% Occupied Bandwidth Plot on Channel 20175

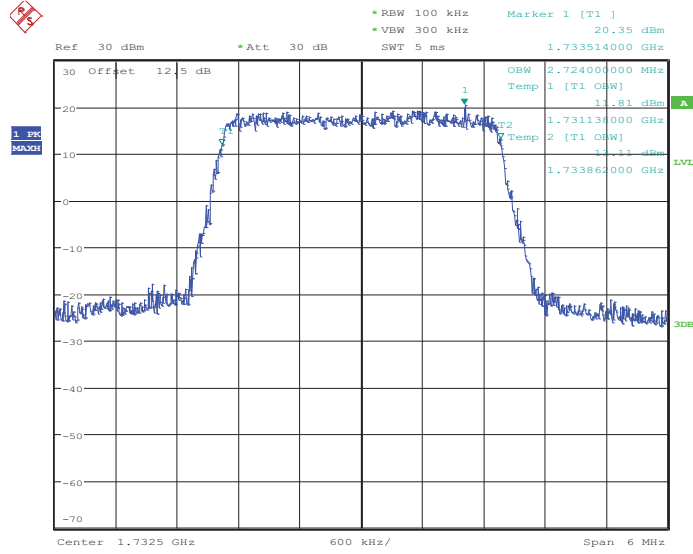

Date: 4.JUN.2014 20:49:58

26dB Bandwidth Plot on Channel 20175

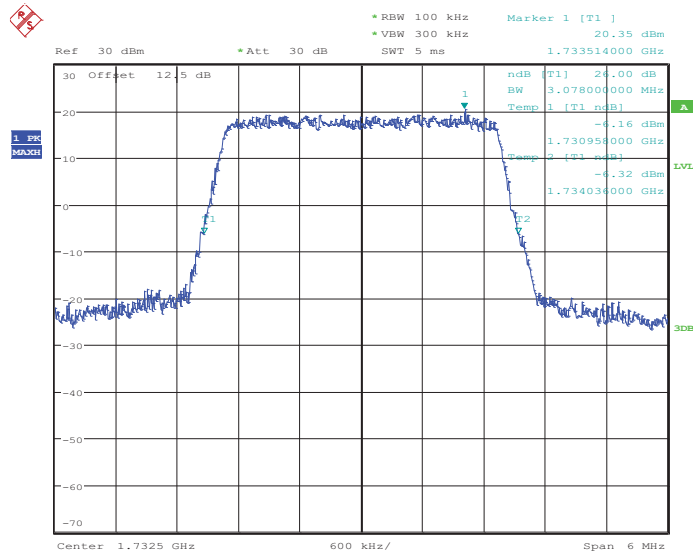

Date: 4.JUN.2014 20:50:34



99% Occupied Bandwidth Plot on Channel 20385

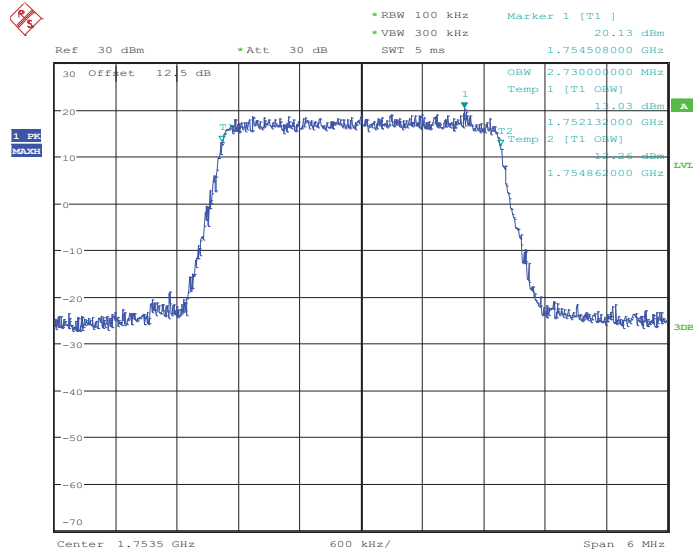

Date: 4.JUN.2014 20:53:10

26dB Bandwidth Plot on Channel 20385

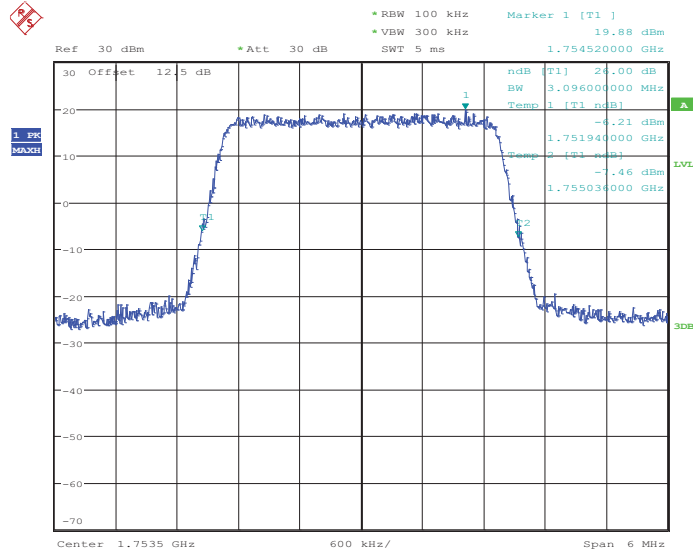

Date: 4.JUN.2014 20:53:45



Band :	LTE Band 4	BW / Mod. :	3MHz / 16QAM
--------	------------	-------------	--------------

99% Occupied Bandwidth Plot on Channel 1965

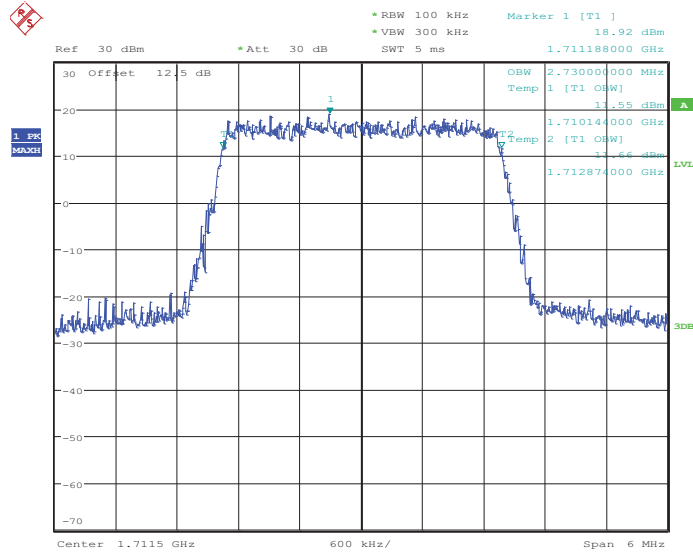

Date: 4.JUN.2014 20:43:54

26dB Bandwidth Plot on Channel 1965

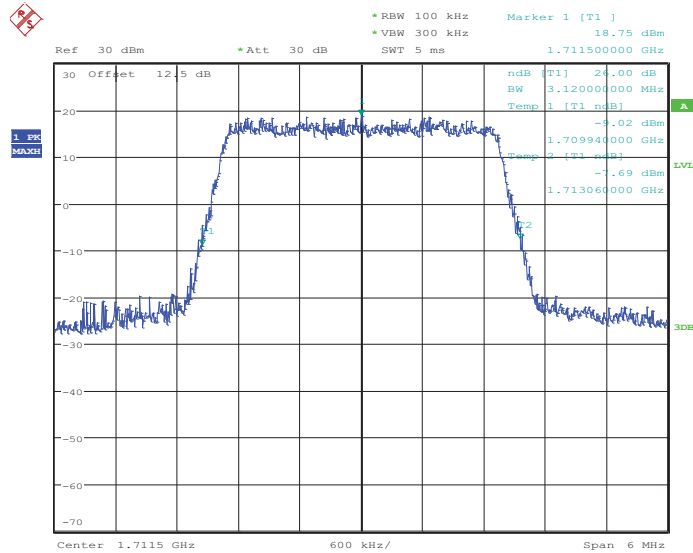

Date: 4.JUN.2014 20:44:31



99% Occupied Bandwidth Plot on Channel 20175

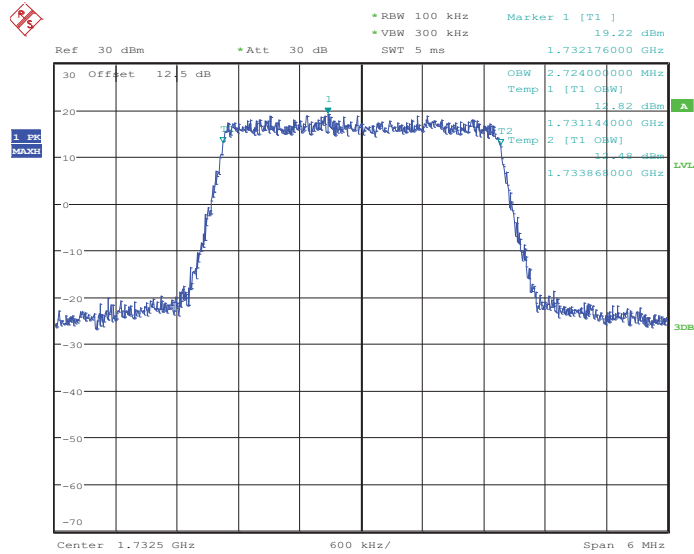

Date: 4.JUN.2014 20:50:15

26dB Bandwidth Plot on Channel 20175

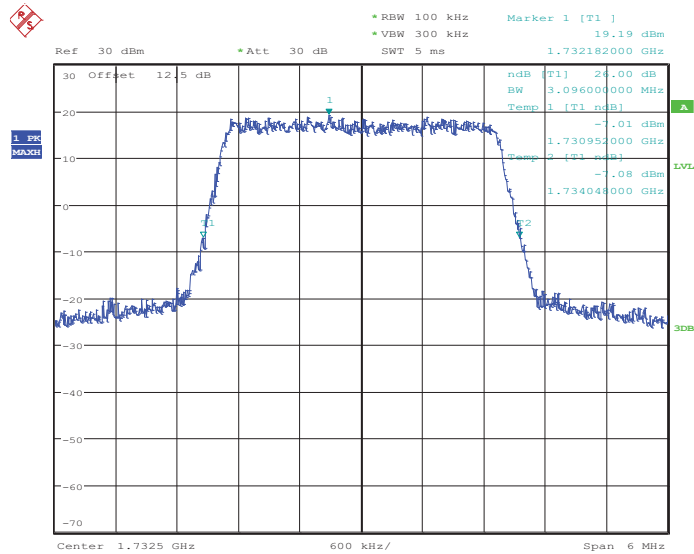

Date: 4.JUN.2014 20:50:52



99% Occupied Bandwidth Plot on Channel 20385

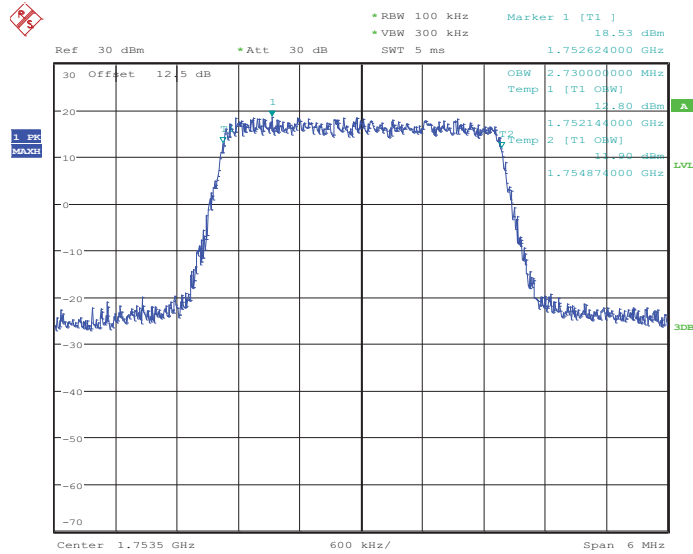

Date: 4.JUN.2014 20:53:27

26dB Bandwidth Plot on Channel 20385

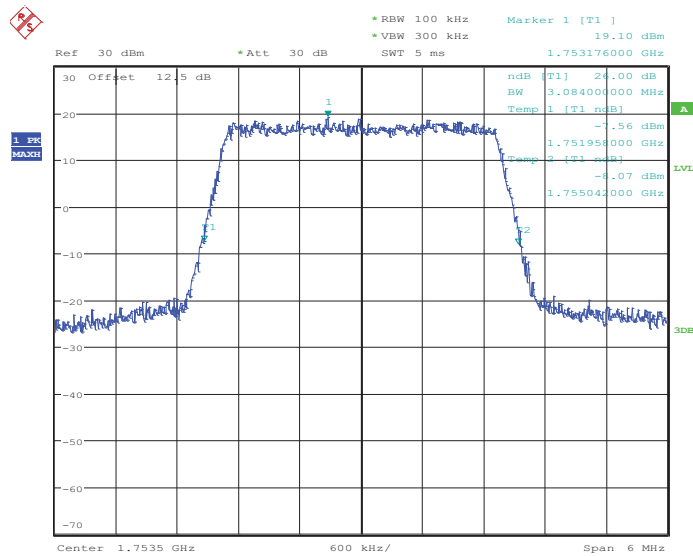

Date: 4.JUN.2014 20:54:04



Band :	LTE Band 4	BW / Mod. :	15MHz / QPSK
--------	------------	-------------	--------------

99% Occupied Bandwidth Plot on Channel 2025

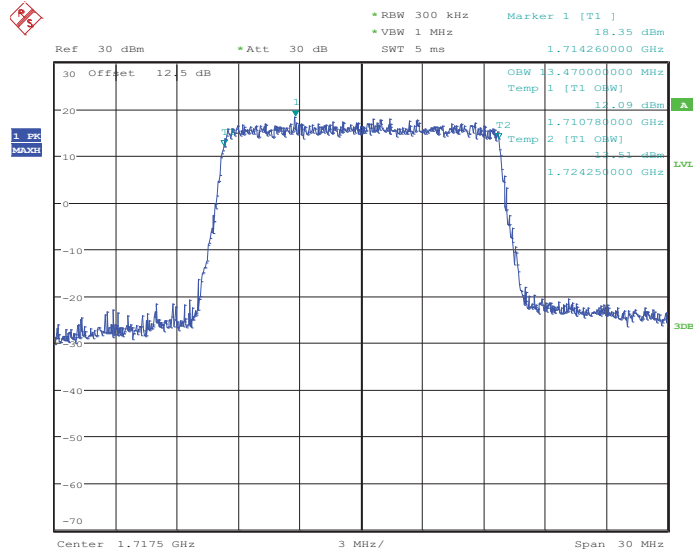

Date: 4.JUN.2014 22:32:58

26dB Bandwidth Plot on Channel 2025

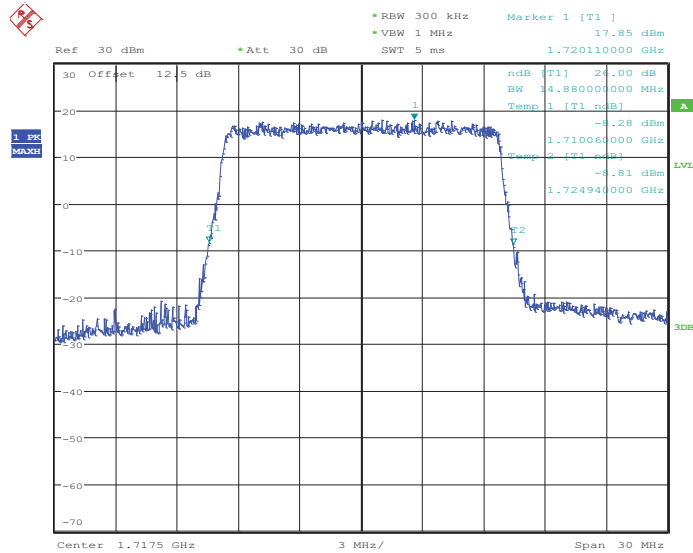

Date: 4.JUN.2014 22:33:33



99% Occupied Bandwidth Plot on Channel 20175

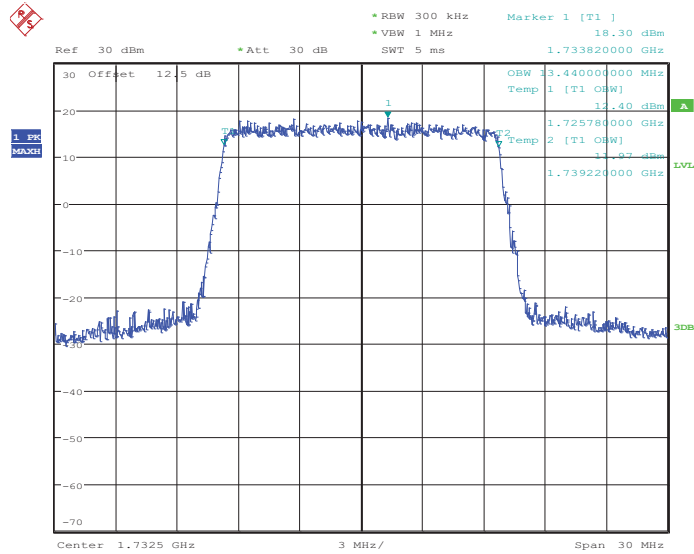

Date: 4.JUN.2014 22:39:20

26dB Bandwidth Plot on Channel 20175

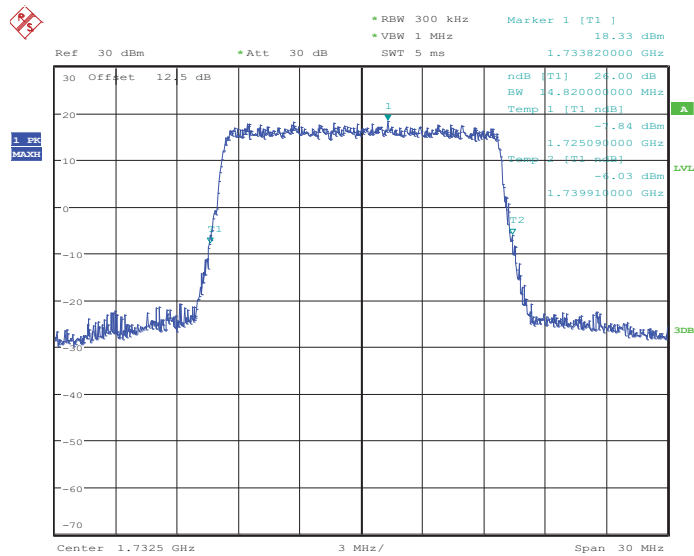

Date: 4.JUN.2014 22:39:56



99% Occupied Bandwidth Plot on Channel 20325

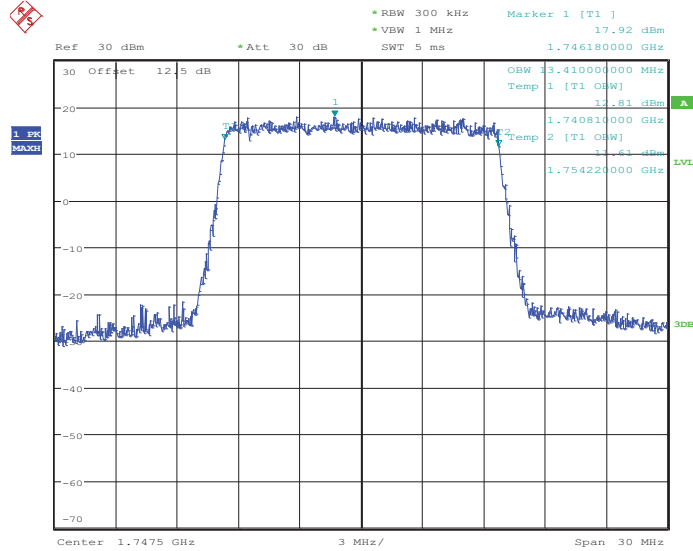

Date: 4.JUN.2014 22:42:32

26dB Bandwidth Plot on Channel 20325

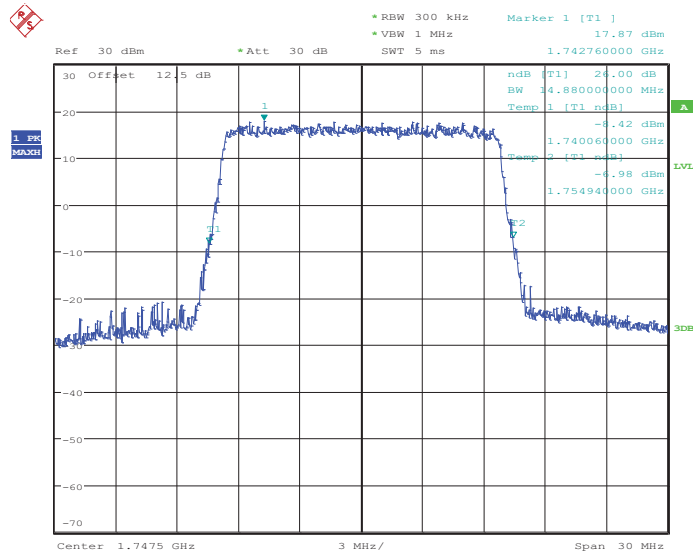

Date: 4.JUN.2014 22:43:07



Band :	LTE Band 4	BW / Mod. :	15MHz / 16QAM
--------	------------	-------------	---------------

99% Occupied Bandwidth Plot on Channel 2025

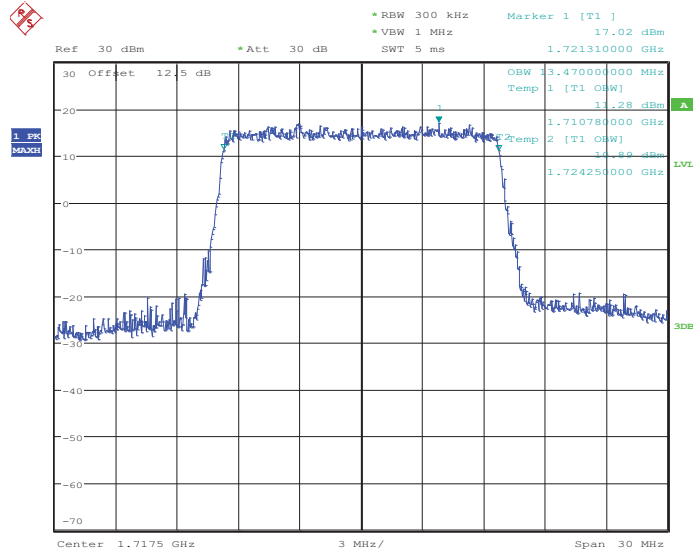

Date: 4.JUN.2014 22:33:15

26dB Bandwidth Plot on Channel 2025

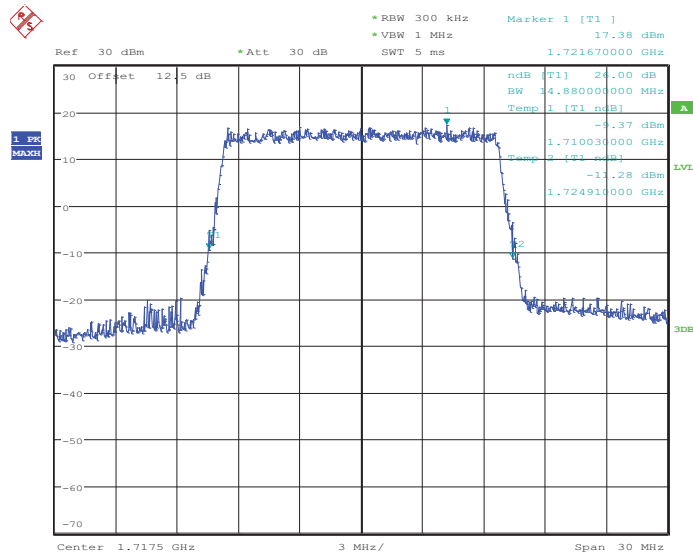

Date: 4.JUN.2014 22:33:52



99% Occupied Bandwidth Plot on Channel 20175

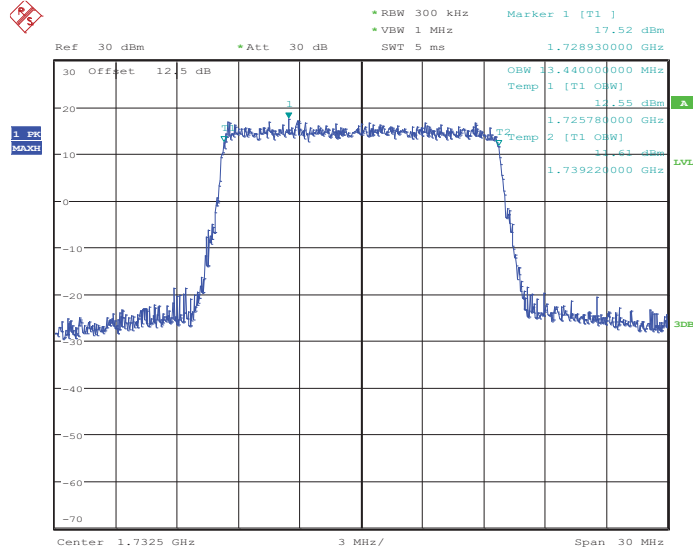

Date: 4.JUN.2014 22:39:37

26dB Bandwidth Plot on Channel 20175

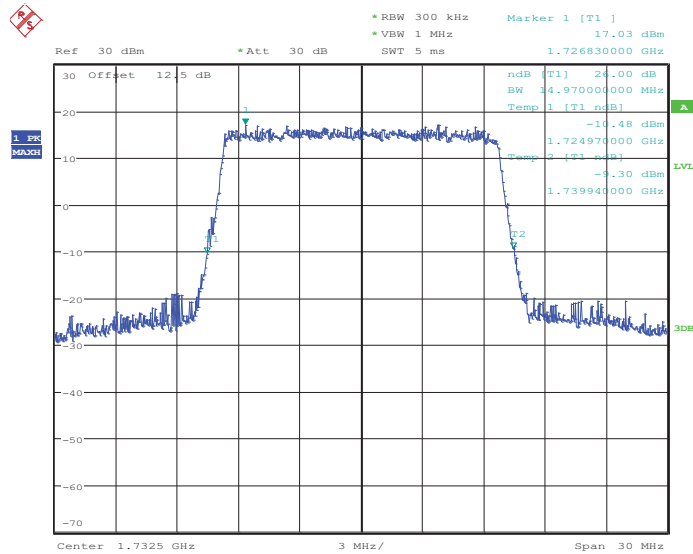

Date: 4.JUN.2014 22:40:14



99% Occupied Bandwidth Plot on Channel 20325

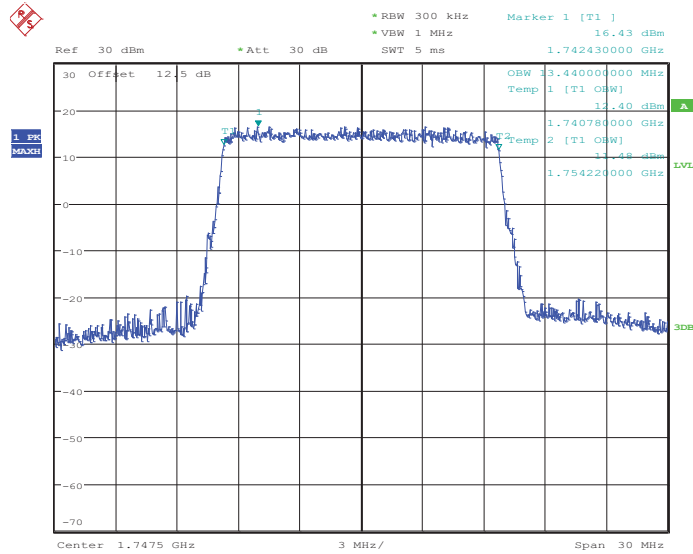

Date: 4.JUN.2014 22:42:48

26dB Bandwidth Plot on Channel 20325

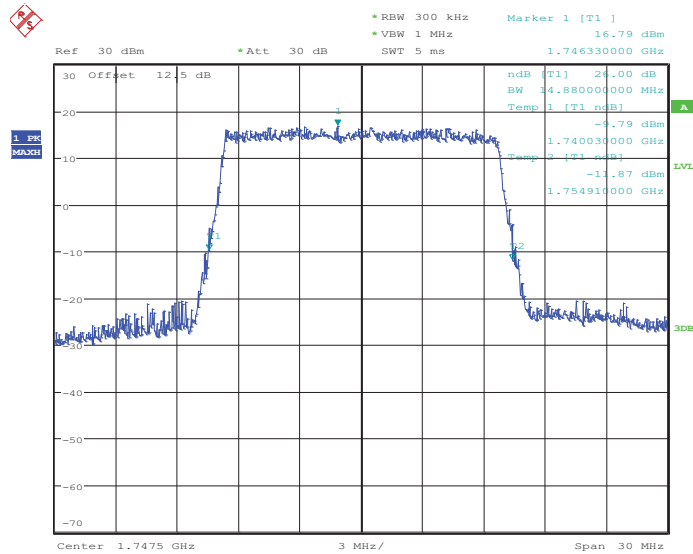

Date: 4.JUN.2014 22:43:25



Band :	LTE Band 4	BW / Mod. :	20MHz / QPSK
--------	------------	-------------	--------------

99% Occupied Bandwidth Plot on Channel 20050

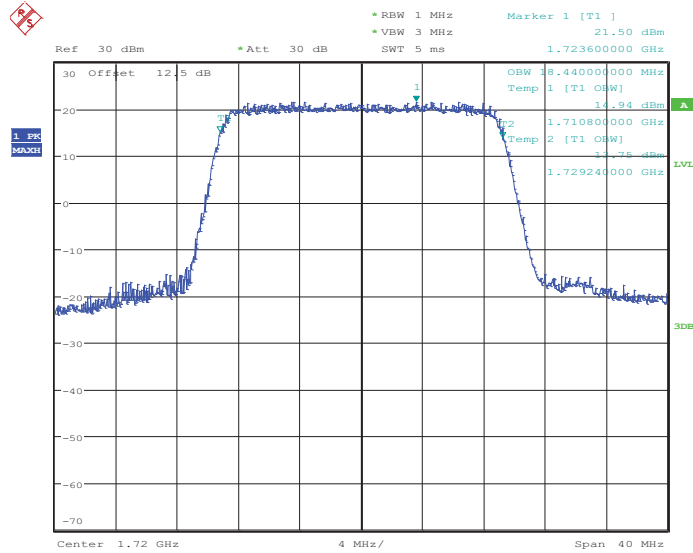

Date: 4.JUN.2014 22:01:09

26dB Bandwidth Plot on Channel 20050

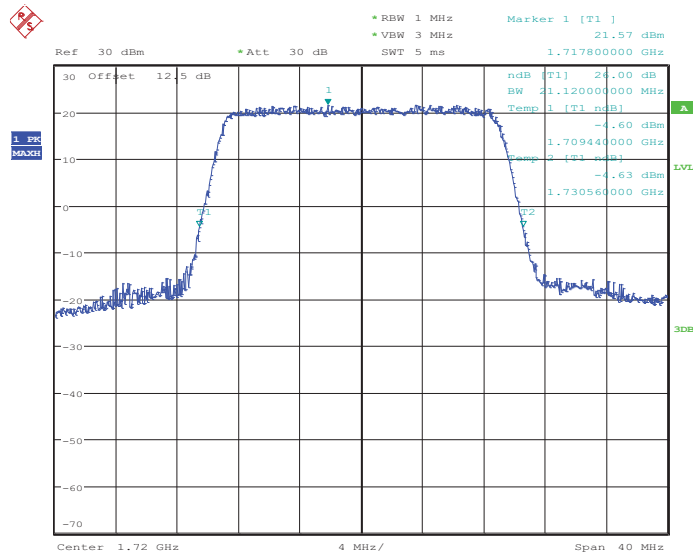

Date: 4.JUN.2014 22:01:44



99% Occupied Bandwidth Plot on Channel 20175

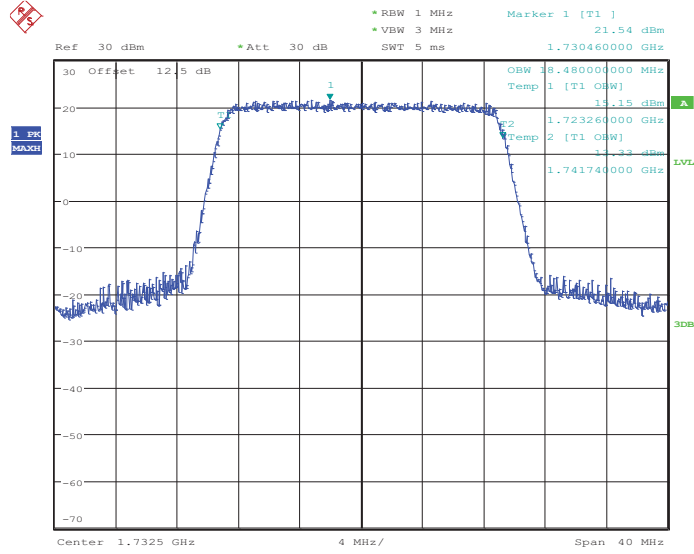

Date: 4.JUN.2014 22:07:31

26dB Bandwidth Plot on Channel 20175

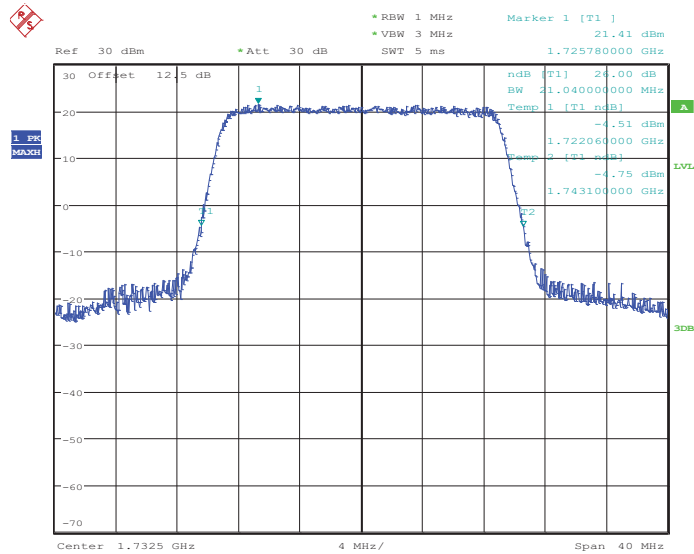

Date: 4.JUN.2014 22:08:07



99% Occupied Bandwidth Plot on Channel 20300

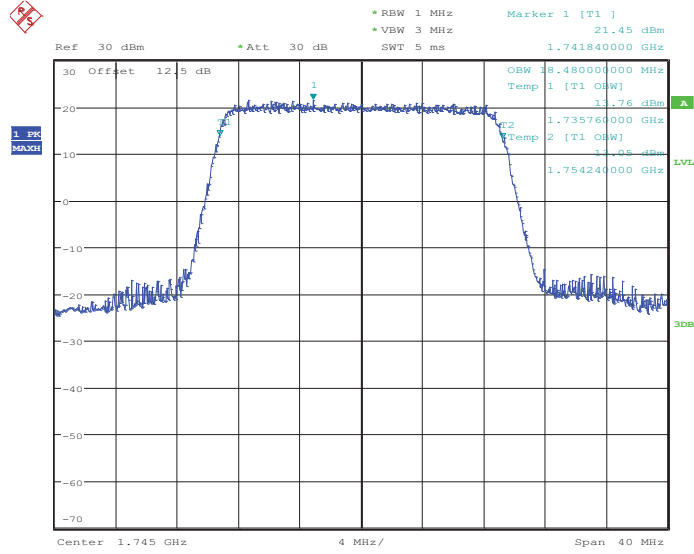

Date: 4.JUN.2014 22:10:43

26dB Bandwidth Plot on Channel 20300

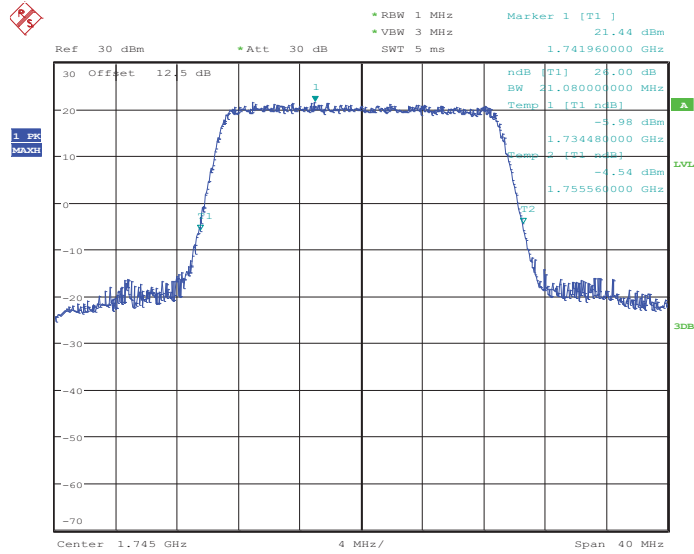

Date: 4.JUN.2014 22:11:18



Band :	LTE Band 4	BW / Mod. :	20MHz / 16QAM
--------	------------	-------------	---------------

99% Occupied Bandwidth Plot on Channel 20050

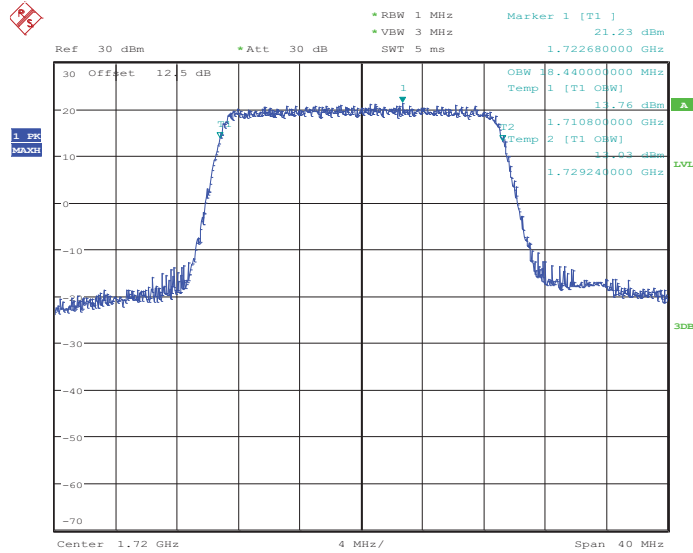

Date: 4.JUN.2014 22:01:26

26dB Bandwidth Plot on Channel 20050

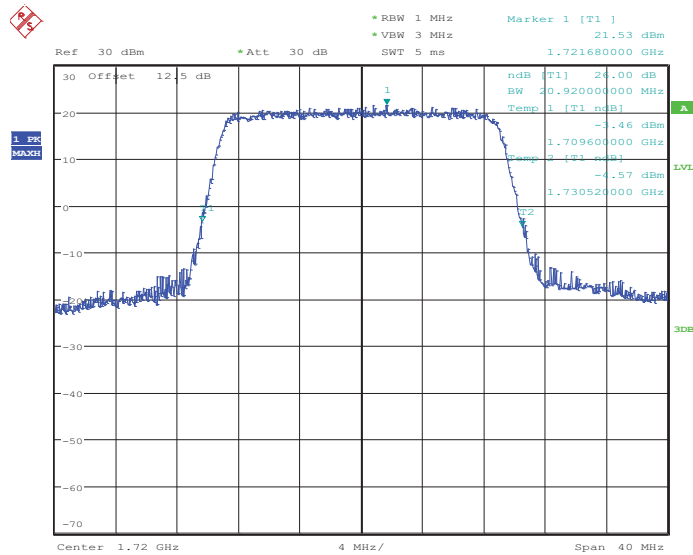

Date: 4.JUN.2014 22:02:03



99% Occupied Bandwidth Plot on Channel 20175

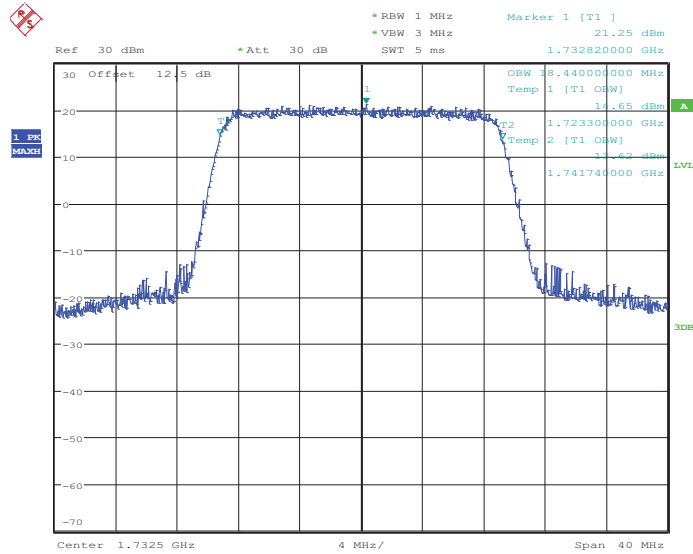

Date: 4.JUN.2014 22:07:48

26dB Bandwidth Plot on Channel 20175

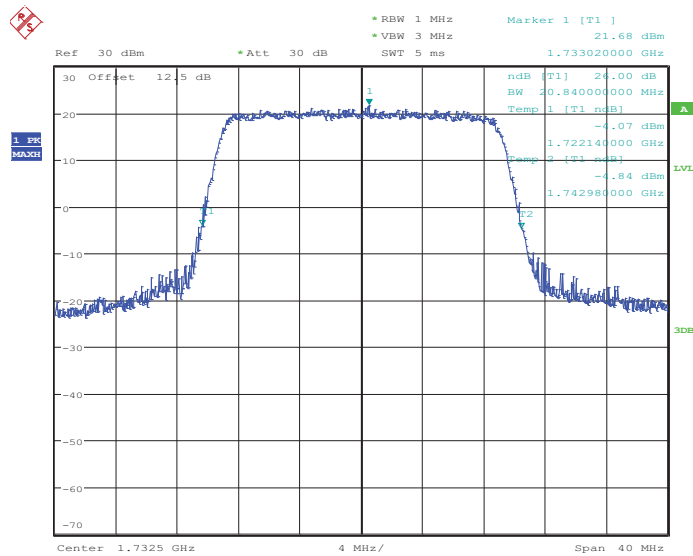

Date: 4.JUN.2014 22:08:25



99% Occupied Bandwidth Plot on Channel 20300

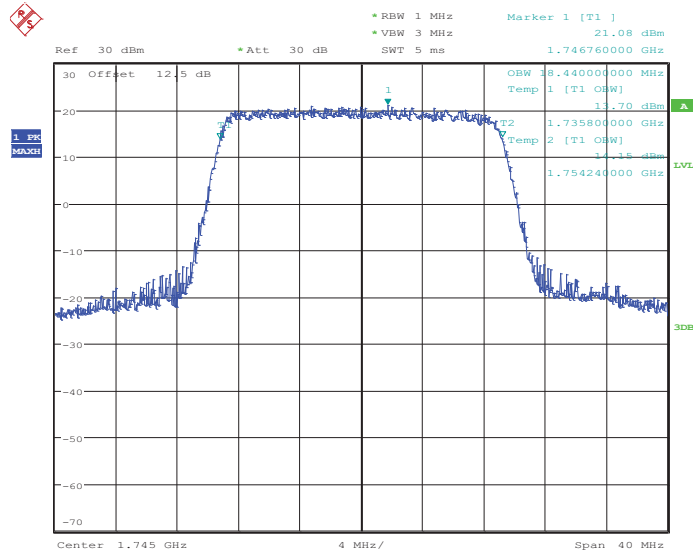

Date: 4.JUN.2014 22:11:00

26dB Bandwidth Plot on Channel 20300

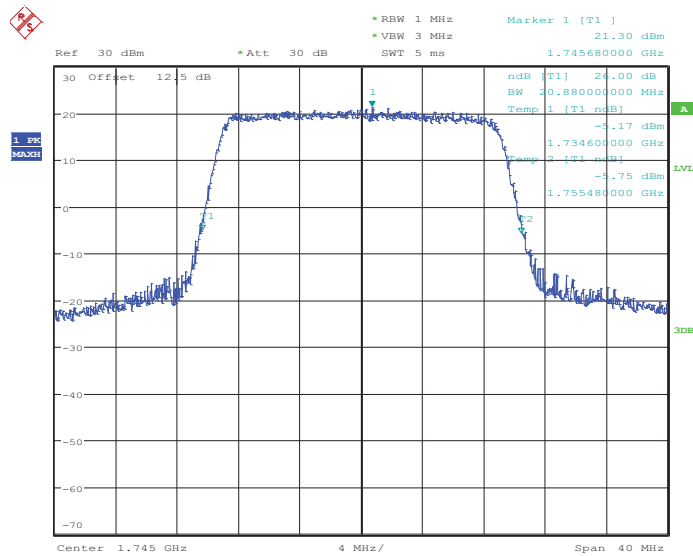

Date: 4.JUN.2014 22:11:37



3.5 Conducted Band Edge Measurement

3.5.1 Description of Conducted Band Edge Measurement

22.917(a) and RSS – 132 for Band 5

For operations in the 824 – 849 MHz band, the FCC limit is $43 + 10\log_{10}(P[\text{Watts}])$ dB below the transmitter power P(Watts) in a 100kHz bandwidth. However, in the 1MHz bands immediately outside and adjacent to the licensee's frequency block, a resolution bandwidth of at least one percent of the emission bandwidth of the fundamental emission of the transmitter may be employed.

24.238 (a) and RSS – 133 for Band 2

For operations in the 1850-1910 and 1930-1990 MHz band, the FCC limit is $43 + 10\log_{10}(P[\text{Watts}])$ dB below the transmitter power P(Watts) in a 1MHz bandwidth. However, in the 1 MHz bands immediately outside and adjacent to the frequency block a resolution bandwidth of at least one percent of the emission bandwidth of the fundamental emission of the transmitter may be employed.

27.53 (f) and RSS – 130 for Band17

For operations in the 698 -746 MHz band, the FCC limit is $43 + 10\log_{10}(P[\text{Watts}])$ dB below the transmitter power P(Watts) in a 100 kHz bandwidth. However, in the 100 kilohertz bands immediately outside and adjacent to a licensee's frequency block, a resolution bandwidth of at least 30 kHz may be employed.

27.53 (g) and RSS – 139 for Band 4

For operations in the 1710 – 1755 MHz band, the FCC limit is $43 + 10\log_{10}(P[\text{Watts}])$ dB below the transmitter power P(Watts) in a 1 MHz bandwidth. However, in the 1MHz bands immediately outside and adjacent to the licensee's frequency block, a resolution bandwidth of at least one percent of the emission bandwidth of the fundamental emission of the transmitter may be employed.

27.53 (l)(4) and RSS – 199 for Band 7

The emissions be operated in the 2496-2690 MHz band, the attenuation factor of transmitter Power (P) shall be not less than $55 + 10 \log (P)$ dB at the channel edge

3.5.2 Measuring Instruments

The measuring equipment is listed in the section 4 of this test report.

3.5.3 Test Procedures

1. The EUT was connected to spectrum analyzer and system simulator via a power divider.
2. The band edges of low and high channels for the highest RF powers were measured. Set RBW \geq 1% EBW in the 1MHz band immediately outside and adjacent to the band edge.
3. Set spectrum analyzer with RMS detector.
4. The RF fundamental frequency should be excluded against the limit line in the operating frequency band.
5. The limit line is derived from $43 + 10\log(P)$ dB below the transmitter power P(Watts)
 $= P(W) - [43 + 10\log(P)]$ (dB)
 $= [30 + 10\log(P)]$ (dBm) - $[43 + 10\log(P)]$ (dB)
 $= -13$ dBm.

3.5.4 Test Setup

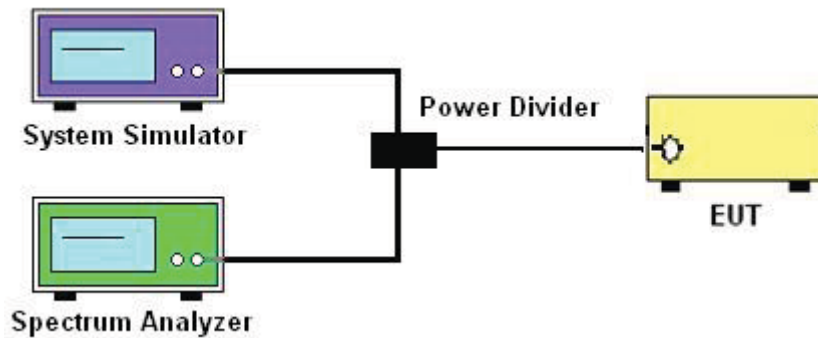



3.5.5 Test Result (Plots) of Conducted Band Edge

Band :	LTE Band 5	Band Width :	1.4MHz / QPSK
--------	------------	--------------	---------------

Lower Band Edge Plot for QPSK-RB Size 1, RB Offset 0

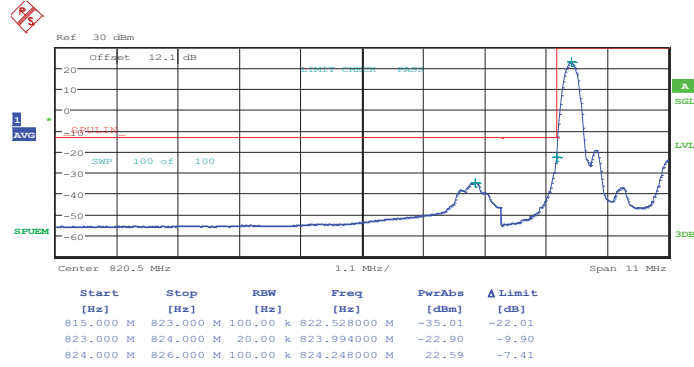

Date: 4.JUN.2014 23:08:51

Lower Band Edge Plot for QPSK-RB Size 6, RB Offset 0

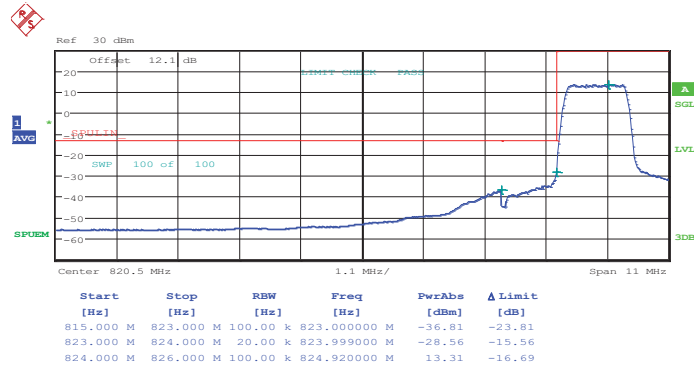

Date: 4.JUN.2014 23:10:26



Higher Band Edge Plot for QPSK-RB Size 1, RB Offset 5

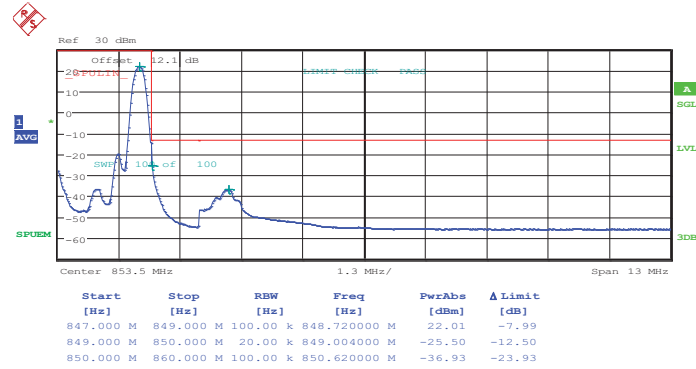

Date: 4.JUN.2014 23:20:00

Higher Band Edge Plot for QPSK-RB Size 6, RB Offset 0

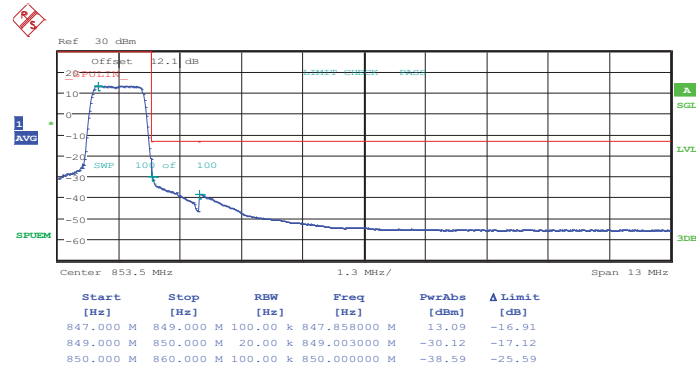

Date: 4.JUN.2014 23:18:25



Band :	LTE Band 5	Band Width :	1.4MHz / 16QAM
---------------	------------	---------------------	----------------

Lower Band Edge Plot for 16QAM -RB Size 1, RB Offset 0

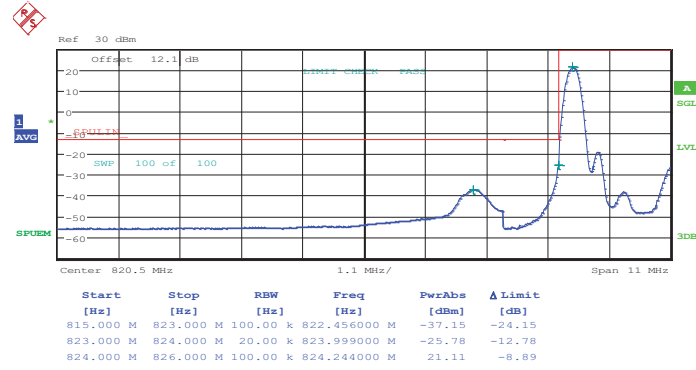

Date: 4.JUN.2014 23:09:38

Lower Band Edge Plot for 16QAM -RB Size 6, RB Offset 0

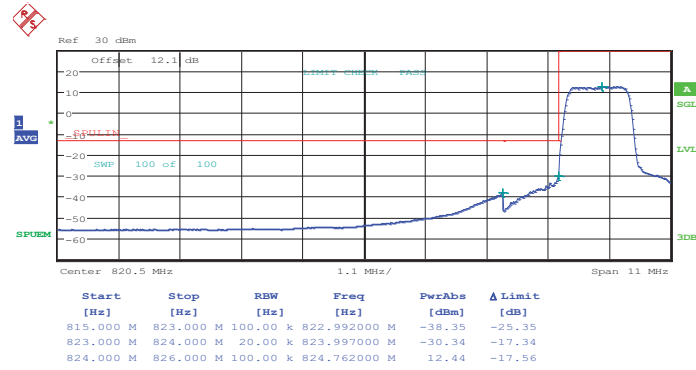

Date: 4.JUN.2014 23:11:14



Higher Band Edge Plot for 16QAM -RB Size 1, RB Offset 5

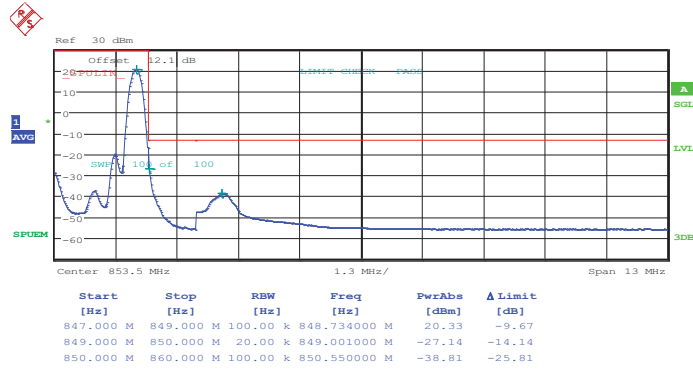

Date: 4.JUN.2014 23:20:47

Higher Band Edge Plot for 16QAM -RB Size 6, RB Offset 0

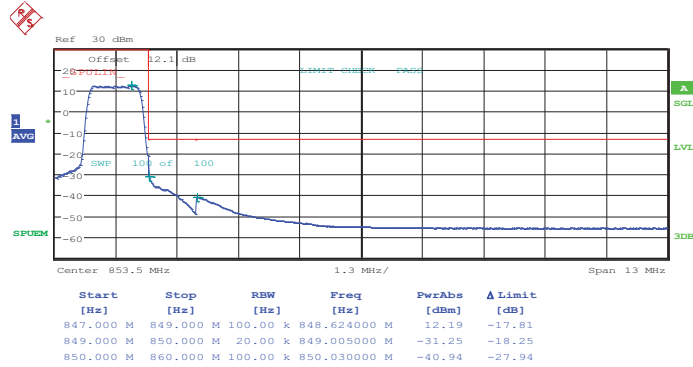

Date: 4.JUN.2014 23:19:12



Band :	LTE Band 5	Band Width :	3MHz / QPSK
---------------	------------	---------------------	-------------

Lower Band Edge Plot for QPSK-RB Size 1, RB Offset 0

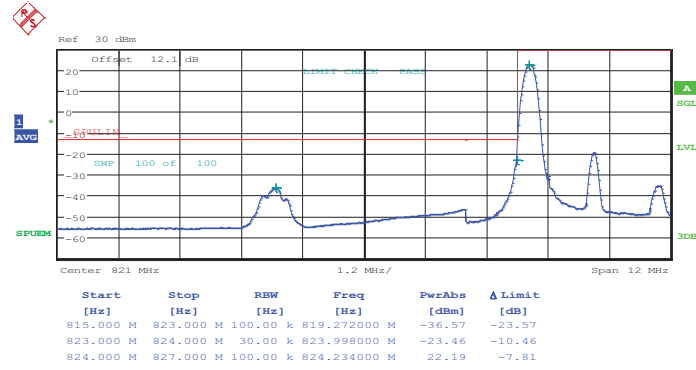

Date: 4.JUN.2014 23:24:46

Lower Band Edge Plot for QPSK-RB Size 15, RB Offset 0

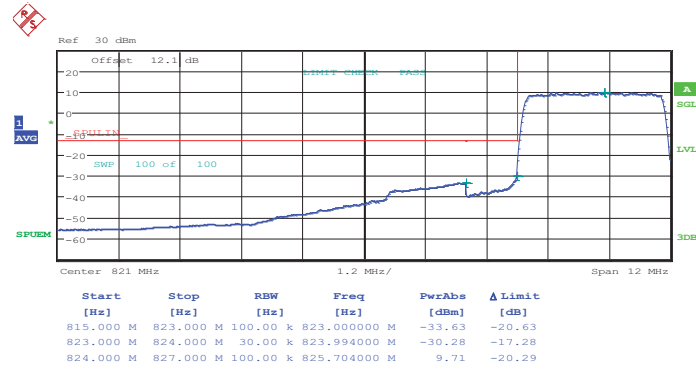

Date: 4.JUN.2014 23:26:21



Higher Band Edge Plot for QPSK-RB Size 1, RB Offset 14

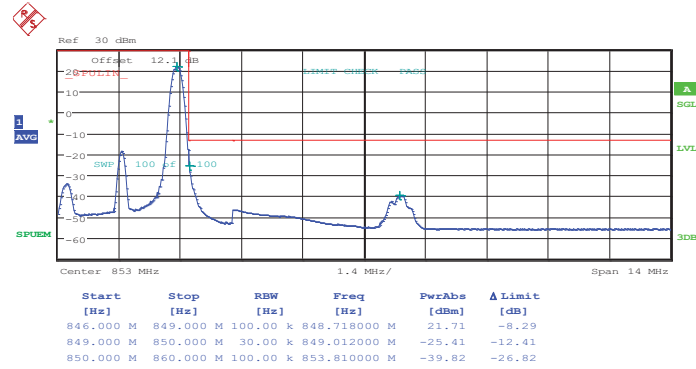

Date: 4.JUN.2014 23:34:20

Higher Band Edge Plot for QPSK-RB Size 15, RB Offset 0

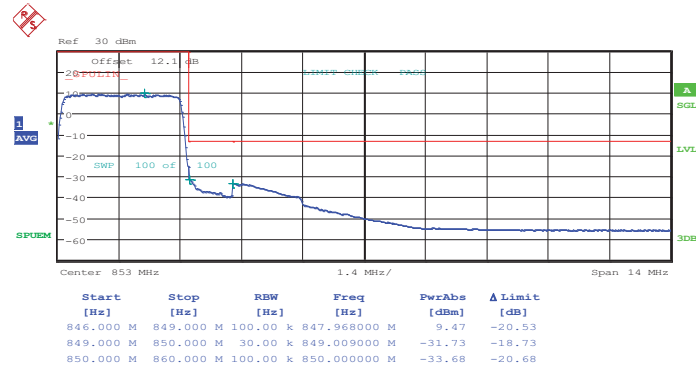

Date: 4.JUN.2014 23:35:55



Band :	LTE Band 5	Band Width :	3MHz / 16QAM
---------------	------------	---------------------	--------------

Lower Band Edge Plot for 16QAM -RB Size 1, RB Offset 0

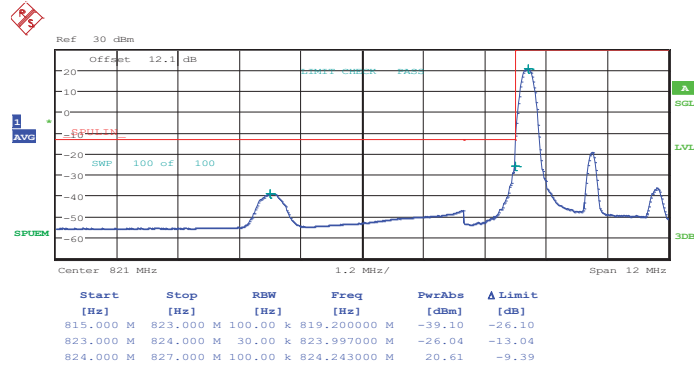

Date: 4.JUN.2014 23:25:34

Lower Band Edge Plot for 16QAM -RB Size 15, RB Offset 0

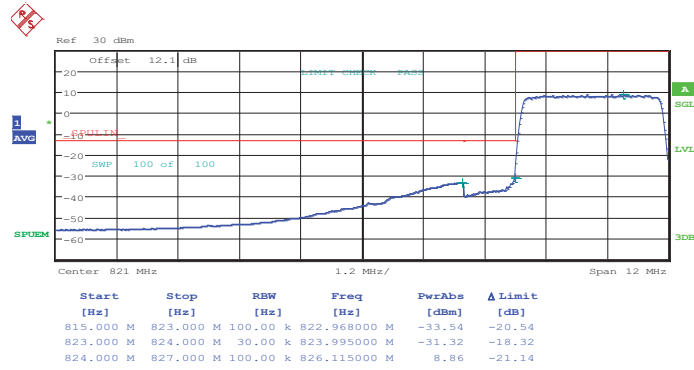

Date: 4.JUN.2014 23:27:09



Higher Band Edge Plot for 16QAM -RB Size 1, RB Offset 14

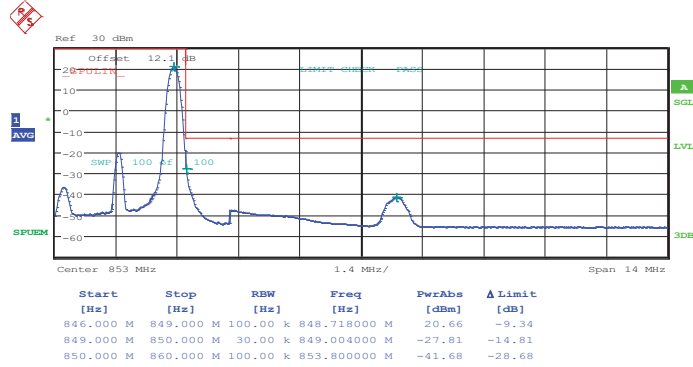

Date: 4.JUN.2014 23:35:07

Higher Band Edge Plot for 16QAM -RB Size 15, RB Offset 0

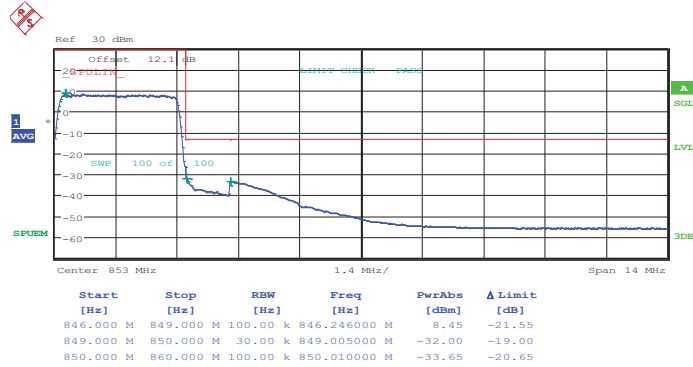

Date: 4.JUN.2014 23:36:43



Band :	LTE Band 2	Band Width :	1.4MHz / QPSK
---------------	------------	---------------------	---------------

Lower Band Edge Plot for QPSK-RB Size 1, RB Offset 0

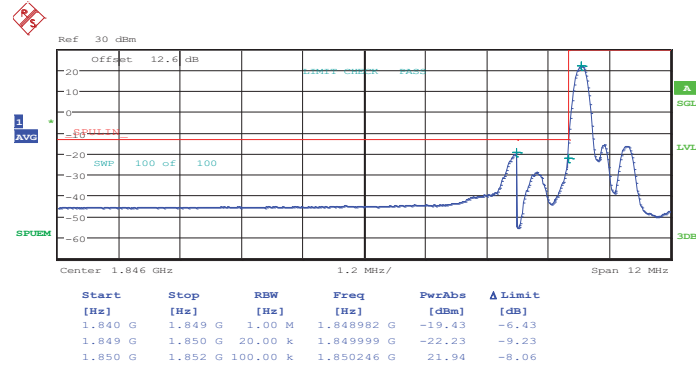

Date: 4.JUN.2014 16:25:03

Lower Band Edge Plot for QPSK-RB Size 6, RB Offset 0

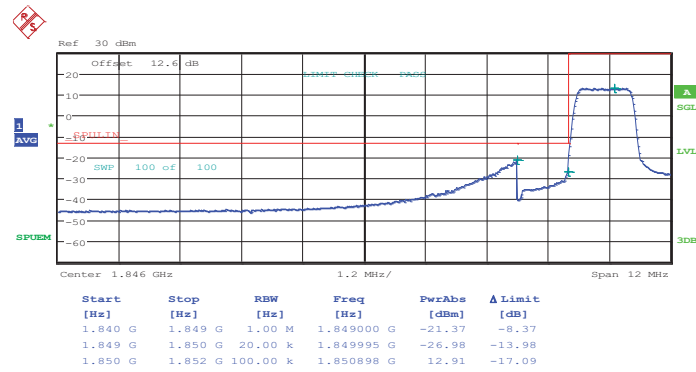

Date: 4.JUN.2014 16:26:39



Higher Band Edge Plot for QPSK-RB Size 1, RB Offset 5

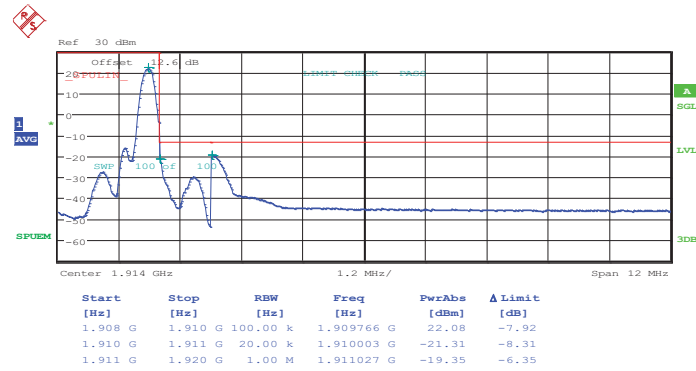

Date: 4.JUN.2014 16:34:40

Higher Band Edge Plot for QPSK-RB Size 6, RB Offset 0

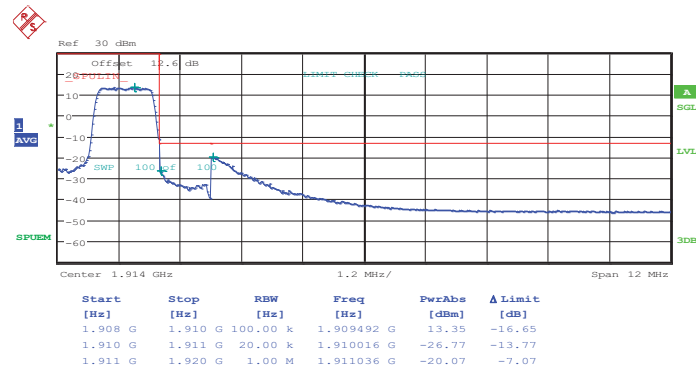

Date: 4.JUN.2014 16:36:15



Band :	LTE Band 2	Band Width :	1.4MHz / 16QAM
---------------	------------	---------------------	----------------

Lower Band Edge Plot for 16QAM -RB Size 1, RB Offset 0

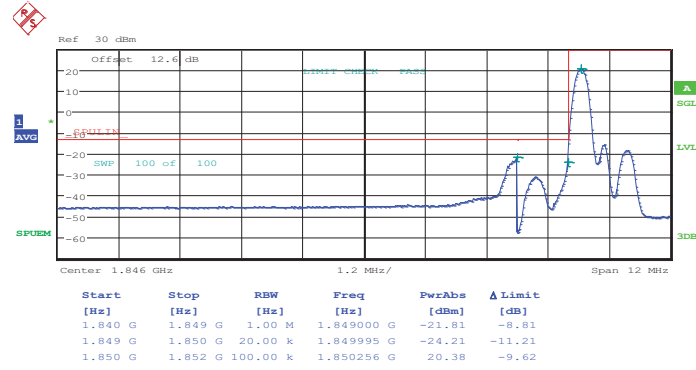

Date: 4.JUN.2014 16:25:51

Lower Band Edge Plot for 16QAM -RB Size 6, RB Offset 0

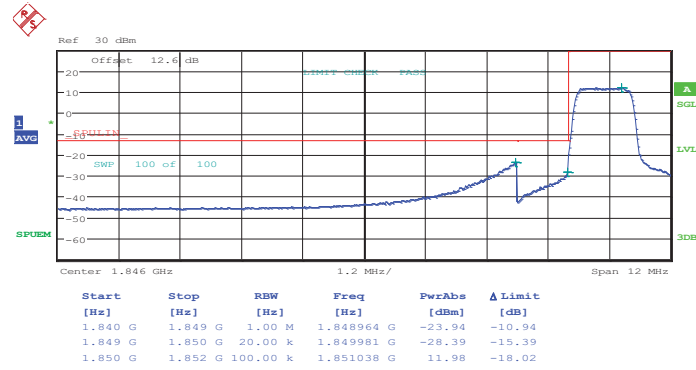

Date: 4.JUN.2014 16:27:27



Higher Band Edge Plot for 16QAM -RB Size 1, RB Offset 5

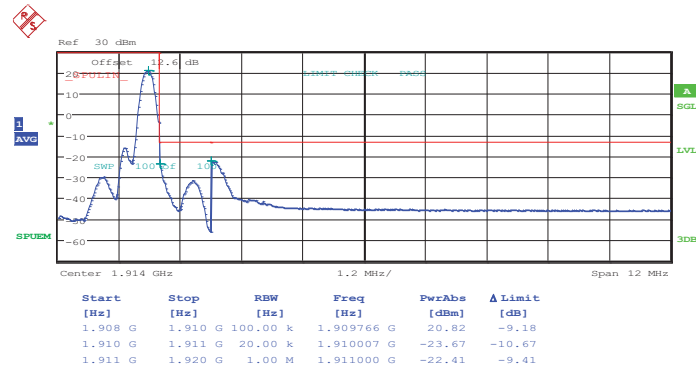

Date: 4.JUN.2014 16:35:28

Higher Band Edge Plot for 16QAM -RB Size 6, RB Offset 0

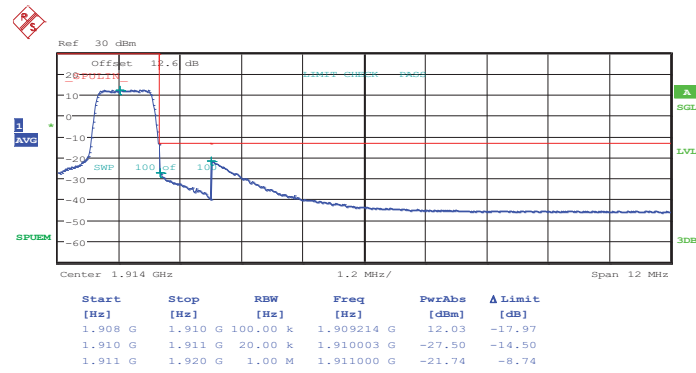

Date: 4.JUN.2014 16:37:03



Band :	LTE Band 2	Band Width :	3MHz / QPSK
---------------	------------	---------------------	-------------

Lower Band Edge Plot for QPSK-RB Size 1, RB Offset 0

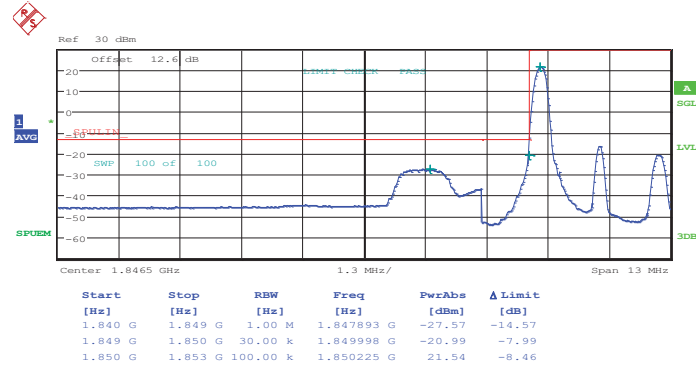

Date: 4.JUN.2014 16:41:05

Lower Band Edge Plot for QPSK-RB Size 15, RB Offset 0

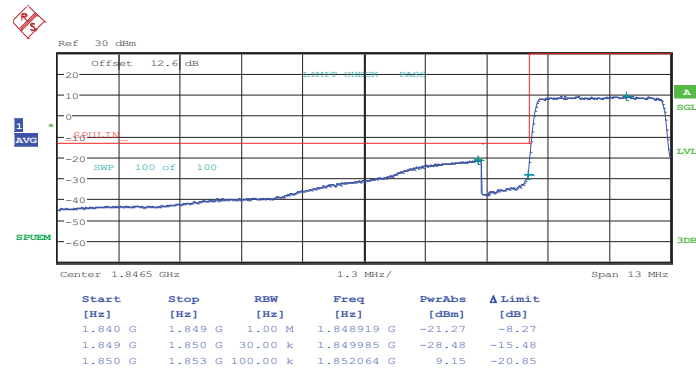

Date: 4.JUN.2014 16:42:40



Higher Band Edge Plot for QPSK-RB Size 1, RB Offset 14

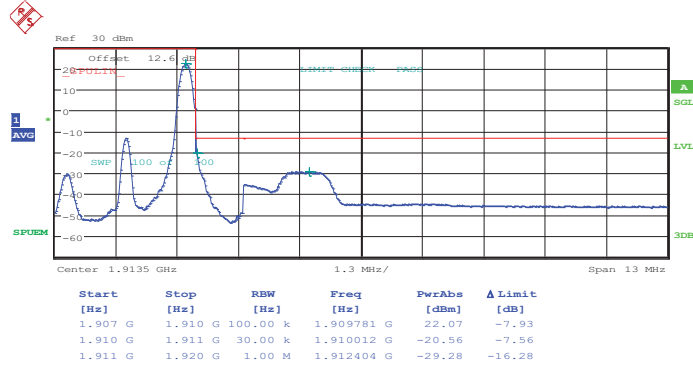

Date: 4.JUN.2014 16:50:42

Higher Band Edge Plot for QPSK-RB Size 15, RB Offset 0

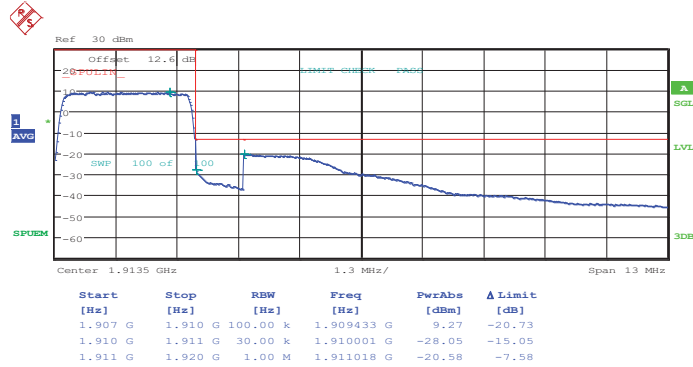

Date: 4.JUN.2014 16:52:18



Band :	LTE Band 2	Band Width :	3MHz / 16QAM
---------------	------------	---------------------	--------------

Lower Band Edge Plot for 16QAM -RB Size 1, RB Offset 0

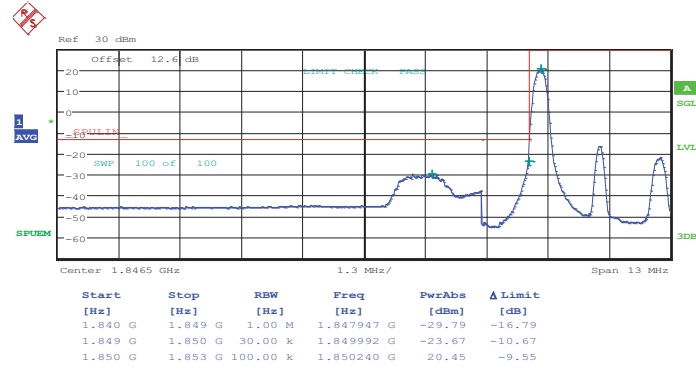

Date: 4.JUN.2014 16:41:52

Lower Band Edge Plot for 16QAM -RB Size 15, RB Offset 0

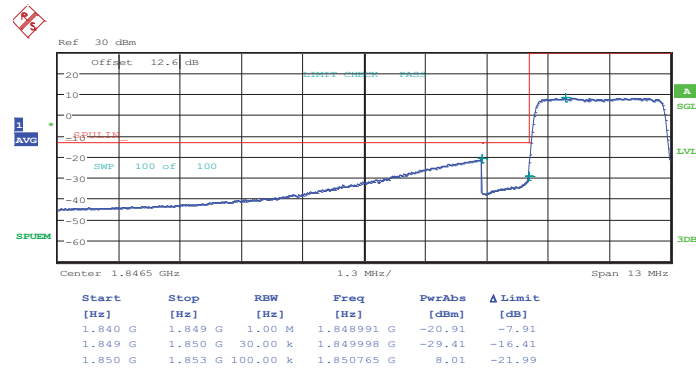

Date: 4.JUN.2014 16:43:28



Higher Band Edge Plot for 16QAM -RB Size 1, RB Offset 14

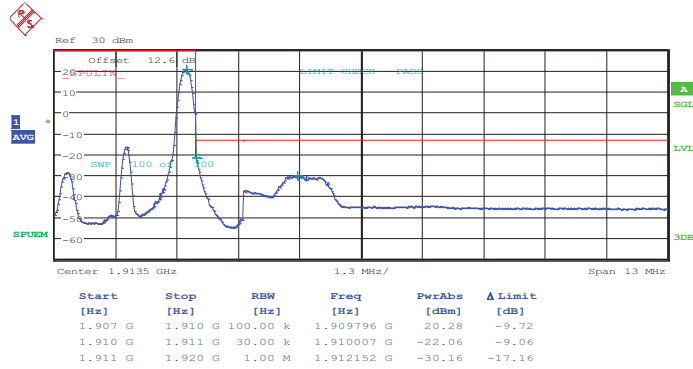

Date: 4.JUN.2014 16:51:30

Higher Band Edge Plot for 16QAM -RB Size 15, RB Offset 0

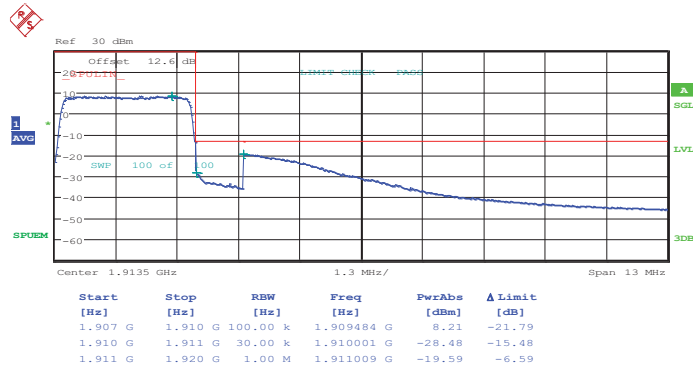

Date: 4.JUN.2014 16:53:06



Band :	LTE Band 2	Band Width :	15MHz / QPSK
---------------	------------	---------------------	--------------

Lower Band Edge Plot for QPSK-RB Size 1, RB Offset 0

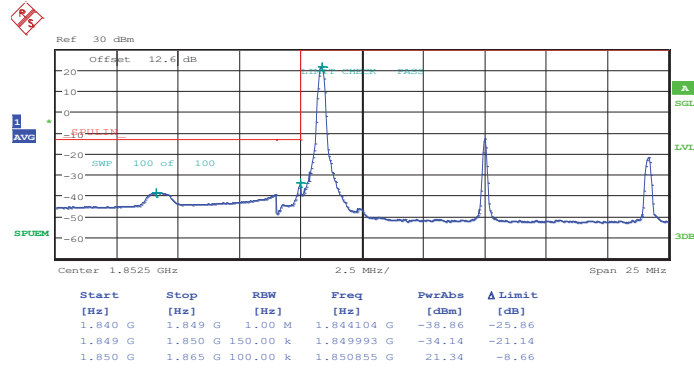

Date: 4.JUN.2014 17:50:47

Lower Band Edge Plot for QPSK-RB Size 75, RB Offset 0

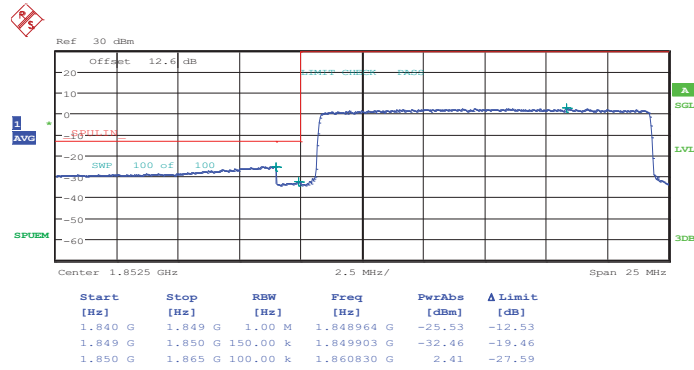

Date: 4.JUN.2014 17:52:22



Higher Band Edge Plot for QPSK-RB Size 1, RB Offset 74

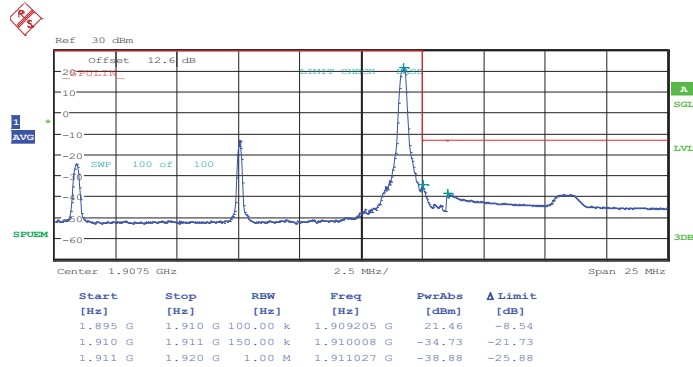

Date: 4.JUN.2014 18:00:22

Higher Band Edge Plot for QPSK-RB Size 75, RB Offset 0

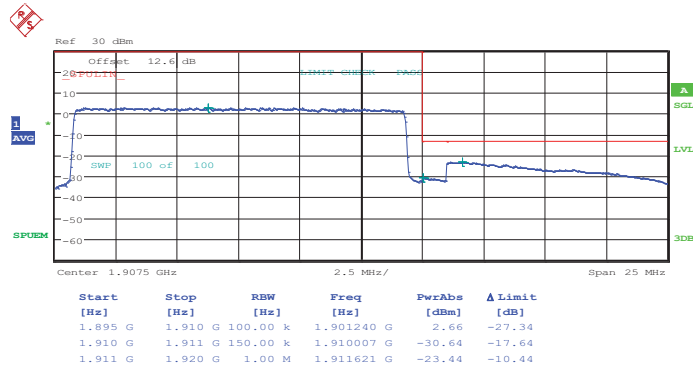

Date: 4.JUN.2014 18:01:57



Band :	LTE Band 2	Band Width :	15MHz / 16QAM
---------------	------------	---------------------	---------------

Lower Band Edge Plot for 16QAM-RB Size 1, RB Offset 0

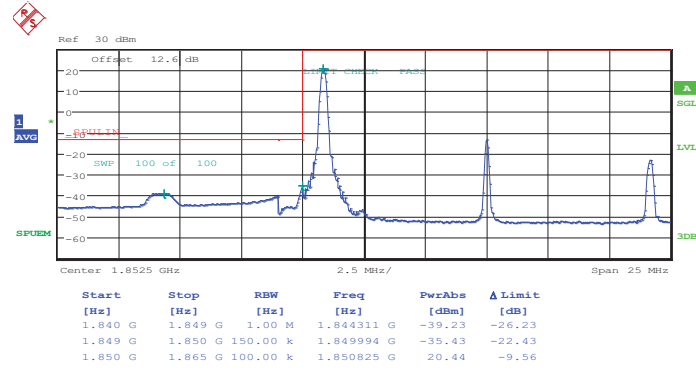

Date: 4.JUN.2014 17:51:34

Lower Band Edge Plot for 16QAM-RB Size 75, RB Offset 0

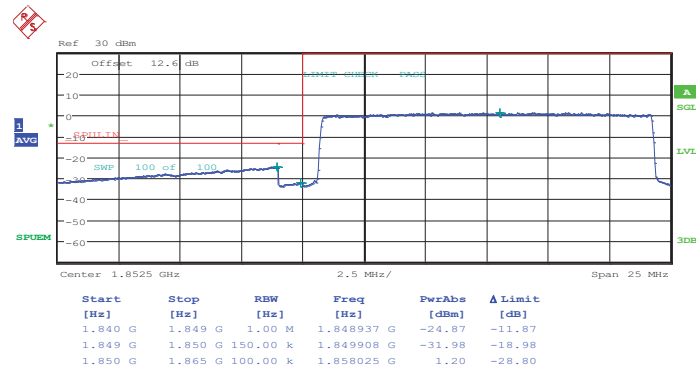

Date: 4.JUN.2014 17:53:10



Higher Band Edge Plot for 16QAM-RB Size 1, RB Offset 74

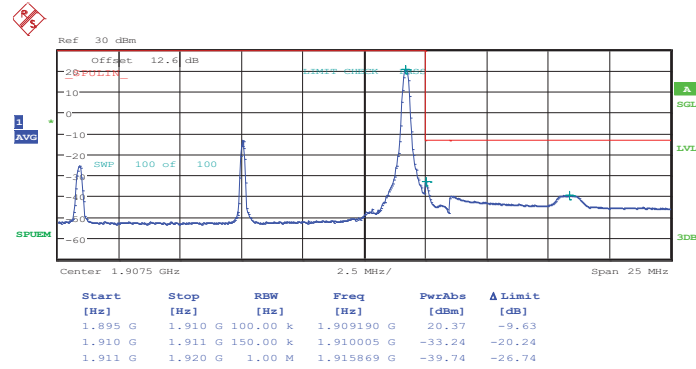

Date: 4.JUN.2014 18:01:09

Higher Band Edge Plot for 16QAM-RB Size 75, RB Offset 0

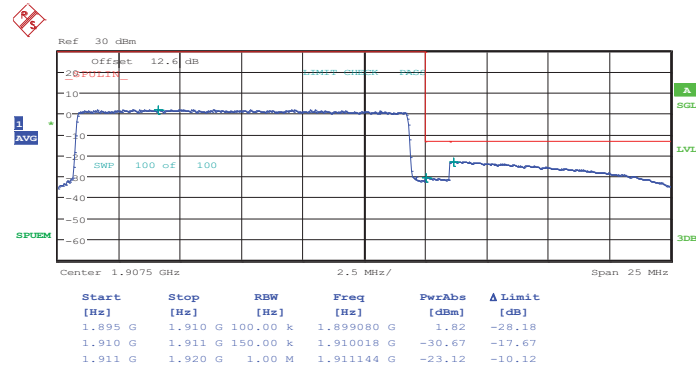

Date: 4.JUN.2014 18:02:44



Band :	LTE Band 2	Band Width :	20MHz / QPSK
---------------	------------	---------------------	--------------

Lower Band Edge Plot for QPSK-RB Size 1, RB Offset 0

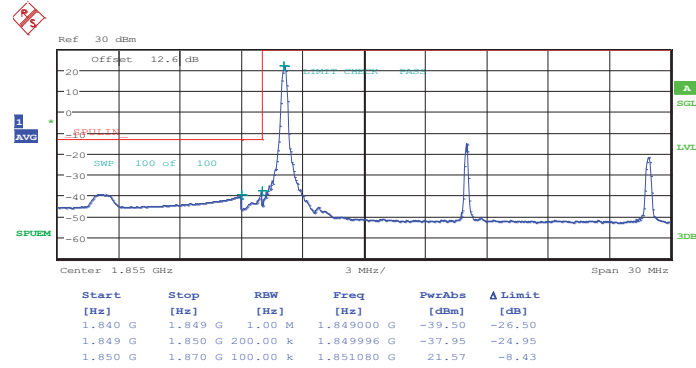

Date: 4.JUN.2014 18:58:28

Lower Band Edge Plot for QPSK-RB Size 100, RB Offset 0

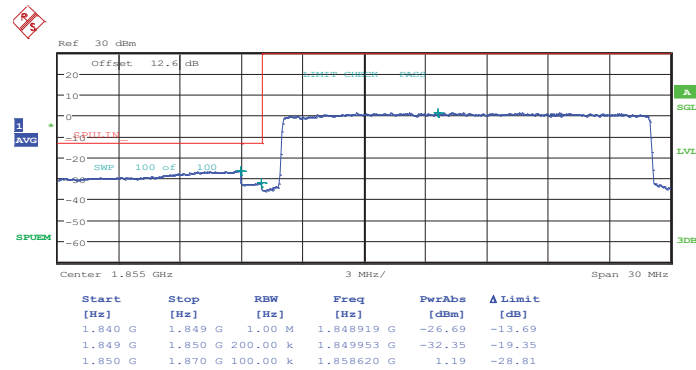

Date: 4.JUN.2014 19:00:03



Higher Band Edge Plot for QPSK-RB Size 1, RB Offset 99

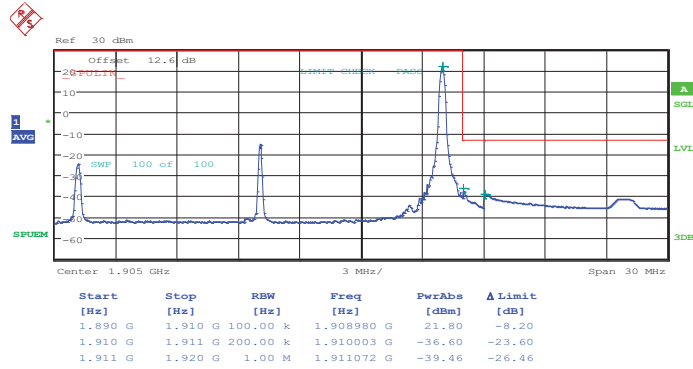

Date: 4.JUN.2014 19:08:01

Higher Band Edge Plot for QPSK-RB Size 100, RB Offset 0

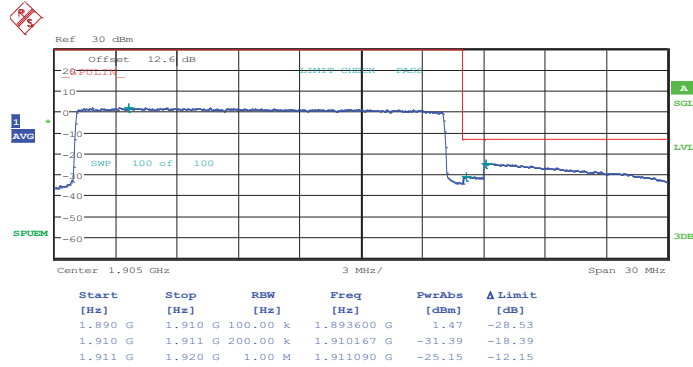

Date: 4.JUN.2014 19:09:37



Band :	LTE Band 2	Band Width :	20MHz / 16QAM
---------------	------------	---------------------	---------------

Lower Band Edge Plot for 16QAM-RB Size 1, RB Offset 0

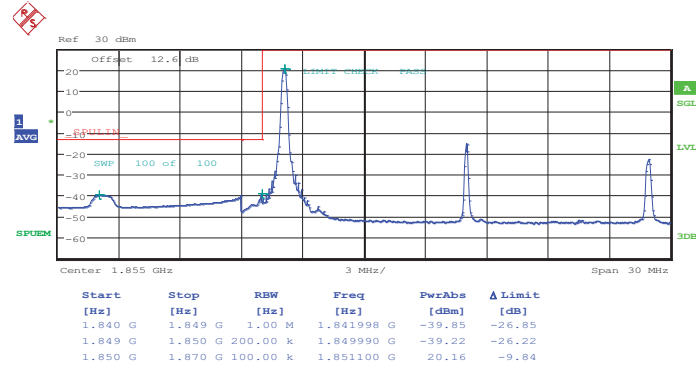

Date: 4.JUN.2014 18:59:16

Lower Band Edge Plot for 16QAM-RB Size 100, RB Offset 0

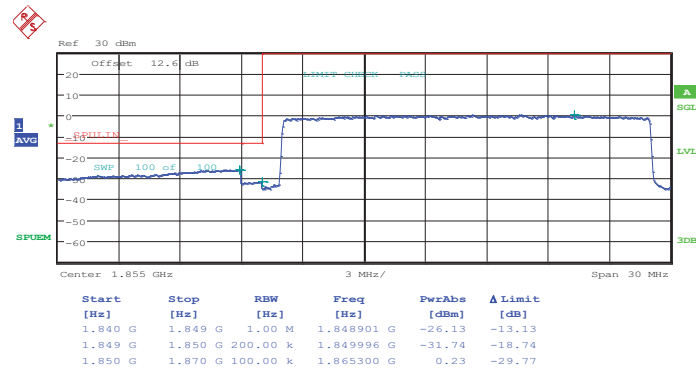

Date: 4.JUN.2014 19:00:51



Higher Band Edge Plot for 16QAM-RB Size 1, RB Offset 99

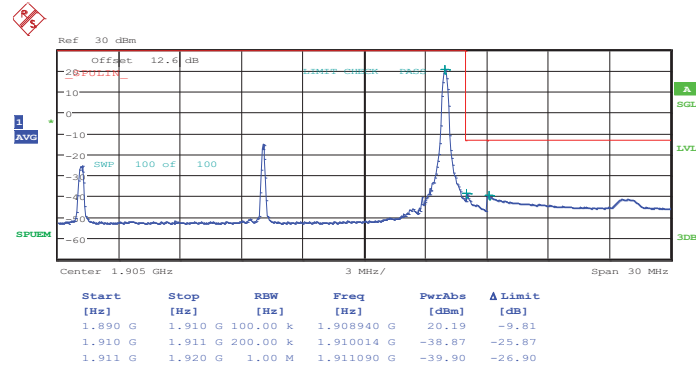

Date: 4.JUN.2014 19:08:49

Higher Band Edge Plot for 16QAM-RB Size 100, RB Offset 0

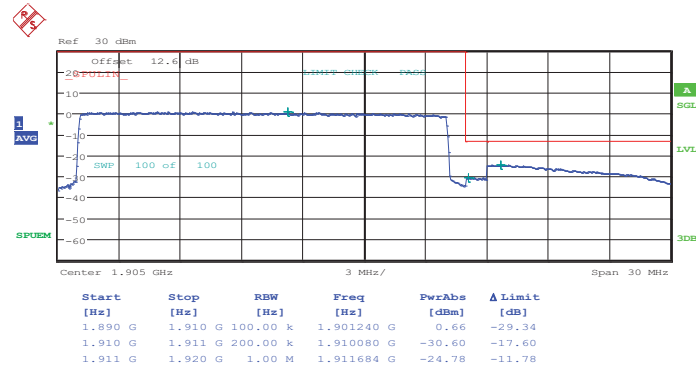

Date: 4.JUN.2014 19:10:24



Band :	LTE Band 4	Band Width :	1.4MHz / QPSK
---------------	------------	---------------------	---------------

Lower Band Edge Plot for QPSK-RB Size 1, RB Offset 0

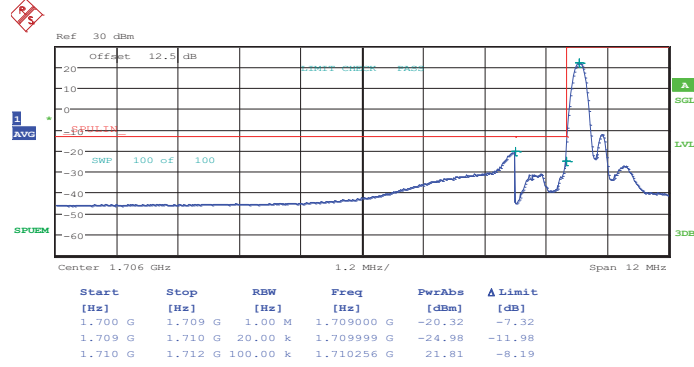

Date: 4.JUN.2014 20:29:24

Lower Band Edge Plot for QPSK-RB Size 6, RB Offset 0

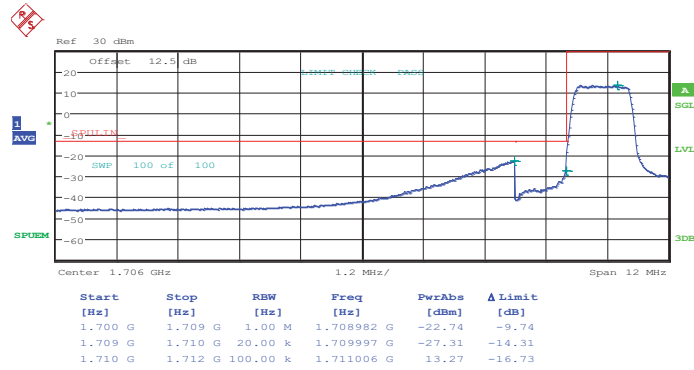

Date: 4.JUN.2014 20:30:59



Higher Band Edge Plot for QPSK-RB Size 1, RB Offset 5

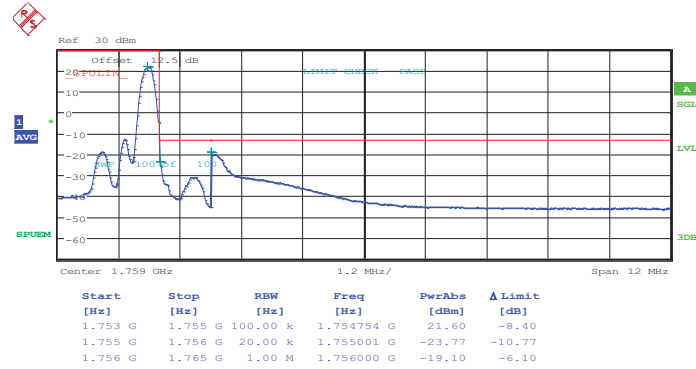

Date: 4.JUN.2014 20:38:56

Higher Band Edge Plot for QPSK-RB Size 6, RB Offset 0

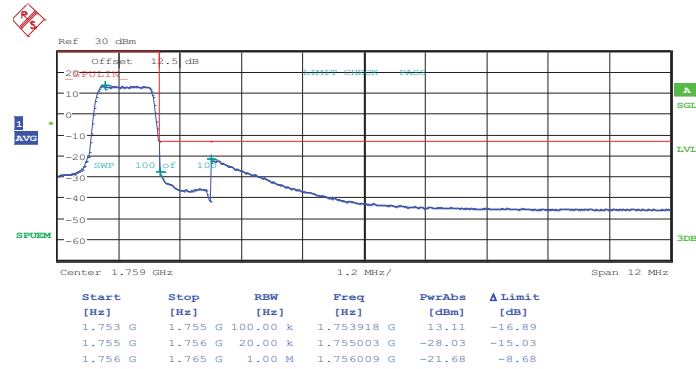

Date: 4.JUN.2014 20:40:31



Band :	LTE Band 4	Band Width :	1.4MHz / 16QAM
---------------	------------	---------------------	----------------

Lower Band Edge Plot for 16QAM -RB Size 1, RB Offset 0

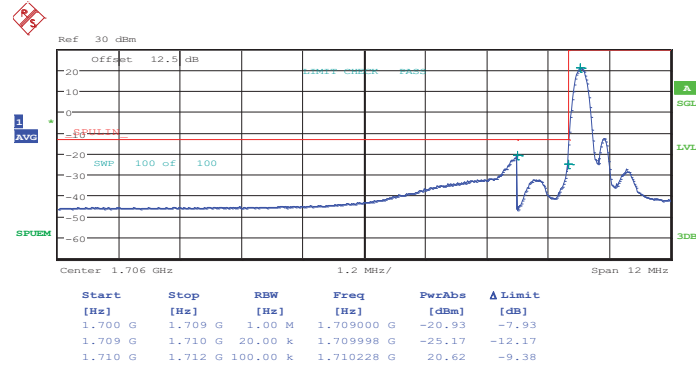

Date: 4.JUN.2014 20:30:11

Lower Band Edge Plot for 16QAM-RB Size 6, RB Offset 0

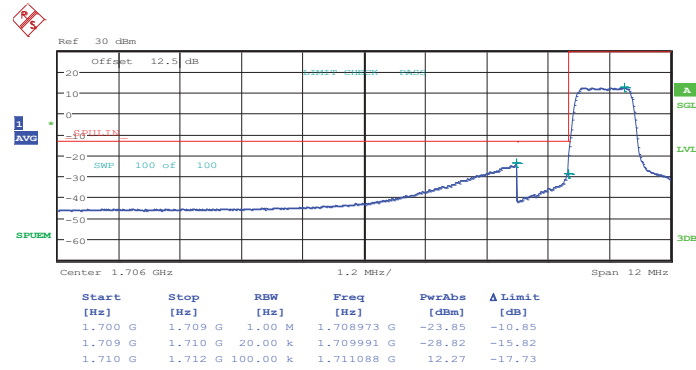

Date: 4.JUN.2014 20:31:46



Higher Band Edge Plot for 16QAM-RB Size 1, RB Offset 5

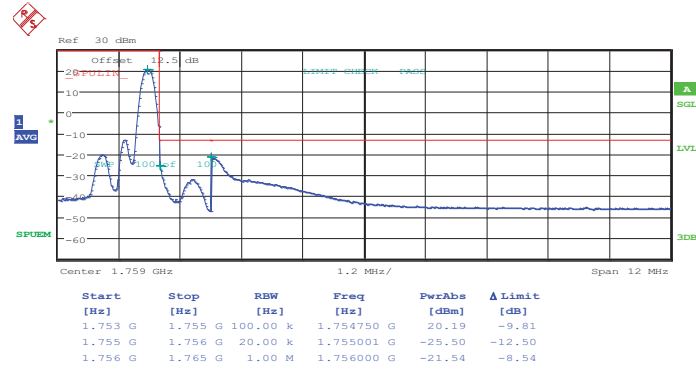

Date: 4.JUN.2014 20:39:44

Higher Band Edge Plot for 16QAM-RB Size 6, RB Offset 0

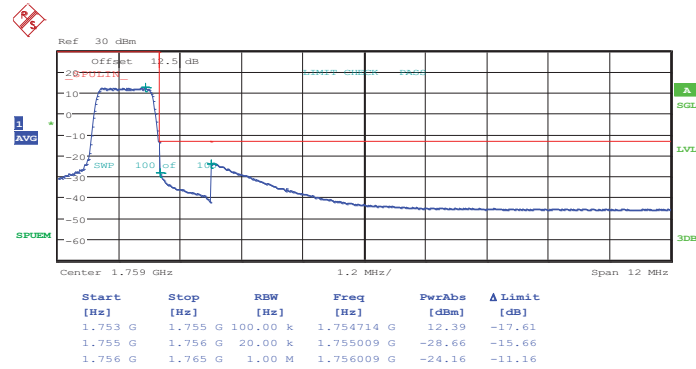

Date: 4.JUN.2014 20:41:19



Band :	LTE Band 4	Band Width :	3MHz / QPSK
---------------	------------	---------------------	-------------

Lower Band Edge Plot for QPSK-RB Size 1, RB Offset 0

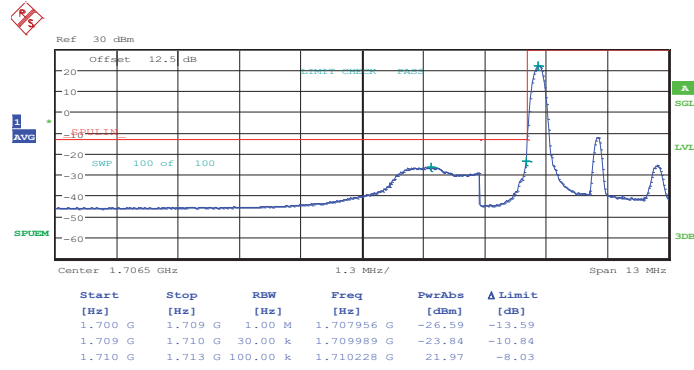

Date: 4.JUN.2014 20:45:18

Lower Band Edge Plot for QPSK-RB Size 15, RB Offset 0

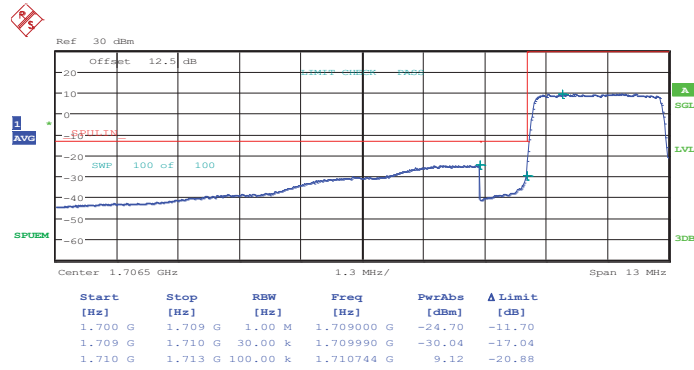

Date: 4.JUN.2014 20:46:53



Higher Band Edge Plot for QPSK-RB Size 1, RB Offset 14

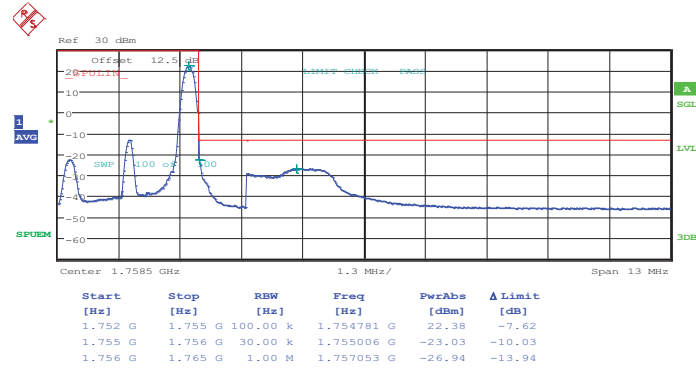

Date: 4.JUN.2014 20:54:51

Higher Band Edge Plot for QPSK-RB Size 15, RB Offset 0

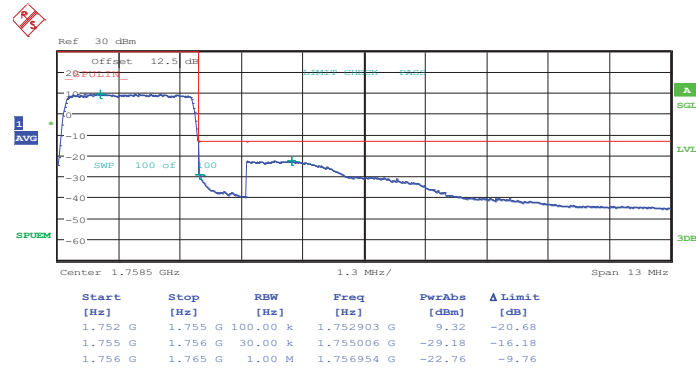

Date: 4.JUN.2014 20:56:26



Band :	LTE Band 4	Band Width :	3MHz / 16QAM
---------------	------------	---------------------	--------------

Lower Band Edge Plot for 16QAM-RB Size 1, RB Offset 0

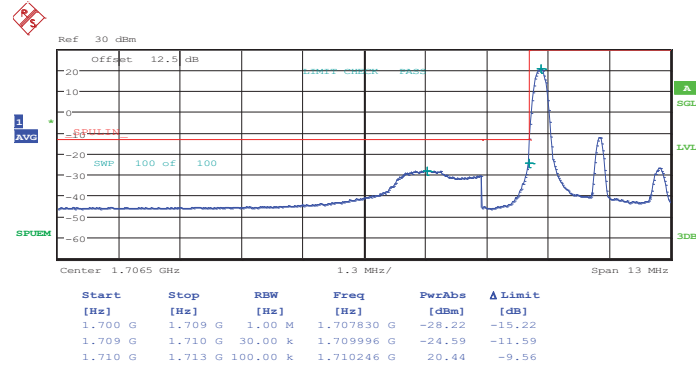

Date: 4.JUN.2014 20:46:06

Lower Band Edge Plot for 16QAM-RB Size 15, RB Offset 0

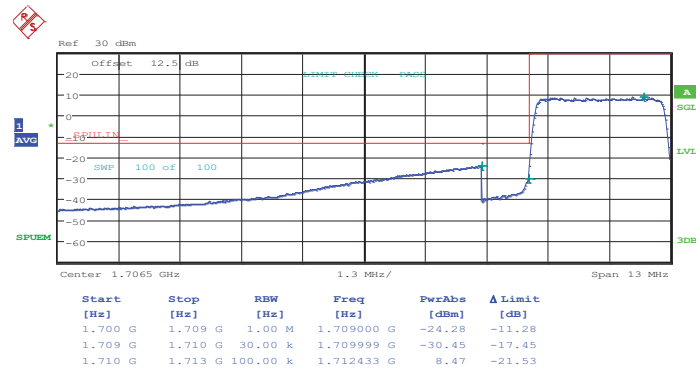

Date: 4.JUN.2014 20:47:41



Higher Band Edge Plot for 16QAM-RB Size 1, RB Offset 14

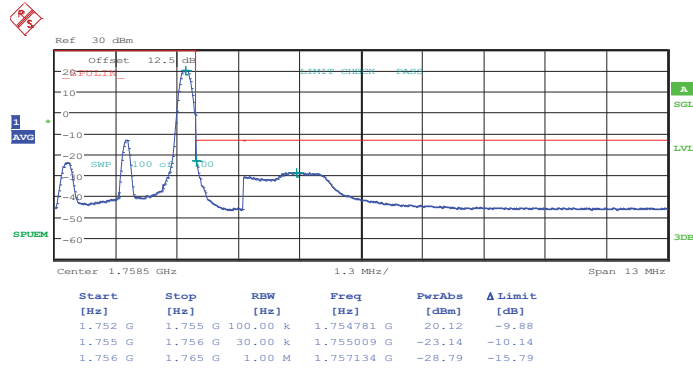

Date: 4.JUN.2014 20:55:39

Higher Band Edge Plot for 16QAM-RB Size 15, RB Offset 0

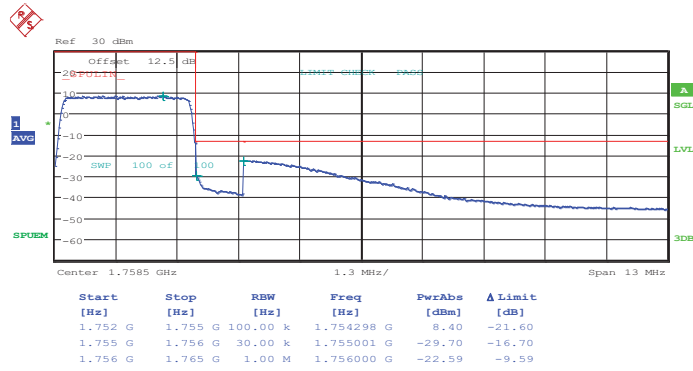

Date: 4.JUN.2014 20:57:13



Band :	LTE Band 4	Band Width :	15MHz / QPSK
---------------	------------	---------------------	--------------

Lower Band Edge Plot for QPSK-RB Size 1, RB Offset 0

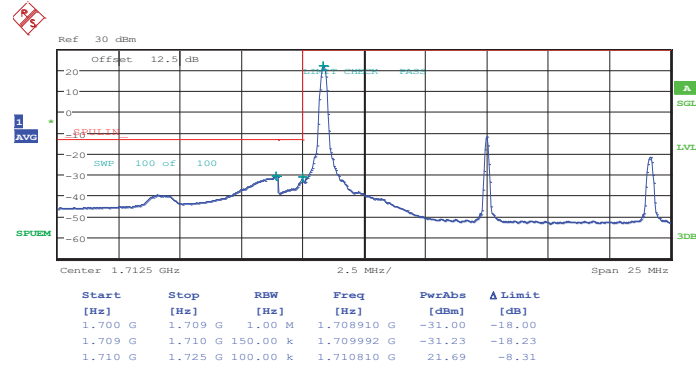

Date: 4.JUN.2014 22:34:39

Lower Band Edge Plot for QPSK-RB Size 75, RB Offset 0

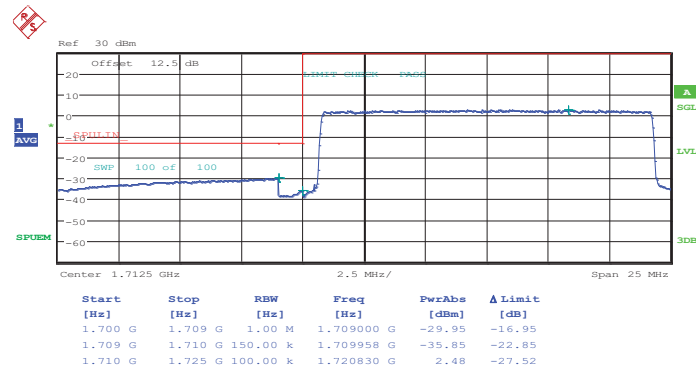

Date: 4.JUN.2014 22:36:14



Higher Band Edge Plot for QPSK-RB Size 1, RB Offset 74

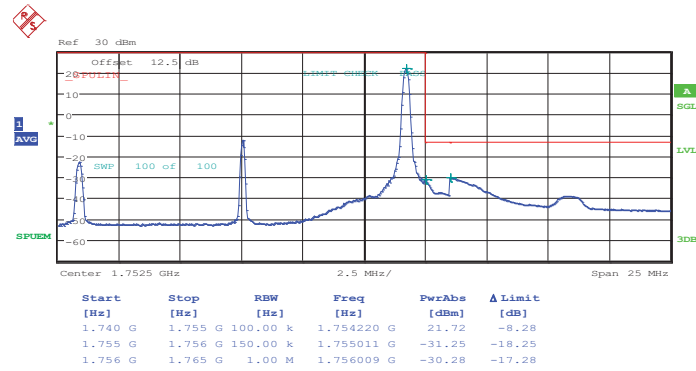

Date: 4.JUN.2014 22:44:13

Higher Band Edge Plot for QPSK-RB Size 75, RB Offset 0

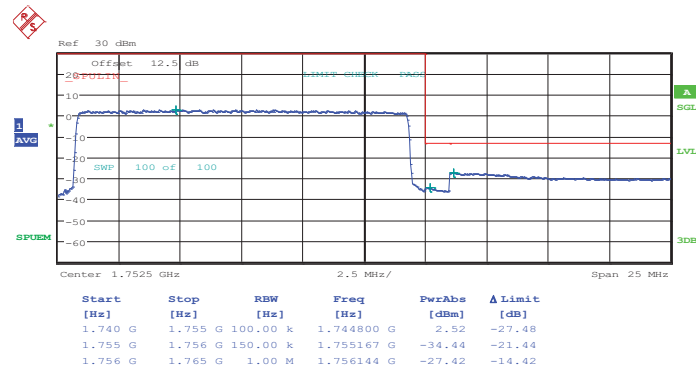

Date: 4.JUN.2014 22:45:48



Band :	LTE Band 4	Band Width :	15MHz / 16QAM
---------------	------------	---------------------	---------------

Lower Band Edge Plot for 16QAM-RB Size 1, RB Offset 0

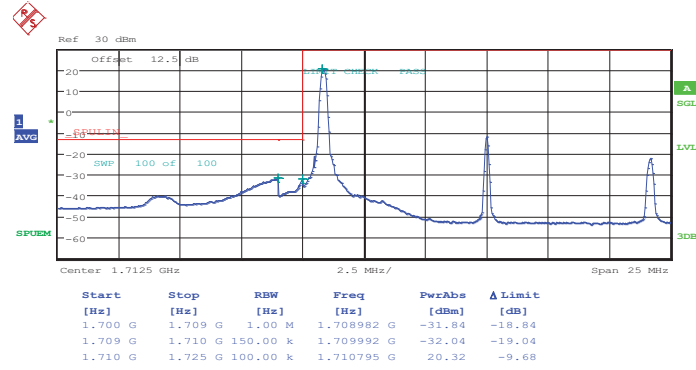

Date: 4.JUN.2014 22:35:27

Lower Band Edge Plot for 16QAM-RB Size 75, RB Offset 0

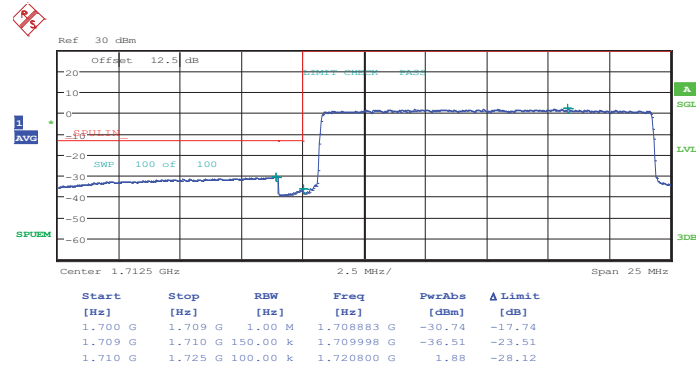

Date: 4.JUN.2014 22:37:02



Higher Band Edge Plot for 16QAM-RB Size 1, RB Offset 74

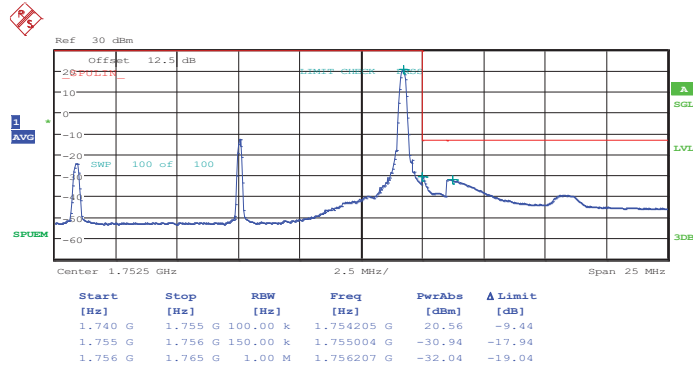

Date: 4.JUN.2014 22:45:01

Higher Band Edge Plot for 16QAM-RB Size 75, RB Offset 0

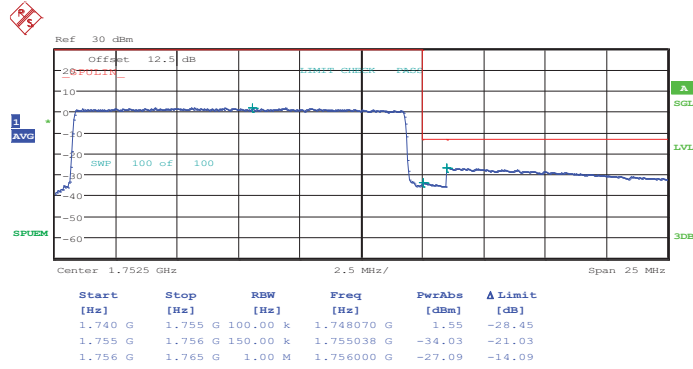

Date: 4.JUN.2014 22:46:36



Band :	LTE Band 4	Band Width :	20MHz / QPSK
---------------	------------	---------------------	--------------

Lower Band Edge Plot for QPSK-RB Size 1, RB Offset 0

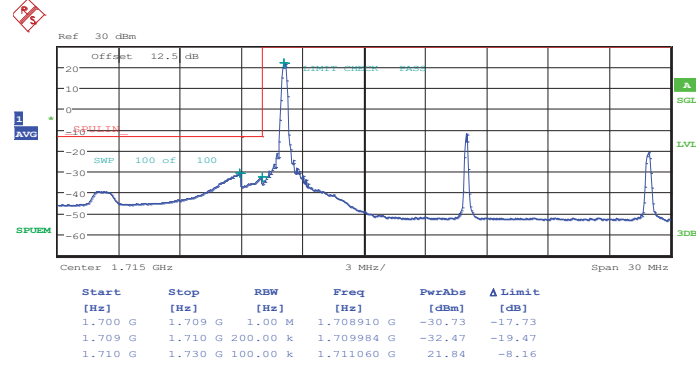

Date: 4.JUN.2014 22:02:50

Lower Band Edge Plot for QPSK-RB Size 100, RB Offset 0

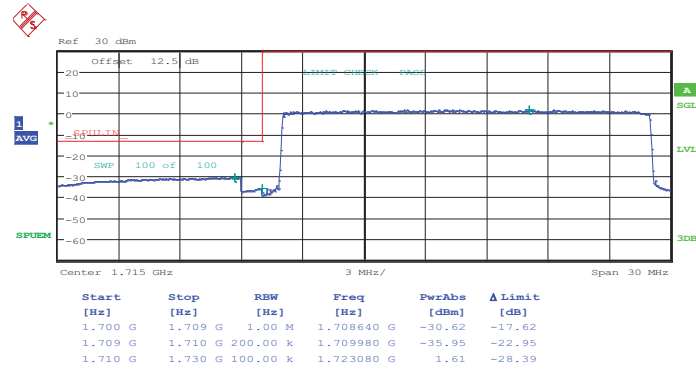

Date: 4.JUN.2014 22:04:25



Higher Band Edge Plot for QPSK-RB Size 1, RB Offset 99

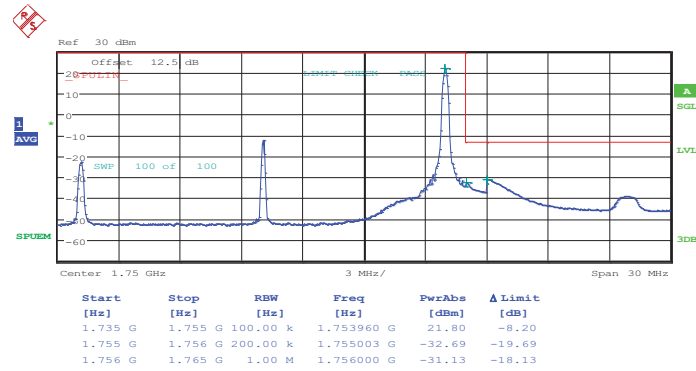

Date: 4.JUN.2014 22:12:24

Higher Band Edge Plot for QPSK-RB Size 100, RB Offset 0

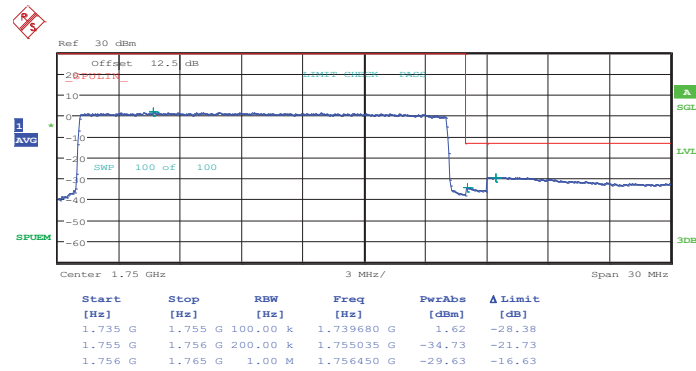

Date: 4.JUN.2014 22:13:59



Band :	LTE Band 4	Band Width :	20MHz / 16QAM
---------------	------------	---------------------	---------------

Lower Band Edge Plot for 16QAM-RB Size 1, RB Offset 0

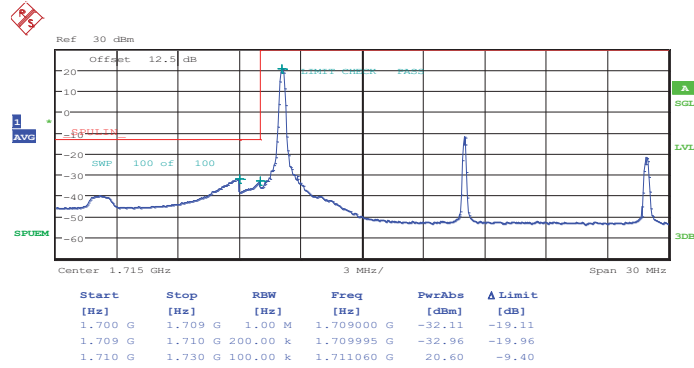

Date: 4.JUN.2014 22:03:38

Lower Band Edge Plot for 16QAM-RB Size 100, RB Offset 0

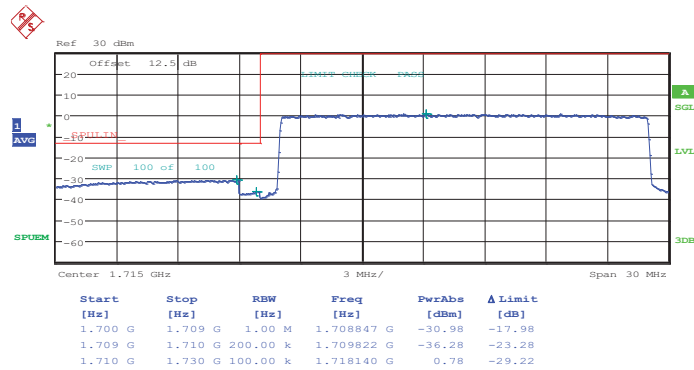

Date: 4.JUN.2014 22:05:13



Higher Band Edge Plot for 16QAM-RB Size 1, RB Offset 99

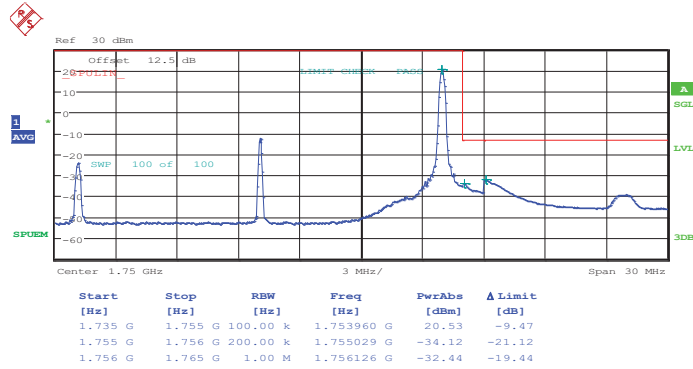

Date: 4.JUN.2014 22:13:12

Higher Band Edge Plot for 16QAM-RB Size 100, RB Offset 0

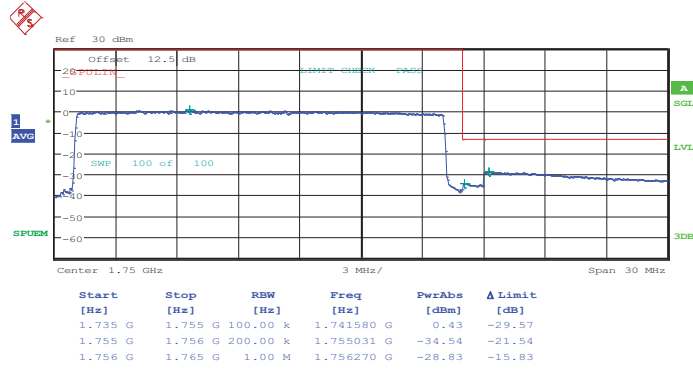

Date: 4.JUN.2014 22:14:47



3.6 Conducted Spurious Emission Measurement

3.6.1 Description of Conducted Spurious Emission Measurement

The power of any emission outside of the authorized operating frequency ranges must be lower than the transmitter power (P) by a factor of at least $43 + 10 \log (P)$ dB.

For Band 7

The power of any emission outside of the authorized operating frequency ranges must be lower than the transmitter power (P) by a factor of at least $55 + 10 \log (P)$ dB.

It is measured by means of a calibrated spectrum analyzer and scanned from 30MHz up to a frequency including its 10th harmonic.

3.6.2 Measuring Instruments

The measuring equipment is listed in the section 4 of this test report.

3.6.3 Test Procedures

1. The EUT was connected to spectrum analyzer and system simulator via a power divider.
2. The RF output of EUT was connected to the spectrum analyzer by RF cable and attenuator. The path loss was compensated to the results for each measurement.
3. The middle channel for the highest RF power within the transmitting frequency was measured.
4. The conducted spurious emission for the whole frequency range was taken.
5. Make the measurement with the spectrum analyzer's RBW = 1MHz, VBW = 3MHz, taking the record of maximum spurious emission.
6. The RF fundamental frequency should be excluded against the limit line in the operating frequency band.
7. The limit line is derived from $43 + 10\log(P)$ dB below the transmitter power P(Watts)
= P(W)- [43 + 10log(P)] (dB)
= [30 + 10log(P)] (dBm) - [43 + 10log(P)] (dB)
= -13dBm.
8. For Band 7
The limit line is derived from $55 + 10\log(P)$ dB below the transmitter power P(Watts)

3.6.4 Test Setup

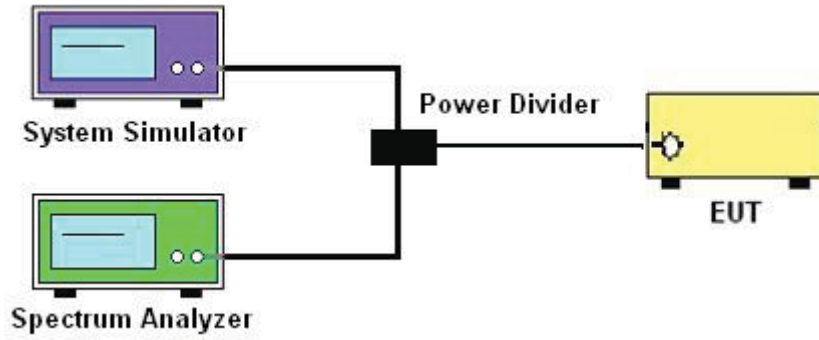



3.6.5 Test Result (Plots) of Conducted Spurious Emission

Band :	LTE Band 5	Channel :	CH20407 (Low)
Band Width :	1.4MHz		

QPSK (RB Size 1, RB Offset 0)

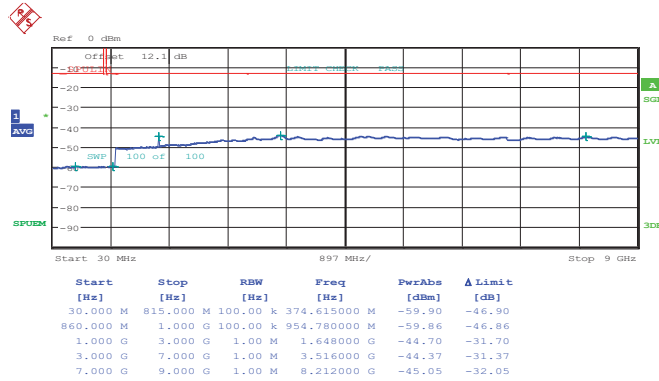

Date: 4.JUN.2014 23:12:14

16QAM (RB Size 1, RB Offset 0)

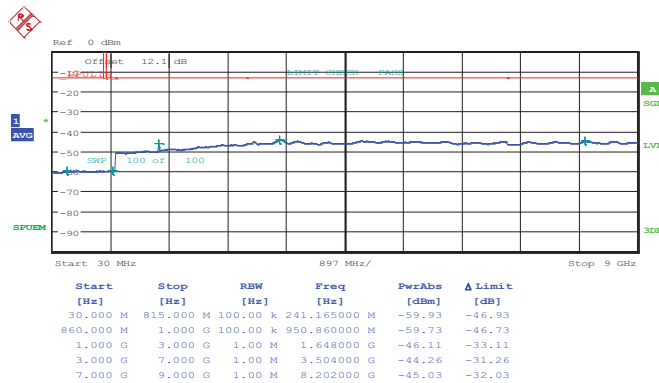

Date: 4.JUN.2014 23:13:14



Band :	LTE Band 5	Channel :	CH20525 (Middle)
Band Width :	1.4MHz		

QPSK (RB Size 1, RB Offset 0)

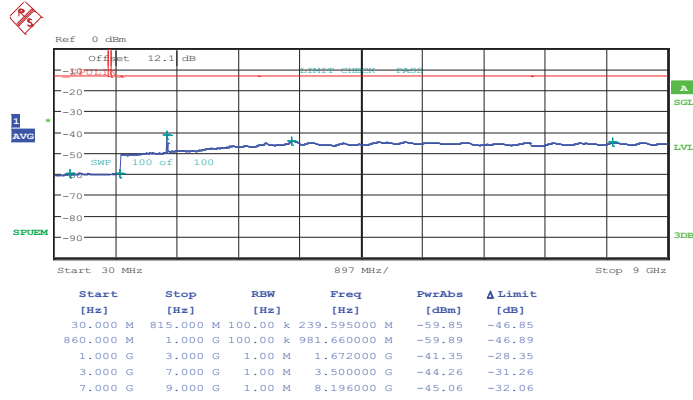

Date: 4.JUN.2014 23:15:25

16QAM (RB Size 1, RB Offset 0)

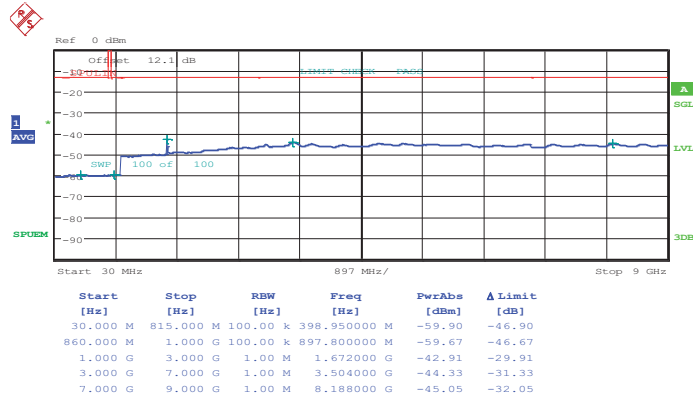

Date: 4.JUN.2014 23:16:26



Band :	LTE Band 5	Channel :	CH20643 (High)
Band Width :	1.4MHz		

QPSK (RB Size 1, RB Offset 0)

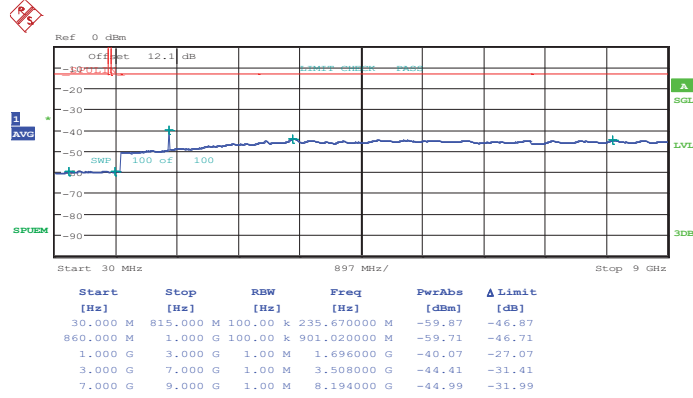

Date: 4.JUN.2014 23:21:48

16QAM (RB Size 1, RB Offset 0)

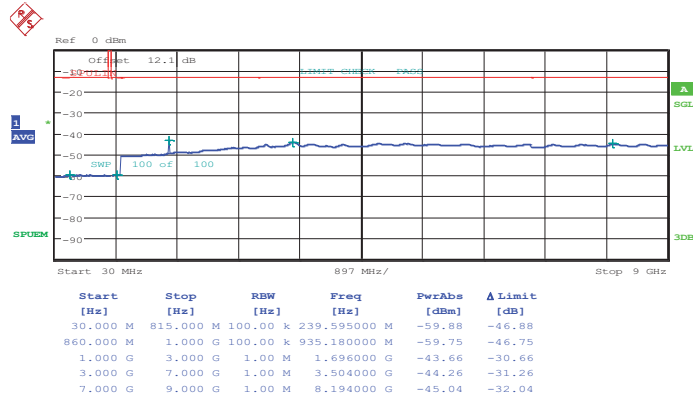

Date: 4.JUN.2014 23:22:48



Band :	LTE Band 5	Channel :	CH20415 (Low)
Band Width :	3MHz		

QPSK (RB Size 1, RB Offset 0)

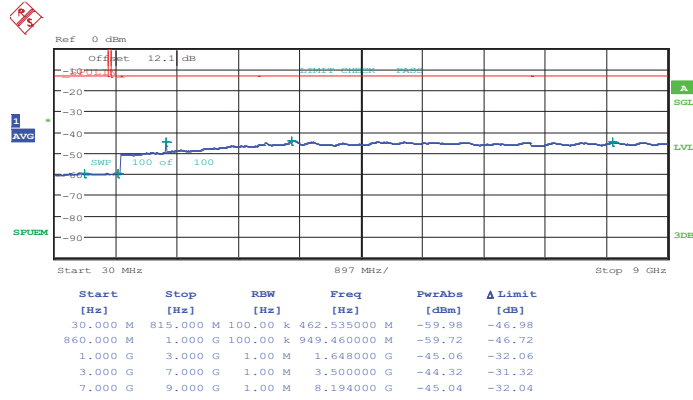

Date: 4.JUN.2014 23:28:09

16QAM (RB Size 1, RB Offset 0)

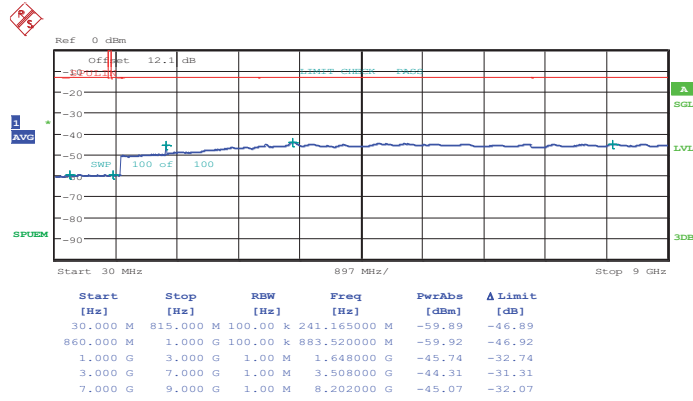

Date: 4.JUN.2014 23:29:10



Band :	LTE Band 5	Channel :	CH20525 (Middle)
Band Width :	3MHz		

QPSK (RB Size 1, RB Offset 0)

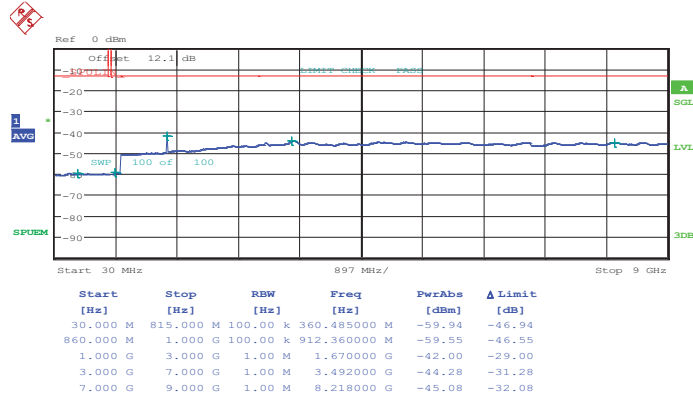

Date: 4.JUN.2014 23:31:21

16QAM (RB Size 1, RB Offset 0)

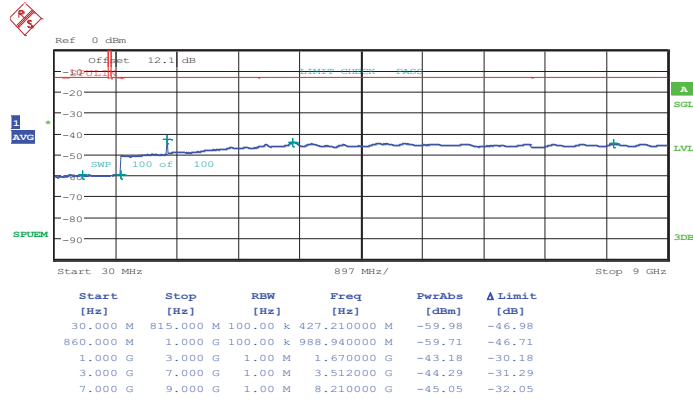

Date: 4.JUN.2014 23:32:21



Band :	LTE Band 5	Channel :	CH20635 (High)
Band Width :	3MHz		

QPSK (RB Size 1, RB Offset 0)

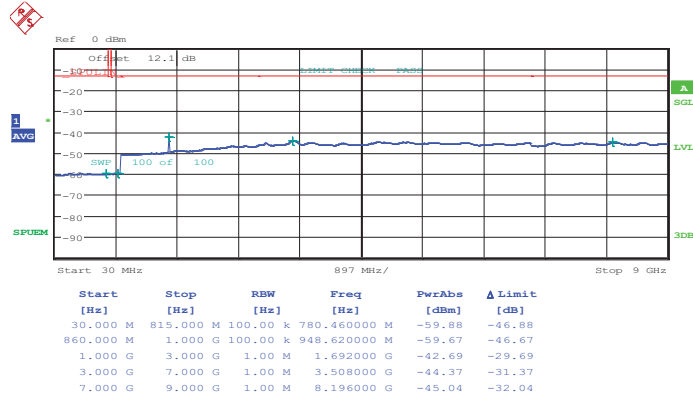

Date: 4.JUN.2014 23:37:43

16QAM (RB Size 1, RB Offset 0)

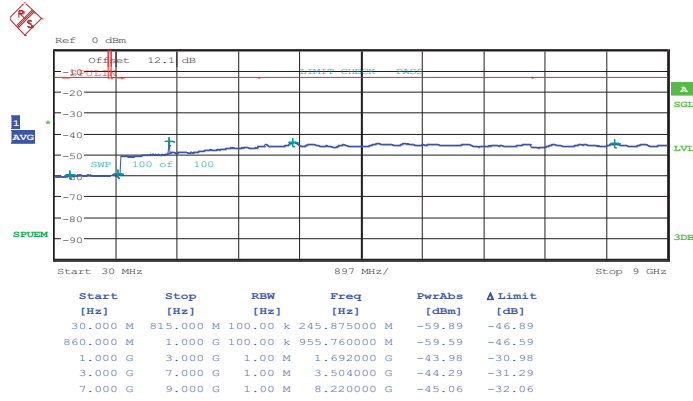

Date: 4.JUN.2014 23:38:44



Band :	LTE Band 2	Channel :	CH18607 (Low)
Band Width :	1.4MHz		

QPSK (RB Size 1, RB Offset 0)

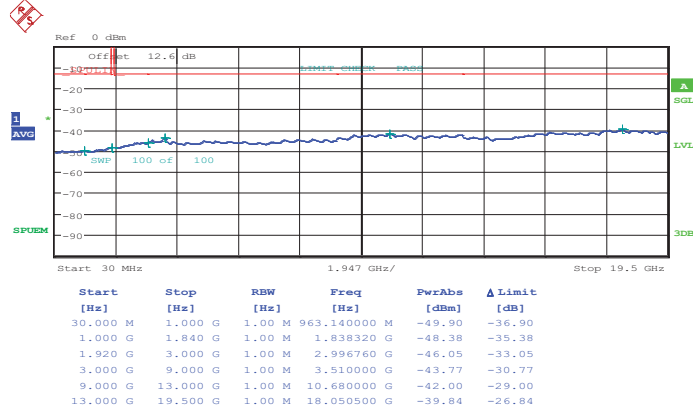

Date: 4.JUN.2014 16:28:28

16QAM (RB Size 1, RB Offset 0)

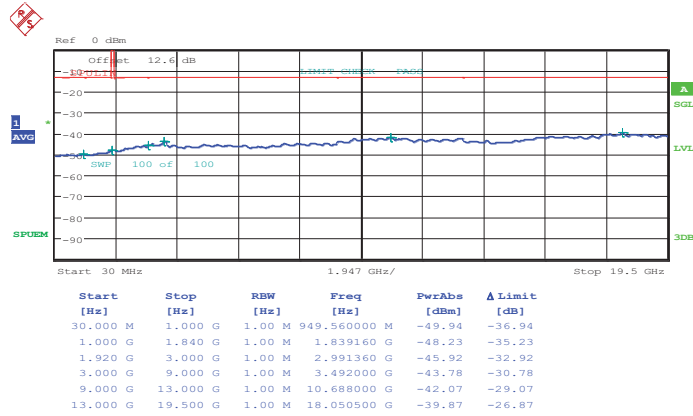

Date: 4.JUN.2014 16:29:28



Band :	LTE Band 2	Channel :	CH18900 (Middle)
Band Width :	1.4MHz		

QPSK (RB Size 1, RB Offset 0)

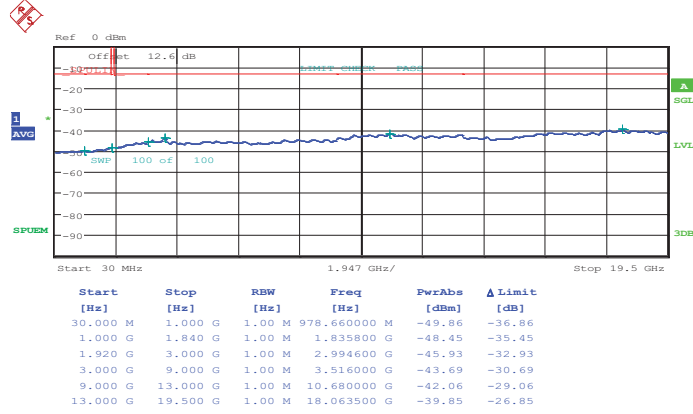

Date: 4.JUN.2014 16:31:40

16QAM (RB Size 1, RB Offset 0)

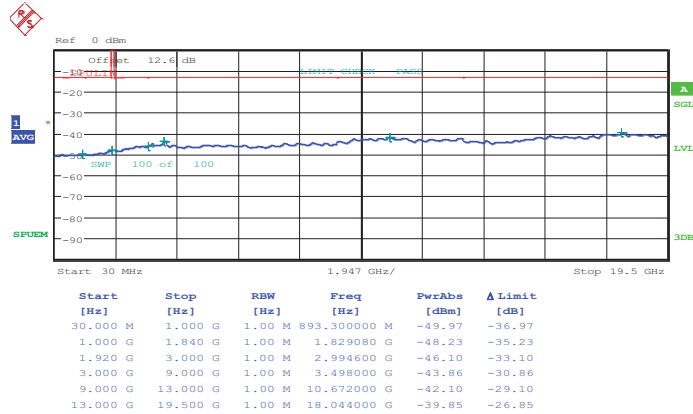

Date: 4.JUN.2014 16:32:41



Band :	LTE Band 2	Channel :	CH19193 (High)
Band Width :	1.4MHz		

QPSK (RB Size 1, RB Offset 0)

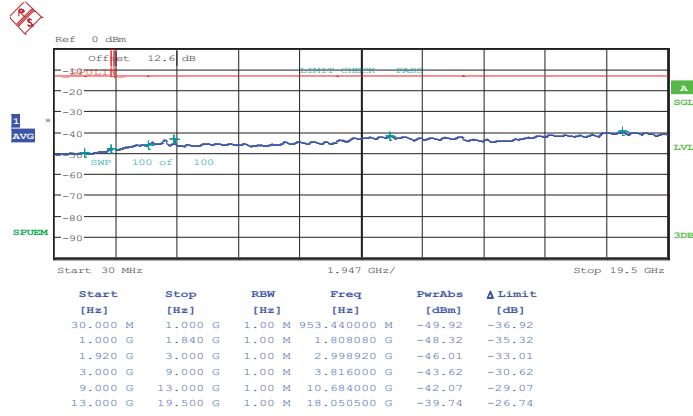

Date: 4.JUN.2014 16:38:04

16QAM (RB Size 1, RB Offset 0)

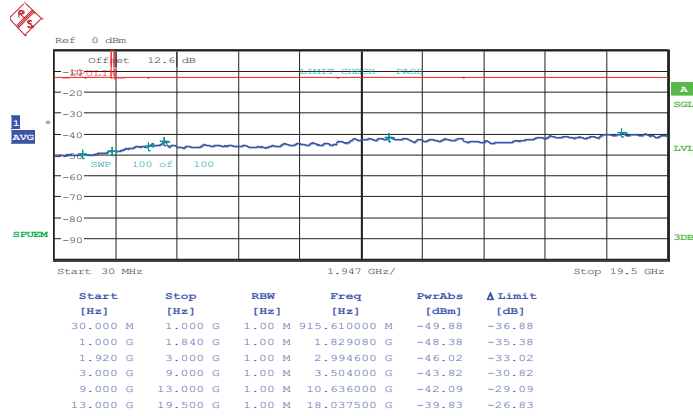

Date: 4.JUN.2014 16:39:05



Band :	LTE Band 2	Channel :	CH18615 (Low)
Band Width :	3MHz		

QPSK (RB Size 1, RB Offset 0)

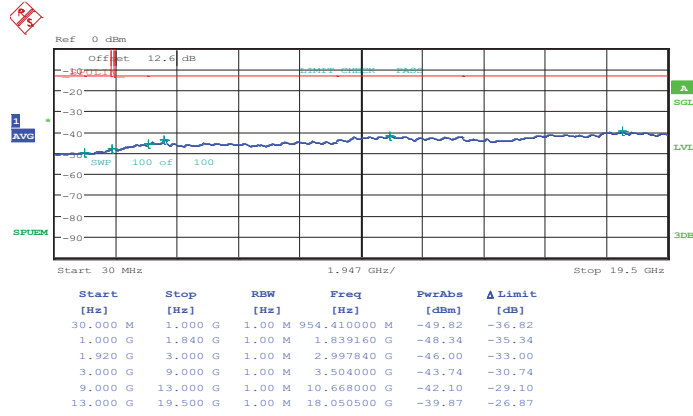

Date: 4.JUN.2014 16:44:29

16QAM (RB Size 1, RB Offset 0)

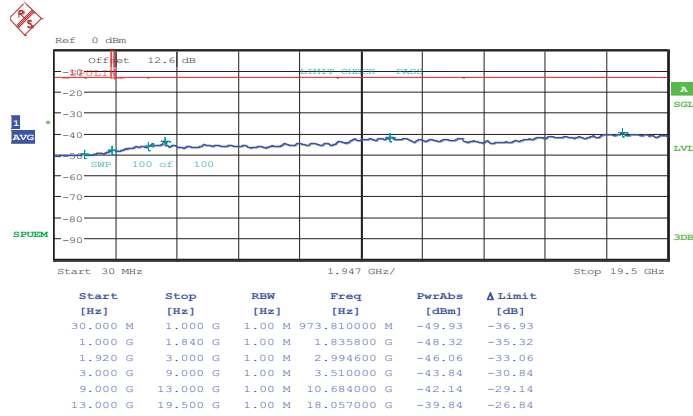

Date: 4.JUN.2014 16:45:30



Band :	LTE Band 2	Channel :	CH18900 (Middle)
Band Width :	3MHz		

QPSK (RB Size 1, RB Offset 0)

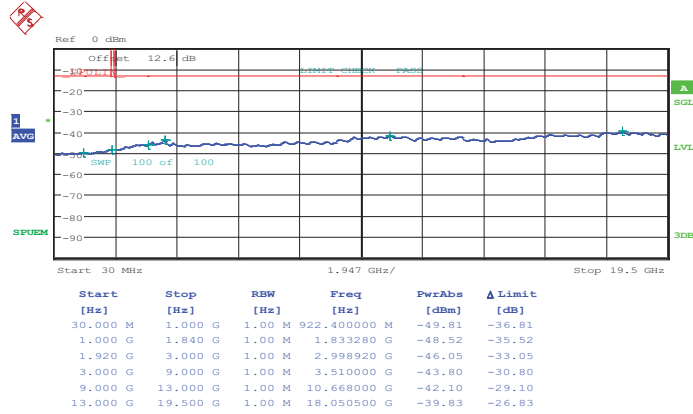

Date: 4.JUN.2014 16:47:42

16QAM (RB Size 1, RB Offset 0)

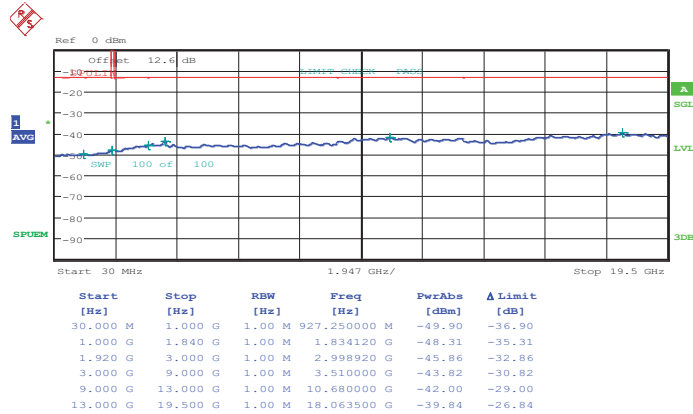

Date: 4.JUN.2014 16:48:43



Band :	LTE Band 2	Channel :	CH19185 (High)
Band Width :	3MHz		

QPSK (RB Size 1, RB Offset 0)

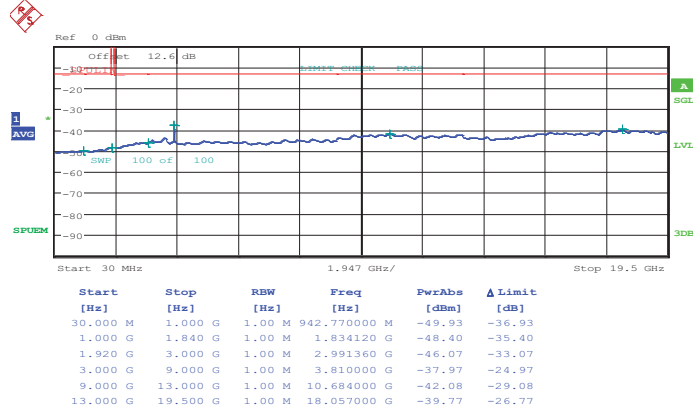

Date: 4.JUN.2014 16:54:07

16QAM (RB Size 1, RB Offset 0)

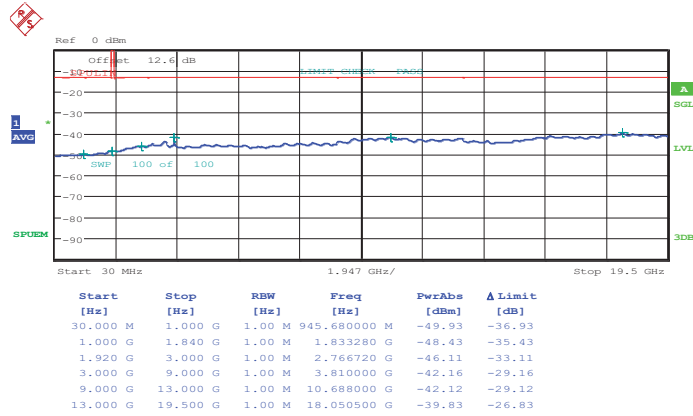

Date: 4.JUN.2014 16:55:08



Band :	LTE Band 2	Channel :	CH18675 (Low)
Band Width :	15MHz		

QPSK (RB Size 1, RB Offset 0)

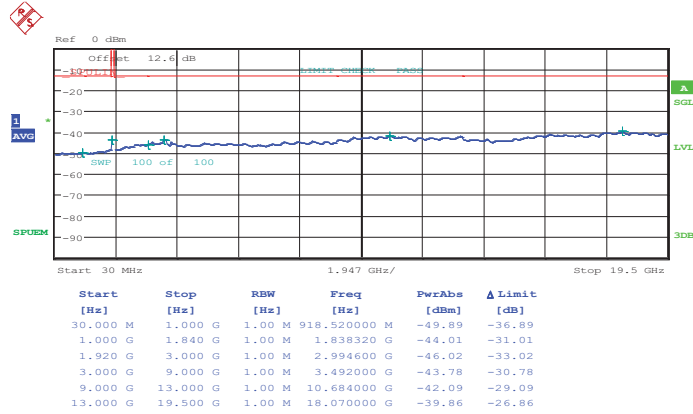

Date: 4.JUN.2014 17:54:10

16QAM (RB Size 1, RB Offset 0)

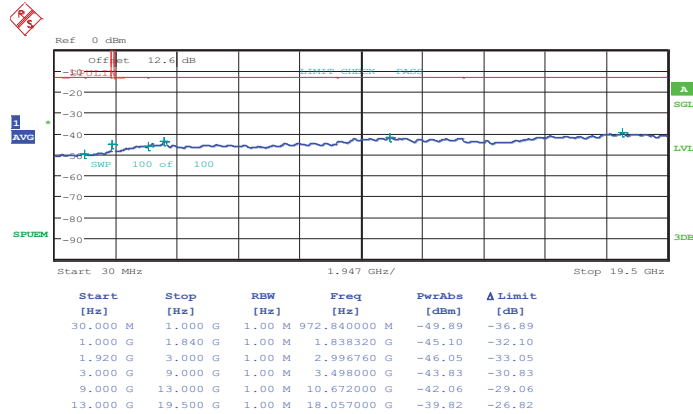

Date: 4.JUN.2014 17:55:11



Band :	LTE Band 2	Channel :	CH18900 (Middle)
Band Width :	15MHz		

QPSK (RB Size 1, RB Offset 0)

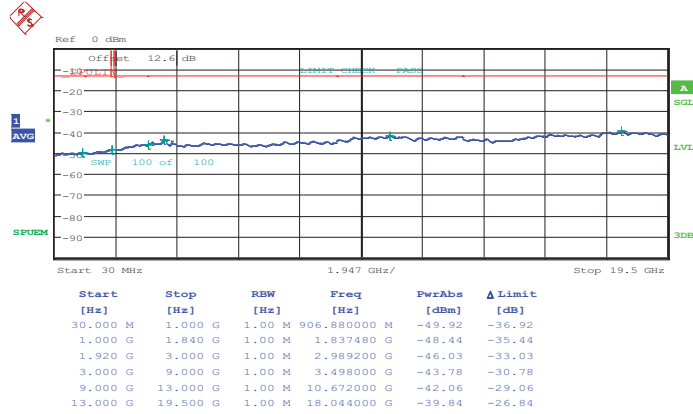

Date: 4.JUN.2014 17:57:22

16QAM (RB Size 1, RB Offset 0)

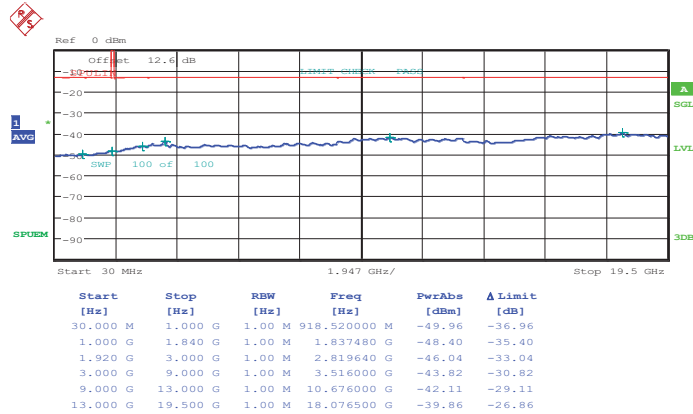

Date: 4.JUN.2014 17:58:23



Band :	LTE Band 2	Channel :	CH19125 (High)
Band Width :	15MHz		

QPSK (RB Size 1, RB Offset 0)

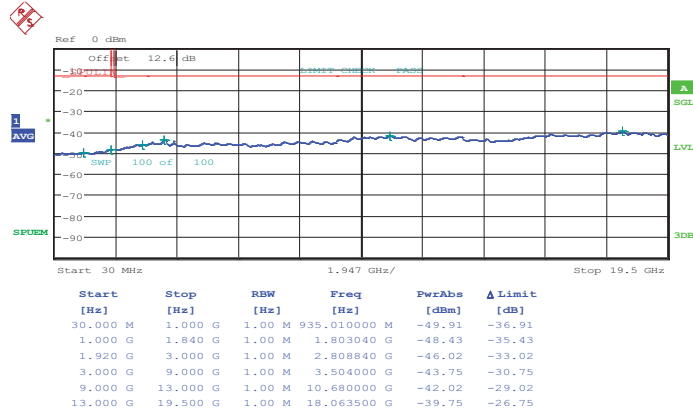

Date: 4.JUN.2014 18:03:45

16QAM (RB Size 1, RB Offset 0)

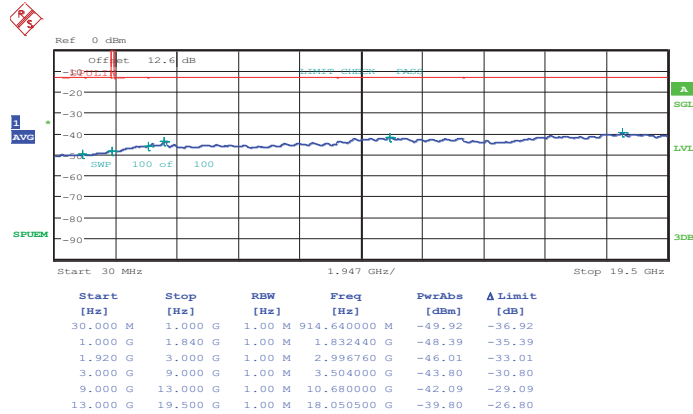

Date: 4.JUN.2014 18:04:46



Band :	LTE Band 2	Channel :	CH18700 (Low)
Band Width :	20MHz		

QPSK (RB Size 1, RB Offset 0)

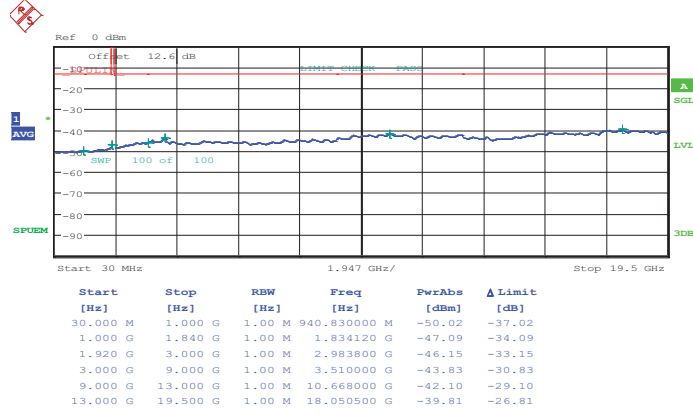

Date: 4.JUN.2014 19:01:51

16QAM (RB Size 1, RB Offset 0)

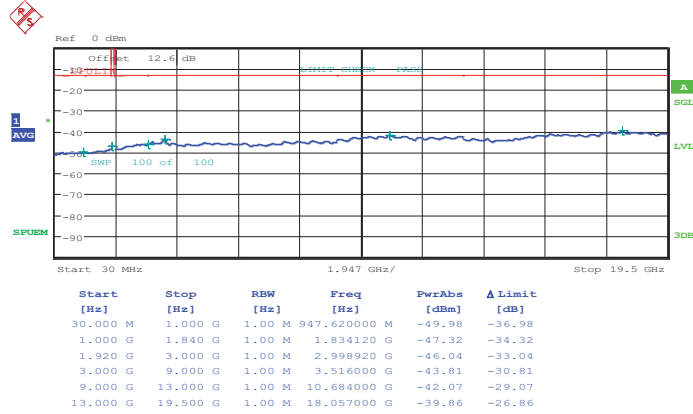

Date: 4.JUN.2014 19:02:52



Band :	LTE Band 2	Channel :	CH18900 (Middle)
Band Width :	20MHz		

QPSK (RB Size 1, RB Offset 0)

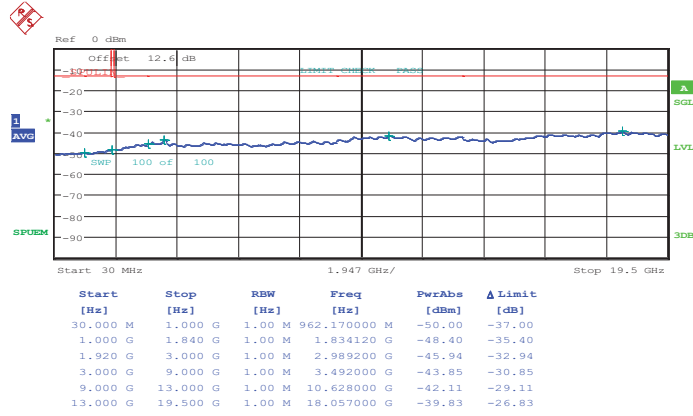

Date: 4.JUN.2014 19:05:03

16QAM (RB Size 1, RB Offset 0)

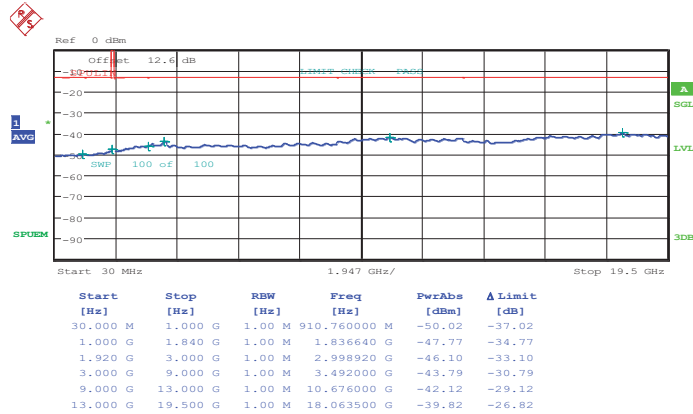

Date: 4.JUN.2014 19:06:04



Band :	LTE Band 2	Channel :	CH19100 (High)
Band Width :	20MHz		

QPSK (RB Size 1, RB Offset 0)

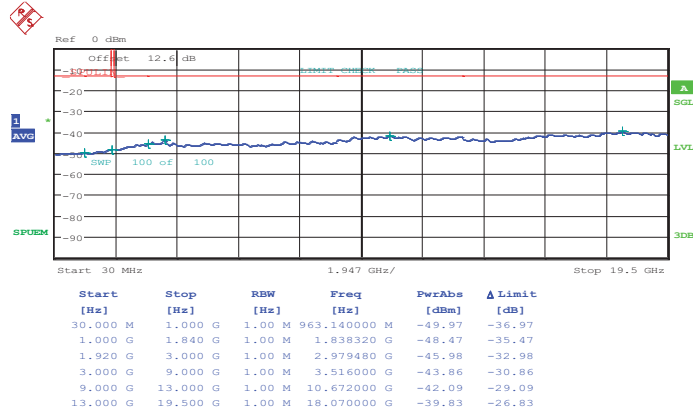

Date: 4.JUN.2014 19:11:25

16QAM (RB Size 1, RB Offset 0)

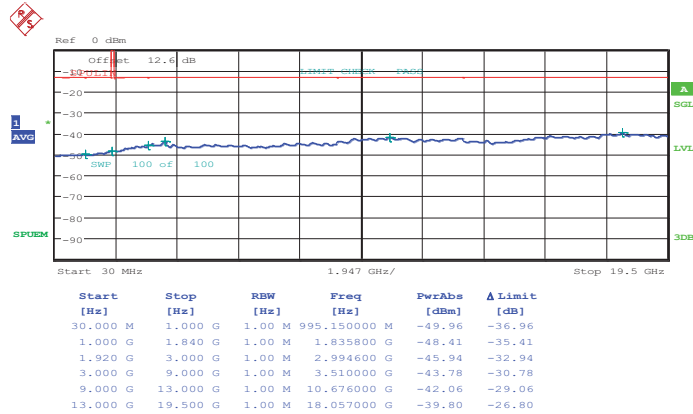

Date: 4.JUN.2014 19:12:25



Band :	LTE Band 4	Channel :	CH19957 (Low)
Band Width :	1.4MHz		

QPSK (RB Size 1, RB Offset 0)

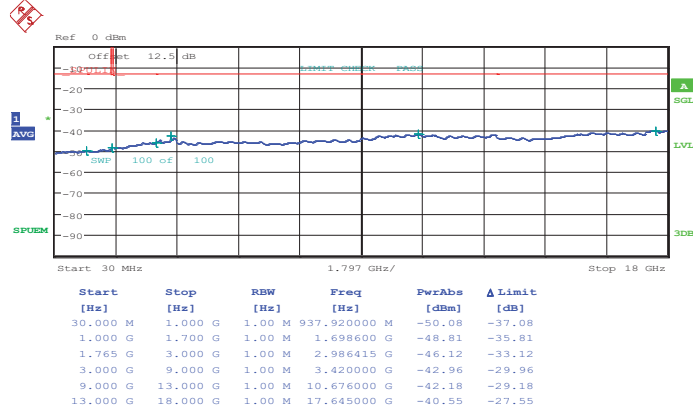

Date: 4.JUN.2014 20:32:47

16QAM (RB Size 1, RB Offset 0)

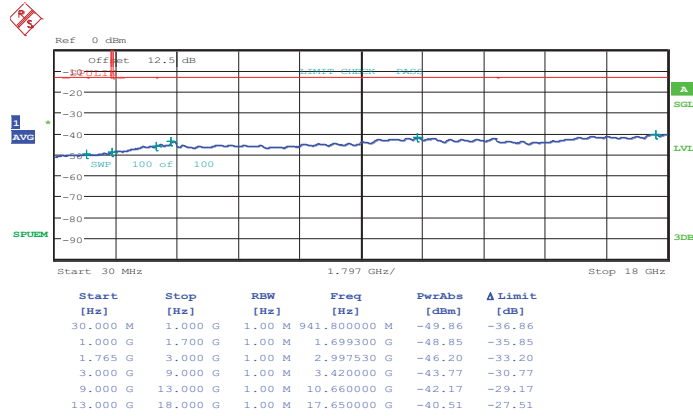

Date: 4.JUN.2014 20:33:47



Band :	LTE Band 4	Channel :	CH20175 (Middle)
Band Width :	1.4MHz		

QPSK (RB Size 1, RB Offset 0)

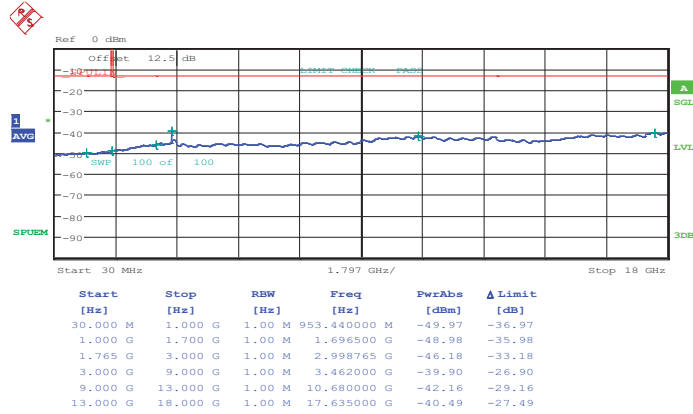

Date: 4.JUN.2014 20:35:58

16QAM (RB Size 1, RB Offset 0)

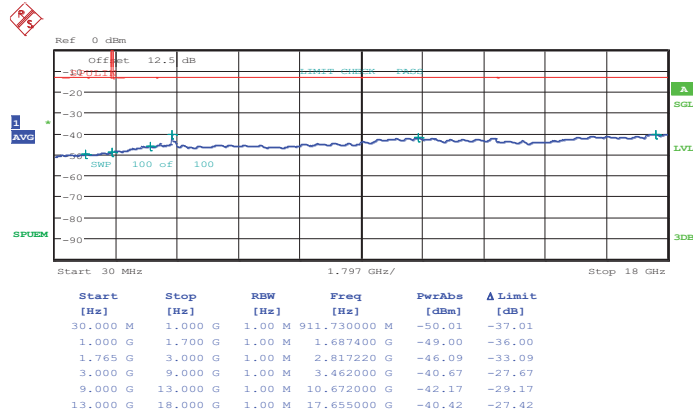

Date: 4.JUN.2014 20:36:59



Band :	LTE Band 4	Channel :	CH20393 (High)
Band Width :	1.4MHz		

QPSK (RB Size 1, RB Offset 0)

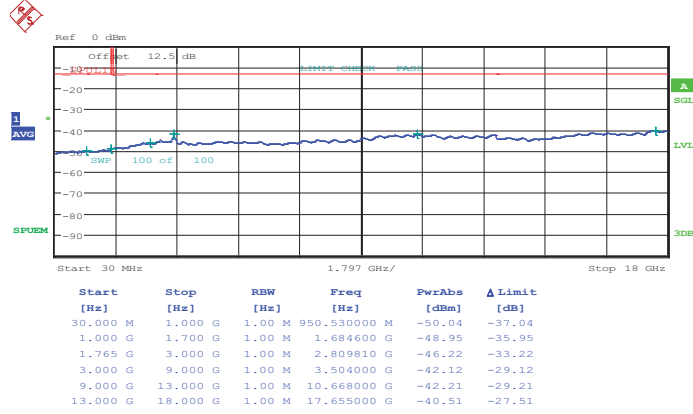

Date: 4.JUN.2014 20:42:19

16QAM (RB Size 1, RB Offset 0)

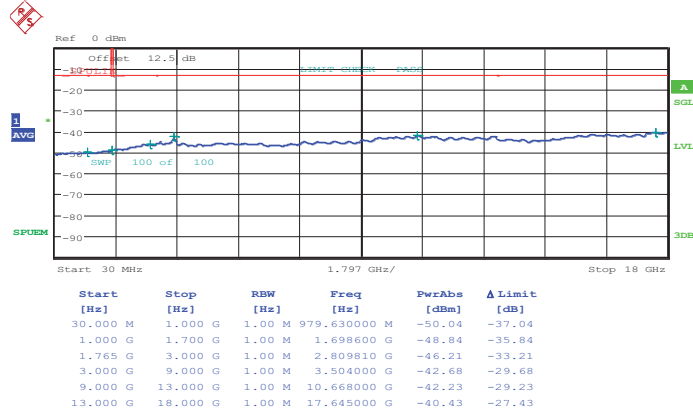

Date: 4.JUN.2014 20:43:20



Band :	LTE Band 4	Channel :	CH19965 (Low)
Band Width :	3MHz		

QPSK (RB Size 1, RB Offset 0)

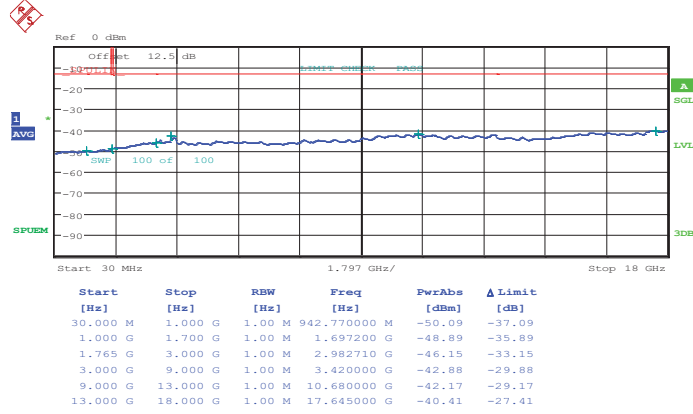

Date: 4.JUN.2014 20:48:41

16QAM (RB Size 1, RB Offset 0)

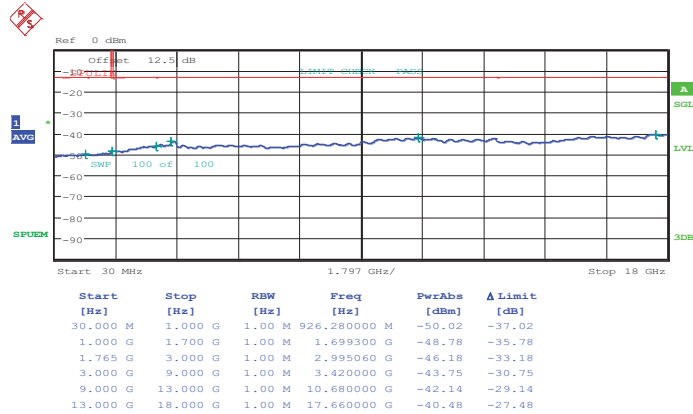

Date: 4.JUN.2014 20:49:42



Band :	LTE Band 4	Channel :	CH20175 (Middle)
Band Width :	3MHz		

QPSK (RB Size 1, RB Offset 0)

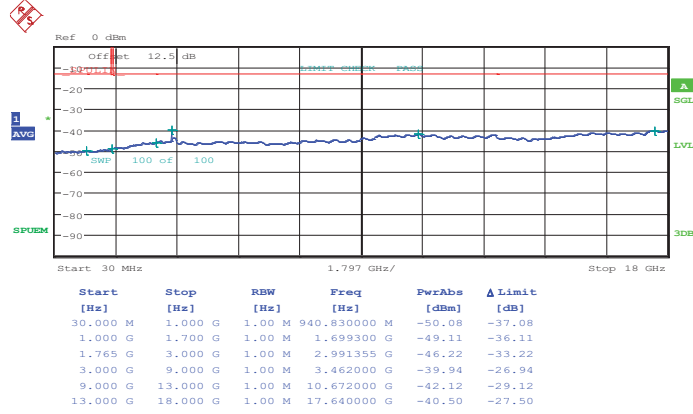

Date: 4.JUN.2014 20:51:52

16QAM (RB Size 1, RB Offset 0)

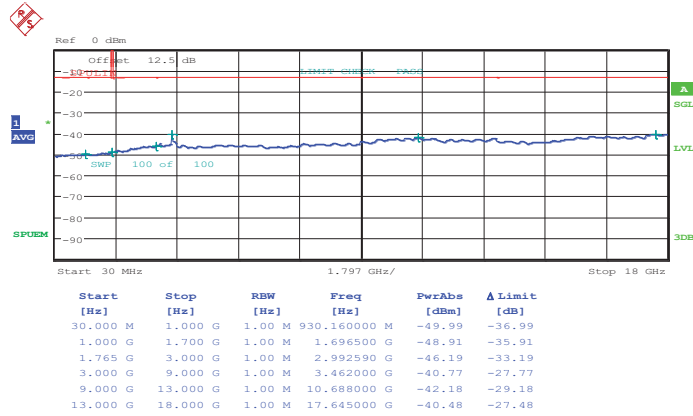

Date: 4.JUN.2014 20:52:53



Band :	LTE Band 4	Channel :	CH20385 (High)
Band Width :	3MHz		

QPSK (RB Size 1, RB Offset 0)

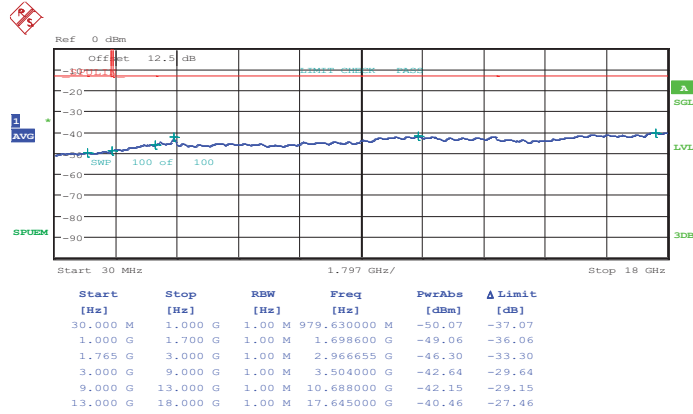

Date: 4.JUN.2014 20:58:14

16QAM (RB Size 1, RB Offset 0)

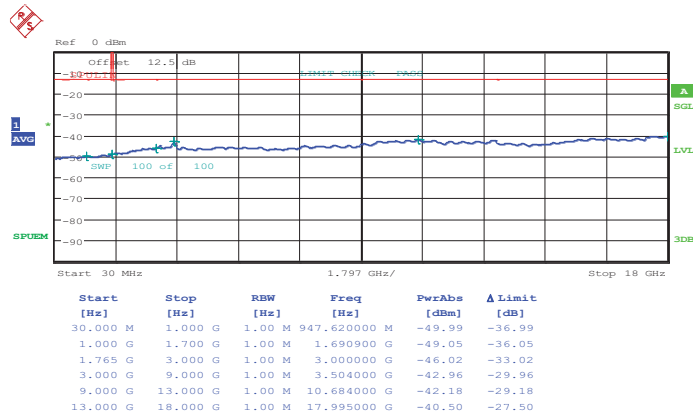

Date: 4.JUN.2014 20:59:14



Band :	LTE Band 4	Channel :	CH20025 (Low)
Band Width :	15MHz		

QPSK (RB Size 1, RB Offset 0)

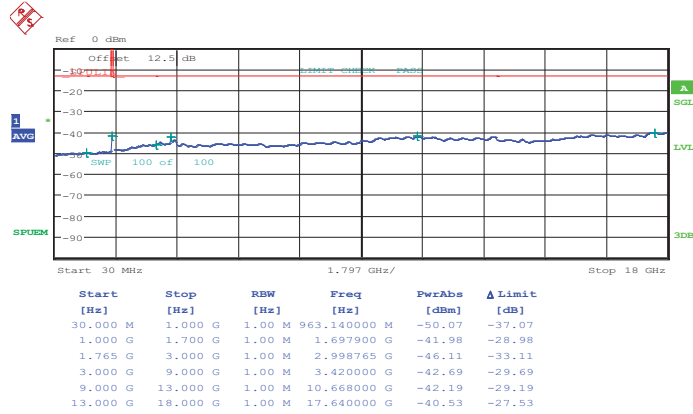

Date: 4.JUN.2014 22:38:03

16QAM (RB Size 1, RB Offset 0)

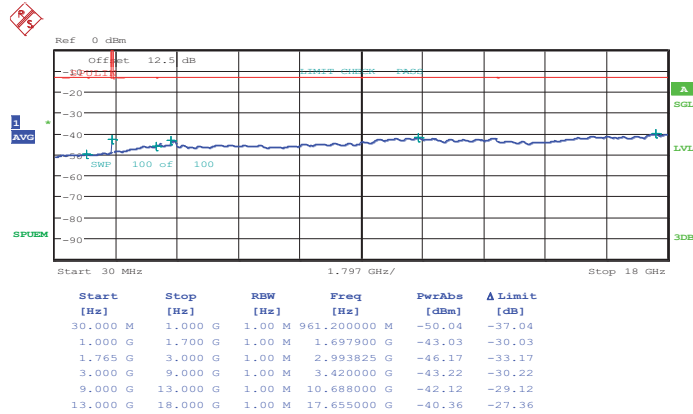

Date: 4.JUN.2014 22:39:04



Band :	LTE Band 4	Channel :	CH20175 (Middle)
Band Width :	15MHz		

QPSK (RB Size 1, RB Offset 0)

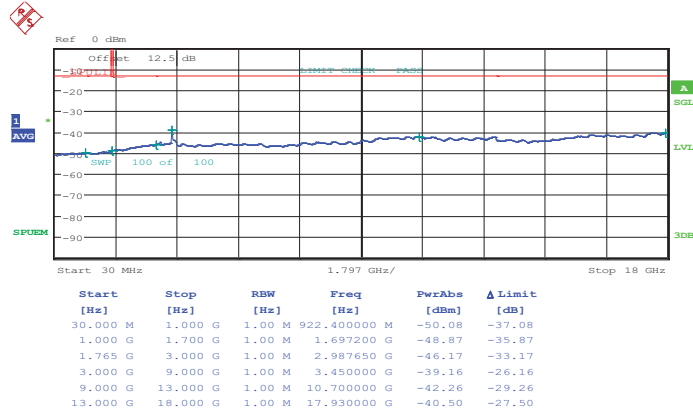

Date: 4.JUN.2014 22:41:14

16QAM (RB Size 1, RB Offset 0)

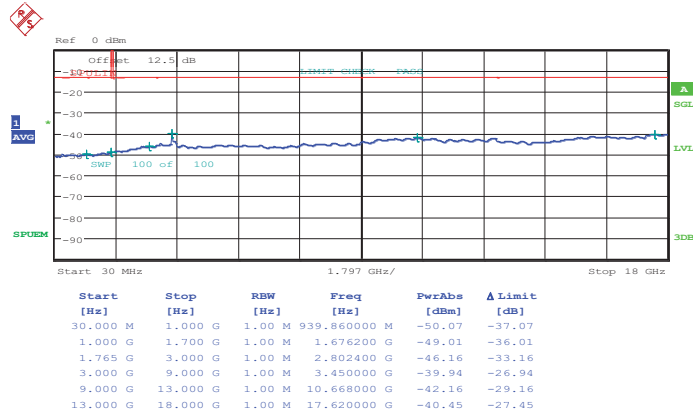

Date: 4.JUN.2014 22:42:15



Band :	LTE Band 4	Channel :	CH20325 (High)
Band Width :	15MHz		

QPSK (RB Size 1, RB Offset 0)

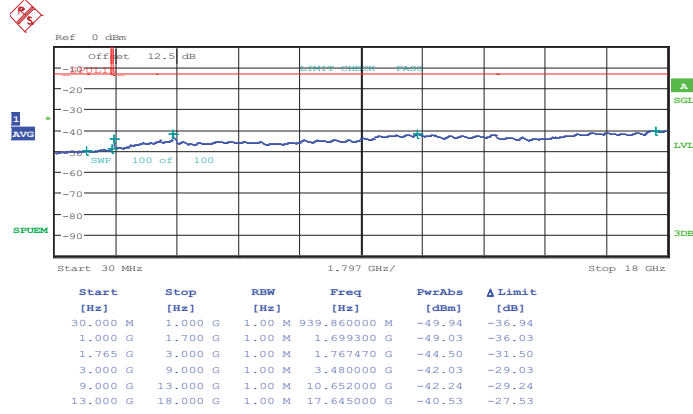

Date: 4.JUN.2014 22:47:36

16QAM (RB Size 1, RB Offset 0)

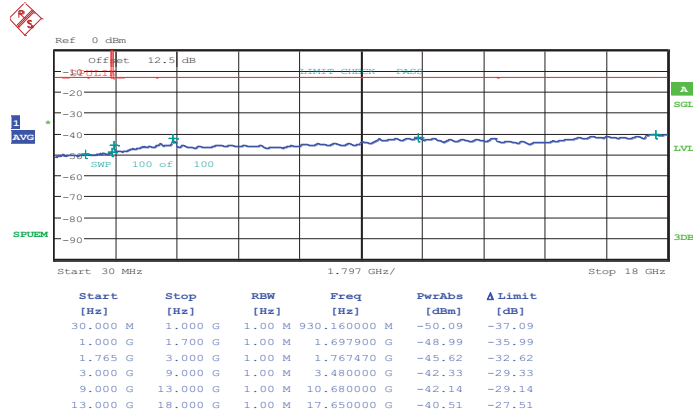

Date: 4.JUN.2014 22:48:37



Band :	LTE Band 4	Channel :	CH20050 (Low)
Band Width :	20MHz		

QPSK (RB Size 1, RB Offset 0)

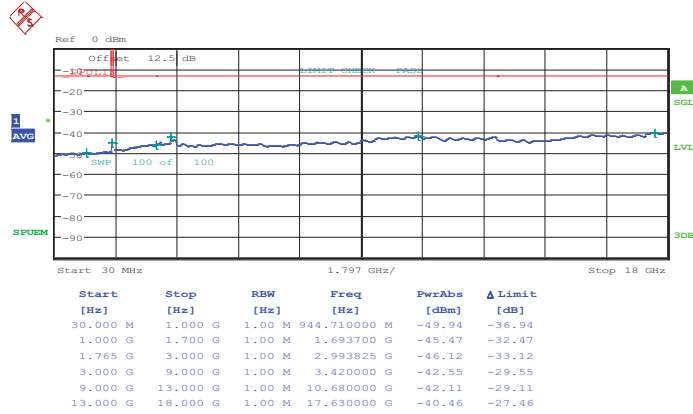

Date: 4.JUN.2014 22:06:14

16QAM (RB Size 1, RB Offset 0)

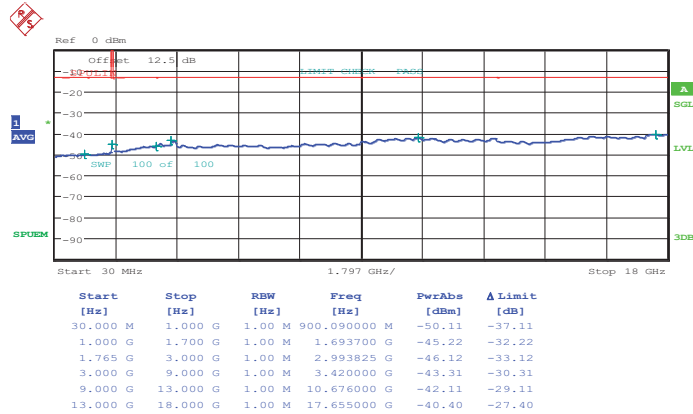

Date: 4.JUN.2014 22:07:15



Band :	LTE Band 4	Channel :	CH20175 (Middle)
Band Width :	20MHz		

QPSK (RB Size 1, RB Offset 0)

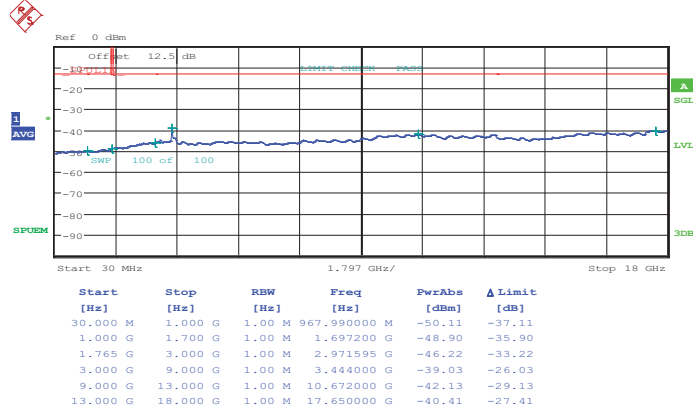

Date: 4.JUN.2014 22:09:25

16QAM (RB Size 1, RB Offset 0)

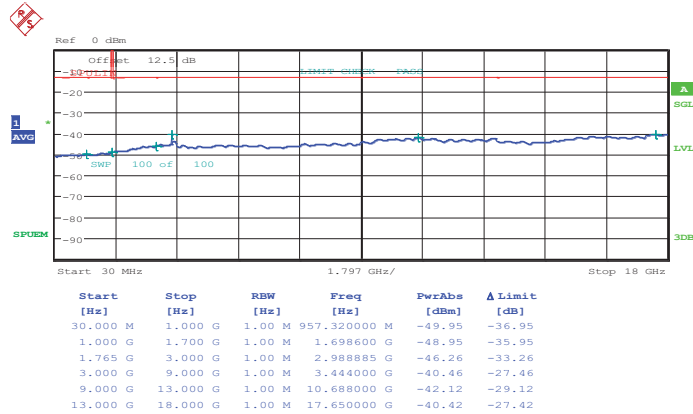

Date: 4.JUN.2014 22:10:26



Band :	LTE Band 4	Channel :	CH20300 (High)
Band Width :	20MHz		

QPSK (RB Size 1, RB Offset 0)

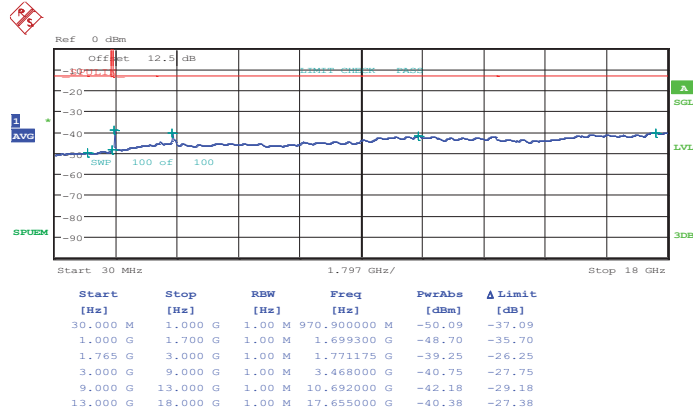

Date: 4.JUN.2014 22:15:48

16QAM (RB Size 1, RB Offset 0)

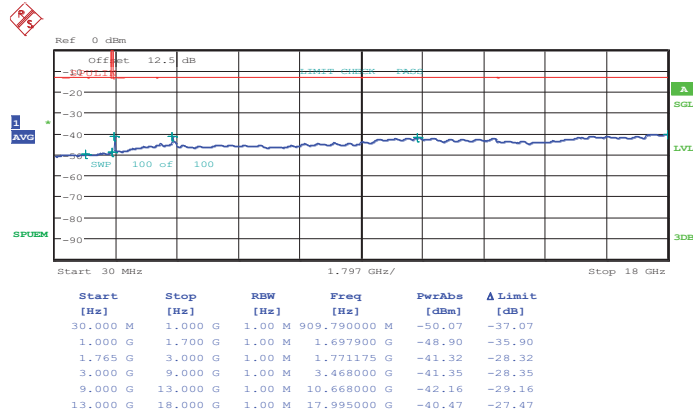

Date: 4.JUN.2014 22:16:49



3.7 Radiated Spurious Emission Measurement

3.7.1 Description of Radiated Spurious Emission

The radiated spurious emission was measured by substitution method according to ANSI / TIA / EIA-603-C-2004. The power of any emission outside of the authorized operating frequency ranges must be attenuated below the transmitter power (P) by a factor of at least $43 + 10 \log (P)$ dB.

For Band 7

The power of any emission outside of the authorized operating frequency ranges must be attenuated below the transmitter power (P) by a factor of at least $55 + 10 \log (P)$ dB.

The spectrum is scanned from 30 MHz up to a frequency including its 10th harmonic.

3.7.2 Measuring Instruments

The measuring equipment is listed in the section 4 of this test report.

3.7.3 Test Procedures

1. The EUT was placed on a rotatable wooden table with 0.8 meter above ground.
2. The EUT was set 3 meters from the receiving antenna, which was mounted on the antenna tower.
3. The table was rotated 360 degrees to determine the position of the highest spurious emission.
4. The height of the receiving antenna is varied between one meter and four meters to search the maximum spurious emission for both horizontal and vertical polarizations.
5. Make the measurement with the spectrum analyzer's RBW = 1MHz, VBW = 3MHz, taking the record of maximum spurious emission.
6. A horn antenna was substituted in place of the EUT and was driven by a signal generator.
7. Tune the output power of signal generator to the same emission level with EUT maximum spurious emission.
8. Taking the record of output power at antenna port.
9. Repeat step 7 to step 8 for another polarization.
10. The RF fundamental frequency should be excluded against the limit line in the operating frequency band.

The limit line is derived from $43 + 10\log(P)$ dB below the transmitter power P(Watts)
= $P(W) - [43 + 10\log(P)]$ (dB)
= $[30 + 10\log(P)]$ (dBm) - $[43 + 10\log(P)]$ (dB)
= -13dBm.

For Band 7

The limit line is derived from $55 + 10\log(P)$ dB below the transmitter power P(Watts)

11. EIRP (dBm) = S.G. Power – Tx Cable Loss + Tx Antenna Gain
12. ERP (dBm) = EIRP - 2.15

3.7.4 Test Setup

For radiated emissions from 30MHz to 1GHz

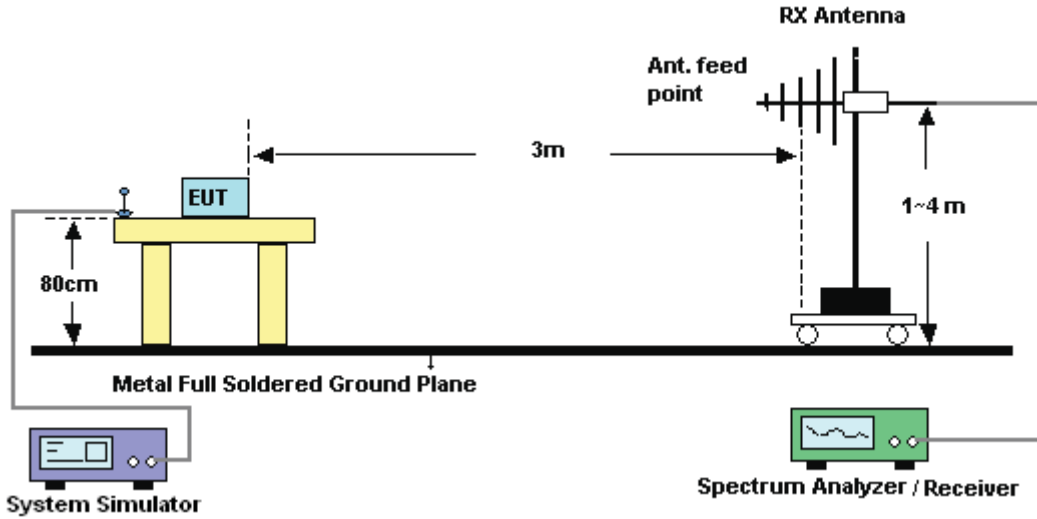

For radiated emissions above 1GHz

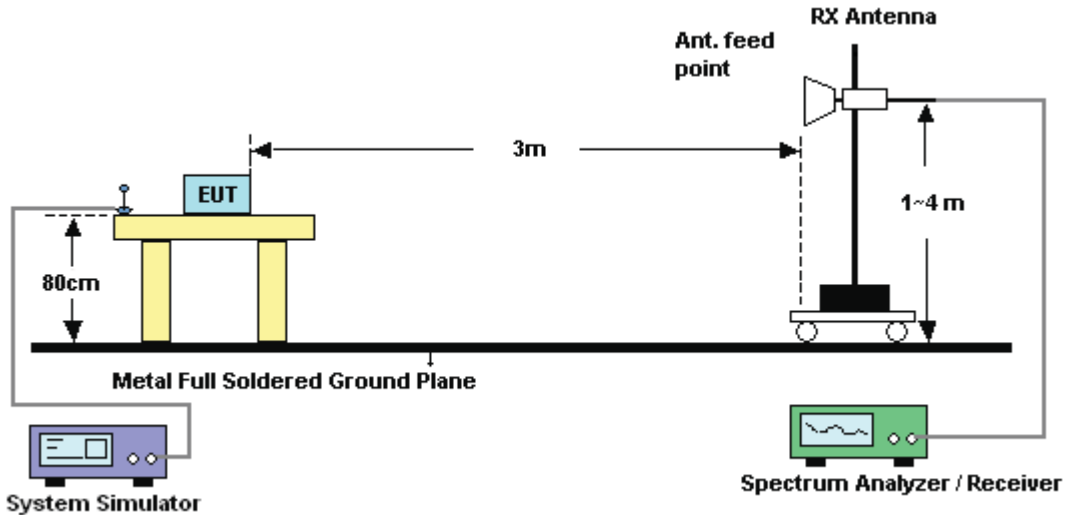



3.7.5 Test Result of Field Strength of Spurious Radiated

<Low Channel>

Band :	LTE Band 5	Temperature :	21~24°C
Test Mode :	1.4MHz QPSK RB Size 1 Offset 0	Relative Humidity :	46~48%
Test Engineer :	Ken Wu	Polarization :	Horizontal
Channel :	20407		
Remark :	Spurious emissions within 30-1000MHz were found more than 20dB below limit line.		

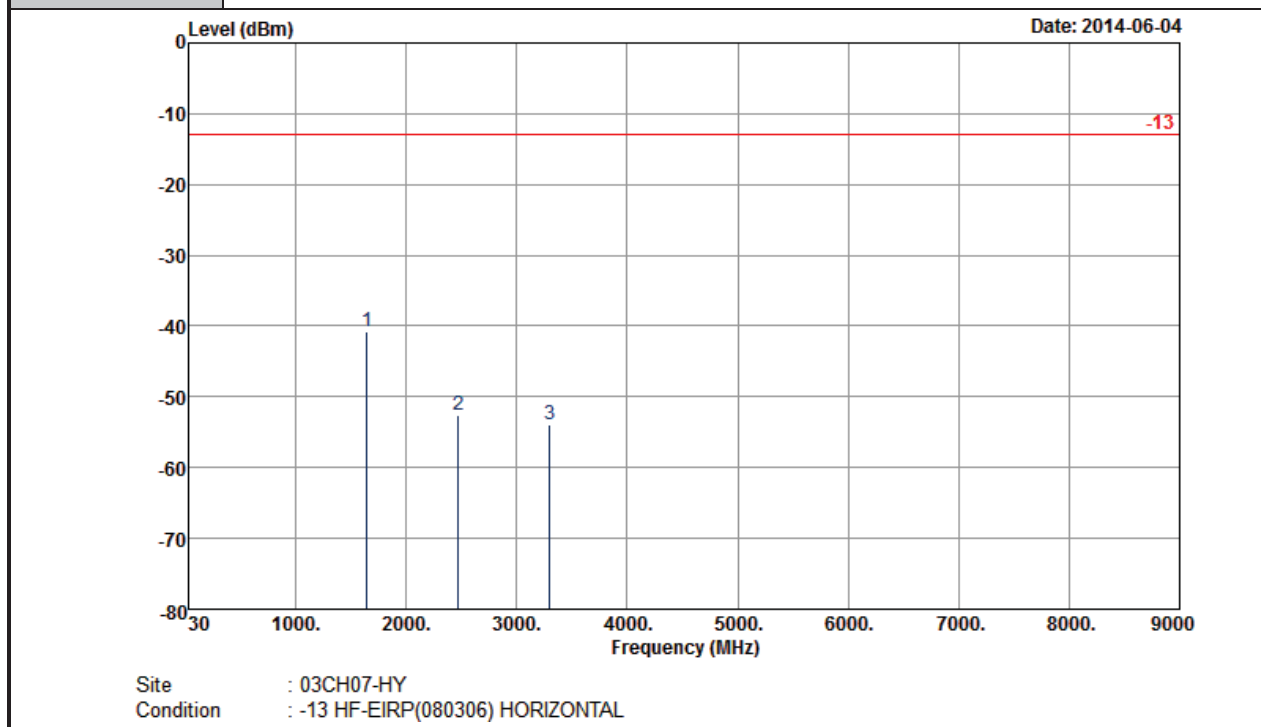

Site : 03CH07-HY
Condition : -13 HF-EIRP(080306) HORIZONTAL

Frequency (MHz)	ERP (dBm)	Limit (dBm)	Over Limit (dB)	SPA Reading (dBm)	S.G. Power (dBm)	TX Cable loss (dB)	TX Antenna Gain (dBi)	Polarization (H/V)	Result
1648	-40.85	-13	-27.85	-49.59	-44.74	1.61	5.50	H	Pass
2472	-52.50	-13	-39.50	-65.87	-56.65	2.09	6.24	H	Pass
3296	-53.98	-13	-40.98	-68	-58.99	3.08	8.09	H	Pass



Band :	LTE Band 5	Temperature :	21~24°C
Test Mode :	1.4MHz QPSK RB Size 1 Offset 0	Relative Humidity :	46~48%
Test Engineer :	Ken Wu	Polarization :	Vertical
Channel :	20407		
Remark :	Spurious emissions within 30-1000MHz were found more than 20dB below limit line.		

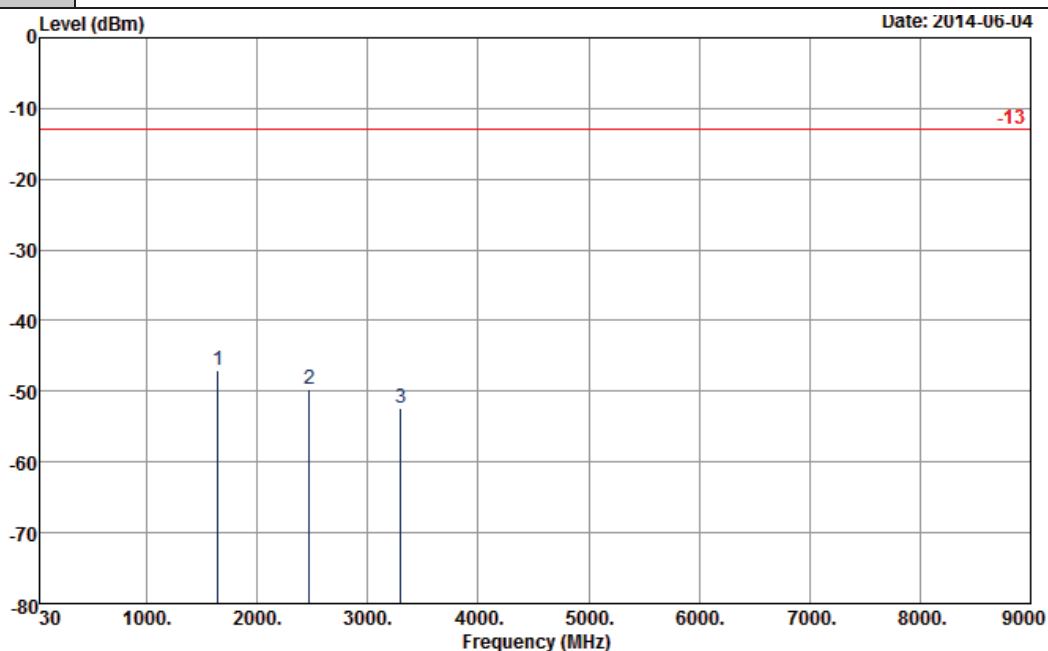

Site : 03CH07-HY
 Condition : -13 HF-EIRP(080306) VERTICAL

Frequency (MHz)	ERP (dBm)	Limit (dBm)	Over Limit (dB)	SPA Reading (dBm)	S.G. Power (dBm)	TX Cable loss (dB)	TX Antenna Gain (dBi)	Polarization (H/V)	Result
1648	-47.00	-13	-34.00	-57.99	-50.89	1.61	5.50	V	Pass
2472	-49.62	-13	-36.62	-63.15	-53.77	2.09	6.24	V	Pass
3296	-52.41	-13	-39.41	-67.96	-57.42	3.08	8.09	V	Pass



<Middle Channel>

Band :	LTE Band 5	Temperature :	21~24°C
Test Mode :	1.4MHz QPSK RB Size 1 Offset 0	Relative Humidity :	46~48%
Test Engineer :	Ken Wu	Polarization :	Horizontal
Channel :	20525		
Remark :	Spurious emissions within 30-1000MHz were found more than 20dB below limit line.		

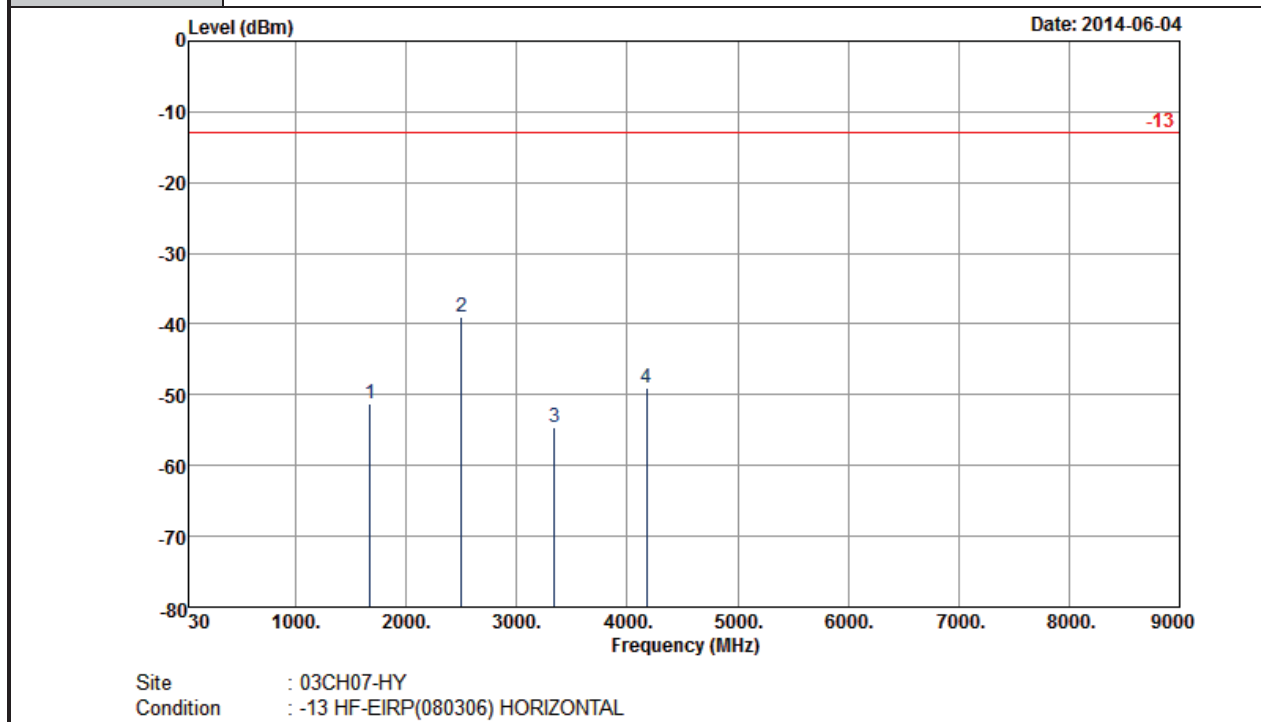

Frequency (MHz)	ERP (dBm)	Limit (dBm)	Over Limit (dB)	SPA Reading (dBm)	S.G. Power (dBm)	TX Cable loss (dB)	TX Antenna Gain (dBi)	Polarization (H/V)	Result
1672	-51.25	-13	-38.25	-60.3	-55.12	1.62	5.49	H	Pass
2504	-39.07	-13	-26.07	-52.37	-43.19	2.1	6.22	H	Pass
3344	-54.58	-13	-41.58	-68.6	-59.62	3.03	8.07	H	Pass
4176	-49.02	-13	-36.02	-65.26	-55.71	2.52	9.21	H	Pass



Band :	LTE Band 5	Temperature :	21~24°C
Test Mode :	1.4MHz QPSK RB Size 1 Offset 0	Relative Humidity :	46~48%
Test Engineer :	Ken Wu	Polarization :	Vertical
Channel :	20525		
Remark :	Spurious emissions within 30-1000MHz were found more than 20dB below limit line.		

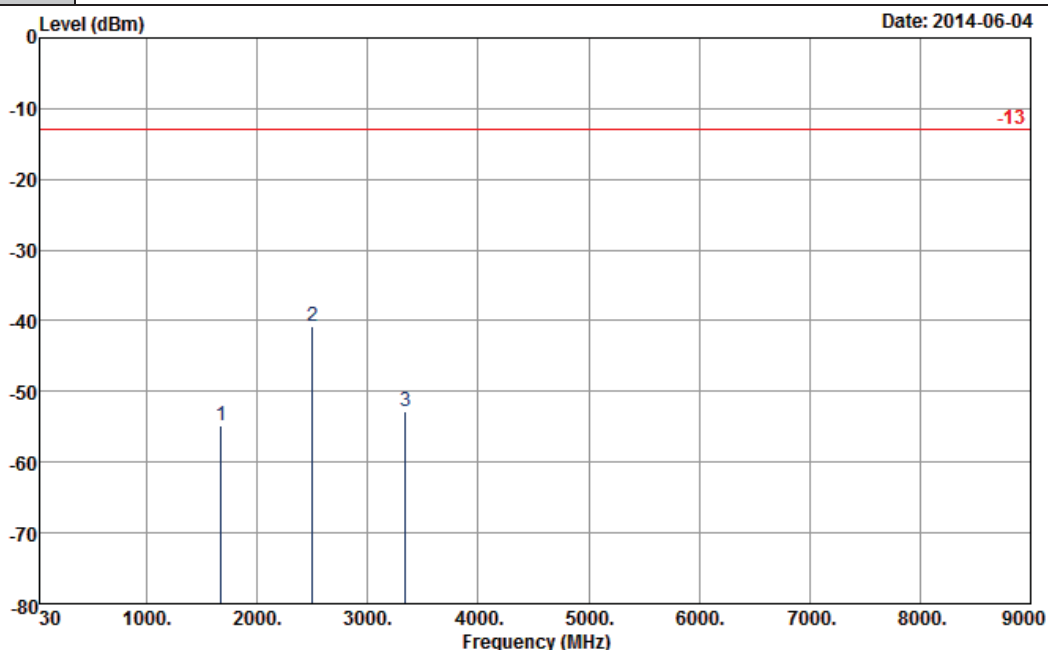

Site : 03CH07-HY
 Condition : -13 HF-EIRP(080306) VERTICAL

Frequency (MHz)	ERP (dBm)	Limit (dBm)	Over Limit (dB)	SPA Reading (dBm)	S.G. Power (dBm)	TX Cable loss (dB)	TX Antenna Gain (dBi)	Polarization (H/V)	Result
1672	-54.81	-13	-41.81	-65.99	-58.68	1.62	5.49	V	Pass
2504	-40.74	-13	-27.74	-54.44	-44.86	2.1	6.22	V	Pass
3344	-52.71	-13	-39.71	-68.21	-57.75	3.03	8.07	V	Pass



<High Channel>

Band :	LTE Band 5	Temperature :	21~24°C
Test Mode :	1.4MHz QPSK RB Size 1 Offset 0	Relative Humidity :	46~48%
Test Engineer :	Ken Wu	Polarization :	Horizontal
Channel :	20643		
Remark :	Spurious emissions within 30-1000MHz were found more than 20dB below limit line.		

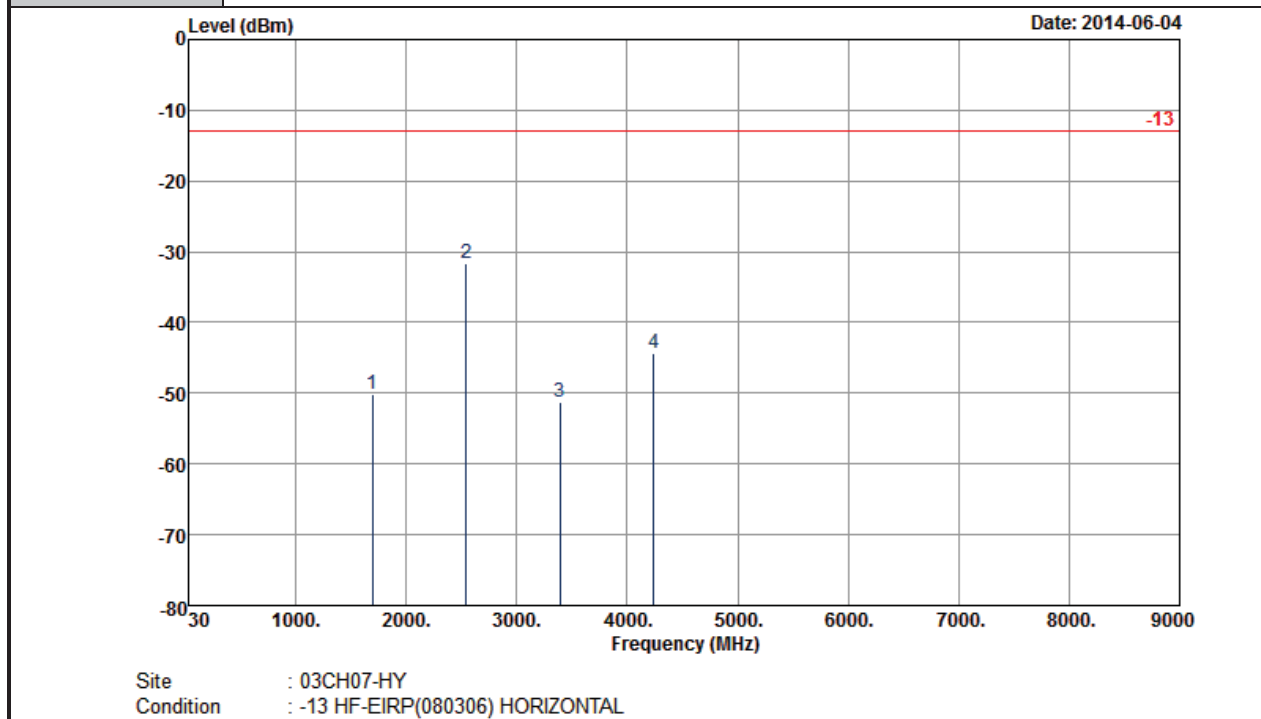

Frequency (MHz)	ERP (dBm)	Limit (dBm)	Over Limit (dB)	SPA Reading (dBm)	S.G. Power (dBm)	TX Cable loss (dB)	TX Antenna Gain (dBi)	Polarization (H/V)	Result
1696	-50.13	-13	-37.13	-59.07	-54.02	1.58	5.47	H	Pass
2544	-31.72	-13	-18.72	-44.98	-36	2.03	6.31	H	Pass
3392	-51.21	-13	-38.21	-65.37	-57.13	2.31	8.23	H	Pass
4240	-44.37	-13	-31.37	-60.62	-50.87	2.75	9.25	H	Pass



Band :	LTE Band 5	Temperature :	21~24°C
Test Mode :	1.4MHz QPSK RB Size 1 Offset 0	Relative Humidity :	46~48%
Test Engineer :	Ken Wu	Polarization :	Vertical
Channel :	20643		
Remark :	Spurious emissions within 30-1000MHz were found more than 20dB below limit line.		

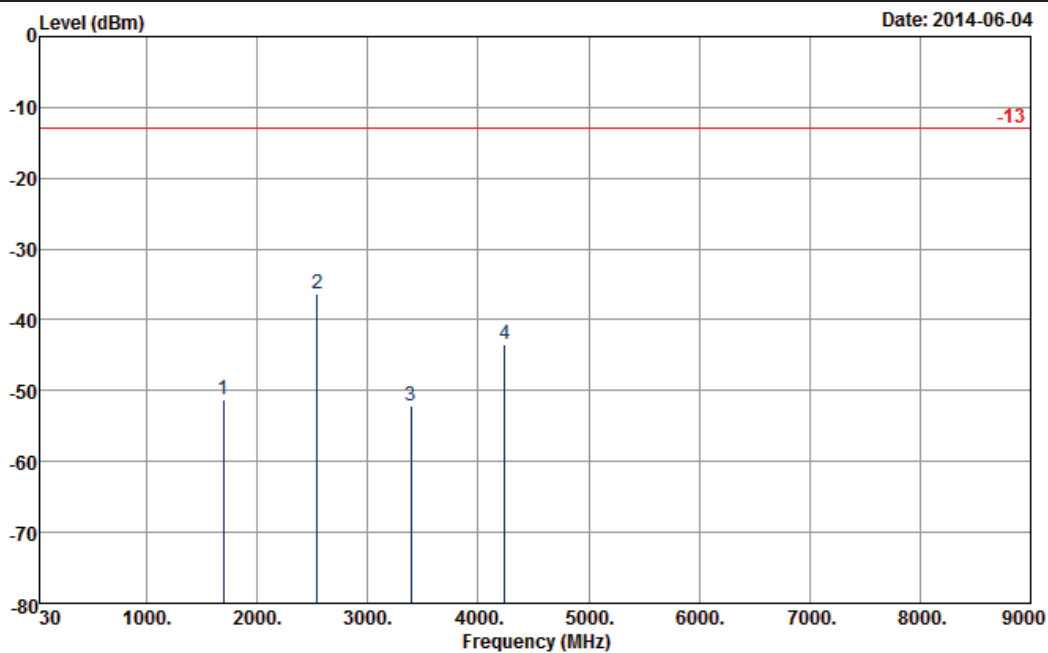

Site : 03CH07-HY
 Condition : -13 HF-EIRP(080306) VERTICAL

Frequency (MHz)	ERP (dBm)	Limit (dBm)	Over Limit (dB)	SPA Reading (dBm)	S.G. Power (dBm)	TX Cable loss (dB)	TX Antenna Gain (dBi)	Polarization (H/V)	Result
1696	-51.18	-13	-38.18	-62.39	-55.07	1.58	5.47	V	Pass
2544	-36.38	-13	-23.38	-50.15	-40.66	2.03	6.31	V	Pass
3392	-52.08	-13	-39.08	-67.61	-58	2.31	8.23	V	Pass
4240	-43.56	-13	-30.56	-60.68	-50.06	2.75	9.25	V	Pass



<Low Channel>

Band :	LTE Band 5	Temperature :	21~24°C
Test Mode :	3MHz QPSK RB Size 1 Offset 0	Relative Humidity :	46~48%
Test Engineer :	Ken Wu	Polarization :	Horizontal
Channel :	20415		
Remark :	Spurious emissions within 30-1000MHz were found more than 20dB below limit line.		

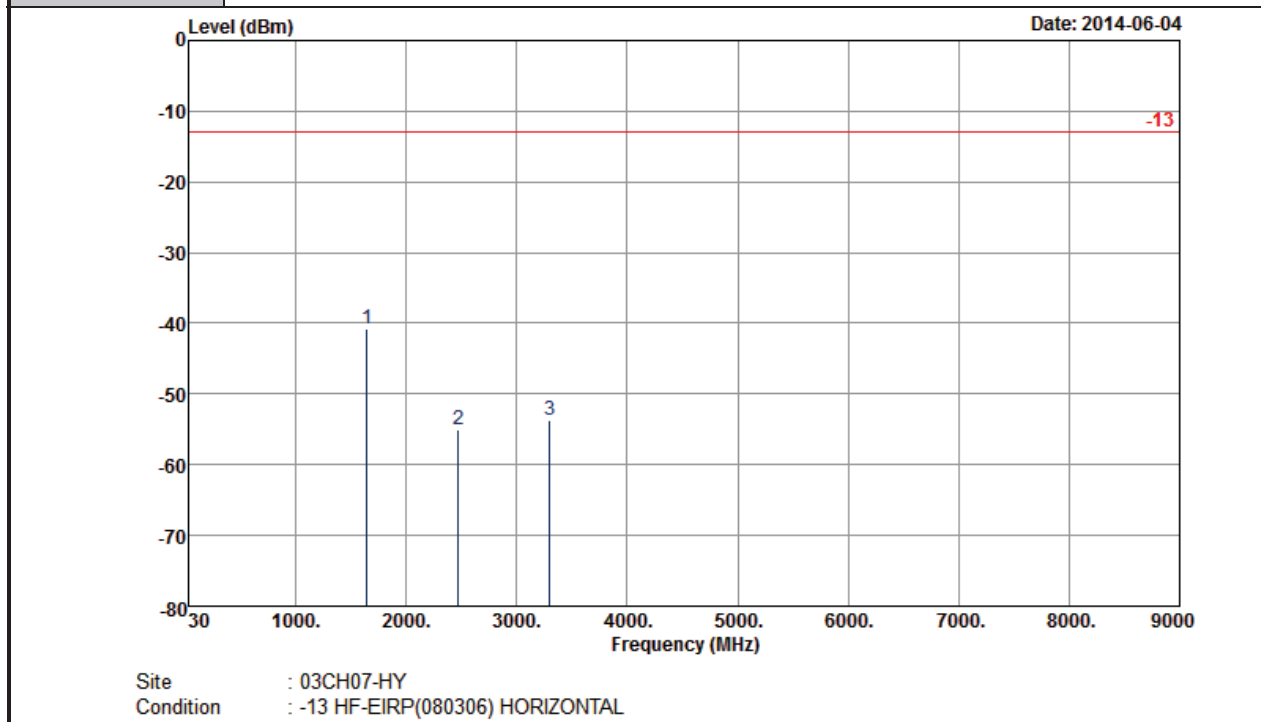

Frequency (MHz)	ERP (dBm)	Limit (dBm)	Over Limit (dB)	SPA Reading (dBm)	S.G. Power (dBm)	TX Cable loss (dB)	TX Antenna Gain (dBi)	Polarization (H/V)	Result
1648	-40.73	-13	-27.73	-49.5	-44.62	1.6	5.49	H	Pass
2472	-54.95	-13	-41.95	-68.12	-59.13	2.08	6.26	H	Pass
3296	-53.72	-13	-40.72	-67.79	-58.74	3.09	8.11	H	Pass



Band :	LTE Band 5	Temperature :	21~24°C
Test Mode :	3MHz QPSK RB Size 1 Offset 0	Relative Humidity :	46~48%
Test Engineer :	Ken Wu	Polarization :	Vertical
Channel :	20415		
Remark :	Spurious emissions within 30-1000MHz were found more than 20dB below limit line.		

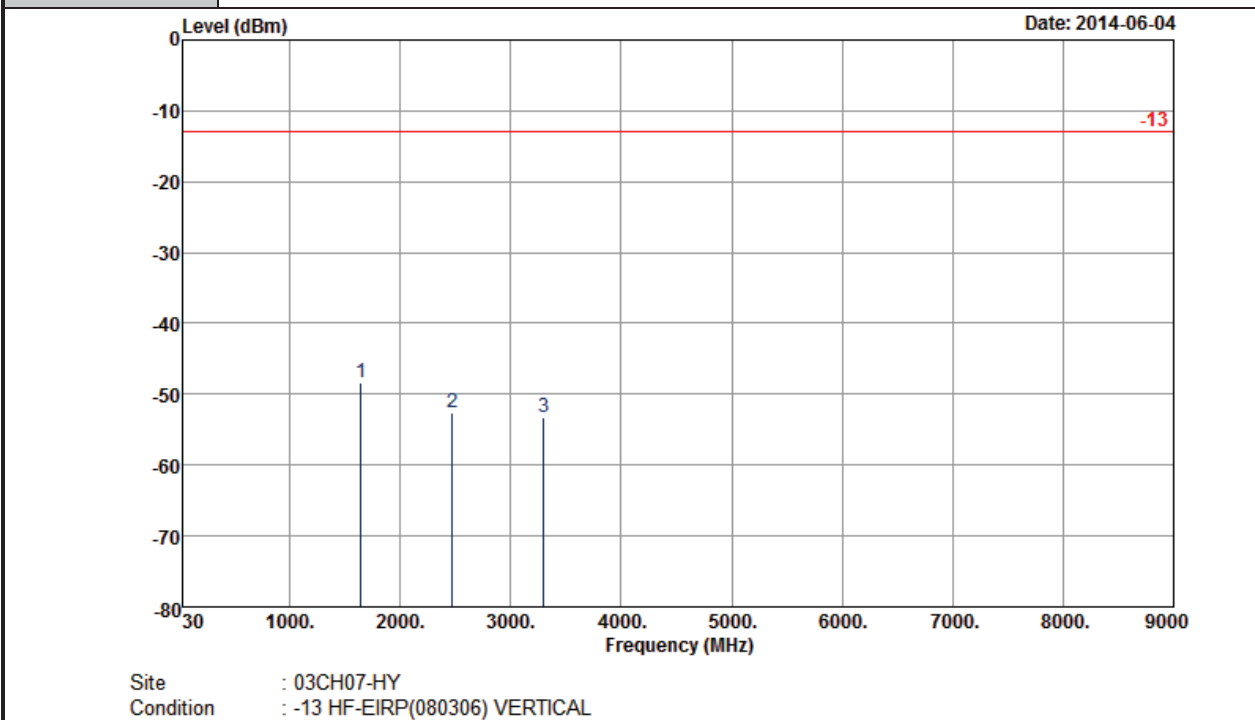

Frequency (MHz)	ERP (dBm)	Limit (dBm)	Over Limit (dB)	SPA Reading (dBm)	S.G. Power (dBm)	TX Cable loss (dB)	TX Antenna Gain (dBi)	Polarization (H/V)	Result
1648	-48.43	-13	-35.43	-59.43	-52.32	1.6	5.49	V	Pass
2472	-52.48	-13	-39.48	-66.1	-56.66	2.08	6.26	V	Pass
3296	-53.27	-13	-40.27	-69.01	-58.29	3.09	8.11	V	Pass



<Middle Channel>

Band :	LTE Band 5	Temperature :	21~24°C
Test Mode :	3MHz QPSK RB Size 1 Offset 0	Relative Humidity :	46~48%
Test Engineer :	Ken Wu	Polarization :	Horizontal
Channel :	20525		
Remark :	Spurious emissions within 30-1000MHz were found more than 20dB below limit line.		

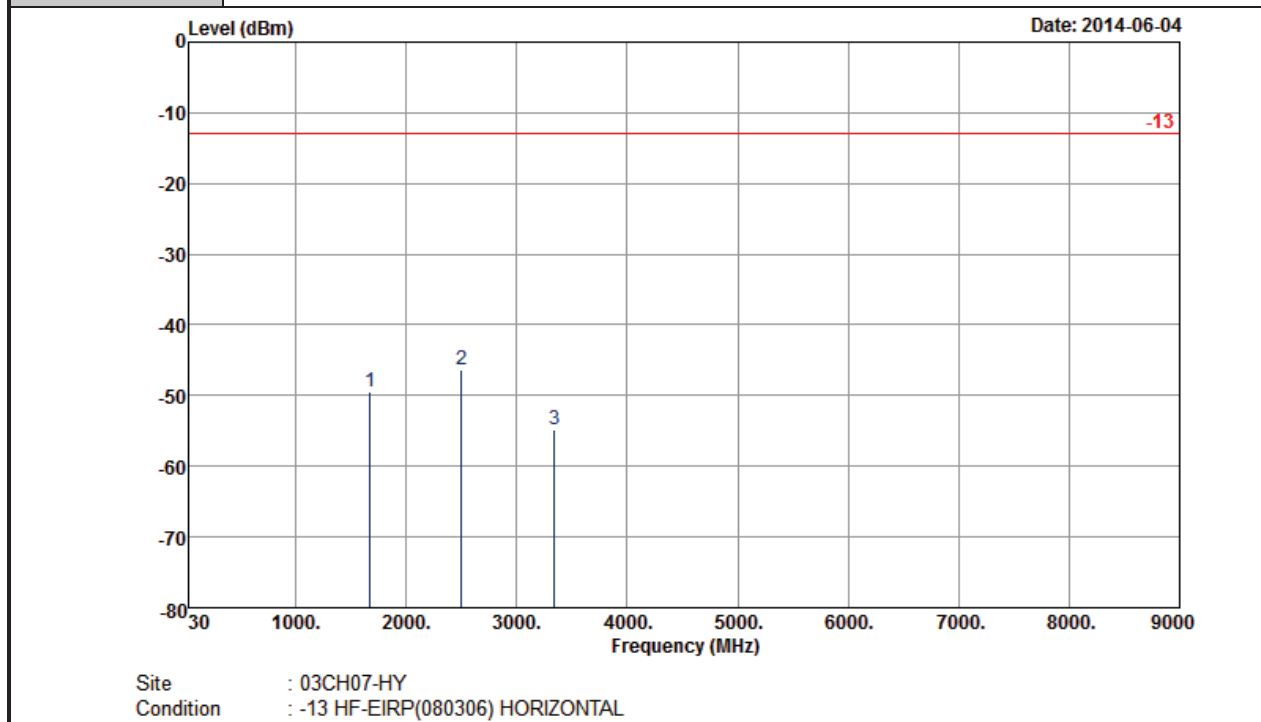

Frequency (MHz)	ERP (dBm)	Limit (dBm)	Over Limit (dB)	SPA Reading (dBm)	S.G. Power (dBm)	TX Cable loss (dB)	TX Antenna Gain (dBi)	Polarization (H/V)	Result
1672	-49.37	-13	-36.37	-58.35	-53.24	1.62	5.49	H	Pass
2504	-46.40	-13	-33.40	-59.61	-50.52	2.1	6.22	H	Pass
3344	-54.75	-13	-41.75	-68.93	-59.79	3.03	8.07	H	Pass



Band :	LTE Band 5	Temperature :	21~24°C
Test Mode :	3MHz QPSK RB Size 1 Offset 0	Relative Humidity :	46~48%
Test Engineer :	Ken Wu	Polarization :	Vertical
Channel :	20525		
Remark :	Spurious emissions within 30-1000MHz were found more than 20dB below limit line.		

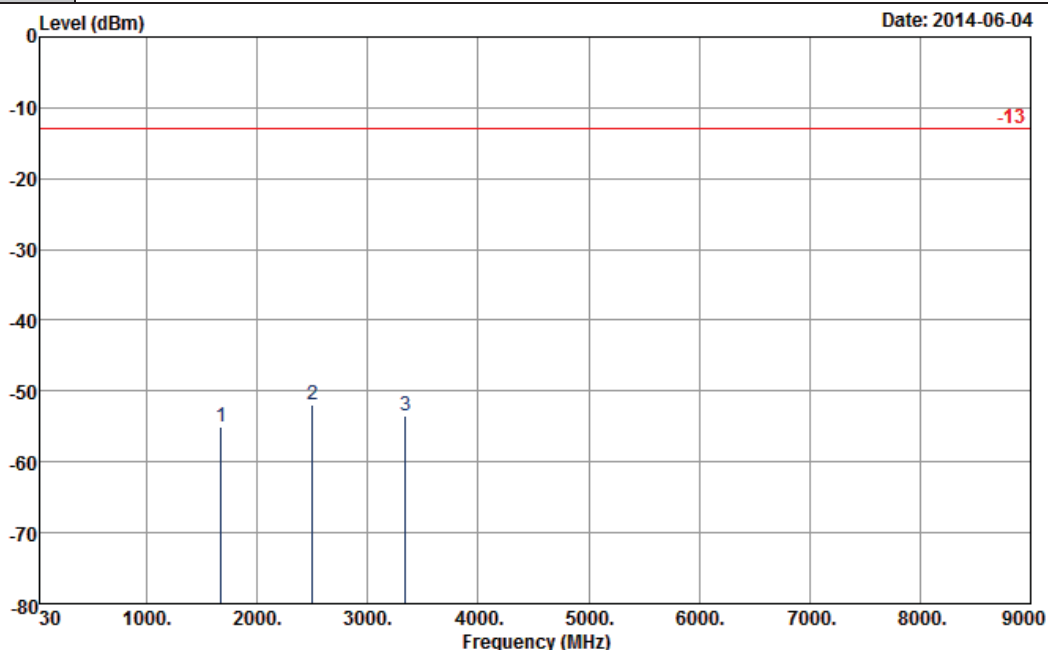

Site : 03CH07-HY
 Condition : -13 HF-EIRP(080306) VERTICAL

Frequency (MHz)	ERP (dBm)	Limit (dBm)	Over Limit (dB)	SPA Reading (dBm)	S.G. Power (dBm)	TX Cable loss (dB)	TX Antenna Gain (dBi)	Polarization (H/V)	Result
1672	-55.02	-13	-42.02	-66.17	-58.89	1.62	5.49	V	Pass
2504	-51.82	-13	-38.82	-65.41	-55.94	2.1	6.22	V	Pass
3344	-53.45	-13	-40.45	-69.01	-58.49	3.03	8.07	V	Pass



<High Channel>

Band :	LTE Band 5	Temperature :	21~24°C
Test Mode :	3MHz QPSK RB Size 1 Offset 0	Relative Humidity :	46~48%
Test Engineer :	Ken Wu	Polarization :	Horizontal
Channel :	20635		
Remark :	Spurious emissions within 30-1000MHz were found more than 20dB below limit line.		

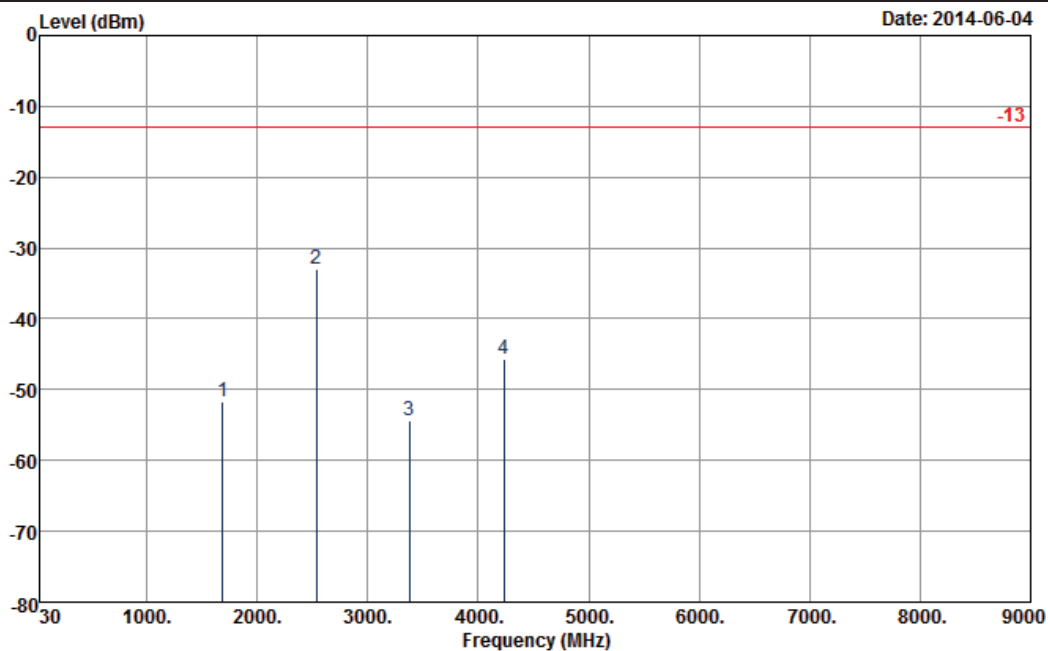

Site : 03CH07-HY
 Condition : -13 HF-EIRP(080306) HORIZONTAL

Frequency (MHz)	ERP (dBm)	Limit (dBm)	Over Limit (dB)	SPA Reading (dBm)	S.G. Power (dBm)	TX Cable loss (dB)	TX Antenna Gain (dBi)	Polarization (H/V)	Result
1688	-51.80	-13	-38.80	-60.76	-55.69	1.56	5.45	H	Pass
2536	-33.08	-13	-20.08	-46.46	-37.34	2.02	6.28	H	Pass
3376	-54.39	-13	-41.39	-68.6	-60.29	2.29	8.19	H	Pass
4232	-45.62	-13	-32.62	-61.9	-52.1	2.73	9.21	H	Pass



Band :	LTE Band 5	Temperature :	21~24°C
Test Mode :	3MHz QPSK RB Size 1 Offset 0	Relative Humidity :	46~48%
Test Engineer :	Ken Wu	Polarization :	Vertical
Channel :	20635		
Remark :	Spurious emissions within 30-1000MHz were found more than 20dB below limit line.		

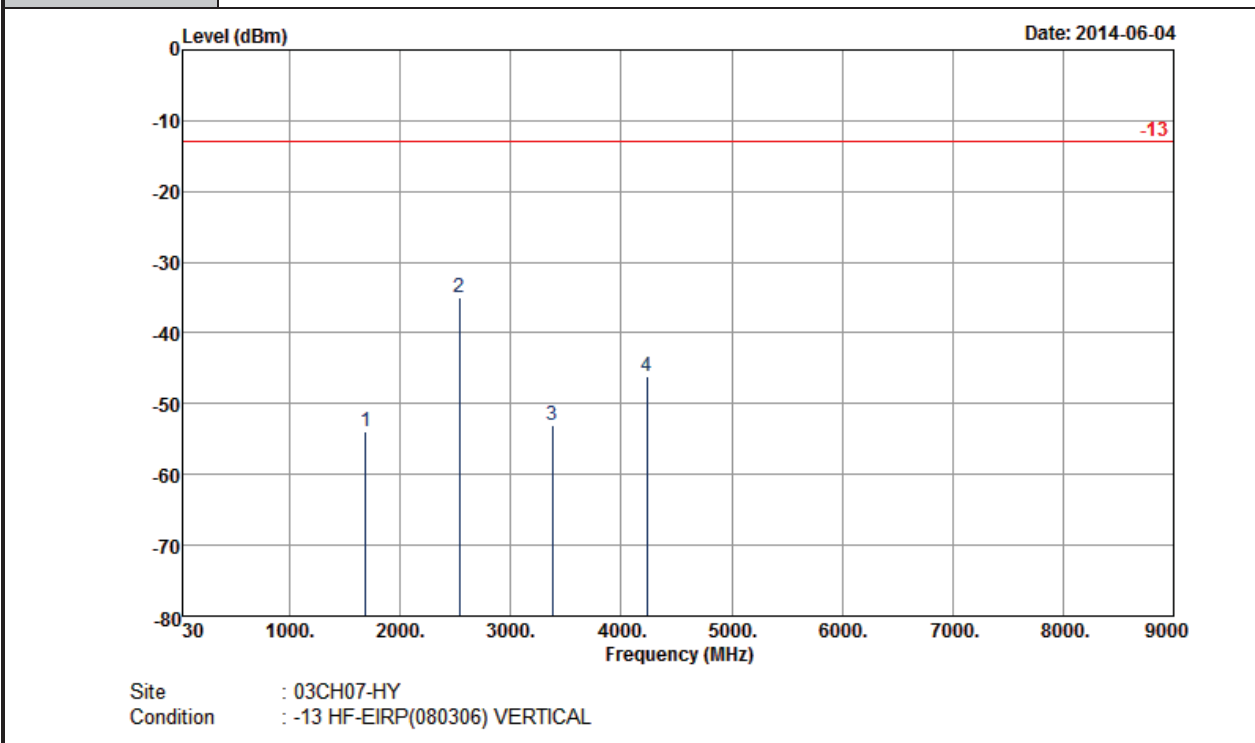

Frequency (MHz)	ERP (dBm)	Limit (dBm)	Over Limit (dB)	SPA Reading (dBm)	S.G. Power (dBm)	TX Cable loss (dB)	TX Antenna Gain (dBi)	Polarization (H/V)	Result
1688	-53.92	-13	-40.92	-65.01	-57.81	1.56	5.45	V	Pass
2536	-35.02	-13	-22.02	-48.87	-39.28	2.02	6.28	V	Pass
3376	-52.98	-13	-39.98	-68.53	-58.88	2.29	8.19	V	Pass
4232	-46.04	-13	-33.04	-63.21	-52.52	2.73	9.21	V	Pass



<Low Channel>

Band :	LTE Band 2	Temperature :	21~24°C
Test Mode :	1.4MHz QPSK RB Size 1 Offset 0	Relative Humidity :	46~48%
Test Engineer :	Ken Wu	Polarization :	Horizontal
Channel :	18607		
Remark :	Spurious emissions within 30-1000MHz were found more than 20dB below limit line.		

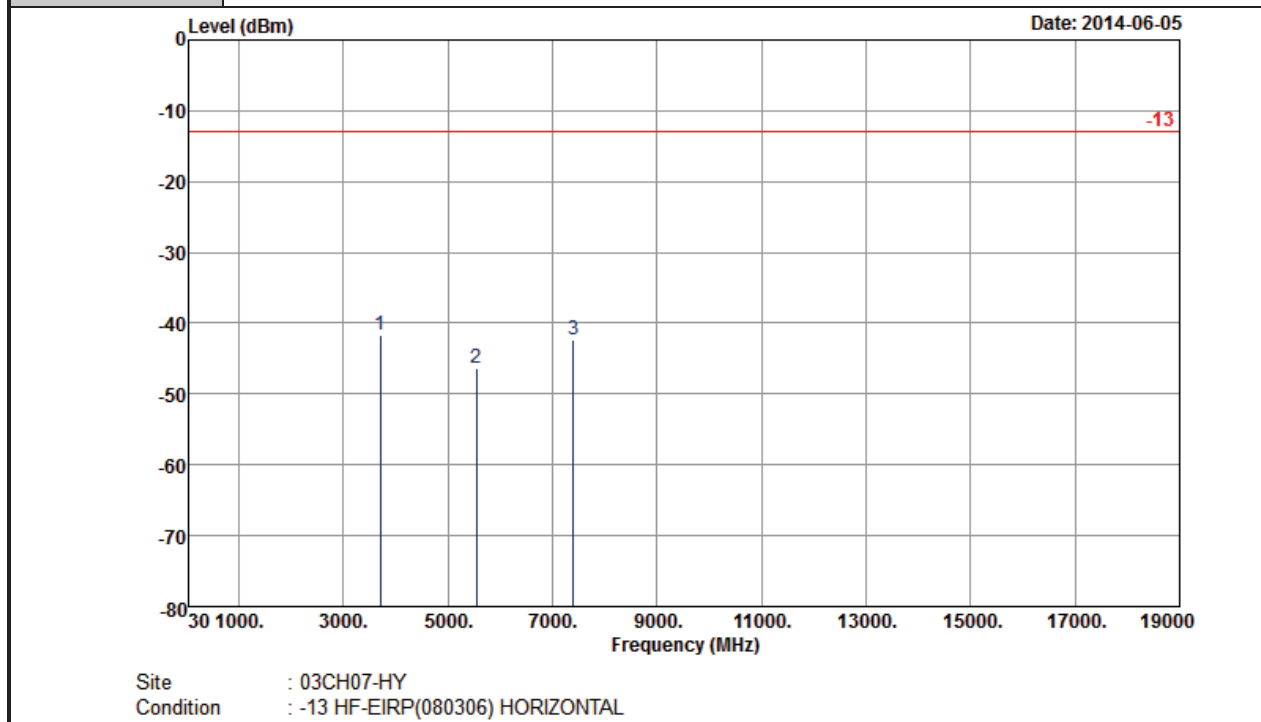

Frequency (MHz)	EIRP (dBm)	Limit (dBm)	Over Limit (dB)	SPA Reading (dBm)	S.G. Power (dBm)	TX Cable loss (dB)	TX Antenna Gain (dBi)	Polarization (H/V)	Result
3700	-41.74	-13	-28.74	-56.8	-48	2.48	8.74	H	Pass
5548	-46.33	-13	-33.33	-66.7	-54.02	2.96	10.65	H	Pass
7403	-42.43	-13	-29.43	-69.71	-51.06	3.48	12.11	H	Pass



Band :	LTE Band 2	Temperature :	21~24°C
Test Mode :	1.4MHz QPSK RB Size 1 Offset 0	Relative Humidity :	46~48%
Test Engineer :	Ken Wu	Polarization :	Vertical
Channel :	18607		
Remark :	Spurious emissions within 30-1000MHz were found more than 20dB below limit line.		

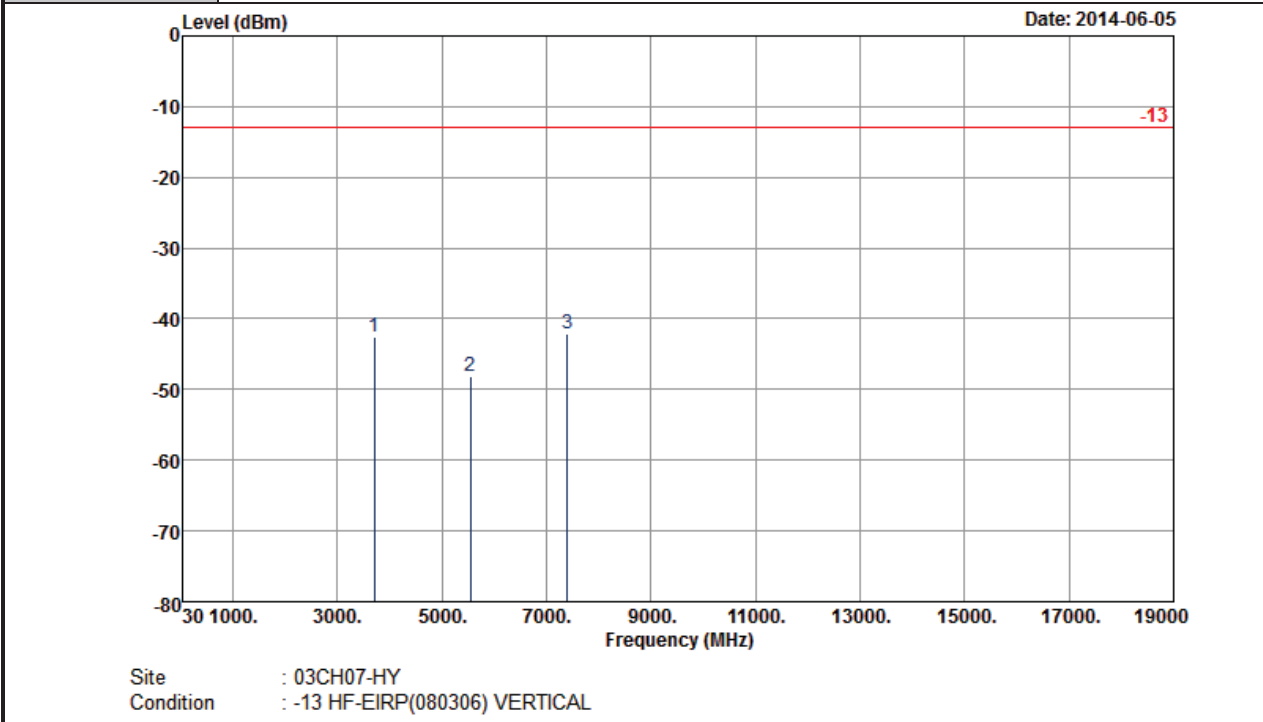

Frequency (MHz)	EIRP (dBm)	Limit (dBm)	Over Limit (dB)	SPA Reading (dBm)	S.G. Power (dBm)	TX Cable loss (dB)	TX Antenna Gain (dBi)	Polarization (H/V)	Result
3700	-42.49	-13	-29.49	-58.67	-48.75	2.48	8.74	V	Pass
5548	-48.15	-13	-35.15	-68.34	-55.84	2.96	10.65	V	Pass
7403	-42.06	-13	-29.06	-69.02	-50.69	3.48	12.11	V	Pass



<Middle Channel>

Band :	LTE Band 2	Temperature :	21~24°C
Test Mode :	1.4MHz QPSK RB Size 1 Offset 0	Relative Humidity :	46~48%
Test Engineer :	Ken Wu	Polarization :	Horizontal
Channel :	18900		
Remark :	Spurious emissions within 30-1000MHz were found more than 20dB below limit line.		

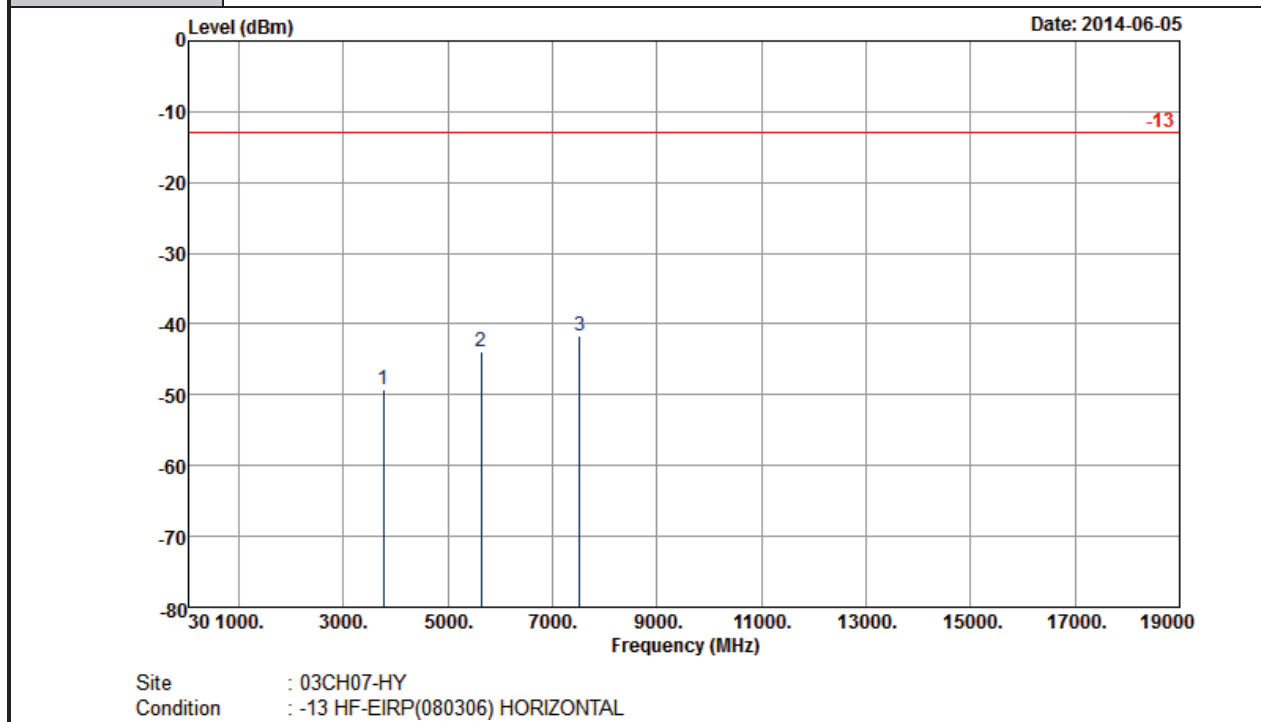

Frequency (MHz)	EIRP (dBm)	Limit (dBm)	Over Limit (dB)	SPA Reading (dBm)	S.G. Power (dBm)	TX Cable loss (dB)	TX Antenna Gain (dBi)	Polarization (H/V)	Result
3756	-49.17	-13	-36.17	-64.52	-55.47	2.51	8.81	H	Pass
5639	-43.97	-13	-30.97	-64.74	-51.68	2.99	10.70	H	Pass
7522	-41.74	-13	-28.74	-68.97	-50.27	3.59	12.12	H	Pass



Band :	LTE Band 2	Temperature :	21~24°C
Test Mode :	1.4MHz QPSK RB Size 1 Offset 0	Relative Humidity :	46~48%
Test Engineer :	Ken Wu	Polarization :	Vertical
Channel :	18900		
Remark :	Spurious emissions within 30-1000MHz were found more than 20dB below limit line.		

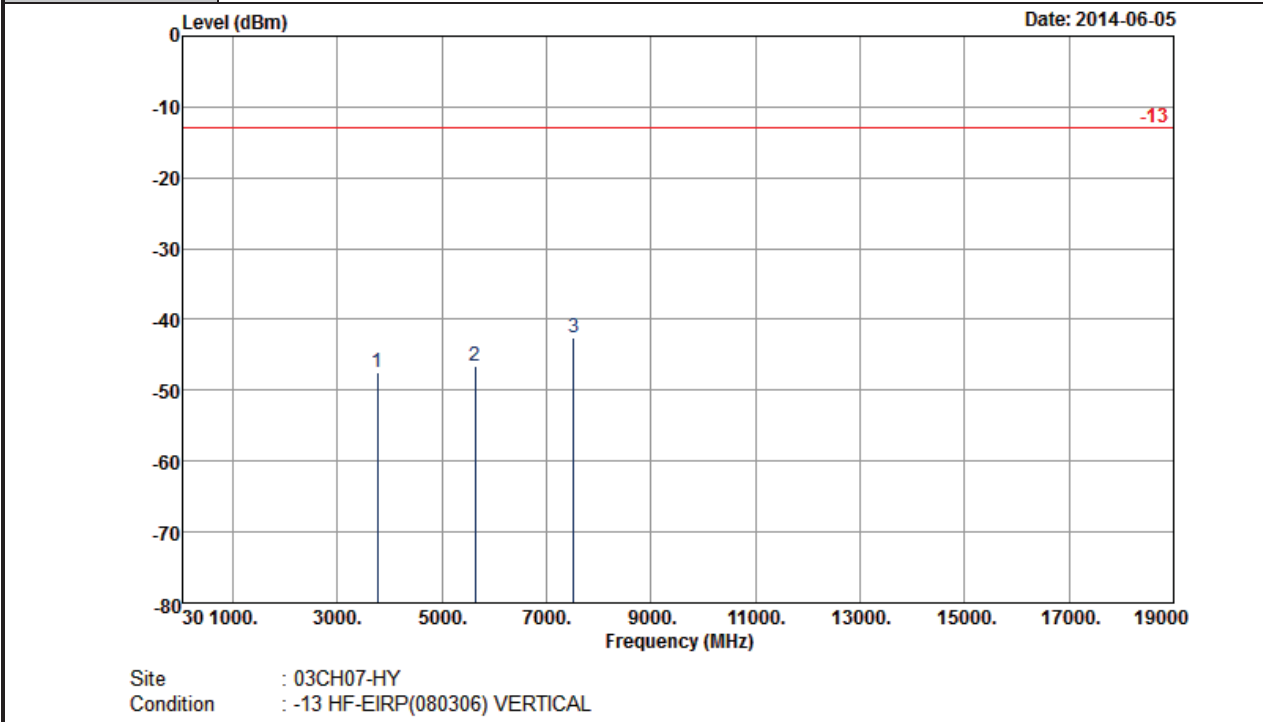

Frequency (MHz)	EIRP (dBm)	Limit (dBm)	Over Limit (dB)	SPA Reading (dBm)	S.G. Power (dBm)	TX Cable loss (dB)	TX Antenna Gain (dBi)	Polarization (H/V)	Result
3756	-47.46	-13	-34.46	-63.89	-53.76	2.51	8.81	V	Pass
5639	-46.62	-13	-33.62	-67.25	-54.33	2.99	10.70	V	Pass
7522	-42.61	-13	-29.61	-69.69	-51.14	3.59	12.12	V	Pass



<High Channel>

Band :	LTE Band 2	Temperature :	21~24°C
Test Mode :	1.4MHz QPSK RB Size 1 Offset 0	Relative Humidity :	46~48%
Test Engineer :	Ken Wu	Polarization :	Horizontal
Channel :	19193		
Remark :	Spurious emissions within 30-1000MHz were found more than 20dB below limit line.		

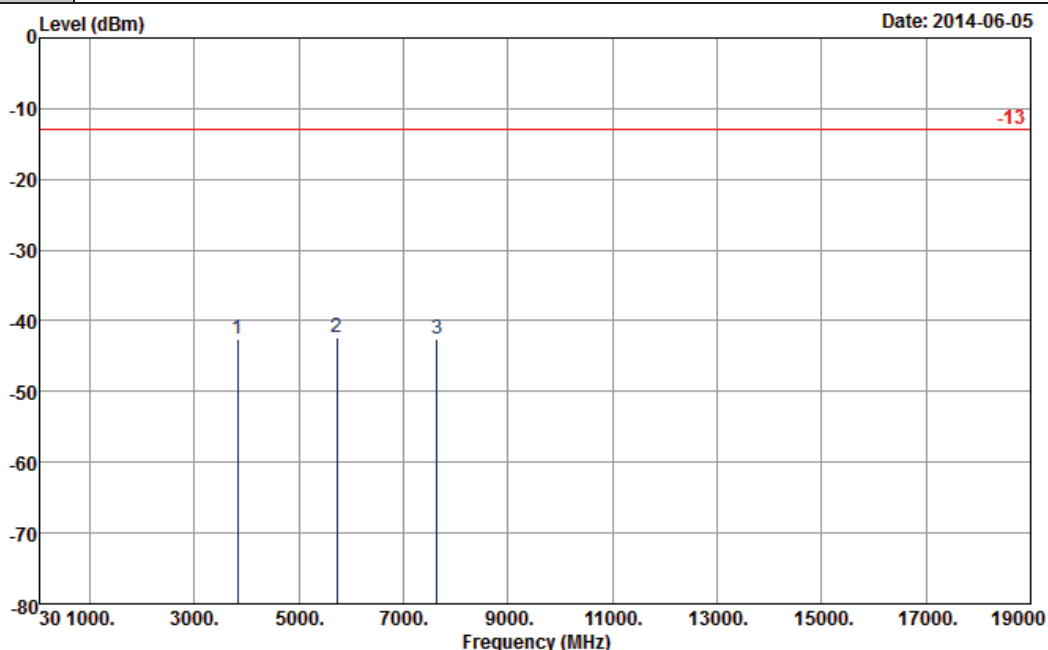

Site : 03CH07-HY
 Condition : -13 HF-EIRP(080306) HORIZONTAL

Frequency (MHz)	EIRP (dBm)	Limit (dBm)	Over Limit (dB)	SPA Reading (dBm)	S.G. Power (dBm)	TX Cable loss (dB)	TX Antenna Gain (dBi)	Polarization (H/V)	Result
3819	-42.53	-13	-29.53	-58.12	-48.79	2.61	8.87	H	Pass
5723	-42.31	-13	-29.31	-63.4	-50.11	3.09	10.89	H	Pass
7641	-42.57	-13	-29.57	-68.91	-51.07	3.68	12.18	H	Pass



Band :	LTE Band 2	Temperature :	21~24°C
Test Mode :	1.4MHz QPSK RB Size 1 Offset 0	Relative Humidity :	46~48%
Test Engineer :	Ken Wu	Polarization :	Vertical
Channel :	19193		
Remark :	Spurious emissions within 30-1000MHz were found more than 20dB below limit line.		

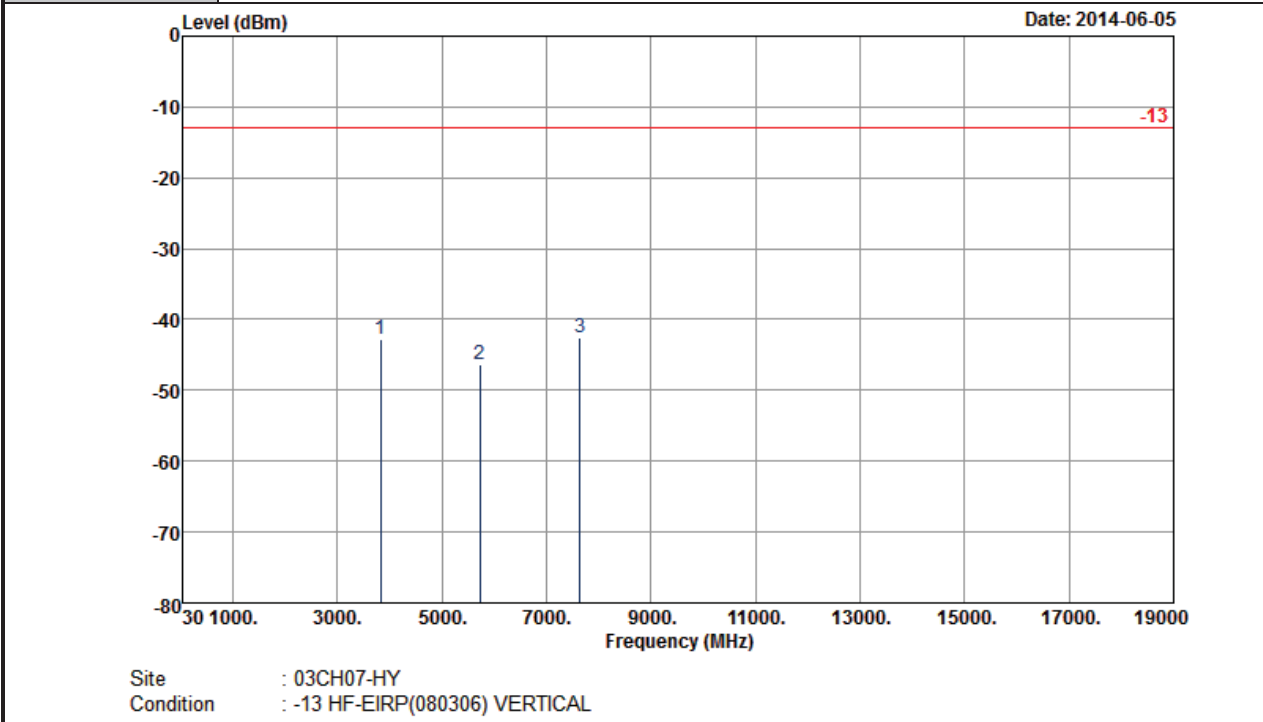

Frequency (MHz)	EIRP (dBm)	Limit (dBm)	Over Limit (dB)	SPA Reading (dBm)	S.G. Power (dBm)	TX Cable loss (dB)	TX Antenna Gain (dBi)	Polarization (H/V)	Result
3819	-42.88	-13	-29.88	-59.5	-49.14	2.61	8.87	V	Pass
5723	-46.30	-13	-33.30	-67.16	-54.1	3.09	10.89	V	Pass
7641	-42.59	-13	-29.59	-68.74	-51.09	3.68	12.18	V	Pass



<Low Channel>

Band :	LTE Band 2	Temperature :	21~24°C
Test Mode :	3MHz QPSK RB Size 1 Offset 0	Relative Humidity :	46~48%
Test Engineer :	Ken Wu	Polarization :	Horizontal
Channel :	18615		
Remark :	Spurious emissions within 30-1000MHz were found more than 20dB below limit line.		

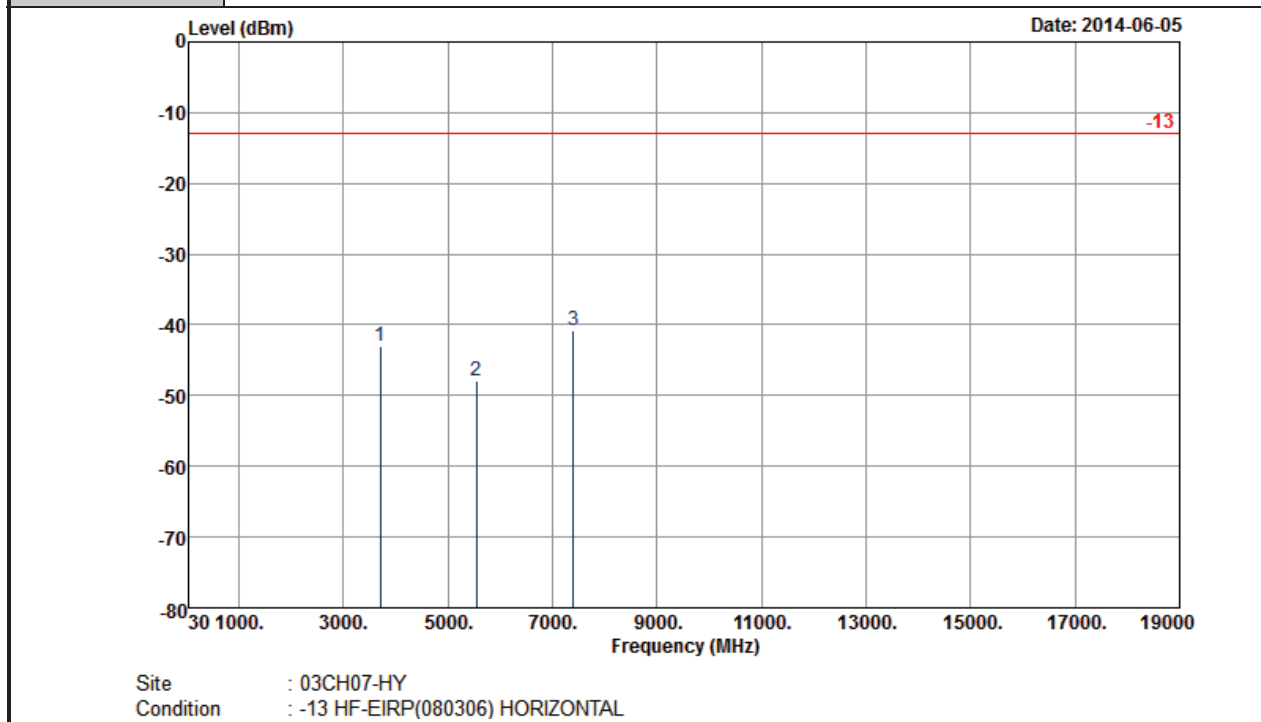

Frequency (MHz)	EIRP (dBm)	Limit (dBm)	Over Limit (dB)	SPA Reading (dBm)	S.G. Power (dBm)	TX Cable loss (dB)	TX Antenna Gain (dBi)	Polarization (H/V)	Result
3700	-43.07	-13	-30.07	-58.26	-49.33	2.47	8.73	H	Pass
5548	-47.87	-13	-34.87	-68.31	-55.62	2.93	10.68	H	Pass
7403	-40.75	-13	-27.75	-68.11	-49.47	3.42	12.14	H	Pass



Band :	LTE Band 2	Temperature :	21~24°C
Test Mode :	3MHz QPSK RB Size 1 Offset 0	Relative Humidity :	46~48%
Test Engineer :	Ken Wu	Polarization :	Vertical
Channel :	18615		
Remark :	Spurious emissions within 30-1000MHz were found more than 20dB below limit line.		

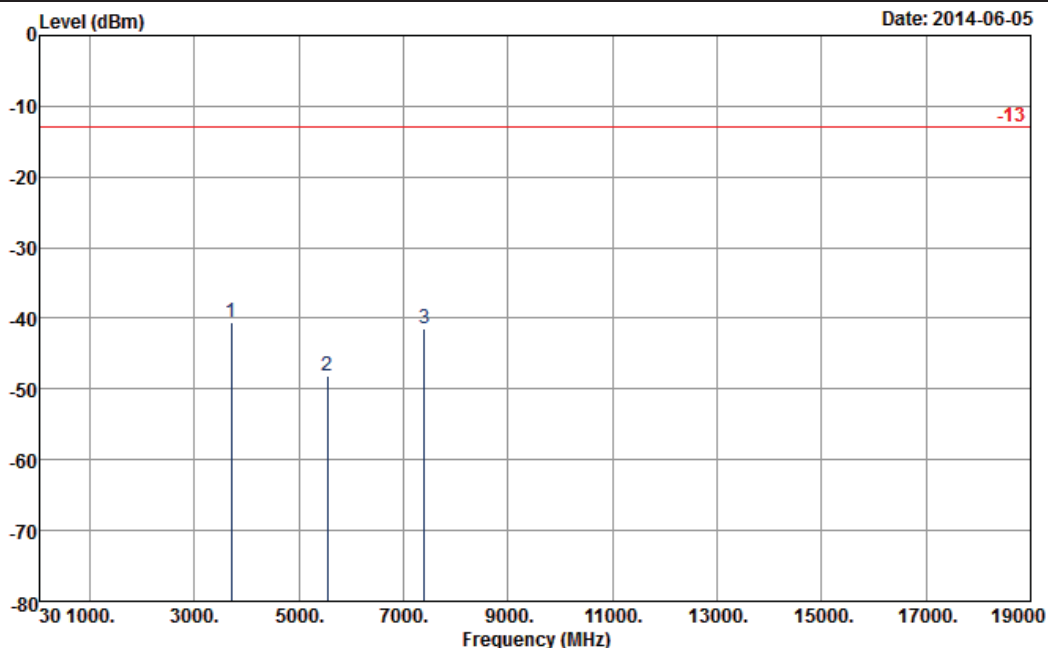

Site : 03CH07-HY
 Condition : -13 HF-EIRP(080306) VERTICAL

Frequency (MHz)	EIRP (dBm)	Limit (dBm)	Over Limit (dB)	SPA Reading (dBm)	S.G. Power (dBm)	TX Cable loss (dB)	TX Antenna Gain (dBi)	Polarization (H/V)	Result
3700	-40.48	-13	-27.48	-56.55	-46.74	2.47	8.73	V	Pass
5548	-48.21	-13	-35.21	-68.41	-55.96	2.93	10.68	V	Pass
7403	-41.53	-13	-28.53	-68.48	-50.25	3.42	12.14	V	Pass



<Middle Channel>

Band :	LTE Band 2	Temperature :	21~24°C
Test Mode :	3MHz QPSK RB Size 1 Offset 0	Relative Humidity :	46~48%
Test Engineer :	Ken Wu	Polarization :	Horizontal
Channel :	18900		
Remark :	Spurious emissions within 30-1000MHz were found more than 20dB below limit line.		

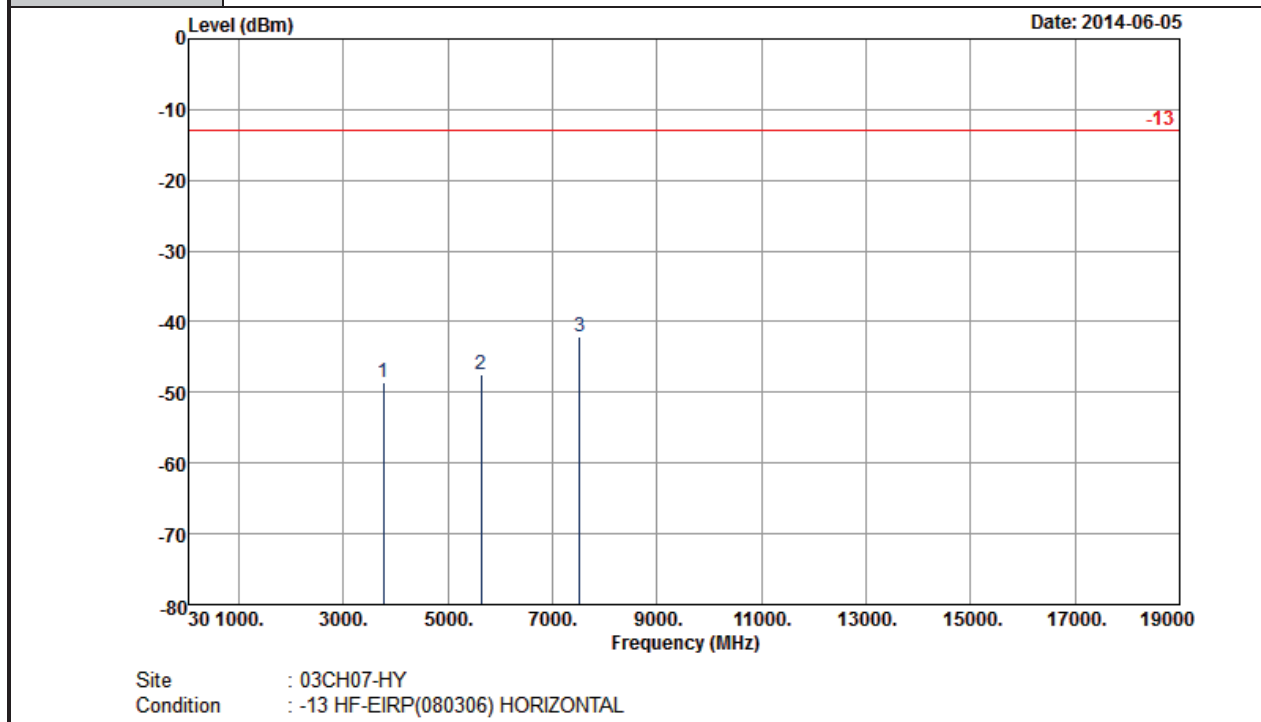

Frequency (MHz)	EIRP (dBm)	Limit (dBm)	Over Limit (dB)	SPA Reading (dBm)	S.G. Power (dBm)	TX Cable loss (dB)	TX Antenna Gain (dBi)	Polarization (H/V)	Result
3756	-48.65	-13	-35.65	-64.02	-54.95	2.51	8.81	H	Pass
5632	-47.47	-13	-34.47	-68.21	-55.18	2.99	10.70	H	Pass
7515	-42.06	-13	-29.06	-69.48	-50.59	3.59	12.12	H	Pass



Band :	LTE Band 2	Temperature :	21~24°C
Test Mode :	3MHz QPSK RB Size 1 Offset 0	Relative Humidity :	46~48%
Test Engineer :	Ken Wu	Polarization :	Vertical
Channel :	18900		
Remark :	Spurious emissions within 30-1000MHz were found more than 20dB below limit line.		

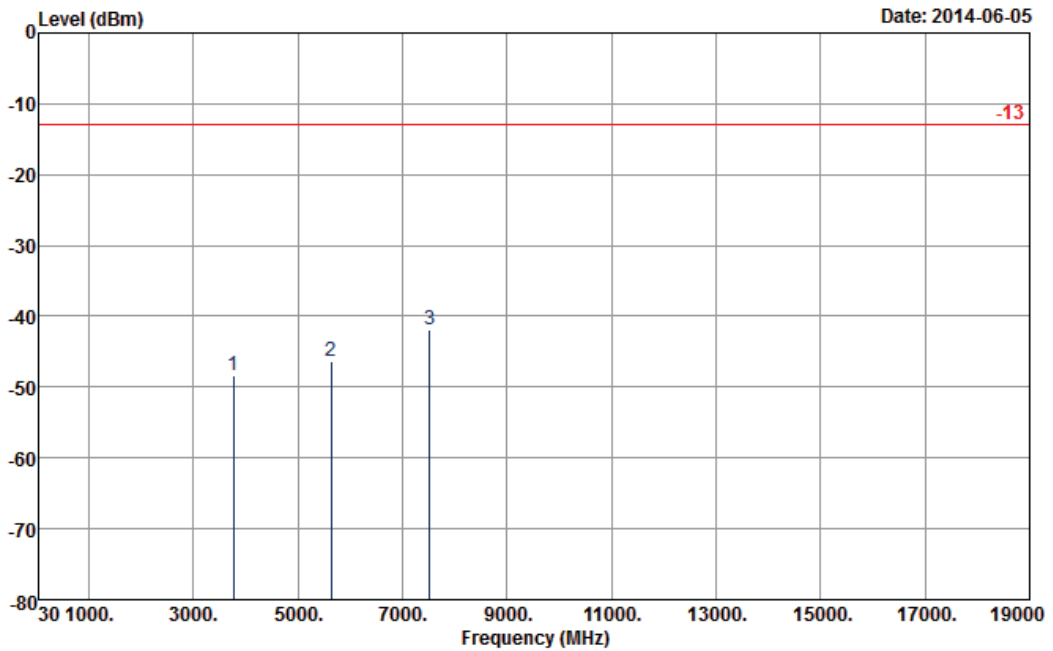

Site : 03CH07-HY
 Condition : -13 HF-EIRP(080306) VERTICAL

Frequency (MHz)	EIRP (dBm)	Limit (dBm)	Over Limit (dB)	SPA Reading (dBm)	S.G. Power (dBm)	TX Cable loss (dB)	TX Antenna Gain (dBi)	Polarization (H/V)	Result
3756	-48.33	-13	-35.33	-64.61	-54.63	2.51	8.81	V	Pass
5639	-46.41	-13	-33.41	-66.95	-54.12	2.99	10.70	V	Pass
7515	-41.99	-13	-28.99	-69.08	-50.52	3.59	12.12	V	Pass



<High Channel>

Band :	LTE Band 2	Temperature :	21~24°C
Test Mode :	3MHz QPSK RB Size 1 Offset 0	Relative Humidity :	46~48%
Test Engineer :	Ken Wu	Polarization :	Horizontal
Channel :	19185		
Remark :	Spurious emissions within 30-1000MHz were found more than 20dB below limit line.		

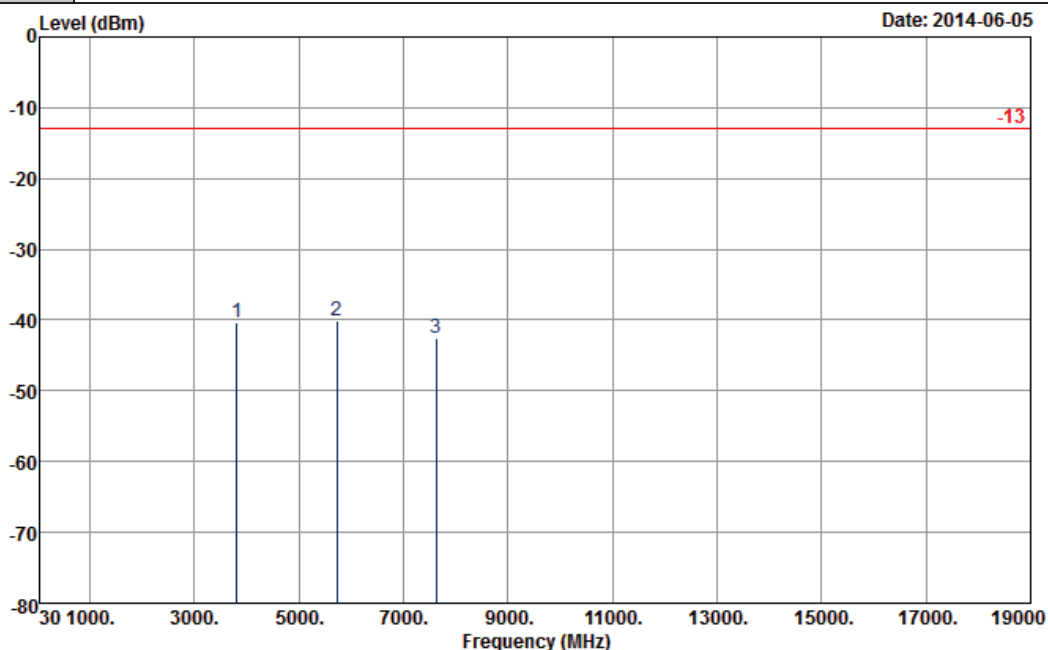

Site : 03CH07-HY
 Condition : -13 HF-EIRP(080306) HORIZONTAL

Frequency (MHz)	EIRP (dBm)	Limit (dBm)	Over Limit (dB)	SPA Reading (dBm)	S.G. Power (dBm)	TX Cable loss (dB)	TX Antenna Gain (dBi)	Polarization (H/V)	Result
3812	-40.34	-13	-27.34	-55.91	-46.57	2.64	8.87	H	Pass
5723	-40.14	-13	-27.14	-61.31	-47.88	3.08	10.82	H	Pass
7627	-42.65	-13	-29.65	-69.25	-51.14	3.64	12.13	H	Pass



Band :	LTE Band 2	Temperature :	21~24°C
Test Mode :	3MHz QPSK RB Size 1 Offset 0	Relative Humidity :	46~48%
Test Engineer :	Ken Wu	Polarization :	Vertical
Channel :	19185		
Remark :	Spurious emissions within 30-1000MHz were found more than 20dB below limit line.		

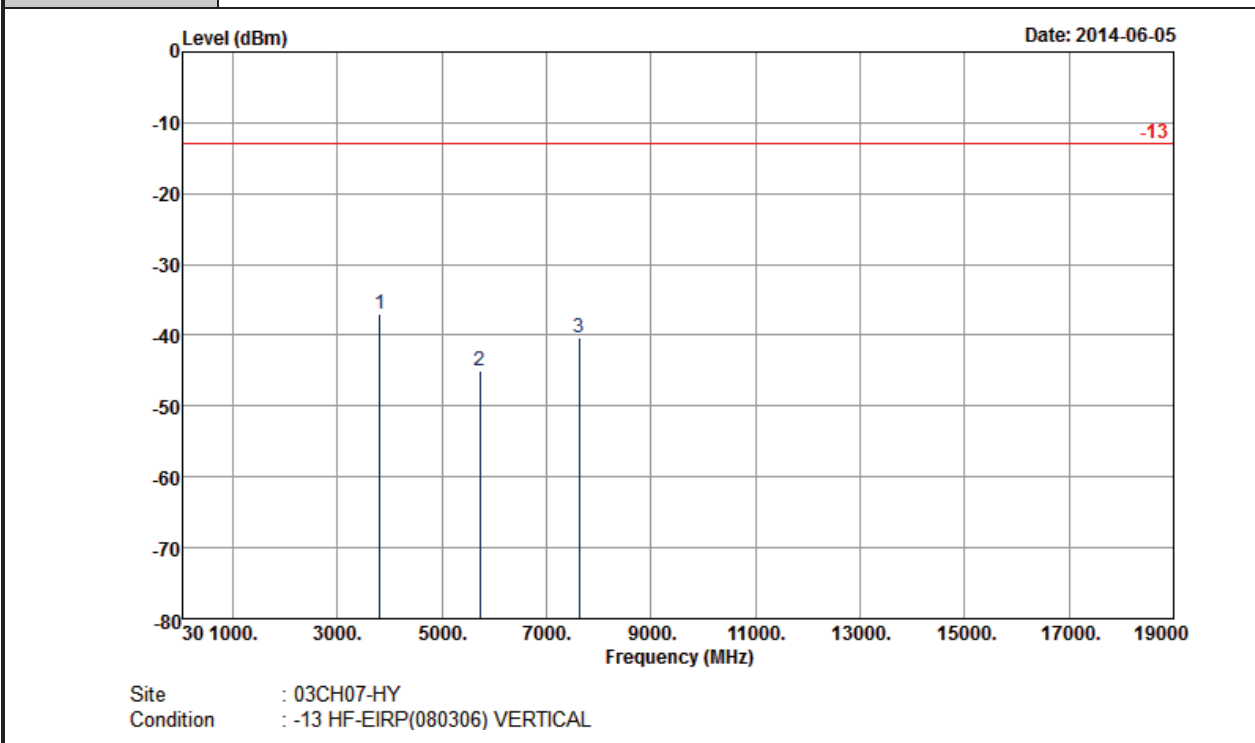

Frequency (MHz)	EIRP (dBm)	Limit (dBm)	Over Limit (dB)	SPA Reading (dBm)	S.G. Power (dBm)	TX Cable loss (dB)	TX Antenna Gain (dBi)	Polarization (H/V)	Result
3812	-36.90	-13	-23.90	-53.35	-43.13	2.64	8.87	V	Pass
5723	-44.92	-13	-31.92	-65.75	-52.66	3.08	10.82	V	Pass
7627	-40.23	-13	-27.23	-66.51	-48.72	3.64	12.13	V	Pass



<Low Channel>

Band :	LTE Band 2	Temperature :	21~24°C
Test Mode :	15MHz QPSK RB Size 1 Offset 0	Relative Humidity :	46~48%
Test Engineer :	Ken Wu	Polarization :	Horizontal
Channel :	18675		
Remark :	Spurious emissions within 30-1000MHz were found more than 20dB below limit line.		

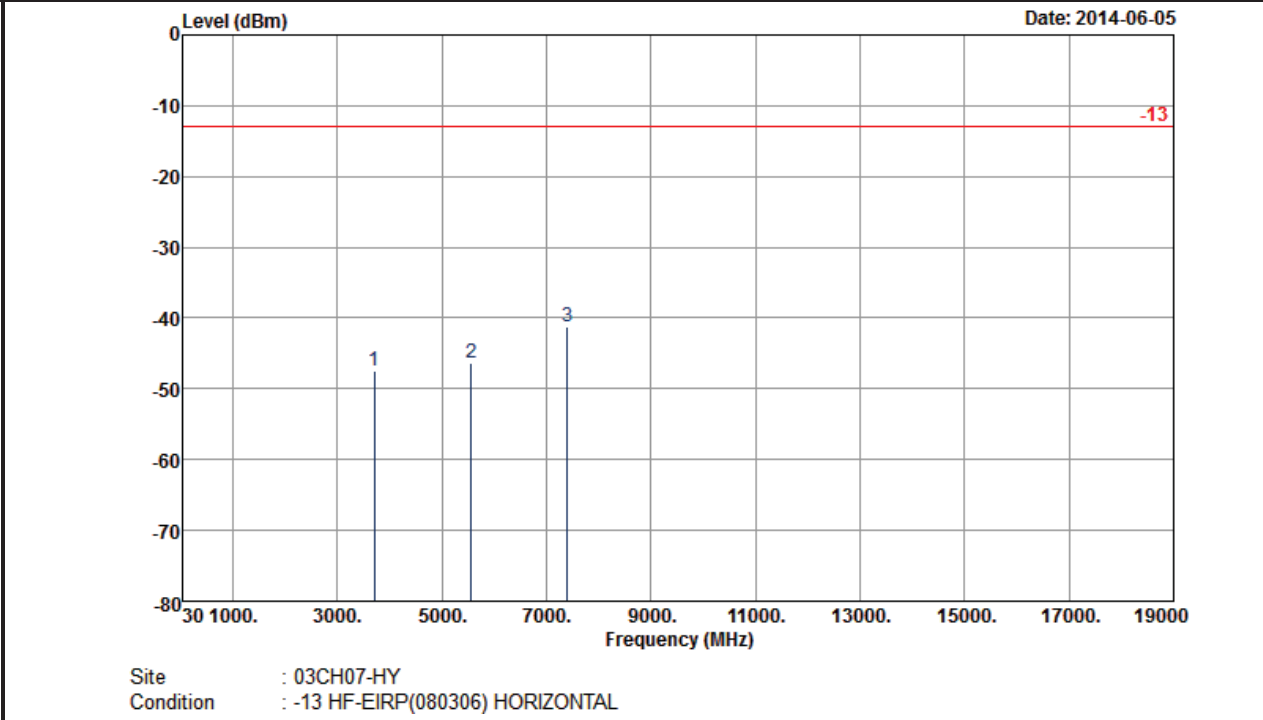

Frequency (MHz)	EIRP (dBm)	Limit (dBm)	Over Limit (dB)	SPA Reading (dBm)	S.G. Power (dBm)	TX Cable loss (dB)	TX Antenna Gain (dBi)	Polarization (H/V)	Result
3700	-47.45	-13	-34.45	-62.81	-53.8	2.49	8.84	H	Pass
5550	-46.25	-13	-33.25	-66.7	-54.1	3.01	10.86	H	Pass
7400	-41.33	-13	-28.33	-69.16	-50.3	3.38	12.35	H	Pass



Band :	LTE Band 2	Temperature :	21~24°C
Test Mode :	15MHz QPSK RB Size 1 Offset 0	Relative Humidity :	46~48%
Test Engineer :	Ken Wu	Polarization :	Vertical
Channel :	18675		
Remark :	Spurious emissions within 30-1000MHz were found more than 20dB below limit line.		

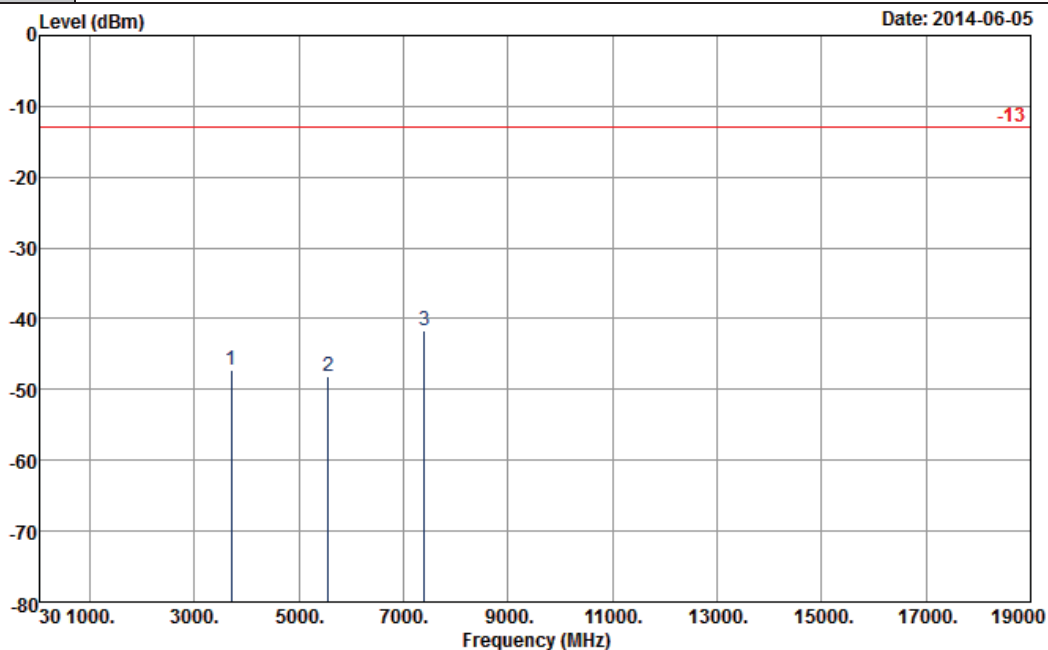

Site : 03CH07-HY
 Condition : -13 HF-EIRP(080306) VERTICAL

Frequency (MHz)	EIRP (dBm)	Limit (dBm)	Over Limit (dB)	SPA Reading (dBm)	S.G. Power (dBm)	TX Cable loss (dB)	TX Antenna Gain (dBi)	Polarization (H/V)	Result
3700	-47.15	-13	-34.15	-63.49	-53.5	2.49	8.84	V	Pass
5550	-48.05	-13	-35.05	-68.63	-55.9	3.01	10.86	V	Pass
7400	-41.73	-13	-28.73	-68.51	-50.7	3.38	12.35	V	Pass



<Middle Channel>

Band :	LTE Band 2	Temperature :	21~24°C
Test Mode :	15MHz QPSK RB Size 1 Offset 0	Relative Humidity :	46~48%
Test Engineer :	Ken Wu	Polarization :	Horizontal
Channel :	18900		
Remark :	Spurious emissions within 30-1000MHz were found more than 20dB below limit line.		

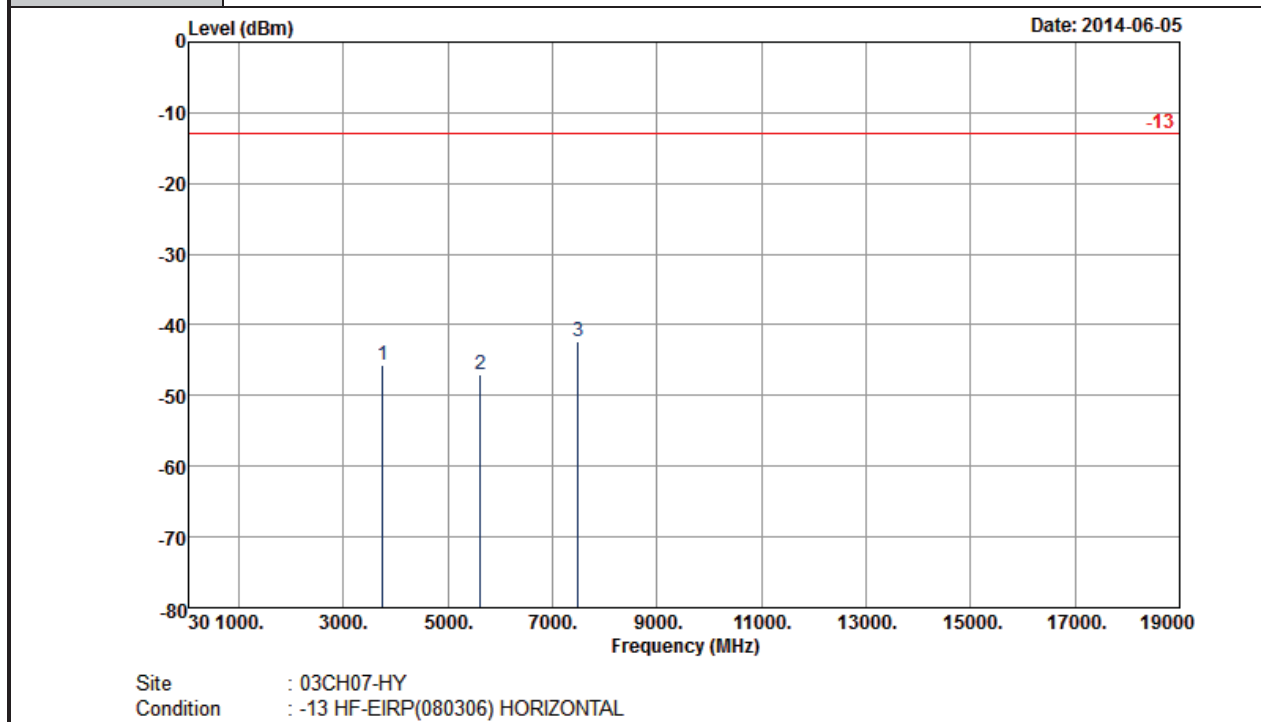

Frequency (MHz)	EIRP (dBm)	Limit (dBm)	Over Limit (dB)	SPA Reading (dBm)	S.G. Power (dBm)	TX Cable loss (dB)	TX Antenna Gain (dBi)	Polarization (H/V)	Result
3745	-45.60	-13	-32.60	-60.98	-51.9	2.51	8.81	H	Pass
5618	-46.99	-13	-33.99	-67.72	-54.7	2.99	10.70	H	Pass
7490	-42.27	-13	-29.27	-69.89	-50.8	3.59	12.12	H	Pass



Band :	LTE Band 2	Temperature :	21~24°C
Test Mode :	15MHz QPSK RB Size 1 Offset 0	Relative Humidity :	46~48%
Test Engineer :	Ken Wu	Polarization :	Vertical
Channel :	18900		
Remark :	Spurious emissions within 30-1000MHz were found more than 20dB below limit line.		

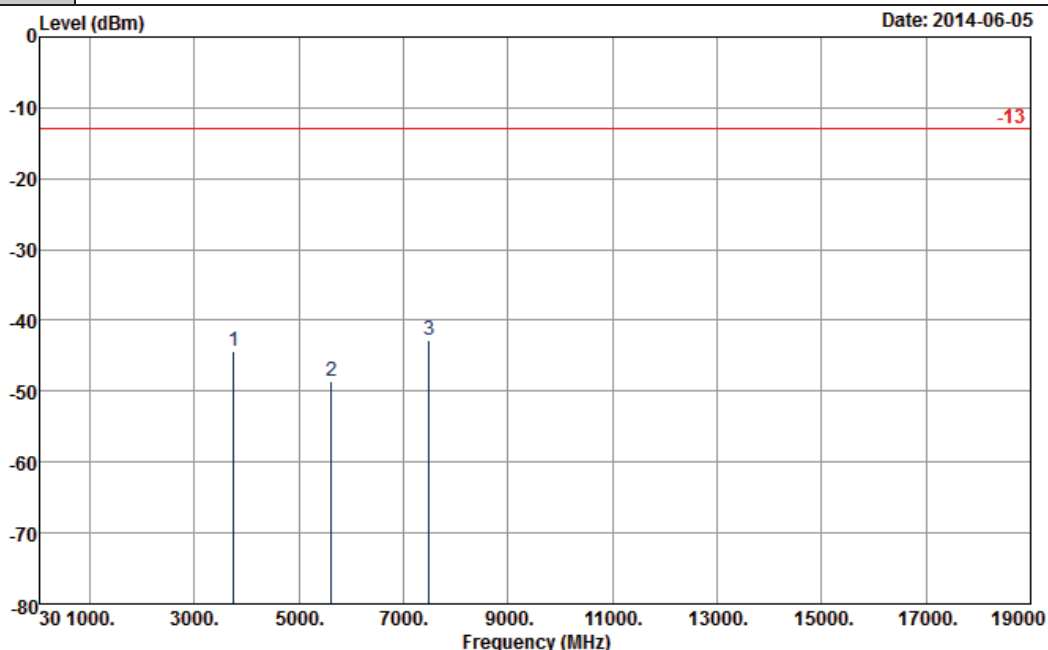

Site : 03CH07-HY
 Condition : -13 HF-EIRP(080306) VERTICAL

Frequency (MHz)	EIRP (dBm)	Limit (dBm)	Over Limit (dB)	SPA Reading (dBm)	S.G. Power (dBm)	TX Cable loss (dB)	TX Antenna Gain (dBi)	Polarization (H/V)	Result
3745	-44.40	-13	-31.40	-60.76	-50.7	2.51	8.81	V	Pass
5618	-48.59	-13	-35.59	-69.23	-56.3	2.99	10.70	V	Pass
7490	-42.87	-13	-29.87	-70.08	-51.4	3.59	12.12	V	Pass



<High Channel>

Band :	LTE Band 2	Temperature :	21~24°C
Test Mode :	15MHz QPSK RB Size 1 Offset 0	Relative Humidity :	46~48%
Test Engineer :	Ken Wu	Polarization :	Horizontal
Channel :	19125		
Remark :	Spurious emissions within 30-1000MHz were found more than 20dB below limit line.		

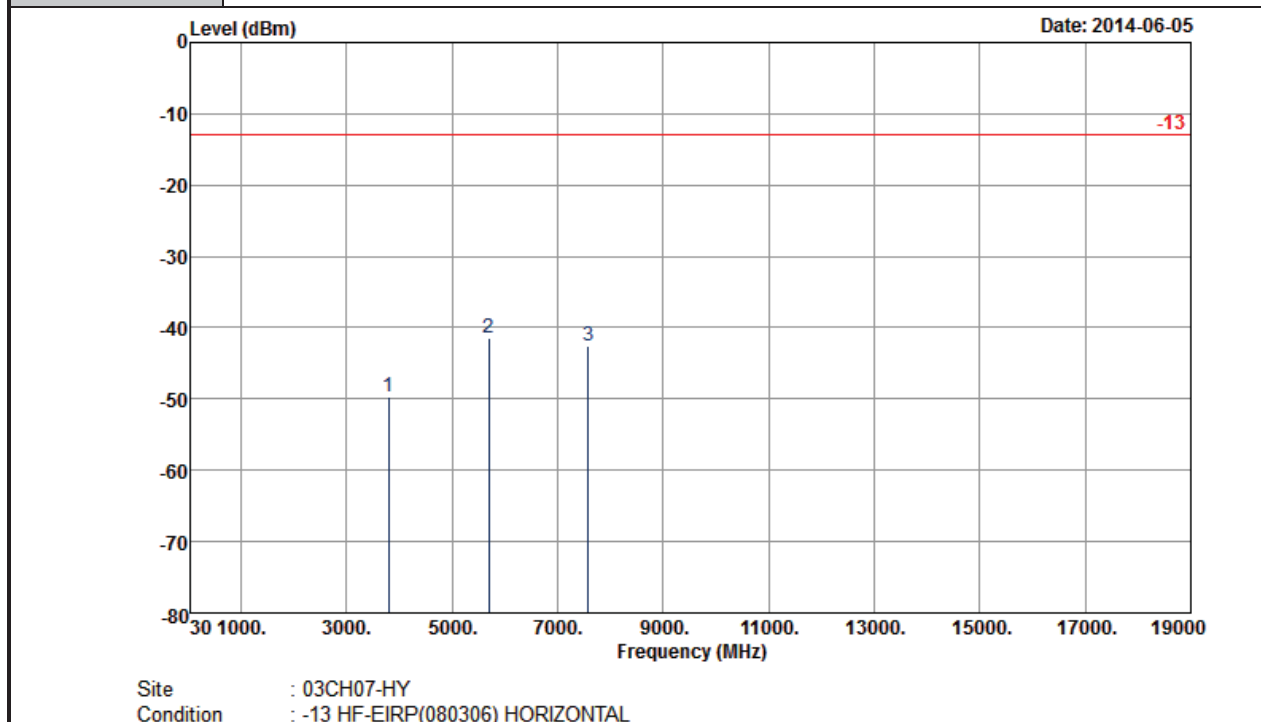

Frequency (MHz)	EIRP (dBm)	Limit (dBm)	Over Limit (dB)	SPA Reading (dBm)	S.G. Power (dBm)	TX Cable loss (dB)	TX Antenna Gain (dBi)	Polarization (H/V)	Result
3791	-43.49	-13	-30.49	-58.94	-49.8	2.52	8.83	H	Pass
5688	-41.47	-13	-28.47	-62.44	-49.2	3.03	10.76	H	Pass
7580	-42.65	-13	-29.65	-69.68	-51.2	3.61	12.16	H	Pass



Band :	LTE Band 2	Temperature :	21~24°C
Test Mode :	15MHz QPSK RB Size 1 Offset 0	Relative Humidity :	46~48%
Test Engineer :	Ken Wu	Polarization :	Vertical
Channel :	19125		
Remark :	Spurious emissions within 30-1000MHz were found more than 20dB below limit line.		

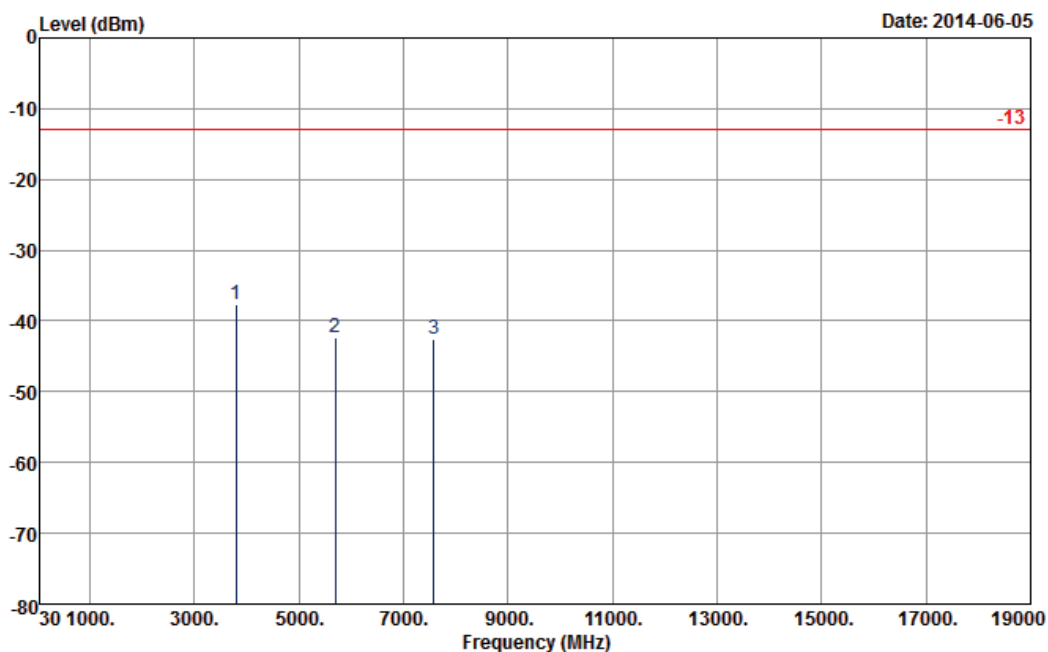

Site : 03CH07-HY
 Condition : -13 HF-EIRP(080306) VERTICAL

Frequency (MHz)	EIRP (dBm)	Limit (dBm)	Over Limit (dB)	SPA Reading (dBm)	S.G. Power (dBm)	TX Cable loss (dB)	TX Antenna Gain (dBi)	Polarization (H/V)	Result
3791	-37.59	-13	-24.59	-54.06	-43.9	2.52	8.83	V	Pass
5688	-42.37	-13	-29.37	-63.31	-50.1	3.03	10.76	V	Pass
7580	-42.65	-13	-29.65	-69.41	-51.2	3.61	12.16	V	Pass



<Low Channel>

Band :	LTE Band 2	Temperature :	21~24°C
Test Mode :	20MHz QPSK RB Size 1 Offset 0	Relative Humidity :	46~48%
Test Engineer :	Ken Wu	Polarization :	Horizontal
Channel :	18700		
Remark :	Spurious emissions within 30-1000MHz were found more than 20dB below limit line.		

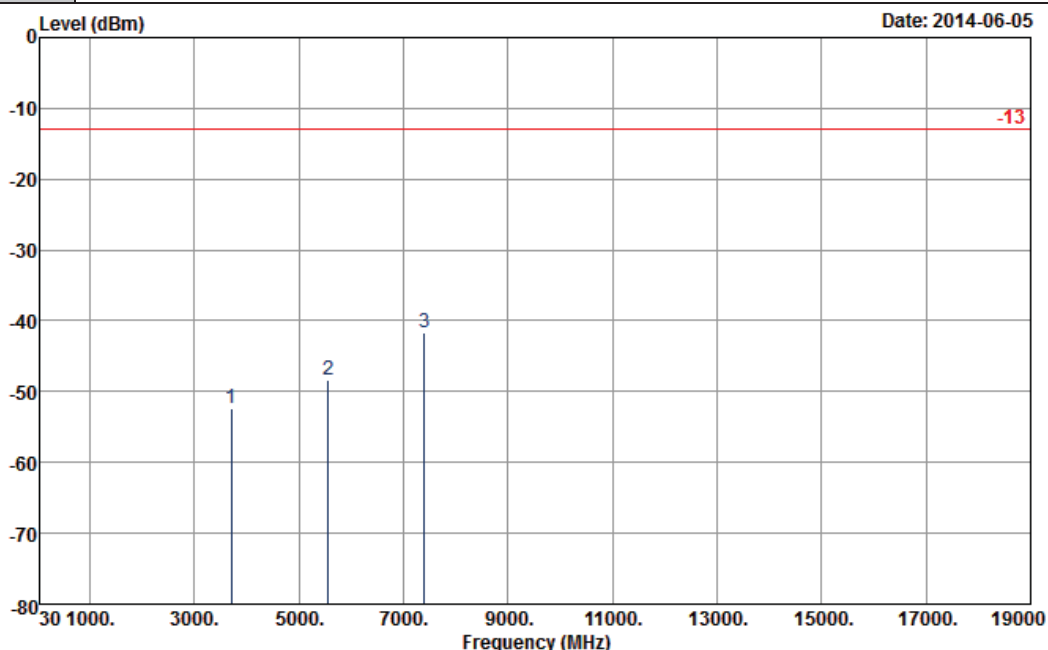

Site : 03CH07-HY
 Condition : -13 HF-EIRP(080306) HORIZONTAL

Frequency (MHz)	EIRP (dBm)	Limit (dBm)	Over Limit (dB)	SPA Reading (dBm)	S.G. Power (dBm)	TX Cable loss (dB)	TX Antenna Gain (dBi)	Polarization (H/V)	Result
3700	-52.42	-13	-39.42	-67.63	-58.8	2.51	8.89	H	Pass
5550	-48.44	-13	-35.44	-69.22	-56.3	3.03	10.89	H	Pass
7400	-41.56	-13	-28.56	-68.7	-50.7	3.24	12.38	H	Pass



Band :	LTE Band 2	Temperature :	21~24°C
Test Mode :	20MHz QPSK RB Size 1 Offset 0	Relative Humidity :	46~48%
Test Engineer :	Ken Wu	Polarization :	Vertical
Channel :	18700		
Remark :	Spurious emissions within 30-1000MHz were found more than 20dB below limit line.		

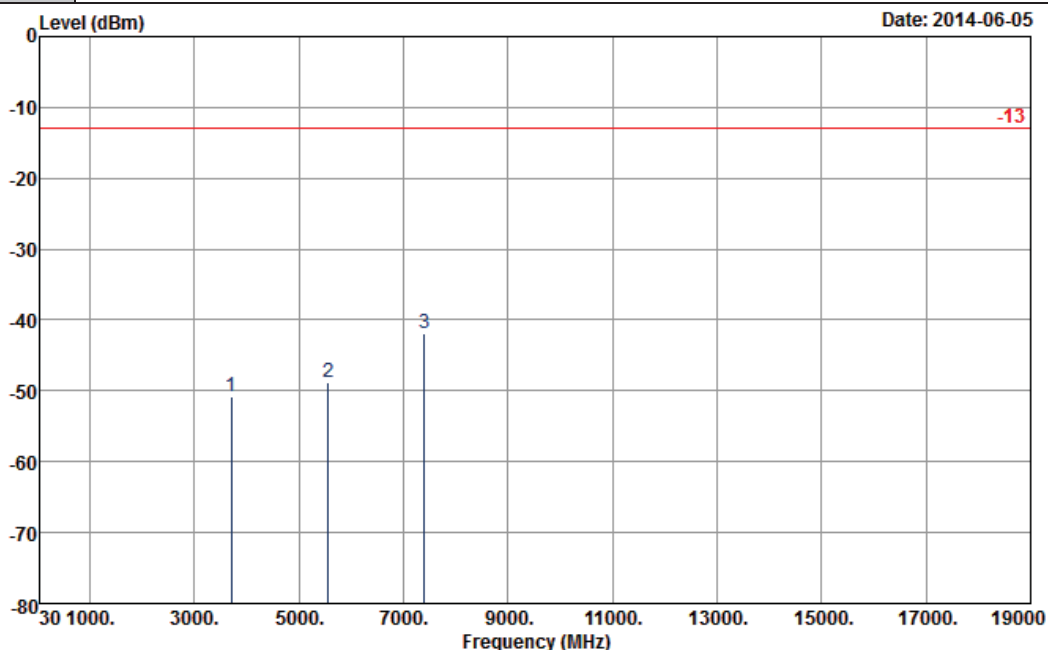

Site : 03CH07-HY
 Condition : -13 HF-EIRP(080306) VERTICAL

Frequency (MHz)	EIRP (dBm)	Limit (dBm)	Over Limit (dB)	SPA Reading (dBm)	S.G. Power (dBm)	TX Cable loss (dB)	TX Antenna Gain (dBi)	Polarization (H/V)	Result
3700	-50.72	-13	-37.72	-67.08	-57.1	2.51	8.89	V	Pass
5550	-48.84	-13	-35.84	-69.49	-56.7	3.03	10.89	V	Pass
7400	-41.86	-13	-28.86	-68.85	-51	3.24	12.38	V	Pass



<Middle Channel>

Band :	LTE Band 2	Temperature :	21~24°C
Test Mode :	20MHz QPSK RB Size 1 Offset 0	Relative Humidity :	46~48%
Test Engineer :	Ken Wu	Polarization :	Horizontal
Channel :	18900		
Remark :	Spurious emissions within 30-1000MHz were found more than 20dB below limit line.		

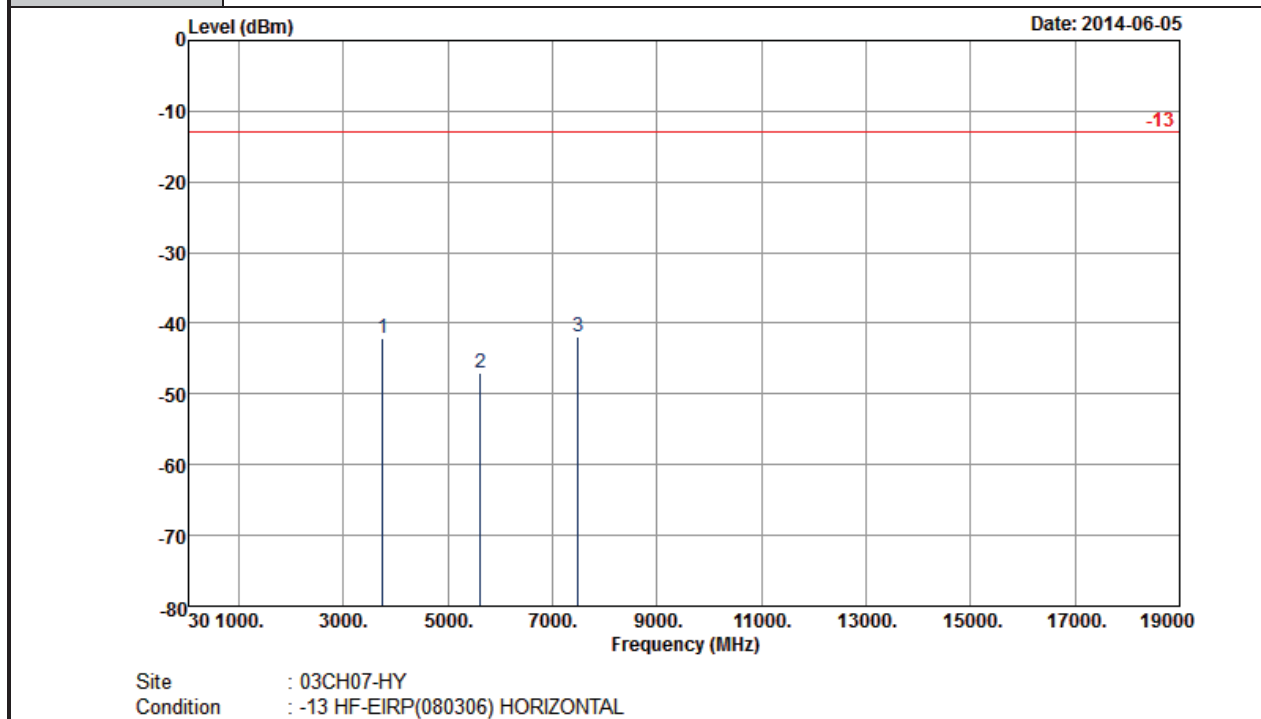

Frequency (MHz)	EIRP (dBm)	Limit (dBm)	Over Limit (dB)	SPA Reading (dBm)	S.G. Power (dBm)	TX Cable loss (dB)	TX Antenna Gain (dBi)	Polarization (H/V)	Result
3742	-42.10	-13	-29.10	-57.54	-48.4	2.51	8.81	H	Pass
5610	-46.99	-13	-33.99	-67.5	-54.7	2.99	10.70	H	Pass
7480	-41.97	-13	-28.97	-69.4	-50.5	3.59	12.12	H	Pass



Band :	LTE Band 2	Temperature :	21~24°C
Test Mode :	20MHz QPSK RB Size 1 Offset 0	Relative Humidity :	46~48%
Test Engineer :	Ken Wu	Polarization :	Vertical
Channel :	18900		
Remark :	Spurious emissions within 30-1000MHz were found more than 20dB below limit line.		

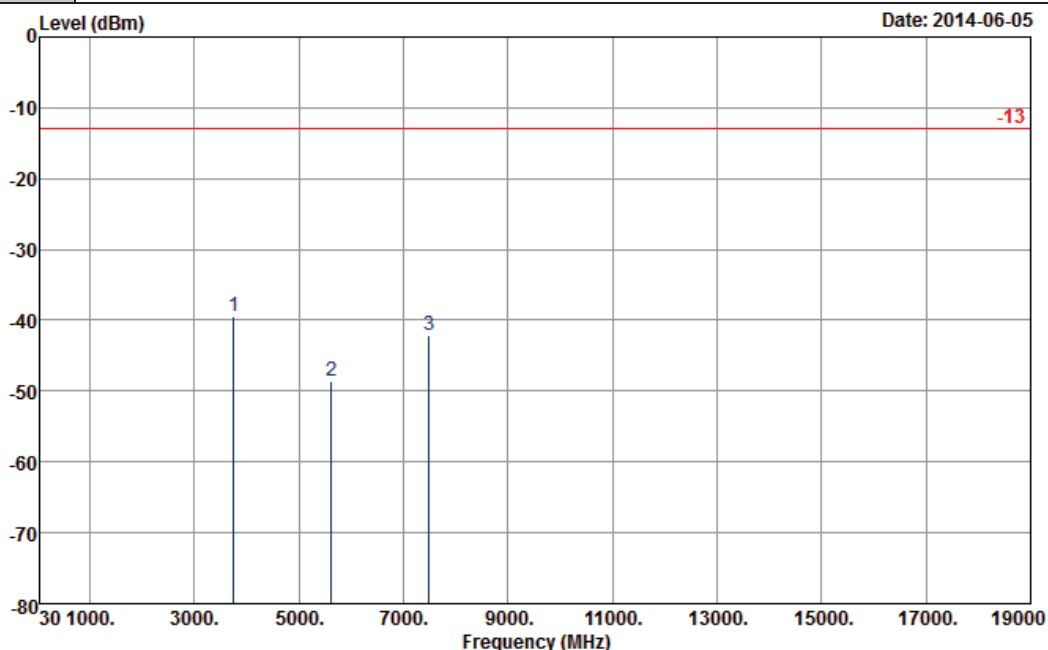

Site : 03CH07-HY
 Condition : -13 HF-EIRP(080306) VERTICAL

Frequency (MHz)	EIRP (dBm)	Limit (dBm)	Over Limit (dB)	SPA Reading (dBm)	S.G. Power (dBm)	TX Cable loss (dB)	TX Antenna Gain (dBi)	Polarization (H/V)	Result
3742	-39.40	-13	-26.40	-55.93	-45.7	2.51	8.81	V	Pass
5610	-48.49	-13	-35.49	-69.36	-56.2	2.99	10.70	V	Pass
7480	-42.17	-13	-29.17	-69.39	-50.7	3.59	12.12	V	Pass



<High Channel>

Band :	LTE Band 2	Temperature :	21~24°C
Test Mode :	20MHz QPSK RB Size 1 Offset 0	Relative Humidity :	46~48%
Test Engineer :	Ken Wu	Polarization :	Horizontal
Channel :	19100		
Remark :	Spurious emissions within 30-1000MHz were found more than 20dB below limit line.		

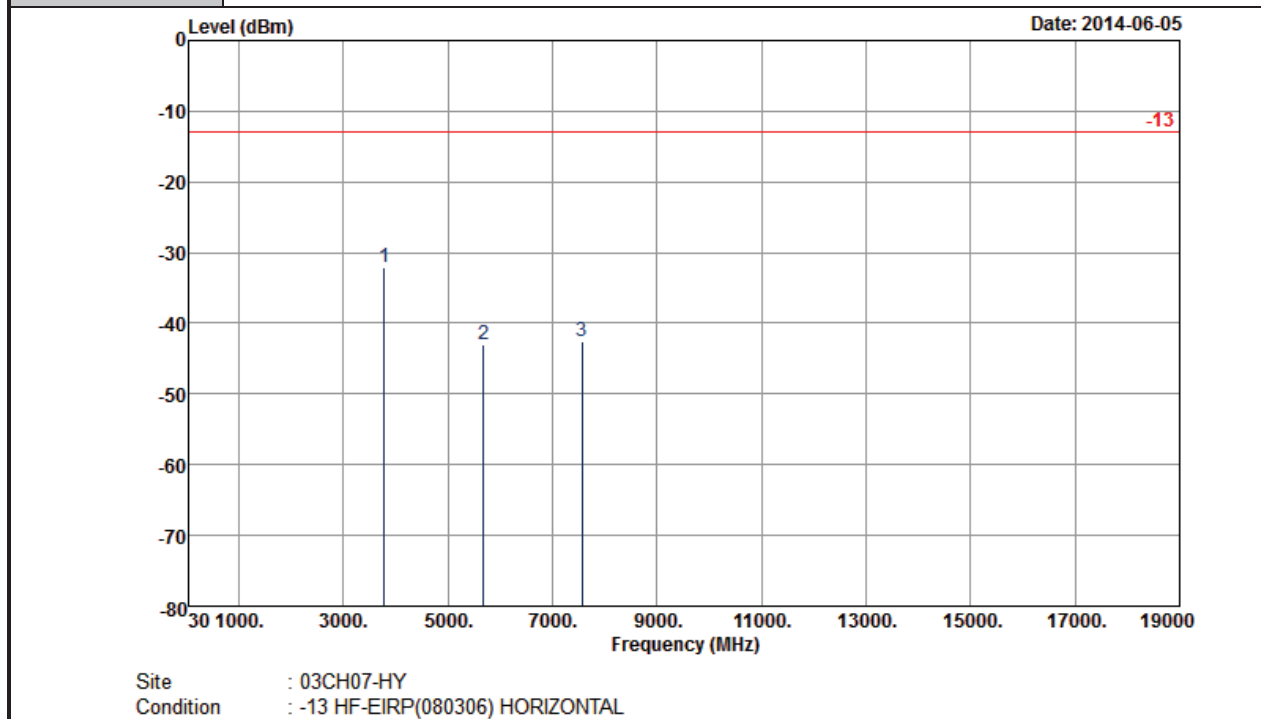

Frequency (MHz)	EIRP (dBm)	Limit (dBm)	Over Limit (dB)	SPA Reading (dBm)	S.G. Power (dBm)	TX Cable loss (dB)	TX Antenna Gain (dBi)	Polarization (H/V)	Result
3784	-32.12	-13	-19.12	-47.71	-38.5	2.52	8.90	H	Pass
5674	-43.05	-13	-30.05	-64.01	-50.8	3.01	10.76	H	Pass
7560	-42.67	-13	-29.67	-69.66	-51.2	3.62	12.15	H	Pass



Band :	LTE Band 2	Temperature :	21~24°C
Test Mode :	20MHz QPSK RB Size 1 Offset 0	Relative Humidity :	46~48%
Test Engineer :	Ken Wu	Polarization :	Vertical
Channel :	19100		
Remark :	Spurious emissions within 30-1000MHz were found more than 20dB below limit line.		

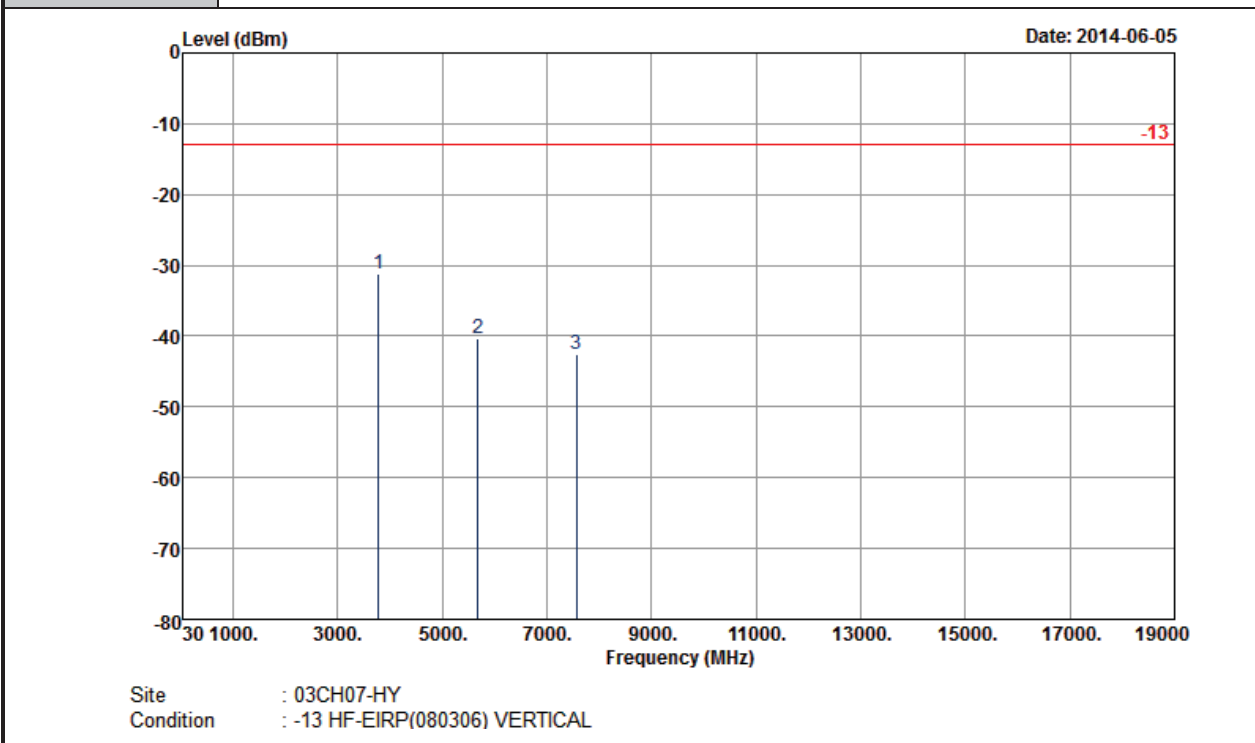

Frequency (MHz)	EIRP (dBm)	Limit (dBm)	Over Limit (dB)	SPA Reading (dBm)	S.G. Power (dBm)	TX Cable loss (dB)	TX Antenna Gain (dBi)	Polarization (H/V)	Result
3784	-31.12	-13	-18.12	-46.71	-37.5	2.52	8.90	V	Pass
5674	-40.35	-13	-27.35	-61.1	-48.1	3.01	10.76	V	Pass
7560	-42.47	-13	-29.47	-69.38	-51	3.62	12.15	V	Pass



<Low Channel>

Band :	LTE Band 4	Temperature :	21~24°C
Test Mode :	1.4MHz QPSK RB Size 1 Offset 0	Relative Humidity :	46~48%
Test Engineer :	Ken Wu	Polarization :	Horizontal
Channel :	19957		
Remark :	Spurious emissions within 30-1000MHz were found more than 20dB below limit line.		

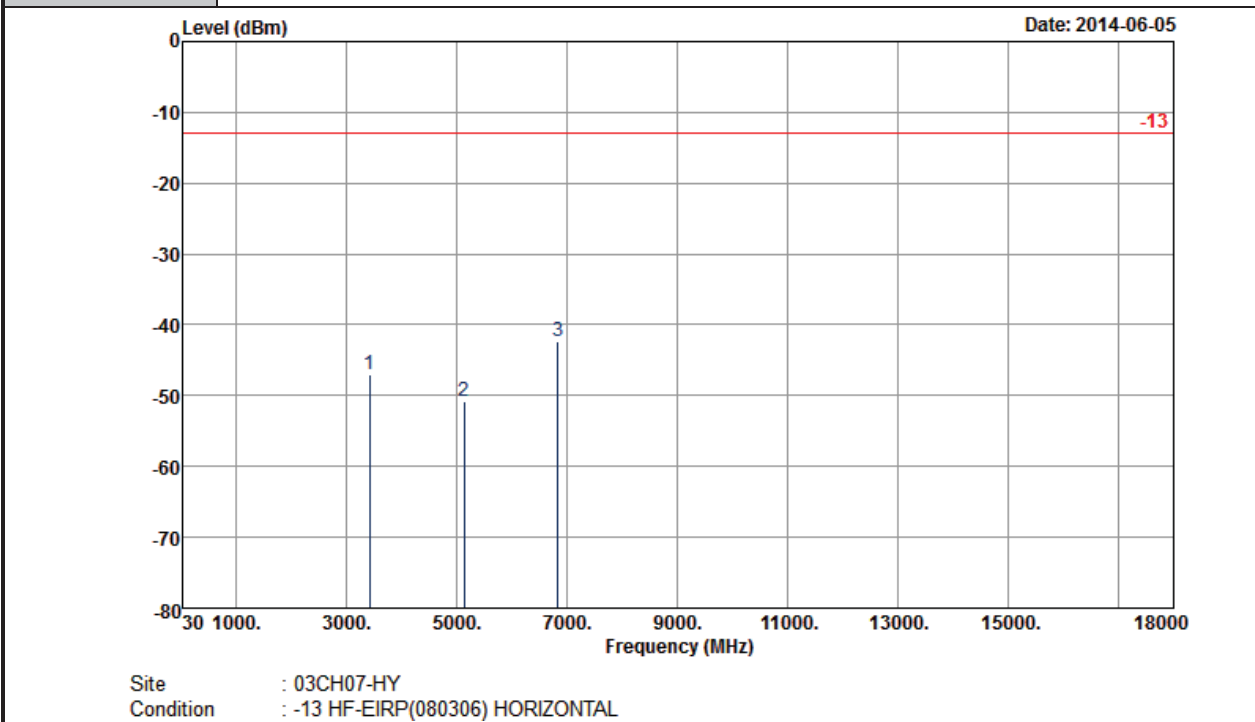

Frequency (MHz)	EIRP (dBm)	Limit (dBm)	Over Limit (dB)	SPA Reading (dBm)	S.G. Power (dBm)	TX Cable loss (dB)	TX Antenna Gain (dBi)	Polarization (H/V)	Result
3420	-47.03	-13	-34.03	-61.28	-50.9	4.41	8.28	H	Pass
5130	-50.73	-13	-37.73	-69.36	-55.3	5.28	9.85	H	Pass
6840	-42.37	-13	-29.37	-68.35	-47.6	6.01	11.24	H	Pass



Band :	LTE Band 4	Temperature :	21~24°C
Test Mode :	1.4MHz QPSK RB Size 1 Offset 0	Relative Humidity :	46~48%
Test Engineer :	Ken Wu	Polarization :	Vertical
Channel :	19957		
Remark :	Spurious emissions within 30-1000MHz were found more than 20dB below limit line.		

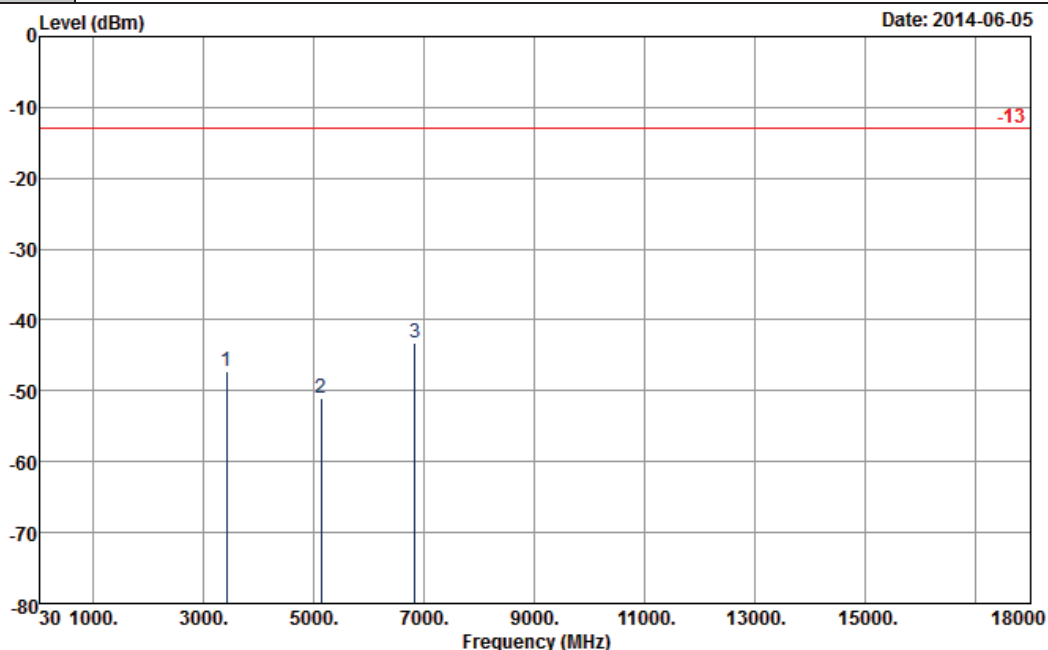

Site : 03CH07-HY
 Condition : -13 HF-EIRP(080306) VERTICAL

Frequency (MHz)	EIRP (dBm)	Limit (dBm)	Over Limit (dB)	SPA Reading (dBm)	S.G. Power (dBm)	TX Cable loss (dB)	TX Antenna Gain (dBi)	Polarization (H/V)	Result
3420	-47.23	-13	-34.23	-62.9	-51.1	4.41	8.28	V	Pass
5130	-50.93	-13	-37.93	-69.02	-55.5	5.28	9.85	V	Pass
6840	-43.17	-13	-30.17	-68.13	-48.4	6.01	11.24	V	Pass



<Middle Channel>

Band :	LTE Band 4	Temperature :	21~24°C
Test Mode :	1.4MHz QPSK RB Size 1 Offset 0	Relative Humidity :	46~48%
Test Engineer :	Ken Wu	Polarization :	Horizontal
Channel :	20175		
Remark :	Spurious emissions within 30-1000MHz were found more than 20dB below limit line.		

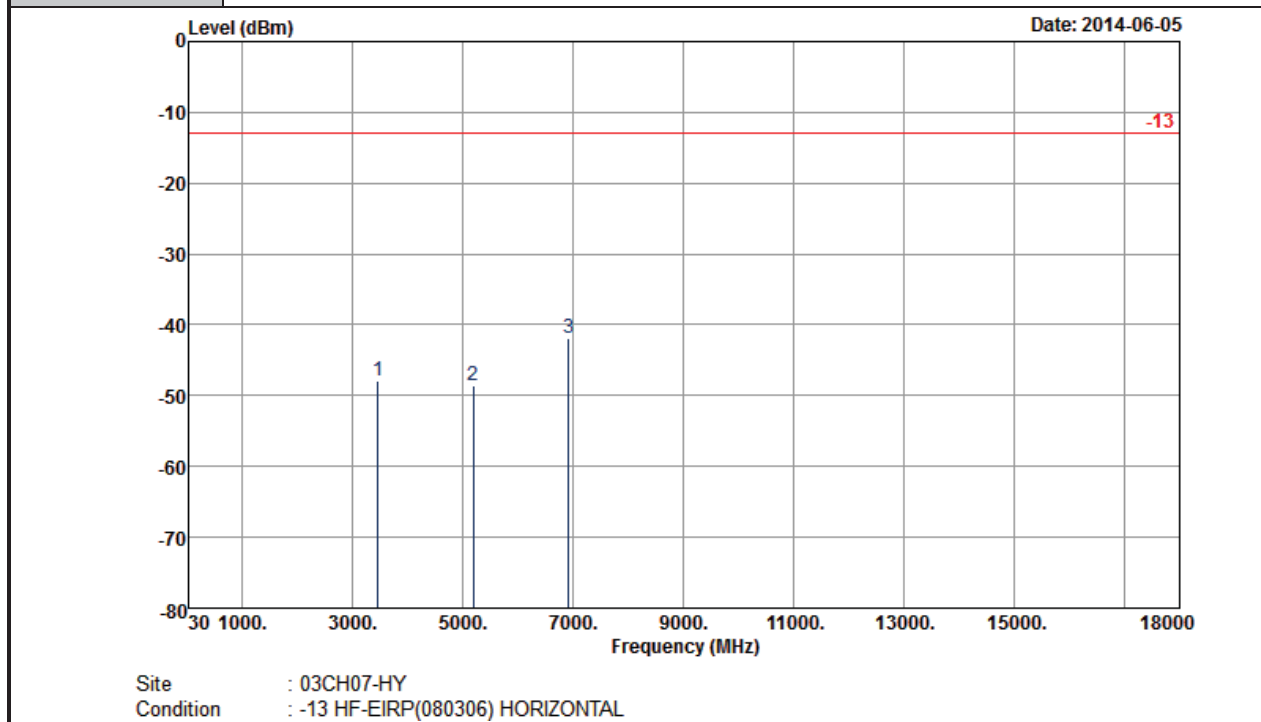

Frequency (MHz)	EIRP (dBm)	Limit (dBm)	Over Limit (dB)	SPA Reading (dBm)	S.G. Power (dBm)	TX Cable loss (dB)	TX Antenna Gain (dBi)	Polarization (H/V)	Result
3463	-47.97	-13	-34.97	-62.35	-51.8	4.48	8.31	H	Pass
5195	-48.66	-13	-35.66	-67.67	-53.3	5.332	9.98	H	Pass
6927	-41.86	-13	-28.86	-68.22	-47.1	6.1	11.34	H	Pass



Band :	LTE Band 4	Temperature :	21~24°C
Test Mode :	1.4MHz QPSK RB Size 1 Offset 0	Relative Humidity :	46~48%
Test Engineer :	Ken Wu	Polarization :	Vertical
Channel :	20175		
Remark :	Spurious emissions within 30-1000MHz were found more than 20dB below limit line.		

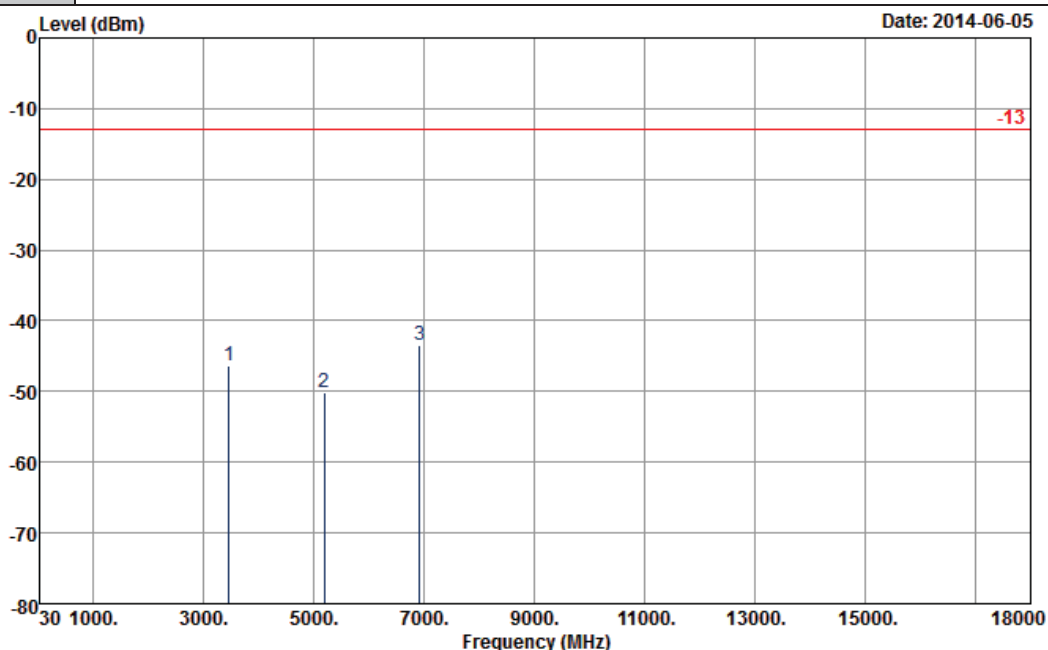

Site : 03CH07-HY
 Condition : -13 HF-EIRP(080306) VERTICAL

Frequency (MHz)	EIRP (dBm)	Limit (dBm)	Over Limit (dB)	SPA Reading (dBm)	S.G. Power (dBm)	TX Cable loss (dB)	TX Antenna Gain (dBi)	Polarization (H/V)	Result
3463	-46.37	-13	-33.37	-62.3	-50.2	4.48	8.31	V	Pass
5195	-50.16	-13	-37.16	-68.86	-54.8	5.332	9.98	V	Pass
6927	-43.46	-13	-30.46	-68.59	-48.7	6.1	11.34	V	Pass



<High Channel>

Band :	LTE Band 4	Temperature :	21~24°C
Test Mode :	1.4MHz QPSK RB Size 1 Offset 0	Relative Humidity :	46~48%
Test Engineer :	Ken Wu	Polarization :	Horizontal
Channel :	20393		
Remark :	Spurious emissions within 30-1000MHz were found more than 20dB below limit line.		

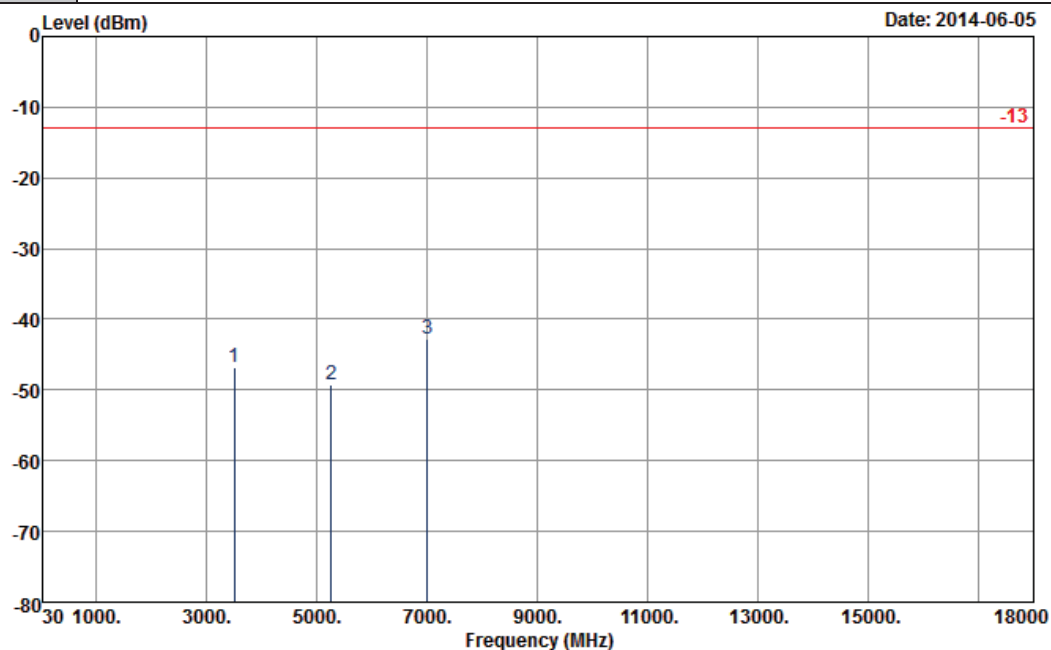

Site : 03CH07-HY
 Condition : -13 HF-EIRP(080306) HORIZONTAL

Frequency (MHz)	EIRP (dBm)	Limit (dBm)	Over Limit (dB)	SPA Reading (dBm)	S.G. Power (dBm)	TX Cable loss (dB)	TX Antenna Gain (dBi)	Polarization (H/V)	Result
3507	-46.83	-13	-33.83	-61.33	-51.1	4.14	8.41	H	Pass
5261	-49.25	-13	-36.25	-68.56	-54.2	5.12	10.07	H	Pass
7014	-42.71	-13	-29.71	-69.17	-48	6.13	11.42	H	Pass



Band :	LTE Band 4	Temperature :	21~24°C
Test Mode :	1.4MHz QPSK RB Size 1 Offset 0	Relative Humidity :	46~48%
Test Engineer :	Ken Wu	Polarization :	Vertical
Channel :	20393		
Remark :	Spurious emissions within 30-1000MHz were found more than 20dB below limit line.		

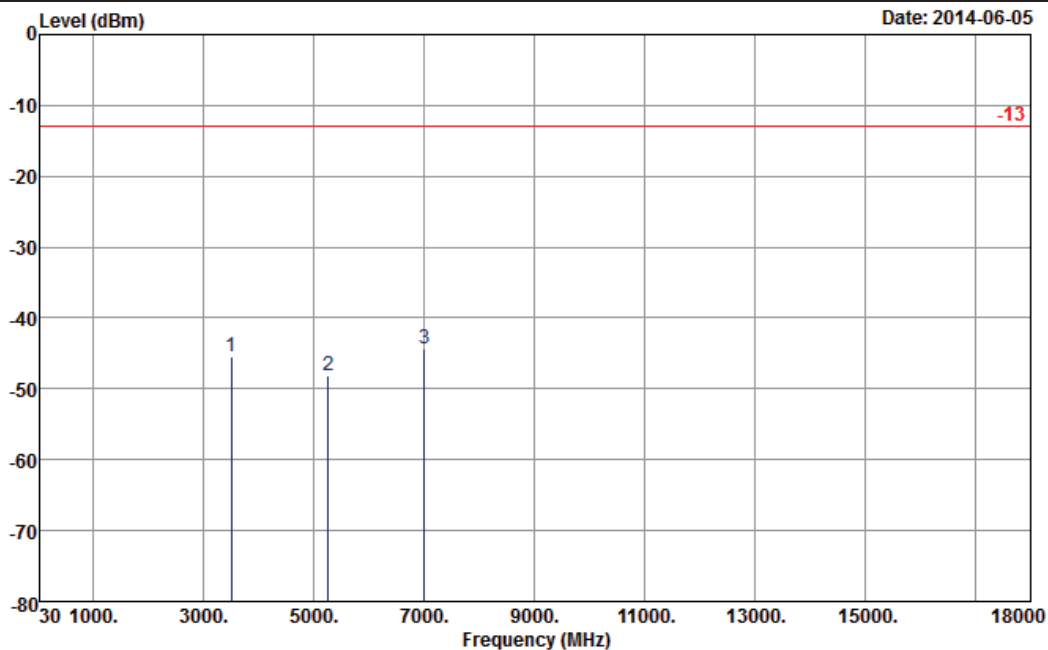

Site : 03CH07-HY
 Condition : -13 HF-EIRP(080306) VERTICAL

Frequency (MHz)	EIRP (dBm)	Limit (dBm)	Over Limit (dB)	SPA Reading (dBm)	S.G. Power (dBm)	TX Cable loss (dB)	TX Antenna Gain (dBi)	Polarization (H/V)	Result
3507	-45.53	-13	-32.53	-60.98	-49.8	4.14	8.41	V	Pass
5261	-48.05	-13	-35.05	-67.12	-53	5.12	10.07	V	Pass
7014	-44.31	-13	-31.31	-69.76	-49.6	6.13	11.42	V	Pass



<Low Channel>

Band :	LTE Band 4	Temperature :	21~24°C
Test Mode :	3MHz QPSK RB Size 1 Offset 0	Relative Humidity :	46~48%
Test Engineer :	Ken Wu	Polarization :	Horizontal
Channel :	19965		
Remark :	Spurious emissions within 30-1000MHz were found more than 20dB below limit line.		

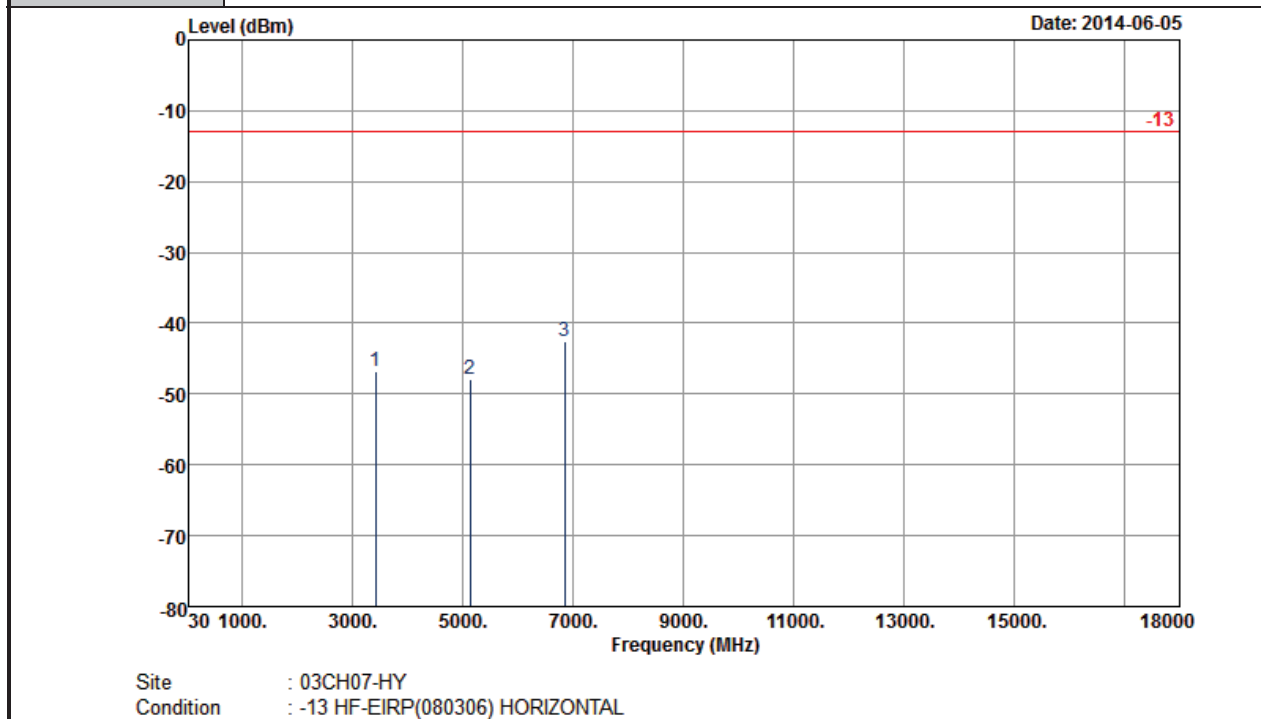

Frequency (MHz)	EIRP (dBm)	Limit (dBm)	Over Limit (dB)	SPA Reading (dBm)	S.G. Power (dBm)	TX Cable loss (dB)	TX Antenna Gain (dBi)	Polarization (H/V)	Result
3423	-46.82	-13	-33.82	-61.17	-50.7	4.43	8.31	H	Pass
5135	-47.93	-13	-34.93	-66.58	-52.5	5.31	9.88	H	Pass
6846	-42.57	-13	-29.57	-68	-47.9	6.02	11.35	H	Pass



Band :	LTE Band 4	Temperature :	21~24°C
Test Mode :	3MHz QPSK RB Size 1 Offset 0	Relative Humidity :	46~48%
Test Engineer :	Ken Wu	Polarization :	Vertical
Channel :	19965		
Remark :	Spurious emissions within 30-1000MHz were found more than 20dB below limit line.		

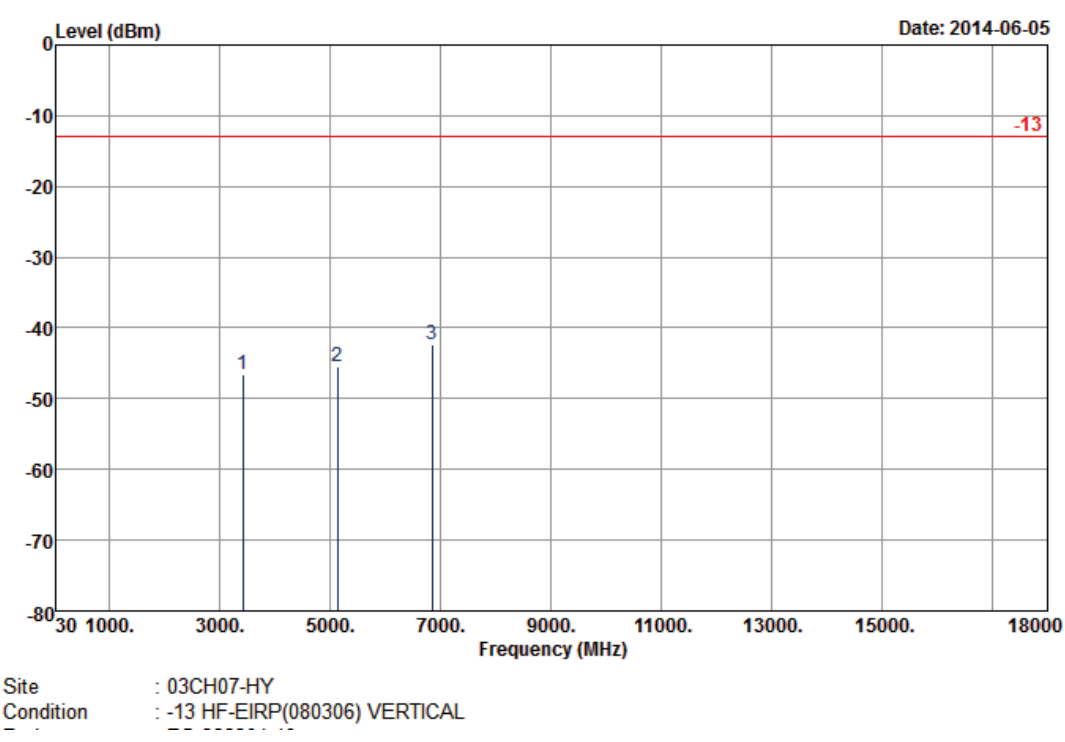

Frequency (MHz)	EIRP (dBm)	Limit (dBm)	Over Limit (dB)	SPA Reading (dBm)	S.G. Power (dBm)	TX Cable loss (dB)	TX Antenna Gain (dBi)	Polarization (H/V)	Result
3423	-46.62	-13	-33.62	-62.3	-50.5	4.43	8.31	V	Pass
5135	-45.53	-13	-32.53	-64.25	-50.1	5.31	9.88	V	Pass
6846	-42.37	-13	-29.37	-67.59	-47.7	6.02	11.35	V	Pass



<Middle Channel>

Band :	LTE Band 4	Temperature :	21~24°C
Test Mode :	3MHz QPSK RB Size 1 Offset 0	Relative Humidity :	46~48%
Test Engineer :	Ken Wu	Polarization :	Horizontal
Channel :	20175		
Remark :	Spurious emissions within 30-1000MHz were found more than 20dB below limit line.		

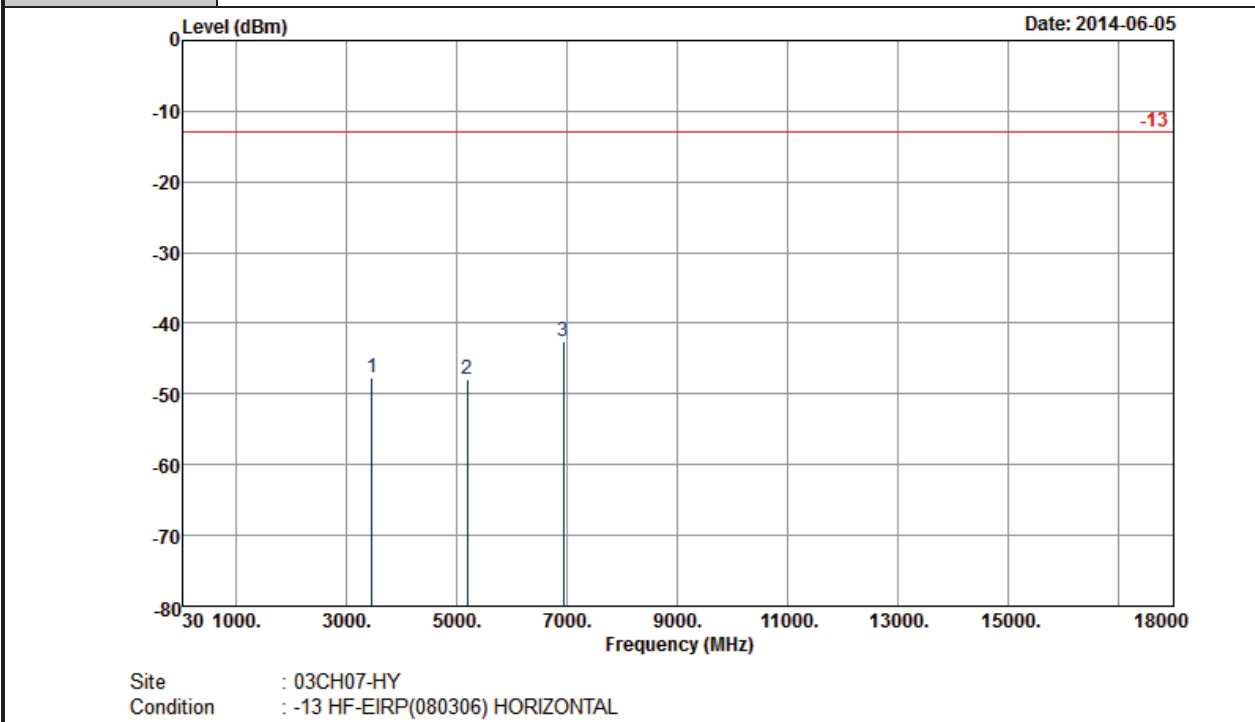

Frequency (MHz)	EIRP (dBm)	Limit (dBm)	Over Limit (dB)	SPA Reading (dBm)	S.G. Power (dBm)	TX Cable loss (dB)	TX Antenna Gain (dBi)	Polarization (H/V)	Result
3465	-47.67	-13	-34.67	-62.27	-51.5	4.48	8.31	H	Pass
5197	-47.86	-13	-34.86	-66.71	-52.5	5.332	9.98	H	Pass
6930	-42.46	-13	-29.46	-68.37	-47.7	6.1	11.34	H	Pass



Band :	LTE Band 4	Temperature :	21~24°C
Test Mode :	3MHz QPSK RB Size 1 Offset 0	Relative Humidity :	46~48%
Test Engineer :	Ken Wu	Polarization :	Vertical
Channel :	20175		
Remark :	Spurious emissions within 30-1000MHz were found more than 20dB below limit line.		

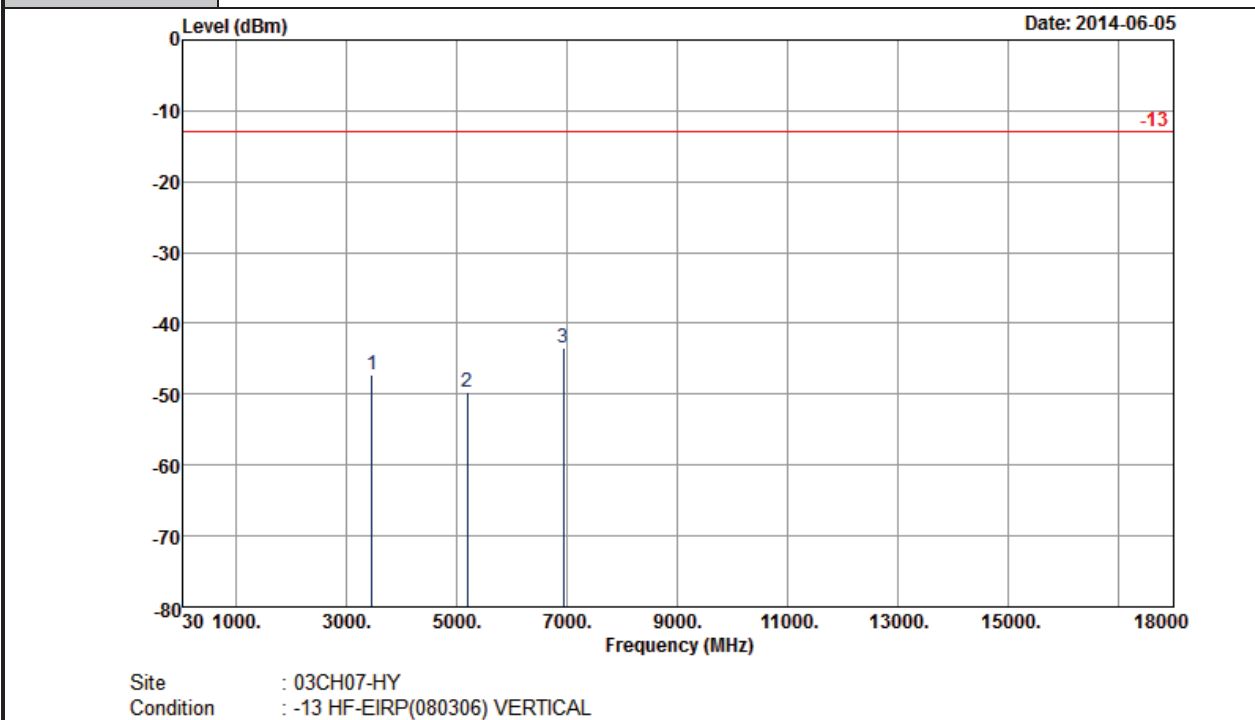

Frequency (MHz)	EIRP (dBm)	Limit (dBm)	Over Limit (dB)	SPA Reading (dBm)	S.G. Power (dBm)	TX Cable loss (dB)	TX Antenna Gain (dBi)	Polarization (H/V)	Result
3465	-47.27	-13	-34.27	-63.15	-51.1	4.48	8.31	V	Pass
5197	-49.76	-13	-36.76	-68.1	-54.4	5.332	9.98	V	Pass
6930	-43.36	-13	-30.36	-68.97	-48.6	6.1	11.34	V	Pass



<High Channel>

Band :	LTE Band 4	Temperature :	21~24°C
Test Mode :	3MHz QPSK RB Size 1 Offset 0	Relative Humidity :	46~48%
Test Engineer :	Ken Wu	Polarization :	Horizontal
Channel :	20385		
Remark :	Spurious emissions within 30-1000MHz were found more than 20dB below limit line.		

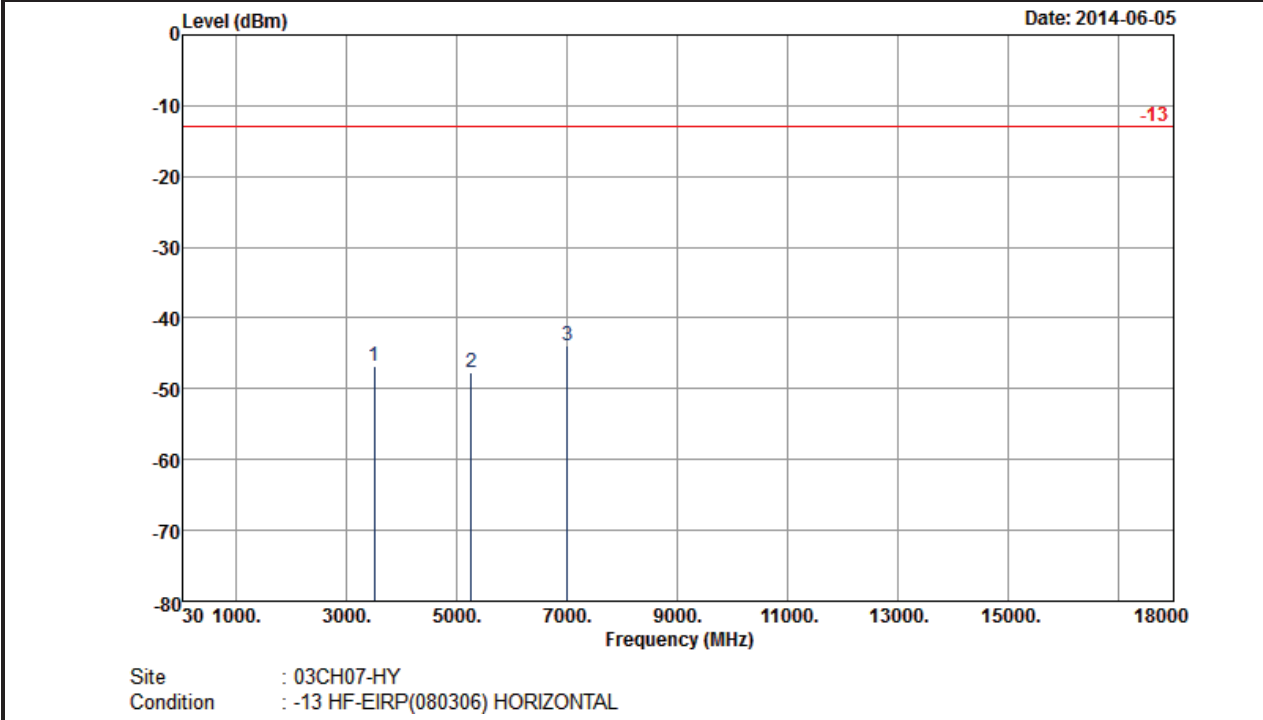

Frequency (MHz)	EIRP (dBm)	Limit (dBm)	Over Limit (dB)	SPA Reading (dBm)	S.G. Power (dBm)	TX Cable loss (dB)	TX Antenna Gain (dBi)	Polarization (H/V)	Result
3506	-46.83	-13	-33.83	-61.45	-51.1	4.14	8.41	H	Pass
5261	-47.75	-13	-34.75	-66.6	-52.7	5.12	10.07	H	Pass
7014	-43.81	-13	-30.81	-69.95	-49.1	6.13	11.42	H	Pass



Band :	LTE Band 4	Temperature :	21~24°C
Test Mode :	3MHz QPSK RB Size 1 Offset 0	Relative Humidity :	46~48%
Test Engineer :	Ken Wu	Polarization :	Vertical
Channel :	20385		
Remark :	Spurious emissions within 30-1000MHz were found more than 20dB below limit line.		

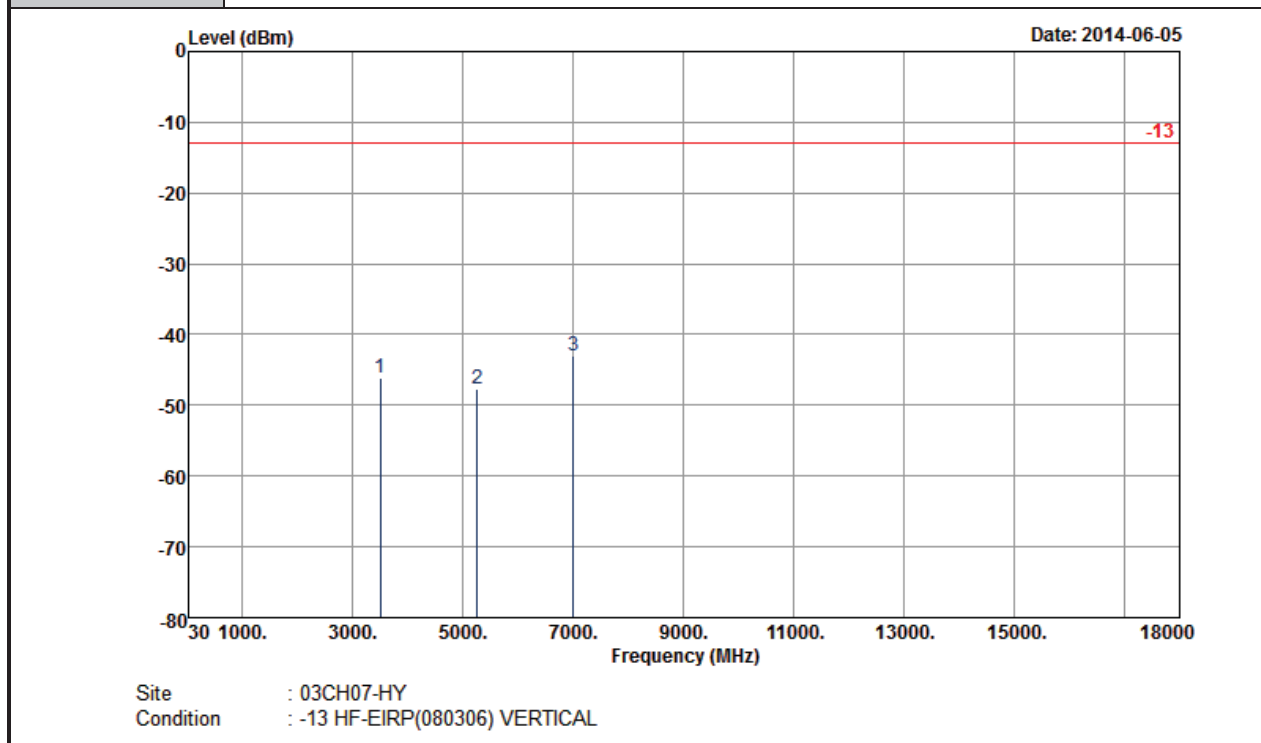

Frequency (MHz)	EIRP (dBm)	Limit (dBm)	Over Limit (dB)	SPA Reading (dBm)	S.G. Power (dBm)	TX Cable loss (dB)	TX Antenna Gain (dBi)	Polarization (H/V)	Result
3506	-46.13	-13	-33.13	-61.84	-50.4	4.14	8.41	V	Pass
5261	-47.65	-13	-34.65	-66.87	-52.6	5.12	10.07	V	Pass
7014	-43.41	-13	-30.41	-69.15	-48.7	6.13	11.42	V	Pass



<Low Channel>

Band :	LTE Band 4	Temperature :	21~24°C
Test Mode :	15MHz QPSK RB Size 1 Offset 0	Relative Humidity :	46~48%
Test Engineer :	Ken Wu	Polarization :	Horizontal
Channel :	20025		
Remark :	Spurious emissions within 30-1000MHz were found more than 20dB below limit line.		

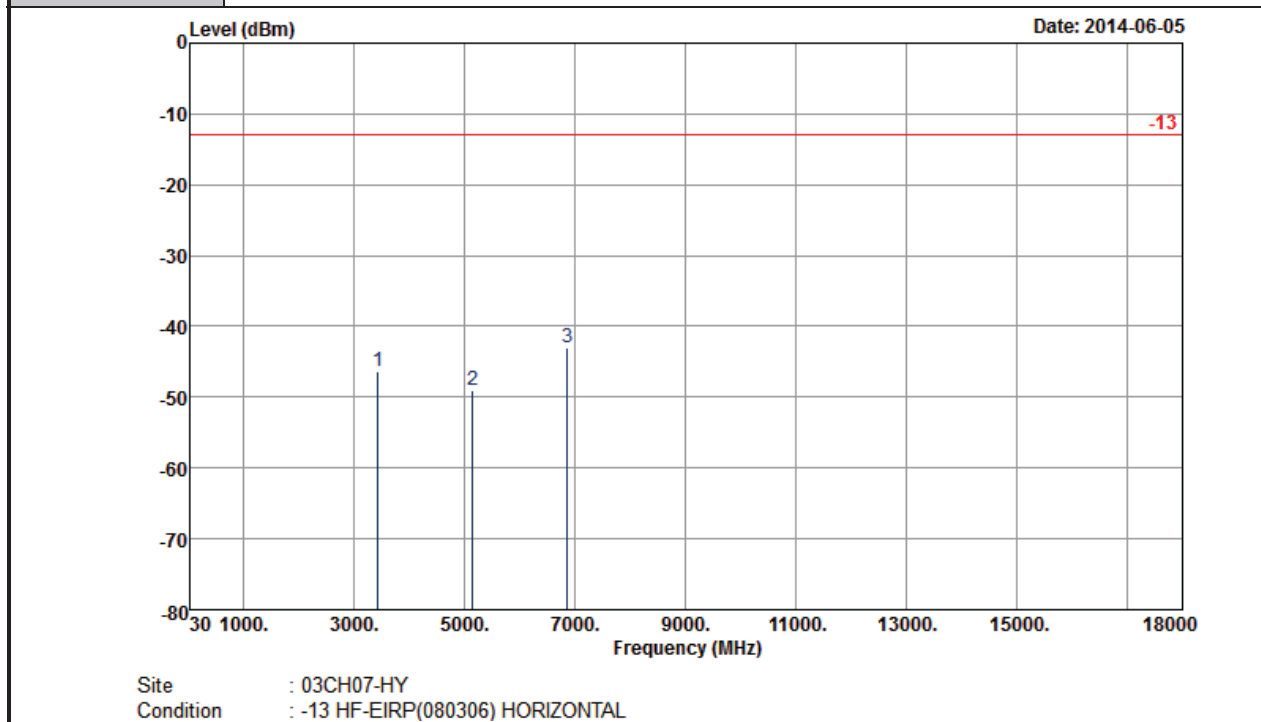

Frequency (MHz)	EIRP (dBm)	Limit (dBm)	Over Limit (dB)	SPA Reading (dBm)	S.G. Power (dBm)	TX Cable loss (dB)	TX Antenna Gain (dBi)	Polarization (H/V)	Result
3435	-46.33	-13	-33.33	-60.83	-50.1	4.59	8.36	H	Pass
5152	-49.06	-13	-36.06	-67.48	-53.7	5.41	10.05	H	Pass
6870	-42.96	-13	-29.96	-68.26	-48.2	6.15	11.39	H	Pass



Band :	LTE Band 4	Temperature :	21~24°C
Test Mode :	15MHz QPSK RB Size 1 Offset 0	Relative Humidity :	46~48%
Test Engineer :	Ken Wu	Polarization :	Vertical
Channel :	20025		
Remark :	Spurious emissions within 30-1000MHz were found more than 20dB below limit line.		

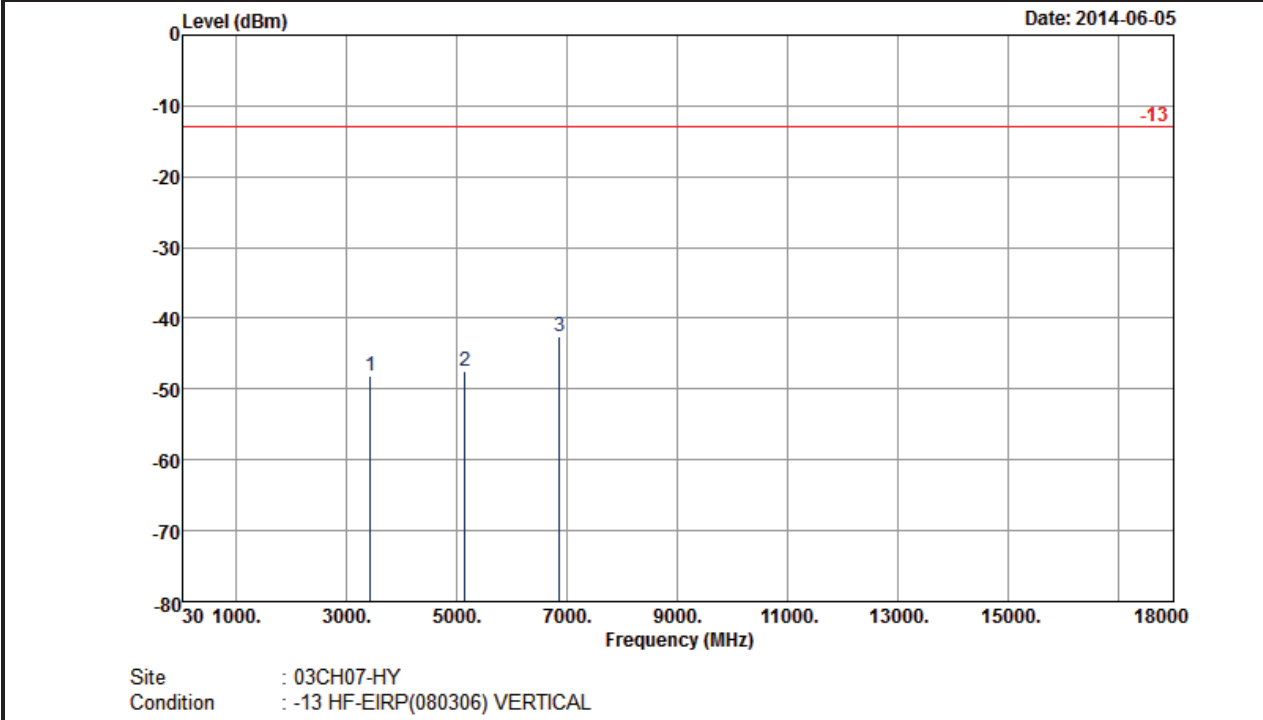

Frequency (MHz)	EIRP (dBm)	Limit (dBm)	Over Limit (dB)	SPA Reading (dBm)	S.G. Power (dBm)	TX Cable loss (dB)	TX Antenna Gain (dBi)	Polarization (H/V)	Result
3435	-48.03	-13	-35.03	-63.76	-51.8	4.59	8.36	V	Pass
5152	-47.46	-13	-34.46	-65.92	-52.1	5.41	10.05	V	Pass
6870	-42.56	-13	-29.56	-66.96	-47.8	6.15	11.39	V	Pass



<Middle Channel>

Band :	LTE Band 4	Temperature :	21~24°C
Test Mode :	15MHz QPSK RB Size 1 Offset 0	Relative Humidity :	46~48%
Test Engineer :	Ken Wu	Polarization :	Horizontal
Channel :	20175		
Remark :	Spurious emissions within 30-1000MHz were found more than 20dB below limit line.		

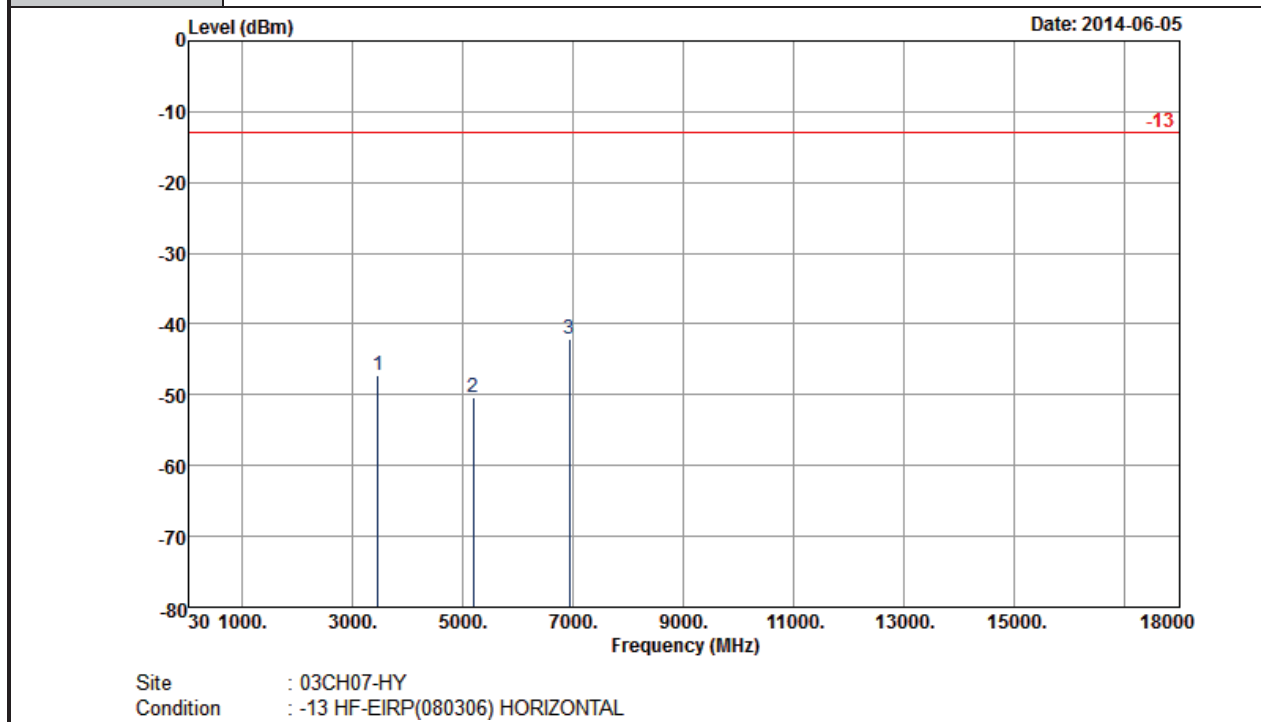

Frequency (MHz)	EIRP (dBm)	Limit (dBm)	Over Limit (dB)	SPA Reading (dBm)	S.G. Power (dBm)	TX Cable loss (dB)	TX Antenna Gain (dBi)	Polarization (H/V)	Result
3465	-47.27	-13	-34.27	-61.74	-51.1	4.48	8.31	H	Pass
5197	-50.36	-13	-37.36	-68.57	-55	5.332	9.98	H	Pass
6930	-42.06	-13	-29.06	-68.24	-47.3	6.1	11.34	H	Pass



Band :	LTE Band 4	Temperature :	21~24°C
Test Mode :	15MHz QPSK RB Size 1 Offset 0	Relative Humidity :	46~48%
Test Engineer :	Ken Wu	Polarization :	Vertical
Channel :	20175		
Remark :	Spurious emissions within 30-1000MHz were found more than 20dB below limit line.		

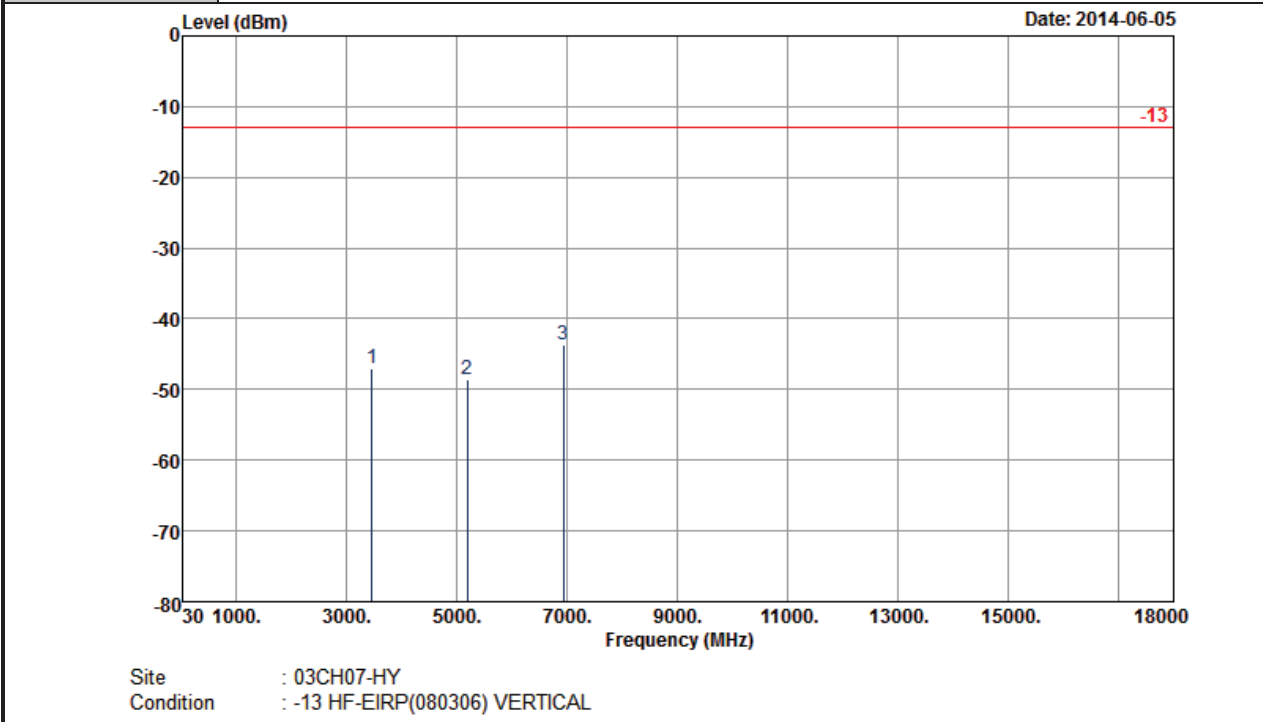

Frequency (MHz)	EIRP (dBm)	Limit (dBm)	Over Limit (dB)	SPA Reading (dBm)	S.G. Power (dBm)	TX Cable loss (dB)	TX Antenna Gain (dBi)	Polarization (H/V)	Result
3465	-47.07	-13	-34.07	-63.24	-50.9	4.48	8.31	V	Pass
5197	-48.56	-13	-35.56	-67.26	-53.2	5.332	9.98	V	Pass
6930	-43.66	-13	-30.66	-68.4	-48.9	6.1	11.34	V	Pass



<High Channel>

Band :	LTE Band 4	Temperature :	21~24°C
Test Mode :	15MHz QPSK RB Size 1 Offset 0	Relative Humidity :	46~48%
Test Engineer :	Ken Wu	Polarization :	Horizontal
Channel :	20325		
Remark :	Spurious emissions within 30-1000MHz were found more than 20dB below limit line.		

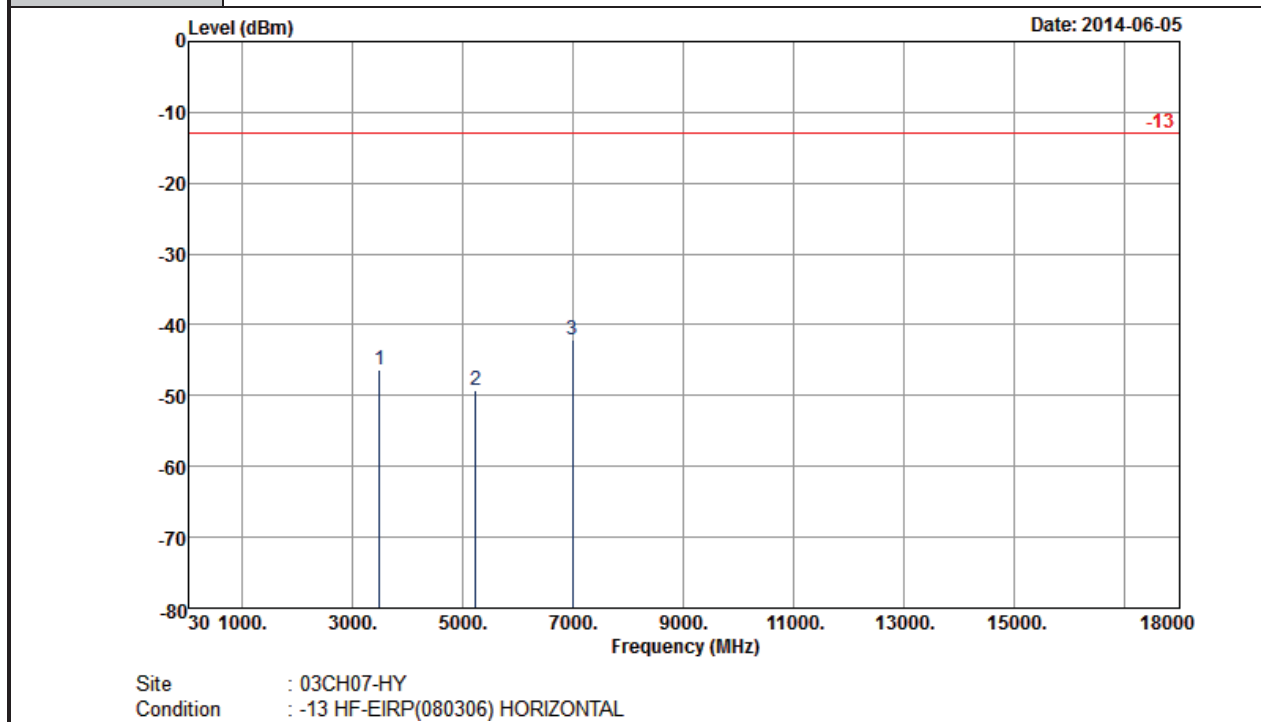

Frequency (MHz)	EIRP (dBm)	Limit (dBm)	Over Limit (dB)	SPA Reading (dBm)	S.G. Power (dBm)	TX Cable loss (dB)	TX Antenna Gain (dBi)	Polarization (H/V)	Result
3495	-46.26	-13	-33.26	-61.01	-50.4	4.24	8.38	H	Pass
5242	-49.33	-13	-36.33	-68.1	-54.2	5.18	10.05	H	Pass
6990	-42.11	-13	-29.11	-68.43	-47.3	6.19	11.38	H	Pass



Band :	LTE Band 4	Temperature :	21~24°C
Test Mode :	15MHz QPSK RB Size 1 Offset 0	Relative Humidity :	46~48%
Test Engineer :	Ken Wu	Polarization :	Vertical
Channel :	20325		
Remark :	Spurious emissions within 30-1000MHz were found more than 20dB below limit line.		

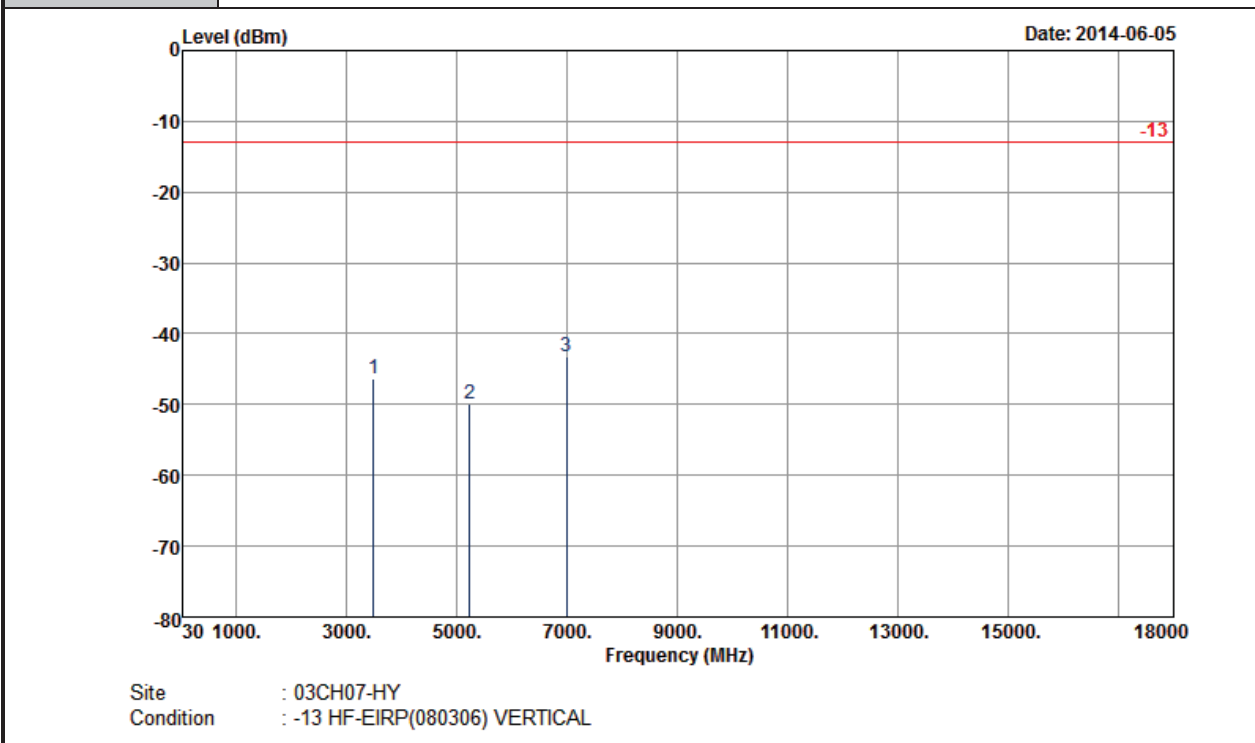

Frequency (MHz)	EIRP (dBm)	Limit (dBm)	Over Limit (dB)	SPA Reading (dBm)	S.G. Power (dBm)	TX Cable loss (dB)	TX Antenna Gain (dBi)	Polarization (H/V)	Result
3495	-46.46	-13	-33.46	-62.1	-50.6	4.24	8.38	V	Pass
5242	-49.93	-13	-36.93	-68.73	-54.8	5.18	10.05	V	Pass
6990	-43.31	-13	-30.31	-68.58	-48.5	6.19	11.38	V	Pass



<Low Channel>

Band :	LTE Band 4	Temperature :	21~24°C
Test Mode :	20MHz QPSK RB Size 1 Offset 0	Relative Humidity :	46~48%
Test Engineer :	Ken Wu	Polarization :	Horizontal
Channel :	20050		
Remark :	Spurious emissions within 30-1000MHz were found more than 20dB below limit line.		

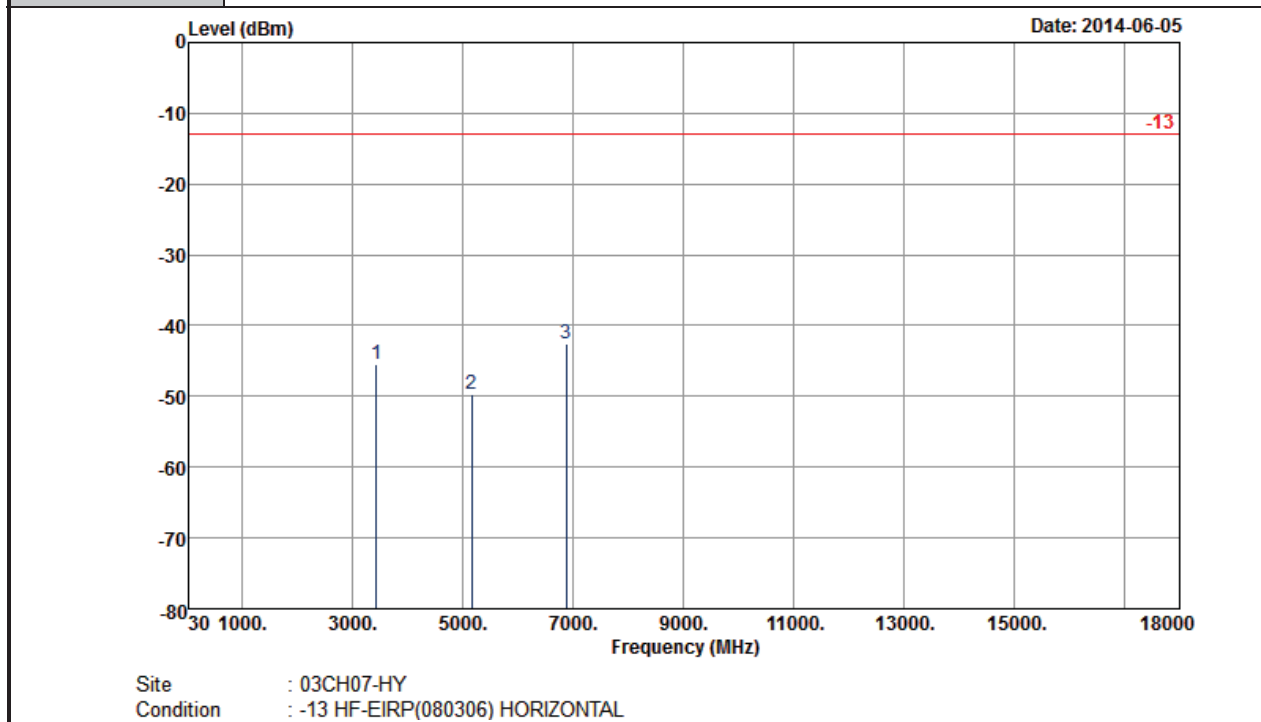

Frequency (MHz)	EIRP (dBm)	Limit (dBm)	Over Limit (dB)	SPA Reading (dBm)	S.G. Power (dBm)	TX Cable loss (dB)	TX Antenna Gain (dBi)	Polarization (H/V)	Result
3441	-45.42	-13	-32.42	-60.13	-49.2	4.62	8.40	H	Pass
5160	-49.77	-13	-36.77	-68.51	-54.4	5.45	10.08	H	Pass
6880	-42.46	-13	-29.46	-68.06	-47.7	6.18	11.42	H	Pass



Band :	LTE Band 4	Temperature :	21~24°C
Test Mode :	20MHz QPSK RB Size 1 Offset 0	Relative Humidity :	46~48%
Test Engineer :	Ken Wu	Polarization :	Vertical
Channel :	20050		
Remark :	Spurious emissions within 30-1000MHz were found more than 20dB below limit line.		

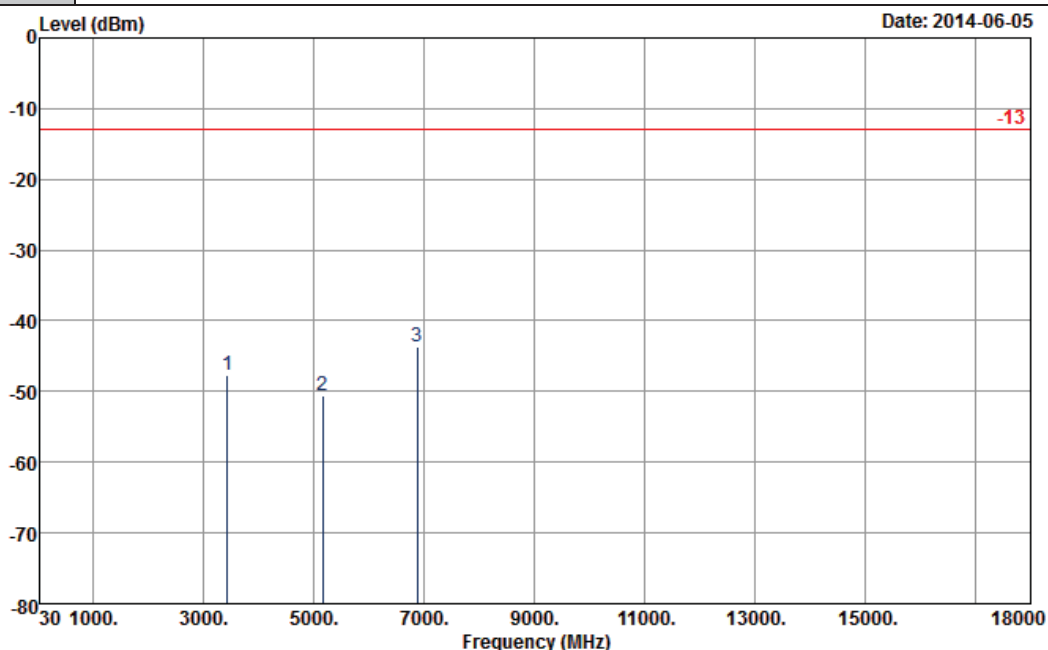

Site : 03CH07-HY
 Condition : -13 HF-EIRP(080306) VERTICAL

Frequency (MHz)	EIRP (dBm)	Limit (dBm)	Over Limit (dB)	SPA Reading (dBm)	S.G. Power (dBm)	TX Cable loss (dB)	TX Antenna Gain (dBi)	Polarization (H/V)	Result
3441	-47.72	-13	-34.72	-63.32	-51.5	4.62	8.40	V	Pass
5160	-50.67	-13	-37.67	-69.26	-55.3	5.45	10.08	V	Pass
6880	-43.66	-13	-30.66	-68.68	-48.9	6.18	11.42	V	Pass



<Middle Channel>

Band :	LTE Band 4	Temperature :	21~24°C
Test Mode :	20MHz QPSK RB Size 1 Offset 0	Relative Humidity :	46~48%
Test Engineer :	Ken Wu	Polarization :	Horizontal
Channel :	20175		
Remark :	Spurious emissions within 30-1000MHz were found more than 20dB below limit line.		

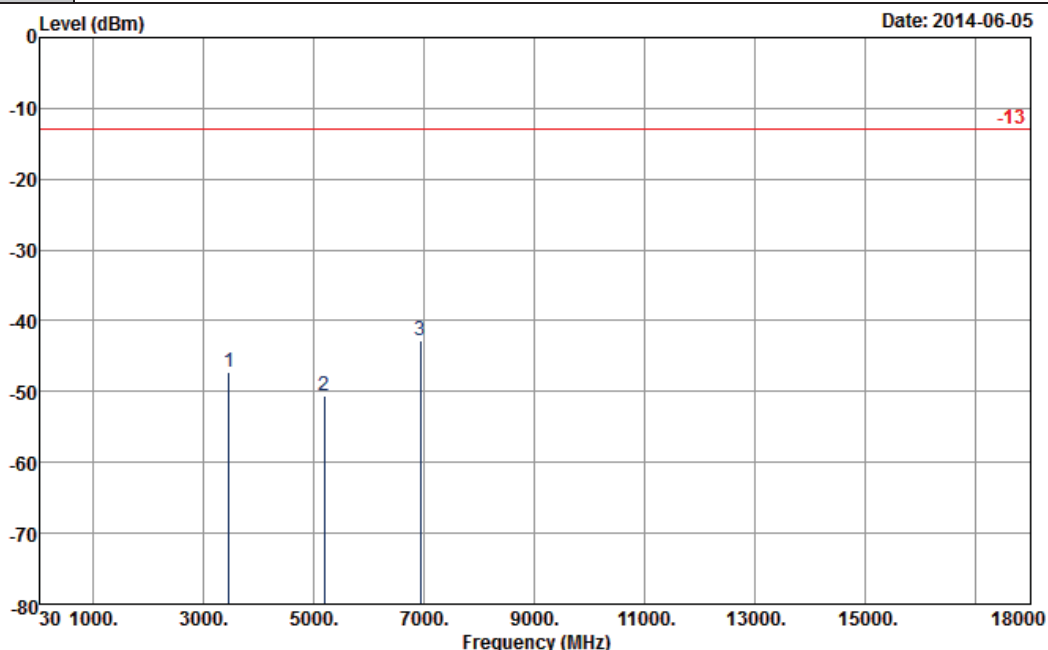

Site : 03CH07-HY
 Condition : -13 HF-EIRP(080306) HORIZONTAL

Frequency (MHz)	EIRP (dBm)	Limit (dBm)	Over Limit (dB)	SPA Reading (dBm)	S.G. Power (dBm)	TX Cable loss (dB)	TX Antenna Gain (dBi)	Polarization (H/V)	Result
3462	-47.27	-13	-34.27	-67.75	-51.1	4.48	8.31	H	Pass
5197	-50.56	-13	-37.56	-68.96	-55.2	5.332	9.98	H	Pass
6930	-42.86	-13	-29.86	-68.4	-48.1	6.1	11.34	H	Pass



Band :	LTE Band 4	Temperature :	21~24°C
Test Mode :	20MHz QPSK RB Size 1 Offset 0	Relative Humidity :	46~48%
Test Engineer :	Ken Wu	Polarization :	Vertical
Channel :	20175		
Remark :	Spurious emissions within 30-1000MHz were found more than 20dB below limit line.		

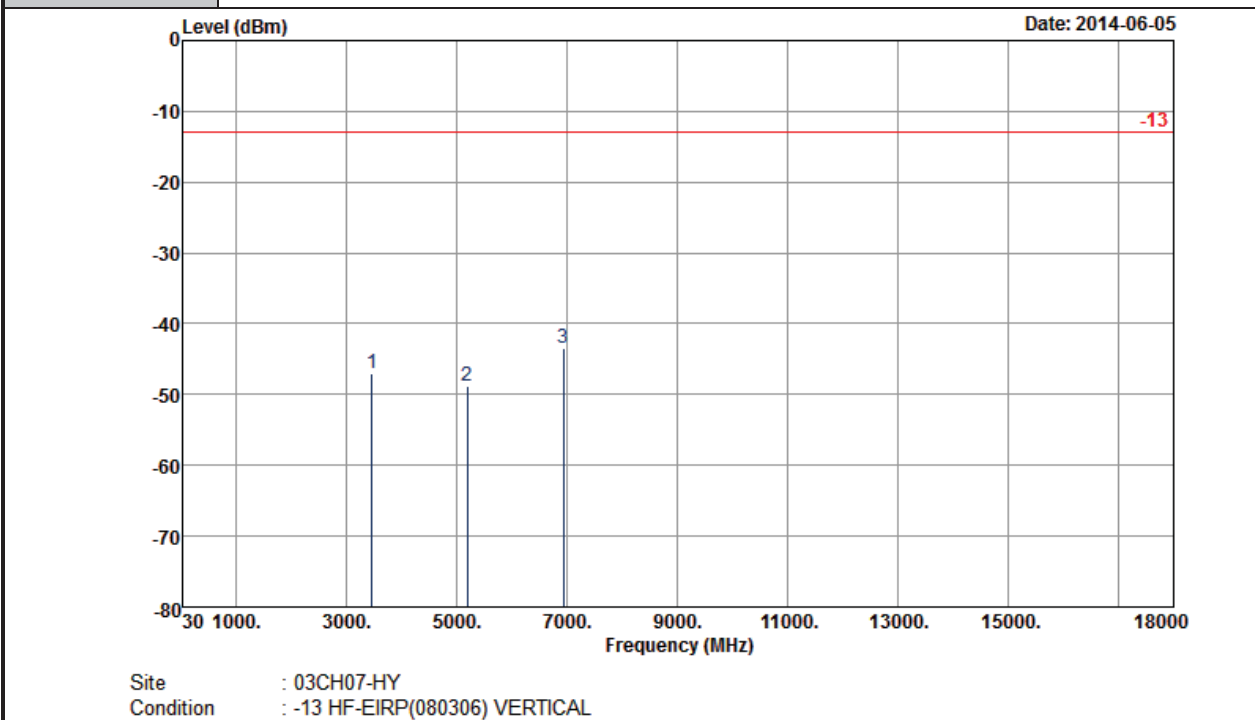

Frequency (MHz)	EIRP (dBm)	Limit (dBm)	Over Limit (dB)	SPA Reading (dBm)	S.G. Power (dBm)	TX Cable loss (dB)	TX Antenna Gain (dBi)	Polarization (H/V)	Result
3462	-47.07	-13	-34.07	-63.03	-50.9	4.48	8.31	V	Pass
5197	-48.86	-13	-35.86	-67.2	-53.5	5.332	9.98	V	Pass
6930	-43.46	-13	-30.46	-68.46	-48.7	6.1	11.34	V	Pass



<High Channel>

Band :	LTE Band 4	Temperature :	21~24°C
Test Mode :	20MHz QPSK RB Size 1 Offset 0	Relative Humidity :	46~48%
Test Engineer :	Ken Wu	Polarization :	Horizontal
Channel :	20300		
Remark :	Spurious emissions within 30-1000MHz were found more than 20dB below limit line.		

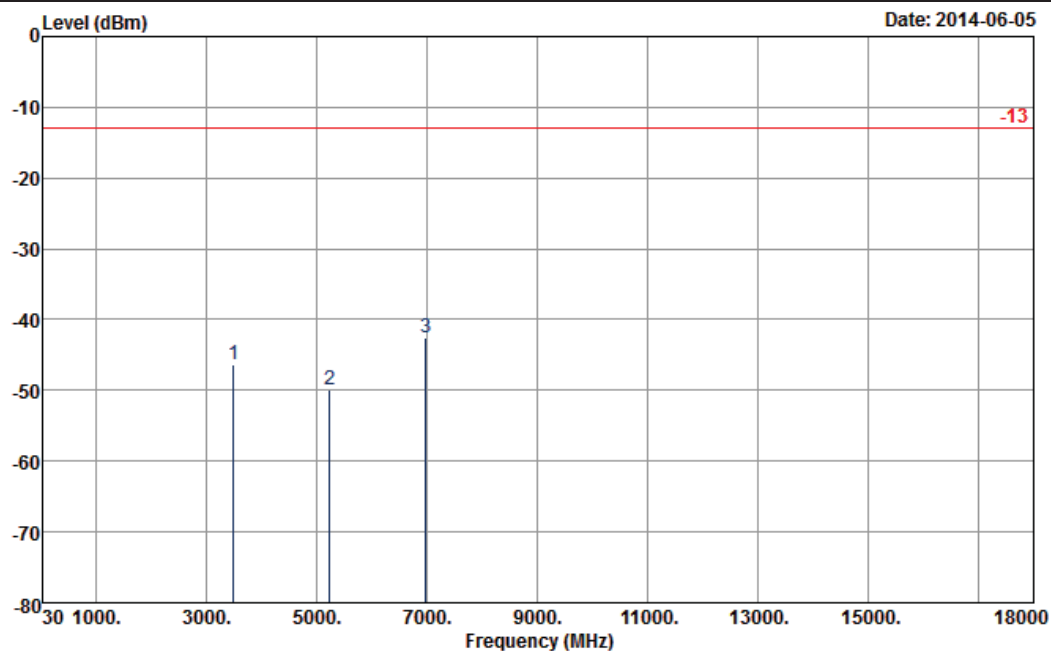

Site : 03CH07-HY
 Condition : -13 HF-EIRP(080306) HORIZONTAL

Frequency (MHz)	EIRP (dBm)	Limit (dBm)	Over Limit (dB)	SPA Reading (dBm)	S.G. Power (dBm)	TX Cable loss (dB)	TX Antenna Gain (dBi)	Polarization (H/V)	Result
3490	-46.41	-13	-33.41	-61.02	-50.5	4.28	8.37	H	Pass
5235	-49.99	-13	-36.99	-68.71	-54.8	5.22	10.03	H	Pass
6980	-42.67	-13	-29.67	-68.65	-47.8	6.23	11.36	H	Pass



Band :	LTE Band 4	Temperature :	21~24°C
Test Mode :	20MHz QPSK RB Size 1 Offset 0	Relative Humidity :	46~48%
Test Engineer :	Ken Wu	Polarization :	Vertical
Channel :	20300		
Remark :	Spurious emissions within 30-1000MHz were found more than 20dB below limit line.		

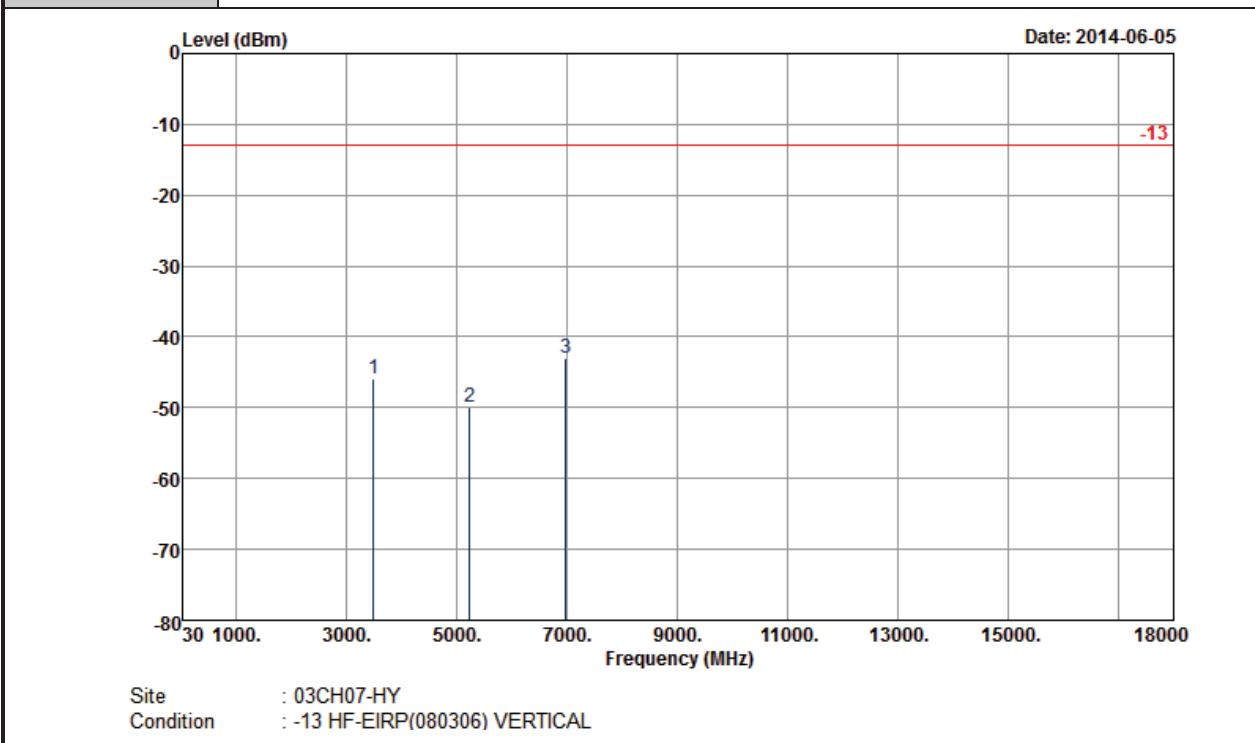

Frequency (MHz)	EIRP (dBm)	Limit (dBm)	Over Limit (dB)	SPA Reading (dBm)	S.G. Power (dBm)	TX Cable loss (dB)	TX Antenna Gain (dBi)	Polarization (H/V)	Result
3490	-46.01	-13	-33.01	-61.65	-50.1	4.28	8.37	V	Pass
5235	-49.89	-13	-36.89	-69	-54.7	5.22	10.03	V	Pass
6980	-43.07	-13	-30.07	-68.55	-48.2	6.23	11.36	V	Pass



3.8 Frequency Stability Measurement

3.8.1 Description of Frequency Stability Measurement

The frequency stability shall be measured by variation of ambient temperature and variation of primary supply voltage to ensure that the fundamental emission stays within the authorized frequency block. The frequency stability of the transmitter shall be maintained within $\pm 0.00025\%$ ($\pm 2.5\text{ppm}$) of the center frequency.

3.8.2 Measuring Instruments

The measuring equipment is listed in the section 4 of this test report.

3.8.3 Test Procedures for Temperature Variation

1. The EUT was set up in the thermal chamber and connected with the system simulator.
2. With power OFF, the temperature was decreased to -30°C and the EUT was stabilized before testing. Power was applied and the maximum change in frequency was recorded within one minute.
3. With power OFF, the temperature was raised in 10°C step up to 50°C . The EUT was stabilized at each step for at least half an hour. Power was applied and the maximum frequency change was recorded within one minute.

3.8.4 Test Procedures for Voltage Variation

1. The EUT was placed in a temperature chamber at $25\pm 5^{\circ}\text{C}$ and connected with the system simulator.
2. The power supply voltage to the EUT was varied from 85% to 115% of the nominal value measured at the input to the EUT.
3. The variation in frequency was measured for the worst case.

3.8.5 Test Setup

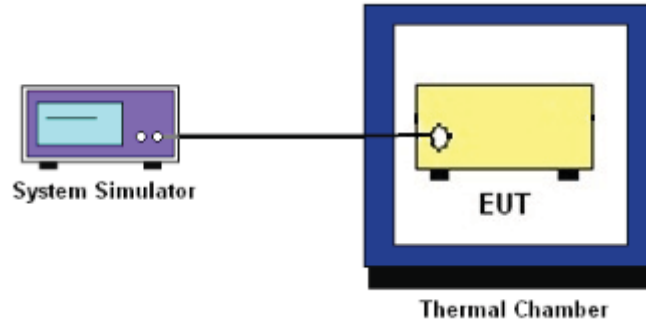



3.8.6 Test Result of Temperature Variation (FCC)

Band :	LTE Band 5 (QPSK)	Limit (ppm) :	2.5
Temperature (°C)	BW 1.4MHz		Result
	Deviation (ppm)		
50	-0.021		PASS
40	0.009		
30	0.011		
20	0.010		
10	-0.018		
0	0.010		
-10	0.012		
-20	0.010		
-30	-0.022		

Band :	LTE Band 5 (16QAM)	Limit (ppm) :	2.5
Temperature (°C)	BW 1.4MHz		Result
	Deviation (ppm)		
50	-0.017		PASS
40	0.013		
30	0.012		
20	-0.017		
10	0.012		
0	0.009		
-10	0.012		
-20	-0.020		
-30	-0.019		



Band :	LTE Band 5 (QPSK)	Limit (ppm) :	2.5
Temperature (°C)	BW 3MHz		Result
	Deviation (ppm)		
50	-0.020		PASS
40	0.008		
30	0.011		
20	0.009		
10	-0.019		
0	0.010		
-10	0.012		
-20	0.010		
-30	-0.022		

Band :	LTE Band 5 (16QAM)	Limit (ppm) :	2.5
Temperature (°C)	BW 3MHz		Result
	Deviation (ppm)		
50	-0.017		PASS
40	0.014		
30	0.012		
20	-0.018		
10	0.012		
0	0.010		
-10	0.011		
-20	-0.020		
-30	-0.018		



Band :	LTE Band 2 (QPSK)	Limit (ppm) :	2.5
Temperature (°C)	BW 1.4MHz		Result
	Deviation (ppm)		
50	0.011		PASS
40	-0.022		
30	0.010		
20	0.011		
10	0.009		
0	-0.017		
-10	0.011		
-20	0.009		
-30	-0.019		

Band :	LTE Band 2 (16QAM)	Limit (ppm) :	2.5
Temperature (°C)	BW 1.4MHz		Result
	Deviation (ppm)		
50	-0.010		PASS
40	-0.007		
30	0.018		
20	0.020		
10	0.020		
0	0.019		
-10	0.021		
-20	0.020		
-30	-0.011		



Band :	LTE Band 2 (QPSK)	Limit (ppm) :	2.5
Temperature (°C)	BW 3MHz		Result
	Deviation (ppm)		
50	0.011		PASS
40	-0.022		
30	0.010		
20	0.012		
10	0.009		
0	-0.018		
-10	0.011		
-20	0.010		
-30	-0.018		

Band :	LTE Band 2 (16QAM)	Limit (ppm) :	2.5
Temperature (°C)	BW 3MHz		Result
	Deviation (ppm)		
50	0.022		PASS
40	0.022		
30	-0.010		
20	-0.008		
10	-0.009		
0	0.021		
-10	0.020		
-20	-0.012		
-30	0.023		



Band :	LTE Band 2 (QPSK)	Limit (ppm) :	2.5
Temperature (°C)	BW 15MHz		Result
	Deviation (ppm)		
50	-0.020		PASS
40	-0.019		
30	0.007		
20	0.010		
10	0.009		
0	0.008		
-10	0.010		
-20	0.009		
-30	-0.021		

Band :	LTE Band 2 (16QAM)	Limit (ppm) :	2.5
Temperature (°C)	BW 15MHz		Result
	Deviation (ppm)		
50	-0.009		PASS
40	-0.007		
30	0.020		
20	0.022		
10	0.021		
0	0.019		
-10	0.023		
-20	0.021		
-30	-0.010		



Band :	LTE Band 2 (QPSK)	Limit (ppm) :	2.5
Temperature (°C)	BW 20MHz		Result
	Deviation (ppm)		
50	-0.008		PASS
40	-0.006		
30	0.021		
20	0.023		
10	0.022		
0	0.020		
-10	0.023		
-20	0.022		
-30	-0.009		

Band :	LTE Band 2 (16QAM)	Limit (ppm) :	2.5
Temperature (°C)	BW 20MHz		Result
	Deviation (ppm)		
50	-0.010		PASS
40	0.020		
30	0.019		
20	0.017		
10	-0.009		
0	0.020		
-10	0.021		
-20	-0.012		
-30	0.020		



Band :	LTE Band 4 (QPSK)	Limit (ppm) :	2.5
Temperature (°C)	BW 1.4MHz		Result
	Deviation (ppm)		
50	0.010		PASS
40	-0.021		
30	0.009		
20	0.009		
10	-0.021		
0	0.009		
-10	0.007		
-20	-0.019		
-30	0.009		

Band :	LTE Band 4 (16QAM)	Limit (ppm) :	2.5
Temperature (°C)	BW 1.4MHz		Result
	Deviation (ppm)		
50	0.010		PASS
40	0.007		
30	0.007		
20	-0.019		
10	-0.022		
0	0.011		
-10	0.012		
-20	-0.019		
-30	0.011		



Band :	LTE Band 4 (QPSK)	Limit (ppm) :	2.5
Temperature (°C)	BW 3MHz		Result
	Deviation (ppm)		
50	0.010		PASS
40	-0.020		
30	0.010		
20	0.009		
10	-0.021		
0	0.009		
-10	0.007		
-20	-0.019		
-30	0.008		

Band :	LTE Band 4 (16QAM)	Limit (ppm) :	2.5
Temperature (°C)	BW 3MHz		Result
	Deviation (ppm)		
50	0.009		PASS
40	0.008		
30	0.007		
20	-0.019		
10	-0.023		
0	0.011		
-10	0.012		
-20	-0.019		
-30	0.011		



Band :	LTE Band 4 (QPSK)	Limit (ppm) :	2.5
Temperature (°C)	BW 15MHz		Result
	Deviation (ppm)		
50	0.006		PASS
40	0.006		
30	-0.020		
20	-0.021		
10	0.010		
0	0.008		
-10	-0.023		
-20	0.007		
-30	0.010		

Band :	LTE Band 4 16QAM)	Limit (ppm) :	2.5
Temperature (°C)	BW 15MHz		Result
	Deviation (ppm)		
50	0.008		PASS
40	-0.019		
30	0.007		
20	-0.017		
10	0.010		
0	0.010		
-10	-0.019		
-20	0.013		
-30	-0.021		



Band :	LTE Band 4 (QPSK)	Limit (ppm) :	2.5
Temperature (°C)	BW 20MHz		Result
	Deviation (ppm)		
50	0.006		PASS
40	0.006		
30	-0.020		
20	-0.021		
10	0.010		
0	0.008		
-10	-0.024		
-20	0.007		
-30	0.010		

Band :	LTE Band 4 (16QAM)	Limit (ppm) :	2.5
Temperature (°C)	BW 20MHz		Result
	Deviation (ppm)		
50	0.008		PASS
40	-0.020		
30	0.007		
20	-0.017		
10	0.009		
0	0.009		
-10	-0.020		
-20	0.012		
-30	-0.020		



3.8.7 Test Result of Voltage Variation (FCC)

Band	Bandwidth	Voltage (Volt)	Deviation (ppm)	Limit (ppm)	Result
LTE Band 5 (QPSK)	1.4M	4.20	0.010	2.5	PASS
		Normal	0.008		
		3.55	-0.020		
	3M	4.20	0.011		
		Normal	0.009		
		3.55	-0.020		
LTE Band 2 (QPSK)	1.4M	4.20	0.009	2.5	PASS
		Normal	0.012		
		3.55	0.010		
	3M	4.20	-0.020		
		Normal	0.007		
		3.55	-0.018		
	15M	4.20	-0.021		
		Normal	0.007		
		3.55	-0.018		
	20M	4.20	0.008		
		Normal	-0.021		
		3.55	0.004		
LTE Band 4 (QPSK)	1.4M	4.20	0.010	2.5	PASS
		Normal	-0.018		
		3.55	0.013		
	3M	4.20	-0.022		
		Normal	0.012		
		3.55	0.011		
	15M	4.20	0.011		
		Normal	-0.017		
		3.55	0.012		
	20M	4.20	-0.021		
		Normal	0.013		
		3.55	0.010		



Band	Bandwidth	Voltage (Volt)	Deviation (ppm)	Limit (ppm)	Result
LTE Band 5 (16QAM)	1.4M	4.20	0.002	2.5	PASS
		Normal	0.002		
		3.55	0.001		
	3M	4.20	0.001		
		Normal	0.002		
		3.55	0.002		
LTE Band 2 (16QAM)	1.4M	4.20	0.012	2.5	PASS
		Normal	-0.020		
		3.55	0.012		
	3M	4.20	0.012		
		Normal	-0.017		
		3.55	0.017		
	15M	4.20	0.012		
		Normal	-0.017		
		3.55	0.008		
	20M	4.20	0.010		
		Normal	0.012		
		3.55	-0.018		
LTE Band 4 (16QAM)	1.4M	4.20	-0.004	2.5	PASS
		Normal	-0.004		
		3.55	-0.019		
	3M	4.20	0.013		
		Normal	0.010		
		3.55	-0.017		
	15M	4.20	0.006		
		Normal	-0.020		
		3.55	-0.019		
	2M	4.20	0.012		
		Normal	0.010		
		3.55	-0.017		

Remark:

1. Normal Voltage = 3.70V.
2. The manufacturer declared that the EUT could work properly between voltage 3.55V ~ 4.20V.



4 List of Measuring Equipment

Instrument	Manufacturer	Model No.	Serial No.	Characteristics	Calibration Date	Test Date	Due Date	Remark
System Simulator	Rohde & Schwarz	CMU200	117995	N/A	Aug. 01, 2013	Jun. 04, 2014	Jul. 31, 2014	Conducted (TH02-HY)
Spectrum Analyzer	Rohde & Schwarz	FSP40	100055	9kHz~40GHz	Jun. 07, 2013	Jun. 04, 2014	Jun. 06, 2014	Conducted (TH02-HY)
Thermal Chamber	Ten Billion	TTH-D3SP	TBN-930701	N/A	Jul. 19, 2013	Jun. 04, 2014	Jul. 18, 2014	Conducted (TH02-HY)
LTE Base Station	Anritsu	MT8820C	6201026480	30MHz~2.7GHz SISO	Jan. 07, 2014	Jun. 04, 2014	Jan. 06, 2015	Conducted (TH02-HY)
Spectrum Analyzer	Rohde & Schwarz	FSV30	101749	10Hz ~ 30GHz	Feb. 10, 2014	Jun. 02, 2014 ~ Jun. 05, 2014	Feb. 09, 2015	Radiation (03CH07-HY)
Bilog Antenna	Schaffner	CBL6111C	2726	30MHz ~ 1GHz	Oct. 10, 2013	Jun. 02, 2014 ~ Jun. 05, 2014	Oct. 09, 2014	Radiation (03CH07-HY)
Double Ridge Horn Antenna	ESCO	3117	75962	1GHz~18GHz	Aug. 22, 2013	Jun. 02, 2014 ~ Jun. 05, 2014	Aug. 21, 2014	Radiation (03CH07-HY)
Preamplifier	COM-POWER	PA-103A	161241	10 MHz ~ 1000MHz	Mar. 17, 2014	Jun. 02, 2014 ~ Jun. 05, 2014	Mar. 16, 2015	Radiation (03CH07-HY)
Preamplifier	Agilent	8449B	3008A02362	1 GHz~26.5 GHz	Nov. 29, 2013	Jun. 02, 2014 ~ Jun. 05, 2014	Nov. 28, 2014	Radiation (03CH07-HY)
Turn Table	ChainTek	ChainTek 3000	N/A	0 ~ 360 degree	N/A	Jun. 02, 2014 ~ Jun. 05, 2014	N/A	Radiation (03CH07-HY)
Antenna Mast	ChainTek	M-400-0	114/8000604 /L	N/A	N/A	Jun. 02, 2014 ~ Jun. 05, 2014	N/A	Radiation (03CH07-HY)
SHF-EHF Horn Antenna	SCHWARZBEC K	BBHA 9170	BBHA91702 51	15GHz- 40GHz	Oct. 03, 2013	Jun. 02, 2014 ~ Jun. 05, 2014	Oct. 02, 2014	Radiation (03CH07-HY)



5 Uncertainty of Evaluation

Uncertainty of Radiated Emission Measurement (30 MHz ~ 1000 MHz)

Measuring Uncertainty for a Level of Confidence of 95% ($U = 2Uc(y)$)	4.50
---	------