



FCC RADIO TEST REPORT

FCC ID : UZ7TC520K
Equipment : Touch Computer
Brand Name : Zebra
Model Name : TC520K
Applicant : Zebra Technologies Corporation
1 Zebra Plaza Holtsville, NY 11742
Manufacturer : Zebra Technologies Corporation
1 Zebra Plaza Holtsville, NY 11742
Standard : FCC Part 15 Subpart C §15.247

The product was received on May 31, 2018 and testing was started from Jul. 10, 2018 and completed on Aug. 29, 2018. We, SPORTON INTERNATIONAL INC., would like to declare that the tested sample has been evaluated in accordance with the test procedures and has been in compliance with the applicable technical standards.

The report must not be used by the client to claim product certification, approval, or endorsement by TAF or any agency of government.

The test results in this report apply exclusively to the tested model / sample. Without written approval of SPORTON INTERNATIONAL INC. EMC & Wireless Communications Laboratory, the test report shall not be reproduced except in full.

Approved by: Joseph Lin

SPORTON INTERNATIONAL INC. EMC & Wireless Communications Laboratory

No. 52, Huaya 1st Rd., Guishan Dist., Taoyuan City, Taiwan (R.O.C.)



Table of Contents

History of this test report.....	3
Summary of Test Result.....	4
1 General Description	5
1.1 Product Feature of Equipment Under Test.....	5
1.2 Product Specification of Equipment Under Test.....	6
1.3 Modification of EUT	7
1.4 Testing Location	8
1.5 Applicable Standards.....	8
2 Test Configuration of Equipment Under Test	9
2.1 Carrier Frequency and Channel	9
2.2 Test Mode.....	10
2.3 Connection Diagram of Test System.....	18
2.4 Support Unit used in test configuration and system	19
2.5 EUT Operation Test Setup	20
2.6 Measurement Results Explanation Example.....	20
3 Test Result	21
3.1 6dB and 99% Bandwidth Measurement	21
3.2 Output Power Measurement.....	25
3.3 Power Spectral Density Measurement	34
3.4 Conducted Band Edges and Spurious Emission Measurement	40
3.5 Radiated Band Edges and Spurious Emission Measurement	101
3.6 AC Conducted Emission Measurement.....	106
3.7 Antenna Requirements.....	108
4 List of Measuring Equipment.....	110
5 Uncertainty of Evaluation.....	112
Appendix A. AC Conducted Emission Test Result	
Appendix B. Radiated Spurious Emission	
Appendix C. Radiated Spurious Emission Plots	
Appendix D. Duty Cycle Plots	
Appendix E. Setup Photographs	



History of this test report

Report No.	Version	Description	Issued Date
FR853105C	01	Initial issue of report	Aug. 29, 2018



Summary of Test Result

Report Clause	Ref Std. Clause	Test Items	Result (PASS/FAIL)	Remark
3.1	15.247(a)(2)	6dB Bandwidth	Pass	-
3.1	2.1049	99% Occupied Bandwidth	Reporting only	-
3.2	15.247(b)	Power Output Measurement	Pass	-
3.3	15.247(e)	Power Spectral Density	Pass	-
3.4	15.247(d)	Conducted Band Edges	Pass	-
		Conducted Spurious Emission	Pass	-
3.5	15.247(d)	Radiated Band Edges and Radiated Spurious Emission	Pass	Under limit 1.16 dB at 2389.240 MHz
3.6	15.207	AC Conducted Emission	Pass	Under limit 15.60 dB at 0.287 MHz
3.7	15.203 & 15.247(b)	Antenna Requirement	Pass	-

Reviewed by: Wii Chang

Report Producer: Nancy Yang



1 General Description

1.1 Product Feature of Equipment Under Test

Product Feature	
Equipment	Touch Computer
Brand Name	Zebra
Model Name	TC520K
FCC ID	UZ7TC520K
EUT supports Radios application	NFC WLAN 11a/b/g/n HT20/HT40 WLAN 11ac VHT20/VHT40/VHT80 Bluetooth BR/EDR/LE
HW Version	DV
SW Version	91-09-14.00-ON-U00-STD
FW Version	FUSION_QA_2_1.0.0.027_O
MFD	20-JUL-18
EUT Stage	Engineering Sample

Remark: The above EUT's information was declared by manufacturer.

Specification of Accessories				
Adapter	Brand Name	Zebra	Part Number	PWR-WUA5V12W0US
Battery 1	Brand Name	Zebra	Part Number	BT-000314-50
Battery 2	Brand Name	Zebra	Part Number	BT-000314-01
USB cable	Brand Name	Zebra	Part Number	CBL-TC51-USB1-01
Headset Jumper 1	Brand Name	Zebra	Part Number	CBL-TC51-HDST25-01
Headset Jumper 2	Brand Name	Zebra	Part Number	CBL-TC51-HDST35-01
2.5mm Earphone	Brand Name	Zebra	Part Number	HDST-25MM-PTVP-01
3.5mm Earphone	Brand Name	Zebra	Part Number	HDST-35MM-PTVP-01
Exoskeleton	Brand Name	Zebra	Part Number	SG-TC51-EX01-01
Trigger Handle	Brand Name	Zebra	Part Number	TRG-TC51-SNP1-01
Soft Holster	Brand Name	Zebra	Part Number	SG-TC51-HLSTR1-01
Hand strap	Brand Name	Zebra	Part Number	SG-TC51-BHDSTP1-03
USB-C Adapter	Brand Name	Zebra	Part Number	ADPTR-TC56-USBC-01
USB Type C cable	Brand Name	Zebra	Part Number	N/A



1.2 Product Specification of Equipment Under Test

Standards-related Product Specification	
Tx/Rx Channel Frequency Range	2412 MHz ~ 2462 MHz
Maximum (Average) Output Power to antenna <CDD Mode>	<p><Ant. 1> 802.11b : 18.45 dBm (0.0700 W) 802.11g : 16.96 dBm (0.0497 W) 802.11n HT20 : 16.92 dBm (0.0492 W) 802.11n HT40 : 16.13 dBm (0.0410 W) 802.11ac VHT20 : 16.85 dBm(0.0484 W) 802.11ac VHT40 : 15.71 dBm(0.0372 W)</p> <p><Ant. 2> 802.11b : 18.34 dBm (0.0682 W) 802.11g : 16.94 dBm (0.0494 W) 802.11n HT20 : 16.99 dBm (0.0500 W) 802.11n HT40 : 16.17 dBm (0.0414 W) 802.11ac VHT20 : 16.96 dBm(0.0497 W) 802.11ac VHT40 : 15.88 dBm(0.0387 W)</p> <p><MIMO Ant. 1 + 2> 802.11b : 21.49 dBm (0.1409 W) 802.11g : 19.95 dBm (0.0989 W) 802.11n HT20 : 19.95 dBm (0.0989 W) 802.11n HT40 : 18.12 dBm (0.0649 W) 802.11ac VHT20 : 19.85 dBm(0.0966 W) 802.11ac VHT40 : 17.98 dBm(0.0628 W)</p>
Maximum Average Output Power to antenna <TXBF Mode>	<p><MIMO Ant. 1 + 2> 802.11ac VHT20 : 19.95 dBm(0.0989 W) 802.11ac VHT40 : 19.41 dBm(0.0873 W)</p>
99% Occupied Bandwidth<CDD Mode>	<p><Ant. 1> 802.11b : 13.45MHz 802.11g : 16.85MHz 802.11n HT20 : 17.90MHz 802.11n HT40 : 36.60MHz</p> <p><Ant. 2> 802.11b : 13.15MHz 802.11g : 16.85MHz 802.11n HT20 : 18.15MHz 802.11n HT40 : 36.60MHz</p> <p><MIMO Ant. 1> 802.11b : 13.90MHz 802.11g : 17.00MHz 802.11n HT20 : 17.90MHz 802.11n HT40 : 36.60MHz</p> <p><MIMO Ant. 2> 802.11b : 13.35MHz 802.11g : 16.90MHz 802.11n HT20 : 18.10MHz 802.11n HT40 : 36.50MHz</p>

Standards-related Product Specification			
99% Occupied Bandwidth<TXBF Mode>	<MIMO Ant. 1> 802.11n VHT20 : 17.70MHz 802.11n VHT40 : 36.70MHz <MIMO Ant. 2> 802.11n VHT20 : 18.65MHz 802.11n VHT40 : 36.60MHz		
Antenna Type / Gain	<Ant. 1>PIFA Antenna with gain 2.8 dBi <Ant. 2>PIFA Antenna with gain 2.3 dBi		
Type of Modulation	802.11b : DSSS (DBPSK / DQPSK / CCK) 802.11g/n : OFDM (BPSK / QPSK / 16QAM / 64QAM) 802.11ac: OFDM (BPSK / QPSK / 16QAM / 64QAM / 256QAM)		
Antenna Function Description		Ant. 0	Ant. 1
	802.11 b/g/n/ac	V	V
	802.11 b/g/n/ac MIMO	V	V
	802.11 ac TXBF	V	V

Note: MIMO Ant. 1+2 is a calculated result from sum of the power MIMO Ant. 1 and MIMO Ant. 2.

1.3 Modification of EUT

No modifications are made to the EUT during all test items.



1.4 Testing Location

Sporton Lab is accredited to ISO 17025 by Taiwan Accreditation Foundation (TAF code : 1190) and the FCC designation No. TW1190 and TW0007 under the FCC 2.948(e) by Mutual Recognition Agreement (MRA) in FCC Test.

Test Site	SPORTON INTERNATIONAL INC.	
Test Site Location	No.52, Huaya 1st Rd., Guishan Dist., Taoyuan City, Taiwan (R.O.C.) TEL: +886-3-327-3456 FAX: +886-3-328-4978	
Test Site No.	Sporton Site No.	
	TH05-HY	CO05-HY

Note: The test site complies with ANSI C63.4 2014 requirement.

Test Site	SPORTON INTERNATIONAL INC.	
Test Site Location	No.58, Aly. 75, Ln. 564, Wenhua 3rd Rd. Guishan Dist., Taoyuan City, Taiwan (R.O.C.) TEL: +886-3-327-0868 FAX: +886-3-327-0855	
Test Site No.	Sporton Site No.	
	03CH12-HY	

Note: The test site complies with ANSI C63.4 2014 requirement.

1.5 Applicable Standards

According to the specifications of the manufacturer, the EUT must comply with the requirements of the following standards:

- ♦ FCC Part 15 Subpart C §15.247
- ♦ FCC KDB Publication No. 558074 D01 DTS Meas. Guidance v04
- ♦ FCC KDB 662911 D01 Multiple Transmitter Output v02r01.
- ♦ ANSI C63.10-2013

Remark:

1. All test items were verified and recorded according to the standards and without any deviation during the test.
2. This EUT has also been tested and complied with the requirements of FCC Part 15, Subpart B, recorded in a separate test report.



2 Test Configuration of Equipment Under Test

- a. The EUT has been associated with peripherals and configuration operated in a manner tended to maximize its emission characteristics in a typical application. Frequency range investigated: conduction emission (150 kHz to 30 MHz), radiation emission (9 kHz to the 10th harmonic of the highest fundamental frequency or to 40 GHz, whichever is lower). For radiated measurement, pre-scanned in three orthogonal panels, X, Y, Z. The worst cases (X plane for Ant. 1 and Ant. 1+2 TXBF mode, Z Plane for Ant. 2 and Ant 1+2 CDD mode) were recorded in this report.

- b. AC power line Conducted Emission was tested under maximum output power.

2.1 Carrier Frequency and Channel

Frequency Band	Channel	Freq. (MHz)	Channel	Freq. (MHz)
2400-2483.5 MHz	1	2412	7	2442
	2	2417	8	2447
	3	2422	9	2452
	4	2427	10	2457
	5	2432	11	2462
	6	2437		



2.2 Test Mode

Final test modes are considering the modulation and worse data rates as below table.

Single Mode

Modulation	Data Rate
802.11b	1 Mbps
802.11g	6 Mbps
802.11n HT20	MCS0
802.11n HT40	MCS0
802.11ac VHT20 (Covered by HT20)	MCS0
802.11ac VHT40 (Covered by HT40)	MCS0

MIMO Mode

Modulation	Data Rate
802.11b	1 Mbps
802.11g	6 Mbps
802.11n HT20	MCS0
802.11n HT40	MCS0
802.11ac VHT20 (Covered by HT20)	MCS0
802.11ac VHT40 (Covered by HT40)	MCS0

TXBF Mode

Modulation	Data Rate
802.11ac VHT20	MCS0
802.11ac VHT40	MCS0

Test Cases	
AC Conducted Emission	Mode 1 :WLAN (2.4GHz) Link + Bluetooth Link + Rugged Charge/USB cable + Scanner + without Exoskeleton + Battery 1 + Adapter (SAWA-65-20005A (5V/2.5A)) + Headset Jumper (CBL-TC51-HDST25-01) + Earphone (HDST-25MM-PTVP-01)
Remark: For Radiated Test Cases, the tests were performed with Rugged Charge/USB Cable, Battery 1, Earphone (HDST-25MM-PTVP-01), Headset Jumper (CBL-TC51-HDST25-01), and without Exoskeleton.	



<CDD Modes>

<Ant. 1>

802.11b mode						
Power vs. Channel			Average Power vs. Data Rate			
Channel	Frequency (MHz)	Data Rate (bps)	Channel	Data Rate (bps)		
		1M		2M	5.5M	11M
Duty Cycle (%)		100.00		98.13	96.03	92.86
CH 01	2412	18.30	CH 11	18.38	18.43	18.42
CH 02	2417	18.42				
CH 06	2437	18.08				
CH 10	2457	18.44				
CH 11	2462	18.45				

802.11g mode										
Power vs. Channel			Average Power vs. Data Rate							
Channel	Frequency (MHz)	Data Rate (bps)	Channel	Data Rate (bps)						
		6M		9M	12M	18M	24M	36M	48M	54M
Duty Cycle (%)		95.28		93.92	91.30	87.97	86.36	78.45	76.67	74.70
CH 01	2412	16.50	CH 02	16.81	16.84	16.94	16.94	16.95	16.87	15.86
CH 02	2417	16.96								
CH 06	2437	16.64								
CH 10	2457	16.79								
CH 11	2462	16.54								

802.11n HT20 mode										
Power vs. Channel			Average Power vs. Data Rate							
Channel	Frequency (MHz)	MCS Index	Channel	MCS Index						
		MCS0		MCS1	MCS2	MCS3	MCS4	MCS5	MCS6	MCS7
Duty Cycle (%)		94.95		91.05	88.10	84.85	80.56	75.56	73.49	72.73
CH 01	2412	15.72	CH 10	16.45	16.91	16.91	16.86	16.88	16.89	15.35
CH 02	2417	16.80								
CH 06	2437	16.53								
CH 10	2457	16.92								
CH 11	2462	16.68								



802.11n HT40 mode										
Power vs. Channel			Average Power vs. Data Rate							
Channel	Frequency (MHz)	MCS Index	Channel	MCS Index						
		MCS0		MCS1	MCS2	MCS3	MCS4	MCS5	MCS6	MCS7
Duty Cycle (%)		90.20		85.42	79.44	75.86	69.12	62.71	61.61	60.95
CH 03	2422	15.44	CH 06	15.72	15.73	15.68	15.60	15.71	15.68	14.14
CH 04	2427	15.94								
CH 06	2437	16.13								
CH 08	2447	15.94								
CH 09	2452	15.30								

802.11ac VHT20 mode											
Power vs. Channel			Average Power vs. Data Rate								
Channel	Frequency (MHz)	MCS Index	Channel	MCS Index							
		MCS0		MCS1	MCS2	MCS3	MCS4	MCS5	MCS6	MCS7	MCS8
Duty Cycle (%)		95.28		92.75	90.72	85.53	83.33	80.82	79.10	77.42	75.00
CH 01	2412	15.60	CH 10	16.43	16.80	16.83	16.74	16.58	16.62	16.58	15.21
CH 02	2417	16.60									
CH 06	2437	16.47									
CH 10	2457	16.85									
CH 11	2462	16.50									

802.11n VHT40 mode												
Power vs. Channel			Average Power vs. Data Rate									
Channel	Frequency (MHz)	MCS Index	Channel	MCS Index								
		MCS0		MCS1	MCS2	MCS3	MCS4	MCS5	MCS6	MCS7	MCS8	MCS9
Duty Cycle (%)		91.35		84.93	80.37	75.00	65.28	63.93	62.50	59.26	58.00	55.10
CH 03	2422	15.18	CH 04	15.70	15.70	15.70	15.65	15.69	15.60	15.67	15.70	14.09
CH 04	2427	15.71										
CH 06	2437	15.68										
CH 08	2447	15.67										
CH 09	2452	15.14										



<CDD Modes>

<Ant. 2>

802.11b mode						
Power vs. Channel			Average Power vs. Data Rate			
Channel	Frequency (MHz)	Data Rate (bps)	Channel	Data Rate (bps)		
		1M		2M	5.5M	11M
Duty Cycle (%)		100.00		98.14	96.03	93.57
CH 01	2412	18.22	CH 11	18.33	18.28	18.32
CH 02	2417	18.32				
CH 06	2437	18.19				
CH 10	2457	18.33				
CH 11	2462	18.34				

802.11g mode										
Power vs. Channel			Average Power vs. Data Rate							
Channel	Frequency (MHz)	Data Rate (bps)	Channel	Data Rate (bps)						
		6M		9M	12M	18M	24M	36M	48M	54M
Duty Cycle (%)		94.39		93.24	92.11	89.35	86.41	80.36	76.40	73.49
CH 01	2412	16.41	CH 10	16.68	16.61	16.93	16.93	16.75	16.74	15.79
CH 02	2417	16.94								
CH 06	2437	16.75								
CH 10	2457	16.94								
CH 11	2462	16.81								

802.11n HT20 mode										
Power vs. Channel			Average Power vs. Data Rate							
Channel	Frequency (MHz)	MCS Index	Channel	MCS Index						
		MCS0		MCS1	MCS2	MCS3	MCS4	MCS5	MCS6	MCS7
Duty Cycle (%)		94.95		90.70	88.00	85.81	79.82	76.40	73.49	71.80
CH 01	2412	15.22	CH 06	16.86	16.96	16.98	16.98	16.97	16.96	15.46
CH 02	2417	16.82								
CH 06	2437	16.99								
CH 10	2457	16.91								
CH 11	2462	16.44								



802.11n HT40 mode										
Power vs. Channel			Average Power vs. Data Rate							
Channel	Frequency (MHz)	MCS Index	Channel	MCS Index						
		MCS0		MCS1	MCS2	MCS3	MCS4	MCS5	MCS6	MCS7
Duty Cycle (%)		90.20		84.38	77.78	74.71	68.38	63.71	58.97	58.18
CH 03	2422	14.34	CH 06	15.91	15.92	15.83	15.75	15.68	15.89	14.28
CH 04	2427	15.26								
CH 06	2437	16.17								
CH 08	2447	15.33								
CH 09	2452	14.84								

802.11ac VHT20 mode											
Power vs. Channel			Average Power vs. Data Rate								
Channel	Frequency (MHz)	MCS Index	Channel	MCS Index							
		MCS0		MCS1	MCS2	MCS3	MCS4	MCS5	MCS6	MCS7	MCS8
Duty Cycle (%)		94.49		91.43	90.72	87.01	82.61	80.00	79.21	77.42	74.70
CH 01	2412	15.20	CH 06	16.83	16.87	16.95	16.93	16.85	16.71	16.83	15.32
CH 02	2417	16.80									
CH 06	2437	16.96									
CH 10	2457	16.90									
CH 11	2462	16.43									

802.11n VHT40 mode												
Power vs. Channel			Average Power vs. Data Rate									
Channel	Frequency (MHz)	MCS Index	Channel	MCS Index								
		MCS0		MCS1	MCS2	MCS3	MCS4	MCS5	MCS6	MCS7	MCS8	MCS9
Duty Cycle (%)		91.35		85.52	79.44	75.28	68.57	63.33	62.28	61.11	56.00	55.10
CH 03	2422	14.33	CH 04	15.86	15.85	15.81	15.74	15.64	15.68	15.60	15.82	14.37
CH 04	2427	15.14										
CH 06	2437	15.88										
CH 08	2447	15.18										
CH 09	2452	14.83										



<CDD Modes>

<MIMO 1+2>

802.11b mode						
Power vs. Channel			Average Power vs. Data Rate			
Channel	Frequency (MHz)	Data Rate (bps)	Channel	Data Rate (bps)		
		1M		2M	5.5M	11M
CH 01	2412	21.25	CH 11	21.45	21.48	21.47
CH 02	2417	21.23				
CH 06	2437	21.40				
CH 10	2457	21.43				
CH 11	2462	21.49				

802.11g mode										
Power vs. Channel			Average Power vs. Data Rate							
Channel	Frequency (MHz)	Data Rate (bps)	Channel	Data Rate (bps)						
		6M		9M	12M	18M	24M	36M	48M	54M
CH 01	2412	19.16	CH 10	19.56	19.53	19.94	19.94	19.70	19.75	18.67
CH 02	2417	19.55								
CH 06	2437	19.71								
CH 10	2457	19.95								
CH 11	2462	19.15								

802.11n HT20 mode										
Power vs. Channel			Average Power vs. Data Rate							
Channel	Frequency (MHz)	MCS Index	Channel	MCS Index						
		MCS0		MCS1	MCS2	MCS3	MCS4	MCS5	MCS6	MCS7
CH 01	2412	17.31	CH 10	19.45	19.94	19.91	19.79	19.73	19.74	18.26
CH 02	2417	19.54								
CH 06	2437	19.59								
CH 10	2457	19.95								
CH 11	2462	18.96								



802.11n HT40 mode										
Power vs. Channel			Average Power vs. Data Rate							
Channel	Frequency (MHz)	MCS Index	Channel	MCS Index						
		MCS0		MCS1	MCS2	MCS3	MCS4	MCS5	MCS6	MCS7
CH 03	2422	16.36	CH 06	18.03	18.04	17.97	17.89	17.99	17.95	16.35
CH 04	2427	17.77								
CH 06	2437	18.12								
CH 08	2447	17.48								
CH 09	2452	17.96								

802.11ac VHT20 mode											
Power vs. Channel			Average Power vs. Data Rate								
Channel	Frequency (MHz)	MCS Index	Channel	MCS Index							
		MCS0		MCS1	MCS2	MCS3	MCS4	MCS5	MCS6	MCS7	MCS8
CH 01	2412	17.27	CH 10	19.41	19.82	19.81	19.59	19.46	19.40	19.56	18.21
CH 02	2417	19.33									
CH 06	2437	19.58									
CH 10	2457	19.85									
CH 11	2462	18.83									

802.11n VHT40 mode												
Power vs. Channel			Average Power vs. Data Rate									
Channel	Frequency (MHz)	MCS Index	Channel	MCS Index								
		MCS0		MCS1	MCS2	MCS3	MCS4	MCS5	MCS6	MCS7	MCS8	MCS9
CH 03	2422	16.35	CH 06	17.97	17.96	17.94	17.86	17.97	17.94	17.83	17.90	16.47
CH 04	2427	17.56										
CH 06	2437	17.98										
CH 08	2447	17.31										
CH 09	2452	17.87										



<TXBF Modes>

<MIMO 1+2>

802.11ac VHT20 mode											
Power vs. Channel			Average Power vs. Data Rate								
Channel	Frequency (MHz)	MCS Index	Channel	MCS Index							
		MCS0		MCS1	MCS2	MCS3	MCS4	MCS5	MCS6	MCS7	MCS8
CH 01	2412	19.63	CH 06	19.81	19.75	19.85	19.85	19.75	19.85	19.75	18.30
CH 06	2437	19.95									
CH 11	2462	19.83									

802.11n VHT40 mode											
Power vs. Channel			Average Power vs. Data Rate								
Channel	Frequency (MHz)	MCS Index	Channel	MCS Index							
		MCS0		MCS1	MCS2	MCS3	MCS4	MCS5	MCS6	MCS7	MCS8
CH 03	2422	19.01	CH 06	19.31	19.21	19.26	19.21	19.26	19.36	19.26	17.81
CH 06	2437	19.41									
CH 09	2452	17.96									

2.3 Connection Diagram of Test System

<Radiated Emission Mode>

<CDD Mode>

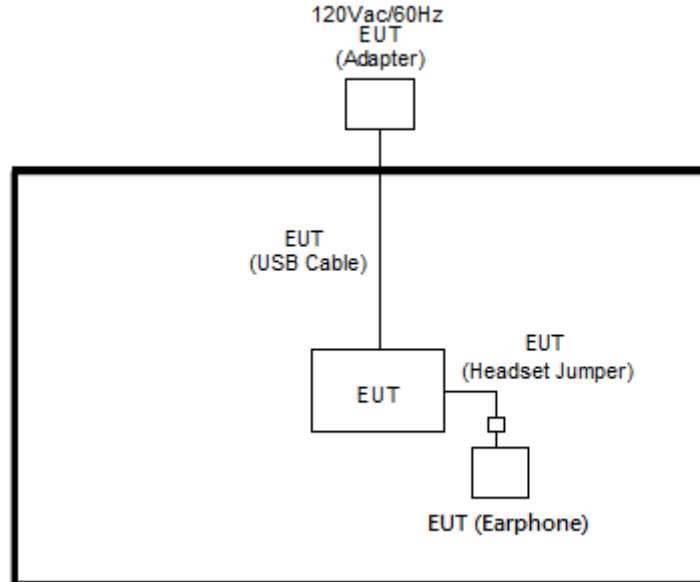

<TXBF Mode>

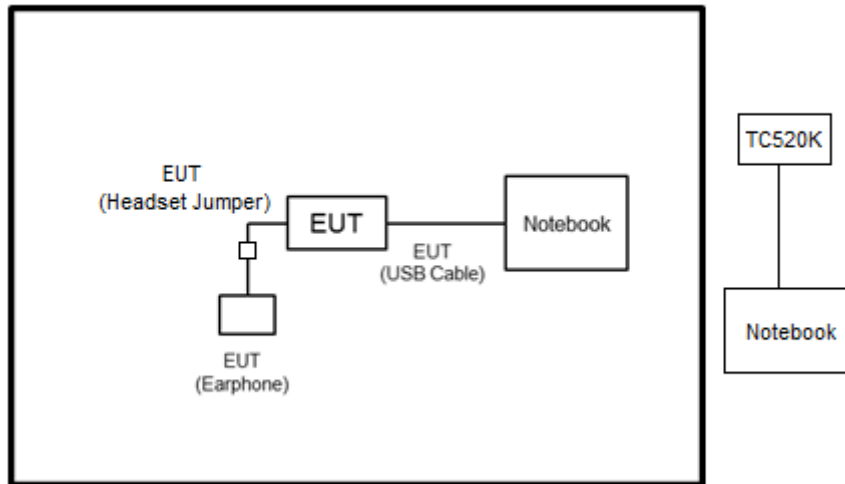

<AC Conducted Emission Mode>

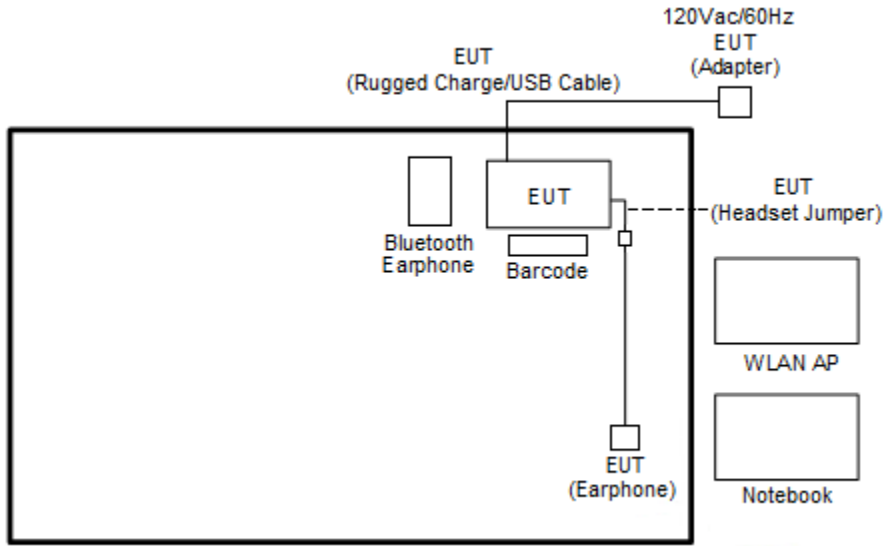

2.4 Support Unit used in test configuration and system

Item	Equipment	Trade Name	Model Name	FCC ID	Data Cable	Power Cord
1.	System Simulator	Anritsu	MT8820C	N/A	N/A	Unshielded, 1.8 m
2.	WLAN AP	ASUS	RT-AC66U	MSQ-RTAC66U	N/A	Unshielded, 1.8 m
3.	Bluetooth Earphone	Sony Ericsson	MW600	PY7DDA-2029	N/A	N/A
4.	Notebook	DELL	Latitude E6320	FCC DoC/ Contains FCC ID: QDS-BRCM1054	N/A	AC I/P: Unshielded, 1.2 m DC O/P: Shielded, 1.8 m
5.	Notebook -01	Lenovo	E335	N/A	N/A	N/A
6.	Notebook -40	Lenovo	E335	N/A	N/A	N/A
7.	SD Card	SanDisk	MicroSD HC	FCC DoC	N/A	N/A



2.5 EUT Operation Test Setup

<CDD Mode>

The RF test items, utility “QRCT” was installed in Notebook which was programmed in order to make the EUT get into the engineering modes to provide channel selection, power level, data rate and the application type and for continuous transmitting signals.

<TXBF Mode>

The RF test items, utility “ADB” was installed in Notebook which was programmed in order to make the EUT get into the engineering modes to provide channel selection, power level, data rate and the application type and for continuous transmitting signals.

2.6 Measurement Results Explanation Example

For all conducted test items:

The offset level is set in the spectrum analyzer to compensate the RF cable loss and attenuator factor between EUT conducted output port and spectrum analyzer. With the offset compensation, the spectrum analyzer reading level is exactly the EUT RF output level.

Example:

The spectrum analyzer offset is derived from RF cable loss and attenuator factor.

Offset = RF cable loss + attenuator factor.

Following shows an offset computation example with cable loss 4.2 dB and 10dB attenuator.

$$\begin{aligned} \text{Offset(dB)} &= \text{RF cable loss(dB)} + \text{attenuator factor(dB)}. \\ &= 4.2 + 10 = 14.2 \text{ (dB)} \end{aligned}$$

3 Test Result

3.1 6dB and 99% Bandwidth Measurement

3.1.1 Limit of 6dB and 99% Bandwidth

The minimum 6 dB bandwidth shall be at least 500 kHz.

3.1.2 Measuring Instruments

See list of measuring equipment of this test report.

3.1.3 Test Procedures

1. The testing follows FCC KDB Publication No. 558074 DTS D01 Meas. Guidance v04.
2. The RF output of EUT was connected to the spectrum analyzer by RF cable and attenuator. The path loss was compensated to the results for each measurement.
3. Set to the maximum power setting and enable the EUT transmit continuously.
4. Make the measurement with the spectrum analyzer's resolution bandwidth (RBW) = 100 kHz. Set the Video bandwidth (VBW) = 300 kHz. In order to make an accurate measurement. The 6 dB bandwidth must be greater than 500 kHz.
5. For 99% Bandwidth Measurement, the spectrum analyzer's resolution bandwidth (RBW) is set 1-5% of the emission bandwidth and set the Video bandwidth (VBW) $\geq 3 * RBW$.
6. Measure and record the results in the test report.

3.1.4 Test Setup

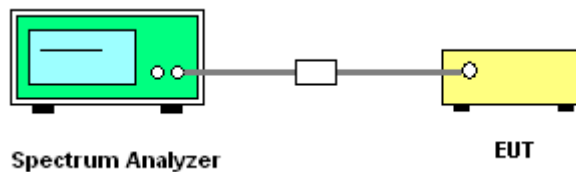



3.1.5 Test Result of 6dB and 99% Occupied Bandwidth

<CDD Mode>

2.4GHz Band										
Mod.	Data Rate	NTX	CH.	Freq. (MHz)	99% Occupied BW (MHz)		6dB BW (MHz)		6dB BW Limit (MHz)	Pass/Fail
					Ant 1	Ant 2	Ant 1	Ant 2		
11b	1Mbps	1	1	2412	13.45	13.10	8.00	8.00	0.50	Pass
11b	1Mbps	1	6	2437	12.95	13.10	8.04	8.04	0.50	Pass
11b	1Mbps	1	11	2462	13.10	13.15	8.00	8.04	0.50	Pass
11g	6Mbps	1	1	2412	16.85	16.85	15.12	15.32	0.50	Pass
11g	6Mbps	1	6	2437	16.75	16.85	15.32	15.48	0.50	Pass
11g	6Mbps	1	11	2462	16.65	16.80	15.12	15.12	0.50	Pass
HT20	MCS0	1	1	2412	17.90	18.00	15.68	16.00	0.50	Pass
HT20	MCS0	1	6	2437	17.90	18.15	15.96	16.00	0.50	Pass
HT20	MCS0	1	11	2462	17.75	17.90	15.12	15.14	0.50	Pass
HT40	MCS0	1	3	2422	36.50	36.40	35.12	35.04	0.50	Pass
HT40	MCS0	1	6	2437	36.60	36.50	35.68	35.04	0.50	Pass
HT40	MCS0	1	9	2452	36.60	36.60	35.72	35.68	0.50	Pass
11b	1Mbps	2	1	2412	13.90	12.95	8.00	8.04	0.50	Pass
11b	1Mbps	2	6	2437	13.10	13.35	8.00	8.04	0.50	Pass
11b	1Mbps	2	11	2462	13.45	13.30	8.04	8.04	0.50	Pass
11g	6Mbps	2	1	2412	17.00	16.75	15.12	15.44	0.50	Pass
11g	6Mbps	2	6	2437	16.75	16.90	15.32	15.44	0.50	Pass
11g	6Mbps	2	11	2462	16.65	16.65	15.12	15.12	0.50	Pass
HT20	MCS0	2	1	2412	17.90	17.90	15.12	16.26	0.50	Pass
HT20	MCS0	2	6	2437	17.90	18.10	15.96	15.96	0.50	Pass
HT20	MCS0	2	11	2462	17.80	17.80	15.08	15.44	0.50	Pass
HT40	MCS0	2	3	2422	36.30	36.50	35.04	35.12	0.50	Pass
HT40	MCS0	2	6	2437	36.60	36.50	35.12	35.04	0.50	Pass
HT40	MCS0	2	9	2452	36.50	36.50	35.76	35.64	0.50	Pass

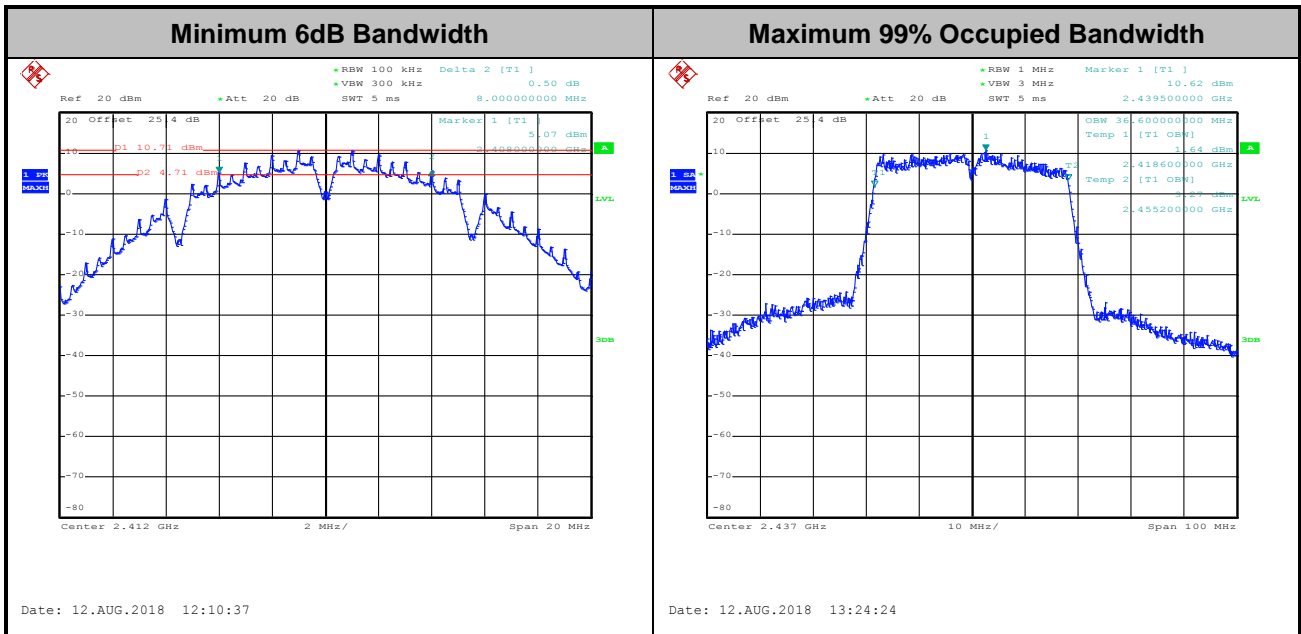

Note : The occupied channel bandwidth is maintained within the band of operation for all of the modulations.



<TXBF Mode>

2.4GHz Band										
Mod.	Data Rate	N _{TX}	CH.	Freq. (MHz)	99% Occupied BW (MHz)		6dB BW (MHz)		6dB BW Limit (MHz)	Pass/Fail
					Ant 1	Ant 2	Ant 1	Ant 2		
VHT20	MCS0	2	1	2412	17.70	18.50	15.12	17.60	0.50	Pass
VHT20	MCS0	2	6	2437	17.70	18.65	15.16	17.60	0.50	Pass
VHT20	MCS0	2	11	2462	17.70	18.40	15.12	17.60	0.50	Pass
VHT40	MCS0	2	3	2422	36.40	36.30	33.76	35.12	0.50	Pass
VHT40	MCS0	2	6	2437	36.70	36.40	32.56	35.12	0.50	Pass
VHT40	MCS0	2	9	2452	36.50	36.60	33.84	35.12	0.50	Pass

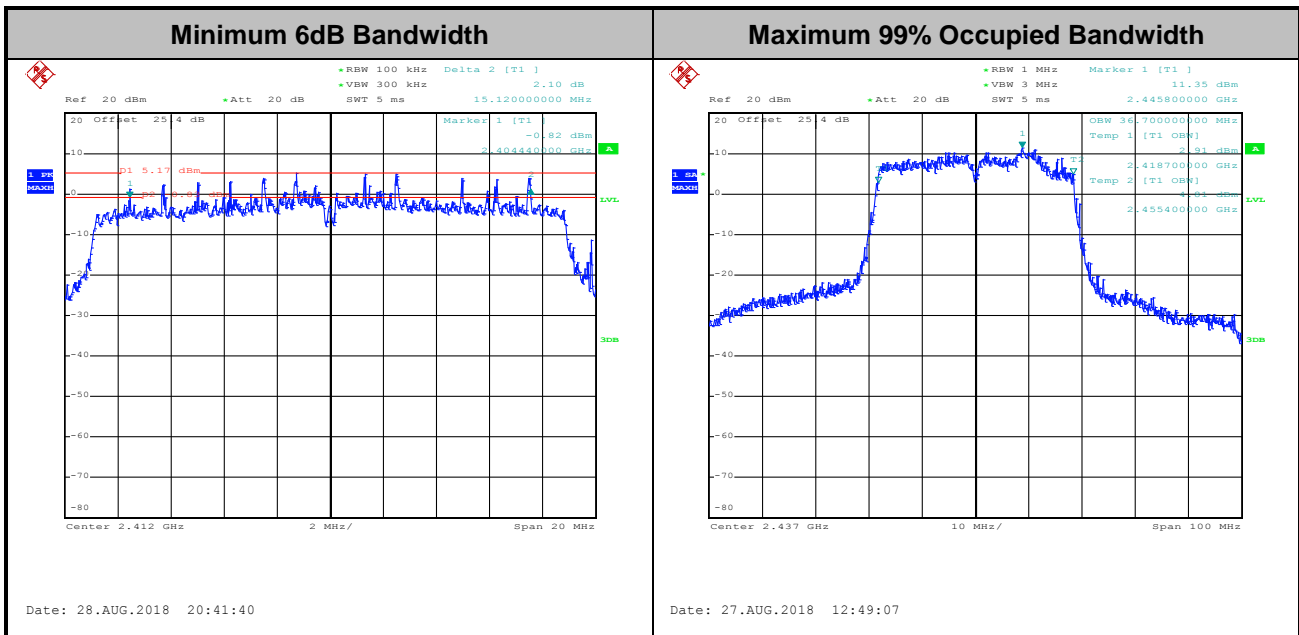

Note : The occupied channel bandwidth is maintained within the band of operation for all of the modulations.



3.2 Output Power Measurement

3.2.1 Limit of Output Power

For systems using digital modulation in the 2400-2483.5MHz, the limit for output power is 30dBm. If transmitting antenna with directional gain greater than 6dBi is used, the output power from the intentional radiator shall be reduced below the above stated value by the amount in dB that the directional gain of the antenna exceeds 6 dBi. In case of point-to-point operation, the limit has to be reduced by 1dB for every 3dB that the directional gain of the antenna exceeds 6dBi.

3.2.2 Measuring Instruments

See list of measuring equipment of this test report.

3.2.3 Test Procedures

<CDD Modes>

1. For Peak Power, the testing follows the Measurement Procedure of FCC KDB No. 558074 DTS D01 Meas. Guidance v04 section 9.1.3 PKPM1 Peak power meter method.
2. For Average Power, the testing follows the Measurement Procedure of FCC KDB No. 558074 DTS D01 Meas. Guidance v04 section 9.2.3.2 Method AVGPM-G.
3. The RF output of EUT was connected to the power meter by RF cable and attenuator. The path loss was compensated to the results for each measurement.
4. Set to the maximum power setting and enable the EUT transmit continuously.
5. Measure the conducted output power and record the results in the test report.
6. For MIMO mode, calculation method follows FCC KDB 662911 D01 Multiple Transmitter Output v02r01.

<TXBF Modes>

1. The testing follows the Measurement Procedure of FCC KDB No. 558074 DTS D01 Meas. Guidance v04 section 9.2.3.2 Method AVGPM-G.
2. The RF output of EUT was connected to the power meter by RF cable and attenuator. The path loss was compensated to the results for each measurement.
3. Set to the maximum power setting and enable the EUT transmit continuously.
4. Measure the conducted output power and record the results in the test report.
5. For MIMO mode, calculation method follows FCC KDB 662911 D01 Multiple Transmitter Output v02r01.

3.2.4 Test Setup

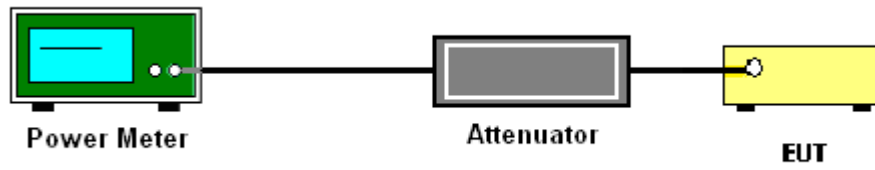



3.2.5 Test Result of Peak Output Power (Reporting Only)

<CDD Modes>

2.4GHz Band											
Mod.	Data Rate	NTX	CH.	Freq. (MHz)	Peak Conducted Power (dBm)			DG (dBi)		EIRP Power (dBm)	
					Ant 1	Ant 2	SUM	Ant 1	Ant 2	Ant 1	Ant 2
11b	1Mbps	1	1	2412	20.79	20.72		2.80	2.30	23.59	23.02
11b	1Mbps	1	2	2417	20.90	20.81		2.80	2.30	23.70	23.11
11b	1Mbps	1	6	2437	20.66	20.66		2.80	2.30	23.46	22.96
11b	1Mbps	1	10	2457	20.91	20.82		2.80	2.30	23.71	23.12
11b	1Mbps	1	11	2462	20.92	20.83		2.80	2.30	23.72	23.13
11g	6Mbps	1	1	2412	20.66	20.85		2.80	2.30	23.46	23.15
11g	6Mbps	1	2	2417	20.89	20.79		2.80	2.30	23.69	23.09
11g	6Mbps	1	6	2437	20.74	20.82		2.80	2.30	23.54	23.12
11g	6Mbps	1	10	2457	21.16	21.16		2.80	2.30	23.96	23.46
11g	6Mbps	1	11	2462	20.63	20.95		2.80	2.30	23.43	23.25
HT20	MCS0	1	1	2412	20.21	20.01		2.80	2.30	23.01	22.31
HT20	MCS0	1	2	2417	20.99	20.99		2.80	2.30	23.79	23.29
HT20	MCS0	1	6	2437	20.81	21.20	-	2.80	2.30	23.61	23.50
HT20	MCS0	1	10	2457	21.59	21.39		2.80	2.30	24.39	23.69
HT20	MCS0	1	11	2462	21.11	20.99		2.80	2.30	23.91	23.29
HT40	MCS0	1	3	2422	21.05	20.05		2.80	2.30	23.85	22.35
HT40	MCS0	1	4	2427	21.39	20.99		2.80	2.30	24.19	23.29
HT40	MCS0	1	6	2437	22.35	22.10		2.80	2.30	25.15	24.40
HT40	MCS0	1	8	2447	21.65	21.12		2.80	2.30	24.45	23.42
HT40	MCS0	1	9	2452	21.12	20.88		2.80	2.30	23.92	23.18
VHT20	MCS0	1	1	2412	19.99	19.99		2.80	2.30	22.79	22.29
VHT20	MCS0	1	2	2417	20.79	20.95		2.80	2.30	23.59	23.25
VHT20	MCS0	1	6	2437	20.89	21.18		2.80	2.30	23.69	23.48
VHT20	MCS0	1	10	2457	21.36	21.38		2.80	2.30	24.16	23.68
VHT20	MCS0	1	11	2462	20.99	20.95		2.80	2.30	23.79	23.25



2.4GHz Band											
Mod.	Data Rate	NTX	CH.	Freq. (MHz)	Peak Conducted Power (dBm)			DG (dBi)		EIRP Power (dBm)	
					Ant 1	Ant 2	SUM	Ant 1	Ant 2	Ant 1	Ant 2
VHT40	MCS0	1	3	2422	20.71	20.18	-	2.80	2.30	23.51	22.48
VHT40	MCS0	1	4	2427	21.15	20.69		2.80	2.30	23.95	22.99
VHT40	MCS0	1	6	2437	21.17	21.21		2.80	2.30	23.97	23.51
VHT40	MCS0	1	8	2447	21.38	20.99		2.80	2.30	24.18	23.29
VHT40	MCS0	1	9	2452	21.25	20.79		2.80	2.30	24.05	23.09
11b	1Mbps	2	1	2412	20.90	20.17	23.56	2.80		26.36	
11b	1Mbps	2	2	2417	20.89	20.41	23.67	2.80		26.47	
11b	1Mbps	2	6	2437	20.89	20.68	23.80	2.80		26.60	
11b	1Mbps	2	10	2457	21.17	21.21	24.20	2.80		27.00	
11b	1Mbps	2	11	2462	21.22	20.56	23.91	2.80		26.71	
11g	6Mbps	2	1	2412	20.69	20.49	23.60	2.80		26.40	
11g	6Mbps	2	2	2417	21.05	20.49	23.79	2.80		26.59	
11g	6Mbps	2	6	2437	21.06	20.83	23.96	2.80		26.76	
11g	6Mbps	2	10	2457	21.69	21.12	24.42	2.80		27.22	
11g	6Mbps	2	11	2462	20.88	20.49	23.70	2.80		26.50	



2.4GHz Band											
Mod.	Data Rate	NTX	CH.	Freq. (MHz)	Peak Conducted Power (dBm)			DG (dBi)		EIRP Power (dBm)	
					Ant 1	Ant 2	SUM	Ant 1	Ant 2	Ant 1	Ant 2
HT20	MCS0	2	1	2412	19.49	18.99	22.26	2.80		25.06	
HT20	MCS0	2	2	2417	21.15	20.49	23.84	2.80		26.64	
HT20	MCS0	2	6	2437	21.13	20.71	23.94	2.80		26.74	
HT20	MCS0	2	10	2457	21.69	21.25	24.49	2.80		27.29	
HT20	MCS0	2	11	2462	20.99	20.31	23.67	2.80		26.47	
HT40	MCS0	2	3	2422	19.49	19.45	22.48	2.80		25.28	
HT40	MCS0	2	4	2427	20.59	20.35	23.48	2.80		26.28	
HT40	MCS0	2	6	2437	21.09	20.59	23.86	2.80		26.66	
HT40	MCS0	2	8	2447	21.01	20.05	23.57	2.80		26.37	
HT40	MCS0	2	9	2452	21.49	20.69	24.12	2.80		26.92	
VHT20	MCS0	2	1	2412	19.39	18.75	22.09	2.80		24.89	
VHT20	MCS0	2	2	2417	20.71	20.49	23.61	2.80		26.41	
VHT20	MCS0	2	6	2437	21.05	20.85	23.96	2.80		26.76	
VHT20	MCS0	2	10	2457	21.52	21.19	24.37	2.80		27.17	
VHT20	MCS0	2	11	2462	20.69	20.39	23.55	2.80		26.35	
VHT40	MCS0	2	3	2422	19.21	19.29	22.26	2.80		25.06	
VHT40	MCS0	2	4	2427	20.25	20.39	23.33	2.80		26.13	
VHT40	MCS0	2	6	2437	20.69	20.31	23.51	2.80		26.31	
VHT40	MCS0	2	8	2447	20.59	20.02	23.32	2.80		26.12	
VHT40	MCS0	2	9	2452	21.25	20.88	24.08	2.80		26.88	



3.2.7 Test Result of Average output Power

<CDD Mode>

2.4GHz Band																		
Mod.	Data Rate	NTX	CH.	Freq. (MHz)	Duty Factor (dB)		Average Conducted Power (dBm)			Conducted Power Limit (dBm)		DG (dBi)		EIRP Power (dBm)		EIRP Power Limit (dBm)		Pass /Fail
					Ant 1	Ant 2	Ant 1	Ant 2	SUM	Ant 1	Ant 2	Ant 1	Ant 2	Ant 1	Ant 2	Ant 1	Ant 2	
11b	1Mbps	1	1	2412	0.00	0.00	18.30	18.22		30.00	30.00	2.80	2.30	21.10	20.52	36.00	36.00	Pass
11b	1Mbps	1	2	2417	0.00	0.00	18.42	18.32		30.00	30.00	2.80	2.30	21.22	20.62	36.00	36.00	Pass
11b	1Mbps	1	6	2437	0.00	0.00	18.08	18.19		30.00	30.00	2.80	2.30	20.88	20.49	36.00	36.00	Pass
11b	1Mbps	1	10	2457	0.00	0.00	18.44	18.33		30.00	30.00	2.80	2.30	21.24	20.63	36.00	36.00	Pass
11b	1Mbps	1	11	2462	0.00	0.00	18.45	18.34		30.00	30.00	2.80	2.30	21.25	20.64	36.00	36.00	Pass
11g	6Mbps	1	1	2412	0.21	0.25	16.50	16.41		30.00	30.00	2.80	2.30	19.30	18.71	36.00	36.00	Pass
11g	6Mbps	1	2	2417	0.21	0.25	16.96	16.94		30.00	30.00	2.80	2.30	19.76	19.24	36.00	36.00	Pass
11g	6Mbps	1	6	2437	0.21	0.25	16.64	16.75		30.00	30.00	2.80	2.30	19.44	19.05	36.00	36.00	Pass
11g	6Mbps	1	10	2457	0.21	0.25	16.79	16.94		30.00	30.00	2.80	2.30	19.59	19.24	36.00	36.00	Pass
11g	6Mbps	1	11	2462	0.21	0.25	16.54	16.81		30.00	30.00	2.80	2.30	19.34	19.11	36.00	36.00	Pass
HT20	MCS0	1	1	2412	0.23	0.23	15.72	15.22		30.00	30.00	2.80	2.30	18.52	17.52	36.00	36.00	Pass
HT20	MCS0	1	2	2417	0.23	0.23	16.80	16.82		30.00	30.00	2.80	2.30	19.60	19.12	36.00	36.00	Pass
HT20	MCS0	1	6	2437	0.23	0.23	16.53	16.99	-	30.00	30.00	2.80	2.30	19.33	19.29	36.00	36.00	Pass
HT20	MCS0	1	10	2457	0.23	0.23	16.92	16.91		30.00	30.00	2.80	2.30	19.72	19.21	36.00	36.00	Pass
HT20	MCS0	1	11	2462	0.23	0.23	16.68	16.44		30.00	30.00	2.80	2.30	19.48	18.74	36.00	36.00	Pass
HT40	MCS0	1	3	2422	0.45	0.45	15.44	14.34		30.00	30.00	2.80	2.30	18.24	16.64	36.00	36.00	Pass
HT40	MCS0	1	4	2427	0.45	0.45	15.94	15.26		30.00	30.00	2.80	2.30	18.74	17.56	36.00	36.00	Pass
HT40	MCS0	1	6	2437	0.45	0.45	16.13	16.17		30.00	30.00	2.80	2.30	18.93	18.47	36.00	36.00	Pass
HT40	MCS0	1	8	2447	0.45	0.45	15.94	15.33		30.00	30.00	2.80	2.30	18.74	17.63	36.00	36.00	Pass
HT40	MCS0	1	9	2452	0.45	0.45	15.30	14.84		30.00	30.00	2.80	2.30	18.10	17.14	36.00	36.00	Pass
VHT20	MCS0	1	1	2412	0.21	0.25	15.60	15.20		30.00	30.00	2.80	2.30	18.40	17.50	36.00	36.00	Pass
VHT20	MCS0	1	2	2417	0.21	0.25	16.60	16.80		30.00	30.00	2.80	2.30	19.40	19.10	36.00	36.00	Pass
VHT20	MCS0	1	6	2437	0.21	0.25	16.47	16.96		30.00	30.00	2.80	2.30	19.27	19.26	36.00	36.00	Pass
VHT20	MCS0	1	10	2457	0.21	0.25	16.85	16.90		30.00	30.00	2.80	2.30	19.65	19.20	36.00	36.00	Pass
VHT20	MCS0	1	11	2462	0.21	0.25	16.50	16.43		30.00	30.00	2.80	2.30	19.30	18.73	36.00	36.00	Pass



2.4GHz Band																		
Mod.	Data Rate	NTX	CH.	Freq. (MHz)	Duty Factor (dB)		Average Conducted Power (dBm)			Conducted Power Limit (dBm)		DG (dBi)		EIRP Power (dBm)		EIRP Power Limit (dBm)		Pass /Fail
					Ant 1	Ant 2	Ant 1	Ant 2	SUM	Ant 1	Ant 2	Ant 1	Ant 2	Ant 1	Ant 2	Ant 1	Ant 2	
VHT40	MCS0	1	3	2422	0.39	0.39	15.18	14.33		30.00	30.00	2.80	2.30	17.98	16.63	36.00	36.00	Pass
VHT40	MCS0	1	4	2427	0.39	0.39	15.71	15.14		30.00	30.00	2.80	2.30	18.51	17.44	36.00	36.00	Pass
VHT40	MCS0	1	6	2437	0.39	0.39	15.68	15.88	-	30.00	30.00	2.80	2.30	18.48	18.18	36.00	36.00	Pass
VHT40	MCS0	1	8	2447	0.39	0.39	15.67	15.18		30.00	30.00	2.80	2.30	18.47	17.48	36.00	36.00	Pass
VHT40	MCS0	1	9	2452	0.39	0.39	15.14	14.83		30.00	30.00	2.80	2.30	17.94	17.13	36.00	36.00	Pass
11b	1Mbps	2	1	2412	0.00	0.00	18.73	17.68	21.25	30.00		2.80		24.05		36.00		Pass
11b	1Mbps	2	2	2417	0.00	0.00	18.70	17.67	21.23	30.00		2.80		24.03		36.00		Pass
11b	1Mbps	2	6	2437	0.00	0.00	18.53	18.25	21.40	30.00		2.80		24.20		36.00		Pass
11b	1Mbps	2	10	2457	0.00	0.00	18.42	18.41	21.43	30.00		2.80		24.23		36.00		Pass
11b	1Mbps	2	11	2462	0.00	0.00	18.86	18.06	21.49	30.00		2.80		24.29		36.00		Pass



2.4GHz Band																	
Mod.	Data Rate	NTX	CH.	Freq. (MHz)	Duty Factor (dB)		Average Conducted Power (dBm)			Conducted Power Limit (dBm)		DG (dBi)		EIRP Power (dBm)		EIRP Power Limit (dBm)	Pass /Fail
					Ant 1	Ant 2	Ant 1	Ant 2	SUM	Ant 1	Ant 2	Ant 1	Ant 2	Ant 1	Ant 2		
11g	6Mbps	2	1	2412	0.21	0.21	16.50	15.77	19.16	30.00		2.80	21.96	36.00	Pass		
11g	6Mbps	2	2	2417	0.21	0.21	17.09	15.90	19.55	30.00		2.80	22.35	36.00	Pass		
11g	6Mbps	2	6	2437	0.21	0.21	16.81	16.59	19.71	30.00		2.80	22.51	36.00	Pass		
11g	6Mbps	2	10	2457	0.21	0.21	17.25	16.60	19.95	30.00		2.80	22.75	36.00	Pass		
11g	6Mbps	2	11	2462	0.21	0.21	16.37	15.90	19.15	30.00		2.80	21.95	36.00	Pass		
HT20	MCS0	2	1	2412	0.22	0.23	14.54	14.04	17.31	30.00		2.80	20.11	36.00	Pass		
HT20	MCS0	2	2	2417	0.22	0.23	16.91	16.11	19.54	30.00		2.80	22.34	36.00	Pass		
HT20	MCS0	2	6	2437	0.22	0.23	16.66	16.50	19.59	30.00		2.80	22.39	36.00	Pass		
HT20	MCS0	2	10	2457	0.22	0.23	17.14	16.72	19.95	30.00		2.80	22.75	36.00	Pass		
HT20	MCS0	2	11	2462	0.22	0.23	16.11	15.78	18.96	30.00		2.80	21.76	36.00	Pass		
HT40	MCS0	2	3	2422	0.45	0.45	13.40	13.30	16.36	30.00		2.80	19.16	36.00	Pass		
HT40	MCS0	2	4	2427	0.45	0.45	14.90	14.61	17.77	30.00		2.80	20.57	36.00	Pass		
HT40	MCS0	2	6	2437	0.45	0.45	15.27	14.94	18.12	30.00		2.80	20.92	36.00	Pass		
HT40	MCS0	2	8	2447	0.45	0.45	14.84	14.07	17.48	30.00		2.80	20.28	36.00	Pass		
HT40	MCS0	2	9	2452	0.45	0.45	15.24	14.64	17.96	30.00		2.80	20.76	36.00	Pass		
VHT20	MCS0	2	1	2412	0.45	0.45	14.54	13.96	17.27	30.00		2.80	20.07	36.00	Pass		
VHT20	MCS0	2	2	2417	0.45	0.45	16.57	16.06	19.33	30.00		2.80	22.13	36.00	Pass		
VHT20	MCS0	2	6	2437	0.45	0.45	16.54	16.60	19.58	30.00		2.80	22.38	36.00	Pass		
VHT20	MCS0	2	10	2457	0.45	0.45	17.04	16.63	19.85	30.00		2.80	22.65	36.00	Pass		
VHT20	MCS0	2	11	2462	0.45	0.45	16.04	15.59	18.83	30.00		2.80	21.63	36.00	Pass		
VHT40	MCS0	2	3	2422	0.25	0.21	13.38	13.29	16.35	30.00		2.80	19.15	36.00	Pass		
VHT40	MCS0	2	4	2427	0.25	0.21	14.52	14.58	17.56	30.00		2.80	20.36	36.00	Pass		
VHT40	MCS0	2	6	2437	0.25	0.21	15.12	14.82	17.98	30.00		2.80	20.78	36.00	Pass		
VHT40	MCS0	2	8	2447	0.25	0.21	14.52	14.06	17.31	30.00		2.80	20.11	36.00	Pass		
VHT40	MCS0	2	9	2452	0.25	0.21	15.22	14.46	17.87	30.00		2.80	20.67	36.00	Pass		



<TXBF Mode>

2.4GHz Band																		
Mod.	Data Rate	NTX	CH.	Freq. (MHz)	Duty Factor (dB)		Average Conducted Power (dBm)			Conducted Power Limit (dBm)		DG (dBi)		EIRP Power (dBm)		EIRP Power Limit (dBm)		Pass /Fail
					Ant 1	Ant 2	Ant 1	Ant 2	SUM	Ant 1	Ant 2	Ant 1	Ant 2	Ant 1	Ant 2	Ant 1	Ant 2	
VHT20	MCS0	2	1	2412	0.00	0.00	16.20	17.00	19.63	30.00		5.56		25.19		36.00		Pass
VHT20	MCS0	2	6	2437	0.00	0.00	16.30	17.50	19.95	30.00		5.56		25.52		36.00		Pass
VHT20	MCS0	2	11	2462	0.00	0.00	16.40	17.20	19.83	30.00		5.56		25.39		36.00		Pass
VHT40	MCS0	2	3	2422	0.00	0.00	16.10	15.90	19.01	30.00		5.56		24.58		36.00		Pass
VHT40	MCS0	2	6	2437	0.00	0.00	16.50	16.30	19.41	30.00		5.56		24.98		36.00		Pass
VHT40	MCS0	2	9	2452	0.00	0.00	15.00	14.90	17.96	30.00		5.56		23.52		36.00		Pass



3.3 Power Spectral Density Measurement

3.3.1 Limit of Power Spectral Density

The peak power spectral density shall not be greater than 8dBm in any 3kHz band at any time interval of continuous transmission.

3.3.2 Measuring Instruments

See list of measuring equipment of this test report.

3.3.3 Test Procedures

<CDD Modes>

Method AVGPSD-2

1. The testing follows Measurement Procedure 10.5 Method AVGPSD-2 of FCC KDB Publication No. 558074 D01 DTS Meas. Guidance v04.
2. The RF output of EUT was connected to the spectrum analyzer by RF cable and attenuator. The path loss was compensated to the results for each measurement.
3. Set to the maximum power setting and enable the EUT transmit continuously.
4. Make the measurement with the spectrum analyzer's resolution bandwidth (RBW) = 10 kHz. Video bandwidth VBW = 30 kHz In order to make an accurate measurement, set the span to 1.5 times DTS Channel Bandwidth. (6dB BW).
5. Number of points in sweep ≥ 2 Span / RBW. (This ensures that bin-to-bin spacing is \leq RBW/2, so that narrowband signals are not lost between frequency bins).
6. Detector = RMS, Sweep time = auto couple.
7. Trace average at least 100 traces in power averaging mode.
8. Add $10 \log(1/x)$, where x is the duty cycle, to the measured power in order to compute the average power during the actual transmission times. For example, add $10 \log(1/0.25) = 6$ dB if the duty cycle is 25 percent.
9. Measure and record the results in the test report.
10. For MIMO mode, calculation method follows FCC KDB 662911 D01 Multiple Transmitter Output v02r01.

Method (c): Measure and add $10 \log(N_{ANT})$ dB.

With this technique, spectrum measurements are performed at each output of the device, but rather than summing the spectra or the spectral peaks across the outputs, the quantity $10 \log(N_{ANT})$ dB is added to each spectrum value before comparing to the emission limit. The addition of $10 \log(N_{ANT})$ dB serves to apportion the emission limit among the N_{ANT} outputs so that each output is permitted to contribute no more than $1/N_{ANT}^{th}$ of the PSD limit .

<TXBF Modes>**Method AVGPSD-3**

1. The testing follows Measurement Procedure 10.7 Method AVGPSD-3 of FCC KDB Publication No. 558074 D01 DTS Meas. Guidance v04.
2. The RF output of EUT was connected to the spectrum analyzer by RF cable and attenuator. The path loss was compensated to the results for each measurement.
3. Set to the maximum power setting and enable the EUT transmit continuously.
4. Make the measurement with the spectrum analyzer's resolution bandwidth (RBW) = 10 kHz. Video bandwidth VBW = 30 kHz In order to make an accurate measurement, set the span to 1.5 times DTS Channel Bandwidth. (6dB BW).
5. Number of points in sweep ≥ 2 Span / RBW. (This ensures that bin-to-bin spacing is \leq RBW/2, so that narrowband signals are not lost between frequency bins).
6. Detector = RMS, Sweep time = auto couple.
7. Trace mode = max hold.
8. Allow max hold to run for at least 60 seconds, or longer as needed to allow the trace to stabilize.
9. Measure and record the results in the test report.
10. For MIMO mode, calculation method follows FCC KDB 662911 D01 Multiple Transmitter Output v02r01.

Method (c): Measure and add $10 \log(N_{ANT})$ dB.

With this technique, spectrum measurements are performed at each output of the device, but rather than summing the spectra or the spectral peaks across the outputs, the quantity $10 \log(N_{ANT})$ dB is added to each spectrum value before comparing to the emission limit. The addition of $10 \log(N_{ANT})$ dB serves to apportion the emission limit among the N_{ANT} outputs so that each output is permitted to contribute no more than $1/N_{ANT}^{th}$ of the PSD limit .

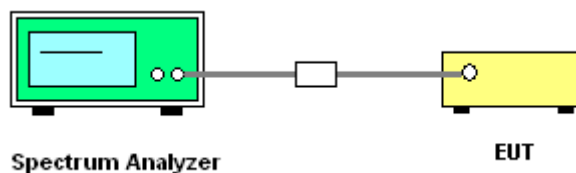
3.3.4 Test Setup



3.3.5 Test Result of Power Spectral Density

<CDD Mode>

2.4GHz Band														
Mod.	Data Rate	NTX	CH.	Freq. (MHz)	Duty Factor (dB)		Average PSD (dBm/10kHz)			DG (dBi)		Average PSD Limit (dBm/3kHz)		Pass/Fail
					Ant 1	Ant 2	Ant 1	Ant 2	Worse + 3.01	Ant 1	Ant 2	Ant 1	Ant 2	
11b	1Mbps	1	1	2412	0.00	0.00	-5.66	-7.97		2.80	2.30	8.00	8.00	Pass
11b	1Mbps	1	6	2437	0.00	0.00	-7.79	-6.37		2.80	2.30	8.00	8.00	Pass
11b	1Mbps	1	11	2462	0.00	0.00	-5.71	-7.85		2.80	2.30	8.00	8.00	Pass
11g	6Mbps	1	1	2412	0.21	0.25	-11.52	-11.93		2.80	2.30	8.00	8.00	Pass
11g	6Mbps	1	6	2437	0.21	0.25	-11.46	-11.88		2.80	2.30	8.00	8.00	Pass
11g	6Mbps	1	11	2462	0.21	0.25	-10.69	-10.94		2.80	2.30	8.00	8.00	Pass
HT20	MCS0	1	1	2412	0.23	0.23	-12.19	-12.78		2.80	2.30	8.00	8.00	Pass
HT20	MCS0	1	6	2437	0.23	0.23	-10.83	-11.49		2.80	2.30	8.00	8.00	Pass
HT20	MCS0	1	11	2462	0.23	0.23	-11.27	-11.74		2.80	2.30	8.00	8.00	Pass
HT40	MCS0	1	3	2422	0.45	0.45	-15.03	-16.91		2.80	2.30	8.00	8.00	Pass
HT40	MCS0	1	6	2437	0.45	0.45	-15.08	-15.21		2.80	2.30	8.00	8.00	Pass
HT40	MCS0	1	11	2462	0.45	0.45	-16.13	-16.72		2.80	2.30	8.00	8.00	Pass
11b	1Mbps	2	1	2412	0.00	0.00	-7.50	-7.04	-4.03	5.56		8.00		Pass
11b	1Mbps	2	6	2437	0.00	0.00	-8.03	-7.63	-4.62	5.56		8.00		Pass
11b	1Mbps	2	11	2462	0.00	0.00	-7.71	-8.03	-4.70	5.56		8.00		Pass
11g	6Mbps	2	1	2412	0.21	0.21	-11.16	-12.87	-8.15	5.56		8.00		Pass
11g	6Mbps	2	6	2437	0.21	0.21	-11.39	-11.82	-8.38	5.56		8.00		Pass
11g	6Mbps	2	11	2462	0.21	0.21	-11.35	-12.50	-8.34	5.56		8.00		Pass
HT20	MCS0	2	1	2412	0.22	0.23	-12.87	-14.17	-9.86	5.56		8.00		Pass
HT20	MCS0	2	6	2437	0.22	0.23	-11.48	-11.71	-8.47	5.56		8.00		Pass
HT20	MCS0	2	11	2462	0.22	0.23	-11.84	-12.87	-8.83	5.56		8.00		Pass
HT40	MCS0	2	3	2422	0.45	0.45	-17.05	-18.15	-14.04	5.56		8.00		Pass
HT40	MCS0	2	6	2437	0.45	0.45	-14.92	-16.30	-11.91	5.56		8.00		Pass
HT40	MCS0	2	11	2462	0.45	0.45	-16.17	-17.06	-13.16	5.56		8.00		Pass



<CDD Modes>

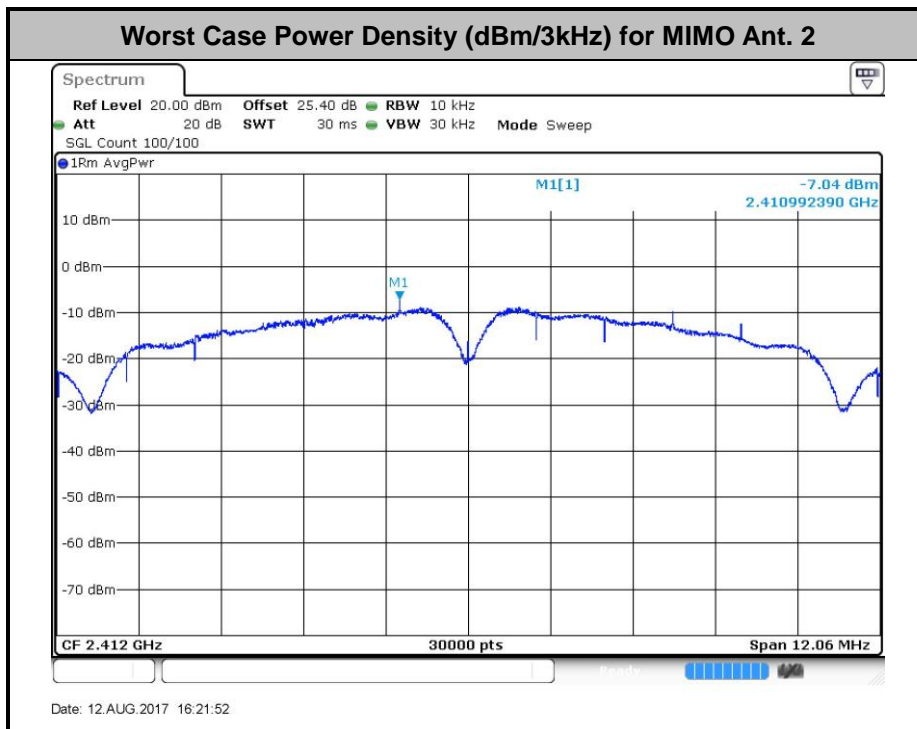
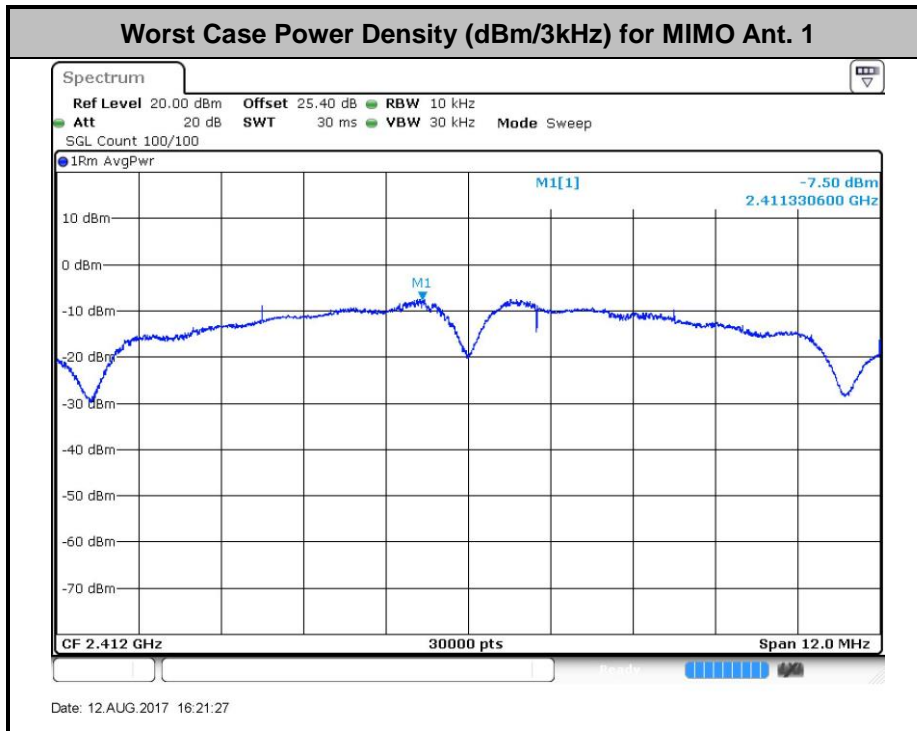



<TXBF Mode>

2.4GHz Band														
Mod.	Data Rate	NTX	CH.	Freq. (MHz)	Duty Factor (dB)		Average PSD (dBm/3kHz)			DG (dBi)		Average PSD Limit (dBm/3kHz)		Pass/Fail
					Ant 1	Ant 2	Ant 1	Ant 2	Worse + 3.01	Ant 1	Ant 2	Ant 1	Ant 2	
VHT20	MCS0	2	1	2412	0.00	0.00	-5.82	-1.58	1.43	5.56		8.00		Pass
VHT20	MCS0	2	6	2437	0.00	0.00	-3.40	-3.24	-0.23	5.56		8.00		Pass
VHT20	MCS0	2	11	2462	0.00	0.00	-3.72	-4.58	-0.71	5.56		8.00		Pass
VHT40	MCS0	2	3	2422	0.00	0.00	-5.94	-4.55	-1.54	5.56		8.00		Pass
VHT40	MCS0	2	6	2437	0.00	0.00	-5.45	-5.38	-2.37	5.56		8.00		Pass
VHT40	MCS0	2	9	2452	0.00	0.00	-5.47	-6.33	-2.46	5.56		8.00		Pass



<TXBF Modes>

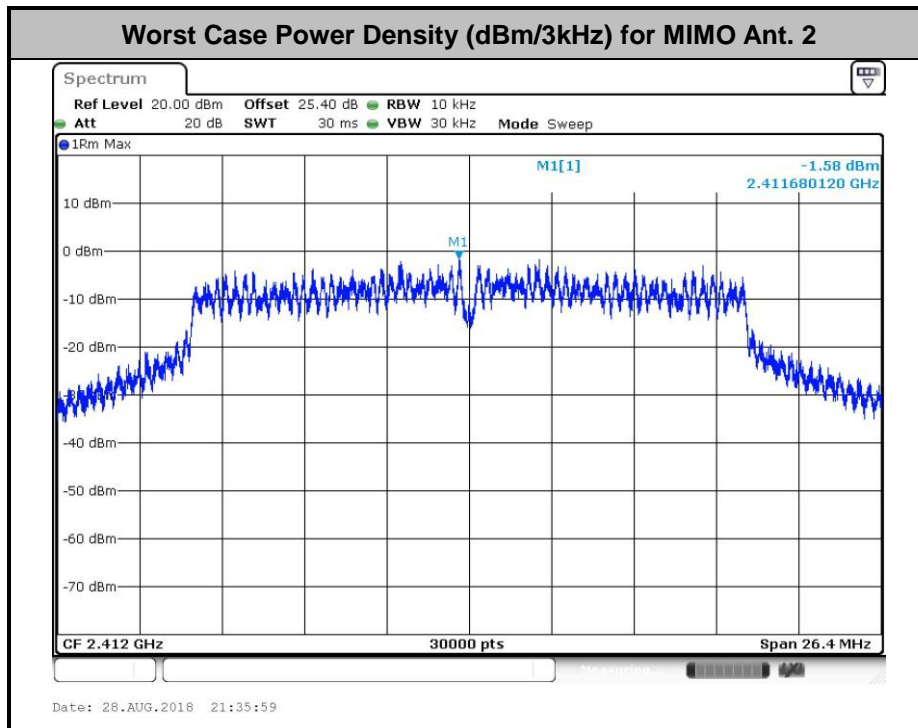
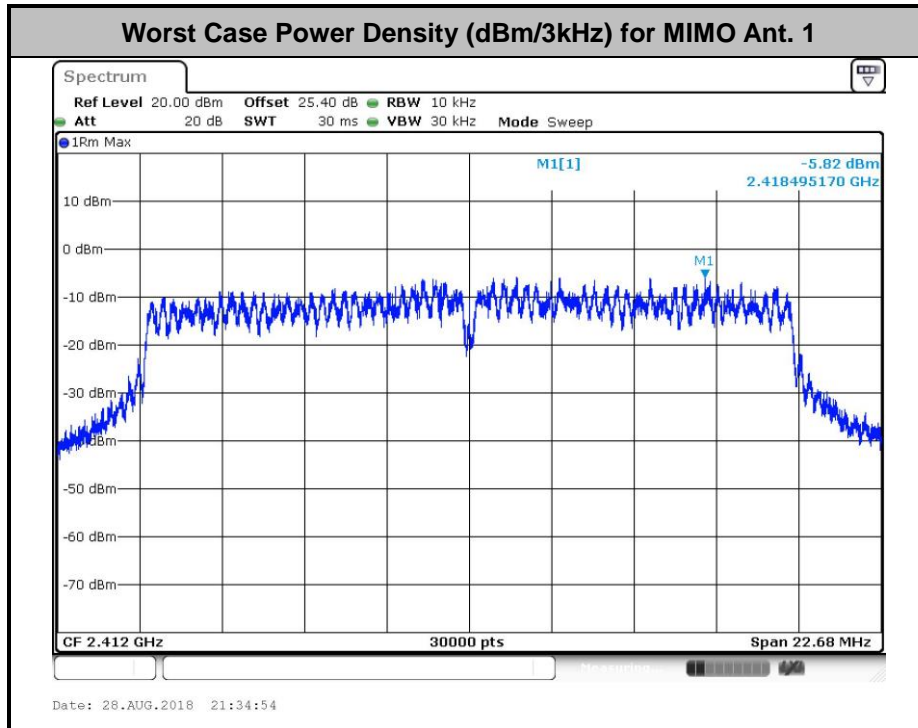

3.4 Conducted Band Edges and Spurious Emission Measurement

3.4.1 Limit of Conducted Band Edges and Spurious Emission Measurement

In any 100 kHz bandwidth outside of the authorized frequency band, the emissions which fall in the non-restricted bands shall be attenuated at least 20 dB / 30dB relative to the maximum PSD level in 100 kHz by RF conducted measurement.

3.4.2 Measuring Instruments

See list of measuring equipment of this test report.

3.4.3 Test Procedures

1. The testing follows FCC KDB Publication No. 558074 D01 DTS Meas. Guidance v04.
2. The RF output of EUT was connected to the spectrum analyzer by RF cable and attenuator. The path loss was compensated to the results for each measurement.
3. Set to the maximum power setting and enable the EUT transmit continuously.
4. Set RBW = 100 kHz, VBW=300 kHz, Peak Detector. Unwanted Emissions measured in any 100 kHz bandwidth outside of the authorized frequency band shall be attenuated by at least 20 dB relative to the maximum in-band peak PSD level in 100 kHz when maximum peak conducted output power procedure is used. If the transmitter complies with the conducted power limits based on the use of RMS averaging over a time interval, the attenuation required under this paragraph shall be 30 dB instead of 20 dB per 15.247(d).
5. Measure and record the results in the test report.
6. The RF fundamental frequency should be excluded against the limit line in the operating frequency band.

3.4.4 Test Setup

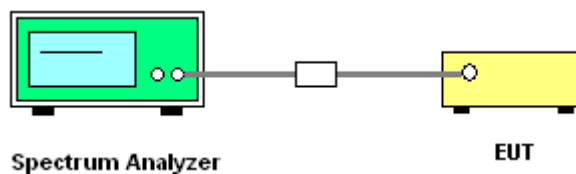



3.4.5 Test Result of Conducted Band Edges and Spurious Emission

Test Engineer : Derek Hsu, Kai Liao, and Bill Kuo	Temperature :	21~25°C
	Relative Humidity :	51~54%

<CDD Mode>

Number of TX = 1, Ant. 1 (Measured)

Test Mode :	802.11b	Test Channel :	01
-------------	---------	----------------	----

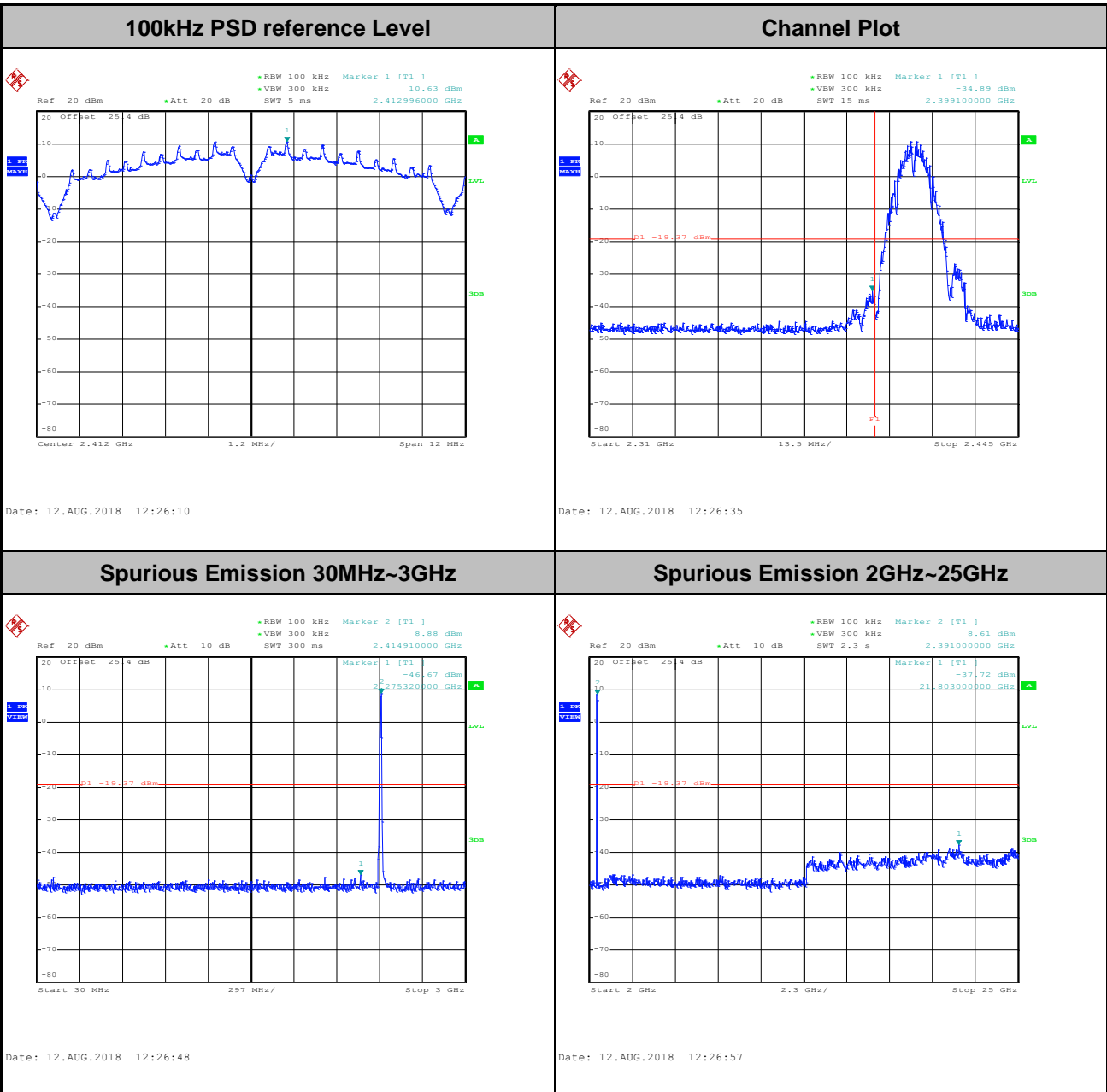



Test Mode :	802.11b	Test Channel :	06
-------------	---------	----------------	----

100kHz PSD reference Level

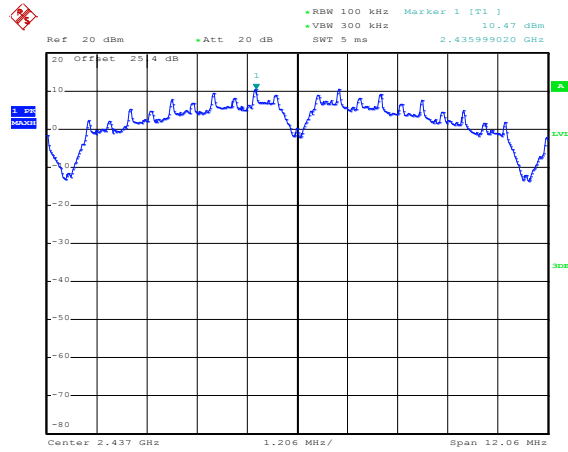

Date: 12.AUG.2018 12:28:58

Spurious Emission 30MHz~3GHz

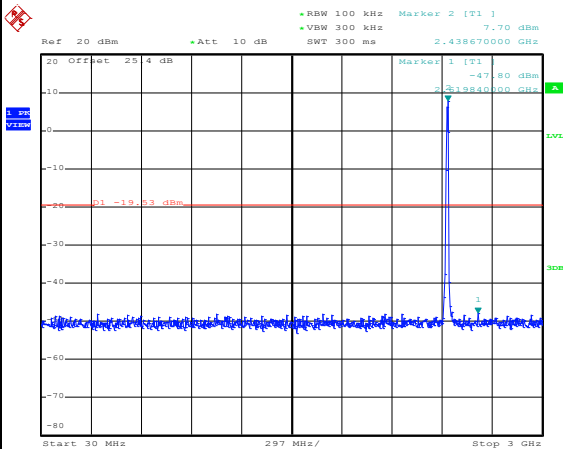

Date: 12.AUG.2018 12:29:35

Spurious Emission 2GHz~25GHz

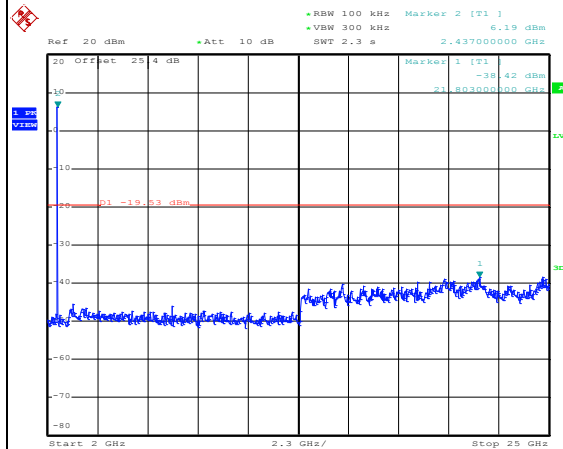

Date: 12.AUG.2018 12:29:43



Test Mode :	802.11b	Test Channel :	11
-------------	---------	----------------	----

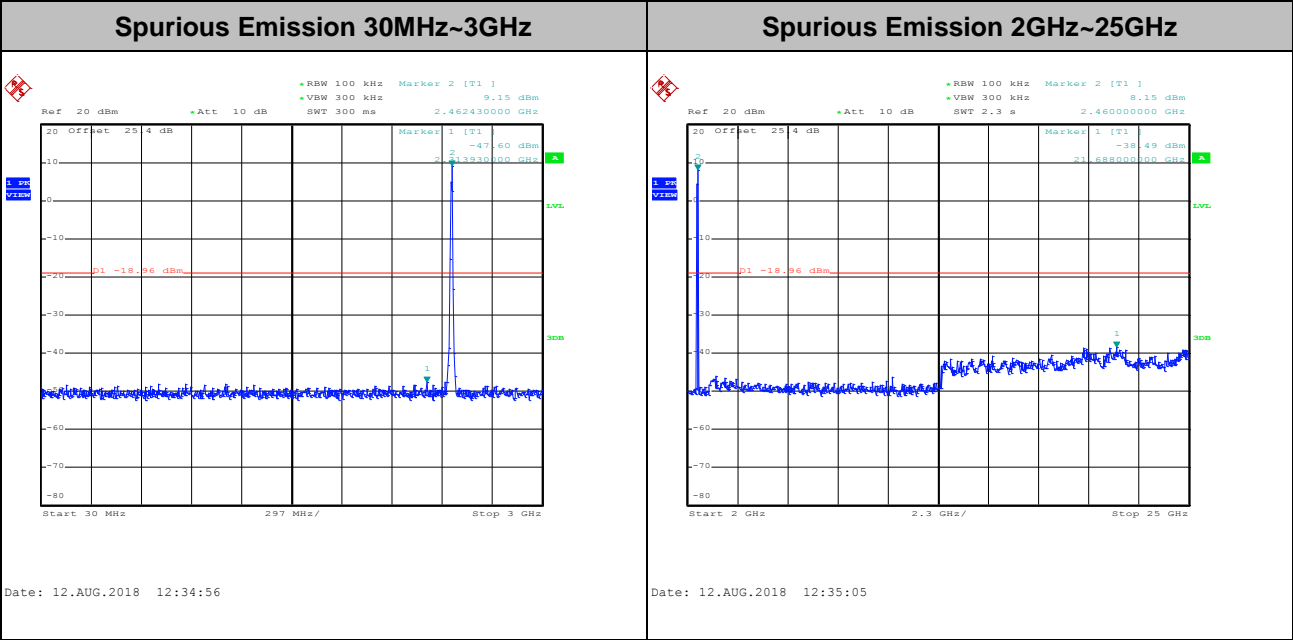
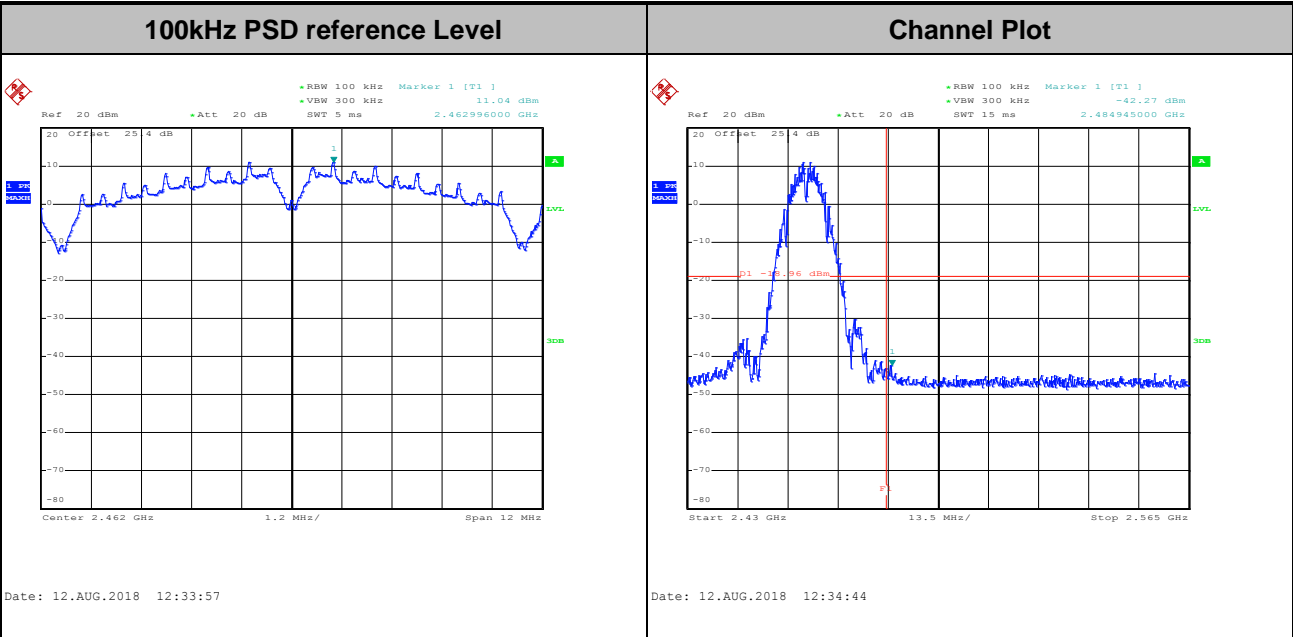



Test Mode : 802.11g Test Channel : 01

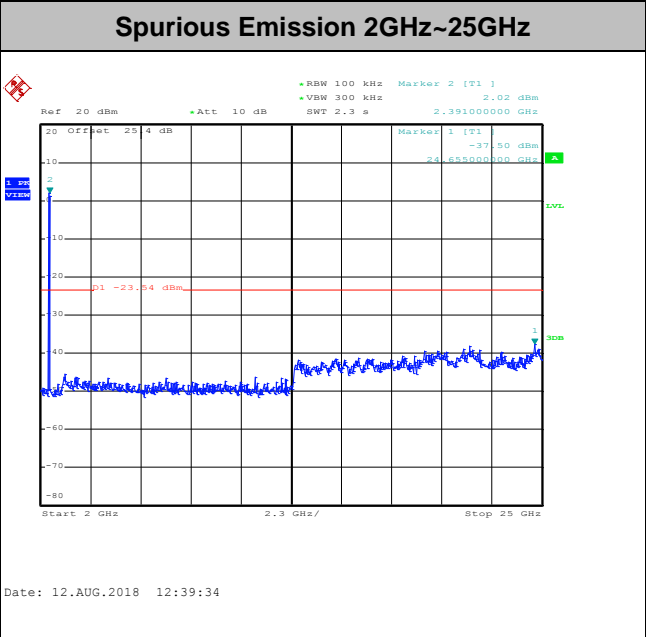
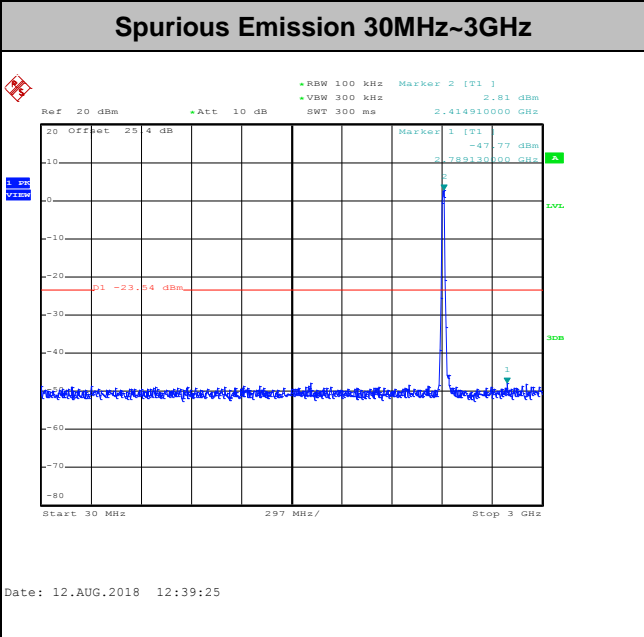
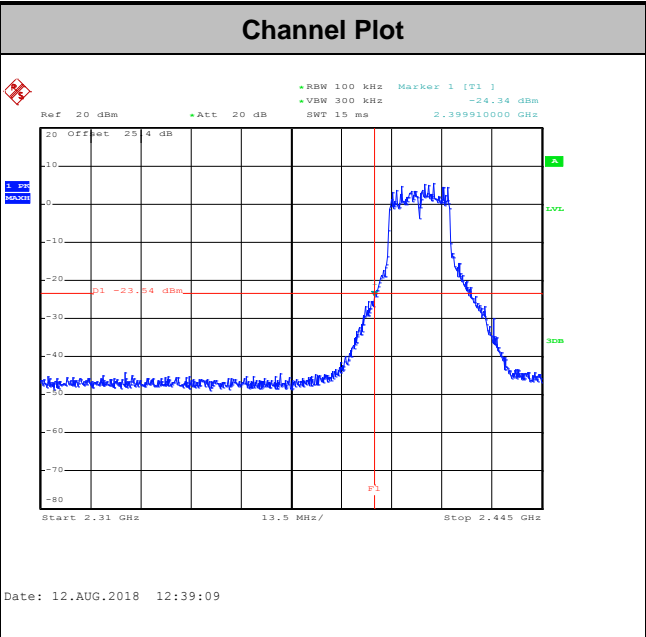
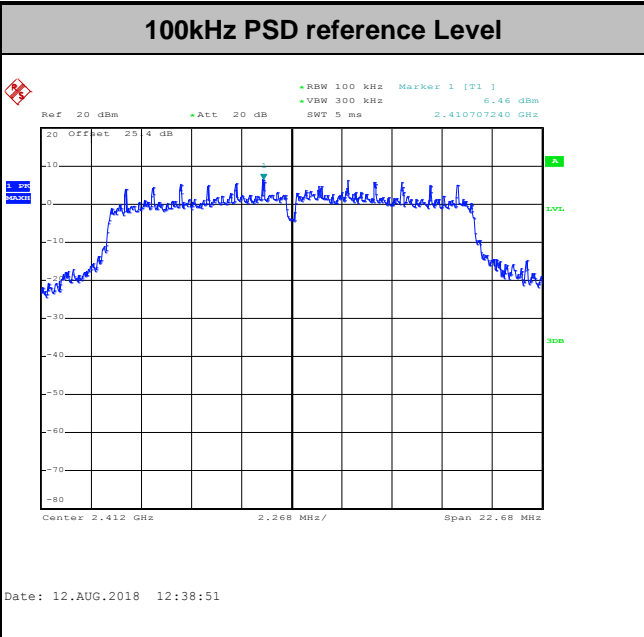



Test Mode :	802.11g	Test Channel :	06
-------------	---------	----------------	----

100kHz PSD reference Level

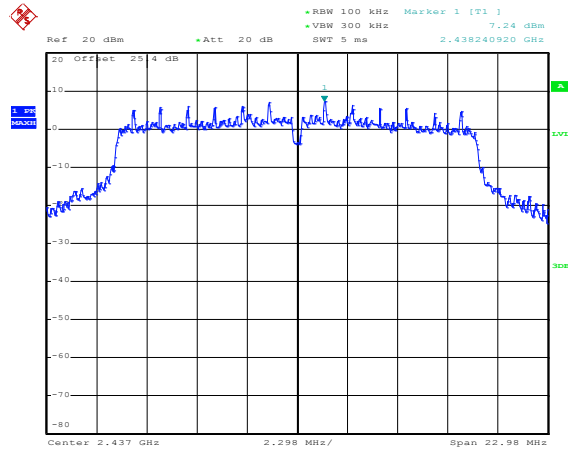

Date: 12.AUG.2018 12:42:11

Spurious Emission 30MHz~3GHz

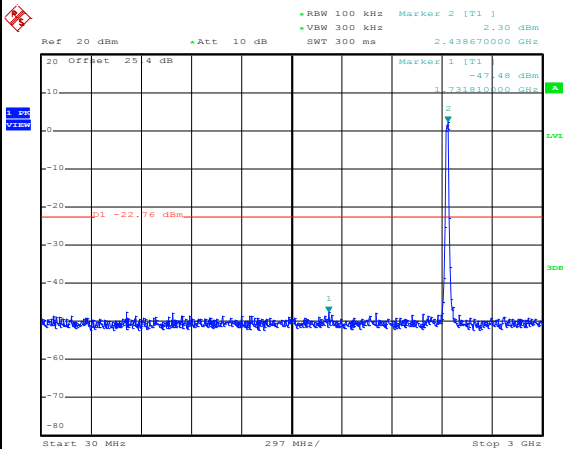

Date: 12.AUG.2018 12:42:29

Spurious Emission 2GHz~25GHz

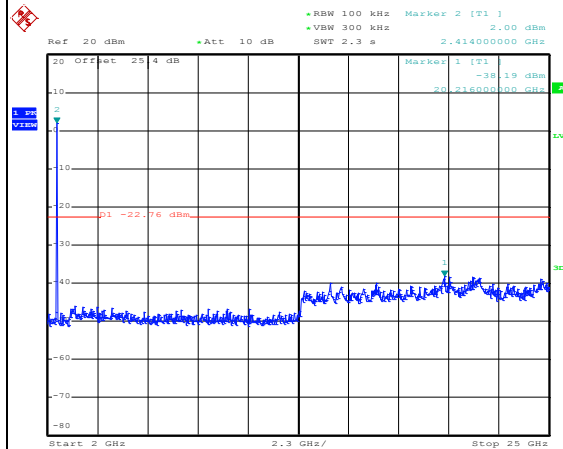

Date: 12.AUG.2018 12:42:38



Test Mode :	802.11g	Test Channel :	11
-------------	---------	----------------	----

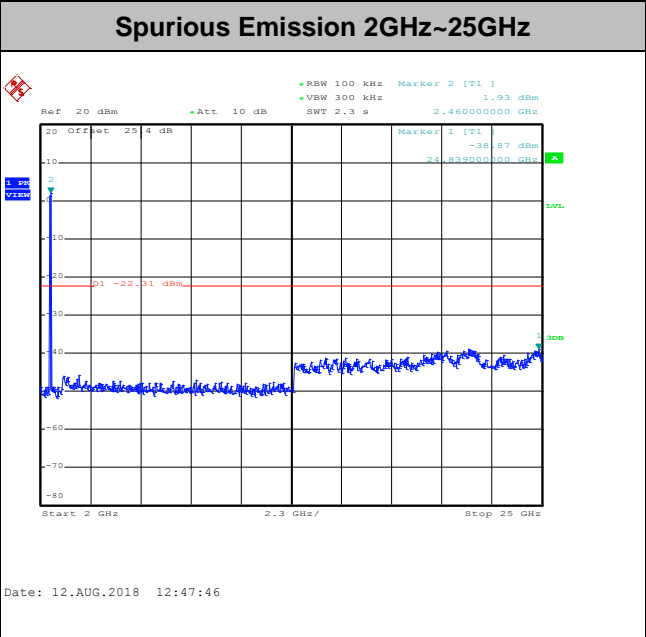
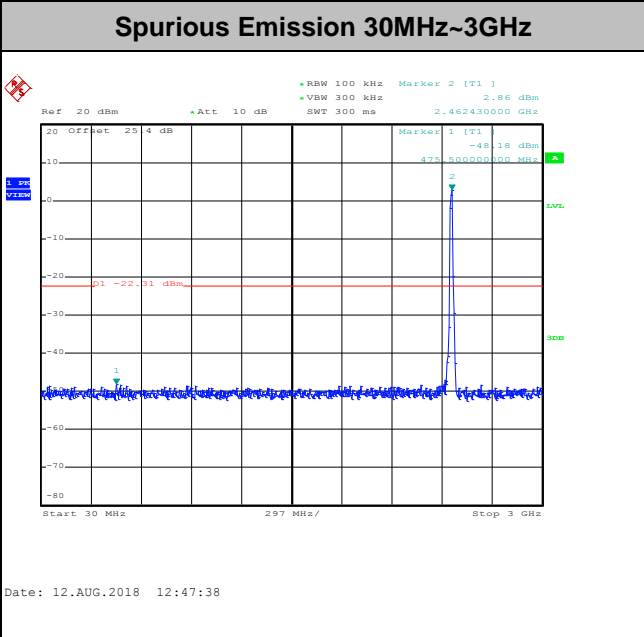
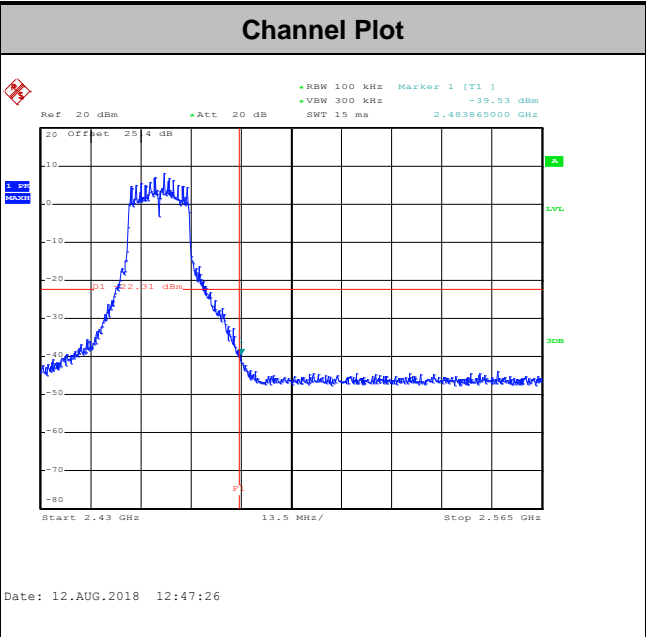
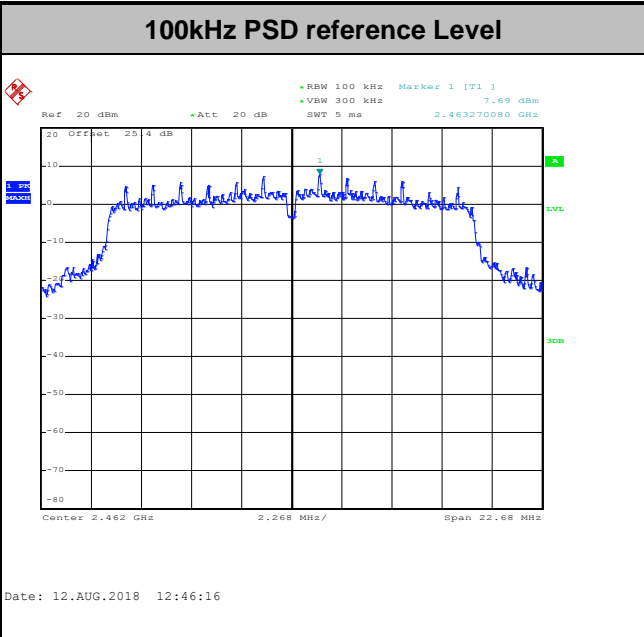



Test Mode : 802.11n HT20 Test Channel : 01

100kHz PSD reference Level

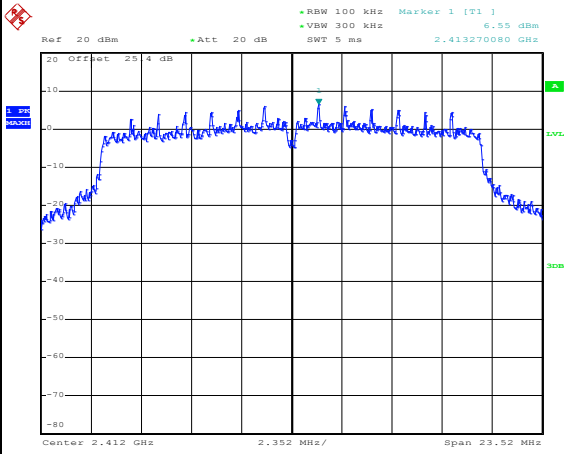

Date: 12.AUG.2018 12:50:36

Channel Plot

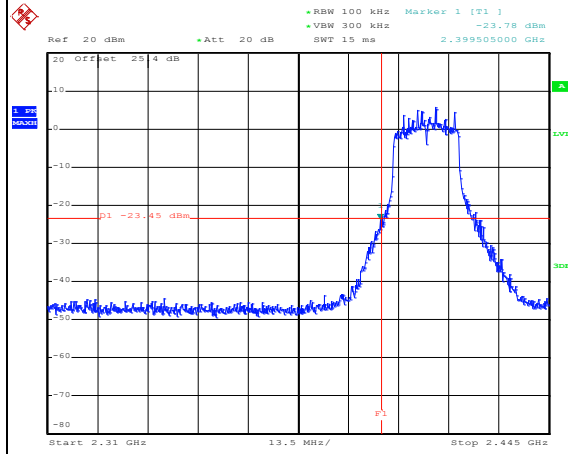

Date: 12.AUG.2018 12:51:43

Spurious Emission 30MHz~3GHz

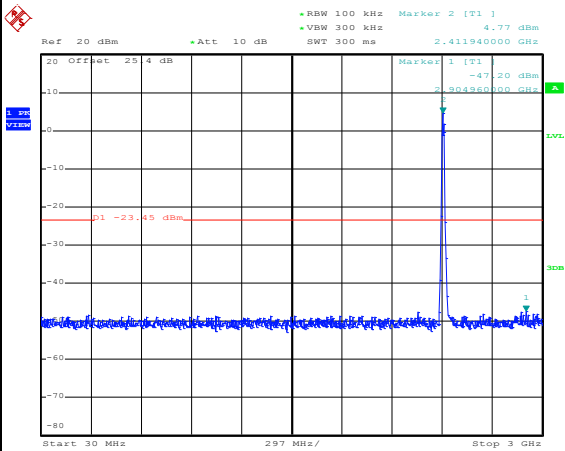

Date: 12.AUG.2018 12:51:58

Spurious Emission 2GHz~25GHz

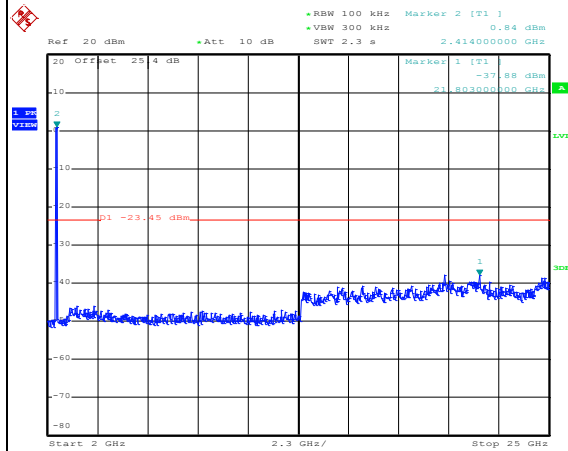

Date: 12.AUG.2018 12:52:06



Test Mode :	802.11n HT20	Test Channel :	06
-------------	--------------	----------------	----

100kHz PSD reference Level

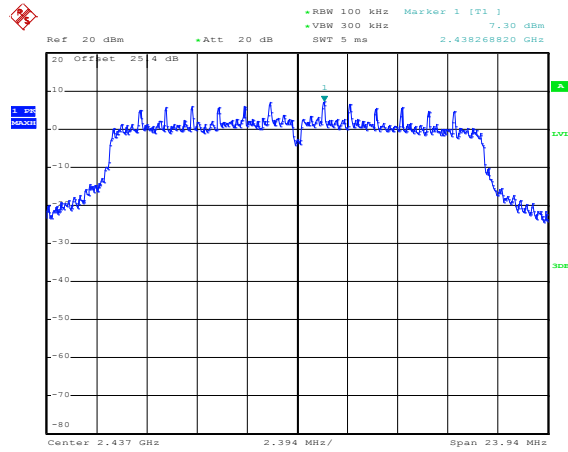

Date: 12.AUG.2018 12:53:47

Spurious Emission 30MHz~3GHz

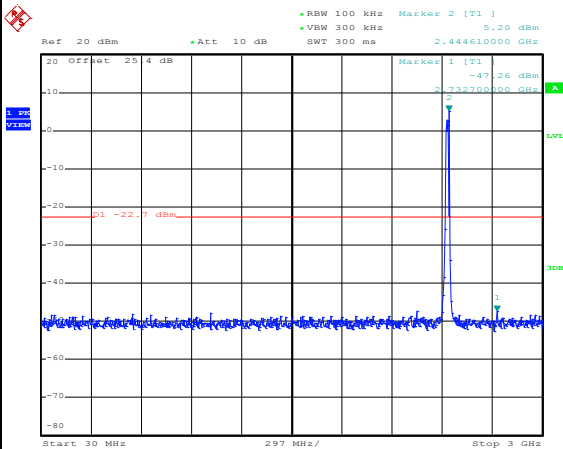

Date: 12.AUG.2018 12:54:03

Spurious Emission 2GHz~25GHz

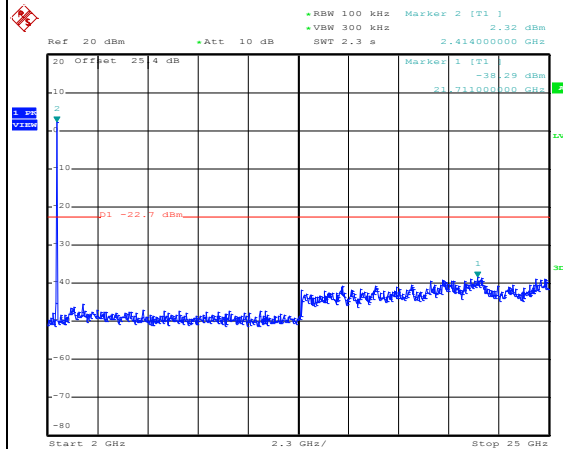

Date: 12.AUG.2018 12:54:11



Test Mode :	802.11n HT20	Test Channel :	11
-------------	--------------	----------------	----

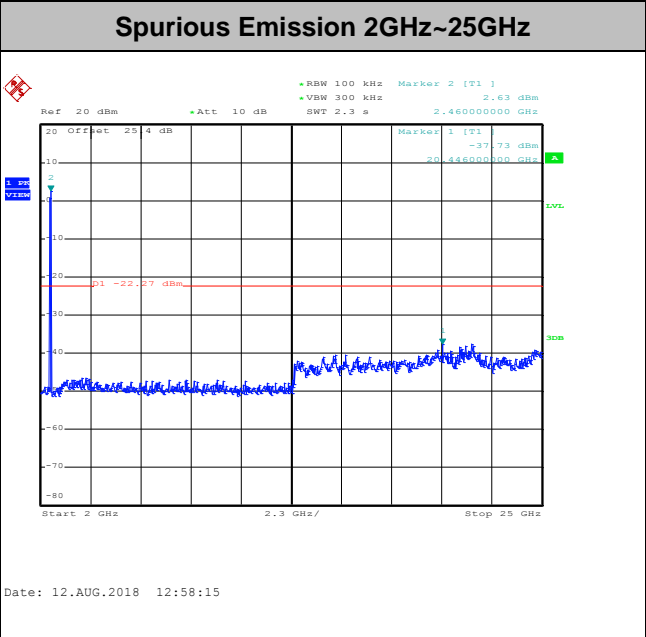
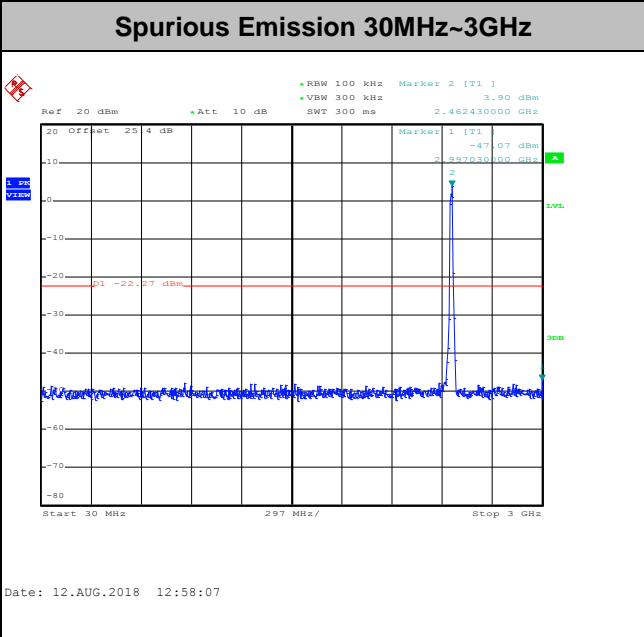
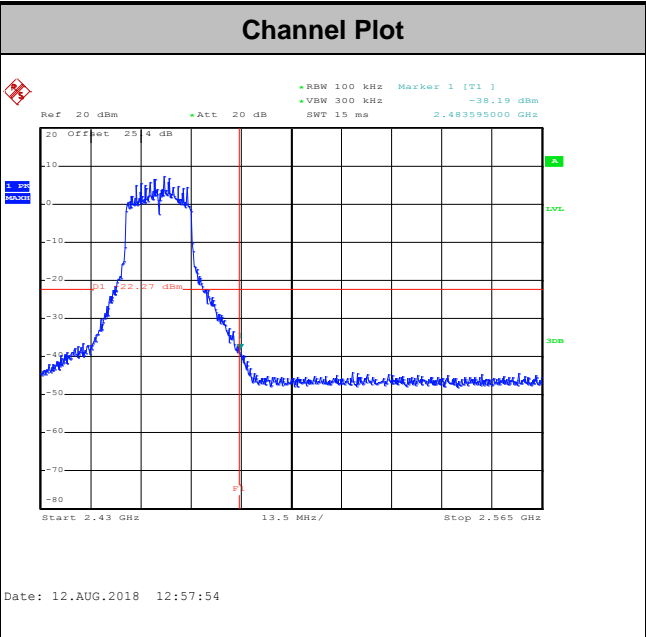
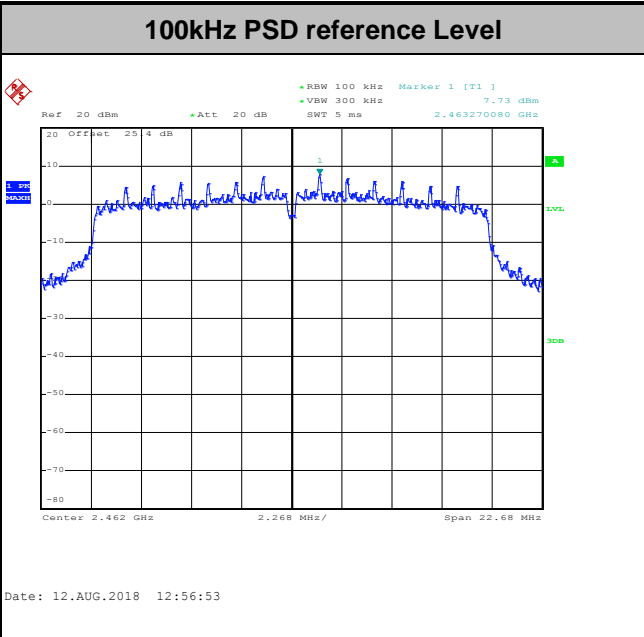



Test Mode :	802.11n HT40	Test Channel :	03
-------------	--------------	----------------	----

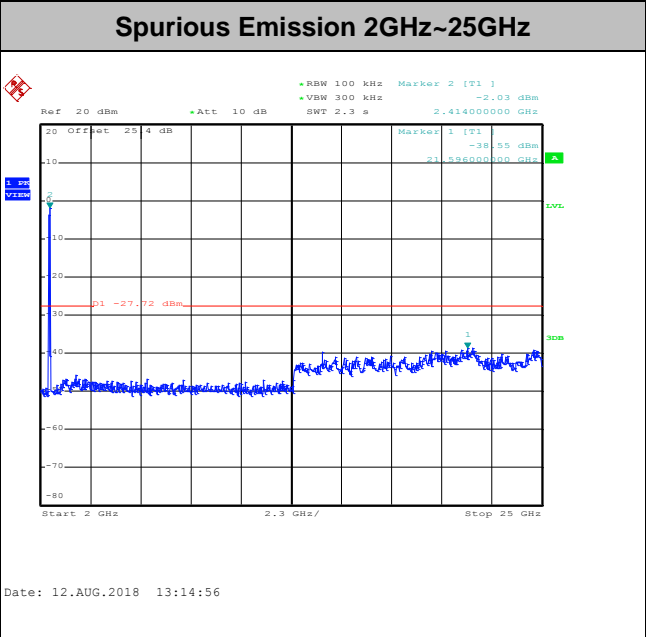
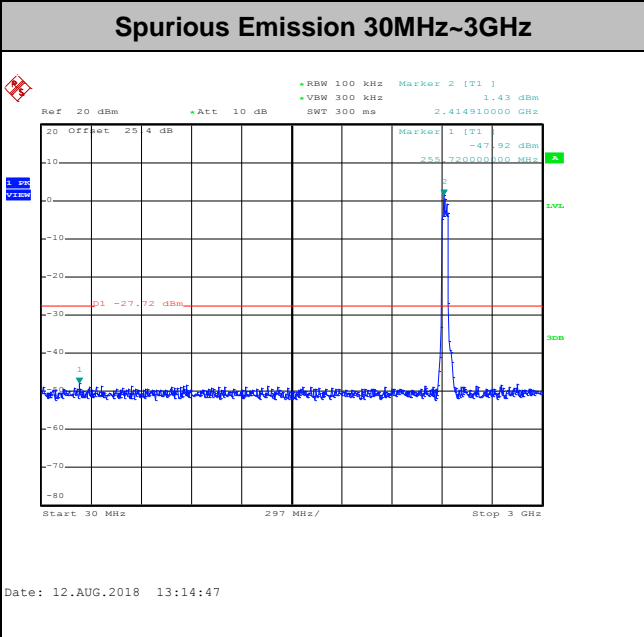
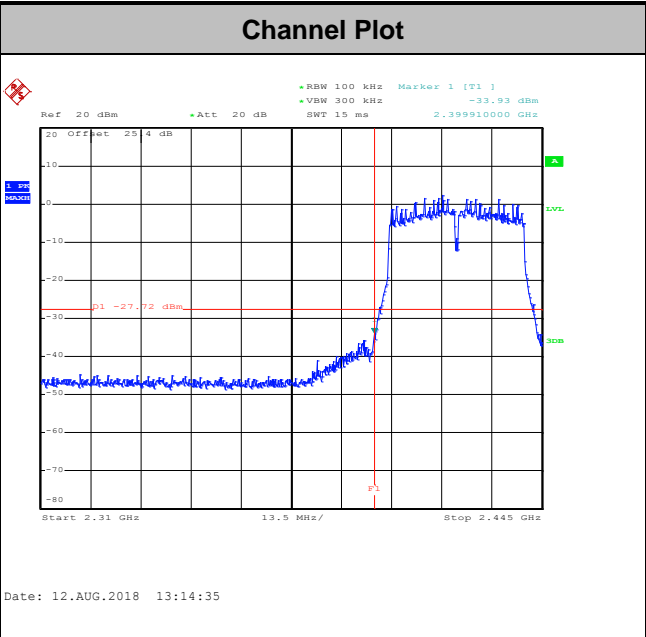
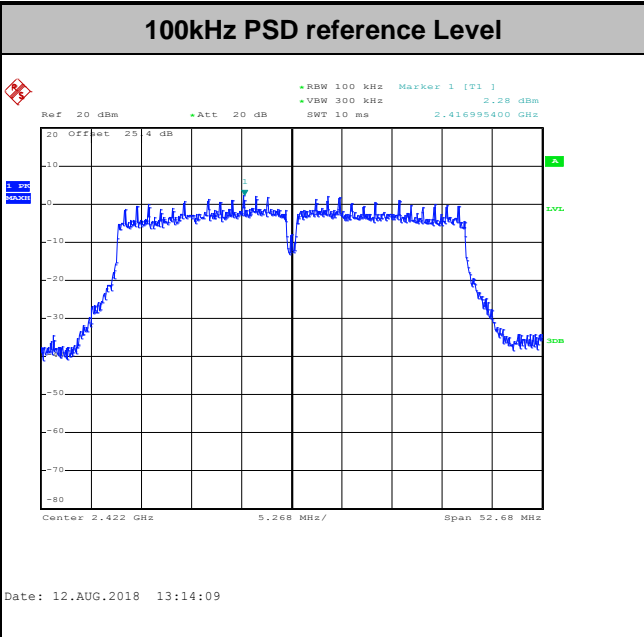



Test Mode :	802.11n HT40	Test Channel :	06
-------------	--------------	----------------	----

100kHz PSD reference Level

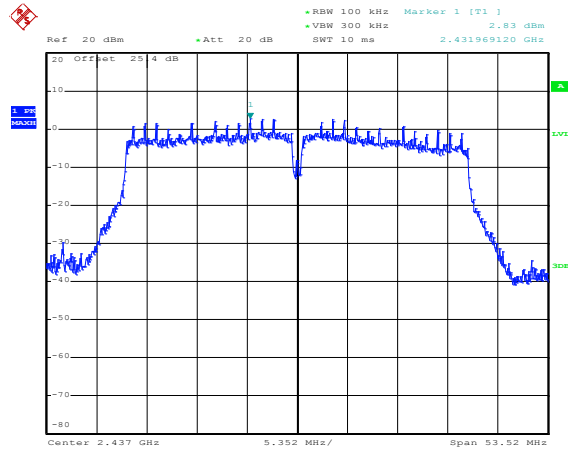

Date: 12.AUG.2018 13:23:15

Spurious Emission 30MHz~3GHz

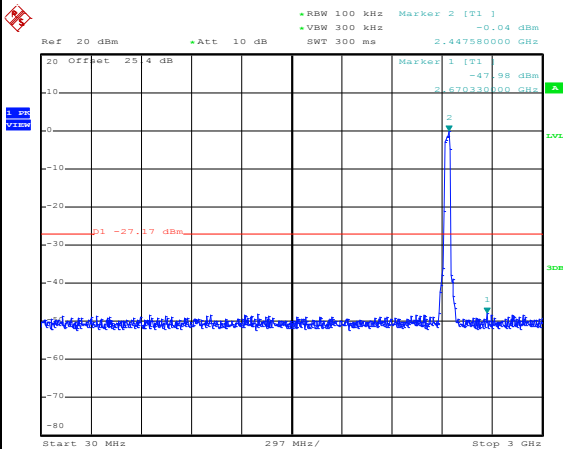

Date: 12.AUG.2018 13:23:57

Spurious Emission 2GHz~25GHz

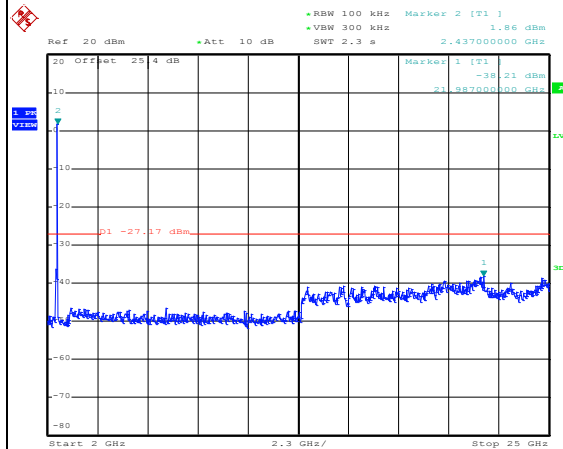

Date: 12.AUG.2018 13:24:05



Test Mode :	802.11n HT40	Test Channel :	09
-------------	--------------	----------------	----

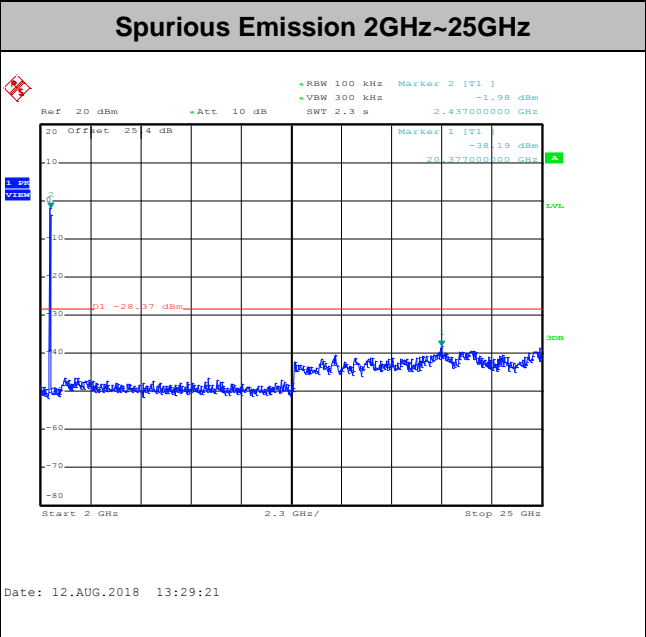
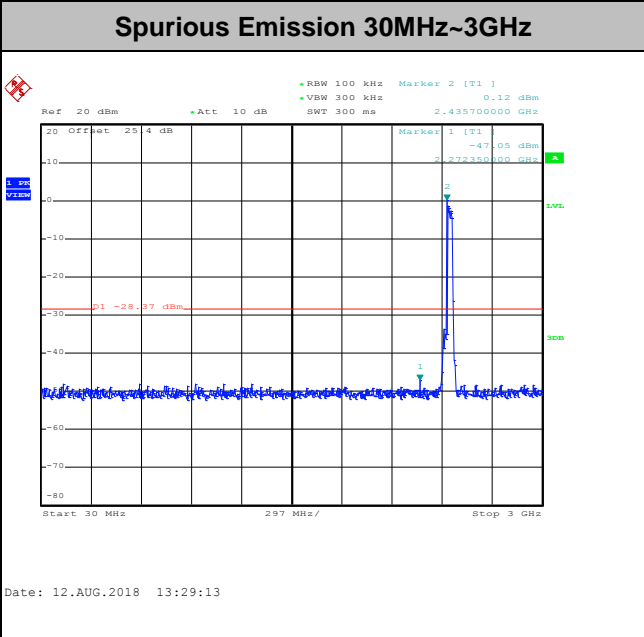
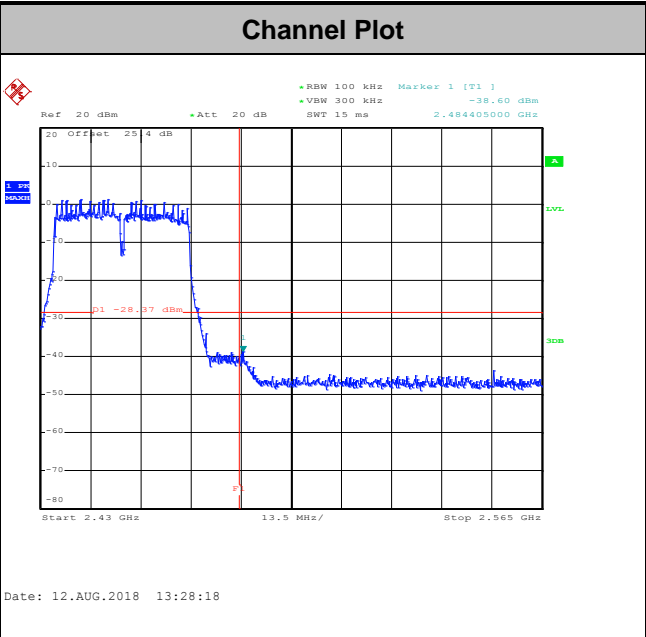
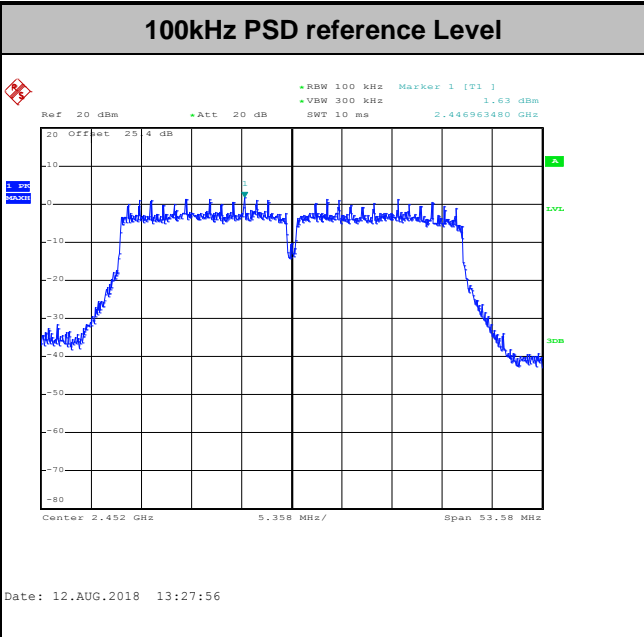



Number of TX = 1, Ant. 2 (Measured)

Test Mode :	802.11b	Test Channel :	01
-------------	---------	----------------	----

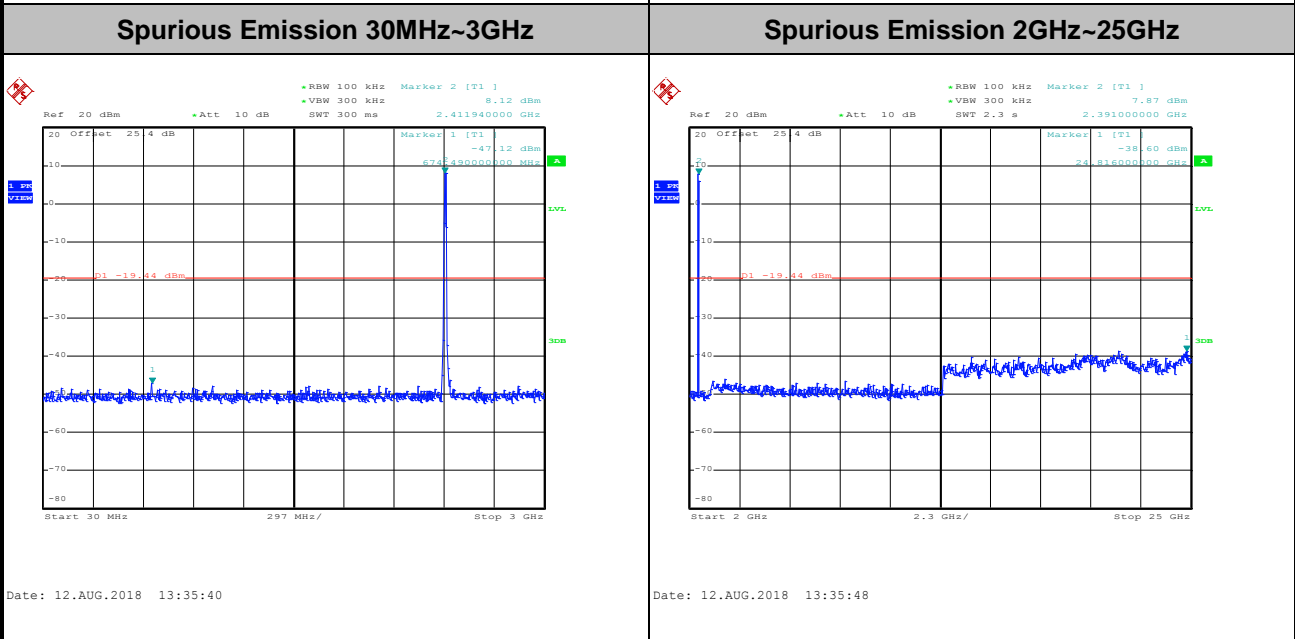
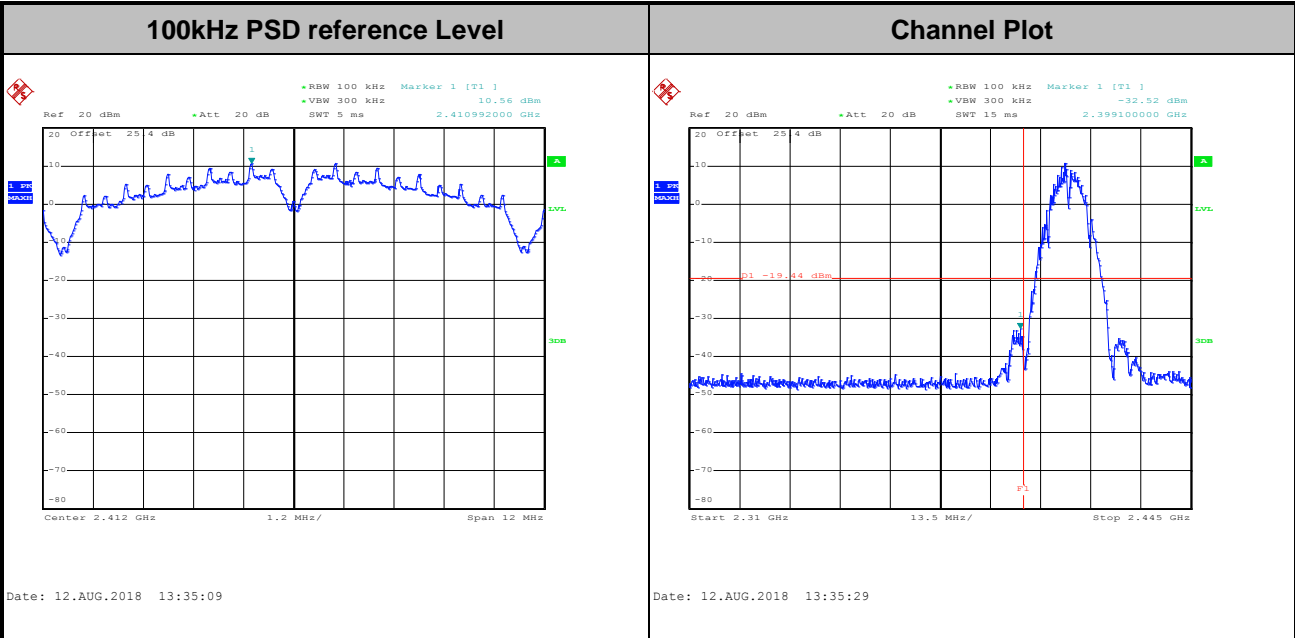



Test Mode :	802.11b	Test Channel :	06
-------------	---------	----------------	----

100kHz PSD reference Level

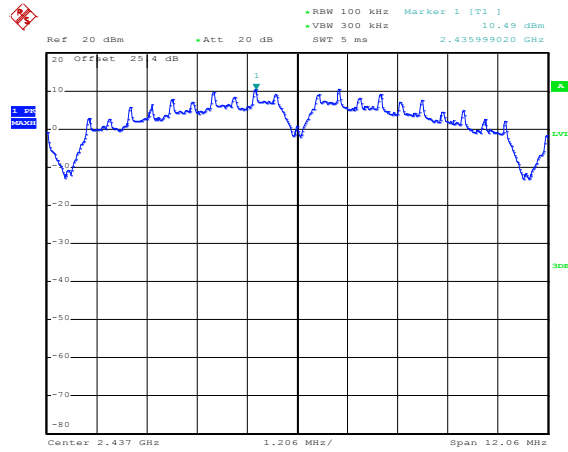

Date: 12.AUG.2018 13:38:48

Spurious Emission 30MHz~3GHz

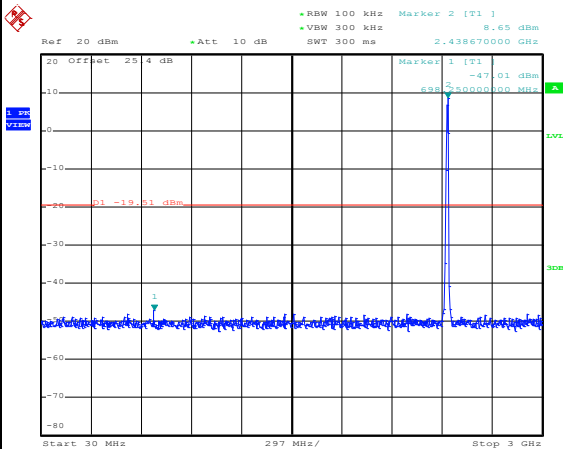

Date: 12.AUG.2018 13:39:01

Spurious Emission 2GHz~25GHz

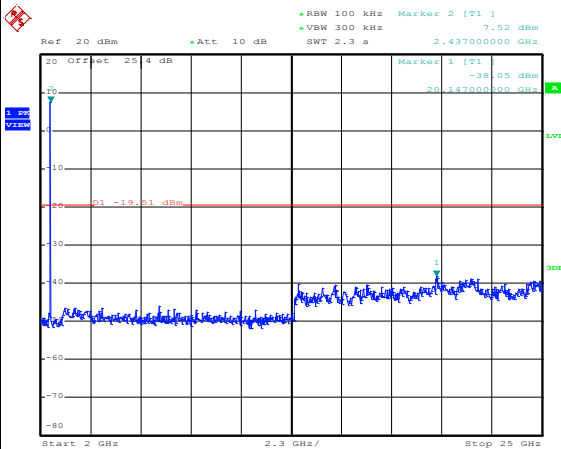

Date: 12.AUG.2018 13:39:09



Test Mode :	802.11b	Test Channel :	11
-------------	---------	----------------	----

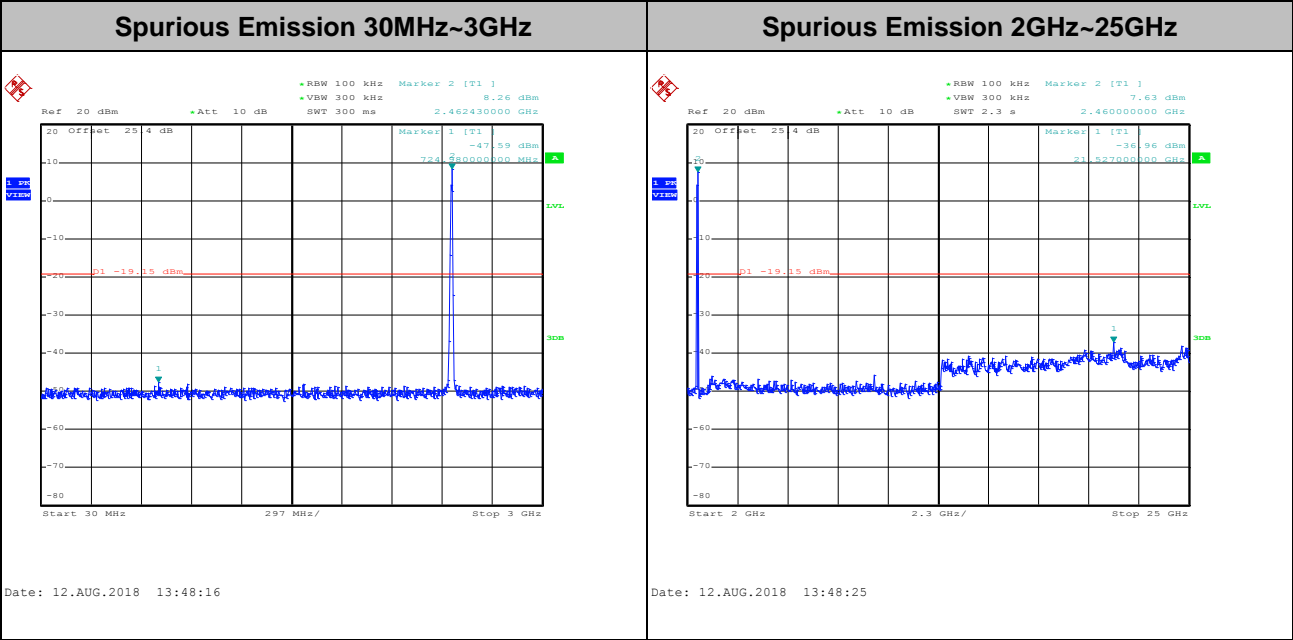
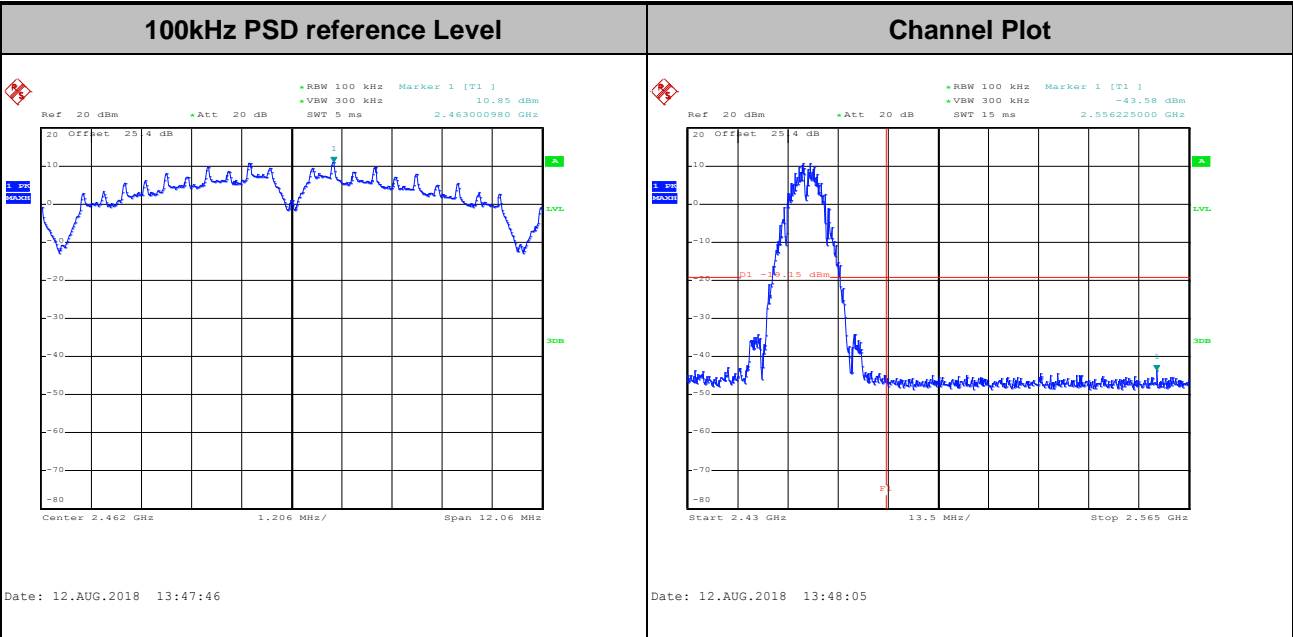



Test Mode : 802.11g Test Channel : 01

100kHz PSD reference Level

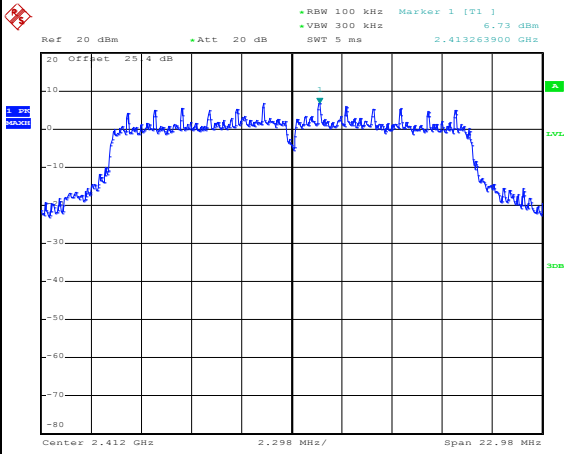

Date: 12.AUG.2018 13:52:24

Channel Plot

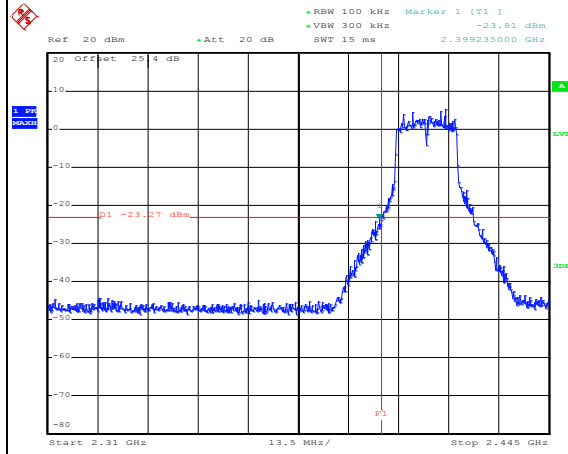

Date: 12.AUG.2018 13:54:36

Spurious Emission 30MHz~3GHz

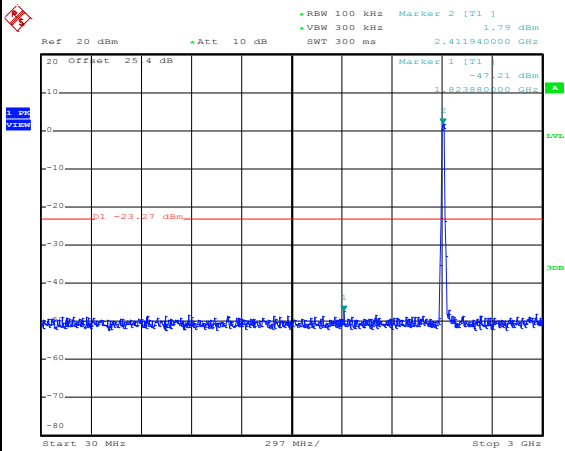

Date: 12.AUG.2018 13:53:09

Spurious Emission 2GHz~25GHz

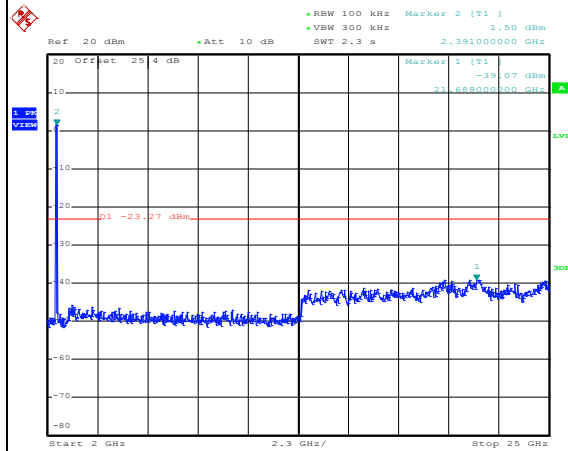

Date: 12.AUG.2018 13:53:18



Test Mode :	802.11g	Test Channel :	06
-------------	---------	----------------	----

100kHz PSD reference Level

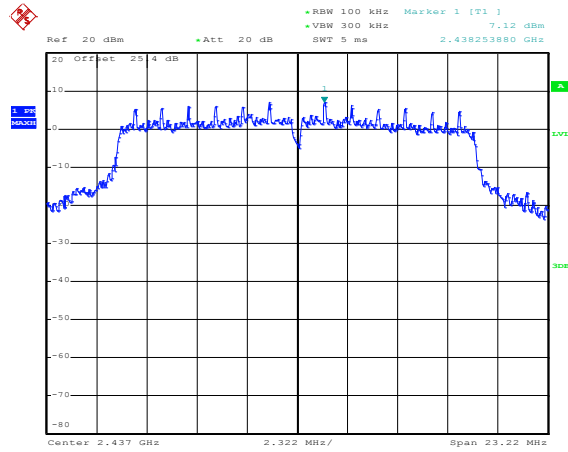

Date: 12.AUG.2018 13:57:30

Spurious Emission 30MHz~3GHz

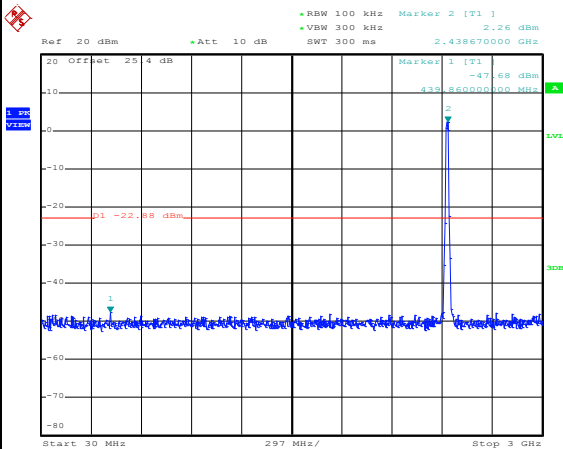

Date: 12.AUG.2018 13:58:06

Spurious Emission 2GHz~25GHz

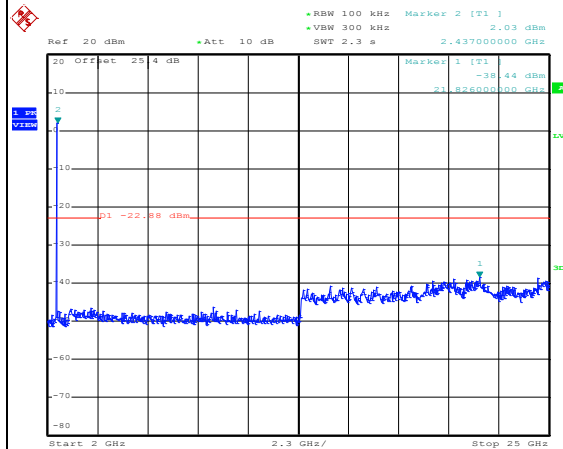

Date: 12.AUG.2018 13:58:15



Test Mode :	802.11g	Test Channel :	11
-------------	---------	----------------	----

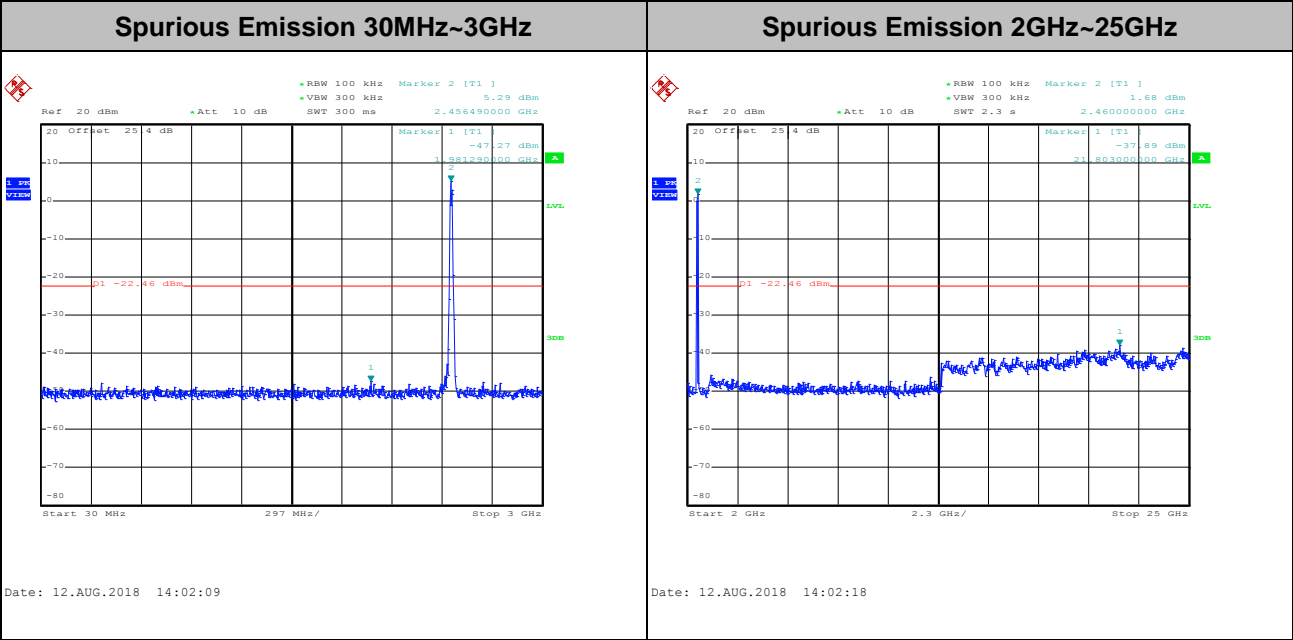
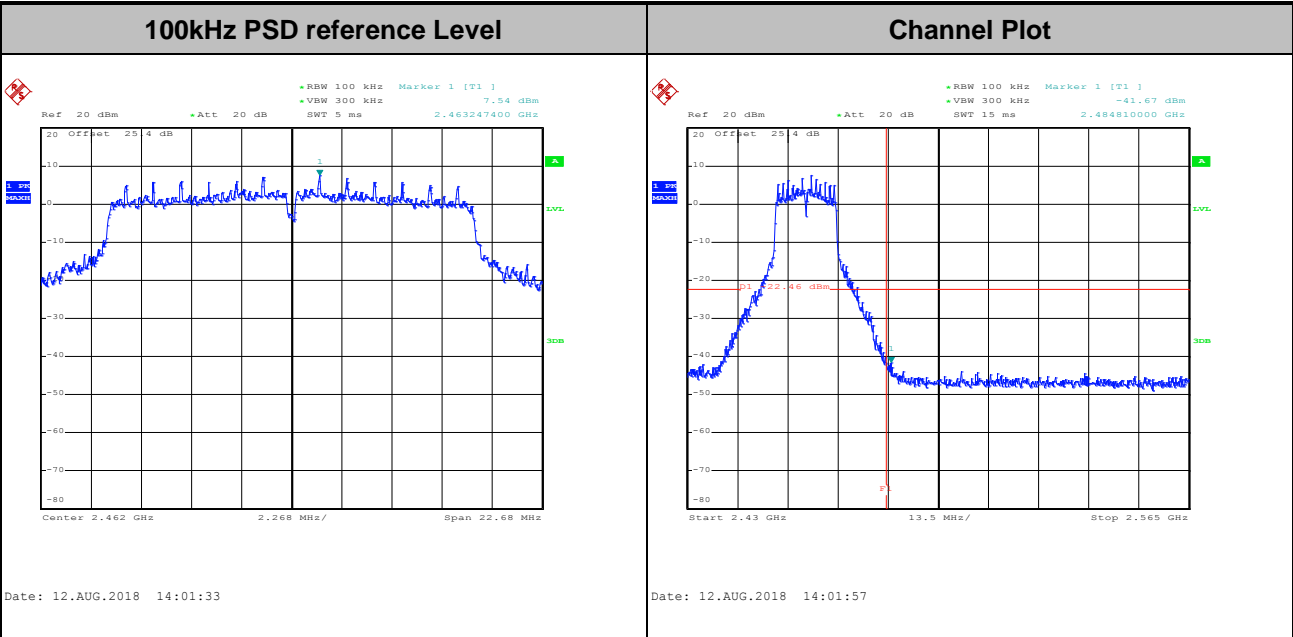



Test Mode : 802.11n HT20 Test Channel : 01

100kHz PSD reference Level

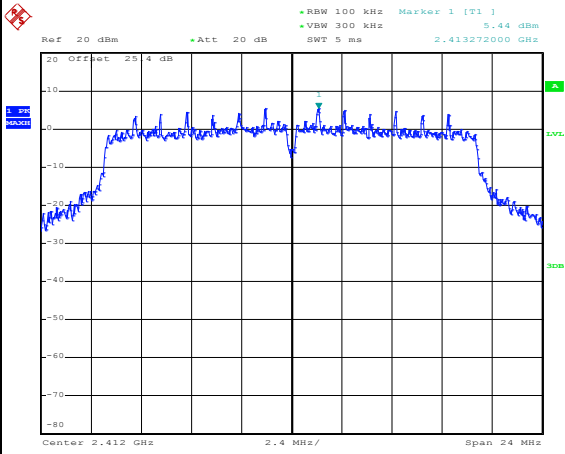

Date: 12.AUG.2018 14:14:05

Channel Plot

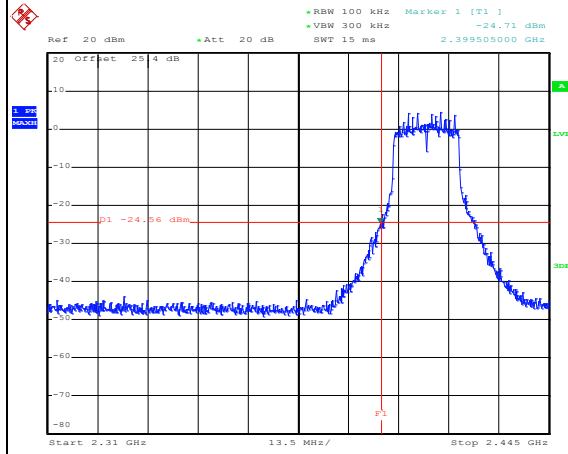

Date: 12.AUG.2018 14:14:22

Spurious Emission 30MHz~3GHz

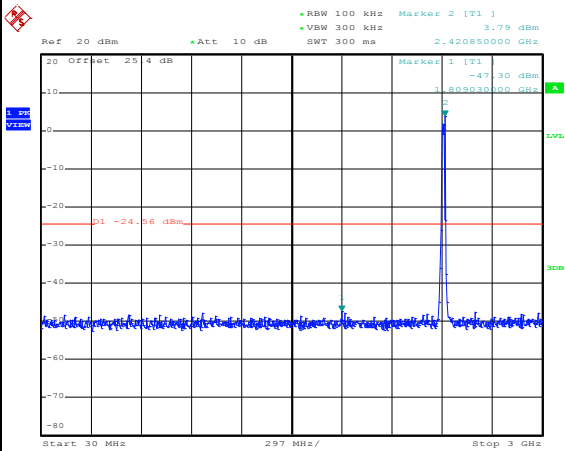

Date: 12.AUG.2018 14:14:34

Spurious Emission 2GHz~25GHz

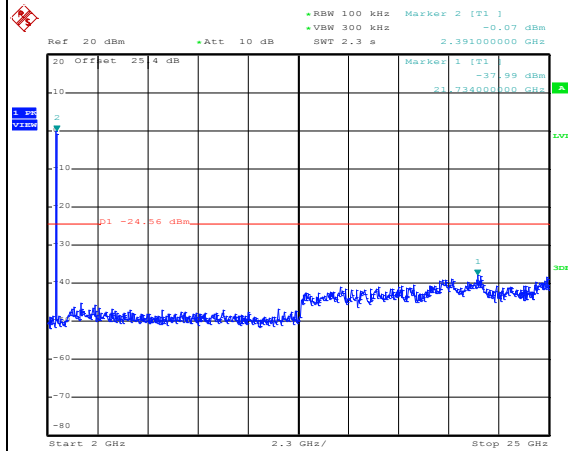

Date: 12.AUG.2018 14:14:43



Test Mode :	802.11n HT20	Test Channel :	06
-------------	--------------	----------------	----

100kHz PSD reference Level

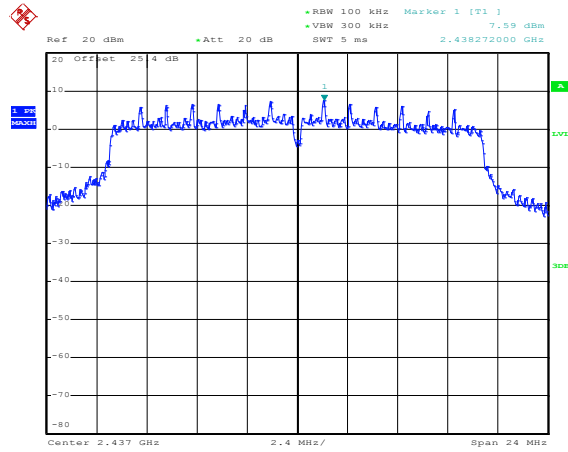

Date: 12.AUG.2018 14:11:48

Spurious Emission 30MHz~3GHz

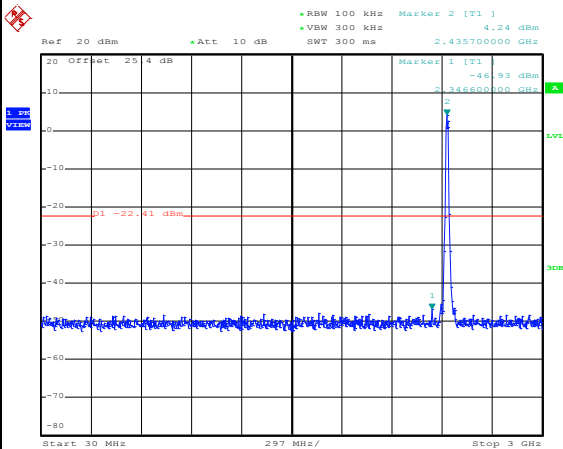

Date: 12.AUG.2018 14:12:27

Spurious Emission 2GHz~25GHz

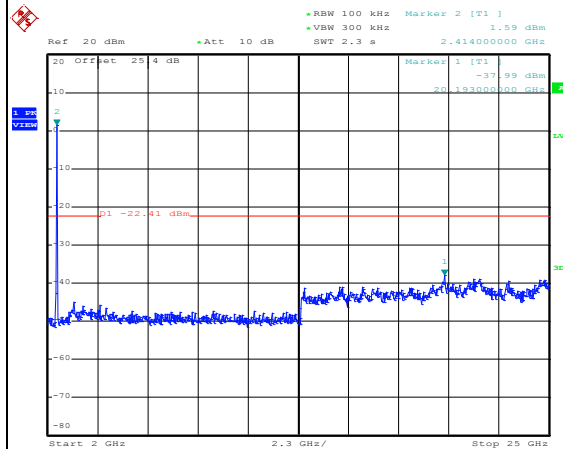

Date: 12.AUG.2018 14:12:36



Test Mode :	802.11n HT20	Test Channel :	11
-------------	--------------	----------------	----

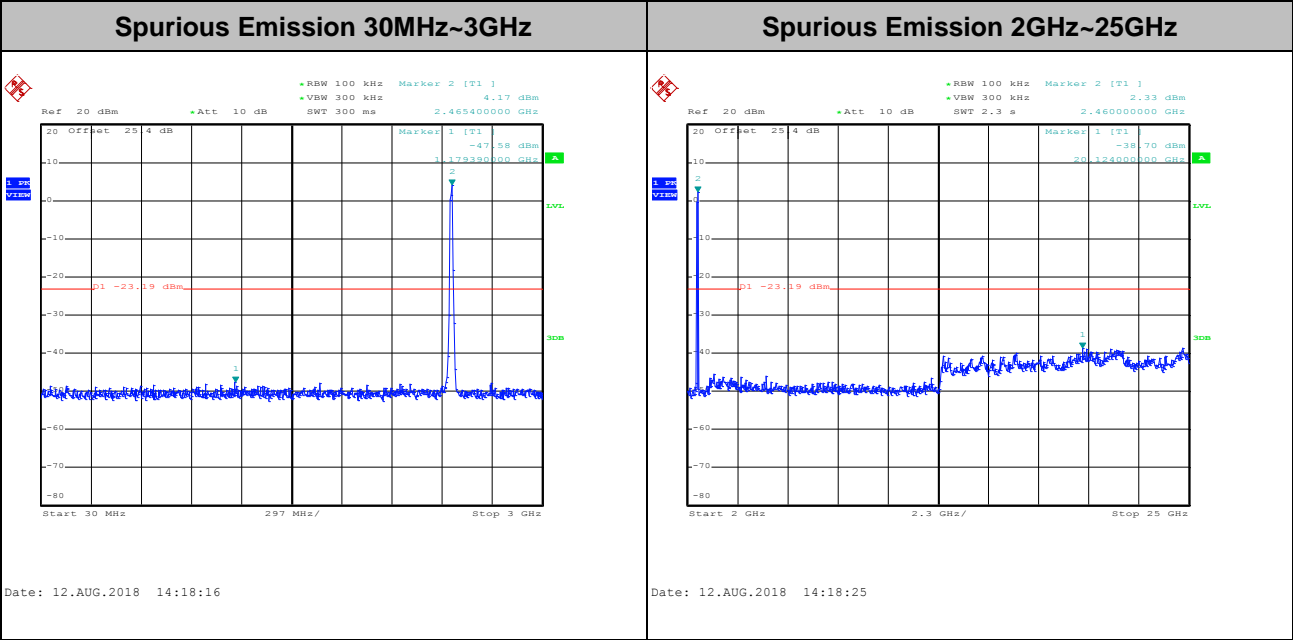
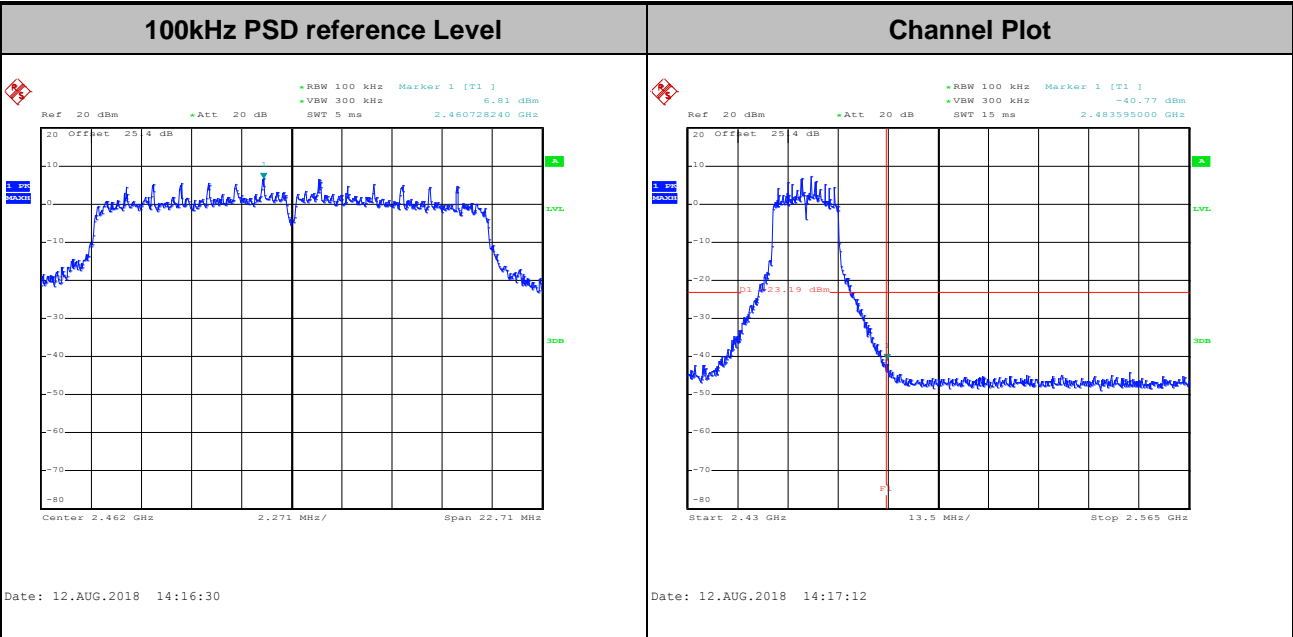



Test Mode : 802.11n HT40 Test Channel : 03

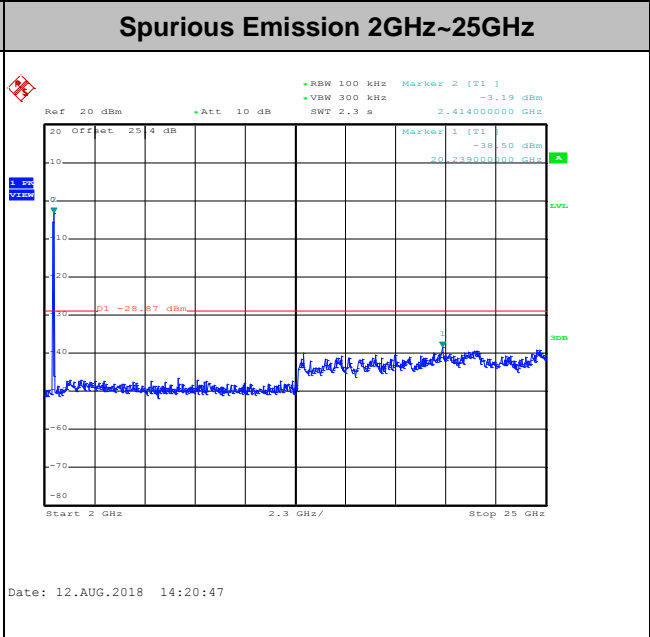
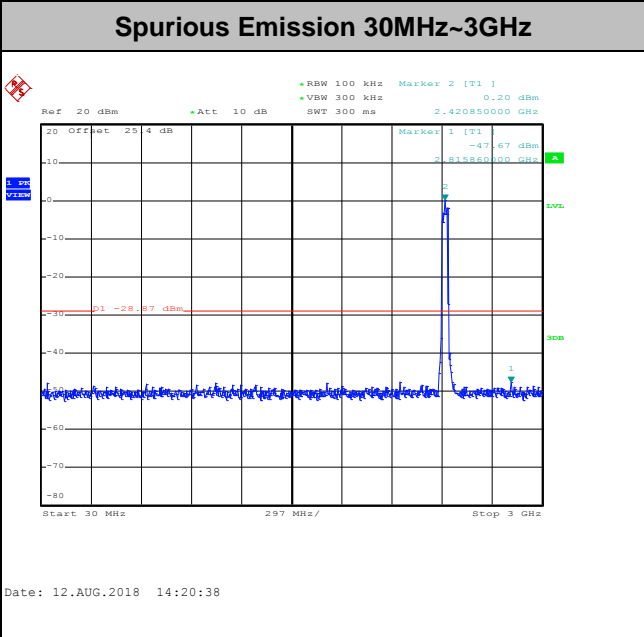
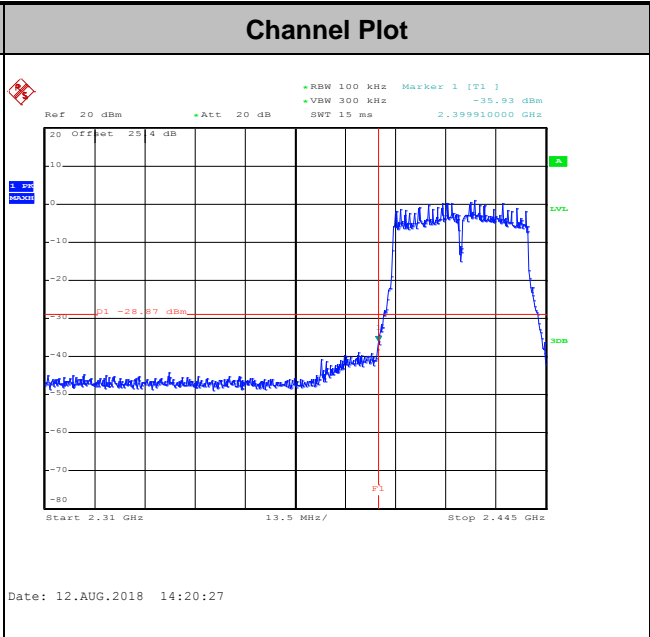
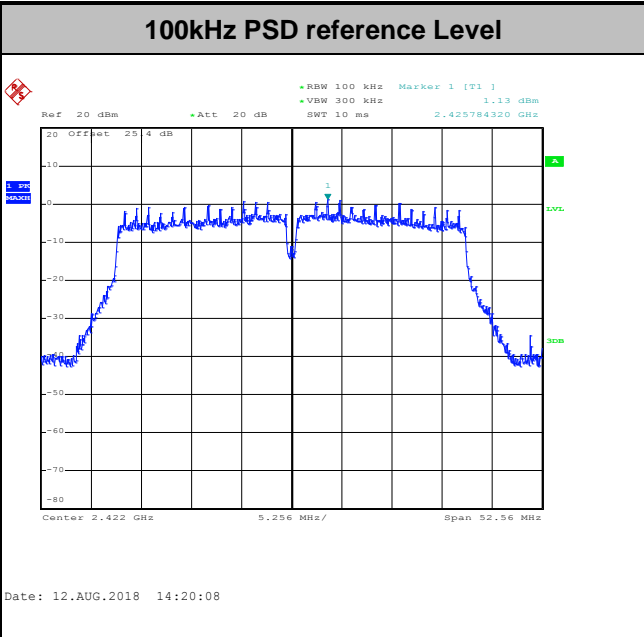



Test Mode :	802.11n HT40	Test Channel :	06
-------------	--------------	----------------	----

100kHz PSD reference Level

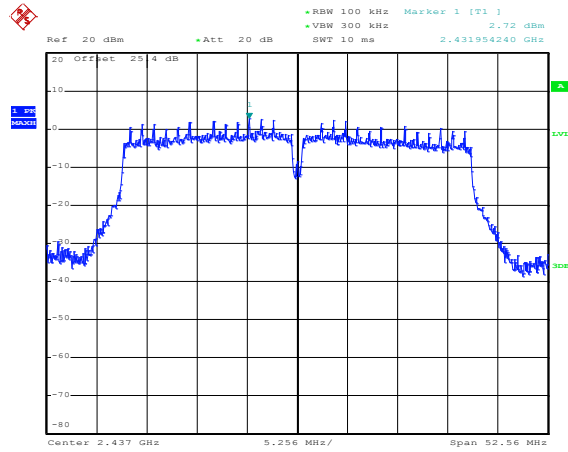

Date: 12.AUG.2018 14:23:28

Spurious Emission 30MHz~3GHz

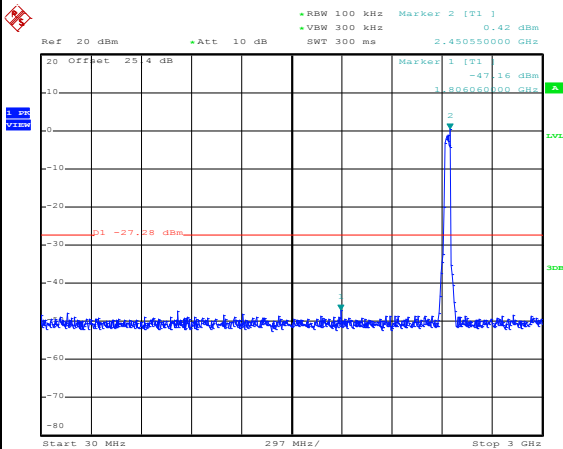

Date: 12.AUG.2018 14:23:42

Spurious Emission 2GHz~25GHz

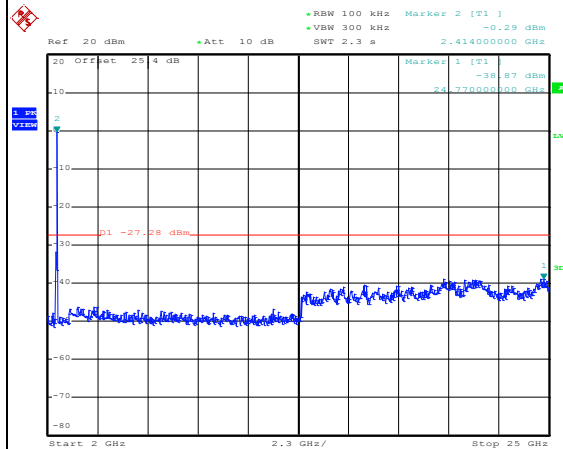

Date: 12.AUG.2018 14:23:50



Test Mode :	802.11n HT40	Test Channel :	09
-------------	--------------	----------------	----

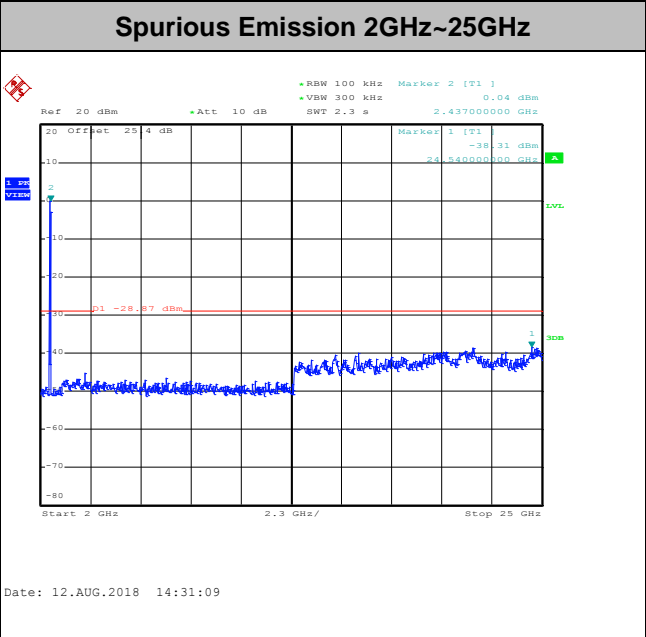
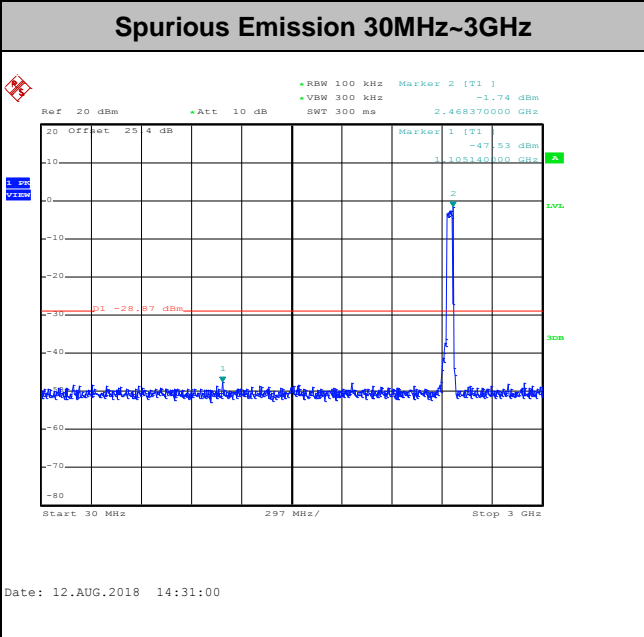
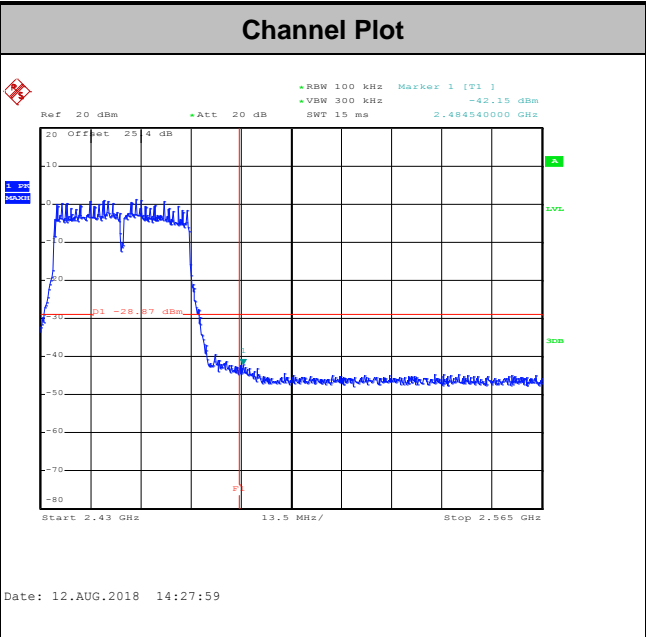
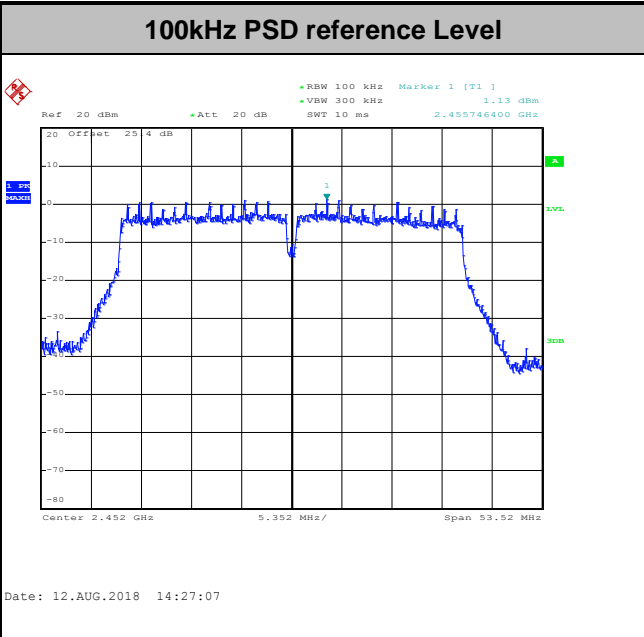



Number of TX = 2, Ant. 1 (Measured)

Test Mode :	802.11b	Test Channel :	01
-------------	---------	----------------	----

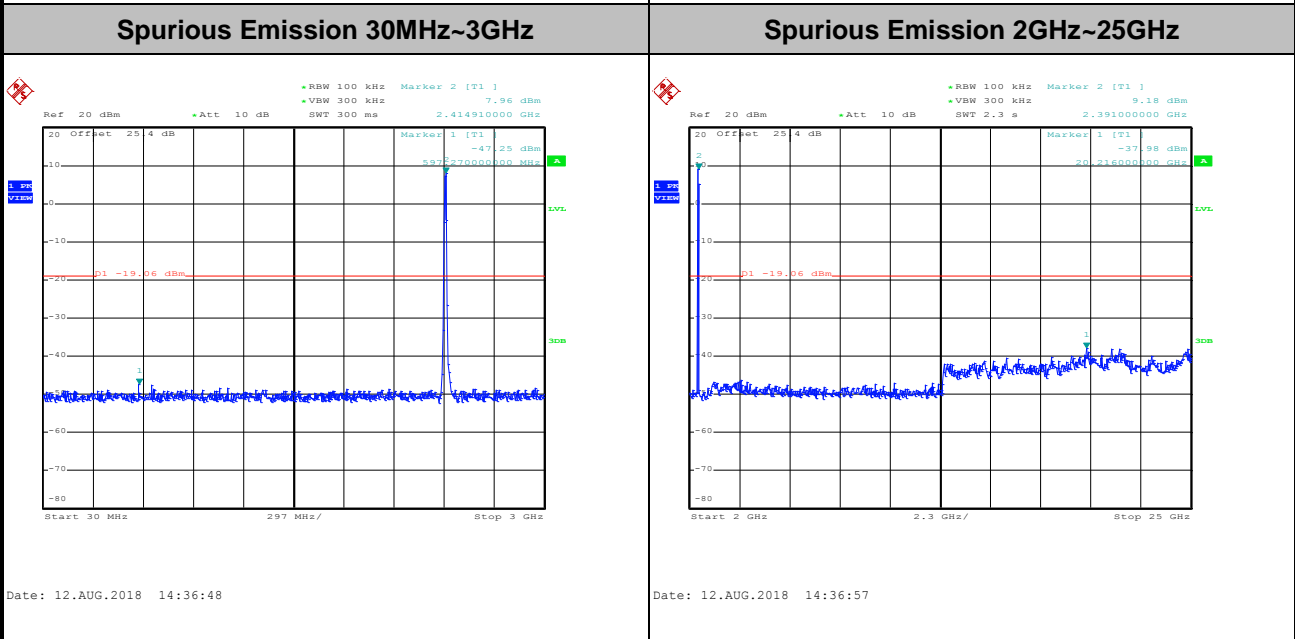
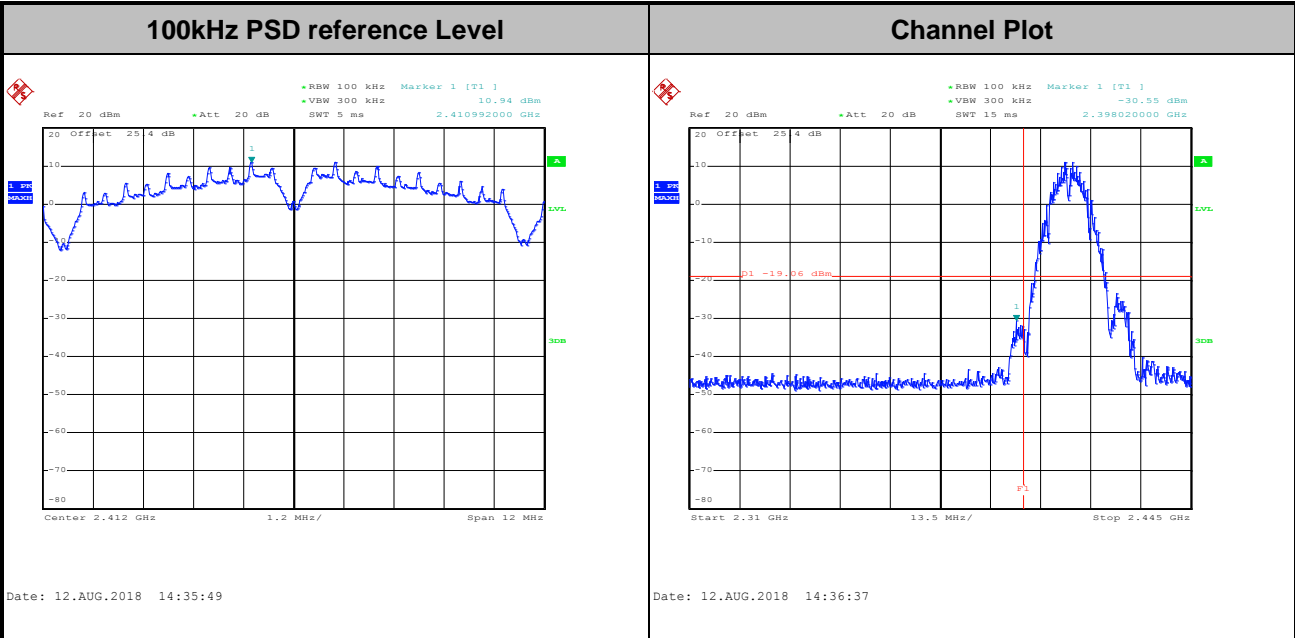



Test Mode :	802.11b	Test Channel :	06
-------------	---------	----------------	----

100kHz PSD reference Level

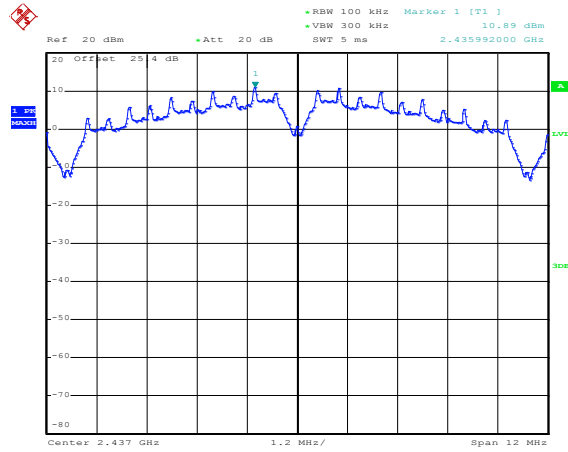

Date: 12.AUG.2018 14:42:46

Spurious Emission 30MHz~3GHz

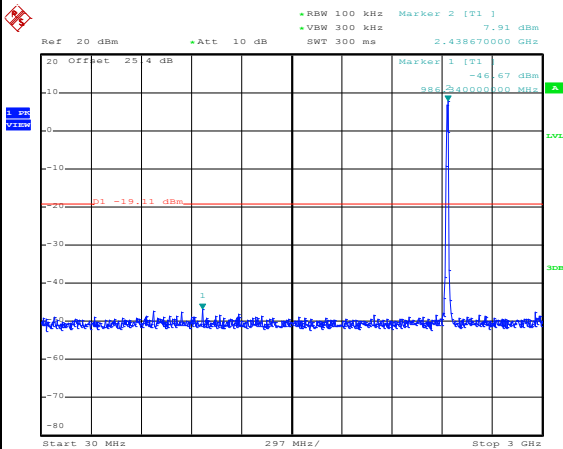

Date: 12.AUG.2018 14:42:58

Spurious Emission 2GHz~25GHz

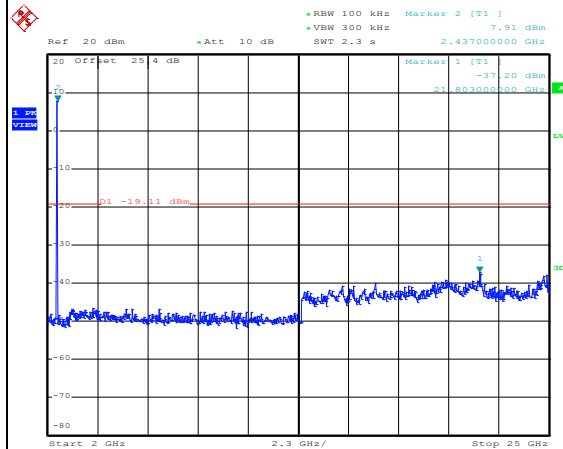

Date: 12.AUG.2018 14:43:07



Test Mode :	802.11b	Test Channel :	11
-------------	---------	----------------	----

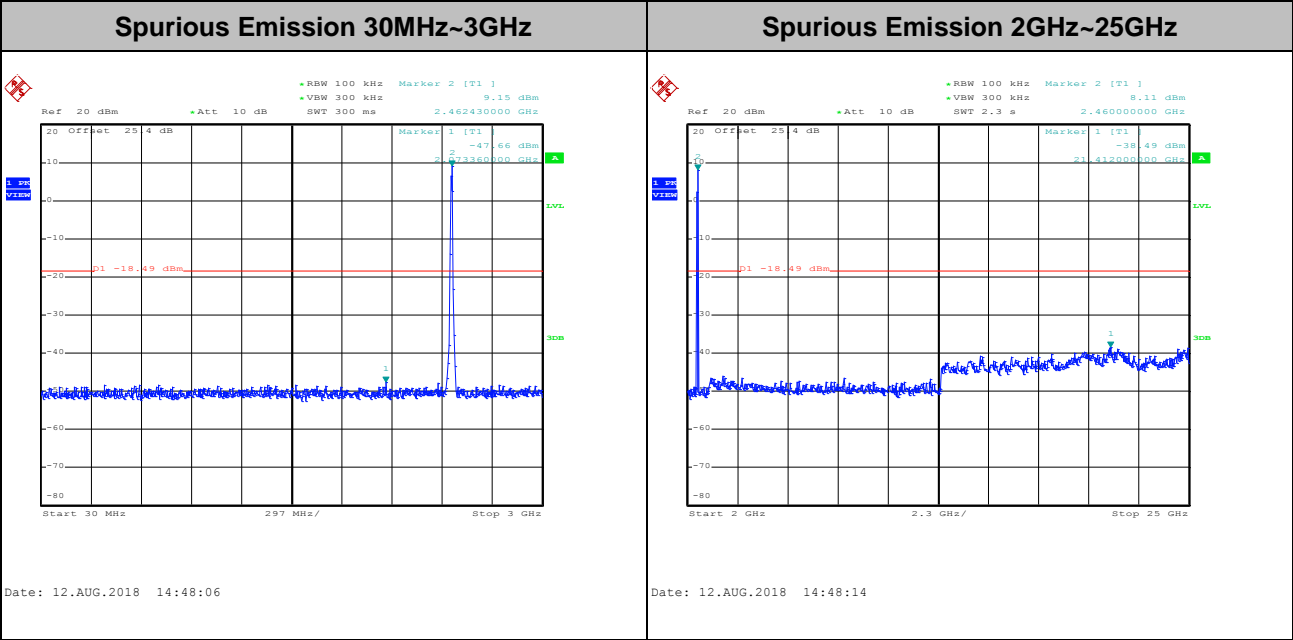
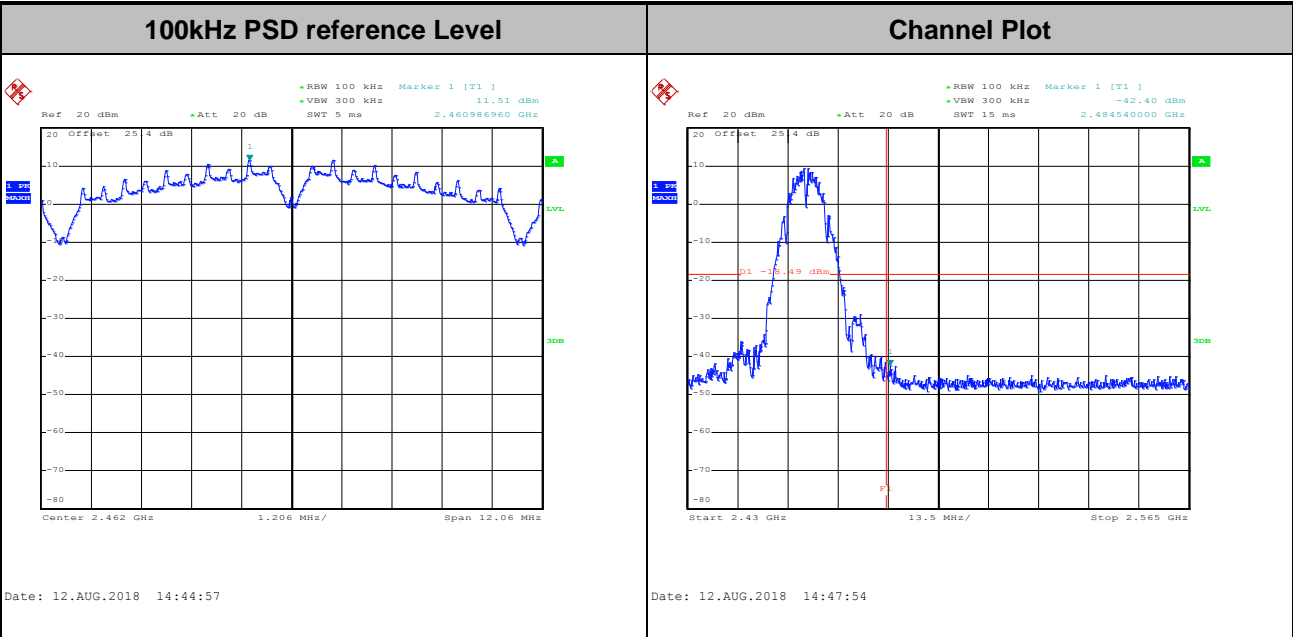



Test Mode : 802.11g Test Channel : 01

100kHz PSD reference Level

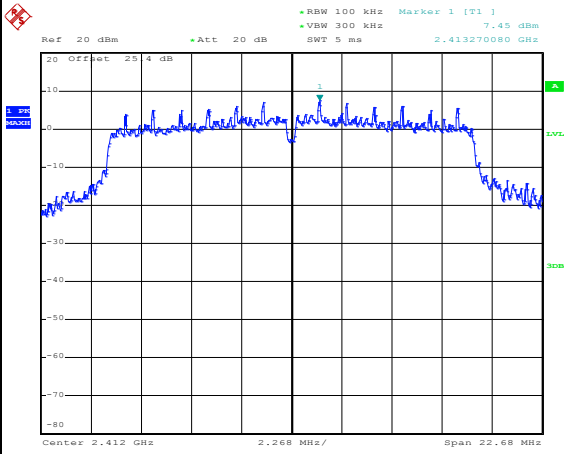

Date: 12.AUG.2018 14:56:13

Channel Plot

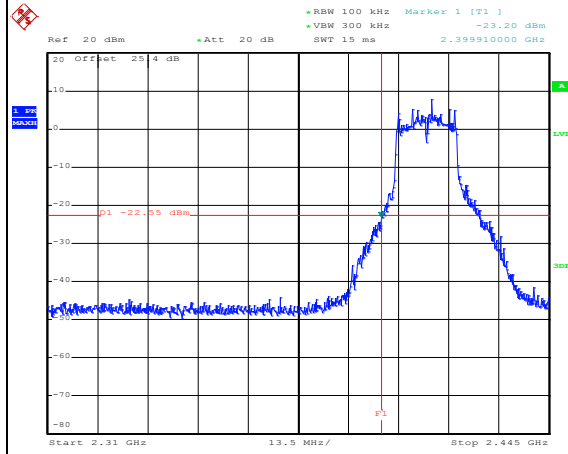

Date: 12.AUG.2018 14:56:58

Spurious Emission 30MHz~3GHz

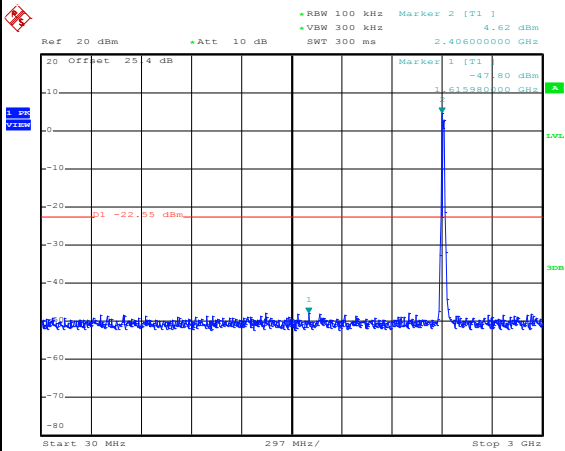

Date: 12.AUG.2018 14:57:11

Spurious Emission 2GHz~25GHz

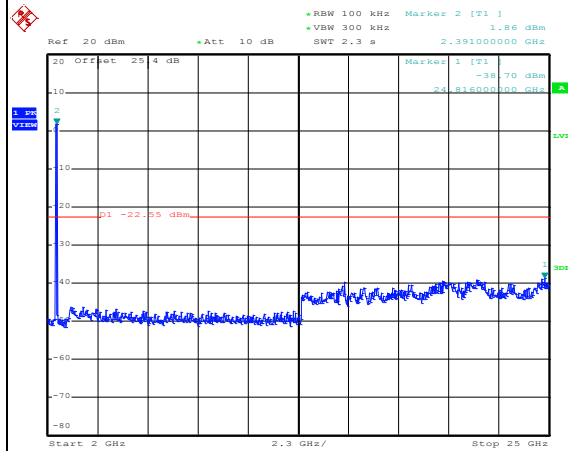

Date: 12.AUG.2018 14:57:20



Test Mode :	802.11g	Test Channel :	06
-------------	---------	----------------	----

100kHz PSD reference Level

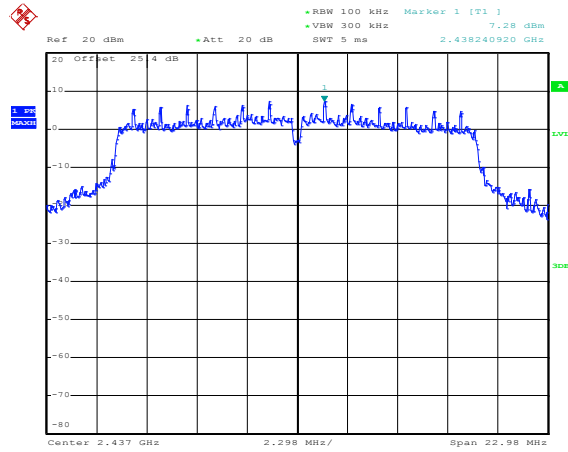

Date: 12.AUG.2018 14:59:23

Spurious Emission 30MHz~3GHz

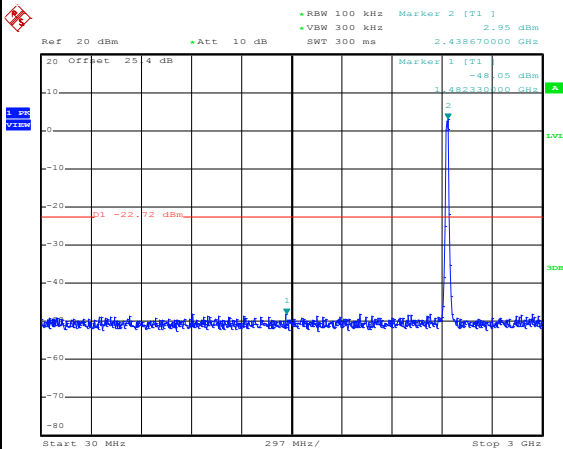

Date: 12.AUG.2018 14:59:36

Spurious Emission 2GHz~25GHz

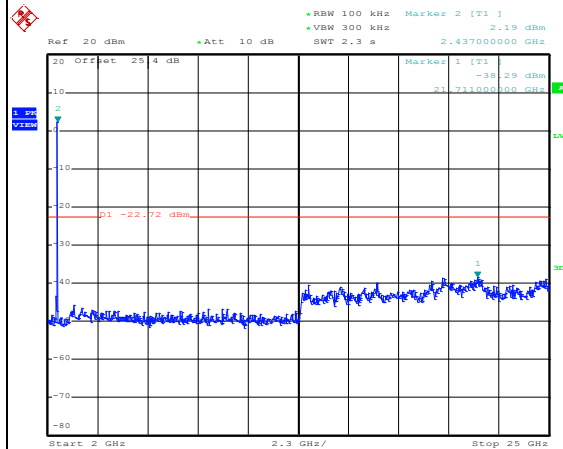

Date: 12.AUG.2018 14:59:44



Test Mode :	802.11g	Test Channel :	11
-------------	---------	----------------	----

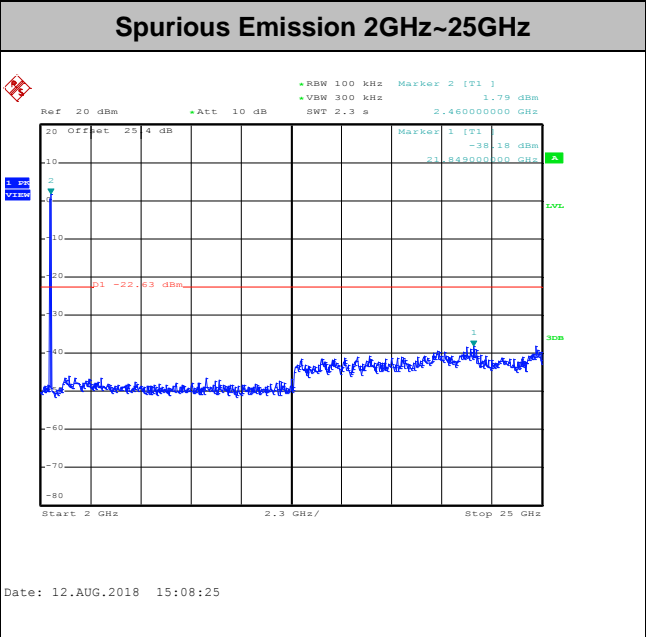
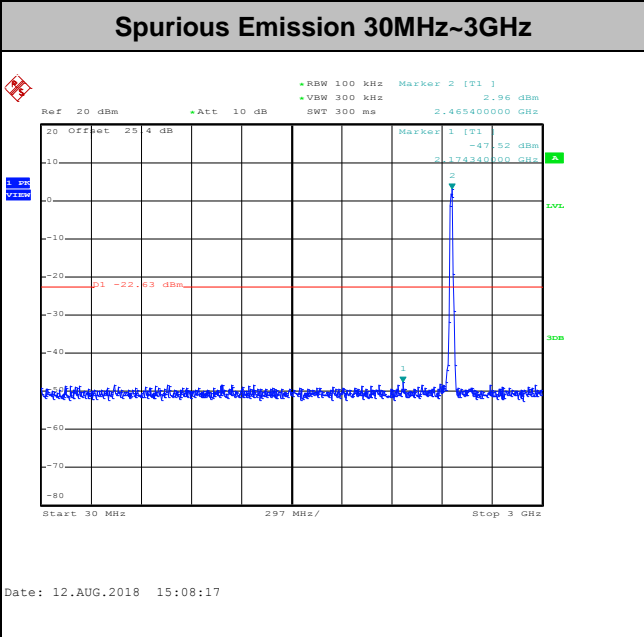
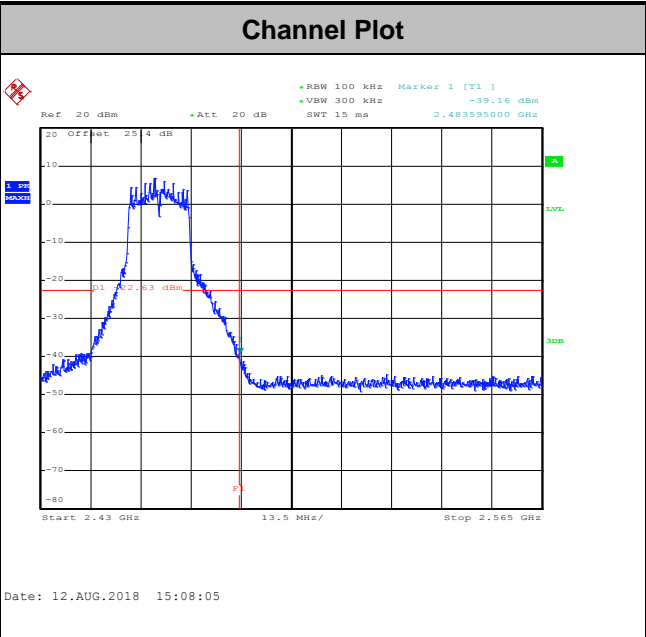
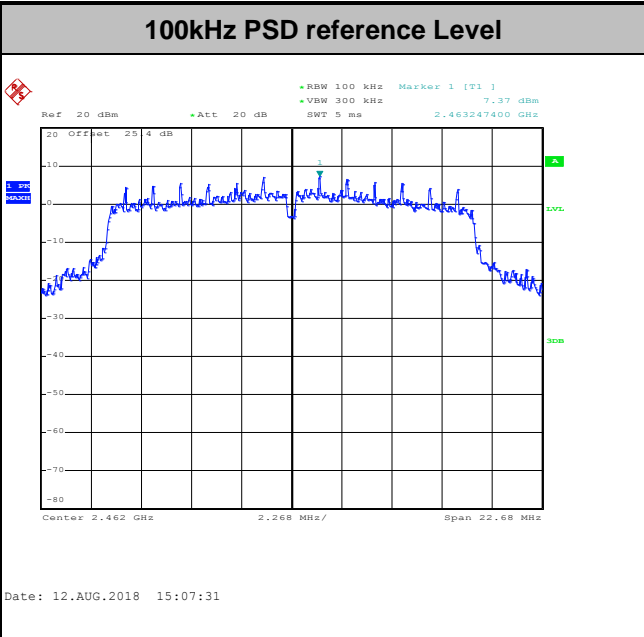



Test Mode : 802.11n HT20 Test Channel : 01

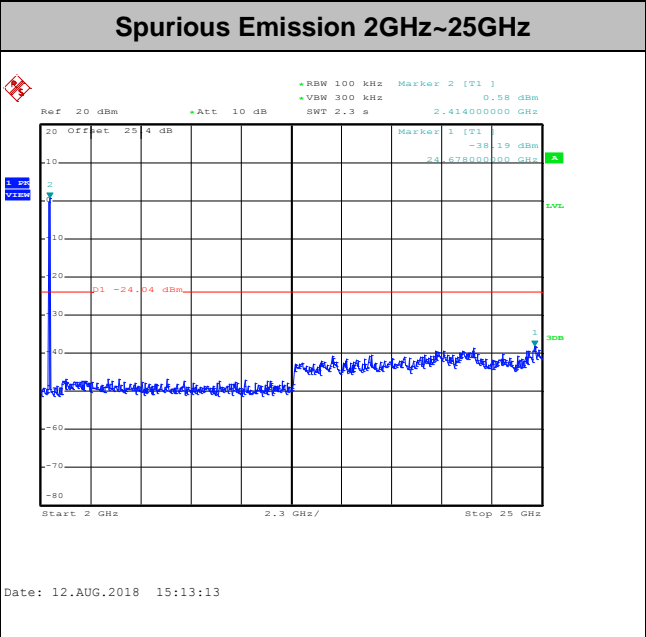
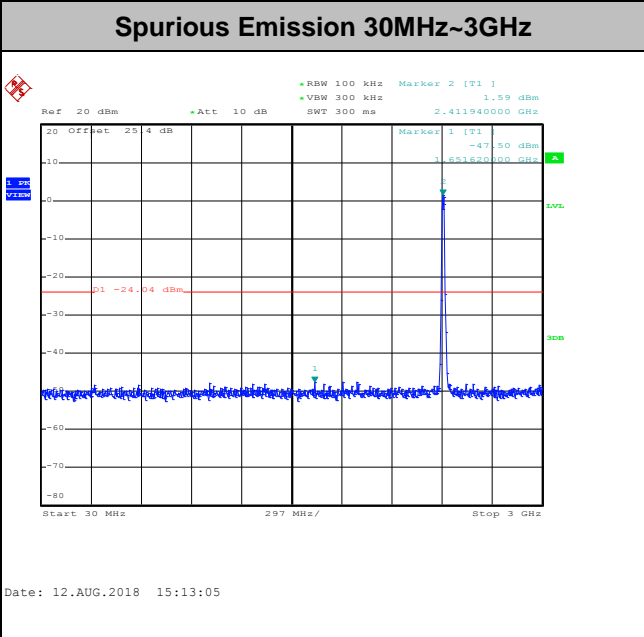
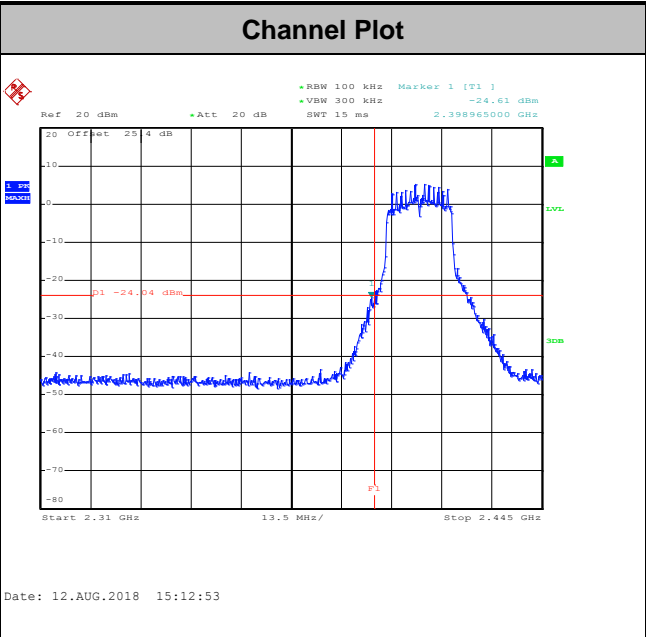
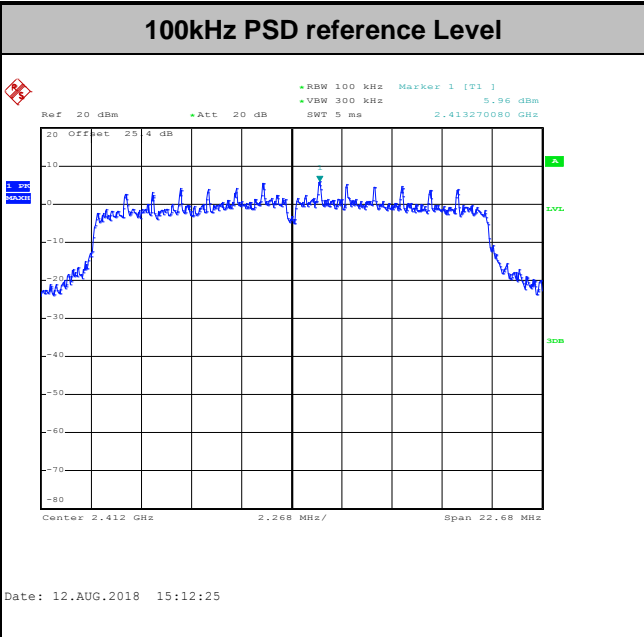



Test Mode :	802.11n HT20	Test Channel :	06
-------------	--------------	----------------	----

100kHz PSD reference Level

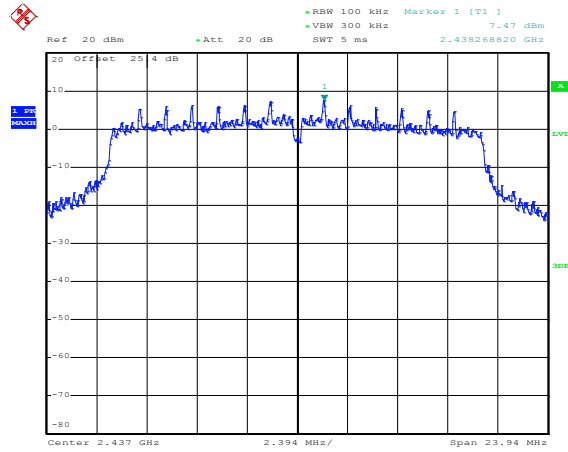

Date: 12.AUG.2018 15:20:42

Spurious Emission 30MHz~3GHz

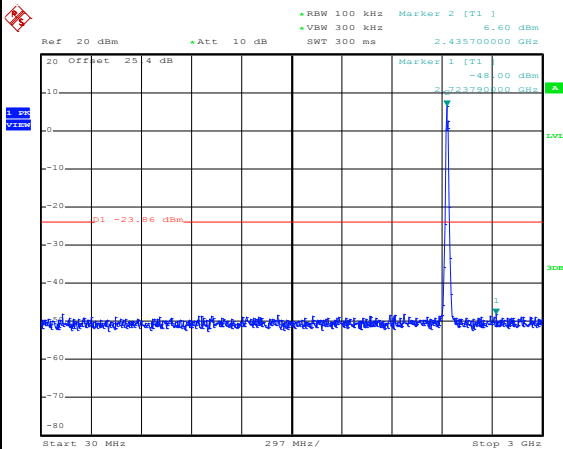

Date: 12.AUG.2018 15:29:47

Spurious Emission 2GHz~25GHz

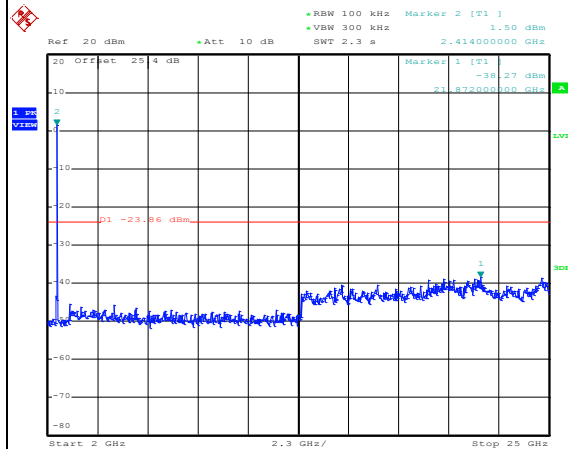

Date: 12.AUG.2018 15:29:55



Test Mode :	802.11n HT20	Test Channel :	11
-------------	--------------	----------------	----

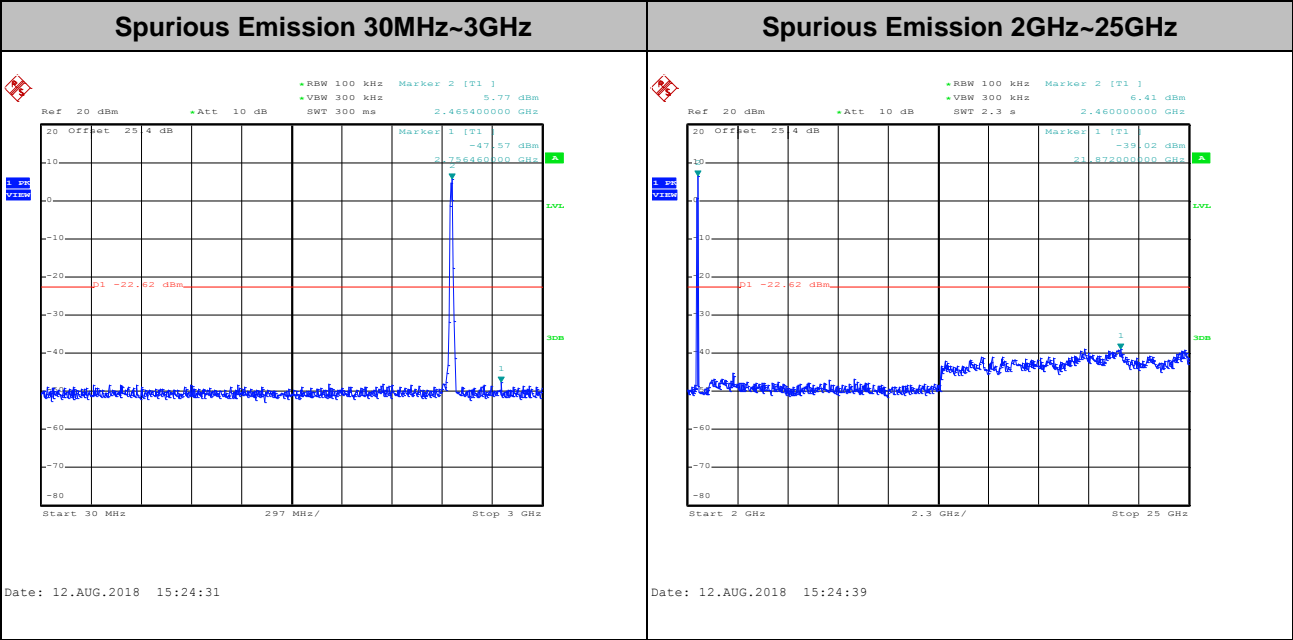
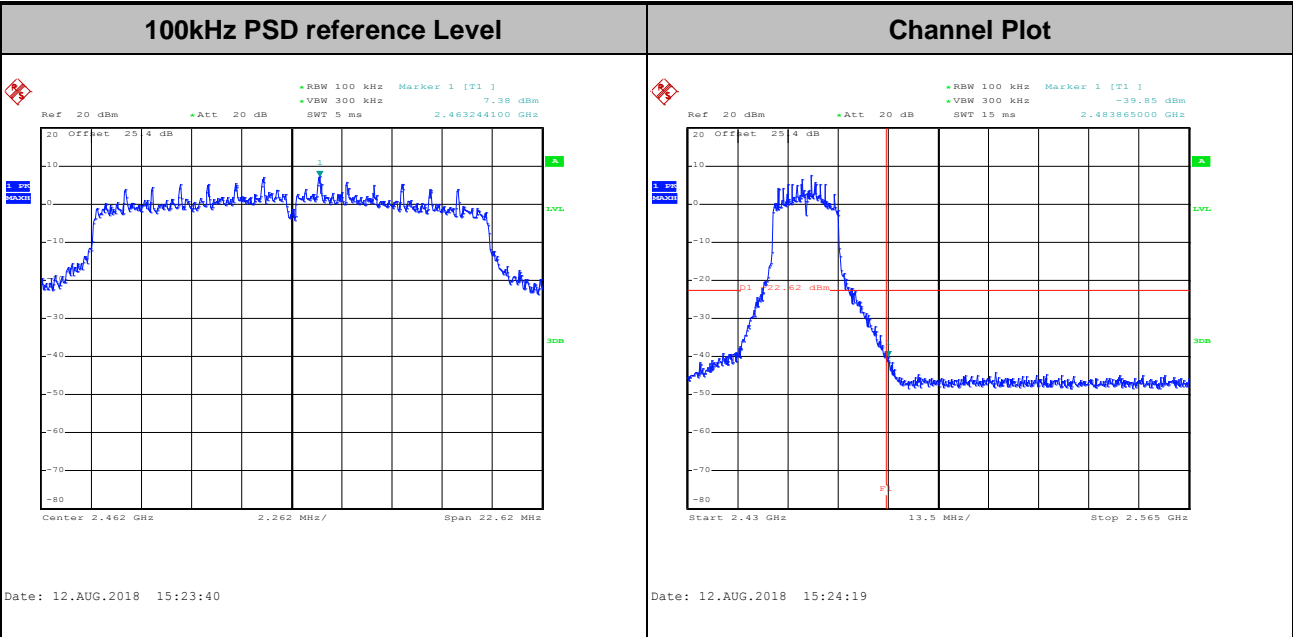



Test Mode : 802.11n HT40 Test Channel : 03

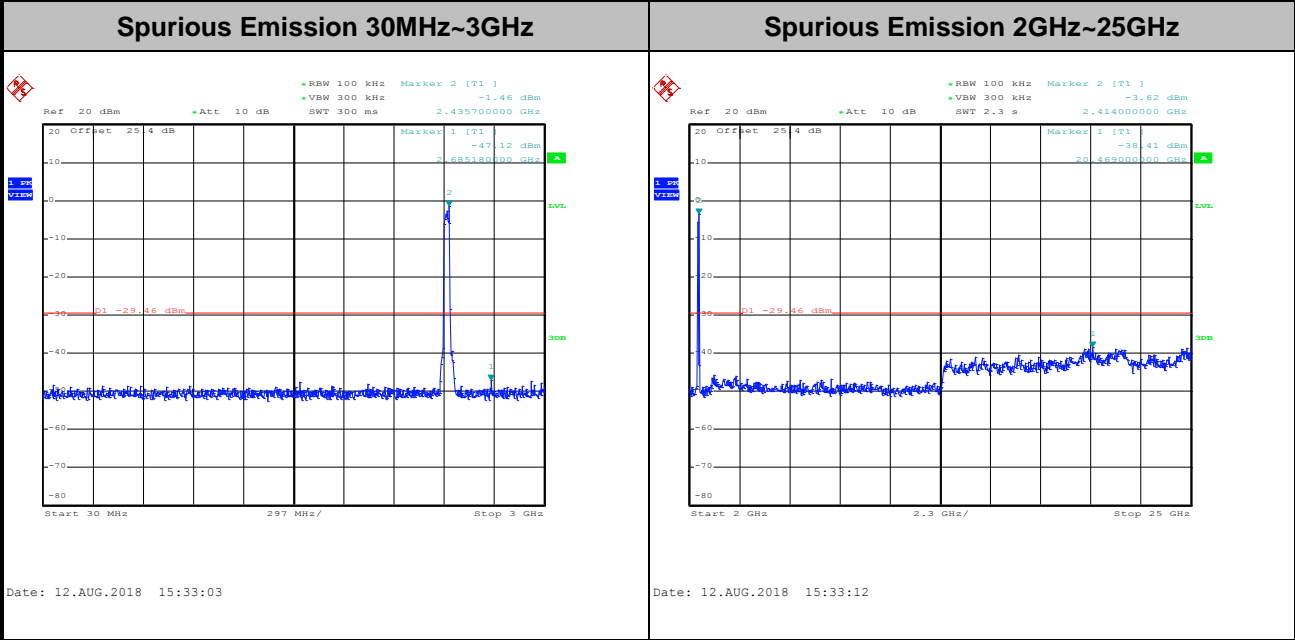
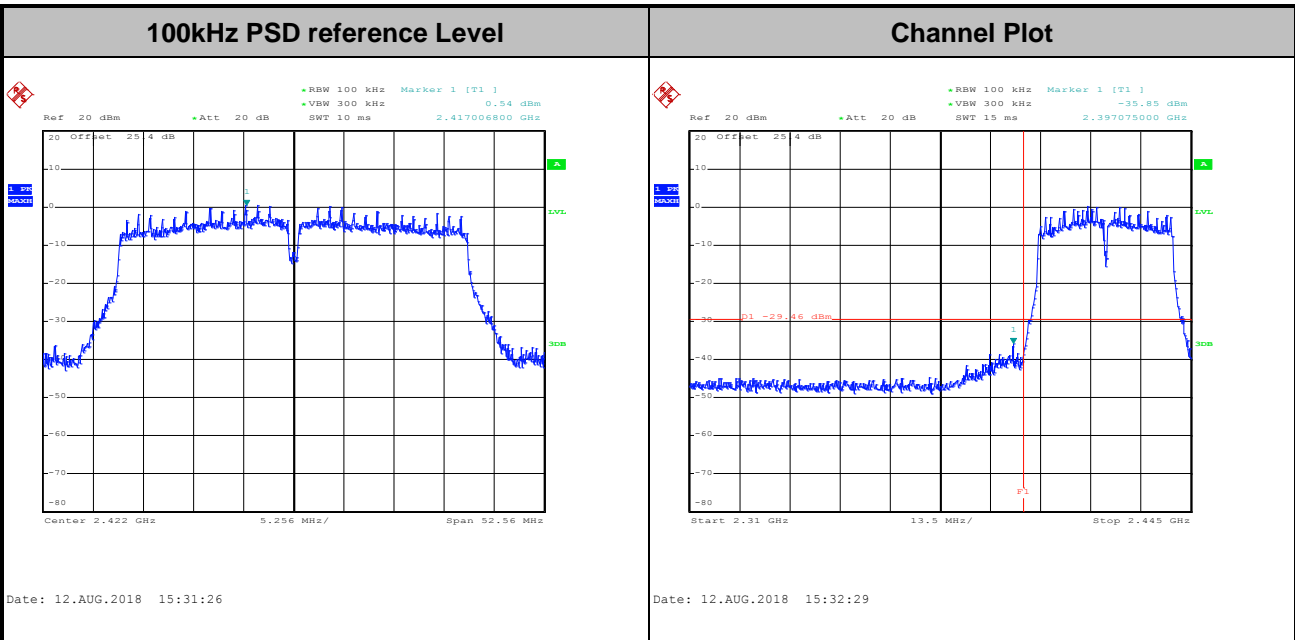



Test Mode :	802.11n HT40	Test Channel :	06
-------------	--------------	----------------	----

100kHz PSD reference Level

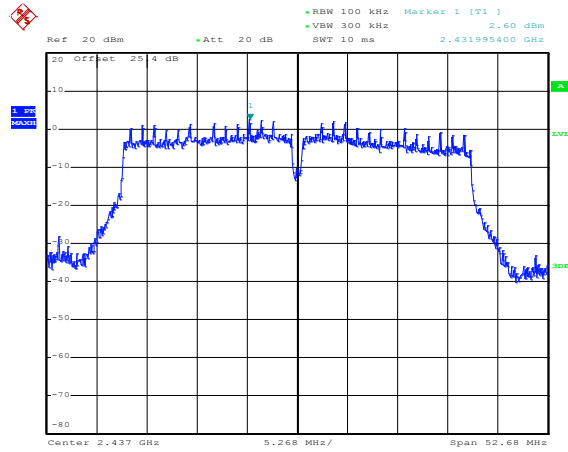

Date: 12.AUG.2018 15:41:20

Spurious Emission 30MHz~3GHz

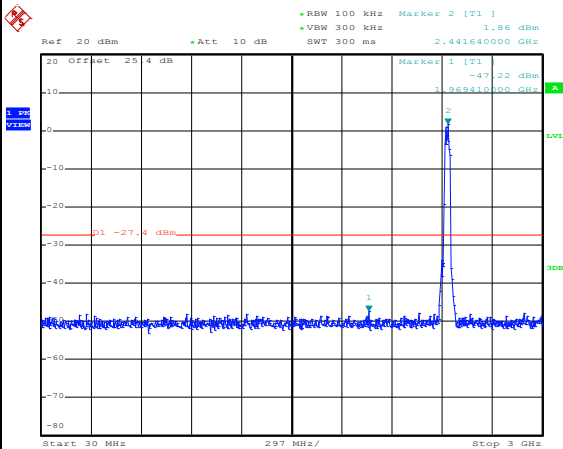

Date: 12.AUG.2018 15:41:33

Spurious Emission 2GHz~25GHz

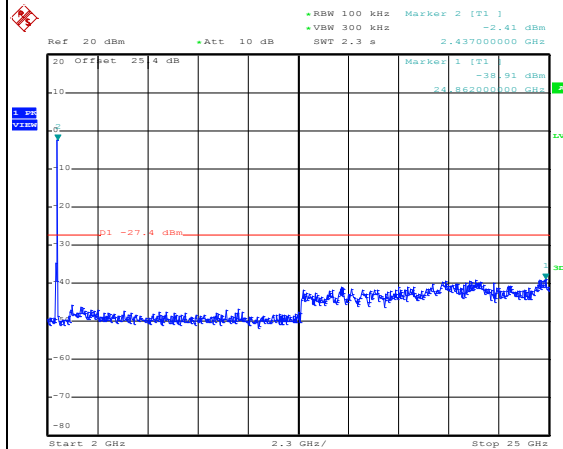

Date: 12.AUG.2018 15:41:41



Test Mode :	802.11n HT40	Test Channel :	09
-------------	--------------	----------------	----

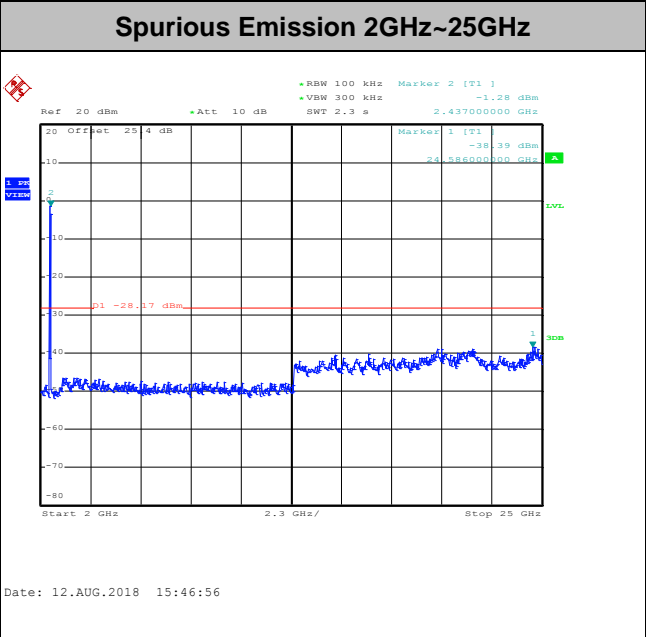
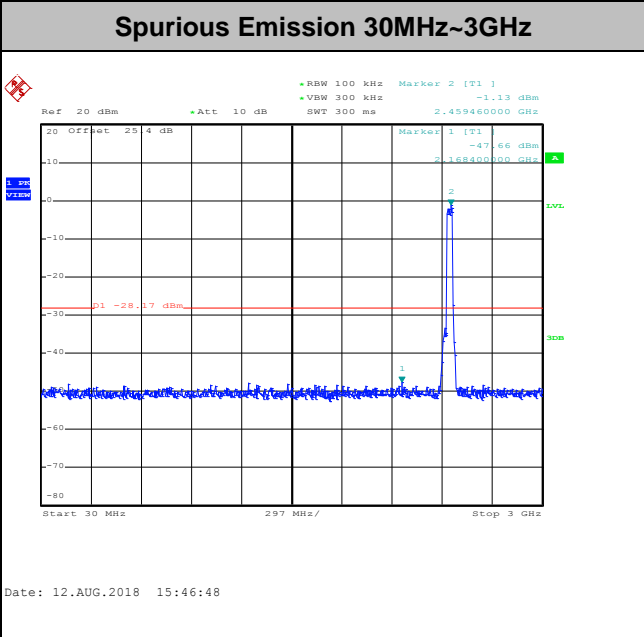
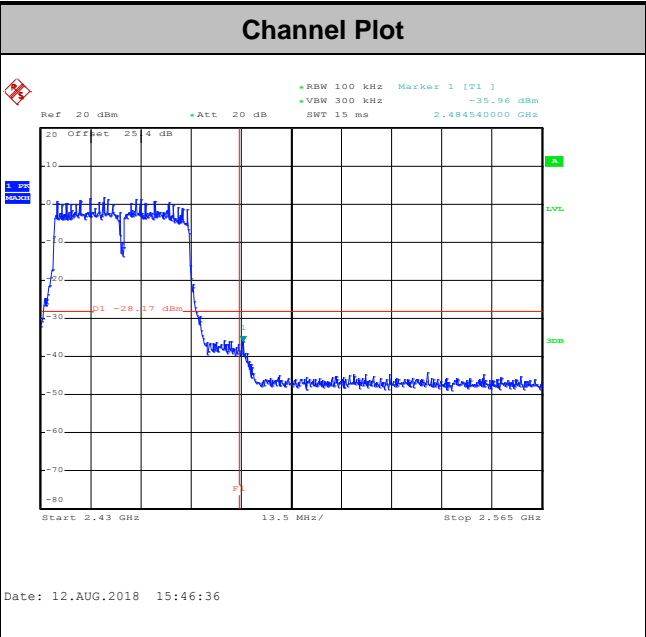
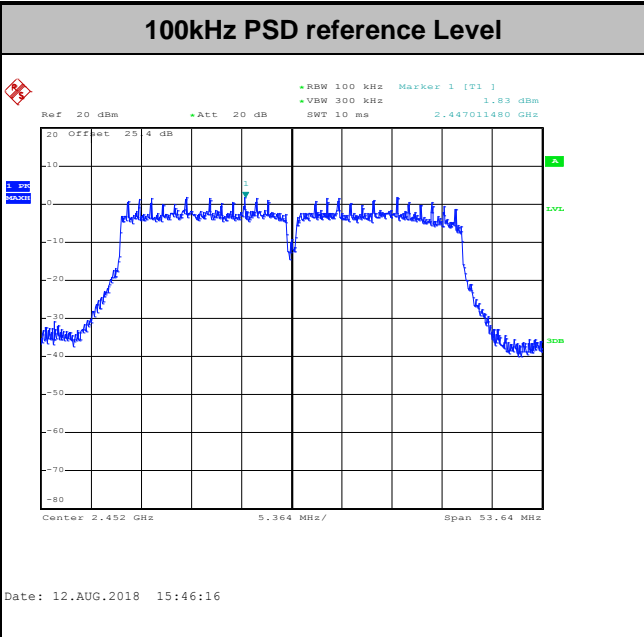



Number of TX = 2, Ant. 2 (Measured)

Test Mode :	802.11b	Test Channel :	01
-------------	---------	----------------	----

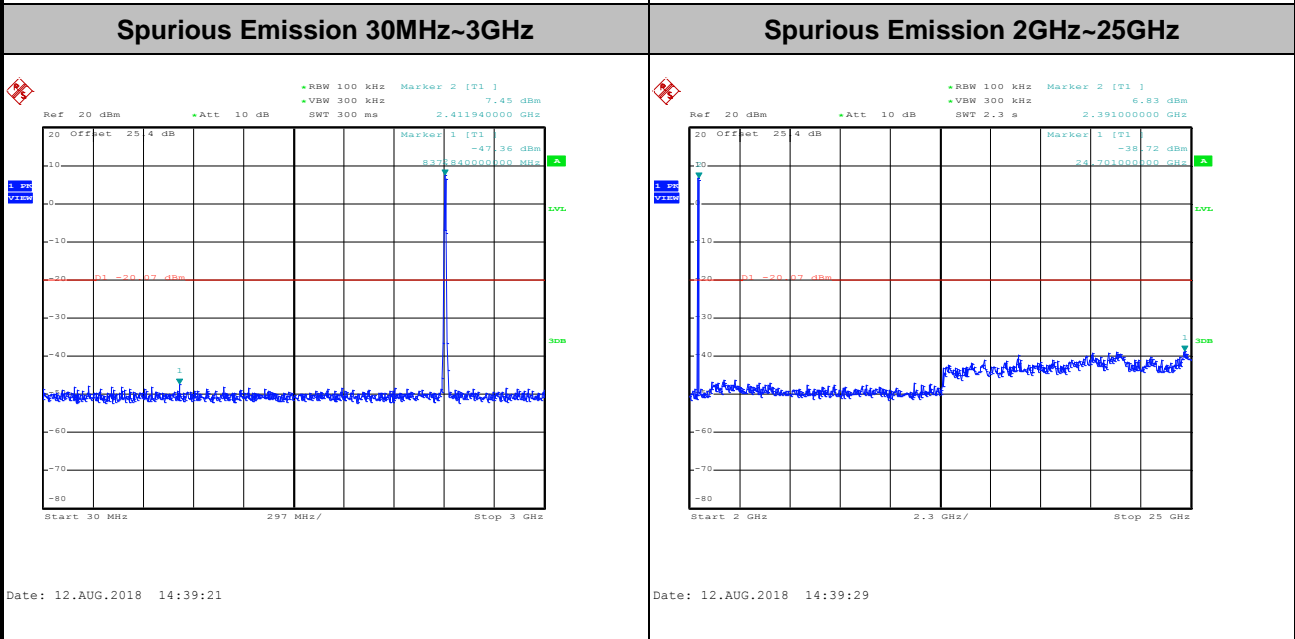
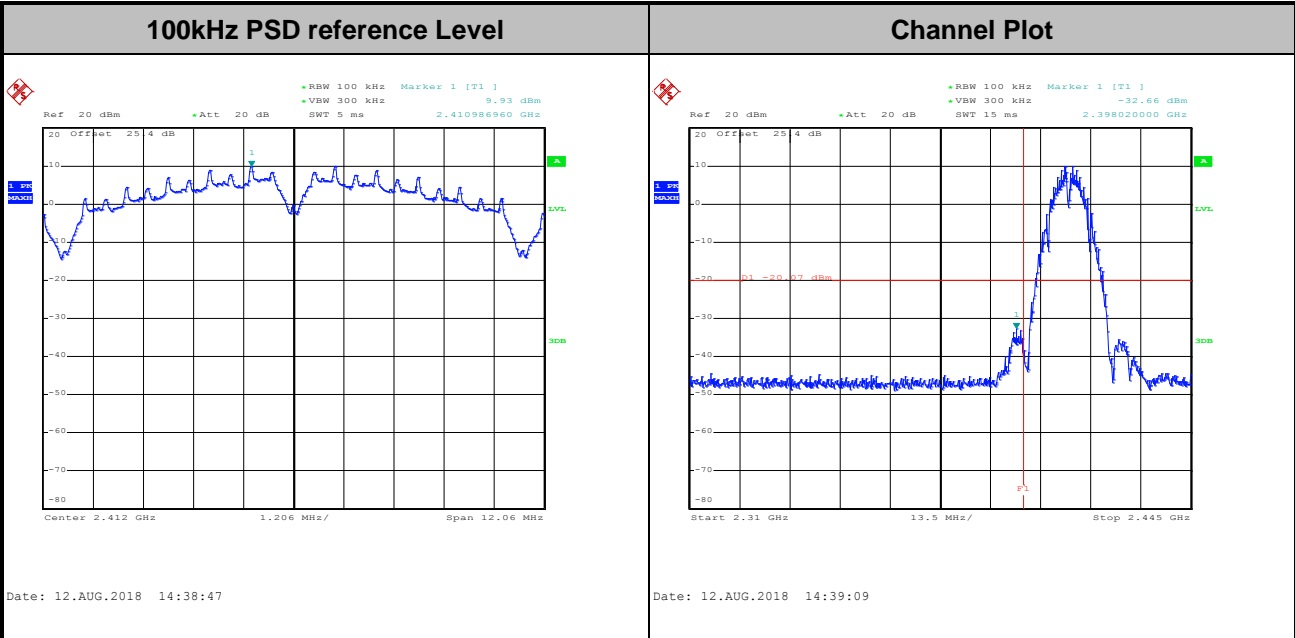



Test Mode :	802.11b	Test Channel :	06
-------------	---------	----------------	----

100kHz PSD reference Level

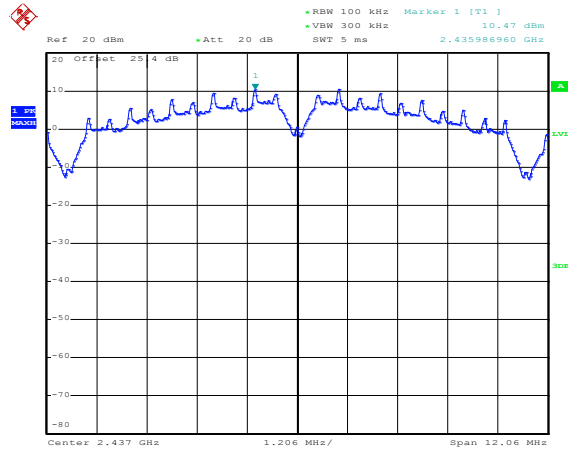

Date: 12.AUG.2018 14:40:51

Spurious Emission 30MHz~3GHz

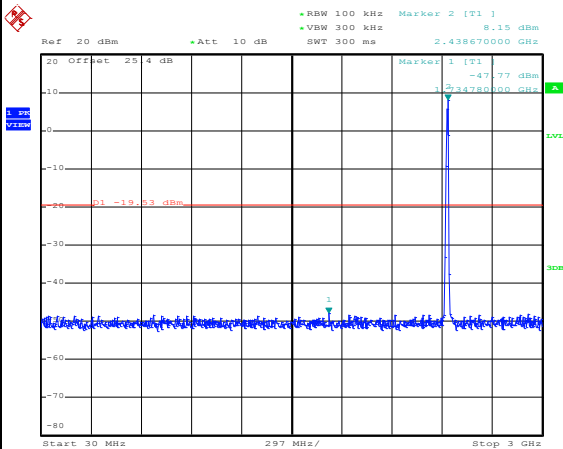

Date: 12.AUG.2018 14:41:05

Spurious Emission 2GHz~25GHz

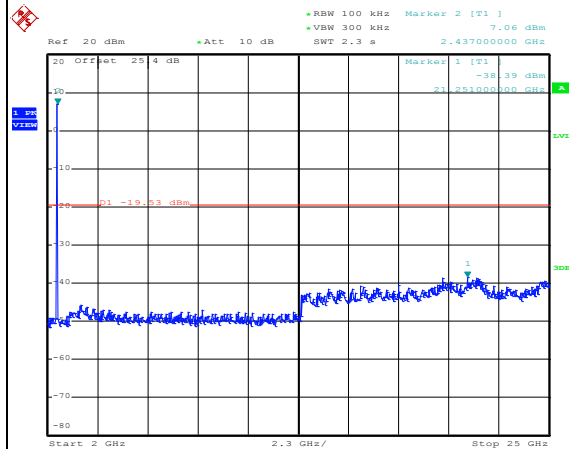

Date: 12.AUG.2018 14:41:14



Test Mode :	802.11b	Test Channel :	11
-------------	---------	----------------	----

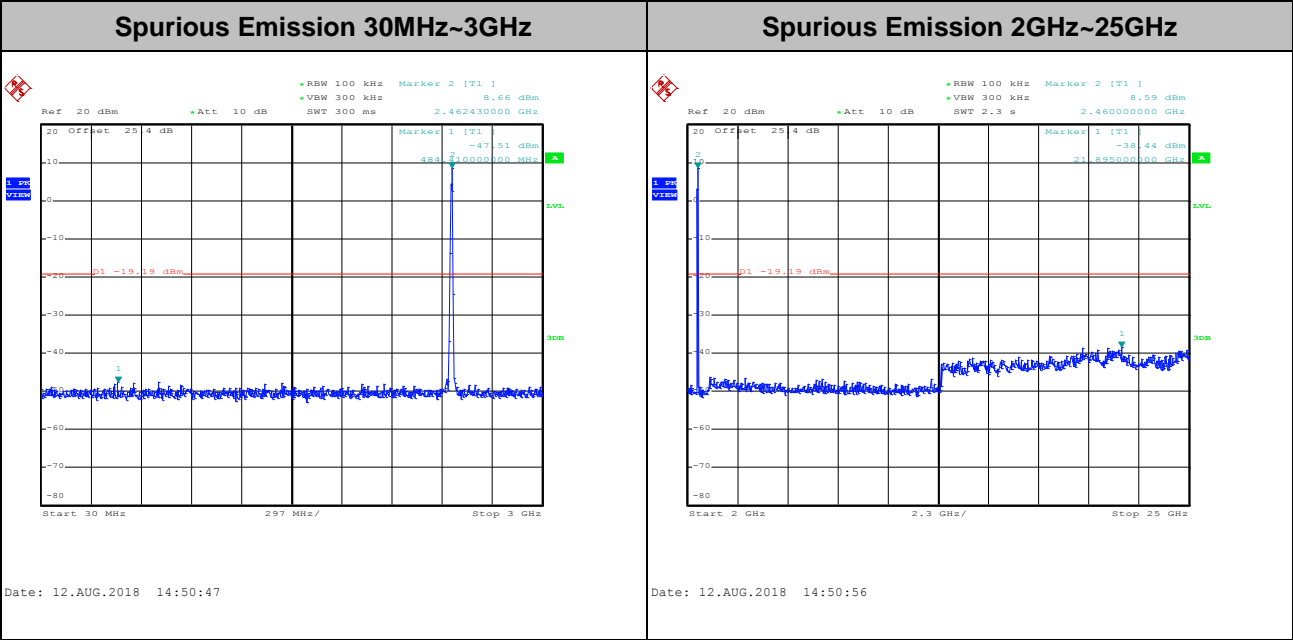
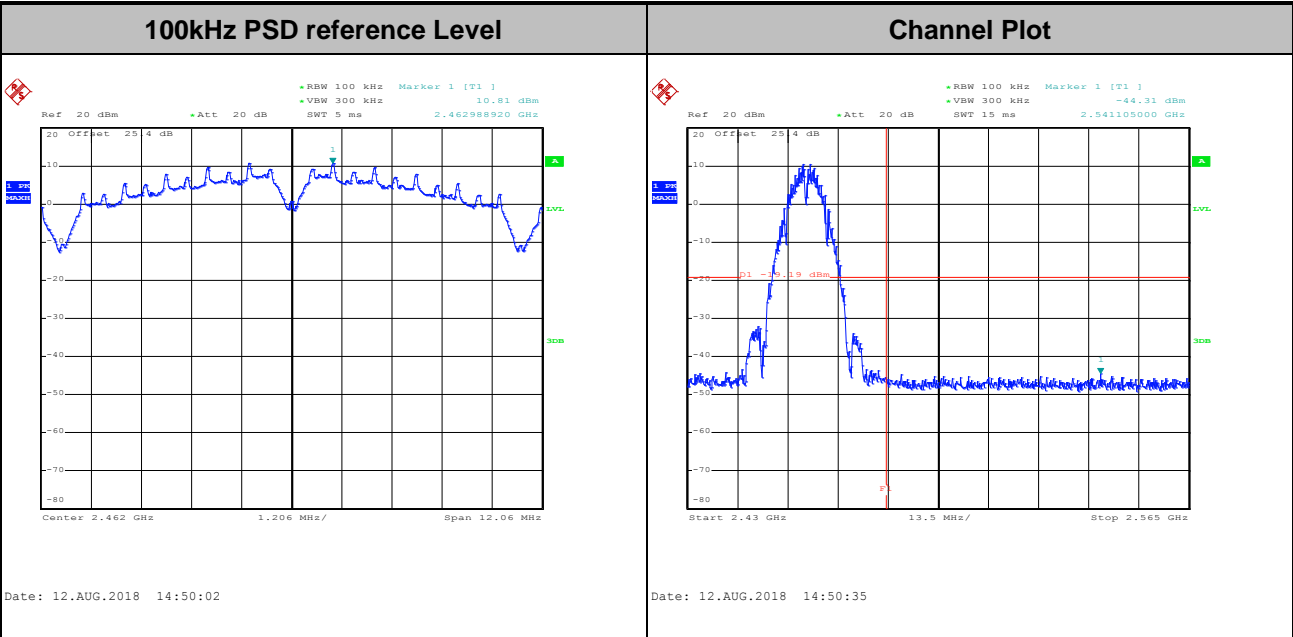



Test Mode : 802.11g Test Channel : 01

100kHz PSD reference Level

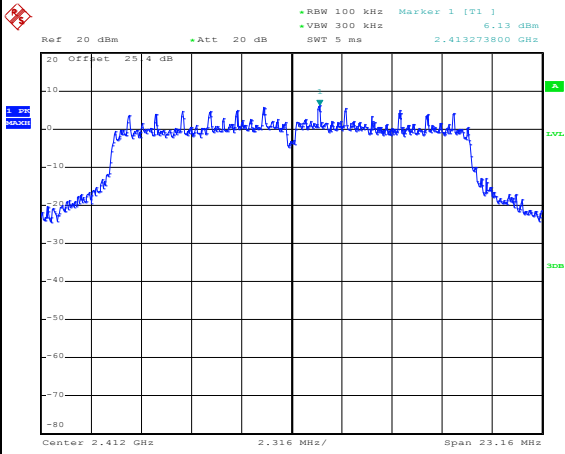

Date: 12.AUG.2018 14:53:30

Channel Plot

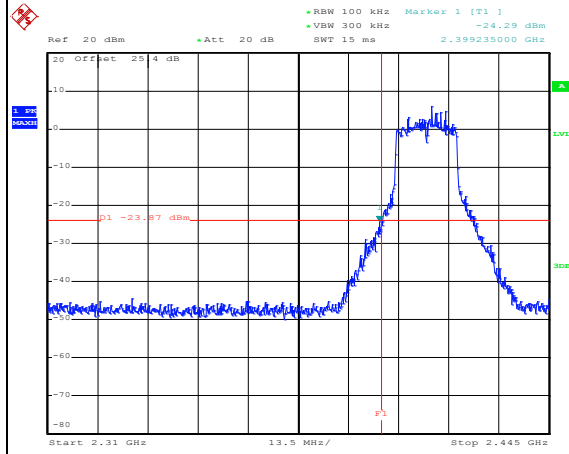

Date: 12.AUG.2018 14:54:09

Spurious Emission 30MHz~3GHz

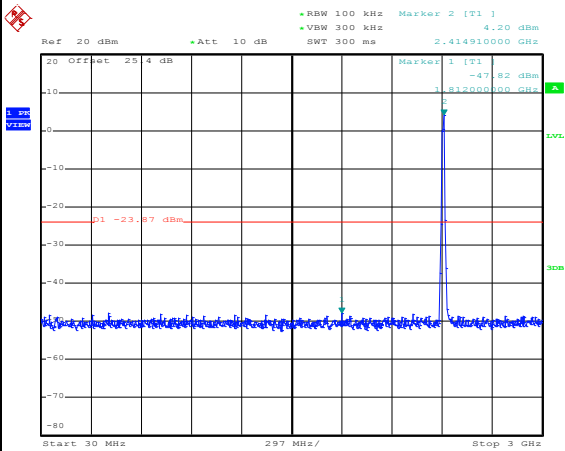

Date: 12.AUG.2018 14:54:23

Spurious Emission 2GHz~25GHz

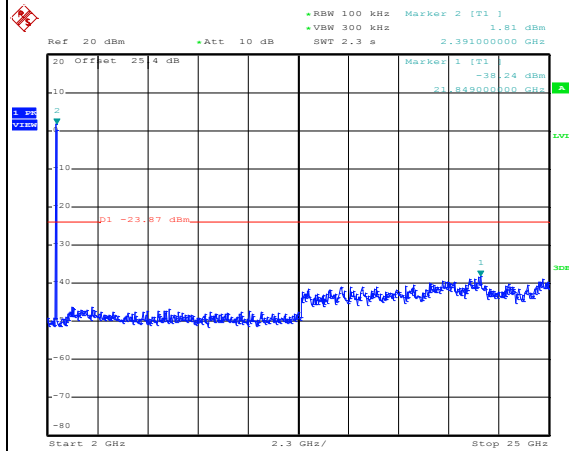

Date: 12.AUG.2018 14:54:31



Test Mode :	802.11g	Test Channel :	06
-------------	---------	----------------	----

100kHz PSD reference Level

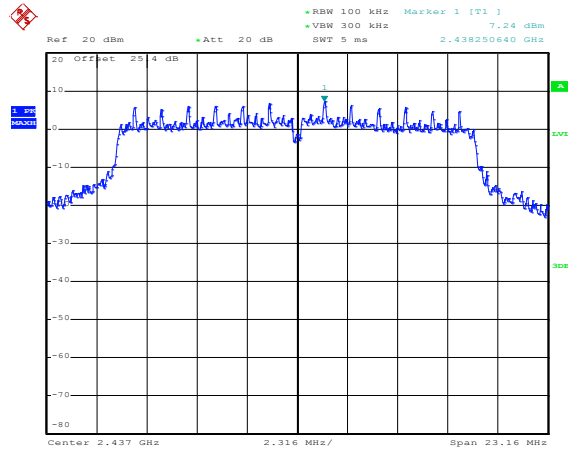

Date: 12.AUG.2018 15:02:08

Spurious Emission 30MHz~3GHz

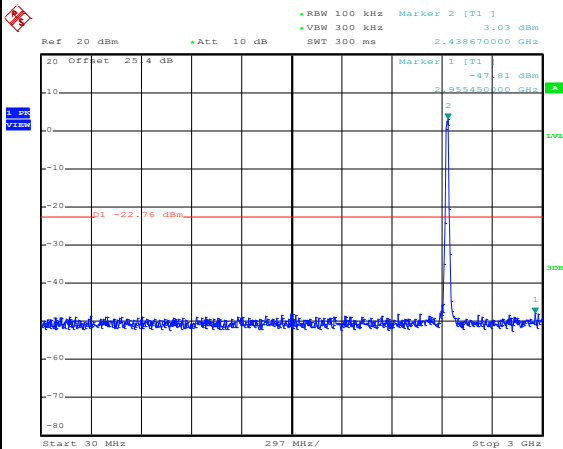

Date: 12.AUG.2018 15:02:22

Spurious Emission 2GHz~25GHz

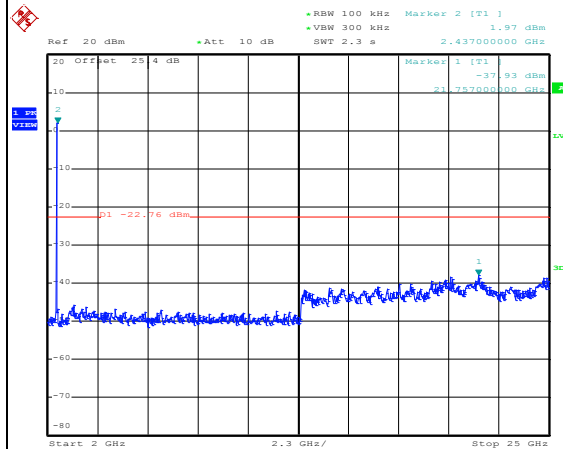

Date: 12.AUG.2018 15:02:31



Test Mode :	802.11g	Test Channel :	11
-------------	---------	----------------	----

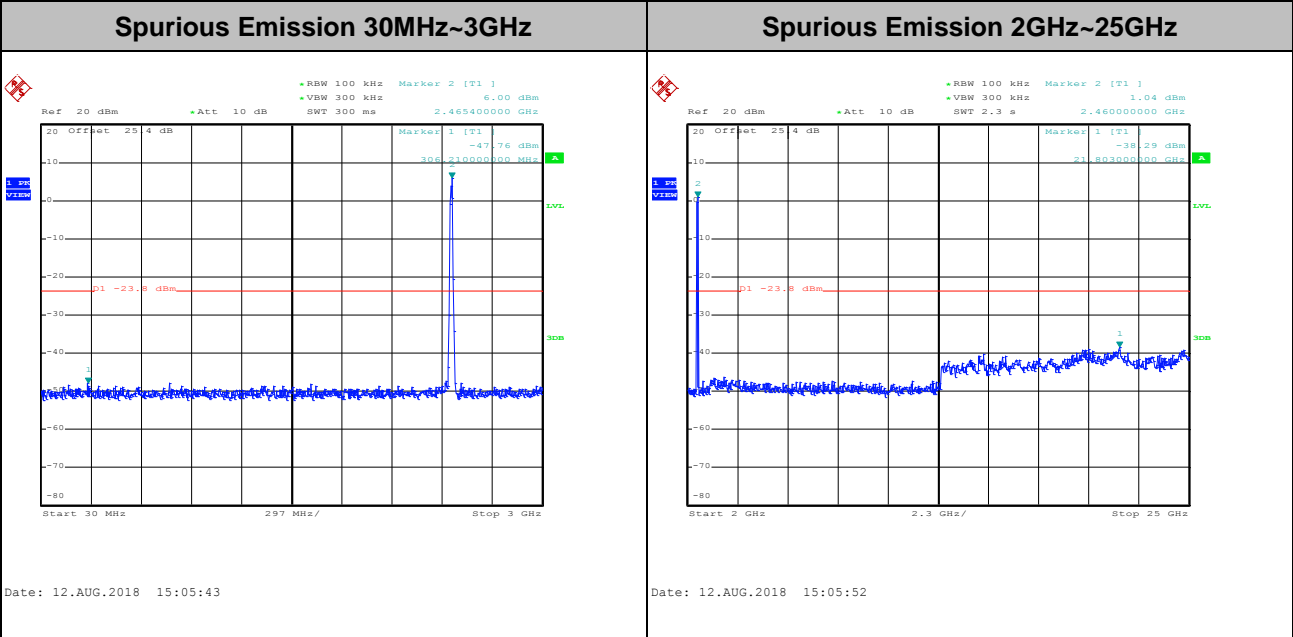
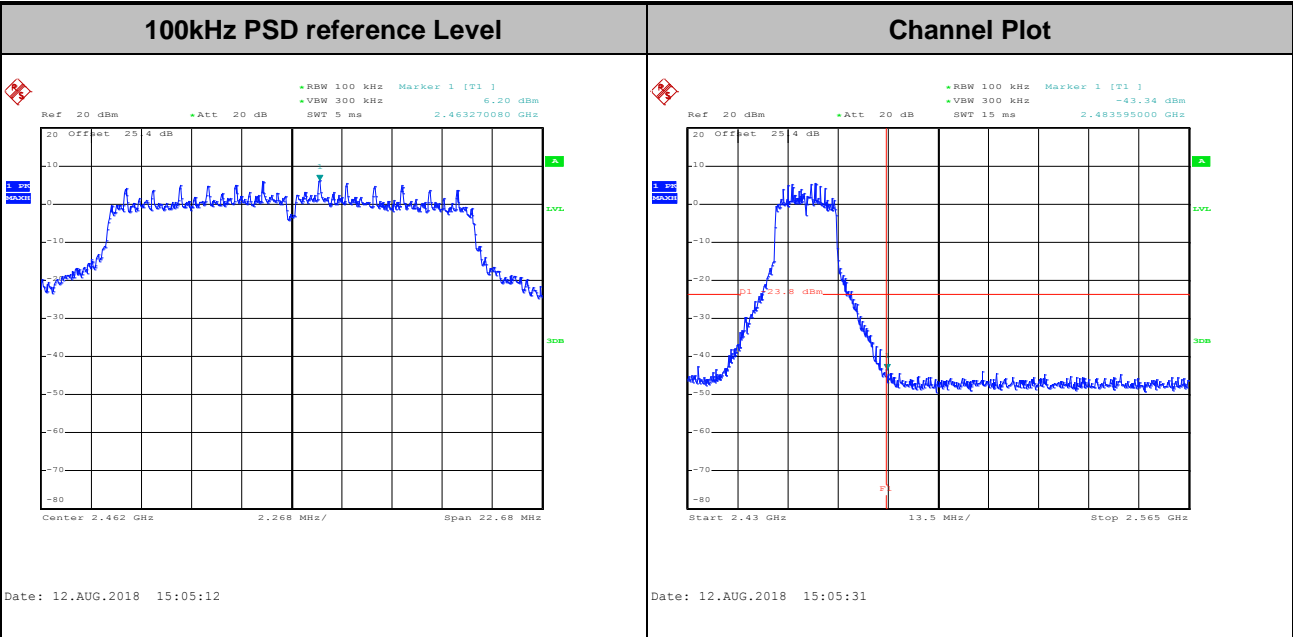



Test Mode :	802.11n HT20	Test Channel :	01
-------------	--------------	----------------	----

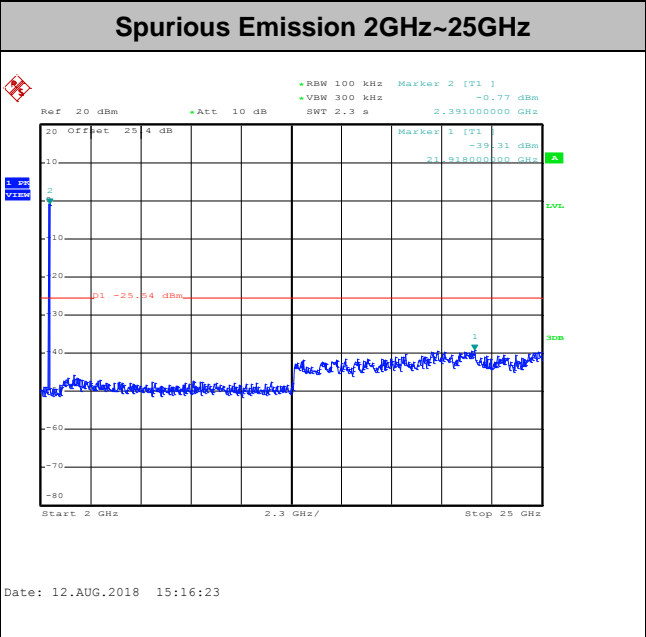
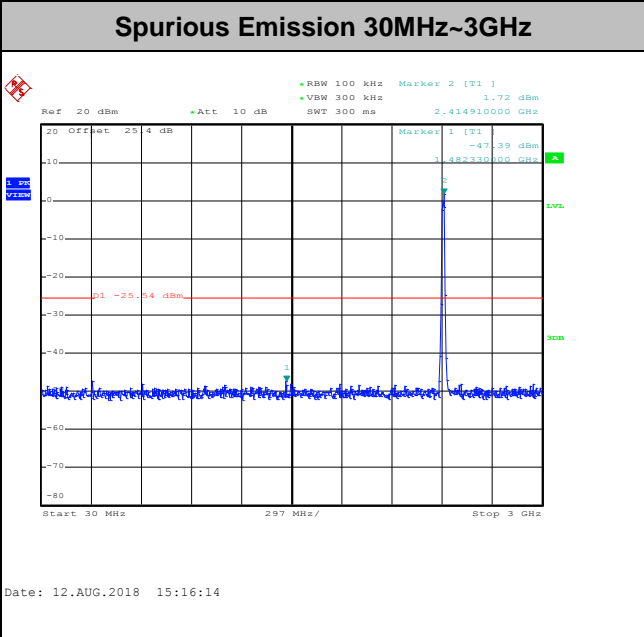
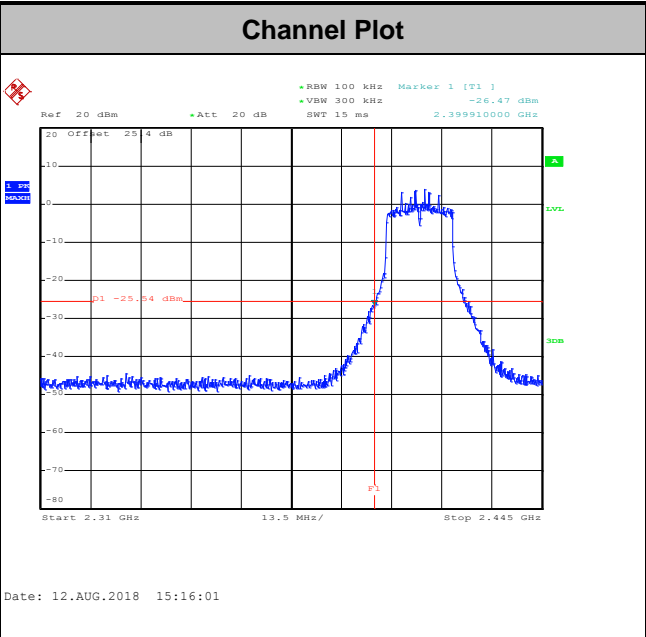
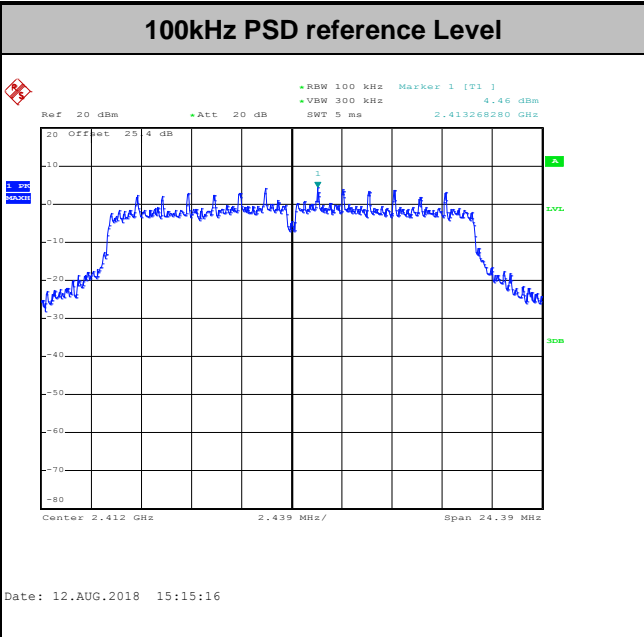



Test Mode :	802.11n HT20	Test Channel :	06
-------------	--------------	----------------	----

100kHz PSD reference Level

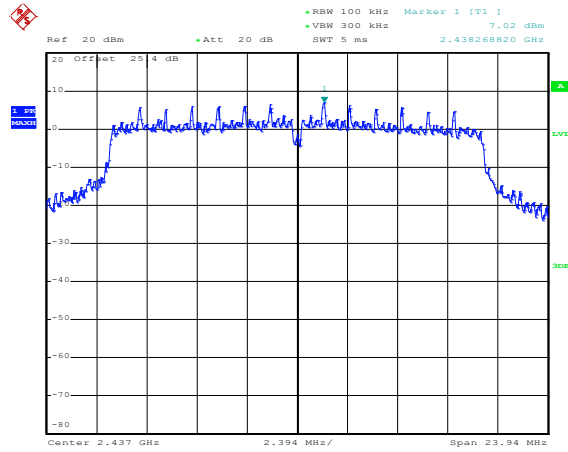

Date: 12.AUG.2018 15:18:10

Spurious Emission 30MHz~3GHz

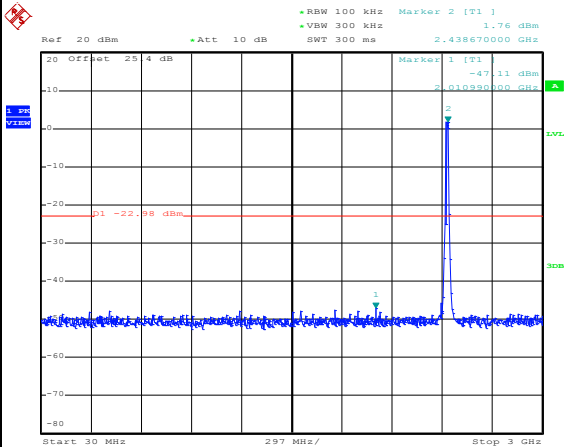

Date: 12.AUG.2018 15:18:47

Spurious Emission 2GHz~25GHz

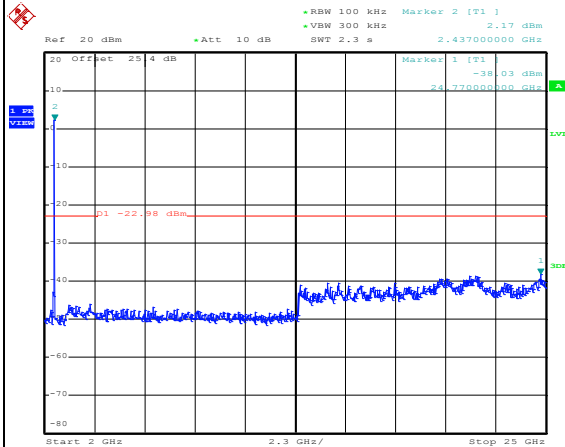

Date: 12.AUG.2018 15:18:56



Test Mode :	802.11n HT20	Test Channel :	11
-------------	--------------	----------------	----

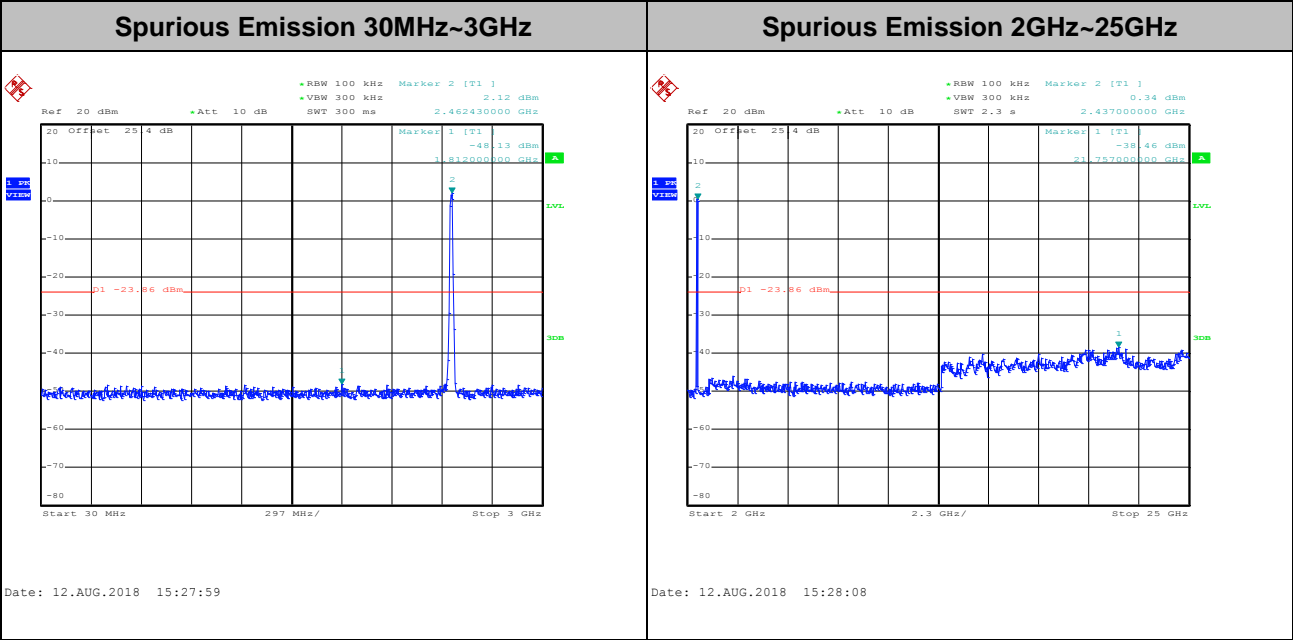
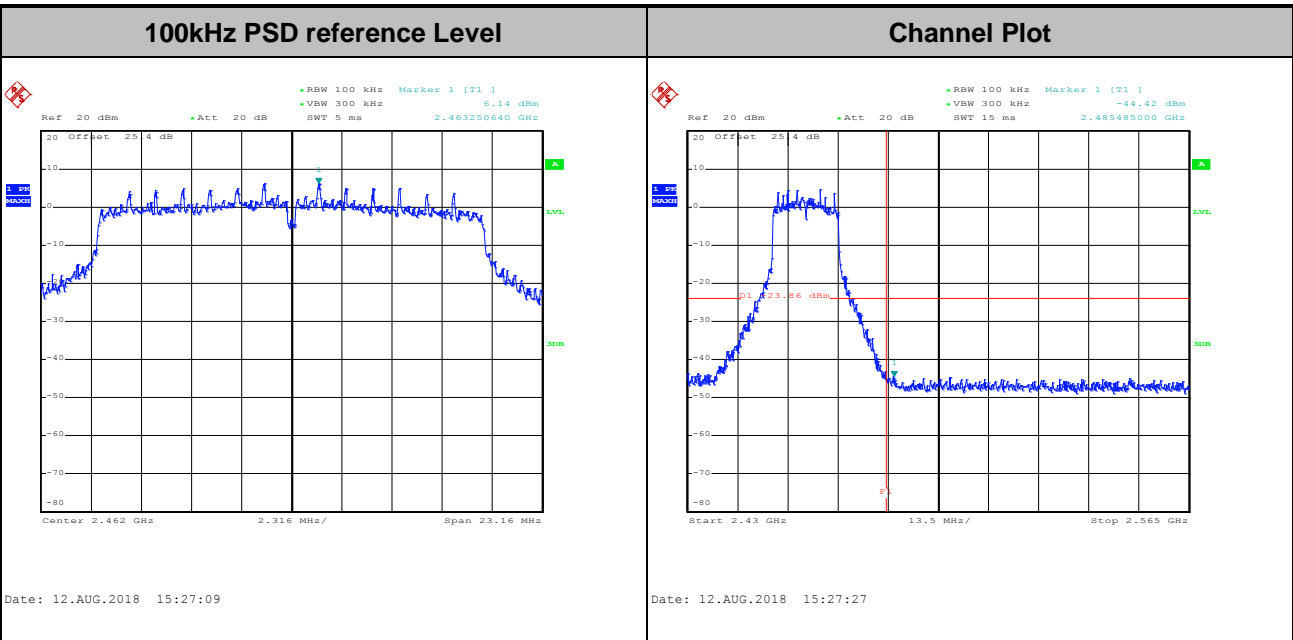



Test Mode :	802.11n HT40	Test Channel :	03
-------------	--------------	----------------	----

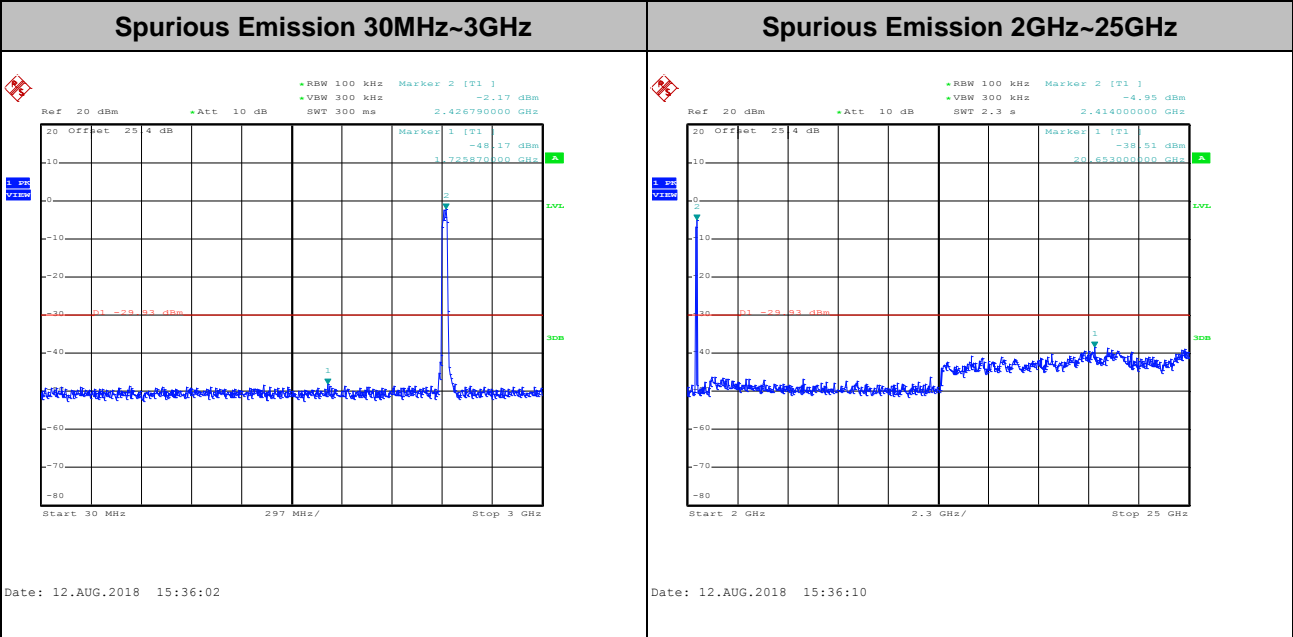
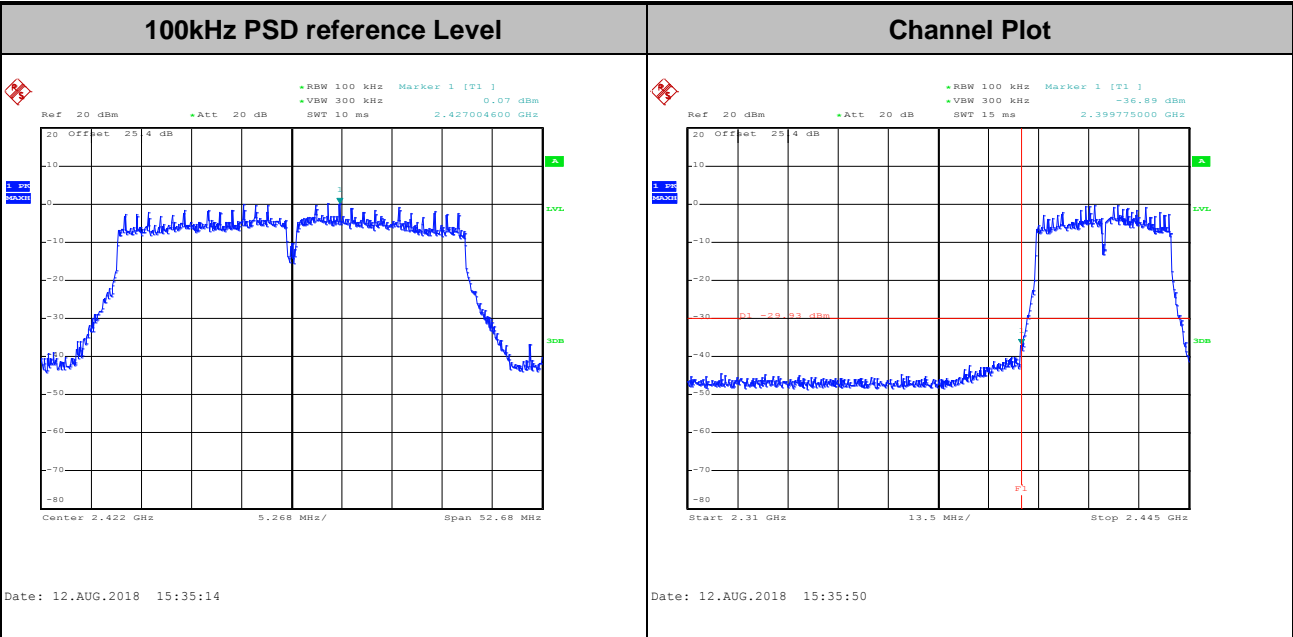



Test Mode :	802.11n HT40	Test Channel :	06
-------------	--------------	----------------	----

100kHz PSD reference Level

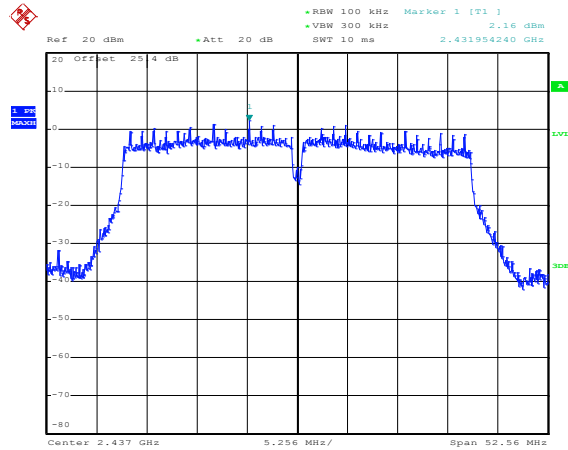

Date: 12.AUG.2018 15:38:15

Spurious Emission 30MHz~3GHz

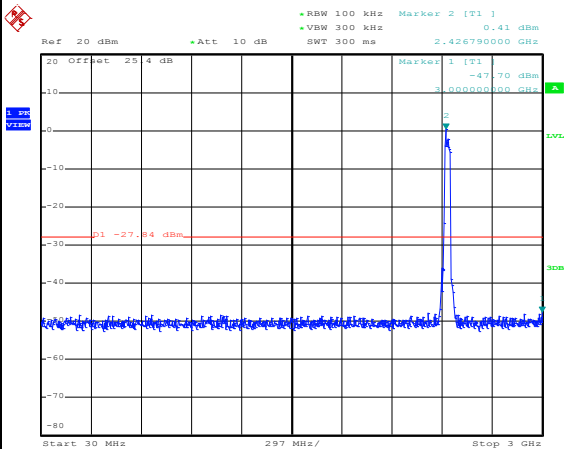

Date: 12.AUG.2018 15:39:31

Spurious Emission 2GHz~25GHz

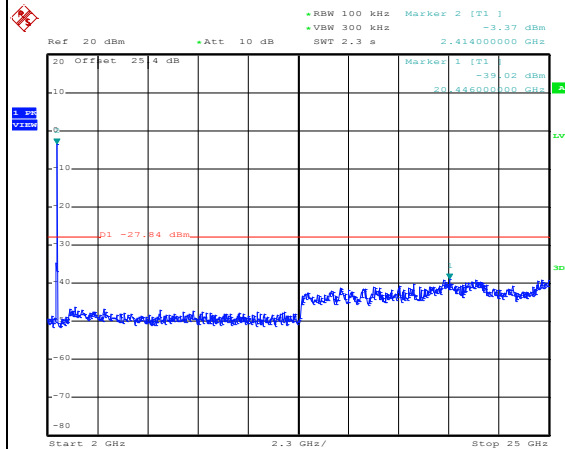

Date: 12.AUG.2018 15:39:40



Test Mode :	802.11n HT40	Test Channel :	09
-------------	--------------	----------------	----

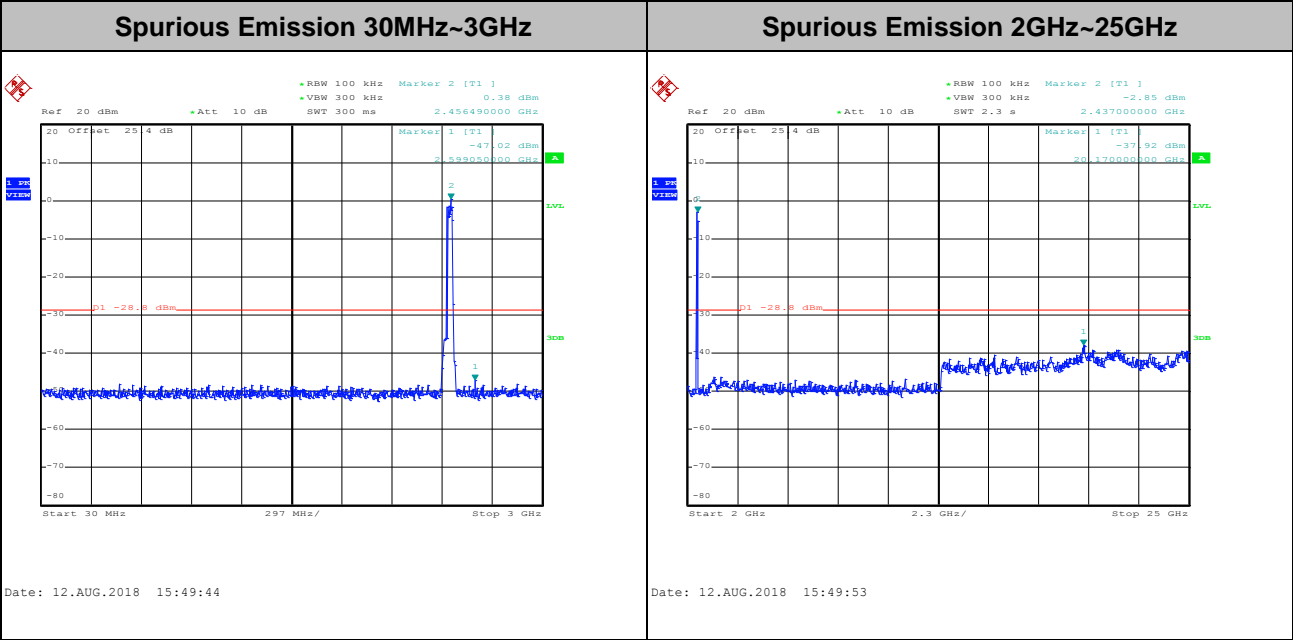
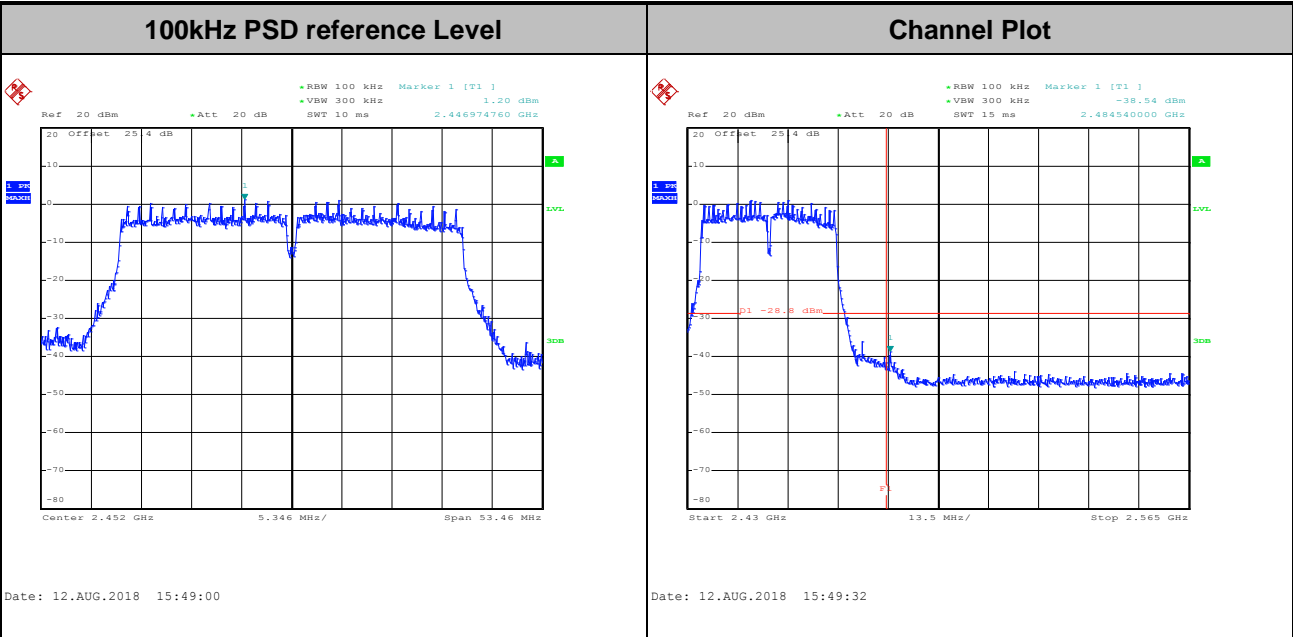



<TXBF Mode>

Number of TX = 2, Ant. 1 (Measured)

Test Mode :	802.11ac VHT20	Test Channel :	01
-------------	----------------	----------------	----

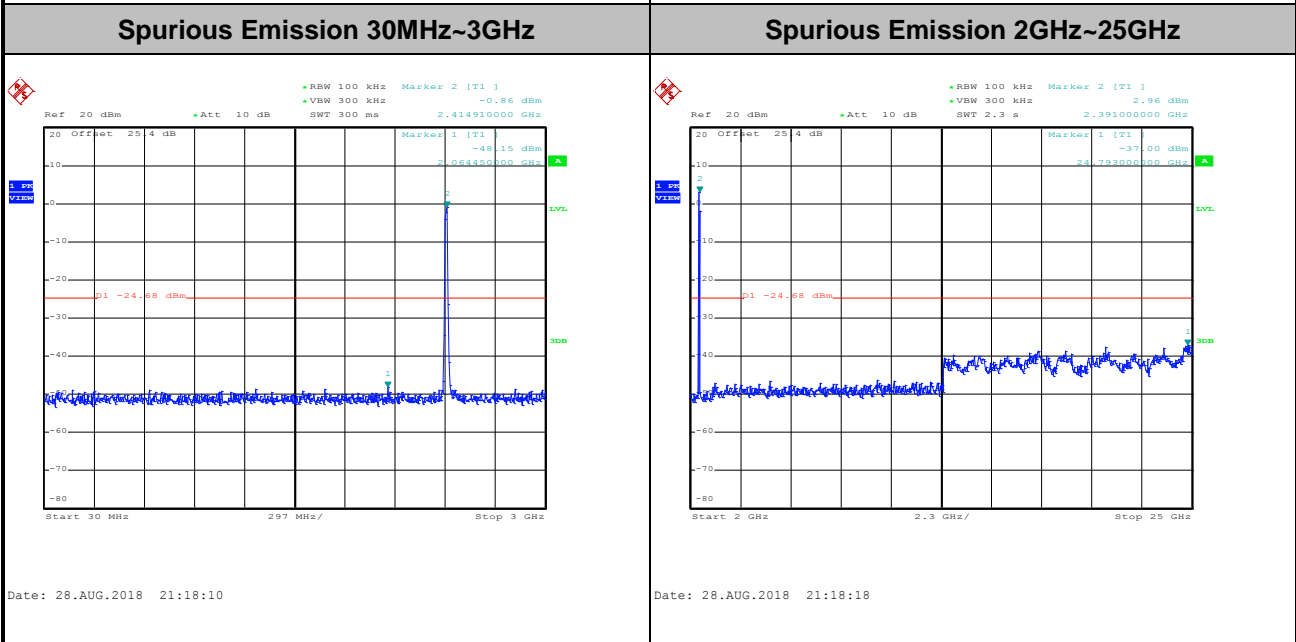
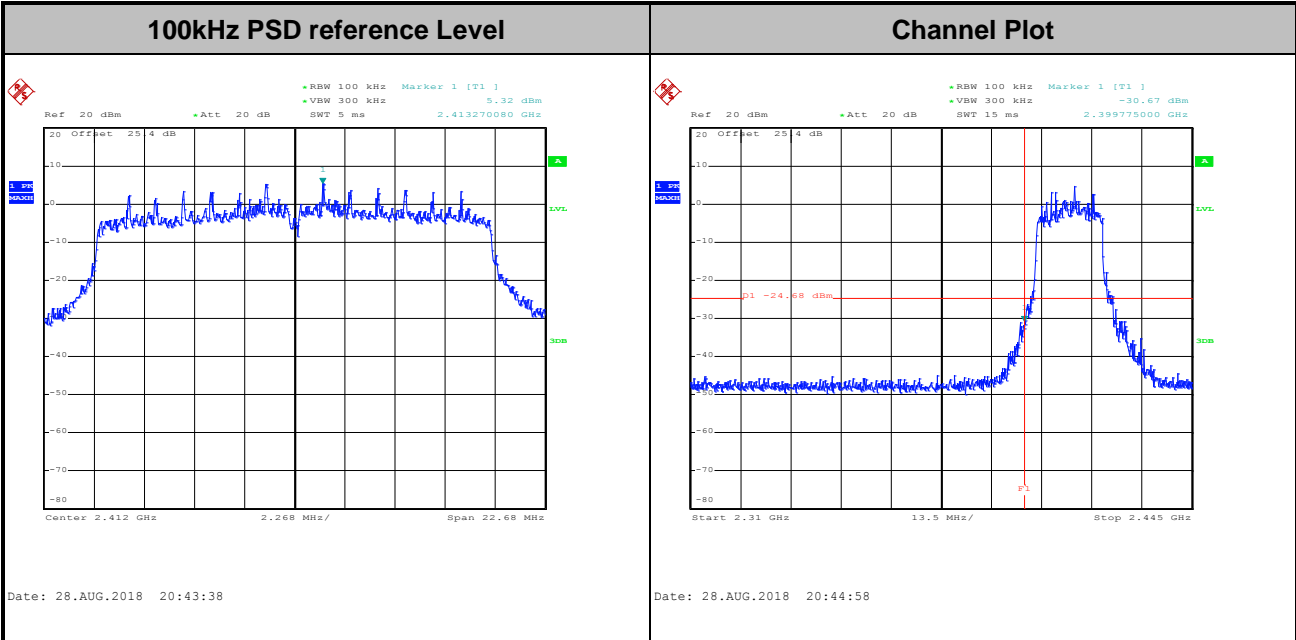



Test Mode :	802.11ac VHT20	Test Channel :	06
-------------	----------------	----------------	----

100kHz PSD reference Level

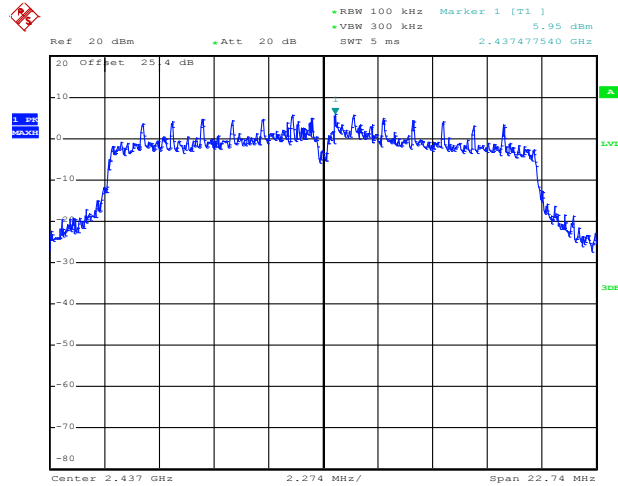

Date: 27.AUG.2018 10:34:35

Spurious Emission 30MHz~3GHz

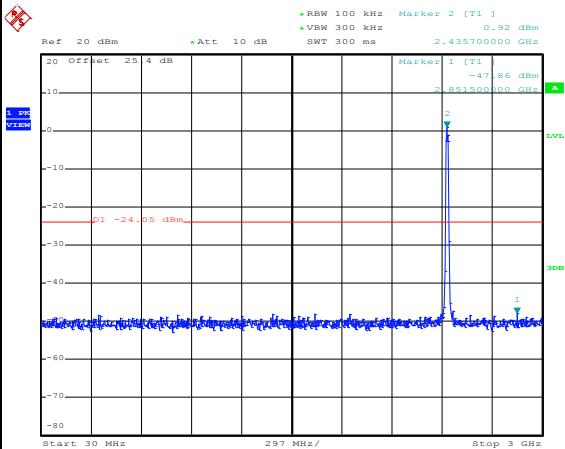

Date: 27.AUG.2018 10:35:37

Spurious Emission 2GHz~25GHz

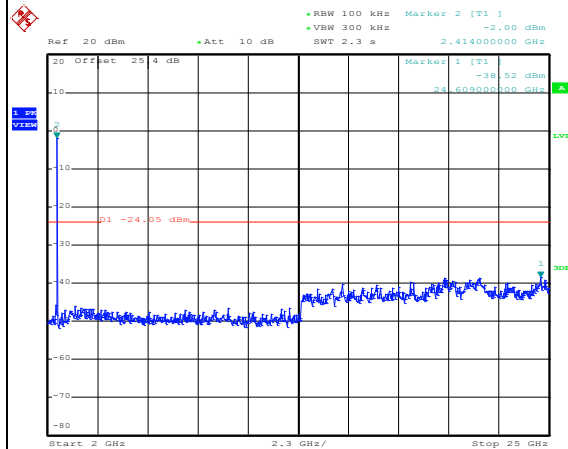

Date: 27.AUG.2018 10:35:46



Test Mode :	802.11ac VHT20	Test Channel :	11
-------------	----------------	----------------	----

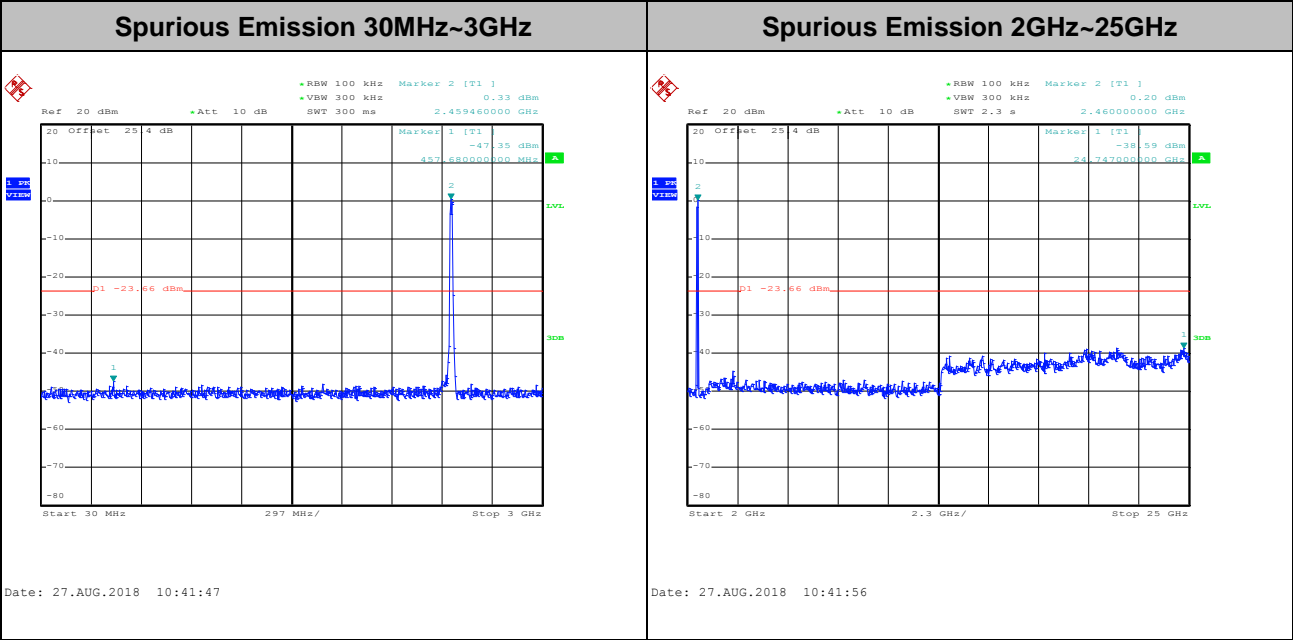
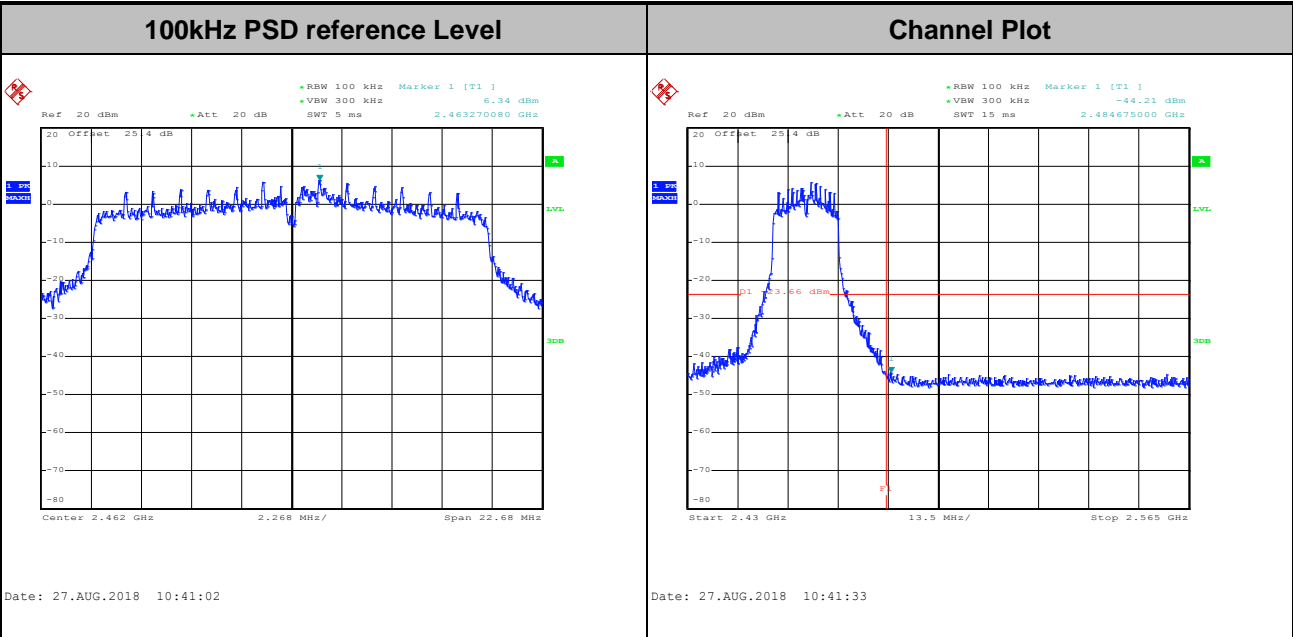



Test Mode : 802.11ac VHT40 Test Channel : 03

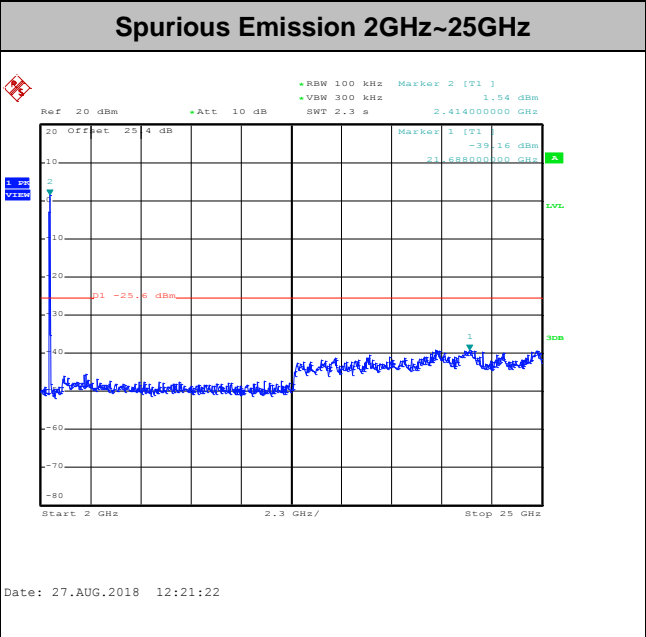
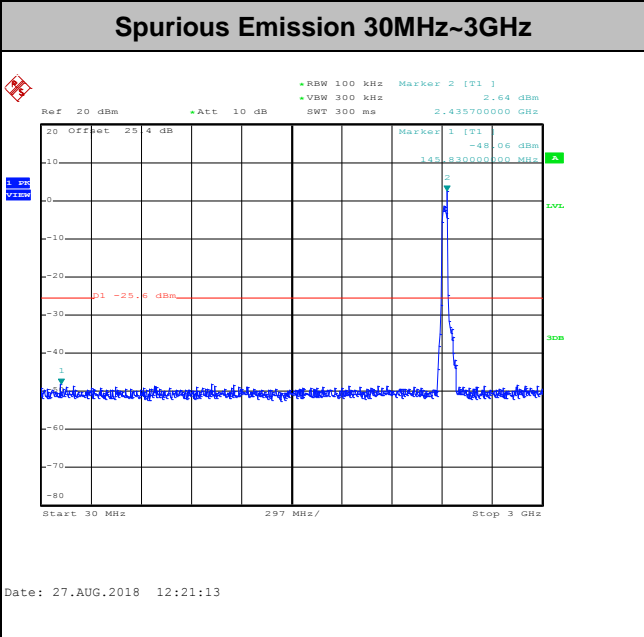
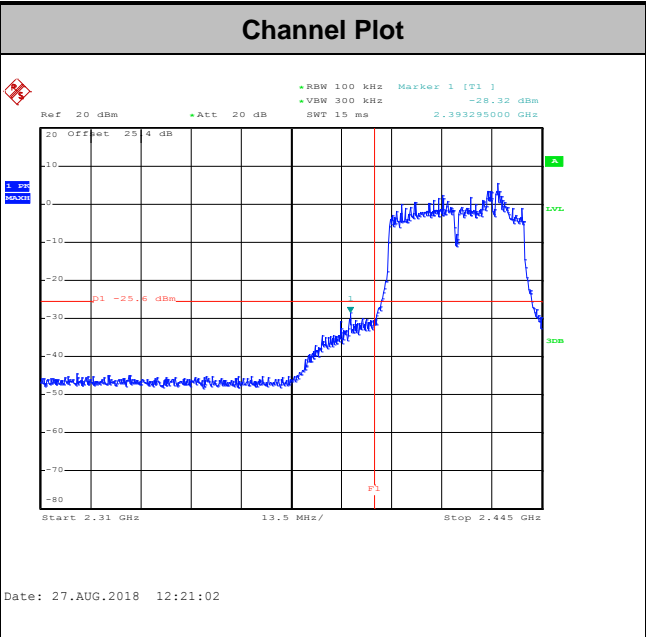
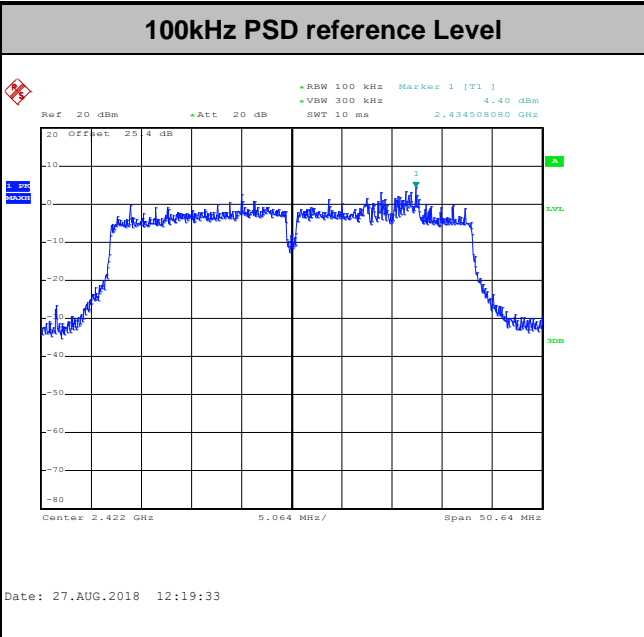



Test Mode :	802.11ac VHT40	Test Channel :	06
-------------	----------------	----------------	----

100kHz PSD reference Level

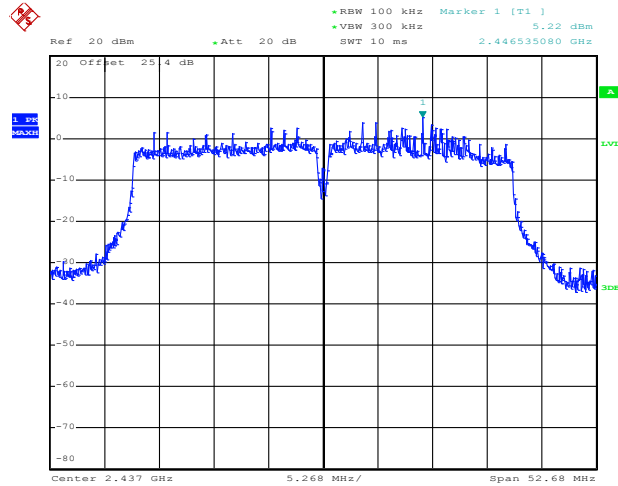

Date: 27.AUG.2018 12:48:25

Spurious Emission 30MHz~3GHz

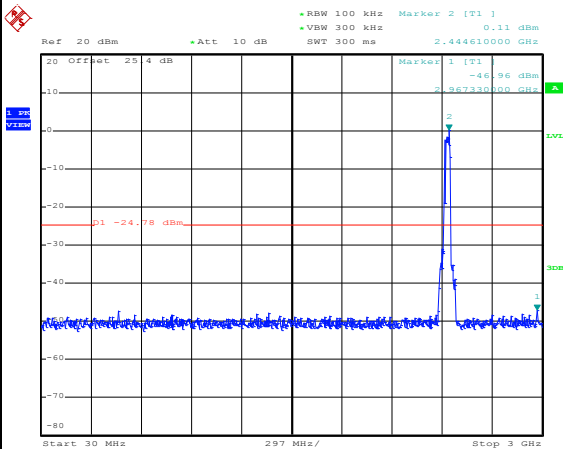

Date: 27.AUG.2018 12:48:40

Spurious Emission 2GHz~25GHz

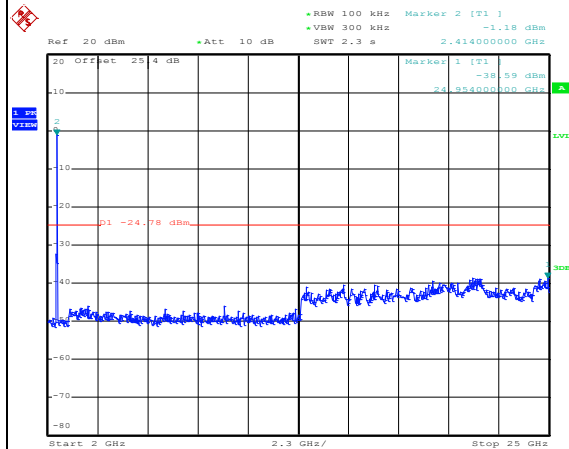

Date: 27.AUG.2018 12:48:48



Test Mode :	802.11ac VHT40	Test Channel :	09
-------------	----------------	----------------	----

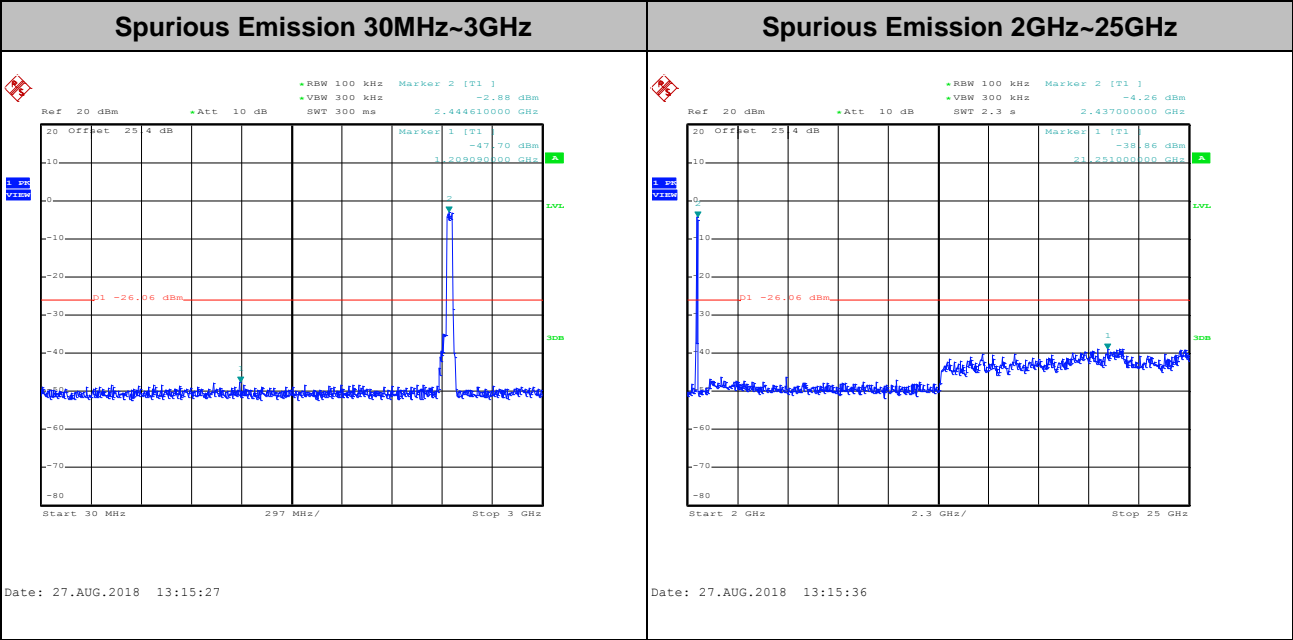
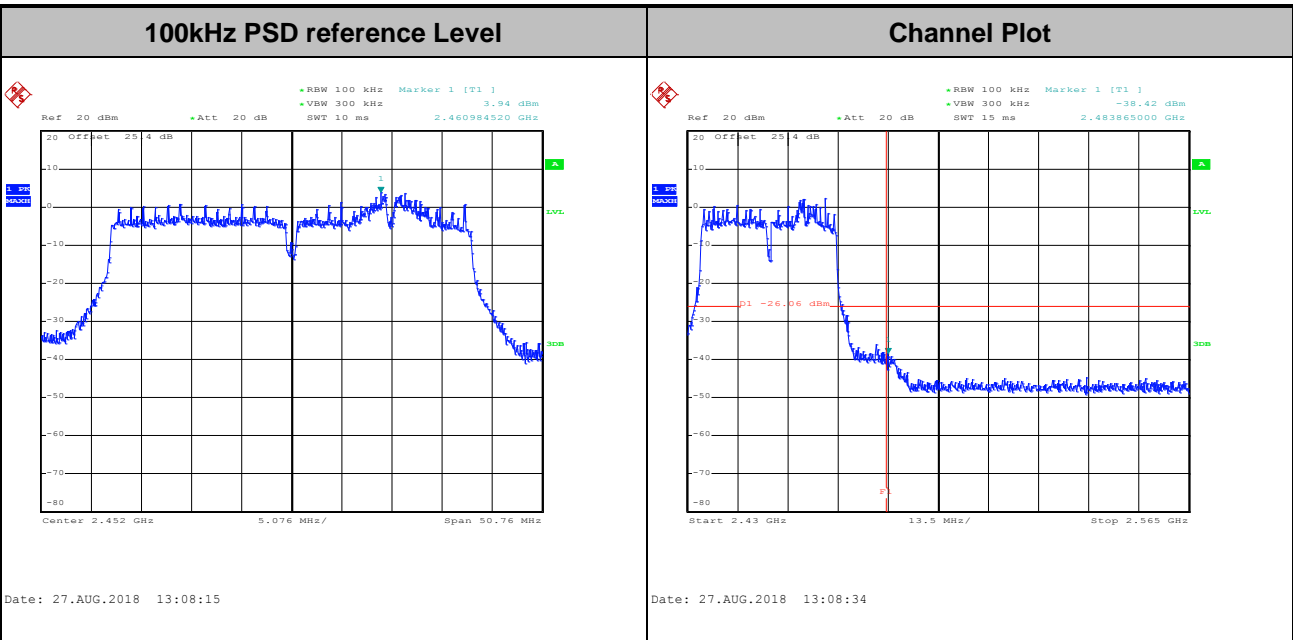



Number of TX = 2, Ant. 2 (Measured)

Test Mode :	802.11ac VHT20	Test Channel :	01
-------------	----------------	----------------	----

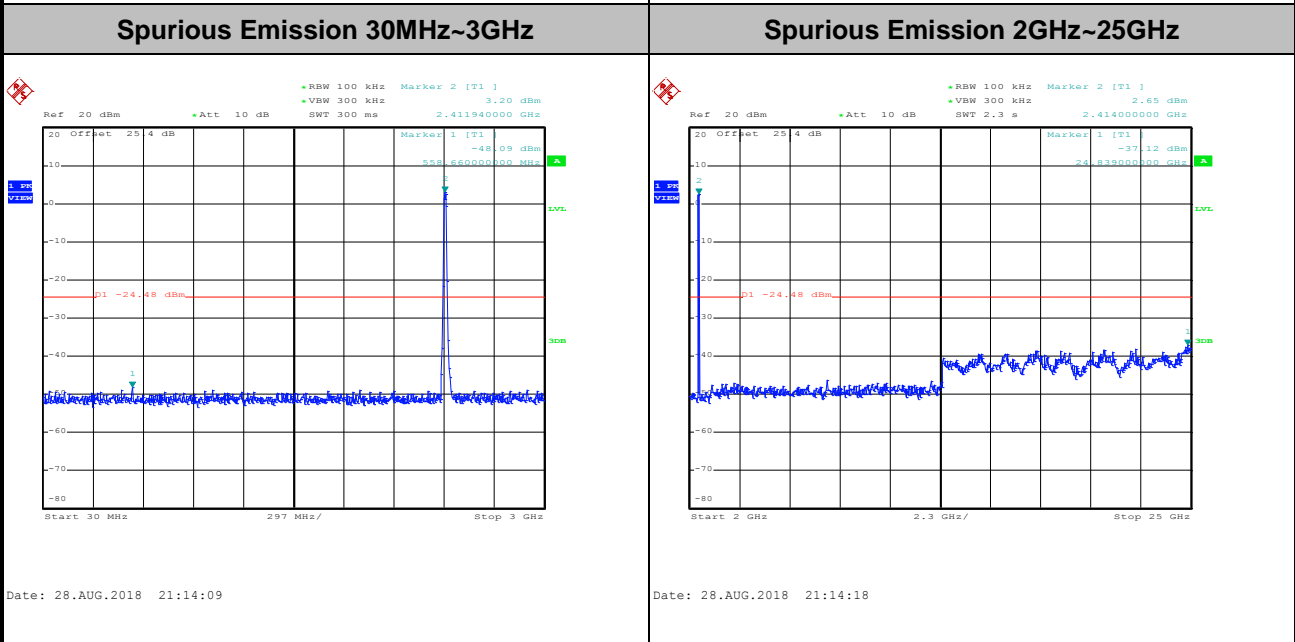
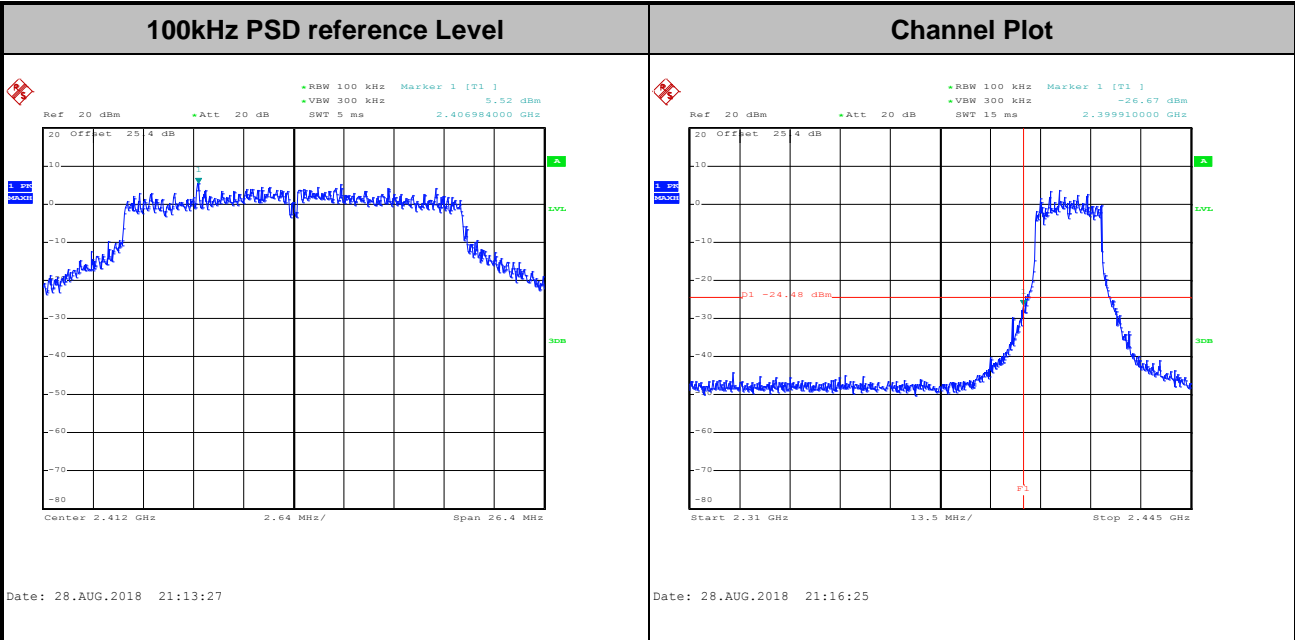



Test Mode :	802.11ac VHT20	Test Channel :	06
-------------	----------------	----------------	----

100kHz PSD reference Level

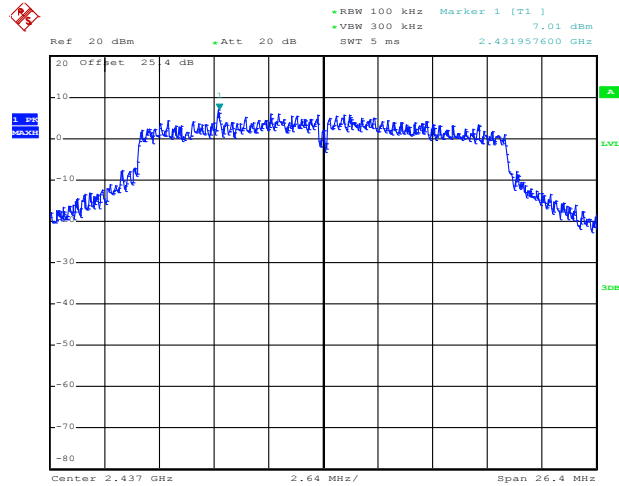

Date: 27.AUG.2018 10:31:49

Spurious Emission 30MHz~3GHz

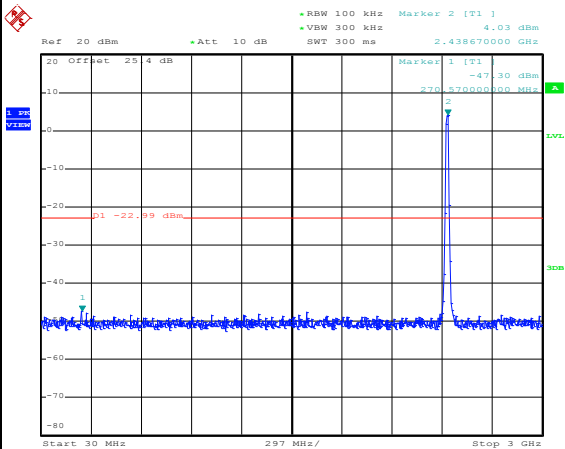

Date: 27.AUG.2018 10:32:02

Spurious Emission 2GHz~25GHz

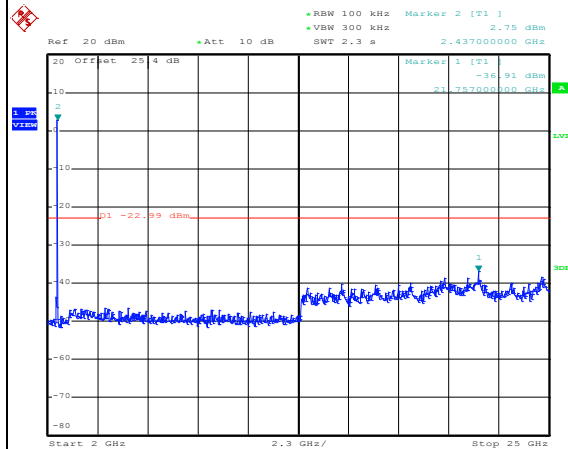

Date: 27.AUG.2018 10:32:11



Test Mode :	802.11ac VHT20	Test Channel :	11
-------------	----------------	----------------	----

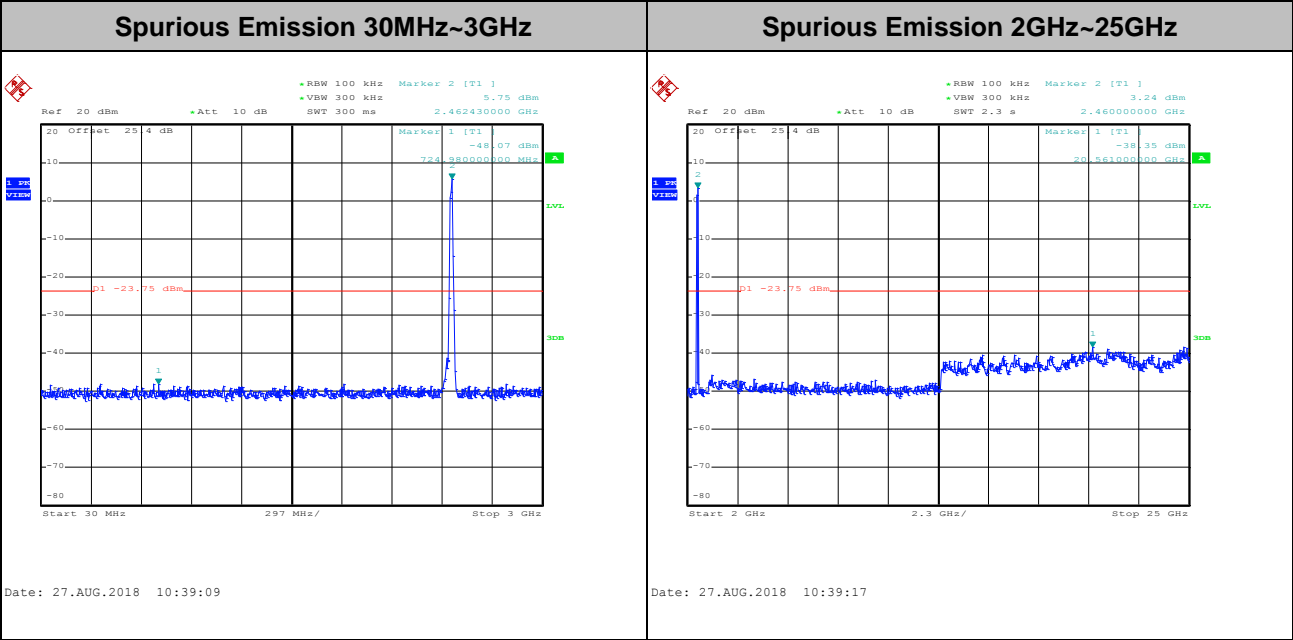
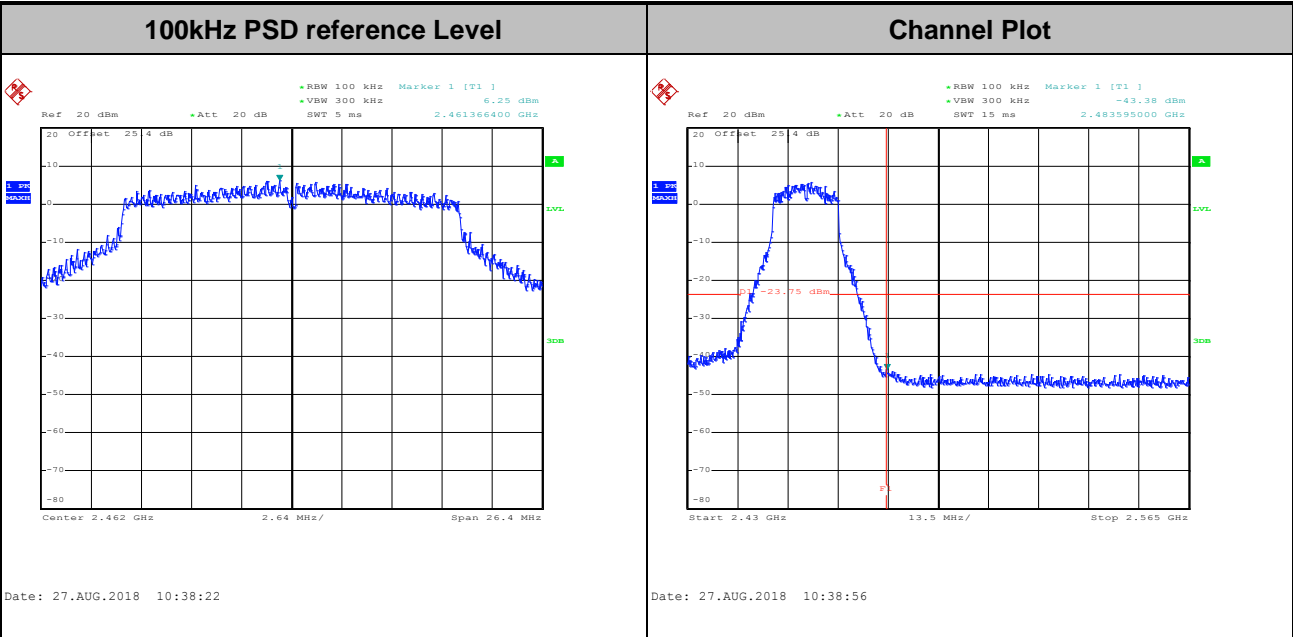



V

Test Mode :	802.11ac VHT40	Test Channel :	03
--------------------	----------------	-----------------------	----

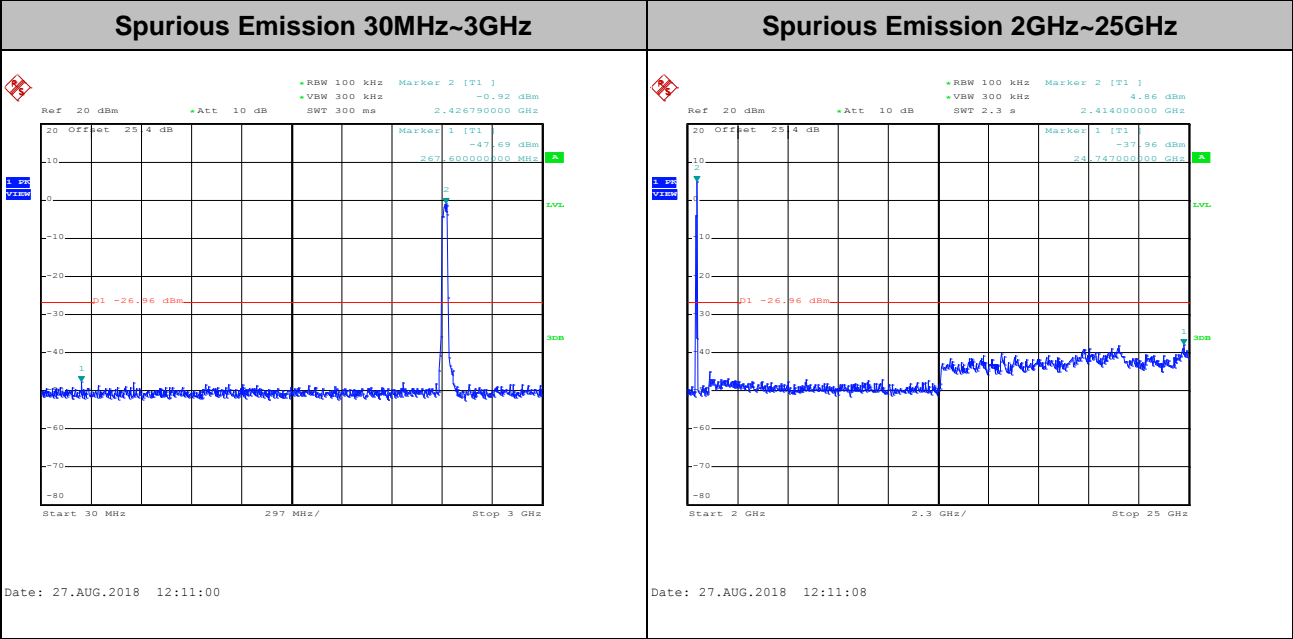
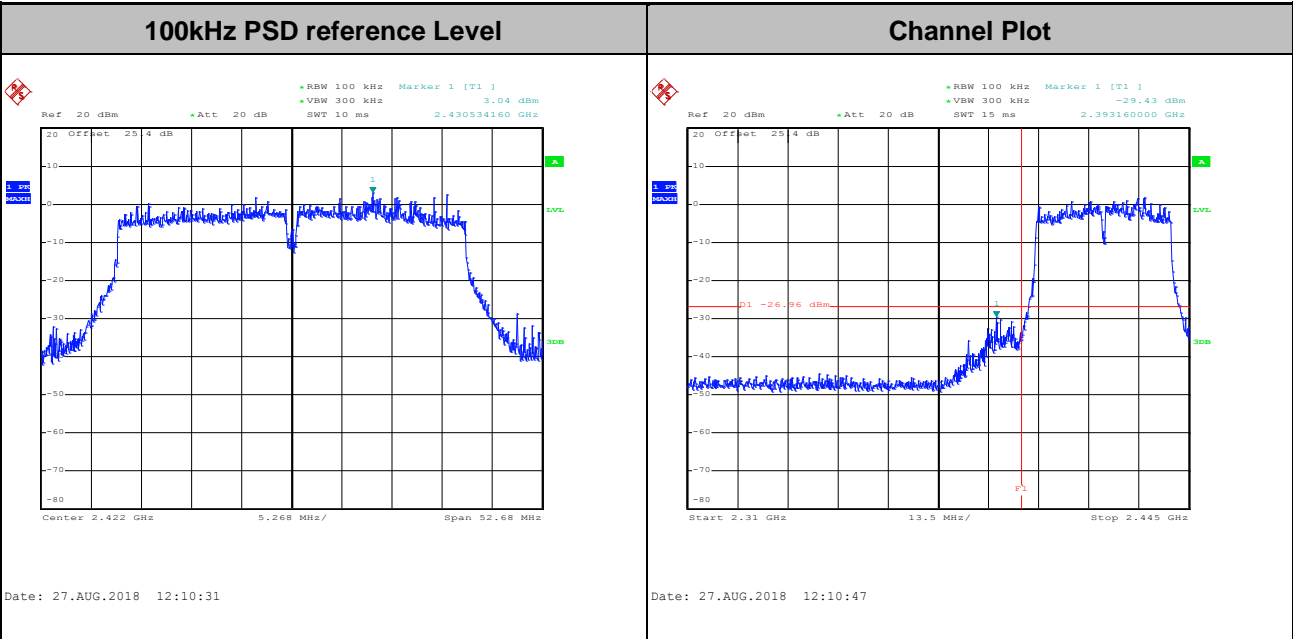



Test Mode :	802.11ac VHT40	Test Channel :	06
-------------	----------------	----------------	----

100kHz PSD reference Level

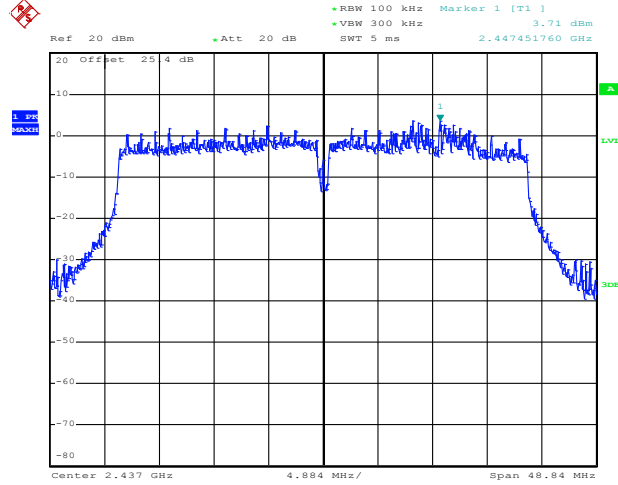

Date: 27.AUG.2018 12:46:49

Spurious Emission 30MHz~3GHz

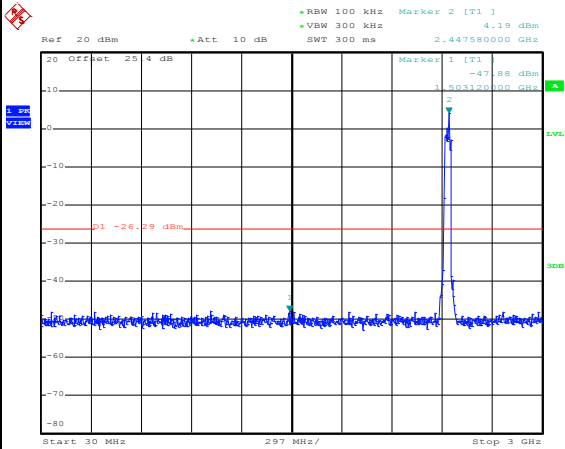

Date: 27.AUG.2018 12:50:14

Spurious Emission 2GHz~25GHz

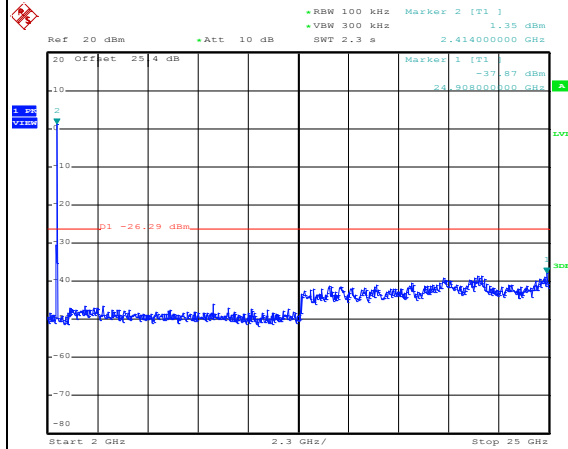

Date: 27.AUG.2018 12:50:22



Test Mode :	802.11ac VHT40	Test Channel :	09
-------------	----------------	----------------	----

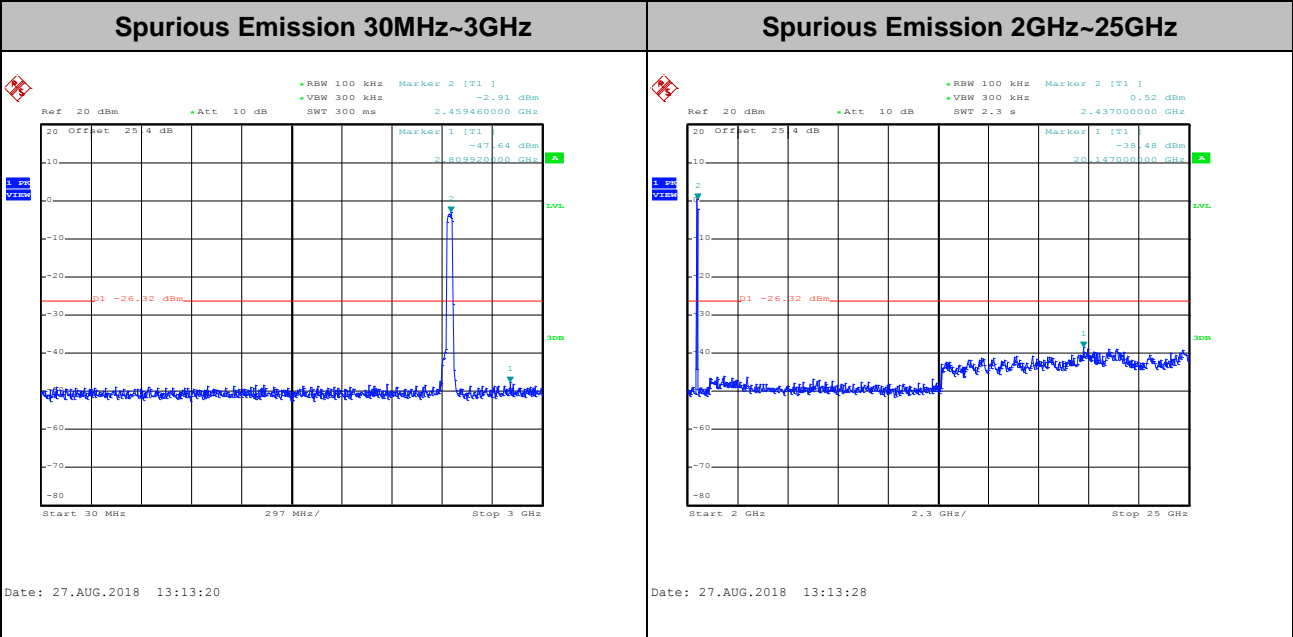
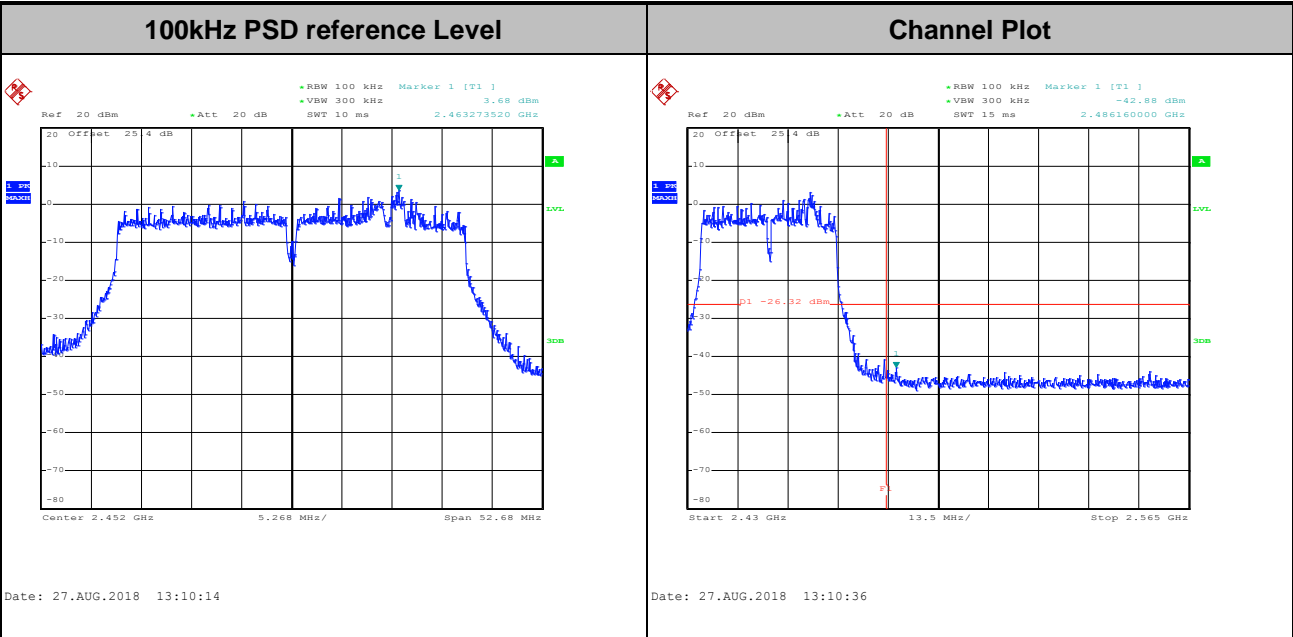



3.5 Radiated Band Edges and Spurious Emission Measurement

3.5.1 Limit of Radiated band edge and Spurious Emission Measurement

In any 100 kHz bandwidth outside the intentional radiator frequency band, all harmonics/spurious must be at least 20 dB below the highest emission level within the authorized band. If the output power of this device was measured by spectrum analyzer, the attenuation under this paragraph shall be 30 dB instead of 20 dB. In addition, radiated emissions which fall in the restricted bands must also comply with the limits as below.

Frequency (MHz)	Field Strength (microvolts/meter)	Measurement Distance (meters)
0.009 – 0.490	2400/F(kHz)	300
0.490 – 1.705	24000/F(kHz)	30
1.705 – 30.0	30	30
30 – 88	100	3
88 – 216	150	3
216 - 960	200	3
Above 960	500	3

3.5.2 Measuring Instruments

See list of measuring equipment of this test report.



3.5.3 Test Procedures

1. The testing follows FCC KDB Publication No. 558074 D01 DTS Meas. Guidance v04.
2. The EUT was arranged to its worst case and then tune the antenna tower (from 1 m to 4 m) and turntable (from 0 degree to 360 degrees) to find the maximum reading. A pre-amp and a high pass filter are used for the test in order to get better signal level.
3. The EUT was placed on a turntable with 0.8 meter for frequency below 1GHz and 1.5 meter for frequency above 1GHz respectively above ground.
4. The EUT was set 3 meters from the interference receiving antenna, which was mounted on the top of a variable height antenna tower.
5. Corrected Reading: Antenna Factor + Cable Loss + Read Level - Preamp Factor = Level
6. For testing below 1GHz, if the emission level of the EUT in peak mode was 3 dB lower than the limit specified, then peak values of EUT will be reported, otherwise, the emissions will be repeated one by one using the CISPR quasi-peak method and reported.
7. For testing above 1GHz, the emission level of the EUT in peak mode was 20dB lower than average limit (that means the emission level in average mode also complies with the limit in average mode), then peak values of EUT will be reported, otherwise, the emissions will be measured in average mode again and reported.
8. Use the following spectrum analyzer settings:
 - (1) Span shall wide enough to fully capture the emission being measured;
 - (2) Set RBW=100 kHz for $f < 1$ GHz; $VBW \geq RBW$; Sweep = auto; Detector function = peak; Trace = max hold;
 - (3) Set RBW = 1 MHz, VBW= 3MHz for $f \geq 1$ GHz for peak measurement.
For average measurement:
 - $VBW = 10$ Hz, when duty cycle is no less than 98 percent.
 - $VBW \geq 1/T$, when duty cycle is less than 98 percent where T is the minimum transmission duration over which the transmitter is on and is transmitting at its maximum power control level for the tested mode of operation.

3.5.4 Test Setup

For radiated emissions below 30MHz

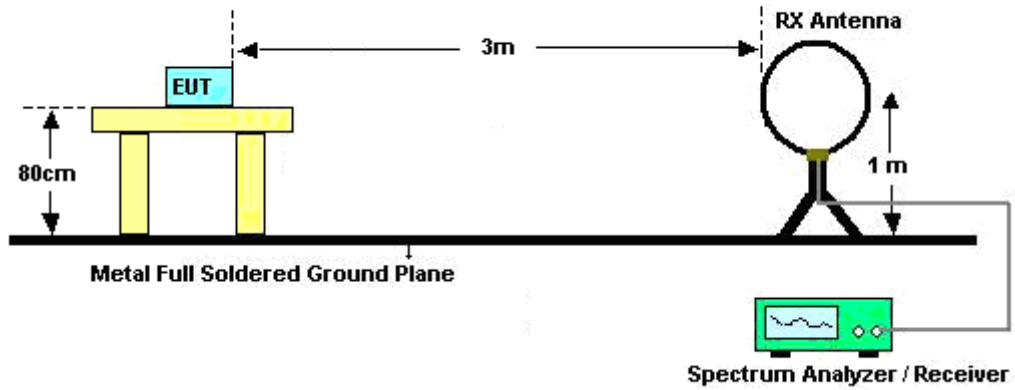

For radiated emissions from 30MHz to 1GHz

<CDD Mode>

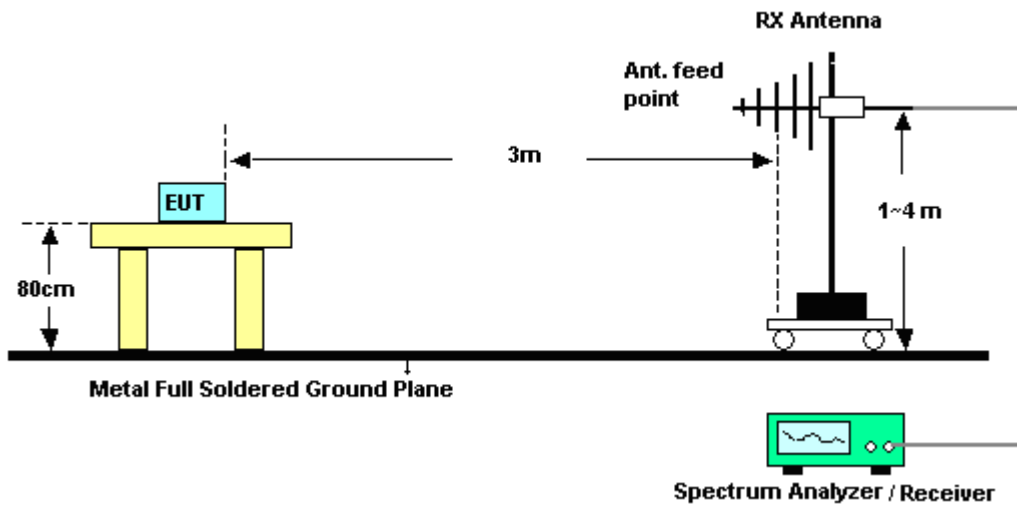

<TXBF Modes>

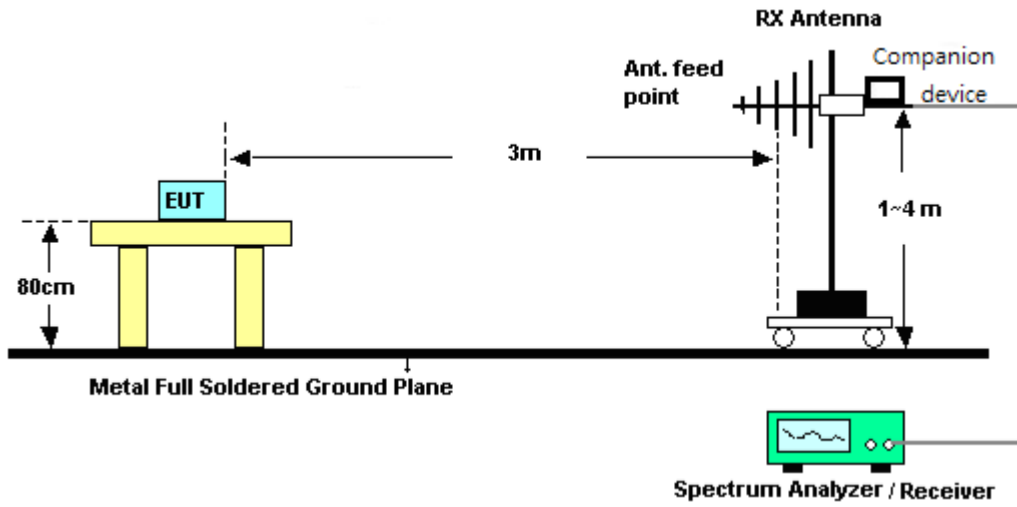

For radiated emissions above 1GHz

<CDD Mode>

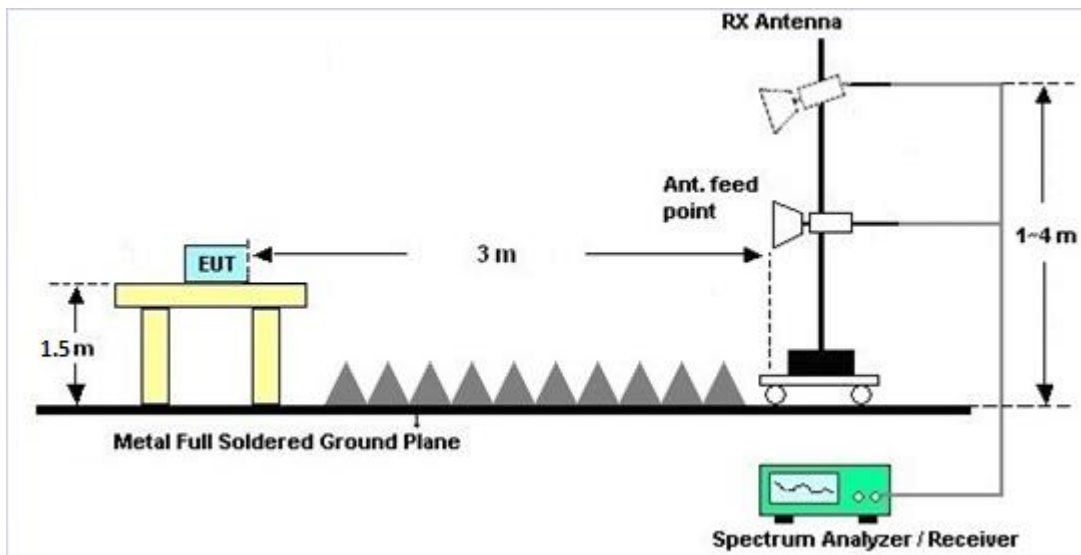

<TXBF Modes>

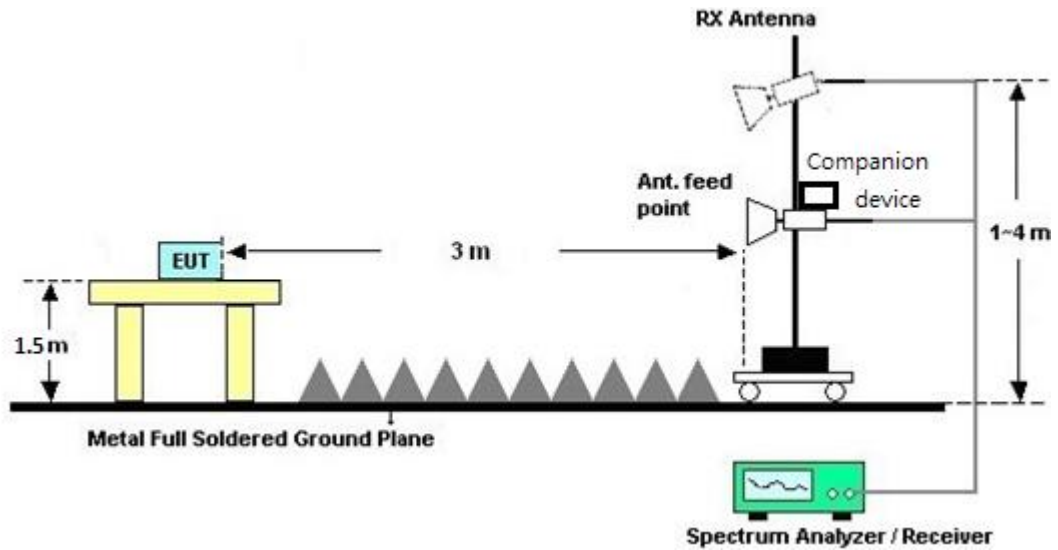

3.5.5 Test Results of Radiated Spurious Emissions (9kHz ~ 30MHz)

The low frequency, which started from 9 kHz to 30MHz, was pre-scanned and the result which was 20dB lower than the limit line was not reported.

There is a comparison data of both open-field test site and semi-Anechoic chamber, and the result came out very similar.

3.5.6 Test Result of Radiated Spurious at Band Edges

Please refer to Appendix B and C.

3.5.7 Duty Cycle

Please refer to Appendix D.

3.5.8 Test Result of Radiated Spurious Emission (30MHz ~ 10th Harmonic)

Please refer to Appendix B and C.



3.6 AC Conducted Emission Measurement

3.6.1 Limit of AC Conducted Emission

For equipment that is designed to be connected to the public utility (AC) power line, the radio frequency voltage that is conducted back onto the AC power line on any frequency or frequencies within the band 150 kHz to 30 MHz shall not exceed the limits in the following table.

Frequency of Emission (MHz)	Conducted Limit (dBµV)	
	Quasi-Peak	Average
0.15-0.5	66 to 56*	56 to 46*
0.5-5	56	46
5-30	60	50

*Decreases with the logarithm of the frequency.

3.6.2 Measuring Instruments

See list of measuring equipment of this test report.

3.6.3 Test Procedures

1. The EUT was placed 0.4 meter from the conducting wall of the shielding room, and it was kept at least 80 centimeters from any other grounded conducting surface.
2. Connect EUT to the power mains through a line impedance stabilization network (LISN).
3. All the support units are connecting to the other LISN.
4. The LISN provides 50 ohm coupling impedance for the measuring instrument.
5. The FCC states that a 50 ohm, 50 microhenry LISN should be used.
6. Both sides of AC line were checked for maximum conducted interference.
7. The frequency range from 150 kHz to 30 MHz was searched.
8. Set the test-receiver system to Peak Detect Function and specified bandwidth (IF bandwidth = 9kHz) with Maximum Hold Mode.

3.6.4 Test Setup

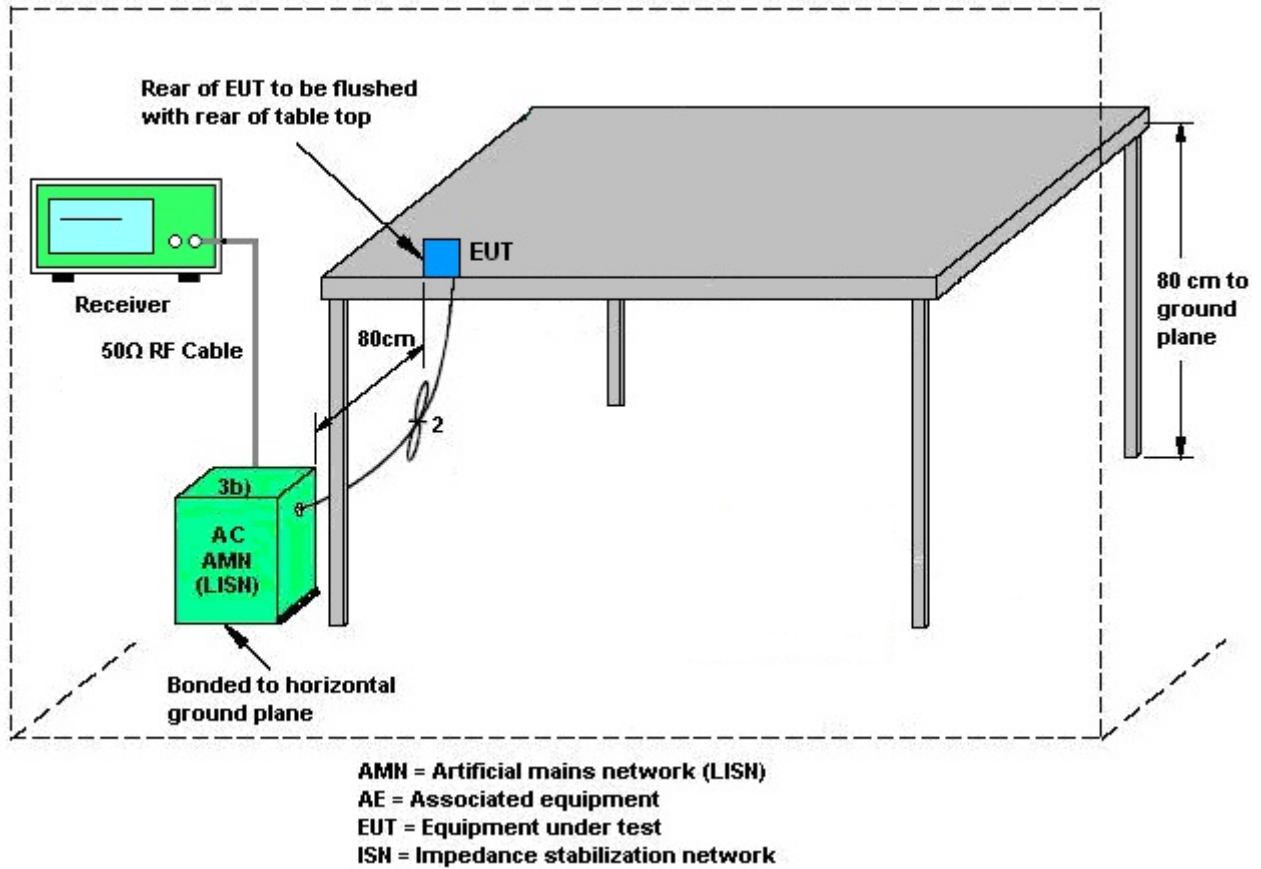

3.6.5 Test Result of AC Conducted Emission

Please refer to Appendix A.



3.7 Antenna Requirements

3.7.1 Standard Applicable

If directional gain of transmitting Antennas is greater than 6dBi, the power shall be reduced by the same level in dB comparing to gain minus 6dBi. The use of a permanently attached Antenna or of an Antenna that uses a unique coupling to the intentional radiator shall be considered sufficient to comply with the rule.

3.7.2 Antenna Anti-Replacement Construction

An embedded-in antenna design is used.

3.7.3 Antenna Gain

<CDD Modes >

FCC KDB 662911 D01 Multiple Transmitter Output v02r01

For CDD transmissions, directional gain is calculated as

Directional gain = G_{ANT} + Array Gain, where Array Gain is as follows.

For power spectral density (PSD) measurements on all devices,

Array Gain = $10 \log(N_{ANT}/N_{SS}=1)$ dB.

For power measurements on IEEE 802.11 devices,

Array Gain = 0 dB (i.e., no array gain) for $N_{ANT} \leq 4$.

Directional gain may be calculated by using the formulas applicable to equal gain antennas with G_{ANT} set equal to the gain of the antenna having the highest gain;

The EUT supports CDD mode.

For power, the directional gain G_{ANT} is set equal to the antenna having the highest gain, i.e., F)2)f)i).

For PSD, the directional gain calculation is following F)2)f)ii) of KDB 662911 D01 v02r01.

The power and PSD limit should be modified if the directional gain of EUT is over 6 dBi,

The directional gain "DG" is calculated as following table.

<CDD Modes>						
			DG for Power (dBi)	DG for PSD (dBi)	Power Limit Reduction (dB)	PSD Limit Reduction (dB)
	Ant. 1 (dBi)	Ant. 2 (dBi)				
2.4 GHz	2.80	2.30	2.80	5.56	0.00	0.00

$Power\ Limit\ Reduction = DG(Power) - 6dBi, (min = 0)$

$PSD\ Limit\ Reduction = DG(PSD) - 6dBi, (min = 0)$



TXBF modes

FCC KDB 662911 D01 Multiple Transmitter Output v02r01

For CDD transmissions, directional gain is calculated as

$$DirectionalGain = 10 \cdot \log \left[\frac{\sum_{j=1}^{N_{SS}} \left\{ \sum_{k=1}^{N_{ANT}} g_{j,k} \right\}^2}{N_{ANT}} \right]$$

where

Each antenna is driven by no more than one spatial stream;

N_{SS} = the number of independent spatial streams of data;

N_{ANT} = the total number of antennas

$g_{j,k} = 10^{G_k / 20}$ if the k th antenna is being fed by spatial stream j , or zero if it is not;
 G_k is the gain in dBi of the k th antenna.

The EUT supports beamforming for 802.11ac modes.

The directional gain calculation is following F)2)e)ii) of KDB 662911 D01 v02r01.

The power and PSD limit should be modified if the directional gain of EUT is over 6 dBi,

The directional gain “DG” is calculated as following table.

			DG for Power (dBi)	DG for PSD (dBi)	Power Limit Reduction (dB)	PSD Limit Reduction (dB)
	Ant. 1 (dBi)	Ant. 2 (dBi)				
2.4 GHz	2.80	2.30	5.56	5.56	0.00	0.00

Power Limit Reduction = DG(Power) – 6dBi, (min = 0)

PSD Limit Reduction = DG(PSD) – 6dBi, (min = 0)



4 List of Measuring Equipment

Instrument	Manufacturer	Model No.	Serial No.	Characteristics	Calibration Date	Test Date	Due Date	Remark
Power Meter	Anritsu	ML2495A	1240001	N/A	Sep. 07, 2017	Jul. 10, 2018~ Aug. 29, 2018	Sep. 06, 2018	Conducted (TH05-HY)
Power Sensor	Anritsu	MA2411B	1207349	300MHz~40GHz	Sep. 07, 2017	Jul. 10, 2018~ Aug. 29, 2018	Sep. 06, 2018	Conducted (TH05-HY)
Spectrum Analyzer	Rohde & Schwarz	FSP40	100057	9kHz~40GHz	Nov. 21, 2017	Jul. 10, 2018~ Aug. 29, 2018	Nov. 20, 2018	Conducted (TH05-HY)
Signal Analyzer	Rohde & Schwarz	FSV40	101397	10Hz~40GHz	Nov. 09, 2017	Jul. 10, 2018~ Aug. 29, 2018	Nov. 08, 2018	Conducted (TH05-HY)
Switch Box & RF Cable	Burgeon	ETF-058	EC130048 4	N/A	Mar. 01, 2018	Jul. 10, 2018~ Aug. 29, 2018	Feb. 28, 2019	Conducted (TH05-HY)
AC Power Source	ChainTek	APC-1000W	N/A	N/A	N/A	Jul. 17, 2018	N/A	Conduction (CO05-HY)
EMI Test Receiver	Rohde & Schwarz	ESR3	102388	3.6GHz	Dec. 08, 2017	Jul. 17, 2018	Dec. 07, 2018	Conduction (CO05-HY)
LISN	Rohde & Schwarz	ENV216	100080	9kHz~30MHz	Nov. 30, 2017	Jul. 17, 2018	Nov. 29, 2018	Conduction (CO05-HY)
Software	Rohde & Schwarz	EMC32 V10.30	N/A	N/A	N/A	Jul. 17, 2018	N/A	Conduction (CO05-HY)
LF Cable	HUBER + SUHNER	RG-214/U	LF01	N/A	Jan. 03, 2018	Jul. 17, 2018	Jan. 02, 2019	Conduction (CO05-HY)
Pulse Limiter	Rohde & Schwarz	ESH3-Z2	100851	N/A	Jan. 03, 2018	Jul. 17, 2018	Jan. 02, 2019	Conduction (CO05-HY)



Instrument	Manufacturer	Model No.	Serial No.	Characteristics	Calibration Date	Test Date	Due Date	Remark
Loop Antenna	Rohde & Schwarz	HFH2-Z2	100488	9 kHz~30 MHz	Nov. 23, 2017	Aug. 02, 2018~ Aug. 27, 2018	Nov. 22, 2018	Radiation (03CH12-HY)
Bilog Antenna	TESEQ	CBL 6111D&00800 N1D01N-06	37059&01	30MHz~1GHz	Oct. 14, 2017	Aug. 02, 2018~ Aug. 27, 2018	Oct. 13, 2018	Radiation (03CH12-HY)
Horn Antenna	SCHWARZBE CK	BBHA 9120D	9120D-132 8	1GHz ~ 18GHz	Oct. 20, 2017	Aug. 02, 2018~ Aug. 27, 2018	Oct. 19, 2018	Radiation (03CH12-HY)
SHF-EHF Horn Antenna	SCHWARZBE CK	BBHA 9170	BBHA9170 584	18GHz ~ 40GHz	Nov. 27, 2017	Aug. 02, 2018~ Aug. 27, 2018	Nov. 26, 2018	Radiation (03CH12-HY)
Preamplifier	COM-POWER	PA-103	161075	10MHz~1GHz	Mar. 26, 2018	Aug. 02, 2018~ Aug. 27, 2018	Mar. 25, 2019	Radiation (03CH12-HY)
Preamplifier	Keysight	83017A	MY532701 48	1GHz~26.5GHz	Jan. 15, 2018	Aug. 02, 2018~ Aug. 27, 2018	Jan. 14, 2019	Radiation (03CH12-HY)
Preamplifier	MITEQ	AMF-7D-0010 1800-30-10P	1590074	1GHz~18GHz	May 21, 2018	Aug. 02, 2018~ Aug. 27, 2018	May 20, 2019	Radiation (03CH12-HY)
Preamplifier	EMEC	EM18G40G	060715	18GHz ~ 40GHz	Dec. 05, 2017	Aug. 02, 2018~ Aug. 27, 2018	Dec. 04, 2018	Radiation (03CH12-HY)
EMI Test Receiver	Rohde & Schwarz	ESU26	100390	20Hz~26.5GHz	Dec. 25, 2017	Aug. 02, 2018~ Aug. 27, 2018	Dec. 24, 2018	Radiation (03CH12-HY)
Filter	Wainwright	WHKX12-270 0-3000-18000 -60ST	SN2	3 GHz Highpass	Mar. 21, 2018	Aug. 02, 2018~ Aug. 27, 2018	Mar. 20, 2019	Radiation (03CH12-HY)
Filter	Wainwright	WLJ4-1000-1 530-6000-40S T	SN3	1.53 GHz Lowpass	Mar. 21, 2018	Aug. 02, 2018~ Aug. 27, 2018	Mar. 20, 2019	Radiation (03CH12-HY)
RF Cable	HUBER + SUHNER	SUCOFLEX 104	MY15539/ 4	30M-18G	Mar. 14, 2018	Aug. 02, 2018~ Aug. 27, 2018	Mar. 13, 2019	Radiation (03CH12-HY)
RF Cable	HUBER + SUHNER	SUCOFLEX 102	505134/2	30M~40GHz	Oct. 17, 2017	Aug. 02, 2018~ Aug. 27, 2018	Oct. 16, 2018	Radiation (03CH12-HY)
RF Cable	HUBER + SUHNER	SUCOFLEX 102	800740/2	30M~40GHz	Oct. 17, 2017	Aug. 02, 2018~ Aug. 27, 2018	Oct. 16, 2018	Radiation (03CH12-HY)
Antenna Mast	EMEC	AM-BS-4500- B	N/A	1m~4m	N/A	Aug. 02, 2018~ Aug. 27, 2018	N/A	Radiation (03CH12-HY)
Turn Table	EMEC	TT2000	N/A	0~360 Degree	N/A	Aug. 02, 2018~ Aug. 27, 2018	N/A	Radiation (03CH12-HY)
Software	Audix	E3 6.2009-8-24	RK-00098 9	N/A	N/A	Aug. 02, 2018~ Aug. 27, 2018	N/A	Radiation (03CH12-HY)



5 Uncertainty of Evaluation

Uncertainty of Conducted Emission Measurement (150kHz ~ 30MHz)

Measuring Uncertainty for a Level of Confidence of 95% ($U = 2Uc(y)$)	2.7
---	-----

Uncertainty of Radiated Emission Measurement (30 MHz ~ 1000 MHz)

Measuring Uncertainty for a Level of Confidence of 95% ($U = 2Uc(y)$)	5.1
---	-----

Uncertainty of Radiated Emission Measurement (1000 MHz ~ 18000 MHz)

Measuring Uncertainty for a Level of Confidence of 95% ($U = 2Uc(y)$)	5.2
---	-----

Uncertainty of Radiated Emission Measurement (18000 MHz ~ 40000 MHz)

Measuring Uncertainty for a Level of Confidence of 95% ($U = 2Uc(y)$)	4.7
---	-----



Appendix A. AC Conducted Emission Test Results

Test Engineer :	Kai-Chun Chu	Temperature :	25~27°C
		Relative Humidity :	50~52%

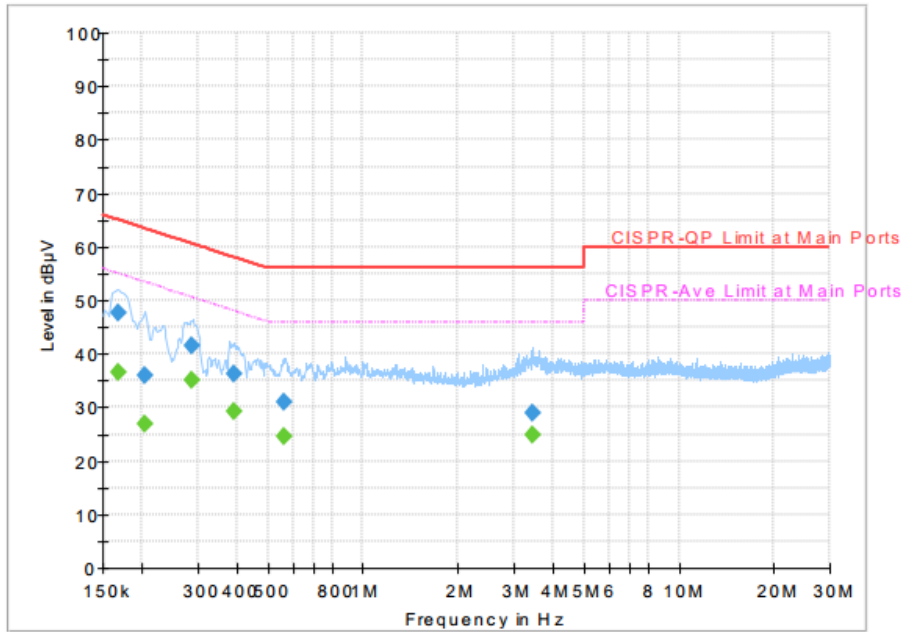

Final Result

Frequency (MHz)	QuasiPeak (dBµV)	CAverage (dBµV)	Limit (dBµV)	Margin (dB)	Line	Filter	Corr. (dB)
0.168000	---	36.58	55.06	18.48	L1	OFF	19.5
0.168000	47.63	---	65.06	17.43	L1	OFF	19.5
0.204000	---	26.76	53.45	26.69	L1	OFF	19.5
0.204000	35.98	---	63.45	27.47	L1	OFF	19.5
0.287250	---	35.00	50.60	15.60	L1	OFF	19.5
0.287250	41.39	---	60.60	19.21	L1	OFF	19.5
0.390750	---	29.15	48.05	18.90	L1	OFF	19.5
0.390750	36.24	---	58.05	21.81	L1	OFF	19.5
0.559500	---	24.60	46.00	21.40	L1	OFF	19.5
0.559500	30.90	---	56.00	25.10	L1	OFF	19.5
3.432750	---	24.87	46.00	21.13	L1	OFF	19.7
3.432750	28.92	---	56.00	27.08	L1	OFF	19.7