



# FCC RADIO TEST REPORT

**FCC ID** : UZ7TC210K  
**Equipment** : Touch computer  
**Brand Name** : Zebra  
**Model Name** : TC210K  
**Applicant** : Zebra Technologies Corporation  
1 Zebra Plaza, Holtsville, NY 11742  
**Manufacturer** : Zebra Technologies Corporation  
1 Zebra Plaza, Holtsville, NY 11742  
**Standard** : FCC Part 15 Subpart E §15.407

The product was received on Jan. 20, 2020 and testing was started from Jan. 22, 2020 and completed on Feb. 28, 2020. We, SPORTON INTERNATIONAL INC., EMC & Wireless Communications Laboratory, would like to declare that the tested sample has been evaluated in accordance with the test procedures and has been in compliance with the applicable technical standards.

The report must not be used by the client to claim product certification, approval, or endorsement by TAF or any agency of government.

The test results in this report apply exclusively to the tested model / sample. Without written approval of SPORTON INTERNATIONAL INC. EMC & Wireless Communications Laboratory, the test report shall not be reproduced except in full.

*Louis Wu*

Approved by: Louis Wu

**SPORTON INTERNATIONAL INC. EMC & Wireless Communications Laboratory**  
No. 52, Huaya 1st Rd., Guishan Dist., Taoyuan City, Taiwan (R.O.C.)



## Table of Contents

History of this test report.....	3
Summary of Test Result.....	4
<b>1 General Description .....</b>	<b>5</b>
1.1 Product Feature of Equipment Under Test.....	5
1.2 Product Specification of Equipment Under Test.....	6
1.3 Modification of EUT .....	6
1.4 Testing Location .....	7
1.5 Applicable Standards.....	7
<b>2 Test Configuration of Equipment Under Test .....</b>	<b>8</b>
2.1 Carrier Frequency and Channel .....	8
2.2 Test Mode.....	9
2.3 Connection Diagram of Test System.....	14
2.4 Support Unit used in test configuration and system .....	15
2.5 EUT Operation Test Setup .....	15
2.6 Measurement Results Explanation Example.....	15
<b>3 Test Result .....</b>	<b>16</b>
3.1 26dB & 99% Occupied Bandwidth Measurement .....	16
3.2 Maximum Conducted Output Power Measurement .....	20
3.3 Power Spectral Density Measurement .....	25
3.4 Unwanted Emissions Measurement.....	30
3.5 AC Conducted Emission Measurement.....	35
3.6 Automatically Discontinue Transmission .....	37
3.7 Antenna Requirements .....	38
<b>4 List of Measuring Equipment.....</b>	<b>39</b>
<b>5 Uncertainty of Evaluation .....</b>	<b>41</b>
<b>Appendix A. AC Conducted Emission Test Result</b>	
<b>Appendix B. Radiated Spurious Emission</b>	
<b>Appendix C. Radiated Spurious Emission Plots</b>	
<b>Appendix D. Duty Cycle Plots</b>	
<b>Appendix E. Setup Photographs</b>	





## Summary of Test Result

Report Clause	Ref Std. Clause	Test Items	Result (PASS/FAIL)	Remark
3.1	15.403(i)	26dB Bandwidth	Pass	-
3.1	2.1049	99% Occupied Bandwidth	Reporting only	-
3.2	15.407(a)	Maximum Conducted Output Power	Pass	-
3.3	15.407(a)	Power Spectral Density	Pass	-
3.4	15.407(b)	Unwanted Emissions	Pass	Under limit 1.45 dB at 5350.08 MHz
3.5	15.207	AC Conducted Emission	Pass	Under limit 17.24 dB at 0.567 MHz
3.6	15.407(c)	Automatically Discontinue Transmission	Pass	-
3.7	15.203 15.407(a)	Antenna Requirement	Pass	-

**Declaration of Conformity:**

The test results with all measurement uncertainty excluded are presented in accordance with the regulation limits or requirements declared by manufacturers.

**Comments and Explanations:**

The declared of product specification for EUT presented in the report are provided by the manufacturer, and the manufacturer takes all the responsibilities for the accuracy of product specification.

**Reviewed by: Wii Chang****Report Producer: Lucy Wu**



# 1 General Description

## 1.1 Product Feature of Equipment Under Test

Product Feature	
Equipment	Touch computer
Brand Name	Zebra
Model Name	TC210K
FCC ID	UZ7TC210K
Sample 1	WLAN, GMS, SE4710, NFC, 3G/32GB, Rear camera, 2-pin connector
Sample 2	WLAN, GMS, No scanner, NFC, 3G/32GB, Front & Rear camera, 2-pin connector
EUT supports Radios application	NFC WLAN 11a/b/g/n HT20/HT40 WLAN 11ac VHT20/VHT40/VHT80 Bluetooth BR/EDR/LE
HW Version	Meteor_EV1_MB_V11
OS Version	Android version 10
SW Version	FUSION_QA_2_1.0.0.007_Q
FW Version	Zebra/TC21MG/TC21:10/03-08-17.00-QG-U00-PRD/88:userdebug/release-keys
MFD	27DEC19
EUT Stage	Engineering sample

Remark: The above EUT's information was declared by manufacturer.

Specification of Accessories				
AC Adapter	Brand Name	Zebra	Part Number	PWR-WUA5V12W0US
Battery 1	Brand Name	Zebra	Part Number	BT-000409-00
Battery 2	Brand Name	Zebra	Part Number	BT-000410-50
Battery 3	Brand Name	Zebra	Part Number	BT-000411-08
USB Cable (TypeA plug to TypeC plug)	Brand Name	Zebra	Part Number	CBL-TC5X-USBC2A-01
Adapter Cable PTT headset(3.5mm to 3.5mm)	Brand Name	Zebra	Part Number	CBL-TC51-HDST35-01
Headset 3.5mm type with PTT/micassy	Brand Name	Zebra	Part Number	HDST-35MM-PTVP-01
Snap on Trigger handle	Brand Name	Zebra	Part Number	TRG-TC2Y-SNP1-01
Belt Holster	Brand Name	Zebra	Part Number	SG-TC2Y-HLSTR1-01
Wearable Arm Mount	Brand Name	Zebra	Part Number	SG-TC2Y-ARMNT-01

Support Unit used in test configuration and system				
Type C to 3.5mm headset adaptor	Trade Name	Google	Model name	Pixel-2-2XL

## 1.2 Product Specification of Equipment Under Test

Standards-related Product Specification	
<b>Tx/Rx Frequency Range</b>	5180 MHz ~ 5240 MHz 5260 MHz ~ 5320 MHz 5500 MHz ~ 5720 MHz
<b>Maximum Output Power to Antenna</b>	<p><b>&lt;5180 MHz ~ 5240 MHz&gt;</b>            802.11a : 20.10 dBm / 0.1023 W            802.11n HT20 : 19.90 dBm / 0.0977 W            802.11n HT40 : 19.60 dBm / 0.0912 W            802.11ac VHT20: 20.00 dBm / 0.1000 W            802.11ac VHT40: 19.70 dBm / 0.0933 W            802.11ac VHT80: 17.70 dBm / 0.0589 W</p> <p><b>&lt;5260 MHz ~ 5320 MHz&gt;</b>            802.11a : 20.40 dBm / 0.1096 W            802.11n HT20 : 20.10 dBm / 0.1023 W            802.11n HT40 : 19.80 dBm / 0.0955 W            802.11ac VHT20: 20.20 dBm / 0.1047 W            802.11ac VHT40: 19.90 dBm / 0.0977 W            802.11ac VHT80: 16.00 dBm / 0.0398 W</p> <p><b>&lt;5500 MHz ~ 5720 MHz&gt;</b>            802.11a : 19.40 dBm / 0.0871 W            802.11n HT20 : 19.30 dBm / 0.0851 W            802.11n HT40 : 18.20 dBm / 0.0661 W            802.11ac VHT20: 19.40 dBm / 0.0871 W            802.11ac VHT40: 18.50 dBm / 0.0708 W            802.11ac VHT80: 18.60 dBm / 0.0724 W</p>
<b>99% Occupied Bandwidth</b>	802.11a : 17.08 MHz 802.11ac VHT20: 18.23 MHz 802.11ac VHT40: 36.76 MHz 802.11ac VHT80: 76.96 MHz
<b>Type of Modulation</b>	802.11a/n : OFDM (BPSK / QPSK / 16QAM / 64QAM) 802.11ac : OFDM (BPSK / QPSK / 16QAM / 64QAM / 256QAM)
<b>Antenna Type / Gain</b>	<p><b>&lt;5180 MHz ~ 5240 MHz&gt;</b>            PIFA Antenna with gain 2.1 dBi</p> <p><b>&lt;5260 MHz ~ 5320 MHz&gt;</b>            PIFA Antenna with gain 2.1 dBi</p> <p><b>&lt;5500 MHz ~ 5700 MHz &gt;</b>            PIFA Antenna with gain 2.9 dBi</p>

## 1.3 Modification of EUT

No modifications are made to the EUT during all test items.



### 1.4 Testing Location

<b>Test Site</b>	SPORTON INTERNATIONAL INC. EMC & Wireless Communications Laboratory	
<b>Test Site Location</b>	No.52, Huaya 1st Rd., Guishan Dist., Taoyuan City, Taiwan (R.O.C.) TEL: +886-3-327-3456 FAX: +886-3-328-4978	
<b>Test Site No.</b>	<b>Sporton Site No.</b>	
	TH05-HY	CO05-HY

**Note:** The test site complies with ANSI C63.4 2014 requirement.

<b>Test Site</b>	SPORTON INTERNATIONAL INC. EMC & Wireless Communications Laboratory	
<b>Test Site Location</b>	No.58, Aly. 75, Ln. 564, Wenhua 3rd, Rd., Guishan Dist., Taoyuan City, Taiwan (R.O.C.) TEL: +886-3-327-0868 FAX: +886-3-327-0855	
<b>Test Site No.</b>	<b>Sporton Site No.</b>	
	03CH15-HY	

**Note:** The test site complies with ANSI C63.4 2014 requirement.

FCC designation No.: TW1190 and TW0007

### 1.5 Applicable Standards

According to the specifications of the manufacturer, the EUT must comply with the requirements of the following standards:

- ♦ FCC Part 15 Subpart E
- ♦ FCC KDB 789033 D02 General UNII Test Procedures New Rules v02r01.
- ♦ FCC KDB 414788 D01 Radiated Test Site v01r01.
- ♦ ANSI C63.10-2013

**Remark:**

1. All test items were verified and recorded according to the standards and without any deviation during the test.
2. This EUT has also been tested and complied with the requirements of FCC Part 15, Subpart B, recorded in a separate test report.



## 2 Test Configuration of Equipment Under Test

- a. The EUT has been associated with peripherals and configuration operated in a manner tended to maximize its emission characteristics in a typical application. Frequency range investigated: conduction emission (150 kHz to 30 MHz), radiation emission (9 kHz to the 10th harmonic of the highest fundamental frequency or to 40 GHz, whichever is lower). For radiated measurement, pre-scanned in three orthogonal panels, X, Y, Z. The worst cases (Z plane) were recorded in this report.
- b. AC power line Conducted Emission was tested under maximum output power.

### 2.1 Carrier Frequency and Channel

Frequency Band	Channel	Freq. (MHz)	Channel	Freq. (MHz)
5150-5250 MHz Band 1 (U-NII-1)	36	5180	44	5220
	38*	5190	46*	5230
	40	5200	48	5240
	42#	5210		

Frequency Band	Channel	Freq. (MHz)	Channel	Freq. (MHz)
5250-5350 MHz Band 2 (U-NII-2A)	52	5260	60	5300
	54*	5270	62*	5310
	56	5280	64	5320
	58#	5290		

Frequency Band	Channel	Freq. (MHz)	Channel	Freq. (MHz)
5470-5725 MHz Band 3 (U-NII-2C)	100	5500	112	5560
	102*	5510	116	5580
	104	5520	132	5660
	106#	5530	134*	5670
	108	5540	136	5680
	110*	5550	140	5700





Frequency Band	Channel	Freq. (MHz)	Channel	Freq. (MHz)
TDWR Channel	118*	5590	124	5620
	120	5600	126*	5630
	122 <sup>#</sup>	5610	128	5640

Frequency Band	Channel	Freq. (MHz)	Channel	Freq. (MHz)
Straddle Channel	138 <sup>#</sup>	5690	144	5720
	142*	5710		

Note:

1. The above Frequency and Channel in "\*" were 802.11n HT40 and 802.11ac VHT40.
2. The above Frequency and Channel in "<sup>#</sup>" were 802.11ac VHT80.

## 2.2 Test Mode

Final test modes are considering the modulation and worse data rates as below table.

Modulation	Data Rate
802.11a	6 Mbps
802.11n HT20 (Covered by VHT20)	MCS0
802.11n HT40 (Covered by VHT40)	MCS0
802.11ac VHT20	MCS0
802.11ac VHT40	MCS0
802.11ac VHT80	MCS0

Test Cases	
AC Conducted Emission	Mode 1 : WLAN (5GHz) Link + NFC On + Bluetooth Link + USB Cable (CBL-TC5X-USBC2A-01) + AC Adapter (PWR-WUA5V12W0US) + Battery1_1X (BT-000409-00) for Sample 1



Ch. #		Band I : 5150-5250 MHz	Band II : 5250-5350 MHz	Band III : 5470-5725MHz
		802.11a	802.11a	802.11a
L	Low	36	52	100
M	Middle	44	60	116
H	High	48	64	140
Straddle		-	-	144

Ch. #		Band I : 5150-5250 MHz	Band II : 5250-5350 MHz	Band III : 5470-5725MHz
		802.11ac VHT20	802.11ac VHT20	802.11ac VHT20
L	Low	36	52	100
M	Middle	44	60	116
H	High	48	64	140
Straddle		-	-	144

Ch. #		Band I : 5150-5250 MHz	Band II : 5250-5350 MHz	Band III : 5470-5725MHz
		802.11ac VHT40	802.11ac VHT40	802.11ac VHT40
L	Low	38	54	102
M	Middle	-	-	110
H	High	46	62	134
Straddle		-	-	142

Ch. #		Band I : 5150-5250 MHz	Band II : 5250-5350 MHz	Band III : 5470-5725MHz
		802.11ac VHT80	802.11ac VHT80	802.11ac VHT80
L	Low	-	-	106
M	Middle	42	58	122
H	High	-	-	-
Straddle		-	-	138

Remark: For radiation spurious emission, the final modulation and the worst data rate was reference the max RF conducted power.



802.11a RF Output Power (dBm)										
Power vs. Channel			Power vs Data Rate							
Channel	Frequency (MHz)	Data Rate (bps)	Channel	Data Rate (bps)						
		6M		9M	12M	18M	24M	36M	48M	54M
Duty Cycle (%)		95.15		94.40	92.80	89.80	87.20	82.30	78.20	76.40
CH 036	5180	20.10	CH 044	19.90	19.90	20.00	19.80	19.40	19.50	19.40
CH 044	5220	20.10								
CH 048	5240	20.10								
CH 052	5260	20.40	CH 052	20.30	20.30	20.30	20.30	19.90	20.00	19.90
CH 060	5300	20.30								
CH 064	5320	20.30								
CH 100	5500	19.10	CH 116	19.30	19.30	19.30	19.20	19.00	19.00	19.00
CH 116	5580	19.40								
CH 140	5700	19.10								
CH 144*	5720	19.30								

Note: The above Frequency and Channel in "\*" were straddle Channel.

802.11n HT20 RF Output Power (dBm)										
Power vs. Channel			Power vs Data Rate							
Channel	Frequency (MHz)	MCS Index	Channel	MCS Index						
		MCS0		MCS1	MCS2	MCS3	MCS4	MCS5	MCS6	MCS7
Duty Cycle (%)		94.80		92.20	89.10	86.50	81.80	77.70	76.10	74.40
CH 036	5180	19.90	CH 044	19.80	19.80	19.80	19.60	19.60	19.60	19.60
CH 044	5220	19.90								
CH 048	5240	19.90								
CH 052	5260	19.70	CH 060	20.00	20.00	20.00	20.00	20.00	20.00	20.00
CH 060	5300	20.10								
CH 064	5320	20.10								
CH 100	5500	19.30	CH 100	19.20	19.20	19.20	19.20	19.20	19.20	19.20
CH 116	5580	19.20								
CH 140	5700	18.40								
CH 144*	5720	19.20								

Note: The above Frequency and Channel in "\*" were straddle Channel.



802.11n HT40 RF Output Power (dBm)										
Power vs. Channel			Power vs Data Rate							
Channel	Frequency (MHz)	MCS Index	Channel	MCS Index						
		MCS0		MCS1	MCS2	MCS3	MCS4	MCS5	MCS6	MCS7
Duty Cycle (%)		90.34		86.00	81.10	77.10	71.10	65.90	64.10	62.50
CH 038	5190	17.90	CH 046	19.50	19.50	19.50	19.40	19.40	19.40	19.40
CH 046	5230	19.60								
CH 054	5270	19.80	CH 054	19.70	19.70	19.70	19.40	19.40	19.40	19.40
CH 062	5310	16.70								
CH 102	5510	17.80	CH 110	18.1	18.1	18.1	17.8	17.8	17.8	17.8
CH 110	5550	18.20								
CH 134	5670	18.20								
CH 142*	5710	18.10								

Note: The above Frequency and Channel in "\*" were straddle Channel.

802.11ac VHT20 RF Output Power (dBm)											
Power vs. Channel			Power vs Data Rate								
Channel	Frequency (MHz)	MCS Index	Channel	MCS Index							
		MCS0		MCS1	MCS2	MCS3	MCS4	MCS5	MCS6	MCS7	MCS8
Duty Cycle (%)		95.78		92.30	89.30	86.70	81.90	78.10	76.40	74.90	71.90
CH 036	5180	20.00	CH 044	19.90	19.90	19.90	19.60	19.60	19.60	19.60	19.60
CH 044	5220	20.00									
CH 048	5240	20.00									
CH 052	5260	19.80	CH 060	20.10	20.10	20.10	20.00	20.10	20.10	20.10	20.10
CH 060	5300	20.20									
CH 064	5320	20.20									
CH 100	5500	19.40	CH 100	19.30	19.30	19.30	19.20	19.30	19.30	19.30	19.30
CH 116	5580	19.30									
CH 140	5700	18.50									
CH 144*	5720	19.30									

Note: The above Frequency and Channel in "\*" were straddle Channel.



802.11ac VHT40 RF Output Power (dBm)												
Power vs. Channel			Power vs Data Rate									
Channel	Frequency (MHz)	MCS Index	Channel	MCS Index								
		MCS0		MCS1	MCS2	MCS3	MCS4	MCS5	MCS6	MCS7	MCS8	MCS9
Duty Cycle (%)		91.35		86.10	81.20	77.30	71.30	66.70	64.70	63.50	60.40	58.90
CH 038	5190	18.00	CH 046	19.6	19.6	19.6	19.5	19.5	19.5	19.4	19.4	19.4
CH 046	5230	19.70		19.8	19.8	19.8	19.7	19.7	19.7	19.6	19.6	19.6
CH 054	5270	19.90	CH 054	19.8	19.8	19.8	19.7	19.7	19.7	19.6	19.6	19.6
CH 062	5310	16.80		18.4	18.4	18.4	18.3	18.3	18.3	18.2	18.2	18.2
CH 102	5510	17.90	CH 110	18.4	18.4	18.4	18.3	18.3	18.3	18.2	18.2	18.2
CH 110	5550	18.50										
CH 134	5670	18.30										
CH 142*	5710	18.40										

Note: The above Frequency and Channel in "\*" were straddle Channel.

802.11ac VHT80 RF Output Power (dBm)												
Power vs. Channel			Power vs Data Rate									
Channel	Frequency (MHz)	MCS Index	Channel	MCS Index								
		MCS0		MCS1	MCS2	MCS3	MCS4	MCS5	MCS6	MCS7	MCS8	MCS9
Duty Cycle (%)		85.93		76.30	70.00	65.30	59.40	54.80	53.40	52.50	49.90	48.70
CH 042	5210	17.70	CH 042	17.60	17.60	17.60	17.40	17.50	17.50	17.50	17.50	17.50
CH 058	5290	16.00	CH 058	15.90	15.90	15.90	15.90	15.80	15.90	15.90	15.90	15.90
CH 106	5530	15.60	CH 122	18.50	18.50	18.50	18.50	18.40	18.40	18.40	18.40	18.30
CH 122	5610	18.60										
CH 138*	5690	18.60										

Note: The above Frequency and Channel in "\*" were straddle Channel.

## 2.3 Connection Diagram of Test System

<For AC Conducted Emission Mode>

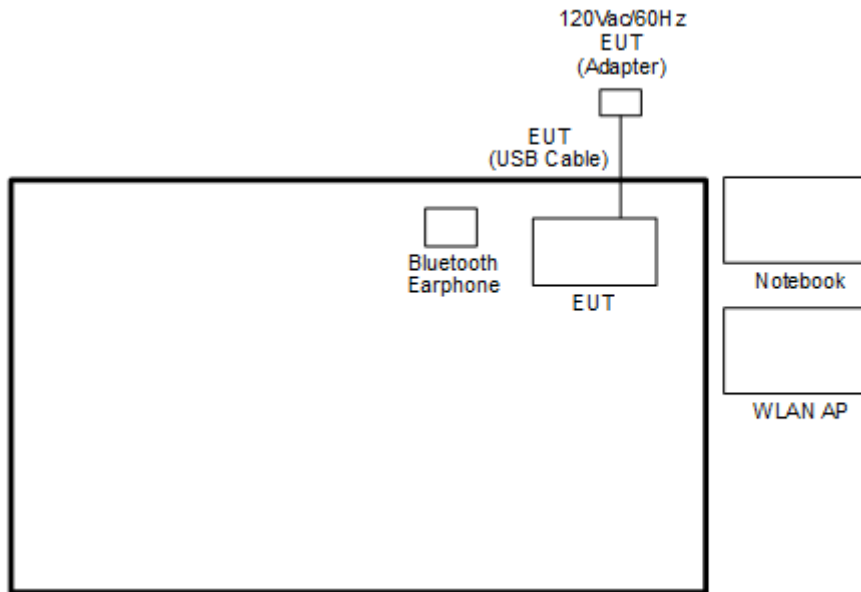

<For WLAN Tx Mode>

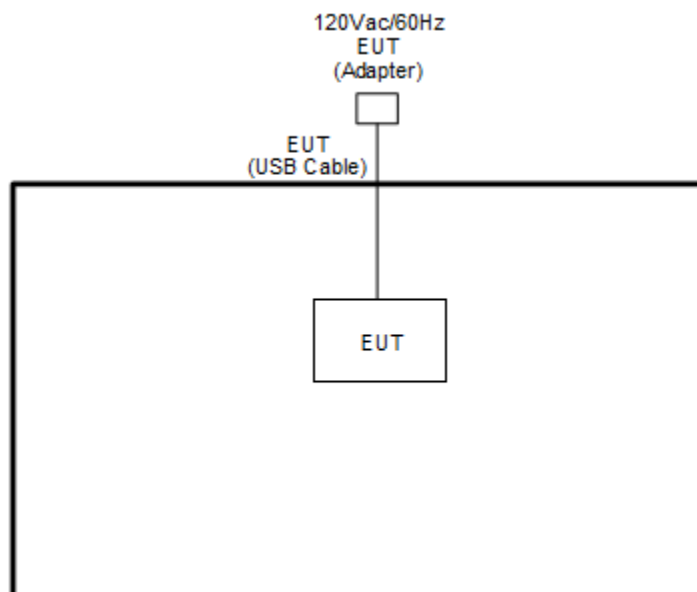



## 2.4 Support Unit used in test configuration and system

Item	Equipment	Trade Name	Model Name	FCC ID	Data Cable	Power Cord
1.	Bluetooth Earphone	Sony Ericsson	MW600	PY7DDA-2029	N/A	N/A
2.	WLAN AP	ASUS	RT-AC66U	MSQ-RTAC66U	N/A	Unshielded, 1.8 m
3.	Notebook	DELL	Latitude E3400	FCC DoC	N/A	AC I/P: Unshielded, 1.2 m DC O/P: Shielded, 1.8 m
4.	SD Card	SanDisk	MicroSD HC	FCC DoC	N/A	N/A

## 2.5 EUT Operation Test Setup

The RF test items, utility "QRCT V4.0.00142.0" was installed in Notebook which was programmed in order to make the EUT get into the engineering modes to provide channel selection, power level, data rate and the application type and for continuous transmitting signals.

## 2.6 Measurement Results Explanation Example

**For all conducted test items:**

The offset level is set in the spectrum analyzer to compensate the RF cable loss and attenuator factor between EUT conducted output port and spectrum analyzer. With the offset compensation, the spectrum analyzer reading level is exactly the EUT RF output level.

Example :

The spectrum analyzer offset is derived from RF cable loss and attenuator factor.

*Offset = RF cable loss + attenuator factor.*

Following shows an offset computation example with cable loss 4.2 dB and 10dB attenuator.

$$\begin{aligned} \text{Offset(dB)} &= \text{RF cable loss(dB)} + \text{attenuator factor(dB)}. \\ &= 4.2 + 10 = 14.2 \text{ (dB)} \end{aligned}$$

### 3 Test Result

#### 3.1 26dB & 99% Occupied Bandwidth Measurement

##### 3.1.1 Description of 26dB & 99% Occupied Bandwidth

This section is for reporting purpose only.

There is no restriction limits for bandwidth.

For Straddle Channel, according to KDB 789033 D02 General UNII Test Procedures New Rules v02r01, if the power and PSD of the devices are uniform and comply with the lower limits specified for the U-NII-2 bands, a single measurement over the entire emission bandwidth can be performed to show compliance.

##### 3.1.2 Measuring Instruments

See list of measuring equipment of this test report.

##### 3.1.3 Test Procedures

1. The testing follows FCC KDB 789033 D02 General UNII Test Procedures New Rules v02r01. Section C) Emission bandwidth
2. Set RBW = approximately 1% of the emission bandwidth.
3. Set the VBW > RBW.
4. Detector = Peak.
5. Trace mode = max hold
6. Measure the maximum width of the emission that is 26 dB down from the peak of the emission. Compare this with the RBW setting of the analyzer. Readjust RBW and repeat measurement as needed until the RBW/EBW ratio is approximately 1%.
7. For 99% Bandwidth Measurement, the spectrum analyzer's resolution bandwidth (RBW) is set 1-5% of the emission bandwidth and set the Video bandwidth (VBW)  $\geq 3 * RBW$ .
8. Measure and record the results in the test report.

##### 3.1.4 Test Setup

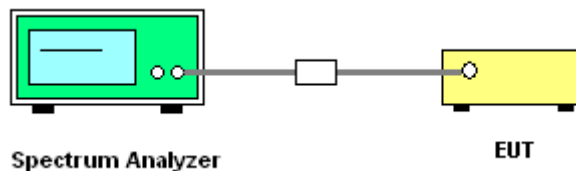





3.1.5 Test Result of 26dB & 99% Occupied Bandwidth

Test Engineer :	AnAn Wu and Luffy Lin	Temperature :	21~25°C
		Relative Humidity :	51~54%

Band I single antenna														
Mod.	Data Rate	NTX	CH.	Freq. (MHz)	99% Bandwidth (MHz)		26 dB Bandwidth (MHz)		IC 99% Bandwidth Power Limit (dBm)		IC 99% Bandwidth EIRP Limit (dBm)		-	Note
					Ant 1	Ant 2	Ant 1	Ant 2	Ant 1	Ant 2	Ant 1	Ant 2		
11a	6Mbps	1	36	5180	16.98	-	26.17	-	-	-	22.30	-	-	-
11a	6Mbps	1	44	5220	16.98	-	25.87	-	-	-	22.30	-		
11a	6Mbps	1	48	5240	16.93	-	25.92	-	-	-	22.29	-		
VHT20	MCS0	1	36	5180	18.13	-	28.42	-	-	-	22.58	-		
VHT20	MCS0	1	44	5220	18.18	-	28.82	-	-	-	22.60	-		
VHT20	MCS0	1	48	5240	18.18	-	28.17	-	-	-	22.60	-		
VHT40	MCS0	1	38	5190	36.56	-	41.99	-	-	-	23.01	-		
VHT40	MCS0	1	46	5230	36.66	-	42.17	-	-	-	23.01	-		
VHT80	MCS0	1	42	5210	76.96	-	84.08	-	-	-	23.01	-		

Band II single antenna															
Mod.	Data Rate	NTX	CH.	Freq. (MHz)	99% Bandwidth (MHz)		26 dB Bandwidth (MHz)		IC 99% Bandwidth Power Limit (dBm)		IC 99% Bandwidth EIRP Limit (dBm)		FCC 26dB Bandwidth Power Limit (dBm)		Note
					Ant 1	Ant 2	Ant 1	Ant 2	Ant 1	Ant 2	Ant 1	Ant 2	Ant 1	Ant 2	
11a	6Mbps	1	52	5260	17.08	-	26.72	-	23.33	-	29.33	-	23.98	-	-
11a	6Mbps	1	60	5300	16.98	-	27.12	-	23.30	-	29.30	-	23.98	-	
11a	6Mbps	1	64	5320	16.83	-	25.38	-	23.26	-	29.26	-	23.98	-	
VHT20	MCS0	1	52	5260	18.13	-	27.62	-	23.58	-	29.58	-	23.98	-	
VHT20	MCS0	1	60	5300	18.23	-	28.82	-	23.61	-	29.61	-	23.98	-	
VHT20	MCS0	1	64	5320	18.18	-	27.92	-	23.60	-	29.60	-	23.98	-	
VHT40	MCS0	1	54	5270	36.66	-	42.35	-	23.98	-	30.00	-	23.98	-	
VHT40	MCS0	1	62	5310	36.46	-	41.90	-	23.98	-	30.00	-	23.98	-	
VHT80	MCS0	1	58	5290	76.96	-	84.56	-	23.98	-	30.00	-	23.98	-	



Band III single antenna																
Mod.	Data Rate	NTX	CH.	Freq. (MHz)	99% Bandwidth In U-NII 2C (MHz)		26 dB Bandwidth In U-NII 2C (MHz)		IC 99% Bandwidth Power Limit (dBm)		IC 99% Bandwidth EIRP Limit (dBm)		FCC 26dB Bandwidth Power Limit (dBm)		6 dB Bandwidth for Straddle Channel (MHz)	
					Ant 1	Ant 2	Ant 1	Ant 2	Ant 1	Ant 2	Ant 1	Ant 2	Ant 1	Ant 2	Ant 1	Ant 2
11a	6Mbps	1	100	5500	16.78	-	25.33	-	23.25	-	29.25	-	23.98	-	----	----
11a	6Mbps	1	116	5580	16.88	-	25.67	-	23.27	-	29.27	-	23.98	-	----	----
11a	6Mbps	1	140	5700	17.03	-	26.42	-	23.31	-	29.31	-	23.98	-	----	----
VHT20	MCS0	1	100	5500	18.03	-	27.22	-	23.56	-	29.56	-	23.98	-	----	----
VHT20	MCS0	1	116	5580	18.18	-	28.82	-	23.60	-	29.60	-	23.98	-	----	----
VHT20	MCS0	1	140	5700	18.23	-	28.57	-	23.61	-	29.61	-	23.98	-	----	----
VHT40	MCS0	1	102	5510	36.56	-	41.90	-	23.98	-	30.00	-	23.98	-	----	----
VHT40	MCS0	1	110	5550	36.46	-	41.99	-	23.98	-	30.00	-	23.98	-	----	----
VHT40	MCS0	1	134	5670	36.76	-	42.71	-	23.98	-	30.00	-	23.98	-	----	----
VHT80	MCS0	1	106	5530	76.96	-	84.24	-	23.98	-	30.00	-	23.98	-	----	----
VHT80	MCS0	1	122	5610	76.84	-	84.24	-	23.98	-	30.00	-	23.98	-	----	----

Band III straddle channel single antenna																
Mod.	Data Rate	NTX	CH.	Freq. (MHz)	99% Bandwidth In U-NII 2C (MHz)		26 dB Bandwidth In U-NII 2C (MHz)		IC 99% Bandwidth Power Limit (dBm)		IC 99% Bandwidth EIRP Limit (dBm)		FCC 26dB Bandwidth Power Limit (dBm)		6 dB Bandwidth for Straddle Channel (MHz)	
					Ant 1	Ant 2	Ant 1	Ant 2	Ant 1	Ant 2	Ant 1	Ant 2	Ant 1	Ant 2	Ant 1	Ant 2
11a	6Mbps	1	144	5720	13.74	-	19.53	-	22.38	-	28.38	-	23.91	-	2.593	-
VHT20	MCS0	1	144	5720	14.24	-	20.03	-	22.54	-	28.54	-	23.98	-	3.142	-
VHT40	MCS0	1	142	5710	33.38	-	36.31	-	23.98	-	30.00	-	23.98	-	3.18	-
VHT80	MCS0	1	138	5690	73.36	-	77.52	-	23.98	-	30.00	-	23.98	-	2.57	-

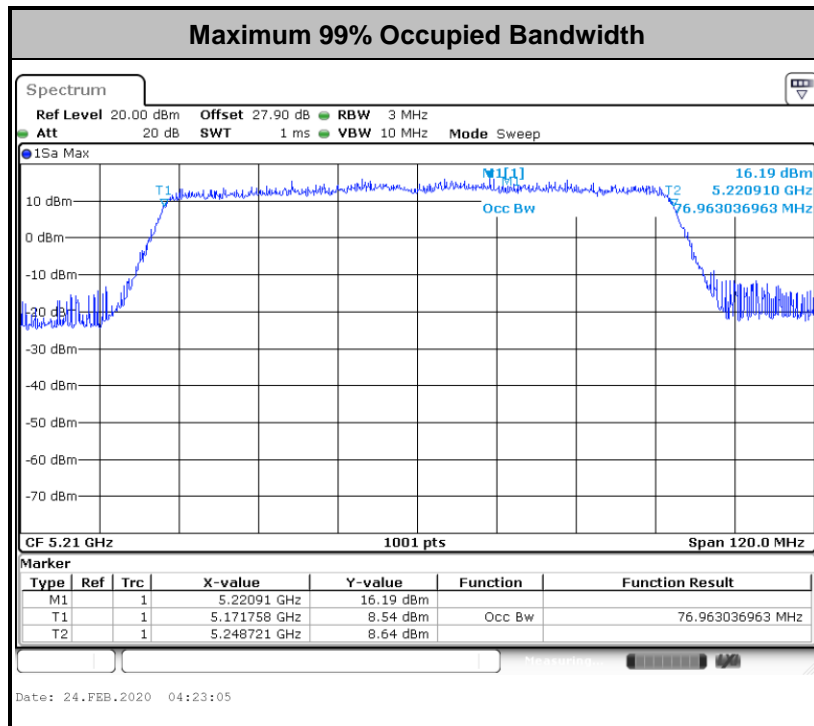
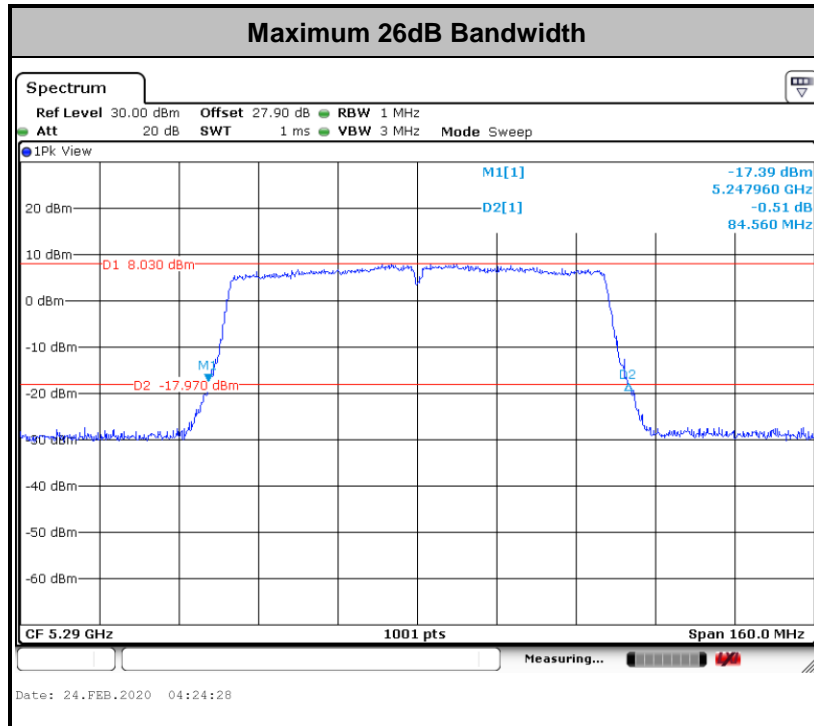

**Note:** The occupied channel bandwidth is maintained within the band of operation for all of the modulations.



## 3.2 Maximum Conducted Output Power Measurement

### 3.2.1 Limit of Maximum Conducted Output Power

<FCC 14-30 CFR 15.407>

**For the 5.15–5.25 GHz bands:**

- For mobile and portable client devices in the 5.15–5.25 GHz band, the maximum conducted output power over the frequency band of operation shall not exceed 250 mW. For an indoor access point operating in the band 5.15-5.25 GHz, the maximum conducted output power over the frequency band of operation shall not exceed 1 W.

**For the 5.25–5.725 GHz bands:**

- The maximum conducted output power over the frequency bands of operation shall not exceed the lesser of 250 mW or  $11 \text{ dBm} + 10 \log B$ , where B is the 26 dB emission bandwidth in megahertz.

For Straddle Channel, according to KDB 789033 D02 General UNII Test Procedures New Rules v02r01, if the power and PSD of the devices are uniform and comply with the lower limits specified for the U-NII-2 bands, a single measurement over the entire emission bandwidth can be performed to show compliance.

If transmitting antennas of directional gain greater than 6 dBi are used, the peak output power shall be reduced by the amount in dB that the directional gain of the antenna exceeds 6 dBi.

Note that U-NII-2 band, devices with a maximum e.i.r.p. greater than 500 mW shall implement TPC in order to have the capability to operate at least 6 dB below the maximum permitted e.i.r.p. of 1 W.

### 3.2.2 Measuring Instruments

See list of measuring equipment of this test report.

### 3.2.3 Test Procedures

The testing follows Method PM-G of FCC KDB 789033 D02 General UNII Test Procedures New Rules v02r01.

Method PM-G (Measurement using an RF average power meter):

1. Measurement is performed using a wideband RF power meter.
2. The EUT is configured to transmit at its maximum power control level.
3. Measure the average power of the transmitter
4. Since the measurement is made only during the ON time of the transmitter, no duty cycle correction factor is required.

For Straddle Channel, according to KDB 789033 D02 General UNII Test Procedures New Rules v02r01, if the power and PSD of the devices are uniform and comply with the lower limits specified for the U-NII-2 bands, a single measurement over the entire emission bandwidth can be performed to show compliance.

### 3.2.4 Test Setup

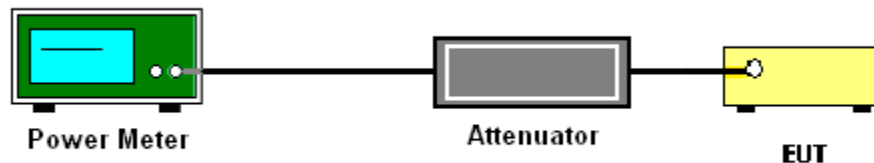



3.2.5 Test Result of Maximum Conducted Output Power

Test Engineer :	AnAn Wu and Luffy Lin	Temperature :	21~25°C
		Relative Humidity :	51~54%

FCC Band I single antenna												
Mod.	Data Rate	NTX	CH.	Freq. (MHz)	Average Conducted Power (dBm)			FCC Conducted Power Limit (dBm)		DG (dBi)		Pass/Fail
					Ant 1	Ant 2	SUM	Ant 1	Ant 2	Ant 1	Ant 2	
11a	6Mbps	1	36	5180	20.10	-	-	24.00	-	2.10	-	Pass
11a	6Mbps	1	44	5220	20.10	-	-	24.00	-	2.10	-	Pass
11a	6Mbps	1	48	5240	20.10	-	-	24.00	-	2.10	-	Pass
HT20	MCS0	1	36	5180	19.90	-	-	24.00	-	2.10	-	Pass
HT20	MCS0	1	44	5220	19.90	-	-	24.00	-	2.10	-	Pass
HT20	MCS0	1	48	5240	19.90	-	-	24.00	-	2.10	-	Pass
HT40	MCS0	1	38	5190	17.90	-	-	24.00	-	2.10	-	Pass
HT40	MCS0	1	46	5230	19.60	-	-	24.00	-	2.10	-	Pass
VHT20	MCS0	1	36	5180	20.00	-	-	24.00	-	2.10	-	Pass
VHT20	MCS0	1	44	5220	20.00	-	-	24.00	-	2.10	-	Pass
VHT20	MCS0	1	48	5240	20.00	-	-	24.00	-	2.10	-	Pass
VHT40	MCS0	1	38	5190	18.00	-	-	24.00	-	2.10	-	Pass
VHT40	MCS0	1	46	5230	19.70	-	-	24.00	-	2.10	-	Pass
VHT80	MCS0	1	42	5210	17.70	-	-	24.00	-	2.10	-	Pass



FCC Band II single antenna													
Mod.	Data Rate	NTX	CH.	Freq. (MHz)	Average Conducted Power (dBm)			FCC Conducted Power Limit (dBm)		DG (dBi)		EIRP Power Limit (dBm)	Pass/Fail
					Ant 1	Ant 2	SUM	Ant 1	Ant 2	Ant 1	Ant 2		
11a	6Mbps	1	52	5260	20.40	-	-	23.98	-	2.10	-	30	Pass
11a	6Mbps	1	60	5300	20.30	-	-	23.98	-	2.10	-	30	Pass
11a	6Mbps	1	64	5320	20.30	-	-	23.98	-	2.10	-	30	Pass
HT20	MCS0	1	52	5260	19.70	-	-	23.98	-	2.10	-	30	Pass
HT20	MCS0	1	60	5300	20.10	-	-	23.98	-	2.10	-	30	Pass
HT20	MCS0	1	64	5320	20.10	-	-	23.98	-	2.10	-	30	Pass
HT40	MCS0	1	54	5270	19.80	-	-	23.98	-	2.10	-	30	Pass
HT40	MCS0	1	62	5310	16.70	-	-	23.98	-	2.10	-	30	Pass
VHT20	MCS0	1	52	5260	19.80	-	-	23.98	-	2.10	-	30	Pass
VHT20	MCS0	1	60	5300	20.20	-	-	23.98	-	2.10	-	30	Pass
VHT20	MCS0	1	64	5320	20.20	-	-	23.98	-	2.10	-	30	Pass
VHT40	MCS0	1	54	5270	19.90	-	-	23.98	-	2.10	-	30	Pass
VHT40	MCS0	1	62	5310	16.80	-	-	23.98	-	2.10	-	30	Pass
VHT80	MCS0	1	58	5290	16.00	-	-	23.98	-	2.10	-	30	Pass



FCC Band III single antenna													
Mod.	Data Rate	NTX	CH.	Freq. (MHz)	Average Conducted Power (dBm)			FCC Conducted Power Limit (dBm)		DG (dBi)		EIRP Power Limit (dBm)	Pass/Fail
					Ant 1	Ant 2	SUM	Ant 1	Ant 2	Ant 1	Ant 2		
11a	6Mbps	1	100	5500	19.10	-	-	23.98	-	2.90	-	30	Pass
11a	6Mbps	1	116	5580	19.40	-	-	23.98	-	2.90	-	30	Pass
11a	6Mbps	1	140	5700	19.10	-	-	23.98	-	2.90	-	30	Pass
HT20	MCS0	1	100	5500	19.30	-	-	23.98	-	2.90	-	30	Pass
HT20	MCS0	1	116	5580	19.20	-	-	23.98	-	2.90	-	30	Pass
HT20	MCS0	1	140	5700	18.40	-	-	23.98	-	2.90	-	30	Pass
HT40	MCS0	1	102	5510	17.80	-	-	23.98	-	2.90	-	30	Pass
HT40	MCS0	1	110	5550	18.20	-	-	23.98	-	2.90	-	30	Pass
HT40	MCS0	1	134	5670	18.20	-	-	23.98	-	2.90	-	30	Pass
VHT20	MCS0	1	100	5500	19.40	-	-	23.98	-	2.90	-	30	Pass
VHT20	MCS0	1	116	5580	19.30	-	-	23.98	-	2.90	-	30	Pass
VHT20	MCS0	1	140	5700	18.50	-	-	23.98	-	2.90	-	30	Pass
VHT40	MCS0	1	102	5510	17.90	-	-	23.98	-	2.90	-	30	Pass
VHT40	MCS0	1	110	5550	18.50	-	-	23.98	-	2.90	-	30	Pass
VHT40	MCS0	1	134	5670	18.30	-	-	23.98	-	2.90	-	30	Pass
VHT80	MCS0	1	106	5530	15.60	-	-	23.98	-	2.90	-	30	Pass
VHT80	MCS0	1	122	5610	18.60	-	-	23.98	-	2.90	-	30	Pass

FCC Band III straddle channel MIMO													
Mod.	Data Rate	NTX	CH.	Freq. (MHz)	Average Conducted Power (dBm)			FCC Conducted Power Limit (dBm)		DG (dBi)		EIRP Power Limit (dBm)	Pass/Fail
					Ant 1	Ant 2	SUM	Ant 1	Ant 2	Ant 1	Ant 2		
11a	6Mbps	1	144	5720	19.30	-	-	23.98	-	2.90	-	30	Pass
HT20	MCS0	1	144	5720	19.20	-	-	23.98	-	2.90	-	30	Pass
HT40	MCS0	1	142	5710	18.10	-	-	23.98	-	2.90	-	30	Pass
VHT20	MCS0	1	144	5720	19.30	-	-	23.98	-	2.90	-	30	Pass
VHT40	MCS0	1	142	5710	18.40	-	-	23.98	-	2.90	-	30	Pass
VHT80	MCS0	1	138	5690	18.60	-	-	23.98	-	2.90	-	30	Pass





### 3.3 Power Spectral Density Measurement

#### 3.3.1 Limit of Power Spectral Density

<FCC 14-30 CFR 15.407>

**For the 5.15–5.25 GHz bands:**

For mobile and portable client devices in the 5.15–5.25 GHz band, the maximum power spectral density shall not exceed 11 dBm in any 1.0 MHz band. For an indoor access point operating in the band 5.15-5.25 GHz, the maximum power spectral density shall not exceed 17 dBm in any 1.0 MHz band.

**For the 5.25–5.725 GHz bands:**

The maximum power spectral density shall not exceed 11 dBm in any 1.0 MHz band.

For Straddle Channel, according to KDB 789033 D02 General UNII Test Procedures New Rules v02r01, if the power and PSD of the devices are uniform and comply with the lower limits specified for the U-NII-2 bands, a single measurement over the entire emission bandwidth can be performed to show compliance.

If transmitting antennas of directional gain greater than 6 dBi are used, the peak output power shall be reduced by the amount in dB that the directional gain of the antenna exceeds 6 dBi.

#### 3.3.2 Measuring Instruments

See list of measuring equipment of this test report.

### 3.3.3 Test Procedures

The testing follows FCC KDB 789033 D02 General UNII Test Procedures New Rules v02r01.  
Section F) Maximum power spectral density.

#### # Method SA-3 #

(power averaging (rms) detection with max hold):

- Set span to encompass the entire emission bandwidth (EBW) of the signal.
  - Set RBW = 1 MHz.
  - Set VBW  $\geq$  3 MHz
  - Number of points in sweep  $\geq$  2 Span / RBW.
  - Sweep time  $\leq$  (number of points in sweep)  $\times$  T, when duty cycle is less than 98 percent where T is the minimum transmission duration over which the transmitter is on and is transmitting at its maximum power control level for the tested mode of operation.
  - Detector = power averaging (rms).
  - Trace mode = max hold.
  - Allow max hold to run for at least 60 seconds, or longer as needed to allow the trace to stabilize.
1. The RF output of EUT was connected to the spectrum analyzer by a low loss cable.
  2. Each plot has already offset with cable loss, and attenuator loss. Measure the PPSD and record it.

### 3.3.4 Test Setup

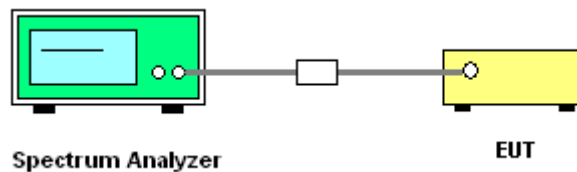



3.3.5 Test Result of Power Spectral Density

Test Engineer :	AnAn Wu and Luffy Lin	Temperature :	21~25°C
		Relative Humidity :	51~54%

FCC Band I single antenna												
Mod.	Data Rate	NTX	CH.	Freq. (MHz)	Average Power Density (dBm/MHz)			Average PSD Limit (dBm/MHz)		DG (dBi)		Pass /Fail
					Ant 1	Ant 2	SUM	Ant 1	Ant 2	Ant 1	Ant 2	
11a	6Mbps	1	36	5180	10.68	-	-	11.00	-	2.10	-	Pass
11a	6Mbps	1	44	5220	10.71	-		11.00	-	2.10	-	Pass
11a	6Mbps	1	48	5240	10.68	-		11.00	-	2.10	-	Pass
VHT20	MCS0	1	36	5180	10.62	-		11.00	-	2.10	-	Pass
VHT20	MCS0	1	44	5220	10.79	-		11.00	-	2.10	-	Pass
VHT20	MCS0	1	48	5240	10.69	-		11.00	-	2.10	-	Pass
VHT40	MCS0	1	38	5190	5.43	-		11.00	-	2.10	-	Pass
VHT40	MCS0	1	46	5230	6.84	-		11.00	-	2.10	-	Pass
VHT80	MCS0	1	42	5210	2.22	-		11.00	-	2.10	-	Pass

Band II single antenna												
Mod.	Data Rate	NT X	CH.	Freq. (MHz)	Average Power Density (dBm/MHz)			Average PSD Limit (dBm/MHz)		DG (dBi)		Pass /Fail
					Ant 1	Ant 2	SUM	Ant 1	Ant 2	Ant 1	Ant 2	
11a	6Mbps	1	52	5260	10.93	-	-	11.00	-	2.10	-	Pass
11a	6Mbps	1	60	5300	10.88	-		11.00	-	2.10	-	Pass
11a	6Mbps	1	64	5320	10.93	-		11.00	-	2.10	-	Pass
VHT20	MCS0	1	52	5260	10.54	-		11.00	-	2.10	-	Pass
VHT20	MCS0	1	60	5300	10.99	-		11.00	-	2.10	-	Pass
VHT20	MCS0	1	64	5320	10.99	-		11.00	-	2.10	-	Pass
VHT40	MCS0	1	54	5270	7.47	-		11.00	-	2.10	-	Pass
VHT40	MCS0	1	62	5310	4.22	-		11.00	-	2.10	-	Pass
VHT80	MCS0	1	58	5290	0.62	-		11.00	-	2.10	-	Pass



Band III single antenna												
Mod.	Data Rate	NTX	CH.	Freq. (MHz)	Average Power Density (dBm/MHz)			Average PSD Limit (dBm/MHz)		DG (dBi)		Pass /Fail
					Ant 1	Ant 2	SUM	Ant 1	Ant 2	Ant 1	Ant 2	
11a	6Mbps	1	100	5500	9.39	-	-	11.00	-	2.90	-	Pass
11a	6Mbps	1	116	5580	10.79	-		11.00	-	2.90	-	Pass
11a	6Mbps	1	140	5700	9.57	-		11.00	-	2.90	-	Pass
VHT20	MCS0	1	100	5500	9.82	-		11.00	-	2.90	-	Pass
VHT20	MCS0	1	116	5580	10.25	-		11.00	-	2.90	-	Pass
VHT20	MCS0	1	140	5700	8.90	-		11.00	-	2.90	-	Pass
VHT40	MCS0	1	102	5510	5.32	-		11.00	-	2.90	-	Pass
VHT40	MCS0	1	110	5550	5.66	-		11.00	-	2.90	-	Pass
VHT40	MCS0	1	134	5670	5.30	-		11.00	-	2.90	-	Pass
VHT80	MCS0	1	106	5530	1.46	-		11.00	-	2.90	-	Pass
VHT80	MCS0	1	122	5610	3.58	-	11.00	-	2.90	-	Pass	

Band III straddle channel single antenna												
Mod.	Data Rate	NTX	CH.	Freq. (MHz)	Average Power Density (dBm/MHz)			Average PSD Limit (dBm/MHz)		DG (dBi)		Pass /Fail
					Ant 1	Ant 2	SUM	Ant 1	Ant 2	Ant 1	Ant 2	
11a	6Mbps	1	144	5720	10.41	-	-	11.00	-	2.90	-	Pass
VHT20	MCS0	1	144	5720	9.72	-		11.00	-	2.90	-	Pass
VHT40	MCS0	1	142	5710	5.94	-		11.00	-	2.90	-	Pass
VHT80	MCS0	1	138	5690	4.17	-		11.00	-	2.90	-	Pass

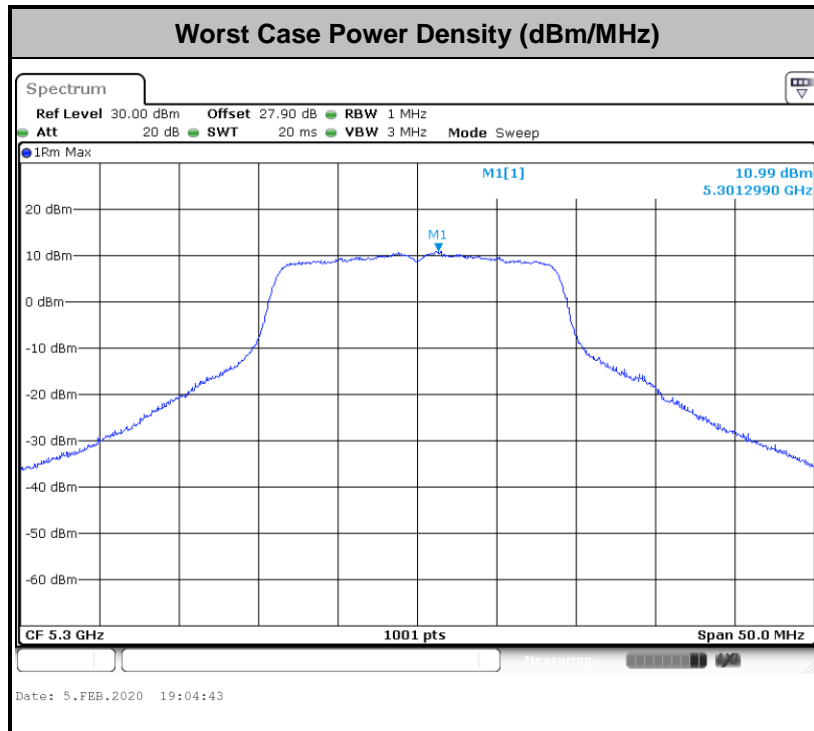



### 3.4 Unwanted Emissions Measurement

This section is to measure unwanted emissions through radiated measurement for band edge spurious emissions and out of band emissions measurement.

#### 3.4.1 Limit of Unwanted Emissions

- (1) For transmitters operating in the 5150-5250 MHz band: all emissions outside of the 5150-5350 MHz band shall not exceed an EIRP of -27dBm/MHz.

For transmitters operating in the 5250-5350 MHz band: all emissions outside of the 5150-5350 MHz band shall not exceed an EIRP of -27 dBm/MHz. Devices operating in the 5250-5350 MHz band that generate emissions in the 5150-5250 MHz band must meet all applicable technical requirements for operation in the 5150-5250 MHz band (including indoor use) or alternatively meet an out-of-band emission EIRP limit of -27 dBm/MHz in the 5150-5250 MHz band.

For transmitters operating in the 5470-5600 MHz and 5650-5725MHz band: all emissions outside of the 5470-5600 MHz and 5650-5725MHz band shall not exceed an EIRP of -27 dBm/MHz.

- (2) Unwanted spurious emissions fallen in restricted bands shall comply with the general field strength limits as below table:

Frequency (MHz)	Field Strength (microvolts/meter)	Measurement Distance (meters)
0.009 – 0.490	2400/F(kHz)	300
0.490 – 1.705	24000/F(kHz)	30
1.705 – 30.0	30	30
30 – 88	100	3
88 – 216	150	3
216 - 960	200	3
Above 960	500	3

**Note:** The following formula is used to convert the EIRP to field strength.

$$E = \frac{1000000\sqrt{30P}}{3} \mu\text{V/m, where P is the eirp (Watts)}$$



EIRP (dBm)	Field Strength at 3m (dBμV/m)
- 27	68.3

(3) KDB789033 D02 v02r01 G)2)c)

- (i) Sections 15.407(b)(1-3) specifies the unwanted emissions limit for the U-NII-1 and U-NII-2 bands. As specified, emissions above 1000 MHz that are outside of the restricted bands are subject to a peak emission limit of -27 dBm/MHz.
- (ii) Section 15.407(b)(4) specifies the unwanted emissions limit for the U-NII-3 band. A band emissions mask is specified in Section 15.407(b)(4)(i). The emission limits are based on the use of a peak detector.

### 3.4.2 Measuring Instruments

See list of measuring equipment of this test report.

### 3.4.3 Test Procedures

1. The testing follows FCC KDB 789033 D02 General UNII Test Procedures New Rules v02r01. Section G) Unwanted emissions measurement.

(1) Procedure for Unwanted Emissions Measurements Below 1000MHz

- RBW = 120 kHz
- VBW = 300 kHz
- Detector = Peak
- Trace mode = max hold

(2) Procedure for Peak Unwanted Emissions Measurements Above 1000 MHz

- RBW = 1 MHz
- VBW ≥ 3 MHz
- Detector = Peak
- Sweep time = auto
- Trace mode = max hold



(3) Procedures for Average Unwanted Emissions Measurements Above 1000MHz

- RBW = 1 MHz
  - VBW = 10 Hz, when duty cycle is no less than 98 percent.
  - $VBW \geq 1/T$ , when duty cycle is less than 98 percent where T is the minimum transmission duration over which the transmitter is on and is transmitting at its maximum power control level for the tested mode of operation.
2. The EUT was placed on a turntable with 0.8 meter for frequency below 1GHz and 1.5 meter for frequency above 1GHz respectively above ground.
  3. The EUT was set 3 meters from the interference receiving antenna which was mounted on the top of a variable height antenna tower.
  4. The antenna is a broadband antenna and its height is adjusted between one meter and four meters above ground to find the maximum value of the field strength for both horizontal polarization and vertical polarization of the antenna.
  5. For each suspected emission, the EUT was arranged to its worst case and then adjust the antenna tower (from 1 m to 4 m) and turntable (from 0 degree to 360 degrees) to find the maximum reading.
  6. For testing below 1GHz, if the emission level of the EUT in peak mode was 3 dB lower than the limit specified, then peak values of EUT will be reported, otherwise, the emissions will be repeated one by one using the CISPR quasi-peak method and reported.
  7. For testing above 1GHz, the emission level of the EUT in peak mode was 20dB lower than average limit (that means the emission level in average mode also complies with the limit in average mode), then peak values of EUT will be reported, otherwise, the emissions will be measured in average mode again and reported.



### 3.4.4 Test Setup

For radiated emissions below 30MHz

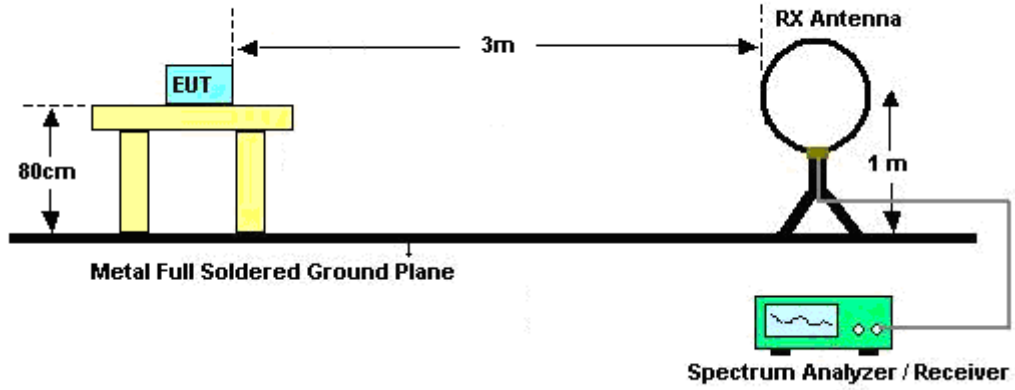

For radiated emissions from 30MHz to 1GHz

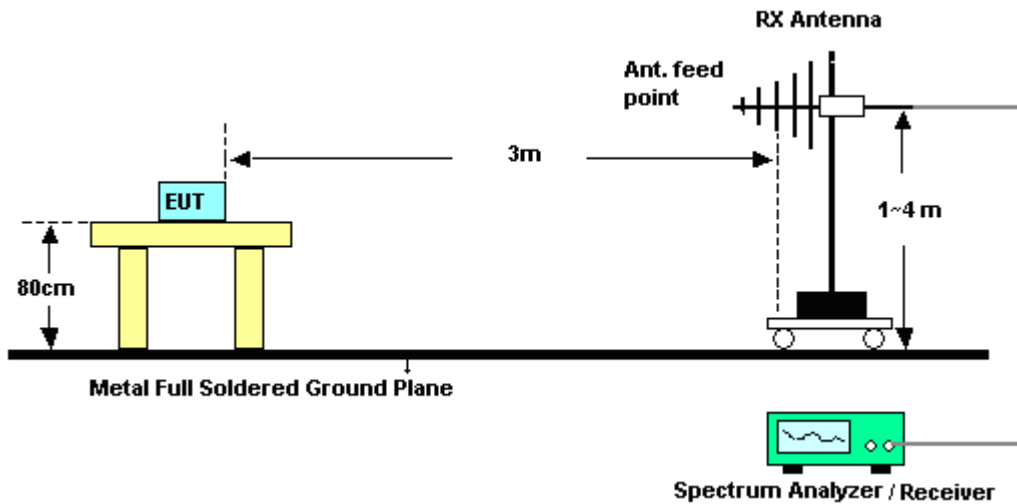

For radiated emissions above 1GHz

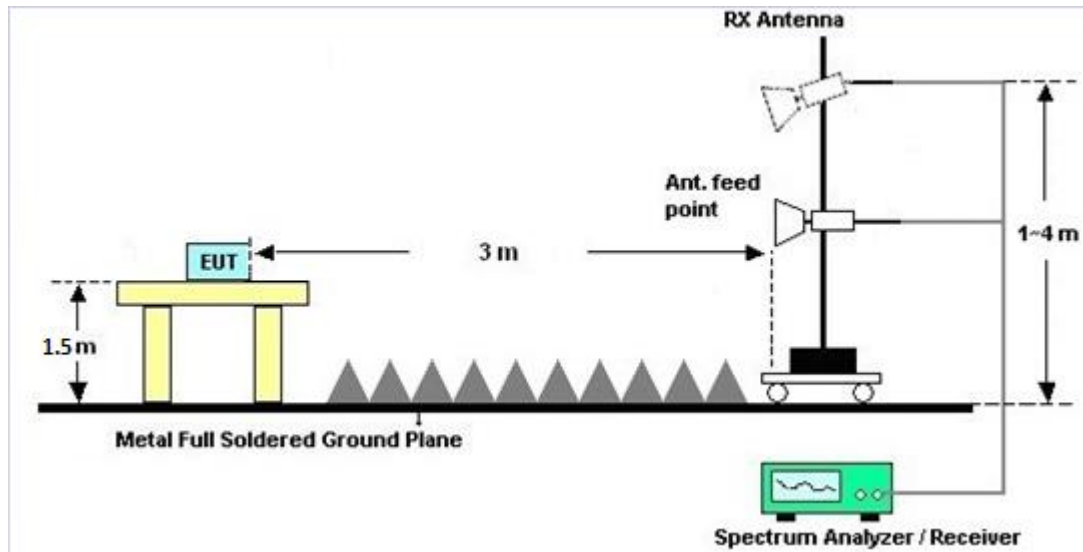

### 3.4.5 Test Results of Radiated Spurious Emissions (9 kHz ~ 30 MHz)

The low frequency, which started from 9 kHz to 30MHz, was pre-scanned and the result which was 20dB lower than the limit line was not reported.

There is a comparison data of both open-field test site and alternative test site - semi-Anechoic chamber according to 414788 D01 Radiated Test Site v01r01, and the result came out very similar.

### 3.4.6 Test Result of Radiated Spurious at Band Edges

Please refer to Appendix B and C.

### 3.4.7 Duty Cycle

Please refer to Appendix D.

### 3.4.8 Test Result of Radiated Spurious Emissions (30MHz ~ 10th Harmonic)

Please refer to Appendix B and C.



### 3.5 AC Conducted Emission Measurement

#### 3.5.1 Limit of AC Conducted Emission

For equipment that is designed to be connected to the public utility (AC) power line, the radio frequency voltage that is conducted back onto the AC power line on any frequency or frequencies within the band 150 kHz to 30 MHz shall not exceed the limits in the following table.

Frequency of emission (MHz)	Conducted limit (dB $\mu$ V)	
	Quasi-peak	Average
0.15-0.5	66 to 56*	56 to 46*
0.5-5	56	46
5-30	60	50

\*Decreases with the logarithm of the frequency.

#### 3.5.2 Measuring Instruments

See list of measuring equipment of this test report.

#### 3.5.3 Test Procedures

1. The EUT was placed 0.4 meter from the conducting wall of the shielding room was kept at least 80 centimeters from any other grounded conducting surface.
2. Connect EUT to the power mains through a line impedance stabilization network (LISN).
3. All the support units are connecting to the other LISN.
4. The LISN provides 50 ohm coupling impedance for the measuring instrument.
5. The FCC states that a 50 ohm, 50 microhenry LISN should be used.
6. Both sides of AC line were checked for maximum conducted interference.
7. The frequency range from 150 kHz to 30 MHz was searched.
8. Set the test-receiver system to Peak Detect Function and specified bandwidth with Maximum Hold Mode.

### 3.5.4 Test Setup



### 3.5.5 Test Result of AC Conducted Emission

Please refer to Appendix A.



## **3.6 Automatically Discontinue Transmission**

### **3.6.1 Limit of Automatically Discontinue Transmission**

The device shall automatically discontinue transmission in case of either absence of information to transmit or operational failure. These provisions are not intended to preclude the transmission of control or signaling information or the use of repetitive codes used by certain digital technologies to complete frame or burst intervals. Applicants shall include in their application for equipment authorization to describe how this requirement is met.

### **3.6.2 Measuring Instruments**

See list of measuring equipment of this test report.

### **3.6.3 Test Result of Automatically Discontinue Transmission**

While the EUT is not transmitting any information, the EUT can automatically discontinue transmission and become standby mode for power saving. The EUT can detect the controlling signal of ACK message transmitting from remote device and verify whether it shall resend or discontinue transmission.



## **3.7 Antenna Requirements**

### **3.7.1 Standard Applicable**

If transmitting antenna directional gain is greater than 6 dBi, both the peak transmit power and the peak power spectral density shall be reduced by the amount in dB that the directional gain of the antenna exceeds 6 dBi.

### **3.7.2 Antenna Anti-Replacement Construction**

An embedded-in antenna design is used.

### **3.7.3 Antenna Gain**

The antenna peak gain of EUT is less than 6 dBi. Therefore, it is not necessary to reduce maximum peak output power limit.



## 4 List of Measuring Equipment

Instrument	Manufacturer	Model No.	Serial No.	Characteristics	Calibration Date	Test Date	Due Date	Remark
Hygrometer	Testo	608-H2	41410069	N/A	Jun. 17, 2019	Jan. 22, 2020~ Feb. 25, 2020	Jun. 16, 2020	Conducted (TH05-HY)
Power Sensor	DARE	RPR3006W	16I00054S NO10	10MHz~6GHz	Dec. 23, 2019	Jan. 22, 2020~ Feb. 25, 2020	Dec. 22, 2020	Conducted (TH05-HY)
Signal Analyzer	Rohde & Schwarz	FSV40	101566	10Hz~40GHz	Jul. 15, 2019	Jan. 22, 2020~ Feb. 25, 2020	Jul. 14, 2020	Conducted (TH05-HY)
Spectrum Analyzer	Rohde & Schwarz	FSP40	100055	9kHz~40GHz	Aug. 14, 2019	Jan. 22, 2020~ Feb. 25, 2020	Aug. 13, 2020	Conducted (TH05-HY)
Switch Box & RF Cable	Burgeon	ETF-058	EC120838 2	N/A	Mar. 27, 2019	Jan. 22, 2020~ Feb. 25, 2020	Mar. 26, 2020	Conducted (TH05-HY)
AC Power Source	ChainTek	APC-1000W	N/A	N/A	N/A	Feb. 14, 2020	N/A	Conduction (CO05-HY)
EMI Test Receiver	Rohde & Schwarz	ESR3	102388	9kHz~3.6GHz	Nov. 15, 2019	Feb. 14, 2020	Nov. 14, 2020	Conduction (CO05-HY)
Hygrometer	Testo	608-H1	34913912	N/A	Mar. 19, 2019	Feb. 14, 2020	Mar. 18, 2020	Conduction (CO05-HY)
LISN	Rohde & Schwarz	ENV216	100080	9kHz~30MHz	Nov. 20, 2019	Feb. 14, 2020	Nov. 19, 2020	Conduction (CO05-HY)
Software	Rohde & Schwarz	EMC32 V10.30	N/A	N/A	N/A	Feb. 14, 2020	N/A	Conduction (CO05-HY)
LF Cable	HUBER + SUHNER	RG-214/U	LF01	N/A	Jan. 02, 2020	Feb. 14, 2020	Jan. 01, 2021	Conduction (CO05-HY)
Pulse Limiter	Rohde & Schwarz	ESH3-Z2	100851	N/A	Jan. 02, 2020	Feb. 14, 2020	Jan. 01, 2021	Conduction (CO05-HY)
Loop Antenna	Rohde & Schwarz	HFH2-Z2	100488	9 kHz~30 MHz	Jan. 09, 2020	Feb. 01, 2020~ Feb. 28, 2020	Jan. 08, 2021	Radiation (03CH15-HY)
Bilog Antenna	TESEQ	CBL 6111D & 00800N1D01 N-06	37059 & 01	30MHz~1GHz	Oct. 12, 2019	Feb. 01, 2020~ Feb. 28, 2020	Oct. 11, 2020	Radiation (03CH15-HY)
Horn Antenna	SCHWARZBE CK	BBHA 9120 D	9120D-211 4	1-18GHz	Jul. 31, 2019	Feb. 01, 2020~ Feb. 28, 2020	Jul. 30, 2020	Radiation (03CH15-HY)
SHF-EHF Horn Antenna	SCHWARZBE CK	BBHA 9170	BBHA9170 584	18GHz- 40GHz	Dec. 10, 2019	Feb. 01, 2020~ Feb. 28, 2020	Dec. 09, 2020	Radiation (03CH15-HY)
Amplifier	SONOMA	310N	363440	9kHz~1GHz	Dec. 27, 2019	Feb. 01, 2020~ Feb. 28, 2020	Dec. 26, 2020	Radiation (03CH15-HY)
Preamplifier	Jet-Power	JPA0118-55-3 03	171000180 0055007	1GHz~18GHz	Apr. 01, 2019	Feb. 01, 2020~ Feb. 28, 2020	May 31, 2020	Radiation (03CH15-HY)
Preamplifier	Keysight	83017A	MY532701 95	1GHz~26.5GHz	Aug. 23, 2019	Feb. 01, 2020~ Feb. 28, 2020	Aug. 22, 2020	Radiation (03CH15-HY)
Preamplifier	EMEC	EM18G40G	060715	18GHz ~ 40GHz	Dec. 13, 2019	Feb. 01, 2020~ Feb. 28, 2020	Dec. 12, 2020	Radiation (03CH15-HY)
EMI Test Receiver	Keysight	N9038A(MXE )	MY554201 70	20MHz~8.4GHz	Mar. 08, 2019	Feb. 01, 2020~ Feb. 28, 2020	Mar. 07, 2020	Radiation (03CH15-HY)
Spectrum Analyzer	Agilent	E4446A	MY501801 36	3Hz~44GHz	Apr. 29, 2019	Feb. 01, 2020~ Feb. 28, 2020	Apr. 28, 2020	Radiation (03CH15-HY)
Antenna Mast	ChainTek	MBS-520-1	N/A	1m~4m	N/A	Feb. 01, 2020~ Feb. 28, 2020	N/A	Radiation (03CH15-HY)



Instrument	Manufacturer	Model No.	Serial No.	Characteristics	Calibration Date	Test Date	Due Date	Remark
Turn Table	ChainTek	T-200-S-1	N/A	0~360 Degree	N/A	Feb. 01, 2020~ Feb. 28, 2020	N/A	Radiation (03CH15-HY)
Software	Audix	E3 6.2009-8-24(k 5)	RK-00045 1	N/A	N/A	Feb. 01, 2020~ Feb. 28, 2020	N/A	Radiation (03CH15-HY)
RF Cable	HUBER + SUHNER	SUCOFLEX 104	MY36980/ 4	30M-18G	Apr. 15, 2019	Feb. 01, 2020~ Feb. 28, 2020	Apr. 14, 2020	Radiation (03CH15-HY)
RF Cable	HUBER + SUHNER	SUCOFLEX 104	MY9838/4 PE	30M-18G	Apr. 15, 2019	Feb. 01, 2020~ Feb. 28, 2020	Apr. 14, 2020	Radiation (03CH15-HY)
RF Cable	HUBER + SUHNER	SUCOFLEX 104	MY802430 /4	30M~18GHz	May 13, 2019	Feb. 01, 2020~ Feb. 28, 2020	May 12, 2020	Radiation (03CH15-HY)
RF Cable	HUBER + SUHNER	SUCOFLEX 102	505134/2	30MHz-40GHz	Feb. 26, 2019	Feb. 01, 2020~ Feb. 28, 2020	Feb. 25, 2020	Radiation (03CH15-HY)
RF Cable	HUBER + SUHNER	SUCOFLEX 102	800740/2	30MHz-40GHz	Feb. 26, 2019	Feb. 01, 2020~ Feb. 28, 2020	Feb. 25, 2020	Radiation (03CH15-HY)
Filter	Wainwright	WLK4-1000-1 530-8000-40S S	SN4	1.53G Low Pass	Jul. 04, 2019	Feb. 01, 2020~ Feb. 28, 2020	Jul. 03, 2020	Radiation (03CH15-HY)
Filter	Wainwright	WHKX8-5872. 5-6750-18000 -40ST	SN6	6.75GHz High Pass Filter	Jul. 02, 2019	Feb. 01, 2020~ Feb. 28, 2020	Jul. 01, 2020	Radiation (03CH15-HY)





## 5 Uncertainty of Evaluation

### Uncertainty of Conducted Emission Measurement (150kHz ~ 30MHz)

Measuring Uncertainty for a Level of Confidence of 95% ( $U = 2Uc(y)$ )	2.0
---	-----

### Uncertainty of Radiated Emission Measurement (30 MHz ~ 1000 MHz)

Measuring Uncertainty for a Level of Confidence of 95% ( $U = 2Uc(y)$ )	5.0
---	-----

### Uncertainty of Radiated Emission Measurement (1000 MHz ~ 18000 MHz)

Measuring Uncertainty for a Level of Confidence of 95% ( $U = 2Uc(y)$ )	5.4
---	-----

### Uncertainty of Radiated Emission Measurement (18000 MHz ~ 40000 MHz)

Measuring Uncertainty for a Level of Confidence of 95% ( $U = 2Uc(y)$ )	5.0
---	-----



## Appendix A. AC Conducted Emission Test Results

Test Engineer :	Tom Lee	Temperature :	21~25°C
		Relative Humidity :	41~52%
Test Voltage :	120Vac / 60Hz	Phase :	Line
Remark :	All emissions not reported here are more than 10 dB below the prescribed limit.		

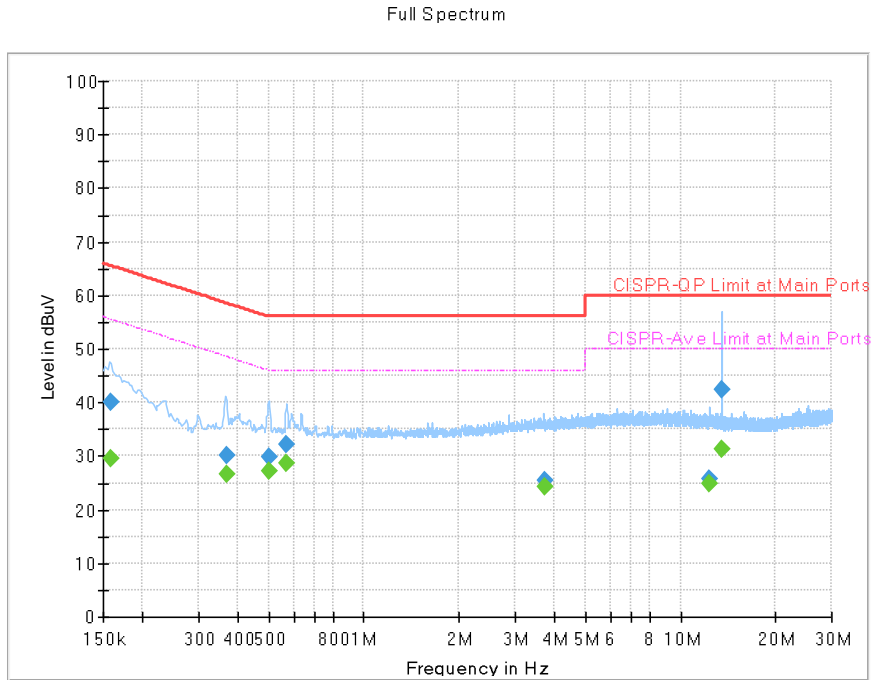

### Final Result

Frequency (MHz)	QuasiPeak (dBuV)	CAverage (dBuV)	Limit (dBuV)	Margin (dB)	Line	Filter	Corr. (dB)
0.159630	---	29.55	55.48	25.93	L1	OFF	19.5
0.159630	40.11	---	65.48	25.37	L1	OFF	19.5
0.368700	---	26.73	48.53	21.80	L1	OFF	19.5
0.368700	30.22	---	58.53	28.31	L1	OFF	19.5
0.500730	---	27.29	46.00	18.71	L1	OFF	19.5
0.500730	29.75	---	56.00	26.25	L1	OFF	19.5
0.567240	---	28.76	46.00	17.24	L1	OFF	19.5
0.567240	32.05	---	56.00	23.95	L1	OFF	19.5
3.709500	---	24.30	46.00	21.70	L1	OFF	19.7
3.709500	25.41	---	56.00	30.59	L1	OFF	19.7
12.295320	---	24.75	50.00	25.25	L1	OFF	20.1
12.295320	25.74	---	60.00	34.26	L1	OFF	20.1
13.560000	---	31.29	50.00	18.71	L1	OFF	20.1
13.560000	42.27	---	60.00	17.73	L1	OFF	20.1



Test Engineer :	Tom Lee	Temperature :	21~25°C
		Relative Humidity :	41~52%
Test Voltage :	120Vac / 60Hz	Phase :	Neutral
Remark :	All emissions not reported here are more than 10 dB below the prescribed limit.		

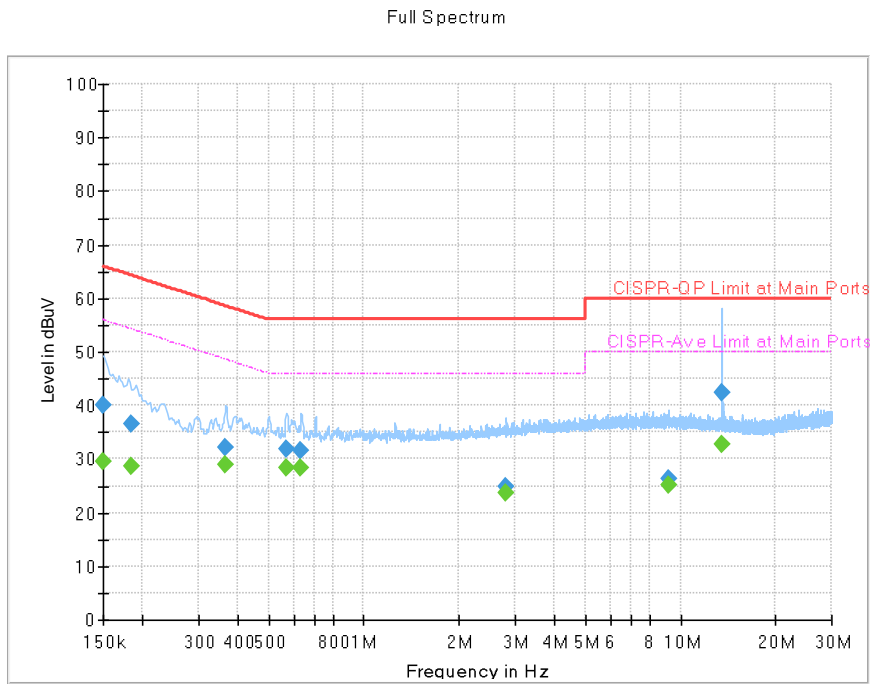

### Final Result

Frequency (MHz)	QuasiPeak (dBuV)	CAverage (dBuV)	Limit (dBuV)	Margin (dB)	Line	Filter	Corr. (dB)
0.150000	---	29.67	56.00	26.33	N	OFF	19.6
0.150000	39.93	---	66.00	26.07	N	OFF	19.6
0.183750	---	28.77	54.31	25.54	N	OFF	19.6
0.183750	36.49	---	64.31	27.82	N	OFF	19.6
0.365910	---	29.05	48.59	19.54	N	OFF	19.6
0.365910	32.16	---	58.59	26.43	N	OFF	19.6
0.567330	---	28.46	46.00	17.54	N	OFF	19.6
0.567330	32.00	---	56.00	24.00	N	OFF	19.6
0.633210	---	28.45	46.00	17.55	N	OFF	19.6
0.633210	31.50	---	56.00	24.50	N	OFF	19.6
2.818950	---	23.71	46.00	22.29	N	OFF	19.6
2.818950	24.72	---	56.00	31.28	N	OFF	19.6
9.125250	---	25.27	50.00	24.73	N	OFF	20.0
9.125250	26.39	---	60.00	33.61	N	OFF	20.0
13.560000	---	32.72	50.00	17.28	N	OFF	20.1
13.560000	42.51	---	60.00	17.49	N	OFF	20.1



## Appendix B. Radiated Spurious Emission

Test Engineer :	Leo Lee , Mancy Chou , and Bigshow Wang	Temperature :	23.9~25.2°C
		Relative Humidity :	53~60%

<Sample 1 with Battery 1>

**Band 1 - 5150~5250MHz**  
**WIFI 802.11a (Band Edge @ 3m)**

WIFI Ant.	Note	Frequency ( MHz )	Level ( dBμV/m )	Over Limit ( dB )	Limit Line ( dBμV/m )	Read Level ( dBμV )	Antenna Factor ( dB/m )	Path Loss ( dB )	Preamp Factor ( dB )	Ant Pos ( cm )	Table Pos ( deg )	Peak Avg. ( P/A )	Pol. ( H/V )	
802.11a CH 36 5180MHz		5149.24	54.19	-19.81	74	43.27	32.1	9.25	30.43	197	49	P	H	
		5148.98	45.28	-8.72	54	34.36	32.1	9.25	30.43	197	49	A	H	
	*	5180	109.5	-	-	98.72	31.92	9.29	30.43	197	49	P	H	
	*	5180	102.17	-	-	91.39	31.92	9.29	30.43	197	49	A	H	
													H	
			5142.22	54.45	-19.55	74	43.55	32.08	9.25	30.43	385	360	P	V
			5150	45.67	-8.33	54	34.74	32.1	9.26	30.43	385	360	A	V
	*		5180	110.45	-	-	99.67	31.92	9.29	30.43	385	360	P	V
	*		5180	103.1	-	-	92.32	31.92	9.29	30.43	385	360	A	V
														V
802.11a CH 44 5220MHz		5147.94	51.61	-22.39	74	40.69	32.1	9.25	30.43	197	51	P	H	
		5148.46	42.61	-11.39	54	31.69	32.1	9.25	30.43	197	51	A	H	
	*	5220	110.83	-	-	100.25	31.68	9.33	30.43	197	51	P	H	
	*	5220	103.13	-	-	92.55	31.68	9.33	30.43	197	51	A	H	
			5389.72	49.98	-24.02	74	39.32	31.64	9.45	30.43	197	51	P	H
			5406.8	41.13	-12.87	54	30.39	31.7	9.47	30.43	197	51	A	H
			5146.64	51.04	-22.96	74	40.13	32.09	9.25	30.43	400	0	P	V
			5146.9	42.54	-11.46	54	31.63	32.09	9.25	30.43	400	0	A	V
	*		5220	111.95	-	-	101.37	31.68	9.33	30.43	400	0	P	V
	*		5220	104.5	-	-	93.92	31.68	9.33	30.43	400	0	A	V
			5381.04	50.61	-23.39	74	40	31.59	9.45	30.43	400	0	P	V
			5352.2	41.61	-12.39	54	31.21	31.41	9.42	30.43	400	0	A	V



<b>802.11a CH 48 5240MHz</b>		5131.82	51.04	-22.96	74	40.17	32.06	9.24	30.43	197	52	P	H
		5149.76	41.37	-12.63	54	30.45	32.1	9.25	30.43	197	52	A	H
	*	5240	109.53	-	-	99.06	31.56	9.34	30.43	197	52	P	H
	*	5240	102.2	-	-	91.73	31.56	9.34	30.43	197	52	A	H
		5444.04	49.56	-24.44	74	38.74	31.7	9.55	30.43	197	52	P	H
		5364.24	40.7	-13.3	54	30.21	31.49	9.43	30.43	197	52	A	H
		5080.08	50.6	-23.4	74	39.89	31.96	9.18	30.43	395	349	P	V
		5134.42	41.22	-12.78	54	30.34	32.07	9.24	30.43	395	349	A	V
	*	5240	111.82	-	-	101.35	31.56	9.34	30.43	395	349	P	V
	*	5240	103.84	-	-	93.37	31.56	9.34	30.43	395	349	A	V
		5410.16	50.17	-23.83	74	39.42	31.7	9.48	30.43	395	349	P	V
		5359.76	41.34	-12.66	54	30.88	31.46	9.43	30.43	395	349	A	V
Remark	1. No other spurious found. 2. All results are PASS against Peak and Average limit line.												



**Band 1 5150~5250MHz**  
**WIFI 802.11a (Harmonic @ 3m)**

WIFI Ant. 1	Note	Frequency ( MHz )	Level ( dBμV/m )	Over Limit ( dB )	Limit Line ( dBμV/m )	Read Level ( dBμV )	Antenna Factor ( dB/m )	Path Loss ( dB )	Preamp Factor ( dB )	Ant Pos ( cm )	Table Pos ( deg )	Peak Avg. ( P/A )	Pol. ( H/V )
802.11a CH 36 5180MHz		10360	43.98	-24.22	68.2	51.27	39.9	13.57	60.76	100	0	P	H
		15540	44.5	-29.5	74	51.04	38	17.01	61.55	100	0	P	H
													H
													H
		10360	43.57	-24.63	68.2	50.86	39.9	13.57	60.76	100	0	P	V
		15540	44.48	-29.52	74	51.02	38	17.01	61.55	100	0	P	V
													V
													V
802.11a CH 44 5220MHz		10440	45.6	-22.6	68.2	52.81	40.1	13.65	60.96	100	0	P	H
		15660	45.12	-28.88	74	51.79	37.58	17.16	61.41	100	0	P	H
													H
													H
		10440	45.91	-22.29	68.2	53.12	40.1	13.65	60.96	100	0	P	V
		15660	44.55	-29.45	74	51.22	37.58	17.16	61.41	100	0	P	V
													V
													V
802.11a CH 48 5240MHz		10480	44.3	-23.9	68.2	51.57	40.1	13.68	61.05	100	0	P	H
		15720	44.35	-29.65	74	51.02	37.46	17.21	61.34	100	0	P	H
													H
													H
		10480	43.86	-24.34	68.2	51.13	40.1	13.68	61.05	100	0	P	V
		15720	43.52	-30.48	74	50.19	37.46	17.21	61.34	100	0	P	V
													V
													V
Remark	1. No other spurious found. 2. All results are PASS against Peak and Average limit line.												



**Band 1 5150~5250MHz**  
**WIFI 802.11ac VHT20 (Band Edge @ 3m)**

WIFI Ant. 1	Note	Frequency ( MHz )	Level ( dBμV/m )	Over Limit ( dB )	Limit Line ( dBμV/m )	Read Level ( dBμV )	Antenna Factor ( dB/m )	Path Loss ( dB )	Preamp Factor ( dB )	Ant Pos ( cm )	Table Pos ( deg )	Peak Avg. ( P/A )	Pol. ( H/V )	
802.11ac VHT20 CH 36 5180MHz		5148.72	54.32	-19.68	74	43.4	32.1	9.25	30.43	198	53	P	H	
		5150	45.64	-8.36	54	34.71	32.1	9.26	30.43	198	53	A	H	
	*	5180	109.69	-	-	98.91	31.92	9.29	30.43	198	53	P	H	
	*	5180	102.27	-	-	91.49	31.92	9.29	30.43	198	53	A	H	
													H	
														H
			5146.64	54.89	-19.11	74	43.98	32.09	9.25	30.43	325	359	P	V
			5148.98	45.73	-8.27	54	34.81	32.1	9.25	30.43	325	359	A	V
		*	5180	110.58	-	-	99.8	31.92	9.29	30.43	325	359	P	V
		*	5180	103.22	-	-	92.44	31.92	9.29	30.43	325	359	A	V
802.11ac VHT20 CH 44 5220MHz		5147.68	51.01	-22.99	74	40.09	32.1	9.25	30.43	199	46	P	H	
		5149.24	42.82	-11.18	54	31.9	32.1	9.25	30.43	199	46	A	H	
		* 5220	110.42	-	-	99.84	31.68	9.33	30.43	199	46	P	H	
		* 5220	102.78	-	-	92.2	31.68	9.33	30.43	199	46	A	H	
			5446.84	50.25	-23.75	74	39.43	31.7	9.55	30.43	199	46	P	H
			5457.2	41.11	-12.89	54	30.23	31.74	9.57	30.43	199	46	A	H
			5138.58	50.88	-23.12	74	39.99	32.08	9.24	30.43	400	353	P	V
			5146.9	42.15	-11.85	54	31.24	32.09	9.25	30.43	400	353	A	V
		*	5220	111.71	-	-	101.13	31.68	9.33	30.43	400	353	P	V
		*	5220	104.12	-	-	93.54	31.68	9.33	30.43	400	353	A	V
		5369.84	50.66	-23.34	74	40.13	31.52	9.44	30.43	400	353	P	V	
		5354.16	41.6	-12.4	54	31.18	31.42	9.43	30.43	400	353	A	V	



<b>802.11ac</b>  <b>VHT20</b>  <b>CH 48</b>  <b>5240MHz</b>		5014.3	50.31	-23.69	74	39.87	31.76	9.11	30.43	204	49	P	H
		5145.86	41.42	-12.58	54	30.51	32.09	9.25	30.43	204	49	A	H
	*	5240	108.32	-	-	97.85	31.56	9.34	30.43	204	49	P	H
	*	5240	99.37	-	-	88.9	31.56	9.34	30.43	204	49	A	H
		5419.12	50.14	-23.86	74	39.37	31.7	9.5	30.43	204	49	P	H
		5370.68	40.76	-13.24	54	30.23	31.52	9.44	30.43	204	49	A	H
		5088.14	50.74	-23.26	74	40	31.98	9.19	30.43	397	358	P	V
		5149.5	41.2	-12.8	54	30.28	32.1	9.25	30.43	397	358	A	V
	*	5240	111.11	-	-	100.64	31.56	9.34	30.43	397	358	P	V
	*	5240	103.51	-	-	93.04	31.56	9.34	30.43	397	358	A	V
		5434.8	50.89	-23.11	74	40.09	31.7	9.53	30.43	397	358	P	V
		5350.52	41.36	-12.64	54	30.97	31.4	9.42	30.43	397	358	A	V
<b>Remark</b>	1. No other spurious found. 2. All results are PASS against Peak and Average limit line.												





**Band 1 5150~5250MHz**  
**WIFI 802.11ac VHT20 (Harmonic @ 3m)**

WIFI Ant. 1	Note	Frequency ( MHz )	Level ( dBμV/m )	Over Limit ( dB )	Limit Line ( dBμV/m )	Read Level ( dBμV )	Antenna Factor ( dB/m )	Path Loss ( dB )	Preamp Factor ( dB )	Ant Pos ( cm )	Table Pos ( deg )	Peak Avg. ( P/A )	Pol. ( H/V )	
802.11ac VHT20 CH 36 5180MHz		10360	44.9	-23.3	68.2	52.19	39.9	13.57	60.76	100	0	P	H	
		15540	44.86	-29.14	74	51.4	38	17.01	61.55	100	0	P	H	
													H	
													H	
			10360	45.37	-22.83	68.2	52.66	39.9	13.57	60.76	100	0	P	V
			15540	45.17	-28.83	74	51.71	38	17.01	61.55	100	0	P	V
														V
802.11ac VHT20 CH 44 5220MHz		10440	45.32	-22.88	68.2	52.53	40.1	13.65	60.96	100	0	P	H	
		15660	45.08	-28.92	74	51.75	37.58	17.16	61.41	100	0	P	H	
													H	
													H	
			10440	45.78	-22.42	68.2	52.99	40.1	13.65	60.96	100	0	P	V
			15660	44.97	-29.03	74	51.64	37.58	17.16	61.41	100	0	P	V
														V
802.11ac VHT20 CH 48 5240MHz		10480	43.54	-24.66	68.2	50.81	40.1	13.68	61.05	100	0	P	H	
		15720	45.26	-28.74	74	51.93	37.46	17.21	61.34	100	0	P	H	
													H	
													H	
			10480	43.62	-24.58	68.2	50.89	40.1	13.68	61.05	100	0	P	V
			15720	44.14	-29.86	74	50.81	37.46	17.21	61.34	100	0	P	V
														V
Remark	1. No other spurious found.													
	2. All results are PASS against Peak and Average limit line.													



Band 1 5150~5250MHz
WIFI 802.11ac VHT40 (Band Edge @ 3m)

Table with 14 columns: WIFI Ant. 1, Note, Frequency (MHz), Level (dBµV/m), Over Limit (dB), Limit Line (dBµV/m), Read Level (dBµV), Antenna Factor (dB/m), Path Loss (dB), Preamp Factor (dB), Ant Pos (cm), Table Pos (deg), Peak Avg. (P/A), Pol. (H/V). Rows include test data for 802.11ac VHT40 CH 38 (5190MHz) and CH 46 (5230MHz).



**Band 1 5150~5250MHz**  
**WIFI 802.11ac VHT40 (Harmonic @ 3m)**

WIFI Ant. 1	Note	Frequency ( MHz )	Level ( dBμV/m )	Over Limit ( dB )	Limit Line ( dBμV/m )	Read Level (dBμV)	Antenna Factor ( dB/m )	Path Loss ( dB )	Preamp Factor ( dB )	Ant Pos ( cm )	Table Pos ( deg )	Peak Avg. (P/A)	Pol. (H/V)
802.11ac VHT40 CH 38 5190MHz		10380	45.13	-23.07	68.2	52.35	40	13.59	60.81	100	0	P	H
		15570	43.63	-30.37	74	50.25	37.85	17.05	61.52	100	0	P	H
													H
													H
		10380	45.25	-22.95	68.2	52.47	40	13.59	60.81	100	0	P	V
		15570	45.84	-28.16	74	52.46	37.85	17.05	61.52	100	0	P	V
													V
802.11ac VHT40 CH 46 5230MHz		10460	44.35	-23.85	68.2	51.59	40.1	13.66	61	100	0	P	H
		15690	44.7	-29.3	74	51.36	37.52	17.19	61.37	100	0	P	H
													H
													H
		10460	43.74	-24.46	68.2	50.98	40.1	13.66	61	100	0	P	V
		15690	43.38	-30.62	74	50.04	37.52	17.19	61.37	100	0	P	V
													V
Remark	1. No other spurious found.												
	2. All results are PASS against Peak and Average limit line.												



**Band 1 5150~5250MHz**  
**WIFI 802.11ac VHT80 (Band Edge @ 3m)**

WIFI Ant. 1	Note	Frequency ( MHz )	Level ( dBμV/m )	Over Limit ( dB )	Limit Line ( dBμV/m )	Read Level (dBμV)	Antenna Factor ( dB/m )	Path Loss ( dB )	Preamp Factor ( dB )	Ant Pos ( cm )	Table Pos ( deg )	Peak Avg. (P/A)	Pol. (H/V)
<b>802.11ac VHT80 CH 42 5210MHz</b>		5140.66	57.92	-16.08	74	47.03	32.08	9.24	30.43	199	48	P	H
		5149.76	51.11	-2.89	54	40.19	32.1	9.25	30.43	199	48	A	H
	*	5210	101.95	-	-	91.32	31.74	9.32	30.43	199	48	P	H
	*	5210	94.26	-	-	83.63	31.74	9.32	30.43	199	48	A	H
		5458.04	50.3	-23.7	74	39.41	31.75	9.57	30.43	199	48	P	H
		5353.32	41.8	-12.2	54	31.39	31.42	9.42	30.43	199	48	A	H
		5149.24	57.22	-16.78	74	46.3	32.1	9.25	30.43	400	353	P	V
		5149.76	49.17	-4.83	54	38.25	32.1	9.25	30.43	400	353	A	V
	*	5210	103.31	-	-	92.68	31.74	9.32	30.43	400	353	P	V
	*	5210	95.91	-	-	85.28	31.74	9.32	30.43	400	353	A	V
		5398.4	50.13	-23.87	74	39.41	31.69	9.46	30.43	400	353	P	V
	5351.36	42.46	-11.54	54	32.06	31.41	9.42	30.43	400	353	A	V	
<b>Remark</b>	1. No other spurious found. 2. All results are PASS against Peak and Average limit line.												



**Band 1 5150~5250MHz  
WIFI 802.11ac VHT80 (Harmonic @ 3m)**

WIFI Ant. 1	Note	Frequency ( MHz )	Level ( dBμV/m )	Over Limit ( dB )	Limit Line ( dBμV/m )	Read Level (dBμV)	Antenna Factor ( dB/m )	Path Loss ( dB )	Preamp Factor ( dB )	Ant Pos ( cm )	Table Pos ( deg )	Peak Avg. (P/A)	Pol. (H/V)	
802.11ac VHT80 CH 42 5210MHz		10420	44.25	-23.95	68.2	51.44	40.1	13.62	60.91	100	0	P	H	
		15630	45.07	-28.93	74	51.75	37.64	17.12	61.44	100	0	P	H	
													H	
													H	
			10420	44.26	-23.94	68.2	51.45	40.1	13.62	60.91	100	0	P	V
			15630	43.46	-30.54	74	50.14	37.64	17.12	61.44	100	0	P	V
														V
													V	
<b>Remark</b>	1. No other spurious found. 2. All results are PASS against Peak and Average limit line.													



**Band 2 - 5250~5350MHz**  
**WIFI 802.11a (Band Edge @ 3m)**

WIFI	Note	Frequency	Level	Over	Limit	Read	Antenna	Path	Preamp	Ant	Table	Peak	Pol.
Ant.				Limit	Line	Level	Factor	Loss	Factor	Pos	Pos	Avg.	
1		( MHz )	( dBμV/m )	( dB )	( dBμV/m )	( dBμV )	( dB/m )	( dB )	( dB )	( cm )	( deg )	(P/A)	(H/V)
802.11a CH 52 5260MHz		5128.18	51.08	-22.92	74	40.22	32.06	9.23	30.43	351	283	P	H
		5104.04	41.07	-12.93	54	30.29	32.01	9.2	30.43	351	283	A	H
	*	5260	110.52	-	-	100.11	31.48	9.36	30.43	351	283	P	H
	*	5260	103.26	-	-	92.85	31.48	9.36	30.43	351	283	A	H
		5458.32	50	-24	74	39.11	31.75	9.57	30.43	351	283	P	H
		5398.32	41.19	-12.81	54	30.47	31.69	9.46	30.43	351	283	A	H
		5061.2	50.1	-23.9	74	39.45	31.92	9.16	30.43	335	357	P	V
		5148.24	41.52	-12.48	54	30.6	32.1	9.25	30.43	335	357	A	V
	*	5260	112.61	-	-	102.2	31.48	9.36	30.43	335	357	P	V
	*	5260	105.14	-	-	94.73	31.48	9.36	30.43	335	357	A	V
		5361.12	50.46	-23.54	74	39.99	31.47	9.43	30.43	335	357	P	V
		5350.08	42.12	-11.88	54	31.73	31.4	9.42	30.43	335	357	A	V
802.11a CH 60 5300MHz		5064.94	50.27	-23.73	74	39.61	31.93	9.16	30.43	363	283	P	H
		5115.6	41.1	-12.9	54	30.28	32.03	9.22	30.43	363	283	A	H
	*	5300	110.17	-	-	99.81	31.4	9.39	30.43	363	283	P	H
	*	5300	102.57	-	-	92.21	31.4	9.39	30.43	363	283	A	H
		5355.12	52.26	-21.74	74	41.83	31.43	9.43	30.43	363	283	P	H
		5350.56	43.06	-10.94	54	32.67	31.4	9.42	30.43	363	283	A	H
		5103.7	49.66	-24.34	74	38.88	32.01	9.2	30.43	349	355	P	V
		5143.82	41.21	-12.79	54	30.3	32.09	9.25	30.43	349	355	A	V
	*	5300	112.56	-	-	102.2	31.4	9.39	30.43	349	355	P	V
	*	5300	105.21	-	-	94.85	31.4	9.39	30.43	349	355	A	V
		5359.44	53.57	-20.43	74	43.11	31.46	9.43	30.43	349	355	P	V
		5350.08	44.96	-9.04	54	34.57	31.4	9.42	30.43	349	355	A	V



<b>802.11a CH 64 5320MHz</b>	*	5320	109.47	-	-	99.1	31.4	9.4	30.43	307	288	P	H
	*	5320	102.15	-	-	91.78	31.4	9.4	30.43	307	288	A	H
		5354.24	53.17	-20.83	74	42.74	31.43	9.43	30.43	307	288	P	H
		5352.8	44.59	-9.41	54	34.18	31.42	9.42	30.43	307	288	A	H
													H
													H
	*	5320	111.08	-	-	100.71	31.4	9.4	30.43	314	358	P	V
	*	5320	103.82	-	-	93.45	31.4	9.4	30.43	314	358	A	V
		5360.8	55.96	-18.04	74	45.5	31.46	9.43	30.43	314	358	P	V
		5350.56	46.03	-7.97	54	35.64	31.4	9.42	30.43	314	358	A	V
													V
													V
<b>Remark</b>	1. No other spurious found. 2. All results are PASS against Peak and Average limit line.												



**Band 2 5250~5350MHz**  
**WIFI 802.11a (Harmonic @ 3m)**

WIFI Ant. 1	Note	Frequency ( MHz )	Level ( dBµV/m )	Over Limit ( dB )	Limit Line ( dBµV/m )	Read Level ( dBµV )	Antenna Factor ( dB/m )	Path Loss ( dB )	Preamp Factor ( dB )	Ant Pos ( cm )	Table Pos ( deg )	Peak Avg. ( P/A )	Pol. ( H/V )
802.11a CH 52 5260MHz		10520	45.2	-23	68.2	52.51	40.12	13.69	61.12	100	0	P	H
		15780	45.41	-28.59	74	52.06	37.34	17.27	61.26	100	0	P	H
													H
													H
		10520	46.32	-21.88	68.2	53.63	40.12	13.69	61.12	100	0	P	V
		15780	44.59	-29.41	74	51.24	37.34	17.27	61.26	100	0	P	V
													V
													V
802.11a CH 60 5300MHz		10600	45.31	-28.69	74	52.62	40.2	13.71	61.22	100	0	P	H
		15900	43.99	-30.01	74	50.93	36.8	17.38	61.12	100	0	P	H
													H
													H
		10600	46.05	-27.95	74	53.36	40.2	13.71	61.22	100	0	P	V
		15900	43.07	-30.93	74	50.01	36.8	17.38	61.12	100	0	P	V
													V
													V
802.11a CH 64 5320MHz		10640	46.01	-27.99	74	53.4	40.16	13.72	61.27	100	0	P	H
		15960	42.38	-31.62	74	49.18	36.92	17.33	61.05	100	0	P	H
													H
													H
		10640	46.54	-27.46	74	53.93	40.16	13.72	61.27	100	0	P	V
		15960	42.76	-31.24	74	49.56	36.92	17.33	61.05	100	0	P	V
													V
													V
Remark	1. No other spurious found. 2. All results are PASS against Peak and Average limit line.												





Band 2 5250~5350MHz
WIFI 802.11ac VHT20 (Band Edge @ 3m)

Table with 14 columns: WIFI Ant. 1, Note, Frequency (MHz), Level (dBµV/m), Over Limit (dB), Limit Line (dBµV/m), Read Level (dBµV), Antenna Factor (dB/m), Path Loss (dB), Preamp Factor (dB), Ant Pos (cm), Table Pos (deg), Peak Avg. (P/A), Pol. (H/V). Rows include data for 802.11ac VHT20 CH 52 (5260MHz) and 802.11ac VHT20 CH 60 (5300MHz).



<b>802.11ac</b> <b>VHT20</b> <b>CH 64</b> <b>5320MHz</b>	*	5320	109.47	-	-	99.1	31.4	9.4	30.43	307	280	P	H
	*	5320	101.94	-	-	91.57	31.4	9.4	30.43	307	280	A	H
		5351.52	53.82	-20.18	74	43.42	31.41	9.42	30.43	307	280	P	H
		5350.88	44.97	-9.03	54	34.57	31.41	9.42	30.43	307	280	A	H
													H
													H
	*	5320	110.87	-	-	100.5	31.4	9.4	30.43	329	356	P	V
	*	5320	103.31	-	-	92.94	31.4	9.4	30.43	329	356	A	V
		5370.88	54.89	-19.11	74	44.35	31.53	9.44	30.43	329	356	P	V
		5351.68	46.26	-7.74	54	35.86	31.41	9.42	30.43	329	356	A	V
													V
													V
<b>Remark</b>	1. No other spurious found. 2. All results are PASS against Peak and Average limit line.												



**Band 2 5250~5350MHz**  
**WIFI 802.11ac VHT20 (Harmonic @ 3m)**

WIFI Ant. 1	Note	Frequency ( MHz )	Level ( dBμV/m )	Over Limit ( dB )	Limit Line ( dBμV/m )	Read Level ( dBμV )	Antenna Factor ( dB/m )	Path Loss ( dB )	Preamp Factor ( dB )	Ant Pos ( cm )	Table Pos ( deg )	Peak Avg. ( P/A )	Pol. ( H/V )	
802.11ac VHT20 CH 52 5260MHz		10520	45.36	-22.84	68.2	52.67	40.12	13.69	61.12	100	0	P	H	
		15780	45.29	-28.71	74	51.94	37.34	17.27	61.26	100	0	P	H	
													H	
													H	
			10520	46.27	-21.93	68.2	53.58	40.12	13.69	61.12	100	0	P	V
			15780	44.92	-29.08	74	51.57	37.34	17.27	61.26	100	0	P	V
														V
802.11ac VHT20 CH 60 5300MHz		10600	45.61	-28.39	74	52.92	40.2	13.71	61.22	100	0	P	H	
		15900	43.36	-30.64	74	50.3	36.8	17.38	61.12	100	0	P	H	
													H	
													H	
			10600	45.21	-28.79	74	52.52	40.2	13.71	61.22	100	0	P	V
			15900	43.77	-30.23	74	50.71	36.8	17.38	61.12	100	0	P	V
														V
802.11ac VHT20 CH 64 5320MHz		10640	46.27	-27.73	74	53.66	40.16	13.72	61.27	100	0	P	H	
		15960	44.94	-29.06	74	51.74	36.92	17.33	61.05	100	0	P	H	
													H	
													H	
			10640	46.49	-27.51	74	53.88	40.16	13.72	61.27	100	0	P	V
			15960	43.99	-30.01	74	50.79	36.92	17.33	61.05	100	0	P	V
														V
Remark	1. No other spurious found.													
	2. All results are PASS against Peak and Average limit line.													



**Band 2 5250~5350MHz**  
**WIFI 802.11ac VHT40 (Band Edge @ 3m)**

WIFI Ant. 1	Note	Frequency ( MHz )	Level ( dBμV/m )	Over Limit ( dB )	Limit Line ( dBμV/m )	Read Level ( dBμV )	Antenna Factor ( dB/m )	Path Loss ( dB )	Preamp Factor ( dB )	Ant Pos ( cm )	Table Pos ( deg )	Peak Avg. ( P/A )	Pol. ( H/V )
802.11ac VHT40 CH 54 5270MHz		5127.84	50.59	-23.41	74	39.73	32.06	9.23	30.43	346	283	P	H
		5147.9	42.02	-11.98	54	31.1	32.1	9.25	30.43	346	283	A	H
	*	5270	106.9	-	-	96.51	31.46	9.36	30.43	346	283	P	H
	*	5270	99.17	-	-	88.78	31.46	9.36	30.43	346	283	A	H
		5351.52	51.38	-22.62	74	40.98	31.41	9.42	30.43	346	283	P	H
		5350.56	43.39	-10.61	54	33	31.4	9.42	30.43	346	283	A	H
		5113.56	50.36	-23.64	74	39.55	32.03	9.21	30.43	335	355	P	V
		5142.12	42.13	-11.87	54	31.23	32.08	9.25	30.43	335	355	A	V
	*	5270	109.79	-	-	99.4	31.46	9.36	30.43	335	355	P	V
	*	5270	102.05	-	-	91.66	31.46	9.36	30.43	335	355	A	V
		5350.32	52.8	-21.2	74	42.41	31.4	9.42	30.43	335	355	P	V
		5350.56	45.81	-8.19	54	35.42	31.4	9.42	30.43	335	355	A	V
802.11ac VHT40 CH 62 5310MHz		5040.8	49.27	-24.73	74	38.71	31.86	9.13	30.43	322	287	P	H
		5109.48	41.45	-12.55	54	30.65	32.02	9.21	30.43	322	287	A	H
	*	5310	103.95	-	-	93.59	31.4	9.39	30.43	322	287	P	H
	*	5310	96.38	-	-	86.02	31.4	9.39	30.43	322	287	A	H
		5351.52	56.17	-17.83	74	45.77	31.41	9.42	30.43	322	287	P	H
		5350.56	49.03	-4.97	54	38.64	31.4	9.42	30.43	322	287	A	H
		5043.18	49.32	-24.68	74	38.74	31.87	9.14	30.43	385	358	P	V
		5088.74	41.48	-12.52	54	30.74	31.98	9.19	30.43	385	358	A	V
	*	5310	106.26	-	-	95.9	31.4	9.39	30.43	385	358	P	V
	*	5310	98.5	-	-	88.14	31.4	9.39	30.43	385	358	A	V
	5354.16	58.71	-15.29	74	48.29	31.42	9.43	30.43	385	358	P	V	
	5350.32	50.9	-3.1	54	40.51	31.4	9.42	30.43	385	358	A	V	
Remark	1. No other spurious found. 2. All results are PASS against Peak and Average limit line.												



**Band 2 5250~5350MHz  
WIFI 802.11ac VHT40 (Harmonic @ 3m)**

WIFI Ant. 1	Note	Frequency ( MHz )	Level ( dBμV/m )	Over Limit ( dB )	Limit Line ( dBμV/m )	Read Level (dBμV)	Antenna Factor ( dB/m )	Path Loss ( dB )	Preamp Factor ( dB )	Ant Pos ( cm )	Table Pos ( deg )	Peak Avg. (P/A)	Pol. (H/V)	
802.11ac VHT40 CH 54 5270MHz		10540	43.57	-24.63	68.2	50.88	40.14	13.7	61.15	100	0	P	H	
		15810	43.56	-30.44	74	50.24	37.25	17.3	61.23	100	0	P	H	
													H	
													H	
			10540	43.57	-24.63	68.2	50.88	40.14	13.7	61.15	100	0	P	V
			15810	43.14	-30.86	74	49.82	37.25	17.3	61.23	100	0	P	V
														V
802.11ac VHT40 CH 62 5310MHz		10620	45.85	-28.15	74	53.19	40.18	13.72	61.24	100	0	P	H	
		15930	43.83	-30.17	74	50.69	36.86	17.36	61.08	100	0	P	H	
													H	
													H	
			10620	46.31	-27.69	74	53.65	40.18	13.72	61.24	100	0	P	V
			15930	44.29	-29.71	74	51.15	36.86	17.36	61.08	100	0	P	V
														V
Remark	1. No other spurious found.													
	2. All results are PASS against Peak and Average limit line.													



**Band 2 5250~5350MHz**  
**WIFI 802.11ac VHT80 (Band Edge @ 3m)**

WIFI Ant. 1	Note	Frequency ( MHz )	Level ( dBμV/m )	Over Limit ( dB )	Limit Line ( dBμV/m )	Read Level (dBμV)	Antenna Factor ( dB/m )	Path Loss ( dB )	Preamp Factor ( dB )	Ant Pos ( cm )	Table Pos ( deg )	Peak Avg. (P/A)	Pol. (H/V)
<b>802.11ac VHT80 CH 58 5290MHz</b>		5078.88	50.06	-23.94	74	39.35	31.96	9.18	30.43	385	269	P	H
		5149.94	41.66	-12.34	54	30.74	32.1	9.25	30.43	385	269	A	H
	*	5290	100.05	-	-	89.68	31.42	9.38	30.43	385	269	P	H
	*	5290	92.65	-	-	82.28	31.42	9.38	30.43	385	269	A	H
		5358.72	57.3	-16.7	74	46.85	31.45	9.43	30.43	385	269	P	H
		5350.56	49.54	-4.46	54	39.15	31.4	9.42	30.43	385	269	A	H
		5115.6	49.53	-24.47	74	38.71	32.03	9.22	30.43	388	351	P	V
		5147.22	41.94	-12.06	54	31.03	32.09	9.25	30.43	388	351	A	V
	*	5290	102.15	-	-	91.78	31.42	9.38	30.43	388	351	P	V
	*	5290	94.64	-	-	84.27	31.42	9.38	30.43	388	351	A	V
		5352.96	59.88	-14.12	74	49.47	31.42	9.42	30.43	388	351	P	V
	5350.32	51.93	-2.07	54	41.54	31.4	9.42	30.43	388	351	A	V	
<b>Remark</b>	1. No other spurious found. 2. All results are PASS against Peak and Average limit line.												



**Band 2 5250~5350MHz  
WIFI 802.11ac VHT80 (Harmonic @ 3m)**

WIFI Ant. 1	Note	Frequency ( MHz )	Level ( dBμV/m )	Over Limit ( dB )	Limit Line ( dBμV/m )	Read Level (dBμV)	Antenna Factor ( dB/m )	Path Loss ( dB )	Preamp Factor ( dB )	Ant Pos ( cm )	Table Pos ( deg )	Peak Avg. (P/A)	Pol. (H/V)	
802.11ac VHT80 CH 58 5290MHz		10580	44.04	-24.16	68.2	51.35	40.18	13.71	61.2	100	0	P	H	
		15870	42.99	-31.01	74	49.85	36.95	17.35	61.16	100	0	P	H	
													H	
													H	
			10580	45.39	-22.81	68.2	52.7	40.18	13.71	61.2	100	0	P	V
			15870	43	-31	74	49.86	36.95	17.35	61.16	100	0	P	V
														V
													V	
<b>Remark</b>	1. No other spurious found. 2. All results are PASS against Peak and Average limit line.													



**Band 3 - 5470~5725MHz**  
**WIFI 802.11a (Band Edge @ 3m)**

WIFI	Note	Frequency	Level	Over	Limit	Read	Antenna	Path	Preamp	Ant	Table	Peak	Pol.	
Ant.				Limit	Line	Level	Factor	Loss	Factor	Pos	Pos	Avg.		
1		( MHz )	( dBμV/m )	( dB )	( dBμV/m )	( dBμV )	( dB/m )	( dB )	( dB )	( cm )	( deg )	( P/A )	( H/V )	
802.11a CH 100 5500MHz		5457.2	53.11	-20.89	74	42.23	31.74	9.57	30.43	226	259	P	H	
		5464.4	54.27	-13.93	68.2	43.32	31.79	9.59	30.43	226	259	P	H	
		5458.32	43.67	-10.33	54	32.78	31.75	9.57	30.43	226	259	A	H	
	*	5500	109.28	-	-	98.05	32	9.66	30.43	226	259	P	H	
	*	5500	101.94	-	-	90.71	32	9.66	30.43	226	259	A	H	
														H
			5453.04	54.88	-19.12	74	44.03	31.72	9.56	30.43	400	352	P	V
			5469.68	57.92	-10.28	68.2	46.93	31.82	9.6	30.43	400	352	P	V
			5459.76	45.39	-8.61	54	34.48	31.76	9.58	30.43	400	352	A	V
	*		5500	112.69	-	-	101.46	32	9.66	30.43	400	352	P	V
	*		5500	104.97	-	-	93.74	32	9.66	30.43	400	352	A	V
														V
802.11a CH 116 5580MHz		5433.52	50.23	-23.77	74	39.43	31.7	9.53	30.43	206	255	P	H	
		5466.4	50.37	-17.83	68.2	39.41	31.8	9.59	30.43	206	255	P	H	
		5459.68	41.13	-12.87	54	30.22	31.76	9.58	30.43	206	255	A	H	
	*	5580	110.56	-	-	99.37	31.86	9.81	30.48	206	255	P	H	
	*	5580	103.14	-	-	91.95	31.86	9.81	30.48	206	255	A	H	
			5754.605	51.7	-16.5	68.2	40.4	32.02	9.87	30.59	206	255	P	H
			5431.84	50.88	-23.12	74	40.09	31.7	9.52	30.43	304	353	P	V
			5469.76	50.5	-17.7	68.2	39.51	31.82	9.6	30.43	304	353	P	V
			5456.32	41.74	-12.26	54	30.86	31.74	9.57	30.43	304	353	A	V
	*		5580	114.04	-	-	102.85	31.86	9.81	30.48	304	353	P	V
	*		5580	106.22	-	-	95.03	31.86	9.81	30.48	304	353	A	V
			5743.58	50.05	-18.15	68.2	38.77	32	9.86	30.58	304	353	P	V





<b>802.11a</b> <b>CH 140</b> <b>5700MHz</b>	*	5700	110.4	-	-	99.09	32	9.86	30.55	266	314	P	H
	*	5700	103.15	-	-	91.84	32	9.86	30.55	266	314	A	H
		5725.24	58.34	-9.86	68.2	47.05	32	9.86	30.57	266	314	P	H
													H
													H
													H
	*	5700	113.44	-	-	102.13	32	9.86	30.55	202	344	P	V
	*	5700	105.78	-	-	94.47	32	9.86	30.55	202	344	A	V
		5725	61.56	-6.64	68.2	50.27	32	9.86	30.57	202	344	P	V
													V
													V
													V
<b>Remark</b>	1. No other spurious found. 2. All results are PASS against Peak and Average limit line.												



**Band 3 - 5470~5725MHz**  
**WIFI 802.11a (Harmonic @ 3m)**

WIFI Ant. 1	Note	Frequency ( MHz )	Level ( dBμV/m )	Over Limit ( dB )	Limit Line ( dBμV/m )	Read Level (dBμV)	Antenna Factor ( dB/m )	Path Loss ( dB )	Preamp Factor ( dB )	Ant Pos ( cm )	Table Pos ( deg )	Peak Avg. (P/A)	Pol. (H/V)	
802.11a CH 100 5500MHz		11000	58.35	-15.65	74	65.59	40.6	13.86	61.7	100	37	P	H	
		11000	48.58	-5.42	54	55.82	40.6	13.86	61.7	100	37	A	H	
		16500	45.12	-23.08	68.2	48.47	38.8	17.55	59.7	100	0	P	H	
													H	
			11000	48.28	-25.72	74	55.52	40.6	13.86	61.7	100	0	P	V
			16500	44.19	-24.01	68.2	47.54	38.8	17.55	59.7	100	0	P	V
														V
802.11a CH 116 5580MHz		11160	61.22	-12.78	74	68.72	40.22	14.14	61.86	100	254	P	H	
		11160	50.76	-3.24	54	58.26	40.22	14.14	61.86	100	254	A	H	
		16740	47.23	-20.97	68.2	48.98	39.98	17.92	59.65	100	0	P	H	
													H	
			11160	59.06	-14.94	74	66.56	40.22	14.14	61.86	194	84	P	V
			11160	48.94	-5.06	54	56.44	40.22	14.14	61.86	194	84	A	V
			16740	47.1	-21.1	68.2	48.85	39.98	17.92	59.65	100	0	P	V
802.11a CH 140 5700MHz		11400	61.15	-12.85	74	68.42	40.3	14.53	62.1	100	259	P	H	
		11400	50.51	-3.49	54	57.78	40.3	14.53	62.1	100	259	A	H	
		17100	47.6	-20.6	68.2	47.94	40.8	18.24	59.38	100	0	P	H	
													H	
			11400	59.15	-14.85	74	66.42	40.3	14.53	62.1	224	294	P	V
			11400	48.39	-5.61	54	55.66	40.3	14.53	62.1	224	294	A	V
			17100	47.62	-20.58	68.2	47.96	40.8	18.24	59.38	100	0	P	V
													V	
Remark	1. No other spurious found. 2. All results are PASS against Peak and Average limit line.													



**Band 3 - 5470~5725MHz**  
**WIFI 802.11ac VHT20 (Band Edge @ 3m)**

WIFI Ant. 1	Note	Frequency ( MHz )	Level ( dBμV/m )	Over Limit ( dB )	Limit Line ( dBμV/m )	Read Level ( dBμV )	Antenna Factor ( dB/m )	Path Loss ( dB )	Preamp Factor ( dB )	Ant Pos ( cm )	Table Pos ( deg )	Peak Avg. ( P/A )	Pol. ( H/V )	
802.11ac VHT20 CH 100 5500MHz		5457.2	53.14	-20.86	74	42.26	31.74	9.57	30.43	254	316	P	H	
		5465.52	53.77	-14.43	68.2	42.82	31.79	9.59	30.43	254	316	P	H	
		5460	44.44	-9.56	54	33.53	31.76	9.58	30.43	254	316	A	H	
	*	5500	109.94	-	-	98.71	32	9.66	30.43	254	316	P	H	
	*	5500	102.47	-	-	91.24	32	9.66	30.43	254	316	A	H	
														H
			5457.36	55.21	-18.79	74	44.33	31.74	9.57	30.43	201	353	P	V
			5467.6	58.45	-9.75	68.2	47.48	31.81	9.59	30.43	201	353	P	V
			5460	45.95	-8.05	54	35.04	31.76	9.58	30.43	201	353	A	V
	*		5500	113.18	-	-	101.95	32	9.66	30.43	201	353	P	V
	*		5500	105.36	-	-	94.13	32	9.66	30.43	201	353	A	V
													V	
802.11ac VHT20 CH 116 5580MHz		5443.36	50.05	-23.95	74	39.24	31.7	9.54	30.43	204	260	P	H	
		5467.36	50.14	-18.06	68.2	39.18	31.8	9.59	30.43	204	260	P	H	
		5459.92	41.19	-12.81	54	30.28	31.76	9.58	30.43	204	260	A	H	
	*	5580	111.18	-	-	99.99	31.86	9.81	30.48	204	260	P	H	
	*	5580	102.78	-	-	91.59	31.86	9.81	30.48	204	260	A	H	
			5728.775	49.83	-18.37	68.2	38.54	32	9.86	30.57	204	260	P	H
			5450.32	50.21	-23.79	74	39.38	31.7	9.56	30.43	302	355	P	V
			5468.56	50	-18.2	68.2	39.03	31.81	9.59	30.43	302	355	P	V
			5453.2	41.64	-12.36	54	30.79	31.72	9.56	30.43	302	355	A	V
	*		5580	113.92	-	-	102.73	31.86	9.81	30.48	302	355	P	V
	*		5580	106.32	-	-	95.13	31.86	9.81	30.48	302	355	A	V
		5728.775	51.03	-17.17	68.2	39.74	32	9.86	30.57	302	355	P	V	



<b>802.11ac</b> <b>VHT20</b> <b>CH 140</b> <b>5700MHz</b>	*	5700	109.5	-	-	98.19	32	9.86	30.55	262	310	P	H
	*	5700	102.03	-	-	90.72	32	9.86	30.55	262	310	A	H
		5725.16	62.55	-5.65	68.2	51.26	32	9.86	30.57	262	310	P	H
													H
													H
													H
	*	5700	112.35	-	-	101.04	32	9.86	30.55	321	345	P	V
	*	5700	104.89	-	-	93.58	32	9.86	30.55	321	345	A	V
		5725	65.45	-2.75	68.2	54.16	32	9.86	30.57	321	345	P	V
													V
													V
													V
<b>Remark</b>	1. No other spurious found. 2. All results are PASS against Peak and Average limit line.												



**Band 3 - 5470~5725MHz**  
**WIFI 802.11ac VHT20 (Harmonic @ 3m)**

WIFI Ant. 1	Note	Frequency ( MHz )	Level ( dBµV/m )	Over Limit ( dB )	Limit Line ( dBµV/m )	Read Level (dBµV)	Antenna Factor ( dB/m )	Path Loss ( dB )	Preamp Factor ( dB )	Ant Pos ( cm )	Table Pos ( deg )	Peak Avg. (P/A)	Pol. (H/V)	
802.11ac VHT20 CH 100 5500MHz		11000	49.58	-24.42	74	56.82	40.6	13.86	61.7	100	0	P	H	
		16500	45.94	-22.26	68.2	49.29	38.8	17.55	59.7	100	0	P	H	
													H	
													H	
			11000	47.05	-26.95	74	54.29	40.6	13.86	61.7	100	0	P	V
			16500	45.73	-22.47	68.2	49.08	38.8	17.55	59.7	100	0	P	V
														V
802.11ac VHT20 CH 116 5580MHz		11160	59.03	-14.97	74	66.53	40.22	14.14	61.86	263	4	P	H	
		11160	47.83	-6.17	54	55.33	40.22	14.14	61.86	263	4	A	H	
		16740	46.26	-21.94	68.2	48.01	39.98	17.92	59.65	100	0	P	H	
													H	
			11160	58.02	-15.98	74	65.52	40.22	14.14	61.86	200	245	P	V
			11160	46.28	-7.72	54	53.78	40.22	14.14	61.86	200	245	A	V
			16740	46.24	-21.96	68.2	47.99	39.98	17.92	59.65	100	0	P	V
802.11ac VHT20 CH 140 5700MHz		11400	60.1	-13.9	74	67.37	40.3	14.53	62.1	189	326	P	H	
		11400	50.75	-3.25	54	58.02	40.3	14.53	62.1	189	326	A	H	
		17100	48.36	-19.84	68.2	48.7	40.8	18.24	59.38	100	0	P	H	
													H	
			11400	59.57	-14.43	74	66.84	40.3	14.53	62.1	200	310	P	V
			11400	49.61	-4.39	54	56.88	40.3	14.53	62.1	200	310	A	V
			17100	48.89	-19.31	68.2	49.23	40.8	18.24	59.38	100	0	P	V
													V	
Remark	1. No other spurious found. 2. All results are PASS against Peak and Average limit line.													



**Band 3 - 5470~5725MHz**  
**WIFI 802.11ac VHT40 (Band Edge @ 3m)**

WIFI Ant. 1	Note	Frequency ( MHz )	Level ( dBμV/m )	Over Limit ( dB )	Limit Line ( dBμV/m )	Read Level ( dBμV )	Antenna Factor ( dB/m )	Path Loss ( dB )	Preamp Factor ( dB )	Ant Pos ( cm )	Table Pos ( deg )	Peak Avg. ( P/A )	Pol. ( H/V )
802.11ac VHT40 CH 102 5510MHz		5459.35	56.05	-17.95	74	45.14	31.76	9.58	30.43	254	315	P	H
		5469.88	61.19	-7.01	68.2	50.2	31.82	9.6	30.43	254	315	P	H
		5459.89	48.64	-5.36	54	37.73	31.76	9.58	30.43	254	315	A	H
	*	5510	105.99	-	-	94.8	31.96	9.67	30.44	254	315	P	H
	*	5510	98.19	-	-	87	31.96	9.67	30.44	254	315	A	H
		5738.54	49.65	-18.55	68.2	38.37	32	9.86	30.58	254	315	P	H
		5459.89	59.7	-14.3	74	48.79	31.76	9.58	30.43	249	342	P	V
		5469.88	66	-2.2	68.2	55.01	31.82	9.6	30.43	249	342	P	V
		5459.62	50.57	-3.43	54	39.66	31.76	9.58	30.43	249	342	A	V
	*	5510	109.02	-	-	97.83	31.96	9.67	30.44	249	342	P	V
	*	5510	101.35	-	-	90.16	31.96	9.67	30.44	249	342	A	V
	5730.35	49.84	-18.36	68.2	38.55	32	9.86	30.57	249	342	P	V	
802.11ac VHT40 CH 110 5550MHz		5458	51.91	-22.09	74	41.02	31.75	9.57	30.43	205	255	P	H
		5460.97	51.09	-17.11	68.2	40.17	31.77	9.58	30.43	205	255	P	H
		5459.35	43.05	-10.95	54	32.14	31.76	9.58	30.43	205	255	A	H
	*	5550	107	-	-	95.91	31.8	9.75	30.46	205	255	P	H
	*	5550	99.33	-	-	88.24	31.8	9.75	30.46	205	255	A	H
		5746.73	51.54	-16.66	68.2	40.26	32	9.86	30.58	205	255	P	H
		5450.44	52.51	-21.49	74	41.68	31.7	9.56	30.43	187	345	P	V
		5468.53	53.32	-14.88	68.2	42.35	31.81	9.59	30.43	187	345	P	V
		5459.35	44.42	-9.58	54	33.51	31.76	9.58	30.43	187	345	A	V
	*	5550	110.22	-	-	99.13	31.8	9.75	30.46	187	345	P	V
	*	5550	102.64	-	-	91.55	31.8	9.75	30.46	187	345	A	V
	5733.185	50.44	-17.76	68.2	39.15	32	9.86	30.57	187	345	P	V	



<b>802.11ac</b>  <b>VHT40</b>  <b>CH 134</b>  <b>5670MHz</b>		5435.47	48.78	-25.22	74	37.98	31.7	9.53	30.43	251	313	P	H
		5462.85	48.15	-20.05	68.2	37.22	31.78	9.58	30.43	251	313	P	H
		5456.56	41.3	-12.7	54	30.42	31.74	9.57	30.43	251	313	A	H
	*	5670	106.88	-	-	95.68	31.88	9.86	30.54	251	313	P	H
	*	5670	99.08	-	-	87.88	31.88	9.86	30.54	251	313	A	H
		5726.325	53.34	-14.86	68.2	42.05	32	9.86	30.57	251	313	P	H
		5392.92	49.58	-24.42	74	38.9	31.66	9.45	30.43	322	353	P	V
		5463.22	49.78	-18.42	68.2	38.85	31.78	9.58	30.43	322	353	P	V
		5446.2	41.36	-12.64	54	30.54	31.7	9.55	30.43	322	353	A	V
	*	5670	109.38	-	-	98.18	31.88	9.86	30.54	322	353	P	V
	*	5670	101.75	-	-	90.55	31.88	9.86	30.54	322	353	A	V
		5726.15	55.27	-12.93	68.2	43.98	32	9.86	30.57	322	353	P	V
<b>Remark</b>	1. No other spurious found. 2. All results are PASS against Peak and Average limit line.												



**Band 3 - 5470~5725MHz**  
**WIFI 802.11ac VHT40 (Harmonic @ 3m)**

WIFI Ant. 1	Note	Frequency ( MHz )	Level ( dBμV/m )	Over Limit ( dB )	Limit Line ( dBμV/m )	Read Level ( dBμV )	Antenna Factor ( dB/m )	Path Loss ( dB )	Preamp Factor ( dB )	Ant Pos ( cm )	Table Pos ( deg )	Peak Avg. ( P/A )	Pol. ( H/V )	
802.11ac VHT40 CH 102 5510MHz		11020	49.48	-24.52	74	56.75	40.56	13.89	61.72	100	0	P	H	
		16530	44.72	-23.48	68.2	47.98	38.83	17.6	59.69	100	0	P	H	
													H	
													H	
			11020	46.77	-27.23	74	54.04	40.56	13.89	61.72	100	0	P	V
			16530	45.65	-22.55	68.2	48.91	38.83	17.6	59.69	100	0	P	V
														V
802.11ac VHT40 CH 110 5550MHz		11100	58.43	-15.57	74	65.85	40.4	13.98	61.8	100	102	P	H	
		11100	46.66	-7.34	54	54.08	40.4	13.98	61.8	100	102	A	H	
		16650	44.47	-23.73	68.2	47.02	39.3	17.82	59.67	100	0	P	H	
													H	
			11100	46.48	-27.52	74	53.9	40.4	13.98	61.8	100	0	P	V
			16650	44.19	-24.01	68.2	46.74	39.3	17.82	59.67	100	0	P	V
														V
802.11ac VHT40 CH 134 5670MHz		11340	57.98	-16.02	74	65.31	40.18	14.53	62.04	200	10	P	H	
		11340	50.13	-3.87	54	57.46	40.18	14.53	62.04	200	10	A	H	
		17010	48.54	-19.66	68.2	49.41	40.62	18.09	59.58	100	0	P	H	
													H	
			11340	49.22	-24.78	74	56.55	40.18	14.53	62.04	100	0	P	V
			17010	47.84	-20.36	68.2	48.71	40.62	18.09	59.58	100	0	P	V
														V
Remark	1. No other spurious found. 2. All results are PASS against Peak and Average limit line.													





**Band 3 5470~5725MHz**  
**WIFI 802.11ac VHT80 (Band Edge @ 3m)**

WIFI Ant. 1	Note	Frequency ( MHz )	Level ( dBμV/m )	Over Limit ( dB )	Limit Line ( dBμV/m )	Read Level ( dBμV )	Antenna Factor ( dB/m )	Path Loss ( dB )	Preamp Factor ( dB )	Ant Pos ( cm )	Table Pos ( deg )	Peak Avg. ( P/A )	Pol. ( H/V )
802.11ac VHT80 CH 106 5530MHz		5459.62	56.17	-17.83	74	45.26	31.76	9.58	30.43	261	315	P	H
		5465.56	57.66	-10.54	68.2	46.71	31.79	9.59	30.43	261	315	P	H
		5459.89	49.02	-4.98	54	38.11	31.76	9.58	30.43	261	315	A	H
	*	5530	101.93	-	-	90.79	31.88	9.71	30.45	261	315	P	H
	*	5530	94	-	-	82.86	31.88	9.71	30.45	261	315	A	H
		5752.715	50.4	-17.8	68.2	39.11	32.01	9.87	30.59	261	315	P	H
		5455.3	58.99	-15.01	74	48.12	31.73	9.57	30.43	205	344	P	V
		5469.88	61.08	-7.12	68.2	50.09	31.82	9.6	30.43	205	344	P	V
		5459.35	51.49	-2.51	54	40.58	31.76	9.58	30.43	205	344	A	V
	*	5530	104.41	-	-	93.27	31.88	9.71	30.45	205	344	P	V
	*	5530	97	-	-	85.86	31.88	9.71	30.45	205	344	A	V
		5762.795	50.61	-17.59	68.2	39.28	32.05	9.87	30.59	205	344	P	V
802.11ac VHT80 CH 122 5610MHz		5449.63	52.14	-21.86	74	41.31	31.7	9.56	30.43	400	257	P	H
		5469.34	51.59	-16.61	68.2	40.6	31.82	9.6	30.43	400	257	P	H
		5458.81	43.7	-10.3	54	32.81	31.75	9.57	30.43	400	257	A	H
	*	5610	103.6	-	-	92.37	31.88	9.85	30.5	400	257	P	H
	*	5610	96.11	-	-	84.88	31.88	9.85	30.5	400	257	A	H
		5739.17	52.22	-15.98	68.2	40.94	32	9.86	30.58	400	257	P	H
		5456.92	54.33	-19.67	74	43.45	31.74	9.57	30.43	330	351	P	V
		5466.1	55.81	-12.39	68.2	44.85	31.8	9.59	30.43	330	351	P	V
		5458.81	45.84	-8.16	54	34.95	31.75	9.57	30.43	330	351	A	V
	*	5610	107.98	-	-	96.75	31.88	9.85	30.5	330	351	P	V
	*	5610	100.53	-	-	89.3	31.88	9.85	30.5	330	351	A	V
		5730.665	54.9	-13.3	68.2	43.61	32	9.86	30.57	330	351	P	V
Remark	1. No other spurious found. 2. All results are PASS against Peak and Average limit line.												



**Band 3 5470~5725MHz**  
**WIFI 802.11ac VHT80 (Harmonic @ 3m)**

WIFI Ant. 1	Note	Frequency ( MHz )	Level ( dBμV/m )	Over Limit ( dB )	Limit Line ( dBμV/m )	Read Level (dBμV)	Antenna Factor ( dB/m )	Path Loss ( dB )	Preamp Factor ( dB )	Ant Pos ( cm )	Table Pos ( deg )	Peak Avg. (P/A)	Pol. (H/V)	
802.11ac VHT80 CH 106 5530MHz		11060	47.64	-26.36	74	54.98	40.48	13.94	61.76	100	0	P	H	
		16590	45.44	-22.76	68.2	48.52	38.89	17.71	59.68	100	0	P	H	
													H	
													H	
			11060	46.38	-27.62	74	53.72	40.48	13.94	61.76	100	0	P	V
			16590	45.88	-22.32	68.2	48.96	38.89	17.71	59.68	100	0	P	V
														V
802.11ac VHT80 CH 122 5610MHz		11220	58.37	-15.63	74	65.87	40.1	14.32	61.92	200	2	P	H	
		11220	47.17	-6.83	54	54.67	40.1	14.32	61.92	200	2	A	H	
		16830	45.91	-22.29	68.2	47.24	40.34	17.96	59.63	100	0	P	H	
													H	
			11220	47.3	-26.7	74	54.8	40.1	14.32	61.92	100	0	P	V
			16830	45.93	-22.27	68.2	47.26	40.34	17.96	59.63	100	0	P	V
														V
Remark	1. No other spurious found.													
	2. All results are PASS against Peak and Average limit line.													



**Band 3 - Straddle Channel**  
**WIFI 802.11a (Band Edge @ 3m)**

WIFI	Note	Frequency	Level	Over	Limit	Read	Antenna	Path	Preamp	Ant	Table	Peak	Pol.
Ant.				Limit	Line	Level	Factor	Loss	Factor	Pos	Pos	Avg.	
1		( MHz )	( dBμV/m )	( dB )	( dBμV/m )	( dBμV )	( dB/m )	( dB )	( dB )	( cm )	( deg )	( P/A )	( H/V )
<b>802.11a CH 144 5720MHz</b>		5427.22	49.86	-24.14	74	39.08	31.7	9.51	30.43	256	316	P	H
		5465.44	49.37	-18.83	68.2	38.42	31.79	9.59	30.43	256	316	P	H
		5458.03	40.93	-13.07	54	30.04	31.75	9.57	30.43	256	316	A	H
	*	5720	110.61	-	-	99.32	32	9.86	30.57	256	316	P	H
	*	5720	103.37	-	-	92.08	32	9.86	30.57	256	316	A	H
		5919.25	51.12	-17.08	68.2	39.35	32.44	10.02	30.69	256	316	P	H
		5424.49	50.05	-23.95	74	39.27	31.7	9.51	30.43	302	349	P	V
		5470	50.69	-17.51	68.2	39.7	31.82	9.6	30.43	302	349	P	V
		5458.81	41.13	-12.87	54	30.24	31.75	9.57	30.43	302	349	A	V
	*	5720	114.09	-	-	102.8	32	9.86	30.57	302	349	P	V
	*	5720	106.73	-	-	95.44	32	9.86	30.57	302	349	A	V
		5948.25	52.02	-16.18	68.2	40.17	32.5	10.06	30.71	302	349	P	V
<b>Remark</b>	1. No other spurious found. 2. All results are PASS against Peak and Average limit line.												



Band 3 - Straddle Channel
WIFI 802.11a (Harmonic @ 3m)

Table with 14 columns: WIFI Ant. 1, Note, Frequency (MHz), Level (dBµV/m), Over Limit (dB), Limit Line (dBµV/m), Read Level (dBµV), Antenna Factor (dB/m), Path Loss (dB), Preamp Factor (dB), Ant Pos (cm), Table Pos (deg), Peak Avg. (P/A), Pol. (H/V). Rows include data for 802.11a CH 144 at 5720MHz and a Remark section.



**Band 3 - Straddle Channel**  
**WIFI 802.11ac VHT20 (Band Edge @ 3m)**

WIFI Ant. 1	Note	Frequency ( MHz )	Level ( dBμV/m )	Over Limit ( dB )	Limit Line ( dBμV/m )	Read Level ( dBμV )	Antenna Factor ( dB/m )	Path Loss ( dB )	Preamp Factor ( dB )	Ant Pos ( cm )	Table Pos ( deg )	Peak Avg. ( P/A )	Pol. ( H/V )
<b>802.11ac VHT20 CH 144 5720MHz</b>		5397.58	50.41	-23.59	74	39.69	31.69	9.46	30.43	193	262	P	H
		5466.22	49.37	-18.83	68.2	38.41	31.8	9.59	30.43	193	262	P	H
		5458.03	40.87	-13.13	54	29.98	31.75	9.57	30.43	193	262	A	H
	*	5720	109.86	-	-	98.57	32	9.86	30.57	193	262	P	H
	*	5720	102.2	-	-	90.91	32	9.86	30.57	193	262	A	H
		5887.25	51.69	-16.51	68.2	40.03	32.35	9.98	30.67	193	262	P	H
		5426.83	49.92	-24.08	74	39.14	31.7	9.51	30.43	331	348	P	V
		5461.15	49.42	-18.78	68.2	38.5	31.77	9.58	30.43	331	348	P	V
		5440.48	41.1	-12.9	54	30.29	31.7	9.54	30.43	331	348	A	V
	*	5720	114.08	-	-	102.79	32	9.86	30.57	331	348	P	V
	*	5720	106.04	-	-	94.75	32	9.86	30.57	331	348	A	V
		5902	52.66	-15.54	68.2	40.94	32.4	10	30.68	331	348	P	V
<b>Remark</b>	1. No other spurious found. 2. All results are PASS against Peak and Average limit line.												



Band 3 - Straddle Channel
WIFI 802.11ac VHT20 (Harmonic @ 3m)

Table with 14 columns: WIFI Ant. 1, Note, Frequency (MHz), Level (dBµV/m), Over Limit (dB), Limit Line (dBµV/m), Read Level (dBµV), Antenna Factor (dB/m), Path Loss (dB), Preamp Factor (dB), Ant Pos (cm), Table Pos (deg), Peak Avg. (P/A), Pol. (H/V). Rows include test data for 802.11ac VHT20 CH 144 5720MHz and a Remark section.



**Band 3 - Straddle Channel**  
**WIFI 802.11ac VHT40 (Band Edge @ 3m)**

WIFI Ant. 1	Note	Frequency ( MHz )	Level ( dBµV/m )	Over Limit ( dB )	Limit Line ( dBµV/m )	Read Level ( dBµV )	Antenna Factor ( dB/m )	Path Loss ( dB )	Preamp Factor ( dB )	Ant Pos ( cm )	Table Pos ( deg )	Peak Avg. ( P/A )	Pol. ( H/V )
<b>802.11ac VHT40 CH 142 5710MHz</b>		5397.58	50.09	-23.91	74	39.37	31.69	9.46	30.43	400	298	P	H
		5466.22	49.5	-18.7	68.2	38.54	31.8	9.59	30.43	400	298	P	H
		5452.18	41.58	-12.42	54	30.74	31.71	9.56	30.43	400	298	A	H
	*	5710	106.94	-	-	95.64	32	9.86	30.56	400	298	P	H
	*	5710	99.22	-	-	87.92	32	9.86	30.56	400	298	A	H
		5941.75	52.65	-15.55	68.2	40.82	32.48	10.05	30.7	400	298	P	H
		5392.51	50.66	-23.34	74	39.98	31.66	9.45	30.43	320	345	P	V
		5462.32	50.44	-17.76	68.2	39.52	31.77	9.58	30.43	320	345	P	V
		5447.5	42.2	-11.8	54	31.38	31.7	9.55	30.43	320	345	A	V
	*	5710	110.51	-	-	99.21	32	9.86	30.56	320	345	P	V
	*	5710	102.71	-	-	91.41	32	9.86	30.56	320	345	A	V
		5920	51.99	-16.21	68.2	40.22	32.44	10.02	30.69	320	345	P	V
<b>Remark</b>	1. No other spurious found. 2. All results are PASS against Peak and Average limit line.												



**Band 3 - Straddle Channel  
WIFI 802.11ac VHT40 (Harmonic @ 3m)**

WIFI Ant. 1	Note	Frequency ( MHz )	Level ( dBµV/m )	Over Limit ( dB )	Limit Line ( dBµV/m )	Read Level ( dBµV )	Antenna Factor ( dB/m )	Path Loss ( dB )	Preamp Factor ( dB )	Ant Pos ( cm )	Table Pos ( deg )	Peak Avg. ( P/A )	Pol. ( H/V )	
802.11ac VHT40 CH 142 5710MHz		11420	59.15	-14.85	74	66.41	40.34	14.52	62.12	192	11	P	H	
		11420	50.69	-3.31	54	57.95	40.34	14.52	62.12	192	11	A	H	
		17130	49.51	-18.69	68.2	49.72	40.8	18.3	59.31	100	0	P	H	
													H	
			11420	49.04	-24.96	74	56.3	40.34	14.52	62.12	100	0	P	V
			17130	48.96	-19.24	68.2	49.17	40.8	18.3	59.31	100	0	P	V
														V
													V	
<b>Remark</b>	1. No other spurious found. 2. All results are PASS against Peak and Average limit line.													





**Band 3 - Straddle Channel**  
**WIFI 802.11ac VHT80 (Band Edge @ 3m)**

WIFI Ant. 1	Note	Frequency ( MHz )	Level ( dBμV/m )	Over Limit ( dB )	Limit Line ( dBμV/m )	Read Level ( dBμV )	Antenna Factor ( dB/m )	Path Loss ( dB )	Preamp Factor ( dB )	Ant Pos ( cm )	Table Pos ( deg )	Peak Avg. ( P/A )	Pol. ( H/V )
<b>802.11ac VHT80 CH 138 5690MHz</b>		5398.36	50.11	-23.89	74	39.39	31.69	9.46	30.43	400	303	P	H
		5463.49	50.06	-18.14	68.2	39.13	31.78	9.58	30.43	400	303	P	H
		5458.81	41.81	-12.19	54	30.92	31.75	9.57	30.43	400	303	A	H
	*	5690	104.85	-	-	93.58	31.96	9.86	30.55	400	303	P	H
	*	5690	96.82	-	-	85.55	31.96	9.86	30.55	400	303	A	H
		5927.2	51.59	-16.61	68.2	39.8	32.45	10.03	30.69	400	303	P	H
		5452.96	51.71	-22.29	74	40.86	31.72	9.56	30.43	319	351	P	V
		5462.71	51.61	-16.59	68.2	40.68	31.78	9.58	30.43	319	351	P	V
		5458.03	41.96	-12.04	54	31.07	31.75	9.57	30.43	319	351	A	V
	*	5690	108.25	-	-	96.98	31.96	9.86	30.55	319	351	P	V
	*	5690	100.63	-	-	89.36	31.96	9.86	30.55	319	351	A	V
		5853.7	53.07	-15.13	68.2	41.57	32.21	9.94	30.65	319	351	P	V
<b>Remark</b>	1. No other spurious found. 2. All results are PASS against Peak and Average limit line.												



**Band 3 - Straddle Channel  
WIFI 802.11ac VHT80 (Harmonic @ 3m)**

WIFI Ant. 1	Note	Frequency ( MHz )	Level ( dBµV/m )	Over Limit ( dB )	Limit Line ( dBµV/m )	Read Level (dBµV)	Antenna Factor ( dB/m )	Path Loss ( dB )	Preamp Factor ( dB )	Ant Pos ( cm )	Table Pos ( deg )	Peak Avg. (P/A)	Pol. (H/V)	
<b>802.11ac VHT80 CH 138 5690MHz</b>		11380	59.4	-14.6	74	66.69	40.26	14.53	62.08	200	357	P	H	
		11380	49.11	-4.89	54	56.4	40.26	14.53	62.08	200	357	A	H	
		17070	48.42	-19.78	68.2	48.94	40.74	18.19	59.45	100	0	P	H	
													H	
			11380	48.56	-25.44	74	55.85	40.26	14.53	62.08			P	V
			17070	49.08	-19.12	68.2	49.6	40.74	18.19	59.45	100	0	P	V
														V
<b>Remark</b>	1. No other spurious found. 2. All results are PASS against Peak and Average limit line.													



Emission below 1GHz  
WIFI 802.11 ac VHT80 (LF @ 3m)

WIFI	Note	Frequency	Level	Over	Limit	Read	Antenna	Path	Preamp	Ant	Table	Peak	Pol.	
Ant.				Limit	Line	Level	Factor	Loss	Factor	Pos	Pos	Avg.		
1		( MHz )	( dBμV/m )	( dB )	( dBμV/m )	( dBμV )	( dB/m )	( dB )	( dB )	( cm )	( deg )	( P/A )	( H/V )	
802.11 ac VHT80 LF		73.65	32.62	-7.38	40	51.14	12.89	1.17	32.58	-	-	P	H	
		123.12	27.5	-16	43.5	40.75	17.73	1.46	32.44	-	-	P	H	
		184.23	26.06	-17.44	43.5	41.46	15.06	1.92	32.38	-	-	P	H	
		293.84	21.78	-24.22	46	33.05	18.98	2.26	32.51	-	-	P	H	
		729.37	39.87	-6.13	46	41.56	27.26	3.49	32.44	-	-	P	H	
		895.24	39.96	-6.04	46	39.36	28.58	3.96	31.94	100	0	P	H	
													H	
													H	
													H	
													H	
													H	
													H	
													H	
			38.73	30.01	-9.99	40	41.55	20	0.8	32.34	100	51	Q	V
			73.65	31.29	-8.71	40	49.81	12.89	1.17	32.58	-	-	P	V
			98.87	25.37	-18.13	43.5	40.24	16.07	1.33	32.27	-	-	P	V
			184.23	24.81	-18.69	43.5	40.21	15.06	1.92	32.38	-	-	P	V
			264.74	20.37	-25.63	46	31.04	19.59	2.18	32.44	-	-	P	V
			894.27	36.5	-9.5	46	35.91	28.57	3.96	31.94	-	-	P	V
														V
													V	
													V	
													V	
													V	
													V	
Remark	1. No other spurious found. 2. All results are PASS against limit line.													



<Sample 1 with Battery 2>

Band 2 - 5250~5350MHz

WIFI 802.11ac VHT80 (Band Edge @ 3m)

WIFI Ant.	Note	Frequency	Level	Over Limit	Limit Line	Read Level	Antenna Factor	Path Loss	Preamp Factor	Ant Pos	Table Pos	Peak Avg.	Pol.
1		( MHz )	( dBμV/m )	( dB )	( dBμV/m )	( dBμV )	( dB/m )	( dB )	( dB )	( cm )	( deg )	( P/A )	( H/V )
802.11ac VHT80 CH 58 5290MHz		5149.94	50.23	-23.77	74	39.31	32.1	9.25	30.43	310	291	P	H
		5144.16	41.79	-12.21	54	30.88	32.09	9.25	30.43	310	291	A	H
	*	5290	100.34	-	-	89.97	31.42	9.38	30.43	310	291	P	H
	*	5290	92.83	-	-	82.46	31.42	9.38	30.43	310	291	A	H
		5352.96	56.38	-17.62	74	45.97	31.42	9.42	30.43	310	291	P	H
		5350.32	49.51	-4.49	54	39.12	31.4	9.42	30.43	310	291	A	H
		5119	50.84	-23.16	74	40.01	32.04	9.22	30.43	317	0	P	V
		5145.18	42.32	-11.68	54	31.41	32.09	9.25	30.43	317	0	A	V
	*	5290	103.09	-	-	92.72	31.42	9.38	30.43	317	0	P	V
	*	5290	95.47	-	-	85.1	31.42	9.38	30.43	317	0	A	V
		5350.32	60.83	-13.17	74	50.44	31.4	9.42	30.43	317	0	P	V
	5350.08	52.55	-1.45	54	42.16	31.4	9.42	30.43	317	0	A	V	
Remark	1. No other spurious found. 2. All results are PASS against Peak and Average limit line.												



**Band 2 5250~5350MHz  
WIFI 802.11ac VHT80 (Harmonic @ 3m)**

WIFI Ant. 1	Note	Frequency ( MHz )	Level ( dBμV/m )	Over Limit ( dB )	Limit Line ( dBμV/m )	Read Level (dBμV)	Antenna Factor ( dB/m )	Path Loss ( dB )	Preamp Factor ( dB )	Ant Pos ( cm )	Table Pos ( deg )	Peak Avg. (P/A)	Pol. (H/V)	
802.11ac VHT80 CH 58 5290MHz		10580	44.16	-24.04	68.2	51.47	40.18	13.71	61.2	100	0	P	H	
		15870	44.71	-29.29	74	51.57	36.95	17.35	61.16	100	0	P	H	
													H	
													H	
			10580	44.85	-23.35	68.2	52.16	40.18	13.71	61.2	100	0	P	V
			15870	43.58	-30.42	74	50.44	36.95	17.35	61.16	100	0	P	V
														V
													V	
<b>Remark</b>	1. No other spurious found. 2. All results are PASS against Peak and Average limit line.													



Emission below 1GHz  
WIFI 802.11 ac VHT80 (LF @ 3m)

WIFI	Note	Frequency	Level	Over	Limit	Read	Antenna	Path	Preamp	Ant	Table	Peak	Pol.	
Ant.				Limit	Line	Level	Factor	Loss	Factor	Pos	Pos	Avg.		
1		( MHz )	( dBμV/m )	( dB )	( dBμV/m )	( dBμV )	( dB/m )	( dB )	( dB )	( cm )	( deg )	( P/A )	( H/V )	
802.11 ac VHT80 LF		67.83	29.09	-10.91	40	47.67	12.54	1.13	32.25	100	0	P	H	
		99.84	26.61	-16.89	43.5	41.32	16.22	1.34	32.27	-	-	P	H	
		124.09	26.08	-17.42	43.5	39.35	17.72	1.46	32.45	-	-	P	H	
		138.64	25.18	-18.32	43.5	38.46	17.65	1.58	32.51	-	-	P	H	
		189.08	22.41	-21.09	43.5	37.87	14.99	1.93	32.38	-	-	P	H	
		848.68	31.53	-14.47	46	30.89	28.61	3.83	31.8	-	-	P	H	
														H
														H
														H
														H
														H
														H
			38.73	32.59	-7.41	40	44.13	20	0.8	32.34	-	-	P	V
			62.98	32.77	-7.23	40	51.53	12.26	1.08	32.1	100	0	P	V
			97.9	27.11	-16.39	43.5	42.15	15.91	1.33	32.28	-	-	P	V
			189.08	22.53	-20.97	43.5	37.99	14.99	1.93	32.38	-	-	P	V
			406.36	24.17	-21.83	46	31.71	22.06	2.6	32.2	-	-	P	V
			885.54	32.78	-13.22	46	32.21	28.55	3.93	31.91	-	-	P	V
														V
														V
													V	
													V	
													V	
													V	
<b>Remark</b>	1. No other spurious found. 2. All results are PASS against limit line.													



<Sample 1 with Battery 3>

Band 2 - 5250~5350MHz

WIFI 802.11ac VHT80 (Band Edge @ 3m)

WIFI Ant.	Note	Frequency	Level	Over Limit	Limit Line	Read Level	Antenna Factor	Path Loss	Preamp Factor	Ant Pos	Table Pos	Peak Avg.	Pol.
1		( MHz )	( dBμV/m )	( dB )	( dBμV/m )	( dBμV )	( dB/m )	( dB )	( dB )	( cm )	( deg )	( P/A )	( H/V )
802.11ac VHT80 CH 58 5290MHz		5117.98	50.68	-23.32	74	39.85	32.04	9.22	30.43	310	286	P	H
		5078.88	41.99	-12.01	54	31.28	31.96	9.18	30.43	310	286	A	H
	*	5290	99.66	-	-	89.29	31.42	9.38	30.43	310	286	P	H
	*	5290	91.89	-	-	81.52	31.42	9.38	30.43	310	286	A	H
		5360.4	56.84	-17.16	74	46.38	31.46	9.43	30.43	310	286	P	H
		5350.32	47.61	-6.39	54	37.22	31.4	9.42	30.43	310	286	A	H
		5104.72	50.33	-23.67	74	39.54	32.01	9.21	30.43	299	358	P	V
		5125.46	42.06	-11.94	54	31.21	32.05	9.23	30.43	299	358	A	V
	*	5290	103.2	-	-	92.83	31.42	9.38	30.43	299	358	P	V
	*	5290	95.63	-	-	85.26	31.42	9.38	30.43	299	358	A	V
		5358.72	58.88	-15.12	74	48.43	31.45	9.43	30.43	299	358	P	V
		5350.32	51.77	-2.23	54	41.38	31.4	9.42	30.43	299	358	A	V
Remark	1. No other spurious found. 2. All results are PASS against Peak and Average limit line.												



**Band 2 5250~5350MHz  
WIFI 802.11ac VHT80 (Harmonic @ 3m)**

WIFI Ant. 1	Note	Frequency ( MHz )	Level ( dBμV/m )	Over Limit ( dB )	Limit Line ( dBμV/m )	Read Level (dBμV)	Antenna Factor ( dB/m )	Path Loss ( dB )	Preamp Factor ( dB )	Ant Pos ( cm )	Table Pos ( deg )	Peak Avg. (P/A)	Pol. (H/V)	
802.11ac VHT80 CH 58 5290MHz		10580	44.57	-23.63	68.2	51.88	40.18	13.71	61.2	100	0	P	H	
		15870	44.72	-29.28	74	51.58	36.95	17.35	61.16	100	0	P	H	
													H	
													H	
			10580	44.89	-23.31	68.2	52.2	40.18	13.71	61.2	100	0	P	V
			15870	44.35	-29.65	74	51.21	36.95	17.35	61.16	100	0	P	V
														V
													V	
<b>Remark</b>	1. No other spurious found. 2. All results are PASS against Peak and Average limit line.													







<Sample 2 with Battery 1>

Band 2 - 5250~5350MHz

WIFI 802.11ac VHT80 (Band Edge @ 3m)

WIFI Ant. 1	Note	Frequency ( MHz )	Level ( dBμV/m )	Over Limit ( dB )	Limit Line ( dBμV/m )	Read Level (dBμV)	Antenna Factor ( dB/m )	Path Loss ( dB )	Preamp Factor ( dB )	Ant Pos ( cm )	Table Pos ( deg )	Peak Avg. (P/A)	Pol. (H/V)
802.11ac VHT80 CH 58 5290MHz		5120.02	50.63	-23.37	74	39.8	32.04	9.22	30.43	253	305	P	H
		5107.44	41.87	-12.13	54	31.08	32.01	9.21	30.43	253	305	A	H
	*	5290	100.98	-	-	90.61	31.42	9.38	30.43	253	305	P	H
	*	5290	93.38	-	-	83.01	31.42	9.38	30.43	253	305	A	H
		5359.44	57.72	-16.28	74	47.26	31.46	9.43	30.43	253	305	P	H
		5350.08	49.77	-4.23	54	39.38	31.4	9.42	30.43	253	305	A	H
		5106.42	50.19	-23.81	74	39.4	32.01	9.21	30.43	202	3	P	V
		5079.9	42.06	-11.94	54	31.35	31.96	9.18	30.43	202	3	A	V
	*	5290	102.91	-	-	92.54	31.42	9.38	30.43	202	3	P	V
	*	5290	95.62	-	-	85.25	31.42	9.38	30.43	202	3	A	V
		5357.76	59.52	-14.48	74	49.07	31.45	9.43	30.43	202	3	P	V
		5350.08	51.57	-2.43	54	41.18	31.4	9.42	30.43	202	3	A	V
Remark	1. No other spurious found. 2. All results are PASS against Peak and Average limit line.												



Band 2 5250~5350MHz
WIFI 802.11ac VHT80 (Harmonic @ 3m)

Table with 14 columns: WIFI Ant. 1, Note, Frequency (MHz), Level (dBµV/m), Over Limit (dB), Limit Line (dBµV/m), Read Level (dBµV), Antenna Factor (dB/m), Path Loss (dB), Preamp Factor (dB), Ant Pos (cm), Table Pos (deg), Peak Avg. (P/A), Pol. (H/V). Rows include data for 802.11ac VHT80 CH 58 5290MHz and a Remark section.



Emission below 1GHz  
WIFI 802.11 ac VHT80 (LF @ 3m)

WIFI Ant.	Note	Frequency	Level	Over Limit	Limit Line	Read Level	Antenna Factor	Path Loss	Preamp Factor	Ant Pos	Table Pos	Peak Avg.	Pol.	
1		( MHz )	( dBμV/m )	( dB )	( dBμV/m )	( dBμV )	( dB/m )	( dB )	( dB )	( cm )	( deg )	( P/A )	( H/V )	
802.11 ac VHT80 LF		67.83	29.55	-10.45	40	48.13	12.54	1.13	32.25	100	0	P	H	
		123.12	27.33	-16.17	43.5	40.58	17.73	1.46	32.44	-	-	P	H	
		180.35	23.4	-20.1	43.5	38.67	15.2	1.91	32.38	-	-	P	H	
		255.04	20.96	-25.04	46	32.35	18.87	2.16	32.42	-	-	P	H	
		418	23.73	-22.27	46	30.87	22.53	2.63	32.3	-	-	P	H	
		697.36	27.59	-18.41	46	30.35	26.23	3.41	32.4	-	-	P	H	
														H
														H
														H
														H
														H
														H
			38.73	32.14	-7.86	40	43.68	20	0.8	32.34	100	0	P	V
			72.68	30.9	-9.1	40	49.57	12.74	1.17	32.58	-	-	P	V
			187.14	21.79	-21.71	43.5	37.25	15	1.92	32.38	-	-	P	V
			329.73	20.08	-25.92	46	30.54	19.65	2.36	32.47	-	-	P	V
			576.11	26.78	-19.22	46	30.39	25.67	3.19	32.47	-	-	P	V
			757.5	29.87	-16.13	46	30.99	27.72	3.56	32.4	-	-	P	V
														V
														V
													V	
													V	
													V	
													V	
Remark	1. No other spurious found. 2. All results are PASS against limit line.													



**Note symbol**

*	<b>Fundamental Frequency</b> which can be ignored. However, the level of any unwanted emissions shall not exceed the level of the fundamental frequency.
!	Test result is <b>over limit</b> line.
P/A	<b>Peak</b> or <b>Average</b>
H/V	<b>Horizontal</b> or <b>Vertical</b>



A calculation example for radiated spurious emission is shown as below:

WIFI	Note	Frequency	Level	Over	Limit	Read	Antenna	Path	Preamp	Ant	Table	Peak	Pol.
Ant.				Limit	Line	Level	Factor	Loss	Factor	Pos	Pos	Avg.	
1		( MHz )	( dBμV/m )	( dB )	( dBμV/m )	( dBμV )	( dB/m )	( dB )	( dB )	( cm )	( deg )	( P/A )	( H/V )
802.11b		2390	55.45	-18.55	74	54.51	32.22	4.58	35.86	103	308	P	H
CH 01													
2412MHz		2390	43.54	-10.46	54	42.6	32.22	4.58	35.86	103	308	A	H

1. Path Loss(dB) = Cable loss(dB) + Filter loss(dB) + Attenuator loss(dB)
2. Level(dBμV/m) = Antenna Factor(dB/m) + Path Loss(dB) + Read Level(dBμV) - Preamp Factor(dB)
3. Over Limit(dB) = Level(dBμV/m) – Limit Line(dBμV/m)

**For Peak Limit @ 2390MHz:**

1. Level(dBμV/m)  
= Antenna Factor(dB/m) + Path Loss(dB) + Read Level(dBμV) - Preamp Factor(dB)  
= 32.22(dB/m) + 4.58(dB) + 54.51(dBμV) – 35.86 (dB)  
= 55.45 (dBμV/m)
2. Over Limit(dB)  
= Level(dBμV/m) – Limit Line(dBμV/m)  
= 55.45(dBμV/m) – 74(dBμV/m)  
= -18.55(dB)

**For Average Limit @ 2390MHz:**

1. Level(dBμV/m)  
= Antenna Factor(dB/m) + Path Loss(dB) + Read Level(dBμV) - Preamp Factor(dB)  
= 32.22(dB/m) + 4.58(dB) + 42.6(dBμV) – 35.86 (dB)  
= 43.54 (dBμV/m)
2. Over Limit(dB) = Level(dBμV/m) – Limit Line(dBμV/m)  
= 43.54(dBμV/m) – 54(dBμV/m)  
= -10.46(dB)

**Both peak and average measured complies with the limit line, so test result is “PASS”.**



### Appendix C. Radiated Spurious Emission

Test Engineer :	Leo Lee , Mancy Chou , and Bigshow Wang	Temperature :	23.9~25.2°C
		Relative Humidity :	53~60%

#### Note symbol

-L	Low channel location
-R	High channel location



<Sample 1 with Battery 1>

**Band 1 - 5150~5250MHz**  
**WIFI 802.11a (Band Edge @ 3m)**

WIFI	Band 1 5150~5250MHz Band Edge @ 3m	
ANT	802.11a CH36 5180MHz	
1	Horizontal	Fundamental
<b>Peak</b>	<p>Site : 03CH15-HY Condition : PEAK_BE_74 3m 91200_15_1620 HORIZONTAL Detector : Peak Project : 010732</p>	<p>Site : 03CH15-HY Condition : PEAK(UNIT) 3m 91200_15_1620 HORIZONTAL Detector : Peak Project : 010732</p>
<b>Avg.</b>	<p>Site : 03CH15-HY Condition : AVG_BE_54 3m 91200_15_1620 HORIZONTAL Detector : Peak Project : 010732</p>	Left blank



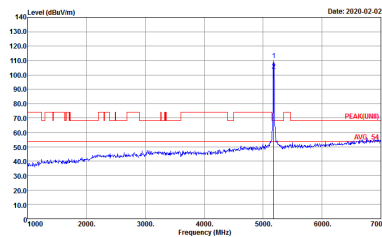
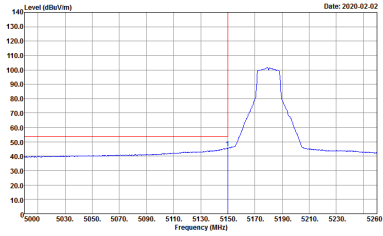

WIFI	Band 1 5150~5250MHz Band Edge @ 3m	
ANT	802.11a CH36 5180MHz	
1	Vertical	Fundamental
Peak	 <p>Site : 03CH15-HY            Condition : PEAK_BE_74 3m 91200_15_1620 VERTICAL            Detector : Peak            Project : 010732</p>	 <p>Site : 03CH15-HY            Condition : PEAK(UNII) 3m 91200_15_1620 VERTICAL            Detector : Peak            Project : 010732</p>
Avg.	 <p>Site : 03CH15-HY            Condition : AVG_BE_54 3m 91200_15_1620 VERTICAL            Detector : Peak            Project : 010732</p>	Left blank

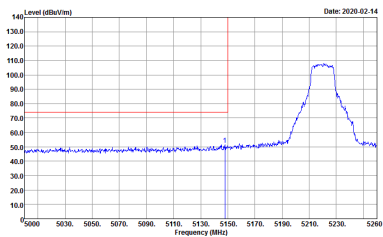
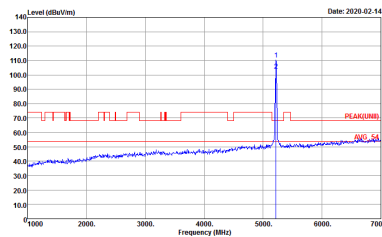

WIFI	Band 1 5150~5250MHz Band Edge @ 3m	
ANT	802.11a CH44 5220MHz - L	
1	Horizontal	Fundamental
Peak	 <p>Site : 03CH15-HY            Condition : PEAK_BE_74 3m 91200_15_1620 HORIZONTAL            Detector : Peak            Project : 010732</p>	 <p>Site : 03CH15-HY            Condition : PEAKUNII 3m 91200_15_1620 HORIZONTAL            Detector : Peak            Project : 010732</p>
Avg.	 <p>Site : 03CH15-HY            Condition : AVG_BE_54 3m 91200_15_1620 HORIZONTAL            Detector : Peak            Project : 010732</p>	Left blank

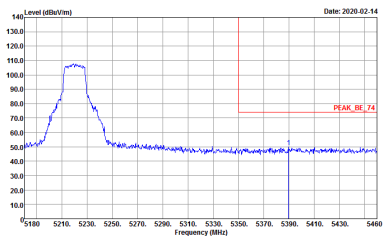
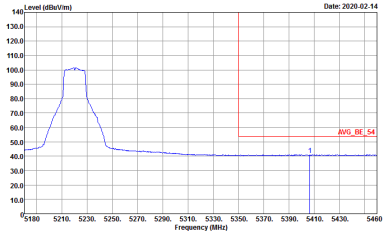

WIFI	Band 1 5150~5250MHz Band Edge @ 3m	
ANT	802.11a CH44 5220MHz - R	
1	Horizontal	Fundamental
<p><b>Peak</b></p>	 <p>Site : 03CH15-HY            Condition : PEAK_BE_74 3m 91200_15_1620 HORIZONTAL            Detector : Peak            Project : 010732</p>	<p>Left blank</p>
<p><b>Avg.</b></p>	 <p>Site : 03CH15-HY            Condition : AVG_BE_54 3m 91200_15_1620 HORIZONTAL            Detector : Peak            Project : 010732</p>	<p>Left blank</p>

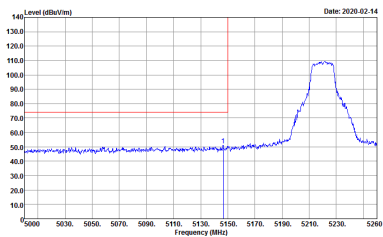
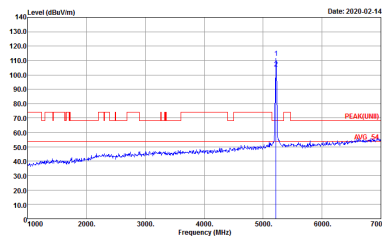
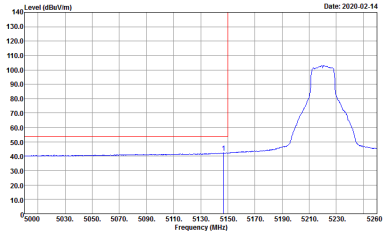

WIFI	Band 1 5150~5250MHz Band Edge @ 3m	
ANT	802.11a CH44 5220MHz - L	
1	Vertical	Fundamental
<p><b>Peak</b></p>	 <p>Site : 03CH15-HY            Condition : PEAK_BE_74 3m 91200_15_1620 VERTICAL            Detector : Peak            Project : 010732</p>	 <p>Site : 03CH15-HY            Condition : PEAK(UNII) 3m 91200_15_1620 VERTICAL            Detector : Peak            Project : 010732</p>
<p><b>Avg.</b></p>	 <p>Site : 03CH15-HY            Condition : AVG_BE_54 3m 91200_15_1620 VERTICAL            Detector : Peak            Project : 010732</p>	<p>Left blank</p>

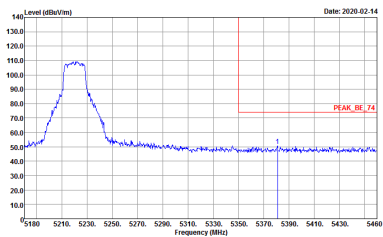
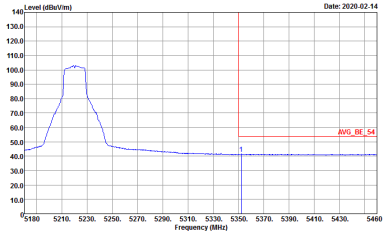

WIFI	Band 1 5150~5250MHz Band Edge @ 3m	
ANT	802.11a CH44 5220MHz - R	
1	Vertical	Fundamental
<p><b>Peak</b></p>	 <p>Site : 03CH15-HY            Condition : PEAK_BE_74 3m 9120D_15_1620 VERTICAL            Detector : Peak            Project : 010732</p>	<p>Left blank</p>
<p><b>Avg.</b></p>	 <p>Site : 03CH15-HY            Condition : AVG_BE_54 3m 9120D_15_1620 VERTICAL            Detector : Peak            Project : 010732</p>	<p>Left blank</p>



WIFI	Band 1 5150~5250MHz Band Edge @ 3m	
ANT	802.11a CH48 5240MHz - L	
1	Horizontal	Fundamental
Peak	<p>Site : 03CH15-HY            Condition : PEAK_BE_74 3m 91200_15_1620 HORIZONTAL            Detector : Peak            Project : 010732</p>	<p>Site : 03CH15-HY            Condition : PEAKUNII 3m 91200_15_1620 HORIZONTAL            Detector : Peak            Project : 010732</p>
Avg.	<p>Site : 03CH15-HY            Condition : AVG_BE_54 3m 91200_15_1620 HORIZONTAL            Detector : Peak            Project : 010732</p>	Left blank

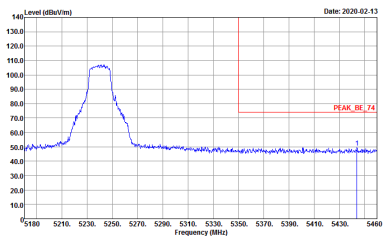
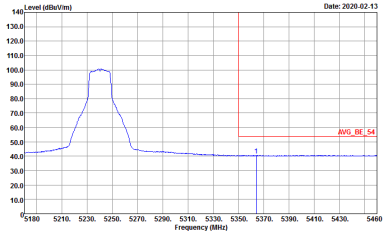

WIFI	Band 1 5150~5250MHz Band Edge @ 3m	
ANT	802.11a CH48 5240MHz - R	
1	Horizontal	Fundamental
<p><b>Peak</b></p>	 <p>Site : 03CH15-HY            Condition : PEAK_BE_74 3m 9120D_15_1620 HORIZONTAL            Detector : Peak            Project : 010732</p>	<p>Left blank</p>
<p><b>Avg.</b></p>	 <p>Site : 03CH15-HY            Condition : AVG_BE_54 3m 9120D_15_1620 HORIZONTAL            Detector : Peak            Project : 010732</p>	<p>Left blank</p>

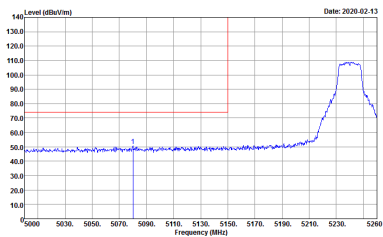
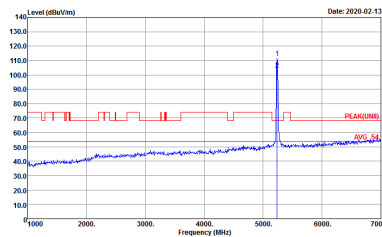
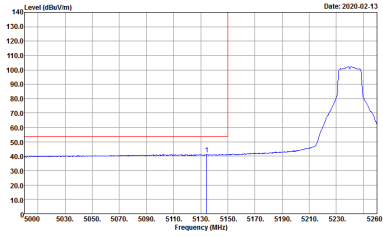

WIFI	Band 1 5150~5250MHz Band Edge @ 3m	
ANT	802.11a CH48 5240MHz - L	
1	Vertical	Fundamental
Peak	 <p>Site : 03CH15-HY            Condition : PEAK_BE_74 3m 91200_15_1620 VERTICAL            Detector : Peak            Project : 010732</p>	 <p>Site : 03CH15-HY            Condition : PEAK(UNII) 3m 91200_15_1620 VERTICAL            Detector : Peak            Project : 010732</p>
Avg.	 <p>Site : 03CH15-HY            Condition : AVG_BE_54 3m 91200_15_1620 VERTICAL            Detector : Peak            Project : 010732</p>	Left blank



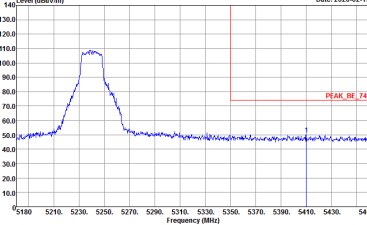
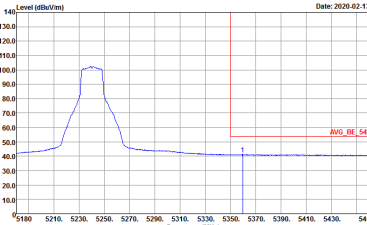

WIFI	Band 1 5150~5250MHz Band Edge @ 3m	
ANT	802.11a CH48 5240MHz - R	
1	Vertical	Fundamental
<p><b>Peak</b></p>	 <p>Site : 03CH15-HY            Condition : PEAK_BE_74 3m 9120D_15_1620 VERTICAL            Detector : Peak            Project : 010732</p>	<p>Left blank</p>
<p><b>Avg.</b></p>	 <p>Site : 03CH15-HY            Condition : AVG_BE_54 3m 9120D_15_1620 VERTICAL            Detector : Peak            Project : 010732</p>	<p>Left blank</p>



**Band 1 5150~5250MHz**  
**WIFI 802.11ac VHT20 (Band Edge @ 3m)**

WIFI	Band 1 5150~5250MHz Band Edge @ 3m	
ANT	802.11ac VHT20 CH36 5180MHz	
1	Horizontal	Fundamental
<b>Peak</b>	<p>Site : 03CH15-HY Condition : PEAK_BE_74 3m 91200_15_1620 HORIZONTAL Detector : Peak Project : 010732</p>	<p>Site : 03CH15-HY Condition : PEAK(UNIT) 3m 91200_15_1620 HORIZONTAL Detector : Peak Project : 010732</p>
<b>Avg.</b>	<p>Site : 03CH15-HY Condition : AVG_BE_54 3m 91200_15_1620 HORIZONTAL Detector : Peak Project : 010732</p>	Left blank

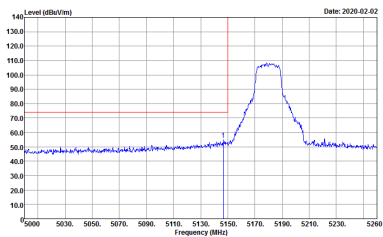
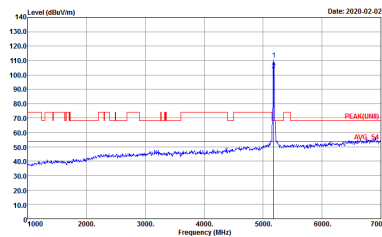
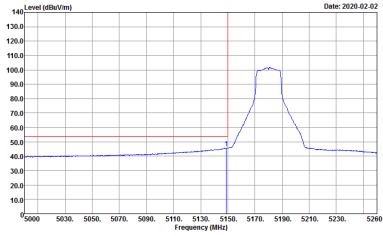

WIFI	Band 1 5150~5250MHz Band Edge @ 3m	
ANT	802.11ac VHT20 CH36 5180MHz	
1	Vertical	Fundamental
Peak	 <p>Site : 03CH15-HY            Condition : PEAK_BE_74 3m 91200_15_1620 VERTICAL            Detector : Peak            Project : 010732</p>	 <p>Site : 03CH15-HY            Condition : PEAK(UNII) 3m 91200_15_1620 VERTICAL            Detector : Peak            Project : 010732</p>
Avg.	 <p>Site : 03CH15-HY            Condition : AVG_BE_54 3m 91200_15_1620 VERTICAL            Detector : Peak            Project : 010732</p>	Left blank



WIFI	Band 1 5150~5250MHz Band Edge @ 3m	
ANT	802.11ac VHT20 CH44 5220MHz - L	
1	Horizontal	Fundamental
Peak		
Avg.		Left blank

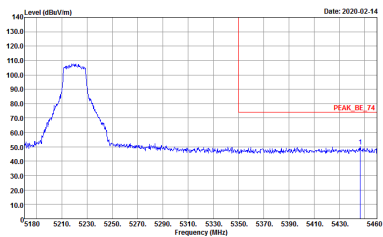
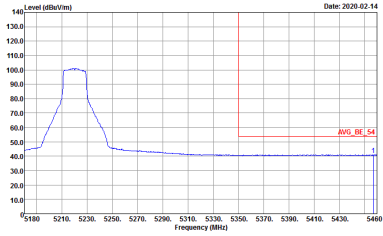

WIFI	Band 1 5150~5250MHz Band Edge @ 3m	
ANT	802.11ac VHT20 CH44 5220MHz - R	
1	Horizontal	Fundamental
<p><b>Peak</b></p>	 <p>Site : 03CH15-HY            Condition : PEAK_BE_74 3m 9120D_15_1620 HORIZONTAL            Detector : Peak            Project : 010732</p>	<p>Left blank</p>
<p><b>Avg.</b></p>	 <p>Site : 03CH15-HY            Condition : AVG_BE_54 3m 9120D_15_1620 HORIZONTAL            Detector : Peak            Project : 010732</p>	<p>Left blank</p>

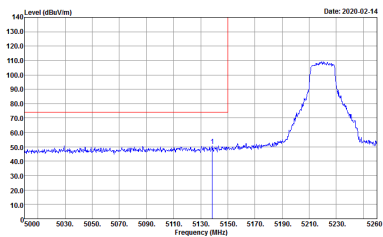
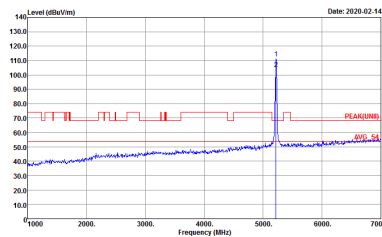
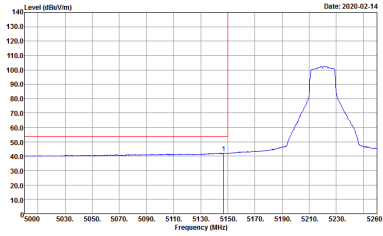

WIFI	Band 1 5150~5250MHz Band Edge @ 3m	
ANT	802.11ac VHT20 CH44 5220MHz - L	
1	Vertical	Fundamental
Peak	 <p>Site : 03CH15-HY            Condition : PEAK_BE_74 3m 91200_15_1620 VERTICAL            Detector : Peak            Project : 010732</p>	 <p>Site : 03CH15-HY            Condition : PEAK(UNII) 3m 91200_15_1620 VERTICAL            Detector : Peak            Project : 010732</p>
Avg.	 <p>Site : 03CH15-HY            Condition : AVG_BE_54 3m 91200_15_1620 VERTICAL            Detector : Peak            Project : 010732</p>	Left blank

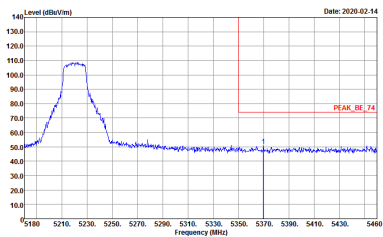
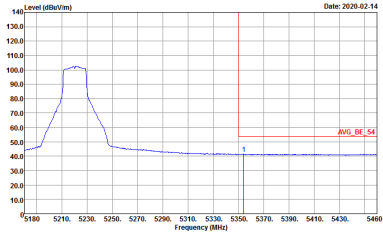

WIFI	Band 1 5150~5250MHz Band Edge @ 3m	
ANT	802.11ac VHT20 CH44 5220MHz - R	
1	Vertical	Fundamental
<p><b>Peak</b></p>	 <p>Site : 03CH15-HY            Condition : PEAK_BE_74 3m 9120D_15_1620 VERTICAL            Detector : Peak            Project : 010732</p>	<p>Left blank</p>
<p><b>Avg.</b></p>	 <p>Site : 03CH15-HY            Condition : AVG_BE_54 3m 9120D_15_1620 VERTICAL            Detector : Peak            Project : 010732</p>	<p>Left blank</p>



WIFI	Band 1 5150~5250MHz Band Edge @ 3m	
ANT	802.11ac VHT20 CH48 5240MHz - L	
1	Horizontal	Fundamental
<p><b>Peak</b></p>	<p>Site : 03CH15-HY            Condition : PEAK_BE_74 3m 91200_15_1620 HORIZONTAL            Detector : Peak            Project : 010732</p>	<p>Site : 03CH15-HY            Condition : PEAK(LIMB) 3m 91200_15_1620 HORIZONTAL            Detector : Peak            Project : 010732</p>
<p><b>Avg.</b></p>	<p>Site : 03CH15-HY            Condition : AVG_BE_54 3m 91200_15_1620 HORIZONTAL            Detector : Peak            Project : 010732</p>	<p>Left blank</p>



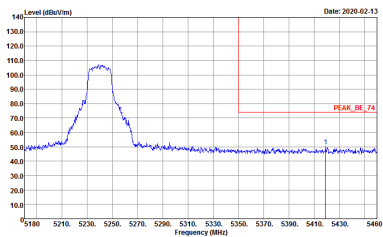
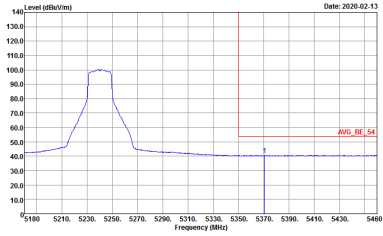

WIFI	Band 1 5150~5250MHz Band Edge @ 3m	
ANT	802.11ac VHT20 CH48 5240MHz - R	
1	Horizontal	Fundamental
<p><b>Peak</b></p>	 <p>Site : 03CH15-HY            Condition : PEAK_BE_74 3m 9120D_15_1620 HORIZONTAL            Detector : Peak            Project : 010732</p>	<p>Left blank</p>
<p><b>Avg.</b></p>	 <p>Site : 03CH15-HY            Condition : AVG_BE_54 3m 9120D_15_1620 HORIZONTAL            Detector : Peak            Project : 010732</p>	<p>Left blank</p>



WIFI	Band 1 5150~5250MHz Band Edge @ 3m	
ANT	802.11ac VHT20 CH48 5240MHz - L	
1	Vertical	Fundamental
Peak	<p>Site : 03CH15-HY            Condition : PEAK_BE_74 3m 91200_15_1620 VERTICAL            Detector : Peak            Project : 010732</p>	<p>Site : 03CH15-HY            Condition : PEAK(UNII) 3m 91200_15_1620 VERTICAL            Detector : Peak            Project : 010732</p>
Avg.	<p>Site : 03CH15-HY            Condition : AVG_BE_54 3m 91200_15_1620 VERTICAL            Detector : Peak            Project : 010732</p>	Left blank

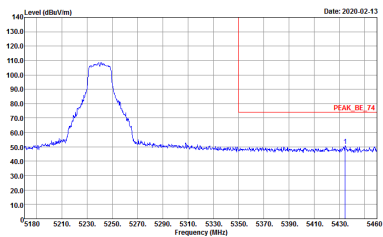
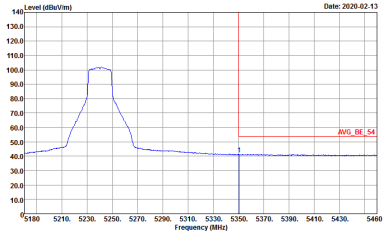

WIFI	Band 1 5150~5250MHz Band Edge @ 3m	
ANT	802.11ac VHT20 CH48 5240MHz - R	
1	Vertical	Fundamental
<p><b>Peak</b></p>	 <p>Site : 03CH15-HY            Condition : PEAK_BE_74 3m 9120D_15_1620 VERTICAL            Detector : Peak            Project : 010732</p>	<p>Left blank</p>
<p><b>Avg.</b></p>	 <p>Site : 03CH15-HY            Condition : AVG_BE_54 3m 9120D_15_1620 VERTICAL            Detector : Peak            Project : 010732</p>	<p>Left blank</p>



**Band 1 5150~5250MHz**  
**WIFI 802.11ac VHT40 (Band Edge @ 3m)**

WIFI	Band 1 5150~5250MHz Band Edge @ 3m	
ANT	802.11ac VHT40 CH38 5190MHz - L	
1	Horizontal	Fundamental
<b>Peak</b>	<p>Date: 2020-02-02</p> <p>Site : 03CH15-HY            Condition : PEAK_BE_74 3m 91200_15_1620 HORIZONTAL            RBW:1000.000KHz VBW:3000.000KHz SWT:Auto            Detector : Peak            Project : 010732            Setting : 17</p>	<p>Date: 2020-02-02</p> <p>Site : 03CH15-HY            Condition : PEAK(UNIT) 3m 91200_15_1620 HORIZONTAL            RBW:1000.000KHz VBW:3000.000KHz SWT:Auto            Detector : Peak            Project : 010732            Setting : 17</p>
<b>Avg.</b>	<p>Date: 2020-02-02</p> <p>Site : 03CH15-HY            Condition : AVG_BE_54 3m 91200_15_1620 HORIZONTAL            RBW:1000.000KHz VBW:3.000KHz SWT:Auto            Detector : Peak            Project : 010732            Setting : 17</p>	<b>Left blank</b>

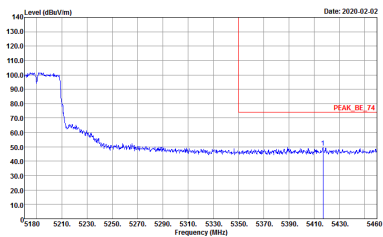
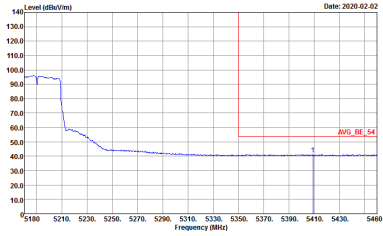

WIFI	Band 1 5150~5250MHz Band Edge @ 3m	
ANT	802.11ac VHT40 CH38 5190MHz - R	
1	Horizontal	Fundamental
<p><b>Peak</b></p>	 <p>Site : 03CH15-HY            Condition : PEAK_BE_74 3m 9120D_15_1620 HORIZONTAL            Detector : Peak            Project : 010732            Setting : 17</p>	<p>Left blank</p>
<p><b>Avg.</b></p>	 <p>Site : 03CH15-HY            Condition : AVG_BE_54 3m 9120D_15_1620 HORIZONTAL            Detector : Peak            Project : 010732            Setting : 17</p>	<p>Left blank</p>

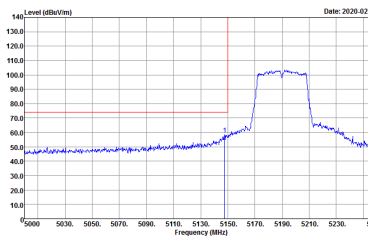
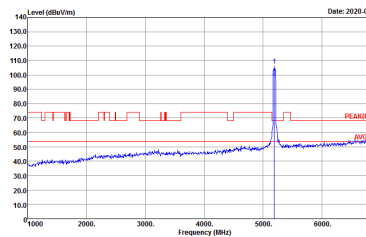
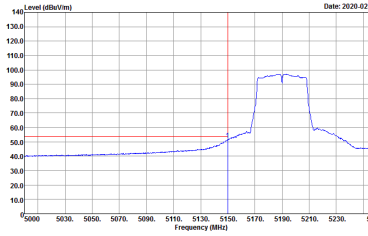

WIFI	Band 1 5150~5250MHz Band Edge @ 3m	
ANT	802.11ac VHT40 CH38 5190MHz - L	
1	Vertical	Fundamental
Peak	 <p>Date: 2020-02-02</p> <p>Site : 03CH15-HY            Condition : PEAK_BE_74 3m 91200_15_1620 VERTICAL            Detector : Peak            Project : 010732            Setting : 17</p>	 <p>Date: 2020-02-02</p> <p>Site : 03CH15-HY            Condition : PEAK(LINII) 3m 91200_15_1620 VERTICAL            Detector : Peak            Project : 010732            Setting : 17</p>
Avg.	 <p>Date: 2020-02-02</p> <p>Site : 03CH15-HY            Condition : AVG_BE_54 3m 91200_15_1620 VERTICAL            Detector : Peak            Project : 010732            Setting : 17</p>	Left blank

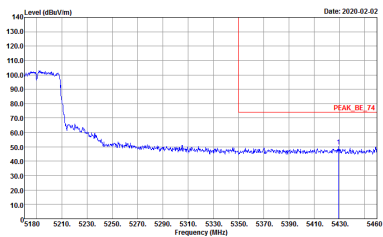
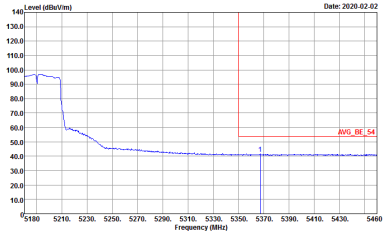

WIFI	Band 1 5150~5250MHz Band Edge @ 3m	
ANT	802.11ac VHT40 CH38 5190MHz - R	
1	Vertical	Fundamental
<p><b>Peak</b></p>	 <p>Site : 03CH15-HY            Condition : PEAK_BE_74 3m 9120D_15_1620 VERTICAL            Detector : Peak            Project : 010732            Setting : 17</p>	<p>Left blank</p>
<p><b>Avg.</b></p>	 <p>Site : 03CH15-HY            Condition : AVG_BE_54 3m 9120D_15_1620 VERTICAL            Detector : Peak            Project : 010732            Setting : 17</p>	<p>Left blank</p>

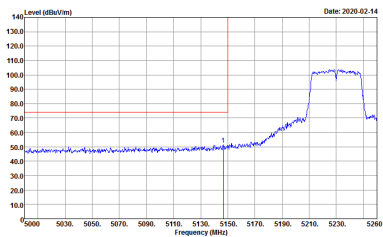
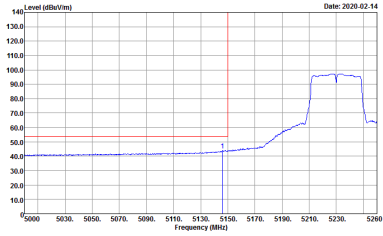

WIFI	Band 1 5150~5250MHz Band Edge @ 3m	
ANT	802.11ac VHT40 CH46 5230MHz - L	
1	Horizontal	Fundamental
Peak	 <p>Date: 2020-02-14</p> <p>Site : 03CH15-HY            Condition : PEAK_BE_74 3m 91200_15_1620 HORIZONTAL            : RBW:1000.000kHz VBW:3000.000kHz SWT:Auto            Detector : Peak            Project : 010732</p>	 <p>Date: 2020-02-14</p> <p>Site : 03CH15-HY            Condition : PEAK(LINII) 3m 91200_15_1620 HORIZONTAL            : RBW:1000.000kHz VBW:3000.000kHz SWT:Auto            Detector : Peak            Project : 010732</p>
Avg.	 <p>Date: 2020-02-14</p> <p>Site : 03CH15-HY            Condition : AVG_BE_54 3m 91200_15_1620 HORIZONTAL            : RBW:1000.000kHz VBW:3.000kHz SWT:Auto            Detector : Peak            Project : 010732</p>	Left blank



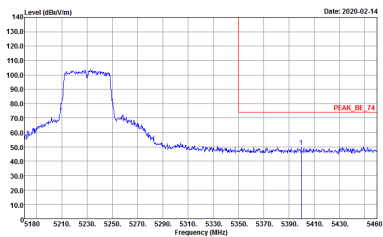
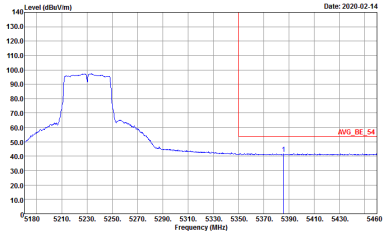

WIFI	Band 1 5150~5250MHz Band Edge @ 3m	
ANT	802.11ac VHT40 CH46 5230MHz - R	
1	Horizontal	Fundamental
<p><b>Peak</b></p>	 <p>Site : 03CH15-HY            Condition : PEAK_BE_74 3m 91200_15_1620 HORIZONTAL            Detector : Peak            Project : 010732</p>	<p>Left blank</p>
<p><b>Avg.</b></p>	 <p>Site : 03CH15-HY            Condition : AVG_BE_54 3m 91200_15_1620 HORIZONTAL            Detector : Peak            Project : 010732</p>	<p>Left blank</p>

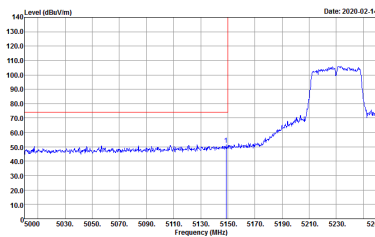
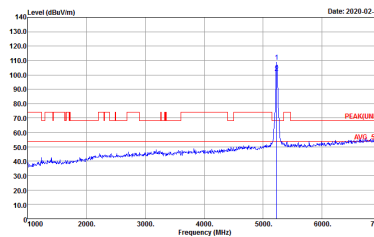
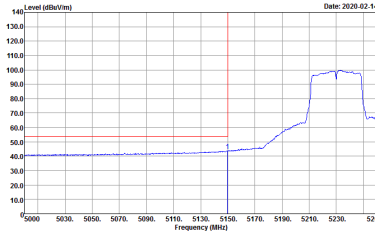

WIFI	Band 1 5150~5250MHz Band Edge @ 3m	
ANT	802.11ac VHT40 CH46 5230MHz - L	
1	Vertical	Fundamental
Peak	 <p>Site : 03CH15-HY            Condition : PEAK_BE_74 3m 91200_15_1620 VERTICAL            Detector : Peak            Project : 010732</p>	 <p>Site : 03CH15-HY            Condition : PEAK(UNII) 3m 91200_15_1620 VERTICAL            Detector : Peak            Project : 010732</p>
Avg.	 <p>Site : 03CH15-HY            Condition : AVG_BE_54 3m 91200_15_1620 VERTICAL            Detector : Peak            Project : 010732</p>	Left blank

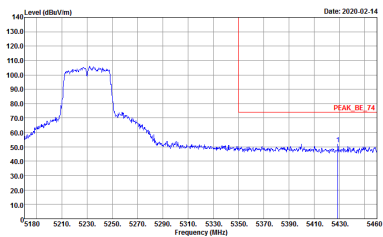
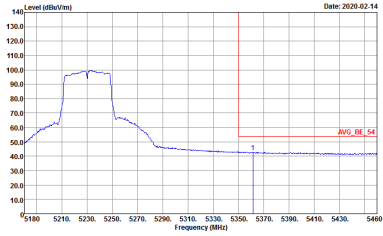

WIFI	Band 1 5150~5250MHz Band Edge @ 3m	
ANT	802.11ac VHT40 CH46 5230MHz - R	
1	Vertical	Fundamental
<p><b>Peak</b></p>	 <p>Site : 03CH15-HY            Condition : PEAK_BE_74 3m 9120D_15_1620 VERTICAL            Detector : Peak            Project : 010732</p>	<p>Left blank</p>
<p><b>Avg.</b></p>	 <p>Site : 03CH15-HY            Condition : AVG_BE_54 3m 9120D_15_1620 VERTICAL            Detector : Peak            Project : 010732</p>	<p>Left blank</p>



**Band 1 5150~5250MHz**  
**WIFI 802.11ac VHT80 (Band Edge @ 3m)**

WIFI	Band 1 5150~5250MHz Band Edge @ 3m	
ANT	802.11ac VHT80 CH42 5210MHz - L	
1	Horizontal	Fundamental
<b>Peak</b>	<p>Site : 03CH15-HY            Condition : PEAK_BE_74 3m 91200_15_1620 HORIZONTAL            RBW:1000.000KHz VBW:3000.000KHz SWT:Auto            Detector : Peak            Project : 010732            Setting : 17</p>	<p>Site : 03CH15-HY            Condition : PEAK(UNIT) 3m 91200_15_1620 HORIZONTAL            RBW:1000.000KHz VBW:3000.000KHz SWT:Auto            Detector : Peak            Project : 010732            Setting : 17</p>
<b>Avg.</b>	<p>Site : 03CH15-HY            Condition : AVG_BE_54 3m 91200_15_1620 HORIZONTAL            RBW:1000.000KHz VBW:3.000KHz SWT:Auto            Detector : Peak            Project : 010732            Setting : 17</p>	Left blank

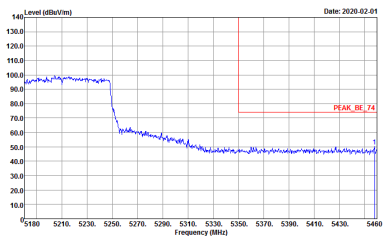
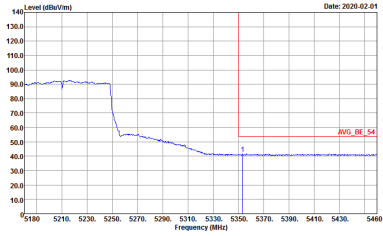

WIFI	Band 1 5150~5250MHz Band Edge @ 3m	
ANT	802.11ac VHT80 CH42 5210MHz - R	
1	Horizontal	Fundamental
<p><b>Peak</b></p>	 <p>Site : 03CH15-HY            Condition : PEAK_BE_74 3m 91200_15_1620 HORIZONTAL            Detector : Peak            Project : 010732            Setting : 17</p>	<p>Left blank</p>
<p><b>Avg.</b></p>	 <p>Site : 03CH15-HY            Condition : AVG_BE_54 3m 91200_15_1620 HORIZONTAL            Detector : Peak            Project : 010732            Setting : 17</p>	<p>Left blank</p>



WIFI	Band 1 5150~5250MHz Band Edge @ 3m	
ANT	802.11ac VHT80 CH42 5210MHz - L	
1	Vertical	Fundamental
Peak	 <p>Date: 2020-02-01</p> <p>Site : 03CH15-HY            Condition : PEAK_BE_74 3m 91200_15_1620 VERTICAL            Detector : Peak            Project : 010732            Setting : 17</p>	 <p>Date: 2020-02-01</p> <p>Site : 03CH15-HY            Condition : PEAK(LINII) 3m 91200_15_1620 VERTICAL            Detector : Peak            Project : 010732            Setting : 17</p>
Avg.	 <p>Date: 2020-02-01</p> <p>Site : 03CH15-HY            Condition : AVG_BE_54 3m 91200_15_1620 VERTICAL            Detector : Peak            Project : 010732            Setting : 17</p>	Left blank

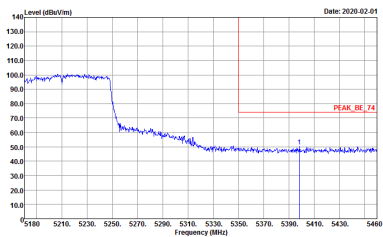
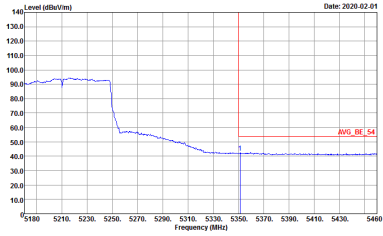

WIFI	Band 1 5150~5250MHz Band Edge @ 3m	
ANT	802.11ac VHT80 CH42 5210MHz - R	
1	Vertical	Fundamental
<p><b>Peak</b></p>	 <p>Site : 03CH15-HY            Condition : PEAK_BE_74 3m 91200_15_1620 VERTICAL            Detector : Peak            Project : 010732            Setting : 17</p>	<p>Left blank</p>
<p><b>Avg.</b></p>	 <p>Site : 03CH15-HY            Condition : AVG_BE_54 3m 91200_15_1620 VERTICAL            Detector : Peak            Project : 010732            Setting : 17</p>	<p>Left blank</p>



**Band 1 - 5150~5250MHz**  
**WIFI 802.11a (Harmonic @ 3m)**

<b>WIFI</b>	<b>Band 1 5150~5250MHz Harmonic @ 3m</b>	
<b>ANT</b>	<b>802.11a CH36 5180MHz</b>	
<b>1</b>	<b>Horizontal</b>	<b>Vertical</b>
<b>Peak</b> <b>Avg.</b>	<p>Site : 03CH15-HY          Condition : PEAK(LINE1) 3m 91200_15_1620 HORIZONTAL          Detector : Peak          Project : 010732</p>	<p>Site : 03CH15-HY          Condition : PEAK(LINE1) 3m 91200_15_1620 VERTICAL          Detector : Peak          Project : 010732</p>



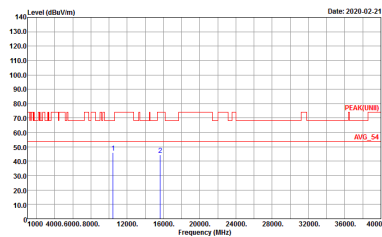

WIFI	Band 1 5150~5250MHz Harmonic @ 3m	
ANT	802.11a CH44 5220MHz	
1	Horizontal	Vertical
<p>Peak</p> <p>Avg.</p>	 <p>Site : 03CH5-11Y          Condition : PEAK(LINE) 3m 91200_15_1620 HORIZONTAL          Detector : Peak          Project : 010732</p>	 <p>Site : 03CH5-11Y          Condition : PEAK(LINE) 3m 91200_15_1620 VERTICAL          Detector : Peak          Project : 010732</p>



WIFI	Band 1 5150~5250MHz Harmonic @ 3m	
ANT	802.11a CH48 5240MHz	
1	Horizontal	Vertical
Peak Avg.	<p>Site : 03CHES-11Y Condition : PEAK(LINEI) 3m 9120D_15_1620 HORIZONTAL Detector : Peak Project : 010732</p>	<p>Site : 03CHES-11Y Condition : PEAK(LINEI) 3m 9120D_15_1620 VERTICAL Detector : Peak Project : 010732</p>



**Band 1 5150~5250MHz  
WIFI 802.11ac VHT20 (Harmonic @ 3m)**

WIFI	Band 1 5150~5250MHz Harmonic @ 3m	
ANT	802.11ac VHT20 CH36 5180MHz	
1	Horizontal	Vertical
<p><b>Peak</b></p> <p><b>Avg.</b></p>	<p>Site : 03CH15-HY Condition : PEAK(UNIT) 3m 91200_15_1620 HORIZONTAL Detector : Peak Project : 010732</p>	<p>Site : 03CH15-HY Condition : PEAK(UNIT) 3m 91200_15_1620 VERTICAL Detector : Peak Project : 010732</p>



<b>WIFI</b>	<b>Band 1 5150~5250MHz Harmonic @ 3m</b>	
<b>ANT</b>	<b>802.11ac VHT20 CH44 5220MHz</b>	
<b>1</b>	<b>Horizontal</b>	<b>Vertical</b>
<b>Peak</b> <b>Avg.</b>	<p>Site : 03CH15-11Y Condition : PEAK(LINE1) 3m 91200_15_1620 HORIZONTAL Detector : Peak Project : 010732</p>	<p>Site : 03CH15-11Y Condition : PEAK(LINE1) 3m 91200_15_1620 VERTICAL Detector : Peak Project : 010732</p>

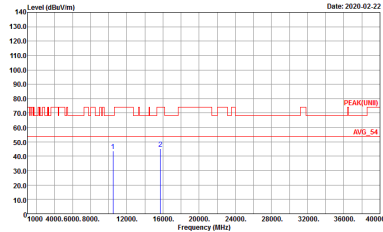
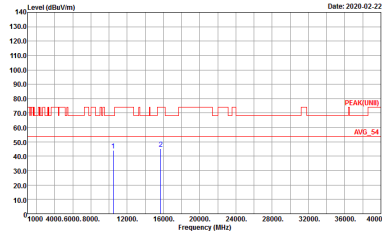

WIFI	Band 1 5150~5250MHz Harmonic @ 3m	
ANT	802.11ac VHT20 CH48 5240MHz	
1	Horizontal	Vertical
<p>Peak</p> <p>Avg.</p>	 <p>Site : 03CH5-11Y  Condition : PEAK(LINEI) 3m 91200_15_1620 HORIZONTAL  Detector : Peak  Project : 010732</p>	 <p>Site : 03CH5-11Y  Condition : PEAK(LINEI) 3m 91200_15_1620 VERTICAL  Detector : Peak  Project : 010732</p>



**Band 1 5150~5250MHz  
WIFI 802.11ac VHT40 (Harmonic @ 3m)**

WIFI	Band 1 5150~5250MHz Harmonic @ 3m	
ANT	802.11ac VHT40 CH38 5190MHz	
1	Horizontal	Vertical
<p><b>Peak</b></p> <p><b>Avg.</b></p>	<p>Site : 03CH15-HY Condition : PEAK(UNIT) 3m 91200_15_1620 HORIZONTAL Detector : Peak Project : 010732</p>	<p>Site : 03CH15-HY Condition : PEAK(UNIT) 3m 91200_15_1620 VERTICAL Detector : Peak Project : 010732</p>



WIFI	Band 1 5150~5250MHz Harmonic @ 3m	
ANT	802.11ac VHT40 CH46 5230MHz	
1	Horizontal	Vertical
Peak Avg.	<p>Site : 03CHES-11Y Condition : PEAK(LINEI) 3m 91200_15_1620 HORIZONTAL Detector : Peak Project : 010732</p>	<p>Site : 03CHES-11Y Condition : PEAK(LINEI) 3m 91200_15_1620 VERTICAL Detector : Peak Project : 010732</p>



**Band 1 5150~5250MHz  
WIFI 802.11ac VHT80 (Harmonic @ 3m)**

WIFI	Band 1 5150~5250MHz Harmonic @ 3m	
ANT	802.11ac VHT80 CH42 5210MHz	
1	Horizontal	Vertical
<p><b>Peak</b></p> <p><b>Avg.</b></p>	<p>Site : 03CH15-HY Condition : PEAK(UNIT) 3m 91200_15_1620 HORIZONTAL Detector : Peak Project : 010732</p>	<p>Site : 03CH15-HY Condition : PEAK(UNIT) 3m 91200_15_1620 VERTICAL Detector : Peak Project : 010732</p>





**Band 2 - 5250~5350MHz**  
**WIFI 802.11a (Band Edge @ 3m)**

WIFI	Band 2 5250~5350MHz Band Edge @ 3m	
ANT	802.11a CH52 5260MHz - L	
1	Horizontal	Fundamental
<b>Peak</b>	<p>Site : 03CH15-HY            Condition : PEAK_BE_74 3m 91200_15_1620 HORIZONTAL            RBW:1000.000KHz VBW:3000.000KHz SWT:Auto            Detector : Peak            Project : 010732</p>	<p>Site : 03CH15-HY            Condition : PEAK(LINE) 3m 91200_15_1620 HORIZONTAL            RBW:1000.000KHz VBW:3000.000KHz SWT:Auto            Detector : Peak            Project : 010732</p>
<b>Avg.</b>	<p>Site : 03CH15-HY            Condition : AV6_BE_54 3m 91200_15_1620 HORIZONTAL            RBW:1000.000KHz VBW:1000KHz SWT:Auto            Detector : Peak            Project : 010732</p>	<b>Left blank</b>



WIFI	Band 2 5250~5350MHz Band Edge @ 3m	
ANT	802.11a CH52 5260MHz - R	
1	Horizontal	Fundamental
<p><b>Peak</b></p>		<p>Left blank</p>
<p><b>Avg.</b></p>		<p>Left blank</p>

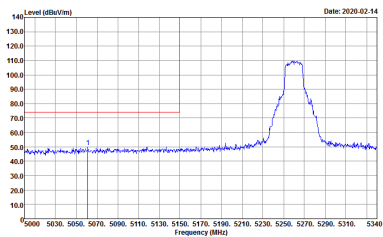
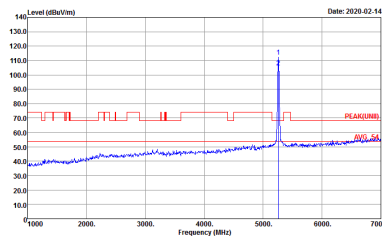
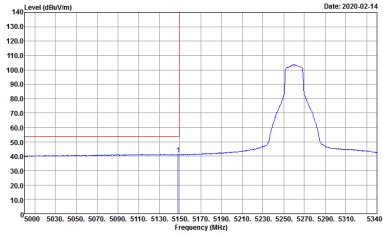

WIFI	Band 2 5250~5350MHz Band Edge @ 3m	
ANT	802.11a CH52 5260MHz - L	
1	Vertical	Fundamental
Peak	 <p>Site : 03CH15-HY            Condition : PEAK_BE_74 3m 9120D_15_1620 VERTICAL            : RBW:1000.000KHz VBW:3000.000KHz SWT:Auto            Detector : Peak            Project : 010732</p>	 <p>Site : 03CH15-HY            Condition : PEAK(UNII) 3m 9120D_15_1620 VERTICAL            : RBW:1000.000KHz VBW:3000.000KHz SWT:Auto            Detector : Peak            Project : 010732</p>
Avg.	 <p>Site : 03CH15-HY            Condition : AVG_BE_54 3m 9120D_15_1620 VERTICAL            : RBW:1000.000KHz VBW:1000KHz SWT:Auto            Detector : Peak            Project : 010732</p>	Left blank

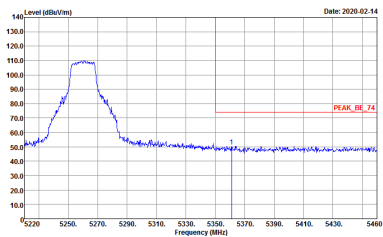
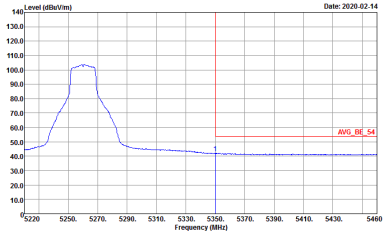

WIFI	Band 2 5250~5350MHz Band Edge @ 3m	
ANT	802.11a CH52 5260MHz - R	
1	Vertical	Fundamental
<p><b>Peak</b></p>	 <p>Site : 03CH15-HY            Condition : PEAK_BE_74 3m 9120D_15_1620 VERTICAL            Detector : Peak            Project : 010732</p>	<p>Left blank</p>
<p><b>Avg.</b></p>	 <p>Site : 03CH15-HY            Condition : AVG_BE_54 3m 9120D_15_1620 VERTICAL            Detector : Peak            Project : 010732</p>	<p>Left blank</p>

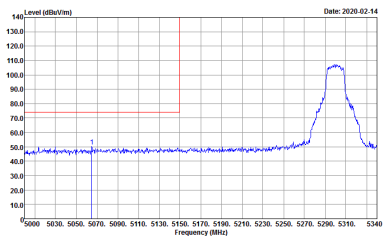
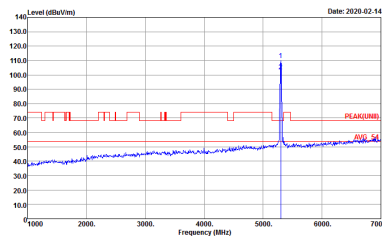
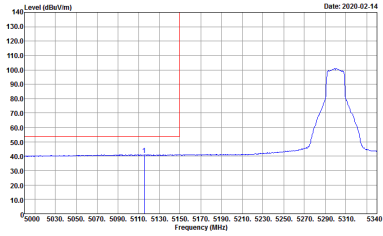

WIFI	Band 2 5250~5350MHz Band Edge @ 3m	
ANT	802.11a CH60 5300MHz - L	
1	Horizontal	Fundamental
Peak	 <p>Site : 03CH15-HY            Condition : PEAK_BE_74 3m 91200_15_1620 HORIZONTAL            Detector : Peak            Project : 010732</p>	 <p>Site : 03CH15-HY            Condition : PEAK(UNII) 3m 91200_15_1620 HORIZONTAL            Detector : Peak            Project : 010732</p>
Avg.	 <p>Site : 03CH15-HY            Condition : AVG_BE_54 3m 91200_15_1620 HORIZONTAL            Detector : Peak            Project : 010732</p>	Left blank

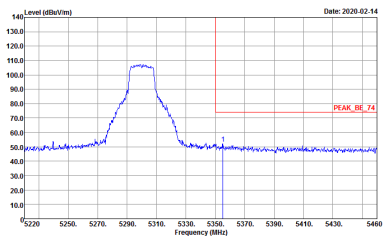
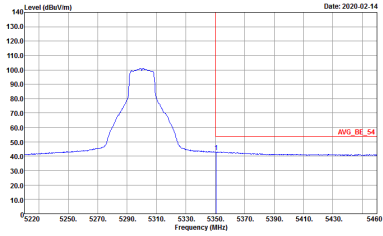

WIFI	Band 2 5250~5350MHz Band Edge @ 3m	
ANT	802.11a CH60 5300MHz - R	
1	Horizontal	Fundamental
<p><b>Peak</b></p>	 <p>Site : 03CH15-HY            Condition : PEAK_BE_74 3m 91200_15_1620 HORIZONTAL            Detector : Peak            Project : 010732</p>	<p>Left blank</p>
<p><b>Avg.</b></p>	 <p>Site : 03CH15-HY            Condition : AVG_BE_54 3m 91200_15_1620 HORIZONTAL            Detector : Peak            Project : 010732</p>	<p>Left blank</p>

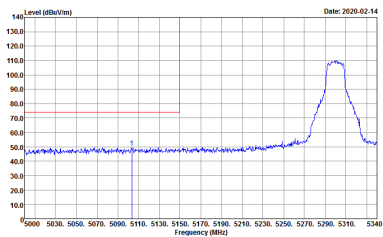
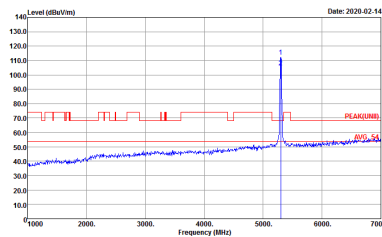
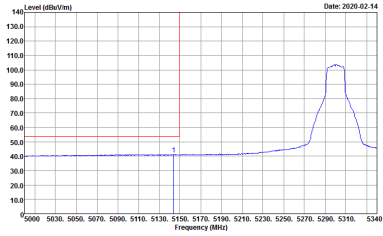

WIFI	Band 2 5250~5350MHz Band Edge @ 3m	
ANT	802.11a CH60 5300MHz - L	
1	Vertical	Fundamental
Peak	 <p>Site : 03CH15-HY            Condition : PEAK_BE_74 3m 91200_15_1620 VERTICAL            Detector : Peak            Project : 010732</p>	 <p>Site : 03CH15-HY            Condition : PEAK(UNII) 3m 91200_15_1620 VERTICAL            Detector : Peak            Project : 010732</p>
Avg.	 <p>Site : 03CH15-HY            Condition : AVG_BE_54 3m 91200_15_1620 VERTICAL            Detector : Peak            Project : 010732</p>	Left blank

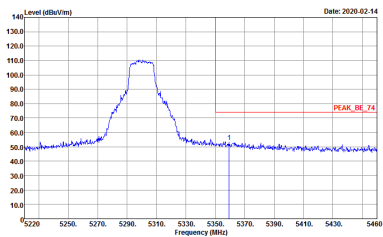
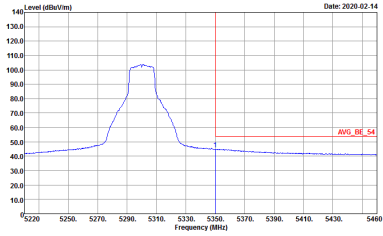

WIFI	Band 2 5250~5350MHz Band Edge @ 3m	
ANT	802.11a CH60 5300MHz - R	
1	Vertical	Fundamental
<p><b>Peak</b></p>	 <p>Site : 03CH15-HY            Condition : PEAK_BE_74 3m 91200_15_1620 VERTICAL            Detector : Peak            Project : 010732</p>	<p>Left blank</p>
<p><b>Avg.</b></p>	 <p>Site : 03CH15-HY            Condition : AVG_BE_54 3m 91200_15_1620 VERTICAL            Detector : Peak            Project : 010732</p>	<p>Left blank</p>



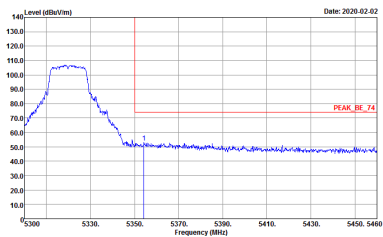
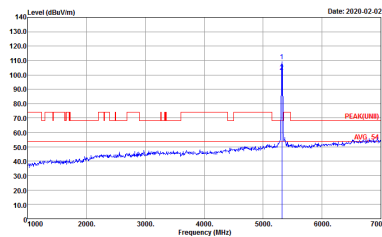
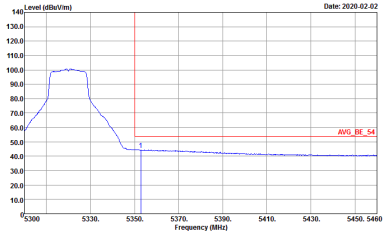

WIFI	Band 2 5250~5350MHz Band Edge @ 3m	
ANT	802.11a CH64 5320MHz	
1	Horizontal	Fundamental
<p><b>Peak</b></p>	 <p>Site : 03CH15-HY            Condition : PEAK_BE_74 3m 91200_15_1620 HORIZONTAL            Detector : Peak            Project : 010732</p>	 <p>Site : 03CH15-HY            Condition : PEAK(LINII) 3m 91200_15_1620 HORIZONTAL            Detector : Peak            Project : 010732</p>
<p><b>Avg.</b></p>	 <p>Site : 03CH15-HY            Condition : AVG_BE_54 3m 91200_15_1620 HORIZONTAL            Detector : Peak            Project : 010732</p>	<p>Left blank</p>

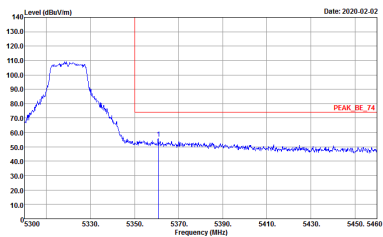
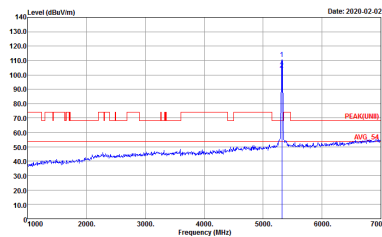
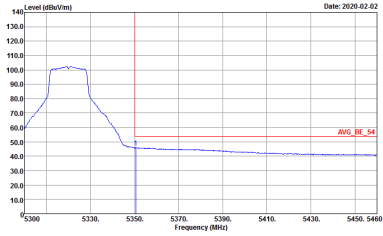

WIFI	Band 2 5250~5350MHz Band Edge @ 3m	
ANT	802.11a CH64 5320MHz	
1	Vertical	Fundamental
<p><b>Peak</b></p>	 <p>Site : 03CH15-HY            Condition : PEAK_BE_74 3m 91200_15_1620 VERTICAL            Detector : Peak            Project : 010732</p>	 <p>Site : 03CH15-HY            Condition : PEAK(LINII) 3m 91200_15_1620 VERTICAL            Detector : Peak            Project : 010732</p>
<p><b>Avg.</b></p>	 <p>Site : 03CH15-HY            Condition : AVG_BE_54 3m 91200_15_1620 VERTICAL            Detector : Peak            Project : 010732</p>	<p>Left blank</p>



**Band 2 5250~5350MHz**  
**WIFI 802.11ac VHT20 (Band Edge @ 3m)**

WIFI	Band 2 5250~5350MHz Band Edge @ 3m	
ANT	802.11ac VHT20 CH52 5260MHz - L	
1	Horizontal	Fundamental
<b>Peak</b>	<p>Site : 03CH15-HY            Condition : PEAK_BE_74 3m 91200_15_1620 HORIZONTAL            RBW:1000.000KHz VBW:3000.000KHz SWT:Auto            Detector : Peak            Project : 010732</p>	<p>Site : 03CH15-HY            Condition : PEAK(UNIT) 3m 91200_15_1620 HORIZONTAL            RBW:1000.000KHz VBW:3000.000KHz SWT:Auto            Detector : Peak            Project : 010732</p>
<b>Avg.</b>	<p>Site : 03CH15-HY            Condition : AVG_BE_54 3m 91200_15_1620 HORIZONTAL            RBW:1000.000KHz VBW:1.000KHz SWT:Auto            Detector : Peak            Project : 010732</p>	Left blank



WIFI	Band 2 5250~5350MHz Band Edge @ 3m	
ANT	802.11ac VHT20 CH52 5260MHz - R	
1	Horizontal	Fundamental
<p><b>Peak</b></p>		<p>Left blank</p>
<p><b>Avg.</b></p>		<p>Left blank</p>



WIFI	Band 2 5250~5350MHz Band Edge @ 3m	
ANT	802.11ac VHT20 CH52 5260MHz - L	
1	Vertical	Fundamental
Peak	<p>Site : 03CH15-HY            Condition : PEAK_BE_74 3m 91200_15_1620 VERTICAL            RBW:1000.000KHz VBW:3000.000KHz SWT:Auto            Detector : Peak            Project : 010732</p>	<p>Site : 03CH15-HY            Condition : PEAK(UNII) 3m 91200_15_1620 VERTICAL            RBW:1000.000KHz VBW:3000.000KHz SWT:Auto            Detector : Peak            Project : 010732</p>
Avg.	<p>Site : 03CH15-HY            Condition : AVG_BE_54 3m 91200_15_1620 VERTICAL            RBW:1000.000KHz VBW:1000KHz SWT:Auto            Detector : Peak            Project : 010732</p>	Left blank



WIFI	Band 2 5250~5350MHz Band Edge @ 3m	
ANT	802.11ac VHT20 CH52 5260MHz - R	
1	Vertical	Fundamental
<p><b>Peak</b></p>		<p>Left blank</p>
<p><b>Avg.</b></p>		<p>Left blank</p>

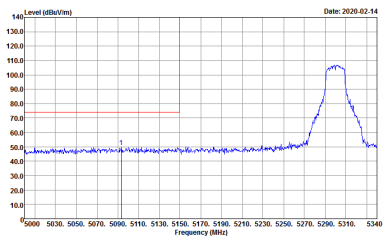
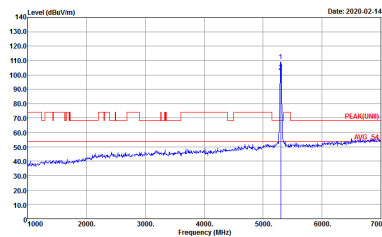
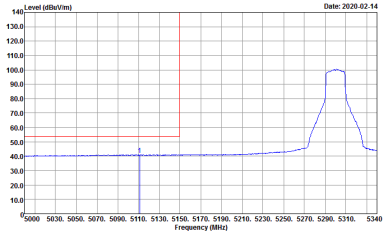

WIFI	Band 2 5250~5350MHz Band Edge @ 3m	
ANT	802.11ac VHT20 CH60 5300MHz - L	
1	Horizontal	Fundamental
Peak	 <p>Site : 03CH15-HY            Condition : PEAK_BE_74 3m 91200_15_1620 HORIZONTAL            Detector : Peak            Project : 010732</p>	 <p>Site : 03CH15-HY            Condition : PEAK(LINII) 3m 91200_15_1620 HORIZONTAL            Detector : Peak            Project : 010732</p>
Avg.	 <p>Site : 03CH15-HY            Condition : AVG_BE_54 3m 91200_15_1620 HORIZONTAL            Detector : Peak            Project : 010732</p>	Left blank

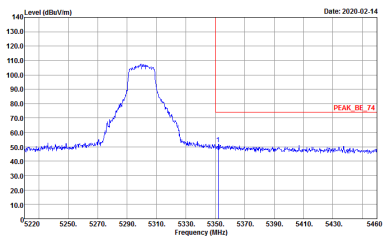
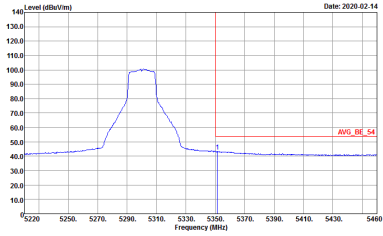

WIFI	Band 2 5250~5350MHz Band Edge @ 3m	
ANT	802.11ac VHT20 CH60 5300MHz - R	
1	Horizontal	Fundamental
<p><b>Peak</b></p>	 <p>Site : 03CH15-HY            Condition : PEAK_BE_74 3m 91200_15_1620 HORIZONTAL            Detector : Peak            Project : 010732</p>	<p>Left blank</p>
<p><b>Avg.</b></p>	 <p>Site : 03CH15-HY            Condition : AVG_BE_54 3m 91200_15_1620 HORIZONTAL            Detector : Peak            Project : 010732</p>	<p>Left blank</p>



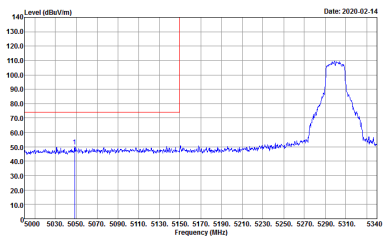
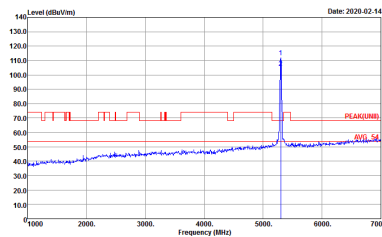
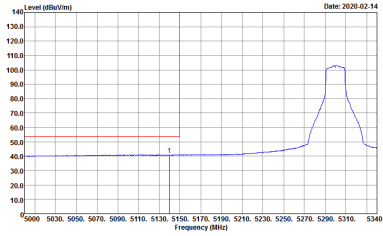

WIFI	Band 2 5250~5350MHz Band Edge @ 3m	
ANT	802.11ac VHT20 CH60 5300MHz - L	
1	Vertical	Fundamental
Peak	 <p>Site : 03CH15-HY            Condition : PEAK_BE_74 3m 91200_15_1620 VERTICAL            Detector : Peak            Project : 010732</p>	 <p>Site : 03CH15-HY            Condition : PEAK(UNII) 3m 91200_15_1620 VERTICAL            Detector : Peak            Project : 010732</p>
Avg.	 <p>Site : 03CH15-HY            Condition : AVG_BE_54 3m 91200_15_1620 VERTICAL            Detector : Peak            Project : 010732</p>	Left blank



WIFI	Band 2 5250~5350MHz Band Edge @ 3m	
ANT	802.11ac VHT20 CH60 5300MHz - R	
1	Vertical	Fundamental
<p><b>Peak</b></p>		<p>Left blank</p>
<p><b>Avg.</b></p>		<p>Left blank</p>

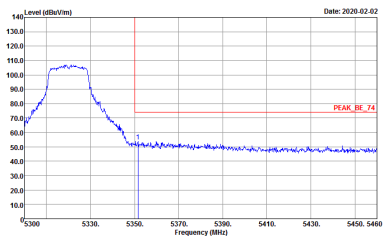
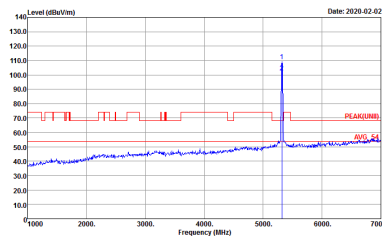
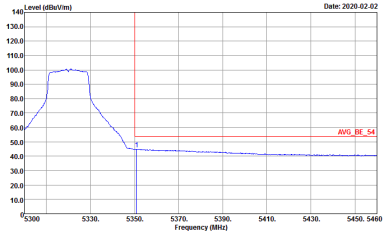

WIFI	Band 2 5250~5350MHz Band Edge @ 3m	
ANT	802.11ac VHT20 CH64 5320MHz	
1	Horizontal	Fundamental
<p><b>Peak</b></p>	 <p>Date: 2020-02-02</p> <p>Site : 03CH15-HY            Condition : PEAK_BE_74 3m 91200_15_1620 HORIZONTAL            RBW:1000.000KHz VBW:3000.000KHz SWT:Auto            Detector : Peak            Project : 010732</p>	 <p>Date: 2020-02-02</p> <p>Site : 03CH15-HY            Condition : PEAK(LINII) 3m 91200_15_1620 HORIZONTAL            RBW:1000.000KHz VBW:3000.000KHz SWT:Auto            Detector : Peak            Project : 010732</p>
<p><b>Avg.</b></p>	 <p>Date: 2020-02-02</p> <p>Site : 03CH15-HY            Condition : AVG_BE_54 3m 91200_15_1620 HORIZONTAL            RBW:1000.000KHz VBW:1000KHz SWT:Auto            Detector : Peak            Project : 010732</p>	<p>Left blank</p>

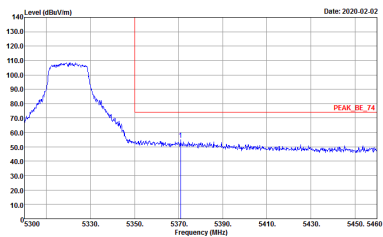
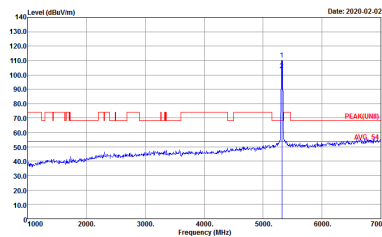
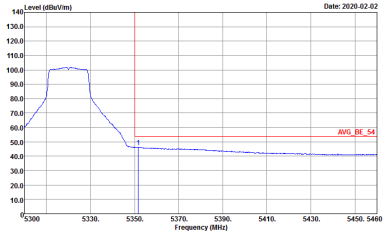

WIFI	Band 2 5250~5350MHz Band Edge @ 3m	
ANT	802.11ac VHT20 CH64 5320MHz	
1	Vertical	Fundamental
<p><b>Peak</b></p>	 <p>Site : 03CH15-HY            Condition : PEAK_BE_74 3m 91200_15_1620 VERTICAL            Detector : Peak            Project : 010732</p>	 <p>Site : 03CH15-HY            Condition : PEAK(LINB) 3m 91200_15_1620 VERTICAL            Detector : Peak            Project : 010732</p>
<p><b>Avg.</b></p>	 <p>Site : 03CH15-HY            Condition : AVG_BE_54 3m 91200_15_1620 VERTICAL            Detector : Peak            Project : 010732</p>	<p>Left blank</p>



**Band 2 5250~5350MHz**  
**WIFI 802.11ac VHT40 (Band Edge @ 3m)**

WIFI	Band 2 5250~5350MHz Band Edge @ 3m	
ANT	802.11ac VHT40 CH54 5270 - L	
1	Horizontal	Fundamental
<b>Peak</b>	<p>Date: 2020-02-14</p> <p>Site : 03CH15-HY            Condition : PEAK_BE_74 3m 91200_15_1620 HORIZONTAL            RBW:1000.000KHz VBW:3000.000KHz SWT:Auto            Detector : Peak            Project : 010732</p>	<p>Date: 2020-02-14</p> <p>Site : 03CH15-HY            Condition : PEAK(UNIT) 3m 91200_15_1620 HORIZONTAL            RBW:1000.000KHz VBW:3000.000KHz SWT:Auto            Detector : Peak            Project : 010732</p>
<b>Avg.</b>	<p>Date: 2020-02-14</p> <p>Site : 03CH15-HY            Condition : AVG_BE_54 3m 91200_15_1620 HORIZONTAL            RBW:1000.000KHz VBW:3.000KHz SWT:Auto            Detector : Peak            Project : 010732</p>	<b>Left blank</b>

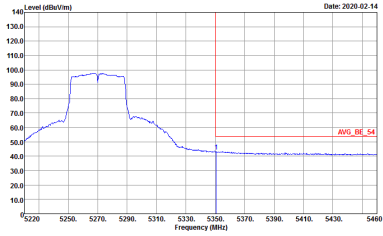

WIFI	Band 2 5250~5350MHz Band Edge @ 3m	
ANT	802.11ac VHT40 CH54 5270 - R	
1	Horizontal	Fundamental
<p><b>Peak</b></p>	 <p>Site : 03CH15-HY            Condition : PEAK_BE_74 3m 91200_15_1620 HORIZONTAL            Detector : Peak            Project : 010732</p>	<p>Left blank</p>
<p><b>Avg.</b></p>	 <p>Site : 03CH15-HY            Condition : AVG_BE_54 3m 91200_15_1620 HORIZONTAL            Detector : Peak            Project : 010732</p>	<p>Left blank</p>

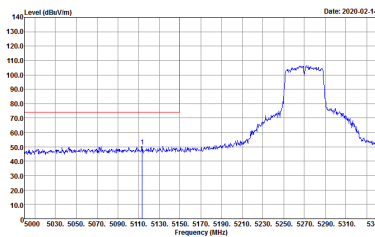
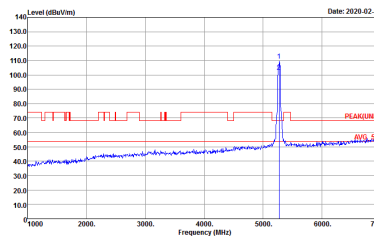
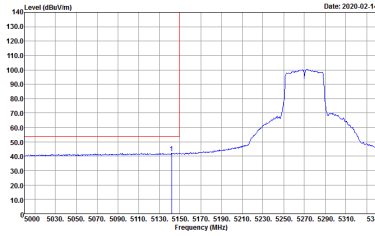

WIFI	Band 2 5250~5350MHz Band Edge @ 3m	
ANT	802.11ac VHT40 CH54 5270 - L	
1	Vertical	Fundamental
Peak	 <p>Site : 03CH15-HY            Condition : PEAK_BE_74 3m 91200_15_1620 VERTICAL            Detector : Peak            Project : 010732</p>	 <p>Site : 03CH15-HY            Condition : PEAK(UNII) 3m 91200_15_1620 VERTICAL            Detector : Peak            Project : 010732</p>
Avg.	 <p>Site : 03CH15-HY            Condition : AVG_BE_54 3m 91200_15_1620 VERTICAL            Detector : Peak            Project : 010732</p>	Left blank

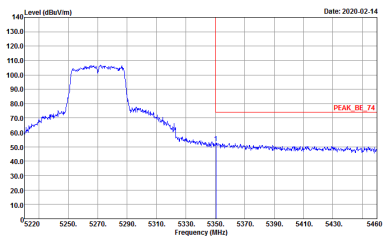
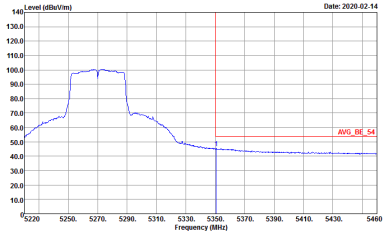

WIFI	Band 2 5250~5350MHz Band Edge @ 3m	
ANT	802.11ac VHT40 CH54 5270 - R	
1	Vertical	Fundamental
<p><b>Peak</b></p>	 <p>Site : 03CH15-HY            Condition : PEAK_BE_74 3m 91200_15_1620 VERTICAL            Detector : Peak            Project : 010732</p>	<p>Left blank</p>
<p><b>Avg.</b></p>	 <p>Site : 03CH15-HY            Condition : AVG_BE_54 3m 91200_15_1620 VERTICAL            Detector : Peak            Project : 010732</p>	<p>Left blank</p>



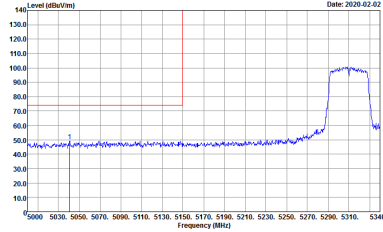
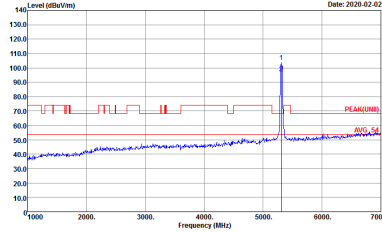
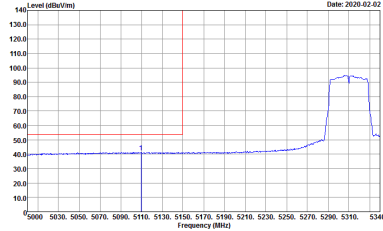

WIFI	Band 2 5250~5350MHz Band Edge @ 3m	
ANT	802.11ac VHT40 CH62 5310 - L	
1	Horizontal	Fundamental
Peak	 <p>Site : 03CH15-HY            Condition : PEAK_BE_74 3m 91200_15_1620 HORIZONTAL            Detector : Peak            Project : 010732            Setting : 16</p>	 <p>Site : 03CH15-HY            Condition : PEAK(LINII) 3m 91200_15_1620 HORIZONTAL            Detector : Peak            Project : 010732            Setting : 16</p>
Avg.	 <p>Site : 03CH15-HY            Condition : AVG_BE_54 3m 91200_15_1620 HORIZONTAL            Detector : Peak            Project : 010732            Setting : 16</p>	Left blank

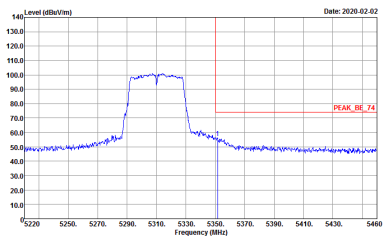
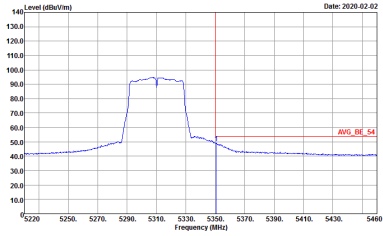

WIFI	Band 2 5250~5350MHz Band Edge @ 3m	
ANT	802.11ac VHT40 CH62 5310 - R	
1	Horizontal	Fundamental
<p><b>Peak</b></p>	 <p>Site : 03CH15-HY            Condition : PEAK_BE_74 3m 91200_15_1620 HORIZONTAL            Detector : Peak            Project : 010732            Setting : 16</p>	<p>Left blank</p>
<p><b>Avg.</b></p>	 <p>Site : 03CH15-HY            Condition : AVG_BE_54 3m 91200_15_1620 HORIZONTAL            Detector : Peak            Project : 010732            Setting : 16</p>	<p>Left blank</p>

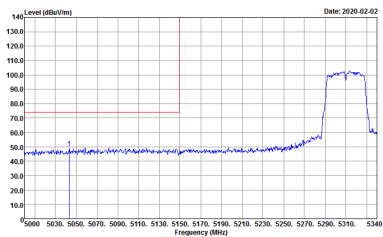
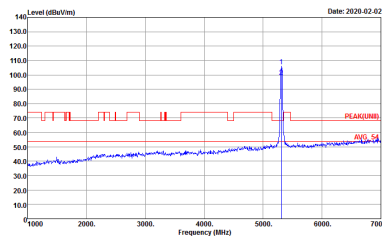
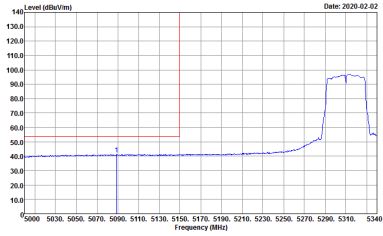

WIFI	Band 2 5250~5350MHz Band Edge @ 3m	
ANT	802.11ac VHT40 CH62 5310 - L	
1	Vertical	Fundamental
Peak	 <p>Date: 2020-02-02</p> <p>Site : 03CH15-HY            Condition : PEAK_BE_74 3m 91200_15_1620 VERTICAL            RBW:1000.000KHz VBW:3000.000KHz SWT:Auto            Detector : Peak            Project : 010732            Setting : 16</p>	 <p>Date: 2020-02-02</p> <p>Site : 03CH15-HY            Condition : PEAK(LINII) 3m 91200_15_1620 VERTICAL            RBW:1000.000KHz VBW:3000.000KHz SWT:Auto            Detector : Peak            Project : 010732            Setting : 16</p>
Avg.	 <p>Date: 2020-02-02</p> <p>Site : 03CH15-HY            Condition : AVG_BE_54 3m 91200_15_1620 VERTICAL            RBW:1000.000KHz VBW:3.000KHz SWT:Auto            Detector : Peak            Project : 010732            Setting : 16</p>	Left blank

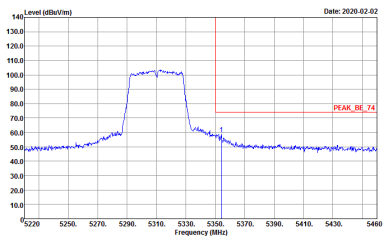
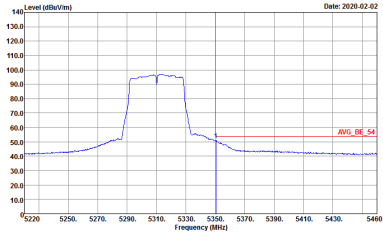

WIFI	Band 2 5250~5350MHz Band Edge @ 3m	
ANT	802.11ac VHT40 CH62 5310 - R	
1	Vertical	Fundamental
<p><b>Peak</b></p>	 <p>Site : 03CH15-HY            Condition : PEAK_BE_74 3m 9120D_15_1620 VERTICAL            Detector : Peak            Project : 010732            Setting : 16</p>	<p>Left blank</p>
<p><b>Avg.</b></p>	 <p>Site : 03CH15-HY            Condition : AVG_BE_54 3m 9120D_15_1620 VERTICAL            Detector : Peak            Project : 010732            Setting : 16</p>	<p>Left blank</p>



**Band 2 5250~5350MHz**  
**WIFI 802.11ac VHT80 (Band Edge @ 3m)**

WIFI	Band 2 5250~5350MHz Band Edge @ 3m	
ANT	802.11ac VHT80 CH58 5290MHz - L	
1	Horizontal	Fundamental
<b>Peak</b>	<p>Site : 03CH15-HY            Condition : PEAK_BE_74 3m 91200_15_1620 HORIZONTAL            RBW:1000.000KHz VBW:3000.000KHz SWT:Auto            Detector : Peak            Project : 010732            Setting : 15.5</p>	<p>Site : 03CH15-HY            Condition : PEAK(UNIT) 3m 91200_15_1620 HORIZONTAL            RBW:1000.000KHz VBW:3000.000KHz SWT:Auto            Detector : Peak            Project : 010732            Setting : 15.5</p>
<b>Avg.</b>	<p>Site : 03CH15-HY            Condition : AVG_BE_54 3m 91200_15_1620 HORIZONTAL            RBW:1000.000KHz VBW:3.000KHz SWT:Auto            Detector : Peak            Project : 010732            Setting : 15.5</p>	Left blank

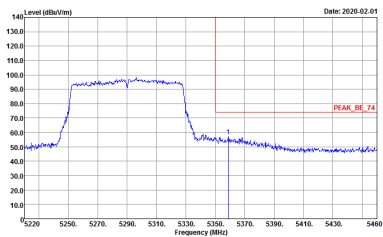

WIFI	Band 2 5250~5350MHz Band Edge @ 3m	
ANT	802.11ac VHT80 CH58 5290MHz - R	
1	Horizontal	Fundamental
<p><b>Peak</b></p>	 <p>Site : 03CH15-HY            Condition : PEAK_BE_74 3m 91200_15_1620 HORIZONTAL            Detector : Peak            Project : 010732            Setting : 15.5</p>	<p>Left blank</p>
<p><b>Avg.</b></p>	 <p>Site : 03CH15-HY            Condition : AVG_BE_54 3m 91200_15_1620 HORIZONTAL            Detector : Peak            Project : 010732            Setting : 15.5</p>	<p>Left blank</p>



WIFI	Band 2 5250~5350MHz Band Edge @ 3m	
ANT	802.11ac VHT80 CH58 5290MHz - L	
1	Vertical	Fundamental
Peak	<p>Site : 03CH15-HY            Condition : PEAK_BE_74 3m 91200_15_1620 VERTICAL            Detector : Peak            Project : 010732            Setting : 15.5</p>	<p>Site : 03CH15-HY            Condition : PEAK(LINII) 3m 91200_15_1620 VERTICAL            Detector : Peak            Project : 010732            Setting : 15.5</p>
Avg.	<p>Site : 03CH15-HY            Condition : AVG_BE_54 3m 91200_15_1620 VERTICAL            Detector : Peak            Project : 010732            Setting : 15.5</p>	Left blank



WIFI	Band 2 5250~5350MHz Band Edge @ 3m	
ANT	802.11ac VHT80 CH58 5290MHz - R	
1	Vertical	Fundamental
<p><b>Peak</b></p>	 <p>Site : 03CH15-HY            Condition : PEAK_BE_74 3m 9120D_15_1620 VERTICAL            Detector : Peak            Project : 010732            Setting : 15.5</p>	<p>Left blank</p>
<p><b>Avg.</b></p>	 <p>Site : 03CH15-HY            Condition : AVG_BE_54 3m 9120D_15_1620 VERTICAL            Detector : Peak            Project : 010732            Setting : 15.5</p>	<p>Left blank</p>





**Band 2 - 5250~5350MHz**  
**WIFI 802.11a (Harmonic @ 3m)**

<b>WIFI</b>	<b>Band 2 5250~5350MHz Harmonic @ 3m</b>	
<b>ANT</b>	<b>802.11a CH52 5260MHz</b>	
<b>1</b>	<b>Horizontal</b>	<b>Vertical</b>
<b>Peak</b> <b>Avg.</b>	<p>Site : 03CH15-HY          Condition : PEAK(UNIT) 3m 91200_15_1620 HORIZONTAL          Detector : Peak          Project : 010732</p>	<p>Site : 03CH15-HY          Condition : PEAK(UNIT) 3m 91200_15_1620 VERTICAL          Detector : Peak          Project : 010732</p>



WIFI	Band 2 5250~5350MHz Harmonic @ 3m	
ANT	802.11a CH60 5300MHz	
1	Horizontal	Vertical
Peak Avg.	<p>Site : 03CH15-11Y Condition : PEAK(LINEI) 3m 91200_15_1620 HORIZONTAL Detector : Peak Project : 010732</p>	<p>Site : 03CH15-11Y Condition : PEAK(LINEI) 3m 91200_15_1620 VERTICAL Detector : Peak Project : 010732</p>



WIFI	Band 2 5250~5350MHz Harmonic @ 3m	
ANT	802.11a CH64 5320MHz	
1	Horizontal	Vertical
Peak Avg.	<p>Site : 03CH15-11Y Condition : PEAK(LINEI) 3m 91200_15_1620 HORIZONTAL Detector : Peak Project : 010732</p>	<p>Site : 03CH15-11Y Condition : PEAK(LINEI) 3m 91200_15_1620 VERTICAL Detector : Peak Project : 010732</p>



**Band 2 5250~5350MHz**  
**WIFI 802.11ac VHT20 (Harmonic @ 3m)**

WIFI	Band 2 5250~5350MHz Harmonic @ 3m	
ANT	802.11ac VHT20 CH52 5260MHz	
1	Horizontal	Vertical
<p><b>Peak</b></p> <p><b>Avg.</b></p>	<p>Site : 03CH15-HY            Condition : PEAK(UNIT) 3m 91200_15_1620 HORIZONTAL            Detector : Peak            Project : 010732</p>	<p>Site : 03CH15-HY            Condition : PEAK(UNIT) 3m 91200_15_1620 VERTICAL            Detector : Peak            Project : 010732</p>

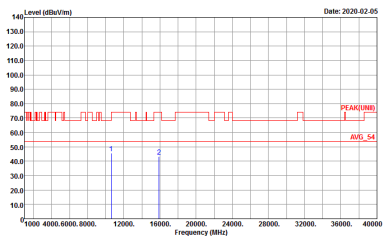
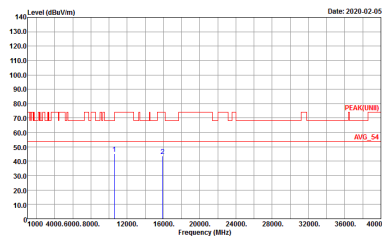

WIFI	Band 2 5250~5350MHz Harmonic @ 3m	
ANT	802.11ac VHT20 CH60 5300MHz	
1	Horizontal	Vertical
<p>Peak</p> <p>Avg.</p>	 <p>Site : 03CHES-11Y          Condition : PEAK(LINEI) 3m 91200_15_1620 HORIZONTAL          Detector : Peak          Project : 010732</p>	 <p>Site : 03CHES-11Y          Condition : PEAK(LINEI) 3m 91200_15_1620 VERTICAL          Detector : Peak          Project : 010732</p>



WIFI	Band 2 5250~5350MHz Harmonic @ 3m	
ANT	802.11ac VHT20 CH64 5320MHz	
1	Horizontal	Vertical
Peak Avg.	<p>Site : 03CHES-11Y Condition : PEAK(LINEI) 3m 9120D_15_1620 HORIZONTAL Detector : Peak Project : 010732</p>	<p>Site : 03CHES-11Y Condition : PEAK(LINEI) 3m 9120D_15_1620 VERTICAL Detector : Peak Project : 010732</p>



**Band 2 5250~5350MHz**  
**WIFI 802.11ac VHT40 (Harmonic @ 3m)**

WIFI	Band 2 5250~5350MHz Harmonic @ 3m	
ANT	802.11ac VHT40 CH54 5270	
1	Horizontal	Vertical
<b>Peak</b>  <b>Avg.</b>	<p>Site : 03CH15-HY          Condition : PEAK(LIMIT) 3m 91200_15_1620 HORIZONTAL          Detector : Peak          Project : 010732</p>	<p>Site : 03CH15-HY          Condition : PEAK(LIMIT) 3m 91200_15_1620 VERTICAL          Detector : Peak          Project : 010732</p>



WIFI	Band 2 5250~5350MHz Harmonic @ 3m	
ANT	802.11ac VHT40 CH62 5310	
1	Horizontal	Vertical
Peak Avg.	<p>Site : 03CH5-11Y Condition : PEAK(LINEI) 3m 91200_15_1620 HORIZONTAL Detector : Peak Project : 010732</p>	<p>Site : 03CH5-11Y Condition : PEAK(LINEI) 3m 91200_15_1620 VERTICAL Detector : Peak Project : 010732</p>





**Band 2 5250~5350MHz**  
**WIFI 802.11ac VHT80 (Harmonic @ 3m)**

WIFI	Band 2 5250~5350MHz Harmonic @ 3m	
ANT	802.11ac VHT80 CH58 5290MHz	
1	Horizontal	Vertical
<p><b>Peak</b></p> <p><b>Avg.</b></p>	<p>Site : 03CH15-HY            Condition : PEAK(UNIT) 3m 91200_15_1620 HORIZONTAL            Detector : Peak            Project : 010732</p>	<p>Site : 03CH15-HY            Condition : PEAK(UNIT) 3m 91200_15_1620 VERTICAL            Detector : Peak            Project : 010732</p>



**Band 3 - 5470~5725MHz**  
**WIFI 802.11a (Band Edge @ 3m)**

WIFI	Band 3 5470~5725MHz Band Edge @ 3m	
ANT	802.11a CH100 5500MHz	
1	Horizontal	Fundamental
<b>Peak</b>	<p>Site : 03CH15-HY            Condition : PEAK_BE(UNIT)_B3 3m 91200_15_1620 HORIZONTAL            Detector : Peak            Project : 010732</p>	<p>Site : 03CH15-HY            Condition : PEAK(UNIT)_3m 91200_15_1620 HORIZONTAL            Detector : Peak            Project : 010732</p>
<b>Avg.</b>	<p>Site : 03CH15-HY            Condition : AVG_BE(UNIT)_B3 3m 91200_15_1620 HORIZONTAL            Detector : Peak            Project : 010732</p>	Left blank

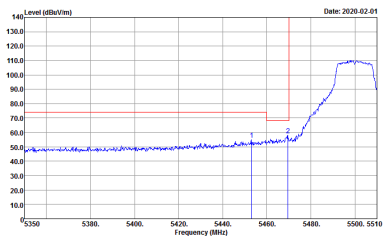
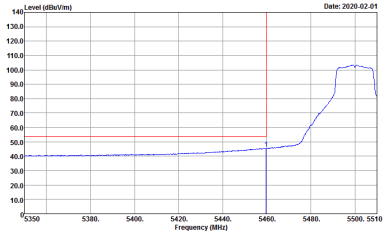

WIFI	Band 3 5470~5725MHz Band Edge @ 3m	
ANT	802.11a CH100 5500MHz	
1	Vertical	Fundamental
Peak	 <p>Site : 03CH15-HY            Condition : PEAK_BE(UNIT), B3 3m 91200_15_1620 VERTICAL            Detector : Peak            Project : 010732</p>	 <p>Site : 03CH15-HY            Condition : PEAK(UNIT) 3m 91200_15_1620 VERTICAL            Detector : Peak            Project : 010732</p>
Avg.	 <p>Site : 03CH15-HY            Condition : AVG_BE(UNIT), B3 3m 91200_15_1620 VERTICAL            Detector : Peak            Project : 010732</p>	Left blank

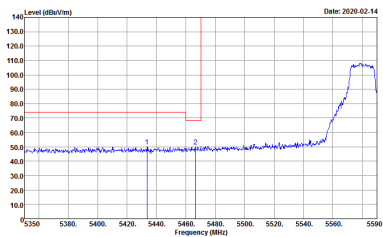
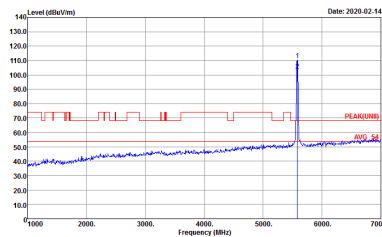
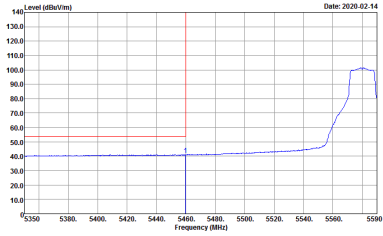

WIFI	Band 3 5470~5725MHz Band Edge @ 3m	
ANT	802.11a CH116 5580MHz - L	
1	Horizontal	Fundamental
Peak	 <p>Site : 03CH15-HY            Condition : PEAK_BE(UNIT), B3 3m 91200_15_1620 HORIZONTAL            Detector : Peak            Project : 010732</p>	 <p>Site : 03CH15-HY            Condition : PEAK(UNIT) 3m 91200_15_1620 HORIZONTAL            Detector : Peak            Project : 010732</p>
Avg.	 <p>Site : 03CH15-HY            Condition : AVG_BE(UNIT), B3 3m 91200_15_1620 HORIZONTAL            Detector : Peak            Project : 010732</p>	Left blank



WIFI	Band 3 5470~5725MHz Band Edge @ 3m	
ANT	802.11a CH116 5580MHz - R	
1	Horizontal	Fundamental
Peak	<p>Site : D3CH15-4/F Condition : PEAK_BE([UNIT]), B3 3m 91200_15_1620 HORIZONTAL Detector : Peak Project : 010732</p>	Left blank

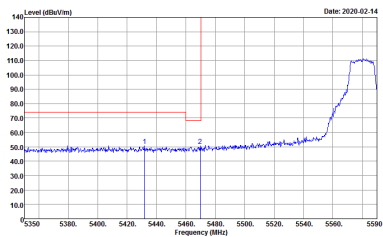
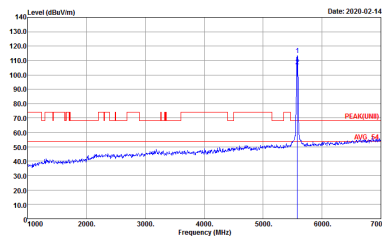
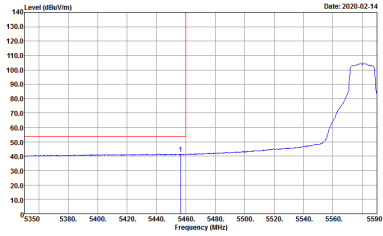

WIFI	Band 3 5470~5725MHz Band Edge @ 3m	
ANT	802.11a CH116 5580MHz - L	
1	Vertical	Fundamental
Peak	 <p>Site : 03CH15-HY            Condition : PEAK_BE(UNIT), B3 3m 91200_15_1620 VERTICAL            Detector : Peak            Project : 010732</p>	 <p>Site : 03CH15-HY            Condition : PEAK(UNIT) 3m 91200_15_1620 VERTICAL            Detector : Peak            Project : 010732</p>
Avg.	 <p>Site : 03CH15-HY            Condition : AVG_BE(UNIT), B3 3m 91200_15_1620 VERTICAL            Detector : Peak            Project : 010732</p>	Left blank



WIFI	Band 3 5470~5725MHz Band Edge @ 3m	
ANT	802.11a CH116 5580MHz - R	
1	Vertical	Fundamental
Peak	<p>Site : D3C315-414 Condition : PEAK_BE([UNIT]), B3 3m 91200_15_1620 VERTICAL Detector : Peak Project : 010732</p>	Left blank

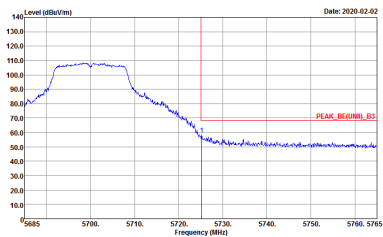
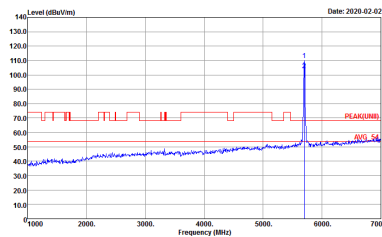

WIFI	Band 3 5470~5725MHz Band Edge @ 3m	
ANT	802.11a CH140 5700MHz	
1	Horizontal	Fundamental
Peak	 <p>Site : 03CH15-11V          Condition : PEAK_BE[UNII], B3 3m 91200_15_1620 HORIZONTAL          Detector : Peak          Project : -010732</p>	 <p>Site : 03CH15-11V          Condition : PEAK[UNII] 3m 91200_15_1620 HORIZONTAL          Detector : Peak          Project : -010732</p>



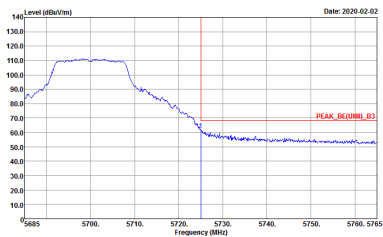
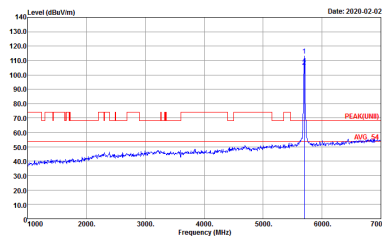

WIFI	Band 3 5470~5725MHz Band Edge @ 3m	
ANT	802.11a CH140 5700MHz	
1	Vertical	Fundamental
Peak	 <p>Site : 03CH15-14V          Condition : PEAK_BE(UNII)_B3 3m 91200_15_1620 VERTICAL          Detector : Peak          Project : -010732</p>	 <p>Site : 03CH15-14V          Condition : PEAK(UNII)_3m 91200_15_1620 VERTICAL          Detector : Peak          Project : -010732</p>



**Band 3 5470~5725MHz  
WIFI 802.11ac VHT20 (Band Edge @ 3m)**

WIFI	Band 3 5470~5725MHz Band Edge @ 3m	
ANT	802.11ac VHT20 CH100 5500MHz	
1	Horizontal	Fundamental
<b>Peak</b>	<p>Site : 03CH15-HY Condition : PEAK_BE(UNIT1)_B3 3m 91200_15_1620 HORIZONTAL Detector : Peak Project : 010732</p>	<p>Site : 03CH15-HY Condition : PEAK(UNIT1) 3m 91200_15_1620 HORIZONTAL Detector : Peak Project : 010732</p>
<b>Avg.</b>	<p>Site : 03CH15-HY Condition : AVG_BE(UNIT1)_B3 3m 91200_15_1620 HORIZONTAL Detector : Peak Project : 010732</p>	Left blank



WIFI	Band 3 5470~5725MHz Band Edge @ 3m	
ANT	802.11ac VHT20 CH100 5500MHz	
1	Vertical	Fundamental
<b>Peak</b>	<p>Site : 03CH15-HY            Condition : PEAK_BE(UNIT), B3 3m 91200_15_1620 VERTICAL            Detector : Peak            Project : 010732</p>	<p>Site : 03CH15-HY            Condition : PEAK(UNIT) 3m 91200_15_1620 VERTICAL            Detector : Peak            Project : 010732</p>
<b>Avg.</b>	<p>Site : 03CH15-HY            Condition : AVG_BE(UNIT), B3 3m 91200_15_1620 VERTICAL            Detector : Peak            Project : 010732</p>	Left blank

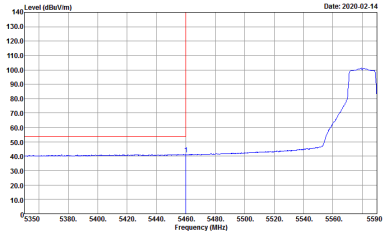

WIFI	Band 3 5470~5725MHz Band Edge @ 3m	
ANT	802.11ac VHT20 CH116 5580MHz - L	
1	Horizontal	Fundamental
Peak	 <p>Site : 03CH15-HY            Condition : PEAK_BE(UNIT), B3 3m 91200_15_1620 HORIZONTAL            Detector : Peak            Project : 010732</p>	 <p>Site : 03CH15-HY            Condition : PEAK(UNIT) 3m 91200_15_1620 HORIZONTAL            Detector : Peak            Project : 010732</p>
Avg.	 <p>Site : 03CH15-HY            Condition : AVG_BE(UNIT), B3 3m 91200_15_1620 HORIZONTAL            Detector : Peak            Project : 010732</p>	Left blank



WIFI	Band 3 5470~5725MHz Band Edge @ 3m	
ANT	802.11ac VHT20 CH116 5580MHz - R	
1	Horizontal	Fundamental
Peak	<p>Site : D3CH15-4/F Condition : PEAK_BE([UNIT]), B3 3m 91200_15_1620 HORIZONTAL Detector : Peak Project : 010732</p>	Left blank

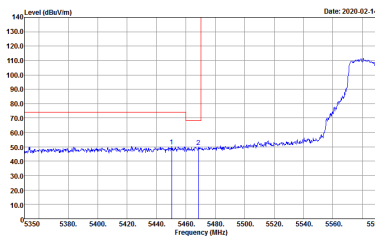
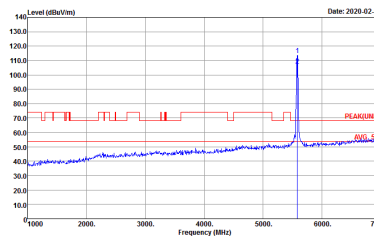
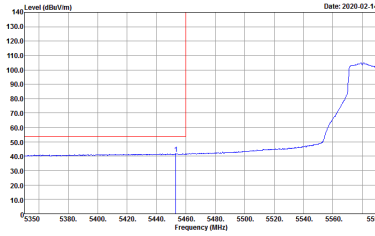

WIFI	Band 3 5470~5725MHz Band Edge @ 3m	
ANT	802.11ac VHT20 CH116 5580MHz - L	
1	Vertical	Fundamental
Peak	 <p>Site : 03CH15-HY            Condition : PEAK_BE(UNIT), B3 3m 91200_15_1620 VERTICAL            Detector : Peak            Project : 010732</p>	 <p>Site : 03CH15-HY            Condition : PEAK(UNIT) 3m 91200_15_1620 VERTICAL            Detector : Peak            Project : 010732</p>
Avg.	 <p>Site : 03CH15-HY            Condition : AVG_BE(UNIT), B3 3m 91200_15_1620 VERTICAL            Detector : Peak            Project : 010732</p>	Left blank



WIFI	Band 3 5470~5725MHz Band Edge @ 3m	
ANT	802.11ac VHT20 CH116 5580MHz - R	
1	Vertical	Fundamental
Peak	<p>Site : D3CH15-414 Condition : PEAK_BE[UNIT], B3 3m 91200_15_1620 VERTICAL Detector : Peak Project : 010732</p>	Left blank

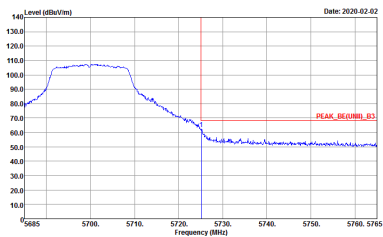
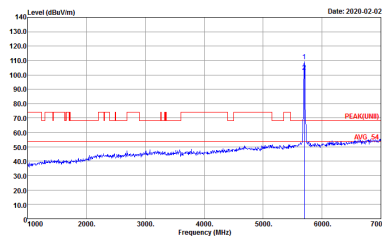

WIFI	Band 3 5470~5725MHz Band Edge @ 3m	
ANT	802.11ac VHT20 CH140 5700MHz	
1	Horizontal	Fundamental
Peak	 <p>Site : 03CH15-111          Condition : PEAK_BE[UNII], B3 3m 91200_15_1620 HORIZONTAL          Detector : Peak          Project : 010732          Setting : 19</p>	 <p>Site : 03CH15-111          Condition : PEAK[UNII] 3m 91200_15_1620 HORIZONTAL          Detector : Peak          Project : 010732          Setting : 19</p>



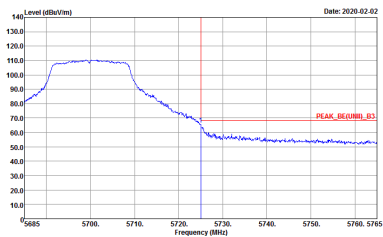
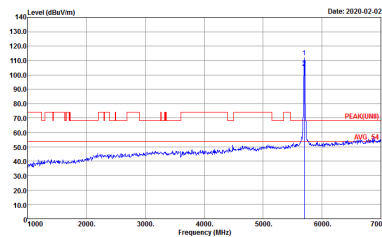

WIFI	Band 3 5470~5725MHz Band Edge @ 3m	
ANT	802.11ac VHT20 CH140 5700MHz	
1	Vertical	Fundamental
Peak	 <p>Site : 03CH15-11V          Condition : PEAK_BE[UNII], B3 3m 91200_15_1620 VERTICAL          Detector : Peak          Project : 010732          Setting : 19</p>	 <p>Site : 03CH15-11V          Condition : PEAK[UNII] 3m 91200_15_1620 VERTICAL          Detector : Peak          Project : 010732          Setting : 19</p>

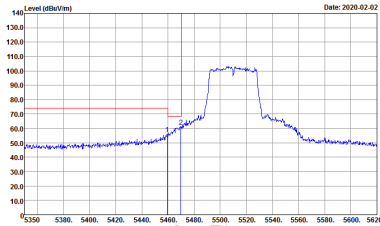
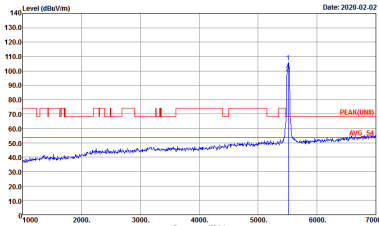
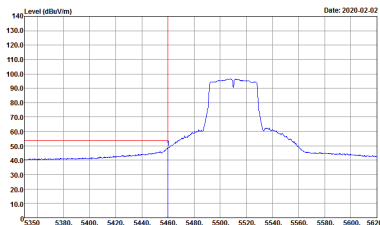

**Band 3 5470~5725MHz**  
**WIFI 802.11ac VHT40 (Band Edge @ 3m)**

WIFI	Band 3 5470~5725MHz Band Edge @ 3m	
ANT	802.11ac VHT40 CH102 5510MHz - L	
1	Horizontal	Fundamental
<b>Peak</b>	 <p>Date: 2020-02-02</p> <p>Site : 03CH15-HY            Condition : PEAK_BE(UNIT1)_B3 3m 91200_15_1620 HORIZONTAL            RBW:1000.000KHz VBW:3000.000KHz SWT:Auto            Detector : Peak            Project : 010732            Setting : 17.5</p>	 <p>Date: 2020-02-02</p> <p>Site : 03CH15-HY            Condition : PEAK(UNIT1) 3m 91200_15_1620 HORIZONTAL            RBW:1000.000KHz VBW:3000.000KHz SWT:Auto            Detector : Peak            Project : 010732            Setting : 17.5</p>
<b>Avg.</b>	 <p>Date: 2020-02-02</p> <p>Site : 03CH15-HY            Condition : AVG_BE(UNIT1)_B3 3m 91200_15_1620 HORIZONTAL            RBW:1000.000KHz VBW:3.000KHz SWT:Auto            Detector : Peak            Project : 010732            Setting : 17.5</p>	Left blank



WIFI	Band 3 5470~5725MHz Band Edge @ 3m	
ANT	802.11ac VHT40 CH102 5510MHz - R	
1	Horizontal	Fundamental
Peak	<p>Site : D3CH15-4/F Condition : PEAK_BE([UNIT], B3 3m 91200_15_1620 HORIZONTAL) Detector : Peak Project : 010732 Setting : 17.5</p>	Left blank

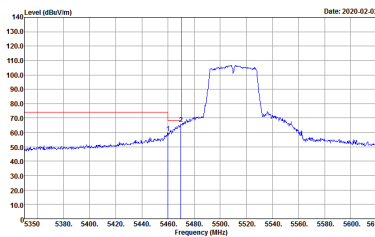
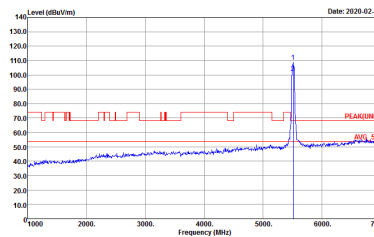
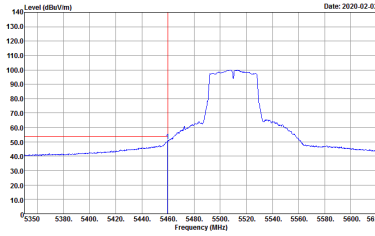

WIFI	Band 3 5470~5725MHz Band Edge @ 3m	
ANT	802.11ac VHT40 CH102 5510MHz - L	
1	Vertical	Fundamental
Peak	 <p>Date: 2020-02-02</p> <p>Site : 03CH15-HY            Condition : PEAK_BE(UNIT), B3 3m 91200_15_1620 VERTICAL            : RBW:1000.000KHz VBW:3000.000KHz SWT:Auto            Detector : Peak            Project : 010732            Setting : 17.5</p>	 <p>Date: 2020-02-02</p> <p>Site : 03CH15-HY            Condition : PEAK(UNIT) 3m 91200_15_1620 VERTICAL            : RBW:1000.000KHz VBW:3000.000KHz SWT:Auto            Detector : Peak            Project : 010732            Setting : 17.5</p>
Avg.	 <p>Date: 2020-02-02</p> <p>Site : 03CH15-HY            Condition : AVG_BE(UNIT), B3 3m 91200_15_1620 VERTICAL            : RBW:1000.000KHz VBW:3.000KHz SWT:Auto            Detector : Peak            Project : 010732            Setting : 17.5</p>	Left blank



WIFI	Band 3 5470~5725MHz Band Edge @ 3m	
ANT	802.11ac VHT40 CH102 5510MHz - R	
1	Vertical	Fundamental
Peak	<p>Site : D3CH15-414 Condition : PEAK_BE([UNIT]), B3 3m 91200_15_1620 VERTICAL Detector : Peak RBW:1000.000KHz, VBW:3000.000KHz, SWT:Auto Project : 010732 Setting : 17.5</p>	Left blank

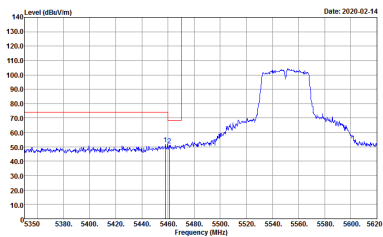
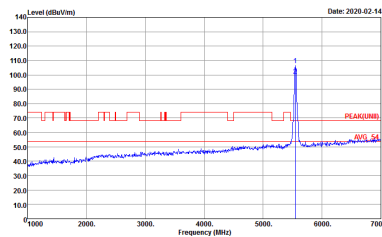
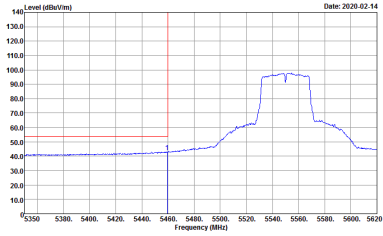

WIFI	Band 3 5470~5725MHz Band Edge @ 3m	
ANT	802.11ac VHT40 CH110 5550MHz - L	
1	Horizontal	Fundamental
Peak	 <p>Date: 2020-02-14</p> <p>Site : 03CH15-HY            Condition : PEAK_BE(UNIT), B3 3m 91200_15_1620 HORIZONTAL            : RBW:1000.000KHz VBW:3000.000KHz SWT:Auto            Detector : Peak            Project : 010732</p>	 <p>Date: 2020-02-14</p> <p>Site : 03CH15-HY            Condition : PEAK(UNIT) 3m 91200_15_1620 HORIZONTAL            : RBW:1000.000KHz VBW:3000.000KHz SWT:Auto            Detector : Peak            Project : 010732</p>
Avg.	 <p>Date: 2020-02-14</p> <p>Site : 03CH15-HY            Condition : AVG_BE(UNIT), B3 3m 91200_15_1620 HORIZONTAL            : RBW:1000.000KHz VBW:3.000KHz SWT:Auto            Detector : Peak            Project : 010732</p>	Left blank



WIFI	Band 3 5470~5725MHz Band Edge @ 3m	
ANT	802.11ac VHT40 CH110 5550MHz - R	
1	Horizontal	Fundamental
Peak	<p>Site : D8CH15-4/F Condition : PEAK_BE([UNIT]), B3 3m 91200_15_1620 HORIZONTAL Detector : Peak Project : 010732</p>	Left blank

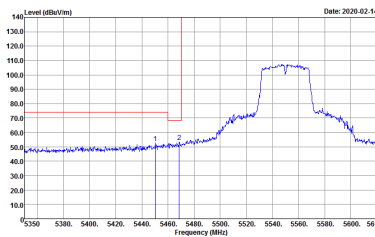
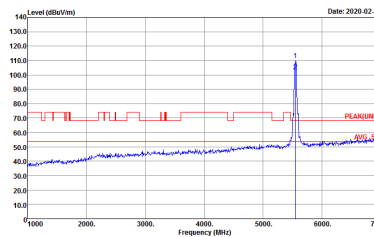
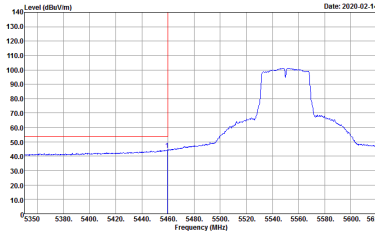

WIFI	Band 3 5470~5725MHz Band Edge @ 3m	
ANT	802.11ac VHT40 CH110 5550MHz - L	
1	Vertical	Fundamental
Peak	 <p>Date: 2020-02-14</p> <p>Site : 03CH15-HY            Condition : PEAK_BE(UNIT), B3 3m 91200_15_1620 VERTICAL            RBW:1000.000KHz VBW:3000.000KHz SWT:Auto            Detector : Peak            Project : 010732</p>	 <p>Date: 2020-02-14</p> <p>Site : 03CH15-HY            Condition : PEAK(UNIT) 3m 91200_15_1620 VERTICAL            RBW:1000.000KHz VBW:3000.000KHz SWT:Auto            Detector : Peak            Project : 010732</p>
Avg.	 <p>Date: 2020-02-14</p> <p>Site : 03CH15-HY            Condition : AVG_BE(UNIT), B3 3m 91200_15_1620 VERTICAL            RBW:1000.000KHz VBW:3000.000KHz SWT:Auto            Detector : Peak            Project : 010732</p>	Left blank





WIFI	Band 3 5470~5725MHz Band Edge @ 3m	
ANT	802.11ac VHT40 CH110 5550MHz - R	
1	Vertical	Fundamental
Peak	<p>Site : D8C415-414 Condition : PEAK_BE[UNIT], B3 3m 91200_15_1620 VERTICAL Detector : Peak Project : 010732</p>	Left blank

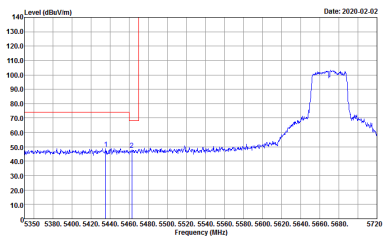
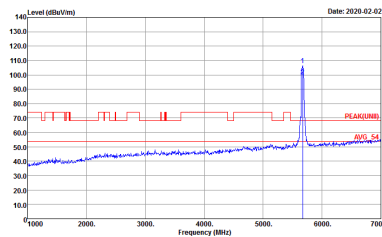
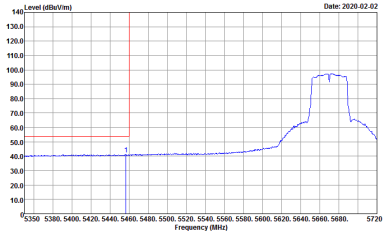

WIFI	Band 3 5470~5725MHz Band Edge @ 3m	
ANT	802.11ac VHT40 CH134 5670MHz - L	
1	Horizontal	Fundamental
Peak	 <p>Date: 2020-02-02</p> <p>Site : 03CH15-HY            Condition : PEAK_BE(UNIT), B3 3m 91200_15_1620 HORIZONTAL            : RBW:1000.000KHz VBW:3000.000KHz SWT:Auto            Detector : Peak            Project : 010732</p>	 <p>Date: 2020-02-02</p> <p>Site : 03CH15-HY            Condition : PEAK(UNIT) 3m 91200_15_1620 HORIZONTAL            : RBW:1000.000KHz VBW:3000.000KHz SWT:Auto            Detector : Peak            Project : 010732</p>
Avg.	 <p>Date: 2020-02-02</p> <p>Site : 03CH15-HY            Condition : AVG_BE(UNIT), B3 3m 91200_15_1620 HORIZONTAL            : RBW:1000.000KHz VBW:3000.000KHz SWT:Auto            Detector : Peak            Project : 010732</p>	Left blank



WIFI	Band 3 5470~5725MHz Band Edge @ 3m	
ANT	802.11ac VHT40 CH134 5670MHz - R	
1	Horizontal	Fundamental
Peak	<p>Site : :D8CH15-4/F Condition : :PEAK_BE([UNIT]), B3 3m 91200_15_1620 HORIZONTAL Detector : :Peak Project : :010732</p>	Left blank

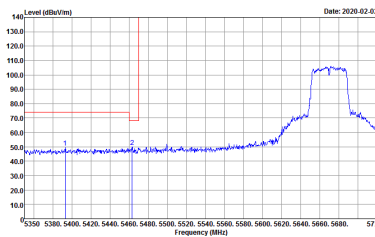
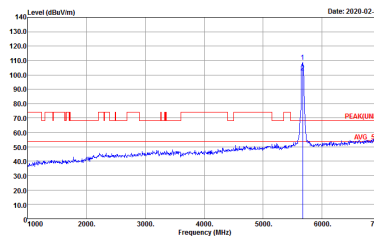
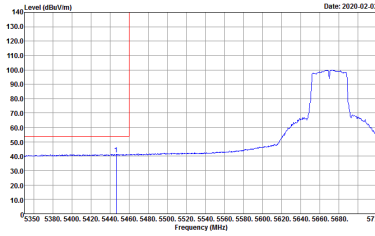

WIFI	Band 3 5470~5725MHz Band Edge @ 3m	
ANT	802.11ac VHT40 CH134 5670MHz - L	
1	Vertical	Fundamental
Peak	 <p>Date: 2020-02-02</p> <p>Site : 03CH15-HY            Condition : PEAK_BE(UNIT), B3 3m 91200_15_1620 VERTICAL            Detector : RBW:1000.000KHz VBW:3000.000KHz SWT:Auto            Project : 010732</p>	 <p>Date: 2020-02-02</p> <p>Site : 03CH15-HY            Condition : PEAK(UNIT) 3m 91200_15_1620 VERTICAL            Detector : Peak            Project : 010732</p>
Avg.	 <p>Date: 2020-02-02</p> <p>Site : 03CH15-HY            Condition : AVG_BE(UNIT), B3 3m 91200_15_1620 VERTICAL            Detector : Peak            Project : 010732</p>	Left blank



WIFI	Band 3 5470~5725MHz Band Edge @ 3m	
ANT	802.11ac VHT40 CH134 5670MHz - R	
1	Vertical	Fundamental
Peak	<p>Site : D8CH15-4/F Condition : PEAK_BE([UNIT]), B3 3m 91200_15_1620 VERTICAL Detector : Peak Project : 010732</p>	Left blank

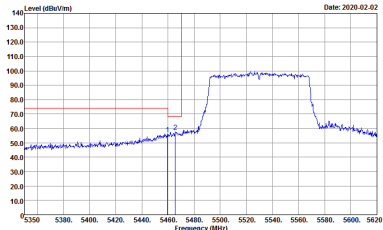
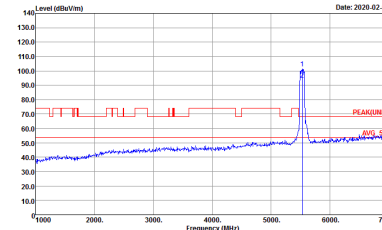
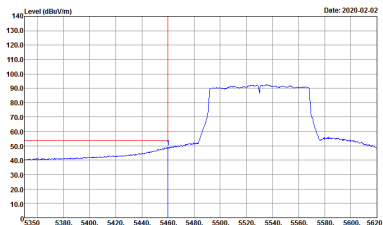

**Band 3 5470~5725MHz**  
**WIFI 802.11ac VHT80 (Band Edge @ 3m)**

WIFI	Band 3 5470~5725MHz Band Edge @ 3m	
ANT	802.11ac VHT80 CH106 5530MHz - L	
1	Horizontal	Fundamental
<b>Peak</b>	 <p>Site : 03CH15-HY            Condition : PEAK_BE(UNIT1)_B3 3m 91200_15_1620 HORIZONTAL            Detector : Peak            Project : 010732            Setting : 16.5</p>	 <p>Site : 03CH15-HY            Condition : PEAK(UNIT1) 3m 91200_15_1620 HORIZONTAL            Detector : Peak            Project : 010732            Setting : 16.5</p>
<b>Avg.</b>	 <p>Site : 03CH15-HY            Condition : AVG_BE(UNIT1)_B3 3m 91200_15_1620 HORIZONTAL            Detector : Peak            Project : 010732            Setting : 16.5</p>	Left blank