

SB1 SMART BADGE USER GUIDE



PRELIMINARY

SB1 SMART BADGE USER GUIDE

72E-164711-01

Rev. 082312

August 2012

PRELIMINARY

No part of this publication may be reproduced or used in any form, or by any electrical or mechanical means, without permission in writing from Motorola. This includes electronic or mechanical means, such as photocopying, recording, or information storage and retrieval systems. The material in this manual is subject to change without notice.

The software is provided strictly on an “as is” basis. All software, including firmware, furnished to the user is on a licensed basis. Motorola grants to the user a non-transferable and non-exclusive license to use each software and firmware program delivered hereunder (licensed program). Except as noted below, such license may not be assigned, sublicensed, or otherwise transferred by the user without prior written consent of Motorola. No right to copy a licensed program in whole or in part is granted, except as permitted under copyright law. The user shall not modify, merge, or incorporate any form or portion of a licensed program with other program material, create a derivative work from a licensed program, or use a licensed program in a network without written permission from Motorola. The user agrees to maintain Motorola’s copyright notice on the licensed programs delivered hereunder, and to include the same on any authorized copies it makes, in whole or in part. The user agrees not to decompile, disassemble, decode, or reverse engineer any licensed program delivered to the user or any portion thereof.

Motorola reserves the right to make changes to any software or product to improve reliability, function, or design.

Motorola does not assume any product liability arising out of, or in connection with, the application or use of any product, circuit, or application described herein.

No license is granted, either expressly or by implication, estoppel, or otherwise under any Motorola, Inc., intellectual property rights. An implied license only exists for equipment, circuits, and subsystems contained in Motorola products.

Revision History

Changes to the original guide are listed below:

Change	Date	Description
Rev. 060412	06/04/12	Draft.
Rev. 080612	08/06/12	Draft 2

PRELIMINARY

PRELIMINARY

TABLE OF CONTENTS

Revision History	iii
------------------------	-----

About This Guide

Introduction	ix
Documentation Set	ix
Configurations	ix
Software Versions	ix
Chapter Descriptions	x
Notational Conventions	x
Related Documents and Software	xi
Service Information	xi

Chapter 1: Getting Started

Unpacking the SB1	1-1
Features	1-2
SB1 Startup	1-3
Charging	1-3
WLAN Setup	1-5
Resetting the SB1	1-6
Powering Off the SB1	1-6

Chapter 2: Operation

Wearing the SB1	2-1
Lanyard	2-1
Holster	2-2
Armband	2-2
Entering Data	2-3
Using a Headset	2-4
Using the Speaker Adapter	2-6
Home Screen	2-7
Notifications	2-8
Locking the SB1	2-9

Setting User Profile	2-9
Enter Name and Title	2-10
Sign Out	2-11
Switch Device	2-11
Applications	2-11
Settings	2-12
Adjusting the Volume	2-13
TEAM Express Settings	2-13
Screen Calibration	2-13
Beeper Settings	2-14
RD Client	2-14
Fusion Settings	2-14
Set Time and Date	2-14
TEAM Express Voice Client	2-16
PTT Audible Indicators	2-16
TEAM Express Voice Client Configuration	2-17
Enable Voice Client Communication	2-17
Select a Talk Group	2-18
Disable TEAM Express Voice Client Communication	2-18
PPT Communication	2-18
Group Broadcast (One to Many)	2-18
Response to a Group Broadcast	2-19
Private Response (One to One)	2-19
Chapter 3: Data Capture	
Introduction	3-1
Scanning Considerations	3-1
Bar Code Reading	3-2
Chapter 4: Accessories	
Introduction	4-1
Single Slot Charging Cradle	4-2
Ten Slot Charge Only Cradle	4-4
Audio Adapter	4-6
Speaker Adapter	4-8
Holster	4-9
Armband	4-11
Lanyard	4-13
Chapter 5: Maintenance & Troubleshooting	
Introduction	5-1
Maintaining the SB1	5-1
Battery Safety Guidelines	5-1
Cleaning	5-2
Approved Cleanser Active Ingredients	5-3
Harmful Ingredients	5-3
Cleaning Instructions	5-3
Special Cleaning Notes	5-3

Materials Required	5-3
Cleaning the SB1	5-3
Housing	5-3
Display	5-3
Exit Window	5-3
Connector	5-4
Cleaning Cradle Connectors	5-4
Cleaning Frequency	5-4
Troubleshooting	5-5
SB1	5-5
Single Slot Charging Cradle	5-6
Ten Slot Charge Only Cradle	5-7
Audio Adapter	5-7
Speaker Adapter	5-7

Appendix A: Specifications

SB1 Technical Specifications	A-1
------------------------------------	-----

Glossary

Index

PRELIMINARY

ABOUT THIS GUIDE

Introduction

This guide provides information about using the SB1 smart badge and accessories.

✓ **NOTE** Screens and windows pictured in this guide are samples and may differ from actual screens.

Documentation Set

The documentation set for the SB1 is divided into guides that provide information for specific user needs.

- **SB1 Regulatory Guide** - provides all regulatory and safety information.
- **SB1 User Guide** - describes how to use the SB1.
- **SB1 Integrator Guide** - describes how to set up the SB1 and accessories.

Configurations



This guide covers the following configurations:

Configuration	Radios	Display	Memory	Data Capture
SB1	WLAN: 802.11 b/g/n	E Ink® touch screen	128 MB RAM/ 128 MB Flash	Bar code reader

Software Versions

This guide covers various software configurations and references are made to software versions. To view the software versions:

1. Press the Home button.

2. Touch . The **Settings** screen appears.
3. Touch . The **More Settings** screen appears.
4. Touch **Software Version**. The **Software Version** screen lists the RhoElements and SB1 Shell versions.

Chapter Descriptions

Topics covered in this guide are as follows:

- [Chapter 1, Getting Started](#), describes the SB1's physical characteristics, how to charge the SB1 and how to start the SB1 for the first time.
- [Chapter 2, Operation](#), provides basic instructions for using the SB1 and navigating the SB1 Shell.
- [Chapter 3, Data Capture](#) provides instructions for using the SB1 to capture data using the bar code reader.
- [Chapter 4, Accessories](#), describes the accessories available for the SB1 and how to use the accessories with the SB1.
- [Chapter 5, Maintenance & Troubleshooting](#), includes instructions on cleaning and storing and provides troubleshooting solutions for potential problems during SB1 operation.
- [Appendix A, Specifications](#), includes a table listing the technical specifications for the SB1.

Notational Conventions

The following conventions are used in this document:

- The term "SB1" refers to the Motorola SB1 smart badge.
- *Italics* are used to highlight the following:
 - Chapters and sections in this and related documents
 - Dialog box, window and screen names
 - Drop-down list and list box names
 - Check box and radio button names
 - Icons on a screen.
- **Bold** text is used to highlight the following:
 - Key names on a keypad
 - Button names on a screen.
- Bullets (•) indicate:
 - Action items
 - Lists of alternatives
 - Lists of required steps that are not necessarily sequential.
- Sequential lists (e.g., those that describe step-by-step procedures) appear as numbered lists.

Related Documents and Software

The following items provide more information about the SB1.

- *SB1 Regulatory Guide*, p/n 72-162415-xx
- *SB1 Integrator Guide*, p/n 72E-164712-xx

For the latest version of this guide and all guides, go to: <http://supportcentral.motorola.com>

Service Information

If you have a problem with your equipment, contact Motorola Solutions Global Customer Support for your region. Contact information is available at: <http://www.motorolasolutions.com/contactsupport>.

When contacting Motorola Solutions Global Customer Support, please have the following information available:

- Serial number of the unit
- Model number or product name
- Software type and version number

Motorola Solutions responds to calls by email, telephone or fax within the time limits set forth in support agreements.

If your problem cannot be solved by Motorola Solutions Global Customer Support, you may need to return your equipment for servicing and will be given specific directions. Motorola Solutions is not responsible for any damages incurred during shipment if the approved shipping container is not used. Shipping the units improperly can possibly void the warranty.

If you purchased your product from a Motorola Solutions business partner, contact that business partner for support.

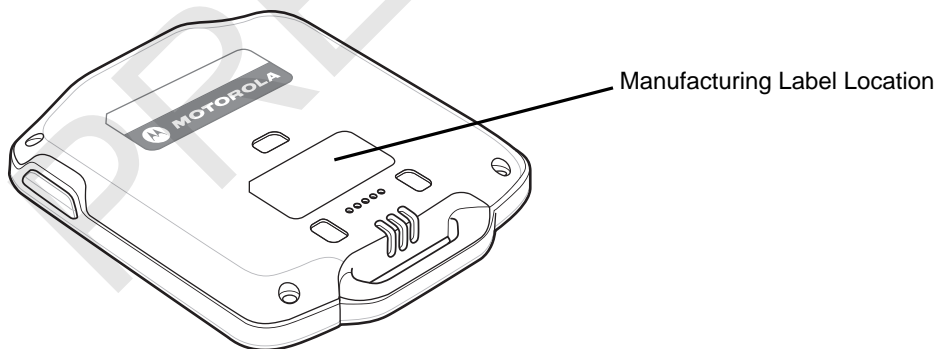

PRELIMINARY

CHAPTER 1 GETTING STARTED

This chapter describes the SB1 physical characteristics, how to charge the SB1 and how to start the SB1 for the first time.

Unpacking the SB1

Carefully remove all protective material from around the SB1 and save the shipping container for later storage and shipping. Verify that the equipment listed below is included:

- SB1 (single unit or multi-unit)
- Regulatory Guide.

Inspect the equipment for damage. If any equipment is missing or damaged, contact the Motorola Solutions Global Customer Support immediately. See [Service Information on page xvi](#) for contact information.

Features

The features of the SB1 are shown in *Figure 1-1*.

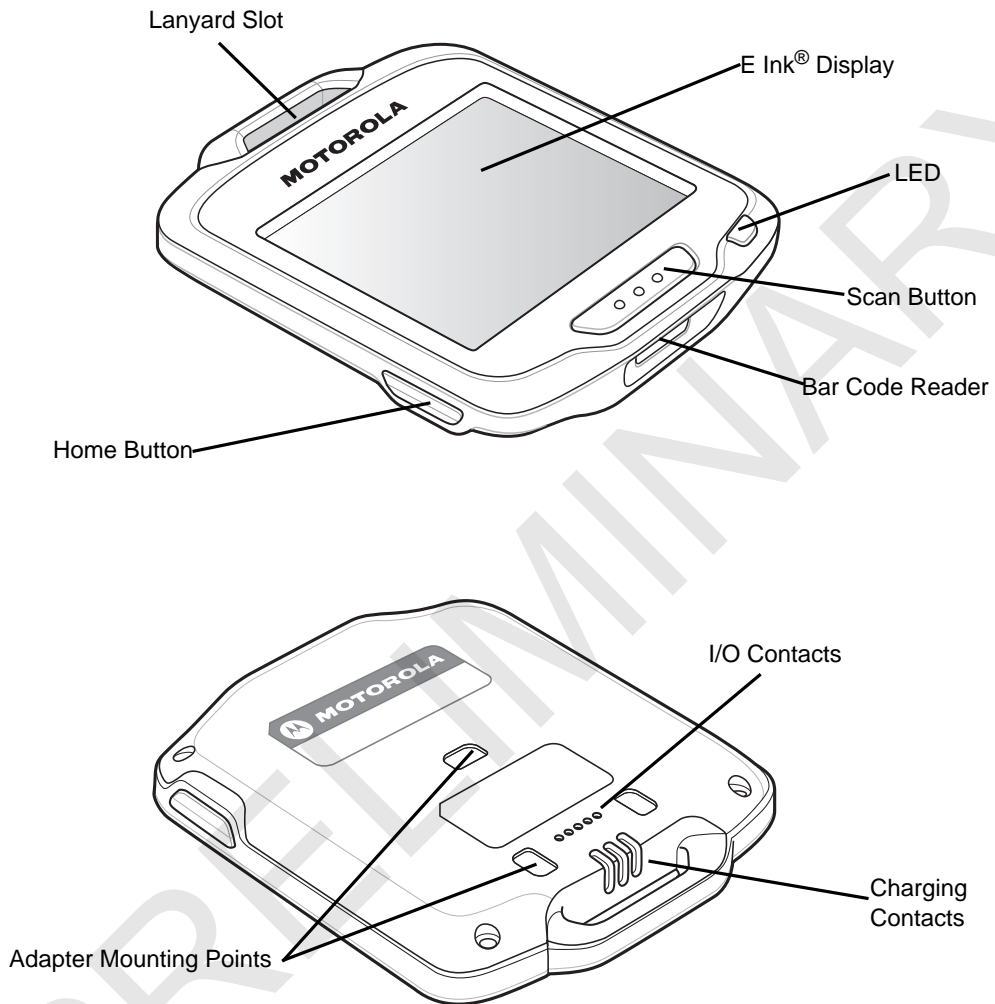

Figure 1-1 SB1 smart badge

Charging the SB1



CAUTION Follow the guidelines for battery safety described in *Battery Safety Guidelines on page 5-1*.

The SB1 must be charged within the 0 °C to +40 °C (32 °F to 104 °F) ambient temperature range.

Out of the box, the SB1 is off and displays the Regulatory label information.



Figure 1-2 Out of the Box Screen

Use the Single Slot Charging cradle or Ten Slot Charge Only cradle to charge the SB1. Refer to the *SB1 Integrator Guide* for accessory setup information.

To charge the SB1, slide it into the cradle slot with the Scan button facing up.

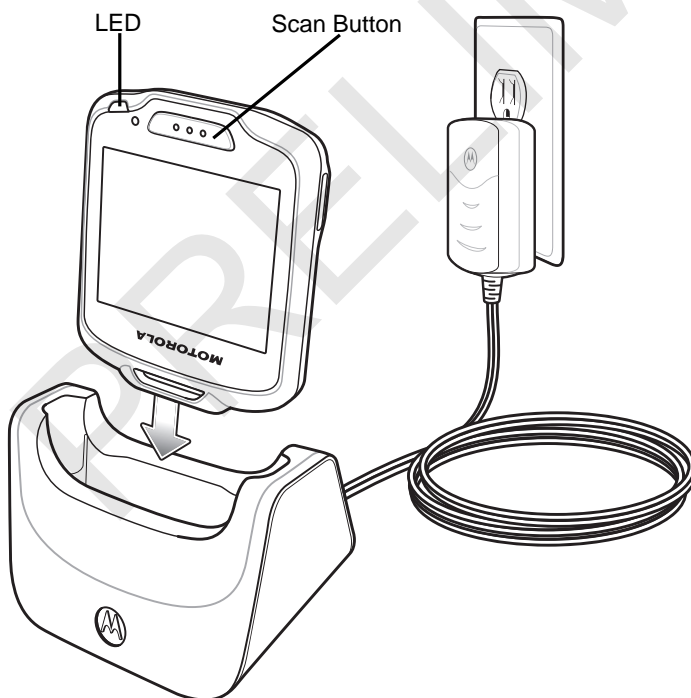

Figure 1-3 Single Slot Charging Cradle

When the SB1 powers up a beep sounds and the Calibration screen displays.

Carefully press and briefly hold finger tip on the center of the **Calibration** screen target. Repeat the procedure as the target moves and stops at different locations on the screen.

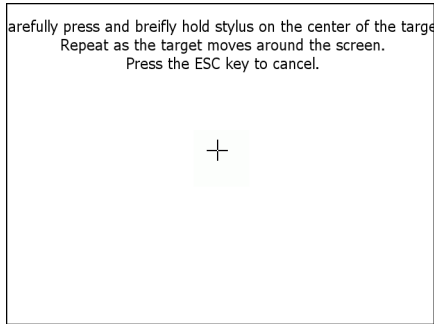

Figure 1-4 Calibration Screen

After the calibration settings are input, tap the screen to save the new calibration settings. The Battery Charging screen appears and the LED indicates the SB1 battery charging status. The battery fully charges in approximately four hours. See [Table 1-1 on page 1-4](#) for charging status indications.

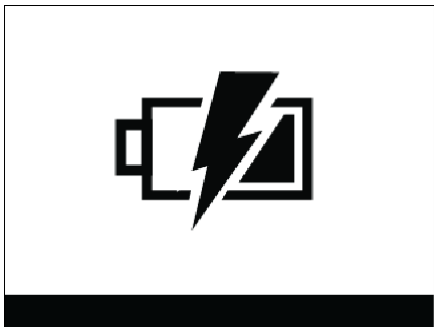

Figure 1-5 Battery Charging Screen

Table 1-1 LED Indicator

LED	Indication
Off	SB1 not placed correctly in the cradle. The cradle is not powered. SB1 is not functioning properly.
Slow Blinking Amber	SB1 is charging.
Solid Green	Charging is complete.
Fast Blinking Amber	Charging error.

Leave the SB1 in the cradle until the LED lights green indicating that it is fully charged.

When using the SB1, the battery charge falls below a predetermine level, it shuts down and displays the Battery Discharged screen. When this occurs, immediately recharge the SB1 battery by placing it into a charging cradle.

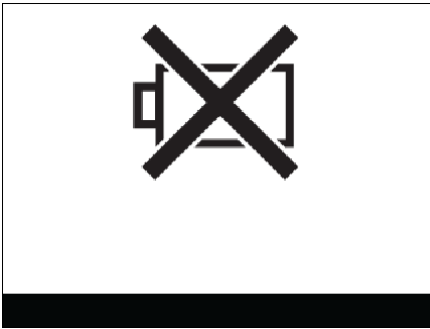

Figure 1-6 Battery Discharged Screen

WLAN Setup

To set up the SB1 on a wireless LAN, refer to the *SB1 Integrator Guide* for detailed instructions.

Resetting the SB1

If the SB1 stops responding to input, perform a reset. A reset stops all running applications and any unsaved data is lost. Simultaneously press and hold the Home and Scan buttons for five seconds. The SB1 beeps and then resets.

Powering Off the SB1

Power off the SB1 when not using for long periods of time.

1. Press the Home button.
2. Touch **↑↓**. The **Settings** screen appears.
3. Touch **≡**. The **More Settings** screen appears.
4. Touch **Advanced Settings**. The **Advanced Settings** screen appears.
5. Touch **Power Off Device**.
6. Touch **OK**. The SB1 shuts down and the Regulatory Information screen appears.

To turn the SB1 back on, press and hold the Scan and Home buttons for at least five seconds.

PRELIMINARY

CHAPTER 2 OPERATION

This chapter provides basic instructions for using the SB1.

Wearing the SB1

The SB1 can be worn on a lanyard around the neck, in a holster on the hip or on an armband.

Lanyard

The lanyard provides easy access to the SB1 and allows the SB1 to be used as an employee badge when not in use.



Figure 2-1 *SB1 on Lanyard*

The SB1 mounts onto the lanyard and can be removed and replaced with ease. An accelerometer instantly orients the screen 180° based on device position for easy viewing by customers and users.

The lanyard is adjustable allowing the user to position the SB1 to a comfortable height. See [Lanyard on page 4-13](#).

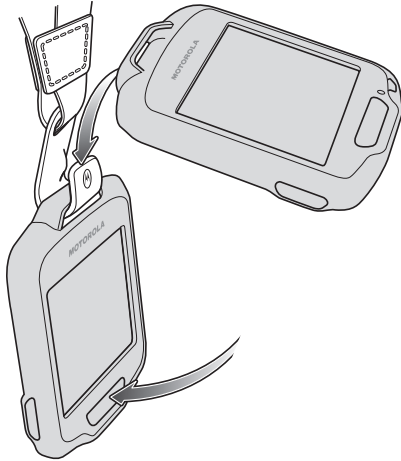

Figure 2-2 *Installing the SB1 onto the Lanyard*

Holster

The holster clips onto a belt or waistband and provides a tether to secure the SB1. See [Holster on page 4-9](#) for setup instructions.

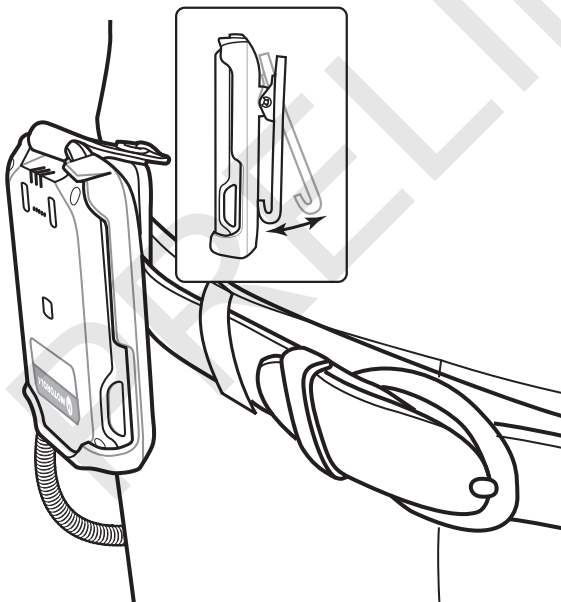

Figure 2-3 *Holster on Belt*

Armband

The armband attaches to the forearm or upper arm and provides mounting for the holster. See [Armband on page 4-11](#) for setup instructions.

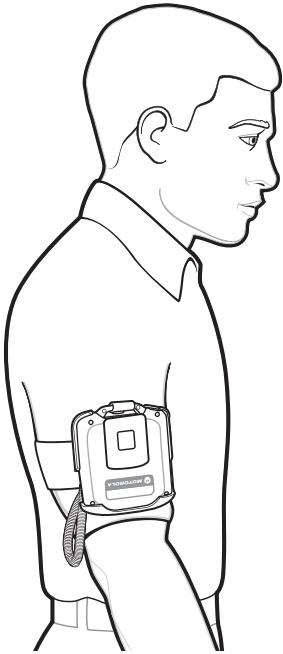

Figure 2-4 Armband

Entering Data

The user uses the tip of their finger to select objects, enter text and accept notifications. Do not use a pen or any other object on the SB1 display. It is designed for finger friendly touch only.

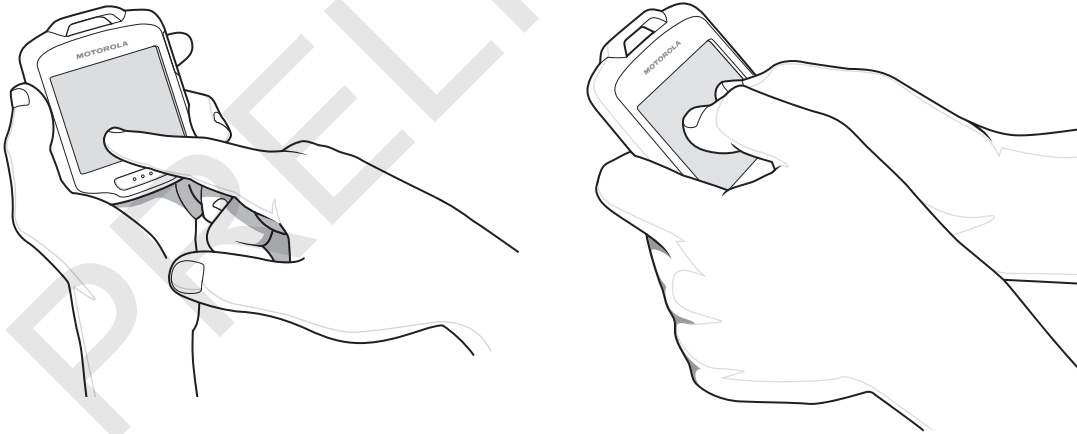

Figure 2-5 Entering Data on Screen

Using a Headset

One option for Push-to-Talk (PTT) communication is using a headset. Motorola Solutions offers two types of headset accessories; earbud headset and speaker headset. The Audio Adapter is required when using a headset. Connect the headset to the Audio Adapter when wearing the SB1 on the lanyard, holster or armband.

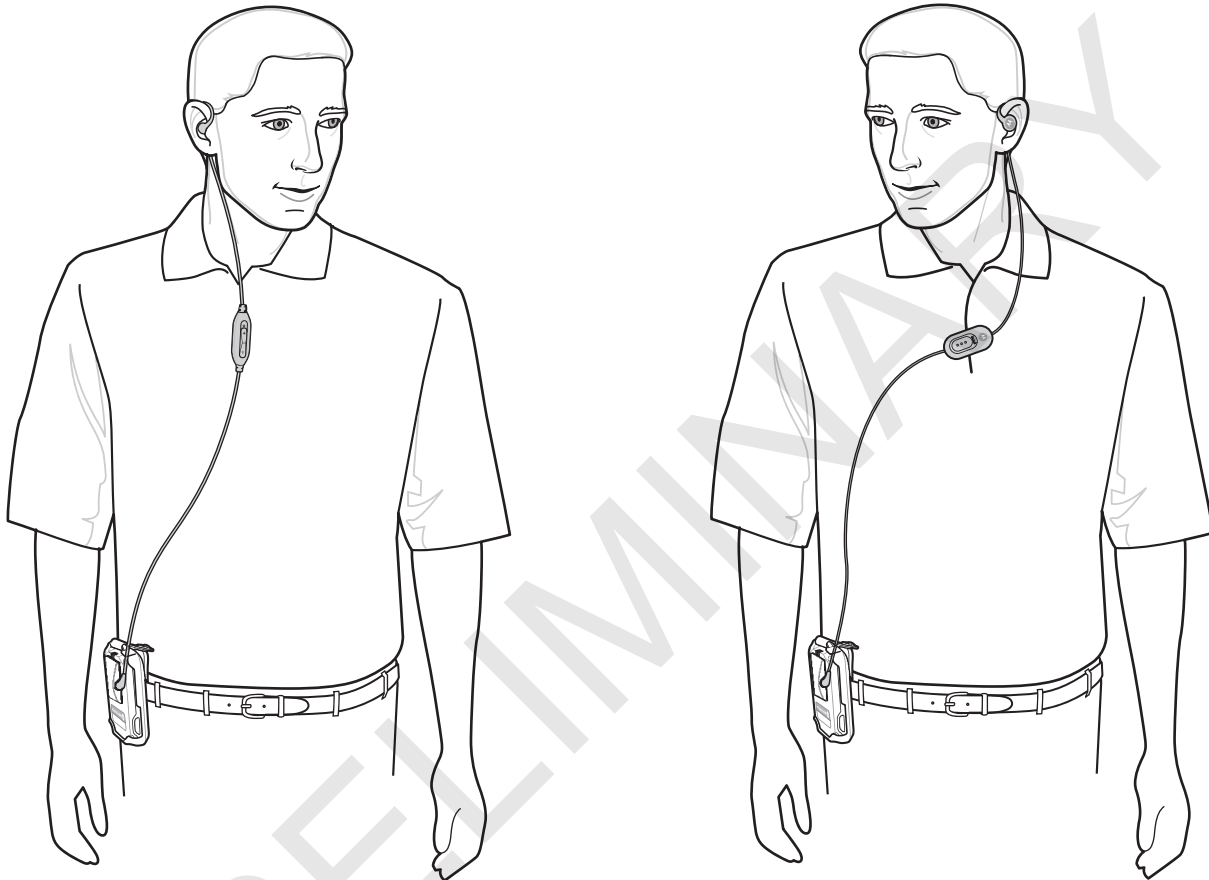

Figure 2-6 *Using Headset with SB1 in Holster*

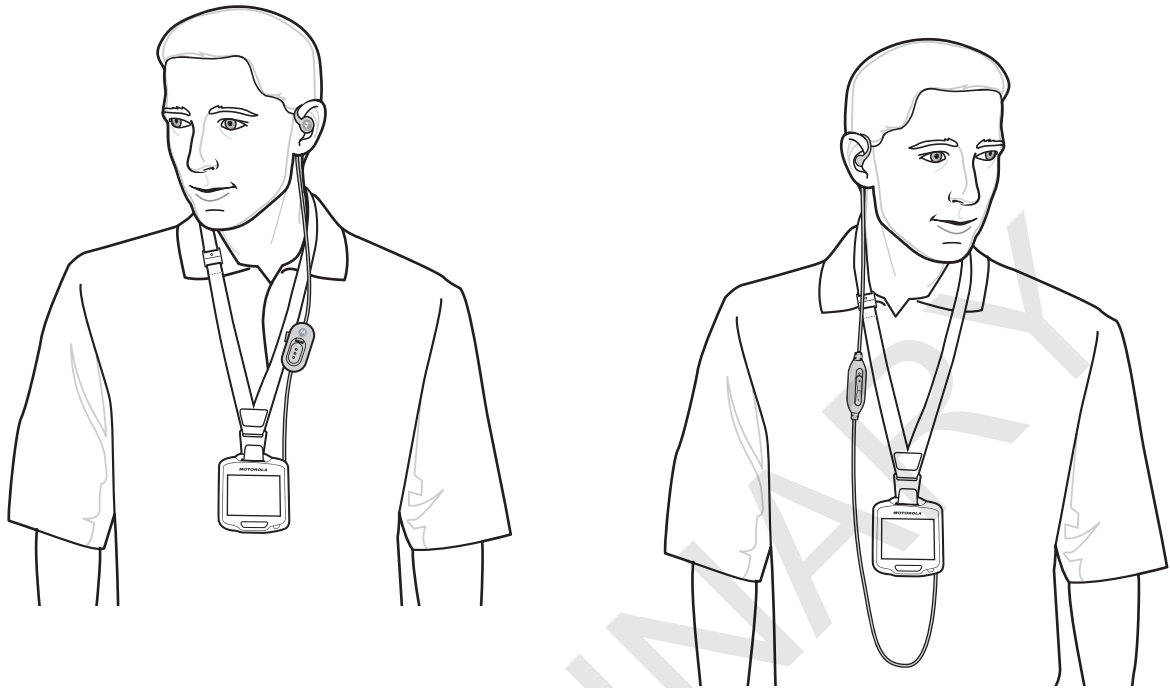

Figure 2-7 Using Headset with SB1 on Lanyard

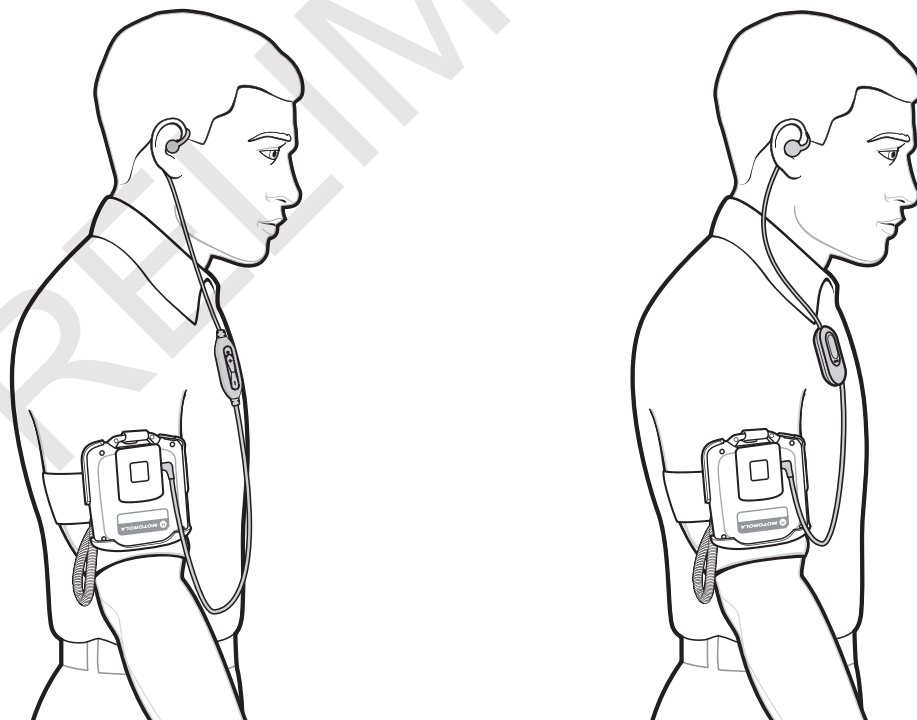

Figure 2-8 Headset with SB1 on Armband

Using the Speaker Adapter

The Speaker Adapter provides PTT communication. When receiving audio, the sound comes from the Speaker Adapter. When the user speaks, the microphone on the front of the SB1 captures the audio.



Figure 2-9 *Using the Speaker Adapter*

Home Screen

The Home screen provides the user access to SB1 configuration, applications, notifications and user profile settings.

Press the Home button on the side of the SB1 to display the Home screen.

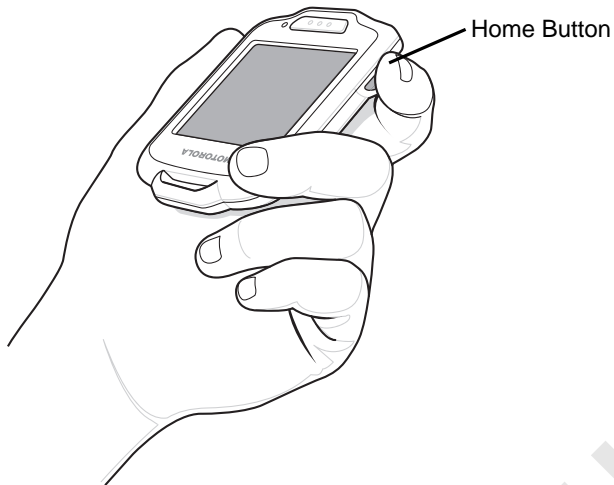

Figure 2-10 Pressing Home Button

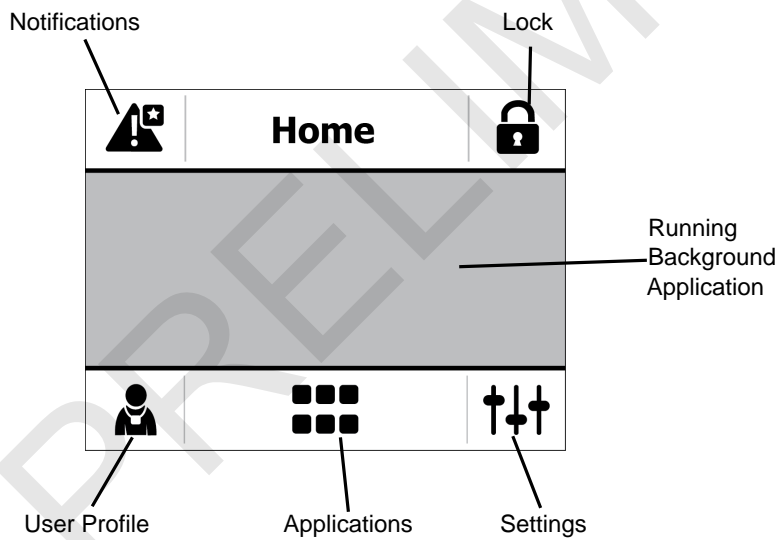



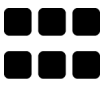



Figure 2-11 Home Screen

Table 2-1 Home Screen Icons

Icon	Description
	Notifications - Touch to open the Notification screen. A star on the icon indicates that new notifications are available.
	Lock - Touch to automatically lock the SB1 and displays the User screen.
	User Profile - Touch to set user profile.
	Applications - Touch to launch the Applications screen.
	Settings - Touch to configure SB1 settings.

Notifications

The SB1 displays notifications for system and application status. When a notification is received, a notification dialog box appears on the screen and a beep sounds. The user can act on the notification or dismiss it depending upon the notification.



Figure 2-12 Sample Notification Dialog Box

If multiple notifications are present, the SB1 displays a dialog box with each notification.

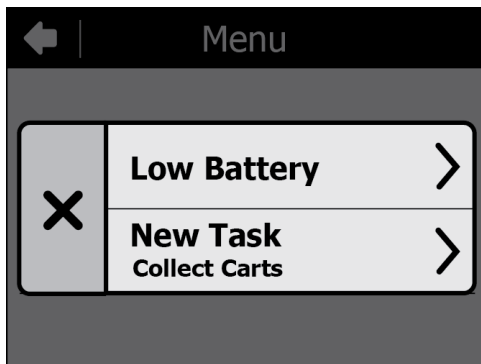

Figure 2-13 Multiple Notifications

Touch one of the notifications to display its notification dialog box. Touch **X** to close the dialog box.

Locking the SB1

Touch the Lock icon to place the SB1 into badge mode. The screen automatically displays the user name and title set in the **Profile** screen.



Figure 2-14 Lock Screen

To return to the Home screen, press the Home button.

Setting User Profile

Use the **Profile** screen to set the user name and user title, sign out of the SB1 and switch devices.

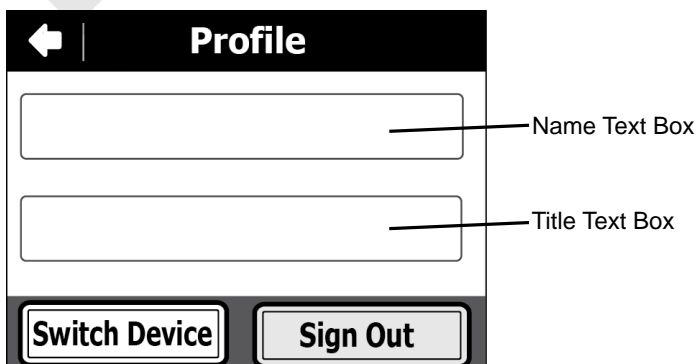

Figure 2-15 Profile Screen

Enter Name and Title

To enter user name:

1. In the **Profile** screen, touch the top text box. The **Enter Name** screen appears.

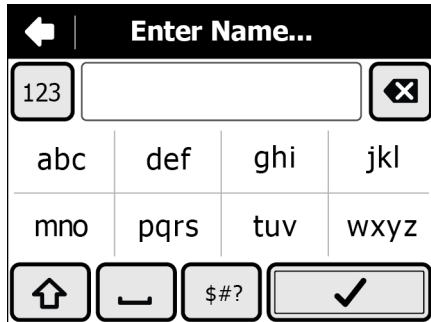

Figure 2-16 Enter Name Screen

2. Press the keypad keys to enter the user name.
 - Use to create capital letter.
 - Touch to display the numeric keypad.
 - Touch to display special character keypad.
 - To create the letter c, quickly touch **abc** three times.
 - Use [Delete] to delete the last character in the text box.
3. Touch to save the name.

To enter user title:

1. In the **Profile** screen, touch the lower text box. The **Enter Title** screen appears.

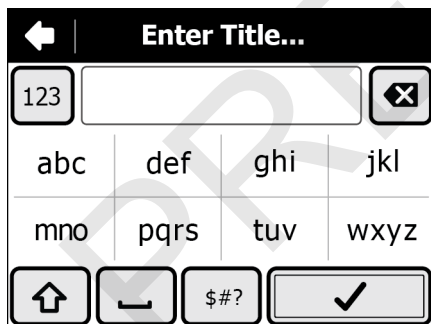

Figure 2-17 Enter Title Screen

2. Press keypad keys to enter the user title.
 - Use to create capital letter.
 - Touch to display the numeric keypad.
 - Touch to display special character keypad.
 - To create the letter c, quickly touch **abc** three times.
 - Use [Delete] to delete the last character in the text box.

3. Touch  to save the user title.

Sign Out

To be supplied.

Switch Device

To be supplied.

Applications

All applications installed on the SB1 can be accessed by touching .

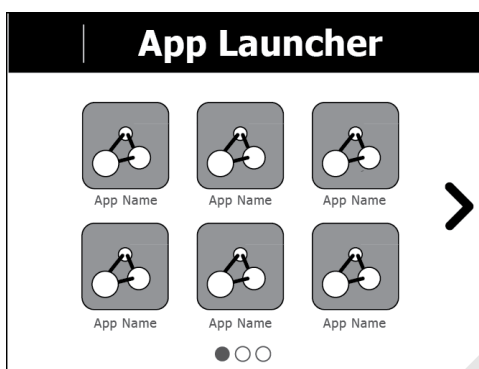





Figure 2-18 App Launcher Screen

The **App Launcher** screen displays an icon for each application. If more than six applications are installed, touch the arrow to move to the next page. Dots appear below the icons indicating the number of application pages available.

Touch an icon to launch that application.

When there is a running application, an  appears in the title bar. Touch the  to exit the App Launcher and return to the last running application.

An  appears on the top corner of all running application icons. Touch the  on the icon to stop that application.

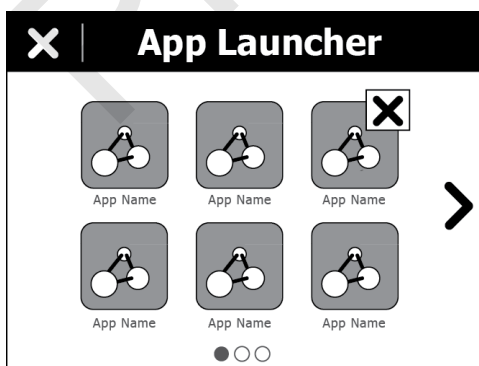

Figure 2-19 App Launcher Screen with Running Application

Settings

Use the **Settings** screen to control SB1 functionality.

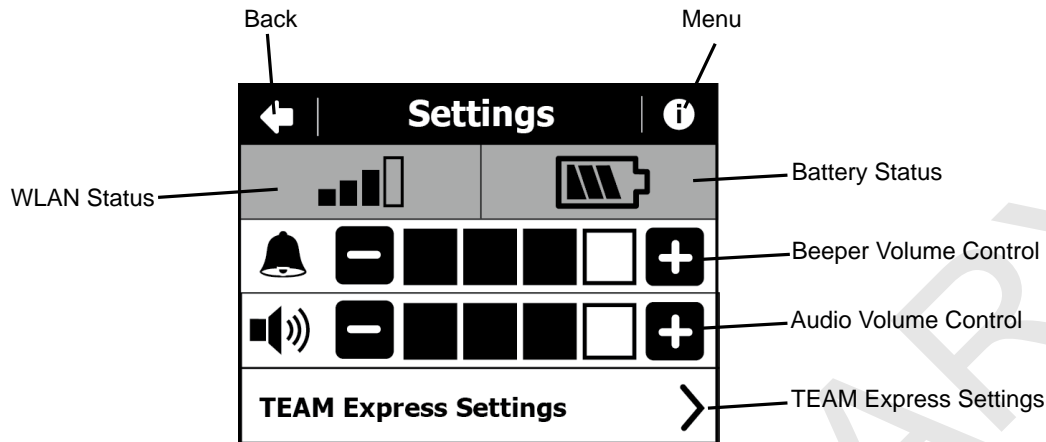

Figure 2-20 Settings Screen

- **WLAN Status** - Displays the signal strength for the WLAN signal. See [Table 2-2 on page 2-12](#).
- **Battery Status** - Displays the battery charge level. See [Table 2-3 on page 2-13](#).
- **Beeper Volume Control** - Use to adjust the speaker volume. See [Adjusting the Volume on page 2-13](#).
- **Audio Control** - Use to control the audio volume through the Audio Adapter. See [Adjusting the Volume on page 2-13](#).
- **TEAM Express Settings** - Touch to configure TEAM Express for Push-to-Talk (PTT) settings. See [TEAM Express Voice Client on page 2-16](#) for more information.
- **More Settings Menu** - Touch  to display additional setting options for setting the date and time, screen calibration, provisioning and wireless LAN configuration.

Table 2-2 WLAN Status













Icon	Status	Action
	Excellent signal strength	WLAN network is ready to use.
	Very good signal strength	WLAN network is ready to use.
	Good signal strength	WLAN network is ready to use.
	Poor signal strength	WLAN network is ready to use. Performance may not be optimum. Notify the network administrator that the signal strength is "Poor".
	Out-of-network range (not associated)	No WLAN network connection. Notify the network administrator.

Table 2-3 Battery Status

Icon	Description
	0% - [does this actually appear?]
	25%
	50%
	75%
	100%

Adjusting the Volume

To adjust the beeper volume and the audio volume on the SB1, touch  to increase volume or  to decrease volume.

TEAM Express Settings

Use the **TEAM Express Setting** to enable TEAM Express for PTT and select a channel. For information on using TEAM Express see [TEAM Express Voice Client on page 2-16](#).

Screen Calibration

If when touching the screen misalignment is observed, the user can re-calibrate the screen.

1. On the **Settings** screen, touch .
2. Touch **Calibrate Screen**.
3. Carefully press and briefly hold finger tip on the center of the target. Repeat the procedure as the target moves and stops at different locations on the screen. This enters the new calibration settings.

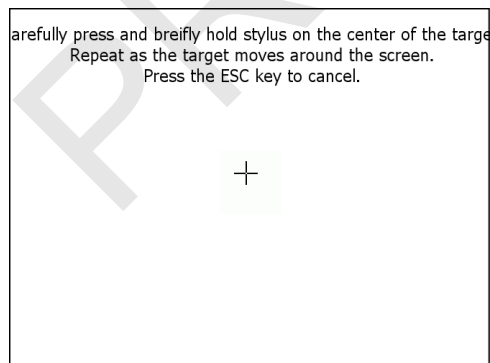





Figure 2-21 Calibration Screen

4. Once all of the new calibration settings are input, tap the screen to save the new calibration settings.

Beeper Settings

To set the alerts on the SB1. The user can select the type of notification that produces an audio alert:

1. Touch . The **Settings** screen appears.
2. Touch . The **Advanced Settings** screen appears.
3. Touch **Beeper Settings**.
4. Touch the **System**, **Server** or **Application** radio button to enable or disable the beeper sound when a notification occurs.
5. Touch  to return to the Home screen.

RD Client



Use the RD Client to provision the SB1. Refer to the *SB1 Smart badge Integrator Guide* for more information.

Fusion Settings

Use the Fusion Settings to configure the SB1 to access the WLAN. Refer to the *SB1 Smart badge Integrator Guide* for more information.

Set Time and Date

To set the time and date on the SB1:

1. Touch . The **Settings** screen appears.
2. Touch . The **More Settings** screen appears.
3. Touch **Advanced Settings**. The **Advanced Settings** screen appears.
4. Touch **Date and time**. The **Set date and time** screen appears.

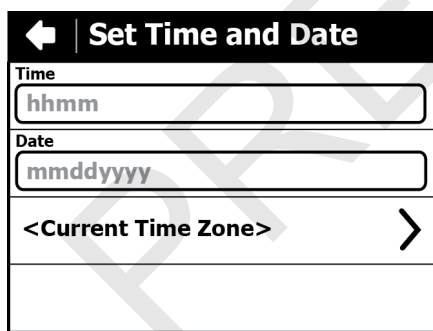

Figure 2-22 *Date and Time Screen*

5. Touch the **Date** field. The **Today** screen appears.



Figure 2-23 Today Screen





6. Touch  to delete the current date.
7. Use the keypad to enter the new date in the format DD/MM/YYYY.
8. Touch . The **Set date and time** screen appears.
9. Touch the **Time** field. The **Now** screen appears.



Figure 2-24 Now Screen

10. Touch  to delete the current time.
11. Use the keypad to enter the new date in the format HH:MM.
12. Touch . The **Set date and time** screen appears.
13. Touch the Time Zone field. The Timezone screen appears.
14. Use the up and down arrows to scroll to the time zone.
15. Touch the time zone option.
16. Touch  to return to the **Advanced Settings** screen.

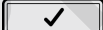
TEAM Express Voice Client

TEAM Express Voice Client creates PTT communication capability between disparate enterprise devices. Leveraging existing Wireless Local Area Network (WLAN) infrastructure, TEAM Express delivers simple PTT communication without the need of a voice communication server.

The Speaker Adapter or Audio Adapter and a Headset are required for PPT communication. See [Chapter 4, Accessories](#) for information on installing the adapters.

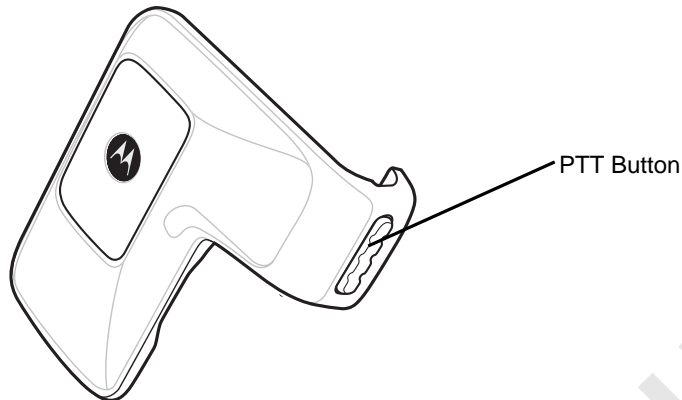

Figure 2-25 Speaker Adapter

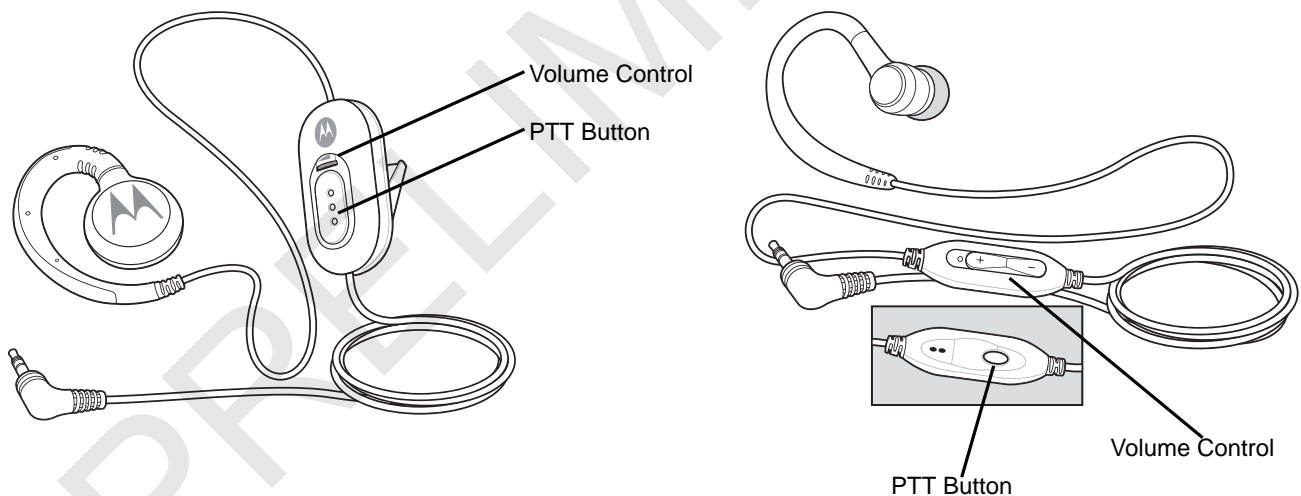

Figure 2-26 Headsets

PTT Audible Indicators

The following tones provide helpful cues when using the voice client.

- **Talk Tone:** Double chirp. Plays when the broadcast (or private) button is depressed. This is a prompt for the user to start talking.
- **Access Tone:** Single beep. Plays when another user just finished a broadcast or response to the user. The user is now able to initiate a Group Broadcast or Private Response.
- **Busy Tone:** Continuous tone. Plays when the broadcast (or private) button is depressed and another user is already communicating on the same talkgroup.

- **Network Tone:**
 - Three increasing beeps. Plays when TEAM Express is acquiring the WLAN connection and ready for voice communication.
 - Three decreasing beeps. Plays when TEAM Express has lost the WLAN connection and is not ready for voice communication.

TEAM Express Voice Client Configuration

Enable Voice Client Communication

To enable the PTT communication:

1. Press the Home button to display the Home screen.
2. Touch $\uparrow\downarrow$. The **Settings** screen appears.
3. Touch **TEAM Express settings**. The **TEAM Express** screen appears.

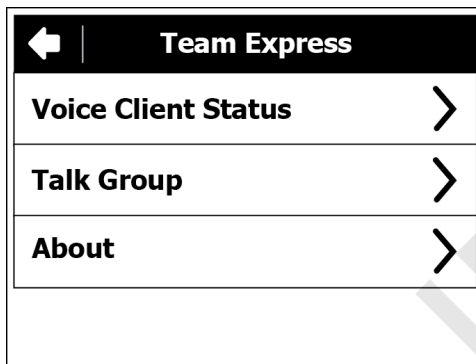

Figure 2-27 TEAM Express Screen

4. Touch **Voice Client Status**.

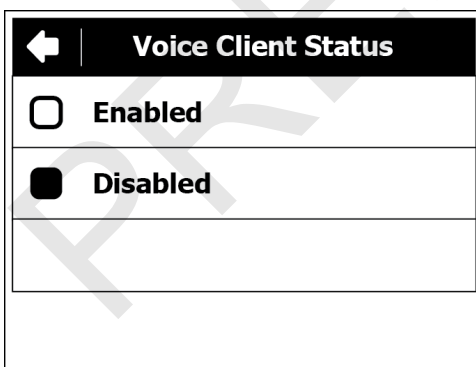

Figure 2-28 Voice Client Status Screen

5. Touch **Enable**.
6. Touch **Save**.
7. Touch \leftarrow .

Select a Talk Group

One of 21 talk groups can be selected by TEAM Express users. However, only one talk group may be enabled at a time on the SB1.

1. Touch **↑↓↑**. The **Settings** screen appears.
2. Touch **TEAM Express settings**. The **TEAM Express** screen appears.
3. Touch **Talk Group**. The **Talk Group** screen appears.

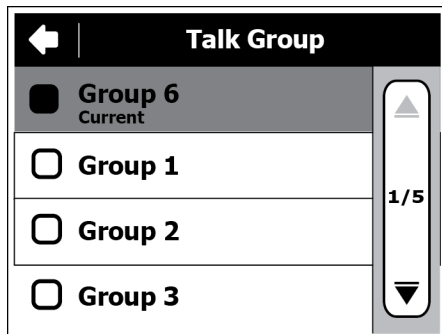

Figure 2-29 Talk Group Screen

4. Touch a **Talk Group** number. Use the arrow buttons to view additional Talk Groups.
5. Touch **Save**.
6. Touch **←** to return to the **TEAM Express** screen.
7. Press the Home button.

Disable TEAM Express Voice Client Communication

To disable the PTT communication:

1. From the Home screen, touch **↑↓↑**. The **Settings** screen appears.
2. Touch **TEAM Express settings**. The **TEAM Express** screen appears.
3. Touch **Voice Client Status**.
4. Touch **Disable**.
5. Touch **Save**.
6. Touch **←** to return to the **TEAM Express** screen.
7. Press the Home button.

PPT Communication

PTT communication may be established as a Group Broadcast or Private Response.

Group Broadcast (One to Many)

1. Press and hold the PTT button on the Speaker Adapter or Headset for more than 300 msec. and listen for the talk tone to play.

If a busy tone is heard, release the PTT button and wait a moment before making another attempt. Ensure that TEAM Express and the WLAN are enabled.

2. Start talking immediately after the talk tone plays.

✓ **NOTE** If the user holds the PTT button for more than 60 seconds, the call is dropped and then restarted preventing others from making Group Broadcast calls. The user should release the Group Broadcast button when finished talking to allow others to make calls.

3. Release the PTT button when finished talking.

Response to a Group Broadcast

To respond to a Group Broadcast:

1. Wait until an access tone is heard.
2. Press and hold the PTT button within 300 msec. and listen for the talk tone to play.

If a busy tone is heard, release the PTT button and wait a moment before making another attempt. Ensure that TEAM Express and the WLAN are enabled.

3. Start talking immediately after the talk tone plays.
4. Release the PTT button when finished talking.

Private Response (One to One)

The Private Response can only be initiated once a Group Broadcast has been established.

The initial Private Response is made to the last talker on the Group Broadcast.

1. Wait until an access tone is heard.
2. Within 10 seconds, double press and hold the PTT button, and listen for the talk tone to play.

If a busy tone is heard, release the PTT button and wait a moment before making another attempt. Ensure that TEAM Express and the WLAN are enabled.

3. Start talking immediately after the talk tone plays.
4. Release the PTT button when finished talking.

PRELIMINARY

CHAPTER 3 DATA CAPTURE

Introduction

The SB1 contains a bar code reader with aimer and illumination for reading bar code data. The reader uses digital camera technology to take a digital picture of a bar code, stores the resulting image in its memory, and executes state-of-the-art software decoding algorithms to extract the data from the image.

Scanning Considerations

Scanning consists of; aim, scan and decode. Scanning performance can be optimized by considering the range.

Any scanning device decodes well over a particular working range (minimum and maximum distances from the bar code). This range varies according to bar code density and scanning device optics.

Scanning within range brings quick and constant decodes; scanning too close or too far away prevents decodes. Move the SB1 closer and further away to find the right working range for the bar codes being scanned. The best way to specify the appropriate working range per bar code density is through a chart called a decode zone. A decode zone simply plots working range as a function of minimum element widths of bar code symbols. See the SB1 Integrator Guide for decode zone chart.



NOTE Contact the Motorola Solutions Global Customer Support if chronic scanning difficulties develop. Decoding of properly printed bar codes should be quick and effortless.

Bar Code Reading

To read bar codes:

1. Ensure that the SB1 is loaded with a scanning application.
2. Aim the exit window at the bar code.

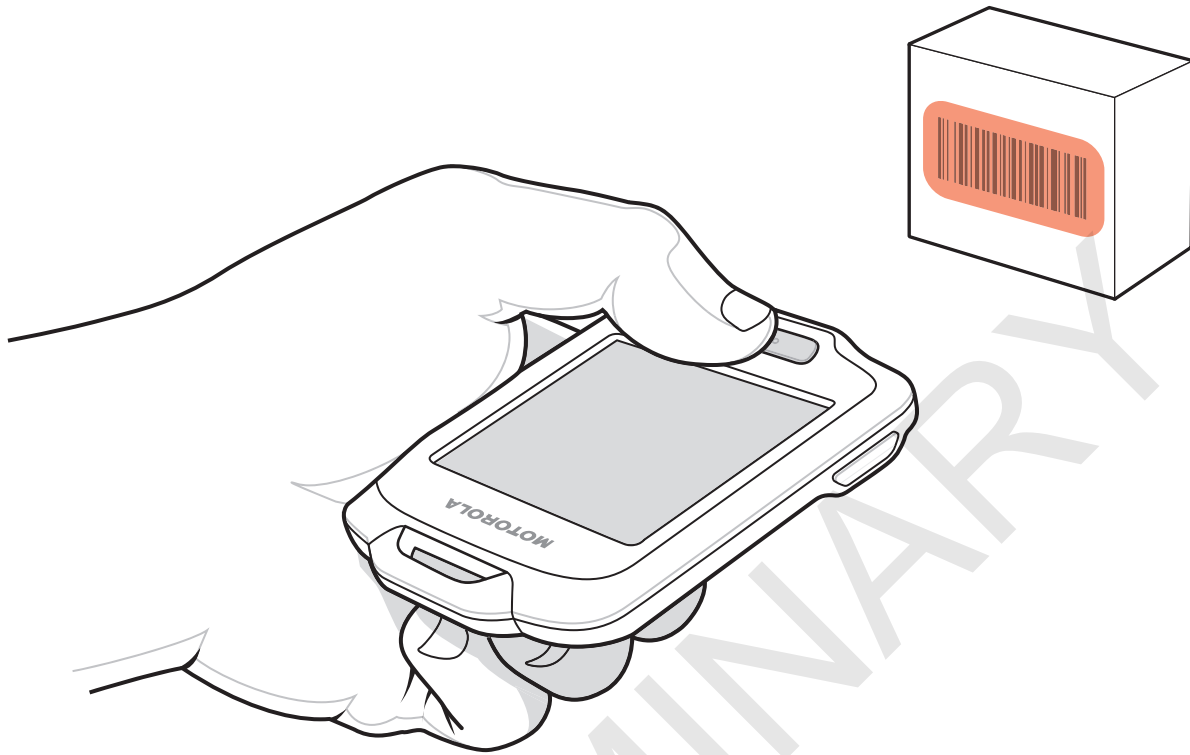

Figure 3-1 *Data Capture*

3. Press the Scan button. Ensure the red illumination covers the entire bar code. The LED Indicator illuminates red to indicate that the illumination is on. The LED Indicator turns green and a beep sounds to indicate a successful decode.
 - Optimal reading distance varies with bar code density.
 - Hold the SB1 farther away for larger symbols.
 - Move the SB1 closer for symbols with bars that are close together.
- ✓ **NOTE** Scanning procedures depend on the application. An application may use different scanning procedures from the one listed above.

Chapter 4 Accessories

Introduction

The SB1 accessories provide a variety of product support capabilities. [Table 4-1](#) lists the SB1 accessories.

Table 4-1 SB1 Accessories

Accessory	Description
Cradles	
Single Slot Charging Cradle	Charges the battery within the SB1.
Ten Slot Charge Only Cradle	Charges up to ten SB1s.
Charging	
Power Supply (12 VDC, 4.16 A)	Provides power to the Ten Slot Charge Only Cradle.
Power Supply (5 VDC, 850 mA)	Provides power to the Single Slot Charging Cradle.
Miscellaneous	
Holster	Provides a clip on holder for the SB1.
Armband	Provides a clip on holder for the SB1.
Lanyard	Use to hold the SB1 around your neck.
Headset Adapter	Provides audio to a wired headset.
Speaker Adapter	Provides speaker for Push-To-Talk functionality.
Earbud Headset	TBS
Speaker Headset	TBS

Single Slot Charging Cradle



CAUTION Ensure to follow the guidelines for battery safety described in *Battery Safety Guidelines on page 5-1*.

Use the Single Slot Charging cradle to charge the SB1 battery. To charge the SB1 battery:

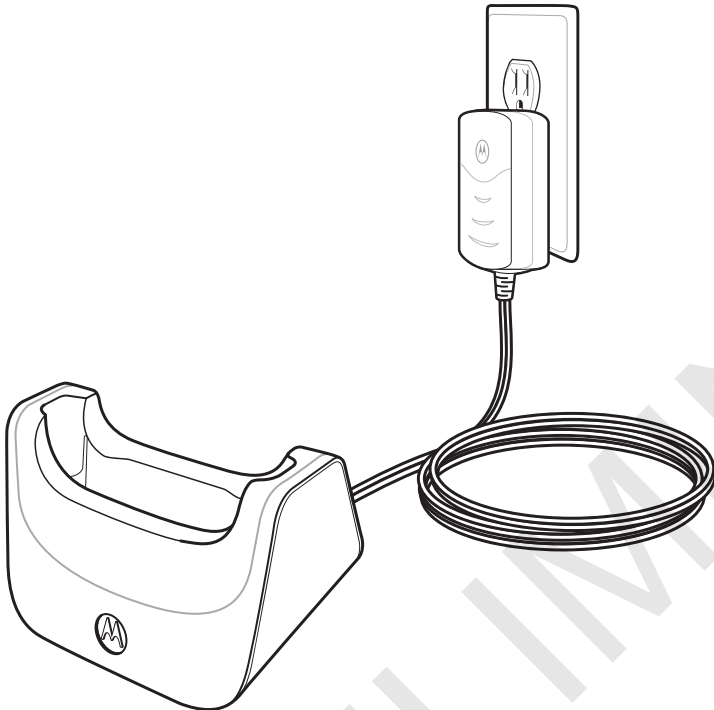

Figure 4-1 *Single Slot USB Cradle*

1. If attached, remove the SB1 from the lanyard or holster tether.
2. Slide the SB1 into the slot with the Scan button facing up.

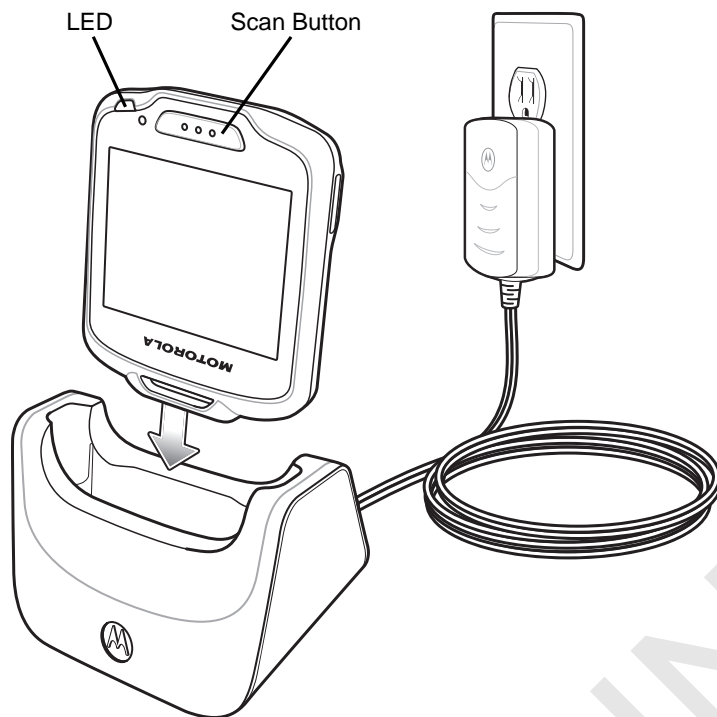

Figure 4-2 Single Slot USB Cradle

The Charging screen displays and the SB1 LED Indicator indicates the SB1 battery charging status. The battery charges in approximately four hours. See [Table 1-1 on page 1-4](#) for charging status indications.

3. When charging is complete remove the SB1 from the cradle.

Ten Slot Charge Only Cradle



CAUTION Ensure that you follow the guidelines for battery safety described in *Battery Safety Guidelines on page 5-1*.

Use the Ten Slot Charge Only cradle to charge up to ten SB1s simultaneously. To charge the SB1:

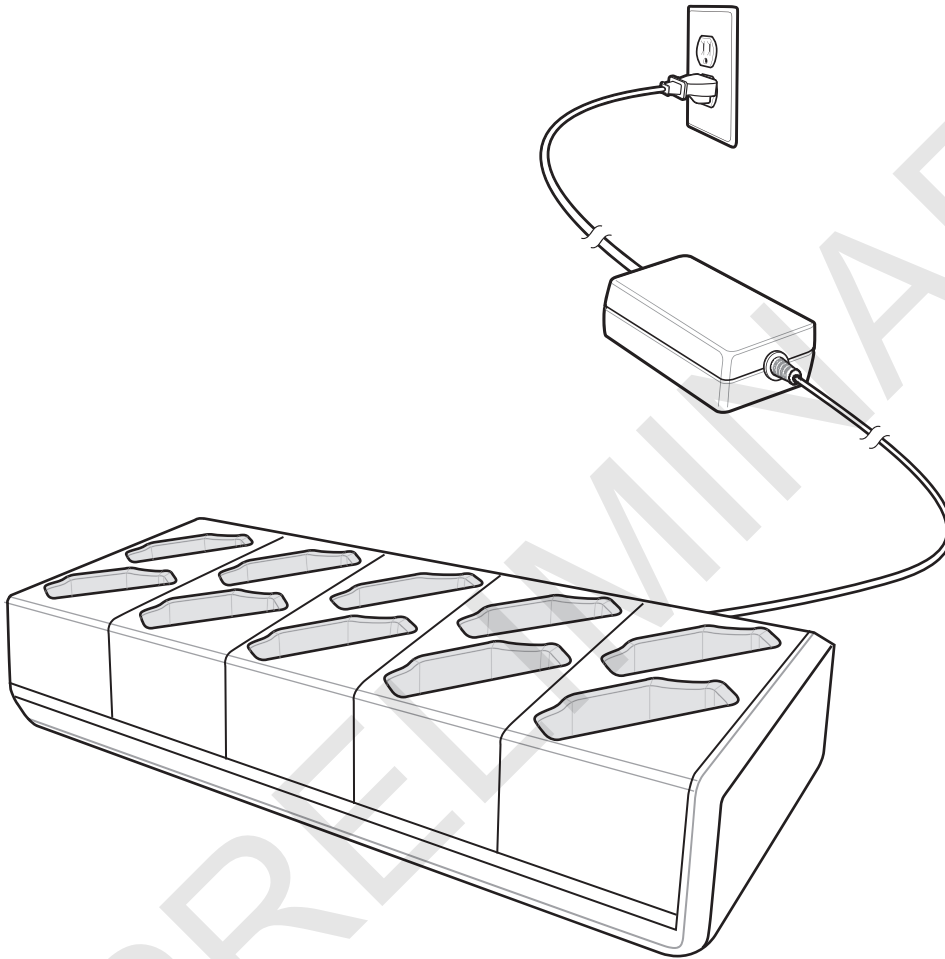

Figure 4-3 Ten Slot Charge Only Cradle

1. If attached, remove the SB1 from the lanyard or holster tether.
2. Slide the SB1 into the slot with the Scan button facing up.
3. Push down on the SB1 until it snaps into place. Verify that the SB1 is secure in the slot.

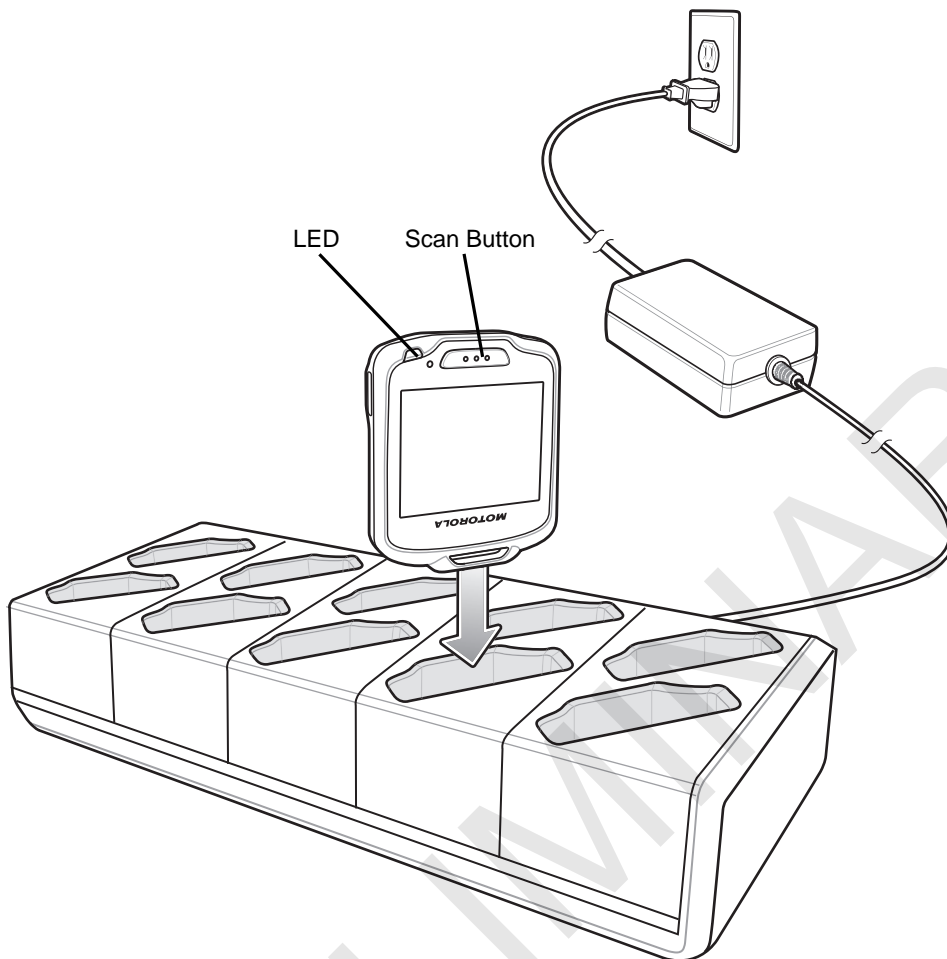

Figure 4-4 Insert SB1 into Ten Slot Charge Only Cradle

The Charging screen displays and the SB1 LED Indicator indicates the SB1 battery charging status. The battery charges in approximately four hours. See [Table 1-1 on page 1-4](#) for charging status indications.

4. When charging is complete, remove the SB1 from the cradle.

Audio Adapter

Use the Audio Adapter to add audio functionality to the SB1. To attached the Audio Adapter to the SB1:

1. Align the Audio Adapter magnets with the adapter mounting points on the back of the SB1.

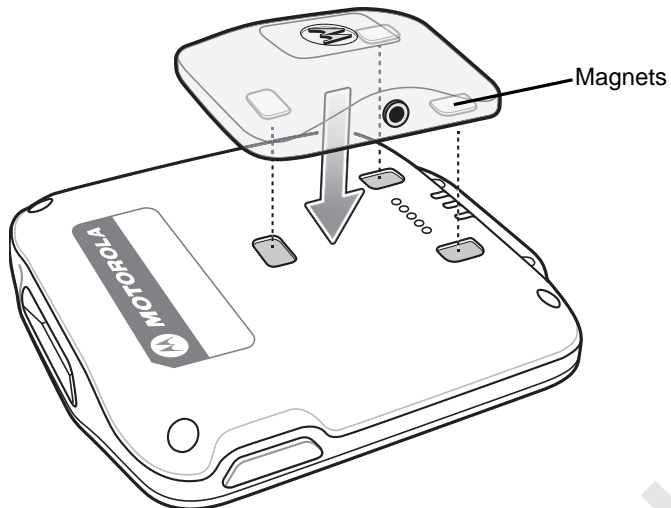

Figure 4-5 *Align Audio Adapter with SB1*

2. Lower the Audio Adapter onto the SB1. The Audio Adapter snaps onto the SB1.
3. Ensure that the adapter is laying flat on the SB1. If not, remove and re-attach.

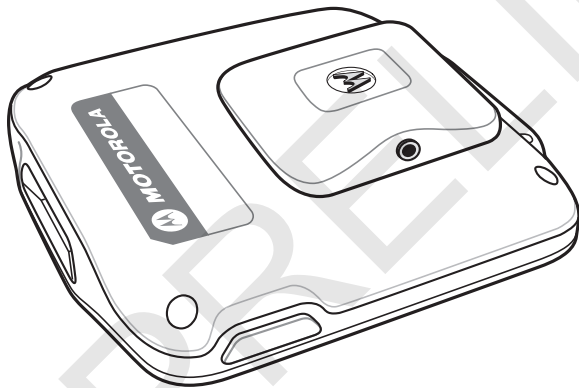

Figure 4-6 *Audio Adapter on SB1*

4. Plug a headset plug into the headset jack on the Audio Adapter.

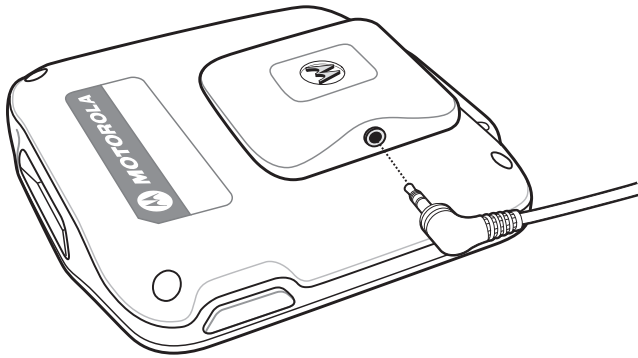

Figure 4-7 *Connect Headset to Audio Adapter*

PRELIMINARY

Speaker Adapter

Use the Speaker Adapter to add audio and push to talk functionality.

To install the Speaker Adapter onto the SB1:

1. Align the Speaker Adapter magnets with the adapter mounting points on the back of the SB1.

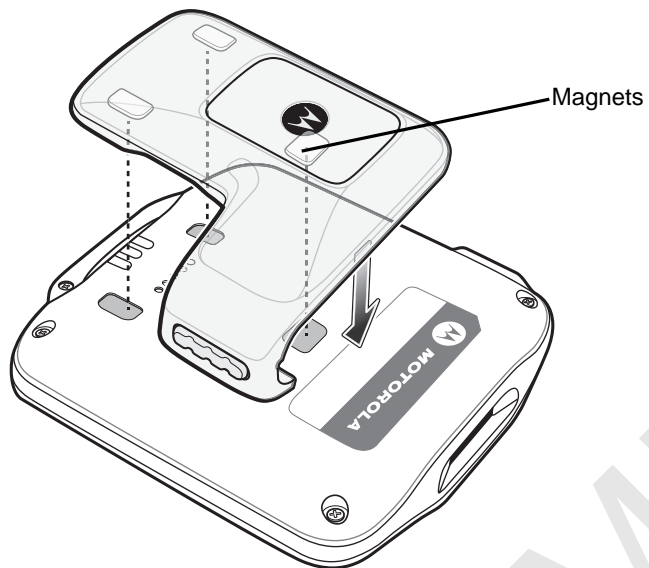

Figure 4-8 *Align Speaker Adapter*

2. Lower the Speaker Adapter onto the SB1. The Speaker Adapter snaps onto the SB1.
3. Ensure that the adapter is laying flat on the SB1. If not, remove and re-attach.

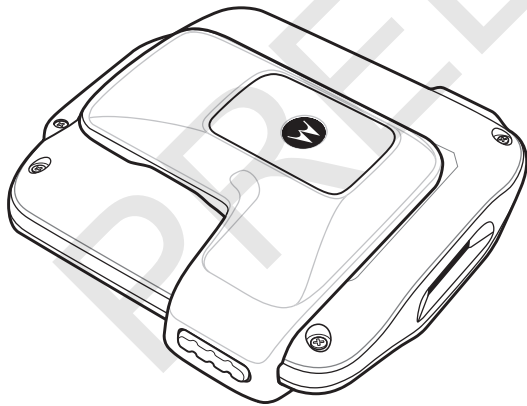

Figure 4-9 *Speaker Adapter Installed*

Holster

Use the holster to store the SB1 provides a holder for the SB1. The holster holds the SB1 on a belt or waist band and provides a tether to attach the SB1 to the holster.

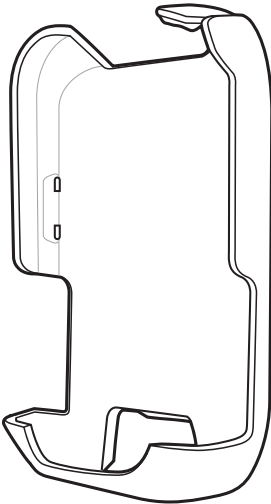

Figure 4-10 *Holster*

1. Feed the loop end of the tether through one of the holes in the holster.
2. Feed the loop end of the tether through the other hole.
3. Pull the loop up so that enough of the loop is above the hole so that the clip end fits through.

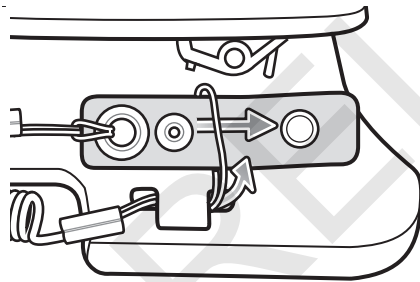

Figure 4-11 *Install SB1 onto Holster*

Feed the clip end of the tether through the loop end.

Continue to feed the tether through the loop and then pull taught.

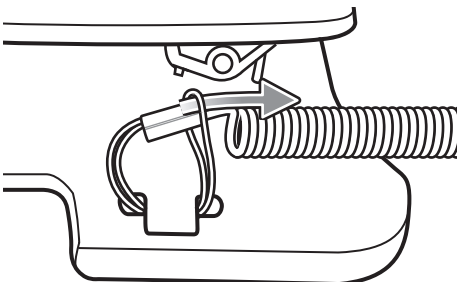

Figure 4-12 *Install SB1 onto Holster*

Feed the clip end through the lanyard slot and snap together.

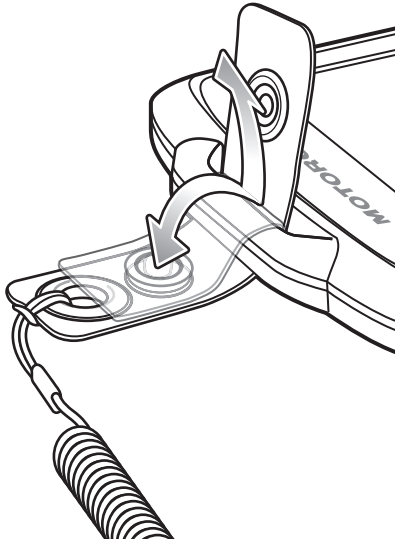

Figure 4-13 *Install Clip onto SB1*

Place the SB1 into the holster with the Scan button facing down and the screen facing the holster. Push the SB1 into the holster until it snaps into place.

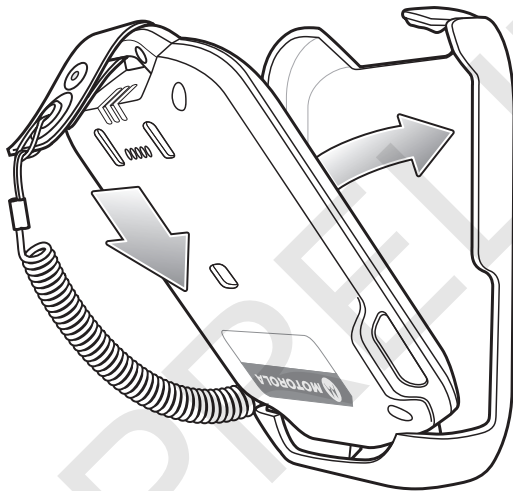

Figure 4-14 *Install SB1 onto Holster*

To remove the SB1 from the holster, pull on the top of the SB1 away from the body.

Armband

Use the Armband to wear the SB1 on the arm.

To install the armband:

Feed the end of the armband through the buckle ensuring that the rubber grip side is facing inside.

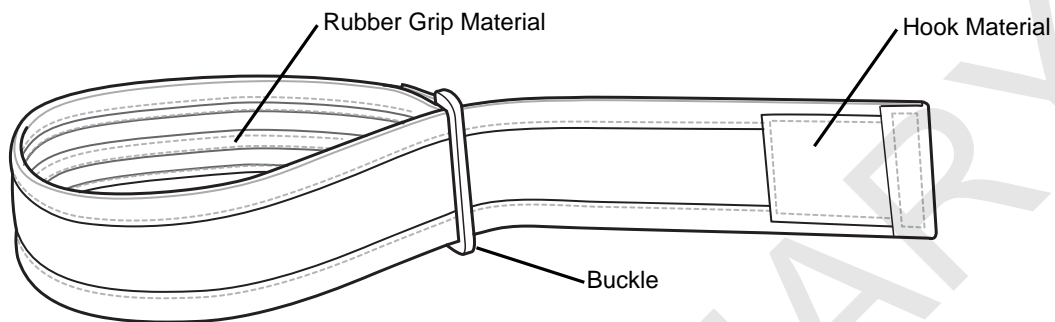

Figure 4-15 Armband

1. Slide the armband onto the arm to a comfortable location.
2. Pull the end of the armband and fold over so that the hook material attaches to the loop material.

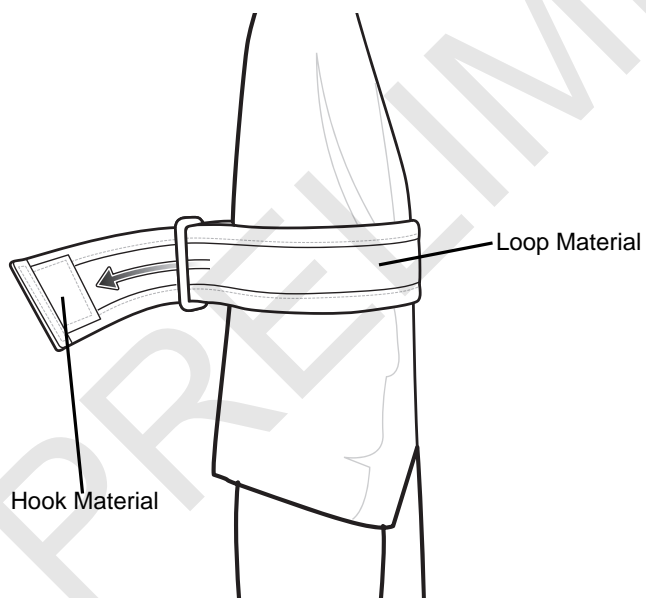

Figure 4-16 Install Armband

3. Insert the clip of the holster in between the two sections of the armband.

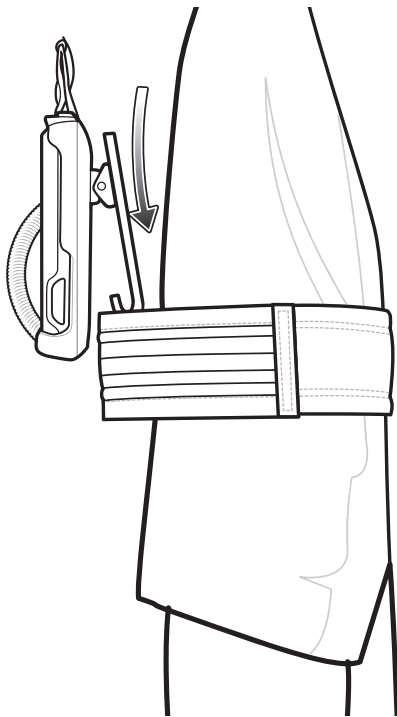

Figure 4-17 *Insert Holster*

4. Lift and then pull the end of the armband to tighten.

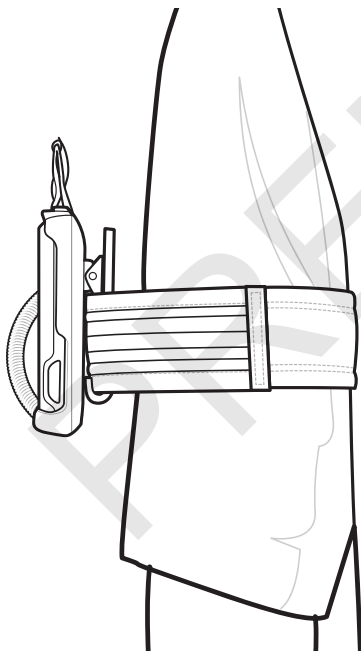

Figure 4-18 *Tighten Armband*

Lanyard

The lanyard provide a means to hold the SB1 on neck.

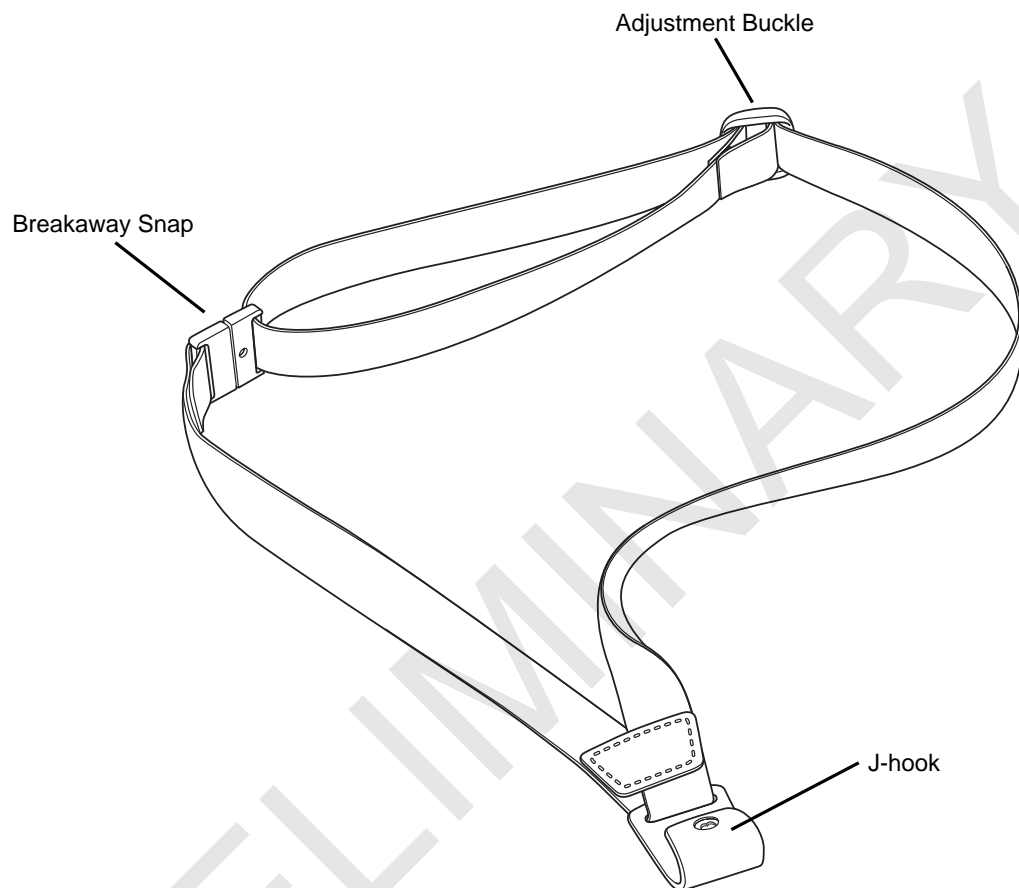

Figure 4-19 Lanyard

Slide the lanyard strap through the Adjustment Buckle to adjust the length of the lanyard. Moving the buckle closer to the Breakaway Snap lengthens the lanyard and moving it away from the Breakaway Snap shortens the lanyard.

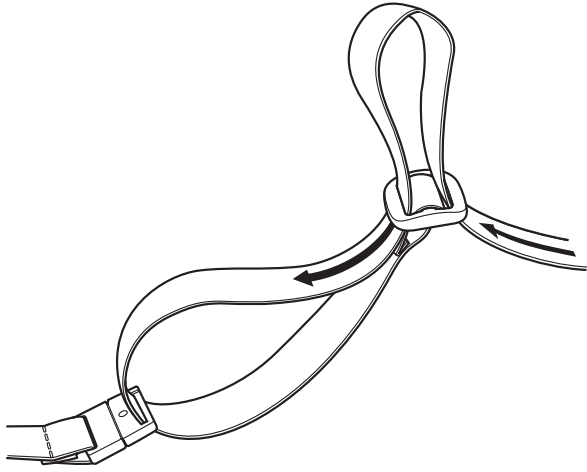

Figure 4-20 *Adjust Lanyard*

PRELIMINARY

Chapter 5 Maintenance & Troubleshooting

Introduction

This chapter includes instructions on cleaning and storing the SB1, and provides troubleshooting solutions for potential problems during SB1 operation.

Maintaining the SB1

For trouble-free service, observe the following tips when using the SB1:

- Do not scratch the screen of the SB1. When working with the SB1, only use finger. Never use an actual pen or pencil or other sharp object on the surface of the SB1 screen.
- Although the SB1 is water and dust resistant, do not expose it to rain or moisture for an extended period of time. In general, treat the SB1 as a pocket calculator or other small electronic instrument.
- The screen of the SB1 is glass. Do not to drop the SB1 or subject it to strong impact.
- Protect the SB1 from temperature extremes. Do not leave it on the dashboard of a car on a hot day, and keep it away from heat sources.
- Do not store or use the SB1 in any location that is dusty, damp, or wet.
- Use a soft lens cloth to clean the SB1. If the surface of the SB1 screen becomes soiled, clean it with a soft cloth moistened with a diluted window-cleaning solution. See [Cleaning on page 5-2](#).

Battery Safety Guidelines



WARNING! Failure to follow these guidelines may result in fire, explosion, or other hazard.

- The area in which the units are charged should be clear of debris and combustible materials or chemicals. Particular care should be taken where the device is charged in a non commercial environment.
- Follow battery usage, storage, and charging guidelines found in this user guide.

- Improper battery use may result in a fire, explosion, or other hazard.
- Do not use a tool to remove the battery from the SB1 or battery charging accessory.
- To charge the mobile device battery, the battery and charger temperatures must be between +32 °F and +104 °F (0 °C and +40 °C)
- Do not use incompatible batteries and chargers. Use of an incompatible battery or charger may present a risk of fire, explosion, leakage, or other hazard. If you have any questions about the compatibility of a battery or a charger, contact Motorola Solutions Global Customer Support.
- For devices that utilize a USB port as a charging source, the device shall only be connected to products that bear the USB-IF logo or have completed the USB-IF compliance program.
- To enable authentication of an approved battery, as required by IEEE1725 clause 10.2.1, all batteries will carry a Motorola hologram. Do not fit any battery without checking it has the Motorola authentication hologram.
- Do not disassemble or open, crush, bend or deform, puncture, or shred.
- Severe impact from dropping any battery-operated device on a hard surface could cause the battery to overheat.
- Do not short circuit a battery or allow metallic or conductive objects to contact the battery terminals.
- Do not modify or remanufacture, attempt to insert foreign objects into the battery, immerse or expose to water or other liquids, or expose to fire, explosion, or other hazard.
- Do not leave or store the equipment in or near areas that might get very hot, such as in a parked vehicle or near a radiator or other heat source. Do not place battery into a microwave oven or dryer.
- Battery usage by children should be supervised.
- Please follow local regulations to properly dispose of used re-chargeable batteries.
- Do not dispose of batteries in fire.
- In the event of a battery leak, do not allow the liquid to come in contact with the skin or eyes. If contact has been made, wash the affected area with large amounts of water and seek medical advice.
- If you suspect damage to your equipment or battery, contact Motorola Solutions Global Customer Support to arrange for inspection.

Cleaning



CAUTION Always wear eye protection.

Read warning label on compressed air and alcohol product before using.

If you have to use any other solution for medical reasons please contact Motorola for more information.



WARNING! Avoid exposing this product to contact with hot oil or other flammable liquids. If such exposure occurs, unplug the device and clean the product immediately in accordance with these guidelines.

Approved Cleanser Active Ingredients

100% of the active ingredients in any cleaner must consist of one or some combination of the following: isopropyl alcohol, bleach/sodium hypochlorite, hydrogen peroxide or mild dish soap.

Harmful Ingredients

The following chemicals are known to damage the plastics on the SB1 and should not come in contact with the device: ammonia solutions, compounds of amines or ammonia; acetone; ketones; ethers; aromatic and chlorinated hydrocarbons; aqueous or alcoholic alkaline solutions; ethanalamine; toluene; trichloroethylene; benzene; carbonic acid and TB-lysoform.

Cleaning Instructions

Do not apply liquid directly to the SB1. Dampen a soft cloth or use pre-moistened wipes. Do not wrap the device in the cloth or wipe, but gently wipe the unit. Be careful not to let liquid pool around the display window or other places. Allow the unit to air dry before use.

Special Cleaning Notes

Many vinyl gloves contain phthalate additives, which are often not recommended for medical use and are known to be harmful to the housing of the SB1. The SB1 should not be handled while wearing vinyl gloves containing phthalates, or before hands are washed to remove contaminant residue after gloves are removed. If products containing any of the harmful ingredients listed above are used prior to handling the SB1, such as hand sanitizer that contain ethanalamine, hands must be completely dry before handling the SB1 to prevent damage to the plastics.

Materials Required

- Alcohol wipes
- Lens tissue
- Cotton tipped applicators
- Isopropyl alcohol
- Can of compressed air with a tube.

Cleaning the SB1

Housing

Using the alcohol wipes, wipe the housing including keys and in-between keys.

Display

The display can be wiped down with the alcohol wipes, but care should be taken not to allow any pooling of liquid around the edges of the display. Immediately dry the display with a soft, non-abrasive cloth to prevent streaking.

Reader Exit Window

Wipe the exit window periodically with a lens tissue or other material suitable for cleaning optical material such as eyeglasses.

Connector

1. Dip the cotton portion of the cotton tipped applicator in isopropyl alcohol.
2. Rub the cotton portion of the cotton tipped applicator back-and-forth across the connector on the bottom of the SB1. Do not leave any cotton residue on the connector.
3. Repeat at least three times.
4. Use the cotton tipped applicator dipped in alcohol to remove any grease and dirt near the connector area.
5. Use a dry cotton tipped applicator and repeat steps 4 through 6.



CAUTION Do not point nozzle at yourself and others, ensure the nozzle or tube is away from your face.

6. Spray compressed air on the connector area by pointing the tube/nozzle about ½ inch away from the surface.
7. Inspect the area for any grease or dirt, repeat if required.

Cleaning Cradle Connectors

To clean the connectors on a cradle:

1. Remove the DC power cable from the cradle.
2. Dip the cotton portion of the cotton tipped applicator in isopropyl alcohol.
3. Rub the cotton portion of the cotton tipped applicator along the pins of the connector. Slowly move the applicator back-and-forth from one side of the connector to the other. Do not let any cotton residue on the connector.
4. All sides of the connector should also be rubbed with the cotton tipped applicator.



CAUTION Do not point nozzle at yourself and others, ensure the nozzle or tube is away from your face.

5. Spray compressed air in the connector area by pointing the tube/nozzle about ½ inch away from the surface.
6. Ensure that there is no lint left by the cotton tipped applicator, remove lint if found.
7. If grease and other dirt can be found on other areas of the cradle, use lint free cloth and alcohol to remove.
8. Allow at least 10 to 30 minutes (depending on ambient temperature and humidity) for the alcohol to air dry before applying power to cradle.

If the temperature is low and humidity is high, longer drying time is required. Warm temperature and dry humidity requires less drying time.

Cleaning Frequency

The cleaning frequency is up to the customer's discretion due to the varied environments in which the mobile devices are used. They may be cleaned as frequently as required. However when used in dirty environments it may be advisable to periodically clean the scanner exit window to ensure optimum scanning performance.

Troubleshooting

SB1

Table 5-1 Troubleshooting the SB1

Problem	Cause	Solution
SB1 does not turn on.	Battery not charged.	Charge the SB1.
	System crash.	Perform a reset. If the SB1 still does not turn on, contact system administrator. For more information see, Resetting the SB1 on page 1-5 .
Battery did not charge.	Battery failed.	Perform a reset. For more information see, Resetting the SB1 on page 1-5 .
	SB1 removed from power source while battery was charging.	Connect power source and begin charging. The battery requires up to four hours to recharge fully.
	Extreme battery temperature.	Battery does not charge if ambient temperature is below 0 °C (32 °F) or above 40 °C (104 °F).
SB1 does not emit sound.	Volume setting is low or turned off.	Increase the volume. See Adjusting the Volume on page 2-13 for more information.
	Audio Adapter not installed properly.	Remove and replace Audio Adapter.
	Headset not plugged into Adapter correctly.	Remove headset plug and insert into Audio Adapter audio jack.
	Speaker Adapter not installed properly.	Remove and replace Speaker Adapter.
Tapping the screen buttons or icons does not activate the corresponding feature.	Touch screen not calibrated correctly.	Re-calibrate the screen. See Screen Calibration on page 2-13 .
	Battery depleted.	Recharge the battery.
The SB1 does not accept scan input.	Scanning application is not loaded.	Verify that the SB1 is loaded with a scanning application. See the system administrator.
	Unreadable bar code.	Ensure the symbol is not defaced.
	Distance between SB1 and bar code is incorrect.	Ensure the SB1 is within proper scanning range.
	SB1 is not programmed for the bar code type.	See system administrator.
	Battery is low.	Check the battery level. When the battery is low, the SB1 automatically goes into suspend mode.

Single Slot Charging Cradle

Table 5-2 *Troubleshooting the Single Slot Charging Cradle*

Problem	Cause	Solution
SB1 battery is not charging.	Cradle is not receiving power.	Ensure the power cable is connected securely to both the cradle and to AC power.
	The SB1 is not fully seated in the cradle.	Remove and re-insert the SB1 into the cradle, ensuring it is correctly seated.
	SB1 was removed from cradle too soon.	If the SB1 battery is fully depleted, it can take up to four hours to fully recharge a battery.
	Battery is faulty.	Verify that other SB1 devices charge properly. If so, contact system administrator.

Ten Slot Charge Only Cradle

Table 5-3 *Troubleshooting the Four Slot Charge Only Cradle*

Problem	Cause	Solution
SB1 battery is not charging.	Cradle is not receiving power.	Ensure the power cable is connected securely to both the cradle and to AC power.
	The SB1 is not fully seated in the cradle.	Remove and re-insert the SB1 into the cradle, ensuring it is correctly seated.
	SB1 was removed from cradle too soon.	If the SB1 battery is fully depleted, it can take up to four hours to fully recharge a battery.
	Battery is faulty.	Verify that other SB1 devices charge properly. If so, contact system administrator.

Audio Adapter

Table 5-4 *Troubleshooting the Audio Adapter*

Problem	Cause	Solution
Audio cannot be heard through headset.	Audio Adapter not connected properly.	Remove Audio Adapter and reinstall.
	Headset is not connected properly.	Remove headset from Audio Adapter and reinstall.
	Volume is too low.	Increase audio volume,

Speaker Adapter

Table 5-5 *Troubleshooting the Speaker Adapter*

Problem	Cause	Solution
Audio cannot be heard through Speaker Adapter.	Speaker Adapter not connected properly.	Remove Speaker Adapter and reinstall.
	Volume is too low.	Increase audio volume,

PRELIMINARY

Appendix A Specifications

This appendix provides specifications for the SB1 and accessories.

SB1 Technical Specifications

Table A-1 summarizes the SB1 technical specifications and intended operating environments.

Table A-1 SB1 Technical Specifications

Item	Description
Physical Characteristics	
Dimensions	92 mm L x 81 mm W x 14 mm D (3.62 in. L x 3.19 in. W x 0.55 in. D)
Weight	110 g (3.8 oz.)
Display	3.0" E Ink Pearl, 4-bit grayscale (16 shades). QVGA 320 x 240 resolution.
Touch Panel	Full screen resistive touch; finger operation (no stylus)
Battery	Rechargeable Lithium-ion 910 mAh
Network Connections	Wireless Local Area Network (WLAN)
Notification	Audio: beeper; Visual: multi-color LED
Audio	Integrated microphone; accessories include optional Speaker Adapter with push-to-talk and Audio Adapter.
Performance Characteristics	
CPU	IMX35 (532 MHz)
Applications	Supports thin client applications and HTML 5 with RhoElements extensions.
Memory	128 MB RAM/128 MB Flash

Table A-1 SB1 Technical Specifications (Continued)

Item	Description
User Environment	
Operating Temperature	0 °C to 40°C (32 °F to 104 °F)
Storage Temperature	-40 °C to 70 °C (-40 °C to 158 °F)
Charging Temperature	0 °C to 40 °C (32 °F to 104 °F)
Humidity	5 to 95% non-condensing
Drop Specification	Multiple 1.22 m (4 ft) drop to tile over concrete per MIL STD 810G specifications
Electrostatic Discharge (ESD)	+/- 15 kV air discharge +/- 8 kV direct discharge
Sealing	IP54
Wireless LAN Data and Voice Communications	
WLAN radio	Wi-Fi IEEE® 802.11b/g/n
Data Rates Supported	1, 2, 5.5, 6, 9, 11, 12, 18, 24, 36, 48, 54 Mbps and MCS0-7
Operating Channels	Channel 1-13 (2412-2472 MHz), Channel 14 (2484 MHz) Japan only; actual operating channels/frequencies depend on regulatory rules and certification agency
Security	Security Modes: Legacy, WPA and WPA2 Encryption: WEP (40 or 128 bit), TKIP and AES Authentication: TLS, TTLS (MS-CHAP), TTLS (MS-CHAP v2), TTLS (CHAP), TTLS (MD5), TTLS (PAP), PEAP-TLS, PEAP (MS-CHAP v2), PEAP (EAP-GTC), EAP-FAST-TLS, EAP-FAST (MS-CHAP v2), EAP-FAST (EAP-GTC) and LEAP
Spreading Technique	Direct Sequence Spread Spectrum (DSSS) and Orthogonal Frequency Division Multiplexing (OFDM)
Data Capture Specifications	
Options	Omni-directional bar code reader with integrated aiming and illumination.

GLOSSARY

Numeric

802.11bgn. A radio protocol that may be used by the SB1 radio.

A

Access Point. Access Point (AP) refers to Motorola's Ethernet Access Point. It is a piece of communications equipment that manages communications between the host computer system and one or more wireless terminals. An AP connects to a wired Ethernet LAN and acts as a bridge between the Ethernet wired network and IEEE 802.11 interoperable radio-equipped mobile units, such as a SB1. The AP allows a mobile user to roam freely through a facility while maintaining a seamless connection to the wired network.

B

Bar Code. A pattern of variable-width bars and spaces which represents numeric or alphanumeric data in machine-readable form. The general format of a bar code symbol consists of a leading margin, start character, data or message character, check character (if any), stop character, and trailing margin. Within this framework, each recognizable symbology uses its own unique format.

Bit. Binary digit. One bit is the basic unit of binary information. Generally, eight consecutive bits compose one byte of data. The pattern of 0 and 1 values within the byte determines its meaning.

Bits per Second (bps). Bits transmitted or received.

Byte. On an addressable boundary, eight adjacent binary digits (0 and 1) combined in a pattern to represent a specific character or numeric value. Bits are numbered from the right, 0 through 7, with bit 0 the low-order bit. One byte in memory is used to store one ASCII character.

boot or boot-up. The process a device goes through when it starts. During boot-up, the device can run self-diagnostic tests and configure hardware and software.

C

Cradle. A cradle is used for charging the terminal battery and for communicating with a host computer, and provides a storage place for the terminal when not in use.

D

Decode. To recognize a bar code symbology (e.g., UPC/EAN) and then analyze the content of the specific bar code scanned.

E

ESD. Electro-Static Discharge

F

Flash Memory. Flash memory is responsible for storing the system firmware and is non-volatile. If the system power is interrupted the data is not be lost.

G

H

Hz. Hertz; A unit of frequency equal to one cycle per second.

Host Computer. A computer that serves other terminals in a network, providing such services as computation, database access, supervisory programs and network control.

I

IP. Internet Protocol. The IP part of the TCP/IP communications protocol. IP implements the network layer (layer 3) of the protocol, which contains a network address and is used to route a message to a different network or subnetwork. IP accepts "packets" from the layer 4 transport protocol (TCP or UDP), adds its own header to it and delivers a "datagram" to the layer 2 data link protocol. It may also break the packet into fragments to support the maximum transmission unit (MTU) of the network.

IP Address. (Internet Protocol address) The address of a computer attached to an IP network. Every client and server station must have a unique IP address. A 32-bit address used by a computer on a IP network. Client workstations have either a permanent address or one that is dynamically assigned to them each session. IP addresses are written as four sets of numbers separated by periods; for example, 204.171.64.2.

L

LAN. Local area network. A radio network that supports data communication within a local area, such as within a warehouse of building.

LED Indicator. A semiconductor diode (LED - Light Emitting Diode) used as an indicator, often in digital displays. The semiconductor uses applied voltage to produce light of a certain frequency determined by the semiconductor's particular chemical composition.

M

R

RAM. Random Access Memory. Data in RAM can be accessed in random order, and quickly written and read.

Reset. A warm boot restarts the SB1 by closing all running programs. All data that is not saved to flash memory is lost.

Resolution. The narrowest element dimension which is distinguished by a particular reading device or printed with a particular device or method.

RF. Radio Frequency.

Router. A device that connects networks and supports the required protocols for packet filtering. Routers are typically used to extend the range of cabling and to organize the topology of a network into subnets. See **Subnet**.

S

SB1. In this text, SB1 refers to the Motorola smart badge. It can be set up to run as a stand-alone device, or it can be set up to communicate with a network, using wireless radio technology.

Scan Area. Area intended to contain a symbol.

Scanner. An electronic device used to scan bar code symbols and produce a digitized pattern that corresponds to the bars and spaces of the symbol.

Scanning Mode. The bar code reader is energized, programmed and ready to read a bar code.

Start/Stop Character. A pattern of bars and spaces that provides the scanner with start and stop reading instructions and scanning direction. The start and stop characters are normally to the left and right margins of a horizontal code.

Subnet. A subset of nodes on a network that are serviced by the same router. See **Router**.

Subnet Mask. A 32-bit number used to separate the network and host sections of an IP address. A custom subnet mask subdivides an IP network into smaller subsections. The mask is a binary pattern that is matched up with the IP address to turn part of the host ID address field into a field for subnets. Default is often 255.255.255.0.

Symbol. A scannable unit that encodes data within the conventions of a certain symbology, usually including start/stop characters, quiet zones, data characters and check characters.

Symbology. The structural rules and conventions for representing data within a particular bar code type (e.g. UPC/EAN, Code 39, PDF417, etc.).

T

U

W

PRELIMINARY

INDEX

A

accessories	1-2
single slot charging cradle	4-2
battery charging	4-2
ten slot charge only cradle	4-4
ten slot cradles	
battery charging	4-4
adjusting volume	2-13
audio volume	2-13

B

bar code reading	3-2
battery charging	
temperature range	1-3
ten slot charge only cradle	4-4
beeper volume	2-13
bullets	x

C

charging, temperature range	1-3
cleaning	5-1
configuration	ix
conventions	
notational	x
cradles	
single slot charging cradle	
battery charging	4-2
ten slot charge only cradle	4-4
ten slot cradles	
battery charging	4-4

D

data capture	ix
--------------	----

display	ix
documentation updates	xi

I

information, service	xi
----------------------	----

M

main battery	1-3
charging	1-3
maintenance	5-1
memory	ix

O

operating environment	A-1
-----------------------	-----

P

parts	1-2
-------	-----

R

radios	ix
resetting	1-6
resetting the SB1	1-6

S

scan button	1-2
scanning	3-1
angle	3-1
range	3-1
scanning considerations	3-1
single slot charging cradle	4-1, 4-2

battery charging	4-2
starting the SB1	1-3
startup	1-3
storing	5-1

T

technical specifications	A-1
temperature	A-2
ten slot charge only cradle	4-4
ten slot cradles	
battery charging	4-4
troubleshooting	5-5
SB1	5-5
single slot charging cradle	5-6
ten slot charge only cradle	5-7

U

unpacking	1-1
updates, documentation	.xi

V

volume	
audio	2-13
beeper	2-13

PRELIMINARY

PRELIMINARY



Motorola Solutions, Inc.
1301 E. Algonquin Rd.
Schaumburg, IL 60196-1078, U.S.A.
<http://www.motorolasolutions.com>

MOTOROLA, MOTO, MOTOROLA SOLUTIONS and the Stylized M Logo are trademarks or registered trademarks of Motorola Trademark Holdings, LLC and are used under license. All other trademarks are the property of their respective owners.

© 2012 Motorola Solutions, Inc. All Rights Reserved.

