

#01_WCDMA II_RMC 12.2Kbps_Bottom Face_3mm_Ch9538

Communication System: WCDMA; Frequency: 1907.6 MHz; Duty Cycle: 1:1

Medium: MSL_1900_190407 Medium parameters used: $f = 1908$ MHz; $\sigma = 1.545$ S/m; $\epsilon_r = 53.032$; $\rho = 1000$ kg/m³

Ambient Temperature : 23.4 °C ; Liquid Temperature : 22.4 °C

DASY5 Configuration

- Probe: ES3DV3 - SN3169; ConvF(4.8, 4.8, 4.8) ; Calibrated: 2018/5/28
- Sensor-Surface: 3mm (Mechanical Surface Detection)
- Electronics: DAE4 Sn1326; Calibrated: 2018/9/18
- Phantom: ELI v5.0; Type: QDOVA002AA; Serial: TP:1227
- Measurement SW: DASY52, Version 52.10 (1); SEMCAD X Version 14.6.11 (7439)

Area Scan (51x61x1): Interpolated grid: dx=1.500 mm, dy=1.500 mm

Maximum value of SAR (interpolated) = 1.79 W/kg

Zoom Scan (5x5x7)/Cube 0: Measurement grid: dx=8mm, dy=8mm, dz=5mm

Reference Value = 10.86 V/m; Power Drift = -0.01 dB

Peak SAR (extrapolated) = 2.16 W/kg

SAR(1 g) = 1.38 W/kg; SAR(10 g) = 0.820 W/kg

Maximum value of SAR (measured) = 1.60 W/kg

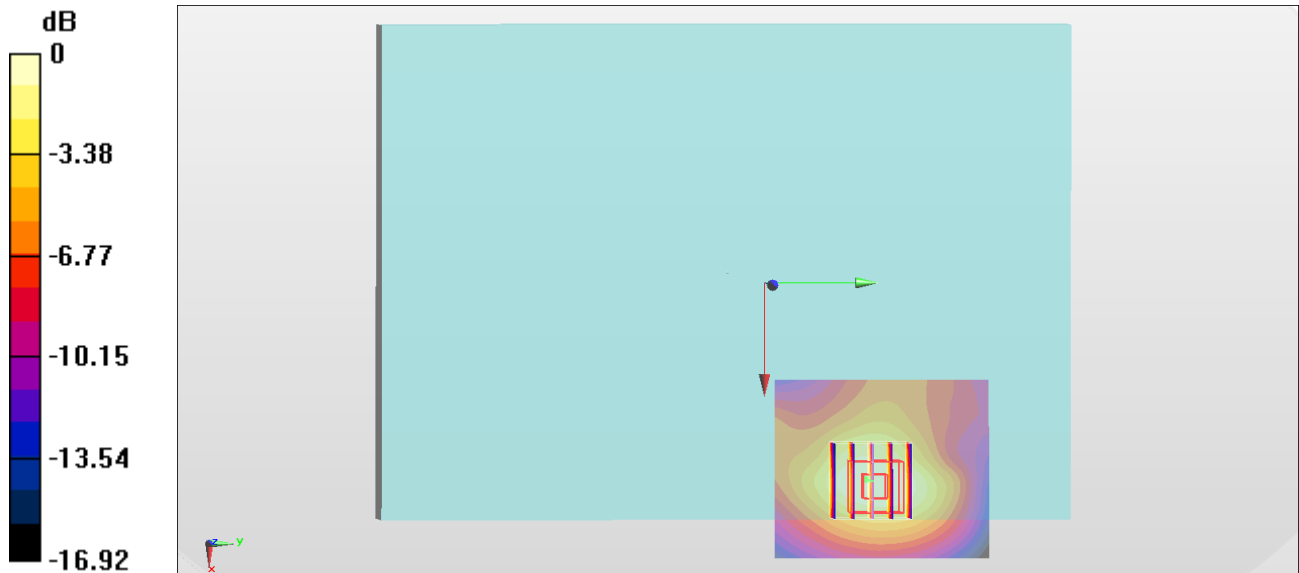

0 dB = 1.60 W/kg = 2.04 dBW/kg

#02_WCDMA IV_RMC 12.2Kbps_Bottom Face_3mm_Ch1413

Communication System: WCDMA; Frequency: 1732.6 MHz; Duty Cycle: 1:1

Medium: MSL_1750_190408 Medium parameters used: $f = 1733$ MHz; $\sigma = 1.416$ S/m; $\epsilon_r = 55.825$; $\rho = 1000$ kg/m³

Ambient Temperature : 23.4 °C ; Liquid Temperature : 22.4 °C

DASY5 Configuration

- Probe: ES3DV3 - SN3169; ConvF(5.06, 5.06, 5.06) ; Calibrated: 2018/5/28
- Sensor-Surface: 3mm (Mechanical Surface Detection)
- Electronics: DAE4 Sn1326; Calibrated: 2018/9/18
- Phantom: ELI v5.0; Type: QDOVA002AA; Serial: TP:1227
- Measurement SW: DASY52, Version 52.10 (1); SEMCAD X Version 14.6.11 (7439)

Area Scan (51x61x1): Interpolated grid: dx=1.500 mm, dy=1.500 mm

Maximum value of SAR (interpolated) = 1.63 W/kg

Zoom Scan (5x5x7)/Cube 0: Measurement grid: dx=8mm, dy=8mm, dz=5mm

Reference Value = 35.17 V/m; Power Drift = -0.01 dB

Peak SAR (extrapolated) = 2.10 W/kg

SAR(1 g) = 1.35 W/kg; SAR(10 g) = 0.830 W/kg

Maximum value of SAR (measured) = 1.60 W/kg

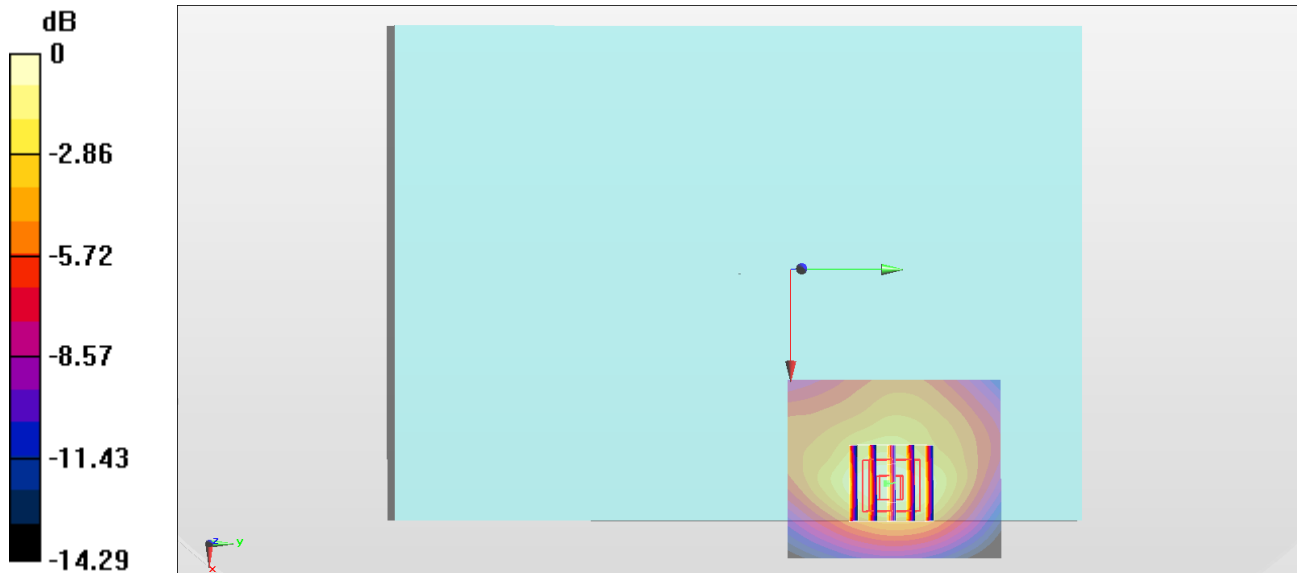

#03_WCDMA V_RMC 12.2Kbps_Bottom Face_3mm_Ch4182

Communication System: WCDMA; Frequency: 836.4 MHz; Duty Cycle: 1:1

Medium: MSL_850_190403 Medium parameters used: $f = 836.4$ MHz; $\sigma = 0.941$ S/m; $\epsilon_r = 54.554$; $\rho = 1000$ kg/m³

Ambient Temperature : 23.6 °C ; Liquid Temperature : 22.6 °C

DASY5 Configuration

- Probe: ES3DV3 - SN3169; ConvF(6.19, 6.19, 6.19) ; Calibrated: 2018/5/28
- Sensor-Surface: 3mm (Mechanical Surface Detection)
- Electronics: DAE4 Sn1326; Calibrated: 2018/9/18
- Phantom: ELI v5.0; Type: QDOVA002AA; Serial: TP:1227
- Measurement SW: DASY52, Version 52.10 (1); SEMCAD X Version 14.6.11 (7439)

Area Scan (51x61x1): Interpolated grid: dx=1.500 mm, dy=1.500 mm

Maximum value of SAR (interpolated) = 1.68 W/kg

Zoom Scan (5x5x7)/Cube 0: Measurement grid: dx=8mm, dy=8mm, dz=5mm

Reference Value = 17.95 V/m; Power Drift = -0.03 dB

Peak SAR (extrapolated) = 2.13 W/kg

SAR(1 g) = 1.38 W/kg; SAR(10 g) = 0.872 W/kg

Maximum value of SAR (measured) = 1.64 W/kg

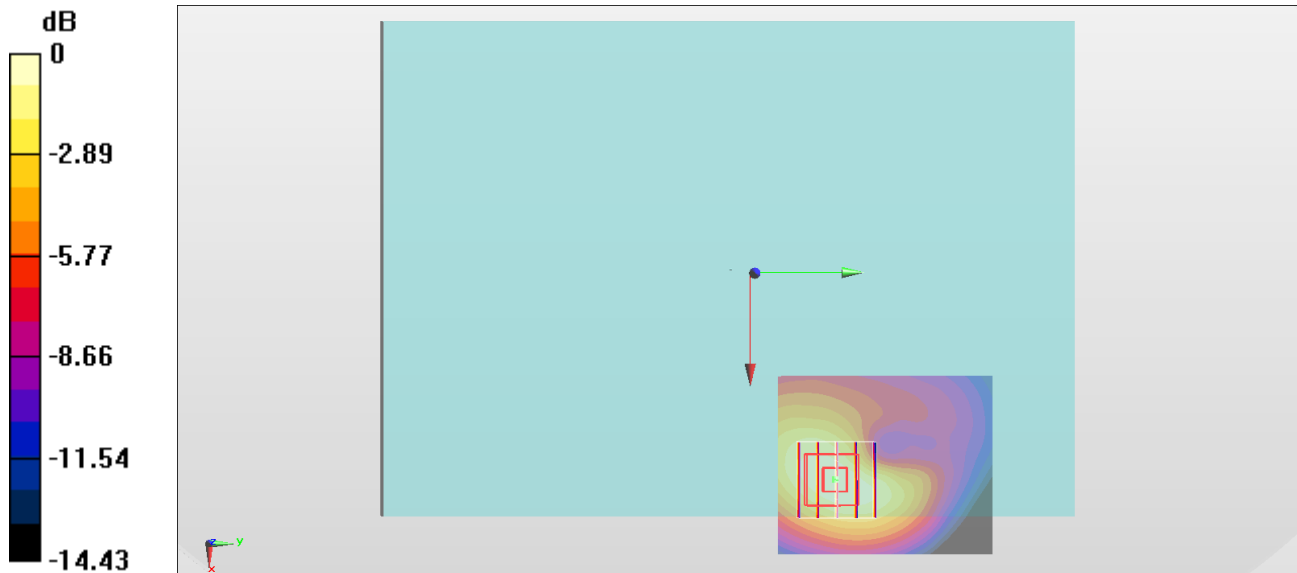

0 dB = 1.64 W/kg = 2.15 dBW/kg

#04_LTE Band 7_20M_QPSK_1_0_Bottom Face_3mm_Ch21350

Communication System: LTE; Frequency: 2560 MHz; Duty Cycle: 1:1

Medium: MSL_2600_190409 Medium parameters used: $f = 2560$ MHz; $\sigma = 2.145$ S/m; $\epsilon_r = 51.76$; $\rho = 1000$ kg/m³

Ambient Temperature : 23.5 °C ; Liquid Temperature : 22.5 °C

DASY5 Configuration

- Probe: EX3DV4 - SN7306; ConvF(7.47, 7.47, 7.47) ; Calibrated: 2018/7/26
- Sensor-Surface: 1.4mm (Mechanical Surface Detection)
- Electronics: DAE3 Sn495; Calibrated: 2018/5/24
- Phantom: ELI v5.0; Type: QDOVA002AA; Serial: TP:1227
- Measurement SW: DASY52, Version 52.10 (1); SEMCAD X Version 14.6.11 (7439)

Area Scan (61x71x1): Interpolated grid: dx=1.200 mm, dy=1.200 mm

Maximum value of SAR (interpolated) = 1.84 W/kg

Zoom Scan (7x7x7)/Cube 0: Measurement grid: dx=5mm, dy=5mm, dz=5mm

Reference Value = 28.82 V/m; Power Drift = -0.14 dB

Peak SAR (extrapolated) = 2.17 W/kg

SAR(1 g) = 1.18 W/kg; SAR(10 g) = 0.646 W/kg

Maximum value of SAR (measured) = 1.78 W/kg

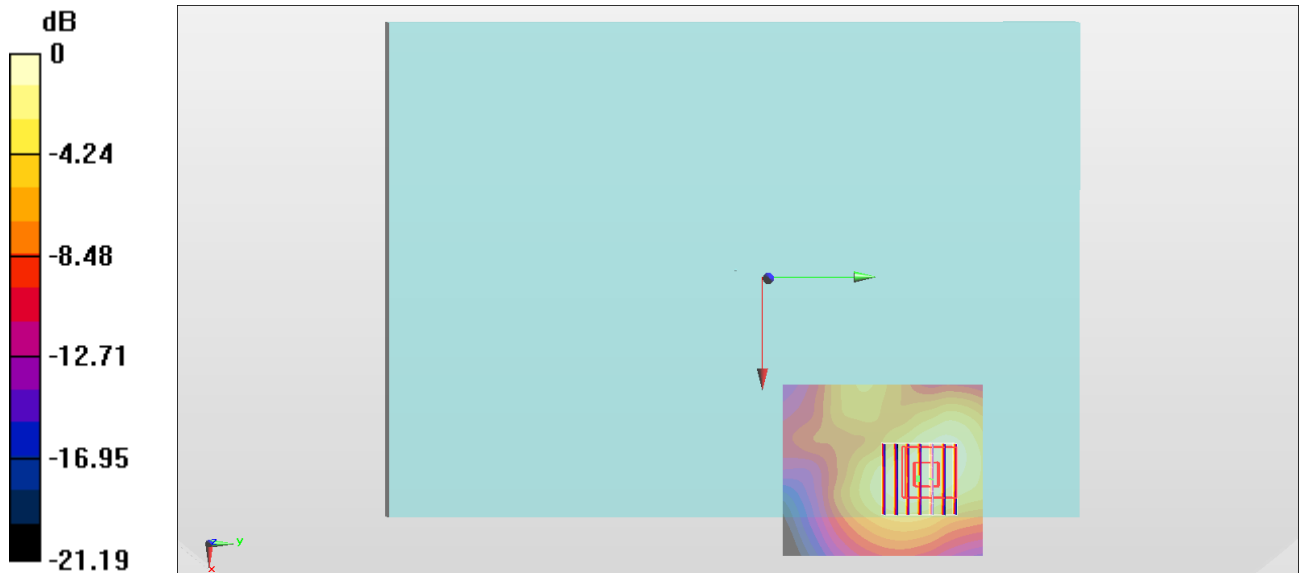

0 dB = 1.78 W/kg = 2.50 dBW/kg

#05_LTE Band 12_10M_QPSK_1_0_Edge 1_0mm_Ch23095

Communication System: LTE; Frequency: 707.5 MHz; Duty Cycle: 1:1

Medium: MSL_750_190404 Medium parameters used : $f = 707.5$ MHz; $\sigma = 0.913$ S/m; $\epsilon_r = 54.713$; $\rho = 1000$ kg/m³

Ambient Temperature : 23.6 °C ; Liquid Temperature : 22.6 °C

DASY5 Configuration

- Probe: ES3DV3 - SN3169; ConvF(6.3, 6.3, 6.3) ; Calibrated: 2018/5/28
- Sensor-Surface: 3mm (Mechanical Surface Detection)
- Electronics: DAE4 Sn1326; Calibrated: 2018/9/18
- Phantom: ELI v5.0; Type: QDOVA002AA; Serial: TP:1227
- Measurement SW: DASY52, Version 52.10 (1); SEMCAD X Version 14.6.11 (7439)

Area Scan (41x101x1): Interpolated grid: dx=1.500 mm, dy=1.500 mm

Maximum value of SAR (interpolated) = 1.33 W/kg

Zoom Scan (5x5x7)/Cube 0: Measurement grid: dx=8mm, dy=8mm, dz=5mm

Reference Value = 39.70 V/m; Power Drift = 0.08 dB

Peak SAR (extrapolated) = 2.16 W/kg

SAR(1 g) = 1.09 W/kg; SAR(10 g) = 0.567 W/kg

Maximum value of SAR (measured) = 1.37 W/kg

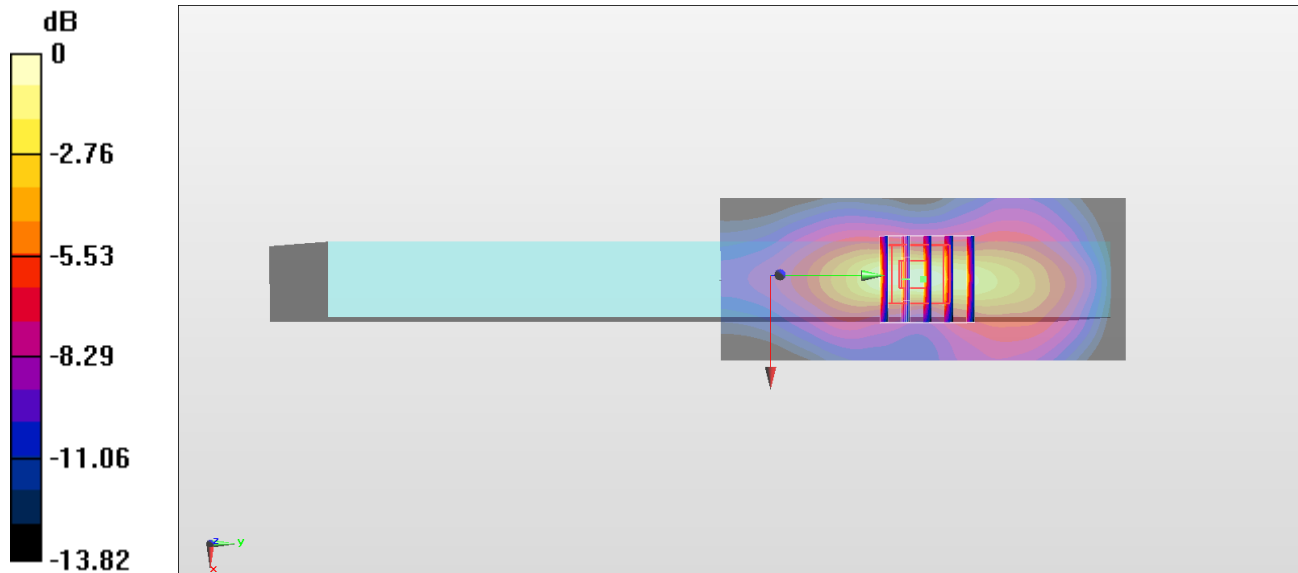

#06_LTE Band 13_10M_QPSK_1_0_Bottom Face_3mm_Ch23230

Communication System: LTE; Frequency: 782 MHz; Duty Cycle: 1:1

Medium: MSL_750_190404 Medium parameters used: $f = 782 \text{ MHz}$; $\sigma = 0.981 \text{ S/m}$; $\epsilon_r = 53.927$; $\rho = 1000 \text{ kg/m}^3$

Ambient Temperature : $23.6 \text{ }^\circ\text{C}$; Liquid Temperature : $22.6 \text{ }^\circ\text{C}$

DASY5 Configuration

- Probe: ES3DV3 - SN3169; ConvF(6.3, 6.3, 6.3) ; Calibrated: 2018/5/28
- Sensor-Surface: 3mm (Mechanical Surface Detection)
- Electronics: DAE4 Sn1326; Calibrated: 2018/9/18
- Phantom: ELI v5.0; Type: QDOVA002AA; Serial: TP:1227
- Measurement SW: DASY52, Version 52.10 (1); SEMCAD X Version 14.6.11 (7439)

Area Scan (51x61x1): Interpolated grid: $dx=1.500 \text{ mm}$, $dy=1.500 \text{ mm}$

Maximum value of SAR (interpolated) = 1.30 W/kg

Zoom Scan (5x5x7)/Cube 0: Measurement grid: $dx=8\text{mm}$, $dy=8\text{mm}$, $dz=5\text{mm}$

Reference Value = 36.61 V/m ; Power Drift = -0.01 dB

Peak SAR (extrapolated) = 1.66 W/kg

SAR(1 g) = 1.08 W/kg ; SAR(10 g) = 0.686 W/kg

Maximum value of SAR (measured) = 1.27 W/kg

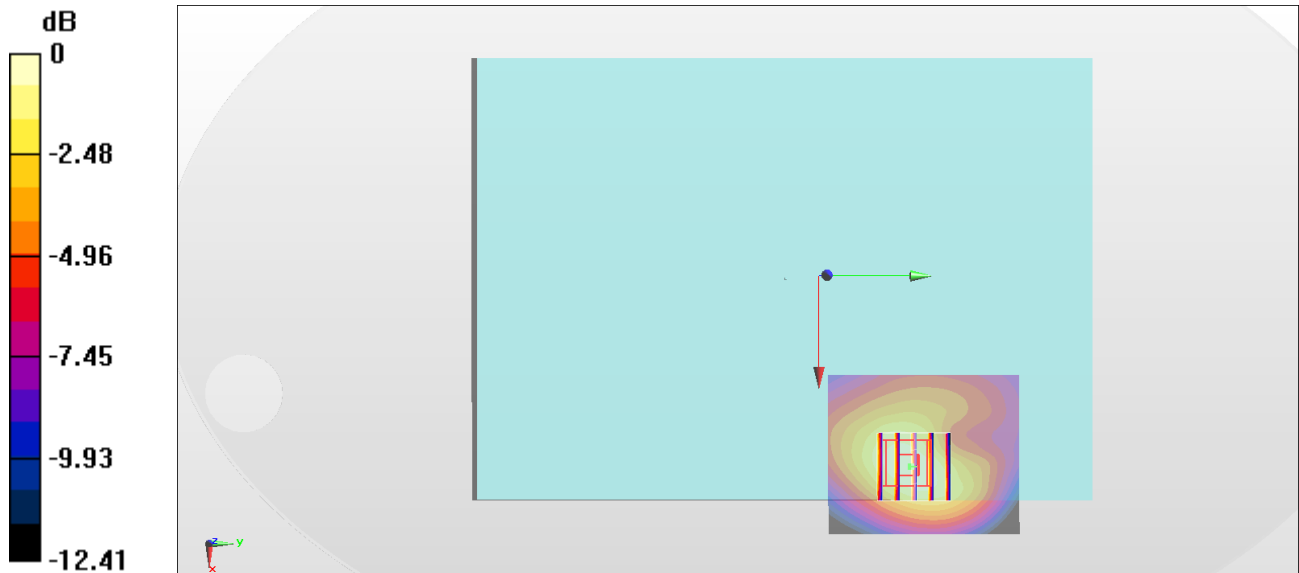

0 dB = 1.27 W/kg = 1.04 dBW/kg

#07_LTE Band 14_10M_QPSK_1_0_Bottom Face_3mm_Ch23330

Communication System: LTE; Frequency: 793 MHz; Duty Cycle: 1:1

Medium: MSL_750_190404 Medium parameters used: $f = 793$ MHz; $\sigma = 0.991$ S/m; $\epsilon_r = 53.807$; $\rho = 1000$ kg/m³

Ambient Temperature : 23.6 °C ; Liquid Temperature : 22.6 °C

DASY5 Configuration

- Probe: ES3DV3 - SN3169; ConvF(6.3, 6.3, 6.3) ; Calibrated: 2018/5/28
- Sensor-Surface: 3mm (Mechanical Surface Detection)
- Electronics: DAE4 Sn1326; Calibrated: 2018/9/18
- Phantom: ELI v5.0; Type: QDOVA002AA; Serial: TP:1227
- Measurement SW: DASY52, Version 52.10 (1); SEMCAD X Version 14.6.11 (7439)

Area Scan (51x61x1): Interpolated grid: dx=1.500 mm, dy=1.500 mm

Maximum value of SAR (interpolated) = 1.42 W/kg

Zoom Scan (5x5x7)/Cube 0: Measurement grid: dx=8mm, dy=8mm, dz=5mm

Reference Value = 38.32 V/m; Power Drift = -0.03 dB

Peak SAR (extrapolated) = 1.81 W/kg

SAR(1 g) = 1.18 W/kg; SAR(10 g) = 0.749 W/kg

Maximum value of SAR (measured) = 1.39 W/kg

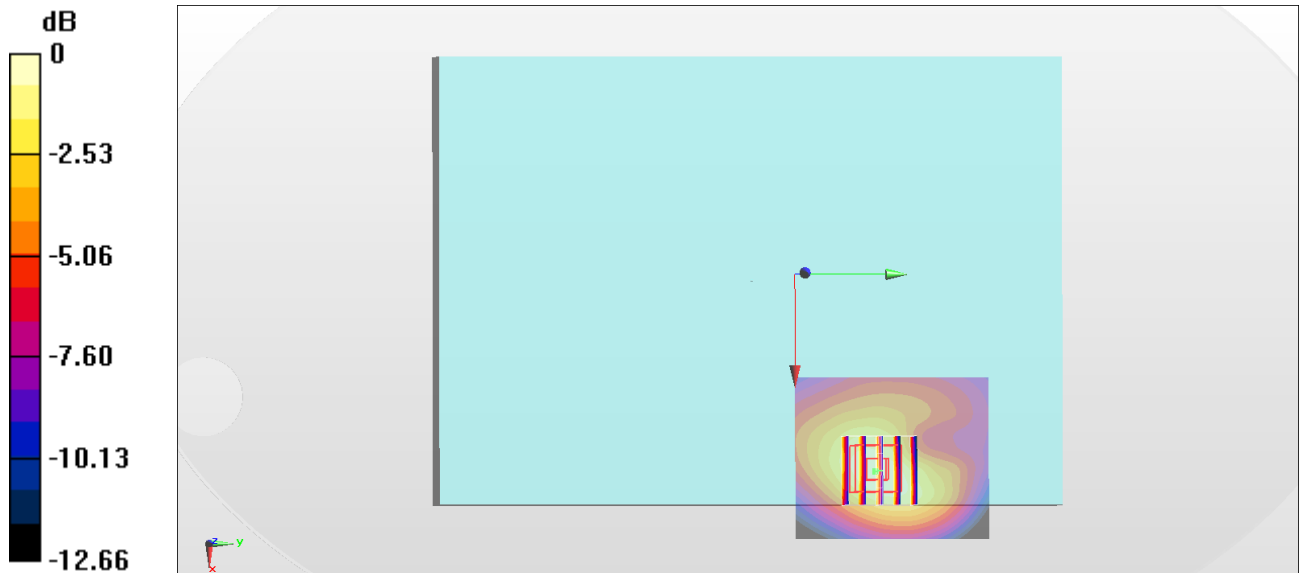

0 dB = 1.39 W/kg = 1.43 dBW/kg

#08_LTE Band 25_20M_QPSK_1_0_Bottom Face_3mm_Ch26590

Communication System: LTE; Frequency: 1905 MHz; Duty Cycle: 1:1

Medium: MSL_1900_190407 Medium parameters used: $f = 1905$ MHz; $\sigma = 1.542$ S/m; $\epsilon_r = 53.044$; $\rho = 1000$ kg/m³

Ambient Temperature : 23.4 °C ; Liquid Temperature : 22.4 °C

DASY5 Configuration

- Probe: ES3DV3 - SN3169; ConvF(4.8, 4.8, 4.8) ; Calibrated: 2018/5/28
- Sensor-Surface: 3mm (Mechanical Surface Detection)
- Electronics: DAE4 Sn1326; Calibrated: 2018/9/18
- Phantom: ELI v5.0; Type: QDOVA002AA; Serial: TP:1227
- Measurement SW: DASY52, Version 52.10 (1); SEMCAD X Version 14.6.11 (7439)

Area Scan (51x61x1): Interpolated grid: dx=1.500 mm, dy=1.500 mm

Maximum value of SAR (interpolated) = 1.48 W/kg

Zoom Scan (5x5x7)/Cube 0: Measurement grid: dx=8mm, dy=8mm, dz=5mm

Reference Value = 31.91 V/m; Power Drift = -0.04 dB

Peak SAR (extrapolated) = 1.90 W/kg

SAR(1 g) = 1.21 W/kg; SAR(10 g) = 0.723 W/kg

Maximum value of SAR (measured) = 1.45 W/kg

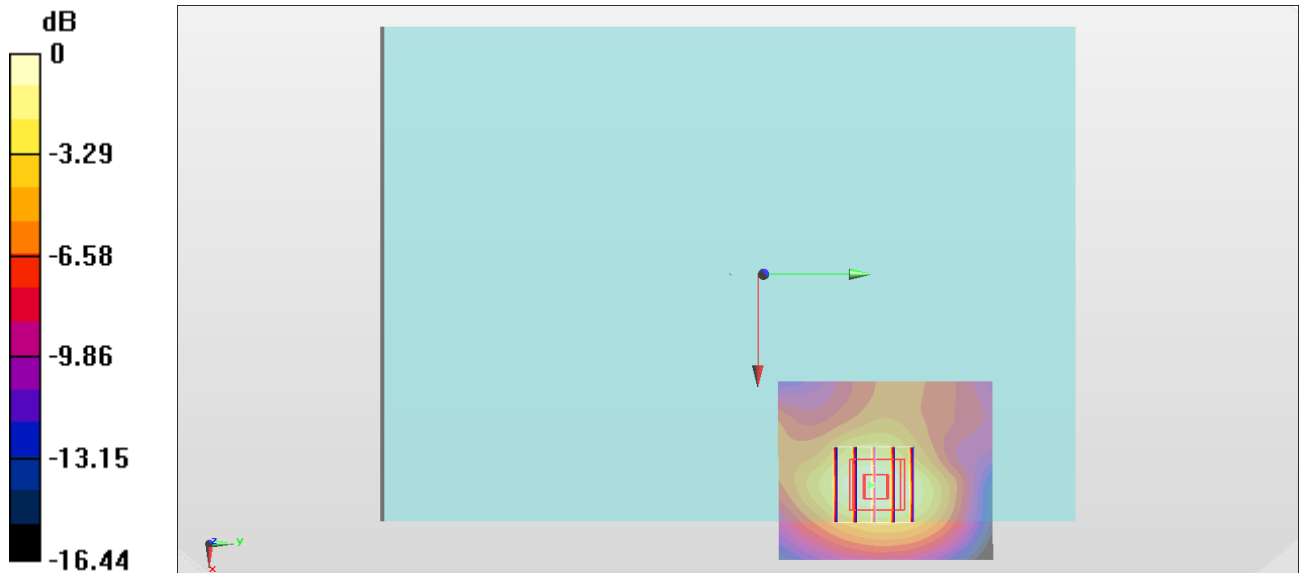

0 dB = 1.45 W/kg = 1.61 dBW/kg

#09_LTE Band 26_15M_QPSK_1_0_Bottom Face_3mm_Ch26865

Communication System: LTE ; Frequency: 831.5 MHz; Duty Cycle: 1:1

Medium: MSL_850_190403 Medium parameters used : $f = 831.5$ MHz; $\sigma = 0.936$ S/m; $\epsilon_r = 54.612$; $\rho = 1000$ kg/m³

Ambient Temperature : 23.6 °C ; Liquid Temperature : 22.6 °C

DASY5 Configuration

- Probe: ES3DV3 - SN3169; ConvF(6.19, 6.19, 6.19) ; Calibrated: 2018/5/28
- Sensor-Surface: 3mm (Mechanical Surface Detection)
- Electronics: DAE4 Sn1326; Calibrated: 2018/9/18
- Phantom: ELI v5.0; Type: QDOVA002AA; Serial: TP:1227
- Measurement SW: DASY52, Version 52.10 (1); SEMCAD X Version 14.6.11 (7439)

Area Scan (51x61x1): Interpolated grid: dx=1.500 mm, dy=1.500 mm

Maximum value of SAR (interpolated) = 1.35 W/kg

Zoom Scan (5x5x7)/Cube 0: Measurement grid: dx=8mm, dy=8mm, dz=5mm

Reference Value = 7.490 V/m; Power Drift = 0.01 dB

Peak SAR (extrapolated) = 1.71 W/kg

SAR(1 g) = 1.11 W/kg; SAR(10 g) = 0.703 W/kg

Maximum value of SAR (measured) = 1.31 W/kg

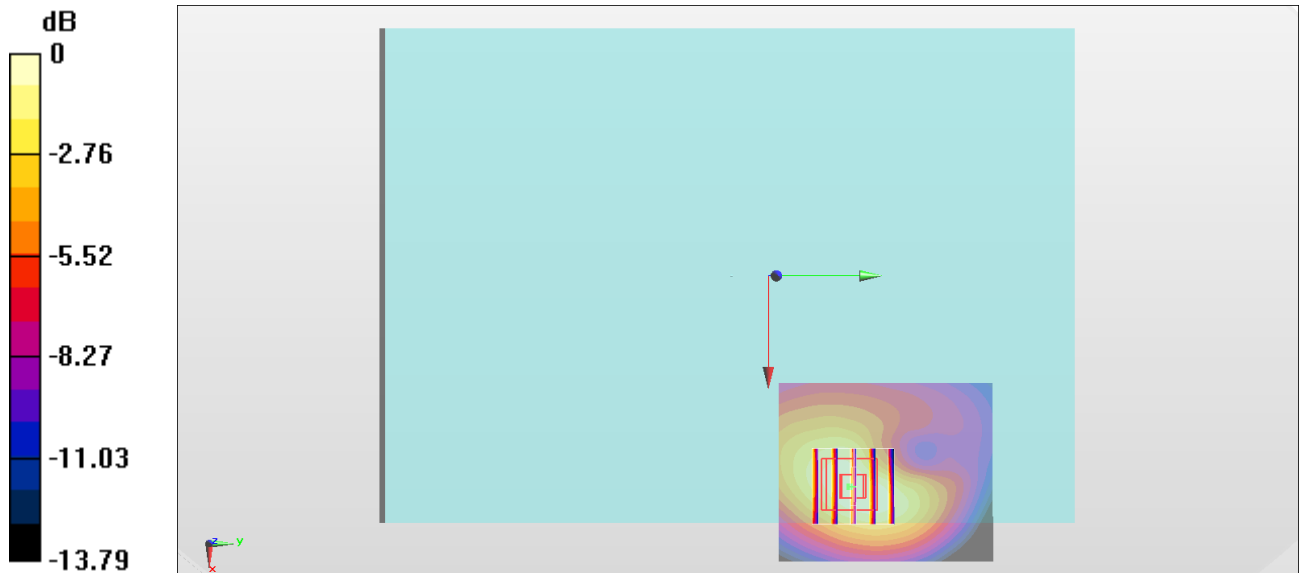

0 dB = 1.31 W/kg = 1.17 dBW/kg

#10_LTE Band 66_20M_QPSK_1_0_Bottom Face_3mm_Ch132322

Communication System: LTE; Frequency: 1745 MHz; Duty Cycle: 1:1

Medium: MSL_1750_190408 Medium parameters used : $f = 1745$ MHz; $\sigma = 1.427$ S/m; $\epsilon_r = 55.685$; $\rho = 1000$ kg/m³

Ambient Temperature : 23.7 °C ; Liquid Temperature : 22.7 °C

DASY5 Configuration

- Probe: ES3DV3 - SN3169; ConvF(5.06, 5.06, 5.06) ; Calibrated: 2018/5/28
- Sensor-Surface: 3mm (Mechanical Surface Detection)
- Electronics: DAE4 Sn1326; Calibrated: 2018/9/18
- Phantom: ELI v5.0; Type: QDOVA002AA; Serial: TP:1227
- Measurement SW: DASY52, Version 52.10 (1); SEMCAD X Version 14.6.11 (7439)

Area Scan (51x61x1): Interpolated grid: dx=1.500 mm, dy=1.500 mm

Maximum value of SAR (interpolated) = 1.63 W/kg

Zoom Scan (5x5x7)/Cube 0: Measurement grid: dx=8mm, dy=8mm, dz=5mm

Reference Value = 34.72 V/m; Power Drift = 0.03 dB

Peak SAR (extrapolated) = 2.11 W/kg

SAR(1 g) = 1.36 W/kg; SAR(10 g) = 0.834 W/kg

Maximum value of SAR (measured) = 1.62 W/kg

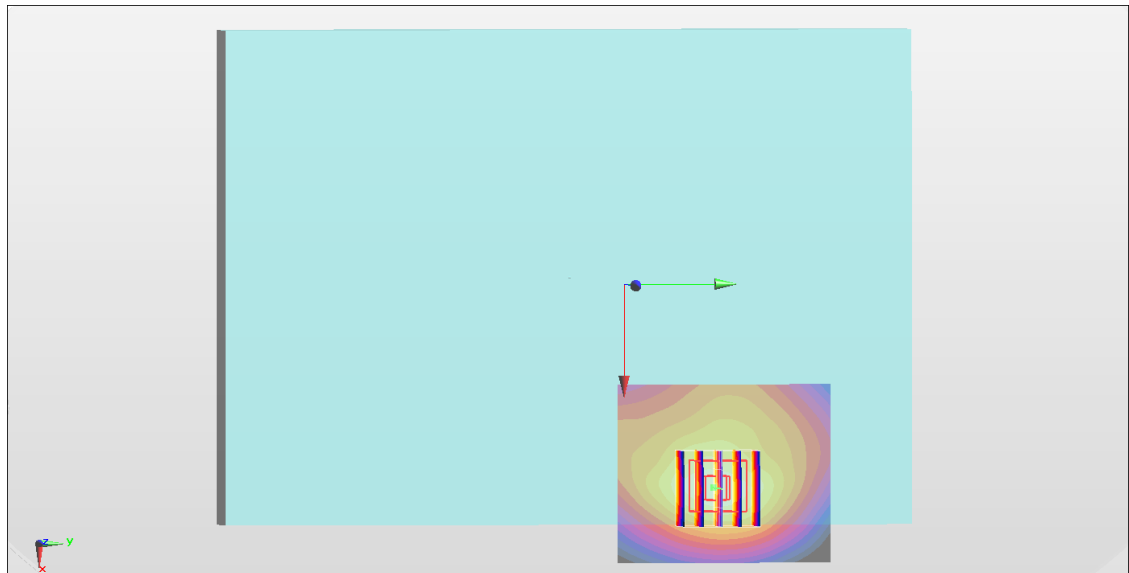
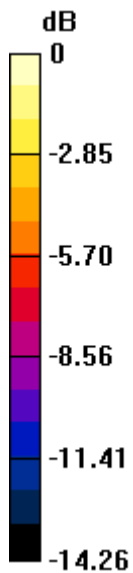

0 dB = 1.62 W/kg = 2.10 dBW/kg

#11_LTE Band 41_20M_QPSK_1_99_Bottom Face_3mm_Ch39750

Communication System: LTE; Frequency: 2506 MHz; Duty Cycle: 1:1.59

Medium: MSL_2600_190409 Medium parameters used: $f = 2506$ MHz; $\sigma = 2.085$ S/m; $\epsilon_r = 51.835$; $\rho = 1000$ kg/m³

Ambient Temperature : 23.5 °C ; Liquid Temperature : 22.5 °C

DASY5 Configuration

- Probe: EX3DV4 - SN7306; ConvF(7.47, 7.47, 7.47) ; Calibrated: 2018/7/26
- Sensor-Surface: 1.4mm (Mechanical Surface Detection)
- Electronics: DAE3 Sn495; Calibrated: 2018/5/24
- Phantom: ELI v5.0; Type: QDOVA002AA; Serial: TP:1227
- Measurement SW: DASY52, Version 52.10 (1); SEMCAD X Version 14.6.11 (7439)

Area Scan (61x71x1): Interpolated grid: dx=1.200 mm, dy=1.200 mm

Maximum value of SAR (interpolated) = 1.35 W/kg

Zoom Scan (7x7x7)/Cube 0: Measurement grid: dx=5mm, dy=5mm, dz=5mm

Reference Value = 25.51 V/m; Power Drift = -0.1 dB

Peak SAR (extrapolated) = 1.41 W/kg

SAR(1 g) = 0.828 W/kg; SAR(10 g) = 0.497 W/kg

Maximum value of SAR (measured) = 1.32 W/kg

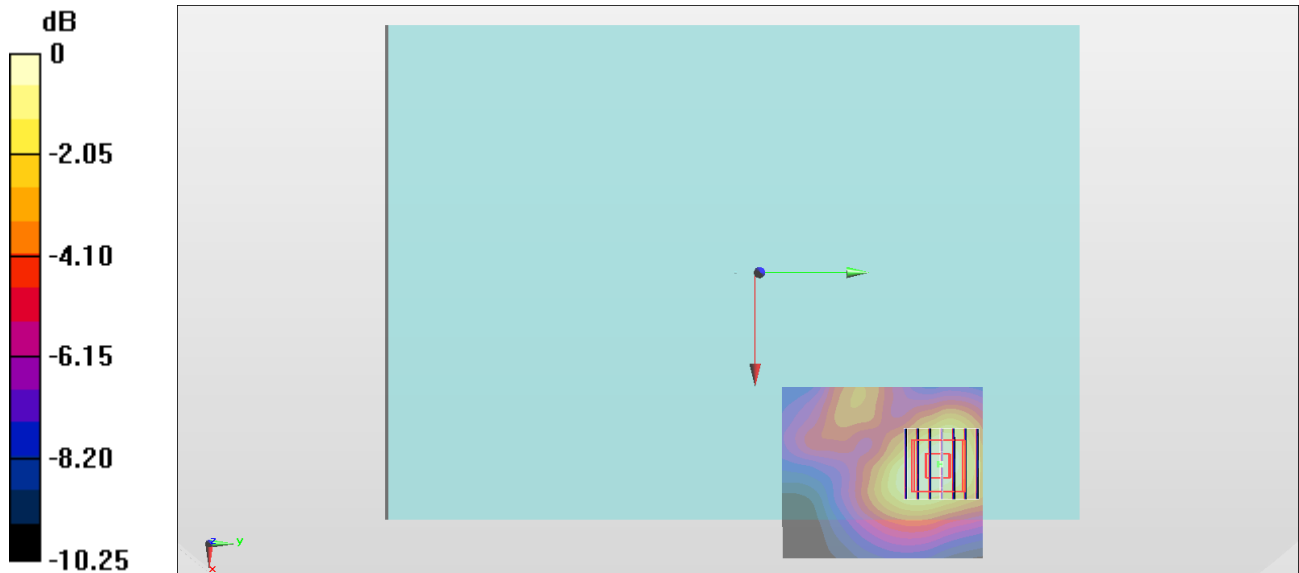

0 dB = 1.32 W/kg = 1.21 dBW/kg

#12_WLAN2.4GHz_802.11b 1Mbps_Bottom Face_0mm_Ch11;Ant 2

Communication System: 802.11b; Frequency: 2462 MHz; Duty Cycle: 1:1

Medium: MSL_2450_190422 Medium parameters used: $f = 2462$ MHz; $\sigma = 2.008$ S/m; $\epsilon_r = 52.948$; $\rho = 1000$ kg/m³

Ambient Temperature : 23.3 °C; Liquid Temperature : 22.3 °C

DASY5 Configuration

- Probe: EX3DV4 - SN3931; ConvF(7.56, 7.56, 7.56) ; Calibrated: 2018/9/27
- Sensor-Surface: 1.4mm (Mechanical Surface Detection)
- Electronics: DAE4 Sn1399; Calibrated: 2018/11/16
- Phantom: ELI v5.0; Type: QDOVA002AA; Serial: TP:1227
- Measurement SW: DASY52, Version 52.10 (1); SEMCAD X Version 14.6.11 (7439)

Area Scan (91x91x1): Interpolated grid: dx=1.200 mm, dy=1.200 mm

Maximum value of SAR (interpolated) = 1.64 W/kg

Zoom Scan (7x7x7)/Cube 0: Measurement grid: dx=5mm, dy=5mm, dz=5mm

Reference Value = 17.11 V/m; Power Drift = -0.01 dB

Peak SAR (extrapolated) = 2.07 W/kg

SAR(1 g) = 1.03 W/kg; SAR(10 g) = 0.491 W/kg

Maximum value of SAR (measured) = 1.66 W/kg

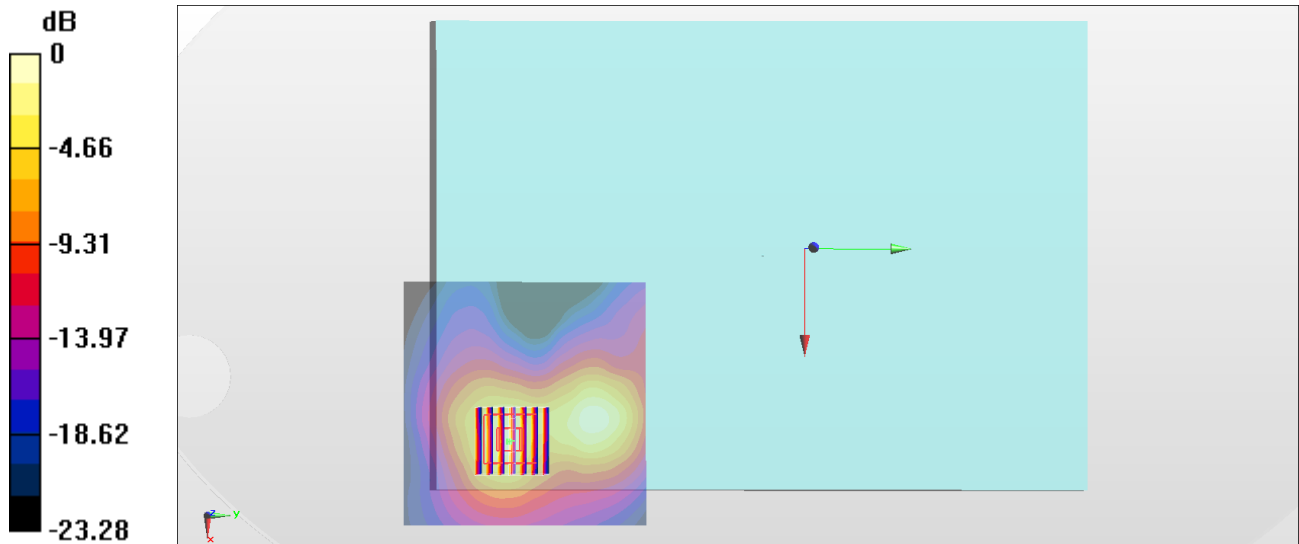

0 dB = 1.66 W/kg = 2.20 dBW/kg

#13_WLAN5GHz_802.11n-HT40 MCS0_Edge 1_0mm_Ch54;Ant 1

Communication System: 802.11n; Frequency: 5270 MHz; Duty Cycle: 1:1.117

Medium: MSL_5G_190421 Medium parameters used: $f = 5270$ MHz; $\sigma = 5.393$ S/m; $\epsilon_r = 48.005$; $\rho = 1000$ kg/m³

Ambient Temperature : 23.5 °C ; Liquid Temperature : 22.5 °C

DASY5 Configuration

- Probe: EX3DV4 - SN3931; ConvF(4.4, 4.4, 4.4) ; Calibrated: 2018/9/27
- Sensor-Surface: 1.4mm (Mechanical Surface Detection)
- Electronics: DAE4 Sn1399; Calibrated: 2018/11/16
- Phantom: ELI v5.0; Type: QDOVA002AA; Serial: TP:1227
- Measurement SW: DASY52, Version 52.10 (1); SEMCAD X Version 14.6.11 (7439)

Area Scan (61x81x1): Interpolated grid: dx=1.000 mm, dy=1.000 mm

Maximum value of SAR (interpolated) = 1.90 W/kg

Zoom Scan (7x7x7)/Cube 0: Measurement grid: dx=4mm, dy=4mm, dz=1.4mm

Reference Value = 20.74 V/m; Power Drift = -0.19 dB

Peak SAR (extrapolated) = 3.61 W/kg

SAR(1 g) = 0.939 W/kg; SAR(10 g) = 0.333 W/kg

Maximum value of SAR (measured) = 2.16 W/kg

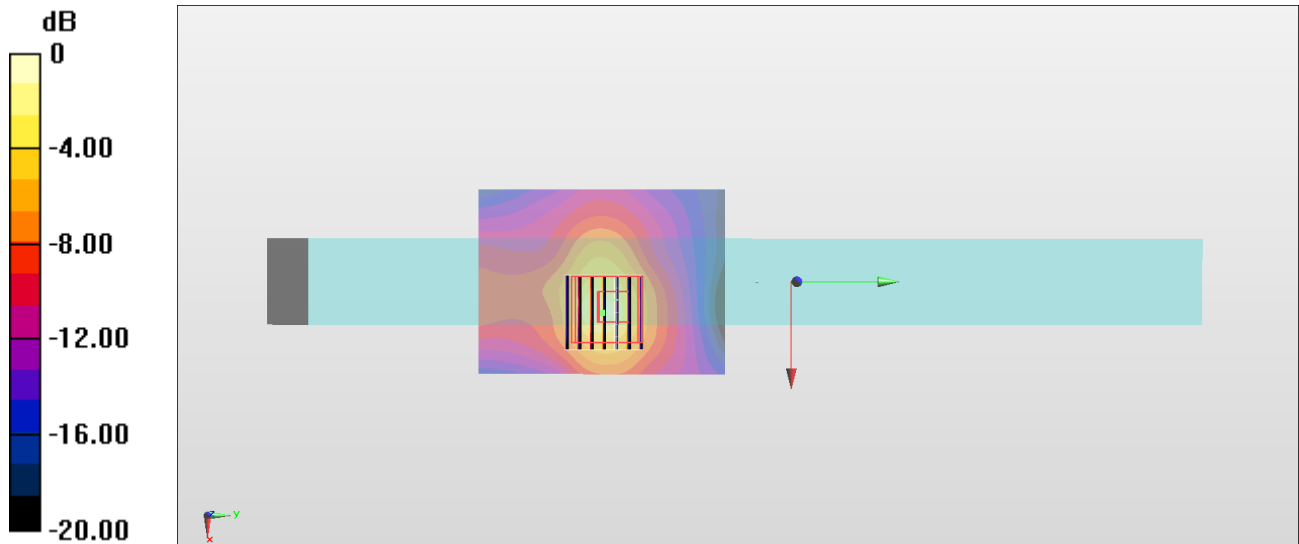

0 dB = 2.16 W/kg = 3.34 dBW/kg

#14_WLAN5GHz_802.11ac-VHT80 MCS0_Edge 1_0mm_Ch106;Ant 1

Communication System: 802.11ac; Frequency: 5530 MHz; Duty Cycle: 1:1.123

Medium: MSL_5G_190421 Medium parameters used : $f = 5530$ MHz; $\sigma = 5.752$ S/m; $\epsilon_r = 47.373$; $\rho = 1000$ kg/m³

Ambient Temperature : 23.5 °C; Liquid Temperature : 22.5 °C

DASY5 Configuration

- Probe: EX3DV4 - SN3931; ConvF(3.82, 3.82, 3.82) ; Calibrated: 2018/9/27
- Sensor-Surface: 1.4mm (Mechanical Surface Detection)
- Electronics: DAE4 Sn1399; Calibrated: 2018/11/16
- Phantom: ELI v5.0; Type: QDOVA002AA; Serial: TP:1227
- Measurement SW: DASY52, Version 52.10 (1); SEMCAD X Version 14.6.11 (7439)

Area Scan (61x101x1): Interpolated grid: dx=1.000 mm, dy=1.000 mm

Maximum value of SAR (interpolated) = 1.39 W/kg

Zoom Scan (7x7x7)/Cube 0: Measurement grid: dx=4mm, dy=4mm, dz=1.4mm

Reference Value = 18.49 V/m; Power Drift = -0.13 dB

Peak SAR (extrapolated) = 3.94 W/kg

SAR(1 g) = 1.02 W/kg; SAR(10 g) = 0.336 W/kg

Maximum value of SAR (measured) = 2.41 W/kg

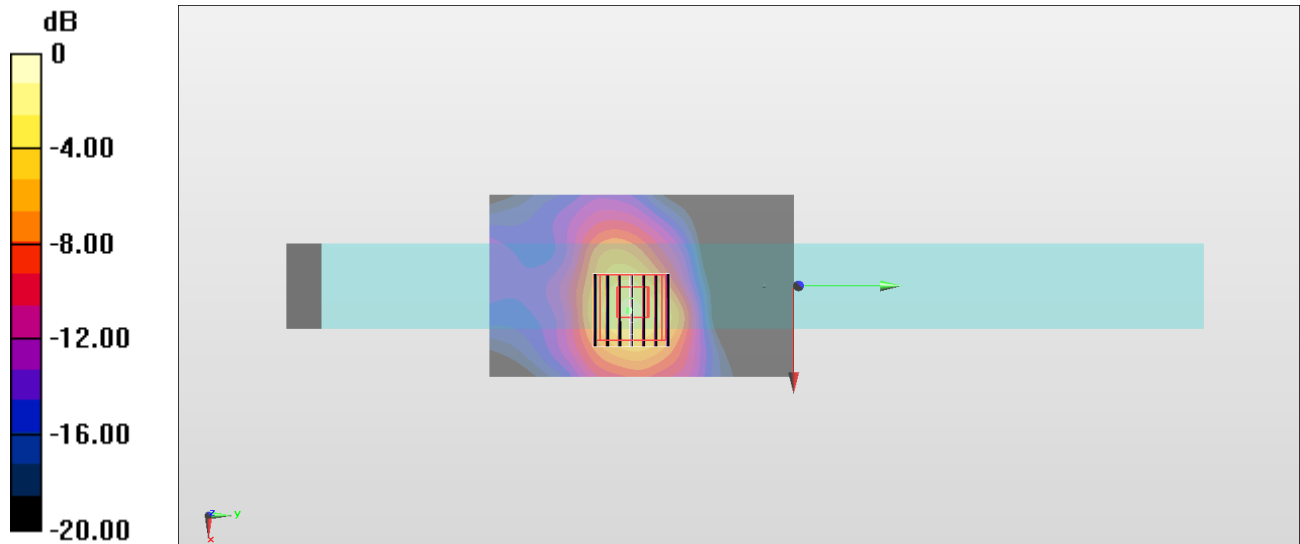

0 dB = 2.41 W/kg = 3.82 dBW/kg

#15_WLAN5GHz_802.11ac-VHT80 MCS0_Edge 1_0mm_Ch155;Ant 1

Communication System: 802.11ac; Frequency: 5775 MHz; Duty Cycle: 1:1.123

Medium: MSL_5G_190421 Medium parameters used: $f = 5775$ MHz; $\sigma = 6.111$ S/m; $\epsilon_r = 46.743$; $\rho = 1000$ kg/m³

Ambient Temperature : 23.5 °C ; Liquid Temperature : 22.5 °C

DASY5 Configuration

- Probe: EX3DV4 - SN3931; ConvF(4.11, 4.11, 4.11) ; Calibrated: 2018/9/27
- Sensor-Surface: 1.4mm (Mechanical Surface Detection)
- Electronics: DAE4 Sn1399; Calibrated: 2018/11/16
- Phantom: ELI v5.0; Type: QDOVA002AA; Serial: TP:1227
- Measurement SW: DASY52, Version 52.10 (1); SEMCAD X Version 14.6.11 (7439)

Area Scan (61x101x1): Interpolated grid: dx=1.000 mm, dy=1.000 mm

Maximum value of SAR (interpolated) = 1.61 W/kg

Zoom Scan (7x7x7)/Cube 0: Measurement grid: dx=4mm, dy=4mm, dz=1.4mm

Reference Value = 19.20 V/m; Power Drift = 0.19 dB

Peak SAR (extrapolated) = 3.94 W/kg

SAR(1 g) = 0.942 W/kg; SAR(10 g) = 0.314 W/kg

Maximum value of SAR (measured) = 2.23 W/kg

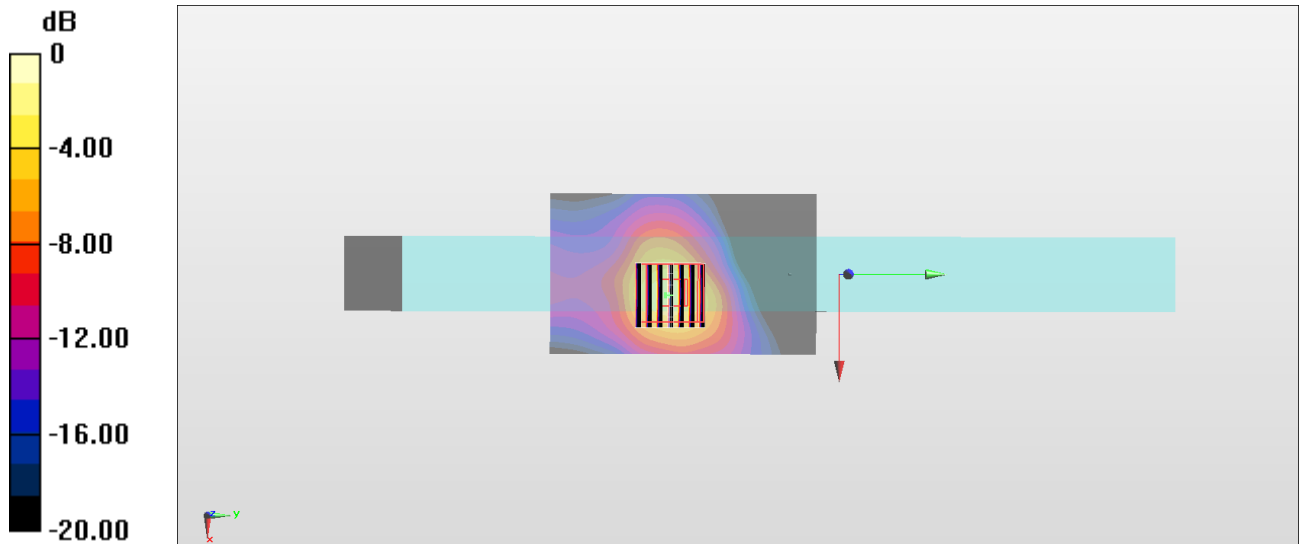

0 dB = 2.23 W/kg = 3.48 dBW/kg

#16_Bluetooth_1Mbps_Edge 1_0mm_Ch0;Ant 1

Communication System: Bluetooth ; Frequency: 2402 MHz;Duty Cycle: 1:1.301

Medium: MSL_2450_190422 Medium parameters used : $f = 2402$ MHz; $\sigma = 1.932$ S/m; $\epsilon_r = 53.137$; $\rho = 1000$ kg/m³

Ambient Temperature : 23.3 °C ; Liquid Temperature : 22.3 °C

DASY5 Configuration

- Probe: ES3DV3 - SN3169;ConvF(4.4, 4.4, 4.4) ;Calibrated: 2018/5/28
- Sensor-Surface: 3mm (Mechanical Surface Detection)
- Electronics: DAE4 Sn1399; Calibrated: 2018/11/16
- Phantom: ELI v5.0; Type: QDOVA002AA; Serial: TP:1227
- Measurement SW: DASY52, Version 52.10 (1); SEMCAD X Version 14.6.11 (7439)

Area Scan (71x81x1): Interpolated grid: dx=1.500 mm, dy=1.500 mm

Maximum value of SAR (interpolated) = 0.0140 W/kg

Zoom Scan (5x5x7)/Cube 0: Measurement grid: dx=8mm, dy=8mm, dz=5mm

Reference Value = 2.512 V/m; Power Drift = 0.09 dB

Peak SAR (extrapolated) = 0.0190 W/kg

SAR(1 g) = 0.010 W/kg; SAR(10 g) = 0.00536 W/kg

Maximum value of SAR (measured) = 0.0126 W/kg

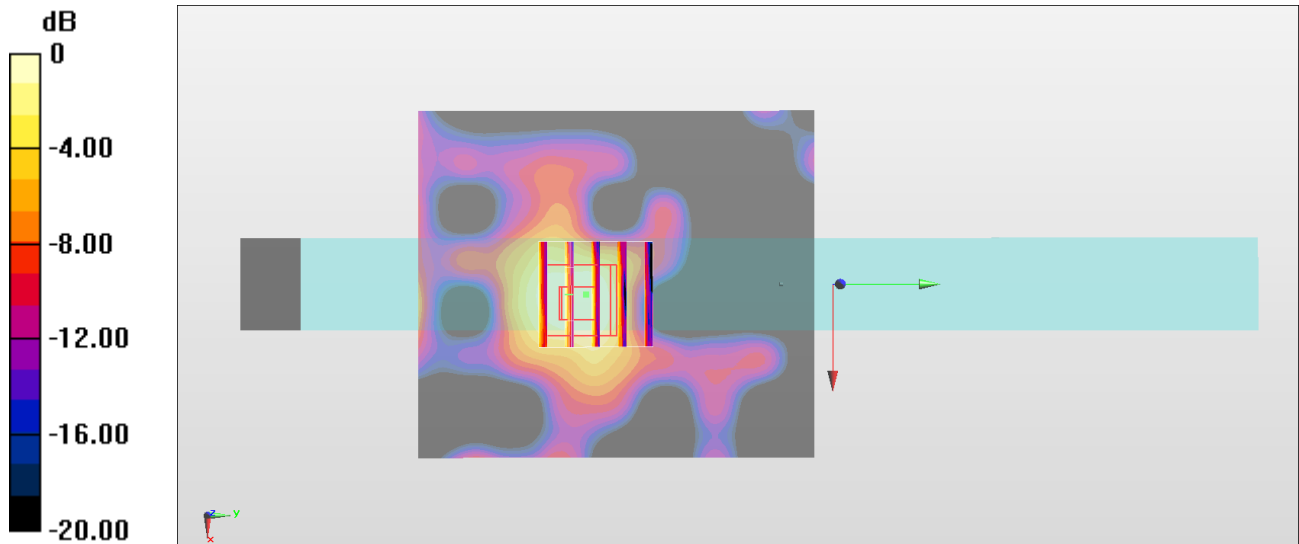

0 dB = 0.0126 W/kg = -19.00 dBW/kg