



FCC RF Test Report

APPLICANT : Zebra Technologies Corporation
EQUIPMENT : Personnel Badge
BRAND NAME : ZEBRA
MODEL NAME : MPACT-BRDGM
FCC ID : UZ7MPACTBRDGM
STANDARD : FCC Part 15 Subpart E §15.407
CLASSIFICATION : (NII) Unlicensed National Information Infrastructure

The product was received on Oct. 06, 2016 and testing was completed on Nov. 07, 2016. We, SPORTON INTERNATIONAL INC., would like to declare that the tested sample has been evaluated in accordance with the test procedures and has been in compliance with the applicable technical standards.

The test results in this report apply exclusively to the tested model / sample. Without written approval of SPORTON INTERNATIONAL INC., the test report shall not be reproduced except in full.

Reviewed by: Joseph Lin / Supervisor

Approved by: Jones Tsai / Manager



SPORTON INTERNATIONAL INC.

No. 52, Hwa Ya 1st Rd., Hwa Ya Technology Park, Kwei-Shan District, Tao Yuan City, Taiwan, R.O.C.

SPORTON INTERNATIONAL INC.
TEL : 886-3-327-3456
FAX : 886-3-328-4978
FCC ID : UZ7MPACTBRDGM

Page Number : 1 of 32
Report Issued Date : Dec. 09, 2016
Report Version : Rev. 01
Report Template No.: BU5-FR15EWL Version 1.4



TABLE OF CONTENTS

SUMMARY OF TEST RESULT 4

1 GENERAL DESCRIPTION 5

1.1 Applicant 5

1.2 Manufacturer 5

1.3 Product Feature of Equipment Under Test 5

1.4 Product Specification of Equipment Under Test 6

1.5 Modification of EUT 6

1.6 Testing Location 7

1.7 Applicable Standards 7

2 TEST CONFIGURATION OF EQUIPMENT UNDER TEST 8

2.1 Carrier Frequency Channel 8

2.2 Test Mode 9

2.3 Connection Diagram of Test System 10

2.4 Support Unit used in test configuration and system 11

2.5 EUT Operation Test Setup 11

2.6 Measurement Results Explanation Example 11

3 TEST RESULT 12

3.1 26dB & 99% Occupied Bandwidth Measurement 12

3.2 Maximum Conducted Output Power Measurement 14

3.3 Power Spectral Density Measurement 16

3.4 Unwanted Radiated Emission Measurement 19

3.5 AC Conducted Emission Measurement 24

3.6 Frequency Stability Measurement 28

3.7 Automatically Discontinue Transmission 29

3.8 Antenna Requirements 30

4 LIST OF MEASURING EQUIPMENTS 31

5 UNCERTAINTY OF EVALUATION 32

APPENDIX A. CONDUCTED TEST RESULTS

APPENDIX B. RADIATED SPURIOUS EMISSION

APPENDIX C. RADIATED SPURIOUS EMISSION PLOTS

APPENDIX D. DUTY CYCLE PLOTS

APPENDIX E. SETUP PHOTOGRAPHS



REVISION HISTORY

REPORT NO.	VERSION	DESCRIPTION	ISSUED DATE
FR600724C	Rev. 01	Initial issue of report	Dec. 09, 2016



SUMMARY OF TEST RESULT

Report Section	FCC Rule	Description	Limit	Result	Remark
3.1	2.1049 15.403(i)	26dB & 99% Bandwidth	-	Pass	-
3.2	15.407(a)	Maximum Conducted Output Power	FCC ≤ 24 dBm (depend on band)	Pass	-
3.3	15.407(a)	Power Spectral Density	FCC ≤ 11 dBm (depend on band)	Pass	-
3.4	15.407(b)	Unwanted Emissions	≤ -17, -27 dBm (depend on band)&15.209(a)	Pass	Under limit 1.00 dB at 5725.000 MHz
3.5	15.207	AC Conducted Emission	15.207(a)	Pass	Under limit 12.30 dB at 0.150 MHz
3.6	15.407(g)	Frequency Stability	Within Operation Band	Pass	-
3.7	15.407(c)	Automatically Discontinue Transmission	Discontinue Transmission	Pass	-
3.8	15.203 & 15.407(a)	Antenna Requirement	N/A	Pass	-



1 General Description

1.1 Applicant

Zebra Technologies Corporation
1 Zebra Plaza, Holtsville, NY 11742

1.2 Manufacturer

Zebra Technologies Corporation
1 Zebra Plaza, Holtsville, NY 11742

1.3 Product Feature of Equipment Under Test

Product Feature	
Equipment	Personnel Badge
Brand Name	ZEBRA
Model Name	MPACT-BRDGM
FCC ID	UZ7MPACTBRDGM
EUT supports Radios application	WLAN 11 a/b/g/n HT20 Bluetooth LE
Wifi Code version	6.0.109.9
Wifi Tools version	9.0.0.341360
EUT Stage	Identical Prototype

Remark: The above EUT's information was declared by manufacturer. Please refer to the specifications or user's manual for more detailed description.



1.4 Product Specification of Equipment Under Test

Standards-related Product Specification	
Tx/Rx Frequency Range	5180 MHz ~ 5240 MHz 5260 MHz ~ 5320 MHz 5500 MHz ~ 5700 MHz
Maximum Output Power to Antenna	<p><EUT with J300 Antenna> <5180 MHz ~ 5240 MHz> 802.11a : 16.98 dBm / 0.0499 W 802.11n HT20 : 16.89 dBm / 0.0489 W <5260 MHz ~ 5320 MHz> 802.11a : 16.93 dBm / 0.0493 W 802.11n HT20 : 16.75 dBm / 0.0473 W <5500 MHz ~ 5700 MHz > 802.11a : 16.45 dBm / 0.0442 W 802.11n HT20 : 16.30 dBm / 0.0427 W <EUT with J301 Antenna> <5180 MHz ~ 5240 MHz> 802.11a : 16.94 dBm / 0.0494 W 802.11n HT20 : 16.88 dBm / 0.0488 W <5260 MHz ~ 5320 MHz> 802.11a : 16.91 dBm / 0.0491 W 802.11n HT20 : 16.74 dBm / 0.0472 W <5500 MHz ~ 5700 MHz > 802.11a : 16.38 dBm / 0.0435 W 802.11n HT20 : 16.26 dBm / 0.0423 W</p>
99% Occupied Bandwidth	<p><EUT with J300 Antenna> 802.11a : 18.05 MHz 802.11n HT20 : 19.20 MHz</p>
Antenna Gain / Gain	Dipole Antenna with gain 4.30 dBi
Type of Modulation	802.11a/n : OFDM (BPSK / QPSK / 16QAM / 64QAM)

Note:

1. WLAN operation in 5600 MHz ~ 5650 MHz is notched.
2. This device has two kinds of WLAN antenna (J300 Antenna and J301 Antenna), and the J300 has max RF Power. Thus, all tests were performed with J300 Antenna.

1.5 Modification of EUT

No modifications are made to the EUT during all test items.



1.6 Testing Location

Sporton Lab is accredited to ISO 17025 by Taiwan Accreditation Foundation (TAF code : 1190) and the FCC designation No. TW1022 under the FCC 2.948(e) by Mutual Recognition Agreement (MRA) in FCC Test.

Test Site	SPORTON INTERNATIONAL INC.		
Test Site Location	No. 52, Hwa Ya 1 st Rd., Hwa Ya Technology Park, Kwei-Shan District, Tao Yuan City, Taiwan, R.O.C. TEL: +886-3-327-3456 FAX: +886-3-328-4978		
Test Site No.	Sporton Site No.		
	TH05-HY	CO05-HY	03CH07-HY

Note: The test site complies with ANSI C63.4 2014 requirement.

1.7 Applicable Standards

According to the specifications of the manufacturer, the EUT must comply with the requirements of the following standards:

- ♦ FCC Part 15 Subpart E
- ♦ FCC KDB 789033 D02 General UNII Test Procedures New Rules v01r03
- ♦ ANSI C63.10-2013

Remark:

1. All test items were verified and recorded according to the standards and without any deviation during the test.
2. This EUT has also been tested and complied with the requirements of FCC Part 15, Subpart B, recorded in a separate test report.



2 Test Configuration of Equipment Under Test

The EUT has been associated with peripherals and configuration operated in a manner tended to maximize its emission characteristics in a typical application. Frequency range investigated: conducted emission (150 kHz to 30 MHz) and radiated emission (9 kHz to the 10th harmonic of the highest fundamental frequency or to 40 GHz, whichever is lower). For radiated measurement, pre-scanned in three orthogonal panels, X, Y, Z. The worst cases (Y plane) were recorded in this report.

2.1 Carrier Frequency Channel

Frequency Band	Channel	Freq. (MHz)	Channel	Freq. (MHz)
5150-5250 MHz Band 1 (U-NII-1)	36	5180	44	5220
	-	-	-	-
	40	5200	48	5240
	-	-	-	-

Frequency Band	Channel	Freq. (MHz)	Channel	Freq. (MHz)
5250-5350 MHz Band 2 (U-NII-2A)	52	5260	60	5300
	-	-	-	-
	56	5280	64	5320
	-	-	-	-

Frequency Band	Channel	Freq. (MHz)	Channel	Freq. (MHz)
5470-5725 MHz Band 3 (U-NII-2C)	100	5500	112	5560
	-	-	116	5580
	104	5520	132	5660
	-	-	-	-
	108	5540	136	5680
	-	-	140	5700



2.2 Test Mode

Final test mode of conducted test items and radiated spurious emissions are considering the modulation and worse data rates as below table.

Modulation	Data Rate
802.11a	6 Mbps
802.11n HT20	MCS0

AC Conducted Emission	Mode 1 : Jamaica charging from Toaster + Bluetooth Idle + WLAN Idle + AC Adapter (PS000084A01)
-----------------------	--

Ch. #		Band I : 5150-5250 MHz	Band II : 5250-5350 MHz	Band III : 5470-5725MHz
		802.11a	802.11a	802.11a
L	Low	36	52	100
M	Middle	44	60	116
H	High	48	64	140

Ch. #		Band I : 5150-5250 MHz	Band II : 5250-5350 MHz	Band III : 5470-5725MHz
		802.11n HT20	802.11n HT20	802.11n HT20
L	Low	36	52	100
M	Middle	44	60	116
H	High	48	64	140

Ch. #		Band I : 5150-5250 MHz	Band II : 5250-5350 MHz	Band III : 5470-5725MHz
		802.11n HT40	802.11n HT40	802.11n HT40
L	Low	38	54	102
M	Middle	-	-	110
H	High	46	62	134

2.3 Connection Diagram of Test System

<WLAN Tx Mode>

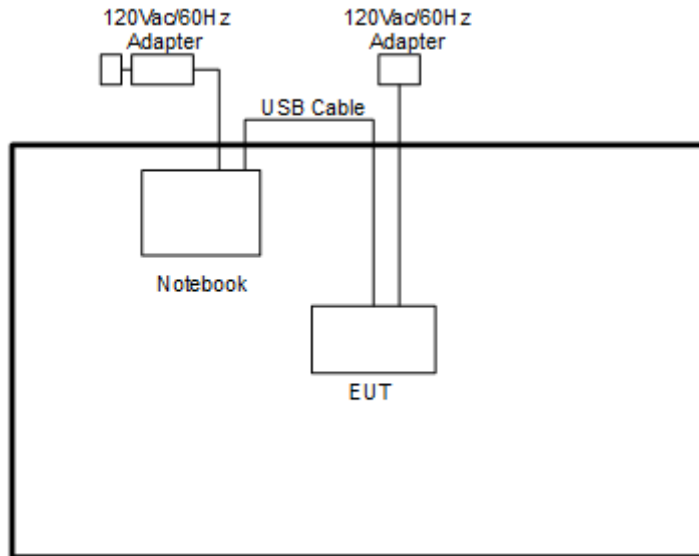

<AC Conducted Emission Mode>

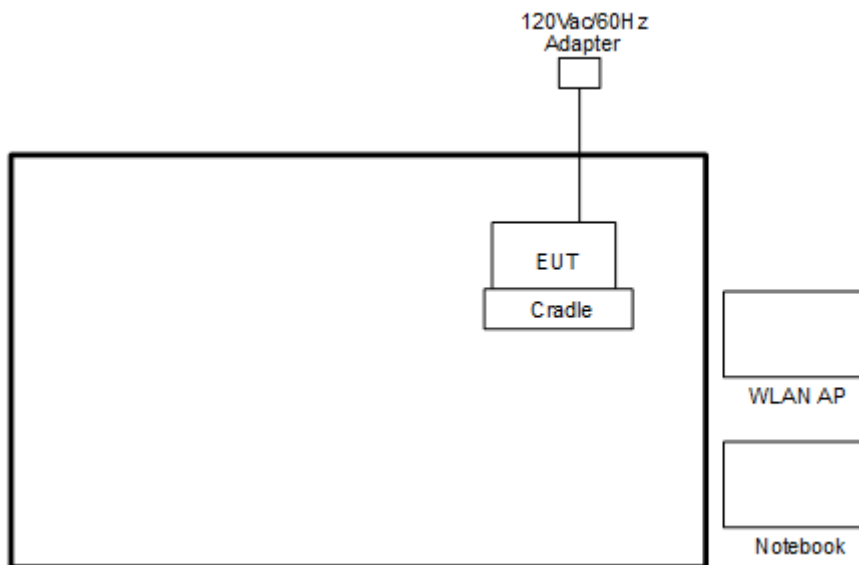



2.4 Support Unit used in test configuration and system

Item	Equipment	Trade Name	Model Name	FCC ID	Data Cable	Power Cord
1.	WLAN AP	D-Link	DIR-628	KA2DIR628A2	N/A	Unshielded, 1.8 m
2.	Notebook	DELL	Latitude E3340	FCC DoC/ Contains FCC ID: PD97260NGU	N/A	AC I/P: Unshielded, 1.2 m DC O/P: Shielded, 1.8 m
3.	Notebook	Lenovo	E335	FCC DoC	N/A	AC I/P: Unshielded, 1.2 m DC O/P: Shielded, 1.8 m
4.	Cradle (Toaster)	Zebra	MPACT-CRADLE	FCC DoC	Shielded, 1.0 m	AC I/P: Unshielded, 1.8 m DC O/P: Unshielded, 1.0 m

2.5 EUT Operation Test Setup

For WLAN function, programmed RF utility, “Tx Tool” installed in the notebook make the EUT provide functions like channel selection and power level for continuous transmitting and receiving signals.

2.6 Measurement Results Explanation Example

For all conducted test items:

The offset level is set in the spectrum analyzer to compensate the RF cable loss and attenuator factor between EUT conducted output port and spectrum analyzer. With the offset compensation, the spectrum analyzer reading level is exactly the EUT RF output level.

Example :

The spectrum analyzer offset is derived from RF cable loss and attenuator factor.

Offset = RF cable loss + attenuator factor.

Following shows an offset computation example with cable loss 4.2 dB and 10dB attenuator.

$$\begin{aligned} \text{Offset(dB)} &= \text{RF cable loss(dB)} + \text{attenuator factor(dB)}. \\ &= 4.2 + 10 = 14.2 \text{ (dB)} \end{aligned}$$

3 Test Result

3.1 26dB & 99% Occupied Bandwidth Measurement

3.1.1 Description of 26dB & 99% Occupied Bandwidth

This section is for reporting purpose only.

There is no restriction limits for bandwidth.

3.1.2 Measuring Instruments

The measuring equipment is listed in the section 4 of this test report.

3.1.3 Test Procedures

1. The testing follows FCC KDB 789033 D02 General UNII Test Procedures New Rules v01r03.
Section C) Emission bandwidth
2. Set RBW = approximately 1% of the emission bandwidth.
3. Set the VBW > RBW.
4. Detector = Peak.
5. Trace mode = max hold
6. Measure the maximum width of the emission that is 26 dB down from the peak of the emission.
Compare this with the RBW setting of the analyzer. Readjust RBW and repeat measurement as needed until the RBW/EBW ratio is approximately 1%.
7. For 99% Bandwidth Measurement, the spectrum analyzer's resolution bandwidth (RBW) is set 1MHz and set the Video bandwidth (VBW) $\geq 3 * RBW$.
8. Measure and record the results in the test report.

3.1.4 Test Setup

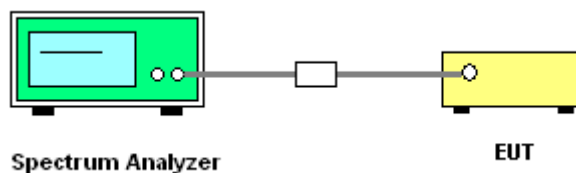



3.1.5 Test Result of 26dB & 99% Occupied Bandwidth Plots

Please refer to Appendix A.

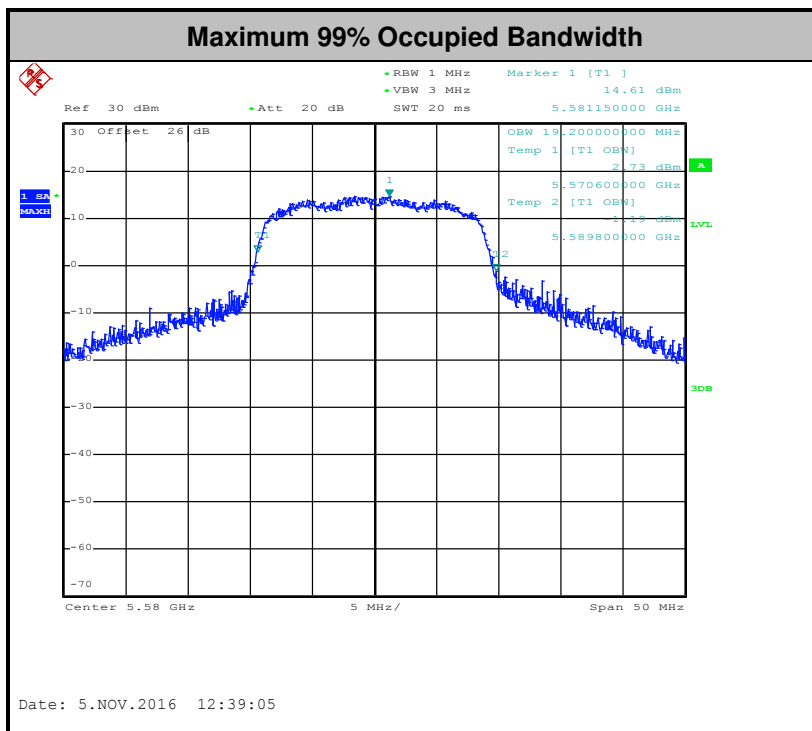
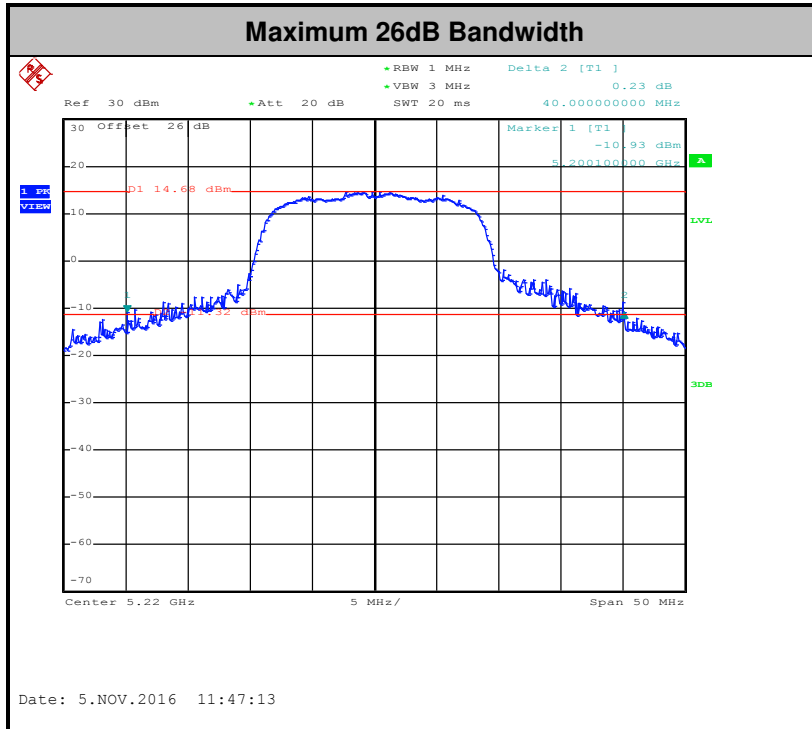



3.2 Maximum Conducted Output Power Measurement

3.2.1 Limit of Maximum Conducted Output Power

For mobile and portable client devices in the 5.15–5.25 GHz band, the maximum conducted output power over the frequency band of operation shall not exceed 250 mW.

For the 5.25–5.725 GHz bands, the maximum conducted output power over the frequency bands of operation shall not exceed the lesser of 250 mW or $11 \text{ dBm} + 10 \log B$, where B is the 26 dB emission bandwidth in megahertz.

For the band 5.725–5.85 GHz, the maximum conducted output power over the frequency band of operation shall not exceed 1 W.

If transmitting antennas of directional gain greater than 6 dBi are used, the peak output power shall be reduced by the amount in dB that the directional gain of the antenna exceeds 6 dBi.

Note that U-NII-2 band, devices with a maximum e.i.r.p. greater than 500 mW shall implement TPC in order to have the capability to operate at least 6 dB below the maximum permitted e.i.r.p. of 1 W.

3.2.2 Measuring Instruments

The measuring equipment is listed in the section 4 of this test report.

3.2.3 Test Procedures

The testing follows Method PM of FCC KDB 789033 D02 General UNII Test Procedures New Rules v01r03.

Method PM (Measurement using an RF average power meter):

1. Measurement is performed using a wideband RF power meter.
2. The EUT is configured to transmit continuously with a consistent duty cycle at its maximum power control level.
3. Measure the average power of the transmitter, and the average power is corrected with duty factor, $10 \log(1/x)$, where x is the duty cycle.

3.2.4 Test Setup

For normal channel:

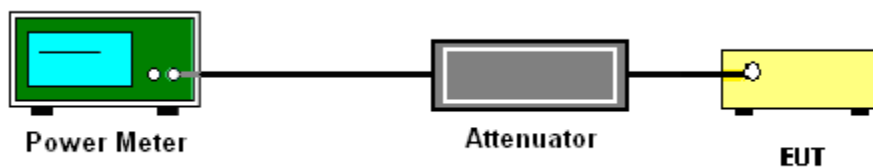

3.2.5 Test Result of Maximum Conducted Output Power

Please refer to Appendix A.



3.3 Power Spectral Density Measurement

3.3.1 Limit of Power Spectral Density

For mobile and portable client devices in the 5.15–5.25 GHz band, the maximum power spectral density shall not exceed 11dBm in any 1 megahertz band.

For the 5.25–5.725 GHz bands, the maximum power spectral density shall not exceed 11 dBm in any 1 megahertz band.

For the band 5.725–5.85 GHz, the maximum power spectral density shall not exceed 30 dBm in any 500-kHz band.

If transmitting antennas of directional gain greater than 6 dBi are used, the peak output power shall be reduced by the amount in dB that the directional gain of the antenna exceeds 6 dBi.

3.3.2 Measuring Instruments

The measuring equipment is listed in the section 4 of this test report.

3.3.3 Test Procedures

The testing follows FCC KDB 789033 D02 General UNII Test Procedures New Rules v01r03.
Section F) Maximum power spectral density.

Method SA-2

(trace averaging across on and off times of the EUT transmissions, followed by duty cycle correction).

1. The testing follows Method SA-2 of FCC KDB 789033 D02 General UNII Test Procedures New Rules v01r03.
 - Measure the duty cycle.
 - Set span to encompass the entire emission bandwidth (EBW) of the signal.
 - Set RBW = 1 MHz.
 - Set VBW \geq 3 MHz.
 - Number of points in sweep \geq 2 Span / RBW.
 - Sweep time = auto.
 - Detector = RMS
 - Trace average at least 100 traces in power averaging mode.
 - Add $10 \log(1/x)$, where x is the duty cycle, to the measured power in order to compute the average power during the actual transmission times. For example, add $10 \log(1/0.25) = 6$ dB if the duty cycle is 25 percent.
2. The RF output of EUT was connected to the spectrum analyzer by a low loss cable.
3. Each plot has already offset with cable loss, and attenuator loss. Measure the PPSD and record it.

3.3.4 Test Setup

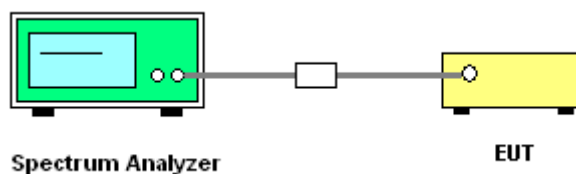



3.3.5 Test Result of Power Spectral Density

Please refer to Appendix A.

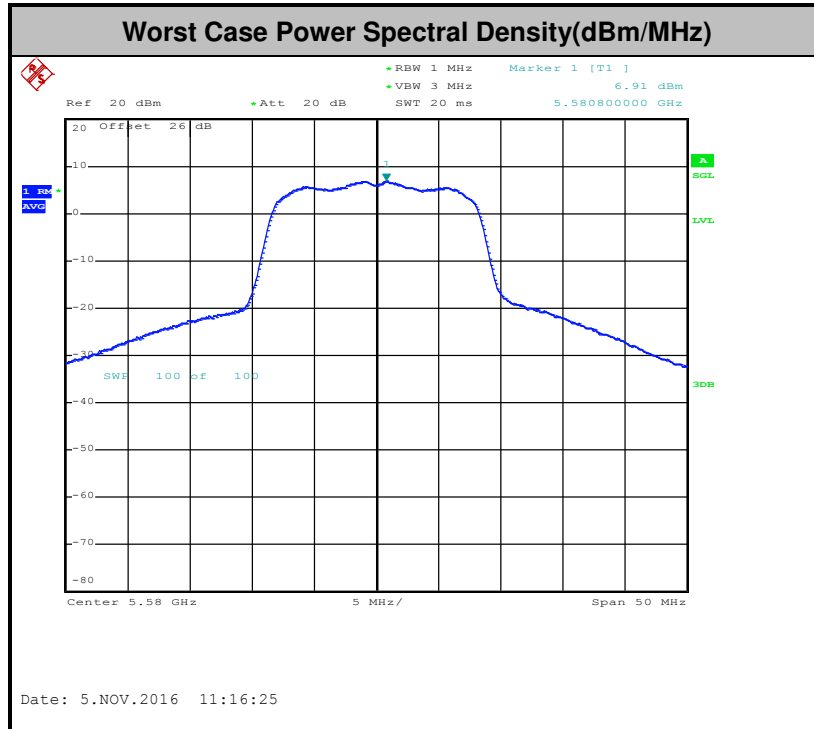

Note: Average Power Density (dB) = Measured value+ Duty Factor



3.4 Unwanted Radiated Emission Measurement

This section as specified in FCC Part 15.407(b) is to measure unwanted emissions through radiated measurement for band edge spurious emissions and out of band emissions measurement. The unwanted emissions shall comply with 15.407(b)(1) to (6), and restricted bands per FCC Part15.205.

3.4.1 Limit of Unwanted Emissions

- (1) For transmitters operating in the 5150-5250 MHz band: all emissions outside of the 5150-5350 MHz band shall not exceed an EIRP of -27dBm/MHz.

For transmitters operating in the 5250-5350 MHz band: all emissions outside of the 5150-5350 MHz band shall not exceed an EIRP of -27 dBm/MHz. Devices operating in the 5250-5350 MHz band that generate emissions in the 5150-5250 MHz band must meet all applicable technical requirements for operation in the 5150-5250 MHz band (including indoor use) or alternatively meet an out-of-band emission EIRP limit of -27 dBm/MHz in the 5150-5250 MHz band.

For transmitters operating in the 5470-5725MHz band: all emissions outside of the 5470-5725MHz band shall not exceed an EIRP of -27 dBm/MHz.

- (2) Unwanted spurious emissions fallen in restricted bands per FCC Part15.205 shall comply with the general field strength limits set forth in § 15.209 as below table,

Frequency (MHz)	Field Strength (microvolts/meter)	Measurement Distance (meters)
0.009 – 0.490	2400/F(kHz)	300
0.490 – 1.705	24000/F(kHz)	30
1.705 – 30.0	30	30
30 – 88	100	3
88 – 216	150	3
216 - 960	200	3
Above 960	500	3

Note: The following formula is used to convert the EIRP to field strength.

$$E = \frac{1000000\sqrt{30P}}{3} \mu V/m, \text{ where } P \text{ is the eirp (Watts)}$$



EIRP (dBm)	Field Strength at 3m (dB μ V/m)
-17	78.3
- 27	68.3

(3) KDB789033 D01 v01r03 G)2)c) As specified in 15.407(b), emissions above 1000 MHz that are outside of the restricted bands are subject to a peak emission limit of -27 dBm/MHz (or -17 dBm/MHz as specified in 15.407(b)(4)). However, an out-of-band emission that complies with both the average and peak limits of 15.209 is not required to satisfy the -27 dBm/MHz or -17 dBm/MHz peak emission limit.

3.4.2 Measuring Instruments

The measuring equipment is listed in the section 4 of this test report.

3.4.3 Test Procedures

1. The testing follows FCC KDB 789033 D02 General UNII Test Procedures New Rules v01r03. Section G) Unwanted emissions measurement.

(1) Procedure for Unwanted Emissions Measurements Below 1000MHz

- RBW = 120 kHz
- VBW = 300 kHz
- Detector = Peak
- Trace mode = max hold

(2) Procedure for Peak Unwanted Emissions Measurements Above 1000 MHz

- RBW = 1 MHz
- VBW \geq 3 MHz
- Detector = Peak
- Sweep time = auto
- Trace mode = max hold

(3) Procedures for Average Unwanted Emissions Measurements Above 1000MHz

- RBW = 1 MHz
- VBW = 10 Hz, when duty cycle is no less than 98 percent.
- VBW \geq 1/T, when duty cycle is less than 98 percent where T is the minimum transmission duration over which the transmitter is on and is transmitting at its maximum power control level for the tested mode of operation.

2. The EUT was placed on a turntable with 0.8 meter for frequency below 1GHz and 1.5 meter for frequency above 1GHz respectively above ground.
3. The EUT was set 3 meters from the interference receiving antenna which was mounted on the top of a variable height antenna tower.
4. The antenna is a broadband antenna and its height is adjusted between one meter and four meters above ground to find the maximum value of the field strength for both horizontal polarization and vertical polarization of the antenna.
5. For each suspected emission, the EUT was arranged to its worst case and then adjust the antenna tower (from 1 m to 4 m) and turntable (from 0 degree to 360 degrees) to find the maximum reading.
6. For testing below 1GHz, if the emission level of the EUT in peak mode was 3 dB lower than the limit specified, then peak values of EUT will be reported, otherwise, the emissions will be repeated one by one using the CISPR quasi-peak method and reported.
7. For testing above 1GHz, the emission level of the EUT in peak mode was 20dB lower than average limit (that means the emission level in average mode also complies with the limit in average mode), then peak values of EUT will be reported, otherwise, the emissions will be measured in average mode again and reported.

3.4.4 Test Setup

For radiated emissions below 30MHz

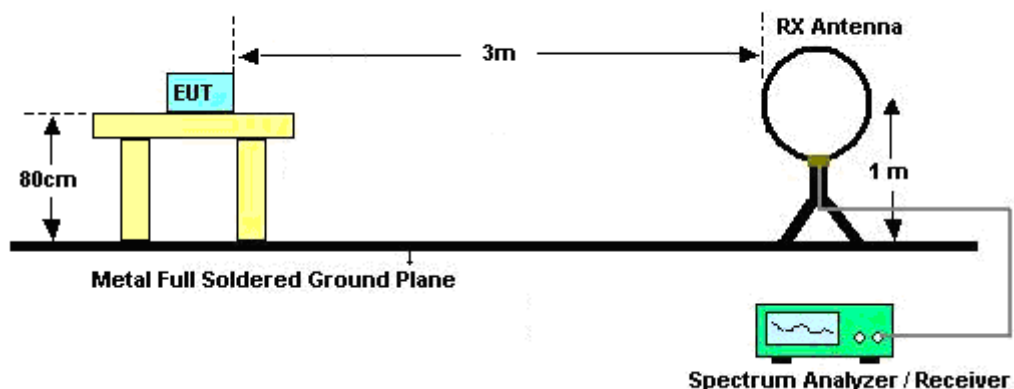

For radiated emissions from 30MHz to 1GHz

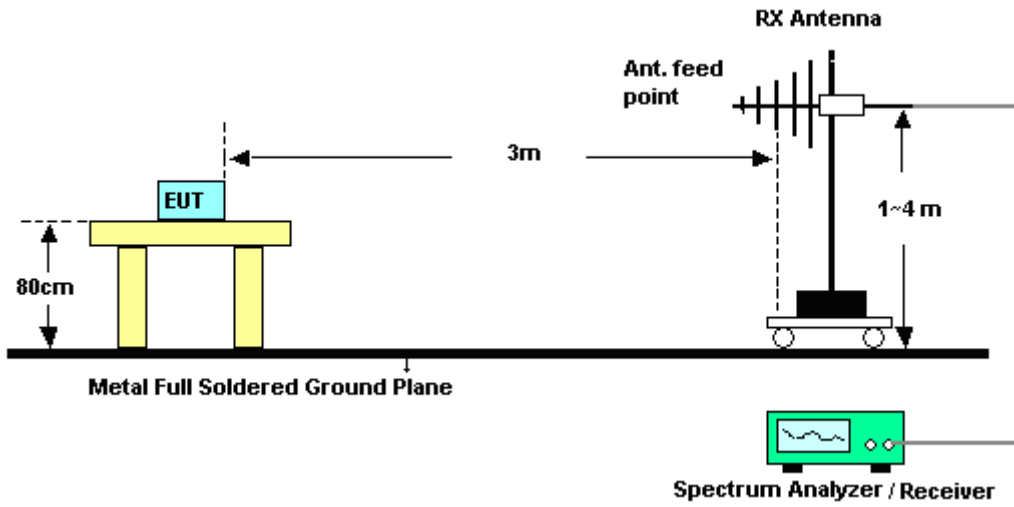

For radiated emissions above 1GHz

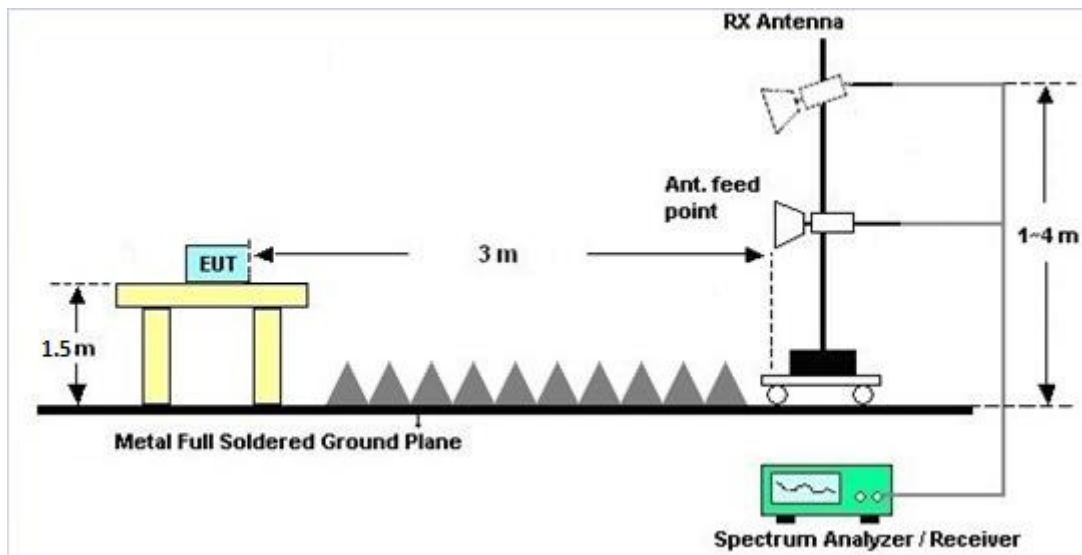



3.4.5 Test Results of Radiated Spurious Emissions (9 kHz ~ 30 MHz)

The low frequency, which started from 9 kHz to 30MHz, was pre-scanned and the result which was 20dB lower than the limit line per 15.31(o) was not reported.

3.4.6 Test Result of Radiated Spurious at Band Edges

Please refer to Appendix B and C.

3.4.7 Duty Cycle

Please refer to Appendix D.

3.4.8 Test Result of Radiated Spurious Emissions (30MHz ~ 10th Harmonic)

Please refer to Appendix B and C.



3.5 AC Conducted Emission Measurement

3.5.1 Limit of AC Conducted Emission

For equipment that is designed to be connected to the public utility (AC) power line, the radio frequency voltage that is conducted back onto the AC power line on any frequency or frequencies within the band 150 kHz to 30 MHz shall not exceed the limits in the following table.

Frequency of emission (MHz)	Conducted limit (dB μ V)	
	Quasi-peak	Average
0.15-0.5	66 to 56*	56 to 46*
0.5-5	56	46
5-30	60	50

*Decreases with the logarithm of the frequency.

3.5.2 Measuring Instruments

The measuring equipment is listed in the section 4 of this test report.

3.5.3 Test Procedures

1. The EUT was placed 0.4 meter from the conducting wall of the shielding room was kept at least 80 centimeters from any other grounded conducting surface.
2. Connect EUT to the power mains through a line impedance stabilization network (LISN).
3. All the support units are connecting to the other LISN.
4. The LISN provides 50 ohm coupling impedance for the measuring instrument.
5. The FCC states that a 50 ohm, 50 microhenry LISN should be used.
6. Both sides of AC line were checked for maximum conducted interference.
7. The frequency range from 150 kHz to 30 MHz was searched.
8. Set the test-receiver system to Peak Detect Function and specified bandwidth with Maximum Hold Mode.

3.5.4 Test Setup

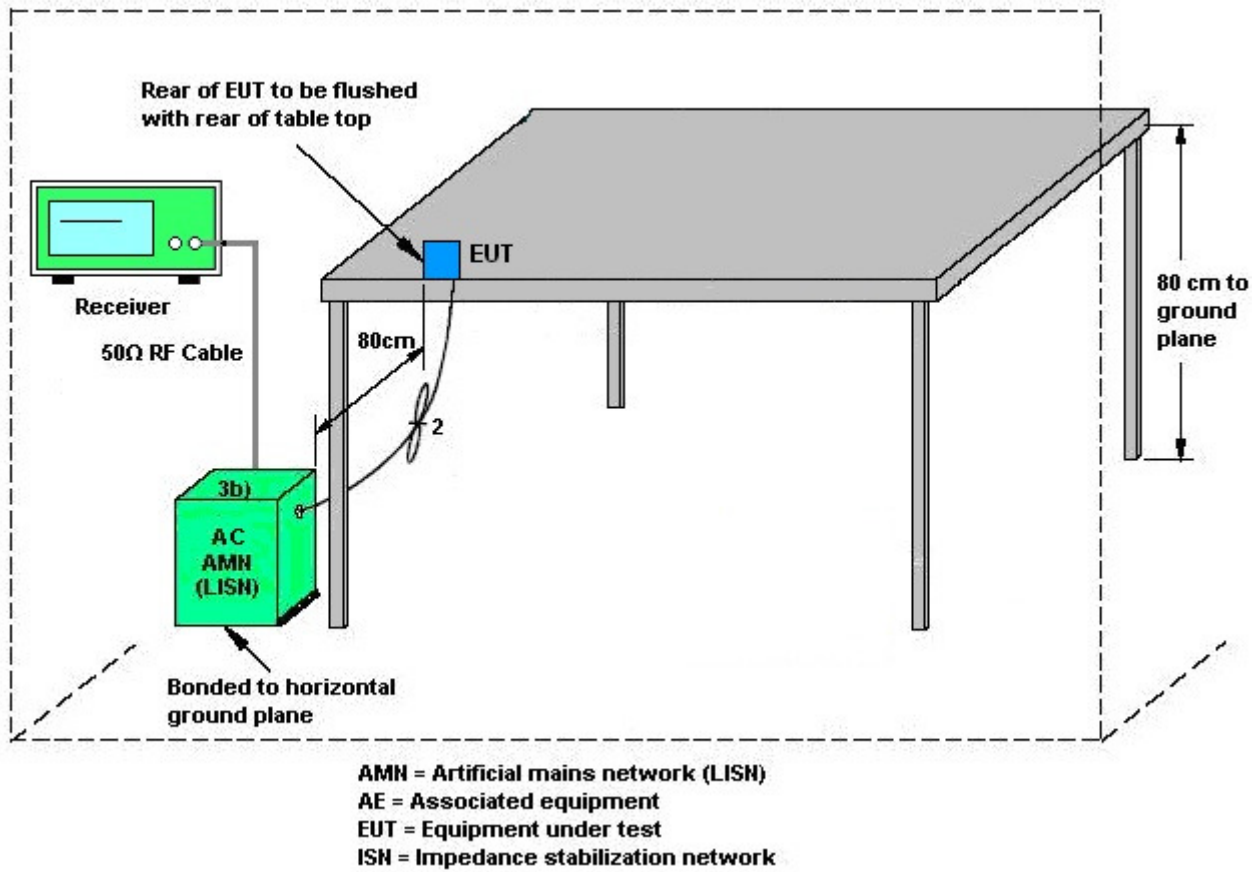

3.5.5 Test Result of AC Conducted Emission

Test Mode :	Mode 1	Temperature :	24~25°C
Test Engineer :	Kai-Chun Chu	Relative Humidity :	49~50%
Test Voltage :	120Vac / 60Hz	Phase :	Line
Function Type :	Jamaica charging from Toaster + Bluetooth Idle + WLAN Idle + AC Adapter (PS000084A01)		

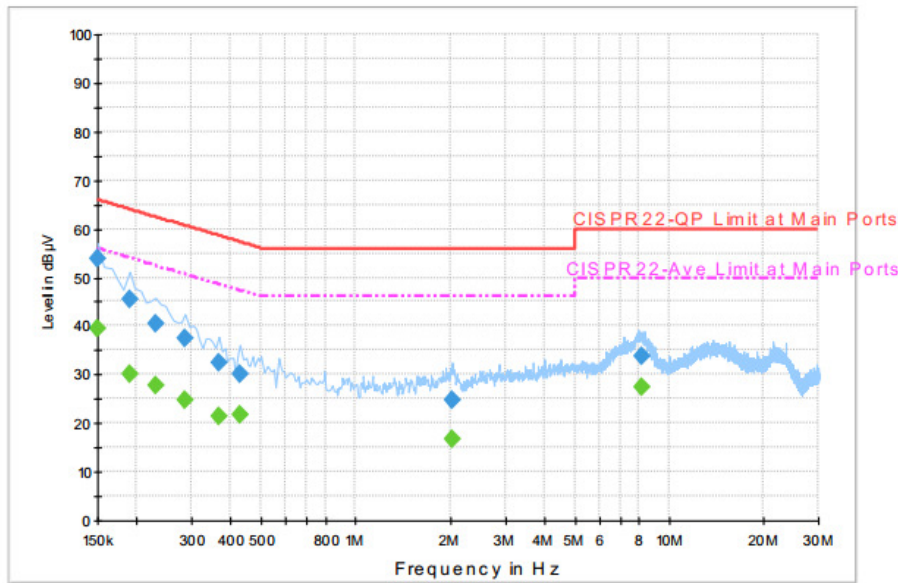

Final Result : Quasi-Peak

Frequency (MHz)	Quasi-Peak (dBµV)	Filter	Line	Corr. (dB)	Margin (dB)	Limit (dBµV)
0.150000	53.7	Off	L1	19.6	12.3	66.0
0.190000	45.5	Off	L1	19.6	18.5	64.0
0.230000	40.4	Off	L1	19.6	22.0	62.4
0.286000	37.5	Off	L1	19.6	23.1	60.6
0.366000	32.6	Off	L1	19.6	26.0	58.6
0.430000	30.1	Off	L1	19.6	27.2	57.3
2.038000	24.7	Off	L1	19.1	31.3	56.0
8.150000	33.7	Off	L1	20.0	26.3	60.0

Final Result : Average

Frequency (MHz)	Average (dBµV)	Filter	Line	Corr. (dB)	Margin (dB)	Limit (dBµV)
0.150000	39.6	Off	L1	19.6	16.4	56.0
0.190000	30.2	Off	L1	19.6	23.8	54.0
0.230000	27.8	Off	L1	19.6	24.6	52.4
0.286000	24.8	Off	L1	19.6	25.8	50.6
0.366000	21.3	Off	L1	19.6	27.3	48.6
0.430000	21.6	Off	L1	19.6	25.7	47.3
2.038000	16.6	Off	L1	19.1	29.4	46.0
8.150000	27.5	Off	L1	20.0	22.5	50.0



Test Mode :	Mode 1	Temperature :	24~25°C
Test Engineer :	Kai-Chun Chu	Relative Humidity :	49~50%
Test Voltage :	120Vac / 60Hz	Phase :	Neutral
Function Type :	Jamaica charging from Toaster + Bluetooth Idle + WLAN Idle + AC Adapter (PS000084A01)		

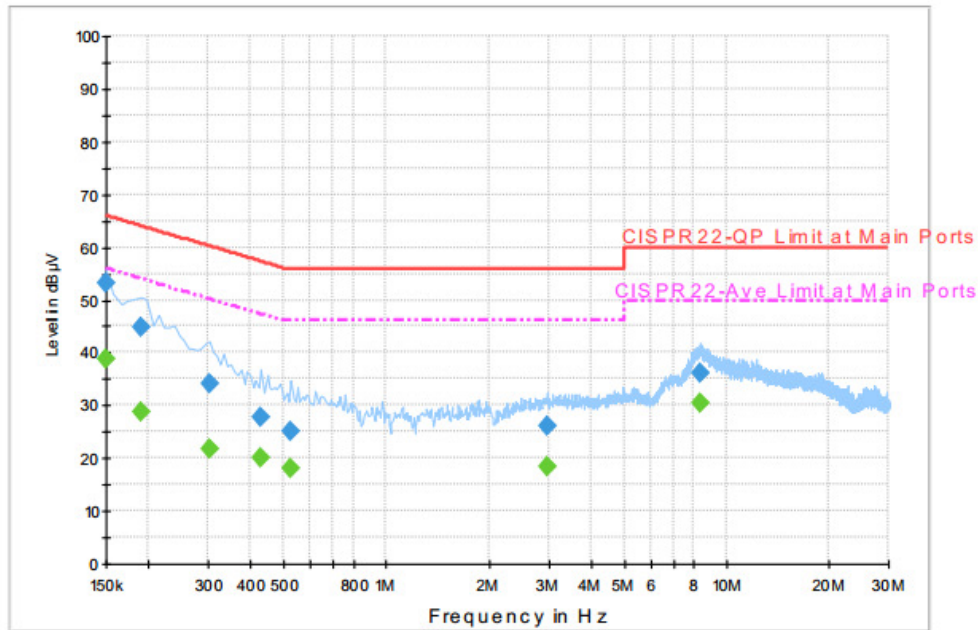

Final Result : Quasi-Peak

Frequency (MHz)	Quasi-Peak (dBµV)	Filter	Line	Corr. (dB)	Margin (dB)	Limit (dBµV)
0.150000	53.2	Off	N	19.6	12.8	66.0
0.190000	44.8	Off	N	19.6	19.2	64.0
0.302000	34.1	Off	N	19.6	26.1	60.2
0.430000	27.7	Off	N	19.6	29.6	57.3
0.526000	24.9	Off	N	19.6	31.1	56.0
2.974000	26.3	Off	N	19.6	29.7	56.0
8.374000	36.1	Off	N	20.0	23.9	60.0

Final Result : Average

Frequency (MHz)	Average (dBµV)	Filter	Line	Corr. (dB)	Margin (dB)	Limit (dBµV)
0.150000	38.7	Off	N	19.6	17.3	56.0
0.190000	28.9	Off	N	19.6	25.1	54.0
0.302000	21.8	Off	N	19.6	28.4	50.2
0.430000	20.1	Off	N	19.6	27.2	47.3
0.526000	18.0	Off	N	19.6	28.0	46.0
2.974000	18.4	Off	N	19.6	27.6	46.0
8.374000	30.5	Off	N	20.0	19.5	50.0

3.6 Frequency Stability Measurement

3.6.1 Limit of Frequency Stability

Manufacturers of U-NII devices are responsible for ensuring frequency stability such that an emission is maintained within the band of operation under all conditions of normal operation as specified in the user's manual.

3.6.2 Measuring Instruments

The measuring equipment is listed in the section 4 of this test report.

3.6.3 Test Procedures

1. To ensure emission at the band edge is maintained within the authorized band, those values shall be measured by radiation emissions at upper and lower frequency points, and finally compensated by frequency deviation as procedures below.
2. The EUT was operated at the maximum output power, and connected to the spectrum analyzer, which is set to maximum hold function and peak detector. The peak value of the power envelope was measured and noted. The upper and lower frequency points were respectively measured relatively 10dB lower than the measured peak value.
3. The frequency deviation was calculated by adding the upper frequency point and the lower frequency point divided by two. Those detailed values of frequency deviation are provided in table below.

3.6.4 Test Setup

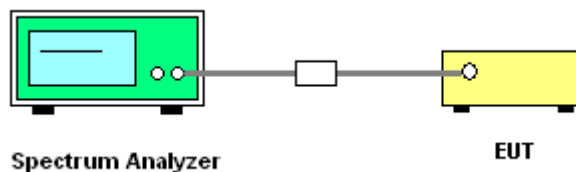

3.6.5 Test Result of Frequency Stability

Please refer to Appendix A.



3.7 Automatically Discontinue Transmission

3.7.1 Limit of Automatically Discontinue Transmission

The device shall automatically discontinue transmission in case of either absence of information to transmit or operational failure. These provisions are not intended to preclude the transmission of control or signaling information or the use of repetitive codes used by certain digital technologies to complete frame or burst intervals. Applicants shall include in their application for equipment authorization to describe how this requirement is met.

3.7.2 Measuring Instruments

The measuring equipment is listed in the section 4 of this test report.

3.7.3 Test Result of Automatically Discontinue Transmission

While the EUT is not transmitting any information, the EUT can automatically discontinue transmission and become standby mode for power saving. The EUT can detect the controlling signal of ACK message transmitting from remote device and verify whether it shall resend or discontinue transmission.



3.8 Antenna Requirements

3.8.1 Standard Applicable

According to FCC 47 CFR Section 15.407(a)(1)(2) ,if transmitting antenna directional gain is greater than 6 dBi, both the peak transmit power and the peak power spectral density shall be reduced by the amount in dB that the directional gain of the antenna exceeds 6 dBi.

3.8.2 Antenna Anti-Replacement Construction

An embedded-in antenna design is used.

3.8.3 Antenna Gain

The antenna gain is less than 6 dBi. Therefore, it is not necessary to reduce maximum peak output power limit.



4 List of Measuring Equipments

Instrument	Manufacturer	Model No.	Serial No.	Characteristics	Calibration Date	Test Date	Due Date	Remark
Power Meter	Anritsu	ML2495A	0932001	300MHz~40GHz	Sep. 29, 2016	Nov. 03, 2016 ~ Nov. 07, 2016	Sep. 28, 2017	Conducted (TH05-HY)
Power Sensor	Anritsu	MA2411B	0846202	300MHz~40GHz	Sep. 29, 2016	Nov. 03, 2016 ~ Nov. 07, 2016	Sep. 28, 2017	Conducted (TH05-HY)
Spectrum Analyzer	Rohde & Schwarz	FSP40	100055	9kHz-40GHz	Jul. 17, 2016	Nov. 03, 2016 ~ Nov. 07, 2016	Jul. 16, 2017	Conducted (TH05-HY)
Temperature Chamber	ESPEC	SH-641	92013720	-40°C ~90°C	Sep. 01, 2016	Nov. 03, 2016 ~ Nov. 07, 2016	Aug. 31, 2017	Conducted (TH05-HY)
Programmable Power Supply	GW Instek	PSS-2005	EL890094	1V~20V 0.5A~5A	Oct. 11, 2016	Nov. 03, 2016 ~ Nov. 07, 2016	Oct. 10, 2017	Conducted (TH05-HY)
AC Power Source	ChainTek	APC-1000W	N/A	N/A	N/A	Oct. 18, 2016	N/A	Conduction (CO05-HY)
EMI Test Receiver	Rohde & Schwarz	ESCI 7	100724	9kHz~7GHz	Aug. 30, 2016	Oct. 18, 2016	Aug. 29, 2017	Conduction (CO05-HY)
LISN	Rohde & Schwarz	ENV216	100080	9kHz~30MHz	Dec. 02, 2015	Oct. 18, 2016	Dec. 01, 2016	Conduction (CO05-HY)
Bilog Antenna	TESEQ	CBL 6111D&00800 N1D01N-06	35419&03	30MHz to 1GHz	Jan. 13, 2016	Oct. 30, 2016 ~ Nov. 05, 2016	Jan. 12, 2017	Radiation (03CH07-HY)
Double Ridge Horn Antenna	ESCO	3117	00075962	1GHz ~ 18GHz	Aug. 19, 2016	Oct. 30, 2016 ~ Nov. 05, 2016	Aug. 18, 2017	Radiation (03CH07-HY)
EMI Test Receiver	Keysight	N9038A (MXE)	MY54130085	20Hz ~ 8.4GHz	Oct. 26, 2016	Oct. 30, 2016 ~ Nov. 05, 2016	Oct. 25, 2017	Radiation (03CH07-HY)
Loop Antenna	Rohde & Schwarz	HFH2-Z2	100315	9 kHz~30 MHz	Sep. 02, 2015	Oct. 30, 2016 ~ Nov. 05, 2016	Sep. 01, 2017	Radiation (03CH07-HY)
Preamplifier	MITEQ	AMF-7D-0010 1800-30-10P	1590075	1GHz ~ 18GHz	Apr. 15, 2016	Oct. 30, 2016 ~ Nov. 05, 2016	Apr. 14, 2017	Radiation (03CH07-HY)
Preamplifier	COM-POWER	PA-103A	161241	10MHz-1GHz	Mar. 18, 2016	Oct. 30, 2016 ~ Nov. 05, 2016	Mar. 17, 2017	Radiation (03CH07-HY)
Preamplifier	Agilent	8449B	3008A02362	1GHz~ 26.5GHz	Oct. 12, 2016	Oct. 30, 2016 ~ Nov. 05, 2016	Oct. 11, 2017	Radiation (03CH07-HY)
Spectrum Analyzer	Agilent	N9010A	MY53470118	10Hz~44GHz	Feb. 27, 2016	Oct. 30, 2016 ~ Nov. 05, 2016	Feb. 26, 2017	Radiation (03CH07-HY)
Antenna Mast	Max-Full	MFA520BS	N/A	1m~4m	N/A	Oct. 30, 2016 ~ Nov. 05, 2016	N/A	Radiation (03CH07-HY)
Turn Table	ChainTek	Chaintek 3000	N/A	0~360 Degree	N/A	Oct. 30, 2016 ~ Nov. 05, 2016	N/A	Radiation (03CH07-HY)
Preamplifier	MITEQ	JS44-1800400 0-33-8P	1840917	18GHz ~ 40GHz	Jun. 14, 2016	Oct. 30, 2016 ~ Nov. 05, 2016	Jun. 13, 2017	Radiation (03CH07-HY)
SHF-EHF Horn Antenna	SCHWARZBECK	BBHA 9170	BBHA917025 1	18GHz- 40GHz	Oct. 07, 2016	Oct. 30, 2016 ~ Nov. 05, 2016	Oct. 06, 2017	Radiation (03CH07-HY)



5 Uncertainty of Evaluation

Uncertainty of Conducted Emission Measurement (150kHz ~ 30MHz)

Measuring Uncertainty for a Level of Confidence of 95% ($U = 2Uc(y)$)	2.7
---	-----

Uncertainty of Radiated Emission Measurement (30 MHz ~ 1000 MHz)

Measuring Uncertainty for a Level of Confidence of 95% ($U = 2Uc(y)$)	5.7
---	-----

Uncertainty of Radiated Emission Measurement (1000 MHz ~ 18000 MHz)

Measuring Uncertainty for a Level of Confidence of 95% ($U = 2Uc(y)$)	5.5
---	-----

Uncertainty of Radiated Emission Measurement (18000 MHz ~ 40000 MHz)

Measuring Uncertainty for a Level of Confidence of 95% ($U = 2Uc(y)$)	5.2
---	-----



Appendix A. Conducted Test Results

<EUT with J300 Antenna>

Test Engineer:	Luffy Lin and Tommy Lee	Temperature:	21~25	°C
Test Date:	2016/11/3~2016/11/7	Relative Humidity:	51~54	%

TEST RESULTS DATA
26dB and 99% OBW

Band I										
Mod.	Data Rate	NTX	CH.	Freq. (MHz)	99% Bandwidth (MHz)	26 dB Bandwidth (MHz)	IC 99% Bandwidth Power Limit (dBm)	IC 99% Bandwidth EIRP Limit (dBm)		
11a	6Mbps	1	36	5180	17.80	32.70	-	22.50		
11a	6Mbps	1	44	5220	17.70	38.10	-	22.48		
11a	6Mbps	1	48	5240	18.05	37.00	-	22.56		
HT20	MCS0	1	36	5180	18.40	34.50	-	22.65		
HT20	MCS0	1	44	5220	18.65	40.00	-	22.71		
HT20	MCS0	1	48	5240	18.65	36.30	-	22.71		

TEST RESULTS DATA
Average Power Table

FCC Band I										
Mod.	Data Rate	NTX	CH.	Freq. (MHz)	Duty Factor (dB)	Average Conducted Power (dBm)	FCC Conducted Power Limit (dBm)	DG (dBi)		Pass/Fail
11a	6Mbps	1	36	5180	0.15	15.90	24.00	4.30		Pass
11a	6Mbps	1	44	5220	0.15	16.95	24.00	4.30		Pass
11a	6Mbps	1	48	5240	0.15	16.98	24.00	4.30		Pass
HT20	MCS0	1	36	5180	0.13	15.77	24.00	4.30		Pass
HT20	MCS0	1	44	5220	0.13	16.89	24.00	4.30		Pass
HT20	MCS0	1	48	5240	0.13	16.79	24.00	4.30		Pass

IC Band I										
Mod.	Data Rate	NTX	CH.	Freq. (MHz)	Duty Factor (dB)	Average Conducted Power (dBm)	IC Conducted Power Limit (dBm)	DG (dBi)	IC EIRP Power Limit (dBm)	Pass/Fail
11a	6Mbps	1	36	5180	0.15	15.90	18.20	4.30	22.50	Pass
11a	6Mbps	1	44	5220	0.15	16.95	18.18	4.30	22.48	Pass
11a	6Mbps	1	48	5240	0.15	16.98	18.26	4.30	22.56	Pass
HT20	MCS0	1	36	5180	0.13	15.77	18.35	4.30	22.65	Pass
HT20	MCS0	1	44	5220	0.13	16.89	18.41	4.30	22.71	Pass
HT20	MCS0	1	48	5240	0.13	16.79	18.41	4.30	22.71	Pass

TEST RESULTS DATA
Power Spectral Density

FCC Band I										
Mod.	Data Rate	NTX	CH.	Freq. (MHz)	Duty Factor (dB)	Average Power Density (dBm/MHz)	Average PSD Limit (dBm/MHz)	DG (dBi)	-	Pass/Fail
11a	6Mbps	1	36	5180	0.15	4.99	11.00	4.30		Pass
11a	6Mbps	1	44	5220	0.15	6.50	11.00	4.30		Pass
11a	6Mbps	1	48	5240	0.15	6.41	11.00	4.30		Pass
HT20	MCS0	1	36	5180	0.13	5.09	11.00	4.30		Pass
HT20	MCS0	1	44	5220	0.13	6.28	11.00	4.30		Pass
HT20	MCS0	1	48	5240	0.13	6.12	11.00	4.30		Pass

TEST RESULTS DATA
26dB and 99% OBW

Band II										
Mod.	Data Rate	NTX	CH.	Freq. (MHz)	99% Bandwidth (MHz)	26 dB Bandwidth (MHz)	IC 99% Bandwidth Power Limit (dBm)	IC 99% Bandwidth EIRP Limit (dBm)	FCC 26dB Bandwidth Power Limit (dBm)	Note
11a	6M bps	1	52	5260	17.75	36.10	23.49	29.49	23.98	
11a	6M bps	1	60	5300	17.70	36.20	23.48	29.48	23.98	
11a	6M bps	1	64	5320	17.60	32.70	23.46	29.46	23.98	
HT20	MCS 0	1	52	5260	18.50	38.20	23.67	29.67	23.98	
HT20	MCS 0	1	60	5300	18.35	35.60	23.64	29.64	23.98	
HT20	MCS 0	1	64	5320	18.20	34.20	23.60	29.60	23.98	

TEST RESULTS DATA
Average Power Table

FCC Band II										
Mod.	Data Rate	NTX	CH.	Freq. (MHz)	Duty Factor (dB)	Average Conducted Power (dBm)	FCC Conducted Power Limit (dBm)	DG (dBi)	EIRP Power Limit (dBm)	Pass/Fail
11a	6M bps	1	52	5260	0.15	16.93	23.98	4.30	26.99	Pass
11a	6M bps	1	60	5300	0.15	16.22	23.98	4.30	26.99	Pass
11a	6M bps	1	64	5320	0.15	15.21	23.98	4.30	26.99	Pass
HT20	MCS 0	1	52	5260	0.13	16.75	23.98	4.30	26.99	Pass
HT20	MCS 0	1	60	5300	0.13	16.23	23.98	4.30	26.99	Pass
HT20	MCS 0	1	64	5320	0.13	15.14	23.98	4.30	26.99	Pass

IC Band II										
Mod.	Data Rate	NTX	CH.	Freq. (MHz)	Duty Factor (dB)	Average Conducted Power (dBm)	IC Conducted Power Limit (dBm)	DG (dBi)	IC EIRP Power Limit (dBm)	Pass/Fail
11a	6M bps	1	52	5260	0.15	16.93	22.69	4.30	26.99	Pass
11a	6M bps	1	60	5300	0.15	16.22	22.69	4.30	26.99	Pass
11a	6M bps	1	64	5320	0.15	15.21	22.69	4.30	26.99	Pass
HT20	MCS 0	1	52	5260	0.13	16.75	22.69	4.30	26.99	Pass
HT20	MCS 0	1	60	5300	0.13	16.23	22.69	4.30	26.99	Pass
HT20	MCS 0	1	64	5320	0.13	15.14	22.69	4.30	26.99	Pass

TEST RESULTS DATA
Power Spectral Density

Band II										
Mod.	Data Rate	NTX	CH.	Freq. (MHz)	Duty Factor (dB)	Average Power Density (dBm/MHz)	Average PSD Limit (dBm/MHz)	DG (dBi)		Pass/Fail
11a	6M bps	1	52	5260	0.15	6.38	11.00	4.30		Pass
11a	6M bps	1	60	5300	0.15	5.39	11.00	4.30		Pass
11a	6M bps	1	64	5320	0.15	4.22	11.00	4.30		Pass
HT20	MCS 0	1	52	5260	0.13	5.96	11.00	4.30		Pass
HT20	MCS 0	1	60	5300	0.13	5.12	11.00	4.30		Pass
HT20	MCS 0	1	64	5320	0.13	3.99	11.00	4.30		Pass

TEST RESULTS DATA
26dB and 99% OBW

Band III										
Mod.	Data Rate	NTX	CH.	Freq. (MHz)	99% Bandwidth (MHz)	26 dB Bandwidth (MHz)	IC 99% Bandwidth Power Limit (dBm)	IC 99% Bandwidth EIRP Limit (dBm)	FCC 26dB Bandwidth Power Limit (dBm)	Note
11a	6M bps	1	100	5500	17.55	38.50	23.44	29.44	23.98	
11a	6M bps	1	116	5580	18.05	39.90	23.56	29.56	23.98	
11a	6M bps	1	140	5700	17.40	34.80	23.41	29.41	23.98	
HT20	MCS 0	1	100	5500	18.40	38.30	23.65	29.65	23.98	
HT20	MCS 0	1	116	5580	19.20	39.80	23.83	29.83	23.98	
HT20	MCS 0	1	140	5700	18.30	35.60	23.62	29.62	23.98	

TEST RESULTS DATA
Average Power Table

FCC Band III										
Mod.	Data Rate	NTX	CH.	Freq. (MHz)	Duty Factor (dB)	Average Conducted Power (dBm)	FCC Conducted Power Limit (dBm)	DG (dBi)	EIRP Power Limit (dBm)	Pass/Fail
11a	6M bps	1	100	5500	0.15	16.17	23.98	4.30	26.99	Pass
11a	6M bps	1	116	5580	0.15	16.45	23.98	4.30	26.99	Pass
11a	6M bps	1	140	5700	0.15	14.65	23.98	4.30	26.99	Pass
HT20	MCS 0	1	100	5500	0.13	15.88	23.98	4.30	26.99	Pass
HT20	MCS 0	1	116	5580	0.13	16.30	23.98	4.30	26.99	Pass
HT20	MCS 0	1	140	5700	0.13	14.55	23.98	4.30	26.99	Pass

IC Band III										
Mod.	Data Rate	NTX	CH.	Freq. (MHz)	Duty Factor (dB)	Average Conducted Power (dBm)	IC Conducted Power Limit (dBm)	DG (dBi)	IC EIRP Power Limit (dBm)	Pass/Fail
11a	6Mbps	1	100	5500	0.15	16.17	22.69	4.30	26.99	Pass
11a	6Mbps	1	116	5580	0.15	16.45	22.69	4.30	26.99	Pass
11a	6Mbps	1	140	5700	0.15	14.65	22.69	4.30	26.99	Pass
HT20	MCS0	1	100	5500	0.13	15.88	22.69	4.30	26.99	Pass
HT20	MCS0	1	116	5580	0.13	16.30	22.69	4.30	26.99	Pass
HT20	MCS0	1	140	5700	0.13	14.55	22.69	4.30	26.99	Pass

TEST RESULTS DATA
Power Spectral Density

Band III										
Mod.	Data Rate	NTX	CH.	Freq. (MHz)	Duty Factor (dB)	Average Power Density (dBm/MHz)	Average PSD Limit (dBm/MHz)	DG (dBi)		Pass/Fail
11a	6M bps	1	100	5500	0.15	6.41	11.00	4.30		Pass
11a	6M bps	1	116	5580	0.15	7.06	11.00	4.30		Pass
11a	6M bps	1	140	5700	0.15	4.48	11.00	4.30		Pass
HT20	MCS 0	1	100	5500	0.13	6.17	11.00	4.30		Pass
HT20	MCS 0	1	116	5580	0.13	6.76	11.00	4.30		Pass
HT20	MCS 0	1	140	5700	0.13	4.17	11.00	4.30		Pass

TEST RESULTS DATA
Frequency Stability

Band I										
Mod.	Data Rate	NTX	CH.	Freq. (MHz)	Center Frequency (MHz)	Frequency Deviation (MHz)	Frequency Stability (ppm)	Temperature (°C)	Voltage (V)	Note
11a	6Mbps	1	36	5180	5179.950	-0.050	-9.65	50	3.7	
11a	6Mbps	1	36	5180	5180.050	0.050	9.65	-30	3.7	
11a	6Mbps	1	36	5180	5179.950	-0.050	-9.65	20	4.2	
11a	6Mbps	1	36	5180	5179.950	-0.050	-9.65	20	3.1	
11a	6Mbps	1	36	5180	5179.950	-0.050	-9.65	20	3.7	

Band II										
Mod.	Data Rate	NTX	CH.	Freq. (MHz)	Center Frequency (MHz)	Frequency Deviation (MHz)	Frequency Stability (ppm)	Temperature (°C)	Voltage (V)	Note
11a	6Mbps	1	64	5320	5319.950	-0.050	-9.40	50	3.7	
11a	6Mbps	1	64	5320	5319.950	-0.050	-9.40	-30	3.7	
11a	6Mbps	1	64	5320	5320.000	0.000	0.00	20	4.2	
11a	6Mbps	1	64	5320	5319.950	-0.050	-9.40	20	3.1	
11a	6Mbps	1	64	5320	5320.000	0.000	0.00	20	3.7	

Band III										
Mod.	Data Rate	NTX	CH.	Freq. (MHz)	Center Frequency (MHz)	Frequency Deviation (MHz)	Frequency Stability (ppm)	Temperature (°C)	Voltage (V)	Note
11a	6Mbps	1	100	5500	5499.950	-0.050	-9.09	50	3.7	
11a	6Mbps	1	100	5500	5500.050	0.050	9.09	-30	3.7	
11a	6Mbps	1	100	5500	5499.950	-0.050	-9.09	20	4.2	
11a	6Mbps	1	100	5500	5499.950	-0.050	-9.09	20	3.1	
11a	6Mbps	1	100	5500	5499.950	-0.050	-9.09	20	3.7	



<EUT with J301 Antenna>

Test Engineer:	Luffy Lin and Tommy Lee	Temperature:	21~25	°C
Test Date:	2016/11/4	Relative Humidity:	51~54	%

TEST RESULTS DATA
Average Power Table

FCC Band I										
Mod.	Data Rate	NTX	CH.	Freq. (MHz)	Duty Factor (dB)	Average Conducted Power (dBm)	FCC Conducted Power Limit (dBm)	DG (dBi)		Pass/Fail
11a	6Mbps	1	36	5180	0.12	15.88	24.00	4.30		Pass
11a	6Mbps	1	44	5220	0.12	16.92	24.00	4.30		Pass
11a	6Mbps	1	48	5240	0.12	16.94	24.00	4.30		Pass
HT20	MCS0	1	36	5180	0.16	15.76	24.00	4.30		Pass
HT20	MCS0	1	44	5220	0.16	16.88	24.00	4.30		Pass
HT20	MCS0	1	48	5240	0.16	16.78	24.00	4.30		Pass

IC Band I										
Mod.	Data Rate	NTX	CH.	Freq. (MHz)	Duty Factor (dB)	Average Conducted Power (dBm)	IC Conducted Power Limit (dBm)	DG (dBi)	IC EIRP Power Limit (dBm)	Pass/Fail
11a	6Mbps	1	36	5180	0.12	15.88	18.71	4.30	23.01	Pass
11a	6Mbps	1	44	5220	0.12	16.92	18.71	4.30	23.01	Pass
11a	6Mbps	1	48	5240	0.12	16.94	18.71	4.30	23.01	Pass
HT20	MCS0	1	36	5180	0.16	15.76	18.71	4.30	23.01	Pass
HT20	MCS0	1	44	5220	0.16	16.88	18.71	4.30	23.01	Pass
HT20	MCS0	1	48	5240	0.16	16.78	18.71	4.30	23.01	Pass

TEST RESULTS DATA
Average Power Table

FCC Band II										
Mod.	Data Rate	NTX	CH.	Freq. (MHz)	Duty Factor (dB)	Average Conducted Power (dBm)	FCC Conducted Power Limit (dBm)	DG (dBi)	EIRP Power Limit (dBm)	Pass/Fail
11a	6M bps	1	52	5260	0.12	16.91	23.98	4.30	26.99	Pass
11a	6M bps	1	60	5300	0.12	16.19	23.98	4.30	26.99	Pass
11a	6M bps	1	64	5320	0.12	15.15	23.98	4.30	26.99	Pass
HT20	MCS 0	1	52	5260	0.16	16.74	23.98	4.30	26.99	Pass
HT20	MCS 0	1	60	5300	0.16	16.19	23.98	4.30	26.99	Pass
HT20	MCS 0	1	64	5320	0.16	15.10	23.98	4.30	26.99	Pass

IC Band II										
Mod.	Data Rate	NTX	CH.	Freq. (MHz)	Duty Factor (dB)	Average Conducted Power (dBm)	IC Conducted Power Limit (dBm)	DG (dBi)	IC EIRP Power Limit (dBm)	Pass/Fail
11a	6M bps	1	52	5260	0.12	16.91	22.69	4.30	26.99	Pass
11a	6M bps	1	60	5300	0.12	16.19	22.69	4.30	26.99	Pass
11a	6M bps	1	64	5320	0.12	15.15	22.69	4.30	26.99	Pass
HT20	MCS 0	1	52	5260	0.16	16.74	22.69	4.30	26.99	Pass
HT20	MCS 0	1	60	5300	0.16	16.19	22.69	4.30	26.99	Pass
HT20	MCS 0	1	64	5320	0.16	15.10	22.69	4.30	26.99	Pass

TEST RESULTS DATA
Average Power Table

FCC Band III										
Mod.	Data Rate	NTX	CH.	Freq. (MHz)	Duty Factor (dB)	Average Conducted Power (dBm)	FCC Conducted Power Limit (dBm)	DG (dBi)	EIRP Power Limit (dBm)	Pass/Fail
11a	6M bps	1	100	5500	0.12	15.97	23.98	4.30	26.99	Pass
11a	6M bps	1	116	5580	0.12	16.38	23.98	4.30	26.99	Pass
11a	6M bps	1	140	5700	0.12	14.63	23.98	4.30	26.99	Pass
HT20	MCS 0	1	100	5500	0.16	15.86	23.98	4.30	26.99	Pass
HT20	MCS 0	1	116	5580	0.16	16.26	23.98	4.30	26.99	Pass
HT20	MCS 0	1	140	5700	0.16	14.54	23.98	4.30	26.99	Pass

IC Band III										
Mod.	Data Rate	NTX	CH.	Freq. (MHz)	Duty Factor (dB)	Average Conducted Power (dBm)	IC Conducted Power Limit (dBm)	DG (dBi)	IC EIRP Power Limit (dBm)	Pass/Fail
11a	6Mbps	1	100	5500	0.12	15.97	22.69	4.30	26.99	Pass
11a	6Mbps	1	116	5580	0.12	16.38	22.69	4.30	26.99	Pass
11a	6Mbps	1	140	5700	0.12	14.63	22.69	4.30	26.99	Pass
HT20	MCS0	1	100	5500	0.16	15.86	22.69	4.30	26.99	Pass
HT20	MCS0	1	116	5580	0.16	16.26	22.69	4.30	26.99	Pass
HT20	MCS0	1	140	5700	0.16	14.54	22.69	4.30	26.99	Pass



Appendix B. Radiated Spurious Emission

Test Engineer :	Jesse Wang and Ken Wu	Temperature :	21~24°C
		Relative Humidity :	50~54%

Band 1 - 5150~5250MHz

WIFI 802.11a (Band Edge @ 3m)

WIFI Ant. 2	Note	Frequency (MHz)	Level (dBμV/m)	Over Limit (dB)	Limit Line (dBμV/m)	Read Level (dBμV)	Antenna Factor (dB/m)	Cable Loss (dB)	Preamp Factor (dB)	Ant Pos (cm)	Table Pos (deg)	Peak Avg. (P/A)	Pol. (H/V)	
802.11a CH 36 5180MHz		5148.2	59.74	-14.26	74	50.06	33.69	11.21	35.22	331	190	P	H	
		5150	52.19	-1.81	54	42.51	33.69	11.21	35.22	331	190	A	H	
	*	5180	104.85	-	-	95.08	33.78	11.21	35.22	331	190	P	H	
	*	5180	96.75	-	-	86.98	33.78	11.21	35.22	331	190	A	H	
													H	
														H
			5147.16	62.53	-11.47	74	52.85	33.69	11.21	35.22	276	348	P	V
			5150	52.94	-1.06	54	43.26	33.69	11.21	35.22	276	348	A	V
	*		5180	105.87	-	-	96.1	33.78	11.21	35.22	276	348	P	V
	*		5180	97.6	-	-	87.83	33.78	11.21	35.22	276	348	A	V
														V
														V
802.11a CH 44 5220MHz		5150	51.19	-22.81	74	41.51	33.69	11.21	35.22	376	325	P	H	
		5149.76	42.1	-11.9	54	32.42	33.69	11.21	35.22	376	325	A	H	
	*	5220	108.07	-	-	98.18	33.86	11.25	35.22	376	325	P	H	
	*	5220	100.25	-	-	90.36	33.86	11.25	35.22	376	325	A	H	
			5433.36	48.32	-25.68	74	37.24	34.43	11.89	35.24	376	325	P	H
			5367.12	40.61	-13.39	54	29.83	34.25	11.76	35.23	376	325	A	H
			5150	53.06	-20.94	74	43.38	33.69	11.21	35.22	245	344	P	V
			5150	43.88	-10.12	54	34.2	33.69	11.21	35.22	245	344	A	V
	*		5220	107.31	-	-	97.42	33.86	11.25	35.22	245	344	P	V
	*		5220	99.05	-	-	89.16	33.86	11.25	35.22	245	344	A	V
			5369.04	48.7	-25.3	74	37.92	34.25	11.76	35.23	245	344	P	V
			5456.4	40.41	-13.59	54	29.29	34.47	11.89	35.24	245	344	A	V



802.11a CH 48 5240MHz		5123.5	49.65	-24.35	74	40.04	33.65	11.18	35.22	373	323	P	H
		5129.22	40.66	-13.34	54	31.05	33.65	11.18	35.22	373	323	A	H
	*	5240	108.32	-	-	98.25	33.91	11.38	35.22	373	323	P	H
	*	5240	100.48	-	-	90.41	33.91	11.38	35.22	373	323	A	H
		5355.36	49.48	-24.52	74	38.74	34.21	11.76	35.23	373	323	P	H
		5351.28	40.86	-13.14	54	30.12	34.21	11.76	35.23	373	323	A	H
		5065.26	49.96	-24.04	74	40.56	33.47	11.14	35.21	229	345	P	V
		5147.68	40.94	-13.06	54	31.26	33.69	11.21	35.22	229	345	A	V
	*	5240	107.65	-	-	97.58	33.91	11.38	35.22	229	345	P	V
	*	5240	99.35	-	-	89.28	33.91	11.38	35.22	229	345	A	V
		5443.44	49.37	-24.63	74	38.29	34.43	11.89	35.24	229	345	P	V
		5353.68	40.38	-13.62	54	29.64	34.21	11.76	35.23	229	345	A	V
Remark	1. No other spurious found. 2. All results are PASS against Peak and Average limit line.												



Band 1 5150~5250MHz

WIFI 802.11a (Harmonic @ 3m)

WIFI Ant. 2	Note	Frequency (MHz)	Level (dBμV/m)	Over Limit (dB)	Limit Line (dBμV/m)	Read Level (dBμV)	Antenna Factor (dB/m)	Cable Loss (dB)	Preamp Factor (dB)	Ant Pos (cm)	Table Pos (deg)	Peak Avg. (P/A)	Pol. (H/V)
802.11a CH 36 5180MHz		10360	50.59	-17.61	68.2	53.54	39.09	17.17	59.21	100	0	P	H
		15540	48.45	-25.55	74	44.95	41.07	19.61	57.18	100	0	P	H
													H
													H
		10360	58.31	-9.89	68.2	61.26	39.09	17.17	59.21	100	0	P	V
		15540	43.6	-30.4	74	40.1	41.07	19.61	57.18	100	0	P	V
													V
													V
802.11a CH 44 5220MHz		10440	51.72	-16.48	68.2	54.55	39.15	17.17	59.15	100	0	P	H
		15660	51.63	-22.37	74	47.75	41.31	19.68	57.11	100	0	P	H
													H
													H
		10440	62.47	-5.73	68.2	65.3	39.15	17.17	59.15	100	0	P	V
		15660	47.18	-26.82	74	43.3	41.31	19.68	57.11	100	0	P	V
													V
													V
802.11a CH 48 5240MHz		10480	51.36	-16.84	68.2	54.11	39.19	17.17	59.11	100	0	P	H
		15720	50.71	-23.29	74	46.6	41.45	19.73	57.07	100	0	P	H
													H
													H
		10480	59.54	-8.66	68.2	62.29	39.19	17.17	59.11	100	0	P	V
		15720	45.4	-28.6	74	41.29	41.45	19.73	57.07	100	0	P	V
													V
													V
Remark	1. No other spurious found. 2. All results are PASS against Peak and Average limit line.												



Band 1 5150~5250MHz
WIFI 802.11n HT20 (Band Edge @ 3m)

WIFI Ant. 2	Note	Frequency (MHz)	Level (dBμV/m)	Over Limit (dB)	Limit Line (dBμV/m)	Read Level (dBμV)	Antenna Factor (dB/m)	Cable Loss (dB)	Preamp Factor (dB)	Ant Pos (cm)	Table Pos (deg)	Peak Avg. (P/A)	Pol. (H/V)	
802.11n HT20 CH 36 5180MHz		5149.5	59.24	-14.76	74	49.56	33.69	11.21	35.22	331	190	P	H	
		5150	52.44	-1.56	54	42.76	33.69	11.21	35.22	331	190	A	H	
	*	5180	104.37	-	-	94.6	33.78	11.21	35.22	331	190	P	H	
	*	5180	96.44	-	-	86.67	33.78	11.21	35.22	331	190	A	H	
													H	
														H
			5150	59.94	-14.06	74	50.26	33.69	11.21	35.22	276	348	P	V
			5150	52.56	-1.44	54	42.88	33.69	11.21	35.22	276	348	A	V
		*	5180	105.15	-	-	95.38	33.78	11.21	35.22	276	348	P	V
		*	5180	97.36	-	-	87.59	33.78	11.21	35.22	276	348	A	V
													V	
													V	
802.11n HT20 CH 44 5220MHz		5149.24	49.67	-24.33	74	39.99	33.69	11.21	35.22	376	325	P	H	
		5150	42.04	-11.96	54	32.36	33.69	11.21	35.22	376	325	A	H	
		*	5220	107.7	-	-	97.81	33.86	11.25	35.22	376	325	P	H
		*	5220	99.98	-	-	90.09	33.86	11.25	35.22	376	325	A	H
			5377.2	48.67	-25.33	74	37.89	34.25	11.76	35.23	376	325	P	H
			5364.72	40.56	-13.44	54	29.78	34.25	11.76	35.23	376	325	A	H
			5145.34	51.85	-22.15	74	42.17	33.69	11.21	35.22	245	344	P	V
			5149.76	44.02	-9.98	54	34.34	33.69	11.21	35.22	245	344	A	V
		*	5220	106.48	-	-	96.59	33.86	11.25	35.22	245	344	P	V
		*	5220	98.76	-	-	88.87	33.86	11.25	35.22	245	344	A	V
		5361.36	48.8	-25.2	74	38.02	34.25	11.76	35.23	245	344	P	V	
		5365.2	40.32	-13.68	54	29.54	34.25	11.76	35.23	245	344	A	V	



802.11n HT20 CH 48 5240MHz		5068.12	49.73	-24.27	74	40.33	33.47	11.14	35.21	373	323	P	H
		5135.72	40.72	-13.28	54	31.11	33.65	11.18	35.22	373	323	A	H
	*	5240	108.22	-	-	98.15	33.91	11.38	35.22	373	323	P	H
	*	5240	100.28	-	-	90.21	33.91	11.38	35.22	373	323	A	H
		5402.64	49.18	-24.82	74	38.18	34.34	11.89	35.23	373	323	P	H
		5351.76	41.14	-12.86	54	30.4	34.21	11.76	35.23	373	323	A	H
		5149.76	50.02	-23.98	74	40.34	33.69	11.21	35.22	229	345	P	V
		5148.98	40.98	-13.02	54	31.3	33.69	11.21	35.22	229	345	A	V
	*	5240	107.69	-	-	97.62	33.91	11.38	35.22	229	345	P	V
	*	5240	99.31	-	-	89.24	33.91	11.38	35.22	229	345	A	V
		5405.76	49.83	-24.17	74	38.83	34.34	11.89	35.23	229	345	P	V
		5351.28	40.5	-13.5	54	29.76	34.21	11.76	35.23	229	345	A	V
Remark	1. No other spurious found. 2. All results are PASS against Peak and Average limit line.												



Band 1 5150~5250MHz

WIFI 802.11n HT20 (Harmonic @ 3m)

WIFI Ant. 2	Note	Frequency (MHz)	Level (dBμV/m)	Over Limit (dB)	Limit Line (dBμV/m)	Read Level (dBμV)	Antenna Factor (dB/m)	Cable Loss (dB)	Preamp Factor (dB)	Ant Pos (cm)	Table Pos (deg)	Peak Avg. (P/A)	Pol. (H/V)	
802.11n HT20 CH 36 5180MHz		10360	48.31	-19.89	68.2	51.26	39.09	17.17	59.21	100	0	P	H	
		15540	49.06	-24.94	74	45.56	41.07	19.61	57.18	100	0	P	H	
													H	
													H	
			10360	59.2	-9	68.2	62.15	39.09	17.17	59.21	100	0	P	V
			15540	43.56	-30.44	74	40.06	41.07	19.61	57.18	100	0	P	V
														V
802.11n HT20 CH 44 5220MHz		10440	50.23	-17.97	68.2	53.06	39.15	17.17	59.15	100	0	P	H	
		15660	53.24	-20.76	74	49.36	41.31	19.68	57.11	100	314	P	H	
		15660	44.1	-9.9	54	40.22	41.31	19.68	57.11	100	314	A	H	
													H	
			10440	59.62	-8.58	68.2	62.45	39.15	17.17	59.15	100	0	P	V
			15600	44	-30	74	40.27	41.21	19.66	57.14	100	0	P	V
														V
802.11n HT20 CH 48 5240MHz		10480	50.05	-18.15	68.2	52.8	39.19	17.17	59.11	100	0	P	H	
		15720	50.21	-23.79	74	46.1	41.45	19.73	57.07	100	0	P	H	
													H	
													H	
			10480	58.71	-9.49	68.2	61.46	39.19	17.17	59.11	100	0	P	V
			15720	44.82	-29.18	74	40.71	41.45	19.73	57.07	100	0	P	V
														V
Remark	1. No other spurious found.													
	2. All results are PASS against Peak and Average limit line.													



Band 1 5150~5250MHz

Band 2 - 5250~5350MHz

WIFI 802.11a (Band Edge @ 3m)

WIFI Ant.	Note	Frequency	Level	Over Limit	Limit Line	Read Level	Antenna Factor	Cable Loss	Preamp Factor	Ant Pos	Table Pos	Peak Avg.	Pol.
2		(MHz)	(dBµV/m)	(dB)	(dBµV/m)	(dBµV)	(dB/m)	(dB)	(dB)	(cm)	(deg)	(P/A)	(H/V)
802.11a CH 52 5260MHz		5124.54	49.83	-24.17	74	40.22	33.65	11.18	35.22	320	190	P	H
		5149.5	40.39	-13.61	54	30.71	33.69	11.21	35.22	320	190	A	H
	*	5260	106.95	-	-	96.81	33.99	11.38	35.23	320	190	P	H
	*	5260	99.12	-	-	88.98	33.99	11.38	35.23	320	190	A	H
		5447.76	49.86	-24.14	74	38.74	34.47	11.89	35.24	320	190	P	H
		5410.8	40.38	-13.62	54	29.38	34.34	11.89	35.23	320	190	A	H
		5070.46	48.28	-25.72	74	38.88	33.47	11.14	35.21	296	347	P	V
		5149.5	40.65	-13.35	54	30.97	33.69	11.21	35.22	296	347	A	V
	*	5260	108.15	-	-	98.01	33.99	11.38	35.23	296	347	P	V
	*	5260	99.75	-	-	89.61	33.99	11.38	35.23	296	347	A	V
		5371.92	49.31	-24.69	74	38.53	34.25	11.76	35.23	296	347	P	V
		5406	40.65	-13.35	54	29.65	34.34	11.89	35.23	296	347	A	V
802.11a CH 60 5300MHz		5010.4	49.59	-24.41	74	40.39	33.34	11.07	35.21	352	189	P	H
		5108.94	40.07	-13.93	54	30.51	33.6	11.18	35.22	352	189	A	H
	*	5300	106.94	-	-	96.58	34.08	11.51	35.23	352	189	P	H
	*	5300	99.05	-	-	88.69	34.08	11.51	35.23	352	189	A	H
		5353.68	51.38	-22.62	74	40.64	34.21	11.76	35.23	352	189	P	H
		5350.08	43.91	-10.09	54	33.17	34.21	11.76	35.23	352	189	A	H
		5045.24	48.69	-25.31	74	39.36	33.43	11.11	35.21	237	328	P	V
		5122.72	40.45	-13.55	54	30.84	33.65	11.18	35.22	237	328	A	V
	*	5300	108.62	-	-	98.26	34.08	11.51	35.23	237	328	P	V
	*	5300	100.46	-	-	90.1	34.08	11.51	35.23	237	328	A	V
		5350.08	61.95	-12.05	74	51.21	34.21	11.76	35.23	237	328	P	V
		5350.08	50.25	-3.75	54	39.51	34.21	11.76	35.23	237	328	A	V



802.11a CH 64 5320MHz	*	5320	105.33	-	-	94.81	34.12	11.63	35.23	348	193	P	H
	*	5320	96.9	-	-	86.38	34.12	11.63	35.23	348	193	A	H
		5352.32	56.87	-17.13	74	46.13	34.21	11.76	35.23	348	193	P	H
		5350.24	48.97	-5.03	54	38.23	34.21	11.76	35.23	348	193	A	H
													H
													H
	*	5320	106.83	-	-	96.31	34.12	11.63	35.23	227	345	P	V
	*	5320	99.13	-	-	88.61	34.12	11.63	35.23	227	345	A	V
		5350.56	60.43	-13.57	74	49.69	34.21	11.76	35.23	227	345	P	V
		5350.08	51.45	-2.55	54	40.71	34.21	11.76	35.23	227	345	A	V
													V
													V
Remark	1. No other spurious found. 2. All results are PASS against Peak and Average limit line.												



Band 2 5250~5350MHz

WIFI 802.11a (Harmonic @ 3m)

WIFI Ant. 2	Note	Frequency (MHz)	Level (dBμV/m)	Over Limit (dB)	Limit Line (dBμV/m)	Read Level (dBμV)	Antenna Factor (dB/m)	Cable Loss (dB)	Preamp Factor (dB)	Ant Pos (cm)	Table Pos (deg)	Peak Avg. (P/A)	Pol. (H/V)
802.11a CH 52 5260MHz		10520	49.58	-18.62	68.2	52.31	39.18	17.17	59.08	100	0	P	H
		15780	52.06	-21.94	74	47.79	41.55	19.75	57.03	100	0	P	H
													H
													H
		10520	59.58	-8.62	68.2	62.31	39.18	17.17	59.08	100	0	P	V
		15780	46.3	-27.7	74	42.03	41.55	19.75	57.03	100	0	P	V
													V
													V
802.11a CH 60 5300MHz		10600	49.29	-24.71	74	52.02	39.06	17.17	58.96	100	0	P	H
		15900	50.75	-23.25	74	46.1	41.79	19.82	56.96	100	0	P	H
													H
													H
		10600	60.42	-13.58	74	63.15	39.06	17.17	58.96	100	335	P	V
		10600	50.21	-3.79	54	52.94	39.06	17.17	58.96	100	335	A	V
		15900	47.01	-26.99	74	42.36	41.79	19.82	56.96	100	0	P	V
													V
802.11a CH 64 5320MHz		10640	46.82	-27.18	74	49.55	39.01	17.17	58.91	100	0	P	H
		15960	53.79	-20.21	74	48.91	41.93	19.87	56.92	100	299	P	H
		15960	45.48	-8.52	54	40.6	41.93	19.87	56.92	100	299	A	H
													H
		10640	57.96	-16.04	74	60.69	39.01	17.17	58.91	100	336	P	V
		10640	48.42	-5.58	54	51.15	39.01	17.17	58.91	100	336	A	V
		15960	47.82	-26.18	74	42.94	41.93	19.87	56.92	100	0	P	V
													V
Remark	1. No other spurious found. 2. All results are PASS against Peak and Average limit line.												



Band 2 5250~5350MHz

WIFI 802.11n HT20 (Band Edge @ 3m)

WIFI Ant. 2	Note	Frequency (MHz)	Level (dBμV/m)	Over Limit (dB)	Limit Line (dBμV/m)	Read Level (dBμV)	Antenna Factor (dB/m)	Cable Loss (dB)	Preamp Factor (dB)	Ant Pos (cm)	Table Pos (deg)	Peak Avg. (P/A)	Pol. (H/V)
802.11n HT20 CH 52 5260MHz		5067.6	48.77	-25.23	74	39.37	33.47	11.14	35.21	320	190	P	H
		5148.2	40.54	-13.46	54	30.86	33.69	11.21	35.22	320	190	A	H
	*	5260	106.81	-	-	96.67	33.99	11.38	35.23	320	190	P	H
	*	5260	98.72	-	-	88.58	33.99	11.38	35.23	320	190	A	H
		5351.04	48.89	-25.11	74	38.15	34.21	11.76	35.23	320	190	P	H
		5350.32	40.19	-13.81	54	29.45	34.21	11.76	35.23	320	190	A	H
		5093.6	48.71	-25.29	74	39.23	33.56	11.14	35.22	296	347	P	V
		5149.5	40.43	-13.57	54	30.75	33.69	11.21	35.22	296	347	A	V
	*	5260	107.85	-	-	97.71	33.99	11.38	35.23	296	347	P	V
	*	5260	99.49	-	-	89.35	33.99	11.38	35.23	296	347	A	V
		5408.88	49.45	-24.55	74	38.45	34.34	11.89	35.23	296	347	P	V
		5411.28	40.53	-13.47	54	29.53	34.34	11.89	35.23	296	347	A	V
802.11n HT20 CH 60 5300MHz		5088.4	48.29	-25.71	74	38.85	33.52	11.14	35.22	352	189	P	H
		5127.66	40.05	-13.95	54	30.44	33.65	11.18	35.22	352	189	A	H
	*	5300	106.74	-	-	96.38	34.08	11.51	35.23	352	189	P	H
	*	5300	98.56	-	-	88.2	34.08	11.51	35.23	352	189	A	H
		5350.32	54.46	-19.54	74	43.72	34.21	11.76	35.23	352	189	P	H
		5350.56	43.37	-10.63	54	32.63	34.21	11.76	35.23	352	189	A	H
		5014.56	48.71	-25.29	74	39.51	33.34	11.07	35.21	237	328	P	V
		5121.42	40.15	-13.85	54	30.59	33.6	11.18	35.22	237	328	A	V
	*	5300	108.6	-	-	98.24	34.08	11.51	35.23	237	328	P	V
	*	5300	100.25	-	-	89.89	34.08	11.51	35.23	237	328	A	V
	5362.08	58.82	-15.18	74	48.04	34.25	11.76	35.23	237	328	P	V	
	5350.56	50.98	-3.02	54	40.24	34.21	11.76	35.23	237	328	A	V	



802.11n HT20 CH 64 5320MHz	*	5320	105.23	-	-	94.71	34.12	11.63	35.23	348	193	P	H
	*	5320	96.93	-	-	86.41	34.12	11.63	35.23	348	193	A	H
		5362.08	57.44	-16.56	74	46.66	34.25	11.76	35.23	348	193	P	H
		5350.4	49.09	-4.91	54	38.35	34.21	11.76	35.23	348	193	A	H
													H
													H
	*	5320	106.71	-	-	96.19	34.12	11.63	35.23	227	345	P	V
	*	5320	98.73	-	-	88.21	34.12	11.63	35.23	227	345	A	V
		5354.08	61.33	-12.67	74	50.59	34.21	11.76	35.23	227	345	P	V
		5350.72	52.05	-1.95	54	41.31	34.21	11.76	35.23	227	345	A	V
													V
													V
Remark	1. No other spurious found. 2. All results are PASS against Peak and Average limit line.												



Band 2 5250~5350MHz

WIFI 802.11n HT20 (Harmonic @ 3m)

WIFI Ant. 2	Note	Frequency (MHz)	Level (dBμV/m)	Over Limit (dB)	Limit Line (dBμV/m)	Read Level (dBμV)	Antenna Factor (dB/m)	Cable Loss (dB)	Preamp Factor (dB)	Ant Pos (cm)	Table Pos (deg)	Peak Avg. (P/A)	Pol. (H/V)	
802.11n HT20 CH 52 5260MHz		10520	49.13	-19.07	68.2	51.86	39.18	17.17	59.08	100	0	P	H	
		15780	52.89	-21.11	74	48.62	41.55	19.75	57.03	100	0	P	H	
													H	
													H	
			10520	59.66	-8.54	68.2	62.39	39.18	17.17	59.08	100	0	P	V
			15780	46.04	-27.96	74	41.77	41.55	19.75	57.03	100	0	P	V
														V
802.11n HT20 CH 60 5300MHz		10600	47.94	-26.06	74	50.67	39.06	17.17	58.96	100	0	P	H	
		15900	55.71	-18.29	74	51.06	41.79	19.82	56.96	100	325	P	H	
		15900	45.38	-8.62	54	40.73	41.79	19.82	56.96	100	325	A	H	
													H	
			10600	59.15	-14.85	74	61.88	39.06	17.17	58.96	100	356	P	V
			10600	50.07	-3.93	54	52.8	39.06	17.17	58.96	100	356	A	V
			15900	48.51	-25.49	74	43.86	41.79	19.82	56.96	100	0	P	V
802.11n HT20 CH 64 5320MHz		10640	46.39	-27.61	74	49.12	39.01	17.17	58.91	100	0	P	H	
		15960	56.78	-17.22	74	51.9	41.93	19.87	56.92	100	325	P	H	
		15960	46.06	-7.94	54	41.18	41.93	19.87	56.92	100	325	A	H	
													H	
			10640	59.73	-14.27	74	62.46	39.01	17.17	58.91	100	336	P	V
			10640	48.73	-5.27	54	51.46	39.01	17.17	58.91	100	336	A	V
			15960	48.41	-25.59	74	43.53	41.93	19.87	56.92	100	0	P	V
													V	
Remark	1. No other spurious found. 2. All results are PASS against Peak and Average limit line.													



Band 2 5250~5350MHz

Band 3 - 5470~5725MHz

WIFI 802.11a (Band Edge @ 3m)

WIFI Ant.	Note	Frequency	Level	Over Limit	Limit Line	Read Level	Antenna Factor	Cable Loss	Preamp Factor	Ant Pos	Table Pos	Peak Avg.	Pol.	
2		(MHz)	(dBµV/m)	(dB)	(dBµV/m)	(dBµV)	(dB/m)	(dB)	(dB)	(cm)	(deg)	(P/A)	(H/V)	
802.11a CH 100 5500MHz		5456.72	56.57	-17.43	74	45.45	34.47	11.89	35.24	356	332	P	H	
		5469.2	62.79	-5.41	68.2	51.63	34.51	11.89	35.24	356	332	P	H	
		5459.6	49.81	-4.19	54	38.69	34.47	11.89	35.24	356	332	A	H	
	*	5500	108.14	-	-	96.89	34.6	11.89	35.24	356	332	P	H	
	*	5500	100.65	-	-	89.4	34.6	11.89	35.24	356	332	A	H	
														H
			5448.08	62.49	-11.51	74	51.37	34.47	11.89	35.24	232	324	P	V
			5465.68	63.13	-5.07	68.2	51.97	34.51	11.89	35.24	232	324	P	V
			5459.28	52.09	-1.91	54	40.97	34.47	11.89	35.24	232	324	A	V
	*		5500	108.01	-	-	96.76	34.6	11.89	35.24	232	324	P	V
	*		5500	100.4	-	-	89.15	34.6	11.89	35.24	232	324	A	V
														V
802.11a CH 116 5580MHz		5429.92	49.14	-24.86	74	38.06	34.43	11.89	35.24	380	322	P	H	
		5469.04	48.32	-19.88	68.2	37.16	34.51	11.89	35.24	380	322	P	H	
		5456.56	40.6	-13.4	54	29.48	34.47	11.89	35.24	380	322	A	H	
	*	5580	108.93	-	-	97.7	34.6	11.89	35.26	380	322	P	H	
	*	5580	101.13	-	-	89.9	34.6	11.89	35.26	380	322	A	H	
			5725	50.45	-17.75	68.2	39.07	34.6	12.06	35.28	380	322	P	H
			5459.2	48.52	-25.48	74	37.4	34.47	11.89	35.24	236	324	P	V
			5465.2	47.09	-21.11	68.2	35.93	34.51	11.89	35.24	236	324	P	V
			5455.36	40.67	-13.33	54	29.55	34.47	11.89	35.24	236	324	A	V
	*		5580	109.62	-	-	98.39	34.6	11.89	35.26	236	324	P	V
	*		5580	101.3	-	-	90.07	34.6	11.89	35.26	236	324	A	V
			5757.475	49.17	-19.03	68.2	37.75	34.6	12.11	35.29	236	324	P	V



802.11a CH 140 5700MHz	*	5700	108.87	-	-	97.55	34.6	12	35.28	363	322	P	H
	*	5700	100.46	-	-	89.14	34.6	12	35.28	363	322	A	H
		5725	66.32	-1.88	68.2	54.94	34.6	12.06	35.28	363	322	P	H
													H
													H
													H
	*	5700	107.51	-	-	96.19	34.6	12	35.28	234	321	P	V
	*	5700	99.99	-	-	88.67	34.6	12	35.28	234	321	A	V
		5725.24	66.73	-1.47	68.2	55.36	34.6	12.06	35.29	234	321	P	V
													V
													V
													V
Remark	1. No other spurious found. 2. All results are PASS against Peak and Average limit line.												



Band 3 - 5470~5725MHz
WIFI 802.11a (Harmonic @ 3m)

WIFI Ant. 2	Note	Frequency (MHz)	Level (dBμV/m)	Over Limit (dB)	Limit Line (dBμV/m)	Read Level (dBμV)	Antenna Factor (dB/m)	Cable Loss (dB)	Preamp Factor (dB)	Ant Pos (cm)	Table Pos (deg)	Peak Avg. (P/A)	Pol. (H/V)	
802.11a CH 100 5500MHz		11000	48.35	-25.65	74	51.08	38.5	17.17	58.4	100	0	P	H	
		16500	53.6	-14.6	68.2	46.47	43	20.23	56.1	100	0	P	H	
													H	
													H	
			11000	55.37	-18.63	74	58.1	38.5	17.17	58.4	100	342	P	V
			11000	48.12	-5.88	54	50.85	38.5	17.17	58.4	100	342	A	V
			16500	46.56	-21.64	68.2	39.43	43	20.23	56.1	100	0	P	V
														V
802.11a CH 116 5580MHz		11160	50.06	-23.94	74	52.16	38.77	17.16	58.03	100	0	P	H	
		16740	56.68	-11.52	68.2	49.35	42.9	20.39	55.96	102	77	P	H	
													H	
													H	
			11160	59.01	-14.99	74	61.11	38.77	17.16	58.03	100	350	P	V
			11160	49.25	-4.75	54	51.35	38.77	17.16	58.03	100	350	A	V
			16740	48.48	-19.72	68.2	41.15	42.9	20.39	55.96	100	0	P	V
														V
802.11a CH 140 5700MHz		11400	47.87	-26.13	74	49.09	39.14	17.16	57.52	100	0	P	H	
		17100	62.07	-6.13	68.2	54.62	42.64	20.65	55.84	100	0	P	H	
													H	
													H	
			11400	55.39	-18.61	74	56.61	39.14	17.16	57.52	100	328	P	V
			11400	46.17	-7.83	54	47.39	39.14	17.16	57.52	100	328	A	V
			17100	52.76	-15.44	68.2	45.31	42.64	20.65	55.84	100	0	P	V
														V
Remark	1. No other spurious found. 2. All results are PASS against Peak and Average limit line.													



Band 3 - 5470~5725MHz
WIFI 802.11n HT20 (Band Edge @ 3m)

WIFI Ant. 2	Note	Frequency (MHz)	Level (dBμV/m)	Over Limit (dB)	Limit Line (dBμV/m)	Read Level (dBμV)	Antenna Factor (dB/m)	Cable Loss (dB)	Preamp Factor (dB)	Ant Pos (cm)	Table Pos (deg)	Peak Avg. (P/A)	Pol. (H/V)	
802.11n HT20 CH 100 5500MHz		5448.72	57.91	-16.09	74	46.79	34.47	11.89	35.24	356	332	P	H	
		5468.4	65.65	-2.55	68.2	54.49	34.51	11.89	35.24	356	332	P	H	
		5459.92	50.22	-3.78	54	39.1	34.47	11.89	35.24	356	332	A	H	
	*	5500	108.15	-	-	96.9	34.6	11.89	35.24	356	332	P	H	
	*	5500	100.15	-	-	88.9	34.6	11.89	35.24	356	332	A	H	
														H
			5454	59.91	-14.09	74	48.79	34.47	11.89	35.24	232	324	P	V
			5467.76	61.52	-6.68	68.2	50.36	34.51	11.89	35.24	232	324	P	V
			5458.8	51.68	-2.32	54	40.56	34.47	11.89	35.24	232	324	A	V
	*		5500	107.85	-	-	96.6	34.6	11.89	35.24	232	324	P	V
	*		5500	99.75	-	-	88.5	34.6	11.89	35.24	232	324	A	V
													V	
802.11n HT20 CH 116 5580MHz		5459.92	48.79	-25.21	74	37.67	34.47	11.89	35.24	380	322	P	H	
		5460	48.79	-19.41	68.2	37.67	34.47	11.89	35.24	380	322	P	H	
		5458.24	40.8	-13.2	54	29.68	34.47	11.89	35.24	380	322	A	H	
	*	5580	108.82	-	-	97.59	34.6	11.89	35.26	380	322	P	H	
	*	5580	100.75	-	-	89.52	34.6	11.89	35.26	380	322	A	H	
			5740.15	50.18	-18.02	68.2	38.76	34.6	12.11	35.29	380	322	P	H
			5449.6	49.24	-24.76	74	38.12	34.47	11.89	35.24	236	324	P	V
			5460.16	49.03	-19.17	68.2	37.91	34.47	11.89	35.24	236	324	P	V
			5458.96	40.76	-13.24	54	29.64	34.47	11.89	35.24	236	324	A	V
	*		5580	108.83	-	-	97.6	34.6	11.89	35.26	236	324	P	V
	*		5580	101.11	-	-	89.88	34.6	11.89	35.26	236	324	A	V
		5759.05	49.38	-18.82	68.2	37.96	34.6	12.11	35.29	236	324	P	V	



802.11n HT20 CH 140 5700MHz	*	5700	107.72	-	-	96.4	34.6	12	35.28	363	322	P	H
	*	5700	99.94	-	-	88.62	34.6	12	35.28	363	322	A	H
		5726.76	67.02	-1.18	68.2	55.65	34.6	12.06	35.29	363	322	P	H
													H
													H
													H
	*	5700	107.46	-	-	96.14	34.6	12	35.28	234	321	P	V
	*	5700	99.63	-	-	88.31	34.6	12	35.28	234	321	A	V
		5725	67.2	-1	68.2	55.82	34.6	12.06	35.28	234	321	P	V
													V
													V
													V
Remark	1. No other spurious found. 2. All results are PASS against Peak and Average limit line.												



Band 3 - 5470~5725MHz
WIFI 802.11n HT20 (Harmonic @ 3m)

WIFI Ant. 2	Note	Frequency (MHz)	Level (dBμV/m)	Over Limit (dB)	Limit Line (dBμV/m)	Read Level (dBμV)	Antenna Factor (dB/m)	Cable Loss (dB)	Preamp Factor (dB)	Ant Pos (cm)	Table Pos (deg)	Peak Avg. (P/A)	Pol. (H/V)	
802.11n HT20 CH 100 5500MHz		11000	47.79	-26.21	74	50.52	38.5	17.17	58.4	100	0	P	H	
		16500	58.17	-10.03	68.2	51.04	43	20.23	56.1	100	0	P	H	
													H	
													H	
			11000	57.97	-16.03	74	60.7	38.5	17.17	58.4	100	342	P	V
			11000	48.18	-5.82	54	50.91	38.5	17.17	58.4	100	342	A	V
			16500	48.44	-19.76	68.2	41.31	43	20.23	56.1	100	0	P	V
														V
802.11n HT20 CH 116 5580MHz		11160	48.21	-25.79	74	50.31	38.77	17.16	58.03	100	0	P	H	
		16740	57.74	-10.46	68.2	50.41	42.9	20.39	55.96	100	0	P	H	
													H	
													H	
			11160	62.54	-11.46	74	64.64	38.77	17.16	58.03	100	334	P	V
			11160	50.34	-3.66	54	52.44	38.77	17.16	58.03	100	334	A	V
			16740	47.99	-20.21	68.2	40.66	42.9	20.39	55.96	100	0	P	V
														V
802.11n HT20 CH 140 5700MHz		11400	49.14	-24.86	74	50.36	39.14	17.16	57.52	100	0	P	H	
		17100	65.2	-3	68.2	57.75	42.64	20.65	55.84	100	0	P	H	
													H	
													H	
			11400	59.32	-14.68	74	60.54	39.14	17.16	57.52	100	25	P	V
			11400	46.84	-7.16	54	48.06	39.14	17.16	57.52	100	25	A	V
			17100	52.19	-16.01	68.2	44.74	42.64	20.65	55.84	100	0	P	V
														V
Remark	1. No other spurious found. 2. All results are PASS against Peak and Average limit line.													



Band 3 - 5470~5725MHz

Emission below 1GHz

WIFI 802.11n HT20 (LF @ 3m)

WIFI Ant.	Note	Frequency (MHz)	Level (dBμV/m)	Over Limit (dB)	Limit Line (dBμV/m)	Read Level (dBμV)	Antenna Factor (dB/m)	Cable Loss (dB)	Preamp Factor (dB)	Ant Pos (cm)	Table Pos (deg)	Peak Avg. (P/A)	Pol. (H/V)	
802.11n HT20 LF		96.69	36.33	-7.17	43.5	50.14	16.01	1.28	31.1	-	-	P	H	
		151.5	39.12	-4.38	43.5	50.83	17.63	1.78	31.12	-	-	P	H	
		210.9	39.4	-4.1	43.5	52.32	16.3	1.87	31.09	100	341	P	H	
		358.1	37.66	-8.34	46	44.86	21.39	2.5	31.09	-	-	P	H	
		479.9	36.99	-9.01	46	40.99	23.76	3.04	30.8	-	-	P	H	
		720	37.73	-8.27	46	37.68	26.71	3.74	30.4	-	-	P	H	
														H
														H
														H
														H
														H
			55.38	35.32	-4.68	40	51.9	13.55	1.07	31.2	100	112	P	V
			95.07	36.97	-6.53	43.5	51.04	15.75	1.28	31.1	-	-	P	V
			157.44	38	-5.5	43.5	50.19	17.21	1.78	31.18	-	-	P	V
			332.9	31.8	-14.2	46	39.67	20.72	2.41	31	-	-	P	V
			479.9	31.39	-14.61	46	35.39	23.76	3.04	30.8	-	-	P	V
			960.1	36.18	-17.82	54	32.25	30.22	4.07	30.36	-	-	P	V
													V	
													V	
													V	
													V	
													V	
													V	
Remark	1. No other spurious found. 2. All results are PASS against limit line.													



Note symbol

*	Fundamental Frequency which can be ignored. However, the level of any unwanted emissions shall not exceed the level of the fundamental frequency.
!	Test result is over limit line.
P/A	Peak or Average
H/V	Horizontal or Vertical



A calculation example for radiated spurious emission is shown as below:

WIFI	Note	Frequency	Level	Over	Limit	Read	Antenna	Cable	Preamp	Ant	Table	Peak	Pol.
Ant.				Limit	Line	Level	Factor	Loss	Factor	Pos	Pos	Avg.	
2		(MHz)	(dBμV/m)	(dB)	(dBμV/m)	(dBμV)	(dB/m)	(dB)	(dB)	(cm)	(deg)	(P/A)	(H/V)
802.11b		2390	55.45	-18.55	74	54.51	32.22	4.58	35.86	103	308	P	H
CH 01													
2412MHz		2390	43.54	-10.46	54	42.6	32.22	4.58	35.86	103	308	A	H

- Level(dBμV/m) =
Antenna Factor(dB/m) + Cable Loss(dB) + Read Level(dBμV) - Preamp Factor(dB)
- Over Limit(dB) = Level(dBμV/m) – Limit Line(dBμV/m)

For Peak Limit @ 2390MHz:

- Level(dBμV/m)
= Antenna Factor(dB/m) + Cable Loss(dB) + Read Level(dBμV) - Preamp Factor(dB)
= 32.22(dB/m) + 4.58(dB) + 54.51(dBμV) – 35.86 (dB)
= 55.45 (dBμV/m)
- Over Limit(dB)
= Level(dBμV/m) – Limit Line(dBμV/m)
= 55.45(dBμV/m) – 74(dBμV/m)
= -18.55(dB)

For Average Limit @ 2390MHz:

- Level(dBμV/m)
= Antenna Factor(dB/m) + Cable Loss(dB) + Read Level(dBμV) - Preamp Factor(dB)
= 32.22(dB/m) + 4.58(dB) + 42.6(dBμV) – 35.86 (dB)
= 43.54 (dBμV/m)
- Over Limit(dB)
= Level(dBμV/m) – Limit Line(dBμV/m)
= 43.54(dBμV/m) – 54(dBμV/m)
= -10.46(dB)

Both peak and average measured complies with the limit line, so test result is “PASS”.



Appendix C. Radiated Spurious Emission

Test Engineer :	Jesse Wang and Ken Wu	Temperature :	21~24°C
		Relative Humidity :	50~54%

Note symbol

-L	Low channel location
-R	High channel location

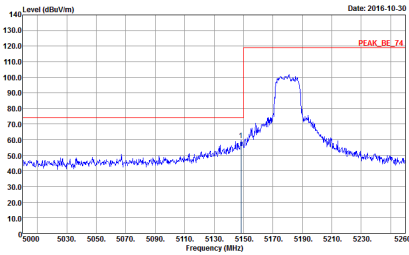
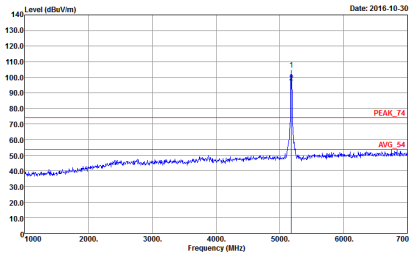
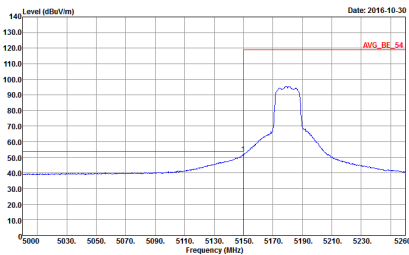

Band 1 - 5150~5250MHz
WIFI 802.11a (Band Edge @ 3m)

WIFI	Band 1 5150~5250MHz Band Edge @ 3m	
ANT	802.11a CH36 5180MHz	
2	Horizontal	Fundamental
Peak	 <p>Site : 03CH07.HY Condition : PEAK_BE_74 3m HF-ANT_130829 HORIZONTAL RBW:1000.000kHz VSW:3000.000kHz SWT:Auto Detector : Peak Project : 600724 Mode : 1 Plane : Y Ant : 1 Setting : 19.5</p>	 <p>Site : 03CH07.HY Condition : PEAK_74 3m HF-ANT_130829 HORIZONTAL RBW:1000.000kHz VSW:3000.000kHz SWT:Auto Detector : Peak Project : 600724 Mode : 1 Plane : Y Ant : 1 Setting : 19.5</p>
Avg.	 <p>Site : 03CH07.HY Condition : AVG_BE_54 3m HF-ANT_130829 HORIZONTAL RBW:1000.000kHz VSW:1.000kHz SWT:Auto Detector : Peak Project : 600724 Mode : 1 Plane : Y Ant : 1 Setting : 19.5</p>	Left blank

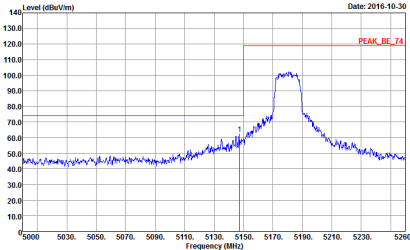
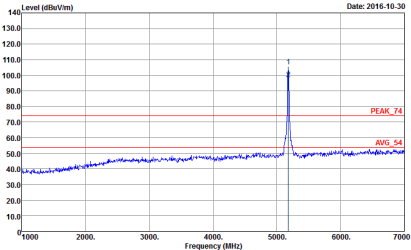
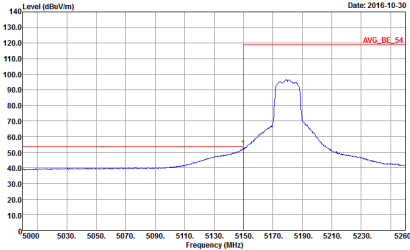

WIFI	Band 1 5150~5250MHz Band Edge @ 3m	
ANT	802.11a CH36 5180MHz	
2	<p style="text-align: center;">Vertical</p>  <p style="text-align: right;">Date: 2016-10-30</p> <p>Site : 03CH07-HY Condition : PEAK_BE_74 3m HF-ANT_130829 VERTICAL : RBW:1000.000kHz VBW:3000.000kHz SWT:Auto Detector : Peak Project : 600724 Mode : 1 Plane : Y Ant : 1 Setting : 19.5</p>	<p style="text-align: center;">Fundamental</p>  <p style="text-align: right;">Date: 2016-10-30</p> <p>Site : 03CH07-HY Condition : PEAK_74 3m HF-ANT_130829 VERTICAL : RBW:1000.000kHz VBW:3000.000kHz SWT:Auto Detector : Peak Project : 600724 Mode : 1 Plane : Y Ant : 1 Setting : 19.5</p>
Peak	 <p style="text-align: right;">Date: 2016-10-30</p> <p>Site : 03CH07-HY Condition : AVG_BE_54 3m HF-ANT_130829 VERTICAL : RBW:1000.000kHz VBW:1.000kHz SWT:Auto Detector : Peak Project : 600724 Mode : 1 Plane : Y Ant : 1 Setting : 19.5</p>	<p style="text-align: center;">Left blank</p>

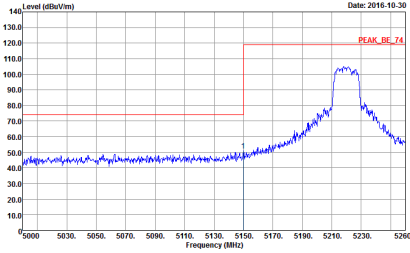
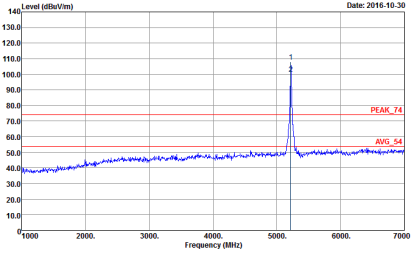
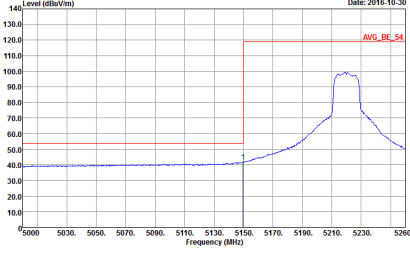

WIFI	Band 1 5150~5250MHz Band Edge @ 3m	
ANT	802.11a CH44 5220MHz - L	
2	Horizontal	Fundamental
Peak	 <p>Date: 2016-10-30</p> <p>Site : 03CH07HY Condition : PEAK_BE_74 3m HF-ANT_130829 HORIZONTAL : RBW:1000.000kHz VBW:3000.000kHz SWT:Auto Detector : Peak Project : 600724 Mode : 2 Plane : Y Ant : 1 Setting : 20</p>	 <p>Date: 2016-10-30</p> <p>Site : 03CH07HY Condition : PEAK_74 3m HF-ANT_130829 HORIZONTAL : RBW:1000.000kHz VBW:3000.000kHz SWT:Auto Detector : Peak Project : 600724 Mode : 2 Plane : Y Ant : 1 Setting : 20</p>
Avg.	 <p>Date: 2016-10-30</p> <p>Site : 03CH07HY Condition : AVG_BE_54 3m HF-ANT_130829 HORIZONTAL : RBW:1000.000kHz VBW:1.000kHz SWT:Auto Detector : Peak Project : 600724 Mode : 2 Plane : Y Ant : 1 Setting : 20</p>	Left blank

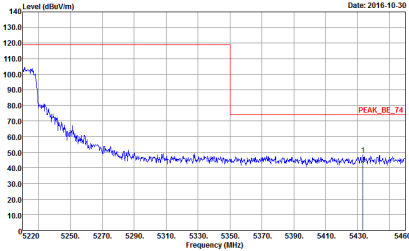
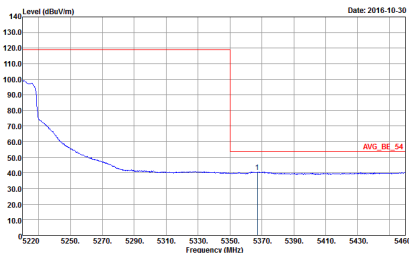

WIFI	Band 1 5150~5250MHz Band Edge @ 3m	
ANT	802.11a CH44 5220MHz - R	
2	Horizontal	Fundamental
Peak	 <p>Site : 03CHM74NY Condition : PEAK_BE_74 3m HF-ANT_130829 HORIZONTAL RBW: 1000.000kHz VSW: 3000.000kHz SWT: Auto Detector : Peak Project : 600724 Mode : Z Plane : Y Ant : 1 Setting : 20</p>	Left blank
Avg.	 <p>Site : 03CHM74NY Condition : AVG_BE_54 3m HF-ANT_130829 HORIZONTAL RBW: 1000.000kHz VSW: 1.000kHz SWT: Auto Detector : Peak Project : 600724 Mode : Z Plane : Y Ant : 1 Setting : 20</p>	Left blank

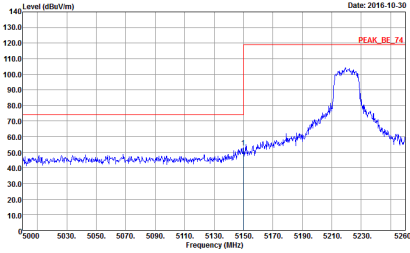
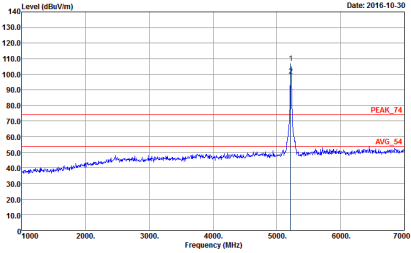
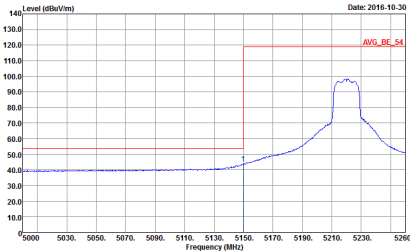

WIFI	Band 1 5150~5250MHz Band Edge @ 3m	
ANT	802.11a CH44 5220MHz - L	
2	Vertical	Fundamental
Peak	 <p>Site : 03CH07HY Condition : PEAK_BE_74 3m HF-ANT_130829 VERTICAL Detector : Peak Project : 600724 Mode : 2 Plane : Y Ant : 1 Setting : 20</p>	 <p>Site : 03CH07HY Condition : PEAK_74 3m HF-ANT_130829 VERTICAL Detector : Peak Project : 600724 Mode : 2 Plane : Y Ant : 1 Setting : 20</p>
Avg.	 <p>Site : 03CH07HY Condition : AVG_BE_54 3m HF-ANT_130829 VERTICAL Detector : Peak Project : 600724 Mode : 2 Plane : Y Ant : 1 Setting : 20</p>	Left blank

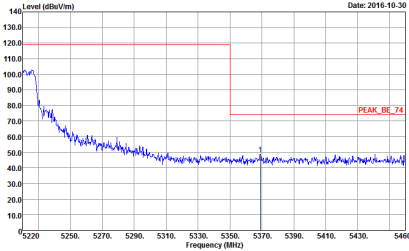
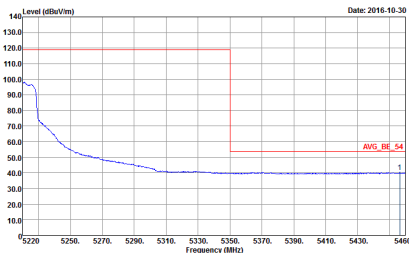

WIFI	Band 1 5150~5250MHz Band Edge @ 3m	
ANT	802.11a CH44 5220MHz - R	
2	Vertical	Fundamental
Peak	 <p>Site : 03CHM74Y Condition : PEAK_BE_74 3m HF-ANT_130829 VERTICAL RBW: 1000.000kHz VSW: 3000.000kHz SWT: Auto Detector : Peak Project : 600724 Mode : 2 Plane : Y Ant : 1 Setting : 20</p>	Left blank
Avg.	 <p>Site : 03CHM74Y Condition : AVG_BE_54 3m HF-ANT_130829 VERTICAL RBW: 1000.000kHz VSW: 1.000kHz SWT: Auto Detector : Peak Project : 600724 Mode : 2 Plane : Y Ant : 1 Setting : 20</p>	Left blank

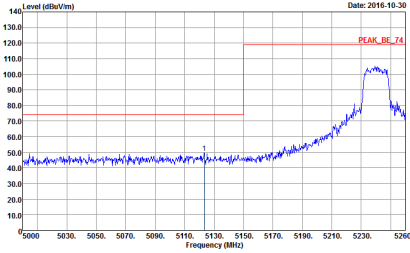
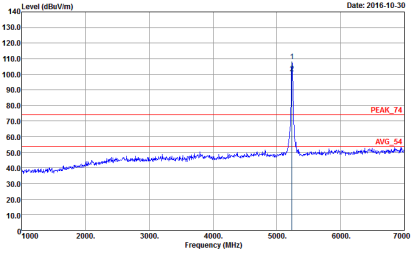
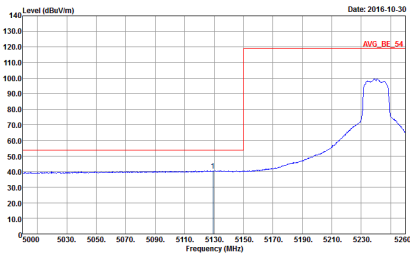

WIFI	Band 1 5150~5250MHz Band Edge @ 3m	
ANT	802.11a CH48 5240MHz - L	
2	Horizontal	Fundamental
Peak	 <p>Date: 2016-10-30</p> <p>Site : 03CH07HY Condition : PEAK_BE_74 3m HF-ANT_130829 HORIZONTAL Detector : Peak Project : 600724 Mode : 3 Plane : Y Ant : 1 Setting : 20</p>	 <p>Date: 2016-10-30</p> <p>Site : 03CH07HY Condition : PEAK_74 3m HF-ANT_130829 HORIZONTAL Detector : Peak Project : 600724 Mode : 3 Plane : Y Ant : 1 Setting : 20</p>
Avg.	 <p>Date: 2016-10-30</p> <p>Site : 03CH07HY Condition : AVG_BE_54 3m HF-ANT_130829 HORIZONTAL Detector : Peak Project : 600724 Mode : 3 Plane : Y Ant : 1 Setting : 20</p>	Left blank

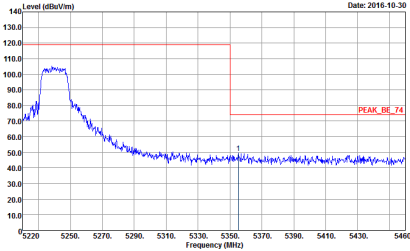
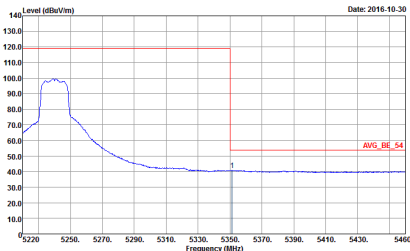

WIFI	Band 1 5150~5250MHz Band Edge @ 3m	
ANT	802.11a CH48 5240MHz - R	
2	Horizontal	Fundamental
<p>Peak</p>	 <p>Date: 2016-10-30</p> <pre> Site : 03CH07HY Condition : PEAK_BE_74 3m HF-ANT_130829 HORIZONTAL : RBW:1000.000kHz VBW:3000.000kHz SWT:Auto Detector : Peak Project : 600724 Mode : 3 Plane : Y Ant : 1 Setting : 20 </pre>	<p>Left blank</p>
<p>Avg.</p>	 <p>Date: 2016-10-30</p> <pre> Site : 03CH07HY Condition : AVG_BE_54 3m HF-ANT_130829 HORIZONTAL : RBW:1000.000kHz VBW:1.000kHz SWT:Auto Detector : Peak Project : 600724 Mode : 3 Plane : Y Ant : 1 Setting : 20 </pre>	<p>Left blank</p>

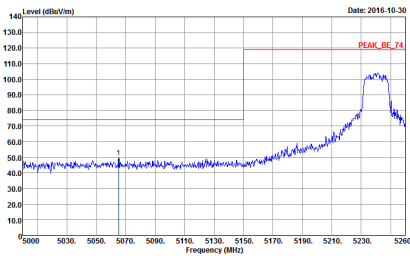
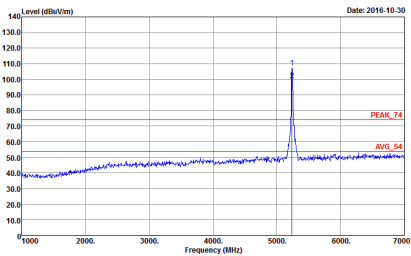
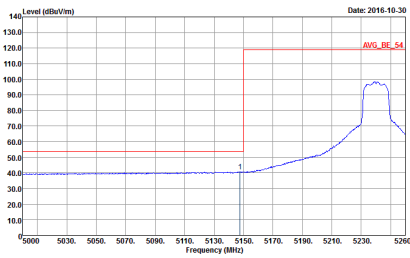

WIFI	Band 1 5150~5250MHz Band Edge @ 3m	
ANT	802.11a CH48 5240MHz - L	
2	Vertical	Fundamental
Peak	 <p>Site : 00CH67.HY Condition : PEAK_BE_74 3m HF-ANT_130829 VERTICAL : RBW:1000.000kHz VSW:3000.000kHz SWT:Auto Detector : Peak Project : 600724 Mode : 3 Plane : Y Ant : 1 Setting : 20</p>	 <p>Site : 00CH67.HY Condition : PEAK_74 3m HF-ANT_130829 VERTICAL : RBW:1000.000kHz VSW:3000.000kHz SWT:Auto Detector : Peak Project : 600724 Mode : 3 Plane : Y Ant : 1 Setting : 20</p>
Avg.	 <p>Site : 00CH67.HY Condition : AVG_BE_54 3m HF-ANT_130829 VERTICAL : RBW:1000.000kHz VSW:1.000kHz SWT:Auto Detector : Peak Project : 600724 Mode : 3 Plane : Y Ant : 1 Setting : 20</p>	Left blank



WIFI	Band 1 5150~5250MHz Band Edge @ 3m	
ANT	802.11a CH48 5240MHz - R	
2	Vertical	Fundamental
Peak	<p>Site : 03CH07-HY Condition : PEAK_BE_74 3m HF-ANT_130829 VERTICAL : RBW:1000.000kHz VBW:3000.000kHz SWT:Auto Detector : Peak Project : 600724 Mode : -3 Plane : Y Ant : 1 Setting : 20</p>	Left blank
Avg.	<p>Site : 03CH07-HY Condition : AVG_BE_54 3m HF-ANT_130829 VERTICAL : RBW:1000.000kHz VBW:1.000kHz SWT:Auto Detector : Peak Project : 600724 Mode : -3 Plane : Y Ant : 1 Setting : 20</p>	Left blank



Band 1 5150~5250MHz
WIFI 802.11n HT20 (Band Edge @ 3m)

WIFI	Band 1 5150~5250MHz Band Edge @ 3m	
ANT	802.11n HT20 CH36 5180MHz	
2	Horizontal	Fundamental
Peak	<p>Date: 2016-10-30</p> <p>Site : 03CH07-HY Condition : PEAK_BE_74 3m HF-ANT_130829 HORIZONTAL RBW: 1000.000kHz VBW: 3000.000kHz SWT: Auto Detector : Peak Project : 600724 Mode : 13 Plane : Y Azl : 1 Setting : 19.5</p>	<p>Date: 2016-10-30</p> <p>Site : 03CH07-HY Condition : PEAK_74 3m HF-ANT_130829 HORIZONTAL RBW: 1000.000kHz VBW: 3000.000kHz SWT: Auto Detector : Peak Project : 600724 Mode : 13 Plane : Y Azl : 1 Setting : 19.5</p>
Avg.	<p>Date: 2016-10-30</p> <p>Site : 03CH07-HY Condition : AVG_BE_54 3m HF-ANT_130829 HORIZONTAL RBW: 1000.000kHz VBW: 1.000kHz SWT: Auto Detector : Peak Project : 600724 Mode : 13 Plane : Y Azl : 1 Setting : 19.5</p>	Left blank

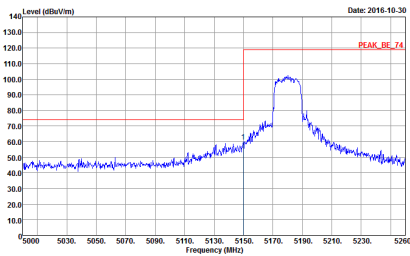
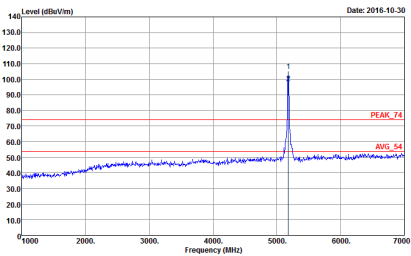
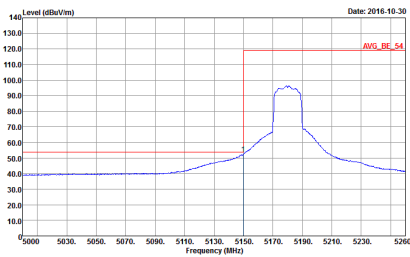

WIFI	Band 1 5150~5250MHz Band Edge @ 3m	
ANT	802.11n HT20 CH36 5180MHz	
2	Vertical	Fundamental
Peak	 <p>Date: 2016-10-30</p> <p>Site : 03CH07-HY Condition : PEAK_BE_74 3m HF-ANT_130829 VERTICAL RBW: 1000.000kHz VBW: 3000.000kHz SWT: Auto Detector : Peak Project : 600724 Mode : 13 Plane : Y Ant : 1 Setting : 19.5</p>	 <p>Date: 2016-10-30</p> <p>Site : 03CH07-HY Condition : PEAK_74 3m HF-ANT_130829 VERTICAL RBW: 1000.000kHz VBW: 3000.000kHz SWT: Auto Detector : Peak Project : 600724 Mode : 13 Plane : Y Ant : 1 Setting : 19.5</p>
Avg.	 <p>Date: 2016-10-30</p> <p>Site : 03CH07-HY Condition : AVG_BE_54 3m HF-ANT_130829 VERTICAL RBW: 1000.000kHz VBW: 1.000kHz SWT: Auto Detector : Peak Project : 600724 Mode : 13 Plane : Y Ant : 1 Setting : 19.5</p>	Left blank

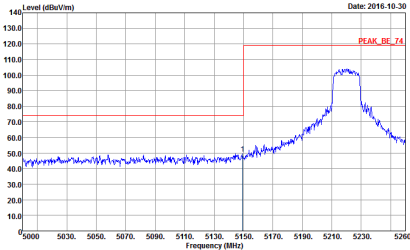
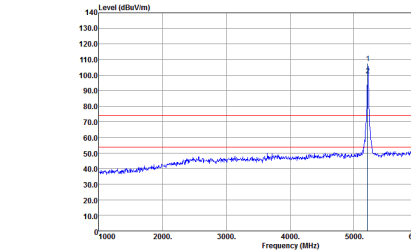
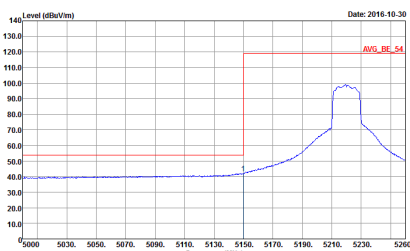

WIFI	Band 1 5150~5250MHz Band Edge @ 3m	
ANT	802.11n HT20 CH44 5220MHz - L	
2	Horizontal	Fundamental
<p>Peak</p>	 <p>Site : 03CH07-HY Condition : PEAK_BE_74 3m HF-ANT_130829 HORIZONTAL Detector : Peak Project : 600724 Mode : 14 Plane : Y Ant : 1 Setting : 20</p>	 <p>Site : 03CH07-HY Condition : PEAK_74 3m HF-ANT_130829 HORIZONTAL Detector : Peak Project : 600724 Mode : 14 Plane : Y Ant : 1 Setting : 20</p>
<p>Avg.</p>	 <p>Site : 03CH07-HY Condition : AVG_BE_54 3m HF-ANT_130829 HORIZONTAL Detector : Peak Project : 600724 Mode : 14 Plane : Y Ant : 1 Setting : 20</p>	<p>Left blank</p>

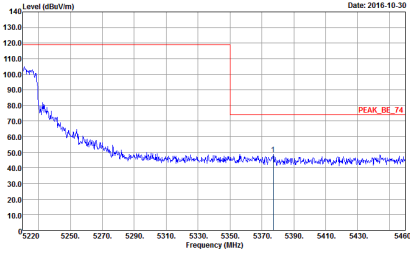
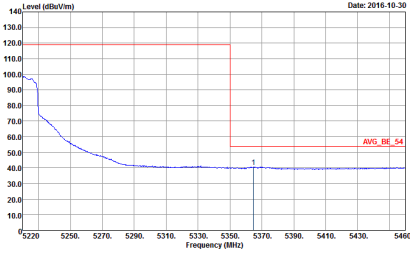

WIFI	Band 1 5150~5250MHz Band Edge @ 3m	
ANT	802.11n HT20 CH44 5220MHz - R	
2	Horizontal	Fundamental
Peak	 <p>Date: 2016-10-30</p> <p>Site : 03CH07HY Condition : PEAK_BE_74 3m HF-ANT_130829 HORIZONTAL Detector : Peak Project : 600724 Mode : 14 Plane : Y Ant : 1 Setting : 20</p>	Left blank
Avg.	 <p>Date: 2016-10-30</p> <p>Site : 03CH07HY Condition : AVG_BE_54 3m HF-ANT_130829 HORIZONTAL Detector : Peak Project : 600724 Mode : 14 Plane : Y Ant : 1 Setting : 20</p>	Left blank

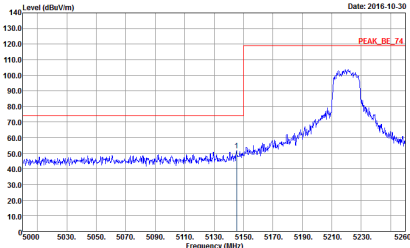
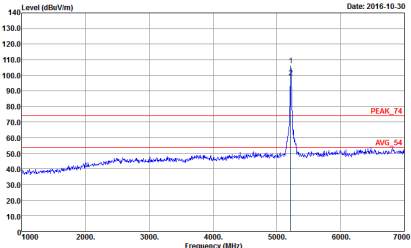
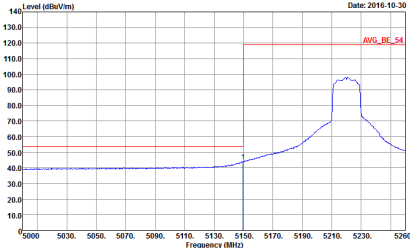

WIFI	Band 1 5150~5250MHz Band Edge @ 3m	
ANT	802.11n HT20 CH44 5220MHz - L	
2	Vertical	Fundamental
Peak	 <p>Date: 2016-10-30</p> <p>Site : 03CH07.HY Condition : PEAK_BE_74 3m HF-ANT_130829 VERTICAL : RBW:1000.000kHz VBW:3000.000kHz SWT:Auto Detector : Peak Project : 600724 Mode : 14 Plane : Y Ant : 1 Setting : 20</p>	 <p>Date: 2016-10-30</p> <p>Site : 03CH07.HY Condition : PEAK_74 3m HF-ANT_130829 VERTICAL : RBW:1000.000kHz VBW:3000.000kHz SWT:Auto Detector : Peak Project : 600724 Mode : 14 Plane : Y Ant : 1 Setting : 20</p>
Avg.	 <p>Date: 2016-10-30</p> <p>Site : 03CH07.HY Condition : AVG_BE_54 3m HF-ANT_130829 VERTICAL : RBW:1000.000kHz VBW:1.000kHz SWT:Auto Detector : Peak Project : 600724 Mode : 14 Plane : Y Ant : 1 Setting : 20</p>	Left blank

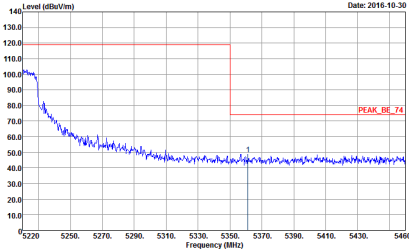
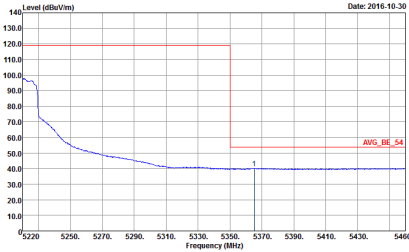

WIFI	Band 1 5150~5250MHz Band Edge @ 3m	
ANT	802.11n HT20 CH44 5220MHz - R	
2	Vertical	Fundamental
Peak	 <p>Date: 2016-10-30</p> <p>Site : 03CH07-HY Condition : PEAK_BE_74 3m HF-ANT_130829 VERTICAL : RBW:1000.000kHz VSW:3000.000kHz SWT:Auto Detector : Peak Project : 600724 Mode : 14 Plane : Y Ant : 1 Setting : 20</p>	Left blank
Avg.	 <p>Date: 2016-10-30</p> <p>Site : 03CH07-HY Condition : AVG_BE_54 3m HF-ANT_130829 VERTICAL : RBW:1000.000kHz VSW:1.000kHz SWT:Auto Detector : Peak Project : 600724 Mode : 14 Plane : Y Ant : 1 Setting : 20</p>	Left blank

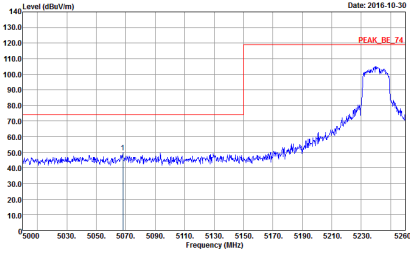
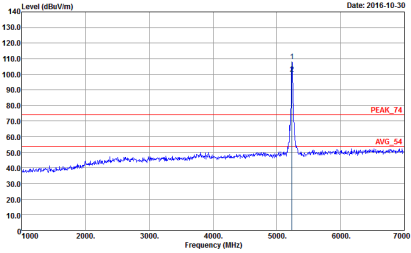
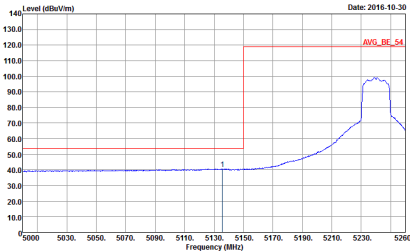

WIFI	Band 1 5150~5250MHz Band Edge @ 3m	
ANT	802.11n HT20 CH48 5240MHz - L	
2	Horizontal	Fundamental
Peak	 <p>Site : 03CH07HY Condition : PEAK_BE_74 3m HF-ANT_130829 HORIZONTAL Detector : Peak Project : 600724 Mode : 15 Plane : Y Ant : 1 Setting : 20</p>	 <p>Site : 03CH07HY Condition : PEAK_74 3m HF-ANT_130829 HORIZONTAL Detector : Peak Project : 600724 Mode : 15 Plane : Y Ant : 1 Setting : 20</p>
Avg.	 <p>Site : 03CH07HY Condition : AVG_BE_54 3m HF-ANT_130829 HORIZONTAL Detector : Peak Project : 600724 Mode : 15 Plane : Y Ant : 1 Setting : 20</p>	Left blank



WIFI	Band 1 5150~5250MHz Band Edge @ 3m	
ANT	802.11n HT20 CH48 5240MHz - R	
2	Horizontal	Fundamental
<p>Peak</p>	<p>Date: 2016-10-30</p> <p>Site : 03CH07HY Condition : PEAK_BE_74 3m HF-ANT_130829 HORIZONTAL Detector : Peak Project : 600724 Mode : 15 Plane : Y Ant : 1 Setting : 20</p>	<p>Left blank</p>
<p>Avg.</p>	<p>Date: 2016-10-30</p> <p>Site : 03CH07HY Condition : AVG_BE_54 3m HF-ANT_130829 HORIZONTAL Detector : Peak Project : 600724 Mode : 15 Plane : Y Ant : 1 Setting : 20</p>	<p>Left blank</p>

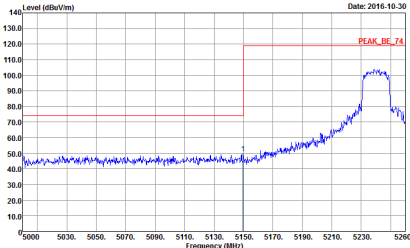
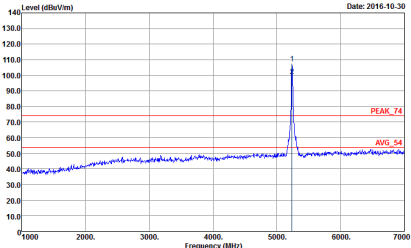
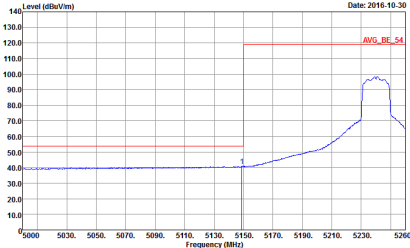

WIFI	Band 1 5150~5250MHz Band Edge @ 3m	
ANT	802.11n HT20 CH48 5240MHz - L	
2	Vertical	Fundamental
Peak	 <p>Date: 2016-10-30</p> <p>Site : 03CH07-HY Condition : PEAK_BE_74 3m HF-ANT_130829 VERTICAL RBW:1000.000kHz VBW:3000.000kHz SWT:Auto Detector : Peak Project : 600724 Mode : 15 Plane : Y Ant : 1 Setting : 20</p>	 <p>Date: 2016-10-30</p> <p>Site : 03CH07-HY Condition : PEAK_74 3m HF-ANT_130829 VERTICAL RBW:1000.000kHz VBW:3000.000kHz SWT:Auto Detector : Peak Project : 600724 Mode : 15 Plane : Y Ant : 1 Setting : 20</p>
Avg.	 <p>Date: 2016-10-30</p> <p>Site : 03CH07-HY Condition : AVG_BE_54 3m HF-ANT_130829 VERTICAL RBW:1000.000kHz VBW:1.000kHz SWT:Auto Detector : Peak Project : 600724 Mode : 15 Plane : Y Ant : 1 Setting : 20</p>	Left blank



WIFI	Band 1 5150~5250MHz Band Edge @ 3m	
ANT	802.11n HT20 CH48 5240MHz - R	
2	Vertical	Fundamental
<p>Peak</p>	<p>Site : 03CH07-HY Condition : PEAK_BE_74 3m HF-ANT_130829 VERTICAL RBW:1000.000kHz VBW:3000.000kHz SWT:Auto Detector : Peak Project : 600724 Mode : 15 Plane : Y Ant : 1 Setting : 20</p>	<p>Left blank</p>
<p>Avg.</p>	<p>Site : 03CH07-HY Condition : AVG_BE_54 3m HF-ANT_130829 VERTICAL RBW:1000.000kHz VBW:1.000kHz SWT:Auto Detector : Peak Project : 600724 Mode : 15 Plane : Y Ant : 1 Setting : 20</p>	<p>Left blank</p>



Band 1 5150~5250MHz

Band 1 - 5150~5250MHz

WIFI 802.11a (Harmonic @ 3m)

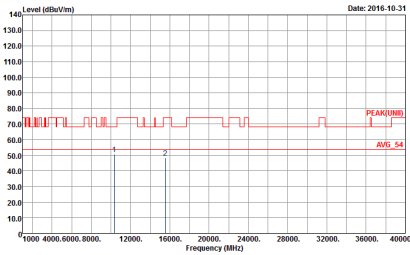
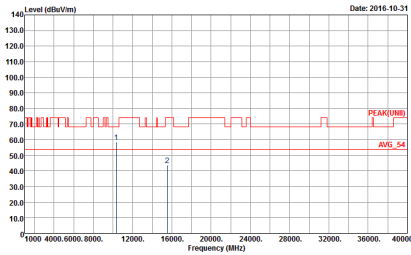
WIFI	Band 1 5150~5250MHz Harmonic @ 3m	
ANT	802.11a CH36 5180MHz	
2	Horizontal	Vertical
<p>Peak Avg.</p>	 <p>Site : 03CH07-HY Condition : PEAK(LNM) 3m SHF-EHF_131029 HORIZONTAL Detector : Peak Project : 600724 Mode : 1 Plane : Y Ant : 1 Setting : 19.5</p>	 <p>Site : 03CH07-HY Condition : PEAK(LNM) 3m SHF-EHF_131029 VERTICAL Detector : Peak Project : 600724 Mode : 1 Plane : Y Ant : 1 Setting : 19.5</p>



WIFI	Band 1 5150~5250MHz Harmonic @ 3m	
ANT	802.11a CH44 5220MHz	
2	Horizontal	Vertical
Peak Avg.	<div style="display: flex; justify-content: space-around;"> <div style="width: 45%;"> </div> <div style="width: 45%;"> </div> </div>	

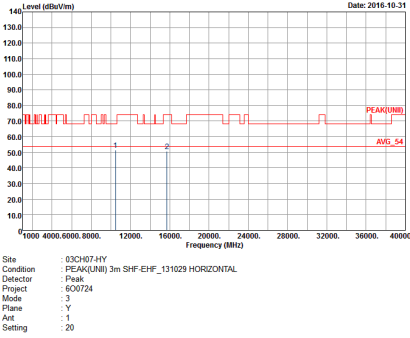
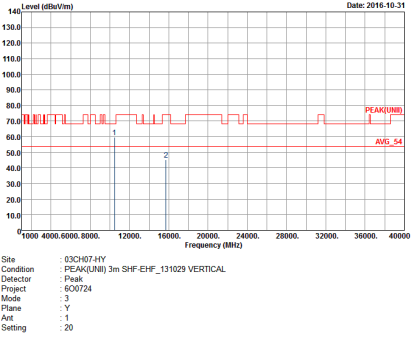

WIFI	Band 1 5150~5250MHz Harmonic @ 3m	
ANT	802.11a CH48 5240MHz	
2	Horizontal	Vertical
Peak Avg.		

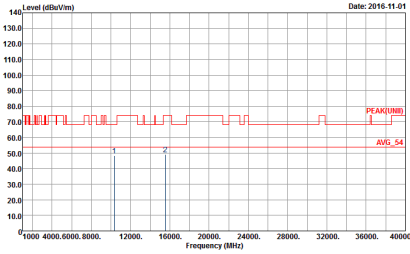
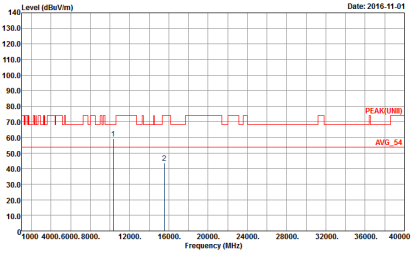

Band 1 5150~5250MHz
WIFI 802.11n HT20 (Harmonic @ 3m)

WIFI	Band 1 5150~5250MHz Harmonic @ 3m	
ANT	802.11n HT20 CH36 5180MHz	
2	Horizontal	Vertical
<p>Peak Avg.</p>	 <p>Site : 03CH07.HY Condition : PEAK(UML) 3m SHF-EHF_131029 HORIZONTAL Detector : Peak Project : 600724 Mode : 13 Plane : Y Ant : 1 Setting : 19.5</p>	 <p>Site : 03CH07.HY Condition : PEAK(UML) 3m SHF-EHF_131029 VERTICAL Detector : Peak Project : 600724 Mode : 13 Plane : Y Ant : 1 Setting : 19.5</p>



WIFI	Band 1 5150~5250MHz Harmonic @ 3m	
ANT	802.11n HT20 CH44 5220MHz	
2	Horizontal	Vertical
Peak Avg.	<div style="display: flex; justify-content: space-around;"> <div style="width: 45%;"> </div> <div style="width: 45%;"> </div> </div>	



WIFI	Band 1 5150~5250MHz Harmonic @ 3m	
ANT	802.11n HT20 CH48 5240MHz	
2	Horizontal	Vertical
Peak Avg.	<div style="display: flex; justify-content: space-around;"> <div style="width: 45%;"> <p>Site : 03CH07HY Condition : PEAK(LIM) 3m SHF-EHF_131029 HORIZONTAL Detector : Peak Project : 600724 Mode : 15 Plane : Y Avt : 1 Setting : 20</p> </div> <div style="width: 45%;"> <p>Site : 03CH07HY Condition : PEAK(LIM) 3m SHF-EHF_131029 VERTICAL Detector : Peak Project : 600724 Mode : 15 Plane : Y Avt : 1 Setting : 20</p> </div> </div>	



Band 1 5150~5250MHz

Band 2 - 5250~5350MHz

WIFI 802.11a (Band Edge @ 3m)

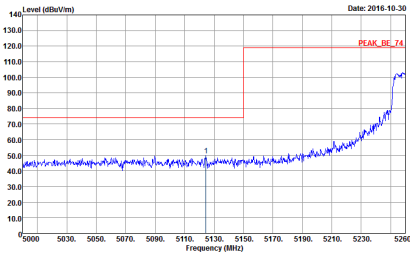
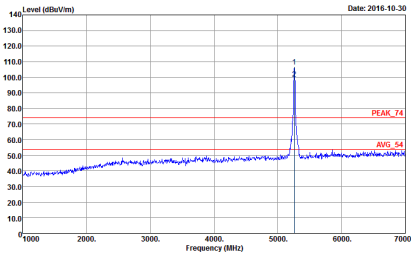
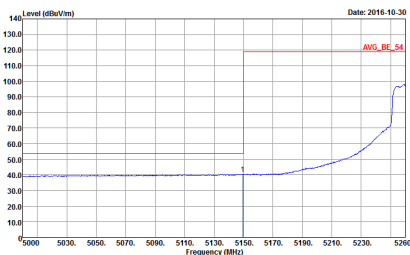
WIFI	Band 2 5250~5350MHz Band Edge @ 3m	
ANT	802.11a CH52 5260MHz - L	
2	Horizontal	Fundamental
Peak	 <p>Site : 03CH07.HY Condition : PEAK_BE_74 3m HF-ANT_130829 HORIZONTAL RBW:1000.000kHz VBW:3000.000kHz SWT:Auto Detector : Peak Project : 600724 Mode : 4 Plane : Y Ant : 1 Setting : 20</p>	 <p>Site : 03CH07.HY Condition : PEAK_74 3m HF-ANT_130829 HORIZONTAL RBW:1000.000kHz VBW:3000.000kHz SWT:Auto Detector : Peak Project : 600724 Mode : 4 Plane : Y Ant : 1 Setting : 20</p>
Avg.	 <p>Site : 03CH07.HY Condition : AVG_BE_54 3m HF-ANT_130829 HORIZONTAL RBW:1000.000kHz VBW:1.000kHz SWT:Auto Detector : Peak Project : 600724 Mode : 4 Plane : Y Ant : 1 Setting : 20</p>	Left blank

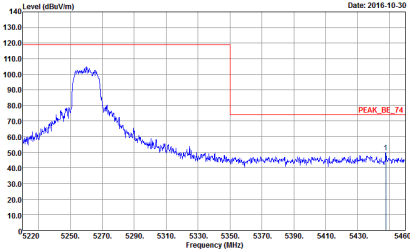
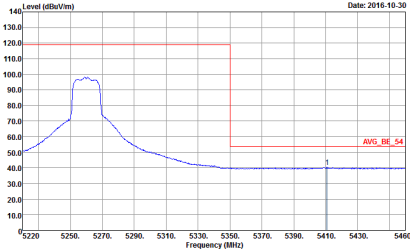

WIFI	Band 2 5250~5350MHz Band Edge @ 3m	
ANT	802.11a CH52 5260MHz - R	
2	Horizontal	Fundamental
Peak	 <p>Site : 03CH07HY Condition : PEAK_BE_74 3m HF-ANT_130829 HORIZONTAL Detector : Peak Project : 600724 Mode : 4 Plane : Y Ant : 1 Setting : 20</p>	Left blank
Avg.	 <p>Site : 03CH07HY Condition : AVG_BE_54 3m HF-ANT_130829 HORIZONTAL Detector : Peak Project : 600724 Mode : 4 Plane : Y Ant : 1 Setting : 20</p>	Left blank

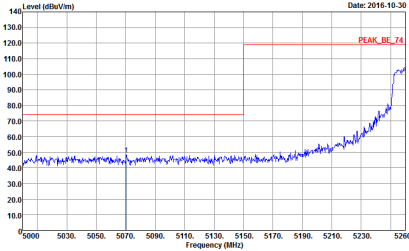
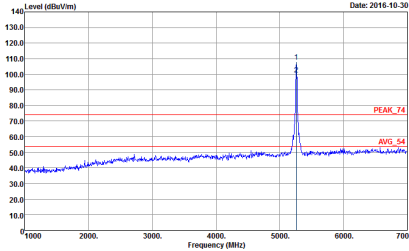
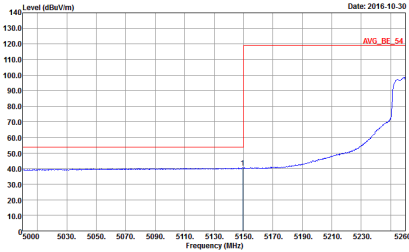

WIFI	Band 2 5250~5350MHz Band Edge @ 3m	
ANT	802.11a CH52 5260MHz - L	
2	Vertical	Fundamental
Peak	 <p>Date: 2016-10-30</p> <p>Site : 03CH07-HY Condition : PEAK_BE_74 3m HF-ANT_130829 VERTICAL RBW:1000.000kHz VBW:3000.000kHz SWT:Auto Detector : Peak Project : 600724 Mode : 4 Plane : Y Ant : 1 Setting : 20</p>	 <p>Date: 2016-10-30</p> <p>Site : 03CH07-HY Condition : PEAK_74 3m HF-ANT_130829 VERTICAL RBW:1000.000kHz VBW:3000.000kHz SWT:Auto Detector : Peak Project : 600724 Mode : 4 Plane : Y Ant : 1 Setting : 20</p>
Avg.	 <p>Date: 2016-10-30</p> <p>Site : 03CH07-HY Condition : AVG_BE_54 3m HF-ANT_130829 VERTICAL RBW:1000.000kHz VBW:1.000kHz SWT:Auto Detector : Peak Project : 600724 Mode : 4 Plane : Y Ant : 1 Setting : 20</p>	Left blank

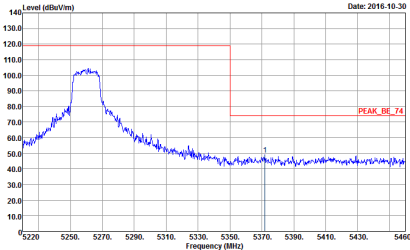
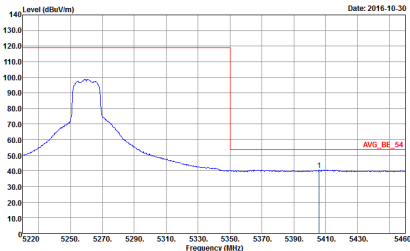

WIFI	Band 2 5250~5350MHz Band Edge @ 3m	
ANT	802.11a CH52 5260MHz - R	
2	Vertical	Fundamental
Peak	 <p> Site : 03CH07-HY Condition : PEAK_BE_74 3m HF-ANT_130829 VERTICAL : RBW:1000.000KHz VBW:3000.000KHz SWT:Auto Detector : Peak Project : 600724 Mode : -4 Plane : Y Azim : 1 Setting : 20 </p>	Left blank
Avg.	 <p> Site : 03CH07-HY Condition : AVG_BE_54 3m HF-ANT_130829 VERTICAL : RBW:1000.000KHz VBW:1.000KHz SWT:Auto Detector : Peak Project : 600724 Mode : -4 Plane : Y Azim : 1 Setting : 20 </p>	Left blank



WIFI	Band 2 5250~5350MHz Band Edge @ 3m	
ANT	802.11a CH60 5300MHz - L	
2	Horizontal	Fundamental
Peak	<p>Date: 2016-10-30</p> <p>Site : 03CH07HY Condition : PEAK_BE_74 3m HF-ANT_130829 HORIZONTAL RBW:1000.000kHz VBW:3000.000kHz SWT:Auto Detector : Peak Project : 600724 Mode : 5 Plane : Y Ant : 1 Setting : 19.5</p>	<p>Date: 2016-10-30</p> <p>Site : 03CH07HY Condition : PEAK_74 3m HF-ANT_130829 HORIZONTAL RBW:1000.000kHz VBW:3000.000kHz SWT:Auto Detector : Peak Project : 600724 Mode : 5 Plane : Y Ant : 1 Setting : 19.5</p>
Avg.	<p>Date: 2016-10-30</p> <p>Site : 03CH07HY Condition : AVG_BE_54 3m HF-ANT_130829 HORIZONTAL RBW:1000.000kHz VBW:1.000kHz SWT:Auto Detector : Peak Project : 600724 Mode : 5 Plane : Y Ant : 1 Setting : 19.5</p>	Left blank

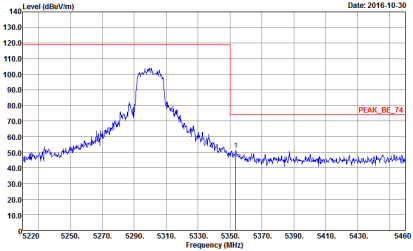
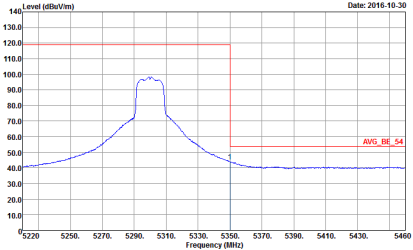

WIFI	Band 2 5250~5350MHz Band Edge @ 3m	
ANT	802.11a CH60 5300MHz - R	
2	Horizontal	Fundamental
Peak	 <p>Date: 2016-10-30</p> <p>Site : 03CH07HY Condition : PEAK_BE_74 3m HF-ANT_130829 HORIZONTAL Detector : Peak Project : 600724 Mode : S Plane : Y Ant : 1 Setting : 19.5</p>	Left blank
Avg.	 <p>Date: 2016-10-30</p> <p>Site : 03CH07HY Condition : AVG_BE_54 3m HF-ANT_130829 HORIZONTAL Detector : Peak Project : 600724 Mode : S Plane : Y Ant : 1 Setting : 19.5</p>	Left blank



WIFI	Band 2 5250~5350MHz Band Edge @ 3m	
ANT	802.11a CH60 5300MHz - L	
2	Vertical	Fundamental
Peak	<p>Site : 03CH07-HY Condition : PEAK_BE_74 3m HF-ANT_130829 VERTICAL RBW:1000.000kHz VBW:3000.000kHz SWT:Auto Detector : Peak Project : 600724 Mode : S Plane : Y Ant : 1 Setting : 19.5</p>	<p>Site : 03CH07-HY Condition : PEAK_74 3m HF-ANT_130829 VERTICAL RBW:1000.000kHz VBW:3000.000kHz SWT:Auto Detector : Peak Project : 600724 Mode : S Plane : Y Ant : 1 Setting : 19.5</p>
Avg.	<p>Site : 03CH07-HY Condition : AVG_BE_54 3m HF-ANT_130829 VERTICAL RBW:1000.000kHz VBW:1.000kHz SWT:Auto Detector : Peak Project : 600724 Mode : S Plane : Y Ant : 1 Setting : 19.5</p>	Left blank

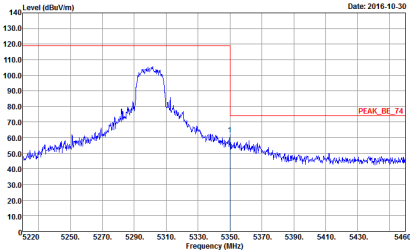
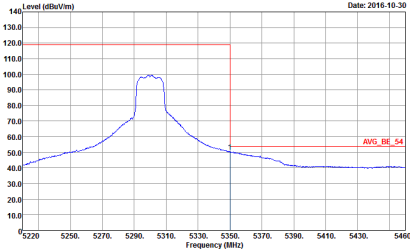

WIFI	Band 2 5250~5350MHz Band Edge @ 3m	
ANT	802.11a CH60 5300MHz - R	
2	Vertical	Fundamental
Peak	 <p>Site : 03CH07-HY Condition : PEAK_BE_74 3m HF-ANT_130829 VERTICAL : RBW:1000.000KHz VBW:3000.000KHz SWT:Auto Detector : Peak Project : 600724 Mode : S Plane : Y Ant : 1 Setting : 19.5</p>	Left blank
Avg.	 <p>Site : 03CH07-HY Condition : AVG_BE_54 3m HF-ANT_130829 VERTICAL : RBW:1000.000KHz VBW:1.000KHz SWT:Auto Detector : Peak Project : 600724 Mode : S Plane : Y Ant : 1 Setting : 19.5</p>	Left blank

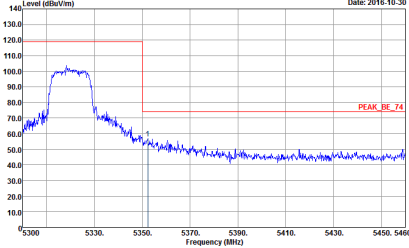
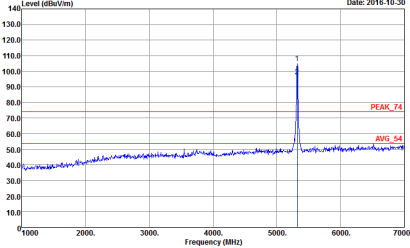
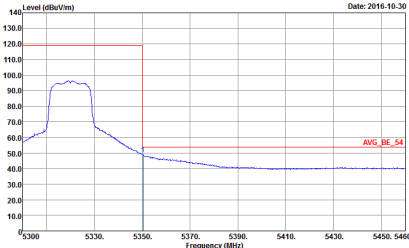

WIFI	Band 2 5250~5350MHz Band Edge @ 3m	
ANT	802.11a CH64 5320MHz	
2	Horizontal	Fundamental
Peak	 <p>Date: 2016-10-30</p> <p>Site : 03CH07HY Condition : PEAK_BE_74 3m HF-ANT_130829 HORIZONTAL RBW:1000.000kHz VBW:3000.000kHz SVWT:Auto Detector : Peak Project : 600724 Mode : 6 Plane : Y Ant : 1 Setting : 18.5</p>	 <p>Date: 2016-10-30</p> <p>Site : 03CH07HY Condition : PEAK_74 3m HF-ANT_130829 HORIZONTAL RBW:1000.000kHz VBW:3000.000kHz SVWT:Auto Detector : Peak Project : 600724 Mode : 6 Plane : Y Ant : 1 Setting : 18.5</p>
Avg.	 <p>Date: 2016-10-30</p> <p>Site : 03CH07HY Condition : AVG_BE_54 3m HF-ANT_130829 HORIZONTAL RBW:1000.000kHz VBW:1.000kHz SVWT:Auto Detector : Peak Project : 600724 Mode : 6 Plane : Y Ant : 1 Setting : 18.5</p>	Left blank

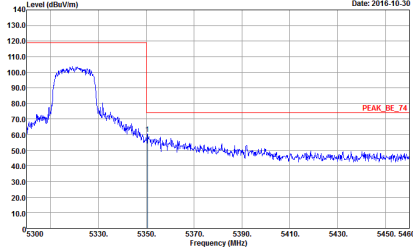
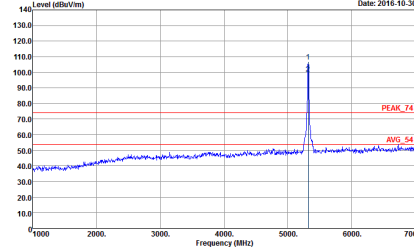
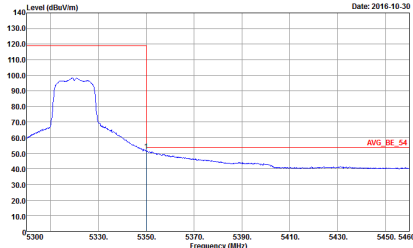

WIFI	Band 2 5250~5350MHz Band Edge @ 3m	
ANT	802.11a CH64 5320MHz	
2	Vertical	Fundamental
Peak	 <p>Date: 2016-10-30</p> <p>Site : 03CH07-HY Condition : PEAK_BE_74 3m HF-ANT_130829 VERTICAL : RBW:1000.000kHz VBW:3000.000kHz SWT:Auto Detector : Peak Project : 600724 Mode : E Plane : Y Ant : 1 Setting : 18.5</p>	 <p>Date: 2016-10-30</p> <p>Site : 03CH07-HY Condition : PEAK_74 3m HF-ANT_130829 VERTICAL : RBW:1000.000kHz VBW:3000.000kHz SWT:Auto Detector : Peak Project : 600724 Mode : E Plane : Y Ant : 1 Setting : 18.5</p>
Avg.	 <p>Date: 2016-10-30</p> <p>Site : 03CH07-HY Condition : AVG_BE_54 3m HF-ANT_130829 VERTICAL : RBW:1000.000kHz VBW:1.000kHz SWT:Auto Detector : Peak Project : 600724 Mode : E Plane : Y Ant : 1 Setting : 18.5</p>	Left blank



Band 2 5250~5350MHz
WIFI 802.11n HT20 (Band Edge @ 3m)

Table with 2 columns (WIFI, ANT) and 2 rows (Peak, Avg.). The table contains spectral analysis plots for 'Horizontal' and 'Fundamental' views, and 'Avg.' and 'Left blank' views. Each plot shows Level (dBuV/m) vs Frequency (MHz) with various markers and site/condition details.

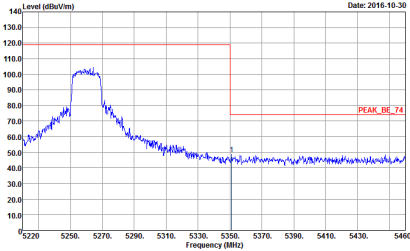
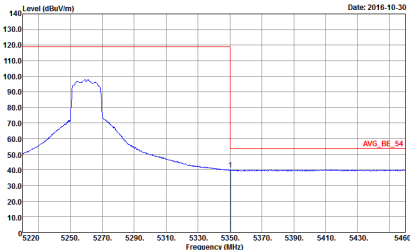

WIFI	Band 2 5250~5350MHz Band Edge @ 3m	
ANT	802.11n HT20 CH52 5260MHz - R	
2	Horizontal	Fundamental
Peak	 <p>Date: 2016-10-30</p> <p>Site : 03CH07HY Condition : PEAK_BE_74 3m HF-ANT_130829 HORIZONTAL Detector : Peak Project : 600724 Mode : 16 Plane : Y Ant : 1 Setting : 20</p>	Left blank
Avg.	 <p>Date: 2016-10-30</p> <p>Site : 03CH07HY Condition : AVG_BE_54 3m HF-ANT_130829 HORIZONTAL Detector : Peak Project : 600724 Mode : 16 Plane : Y Ant : 1 Setting : 20</p>	Left blank



WIFI	Band 2 5250~5350MHz Band Edge @ 3m	
ANT	802.11n HT20 CH52 5260MHz - L	
2	Vertical	Fundamental
Peak	<p>Site : 03CH07-HY Condition : PEAK_BE_74 3m HF-ANT_130829 VERTICAL RBW:1000.000kHz VBW:3000.000kHz SWT:Auto Detector : Peak Project : 600724 Mode : 16 Plane : Y Ant : 1 Setting : 20</p>	<p>Site : 03CH07-HY Condition : PEAK_74 3m HF-ANT_130829 VERTICAL RBW:1000.000kHz VBW:3000.000kHz SWT:Auto Detector : Peak Project : 600724 Mode : 16 Plane : Y Ant : 1 Setting : 20</p>
Avg.	<p>Site : 03CH07-HY Condition : AVG_BE_54 3m HF-ANT_130829 VERTICAL RBW:1000.000kHz VBW:1.000kHz SWT:Auto Detector : Peak Project : 600724 Mode : 16 Plane : Y Ant : 1 Setting : 20</p>	Left blank

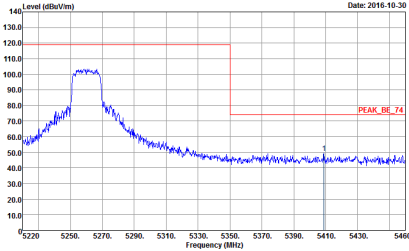
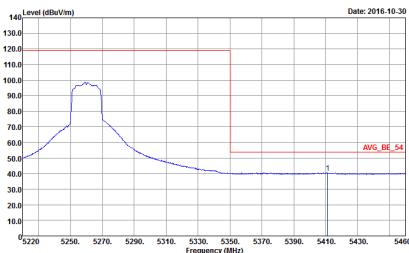

WIFI	Band 2 5250~5350MHz Band Edge @ 3m	
ANT	802.11n HT20 CH52 5260MHz - R	
2	Vertical	Fundamental
<p>Peak</p>	 <p>Site : 03CH07-HY Condition : PEAK_BE_74 3m HF-ANT_130829 VERTICAL Detector : Peak Project : 600724 Mode : 16 Plane : Y Ant : 1 Setting : 20</p>	<p>Left blank</p>
<p>Avg.</p>	 <p>Site : 03CH07-HY Condition : AVG_BE_54 3m HF-ANT_130829 VERTICAL Detector : Peak Project : 600724 Mode : 16 Plane : Y Ant : 1 Setting : 20</p>	<p>Left blank</p>

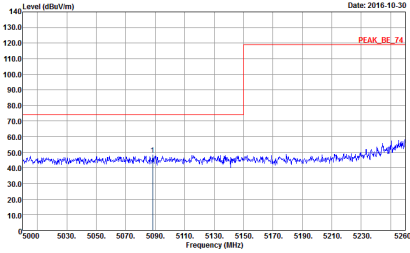
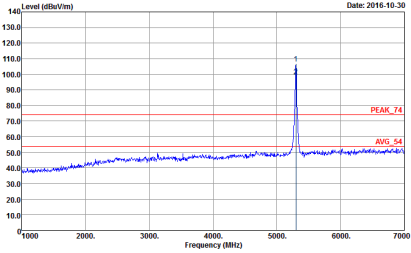
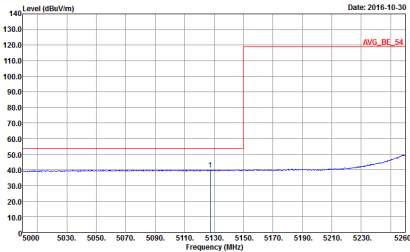

WIFI	Band 2 5250~5350MHz Band Edge @ 3m	
ANT	802.11n HT20 CH60 5300MHz - L	
2	Horizontal	Fundamental
Peak	 <p>Date: 2016-10-30</p> <p>Level (dBuV/m)</p> <p>Frequency (MHz)</p> <p>PEAK_BE_74</p> <p>Site : 03CH07HY Condition : PEAK_BE_74 3m HF-ANT_130829 HORIZONTAL RBW:1000.000kHz VBW:3000.000kHz SWT:Auto Detector : Peak Project : 600724 Mode : 17 Plane : V Ant : 1 Setting : 19.5</p>	 <p>Date: 2016-10-30</p> <p>Level (dBuV/m)</p> <p>Frequency (MHz)</p> <p>PEAK_74</p> <p>AVG_54</p> <p>Site : 03CH07HY Condition : PEAK_74 3m HF-ANT_130829 HORIZONTAL RBW:1000.000kHz VBW:3000.000kHz SWT:Auto Detector : Peak Project : 600724 Mode : 17 Plane : V Ant : 1 Setting : 19.5</p>
Avg.	 <p>Date: 2016-10-30</p> <p>Level (dBuV/m)</p> <p>Frequency (MHz)</p> <p>AVG_BE_54</p> <p>Site : 03CH07HY Condition : AVG_BE_54 3m HF-ANT_130829 HORIZONTAL RBW:1000.000kHz VBW:1.000kHz SWT:Auto Detector : Peak Project : 600724 Mode : 17 Plane : V Ant : 1 Setting : 19.5</p>	Left blank

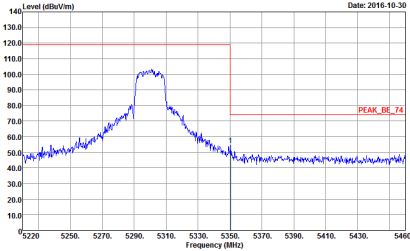
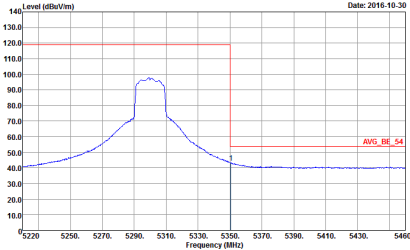

WIFI	Band 2 5250~5350MHz Band Edge @ 3m	
ANT	802.11n HT20 CH60 5300MHz - R	
2	Horizontal	Vertical
Peak	 <p>Date: 2016-10-30</p> <p>Site : 03CH07HY Condition : PEAK_BE_74 3m HF-ANT_130829 HORIZONTAL Detector : Peak Project : 600724 Mode : T7 Plane : V Ant : 1 Setting : 19.5</p>	Left blank
Avg.	 <p>Date: 2016-10-30</p> <p>Site : 03CH07HY Condition : AVG_BE_54 3m HF-ANT_130829 HORIZONTAL Detector : Peak Project : 600724 Mode : T7 Plane : V Ant : 1 Setting : 19.5</p>	Left blank

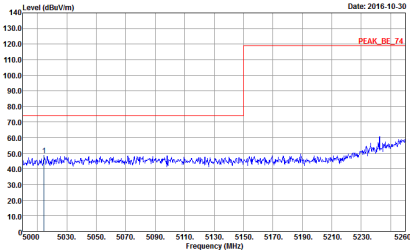
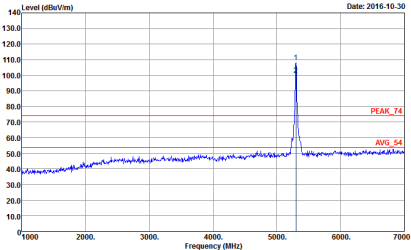
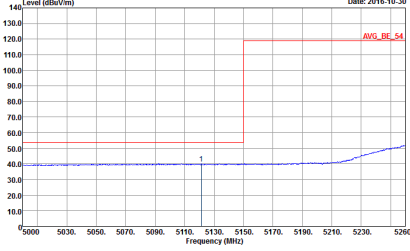

WIFI	Band 2 5250~5350MHz Band Edge @ 3m	
ANT	802.11n HT20 CH60 5300MHz - L	
2	Vertical	Fundamental
Peak	 <p>Date: 2016-10-30</p> <p>Site : 03CH07.HY Condition : PEAK_BE_74 3m HF-ANT_130829 VERTICAL : RBW:1000.000kHz VBW:3000.000kHz SWT:Auto Detector : Peak Project : 600724 Mode : IT Plane : Y Ant : 1 Setting : 19.5</p>	 <p>Date: 2016-10-30</p> <p>Site : 03CH07.HY Condition : PEAK_74 3m HF-ANT_130829 VERTICAL : RBW:1000.000kHz VBW:3000.000kHz SWT:Auto Detector : Peak Project : 600724 Mode : IT Plane : Y Ant : 1 Setting : 19.5</p>
Avg.	 <p>Date: 2016-10-30</p> <p>Site : 03CH07.HY Condition : AVG_BE_54 3m HF-ANT_130829 VERTICAL : RBW:1000.000kHz VBW:1.000kHz SWT:Auto Detector : Peak Project : 600724 Mode : IT Plane : Y Ant : 1 Setting : 19.5</p>	Left blank

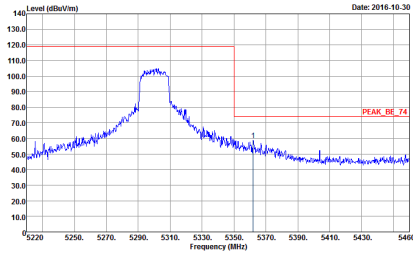
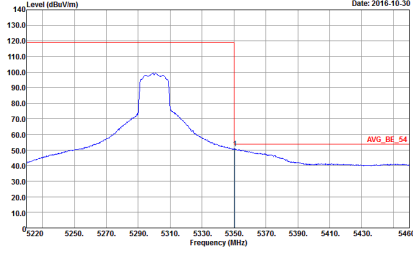

WIFI	Band 2 5250~5350MHz Band Edge @ 3m	
ANT	802.11n HT20 CH60 5300MHz - R	
2	Vertical	Fundamental
<p>Peak</p>	 <p>Site : 03CH07HY Condition : PEAK_BE_74 3m HF-ANT_130829 VERTICAL Detector : Peak Project : 600724 Mode : T7 Plane : Y Ant : 1 Setting : 19.5</p>	<p>Left blank</p>
<p>Avg.</p>	 <p>Site : 03CH07HY Condition : AVG_BE_54 3m HF-ANT_130829 VERTICAL Detector : Peak Project : 600724 Mode : T7 Plane : Y Ant : 1 Setting : 19.5</p>	<p>Left blank</p>



WIFI	Band 2 5250~5350MHz Band Edge @ 3m	
ANT	802.11n HT20 CH64 5320MHz	
2	Horizontal	Fundamental
Peak	<p> Site : 03CH07-HY Condition : PEAK_BE_74 3m HF-ANT_130829 HORIZONTAL RBW:1000.000kHz VBW:3000.000kHz SWT:Auto Detector : Peak Project : 600724 Mode : 18 Plane : Y Ant : 1 Setting : 18.5 </p>	<p> Site : 03CH07-HY Condition : PEAK_74 3m HF-ANT_130829 HORIZONTAL RBW:1000.000kHz VBW:3000.000kHz SWT:Auto Detector : Peak Project : 600724 Mode : 18 Plane : Y Ant : 1 Setting : 18.5 </p>
Avg.	<p> Site : 03CH07-HY Condition : AVG_BE_54 3m HF-ANT_130829 HORIZONTAL RBW:1000.000kHz VBW:1.000kHz SWT:Auto Detector : Peak Project : 600724 Mode : 18 Plane : Y Ant : 1 Setting : 18.5 </p>	Left blank

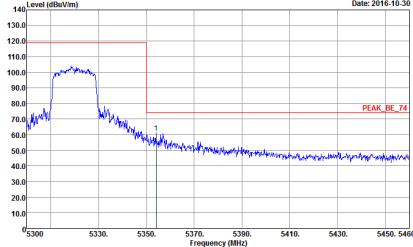
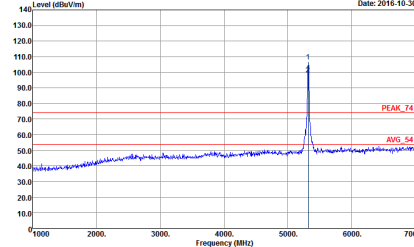
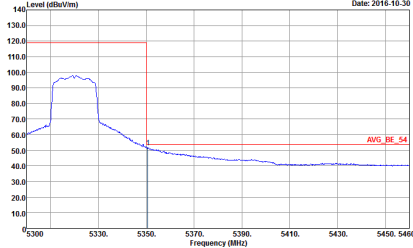

WIFI	Band 2 5250~5350MHz Band Edge @ 3m	
ANT	802.11n HT20 CH64 5320MHz	
2	<p style="text-align: center;">Vertical</p>  <p style="text-align: right;">Date: 2016-10-30</p> <pre> Site : 03CH07.HY Condition : PEAK_BE_74 3m HF-ANT_130829 VERTICAL : RBW:1000.000kHz VBW:3000.000kHz SWT:Auto Detector : Peak Project : 600724 Mode : IS Plane : Y Ant : 1 Setting : 18.5 </pre>	<p style="text-align: center;">Fundamental</p>  <p style="text-align: right;">Date: 2016-10-30</p> <pre> Site : 03CH07.HY Condition : PEAK_74 3m HF-ANT_130829 VERTICAL : RBW:1000.000kHz VBW:3000.000kHz SWT:Auto Detector : Peak Project : 600724 Mode : IS Plane : Y Ant : 1 Setting : 18.5 </pre>
Peak	 <p style="text-align: right;">Date: 2016-10-30</p> <pre> Site : 03CH07.HY Condition : AVG_BE_54 3m HF-ANT_130829 VERTICAL : RBW:1000.000kHz VBW:1.000kHz SWT:Auto Detector : Peak Project : 600724 Mode : IS Plane : Y Ant : 1 Setting : 18.5 </pre>	<p style="text-align: center;">Left blank</p>



Band 2 5250~5350MHz

Band 2 - 5250~5350MHz

WIFI 802.11a (Harmonic @ 3m)

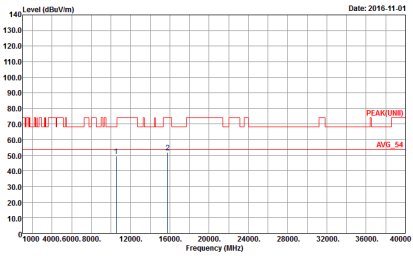
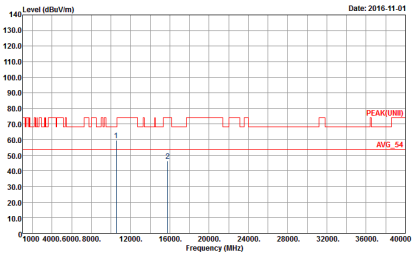
WIFI	Band 2 5250~5350MHz Harmonic @ 3m	
ANT	802.11a CH52 5260MHz	
2	Horizontal	Vertical
<p>Peak Avg.</p>	 <p>Site : 03CH07-HY Condition : PEAK(LIM) 3m SHF-EHF_131029 HORIZONTAL Detector : Peak Project : 600724 Mode : 4 Plane : Y Ant : 1 Setting : 20</p>	 <p>Site : 03CH07-HY Condition : PEAK(LIM) 3m SHF-EHF_131029 VERTICAL Detector : Peak Project : 600724 Mode : 4 Plane : Y Ant : 1 Setting : 20</p>



WIFI	Band 2 5250~5350MHz Harmonic @ 3m	
ANT	802.11a CH60 5300MHz	
2	Horizontal	Vertical
Peak Avg.		

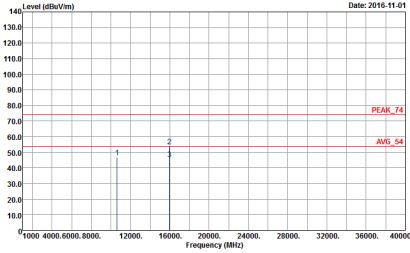
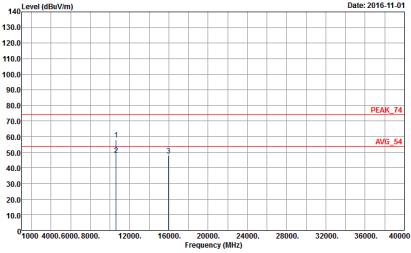

WIFI	Band 2 5250~5350MHz Harmonic @ 3m	
ANT	802.11a CH64 5320MHz	
2	Horizontal	Vertical
Peak Avg.	 <p>Site : 03CH07.HY Condition : PEAK_T4 3m SHF-EHF_131029 HORIZONTAL Detector : Peak Project : 600724 Mode : 6 Plane : Y Alt : 1 Setting : 18.5</p>	 <p>Site : 03CH07.HY Condition : PEAK_T4 3m SHF-EHF_131029 VERTICAL Detector : Peak Project : 600724 Mode : 6 Plane : Y Alt : 1 Setting : 18.5</p>



Band 2 5250~5350MHz
WIFI 802.11n HT20 (Harmonic @ 3m)

Table with 3 columns: WIFI, ANT, and measurement results for Horizontal and Vertical orientations. Includes peak and average level graphs and technical specifications.

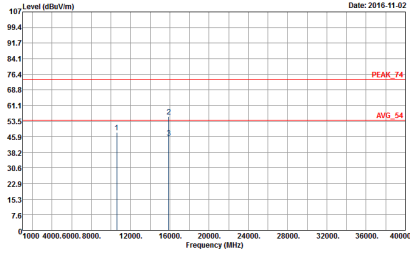
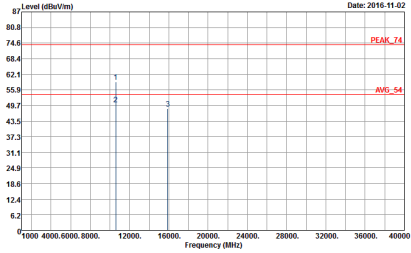

WIFI	Band 2 5250~5350MHz Harmonic @ 3m	
ANT	802.11n HT20 CH60 5300MHz	
2	Horizontal	Vertical
Peak Avg.	 <p>Site : 03CH07.HY Condition : PEAK_T4 3m SHF-EHF_131029 HORIZONTAL Detector : Peak Project : 600724 Mode : IT Plane : Y Alt : 1 Setting : 19.5</p>	 <p>Site : 03CH07.HY Condition : PEAK_T4 3m SHF-EHF_131029 VERTICAL Detector : Peak Project : 600724 Mode : IT Plane : Y Alt : 1 Setting : 19.5</p>

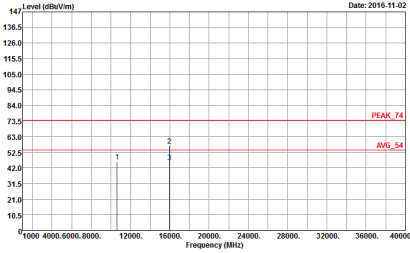
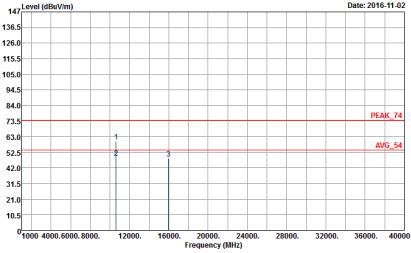

WIFI	Band 2 5250~5350MHz Harmonic @ 3m	
ANT	802.11n HT20 CH64 5320MHz	
2	Horizontal	Vertical
Peak Avg.	 <p>Site : 03CH07.HY Condition : PEAK_74 3m SHF-EHF_131029 HORIZONTAL Detector : Peak Project : 600724 Mode : IS Plane : Y Alt : 1 Setting : 18.5</p>	 <p>Site : 03CH07.HY Condition : PEAK_74 3m SHF-EHF_131029 VERTICAL Detector : Peak Project : 600724 Mode : IS Plane : Y Alt : 1 Setting : 18.5</p>



Band 2 5250~5350MHz

Band 3 - 5470~5725MHz

WIFI 802.11a (Band Edge @ 3m)

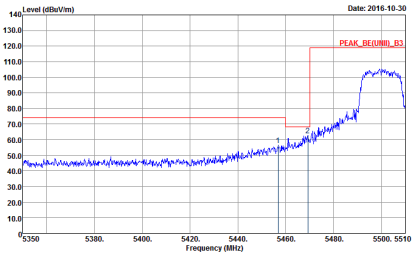
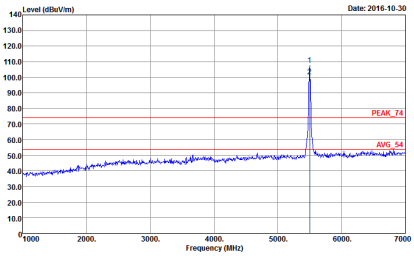
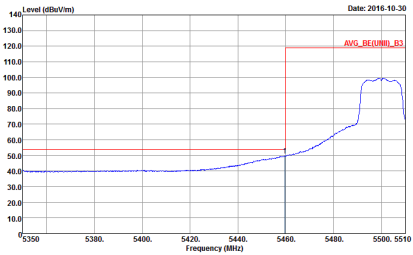
WIFI	Band 3 5470~5725MHz Band Edge @ 3m	
ANT	802.11a CH100 5500MHz	
2	Horizontal	Fundamental
Peak	 <p>Site : 03CH07-HY Condition : PEAK_BE(UM)_B3 3m HF-ANT_130829 HORIZONTAL Detector : Peak Project : 600724 Mode : 7 Plane : Y Ant : 1 Setting : 19.5 : 68.3</p>	 <p>Site : 03CH07-HY Condition : PEAK_T4 3m HF-ANT_130829 HORIZONTAL Detector : Peak Project : 600724 Mode : 7 Plane : Y Ant : 1 Setting : 19.5 : 68.3</p>
Avg.	 <p>Site : 03CH07-HY Condition : AVG_BE(UM)_B3 3m HF-ANT_130829 HORIZONTAL Detector : Peak Project : 600724 Mode : 7 Plane : Y Ant : 1 Setting : 19.5 : 68.3</p>	Left blank



WIFI	Band 3 5470~5725MHz Band Edge @ 3m	
ANT	802.11a CH100 5500MHz	
2	Vertical	Fundamental
Peak	<p>Site : 03CH07HY Condition : PEAK_BE(UN)D_B3 3m HF-ANT_130829 VERTICAL RBW:1000.000kHz VBW:3000.000kHz SWT:Auto Detector : Peak Project : 600724 Mode : 7 Plane : Y Ant : 1 Setting : 19.5</p>	<p>Site : 03CH07HY Condition : PEAK_F4 3m HF-ANT_130829 VERTICAL RBW:1000.000kHz VBW:3000.000kHz SWT:Auto Detector : Peak Project : 600724 Mode : 7 Plane : Y Ant : 1 Setting : 19.5</p>
Avg.	<p>Site : 03CH07HY Condition : AVG_BE(UN)D_B3 3m HF-ANT_130829 VERTICAL RBW:1000.000kHz VBW:1.000kHz SWT:Auto Detector : Peak Project : 600724 Mode : 7 Plane : Y Ant : 1 Setting : 19.5</p>	Left blank



WIFI	Band 3 5470~5725MHz Band Edge @ 3m	
ANT	802.11a CH116 5580MHz - L	
2	Horizontal	Fundamental
<p>Peak</p>	<p>Date: 2016-10-30</p> <p>Site : 03CH07-HY Condition : PEAK_BE(UNI)_B3 3m HF-ANT_130829 HORIZONTAL RBW:1000.000kHz VBW:3000.000kHz SWT:Auto Detector : Peak Project : 600724 Mode : 0 Plane : Y Ant : 1 Setting : 68.3</p>	<p>Date: 2016-10-30</p> <p>Site : 03CH07-HY Condition : PEAK_T4 3m HF-ANT_130829 HORIZONTAL RBW:1000.000kHz VBW:3000.000kHz SWT:Auto Detector : Peak Project : 600724 Mode : 0 Plane : Y Ant : 1 Setting : 68.3</p>
<p>Avg.</p>	<p>Date: 2016-10-30</p> <p>Site : 03CH07-HY Condition : AVG_BE(UNI)_B3 3m HF-ANT_130829 HORIZONTAL RBW:1000.000kHz VBW:1.000kHz SWT:Auto Detector : Peak Project : 600724 Mode : 0 Plane : Y Ant : 1 Setting : 68.3</p>	<p>Left blank</p>



WIFI	Band 3 5470~5725MHz Band Edge @ 3m	
ANT	802.11a CH116 5580MHz - R	
2	Horizontal	Fundamental
Peak	<p>Site : 03CH07HY Condition : PEAK_BEQUND_B3 3m HF-ANT: 130829 HORIZONTAL Defector : Peak Project : 600724 Mode : S Plane : Y Ant : 1 Setting : 20 : 68.3</p>	Left blank

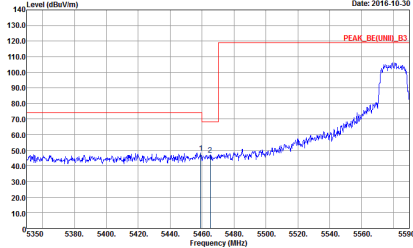
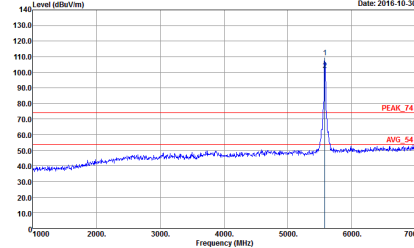
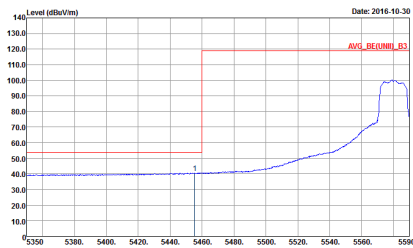

WIFI	Band 3 5470~5725MHz Band Edge @ 3m	
ANT	802.11a CH116 5580MHz - L	
2	Vertical	Fundamental
Peak	 <p>Site : 03CH07.HY Condition : PEAK_BE(UM)_B3 3m HF ANT_130829 VERTICAL : RBW:1000.000kHz VBW:3000.000kHz SWT:Auto Detector : Peak Project : 600724 Mode : S Plane : Y Ant : 1 Setting : 20 : 68.3</p>	 <p>Site : 03CH07.HY Condition : PEAK_74 3m HF ANT_130829 VERTICAL : RBW:1000.000kHz VBW:3000.000kHz SWT:Auto Detector : Peak Project : 600724 Mode : S Plane : Y Ant : 1 Setting : 20 : 68.3</p>
Avg.	 <p>Site : 03CH07.HY Condition : AVG_BE(UM)_B3 3m HF ANT_130829 VERTICAL : RBW:1000.000kHz VBW:1.000kHz SWT:Auto Detector : Peak Project : 600724 Mode : S Plane : Y Ant : 1 Setting : 20 : 68.3</p>	Left blank



WIFI	Band 3 5470~5725MHz Band Edge @ 3m	
ANT	802.11a CH116 5580MHz - R	
2	Vertical	Fundamental
Peak	<p>Site : 03CH07-HY Condition : PEAK_BE(UMI)_B3 3m HF ANT_130829 VERTICAL : RBW:1000.000kHz VBW:3000.000kHz SWT:Auto Detector : Peak Project : 600724 Mode : S Plane : Y Att : 1 Setting : 20 : 68.3</p>	Left blank



WIFI	Band 3 5470~5725MHz Band Edge @ 3m	
ANT	802.11a CH140 5700MHz	
2	Horizontal	Fundamental
Peak	<p>Site : 03CH07HY Condition : PEAK_BE(UH)_B3 3m HF-ANT_130829 HORIZONTAL RBW:1000.000kHz VBW:3000.000kHz SWT:Auto Detector : Peak Project : 600724 Mode : 9 Plane : Y Ant : 1 Setting : 68.3</p>	<p>Site : 03CH07HY Condition : PEAK_T4 3m HF-ANT_130829 HORIZONTAL RBW:1000.000kHz VBW:3000.000kHz SWT:Auto Detector : Peak Project : 600724 Mode : 9 Plane : Y Ant : 1 Setting : 68.3</p>

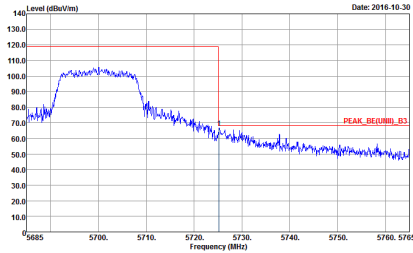
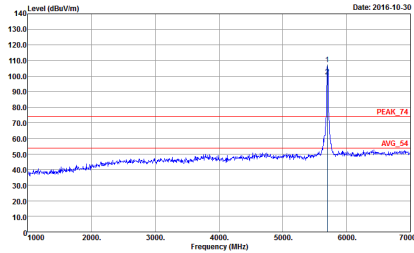

WIFI	Band 3 5470~5725MHz Band Edge @ 3m	
ANT	802.11a CH140 5700MHz	
2	Vertical	Fundamental
Peak	 <p> Site : 03CH07HY Condition : PEAK_BE(UBB)_B3 3m HF-ANT: 130829 VERTICAL Detector : Peak Project : 600724 Mode : S Plane : Y Ant : 1 Setting : 19 : 68.3 </p>	 <p> Site : 03CH07HY Condition : PEAK_T4 3m HF-ANT: 130829 VERTICAL Detector : Peak Project : 600724 Mode : S Plane : Y Ant : 1 Setting : 19 : 68.3 </p>

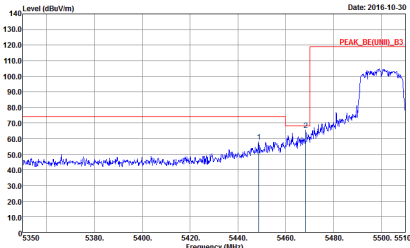
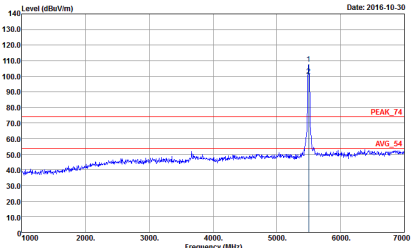
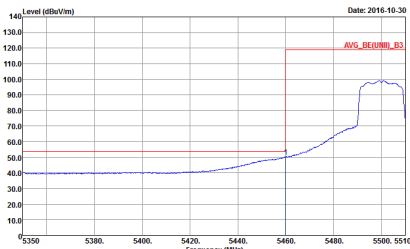

Band 3 5470~5725MHz
WIFI 802.11n HT20 (Band Edge @ 3m)

WIFI	Band 3 5470~5725MHz Band Edge @ 3m	
ANT	802.11n HT20 CH100 5500MHz	
2	Horizontal	Fundamental
Peak	 <p>Date: 2016-10-30</p> <pre> Site : 03CH07.HY Condition : PEAK_BE(UMI)_B3 3m HF-ANT_130829 HORIZONTAL Detector : Peak Project : 600724 Mode : 19 Plane : Y Ant : 1 Setting : 19.5 : 68.3 </pre>	 <p>Date: 2016-10-30</p> <pre> Site : 03CH07.HY Condition : PEAK_T4 3m HF-ANT_130829 HORIZONTAL Detector : Peak Project : 600724 Mode : 19 Plane : Y Ant : 1 Setting : 19.5 : 68.3 </pre>
Avg.	 <p>Date: 2016-10-30</p> <pre> Site : 03CH07.HY Condition : AVG_BE(UMI)_B3 3m HF-ANT_130829 HORIZONTAL Detector : Peak Project : 600724 Mode : 19 Plane : Y Ant : 1 Setting : 19.5 : 68.3 </pre>	Left blank



WIFI	Band 3 5470~5725MHz Band Edge @ 3m	
ANT	802.11n HT20 CH100 5500MHz	
2	Vertical	Fundamental
Peak	<p>Site : 03CH07.HY Condition : PEAK_BE(UM)_B3 3m HF ANT_130829 VERTICAL : RBW:1000.000kHz VBW:3000.000kHz SWT:Auto Detector : Peak Project : 600724 Mode : 19 Plane : Y Ant : 1 Setting : 19.5 : 68.3</p>	<p>Site : 03CH07.HY Condition : PEAK_74 3m HF ANT_130829 VERTICAL : RBW:1000.000kHz VBW:3000.000kHz SWT:Auto Detector : Peak Project : 600724 Mode : 19 Plane : Y Ant : 1 Setting : 19.5 : 68.3</p>
Avg.	<p>Site : 03CH07.HY Condition : AVG_BE(UM)_B3 3m HF ANT_130829 VERTICAL : RBW:1000.000kHz VBW:1.000kHz SWT:Auto Detector : Peak Project : 600724 Mode : 19 Plane : Y Ant : 1 Setting : 19.5 : 68.3</p>	Left blank



WIFI	Band 3 5470~5725MHz Band Edge @ 3m	
ANT	802.11n HT20 CH116 5580MHz - L	
2	Horizontal	Fundamental
<p>Peak</p>	<p>Date: 2016-10-30</p> <p>Site : 03CH07-HY Condition : PEAK_BE(UMI)_B3 3m HF-ANT_130829 HORIZONTAL Detector : Peak Project : 600724 Mode : 20 Plane : Y Ant : 1 Setting : 68.3</p>	<p>Date: 2016-10-30</p> <p>Site : 03CH07-HY Condition : PEAK_T4 3m HF-ANT_130829 HORIZONTAL Detector : Peak Project : 600724 Mode : 20 Plane : Y Ant : 1 Setting : 68.3</p>
<p>Avg.</p>	<p>Date: 2016-10-30</p> <p>Site : 03CH07-HY Condition : AVG_BE(UMI)_B3 3m HF-ANT_130829 HORIZONTAL Detector : Peak Project : 600724 Mode : 20 Plane : Y Ant : 1 Setting : 68.3</p>	<p>Left blank</p>

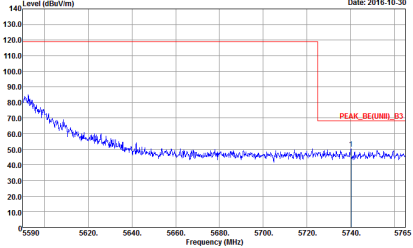

WIFI	Band 3 5470~5725MHz Band Edge @ 3m	
ANT	802.11n HT20 CH116 5580MHz - R	
2	Horizontal	Fundamental
Peak	 <p>Site : 03CH07HY Condition : PEAK_BECOND_B3 3m HF-ANT_130829 HORIZONTAL Detector : Peak Project : 600724 Mode : 20 Plane : Y Ant. : 1 Setting : 68.3</p>	Left blank

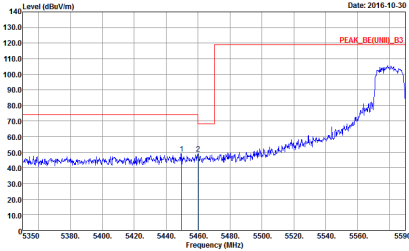
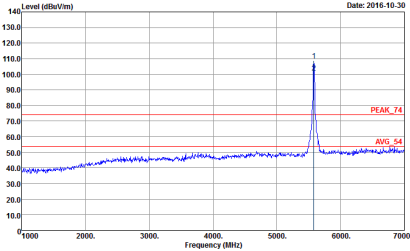
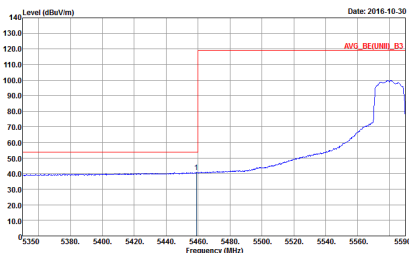

WIFI	Band 3 5470~5725MHz Band Edge @ 3m	
ANT	802.11n HT20 CH116 5580MHz - L	
2	Vertical	Fundamental
<p>Peak</p>	 <p>Site : 03CH07-HY Condition : PEAK_BE(UML)_B3 3m HF-ANT_130829 VERTICAL : RBW:1000.000kHz VBW:3000.000kHz SWT:Auto Detector : Peak Project : 600724 Mode : 20 Plane : Y Ant : 1 Setting : 68.3</p>	 <p>Site : 03CH07-HY Condition : PEAK_T4 3m HF-ANT_130829 VERTICAL : RBW:1000.000kHz VBW:3000.000kHz SWT:Auto Detector : Peak Project : 600724 Mode : 20 Plane : Y Ant : 1 Setting : 68.3</p>
<p>Avg.</p>	 <p>Site : 03CH07-HY Condition : AVG_BE(UML)_B3 3m HF-ANT_130829 VERTICAL : RBW:1000.000kHz VBW:1.000kHz SWT:Auto Detector : Peak Project : 600724 Mode : 20 Plane : Y Ant : 1 Setting : 68.3</p>	<p>Left blank</p>

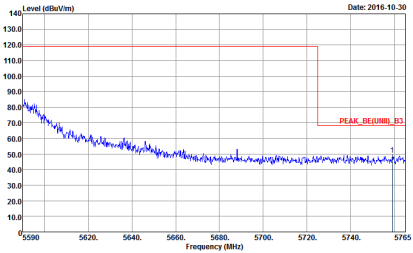

WIFI	Band 3 5470~5725MHz Band Edge @ 3m	
ANT	802.11n HT20 CH116 5580MHz - R	
2	Vertical	Fundamental
Peak	 <p>Site : 03CH07HY Condition : PEAK_BE(UND)_E3 3m HF-ANT: 130829 VERTICAL Detector : Peak Project : 600724 Mode : 20 Plane : Y Ant : 1 Setting : 68.3</p>	Left blank

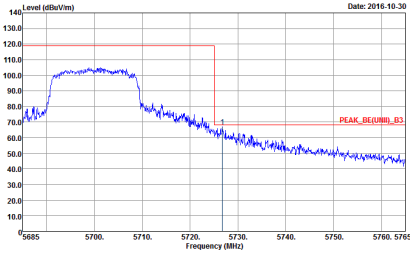
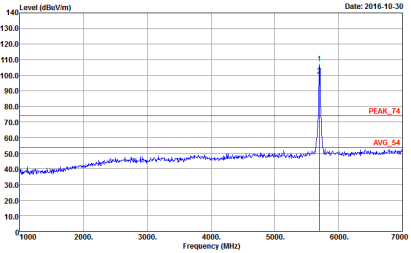

WIFI	Band 3 5470~5725MHz Band Edge @ 3m	
ANT	802.11n HT20 CH140 5700MHz	
2	Horizontal	Fundamental
Peak	 <p>Date: 2016-10-30</p> <p>Site : 03CH07HY Condition : PEAK_BE(UH)_B3 3m HF-ANT_130829 HORIZONTAL RBW:1000.000kHz VBW:3000.000kHz SWT:Auto Detector : Peak Project : 600724 Mode : Z1 Plane : Y Ant : 1 Setting : 68.3</p>	 <p>Date: 2016-10-30</p> <p>Site : 03CH07HY Condition : PEAK_T4 3m HF-ANT_130829 HORIZONTAL RBW:1000.000kHz VBW:3000.000kHz SWT:Auto Detector : Peak Project : 600724 Mode : Z1 Plane : Y Ant : 1 Setting : 68.3</p>

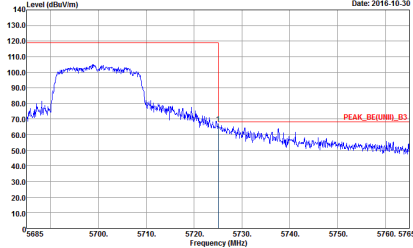
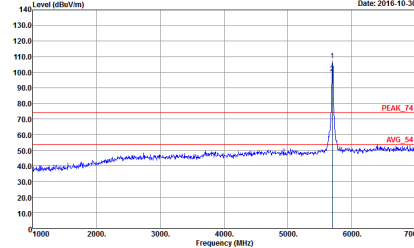

WIFI	Band 3 5470~5725MHz Band Edge @ 3m	
ANT	802.11n HT20 CH140 5700MHz	
2	Vertical	Fundamental
<p>Peak.</p>	 <p>Site : 03CH07.HY Condition : PEAK_BE(UMI)_B3 3m HF ANT_130829 VERTICAL : RBW:1000.000kHz VBW:3000.000kHz SWT:Auto Detector : Peak Project : 600724 Mode : Z1 Plane : Y Ant : 1 Setting : 19 : 68.3</p>	 <p>Site : 03CH07.HY Condition : PEAK_74 3m HF ANT_130829 VERTICAL : RBW:1000.000kHz VBW:3000.000kHz SWT:Auto Detector : Peak Project : 600724 Mode : Z1 Plane : Y Ant : 1 Setting : 19 : 68.3</p>



Band 3 5470~5725MHz

Band 3 - 5470~5725MHz

WIFI 802.11a (Harmonic @ 3m)

WIFI	Band 3 5470~5725MHz Harmonic @ 3m	
ANT	802.11a CH100 5500MHz	
2	Horizontal	Vertical
<p>Peak</p> <p>Avg.</p>		

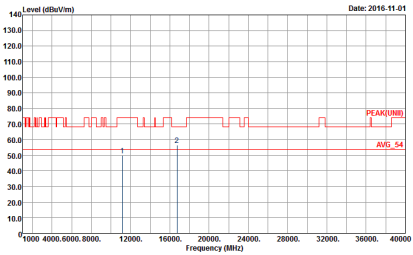
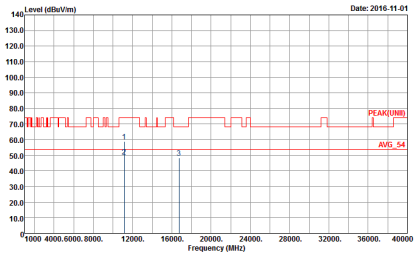

WIFI	Band 3 5470~5725MHz Harmonic @ 3m	
ANT	802.11a CH116 5580MHz	
2	Horizontal	Vertical
<p>Peak Avg.</p>	 <p>Site : 03CH074HY Condition : PEAK(AVG) 3m SHF_EHF_131029 HORIZONTAL Detector : Peak Project : 600724 Mode : S Plane : Y Ant : 1 Setting : 20 : 68.3</p>	 <p>Site : 03CH074HY Condition : PEAK(AVG) 3m SHF_EHF_131029 VERTICAL Detector : Peak Project : 600724 Mode : S Plane : Y Ant : 1 Setting : 20 : 68.3</p>

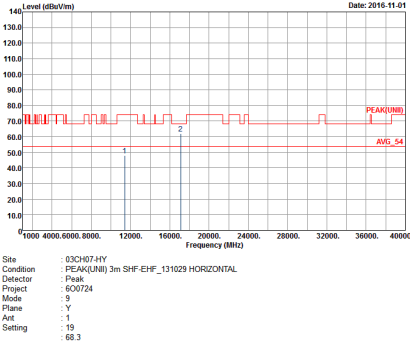
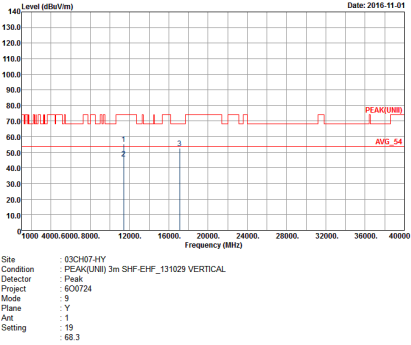

WIFI	Band 3 5470~5725MHz Harmonic @ 3m	
ANT	802.11a CH140 5700MHz	
2	Horizontal	Vertical
Peak Avg.		

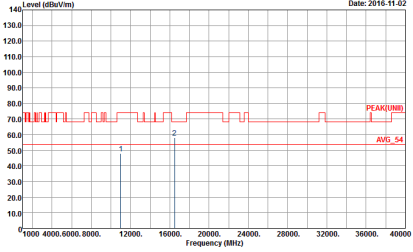
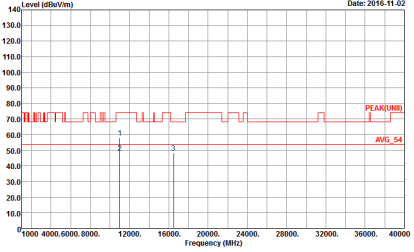

Band 3 5470~5725MHz
WIFI 802.11n HT20 (Harmonic @ 3m)

WIFI	Band 3 5470~5725MHz Harmonic @ 3m	
ANT	802.11n HT20 CH100 5500MHz	
2	Horizontal	Vertical
<p>Peak Avg.</p>	 <p>Date: 2016-11-02</p> <pre> Site : 03CH07-HY Condition : PEAK(LIN) 3m SHF-EHF_131029 HORIZONTAL Detector : Peak Project : 600724 Mode : 19 Plane : Y Ant : 1 Setting : 19.5 : 68.3 </pre>	 <p>Date: 2016-11-02</p> <pre> Site : 03CH07-HY Condition : PEAK(LIN) 3m SHF-EHF_131029 VERTICAL Detector : Peak Project : 600724 Mode : 19 Plane : Y Ant : 1 Setting : 19.5 : 68.3 </pre>



WIFI	Band 3 5470~5725MHz Harmonic @ 3m	
ANT	802.11n HT20 CH116 5580MHz	
2	Horizontal	Vertical
<p>Peak</p> <p>Avg.</p>		

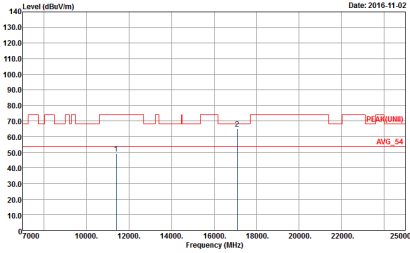
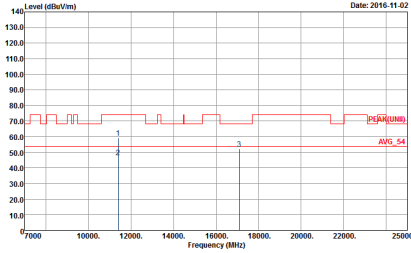

WIFI	Band 3 5470~5725MHz Harmonic @ 3m	
ANT	802.11n HT20 CH140 5700MHz	
2	Horizontal	Vertical
<p>Peak</p> <p>Avg.</p>	 <p>Date: 2016-11-02</p> <p>Site : 03CH07.HY Condition : PEAK(LIM) 3m SHF_EHF_131029 HORIZONTAL Detector : Peak Project : 600724 Mode : 21 Plane : Y Ant : 1 Setting : 19 : 68.3</p>	 <p>Date: 2016-11-02</p> <p>Site : 03CH07.HY Condition : PEAK(LIM) 3m SHF_EHF_131029 VERTICAL Detector : Peak Project : 600724 Mode : 21 Plane : Y Ant : 1 Setting : 19 : 68.3</p>



Band 3 5470~5725MHz

Emission below 1GHz

5GHz WIFI 802.11n HT20 (LF)

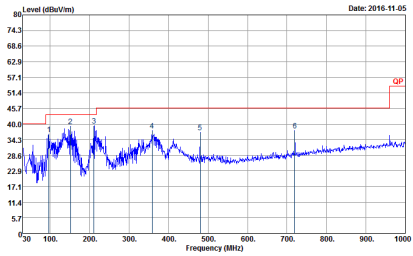
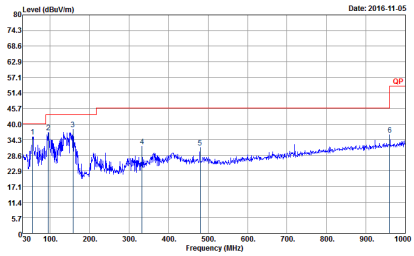
WIFI	5GHz WIFI	
ANT	802.11n HT20 LF	
2	Horizontal	Vertical
<p>QP / Peak</p>	 <p>Site : 03CH07-HY Condition : QP 3m LF-ANT-35419(6) HORIZONTAL Project : 600724 Mode : 25 Plane : Y Ant : 1</p>	 <p>Site : 03CH07-HY Condition : QP 3m LF-ANT-35419(6) VERTICAL Project : 600724 Mode : 25 Plane : Y Ant : 1</p>

Appendix D Duty Cycle Plots

<EUT with J300 Antenna>

Band	Duty Cycle(%)	T(us)	1/T(kHz)	VBW Setting
802.11a	96.55	1400	0.71	1kHz
5GHz 802.11n HT20	97.04	1310	0.76	1kHz

802.11a

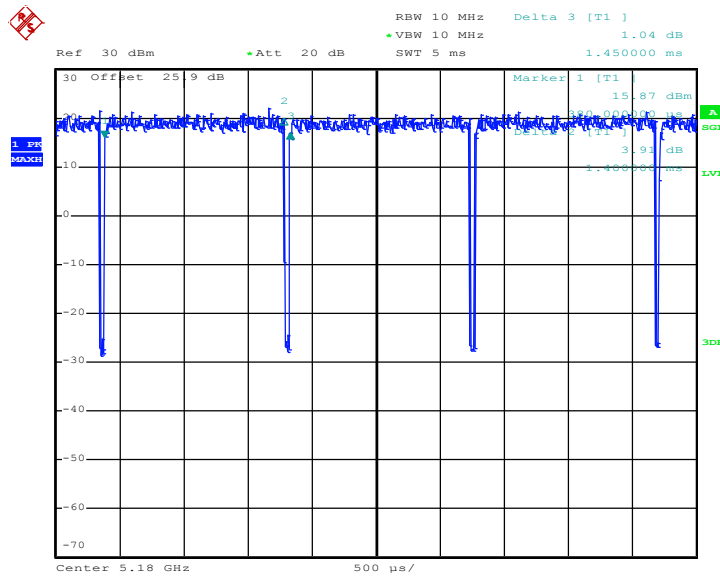

Date: 3.NOV.2016 16:22:17



802.11n HT20

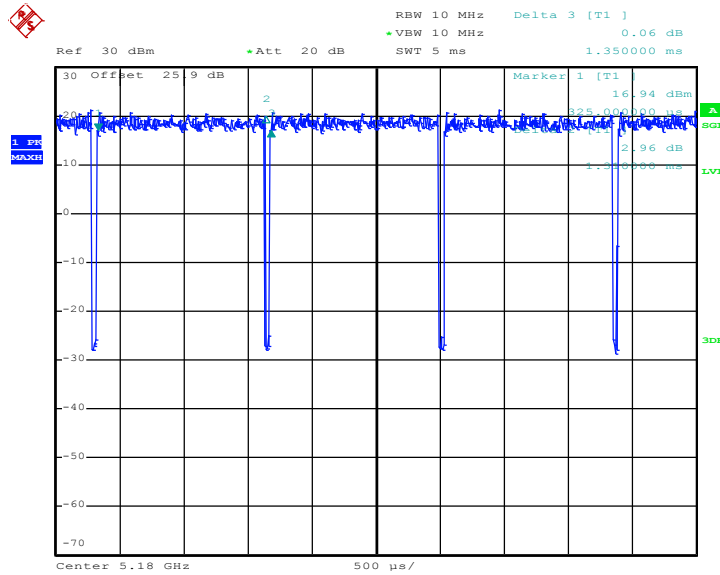

Date: 3.NOV.2016 16:28:08

<EUT with J301 Antenna>

Band	Duty Cycle(%)	T(us)	1/T(kHz)	VBW Setting
802.11a	97.22	1400	0.71	1kHz
5GHz 802.11n HT20	96.36	1310	0.76	1kHz

802.11a

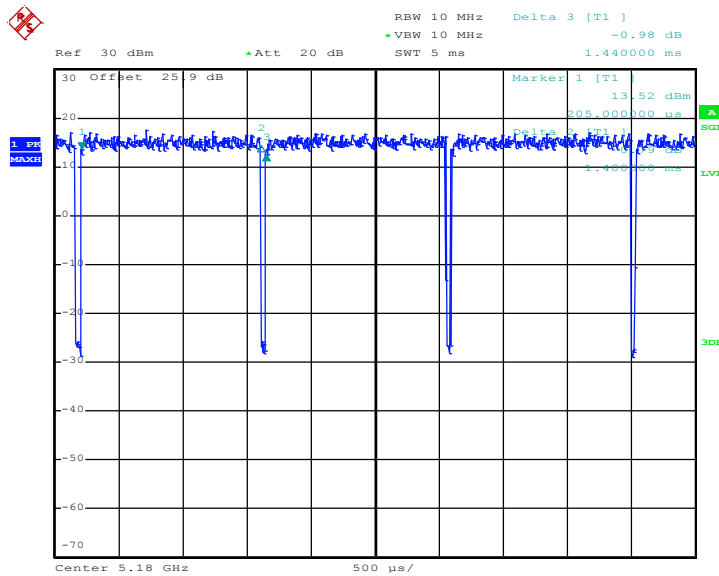

Date: 4.NOV.2016 16:56:02



5GHz 802.11n HT20

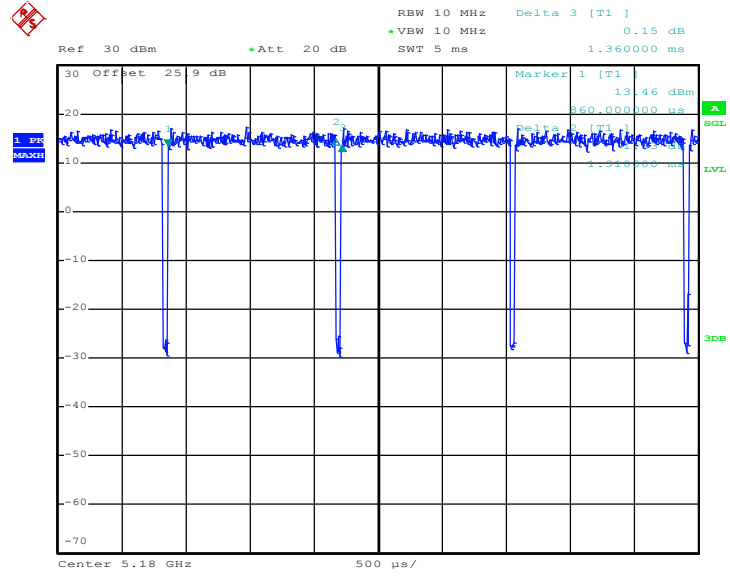

Date: 4.NOV.2016 16:51:51