

Supplementary FCC Test Report

Report No.: RF120904C23H

FCC ID: UZ7MK3190

Test Model: MK3190

Received Date: Dec. 28, 2015

Test Date: Jan. 08, 2016 ~ Jan. 11, 2016

Issued Date: Jan. 18, 2016

Applicant: Zebra Technologies Corporation

Address: 1 Zebra Plaza, Holtsville, NY 11742

Issued By: Bureau Veritas Consumer Products Services (H.K.) Ltd., Taoyuan Branch

Lab Address: No. 47-2, 14th Ling, Chia Pau Vil., Lin Kou Dist., New Taipei City, Taiwan
(R.O.C)

Test Location (1): No. 19, Hwa Ya 2nd Rd, Wen Hwa Tsuen, Kwei Shan Hsiang, Taoyuan
Hsien 333, Taiwan, R.O.C.



This report is for your exclusive use. Any copying or replication of this report to or for any other person or entity, or use of our name or trademark, is permitted only with our prior written permission. This report sets forth our findings solely with respect to the test samples identified herein. The results set forth in this report are not indicative or representative of the quality or characteristics of the lot from which a test sample was taken or any similar or identical product unless specifically and expressly noted. Our report includes all of the tests requested by you and the results thereof based upon the information that you provided to us. You have 60 days from date of issuance of this report to notify us of any material error or omission caused by our negligence, provided, however, that such notice shall be in writing and shall specifically address the issue you wish to raise. A failure to raise such issue within the prescribed time shall constitute your unqualified acceptance of the completeness of this report, the tests conducted and the correctness of the report contents. Unless specific mention, the uncertainty of measurement has been explicitly taken into account to declare the compliance or non-compliance to the specification. The report must not be used by the client to claim product certification, approval, or endorsement by TAF or any government agencies.

Table of Contents

Report Issue History Record	4
Release Control Record	5
1 Certificate of Conformity	6
2 Summary of Test Results.....	7
2.1 Measurement Uncertainty.....	7
2.2 Modification Record	7
3 General Information	8
3.1 General Description of EUT	8
3.2 Description of Test Modes.....	9
3.2.1 Test Mode Applicability and Tested Channel Detail.....	9
3.3 Duty Cycle of Test Signal	10
3.4 Description of Support Units	11
3.4.1 Configuration of System under Test	11
3.5 General Description of Applied Standards.....	11
4 Test Types and Results	12
4.1 Radiated Emission and Bandedge Measurement	12
4.1.1 Limits of Radiated Emission and Bandedge Measurement	12
4.1.2 Limits of Unwanted Emission Out of the Restricted Bands	12
4.1.3 Test Instruments	13
4.1.4 Test Procedures.....	14
4.1.5 Deviation from Test Standard	14
4.1.6 Test Set Up	15
4.1.7 EUT Operating Conditions.....	15
4.1.8 Test Results	16
4.2 Conducted Emission Measurement.....	23
4.2.1 Limits of Conducted Emission Measurement	23
4.2.2 Test Instruments	23
4.2.3 Test Procedures.....	24
4.2.4 Deviation from Test Standard	24
4.2.5 Test Setup.....	24
4.2.6 EUT Operating Conditions.....	24
4.2.7 Test Results	25
4.3 Transmit Power Measurement.....	27
4.3.1 Limits of Transmit Power Measurement	27
4.3.2 Test Setup.....	27
4.3.3 Test Instruments	28
4.3.4 Test Procedure	28
4.3.5 Deviation from Test Standard	28
4.3.6 EUT Operating Conditions.....	28
4.3.7 Test Result	29
4.4 Peak Power Spectral Density Measurement	31
4.4.1 Limits of Peak Power Spectral Density Measurement	31
4.4.2 Test Setup.....	31
4.4.3 Test Instruments	31
4.4.4 Test Procedures.....	31
4.4.5 Deviation from Test Standard	31
4.4.6 EUT Operating Conditions.....	31
4.4.7 Test Results	32
4.5 6 dB Bandwidth Measurement.....	33
4.5.1 Limits of 6 dB Bandwidth Measurement.....	33
4.5.2 Test Setup.....	33
4.5.3 Test Instruments	33



4.5.4 Test Procedure	33
4.5.5 Deviation from Test Standard	33
4.5.6 EUT Operating Condition	33
4.5.7 Test Results	34
5 Pictures of Test Arrangements.....	35
Appendix – Information on the Testing Laboratories	36



Report Issue History Record

Issue No.	Description	Date Issued
1	Original Release	Oct. 11, 2012
2	Update standard to the latest version	Jan. 18, 2016



A D T

Release Control Record

Issue No.	Description	Date Issued
RF120904C23H	Original Release	Jan. 18, 2016

1 Certificate of Conformity

Product: Micro Kiosk

Brand: Zebra

Test Model: MK3190

Sample Status: Engineering Sample

Applicant: Zebra Technologies Corporation

Test Date: Jan. 08, 2016 ~ Jan. 11, 2016

Standards: 47 CFR FCC Part 15, Subpart E (Section 15.407)
ANSI C63.10:2009

This report is issued as a supplementary report to BV ADT report no.: RF120904C23A R2. This report shall be used by combining with its original report.

Prepared by : *Vera Huang* , **Date:** Jan. 18, 2016
Vera Huang / Specialist

Approved by : *Stanley Wu* , **Date:** Jan. 18, 2016
Stanley Wu / Assistant Manager

2 Summary of Test Results

47 CFR FCC Part 15, Subpart E (Section 15.407)			
FCC Clause	Test Item	Result	Remarks
15.407(b)(6)	AC Power Conducted Emissions	Pass	Meet the requirement of limit. Minimum passing margin is -15.00 dB at 0.44881 MHz.
15.407(b)(1/2/3/4/6)	Radiated Emissions & Band Edge Measurement	Pass	Meet the requirement of limit. Minimum passing margin is -1.12 dB at 5714 MHz.
15.407(a)(1/2/3)	Max Average Transmit Power	Pass	Meet the requirement of limit.
15.407(a)(1/2/3)	Peak Power Spectral Density	Pass	Meet the requirement of limit.
15.407(e)	6 dB Bandwidth	Pass	Meet the requirement of limit. (U-NII-3 Band only)
15.203	Antenna Requirement	Pass	No antenna connector is used.

2.1 Measurement Uncertainty

Where relevant, the following measurement uncertainty levels have been estimated for tests performed on the EUT as specified in CISPR 16-4-2:

Measurement	Frequency	Expanded Uncertainty (k=2) (±)
Conducted Emissions at mains ports	150 kHz ~ 30 MHz	2.44 dB
Radiated Emissions up to 1 GHz	30 MHz ~ 200 MHz	2.93 dB
	200 MHz ~ 1000 MHz	2.95 dB
Radiated Emissions above 1 GHz	1 GHz ~ 18 GHz	2.26 dB
	18 GHz ~ 40 GHz	1.94 dB

2.2 Modification Record

There were no modifications required for compliance.

3 General Information

3.1 General Description of EUT

Product	Micro Kiosk	
Brand	Zebra	
Test Model	MK3190	
Power Supply Rating	12 Vdc (adapter)	
Modulation Type	64QAM, 16QAM, QPSK, BPSK	
Modulation Technology	OFDM	
Transfer Rate	802.11a: 54.0/ 48.0/ 36.0/ 24.0/ 18.0/ 12.0/ 9.0/ 6.0 Mbps 802.11n: up to MCS7	
Operating Frequency	5745 ~ 5825 MHz	
Number of Channel	5745 ~ 5825 MHz: 5 for 802.11a, 802.11n (HT20)	
Output Power	77.09 mW for 5745 ~ 5825 MHz	
Antenna Type	Main	PCB antenna with 4.275dBi gain
	Aux.	PCB antenna with 3.315dBi gain
Antenna Connector	N/A	
Accessory Device	Refer to Note as below	
Data Cable Supplied	Refer to Note as below	
BSP version (OS Version)	7.002824	
OEM Version	1.47.0028	
MFD Date	2-Nov-12	
Fusion Version	X 2.01.0.0.091R	

Note:

1. This report is issued as a supplementary report to BV ADT report no.: RF120904C23A R2. The difference compared with original report is updating the standard to the latest version. Therefore, all test items for 5745 ~ 5825 MHz had been retest.
2. The EUT provides one completed transmitter and two receivers.

Modulation Mode	Tx Function
802.11a	1TX
802.11n (HT20)	1TX

3. The EUT contains following accessory devices.

Product	Brand	Model	Description
Adapter	HIPRO	HP-A0502R3D	I/P: 100-240Vac, 50/60Hz, 2.4A O/P: 12Vdc, 4.16A 1.8m shielded cable w/ one core

4. The above EUT information is declared by manufacturer and for more detailed features description, please refer to the manufacturer's specifications or user's manual.

3.2 Description of Test Modes

FOR 5745 ~ 5825 MHz:

5 channels are provided for 802.11a, 802.11n (HT20):

Channel	Frequency (MHz)	Channel	Frequency (MHz)
149	5745	161	5805
153	5765	165	5825
157	5785		

3.2.1 Test Mode Applicability and Tested Channel Detail

EUT Configure Mode	Applicable To				Description
	RE \geq 1G	RE $<$ 1G	PLC	APCM	
-	√	√	√	√	-

Where **RE \geq 1G**: Radiated Emission above 1 GHz

RE $<$ 1G: Radiated Emission below 1 GHz

PLC: Power Line Conducted Emission

APCM: Antenna Port Conducted Measurement

NOTE:

1. The EUT had been pre-tested on the positioned of each 3 axis. The worst case was found when positioned on **X-plane**.
2. "-" means no effect.

Radiated Emission Test (Above 1 GHz):

- Pre-Scan has been conducted to determine the worst-case mode from all possible combinations between available modulations, data rates and antenna ports (if EUT with antenna diversity architecture).
- Following channel(s) was (were) selected for the final test as listed below.

EUT Configure Mode	Mode	Frequency Band (MHz)	Available Channel	Tested Channel	Modulation Technology	Modulation Type	Data Rate (Mbps)
-	802.11a	5745-5825	149 to 165	149, 157, 165	OFDM	BPSK	6.0
-	802.11n (HT20)		149 to 165	149, 157, 165	OFDM	BPSK	MCS0

Radiated Emission Test (Below 1 GHz):

- Pre-Scan has been conducted to determine the worst-case mode from all possible combinations between available modulations, data rates and antenna ports (if EUT with antenna diversity architecture).
- Following channel(s) was (were) selected for the final test as listed below.

EUT Configure Mode	Mode	Frequency Band (MHz)	Available Channel	Tested Channel	Modulation Technology	Modulation Type	Data Rate (Mbps)
-	802.11a	5745-5825	149 to 165	149	OFDM	BPSK	MCS0

Power Line Conducted Emission Test:

- Pre-Scan has been conducted to determine the worst-case mode from all possible combinations between available modulations, data rates and antenna ports (if EUT with antenna diversity architecture).
- Following channel(s) was (were) selected for the final test as listed below.

EUT Configure Mode	Mode	Frequency Band (MHz)	Available Channel	Tested Channel	Modulation Technology	Modulation Type	Data Rate (Mbps)
-	802.11a	5745-5825	149 to 165	149	OFDM	BPSK	MCS0

Antenna Port Conducted Measurement:

- This item includes all test value of each mode, but only includes spectrum plot of worst value of each mode.
- Pre-Scan has been conducted to determine the worst-case mode from all possible combinations between available modulations, data rates and antenna ports (if EUT with antenna diversity architecture).
- Following channel(s) was (were) selected for the final test as listed below.

EUT Configure Mode	Mode	Frequency Band (MHz)	Available Channel	Tested Channel	Modulation Technology	Modulation Type	Data Rate (Mbps)
-	802.11a	5745-5825	149 to 165	149, 157, 165	OFDM	BPSK	6.0
-	802.11n (HT20)		149 to 165	149, 157, 165	OFDM	BPSK	MCS0

Test Condition:

Applicable To	Environmental Conditions	Input Power	Tested by
RE≥1G	25 deg. C, 65 % RH	120 Vac, 60 Hz	Gavin Wu
RE<1G	25 deg. C, 65 % RH	120 Vac, 60 Hz	Gavin Wu
PLC	25 deg. C, 65 % RH	120 Vac, 60 Hz	Toby Tian
APCM	25 deg. C, 65 % RH	120 Vac, 60 Hz	Luke Chen

3.3 Duty Cycle of Test Signal

Duty cycle of test signal is > 98 %, duty factor is not required.

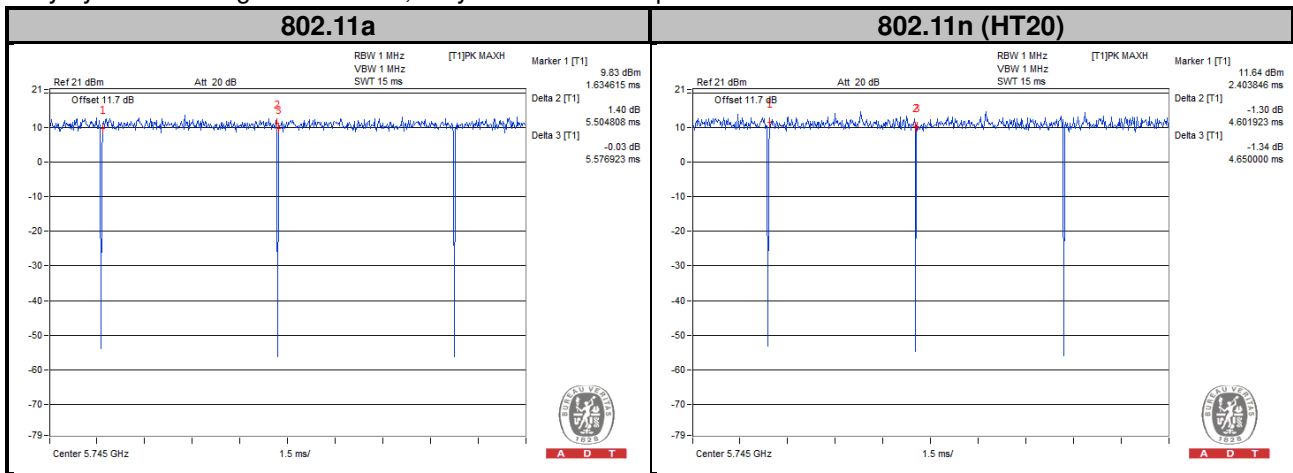

3.4 Description of Support Units

The EUT has been tested as an independent unit together with other necessary accessories or support units.

3.4.1 Configuration of System under Test

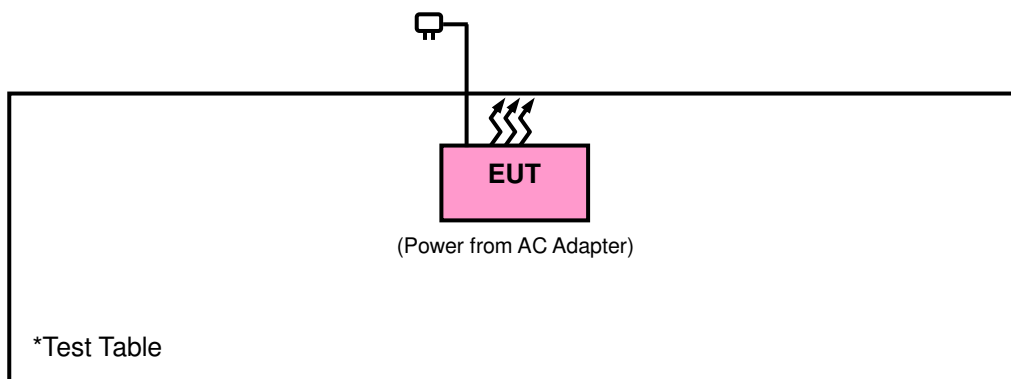

3.5 General Description of Applied Standards

The EUT is a RF Product. According to the specifications of the manufacturer, it must comply with the requirements of the following standards:

FCC Part 15, Subpart E (15.407)

789033 D02 General UNII Test Procedures New Rules v01

644545 D01 Guidance for IEEE 802 11ac v01r02

ANSI C63.10-2009

All test items have been performed and recorded as per the above standards.

NOTE: The EUT has been verified to comply with the requirements of FCC Part 15, Subpart B, Class B (DoC).
The test report has been issued separately.

4 Test Types and Results

4.1 Radiated Emission and Bandedge Measurement

4.1.1 Limits of Radiated Emission and Bandedge Measurement

Radiated emissions which fall in the restricted bands must comply with the radiated emission limits specified as below table. Other emissions shall be at least 20 dB below the highest level of the desired power:

Frequencies (MHz)	Field Strength (microvolts/meter)	Measurement Distance (meters)
0.009 ~ 0.490	2400/F (kHz)	300
0.490 ~ 1.705	24000/F (kHz)	30
1.705 ~ 30.0	30	30
30 ~ 88	100	3
88 ~ 216	150	3
216 ~ 960	200	3
Above 960	500	3

NOTE:

1. The lower limit shall apply at the transition frequencies.
2. Emission level (dBuV/m) = 20 log Emission level (uV/m).
3. For frequencies above 1000 MHz, the field strength limits are based on average detector, however, the peak field strength of any emission shall not exceed the maximum permitted average limits, specified above by more than 20 dB under any condition of modulation.

4.1.2 Limits of Unwanted Emission Out of the Restricted Bands

Applicable To	Limit	
789033 D02 General UNII Test Procedures New Rules v01	Field Strength at 3 m	
	PK: 74 (dBμV/m)	AV: 54 (dBμV/m)
Applicable To	EIRP Limit	Equivalent Field Strength at 3 m
15.407(b)(1)	PK: -27 (dBm/MHz)	PK: 68.2 (dBμV/m)
15.407(b)(2)		
15.407(b)(3)		
15.407(b)(4)	PK: -27 (dBm/MHz) ^{*1} PK: -17 (dBm/MHz) ^{*2}	PK: 68.2 (dBμV/m) ^{*1} PK: 78.2 (dBμV/m) ^{*2}

NOTE: ^{*1} beyond 10 MHz of the band edge ^{*2} within 10 MHz of band edge

The following formula is used to convert the equipment isotropic radiated power (eirp) to field strength:

$$E = \frac{1000000\sqrt{30P}}{3} \mu\text{V/m, where } P \text{ is the eirp (Watts).}$$

4.1.3 Test Instruments

Description & Manufacturer	Model No.	Serial No.	Date of Calibration	Due Date of Calibration
Test Receiver Agilent	N9038A	MY51210203	Jan. 21, 2015	Jan. 21, 2016
Spectrum Analyzer Agilent	N9010A	MY52220314	Sep. 03, 2015	Sep. 02, 2016
Spectrum Analyzer ROHDE & SCHWARZ	FSU43	101261	Dec. 17, 2015	Dec. 16, 2016
BILOG Antenna SCHWARZBECK	VULB9168	9168-472	Feb. 04, 2015	Feb. 04, 2016
HORN Antenna SCHWARZBECK	BBHA 9120 D	9120D-969	Feb. 09, 2015	Feb. 09, 2016
HORN Antenna SCHWARZBECK	BBHA 9170	9170-480	Feb. 04, 2015	Feb. 04, 2016
Loop Antenna	EM-6879	269	Jul. 31, 2015	Jul. 30, 2016
Preamplifier EMCI	EMC 012645	980115	Dec. 21, 2015	Dec. 20, 2016
Preamplifier EMCI	EMC 184045	980116	Dec. 21, 2015	Dec. 20, 2016
Preamplifier EMCI	EMC 330H	980112	Dec. 28, 2015	Dec. 27, 2016
Power Meter Anritsu	ML2495A	1232002	Sep. 21, 2015	Sep. 20, 2016
Power Sensor Anritsu	MA2411B	1207325	Sep. 21, 2015	Sep. 20, 2016
RF signal cable HUBER+SUHNNER	SUCOFLEX 104	309219/4 2950114	Oct. 12, 2015	Oct. 11, 2016
RF signal cable HUBER+SUHNNER	SUCOFLEX 104	250130/4	Oct. 12, 2015	Oct. 11, 2016
RF Coaxial Cable Worken	8D-FB	Cable-Ch10-01	Oct. 12, 2015	Oct. 11, 2016
Software BV ADT	E3 6.120103	NA	NA	NA
Antenna Tower MF	MFA-440H	NA	NA	NA
Turn Table MF	MFT-201SS	NA	NA	NA
Antenna Tower & Turn Table Controller MF	MF-7802	NA	NA	NA

- Note: 1. The calibration interval of the above test instruments is 12 months and the calibrations are traceable to NML/ROC and NIST/USA.
2. The test was performed in HwaYa Chamber 10.
3. The horn antenna and preamplifier (model: EMC 184045) are used only for the measurement of emission frequency above 1 GHz if tested.
4. The FCC Site Registration No. is 690701.
5. The IC Site Registration No. is IC7450F-10.

4.1.4 Test Procedures

- a. The EUT was placed on the top of a rotating table 0.8 meters above the ground at 3 meter chamber room for test. The table was rotated 360 degrees to determine the position of the highest radiation.
- b. The EUT was set 3 meters away from the interference-receiving antenna, which was mounted on the top of a variable-height antenna tower.
- c. The height of antenna is varied from one meter to four meters above the ground to determine the maximum value of the field strength. Both horizontal and vertical polarizations of the antenna are set to make the measurement.
- d. For each suspected emission, the EUT was arranged to its worst case and then the antenna was tuned to heights from 1 meter to 4 meters and the rotatable table was turned from 0 degrees to 360 degrees to find the maximum reading.
- e. The test-receiver system was set to quasi-peak detect function and specified bandwidth with maximum hold mode when the test frequency is below 1 GHz.
- f. The test-receiver system was set to peak and average detected function and specified bandwidth with maximum hold mode when the test frequency is above 1 GHz. If the peak reading value also meets average limit, measurement with the average detector is unnecessary.

Note:

1. The resolution bandwidth and video bandwidth of test receiver/spectrum analyzer is 120 kHz for Quasi-peak detection (QP) at frequency below 1 GHz.
2. The resolution bandwidth of test receiver/spectrum analyzer is 1 MHz and the video bandwidth is 3 MHz for Peak detection (PK) at frequency above 1 GHz.
3. The resolution bandwidth of test receiver/spectrum analyzer is 1 MHz and the video bandwidth is 3 MHz for RMS Average (Duty cycle < 98 %) for Average detection (AV) at frequency above 1 GHz, then the measurement results was added to a correction factor ($10 \log(1/\text{duty cycle})$).
4. The resolution bandwidth of test receiver/spectrum analyzer is 1 MHz and the video bandwidth is 10 Hz (Duty cycle ≥ 98 %) for Average detection (AV) at frequency above 1 GHz.
5. All modes of operation were investigated and the worst-case emissions are reported.

4.1.5 Deviation from Test Standard

No deviation.

4.1.6 Test Set Up

<Frequency Range below 1 GHz>

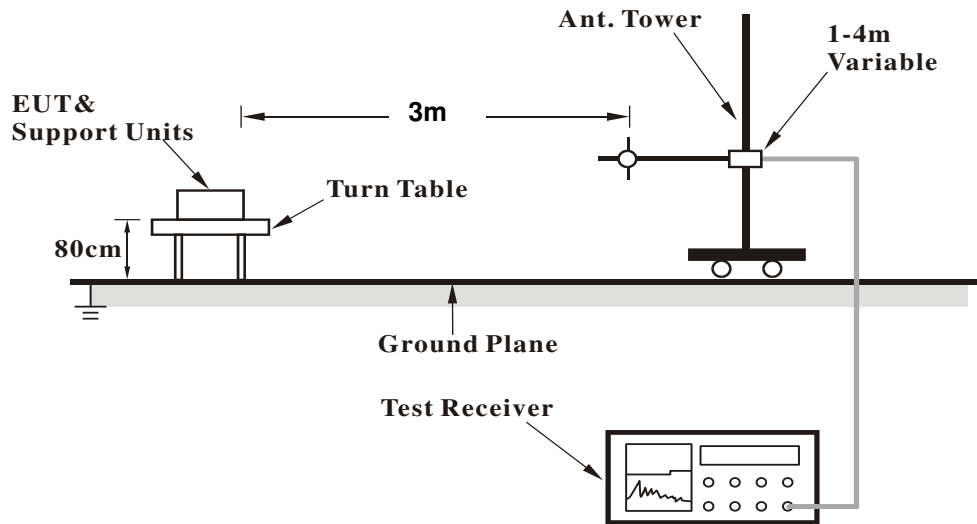

<Frequency Range above 1 GHz>

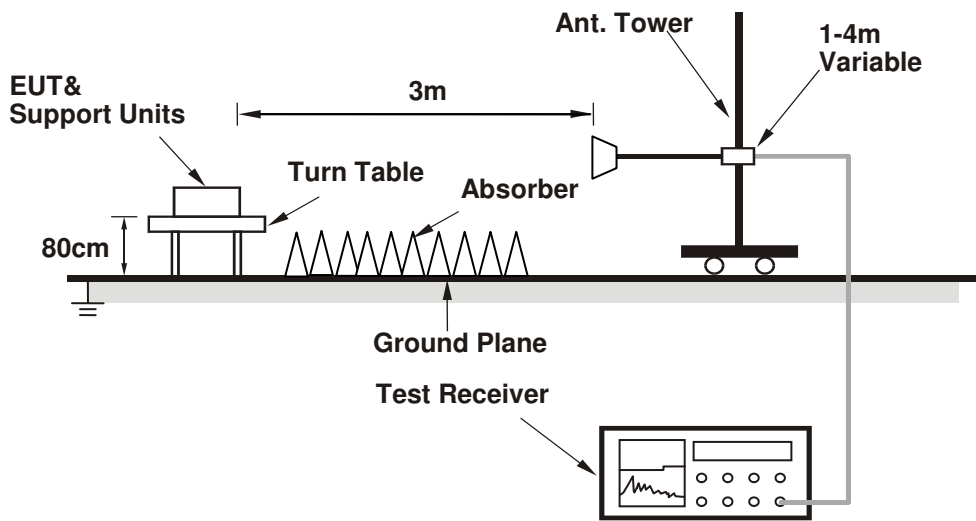

For the actual test configuration, please refer to the attached file (Test Setup Photo).

4.1.7 EUT Operating Conditions

- a. Placed the EUT on a testing table.
- b. Use the software to control the EUT under transmission condition continuously at specific channel frequency.

4.1.8 Test Results
ABOVE 1 GHz DATA :
802.11a

EUT Test Condition		Measurement Detail	
Channel	Channel 149	Frequency Range	1 GHz ~ 40 GHz
Input Power	120 Vac, 60 Hz	Detector Function	Peak (PK) Average (AV)
Environmental Conditions	25 deg. C, 65 % RH	Tested By	Gavin Wu

Antenna Polarity & Test Distance: Horizontal at 3 m										
Frequency (MHz)	Emission Level (dBuV/m)	Read Level (dBuV)	Limit (dBuV/m)	Margin (dB)	Antenna Factor (dB/m)	Cable Loss (dB)	Preamp Factor (dB)	Antenna Height (cm)	Table Angle (Degree)	Remark
*5714	67.08	65.89	68.2	-1.12	31.93	6.69	37.43	180	218	Peak
*5725	76.35	75.07	78.2	-1.85	31.96	6.75	37.43	180	218	Peak
5745	102.49	101.22			31.99	6.75	37.47	180	218	Average
5745	112.29	111.02			31.99	6.75	37.47	180	218	Peak
*5850	61.78	60.26	78.2	-16.42	32.15	6.88	37.51	180	218	Peak
*5861	61.56	59.93	68.2	-6.64	32.18	6.95	37.5	180	218	Peak
Antenna Polarity & Test Distance: Vertical at 3 m										
Frequency (MHz)	Emission Level (dBuV/m)	Read Level (dBuV)	Limit (dBuV/m)	Margin (dB)	Antenna Factor (dB/m)	Cable Loss (dB)	Preamp Factor (dB)	Antenna Height (cm)	Table Angle (Degree)	Remark
*5714	61.78	60.59	68.2	-6.42	31.93	6.69	37.43	164	321	Peak
*5725	71.04	69.76	78.2	-7.16	31.96	6.75	37.43	164	321	Peak
5745	92.82	91.55			31.99	6.75	37.47	164	321	Average
5745	102.43	101.16			31.99	6.75	37.47	164	321	Peak
*5850	61.11	59.59	78.2	-17.09	32.15	6.88	37.51	164	321	Peak
*5861	60.34	58.71	68.2	-7.86	32.18	6.95	37.5	164	321	Peak

Remarks:

- Emission Level = Read Level + Antenna Factor + Cable Loss - Preamp Factor
Margin value = Emission level – Limit value
- 5745 MHz: Fundamental frequency.
- *: Out of restricted band



A D T

EUT Test Condition		Measurement Detail	
Channel	Channel 157	Frequency Range	1 GHz ~ 40 GHz
Input Power	120 Vac, 60 Hz	Detector Function	Peak (PK) Average (AV)
Environmental Conditions	25 deg. C, 65 % RH	Tested By	Gavin Wu

Antenna Polarity & Test Distance: Horizontal at 3 m										
Frequency (MHz)	Emission Level (dBuV/m)	Read Level (dBuV)	Limit (dBuV/m)	Margin (dB)	Antenna Factor (dB/m)	Cable Loss (dB)	Preamp Factor (dB)	Antenna Height (cm)	Table Angle (Degree)	Remark
*5714	67	65.81	68.2	-1.2	31.93	6.69	37.43	178	214	Peak
*5725	69.89	68.61	78.2	-8.31	31.96	6.75	37.43	178	214	Peak
5785	105.67	104.35			32.04	6.82	37.54	178	214	Average
5785	114.78	113.46			32.04	6.82	37.54	178	214	Peak
*5850	66.47	64.95	78.2	-11.73	32.15	6.88	37.51	178	214	Peak
*5861	64.49	62.86	68.2	-3.71	32.18	6.95	37.5	178	214	Peak

Antenna Polarity & Test Distance: Vertical at 3 m										
Frequency (MHz)	Emission Level (dBuV/m)	Read Level (dBuV)	Limit (dBuV/m)	Margin (dB)	Antenna Factor (dB/m)	Cable Loss (dB)	Preamp Factor (dB)	Antenna Height (cm)	Table Angle (Degree)	Remark
*5714	60.87	59.68	68.2	-7.33	31.93	6.69	37.43	162	320	Peak
*5725	60.84	59.56	78.2	-17.36	31.96	6.75	37.43	162	320	Peak
5785	96.92	95.6			32.04	6.82	37.54	162	320	Average
5785	107.23	105.91			32.04	6.82	37.54	162	320	Peak
*5850	62.18	60.66	78.2	-16.02	32.15	6.88	37.51	162	320	Peak
*5861	61.68	60.05	68.2	-6.52	32.18	6.95	37.5	162	320	Peak

Remarks:

- Emission Level = Read Level + Antenna Factor + Cable Loss - Preamp Factor
Margin value = Emission level – Limit value
- 5785 MHz: Fundamental frequency.
- *: Out of restricted band



EUT Test Condition		Measurement Detail	
Channel	Channel 165	Frequency Range	1 GHz ~ 40 GHz
Input Power	120 Vac, 60 Hz	Detector Function	Peak (PK) Average (AV)
Environmental Conditions	25 deg. C, 65 % RH	Tested By	Gavin Wu

Antenna Polarity & Test Distance: Horizontal at 3 m										
Frequency (MHz)	Emission Level (dBuV/m)	Read Level (dBuV)	Limit (dBuV/m)	Margin (dB)	Antenna Factor (dB/m)	Cable Loss (dB)	Preamp Factor (dB)	Antenna Height (cm)	Table Angle (Degree)	Remark
*5714	60.58	59.39	68.2	-7.62	31.93	6.69	37.43	185	216	Peak
*5725	60.52	59.24	78.2	-17.68	31.96	6.75	37.43	185	216	Peak
5825	102.93	101.46			32.12	6.88	37.53	185	216	Average
5825	112.3	110.83			32.12	6.88	37.53	185	216	Peak
*5850	74.87	73.35	78.2	-3.33	32.15	6.88	37.51	185	216	Peak
*5861	66.68	65.05	68.2	-1.52	32.18	6.95	37.5	185	216	Peak
Antenna Polarity & Test Distance: Vertical at 3 m										
Frequency (MHz)	Emission Level (dBuV/m)	Read Level (dBuV)	Limit (dBuV/m)	Margin (dB)	Antenna Factor (dB/m)	Cable Loss (dB)	Preamp Factor (dB)	Antenna Height (cm)	Table Angle (Degree)	Remark
*5714	60.38	59.19	68.2	-7.82	31.93	6.69	37.43	161	316	Peak
*5725	60.6	59.32	78.2	-17.6	31.96	6.75	37.43	161	316	Peak
5825	94.51	93.04			32.12	6.88	37.53	161	316	Average
5825	104.15	102.68			32.12	6.88	37.53	161	316	Peak
*5850	67.84	66.32	78.2	-10.36	32.15	6.88	37.51	161	316	Peak
*5861	63.94	62.31	68.2	-4.26	32.18	6.95	37.5	161	316	Peak

Remarks:

- Emission Level = Read Level + Antenna Factor + Cable Loss - Preamp Factor
Margin value = Emission level – Limit value
- 5825 MHz: Fundamental frequency.
- *: Out of restricted band

802.11n (HT20)

EUT Test Condition		Measurement Detail	
Channel	Channel 149	Frequency Range	1 GHz ~ 40 GHz
Input Power	120 Vac, 60 Hz	Detector Function	Peak (PK) Average (AV)
Environmental Conditions	25 deg. C, 65 % RH	Tested By	Gavin Wu

Antenna Polarity & Test Distance: Horizontal at 3 m

Frequency (MHz)	Emission Level (dBuV/m)	Read Level (dBuV)	Limit (dBuV/m)	Margin (dB)	Antenna Factor (dB/m)	Cable Loss (dB)	Preamp Factor (dB)	Antenna Height (cm)	Table Angle (Degree)	Remark
*5714	66.6	65.41	68.2	-1.6	31.93	6.69	37.43	180	215	Peak
*5725	76.75	75.47	78.2	-1.45	31.96	6.75	37.43	180	215	Peak
5745	101.98	100.71			31.99	6.75	37.47	180	215	Average
5745	111.31	110.04			31.99	6.75	37.47	180	215	Peak
*5850	59.81	58.29	78.2	-18.39	32.15	6.88	37.51	180	215	Peak
*5861	59.59	57.96	68.2	-8.61	32.18	6.95	37.5	180	215	Peak

Antenna Polarity & Test Distance: Vertical at 3 m

Frequency (MHz)	Emission Level (dBuV/m)	Read Level (dBuV)	Limit (dBuV/m)	Margin (dB)	Antenna Factor (dB/m)	Cable Loss (dB)	Preamp Factor (dB)	Antenna Height (cm)	Table Angle (Degree)	Remark
*5714	61.74	60.55	68.2	-6.46	31.93	6.69	37.43	156	321	Peak
*5725	73.56	72.28	78.2	-4.64	31.96	6.75	37.43	156	321	Peak
5745	92.5	91.23			31.99	6.75	37.47	156	321	Average
5745	102.91	101.64			31.99	6.75	37.47	156	321	Peak
*5850	60.62	59.1	78.2	-17.58	32.15	6.88	37.51	156	321	Peak
*5861	60.74	59.11	68.2	-7.46	32.18	6.95	37.5	156	321	Peak

Remarks:

- Emission Level = Read Level + Antenna Factor + Cable Loss - Preamp Factor
Margin value = Emission level – Limit value
- 5745 MHz: Fundamental frequency.
- *: Out of restricted band



A D T

EUT Test Condition		Measurement Detail	
Channel	Channel 157	Frequency Range	1 GHz ~ 40 GHz
Input Power	120 Vac, 60 Hz	Detector Function	Peak (PK) Average (AV)
Environmental Conditions	25 deg. C, 65 % RH	Tested By	Gavin Wu

Antenna Polarity & Test Distance: Horizontal at 3 m										
Frequency (MHz)	Emission Level (dBuV/m)	Read Level (dBuV)	Limit (dBuV/m)	Margin (dB)	Antenna Factor (dB/m)	Cable Loss (dB)	Preamp Factor (dB)	Antenna Height (cm)	Table Angle (Degree)	Remark
*5714	66.57	65.38	68.2	-1.63	31.93	6.69	37.43	160	216	Peak
*5725	67.49	66.21	78.2	-10.71	31.96	6.75	37.43	160	216	Peak
5785	105.14	103.82			32.04	6.82	37.54	160	216	Average
5785	114.64	113.32			32.04	6.82	37.54	160	216	Peak
*5850	64.4	62.88	78.2	-13.8	32.15	6.88	37.51	160	216	Peak
*5861	63.28	61.65	68.2	-4.92	32.18	6.95	37.5	160	216	Peak

Antenna Polarity & Test Distance: Vertical at 3 m										
Frequency (MHz)	Emission Level (dBuV/m)	Read Level (dBuV)	Limit (dBuV/m)	Margin (dB)	Antenna Factor (dB/m)	Cable Loss (dB)	Preamp Factor (dB)	Antenna Height (cm)	Table Angle (Degree)	Remark
*5714	60.67	59.48	68.2	-7.53	31.93	6.69	37.43	138	319	Peak
*5725	61.02	59.74	78.2	-17.18	31.96	6.75	37.43	138	319	Peak
5785	96.47	95.15			32.04	6.82	37.54	138	319	Average
5785	106.35	105.03			32.04	6.82	37.54	138	319	Peak
*5850	61.43	59.91	78.2	-16.77	32.15	6.88	37.51	138	319	Peak
*5861	60.63	59	68.2	-7.57	32.18	6.95	37.5	138	319	Peak

Remarks:

- Emission Level = Read Level + Antenna Factor + Cable Loss - Preamp Factor
Margin value = Emission level – Limit value
- 5785 MHz: Fundamental frequency.
- *: Out of restricted band



A D T

EUT Test Condition		Measurement Detail	
Channel	Channel 165	Frequency Range	1 GHz ~ 40 GHz
Input Power	120 Vac, 60 Hz	Detector Function	Peak (PK) Average (AV)
Environmental Conditions	25 deg. C, 65 % RH	Tested By	Gavin Wu

Antenna Polarity & Test Distance: Horizontal at 3 m										
Frequency (MHz)	Emission Level (dBuV/m)	Read Level (dBuV)	Limit (dBuV/m)	Margin (dB)	Antenna Factor (dB/m)	Cable Loss (dB)	Preamp Factor (dB)	Antenna Height (cm)	Table Angle (Degree)	Remark
*5714	59.97	58.78	68.2	-8.23	31.93	6.69	37.43	176	214	Peak
*5725	58.76	57.48	78.2	-19.44	31.96	6.75	37.43	176	214	Peak
5825	102.87	101.4			32.12	6.88	37.53	176	214	Average
5825	112.12	110.65			32.12	6.88	37.53	176	214	Peak
*5850	75.86	74.34	78.2	-2.34	32.15	6.88	37.51	176	214	Peak
*5861	66.31	64.68	68.2	-1.89	32.18	6.95	37.5	176	214	Peak

Antenna Polarity & Test Distance: Vertical at 3 m										
Frequency (MHz)	Emission Level (dBuV/m)	Read Level (dBuV)	Limit (dBuV/m)	Margin (dB)	Antenna Factor (dB/m)	Cable Loss (dB)	Preamp Factor (dB)	Antenna Height (cm)	Table Angle (Degree)	Remark
*5714	60.31	59.12	68.2	-7.89	31.93	6.69	37.43	161	315	Peak
*5725	59.47	58.19	78.2	-18.73	31.96	6.75	37.43	161	315	Peak
5825	94.15	92.68			32.12	6.88	37.53	161	315	Average
5825	103.59	102.12			32.12	6.88	37.53	161	315	Peak
*5850	67.83	66.31	78.2	-10.37	32.15	6.88	37.51	161	315	Peak
*5861	62.53	60.9	68.2	-5.67	32.18	6.95	37.5	161	315	Peak

Remarks:

- Emission Level = Read Level + Antenna Factor + Cable Loss - Preamp Factor
Margin value = Emission level – Limit value
- 5825 MHz: Fundamental frequency.
- *: Out of restricted band

9 kHz ~ 30 MHz DATA:

The amplitude of spurious emissions attenuated more than 20 dB below the permissible value is not required to be report.

30 MHz ~ 1 GHz WORST-CASE DATA:

802.11a

EUT Test Condition		Measurement Detail	
Channel	Channel 149	Frequency Range	30 MHz ~ 1 GHz
Input Power	120 Vac, 60 Hz	Detector Function	Peak (PK) Quasi-peak (QP)
Environmental Conditions	25 deg. C, 65 % RH	Tested By	Gavin Wu

Antenna Polarity & Test Distance: Horizontal at 3 m

Frequency (MHz)	Emission Level (dBuV/m)	Read Level (dBuV)	Limit (dBuV/m)	Margin (dB)	Antenna Factor (dB/m)	Cable Loss (dB)	Preamp Factor (dB)	Antenna Height (cm)	Table Angle (Degree)	Remark
89.67	27.2	49.9	43.5	-16.3	8.3	0.96	31.96	104	252	Peak
166.35	31.76	50.35	43.5	-11.74	12.05	1.13	31.77	112	133	Peak
192	33.33	53.84	43.5	-10.17	9.91	1.27	31.69	102	127	Peak
309.1	27.2	44.31	46	-18.8	13.17	1.66	31.94	104	99	Peak
412	29.29	43.78	46	-16.71	15.58	1.93	32	111	208	Peak
437.9	32.77	46.7	46	-13.23	16.1	1.97	32	139	57	Peak

Antenna Polarity & Test Distance: Vertical at 3 m

Frequency (MHz)	Emission Level (dBuV/m)	Read Level (dBuV)	Limit (dBuV/m)	Margin (dB)	Antenna Factor (dB/m)	Cable Loss (dB)	Preamp Factor (dB)	Antenna Height (cm)	Table Angle (Degree)	Remark
95.88	31.94	54.12	43.5	-11.56	8.76	1.02	31.96	136	289	Peak
115.32	30.85	51.05	43.5	-12.65	10.55	1.12	31.87	129	218	Peak
283.26	25.13	42.86	46	-20.87	12.45	1.59	31.77	109	45	Peak
360.2	28.17	43.96	46	-17.83	14.38	1.8	31.97	108	273	Peak
436.5	28.1	42.07	46	-17.9	16.06	1.97	32	126	92	Peak
487.6	29.16	41.8	46	-16.84	17.08	2.07	31.79	109	100	Peak

Remarks:

- Emission Level = Read Level + Antenna Factor + Cable Loss - Preamp Factor
Margin value = Emission level – Limit value

4.2 Conducted Emission Measurement

4.2.1 Limits of Conducted Emission Measurement

Frequency (MHz)	Conducted Limit (dBuV)	
	Quasi-peak	Average
0.15 - 0.5	66 - 56	56 - 46
0.50 - 5.0	56	46
5.0 - 30.0	60	50

Note: 1. The lower limit shall apply at the transition frequencies.

2. The limit decreases in line with the logarithm of the frequency in the range of 0.15 to 0.50 MHz.

4.2.2 Test Instruments

Description & Manufacturer	Model No.	Serial No.	Date Of Calibration	Due Date Of Calibration
Test Receiver ROHDE & SCHWARZ	ESCI	100613	Nov. 16, 2015	Nov. 15, 2016
RF signal cable (with 10dB PAD) Woken	5D-FB	Cable-cond1-01	Dec. 26, 2015	Dec. 25, 2016
LISN ROHDE & SCHWARZ (EUT)	ESH3-Z5	835239/001	Feb. 26, 2015	Feb. 25, 2016
LISN ROHDE & SCHWARZ (Peripheral)	ESH3-Z5	100311	Jul. 24, 2015	Jul. 23, 2016
Software ADT	BV ADT_Cond_ V7.3.7.3	NA	NA	NA

Note: 1. The calibration interval of the above test instruments is 12 months and the calibrations are traceable to NML/ROC and NIST/USA.

2. The test was performed in HwaYa Shielded Room 1.

3. The VCCI Site Registration No. is C-2040.

4.2.3 Test Procedures

- a. The EUT was placed 0.4 meters from the conducting wall of the shielded room with EUT being connected to the power mains through a line impedance stabilization network (LISN). Other support units were connected to the power mains through another LISN. The two LISNs provide 50 ohm/ 50uH of coupling impedance for the measuring instrument.
- b. Both lines of the power mains connected to the EUT were checked for maximum conducted interference.
- c. The frequency range from 150 kHz to 30 MHz was searched. Emission levels under (Limit -20 dB) was not recorded.

NOTE: All modes of operation were investigated and the worst-case emissions are reported.

4.2.4 Deviation from Test Standard

No deviation.

4.2.5 Test Setup

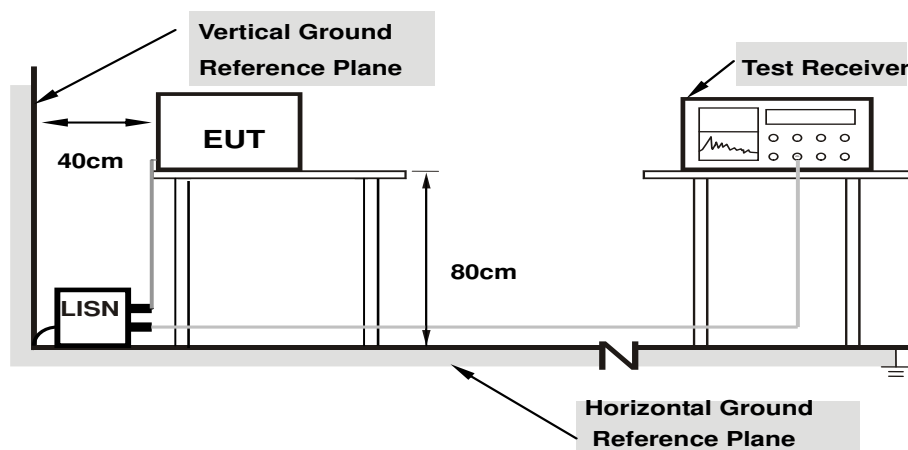

- Note: 1.Support units were connected to second LISN.**
2.Both of LISNs (AMN) are 80 cm from EUT and at least 80 from other units and other metal planes

For the actual test configuration, please refer to the attached file (Test Setup Photo).

4.2.6 EUT Operating Conditions

- a. Placed the EUT on a testing table.
- b. Use the software to control the EUT under transmission condition continuously at specific channel frequency.

4.2.7 Test Results

Frequency Range	150kHz ~ 30MHz	Detector Function & Resolution Bandwidth	Quasi-Peak (QP) / Average (AV), 9kHz
Input Power	120Vac, 60Hz	Environmental Conditions	25°C, 65%RH
Tested by	Toby Tian	Test Date	2016/1/10

Phase Of Power : Line (L)										
No	Frequency (MHz)	Correction Factor (dB)	Reading Value (dBuV)		Emission Level (dBuV)		Limit (dBuV)		Margin (dB)	
			Q.P.	AV.	Q.P.	AV.	Q.P.	AV.	Q.P.	AV.
1	0.15000	9.93	37.51	24.47	47.44	34.40	66.00	56.00	-18.56	-21.60
2	0.18180	9.94	32.97	17.83	42.91	27.77	64.40	54.40	-21.49	-26.63
3	0.22624	9.96	24.98	15.76	34.94	25.72	62.59	52.59	-27.65	-26.87
4	0.28200	9.98	19.28	6.98	29.26	16.96	60.76	50.76	-31.49	-33.79
5	0.44999	10.04	28.19	21.67	38.23	31.71	56.88	46.88	-18.65	-15.17
6	18.24200	10.96	21.71	18.36	32.67	29.32	60.00	50.00	-27.33	-20.68

Remarks:

1. Q.P. and AV. are abbreviations of quasi-peak and average individually.
2. The emission levels of other frequencies were very low against the limit.
3. Margin value = Emission level – Limit value
4. Correction factor = Insertion loss + Cable loss
5. Emission Level = Correction Factor + Reading Value

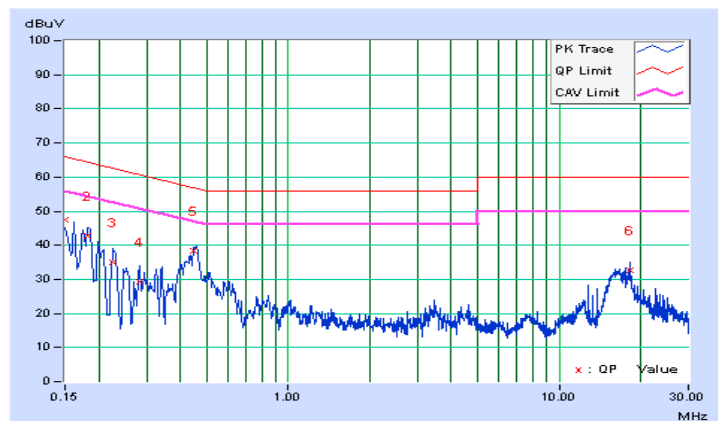

Frequency Range	150kHz ~ 30MHz	Detector Function & Resolution Bandwidth	Quasi-Peak (QP) / Average (AV), 9kHz
Input Power	120Vac, 60Hz	Environmental Conditions	25°C, 65%RH
Tested by	Toby Tian	Test Date	2016/1/10

Phase Of Power : Neutral (N)										
No	Frequency (MHz)	Correction Factor (dB)	Reading Value (dBuV)		Emission Level (dBuV)		Limit (dBuV)		Margin (dB)	
			Q.P.	AV.	Q.P.	AV.	Q.P.	AV.	Q.P.	AV.
1	0.15000	9.92	36.61	24.49	46.53	34.41	66.00	56.00	-19.47	-21.59
2	0.16977	9.93	35.75	21.66	45.68	31.59	64.97	54.97	-19.29	-23.38
3	0.18200	9.93	32.19	17.63	42.12	27.56	64.39	54.39	-22.27	-26.83
4	0.21406	9.95	27.60	12.04	37.55	21.99	63.05	53.05	-25.50	-31.06
5	0.44881	10.04	28.24	21.86	38.28	31.90	56.90	46.90	-18.62	-15.00
6	18.24200	10.81	21.73	18.55	32.54	29.36	60.00	50.00	-27.46	-20.64

Remarks:

1. Q.P. and AV. are abbreviations of quasi-peak and average individually.
2. The emission levels of other frequencies were very low against the limit.
3. Margin value = Emission level – Limit value
4. Correction factor = Insertion loss + Cable loss
5. Emission Level = Correction Factor + Reading Value

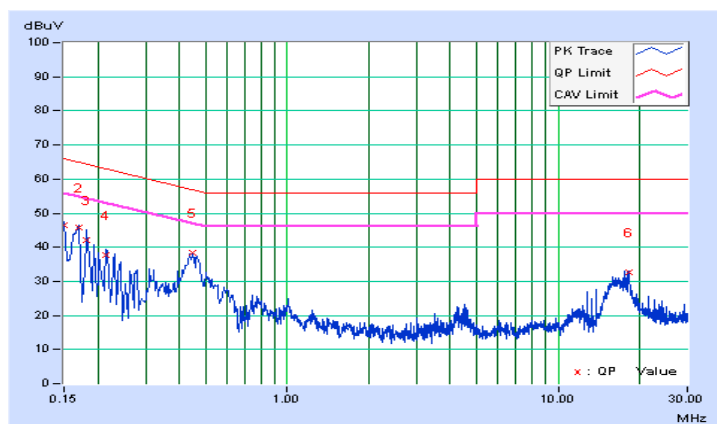

4.3 Transmit Power Measurement

4.3.1 Limits of Transmit Power Measurement

Operation Band	EUT Category	Limit
U-NII-1	Outdoor Access Point	1 Watt (30 dBm) (Max. e.i.r.p \leq 125 mW (21 dBm) at any elevation angle above 30 degrees as measured from the horizon)
	Fixed point-to-point Access Point	1 Watt (30 dBm)
	Indoor Access Point	1 Watt (30 dBm)
	Mobile and Portable client device	250 mW (24 dBm)
U-NII-2A		250 mW (24 dBm) or 11 dBm+10 log B*
U-NII-2C		250 mW (24 dBm) or 11 dBm+10 log B*
U-NII-3	√	1 Watt (30 dBm)

*B is the 26 dB emission bandwidth in megahertz

Per KDB 662911 Method of conducted output power measurement on IEEE 802.11 devices,

Array Gain = 0 dB (i.e., no array gain) for $N_{ANT} \leq 4$;

Array Gain = 0 dB (i.e., no array gain) for channel widths ≥ 40 MHz for any N_{ANT} ;

Array Gain = $5 \log(N_{ANT}/N_{SS})$ dB or 3 dB, whichever is less for 20 MHz channel widths with $N_{ANT} \geq 5$.

For power measurements on all other devices: Array Gain = $10 \log(N_{ANT}/N_{SS})$ dB.

4.3.2 Test Setup

<Power Output Measurement>

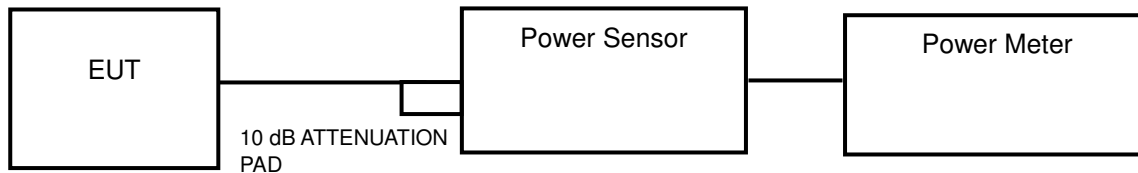

4.3.3 Test Instruments

Refer to section 4.1.2 to get information of above instrument.

4.3.4 Test Procedure

Average Power Measurement

Method PM is used to perform output power measurement, trigger and gating function of wide band power meter is enabled to measure max output power of TX on burst. Duty factor is not added to measured value.

4.3.5 Deviation from Test Standard

No deviation.

4.3.6 EUT Operating Conditions

The software provided by client to enable the EUT under transmission condition continuously at lowest, middle and highest channel frequencies individually.

4.3.7 Test Result

Power Output:

802.11a,
Main Ant.

Channel	Frequency (MHz)	Chain	Data Rate							
			6M bps	9M bps	12M bps	18M bps	24M bps	36M bps	48M bps	54M bps
149	5745	A	14.09	13.03	13.97	13.94	13.88	13.82	14.00	14.07
157	5785	A	18.86	18.80	18.76	18.73	18.75	18.82	18.83	18.85
165	5825	A	15.14	15.08	15.03	14.97	14.92	15.05	15.11	15.13

Aux. Ant.

Channel	Frequency (MHz)	Chain	Data Rate							
			6M bps	9M bps	12M bps	18M bps	24M bps	36M bps	48M bps	54M bps
149	5745	B	14.00	13.94	13.87	13.82	13.77	13.73	13.90	13.98
157	5785	B	18.19	18.14	18.12	18.15	18.12	18.16	18.11	18.18
165	5825	B	14.98	14.91	14.86	14.80	14.76	14.72	14.84	14.96

Channel	Frequency (MHz)	Maximum Conducted Power (mW)	Maximum Conducted Power (dBm)	Power Limit (dBm)	Pass / Fail
149	5745	25.64	14.09	30	Pass
157	5785	76.91	18.86	30	Pass
165	5825	32.66	15.14	30	Pass

802.11n (HT20)

Main Ant.

Channel	Frequency (MHz)	Chain	Data Rate							
			6M bps	9M bps	12M bps	18M bps	24M bps	36M bps	48M bps	54M bps
149	5745	A	14.14	14.08	14.04	13.97	13.92	14.01	14.07	14.13
157	5785	A	18.87	18.72	18.66	18.63	18.58	18.65	18.75	18.78
165	5825	A	15.46	15.40	15.36	15.30	15.27	15.33	15.38	15.43

Aux. Ant.

Channel	Frequency (MHz)	Chain	Data Rate							
			6M bps	9M bps	12M bps	18M bps	24M bps	36M bps	48M bps	54M bps
149	5745	B	14.07	14.00	13.95	13.87	13.82	13.77	13.85	13.98
157	5785	B	18.53	18.47	18.44	18.42	18.39	18.46	18.37	18.51
165	5825	B	15.22	15.16	15.11	15.07	14.98	15.10	15.14	15.20

Channel	Frequency (MHz)	Maximum Conducted Power (mW)	Maximum Conducted Power (dBm)	Power Limit (dBm)	Pass / Fail
149	5745	25.94	14.14	30	Pass
157	5785	77.09	18.87	30	Pass
165	5825	35.16	15.46	30	Pass

4.4 Peak Power Spectral Density Measurement

4.4.1 Limits of Peak Power Spectral Density Measurement

Operation Band	EUT Category		Limit
U-NII-1		Outdoor Access Point	17 dBm/MHz
		Fixed point-to-point Access Point	
		Indoor Access Point	
		Mobile and Portable client device	11 dBm/MHz
U-NII-2A			11 dBm/MHz
U-NII-2C			11 dBm/MHz
U-NII-3		√	30 dBm/500 kHz

4.4.2 Test Setup

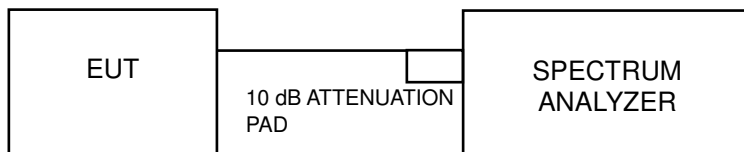

4.4.3 Test Instruments

Refer to section 4.1.3 to get information of above instrument.

4.4.4 Test Procedures

For U-NII-3 band:

1. Set span to encompass the entire emission bandwidth (EBW) of the signal.
2. Set RBW = 300 kHz, Set VBW ≥ 1 MHz, Detector = RMS
3. Use the peak marker function to determine the maximum power level in any 300 kHz band segment within the fundamental EBW.
4. Scale the observed power level to an equivalent value in 500 kHz by adjusting (reducing) the measured power by a bandwidth correction factor (BWCF) where $BWCF = 10\log(500\text{ kHz}/300\text{ kHz})$
5. Sweep time = auto, trigger set to “free run”.
6. Trace average at least 100 traces in power averaging mode.
7. Record the max value

4.4.5 Deviation from Test Standard

No deviation.

4.4.6 EUT Operating Conditions

The software provided by client to enable the EUT under transmission condition continuously at lowest, middle and highest channel frequencies individually.

4.4.7 Test Results

802.11a

Channel	Freq. (MHz)	PSD (dBm/500 kHz)	Limit (dBm/500 kHz)	Pass / Fail
149	5745	-0.39	30	Pass
157	5785	4.52	30	Pass
165	5825	1.31	30	Pass

802.11n (HT20)

Channel	Freq. (MHz)	PSD (dBm/500 kHz)	Limit (dBm/500 kHz)	Pass / Fail
149	5745	-0.50	30	Pass
157	5785	4.36	30	Pass
165	5825	1.50	30	Pass

Spectrum Plot of Worst Value

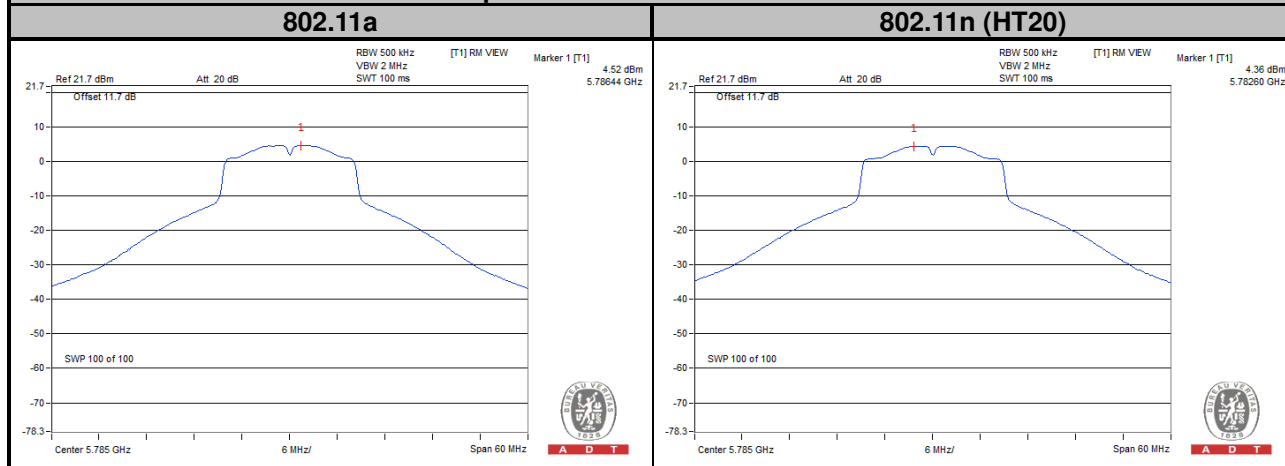

4.5 6 dB Bandwidth Measurement

4.5.1 Limits of 6 dB Bandwidth Measurement

The minimum of 6 dB Bandwidth Measurement is 0.5 MHz.

4.5.2 Test Setup

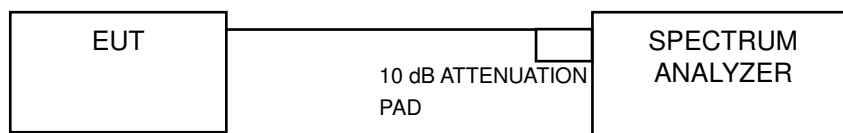

4.5.3 Test Instruments

Refer to section 4.1.3 to get information of above instrument.

4.5.4 Test Procedure

MEASUREMENT PROCEDURE REF

- Set resolution bandwidth (RBW) = 100 kHz
- Set the video bandwidth (VBW) $\geq 3 \times$ RBW, Detector = Peak.
- Trace mode = max hold.
- Sweep = auto couple.
- Measure the maximum width of the emission that is constrained by the frequencies associated with the two amplitude points (upper and lower) that are attenuated by 6 dB relative to the maximum level measured in the fundamental emission

4.5.5 Deviation from Test Standard

No deviation.

4.5.6 EUT Operating Condition

The software provided by client to enable the EUT under transmission condition continuously at lowest, middle and highest channel frequencies individually.

4.5.7 Test Results

802.11a

Channel	Frequency (MHz)	6 dB Bandwidth (MHz)	Minimum Limit (MHz)	Pass / Fail
149	5745	15.14	0.5	Pass
157	5785	15.32	0.5	Pass
165	5825	15.15	0.5	Pass

802.11n (HT20)

Channel	Frequency (MHz)	6 dB Bandwidth (MHz)	Minimum Limit (MHz)	Pass / Fail
149	5745	13.84	0.5	Pass
157	5785	16.35	0.5	Pass
165	5825	15.11	0.5	Pass

Spectrum Plot of Worst Value

802.11a

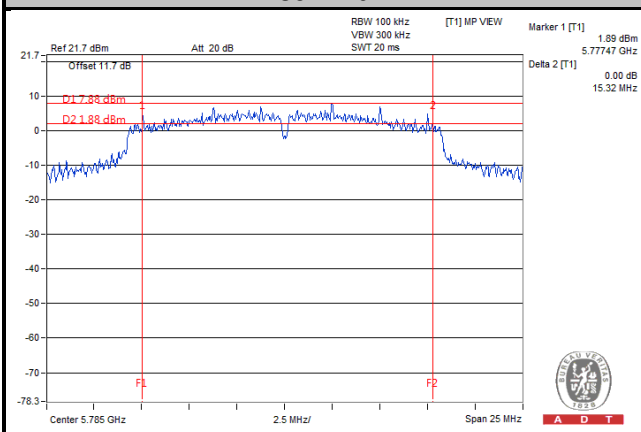

802.11n (HT20)

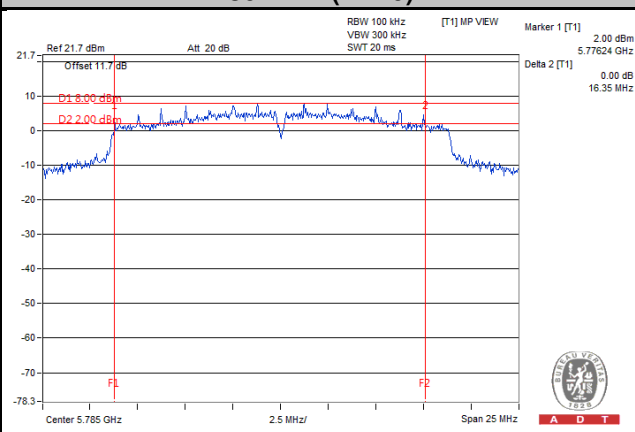



5 Pictures of Test Arrangements

Please refer to the attached file (Test Setup Photo).



Appendix – Information on the Testing Laboratories

We, Bureau Veritas Consumer Products Services (H.K.) Ltd., Taoyuan Branch, were founded in 1988 to provide our best service in EMC, Radio, Telecom and Safety consultation. Our laboratories are accredited and approved according to ISO/IEC 17025.

If you have any comments, please feel free to contact us at the following:

Linko EMC/RF Lab

Tel: 886-2-26052180

Fax: 886-2-26051924

Hsin Chu EMC/RF/Telecom Lab

Tel: 886-3-6668565

Fax: 886-3-6668323

Hwa Ya EMC/RF/Safety

Tel: 886-3-3183232

Fax: 886-3-3270892

Email: service.adt@tw.bureauveritas.com

Web Site: www.bureauveritas-adt.com

The address and road map of all our labs can be found in our web site also.

--- END ---