



A D T

# SUPPLEMENTARY FCC TEST REPORT (15.407)

**REPORT NO.:** RF980316L09M

**MODEL NO.:** MC9590

**FCC ID:** UZ7MC9590

**RECEIVED:** Feb. 03, 2015

**TESTED:** Mar. 27, 2015 ~ Apr. 29, 2015

**ISSUED:** May 12, 2015

**APPLICANT:** Zebra Technologies Corporation

**ADDRESS:** 1 Zebra Plaza, Holtsville, NY 11742

**ISSUED BY:** Bureau Veritas Consumer Products Services  
(H.K.) Ltd., Taoyuan Branch

**LAB ADDRESS:** No. 47-2, 14th Ling, Chia Pau Vil., Lin Kou Dist.,  
New Taipei City, Taiwan ( R.O.C )

**TEST LOCATION:** No. 19, Hwa Ya 2nd Rd, Wen Hwa Tsuen, Kwei  
Shan Hsiang, Taoyuan Hsien 333, Taiwan, R.O.C.

This report should not be used by the client to claim product certification, approval, or endorsement by TAF or any government agencies.



This report is for your exclusive use. Any copying or replication of this report to or for any other person or entity, or use of our name or trademark, is permitted only with our prior written permission. This report sets forth our findings solely with respect to the test samples identified herein. The results set forth in this report are not indicative or representative of the quality or characteristics of the lot from which a test sample was taken or any similar or identical product unless specifically and expressly noted. Our report includes all of the tests requested by you and the results thereof based upon the information that you provided to us. You have 60 days from date of issuance of this report to notify us of any material error or omission caused by our negligence, provided, however, that such notice shall be in writing and shall specifically address the issue you wish to raise. A failure to raise such issue within the prescribed time shall constitute your unqualified acceptance of the completeness of this report, the tests conducted and the correctness of the report contents. Unless specific mention, the uncertainty of measurement has been explicitly taken into account to declare the compliance or non-compliance to the specification.



# TABLE OF CONTENTS

REPORT ISSUE HISTORY RECORD .....	4
RELEASE CONTROL RECORD .....	5
1. CERTIFICATION.....	6
2. SUMMARY OF TEST RESULTS .....	7
2.1 MEASUREMENT UNCERTAINTY .....	7
3. GENERAL INFORMATION.....	8
3.1 GENERAL DESCRIPTION OF EUT.....	8
3.2 DESCRIPTION OF TEST MODES.....	9
3.2.1 TEST MODE APPLICABILITY AND TESTED CHANNEL DETAIL.....	10
3.3 DESCRIPTION OF SUPPORT UNITS.....	11
3.3.1 CONFIGURATION OF SYSTEM UNDER TEST .....	11
3.4 DUTY CYCLE TEST SIGNAL.....	12
3.5 GENERAL DESCRIPTION OF APPLIED STANDARDS.....	12
4. TEST TYPES AND RESULTS .....	13
4.1 RADIATED EMISSION AND BANDEDGE MEASUREMENT .....	13
4.1.1 LIMITS OF RADIATED EMISSION AND BANDEDGE MEASUREMENT .....	13
4.1.2 LIMITS OF UNWANTED EMISSION OUT OF THE RESTRICTED BANDS .....	13
4.1.3 TEST INSTRUMENTS.....	14
4.1.4 TEST PROCEDURES .....	15
4.1.5 DEVIATION FROM TEST STANDARD .....	15
4.1.6 TEST SETUP .....	16
4.1.7 EUT OPERATING CONDITIONS .....	16
4.1.8 TEST RESULTS.....	17
4.2 CONDUCTED EMISSION MEASUREMENT .....	29
4.2.1 LIMITS OF CONDUCTED EMISSION MEASUREMENT .....	29
4.2.2 TEST INSTRUMENTS.....	29
4.2.3 TEST PROCEDURES .....	30
4.2.4 DEVIATION FROM TEST STANDARD .....	30
4.2.5 TEST SETUP .....	31
4.2.6 EUT OPERATING CONDITIONS .....	31
4.2.7 TEST RESULTS.....	32
4.3 TRANSMIT POWER MEASUREMENT.....	34
4.3.1 LIMITS OF TRANSMIT POWER MEASUREMENT .....	34
4.3.2 TEST SETUP .....	34
4.3.3 TEST INSTRUMENTS.....	34
4.3.4 TEST PROCEDURE.....	34
4.3.5 DEVIATION FROM TEST STANDARD .....	34
4.3.6 EUT OPERATING CONDITIONS .....	34
4.3.7 TEST RESULTS.....	35
4.4 PEAK POWER SPECTRAL DENSITY MEASUREMENT .....	36
4.4.1 LIMITS OF PEAK POWER SPECTRAL DENSITY MEASUREMENT .....	36
4.4.2 TEST SETUP .....	36
4.4.3 TEST INSTRUMENTS.....	36
4.4.4 TEST PROCEDURES .....	36
4.4.5 DEVIATION FROM TEST STANDARD .....	36
4.4.6 EUT OPERATING CONDITIONS .....	36
4.4.7 TEST RESULTS.....	37
4.5 6dB BANDWIDTH MEASUREMENT .....	38
4.5.1 LIMITS OF 6dB BANDWIDTH MEASUREMENT .....	38
4.5.2 TEST SETUP .....	38
4.5.3 TEST INSTRUMENTS.....	38
4.5.4 TEST PROCEDURE.....	38



A D T

4.5.5	DEVIATION FROM TEST STANDARD .....	38
4.5.6	EUT OPERATING CONDITIONS .....	38
4.5.7	TEST RESULTS.....	39
5.	PHOTOGRAPHS OF THE TEST CONFIGURATION.....	40
6.	INFORMATION ON THE TESTING LABORATORIES .....	41
7.	APPENDIX A - MODIFICATIONS RECORDERS FOR ENGINEERING CHANGES TO THE EUT BY THE LAB .....	42



A D T

## REPORT ISSUE HISTORY RECORD

ISSUE NO.	REASON FOR CHANGE	DATE ISSUED
1	Original release.	Apr. 02, 2009
2	1. Update applicant and brand name 2. Update the standard to the latest version for WLAN 5G band 4	Apr. 29, 2015
3	1. Update applicant address 2. Update the Wireless Fusion, OS version, OEM version	May 12, 2015



A D T

## RELEASE CONTROL RECORD

ISSUE NO.	REASON FOR CHANGE	DATE ISSUED
RF980316L09M	Original release	May 12, 2015



## 1. CERTIFICATION

**PRODUCT:** Mobile Computer  
**MODEL NO.:** MC9590  
**BRAND:** Zebra  
**APPLICANT:** Zebra Technologies Corporation  
**TESTED:** Mar. 27, 2015 ~ Apr. 29, 2015  
**TEST SAMPLE:** ENGINEERING SAMPLE  
**STANDARDS:** **FCC Part 15, Subpart E (Section 15.407)**  
ANSI C63.10-2009

The above equipment (model: MC9590) has been tested by **Bureau Veritas Consumer Products Services (H.K.) Ltd., Taoyuan Branch**, and found compliance with the requirement of the above standards. The test record, data evaluation & Equipment Under Test (EUT) configurations represented herein are true and accurate accounts of the measurements of the sample's EMC characteristics under the conditions specified in this report.

**PREPARED BY** : Evonne Liu , **DATE** : May 12, 2015  
Evonne Liu / Specialist

**APPROVED BY** : Sam Chen , **DATE** : May 12, 2015  
Sam Chen / Senior Project Engineer

## 2. SUMMARY OF TEST RESULTS

The EUT has been tested according to the following specifications:

APPLIED STANDARD: FCC PART 15, SUBPART E (SECTION 15.407)			
STANDARD SECTION	TEST TYPE	RESULT	REMARK
15.407(b)(6)	AC Power Conducted Emission	PASS	Meet the requirement of limit. Minimum passing margin is -11.59dB at 0.72084MHz.
15.407(b/1/2/3) (b)(6)	Radiated Emissions	PASS	Meet the requirement of limit. Minimum passing margin is -2.27dB at 5861MHz.
15.407(a/1/2/3)	Max Average Transmit Power	PASS	Meet the requirement of limit.
15.407(a/1/2/3)	Peak Power Spectral Density	PASS	Meet the requirement of limit.
15.407(e)	6dB bandwidth	PASS	Meet the requirement of limit. (U-NII-3 Band only)
15.407(g)	Frequency Stability	NA	Refer to Note
15.203	Antenna Requirement	NA	Refer to Note

**NOTE:** Only conducted & radiated emission, Max Average Transmit Power, Peak Power Spectral Density and 6dB bandwidth tests were performed for this addendum. Refer to original report for other test data.

### 2.1 MEASUREMENT UNCERTAINTY

Where relevant, the following measurement uncertainty levels have been estimated for tests performed on the EUT as specified in CISPR 16-4-2:

MEASUREMENT	FREQUENCY	UNCERTAINTY
Conducted emissions	9kHz~30MHz	2.44 dB
Radiated emissions	30MHz ~ 200MHz	2.93 dB
	200MHz ~1000MHz	2.95 dB
	1GHz ~ 18GHz	2.26 dB
	18GHz ~ 40GHz	1.94 dB

This uncertainty represents an expanded uncertainty expressed at approximately the 95% confidence level using a coverage factor of  $k = 2$ .

### 3. GENERAL INFORMATION

#### 3.1 GENERAL DESCRIPTION OF EUT

<b>EUT</b>	Mobile Computer
<b>MODEL NO.</b>	MC9590
<b>POWER SUPPLY</b>	12.0Vdc (adapter) 3.7Vdc (battery)
<b>MODULATION TYPE</b>	64QAM, 16QAM, QPSK, BPSK
<b>MODULATION TECHNOLOGY</b>	OFDM
<b>TRANSFER RATE</b>	802.11a: 54.0/ 48.0/ 36.0/ 24.0/ 18.0/ 12.0/ 9.0/ 6.0Mbps
<b>OPERATING FREQUENCY</b>	5745 ~ 5825MHz
<b>NUMBER OF CHANNEL</b>	5745 ~ 5825MHz: 5 for 802.11a
<b>OUTPUT POWER</b>	27.04mW
<b>ANTENNA TYPE</b>	Main: PIFA antenna with 3.52dBi gain Aux.: PIFA antenna with 4.0dBi gain
<b>ANTENNA CONNECTOR</b>	NA
<b>DATA CABLE</b>	Refer to Note as below
<b>ACCESSORY DEVICES</b>	Refer to Note as below
<b>WIRELESS FUSION</b>	3.00.2.0.031R
<b>OS VERSION</b>	05.02.29217
<b>OEM VERSION</b>	05.47.0002

**NOTE:**

1. This report is issued as a supplementary report of BV ADT report no.: RF980316L09. The difference compared with original report is update the standard to the latest version for WLAN 5G band 4.
2. The models as identified below are identical to each other except of the following options:
3. - Barcode reader: 1D laser scanner / 2D Imager

<b>Brand</b>	<b>Model</b>	<b>Description</b>
Motorola	MC9590	WLAN 1D Calculator Numeric
Motorola	MC9590	WLAN 2D Calculator Numeric
Motorola	MC9590	WLAN 1D Alpha Primary
<b>Motorola</b>	<b>MC9590</b>	<b>WLAN 2D Alpha Primary</b>
Motorola	MC9590	WLAN 1D Telephony Numeric
Motorola	MC9590	WLAN 2D Telephony Numeric
Motorola	MC9590	WLAN 1D Alpha Numeric Wide
Motorola	MC9590	WLAN 2D Alpha Numeric Wide

\*\*The worst case had been marked by boldface.





4. The EUT contains following accessory devices.

ITEM	BRAND	MODEL	SPECIFICATION
Adapter	HIPRO	HP-O2040D43	I/P: 100-240Vac, 50-60Hz, 1.5A O/P: 12Vdc, 3.33A AC 1.7m cable w/o core DC 1.8m cable w/ one core
Battery	Motorola	82-111636-01	3.7Vdc, 4800mAh, 17.7Wh
Earphone	Motorola	NA	0.8m w/ one core
USB charging Y cable	Motorola	NA	1.8m w/ one core

5. The EUT provides one completed transmitter and two receivers.

MODULATION MODE	TX FUNCTION
802.11a	1TX

6. The above EUT information is declared by the manufacturer and for more detailed features description, please refer to the manufacturer's specifications or User's Manual.

### 3.2 DESCRIPTION OF TEST MODES

**FOR 5.0GHz (5745 ~ 5825MHz):**

5 channels are provided for 802.11a:

CHANNEL	FREQUENCY	CHANNEL	FREQUENCY
149	5745MHz	161	5805MHz
153	5765MHz	165	5825MHz
157	5785MHz		



A D T

### 3.2.1 TEST MODE APPLICABILITY AND TESTED CHANNEL DETAIL

EUT CONFIGURE MODE	APPLICABLE TO				DESCRIPTION
	RE $\geq$ 1G	RE<1G	PLC	APCM	
A	√	√	√	√	Main Ant.
B	√	√	-	-	Aux Ant.

Where **RE $\geq$ 1G**: Radiated Emission above 1GHz **RE<1G**: Radiated Emission below 1GHz  
**PLC**: Power Line Conducted Emission **APCM**: Antenna Port Conducted Measurement

**NOTE:** The EUT had been pre-tested on the positioned of each 3 axis. The worst case was found when positioned on **X-plane**.

#### **RADIATED EMISSION TEST (ABOVE 1GHz):**

Pre-Scan has been conducted to determine the worst-case mode from all possible combinations between available modulations, data rates and antenna ports (if EUT with antenna diversity architecture).

Following channel(s) was (were) selected for the final test as listed below.

EUT CONFIGURE MODE	MODE	FREQ. BAND (MHz)	AVAILABLE CHANNEL	TESTED CHANNEL	MODULATION TECHNOLOGY	MODULATION TYPE	DATA RATE (Mbps)
A, B	802.11a	5745-5825	149 to 165	149, 157, 165	OFDM	BPSK	6.0

#### **RADIATED EMISSION TEST (BELOW 1GHz):**

Pre-Scan has been conducted to determine the worst-case mode from all possible combinations between available modulations, data rates and antenna ports (if EUT with antenna diversity architecture).

Following channel(s) was (were) selected for the final test as listed below.

EUT CONFIGURE MODE	MODE	FREQ. BAND (MHz)	AVAILABLE CHANNEL	TESTED CHANNEL	MODULATION TECHNOLOGY	MODULATION TYPE	DATA RATE (Mbps)
A, B	802.11a	5745-5825	149 to 165	149, 157, 165	OFDM	BPSK	6.0

#### **POWER LINE CONDUCTED EMISSION TEST:**

EUT CONFIGURE MODE	MODE	FREQ. BAND (MHz)	AVAILABLE CHANNEL	TESTED CHANNEL	MODULATION TECHNOLOGY	MODULATION TYPE	DATA RATE (Mbps)
A	802.11a	5745-5825	149 to 165	165	OFDM	BPSK	6.0

#### **BANDEDGE MEASUREMENT:**

Pre-Scan has been conducted to determine the worst-case mode from all possible combinations between available modulations, data rates and antenna ports (if EUT with antenna diversity architecture).

Following channel(s) was (were) selected for the final test as listed below.

EUT CONFIGURE MODE	MODE	FREQ. BAND (MHz)	AVAILABLE CHANNEL	TESTED CHANNEL	MODULATION TECHNOLOGY	MODULATION TYPE	DATA RATE (Mbps)
A	802.11a	5745-5825	149 to 165	149, 157, 165	OFDM	BPSK	6.0

**ANTENNA PORT CONDUCTED MEASUREMENT:**

- This item includes all test value of each mode, but only includes spectrum plot of worst value of each mode.
- Pre-Scan has been conducted to determine the worst-case mode from all possible combinations between available modulations, data rates and antenna ports (if EUT with antenna diversity architecture).
- Following channel(s) was (were) selected for the final test as listed below.

EUT CONFIGURE MODE	MODE	FREQ. BAND (MHz)	AVAILABLE CHANNEL	TESTED CHANNEL	MODULATION TECHNOLOGY	MODULATION TYPE	DATA RATE (Mbps)
A	802.11a	5745-5825	149 to 165	149, 157, 165	OFDM	BPSK	6.0

**TEST CONDITION:**

APPLICABLE TO	ENVIRONMENTAL CONDITIONS	INPUT POWER	TESTED BY
RE≥1G	25deg. C, 65%RH	120Vac, 60Hz	Anson Lin
RE<1G	25deg. C, 65%RH	120Vac, 60Hz	Anson Lin
PLC	25deg. C, 65%RH	120Vac, 60Hz	Toby Tian
APCM	25deg. C, 65%RH	120Vac, 60Hz	Taylor Liu

**3.3 DESCRIPTION OF SUPPORT UNITS**

The EUT has been tested as an independent unit together with other necessary accessories or support units.

**3.3.1 CONFIGURATION OF SYSTEM UNDER TEST**

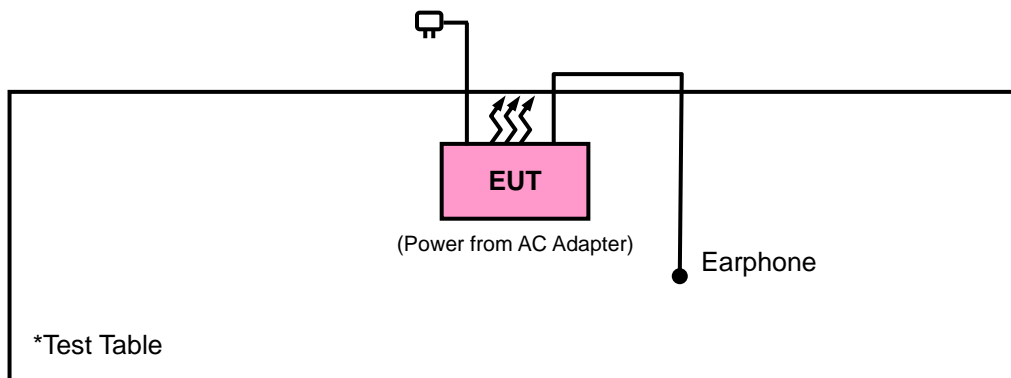

### 3.4 DUTY CYCLE TEST SIGNAL

#### MODULATION TYPE: BPSK

If duty cycle is < 98%, duty factor shall be considered.

**802.11a:** Duty cycle =  $1.001/1.025 = 0.976$ , Duty factor =  $10 * \log(1/0.976) = 0.10$

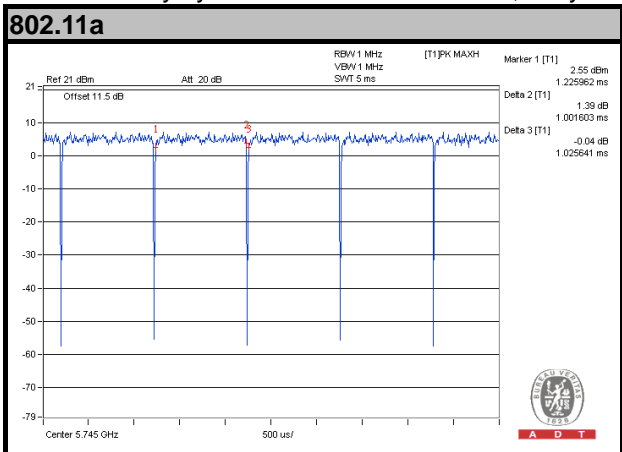

### 3.5 GENERAL DESCRIPTION OF APPLIED STANDARDS

The EUT is a RF Product. According to the specifications of the manufacturer, it must comply with the requirements of the following standards:

**FCC Part 15, Subpart E (15.407)**

**789033 D02 General UNII Test Procedures New Rules**

**v01 ANSI C63.10-2009**

All test items have been performed and recorded as per the above standards.

## 4. TEST TYPES AND RESULTS

### 4.1 RADIATED EMISSION AND BANDEDGE MEASUREMENT

#### 4.1.1 LIMITS OF RADIATED EMISSION AND BANDEDGE MEASUREMENT

Radiated emissions which fall in the restricted bands must comply with the radiated emission limits specified as below table:

FREQUENCIES (MHz)	FIELD STRENGTH (microvolts/meter)	MEASUREMENT DISTANCE (meters)
0.009 ~ 0.490	2400/F(kHz)	300
0.490 ~ 1.705	24000/F(kHz)	30
1.705 ~ 30.0	30	30
30 ~ 88	100	3
88 ~ 216	150	3
216 ~ 960	200	3
Above 960	500	3

**NOTE:**

1. The lower limit shall apply at the transition frequencies.
2. Emission level (dBuV/m) = 20 log Emission level (uV/m).
3. For frequencies above 1000MHz, the field strength limits are based on average detector, however, the peak field strength of any emission shall not exceed the maximum permitted average limits, specified above by more than 20dB under any condition of modulation.

#### 4.1.2 LIMITS OF UNWANTED EMISSION OUT OF THE RESTRICTED BANDS

APPLICABLE TO	LIMIT	
789033 D02 General UNII Test Procedures New Rules v01	FIELD STRENGTH AT 3m	
	PK: 74 (dBµV/m)	AV: 54 (dBµV/m)
APPLICABLE TO	EIRP LIMIT	EQUIVALENT FIELD STRENGTH AT 3m
15.407(b)(1)	PK: -27 (dBm/MHz)	PK: 68.2 (dBµV/m)
15.407(b)(2)		
15.407(b)(3)		
15.407(b)(4)	PK: -27 (dBm/MHz) <sup>*1</sup> PK: -17 (dBm/MHz) <sup>*2</sup>	PK: 68.2 (dBµV/m) <sup>*1</sup> PK: 78.2 (dBµV/m) <sup>*2</sup>

**NOTE:** <sup>\*1</sup> beyond 10MHz of the band edge      <sup>\*2</sup> within 10 MHz of band edge

The following formula is used to convert the equipment isotropic radiated power (eirp) to field strength:

$$E = \frac{1000000\sqrt{30P}}{3} \mu\text{V/m, where P is the eirp (Watts).}$$



**4.1.3 TEST INSTRUMENTS**

DESCRIPTION & MANUFACTURER	MODEL NO.	SERIAL NO.	DATE OF CALIBRATION	DUE DATE OF CALIBRATION
Test Receiver ROHDE & SCHWARZ	ESCI	100424	Oct. 06, 2014	Oct. 05, 2015
Spectrum Analyzer ROHDE & SCHWARZ	FSU43	101261	Dec. 10, 2014	Dec. 09, 2015
BILOG Antenna SCHWARZBECK	VULB9168	9168-472	Feb. 04, 2015	Feb. 04, 2016
HORN Antenna SCHWARZBECK	BBHA 9120 D	9120D-969	Feb. 09, 2015	Feb. 09, 2016
HORN Antenna SCHWARZBECK	BBHA 9170	9170-480	Feb. 04, 2015	Feb. 04, 2016
Preamplifier EMCI	EMC 012645	980115	Dec. 12, 2014	Dec. 11, 2015
Preamplifier EMCI	EMC 184045	980116	Jan. 09, 2015	Jan. 08, 2016
Preamplifier EMCI	EMC 330H	980112	Dec. 25, 2014	Dec. 24, 2015
RF signal cable HUBER+SUHNNER	SUCOFLEX 104	309219/4 2950114	Oct. 18, 2014	Oct. 17, 2015
RF signal cable HUBER+SUHNNER	SUCOFLEX 104	250130/4	Oct. 18, 2014	Oct. 17, 2015
RF signal cable Worken	RG-213	NA	Nov. 07, 2014	Nov. 06, 2015
Software BV ADT	E3 6.120103	NA	NA	NA
Antenna Tower MF	MFA-440H	NA	NA	NA
Turn Table MF	MFT-201SS	NA	NA	NA
Antenna Tower & Turn Table Controller MF	MF-7802	NA	NA	NA
Power Meter	ML2495A	1232002	Sep. 17, 2014	Sep. 16, 2015
Power Sensor	MA2411B	1207325	Sep. 17, 2014	Sep. 16, 2015

- NOTE:**
1. The calibration interval of the above test instruments is 12 months and the calibrations are traceable to NML/ROC and NIST/USA.
  2. The calibration interval of the loop antenna is 24 months and the calibrations are traceable to NML/ROC and NIST/USA.
  3. The test was performed in HwaYa Chamber 10.
  4. The horn antenna and HP preamplifier (model: 8449B) are used only for the measurement of emission frequency above 1GHz if tested.
  5. The FCC Site Registration No. is 690701.
  6. The IC Site Registration No. is IC 7450F-10.

#### 4.1.4 TEST PROCEDURES

- a. The EUT was placed on the top of a rotating table 0.8 meters (for below 1GHz) / 1.5 meters (for above 1GHz) above the ground at 3 meter chamber room for test. The table was rotated 360 degrees to determine the position of the highest radiation.
- b. The EUT was set 3 meters away from the interference-receiving antenna, which was mounted on the top of a variable-height antenna tower.
- c. The antenna is a broadband antenna, and its height is varied from one meter to four meters above the ground to determine the maximum value of the field strength. Both horizontal and vertical polarizations of the antenna are set to make the measurement.
- d. For each suspected emission, the EUT was arranged to its worst case and then the antenna was tuned to heights from 1 meter to 4 meters and the rotatable table was turned from 0 degrees to 360 degrees to find the maximum reading.
- e. The test-receiver system was set to Peak Detect Function and Specified Bandwidth with Maximum Hold Mode.
- f. If the emission level of the EUT in peak mode was 10dB lower than the limit specified, then testing could be stopped and the peak values of the EUT would be reported. Otherwise the emissions that did not have 10dB margin would be re-tested one by one using peak, quasi-peak or average method as specified and then reported in a data sheet.

#### NOTE:

1. The resolution bandwidth and video bandwidth of test receiver/spectrum analyzer is 120kHz for Peak detection (PK) and Quasi-peak detection (QP) at frequency below 1GHz.
2. The resolution bandwidth of test receiver/spectrum analyzer is 1MHz and video bandwidth is 3MHz for Peak detection at frequency above 1GHz.
3. The resolution bandwidth of test receiver/spectrum analyzer is 1MHz and the video bandwidth is 1kHz (Duty cycle < 98%) or 10Hz (Duty cycle > 98%) for Average detection (AV) at frequency above 1GHz.
4. All modes of operation were investigated and the worst-case emissions are reported.

#### 4.1.5 DEVIATION FROM TEST STANDARD

No deviation.

**4.1.6 TEST SETUP**

<Frequency Range 30MHz ~ 1GHz>

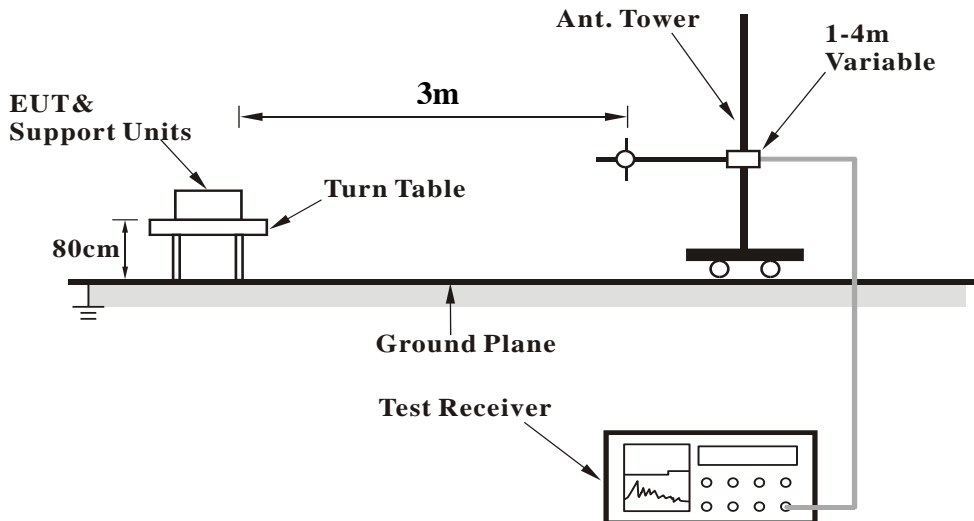

<Frequency Range above 1GHz>

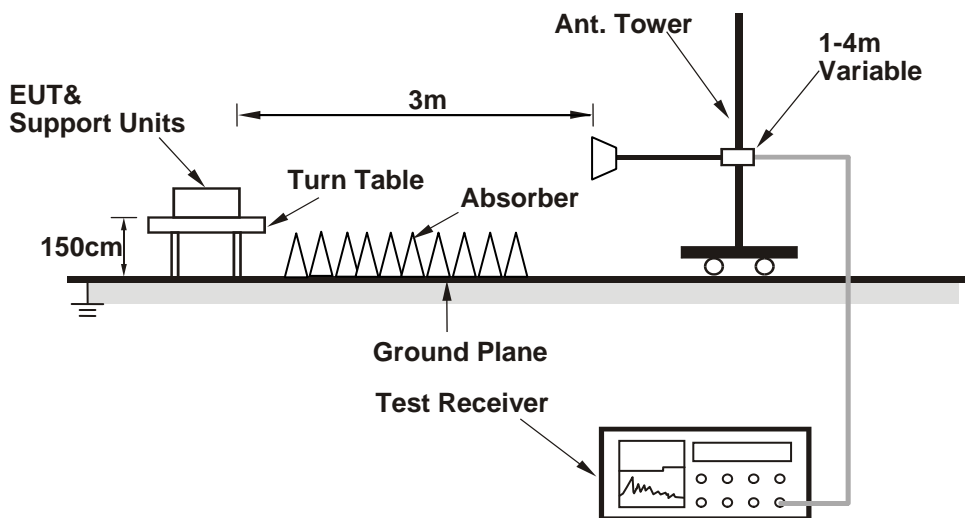

For the actual test configuration, please refer to the attached file (Test Setup Photo).

**4.1.7 EUT OPERATING CONDITIONS**

- a. Placed the EUT on a testing table.
- b. Use the software to control the EUT under transmission condition continuously at specific channel frequency.





A D T

**4.1.8 TEST RESULTS**

**ABOVE 1GHz WORST-CASE DATA**

802.11a

MODE A

EUT TEST CONDITION		MEASUREMENT DETAIL	
CHANNEL	Channel 149	FREQUENCY RANGE	1GHz ~ 40GHz
INPUT POWER	120Vac, 60 Hz	DETECTOR FUNCTION	Peak (PK) Average (AV)
ENVIRONMENTAL CONDITIONS	25deg. C, 65%RH	TESTED BY	Anson Lin

**ANTENNA POLARITY & TEST DISTANCE: HORIZONTAL AT 3 M**

FREQ. (MHz)	EMISSION LEVEL (dBuV/m)	READ LEVEL (dBuV)	LIMIT (dBuV/m)	MARGIN (dB)	ANTENNA FACTOR (dB/m)	CABLE LOSS (dB)	PREAMP FACTOR (dB)	ANTENNA HEIGHT (cm)	TABLE ANGLE (Degree)	REMARK
5714	61.8	61.71	68.2	-6.4	31.93	5.59	37.43	100	246	Peak
5725	68.58	68.46	78.2	-9.62	31.96	5.59	37.43	100	246	Peak
5745	90.67	90.55			31.99	5.6	37.47	100	246	Average
5745	100.33	100.21			31.99	5.6	37.47	100	246	Peak
5850	60.36	60.06	78.2	-17.84	32.15	5.66	37.51	100	246	Peak
5861	59.57	59.23	68.2	-8.63	32.18	5.66	37.5	100	246	Peak
11490	41.36	45.23	54	-12.64	39.91	9.05	52.83	100	217	Average
11490	52.07	55.94	74	-21.93	39.91	9.05	52.83	100	217	Peak

**ANTENNA POLARITY & TEST DISTANCE: VERTICAL AT 3 M**

FREQ. (MHz)	EMISSION LEVEL (dBuV/m)	READ LEVEL (dBuV)	LIMIT (dBuV/m)	MARGIN (dB)	ANTENNA FACTOR (dB/m)	CABLE LOSS (dB)	PREAMP FACTOR (dB)	ANTENNA HEIGHT (cm)	TABLE ANGLE (Degree)	REMARK
5714	62.14	62.05	68.2	-6.06	31.93	5.59	37.43	108	198	Peak
5725	70.51	70.39	78.2	-7.69	31.96	5.59	37.43	108	198	Peak
5745	93.36	93.24			31.99	5.6	37.47	108	198	Average
5745	102.93	102.81			31.99	5.6	37.47	108	198	Peak
5850	59.37	59.07	78.2	-18.83	32.15	5.66	37.51	108	198	Peak
5861	59.19	58.85	68.2	-9.01	32.18	5.66	37.5	108	198	Peak
11490	41.29	45.16	54	-12.71	39.91	9.05	52.83	100	337	Average
11490	51.11	54.98	74	-22.89	39.91	9.05	52.83	100	337	Peak

**REMARKS:**

- Emission Level = Read Level + Antenna Factor + Cable Loss - Preamp Factor  
Margin value = Emission level – Limit value
- 5745MHz: Fundamental frequency.
- 5714MHz & 5725MHz & 5850MHz & 5861MHz: Out of restricted band



A D T

EUT TEST CONDITION		MEASUREMENT DETAIL	
CHANNEL	Channel 157	FREQUENCY RANGE	1GHz ~ 40GHz
INPUT POWER	120Vac, 60 Hz	DETECTOR FUNCTION	Peak (PK) Average (AV)
ENVIRONMENTAL CONDITIONS	25deg. C, 65%RH	TESTED BY	Anson Lin

**ANTENNA POLARITY & TEST DISTANCE: HORIZONTAL AT 3 M**

FREQ. (MHz)	EMISSION LEVEL (dBuV/m)	READ LEVEL (dBuV)	LIMIT (dBuV/m)	MARGIN (dB)	ANTENNA FACTOR (dB/m)	CABLE LOSS (dB)	PREAMP FACTOR (dB)	ANTENNA HEIGHT (cm)	TABLE ANGLE (Degree)	REMARK
5714	58.52	58.43	68.2	-9.68	31.93	5.59	37.43	120	246	Peak
5725	60.35	60.23	78.2	-17.85	31.96	5.59	37.43	120	246	Peak
5785	92.37	92.25			32.04	5.62	37.54	120	246	Average
5785	101.59	101.47			32.04	5.62	37.54	120	246	Peak
5850	59.32	59.02	78.2	-18.88	32.15	5.66	37.51	120	246	Peak
5861	59.84	59.5	68.2	-8.36	32.18	5.66	37.5	120	246	Peak
11570	41.36	45.82	54	-12.64	39.78	9.09	53.33	100	128	Average
11570	51.3	55.76	74	-22.7	39.78	9.09	53.33	100	128	Peak

**ANTENNA POLARITY & TEST DISTANCE: VERTICAL AT 3 M**

FREQ. (MHz)	EMISSION LEVEL (dBuV/m)	READ LEVEL (dBuV)	LIMIT (dBuV/m)	MARGIN (dB)	ANTENNA FACTOR (dB/m)	CABLE LOSS (dB)	PREAMP FACTOR (dB)	ANTENNA HEIGHT (cm)	TABLE ANGLE (Degree)	REMARK
5714	59.37	59.28	68.2	-8.83	31.93	5.59	37.43	113	248	Peak
5725	60.28	60.16	78.2	-17.92	31.96	5.59	37.43	113	248	Peak
5785	95.27	95.15			32.04	5.62	37.54	113	248	Average
5785	105.07	104.95			32.04	5.62	37.54	113	248	Peak
5850	59.32	59.02	78.2	-18.88	32.15	5.66	37.51	113	248	Peak
5861	59.11	58.77	68.2	-9.09	32.18	5.66	37.5	113	248	Peak
11570	41.47	45.93	54	-12.53	39.78	9.09	53.33	100	129	Average
11570	50.57	55.03	74	-23.43	39.78	9.09	53.33	100	129	Peak

**REMARKS:**

- Emission Level = Read Level + Antenna Factor + Cable Loss - Preamp Factor  
Margin value = Emission level – Limit value
- 5785MHz: Fundamental frequency.
- 5714MHz & 5725MHz & 5850MHz & 5861MHz: Out of restricted band



A D T

EUT TEST CONDITION		MEASUREMENT DETAIL	
CHANNEL	Channel 165	FREQUENCY RANGE	1GHz ~ 40GHz
INPUT POWER	120Vac, 60 Hz	DETECTOR FUNCTION	Peak (PK) Average (AV)
ENVIRONMENTAL CONDITIONS	25deg. C, 65%RH	TESTED BY	Anson Lin

**ANTENNA POLARITY & TEST DISTANCE: HORIZONTAL AT 3 M**

FREQ. (MHz)	EMISSION LEVEL (dBuV/m)	READ LEVEL (dBuV)	LIMIT (dBuV/m)	MARGIN (dB)	ANTENNA FACTOR (dB/m)	CABLE LOSS (dB)	PREAMP FACTOR (dB)	ANTENNA HEIGHT (cm)	TABLE ANGLE (Degree)	REMARK
5714	59.36	59.27	68.2	-8.84	31.93	5.59	37.43	118	246	Peak
5725	59.33	59.21	78.2	-18.87	31.96	5.59	37.43	118	246	Peak
5825	92.29	92.06			32.12	5.64	37.53	118	246	Average
5825	101.95	101.72			32.12	5.64	37.53	118	246	Peak
5850	65.26	64.96	78.2	-12.94	32.15	5.66	37.51	118	246	Peak
5861	60.71	60.37	68.2	-7.49	32.18	5.66	37.5	118	246	Peak
11650	41.12	45.7	54	-12.88	39.65	9.12	53.35	100	188	Average
11650	52.65	57.23	74	-21.35	39.65	9.12	53.35	100	188	Peak

**ANTENNA POLARITY & TEST DISTANCE: VERTICAL AT 3 M**

FREQ. (MHz)	EMISSION LEVEL (dBuV/m)	READ LEVEL (dBuV)	LIMIT (dBuV/m)	MARGIN (dB)	ANTENNA FACTOR (dB/m)	CABLE LOSS (dB)	PREAMP FACTOR (dB)	ANTENNA HEIGHT (cm)	TABLE ANGLE (Degree)	REMARK
5714	59.15	59.06	68.2	-9.05	31.93	5.59	37.43	121	248	Peak
5725	58.85	58.73	78.2	-19.35	31.96	5.59	37.43	121	248	Peak
5825	95.36	95.13			32.12	5.64	37.53	121	248	Average
5825	104.8	104.57			32.12	5.64	37.53	121	248	Peak
5850	68.14	67.84	78.2	-10.06	32.15	5.66	37.51	121	248	Peak
5861	62.84	62.5	68.2	-5.36	32.18	5.66	37.5	121	248	Peak
11650	40.76	45.34	54	-13.24	39.65	9.12	53.35	100	151	Average
11650	51.63	56.21	74	-22.37	39.65	9.12	53.35	100	151	Peak

**REMARKS:**

- Emission Level = Read Level + Antenna Factor + Cable Loss - Preamp Factor  
Margin value = Emission level – Limit value
- 5825MHz: Fundamental frequency.
- 5714MHz & 5725MHz & 5850MHz & 5861MHz: Out of restricted band



A D T

**BELOW 1GHz WORST-CASE DATA:**

EUT TEST CONDITION		MEASUREMENT DETAIL	
CHANNEL	Channel 149	FREQUENCY RANGE	30MHz ~ 1GHz
INPUT POWER	120Vac, 60 Hz	DETECTOR FUNCTION	Peak (PK) Quasi-peak (QP)
ENVIRONMENTAL CONDITIONS	25deg. C, 65%RH	TESTED BY	Anson Lin

**ANTENNA POLARITY & TEST DISTANCE: HORIZONTAL AT 3 M**

FREQ. (MHz)	EMISSION LEVEL (dBuV/m)	READ LEVEL (dBuV)	LIMIT (dBuV/m)	MARGIN (dB)	ANTENNA FACTOR (dB/m)	CABLE LOSS (dB)	PREAMP FACTOR (dB)	ANTENNA HEIGHT (cm)	TABLE ANGLE (Degree)	REMARK
57	21.74	40.03	40	-18.26	12.25	0.81	31.35	125	305	Peak
153.66	31.15	48.76	43.5	-12.35	12.72	1.36	31.69	120	344	Peak
202.26	23.85	44.48	43.5	-19.65	9.48	1.61	31.72	128	206	Peak
309.8	28.18	44.87	46	-17.82	13.17	2.08	31.94	100	194	Peak
454	21.89	34.83	46	-24.11	16.41	2.63	31.98	115	278	Peak
574.4	24.23	34.3	46	-21.77	19.01	3.02	32.1	108	0	Peak

**ANTENNA POLARITY & TEST DISTANCE: VERTICAL AT 3 M**

FREQ. (MHz)	EMISSION LEVEL (dBuV/m)	READ LEVEL (dBuV)	LIMIT (dBuV/m)	MARGIN (dB)	ANTENNA FACTOR (dB/m)	CABLE LOSS (dB)	PREAMP FACTOR (dB)	ANTENNA HEIGHT (cm)	TABLE ANGLE (Degree)	REMARK
85.62	28.34	50.86	40	-11.66	8.22	1	31.74	101	264	Peak
150.69	27.07	44.63	43.5	-16.43	12.71	1.34	31.61	106	284	Peak
195.24	23.91	44.36	43.5	-19.59	9.7	1.57	31.72	102	331	Peak
327.3	23.59	39.68	46	-22.41	13.59	2.15	31.83	119	25	Peak
464.5	22.48	35.14	46	-23.52	16.62	2.66	31.94	133	323	Peak
654.9	25.31	33.77	46	-20.69	20.27	3.26	31.99	117	16	Peak

**REMARKS:** Emission Level = Read Level + Antenna Factor + Cable Loss - Preamp Factor

Margin value = Emission level – Limit value



A D T

EUT TEST CONDITION		MEASUREMENT DETAIL	
CHANNEL	Channel 157	FREQUENCY RANGE	30MHz ~ 1GHz
INPUT POWER	120Vac, 60 Hz	DETECTOR FUNCTION	Peak (PK) Quasi-peak (QP)
ENVIRONMENTAL CONDITIONS	25deg. C, 65%RH	TESTED BY	Anson Lin

ANTENNA POLARITY & TEST DISTANCE: HORIZONTAL AT 3 M										
FREQ. (MHz)	EMISSION LEVEL (dBuV/m)	READ LEVEL (dBuV)	LIMIT (dBuV/m)	MARGIN (dB)	ANTENNA FACTOR (dB/m)	CABLE LOSS (dB)	PREAMP FACTOR (dB)	ANTENNA HEIGHT (cm)	TABLE ANGLE (Degree)	REMARK
56.73	21.43	39.72	40	-18.57	12.25	0.81	31.35	121	282	Peak
153.66	32.05	49.66	43.5	-11.45	12.72	1.36	31.69	122	321	Peak
200.37	23.73	44.48	43.5	-19.77	9.4	1.6	31.75	106	277	Peak
304.2	28.07	44.83	46	-17.93	13.06	2.07	31.89	125	198	Peak
493.2	21.76	33.52	46	-24.24	17.2	2.76	31.72	111	150	Peak
626.2	24.68	33.73	46	-21.32	19.93	3.17	32.15	138	297	Peak
ANTENNA POLARITY & TEST DISTANCE: VERTICAL AT 3 M										
FREQ. (MHz)	EMISSION LEVEL (dBuV/m)	READ LEVEL (dBuV)	LIMIT (dBuV/m)	MARGIN (dB)	ANTENNA FACTOR (dB/m)	CABLE LOSS (dB)	PREAMP FACTOR (dB)	ANTENNA HEIGHT (cm)	TABLE ANGLE (Degree)	REMARK
85.89	28.09	50.64	40	-11.91	8.23	1	31.78	129	205	Peak
153.93	29.25	46.89	43.5	-14.25	12.72	1.36	31.72	113	323	Peak
220.89	23.9	43.66	46	-22.1	10.26	1.7	31.72	110	289	Peak
322.4	23.15	39.42	46	-22.85	13.47	2.13	31.87	110	134	Peak
445.6	22.22	35.38	46	-23.78	16.23	2.6	31.99	129	295	Peak
610.8	24.47	33.7	46	-21.53	19.74	3.12	32.09	132	103	Peak

**REMARKS:** Emission Level = Read Level + Antenna Factor + Cable Loss - Preamp Factor  
Margin value = Emission level – Limit value



A D T

EUT TEST CONDITION		MEASUREMENT DETAIL	
CHANNEL	Channel 165	FREQUENCY RANGE	30MHz ~ 1GHz
INPUT POWER	120Vac, 60 Hz	DETECTOR FUNCTION	Peak (PK) Quasi-peak (QP)
ENVIRONMENTAL CONDITIONS	25deg. C, 65%RH	TESTED BY	Anson Lin

**ANTENNA POLARITY & TEST DISTANCE: HORIZONTAL AT 3 M**

FREQ. (MHz)	EMISSION LEVEL (dBuV/m)	READ LEVEL (dBuV)	LIMIT (dBuV/m)	MARGIN (dB)	ANTENNA FACTOR (dB/m)	CABLE LOSS (dB)	PREAMP FACTOR (dB)	ANTENNA HEIGHT (cm)	TABLE ANGLE (Degree)	REMARK
56.73	21.63	39.92	40	-18.37	12.25	0.81	31.35	134	339	Peak
159.87	31.14	48.9	43.5	-12.36	12.73	1.39	31.88	106	259	Peak
204.15	23	43.51	43.5	-20.5	9.56	1.62	31.69	126	16	Peak
321.7	27.78	44.05	46	-18.22	13.47	2.13	31.87	111	291	Peak
493.9	22.87	34.63	46	-23.13	17.2	2.76	31.72	118	253	Peak
645.1	25.38	34.06	46	-20.62	20.15	3.23	32.06	112	318	Peak

**ANTENNA POLARITY & TEST DISTANCE: VERTICAL AT 3 M**

FREQ. (MHz)	EMISSION LEVEL (dBuV/m)	READ LEVEL (dBuV)	LIMIT (dBuV/m)	MARGIN (dB)	ANTENNA FACTOR (dB/m)	CABLE LOSS (dB)	PREAMP FACTOR (dB)	ANTENNA HEIGHT (cm)	TABLE ANGLE (Degree)	REMARK
84.54	28.41	50.91	40	-11.59	8.2	0.99	31.69	119	233	Peak
153.12	29.54	47.15	43.5	-13.96	12.72	1.36	31.69	117	66	Peak
220.62	24	43.76	46	-22	10.26	1.7	31.72	115	343	Peak
328	24.23	40.3	46	-21.77	13.61	2.15	31.83	120	143	Peak
460.3	22.5	35.29	46	-23.5	16.54	2.65	31.98	122	156	Peak
616.4	24.16	33.35	46	-21.84	19.81	3.14	32.14	109	271	Peak

**REMARKS:** Emission Level = Read Level + Antenna Factor + Cable Loss - Preamp Factor

Margin value = Emission level – Limit value



A D T

**ABOVE 1GHz WORST-CASE DATA**

**MODE B**

EUT TEST CONDITION		MEASUREMENT DETAIL	
CHANNEL	Channel 149	FREQUENCY RANGE	1GHz ~ 40GHz
INPUT POWER	120Vac, 60 Hz	DETECTOR FUNCTION	Peak (PK) Average (AV)
ENVIRONMENTAL CONDITIONS	25deg. C, 65%RH	TESTED BY	Anson Lin

**ANTENNA POLARITY & TEST DISTANCE: HORIZONTAL AT 3 M**

FREQ. (MHz)	EMISSION LEVEL (dBuV/m)	READ LEVEL (dBuV)	LIMIT (dBuV/m)	MARGIN (dB)	ANTENNA FACTOR (dB/m)	CABLE LOSS (dB)	PREAMP FACTOR (dB)	ANTENNA HEIGHT (cm)	TABLE ANGLE (Degree)	REMARK
5714	60.1	60.01	68.2	-8.1	31.93	5.59	37.43	120	98	Peak
5725	65.32	65.2	78.2	-12.88	31.96	5.59	37.43	120	98	Peak
5745	90.83	90.71			31.99	5.6	37.47	120	98	Average
5745	100.4	100.28			31.99	5.6	37.47	120	98	Peak
5850	58.18	57.88	78.2	-20.02	32.15	5.66	37.51	120	98	Peak
5861	58.02	57.68	68.2	-10.18	32.18	5.66	37.5	120	98	Peak
11490	43.06	46.93	54	-10.94	39.91	9.05	52.83	100	160	Average
11490	52.26	56.13	74	-21.74	39.91	9.05	52.83	100	160	Peak

**ANTENNA POLARITY & TEST DISTANCE: VERTICAL AT 3 M**

FREQ. (MHz)	EMISSION LEVEL (dBuV/m)	READ LEVEL (dBuV)	LIMIT (dBuV/m)	MARGIN (dB)	ANTENNA FACTOR (dB/m)	CABLE LOSS (dB)	PREAMP FACTOR (dB)	ANTENNA HEIGHT (cm)	TABLE ANGLE (Degree)	REMARK
5714	64.37	64.28	68.2	-3.83	31.93	5.59	37.43	100	110	Peak
5725	73.11	72.99	78.2	-5.09	31.96	5.59	37.43	100	110	Peak
5745	97.28	97.16			31.99	5.6	37.47	100	110	Average
5745	106.88	106.76			31.99	5.6	37.47	100	110	Peak
5850	58.09	57.79	78.2	-20.11	32.15	5.66	37.51	100	110	Peak
5861	59.37	59.03	68.2	-8.83	32.18	5.66	37.5	100	110	Peak
11490	43.49	47.36	54	-10.51	39.91	9.05	52.83	100	223	Average
11490	51.67	55.54	74	-22.33	39.91	9.05	52.83	100	223	Peak

**REMARKS:**

- Emission Level = Read Level + Antenna Factor + Cable Loss - Preamp Factor  
Margin value = Emission level – Limit value
- 5745MHz: Fundamental frequency.
- 5714MHz & 5725MHz & 5850MHz & 5861MHz: Out of restricted band



A D T

EUT TEST CONDITION		MEASUREMENT DETAIL	
CHANNEL	Channel 157	FREQUENCY RANGE	1GHz ~ 40GHz
INPUT POWER	120Vac, 60 Hz	DETECTOR FUNCTION	Peak (PK) Average (AV)
ENVIRONMENTAL CONDITIONS	25deg. C, 65%RH	TESTED BY	Anson Lin

**ANTENNA POLARITY & TEST DISTANCE: HORIZONTAL AT 3 M**

FREQ. (MHz)	EMISSION LEVEL (dBuV/m)	READ LEVEL (dBuV)	LIMIT (dBuV/m)	MARGIN (dB)	ANTENNA FACTOR (dB/m)	CABLE LOSS (dB)	PREAMP FACTOR (dB)	ANTENNA HEIGHT (cm)	TABLE ANGLE (Degree)	REMARK
5714	57.71	57.62	68.2	-10.49	31.93	5.59	37.43	118	97	Peak
5725	58.03	57.91	78.2	-20.17	31.96	5.59	37.43	118	97	Peak
5785	92.46	92.34			32.04	5.62	37.54	118	97	Average
5785	101.81	101.69			32.04	5.62	37.54	118	97	Peak
5850	58.9	58.6	78.2	-19.3	32.15	5.66	37.51	118	97	Peak
5861	58.07	57.73	68.2	-10.13	32.18	5.66	37.5	118	97	Peak
11570	40.9	45.36	54	-13.1	39.78	9.09	53.33	100	256	Average
11570	51.19	55.65	74	-22.81	39.78	9.09	53.33	100	256	Peak

**ANTENNA POLARITY & TEST DISTANCE: VERTICAL AT 3 M**

FREQ. (MHz)	EMISSION LEVEL (dBuV/m)	READ LEVEL (dBuV)	LIMIT (dBuV/m)	MARGIN (dB)	ANTENNA FACTOR (dB/m)	CABLE LOSS (dB)	PREAMP FACTOR (dB)	ANTENNA HEIGHT (cm)	TABLE ANGLE (Degree)	REMARK
5714	59.84	59.75	68.2	-8.36	31.93	5.59	37.43	111	112	Peak
5725	59.74	59.62	78.2	-18.46	31.96	5.59	37.43	111	112	Peak
5785	98.31	98.19			32.04	5.62	37.54	111	112	Average
5785	107.92	107.8			32.04	5.62	37.54	111	112	Peak
5850	59.52	59.22	78.2	-18.68	32.15	5.66	37.51	111	112	Peak
5861	59.21	58.87	68.2	-8.99	32.18	5.66	37.5	111	112	Peak
11570	41.16	45.62	54	-12.84	39.78	9.09	53.33	100	358	Average
11570	51.41	55.87	74	-22.59	39.78	9.09	53.33	100	358	Peak

**REMARKS:**

- Emission Level = Read Level + Antenna Factor + Cable Loss - Preamp Factor  
Margin value = Emission level – Limit value
- 5785MHz: Fundamental frequency.
- 5714MHz & 5725MHz & 5850MHz & 5861MHz: Out of restricted band





A D T

EUT TEST CONDITION		MEASUREMENT DETAIL	
CHANNEL	Channel 165	FREQUENCY RANGE	1GHz ~ 40GHz
INPUT POWER	120Vac, 60 Hz	DETECTOR FUNCTION	Peak (PK) Average (AV)
ENVIRONMENTAL CONDITIONS	25deg. C, 65%RH	TESTED BY	Anson Lin

**ANTENNA POLARITY & TEST DISTANCE: HORIZONTAL AT 3 M**

FREQ. (MHz)	EMISSION LEVEL (dBuV/m)	READ LEVEL (dBuV)	LIMIT (dBuV/m)	MARGIN (dB)	ANTENNA FACTOR (dB/m)	CABLE LOSS (dB)	PREAMP FACTOR (dB)	ANTENNA HEIGHT (cm)	TABLE ANGLE (Degree)	REMARK
5714	58.02	57.93	68.2	-10.18	31.93	5.59	37.43	102	197	Peak
5725	58.64	58.52	78.2	-19.56	31.96	5.59	37.43	102	197	Peak
5825	91.74	91.51			32.12	5.64	37.53	102	197	Average
5825	101.3	101.07			32.12	5.64	37.53	102	197	Peak
5850	64.2	63.9	78.2	-14	32.15	5.66	37.51	102	197	Peak
5861	60.01	59.67	68.2	-8.19	32.18	5.66	37.5	102	197	Peak
11650	41.26	45.84	54	-12.74	39.65	9.12	53.35	100	212	Average
11650	51.72	56.3	74	-22.28	39.65	9.12	53.35	100	212	Peak

**ANTENNA POLARITY & TEST DISTANCE: VERTICAL AT 3 M**

FREQ. (MHz)	EMISSION LEVEL (dBuV/m)	READ LEVEL (dBuV)	LIMIT (dBuV/m)	MARGIN (dB)	ANTENNA FACTOR (dB/m)	CABLE LOSS (dB)	PREAMP FACTOR (dB)	ANTENNA HEIGHT (cm)	TABLE ANGLE (Degree)	REMARK
5714	58.09	58	68.2	-10.11	31.93	5.59	37.43	101	96	Peak
5725	60.5	60.38	78.2	-17.7	31.96	5.59	37.43	101	96	Peak
5825	98	97.77			32.12	5.64	37.53	101	96	Average
5825	108.35	108.12			32.12	5.64	37.53	101	96	Peak
5850	72.69	72.39	78.2	-5.51	32.15	5.66	37.51	101	96	Peak
5861	65.93	65.59	68.2	-2.27	32.18	5.66	37.5	101	96	Peak
11650	41.21	45.79	54	-12.79	39.65	9.12	53.35	100	293	Average
11650	52.84	57.42	74	-21.16	39.65	9.12	53.35	100	293	Peak

**REMARKS:**

- Emission Level = Read Level + Antenna Factor + Cable Loss - Preamp Factor  
Margin value = Emission level – Limit value
- 5825MHz: Fundamental frequency.
- 5714MHz & 5725MHz & 5850MHz & 5861MHz: Out of restricted band



A D T

**BELOW 1GHz WORST-CASE DATA:**

EUT TEST CONDITION		MEASUREMENT DETAIL	
CHANNEL	Channel 149	FREQUENCY RANGE	30MHz ~ 1GHz
INPUT POWER	120Vac, 60 Hz	DETECTOR FUNCTION	Peak (PK) Quasi-peak (QP)
ENVIRONMENTAL CONDITIONS	25deg. C, 65%RH	TESTED BY	Anson Lin

ANTENNA POLARITY & TEST DISTANCE: HORIZONTAL AT 3 M										
FREQ. (MHz)	EMISSION LEVEL (dBuV/m)	READ LEVEL (dBuV)	LIMIT (dBuV/m)	MARGIN (dB)	ANTENNA FACTOR (dB/m)	CABLE LOSS (dB)	PREAMP FACTOR (dB)	ANTENNA HEIGHT (cm)	TABLE ANGLE (Degree)	REMARK
57	22.39	40.68	40	-17.61	12.25	0.81	31.35	110	334	Peak
153.93	31.18	48.82	43.5	-12.32	12.72	1.36	31.72	113	26	Peak
201.72	24.09	44.79	43.5	-19.41	9.44	1.6	31.74	137	245	Peak
318.9	27.86	44.24	46	-18.14	13.4	2.12	31.9	105	87	Peak
394.5	23.24	37.71	46	-22.76	15.21	2.4	32.08	118	138	Peak
609.4	24.53	33.79	46	-21.47	19.72	3.12	32.1	132	113	Peak
ANTENNA POLARITY & TEST DISTANCE: VERTICAL AT 3 M										
FREQ. (MHz)	EMISSION LEVEL (dBuV/m)	READ LEVEL (dBuV)	LIMIT (dBuV/m)	MARGIN (dB)	ANTENNA FACTOR (dB/m)	CABLE LOSS (dB)	PREAMP FACTOR (dB)	ANTENNA HEIGHT (cm)	TABLE ANGLE (Degree)	REMARK
84	27.67	50.17	40	-12.33	8.2	0.99	31.69	122	170	Peak
154.47	27.71	45.35	43.5	-15.79	12.72	1.36	31.72	105	17	Peak
194.16	24.1	44.48	43.5	-19.4	9.77	1.56	31.71	105	303	Peak
325.9	22.87	39	46	-23.13	13.57	2.14	31.84	105	20	Peak
454	22.35	35.29	46	-23.65	16.41	2.63	31.98	108	352	Peak
574.4	23.94	34.01	46	-22.06	19.01	3.02	32.1	136	76	Peak

**REMARKS:** Emission Level = Read Level + Antenna Factor + Cable Loss - Preamp Factor  
Margin value = Emission level – Limit value



A D T

EUT TEST CONDITION		MEASUREMENT DETAIL	
CHANNEL	Channel 157	FREQUENCY RANGE	30MHz ~ 1GHz
INPUT POWER	120Vac, 60 Hz	DETECTOR FUNCTION	Peak (PK) Quasi-peak (QP)
ENVIRONMENTAL CONDITIONS	25deg. C, 65%RH	TESTED BY	Anson Lin

ANTENNA POLARITY & TEST DISTANCE: HORIZONTAL AT 3 M										
FREQ. (MHz)	EMISSION LEVEL (dBuV/m)	READ LEVEL (dBuV)	LIMIT (dBuV/m)	MARGIN (dB)	ANTENNA FACTOR (dB/m)	CABLE LOSS (dB)	PREAMP FACTOR (dB)	ANTENNA HEIGHT (cm)	TABLE ANGLE (Degree)	REMARK
56.73	22.17	40.46	40	-17.83	12.25	0.81	31.35	119	204	Peak
155.01	31.49	49.14	43.5	-12.01	12.72	1.37	31.74	121	191	Peak
200.91	24.04	44.79	43.5	-19.46	9.4	1.6	31.75	108	124	Peak
317.5	27.45	43.89	46	-18.55	13.36	2.11	31.91	101	139	Peak
410.6	23.88	37.87	46	-22.12	15.54	2.46	31.99	120	288	Peak
628.3	24.57	33.6	46	-21.43	19.95	3.17	32.15	127	239	Peak
ANTENNA POLARITY & TEST DISTANCE: VERTICAL AT 3 M										
FREQ. (MHz)	EMISSION LEVEL (dBuV/m)	READ LEVEL (dBuV)	LIMIT (dBuV/m)	MARGIN (dB)	ANTENNA FACTOR (dB/m)	CABLE LOSS (dB)	PREAMP FACTOR (dB)	ANTENNA HEIGHT (cm)	TABLE ANGLE (Degree)	REMARK
82.92	27.46	49.94	40	-12.54	8.18	0.99	31.65	102	143	Peak
153.66	27.93	45.54	43.5	-15.57	12.72	1.36	31.69	113	161	Peak
194.97	23.67	44.12	43.5	-19.83	9.7	1.57	31.72	132	258	Peak
329.4	23.37	39.36	46	-22.63	13.66	2.16	31.81	134	121	Peak
413.4	22.71	36.64	46	-23.29	15.6	2.48	32.01	115	46	Peak
684.3	25.61	33.45	46	-20.39	20.63	3.37	31.84	127	289	Peak

**REMARKS:** Emission Level = Read Level + Antenna Factor + Cable Loss - Preamp Factor

Margin value = Emission level – Limit value



A D T

EUT TEST CONDITION		MEASUREMENT DETAIL	
CHANNEL	Channel 165	FREQUENCY RANGE	30MHz ~ 1GHz
INPUT POWER	120Vac, 60 Hz	DETECTOR FUNCTION	Peak (PK) Quasi-peak (QP)
ENVIRONMENTAL CONDITIONS	25deg. C, 65%RH	TESTED BY	Anson Lin

**ANTENNA POLARITY & TEST DISTANCE: HORIZONTAL AT 3 M**

FREQ. (MHz)	EMISSION LEVEL (dBuV/m)	READ LEVEL (dBuV)	LIMIT (dBuV/m)	MARGIN (dB)	ANTENNA FACTOR (dB/m)	CABLE LOSS (dB)	PREAMP FACTOR (dB)	ANTENNA HEIGHT (cm)	TABLE ANGLE (Degree)	REMARK
56.73	22.05	40.34	40	-17.95	12.25	0.81	31.35	105	245	Peak
153.93	31.52	49.16	43.5	-11.98	12.72	1.36	31.72	134	64	Peak
201.45	23.55	44.25	43.5	-19.95	9.44	1.6	31.74	122	296	Peak
317.5	27.97	44.41	46	-18.03	13.36	2.11	31.91	105	322	Peak
394.5	23.71	38.18	46	-22.29	15.21	2.4	32.08	100	275	Peak
621.3	24.85	33.99	46	-21.15	19.87	3.15	32.16	112	72	Peak

**ANTENNA POLARITY & TEST DISTANCE: VERTICAL AT 3 M**

FREQ. (MHz)	EMISSION LEVEL (dBuV/m)	READ LEVEL (dBuV)	LIMIT (dBuV/m)	MARGIN (dB)	ANTENNA FACTOR (dB/m)	CABLE LOSS (dB)	PREAMP FACTOR (dB)	ANTENNA HEIGHT (cm)	TABLE ANGLE (Degree)	REMARK
84	28.02	50.52	40	-11.98	8.2	0.99	31.69	119	241	Peak
153.12	27.68	45.29	43.5	-15.82	12.72	1.36	31.69	103	4	Peak
196.05	23.27	43.79	43.5	-20.23	9.64	1.57	31.73	128	284	Peak
329.4	22.81	38.8	46	-23.19	13.66	2.16	31.81	122	325	Peak
421.1	23.31	37.1	46	-22.69	15.75	2.51	32.05	134	198	Peak
601.7	24.37	33.89	46	-21.63	19.62	3.09	32.23	122	138	Peak

**REMARKS:** Emission Level = Read Level + Antenna Factor + Cable Loss - Preamp Factor

Margin value = Emission level – Limit value

## 4.2 CONDUCTED EMISSION MEASUREMENT

### 4.2.1 LIMITS OF CONDUCTED EMISSION MEASUREMENT

FREQUENCY OF EMISSION (MHz)	CONDUCTED LIMIT (dB $\mu$ V)	
	Quasi-peak	Average
0.15 ~ 0.5	66 to 56	56 to 46
0.5 ~ 5	56	46
5 ~ 30	60	50

**NOTE:**

1. The lower limit shall apply at the transition frequencies.
2. The limit decreases in line with the logarithm of the frequency in the range of 0.15 to 0.50MHz.
3. All emanations from a class A/B digital device or system, including any network of conductors and apparatus connected thereto, shall not exceed the level of field strengths specified above.

### 4.2.2 TEST INSTRUMENTS

DESCRIPTION & MANUFACTURER	MODEL NO.	SERIAL NO.	DATE OF CALIBRATION	DUE DATE OF CALIBRATION
Test Receiver ROHDE & SCHWARZ	ESCI	100613	Nov. 11, 2014	Nov. 10, 2015
RF signal cable Woken	5D-FB	Cable-HYC01-01	Dec. 26, 2014	Dec. 25, 2015
LISN ROHDE & SCHWARZ (EUT)	ESH3-Z5	835239/001	Mar. 02, 2015	Mar. 01, 2016
LISN ROHDE & SCHWARZ (Peripheral)	ESH3-Z5	100311	Jul. 21, 2014	Jul. 20, 2015
Software ADT	BV ADT_Cond_ V7.3.7.3	NA	NA	NA

- NOTE:**
1. The calibration interval of the above test instruments is 12 months and the calibrations are traceable to NML/ROC and NIST/USA.
  2. The test was performed in HwaYa Shielded Room 1.
  3. The VCCI Site Registration No. is C-2040.

#### 4.2.3 TEST PROCEDURES

- a. The EUT was placed 0.4 meters from the conducting wall of the shielded room with EUT being connected to the power mains through a line impedance stabilization network (LISN). Other support units were connected to the power mains through another LISN. The two LISNs provide 50 ohm/ 50uH of coupling impedance for the measuring instrument.
- b. Both lines of the power mains connected to the EUT were checked for maximum conducted interference.
- c. The frequency range from 150kHz to 30MHz was searched. Emission levels under (Limit - 20dB) was not recorded.

**NOTE:** All modes of operation were investigated and the worst-case emissions are reported.

#### 4.2.4 DEVIATION FROM TEST STANDARD

No deviation.

#### 4.2.5 TEST SETUP

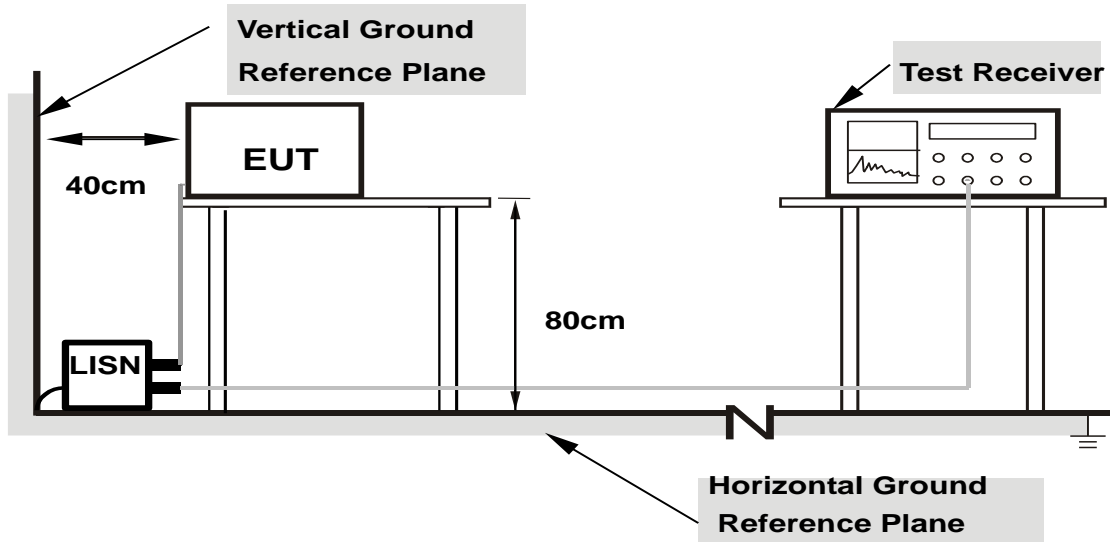

- Note:**
1. Support units were connected to second LISN.
  2. Both of LISNs (AMN) are 80 cm from EUT and at least 80 from other units and other metal planes

For the actual test configuration, please refer to the attached file (Test Setup Photo).

#### 4.2.6 EUT OPERATING CONDITIONS

Same as section 4.1.6.

#### 4.2.7 TEST RESULTS

##### CONDUCTED WORST-CASE DATA :

Frequency Range	150kHz ~ 30MHz	Detector Function & Resolution Bandwidth	Quasi-Peak (QP) / Average (AV), 9kHz
Input Power	120Vac, 60Hz	Environmental Conditions	25°C, 65%RH
Tested by	Toby Tian	Test Date	2015/4/29

Phase Of Power : Line (L)										
No	Frequency (MHz)	Correction Factor (dB)	Reading Value (dBuV)		Emission Level (dBuV)		Limit (dBuV)		Margin (dB)	
			Q.P.	AV.	Q.P.	AV.	Q.P.	AV.	Q.P.	AV.
1	0.20511	0.06	49.35	39.90	49.41	39.96	63.40	53.40	-13.99	-13.44
2	0.31031	0.06	39.43	30.94	39.49	31.00	59.96	49.96	-20.47	-18.96
3	0.61920	0.07	36.52	33.68	36.59	33.75	56.00	46.00	-19.41	-12.25
<b>4</b>	<b>0.72084</b>	<b>0.07</b>	<b>36.59</b>	<b>34.34</b>	<b>36.66</b>	<b>34.41</b>	<b>56.00</b>	<b>46.00</b>	<b>-19.34</b>	<b>-11.59</b>
5	2.47254	0.14	33.00	21.77	33.14	21.91	56.00	46.00	-22.86	-24.09
6	3.08675	0.16	35.95	22.54	36.11	22.70	56.00	46.00	-19.89	-23.30

##### Remarks:

1. Q.P. and AV. are abbreviations of quasi-peak and average individually.
2. The emission levels of other frequencies were very low against the limit.
3. Margin value = Emission level – Limit value
4. Correction factor = Insertion loss + Cable loss
5. Emission Level = Correction Factor + Reading Value

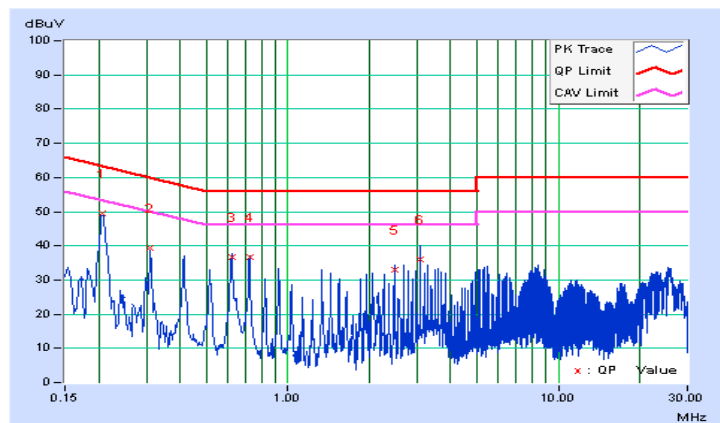





A D T

Frequency Range	150kHz ~ 30MHz	Detector Function & Resolution Bandwidth	Quasi-Peak (QP) / Average (AV), 9kHz
Input Power	120Vac, 60Hz	Environmental Conditions	25°C, 65%RH
Tested by	Toby Tian	Test Date	2015/4/29

Phase Of Power : Neutral (N)										
No	Frequency (MHz)	Correction Factor (dB)	Reading Value (dBuV)		Emission Level (dBuV)		Limit (dBuV)		Margin (dB)	
			Q.P.	AV.	Q.P.	AV.	Q.P.	AV.	Q.P.	AV.
1	0.20865	0.05	46.49	37.98	46.54	38.03	63.26	53.26	-16.72	-15.23
2	0.31021	0.06	39.15	31.94	39.21	32.00	59.96	49.96	-20.76	-17.97
3	0.61920	0.07	36.11	32.89	36.18	32.96	56.00	46.00	-19.82	-13.04
4	0.92809	0.08	33.49	31.19	33.57	31.27	56.00	46.00	-22.43	-14.73
5	2.46863	0.13	32.93	24.76	33.06	24.89	56.00	46.00	-22.94	-21.11
6	3.29364	0.16	33.62	21.84	33.78	22.00	56.00	46.00	-22.22	-24.00

Remarks:

1. Q.P. and AV. are abbreviations of quasi-peak and average individually.
2. The emission levels of other frequencies were very low against the limit.
3. Margin value = Emission level – Limit value
4. Correction factor = Insertion loss + Cable loss
5. Emission Level = Correction Factor + Reading Value

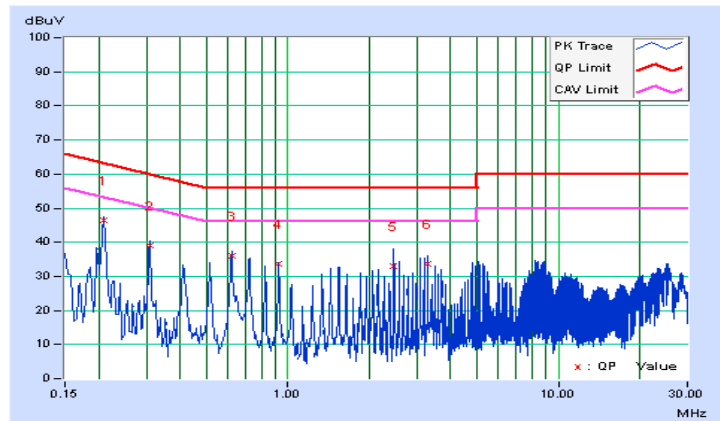

### 4.3 TRANSMIT POWER MEASUREMENT

#### 4.3.1 LIMITS OF TRANSMIT POWER MEASUREMENT

OPERATION BAND	EUT CATEGORY		LIMIT
U-NII-1		Outdoor Access Point	1 Watt (30 dBm) (Max. e.i.r.p $\leq$ 125mW(21 dBm) at any elevation angle above 30 degrees as measured from the horizon)
		Fixed point-to-point Access Point	1 Watt (30 dBm)
		Indoor Access Point	1 Watt (30 dBm)
		Mobile and Portable client device	250mW (24 dBm)
U-NII-2A		---	250mW (24 dBm) or 11 dBm+10 log B*
U-NII-2C		---	250mW (24 dBm) or 11 dBm+10 log B*
U-NII-3	√	---	1 Watt (30 dBm)

**NOTE:** Where B is the 26dB emission bandwidth in MHz.

#### 4.3.2 TEST SETUP

##### FOR POWER OUTPUT MEASUREMENT

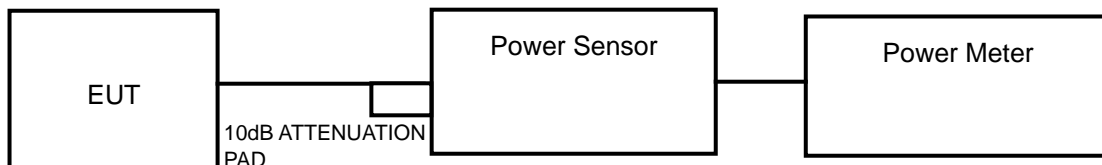

#### 4.3.3 TEST INSTRUMENTS

Refer to section 4.1.3 to get information of above instrument.

#### 4.3.4 TEST PROCEDURE

##### FOR AVERAGE POWER MEASUREMENT

Method PM is used to perform output power measurement, trigger and gating function of wide band power meter is enabled to measure max output power of TX on burst. Duty factor is not added to measured value.

#### 4.3.5 DEVIATION FROM TEST STANDARD

No deviation.

#### 4.3.6 EUT OPERATING CONDITIONS

The software provided by client to enable the EUT under transmission condition continuously at specific channel frequencies individually.



A D T

#### 4.3.7 TEST RESULTS

##### POWER OUTPUT

802.11a

Main Ant.

CHANNEL	FREQUENCY (MHz)	DATA RATE							
		6M bps	9M bps	12M bps	18M bps	24M bps	36M bps	48M bps	54M bps
149	5745	14.12	14.10	14.09	14.11	13.11	13.17	10.56	10.51
157	5785	14.18	14.19	14.10	14.14	12.86	12.88	10.29	10.27
165	5825	14.22	14.20	14.02	14.00	12.91	12.92	10.06	10.02

Aux Ant.

CHANNEL	FREQUENCY (MHz)	DATA RATE							
		6M bps	9M bps	12M bps	18M bps	24M bps	36M bps	48M bps	54M bps
149	5745	14.27	14.26	14.25	14.26	13.61	13.62	11.11	11.10
157	5785	14.25	14.24	14.19	14.23	13.27	13.23	10.71	10.68
165	5825	14.31	14.27	14.07	14.15	12.96	12.95	10.13	10.10

802.11a

CHANNEL	CHANNEL FREQUENCY (MHz)	MAX. CONDUCTED POWER (mW)	MAX. CONDUCTED POWER (dBm)	POWER LIMIT (dBm)	PASS/FAIL
149	5745	27.04	14.32	30	PASS
157	5785	26.73	14.27	30	PASS
165	5825	25.53	14.07	30	PASS

## 4.4 PEAK POWER SPECTRAL DENSITY MEASUREMENT

### 4.4.1 LIMITS OF PEAK POWER SPECTRAL DENSITY MEASUREMENT

Operation Band	EUT Category		LIMIT
U-NII-1		Outdoor Access Point	17dBm/ MHz
		Fixed point-to-point Access Point	
		Indoor Access Point	
		Mobile and Portable client device	11dBm/ MHz
U-NII-2A		---	11dBm/ MHz
U-NII-2C		---	11dBm/ MHz
U-NII-3	√	---	30dBm/ 500kHz

### 4.4.2 TEST SETUP

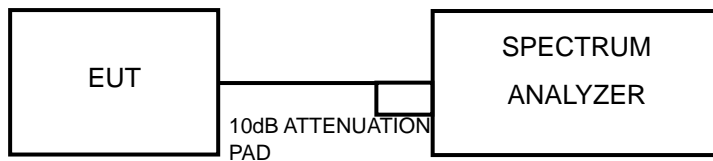

### 4.4.3 TEST INSTRUMENTS

Refer to section 4.1.3 to get information of above instrument.

### 4.4.4 TEST PROCEDURES

**For U-NII-3 band:**

- 1) Set span to encompass the entire emission bandwidth (EBW) of the signal.
- 2) Set RBW = 500 kHz, Set VBW  $\geq$  3 RBW, Detector = RMS
- 3) Sweep time = auto, trigger set to "free run".
- 4) Trace average at least 100 traces in power averaging mode.
- 5) Record the max value and add  $10 \log (1/\text{duty cycle})$

### 4.4.5 DEVIATION FROM TEST STANDARD

No deviation.

### 4.4.6 EUT OPERATING CONDITIONS

Same as Item 4.3.6.



A D T

### 4.4.7 TEST RESULTS

#### For U-NII-3 Band

#### 802.11a

CHANNEL	FREQUENCY (MHz)	PSD W/O DUTY FACTOR (dBm)	DUTY FACTOR	PSD WITH DUTY FACTOR (dBm)	LIMIT (dBm/500kHz)	PASS/FAIL
149	5745	-0.82	0.10	-0.72	30	PASS
157	5785	-0.73	0.10	-0.63	30	PASS
165	5825	-0.53	0.10	-0.43	30	PASS

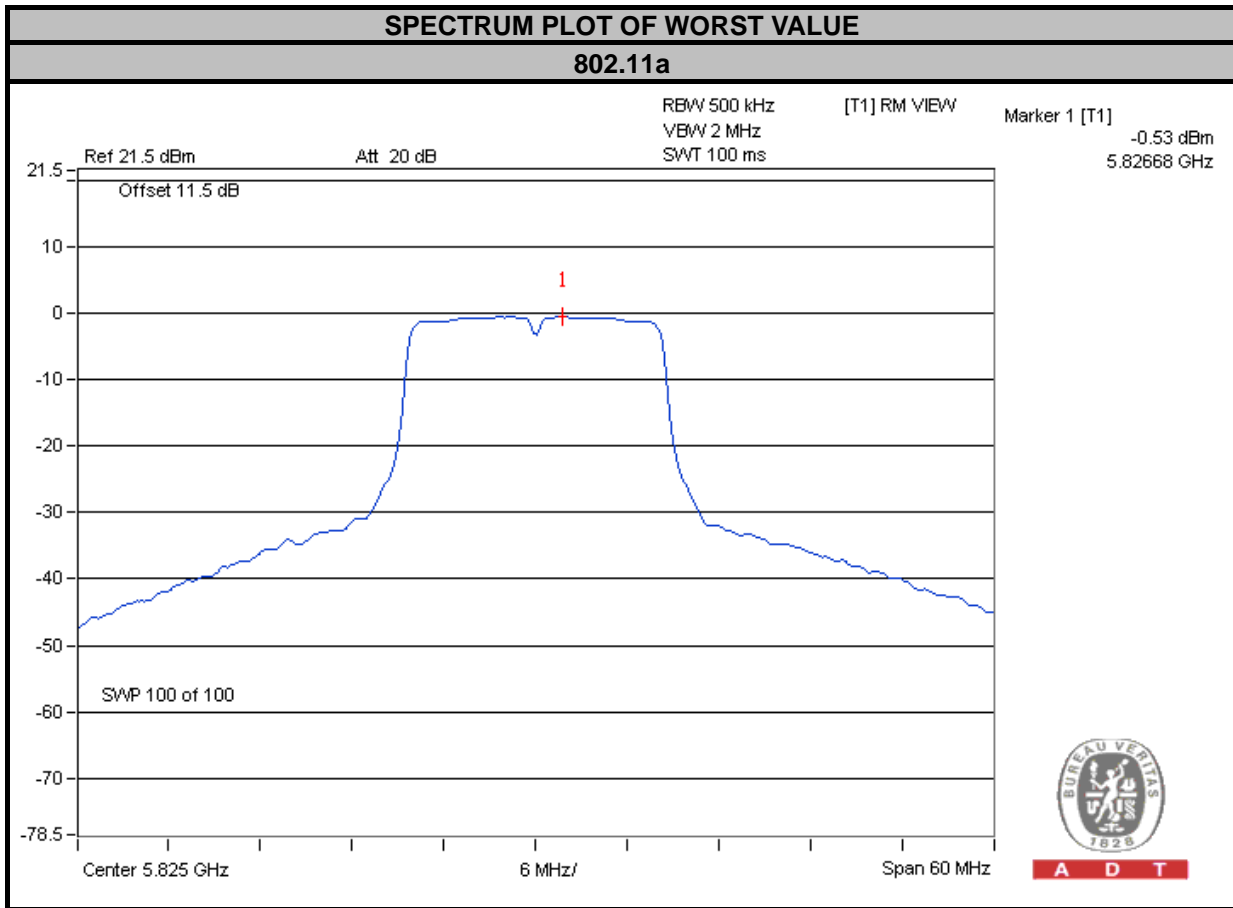

## 4.5 6dB BANDWIDTH MEASUREMENT

### 4.5.1 LIMITS OF 6dB BANDWIDTH MEASUREMENT

The minimum of 6dB Bandwidth Measurement is 0.5MHz.

### 4.5.2 TEST SETUP

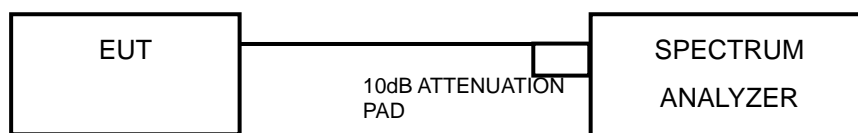

### 4.5.3 TEST INSTRUMENTS

Refer to section 4.1.3 to get information of above instrument.

### 4.5.4 TEST PROCEDURE

- Set resolution bandwidth (RBW) = 100kHz
- Set the video bandwidth (VBW)  $\geq 3 \times$  RBW, Detector = Peak.
- Trace mode = max hold.
- Sweep = auto couple.
- Measure the maximum width of the emission that is constrained by the frequencies associated with the two amplitude points (upper and lower) that are attenuated by 6 dB relative to the maximum level measured in the fundamental emission.

### 4.5.5 DEVIATION FROM TEST STANDARD

No deviation.

### 4.5.6 EUT OPERATING CONDITIONS

The software provided by client to enable the EUT under transmission condition continuously at lowest, middle and highest channel frequencies individually.



A D T

### 4.5.7 TEST RESULTS

#### 802.11a

CHANNEL	FREQUENCY (MHz)	6dB BANDWIDTH (MHz)	MINIMUM LIMIT (MHz)	PASS / FAIL
149	5745	16.37	0.5	PASS
157	5785	16.37	0.5	PASS
165	5825	16.37	0.5	PASS

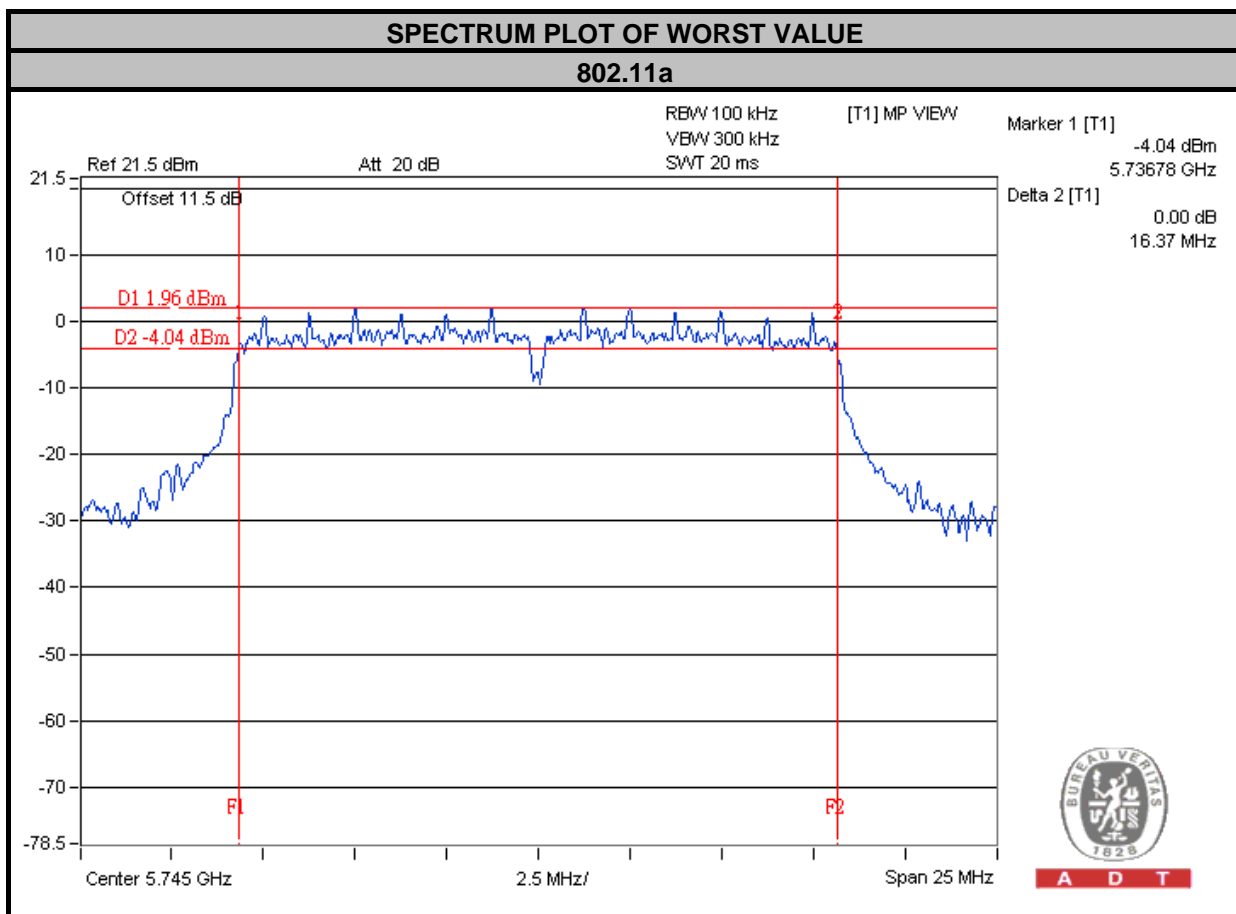



A D T

## 5. PHOTOGRAPHS OF THE TEST CONFIGURATION

Please refer to the attached file (Test Setup Photo).





## 6. INFORMATION ON THE TESTING LABORATORIES

We, Bureau Veritas Consumer Products Services (H.K.) Ltd., Taoyuan Branch, were founded in 1988 to provide our best service in EMC, Radio, Telecom and Safety consultation. Our laboratories are accredited and approved according to ISO/IEC 17025.

If you have any comments, please feel free to contact us at the following:

**Linko EMC/RF Lab:**

Tel: 886-2-26052180

Fax: 886-2-26051924

**Hsin Chu EMC/RF/Telecom Lab:**

Tel: 886-3-5935343

Fax: 886-3-5935342

**Hwa Ya EMC/RF/Safety Lab:**

Tel: 886-3-3183232

Fax: 886-3-3270892

**Email:** [service.adt@tw.bureauveritas.com](mailto:service.adt@tw.bureauveritas.com)

**Web Site:** [www.bureauveritas-adt.com](http://www.bureauveritas-adt.com)

The address and road map of all our labs can be found in our web site also.



A D T

## 7. APPENDIX A - MODIFICATIONS RECORDERS FOR ENGINEERING CHANGES TO THE EUT BY THE LAB

No any modifications are made to the EUT by the lab during the test.

---END---