



A D T

FCC TEST REPORT (15.407)

REPORT NO.: RF980316L09-1

MODEL NO.: MC9590

RECEIVED: Mar. 16, 2009

TESTED: Mar. 24 ~ Mar. 30, 2009

ISSUED: Apr. 01, 2009

APPLICANT: Motorola, Inc.

ADDRESS: One Motorola Plaza, Holtsville, NY 11742-1300
USA

ISSUED BY: Bureau Veritas Consumer Products Services
(H.K.) Ltd., Taoyuan Branch

LAB ADDRESS: No. 47, 14th Ling, Chia Pau Tsuen, Lin Kou
Hsiang, Taipei Hsien 244, Taiwan, R.O.C.

TEST LOCATION: No. 19, Hwa Ya 2nd Rd, Wen Hwa Tsuen, Kwei
Shan Hsiang, Taoyuan Hsien 333, Taiwan,
R.O.C.

This test report consists of 76 pages in total. It may be duplicated completely for legal use with the approval of the applicant. It should not be reproduced except in full, without the written approval of our laboratory. The client should not use it to claim product endorsement by TAF or any government agencies. The test results in the report only apply to the tested sample.



Table of Contents

1.	CERTIFICATION.....	4
2.	SUMMARY OF TEST RESULTS	5
2.1	MEASUREMENT UNCERTAINTY.....	5
3.	GENERAL INFORMATION.....	6
3.1	GENERAL DESCRIPTION OF EUT	6
3.2	DESCRIPTION OF TEST MODES	8
3.2.1	CONFIGURATION OF SYSTEM UNDER TEST	8
3.2.2	TEST MODE APPLICABILITY AND TESTED CHANNEL DETAIL	9
3.3	GENERAL DESCRIPTION OF APPLIED STANDARDS	11
3.4	DESCRIPTION OF SUPPORT UNITS	11
4.	TEST TYPES AND RESULTS	12
4.1	RADIATED EMISSION MEASUREMENT	12
4.1.1	LIMITS OF RADIATED EMISSION MEASUREMENT	12
4.1.2	LIMITS OF UNWANTED EMISSION OUT OF THE RESTRICTED BANDS	12
4.1.3	TEST INSTRUMENTS.....	13
4.1.4	TEST PROCEDURES	14
4.1.5	DEVIATION FROM TEST STANDARD.....	14
4.1.6	TEST SETUP.....	15
4.1.7	EUT OPERATING CONDITION.....	15
4.1.8	TEST RESULTS	16
4.2	CONDUCTED EMISSION MEASUREMENT	27
4.2.1	LIMITS OF CONDUCTED EMISSION MEASUREMENT	27
4.2.2	TEST INSTRUMENTS.....	27
4.2.3	TEST PROCEDURES	28
4.2.4	DEVIATION FROM TEST STANDARD.....	28
4.2.5	TEST SETUP.....	29
4.2.6	EUT OPERATING CONDITIONS	29
4.2.7	TEST RESULTS	30
4.3	MAXIMUM CONDUCTED OUTPUT POWER MEASUREMENT	34
4.3.1	LIMITS OF MAXIMUM CONDUCTED OUTPUT POWER MEASUREMENT.....	34
4.3.2	TEST INSTRUMENTS.....	34
4.3.3	TEST PROCEDURES	34
4.3.4	DEVIATION FROM TEST STANDARD.....	35
4.3.5	TEST SETUP.....	35
4.3.6	EUT OPERATING CONDITIONS	35
4.3.7	TEST RESULTS	36
4.4	PEAK POWER EXCURSION MEASUREMENT	42
4.4.1	LIMITS OF PEAK POWER EXCURSION MEASUREMENT.....	42
4.4.2	TEST INSTRUMENTS.....	42



A D T

4.4.3	TEST PROCEDURE.....	42
4.4.4	DEVIATION FROM TEST STANDARD.....	43
4.4.5	TEST SETUP.....	43
4.4.6	EUT OPERATING CONDITIONS.....	43
4.4.7	TEST RESULTS.....	44
4.5	PEAK POWER SPECTRAL DENSITY MEASUREMENT.....	54
4.5.1	LIMITS OF PEAK POWER SPECTRAL DENSITY MEASUREMENT.....	54
4.5.2	TEST INSTRUMENTS.....	54
4.5.3	TEST PROCEDURES.....	54
4.5.4	DEVIATION FROM TEST STANDARD.....	55
4.5.5	TEST SETUP.....	55
4.5.6	EUT OPERATING CONDITIONS.....	55
4.5.7	TEST RESULTS.....	56
4.6	FREQUENCY STABILITY.....	61
4.6.1	LIMITS OF FREQUENCY STABILITY MEASUREMENT.....	61
4.6.2	TEST INSTRUMENTS.....	61
4.6.3	TEST PROCEDURE.....	61
4.6.4	DEVIATION FROM TEST STANDARD.....	62
4.6.5	TEST SETUP.....	62
4.6.6	EUT OPERATING CONDITION.....	62
4.6.7	TEST RESULTS.....	63
4.7	BAND EDGES MEASUREMENT.....	64
4.7.1	TEST INSTRUMENTS.....	64
4.7.2	TEST PROCEDURE.....	64
4.7.3	EUT OPERATING CONDITION.....	64
4.7.4	TEST RESULTS.....	64
4.8	ANTENNA REQUIREMENT.....	73
4.8.1	STANDARD APPLICABLE.....	73
4.8.2	ANTENNA CONNECTED CONSTRUCTION.....	73
5.	PHOTOGRAPHS OF THE TEST CONFIGURATION.....	74
6.	INFORMATION ON THE TESTING LABORATORIES.....	75
7.	APPENDIX A - MODIFICATIONS RECORDERS FOR ENGINEERING CHANGES TO THE EUT BY THE LAB.....	76



A D T

1. CERTIFICATION

PRODUCT: Mobile Computer
MODEL NO.: MC9590
BRAND: Motorola
APPLICANT: Motorola, Inc.
TEST SAMPLE: ENGINEERING SAMPLE
TESTED: Mar. 24 ~ Mar. 30, 2009
STANDARDS: **FCC Part 15, Subpart E (Section 15.407)**
ANSI C63.4-2003

The above equipment (Model: MC9590) has been tested by **Bureau Veritas Consumer Products Services (H.K.) Ltd., Taoyuan Branch**, and found compliance with the requirement of the above standards. The test record, data evaluation & Equipment Under Test (EUT) configurations represented herein are true and accurate accounts of the measurements of the sample's EMC characteristics under the conditions specified in this report.

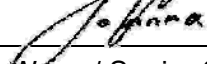
PREPARED BY :  , **DATE** : Apr. 01, 2009
Joanna Wang / Senior Specialist

TECHNICAL ACCEPTANCE :  , **DATE** : Apr. 01, 2009
Responsible for RF Long Chen / Senior Engineer

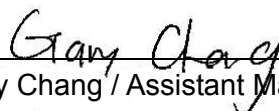
APPROVED BY :  , **DATE** : Apr. 01, 2009
Gary Chang / Assistant Manager



2. SUMMARY OF TEST RESULTS

The EUT has been tested according to the following specifications:

APPLIED STANDARD: FCC PART 15, SUBPART E (SECTION 15.407)			
STANDARD SECTION	TEST TYPE AND LIMIT	RESULT	REMARK
15.407(b)(5)	AC Power Conducted Emission	PASS	Meet the requirement of limit. Minimum passing margin is -18.09dB at 0.205MHz.
15.407(b/1/2/3)(b)(5)	Electric Field Strength Spurious Emissions, 30MHz ~ 40000MHz	PASS	Meet the requirement of limit. Minimum passing margin is -3.49dB at 11200.00MHz.
15.407(a/1/2/3)	Peak Transmit Power	PASS	Meet the requirement of limit.
15.407(a)(6)	Peak Power Excursion	PASS	Meet the requirement of limit.
15.407(a/1/2/3)	Peak Power Spectral Density	PASS	Meet the requirement of limit.
15.407(g)	Frequency Stability	PASS	Meet the requirement of limit.

2.1 MEASUREMENT UNCERTAINTY

Where relevant, the following measurement uncertainty levels have been estimated for tests performed on the EUT as specified in CISPR 16-4-2:

MEASUREMENT	FREQUENCY	UNCERTAINTY
Conducted emissions	9kHz~30MHz	2.44dB
Radiated emissions	30MHz ~ 200MHz	3.34dB
	200MHz ~1000MHz	3.35dB
	1GHz ~ 18GHz	2.26dB
	18GHz ~ 40GHz	1.94dB

This uncertainty represents an expanded uncertainty expressed at approximately the 95% confidence level using a coverage factor of k = 2.



A D T

3. GENERAL INFORMATION

3.1 GENERAL DESCRIPTION OF EUT

EUT	Mobile Computer
MODEL NO.	MC9590
FCC ID	UZ7MC9590
POWER SUPPLY	3.7Vdc from rechargeable lithium battery 12Vdc from power adapter
MODULATION TYPE	CCK, DQPSK, DBPSK for DSSS 64QAM, 16QAM, QPSK, BPSK for OFDM
MODULATION TECHNOLOGY	DSSS, OFDM
TRANSFER RATE	54.0/ 48.0/ 36.0/ 24.0/ 18.0/ 12.0/ 9.0/ 6.0Mbps
FREQUENCY RANGE	5180 ~ 5320MHz & 5500 ~ 5700MHz
NUMBER OF CHANNEL	5180 ~ 5320MHz: 8 for 802.11a 5500 ~ 5700MHz: 11 for 802.11a
OUTPUT POWER	13.032mW for 5180 ~ 5320MHz 22.542mW for 5500 ~ 5700MHz
ANTENNA TYPE	Main antenna: PIFA antenna with 3.52dBi gain Aux. antenna: PIFA antenna with 4.0dBi gain
DATA CABLE	Refer to NOTE as below
I/O PORTS	Refer to user's manual
ACCESSORY DEVICES	Battery

NOTE:

- The models identified as below are identical to each other except of the following options:
- Barcode reader: 1D laser scanner / 2D Imager

BRAND	MODEL	DESCRIPTION
Motorola	MC9590	WLAN 1D Calculator Numeric
Motorola	MC9590	WLAN 2D Calculator Numeric
Motorola	MC9590	WLAN 1D Alpha Primary
Motorola	MC9590	WLAN 2D Alpha Primary
Motorola	MC9590	WLAN 1D Telephony Numeric
Motorola	MC9590	WLAN 2D Telephony Numeric
Motorola	MC9590	WLAN 1D Alpha Numeric Wide
Motorola	MC9590	WLAN 2D Alpha Numeric Wide

**the worst case had been marked by boldface.

- The EUT has one lithium battery listed as below:

BRAND:	MOTOROLA
MODEL:	82-111636-01
RATING:	3.7Vdc, 4800mAh, 17.7Wh



A D T

3. The EUT is a Mobile Computer. The functions of EUT listed as below:

	TEST STANDARD	REFERENCE REPORT
WLAN 802.11b/g	FCC Part 15, Subpart C (Section 15.247)	RF980316L09
WLAN 802.11a (5745-5825 MHz)		
WLAN 802.11a (5180 ~ 5320MHz, 5500 ~ 5700MHz)	FCC Part 15, Subpart E (Section 15.407)	RF980316L09-1
WLAN 802.11a (For DFS report) (5260 ~ 5320MHz, 5500 ~ 5700MHz)	FCC Part 15, Subpart E (Section 15.407)	RF980316L09-3
BLUETOOTH	FCC Part 15, Subpart C (Section 15.247)	RF980316L09-2

4. The following accessories are for support units only.

PRODUCT	BRAND	MODEL	P/N	DESCRIPTION
USB charging Y cable	Motorola	-	25-116365-01R	1.8m shielded cable with one core
Headset	Motorola	-	50-11300-050R	0.8m non-shielded cable with one core
Adapter	HIPRO	HP-O2040D43	-	Input: 100-240Vac, 50-60Hz, 1.5A Output: 12Vdc, 3.33A, MAX 40W Power line: AC 1.7m non-shielded cable without core DC1.8m non-shielded cable with one core

5. The EUT operates in both the 5GHz and 2.4GHz Bands and compatibility with 802.11a and 802.11b, 802.11g technology.

6. The EUT operates in the 2.4GHz/5GHz frequency spectrum with throughput of up to 54Mbps.

7. The above EUT information was declared by manufacturer and for more detailed features description, please refer to the manufacturer's specifications or user's manual.

3.2 DESCRIPTION OF TEST MODES

Operated in 5180 ~ 5320MHz

8 channels are provided for 802.11a

CHANNEL	FREQUENCY	CHANNEL	FREQUENCY
36	5180 MHz	52	5260 MHz
40	5200 MHz	56	5280 MHz
44	5220 MHz	60	5300 MHz
48	5240 MHz	64	5320 MHz

Operated in 5500 ~ 5700MHz

11 channels are provided for 802.11a

CHANNEL	FREQUENCY	CHANNEL	FREQUENCY
100	5500 MHz	124	5620 MHz
104	5520 MHz	128	5640 MHz
108	5540 MHz	132	5660 MHz
112	5560 MHz	136	5680 MHz
116	5580 MHz	140	5700 MHz
120	5600 MHz		

3.2.1 CONFIGURATION OF SYSTEM UNDER TEST

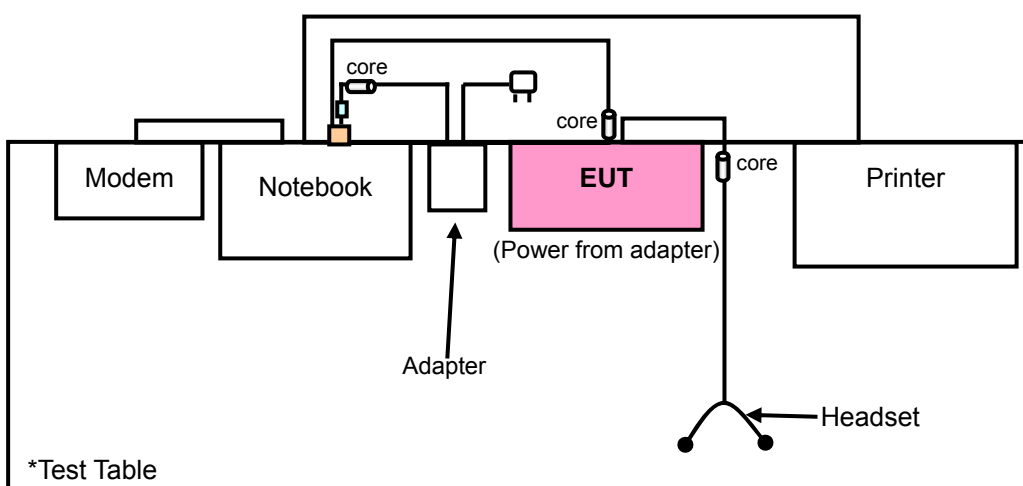



A D T

3.2.2 TEST MODE APPLICABILITY AND TESTED CHANNEL DETAIL

EUT CONFIGURE MODE	APPLICABLE TO				DESCRIPTION
	RE≥1G	RE<1G	PLC	APCM	
-	√	√	√	√	-

Where **RE≥1G**: Radiated Emission above 1GHz **RE<1G**: Radiated Emission below 1GHz
PLC: Power Line Conducted Emission **APCM**: Antenna Port Conducted Measurement

RADIATED EMISSION TEST (ABOVE 1GHz):

- Pre-Scan has been conducted to determine the worst-case mode from all possible combinations between available modulations, data rates, XYZ axis and antenna ports (if EUT with antenna diversity architecture).
- Following channel(s) was (were) selected for the final test as listed below.

MODE	FREQ. BAND (MHz)	AVAILABLE CHANNEL	TESTED CHANNEL	MODULATION TECHNOLOGY	MODULATION TYPE	DATA RATE (Mbps)	AXIS
802.11a	5180-5320	36 to 64	36, 40, 48, 52, 60, 64	OFDM	BPSK	6.0	Z
802.11a	5500-5700	100 to 140	100, 120, 140	OFDM	BPSK	6.0	Z

RADIATED EMISSION TEST (BELOW 1GHz):

- Pre-Scan has been conducted to determine the worst-case mode from all possible combinations between available modulations, data rates, XYZ axis and antenna ports (if EUT with antenna diversity architecture).
- Following channel(s) was (were) selected for the final test as listed below.

MODE	FREQ. BAND (MHz)	AVAILABLE CHANNEL	TESTED CHANNEL	MODULATION TECHNOLOGY	MODULATION TYPE	DATA RATE (Mbps)	AXIS
802.11a	5180-5320	36 to 64	36	OFDM	BPSK	6.0	Z
802.11a	5500-5700	100 to 140	120	OFDM	BPSK	6.0	Z

POWER LINE CONDUCTED EMISSION TEST:

- Pre-Scan has been conducted to determine the worst-case mode from all possible combinations between available modulations, data rates and antenna ports (if EUT with antenna diversity architecture).
- Following channel(s) was (were) selected for the final test as listed below.

MODE	FREQ. BAND (MHz)	AVAILABLE CHANNEL	TESTED CHANNEL	MODULATION TECHNOLOGY	MODULATION TYPE	DATA RATE (Mbps)
802.11a	5180-5320	36 to 64	36	OFDM	BPSK	6.0
802.11a	5500-5700	100 to 140	120	OFDM	BPSK	6.0

BANDEDGE MEASUREMENT:

- Pre-Scan has been conducted to determine the worst-case mode from all possible combinations between available modulations, data rates and antenna ports (if EUT with antenna diversity architecture).
- Following channel(s) was (were) selected for the final test as listed below.

MODE	FREQ. BAND (MHz)	AVAILABLE CHANNEL	TESTED CHANNEL	MODULATION TECHNOLOGY	MODULATION TYPE	DATA RATE (Mbps)
802.11a	5180-5320	36 to 64	36, 64	OFDM	BPSK	6.0
802.11a	5500-5700	100 to 140	100, 140	OFDM	BPSK	6.0

ANTENNA PORT CONDUCTED MEASUREMENT:

- Pre-Scan has been conducted to determine the worst-case mode from all possible combinations between available modulations, data rates and antenna ports (if EUT with antenna diversity architecture).
- Following channel(s) was (were) selected for the final test as listed below.

MODE	FREQ. BAND (MHz)	AVAILABLE CHANNEL	TESTED CHANNEL	MODULATION TECHNOLOGY	MODULATION TYPE	DATA RATE (Mbps)
802.11a	5180-5320	36 to 64	36, 40, 48, 52, 60, 64	OFDM	BPSK	6.0
802.11a	5500-5700	100 to 140	100, 120, 140	OFDM	BPSK	6.0



3.3 GENERAL DESCRIPTION OF APPLIED STANDARDS

The EUT is a RF Product. According to the specifications of the manufacturer, it must comply with the requirements of the following standards:

FCC Part 15, Subpart E (15.407)

ANSI C63.4-2003

All test items have been performed and recorded as per the above standards.

NOTE: The EUT is also considered as a kind of computer peripheral, because the connection to computer is necessary for typical use. It has been verified to comply with the requirements of FCC Part 15, Subpart B, Class B (DoC). The test report has been issued separately.

3.4 DESCRIPTION OF SUPPORT UNITS

The EUT has been tested as an independent unit together with other necessary accessories or support units. The following support units or accessories were used to form a representative test configuration during the tests.

NO.	PRODUCT	BRAND	MODEL NO.	SERIAL NO.	FCC ID
1	NOTEBOOK	DELL	PP05L	12130898320	E2K24CLNS
2	PRINTER	EPSON	LQ-300+	DCGY054011	FCC DoC Approved
3	MODEM	ACEEX	1414V/3	0401008253	IFAXDM1414

NO.	SIGNAL CABLE DESCRIPTION OF THE ABOVE SUPPORT UNITS
1	1.8m shielded USB cable with one core.
2	1.8m braid shielded wire, DB25 connector, w/o core.
3	1.2m braid shielded wire, DB25 & DB9 connector, w/o core.

NOTE 1: All power cords of the above support units are non shielded (1.8m).

NOTE 2: The 1.8m USB cable was supplied from client and only for test.



4. TEST TYPES AND RESULTS

4.1 RADIATED EMISSION MEASUREMENT

4.1.1 LIMITS OF RADIATED EMISSION MEASUREMENT

Emissions radiated outside of the specified bands, shall be according to the general radiated limits in 15.209 as following:

FREQUENCIES (MHz)	FIELD STRENGTH (microvolts/meter)	MEASUREMENT DISTANCE (meters)
0.009 ~ 0.490	2400/F(kHz)	300
0.490 ~ 1.705	24000/F(kHz)	30
1.705 ~ 30.0	30	30
30 ~ 88	100	3
88 ~ 216	150	3
216 ~ 960	200	3
Above 960	500	3

NOTE:

1. The lower limit shall apply at the transition frequencies.
2. Emission level (dBuV/m) = 20 log Emission level (uV/m).
3. As shown in 15.35(b), for frequencies above 1000MHz, the field strength limits are based on average detector, however, the peak field strength of any emission shall not exceed the maximum permitted average limits, specified above by more than 20dB under any condition of modulation.

4.1.2 LIMITS OF UNWANTED EMISSION OUT OF THE RESTRICTED BANDS

FREQUENCIES (MHz)	EIRP LIMIT (dBm)	EQUIVALENT FIELD STRENGTH AT 3m (dBµV/m) *NOTE
	PK	PK
5150 ~ 5350	-27	68.3
5470 ~ 5725	-27	68.3

NOTE:

The following formula is used to convert the equipment isotropic radiated power (eirp) to field strength:

$$E = \frac{1000000\sqrt{30P}}{3} \mu\text{V/m, where P is the eirp (Watts).$$

4.1.3 TEST INSTRUMENTS

DESCRIPTION & MANUFACTURER	MODEL NO.	SERIAL NO.	DATE OF CALIBRATION	DUE DATE OF CALIBRATION
Test Receiver ROHDE & SCHWARZ	ESI7	100033	Jun. 30, 2008	Jun. 29, 2009
Spectrum Analyzer ROHDE & SCHWARZ	FSP40	100041	Apr. 22, 2008	Apr. 21, 2009
BILOG Antenna SCHWARZBECK	VULB9168	9168-160	May 02, 2008	May 01, 2009
HORN Antenna SCHWARZBECK	9120D	9120D-209	Jun. 24, 2008	Jun. 23, 2009
HORN Antenna SCHWARZBECK	BBHA 9170	BBHA9170243	Dec. 25, 2008	Dec. 24, 2009
Preamplifier Agilent	8447D	2944A10633	Nov. 03, 2008	Nov. 02, 2009
Preamplifier Agilent	8449B	3008A01964	Oct. 23, 2008	Oct. 22, 2009
RF signal cable HUBER+SUHNNER	SUCOFLEX 104	238141/4	May 20, 2008	May 19, 2009
RF signal cable HUBER+SUHNNER	SUCOFLEX 104	12738/6	May 20, 2008	May 19, 2009
Software ADT.	ADT_Radiated_ V7.6.15.9.2	NA	NA	NA
Antenna Tower inn-co GmbH	MA 4000	013303	NA	NA
Antenna Tower Controller inn-co GmbH	CO2000	017303	NA	NA
Turn Table ADT.	TT100.	TT93021703	NA	NA
Turn Table Controller ADT.	SC100.	SC93021703	NA	NA

- NOTE:**
1. The calibration interval of the above test instruments is 12 months and the calibrations are traceable to NML/ROC and NIST/USA.
 2. The test was performed in HwaYa Chamber 3.
 3. The horn antenna and HP preamplifier (model: 8449B) are used only for the measurement of emission frequency above 1GHz if tested.
 4. The FCC Site Registration No. is 988962.
 5. The IC Site Registration No. is IC 7450F-3.

4.1.4 TEST PROCEDURES

- a. The EUT was placed on the top of a rotating table 0.8 meters above the ground at a 3 meter semi-anechoic chamber. The table was rotated 360 degrees to determine the position of the highest radiation.
- b. The EUT was set 3 meters away from the interference-receiving antenna, which was mounted on the top of a variable-height antenna tower.
- c. The antenna is a broadband antenna, and its height is varied from one meter to four meters above the ground to determine the maximum value of the field strength. Both horizontal and vertical polarizations of the antenna are set to make the measurement.
- d. For each suspected emission, the EUT was arranged to its worst case and then the antenna was tuned to heights from 1 meter to 4 meters and the rotatable table was turned from 0 degrees to 360 degrees to find the maximum reading.
- e. The test-receiver system was set to Peak Detect Function and Specified Bandwidth with Maximum Hold Mode.
- f. If the emission level of the EUT in peak mode was 10dB lower than the limit specified, then testing could be stopped and the peak values of the EUT would be reported. Otherwise the emissions that did not have 10dB margin would be re-tested one by one using peak, quasi-peak or average method as specified and then reported in a data sheet.

NOTE:

1. The resolution bandwidth and video bandwidth of test receiver/spectrum analyzer is 120kHz for Peak detection (PK) and Quasi-peak detection (QP) at frequency below 1GHz.
2. The resolution bandwidth of test receiver/spectrum analyzer is 1MHz and video bandwidth is 3MHz for Peak detection at frequency above 1GHz.
3. The resolution bandwidth of test receiver/spectrum analyzer is 1MHz and the video bandwidth is 10Hz for Average detection (AV) at frequency above 1GHz.
4. All modes of operation were investigated and the worst-case emissions are reported.

4.1.5 DEVIATION FROM TEST STANDARD

No deviation.

4.1.6 TEST SETUP

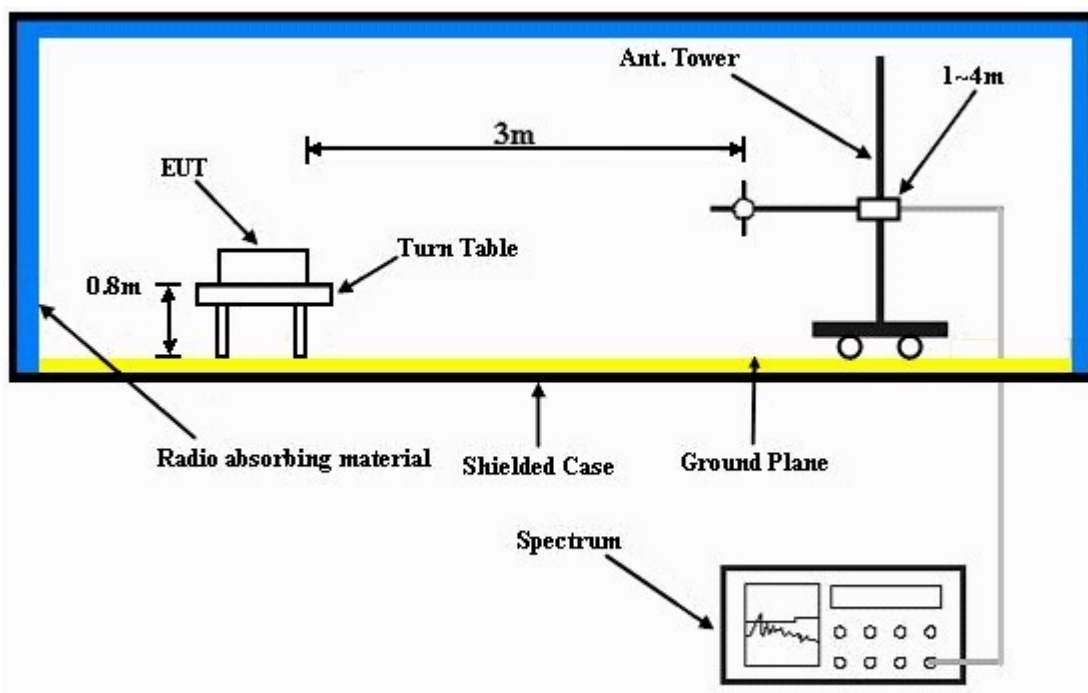

For the actual test configuration, please refer to the attached file (Test Setup Photo).

4.1.7 EUT OPERATING CONDITION

- a. Connected the EUT to a notebook via a USB cable and placed on a testing table.
- b. The EUT runs a test program (provided by manufacture) to transmit at specific channel.
- c. The necessary accessories enable the system in full functions.



A D T

4.1.8 TEST RESULTS

802.11a OFDM MODULATION

EUT TEST CONDITION		MEASUREMENT DETAIL	
CHANNEL	Channel 36	FREQUENCY RANGE	1 ~ 40GHz
INPUT POWER (SYSTEM)	120Vac, 60Hz	DETECTOR FUNCTION	Peak (PK) Average (AV)
ENVIRONMENTAL CONDITIONS	23deg. C, 70%RH 1014hPa	TESTED BY	Match Tsui

ANTENNA POLARITY & TEST DISTANCE: HORIZONTAL AT 3 M								
NO.	FREQ. (MHz)	EMISSION LEVEL (dBuV/m)	LIMIT (dBuV/m)	MARGIN (dB)	ANTENNA HEIGHT (m)	TABLE ANGLE (Degree)	RAW VALUE (dBuV)	CORRECTION FACTOR (dB/m)
1	5150.00	62.84 PK	74.00	-11.16	1.10 H	182	23.75	39.09
2	5150.00	44.78 AV	54.00	-9.22	1.10 H	182	5.69	39.09
3	*5180.00	109.74 PK			1.10 H	182	70.56	39.18
4	*5180.00	99.14 AV			1.10 H	182	59.96	39.18
5	#10360.00	60.62 PK	68.30	-7.68	1.00 H	130	11.15	49.47
6	#10360.00	48.22 AV	54.00	-5.78	1.00 H	130	-1.25	49.47
ANTENNA POLARITY & TEST DISTANCE: VERTICAL AT 3 M								
NO.	FREQ. (MHz)	EMISSION LEVEL (dBuV/m)	LIMIT (dBuV/m)	MARGIN (dB)	ANTENNA HEIGHT (m)	TABLE ANGLE (Degree)	RAW VALUE (dBuV)	CORRECTION FACTOR (dB/m)
1	5150.00	64.97 PK	74.00	-9.03	1.02 V	131	25.88	39.09
2	5150.00	46.64 AV	54.00	-7.36	1.02 V	131	7.55	39.09
3	*5180.00	110.82 PK			1.01 V	135	71.64	39.18
4	*5180.00	100.34 AV			1.01 V	135	61.16	39.18
5	#10360.00	60.88 PK	68.30	-7.42	1.10 V	308	11.41	49.47
6	#10360.00	47.78 AV	54.00	-6.22	1.10 V	308	-1.69	49.47

- REMARKS:**
1. Emission level (dBuV/m) = Raw Value (dBuV) + Correction Factor (dB/m).
 2. Correction Factor (dB/m) = Antenna Factor (dB/m) + Cable Factor (dB).
 3. The other emission levels were very low against the limit.
 4. Margin value = Emission level – Limit value.
 5. “ * “: Fundamental frequency.
 6. “#”: The radiated frequency is out the restricted band.



A D T

EUT TEST CONDITION		MEASUREMENT DETAIL	
CHANNEL	Channel 40	FREQUENCY RANGE	1 ~ 40GHz
INPUT POWER (SYSTEM)	120Vac, 60Hz	DETECTOR FUNCTION	Peak (PK) Average (AV)
ENVIRONMENTAL CONDITIONS	23deg. C, 70%RH 1014hPa	TESTED BY	Match Tsui

ANTENNA POLARITY & TEST DISTANCE: HORIZONTAL AT 3 M								
NO.	FREQ. (MHz)	EMISSION LEVEL (dBuV/m)	LIMIT (dBuV/m)	MARGIN (dB)	ANTENNA HEIGHT (m)	TABLE ANGLE (Degree)	RAW VALUE (dBuV)	CORRECTION FACTOR (dB/m)
1	*5200.00	110.04 PK			1.09 H	179	70.80	39.24
2	*5200.00	99.48 AV			1.09 H	179	60.24	39.24
3	#10400.00	62.01 PK	68.30	-6.29	1.09 H	174	12.41	49.60
ANTENNA POLARITY & TEST DISTANCE: VERTICAL AT 3 M								
NO.	FREQ. (MHz)	EMISSION LEVEL (dBuV/m)	LIMIT (dBuV/m)	MARGIN (dB)	ANTENNA HEIGHT (m)	TABLE ANGLE (Degree)	RAW VALUE (dBuV)	CORRECTION FACTOR (dB/m)
1	*5200.00	111.08 PK			1.15 V	129	71.84	39.24
2	*5200.00	100.45 AV			1.15 V	129	61.21	39.24
3	#10400.00	61.35 PK	68.30	-6.95	1.42 V	333	11.75	49.60

- REMARKS:**
1. Emission level (dBuV/m) = Raw Value (dBuV) + Correction Factor (dB/m).
 2. Correction Factor (dB/m) = Antenna Factor (dB/m) + Cable Factor (dB).
 3. The other emission levels were very low against the limit.
 4. Margin value = Emission level – Limit value.
 5. “ * “: Fundamental frequency.
 6. “#”:The radiated frequency is out the restricted band.



A D T

EUT TEST CONDITION		MEASUREMENT DETAIL	
CHANNEL	Channel 48	FREQUENCY RANGE	1 ~ 40GHz
INPUT POWER (SYSTEM)	120Vac, 60Hz	DETECTOR FUNCTION	Peak (PK) Average (AV)
ENVIRONMENTAL CONDITIONS	23deg. C, 70%RH 1014hPa	TESTED BY	Match Tsui

ANTENNA POLARITY & TEST DISTANCE: HORIZONTAL AT 3 M								
NO.	FREQ. (MHz)	EMISSION LEVEL (dBuV/m)	LIMIT (dBuV/m)	MARGIN (dB)	ANTENNA HEIGHT (m)	TABLE ANGLE (Degree)	RAW VALUE (dBuV)	CORRECTION FACTOR (dB/m)
1	*5240.00	110.32 PK			1.07 H	179	71.01	39.31
2	*5240.00	99.94 AV			1.07 H	179	60.63	39.31
3	#10480.00	61.35 PK	68.30	-6.95	1.09 H	155	11.62	49.73
ANTENNA POLARITY & TEST DISTANCE: VERTICAL AT 3 M								
NO.	FREQ. (MHz)	EMISSION LEVEL (dBuV/m)	LIMIT (dBuV/m)	MARGIN (dB)	ANTENNA HEIGHT (m)	TABLE ANGLE (Degree)	RAW VALUE (dBuV)	CORRECTION FACTOR (dB/m)
1	*5240.00	111.21 PK			1.14 V	141	71.90	39.31
2	*5240.00	100.86 AV			1.14 V	141	61.55	39.31
3	#10480.00	61.21 PK	68.30	-7.09	1.29 V	312	11.48	49.73

- REMARKS:**
1. Emission level (dBuV/m) = Raw Value (dBuV) + Correction Factor (dB/m).
 2. Correction Factor (dB/m) = Antenna Factor (dB/m) + Cable Factor (dB).
 3. The other emission levels were very low against the limit.
 4. Margin value = Emission level – Limit value.
 5. “ * “: Fundamental frequency.
 6. “#”:The radiated frequency is out the restricted band.



A D T

EUT TEST CONDITION		MEASUREMENT DETAIL	
CHANNEL	Channel 52	FREQUENCY RANGE	1 ~ 40GHz
INPUT POWER (SYSTEM)	120Vac, 60Hz	DETECTOR FUNCTION	Peak (PK) Average (AV)
ENVIRONMENTAL CONDITIONS	23deg. C, 70%RH 1014hPa	TESTED BY	Match Tsui

ANTENNA POLARITY & TEST DISTANCE: HORIZONTAL AT 3 M								
NO.	FREQ. (MHz)	EMISSION LEVEL (dBuV/m)	LIMIT (dBuV/m)	MARGIN (dB)	ANTENNA HEIGHT (m)	TABLE ANGLE (Degree)	RAW VALUE (dBuV)	CORRECTION FACTOR (dB/m)
1	*5260.00	110.14 PK			1.05 H	188	70.79	39.35
2	*5260.00	99.84 AV			1.05 H	188	60.49	39.35
3	#10520.00	61.98 PK	68.30	-6.32	1.11 H	164	12.22	49.76
ANTENNA POLARITY & TEST DISTANCE: VERTICAL AT 3 M								
NO.	FREQ. (MHz)	EMISSION LEVEL (dBuV/m)	LIMIT (dBuV/m)	MARGIN (dB)	ANTENNA HEIGHT (m)	TABLE ANGLE (Degree)	RAW VALUE (dBuV)	CORRECTION FACTOR (dB/m)
1	*5260.00	111.16 PK			1.10 V	134	71.81	39.35
2	*5260.00	100.79 AV			1.10 V	134	61.44	39.35
3	#10520.00	61.41 PK	68.30	-6.89	1.33 V	330	11.65	49.76

- REMARKS:**
1. Emission level (dBuV/m) = Raw Value (dBuV) + Correction Factor (dB/m).
 2. Correction Factor (dB/m) = Antenna Factor (dB/m) + Cable Factor (dB).
 3. The other emission levels were very low against the limit.
 4. Margin value = Emission level – Limit value.
 5. “ * “: Fundamental frequency.
 6. “#”:The radiated frequency is out the restricted band.



A D T

EUT TEST CONDITION		MEASUREMENT DETAIL	
CHANNEL	Channel 60	FREQUENCY RANGE	1 ~ 40GHz
INPUT POWER (SYSTEM)	120Vac, 60Hz	DETECTOR FUNCTION	Peak (PK) Average (AV)
ENVIRONMENTAL CONDITIONS	23deg. C, 70%RH 1014hPa	TESTED BY	Match Tsui

ANTENNA POLARITY & TEST DISTANCE: HORIZONTAL AT 3 M								
NO.	FREQ. (MHz)	EMISSION LEVEL (dBuV/m)	LIMIT (dBuV/m)	MARGIN (dB)	ANTENNA HEIGHT (m)	TABLE ANGLE (Degree)	RAW VALUE (dBuV)	CORRECTION FACTOR (dB/m)
1	*5300.00	110.46 PK			1.00 H	109	71.04	39.42
2	*5300.00	99.60 AV			1.00 H	109	60.18	39.42
3	10600.00	61.12 PK	74.00	-12.88	1.48 H	180	11.36	49.76
4	10600.00	48.35 AV	54.00	-5.65	1.48 H	180	-1.41	49.76
ANTENNA POLARITY & TEST DISTANCE: VERTICAL AT 3 M								
NO.	FREQ. (MHz)	EMISSION LEVEL (dBuV/m)	LIMIT (dBuV/m)	MARGIN (dB)	ANTENNA HEIGHT (m)	TABLE ANGLE (Degree)	RAW VALUE (dBuV)	CORRECTION FACTOR (dB/m)
1	*5300.00	111.40 PK			1.18 V	130	71.98	39.42
2	*5300.00	100.85 AV			1.18 V	130	61.43	39.42
3	10600.00	60.46 PK	74.00	-13.54	1.00 V	0	10.70	49.76
4	10600.00	47.64 AV	54.00	-6.36	1.00 V	0	-2.12	49.76

- REMARKS:**
1. Emission level (dBuV/m) = Raw Value (dBuV) + Correction Factor (dB/m).
 2. Correction Factor (dB/m) = Antenna Factor (dB/m) + Cable Factor (dB).
 3. The other emission levels were very low against the limit.
 4. Margin value = Emission level – Limit value.
 5. “ * “: Fundamental frequency.



A D T

EUT TEST CONDITION		MEASUREMENT DETAIL	
CHANNEL	Channel 64	FREQUENCY RANGE	1 ~ 40GHz
INPUT POWER (SYSTEM)	120Vac, 60Hz	DETECTOR FUNCTION	Peak (PK) Average (AV)
ENVIRONMENTAL CONDITIONS	23deg. C, 70%RH 1014hPa	TESTED BY	Match Tsui

ANTENNA POLARITY & TEST DISTANCE: HORIZONTAL AT 3 M								
NO.	FREQ. (MHz)	EMISSION LEVEL (dBuV/m)	LIMIT (dBuV/m)	MARGIN (dB)	ANTENNA HEIGHT (m)	TABLE ANGLE (Degree)	RAW VALUE (dBuV)	CORRECTION FACTOR (dB/m)
1	*5320.00	109.98 PK			1.04 H	160	70.56	39.42
2	*5320.00	99.59 AV			1.04 H	160	60.17	39.42
3	5350.00	63.71 PK	74.00	-10.29	1.13 H	163	24.29	39.42
4	5350.00	47.87 AV	54.00	-6.13	1.13 H	163	8.45	39.42
5	10640.00	61.85 PK	74.00	-12.15	1.15 H	150	12.01	49.84
6	10640.00	48.22 AV	54.00	-5.78	1.15 H	150	-1.62	49.84
ANTENNA POLARITY & TEST DISTANCE: VERTICAL AT 3 M								
NO.	FREQ. (MHz)	EMISSION LEVEL (dBuV/m)	LIMIT (dBuV/m)	MARGIN (dB)	ANTENNA HEIGHT (m)	TABLE ANGLE (Degree)	RAW VALUE (dBuV)	CORRECTION FACTOR (dB/m)
1	*5320.00	111.84 PK			1.19 V	136	72.42	39.42
2	*5320.00	101.49 AV			1.19 V	136	62.07	39.42
3	5350.00	65.58 PK	74.00	-8.42	1.19 V	129	26.16	39.42
4	5350.00	50.06 AV	54.00	-3.94	1.19 V	129	10.64	39.42
5	10640.00	60.99 PK	74.00	-13.01	1.38 V	309	11.15	49.84
6	10640.00	47.79 AV	54.00	-6.21	1.38 V	309	-2.05	49.84

- REMARKS:**
1. Emission level (dBuV/m) = Raw Value (dBuV) + Correction Factor (dB/m).
 2. Correction Factor (dB/m) = Antenna Factor (dB/m) + Cable Factor (dB).
 3. The other emission levels were very low against the limit.
 4. Margin value = Emission level – Limit value.
 5. “ * “: Fundamental frequency.



A D T

EUT TEST CONDITION		MEASUREMENT DETAIL	
CHANNEL	Channel 100	FREQUENCY RANGE	1 ~ 40GHz
INPUT POWER (SYSTEM)	120Vac, 60Hz	DETECTOR FUNCTION	Peak (PK) Average (AV)
ENVIRONMENTAL CONDITIONS	23deg. C, 70%RH 1014hPa	TESTED BY	Match Tsui

ANTENNA POLARITY & TEST DISTANCE: HORIZONTAL AT 3 M								
NO.	FREQ. (MHz)	EMISSION LEVEL (dBuV/m)	LIMIT (dBuV/m)	MARGIN (dB)	ANTENNA HEIGHT (m)	TABLE ANGLE (Degree)	RAW VALUE (dBuV)	CORRECTION FACTOR (dB/m)
1	5460.00	56.84 PK	74.00	-17.16	1.00 H	276	17.32	39.52
2	5460.00	44.41 AV	54.00	-9.59	1.00 H	276	4.89	39.52
3	#5470.00	63.49 PK	68.30	-4.81	1.00 H	297	23.95	39.54
4	*5500.00	107.68 PK			1.06 H	290	68.09	39.59
5	*5500.00	96.94 AV			1.06 H	290	57.35	39.59
6	11000.00	61.45 PK	74.00	-12.55	1.08 H	85	11.22	50.23
7	11000.00	48.30 AV	54.00	-5.70	1.08 H	85	-1.93	50.23
ANTENNA POLARITY & TEST DISTANCE: VERTICAL AT 3 M								
NO.	FREQ. (MHz)	EMISSION LEVEL (dBuV/m)	LIMIT (dBuV/m)	MARGIN (dB)	ANTENNA HEIGHT (m)	TABLE ANGLE (Degree)	RAW VALUE (dBuV)	CORRECTION FACTOR (dB/m)
1	5460.00	59.24 PK	74.00	-14.76	1.07 V	316	19.72	39.52
2	5460.00	46.78 AV	54.00	-7.22	1.07 V	316	7.26	39.52
3	#5470.00	64.31 PK	68.30	-3.99	1.17 V	322	24.77	39.54
4	*5500.00	109.68 PK			1.15 V	318	70.09	39.59
5	*5500.00	99.20 AV			1.15 V	318	59.61	39.59
6	11000.00	61.23 PK	74.00	-12.77	1.00 V	260	11.00	50.23
7	11000.00	48.15 AV	54.00	-5.85	1.00 V	260	-2.08	50.23

- REMARKS:**
1. Emission level (dBuV/m) = Raw Value (dBuV) + Correction Factor (dB/m).
 2. Correction Factor (dB/m) = Antenna Factor (dB/m) + Cable Factor (dB).
 3. The other emission levels were very low against the limit.
 4. Margin value = Emission level – Limit value.
 5. “ * “: Fundamental frequency.
 6. “#”:The radiated frequency is out the restricted band.



A D T

EUT TEST CONDITION		MEASUREMENT DETAIL	
CHANNEL	Channel 120	FREQUENCY RANGE	1 ~ 40GHz
INPUT POWER (SYSTEM)	120Vac, 60Hz	DETECTOR FUNCTION	Peak (PK) Average (AV)
ENVIRONMENTAL CONDITIONS	23deg. C, 70%RH 1014hPa	TESTED BY	Match Tsui

ANTENNA POLARITY & TEST DISTANCE: HORIZONTAL AT 3 M								
NO.	FREQ. (MHz)	EMISSION LEVEL (dBuV/m)	LIMIT (dBuV/m)	MARGIN (dB)	ANTENNA HEIGHT (m)	TABLE ANGLE (Degree)	RAW VALUE (dBuV)	CORRECTION FACTOR (dB/m)
1	*5600.00	110.06 PK			1.10 H	342	70.34	39.72
2	*5600.00	99.91 AV			1.10 H	342	60.19	39.72
3	11200.00	64.82 PK	74.00	-9.18	1.07 H	317	14.68	50.14
4	11200.00	50.51 AV	54.00	-3.49	1.07 H	317	0.37	50.14
ANTENNA POLARITY & TEST DISTANCE: VERTICAL AT 3 M								
NO.	FREQ. (MHz)	EMISSION LEVEL (dBuV/m)	LIMIT (dBuV/m)	MARGIN (dB)	ANTENNA HEIGHT (m)	TABLE ANGLE (Degree)	RAW VALUE (dBuV)	CORRECTION FACTOR (dB/m)
1	*5600.00	111.79 PK			1.03 V	309	72.07	39.72
2	*5600.00	101.41 AV			1.03 V	309	61.69	39.72
3	11200.00	62.69 PK	74.00	-11.31	1.20 V	21	12.55	50.14
4	11200.00	49.03 AV	54.00	-4.97	1.20 V	21	-1.11	50.14

- REMARKS:**
1. Emission level (dBuV/m) = Raw Value (dBuV) + Correction Factor (dB/m).
 2. Correction Factor (dB/m) = Antenna Factor (dB/m) + Cable Factor (dB).
 3. The other emission levels were very low against the limit.
 4. Margin value = Emission level – Limit value.
 5. “ * ”: Fundamental frequency.



A D T

EUT TEST CONDITION		MEASUREMENT DETAIL	
CHANNEL	Channel 140	FREQUENCY RANGE	1 ~ 40GHz
INPUT POWER (SYSTEM)	120Vac, 60Hz	DETECTOR FUNCTION	Peak (PK) Average (AV)
ENVIRONMENTAL CONDITIONS	23deg. C, 70%RH 1014hPa	TESTED BY	Match Tsui

ANTENNA POLARITY & TEST DISTANCE: HORIZONTAL AT 3 M								
NO.	FREQ. (MHz)	EMISSION LEVEL (dBuV/m)	LIMIT (dBuV/m)	MARGIN (dB)	ANTENNA HEIGHT (m)	TABLE ANGLE (Degree)	RAW VALUE (dBuV)	CORRECTION FACTOR (dB/m)
1	*5700.00	103.56 PK			1.11 H	245	63.76	39.80
2	*5700.00	93.80 AV			1.11 H	245	54.00	39.80
3	#5725.00	60.39 PK	68.30	-7.91	1.11 H	245	20.55	39.84
4	11400.00	60.87 PK	74.00	-13.13	1.27 H	283	10.85	50.02
5	11400.00	48.29 AV	54.00	-5.71	1.27 H	283	-1.73	50.02
ANTENNA POLARITY & TEST DISTANCE: VERTICAL AT 3 M								
NO.	FREQ. (MHz)	EMISSION LEVEL (dBuV/m)	LIMIT (dBuV/m)	MARGIN (dB)	ANTENNA HEIGHT (m)	TABLE ANGLE (Degree)	RAW VALUE (dBuV)	CORRECTION FACTOR (dB/m)
1	*5700.00	105.68 PK			1.02 V	320	65.88	39.80
2	*5700.00	94.95 AV			1.02 V	320	55.15	39.80
3	#5725.00	62.47 PK	68.30	-5.83	1.11 V	326	22.63	39.84
4	11400.00	61.38 PK	74.00	-12.62	1.00 V	100	11.36	50.02
5	11400.00	47.72 AV	54.00	-6.28	1.00 V	100	-2.30	50.02

- REMARKS:**
1. Emission level (dBuV/m) = Raw Value (dBuV) + Correction Factor (dB/m).
 2. Correction Factor (dB/m) = Antenna Factor (dB/m) + Cable Factor (dB).
 3. The other emission levels were very low against the limit.
 4. Margin value = Emission level – Limit value.
 5. “ * “: Fundamental frequency.
 6. “#”:The radiated frequency is out the restricted band.



A D T

BELOW 1GHz WORST-CASE DATA : 802.11a OFDM MODULATION

EUT TEST CONDITION		MEASUREMENT DETAIL	
CHANNEL	Channel 36	FREQUENCY RANGE	Below 1000MHz
INPUT POWER (SYSTEM)	120Vac, 60Hz	DETECTOR FUNCTION	Quasi-Peak
ENVIRONMENTAL CONDITIONS	22deg. C, 67%RH 1017hPa	TESTED BY	Match Tsui

ANTENNA POLARITY & TEST DISTANCE: HORIZONTAL AT 3 M

No.	Freq. (MHz)	Emission Level (dBuV/m)	Limit (dBuV/m)	Margin (dB)	Antenna Height (m)	Table Angle (Degree)	Raw Value (dBuV)	Correction Factor (dB/m)
1	92.12	29.48 QP	43.50	-14.02	2.00 H	226	20.79	8.68
2	99.89	32.89 QP	43.50	-10.61	1.50 H	244	21.33	11.56
3	148.50	34.90 QP	43.50	-8.60	2.00 H	253	21.04	13.86
4	162.11	32.96 QP	43.50	-10.54	1.50 H	262	18.77	14.19
5	195.16	28.02 QP	43.50	-15.48	1.00 H	235	17.29	10.73
6	243.77	30.66 QP	46.00	-15.34	1.00 H	217	17.25	13.41
7	663.74	38.24 QP	46.00	-7.76	1.00 H	283	14.11	24.14

ANTENNA POLARITY & TEST DISTANCE: VERTICAL AT 3 M

No.	Freq. (MHz)	Emission Level (dBuV/m)	Limit (dBuV/m)	Margin (dB)	Antenna Height (m)	Table Angle (Degree)	Raw Value (dBuV)	Correction Factor (dB/m)
1	45.45	33.21 QP	40.00	-6.79	1.00 V	310	19.07	14.14
2	94.06	36.49 QP	43.50	-7.01	1.00 V	292	27.09	9.40
3	101.84	37.01 QP	43.50	-6.49	1.00 V	301	25.43	11.58
4	132.95	29.28 QP	43.50	-14.22	1.00 V	289	16.93	12.36
5	245.72	29.15 QP	46.00	-16.85	1.00 V	286	15.61	13.54
6	665.68	37.25 QP	46.00	-8.75	1.00 V	220	13.07	24.18
7	725.96	29.89 QP	46.00	-16.11	2.00 V	274	4.61	25.28

- REMARKS:**
1. Emission level (dBuV/m) = Raw Value (dBuV) + Correction Factor (dB/m).
 2. Correction Factor (dB/m) = Antenna Factor (dB/m) + Cable Factor (dB).
 3. The other emission levels were very low against the limit.
 4. Margin value = Emission level – Limit value.



A D T

EUT TEST CONDITION		MEASUREMENT DETAIL	
CHANNEL	Channel 120	FREQUENCY RANGE	Below 1000MHz
INPUT POWER (SYSTEM)	120Vac, 60Hz	DETECTOR FUNCTION	Quasi-Peak
ENVIRONMENTAL CONDITIONS	22deg. C, 67%RH 1017hPa	TESTED BY	Match Tsui

ANTENNA POLARITY & TEST DISTANCE: HORIZONTAL AT 3 M								
No.	Freq. (MHz)	Emission Level (dBuV/m)	Limit (dBuV/m)	Margin (dB)	Antenna Height (m)	Table Angle (Degree)	Raw Value (dBuV)	Correction Factor (dB/m)
1	99.89	32.43 QP	43.50	-11.07	2.00 H	265	20.87	11.56
2	146.56	34.89 QP	43.50	-8.61	2.00 H	73	21.25	13.64
3	166.00	31.36 QP	43.50	-12.14	1.50 H	262	17.41	13.95
4	202.94	28.06 QP	43.50	-15.44	1.00 H	208	17.40	10.66
5	261.27	30.05 QP	46.00	-15.95	1.00 H	238	16.25	13.80
6	665.68	38.21 QP	46.00	-7.79	1.00 H	283	14.02	24.18
ANTENNA POLARITY & TEST DISTANCE: VERTICAL AT 3 M								
No.	Freq. (MHz)	Emission Level (dBuV/m)	Limit (dBuV/m)	Margin (dB)	Antenna Height (m)	Table Angle (Degree)	Raw Value (dBuV)	Correction Factor (dB/m)
1	45.45	33.93 QP	40.00	-6.07	1.00 V	313	19.79	14.14
2	94.06	36.69 QP	43.50	-6.81	1.50 V	262	27.28	9.40
3	103.78	37.15 QP	43.50	-6.35	1.00 V	259	25.60	11.55
4	131.00	30.13 QP	43.50	-13.37	1.00 V	292	17.93	12.20
5	459.59	29.00 QP	46.00	-17.00	1.00 V	250	9.48	19.52
6	665.68	36.91 QP	46.00	-9.09	1.00 V	262	12.72	24.18

- REMARKS:**
1. Emission level (dBuV/m) = Raw Value (dBuV) + Correction Factor (dB/m).
 2. Correction Factor (dB/m) = Antenna Factor (dB/m) + Cable Factor (dB).
 3. The other emission levels were very low against the limit.
 4. Margin value = Emission level – Limit value.

4.2 CONDUCTED EMISSION MEASUREMENT

4.2.1 LIMITS OF CONDUCTED EMISSION MEASUREMENT

FREQUENCY OF EMISSION (MHz)	CONDUCTED LIMIT (dB μ V)	
	Quasi-peak	Average
0.15 ~ 0.5	66 to 56	56 to 46
0.5 ~ 5	56	46
5 ~ 30	60	50

- NOTE:** 1. The lower limit shall apply at the transition frequencies.
2. The limit decreases in line with the logarithm of the frequency in the range of 0.15 to 0.50MHz.
3. All emanations from a class A/B digital device or system, including any network of conductors and apparatus connected thereto, shall not exceed the level of field strengths specified above.

4.2.2 TEST INSTRUMENTS

DESCRIPTION & MANUFACTURER	MODEL NO.	SERIAL NO.	DATE OF CALIBRATION	DUE DATE OF CALIBRATION
Test Receiver ROHDE & SCHWARZ	ESCS30	100291	Nov. 19, 2008	Nov. 18, 2009
RF signal cable Woken	5D-FB	Cable-HYC01-01	Dec. 31, 2008	Dec. 30, 2009
LISN ROHDE & SCHWARZ	ESH3-Z5	100312	Jun. 13, 2008	Jun. 12, 2009
LISN ROHDE & SCHWARZ	ESH2-Z5	100104	Dec. 04, 2008	Dec. 03, 2009
Software ADT	ADT_Cond_ V7.3.7	NA	NA	NA

- NOTE:** 1. The calibration interval of the above test instruments is 12 months and the calibrations are traceable to NML/ROC and NIST/USA.
2. The test was performed in HwaYa Shielded Room 1.
3. The VCCI Site Registration No. is C-2040.

4.2.3 TEST PROCEDURES

- a. The EUT was placed 0.4 meters from the conducting wall of the shielded room with EUT being connected to the power mains through a line impedance stabilization network (LISN). Other support units were connected to the power mains through another LISN. The two LISNs provide 50 ohm/ 50uH of coupling impedance for the measuring instrument.
- b. Both lines of the power mains connected to the EUT were checked for maximum conducted interference.
- c. The frequency range from 150kHz to 30MHz was searched. Emission levels under (Limit - 20dB) was not recorded.

4.2.4 DEVIATION FROM TEST STANDARD

No deviation.

4.2.5 TEST SETUP

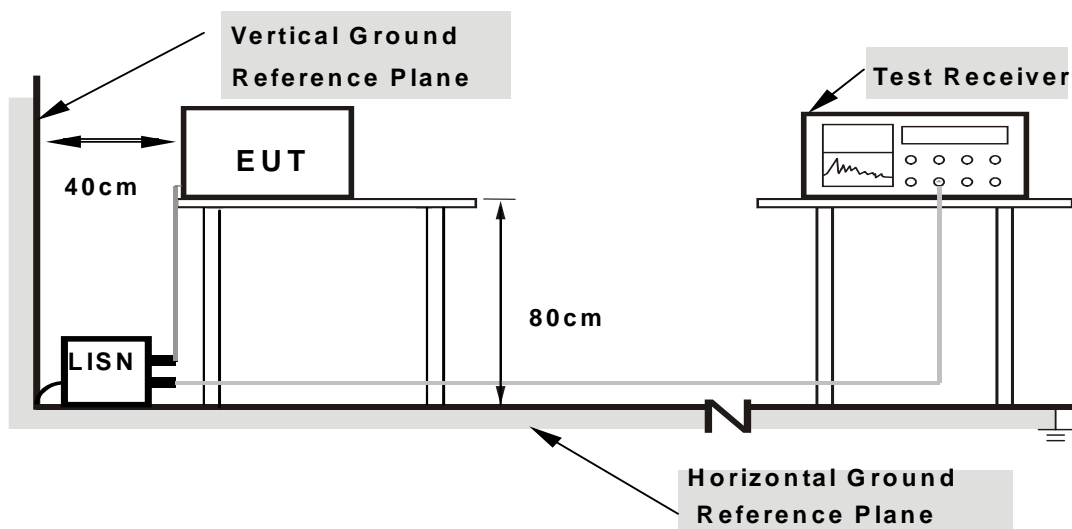

Note: 1.Support units were connected to second LISN.

2.Both of LISNs (AMN) are 80 cm from EUT and at least 80 from other units and other metal planes

For the actual test configuration, please refer to the attached file (Test Setup Photo).

4.2.6 EUT OPERATING CONDITIONS

Same as 4.1.6.



A D T

4.2.7 TEST RESULTS

CONDUCTED WORST-CASE DATA : 802.11a OFDM MODULATION

EUT TEST CONDITION		MEASUREMENT DETAIL	
CHANNEL	Channel 36	PHASE	Line 1
MODULATION TYPE	BPSK	INPUT POWER (SYSTEM)	120Vac, 60Hz
TRANSFER RATE	6.0Mbps	6dB BANDWIDTH	9kHz
ENVIRONMENTAL CONDITIONS	25deg. C, 65%RH, 982hPa	TESTED BY	Mark Liao

No	Freq.	Corr.	Reading Value		Emission Level		Limit		Margin	
	[MHz]	Factor (dB)	Q.P. [dB (uV)]	AV. [dB (uV)]	Q.P. [dB (uV)]	AV. [dB (uV)]	Q.P. [dB (uV)]	AV. [dB (uV)]	Q.P. (dB)	AV. (dB)
	1	0.205	0.13	45.20	-	45.33	-	63.42	53.42	-18.09
2	0.306	0.14	35.25	-	35.39	-	60.07	50.07	-24.69	-
3	0.408	0.14	30.41	-	30.55	-	57.69	47.69	-27.14	-
4	2.961	0.30	29.41	-	29.71	-	56.00	46.00	-26.29	-
5	5.203	0.43	29.98	-	30.41	-	60.00	50.00	-29.59	-
6	23.168	1.19	25.84	-	27.03	-	60.00	50.00	-32.97	-

- REMARKS:**
1. Q.P. and AV. are abbreviations of quasi-peak and average individually.
 2. "-": The Quasi-peak reading value also meets average limit and measurement with the average detector is unnecessary.
 3. The emission levels of other frequencies were very low against the limit.
 4. Margin value = Emission level - Limit value
 5. Correction factor = Insertion loss + Cable loss
 6. Emission Level = Correction Factor + Reading Value.

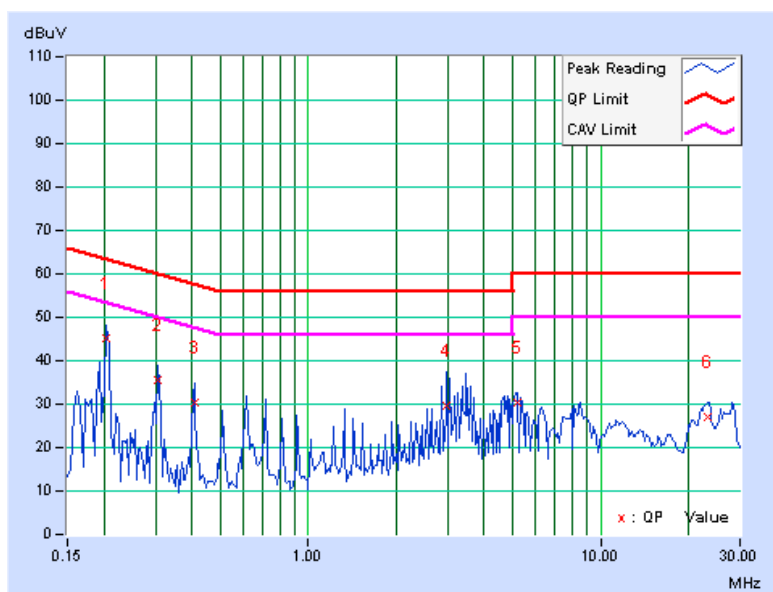



A D T

EUT TEST CONDITION		MEASUREMENT DETAIL	
CHANNEL	Channel 36	PHASE	Line 2
MODULATION TYPE	BPSK	INPUT POWER (SYSTEM)	120Vac, 60Hz
TRANSFER RATE	6.0Mbps	6dB BANDWIDTH	9kHz
ENVIRONMENTAL CONDITIONS	25deg. C, 65%RH, 982hPa	TESTED BY	Mark Liao

No	Freq. [MHz]	Corr. Factor [dB]	Reading Value [dB (uV)]		Emission Level [dB (uV)]		Limit [dB (uV)]		Margin (dB)	
			Q.P.	AV.	Q.P.	AV.	Q.P.	AV.	Q.P.	AV.
1	0.201	0.15	44.17	-	44.32	-	63.58	53.58	-19.26	-
2	0.302	0.16	33.97	-	34.13	-	60.18	50.18	-26.05	-
3	0.412	0.16	28.74	-	28.90	-	57.61	47.61	-28.71	-
4	0.716	0.18	28.94	-	29.12	-	56.00	46.00	-26.88	-
5	2.855	0.31	27.78	-	28.09	-	56.00	46.00	-27.91	-
6	25.516	0.85	30.28	-	31.13	-	60.00	50.00	-28.87	-

- REMARKS:**
1. Q.P. and AV. are abbreviations of quasi-peak and average individually.
 2. "-": The Quasi-peak reading value also meets average limit and measurement with the average detector is unnecessary.
 3. The emission levels of other frequencies were very low against the limit.
 4. Margin value = Emission level - Limit value
 5. Correction factor = Insertion loss + Cable loss
 6. Emission Level = Correction Factor + Reading Value.

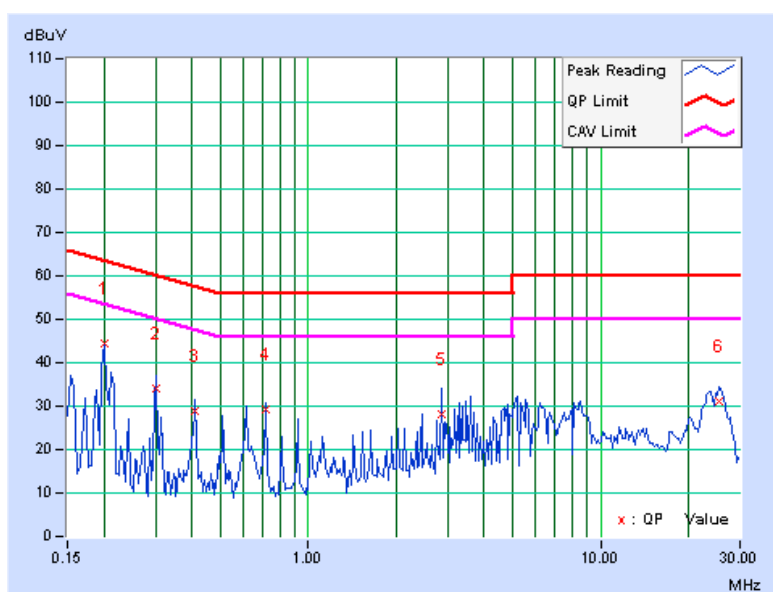



A D T

EUT TEST CONDITION		MEASUREMENT DETAIL	
CHANNEL	Channel 120	PHASE	Line 1
MODULATION TYPE	BPSK	INPUT POWER (SYSTEM)	120Vac, 60Hz
TRANSFER RATE	6.0Mbps	6dB BANDWIDTH	9kHz
ENVIRONMENTAL CONDITIONS	25deg. C, 65%RH, 982hPa	TESTED BY	Mark Liao

No	Freq. [MHz]	Corr. Factor [dB]	Reading Value [dB (uV)]		Emission Level [dB (uV)]		Limit [dB (uV)]		Margin (dB)	
			Q.P.	AV.	Q.P.	AV.	Q.P.	AV.	Q.P.	AV.
1	0.207	0.13	42.92	-	43.05	-	63.33	53.33	-20.28	-
2	0.310	0.14	32.43	-	32.57	-	59.97	49.97	-27.40	-
3	0.408	0.14	31.05	-	31.19	-	57.69	47.69	-26.50	-
4	0.716	0.16	30.57	-	30.73	-	56.00	46.00	-25.27	-
5	2.961	0.30	30.70	-	31.00	-	56.00	46.00	-25.00	-
6	28.270	1.23	25.49	-	26.72	-	60.00	50.00	-33.28	-

- REMARKS:**
1. Q.P. and AV. are abbreviations of quasi-peak and average individually.
 2. "-": The Quasi-peak reading value also meets average limit and measurement with the average detector is unnecessary.
 3. The emission levels of other frequencies were very low against the limit.
 4. Margin value = Emission level - Limit value
 5. Correction factor = Insertion loss + Cable loss
 6. Emission Level = Correction Factor + Reading Value.

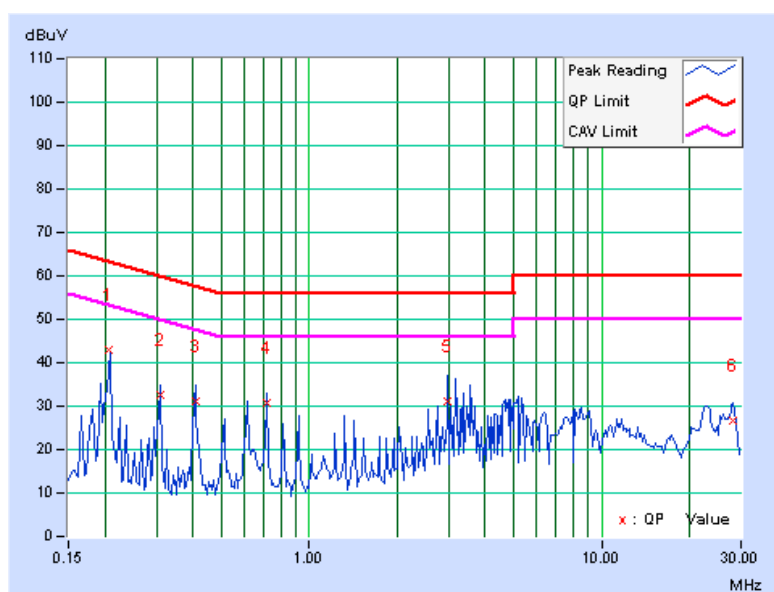



A D T

EUT TEST CONDITION		MEASUREMENT DETAIL	
CHANNEL	Channel 120	PHASE	Line 2
MODULATION TYPE	BPSK	INPUT POWER (SYSTEM)	120Vac, 60Hz
TRANSFER RATE	6.0Mbps	6dB BANDWIDTH	9kHz
ENVIRONMENTAL CONDITIONS	25deg. C, 65%RH, 982hPa	TESTED BY	Mark Liao

No	Freq. [MHz]	Corr. Factor (dB)	Reading Value [dB (uV)]		Emission Level [dB (uV)]		Limit [dB (uV)]		Margin (dB)	
			Q.P.	AV.	Q.P.	AV.	Q.P.	AV.	Q.P.	AV.
1	0.205	0.15	44.79	-	44.94	-	63.42	53.42	-18.48	-
2	0.306	0.16	35.34	-	35.50	-	60.07	50.07	-24.58	-
3	0.412	0.16	28.33	-	28.49	-	57.61	47.61	-29.12	-
4	0.615	0.17	30.31	-	30.48	-	56.00	46.00	-25.52	-
5	2.961	0.32	29.77	-	30.09	-	56.00	46.00	-25.91	-
6	25.410	0.86	29.18	-	30.04	-	60.00	50.00	-29.96	-

- REMARKS:**
1. Q.P. and AV. are abbreviations of quasi-peak and average individually.
 2. "-": The Quasi-peak reading value also meets average limit and measurement with the average detector is unnecessary.
 3. The emission levels of other frequencies were very low against the limit.
 4. Margin value = Emission level - Limit value
 5. Correction factor = Insertion loss + Cable loss
 6. Emission Level = Correction Factor + Reading Value.

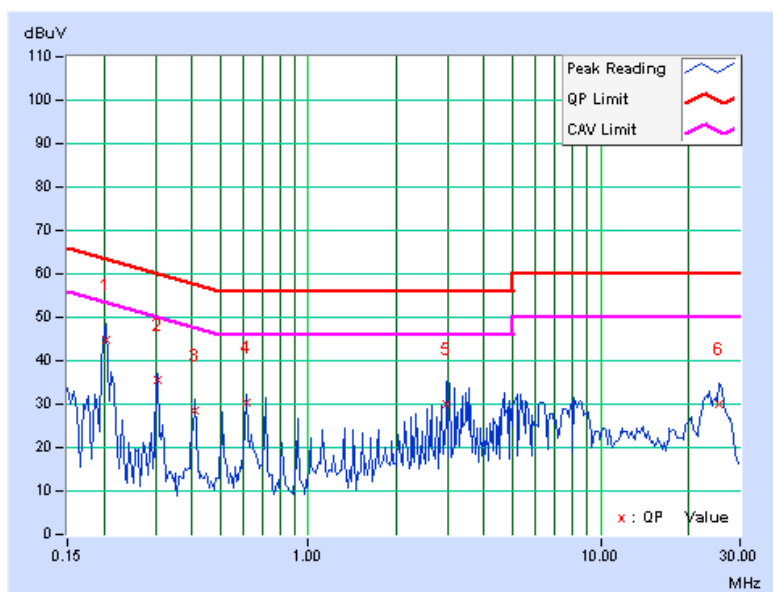



4.3 MAXIMUM CONDUCTED OUTPUT POWER MEASUREMENT

4.3.1 LIMITS OF MAXIMUM CONDUCTED OUTPUT POWER MEASUREMENT

FREQUENCY BAND	LIMIT
5.150 ~ 5.250GHz	The lesser of 50mW (17dBm) or 4dBm + 10logB
5.250 ~ 5.350GHz	The lesser of 250mW (24dBm) or 11dBm + 10logB
5.470 ~ 5.725GHz	The lesser of 250mW (24dBm) or 11dBm + 10logB

NOTE: Where B is the 26dB emission bandwidth in MHz.

4.3.2 TEST INSTRUMENTS

FOR POWER OUTPUT MEASUREMENT

DESCRIPTION & MANUFACTURER	MODEL NO.	SERIAL NO.	DATE OF CALIBRATION	CALIBRATED UNTIL
High Speed Peak Power Meter	ML2495A	0824012	Aug. 04, 2008	Aug. 03, 2009
Power Sensor	MA2411B	0738138	Aug. 04, 2008	Aug. 03, 2009

NOTE:

1. The calibration interval of the above test instruments is 12 months and the calibrations are traceable to NML/ROC and NIST/USA.
2. Measurement Bandwidth of ML2495A is 65MHz greater than 26dB bandwidth of emission.

FOR 26dB OCCUPIED BANDWIDTH

DESCRIPTION & MANUFACTURER	MODEL NO.	SERIAL NO.	DATE OF CALIBRATION	DUE DATE OF CALIBRATION
R&S SPECTRUM ANALYZER	FSP40	100041	Apr. 22, 2008	Apr. 21, 2009

NOTE: The calibration interval of the above test instruments is 12 months and the calibrations are traceable to NML/ROC and NIST/USA.

4.3.3 TEST PROCEDURES

FOR POWER OUTPUT MEASUREMENT

A power sensor was used on the output port of the EUT. A power meter was used to read the response of the power sensor. Record the power level.

FOR 26dB OCCUPIED BANDWIDTH

The transmitter output was connected to the spectrum analyzer through an attenuator. The bandwidth of the fundamental frequency was measured by spectrum analyzer with 300kHz RBW and 1MHz VBW. The 26dB bandwidth is defined as the total spectrum the power of which is higher than peak power minus 26dB.

4.3.4 DEVIATION FROM TEST STANDARD

No deviation.

4.3.5 TEST SETUP

FOR POWER OUTPUT MEASUREMENT

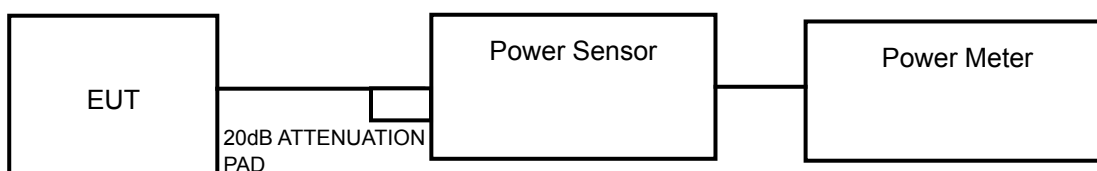

FOR 26dB OCCUPIED BANDWIDTH

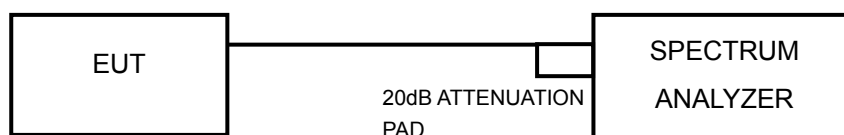

4.3.6 EUT OPERATING CONDITIONS

Same as Item 4.3.6.

4.3.7 TEST RESULTS

POWER OUTPUT: 802.11a OFDM MODULATION

MODULATION TYPE	BPSK	TRANSFER RATE	6.0Mbps
INPUT POWER (SYSTEM)	120Vac, 60Hz	ENVIRONMENTAL CONDITIONS	25deg.C, 65%RH, 991hPa
TESTED BY	Brad Wu		

CHANNEL	CHANNEL FREQUENCY (MHz)	OUTPUT POWER (mW)	OUTPUT POWER (dBm)	POWER LIMIT (dBm)	PASS / FAIL
36	5180	13.032	11.15	17	PASS
40	5200	12.942	11.12	17	PASS
48	5240	11.324	10.54	17	PASS
52	5260	10.740	10.31	24	PASS
60	5300	9.661	9.85	24	PASS
64	5320	10.093	10.04	24	PASS
100	5500	10.046	10.02	24	PASS
120	5600	22.542	13.53	24	PASS
140	5700	8.017	9.04	24	PASS



A D T

26dB OCCUPIED BANDWIDTH: 802.11a OFDM MODULATION

MODULATION TYPE	BPSK	TRANSFER RATE	6.0Mbps
INPUT POWER (SYSTEM)	120Vac, 60Hz	ENVIRONMENTAL CONDITIONS	25deg.C, 65%RH, 991hPa
TESTED BY	Brad Wu		

CHANNEL	CHANNEL FREQUENCY (MHz)	26dBc OCCUPIED BANDWIDTH (MHz)	PASS / FAIL
36	5180	20.87	PASS
40	5200	20.89	PASS
48	5240	20.81	PASS
52	5260	20.86	PASS
60	5300	20.94	PASS
64	5320	20.83	PASS
100	5500	20.89	PASS
120	5600	25.65	PASS
140	5700	20.84	PASS

CH 36

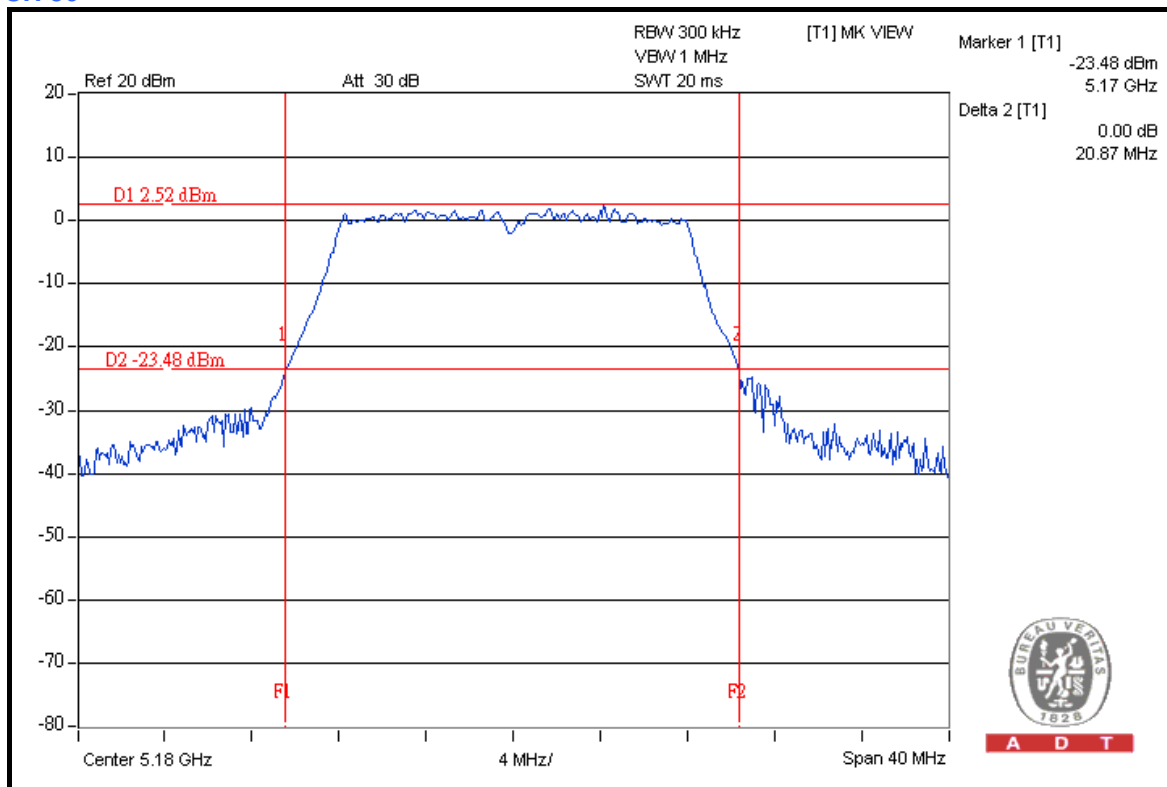

A D T



A D T

CH 40

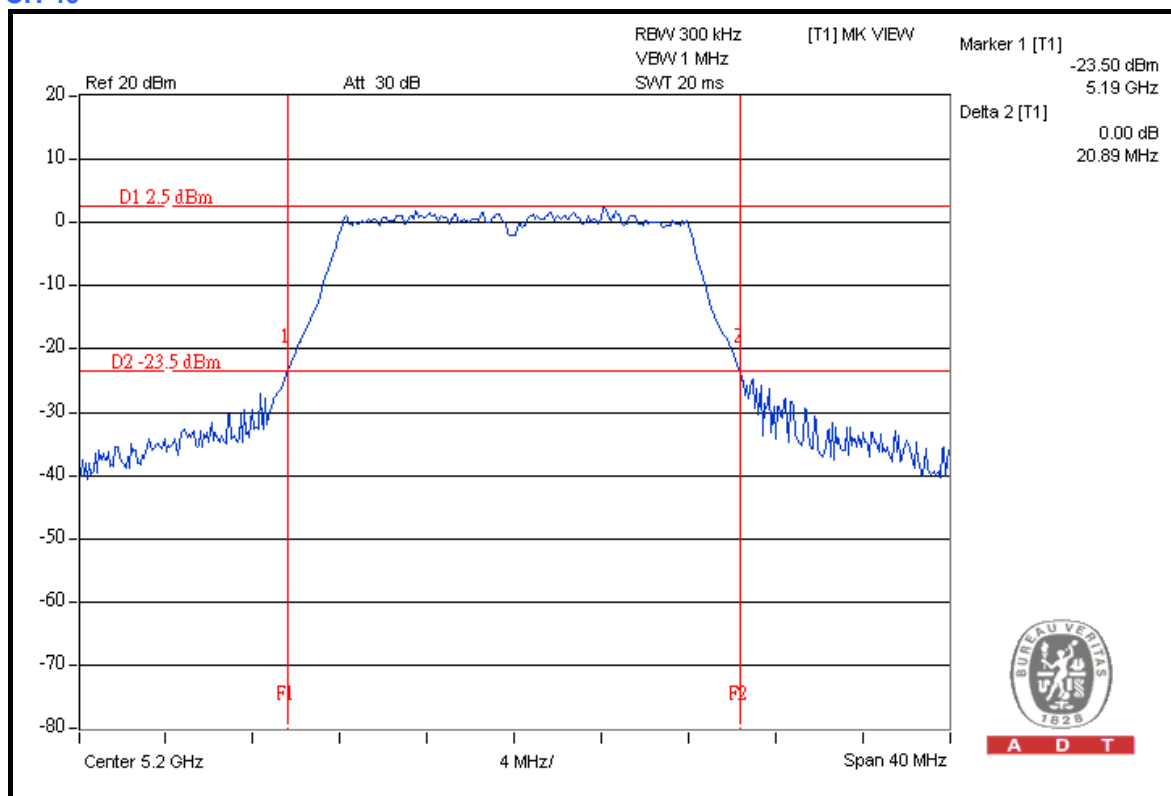

A D T

CH 48

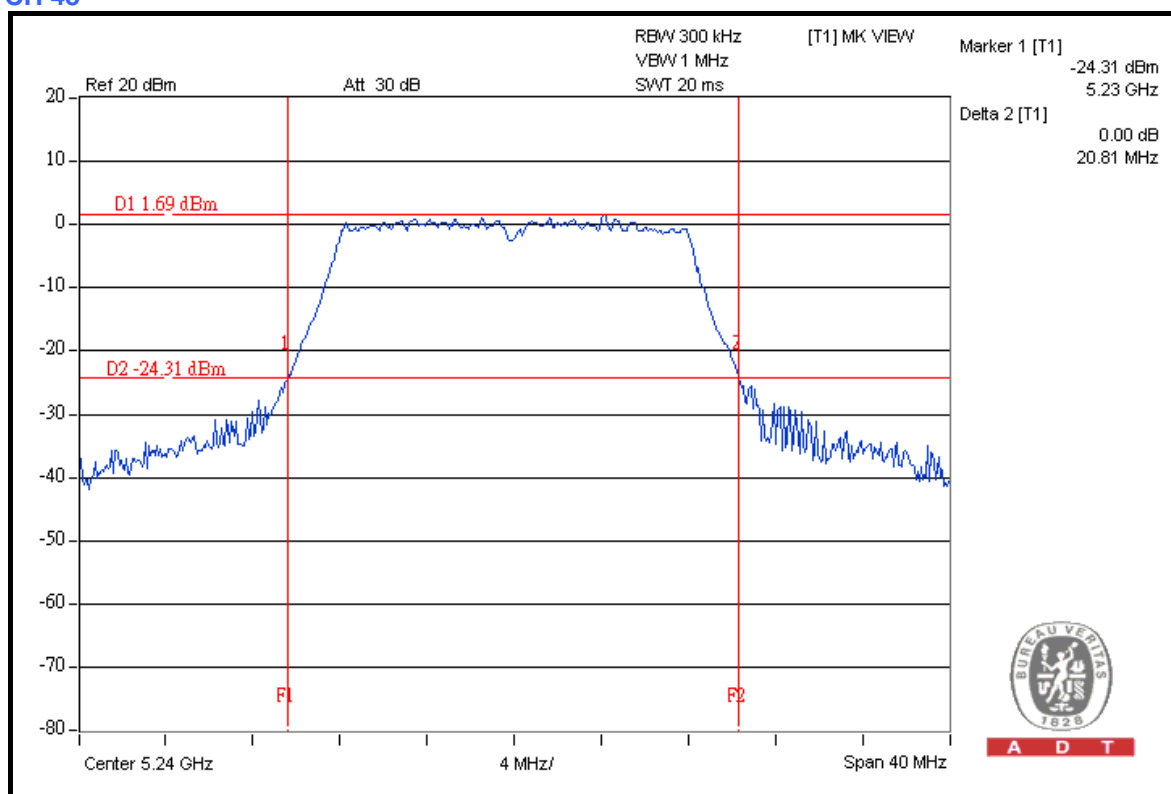

A D T



A D T

CH 52

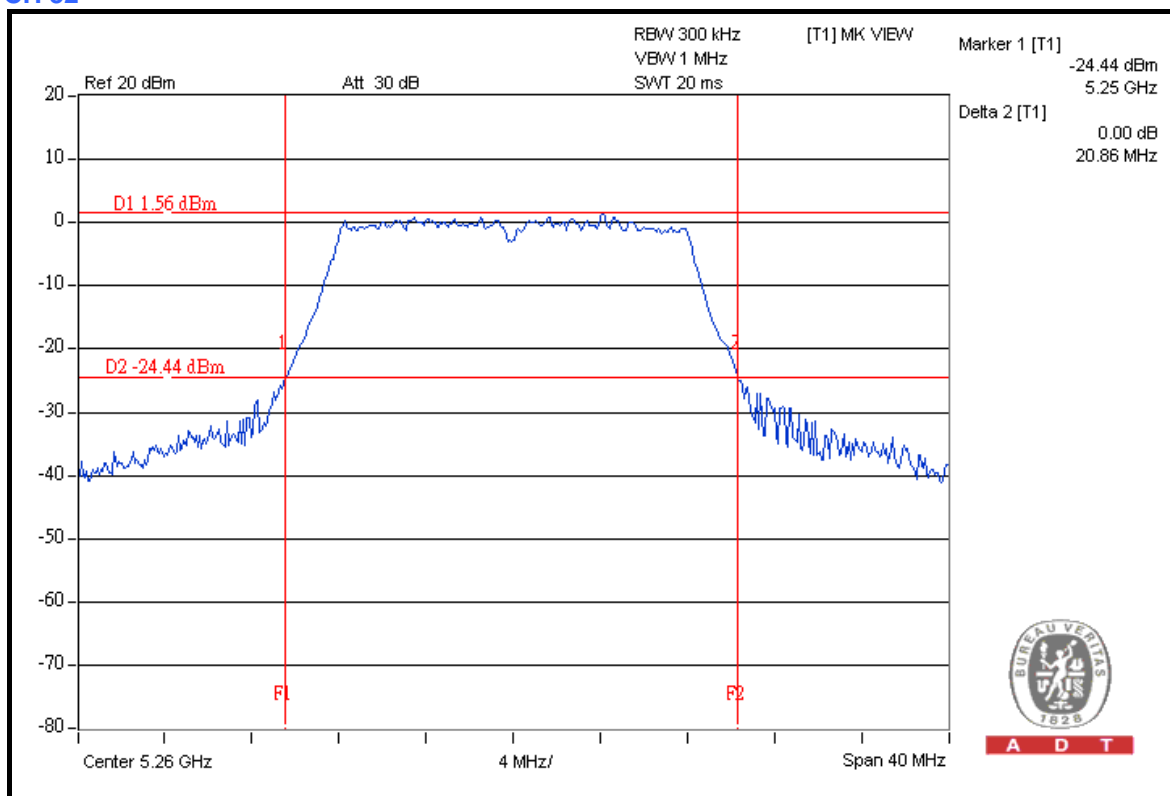

CH 60

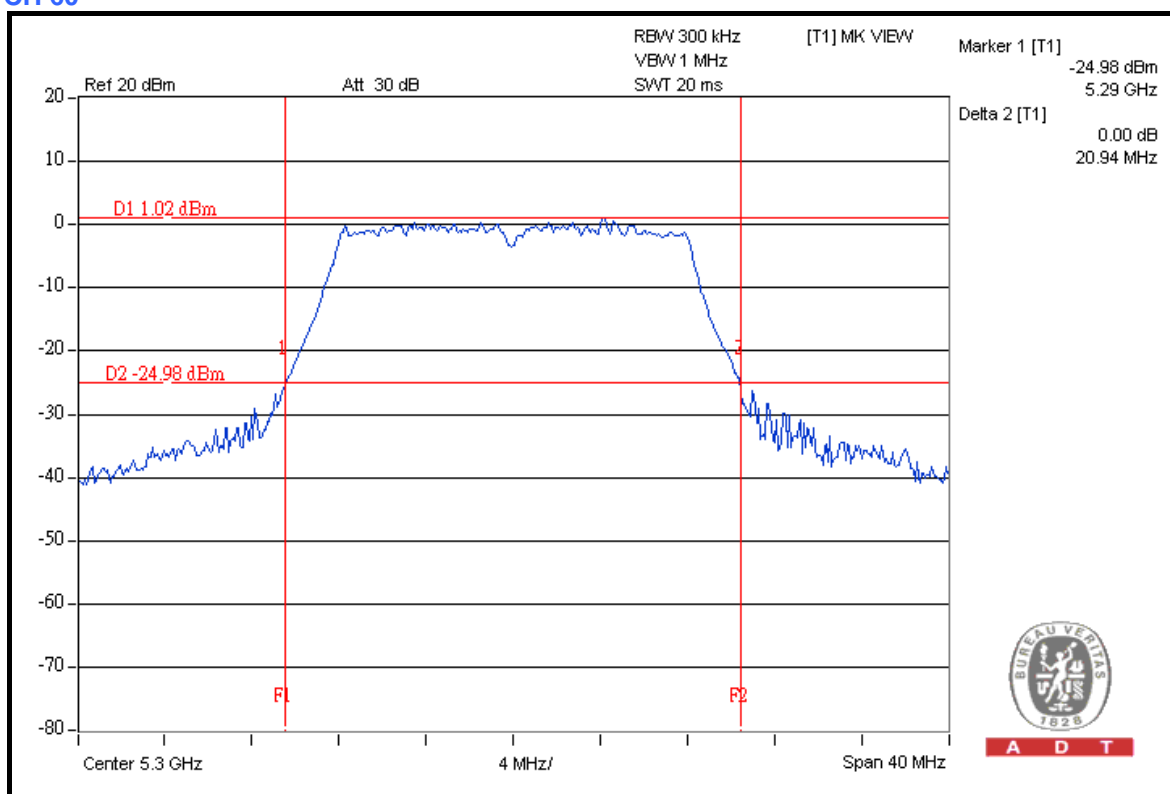



A D T

CH 64

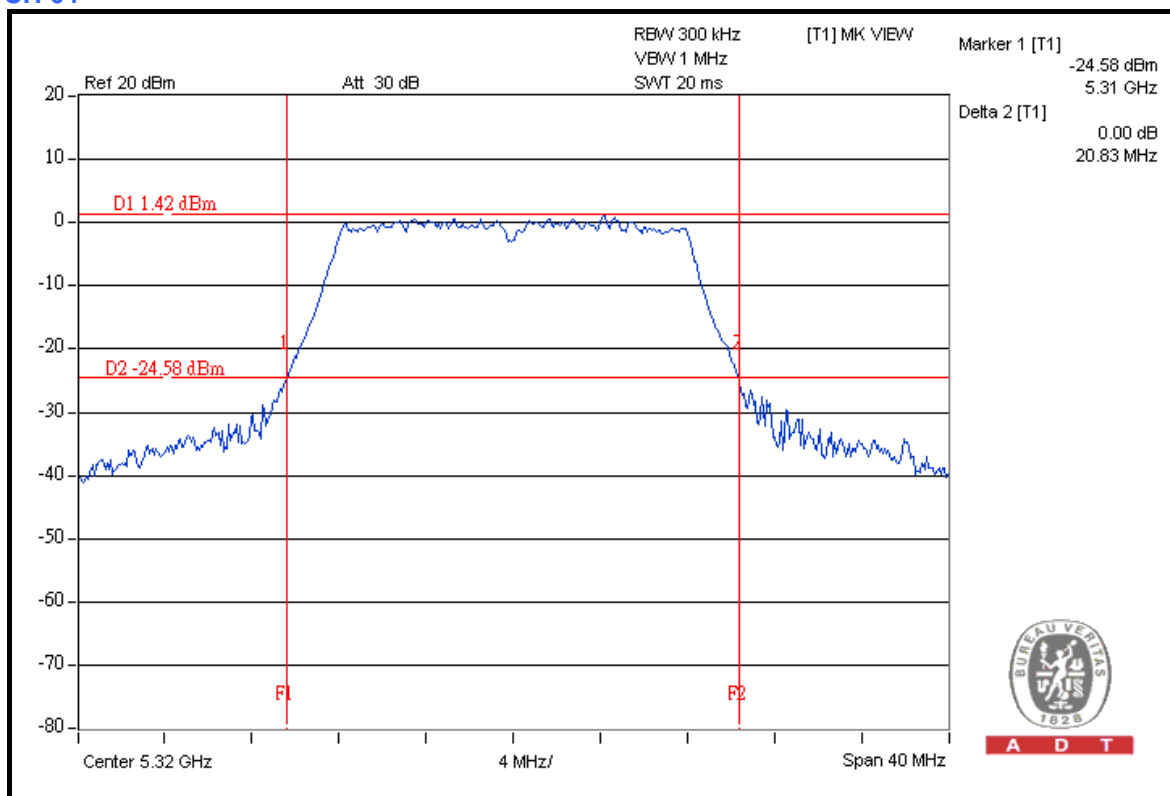

CH 100

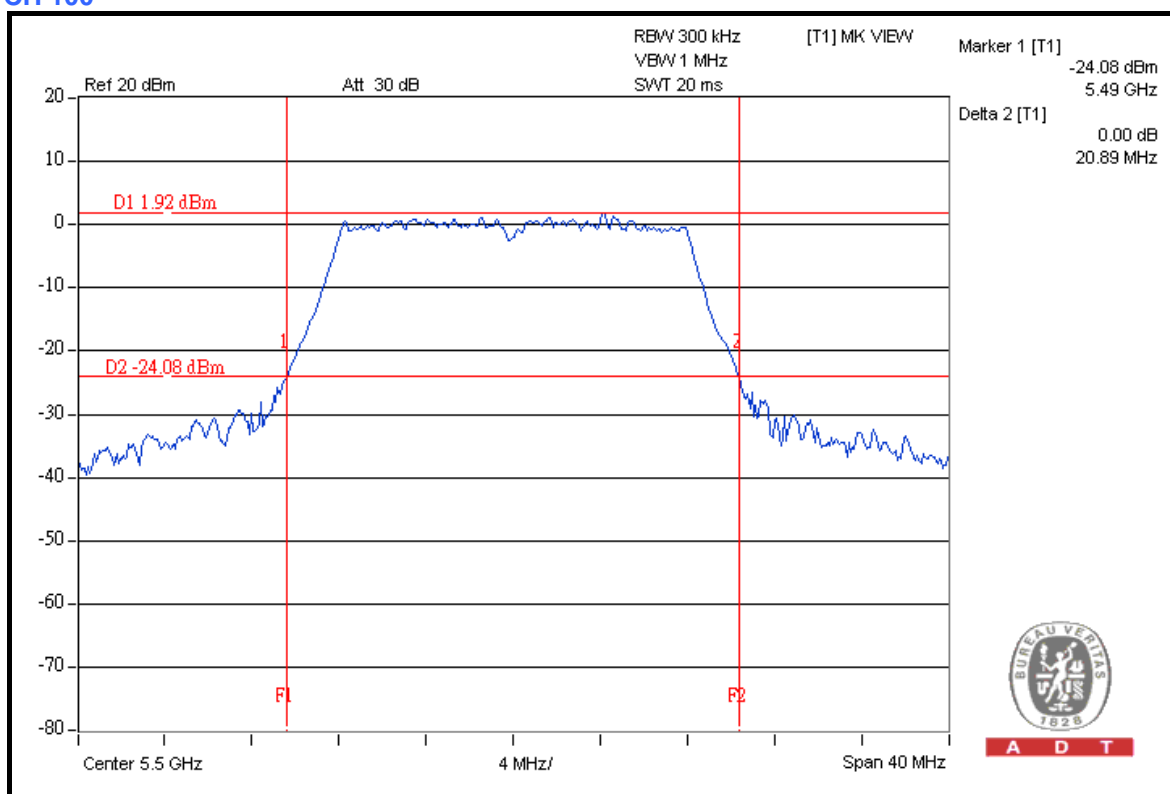



A D T

CH 120

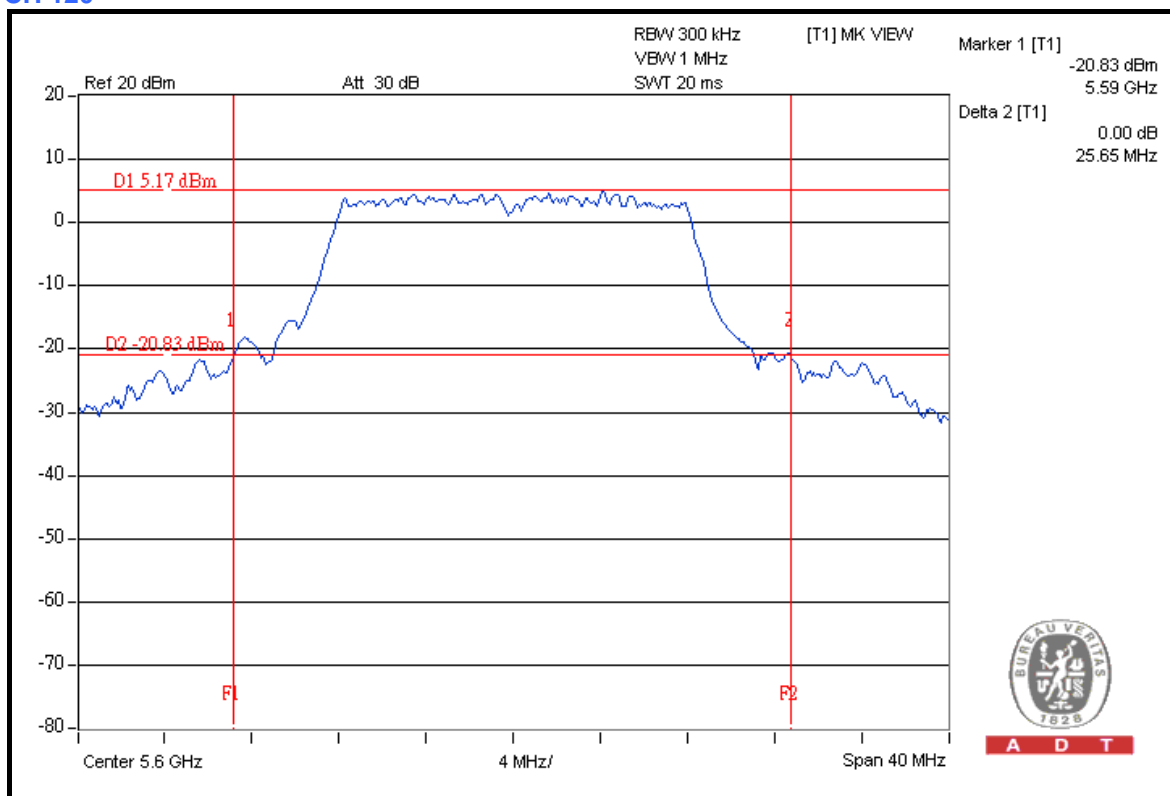

A D T

CH 140

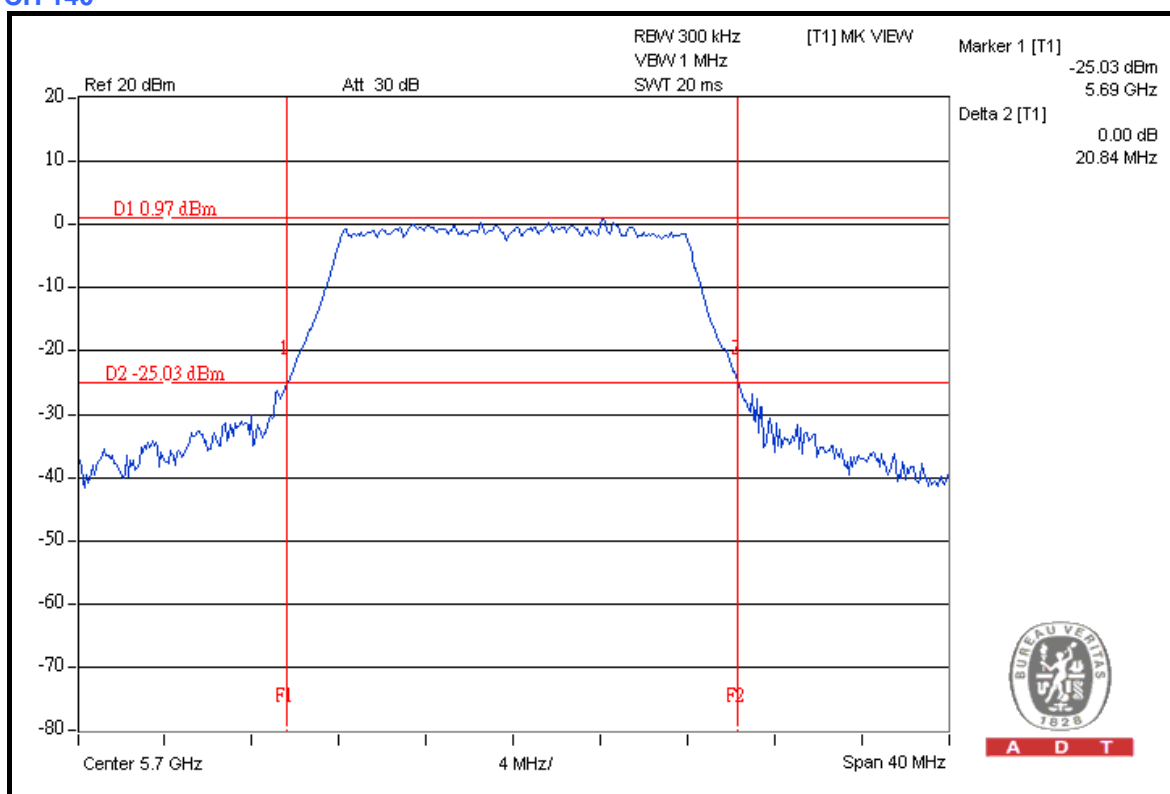

A D T

4.4 PEAK POWER EXCURSION MEASUREMENT

4.4.1 LIMITS OF PEAK POWER EXCURSION MEASUREMENT

FREQUENCY BAND	LIMIT
5.150 ~ 5.250GHz	13dB
5.250 ~ 5.350GHz	13dB
5.470 ~ 5.725GHz	13dB

4.4.2 TEST INSTRUMENTS

DESCRIPTION & MANUFACTURER	MODEL NO.	SERIAL NO.	DATE OF CALIBRATION	CALIBRATED UNTIL
R&S SPECTRUM ANALYZER	FSP40	100041	Apr. 22, 2008	Apr. 21, 2009

NOTE: The calibration interval of the above test instruments is 12 months and the calibrations are traceable to NML/ROC and NIST/USA.

4.4.3 TEST PROCEDURE

- a. The transmitter output was connected to the spectrum analyzer.
- b. Set the spectrum bandwidth span to view the entire spectrum.
- c. Using peak detector and Max-hold function for Trace 1 (RB = 1MHz, VB = 3MHz) and 2 (RB = 1MHz, VB = 300 kHz).
- d. The differences between Trace1 and Trace 2 in any 1MHz band at f1 to f2 range were recorded and showed to another trace.

4.4.4 DEVIATION FROM TEST STANDARD

No deviation.

4.4.5 TEST SETUP

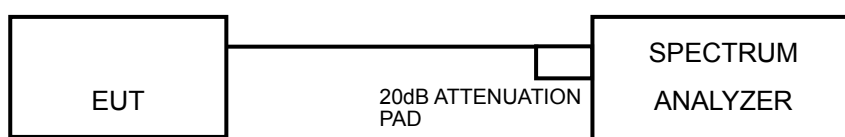

4.4.6 EUT OPERATING CONDITIONS

The software provided by client to enable the EUT under transmission condition continuously at specific channel frequencies individually.



A D T

4.4.7 TEST RESULTS

802.11a OFDM MODULATION

MODULATION TYPE	BPSK	TRANSFER RATE	6.0Mbps
INPUT POWER (SYSTEM)	120Vac, 60Hz	ENVIRONMENTAL CONDITIONS	25deg.C, 65%RH, 991hPa
TESTED BY	Brad Wu		

CHANNEL	CHANNEL FREQUENCY (MHz)	PEAK POWER EXCURSION (dB)	PEAK TO AVERAGE EXCURSION LIMIT (dB)	PASS/FAIL
36	5180	7.24	13	PASS
40	5200	8.01	13	PASS
48	5240	7.12	13	PASS
52	5260	8.26	13	PASS
60	5300	6.40	13	PASS
64	5320	6.59	13	PASS
100	5500	7.55	13	PASS
120	5600	7.15	13	PASS
140	5700	6.50	13	PASS



A D T

CH 36

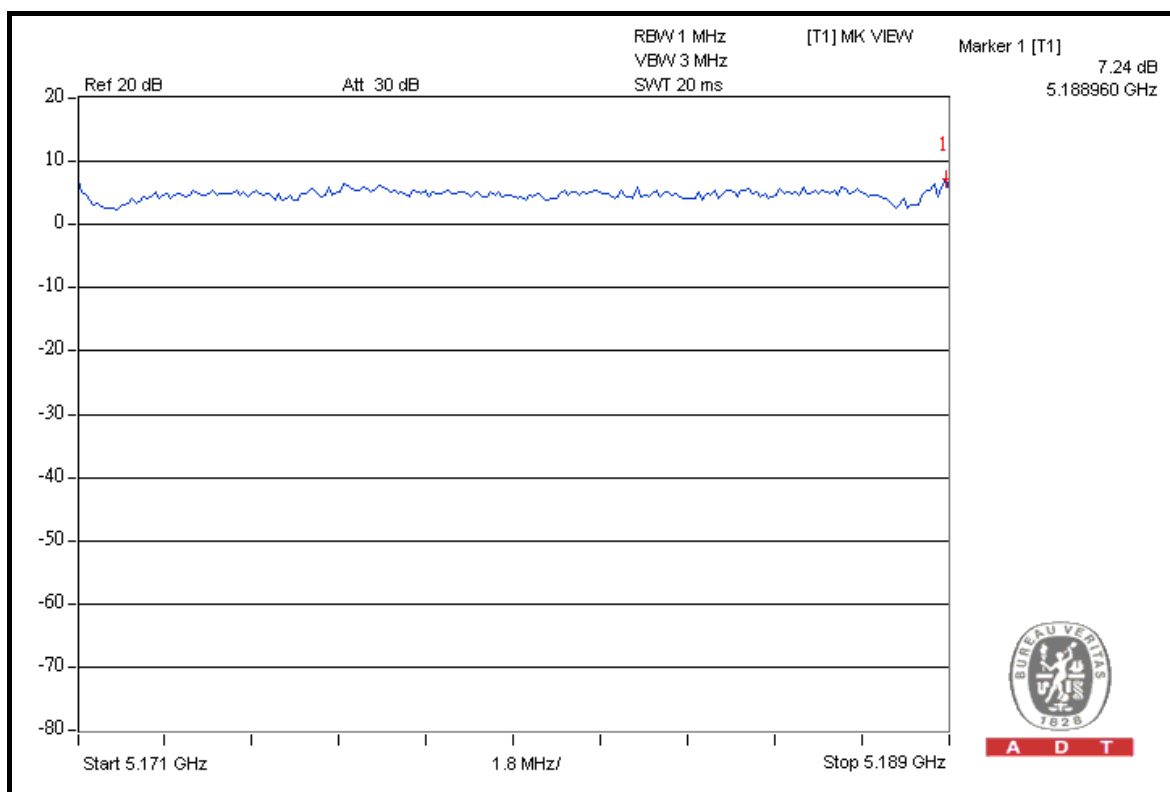
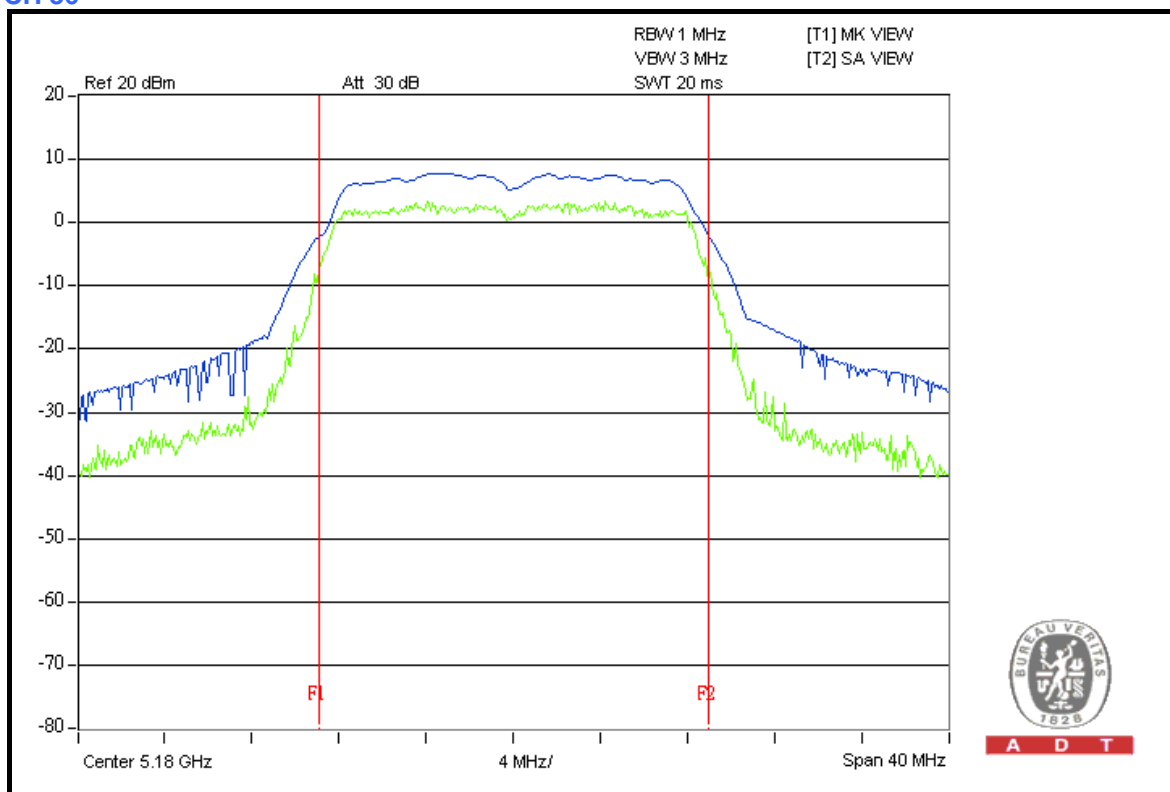



A D T

CH 40

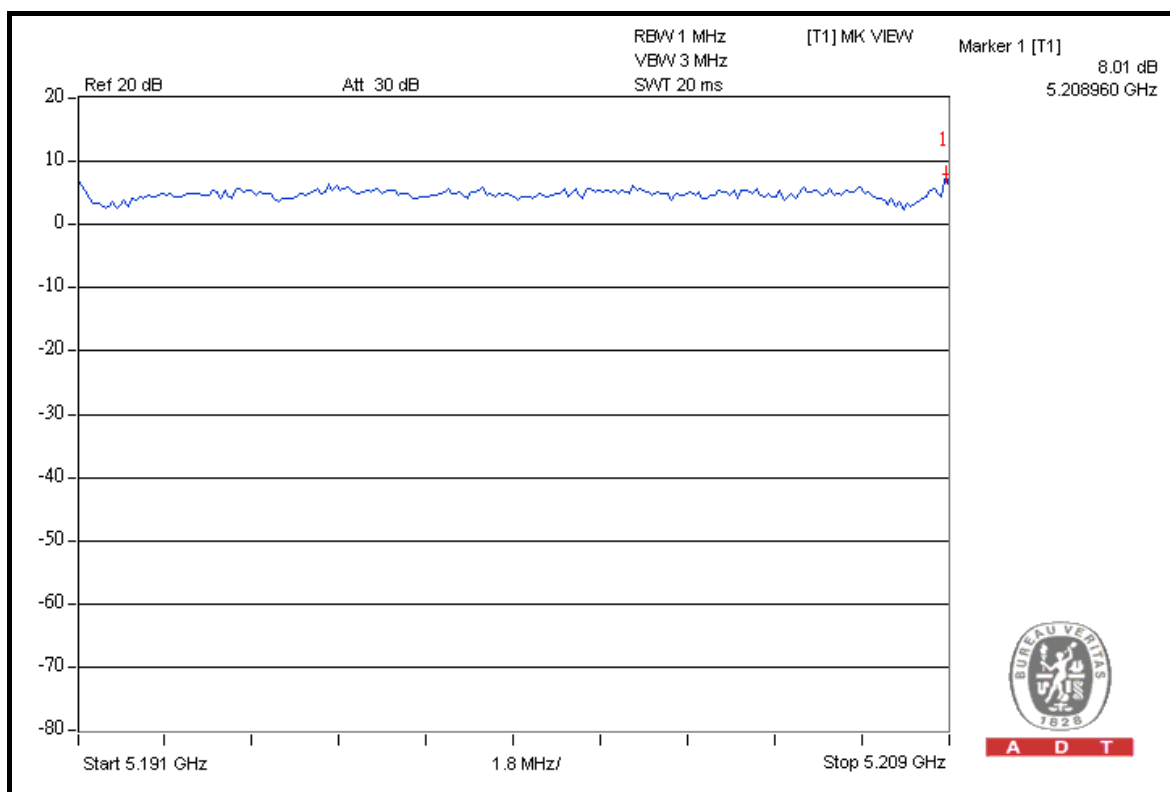
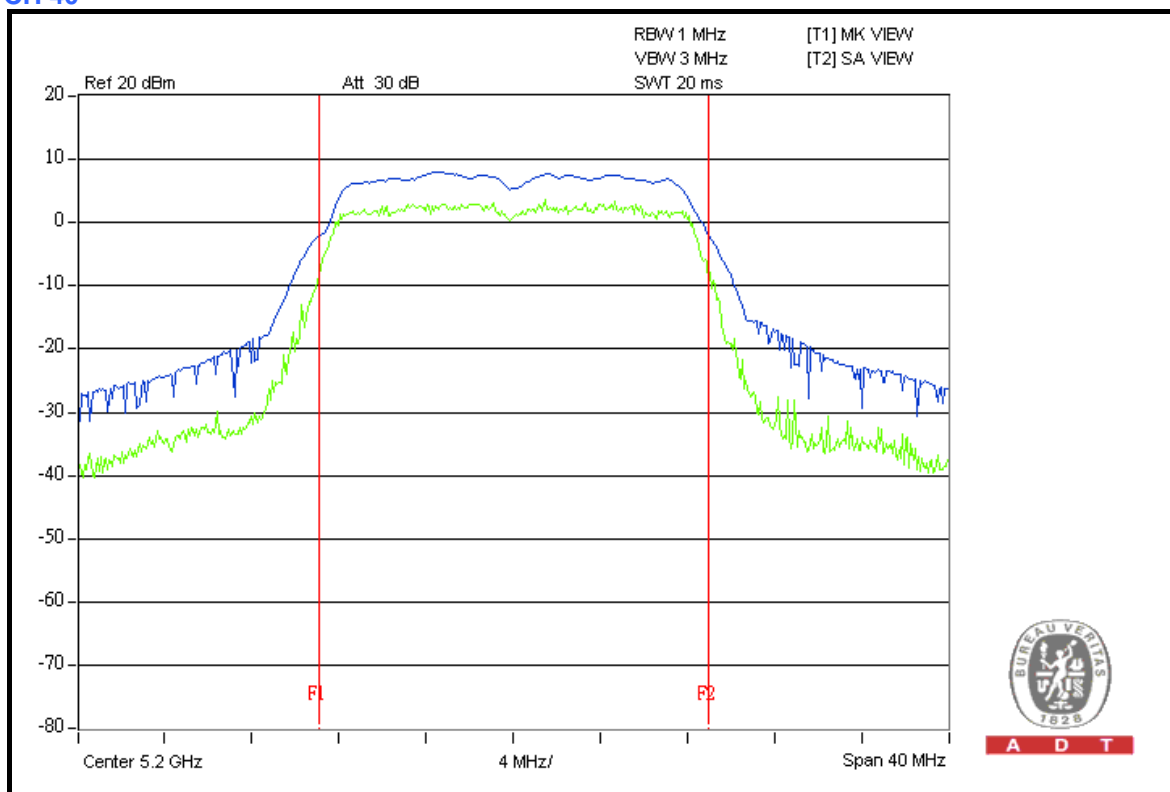



A D T

CH 48

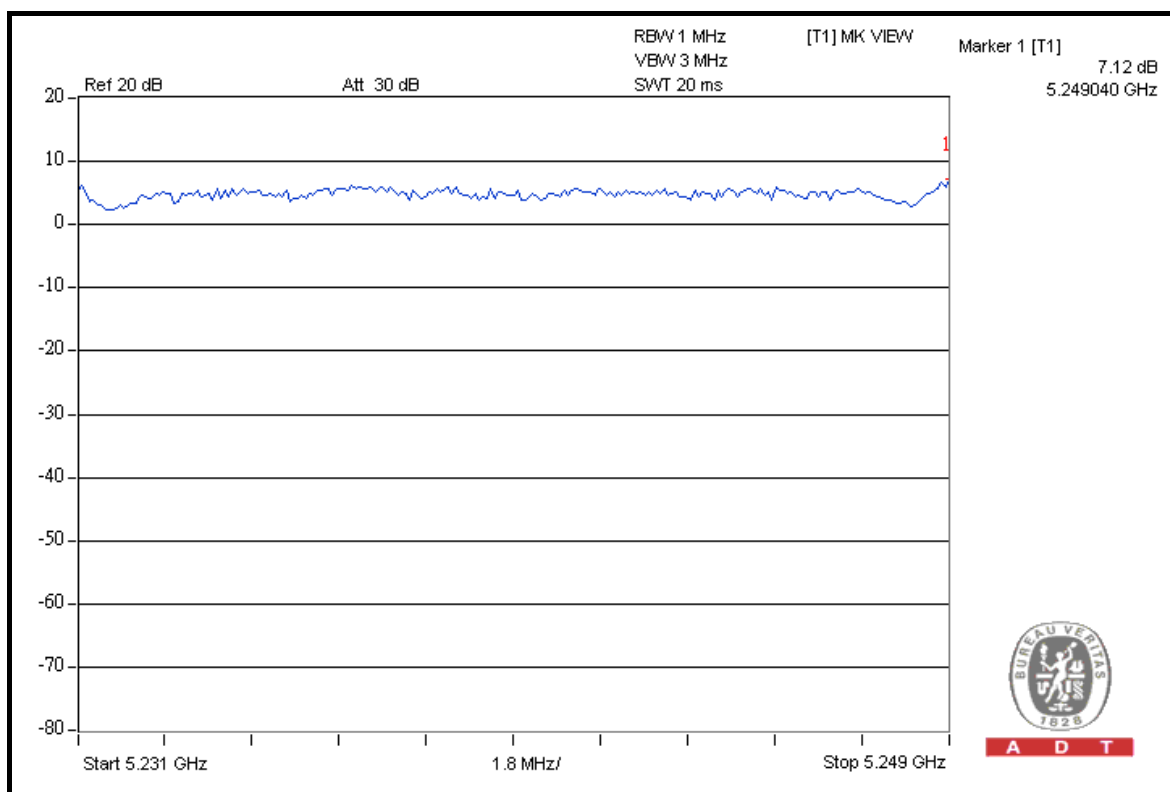
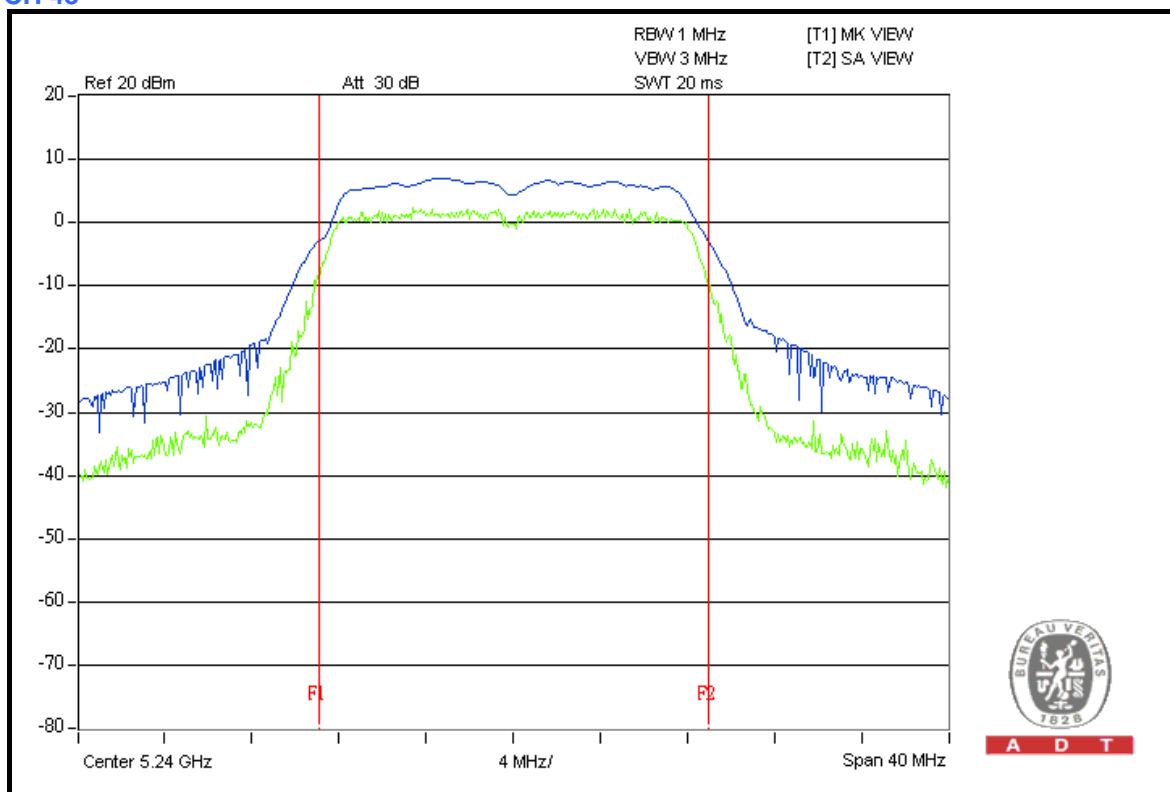



A D T

CH 52

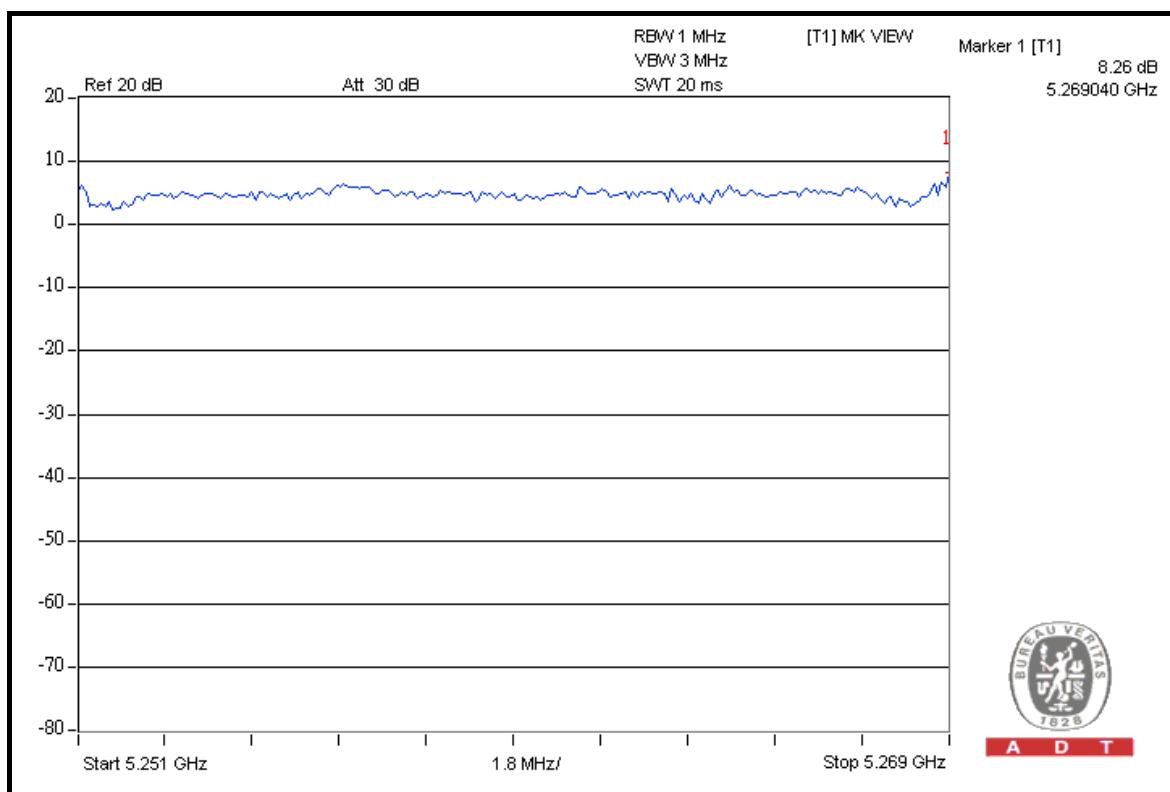
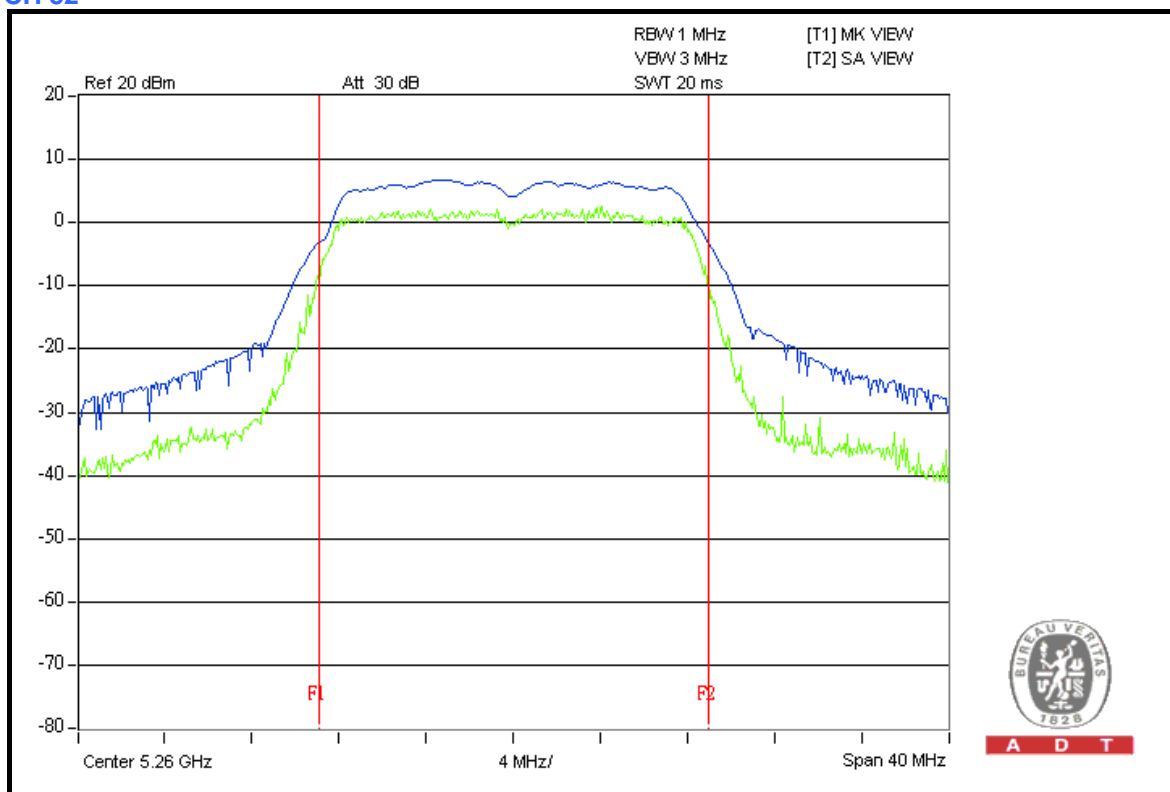



A D T

CH 60

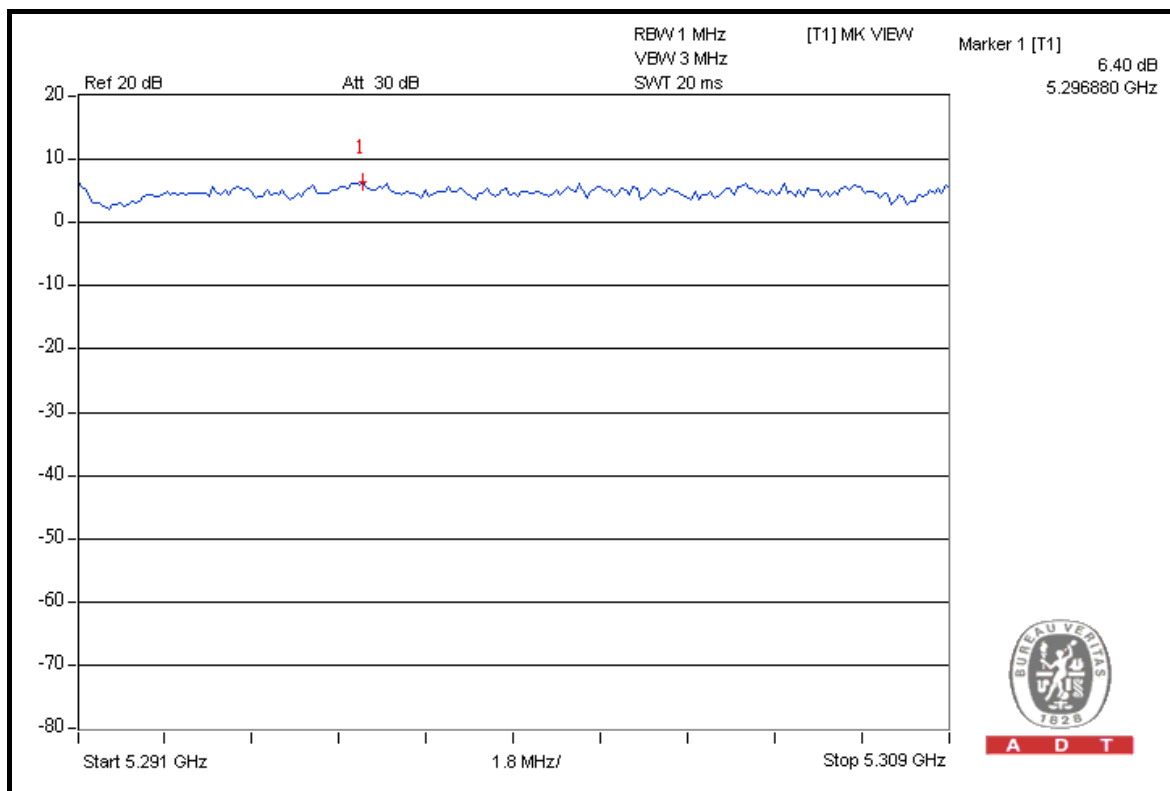
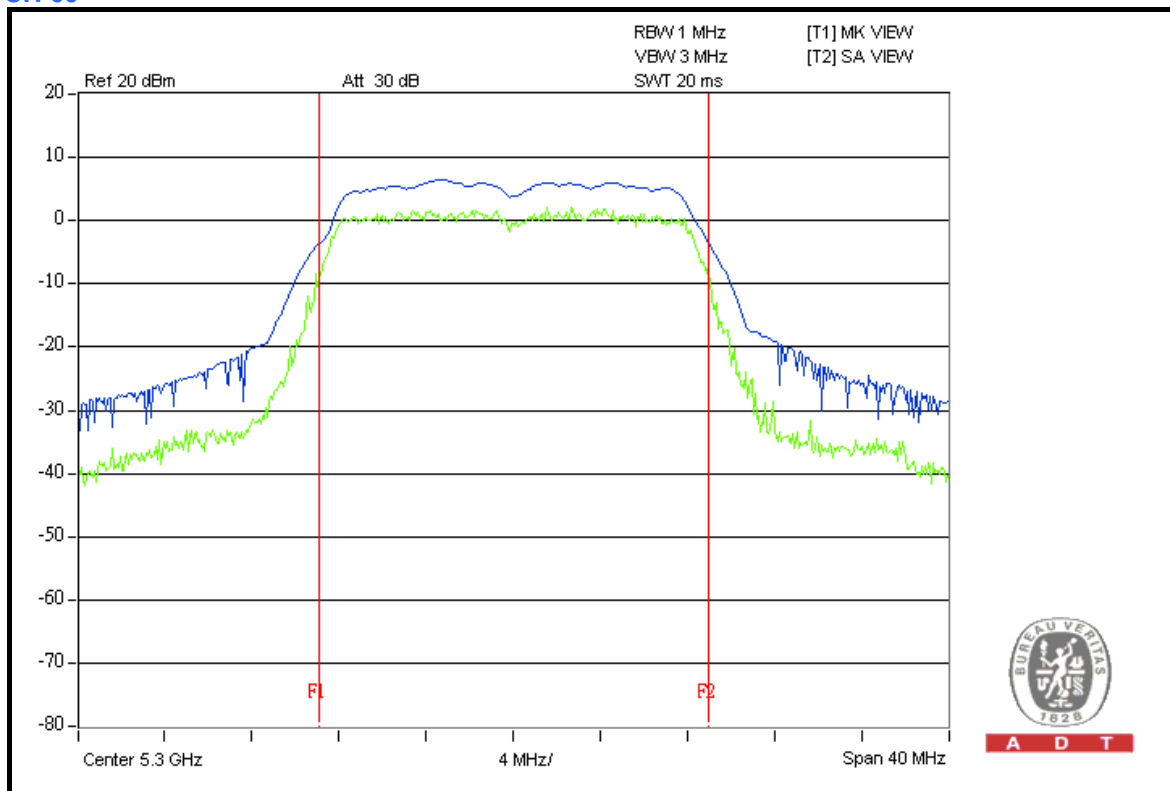



A D T

CH 64

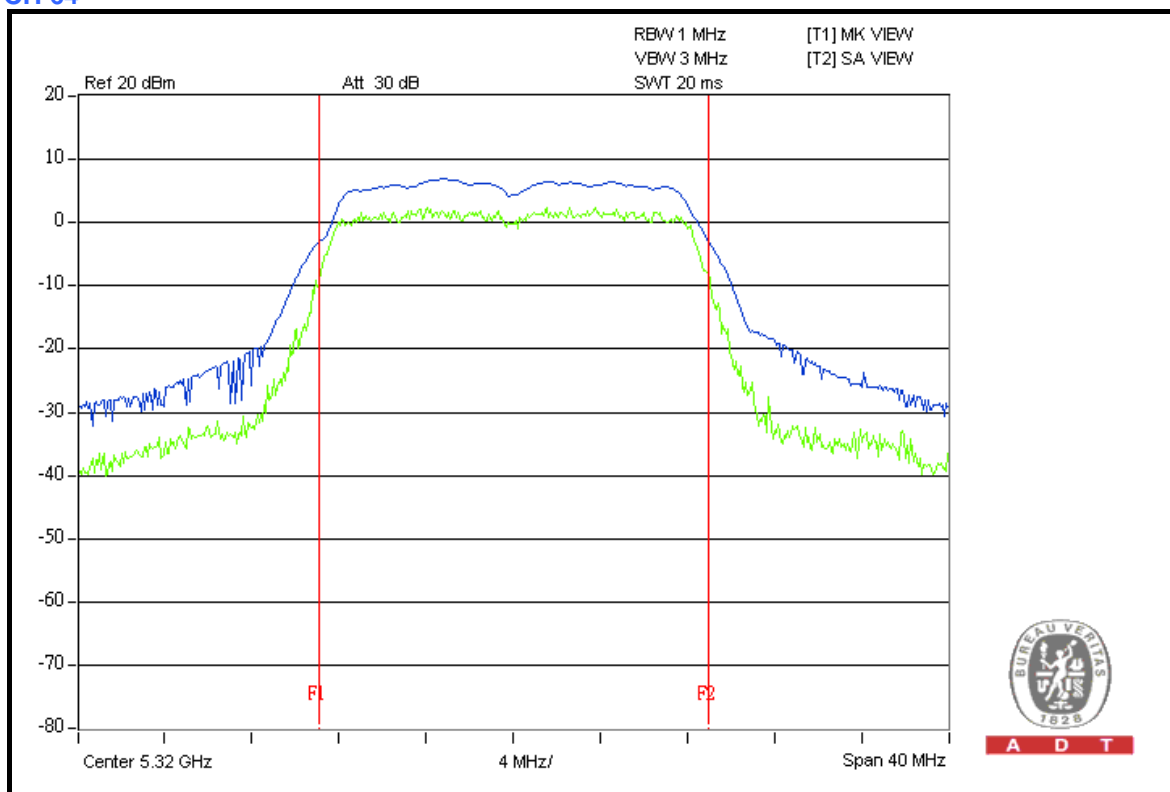

A D T

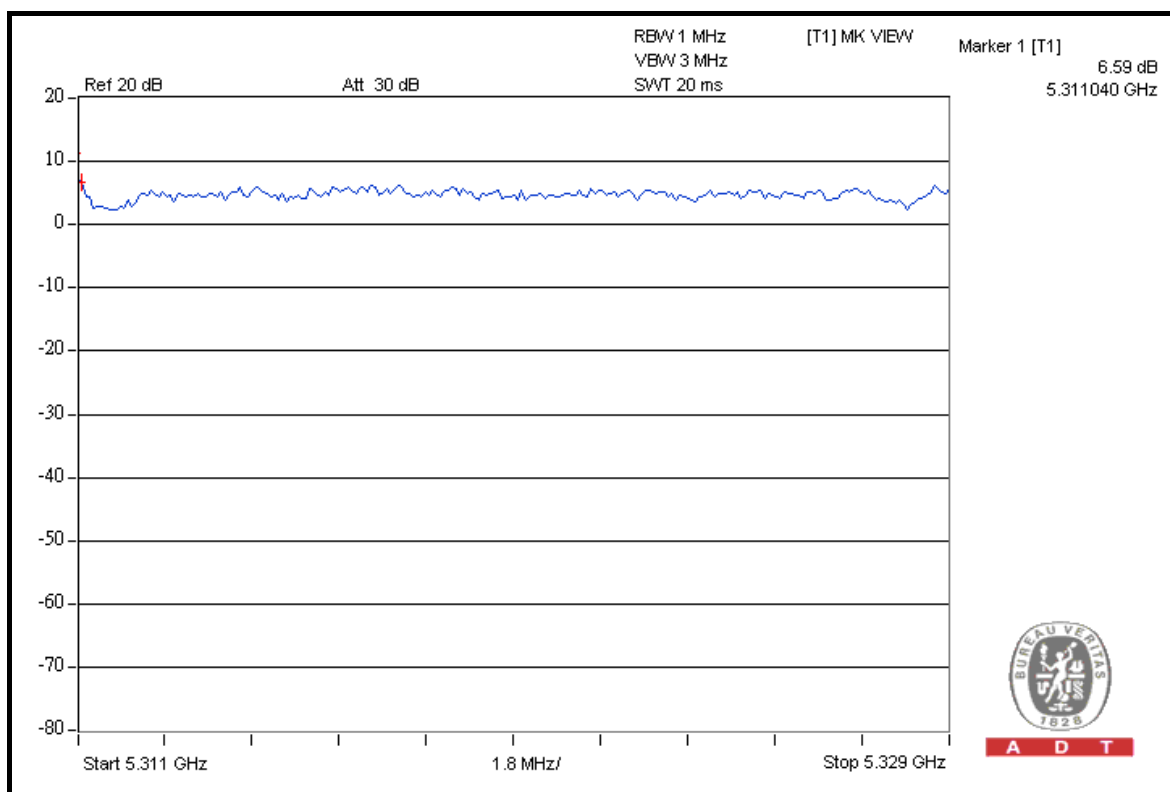

A D T



A D T

CH 100

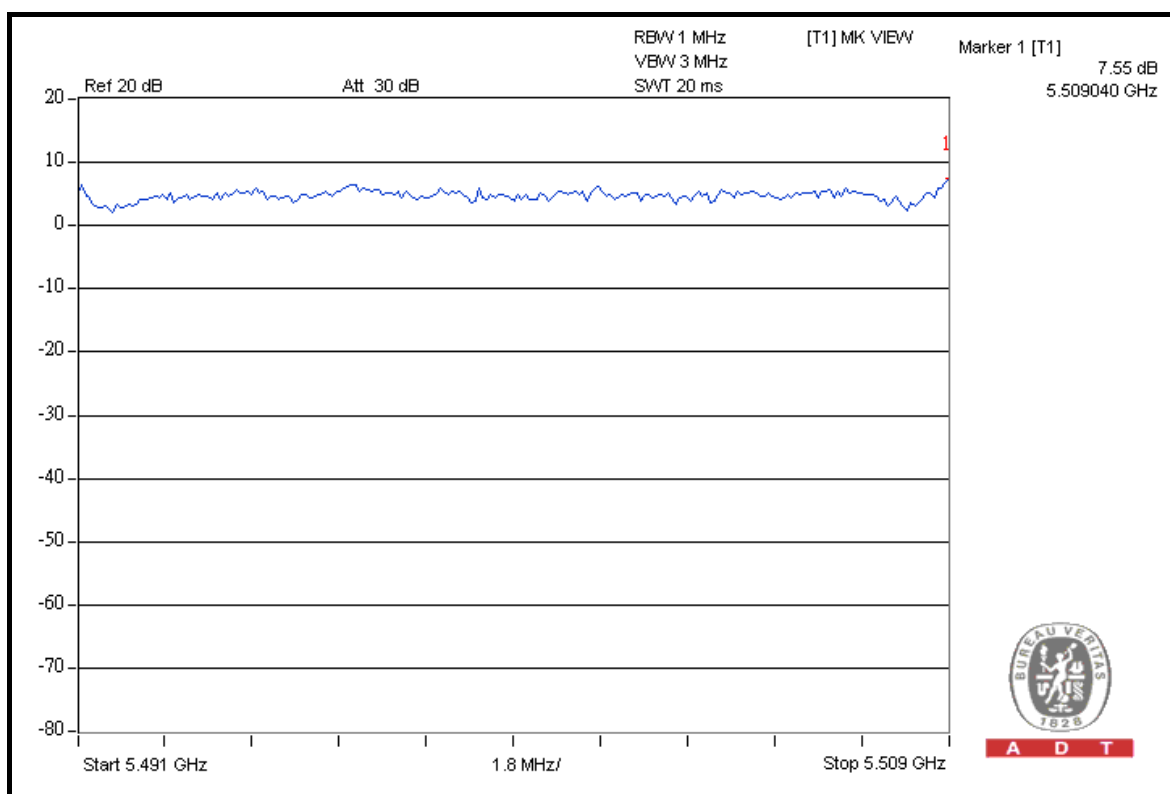
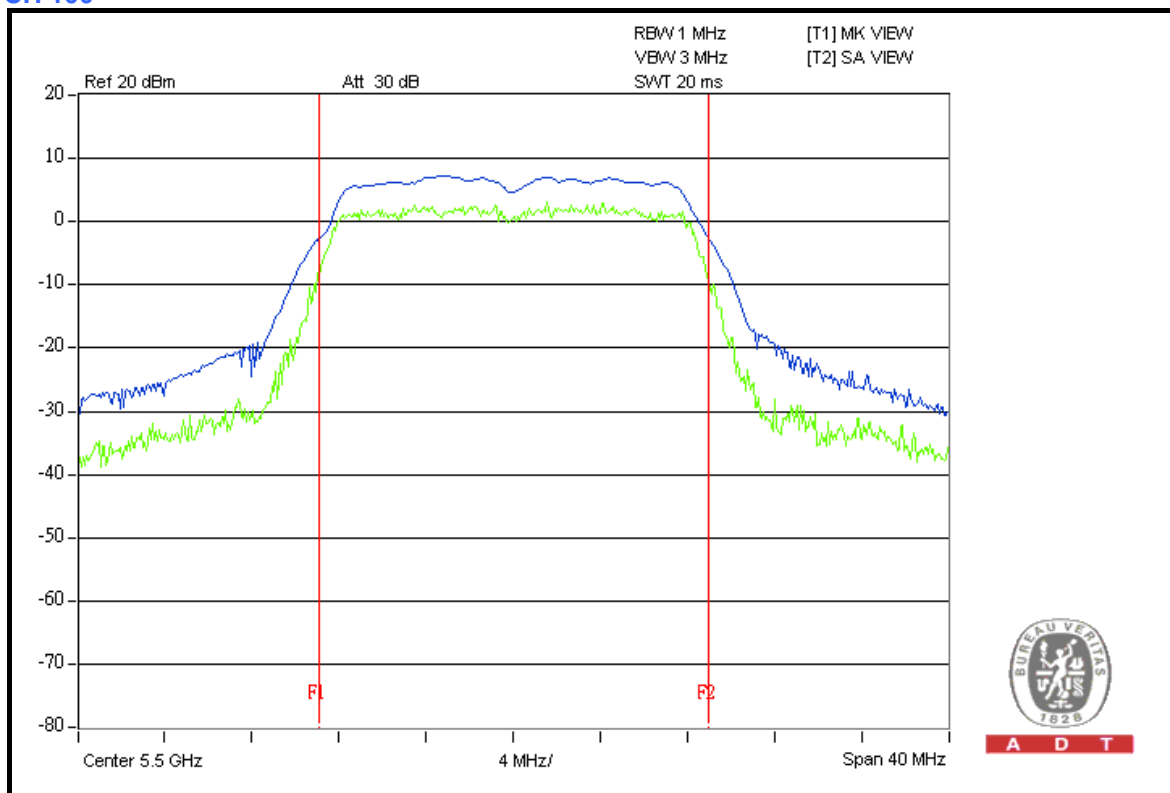



A D T

CH 120

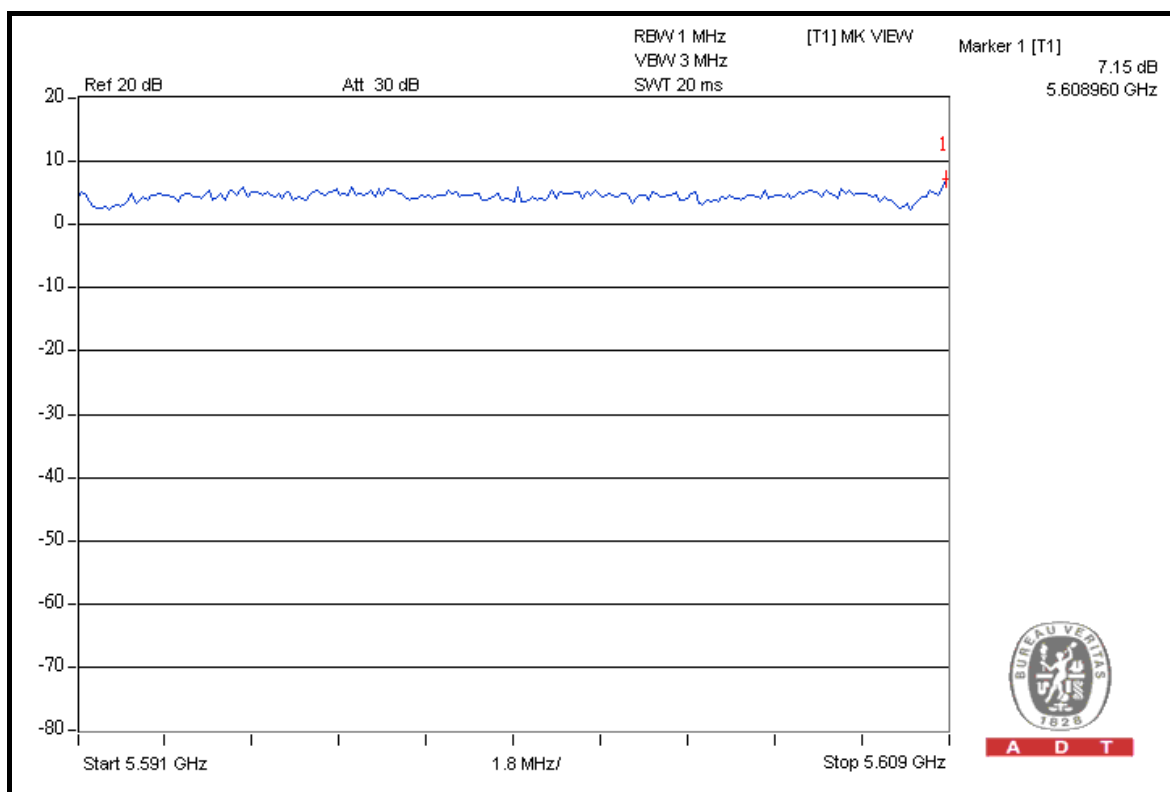
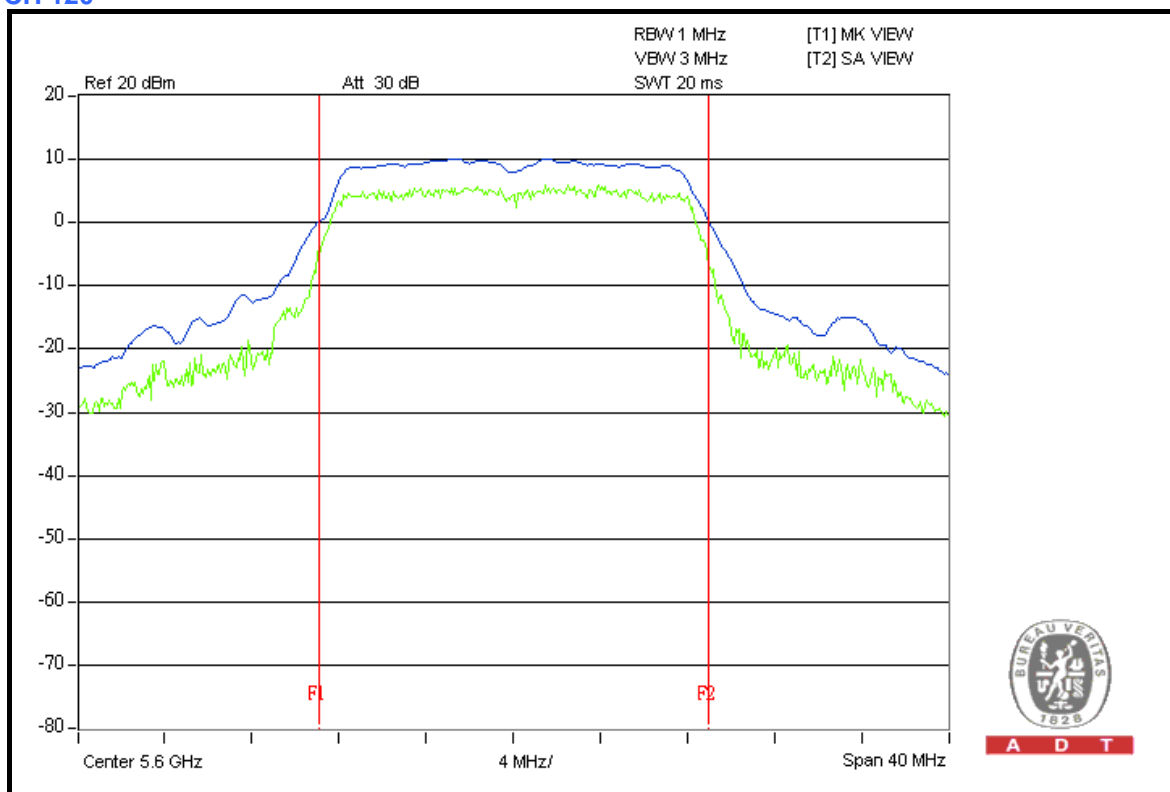



A D T

CH 140

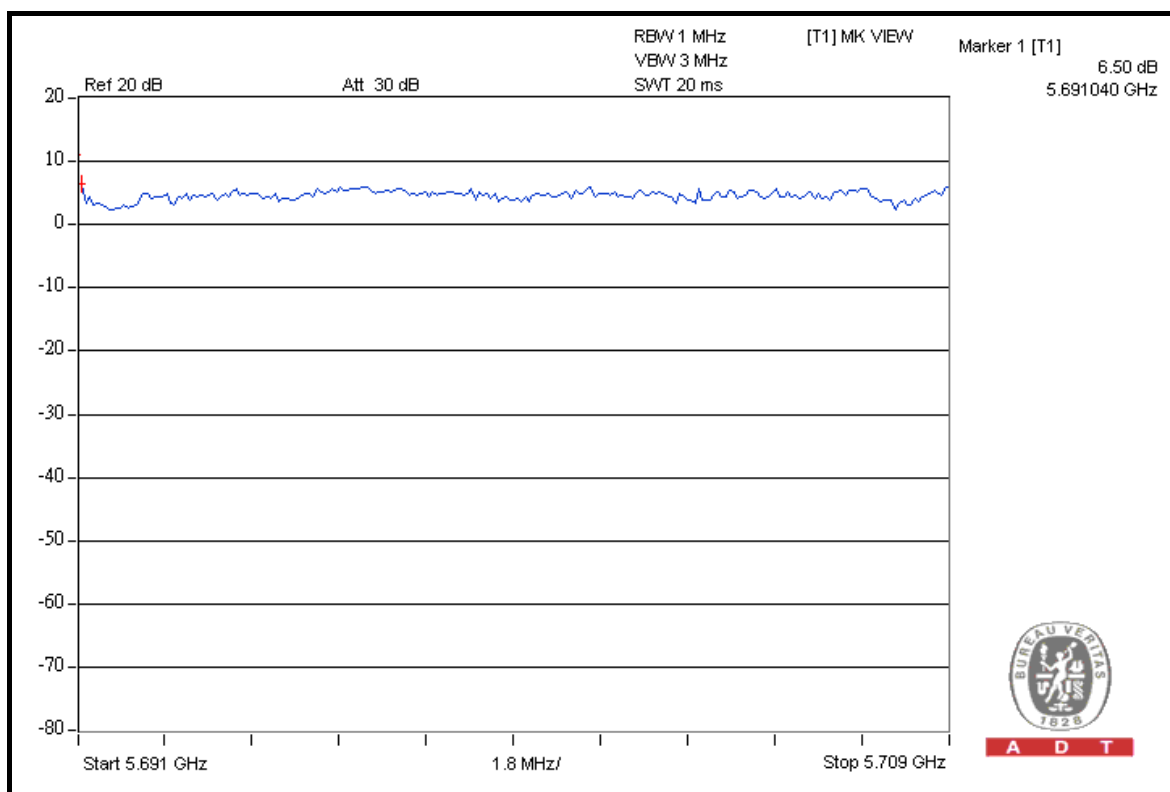
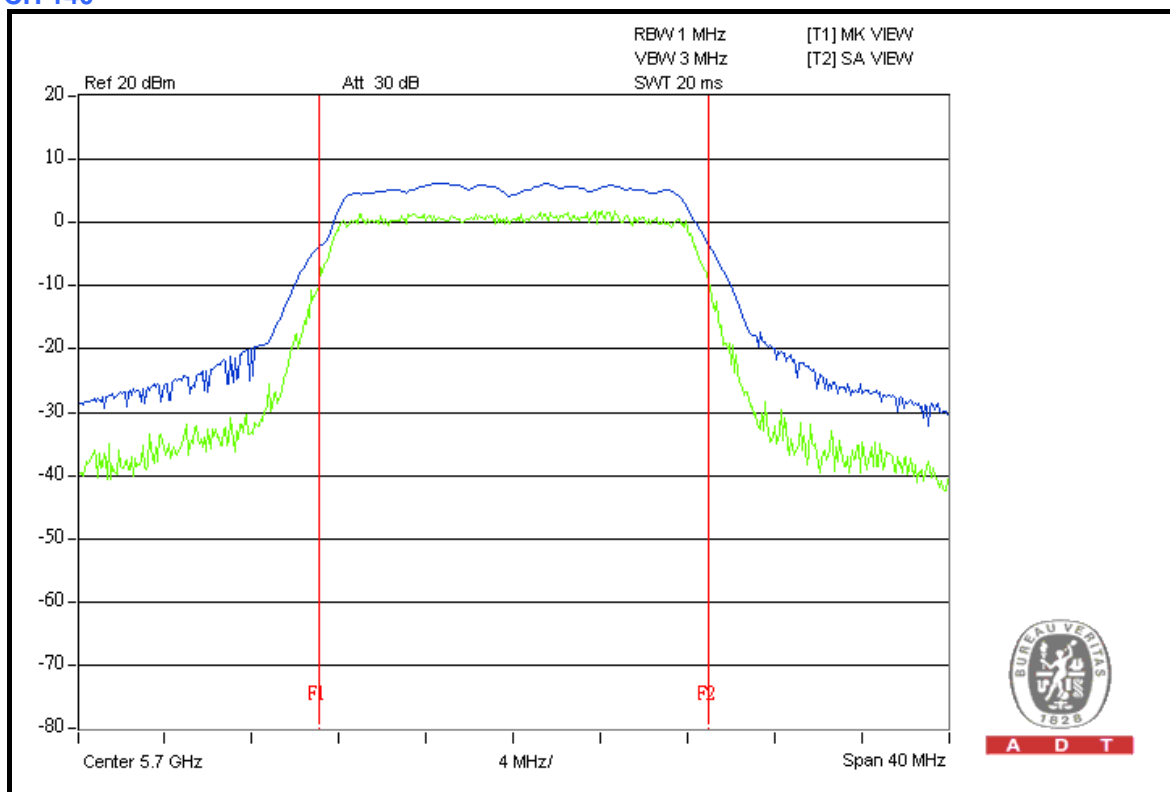



4.5 PEAK POWER SPECTRAL DENSITY MEASUREMENT

4.5.1 LIMITS OF PEAK POWER SPECTRAL DENSITY MEASUREMENT

FREQUENCY BAND	LIMIT
5.150 ~ 5.250GHz	4dBm
5.250 ~ 5.350GHz	11dBm
5.470 ~ 5.725GHz	11dBm

4.5.2 TEST INSTRUMENTS

DESCRIPTION & MANUFACTURER	MODEL NO.	SERIAL NO.	DATE OF CALIBRATION	CALIBRATED UNTIL
R&S SPECTRUM ANALYZER	FSP40	100041	Apr. 22, 2008	Apr. 21, 2009

NOTE: The calibration interval of the above test instruments is 12 months and the calibrations are traceable to NML/ROC and NIST/USA.

4.5.3 TEST PROCEDURES

- a. The transmitter output was connected to the spectrum analyzer.
- b. Set RBW = 1MHz, VBW = 3MHz. The PPSD is the highest level found across the emission in any 1MHz band.

4.5.4 DEVIATION FROM TEST STANDARD

No deviation.

4.5.5 TEST SETUP

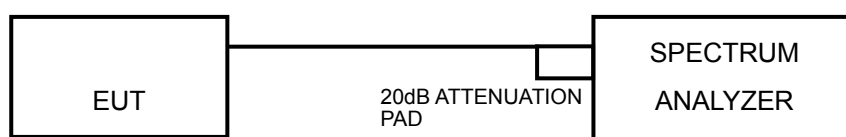

4.5.6 EUT OPERATING CONDITIONS

Same as 5.3.6.



A D T

4.5.7 TEST RESULTS

802.11a OFDM MODULATION

MODULATION TYPE	BPSK	TRANSFER RATE	6.0Mbps
INPUT POWER (SYSTEM)	120Vac, 60Hz	ENVIRONMENTAL CONDITIONS	25deg.C, 65%RH, 991hPa
TESTED BY	Brad Wu		

CHANNEL	CHANNEL FREQUENCY (MHz)	RF POWER LEVEL IN 1MHz BW (dBm)	MAXIMUM LIMIT (dBm)	PASS / FAIL
36	5180	-2.82	4	PASS
40	5200	-2.76	4	PASS
48	5240	-3.55	4	PASS
52	5260	-3.51	11	PASS
60	5300	-4.14	11	PASS
64	5320	-3.71	11	PASS
100	5500	-3.36	11	PASS
120	5600	-0.06	11	PASS
140	5700	-4.39	11	PASS

CH 36

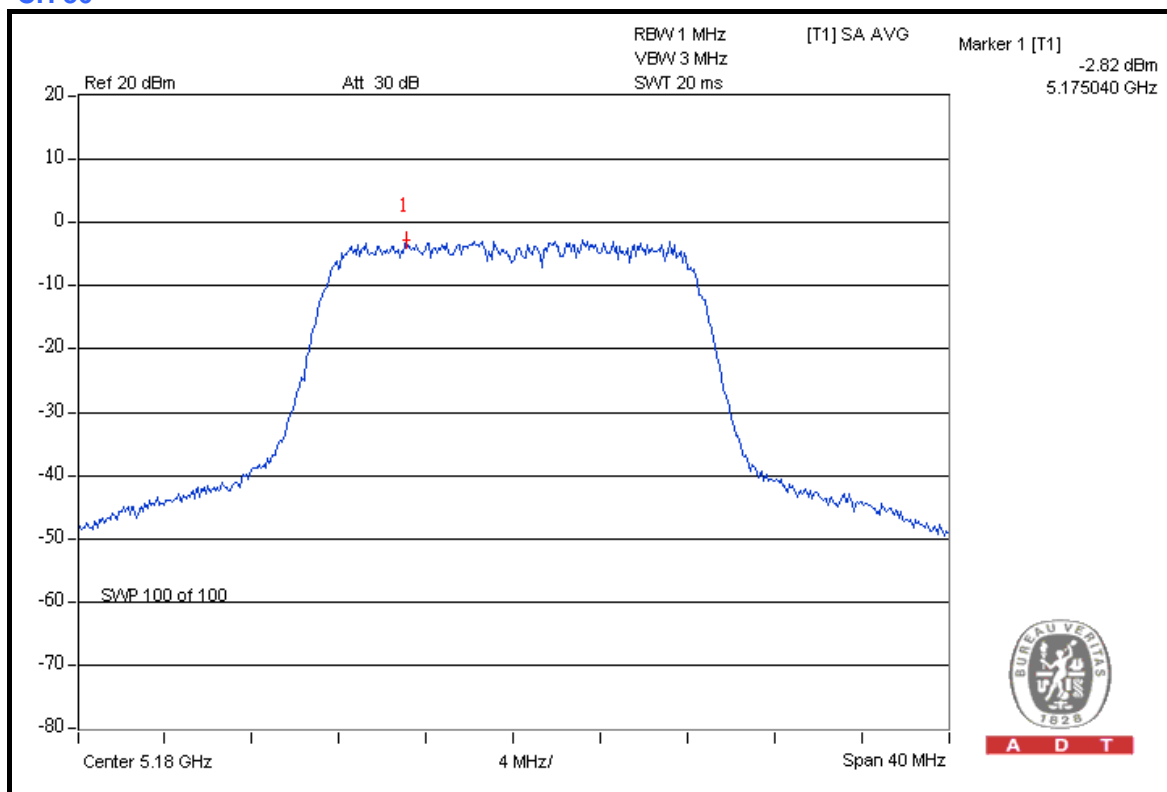

A D T



A D T

CH 40

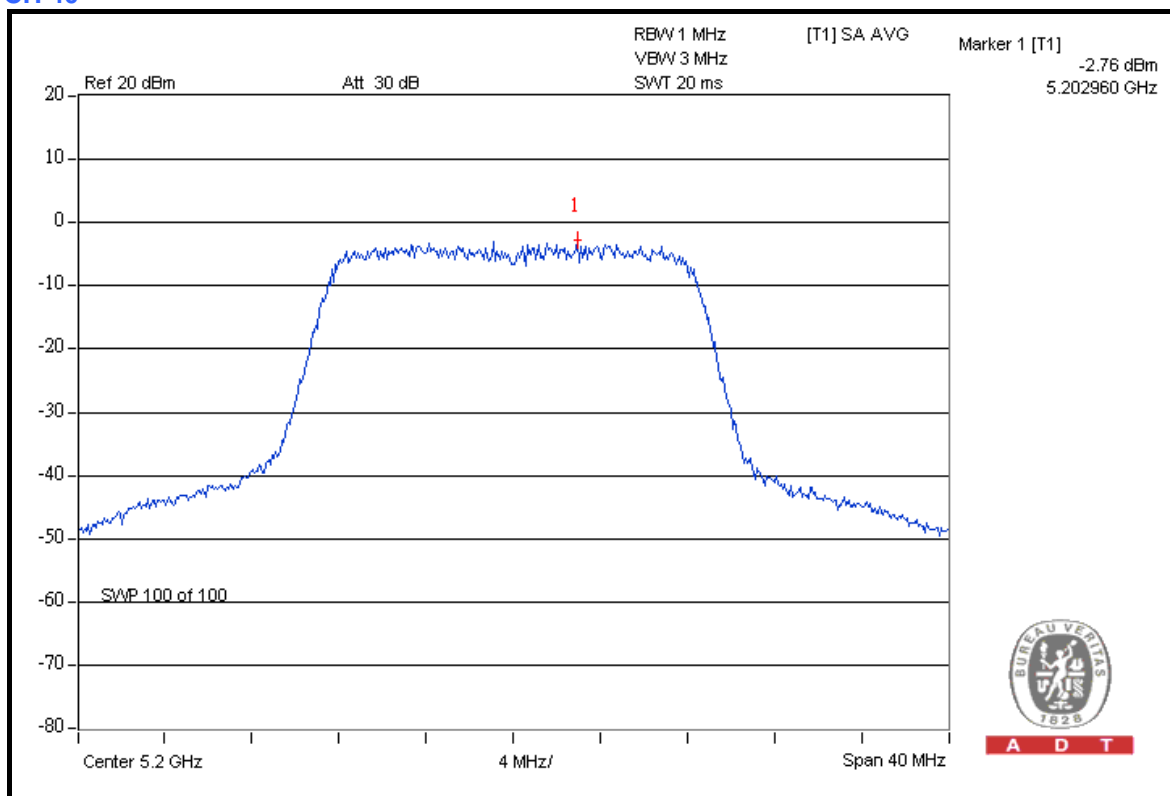

CH 48

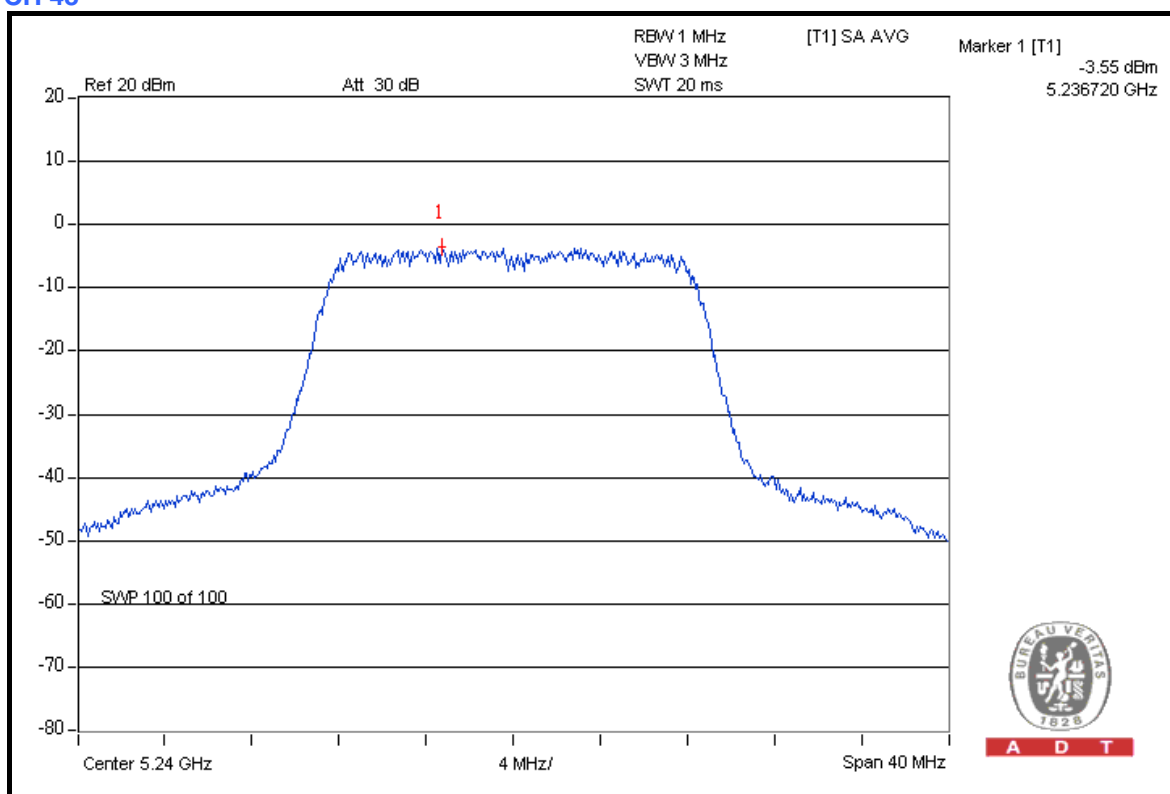



A D T

CH 52

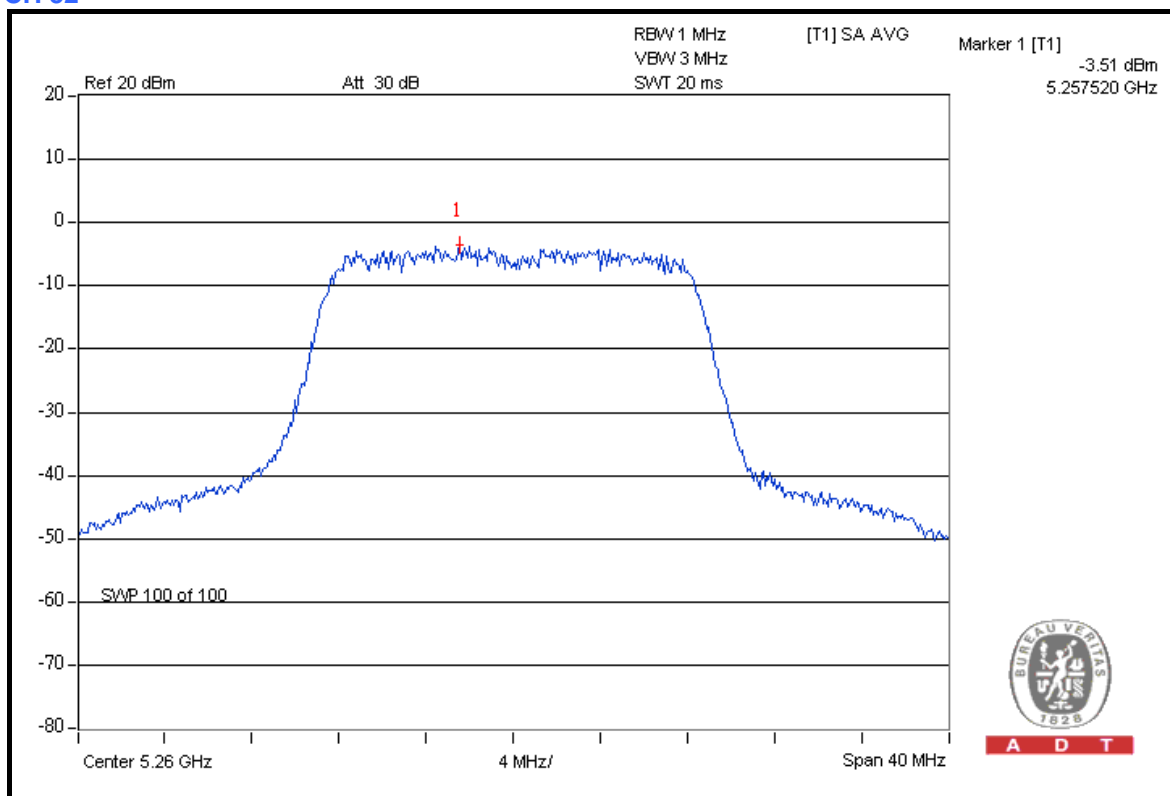

CH 60

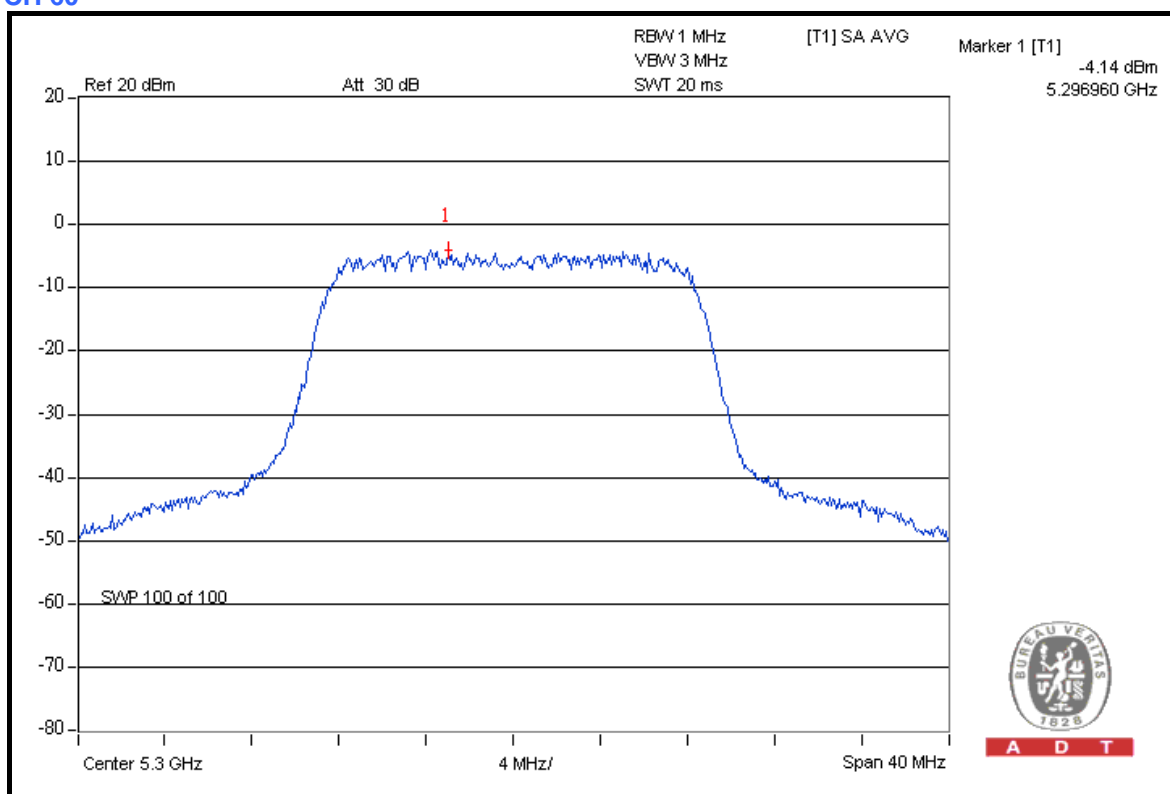



A D T

CH 64

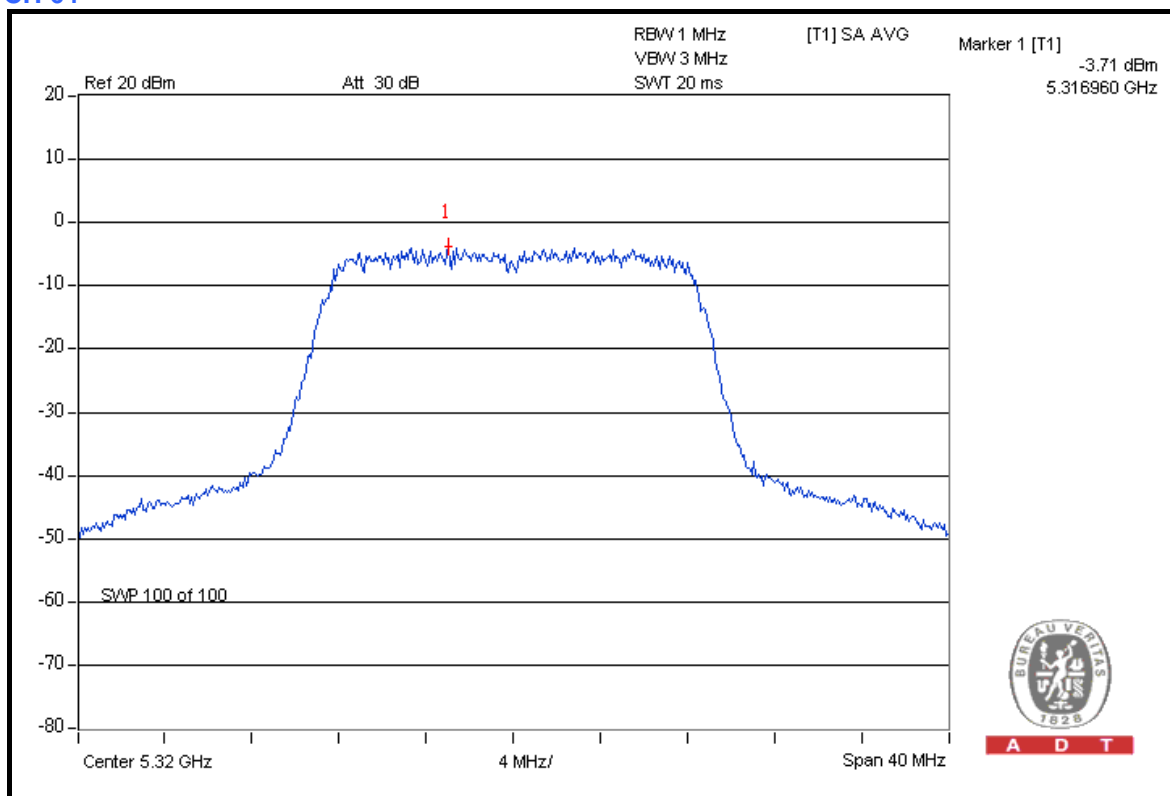

CH 100

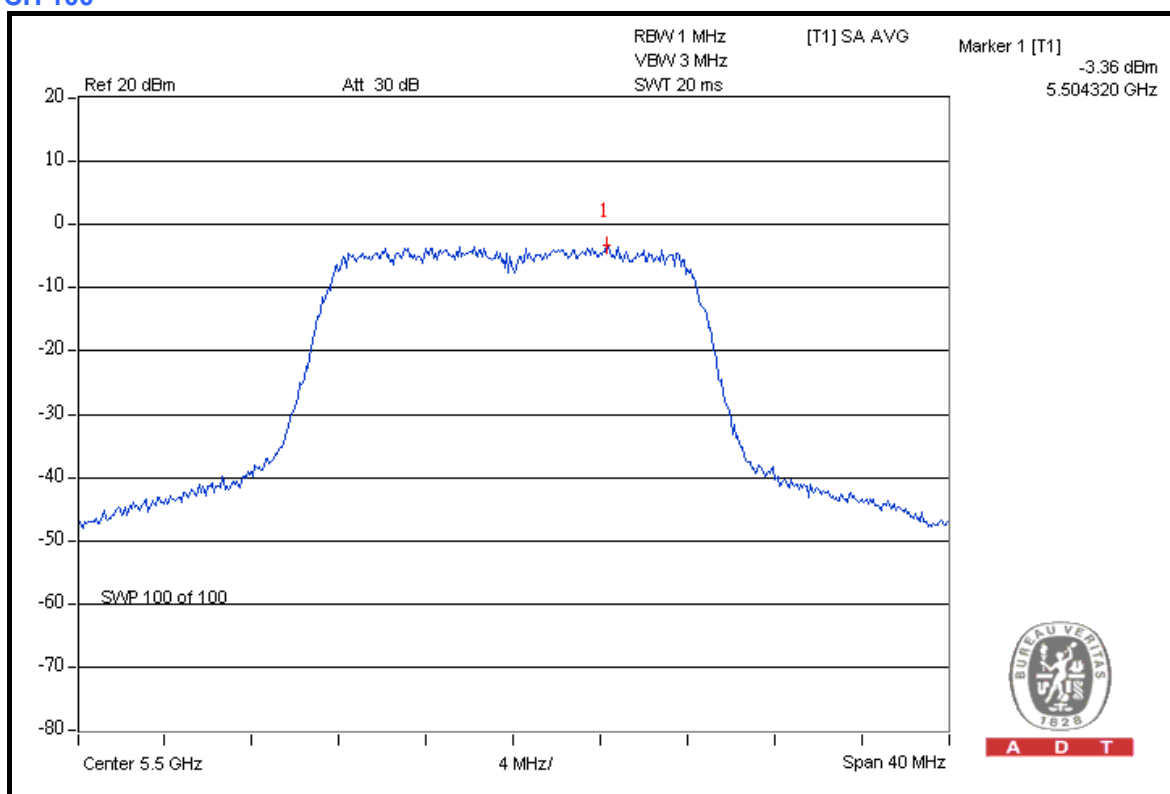



A D T

CH 120

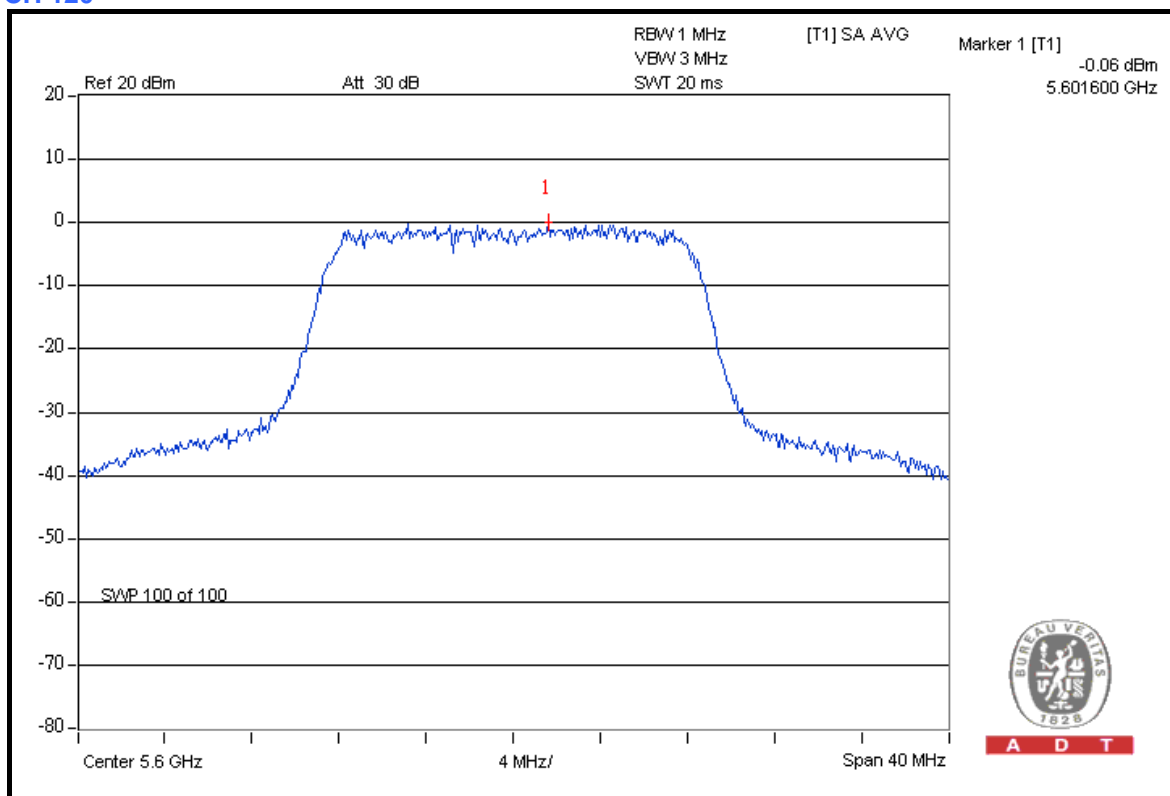

CH 140

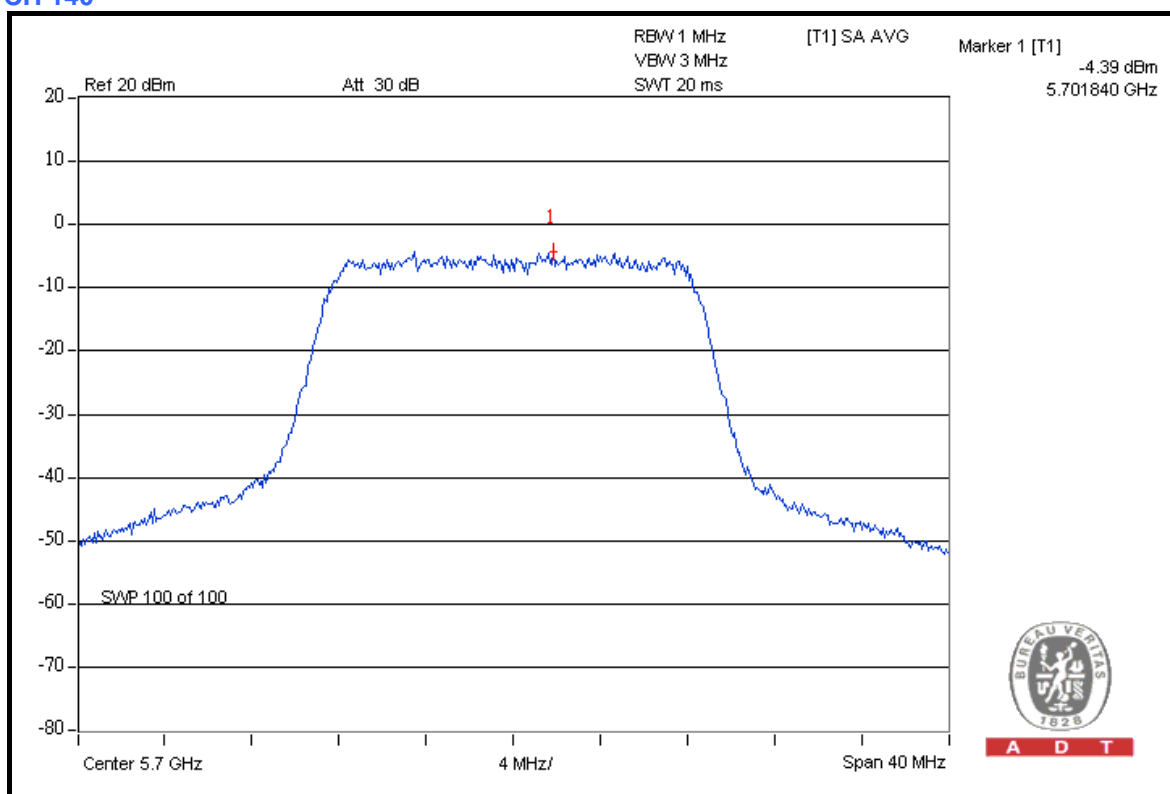

4.6 FREQUENCY STABILITY

4.6.1 LIMITS OF FREQUENCY STABILITY MEASUREMENT

The frequency tolerance of the carrier signal shall be maintained within the band of operation frequency over a temperature variation of –30 degrees to 50 degrees C at normal supply voltage, and for a variation in the primary supply voltage from 85% to 115% of the rated supply voltage at a temperature of 20 degrees C.

4.6.2 TEST INSTRUMENTS

DESCRIPTION & MANUFACTURER	MODEL NO.	SERIAL NO.	DATE OF CALIBRATION	CALIBRATED UNTIL
R&S SPECTRUM ANALYZER	FSP40	100041	Apr. 22, 2008	Apr. 21, 2009
WIT STANDARD TEMPERATURE AND HUMIDITY CHAMBER	TH-4S-C	W981030	Jun. 28, 2008	Jun. 27, 2009

NOTE: The calibration interval of the above test instruments is 12 months and the calibrations are traceable to NML/ROC and NIST/USA.

4.6.3 TEST PROCEDURE

- a. The EUT was placed inside the environmental test chamber and powered by nominal DC voltage.
- b. Turn the EUT on and couple its output to a spectrum analyzer.
- c. Turn the EUT off and set the chamber to the highest temperature specified.
- d. Allow sufficient time (approximately 30 min) for the temperature of the chamber to stabilize, turn the EUT on and measure the operating frequency after 2, 5, and 10 minutes.
- e. Repeat step 2 and 3 with the temperature chamber set to the lowest temperature.
- f. The test chamber was allowed to stabilize at +20 degree C for a minimum of 30 minutes. The supply voltage was then adjusted on the EUT from 85% to 115% and the frequency record.

4.6.4 DEVIATION FROM TEST STANDARD

No deviation.

4.6.5 TEST SETUP

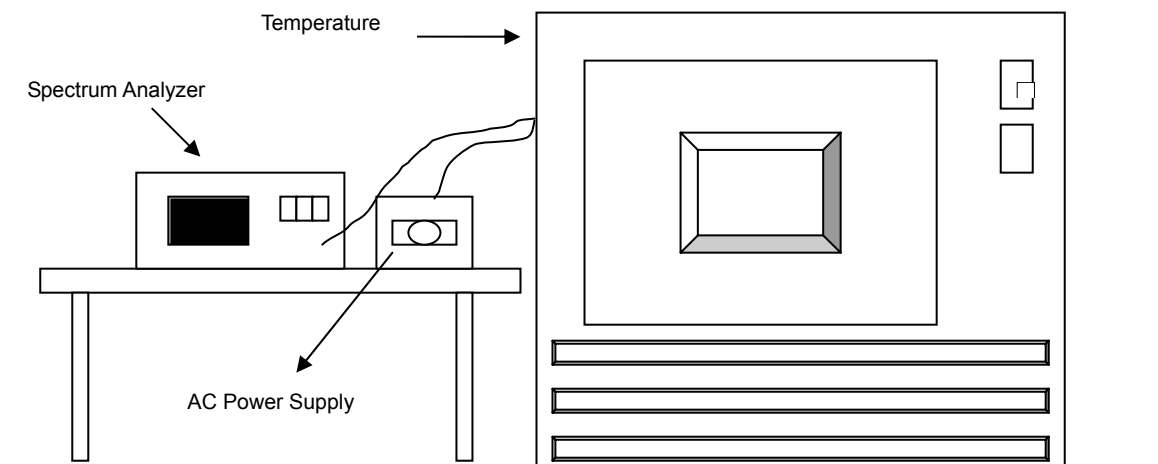

4.6.6 EUT OPERATING CONDITION

Same as Item 4.1.7.



4.6.7 TEST RESULTS

OPERATING FREQUENCY: 5320MHz									
TEMP. (°C)	POWER SUPPLY (Vac)	0 MINUTE		2 MINUTE		5 MINUTE		10 MINUTE	
		(MHz)	(%)	(MHz)	(%)	(MHz)	(%)	(MHz)	(%)
50	126.5	5319.999283	-0.0000135	5319.999042	-0.0000180	5319.999258	-0.0000139	5319.999106	-0.0000168
	110.0	5319.983950	-0.0003017	5319.983660	-0.0003071	5319.983544	-0.0003093	5319.983674	-0.0003069
	93.5	5319.986844	-0.0002473	5319.987135	-0.0002418	5319.986926	-0.0002458	5319.987038	-0.0002436
40	126.5	5319.978646	-0.0004014	5319.978561	-0.0004030	5319.979004	-0.0003947	5319.979335	-0.0003884
	110.0	5319.985543	-0.0002717	5319.985217	-0.0002779	5319.985225	-0.0002777	5319.985303	-0.0002763
	93.5	5319.997076	-0.0000550	5319.997060	-0.0000553	5319.996970	-0.0000570	5319.997039	-0.0000557
30	126.5	5319.979963	-0.0003766	5319.980034	-0.0003753	5319.980199	-0.0003722	5319.980033	-0.0003753
	110.0	5319.986181	-0.0002598	5319.986144	-0.0002605	5319.986199	-0.0002594	5319.986471	-0.0002543
	93.5	5320.004176	0.0000785	5320.004421	0.0000831	5320.004212	0.0000792	5320.004360	0.0000820
20	126.5	5319.986907	-0.0002461	5319.986627	-0.0002514	5319.986814	-0.0002479	5319.986964	-0.0002450
	110.0	5319.987030	-0.0002438	5319.987163	-0.0002413	5319.987219	-0.0002402	5319.987150	-0.0002415
	93.5	5320.011723	0.0002204	5320.011690	0.0002197	5320.011451	0.0002152	5320.011350	0.0002133
10	126.5	5319.994818	-0.0000974	5319.994729	-0.0000991	5319.994874	-0.0000964	5319.994653	-0.0001005
	110.0	5320.002492	0.0000468	5320.002537	0.0000477	5320.002642	0.0000497	5320.002390	0.0000449
	93.5	5320.018210	0.0003423	5320.018241	0.0003429	5320.017897	0.0003364	5320.017860	0.0003357
0	126.5	5319.997456	-0.0000478	5319.997550	-0.0000461	5319.997653	-0.0000441	5319.997552	-0.0000460
	110.0	5320.009768	0.0001836	5320.009736	0.0001830	5320.009807	0.0001843	5320.009824	0.0001847
	93.5	5320.024547	0.0004614	5320.024212	0.0004551	5320.024203	0.0004549	5320.024155	0.0004540
-10	126.5	5320.009880	0.0001857	5320.009948	0.0001870	5320.009720	0.0001827	5320.009710	0.0001825
	110.0	5320.016168	0.0003039	5320.016444	0.0003091	5320.015995	0.0003007	5320.015820	0.0002974
	93.5	5320.030536	0.0005740	5320.030505	0.0005734	5320.030539	0.0005740	5320.030610	0.0005754
-20	126.5	5320.015301	0.0002876	5320.015529	0.0002919	5320.015505	0.0002914	5320.015288	0.0002874
	110.0	5320.020497	0.0003853	5320.020424	0.0003839	5320.020412	0.0003837	5320.020660	0.0003883
	93.5	5320.035456	0.0006665	5320.035324	0.0006640	5320.035501	0.0006673	5320.035482	0.0006670
-30	126.5	5320.021068	0.0003960	5320.020921	0.0003933	5320.020833	0.0003916	5320.021149	0.0003975
	110.0	5320.034842	0.0006549	5320.034670	0.0006517	5320.034926	0.0006565	5320.034814	0.0006544
	93.5	5320.037394	0.0007029	5320.037264	0.0007005	5320.037222	0.0006997	5320.037506	0.0007050

4.7 BAND EDGES MEASUREMENT

4.7.1 TEST INSTRUMENTS

DESCRIPTION & MANUFACTURER	MODEL NO.	SERIAL NO.	DATE OF CALIBRATION	CALIBRATED UNTIL
R&S SPECTRUM ANALYZER	FSP40	100041	Apr. 22, 2008	Apr. 21, 2009

NOTE: The calibration interval of the above test instruments is 12 months and the calibrations are traceable to NML/ROC and NIST/USA.

4.7.2 TEST PROCEDURE

The transmitter output was connected to the spectrum analyzer via a low lose cable. Set both RBW and VBW of spectrum analyzer to 1MHz and 3MHz with suitable frequency span including 100MHz bandwidth from band edge. The band edges was measured and recorded.

4.7.3 EUT OPERATING CONDITION

The software provided by client to enable the EUT under transmission condition continuously at specific channel frequencies individually.

4.7.4 TEST RESULTS

For signals in the restricted bands above and below the 5.18 to 5.32GHz and 5.50 to 5.70GHz allocated band a measurement was made of the amplitude of the spurious emissions with respect to the intentional signals. The relative amplitude, in dBc, was applied to the average and peak filed strength of the intentional signal made on the OATS to calculate the field strength of the unintentional signals.

The spectrum plots (Peak RBW = 1MHz, VBW = 3MHz) are attached on the following pages.

FOR 5180-5320MHz BAND: 802.11a OFDM MODULATION

Channel 36 (5180MHz)

The band edge emission plot on the next page shows 43.08dBc between carrier maximum power and local maximum emission in restrict band. The emission of carrier strength list in the test result of channel 36 is 110.82dBuV/m (Peak), so the maximum field strength in restrict band is $110.82 - 43.08 = 67.74$ dBuV/m which is under 74dBuV/m limit.

The band edge emission plot on the next page shows 50.80dBc between carrier maximum power and local maximum emission in restrict band. The emission of carrier strength list in the test result of channel 36 is 100.34dBuV/m (Average), so the maximum field strength in restrict band is $100.34 - 50.80 = 49.54$ dBuV/m which is under 54dBuV/m limit.

Channel 64 (5320MHz)

The band edge emission plot on the next second page shows 41.20dBc between carrier maximum power and local maximum emission in restrict band. The emission of carrier strength list in the test result of channel 64 is 111.84dBuV/m (Peak), so the maximum field strength in restrict band is $111.84 - 41.20 = 70.64$ dBuV/m which is under 74dBuV/m limit.

The band edge emission plot on the next third page shows 50.09dBc between carrier maximum power and local maximum emission in restrict band. The emission of carrier strength list in the test result of channel 64 is 101.49dBuV/m (Average), so the maximum field strength in restrict band is $101.49 - 50.09 = 51.40$ dBuV/m which is under 54dBuV/m limit.



A D T

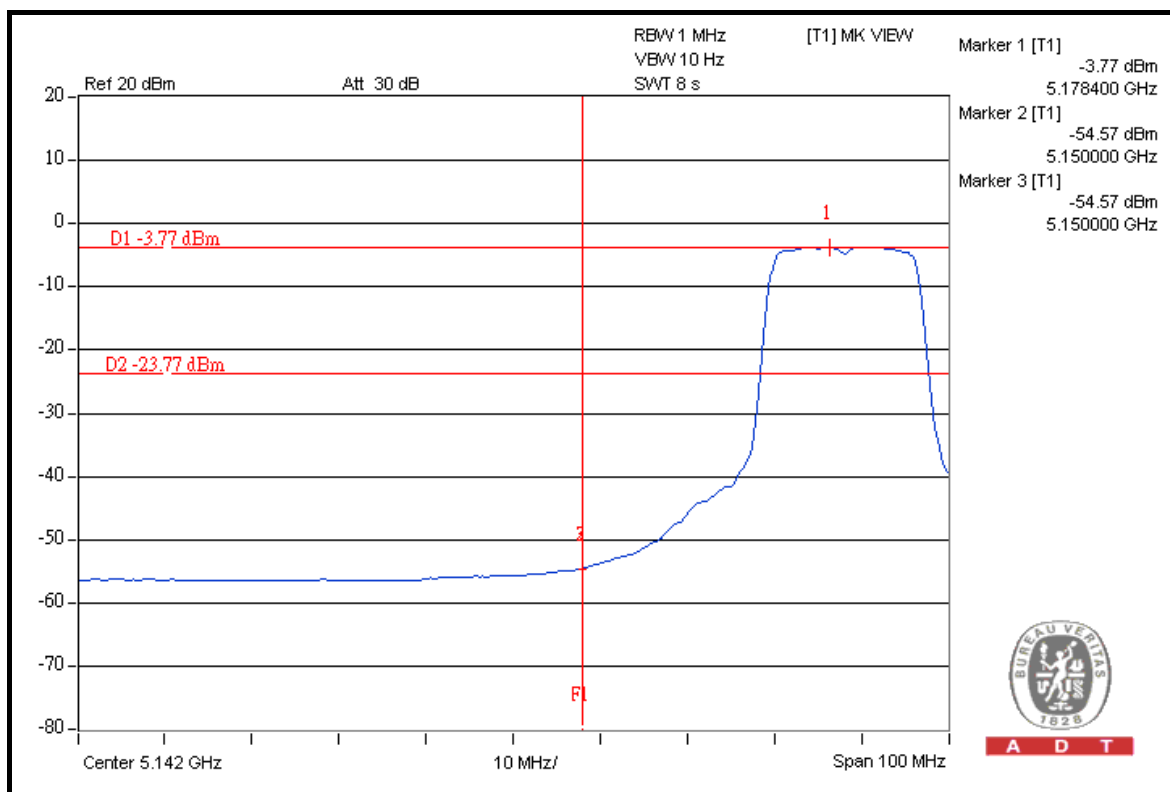
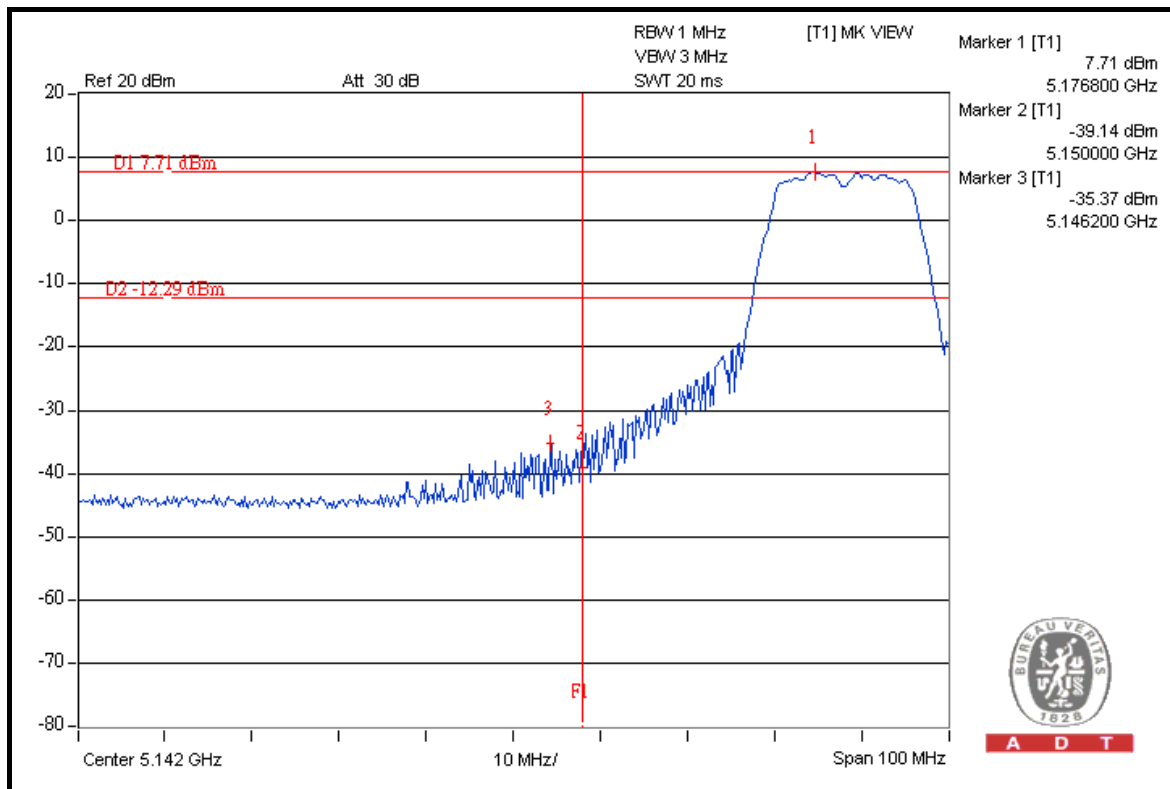



A D T

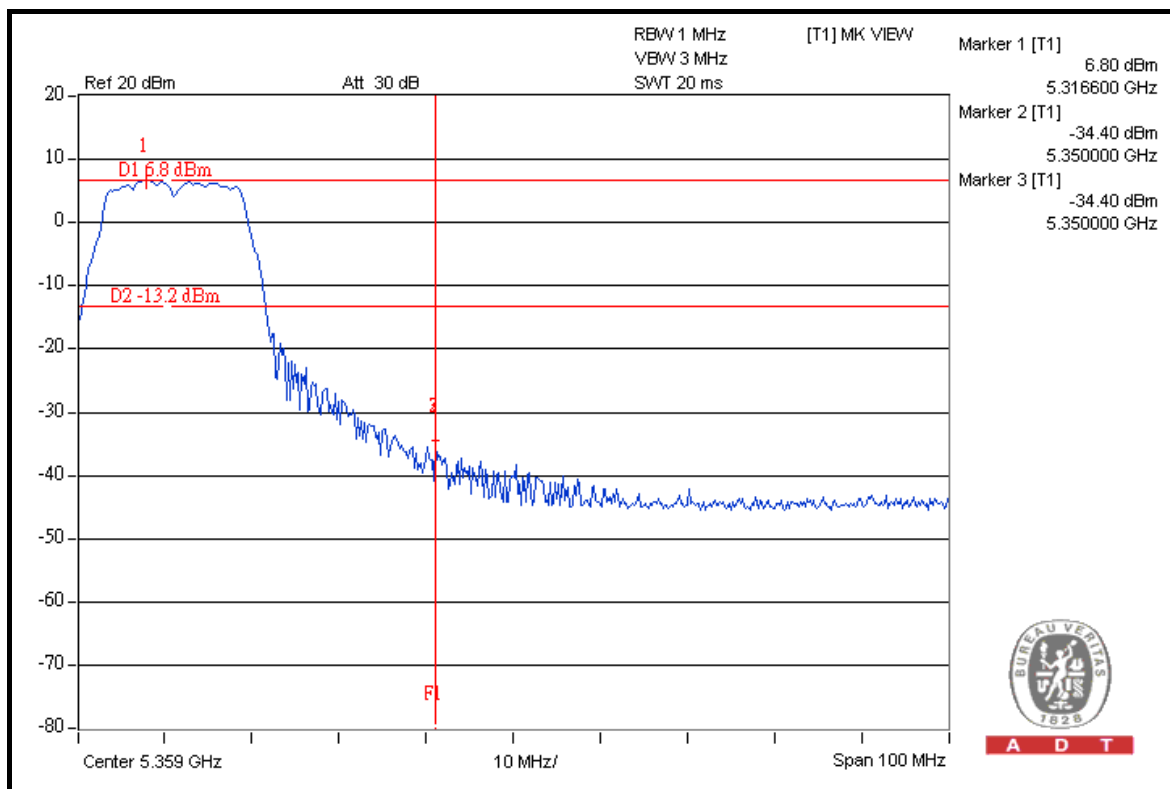
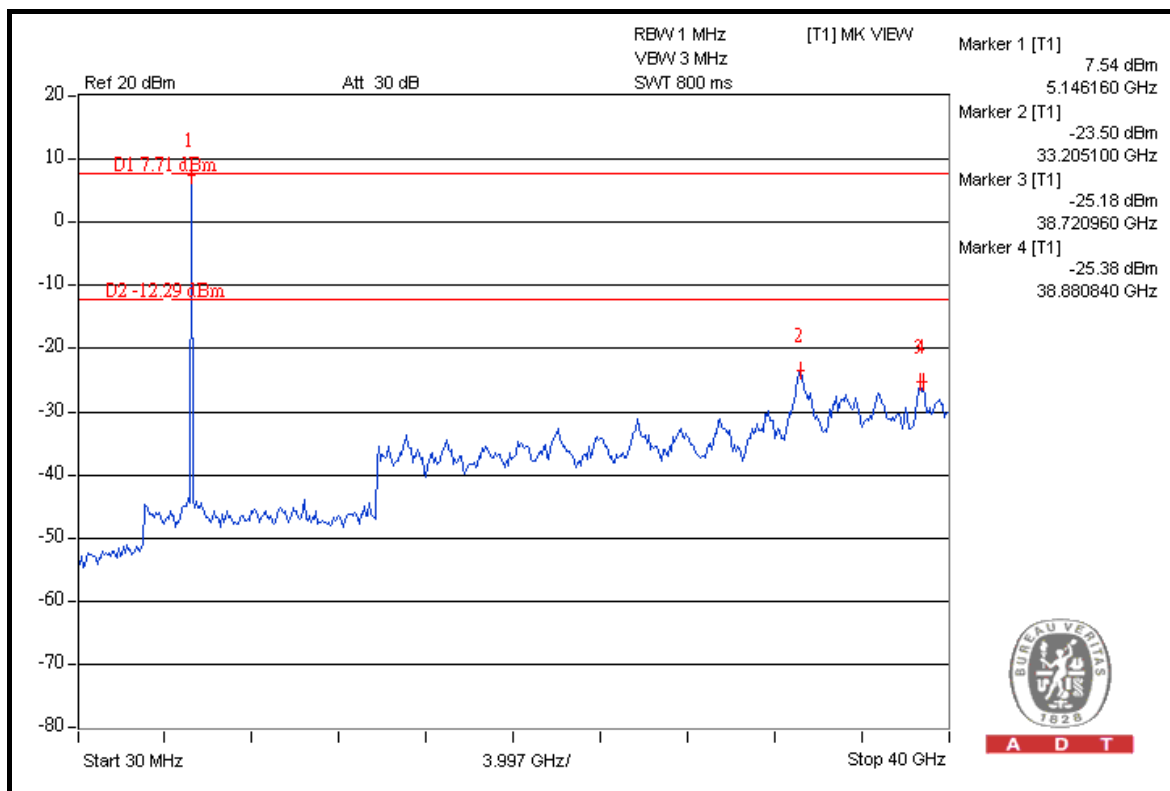



A D T

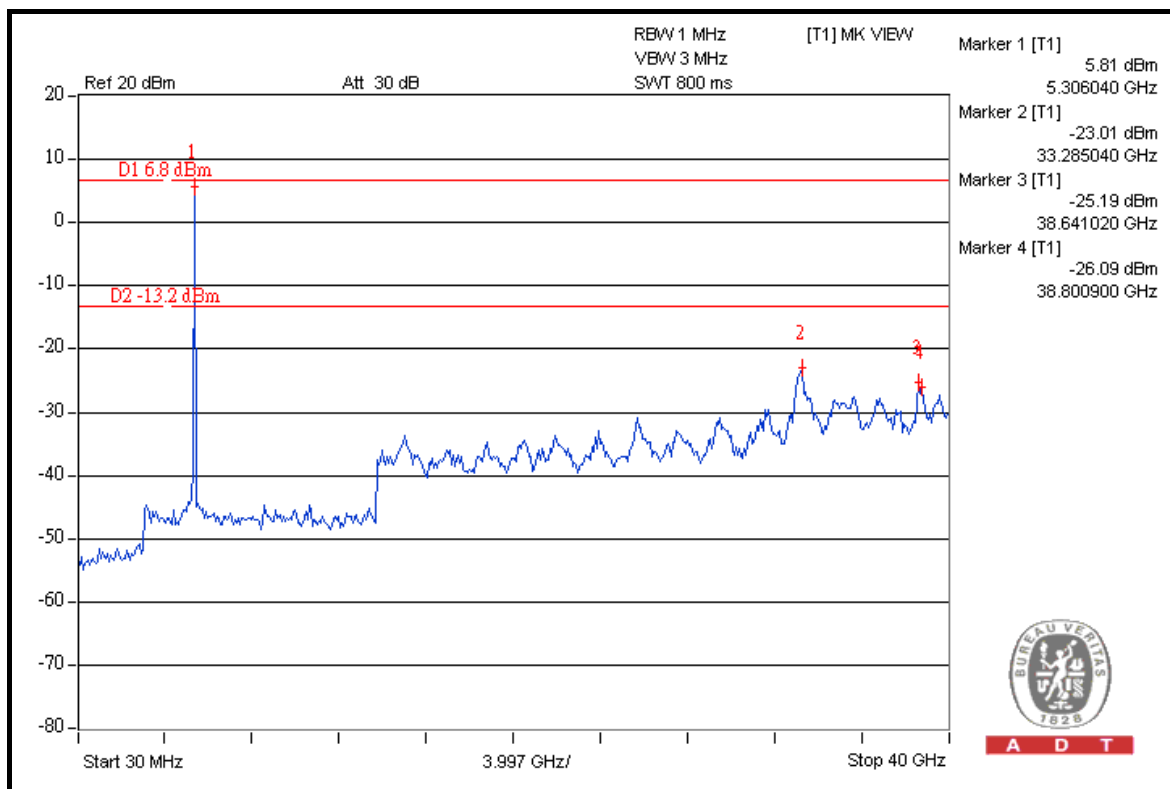
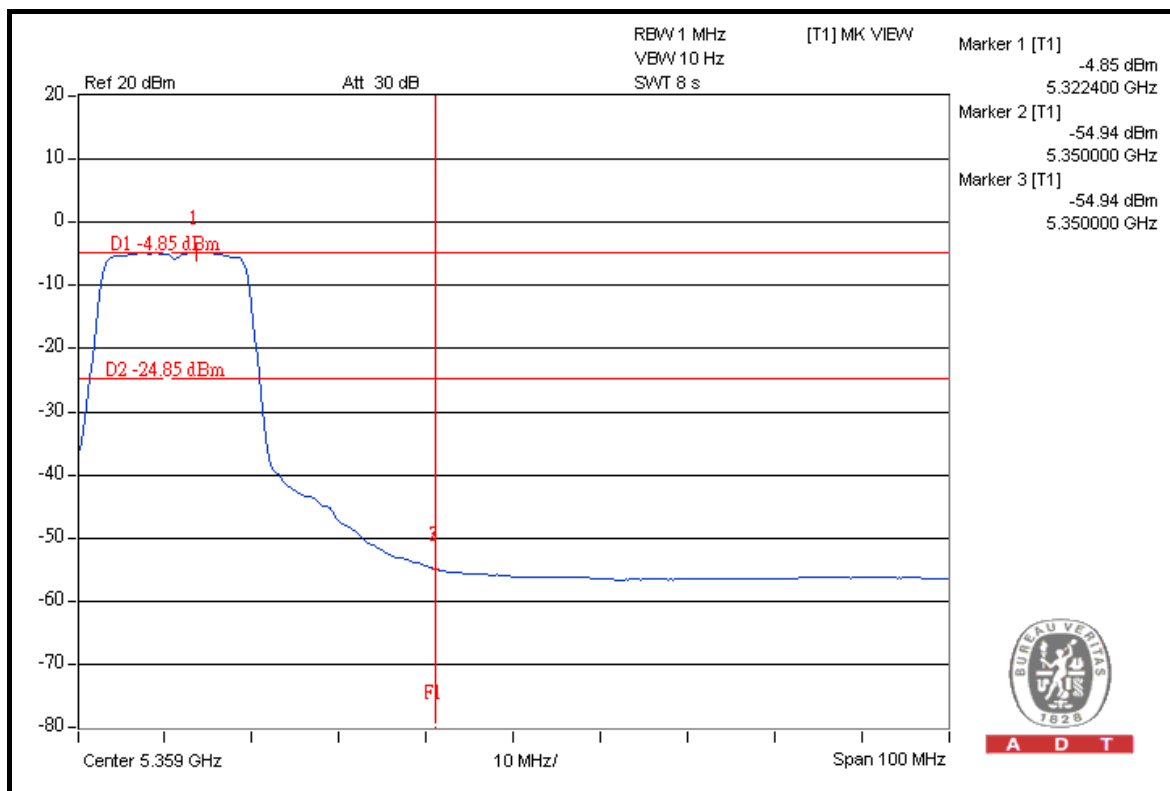

FOR 5500-5700MHz BAND: 802.11a OFDM MODULATION

Channel 100 (5500MHz)

The band edge emission plot (5.460GHz) on the next page shows 49.89dBc between carrier maximum power and local maximum emission out of band emission. The emission of carrier strength list in the test result of channel 100 is 109.68dBuV/m (Peak), so the maximum field strength out of band emission is $109.68 - 49.89 = 59.79$ dBuV/m which is under 74dBuV/m limit.

The band edge emission plot (5.460GHz) on the next page shows 51.32dBc between carrier maximum power and local maximum emission in restrict band. The emission of carrier strength list in the test result of channel 100 is 99.20dBuV/m (Average), so the maximum field strength in restrict band is $99.20 - 51.32 = 47.88$ dBuV/m which is under 54dBuV/m limit.

The band edge emission plot (5.470GHz) on the next page shows 44.58dBc between carrier maximum power and local maximum emission in restrict band. The emission of carrier strength list in the test result of channel 100 is 109.68dBuV/m (Peak), so the maximum field strength in restrict band is $109.68 - 44.58 = 65.10$ dBuV/m which is under 68.3dBuV/m limit.

Channel 140 (5700MHz)

The band edge emission plot on the next second page shows 39.69dBc between carrier maximum power and local maximum emission in restrict band. The emission of carrier strength list in the test result of channel 140 is 105.68dBuV/m (Peak), so the maximum field strength in restrict band is $105.68 - 39.69 = 65.99$ dBuV/m which is under 68.3dBuV/m limit.



A D T

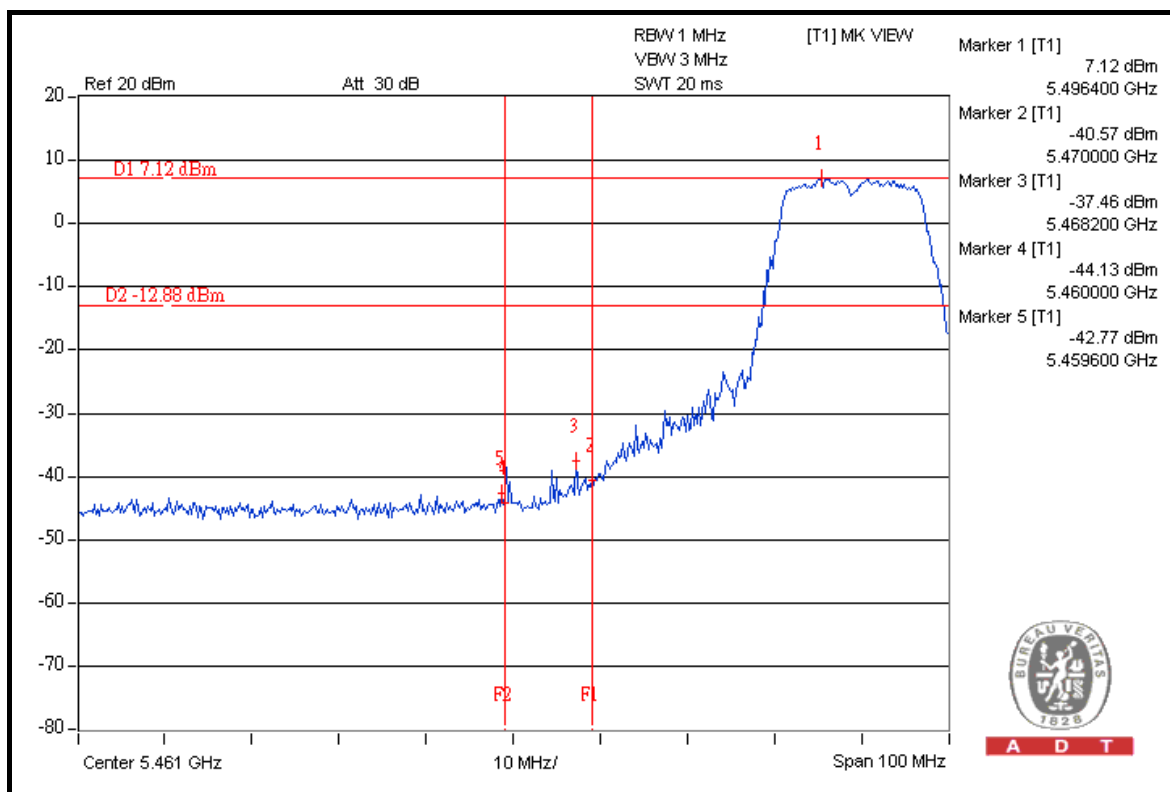

A D T

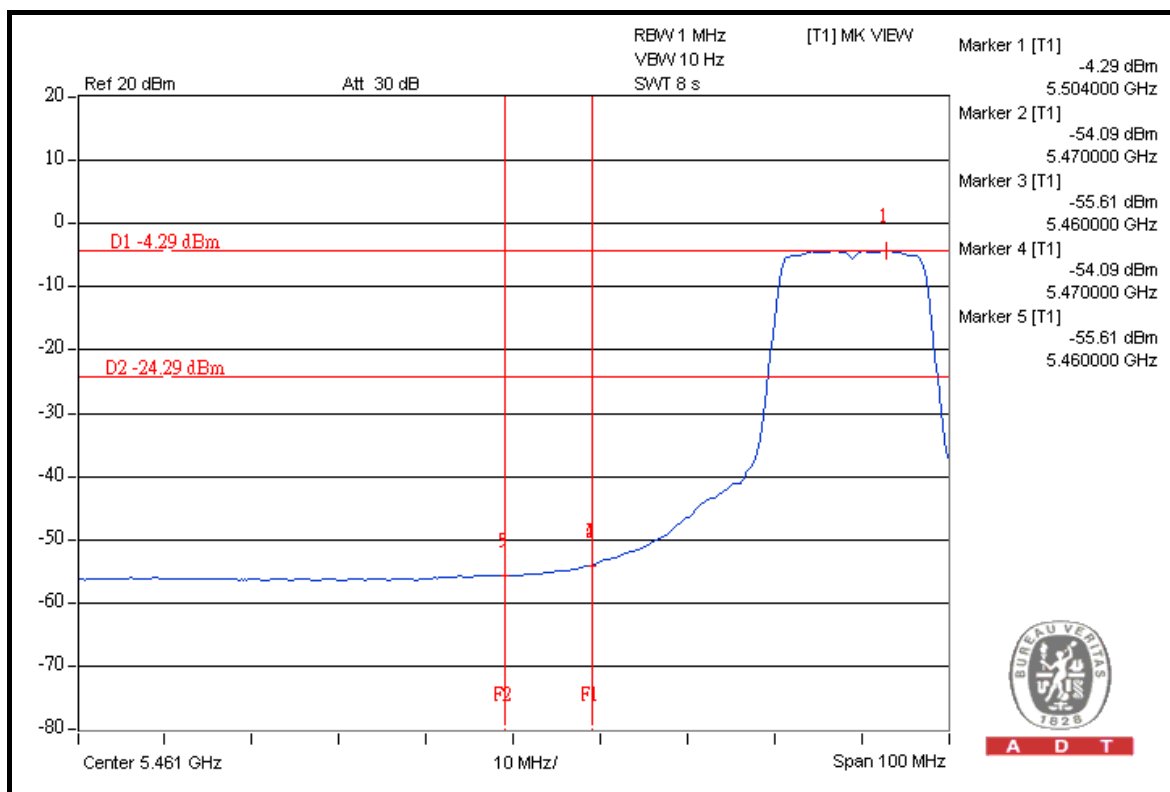

A D T



A D T

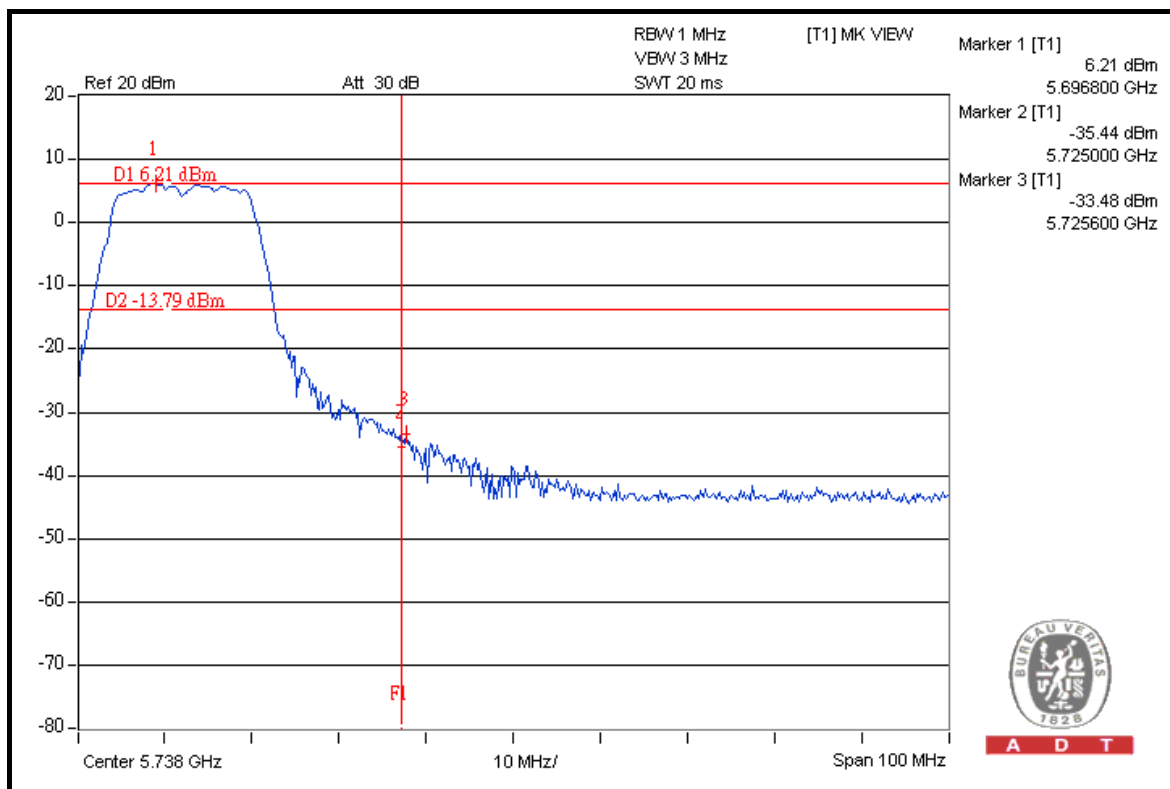
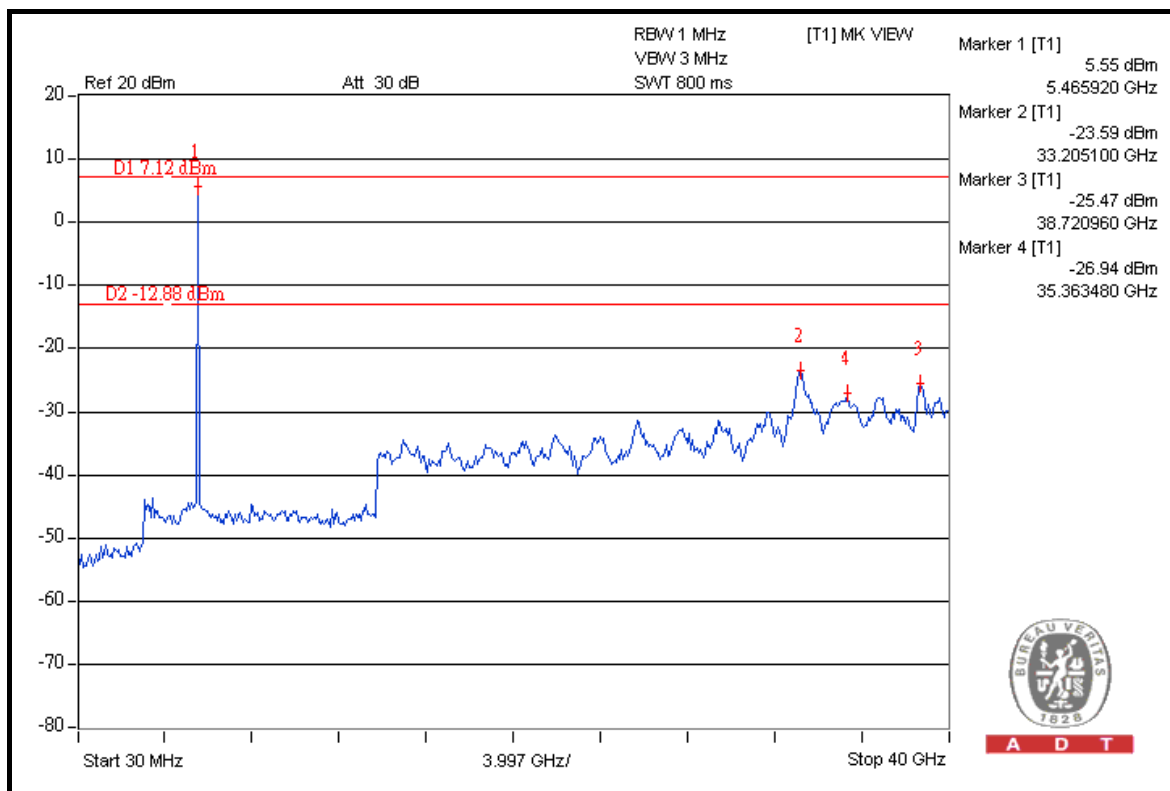



A D T

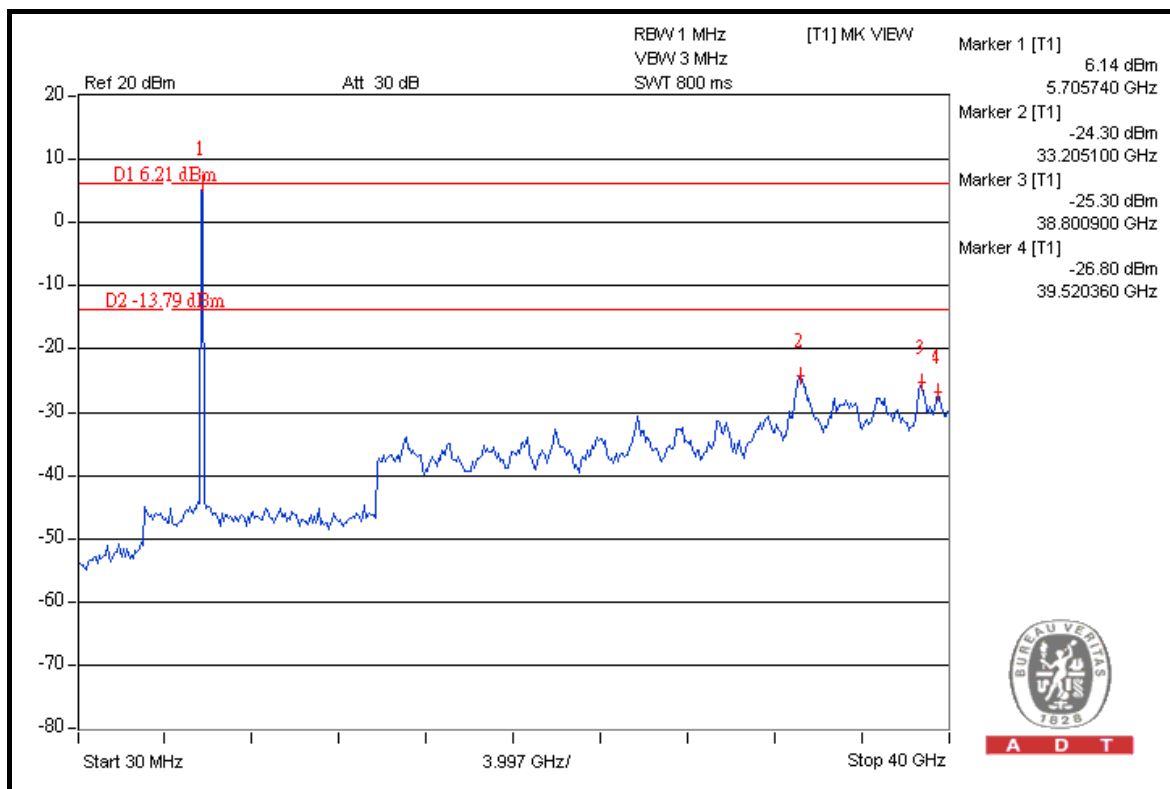
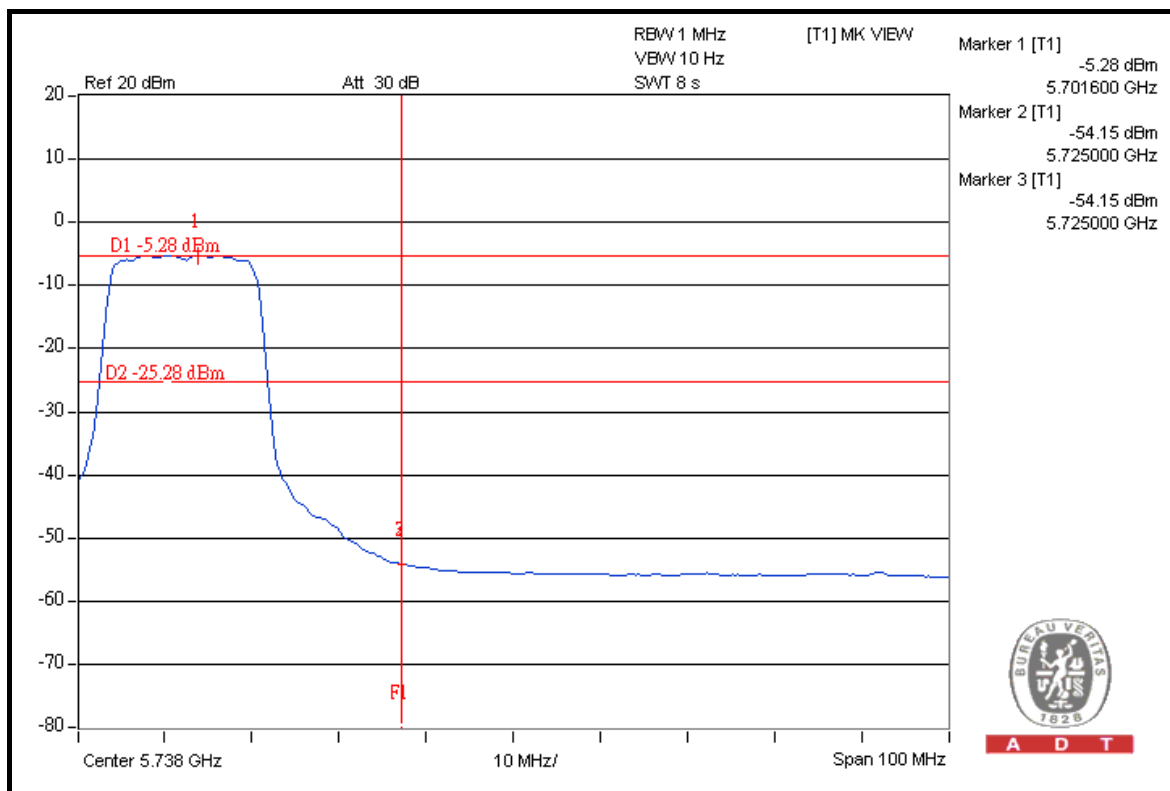

4.8 ANTENNA REQUIREMENT

4.8.1 STANDARD APPLICABLE

For intentional device, according to FCC 47 CFR Section 15.203, an intentional radiator shall be designed to ensure that no antenna other than that furnished by the responsible party shall be used with the device.

And according to FCC 47 CFR Section 15.407(a), if transmitting antennas of directional gain greater than 6dBi are used, the power shall be reduced by the amount in dB that the directional gain of the antenna exceeds 6dBi.

4.8.2 ANTENNA CONNECTED CONSTRUCTION

The antennas used in this product is PIFA antenna without connector. The maximum Gain of the antenna is 4.0dBi.

5. PHOTOGRAPHS OF THE TEST CONFIGURATION

Please refer to the attached file (Test Setup Photo).



6. INFORMATION ON THE TESTING LABORATORIES

We, Bureau Veritas Consumer Products Services (H.K.) Ltd., Taoyuan Branch, were founded in 1988 to provide our best service in EMC, Radio, Telecom and Safety consultation. Our laboratories are accredited and approved by the following approval agencies according to ISO/IEC 17025.

USA	FCC, NVLAP
Germany	TUV Rheinland
Japan	VCCI
Norway	NEMKO
Canada	INDUSTRY CANADA , CSA
R.O.C.	TAF, BSMI, NCC
Netherlands	Telefication
Singapore	GOST-ASIA(MOU)
Russia	CERTIS(MOU)

Copies of accreditation certificates of our laboratories obtained from approval agencies can be downloaded from our web site:
www.adt.com.tw/index.5/phtml. If you have any comments, please feel free to contact us at the following:

Linko EMC/RF Lab:
Tel: 886-2-26052180
Fax: 886-2-26051924

Hsin Chu EMC/RF Lab:
Tel: 886-3-5935343
Fax: 886-3-5935342

Hwa Ya EMC/RF/Safety Telecom Lab:
Tel: 886-3-3183232
Fax: 886-3-3185050

Web Site: www.adt.com.tw

The address and road map of all our labs can be found in our web site also.

7. APPENDIX A - MODIFICATIONS RECORDERS FOR ENGINEERING CHANGES TO THE EUT BY THE LAB

No any modifications are made to the EUT by the lab during the test.

---END---