



FCC RADIO TEST REPORT

FCC ID : UZ7MC930B
Equipment : Mobile computer
Brand Name : Zebra
Model Name : MC930B
Applicant : Zebra Technologies Corporation
1 Zebra Plaza, Holtsville, NY 11742
Manufacturer : Zebra Technologies Corporation
1 Zebra Plaza, Holtsville, NY 11742
Standard : FCC Part 15 Subpart C §15.247

The product was received on Nov. 26, 2018 and testing was started from Feb. 06, 2019 and completed on Mar. 06, 2019. We, SPORTON INTERNATIONAL INC. EMC & Wireless Communications Laboratory, would like to declare that the tested sample has been evaluated in accordance with the test procedures and has been in compliance with the applicable technical standards.

The report must not be used by the client to claim product certification, approval, or endorsement by TAF or any agency of government.

The test results in this variant report apply exclusively to the tested model / sample. Without written approval of SPORTON INTERNATIONAL INC. EMC & Wireless Communications Laboratory, the test report shall not be reproduced except in full.

Approved by: Jones Tsai

SPORTON INTERNATIONAL INC. EMC & Wireless Communications Laboratory
No. 52, Huaya 1st Rd., Guishan Dist., Taoyuan City, Taiwan (R.O.C.)



Table of Contents

History of this test report.....	3
Summary of Test Result.....	4
1 General Description	5
1.1 Product Feature of Equipment Under Test.....	5
1.2 Product Specification of Equipment Under Test.....	6
1.3 Modification of EUT	6
1.4 Testing Location	7
1.5 Applicable Standards.....	7
2 Test Configuration of Equipment Under Test	8
2.1 Carrier Frequency and Channel	8
2.2 Test Mode.....	8
2.3 Connection Diagram of Test System.....	9
2.4 EUT Operation Test Setup	9
3 Test Result	10
3.1 Radiated Band Edges and Spurious Emission Measurement	10
4 List of Measuring Equipment.....	14
5 Uncertainty of Evaluation	15
Appendix A. Radiated Spurious Emission	
Appendix B. Radiated Spurious Emission Plots	
Appendix C. Duty Cycle Plots	
Appendix D. Setup Photographs	



History of this test report

Report No.	Version	Description	Issued Date
FR8N2627C	01	Initial issue of report	Mar. 12, 2019



Summary of Test Result

Report Clause	Ref Std. Clause	Test Items	Result (PASS/FAIL)	Remark
-	15.247(a)(2)	6dB Bandwidth	Not Required	-
-	2.1049	99% Occupied Bandwidth	Not Required	-
-	15.247(b)	Power Output Measurement	Not Required	-
-	15.247(e)	Power Spectral Density	Not Required	-
-	15.247(d)	Conducted Band Edges	Not Required	-
		Conducted Spurious Emission	Not Required	-
3.1	15.247(d)	Radiated Band Edges and Radiated Spurious Emission	Pass	Under limit 2.16 dB at 2484.720 MHz
-	15.207	AC Conducted Emission	Not Required	-
-	15.203 & 15.247(b)	Antenna Requirement	Not Required	-

Remark:

1. Not required means after assessing, test items are not necessary to carry out.
2. This is a variant report which can be referred to Product Equality Declaration. Since the test result is not affected by the changes, all the test cases were performed on original report which can be referred to Sporton Report Number FR8N2626C.

Declaration of Conformity:

The test results with all measurement uncertainty excluded are presented in accordance with the regulation limits or requirements declared by manufacturers.

Comments and Explanations:

The declared of product specification for EUT presented in the report are provided by the manufacturer, and the manufacturer takes all the responsibilities for the accuracy of product specification.

Reviewed by: Wii Chang

Report Producer: Dara Chiu



1 General Description

1.1 Product Feature of Equipment Under Test

Product Feature	
Equipment	Mobile computer
Brand Name	Zebra
Model Name	MC930B
FCC ID	UZ7MC930B
Sample 1	EUT with SKU 1
Sample 2	EUT with SKU 2
Sample 3	EUT with SKU 3
Sample 4	EUT with SKU 4
Sample 5	EUT with SKU 5
Sample 6	EUT with SKU 6
Sample 7	EUT with SKU 7
EUT supports Radios application	WLAN 11a/b/g/n HT20/HT40 WLAN 11ac VHT20/VHT40/VHT80 Bluetooth BR/EDR/LE
HW Version	EV1
SW Version	01-14-11.00-OG
FW Version	FUSION_QA_2_1.3.0.004_O
MFD	28OCT18
EUT Stage	Engineering Sample

Remark:

1. The above EUT's information was declared by manufacturer.
2. The tests were performed with Sample 1.

Specification of Accessories				
Adapter (5V/2.5A)	Brand Name	Zebra	Part Number	PWR-WUA5V12W0US
USB-C Adapter	Brand Name	Zebra	Part Number	CBL-MC93-USBCHG-01
USB-C cable	Brand Name	Zebra	Part Number	CBL-TC2X-USBC-01
Std Battery	Brand Name	Zebra	Part Number	BT-000370-00
Holster	Brand Name	Zebra	Part Number	051607-79N1-18



<Sample Information>

Model Name	MC930P					MC930B	
	SKU3	SKU4	SKU5	SKU6	SKU7	SKU1	SKU2
Organization / Function / Group	EV1a-G21	EV1a-G22	EV1a-G23	EV1a-F11	EV1a-F13	EV1a-G02	EV1a-G03
nm	G-2S-1D-53k	G-2S-2D-53k	G-2S-LRI-53k	G-1F-1D-53k	G-1F-LRI-53k	G-BS-2D-53k	G-BS-LRI-53k
Product Number	MC930P-GS BDG4NA	MC930P-GS DDG4NA	MC930P-GS FDG4NA	MC930P-GF ADG4NA	MC930P-GF EDG4NA	MC930B-GS CDG4NA	MC930B-GSE DG4NA
Form factor	Gun	Gun	Gun	Gun	Gun	Gun	Gun
Package/Component Category	Pkg2	Pkg2	Pkg2	Pkg1 CS	Pkg 1 CS	Base	Base
NFC	YES	YES	YES	YES	YES	NO	NO
Vib	YES	YES	YES	YES	YES	NO	NO
Camera	YES	YES	YES	NO	NO	NO	NO
NI	NO	NO	NO	NO	NO	NO	NO
Side Trigger	NO	NO	NO	NO	NO	NO	NO
Display + TP Stackup	Option2	Option2	Option2	Option5	Option5	Option 2	Option 2
Scanner	SE965	SE4750SR	SE4850	SE965	SE4850	SE4750SR	SE4850
Battery	Std	Std	Std	Fzr	Fzr	Std	Std
Keyboard	53 Key	53 Key	53 Key	53 Key	53 Key	53 Key	53 Key
Build Date	Oct 2018	Oct 2018	Oct 2018	Nov 2018	Nov 2018	Oct 2018	Oct 2018

1.2 Product Specification of Equipment Under Test

Standards-related Product Specification			
Tx/Rx Channel Frequency Range	2412 MHz ~ 2462 MHz		
Antenna Type / Gain	<Ant. 1>Patch Antenna with gain 3.85 dBi <Ant. 2>Patch Antenna with gain 4.58 dBi		
Type of Modulation	802.11b : DSSS (DBPSK / DQPSK / CCK) 802.11g/n : OFDM (BPSK / QPSK / 16QAM / 64QAM) 802.11ac: OFDM (BPSK / QPSK / 16QAM / 64QAM / 256QAM)		
Antenna Function Description		Ant. 1	Ant. 2
	802.11 b/g/n/ac	V	V
	802.11 b/g/n/ac MIMO	V	V
	802.11 ac TXBF	V	V

Note: MIMO Ant. 1+2 is a calculated result from sum of the power MIMO Ant. 1 and MIMO Ant. 2.

1.3 Modification of EUT

No modifications are made to the EUT during all test items.



1.4 Testing Location

Test Site	SPORTON INTERNATIONAL INC.
Test Site Location	No.52, Huaya 1st Rd., Guishan Dist., Taoyuan City, Taiwan (R.O.C.) TEL: +886-3-327-3456 FAX: +886-3-328-4978
Test Site No.	Sporton Site No.
	03CH07-HY

Note: The test site complies with ANSI C63.4 2014 requirement.

FCC Designation No. TW1190

1.5 Applicable Standards

According to the specifications of the manufacturer, the EUT must comply with the requirements of the following standards:

- ♦ FCC Part 15 Subpart C §15.247
- ♦ FCC KDB Publication No. 558074 D01 DTS Meas. Guidance v05r01
- ♦ FCC KDB 414788 D01 Radiated Test Site v01r01.
- ♦ FCC KDB 662911 D01 Multiple Transmitter Output v02r01.
- ♦ ANSI C63.10-2013

Remark:

1. All test items were verified and recorded according to the standards and without any deviation during the test.
2. This EUT has also been tested and complied with the requirements of FCC Part 15, Subpart B, recorded in a separate test report.



2 Test Configuration of Equipment Under Test

The EUT has been associated with peripherals and configuration operated in a manner tended to maximize its emission characteristics in a typical application. Frequency range investigated: radiation emission (9 kHz to the 10th harmonic of the highest fundamental frequency or to 40 GHz, whichever is lower). For radiated measurement, pre-scanned in three orthogonal panels, X, Y, Z. The worst cases (Y plane) were recorded in this report.

2.1 Carrier Frequency and Channel

Frequency Band	Channel	Freq. (MHz)	Channel	Freq. (MHz)
2400-2483.5 MHz	1	2412	7	2442
	2	2417	8	2447
	3	2422	9	2452
	4	2427	10	2457
	5	2432	11	2462
	6	2437		

2.2 Test Mode

Final test modes are considering the modulation and worse data rates as below table.

<MIMO Mode>

Modulation	Data Rate
802.11b	1 Mbps
802.11n HT40	MCS0

2.3 Connection Diagram of Test System

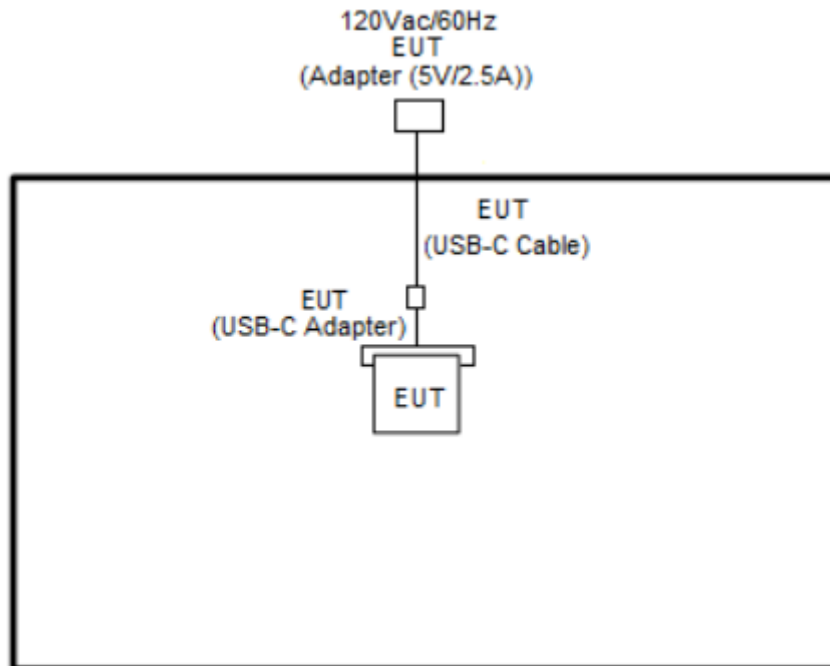

2.4 EUT Operation Test Setup

The RF test items, utility “QRCT” was installed in Notebook which was programmed in order to make the EUT get into the engineering modes to provide channel selection, power level, data rate and the application type and for continuous transmitting signals.



3 Test Result

3.1 Radiated Band Edges and Spurious Emission Measurement

3.1.1 Limit of Radiated band edge and Spurious Emission Measurement

In any 100 kHz bandwidth outside the intentional radiator frequency band, all harmonics/spurious must be at least 20 dB below the highest emission level within the authorized band. If the output power of this device was measured by spectrum analyzer, the attenuation under this paragraph shall be 30 dB instead of 20 dB. In addition, radiated emissions which fall in the restricted bands must also comply with the limits as below.

Frequency (MHz)	Field Strength (microvolts/meter)	Measurement Distance (meters)
0.009 – 0.490	2400/F(kHz)	300
0.490 – 1.705	24000/F(kHz)	30
1.705 – 30.0	30	30
30 – 88	100	3
88 – 216	150	3
216 - 960	200	3
Above 960	500	3

3.1.2 Measuring Instruments

See list of measuring equipment of this test report.

**3.1.3 Test Procedures**

1. The testing follows the ANSI C63.10 Section 11.12.1 Radiated emission measurements
2. The EUT was arranged to its worst case and then tune the antenna tower (from 1 m to 4 m) and turntable (from 0 degree to 360 degrees) to find the maximum reading. A pre-amp and a high pass filter are used for the test in order to get better signal level.
3. The EUT was placed on a turntable with 0.8 meter for frequency below 1GHz and 1.5 meter for frequency above 1GHz respectively above ground.
4. The EUT was set 3 meters from the interference receiving antenna, which was mounted on the top of a variable height antenna tower.
5. Corrected Reading: Antenna Factor + Cable Loss + Read Level - Preamp Factor = Level
6. For testing below 1GHz, if the emission level of the EUT in peak mode was 3 dB lower than the limit specified, then peak values of EUT will be reported, otherwise, the emissions will be repeated one by one using the CISPR quasi-peak method and reported.
7. For testing above 1GHz, the emission level of the EUT in peak mode was 20dB lower than average limit (that means the emission level in average mode also complies with the limit in average mode), then peak values of EUT will be reported, otherwise, the emissions will be measured in average mode again and reported.
8. Use the following spectrum analyzer settings:
 - (1) Span shall wide enough to fully capture the emission being measured;
 - (2) Set RBW=100 kHz for $f < 1$ GHz; VBW = RBW; Sweep = auto; Detector function = peak; Trace = max hold;
 - (3) Set RBW = 1 MHz, VBW= 3MHz for $f \geq 1$ GHz for peak measurement.
For average measurement:
 - VBW = 10 Hz, when duty cycle is no less than 98 percent.
 - VBW $\geq 1/T$, when duty cycle is less than 98 percent where T is the minimum transmission duration over which the transmitter is on and is transmitting at its maximum power control level for the tested mode of operation.

3.1.4 Test Setup

For radiated emissions below 30MHz

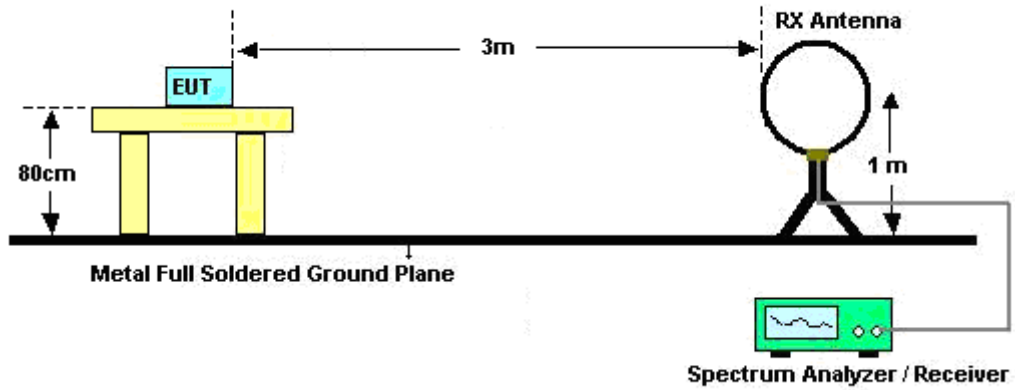

For radiated emissions from 30MHz to 1GHz

<CDD Mode>

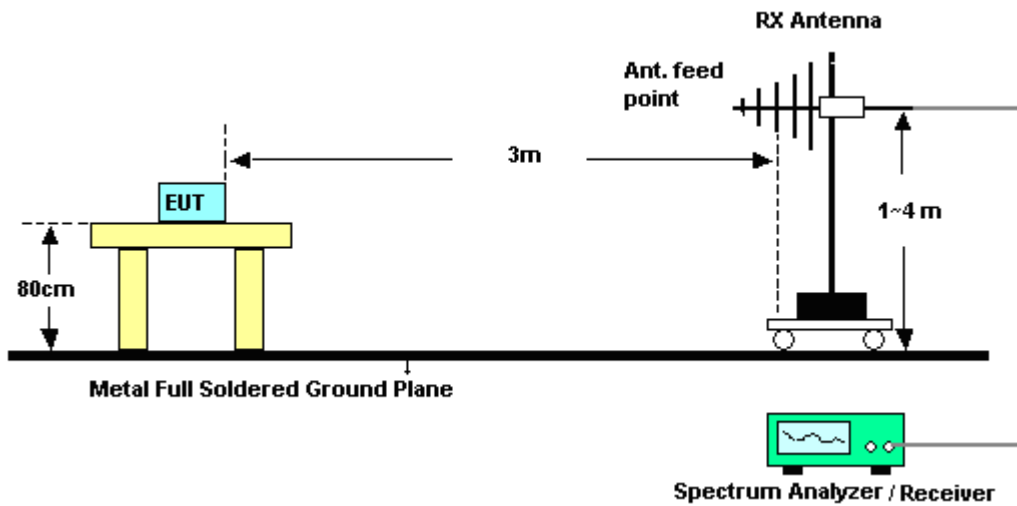

For radiated emissions above 1GHz

<CDD Mode>

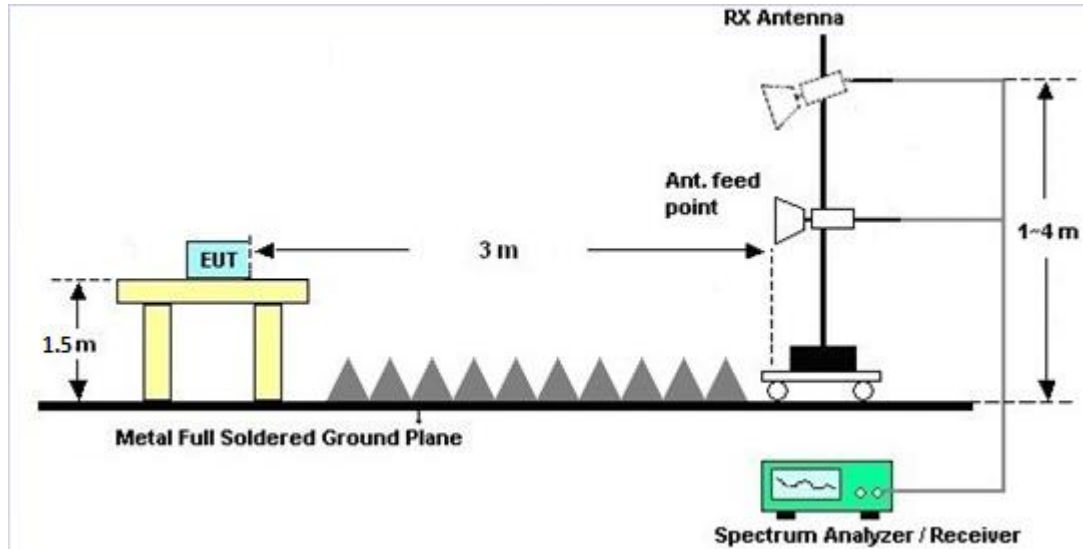

3.1.5 Test Results of Radiated Spurious Emissions (9kHz ~ 30MHz)

The low frequency, which started from 9 kHz to 30MHz, was pre-scanned and the result which was 20dB lower than the limit line was not reported.

There is a comparison data of both open-field test site and alternative test site - semi-Anechoic chamber according to 414788 D01 Radiated Test Site v01r01, and the result came out very similar.

3.1.6 Test Result of Radiated Spurious at Band Edges

Please refer to Appendix A and B.

3.1.7 Duty Cycle

Please refer to Appendix C.

3.1.8 Test Result of Radiated Spurious Emission (30MHz ~ 10th Harmonic)

Please refer to Appendix A and B.



4 List of Measuring Equipment

Instrument	Manufacturer	Model No.	Serial No.	Characteristics	Calibration Date	Test Date	Due Date	Remark
Preamplifier	Agilent	8449B	3008A01917	1GHz~26.5GHz	Apr. 23, 2018	Feb. 06, 2019 ~ Mar. 06, 2019	Apr. 22, 2019	Radiation (03CH07-HY)
Bilog Antenna	TESEQ	CBL 6111D&00800 N1D01N-06	35419&03	30MHz to 1GHz	Dec. 16, 2018	Feb. 06, 2019 ~ Mar. 06, 2019	Dec. 15, 2019	Radiation (03CH07-HY)
Double Ridge Horn Antenna	ESCO	3117	00075962	1GHz ~ 18GHz	Dec. 02, 2018	Feb. 06, 2019 ~ Mar. 06, 2019	Dec. 01, 2019	Radiation (03CH07-HY)
Loop Antenna	Rohde & Schwarz	HFH2-Z2	100315	9 kHz~30 MHz	May 15, 2017	Feb. 06, 2019 ~ Mar. 06, 2019	May 14, 2019	Radiation (03CH07-HY)
Preamplifier	MITEQ	AMF-7D-0010 1800-30-10P	1590075	1GHz ~ 18GHz	Apr. 25, 2018	Feb. 06, 2019 ~ Mar. 06, 2019	Apr. 24, 2019	Radiation (03CH07-HY)
Preamplifier	COM-POWER	PA-103A	161241	10MHz-1GHz	May 21, 2018	Feb. 06, 2019 ~ Mar. 06, 2019	May 20, 2019	Radiation (03CH07-HY)
RF Cable	HUBER + SUHNER	SUCOFLEX 104	MY28655/4, MY24971/4, MY15682/4	30MHz~1GHz	Feb. 27, 2018	Feb. 06, 2019 ~ Feb. 23, 2019	Feb. 26, 2019	Radiation (03CH07-HY)
RF Cable	HUBER + SUHNER	SUCOFLEX 104	MY28655/4, MY24971/4, MY15682/4	30MHz~1GHz	Feb. 26, 2019	Mar. 06, 2019	Feb. 25, 2020	Radiation (03CH07-HY)
RF Cable	HUBER + SUHNER	SF102/2*11SK 252	MY4278/2	9kHz~40GHz	May 17, 2018	Feb. 06, 2019 ~ Feb. 23, 2019	May 16, 2019	Radiation (03CH07-HY)
RF Cable	HUBER + SUHNER	SF102/2*11SK 252	MY4278/2	9kHz~40GHz	Feb. 26, 2019	Mar. 06, 2019	Feb. 25, 2020	Radiation (03CH07-HY)
RF Cable	HUBER + SUHNER	SUCOFLEX 104	MY28655/4, MY24971/4, MY15682/4	1GHz~18GHz	Feb. 27, 2018	Feb. 06, 2019 ~ Feb. 23, 2019	Feb. 26, 2019	Radiation (03CH07-HY)
RF Cable	HUBER + SUHNER	SUCOFLEX 104	MY28655/4, MY24971/4, MY15682/4	1GHz~18GHz	Feb. 26, 2019	Mar. 06, 2019	Feb. 25, 2020	Radiation (03CH07-HY)
Antenna Mast	Max-Full	MFA520BS	N/A	1m~4m	N/A	Feb. 06, 2019 ~ Mar. 06, 2019	N/A	Radiation (03CH07-HY)
Turn Table	ChainTek	Chaintek 3000	N/A	0~360 Degree	N/A	Feb. 06, 2019 ~ Mar. 06, 2019	N/A	Radiation (03CH07-HY)
Amplifier	MITEQ	TTA1840-35-H G	1871923	18GHz~40GHz, VSWR : 2.5:1 max	Jul. 16, 2018	Feb. 06, 2019 ~ Mar. 06, 2019	Jul. 15, 2019	Radiation (03CH07-HY)
Software	Audix	E3 6.2009-8-24	RK-001042	N/A	N/A	Feb. 06, 2019 ~ Mar. 06, 2019	N/A	Radiation (03CH07-HY)
SHF-EHF Horn Antenna	SCHWARZBE CK	BBHA 9170	BBHA917025 1	18GHz- 40GHz	Nov. 20, 2018	Feb. 06, 2019 ~ Mar. 06, 2019	Nov. 19, 2019	Radiation (03CH07-HY)
Spectrum Analyzer	Agilent	N9010A	MY53470118	10Hz~44GHz	Apr. 17, 2018	Feb. 06, 2019 ~ Mar. 06, 2019	Apr. 16, 2019	Radiation (03CH07-HY)



5 Uncertainty of Evaluation

Uncertainty of Radiated Emission Measurement (30 MHz ~ 1000 MHz)

Measuring Uncertainty for a Level of Confidence of 95% ($U = 2Uc(y)$)	5.7
---	-----

Uncertainty of Radiated Emission Measurement (1000 MHz ~ 18000 MHz)

Measuring Uncertainty for a Level of Confidence of 95% ($U = 2Uc(y)$)	5.5
---	-----

Uncertainty of Radiated Emission Measurement (18000 MHz ~ 40000 MHz)

Measuring Uncertainty for a Level of Confidence of 95% ($U = 2Uc(y)$)	5.2
---	-----



Appendix A. Radiated Spurious Emission

Test Engineer :	Jesse Wang, Stan Hsieh, and Troye Hsieh	Temperature :	20~25°C
		Relative Humidity :	55~60%

**2.4GHz 2400~2483.5MHz
WIFI 802.11b (Band Edge @ 3m)**

WIFI Ant. 1+2	Note	Frequency (MHz)	Level (dBμV/m)	Over Limit (dB)	Limit Line (dBμV/m)	Read Level (dBμV)	Antenna Factor (dB/m)	Path Loss (dB)	Preamp Factor (dB)	Ant Pos (cm)	Table Pos (deg)	Peak Avg. (P/A)	Pol. (H/V)
802.11b CH 11 2462MHz	*	2462	109.43	-	-	94.36	32.2	17.84	34.97	400	189	P	H
	*	2462	106.33	-	-	91.26	32.2	17.84	34.97	400	189	A	H
		2483.76	56.77	-17.23	74	41.7	32.2	17.84	34.97	400	189	P	H
		2483.5	49.75	-4.25	54	34.68	32.2	17.84	34.97	400	189	A	H
													H
													H
	*	2462	115.37	-	-	100.3	32.2	17.84	34.97	144	300	P	V
	*	2462	112.18	-	-	97.11	32.2	17.84	34.97	144	300	A	V
		2483.72	58.03	-15.97	74	42.96	32.2	17.84	34.97	144	300	P	V
		2484.72	51.84	-2.16	54	36.77	32.2	17.84	34.97	144	300	A	V
													V
													V
Remark	1. No other spurious found. 2. All results are PASS against Peak and Average limit line.												



2.4GHz 2400~2483.5MHz

WIFI 802.11b (Harmonic @ 3m)

WIFI Ant. 1+2	Note	Frequency (MHz)	Level (dBμV/m)	Over Limit (dB)	Limit Line (dBμV/m)	Read Level (dBμV)	Antenna Factor (dB/m)	Path Loss (dB)	Preamp Factor (dB)	Ant Pos (cm)	Table Pos (deg)	Peak Avg. (P/A)	Pol. (H/V)	
802.11b CH 11 2462MHz		4924	49.88	-24.12	74	63.4	34.17	11.45	59.14	100	0	P	H	
		7386	48.83	-25.17	74	57.52	35.5	14.07	58.26	100	0	P	H	
													H	
													H	
			4924	47.73	-26.27	74	61.25	34.17	11.45	59.14	100	0	P	V
			7386	48.34	-25.66	74	57.03	35.5	14.07	58.26	100	0	P	V
														V
														V
Remark	1. No other spurious found. 2. All results are PASS against Peak and Average limit line.													



**2.4GHz 2400~2483.5MHz
WIFI 802.11n HT40 (Band Edge @ 3m)**

WIFI Ant. 1+2	Note	Frequency (MHz)	Level (dBμV/m)	Over Limit (dB)	Limit Line (dBμV/m)	Read Level (dBμV)	Antenna Factor (dB/m)	Path Loss (dB)	Preamp Factor (dB)	Ant Pos (cm)	Table Pos (deg)	Peak Avg. (P/A)	Pol. (H/V)
802.11n HT40 CH 06 2437MHz		2386.72	54.45	-19.55	74	39.69	32	17.44	34.68	302	137	P	H
		2389.52	45.73	-8.27	54	30.97	32	17.44	34.68	302	137	A	H
	*	2437	103.73	-	-	88.71	32.2	17.5	34.68	302	137	P	H
	*	2437	95.53	-	-	80.51	32.2	17.5	34.68	302	137	A	H
		2484.04	55.64	-18.36	74	40.56	32.2	17.56	34.68	302	137	P	H
		2483.5	47.02	-6.98	54	31.94	32.2	17.56	34.68	302	137	A	H
		2389.8	59.11	-14.89	74	44.35	32	17.44	34.68	128	0	P	V
		2389.8	49.46	-4.54	54	34.7	32	17.44	34.68	128	0	A	V
	*	2437	111.79	-	-	96.77	32.2	17.5	34.68	128	0	P	V
	*	2437	103.42	-	-	88.4	32.2	17.5	34.68	128	0	A	V
		2483.9	60.87	-13.13	74	45.79	32.2	17.56	34.68	128	0	P	V
		2483.55	51.43	-2.57	54	36.35	32.2	17.56	34.68	128	0	A	V
Remark	1. No other spurious found. 2. All results are PASS against Peak and Average limit line.												

**2.4GHz 2400~2483.5MHz
WIFI 802.11n HT40 (Harmonic @ 3m)**

WIFI Ant. 1+2	Note	Frequency (MHz)	Level (dBμV/m)	Over Limit (dB)	Limit Line (dBμV/m)	Read Level (dBμV)	Antenna Factor (dB/m)	Path Loss (dB)	Preamp Factor (dB)	Ant Pos (cm)	Table Pos (deg)	Peak Avg. (P/A)	Pol. (H/V)
802.11n HT40 CH 06 2437MHz		4874	42.72	-31.28	74	56.8	34.13	11.03	59.24	100	0	P	H
		7311	43.03	-30.97	74	51.8	35.7	13.66	58.13	100	0	P	H
													H
													H
		4874	41.62	-32.38	74	55.7	34.13	11.03	59.24	100	0	P	V
		7311	43.85	-30.15	74	52.62	35.7	13.66	58.13	100	0	P	V
													V
													V
Remark	1. No other spurious found. 2. All results are PASS against Peak and Average limit line.												



Emission below 1GHz
2.4GHz WIFI 802.11g (LF)

WIFI	Note	Frequency	Level	Over	Limit	Read	Antenna	Path	Preamp	Ant	Table	Peak	Pol.	
Ant.				Limit	Line	Level	Factor	Loss	Factor	Pos	Pos	Avg.		
1+2		(MHz)	(dBμV/m)	(dB)	(dBμV/m)	(dBμV)	(dB/m)	(dB)	(dB)	(cm)	(deg)	(P/A)	(H/V)	
2.4GHz 802.11b LF		30	29.05	-10.95	40	33.3	24.6	1.33	30.18	100	0	P	H	
		46.47	25.08	-14.92	40	38.01	15.89	1.34	30.16	-	-	P	H	
		126.66	27.12	-16.38	43.5	37.57	17.59	2.01	30.05	-	-	P	H	
		798.4	30.99	-15.01	46	27.78	27.96	4.6	29.35	-	-	P	H	
		871.9	32.72	-13.28	46	27.91	28.95	4.88	29.02	-	-	P	H	
		952.4	34.16	-11.84	46	27.16	30.49	5.05	28.54	-	-	P	H	
														H
														H
														H
														H
														H
														H
														H
			30	32.76	-7.24	40	37.01	24.6	1.33	30.18	100	0	P	V
			36.21	26.94	-13.06	40	34.27	21.51	1.33	30.17	-	-	P	V
			38.64	26.94	-13.06	40	35.89	19.88	1.34	30.17	-	-	P	V
			438.6	33.25	-12.75	46	36.87	22.81	3.48	29.91	-	-	P	V
			881.7	34.13	-11.87	46	29.34	28.88	4.89	28.98	-	-	P	V
			965.7	34.95	-19.05	54	27.47	30.88	5.06	28.46	-	-	P	V
														V
													V	
													V	
													V	
													V	
													V	
Remark	1. No other spurious found. 2. All results are PASS against limit line.													



Note symbol

*	Fundamental Frequency which can be ignored. However, the level of any unwanted emissions shall not exceed the level of the fundamental frequency.
!	Test result is over limit line.
P/A	Peak or Average
H/V	Horizontal or Vertical



A calculation example for radiated spurious emission is shown as below:

WIFI	Note	Frequency	Level	Over	Limit	Read	Antenna	Path	Preamp	Ant	Table	Peak	Pol.
Ant.				Limit	Line	Level	Factor	Loss	Factor	Pos	Pos	Avg.	
1+2		(MHz)	(dBμV/m)	(dB)	(dBμV/m)	(dBμV)	(dB/m)	(dB)	(dB)	(cm)	(deg)	(P/A)	(H/V)
802.11b		2390	55.45	-18.55	74	54.51	32.22	4.58	35.86	103	308	P	H
CH 01													
2412MHz		2390	43.54	-10.46	54	42.6	32.22	4.58	35.86	103	308	A	H

1. Path Loss(dB) = Cable loss(dB) + Filter loss(dB) + Attenuator loss(dB)
2. Level(dBμV/m) =
Antenna Factor(dB/m) + Path Loss(dB) + Read Level(dBμV) - Preamp Factor(dB)
3. Over Limit(dB) = Level(dBμV/m) – Limit Line(dBμV/m)

For Peak Limit @ 2390MHz:

1. Level(dBμV/m)
= Antenna Factor(dB/m) + Path Loss(dB) + Read Level(dBμV) - Preamp Factor(dB)
= 32.22(dB/m) + 4.58(dB) + 54.51(dBμV) – 35.86 (dB)
= 55.45 (dBμV/m)
2. Over Limit(dB)
= Level(dBμV/m) – Limit Line(dBμV/m)
= 55.45(dBμV/m) – 74(dBμV/m)
= -18.55(dB)

For Average Limit @ 2390MHz:

1. Level(dBμV/m)
= Antenna Factor(dB/m) + Path Loss(dB) + Read Level(dBμV) - Preamp Factor(dB)
= 32.22(dB/m) + 4.58(dB) + 42.6(dBμV) – 35.86 (dB)
= 43.54 (dBμV/m)
2. Over Limit(dB)
= Level(dBμV/m) – Limit Line(dBμV/m)
= 43.54(dBμV/m) – 54(dBμV/m)
= -10.46(dB)

Both peak and average measured complies with the limit line, so test result is “PASS”.



Appendix B. Radiated Spurious Emission Plots

Test Engineer :	Jesse Wang, Stan Hsieh, and Troye Hsieh	Temperature :	20~25°C
		Relative Humidity :	55~60%

Note symbol

-L	Low channel location
-R	High channel location



2.4GHz 2400~2483.5MHz
WIFI 802.11b (Band Edge @ 3m)

WIFI	2.4GHz 2400~2483.5MHz Band Edge @ 3m	
ANT	802.11b CH11 2462MHz	
1+2	Horizontal	Fundamental
Peak	<p>Site : 03CH07-HY Condition : PEAK_BE_74 3m HF_ANT_00075962 HORIZONTAL Detector : Peak Project : 8N2627 Mode : 1</p>	<p>Site : 03CH07-HY Condition : PEAK_74 3m HF_ANT_00075962 HORIZONTAL Detector : Peak Project : 8N2627 Mode : 1</p>
Avg.	<p>Site : 03CH07-HY Condition : AVG_BE_54 3m HF_ANT_00075962 HORIZONTAL Detector : Peak Project : 8N2627 Mode : 1</p>	<p>Site : 03CH07-HY Condition : AVG_54 3m HF_ANT_00075962 HORIZONTAL Detector : Peak Project : 8N2627 Mode : 1</p>

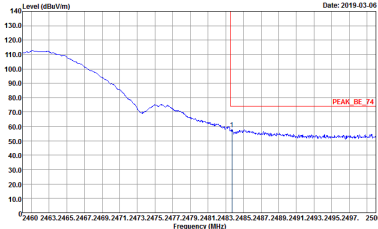
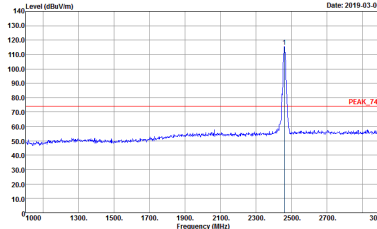
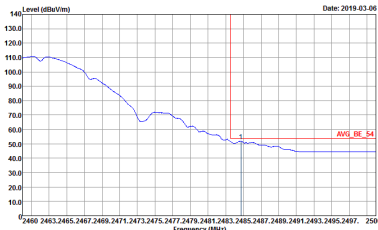
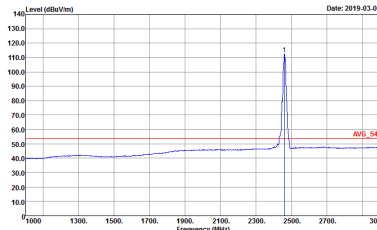

WIFI	2.4GHz 2400~2483.5MHz Band Edge @ 3m	
ANT	802.11b CH11 2462MHz	
1+2	Vertical	Fundamental
Peak	 <p>Date: 2019-03-06</p> <p>Site : 03CH07-HY Condition : PEAK_BE_74 3m HF_ANT_00075962 VERTICAL Detector : Peak Project : 8N2627 Mode : 1</p>	 <p>Date: 2019-03-06</p> <p>Site : 03CH07-HY Condition : PEAK_74 3m HF_ANT_00075962 VERTICAL Detector : Peak Project : 8N2627 Mode : 1</p>
Avg.	 <p>Date: 2019-03-06</p> <p>Site : 03CH07-HY Condition : AVG_BE_54 3m HF_ANT_00075962 VERTICAL Detector : Peak Project : 8N2627 Mode : 1</p>	 <p>Date: 2019-03-06</p> <p>Site : 03CH07-HY Condition : AVG_54 3m HF_ANT_00075962 VERTICAL Detector : Peak Project : 8N2627 Mode : 1</p>



2.4GHz 2400~2483.5MHz

WIFI 802.11n HT40 (Band Edge @ 3m)

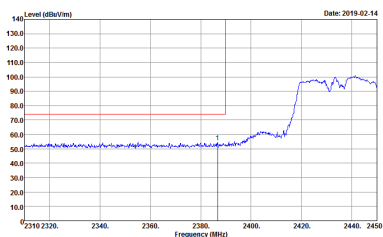
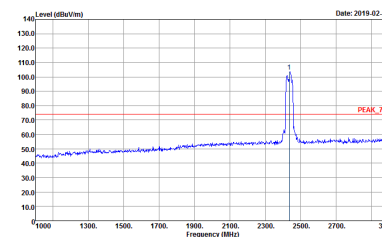
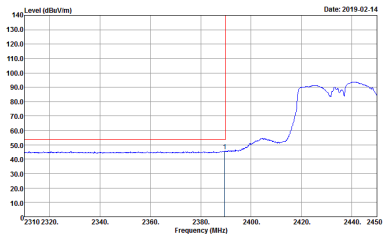
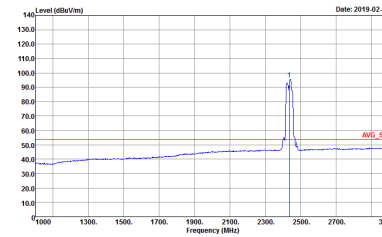
WIFI	2.4GHz 2400~2483.5MHz Band Edge @ 3m	
ANT	802.11n HT40 CH06 2437MHz - L	
1+2	Horizontal	Fundamental
Peak	 <p>Site : 03CH07-HY Condition : PEAK_BE_74 3m HF_ANT_00075962 HORIZONTAL Detector : Peak Project : BN2627 Mode : 4</p>	 <p>Site : 03CH07-HY Condition : PEAK_74 3m HF_ANT_00075962 HORIZONTAL Detector : Peak Project : BN2627 Mode : 4</p>
Avg.	 <p>Site : 03CH07-HY Condition : AVG_BE_54 3m HF_ANT_00075962 HORIZONTAL Detector : Peak Project : BN2627 Mode : 4</p>	 <p>Site : 03CH07-HY Condition : AVG_54 3m HF_ANT_00075962 HORIZONTAL Detector : Peak Project : BN2627 Mode : 4</p>

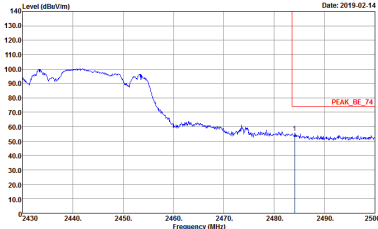
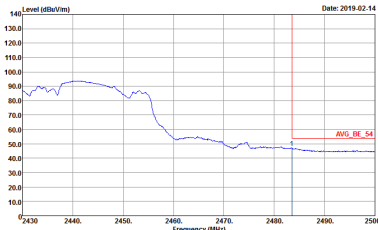

WIFI	2.4GHz 2400~2483.5MHz Band Edge @ 3m	
ANT	802.11n HT40 CH06 2437MHz - R	
1+2	Horizontal	Fundamental
<p>Peak</p>	 <p>Date: 2019-02-14</p> <p>Site : 03CH07-HY Condition : PEAK_BE_74 3m HF_ANT_00075962 HORIZONTAL Detector : Peak Project : BN2627 Mode : 4</p>	<p>Left blank</p>
<p>Avg.</p>	 <p>Date: 2019-02-14</p> <p>Site : 03CH07-HY Condition : AVG_BE_54 3m HF_ANT_00075962 HORIZONTAL Detector : Peak Project : BN2627 Mode : 4</p>	<p>Left blank</p>

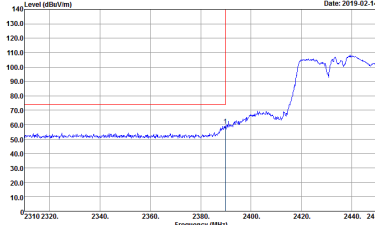
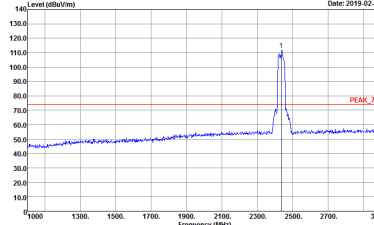
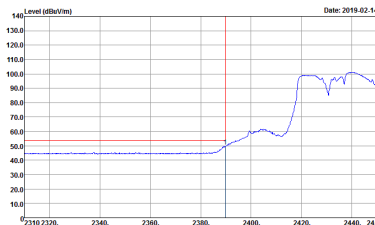
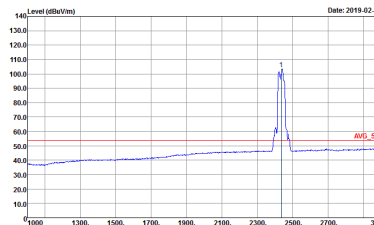

WIFI	2.4GHz 2400~2483.5MHz Band Edge @ 3m	
ANT	802.11n HT40 CH06 2437MHz - L	
1+2	Vertical	Fundamental
Peak	 <p>Date: 2019-02-14</p> <p>Site : 03CH07-HY Condition : PEAK_BE_74 3m HF_ANT_00075962 VERTICAL Detector : Peak Project : 8N2627 Mode : 4</p>	 <p>Date: 2019-02-14</p> <p>Site : 03CH07-HY Condition : PEAK_74 3m HF_ANT_00075962 VERTICAL Detector : Peak Project : 8N2627 Mode : 4</p>
Avg.	 <p>Date: 2019-02-14</p> <p>Site : 03CH07-HY Condition : AVG_BE_54 3m HF_ANT_00075962 VERTICAL Detector : Peak Project : 8N2627 Mode : 4</p>	 <p>Date: 2019-02-14</p> <p>Site : 03CH07-HY Condition : AVG_54 3m HF_ANT_00075962 VERTICAL Detector : Peak Project : 8N2627 Mode : 4</p>



WIFI	2.4GHz 2400~2483.5MHz Band Edge @ 3m	
ANT	802.11n HT40 CH06 2437MHz - R	
1+2	Horizontal	Fundamental
Peak	<p>Site : 03CH07-HY Condition : PEAK_BE_74 3m HF_ANT_00075962 VERTICAL Detector : Peak Project : SN2627 Mode : 4</p>	Left blank
Avg.	<p>Site : 03CH07-HY Condition : AVG_BE_54 3m HF_ANT_00075962 VERTICAL Detector : Peak Project : SN2627 Mode : 4</p>	Left blank



2.4GHz 2400~2483.5MHz

WIFI 802.11b (Harmonic @ 3m)

WIFI	2.4GHz 2400~2483.5MHz Harmonic @ 3m	
ANT	802.11b CH11 2462MHz	
1+2	Horizontal	Vertical
Peak Avg.	<p>Site : 03C407-4Y Condition : PEAK_74 3m SHF-EHF_131029 HORIZONTAL Detector : Peak Project : 8N2627 Mode : 1</p>	<p>Site : 03C407-4Y Condition : PEAK_74 3m SHF-EHF_131029 VERTICAL Detector : Peak Project : 8N2627 Mode : 1</p>



2.4GHz 2400~2483.5MHz
WIFI 802.11n HT40 (Harmonic @ 3m)

WIFI	2.4GHz 2400~2483.5MHz Harmonic @ 3m	
ANT	802.11n HT40 CH06 2437MHz	
1+2	Horizontal	Vertical
Peak Avg.	<p>Site : 03CH07-4Y Condition : PEAK_74 3m SHF-EHF_131029 HORIZONTAL Detector : Peak Project : 8N2627 Mode : 4</p>	<p>Site : 03CH07-4Y Condition : PEAK_74 3m SHF-EHF_131029 VERTICAL Detector : Peak Project : 8N2627 Mode : 4</p>



Emission below 1GHz
2.4GHz WIFI 802.11b (LF)

WIFI	2.4GHz 2400~2483.5MHz	
ANT	802.11b LF	
1+2	Horizontal	Vertical
QP / Peak	<p>Site : 03CH07-11Y Condition : QP 3m LF-ANT-35419(G) HORIZONTAL Detector : Peak Project : FR2627 Mode : 9</p>	<p>Site : 03CH07-11Y Condition : QP 3m LF-ANT-35419(G) VERTICAL Detector : Peak Project : FR2627 Mode : 9</p>



Appendix C. Duty Cycle Plots

Antenna	Band	Duty Cycle (%)	T(us)	1/T(kHz)	VBW Setting	Duty Factor(dB)
1	802.11b	100.00	-	-	10Hz	0.00
2	802.11b	100.00	-	-	10Hz	0.00
1+2	802.11b Ant. 1	100.00	-	-	10Hz	0.00
1+2	802.11b Ant. 2	100.00	-	-	10Hz	0.00
1	802.11g	95.82	2065.00	0.48	1kHz	0.19
2	802.11g	95.10	2057.00	0.49	1kHz	0.22
1+2	802.11g Ant. 1	95.62	2073.00	0.48	1kHz	0.19
1+2	802.11g Ant. 2	95.61	2068.00	0.48	1kHz	0.19
1	2.4GHz 802.11n HT20	95.30	1928.00	0.52	1kHz	0.21
2	2.4GHz 802.11n HT20	95.06	1925.00	0.52	1kHz	0.22
1+2	2.4GHz 802.11n HT20 Ant. 1	95.30	1928.00	0.52	1kHz	0.21
1+2	2.4GHz 802.11n HT20 Ant. 2	95.29	1920.00	0.52	1kHz	0.21
1	2.4GHz 802.11n HT40	91.88	950.00	1.05	3kHz	0.37
2	2.4GHz 802.11n HT40	91.95	948.00	1.05	3kHz	0.36
1+2	2.4GHz 802.11n HT40 Ant. 1	92.05	950.00	1.05	3kHz	0.36
1+2	2.4GHz 802.11n HT40 Ant. 2	91.76	947.00	1.06	3kHz	0.37
1	2.4GHz 802.11ac20	95.32	1937.00	0.52	1kHz	0.21
2	2.4GHz 802.11ac20	95.45	1930.00	0.52	1kHz	0.20
1+2	2.4GHz 802.11ac20 for Ant. 1	95.32	1935.00	0.52	1kHz	0.21
1+2	2.4GHz 802.11ac20 for Ant. 2	95.18	1935.00	0.52	1kHz	0.21
1	2.4GHz 802.11ac40	91.53	951.00	1.05	3kHz	0.38
2	2.4GHz 802.11ac40	91.78	949.00	1.05	3kHz	0.37
1+2	2.4GHz 802.11ac40 for Ant. 1	91.91	954.00	1.05	3kHz	0.37
1+2	2.4GHz 802.11ac40 for Ant. 2	91.80	951.00	1.05	3kHz	0.37



<Ant. 1>

802.11b

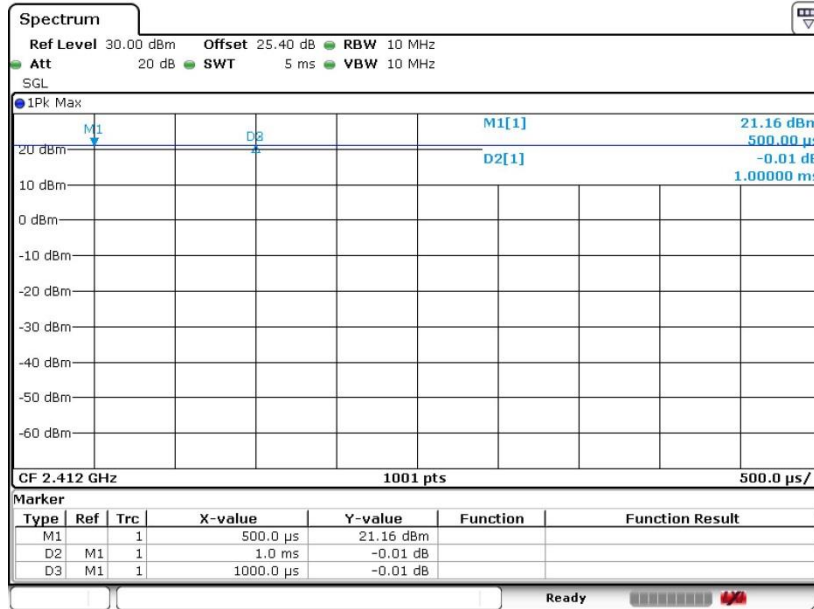

Date: 6.FEB.2019 22:48:37

802.11g

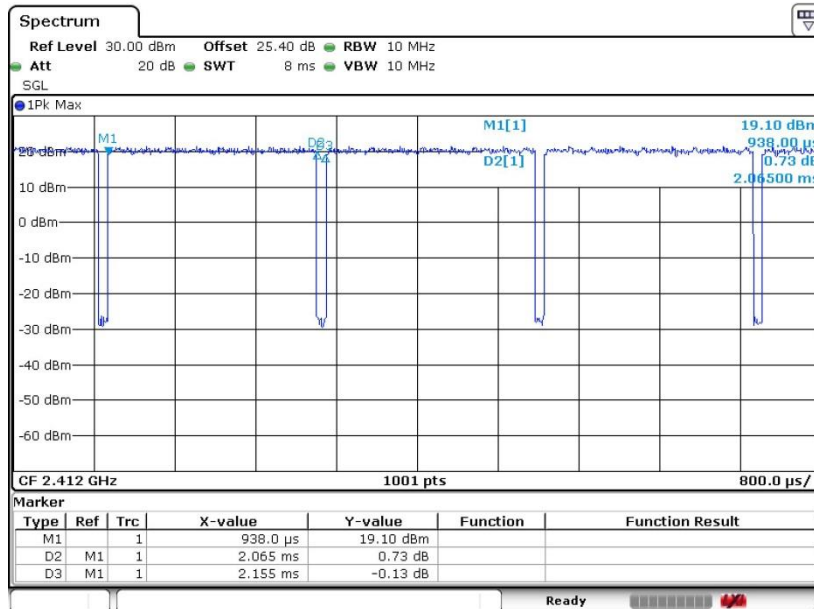

Date: 6.FEB.2019 23:14:13



802.11n HT20

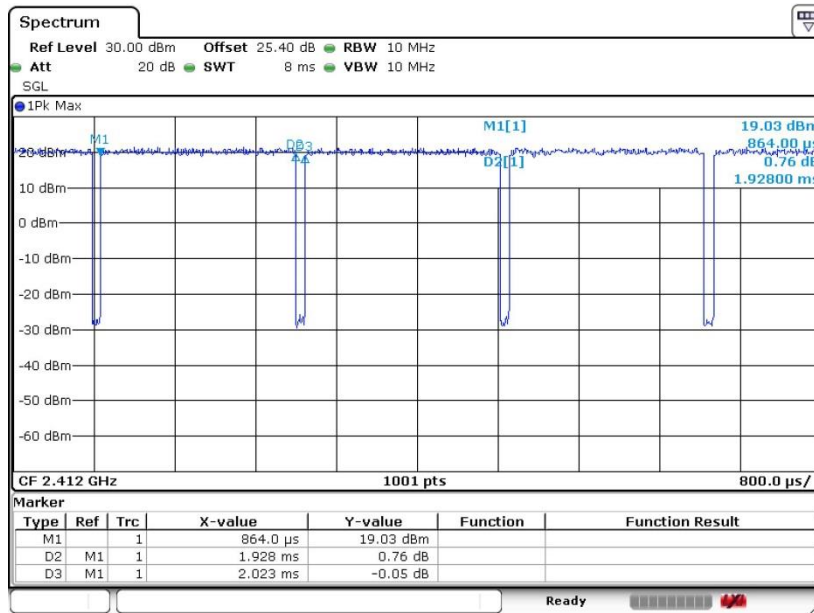

Date: 6.FEB.2019 23:29:50

802.11n HT40

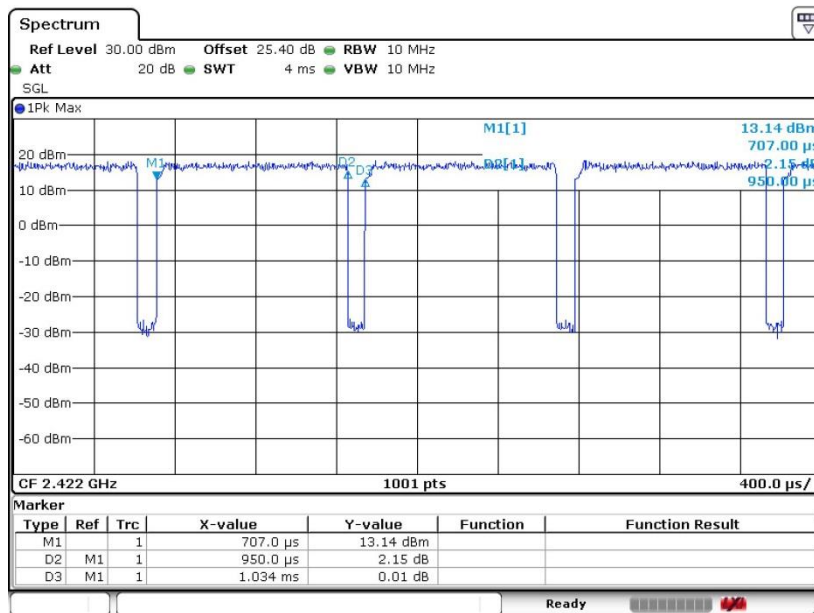

Date: 7.FEB.2019 00:10:43



802.11ac VHT20

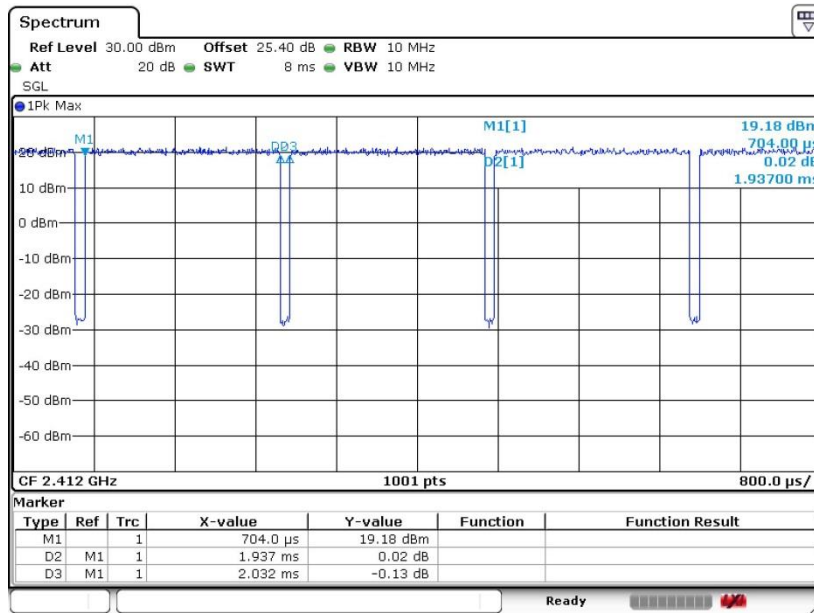

Date: 6.FEB.2019 23:54:09

802.11ac VHT40

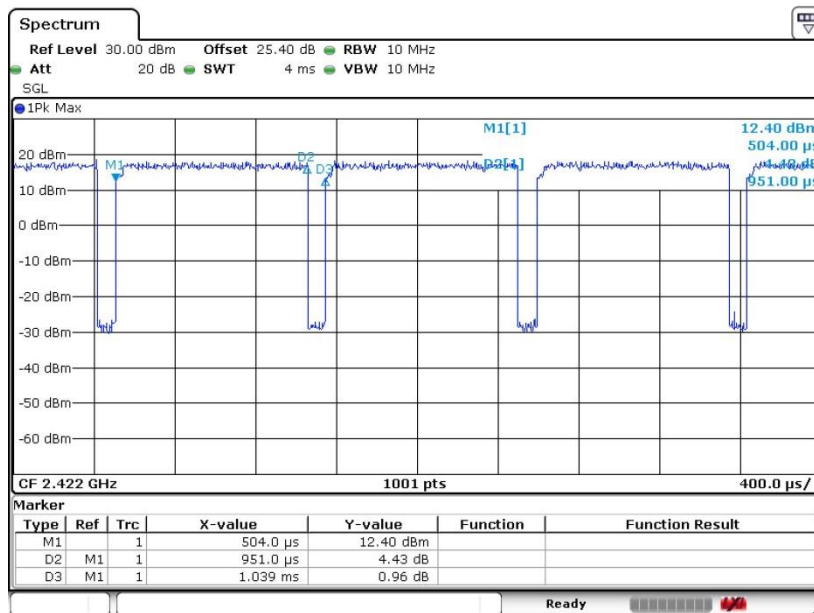

Date: 7.FEB.2019 00:30:06



<Ant. 2>

802.11b

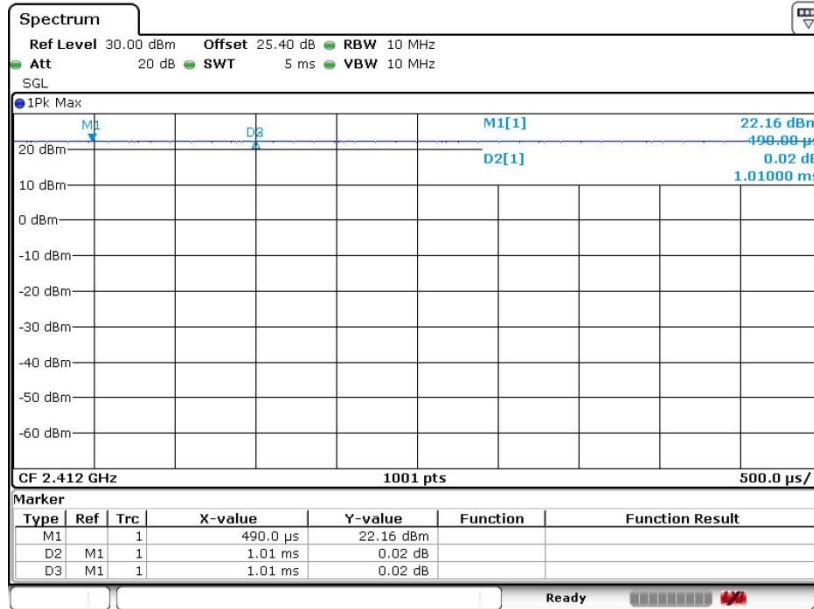

Date: 6.FEB.2019 22:54:59

802.11g

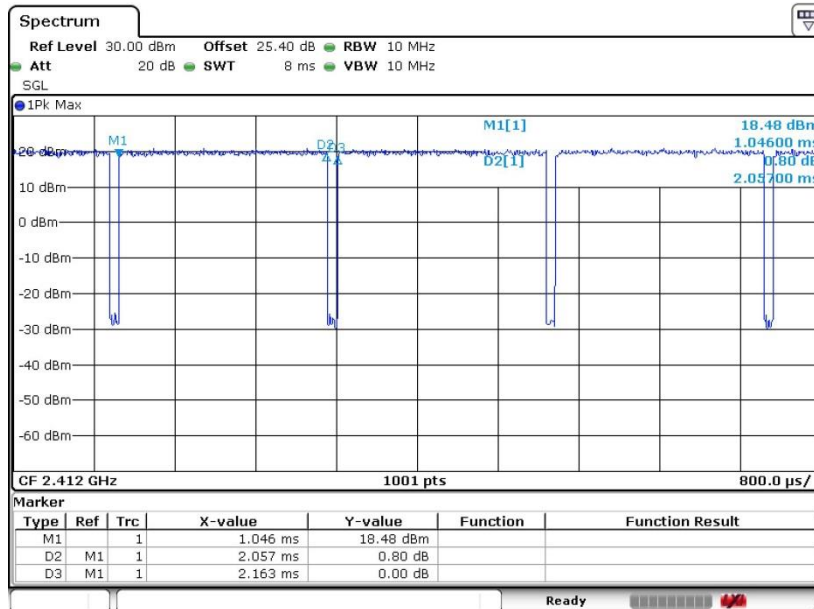

Date: 6.FEB.2019 23:17:27



802.11n HT20

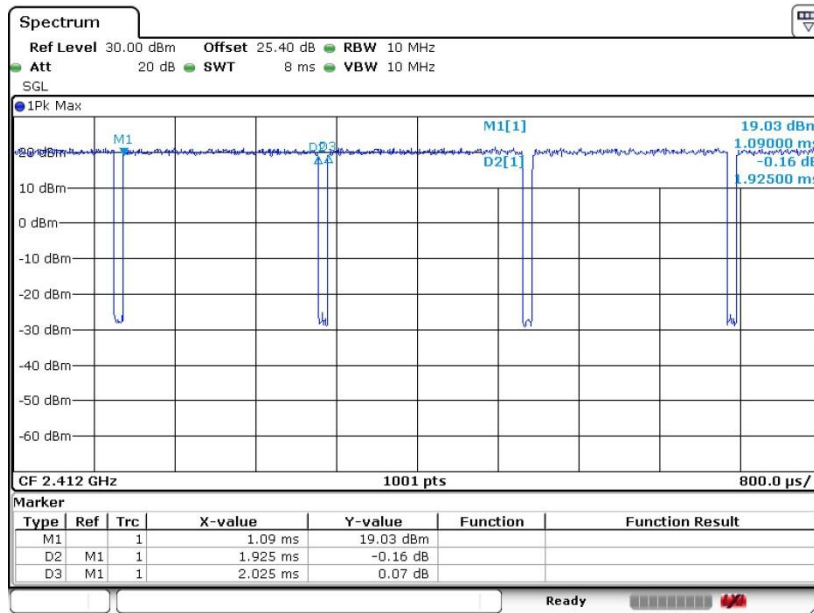

Date: 6.FEB.2019 23:38:14

802.11n HT40

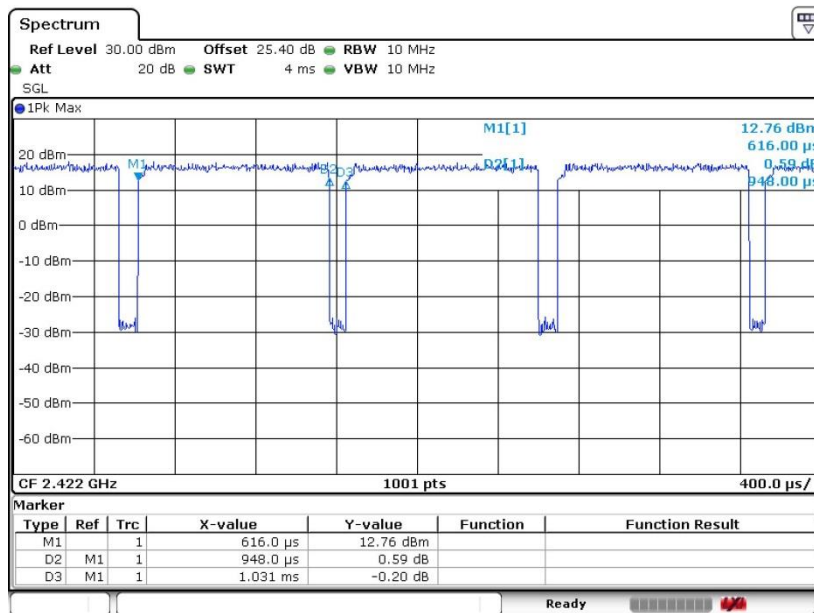

Date: 7.FEB.2019 00:14:37



802.11ac VHT20

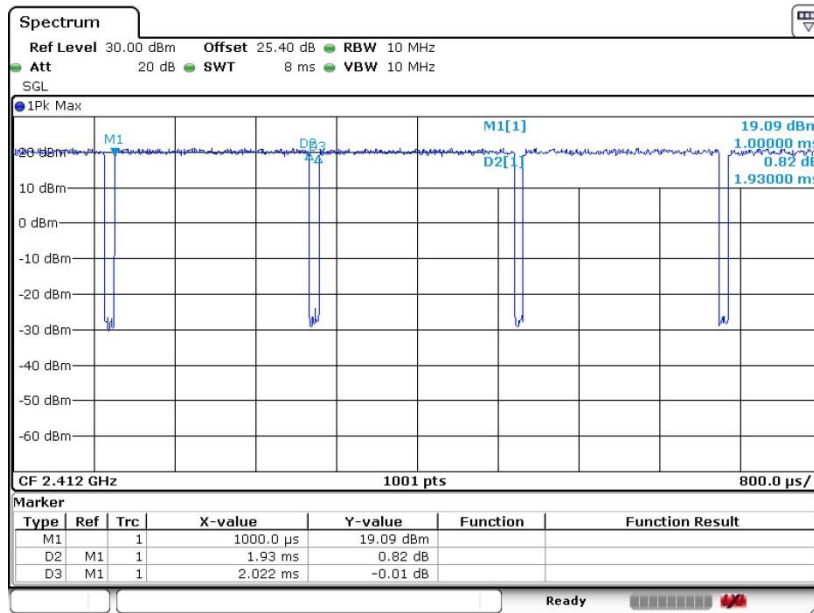

Date: 6.FEB.2019 23:58:45

802.11ac VHT40

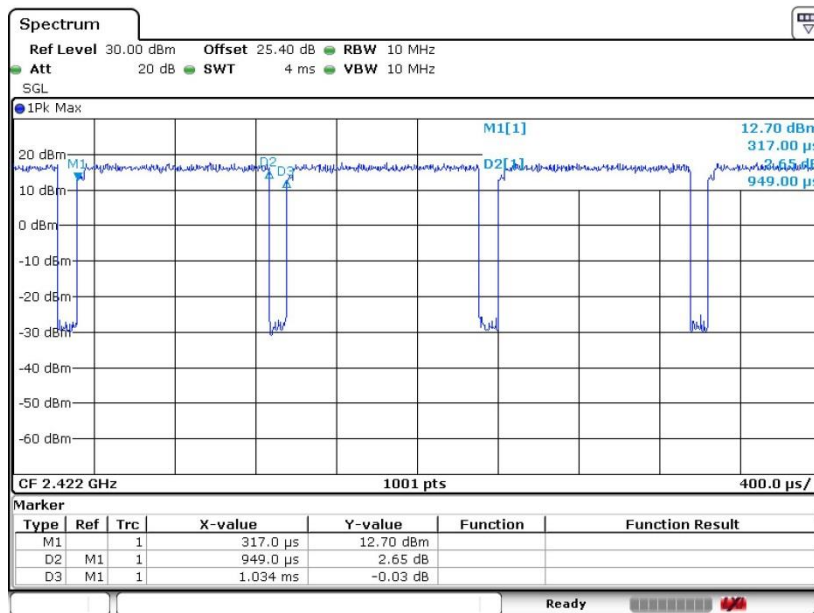

Date: 7.FEB.2019 00:35:27



MIMO <Ant. 1>

802.11b

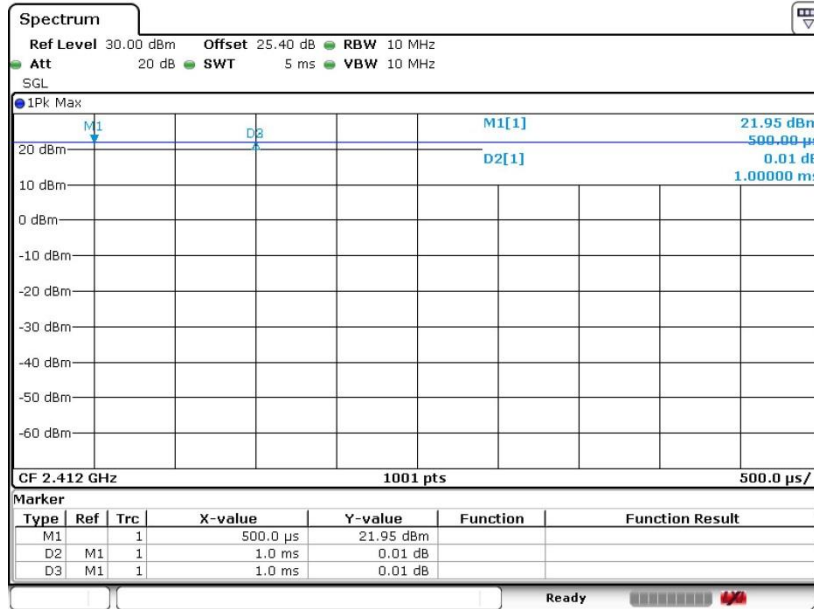

Date: 6.FEB.2019 23:01:36

802.11g

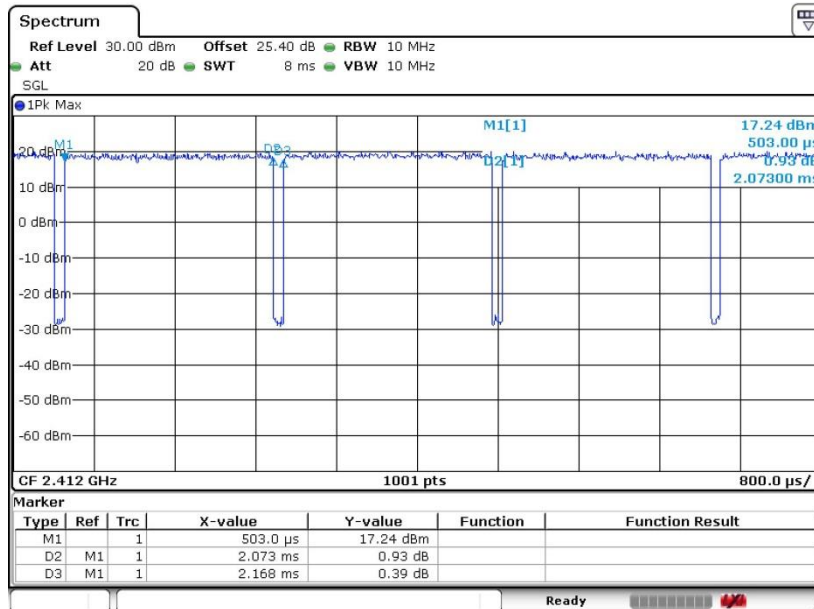

Date: 6.FEB.2019 23:22:01



802.11n HT20

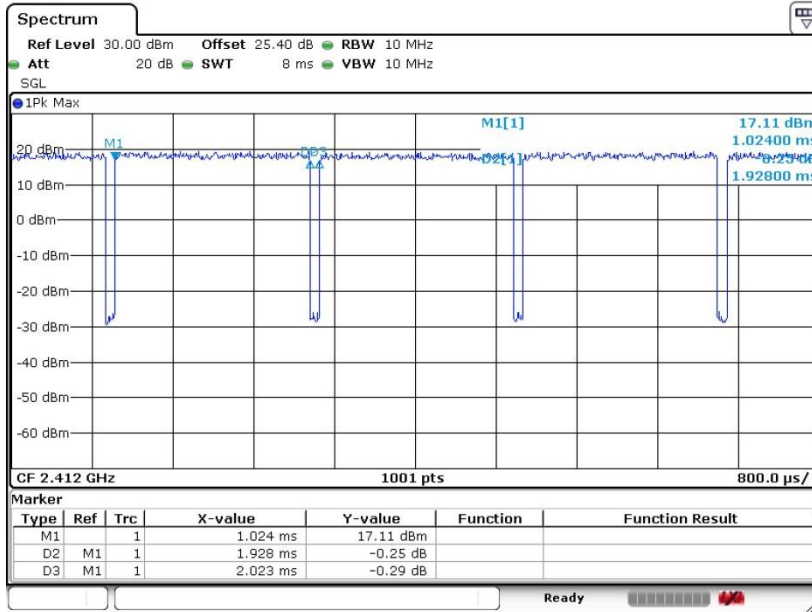

Date: 6.FEB.2019 23:43:27

802.11n HT40

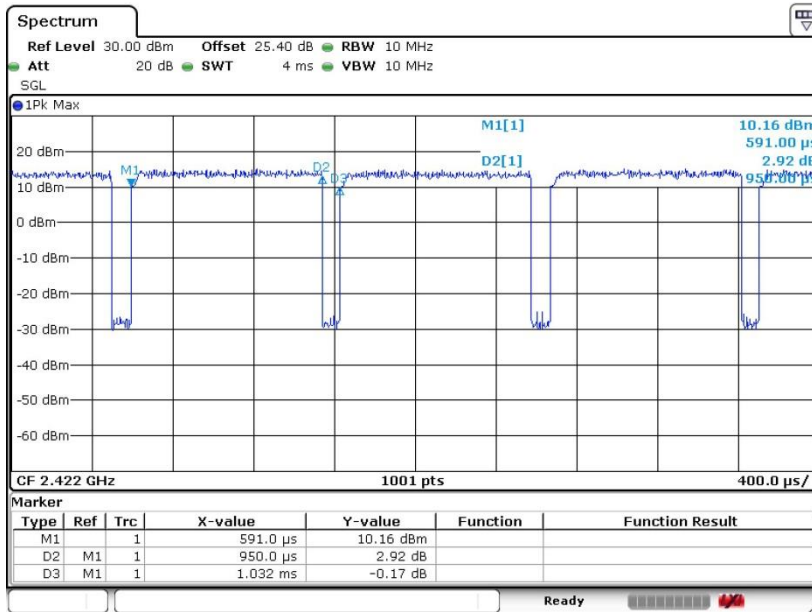

Date: 7.FEB.2019 00:18:30



802.11ac VHT20

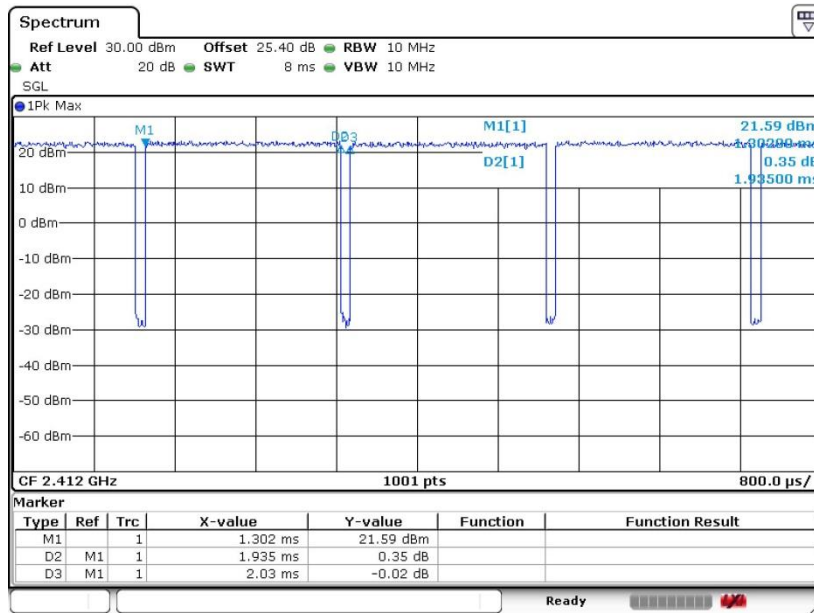

Date: 7.FEB.2019 00:02:37

802.11ac VHT40

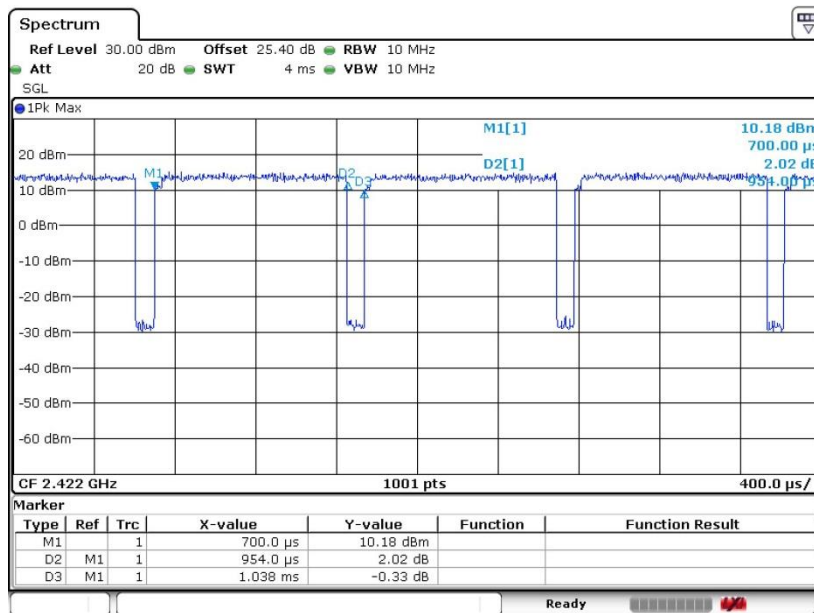

Date: 7.FEB.2019 00:39:13



MIMO <Ant. 2>

802.11b

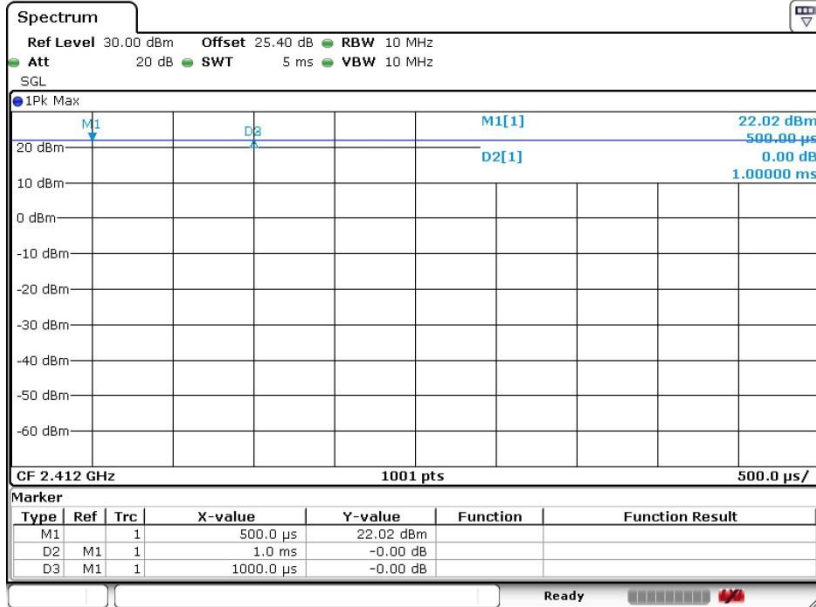

Date: 6.FEB.2019 23:06:12

802.11g

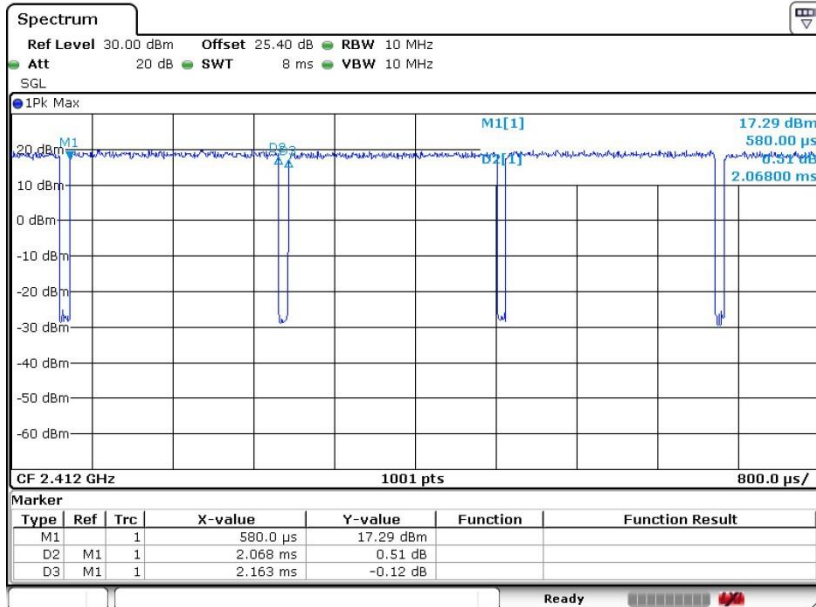

Date: 6.FEB.2019 23:23:11



802.11n HT20

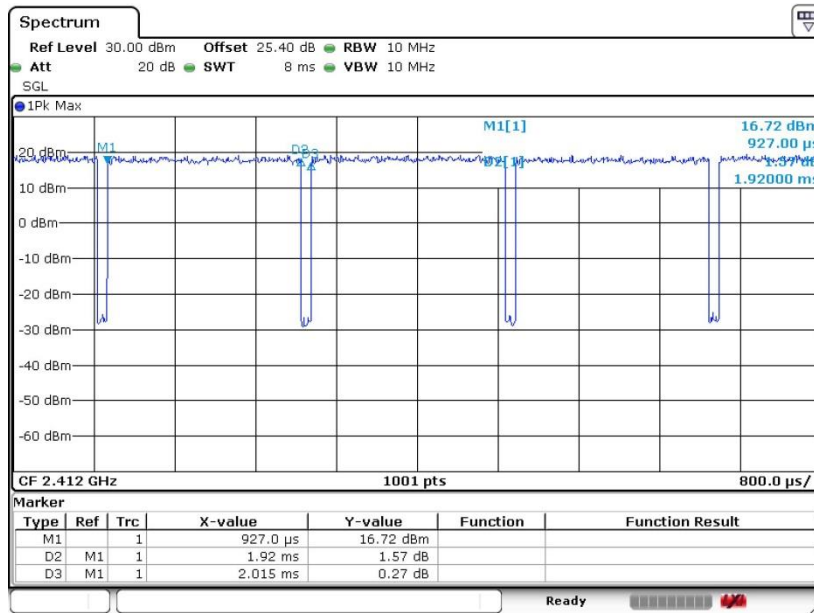

Date: 6.FEB.2019 23:44:21

802.11n HT40

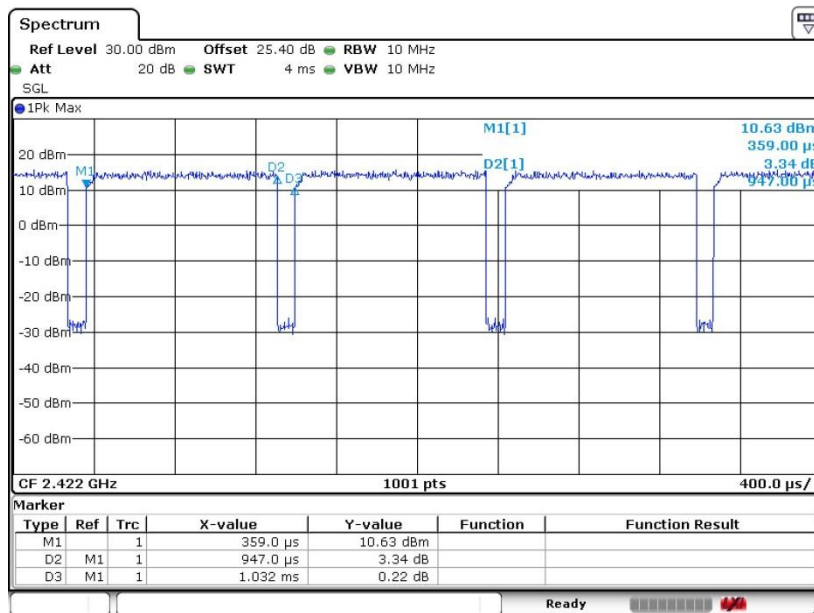

Date: 7.FEB.2019 00:21:17



802.11ac VHT20

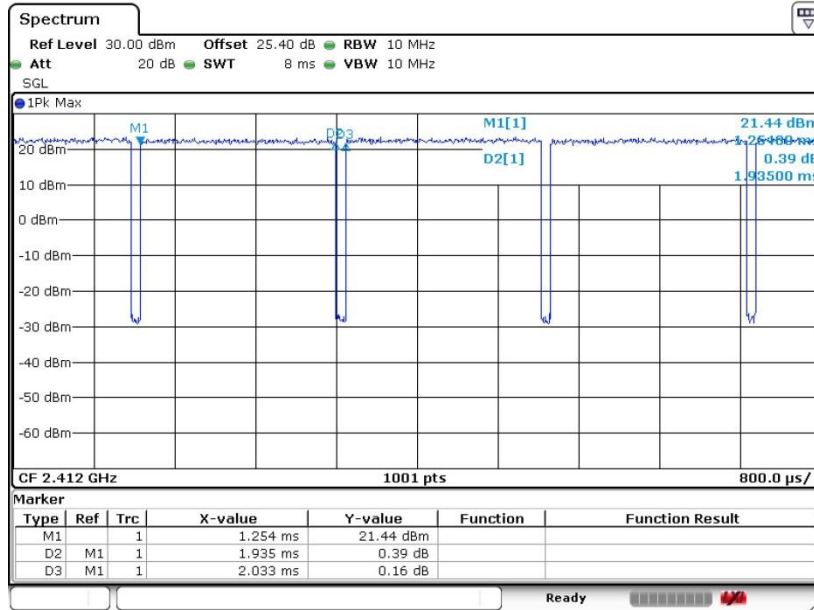

Date: 7.FEB.2019 00:03:37

802.11ac VHT40

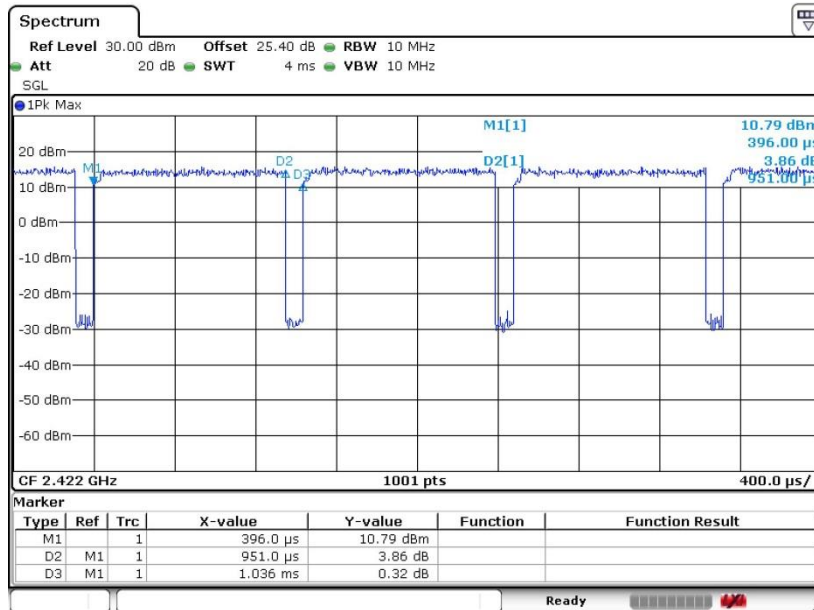

Date: 7.FEB.2019 00:40:09