



FCC RADIO TEST REPORT

FCC ID : UZ7MC930B
Equipment : Mobile computer
Brand Name : Zebra
Model Name : MC930B
Applicant : Zebra Technologies Corporation
1 Zebra Plaza, Holtsville, NY 11742
Manufacturer : Zebra Technologies Corporation
1 Zebra Plaza, Holtsville, NY 11742
Standard : FCC Part 15 Subpart E §15.407

The product was received on Nov. 26, 2018 and testing was started from Feb. 07, 2019 and completed on Feb. 23, 2019. We, SPORTON INTERNATIONAL INC. EMC & Wireless Communications Laboratory, would like to declare that the tested sample has been evaluated in accordance with the test procedures and has been in compliance with the applicable technical standards.

The report must not be used by the client to claim product certification, approval, or endorsement by TAF or any agency of government.

The test results in this variant report apply exclusively to the tested model / sample. Without written approval of SPORTON INTERNATIONAL INC. EMC & Wireless Communications Laboratory, the test report shall not be reproduced except in full.

Approved by: Jones Tsai

SPORTON INTERNATIONAL INC. EMC & Wireless Communications Laboratory

No. 52, Huaya 1st Rd., Guishan Dist., Taoyuan City, Taiwan (R.O.C.)



Table of Contents

History of this test report..... 3

Summary of Test Result..... 4

1 General Description 5

 1.1 Product Feature of Equipment Under Test..... 5

 1.2 Product Specification of Equipment Under Test..... 7

 1.3 Modification of EUT 7

 1.4 Testing Location 7

 1.5 Applicable Standards..... 8

2 Test Configuration of Equipment Under Test 9

 2.1 Carrier Frequency and Channel 9

 2.2 Test Mode..... 10

 2.3 Connection Diagram of Test System 11

 2.4 EUT Operation Test Setup 11

3 Test Result 12

 3.1 Unwanted Emissions Measurement 12

4 List of Measuring Equipment..... 17

5 Uncertainty of Evaluation 18

Appendix A. Radiated Spurious Emission

Appendix B. Radiated Spurious Emission Plots

Appendix C. Duty Cycle Plots

Appendix D. Setup Photographs



History of this test report

Report No.	Version	Description	Issued Date
FR8N2627D	01	Initial issue of report	Mar. 12, 2019



Summary of Test Result

Report Clause	Ref Std. Clause	Test Items	Result (PASS/FAIL)	Remark
-	15.403(i)	26dB Bandwidth	Not Required	-
-	2.1049	99% Occupied Bandwidth	Not Required	-
-	15.407(a)	Maximum Conducted Output Power	Not Required	-
-	15.407(a)	Power Spectral Density	Not Required	-
3.1	15.407(b)	Unwanted Emissions	Pass	Under limit 1.44 dB at 5457.760 MHz
-	15.207	AC Conducted Emission	Not Required	-
-	15.407(c)	Automatically Discontinue Transmission	Not Required	-
-	15.203 15.407(a)	Antenna Requirement	Not Required	-

Remark:

1. Not required means after assessing, test items are not necessary to carry out.
2. This is a variant report which can be referred to Product Equality Declaration. Since the test result is not affected by the changes, all the test cases were performed on original report which can be referred to Sporton Report Number FR8N2626E.

Declaration of Conformity:

The test results with all measurement uncertainty excluded are presented in accordance with the regulation limits or requirements declared by manufacturers.

Comments and Explanations:

The declared of product specification for EUT presented in the report are provided by the manufacturer, and the manufacturer takes all the responsibilities for the accuracy of product specification.

Reviewed by: Wii Chang

Report Producer: Dara Chiu



1 General Description

1.1 Product Feature of Equipment Under Test

Product Feature	
Equipment	Mobile computer
Brand Name	Zebra
Model Name	MC930B
FCC ID	UZ7MC930B
Sample 1	EUT with SKU 1
Sample 2	EUT with SKU 2
Sample 3	EUT with SKU 3
Sample 4	EUT with SKU 4
Sample 5	EUT with SKU 5
Sample 6	EUT with SKU 6
Sample 7	EUT with SKU 7
EUT supports Radios application	WLAN 11a/b/g/n HT20/HT40 WLAN 11ac VHT20/VHT40/VHT80 Bluetooth BR/EDR/LE
HW Version	EV1
SW Version	01-14-11.00-OG
FW Version	FUSION_QA_2_1.3.0.004_O
MFD	28OCT18
EUT Stage	Engineering Sample

Remark:

1. The above EUT's information was declared by manufacturer.
2. The tests were performed with Sample 1.

Specification of Accessories				
Adapter (5V/2.5A)	Brand Name	Zebra	Part Number	PWR-WUA5V12W0US
USB-C Adapter	Brand Name	Zebra	Part Number	CBL-MC93-USBCHG-01
USB-C cable	Brand Name	Zebra	Part Number	CBL-TC2X-USBC-01
Std Battery	Brand Name	Zebra	Part Number	BT-000370-00
Holster	Brand Name	Zebra	Part Number	051607-79N1-18

**<Sample Information>**

Model Name	MC930P					MC930B	
	SKU3	SKU4	SKU5	SKU6	SKU7	SKU1	SKU2
Organization / Function / Group	EV1a-G21	EV1a-G22	EV1a-G23	EV1a-F11	EV1a-F13	EV1a-G02	EV1a-G03
nm	G-2S-1D-53k	G-2S-2D-53k	G-2S-LRI-53k	G-1F-1D-53k	G-1F-LRI-53k	G-BS-2D-53k	G-BS-LRI-53k
Product Number	MC930P-GS BDG4NA	MC930P-GS DDG4NA	MC930P-GS FDG4NA	MC930P-GF ADG4NA	MC930P-GF EDG4NA	MC930B-GS CDG4NA	MC930B-GSE DG4NA
Form factor	Gun	Gun	Gun	Gun	Gun	Gun	Gun
Package/Component Category	Pkg2	Pkg2	Pkg2	Pkg1 CS	Pkg 1 CS	Base	Base
NFC	YES	YES	YES	YES	YES	NO	NO
Vib	YES	YES	YES	YES	YES	NO	NO
Camera	YES	YES	YES	NO	NO	NO	NO
NI	NO	NO	NO	NO	NO	NO	NO
Side Trigger	NO	NO	NO	NO	NO	NO	NO
Display + TP Stackup	Option2	Option2	Option2	Option5	Option5	Option 2	Option 2
Scanner	SE965	SE4750SR	SE4850	SE965	SE4850	SE4750SR	SE4850
Battery	Std	Std	Std	Fzr	Fzr	Std	Std
Keyboard	53 Key	53 Key	53 Key	53 Key	53 Key	53 Key	53 Key
Build Date	Oct 2018	Oct 2018	Oct 2018	Nov 2018	Nov 2018	Oct 2018	Oct 2018



1.2 Product Specification of Equipment Under Test

Standards-related Product Specification													
Tx/Rx Frequency Range	5180 MHz ~ 5240 MHz 5260 MHz ~ 5320 MHz 5500 MHz ~ 5720 MHz												
Antenna Type / Gain	<5180 MHz ~ 5240 MHz> Ant. 1 : Patch Antenna with gain 4.52 dBi Ant. 2 : Patch Antenna with gain 3.12 dBi <5260 MHz ~ 5320 MHz> Ant. 1 : Patch Antenna with gain 4.12 dBi Ant. 2 : Patch Antenna with gain 3.92 dBi <5500 MHz ~ 5720 MHz> Ant. 1 : Patch Antenna with gain 2.88 dBi Ant. 2 : Patch Antenna with gain 3.92 dBi												
Type of Modulation	802.11a/n : OFDM (BPSK/QPSK/16QAM/64QAM) 802.11ac : OFDM (BPSK/QPSK/16QAM/64QAM/256QAM)												
Antenna Function Description	<table border="1"> <thead> <tr> <th></th> <th>Ant. 1</th> <th>Ant. 2</th> </tr> </thead> <tbody> <tr> <td>802.11 a/n/ac</td> <td>V</td> <td>V</td> </tr> <tr> <td>802.11 a/n/ac MIMO</td> <td>V</td> <td>V</td> </tr> <tr> <td>802.11 ac TXBF</td> <td>V</td> <td>V</td> </tr> </tbody> </table>		Ant. 1	Ant. 2	802.11 a/n/ac	V	V	802.11 a/n/ac MIMO	V	V	802.11 ac TXBF	V	V
	Ant. 1	Ant. 2											
802.11 a/n/ac	V	V											
802.11 a/n/ac MIMO	V	V											
802.11 ac TXBF	V	V											

Note: MIMO Ant. 1+2 is a calculated result from sum of the power MIMO Ant. 1 and MIMO Ant. 2.

1.3 Modification of EUT

No modifications are made to the EUT during all test items.

1.4 Testing Location

Test Site	SPORTON INTERNATIONAL INC.
Test Site Location	No.52, Huaya 1st Rd., Guishan Dist., Taoyuan City, Taiwan (R.O.C.) TEL: +886-3-327-3456 FAX: +886-3-328-4978
Test Site No.	Sporton Site No.
	03CH07-HY

Note: The test site complies with ANSI C63.4 2014 requirement.

FCC Designation No. TW1190



1.5 Applicable Standards

According to the specifications of the manufacturer, the EUT must comply with the requirements of the following standards:

- ♦ FCC Part 15 Subpart E
- ♦ FCC KDB 789033 D02 General UNII Test Procedures New Rules v02r01.
- ♦ FCC KDB 414788 D01 Radiated Test Site v01r01.
- ♦ FCC KDB 662911 D01 Multiple Transmitter Output v02r01.
- ♦ ANSI C63.10-2013

Remark:

1. All test items were verified and recorded according to the standards and without any deviation during the test.
2. This EUT has also been tested and complied with the requirements of FCC Part 15, Subpart B, recorded in a separate test report.



2 Test Configuration of Equipment Under Test

The EUT has been associated with peripherals and configuration operated in a manner tended to maximize its emission characteristics in a typical application. Frequency range investigated: Radiation emission (9 kHz to the 10th harmonic of the highest fundamental frequency or to 40 GHz, whichever is lower). For radiated measurement, pre-scanned in three orthogonal panels, X, Y, Z. The worst cases (Z plane) were recorded in this report.

2.1 Carrier Frequency and Channel

Frequency Band	Channel	Freq. (MHz)	Channel	Freq. (MHz)
5150-5250 MHz Band 1 (U-NII-1)	36	5180	44	5220
	38*	5190	46*	5230
	40	5200	48	5240
	42 [#]	5210		
5250-5350 MHz Band 2 (U-NII-2A)	52	5260	60	5300
	54*	5270	62*	5310
	56	5280	64	5320
	58 [#]	5290		
5470-5725 MHz Band 3 (U-NII-2C)	100	5500	112	5560
	102*	5510	116	5580
	104	5520	132	5660
	106 [#]	5530	134*	5670
	108	5540	136	5680
	110*	5550	140	5700
TDWR Channel	118*	5590	124	5620
	120	5600	126*	5630
	122 [#]	5610	128	5640



Frequency Band	Channel	Freq. (MHz)	Channel	Freq. (MHz)
Straddle Channel	138 [#]	5690	144	5720
	142 [*]	5710		

Note:

1. The above Frequency and Channel in "*" were 802.11n HT40 and 802.11ac VHT40.
2. The above Frequency and Channel in "#" were 802.11ac VHT80.

2.2 Test Mode

Final test modes are considering the modulation and worse data rates as below table.

MIMO Mode

Modulation	Data Rate
802.11a	6 Mbps
802.11n HT40	MCS0
802.11ac VHT80	MCS0

Ch. #		Band I : 5150-5250 MHz	Band II : 5250-5350 MHz	Band III : 5470-5725MHz
		802.11a	802.11a	802.11a
L	Low	36	-	-
M	Middle	-	-	-
H	High	-	-	-
Straddle		-	-	-

Ch. #		Band I : 5150-5250 MHz	Band II : 5250-5350 MHz	Band III : 5470-5725MHz
		802.11n HT40	802.11n HT40	802.11n HT40
L	Low	-	-	-
M	Middle	-	-	-
H	High	-	62	-
Straddle		-	-	-

Ch. #		Band I : 5150-5250 MHz	Band II : 5250-5350 MHz	Band III : 5470-5725MHz
		802.11ac VHT80	802.11ac VHT80	802.11ac VHT80
L	Low	-	-	106
M	Middle	-	-	-
H	High	-	-	-
Straddle		-	-	-

2.3 Connection Diagram of Test System

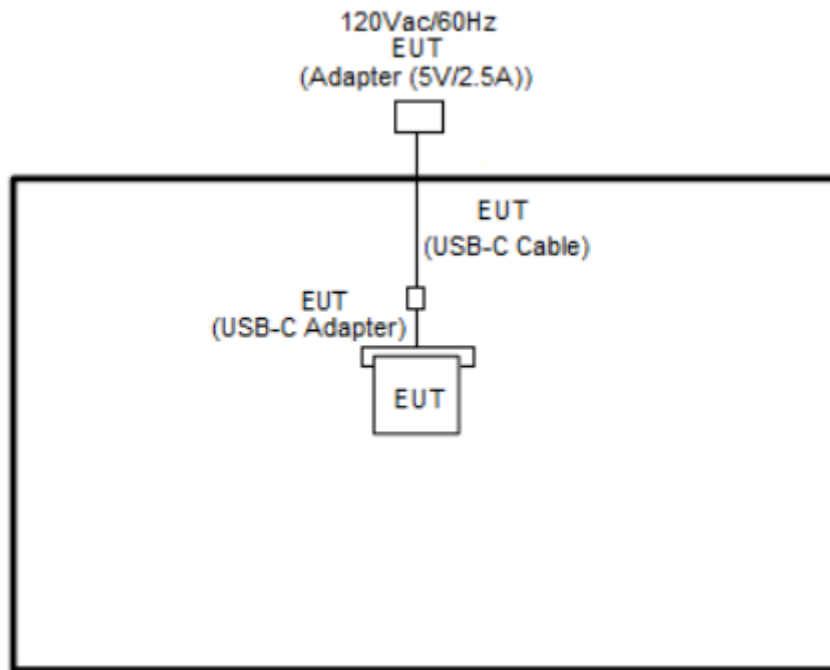

2.4 EUT Operation Test Setup

The RF test items, utility “QRCT” was installed in Notebook which was programmed in order to make the EUT get into the engineering modes to provide channel selection, power level, data rate and the application type and for continuous transmitting signals.



3 Test Result

3.1 Unwanted Emissions Measurement

This section is to measure unwanted emissions through radiated measurement for band edge spurious emissions and out of band emissions measurement.

3.1.1 Limit of Unwanted Emissions

- (1) For transmitters operating in the 5150-5250 MHz band: all emissions outside of the 5150-5350 MHz band shall not exceed an EIRP of -27dBm/MHz.

For transmitters operating in the 5250-5350 MHz band: all emissions outside of the 5150-5350 MHz band shall not exceed an EIRP of -27 dBm/MHz. Devices operating in the 5250-5350 MHz band that generate emissions in the 5150-5250 MHz band must meet all applicable technical requirements for operation in the 5150-5250 MHz band (including indoor use) or alternatively meet an out-of-band emission EIRP limit of -27 dBm/MHz in the 5150-5250 MHz band.

For transmitters operating in the 5470-5600 MHz and 5650-5725MHz band: all emissions outside of the 5470-5600 MHz and 5650-5725MHz band shall not exceed an EIRP of -27 dBm/MHz.

- (2) Unwanted spurious emissions fallen in restricted bands shall comply with the general field strength limits as below table,

Frequency (MHz)	Field Strength (microvolts/meter)	Measurement Distance (meters)
0.009 – 0.490	2400/F(kHz)	300
0.490 – 1.705	24000/F(kHz)	30
1.705 – 30.0	30	30
30 – 88	100	3
88 – 216	150	3
216 - 960	200	3
Above 960	500	3

Note: The following formula is used to convert the EIRP to field strength.

$$E = \frac{1000000\sqrt{30P}}{3} \mu\text{V/m, where P is the eirp (Watts)}$$

EIRP (dBm)	Field Strength at 3m (dBμV/m)
- 27	68.3



(3) KDB789033 D02 v02r01 G)2)c)

- (i) Section 15.407(b)(1) to (b)(3) specify the unwanted emission limits for the U-NII-1 and U-NII-2 bands. As specified, emissions above 1000 MHz that are outside of the restricted bands are subject to a peak emission limit of -27 dBm/MHz.³
- (ii) Section 15.407(b)(4) specifies the unwanted emission limit for the U-NII-3 band. A band emissions mask is specified in Section 15.407(b)(4)(i). The emission limits are in terms of a Peak detector. An alternative to the band emissions mask is specified in Section 15.407(b)(4)(ii). The alternative limits are based on the highest antenna gain specified in the filing. There are also marketing and importation restrictions for the devices using the alternative limit.⁴

Note 3: An out-of-band emission that complies with both the average and peak limits of Section 15.209 is not required to satisfy the -27 dBm/MHz peak emission limit.

Note 4: Only devices with antenna gains of 10 dBi or less may be approved using the emission limits specified in Section 15.247(d) till March 2, 2018; all other devices operating in this band must use the mask specified in Section 15.407(b)(4)(i).

3.1.2 Measuring Instruments

See list of measuring equipment of this test report.

3.1.3 Test Procedures

1. The testing follows FCC KDB 789033 D02 General UNII Test Procedures New Rules v02r01. Section G) Unwanted emissions measurement.

(1) Procedure for Unwanted Emissions Measurements Below 1000MHz

- RBW = 120 kHz
- VBW = 300 kHz
- Detector = Peak
- Trace mode = max hold

(2) Procedure for Peak Unwanted Emissions Measurements Above 1000 MHz

- RBW = 1 MHz
- VBW ≥ 3 MHz
- Detector = Peak
- Sweep time = auto
- Trace mode = max hold

(3) Procedures for Average Unwanted Emissions Measurements Above 1000MHz

- RBW = 1 MHz
- VBW = 10 Hz, when duty cycle is no less than 98 percent.
- VBW ≥ 1/T, when duty cycle is less than 98 percent where T is the minimum transmission duration over which the transmitter is on and is transmitting at its maximum power control level for the tested mode of operation.



2. The EUT was placed on a turntable with 0.8 meter for frequency below 1GHz and 1.5 meter for frequency above 1GHz respectively above ground.
3. The EUT was set 3 meters from the interference receiving antenna which was mounted on the top of a variable height antenna tower.
4. The antenna is a broadband antenna and its height is adjusted between one meter and four meters above ground to find the maximum value of the field strength for both horizontal polarization and vertical polarization of the antenna.
5. For each suspected emission, the EUT was arranged to its worst case and then adjust the antenna tower (from 1 m to 4 m) and turntable (from 0 degree to 360 degrees) to find the maximum reading.
6. For testing below 1GHz, if the emission level of the EUT in peak mode was 3 dB lower than the limit specified, then peak values of EUT will be reported, otherwise, the emissions will be repeated one by one using the CISPR quasi-peak method and reported.
7. For testing above 1GHz, the emission level of the EUT in peak mode was 20dB lower than average limit (that means the emission level in average mode also complies with the limit in average mode), then peak values of EUT will be reported, otherwise, the emissions will be measured in average mode again and reported.

3.1.4 Test Setup

For radiated emissions below 30MHz

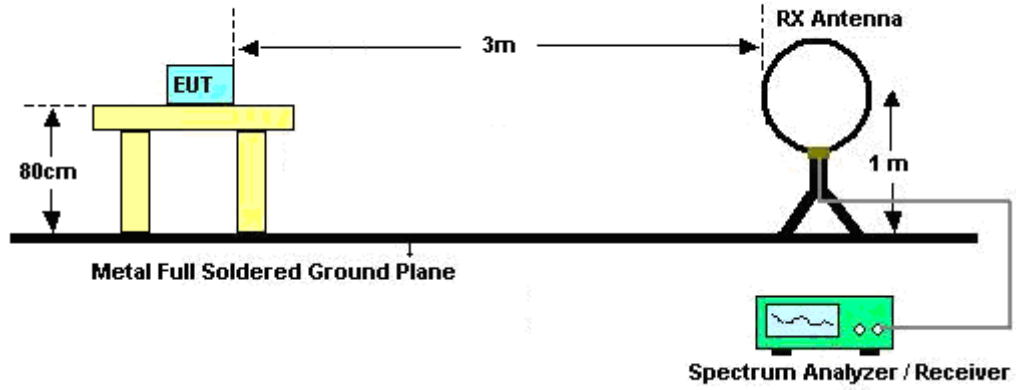

For radiated emissions from 30MHz to 1GHz

<CDD Mode>

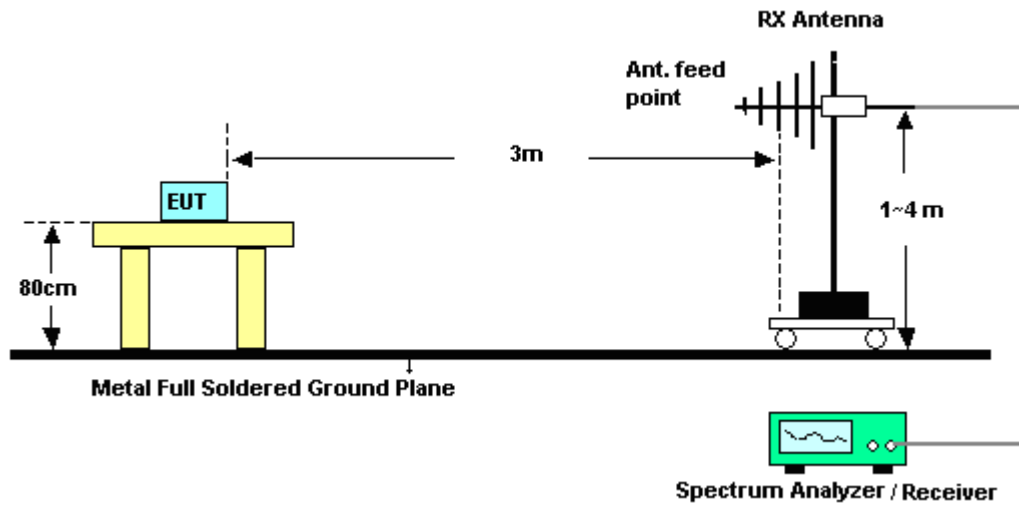

For radiated emissions above 1GHz

<CDD Mode>

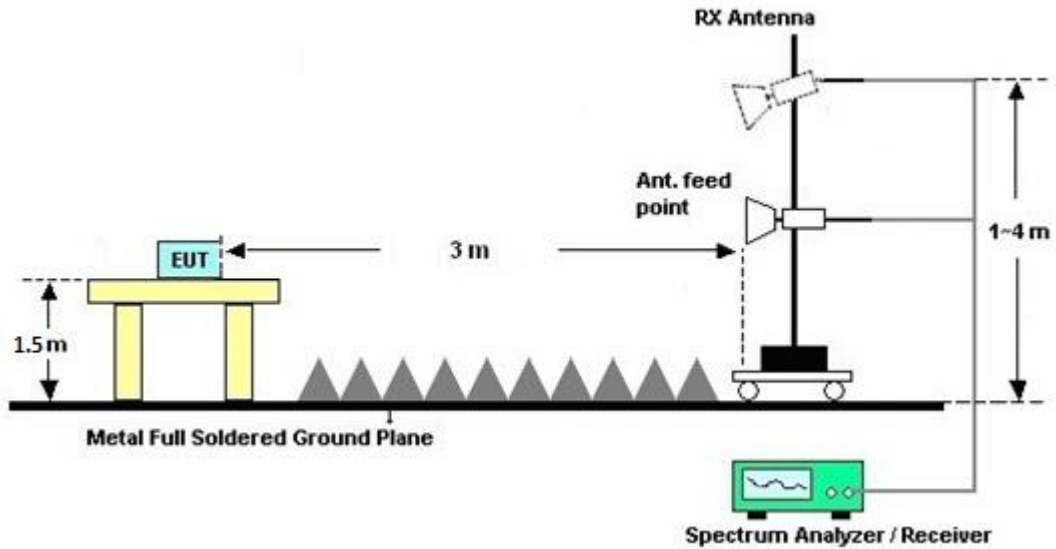

3.1.5 Test Results of Radiated Spurious Emissions (9 kHz ~ 30 MHz)

The low frequency, which started from 9 kHz to 30MHz, was pre-scanned and the result which was 20dB lower than the limit line was not reported.

There is a comparison data of both open-field test site and alternative test site - semi-Anechoic chamber according to 414788 D01 Radiated Test Site v01r01, and the result came out very similar.

3.1.6 Test Result of Radiated Spurious at Band Edges

Please refer to Appendix A and B.

3.1.7 Duty Cycle

Please refer to Appendix C.

3.1.8 Test Result of Radiated Spurious Emissions (30MHz ~ 10th Harmonic)

Please refer to Appendix A and B.



4 List of Measuring Equipment

Instrument	Manufacturer	Model No.	Serial No.	Characteristics	Calibration Date	Test Date	Due Date	Remark
Preamplifier	Agilent	8449B	3008A01917	1GHz~26.5GHz	Apr. 23, 2018	Feb. 07, 2019 ~ Feb. 23, 2019	Apr. 22, 2019	Radiation (03CH07-HY)
Bilog Antenna	TESEQ	CBL 6111D&00800 N1D01N-06	35419&03	30MHz to 1GHz	Dec. 16, 2018	Feb. 07, 2019 ~ Feb. 23, 2019	Dec. 15, 2019	Radiation (03CH07-HY)
Double Ridge Horn Antenna	ESCO	3117	00075962	1GHz ~ 18GHz	Dec. 02, 2018	Feb. 07, 2019 ~ Feb. 23, 2019	Dec. 01, 2019	Radiation (03CH07-HY)
Loop Antenna	Rohde & Schwarz	HFH2-Z2	100315	9 kHz~30 MHz	May 15, 2017	Feb. 07, 2019 ~ Feb. 23, 2019	May 14, 2019	Radiation (03CH07-HY)
Preamplifier	MITEQ	AMF-7D-0010 1800-30-10P	1590075	1GHz ~ 18GHz	Apr. 25, 2018	Feb. 07, 2019 ~ Feb. 23, 2019	Apr. 24, 2019	Radiation (03CH07-HY)
Preamplifier	COM-POWER	PA-103A	161241	10MHz-1GHz	May 21, 2018	Feb. 07, 2019 ~ Feb. 23, 2019	May 20, 2019	Radiation (03CH07-HY)
RF Cable	HUBER + SUHNER	SUCOFLEX 104	MY28655/4, MY24971/4, MY15682/4	30MHz~1GHz	Feb. 27, 2018	Feb. 07, 2019 ~ Feb. 23, 2019	Feb. 26, 2019	Radiation (03CH07-HY)
RF Cable	HUBER + SUHNER	SUCOFLEX 104	MY28655/4, MY24971/4, MY15682/4	1GHz~18GHz	Feb. 27, 2018	Feb. 07, 2019 ~ Feb. 23, 2019	Feb. 26, 2019	Radiation (03CH07-HY)
Antenna Mast	Max-Full	MFA520BS	N/A	1m~4m	N/A	Feb. 07, 2019 ~ Feb. 23, 2019	N/A	Radiation (03CH07-HY)
Turn Table	ChainTek	Chaintek 3000	N/A	0~360 Degree	N/A	Feb. 07, 2019 ~ Feb. 23, 2019	N/A	Radiation (03CH07-HY)
Amplifier	MITEQ	TTA1840-35-H G	1871923	18GHz~40GHz, VSWR : 2.5:1 max	Jul. 16, 2018	Feb. 07, 2019 ~ Feb. 23, 2019	Jul. 15, 2019	Radiation (03CH07-HY)
Software	Audix	E3 6.2009-8-24	RK-001042	N/A	N/A	Feb. 07, 2019 ~ Feb. 23, 2019	N/A	Radiation (03CH07-HY)
SHF-EHF Horn Antenna	SCHWARZBE CK	BBHA 9170	BBHA917025 1	18GHz- 40GHz	Nov. 20, 2018	Feb. 07, 2019 ~ Feb. 23, 2019	Nov. 19, 2019	Radiation (03CH07-HY)
RF Cable	HUBER + SUHNER	SF102/2*11SK 252	MY4278/2	9kHz~40GHz	May 17, 2018	Feb. 07, 2019 ~ Feb. 23, 2019	May 16, 2019	Radiation (03CH07-HY)
Spectrum Analyzer	Agilent	N9010A	MY53470118	10Hz~44GHz	Apr. 17, 2018	Feb. 07, 2019 ~ Feb. 23, 2019	Apr. 16, 2019	Radiation (03CH07-HY)



5 Uncertainty of Evaluation

Uncertainty of Radiated Emission Measurement (30 MHz ~ 1000 MHz)

Measuring Uncertainty for a Level of Confidence of 95% ($U = 2Uc(y)$)	5.7
---	-----

Uncertainty of Radiated Emission Measurement (1000 MHz ~ 18000 MHz)

Measuring Uncertainty for a Level of Confidence of 95% ($U = 2Uc(y)$)	5.5
---	-----

Uncertainty of Radiated Emission Measurement (18000 MHz ~ 40000 MHz)

Measuring Uncertainty for a Level of Confidence of 95% ($U = 2Uc(y)$)	5.2
---	-----



Appendix A. Radiated Spurious Emission

Test Engineer :	Jesse Wang, Stan Hsieh, and Troye Hsieh	Temperature :	20~25°C
		Relative Humidity :	55~60%

Band 1 - 5150~5250MHz
WIFI 802.11a (Band Edge @ 3m)

WIFI Ant.	Note	Frequency (MHz)	Level (dBμV/m)	Over Limit (dB)	Limit Line (dBμV/m)	Read Level (dBμV)	Antenna Factor (dB/m)	Path Loss (dB)	Preamp Factor (dB)	Ant Pos (cm)	Table Pos (deg)	Peak Avg. (P/A)	Pol. (H/V)	
802.11a CH 36 5180MHz		5147.16	58.75	-15.25	74	48.47	34.3	11.03	35.05	349	300	P	H	
		5150	51.42	-2.58	54	41.14	34.3	11.03	35.05	349	300	A	H	
	*	5180	116.1	-	-	105.82	34.3	11.03	35.05	349	300	P	H	
	*	5180	108.67	-	-	98.39	34.3	11.03	35.05	349	300	A	H	
													H	
														H
			5150	58.76	-15.24	74	48.48	34.3	11.03	35.05	365	252	P	V
			5148.98	51.2	-2.8	54	40.92	34.3	11.03	35.05	365	252	A	V
	*		5180	113.24	-	-	102.96	34.3	11.03	35.05	365	252	P	V
	*		5180	105.84	-	-	95.56	34.3	11.03	35.05	365	252	A	V
														V
														V
Remark	1. No other spurious found. 2. All results are PASS against Peak and Average limit line.													



Band 1 5150~5250MHz

WIFI 802.11a (Harmonic @ 3m)

WIFI Ant. 1+2	Note	Frequency (MHz)	Level (dBμV/m)	Over Limit (dB)	Limit Line (dBμV/m)	Read Level (dBμV)	Antenna Factor (dB/m)	Path Loss (dB)	Preamp Factor (dB)	Ant Pos (cm)	Table Pos (deg)	Peak Avg. (P/A)	Pol. (H/V)	
802.11a CH 36 5180MHz		10360	46.73	-21.47	68.2	51.73	37.33	17	59.33	400	0	P	H	
		15540	50.17	-23.83	74	45.97	40.27	20.52	56.59	400	0	P	H	
													H	
													H	
			10360	46.47	-21.73	68.2	51.47	37.33	17	59.33	100	0	P	V
			15540	50.38	-23.62	74	46.18	40.27	20.52	56.59	100	0	P	V
														V
														V
Remark	1. No other spurious found. 2. All results are PASS against Peak and Average limit line.													



Band 2 5250~5350MHz
WIFI 802.11n HT40 (Band Edge @ 3m)

WIFI Ant. 1+2	Note	Frequency (MHz)	Level (dBμV/m)	Over Limit (dB)	Limit Line (dBμV/m)	Read Level (dBμV)	Antenna Factor (dB/m)	Path Loss (dB)	Preamp Factor (dB)	Ant Pos (cm)	Table Pos (deg)	Peak Avg. (P/A)	Pol. (H/V)
802.11n HT40 CH 62 5310MHz		5141.75	48.95	-25.05	74	38.67	34.3	11.03	35.05	200	294	P	H
		5138.6	39.98	-14.02	54	29.87	34.2	10.96	35.05	200	294	A	H
	*	5310	109.52	-	-	99.04	34.4	11.13	35.05	200	294	P	H
	*	5310	101.7	-	-	91.22	34.4	11.13	35.05	200	294	A	H
		5350.32	61.31	-12.69	74	50.47	34.4	11.49	35.05	200	294	P	H
		5350.32	52.49	-1.51	54	42	34.4	11.14	35.05	200	294	A	H
		5082.95	47.95	-26.05	74	38.06	34.03	10.9	35.04	300	243	P	V
		5121.8	39.87	-14.13	54	29.86	34.1	10.96	35.05	300	243	A	V
	*	5310	104.66	-	-	94.18	34.4	11.13	35.05	300	243	P	V
	*	5310	97.52	-	-	87.04	34.4	11.13	35.05	300	243	A	V
		5350.08	55.14	-18.86	74	44.65	34.4	11.14	35.05	300	243	P	V
		5350.08	48.52	-5.48	54	38.03	34.4	11.14	35.05	300	243	A	V
Remark	1. No other spurious found. 2. All results are PASS against Peak and Average limit line.												

Band 2 5250~5350MHz
WIFI 802.11n HT40 (Harmonic @ 3m)

WIFI Ant. 1+2	Note	Frequency (MHz)	Level (dBμV/m)	Over Limit (dB)	Limit Line (dBμV/m)	Read Level (dBμV)	Antenna Factor (dB/m)	Path Loss (dB)	Preamp Factor (dB)	Ant Pos (cm)	Table Pos (deg)	Peak Avg. (P/A)	Pol. (H/V)	
802.11n HT40 CH 62 5310MHz		10620	48.66	-25.34	74	52.86	37.52	17.31	59.03	100	0	P	H	
		15930	50.32	-23.68	74	45.43	40.7	20.7	56.51	100	0	P	H	
													H	
													H	
			10620	47.51	-26.49	74	51.71	37.52	17.31	59.03	100	0	P	V
			15930	50.58	-23.42	74	45.69	40.7	20.7	56.51	100	0	P	V
														V
														V
Remark	1. No other spurious found. 2. All results are PASS against Peak and Average limit line.													



Band 3 - 5470~5725MHz
WIFI 802.11ac VHT80 (Band Edge @ 3m)

WIFI Ant. 1+2	Note	Frequency (MHz)	Level (dBμV/m)	Over Limit (dB)	Limit Line (dBμV/m)	Read Level (dBμV)	Antenna Factor (dB/m)	Path Loss (dB)	Preamp Factor (dB)	Ant Pos (cm)	Table Pos (deg)	Peak Avg. (P/A)	Pol. (H/V)
802.11ac VHT80 CH 106 5530MHz		5456.32	59.98	-14.02	74	49.14	34.7	11.2	35.06	219	297	P	H
		5460.88	61.11	-7.09	68.2	49.88	34.7	11.59	35.06	219	297	P	H
		5457.76	52.56	-1.44	54	41.72	34.7	11.2	35.06	219	297	A	H
	*	5530	108.89	-	-	97.83	34.83	11.3	35.07	219	297	P	H
	*	5530	101.22	-	-	90.16	34.83	11.3	35.07	219	297	A	H
		5730.98	50.92	-17.28	68.2	39.69	34.83	11.5	35.1	219	297	P	H
		5454.64	53.25	-20.75	74	42.41	34.7	11.2	35.06	398	253	P	V
		5463.28	54.68	-13.52	68.2	43.72	34.77	11.25	35.06	398	253	P	V
		5458.48	45.4	-8.6	54	34.56	34.7	11.2	35.06	398	253	A	V
	*	5530	103.65	-	-	92.59	34.83	11.3	35.07	398	253	P	V
	*	5530	96.09	-	-	85.03	34.83	11.3	35.07	398	253	A	V
		5759.96	50.39	-17.81	68.2	39.13	34.83	11.53	35.1	398	253	P	V
Remark	1. No other spurious found. 2. All results are PASS against Peak and Average limit line.												

Band 3 5470~5725MHz
WIFI 802.11ac VHT80 (Harmonic @ 3m)

WIFI Ant. 1+2	Note	Frequency (MHz)	Level (dBμV/m)	Over Limit (dB)	Limit Line (dBμV/m)	Read Level (dBμV)	Antenna Factor (dB/m)	Path Loss (dB)	Preamp Factor (dB)	Ant Pos (cm)	Table Pos (deg)	Peak Avg. (P/A)	Pol. (H/V)	
802.11ac VHT80 CH 106 5530MHz		11060	49	-25	74	51.6	37.87	17.87	58.34	100	0	P	H	
		16590	51.91	-16.29	68.2	44.97	41.82	21.25	56.13	100	0	P	H	
													H	
													H	
			11060	47.98	-26.02	74	50.58	37.87	17.87	58.34	100	0	P	V
			16590	52.03	-16.17	68.2	45.09	41.82	21.25	56.13	100	0	P	V
														V
														V
Remark	1. No other spurious found. 2. All results are PASS against Peak and Average limit line.													



Emission below 1GHz
WIFI 802.11ac VHT80 (LF @ 3m)

WIFI	Note	Frequency	Level	Over	Limit	Read	Antenna	Path	Preamp	Ant	Table	Peak	Pol.	
Ant.				Limit	Line	Level	Factor	Loss	Factor	Pos	Pos	Avg.		
1+2		(MHz)	(dBμV/m)	(dB)	(dBμV/m)	(dBμV)	(dB/m)	(dB)	(dB)	(cm)	(deg)	(P/A)	(H/V)	
802.11ac VHT80 LF		30	29.15	-10.85	40	33.4	24.6	1.33	30.18	100	0	P	H	
		47.82	25.18	-14.82	40	38.51	15.48	1.34	30.15	-	-	P	H	
		129.36	27.47	-16.03	43.5	38.02	17.48	2.01	30.04	-	-	P	H	
		905.5	32.67	-13.33	46	27.72	28.85	4.96	28.86	-	-	P	H	
		937	33.76	-12.24	46	27.72	29.72	4.97	28.65	-	-	P	H	
		966.4	34.08	-19.92	54	26.59	30.88	5.06	28.45	-	-	P	H	
														H
														H
														H
														H
														H
														H
			178.5	40.15	-3.35	43.5	52.8	15.09	2.25	29.99	100	0	P	V
			181.74	39.52	-3.98	43.5	52.17	14.96	2.37	29.98	-	-	P	V
			273	40.22	-5.78	46	48.29	19.01	2.87	29.95	-	-	P	V
			836.9	33.71	-12.29	46	29.74	28.41	4.74	29.18	-	-	P	V
			963.6	34.5	-19.5	54	27.02	30.89	5.06	28.47	-	-	P	V
			979.7	34.82	-19.18	54	27.3	30.82	5.06	28.36	-	-	P	V
														V
														V
													V	
													V	
													V	
													V	
Remark	1. No other spurious found. 2. All results are PASS against limit line.													



Note symbol

*	Fundamental Frequency which can be ignored. However, the level of any unwanted emissions shall not exceed the level of the fundamental frequency.
!	Test result is over limit line.
P/A	Peak or Average
H/V	Horizontal or Vertical



A calculation example for radiated spurious emission is shown as below:

WIFI	Note	Frequency	Level	Over	Limit	Read	Antenna	Path	Preamp	Ant	Table	Peak	Pol.
Ant.				Limit	Line	Level	Factor	Loss	Factor	Pos	Pos	Avg.	
1+2		(MHz)	(dBμV/m)	(dB)	(dBμV/m)	(dBμV)	(dB/m)	(dB)	(dB)	(cm)	(deg)	(P/A)	(H/V)
802.11b		2390	55.45	-18.55	74	54.51	32.22	4.58	35.86	103	308	P	H
CH 01													
2412MHz		2390	43.54	-10.46	54	42.6	32.22	4.58	35.86	103	308	A	H

1. Path Loss(dB) = Cable loss(dB) + Filter loss(dB) + Attenuator loss(dB)
2. Level(dBμV/m) = Antenna Factor(dB/m) + Path Loss(dB) + Read Level(dBμV) - Preamp Factor(dB)
3. Over Limit(dB) = Level(dBμV/m) – Limit Line(dBμV/m)

For Peak Limit @ 2390MHz:

1. Level(dBμV/m)
= Antenna Factor(dB/m) + Path Loss(dB) + Read Level(dBμV) - Preamp Factor(dB)
= 32.22(dB/m) + 4.58(dB) + 54.51(dBμV) – 35.86 (dB)
= 55.45 (dBμV/m)
2. Over Limit(dB)
= Level(dBμV/m) – Limit Line(dBμV/m)
= 55.45(dBμV/m) – 74(dBμV/m)
= -18.55(dB)

For Average Limit @ 2390MHz:

1. Level(dBμV/m)
= Antenna Factor(dB/m) + Path Loss(dB) + Read Level(dBμV) - Preamp Factor(dB)
= 32.22(dB/m) + 4.58(dB) + 42.6(dBμV) – 35.86 (dB)
= 43.54 (dBμV/m)
2. Over Limit(dB) = Level(dBμV/m) – Limit Line(dBμV/m)
= 43.54(dBμV/m) – 54(dBμV/m)
= -10.46(dB)

Both peak and average measured complies with the limit line, so test result is “PASS”.



Appendix B. Radiated Spurious Emission Plots

Test Engineer :	Jesse Wang, Stan Hsieh, and Troye Hsieh	Temperature :	20~25°C
		Relative Humidity :	55~60%

Note symbol

-L	Low channel location
-R	High channel location



Band 1 - 5150~5250MHz
WIFI 802.11a (Band Edge @ 3m)

WIFI	Band 1 5150~5250MHz Band Edge @ 3m	
ANT	802.11a CH36 5180MHz	
1+2	Horizontal	Fundamental
Peak	<p> Site : 03CH07-HY Condition : PEAK_BE_74 3m HF_ANT_00075962 HORIZONTAL Detector : Peak Project : 8N2627 Mode : 1 </p>	<p> Site : 03CH07-HY Condition : PEAK_74 3m HE_ANT_00075962 HORIZONTAL Detector : Peak Project : 8N2627 Mode : 1 </p>
Avg.	<p> Site : 03CH07-HY Condition : AVG_BE_54 3m HE_ANT_00075962 HORIZONTAL Detector : Peak Project : 8N2627 Mode : 1 </p>	Left blank



WIFI	Band 1 5150~5250MHz Band Edge @ 3m	
ANT	802.11a CH36 5180MHz	
1+2	Vertical	Fundamental
Peak	<p>Site : 03CH07-HY Condition : PEAK_BE_74 3m HF_ANT_00075962 VERTICAL Detector : RBW:1000.000kHz VBW:3000.000kHz SWT:Auto Project : Peak Mode : 1</p>	<p>Site : 03CH07-HY Condition : PEAK_74 3m HF_ANT_00075962 VERTICAL Detector : RBW:1000.000kHz VBW:3000.000kHz SWT:Auto Project : Peak Mode : 1</p>
Avg.	<p>Site : 03CH07-HY Condition : AVG_BE_54 3m HF_ANT_00075962 VERTICAL Detector : RBW:1000.000kHz VBW:1.000kHz SWT:Auto Project : Peak Mode : 1</p>	Left blank



Band 1 - 5150~5250MHz
WIFI 802.11a (Harmonic @ 3m)

WIFI	Band 1 5150~5250MHz Harmonic @ 3m	
ANT	802.11a CH36 5180MHz	
1+2	Horizontal	Vertical
Peak Avg.	<p>Site : 03CH07-11Y Condition : PEAK(LINE) 3m SHF-EHF_131029 HORIZONTAL Detector : Peak Project : FR2627 Mode : 1</p>	<p>Site : 03CH07-11Y Condition : PEAK(LINE) 3m SHF-EHF_131029 VERTICAL Detector : Peak Project : FR2627 Mode : 1</p>

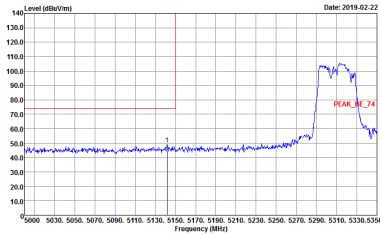
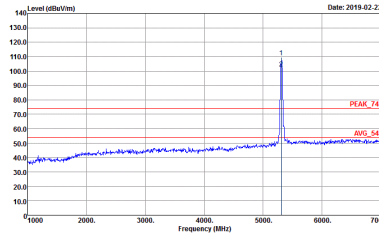
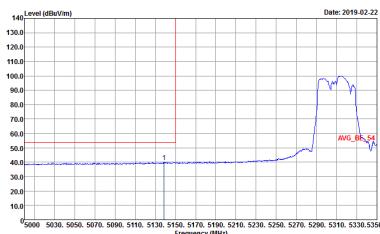

**Band 2 5250~5350MHz
WIFI 802.11n HT40 (Band Edge @ 3m)**

WIFI	Band 2 5250~5350MHz Band Edge @ 3m	
ANT	802.11n HT40 CH62 5310 - L	
1+2	Horizontal	Fundamental
<p align="center">Peak</p>	 <p>Date: 2019-02-22</p> <p>Site : 03CH07-HY Condition : PEAK_BE_74 3m HF_ANT_00075962 HORIZONTAL : RBW:1000.000kHz VBW:3000.000kHz SWF:Auto Detector : Peak Project : 8N2627 Mode : 10</p>	 <p>Date: 2019-02-22</p> <p>Site : 03CH07-HY Condition : PEAK_74 3m HF_ANT_00075962 HORIZONTAL : RBW:1000.000kHz VBW:3000.000kHz SWF:Auto Detector : Peak Project : 8N2627 Mode : 10</p>
<p align="center">Avg.</p>	 <p>Date: 2019-02-22</p> <p>Site : 03CH07-HY Condition : AVG_BE_54 3m HF_ANT_00075962 HORIZONTAL : RBW:1000.000kHz VBW:3.000kHz SWF:Auto Detector : Peak Project : 8N2627 Mode : 10</p>	<p align="center">Left blank</p>

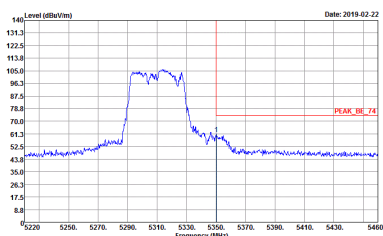
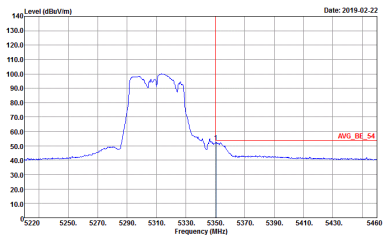

WIFI	Band 2 5250~5350MHz Band Edge @ 3m	
ANT	802.11n HT40 CH62 5310 - R	
1+2	Horizontal	Fundamental
<p>Peak</p>	 <p>Site : 03CH07-HY Condition : PEAK_BE_74 3m HF_ANT_00075962 HORIZONTAL Detector : Peak Project : BN2627 Mode : 10</p>	<p>Left blank</p>
<p>Avg.</p>	 <p>Site : 03CH07-HY Condition : AVG_BE_54 3m HF_ANT_00075962 HORIZONTAL Detector : Peak Project : BN2627 Mode : 10</p>	<p>Left blank</p>



WIFI	Band 2 5250~5350MHz Band Edge @ 3m	
ANT	802.11n HT40 CH62 5310 - L	
1+2	Vertical	Fundamental
<p>Peak</p>	<p>Site : 03CH07-HY Condition : PEAK_BE_74 3m HF_ANT_00075962 VERTICAL Detector : Peak Project : 8N2627 Mode : 10</p>	<p>Site : 03CH07-HY Condition : PEAK_74 3m HF_ANT_00075962 VERTICAL Detector : Peak Project : 8N2627 Mode : 10</p>
<p>Avg.</p>	<p>Site : 03CH07-HY Condition : AVG_BE_S4 3m HF_ANT_00075962 VERTICAL Detector : Peak Project : 8N2627 Mode : 10</p>	<p>Left blank</p>

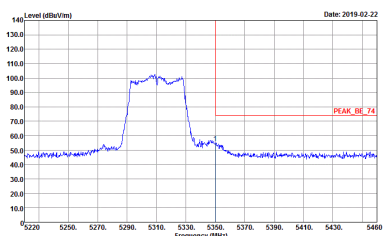
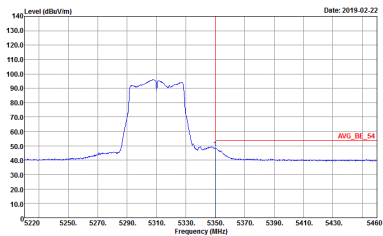

WIFI	Band 2 5250~5350MHz Band Edge @ 3m	
ANT	802.11n HT40 CH62 5310 - R	
1+2	Vertical	Fundamental
<p>Peak</p>	 <p>Site : 03CH07-HY Condition : PEAK_BE_74 3m HF_ANT_00075962 VERTICAL Detector : Peak Project : BN2627 Mode : 10</p>	<p>Left blank</p>
<p>Avg.</p>	 <p>Site : 03CH07-HY Condition : AVG_BE_54 3m HF_ANT_00075962 VERTICAL Detector : Peak Project : BN2627 Mode : 10</p>	<p>Left blank</p>



**Band 2 5250~5350MHz
WIFI 802.11n HT40 (Harmonic @ 3m)**

WIFI	Band 2 5250~5350MHz Harmonic @ 3m	
ANT	802.11n HT40 CH62 5310	
1+2	Horizontal	Vertical
Peak Avg.	<p>Site : 03CH07-HY Condition : PEAK(UNI) 3m SHF-EHF_131029 HORIZONTAL Detector : Peak Project : 8N2627 Mode : 10</p>	<p>Site : 03CH07-HY Condition : PEAK(UNI) 3m SHF-EHF_131029 VERTICAL Detector : Peak Project : 8N2627 Mode : 10</p>



Band 3 5470~5725MHz
WIFI 802.11ac VHT80 (Band Edge @ 3m)

WIFI	Band 3 5470~5725MHz Band Edge @ 3m	
ANT	802.11ac VHT80 CH106 5530MHz - L	
1+2	Horizontal	Fundamental
Peak	<p> Site : 03CH07-HY Condition : PEAK_BE(LIN)I, B3 3m HF_ ANT_00075962 HORIZONTAL Detector : Peak Project : 8N2627 Mode : 15 </p>	<p> Site : 03CH07-HY Condition : PEAK(LIN)I 3m HF_ ANT_00075962 HORIZONTAL Detector : Peak Project : 8N2627 Mode : 15 </p>
Avg.	<p> Site : 03CH07-HY Condition : AVG_BE(LIN)I, B3 3m HF_ ANT_00075962 HORIZONTAL Detector : Peak Project : 8N2627 Mode : 15 </p>	Left blank



WIFI	Band 3 5470~5725MHz Band Edge @ 3m	
ANT	802.11ac VHT80 CH106 5530MHz - R	
1+2	Horizontal	Fundamental
Peak	<p>Site : GSCH07-HY Condition : PEAK_BE(LINII)_B3 3m HF_ANT_00075962 HORIZONTAL Detector : Peak Project : SN2627 Mode : 15</p>	Left blank

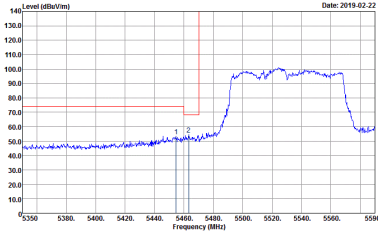
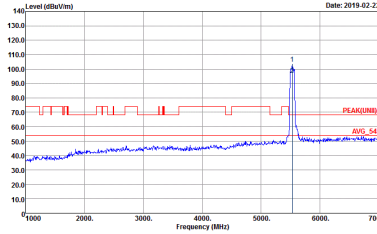
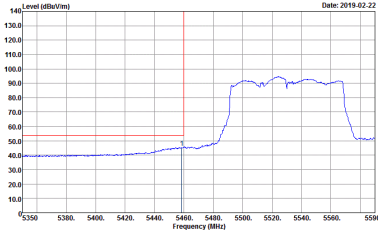

WIFI	Band 3 5470~5725MHz Band Edge @ 3m	
ANT	802.11ac VHT80 CH106 5530MHz - L	
1+2	Vertical	Fundamental
Peak	 <p>Site : 03CH07-HY Condition : PEAK_BE(UNII)_B3 3m HF_ANT_00075962 VERTICAL Detector : Peak Project : 8N2627 Mode : 15</p>	 <p>Site : 03CH07-HY Condition : PEAK(UNII) 3m HF_ANT_00075962 VERTICAL Detector : Peak Project : 8N2627 Mode : 15</p>
Avg.	 <p>Site : 03CH07-HY Condition : AHC_BE(UNII)_B3 3m HF_ANT_00075962 VERTICAL Detector : Peak Project : 8N2627 Mode : 15</p>	Left blank



WIFI	Band 3 5470~5725MHz Band Edge @ 3m	
ANT	802.11ac VHT80 CH106 5530MHz - R	
1+2	Vertical	Fundamental
Peak	<p>Site : Q3CH07-HY Condition : PEAK_BE(LIN11)_B3 3m HF_ANT_00075962 VERTICAL Detector : Peak Project : SN2627 Mode : 15</p>	Left blank



Band 3 5470~5725MHz
WIFI 802.11ac VHT80 (Harmonic @ 3m)

Table with 4 columns: WIFI, ANT, 1+2, and two sub-columns for Horizontal and Vertical. It contains two spectral plots and associated metadata for Peak and Avg. measurements.



Emission below 1GHz
5GHz WIFI 802.11ac VHT80 (LF)

WIFI	5GHz WIFI	
ANT	802.11ac VHT80 LF	
1+2	Horizontal	Vertical
QP / Peak	<p>Site : 03CH07-11Y Condition : QP 3m LF-ANT-35419(G) HORIZONTAL Detector : Peak Project : 8N2627 Mode : 17</p>	<p>Site : 03CH07-11Y Condition : QP 3m LF-ANT-35419(G) VERTICAL Detector : Peak Project : 8N2627 Mode : 17</p>



Appendix C. Duty Cycle Plots

Antenna	Band	Duty Cycle (%)	T(us)	1/T(kHz)	VBW Setting	Duty Factor (dB)
1	802.11a	95.82	2062.00	0.48	1kHz	0.19
2	802.11a	95.83	2070.00	0.48	1kHz	0.18
1+2	802.11a for Ant. 1	95.46	2060.00	0.49	1kHz	0.20
1+2	802.11a for Ant. 2	95.82	2062.00	0.48	1kHz	0.19
1	5GHz 802.11n HT20	95.45	1928.00	0.52	1kHz	0.20
2	5GHz 802.11n HT20	95.54	1928.00	0.52	1kHz	0.20
1+2	5GHz 802.11n HT20 for Ant. 1	95.15	1922.00	0.52	1kHz	0.22
1+2	5GHz 802.11n HT20 for Ant. 2	95.45	1928.00	0.52	1kHz	0.20
1	5GHz 802.11n HT40	91.86	948.00	1.05	3kHz	0.37
2	5GHz 802.11n HT40	92.19	944.00	1.06	3kHz	0.35
1+2	5GHz 802.11n HT40 for Ant. 1	92.58	948.00	1.05	3kHz	0.33
1+2	5GHz 802.11n HT40 for Ant. 2	91.51	948.00	1.05	3kHz	0.39
1	5GHz 802.11ac VHT20	95.55	1932.00	0.52	1kHz	0.20
2	5GHz 802.11ac VHT20	95.17	1932.00	0.52	1kHz	0.21
1+2	5GHz 802.11ac VHT20 for Ant. 1	95.17	1932.00	0.52	1kHz	0.21
1+2	5GHz 802.11ac VHT20 for Ant. 2	95.28	1938.00	0.52	1kHz	0.21
1	5GHz 802.11ac VHT40	92.25	952.00	1.05	3kHz	0.35
2	5GHz 802.11ac VHT40	91.54	952.00	1.05	3kHz	0.38
1+2	5GHz 802.11ac VHT40 for Ant. 1	91.54	952.00	1.05	3kHz	0.38
1+2	5GHz 802.11ac VHT40 for Ant. 2	92.25	952.00	1.05	3kHz	0.35
1	5GHz 802.11ac VHT80	85.93	464.00	2.16	3kHz	0.66
2	5GHz 802.11ac VHT80	85.93	464.00	2.16	3kHz	0.66
1+2	5GHz 802.11ac VHT80 for Ant. 1	85.29	464.00	2.16	3kHz	0.69
1+2	5GHz 802.11ac VHT80 for Ant. 2	85.61	464.00	2.16	3kHz	0.67



<Ant. 1>

802.11a

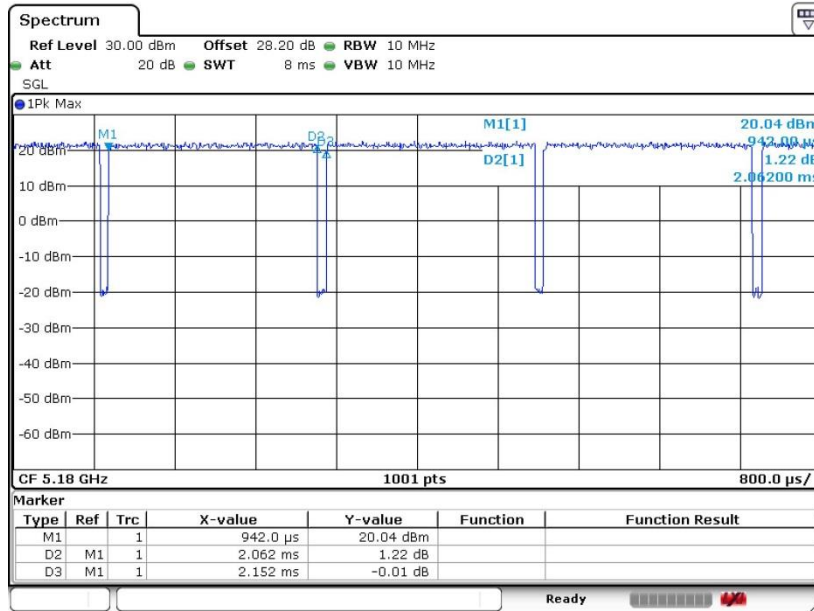

Date: 7.FEB.2019 02:54:44

802.11n HT20

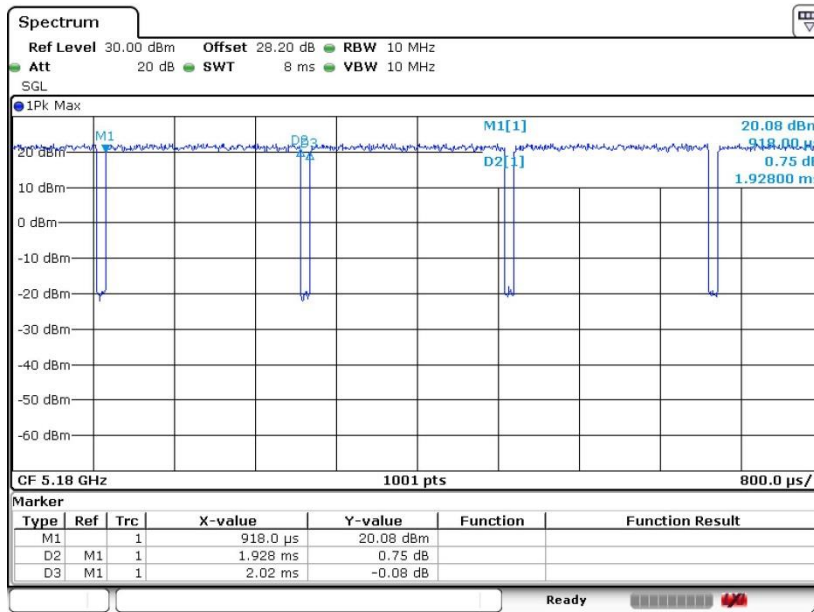

Date: 7.FEB.2019 03:00:21



802.11n HT40

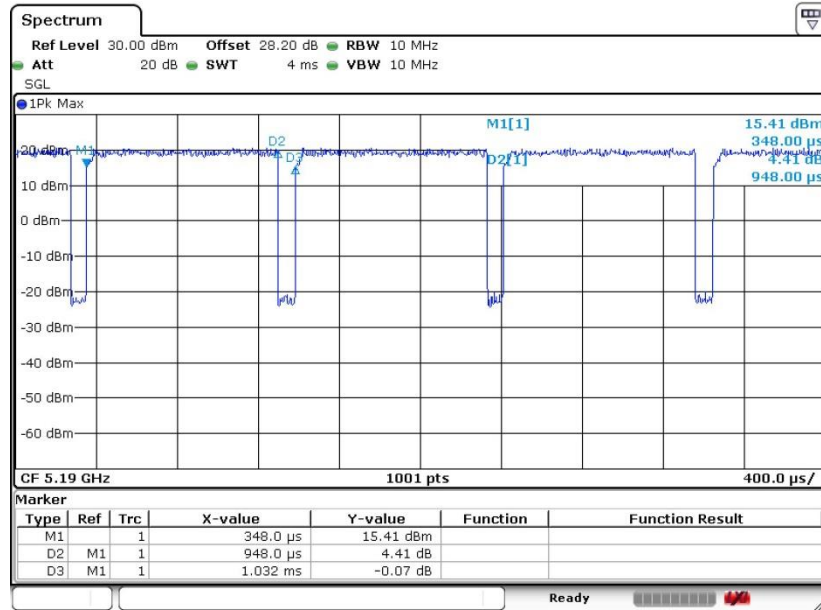

Date: 7.FEB.2019 03:04:33

802.11ac VHT20

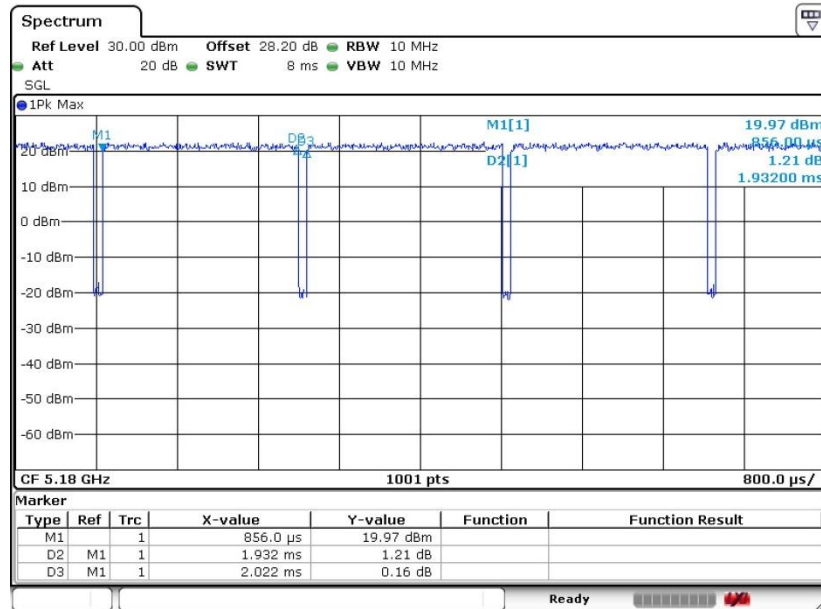

Date: 7.FEB.2019 03:10:20



802.11ac VHT40

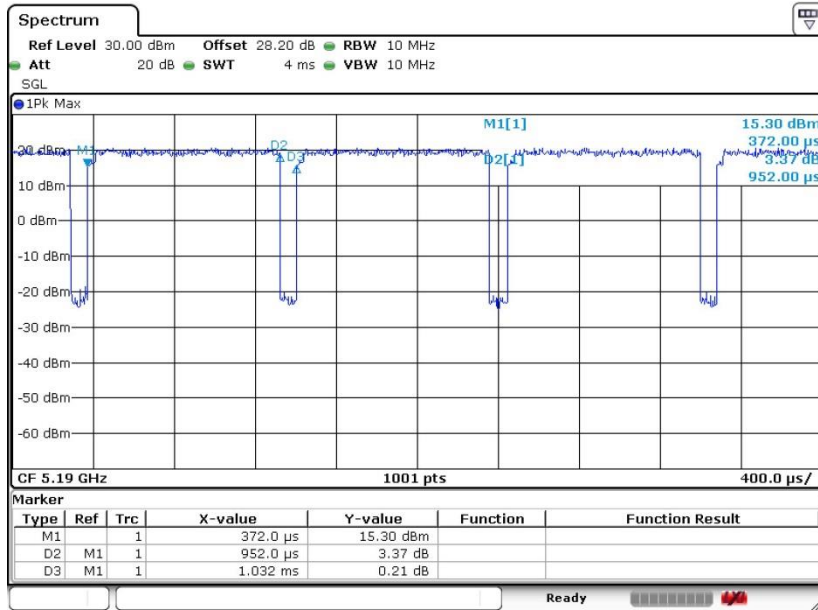

Date: 7.FEB.2019 03:14:18

802.11ac VHT80

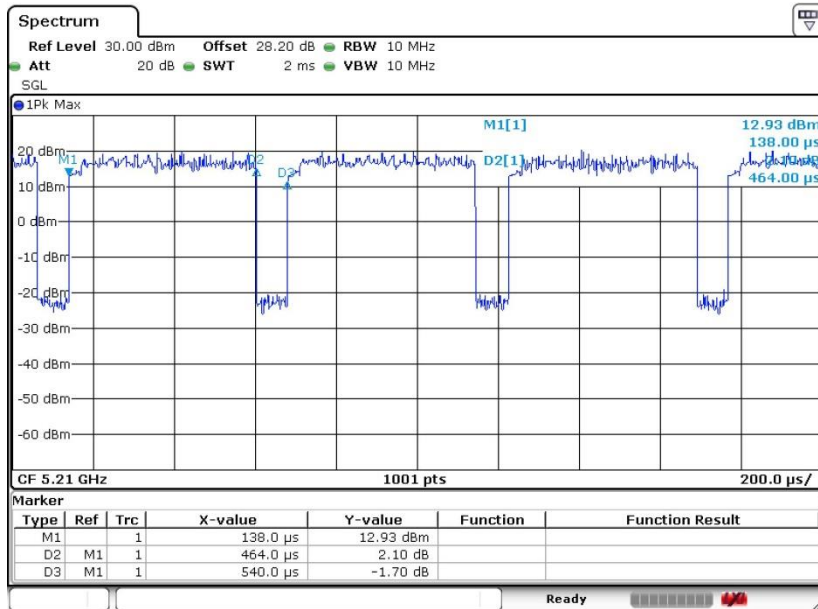

Date: 7.FEB.2019 03:18:27



<Ant. 2>

802.11a

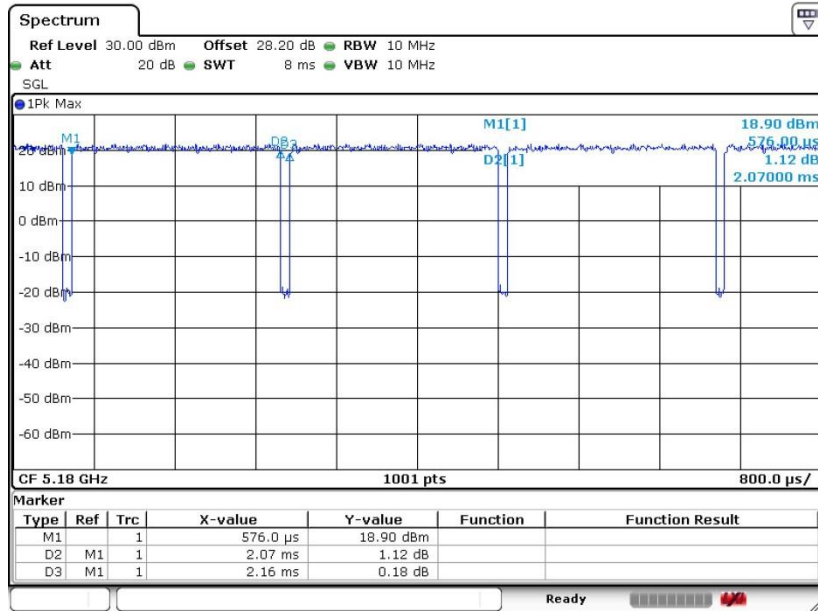

Date: 7.FEB.2019 02:55:59

802.11n HT20

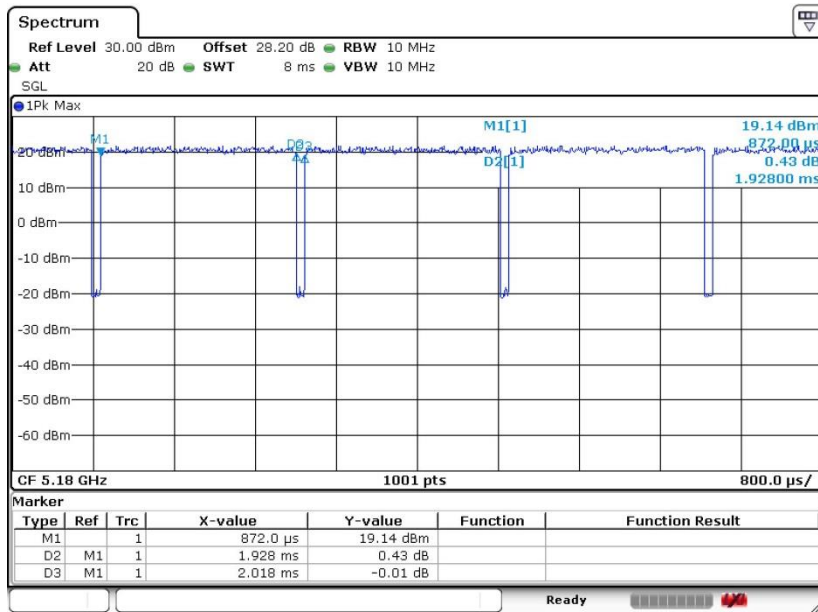

Date: 7.FEB.2019 03:01:21



802.11n HT40

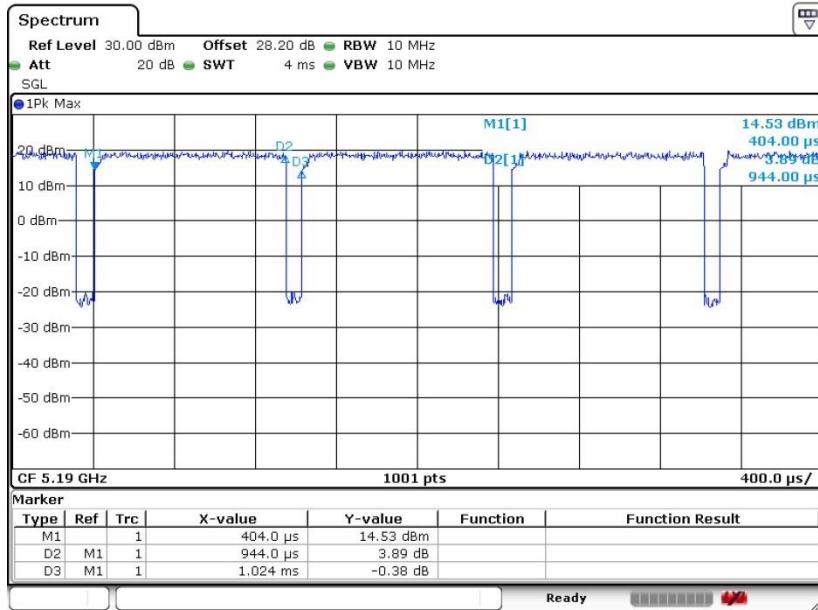

Date: 7.FEB.2019 03:05:46

802.11ac VHT20

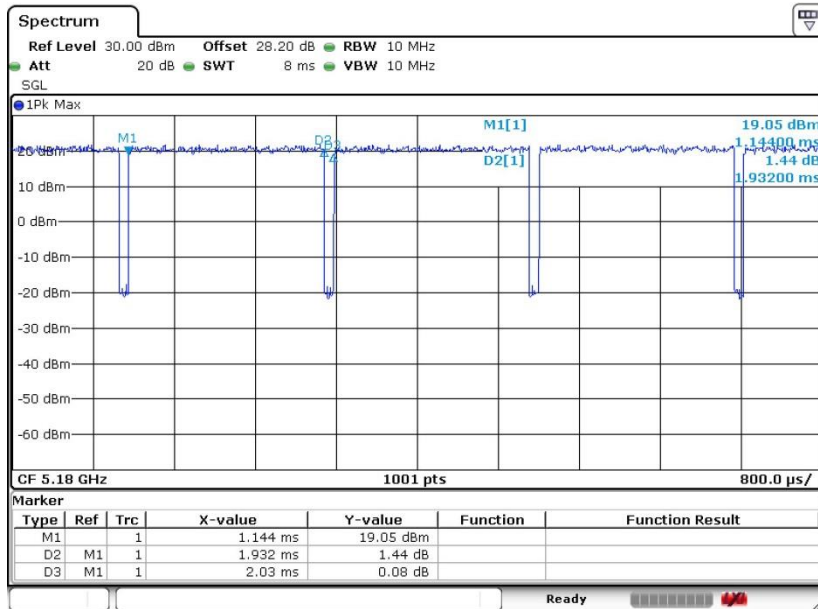

Date: 7.FEB.2019 03:11:23



802.11ac VHT40

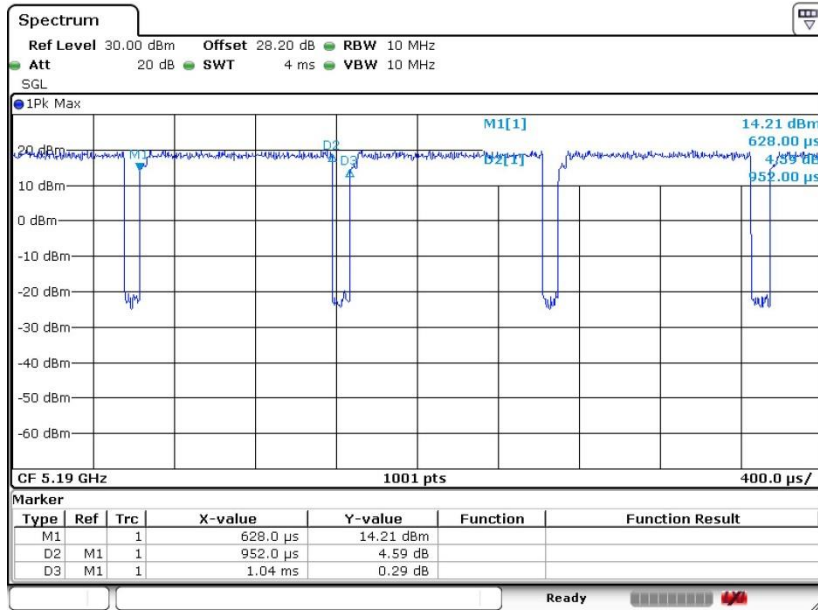

Date: 7.FEB.2019 03:15:10

802.11ac VHT80

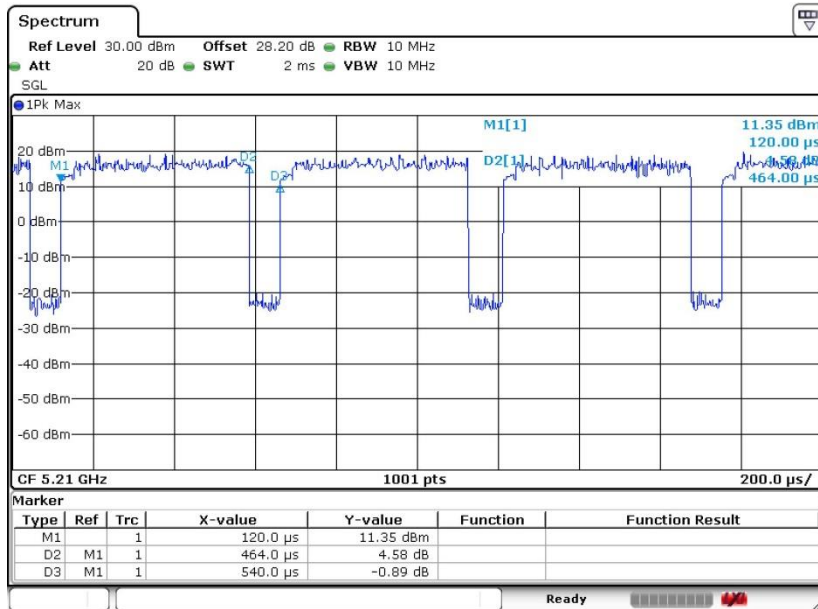

Date: 7.FEB.2019 03:19:25



MIMO <Ant. 1>

802.11a

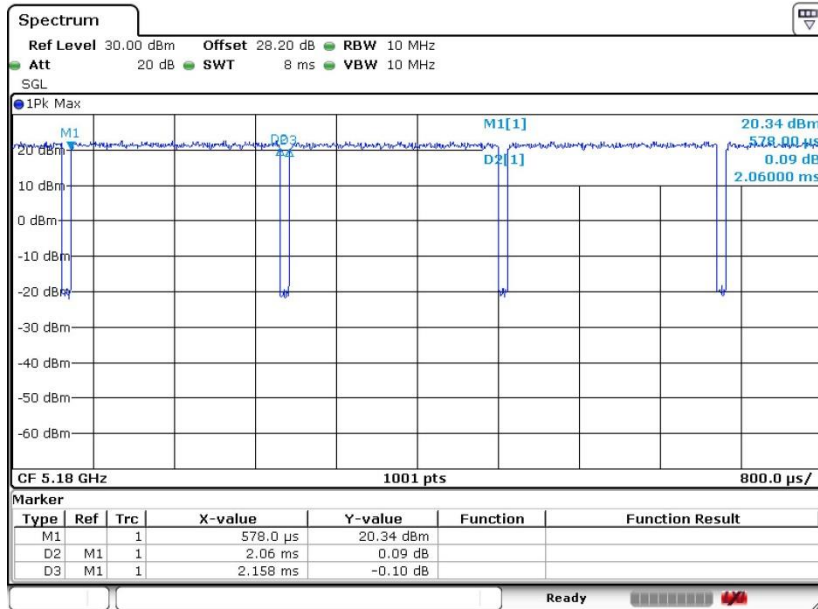

Date: 7.FEB.2019 02:57:09

802.11n HT20

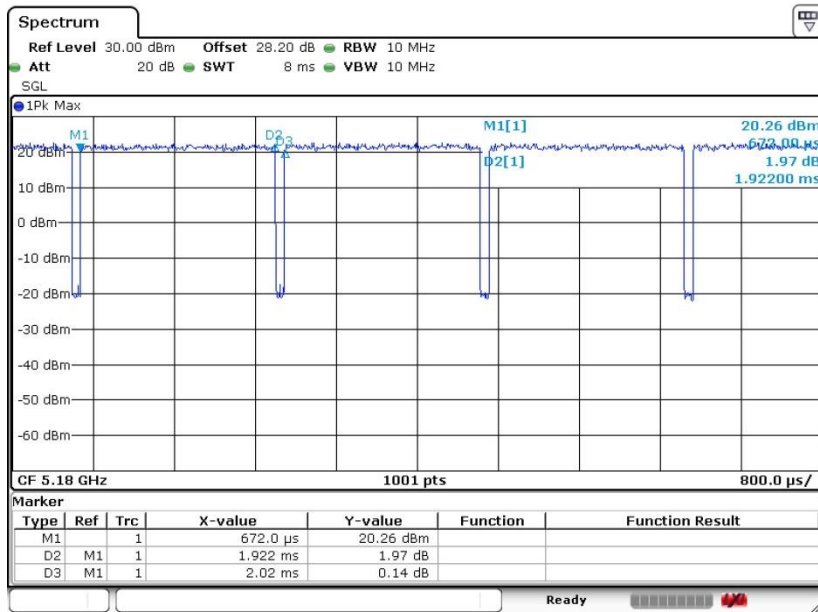

Date: 7.FEB.2019 03:02:29



802.11n HT40

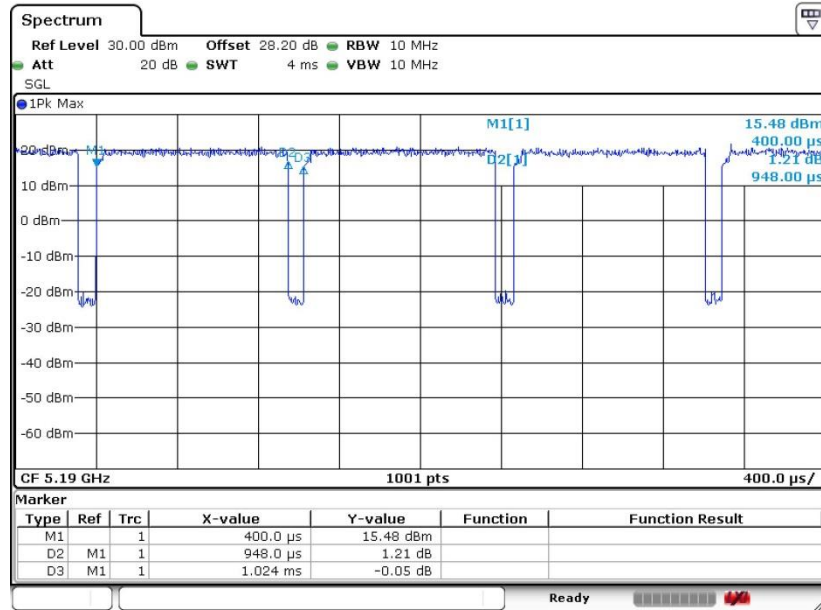

Date: 7.FEB.2019 03:06:54

802.11ac VHT20

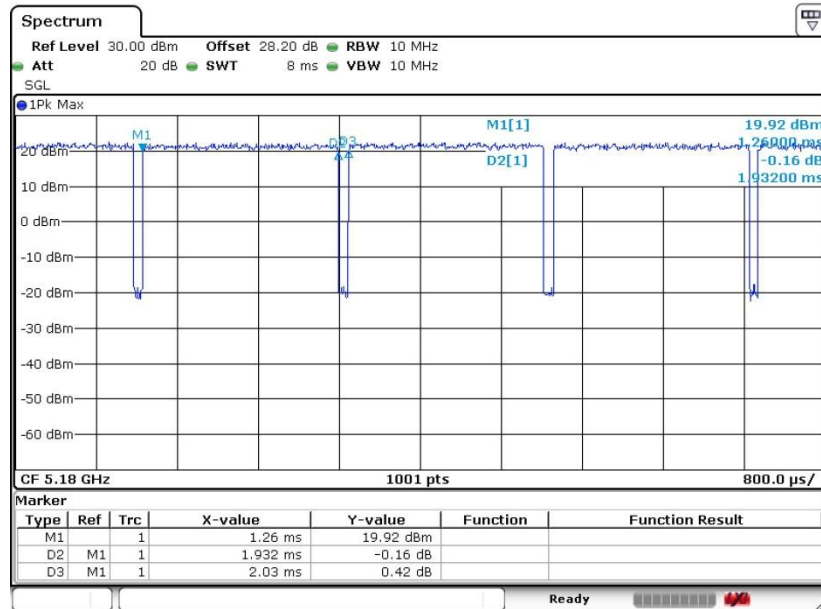

Date: 7.FEB.2019 03:12:21



802.11ac VHT40

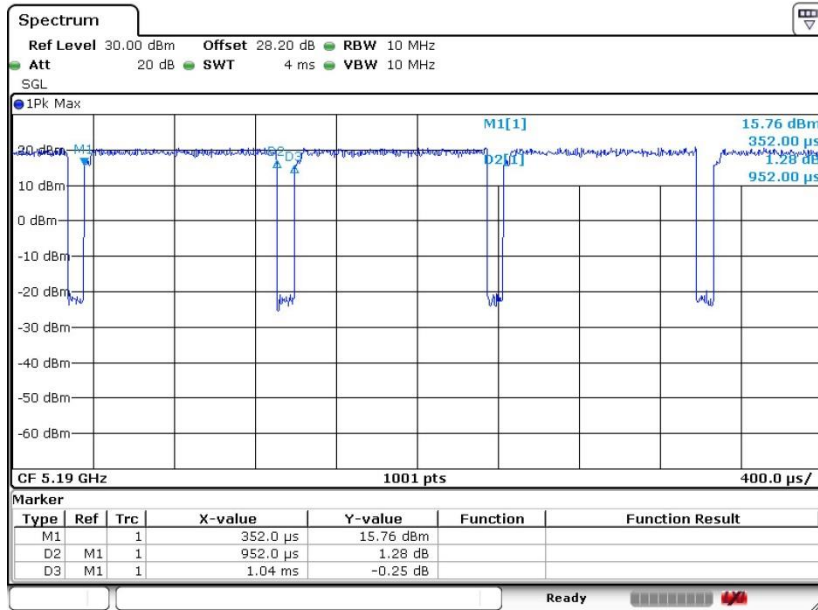

Date: 7.FEB.2019 03:16:05

802.11ac VHT80

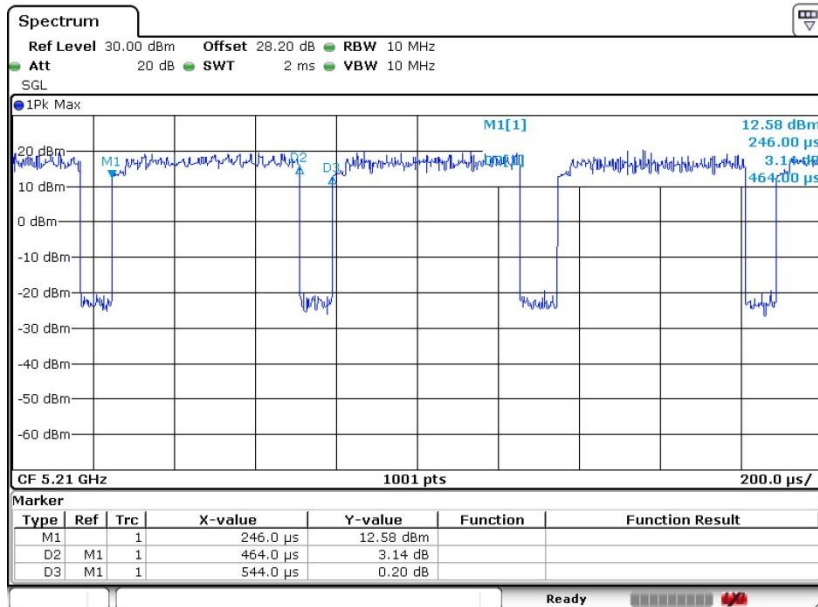

Date: 7.FEB.2019 03:20:27



MIMO <Ant. 2>

802.11a

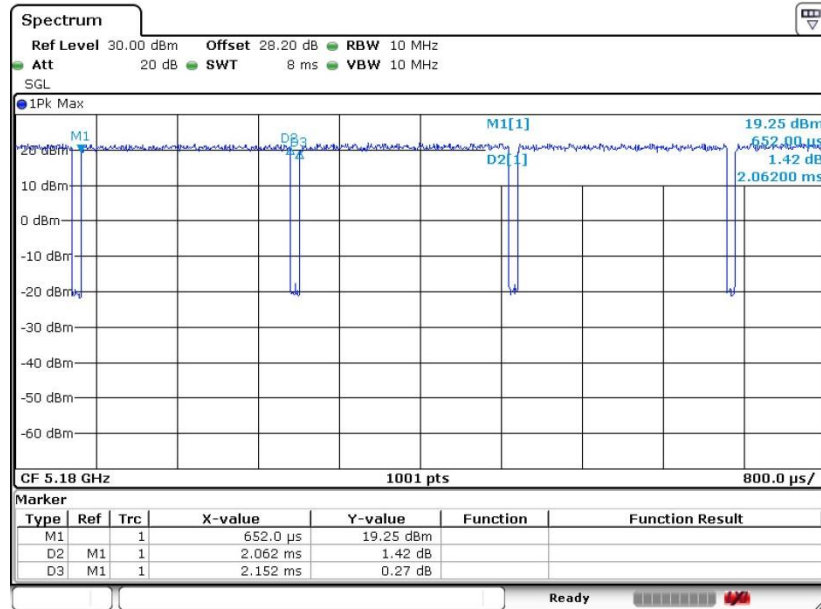

Date: 7.FEB.2019 02:58:52

802.11n HT20

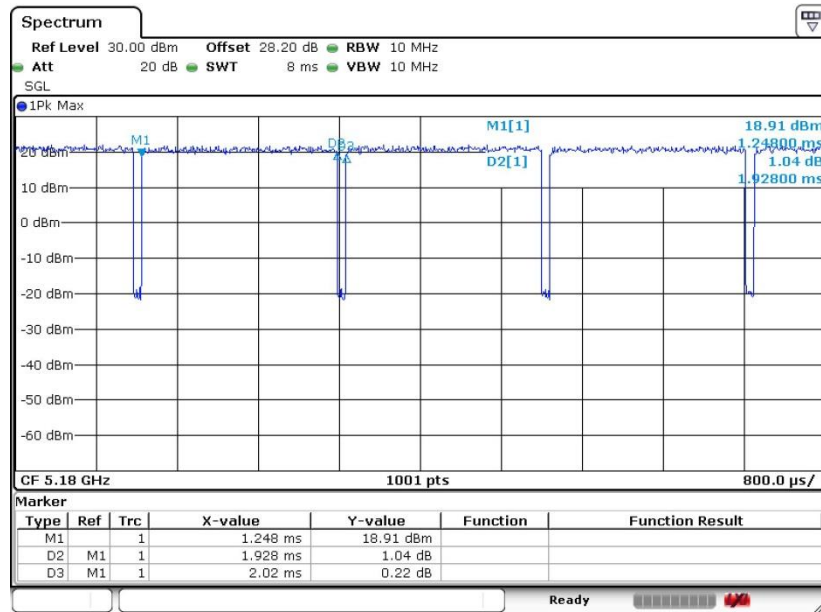

Date: 7.FEB.2019 03:03:15



802.11n HT40

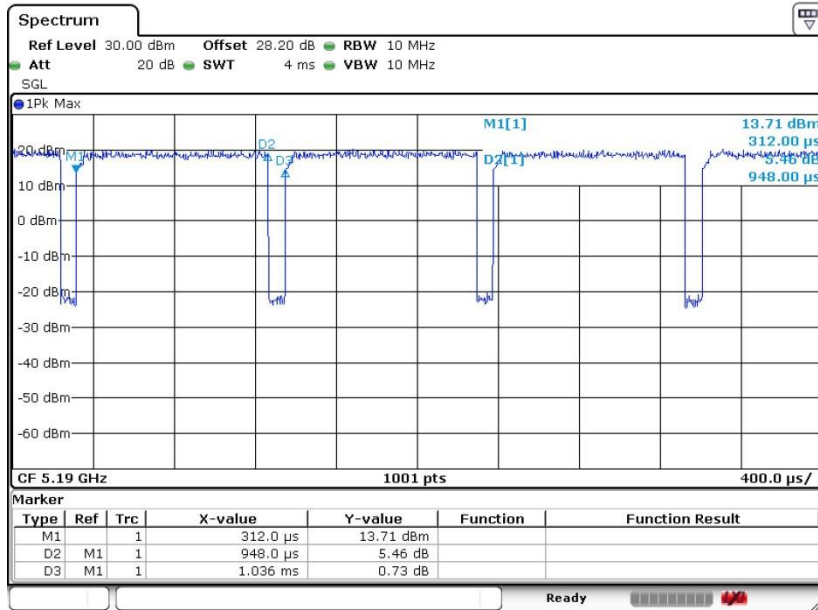

Date: 7.FEB.2019 03:08:57

802.11ac VHT20

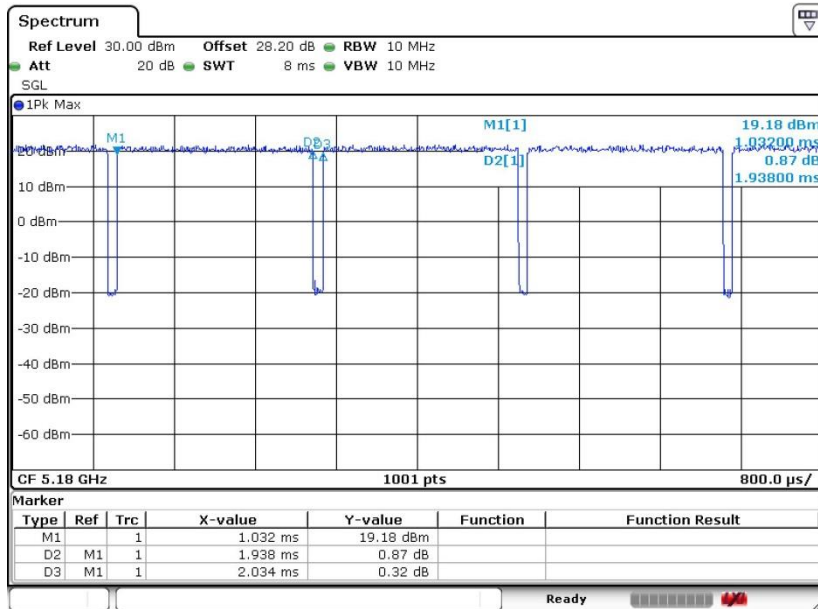

Date: 7.FEB.2019 03:13:03



802.11ac VHT40

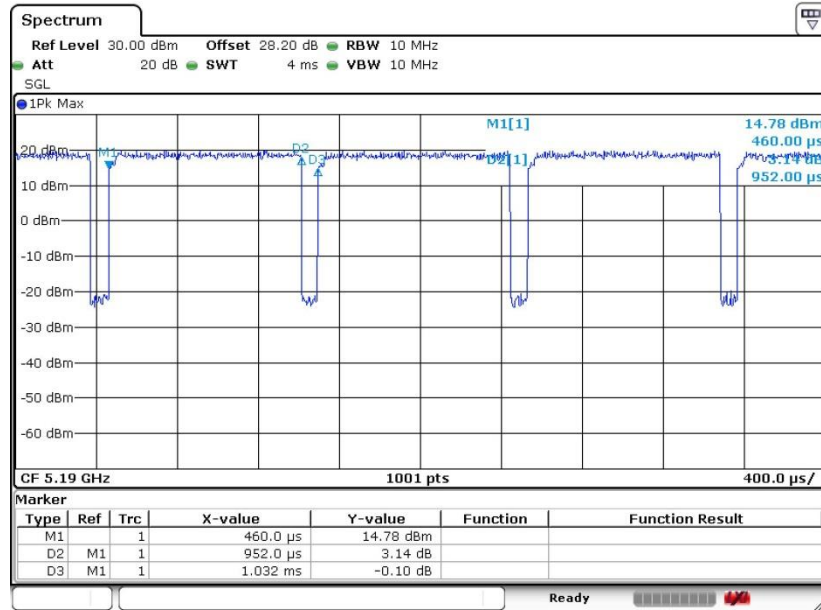

Date: 7.FEB.2019 03:17:05

802.11ac VHT80

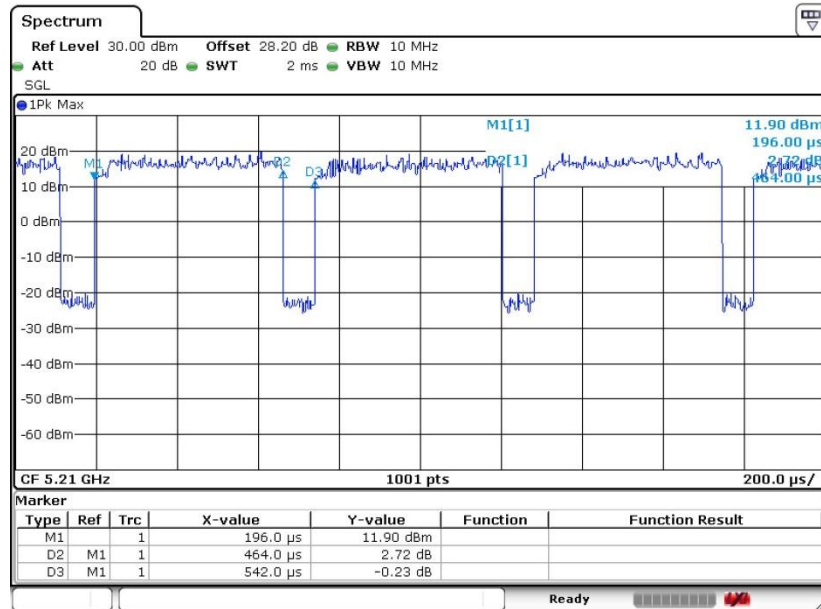

Date: 7.FEB.2019 03:21:19